



US007149867B2

(12) **United States Patent**  
**Poznanovic et al.**

(10) **Patent No.:** **US 7,149,867 B2**  
(45) **Date of Patent:** **Dec. 12, 2006**

(54) **SYSTEM AND METHOD OF ENHANCING EFFICIENCY AND UTILIZATION OF MEMORY BANDWIDTH IN RECONFIGURABLE HARDWARE**

(75) Inventors: **Daniel Poznanovic**, Colorado Springs, CO (US); **David E. Caliga**, Colorado Springs, CO (US); **Jeffrey Hammes**, Colorado Springs, CO (US)

(73) Assignee: **SRC Computers, Inc.**, Colorado Springs, CO (US)

(\*) Notice: Subject to any disclaimer, the term of this patent is extended or adjusted under 35 U.S.C. 154(b) by 0 days.

(21) Appl. No.: **10/869,200**

(22) Filed: **Jun. 16, 2004**

(65) **Prior Publication Data**

US 2004/0260884 A1 Dec. 23, 2004

**Related U.S. Application Data**

(60) Provisional application No. 60/479,339, filed on Jun. 18, 2003.

(51) **Int. Cl.**  
**G06F 12/00** (2006.01)

(52) **U.S. Cl.** ..... **711/170; 711/154**

(58) **Field of Classification Search** ..... **711/170-173; 712/15**

See application file for complete search history.

(56) **References Cited**

**U.S. PATENT DOCUMENTS**

6,076,152	A	6/2000	Huppenthal et al.	
6,243,791	B1 *	6/2001	Vondran, Jr.	711/120
6,247,110	B1	6/2001	Huppenthal et al.	
6,460,122	B1 *	10/2002	Otterness et al.	711/154
6,507,898	B1 *	1/2003	Gibson et al.	711/168
6,594,736	B1	6/2003	Parks	

6,714,041	B1 *	3/2004	Darling et al.	326/38
2003/0046492	A1 *	3/2003	Gschwind et al.	711/118
2003/0046530	A1 *	3/2003	Poznanovic	713/100
2003/0084244	A1 *	5/2003	Paulraj	711/118
2003/0088737	A1 *	5/2003	Burton	711/118
2003/0208658	A1 *	11/2003	Magoshi	711/122
2005/0044327	A1 *	2/2005	Howard et al.	711/147

**OTHER PUBLICATIONS**

“Summary: The Cache Read/Write Process,” The PC Guide, 2001, www.pcguid.com/ref/mbsys/cache/func.htm.\*  
Chien et al., “Safe and Protected Execution for the Morph/AMRM Reconfigurable Processor,” IEEE, 1999, pp. 1-13.\*  
IEEE 100: The Authoritative Dictionary of IEEE Standards Terms, Standards Information Network, 2000, pp. 874.\*

\* cited by examiner

*Primary Examiner*—Gary Portka

*Assistant Examiner*—Shane M. Thomas

(74) *Attorney, Agent, or Firm*—William J. Kubida; Michael C. Martensen; Hogan & Hartson LLP

(57) **ABSTRACT**

A reconfigurable processor that includes a computational unit and a data prefetch unit coupled to the computational unit, where the data prefetch unit retrieves data from a memory and supplies the data to the computational unit through memory and a data access unit, and where the data prefetch unit, memory, and data access unit is configured by a program. Also, a reconfigurable hardware system that includes a common memory; and one or more reconfigurable processors coupled to the common memory, where at least one of the reconfigurable processors includes a data prefetch unit to read and write data between the unit and the common memory, and where the data prefetch unit is configured by a program executed on the system. In addition, a method of transferring data that includes transferring data between a memory and a data prefetch unit in a reconfigurable processor; and transferring the data between a computational unit and the data prefetch unit.

**19 Claims, 12 Drawing Sheets**

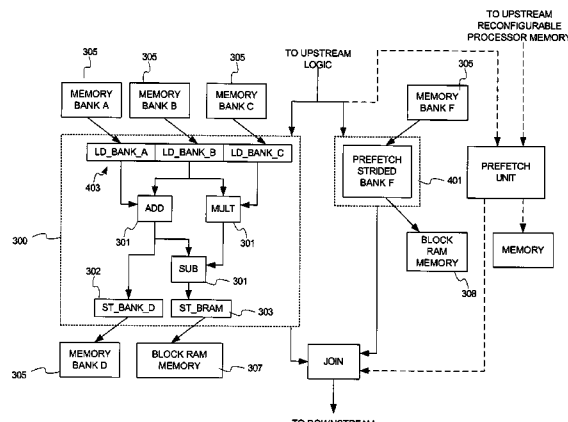

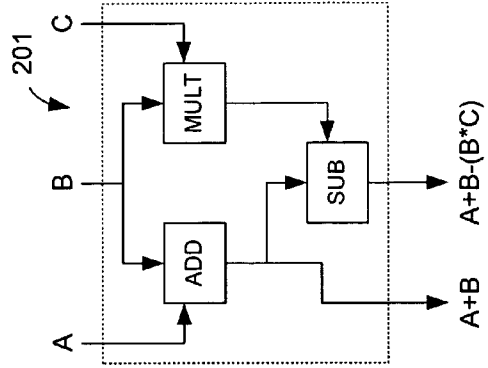
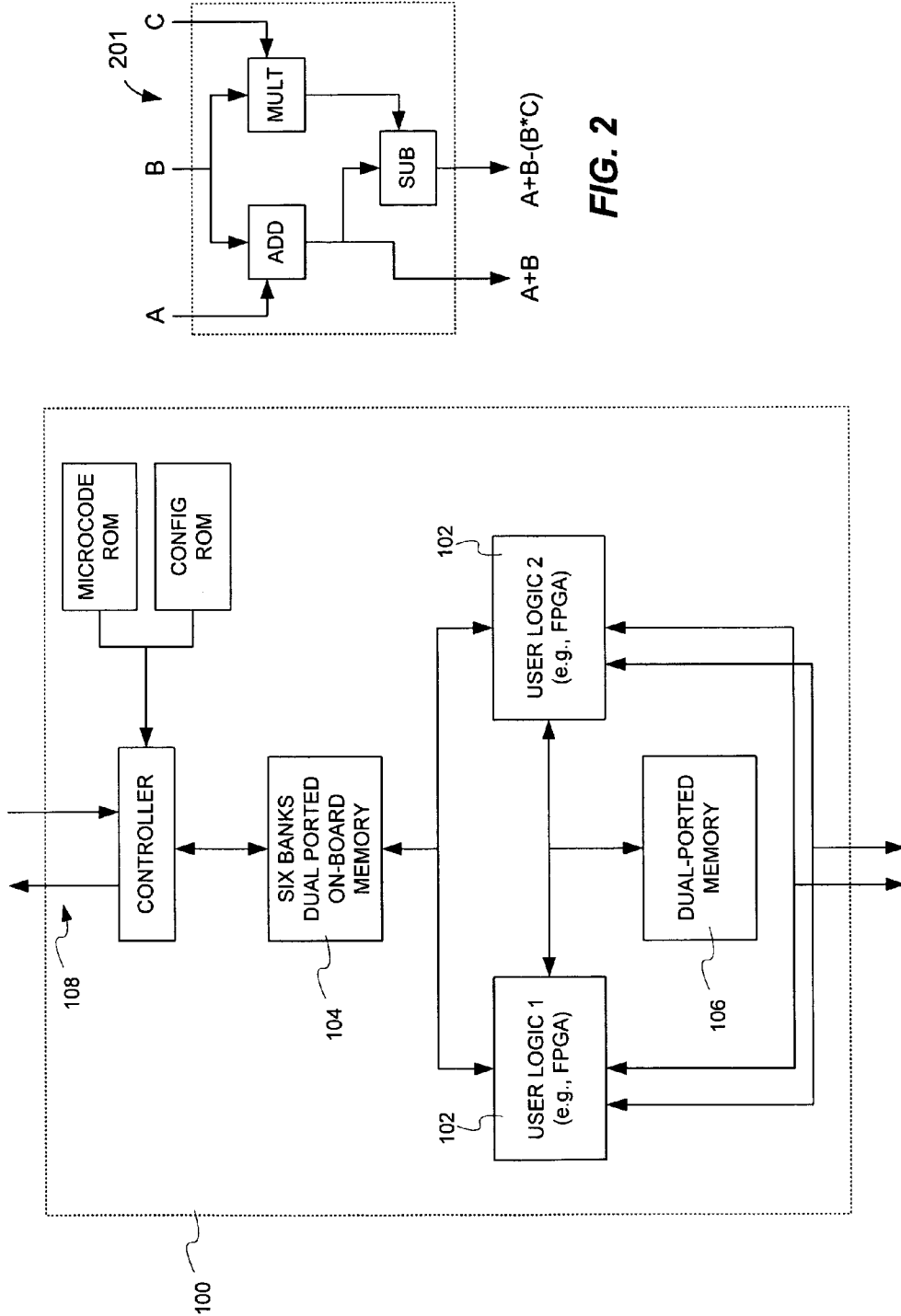

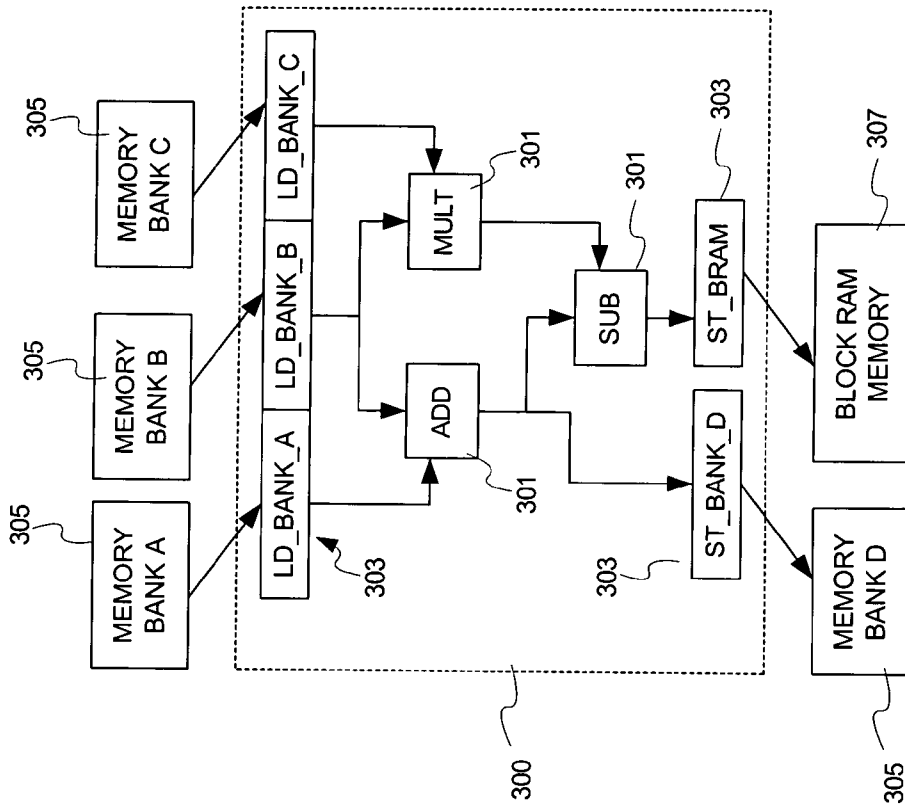

FIG. 3

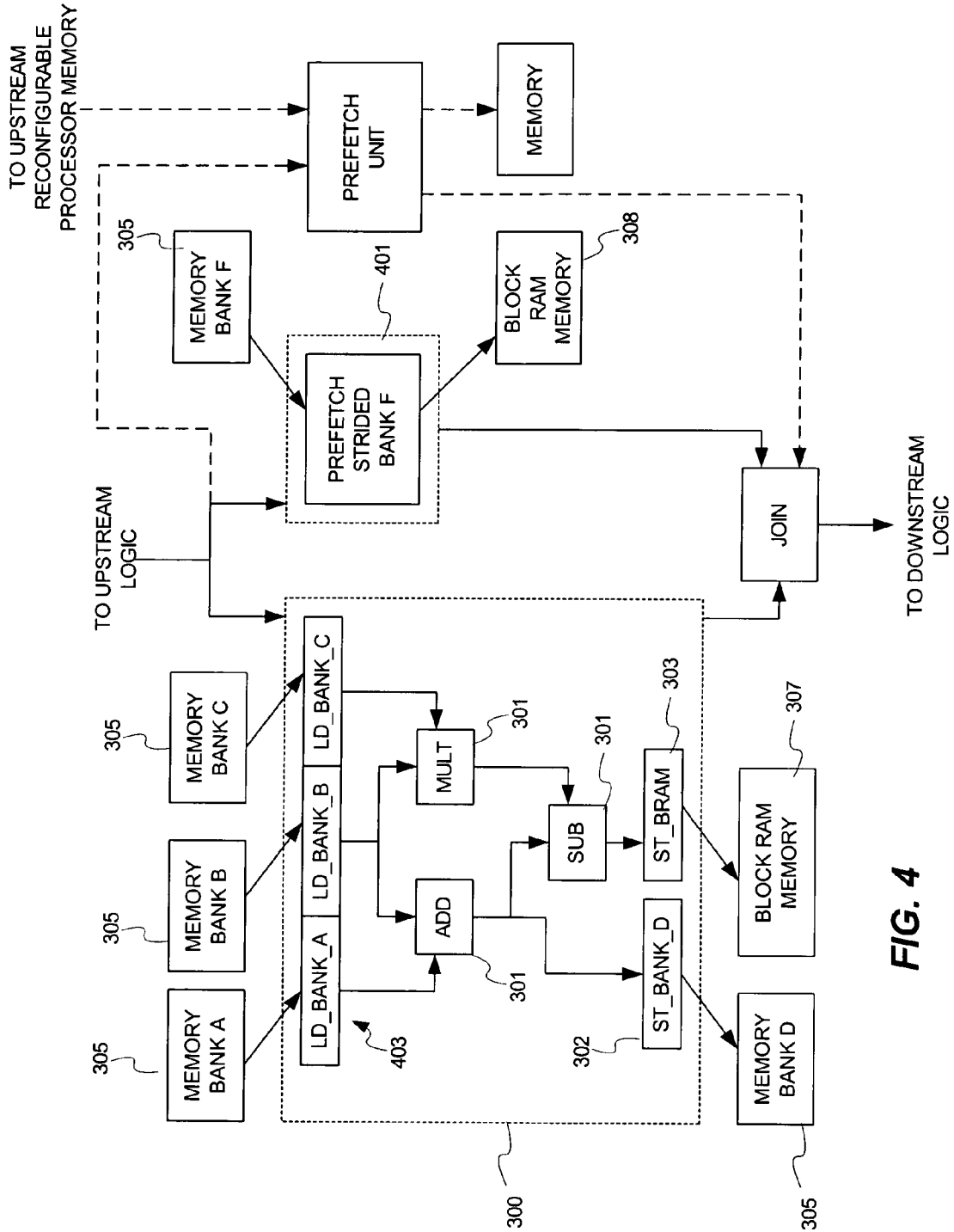

FIG. 4

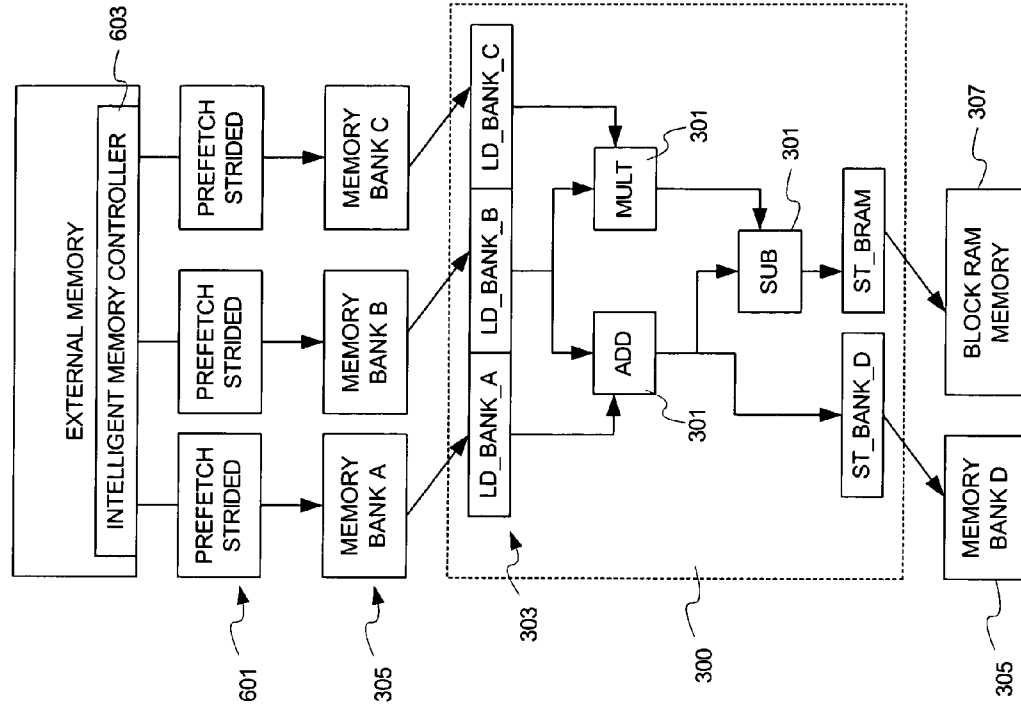

FIG. 6

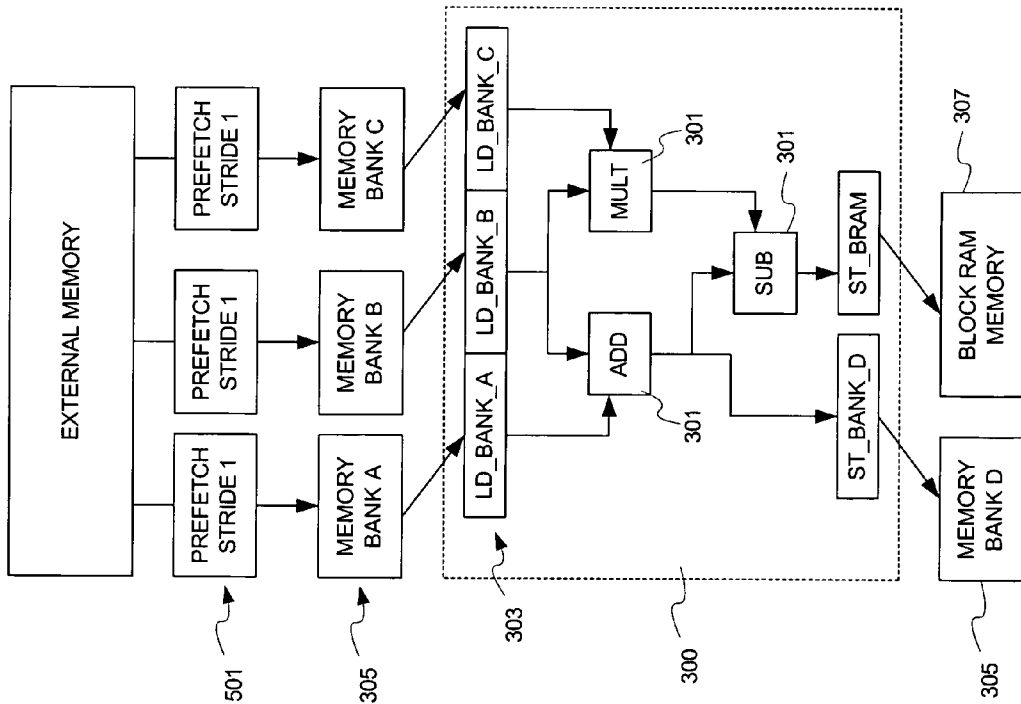

FIG. 5

# Explore Litigation Insights

Docket Alarm provides insights to develop a more informed litigation strategy and the peace of mind of knowing you're on top of things.

## Real-Time Litigation Alerts



Keep your litigation team up-to-date with **real-time alerts** and advanced team management tools built for the enterprise, all while greatly reducing PACER spend.

Our comprehensive service means we can handle Federal, State, and Administrative courts across the country.

## Advanced Docket Research



With over 230 million records, Docket Alarm's cloud-native docket research platform finds what other services can't. Coverage includes Federal, State, plus PTAB, TTAB, ITC and NLRB decisions, all in one place.

Identify arguments that have been successful in the past with full text, pinpoint searching. Link to case law cited within any court document via Fastcase.

## Analytics At Your Fingertips



Learn what happened the last time a particular judge, opposing counsel or company faced cases similar to yours.

Advanced out-of-the-box PTAB and TTAB analytics are always at your fingertips.

## API

Docket Alarm offers a powerful API (application programming interface) to developers that want to integrate case filings into their apps.

## LAW FIRMS

Build custom dashboards for your attorneys and clients with live data direct from the court.

Automate many repetitive legal tasks like conflict checks, document management, and marketing.

## FINANCIAL INSTITUTIONS

Litigation and bankruptcy checks for companies and debtors.

## E-DISCOVERY AND LEGAL VENDORS

Sync your system to PACER to automate legal marketing.