

- [54] **REPROGRAMMABLE INSTRUCTION SET ACCELERATOR**
- [76] **Inventor:** Stephen M. Trimberger, 1261 Chateau Dr., San Jose, Calif. 95120
- [*] **Notice:** The term of this patent shall not extend beyond the expiration date of Pat. No. 5,737,631.
- [21] **Appl. No.:** 417,337
- [22] **Filed:** Apr. 5, 1995
- [51] **Int. Cl.⁶** G06F 15/76; G06F 9/30
- [52] **U.S. Cl.** 395/800.37; 395/376
- [58] **Field of Search** 395/430, 384, 395/385, 386, 387, 388, 389, 800.37, 376; 326/39

projects/transit/tn100/tn100.html, Jan. 29, 1994.
 French, P. et al. "A Self-Reconfiguring Processor", Proceedings from 1993 Workshop on FPGAs for Custom Computing Machines, IEEE, pp. 50-59, 1993.

(List continued on next page.)

Primary Examiner—Tod R. Swann
Assistant Examiner—Conley B. King, Jr.
Attorney, Agent, or Firm—Mark A. Haynes; Adam H. Tachner; Jeanette S. Harms

[57] **ABSTRACT**

A microprocessor comprises a defined execution unit coupled to internal buses of the processor for execution of a predefined set of instructions, combined with a programmable execution unit coupled to the internal buses for execution of a programmed instruction providing an on chip reprogrammable instruction set accelerator RISA. The programmable execution unit may be made using a field programmable gate array having a configuration store, and resources for accessing the configuration store to program the programmable execution unit. An instruction register is included in the data processor which holds a current instruction for execution, and is coupled to an instruction data path to supply the instruction to the defined instruction unit and to the programmable instruction unit in parallel, through appropriate decoding resources. A condition code register is coupled to instruction fetching resources, and connected to receive condition codes from both the defined execution unit and from the programmable execution unit. The programmable execution unit includes logic to signal the instruction fetching resources to provide a next instruction when execution of the programmed instruction is done. Resources for accessing the configuration store to program the programmable execution unit are provided, which can utilize the internal buses of the data processor or be completely independent of them.

[56] **References Cited**

U.S. PATENT DOCUMENTS

Re. 34,363	8/1993	Freeman	307/465
5,109,503	4/1992	Cruickshank et al.	395/500
5,301,344	4/1994	Kolchinsky	395/800
5,321,845	6/1994	Sawase et al.	395/800
5,336,950	8/1994	Popli et al.	307/465
5,361,373	11/1994	Gilson	395/800
5,386,518	1/1995	Reagle et al.	395/325
5,430,734	7/1995	Gilson	371/22.2
5,471,593	11/1995	Branigin	395/375
5,511,173	4/1996	Yamaura et al.	395/375
5,517,628	5/1996	Morrison et al.	395/375
5,535,406	7/1996	Kolchinsky	395/800
5,537,601	7/1996	Kimura et al.	395/800
5,574,930	11/1996	Halverson, Jr. et al.	395/800

OTHER PUBLICATIONS

DeHon, A. "DPGA-Coupled Microprocessors: Commodity ICs for the Early 21st Century", M.I.T. Transit Project, Transit Note #100, from internet site <http://www.ai.mit.edu/>

40 Claims, 3 Drawing Sheets

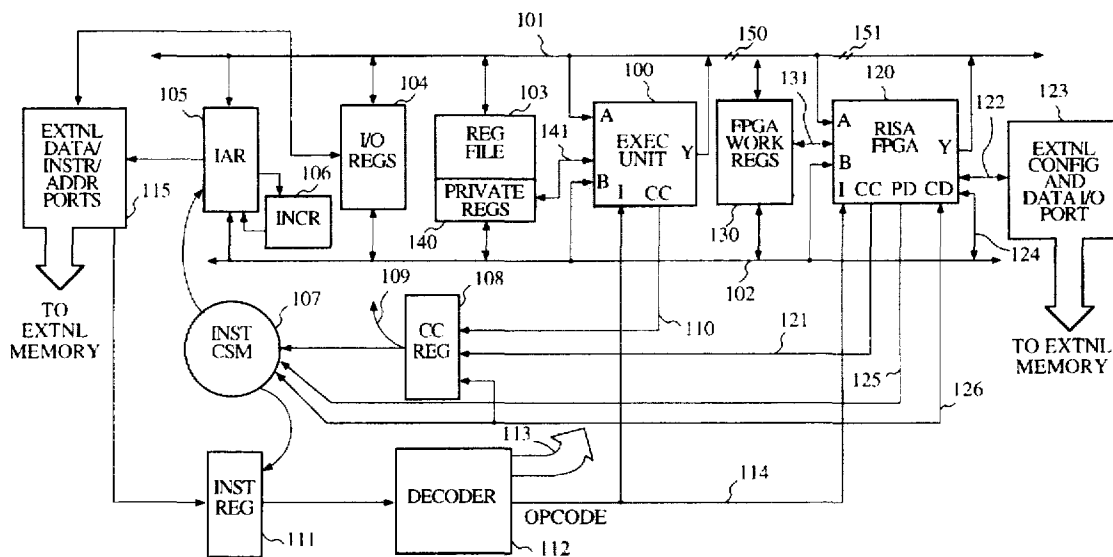

- Iseli, C. et al. "Spyder: A Reconfigurable VLIW Processor using FPGAs". Proceedings from 1993 Workshop on FPGAs for Custom Computing Machines. IEEE, pp. 17-24, 1993.
- Casselman, S. "Virtual Computing and The Virtual Computer". Proceedings from 1993 Workshop on FPGAs for Custom Computing Machines, pp. 43-48, 1993.
- Trimberger, S. "A Reprogrammable Gate Array and Applications". Proceedings of the IEEE, pp. 1030-1041, Jul. 1993.
- Hennessy J. et al. Computer Architecture: A Quantitative Approach, Chapter 5, Appendix E, 1990.
- Box, B., "Field Programmable Gate Array Based Reconfigurable Preprocessor", Apr. 10, 1994; IEEE, pp. 40-48.
- DeHon, A., "DPGA-Coupled Microprocessors: Commodity ICs for the Early 21st Century", Apr. 10, 1994, IEEE, pp. 31-39.
- Thorson, M., "General-Purpose Coprocessors". E-Mail Transcript, Jul. 3, 1992, 5 pages.
- Razdan, R., "PRISC: Programmable Reduced Instruction Set Computers". Doctor of Philosophy Thesis, May 1994, 116 pages.
- Razdan, R.; Brace, K; and Smith, M.; "PRISC Software Acceleration Techniques", IEEE, May 1994, pp. 145-149.
- Trimberger, S., "Field-Programmable Gate Array Technology". Design Applications, Section 2.6, pp. 68-90, Copyright 1994.
- Wirthlin, M., Hutchings, Brad, Gilson, K., "The Nano Processor: a Low Resource Reconfigurable Processor". Apr. 10, 1994, IEEE, pp. 23-30.

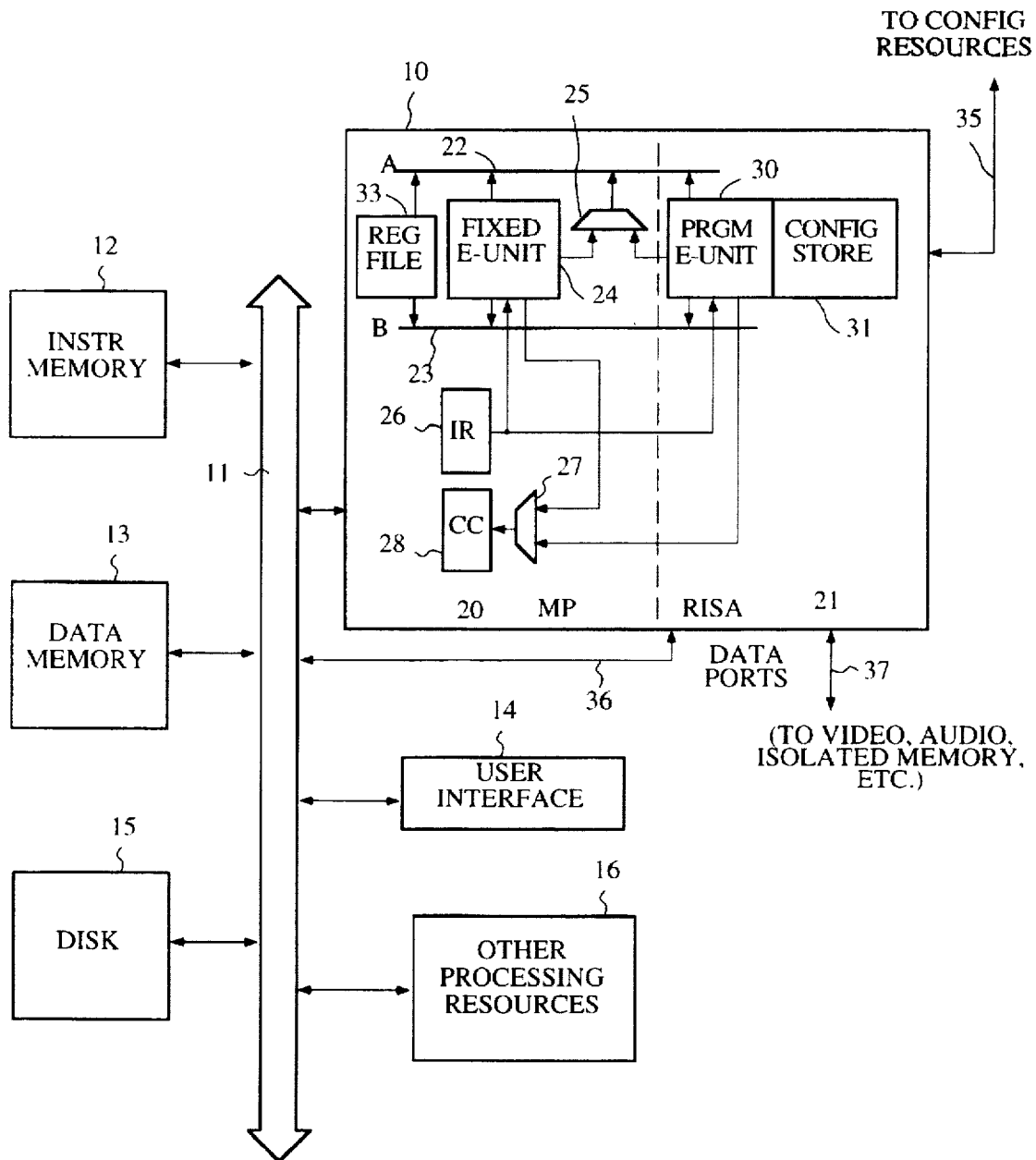

FIG. 1

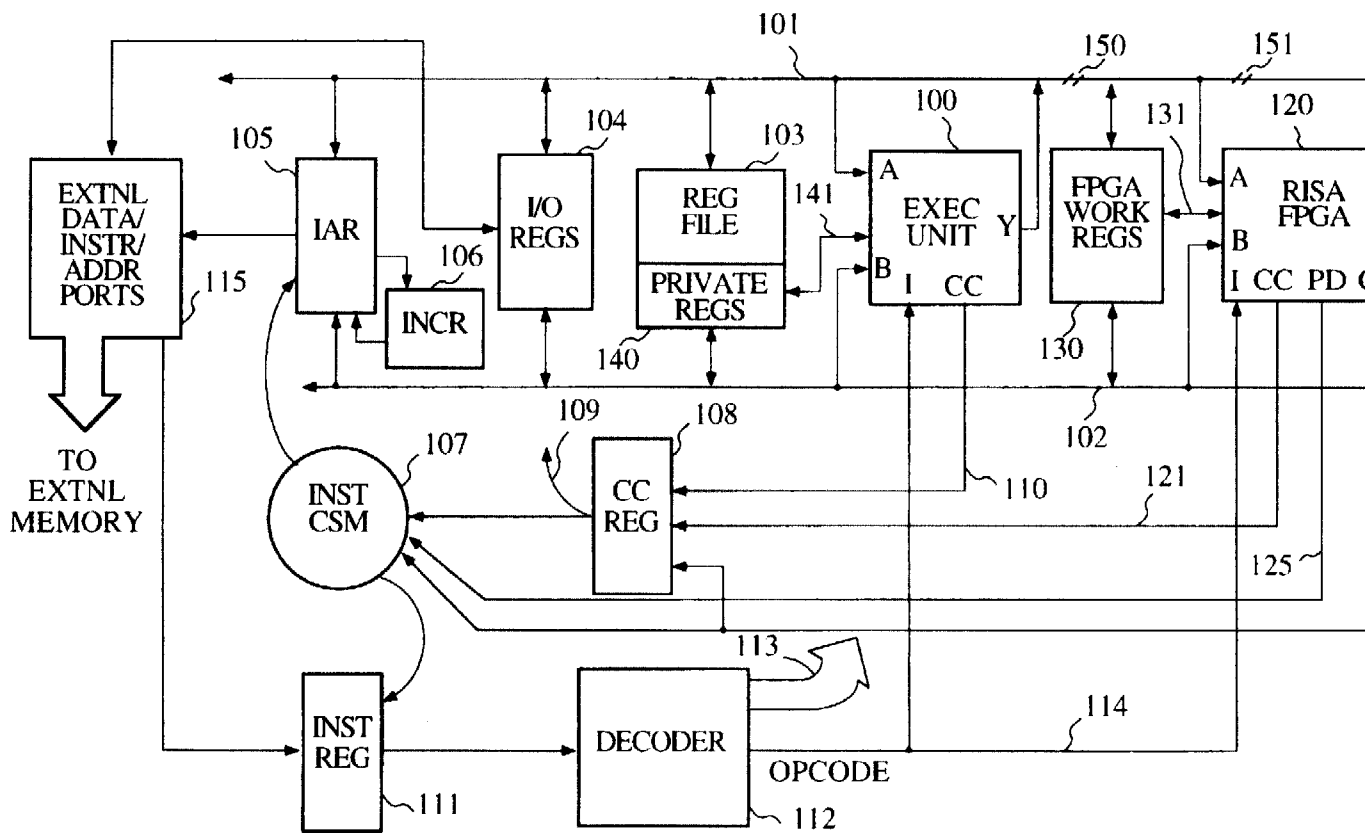

FIG. 2

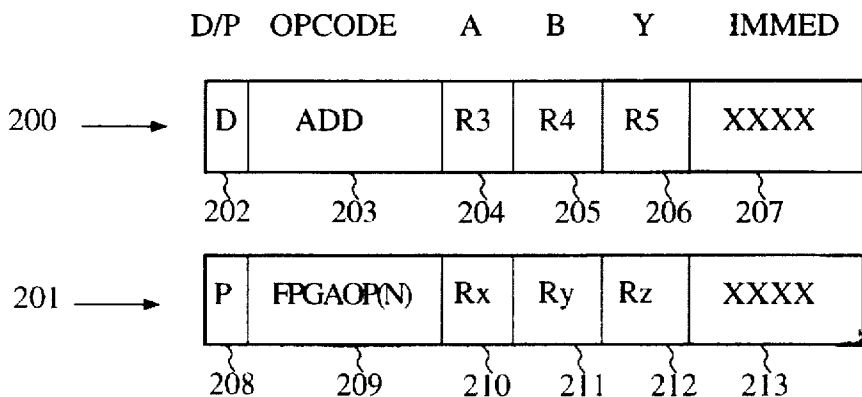

FIG. 3

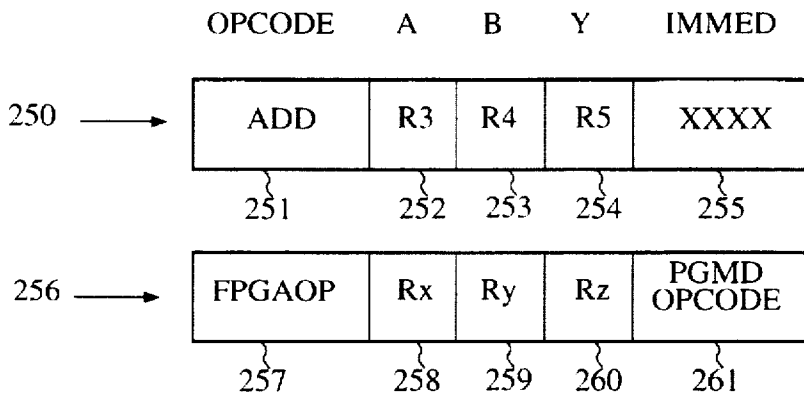

FIG. 4

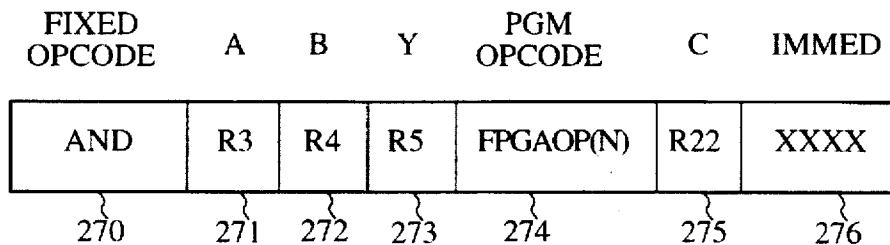

FIG. 5

Explore Litigation Insights

Docket Alarm provides insights to develop a more informed litigation strategy and the peace of mind of knowing you're on top of things.

Real-Time Litigation Alerts



Keep your litigation team up-to-date with **real-time alerts** and advanced team management tools built for the enterprise, all while greatly reducing PACER spend.

Our comprehensive service means we can handle Federal, State, and Administrative courts across the country.

Advanced Docket Research



With over 230 million records, Docket Alarm's cloud-native docket research platform finds what other services can't. Coverage includes Federal, State, plus PTAB, TTAB, ITC and NLRB decisions, all in one place.

Identify arguments that have been successful in the past with full text, pinpoint searching. Link to case law cited within any court document via Fastcase.

Analytics At Your Fingertips



Learn what happened the last time a particular judge, opposing counsel or company faced cases similar to yours.

Advanced out-of-the-box PTAB and TTAB analytics are always at your fingertips.

API

Docket Alarm offers a powerful API (application programming interface) to developers that want to integrate case filings into their apps.

LAW FIRMS

Build custom dashboards for your attorneys and clients with live data direct from the court.

Automate many repetitive legal tasks like conflict checks, document management, and marketing.

FINANCIAL INSTITUTIONS

Litigation and bankruptcy checks for companies and debtors.

E-DISCOVERY AND LEGAL VENDORS

Sync your system to PACER to automate legal marketing.