

---

# Introduction to Internal Combustion Engines



© Richard Stone 1985, 1992, 1999

All rights reserved. No reproduction, copy or transmission of this publication may be made without written permission.

No paragraph of this publication may be reproduced, copied or transmitted save with written permission or in accordance with the provisions of the Copyright, Designs and Patents Act 1988, or under the terms of any licence permitting limited copying issued by the Copyright Licensing Agency, 90 Tottenham Court Road, London W1P 9HE.

Any person who does any unauthorised act in relation to this publication may be liable to criminal prosecution and civil claims for damages.

The author has asserted his right to be identified as the author of this work in accordance with the Copyright, Designs and Patents Act 1988.

First published 1985  
Second edition 1992  
Reprinted six times  
Third edition 1999  
MACMILLAN PRESS LTD  
Houndmills, Basingstoke, Hampshire RG21 6XS  
and London  
Companies and representatives throughout the world

ISBN 0-333-74013-0

A catalogue record for this book is available from the British Library.

This book is printed on paper suitable for recycling and made from fully managed and sustained forest sources.

10 9 8 7 6 5 4 3 2 1  
08 07 06 05 04 03 02 01 00 99

Typeset by EXPO Holdings, Malaysia

Printed in Great Britain by  
Antony Rowe Ltd  
Chippenham, Wiltshire

# Contents

Preface to the Third Edition	xi
Acknowledgements	xiii
Notation	xv
<b>1 Introduction</b>	<b>1</b>
1.1 Fundamental operating principles	1
1.2 Early internal combustion engine development	6
1.3 Characteristics of internal combustion engines	10
1.4 Additional types of internal combustion engine	14
1.4.1 The Wankel engine	14
1.4.2 Stratified charge engines	15
1.5 Prospects for internal combustion engines	16
1.6 Fuel cells	19
1.7 Question	21
<b>2 Thermodynamic principles</b>	<b>22</b>
2.1 Introduction and definitions of efficiency	22
2.2 Ideal air standard cycles	25
2.2.1 The ideal air standard Otto cycle	25
2.2.2 The ideal air standard Diesel cycle	26
2.2.3 The ideal air standard Dual cycle	29
2.2.4 The ideal air standard Atkinson cycle	30
2.3 Comparison between thermodynamic and mechanical cycles	30
2.4 Additional performance parameters for internal combustion engines	32
2.5 Fuel-air cycle	35
2.6 Computer models	38
2.7 Conclusions	41
2.8 Examples	42
2.9 Questions	47
<b>3 Combustion and fuels</b>	<b>50</b>
3.1 Introduction	50
3.2 Combustion chemistry and fuel chemistry	52
3.3 Combustion thermodynamics	59
3.3a Use of conventional thermodynamic tabulations	62
3.3b Use of thermodynamic tabulations in Appendix A	65
3.3.1 The effect of the state of the reactants and products on the calorific values	66
3.4 Dissociation	66
3.4.1 Calculation of the equilibrium combustion temperature and pressure	68

3.5	Pre-mixed combustion in spark ignition engines	71
3.5.1	Normal combustion	71
3.5.2	Abnormal combustion	74
3.6	Combustion in compression ignition engines	75
3.7	Fuels and additives	77
3.7.1	Characteristics of petrol	77
3.7.2	In-vehicle performance of fuels, and the potential of alcohols	86
3.7.3	Characteristics of diesel fuel	90
3.7.4	Diesel fuel additives	94
3.7.5	Alternative diesel fuels	96
3.8	Engine emissions and hydrocarbon oxidation	98
3.8.1	Introduction	98
3.8.2	Nitric oxide formation	101
3.8.3	Hydrocarbon oxidation	106
3.8.4	Carbon monoxide emissions	109
3.9	Combustion modelling	109
3.9.1	Introduction	109
3.9.2	Zero-dimensional models	110
3.9.3	Quasi-dimensional models	112
3.9.4	Multi-dimensional models	113
3.10	Conclusions	113
3.11	Examples	114
3.12	Questions	133
<b>4</b>	<b>Spark ignition engines</b>	<b>142</b>
4.1	Introduction	142
4.2	Combustion chambers	147
4.2.1	Conventional combustion chambers	147
4.2.2	High compression ratio combustion chambers and fast burn combustion systems	152
4.2.3	Advanced combustion systems	155
4.2.4	Direct injection stratified charge engines	162
4.3	Catalysts and emissions from spark ignition engines	164
4.3.1	Introduction	164
4.3.2	Development of three-way catalysts	169
4.3.3	Lean-burn $\text{NO}_x$ reducing catalysts	175
4.3.4	Emissions legislation trends	176
4.4	Cycle-by-cycle variations in combustion	181
4.5	Ignition systems	184
4.5.1	Ignition system overview	184
4.5.2	The ignition process	190
4.6	Mixture preparation	192
4.6.1	Introduction	192
4.6.2	Variable jet carburettor	194
4.6.3	Fixed jet carburettor	195
4.6.4	Fuel injection	198
4.6.5	Mixture preparation	202
4.7	Electronic control of engines	207
4.8	Conclusions	211



4.9	Example	212
4.10	Questions	213
<b>5</b>	<b>Compression ignition engines</b>	<b>216</b>
5.1	Introduction	216
5.2	Direct injection (DI) systems	219
5.3	Indirect injection (IDI) systems	224
5.4	Cold starting of compression ignition engines	230
5.5	Fuel injection equipment	231
5.5.1	Injection system overview	232
5.5.2	Fuel injectors	234
5.5.3	Traditional injection pumps	241
5.5.4	Interconnection of traditional pumps and injectors	246
5.5.5	Common rail and electronic unit injector systems	250
5.6	Diesel engine emissions	256
5.6.1	Emissions legislation	256
5.6.2	Sources and control of engine out emissions	257
5.6.3	After treatment of diesel emissions	264
5.7	Conclusions	265
5.8	Example	268
5.9	Questions	269
<b>6</b>	<b>Induction and Exhaust Processes</b>	<b>272</b>
6.1	Introduction	272
6.2	Valve gear	273
6.2.1	Valve types	273
6.2.2	Valve-operating systems	273
6.2.3	Dynamic behaviour of valve gear	276
6.3	Flow characteristics of poppet valves	285
6.4	Valve timing	293
6.4.1	Effects of valve timing	293
6.4.2	Variable valve timing	297
6.5	Unsteady compressible fluid flow	301
6.6	Manifold design	309
6.6.1	General principles	309
6.6.2	Acoustic modelling techniques	312
6.7	Silencing	315
6.8	Conclusions	317
6.9	Questions	318
<b>7</b>	<b>Two-stroke engines</b>	<b>320</b>
7.1	Introduction	320
7.2	Two-stroke gas flow performance parameters	323
7.3	Scavenging systems	325
7.4	Scavenge modelling	326
7.4.1	Perfect displacement scavenging model	326
7.4.2	Perfect mixing scavenging model	327
7.4.3	Complex scavenging models	329
7.5	Experimental techniques for evaluating scavenge and results for port flow coefficients	331

7.5.1	Firing engine tests	332
7.5.2	Non-firing engine tests	333
7.5.3	Port flow characteristics	334
7.6	Engine performance and technology	335
7.7	Concluding remarks	340
7.8	Questions	343
<b>8</b>	<b>In-cylinder motion and turbulent combustion</b>	<b>345</b>
8.1	Introduction	345
8.2	Flow measurement techniques	346
8.2.1	Background	346
8.2.2	Hot wire anemometry	347
8.2.3	Laser Doppler anemometry	349
8.2.4	Particle Image Velocimetry	351
8.2.5	Comparison of anemometry techniques	351
8.3	Turbulence	352
8.3.1	Turbulence definitions	352
8.3.2	In-cylinder turbulence	357
8.4	Turbulent combustion modelling	361
8.4.1	A turbulent entrainment model of combustion	361
8.4.2	Laminar burning velocities	365
8.4.3	The effect of turbulence on flame behaviour	367
8.5	Conclusions	369
8.6	Questions	371
<b>9</b>	<b>Turbocharging</b>	<b>372</b>
9.1	Introduction	372
9.2	Radial flow and axial flow machines	375
9.2.1	Introduction and fluid mechanics	375
9.2.2	Thermodynamics of turbochargers	379
9.3	Turbocharging the compression ignition engine	387
9.4	Turbocharging the spark ignition engine	393
9.5	Practical considerations and systems	396
9.5.1	Transient response	396
9.5.2	Variable-geometry turbochargers, superchargers and two-stage turbocharging	398
9.6	Conclusions	402
9.7	Examples	406
9.8	Questions	409
<b>10</b>	<b>Engine modelling</b>	<b>417</b>
10.1	Introduction	417
10.2	Zero-dimensional modelling	419
10.2.1	Thermodynamics	419
10.2.2	Gas properties	422
10.2.3	Burn rate	423
10.2.4	Engine gas side heat transfer	429
10.2.5	Induction and exhaust processes	433
10.2.6	Engine friction	436

	10.3	Application of modelling to a turbocharged medium-speed diesel engine	437
	10.3.1	Introduction	437
	10.3.2	Building and validating the model	437
	10.3.3	The effect of valve overlap on engine operation	439
	10.4	Conclusions	442
	<b>11</b>	<b>Mechanical design considerations</b>	<b>445</b>
	11.1	Introduction	445
	11.2	The disposition and number of the cylinders	446
	11.3	Cylinder block and head materials	451
	11.4	The piston and rings	453
	11.5	The connecting-rod, crankshaft, camshaft and valves	457
	11.6	Lubrication and bearings	459
	11.6.1	Lubrication	459
	11.6.2	Bearing materials	463
	11.7	Advanced design concepts	466
	11.8	Conclusions	469
	11.9	Questions	469
	<b>12</b>	<b>Heat transfer in internal combustion engines</b>	<b>471</b>
	12.1	In-cylinder heat transfer	471
	12.2	Engine cooling	474
	12.2.1	Background	474
	12.2.2	Spark ignition engines	477
	12.2.3	Compression ignition engines	482
	12.3	Liquid coolant systems	486
2	12.3.1	Conventional coolant systems	486
5	12.3.2	Cooling media performance	488
5	12.3.3	Advanced cooling concepts	493
9	12.4	Conclusions	499
7			
3	<b>13</b>	<b>Experimental facilities</b>	<b>500</b>
5	13.1	Introduction	500
5	13.2	Quasi-steady engine instrumentation	502
3	13.2.1	Dynamometers	503
2	13.2.2	Fuel-consumption measurement	506
5	13.2.3	Air flow rate	508
9	13.2.4	Temperature and pressure	510
7	13.2.5	In-cylinder pressure measurement	511
7	13.2.6	Techniques for estimating indicated power	517
9	13.2.7	Engine test conditions	518
9	13.2.8	Energy balance	519
2	13.3	Experimental accuracy	521
3	13.4	Measurement of exhaust emissions	523
9	13.4.1	Infra-red absorption	524
133	13.4.2	Flame ionisation detection (FID)	526
136	13.4.3	Chemiluminescence	528
	13.4.4	Oxygen and air/fuel ratio analysers	529
	13.4.5	Exhaust smoke and particulates	533

13.4.6	Determination of EGR and exhaust residual (ER) levels	535
13.4.7	Determination of the air/fuel ratio from exhaust emissions	537
13.5	Computer-based combustion analysis	541
13.5.1	Introduction	541
13.5.2	Burn rate analysis	544
13.5.3	Heat release analysis	547
13.6	Advanced test systems	550
13.7	Conclusions	553
13.8	Question	554
<b>14</b>	<b>Case studies</b>	<b>555</b>
14.1	Introduction	555
14.2	The Rover K series engine	555
14.2.1	Introduction	555
14.2.2	The K16 base engine design	556
14.2.3	The Rover K series engine coolant and lubrication circuits	558
14.2.4	The Rover K series engine manifolding, fuelling and ignition systems	562
14.2.5	The Rover K series engine performance development	562
14.2.6	Concluding remarks	564
14.3	Chrysler 2.2 litre spark ignition engine	564
14.3.1	Background	564
14.3.2	The cylinder head	566
14.3.3	The cylinder block and associated components	568
14.3.4	Combustion control	569
14.3.5	Engine development	570
14.4	Ford 2.5 litre DI diesel engine	570
14.4.1	Background	570
14.4.2	Description	571
14.4.3	Combustion system	574
14.4.4	Turbocharged engine development	577
	Appendix A: Thermodynamic data	582
	Appendix B: Answers to numerical problems	612
	Appendix C: The use of SI units	614
	Bibliography	617
	References	619
	Index	635

speed reduces the number of gearbox ratios that are needed for starting and hill climbing. However, if the turbocharger is matched to give high torque at low speeds, then at high speeds the pressure ratio will be too great, and the turbocharger may also over-speed. This problem is particularly severe on passenger car engines and an exhaust by-pass valve (waste-gate) is often used. The by-pass valve is spring regulated and, at high flow rates when the pressure rises, it allows some exhaust to by-pass the turbine, thus limiting the compressor pressure ratio.

Turbocharging is particularly popular for automotive applications since it enables smaller, lighter and more compact power units to be used. This is essential in cars if the performance of a compression ignition engine is to approach that of a spark ignition engine. In trucks the advantages are even greater. With a lighter engine in a vehicle that has a gross weight limit, the payload can be increased. Also, when the vehicle is empty the weight is reduced and the vehicle fuel consumption is improved. The specific fuel consumption of a turbocharged compression ignition engine is better than that for a naturally aspirated engine, but additional gains can be made by retuning the engine. If the maximum torque occurs at an even lower engine speed, the mechanical losses in the engine will be reduced and the specific fuel consumption will be further improved. However, the gearing will then have to be changed to ensure that the minimum specific fuel consumption occurs at the normal operating point. Ford (1982) claim that turbocharging can reduce the weight of truck engines by 30 per cent, and improve the specific fuel consumption by from 4 to 16 per cent. Figure 9.20 shows a comparison of naturally aspirated and turbocharged truck engines of equivalent power outputs.

In passenger cars a turbocharged compression ignition engine can offer a performance approaching that of a comparably sized spark ignition engine; its torque will be greater but its maximum speed lower. Compression ignition engines can give a better fuel consumption than spark ignition engines, but this will depend on the driving pattern (Radermacher, 1982) and whether the comparison uses a volumetric or gravimetric basis (see chapter 3, section 3.7).

## 9.4 Turbocharging the spark ignition engine

Turbocharging the spark ignition engine is more difficult than turbocharging the compression ignition engine. The material from the previous section applies, but in addition spark ignition engines require a wider air flow range (owing to a wider speed range and throttling), a faster response, and more careful control to avoid either pre-ignition or self-ignition (knock). The fuel economy of a spark ignition engine is not necessarily improved by turbocharging. To avoid both knock and self-ignition it is common practice to lower the compression ratio, thus lowering the cycle efficiency. This may or may not be offset by the frictional losses representing a smaller fraction of the engine output.

The turbocharger raises the temperature and pressure at inlet to the spark ignition engine, and consequently pressures and temperatures are raised throughout the ensuing processes. The effect of inlet pressure and temperature on the knock-limited operation of an engine running at constant speed, with a constant compression ratio, is shown in figure 9.21. Higher octane fuels and rich mixtures both permit operation with higher boost pressures and temperatures. Retarding the ignition timing will reduce the peak pressures and temperatures to provide further control on knock. Unfortunately there will be a trade-off in power

**Figure 9.20**  
Comparison of comparably powerful naturally aspirated and turbocharged engines (Ford, 1982).

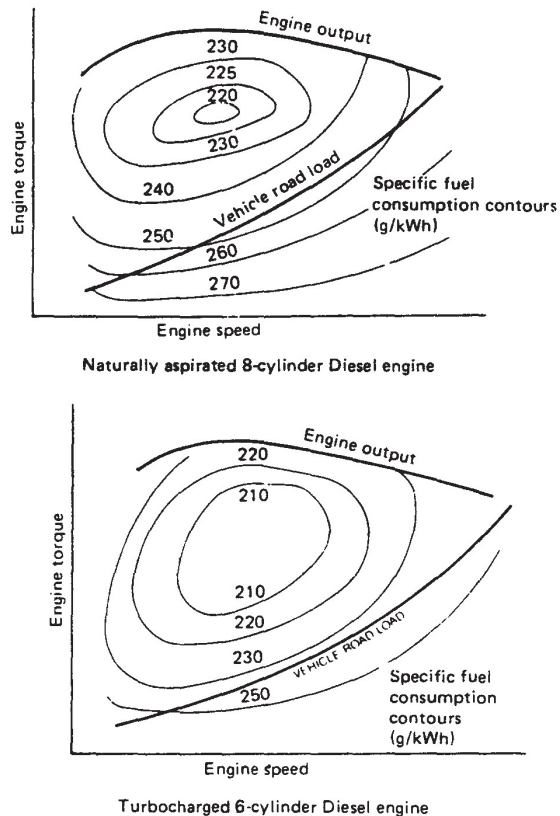

and economy and the exhaust temperature will be higher; this can cause problems with increased heat transfer in the engine and turbocharger. Reducing the compression ratio is the commonest way of inhibiting knock and retarding the ignition is used to ensure knock-free operation under all conditions.

**Figure 9.21**  
Influence of charge temperature on charge pressure (knock-limited) with different air/fuel ratios and fuel qualities (with acknowledgement to Watson and Janota, 1982).

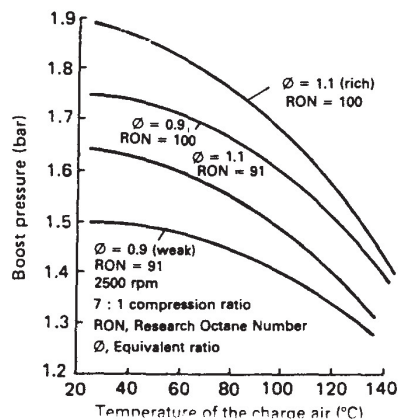

Inter-cooling may appear attractive, but in practice it is very rarely used. Compared with a compression ignition engine, the lower pressure ratios cause a lower charge temperature, which would then necessitate a larger inter-cooler for a given temperature drop. Furthermore, the volume of the inter-cooler impairs the transient response, and this is more significant in spark ignition engines with their low inertia and rapid response. Finally, a very significant temperature drop occurs through fuel evaporation, a process that cannot occur in compression ignition engines.

Water injection has been used in pressure-charged military spark ignition engines as a means of cooling the charge, so as to increase the charge density and inhibit the onset of knock. Saab have demonstrated the use of water injection in their 2.3 litre turbocharged spark ignition engine. Water injection (at up to 0.5 litre/min) is used at full throttle conditions above 3000 rpm, permitting an increase in power from 120 kW at 4200 rpm to 175 kW at 5600 rpm for stoichiometric operation.

The fuel/air mixture can be prepared by either carburation or fuel injection, either before or after the turbocharger. Fuel injection systems are simplest since they deduce air mass flow rate and will be designed to be insensitive to pressure variations. In engines with carburettors it may appear more attractive to keep the carburettor and inlet manifold from the naturally aspirated engine. However, the carburettor then has to deal with a flow of varying pressure. The carburettor can be rematched by changing the jets, and the float chamber can be pressurised. Unfortunately, it is difficult to obtain the required mixture over the full range of pressures and flow rates. In general it is better to place the carburettor before the compressor for a variety of reasons. The main complication is that the compressor rotor seal needs improvement to prevent dilution of the fuel/air mixture at part load and idling conditions. The most effective solution is to replace the piston ring type seals with a carbon ring lightly loaded against a thrust face. A disadvantage of placing the carburettor before the compressor is that the volume of air and fuel between the carburettor and engine is increased. This can cause fuel hold-up when the throttle is opened, and a rich mixture on over-run when the throttle is closed, as discussed in chapter 4, section 4.6.1.

The advantage of placing the carburettor or single point fuel injection before the compressor are:

- (i) the carburettor operates at ambient pressure
- (ii) there is reduced charge temperature
- (iii) compressor operation is further from the surge limit
- (iv) there is a more homogeneous mixture at entry to the cylinders.

If the carburettor operates at ambient pressure then the fuel pump can be standard and the carburettor can be re-jetted or changed to allow for the increased volumetric flow rate.

The charge temperature will be lower if the carburettor is placed before the compressor. Assuming constant specific heat capacities, and a constant enthalpy of evaporation for the fuel, then the temperature drop across the carburettor ( $\Delta T_{\text{carb}}$ ) will be the same regardless of the carburettor position. The temperature rise across the compressor is given by equation (9.6)

$$T_2 = T_1 \left[ 1 + \frac{(p_2/p_1)^{(\gamma-1)/\gamma} - 1}{\eta_c} \right]$$

**Figure 9.22**  
Comparative specific fuel consumption of a turbocharged and naturally aspirated engine scaled for the same maximum torque (with acknowledgement to Watson and Janota, 1982).

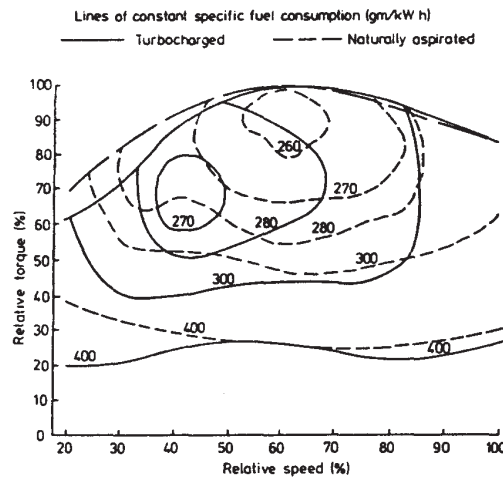

The term in square brackets is greater than unity, so that  $\Delta T_{\text{carb}}$  will be magnified if the carburettor is placed before the compressor. In addition, the ratio of the specific heat capacities ( $\gamma$ ) will be reduced by the presence of the fuel, so causing a further lowering of the charge temperature. This is illustrated by example 9.2, which also shows that the compressor work will be slightly reduced. The reduced charge temperature is very important since it allows a wider knock-free operation – see figure 9.20.

In spark ignition engines the compressor operates over a wider range of flows, and ensuring that the operation is always away from the surge line can be a greater problem than in compression ignition engines. If the carburettor, and thus the throttle, is placed before the compressor the surge margin is increased at part throttle. Consider a given compressor pressure ratio and mass flow rate and refer back to figure 9.17. The throttle does not change the temperature at inlet to the compressor ( $T_1$ ), but it reduces the pressure ( $p_1$ ) and will thus move the operating point to the right of the operating point when the throttle is placed after the compressor and  $p_1$  is not reduced.

By the time a fuel/air mixture passes through the compressor it will be more homogeneous than at entry to the compressor. Furthermore, the flow from the compressor would not be immediately suitable for flow through a carburettor.

Performance figures vary, but typically a mixture boost pressure of 1.5 bar would raise the maximum torque by 30 per cent and maximum power by up to 60 per cent. Figure 9.22 shows the comparative specific fuel consumption of a turbocharged and naturally aspirated spark ignition engine. The turbocharged engine has improved fuel consumption at low outputs, but an inferior consumption at higher outputs. The effect on vehicle consumption would depend on the particular driving pattern.

## 9.5 Practical considerations and systems

### 9.5.1 Transient response

The transient response of turbocharged engines is discussed in detail by Watson and Janota (1982). The problems are most severe with spark ignition engines



because of their wide speed range and low inertia; the problems are also significant with the more highly turbocharged compression ignition engines. The poor performance under changing speed or load conditions derives from the nature of the energy transfer between the engine and the turbocharger. When the engine accelerates or the load increases, only part of the energy available at the turbine appears as compressor work, the balance is used in accelerating the turbocharger rotor. Additional lags are provided by the volumes in the inlet and exhaust systems between the engine and turbocharger; these volumes should be minimised for good transient response. Furthermore, the inlet volume should be minimised in spark ignition engines to limit the effect of fuel hold-up on the fuel-wetted surfaces. Turbocharger lag cannot be eliminated without some additional energy output, but the effect can be minimised. One approach is to under-size the turbocharger, since the rotor inertia increases with (length)<sup>5</sup>, while the flow area increases with (length)<sup>2</sup>. Then to prevent undue back-pressure in the exhaust, an exhaust by-pass valve can be fitted. An alternative approach is to replace a single turbocharger by two smaller units.

The same matching procedure is used for spark ignition engines and compression ignition engines. However, the wider speed and flow range of the spark ignition engine necessitate greater compromises in the matching of turbomachinery to a reciprocating engine. If the turbocharger is matched for the maximum flow then the performance at low flows will be very poor, and the large turbocharger size will give a poor transient response. When a smaller turbocharger is fitted, the efficiency at low flow rates will be greater and the boost pressure will be higher throughout the range; the lower inertia will also reduce turbocharger lag. However, at higher flow rates the boost pressure would become excessive unless modified; two approaches are shown in figure 9.23.

The compressor pressure can be directly controlled by a relief valve, to keep the boost pressure below the knock-limited value. The flow from the relief valve does not represent a complete loss of work since the turbine work derives from energy that would otherwise be dissipated during the exhaust blow-down. The blow-off flow can be used to cool the turbine and exhaust systems. If the carburettor is placed before the compressor, the blow-off flow has to be returned to the compressor inlet, which results in yet higher charge temperatures.

The exhaust waste-gate system (figure 9.23b) is more attractive since it also permits a smaller turbine to be used, because it no longer has to be sized for the maximum flow. Turbocharger lag is reduced by the low inertia, and the control system ensures that the waste-gate closes during acceleration. The main difficulty is in designing a cheap reliable system that will operate at the high temperatures.

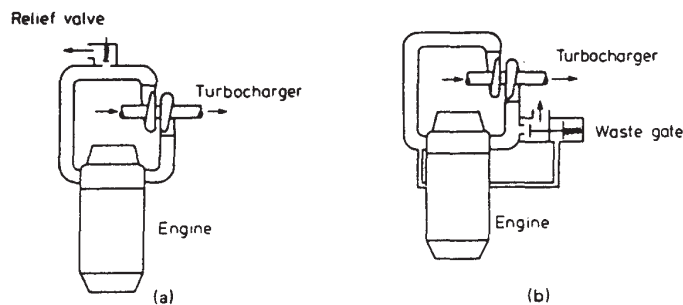

**Figure 9.23**  
 (a) Compressor pressure-relief valve control system. (b) Boost pressure-sensitive waste gate control system (with acknowledgement to Watson and Janota, 1982).

Variable-area turbines, compressor restrictors and turbine outlet restrictors can also be used to control the boost pressure; restrictors of any form are an unsatisfactory solution.

The transient response of an engine can be modelled by an extension to the type of simulation described in chapter 10 (Charlton *et al.*, 1991). This requires a knowledge of the engine, load and turbocharger inertias, and the governor and fuel injection pump (or engine management system) dynamic response. At the end of each cycle a torque balance needs to be made on each rotating component, so that any torque surplus (or deficit) can be used to accelerate (or decelerate) the relevant shaft. A change in a parameter, such as the boost pressure, can then be used to determine the new fuelling level and injection timing. Transient simulations are a useful method of identifying the strategies that might lead to better load acceptance on turbocharged engines.

### 9.5.2 Variable-geometry turbochargers, superchargers and two-stage turbocharging

#### *Variable-geometry turbochargers*

Variable-geometry turbines have already been discussed in section 9.2.1, and illustrated by figures 9.8 and 9.9. Figure 9.24 illustrates the benefits to the low speed torque of using the Holset moving sidewall variable-geometry turbine of figure 9.9 in a truck engine application. The maximum torque engine speed range is extended by 40 per cent, and there is a 43 per cent improvement in the torque at 1000 rpm.

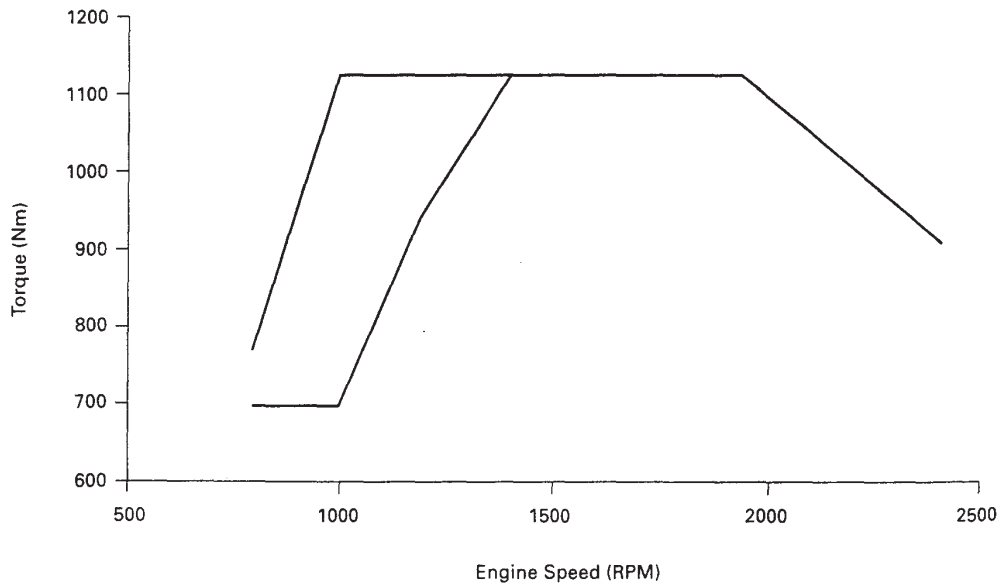

**Figure 9.24** The increase in low engine speed torque, through the use of a moving sidewall variable-geometry radial flow turbine (courtesy of Holset).

**Table 9.1** Performance comparison of the waste-gate and variable-geometry turbo-charger Fiat JTD direct injection diesel engines

Model	1.9 JTD	2.4 JTD
Swept volume (cm <sup>3</sup> )	1910	2387
Number of cylinders	4	5
Turbocharger system	Waste-gate	Variable-geometry
Maximum torque (N m)	255	304
bmep (bar)	16.8	16.0
at (rpm)	2000–2500	2000–2500
Maximum power (kW)	77	100
bmep (bar)	12.4	12.6
at (rpm)	3900	4000

The nozzle position controls the flow area, and thus the turbine back-pressure, and the work output. This in turn determines the compressor boost pressure and the engine torque that is possible with an appropriate fuelling level. It is thus possible to control the turbocharger speed and boost pressure without using a waste-gate. The nozzle position is varied by a pneumatic actuator, controlled by the engine management system, in response to:

- 1 engine speed,
- 2 throttle demand,
- 3 inlet manifold temperature and pressure,
- 4 exhaust manifold pressure (optional),
- 5 ambient pressure,
- 6 turbocharger speed, and
- 7 fuelling.

The variable-geometry turbine area can also be used to increase the turbine back-pressure, thereby increasing the engine braking.

Variable-geometry turbochargers are also used on smaller automotive diesel engines, and in the case of the Fiat JTD engines, the variable-geometry turbocharger is used to maintain a high bmep at high engine speed (Piccone and Rinolfi, 1998). The JTD engines are direct injection, with a bore of 82.0 mm, a stroke of 90.4 mm, an air-to-air inter-cooler, two valves per cylinder, an electronically controlled common rail fuel injection system, EGR, and a compression ratio of 18.5 : 1. Table 9.1 compares the performance of two JTD engines.

Table 9.1 shows how the variable-geometry turbocharger has led to a higher specific output by a combination of a higher bmep occurring at a higher speed.

### Supercharging

One way of eliminating turbo-lag is to use a supercharger (a mechanically driven compressor), and this is the approach adopted by Jaguar for a spark ignition engine (Joyce, 1994). The Jaguar engine has a swept volume of 4 litres, so in normal use it will be operating under comparatively low load and speed conditions, the very conditions from which turbo-lag would be most significant. Obviously a super-

charger will lead to worse fuel economy than a turbocharger, since there is no recovery of the exhaust gas expansion work. However, because of the limit to boost pressure imposed by fuel quality and knock, the pressure ratio will be comparatively low, and the fuel economy penalty will not be unacceptable. In any case, people who want a supercharged 4 litre engine will probably be more concerned with performance than economy. Jaguar adopted a Roots compressor with a pressure ratio of 1.5 and an air/coolant/air inter-cooler. The Roots compressor has no internal compression, and this limits the compressor efficiency, especially at high pressure ratios, when the effect of compression irreversibilities increases (Stone, 1988). The other main loss is leakage past the rotors, which depends solely on the pressure ratio and seal clearances, and not on the flow rate through the compressor. Leakage losses are most significant at low speeds since the flow rates are low and the running clearances are greatest (due to the comparatively low temperature of the compressor); Jaguar found that inlet system deposits on the Roots blower rotors led to an in-service reduction in the leakage loss.

At part-load operation the supercharger is unnecessary, so one option is to use a clutch to control its use. However, to avoid a loss of refinement through engaging and disengaging the supercharger, Jaguar adopted a permanent drive with a step-up speed ratio of 2.5 (the drive has to meet a requirement of 34 kW). (If a continuously variable ratio drive is available, then throttling losses can be reduced at part-load operation by running the supercharger more slowly, and using it as an expander.) So as to avoid unnecessary compression in the supercharger, a by-pass valve opens at part load (in response to manifold pressure); the main throttle is upstream of the supercharger.

An inter-cooler is used since otherwise the performance gains from supercharging could be reduced by about 50 per cent. Without an inter-cooler, the supercharger outlet temperature would be limited to about 80°C (compared to 120°C with the inter-cooler), and after the inter-cooler the temperature might be about 50°C. The inter-cooler thus increases the output of the engine in two ways. Firstly, the higher pressure ratio and the cooler air temperature both increase the air density, and secondly, the lower temperature allows a higher boost pressure or compression ratio for knock-free operation with a given quality fuel.

Table 9.2 compares the naturally aspirated and supercharged Jaguar AJ6 engines. Both have an aluminium cylinder head with 4 valves per cylinder, a bore of 91 mm and a stroke of 102 mm.

The supercharged engine uses the same camshafts (242°ca valve open period) as the naturally aspirated engine, but with zero overlap at tdc, so as to avoid short-circuiting loss of the mixture at high-load conditions, and to give good idle stability.

The supercharged engine has a higher power and torque output than the naturally aspirated 6 litre V12 engine, and table 9.3 compares the brake specific

**Table 9.2** *The naturally aspirated and supercharged Jaguar AJ6 engines*

	Naturally aspirated	Supercharged
Compression ratio	9.5	8.5
Maximum torque (N m)	370 at 3500 rpm	510 at 3000 rpm
bmep (bar)	11.6	16.0
Maximum power (kW)	166 at 5000 rpm	240 at 5000 rpm
bmep (bar)	10.0	14.4

**Table 9.3** Comparison of the brake specific fuel consumptions (g/kWh) for naturally aspirated and supercharged Jaguar engines at 2000 rpm, for a fixed bmep and a fixed torque

Engine type	2 bar bmep	64 N m torque
6.0 litre V12	0.414	0.54
4.0 litre supercharged	0.412	0.41
4.0 litre naturally aspirated	0.390	0.39

fuel consumptions of the engine at both the same bmep and the same torque (corresponding to a bmep of 2 bar for the 4 litre engine and 1.33 bar for the 6 litre engine).

The supercharged engine shows a slight loss of fuel economy compared with the naturally aspirated engine, but a substantial fuel economy benefit compared to the V12 engine, especially when the comparison is on the basis of a specified torque. The greater output of the supercharged engine allows a higher gearing compared to the naturally aspirated engine, which partially compensates for the lower fuel economy of the engine.

### Two-stage supercharging

Figure 9.25 illustrates an arrangement for two-stage turbocharging, in which the smaller high-pressure turbocharger has a turbine by-pass which opens as the inlet manifold boost pressure rises (Pfluger, 1997). At low mass flows the by-pass is closed, so that best use is made of the available expansion in the small turbine. As

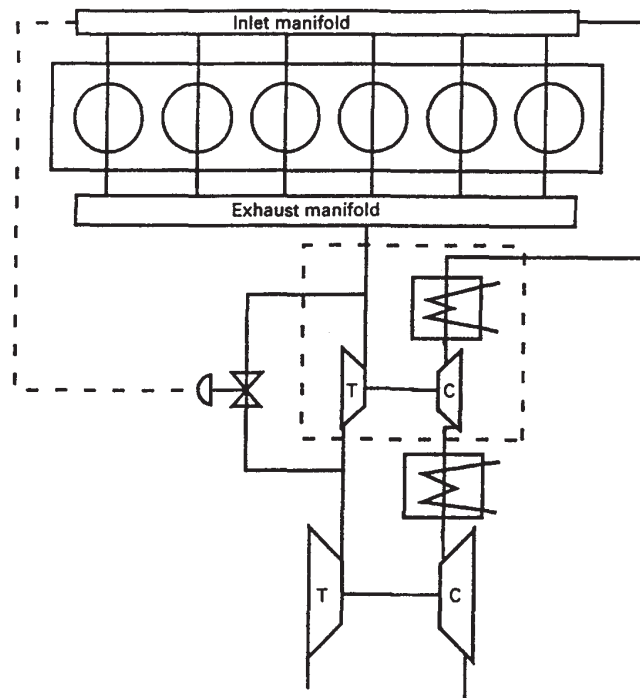

**Figure 9.25** Arrangement for two-stage turbocharging, in which the smaller high-pressure turbocharger has a turbine by-pass which opens as the inlet manifold boost pressure rises (adapted from Pfluger, 1997).

the gas flows increase with load and speed, progressively more expansion work is extracted in the larger turbine that drives the low-pressure compressor.

Figure 9.26 shows how two-stage turbocharging leads to an improvement in the low speed torque, an increase in the maximum power output, and a reduction in the brake specific fuel consumption. Two-stage turbocharging also leads to a better transient response.

Two-stage turbocharging is also used for very high specific output applications, and a very well-documented example is the marine racing engine based on the Ford Dover diesel engine (Kaye, 1989). The Dover engine is also discussed in figures 1.10, 11.9 and 11.18. This engine has a maximum bmep of 33 bar and a specific output of 66 kW/litre. Figure 9.27 shows the arrangement of the turbochargers and inter-coolers; in marine applications inter-cooling is assisted by the typical sea water temperature of 12°C. Figure 9.28 shows the operating points on the compressor operating maps, for the maximum bmep of 33.0 bar and for 27.4 bar. Table 9.4 summarises the full-load operating conditions, and some analysis of these and other data forms the basis of question 9.16.

The maximum cylinder pressure has increased from 125 to 162 bar, and this has been limited by reducing the compression ratio from about 15:1 to 10.5:1, and by operating with relatively retarded injection timing. The dynamic start of injection is about 5° btdc with a duration of 36°ca, so combustion only commences after the start of the expansion stroke. The reduced compression ratio led to cold starting and warm-up difficulties; these were overcome by the use of ether (not just for starting) and other techniques detailed by Kaye (1989).

The basic engine structure required remarkably little modification for the higher loadings. The crankshaft main bearing webs were thickened, and used with steel bearing caps. A steel camshaft was used without a keyway to locate the drive gear, owing to the higher loads imposed on this from the fuel injection pump drive gear.

## 9.6 Conclusions

Turbocharging is a very important means of increasing the output of internal combustion engines. Significant increases in output are obtained, yet the turbocharger system leads to only small increases in the engine weight and volume.

Table 9.4 Operating conditions for the Sabre Marathon 6.8 litre diesel engine (Kaye, 1989)

Power	448 kW at 2400 rpm	compression ratio	10.5:1
Torque	1780 N m	bmep	33 bar
bsfc	268 g/kWh	air/fuel ratio	21.9
Air flow rate	590 litres/s	Bosch Smoke Number	2.0
<b>Turbocharger performance</b>	<b>Low pressure</b>	<b>High pressure</b>	
Temperature after compressor	168°C	217°C	
Temperature after cooler	64°C	49°C	
Compressor pressure ratio	2.14	2.50	
Overall pressure ratio (after cooler losses)	5.1		
Turbine entry temperature	716	790°C	
Exhaust temperature	601°C		



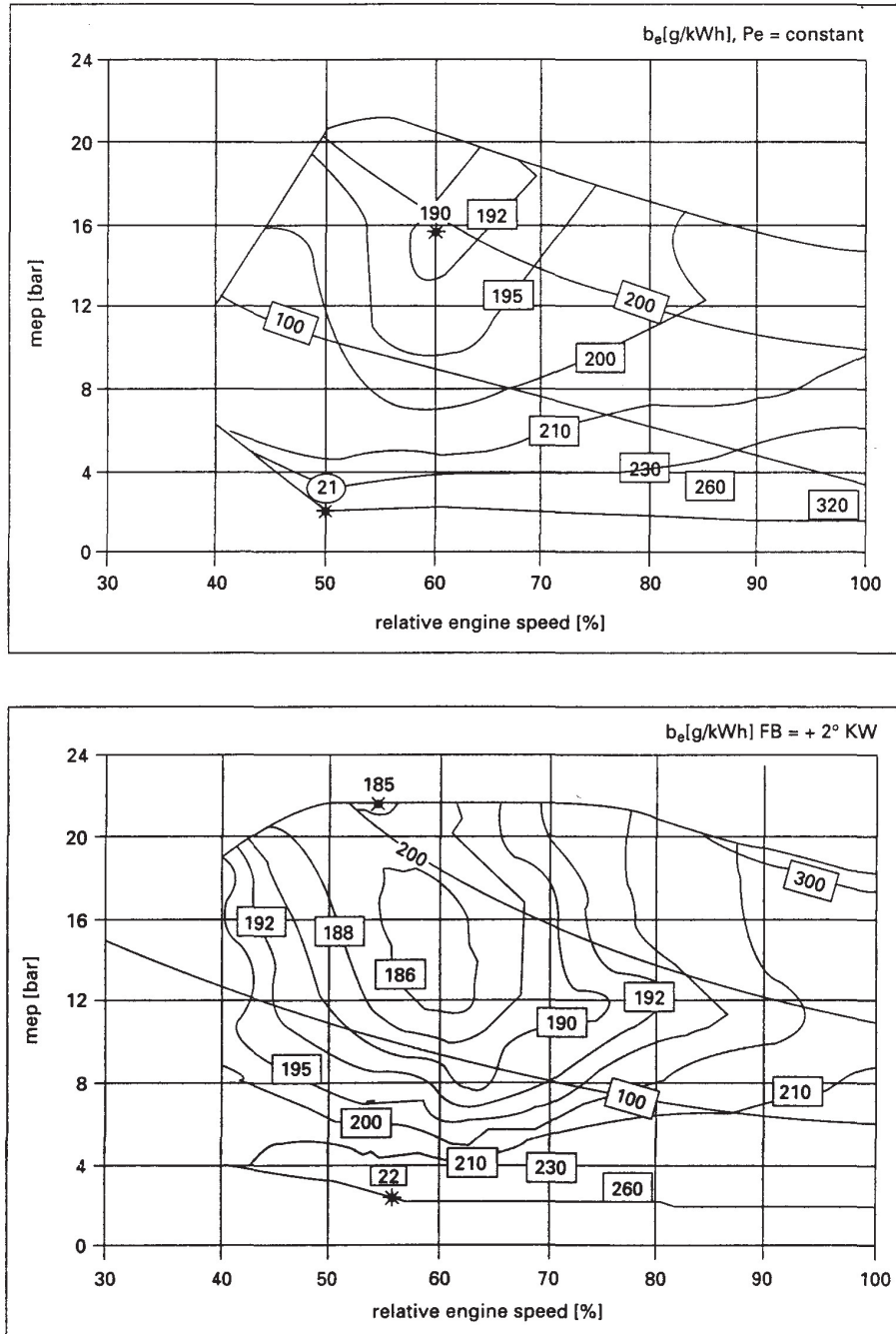

Figure 9.26 Torque and fuel economy comparisons between single-stage and two-stage turbocharging (adapted from Pfluger, 1997).

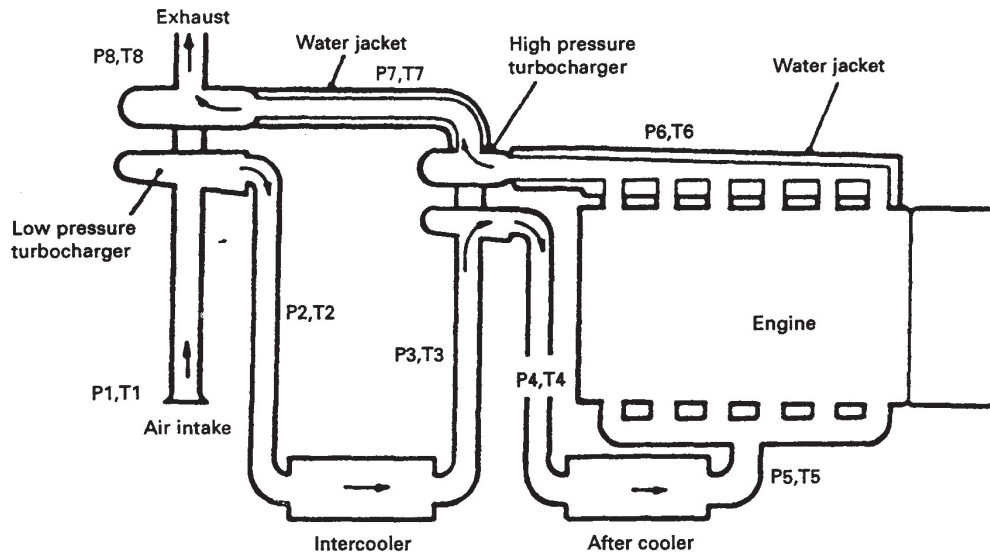

Figure 9.27  
Arrangement of the turbochargers and inter-coolers for the Sabre Marathon diesel engine at 2400 rpm (Kaye, 1989).  
© IMechE/ Professional Engineering Publishing Limited.

The fuel economy of compression ignition engines is usually improved by turbocharging, since the mechanical losses do not increase in direct proportion to the gains in power output. The same is not necessarily true of spark ignition engines, since turbocharging invariably necessitates a reduction in compression ratio to avoid knock (self-ignition of the fuel/air mixture). The reduction in compression ratio reduces the indicated efficiency and this usually negates any improvement in the mechanical efficiency.

The relatively low flow rate in turbochargers leads to the use of radial flow compressors and turbines. In general, axial flow machines are more efficient, but only for high flow rates. Only in the largest turbochargers (such as those for marine applications) are axial flow turbines used. Turbochargers are unlike positive displacement machines, since they rely on dynamic flow effects; this implies high velocity flows, and consequently the rotational speeds are an order of magnitude greater than reciprocating machines. The characteristics of reciprocating machines are fundamentally different from those of turbochargers, and thus great care is needed in the matching of turbochargers to internal combustion engines. The main considerations in turbocharging matching are:

- (i) to ensure that the turbocharger is operating in an efficient regime
- (ii) to ensure that the compressor is operating away from the surge line (surge is a flow reversal that occurs when the pressure ratio increases and the flow rate decreases)
- (iii) to ensure a good transient response.

Turbochargers inevitably suffer from turbo-lag; when either the engine load or speed increases, only part of the energy available from the turbine is available as



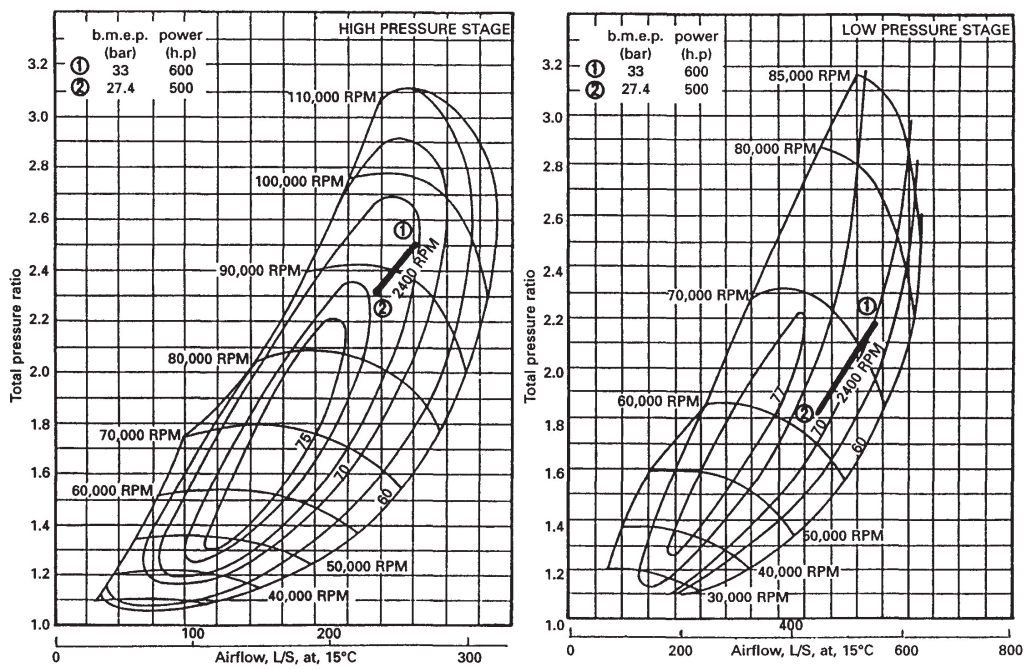

Figure 9.28 Operating points on the compressor operating maps for the Sabre Marathon diesel engine at 2400 rpm (adapted from Kaye, 1989).

compressor work – the balance is needed to accelerate the turbocharger rotor. The finite volumes in the inlet and exhaust system also lead to additional delays that impair the transient response.

As well as offering thermodynamic advantages, turbochargers also offer commercial advantages. In trucks, the reduced weight of a turbocharged engine gives an increase in the vehicle payload. A manufacturer can add turbocharged versions of an engine to his range more readily than producing a new engine series. Furthermore, turbocharged engines can invariably be fitted into the same vehicle range – an important marketing consideration.

## 9.7 Examples

### EXAMPLE 9.1

A diesel engine is fitted with a turbocharger, which comprises a radial compressor driven by a radial exhaust gas turbine. The air is drawn into the compressor at a pressure of 0.95 bar and at a temperature of 15°C, and is delivered to the engine at a pressure of 2.0 bar. The engine is operating on a gravimetric air/fuel ratio of 18 : 1, and the exhaust leaves the engine at a temperature of 600°C and at a pressure of 1.8 bar; the turbine exhausts at 1.05 bar. The isentropic efficiencies of the compressor and turbine are 70 per cent and 80 per cent, respectively. Using the values

$$c_{p,\text{air}} = 1.01 \text{ kJ/kg K}, \gamma_{\text{air}} = 1.4$$

and

$$c_{p,\text{ex}} = 1.15 \text{ kJ/kg K}, \gamma_{\text{ex}} = 1.33$$

- calculate (i) the temperature of the air leaving the compressor  
 (ii) the temperature of the gases leaving the turbine  
 (iii) the mechanical power loss in the turbocharger expressed as a percentage of the power generated in the turbine.

Solution:

Referring to figure 9.29 (a new version of figure 9.10), the real and ideal temperatures can be evaluated along with the work expressions.

- (i) If the compression were isentropic,  $T_{2s} = T_1 \left( \frac{p_2}{p_1} \right)^{(\gamma-1)/\gamma}$

$$T_{2s} = 288 \left( \frac{2.0}{0.95} \right)^{(1.4-1)/1.4} = 356 \text{ K, or } 83^\circ\text{C}$$

From the definition of compressor isentropic efficiency,  $\eta_c = \frac{T_{2s} - T_1}{T_2 - T_1}$

$$T_2 = \frac{T_{2s} - T_1}{\eta_c} + T_1 = \frac{83 - 15}{0.7} + 15 = 133^\circ\text{C}$$

- (ii) If the turbine were isentropic,  $T_{4s} = T_3 \left( \frac{p_4}{p_3} \right)^{(\gamma-1)/\gamma}$

$$T_{4s} = 873 \left( \frac{1.05}{1.8} \right)^{(1.33-1)/1.33} = 762.9 \text{ K, or } 490^\circ\text{C}$$

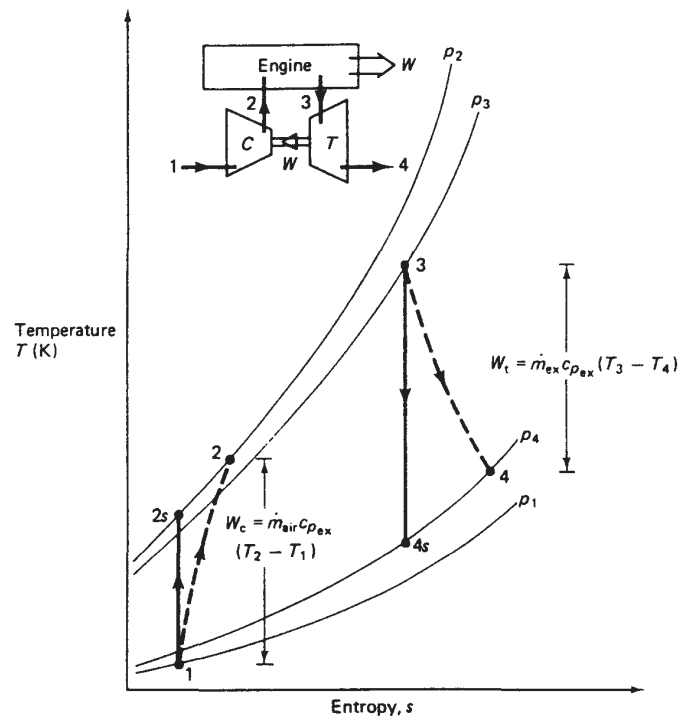

Figure 9.29  
Temperature/entropy  
diagram for a  
turbocharger.

From the definition of turbine isentropic efficiency,  $\eta_t = \frac{T_3 - T_4}{T_3 - T_{4s}}$

$$T_4 = T_3 - \eta_t(T_3 - T_{4s}) = 600 - 0.8(600 - 490) = 512^\circ\text{C}$$

(iii) Compressor power  $\dot{W}_c = \dot{m}_{\text{air}} c_{p,\text{air}} (T_2 - T_1)$   
 $= \dot{m}_{\text{air}} 1.01(113 - 15) \text{ kW}$   
 $= \dot{m}_{\text{air}} 98.98 \text{ kW}$

from the air/fuel ratio

$$\dot{m}_{\text{ex}} = \dot{m}_{\text{air}} \left( 1 + \frac{1}{18} \right)$$

and turbine power

$$\begin{aligned} \dot{W}_t &= \dot{m}_{\text{ex}} c_{p,\text{ex}} (T_3 - T_4) \\ &= \dot{m}_{\text{air}} 1.056 \times 1.15(600 - 512) \\ &= \dot{m}_{\text{air}} 106.82 \text{ kW} \end{aligned}$$

Thus, the mechanical power loss as a percentage of the power generated in the turbine is

$$\frac{106.82 \times 98.98}{106.82} \times 100 = 7.34 \text{ per cent}$$

This result is in broad agreement with figure 9.11, which is for a slightly different pressure ratio and constant gas flow rates and properties.

## EXAMPLE 9.2

Compare the cooling effect of fuel evaporation on charge temperature in a turbocharged spark ignition engine for the following two cases:

- (a) the carburettor placed before the compressor
- (b) the carburettor placed after the compressor.

The specific heat capacity of the air and the latent heat of evaporation of the fuel are both constant. For the air/fuel ratio of 12.5 : 1, the evaporation of the fuel causes a 25 K drop in mixture temperature. The compressor efficiency is 70 per cent for the pressure ratio of 1.5, and the ambient air is at 15°C. Assume the following property values:

for air  $c_p = 1.01 \text{ kJ/kg K}$ ,  $\gamma = 1.4$

for air/fuel mixture  $c_p = 1.05 \text{ kJ/kg K}$ ,  $\gamma = 1.34$

Finally, compare the compressor work in both cases.

Solution:

Both arrangements are shown in figure 9.30.

- (a)  $T_1 = 15^\circ\text{C} = 288 \text{ K}$   
 $T_2 = T_1 - 25 = 263 \text{ K}$

If the compressor were isentropic,  $T_{3s} = 263 (1.5)^{(1.34-1)/1.34} = 291.5 \text{ K}$

From the definition of compressor isentropic efficiency

$$T_3 = \frac{T_{3s} - T_2}{\eta_c} + T_2 = \frac{291.5 - 263}{0.7} + 263 = 303.7 \text{ K}$$

- (b)  $T_4 = 288 \text{ K}$

From isentropic compression  $T_{5s} = 288 (1.5)^{1.4-1/1.4} = 323.4 \text{ K}$

Figure 9.30  
Possible arrangement for the carburettor and compressor in a spark ignition engine:  
(a) carburettor placed before the compressor;  
(b) carburettor placed after the compressor.

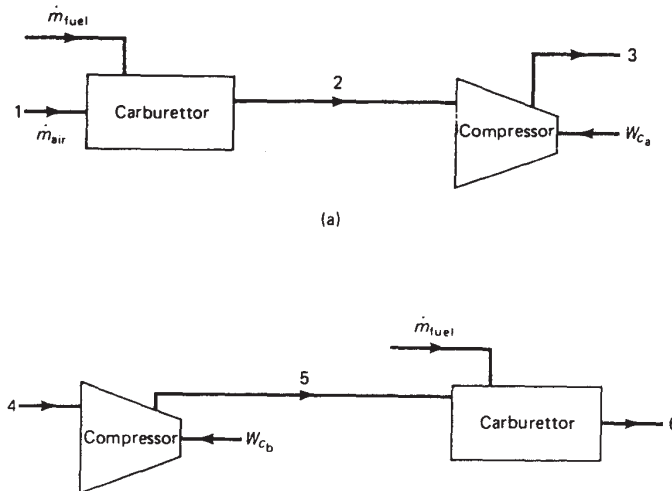

From the definition of compressor isentropic efficiency

$$T_5 = \frac{T_{5s} - T_4}{\eta_c} + T_4 = \frac{323.4 - 288}{0.7} + 288 = 338.5 \text{ K}$$

$$T_6 = T_5 - 25 = 338.5 - 25 = 313.5 \text{ K}$$

Since  $T_6 > T_3$ , it is advantageous to place the carburettor before the compressor. Comparing the compressor power for the two cases:

$$\begin{aligned} (W_c)_a &= \dot{m}_{\text{mix}} c_{p,\text{mix}} (T_3 - T_2) \\ &= 1.08 \dot{m}_{\text{air}} 1.05 (303.7 - 263) \\ &= 46.15 \dot{m}_{\text{air}} \text{ kW} \end{aligned}$$

$$\begin{aligned} (W_c)_b &= \dot{m}_{\text{air}} c_{p,\text{air}} (T_5 - T_4) \\ &= \dot{m}_{\text{air}} 1.01 (338.5 - 288) \\ &= 51.01 \dot{m}_{\text{air}} \text{ kW} \end{aligned}$$

Thus placing the carburettor before the compressor offers a further advantage in reduced compressor work.

The assumption in this example are somewhat idealised. When the carburettor is placed before the compressor, the fuel will not be completely evaporated before entering the compressor, and evaporation will continue during the compression process. However, less fuel is likely to enter the cylinders in droplet form if the carburettor is placed before the compressor rather than after.

## 9.8 Questions

**9.1** A spark ignition engine is fitted with a turbocharger that comprises a radial flow compressor driven by a radial flow exhaust gas turbine. The gravimetric air/fuel ratio is 12 : 1, with the fuel being injected between the compressor and the engine. The air is drawn into the compressor at a pressure of 1 bar and at a temperature of 15°C. The compressor delivery pressure is 1.4 bar. The exhaust gases from the engine enter the turbine at a pressure of 1.3 bar and a temperature of 710°C; the gases leave the turbine at a pressure of 1.1 bar. The isentropic efficiencies of the compressor and turbine are 75 per cent and 85 per cent, respectively.

Treating the exhaust gases as a perfect gas with the same properties as air, calculate:

- (i) the temperature of the gases leaving the compressor and turbine
- (ii) the mechanical efficiency of the turbocharger.

**9.2** Why is it more difficult to turbocharge spark ignition engines than compression ignition engines? Under what circumstances might a supercharger be more appropriate?

**9.3** Why do compression ignition engines have greater potential than spark ignition engines for improvements in power output and fuel economy as a result of turbocharging? When is it most appropriate to specify an inter-cooler? [Consider equation (9.10) to illustrate the answer.]

**9.4** Derive an expression that relates compressor delivery pressure ( $p_2$ ) to turbine inlet pressure ( $p_3$ ) for a turbocharger with a mechanical efficiency  $\eta_{\text{mech}}$ , and compressor and turbine isentropic efficiencies  $\eta_c$  and  $\eta_t$ , respectively. The compressor inlet conditions are  $p_1$ ,  $T_1$ , the turbine inlet temperature is  $T_3$  and the outlet pressure is  $p_4$ . The air/fuel ratio (AFR) and the differences between the properties of air (suffix a) and exhaust (suffix e) must all be considered. Assume  $p_4 = p_1$ .

**9.5** Why do turbochargers most commonly use radial flow compressors and turbines with non-constant pressure supply to the turbine?

**9.6** Why does turbocharging a compression ignition engine normally lead to an improvement in fuel economy, while turbocharging a spark ignition engine usually leads to decreased fuel economy?

**9.7** Show that the density ratio across a compressor and inter-cooler is given by

$$\frac{\rho_3}{\rho_1} = \frac{P_2}{P_1} \left[ 1 + (1 - \varepsilon) \frac{(P_2/P_1)^{\frac{\gamma-1}{\gamma}} - 1}{\eta_c} \right]^{-1}$$

where 1 refers to compressor entry  
 2 refers to compressor delivery  
 3 refers to inter-cooler exit  
 $\eta_c$  = compressor isentropic efficiency  
 $\varepsilon$  = inter-cooler effectiveness =  $(T_2 - T_3)/(T_2 - T_1)$ .

Neglect the pressure drop in the inter-cooler, and state any assumption that you make.

Plot a graph of the density ratio against effectiveness for pressure ratios 2 and 3, for ambient conditions of 1 bar, 300 K, if the compressor isentropic efficiency is 70 per cent.

What are the advantages and disadvantages in using an inter-cooler? Explain under what circumstances it should be used.

**9.8** A turbocharged diesel engine has an exhaust gas flow rate of 0.15 kg/s. The turbine entry conditions are 500°C at 1.5 bar, and the exit conditions are 450°C at 1.1 bar.

(a) Calculate the turbine isentropic efficiency and power output.

The engine design is changed to reduce the heat transfer from the combustion chamber, and for the same operating conditions the exhaust temperature becomes 550°C. The pressure ratio remains the same, and assume the same turbine isentropic efficiency.

(b) Calculate the increase in power output from the turbine.

How will the performance of the engine be changed by reducing the heat transfer, in terms of economy, power output and emissions?

Assume ratio of specific heat capacities = 1.3, and  $c_p = 1.15$  kJ/kg K.

**9.9** A compressor with the performance characteristics shown in figure 9.31 is operating with a mass flow rate ( $\dot{m}$ ) of 49.5 g/s at an isentropic efficiency of 60 per cent. The compressor is fitted to a turbocharged and inter-cooled diesel engine.

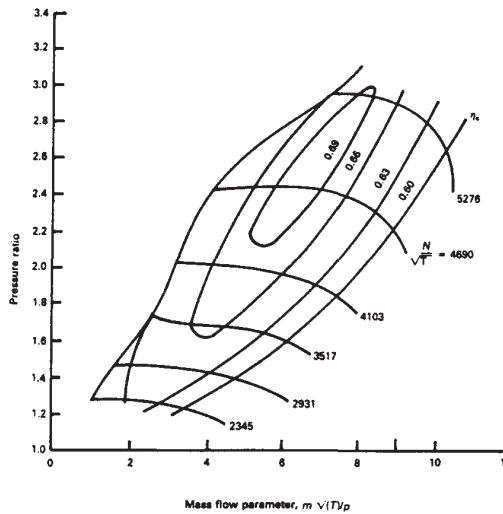

Figure 9.31  
Compressor map.

Assume

- $p$  (the compressor inlet pressure) is  $95 \text{ kN/m}^2$
- $T$  (the inlet temperature) is  $291 \text{ K}$
- $\gamma$  (the ratio of gas specific heat capacities) is  $1.4$
- $c_p = 1.01 \text{ kJ/kg K}$ .

Calculate the pressure ratio, the compressor speed, the compressor delivery temperature and the compressor power.

If the inter-cooler is removed and the air/fuel ratio is kept constant, how would the compressor operating point be affected? Neglecting any change in the compressor efficiency and pressure ratio, estimate the maximum increase in output that the inter-cooler could lead to. State clearly any assumptions that you make.

**9.10** A turbocharged six-cylinder four-stroke diesel engine has a swept volume of 39 litres. The inlet manifold conditions are 2.0 bar and  $53^\circ\text{C}$ . The volumetric efficiency of the engine is 95 per cent, and it is operating at a load of 16.1 bar bmeq, at 1200 rpm with an air/fuel ratio of 21.4. The power delivered to the compressor is 100 kW, with entry conditions of  $25^\circ\text{C}$  and 0.95 bar. The fuel has a calorific value of 42 MJ/kg.

Stating any assumptions, calculate:

- (a) the power output of the engine
- (b) the brake efficiency of the engine
- (c) the compressor isentropic efficiency
- (d) the effectiveness of the inter-cooler.

Estimate the effect of removing the inter-cooler on the power output and emissions of the engine, and the operating point of the turbocharger.

**9.11** A turbocharged diesel engine has a compressor operating point that is marked by a cross on figure 9.32. If the compressor entry conditions are a pressure of 1 bar and a temperature of  $20^\circ\text{C}$ , determine the volume flow rate out of the compressor



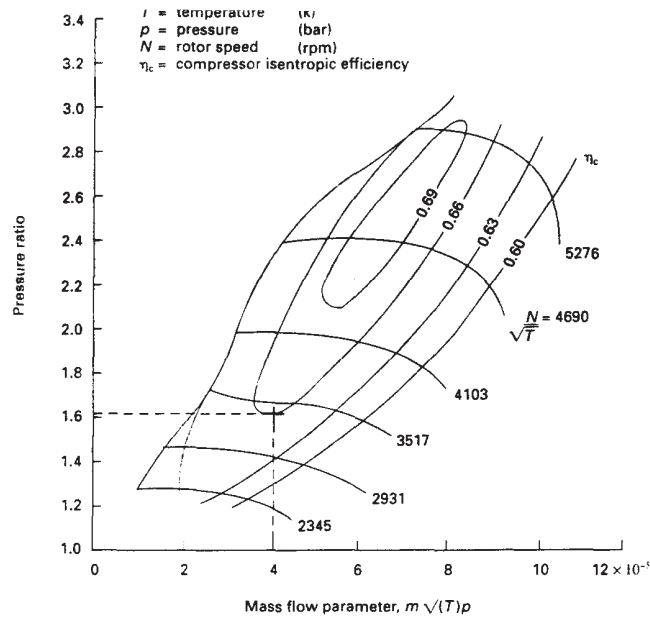

and the power absorbed by the compressor. Assume the following properties for air:  $\gamma = 1.4$ ;  $c_p = 1.01$  kJ/kg K.

The fuelling rate to the engine is increased and when the air mass flow rate into the engine is increased by 50 per cent the volume flow rate out of the compressor increases by 22 per cent. Stating any assumptions, establish approximately the new operating point for the compressor, its rotor speed and the power that it is absorbing.

List briefly the advantages and disadvantages of turbocharging a diesel engine, and how the disadvantages can be ameliorated.

**9.12** The Rolls Royce Crecy engine (for which some development was undertaken in the University of Oxford, Department of Engineering Science during the 1939–45 war by Ricardo) was intended for aircraft use. The Crecy was a supercharged two-stroke engine with a swept volume of 26 litres. The predicted performance at an altitude of 4500 m ( $p = 0.578$  bar,  $T = 259$  K) and a speed of 792 km/h was

supercharger pressure rise 1.05 bar  
 supercharger isentropic efficiency 0.70  
 engine speed 3000 rpm  
 trapped gravimetric air/fuel ratio 15 : 1  
 brake specific fuel consumption 225 g/kWh  
 brake power output 1740 kW  
 air flow rate 5.4 kg/s  
 exhaust temperature 750°C  
 exhaust duct outlet area 0.042 m<sup>2</sup>  
 mean molar mass of the exhaust products 28.5 kg/kmol

The engine had in-cylinder fuel injection, and the valve timing was such that a large flow of air (the scavenge flow) would not be trapped in the cylinder. You may neglect



the pressure rise in the inlet system to the supercharger due to the forward motion of the aircraft. Stating any other assumption that you make:

- (1) Calculate the scavenge flow as a percentage of the total flow into the supercharger.
- (2) If the frictional losses in the engine are equivalent to a frictional mean effective pressure (fmep) of 1 bar, calculate the indicated mean effective pressure (imep).
- (3) Determine the volumetric efficiency based on the inlet manifold conditions and the trapped mass in the cylinder.
- (4) Calculate the thrust from the exhaust, and compare this 'jet power' to the brake power of the engine.

List four of the advantages/disadvantages of in-cylinder petrol injection.

**9.13** A Sulzer RTA two-stroke diesel engine has a bore of 0.84 m and a stroke of 2.09 m; the bmep is 15.53 bar. If the engine operates at a speed of 70 rpm, calculate the power output per cylinder. If the brake specific fuel consumption is 167 g/kWh, calculate the fuel mass flow rate and the brake efficiency (assuming the fuel to have a calorific value of 42 MJ/kg).

Such engines are turbocharged and inter-cooled. Assuming the following data:

turbine isentropic efficiency 0.90  
 turbocharger mechanical efficiency 0.98  
 specific heat capacity of air 1.01 kJ/kg K  
 specific heat capacity of the exhaust products 1.20 kJ/kg K  
 ratio of the heat capacities of air ( $\gamma_a$ ) 1.4  
 ratio of the heat capacities of the exhaust products ( $\gamma_{ex}$ ) 1.3  
 compressor entry pressure 1.0 bar  
 compressor entry temperature 300 K

Stating clearly any assumptions, determine the relationship between the compressor pressure ratio and the turbine entry temperature, such that the compressor delivery pressure is always greater than the turbine entry pressure. Plot the results for pressure ratios in the range 2–3 (using a scale length of 100 mm) for compressor isentropic efficiencies of 0.65 and 0.75 – use a scale of 1 K/mm for the temperature axis.

Why, especially in a two-stroke engine, is it desirable for the compressor delivery pressure to be greater than the turbine entry pressure?

**9.14** A turbocharged 2 litre direct injection diesel engine operates on a four-stroke cycle. At 2900 rpm and a bmep of 9.7 bar (full load), it is operating with a 22 : 1 gravimetric air/fuel ratio and a brake specific fuel consumption of 230 g/kWh. The turbocharger is fitted with a waste-gate to regulate the pressure ratio to 2.0, and the compressor map is shown on figure 9.33, for which the pressure units are kN/m<sup>2</sup>, the mass flow is in g/s, and the temperature units are K. The turbine entry temperature is 850 K, its pressure ratio is also 2.0, and the turbine isentropic efficiency is 0.75.

The compressor entry conditions are 1 bar and 298 K, and you should assume the following thermodynamic properties:

	Air	Exhaust
Specific heat capacity at constant pressure, $c_p$	1.01	1.12 kJ/kg K
Ratio of heat capacities, $\gamma$	1.4	1.33

Figure 9.33

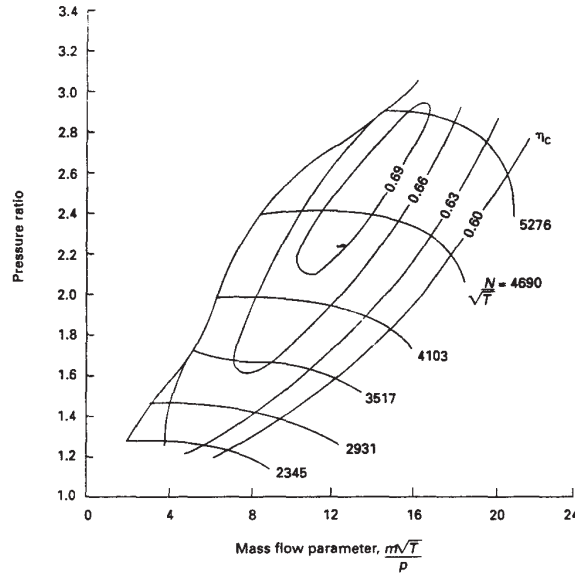

- Stating any assumptions that you make, calculate the brake power output of the engine, its volumetric efficiency (based on inlet manifold conditions) and the fraction of the exhaust gas that passes through the turbine.
- Explain, by means of an annotated sketch, how the waste-gate operates to control the boost pressure.
- Suggest ways of increasing the bmep of this engine in order of increasing complexity, with an indication of the likely increase in output (and how this would be calculated). Comment on how other aspects of the engine performance would be affected.

**9.15** In a turbocharged engine, it is desirable for the compressor boost pressure to be greater than the back-pressure from the turbine. Assuming steady flow, and the following locations:

- |                          |   |
|--------------------------|---|
| entry to the compressor  | 1 |
| exit from the compressor | 2 |
| entry to the turbine     | 3 |
| exit from the turbine    | 4 |

devise an expression for the pressure ratio  $p_2/p_3$  in terms of

- the temperature ratio,  $T_3/T_1$
- the pressure ratio,  $p_2/p_1$
- the compressor isentropic efficiency,  $\eta_c$
- the turbine isentropic efficiency,  $\eta_t$
- the turbocharger mechanical efficiency,  $\eta_m$  and
- the air/fuel ratio, AFR.

Assume that the air and exhaust products behave as perfect gases with the same property values, but allow for any differences in the mass flows through the compressor and turbine. State clearly any additional assumptions that you make.

Comment briefly on all of the assumptions. What might the effect of a compact exhaust manifold be when using steady-flow turbocharger performance data for predicting the performance of a turbocharged diesel engine?

**9.16** The Sabre Marathon engine is a two-stage turbocharger conversion of the Ford Dover diesel engine, with inter-coolers after each compressor. Figure 9.27 shows the arrangement of the turbochargers and inter-coolers, figure 9.28 shows the compressor maps. The engine has an output of 448 kW at 2400 rpm, from a swept volume of 6.8 litre. At this operating point the bsfc is 268 g/kWh, the air/fuel ratio is 21.9 : 1, and the operating points of the turbochargers are as follows:

Turbocharger performance	Low pressure	High pressure
Temperature before compressor	25	64°C
Temperature after compressor	168	217°C
Temperature after cooler	64	49°C
Compressor pressure ratio	2.14	2.50
Turbine entry temperature	716	790°C
Exhaust temperature		601°C

- Calculate the power used by each compressor and its isentropic efficiency.
- Compare the compressor operating points with those shown on the compressor maps in figure 9.28 (note that the air flow rates need to be pseudo non-dimensionalised as  $(m\sqrt{T})/p$ ); assume that the compressor maps have a datum pressure of 1 bar.
- Determine the effectiveness of the inter-coolers, assuming a cooling medium is available at 15°C.
- If the overall pressure ratio is 5.1 (after allowing for pressure drops in the inter-coolers), what is the volumetric efficiency of the engine?
- Assuming no mechanical losses in the turbochargers, calculate the apparent value for the heat capacity of the exhaust gases in each turbocharger, and comment on these values.

Data: Calorific value of diesel fuel = 42 MJ/kg.

For air, take  $c_p = 1.01$  kJ/kg K and  $c_v = 0.721$  kJ/kg K.

**9.17** The Ford Essex V6 spark ignition engine was the subject of a turbocharging study, using an Airesearch T-04B turbocharger; the carburettor was placed downstream of the compressor. The compression ratio was reduced from 9.1 : 1 to 7.6 : 1, so as to avoid combustion 'knock', and it may be assumed that the reduction in the indicated efficiency is 1.5 times that of the reduction in the corresponding Otto cycle. At 3000 rpm, the bmep was increased from 9.6 bar (when naturally aspirated) to 11.1 bar when turbocharged with a boost pressure ratio of 1.4. The fmep is (independent of load) 1.2 bar, and the air flow rate into the engine is 105 g/s.

Assuming that the air/fuel ratio, the pumping work and the volumetric efficiency are unchanged, calculate the density of the air leaving the compressor and the compressor isentropic efficiency (assuming an ambient temperature of 25°C and pressure of 1 bar). Determine and comment on the change in the brake specific fuel consumption, and any other assumptions that have been made.

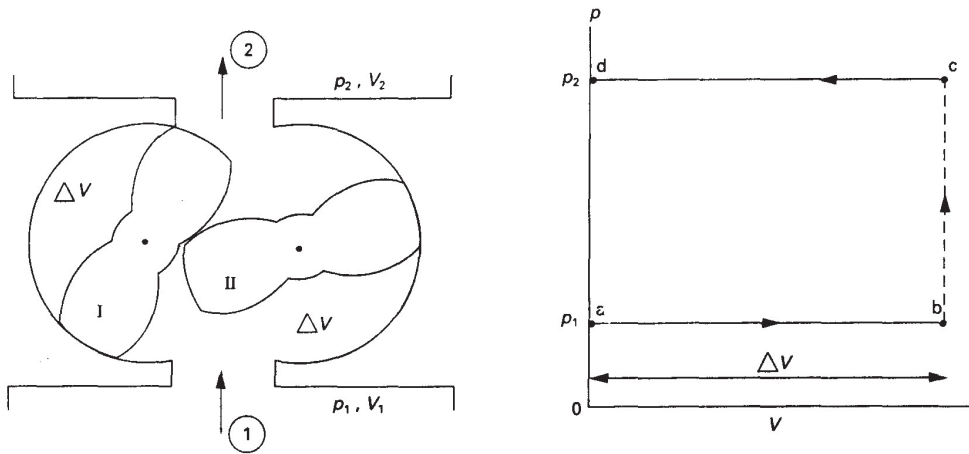

**Figure 9.34**  
Operation of a Roots blower.

**9.18** A 4 litre swept volume spark ignition engine is supercharged using a Roots blower to give a pressure ratio of 1.5. At maximum power, the engine output is 240 kW at 5000 rpm.

The operation of a Roots blower is described by figure 9.34. A volume of air  $\Delta V$  is trapped at ambient pressure, and the pressure is unchanged until this trapped volume is transported to the high-pressure side. At the instant that the high-pressure port is uncovered (once rotor I has turned a little more), the air in the rotor is compressed by the irreversible reverse flow of the high-pressure air from downstream of the Roots blower. The work done is thus the rectangular area abcd in figure 9.34. This work is executed as the rotor turns, to displace the volume ( $\Delta V$ ) of high-pressure gas (corresponding to the trapped volume of the rotor) out of the Roots blower. This model assumes that the downstream volume is sufficiently large, compared to the trapped volume, for the delivery pressure to remain constant. Show that the type efficiency of the Roots blower (the work required from a perfect Roots blower divided by the work required in an isentropic compressor) is

$$\frac{\gamma}{\gamma - 1} \frac{(p_2/p_1)^{\frac{\gamma-1}{\gamma}} - 1}{p_2/p_1 - 1}$$

The performance of a Roots compressor is further compromised by its mechanical losses and its volumetric efficiency. Because of losses (including internal leakage), the volume flow rate into the compressor is reduced, but the work is still area abcd in figure 9.34. If the air mass flow rate is 243 g/s at ambient conditions of 1 bar and 25°C, calculate the power requirement of a Roots compressor with a pressure ratio of 1.5, for mechanical and volumetric efficiencies both of 80 per cent. What would the exit air temperature be from the Roots blower?

After inter-cooling the air temperature is reduced to 50°C. Neglecting any pressure drop in the inter-cooler, calculate the volumetric efficiency of the engine.