

UNITED STATES PATENT AND TRADEMARK OFFICE

BEFORE THE PATENT TRIAL AND APPEAL BOARD

MEDTRONIC, INC. and MEDTRONIC VASCULAR, INC.,
Petitioner,

v.

TELEFLEX INNOVATIONS S.À.R.L.,
Patent Owner.

IPR2020-00136
Patent RE45,776 E

Before SHERIDAN K. SNEDDEN, JON B. TORNQUIST, and
CHRISTOPHER G. PAULRAJ, *Administrative Patent Judges*.

PAULRAJ, *Administrative Patent Judge*.

DECISION
Granting Institution of *Inter Partes* Review
35 U.S.C. § 314

I. INTRODUCTION

A. *Background and Summary*

On November 12, 2019, Medtronic, Inc. and Medtronic Vascular, Inc. (“Petitioner”) filed a Petition requesting an *inter partes* review of claims 25–27, 29–33, 35–39, 41–49, and 52–56 of U.S. Patent No. RE45,776 (“the ’776 patent,” Ex. 1401). Paper 1 (“Pet.”). Vascular Solutions, Inc. (“Patent Owner”) filed a Preliminary Response. Papers 9 (confidential version), 10 (redacted version) (“Prelim. Resp.”). Pursuant to our authorization, Petitioner filed a Reply addressing its burden on secondary considerations and reduction to practice, and Patent Owner filed a Sur-Reply addressing Petitioner’s burden on those issues. Paper 14; Paper 15. Also pursuant to our authorization, Petitioner filed another Reply and Patent Owner filed another Sur-Reply addressing the factors for discretionary denial under 35 U.S.C. § 314(a). Paper 17; Paper 18.

We have the authority and discretion to determine whether to institute an *inter partes* review. 35 U.S.C. § 314 (2018); 37 C.F.R. §42.4(a) (2019). We may not institute an *inter partes* review “unless . . . there is a reasonable likelihood that the petitioner would prevail with respect to at least 1 of the claims challenged in the petition.” 35 U.S.C. § 314(a). Upon considering the arguments and evidence of record, we institute *inter partes* review of claims 25–27, 29–33, 35–37, 39, 41–49, and 52–56 of the ’776 patent.

B. *Real Parties-in-Interest*

Petitioner identifies Medtronic, Inc. and Medtronic Vascular, Inc. as the real parties-in-interest, and notes that “Medtronic plc is the ultimate parent of both entities.” Pet. 5. Patent Owner identifies the real parties-in-interest for itself as Teleflex Medical Devices S.A.R.L., Vascular Solutions

IPR2020-00136
Patent RE45,776 E

LLC, Arrow International, Inc., and Teleflex LLC and notes that “Teleflex Incorporated is the ultimate parent of the entities listed above.” Paper 4, 2.

C. *Related Matters*

Patent Owner is asserting the ’776 patent against Petitioner in the United States District Court for the District of Minnesota in *Vascular Solutions LLC, et al. v. Medtronic, Inc., et al.* No. 19-cv-01760 (“*Medtronic*”). Pet. 5–6; Paper 4, 2. The ’776 patent is also the subject of a declaratory judgement action filed by another party, *QXMedical, LLC v. Vascular Solutions, LLC*, No. 17-cv-01969 (“*QXM*”), which has been currently stayed pending our institution decision. Paper 17; Paper 18. Petitioner further notes that the ’776 patent is a reissue of U.S. Patent No. 8,292,850, which was the subject of a prior district court action and *inter partes* reviews in IPR2014-00762 and IPR2014-00763 filed by a different petitioner. Pet. 6.

Petitioner has also filed another petition challenging the ’776 patent based on different prior art, and we instituted *inter partes* review based on that petition on June 8, 2020. IPR2020-00135, Paper 22.¹ In addition, Petitioner filed concurrent petitions challenging other related patents: U.S. Patent No. 8,048,032 (IPR2020-00126; IPR2020-00127), RE45,830 (IPR2020-00128; IPR2020-00129; IPR2020-00130; IPR2020-00131), RE 45,760 (IPR2020-00132; IPR2020-00133; IPR2020-00134), and RE47,379 (IPR2020-00137; IPR2020-00138).

¹ In accordance with our Trial Practice Guide, Petitioner provides an explanation of material differences and ranking for the multiple petitions directed to each challenged patent. Paper 3. Patent Owner responds that Petitioner has not justified institution on multiple petitions. Paper 8. We address Patent Owner’s arguments for discretionary denial based on the multiple petitions below.

D. The '776 Patent

The '776 patent, entitled “Coaxial Guide Catheter for Interventional Cardiology Procedures,” issued on October 27, 2015, as a re-issue of U.S. Patent No. 8,292,850, which claims priority to a non-provisional application filed May 3, 2006. Ex. 1401, codes (45), (60), (64).²

The '776 patent relates generally to a coaxial guide catheter for use with interventional cardiology devices that are insertable into a branch artery that branches off from a main artery. Ex. 1401, Abstract. According to the '776 patent, interventional cardiology procedures often include inserting guidewires or other instruments through catheters into coronary arteries that branch off from the aorta. *Id.* at 1:45–47. In coronary artery disease, the coronary arteries may be narrowed or occluded by atherosclerotic plaques or other lesions in a phenomenon known as stenosis. *Id.* at 1:50–55. In treating the stenosis, a guide catheter is inserted through the aorta and into the ostium of the coronary artery, sometimes with the aid of a guidewire, and is passed beyond the occlusion or stenosis. *Id.* at 1:59–65. However, crossing tough lesions can create enough backward force to dislodge the guide catheter from the ostium of the artery being treated, which can make it difficult or impossible for the interventional cardiologist to treat certain forms of coronary artery disease. *Id.* at 1:65–67.

To solve this problem, the '776 patent describes a coaxial guide catheter that is deliverable through standard guidewires by utilizing a guidewire rail segment to permit delivery without blocking use of the guide catheter. *Id.* at 3:15–18. The '776 patent teaches that the coaxial guide

² Petitioner does not contest the priority date for the '776 patent in this proceeding. We consider May 3, 2006 to be the effective filing date for purposes of our analysis.

catheter preferably includes a tapered inner catheter that runs over a standard 0.014 inch coronary guidewire to allow atraumatic placement within the coronary artery, and this feature allows removal of the tapered inner catheter after the coaxial guide catheter is in place. *Id.* at 3:24–27. Figures 1 and 2, reproduced below, show a coaxial guide catheter and a tapered inner catheter in accordance with the invention described in the '776 patent:

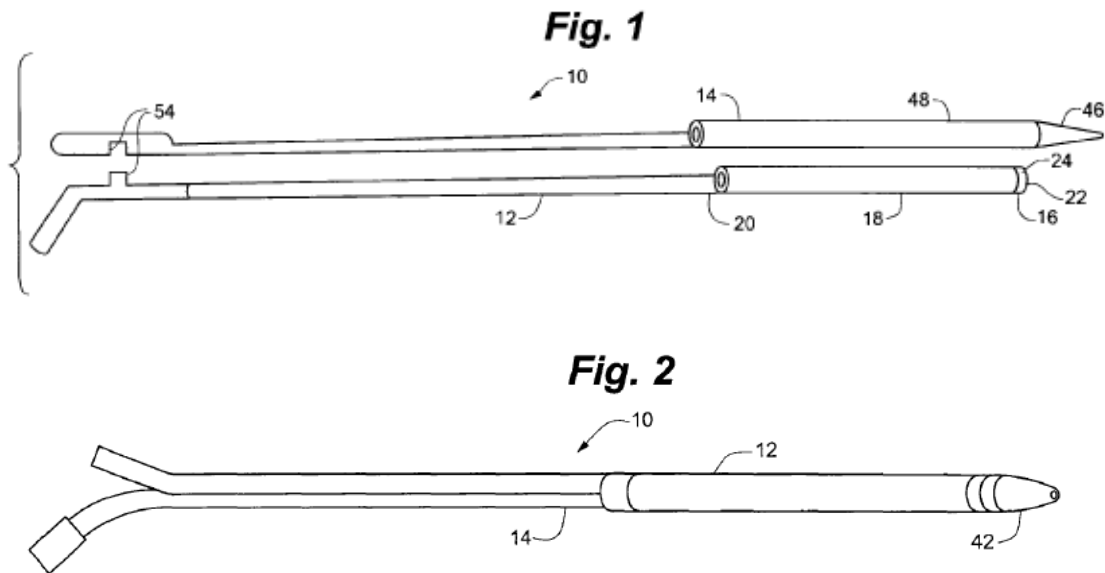

Figure 1 is a schematic depiction of the coaxial guide catheter and tapered inner catheter separately, and Figure 2 depicts those two elements assembled together. *Id.* at 5:47–52; Figs. 1 and 2. As shown above, coaxial guide catheter assembly 10 includes coaxial guide catheter 12 and tapered inner catheter 14. *Id.* at 6:37–39. Coaxial guide catheter 12 includes tip portion 16, reinforced portion 18, and rigid portion 20. *Id.* at 6:40–41. Tip portion 16 generally includes bump tip 22 and marker band 24. *Id.* at 6:44–45. Bump tip 22 includes taper 26 and is relatively flexible. *Id.* at 6:45–46. Marker band 24 is formed of a radiopaque material such as platinum/iridium alloy. *Id.* at 6:49–50. Tapered inner catheter tip 42 includes tapered portion 46 at a distal end thereof, and straight portion 48. *Id.* at 7:22–23. Both

Explore Litigation Insights

Docket Alarm provides insights to develop a more informed litigation strategy and the peace of mind of knowing you're on top of things.

Real-Time Litigation Alerts



Keep your litigation team up-to-date with **real-time alerts** and advanced team management tools built for the enterprise, all while greatly reducing PACER spend.

Our comprehensive service means we can handle Federal, State, and Administrative courts across the country.

Advanced Docket Research



With over 230 million records, Docket Alarm's cloud-native docket research platform finds what other services can't. Coverage includes Federal, State, plus PTAB, TTAB, ITC and NLRB decisions, all in one place.

Identify arguments that have been successful in the past with full text, pinpoint searching. Link to case law cited within any court document via Fastcase.

Analytics At Your Fingertips



Learn what happened the last time a particular judge, opposing counsel or company faced cases similar to yours.

Advanced out-of-the-box PTAB and TTAB analytics are always at your fingertips.

API

Docket Alarm offers a powerful API (application programming interface) to developers that want to integrate case filings into their apps.

LAW FIRMS

Build custom dashboards for your attorneys and clients with live data direct from the court.

Automate many repetitive legal tasks like conflict checks, document management, and marketing.

FINANCIAL INSTITUTIONS

Litigation and bankruptcy checks for companies and debtors.

E-DISCOVERY AND LEGAL VENDORS

Sync your system to PACER to automate legal marketing.