

Doc Code: PA..

Document Description: Power of Attorney

PTO/AIA/82B(07-12)

Approved for use through 11/30/2014. OMB 0551-0035

U.S. Patent and Trademark Office; U.S. DEPARTMENT OF COMMERCE

Under the Paperwork Reduction Act of 1995, no persons are required to respond to a collection of information unless it displays a valid OMB control number.

# POWER OF ATTORNEY BY APPLICANT

I hereby revoke all previous powers of attorney given in the application identified in the attached transmittal letter.

I hereby appoint Practitioner(s) associated with the following Customer Number as my/our attorney(s) or agent(s), and to transact all business in the United States Patent and Trademark Office connected therewith for the application referenced in the attached transmittal letter (form PTO/AIA/82A or equivalent):

05251

OR

I hereby appoint Practitioner(s) named below as my/our attorney(s) or agent(s), and to transact all business in the United States Patent and Trademark Office connected therewith for the application referenced in the attached transmittal letter (form PTO/AIA/82A or equivalent):

Name	Registration Number	Name	Registration Number

Please recognize or change the correspondence address for the application identified in the attached transmittal letter to:

The address associated with the above-mentioned Customer Number.

OR

The address associated with Customer Number:

OR

Firm or Individual Name

Address

City

State

Zip

Country

Telephone

Email

I am the Applicant:

Inventor or Joint Inventor

Legal Representative of a Deceased or Legally Incapacitated Inventor

Assignee or Person to Whom the Inventor is Under an Obligation to Assign

Person Who Otherwise Shows Sufficient Proprietary Interest (e.g., a petition under 37 CFR 1.46(b)(2) was granted in the application or is concurrently being filed with this document)

### SIGNATURE of Applicant for Patent

Signature

*Lin Chung HO*

Date

December 6, 2013

Name

Chung-Ho LIN

Telephone

Title and Company

President/ABILITY OPTO-ELECTRONICS TECHNOLOGY CO., LTD.

NOTE: Signature - This form must be signed by the applicant in accordance with 37 CFR 1.33. See 37 CFR 1.4 for signature requirements and certifications. Submit multiple forms for more than one signature, see below \*.

\*Total of \_\_\_\_\_ forms are submitted.

This collection of information is required by 37 CFR 1.31, 1.32 and 1.33. The information is required to obtain or retain a benefit by the public which is to file (and by the USPTO to process) an application. Confidentiality is governed by 35 U.S.C. 122 and 37 CFR 1.11 and 1.14. This collection is estimated to take 3 minutes to complete, including gathering, preparing, and submitting the completed application form to the USPTO. Time will vary depending upon the individual case. Any comments on the amount of time you require to complete this form and/or suggestions for reducing this burden, should be sent to the Chief Information Officer, U.S. Patent and Trademark Office, U.S. Department of Commerce, P.O. Box 1450, Alexandria, VA 22313-1450. DO NOT SEND FEES OR COMPLETED FORMS TO THIS ADDRESS. SEND TO: Commissioner for Patents, P.O. Box 1450, Alexandria, VA 22313-1450.

If you need assistance in completing the form, call 1-800-PTO-9199 and select option 2.

## Electronic Patent Application Fee Transmittal

<b>Application Number:</b>	
<b>Filing Date:</b>	
<b>Title of Invention:</b>	LENS ASSEMBLY
<b>First Named Inventor/Applicant Name:</b>	Hung-Kuo Yu
<b>Filer:</b>	Thomas Moga/Sandra Lewis
<b>Attorney Docket Number:</b>	SIIP.201299

Filed as Large Entity

### Utility under 35 USC 111(a) Filing Fees

Description	Fee Code	Quantity	Amount	Sub-Total in USD(\$)
<b>Basic Filing:</b>				
Utility application filing	1011	1	280	280
Utility Search Fee	1111	1	600	600
Utility Examination Fee	1311	1	720	720

**Pages:**

**Claims:**

**Miscellaneous-Filing:**

**Petition:**

**Patent-Appeals-and-Interference:**

Description	Fee Code	Quantity	Amount	Sub-Total in USD(\$)
<b>Post-Allowance-and-Post-Issuance:</b>				
<b>Extension-of-Time:</b>				
<b>Miscellaneous:</b>				
<b>Total in USD (\$)</b>				<b>1600</b>

## Electronic Acknowledgement Receipt

<b>EFS ID:</b>	17765942
<b>Application Number:</b>	14141665
<b>International Application Number:</b>	
<b>Confirmation Number:</b>	9554
<b>Title of Invention:</b>	LENS ASSEMBLY
<b>First Named Inventor/Applicant Name:</b>	Hung-Kuo Yu
<b>Customer Number:</b>	5251
<b>Filer:</b>	Thomas Moga/Sandra Lewis
<b>Filer Authorized By:</b>	Thomas Moga
<b>Attorney Docket Number:</b>	SIIP.201299
<b>Receipt Date:</b>	27-DEC-2013
<b>Filing Date:</b>	
<b>Time Stamp:</b>	12:01:18
<b>Application Type:</b>	Utility under 35 USC 111(a)

### Payment information:

Submitted with Payment	yes
Payment Type	Credit Card
Payment was successfully received in RAM	\$1600
RAM confirmation Number	6508
Deposit Account	192112
Authorized User	MOGA, THOMAS T.

The Director of the USPTO is hereby authorized to charge indicated fees and credit any overpayment as follows:

Charge any Additional Fees required under 37 C.F.R. Section 1.16 (National application filing, search, and examination fees)

Charge any Additional Fees required under 37 C.F.R. Section 1.17 (Patent application and reexamination processing fees)



<b>File Listing:</b>					
<b>Document Number</b>	<b>Document Description</b>	<b>File Name</b>	<b>File Size(Bytes)/ Message Digest</b>	<b>Multi Part /.zip</b>	<b>Pages (if appl.)</b>
1	Application Data Sheet	SIIP201299ApplicationDataSheet.pdf	89846 9b9e11601080a06a084ff8fabf1da4dbc5bb6aa0	no	7
<b>Warnings:</b>					
<b>Information:</b>					
This is not an USPTO supplied ADS fillable form					
2		SIIP201299Specification.pdf	671188 48d1bdc6383477109a34ef53a003c7134ccdf959	yes	22
	<b>Multipart Description/PDF files in .zip description</b>				
	<b>Document Description</b>		<b>Start</b>	<b>End</b>	
	Specification		1	17	
	Claims		18	21	
	Abstract		22	22	
<b>Warnings:</b>					
<b>Information:</b>					
3	Drawings-only black and white line drawings	SIIP201299Drawings.pdf	86311 0a7703b49f829b193cc037279b818ec0145edeaf6	no	9
<b>Warnings:</b>					
<b>Information:</b>					
4	Oath or Declaration filed	SIIP201299DeclarationandAssignment.pdf	180070 7195066b94458f07752123308d02ce9cd68e5fb9	no	3
<b>Warnings:</b>					
<b>Information:</b>					
5	Power of Attorney	SIIP201299PowerofAttorney.pdf	72384 c432ef0432b15c24c2721a26c8ff61202f7dc89a	no	1
<b>Warnings:</b>					
<b>Information:</b>					
6	Fee Worksheet (SB06)	fee-info.pdf	32742 b3f6fbce300a86a8b7b6fe7918df0c0b934ce241	no	2
<b>Warnings:</b>					
<b>Information:</b>					
<b>Total Files Size (in bytes):</b>			1132541		

**This Acknowledgement Receipt evidences receipt on the noted date by the USPTO of the indicated documents, characterized by the applicant, and including page counts, where applicable. It serves as evidence of receipt similar to a Post Card, as described in MPEP 503.**

**New Applications Under 35 U.S.C. 111**

**If a new application is being filed and the application includes the necessary components for a filing date (see 37 CFR 1.53(b)-(d) and MPEP 506), a Filing Receipt (37 CFR 1.54) will be issued in due course and the date shown on this Acknowledgement Receipt will establish the filing date of the application.**

**National Stage of an International Application under 35 U.S.C. 371**

**If a timely submission to enter the national stage of an international application is compliant with the conditions of 35 U.S.C. 371 and other applicable requirements a Form PCT/DO/EO/903 indicating acceptance of the application as a national stage submission under 35 U.S.C. 371 will be issued in addition to the Filing Receipt, in due course.**

**New International Application Filed with the USPTO as a Receiving Office**

**If a new international application is being filed and the international application includes the necessary components for an international filing date (see PCT Article 11 and MPEP 1810), a Notification of the International Application Number and of the International Filing Date (Form PCT/RO/105) will be issued in due course, subject to prescriptions concerning national security, and the date shown on this Acknowledgement Receipt will establish the international filing date of the application.**

Under the Paperwork Reduction Act of 1995, no persons are required to respond to a collection of information unless it contains a valid OMB control number.

<b>Application Data Sheet 37 CFR 1.76</b>		Attorney Docket Number	SIIP.201299
		Application Number	
Title of Invention	LENS ASSEMBLY		
<p>The application data sheet is part of the provisional or nonprovisional application for which it is being submitted. The following form contains the bibliographic data arranged in a format specified by the United States Patent and Trademark Office as outlined in 37 CFR 1.76. This document may be completed electronically and submitted to the Office in electronic format using the Electronic Filing System (EFS) or the document may be printed and included in a paper filed application.</p>			

**Secrecy Order 37 CFR 5.2**

<input type="checkbox"/>	Portions or all of the application associated with this Application Data Sheet may fall under a Secrecy Order pursuant to 37 CFR 5.2 (Paper filers only. Applications that fall under Secrecy Order may not be filed electronically.)
--------------------------	---

**Inventor Information:**

Inventor 1					Remove
Legal Name					
Prefix	Given Name	Middle Name	Family Name	Suffix	
	Hung-Kuo		Yu		
Residence Information (Select One) <input type="radio"/> US Residency <input checked="" type="radio"/> Non US Residency <input type="radio"/> Active US Military Service					
City	Taichung City	Country of Residence <sup>i</sup>		TW	

**Mailing Address of Inventor:**

Address 1	2F., No. 33, Keya Rd., Daya Dist.				
Address 2					
City	Taichung City	State/Province			
Postal Code	42881	Country <sup>i</sup>	TW		

Inventor 2					Remove
Legal Name					
Prefix	Given Name	Middle Name	Family Name	Suffix	
	Chao-Hsiang		Yang		
Residence Information (Select One) <input type="radio"/> US Residency <input checked="" type="radio"/> Non US Residency <input type="radio"/> Active US Military Service					
City	Taichung City	Country of Residence <sup>i</sup>		TW	

**Mailing Address of Inventor:**

Address 1	2F., No. 33, Keya Rd., Daya Dist.				
Address 2					
City	Taichung City	State/Province			
Postal Code	42881	Country <sup>i</sup>	TW		

All Inventors Must Be Listed - Additional Inventor Information blocks may be generated within this form by selecting the **Add** button.

Add

**Correspondence Information:**

AOET, Ex. 1004

Page 7

Under the Paperwork Reduction Act of 1995, no persons are required to respond to a collection of information unless it contains a valid OMB control number.

<b>Application Data Sheet 37 CFR 1.76</b>		Attorney Docket Number	SIIP.201299
		Application Number	
Title of Invention	LENS ASSEMBLY		

**Enter either Customer Number or complete the Correspondence Information section below.  
 For further information see 37 CFR 1.33(a).**

**An Address is being provided for the correspondence information of this application.**

Customer Number	05251		
Email Address	tmoga@shb.com	<input type="button" value="Add Email"/>	<input type="button" value="Remove Email"/>
Email Address	tball@shb.com	<input type="button" value="Add Email"/>	<input type="button" value="Remove Email"/>
Email Address	smlewis@shb.com		<input type="button" value="Remove Email"/>

### Application Information:

Title of the Invention	LENS ASSEMBLY		
Attorney Docket Number	SIIP.201299	Small Entity Status Claimed <input type="checkbox"/>	
Application Type	Nonprovisional		
Subject Matter	Utility		
Total Number of Drawing Sheets (if any)	9	Suggested Figure for Publication (if any)	

### Filing By Reference :

Only complete this section when filing an application by reference under 35 U.S.C. 111(c) and 37 CFR 1.57(a). Do not complete this section if application papers including a specification and any drawings are being filed. Any domestic benefit or foreign priority information must be provided in the appropriate section(s) below (i.e., "Domestic Benefit/National Stage Information" and "Foreign Priority Information").

For the purposes of a filing date under 37 CFR 1.53(b), the description and any drawings of the present application are replaced by this reference to the previously filed application, subject to conditions and requirements of 37 CFR 1.57(a).

Application number of the previously filed application	Filing date (YYYY-MM-DD)	Intellectual Property Authority or Country

### Publication Information:

Request Early Publication (Fee required at time of Request 37 CFR 1.219)

**Request Not to Publish.** I hereby request that the attached application not be published under 35 U.S.C. 122(b) and certify that the invention disclosed in the attached application **has not and will not** be the subject of an application filed in another country, or under a multilateral international agreement, that requires publication at eighteen months after filing.

### Representative Information:

Representative information should be provided for all practitioners having a power of attorney in the application. Providing this information in the Application Data Sheet does not constitute a power of attorney in the application (see 37 CFR 1.32). Either enter Customer Number or complete the Representative Name section below. If both sections are completed the customer Number will be used for the Representative Information during processing.

<b>Application Data Sheet 37 CFR 1.76</b>		Attorney Docket Number	SIIP.201299	
		Application Number		
Title of Invention	LENS ASSEMBLY			
Please Select One:	<input checked="" type="radio"/> Customer Number	<input type="radio"/> US Patent Practitioner	<input type="radio"/> Limited Recognition (37 CFR 11.9)	
Customer Number	05251			

### Domestic Benefit/National Stage Information:

This section allows for the applicant to either claim benefit under 35 U.S.C. 119(e), 120, 121, or 365(c) or indicate National Stage entry from a PCT application. Providing this information in the application data sheet constitutes the specific reference required by 35 U.S.C. 119(e) or 120, and 37 CFR 1.78.

When referring to the current application, please leave the application number blank.

Prior Application Status				<a href="#">Remove</a>
Application Number	Continuity Type	Prior Application Number	Filing Date (YYYY-MM-DD)	
Additional Domestic Benefit/National Stage Data may be generated within this form by selecting the <b>Add</b> button.				

### Foreign Priority Information:

This section allows for the applicant to claim priority to a foreign application. Providing this information in the application data sheet constitutes the claim for priority as required by 35 U.S.C. 119(b) and 37 CFR 1.55(d). When priority is claimed to a foreign application that is eligible for retrieval under the priority document exchange program (PDX)<sup>i</sup> the information will be used by the Office to automatically attempt retrieval pursuant to 37 CFR 1.55(h)(1) and (2). Under the PDX program, applicant bears the ultimate responsibility for ensuring that a copy of the foreign application is received by the Office from the participating foreign intellectual property office, or a certified copy of the foreign priority application is filed, within the time period specified in 37 CFR 1.55(g)(1).

			<a href="#">Remove</a>
Application Number	Country <sup>i</sup>	Filing Date (YYYY-MM-DD)	Access Code <sup>i</sup> (if applicable)
102131525	TW	2013-09-02	
Additional Foreign Priority Data may be generated within this form by selecting the <b>Add</b> button.			

<b>Application Data Sheet 37 CFR 1.76</b>		Attorney Docket Number	SIIP.201299
		Application Number	
Title of Invention	LENS ASSEMBLY		

## Statement under 37 CFR 1.55 or 1.78 for AIA (First Inventor to File) Transition Applications

<p>This application (1) claims priority to or the benefit of an application filed before March 16, 2013 and (2) also contains, or contained at any time, a claim to a claimed invention that has an effective filing date on or after March 16, 2013.</p> <p><input type="checkbox"/> NOTE: By providing this statement under 37 CFR 1.55 or 1.78, this application, with a filing date on or after March 16, 2013, will be examined under the first inventor to file provisions of the AIA.</p>
--

## Authorization to Permit Access:

<input checked="" type="checkbox"/> Authorization to Permit Access to the Instant Application by the Participating Offices
<p>If checked, the undersigned hereby grants the USPTO authority to provide the European Patent Office (EPO), the Japan Patent Office (JPO), the Korean Intellectual Property Office (KIPO), the World Intellectual Property Office (WIPO), and any other intellectual property offices in which a foreign application claiming priority to the instant patent application is filed access to the instant patent application. See 37 CFR 1.14(c) and (h). This box should not be checked if the applicant does not wish the EPO, JPO, KIPO, WIPO, or other intellectual property office in which a foreign application claiming priority to the instant patent application is filed to have access to the instant patent application.</p> <p>In accordance with 37 CFR 1.14(h)(3), access will be provided to a copy of the instant patent application with respect to: 1) the instant patent application-as-filed; 2) any foreign application to which the instant patent application claims priority under 35 U.S.C. 119(a)-(d) if a copy of the foreign application that satisfies the certified copy requirement of 37 CFR 1.55 has been filed in the instant patent application; and 3) any U.S. application-as-filed from which benefit is sought in the instant patent application.</p> <p>In accordance with 37 CFR 1.14(c), access may be provided to information concerning the date of filing this Authorization.</p>

## Applicant Information:

<p>Providing assignment information in this section does not substitute for compliance with any requirement of part 3 of Title 37 of CFR to have an assignment recorded by the Office.</p>
--

<b>Application Data Sheet 37 CFR 1.76</b>	Attorney Docket Number	SIIP.201299
	Application Number	
Title of Invention	LENS ASSEMBLY	

<b>Applicant 1</b>			
If the applicant is the inventor (or the remaining joint inventor or inventors under 37 CFR 1.45), this section should not be completed. The information to be provided in this section is the name and address of the legal representative who is the applicant under 37 CFR 1.43; or the name and address of the assignee, person to whom the inventor is under an obligation to assign the invention, or person who otherwise shows sufficient proprietary interest in the matter who is the applicant under 37 CFR 1.46. If the applicant is an applicant under 37 CFR 1.46 (assignee, person to whom the inventor is obligated to assign, or person who otherwise shows sufficient proprietary interest) together with one or more joint inventors, then the joint inventor or inventors who are also the applicant should be identified in this section.			
<input type="button" value="Clear"/>			
<input checked="" type="radio"/> Assignee	<input type="radio"/> Legal Representative under 35 U.S.C. 117	<input type="radio"/> Joint Inventor	
<input type="radio"/> Person to whom the inventor is obligated to assign.		<input type="radio"/> Person who shows sufficient proprietary interest	
If applicant is the legal representative, indicate the authority to file the patent application, the inventor is:			
Name of the Deceased or Legally Incapacitated Inventor : <input type="text"/>			
If the Applicant is an Organization check here. <input checked="" type="checkbox"/>			
Organization Name	ABILITY OPTO-ELECTRONICS TECHNOLOGY CO., LTD.		
<b>Mailing Address Information For Applicant:</b>			
Address 1	2F., No. 33, Keya Rd., Daya Dist.		
Address 2			
City	Taichung City	State/Province	
Country	TW	Postal Code	42881
Phone Number		Fax Number	
Email Address			
Additional Applicant Data may be generated within this form by selecting the Add button.			

## Assignee Information including Non-Applicant Assignee Information:

Providing assignment information in this section does not substitute for compliance with any requirement of part 3 of Title 37 of CFR to have an assignment recorded by the Office.	
<b>Assignee 1</b>	
Complete this section if assignee information, including non-applicant assignee information, is desired to be included on the patent application publication. An assignee-applicant identified in the "Applicant Information" section will appear on the patent application publication as an applicant. For an assignee-applicant, complete this section only if identification as an assignee is also desired on the patent application publication.	
If the Assignee or Non-Applicant Assignee is an Organization check here. <input type="checkbox"/>	

Under the Paperwork Reduction Act of 1995, no persons are required to respond to a collection of information unless it contains a valid OMB control number.

<b>Application Data Sheet 37 CFR 1.76</b>		Attorney Docket Number	SIIP.201299
		Application Number	
Title of Invention	LENS ASSEMBLY		

Prefix	Given Name	Middle Name	Family Name	Suffix

**Mailing Address Information For Assignee including Non-Applicant Assignee:**

Address 1				
Address 2				
City				State/Province
Country <sup>i</sup>			Postal Code	
Phone Number				Fax Number
Email Address				

Additional Assignee or Non-Applicant Assignee Data may be generated within this form by selecting the Add button.

**Signature:**

NOTE: This form must be signed in accordance with 37 CFR 1.33. See 37 CFR 1.4 for signature requirements and certifications.					
<b>Signature</b>	/Thomas T. Moga/			Date (YYYY-MM-DD)	2013-12-27
First Name	Thomas	Last Name	Moga	Registration Number	34881
Additional Signature may be generated within this form by selecting the Add button.					

This collection of information is required by 37 CFR 1.76. The information is required to obtain or retain a benefit by the public which is to file (and by the USPTO to process) an application. Confidentiality is governed by 35 U.S.C. 122 and 37 CFR 1.14. This collection is estimated to take 23 minutes to complete, including gathering, preparing, and submitting the completed application data sheet form to the USPTO. Time will vary depending upon the individual case. Any comments on the amount of time you require to complete this form and/or suggestions for reducing this burden, should be sent to the Chief Information Officer, U.S. Patent and Trademark Office, U.S. Department of Commerce, P.O. Box 1450, Alexandria, VA 22313-1450. DO NOT SEND FEES OR COMPLETED FORMS TO THIS ADDRESS. **SEND TO: Commissioner for Patents, P.O. Box 1450, Alexandria, VA 22313-1450.**



# Privacy Act Statement

The Privacy Act of 1974 (P.L. 93-579) requires that you be given certain information in connection with your submission of the attached form related to a patent application or patent. Accordingly, pursuant to the requirements of the Act, please be advised that: (1) the general authority for the collection of this information is 35 U.S.C. 2(b)(2); (2) furnishing of the information solicited is voluntary; and (3) the principal purpose for which the information is used by the U.S. Patent and Trademark Office is to process and/or examine your submission related to a patent application or patent. If you do not furnish the requested information, the U.S. Patent and Trademark Office may not be able to process and/or examine your submission, which may result in termination of proceedings or abandonment of the application or expiration of the patent.

The information provided by you in this form will be subject to the following routine uses:

1. The information on this form will be treated confidentially to the extent allowed under the Freedom of Information Act (5 U.S.C. 552) and the Privacy Act (5 U.S.C. 552a). Records from this system of records may be disclosed to the Department of Justice to determine whether the Freedom of Information Act requires disclosure of these records.
2. A record from this system of records may be disclosed, as a routine use, in the course of presenting evidence to a court, magistrate, or administrative tribunal, including disclosures to opposing counsel in the course of settlement negotiations.
3. A record in this system of records may be disclosed, as a routine use, to a Member of Congress submitting a request involving an individual, to whom the record pertains, when the individual has requested assistance from the Member with respect to the subject matter of the record.
4. A record in this system of records may be disclosed, as a routine use, to a contractor of the Agency having need for the information in order to perform a contract. Recipients of information shall be required to comply with the requirements of the Privacy Act of 1974, as amended, pursuant to 5 U.S.C. 552a(m).
5. A record related to an International Application filed under the Patent Cooperation Treaty in this system of records may be disclosed, as a routine use, to the International Bureau of the World Intellectual Property Organization, pursuant to the Patent Cooperation Treaty.
6. A record in this system of records may be disclosed, as a routine use, to another federal agency for purposes of National Security review (35 U.S.C. 181) and for review pursuant to the Atomic Energy Act (42 U.S.C. 218(c)).
7. A record from this system of records may be disclosed, as a routine use, to the Administrator, General Services, or his/her designee, during an inspection of records conducted by GSA as part of that agency's responsibility to recommend improvements in records management practices and programs, under authority of 44 U.S.C. 2904 and 2906. Such disclosure shall be made in accordance with the GSA regulations governing inspection of records for this purpose, and any other relevant (i.e., GSA or Commerce) directive. Such disclosure shall not be used to make determinations about individuals.
8. A record from this system of records may be disclosed, as a routine use, to the public after either publication of the application pursuant to 35 U.S.C. 122(b) or issuance of a patent pursuant to 35 U.S.C. 151. Further, a record may be disclosed, subject to the limitations of 37 CFR 1.14, as a routine use, to the public if the record was filed in an application which became abandoned or in which the proceedings were terminated and which application is referenced by either a published application, an application open to public inspections or an issued patent.
9. A record from this system of records may be disclosed, as a routine use, to a Federal, State, or local law enforcement agency, if the USPTO becomes aware of a violation or potential violation of law or regulation.

**LENS ASSEMBLY****CROSS-REFERENCE TO RELATED APPLICATION**

This application claims priority of Taiwanese Application No. 102131525, filed on September 2, 2013.

5 **BACKGROUND OF THE INVENTION****1. Field of the Invention**

The present invention relates to a lens assembly, more particularly to a compact wide-angle four-piece imaging lens assembly.

10 **2. Description of the Related Art**

A conventional imaging lens assembly is frequently adopted in an electronic product, such as a mobile phone, a smart phone, a tablet computer, a notebook computer, a camera and so forth. With the continuous improvement  
15 of electronic products, a tendency toward compact design while maintaining high performance of the electronic products is desired. Accordingly, an imaging lens assembly is also developed toward a trend of being compact and having thin dimensions. Meanwhile, for the  
20 purpose of raising resolving power, an imaging lens assembly is required to progress to have a wider angle of view.

Even though conventional imaging lens assemblies, such as the optical lens assemblies disclosed in  
25 Taiwanese Patent Application Publication Numbers 201215941, 201224568 and 201239443, are provided with four-piece lens frameworks, these imaging lens

assemblies may not further satisfy a desire for compact design and a wider angle of view.

Accordingly, in order to enable an electronic device to achieve effects of both compact design and high performance, a wide-angle imaging lens assembly capable of improving resolving power thereof and having miniature dimensions is desired on the market.

#### **SUMMARY OF THE INVENTION**

Therefore, an object of the present invention is to provide a four-piece imaging lens assembly which has compact and thin dimensions and which has a wider angle of view for improving resolving power thereof.

Accordingly, a lens assembly of the present invention comprises a lens set and a non-adjustable diaphragm. The lens set includes a first lens, a second lens, a third lens and a fourth lens arranged in sequence from an object side to an image side along an optical axis of the lens assembly. The first lens has a positive optical power adjacent to the optical axis, and has a convex object-side surface which faces the object side, and an image-side surface which faces the image side. At least one of the object-side surface and the image-side surface of the first lens is an aspherical surface. The second lens has a positive optical power adjacent to the optical axis, and has a convex image-side surface which faces the image side, and an object-side surface which faces the object side. At least one of

the object-side surface and the image-side surface of the second lens is an aspherical surface. The third lens has a negative optical power adjacent to the optical axis, and has a concave object-side surface which faces the object side, and a convex image-side surface which faces the image side. At least one of the object-side surface and the image-side surface of the third lens is an aspherical surface. The fourth lens has a positive optical power adjacent to the optical axis, and has an image-side surface which faces the image side and which has a concave portion around the optical axis, an object-side surface which faces the object side, and a peripheral surface which interconnects the object-side surface and the image-side surface. Each of the object-side surface and the image-side surface of the fourth lens is an aspherical surface. At least one of the object-side surface and the image-side surface of the fourth lens has an inflection point located between the optical axis and the peripheral surface. The non-adjustable diaphragm is located between the object side and the second lens of the lens set. The lens assembly satisfies

$$15 < \text{HFOV}/f < 50,$$

in which, HFOV represents one half of a maximum angle of view of the lens assembly and has a unit of degree, and  $f$  represents a focal length of the lens assembly and has a unit of millimeter.

**BRIEF DESCRIPTION OF THE DRAWINGS**

Other features and advantages of the present invention will become apparent in the following detailed description of the three preferred embodiments with reference to the accompanying drawings, of which:

Figure 1 is a schematic diagram illustrating a first preferred embodiment of a lens assembly according to the present invention;

Figure 2 illustrates simulation results of astigmatism aberration and distortion aberration of the first preferred embodiment;

Figure 3 illustrates simulation result of spherical aberration of the first preferred embodiment;

Figure 4 is a schematic diagram illustrating a second preferred embodiment of a lens assembly according to the present invention;

Figure 5 illustrates simulation results of astigmatism aberration and distortion aberration of the second preferred embodiment;

Figure 6 illustrates simulation result of spherical aberration of the second preferred embodiment;

Figure 7 is a schematic diagram illustrating a third preferred embodiment of a lens assembly according to the present invention;

Figure 8 illustrates simulation results of astigmatism aberration and distortion aberration of the third preferred embodiment; and

Figure 9 illustrates simulation result of spherical aberration of the third preferred embodiment.

#### **DETAILED DESCRIPTION OF THE PREFERRED EMBODIMENTS**

Referring to Figure 1, a first preferred embodiment of a lens assembly, according to the present invention, comprises a lens set 1, a non-adjustable diaphragm 2, and a filter lens 3.

The lens set 1 includes a first lens 11, a second lens 12, a third lens 13 and a fourth lens 14 arranged in sequence from an object side to an image side along an optical axis L of the lens assembly. The first lens 11 has a positive optical power adjacent to the optical axis L, and has a convex object-side surface 111 which faces the object side, and an image-side surface 112 which faces the image side. At least one of the object-side surface 111 and the image-side surface 112 of the first lens 11 is an aspherical surface. The second lens 12 has a positive optical power adjacent to the optical axis L, and has a convex image-side surface 121 which faces the image side, and an object-side surface 122 which faces the object side. At least one of the object-side surface 121 and the image-side surface 122 of the second lens 12 is an aspherical surface. The third lens 13 has a negative optical power adjacent to the optical axis L, and has a concave object-side surface 131 which faces the object side, and a convex image-side surface 132 which faces the image side. At least one

of the object-side surface 131 and the image-side surface 132 of the third lens 13 is an aspherical surface. The fourth lens 14 has a positive optical power adjacent to the optical axis L, and has an image-side surface 141 which faces the image side and which has a concave portion around the optical axis L, an object-side surface 142 which faces the object side, and a peripheral surface 143 which interconnects the object-side surface 141 and the image-side surface 142. Each of the object-side surface 141 and the image-side surface 142 of the fourth lens 14 is an aspherical surface. At least one of the object-side surface 141 and the image-side surface 142 of the fourth lens 14 has an inflection point located between the optical axis L and the peripheral surface 143.

The non-adjustable diaphragm 2 is located between the object side and the second lens 12 of the lens set 1.

The lens assembly satisfies the following conditions:

$$15 < \text{HFOV}/f < 50, \quad (1)$$

$$0.8 < |f/f_3| < 2.5, \quad (2)$$

$$0.3 < ct_1/ct_2 < 2.0, \text{ and} \quad (3)$$

$$0 < ct_3/ct_4 < 1.0, \quad (4)$$

in which, HFOV represents one half of a maximum angle of view of the lens assembly and has a unit of degree, f represents a focal length of the lens assembly and

has a unit of millimeter,  $f_3$  is a focal length of the  
 third lens 13 and has a unit of millimeter,  $ct_1$  represents  
 a center thickness of the first lens 11,  $ct_2$  represents  
 a center thickness of the second lens 12,  $ct_3$  represents  
 5 a center thickness of the third lens 13,  $ct_4$  represents  
 a center thickness of the fourth lens 14, and each of  
 $ct_1$ ,  $ct_2$ ,  $ct_3$  and  $ct_4$  has a unit of millimeter.

Preferably, the lens assembly of the present  
 invention further satisfies the following conditions:

10  $HFOV > 35^\circ$ , and (5)

$f < 2.7$  mm. (6)

The condition (1) explicates that a higher value of  
 HFOV represents a wider angle of view of the lens assembly  
 of the present invention so as to increase the resolving  
 15 power thereof, while a lower value of the focal length  
 $f$  enables a more compact lens assembly. Conditions (5)  
 and (6) further explicate advantages of the wider angle  
 of view and the compact and thin dimensions of the lens  
 assembly of the present invention.

20 It is noted that the lens assembly of the present  
 invention further satisfies the following conditions:

$Nd_3 > 1.56$ , (7)

$V_3 < 29$ , (8)

$Nd_2 < 1.56$ , (9)

25  $V_2 > 29$ , (10)

in which,  $Nd_3$  is a refractive index of the third lens  
 13 for light with a wavelength equal to 587 nanometers,



V3 is a coefficient of dispersion of the third lens 13 for light with a wavelength equal to 587 nanometers, Nd2 is a refractive index of the second lens 12 for light with a wavelength equal to 587 nanometers, and V2 is a coefficient of dispersion of the second lens 12 for light with a wavelength equal to 587 nanometers. Conditions (7) to (10) explicate that an absolute value of the optical power of the third lens 13 is greater than an absolute value of the optical power of the second lens 12 of the present invention.

Moreover, the aspherical surfaces of the lens assembly of the present invention satisfy:

$$z = \frac{ch^2}{1 + [1 - (k+1)c^2h^2]^{0.5}} + Ah^4 + Bh^6 + Ch^8 + Dh^{10} + Eh^{12} + Fh^{14} + Gh^{16} + Hh^{18} + Jh^{20} + \dots$$

in which, z is a displacement, along the optical axis L, of the aspherical surface from a vertex of the aspherical surface at a distance h from the optical axis L, c is a reciprocal of the radius of curvature, k is the conic constant, and A, B, C, D, E, F, G, H, J and so forth are aspheric coefficients. Surface profiles of the aspherical surfaces are able to correct aberrations, reduce tolerance sensitivity and provide a wide-angle capability.

<First Preferred Embodiment>

Referring to Figure 1 to Figure 3, parameters of the first preferred embodiment of the lens assembly are

summarized as follows:  $f_1=2.19$  mm  $f_2=2.05$  mm,  $f_3=-1.16$  mm,  $f_4=1.52$  mm,  $f=1.60$  mm,  $ct_1=0.284$  mm,  $ct_2=0.368$  mm,  $ct_3=0.190$  mm,  $ct_4=0.472$  mm,  $HFOV=44^\circ$ .

The first preferred embodiment of the lens assembly satisfies condition (1) to condition (11), where:  
 5  $HFOV/f=27.5$ ,  $|f/f_3|=1.38$ ,  $ct_1/ct_2=0.77$ ,  $ct_3/ct_4=0.40$ ,  $Nd_2=1.535$ ,  $Nd_3=1.636$ ,  $V_2=56.07$ ,  $V_3=23.89$ .

Figure 2 illustrates astigmatism aberration and distortion aberration of the first preferred embodiment.  
 10 Figure 3 illustrates spherical aberration of the first preferred embodiment. Table 1 below shows the parameters of components of the first preferred embodiment, in which the filter lens 3 has an object-side surface 31 and an image-side surface 32.

15

Table I

First preferred embodiment						
Component/ Surface		Radius of curvature	Thickness/ Interspace	Refractive index	Abbe number	Focal Length (mm)
Non-adjustable diaphragm 2		$\infty$	-0.03			
First lens 11	Object-side surface 111	1.361	0.284	1.535	56.07	2.19
	Image-side surface 112	-8.119	0.194			

Second lens 12	Object-side surface 121	-2.042	0.368	1.535	56.07	2.05
	Image-side surface 122	-0.760	0.159			
Third lens 13	Object-side surface 131	-0.289	0.190	1.636	23.89	-1.16
	Image-side surface 132	-0.596	0.038			
Fourth lens 14	Object-side surface 141	0.488	0.472	1.535	56.07	1.52
	Image-side surface 142	0.805	0.25			
Filter lens 3	Object-side surface 31	$\infty$	0.21	1.517	64.17	
	Image-side surface 32	$\infty$	0.332			

Coefficients for the aspherical surfaces of the first preferred embodiment are provided in Table 2 below.

Table 2

	First lens 11		Second lens 12	
	Object-side surface 111	Image-side surface 112	Object-side surface 121	Image-side surface 122
k	0	0	6.191788	-3.784132
A	-0.2065838	-0.7720604	-1.4905075	-1.1446487
B	-3.3390093	1.4937038	13.548352	-13.499105
C	45.617387	-48.87327	-222.85883	142.67618
D	-568.5172	417.56966	1762.543	-811.19607

E	3836.6411	-1866.3668	-7503.2608	2964.6502
F	-14300.609	3693.0414	17228.893	-6161.6996
G	22470.012	-1072.5651	-16174.808	5342.7346
	Third lens 13		Fourth lens 14	
	Object-side surface 131	Image-side surface 132	Object-side surface 141	Image-side surface 142
k	-3.838175	-1.077898	-7.06691	-2.241616
A	-4.9202522	-0.5217609	0.10412867	-0.3678477
B	18.914991	0.96784978	-1.6835431	0.10715581
C	-20.771041	12.065814	4.2811759	0.31062561
D	12.125511	-36.497597	-6.3438122	-0.5323217
E	-142.85927	22.957229	5.6351203	0.37789525
F	243.02698	33.940443	-2.7711759	-0.1331061
G	30.761799	-33.635537	0.58039414	0.018683511

<Second Preferred Embodiment>

Referring to Figure 4 to Figure 6, parameters of a second preferred embodiment of the lens assembly, according to the present invention, are summarized as follows:  $f_1=2.39$  mm,  $f_2=2.08$  mm,  $f_3=-1.45$  mm,  $f_4=1.85$  mm,  $f=1.60$  mm,  $ct_1=0.276$  mm,  $ct_2=0.392$  mm,  $ct_3=0.204$  mm,  $ct_4=0.450$  mm,  $HFOV=44^\circ$ , and are further tabulated in Table 3.

The second preferred embodiment of the lens assembly satisfies condition (1) to condition (11), where:  $HFOV/f=27.5$ ,  $|f/f_3|=1.10$ ,  $ct_1/ct_2=0.70$ ,  $ct_3/ct_4=0.45$ ,  $Nd_2=1.535$ ,  $Nd_3=1.636$ ,  $V_2=56.07$ ,  $V_3=23.89$ .

Figure 5 illustrates astigmatism aberration and distortion aberration of the second preferred embodiment. Figure 6 illustrates spherical aberration of the second preferred embodiment.

5 Table 3

Second preferred embodiment						
Component/ Surface		Radius of curvature	Thickness/ Interspace	Refractive index	Abbe number	Focal length (mm)
First lens 11	Object-side surface 111	1.172	0.276	1.535	56.07	2.39
	Image-side surface 112	12.524	0.002			
Non-adjustable diaphragm 2		$\infty$	0.193			
Second lens 12	Object-side surface 121	-2.352	0.392	1.535	56.07	2.08
	Image-side surface 122	-0.800	0.165			
Third lens 13	Object-side surface 131	-0.295	0.204	1.636	23.89	-1.45
	Image-side surface 132	-0.550	0.022			
Fourth lens 14	Object-side surface 141	0.526	0.450	1.535	56.07	1.85
	Image-side surface 142	0.786	0.25			

Filter lens 3	Object-side surface 31	$\infty$	0.21	1.517	64.17	
	Image-side surface 32	$\infty$	0.352			

Coefficients for the aspherical surfaces of the second preferred embodiment are provided in the following Table 4.

Table 4

	First lens 11		Second lens 12	
	Object-side surface 111	Image-side surface 112	Object-side surface 121	Image-side surface 122
k	-27.67006	0	0	-0.1133277
A	1.9885098	-0.37701082	-0.96274237	-0.00025411
B	-16.754161	-0.49422655	2.5787486	-13.638266
C	121.87784	-25.697915	-75.20593	119.14826
D	-697.96568	372.82808	563.02784	-775.83633
E	2523.3236	-3090.4143	-2537.022	3121.5568
F	-5159.4588	12641.669	4107.643	-6765.6192
G	4272.9124	-20091.048	1821.596	6044.1686
	Third lens 13		Fourth lens 14	
	Object-side Surface 131	Image-side surface 132	Object-side Surface 141	Image-side surface 142
k	-3.670904	-1.681659	-7.045281	-3.872049
A	-3.9824733	-0.37652375	0.000309204	-0.15744128
B	9.3522783	-3.5402459	-1.3786241	-0.21216838
C	-14.277191	22.786238	3.9107049	0.6311134
D	58.628841	-34.875393	-6.1155891	-0.74118053

E	13.198369	-6.5038799	5.4923776	0.45196807
F	-631.1631	60.790568	-2.6266688	-0.14266076
G	956.17439	-37.919506	0.51902791	0.01825282

<Third Preferred Embodiment>

Referring to Figure 7 to Figure 9, parameters of a third preferred embodiment of the lens assembly, according to the present invention, are summarized as follows:  $f_1=2.55$  mm,  $f_2=0.86$  mm,  $f_3=-0.61$  mm,  $f_4=0.98$  mm,  $f=1.13$  mm,  $ct_1=0.239$  mm,  $ct_2=0.266$  mm,  $ct_3=0.187$  mm,  $ct_4=0.429$  mm, HFOV=44°, and are further tabulated in Table 5.

The third preferred embodiment of the lens assembly satisfies condition (1) to condition (11), where:  $HFOV/f=39.0$ ,  $|f/f_3|=1.85$ ,  $ct_1/ct_2=0.90$ ,  $ct_3/ct_4=0.44$ ,  $Nd_2=1.535$ ,  $Nd_3=1.636$ ,  $V_2=56.07$ ,  $V_3=23.89$ .

Figure 8 illustrates astigmatism aberration and distortion aberration of the third preferred embodiment. Figure 9 illustrates spherical aberration of the third preferred embodiment.

Table 5

Third preferred embodiment					
Component/ Surface	Radius of curvature	Thickness/ Interspace	Refractive index	Abbe number	Focal length (mm)
Non-adjustable diaphragm 2	∞	-0.001			

First lens 11	Object-side surface 111	1.903	0.239	1.535	56.07	2.55
	Image-side surface 112	-4.616	0.062			
Second lens 12	Object-side surface 121	3.029	0.266	1.535	56.07	0.86
	Image-side surface 122	-0.528	0.095			
Third lens 13	Object-side surface 131	-0.184	0.187	1.636	23.89	-0.61
	Image-side surface 132	-0.483	0.092			
Fourth lens 14	Object-side surface 141	0.430	0.429	1.535	56.07	0.98
	Image-side surface 142	1.549	0.125			
Filter lens 3	Object-side surface 31	$\infty$	0.210	1.517	64.17	
	Image-side surface 32	$\infty$	0.325			

Coefficients for the aspherical surfaces of the third preferred embodiment are provided in the following Table 6.

Table 6

	First lens 11		Second lens 12	
	Object-side surface 111	Image-side surface 112	Object-side Surface 121	Image-side surface 122
k	8.58328	-2824.922	42.97767	0.7395685



A	-1.2031657	-9.8439198	-7.1130345	0.63242517
B	12.223278	116.10956	4.0234552	-132.3459
C	-1918.3111	-1775.4567	-507.43521	2590.488
D	6722.3948	-15124.178	-7707.7496	-20847.637
E	2123163.2	652775.39	80989.53	138170.7
F	-52922573	-5158083.1	1130631.4	-1000249.5
G	3.7786e+008	11596365	-8089358.7	3411687.3
	Third lens 13		Fourth lens 14	
	Object-side Surface 131	Image-side surface 132	Object-side Surface 141	Image-side surface 142
k	-1.926854	-0.3569793	-5.810289	1.443596
A	-4.0319876	-0.15762397	-0.05755995	-0.20237191
B	-130.00916	8.7724173	-1.4813813	0.7721049
C	3983.5728	116.23539	9.9370396	-8.9338663
D	-22497.967	-218.09901	-60.63752	26.574088
E	-103474.15	-4855.6445	190.69088	-38.350854
F	1277642.5	24221.919	-287.85565	27.456949
G	-3002346	-32489.178	163.69987	-8.006268

To sum up, the effects of the present invention may be summarized as follows:

1. A feature of the present invention resides in that the lens assembly satisfies  $15 < \text{HFOV}/f < 50$ . Moreover, the lens assembly also satisfies condition (1) to condition (11) so as to increase the resolving power of the lens assembly, increase angle of view thereof, and reduce a thickness thereof to achieve a compact design.

2. A higher value of HFOV of the lens assembly represents a wider angle of view of the lens assembly so as to increase the resolving power thereof.

3. A lower value of the focal length  $f$  of the lens assembly enables smaller and thinner dimensions thereof.

Therefore, the lens assembly of the present invention may have compact and thin dimensions while exhibiting high performances.

10 While the present invention has been described in connection with what are considered the most practical and preferred embodiments, it is understood that this invention is not limited to the disclosed embodiments but is intended to cover various arrangements included  
15 within the spirit and scope of the broadest interpretation so as to encompass all such modifications and equivalent arrangements.

**WHAT IS CLAIMED IS:**

1. A lens assembly comprising:

a lens set which includes a first lens, a second lens,  
a third lens and a fourth lens arranged in sequence from  
5 an object side to an image side along an optical axis  
of said lens assembly, wherein

said first lens has a positive optical power  
adjacent to the optical axis, and has a convex  
object-side surface which faces the object side, and  
10 an image-side surface which faces the image side, at  
least one of said object-side surface and said image-side  
surface of said first lens being an aspherical surface,

said second lens has a positive optical power  
adjacent to the optical axis, and has a convex image-side  
15 surface which faces the image side, and an object-side  
surface which faces the object side, at least one of  
said object-side surface and said image-side surface  
of said second lens being an aspherical surface,

said third lens has a negative optical power  
20 adjacent to the optical axis, and has a concave  
object-side surface which faces the object side, and  
a convex image-side surface which faces the image side,  
at least one of said object-side surface and said  
image-side surface of said third lens being an aspherical  
25 surface,

said fourth lens has a positive optical power  
adjacent to the optical axis, and has an image-side

surface which faces the image side and which has a concave portion around the optical axis, an object-side surface which faces the object side, and a peripheral surface which interconnects said object-side surface and said image-side surface, each of said object-side surface and said image-side surface of said fourth lens being an aspherical surface, at least one of said object-side surface and said image-side surface of said fourth lens having an inflection point located between the optical axis and said peripheral surface; and

a non-adjustable diaphragm located between the object side and said second lens of said lens set;

wherein said lens assembly satisfies

$$15 < \text{HFOV}/f < 50,$$

in which, HFOV represents one half of a maximum angle of view of said lens assembly and has a unit of degree, and f represents a focal length of said lens assembly and has a unit of millimeter.

2. The lens assembly as claimed in Claim 1, further satisfying:

$$\text{HFOV} > 35^\circ.$$

3. The lens assembly as claimed in Claim 1, further satisfying:

$$f < 2.7 \text{ mm}.$$

4. The lens assembly as claimed in Claim 1, further satisfying:

$Nd3 > 1.56$ , and

$V3 < 29$ ,

5 in which,  $Nd3$  is a refractive index of said third lens for light with a wavelength equal to 587 nanometers, and  $V3$  is a coefficient of dispersion of said third lens for light with a wavelength equal to 587 nanometers.

10 5. The lens assembly as claimed in Claim 4, further satisfying:

$Nd2 < 1.56$ , and

$V2 > 29$ ,

15 in which,  $Nd2$  is a refractive index of said second lens for light with a wavelength equal to 587 nanometers, and  $V2$  is a coefficient of dispersion of said second lens for light with a wavelength equal to 587 nanometers.

20 6. The lens assembly as claimed in Claim 1, further satisfying:

$0.8 < |f/f3| < 2.5$ ,

in which,  $f3$  is a focal length of said third lens and has a unit of millimeter.

25 7. The lens assembly as claimed in Claim 1, further satisfying:

$0.3 < ct1/ct2 < 2.0$ , and

$$0 < ct3/ct4 < 1.0,$$

in which, ct1 represents a center thickness of said first lens, ct2 represents a center thickness of said second lens, ct3 represents a center thickness of said third lens, ct4 represents a center thickness of said fourth lens, and each of ct1, ct2, ct3 and ct4 has a unit of millimeter.

**ABSTRACT OF THE DISCLOSURE**

A lens assembly includes a lens set which includes a first lens, a second lens, a third lens and a fourth lens arranged in sequence along an optical axis. The first lens has a positive optical power. The second lens has a positive optical power. The third lens has a negative optical power. The fourth lens has a positive optical power, and has an image-side surface, an object-side surface, and a peripheral surface interconnecting the two. At least one of the object-side and image-side surfaces has an inflection point located between the optical axis and the peripheral surface. The lens assembly satisfies  $15 < \text{HFOV}/f < 50$ , in which, HFOV represents one half of a maximum angle of view of the lens assembly, and  $f$  represents a focal length thereof.

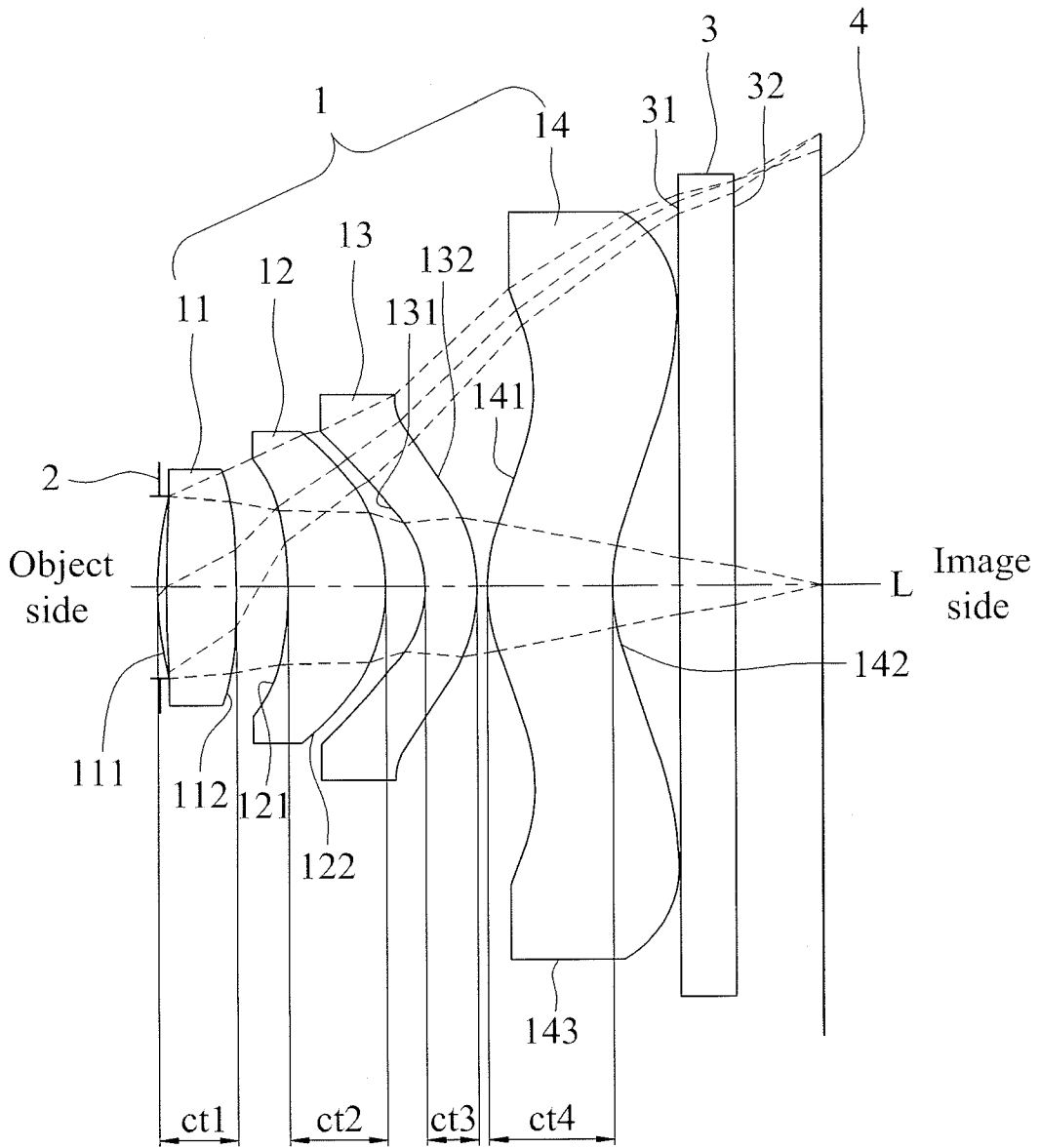

FIG.1



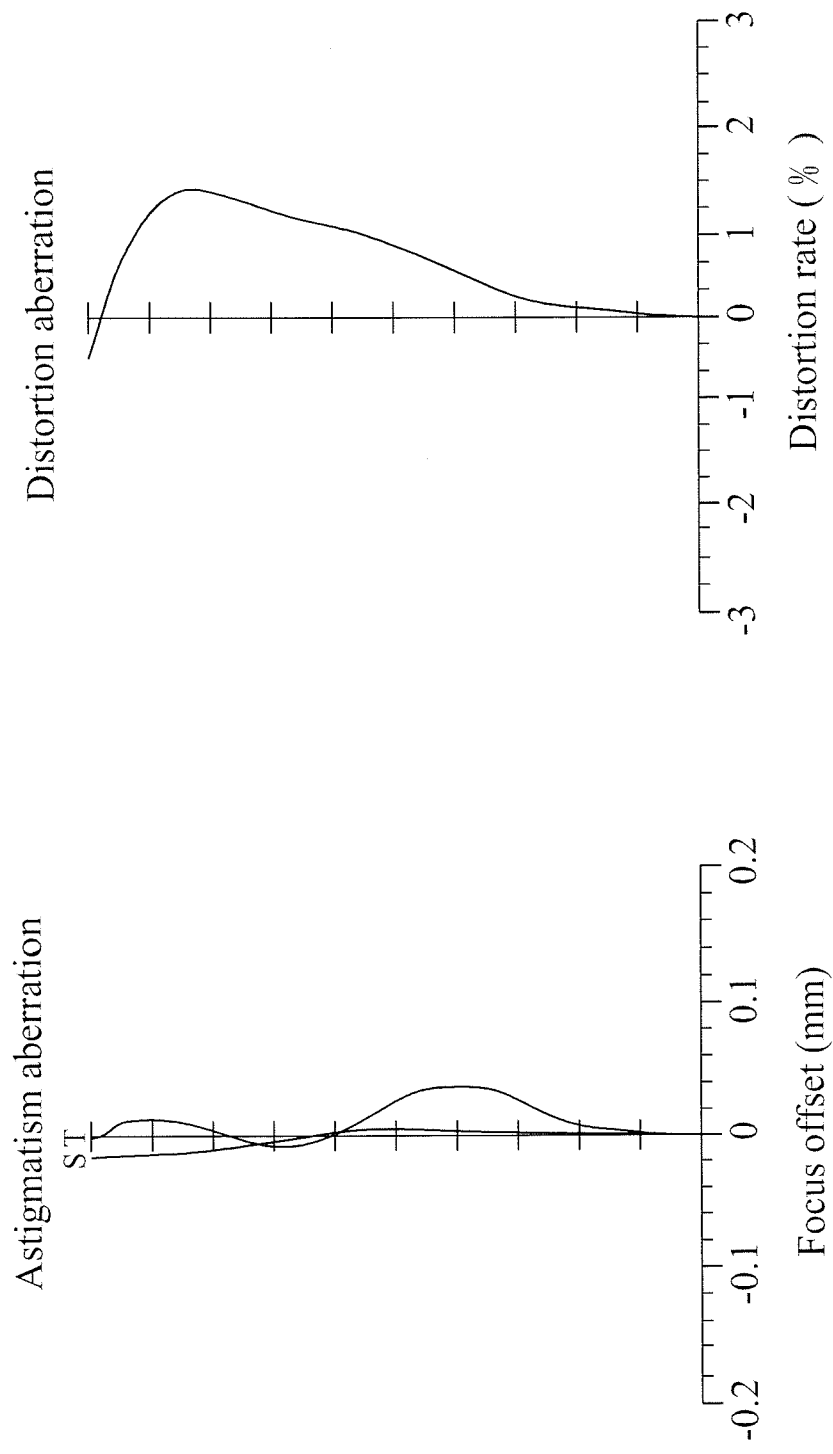

FIG.2

Spherical aberration

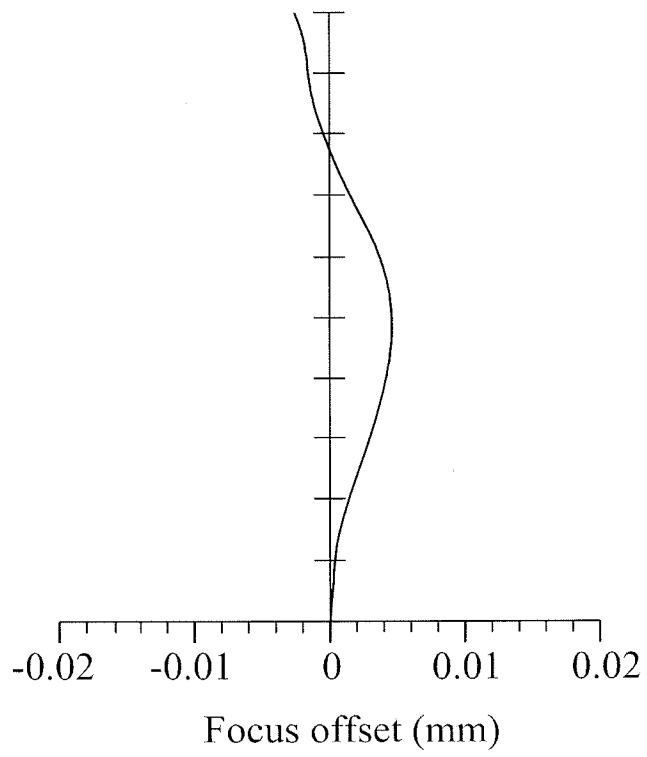

FIG.3

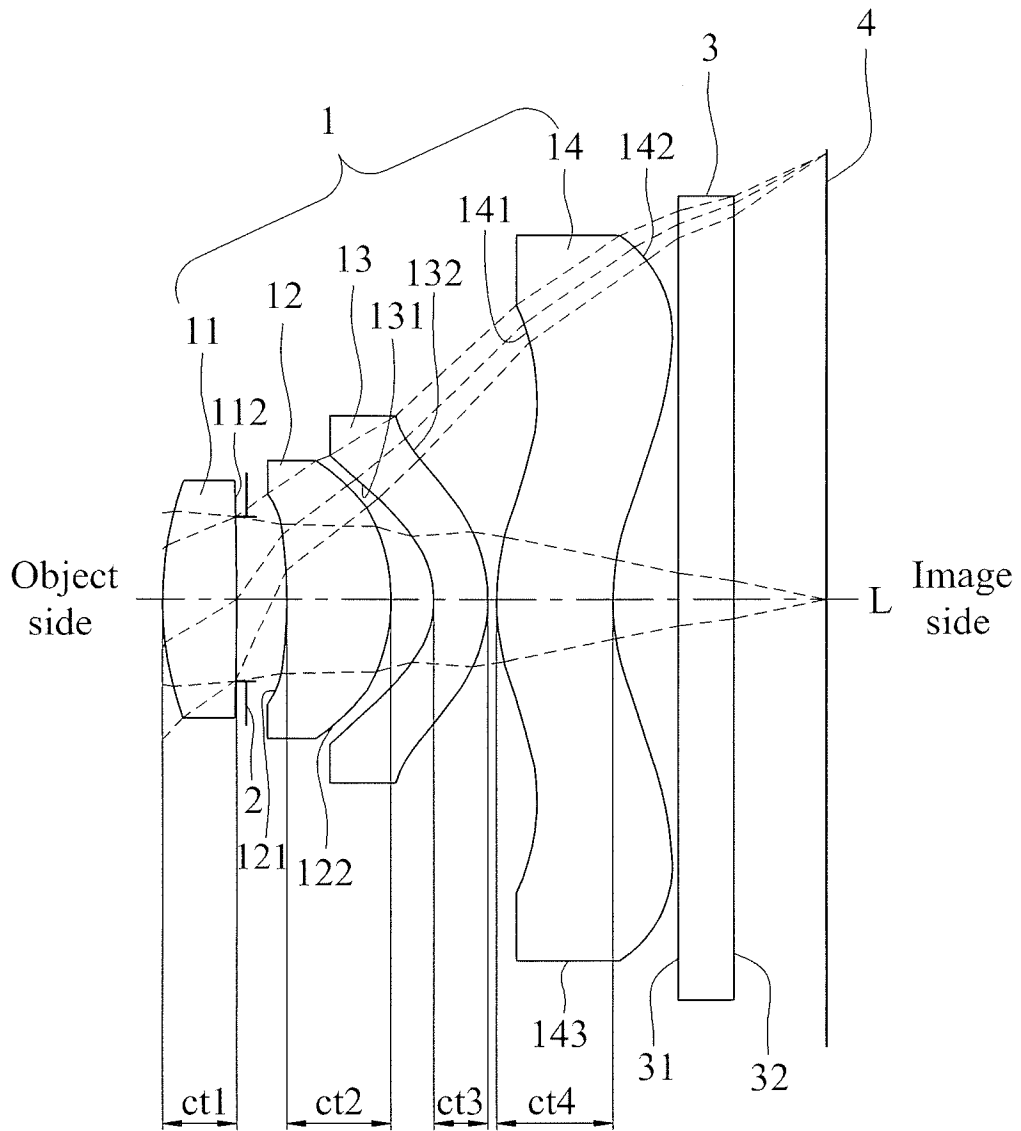

FIG.4

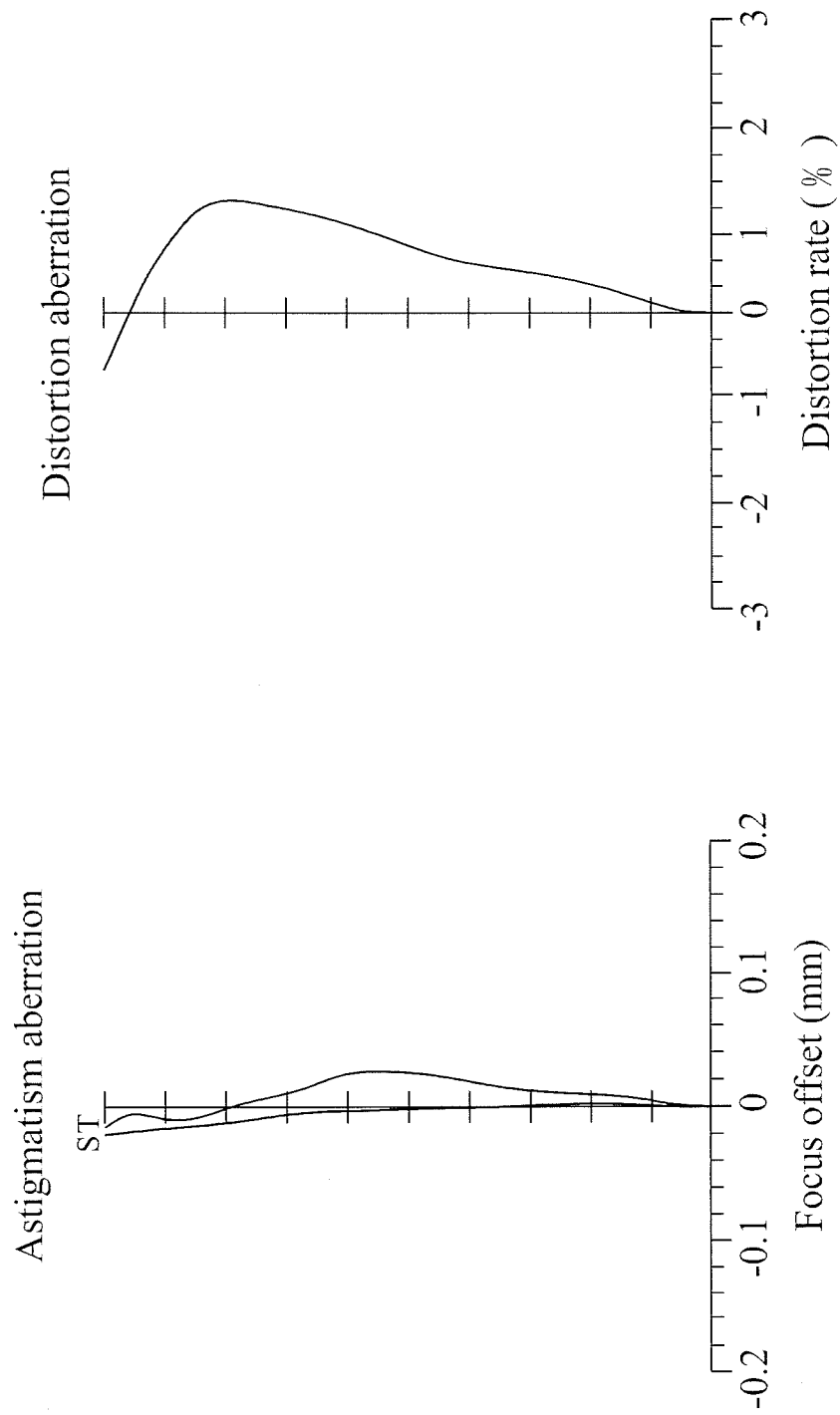

FIG.5

Spherical aberration

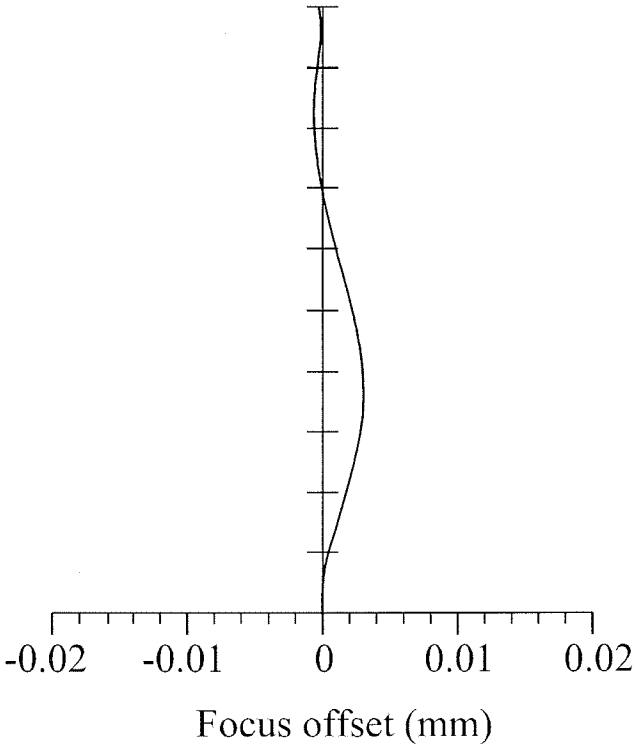

FIG.6

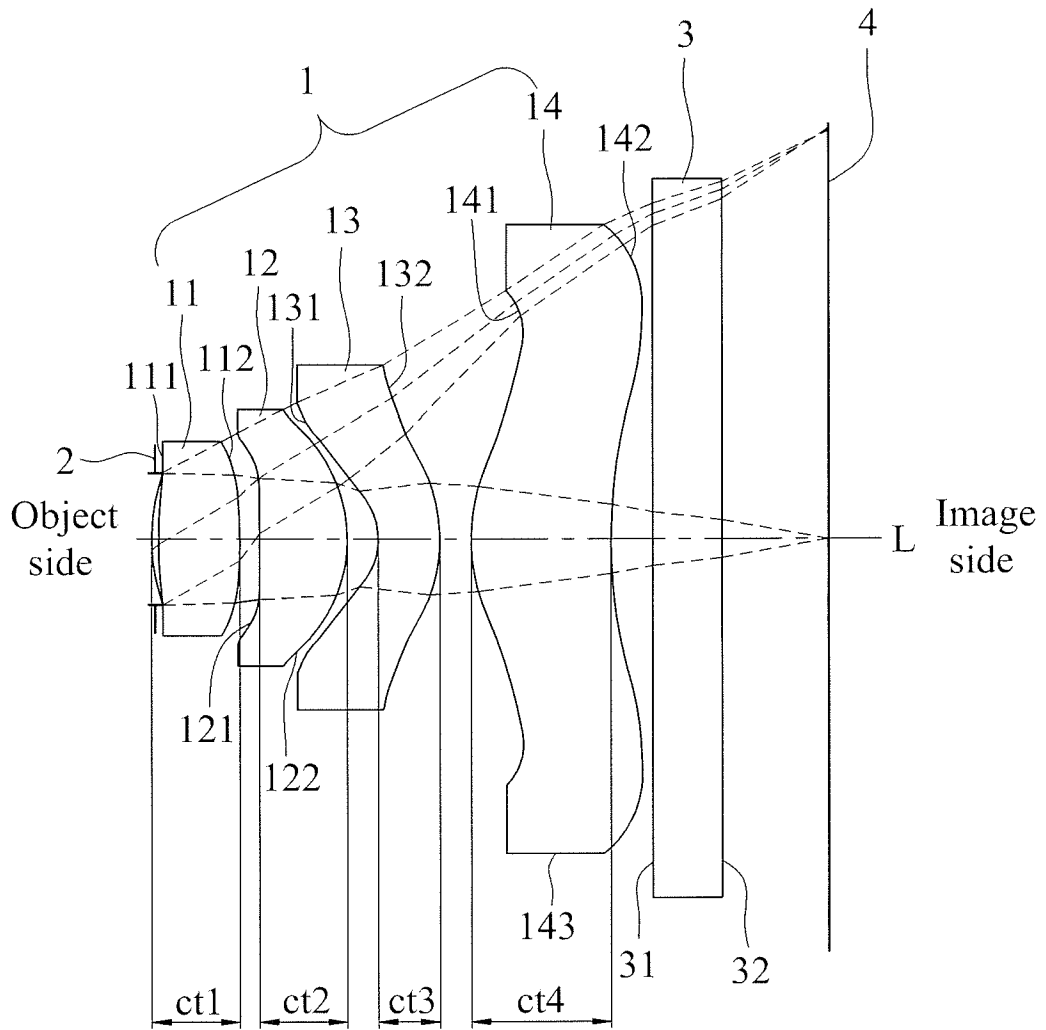

FIG.7

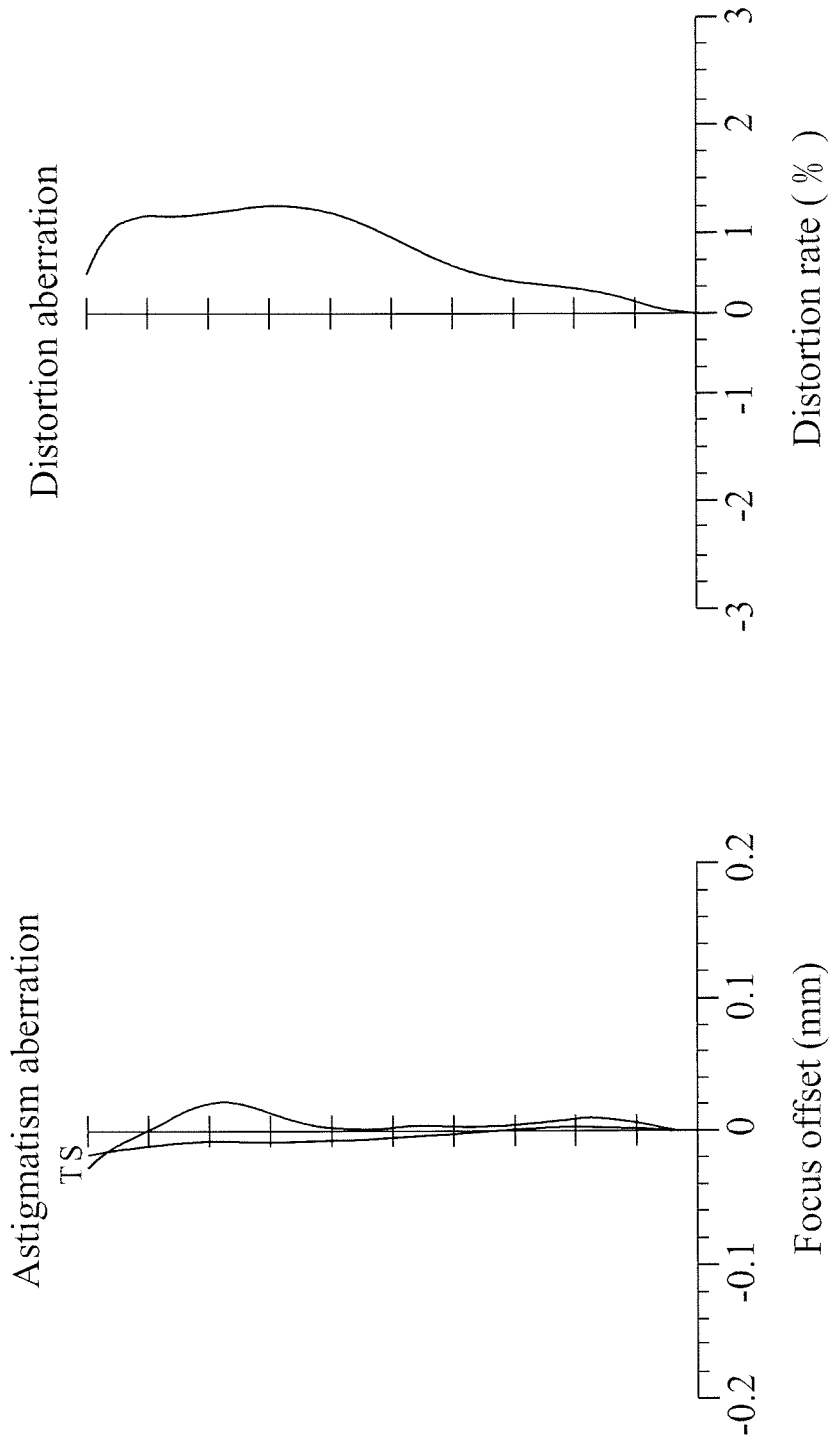

FIG.8

Spherical aberration

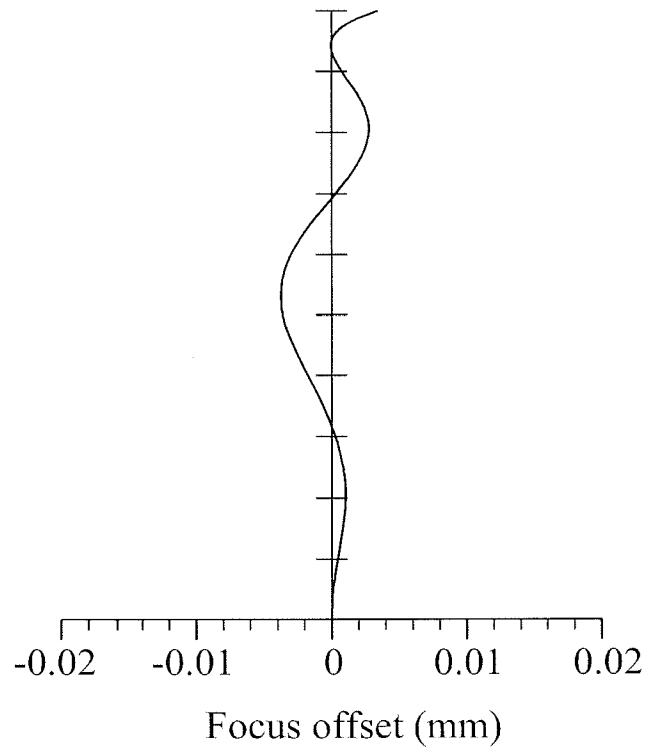

FIG.9



**COMBINED DECLARATION FOR UTILITY OR DESIGN PATENT APPLICATION,  
ASSIGNMENT AND APPOINTMENT OF ATTORNEY (37 C.F.R. §1.63)**

*(Earliest US or PCT application filing date must be on or after September 16, 2012)*

As the below named inventor(s), I hereby declare that:

This declaration is directed to:

- The attached application,  
 US or PCT International Application No. \_\_\_\_\_ filed on \_\_\_\_\_

The TITLE of Invention is:

LENS ASSEMBLY

I made or authorized the making of an application for the invention (design, if applicable) identified by the above Title.

I believe that I am the original inventor or an original joint inventor of the invention (design, if applicable) claimed in the application.

I hereby acknowledge that any willful false statement made in this declaration is punishable under *Title 18, U.S. Code, §1001* by fine or imprisonment of not more than (5) years, or both.

I hereby state that I have reviewed and understand the contents of the above-identified application, including the claims; and I understand and am competent to execute this Declaration for Utility or Design Patent Application and Appointment of Attorney.

I am aware of and acknowledge the duty to disclose information which is material to the patentability of this application in accordance with *Title 37, Code of Federal Regulations, §1.56*

**POWER OF ATTORNEY & CORRESPONDENCE ADDRESS**

I hereby appoint the practitioners of **Shook, Hardy & Bacon L.L.P.** associated with **CUSTOMER NUMBER 05251** as my attorneys or agents to prosecute this application and transact all business in the United States Patent and Trademark Office connected therewith. **Please direct all correspondence to the address associated with the above-noted Customer Number.**

**ASSIGNMENT & APPLICANT INFORMATION**

WHEREAS, I/We, whose full legal names, mailing addresses and residence addresses appear below hereinafter referred to as ASSIGNOR, have invented certain new and useful improvements in the application identified above (hereinafter referred to as THE INVENTION or design, if applicable) for which a patent is sought;

WHEREAS, ABILITY OPTO-ELECTRONICS TECHNOLOGY CO., LTD., whose mailing address is 2F., No. 33, Keya Rd., Daya Dist., Taichung City, Taiwan (hereinafter referred to as ASSIGNEE), is desirous of acquiring the entire right, title and interest in and to said application and the invention(s) and improvement(s) therein disclosed, for the United States of America, and any Letters Patent which may issue therefor in the United States and all divisions, continuations, reissues, renewals and/or extensions thereof.

NOW, THEREFORE, for good and valuable consideration, receipt of which is hereby acknowledged, we, ASSIGNOR does hereby assign, sell, transfer and set over unto the ASSIGNEE the entire right, title and interest in and to said application and the invention(s) and improvement(s) therein disclosed, for the United States of America, and any Letters Patent which may issue therefor in the United States and all divisions, continuations, reissues, renewals and/or extensions thereof, said ASSIGNEE to have and to hold the interests herein assigned to the full ends of the terms of said Letters Patent and any and all divisions, continuations, reissues, renewals and/or extensions thereof, respectively, as fully and entirely as the same would have been held and enjoyed by the ASSIGNOR had this assignment not been made.

ACCORDINGLY, ASSIGNOR hereby acknowledges ASSIGNEE as sole APPLICANT for and to said INVENTION (design, if applicable) as defined under *Title 37, Code of Federal Regulations §§1.42 and 1.46*, and as defined and recognized under all available international conventions and treaties in respect of said INVENTION (design, if applicable).

ALSO, ASSIGNOR hereby agrees to execute any documents that legally may be required in connection with the filing, prosecution and maintenance of said application or any other patent application(s) or inventor certificate(s) in the United States, including additional documents that may be required to affirm the rights of ASSIGNEE in and to said INVENTION, all without further consideration. ASSIGNOR also agrees, without further consideration and at ASSIGNEE'S expense, to identify and communicate to ASSIGNEE at ASSIGNEE'S request documents and information concerning the INVENTION (design, if applicable) that are within ASSIGNOR'S possession or control, and to provide further assurances and testimony on behalf of ASSIGNEE that lawfully may be required of ASSIGNOR in respect of the prosecution, maintenance and defense of any patent application or patent encompassed within the terms of this instrument. ASSIGNOR'S obligations under this instrument shall extend to ASSIGNOR'S heirs, executors, administrators and other legal representatives.

ASSIGNOR hereby authorizes and requests the Commissioner of Patents and Trademarks to issue any and all United States Letters Patent referred to above to ASSIGNEE of the entire right, title and interest in and to the same, for ASSIGNEE'S sole use and behalf; and for the use and behalf of ASSIGNEE'S legal representatives and successors, to the full end of the term for which such Letters patent may be granted, as fully and entirely as the same would have been held by ASSIGNOR had this assignment and sale not been made.

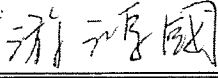
<i>Full Legal Name of First or Sole Inventor (First and Middle + FAMILY NAME or SURNAME)</i>			
Hung-Kuo YU			
<i>Residence Address - Street</i>		<i>Mailing Address - Street</i>	
2F., No. 33, Keya Rd., Daya Dist.		2F., No. 33, Keya Rd., Daya Dist.	
<i>City</i>		<i>City</i>	
Taichung City		Taichung City	
<i>State or Country</i>		<i>State or Country</i>	
Taiwan		Taiwan	
<i>Postal Code</i>		<i>Postal Code</i>	
42881		42881	
<i>SIGNATURE</i>		<i>DATE</i>	
 Hung-Kuo Yu		December 6, 2013	

See following pages for additional joint inventors.

<i>Full Legal Name of Next Inventor (First and Middle + FAMILY NAME or SURNAME)</i>			
Chao-Hsiang YANG			
<i>Residence Address - Street</i>		<i>Mailing Address - Street</i>	
2F., No. 33, Keya Rd., Daya Dist.		2F., No. 33, Keya Rd., Daya Dist.	
<i>City</i>		<i>City</i>	
Taichung City		Taichung City	
<i>State or Country</i>	<i>Postal Code</i>	<i>State or Country</i>	<i>Postal Code</i>
Taiwan	42881	Taiwan	42881
<i>SIGNATURE</i>		<i>DATE</i>	
楊朝翔 Chao-Hsiang Yang		December 6, 2013	

<i>Full Legal Name of Next Inventor (First and Middle + FAMILY NAME or SURNAME)</i>			
<i>Residence Address - Street</i>		<i>Mailing Address - Street</i>	
<i>City</i>		<i>City</i>	
<i>State or Country</i>	<i>Postal Code</i>	<i>State or Country</i>	<i>Postal Code</i>
<i>SIGNATURE</i>		<i>DATE</i>	

<i>Full Legal Name of Next Inventor (First and Middle + FAMILY NAME or SURNAME)</i>			
<i>Residence Address - Street</i>		<i>Mailing Address - Street</i>	
<i>City</i>		<i>City</i>	
<i>State or Country</i>	<i>Postal Code</i>	<i>State or Country</i>	<i>Postal Code</i>
<i>SIGNATURE</i>		<i>DATE</i>	

<i>Full Legal Name of Next Inventor (First and Middle + FAMILY NAME or SURNAME)</i>			
<i>Residence Address - Street</i>		<i>Mailing Address - Street</i>	
<i>City</i>		<i>City</i>	
<i>State or Country</i>	<i>Postal Code</i>	<i>State or Country</i>	<i>Postal Code</i>
<i>SIGNATURE</i>		<i>DATE</i>	

**PATENT ASSIGNMENT COVER SHEET**

Electronic Version v1.1  
 Stylesheet Version v1.2

EPAS ID: PAT2661329

<b>SUBMISSION TYPE:</b>	NEW ASSIGNMENT
<b>NATURE OF CONVEYANCE:</b>	ASSIGNMENT

<b>CONVEYING PARTY DATA</b>	
<b>Name</b>	<b>Execution Date</b>
HUNG-KUO YU	12/06/2013
CHAO-HSIANG YANG	12/06/2013

<b>RECEIVING PARTY DATA</b>	
<b>Name:</b>	ABILITY OPTO-ELECTRONICS TECHNOLOGY CO., LTD
<b>Street Address:</b>	2F., NO. 33, KEYA RD., DAYA DIST.
<b>City:</b>	TAICHUNG CITY
<b>State/Country:</b>	TAIWAN
<b>Postal Code:</b>	42881

<b>PROPERTY NUMBERS Total: 1</b>	
<b>Property Type</b>	<b>Number</b>
Application Number:	14141665

<b>CORRESPONDENCE DATA</b>	
<b>Fax Number:</b>	(816)421-5547
<b>Phone:</b>	816-474-6550
<b>Email:</b>	smlewis@shb.com
<i>Correspondence will be sent via US Mail when the email attempt is unsuccessful.</i>	
<b>Correspondent Name:</b>	SHOOK, HARDY & BACON LLP INTELLECTUAL PR
<b>Address Line 1:</b>	2555 GRAND BLVD
<b>Address Line 4:</b>	KANSAS CITY, MISSOURI 64108-2613

<b>ATTORNEY DOCKET NUMBER:</b>	SIIP.201299
<b>NAME OF SUBMITTER:</b>	THOMAS T. MOGA
<b>Signature:</b>	/Thomas T. Moga/
<b>Date:</b>	12/27/2013

OP \$40.00 14141665

This document serves as an Oath/Declaration (37 CFR 1.63).

**Total Attachments: 3**

source=SIIP201299DeclarationandAssignment#page1.tif

source=SIIP201299DeclarationandAssignment#page2.tif

source=SIIP201299DeclarationandAssignment#page3.tif

**COMBINED DECLARATION FOR UTILITY OR DESIGN PATENT APPLICATION,  
ASSIGNMENT AND APPOINTMENT OF ATTORNEY (37 C.F.R. §1.63)**

*(Earliest US or PCT application filing date must be on or after September 16, 2012)*

As the below named inventor(s), I hereby declare that:

This declaration is directed to:

- The attached application,  
 US or PCT International Application No. \_\_\_\_\_ filed on \_\_\_\_\_

The TITLE of Invention is:

LENS ASSEMBLY

I made or authorized the making of an application for the invention (design, if applicable) identified by the above Title.

I believe that I am the original inventor or an original joint inventor of the invention (design, if applicable) claimed in the application.

I hereby acknowledge that any willful false statement made in this declaration is punishable under *Title 18, U.S. Code, §1001* by fine or imprisonment of not more than (5) years, or both.

I hereby state that I have reviewed and understand the contents of the above-identified application, including the claims; and I understand and am competent to execute this Declaration for Utility or Design Patent Application and Appointment of Attorney.

I am aware of and acknowledge the duty to disclose information which is material to the patentability of this application in accordance with *Title 37, Code of Federal Regulations, §1.56*

**POWER OF ATTORNEY & CORRESPONDENCE ADDRESS**

I hereby appoint the practitioners of **Shook, Hardy & Bacon L.L.P.** associated with **CUSTOMER NUMBER 05251** as my attorneys or agents to prosecute this application and transact all business in the United States Patent and Trademark Office connected therewith. **Please direct all correspondence to the address associated with the above-noted Customer Number.**

**ASSIGNMENT & APPLICANT INFORMATION**

WHEREAS, I/We, whose full legal names, mailing addresses and residence addresses appear below hereinafter referred to as ASSIGNOR, have invented certain new and useful improvements in the application identified above (hereinafter referred to as THE INVENTION or design, if applicable) for which a patent is sought;

WHEREAS, ABILITY OPTO-ELECTRONICS TECHNOLOGY CO., LTD., whose mailing address is 2F., No. 33, Keya Rd., Daya Dist., Taichung City, Taiwan (hereinafter referred to as ASSIGNEE), is desirous of acquiring the entire right, title and interest in and to said application and the invention(s) and improvement(s) therein disclosed, for the United States of America, and any Letters Patent which may issue therefor in the United States and all divisions, continuations, reissues, renewals and/or extensions thereof.

NOW, THEREFORE, for good and valuable consideration, receipt of which is hereby acknowledged, we, ASSIGNOR does hereby assign, sell, transfer and set over unto the ASSIGNEE the entire right, title and interest in and to said application and the invention(s) and improvement(s) therein disclosed, for the United States of America, and any Letters Patent which may issue therefor in the United States and all divisions, continuations, reissues, renewals and/or extensions thereof, said ASSIGNEE to have and to hold the interests herein assigned to the full ends of the terms of said Letters Patent and any and all divisions, continuations, reissues, renewals and/or extensions thereof, respectively, as fully and entirely as the same would have been held and enjoyed by the ASSIGNOR had this assignment not been made.

ACCORDINGLY, ASSIGNOR hereby acknowledges ASSIGNEE as sole APPLICANT for and to said INVENTION (design, if applicable) as defined under *Title 37, Code of Federal Regulations §§1.42 and 1.46*, and as defined and recognized under all available international conventions and treaties in respect of said INVENTION (design, if applicable).

ALSO, ASSIGNOR hereby agrees to execute any documents that legally may be required in connection with the filing, prosecution and maintenance of said application or any other patent application(s) or inventor certificate(s) in the United States, including additional documents that may be required to affirm the rights of ASSIGNEE in and to said INVENTION, all without further consideration. ASSIGNOR also agrees, without further consideration and at ASSIGNEE'S expense, to identify and communicate to ASSIGNEE at ASSIGNEE'S request documents and information concerning the INVENTION (design, if applicable) that are within ASSIGNOR'S possession or control, and to provide further assurances and testimony on behalf of ASSIGNEE that lawfully may be required of ASSIGNOR in respect of the prosecution, maintenance and defense of any patent application or patent encompassed within the terms of this instrument. ASSIGNOR'S obligations under this instrument shall extend to ASSIGNOR'S heirs, executors, administrators and other legal representatives.

ASSIGNOR hereby authorizes and requests the Commissioner of Patents and Trademarks to issue any and all United States Letters Patent referred to above to ASSIGNEE of the entire right, title and interest in and to the same, for ASSIGNEE'S sole use and behalf; and for the use and behalf of ASSIGNEE'S legal representatives and successors, to the full end of the term for which such Letters patent may be granted, as fully and entirely as the same would have been held by ASSIGNOR had this assignment and sale not been made.

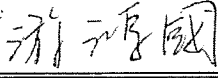
<i>Full Legal Name of First or Sole Inventor (First and Middle + FAMILY NAME or SURNAME)</i>			
Hung-Kuo YU			
<i>Residence Address - Street</i>		<i>Mailing Address - Street</i>	
2F., No. 33, Keya Rd., Daya Dist.		2F., No. 33, Keya Rd., Daya Dist.	
<i>City</i>		<i>City</i>	
Taichung City		Taichung City	
<i>State or Country</i>	<i>Postal Code</i>	<i>State or Country</i>	<i>Postal Code</i>
Taiwan	42881	Taiwan	42881
<i>SIGNATURE</i>		Hung-Kuo Yu	<i>DATE</i>
			December 6, 2013

See following pages for additional joint inventors.

<i>Full Legal Name of Next Inventor (First and Middle + FAMILY NAME or SURNAME)</i>			
Chao-Hsiang YANG			
<i>Residence Address - Street</i>		<i>Mailing Address - Street</i>	
2F., No. 33, Keya Rd., Daya Dist.		2F., No. 33, Keya Rd., Daya Dist.	
<i>City</i>		<i>City</i>	
Taichung City		Taichung City	
<i>State or Country</i>	<i>Postal Code</i>	<i>State or Country</i>	<i>Postal Code</i>
Taiwan	42881	Taiwan	42881
<i>SIGNATURE</i>		<i>DATE</i>	
楊朝翔 Chao-Hsiang Yang		December 6, 2013	

<i>Full Legal Name of Next Inventor (First and Middle + FAMILY NAME or SURNAME)</i>			
<i>Residence Address - Street</i>		<i>Mailing Address - Street</i>	
<i>City</i>		<i>City</i>	
<i>State or Country</i>	<i>Postal Code</i>	<i>State or Country</i>	<i>Postal Code</i>
<i>SIGNATURE</i>		<i>DATE</i>	

<i>Full Legal Name of Next Inventor (First and Middle + FAMILY NAME or SURNAME)</i>			
<i>Residence Address - Street</i>		<i>Mailing Address - Street</i>	
<i>City</i>		<i>City</i>	
<i>State or Country</i>	<i>Postal Code</i>	<i>State or Country</i>	<i>Postal Code</i>
<i>SIGNATURE</i>		<i>DATE</i>	

<i>Full Legal Name of Next Inventor (First and Middle + FAMILY NAME or SURNAME)</i>			
<i>Residence Address - Street</i>		<i>Mailing Address - Street</i>	
<i>City</i>		<i>City</i>	
<i>State or Country</i>	<i>Postal Code</i>	<i>State or Country</i>	<i>Postal Code</i>
<i>SIGNATURE</i>		<i>DATE</i>	





UNITED STATES PATENT AND TRADEMARK OFFICE

UNITED STATES DEPARTMENT OF COMMERCE
United States Patent and Trademark Office
Address: COMMISSIONER FOR PATENTS
P.O. Box 1450
Alexandria, Virginia 22313-1450
www.uspto.gov

Table with 7 columns: APPLICATION NUMBER, FILING or 371(c) DATE, GRP ART UNIT, FIL FEE REC'D, ATTY. DOCKET NO, TOT CLAIMS, IND CLAIMS. Row 1: 14/141,665, 12/27/2013, 2872, 1600, SIIP.201299, 7, 1

CONFIRMATION NO. 9554

5251
SHOOK, HARDY & BACON LLP
INTELLECTUAL PROPERTY DEPARTMENT
2555 GRAND BLVD
KANSAS CITY, MO 64108-2613

FILING RECEIPT



Date Mailed: 01/09/2014

Receipt is acknowledged of this non-provisional patent application. The application will be taken up for examination in due course. Applicant will be notified as to the results of the examination. Any correspondence concerning the application must include the following identification information: the U.S. APPLICATION NUMBER, FILING DATE, NAME OF APPLICANT, and TITLE OF INVENTION. Fees transmitted by check or draft are subject to collection. Please verify the accuracy of the data presented on this receipt. If an error is noted on this Filing Receipt, please submit a written request for a Filing Receipt Correction. Please provide a copy of this Filing Receipt with the changes noted thereon. If you received a "Notice to File Missing Parts" for this application, please submit any corrections to this Filing Receipt with your reply to the Notice. When the USPTO processes the reply to the Notice, the USPTO will generate another Filing Receipt incorporating the requested corrections

Inventor(s)

Hung-Kuo Yu, Taichung City, TAIWAN;
Chao-Hsiang Yang, Taichung City, TAIWAN;

Applicant(s)

ABILITY OPTO-ELECTRONICS TECHNOLOGY CO., LTD., Taichung City, TAIWAN

Assignment For Published Patent Application

ABILITY OPTO-ELECTRONICS TECHNOLOGY CO., LTD., Taichung City, TAIWAN

Power of Attorney: The patent practitioners associated with Customer Number 05251

Domestic Applications for which benefit is claimed - None.

A proper domestic benefit claim must be provided in an Application Data Sheet in order to constitute a claim for domestic benefit. See 37 CFR 1.76 and 1.78.

Foreign Applications (You may be eligible to benefit from the Patent Prosecution Highway program at the USPTO. Please see http://www.uspto.gov for more information.)
TAIWAN 10213525 09/02/2013

Permission to Access - A proper Authorization to Permit Access to Application by Participating Offices (PTO/SB/39 or its equivalent) has been received by the USPTO.

If Required, Foreign Filing License Granted: 01/09/2014

The country code and number of your priority application, to be used for filing abroad under the Paris Convention, is US 14/141,665

Projected Publication Date: 03/05/2015

Non-Publication Request: No

**Early Publication Request: No  
Title**

LENS ASSEMBLY

**Preliminary Class**

359

**Statement under 37 CFR 1.55 or 1.78 for AIA (First Inventor to File) Transition Applications: No**

## **PROTECTING YOUR INVENTION OUTSIDE THE UNITED STATES**

Since the rights granted by a U.S. patent extend only throughout the territory of the United States and have no effect in a foreign country, an inventor who wishes patent protection in another country must apply for a patent in a specific country or in regional patent offices. Applicants may wish to consider the filing of an international application under the Patent Cooperation Treaty (PCT). An international (PCT) application generally has the same effect as a regular national patent application in each PCT-member country. The PCT process **simplifies** the filing of patent applications on the same invention in member countries, but **does not result** in a grant of "an international patent" and does not eliminate the need of applicants to file additional documents and fees in countries where patent protection is desired.

Almost every country has its own patent law, and a person desiring a patent in a particular country must make an application for patent in that country in accordance with its particular laws. Since the laws of many countries differ in various respects from the patent law of the United States, applicants are advised to seek guidance from specific foreign countries to ensure that patent rights are not lost prematurely.

Applicants also are advised that in the case of inventions made in the United States, the Director of the USPTO must issue a license before applicants can apply for a patent in a foreign country. The filing of a U.S. patent application serves as a request for a foreign filing license. The application's filing receipt contains further information and guidance as to the status of applicant's license for foreign filing.

Applicants may wish to consult the USPTO booklet, "General Information Concerning Patents" (specifically, the section entitled "Treaties and Foreign Patents") for more information on timeframes and deadlines for filing foreign patent applications. The guide is available either by contacting the USPTO Contact Center at 800-786-9199, or it can be viewed on the USPTO website at <http://www.uspto.gov/web/offices/pac/doc/general/index.html>.

For information on preventing theft of your intellectual property (patents, trademarks and copyrights), you may wish to consult the U.S. Government website, <http://www.stopfakes.gov>. Part of a Department of Commerce initiative, this website includes self-help "toolkits" giving innovators guidance on how to protect intellectual property in specific countries such as China, Korea and Mexico. For questions regarding patent enforcement issues, applicants may call the U.S. Government hotline at 1-866-999-HALT (1-866-999-4258).

**LICENSE FOR FOREIGN FILING UNDER**  
**Title 35, United States Code, Section 184**  
**Title 37, Code of Federal Regulations, 5.11 & 5.15**

**GRANTED**

The applicant has been granted a license under 35 U.S.C. 184, if the phrase "IF REQUIRED, FOREIGN FILING LICENSE GRANTED" followed by a date appears on this form. Such licenses are issued in all applications where the conditions for issuance of a license have been met, regardless of whether or not a license may be required as set forth in 37 CFR 5.15. The scope and limitations of this license are set forth in 37 CFR 5.15(a) unless an earlier license has been issued under 37 CFR 5.15(b). The license is subject to revocation upon written notification. The date indicated is the effective date of the license, unless an earlier license of similar scope has been granted under 37 CFR 5.13 or 5.14.

This license is to be retained by the licensee and may be used at any time on or after the effective date thereof unless it is revoked. This license is automatically transferred to any related applications(s) filed under 37 CFR 1.53(d). This license is not retroactive.

The grant of a license does not in any way lessen the responsibility of a licensee for the security of the subject matter as imposed by any Government contract or the provisions of existing laws relating to espionage and the national security or the export of technical data. Licensees should apprise themselves of current regulations especially with respect to certain countries, of other agencies, particularly the Office of Defense Trade Controls, Department of State (with respect to Arms, Munitions and Implements of War (22 CFR 121-128)); the Bureau of Industry and Security, Department of Commerce (15 CFR parts 730-774); the Office of Foreign Assets Control, Department of Treasury (31 CFR Parts 500+) and the Department of Energy.

**NOT GRANTED**

No license under 35 U.S.C. 184 has been granted at this time, if the phrase "IF REQUIRED, FOREIGN FILING LICENSE GRANTED" DOES NOT appear on this form. Applicant may still petition for a license under 37 CFR 5.12, if a license is desired before the expiration of 6 months from the filing date of the application. If 6 months has lapsed from the filing date of this application and the licensee has not received any indication of a secrecy order under 35 U.S.C. 181, the licensee may foreign file the application pursuant to 37 CFR 5.15(b).

---

***SelectUSA***

The United States represents the largest, most dynamic marketplace in the world and is an unparalleled location for business investment, innovation, and commercialization of new technologies. The U.S. offers tremendous resources and advantages for those who invest and manufacture goods here. Through SelectUSA, our nation works to promote and facilitate business investment. SelectUSA provides information assistance to the international investor community; serves as an ombudsman for existing and potential investors; advocates on behalf of U.S. cities, states, and regions competing for global investment; and counsels U.S. economic development organizations on investment attraction best practices. To learn more about why the United States is the best country in the world to develop technology, manufacture products, deliver services, and grow your business, visit <http://www.SelectUSA.gov> or call +1-202-482-6800.

**PATENT APPLICATION FEE DETERMINATION RECORD**

Substitute for Form PTO-875

Application or Docket Number  
14/141,665

**APPLICATION AS FILED - PART I**

(Column 1) (Column 2)

FOR	NUMBER FILED	NUMBER EXTRA
BASIC FEE (37 CFR 1.16(a), (b), or (c))	N/A	N/A
SEARCH FEE (37 CFR 1.16(k), (l), or (m))	N/A	N/A
EXAMINATION FEE (37 CFR 1.16(o), (p), or (q))	N/A	N/A
TOTAL CLAIMS (37 CFR 1.16(j))	7	minus 20 = *
INDEPENDENT CLAIMS (37 CFR 1.16(h))	1	minus 3 = *
APPLICATION SIZE FEE (37 CFR 1.16(s))	If the specification and drawings exceed 100 sheets of paper, the application size fee due is \$310 (\$155 for small entity) for each additional 50 sheets or fraction thereof. See 35 U.S.C. 41(a)(1)(G) and 37 CFR 1.16(s).	
MULTIPLE DEPENDENT CLAIM PRESENT (37 CFR 1.16(j))		

**SMALL ENTITY**

RATE(\$)	FEE(\$)
N/A	
N/A	
N/A	
TOTAL	

**OR OTHER THAN SMALL ENTITY**

RATE(\$)	FEE(\$)
N/A	280
N/A	600
N/A	720
x 80 =	0.00
x 420 =	0.00
	0.00
	0.00
TOTAL	1600

\* If the difference in column 1 is less than zero, enter "0" in column 2.

**APPLICATION AS AMENDED - PART II**

(Column 1) (Column 2) (Column 3)

AMENDMENT A		CLAIMS REMAINING AFTER AMENDMENT		HIGHEST NUMBER PREVIOUSLY PAID FOR	PRESENT EXTRA
	Total (37 CFR 1.16(j))	*	Minus	**	=
Independent (37 CFR 1.16(h))	*	Minus	***	=	
Application Size Fee (37 CFR 1.16(s))					
FIRST PRESENTATION OF MULTIPLE DEPENDENT CLAIM (37 CFR 1.16(j))					

**SMALL ENTITY**

RATE(\$)	ADDITIONAL FEE(\$)
x =	
x =	
TOTAL ADD'L FEE	

**OR OTHER THAN SMALL ENTITY**

RATE(\$)	ADDITIONAL FEE(\$)
x =	
x =	
TOTAL ADD'L FEE	

(Column 1) (Column 2) (Column 3)

AMENDMENT B		CLAIMS REMAINING AFTER AMENDMENT		HIGHEST NUMBER PREVIOUSLY PAID FOR	PRESENT EXTRA
	Total (37 CFR 1.16(j))	*	Minus	**	=
Independent (37 CFR 1.16(h))	*	Minus	***	=	
Application Size Fee (37 CFR 1.16(s))					
FIRST PRESENTATION OF MULTIPLE DEPENDENT CLAIM (37 CFR 1.16(j))					

**SMALL ENTITY**

RATE(\$)	ADDITIONAL FEE(\$)
x =	
x =	
TOTAL ADD'L FEE	

**OR OTHER THAN SMALL ENTITY**

RATE(\$)	ADDITIONAL FEE(\$)
x =	
x =	
TOTAL ADD'L FEE	

\* If the entry in column 1 is less than the entry in column 2, write "0" in column 3.

\*\* If the "Highest Number Previously Paid For" IN THIS SPACE is less than 20, enter "20".

\*\*\* If the "Highest Number Previously Paid For" IN THIS SPACE is less than 3, enter "3".

The "Highest Number Previously Paid For" (Total or Independent) is the highest found in the appropriate box in column 1.



UNITED STATES PATENT AND TRADEMARK OFFICE

UNITED STATES DEPARTMENT OF COMMERCE  
United States Patent and Trademark Office  
Address: COMMISSIONER FOR PATENTS  
P.O. Box 1450  
Alexandria, Virginia 22313-1450  
www.uspto.gov

APPLICATION NUMBER	FILING OR 371(C) DATE	FIRST NAMED APPLICANT	ATTY. DOCKET NO./TITLE
14/141,665	12/27/2013	Hung-Kuo Yu	SIIP.201299

**CONFIRMATION NO. 9554**

**POA ACCEPTANCE LETTER**

5251  
SHOOK, HARDY & BACON LLP  
INTELLECTUAL PROPERTY DEPARTMENT  
2555 GRAND BLVD  
KANSAS CITY, MO 64108-2613



Date Mailed: 01/09/2014

**NOTICE OF ACCEPTANCE OF POWER OF ATTORNEY**

This is in response to the Power of Attorney filed 12/27/2013.

The Power of Attorney in this application is accepted. Correspondence in this application will be mailed to the above address as provided by 37 CFR 1.33.

/btsebhatu/

Office of Data Management, Application Assistance Unit (571) 272-4000, or (571) 272-4200, or 1-888-786-0101

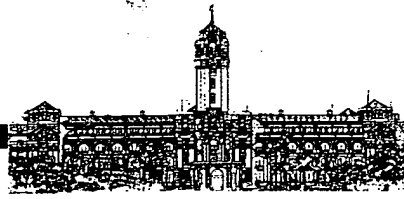

中華民國經濟部智慧財產局

INTELLECTUAL PROPERTY OFFICE  
MINISTRY OF ECONOMIC AFFAIRS  
REPUBLIC OF CHINA

茲證明所附文件，係本局存檔中原申請案的副本，正確無訛，  
其申請資料如下：

This is to certify that annexed is a true copy from the records of this office of  
the application as originally filed which is identified hereunder：

申 請 日：西元 2013 年 09 月 02 日  
Application Date Sep. 2, 2013

申 請 案 號：102131525  
Application No.

申 請 人：先進光電科技股份有限公司  
Applicant(s)

發 明 人：游鴻國  
Inventor(s)

局 長

Director General

王美花

西元 2013 年 10 月 14 日  
Oct. 14, 2013

# 發明摘要

※ 申請案號：

※ 申請日：

※IPC 分類：

**【發明名稱】** 薄型廣角四片式成像鏡頭組

## 【中文】

一種薄型廣角四片式成像鏡頭組包含一光學組及一固定光欄，光學組沿光軸從物側至像側依序包括第一、第二、第三及第四鏡片，屈光力為正正負正，第一鏡片朝向物側在靠近中心光軸附近為為凸面，第二鏡片朝向像側在靠近中心光軸附近為為凸面，第三鏡片朝向物側在靠近中心光軸附近為為凹面且朝向像側在靠近中心光軸附近為為凸面，第四鏡片朝向像側在靠近中心光軸附近為凹面，且從光軸至非球面終止點至少有一反曲點，固定光欄位於物側與第二鏡片間，滿足  $15 < \text{HFOV}/f < 50$ ，HFOV 為該鏡頭組最大使用之可視角度的一半， $f$  為成像鏡頭組焦距值，HFOV 值大及  $f$  值小可使整體鏡頭組體積更加緊密化並且提高解像力，因此本發明能兼具輕薄短小與高效能優勢。

## 【英文】

**【代表圖】**

**【本案指定代表圖】：**圖（ 1 ）。

**【本代表圖之元件符號簡單說明】：**

1.....	光學組	14.....	第四鏡片
11.....	第一鏡片	2.....	固定光欄
12.....	第二鏡片	ct1~ct4.....	厚度
13.....	第三鏡片		

**【本案若有化學式時，請揭示最能顯示發明特徵的化學式】：**



# 發明專利說明書

(本說明書格式、順序，請勿任意更動)

**【發明名稱】** 薄型廣角四片式成像鏡頭組

**【技術領域】**

**【0001】** 本發明是有關於一種成像鏡頭組，特別是指一種薄型廣角四片式成像鏡頭組。

**【先前技術】**

**【0002】** 以往的成像鏡頭組，是適用於行動電話、智慧型手機、平板電腦、筆記型電腦以及攝像頭等電子產品當中的成像鏡頭組。隨著此類電子產品不斷地發展，逐漸朝向輕薄短小的設計傾向，但又同時要求高效能，因此，連帶地使得成像鏡頭組朝向整體更加緊密化的薄型尺寸發展，而爲了提高解像力，成像鏡頭組也需要朝向更廣角的方向發展。

**【0003】** 而以往的成像鏡頭組，如專利 TW201215941A、TW201224568A、TW201239443A 等，雖然揭露有四片式的成像鏡頭組，但前揭專利的實施態樣均未能進一步滿足薄型、廣角的需求。

**【0004】** 因此，爲了能讓電子產品兼具輕薄短小與高效能的優勢，一種可以使整體更加緊密化的薄型尺寸，且能提高解像力的廣角成像鏡頭組爲目前市場所需。

**【發明內容】**

**【0005】** 因此，本發明之目的，即在提供一種可以使整

體更加緊密化的薄型尺寸，且能提高解像力的薄型廣角四片式成像鏡頭組。

【0006】於是，本發明薄型廣角四片式成像鏡頭組，包含一個光學組，及一個固定光欄，該光學組沿一個光軸從物側至像側依序包括一個第一鏡片、一個第二鏡片、一個第三鏡片，及一個第四鏡片，該第一鏡片，具有在靠近中心光軸附近為正屈光力且朝向物側為凸面，且該第一鏡片至少有一面為非球面，該第二鏡片，具有在靠近中心光軸附近為正屈光力且朝向像側為凸面，且該第二鏡片至少有一面為非球面，該第三鏡片，具有在靠近中心光軸附近為負屈光力且朝向物側為凹面且朝向像側為凸面，且該第三鏡片至少有一面為非球面，該第四鏡片，具有在靠近中心光軸附近為正屈光力且朝向像側為凹面，且該第四鏡片的兩面都為非球面，且兩面至少一面從該光軸至非球面終止點至少有一個反曲點，該固定光欄位於物側與該第二鏡片間，其中，該薄型廣角四片式成像鏡頭組滿足條件：

【0007】  $15 < \text{HFOV}/f < 50$ ，

【0008】HFOV 為該鏡頭組最大使用之可視角度的一半，單位為 $^{\circ}$ ， $f$ 為該薄型廣角四片式成像鏡頭組的焦距值，單位為mm。

【0009】本發明所述的薄型廣角四片式成像鏡頭組，其中，該薄型廣角四片式成像鏡頭組滿足條件：

【0010】  $\text{HFOV} > 35^{\circ}$ 。

【0011】本發明所述的薄型廣角四片式成像鏡頭組，其

● 中，該薄型廣角四片式成像鏡頭組滿足條件：

【0012】  $f < 2.7 \text{ mm}$ 。

【0013】 本發明所述的薄型廣角四片式成像鏡頭組，其中，該薄型廣角四片式成像鏡頭組滿足條件：

【0014】  $Nd3 > 1.56$ ，

【0015】  $V3 < 29$ ，

【0016】  $Nd3$  為該第三鏡片的折射率， $V3$  為該第三鏡片的色散係數。

【0017】 本發明所述的薄型廣角四片式成像鏡頭組，其中，該薄型廣角四片式成像鏡頭組滿足條件：

【0018】  $Nd2 < 1.56$ ，

【0019】  $V2 > 29$ ，

【0020】  $Nd2$  為該第二鏡片的折射率， $V2$  為該第二鏡片的色散係數。

【0021】 本發明所述的薄型廣角四片式成像鏡頭組，其中，該薄型廣角四片式成像鏡頭組滿足條件：

【0022】  $0.8 < |f/f3| < 2.5$ ，

【0023】  $f3$  為該第三鏡片的焦距值，單位為 mm。

【0024】 本發明所述的薄型廣角四片式成像鏡頭組，其中，該薄型廣角四片式成像鏡頭組滿足條件：

【0025】  $0.3 < ct1/ct2 < 2.0$ ，

【0026】  $0 < ct3/ct4 < 1.0$ ，

【0027】  $ct1$  為該第一鏡片的中心厚度， $ct2$  為該第二鏡片的中心厚度， $ct3$  為該第三鏡片的中心厚度， $ct4$  為該第

四鏡片的中心厚度，單位皆為mm。

【0028】本發明之功效在於該薄型廣角四片式成像鏡頭組滿足  $15 < \text{HFOV}/f < 50$ ，HFOV 值大代表本發明的可視角度相當大而能提高解像力，而  $f$  值小說明本發明是可使整體更加緊密化的薄型尺寸，因此本發明能讓電子產品兼具輕薄短小與高效能的優勢，而確實能滿足本發明的目的。

【圖式簡單說明】

【0029】本發明之其他的特徵及功效，將於參照圖式的實施方式中清楚地呈現，其中：

圖 1 是一個光學結構示意圖，說明本發明薄型廣角四片式成像鏡頭組的第一具體實施例；

圖 2 是一個示意圖，說明本第一具體實施例的非點像差與歪曲像差；

圖 3 是一個示意圖，說明本第一具體實施例的球面像差；

圖 4 是一個光學結構示意圖，說明本發明薄型廣角四片式成像鏡頭組的第二具體實施例；

圖 5 是一個示意圖，說明本第二具體實施例的非點像差與歪曲像差；

圖 6 是一個示意圖，說明本第二具體實施例的球面像差；

圖 7 是一個光學結構示意圖，說明本發明薄型廣角四片式成像鏡頭組的第三具體實施例；

圖 8 是一個示意圖，說明本第三具體實施例的非點像差與歪曲像差；及

圖 9 是一個示意圖，說明本第三具體實施例的球面像差。

## ● 【實施方式】

【0030】 參閱圖 1，本發明薄型廣角四片式成像鏡頭組包含一個光學組 1、一個固定光欄 2、一個濾鏡片 3，及一個成像面 4。

【0031】 該光學組 1 沿一個光軸 L 從物側至像側依序包括一個第一鏡片 11、一個第二鏡片 12、一個第三鏡片 13，及一個第四鏡片 14，該第一鏡片 11，具有在靠近中心光軸 L 附近為正屈光力且朝向物側為凸面，且該第一鏡片 11 至少有一面為非球面，該第二鏡片 12，具有在靠近中心光軸 L 附近為正屈光力且朝向像側為凸面，且該第二鏡片 12 至少有一面為非球面，該第三鏡片 13，具有在靠近中心光軸 L 附近為負屈光力且朝向物側為凹面且朝向像側為凸面，且該第三鏡片 13 至少有一面為非球面，該第四鏡片 14，具有在靠近中心光軸 L 附近為正屈光力且朝向像側為凹面，且該第四鏡片 14 的兩面都為非球面，且兩面至少一面從該光軸 L 至非球面終止點至少有一個反曲點，該固定光欄 2 位於物側與該第二鏡片 12 間，其中，該薄型廣角四片式成像鏡頭組滿足條件：

$$\text{【0032】 } 15 < \text{HFOV}/f < 50 \quad (1),$$

$$\text{【0033】 } 0.8 < |f/f_3| < 2.5 \quad (2),$$

$$\text{【0034】 } 0.3 < ct_1/ct_2 < 2.0 \quad (3),$$

$$\text{【0035】 } 0 < ct_3/ct_4 < 1.0 \quad (4),$$

【0036】 HFOV 為該鏡頭組最大使用之可視角度的一半，單位為 $^{\circ}$ ，f 為該薄型廣角四片式成像鏡頭組的焦距

值，單位為 mm， $f_3$  為該第三鏡片 13 的焦距值，單位為 mm， $ct_1$  為該第一鏡片 11 的中心厚度， $ct_2$  為該第二鏡片 12 的中心厚度， $ct_3$  為該第三鏡片 13 的中心厚度， $ct_4$  為該第四鏡片 14 的中心厚度，單位皆為 mm。

【0037】更佳地，該薄型廣角四片式成像鏡頭組滿足條件：

【0038】  $HFOV > 35^\circ$  (5)，

【0039】  $f < 2.7 \text{ mm}$  (6)，

【0040】條件式(1)說明 HFOV 值大代表本發明的可視角度相當大而能提高解像力，而  $f$  值小說明本發明是可使整體更加緊密化的薄型尺寸，而條件式(5)與條件式(6)則是進一步闡述了本發明的可視角度大以及薄型尺寸的優勢。

【0041】值得說明的是，該薄型廣角四片式成像鏡頭組滿足條件：

【0042】  $Nd_3 > 1.56$  (7)，

【0043】  $V_3 < 29$  (8)，

【0044】  $Nd_2 < 1.56$  (9)，

【0045】  $V_2 > 29$  (10)，

【0046】 $Nd_3$  為該第三鏡片 13 的折射率， $V_3$  為該第三鏡片 13 的色散係數， $Nd_2$  為該第二鏡片 12 的折射率， $V_2$  為該第二鏡片 12 的色散係數，條件式(7)至條件式(10)闡明了本發明由該第三鏡片 13 提供的屈光力大於該第二鏡片 12 所提供的屈光力。

【0047】附帶一提的是，本發明的非球面的面型滿足條

件：

$$z = \frac{ch^2}{1+[1-(k+1)c^2h^2]^{0.5}} + Ah^4 + Bh^6 + Ch^8 + Dh^{10} + Eh^{12} + Fh^{14} + Gh^{16} + Hh^{18} + Jh^{20} + \dots$$

【0048】

【0049】

(11)，

【0050】 其中， $z$  為沿該光軸  $L$  方向在高度為  $h$  的位置以表面頂點作參考的位置值， $k$  為錐常度量， $c$  為曲率半徑的倒數， $A$ 、 $B$ 、 $C$ 、 $D$ 、 $E$ 、 $F$ 、 $G$ 、 $H$ 、 $J$ ……為高階非球面係數，非球面的面型在於可以矯正像差以及降低公差敏感度，也使本發明具有廣角效能。

【0051】 <第一具體實施例>

【0052】 配合參閱圖 1、圖 2 與圖 3，且本第一具體實施例的各項參數為： $f_1=2.19$  mm， $f_2=2.05$  mm， $f_3=-1.16$  mm， $f_4=1.52$  mm， $f=1.60$  mm， $ct_1=0.284$  mm， $ct_2=0.368$  mm， $ct_3=0.190$  mm， $ct_4=0.472$  mm， $HFOV=44^\circ$ 。

【0053】 本第一具體實施例滿足條件式 (1) 至 (11)， $HFOV/f=27.5$ ， $|f/f_3|=1.38$ ， $ct_1/ct_2=0.77$ ， $ct_3/ct_4=0.40$ ， $Nd_2=1.535$ ， $Nd_3=1.636$ ， $V_2=56.07$ ， $V_3=23.89$ 。

【0054】 圖 2 表現本第一具體實施例的非點像差與歪曲像差，圖 3 表現球面像差。

【0055】

第一具體實施例鏡片數據

表面		曲率半徑 (Radius)	厚度/間隔 (Thickness)	折射率 (N <sub>d</sub> )	阿貝數 (V <sub>d</sub> )	焦長 (mm)
固定光圈		∞	-0.03			
第一鏡片 11	第一面	1.361	0.284	1.535	56.07	2.19
	第二面	-8.119	0.194			
第二鏡片 12	第三面	-2.042	0.368	1.535	56.07	2.05
	第四面	-0.760	0.159			
第三鏡片 13	第五面	-0.289	0.190	1.636	23.89	-1.16
	第六面	-0.596	0.038			
第四鏡片 14	第七面	0.488	0.472	1.535	56.07	1.52
	第八面	0.805	0.25			
濾鏡片	第九面	∞	0.21	1.517	64.17	
	第十面	∞	0.332			

【0056】 第一具體實施例非球面參數為：

【0057】

	第一面	第二面	第三面	第四面	第五面	第六面	第七面	第八面
k	0	0	6.191788	-3.784132	-3.838175	-1.077898	-7.06691	-2.241616
A	-0.2065838	-0.7720604	-1.4905075	-1.1446487	-4.9202522	-0.5217609	0.10412867	-0.3678477
B	-3.3390093	1.4937038	13.548352	-13.499105	18.914991	0.96784978	-1.6835431	0.10715581
C	45.617387	-48.87327	-222.85883	142.67618	-20.771041	12.065814	4.2811759	0.31062561
D	-568.5172	417.56966	1762.543	-811.19607	12.125511	-36.497597	-6.3438122	-0.5323217
E	3836.6411	-1866.3668	-7503.2608	2964.6502	-142.85927	22.957229	5.6351203	0.37789525
F	-14300.609	3693.0414	17228.893	-6161.6996	243.02698	33.940443	-2.7711759	-0.1331061
G	22470.012	-1072.5651	-16174.808	5342.7346	30.761799	-33.635537	0.58039414	0.018683511

【0058】 <第二具體實施例>

【0059】 配合參閱圖 3、圖 4 與圖 5，且本第二具體實施



例的各項參數為： $f_1=2.39$  mm， $f_2=2.08$  mm， $f_3=-1.45$  mm， $f_4=1.85$  mm， $f=1.60$  mm， $ct_1=0.276$  mm， $ct_2=0.392$  mm， $ct_3=0.204$  mm， $ct_4=0.450$  mm， $HFOV=44^\circ$ 。

【0060】本第二具體實施例滿足條件式(1)至(11)  
 $HFOV/f=27.5$ ， $|f/f_3|=1.10$ ， $ct_1/ct_2=0.70$ ， $ct_3/ct_4=0.45$ ，  
 $Nd_2=1.535$ ， $Nd_3=1.636$ ， $V_2=56.07$ ， $V_3=23.89$ 。

【0061】圖 4 表現本第二具體實施例的非點像差與歪曲像差，圖 5 表現球面像差。

【0062】

第二具體實施例鏡片數據						
表面		曲率半徑 (Radius)	厚度/間隔 (Thickness)	折射率 (Nd)	阿貝數 (Vd)	焦長 (mm)
第一鏡片 11	第一面	1.172	0.276	1.535	56.07	2.39
	第二面	12.524	0.002			
固定光圈		$\infty$	0.193			
第二鏡片 12	第三面	-2.352	0.392	1.535	56.07	2.08
	第四面	-0.800	0.165			
第三鏡片 13	第五面	-0.295	0.204	1.636	23.89	-1.45
	第六面	-0.550	0.022			
第四鏡片 14	第七面	0.526	0.450	1.535	56.07	1.85
	第八面	0.786	0.25			
濾鏡片	第九面	$\infty$	0.21	1.517	64.17	
	第十面	$\infty$	0.352			

【0063】第二具體實施例非球面參數為：

【0064】

	第一面	第二面	第三面	第四面	第五面	第六面	第七面	第八面
k	-27.67006	0	0	-0.1133277	-3.670904	-1.681659	-7.045281	-3.872049
A	1.9885098	-0.37701082	-0.96274237	-0.00025411	-3.9824733	-0.37652375	0.000309204	-0.15744128
B	-16.754161	-0.49422655	2.5787486	-13.638266	9.3522783	-3.5402459	-1.3786241	-0.21216838
C	121.87784	-25.697915	-75.20593	119.14826	-14.277191	22.786238	3.9107049	0.6311134
D	-697.96558	372.82808	563.02784	-775.83633	58.628841	-34.875393	-6.1155891	-0.74118053
E	2523.3236	-3090.4143	-2537.022	3121.5568	13.198369	-6.5038799	5.4923776	0.45196807
F	-5159.4588	12641.659	4107.643	-6765.6192	-631.1631	60.790568	-2.5266688	-0.14266076
G	4272.9124	-20091.048	1821.596	6044.1686	956.17439	-37.919506	0.51902791	0.01825282

【0065】 <第三具體實施例>

【0066】 配合參閱圖 6、圖 7 與圖 8，且本第三具體實施例的各項參數為： $f_1=2.55$  mm， $f_2=0.86$  mm， $f_3=-0.61$  mm， $f_4=0.98$  mm， $f=1.13$  mm， $ct_1=0.239$  mm， $ct_2=0.266$  mm， $ct_3=0.187$  mm， $ct_4=0.429$  mm， $HFOV=44^\circ$ 。

【0067】 本第三具體實施例滿足條件式(1)至(11)  
 $HFOV/f=39.0$ ， $|f/f_3|=1.85$ ， $ct_1/ct_2=0.90$ ， $ct_3/ct_4=0.44$ ，  
 $Nd_2=1.535$ ， $Nd_3=1.636$ ， $V_2=56.07$ ， $V_3=23.89$ 。

【0068】 圖 7 表現本第三具體實施例的非點像差與歪曲像差，圖 8 表現球面像差。

【0069】

第三具體實施例鏡片數據						
表面		曲率半徑 (Radius)	厚度/間隔 (Thickness)	折射率 (Nd)	阿貝數 (Vd)	焦長 (mm)
固定光圈		$\infty$	-0.001			
第一鏡片 11	第一面	1.903	0.239	1.535	56.07	2.55
	第二面	-4.616	0.062			

第二鏡片 12	第三面	3.029	0.266	1.535	56.07	0.86
	第四面	-0.528	0.095			
第三鏡片 13	第五面	-0.184	0.187	1.636	23.89	-0.61
	第六面	-0.483	0.092			
第四鏡片 14	第七面	0.430	0.429	1.535	56.07	0.98
	第八面	1.549	0.125			
濾鏡片	第九面	∞	0.210	1.517	64.17	
	第十面	∞	0.325			

【0070】 第三具體實施例非球面參數為：

【0071】

	第一面	第二面	第三面	第四面	第五面	第六面	第七面	第八面
k	8.58328	-2824.922	42.97767	0.7395685	-1.926854	-0.3569793	-5.810289	1.443596
A	-1.2031657	-9.8439198	-7.1130345	0.63242517	-4.0319876	-0.15762397	-0.05755995	-0.20237191
B	12.223278	116.10956	4.0234552	-132.3459	-130.00916	3.7724173	-1.4813813	0.7721049
C	-1918.3111	-1775.4567	-507.43521	2590.488	3983.5728	116.23539	9.9370396	-8.9338663
D	6722.3948	-15124.178	-7707.7496	-20847.637	-22497.967	-218.09901	-60.63752	26.574088
E	2123163.2	652775.39	80989.53	138170.7	-103474.15	-4855.6445	190.69088	-38.350854
F	-52922573	-5158083.1	1130631.4	-1000249.5	1277642.5	24221.919	-287.85565	27.456949
G	3.7786e+008	11596365	-8089358.7	3411687.3	-3002346	-32489.178	163.69987	-8.006268

【0072】 綜上所述，本發明之功效如下：

【0073】 一、本發明的特徵在於該薄型廣角四片式成像鏡頭組滿足  $15 < \text{HFOV}/f < 50$ ，此外，本發明也藉由滿足條件式(2)至(11)來提高解像力、提高廣角角度、降低厚度更加薄型化。

【0074】 二、HFOV 值大代表本發明的可視角度相當大

而能提高解像力。

【0075】 三、 $f$  值小說明本發明是可使整體更加緊密化的薄型尺寸。

【0076】 本發明能讓電子產品兼具輕薄短小與高效能的優勢，而確實能滿足本發明的目的。

【0077】 惟以上所述者，僅為本發明之較佳實施例而已，當不能以此限定本發明實施之範圍，即大凡依本發明申請專利範圍及專利說明書內容所作之簡單的等效變化與修飾，皆仍屬本發明專利涵蓋之範圍內。

● **【符號說明】**

**【0078】**

1	光學組	2	固定光欄
11	第一鏡片	3	濾鏡片
12	第二鏡片	4	成像面
13	第三鏡片	L	光軸
14	第四鏡片	ct1~ct4	厚度

**【生物材料寄存】**

國內寄存資訊【請依：寄存機構、日期、號碼順序註記】

國外寄存資訊【請依：寄存國家、機構、日期、號碼順序註記】

**【序列表】** (請換頁單獨記載)

# 申請專利範圍

1. 一種薄型廣角四片式成像鏡頭組，包含：

一個光學組，該光學組沿一個光軸從物側至像側依序包括一個第一鏡片、一個第二鏡片、一個第三鏡片，及一個第四鏡片，

該第一鏡片，具有在靠近中心光軸附近為正屈光力且朝向物側為凸面，且該第一鏡片至少有一面為非球面，

該第二鏡片，具有在靠近中心光軸附近為正屈光力且朝向像側為凸面，且該第二鏡片至少有一面為非球面，

該第三鏡片，具有在靠近中心光軸附近為負屈光力且朝向物側為凹面且朝向像側為凸面，且該第三鏡片至少有一面為非球面，

該第四鏡片，具有在靠近中心光軸附近為正屈光力且朝向像側為凹面，且該第四鏡片的兩面都為非球面，且兩面至少一面從該光軸至非球面終止點至少有一個反曲點；及

一個固定光欄，位於物側與該第二鏡片間，

其中，該薄型廣角四片式成像鏡頭組滿足條件：

$$15 < \text{HFOV}/f < 50,$$

HFOV 為該鏡頭組最大使用之可視角度的一半，單位為°，f 為該薄型廣角四片式成像鏡頭組的焦距值，單位為 mm。

2. 如請求項 1 所述的薄型廣角四片式成像鏡頭組，其中，該薄型廣角四片式成像鏡頭組滿足條件：  
 $HFOV > 35^\circ$ 。
3. 如請求項 1 所述的薄型廣角四片式成像鏡頭組，其中，該薄型廣角四片式成像鏡頭組滿足條件：  
 $f < 2.7 \text{ mm}$ 。
4. 如請求項 1 所述的薄型廣角四片式成像鏡頭組，其中，該薄型廣角四片式成像鏡頭組滿足條件：  
 $Nd3 > 1.56$ ，  
 $V3 < 29$ ，  
 $Nd3$  為該第三鏡片的折射率， $V3$  為該第三鏡片的色散係數。
5. 如請求項 4 所述的薄型廣角四片式成像鏡頭組，其中，該薄型廣角四片式成像鏡頭組滿足條件：  
 $Nd2 < 1.56$ ，  
 $V2 > 29$ ，  
 $Nd2$  為該第二鏡片的折射率， $V2$  為該第二鏡片的色散係數。
6. 如請求項 1 所述的薄型廣角四片式成像鏡頭組，其中，該薄型廣角四片式成像鏡頭組滿足條件：  
 $0.8 < |f/f3| < 2.5$ ，  
 $f3$  為該第三鏡片的焦距值，單位為 mm。
7. 如請求項 1 所述的薄型廣角四片式成像鏡頭組，其中，該薄型廣角四片式成像鏡頭組滿足條件：

$$0.3 < ct1/ct2 < 2.0,$$

$$0 < ct3/ct4 < 1.0,$$

ct1 為該第一鏡片的中心厚度，ct2 為該第二鏡片的中心厚度，ct3 為該第三鏡片的中心厚度，ct4 為該第四鏡片的中心厚度，單位皆為 mm。



# 圖式



圖1



圖2

球面像差

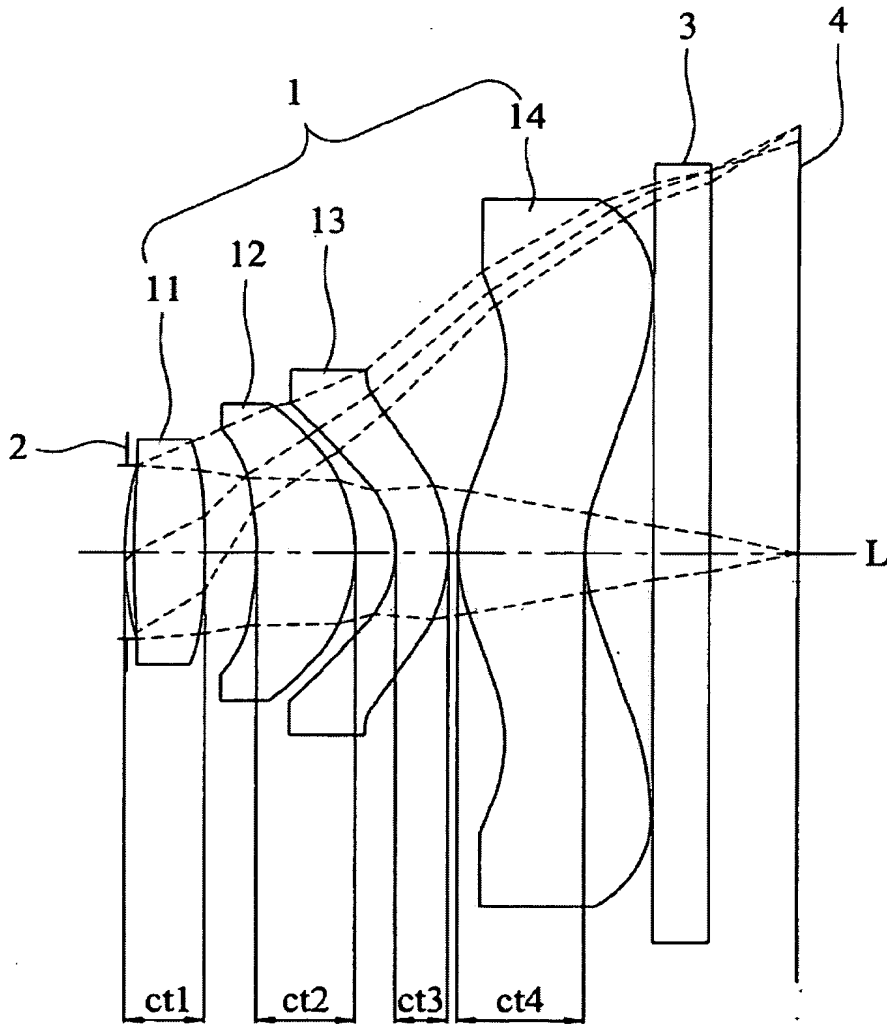

圖3

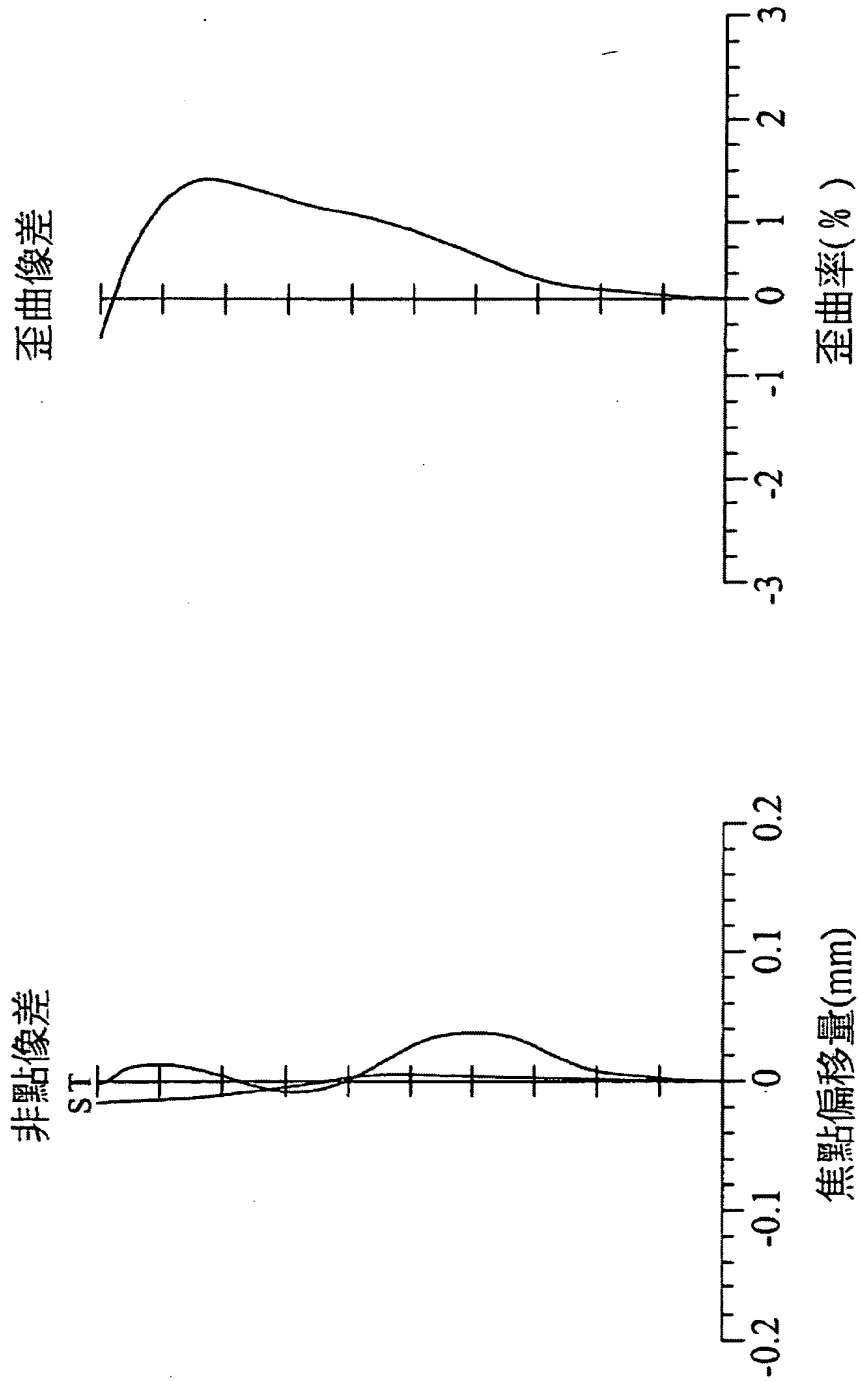

圖4

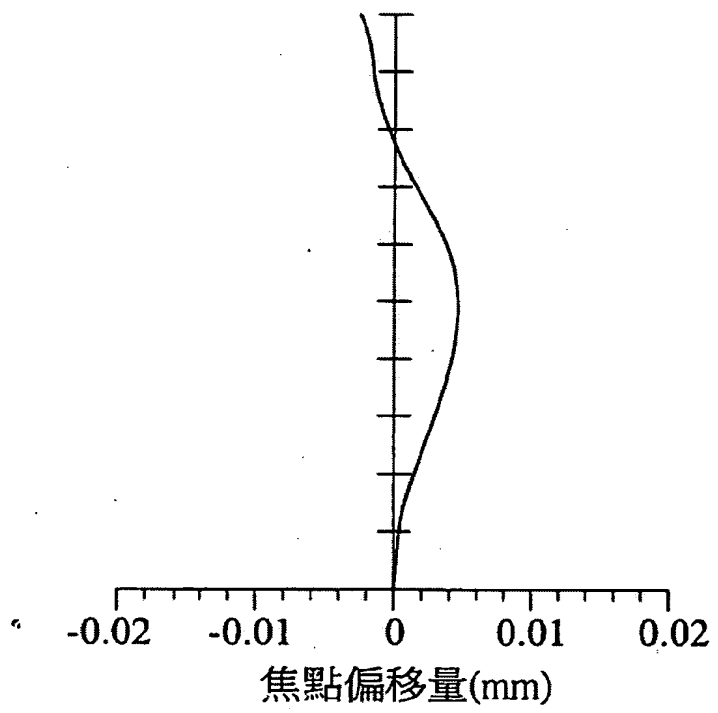

圖5

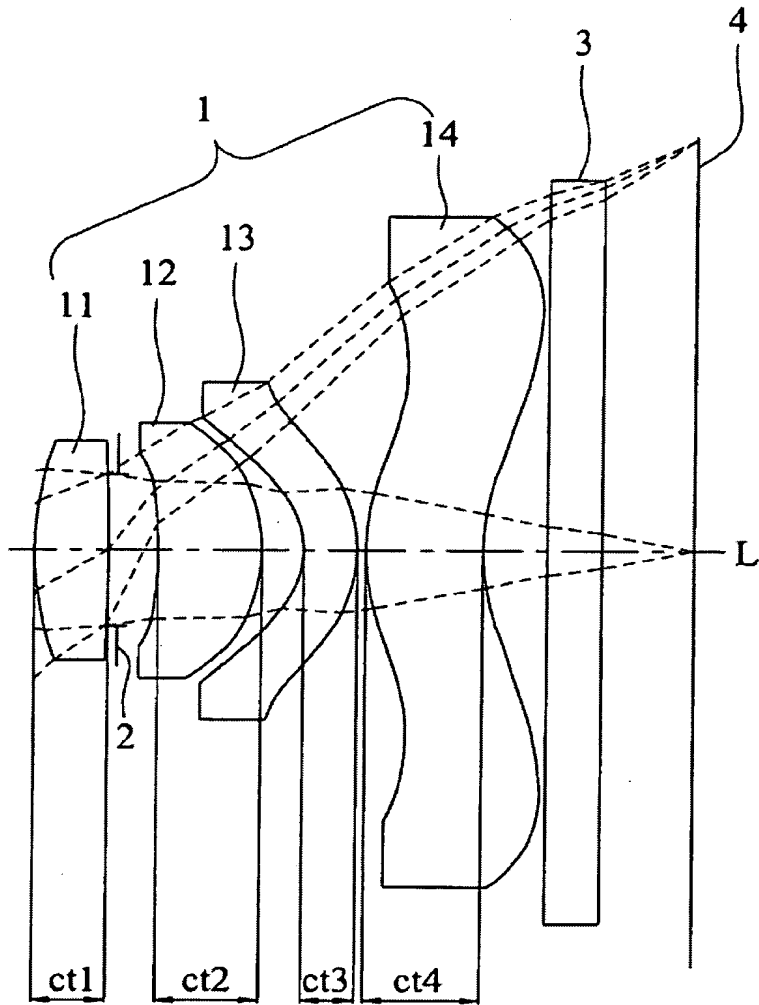

圖6

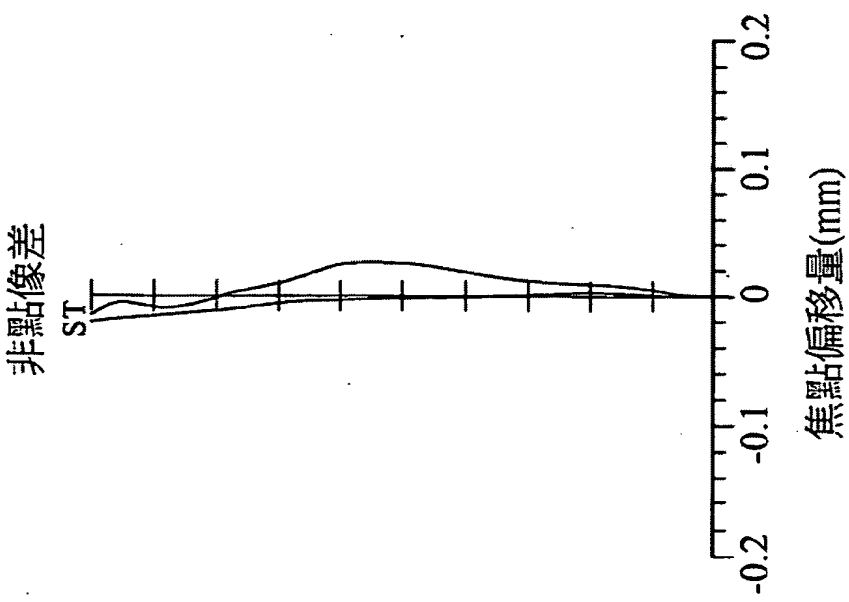
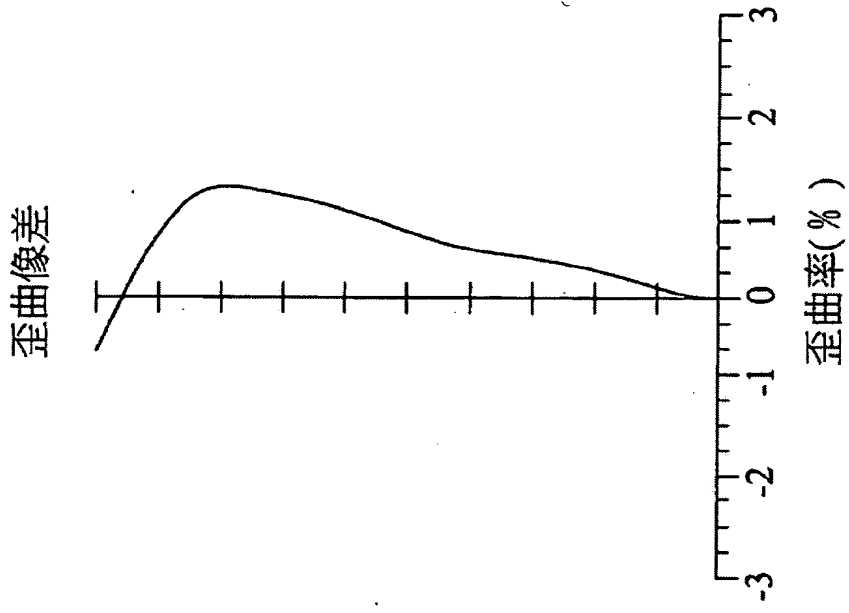

圖7

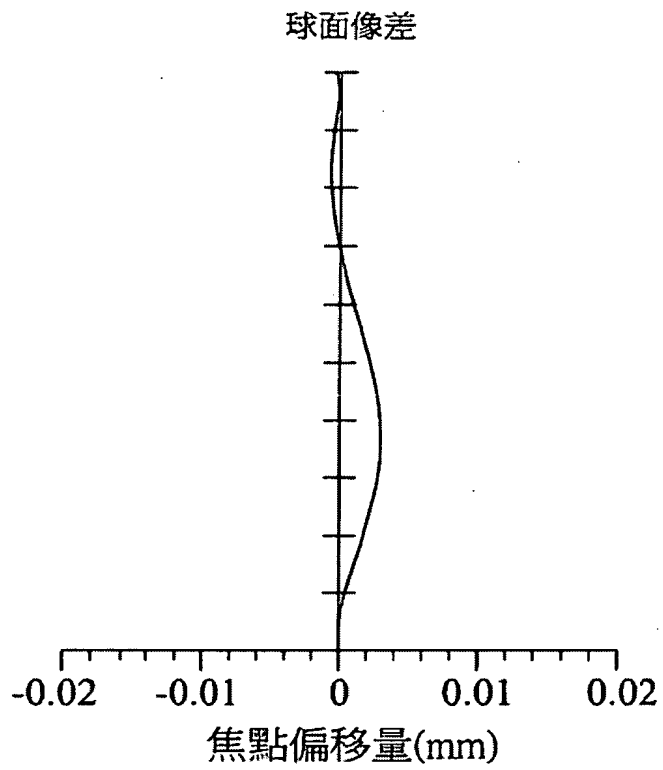

圖8

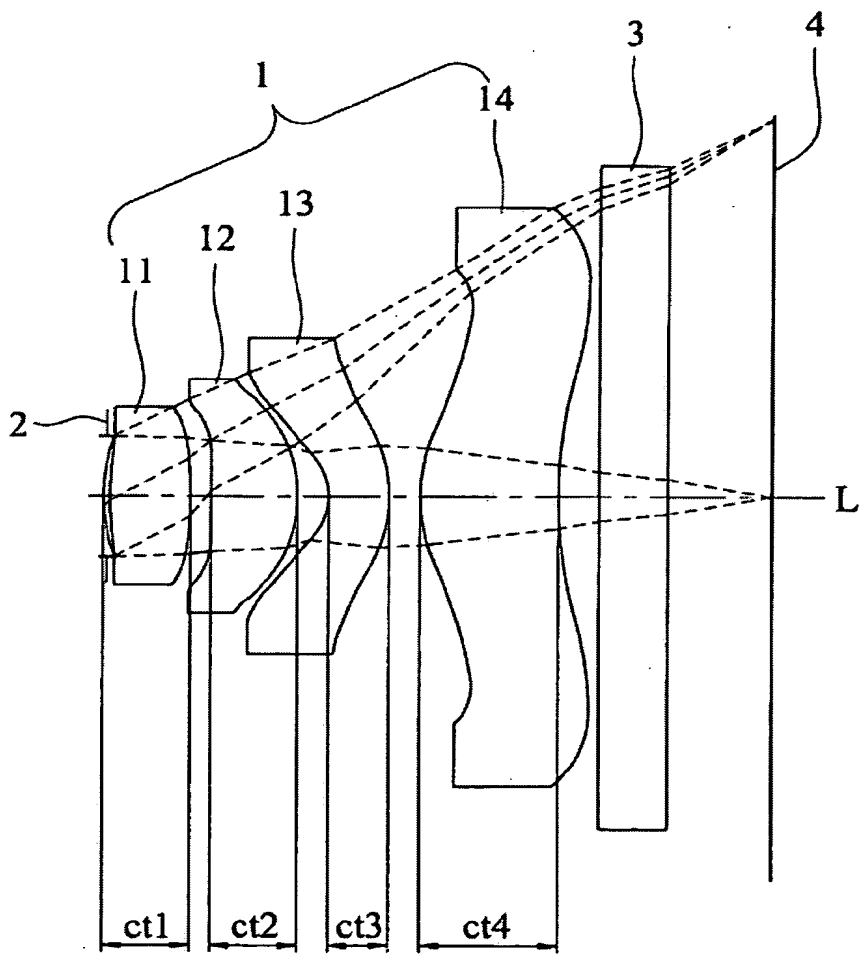

球面像差

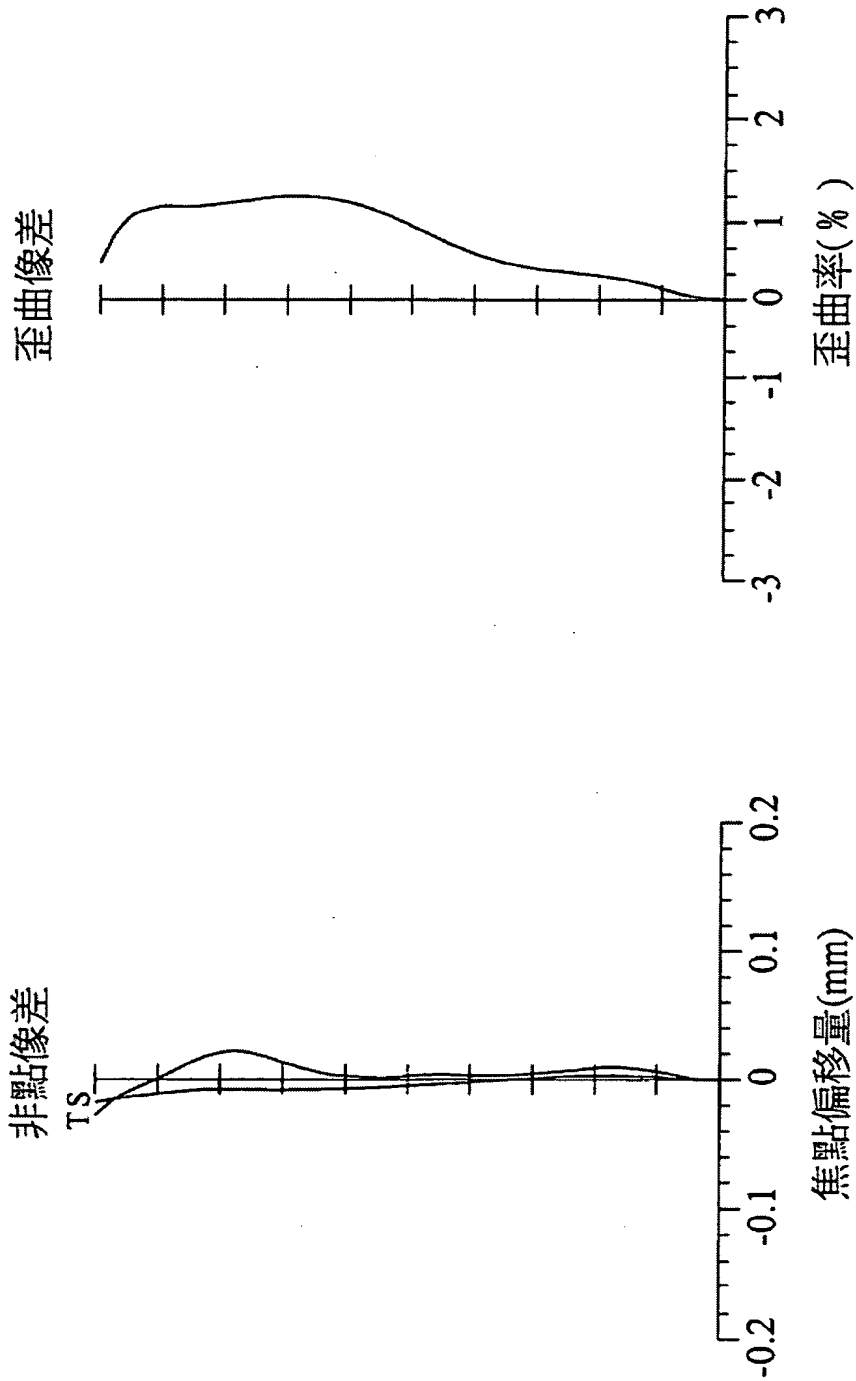

圖9

FW

Doc Code: TRAN.LET

Document Description: Transmittal Letter

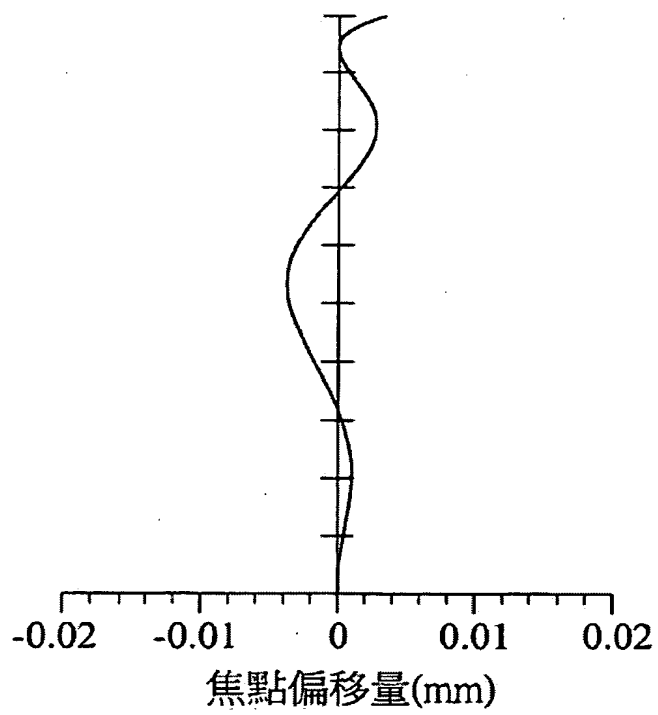
PTO/SB/21 (07-09)  
 Approved for use through 07/31/2012. OMB 0651-0031  
 U.S. Patent and Trademark Office; U.S. DEPARTMENT OF COMMERCE

Under the Paperwork Reduction Act of 1995, no persons are required to respond to a collection of information unless it displays a valid OMB control number.

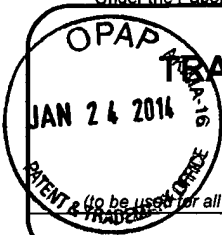
 <p><b>TRANSMITTAL FORM</b></p>	Application Number	14/141,665
	Filing Date	December 27, 2013
	First Named Inventor	Hung-Kuo Yu
	Art Unit	2872
	Examiner Name	Not Assigned
	Attorney Docket Number	SIIP.201299
Total Number of Pages in This Submission		

ENCLOSURES (Check all that apply)		
<input type="checkbox"/> Fee Transmittal Form	<input type="checkbox"/> Drawing(s)	<input type="checkbox"/> After Allowance Communication to TC
<input type="checkbox"/> Fee Attached	<input type="checkbox"/> Licensing-related Papers	<input type="checkbox"/> Appeal Communication to Board of Appeals and Interferences
<input type="checkbox"/> Amendment/Reply	<input type="checkbox"/> Petition	<input type="checkbox"/> Appeal Communication to TC (Appeal Notice, Brief, Reply Brief)
<input type="checkbox"/> After Final	<input type="checkbox"/> Petition to Convert to a Provisional Application	<input type="checkbox"/> Proprietary Information
<input type="checkbox"/> Affidavits/declaration(s)	<input type="checkbox"/> Power of Attorney, Revocation Change of Correspondence Address	<input type="checkbox"/> Status Letter
<input type="checkbox"/> Extension of Time Request	<input type="checkbox"/> Terminal Disclaimer	<input type="checkbox"/> Other Enclosure(s) (please identify below):
<input type="checkbox"/> Express Abandonment Request	<input type="checkbox"/> Request for Refund	
<input type="checkbox"/> Information Disclosure Statement	<input type="checkbox"/> CD, Number of CD(s) _____	
<input checked="" type="checkbox"/> Certified Copy of Priority Document(s)	<input type="checkbox"/> Landscape Table on CD	
<input type="checkbox"/> Reply to Missing Parts/ Incomplete Application	<input type="checkbox"/> Remarks	
<input type="checkbox"/> Reply to Missing Parts under 37 CFR 1.52 or 1.53		

SIGNATURE OF APPLICANT, ATTORNEY, OR AGENT			
Firm Name	Shook Hardy & Bacon L.L.P.		
Signature	/Thomas T. Moga/		
Printed name	Thomas T. Moga		
Date	January 17, 2014	Reg. No.	34,881

CERTIFICATE OF TRANSMISSION/MAILING			
I hereby certify that this correspondence is being facsimile transmitted to the USPTO or deposited with the United States Postal Service with sufficient postage as first class mail in an envelope addressed to: Commissioner for Patents, P.O. Box 1450, Alexandria, VA 22313-1450 on the date shown below:			
Signature	/Saundra M. Lewis/		
Typed or printed name	Saundra M. Lewis	Date	January 17, 2014

This collection of information is required by 37 CFR 1.5. The information is required to obtain or retain a benefit by the public which is to file (and by the USPTO to process) an application. Confidentiality is governed by 35 U.S.C. 122 and 37 CFR 1.11 and 1.14. This collection is estimated to 2 hours to complete, including gathering, preparing, and submitting the completed application form to the USPTO. Time will vary depending upon the individual case. Any comments on the amount of time you require to complete this form and/or suggestions for reducing this burden, should be sent to the Chief Information Officer, U.S. Patent and Trademark Office, U.S. Department of Commerce, P.O. Box 1450, Alexandria, VA 22313-1450. DO NOT SEND FEES OR COMPLETED FORMS TO THIS ADDRESS. SEND TO: Commissioner for Patents, P.O. Box 1450, Alexandria, VA 22313-1450.

If you need assistance in completing the form, call 1-800-PTO-9199 and select option 2.



## Privacy Act Statement

The Privacy Act of 1974 (P.L. 93-579) requires that you be given certain information in connection with your submission of the attached form related to a patent application or patent. Accordingly, pursuant to the requirements of the Act, please be advised that: (1) the general authority for the collection of this information is 35 U.S.C. 2(b)(2); (2) furnishing of the information solicited is voluntary; and (3) the principal purpose for which the information is used by the U.S. Patent and Trademark Office is to process and/or examine your submission related to a patent application or patent. If you do not furnish the requested information, the U.S. Patent and Trademark Office may not be able to process and/or examine your submission, which may result in termination of proceedings or abandonment of the application or expiration of the patent.

The information provided by you in this form will be subject to the following routine uses:

1. The information on this form will be treated confidentially to the extent allowed under the Freedom of Information Act (5 U.S.C. 552) and the Privacy Act (5 U.S.C. 552a). Records from this system of records may be disclosed to the Department of Justice to determine whether disclosure of these records is required by the Freedom of Information Act.
2. A record from this system of records may be disclosed, as a routine use, in the course of presenting evidence to a court, magistrate, or administrative tribunal, including disclosures to opposing counsel in the course of settlement negotiations.
3. A record in this system of records may be disclosed, as a routine use, to a Member of Congress submitting a request involving an individual, to whom the record pertains, when the individual has requested assistance from the Member with respect to the subject matter of the record.
4. A record in this system of records may be disclosed, as a routine use, to a contractor of the Agency having need for the information in order to perform a contract. Recipients of information shall be required to comply with the requirements of the Privacy Act of 1974, as amended, pursuant to 5 U.S.C. 552a(m).
5. A record related to an International Application filed under the Patent Cooperation Treaty in this system of records may be disclosed, as a routine use, to the International Bureau of the World Intellectual Property Organization, pursuant to the Patent Cooperation Treaty.
6. A record in this system of records may be disclosed, as a routine use, to another federal agency for purposes of National Security review (35 U.S.C. 181) and for review pursuant to the Atomic Energy Act (42 U.S.C. 218(c)).
7. A record from this system of records may be disclosed, as a routine use, to the Administrator, General Services, or his/her designee, during an inspection of records conducted by GSA as part of that agency's responsibility to recommend improvements in records management practices and programs, under authority of 44 U.S.C. 2904 and 2906. Such disclosure shall be made in accordance with the GSA regulations governing inspection of records for this purpose, and any other relevant (*i.e.*, GSA or Commerce) directive. Such disclosure shall not be used to make determinations about individuals.
8. A record from this system of records may be disclosed, as a routine use, to the public after either publication of the application pursuant to 35 U.S.C. 122(b) or issuance of a patent pursuant to 35 U.S.C. 151. Further, a record may be disclosed, subject to the limitations of 37 CFR 1.14, as a routine use, to the public if the record was filed in an application which became abandoned or in which the proceedings were terminated and which application is referenced by either a published application, an application open to public inspection or an issued patent.
9. A record from this system of records may be disclosed, as a routine use, to a Federal, State, or local law enforcement agency, if the USPTO becomes aware of a violation or potential violation of law or regulation.

<b>INFORMATION DISCLOSURE STATEMENT BY APPLICANT</b> ( Not for submission under 37 CFR 1.99)	Application Number		14141665	
	Filing Date		2013-12-27	
	First Named Inventor	Hung-Kuo Yu		
	Art Unit	2872		
	Examiner Name	Stephone B. Allen		
	Attorney Docket Number	SIIP.201299		

U.S. PATENTS						
Examiner Initial*	Cite No	Patent Number	Kind Code <sup>1</sup>	Issue Date	Name of Patentee or Applicant of cited Document	Pages, Columns, Lines where Relevant Passages or Relevant Figures Appear
	1	8014080		2011-09-06	Chen, et al.	

If you wish to add additional U.S. Patent citation information please click the Add button.

U.S. PATENT APPLICATION PUBLICATIONS						
Examiner Initial*	Cite No	Publication Number	Kind Code <sup>1</sup>	Publication Date	Name of Patentee or Applicant of cited Document	Pages, Columns, Lines where Relevant Passages or Relevant Figures Appear
	1	20110128615		2011-06-02	Tsai	
	2	20120099009		2012-04-26	Hsu, et al.	
	3	20120140339		2012-06-07	Huang, et al.	
	4	20120250164		2012-10-04	Tsai, et al.	

If you wish to add additional U.S. Published Application citation information please click the Add button.

FOREIGN PATENT DOCUMENTS								
Examiner Initial*	Cite No	Foreign Document Number <sup>2</sup>	Country Code <sup>2</sup>	Kind Code <sup>4</sup>	Publication Date	Name of Patentee or Applicant of cited Document	Pages, Columns, Lines where Relevant Passages or Relevant Figures Appear	T <sup>5</sup>

**INFORMATION DISCLOSURE  
STATEMENT BY APPLICANT**

( Not for submission under 37 CFR 1.99)

Application Number		14141665
Filing Date		2013-12-27
First Named Inventor	Hung-Kuo Yu	
Art Unit	2872	
Examiner Name	Stephone B. Allen	
Attorney Docket Number	SIIP.201299	

1	2004102234	JP	A	2004-04-02	Susumu	<input type="checkbox"/>
2	2007178689	JP	A	2007-07-12	Masaki, et al.	<input type="checkbox"/>
3	2009192819	JP	A	2009-08-27	Yoshikazu	<input type="checkbox"/>

If you wish to add additional Foreign Patent Document citation information please click the Add button

**NON-PATENT LITERATURE DOCUMENTS**

Examiner Initials*	Cite No	Include name of the author (in CAPITAL LETTERS), title of the article (when appropriate), title of the item (book, magazine, journal, serial, symposium, catalog, etc), date, pages(s), volume-issue number(s), publisher, city and/or country where published.	T <sup>5</sup>
	1		<input type="checkbox"/>

If you wish to add additional non-patent literature document citation information please click the Add button

**EXAMINER SIGNATURE**

Examiner Signature	Date Considered
--------------------	-----------------

\*EXAMINER: Initial if reference considered, whether or not citation is in conformance with MPEP 609. Draw line through a citation if not in conformance and not considered. Include copy of this form with next communication to applicant.

<sup>1</sup> See Kind Codes of USPTO Patent Documents at [www.USPTO.GOV](http://www.USPTO.GOV) or MPEP 901.04. <sup>2</sup> Enter office that issued the document, by the two-letter code (WIPO Standard ST.3). <sup>3</sup> For Japanese patent documents, the indication of the year of the reign of the Emperor must precede the serial number of the patent document. <sup>4</sup> Kind of document by the appropriate symbols as indicated on the document under WIPO Standard ST.16 if possible. <sup>5</sup> Applicant is to place a check mark here if English language translation is attached.

**INFORMATION DISCLOSURE  
STATEMENT BY APPLICANT**  
( Not for submission under 37 CFR 1.99)

Application Number	14141665
Filing Date	2013-12-27
First Named Inventor	Hung-Kuo Yu
Art Unit	2872
Examiner Name	Stephone B. Allen
Attorney Docket Number	SIIP.201299

**CERTIFICATION STATEMENT**

Please see 37 CFR 1.97 and 1.98 to make the appropriate selection(s):

That each item of information contained in the information disclosure statement was first cited in any communication from a foreign patent office in a counterpart foreign application not more than three months prior to the filing of the information disclosure statement. See 37 CFR 1.97(e)(1).

**OR**

That no item of information contained in the information disclosure statement was cited in a communication from a foreign patent office in a counterpart foreign application, and, to the knowledge of the person signing the certification after making reasonable inquiry, no item of information contained in the information disclosure statement was known to any individual designated in 37 CFR 1.56(c) more than three months prior to the filing of the information disclosure statement. See 37 CFR 1.97(e)(2).

See attached certification statement.

The fee set forth in 37 CFR 1.17 (p) has been submitted herewith.

A certification statement is not submitted herewith.

**SIGNATURE**

A signature of the applicant or representative is required in accordance with CFR 1.33, 10.18. Please see CFR 1.4(d) for the form of the signature.

Signature	/Thomas T. Moga/	Date (YYYY-MM-DD)	2015-01-02
Name/Print	Thomas T. Moga	Registration Number	34,881

This collection of information is required by 37 CFR 1.97 and 1.98. The information is required to obtain or retain a benefit by the public which is to file (and by the USPTO to process) an application. Confidentiality is governed by 35 U.S.C. 122 and 37 CFR 1.14. This collection is estimated to take 1 hour to complete, including gathering, preparing and submitting the completed application form to the USPTO. Time will vary depending upon the individual case. Any comments on the amount of time you require to complete this form and/or suggestions for reducing this burden, should be sent to the Chief Information Officer, U.S. Patent and Trademark Office, U.S. Department of Commerce, P.O. Box 1450, Alexandria, VA 22313-1450. **DO NOT SEND FEES OR COMPLETED FORMS TO THIS ADDRESS. SEND TO: Commissioner for Patents, P.O. Box 1450, Alexandria, VA 22313-1450.**

## Privacy Act Statement

The Privacy Act of 1974 (P.L. 93-579) requires that you be given certain information in connection with your submission of the attached form related to a patent application or patent. Accordingly, pursuant to the requirements of the Act, please be advised that: (1) the general authority for the collection of this information is 35 U.S.C. 2(b)(2); (2) furnishing of the information solicited is voluntary; and (3) the principal purpose for which the information is used by the U.S. Patent and Trademark Office is to process and/or examine your submission related to a patent application or patent. If you do not furnish the requested information, the U.S. Patent and Trademark Office may not be able to process and/or examine your submission, which may result in termination of proceedings or abandonment of the application or expiration of the patent.

The information provided by you in this form will be subject to the following routine uses:

1. The information on this form will be treated confidentially to the extent allowed under the Freedom of Information Act (5 U.S.C. 552) and the Privacy Act (5 U.S.C. 552a). Records from this system of records may be disclosed to the Department of Justice to determine whether the Freedom of Information Act requires disclosure of these records.
2. A record from this system of records may be disclosed, as a routine use, in the course of presenting evidence to a court, magistrate, or administrative tribunal, including disclosures to opposing counsel in the course of settlement negotiations.
3. A record in this system of records may be disclosed, as a routine use, to a Member of Congress submitting a request involving an individual, to whom the record pertains, when the individual has requested assistance from the Member with respect to the subject matter of the record.
4. A record in this system of records may be disclosed, as a routine use, to a contractor of the Agency having need for the information in order to perform a contract. Recipients of information shall be required to comply with the requirements of the Privacy Act of 1974, as amended, pursuant to 5 U.S.C. 552a(m).
5. A record related to an International Application filed under the Patent Cooperation Treaty in this system of records may be disclosed, as a routine use, to the International Bureau of the World Intellectual Property Organization, pursuant to the Patent Cooperation Treaty.
6. A record in this system of records may be disclosed, as a routine use, to another federal agency for purposes of National Security review (35 U.S.C. 181) and for review pursuant to the Atomic Energy Act (42 U.S.C. 218(c)).
7. A record from this system of records may be disclosed, as a routine use, to the Administrator, General Services, or his/her designee, during an inspection of records conducted by GSA as part of that agency's responsibility to recommend improvements in records management practices and programs, under authority of 44 U.S.C. 2904 and 2906. Such disclosure shall be made in accordance with the GSA regulations governing inspection of records for this purpose, and any other relevant (i.e., GSA or Commerce) directive. Such disclosure shall not be used to make determinations about individuals.
8. A record from this system of records may be disclosed, as a routine use, to the public after either publication of the application pursuant to 35 U.S.C. 122(b) or issuance of a patent pursuant to 35 U.S.C. 151. Further, a record may be disclosed, subject to the limitations of 37 CFR 1.14, as a routine use, to the public if the record was filed in an application which became abandoned or in which the proceedings were terminated and which application is referenced by either a published application, an application open to public inspections or an issued patent.
9. A record from this system of records may be disclosed, as a routine use, to a Federal, State, or local law enforcement agency, if the USPTO becomes aware of a violation or potential violation of law or regulation.

(19) 日本国特許庁(JP)

(12) 公開特許公報(A)

(11) 特許出願公開番号

特開2004-102234

(P2004-102234A)

(43) 公開日 平成16年4月2日(2004. 4. 2)

(51) Int. Cl.<sup>7</sup>

F 1

テーマコード (参考)

GO2B 13/00  
GO2B 13/18  
HO4N 5/225

GO2B 13/00  
GO2B 13/18  
HO4N 5/225

2H087  
5C022

D

審査請求 未請求 請求項の数 20 O L (全 35 頁)

(21) 出願番号 特願2003-171896 (P2003-171896)  
(22) 出願日 平成15年6月17日 (2003. 6. 17)  
(31) 優先権主張番号 特願2002-209625 (P2002-209625)  
(32) 優先日 平成14年7月18日 (2002. 7. 18)  
(33) 優先権主張国 日本国 (JP)

(71) 出願人 000001270  
コニカミノルタホールディングス株式会社  
東京都千代田区丸の内一丁目6番1号

(74) 代理人 100090033  
弁理士 荒船 博司

(72) 発明者 山口 進  
東京都八王子市石川町2970番地 コニ  
カオプト株式会社内

Fターム(参考) 2H087 KA01 LA01 NA02 PA04 PA17  
PB04 QA02 QA06 QA12 QA14  
QA21 QA26 QA32 QA36 QA42  
QA45 RA01 RA32 RA43 SA23  
SA26 SA30 SA32 SA33 SA71  
SB02 SB12 SB22 SB32 UA01  
5C022 AC54

(54) 【発明の名称】 撮像レンズ、撮像ユニット及びこれを備える携帯端末

(57) 【要約】

【課題】従来より小型であること、また、プラスチックレンズでの温度変化時の像点位置変動を抑えることを課題とする。

【解決手段】物体側から順に配置される第1レンズ、第2レンズ、第3レンズ、第4レンズを有し、第1レンズは正の屈折力を有すると共に物体側に向ける凸面を有し、第2レンズは正の屈折力を有し、第3レンズは負の屈折力を有すると共に物体側に向ける凹面を有するメニスカス形状であり、第4レンズは正又は負の屈折力を有すると共に物体側に向ける凸面を有するメニスカス形状である、という構成を採っている。

【選択図】 図5

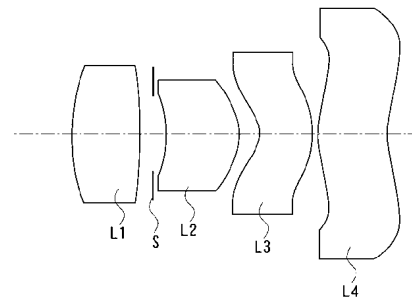



## 【特許請求の範囲】

## 【請求項1】

物体側から順に配置される第1レンズ、第2レンズ、第3レンズ、第4レンズを有し、前記第1レンズは正の屈折力を有すると共に物体側に向ける凸面を有し、前記第2レンズは正の屈折力を有し、前記第3レンズは負の屈折力を有すると共に物体側に向ける凹面を有するメニスカス形状であり、前記第4レンズは正又は負の屈折力を有すると共に物体側に向ける凸面を有するメニスカス形状であることを特徴とする撮像レンズ。

## 【請求項2】

前記第1レンズの物体側面から撮像レンズ全系の像側焦点までの光軸上の距離をL、有効画面对角線長を2Y、前記第1レンズと第2レンズの合成焦点距離をf12、撮像レンズ全系の焦点距離をf、前記第1レンズのアッペ数を $\nu 1$ 、前記第2レンズのアッペ数を $\nu 2$ 、前記第3レンズのアッペ数を $\nu 3$ としたときに、下記の(1)、(2)、(3)の条件式を満たすことを特徴とする請求項1記載の撮像レンズ。

$$L / 2Y < 1.60 \quad (1)$$

$$0.40 < f12 / f < 0.70 \quad (2)$$

$$2.5 < \{ (\nu 1 + \nu 2) / 2 \} - \nu 3 \quad (3)$$

## 【請求項3】

撮像レンズ全系で最も物体側に配置された開口絞りを備えることを特徴とする請求項1記載の撮像レンズ。

## 【請求項4】

前記開口絞りから撮像レンズ全系の像側焦点までの光軸上の距離をL'、有効画面对角線長を2Y、前記第1レンズと第2レンズの合成焦点距離をf12、撮像レンズ全系の焦点距離をf、前記第1レンズのアッペ数を $\nu 1$ 、前記第2レンズのアッペ数を $\nu 2$ 、前記第3レンズのアッペ数を $\nu 3$ としたときに、下記の(4)、(5)、(6)の条件式を満たすことを特徴とする請求項3記載の撮像レンズ。

$$L' / 2Y < 1.60 \quad (4)$$

$$0.40 < f12 / f < 0.70 \quad (5)$$

$$2.5 < \{ (\nu 1 + \nu 2) / 2 \} - \nu 3 \quad (6)$$

## 【請求項5】

撮像レンズ全系の焦点距離をf、前記第3レンズの物体側面の曲率半径をR5、前記第3レンズのd線に対する屈折率をN3、前記第3レンズの像側面と第4レンズの物体側面により形成される空気レンズの焦点距離をfaとしたときに、下記の(7)、(8)の条件式を満たすことを特徴とする請求項1、2、3又は4記載の撮像レンズ。

$$-0.40 < R5 / \{ (N3 - 1) \cdot f \} < -0.20 \quad (7)$$

$$0.30 < fa / f < 0.50 \quad (8)$$

## 【請求項6】

前記焦点距離f、前記曲率半径R5、前記屈折率N3、前記焦点距離をfaについて、下記の(9)の条件式を満たすことを特徴とする請求項5記載の撮像レンズ。

$$-0.40 < R5 / \{ (N3 - 1) \cdot f \} < -0.25 \quad (9)$$

## 【請求項7】

前記第4レンズの像側面は、

当該像側面の頂点を原点とし、光軸方向にX軸をとり、光軸に対して垂直な方向の高さをh、前記第4レンズの像側面のi次の非球面係数をAi、前記第4レンズの像側面の曲率半径をR8、前記第4レンズの像側面の円錐係数をK8とした場合に、

次式(11)に表される非球面変位量Xと次式(12)に表される非球面の回転2次曲面成分変位量X0とが、最大有効半径hma×に対してhma××0.5 < h < hma×となる任意の光軸垂直方向の高さhの範囲で、下記の(10)の条件式を満たすことを特徴とする請求項1から6のいずれか一項に記載の撮像レンズ。

X - X<sub>0</sub> < 0  
0)

(1

【数1】

$$X = \frac{h^2/R8}{1 + \sqrt{1 - (1 + K8)h^2/R8^2}} + \sum A_i h^i \quad (11)$$

$$X_0 = \frac{h^2/R8}{1 + \sqrt{1 - (1 + K8)h^2/R8^2}} \quad (12)$$

10

【請求項8】

前記第1レンズがガラス材料から形成され、前記第2、第3、第4レンズはいずれもプラスチック材料から形成されていることを特徴とする、請求項1から7のいずれか一項に記載の撮像レンズ。

【請求項9】

前記第2、第3、第4レンズの合成焦点距離をf<sub>234</sub>、撮像レンズ全系の焦点距離をfとし、下記(13)の条件式を満たすことを特徴とする請求項8記載の撮像レンズ。

$$|f / f_{234} - 1| < 0.7 \quad (13)$$

(1 20

【請求項10】

前記プラスチック材料は、飽和吸水率が0.7%以下の材料であることを特徴とする、請求項8又は9記載の撮像レンズ。

【請求項11】

物体側から順に配置される第1レンズ、第2レンズ、第3レンズ、第4レンズを有し、前記第1レンズは正の屈折力を有すると共に物体側に凸面を向ける形状とされ、前記第2、第3、第4レンズの内、一つ又は二つのレンズは正の屈折力を有し、少なくとも、前記第1から第4のレンズの内、正の屈折力を有する一つのレンズがガラス材料から形成され、正の屈折力を有するもう一つのレンズ及び負の屈折力を有する一つのレンズがプラスチック材料から形成され、前記第4レンズの像側面は、当該像側面の頂点を原点とし、光軸方向にX軸をとり、光軸に対して垂直な方向の高さをh、前記第4レンズの像側面のi次の非球面係数をA<sub>i</sub>、前記第4レンズの像側面の曲率半径をR<sub>8</sub>、前記第4レンズの像側面の円錐係数をK<sub>8</sub>とした場合に、

30

次式(15)に表される非球面変位量Xと次式(16)に表される非球面の回転2次曲面成分変位量X<sub>0</sub>とが、最大有効半径h<sub>max</sub>に対してh<sub>max</sub> × 0.5 < h < h<sub>max</sub>となる任意の光軸垂直方向の高さhの範囲で、下記(14)の条件式を満たすことを特徴とする撮像レンズ。

X - X<sub>0</sub> < 0  
4)

(1 40

【数2】

$$X = \frac{h^2/R8}{1 + \sqrt{1 - (1 + K8)h^2/R8^2}} + \sum A_i h^i \quad (15)$$

$$X_0 = \frac{h^2/R8}{1 + \sqrt{1 - (1 + K8)h^2/R8^2}} \quad (16)$$

50

## 【請求項 12】

前記正の屈折力を有すると共にガラス材料から形成されたレンズを除く他の全てのレンズはいずれもプラスチック材料から形成されていることを特徴とする請求項 11 記載の撮像レンズ。

## 【請求項 13】

前記第 1 のレンズが、ガラス材料から形成されていることを特徴とする請求項 12 記載の撮像レンズ。

## 【請求項 14】

前記第 2、第 3、第 4 レンズの合成焦点距離を  $f_{234}$ 、撮像レンズ全系の焦点距離を  $f$  としたときに、下記の (17) の条件式を満たすことを特徴とする請求項 10 記載の撮像レンズ。

$$|f/f_{234}| < 0.7 \quad (17)$$

## 【請求項 15】

前記プラスチック材料はいずれも飽和吸水率 0.7% 以下であることを特徴とする、請求項 11、12、13 又は 14 記載の撮像レンズ。

## 【請求項 16】

前記第 1 レンズの物体側面から撮像レンズ全系の像側焦点までの光軸上の距離を  $L$ 、有効画面对角線長を  $2Y$ 、前記第 1 レンズと第 2 レンズの合成焦点距離を  $f_{12}$ 、撮像レンズ全系の焦点距離を  $f$ 、最も正の屈折力の強いレンズのアッペ数を  $\nu_P$ 、最も負の屈折力の強いレンズのアッペ数を  $\nu_N$  としたときに、下記の (18)、(19)、(20) の条件式を満たすことを特徴とする請求項 8、9、10、11 又は 12 記載の撮像レンズ。

$$L/2Y < 1.60 \quad (18)$$

$$0.40 < f_{12}/f < 0.70 \quad (19)$$

$$25 < \nu_P - \nu_N \quad (20)$$

## 【請求項 17】

前記第 2 レンズは正の屈折力を有し、前記第 3 レンズは負の屈折力を有することを特徴とする請求項 11 から 16 のいずれが一項に記載の撮像レンズ。

## 【請求項 18】

光電変換部を有する固体撮像素子と、この固体撮像素子の光電変換部に被写体像を結像させる撮像レンズと、前記固体撮像素子を保持すると共にその電気信号の送受を行う外部接続用端子を有する基板と、物体側からの光入射用の開口部を有し遮光部材からなる本体とが一体的に形成された撮像ユニットであって、

前記撮像レンズの光軸方向における前記撮像ユニットの長さが 15 [mm] 以下であり、前記撮像レンズは、物体側から順に配置される 4 枚のレンズから構成されると共に、最も物体側に配置されるレンズは、正の屈折力を有することを特徴とする撮像ユニット。

## 【請求項 19】

光電変換部を有する固体撮像素子と、この固体撮像素子の光電変換部に被写体像を結像させる撮像レンズと、前記固体撮像素子を保持すると共にその電気信号の送受を行う外部接続用端子を有する基板と、物体側からの光入射用の開口部を有し遮光部材からなる本体とが一体的に形成された撮像ユニットであって、

前記撮像レンズの光軸方向における前記撮像ユニットの長さが 15 [mm] 以下であり、前記撮像レンズとして請求項 1 から 17 のいずれが一項に記載の撮像レンズを備えることを特徴とする撮像ユニット。

## 【請求項 20】

請求項 18 又は 19 記載の撮像ユニットを備えることを特徴とする携帯端末。

## 【発明の詳細な説明】

## 【0001】

【発明の属する技術分野】

本発明は、CCD型イメージセンサやCMOS型イメージセンサ等の固体撮像素子の光学系として好適な撮像レンズと当該撮像レンズを有する撮像ユニットとこれを備える携帯端末に関する。

【0002】

【従来の技術】

近年、CCD (Charged Coupled Device) 型イメージセンサあるいはCMOS (Complementary Metal Oxide Semiconductor) 型イメージセンサ等の固体撮像素子を用いた撮像装置の高性能化、小型化に伴い、撮像装置を備えた携帯端末やパーソナルコンピュータが普及しつつある。

10

そして、これら携帯端末やパーソナルコンピュータの小型化或いは機能の増加による高密度化に伴い、これらの撮像装置の小型化を図るために当該撮像装置に搭載される撮像レンズへのさらなる小型化への要求が高まっている。

【0003】

このような小型の撮像装置用の撮像レンズとして、1枚あるいは2枚構成のレンズに比べ高性能化が可能という理由から、近年では、物体側より順に、正の屈折力を有する第1レンズ、負の屈折力を有する第2レンズ、正の屈折力を有する第3レンズを配置した3枚構成のレンズを備えるいわゆるトリプレットタイプの撮像レンズが知られている(例えば、特許文献1参照)。

【0004】

20

【特許文献1】

特開2001-75006号公報(第1図)

【0005】

【発明が解決しようとする課題】

しかしながら、特開2001-75006号公報に記載されているタイプのレンズは、広い画角を確保しながら諸収差が良好に補正されたタイプではあるが、その一方では、光軸方向に沿った全長(その開口絞りから像側焦点までの距離)の小型化には向いていなかった。

【0006】

本発明はこのような問題点に鑑み、複数レンズで構成される撮像レンズの小型化を図ることを、その目的とする。また、本発明は、小型で諸収差を良好に補正され且つ温度変化時の像点位置変動を抑えた撮像レンズ、撮像ユニット及び携帯端末を提供することを、もう一つの目的とする。

30

【0007】

【課題を解決するための手段】

請求項1記載の発明は、物体側から順に配置される第1レンズ、第2レンズ、第3レンズ、第4レンズを有し、第1レンズは正の屈折力を有すると共に物体側に向ける凸面を有し、第2レンズは正の屈折力を有し、第3レンズは負の屈折力を有すると共に物体側に向ける凹面を有するメニスカス形状であり、第4レンズは正又は負の屈折力を有すると共に物体側に向ける凸面を有するメニスカス形状である、という構成を採っている。

40

【0008】

上記構成にあっては、第1~4の四つのレンズがその番号順に並んで配置されていると共に、その使用時にあっては、第1レンズが物体側に、第4レンズが像側に向けられる。かかる使用状態において、比較的屈折力の大きい正レンズ群と負レンズを物体側から順に配置すること及び第1レンズの凸面を物体側に向けることで、レンズ全長(第1レンズの物体側面から撮像レンズ全系の像側焦点までの光軸上の距離、但し請求項3記載の発明のように、撮像レンズ全系の最も物体側に開口絞りが配置される撮像レンズにおいては、開口絞りから撮像レンズ全系の撮像側焦点までの光軸上の距離をいう、請求の範囲を含む本明細書中の全ての記載について同じものとする)の小型化を図っている。

また、メニスカス形状の第3レンズの凹面を物体側に向け、メニスカス形状の第4レンズ

50

の凸面を物体側に向ける配置とすると、これらのレンズ間には正の屈折力を有する空気レンズが形成される。従って、これによりさらなるレンズ全長の小型化と画面周辺部でのテレセントリック特性の確保が実現する。

なお、第4レンズについては、その形状及び凸面の向きについては上述の通りであるが、その屈折力については正であっても負であっても良い。以下、「正又は負の屈折力」という場合には、正の屈折力を有する場合と負の屈折力を有する場合のいずれでも良いということを示すものとする。

【0009】

請求項2記載の発明は、請求項1記載の発明と同様の構成を備えると共に、第1レンズの物体側面から撮像レンズ全系の像側焦点までの光軸上の距離をL、有効画面对角線長を2Y、第1レンズと第2レンズの合成焦点距離をf12、撮像レンズ全系の焦点距離をf、第1レンズのアッペ数を $\nu 1$ 、第2レンズのアッペ数を $\nu 2$ 、第3レンズのアッペ数を $\nu 3$ としたときに、下記の(1)、(2)、(3)の条件式を満たす、という構成を採っている。

【0010】

$L/2Y < 1.60$  (1)

$0.40 < f12/f < 0.70$  (2)

$2.5 < \{(\nu 1 + \nu 2)/2\} - \nu 3$  (3)

【0011】

上記の条件式(1)～(3)は、小型で収差が良好に補正された撮像レンズを得るための条件式である。なお、条件式中の符号Lは第1レンズの物体側面から撮像レンズ全系の像側焦点までの光軸上の距離を示すが、この場合において「像側焦点」とは、撮像レンズに光軸と平行な平行光線が入射した場合の像点をいう。また、撮像レンズの最も像側の面から像側焦点までの間にローパスフィルタ等の平行平板形状の光学部材が配置された場合には、これを空気換算距離におおした上で(1)式を満たす場合を含むものとする。

まず、条件式(1)はレンズ全長の小型化を達成するための条件式である。条件式(1)の上限値を下回るとレンズ全長が小型化の傾向を示す。

さらに、第1レンズ及び第2レンズの合成焦点距離を適切に設定する条件式(2)により、その下限値を上回る設定とすることで、第1レンズと第2レンズの合成の正の屈折力が必要以上に大きくなり、高次の球面収差やコマ収差の発生が抑えられ、その上限値を下回る設定とすることで、第1レンズと第2レンズの合成の正の屈折力が適度に確保され、レンズ全長の小型化も図られる。

さらに、正の屈折力を有する第1レンズ及び第2レンズと負の屈折力を有する第3レンズでの色収差補正の条件式(3)により、その下限値を上回る設定とすることで、軸上色収差、倍率色収差の補正が図られる。

【0012】

請求項3記載の発明は、請求項1記載の発明と同様の構成を備えると共に、撮像レンズ全系で最も物体側に配置された開口絞りを備える、という構成を採っている。

最も物体側に開口絞りを配置する構成とすることで、射出瞳位置を像面から遠ざけることができ、これにより、レンズ最終面を射出した光束の主光線が固体撮像素子に垂直に近い角度で入射するようになり、即ち、固体撮像素子に用いる撮像レンズに必要な像面テレセントリック特性を良好に確保でき、画面周辺部におけるシェーディング減少を軽減することができ、

【0013】

請求項4記載の発明は、請求項3記載の発明と同様の構成を備えると共に、開口絞りから撮像レンズ全系の像側焦点までの光軸上の距離をL'、有効画面对角線長を2Y、第1レンズと第2レンズの合成焦点距離をf12、撮像レンズ全系の焦点距離をf、第1レンズのアッペ数を $\nu 1$ 、第2レンズのアッペ数を $\nu 2$ 、第3レンズのアッペ数を $\nu 3$ としたときに、下記の(4)、(5)、(6)の条件式を満たす、という構成を採っている。

$$L' / 2Y < 1.60 \quad (4)$$

$$0.40 < f_{12} / f < 0.70 \quad (5)$$

$$25 < \{ (\nu_1 + \nu_2) / 2 \} - \nu_3 \quad (6)$$

## 【0014】

上記の条件式(4)～(6)は、小型で収差が良好に補正された撮像レンズを得るための条件式である。なお、条件式中の符号L'は開口絞りから撮像レンズ全系の像側焦点までの光軸上の距離を示すが、この場合において「像側焦点」とは、撮像レンズに光軸と平行な平行光線が入射した場合の像点をいう。また、開口絞りから像側焦点までの間にローパスフィルタ等の平行平板形状の光学部材が配置された場合には、これを空気換算距離にな

10

おした上で(4)式を満たす場合を含むものとする。また、開口絞りが撮像レンズの最も物体側に配置される場合には、レンズ全長は開口絞りから撮像レンズ全系の像側焦点までの光軸上の距離とすることもでき、このように計算するのが望ましい。

まず、条件式(4)はレンズ全長の小型化を達成するための条件式である。条件式(4)の上限値を下回るとレンズ全長が小型化の傾向を示す。

さらに、第1レンズ及び第2レンズの合成焦点距離を適切に設定する条件式(5)により、その下限値を上回る設定とすることで、第1レンズと第2レンズの合成の正の屈折力が必要以上に大きくなり、高次の球面収差やコマ収差の発生が抑えられ、その上限値を下回る設定とすることで、第1レンズと第2レンズの合成の正の屈折力が適度に確保され、

20

レンズ全長の小型化も図られる。さらに、正の屈折力を有する第1レンズ及び第2レンズと負の屈折力を有する第3レンズでの色収差補正の条件式(6)により、その下限値を上回る設定とすることで、軸上色収差、倍率色収差の補正が図られる。

## 【0015】

請求項5記載の発明は、請求1、2、3又は4記載の発明と同様の構成を備えると共に、撮像レンズ全系の焦点距離をf、第3レンズの物体側面の曲率半径をR5、第3レンズのd線に対する屈折率をN3、第3レンズの像側面と第4レンズの物体側面とにより形成される空気レンズの焦点距離をfaとしたときに、下記の(7)、(8)の条件式を満たす、という構成を採っている。

30

## 【0016】

$$-0.40 < R5 / \{ (N3 - 1) \cdot f \} < -0.20 \quad (7)$$

$$0.30 < fa / f < 0.50 \quad (8)$$

## 【0017】

条件式(7)は、第3レンズ物体側面の負の屈折力を適切に設定することにより、像面湾曲の補正を容易にし、像面を平坦にするための条件である。ここで、第3レンズ物体側面の焦点距離は、曲率半径(R5)と第3レンズの屈折率(N3)を用いてR5 / (N3 - 1)で計算され、条件式(7)は第3レンズ物体側面の焦点距離と撮像レンズ全系の焦点距離の比を表している。

条件式(7)における上限値を下回ること、第3レンズ物体側面の負の屈折力が必要以上に大きくなりすぎず、オーバーな球面収差の過度の発生や、軸外光束のコマフレアの発生の抑制が図られる。一方、下限値を上回ることで、第3レンズ物体側面の負の屈折力を維持できるため、正のペッツバール和が減少し、像面湾曲の補正に加えて軸上色収差や倍率色収差の良好な補正が図られる。

40

条件式(8)は、第3レンズ像側面と第4レンズ物体側面の間に形成される空気レンズの正の屈折力を適切に設定するためのものである。かかる空気レンズの焦点距離faは、第3レンズのd線に対する屈折率をN3、第4レンズのd線に対する屈折率をN4、第3レンズの像側面の曲率半径をR6、第4レンズの物体側面の曲率半径をR7、第3レンズと第4レンズの軸上の空気間隔をD6としたときに、

$$fa = R6 \cdot R7 / \{ R7 \cdot (1 - N3) + R6 \cdot (N4 - 1) - D6 \cdot (1 - N3) \} \quad 50$$

(N4-1)}

を求めることができるとする。

そして、条件式(8)を満たすことで、像面湾曲や歪曲収差の補正と、像側光束のテレセントリック特性の確保が図られる。

【0018】

請求項6記載の発明は、請求項5記載の発明と同様の構成を備えると共に、焦点距離 $f$ 、曲率半径 $R5$ 、屈折率 $N3$ について、下記の(9)の条件式を満たす、という構成を採っている。

$$-0.40 < R5 / ((N3 - 1) \cdot f) < -0.25 \quad (9)$$

【0019】

条件式(9)は、前述した条件式(7)と同様に、第3レンズ物体側面の負の屈折力を適切に設定することにより、像面湾曲の補正を容易にし、像面を平坦にするための条件である。この条件式(9)の上限値を下回ることで、第3レンズ物体側面の負の屈折力が必要以上に大きくなりすぎず、オーバーな球面収差の過度の発生や、軸外光束のコマフレアの発生の抑制が図られる、という点においてより望ましい。

【0020】

請求項7記載の発明は、請求項1から6のいずれか一項に記載の発明と同様の構成を備えると共に、第4レンズの像側面は、当該像側面の頂点を原点とし、光軸方向に $X$ 軸をとり、光軸に対して垂直な方向の高さを $h$ 、第4レンズの像側面の $i$ 次の非球面係数を $A_i$ 、第4レンズの像側面の曲率半径を $R8$ 、第4レンズの像側面の円錐係数を $K8$ とした場合に、次式(11)に表される非球面変位量 $X$ と次式(12)に表される非球面の回転2次曲面成分変位量 $X0$ とが、最大有効半径 $h_{max}$ に対して $h_{max} \times 0.5 < h < h_{max}$ となる任意の光軸垂直方向の高さ $h$ の範囲で、下記の(10)の条件式を満たす、という構成を採っている。

【0021】

$$X - X0 < 0 \quad (10)$$

【数8】

$$X = \frac{h^2/R8}{1 + \sqrt{1 - (1 + K8)h^2/R8^2}} + \sum A_i h^i \quad (11)$$

$$X0 = \frac{h^2/R8}{1 + \sqrt{1 - (1 + K8)h^2/R8^2}} \quad (12)$$

【0022】

ここで、像側面の頂点とは像側面と光軸との交点のことをいうものとする。

一般に複数のレンズを組み合わせて使用する場合において、レンズ全長を小型化していくとバックフォーカスが短くなりがちで、そのため像側光束のテレセントリック特性の確保が困難になりがちである。従って、最も像側に位置する面である第4レンズ像側面を非球面とし、条件式(10)、(11)、(12)を満たす非球面形状とすることで、特に高画角の光束におけるテレセントリック特性の確保が図られることとなる。

【0023】

請求項8記載の発明は、請求項1から7のいずれか一項に記載の発明と同様の構成を備えると共に、第1レンズがガラス材料から形成され、第2、第3、第4レンズはいずれもプラスチック材料から形成されている、という構成を採っている。

【0024】

プラスチック材料から形成する、とはプラスチック材料を母材としてその表面に反射防止や表面硬度向上を目的としたコーティング処理を行った場合を含むものとする。以下の記

載全ても、同様とする。

撮像レンズを構成するレンズを、射出成形により製造されるプラスチックレンズで構成すると、撮像レンズの小型軽量化と低コスト化には有利である。しかしながら、プラスチック材料は温度変化時の屈折率変化が大きいため、全てのレンズをプラスチックレンズで構成すると、温度によりレンズ全体の像点位置が変動してしまうという欠点を抱えている。本発明の構成は、プラスチックレンズを多用しながら、撮像レンズ全系での温度変化時の像点位置変動を補償する構成である。即ち、正の第1レンズを、温度変化時の屈折率変化がほとんど無いガラス材料から形成している。そして、その他の第2～4レンズをプラスチック材料で形成しているが、これらの中で第2レンズと第3レンズとが比較的屈折力の大きい正レンズと負レンズであるため、温度変化時の像点位置変動への影響が相殺する方向に作用し、撮像レンズ全系での温度変化時の像点位置の変動を小さく抑えることができる。

10

【0025】

請求項9記載の発明は、請求項8記載の発明と同様の構成を備えると共に、第2、第3、第4レンズの合成焦点距離を $f_{234}$ 、撮像レンズ全系の焦点距離を $f$ としたときに、下記の(18)の条件式を満たす、という構成を採っている。

$$|f/f_{234}| < 0.7 \quad (18)$$

【0026】

条件式(18)は、プラスチックから形成されたレンズの合成焦点距離を規定するものである。プラスチック材料によるレンズの温度変化時の像点位置変動は、その屈折力の大きさにより影響を受けるため、プラスチック材料による第2～4レンズの合成焦点距離を大きく設定して屈折力の総和を低く抑えることにより、それに応じて温度変化時の像点位置変動も小さくなる。

20

【0027】

請求項10記載の発明は、請求項8又は9記載の発明と同様の構成を備えると共に、プラスチック材料を飽和吸水率が0.7%以下の材料とする、という構成を採っている。

プラスチック材料はガラス材料に比べ、飽和吸水率が大きいため、急激な温度変化があると過渡的に吸水量の不均一分布が発生し、屈折率が均一にならず良好な結像性能が得られなくなる傾向にある。従って、飽和吸水率が少ないプラスチックをレンズの材料と使用することにより、湿度変化による性能劣化の低減を図っている。

30

【0028】

請求項11記載の発明は、物体側から順に配置される第1レンズ、第2レンズ、第3レンズ、第4レンズを有し、第1レンズは正の屈折力を有すると共に物体側に凸面を向ける配置とされ、第2、第3、第4レンズの内の一又は二つのレンズは正の屈折力を有し、少なくとも、第1から第4のレンズの内、正の屈折力を有する一つのレンズがガラス材料から形成され、正の屈折力を有するもう一つのレンズ及び負の屈折力を有する一つのレンズがプラスチック材料から形成され、第4レンズの像側面は、当該像側面の頂点を原点とし、光軸方向に $X$ 軸をとり、光軸に対して垂直な方向の高さを $h$ 、第4レンズの像側面の $i$ 次の非球面係数を $A_i$ 、第4レンズの像側面の曲率半径を $R_8$ 、第4レンズの像側面の円錐係数を $K_8$ とした場合に、次式(15)に表される非球面変位量 $X$ と次式(16)に表される非球面の回転2次曲面成分変位量 $X_0$ とが、最大有効半径 $h_{max}$ に対して $h_{max} \times 0.5 < h < h_{max}$ となる任意の光軸垂直方向の高さ $h$ の範囲で、下記の(14)の条件式を満たす、という構成を採っている。

40

【0029】

$$X - X_0 < 0 \quad (14)$$

【数4】



$$X = \frac{h^2/R8}{1 + \sqrt{1 - (1 + K8)h^2/R8^2}} + \sum A_i h^i \quad (15)$$

$$X0 = \frac{h^2/R8}{1 + \sqrt{1 - (1 + K8)h^2/R8^2}} \quad (16)$$

## 【0030】

ここで、像側面の頂点とは像側面と光軸との交点のことをいうものとする。  
 上記構成にあっては、第1～4の4つのレンズがその番号順に並んで配置されていると共に、その使用時にあっては、第1レンズが物体側に、第4レンズが像側に向けられる。かかる使用状態において、最も物体側に凸面を向けた正の第1レンズを配置すること、第1レンズを負レンズとした場合に比べ、レンズ全長の小型化に有利な構成となる。  
 さらに、本発明の構成は、第1～4レンズの内の一部のレンズをプラスチック材料から形成している。前述したように、プラスチックレンズは、撮像レンズの小型軽量化と低コスト化に有利であるが、温度変化時の屈折率変化の大きさをやえにレンズの像点位置が変動してしまうという欠点を抱えている。

10

そこで、本発明の構成は、プラスチックレンズを多用しながら、撮像レンズ全系での温度変化時の像点位置変動を補償する構成を採っている。本発明では、1枚の正レンズを、温度変化時の屈折率変化がほとんど無いガラス材料から形成し、少なくとも1枚の正レンズ、少なくとも1枚の負レンズを含む2枚のレンズをプラスチック材料で形成している。従って、大きな正の屈折力をガラスレンズとプラスチックレンズとで分担することができ、かつ、プラスチックレンズの中に、比較的屈折力の大きい正レンズと負レンズを含む構成となることから、温度変化時の像点位置変動への寄与が相殺する方向に作用し、撮像レンズ全系での温度変化時の像点位置の変動を小さく抑えることができる。  
 さらに、本発明の構成では、第4レンズについて、請求項4記載の発明と同様に、その像側面を条件式(14)、(15)、(16)を満たす非球面形状とすることで、特に高画角の光束におけるテレセントリック特性の確保を図っている。

20

## 【0031】

請求項12記載の発明は、請求項11記載の発明と同様の構成を備えると共に、正の屈折力を有すると共にガラス材料から形成されたレンズを除く他の全てのレンズはいずれもプラスチック材料から形成されている、という構成を採っている。

30

## 【0032】

上記構成では、一枚の正の屈折力を有するレンズのみをガラス材料から形成し、残りの3枚のレンズを全てプラスチック材料から形成することで、プラスチックレンズをより多用することになる。従って、レンズをプラスチック材料で形成する利点をより効果的に実現する。

## 【0033】

請求項13記載の発明は、請求項12記載の発明と同様の構成を備えると共に、第1のレンズがガラス材料から形成されている、という構成を採っている。

40

上記構成では、請求項9記載の発明と同様の機能を有し、さらに、最も物体側に位置し、外的要因による損傷を受け易い第1レンズを、傷の付きやすいプラスチック材料ではなくガラス材料とし、傷の発生を低減すると共に傷の付きやすい他のプラスチック材料からなるレンズの保護を図っている。

## 【0034】

請求項14記載の発明は、請求項13記載の発明と同様の構成を備えると共に、第2、第3、第4レンズの合成焦点距離を $f_{234}$ 、撮像レンズ全系の焦点距離を $f$ としたときに、下記の(17)の条件式を満たす、という構成を採っている。

$$|f/f_{234}| < 0.7$$

(1 50

7)

## 【0035】

条件式(17)は、前述した式(13)と同様に、プラスチックから形成されたレンズの合成焦点距離を規定するものである。従って、式(17)に従って、プラスチック材料による第2～4レンズの合成焦点距離を大きく設定して合成屈折力の総和を低く抑えることにより、それに応じて温度変化時の像点位置変動も小さくなる。

## 【0036】

請求項15記載の発明は、請求項11、12、13又は14記載の発明と同様の構成を備えると共に、プラスチック材料を飽和吸水率が0.7%以下の材料とする、という構成を採っている。

請求項10記載の発明と同様に、飽和吸水率が少ないプラスチックをレンズの材料と使用することにより、湿度変化による性能劣化の解消を図っている。

## 【0037】

請求項16記載の発明は、請求項11、12、13、14又は15記載の発明と同様の構成を備えると共に、第1レンズの物体側面から撮像レンズ全系の像側焦点までの光軸上の距離をL、有効画面对角線長を2Y、第1レンズと第2レンズの合成焦点距離をf12、撮像レンズ全系の焦点距離をf、最も正の屈折力の強いレンズのアッペ数を $\nu P$ 、最も負の屈折力の強いレンズのアッペ数を $\nu N$ としたときに、下記の(18)、(19)、(20)の条件式を満たす、という構成を採っている。

## 【0038】

$$L/2Y < 1.60 \quad (18)$$

$$0.40 < f12/f < 0.70 \quad (19)$$

$$25 < \nu P - \nu N \quad (20)$$

)

## 【0039】

上記の条件式(18)～(20)は、小型で収差が良好に補正された撮像レンズを得るための条件式である。

上記条件式(18)は前述した式(1)と同様に、レンズ全長の小型化を達成するための条件式である。

さらに、条件式(19)は、前述した条件式(2)と同様に、第1、第2レンズの合成焦点距離を適切に設定する。即ち、その下限値を上回る設定とすることで、高次の球面収差やコマ収差の発生が抑えられ、その上限値を下回る設定とすることで、レンズ全長の小型化も図られる。

さらに、条件式(20)は、色収差を良好に補正するため、最も屈折力の強い正レンズのアッペ数と、最も負の屈折力の強い負レンズのアッペ数を規定するものである。下限を上回ることで、軸上色収差、倍率色収差をバランス良く補正される。

## 【0040】

請求項17記載の発明は、請求項11から16のいずれか一項に記載の発明と同様の構成を備えると共に、第2レンズは正の屈折力を有し、第3レンズは負の屈折力を有する、という構成を採っている。

上記構成では、比較的屈折力の大きい正レンズ群と負レンズを、物体側より順に配置することによる構成は、レンズ全長(第1レンズの物体側面から撮像レンズ全系の像側焦点までの光軸上の距離)を小型化し易い構成である。

## 【0041】

請求項18記載の発明は、光電変換部を有する固体撮像素子と、この固体撮像素子の光電変換部に被写体像を結像させる撮像レンズと、固体撮像素子を保持すると共にその電気信号の送受を行う外部接続用端子を有する基板と、物体側からの光入射用の開口部を有し遮光部材からなる体とが一体的に形成された撮像ユニットであって、撮像レンズの光軸方向における撮像ユニットの長さが15[m m]以下であって、撮像レンズは、物体側から

順に配置される4枚のレンズから構成されると共に、最も物体側に配置されるレンズは、正の屈折力を有する、という構成を採っている。

#### 【0042】

上記「光入射用の開口部」とは、必ずしも孔等の空間を形成するものに限らず、物体側からの入射光を透過可能な領域が形成された部分を指すものとする。請求項19記載の発明についても同様である。

上記構成は、例えば、可搬性を有する小型の電子機器への搭載等を目的として小型、軽量化の要求に対応するための撮像ユニットであり、上記構成では、最も物体側のレンズを正レンズとすることで、レンズ全長の小型化に有利な構成を採り、撮像ユニット全体の光軸方向長寸の小型化を図りながら、撮像レンズを4枚のレンズから構成することを特徴とする。

10

上述の記載において、「撮像ユニットの長さが15[m m]以下」とあるのは、上記全ての構成を備えた撮像ユニットの光軸方向に沿った全長を意味するものとする。従って、例えば、基板の表の面上に本体が設けられ、基板の背面に電子部品等が実装された場合にあっては、本体の物体側となる先端部から背面上で突出する電子部品の先端部までの距離が15[m m]以下となることを想定する。なお、後述する請求項19記載の発明についても同様とする。

撮像レンズを構成するレンズは、各種の収差の補正、固体撮像素子に対するテレセントリック特性の向上等を実現し、撮像画質の向上を図るために、そのレンズ枚数を多く搭載することが望ましいが、小型電子機器等に搭載される撮像ユニットにあってはレンズ枚数はせいせい3枚程度のものが一般的であり、レンズ枚数を4枚使用する本発明の構成は、上記画質向上のために有利な構成といえる。また、撮像ユニットの小型化を図る場合、その撮像レンズを構成する各レンズの小型化を伴うが、その際、必然的にレンズ面の曲率半径が小さくなってしまふ。しかしながら、曲率半径が小さくなればなるほど、レンズの加工精度を維持することが困難となる。本発明では、撮像レンズを4枚構成としているので、複数のレンズを使用して屈折力の分散を図ることにより、各レンズのレンズ面の曲率半径の小型化の要求を緩和することもできるので、レンズの加工精度を維持することが容易となり得、さらなる画質の向上にも有利な構成といえる。

20

さらに、撮像ユニット全体の軽量化を図るためには、その撮像レンズを構成する各レンズについて、一般的なガラス材料に替えてよりプラスチック材料からなるレンズの枚数を増やしていけば良い。

30

しかし、プラスチック材料は温度変化時の屈折率変化が大きいため、全てのレンズをプラスチックレンズで構成すると、温度によりレンズ全体の像点位置が変動してしまうという欠点を抱えてしまふ。このような温度変化による像点位置の変動は、高画素の固体撮像素子を搭載し、かつオートフォーカス機構を持ち合わせていない撮像装置（いわゆるパンフォーカス方式の撮像装置）において特に問題となる。高画素な固体撮像素子であれば画素ピッチが小さいため、画素ピッチに比例する焦点深度が狭くなるため、像点位置変動の許容幅が狭くなる。また、パンフォーカス方式の撮像装置は、もともと基準距離として数十cmの被写体にピントを合わせ、無限遠方から至近距離を被写界深度でカバーする方式である。従って、無限遠方や至近距離の被写体の画質は、基準距離の被写体の画質にくらべ若干量ピントのぼけた画像になっているため、温度変化時に像点位置変動が生ずると、無限遠方または至近距離の画質が極端に劣化するため好ましくない。

40

これを解決するためには、少なくとも1枚のレンズをガラスレンズとし、少なくとも1枚の正レンズと少なくとも1枚の負レンズを含む2枚以上をプラスチックレンズで構成するとよい。これにより、撮像レンズ全系の正の屈折力を確保しながらも、プラスチックレンズの屈折力の総和を小さく抑えることができ、温度変化時の像点位置変動への寄与を正レンズと負レンズで相殺させることが可能となる。撮像レンズをこのような構成とするためには、設計的な自由度という観点から、3枚構成では不適であり4枚構成の撮像レンズが必要となる。なお、撮像レンズを5枚以上の構成とすると、撮像ユニットが大型になりがちで好ましくない。

50

## 【0043】

請求項19記載の発明は、光電変換部を有する固体撮像素子と、この固体撮像素子の光電変換部に被写体像を結像させる撮像レンズと、固体撮像素子を保持すると共にその電気信号の送受を行う外部接続用端子を有する基板と、物体側からの光入射用の開口部を有し遮光部材からなる体とが一体的に形成された撮像ユニットであって、撮像レンズの光軸方向における撮像ユニットの長さが15[m m]以下であり、撮像レンズとして請求項1から17のいずれか一項に記載の撮像レンズを備える、という構成を採っている。  
上記構成では、前述した各請求項記載の撮像レンズを搭載することにより、前述した小型化、軽量化、高画質化等の利点を備える撮像ユニットを実現する。

## 【0044】

請求項20記載の発明は、請求項18又は19記載の撮像ユニットを備える、という構成を採っている。かかる構成では、前述した撮像ユニットを搭載することにより、小型化、軽量化及び高画質の撮像可能な携帯端末を実現する。

## 【0045】

## 【発明の実施の形態】

本発明の実施形態を図1、2に基づいて説明する。図1は本実施形態たる撮像ユニット50の斜視図を示し、図2は撮像ユニット50の撮像光学系の光軸に沿った断面図である。上記撮像ユニット50は、光電変換部51aを有する固体撮像素子としてのCMOS型イメージセンサ51と、このイメージセンサ51の光電変換部51aに被写体像を結像させる撮像光学系10と、イメージセンサ51を保持すると共にその電気信号の送受を行う外部接続用端子54を有する基板52と、物体側からの光入射用の開口部を有し遮光部材からなる鏡筒としての体58とを備え、これらが一体的に形成されている。

## 【0046】

上記イメージセンサ51は、その受光側の平面の中央部に、画素（光電変換素子）が2次元的に配置された、受光部としての光電変換部51aが形成されており、その周囲には信号処理回路51bが形成されている。かかる信号処理回路は、各画素を順次駆動し信号電荷を得る駆動回路部と、各信号電荷をデジタル信号に変換するA/D変換部と、このデジタル信号を用いて画像信号出力を形成する信号処理部等から構成されている。また、イメージセンサ51の受光側の平面の外縁近傍には、多数のパッド（図示略）が配置されており、ワイヤWを介して基板52に接続されている。イメージセンサ51は、光電変換部51aからの信号電荷をデジタルYUV信号等の画像信号等に変換し、ワイヤWを介して基板52上の所定の回路に出力する。ここで、Yは輝度信号、U(=R-Y)は赤と輝度信号との色差信号、V(=B-Y)は青と輝度信号との色差信号である。  
なお、固体撮像素子は上記CMOS型のイメージセンサに限定されるものではなく、CCD等の他のものを使用しても良い。

## 【0047】

基板52は、その一平面上で上記イメージセンサ51及び体58を支持する支持平板52aと、支持平板52aの背面（イメージセンサ51と反対側の面）にその一端部が接続されたフレキシブル基板52bとを備えている。

支持平板52aは、表裏面に設けられた多数の信号伝達用パッドを有しており、その一平面側で前述したイメージセンサ51のワイヤWと接続され、背面側でフレキシブル基板52bと接続されている。

フレキシブル基板52bは、上記の如くその一端部が支持平板52aと接続され、その他端部に設けられた外部出力端子54を介して支持平板52aと外部回路（例えば、撮像ユニットを実装した上位装置が有する制御回路）とを接続し、外部回路からイメージセンサ51を駆動するための電圧やクロック信号の供給を受けたり、また、デジタルYUV信号を外部回路へ出力したりすることを可能とする。さらに、フレキシブル基板52bの長手方向の中間部が可塑性又は変形性を備え、その変形により、支持平板52aに対して外部出力端子の向きや配置に自由度を与えている。

## 【0048】

次に、体53及び撮像光学系10について説明する。体53は、基板52の支持平板52aにおけるイメージセンサ51が設けられた平面上に当該イメージセンサ51をその内側に格納した状態で接着により固定装備されている。そして、撮像光学系10は体53の内部に格納保持されている。

#### 【0049】

図2に示すように、撮像光学系10は、物体側からの赤外線の入射を防ぐIR（赤外線）カットフィルタ24と、物体側から第1レンズL1、絞りS、第2レンズL2、第3レンズL3、第4レンズL4の順で体53内に支持配置された撮像レンズと、を有している。この撮像光学系10は、各レンズL1、L2、L3、L4を通して、イメージセンサ51の光電変換部51aに対して被写体像の結像を行うためのものである。なお、図2では左側を物体側、右側を像側としており、図2における一点鎖線を各レンズL1、L2、L3、L4の共通する光軸Lとする。

上記IRカットフィルタ24は、赤外線吸収特性を有する材料から形成され、体53の物体側面に接着されている。

また、絞りSは、撮像レンズ全系のFナンバーを決定する機能を有している。

#### 【0050】

体53は、基板52に直接固定されるベース体55と、第4レンズL4を保持するレンズホルダ56と、レンズホルダ56とにより全てのレンズL1、L2、L3、L4を挟持するレンズ抑え57とを備え、これらが一体的に連結されて全体的に略円筒状を形成する。また、レンズ抑え57、レンズホルダ56、ベース体55は、一体的に連結された状態で、各々の中心線が同一軸上となるように、設定されている。

上記レンズ抑え57、レンズホルダ56、ベース体55は、撮像時において、物体側からこの順番となるように配置され、いずれも略筒状を成す。ベース体55は、内径が最も大きく、その内側に、レンズホルダ56を格納する。ベース体55の内周面上には雌ネジが形成され、他方、レンズホルダ56の外周面上には雄ネジが形成され、これらは相互に螺合して連結される。また、レンズホルダ56は、レンズ抑え57よりもその内径が大きく、レンズホルダ56の内側に、レンズ抑え57を格納する。レンズホルダ56の内周面上には雌ネジが形成され、他方、レンズ抑え57の外周面上には雄ネジが形成され、これらは相互に螺合して連結される。

#### 【0051】

ここで、各レンズL1～L4について一部説明する。

複数レンズ構成の撮像ユニットは、本出願と同一出願人による特開2002-083880号にも記載されている。かかる特開2002-083880号に記載されているタイプのレンズは、全てのレンズをプラスチックレンズとし、高性能化と大量生産性を両立したタイプである。しかしながら、その一方で、プラスチックレンズは、温度変化に応じて屈折率変化を生じ、像点位置の変動が大きくなるという問題があった。また、小型の撮像レンズを有する小型の撮像装置においては、レンズの合焦機構を有しない、いわゆるパンフォーカス方式である場合が多く、より高画質な固体撮像素子を用いる際には、上記温度変化による影響は無視できないものともなりうる。そこで、本実施形態の撮像ユニット50の光学系に使用される各レンズL1～L4は、以下に示す構成により上記温度変化に対する影響の抑制を図っている。

上記各レンズL1～L4は後述するが、L1がガラス材料から形成され、L2～L4はプラスチック材料から形成されている。

近年では、撮像装置全体の小型化を目的とし、同じ画素数の固体撮像素子であっても、画素ピッチが小さく、結果として受光部（光電変換部）の画面サイズの小さいものが開発されている。このような画面サイズの小さい固体撮像素子向けの撮像レンズは、同じ画角を確保するためには、全系の焦点距離を短くする必要があるので、各レンズの曲率半径や外径がかなり小さくなってしまふ。従って、研磨加工により製造されるガラスレンズでは加工が困難となる。従って、各レンズL2～L4はいずれもプラスチックを素材として射出成形により形成されている。そして、レンズL2～L4は、射出成形により形成されるこ

とから、各レンズの外周にフランジ部を設けることが可能である。第4レンズL4は、他と比して外形が最も大きなフランジ部を有し、当該フランジ部の物体側の面には凹部が形成されている。そして、この凹部には、第3レンズL3がそのフランジ部と共にめ込まれる。この際、撮像レンズL3と第4レンズL4とは、その光軸が一致するように、凹部は形成されている。

第3レンズL3は、第2レンズL2と比して外形が大きなフランジ部を有し、当該フランジ部の物体側の面には凹部が形成されている。そして、この凹部には、第2レンズL2がそのフランジ部と共にめ込まれる。この際、第2レンズL2と第3レンズL3とは、その光軸が一致するように、凹部は形成されている。

第2レンズL2は、第1レンズL1と比して外形が大きなフランジ部を有し、当該フランジ部の物体側の面には凹部が形成されている。そして、この凹部には、第1レンズL1がめ込まれる。この際、第1レンズL1と第2レンズL2とは、その光軸が一致するように、凹部は形成されている。

10

従って、各レンズL1～L4は、各々のフランジ部を介して、重ね合わせることにより、相互の光軸が全て同一直線上に一致させることが可能である。

そして、各レンズL2～L4の各凹部及び各凸部の軸方向の精度も射出成形により可能な精度とすることができるので、各レンズL1、L2、L3、L4の光軸方向間隔も所定の精度を維持することが可能である。これらのため、光学系の組み立て精度の向上を図ることが可能となる。さらに、組み立てが容易となり、生産性の向上も図っている。

#### 【0052】

20

各レンズL1～L4について、上記前提をふまえた上で、体53の説明を再開する。

体53のレンズホルダ56はその像側となる端部が閉塞された有底円筒状であり、その底面の中央部が大きく貫通され、外部光を通過させる。他方、レンズ抑え57は、その物体側となる端部が閉塞された有底円筒状であり、その底面の中央部が大きく貫通され、外部光を通過させる。そして、レンズホルダ56の内径は、第4レンズL4の外形と等しく設定され、当該第4レンズL4を格納することで、レンズホルダ56の中心線と第4レンズL4の光軸とを一致するように位置決めすることが可能である。そして、各レンズL1～L4は前述したように、重ね合わせられた状態で、レンズホルダ56にレンズ抑え57を装着すると、各々の底面により、重ね合わせられた状態のレンズL1～L4が挟持され、ベース体55、レンズホルダ56及びレンズ抑え57の中心線と各レンズL1～L4の光軸を全て同一軸上に一致させるが可能である。なお、レンズホルダ56等の中心線がイメージセンサ51の光電変換面51aの中心と一致するように、体53は、基板52に対して固定装備される。なお、体53は、レンズホルダ56の内周面及び内底面のみで第4レンズL4を支持し、また、レンズ抑え57の内底面のみで第1レンズL1の外周のみを支持し、その他の内周部のいずれも各レンズL1、L2、L3、L4に接触しない構造となっている。

30

さらに、ベース体55とレンズホルダ56とは相互間のネジ部の中心線が各レンズL1～L4の光軸と一致するので、レンズホルダ56の回転操作により合焦状態が最良になるようにイメージセンサ51に対する各レンズL1～L4の位置を調整することが可能である。なお、上記レンズの位置調節後には、ベース体55とレンズホルダ56とは接着固定される。

40

#### 【0053】

また、体53の物体側端面、第2レンズL2と第3レンズL3との間及び第3レンズL3と第4レンズL4との間には、それぞれ第1の遮光マスク21、第2の遮光マスク22及び第3の遮光マスク23が配置されている。かかる遮光マスク21、22、23はそれぞれ円形の開口を有し、結像に寄与しない不要光のカットを目的として配置されている。各マスク21、22、23は、いずれも光を遮断する円板状の部材の中心に所定の内径の貫通穴が設けられており、いずれのマスク21、22、23についても、当該貫通穴の中心線は各レンズL1～L4の光軸と一致するように装備されている。

#### 【0054】

50

第1の遮光マスク21は、前述したように、体53の物体側端面に配設装備されている。  
 第2の遮光マスク22は、第3レンズL3の凹部内に配置され、第2レンズL2と第3レンズL3とに挟持される。第3の遮光マスク23は、第4レンズL4の凹部内に配置され、第3レンズL3と第4レンズL4とに挟持される。

なお、第3レンズL3と第4レンズL4とは、それぞれ凹部内に遮光マスク22、23の格納用の窪みが形成されており、各レンズL2～L4の合状態における相互間距離に影響を及ぼさない構造となっている。

【0055】

前述した絞り8と各遮光マスク21、22、23との相互の作用により、物体側から入射した光が各レンズL1、L2、L3、L4のレンズ有効径の外側に入射することを防止し、ゴーストやフレアの発生を抑えることができる。

10

【0056】

上述した撮像ユニット50の使用態様について説明する。図3は、撮像ユニット50を携帯端末としての携帯電話機100に装備した状態を示す。また、図4は携帯電話機100の制御ブロック図である。

撮像ユニット50は、例えば、撮像光学系における体53の物体側端面が携帯電話機100の背面（液晶表示部側を正面とする）に設けられ、液晶表示部の下方に相当する位置に配設される。

そして、撮像ユニット50の外部接続端子54は、携帯電話機100の制御部101と接続され、輝度信号や色差信号等の画像信号を制御部101側に出力する。

20

一方、携帯電話機100は、図4に示すように、各部を統括的に制御すると共に、各処理に依じたプログラムを実行する制御部（CPU）101と、番号等をキーにより支持入力するための入力部60と、所定のデータの他に撮像した映像等を表示する表示部70と、外部サーバとの間の各種情報通信を実現するための無線通信部80と、携帯電話機100のシステムプログラムや各種処理プログラム及び端末ID等の必要な諸データを記憶している記憶部（ROM）91と、制御部101によって実行される各種処理プログラムやデータ、若しくは処理データ、或いは撮像ユニット50により撮像データ等を一時的に格納する作業領域として用いられる及び一時記憶部（RAM）92とを備えている。

そして、撮像ユニット50から入力された画像信号は、上記携帯電話機100の制御系により、記憶部92に記憶されたり、或いは表示部70で表示され、さらには、無線通信部80を介して映像情報として外部に送信される。

30

【0057】

【実施例】

次に、撮像レンズの仕様について、実施例1、2、3、4に基づいて説明するが、各仕様はこれに限定されるものではない。ここで、各実施例に使用する記号は下記の通りである。

- f : 撮像レンズ全系の焦点距離
- f<sub>B</sub> : バックフォーカス
- F : Fナンバー
- 2Y : 有効画面对角線長（固体撮像素子の矩形受光面における対角線長）
- R : 屈折面の曲率半径
- D : 屈折面の軸上面間隔
- N<sub>d</sub> : レンズ材料のd線での屈折率
- ν<sub>d</sub> : レンズ材料のアッペ数

40

【0058】

また、各実施例において、非球面の形状は、面の頂点を原点とし光軸方向をX軸とした直交座標系において、頂点曲率半径をR、円錐定数をK、非球面係数をA<sub>4</sub>、A<sub>6</sub>、A<sub>8</sub>、A<sub>10</sub>、A<sub>12</sub>として以下の「数5」で表す。

【0059】

【数5】

50

$$X = \frac{h^2/R}{1 + \sqrt{1 - (1 + K)h^2/R^2}} + A_4h^4 + A_6h^6 + A_8h^8 + A_{10}h^{10} + A_{12}h^{12}$$

但し、 $h = \sqrt{Y^2 + Z^2}$

【0060】

図5は本発明の実施例1、2にかがる小型の撮像レンズの代表的な断面図である。

(第1実施例)

レンズデータを表1、2、3に示す。

【0061】

【表1】

(実施例1)

f=4.191 mm    fB=1.795 mm    F=2.88    2Y=5.08 mm

面番号	R (mm)	D (mm)	Nd	νd
1	4.425	1.10	1.58313	59.4
2	-9.128	0.20		
絞り	∞	0.20		
3	-3.207	1.20	1.53040	56.0
4	-1.092	0.34		
5	-0.726	0.86	1.58300	30.0
6	-1.524	0.10		
7	2.538	1.14	1.53040	56.0
8	2.712			

【0062】

【表2】

10

20

30



## 非球面係数

第 3 面	$K = 9.21940$ $A4 = -1.90800 \times 10^{-2}$ $A6 = 3.78880 \times 10^{-2}$ $A8 = -1.01770 \times 10^{-1}$ $A10 = 1.61350 \times 10^{-1}$	
第 4 面	$K = -2.43830 \times 10^{-1}$ $A4 = 1.33880 \times 10^{-1}$ $A6 = 1.41590 \times 10^{-2}$ $A8 = 9.87250 \times 10^{-3}$ $A10 = 2.11700 \times 10^{-2}$	10
第 5 面	$K = -1.91890$ $A4 = 1.13150 \times 10^{-1}$ $A6 = 8.99300 \times 10^{-3}$ $A8 = -3.76430 \times 10^{-3}$ $A10 = 6.11200 \times 10^{-3}$ $A12 = -3.26330 \times 10^{-3}$	20
第 6 面	$K = -3.37000 \times 10^{-1}$ $A4 = 8.35040 \times 10^{-2}$ $A6 = 2.41350 \times 10^{-2}$ $A8 = -5.17700 \times 10^{-3}$ $A10 = -3.05050 \times 10^{-3}$ $A12 = 1.39000 \times 10^{-3}$	
第 7 面	$K = -11.9490$ $A4 = -2.26290 \times 10^{-2}$ $A6 = -1.73770 \times 10^{-3}$ $A8 = 1.64710 \times 10^{-3}$ $A10 = -3.32140 \times 10^{-4}$ $A12 = -1.80240 \times 10^{-4}$	30
第 8 面	$K = -4.42490$ $A4 = -4.22960 \times 10^{-2}$ $A6 = 9.36890 \times 10^{-3}$ $A8 = -2.19520 \times 10^{-3}$ $A10 = 2.15000 \times 10^{-4}$ $A12 = -1.52000 \times 10^{-5}$	40

【 0 0 6 3 】

【 表 3 】

		実施例 1
(1), (18)	$L/2Y$	1. 36
(2), (5), (19)	$f_{12}/f$	0. 55
(3), (6)	$\{(\nu_1 + \nu_2)/2\} - \nu_3$	27. 7
(7), (9)	$R5/\{(N3-1) \cdot f\}$	-0. 30
(8)	$f_a/f$	0. 41
(10), (14)	$X-X_0$	$h=h_{\max} (2. 2\text{mm})$ $-0. 0758$ $h=0. 7 \times h_{\max}$ $-0. 0169$ $h=0. 5 \times h_{\max}$ $-0. 0050$
(13), (17)	$ f/f_{234} $	0. 46
(20)	$\nu_P - \nu_N$	26. 0

10

20

## 【0064】

図中L1は第1レンズ、L2は第2レンズ、L3は第3レンズ、L4は第4レンズ、Sは絞りを示す。図6は実施例1の収差図（球面収差、非点収差、歪曲収差、メリディオナルコマ収差）である。

30

第1レンズL1はガラス材料から形成され、第2レンズL2および第4レンズL4は、ポリオレフィン系のプラスチックレンズで、飽和吸水率は0.01%以下である。また、第3レンズL3はポリカーボネイト系のプラスチックレンズで、飽和吸水率は0.4%である。

なお、プラスチック材料の温度による屈折率 $n_d$ の変化は表4に示す通りである。これより、常温（20〔℃〕）に対し+80〔℃〕上昇時のバックフォーカス変化量（ $\Delta f_B$ ）は+0.001〔mm〕となる。

## 【0065】

## 【表4】

40

	常温での屈折率	常温+30℃での屈折率
第2レンズ、第4レンズ	1. 5304	1. 5276
第3レンズ	1. 5830	1. 5788

## 【0066】

50

(実施例 2)

レンズデータを表 5, 6, 7 に示す。

【 0 0 6 7 】

【 表 5 】

(実施例 2)

$f=4.200$  mm     $fB=1.791$  mm     $F=2.88$      $2Y=5.08$  mm

面番号	R (mm)	D (mm)	N d	$\nu$ d
1	3.917	1.10	1.51633	64.1
2	-8.052	0.20		
絞り	$\infty$	0.20		
3	-3.422	1.20	1.53040	56.0
4	-1.083	0.31		
5	-0.732	0.86	1.58300	30.0
6	-1.527	0.10		
7	2.426	1.07	1.53040	56.0
8	2.322			

10

20

【 0 0 6 8 】

【 表 6 】

## 非球面係数

第 3 面	$K = 9.31360$ $A4 = -3.44480 \times 10^{-2}$ $A6 = 5.08930 \times 10^{-2}$ $A8 = -1.53070 \times 10^{-1}$ $A10 = 1.61750 \times 10^{-1}$	
第 4 面	$K = -4.31080 \times 10^{-1}$ $A4 = 1.22030 \times 10^{-1}$ $A6 = -1.44230 \times 10^{-2}$ $A8 = 1.37060 \times 10^{-2}$ $A10 = 9.35930 \times 10^{-3}$	10
第 5 面	$K = -2.00120$ $A4 = 1.12270 \times 10^{-1}$ $A6 = 2.28080 \times 10^{-3}$ $A8 = -8.64850 \times 10^{-3}$ $A10 = 7.55610 \times 10^{-3}$ $A12 = -2.07840 \times 10^{-3}$	20
第 6 面	$K = -6.31350 \times 10^{-1}$ $A4 = 8.67650 \times 10^{-2}$ $A6 = 2.05150 \times 10^{-2}$ $A8 = -8.87260 \times 10^{-3}$ $A10 = -1.70460 \times 10^{-3}$ $A12 = 1.04610 \times 10^{-3}$	
第 7 面	$K = -10.5550$ $A4 = -2.40450 \times 10^{-2}$ $A6 = -1.81580 \times 10^{-3}$ $A8 = 1.68150 \times 10^{-3}$ $A10 = -3.21750 \times 10^{-4}$ $A12 = -1.78030 \times 10^{-4}$	30
第 8 面	$K = -4.87370$ $A4 = -4.23390 \times 10^{-2}$ $A6 = 9.32800 \times 10^{-3}$ $A8 = -2.20080 \times 10^{-3}$ $A10 = 2.16970 \times 10^{-4}$ $A12 = -1.49000 \times 10^{-5}$	40

【 0 0 6 9 】

【 表 7 】

		実施例 2
(1), (18)	$L/2Y$	1. 34
(2), (5), (19)	$f12/f$	0. 54
(3), (6)	$\{(\nu 1+\nu 2)/2\}-\nu 3$	30. 1
(7), (9)	$R5/\{(N3-1)\cdot f\}$	-0. 30
(8)	$fa/f$	0. 40
(10), (14)	$X-X0$	$h=h_{max} (2. 2mm)$ $-0. 0757$ $h=0. 7\times h_{max}$ $-0. 0170$ $h=0. 5\times h_{max}$ $-0. 0050$
(13), (17)	$ f/f234 $	0. 43
(20)	$\nu P-\nu N$	26. 0

## 【0070】

図7は実施例2の収差図（球面収差、非点収差、歪曲収差、メリディオナルコマ収差）である。

第1レンズL1はガラス材料から形成され、第2レンズL2および第4レンズL4は、ポリオレフィン系のプラスチックレンズで、飽和吸水率は0.01%以下である。また、第3レンズL3はポリカーボネイト系のプラスチックレンズで、飽和吸水率は0.4%である。

なお、プラスチック材料の温度による屈折率 $n_d$ の変化は表8に示す通りである。これより、常温（20〔℃〕）に対し+30〔℃〕上昇時のバックフォーカス変化量（ $\Delta f_B$ ）は+0.001〔mm〕となる。

## 【0071】

## 【表8】

	常温での屈折率	常温+30℃での屈折率
第2レンズ、第4レンズ	1.5304	1.5276
第3レンズ	1.5830	1.5788

## 【0072】

（第8実施例）

レンズデータを表9、10、11、12に示す。

【 0 0 7 3 】

【 表 9 】

(実施例 3)

f=5. 309 mm    fB=0. 511 mm    F=2. 88    2Y=6. 48 mm

面番号	R (mm)	D (mm)	N d	$\nu$ d
絞り	$\infty$	0. 00		
1	3. 227	1. 27	1. 69680	55. 5
2	-87. 050	0. 44		
3	-3. 364	1. 40	1. 52500	56. 0
4	-1. 626	0. 35		
5	-1. 021	0. 90	1. 58300	30. 0
6	-2. 147	0. 10		
7	2. 462	1. 10	1. 52500	56. 0
8	2. 283	1. 00		
9	$\infty$	0. 30	1. 51633	64. 1
10	$\infty$			

10

20

【 0 0 7 4 】

【 表 1 0 】

## 非球面係数

第 3 面	$K = -3.69470$ $A4 = -2.00408 \times 10^{-2}$ $A6 = 5.93561 \times 10^{-3}$ $A8 = 5.22016 \times 10^{-4}$ $A10 = -2.38137 \times 10^{-4}$	
第 4 面	$K = -8.46375 \times 10^{-1}$ $A4 = -2.02564 \times 10^{-2}$ $A6 = 1.62756 \times 10^{-2}$ $A8 = -4.14965 \times 10^{-3}$ $A10 = 6.66591 \times 10^{-4}$	10
第 5 面	$K = -8.10560 \times 10^{-1}$ $A4 = 6.31710 \times 10^{-2}$ $A6 = 4.14530 \times 10^{-4}$ $A8 = 4.30470 \times 10^{-3}$ $A10 = -2.38210 \times 10^{-3}$ $A12 = 3.81300 \times 10^{-4}$	20
第 6 面	$K = -4.69690 \times 10^{-1}$ $A4 = 1.50160 \times 10^{-2}$ $A6 = 9.94400 \times 10^{-3}$ $A8 = -2.33050 \times 10^{-3}$ $A10 = 3.92580 \times 10^{-4}$ $A12 = -2.86340 \times 10^{-5}$	
第 7 面	$K = -8.06986$ $A4 = -1.22203 \times 10^{-2}$ $A6 = -1.10253 \times 10^{-3}$ $A8 = 2.97022 \times 10^{-4}$ $A10 = -1.61617 \times 10^{-5}$ $A12 = -1.33104 \times 10^{-6}$	30
第 8 面	$K = -4.95420$ $A4 = -1.49047 \times 10^{-2}$ $A6 = 7.29589 \times 10^{-4}$ $A8 = -2.84963 \times 10^{-4}$ $A10 = 4.02284 \times 10^{-5}$ $A12 = -2.14994 \times 10^{-6}$	40

【 0 0 7 5 】

【 表 1 1 】

		実施例 3
(1), (18)	$L/2Y$	1. 12
(2), (5), (19)	$f12/f$	0. 60
(3), (6)	$\{(\nu 1+\nu 2)/2\}-\nu 3$	25. 75
(7), (9)	$R5/\{(N3-1)\cdot f\}$	-0. 33
(8)	$fa/f$	0. 39
(10), (14)	$X-X0$	$h=h_{\max}(2.9\text{mm})$ $-1.1140$ $h=0.7\times h_{\max}$ $-0.0247$ $h=0.5\times h_{\max}$ $-0.0063$
(13), (17)	$ f/f234 $	0. 15
(20)	$\nu P-\nu N$	25. 5

10

20

【0076】

【表12】

	常温での屈折率	常温+30℃での屈折率
第2レンズ、第4レンズ	1. 5250	1. 5214
第3レンズ	1. 5830	1. 5788

30

【0077】

図8は実施例3にかかると小型の撮像レンズの断面図である。図中L1は第1レンズ、L2は第2レンズ、L3は第3レンズ、L4は第4レンズ、Sは絞りを示す。図9は実施例3の収差図（球面収差、非点収差、歪曲収差、メリディオナルコマ収差）である。

40

本実施例は最も物体側に開口絞りSを配置し、また、最も像側には、赤外線カットフィルタ相当の平行平板Fを配置した設計例である。

第1レンズL1はガラス材料から形成され、第2レンズL2および第4レンズL4はポリオレフィン系のプラスチックレンズで、飽和吸水率は0.01%以下である。また、第3レンズL3はポリカーボネイト系のプラスチックレンズで、飽和吸水率は0.4%である。

なお、プラスチック材料の温度による屈折率 $n_d$ の変化は表12に示す通りである。これより、常温(20[℃])に対し+30[℃]上昇時のバックフォーカス変化量( $\Delta f_B$ )は-0.006[mm]となる。

50



【 0 0 7 8 】

( 第 4 実 施 例 )

レンズデータを表 1 3 , 1 4 , 1 5 , 1 6 に示す。

【 0 0 7 9 】

【 表 1 3 】

( 実 施 例 3 )

f=3. 952 mm    fB=0. 437 mm    F=2. 88    2Y=4. 76 mm

面番号	R (mm)	D (mm)	Nd	$\nu d$	
絞り	$\infty$	0. 05			10
1	3. 913	0. 93	1. 69680	55. 5	
2	346. 379	0. 18			
3	-20. 920	1. 20	1. 52500	56. 0	
4	-1. 410	0. 32			
5	-0. 566	0. 80	1. 58300	30. 0	
6	-1. 702	0. 10			20
7	1. 248	1. 04	1. 52500	56. 0	
8	2. 707	0. 75			
9	$\infty$	0. 30	1. 51633	64. 1	
10	$\infty$	0. 20			
11	$\infty$	0. 40	1. 51633	64. 1	
12	$\infty$				30

【 0 0 8 0 】

【 表 1 4 】

## 非球面係数

第3面	$K = -1.34157 \times 10^3$ $A4 = -1.15552 \times 10^{-2}$ $A6 = -9.72356 \times 10^{-2}$ $A8 = 1.64161 \times 10^{-1}$ $A10 = -1.69526 \times 10^{-1}$ $A12 = 5.93581 \times 10^{-2}$	
第4面	$K = -3.64290$ $A4 = -7.87313 \times 10^{-2}$ $A6 = -8.13418 \times 10^{-2}$ $A8 = 6.89382 \times 10^{-2}$ $A10 = -1.35061 \times 10^{-2}$ $A12 = -1.46313 \times 10^{-3}$	10
第5面	$K = -2.20465$ $A4 = -1.19476 \times 10^{-1}$ $A6 = 1.02295 \times 10^{-1}$ $A8 = -4.96877 \times 10^{-2}$ $A10 = 3.08960 \times 10^{-2}$ $A12 = -8.23237 \times 10^{-3}$	20
第6面	$K = -1.11107$ $A4 = 3.10033 \times 10^{-2}$ $A6 = 2.14144 \times 10^{-2}$ $A8 = -2.26865 \times 10^{-3}$ $A10 = -1.88014 \times 10^{-3}$ $A12 = 4.46605 \times 10^{-4}$	
第7面	$K = -4.23704$ $A4 = -8.16271 \times 10^{-4}$ $A6 = 1.75735 \times 10^{-3}$ $A8 = -1.91328 \times 10^{-3}$ $A10 = 4.88327 \times 10^{-4}$ $A12 = -5.69413 \times 10^{-5}$	30
第8面	$K = -8.14983 \times 10^{-1}$ $A4 = -2.99336 \times 10^{-2}$ $A6 = 4.55187 \times 10^{-3}$ $A8 = -1.39696 \times 10^{-3}$ $A10 = 1.81788 \times 10^{-4}$ $A12 = -1.40282 \times 10^{-5}$	40

【0081】

【表15】

		実施例 4
(1), (18)	$L/2Y$	1. 35
(2), (5), (19)	$f_{12}/f$	0. 58
(3), (6)	$\{(\nu_1 + \nu_2)/2\} - \nu_3$	25. 75
(7), (9)	$R_5/\{(N_3-1) \cdot f\}$	-0. 25
(8)	$f_a/f$	0. 34
(10), (14)	$X-X_0$	$h=h_{\max}(2. 3\text{mm})$ $-0. 8121$ $h=0. 7 \times h_{\max}$ $-0. 1679$ $h=0. 5 \times h_{\max}$ $-0. 0454$
(13), (17)	$ f/f_{234} $	0. 60
(20)	$\nu_P - \nu_N$	26. 0

10

20

【0082】

【表16】

	常温での屈折率	常温+30℃での屈折率
第2レンズ、第4レンズ	1. 5250	1. 5214
第3レンズ	1. 5830	1. 5788

30

【0083】

図10は実施例4にかかる小型の撮像レンズの断面図である。図中L1は第1レンズ、L2は第2レンズ、L3は第3レンズ、L4は第4レンズ、Sは絞りを示す。図11は実施例4の収差図（球面収差、非点収差、歪曲収差、メリディオナルコマ収差）である。

40

本実施例は最も物体側に開口絞りSを配置し、また、最も像側には、赤外線カットフィルタ及び固体撮像素子のシールガラス相当の平行平板F、Pを配置した設計例である。

第1レンズL1はガラス材料から形成され、第2レンズL2および第4レンズL4はポリオレフィン系のプラスチックレンズで、飽和吸水率は0. 01%以下である。また、第3レンズL3はポリカーボネイト系のプラスチックレンズで、飽和吸水率は0. 4%である。

なお、プラスチック材料の温度による屈折率 $n_d$ の変化は表16に示す通りである。これより、常温（20 [℃]）に対し+30 [℃]上昇時のバックフォーカス変化量（ $\Delta f_B$ ）は+0. 010 [mm]となる。

50

## 【0084】

(その他)

ここで、上記各実施例における温度上昇時のバックフォーカス変化量 ( $\Delta f_B$ ) であるが、計算上は温度上昇時のプラスチックレンズの熱膨張の影響は無視して求めた値である。なぜなら、温度変化時の像点位置変動は、プラスチックレンズの屈折率変化に主に起因するからである。

## 【0085】

なお、上記各実施例は、像側光束のテレセントリック特性については必ずしも十分な設計にはなっていない。テレセントリック特性とは、各像点に対する光束の主光線が、レンズ最終面を射出した後、光軸とほぼ平行になることをいい、換言すれば光学系の射出瞳位置が像面から十分離れることである。テレセントリック特性が悪くなると、光束が固体撮像素子に対し斜めより入射し、画面周辺部において実質的な開口効率が減少する現象（シェーディング）が生じ、周辺光量不足となってしまう。しかし、最近の技術では、固体撮像素子の色フィルタやマイクロレンズアレイの配列の見直し等によって、前述のシェーディング現象を軽減することができる。従って、本実施例は、テレセントリック特性の要求が緩和された分について、より小型化を目指した設計例となっている。

## 【0086】

【発明の効果】

請求項1記載の発明によれば、比較的屈折力の大きい正レンズ群と負レンズが物体側より順に配置されることとなり、かかる構成によりレンズ全長の小型化を容易に行うことが可能である。さらに、第1レンズの凸面を物体側に向けることによりレンズ全長の小型化を図ることが可能である。

さらに、収差補正に関しては、正の屈折力を有する第1レンズ、第2レンズの2枚の正レンズを最も物体側に配置することで、正の屈折力を分担でき、球面収差やコマ収差の発生を抑えることができる。

また、第3レンズを物体側に凹面を向けたメニスカス形状の負レンズとすることで、球面収差、コマ収差、非点収差を良好に補正することができる。さらに、第4レンズを物体側に凸面を向けたメニスカス形状とすることで、画面周辺部での像側光束のテレセントリック特性の確保が容易になる。

## 【0087】

請求項2記載の発明は、条件式(1)に従うことにより、その上限値を下回る設定とすることで、レンズ全長を短くでき、相乗的にレンズ外径も小さくできる。従って、これにより、撮像装置全体の小型軽量化が可能となる。

また、条件式(2)に従うことにより、その下限値を上回る設定とすることで、第1レンズと第2レンズの合成の正の屈折力の大きさを適度に抑え、高次の球面収差やコマ収差の発生を小さく抑えることが可能となり、上限値を下回る設定とすることで、第1レンズと第2レンズの合成の正の屈折力を適度に確保でき、レンズ全長の短縮が可能となる。

さらに、条件式(3)に従うことにより、その下限値を上回る設定とすることで、軸上色収差、倍率色収差をバランス良く補正することが可能となる。

## 【0088】

条件式(1)～(3)は、小型で収差が良好に補正された撮像レンズを得るための条件式である。即ち、条件式(1)はレンズ全長の小型化を達成するための条件式である。条件式(1)の上限値を下回るとレンズ全長が小型化の傾向を示す。なお、条件式中の符号Lは第1レンズの物体側面から撮像レンズ全系の像側焦点までの光軸上の距離を示すが、この場合において「像側焦点」とは、撮像レンズに光軸と平行な平行光線が入射した場合の像点をいう。

## 【0089】

請求項3記載の発明は、撮像レンズ全系で最も物体側に配置された開口絞りを備えているため、射出瞳位置を像面から遠ざけて、レンズ最終面を射出した光束の主光線を固体撮像素子に垂直に近い角度で入射させることができ、固体撮像素子に用いる撮像レンズに必要

な像面テレセントリック特性を良好に確保でき、画面周辺部におけるシェーディング減少を軽減することが可能となる。

【0090】

請求項4記載の発明は、条件式(4)に従うことにより、その上限値を下回る設定とすることで、レンズ全長を短くでき、相乗的にレンズ外径も小さくできる。従って、これにより、撮像装置全体の小型軽量化が可能となる。

また、条件式(5)に従うことにより、その下限値を上回る設定とすることで、第1レンズと第2レンズの合成の正の屈折力の大きさを適度に抑え、高次の球面収差やコマ収差の発生を小さく抑えることが可能となり、上限値を下回る設定とすることで、第1レンズと第2レンズの合成の正の屈折力を適度に確保でき、レンズ全長の短縮が可能となる。

10

さらに、条件式(6)に従うことにより、その下限値を上回る設定とすることで、軸上色収差、倍率色収差をバランス良く補正することが可能となる。

【0091】

条件式(4)～(6)は、小型で収差が良好に補正された撮像レンズを得るための条件式である。即ち、条件式(4)はレンズ全長の小型化を達成するための条件式である。条件式(4)の上限値を下回るとレンズ全長が小型化の傾向を示す。なお、条件式中の符号 $l_1$ は開口絞りから撮像レンズ全系の像側焦点までの光軸上の距離を示すが、この場合において「像側焦点」とは、撮像レンズに光軸と平行な平行光線が入射した場合の像点をいう。

【0092】

請求項5記載の発明によれば、条件式(7)に従って、その上限値を下回る設定とすることで、第3レンズ物体側面の負の屈折力が過大となることを回避し、オーバーな球面収差の過度の発生や、軸外光束のコマフレアの発生を抑制することができ、良好な画質が得ることが可能となる。また、下限値を上回る設定とすることで、第3レンズ物体側面の負の屈折力を維持でき、正のベッツパール和が減少し、像面湾曲の補正及び軸上色収差や倍率色収差の補正を良好に行うことが可能となる。

20

さらに、条件式(8)に基づいて、第3レンズと第4レンズ間に形成される空気レンズの正の屈折力を適切に設定することができ、像面湾曲や歪曲収差の補正と像側光束のテレセントリック特性の確保をバランスよく行うことが可能となる。

【0093】

請求項6記載の発明は、 $R5 / ((N3 - 1) \cdot f)$ の値の上限値をより望ましい値とすることにより、第3レンズ物体側面の負の屈折力が必要以上に大きくなりすぎず、オーバーな球面収差の過度の発生や、軸外光束のコマフレアの発生を抑制が図られる。

30

【0094】

請求項7記載の発明によれば、最も像側に位置する面である第4レンズ像側面を条件式(10)を満たす非球面形状とすることで、特に高画角の光束におけるテレセントリック特性の確保が図ることが可能となる。

【0095】

請求項8記載の発明によれば、正の第1レンズは温度変化時の屈折率変化がほとんど無いガラス材料から形成すると共に、他の第2～4レンズをプラスチック材料で形成しているが、第2レンズと第3レンズとが比較的屈折力の大きい正レンズと負レンズであることから、温度変化時の像点位置変動への影響を相殺することができ、撮像レンズ全系での温度変化時の像点位置の変動を小さく抑えることが可能である。

40

従って、プラスチック材料による影響を低減した上で、プラスチック材料がもたらす効果である小型軽量化と低コスト化を実現することが可能となる。

また、第1レンズをガラスレンズとすることで、傷つきやすいプラスチックレンズを露出させる必要がなく保守性の向上を図ることが可能である。

さらに、第1レンズと第2レンズとはいずれも正の屈折力を有し、それぞれにて必要となる屈折力を分担しているため、各レンズの曲率半径を極端に小さくしなくとも良いので、第1レンズたるガラスレンズの加工を容易とし、生産性の向上を図ることが可能となる。

50

さらに、第2～4レンズをプラスチック材料とすることから、一体成形によりレンズ有効径外側のフランジ部の形状を自由に設計することも可能となる。仮に、各レンズのフランジ部を相互に合自在とした場合には、複数枚のレンズの光軸を容易に一致させることができる構造をとることができる。さらに、フランジが各レンズ間隔を規定する構造とした場合には、スペーサーを不要とし、部品点数の軽減により生産性の向上を図ることが可能となる。

また、レンズをプラスチック材料を形成することからレンズに非球面を容易に形成することが可能となり、収差補正を容易に行うことが可能となる。

【0096】

請求項9記載の発明は、条件式(13)を満たすように設定することにより、プラスチックレンズの合成焦点距離を大きく設定して屈折力の総和を小さく抑え、温度変化時の像点位置変動を小さく抑えることが可能となる。

10

【0097】

請求項10記載の発明では、プラスチック材料として飽和吸水率が0.7%以下のものを用いることにより、急激な湿度変化による屈折率の不均一化を抑制し、より良好な結像性能を維持しながら、プラスチックレンズの利点をも得ることが可能となる。

【0098】

請求項11記載の発明では、最も物体側に凸面を向けた正の第1レンズを配置すること、第1レンズを負レンズとした場合に比べ、レンズ全長の小型化を図ることが可能である。

20

さらに、1枚の正レンズをガラスレンズ、もう1枚の正レンズと1枚の負レンズをプラスチックレンズとすること、大きな正の屈折力をガラスレンズとプラスチックレンズとで分担することができ、かつ、正負の屈折力を有するプラスチックレンズ同士により温度変化時の像点位置変動への影響を相殺させ、撮像レンズ全系での温度変化時の像点位置の変動を小さく抑えることが可能である。従って、本発明により、温度変化の影響を排除しつつ、プラスチックレンズによる小型軽量化、量産化等、請求項5記載の発明とほぼ同様の効果を得ることが可能である。

さらに、本発明は、第4レンズ像側面を所定の非球面形状とすること、特に高画角の光束におけるテレセントリック特性の確保が実現することが可能となっている。

【0099】

請求項12記載の発明によれば、第1～4レンズの内の三つのレンズをプラスチック材料から形成することから、レンズがプラスチック材料であることの利点、レンズの小型軽量化、量産性による低コスト化、非球面形成の容易化等をより効果的に実現することが可能である。

30

【0100】

請求項13記載の発明は、第1レンズをガラス材料とすることにより、最も損傷を受けやすい配置にあってその傷の発生を低減すると共に、他のプラスチック材料からなるレンズの保護を図り、保守性の向上を図っている。

【0101】

請求項14記載の発明は、条件式(17)を満たすように設定することにより、プラスチックレンズの合成焦点距離を大きく設定して屈折力の総和を小さく抑え、温度変化時の像点位置変動を小さく抑えることが可能となる。

40

【0102】

請求項15記載の発明では、プラスチック材料として飽和吸水率が0.7%以下のものを用いることにより、急激な湿度変化による屈折率の不均一化を抑制し、より良好な結像性能を維持しながら、プラスチックレンズの利点をも得ることが可能となる。

【0103】

請求項16記載の発明は、条件式(18)によりレンズ全長を短くでき、撮像装置全体の小型軽量化が可能となる。

また、条件式(19)により、高次の球面収差やコマ収差の発生を小さく抑えつつも適度

50

にレンズ全長の短縮が可能となる。

さらに、条件式(20)により、軸上色収差、倍率色収差をバランス良く補正することが可能となる。

【0104】

請求項17記載の発明では、比較的屈折力の大きい正レンズ群と負レンズを、物体側より順に配置したことにより、レンズ全長の小型化を図ることが可能である。

【0105】

請求項18記載の発明は、最も物体側となるレンズを正の屈折力を有するレンズとして光軸方向の小型化を図りつつ、4枚のレンズにより撮像レンズを構成している。

そして、レンズ枚数を4枚とすることにより、各種の収差の補正、テレセントリック特性の向上、屈折力の分散等への対応を容易とすると共に、プラスチックレンズの使用枚数の増加にも容易に対応可能とし、小型化、高画質化、軽量化に有利な撮像ユニットを提供することを可能としている。

【0106】

請求項19記載の発明によれば、上述した各効果を実現可能な撮像レンズを搭載することにより、小型化、軽量化、高画質化等の利点を備える撮像ユニットを提供することが可能である。

【0107】

請求項20記載の発明によれば、請求項18又は19記載の発明による各効果を実現可能な撮像ユニットを搭載することにより、小型化、軽量化及び高画質の撮像可能な携帯端末を提供することが可能である。

【図面の簡単な説明】

【図1】発明の実施形態たる撮像ユニットの斜視図である。

【図2】撮像レンズ部の各レンズの光軸を含む断面における断面図を示している。

【図3】図3(A)は撮像ユニットを適用した携帯電話機の正面図、図3(B)は撮像ユニットを適用した携帯電話機の背面図を示す。

【図4】図3の携帯電話機の制御ブロック図である。

【図5】本発明の実施例1、2にかかると小型の撮像レンズの代表的な断面図である。

【図6】実施例1の収差図(球面収差、非点収差、歪曲収差、メリディオナルコマ収差)である。

【図7】実施例2の収差図(球面収差、非点収差、歪曲収差、メリディオナルコマ収差)である。

【図8】実施例3にかかると小型の撮像レンズの断面図である。

【図9】実施例3の収差図(球面収差、非点収差、歪曲収差、メリディオナルコマ収差)である。

【図10】実施例4にかかると小型の撮像レンズの断面図である。

【図11】実施例4の収差図(球面収差、非点収差、歪曲収差、メリディオナルコマ収差)である。

【符号の説明】

L1 第1レンズ

L2 第2レンズ

L3 第3レンズ

L4 第4レンズ

S 開口絞り

50 撮像ユニット

100 携帯電話機(携帯端末)

【図1】

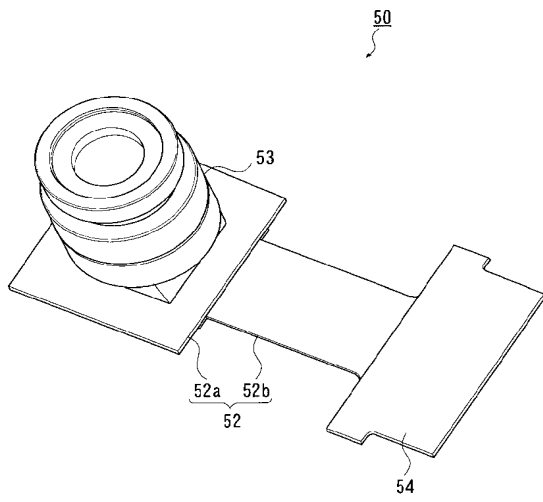

【図2】

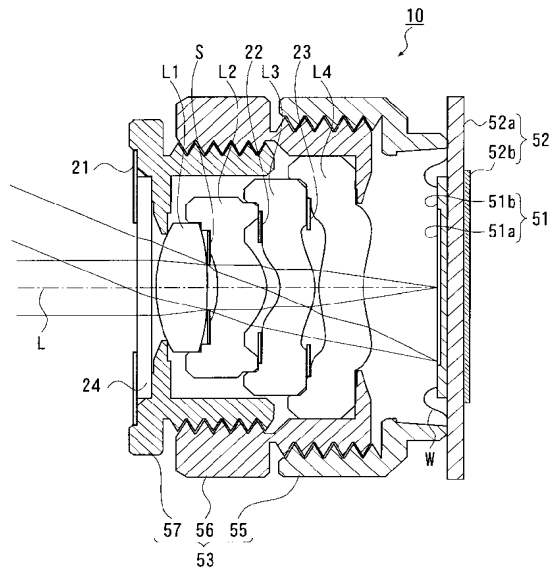

【図3】

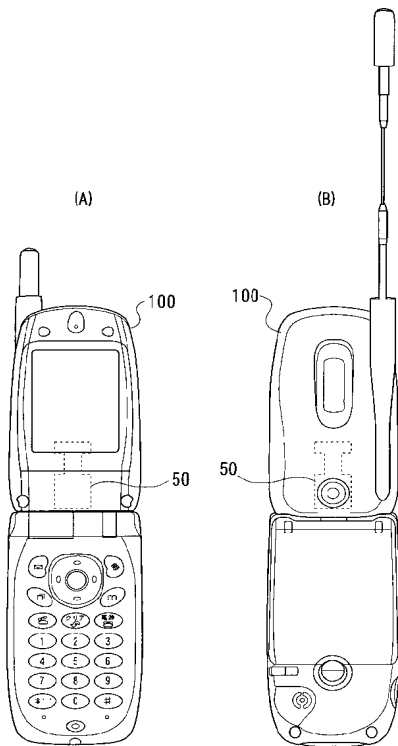

【図4】

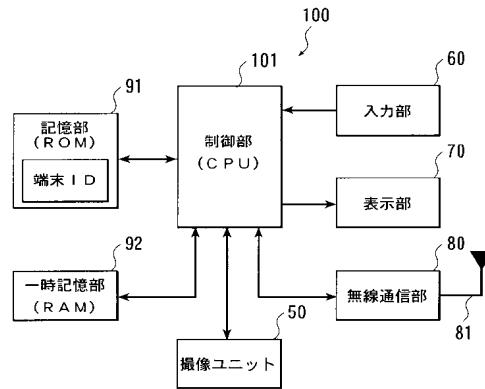



【 図 5 】

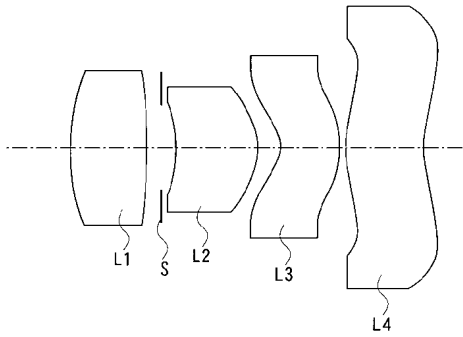

【 図 6 】

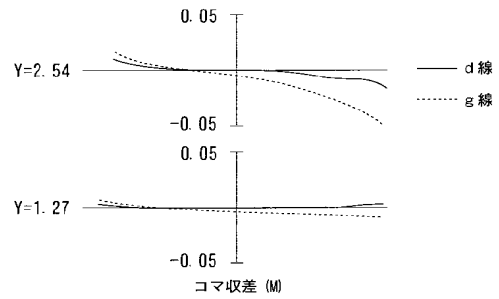
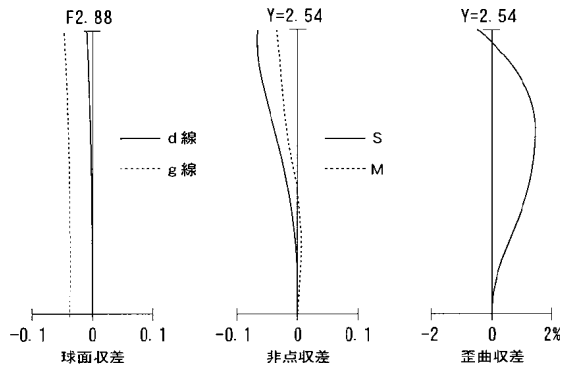

【 図 7 】

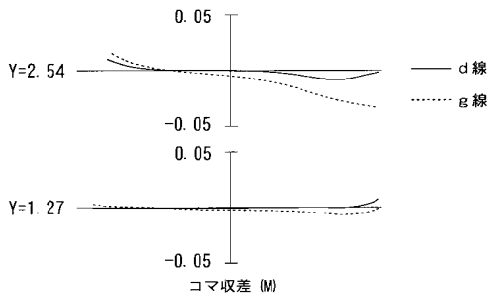
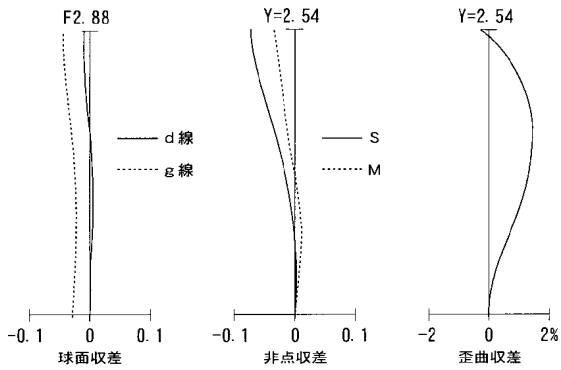

【 図 8 】

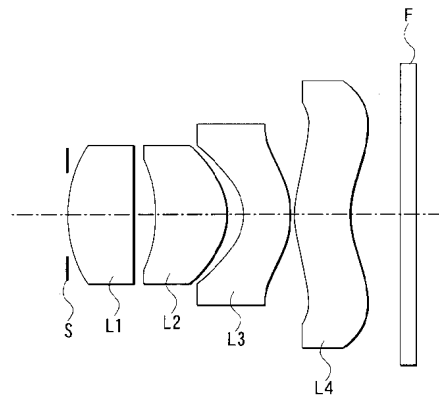

【 図 9 】

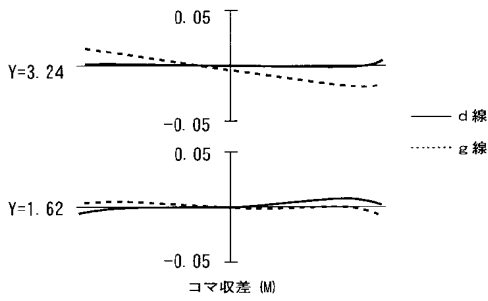
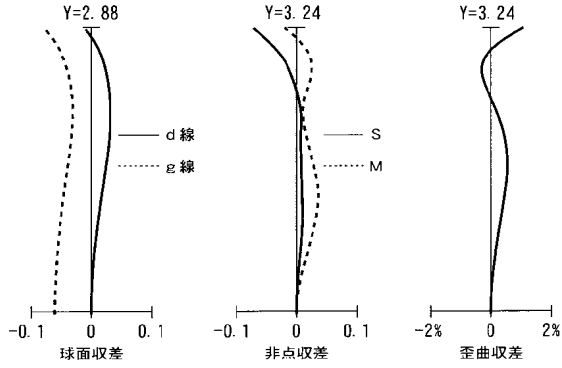

【 図 10 】

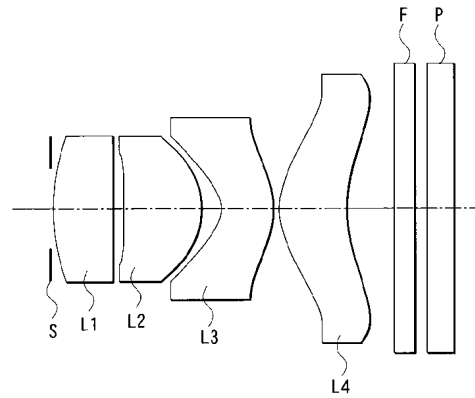

【 図 11 】

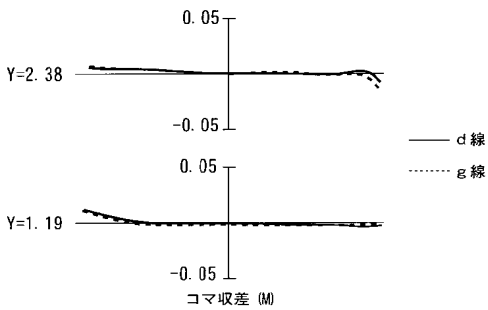
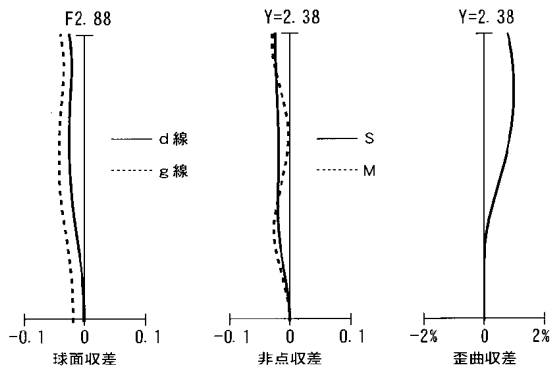

(19) 日本国特許庁 (JP)

(12) 公開特許公報 (A)

(11) 特許出願公開番号

特開2007-178689

(P2007-178689A)

(43) 公開日 平成19年7月12日 (2007.7.12)

(51) Int. Cl.	F 1	テーマコード (参考)
<b>GO2B 13/00 (2006.01)</b>	GO2B 13/00	2H087
<b>GO2B 13/18 (2006.01)</b>	GO2B 13/18	

審査請求 未請求 請求項の数 9 O L (全 24 頁)

(21) 出願番号 特願2005-376662 (P2005-376662)  
 (22) 出願日 平成17年12月27日 (2005.12.27)

(71) 出願人 000006633  
 京セラ株式会社  
 京都府京都市伏見区竹田鳥羽殿町6番地  
 (74) 代理人 100094053  
 弁理士 佐藤 隆久  
 (72) 発明者 藤原 正樹  
 東京都世田谷区玉川台2丁目14番9号  
 京セラ株式会社東京用賀事業所内  
 (72) 発明者 大原 直人  
 東京都世田谷区玉川台2丁目14番9号  
 京セラ株式会社東京用賀事業所内  
 Fターム (参考) 2H087 KA03 LA01 NA01 PA03 PA04  
 PA17 PA18 PB04 QA02 QA06  
 QA14 QA21 QA22 QA26 QA32  
 QA37 QA42 QA45 QA46 RA04  
 RA05 RA12 RA13 RA34 RA42

(54) 【発明の名称】 撮像レンズ、光学モジュール、および携帯端末

(57) 【要約】

【課題】 全長が短く、諸収差が良好に補正され、安価で生産効率の高い撮像レンズ、光学モジュール、および携帯端末を提供する。

【解決手段】 撮像レンズ100が、物体側OBJSより、開口絞り部110、物体側と像面側共に両凸の第1レンズ120、物体側に凹の第2メニスカスレンズ130、物体側に凹となる第3メニスカスレンズ140、物体側に凸となり両面非球面となる第4メニスカスレンズ150により構成されている。

【選択図】 図1

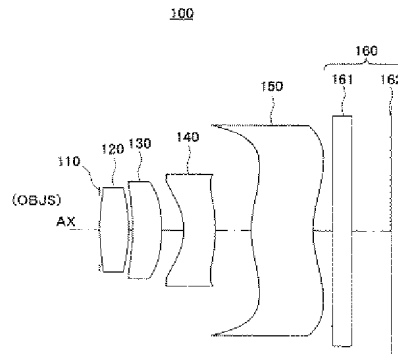

## 【特許請求の範囲】

## 【請求項1】

撮像素子を対象とした撮像光学系を有する撮像レンズであって、前記撮像光学系は、物体側から順に配置された、  
開口絞りと、  
物体側と像面側共に両凸のパワーが正となる第1レンズと、  
物体側に凹のパワーが正となる第2レンズと、  
物体側に凹となる第3レンズと、  
物体側に凸となる両面非球面の第4レンズと、を含み、  
前記撮像光学系において下記の条件式(1)を満足する撮像レンズ。

$$0.15 < f_1 / f_2 < 0.9 \quad \dots (1)$$

ただし、 $f_1$ は第1レンズの焦点距離を、 $f_2$ は第2レンズの焦点距離をそれぞれ表している。

## 【請求項2】

前記第1レンズと前記第2レンズが接合されている請求項1記載の撮像レンズ。

## 【請求項3】

前記撮像光学系において、絞りから像面までの距離の全長を $L$ 、全系の焦点距離を $f$ とするととき下記の条件式(1)を満足する請求項1または2に記載の撮像レンズ。

$$1.0 < L / f < 2.0 \quad \dots (2)$$

## 【請求項4】

前記撮像光学系において、絞りから像面までの距離の全長を $L$ 、全系の焦点距離を $f$ とするととき下記の条件式(2)を満足する請求項1または2に記載の撮像レンズ。

$$1.0 < L / f < 1.5 \quad \dots (3)$$

## 【請求項5】

前記撮像光学系において、前記第4レンズは下記の条件式(4)を満足する請求項1から4のいずれか一に記載の撮像レンズ。

$$0.55 < D_{4min} / D_{4max} \quad \dots (4)$$

ただし、 $D_{4min}$ は有効径内における第4レンズの最薄肉厚を、 $D_{4max}$ は有効径内における第4レンズの最厚肉厚をそれぞれ表している。

## 【請求項6】

前記撮像光学系において下記の条件式(5)を満足する請求項1から5のいずれか一に記載の撮像レンズ。

$$|1 / f_4| < 0.1 \quad \dots (5)$$

ただし、 $f_4$ は第4レンズの焦点距離を表している。

## 【請求項7】

撮像素子を対象とした撮像光学系を有する撮像レンズと、前記撮像レンズを保持するレンズ保持体と、を有し、前記撮像レンズの前記撮像光学系は、物体側から順に配置された、  
開口絞りと、  
物体側と像面側共に両凸のパワーが正となる第1レンズと、  
物体側に凹のパワーが正となる第2レンズと、  
物体側に凹となる第3レンズと、  
物体側に凸となる両面非球面の第4レンズと、を含み、  
前記撮像光学系において下記の条件式(1)を満足する光学モジュール。

$$0.15 < f_1 / f_2 < 0.9 \quad \dots (1)$$

ただし、 $f_1$ は第1レンズの焦点距離を、 $f_2$ は第2レンズの焦点距離をそれぞれ表している。

【請求項8】

光学モジュールと、  
前記光学モジュールを収納する筐体と、を有し、  
前記光学モジュールは、  
撮像素子を対象とした撮像光学系を有する撮像レンズと、  
前記撮像レンズを保持するレンズ保持体と、を有し、  
前記撮像レンズの前記撮像光学系は、物体側から順に配置された、  
開口絞りと、  
物体側と像面側共に両凸のパワーが正となる第1レンズと、  
物体側に凹のパワーが正となる第2レンズと、  
物体側に凹となる第3レンズと、  
物体側に凸となる両面非球面の第4レンズと、を含み、  
前記撮像光学系において下記の条件式(1)を満足する  
携帯端末。

$$0.15 < f_1 / f_2 < 0.9 \quad \dots (1)$$

ただし、 $f_1$ は第1レンズの焦点距離を、 $f_2$ は第2レンズの焦点距離をそれぞれ表している。

【請求項9】

電力供給手段を有し、  
前記光学モジュールは前記電力供給手段により電力の供給を受ける  
請求項8記載の携帯端末。

【発明の詳細な説明】

【技術分野】

【0001】

本発明は、撮像素子を用いたデジタルスチルカメラや携帯電話搭載カメラ、携帯情報端末搭載カメラといった全長の規制の厳しい撮像装置に係り、特に、携帯電話機等にも搭載可能な好適なレンズ全長および高い光学性能を有するデジタル入力機器(カメラモジュール)に適した撮像レンズ、光学モジュール、および携帯端末に関するものである。

【背景技術】

【0002】

近年、携帯電話の普及に伴い携帯端末に搭載するカメラモジュールの需要が高くなってきている。そして、この傾向はますます強くなると予想される。

【0003】

また、撮像素子も進展して、より小型化し高画素化になってきている。このため、サイズについてもよりコンパクトにすることができるようになっている。

その結果、小型の撮像レンズが市場から要求されることとなった。

【0004】

カメラモジュールが小型になると明るさも重要な要素となる。撮像素子が小さくなり画素も小さくなったため十分な光量を得るためには明るい撮像レンズ(Fナンバーが小さい撮像レンズ)にする必要がある。

【0005】

さらに低価格競争が激しいため、撮像レンズも低コストに抑える必要がある。レンズが5枚構成ではコストが高く全長も長くなってしまふ。樹脂レンズ3枚では高画素に対応した十分な性能がでない。

そこで、ガラスも含めた4枚構成とすることが実用的である。

【0006】

4枚構成を採用した撮像レンズとしては、物体側に絞りを配置した、いわゆる前絞りにした4枚構成の撮像レンズが、たとえば特許文献1に開示されている。

## 【0007】

特許文献1に開示された第1の撮像レンズは、物体側から像面側へと順に開口絞り、負の屈折力を有する第1レンズと、第1レンズと接合あるいは分離して配される正の屈折力を有する第2レンズと、物体側に凹面を向けたメニスカス状の正の屈折力を有する第3レンズと、少なくとも一つの屈折面を非球面形状とした弱い負の屈折力を有する第4レンズとを有している。

## 【0008】

さらに、4枚構成の撮像レンズとしては、以下に示すような構成を有する第2から第4の撮像レンズが種々提案されている。

## 【0009】

第2の撮像レンズは、最も物体側に開口絞りを配し、以降物体側より順に、第1レンズ群、第2レンズ群、および第3レンズ群から構成され、第1レンズ群は物体側より順に、正の屈折力を有する第1レンズ、および第1レンズと接合あるいは分離して構成される負の屈折力を有する第2レンズを配して構成され、第2レンズ群は少なくとも一つの屈折面を非球面形状とした正レンズである第3レンズのみで構成され、第3レンズ群は少なくとも一つの屈折面を非球面形状とした負レンズである第4レンズのみで構成される。

## 【0010】

第3の撮像レンズは、最も物体側に開口絞りを配し、以降物体側より順に、第1レンズ群、第2レンズ群、および第3レンズ群から構成され、第1レンズ群は物体側より順に、正の屈折力を有する第1レンズ、および第1レンズと接合して配置され、負の屈折力を有する第2レンズを配して構成され、かつ、第2レンズは、物体側に凹面を向けたメニスカスレンズであり、第2レンズ群は、少なくとも一つの屈折面を非球面形状とし物体側に凹面を向けたメニスカスレンズである第3レンズのみで構成され、第3レンズ群は、少なくとも一つの屈折面を非球面形状とし、物体側に凸面を向けたメニスカスレンズである第4レンズのみで構成される。

## 【0011】

第4の撮像レンズは、物体側から開口絞り、第1レンズ、第2レンズ、第3レンズ、第4レンズの順に配置された撮像レンズであって、第1レンズは両凸形状の正レンズであり、2レンズは、物体側の面が第1レンズの像側の面と接合された両凹形状、または、平凹形状の負レンズであり、第3レンズは少なくとも一つの屈折面を非球面形状とし、像側に凸面を向けた正メニスカスレンズであり、第4レンズは少なくとも一つの屈折面を非球面形状とし、物体側に凸面を向けた正メニスカスレンズである。

【特許文献1】特開2004-184987号公報

## 【発明の開示】

## 【発明が解決しようとする課題】

## 【0012】

しかしながら、上述した各撮像レンズでは、色収差等の諸収差を良好に補正することができず、全長を短くすることが困難で、また、像面への入力角度を抑えることが困難であるという不利益がある。

## 【0013】

本発明の目的は、全長が短く、諸収差が良好に補正され、安価で生産効率の高い撮像レンズ、光学モジュール、および携帯端末を提供することにある。

## 【課題を解決するための手段】

## 【0014】

上記目的を達成するため、本発明の第1の観点は、撮像素子を対象とした撮像光学系を有する撮像レンズであって、前記撮像光学系は、物体側から順に配置された、開口絞り、物体側と像面側共に両凸のパワーが正となる第1レンズと、物体側に凹のパワーが正となる第2レンズと、物体側に凹となる第3レンズと、物体側に凸となる両面非球面の第4レンズと、を含み、前記撮像光学系において下記の条件式(1)を満足する。

$$0.15 < f_1 / f_2 < 0.9 \quad \dots (1)$$

ただし、 $f_1$ は第1レンズの焦点距離を、 $f_2$ は第2レンズの焦点距離をそれぞれ表している。

【0015】

好適には、前記第1レンズと前記第2レンズが接合されている。

【0016】

好適には、前記撮像光学系において、絞りから像面までの距離の全長を $L$ 、全系の焦点距離を $f$ とするとき下記の条件式(2)を満足する。

$$1. 0 < L/f < 2.0 \quad \dots (2)$$

【0017】

好適には、前記撮像光学系において、絞りから像面までの距離の全長を $L$ 、全系の焦点距離を $f$ とするとき下記の条件式(3)を満足する。

$$1. 0 < L/f < 1.5 \quad \dots (3)$$

【0018】

好適には、前記撮像光学系において、前記第4レンズは下記の条件式(4)を満足する。

$$0.55 < D_{4min}/D_{4max} \quad \dots (4)$$

ただし、 $D_{4min}$ は有効径内における第4レンズの最薄肉厚を、 $D_{4max}$ は有効径内における第4レンズの最厚肉厚をそれぞれ表している。

【0019】

好適には、前記撮像光学系において下記の条件式(5)を満足する。

$$|1/f_4| < 0.1 \quad \dots (5)$$

ただし、 $f_4$ は第4レンズの焦点距離を表している。

【0020】

本発明の第2の観点の光学モジュールは、撮像素子を対象とした撮像光学系を有する撮像レンズと、前記撮像レンズを保持するレンズ保持体と、を有し、前記撮像レンズの前記撮像光学系は、物体側から順に配置された、開口絞りと、物体側と像面側共に両凸のパワーが正となる第1レンズと、物体側に凹のパワーが正となる第2レンズと、物体側に凹となる第3レンズと、物体側に凸となる両面非球面の第4レンズと、を含み、前記撮像光学系において上記の条件式(1)を満足する。

【0021】

本発明の第3の観点の携帯端末は、光学モジュールと、前記光学モジュールを収納する筐体と、を有し、前記光学モジュールは、撮像素子を対象とした撮像光学系を有する撮像レンズと、前記撮像レンズを保持するレンズ保持体と、を有し、前記撮像レンズの前記撮像光学系は、物体側から順に配置された、開口絞りと、物体側と像面側共に両凸のパワーが正となる第1レンズと、物体側に凹のパワーが正となる第2レンズと、物体側に凹となる第3レンズと、物体側に凸となる両面非球面の第4レンズと、を含み、前記撮像光学系において上記の条件式(1)を満足する。

【0022】

好適には、電力供給手段を有し、前記光学モジュールは前記電力供給手段により電力の供給を受ける。

【発明の効果】

【0023】

本発明によれば、全長が短く、諸収差が良好に補正され、安価で生産効率の高い撮像レンズを提供することができる。

その結果、情報端末、携帯電話機等に搭載可能なコンパクトな撮像レンズを実現することができる。

【発明を実施するための最良の形態】

【0024】

以下、本発明の実施形態を添付図面に関連付けて説明する。

【0025】

図1は、本実施形態に係る撮像レンズの基本構成を示す図である。

【0026】

この撮像レンズ100は、図1に示すように、物体側OBJSから順に配置された、開口絞り部110、パワーが正となる第1レンズ120、パワーが正となる第2レンズ130、物体側が凹となる第3メニスカスレンズ140、物体側が凸となる第4メニスカスレンズ150、および撮像部160により構成されている。

【0027】

これらの構成要素のうち、開口絞り部110、パワーが正となる第1レンズ120、パワーが正となる第2レンズ130、物体側が凹となる第3メニスカスレンズ140、物体側が凸となる第4メニスカスレンズ150により撮像レンズ100の撮像光学系が構成されている。

【0028】

第1レンズ120は、たとえば物体側と像面側共に凸面であり物体側の面を非球面としたパワーが正となるレンズにより構成される。

第2レンズ130は、たとえば物体側に凹面としたパワーが正となるレンズにより構成される。

第3レンズ140は、たとえば物体側に凹となるパワーが負の両面非球面のメニスカスレンズにより構成される。

第4レンズ150は、たとえば物体側に凸となるパワーが正の両面非球面のメニスカスレンズにより構成される。

たとえば、第1レンズ120、第2レンズ130はガラスにより形成され、第3レンズ140および第4レンズ150は樹脂により形成される。

【0029】

撮像部160は、第4レンズ150側から、ガラス製の平行平板（カバーガラス）161と、たとえばCCDあるいはCMOSセンサ等からなる撮像素子162が順に配置されている。

撮像光学系を介した被写体（物体）からの光が、撮像素子162の撮像面上に結像される。

【0030】

以上の第1レンズ120、第2レンズ130、第3レンズ140、および第4レンズ150を有する撮像光学系は、第1レンズ、第2レンズが共に正のレンズ構成となっている。全長が短く、諸収差が良好に補正された撮像レンズを実現している。

【0031】

以上のような構成を有する本実施形態に係る撮像レンズ100は、携帯電話機等に搭載可能なようにコンパクト化を実現し、全長が短く、諸収差が良好に補正され、生産性を高くするため、以下に説明するような、各種条件が設定されている。

以下に、本実施形態に係る撮像レンズ100において設定された各条件について説明する。

【0032】

まず、本実施形態の撮像レンズ100においては、前述したように、物体側より、開口絞り部110、第1レンズ120、第2レンズ130、第3レンズ140および、第4レンズ150によって構成する。

さらに、撮像レンズ100においては、第1レンズ、第2レンズに正のパワー、第3レンズに負のパワーを集中させ、第4レンズはパワーを弱くし、非球面を使用して収差補正の効果を持たせている。

【0033】

本実施形態の撮像光学系において、第1レンズ120の焦点距離を $f_1$ 、第2レンズ130の焦点距離を $f_2$ とするととき下記の条件式(1)を満足する。

$$0.15 < f_1 / f_2 < 0.9 \quad \dots (\text{条件式1})$$

第1レンズ120、第2レンズ130はいずれも正のパワーを持つが、2枚のレンズに



バランスよくパワーを配分することで、各レンズの曲率を緩く、製造しやすい構成とすることができる。

## 【0034】

本実施形態の撮像光学系において、絞りから像面までの距離の全長をL、全系の焦点距離をfとするととき下記の条件式(2)を満足する。

$$1. 0 < L/f < 2.0 \quad \dots (\text{条件式2})$$

Lを大きく(全長を長く)してしまうとこの式は成り立たなくなるうえにコンパクト化という趣旨からはずれてしまう。さらに、1.0以下とすると性能を維持することが困難なうえに、十分な肉厚もしくはコバ厚を確保できなくなってしまう。以上のことから上記条件式1を満たすバランスが好ましい。

全長に対する規制を保持しつつ、性能を維持するため、さらに携帯カメラモジュールを前提としたとき性能と同時に全長に対する規制も加わるため下記の条件式(3)を満足することが好ましい。

$$1. 0 < L/f < 1.5 \quad \dots (\text{条件式3})$$

## 【0035】

本実施形態の撮像光学系において、好適には第4レン150ズには樹脂レンズを適用する。これはコストを安価に抑えることを目的とした条件である。ただし、樹脂レンズにおいて偏肉が大きいと成型時に不良となりやすい。このため、樹脂レンズの成型を容易にするため、下記の条件式(4)を満足するよう構成している。

$$0.55 < D4_{\min}/D4_{\max} \quad \dots (\text{条件式4})$$

ただし、D4<sub>min</sub>は有効径内における第4レンズの最薄肉厚を、D4<sub>max</sub>は有効径内における第4レンズの最厚肉厚をそれぞれ表している。

## 【0036】

本実施形態の撮像光学系において、第4レンズ140の焦点距離をf4とするととき下記の条件式(5)を満足する。

$$|1/f4| < 0.1 \quad \dots (\text{条件式5})$$

第4レンズ150は収差補正のためのレンズであり、非球面を多用した設計となっている。パワーを強くすると、非常に公差感度が厳しいレンズとなる。このため、製造しやすいレンズとするため、パワーを小さく抑えている。

## 【0037】

なお、レンズの非球面の形状は、物体側から像面側へ向かう方向を正とし、kを円錐係数、A、B、C、Dを非球面係数、rを中心曲率半径としたとき次式で表される。hは光線の高さ、cは中心曲率半径の逆数をそれぞれ表している。ただし、Zは面頂点に対する接平面からの深さを、Aは4次の非球面係数を、Bは6次の非球面係数を、Cは8次の非球面係数を、Dは10次の非球面係数をそれぞれ表している。

## 【0038】

## 【数1】

非球面方程式

$$Z = \frac{ch^2}{1 + \sqrt{1 - (1+k)c^2h^2}} + Ah^4 + Bh^6 + Ch^8 + Dh^{10}$$

## 【0039】

以上の構成を採ることにより、目的の撮像レンズを実現できる。

## 【0040】

また、図2に示すように、本実施形態の撮像レンズ100において、第1レンズ120の物体側面1の中心曲率半径はR1に、第1レンズ120の像面側面2の中心曲率半径はR2に、第2レンズの物体側面3の中心曲率半径はR3に、第2レンズ130の像面側面4の中心曲率半径はR4に、第3レンズ140の物体側面5の中心曲率半径はR5に、第

3レンズ140の像面側面6の中心曲率半径はR6に、第4レンズ150の物体側面7の中心曲率半径はR7に、第4レンズ150の像面側面8の中心曲率半径はR8に、撮像部160のカバーガラス161の第4レンズ150側の面9の中心曲率半径はR9に、カバーガラス161の撮像素子162側の面10の中心曲率半径はR10に設定されている。なお、カバーガラス161の両面9、10の中心曲率半径R9、R10は0である。また、第1レンズ120の屈折率は $n_1$ 、分散値は $\nu_1$ 、第2レンズ130の屈折率は $n_2$ 、分散値は $\nu_2$ 、第3レンズ140の屈折率は $n_3$ 、分散値は $\nu_3$ 、第4レンズ150の屈折率は $n_4$ 、分散値は $\nu_4$ に設定される。

## 【0041】

撮像レンズ100において、物体側OBJ Sより入射した光は、開口絞り部110を通過し、第1レンズ120の物体側R1面1、像面側R2面2、第2レンズ130の物体側R3面3、像面側R4面4、第3レンズ140の物体側R5面5、像面側R6面6、第4レンズ150の物体側R7面7、像面側R8面8、カバーガラス161の物体側R9面9、像面側R10面10を順次通過し撮像素子162へと集光される。

## 【0042】

また、図2に示すように、絞り部110と第1レンズ120のR1面1までの距離をD1、第1レンズ110の厚さとなるR1面1とR2面2間の距離をD2、第2レンズ130の厚さとなるR2面2とR3面3間の距離をD3、第2レンズ130のR3面3と第3レンズ140のR4面4間の距離をD4、第3レンズ140の厚さとなるR4面4とR5面5間の距離をD5、第3レンズ140のR5面5と第4レンズ150のR6面6間の距離をD6、第4レンズ150の厚さとなるR6面6とR7面7間の距離をD7、第4レンズ150のR7面7とカバーガラス161のR8面8間の距離をD8、カバーガラス161の厚さとなるR8面8間とR9面9の距離をD9とする。

## 【0043】

本実施形態のように、開口絞り部110を最も物体側に置くことによって、全長を短くして射出瞳を長くとることで撮像素子162への入射角度をできるだけ小さくする（浅くする）ことができる。

## 【0044】

以下に、撮像レンズの具体的な数値による実施例1～5を示す。なお、実施例2から4は第1レンズ、第2レンズ接合タイプの実施例である。第1レンズと第2レンズを接合することにより、全長を短くできるとともに、組み立て時の公差を小さくすることができるようになる。

## 【0045】

## (実施例1)

表1および表2に実施例1の各数値を示す。実施例の各数値は図1および図2の撮像レンズ100に対応している。

表1は、実施例1における撮像レンズの各面番号に対応した絞り、各レンズ、カバーガラスの曲率半径(R: mm)、間隔(D: mm)、屈折率(N)、および分散値( $\nu$ )を示している。

## 【0046】

【表1】

(実施例1)

	曲率半径		間隔		屈折率		分散値	
			D1	0.000	絞り			
1	R1	4.814	D2	0.750	N1	1.618	v 1	63.9
2	R2	-5.123	D3	0.100				
3	R3	-7.307	D4	0.750	N2	1.694	v 2	53.2
4	R4	-5.044	D5	0.569				
5	R5	-1.872	D6	0.809	N3	1.607	v 3	27
6	R6	-5.654	D7	0.924				
7	R7	2.61	D8	1.593	N4	1.53	v 4	55.8
8	R8	2.863	D9	0.500				
9	R9	0	D10	0.5	硝子			
10	R10	0						

【0047】

表2は、実施例1における非球面を含む第1レンズ120、第2レンズ130、第3レンズ140、及び第4レンズ150の所定面の非球面係数を示す。表2において、kは円錐定数を、Aは4次の非球面係数を、Bは6次の非球面係数を、Cは8次の非球面係数を、Dは10次の非球面係数をそれぞれ表している。

【0048】

【表2】

非球面方程式

$$Z = \frac{ch^2}{1 + \sqrt{1 - (1+k)c^2h^2}} + Ah^4 + Bh^6 + Ch^8 + Dh^{10}$$

(実施例1)

	実施例				
	円錐定数 k	A	B	C	D
1	6.27504	-0.0225	-0.006725	0.0001776	-0.0008011
2					
3					
4	8.16079	-0.03868	0.00776	0.0003529	
5	-0.41645	-0.06005	0.08468	-0.02514	0.002654
6	8.18908	-0.04750	0.05783	-0.01301	0.001240
7	-7.9805	-0.02847	0.005036	-0.0005198	
8	-6.86511	-0.01737	0.001628	-0.0001217	

## 【0049】

図3は、実施例1において、球面収差、非点収差、および歪曲収差を示す収差図である。図3(A)が球面収差、図3(B)が非点収差を、図3(C)が歪曲収差をそれぞれ示している。図3(C)中、破線Mはメリディオナル像面におけるd線の値、実線Sはサジタル像面におけるd線の値をそれぞれ示している。

図3からわかるように、実施例1によれば、球面、非点、歪曲の諸収差が良好に補正され、結像性能に優れた撮像レンズが得られる。

## 【0050】

(実施例2)

表3および表4に実施例2の各数値を示す。実施例の各数値は図4の撮像レンズ100Aに対応している。

表3は、実施例2における撮像レンズの各面番号に対応した絞り、各レンズ、カバーガラスの曲率半径(R: mm)、間隔(D: mm)、屈折率(N)、および分散値(ν)を示している。

## 【0051】

## 【表3】

(実施例2)

	曲率半径		間隔		屈折率		分散値	
			D1	0.100	絞り			
1	R1	3.947	D2	0.828	N1	1.743	ν 1	49.3
2	R2	-4.187	D3	0.750	N2	1.689	ν 2	31.2
3	R3	-8.835	D4	0.613				
4	R4	-1.607	D5	0.750	N3	1.632	ν 3	23.0
5	R5	-3.050	D6	0.978				
6	R6	3.592	D7	1.567	N4	1.53	ν 4	55.8
7	R7	3.475	D8	0.500				
8	R8	0	D9	0.500	硝子			
9	R9	0						

## 【0052】

表4は、実施例1における非球面を含む第1レンズ120、第2レンズ130、第3レンズ140、および第4レンズ150の所定面の非球面係数を示す。表4において、kは円錐定数を、Aは4次の非球面係数を、Bは6次の非球面係数を、Cは8次の非球面係数を、Dは10次の非球面係数をそれぞれ表している。

## 【0053】

【表4】

非球面方程式

$$Z = \frac{ch^2}{1 + \sqrt{1 - (1+k)c^2h^2}} + Ah^4 + Bh^6 + Ch^8 + Dh^{10}$$

(実施例2)

	実施例				
	円錐定数 k	A	B	C	D
1	5.97577	-0.02078	-0.003459	-0.003783	
2					
3	20.83574	-0.03527	0.0009645		
4	-0.49736	-0.009696	0.06422	-0.02328	0.002759
5	-0.52624	0.0001100	0.03895	-0.006683	
6	-21.40522	-0.004941	0.0002607		
7	-16.69088	-0.005082	-0.0002180		

## 【0054】

図5は、実施例2において、球面収差、非点収差、および歪曲収差を示す収差図である。図5(A)が球面収差、図5(B)が非点収差を、図5(C)が歪曲収差をそれぞれ示している。図5(C)中、破線Mはメリディオナル像面におけるd線の値、実線Sはサジタル像面におけるd線の値をそれぞれ示している。

図5からわかるように、実施例2によれば、球面、非点、歪曲の諸収差が良好に補正され、結像性能に優れた撮像レンズが得られる。

## 【0055】

(実施例3)

表5および表6に実施例3の各数値を示す。実施例の各数値は図6の撮像レンズ100Bに対応している。

表5は、実施例3における撮像レンズの各面番号に対応した絞り、各レンズ、カバーガラスの曲率半径(R: mm)、間隔(D: mm)、屈折率(N)、および分散値(ν)を示している。

## 【0056】

【表5】

(実施例3)

	曲率半径		間隔		屈折率		分散値	
			D1	0.050	絞り			
1	R1	3.081	D2	0.776	N1	1.743	ν 1	49.3
2	R2	-6.687	D3	0.750	N2	1.689	ν 2	31.2
3	R3	-9.931	D4	0.363				
4	R4	-1.670	D5	0.750	N3	1.632	ν 3	23.0
5	R5	-4.089	D6	1.066				
6	R6	2.798	D7	1.163	N4	1.53	ν 4	55.8
7	R7	2.512	D8	0.632				
8	R8	0	D9	0.300	硝子			
9	R9	0						

【0057】

表6は、実施例3における非球面を含む第1レンズ120、第2レンズ130、第3レンズ140、および第4レンズ150の所定面の非球面係数を示す。表6において、kは円錐定数を、Aは4次の非球面係数を、Bは6次の非球面係数を、Cは8次の非球面係数を、Dは10次の非球面係数をそれぞれ表している。

【0058】

【表6】

非球面方程式

$$Z = \frac{ch^2}{1 + \sqrt{1 - (1+k)c^2h^2}} + Ah^4 + Bh^6 + Ch^8 + Dh^{10}$$

(実施例3)

	実施例				
	円錐定数 k	A	B	C	D
1	1.7944	-0.01417	-0.002329	-0.004243	
2					
3	29.48045	-0.06769	-0.003153		
4	-0.23938	-0.05555	0.09008	-0.03686	0.004110
5	1.59477	-0.009667	0.06585	-0.01343	
6	-15.43648	-0.01813	0.001354		
7	-11.87367	-0.01213	-0.000244		

【0059】

図7は、実施例3において、球面収差、非点収差、および歪曲収差を示す収差図である。図7(A)が球面収差、図7(B)が非点収差を、図7(C)が歪曲収差をそれぞれ示している。図7(C)中、破線Mはメリディオナル像面におけるd線の値、実線Sはサジ

タル像面におけるd線での値をそれぞれ示している。

図7からわかるように、実施例3によれば、球面、非点、歪曲の諸収差が良好に補正され、結像性能に優れた撮像レンズが得られる。

【0060】

(実施例4)

表7および表8に実施例4の各数値を示す。実施例の各数値は図8の撮像レンズ100Cに対応している。

表7は、実施例4における撮像レンズの各面番号に対応した絞り、各レンズ、カバーガラスの曲率半径(R: mm)、間隔(D: mm)、屈折率(N)、および分散値(ν)を示している。

【0061】

【表7】

(実施例4)

	曲率半径		間隔		屈折率		分散値	
			D1	0.100	絞り			
1	R1	3.229	D2	0.875	N1	1.743	ν 1	49.3
2	R2	-4.380	D3	0.750	N2	1.689	ν 2	31.2
3	R3	-12.448	D4	0.412				
4	R4	-1.686	D5	0.750	N3	1.632	ν 3	23
5	R5	-3.153	D6	1.221				
6	R6	3.075	D7	1.043	N4	1.53	ν 4	55.8
7	R7	2.181	D8	0.550				
8	R8	0	D9	0.300	硝子			
9	R9	0						

【0062】

表8は、実施例4における非球面を含む第1レンズ120、第2レンズ130、第3レンズ140、および第4レンズ150の所定面の非球面係数を示す。表8において、kは円錐定数を、Aは4次の非球面係数を、Bは6次の非球面係数を、Cは8次の非球面係数を、Dは10次の非球面係数をそれぞれ表している。

【0063】

【表8】

非球面方程式

$$Z = \frac{ch^2}{1 + \sqrt{1 - (1+k)c^2h^2}} + Ah^4 + Bh^6 + Ch^8 + Dh^{10}$$

(実施例4)

	実施例				
	円錐定数 k	A	B	C	D
1	1.70492	-0.01228	-0.002219	-0.002384	
2					
3	32.70598	-0.05362	-0.001302		
4	-0.42689	-0.03343	0.08456	-0.03792	0.005450
5	-1.07384	0.001062	0.5569	-0.01103	
6	-29.8015	-0.01631	0.001200		
7	-13.84597	-0.01058	-0.0002732		

## 【0064】

図9は、実施例4において、球面収差、非点収差、および歪曲収差を示す収差図である。図9(A)が球面収差、図9(B)が非点収差を、図9(C)が歪曲収差をそれぞれ示している。図9(C)中、破線Mはメリディオナル像面におけるd線の値、実線Sはサジタル像面におけるd線の値をそれぞれ示している。

図9からわかるように、実施例4によれば、球面、非点、歪曲の諸収差が良好に補正され、結像性能に優れた撮像レンズが得られる。

## 【0065】

(実施例5)

表9および表10に実施例5の各数値を示す。実施例の各数値は図10の撮像レンズ100Dに対応している。

表9は、実施例5における撮像レンズの各面番号に対応した絞り、各レンズ、カバーガラスの曲率半径(R: mm)、間隔(D: mm)、屈折率(N)、および分散値(ν)を示している。

## 【0066】



【表9】

(実施例5)

	曲率半径		間隔		屈折率		分散値	
			D1	0.000	絞り			
1	R1	10.91	D2	1.157	N1	1.618	v 1	63.9
2	R2	-3.934	D3	0.1				
3	R3	-8.664	D4	1.605	N2	1.694	v 2	53.2
4	R4	-3.988	D5	0.553				
5	R5	-1.639	D6	0.838	N3	1.607	v 3	27
6	R6	-5.237	D7	0.795				
7	R7	1.954	D8	1.443	N4	1.53	v 4	55.8
8	R8	2.183	D9	0.5				
9	R9	0	D10	0.5	硝子			
10	R10	0						

【0067】

表10は、実施例5における非球面を含む第1レンズ120、第2レンズ130、第3レンズ140、および第4レンズ150の所定面の非球面係数を示す。

表10において、kは円錐定数を、Aは4次の非球面係数を、Bは6次の非球面係数を、Cは8次の非球面係数を、Dは10次の非球面係数をそれぞれ表している。

【0068】

【表10】

非球面方程式

$$Z = \frac{ch^2}{1 + \sqrt{1 - (1+k)c^2h^2}} + Ah^4 + Bh^6 + Ch^8 + Dh^{10}$$

(実施例5)

	実施例				
	円錐定数 k	A	B	C	D
1	11.5706	-0.0139	-0.0001	-0.0019	0.0006
2					
3					
4	3.0247	-0.0295	0.0087	0.00007916	
5	-0.25	-0.055	0.0842	-0.0244	0.0033
6	5.6043	-0.0702	0.0561	-0.0129	0.0013
7	-5.2864	-0.0258	0.0039	-0.0004	
8	-5.2071	-0.0122	0.0009	-0.0000635	

【0069】

図11は、実施例5において、球面収差、非点収差、および歪曲収差を示す収差図であ

る。図11(A)が球面収差、図11(B)が非点収差を、図11(C)が歪曲収差をそれぞれ示している。図11(C)中、破線Mはメリディオナル像面におけるd線の値、実線Sはサジタル像面におけるd線の値をそれぞれ示している。

図11からわかるように、実施例4によれば、球面、非点、歪曲の諸収差が良好に補正され、結像性能に優れた撮像レンズが得られる。

【0070】

以上説明したように、本実施形態によれば、撮像レンズ100が、物体側OBJSから順に配置された、開口絞り部110、パワーが正となる第1レンズ120、パワーが正となる第2レンズ130、物体側が凹となるパワーが負の第3メニスカスレンズ140、物体側が凸となる両面非球面の第4メニスカスレンズ150および撮像部160により構成されていることから、全長が短く、諸収差が良好に補正された撮像レンズを実現することができる。

収差補正において、各レンズ群のパワー配置を最適化することでコンパクト化を達成しており、さらに非球面を適宜配置することで、さらにコンパクト化を実現できる。これらの条件を最適化することにより、コンパクトなレンズにも関わらず高性能で、さらに歪曲を小さくすることができる利点がある。

なお、本実施例では、非球面を配置した場合について説明しているが球面であってもよい。

【0071】

撮像素子162への入射角度規制に対する射出瞳位置の条件を所望の条件に規定することにより、広画角、コンパクトでありながら、射出瞳の規制緩和を行うことが可能となる。

【0072】

以上説明したような特徴を有する撮像レンズ100、100A~100Dは、撮像素子を用いたデジタルスチルカメラや携帯電話搭載カメラ、携帯情報端末搭載カメラといった全長の規制の厳しい撮像装置に適用可能である。

特に、携帯電話機等にも搭載可能な好適なレンズ全長および高い光学性能を有することから、デジタル入力機器(カメラ(光学)モジュール)に適している。

【0073】

図12および図13は、本実施形態に係る撮像レンズを採用したカメラ(光学)モジュールを搭載した携帯電話機の一実施形態を示す外観斜視図である。携帯電話機1はいわゆる折り畳み式の携帯電話機として構成されており、図12は開状態を、図13は閉状態を示している。

【0074】

携帯電話機1は、受話筐体2と、送話筐体3とを備え、受話筐体2および送話筐体3は連結部4により開閉可能に連結されている。受話筐体2および送話筐体3は、閉状態で互いに対向する面(正面)側の正面側ケース2c、3cと、その背面側の背面側ケース2d、3dとをそれぞれ備えている。これらケースは、たとえば樹脂によりそれぞれ一体成形される。

【0075】

受話筐体2には、正面側に画像を表示するメイン表示部5と、その背面側に画像を表示するサブ表示部6とが、それぞれ各面に沿って設けられている。メイン表示部5およびサブ表示部6は、たとえば液晶表示ディスプレイによって構成される。また、受話筐体2には、背面側ケース2dに設けられた開口部2eから被写体を撮像するための光学モジュール7と、背面側から発光するストロボ8とが設けられている。

【0076】

送話筐体3は正面側に操作部9を備えている。操作部9には、テンキーボタン9a等の携帯電話機1を操作するための各種ボタンが配置されている。携帯電話機1は、テンキーボタン9aへの入力操作に応じて、無線通信や光学モジュール7による撮像を行う。

【0077】

なお、携帯電話機1の内部には、無線通信用の高周波回路やアンテナ、通話用のマイクやスピーカが設けられているが、図示は省略する。

また、同様に図示は省略しているが、操作部9の反対面にはカバーを有し、カバーを開放すると電池収納部があり、電力供給手段としての電池が収納されている。

本実施形態においては、この電池から光学モジュール7の駆動源に電力を供給することで、部品点数の削減、および携帯電話機1の小型化を実現している。

【0078】

光学モジュール7には、前述したように、本実施形態に係る撮像レンズ100、100A~100Dを採用している。

以下、光学モジュールの構成例について、図14(A)、(B)、および図15に関連付けて説明する。

【0079】

図14(A)は、光学モジュール7の概観斜視図、図14(B)は、図14(A)のI-I-I-I線における断面図である。なお、図14に設定した直交座標系のy軸方向が光軸方向であり、図14(A)の紙面左下側および図14(B)の紙面上方側が物体側(被写体側;図13の紙面上方側)である。

また、図15は、本実施形態の撮像レンズが搭載されるレンズユニットの内部構成を物体側(被写体側)からみた斜視図である。

【0080】

光学モジュール7は、光軸方向において、物体側(被写体側)から順に、被写体側カバー11、シャッターユニット12、レンズユニット14、基板カバー15および基板16が積層され、全体形状が光軸方向に薄い薄型直方体に概ね形成されている。

【0081】

具体的には、被写体側カバー11、レンズユニット14、基板カバー15、基板16は、光軸方向にみて略同程度の大きさの略矩形形状に形成されており、これら各部の側面は全体形状の側面を構成し、被写体側カバー11および基板16は全体形状の被写体側の面およびその裏面を構成している。光学モジュール7は比較的小型のモジュールとして構成されており、たとえば、光軸に直交する面の広さは22mm×16mm、光軸方向の厚さは6.9mmである。

【0082】

なお、光学モジュール7は、図14(B)および図15に示すように、レンズを光軸方向に駆動するためのモータ13を内蔵しており、レンズの光軸方向の移動による合焦位置の調整が可能である。

【0083】

被写体側カバー11は、全体として矩形の箱体状に形成され、被写体側の板面と、板面の外周を囲む側面とを有している。x軸方向の一端側には、被写体側カバー11の広さの略半分の大きさの矩形形状の開口部が開口し、シャッターユニット12の大部分が露出する。被写体側カバー11は、たとえば金属により形成されている。なお、光学モジュール7において、被写体側カバー11は、省略してもよい。

【0084】

シャッターユニット12は、外形が、全体としてレンズユニット14の略半分の広さを有する薄型の略直方体状に形成されている。

シャッターユニット12のレンズユニット14側には、光路を中心とする円形の凹部12aが設けられており、凹部12aには本実施形態の撮像レンズに相当するレンズ群21が挿入され、凹部12aはレンズ群21の移動領域の一部を規定することも可能である。

【0085】

モータ13は、光軸に対してシャッターユニット12と並列に、すなわち、光軸に直交する方向においてシャッターユニット12とモータ13とが配列されるようにレンズユニット14の被写体側に設けられている。また、モータ13はレンズ群21の径方向外側に位置する。

## 【0086】

レンズユニット14は、レンズ群21と、レンズ群21を保持するレンズ保持体22と、レンズ保持体22をレンズ群21の光軸方向に移動可能に保持する図示しないレンズ用基体とを備えている。

## 【0087】

レンズ群21は、図4に示すように、たとえば、4枚の光学レンズを含んで構成され、被写体側から第1レンズ群23（図4等の第1レンズ120、第2レンズ130を接合したもの）、第2レンズ24（図1等の第3レンズ140）、第3レンズ25（図1等の第4レンズ150）の順に積層されている。第1レンズ群23、第2レンズ24、第3レンズ25は、被写体側から徐々に径が大きくなるように構成されている。なお、単一のレンズがレンズ保持体22に保持されていてもよい。また、本実施形態では、図4のレンズ群の場合について説明したが、図1のように、第1レンズ120と第2レンズ130を分離したものでもよい。

## 【0088】

レンズ保持体22は、各レンズ23、24、25がそれぞれ嵌合挿入されるように、階段状に縮径する円形の凹部を有している。当該凹部に第1レンズ群23、第2レンズ24、第3レンズ25の順に各レンズが収納されて積層され、さらにリング状のリテーナ26が積層されるとともに、リテーナ26がレンズ保持体22に接着剤等の固定手段により固定されることにより、レンズ群21はレンズ保持体22に保持される。レンズ保持体22は、たとえば樹脂により形成されている。

## 【0089】

基板カバー15は、たとえば樹脂により形成され、全体形状は概ね薄型の直方体である。基板カバー15には、光路を確保するための開口部が設けられている。また、基板カバー15の基板16側には、基板16に設けられる各種の部品を収容可能な凹部15b（図14（B）参照）が複数設けられている。なお、基板カバー15のレンズユニット14側にはIRカットフィルタが設けられている。

## 【0090】

基板16は、硬質の基板材料により剛体の基板として構成され、全体として略矩形形状に形成されている。基板16は、たとえば硬質の樹脂により形成された絶縁層に、パターン層、グランド層、電源層が積層された多層式のプリント基板である。

## 【0091】

なお、図14（A）および図14（B）に示すように、基板16は、光学モジュール7の全体形状における被写体側の反対側の面を構成しており、光学モジュール7が携帯電話機1に実装される際には、たとえば、基板16の被写体側と反対側の面16aが、携帯電話機1の内部に設けられた不図示の基板等の適宜な部材に当接し、携帯電話機1に保持される。フレキシブルプリント配線基板（FPC27）には、携帯電話機1の内部に設けられた基板等と接続するためのコネクタ28が設けられている。

## 【0092】

撮像素子29は、たとえばCCDやCMOSセンサにより形成され、受光した光に応じた信号を出力する。撮像素子29により出力された信号は、基板16およびFPC27を介して携帯電話機1の表示部用の基板等に設けられた画像処理部に出力されて処理される。そして光像の画像はメイン表示部5またはサブ表示部6に表示される。

この撮像素子29は、図1等の撮像レンズ100、100A～100Dの撮像素子150に相当する。

## 【0093】

レンズ保持体22は、レンズ21の径方向外側に突出する被案内22a、22bを備えている。被案内22aには貫通孔22cが設けられ、当該貫通孔22cにガイド軸51が挿通されている。ガイド軸51は光軸方向に延びてレンズ用基体に固定されており、被案内22aを光軸方向に案内する。被案内22bは、レンズ用基体に設けられた凹状のレール部に挿入されている。

## 【0094】

モータ13は、たとえばステッピングモータにより構成され、ロータ等を含むモータ本体13aと、モータ本体13aから延出し、回転駆動される出力軸13bとを有している。モータ本体13aはたとえば略円筒形に形成され、出力軸13bは当該円筒形の端面から延出する。

## 【0095】

図15に示すように、モータ本体13aは、出力軸13b方向の長さが出力軸13bに直交する方向の幅よりも大きい。また、モータ本体13aの長さとして出力軸13bの長さを積算した長さは、レンズ群21の径よりも大きく、モータ本体13aの出力軸13bに直交する方向の幅はレンズ群21の光軸方向の厚さよりも小さい(図14(B)参照)。

## 【0096】

モータ13は、出力軸13bが、光軸に直交する方向であってシャッタユニット12との配列方向に対して直交する方向(z軸方向)に沿って延びるように配置されている。すなわち、モータ13の全体形状における長手方向を光軸に直交に、短手方向を光軸に平行にして配置されている。

## 【0097】

モータ本体13aのシャッタユニット12と反対側の側面には、端子フォルダ52が設けられており、端子フォルダ52の端子52aは、FPCに接続されている。

モータ13の動作は、携帯電話機1の不図示の制御部により、FPC27や基板16、端子フォルダ52を介して制御される。

## 【0098】

図15に示すように、レンズユニット14には、モータ13の出力軸13bの回転を光軸方向の直線運動に変換してレンズ保持体22に伝達する伝達機構53が設けられている。

## 【0099】

伝達機構53は、モータ13の出力軸13bに設けられるウォーム54と、ウォーム54と噛合するウォームホイール55と、ウォームホイール55と噛合するカムギア56とを備えている。なお、ウォーム54、ウォームホイール55およびカムギア56は後述するカム部56bを駆動するカム駆動部として機能する。

## 【0100】

ウォーム54とウォームホイール55とはウォーム歯車装置を構成し、出力軸13bの光軸に直交する軸回りの回転を光軸に平行な軸回りの回転に変換する。すなわち、ウォーム54は光軸に直交する軸回りに回転し、ウォームホイール55はウォーム54により伝達された駆動力により光軸に平行な軸回りに回転する。

## 【0101】

また、図15に示すように、レンズユニット14には、カムギア56のカム部56bの内側の突起部の有無検出により、回転位置の検出、ひいてはレンズ保持体22の光軸方向の位置の検出をするための光電センサ61が設けられている。

## 【0102】

カムギア56は、外周部の一部にギア部56aを、外周部の他の一部にカム部56bを備えている。ギア部56aおよびカム部56bは、それぞれカムギア56の略半周に亘って形成されている。ギア部56aはウォームホイール55と噛合し、カムギア56は光軸に平行な軸回りに回転する。

## 【0103】

カム部56bは、カムギア56の回転軸に直交する面に対して傾斜する、すなわち、光軸に直交する面に傾斜するカム面56cを有している。一方、レンズ保持体22は、カム面56cに当接する当接部22dを有しており、当接部22dはカムギア56の回転に伴ってカム面56cに摺動可能である。

## 【0104】

このように、本実施形態の撮像レンズ100、100A~100Dは、撮像素子を用い

たデジタルスチルカメラや携帯電話搭載カメラ、携帯情報端末搭載カメラといった全長の規制の厳しい撮像装置に容易に搭載可能である。

また、撮像レンズ100、100A～100Dは、携帯電話機等にも搭載可能な好適なレンズ全長を有していることはもとより、高い光学性能を有することから、高精度な画像を得ることが可能である。

【図面の簡単な説明】

【0105】

【図1】本実施形態の撮像レンズの基本構成を示す図である。

【図2】本実施形態において、撮像レンズの絞り部、各レンズ、並びに撮像部を構成するカバーガラスに対して付与した面番号を示す図である。

【図3】実施例1において、球面収差、非点収差、および歪曲収差を示す収差図である。

【図4】実施例2において採用した撮像レンズの構成を示す図である。

【図5】実施例2において、球面収差、非点収差、および歪曲収差を示す収差図である。

【図6】実施例3において採用した撮像レンズの構成を示す図である。

【図7】実施例3において、球面収差、非点収差、および歪曲収差を示す収差図である。

【図8】実施例4において採用した撮像レンズの構成を示す図である。

【図9】実施例4において、球面収差、非点収差、および歪曲収差を示す収差図である。

【図10】実施例5において採用した撮像レンズの構成を示す図である。

【図11】実施例5において、球面収差、非点収差、および歪曲収差を示す収差図である。

【図12】本実施形態に係る撮像レンズを採用したカメラ（光学）モジュールを搭載した携帯電話機の一実施形態を示す外観斜視図であって、開状態を示す図である。

【図13】本実施形態に係る撮像レンズを採用したカメラ（光学）モジュールを搭載した携帯電話機の一実施形態を示す外観斜視図であって、閉状態を示す図である。

【図14】本実施形態に係る光学モジュールの概観斜視図と断面図である。

【図15】本実施形態の撮像レンズが搭載されるレンズユニットの内部構成を物体側（被写体側）からみた斜視図である。

【符号の説明】

【0106】

- 100、100A～100D・・・撮像レンズ
- 110・・・開口絞り部
- 120・・・第1レンズ
- 130・・・第2レンズ
- 140・・・第3レンズ
- 150・・・第4レンズ
- 161・・・ガラス製の平行平板（カバーガラス）
- 162・・・撮像素子

【図1】

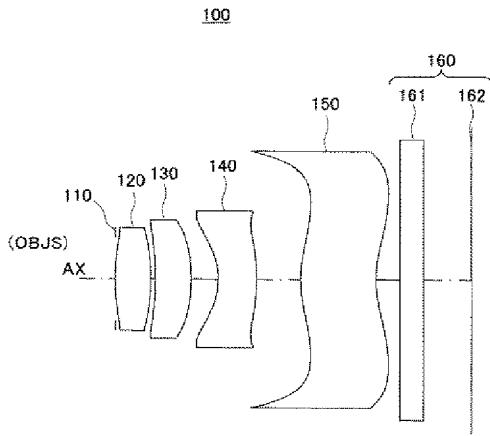

【図2】

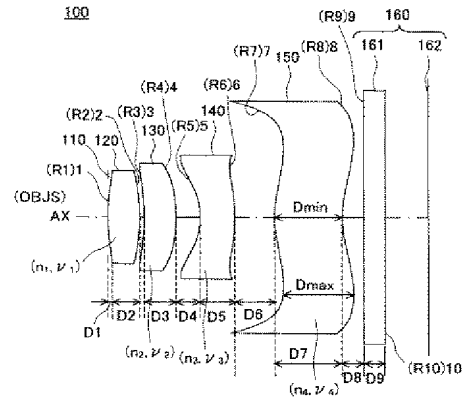

【図3】

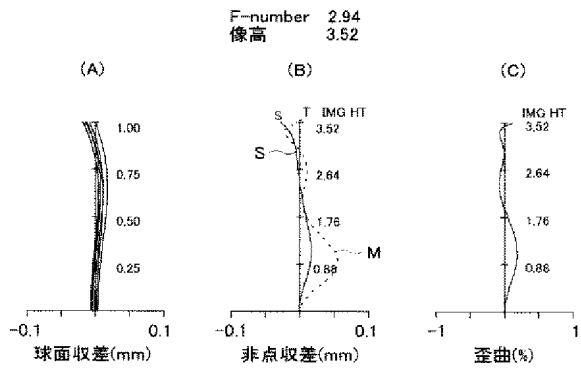

【図4】

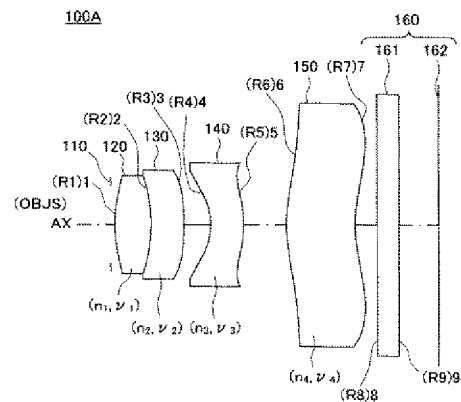

【図5】

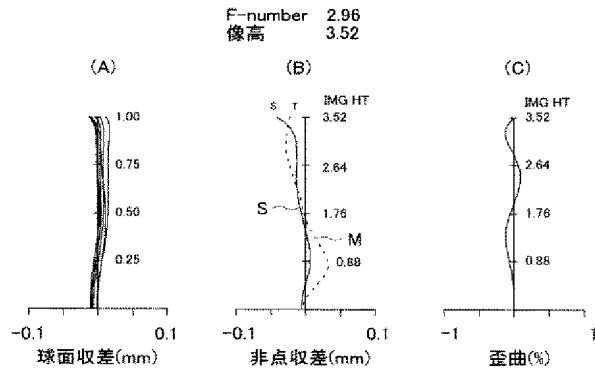

【図6】

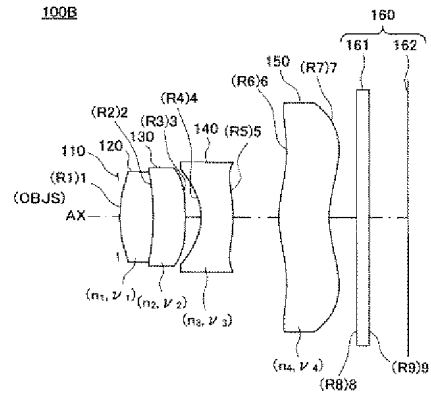

【図7】

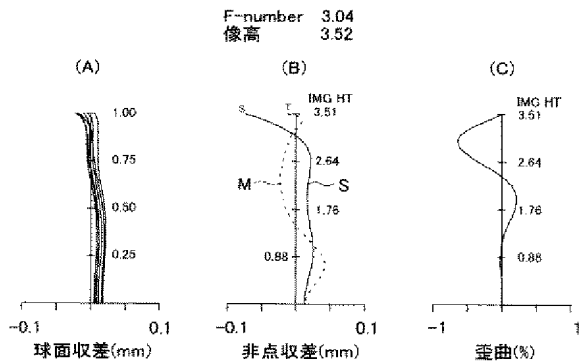

【図9】

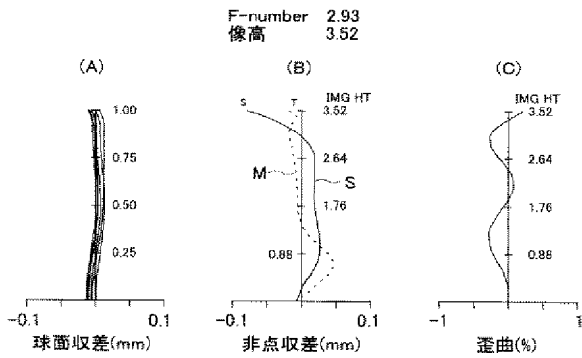

【図8】

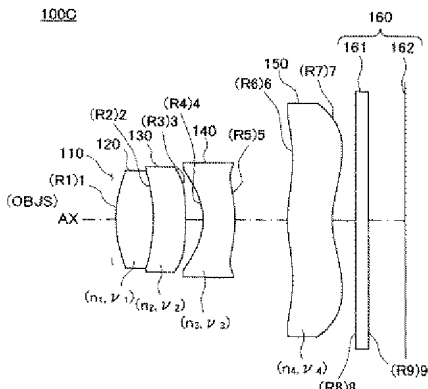

【図10】

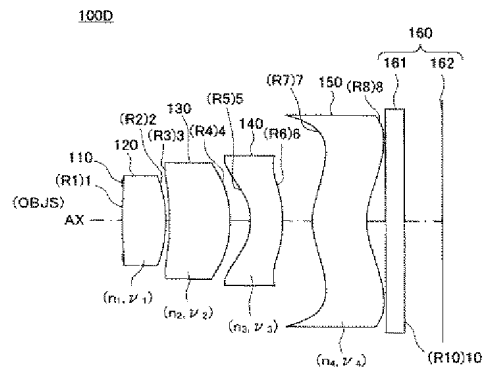



【図11】

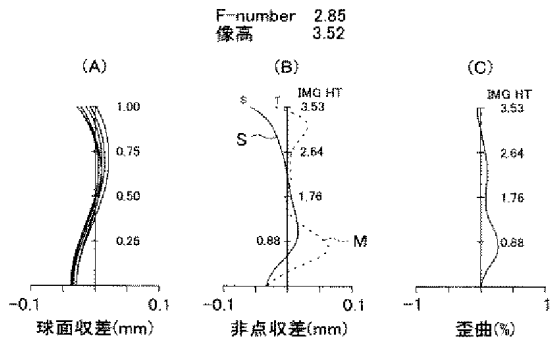

【図12】

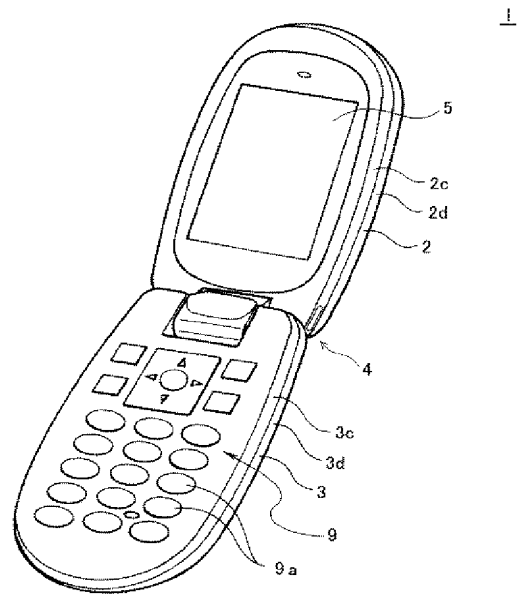

【図13】

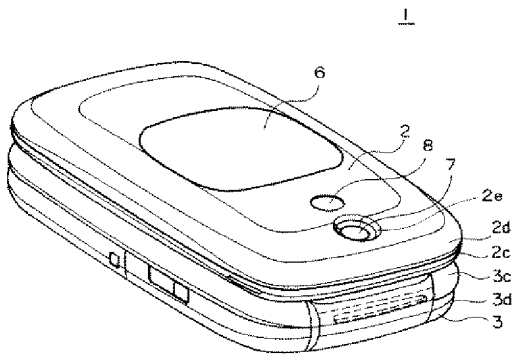

【図14】

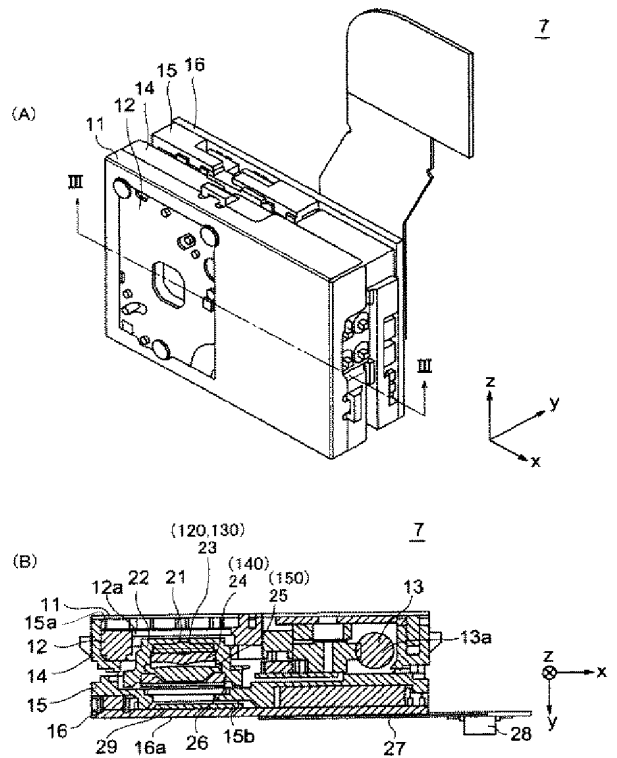

【図15】

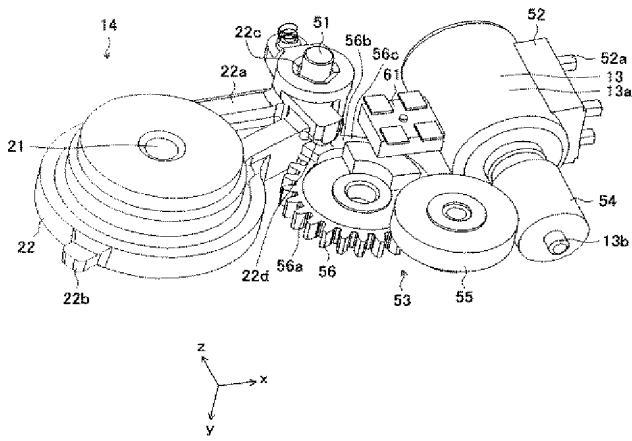



(19) 日本国特許庁 (JP)

(12) 公開特許公報 (A)

(11) 特許出願公開番号

特開2009-192819

(P2009-192819A)

(43) 公開日 平成21年8月27日 (2009.8.27)

(51) Int. Cl.	F 1	テーマコード (参考)
<b>GO 2 B 13/00 (2006.01)</b>	GO 2 B 13/00	2 H 0 8 7
<b>GO 2 B 13/18 (2006.01)</b>	GO 2 B 13/18	

審査請求 未請求 請求項の数 5 O L (全 12 頁)

(21) 出願番号 特願2008-33396 (P2008-33396)  
 (22) 出願日 平成20年2月14日 (2008.2.14)

(71) 出願人 000005430  
 フジノン株式会社  
 埼玉県さいたま市北区植竹町 1 丁目 3 2 4  
 番地  
 (74) 代理人 100109656  
 弁理士 三反崎 泰司  
 (74) 代理人 100098785  
 弁理士 藤島 洋一郎  
 (72) 発明者 篠原 義和  
 埼玉県さいたま市北区植竹町 1 丁目 3 2 4  
 番地 フジノン株式会社内  
 F ターム (参考) 2H087 KA01 LA01 PA04 PA17 PB04  
 QA02 QA06 QA12 QA21 QA26  
 QA32 QA42 QA45 RA05 RA12  
 RA13 RA42 RA43

(54) 【発明の名称】 撮像レンズおよび撮像装置

(57) 【要約】

【課題】 広角化を図りやすく、かつ製造適正の良いレンズ系を実現できるようにした撮像レンズ、およびその撮像レンズを搭載して高解像の撮像画像を得ることができる撮像装置を提供する。

【解決手段】 物体側から順に、正レンズからなる第1レンズG1と、絞りStと、正レンズからなる第2レンズG2と、負メニスカスレンズからなる第3レンズG3と、光軸近傍の形状が物体側に凸面を向けた正メニスカスレンズである第4レンズG4とを備え、第2レンズG2と第3レンズG3との間の空気間隔が、光軸近傍よりも周辺部の方が小さくなるようにし、かつ、以下の条件を満足するように構成する。ただし、f1は第1レンズG1の焦点距離、f2は第2レンズG2の焦点距離、f3は第3レンズG3の焦点距離、fは全系の焦点距離とする。

$f 1 > f 2 > | f 3 | \dots (1)$

$1.0 < f / f 2 < 1.5 \dots (2)$

【選択図】 図1

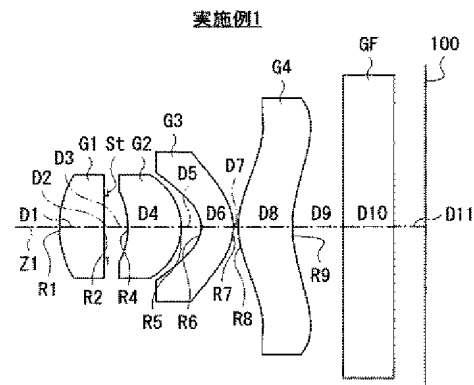

## 【特許請求の範囲】

## 【請求項1】

物体側から順に、

物体側に凸面を向けた正レンズからなる第1レンズと、

絞りと、

像側に凸面を向けた正レンズからなる第2レンズと、

物体側に凹面を向けた負メニスカスレンズからなる第3レンズと、

光軸近傍の形状が物体側に凸面を向けた正メニスカスレンズである第4レンズと

を備え、

前記第2レンズと前記第3レンズとの間の空気間隔が、光軸近傍よりも周辺部の方が小さくなるように構成され、

かつ、以下の条件を満足する

ことを特徴とする撮像レンズ。

$$f_1 > f_2 > |f_3| \quad \dots (1)$$

$$1.0 < f/f_2 < 1.5 \quad \dots (2)$$

ただし、

$f_1$  : 第1レンズの焦点距離

$f_2$  : 第2レンズの焦点距離

$f_3$  : 第3レンズの焦点距離

$f$  : 全系の焦点距離

とする。

## 【請求項2】

さらに以下の条件を満足する

ことを特徴とする請求項1に記載の撮像レンズ。

$$\nu d_3 < 35 \quad \dots (3)$$

ただし、

$\nu d_3$  : 第3レンズのd線に関するアッベ数

とする。

## 【請求項3】

さらに以下の条件を満足する

ことを特徴とする請求項1または2に記載の撮像レンズ。

$$0.2 < Bf/TL < 0.5 \quad \dots (4)$$

ただし、

$Bf$  : バックフォーカス (空気換算長)

$TL$  : 全長 (最も物体側の面から像面までの光軸上距離)

とする。

## 【請求項4】

さらに以下の条件を満足する

ことを特徴とする請求項1ないし3のいずれか1項に記載の撮像レンズ。

$$0.7 < Y_{max}/f < 0.9 \quad \dots (5)$$

ただし、

$Y_{max}$  : 最大像高

とする。

## 【請求項5】

請求項1ないし4のいずれか1項に記載の撮像レンズと、

前記撮像レンズによって形成された光学像に応じた撮像信号を出力する撮像素子と

を備えたことを特徴とする撮像装置。

## 【発明の詳細な説明】

## 【技術分野】

【0001】

本発明は、CCD (Charge Coupled Device) やCMOS (Complementary Metal Oxide Semiconductor) 等の撮像素子上に被写体の光学像を結像させる撮像レンズ、およびその撮像レンズを搭載して撮影を行うデジタルスチルカメラやカメラ付き携帯電話機および情報携帯端末 (PDA: Personal Digital Assistance) 等の撮像装置に関する。

【背景技術】

【0002】

近年、パーソナルコンピュータの一般家庭等への普及に伴い、撮影した風景や人物像等の画像情報をパーソナルコンピュータに入力することができるデジタルスチルカメラが急速に普及している。また、携帯電話に画像入力用のカメラモジュールが搭載されることも多くなっている。このような撮像機能を有する機器には、CCDやCMOSなどの撮像素子が用いられている。近年、これらの撮像素子のコンパクト化が進み、撮像機器全体ならびにそれに搭載される撮像レンズにも、コンパクト性が要求されている。また同時に、撮像素子の高画素化も進んでおり、撮像レンズの高解像、高性能化が要求されている。例えば2メガピクセル以上、さらに好適には5メガピクセル以上の高画素に対応した性能が要求されている。

【0003】

このような要求を満足するために、従来では、全体として4枚のレンズを用いた構成の撮像レンズが開発されている (特許文献1ないし3参照)。

【0004】

【特許文献1】特開2002-228922号公報

【特許文献2】特開2004-53813号公報

【特許文献3】特開2004-102234号公報

【発明の開示】

【発明が解決しようとする課題】

【0005】

従来、4枚構成の撮像レンズにおいて、開口絞りを最も物体側に配置したものが知られている (特許文献1参照)。しかしながら、広角化になるに従い、開口絞りを最も物体側に配置すると、製造誤差やレンズ面の位置ずれに対する性能劣化の感度が大きくなりやすく、製造適正が悪くなる傾向となる。一方、特許文献2、3には、開口絞りを第1レンズと第2レンズとの間に配置した撮像レンズが開示されているが、レンズ系内で相対的に第1レンズのパワーが強く、広角化を図ろうとすると、特に像面湾曲の性能劣化が生じてしまい、性能的に不十分なレンズ系となってしまう。広角化を図ったとしても、高性能な、例えば2メガピクセル以上、さらに好ましくは5メガピクセルから10メガピクセル程度の高画素にも対応した性能のレンズの開発が望まれている。

【0006】

本発明はかかる問題点に鑑みてなされたもので、その目的は、広角化を図りやすく、かつ製造適正の良いレンズ系を実現できるようにした撮像レンズ、およびその撮像レンズを搭載して高解像の撮像画像を得ることができる撮像装置を提供することにある。

【課題を解決するための手段】

【0007】

本発明による撮像レンズは、物体側から順に、物体側に凸面を向けた正レンズからなる第1レンズと、絞りと、像側に凸面を向けた正レンズからなる第2レンズと、物体側に凹面を向けた負メニスカスレンズからなる第3レンズと、光軸近傍の形状が物体側に凸面を向けた正メニスカスレンズである第4レンズとを備え、第2レンズと第3レンズとの間の空気間隔が、光軸近傍よりも周辺部の方が小さくなるように構成され、かつ、以下の条件を満足するものである。ただし、 $f_1$ は第1レンズの焦点距離、 $f_2$ は第2レンズの焦点距離、 $f_3$ は第3レンズの焦点距離、 $f$ は全系の焦点距離とする。

$$f_1 > f_2 > |f_3| \quad \dots (1)$$

$$1.0 < f/f_2 < 1.5 \quad \dots (2)$$

## 【0008】

本発明による撮像レンズでは、全体として4枚構成のレンズ系において、各レンズ要素の構成が適切なものとされていることで、広角化を図りやすく、製造適正の良いレンズ系を得やすくなる。特に、絞りを第1レンズと第2レンズとの間に配置していることで、製造誤差等に対する性能劣化の感度が小さくなり、製造適正に優れている。また、レンズ系内で相対的に第1レンズのパワーを弱くする一方、第2レンズおよび第3レンズのパワーを強くすることで、広角化に伴う像面湾曲の性能劣化等を改善し、広角化しやすくなっている。

そして、さらに、次の好ましい構成を適宜採用して満足することで、光学性能をより良好なものとすることができると共に、広角化を図りやすくなる。

## 【0009】

本発明による撮像レンズは、以下の条件を満足することが好ましい。これにより、色収差の補正に有利となる。ただし、 $\nu d 3$ は第3レンズのd線に関するアッベ数とする。

$$\nu d 3 < 35 \quad \dots\dots (3)$$

## 【0010】

また、以下の条件を満足することが好ましい。これにより、全長の短縮化を図りつつ、フィルタ等の光学部材を配置するのに必要なバックフォーカスが確保される。

$$0.2 < Bf / TL < 0.5 \quad \dots\dots (4)$$

ただし、 $Bf$ はバックフォーカス(空気換算長)、 $TL$ は全長(最も物体側の面から像面までの光軸上距離)とする。

## 【0011】

また、本発明による撮像レンズは、以下の条件を満足し、比較的広角側での使用に適している。

$$0.7 < Y_{max} / f < 0.9 \quad \dots\dots (5)$$

ただし、 $Y_{max}$ は最大像高とする。

## 【0012】

本発明による撮像装置は、本発明による撮像レンズと、この撮像レンズによって形成された光学像に応じた撮像信号を出力する撮像素子とを備えたものである。

本発明による撮像装置では、本発明の撮像レンズによって得られた比較的広角で高解像の光学像に基づいて高解像の撮像信号が得られる。

## 【発明の効果】

## 【0013】

本発明の撮像レンズによれば、全体として4枚構成のレンズ系において、各レンズ要素の構成を最適化し、特に絞りを第1レンズと第2レンズとの間に配置すると共に、レンズ系内で相対的に第1レンズのパワーを弱くする一方、第2レンズおよび第3レンズのパワーを強くするようにしたので、広角化を図りやすく、製造適正の良いレンズ系を実現できる。

## 【0014】

また、本発明の撮像装置によれば、上記本発明の高性能の撮像レンズによって形成された光学像に応じた撮像信号を出力するようにしたので、比較的広角で高解像の撮影画像を得ることができる。

## 【発明を実施するための最良の形態】

## 【0015】

以下、本発明の実施の形態について図面を参照して詳細に説明する。

図1は、本発明の一実施の形態に係る撮像レンズの第1の構成例を示している。この構成例は、後述の第1の数値実施例(図6(A)、(B))のレンズ構成に対応している。図2～図5は、第2～第5の構成例を示しており、後述の第2～第5の数値実施例(図7(A)、(B)～図10(A)、(B))のレンズ構成に対応している。図1～図5において、符号 $R_i$ は、最も物体側の構成要素の面を1番目として、像側(結像側)に向かうに従い順次増加するようにして符号を付した $i$ 番目の面の曲率半径を示す。符号 $D_i$ は、

i 番目の面と i + 1 番目の面との光軸 Z 1 上の面間隔を示す。

【0016】

本実施の形態に係る撮像レンズは、CCDやCMOS等の撮像素子を用いた各種撮像機器、特に、比較的小型の携帯端末機器、例えばデジタルスチルカメラ、カメラ付き携帯電話機、およびPDA等に用いて好適なものである。この撮像レンズは、光軸Z1に沿って、物体側から順に、第1レンズG1と、第2レンズG2と、第3レンズG3と、第4レンズG4とを備えている。この撮像レンズはまた、絞りStを有している。絞りStは、光学的な開口絞りであり、第1レンズG1と第2レンズG2との間に配置されている。

【0017】

本実施の形態に係る撮像装置は、本実施の形態に係る撮像レンズと、この撮像レンズによって形成された光学像に応じた撮像信号を出力するCCDなどの撮像素子100とを備えて構成される。撮像素子100は、この撮像レンズの結像面（撮像面）に配置される。第4レンズG4と撮像素子100の間には、レンズを装着するカメラ側の構成に応じて、種々の光学部材GFが配置されていても良い。例えば撮像面保護用のカバーガラスや赤外線カットフィルタなどの平板状の光学部材が配置されていても良い。この場合、光学部材GFとして例えば平板状のカバーガラスに、赤外線カットフィルタやNDフィルタ等のフィルタ効果のあるコートが施されたものを使用しても良い。

【0018】

また、この撮像レンズにおいて、第1レンズG1ないし第4レンズG4のすべて、または少なくとも1つのレンズ面に赤外線カットフィルタやNDフィルタ等のフィルタ効果のあるコートや、反射防止のコートが施されていても良い。

【0019】

この撮像レンズにおいて、第1レンズG1は物体側に凸面を向けた正レンズからなる。第1レンズG1は物体側に凸面を向けた正メニスカスレンズであることが好ましい。第2レンズG2は、像側に凸面を向けた正レンズからなる。第2レンズG2は像側に凸面を向けた正メニスカスレンズであることが好ましい。第3レンズG3は、物体側に凹面を向けた負メニスカスレンズからなる。

【0020】

第4レンズG4は、光軸近傍の形状が物体側に凸面を向けた正メニスカスレンズとされている。第4レンズG4の両面は非球面形状とされている。第1レンズG1、第2レンズG2、および第3レンズG3のそれぞれについても、少なくとも1面に非球面を含んでいることが好ましい。第4レンズG4は、像側の面が、光軸近傍では像側に凹形状で、周辺部では像側に凸形状となるような非球面とされていることが好ましい。また物体側の面が、光軸近傍において物体側に凸形状であると共に周辺部では物体側に凹形状となるような非球面とされていることが好ましい。ここで、非球面形状に関しては、特に、第4レンズG4を中心部と周辺部とで異なる形状に変化させることで、像面の中心部から周辺部にわたって像面湾曲を良好に補正することができる。第4レンズG4では、第1レンズG1、第2レンズG2、および第3レンズG3に比べて、画角ごとに光束が分離される。このため、撮像素子100に最も近い最終レンズ面である第4レンズG4の像側の面を、光軸近傍において像側に凹形状で周辺部において像側に凸形状となるようにすることで、画角ごとの収差補正が適切になされ、光束の撮像素子への入射角度が一定の角度以下に制御される。従って、結像面全域における光量むらを軽減することができると共に、像面湾曲や歪曲収差等の補正に有利となる。

【0021】

本実施の形態に係る撮像レンズは、以下の条件を満足し、レンズ系内で相対的に第1レンズG1のパワーを弱くする一方、第2レンズG2および第3レンズG3のパワーが比較的強くなるような構成とされている。第3レンズG3のパワーを強くするために、第2レンズG2と第3レンズG3との間の空気間隔D5は、光軸近傍よりも周辺部の方が小さくなるように構成されている。そのような構成とすることで、第3レンズG3の物体側の面の曲率半径R6の絶対値が、第2レンズG2の像側の面の曲率半径R5の絶対値よりも小



さくなり、第3レンズG3のパワーを強くすることができる。

$$f_1 > f_2 > |f_3| \dots (1)$$

$$1.0 < f/f_2 < 1.5 \dots (2)$$

ただし、 $f_1$ は第1レンズG1の焦点距離、 $f_2$ は第2レンズG2の焦点距離、 $f_3$ は第3レンズG3の焦点距離、 $f$ は全系の焦点距離とする。

【0022】

また、以下の条件を満足することが好ましい。ただし、 $\nu d_3$ は第3レンズG3のd線に関するアッペ数とする。また、 $Bf$ はバックフォーカス(空気換算長)、 $TL$ は全長(最も物体側の面から像面までの光軸上距離)とする。 $Y_{max}$ は最大像高とする。

$$\nu d_3 < 35 \dots (3)$$

$$0.2 < Bf/TL < 0.5 \dots (4)$$

$$0.7 < Y_{max}/f < 0.9 \dots (5)$$

【0023】

次に、以上のように構成された撮像レンズの作用および効果、特に条件式に関する作用および効果をより詳細に説明する。

【0024】

本実施の形態に係る撮像レンズでは、全体として4枚構成のレンズ系において、各レンズ要素の構成が適切なものとされていることで、広角化を図りやすく、製造適正の良いレンズ系を得やすくなる。特に、絞り $St$ を第1レンズG1と第2レンズG2との間に配置していることで、製造誤差等に対する性能劣化の感度が小さくなり、製造適正に優れている。

【0025】

また、条件式(1)、(2)を満足して、レンズ系内で相対的に第1レンズG1のパワーを弱くする一方、第2レンズG2および第3レンズG3のパワーを強くすることで、広角化に伴う像面湾曲の性能劣化等を改善し、広角化しやすくなっている。より詳しくは、条件式(1)における、 $f_1 > f_2$ の関係を満たすことで、正レンズのうち、第2レンズG2が主たる結像機能を占めることになり、広角化を図った場合に像面湾曲の少ない性能の良いレンズ系が得られる。 $f_1 > f_2$ の関係が逆転すると像面湾曲が大きなレンズ系になってしまう。また、 $f_2 > |f_3|$ の関係を満たすことで、軸上色収差と倍率色収差を軽減することができ高画素化に対応したレンズ系となる、 $f_2 > |f_3|$ の関係が逆転すると、色収差の大きなレンズ系になってしまう。

【0026】

条件式(2)は、全体に占める第2レンズG2のパワーが大きいことを意味している。条件式(2)の下限を下回ると第1レンズG1にパワーが集中して像面湾曲が大きいレンズ系になってしまう。条件式(2)の上限を超えて第2レンズG2のパワーが強くなりすぎると軸上色収差と倍率色収差の大きいレンズ系になってしまう。より良好な収差補正を行うために、第2レンズG2に関して以下の条件式(2A)を満たすことが好ましい。

$$1.0 < f/f_2 < 1.3 \dots (2A)$$

【0027】

条件式(3)は、第3レンズG3の適切な分散を規定している。条件式(3)の上限を超えると色収差補正が不十分になってしまう。より良好な色収差補正を行うためには、第3レンズG3のアッペ数 $\nu d_3$ が以下の条件式(3A)を満たすことが好ましい。

$$\nu d_3 < 30 \dots (3A)$$

【0028】

条件式(4)は、全長 $TL$ に占めるバックフォーカス $Bf$ の割合を示している。なお、条件式(4)におけるバックフォーカス $Bf$ の値は、フィルタやカバーガラス等が配置されている場合には空気換算長とする。条件式(4)の下限を下回るとバックフォーカスが短くなり、赤外カットフィルタやローパスフィルタやカバーガラス等を配置するスペースが確保できなくなってしまう。また逆に上限を超えてバックフォーカスが長くなりすぎると、全長が長くなりすぎて商品価値の低い設計になってしまう。バックフォーカス $Bf$ に

関しては、以下の条件式(4A)を満たすことがより好ましい。

$$0.3 < Bf / TL < 0.5 \quad \dots (4A)$$

【0029】

条件式(5)は、撮影画角に相当するものである。本実施の形態に係る撮像レンズは、条件式(5)を満足するような、比較的広角側での使用に適している。

【0030】

以上のようにして、本実施の形態に係る撮像レンズによれば、全体として4枚構成のレンズ系において、各レンズ要素の構成を最適化するようにしたので、広角化を図りやすく、製造適正の良いレンズ系を実現できる。また、適宜好ましい条件を満足することで、広角化を図ったとしても、高性能な、例えば2メガピクセル以上、さらに好適には5メガピクセルから10メガピクセルの高画素にも対応した性能を得ることができる。また、本実施の形態に係る撮像装置によれば、本実施の形態に係る高性能の撮像レンズによって形成された光学像に応じた撮像信号を出力するようにしたので、比較的広角で高解像の撮影画像を得ることができる。

【実施例】

【0031】

次に、本実施の形態に係る撮像レンズの具体的な数値実施例について説明する。以下では、複数の数値実施例をまとめて説明する。

【0032】

図6(A)、(B)は、図1に示した撮像レンズの構成に対応する具体的なレンズデータを示している。特に図6(A)にはその基本的なレンズデータを示し、図6(B)には非球面に関するデータを示す。図6(A)に示したレンズデータにおける面番号 $S_i$ の欄には、実施例1に係る撮像レンズについて、最も物体側の構成要素の面を1番目として、像側に向かうに従い順次増加するようにして符号を付した $i$ 番目の面の番号を示している。曲率半径 $R_i$ の欄には、図1において付した符号 $R_i$ に対応させて、物体側から $i$ 番目の面の曲率半径の値(mm)を示す。面間隔 $D_i$ の欄についても、同様に物体側から $i$ 番目の面 $S_i$ と $i+1$ 番目の面 $S_{i+1}$ との光軸上の間隔(mm)を示す。 $N_{dj}$ の欄には、物体側から $j$ 番目の光学要素の $d$ 線(587.6nm)に対する屈折率の値を示す。 $\nu_{dj}$ の欄には、物体側から $j$ 番目の光学要素の $d$ 線に対するアッベ数の値を示す。

【0033】

この実施例1に係る撮像レンズは、第1レンズ $G_1$ ないし第4レンズ $G_4$ の両面がすべて非球面形状となっている。図6(A)の基本レンズデータには、これらの非球面の曲率半径として、光軸近傍の曲率半径の数値を示している。

【0034】

図6(B)には実施例1の撮像レンズにおける非球面データを示す。非球面データとして示した数値において、記号“E”は、その次に続く数値が10を底とした“べき指数”であることを示し、その10を底とした指数関数で表される数値が“E”の前の数値に乗算されることを示す。例えば、「 $1.0E-0.2$ 」であれば、「 $1.0 \times 10^{-0.2}$ 」であることを示す。

【0035】

実施例1の撮像レンズの非球面データとしては、以下の式(A)によって表される非球面形状の式における各係数 $B_n$ 、 $K$ の値を記す。 $Z$ は、より詳しくは、光軸から高さ $h$ の位置にある非球面上の点から、非球面の頂点の接平面(光軸に垂直な平面)に下ろした垂線の長さ(mm)を示す。

$$Z = C \cdot h^2 / \{ 1 + (1 - K \cdot C^2 \cdot h^2)^{1/2} \} + \sum B_n \cdot h^n \quad \dots (A)$$

( $n=3$ 以上の整数)

ただし、

$Z$ : 非球面の深さ(mm)

$h$ : 光軸からレンズ面までの距離(高さ)(mm)

$K$ : 離心率

CC：近軸曲率 =  $1/R$

(R：近軸曲率半径)

$B_n$ ：第n次の非球面係数

【0036】

実施例1の撮像レンズは、非球面係数 $B_n$ として $B_3 \sim B_{16}$ までの次数を有効に用いて表されている。

【0037】

以上の実施例1の撮像レンズと同様にして、図2に示した撮像レンズの構成に対応する具体的なレンズデータを実施例2として、図7(A)、(B)に示す。また同様にして、図3～図5に示した撮像レンズの構成に対応する具体的なレンズデータを実施例3～5として、図8(A)、(B)～図10(A)、(B)に示す。これらの実施例2～5では、実施例1の撮像レンズと同様、第1レンズG1ないし第4レンズG4の両面がすべて非球面形状となっている。

【0038】

また、図11には、上述の各条件式に関する値を、各実施例についてまとめたものを示す。図11から分かるように、各実施例の値が各条件式の数値範囲内となっている。

【0039】

図12(A)～図12(C)はそれぞれ、実施例1の撮像レンズにおける球面収差、非点収差、およびディストーション(歪曲収差)を示している。なお、非点収差図において、Sはサジタル方向、Tはタンジェンシャル方向の収差を示す。Yは像高を示す。

【0040】

同様にして、実施例2～5に係る撮像レンズにおける諸収差を、図13(A)、(B)、(C)～図16(A)、(B)、(C)に示す。

【0041】

以上の各数値データおよび各収差図から分かるように、各実施例について、各レンズ要素の構成が最適化され、良好な光学性能を保持しながら、広角で小型化の図られたレンズ系が実現できている。特に、8メガピクセル程度の画素数に好適な性能が得られている。

【0042】

なお、本発明は、上記実施の形態および各実施例に限定されず種々の変形実施が可能である。例えば、各レンズ成分の曲率半径、面間隔および屈折率の値などは、上記各数値実施例で示した値に限定されず、他の値をとり得る。

【0043】

また、上記各実施例では、すべて固定焦点で使用する前提での記載とされているが、フォーカス調整可能な構成とすることも可能である。例えばレンズ系全体を繰り出したり、一部のレンズを光軸上で動かしてオートフォーカス可能な構成とすることも可能である。

また、上記各実施例では、8メガピクセル程度の画素数に好適な設計例を示したが、本発明の撮像レンズは、例えば10メガピクセル程度のより高い画素数であっても良好な性能が得られる。また、8メガピクセルよりも低い画素数であっても良好な性能が得られる。

【図面の簡単な説明】

【0044】

【図1】本発明の一実施の形態に係る撮像レンズの第1の構成例を示すものであり、実施例1に対応するレンズ断面図である。

【図2】本発明の一実施の形態に係る撮像レンズの第2の構成例を示すものであり、実施例2に対応するレンズ断面図である。

【図3】本発明の一実施の形態に係る撮像レンズの第3の構成例を示すものであり、実施例3に対応するレンズ断面図である。

【図4】本発明の一実施の形態に係る撮像レンズの第4の構成例を示すものであり、実施例4に対応するレンズ断面図である。

【図5】本発明の一実施の形態に係る撮像レンズの第5の構成例を示すものであり、実施

例5に対応するレンズ断面図である。

【図6】本発明の実施例1に係る撮像レンズのレンズデータを示す図であり、(A)は基本的なレンズデータを示し、(B)は非球面のデータを示す。

【図7】本発明の実施例2に係る撮像レンズのレンズデータを示す図であり、(A)は基本的なレンズデータを示し、(B)は非球面のデータを示す。

【図8】本発明の実施例3に係る撮像レンズのレンズデータを示す図であり、(A)は基本的なレンズデータを示し、(B)は非球面のデータを示す。

【図9】本発明の実施例4に係る撮像レンズのレンズデータを示す図であり、(A)は基本的なレンズデータを示し、(B)は非球面のデータを示す。

【図10】本発明の実施例5に係る撮像レンズのレンズデータを示す図であり、(A)は基本的なレンズデータを示し、(B)は非球面のデータを示す。

【図11】条件式に関する値を各実施例についてまとめて示した図である。

【図12】本発明の実施例1に係る撮像レンズの諸収差を示す収差図であり、(A)は球面収差、(B)は非点収差、(C)はディストーションを示す。

【図13】本発明の実施例2に係る撮像レンズの諸収差を示す収差図であり、(A)は球面収差、(B)は非点収差、(C)はディストーションを示す。

【図14】本発明の実施例3に係る撮像レンズの諸収差を示す収差図であり、(A)は球面収差、(B)は非点収差、(C)はディストーションを示す。

【図15】本発明の実施例4に係る撮像レンズの諸収差を示す収差図であり、(A)は球面収差、(B)は非点収差、(C)はディストーションを示す。

【図16】本発明の実施例5に係る撮像レンズの諸収差を示す収差図であり、(A)は球面収差、(B)は非点収差、(C)はディストーションを示す。

【符号の説明】

【0045】

G1…第1レンズ、G2…第2レンズ、G3…第3レンズ、G4…第4レンズ、GF…光学部材、St…開口絞り、Ri…物体側から第i番目のレンズ面の曲率半径、Di…物体側から第i番目と第i+1番目のレンズ面との面間隔、Z1…光軸、100…撮像素子。

【図1】

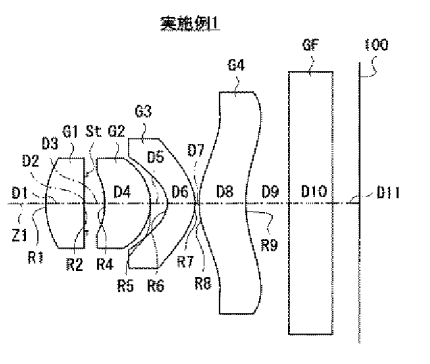

【図3】

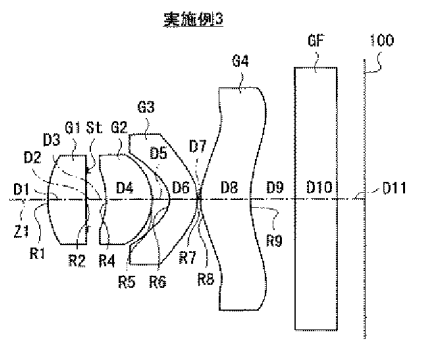

【図2】

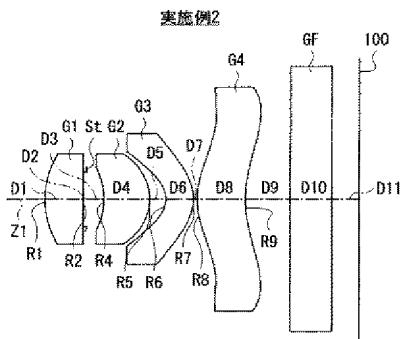

【図4】

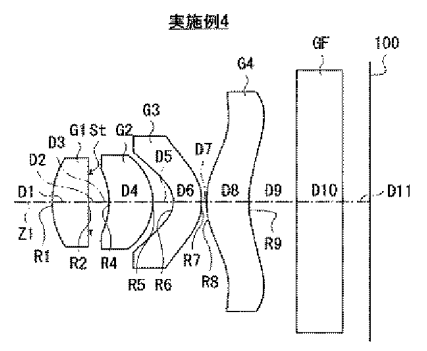

【図5】

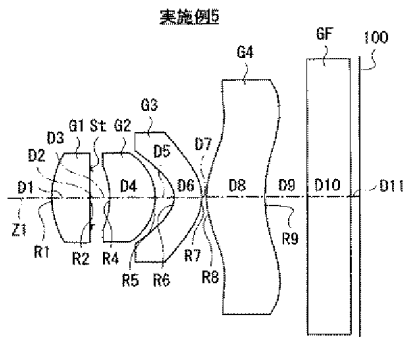

【図6】

実施例1・基本パラメータ

	S1 (面番号)	R1 (曲率半径)	D1 (面間隔)	Nd1 (屈折率)	γd1 (7°傾角)
G1	1	2.389	0.88	1.511956	56.5
	2	12.6549	0.06		
	3(絞り)	-	0.41		
G2	4	-3.0266	1.07	1.511956	56.5
	5	-1.3461	0.41		
G3	6	-0.8753	0.65	1.620288	25.5
	7	-1.3953	0.10		
G4	8	1.7577	1.10	1.511956	56.5
	9	3.7296	1.00		
GF	10	∞	0.98	1.516463	64.1
	11	∞	0.64		

実施例1・非球面パラメータ

面番号	K	B3	B4	B5	B6
1	0.00E+00	-1.39E-02	4.11E-02	4.00E-03	-9.87E-02
2	0.00E+00	9.88E-03	-8.37E-02	1.08E-01	1.59E-01
4	-1.00E+00	8.20E-02	-4.17E-01	6.38E-01	-6.23E-01
5	-1.00E+00	2.21E-02	-2.11E-01	1.95E-01	-1.23E-01
6	-9.52E-01	-6.02E-02	-6.85E-02	3.56E-02	-6.49E-02
7	-1.00E+00	-5.78E-02	8.48E-02	-8.92E-02	2.72E-02
8	-9.09E-01	-3.40E-02	-5.45E-02	3.73E-02	-4.87E-03
9	-1.92E-06	-7.21E-04	-9.85E-03	-4.06E-04	2.08E-04
面番号	B7	B8	B9	B10	B11
1	1.38E-01	-2.93E-02	-9.67E-02	7.94E-02	2.14E-02
2	-4.04E-01	-2.18E-01	1.52E-01	9.29E-01	-6.04E-01
4	4.00E-02	5.55E-01	-9.29E-01	5.53E-01	5.56E-02
5	-2.47E-02	6.58E-03	1.51E-02	2.58E-02	4.26E-03
6	-7.30E-03	5.19E-02	4.25E-02	-2.58E-02	-3.92E-03
7	6.63E-04	1.03E-03	2.88E-03	-1.18E-03	1.37E-04
8	-2.52E-03	1.04E-03	-6.20E-04	1.26E-04	5.58E-05
9	-1.04E-03	2.72E-04	1.11E-04	-3.40E-05	-3.91E-06
面番号	B12	B13	B14	B15	B16
1	-1.54E-02	-7.13E-02	4.91E-02	1.46E-02	-1.32E-02
2	-2.95E-01	-1.53E-02	1.74E-01	-2.27E-01	2.23E-01
4	-7.09E-02	-9.42E-02	9.43E-02	-1.81E-01	9.66E-02
5	-1.06E-02	-9.38E-03	-2.65E-03	-4.28E-03	7.54E-03
6	-4.37E-03	-2.98E-03	-2.98E-04	0.00E+00	1.96E-03
7	-6.81E-05	-1.12E-04	-8.36E-05	-1.73E-05	3.99E-05
8	2.01E-07	-4.28E-06	-2.45E-07	-6.90E-07	2.10E-07
9	1.05E-06	5.09E-07	-9.97E-08	-2.48E-08	1.94E-09

【図7】

実施例2・基本パラメータ

	S1 (面番号)	R1 (曲率半径)	D1 (面間隔)	Nd1 (屈折率)	nd1 (アッパ数)
G1	1	2.4075	0.88	1.511956	56.5
	2	12.8176	0.06		
	3(絞り)		0.42		
G2	4	-3.0728	1.07	1.511956	56.5
	5	-1.2964	0.37		
G3	6	-0.6593	0.65	1.620288	25.5
	7	-1.4665	0.10		
G4	8	1.6653	1.17	1.511956	56.5
	9	3.5277	1.00		
GF	10	∞	0.98	1.518463	64.1
	11	∞	0.64		

実施例2・非球面パラメータ

面番号	K	B3	B4	B5	B6
1	0.00E+00	-2.98E-03	2.64E-02	2.90E-03	-9.01E-02
2	0.00E+00	-3.12E-03	-2.73E-02	2.38E-02	1.49E-01
4	-1.00E+00	4.00E-02	-3.21E-01	5.81E-01	-6.66E-01
5	-1.00E+00	2.10E-02	-2.02E-01	1.89E-01	-1.25E-01
6	-9.59E-01	-2.92E-02	-6.61E-02	2.71E-02	-7.13E-02
7	-9.98E-01	-6.13E-02	9.99E-02	-9.19E-02	2.38E-02
8	-9.55E-01	-5.86E-02	-4.61E-02	4.42E-02	-9.00E-03
9	-4.29E-09	-6.89E-03	-5.90E-03	-2.96E-03	7.23E-04
B7					
1	1.44E-01	-2.91E-02	-1.02E-01	7.44E-02	2.12E-02
2	-3.45E-01	-1.46E-01	9.89E-02	9.64E-01	-6.47E-01
4	2.67E-02	5.94E-01	-8.61E-01	5.93E-01	2.37E-02
5	-2.07E-02	6.64E-03	1.26E-02	2.56E-02	4.52E-03
6	-1.07E-02	5.09E-02	4.36E-02	-2.49E-02	-3.49E-03
7	-6.01E-04	5.99E-04	3.00E-03	-9.96E-04	2.92E-04
8	-2.85E-03	1.29E-03	-5.81E-04	1.37E-04	5.76E-05
9	-8.10E-04	1.69E-04	1.12E-04	-3.00E-05	-6.18E-06
B12					
1	-1.45E-02	-6.99E-02	5.04E-02	1.59E-02	-1.50E-02
2	-2.76E-01	-3.70E-02	1.88E-01	-1.70E-01	2.02E-01
4	-1.59E-01	-1.74E-01	8.17E-02	-1.07E-01	1.42E-01
5	-9.91E-03	-9.02E-03	-2.76E-03	-4.77E-03	7.63E-03
6	-3.91E-03	-2.51E-03	5.08E-04	0.00E+00	1.29E-03
7	-6.36E-06	-1.05E-04	-9.92E-05	-3.07E-05	4.22E-05
8	-1.40E-06	-5.32E-06	-3.18E-07	-6.96E-07	2.38E-07
9	1.34E-06	6.25E-07	-7.33E-08	-3.76E-08	2.02E-09

【図9】

実施例4・基本パラメータ

	S1 (面番号)	R1 (曲率半径)	D1 (面間隔)	Nd1 (屈折率)	nd1 (アッパ数)
G1	1	2.3961	0.74	1.511956	56.5
	2	24.0152	0.06		
	3(絞り)		0.39		
G2	4	-2.8241	0.93	1.511956	56.5
	5	-1.284	0.41		
G3	6	-0.6162	0.65	1.609879	27.2
	7	-1.2937	0.10		
G4	8	1.4478	0.88	1.511956	56.5
	9	2.9445	1.00		
GF	10	∞	0.98	1.518463	64.1
	11	∞	0.58		

実施例4・非球面パラメータ

面番号	K	B3	B4	B5	B6
1	0.00E+00	-1.68E-02	4.51E-02	9.75E-03	-1.59E-01
2	0.00E+00	2.47E-02	-1.79E-01	2.61E-01	2.61E-01
4	-1.00E+00	8.72E-02	-5.16E-01	9.15E-01	-9.94E-01
5	-1.00E+00	1.86E-02	-2.40E-01	2.57E-01	-1.99E-01
6	-5.45E-01	-2.48E-02	-3.35E-02	7.69E-02	-1.14E-01
7	-9.85E-01	-1.02E-01	1.12E-01	-1.11E-01	5.39E-02
8	-6.52E-03	-8.73E-02	-5.44E-02	3.23E-02	4.79E-04
9	-1.86E-02	1.59E-02	-4.05E-02	9.09E-03	-1.78E-03
B7					
1	2.40E-01	-7.20E-02	-2.03E-01	2.01E-01	6.24E-02
2	-7.84E-01	-6.41E-01	6.46E-01	2.50E+00	-1.66E+00
4	9.58E-02	1.08E+00	-2.09E+00	1.35E+00	2.99E-01
5	-3.94E-02	3.05E-02	5.03E-02	6.06E-02	3.58E-03
6	-2.98E-02	9.10E-02	8.70E-02	-5.80E-02	-2.65E-03
7	1.75E-03	2.23E-04	3.77E-03	-4.33E-03	-2.47E-04
8	-4.05E-03	1.48E-03	-1.42E-03	2.82E-04	1.45E-04
9	-3.73E-05	1.65E-04	7.46E-05	-1.10E-04	8.80E-06
B12					
1	-4.41E-02	-2.32E-01	1.64E-01	4.76E-02	-4.50E-02
2	-1.03E+00	-2.29E-01	5.35E-01	-7.77E-01	1.23E+00
4	-1.55E-02	-3.75E-01	-6.93E-02	-1.17E+00	1.22E+00
5	-3.83E-02	-3.16E-02	-5.57E-03	-1.15E-02	2.62E-02
6	-7.14E-03	-8.42E-03	-6.81E-03	0.00E+00	7.95E-03
7	-5.30E-05	8.65E-05	4.72E-05	4.43E-05	3.54E-06
8	5.69E-06	-1.06E-05	-8.34E-07	-2.66E-06	7.39E-07
9	5.95E-06	1.75E-06	-1.81E-07	-4.67E-08	6.55E-08

【図8】

実施例3・基本パラメータ

	S1 (面番号)	R1 (曲率半径)	D1 (面間隔)	Nd1 (屈折率)	nd1 (アッパ数)
G1	1	2.437	0.87	1.511956	56.5
	2	13.4644	0.06		
	3(絞り)		0.42		
G2	4	-3.1731	1.07	1.511956	56.5
	5	-1.3207	0.38		
G3	6	-0.6521	0.65	1.620288	25.5
	7	-1.538	0.10		
G4	8	1.4733	1.18	1.511956	56.5
	9	3.4945	1.00		
GF	10	∞	0.98	1.518463	64.1
	11	∞	0.64		

実施例3・非球面パラメータ

面番号	K	B3	B4	B5	B6
1	0.00E+00	-3.23E-03	2.72E-02	-1.82E-03	-8.67E-02
2	0.00E+00	-5.22E-03	-1.80E-04	-5.65E-02	1.86E-01
4	-1.00E+00	3.43E-02	-2.83E-01	5.15E-01	-6.59E-01
5	-1.00E+00	2.23E-02	-1.89E-01	1.77E-01	-1.33E-01
6	-8.71E-01	2.76E-03	-7.58E-02	1.41E-02	-7.58E-02
7	-8.41E-01	-7.50E-02	1.07E-01	-9.03E-02	2.35E-02
8	-4.90E-01	-9.16E-02	-4.51E-02	5.16E-02	-1.22E-02
9	-3.30E-01	-7.06E-03	-3.28E-03	-4.73E-03	8.69E-04
B7					
1	1.48E-01	-2.81E-02	-1.07E-01	7.38E-02	2.53E-02
2	-2.73E-01	-7.27E-02	-4.04E-02	8.49E-01	-6.79E-01
4	6.37E-02	6.40E-01	-8.50E-01	5.37E-01	-8.28E-02
5	-1.63E-02	9.02E-03	1.19E-02	2.65E-02	4.56E-03
6	-1.04E-02	5.37E-02	4.77E-02	-2.29E-02	-3.54E-03
7	-6.55E-04	3.65E-04	3.06E-03	-9.20E-04	3.74E-04
8	-2.82E-03	1.52E-03	-5.41E-04	1.23E-04	5.30E-05
9	-5.32E-04	8.49E-05	1.20E-04	-2.31E-05	-1.01E-05
B12					
1	-1.52E-02	-7.09E-02	5.00E-02	1.75E-02	-1.58E-02
2	-2.10E-01	9.92E-02	3.28E-01	-1.34E-01	-4.68E-02
4	-2.28E-01	-1.22E-01	2.91E-01	9.66E-02	-1.63E-01
5	-1.02E-02	-9.50E-03	-3.15E-03	-4.97E-03	8.19E-03
6	-4.86E-03	-3.59E-03	-5.66E-04	0.00E+00	1.98E-03
7	8.16E-06	-1.22E-04	-1.26E-04	-3.78E-05	5.35E-05
8	-2.91E-06	-5.52E-06	1.47E-07	-7.31E-07	2.30E-07
9	1.28E-06	7.57E-07	-1.66E-08	-5.43E-08	3.01E-09

【図10】

実施例5・基本パラメータ

	S1 (面番号)	R1 (曲率半径)	D1 (面間隔)	Nd1 (屈折率)	nd1 (アッパ数)
G1	1	2.1643	0.91	1.511956	56.5
	2	8.1905	0.06		
	3(絞り)		0.42		
G2	4	-3.3286	1.07	1.533675	55.4
	5	-1.4162	0.43		
G3	6	-0.6667	0.65	1.620288	25.5
	7	-1.5134	0.10		
G4	8	1.5658	1.38	1.511956	56.5
	9	3.3876	1.00		
GF	10	∞	0.98	1.518463	64.1
	11	∞	0.23		

実施例5・非球面パラメータ

面番号	K	B3	B4	B5	B6
1	0.00E+00	-6.24E-03	3.59E-02	2.33E-03	-8.85E-02
2	0.00E+00	2.58E-03	-1.59E-02	-5.39E-02	2.06E-01
4	-1.00E+00	3.74E-02	-2.94E-01	5.20E-01	-6.54E-01
5	-1.00E+00	2.82E-02	-1.96E-01	1.80E-01	-1.28E-01
6	-8.23E-01	1.22E-02	-7.80E-02	1.25E-02	-7.96E-02
7	-7.78E-01	-7.11E-02	1.07E-01	-9.26E-02	2.33E-02
8	-5.61E-01	-8.11E-02	-5.05E-02	5.04E-02	-1.16E-02
9	-9.96E-01	-9.76E-03	-5.86E-03	-1.90E-03	9.42E-04
B7					
1	1.43E-01	-2.82E-02	-1.08E-01	7.59E-02	2.84E-02
2	-2.51E-01	-1.50E-02	-1.49E-01	7.88E-01	-6.78E-01
4	7.71E-02	6.43E-01	-8.67E-01	5.10E-01	-7.64E-02
5	-1.64E-02	7.43E-03	1.05E-02	2.45E-02	3.91E-03
6	-1.23E-02	5.35E-02	4.76E-02	-2.27E-02	-3.33E-03
7	-6.70E-04	4.28E-04	3.09E-03	-8.98E-04	3.86E-04
8	-2.59E-03	1.58E-03	-5.47E-04	1.10E-04	4.90E-05
9	-6.98E-04	3.22E-05	1.29E-04	-1.82E-05	-9.78E-06
B12					
1	-1.50E-02	-7.18E-02	4.93E-02	1.75E-02	-1.59E-02
2	-1.57E-01	1.76E-01	3.82E-01	-1.53E-01	-1.72E-01
4	-2.75E-01	-9.03E-02	4.00E-01	1.86E-01	-3.58E-01
5	-9.59E-03	-7.85E-03	-2.59E-03	-4.85E-03	7.43E-03
6	-4.91E-03	-3.60E-03	-4.57E-04	0.00E+00	1.99E-03
7	5.17E-06	-1.26E-04	-1.31E-04	-4.58E-05	5.55E-05
8	-3.30E-06	-5.28E-06	6.64E-07	-6.73E-07	2.14E-07
9	1.29E-06	6.88E-07	-3.98E-08	-6.81E-08	7.61E-09

【図11】

条件式に関する値						
式の番号	実施例 1	実施例 2	実施例 3	実施例 4	実施例 5	
f	4.56	4.56	4.56	4.14	4.56	
Ymax	3.57	3.57	3.57	3.24	3.57	
TL	7.30	7.33	7.35	6.05	6.98	
Bf	2.63	2.62	2.62	2.53	2.21	
f1	(1)	5.60	5.63	5.66	5.14	5.47
f2	(1)	3.90	3.63	3.69	3.82	3.87
f3	(1)	-3.23	-2.79	-2.53	-2.90	-2.72
f/f2	(2)	1.17	1.26	1.24	1.08	1.18
f1/f2		1.44	1.55	1.53	1.35	1.41
f2/f3		-1.21	-1.30	-1.46	-1.32	-1.42
$\nu$ d3	(3)	25.5	25.5	25.5	27.2	25.5
Bf/TL	(4)	0.36	0.36	0.36	0.42	0.32
Ymax/f	(5)	0.78	0.78	0.78	0.78	0.78

【図12】

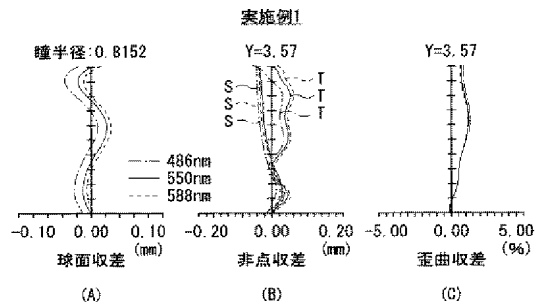

【図13】

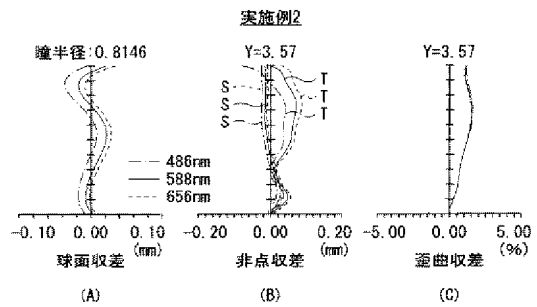

【図14】

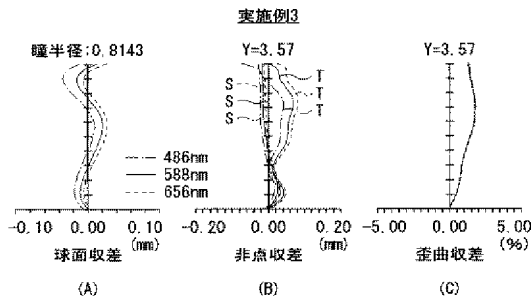

【図16】

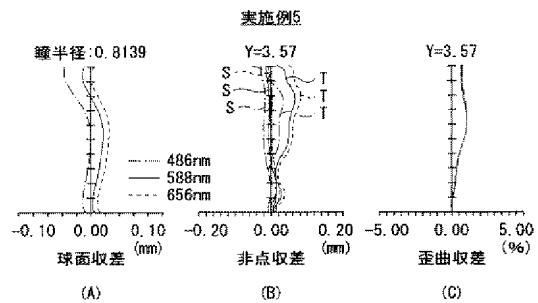

【図15】

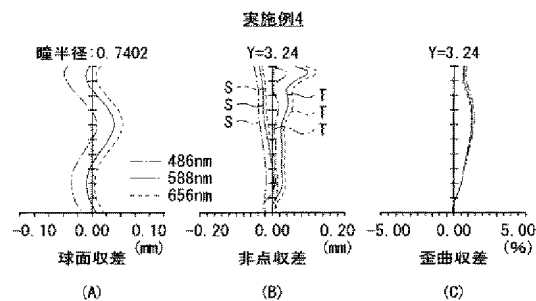





**Abstract of JP 2009192819(A)**

IMAGING LENS AND IMAGING APPARATUS

To provide an imaging lens designed so that the wide angle is made easy and a lens system suitable for manufacture is achieved and an imaging apparatus provided with the imaging lens and capable of obtaining high-resolution taken images. SOLUTION: The imaging lens includes in order from an object side: a first lens G1 comprising a positive lens; a stop St; a second lens G2 comprising a positive lens; a third lens G3 comprising a negative meniscus lens; and a fourth lens G4 which is a positive meniscus lens, wherein the shape near an optical axis has a convex surface directed to the object side. An air space between the second lens G2 and the third lens G3 is made smaller in a periphery than near the optical axis. Formulae (1) and (2) given below are satisfied: (1)  $f_1 > f_2 > \frac{3}{4} f_3$  and (2)  $1.0 < f/f_2 < 1.5$ , wherein  $f_1$ ,  $f_2$  and  $f_3$  are focal lengths of the first lens, the second lens, and the third lens, respectively and  $f$  is an focal length of the whole lens system.

**Abstract of JP 2007178689(A)**

IMAGING LENS, OPTICAL MODULE, AND MOBILE TERMINAL

To provide an inexpensive imaging lens that has a short entire length, ensures satisfactory corrections of various aberrations, and has high production efficiency, and to provide an optical module and a mobile terminal. SOLUTION: The imaging lens 100 is constituted of, in order from the object side OBJ: an aperture diaphragm part 110; a first lens 120 whose object side and image face side are both convex; a second meniscus lens 130 whose object side is concave; a third meniscus lens 140 whose object side is concave; and a fourth meniscus lens 150 whose object side is convex and whose both sides are aspherical.

**Abstract of JP 2004102234(A)**

IMAGE PICKUP LENS, IMAGE PICKUP UNIT AND PORTABLE TERMINAL  
HAVING THE LENS AND THE UNIT

To reduce the size compared with a conventional one and to suppress a fluctuation in image point location of plastic lenses caused by a variation in temperature. ;SOLUTION:

First, second, third and fourth lenses are arranged in that order from an object side. The first lens has positive refractive power and has a convex face toward the object side. The second lens has positive refractive power. The third lens has negative refractive power and has a meniscus shape having a concave face toward the object side. The fourth lens has positive or negative refractive power and has a meniscus shape having a convex toward the object side.

## Electronic Acknowledgement Receipt

<b>EFS ID:</b>	21109610
<b>Application Number:</b>	14141665
<b>International Application Number:</b>	
<b>Confirmation Number:</b>	9554
<b>Title of Invention:</b>	LENS ASSEMBLY
<b>First Named Inventor/Applicant Name:</b>	Hung-Kuo Yu
<b>Customer Number:</b>	5251
<b>Filer:</b>	Thomas Moga/Sandra Lewis
<b>Filer Authorized By:</b>	Thomas Moga
<b>Attorney Docket Number:</b>	SIIP.201299
<b>Receipt Date:</b>	02-JAN-2015
<b>Filing Date:</b>	27-DEC-2013
<b>Time Stamp:</b>	16:56:14
<b>Application Type:</b>	Utility under 35 USC 111(a)

### Payment information:

Submitted with Payment	no
------------------------	----

### File Listing:

Document Number	Document Description	File Name	File Size(Bytes)/ Message Digest	Multi Part /.zip	Pages (if appl.)
1	Information Disclosure Statement (IDS) Form (SB08)	SIIP201299InformationDisclosureStatement.pdf	484581 <small>f0438655ee293e488846fcf272210c811bafca66c</small>	no	4

### Warnings:

### Information:

This is not an USPTO supplied IDS fillable form

2	Foreign Reference	JP2004102234A.pdf	1462789	no	35
			933bff176eae35a8a6a16f5747464f95852789b2		

**Warnings:**

**Information:**

3	Foreign Reference	JP2007178689A.pdf	864786	no	25
			1ff98094ded469bf63697d15c17ceac51ada581f		

**Warnings:**

**Information:**

4	Foreign Reference	JP2009192819A.pdf	564998	no	13
			0a86171dea63ea8550591b20a84bcc9811247f8		

**Warnings:**

**Information:**

5	Other Reference-Patent/App/Search documents	SIIP201299EnglishAbstractsofJ PReferences.pdf	31870	no	2
			bdc2515837d93c0804029fd5a64d88e302b88ba		

**Warnings:**

**Information:**

<b>Total Files Size (in bytes):</b>	3409024
-------------------------------------	---------

**This Acknowledgement Receipt evidences receipt on the noted date by the USPTO of the indicated documents, characterized by the applicant, and including page counts, where applicable. It serves as evidence of receipt similar to a Post Card, as described in MPEP 503.**

**New Applications Under 35 U.S.C. 111**

**If a new application is being filed and the application includes the necessary components for a filing date (see 37 CFR 1.53(b)-(d) and MPEP 506), a Filing Receipt (37 CFR 1.54) will be issued in due course and the date shown on this Acknowledgement Receipt will establish the filing date of the application.**

**National Stage of an International Application under 35 U.S.C. 371**

**If a timely submission to enter the national stage of an international application is compliant with the conditions of 35 U.S.C. 371 and other applicable requirements a Form PCT/DO/EO/903 indicating acceptance of the application as a national stage submission under 35 U.S.C. 371 will be issued in addition to the Filing Receipt, in due course.**

**New International Application Filed with the USPTO as a Receiving Office**

**If a new international application is being filed and the international application includes the necessary components for an international filing date (see PCT Article 11 and MPEP 1810), a Notification of the International Application Number and of the International Filing Date (Form PCT/RO/105) will be issued in due course, subject to prescriptions concerning national security, and the date shown on this Acknowledgement Receipt will establish the international filing date of the application.**



UNITED STATES PATENT AND TRADEMARK OFFICE

UNITED STATES DEPARTMENT OF COMMERCE
United States Patent and Trademark Office
Address: COMMISSIONER FOR PATENTS
P.O. Box 1450
Alexandria, Virginia 22313-1450
www.uspto.gov

Table with 5 columns: APPLICATION NO., FILING DATE, FIRST NAMED INVENTOR, ATTORNEY DOCKET NO., CONFIRMATION NO.
14/141,665 12/27/2013 Hung-Kuo Yu SIIP.201299 9554

5251 7590 01/15/2015
SHOOK, HARDY & BACON LLP
INTELLECTUAL PROPERTY DEPARTMENT
2555 GRAND BLVD
KANSAS CITY, MO 64108-2613

EXAMINER

JONES, JAMES

ART UNIT PAPER NUMBER

2872

NOTIFICATION DATE DELIVERY MODE

01/15/2015

ELECTRONIC

Please find below and/or attached an Office communication concerning this application or proceeding.

The time period for reply, if any, is set in the attached communication.

Notice of the Office communication was sent electronically on above-indicated "Notification Date" to the following e-mail address(es):

IPDOCKET@SHB.COM
IPRCDKT@SHB.COM
BPARKERSON@SHB.COM

<b>Office Action Summary</b>	<b>Application No.</b> 14/141,665	<b>Applicant(s)</b> YU ET AL.	
	<b>Examiner</b> JAMES JONES	<b>Art Unit</b> 2872	<b>AIA (First Inventor to File) Status</b> Yes

**-- The MAILING DATE of this communication appears on the cover sheet with the correspondence address --**

**Period for Reply**

A SHORTENED STATUTORY PERIOD FOR REPLY IS SET TO EXPIRE 3 MONTHS FROM THE MAILING DATE OF THIS COMMUNICATION.

- Extensions of time may be available under the provisions of 37 CFR 1.136(a). In no event, however, may a reply be timely filed after SIX (6) MONTHS from the mailing date of this communication.
- If NO period for reply is specified above, the maximum statutory period will apply and will expire SIX (6) MONTHS from the mailing date of this communication.
- Failure to reply within the set or extended period for reply will, by statute, cause the application to become ABANDONED (35 U.S.C. § 133). Any reply received by the Office later than three months after the mailing date of this communication, even if timely filed, may reduce any earned patent term adjustment. See 37 CFR 1.704(b).

**Status**

- 1)  Responsive to communication(s) filed on \_\_\_\_\_.  
 A declaration(s)/affidavit(s) under **37 CFR 1.130(b)** was/were filed on \_\_\_\_\_.
- 2a)  This action is **FINAL**.                      2b)  This action is non-final.
- 3)  An election was made by the applicant in response to a restriction requirement set forth during the interview on \_\_\_\_\_; the restriction requirement and election have been incorporated into this action.
- 4)  Since this application is in condition for allowance except for formal matters, prosecution as to the merits is closed in accordance with the practice under *Ex parte Quayle*, 1935 C.D. 11, 453 O.G. 213.

**Disposition of Claims\***

- 5)  Claim(s) 1-7 is/are pending in the application.  
5a) Of the above claim(s) \_\_\_\_\_ is/are withdrawn from consideration.
- 6)  Claim(s) \_\_\_\_\_ is/are allowed.
- 7)  Claim(s) 1-3.6 and 7 is/are rejected.
- 8)  Claim(s) 4 and 5 is/are objected to.
- 9)  Claim(s) \_\_\_\_\_ are subject to restriction and/or election requirement.

\* If any claims have been determined allowable, you may be eligible to benefit from the **Patent Prosecution Highway** program at a participating intellectual property office for the corresponding application. For more information, please see [http://www.uspto.gov/patents/init\\_events/pph/index.jsp](http://www.uspto.gov/patents/init_events/pph/index.jsp) or send an inquiry to [PPHfeedback@uspto.gov](mailto:PPHfeedback@uspto.gov).

**Application Papers**

- 10)  The specification is objected to by the Examiner.
- 11)  The drawing(s) filed on 12/27/2013 is/are: a)  accepted or b)  objected to by the Examiner.  
Applicant may not request that any objection to the drawing(s) be held in abeyance. See 37 CFR 1.85(a).  
Replacement drawing sheet(s) including the correction is required if the drawing(s) is objected to. See 37 CFR 1.121(d).

**Priority under 35 U.S.C. § 119**

- 12)  Acknowledgment is made of a claim for foreign priority under 35 U.S.C. § 119(a)-(d) or (f).

**Certified copies:**

- a)  All    b)  Some\*\*    c)  None of the:
1.  Certified copies of the priority documents have been received.
  2.  Certified copies of the priority documents have been received in Application No. \_\_\_\_\_.
  3.  Copies of the certified copies of the priority documents have been received in this National Stage application from the International Bureau (PCT Rule 17.2(a)).

\*\* See the attached detailed Office action for a list of the certified copies not received.

**Attachment(s)**

- |  |   |
|--|---|
| 1) <input checked="" type="checkbox"/> Notice of References Cited (PTO-892)  | 3) <input type="checkbox"/> Interview Summary (PTO-413)<br>Paper No(s)/Mail Date. _____ |
| 2) <input checked="" type="checkbox"/> Information Disclosure Statement(s) (PTO/SB/08a and/or PTO/SB/08b)<br>Paper No(s)/Mail Date <u>12/27/2013</u> | 4) <input type="checkbox"/> Other: _____  |
- AOET, Ex. 1004**

Art Unit: 2872

1. The present application, filed on or after March 16, 2013, is being examined under the first inventor to file provisions of the AIA.

***Priority***

2. Receipt is acknowledged of certified copies of papers submitted under 35 U.S.C. 119(a)-(d), which papers have been placed of record in the file.

***Information Disclosure Statement***

3. The information disclosure statement (IDS) submitted on 1/2/2015 is in compliance with the provisions of 37 CFR 1.97. Accordingly, the information disclosure statement is being considered by the examiner.

***Claim Rejections - 35 USC § 102***

4. The following is a quotation of the appropriate paragraphs of 35 U.S.C. 102 that form the basis for the rejections under this section made in this Office action:

A person shall be entitled to a patent unless –

(a)(1) the claimed invention was patented, described in a printed publication, or in public use, on sale or otherwise available to the public before the effective filing date of the claimed invention.

5. Claims 1-3, 6 and 7 are rejected under 35 U.S.C. 102b as being anticipated by Huang (8189272) hereafter Huang.

Regarding claim 1, Huang discloses in fig. 4A a lens assembly comprising: a lens set which includes a first lens, a second lens, a third lens and a fourth lens arranged in sequence from an object side to an image side along an optical axis of said lens

Art Unit: 2872

assembly, wherein said first lens (410) has a positive optical power adjacent to the optical axis, and has a convex object-side surface (411) which faces the object side, and an image-side surface (412) which faces the image side, at least one of said object-side surface and said image-side surface of said first lens being an aspherical (abstract, line 9) surface, said second lens (420) has a positive optical power adjacent to the optical axis, and has a convex (422) image-side surface which faces the image side, and an object-side surface (421) which faces the object side, at least one of said object-side surface and said image-side surface of said second lens being an aspherical surface (abstract, line 9), said third lens (430) has a negative optical power adjacent to the optical axis, and has a concave object-side surface (431) which faces the object side, and a convex image-side surface (432) which faces the image side, at least one of said object-side surface (441) and said image-side surface of said third lens being an aspherical surface (abstract, line 9), said fourth lens (440) has a positive optical power adjacent to the optical axis, and has an image-side surface (442) which faces the image side and which has a concave portion (shown in fig. 4A) around the optical axis, an object-side surface (441) which faces the object side, and a peripheral surface which interconnects said object-side surface and said image-side surface, each of said object-side surface and said image-side surface of said fourth lens being an aspherical surface (fig. 4a, abstract, line 9), at least one of said object-side surface and said image-side surface of said fourth lens having an inflection point located between the optical axis and said peripheral surface; and a non-adjustable diaphragm (400) located between the object side and said second lens of said lens set (fig. 4A); wherein said lens assembly



Art Unit: 2872

satisfies  $15 < \text{HFOV}/f < 50$ , in which, HFOV represents one half of a maximum angle of view of said lens assembly and has a unit of degree, and  $f$  represents a focal length of said lens assembly and has a unit of millimeter (col. 12, lines 43-45).

Regarding claim 2, Huang discloses the lens assembly as claimed in Claim 1, further satisfying:  $\text{HFOV} > 35^\circ$  (col. 12, lines 43-45).

Regarding claim 3, Huang discloses the lens assembly as claimed in Claim 1, further satisfying:  $f < 2.7 \text{ mm}$  (col. 12, line 43).

Regarding claim 6, Huang discloses the lens assembly as claimed in Claim 1, further satisfying:  $0.8 < |f/f_3| < 2.5$ , in which,  $f_3$  is a focal length of said third lens and has a unit of millimeter (shown in fig. 14).

Regarding claim 7, Huang discloses the lens assembly as claimed in Claim 1, further satisfying:  $0.3 < ct_1/ct_2 < 2.0$ , and  $0 < ct_3/ct_4 < 1.0$ , in which,  $ct_1$  represents a center thickness of said first lens,  $ct_2$  represents a center thickness of said second lens,  $ct_3$  represents a center thickness of said third lens,  $ct_4$  represents a center thickness of said fourth lens, and each of  $ct_1$ ,  $ct_2$ ,  $ct_3$  and  $ct_4$  has a unit of millimeter (shown in fig. 14).

### ***Allowable Subject Matter***

6. Claims 4 and 5 are objected to as being dependent upon a rejected base claim, but would be allowable if rewritten in independent form including all of the limitations of the base claim and any intervening claims.

Art Unit: 2872

7. The following is a statement of reasons for the indication of allowable subject matter: the prior art does not disclose the claimed combination of limitations to warrant a rejection under 35 USC 102 or 103.

Regarding claim 4 (and its dependent) the prior art does not disclose the claimed lens assembly specifically including as the distinguishing features in combination with the other limitations the claimed lens assembly satisfying  $Nd_3 > 1.56$ , and  $V_3 < 29$ .

### ***Conclusion***

Any inquiry concerning this communication or earlier communications from the examiner should be directed to JAMES JONES whose telephone number is (571)270-1278. The examiner can normally be reached on Monday thru Friday, 9 a.m. to 6:00 p.m. est. time.

If attempts to reach the examiner by telephone are unsuccessful, the examiner's supervisor, Thomas Pham can be reached on (571) 272-3689. The fax phone number for the organization where this application or proceeding is assigned is 571-273-8300.

Art Unit: 2872

Information regarding the status of an application may be obtained from the Patent Application Information Retrieval (PAIR) system. Status information for published applications may be obtained from either Private PAIR or Public PAIR. Status information for unpublished applications is available through Private PAIR only. For more information about the PAIR system, see <http://pair-direct.uspto.gov>. Should you have questions on access to the Private PAIR system, contact the Electronic Business Center (EBC) at 866-217-9197 (toll-free). If you would like assistance from a USPTO Customer Service Representative or access to the automated information system, call 800-786-9199 (IN USA OR CANADA) or 571-272-1000.

/JAMES JONES/  
Primary Examiner, Art Unit 2872  
1/9/2015

<b>Notice of References Cited</b>	Application/Control No. 14/141,665	Applicant(s)/Patent Under Reexamination YU ET AL.	
	Examiner JAMES JONES	Art Unit 2872	Page 1 of 1

**U.S. PATENT DOCUMENTS**

*	Document Number Country Code-Number-Kind Code	Date MM-YYYY	Name	Classification
*	A US-8,189,272	05-2012	Huang et al.	359/715
	B US-			
	C US-			
	D US-			
	E US-			
	F US-			
	G US-			
	H US-			
	I US-			
	J US-			
	K US-			
	L US-			
	M US-			

**FOREIGN PATENT DOCUMENTS**

*	Document Number Country Code-Number-Kind Code	Date MM-YYYY	Country	Name	Classification
	N				
	O				
	P				
	Q				
	R				
	S				
	T				

**NON-PATENT DOCUMENTS**

*	Document Number Country Code-Number-Kind Code	Date MM-YYYY	Country	Name	Classification
	Include as applicable: Author, Title Date, Publisher, Edition or Volume, Pertinent Pages)				
	U				
	V				
	W				
	X				

\*A copy of this reference is not being furnished with this Office action. (See MPEP § 707.05(a).)  
Dates in MM-YYYY format are publication dates. Classifications may be US or foreign.

Receipt date: 01/02/2015

14141665 - GAIL:2872

Doc code: IDS

Doc description: Information Disclosure Statement (IDS) Filed

Approved for use through 07/31/2012. OMB 0651-0031  
U.S. Patent and Trademark Office, U.S. DEPARTMENT OF COMMERCE

Under the Paperwork Reduction Act of 1995, no persons are required to respond to a collection of information unless it contains a valid OMB control number.

<b>INFORMATION DISCLOSURE STATEMENT BY APPLICANT</b> ( Not for submission under 37 CFR 1.99)	Application Number		14141665	
	Filing Date		2013-12-27	
	First Named Inventor	Hung-Kuo Yu		
	Art Unit	2872		
	Examiner Name	Stephone B. Allen		
	Attorney Docket Number	SIIP.201299		

U.S.PATENTS						
Examiner Initial*	Cite No	Patent Number	Kind Code <sup>1</sup>	Issue Date	Name of Patentee or Applicant of cited Document	Pages, Columns, Lines where Relevant Passages or Relevant Figures Appear
	1	6014080		2011-09-06	Chen, et al.	

If you wish to add additional U.S. Patent citation information please click the Add button.

U.S.PATENT APPLICATION PUBLICATIONS						
Examiner Initial*	Cite No	Publication Number	Kind Code <sup>1</sup>	Publication Date	Name of Patentee or Applicant of cited Document	Pages, Columns, Lines where Relevant Passages or Relevant Figures Appear
	1	20110128615		2011-06-02	Tsai	
	2	20120099009		2012-04-26	Hsu, et al.	
	3	20120140339		2012-06-07	Huang, et al.	
	4	20120250164		2012-10-04	Tsai, et al.	

If you wish to add additional U.S. Published Application citation information please click the Add button.

FOREIGN PATENT DOCUMENTS							
Examiner Initial*	Cite No	Foreign Document Number <sup>2</sup>	Country Code <sup>2</sup>	Kind Code <sup>4</sup>	Publication Date	Name of Patentee or Applicant of cited Document	Pages, Columns, Lines where Relevant Passages or Relevant Figures Appear
							T <sup>5</sup>

AOET, Ex. 1004

Page 177

<b>INFORMATION DISCLOSURE STATEMENT BY APPLICANT</b> ( Not for submission under 37 CFR 1.99)	Application Number	14141665	14141665 - GAU: 2872
	Filing Date	2013-12-27	
	First Named Inventor	Hung-Kuo Yu	
	Art Unit	2872	
	Examiner Name	Stephone B. Allen	
	Attorney Docket Number	SIIP.201299	

1	2004102234	JP	A	2004-04-02	Susumu	<input type="checkbox"/>
2	2007178689	JP	A	2007-07-12	Masaki, et al.	<input type="checkbox"/>
3	2009192819	JP	A	2009-08-27	Yoshikazu	<input type="checkbox"/>

If you wish to add additional Foreign Patent Document citation information please click the Add button

**NON-PATENT LITERATURE DOCUMENTS**

Examiner Initials*	Cite No	Include name of the author (in CAPITAL LETTERS), title of the article (when appropriate), title of the item (book, magazine, journal, serial, symposium, catalog, etc), date, pages(s), volume-issue number(s), publisher, city and/or country where published.	T <sup>5</sup>
	1		<input type="checkbox"/>

If you wish to add additional non-patent literature document citation information please click the Add button

**EXAMINER SIGNATURE**

Examiner Signature	/James Jones/	Date Considered	01/09/2015
--------------------	---------------	-----------------	------------

\*EXAMINER: Initial if reference considered, whether or not citation is in conformance with MPEP 609. Draw line through a citation if not in conformance and not considered. Include copy of this form with next communication to applicant.

<sup>1</sup> See Kind Codes of USPTO Patent Documents at [www.USPTO.GOV](http://www.USPTO.GOV) or MPEP 901.04. <sup>2</sup> Enter office that issued the document, by the two-letter code (WIPO Standard ST.3). <sup>3</sup> For Japanese patent documents, the indication of the year of the reign of the Emperor must precede the serial number of the patent document. <sup>4</sup> Kind of document by the appropriate symbols as indicated on the document under WIPO Standard ST.16 if possible. <sup>5</sup> Applicant is to place a check mark here if English language translation is attached.

<b>INFORMATION DISCLOSURE STATEMENT BY APPLICANT</b> ( Not for submission under 37 CFR 1.99)	Application Number	14141665	14141665 - GAU: 2872
	Filing Date	2013-12-27	
	First Named Inventor	Hung-Kuo Yu	
	Art Unit	2872	
	Examiner Name	Stephone B. Allen	
	Attorney Docket Number	SIIP.201299	

**CERTIFICATION STATEMENT**

Please see 37 CFR 1.97 and 1.98 to make the appropriate selection(s):

That each item of information contained in the information disclosure statement was first cited in any communication from a foreign patent office in a counterpart foreign application not more than three months prior to the filing of the information disclosure statement. See 37 CFR 1.97(e)(1).

**OR**

That no item of information contained in the information disclosure statement was cited in a communication from a foreign patent office in a counterpart foreign application, and, to the knowledge of the person signing the certification after making reasonable inquiry, no item of information contained in the information disclosure statement was known to any individual designated in 37 CFR 1.56(c) more than three months prior to the filing of the information disclosure statement. See 37 CFR 1.97(e)(2).

- See attached certification statement.
- The fee set forth in 37 CFR 1.17 (p) has been submitted herewith.
- A certification statement is not submitted herewith.

**SIGNATURE**

A signature of the applicant or representative is required in accordance with CFR 1.33, 10.18. Please see CFR 1.4(d) for the form of the signature.

Signature	/Thomas T. Moga/	Date (YYYY-MM-DD)	2015-01-02
Name/Print	Thomas T. Moga	Registration Number	34,881

This collection of information is required by 37 CFR 1.97 and 1.98. The information is required to obtain or retain a benefit by the public which is to file (and by the USPTO to process) an application. Confidentiality is governed by 35 U.S.C. 122 and 37 CFR 1.14. This collection is estimated to take 1 hour to complete, including gathering, preparing and submitting the completed application form to the USPTO. Time will vary depending upon the individual case. Any comments on the amount of time you require to complete this form and/or suggestions for reducing this burden, should be sent to the Chief Information Officer, U.S. Patent and Trademark Office, U.S. Department of Commerce, P.O. Box 1450, Alexandria, VA 22313-1450. **DO NOT SEND FEES OR COMPLETED FORMS TO THIS ADDRESS. SEND TO: Commissioner for Patents, P.O. Box 1450, Alexandria, VA 22313-1450.**

**Privacy Act Statement**

The Privacy Act of 1974 (P.L. 93-579) requires that you be given certain information in connection with your submission of the attached form related to a patent application or patent. Accordingly, pursuant to the requirements of the Act, please be advised that: (1) the general authority for the collection of this information is 35 U.S.C. 2(b)(2); (2) furnishing of the information solicited is voluntary; and (3) the principal purpose for which the information is used by the U.S. Patent and Trademark Office is to process and/or examine your submission related to a patent application or patent. If you do not furnish the requested information, the U.S. Patent and Trademark Office may not be able to process and/or examine your submission, which may result in termination of proceedings or abandonment of the application or expiration of the patent.

The information provided by you in this form will be subject to the following routine uses:

1. The information on this form will be treated confidentially to the extent allowed under the Freedom of Information Act (5 U.S.C. 552) and the Privacy Act (5 U.S.C. 552a). Records from this system of records may be disclosed to the Department of Justice to determine whether the Freedom of Information Act requires disclosure of these records.
2. A record from this system of records may be disclosed, as a routine use, in the course of presenting evidence to a court, magistrate, or administrative tribunal, including disclosures to opposing counsel in the course of settlement negotiations.
3. A record in this system of records may be disclosed, as a routine use, to a Member of Congress submitting a request involving an individual, to whom the record pertains, when the individual has requested assistance from the Member with respect to the subject matter of the record.
4. A record in this system of records may be disclosed, as a routine use, to a contractor of the Agency having need for the information in order to perform a contract. Recipients of information shall be required to comply with the requirements of the Privacy Act of 1974, as amended, pursuant to 5 U.S.C. 552a(m).
5. A record related to an International Application filed under the Patent Cooperation Treaty in this system of records may be disclosed, as a routine use, to the International Bureau of the World Intellectual Property Organization, pursuant to the Patent Cooperation Treaty.
6. A record in this system of records may be disclosed, as a routine use, to another federal agency for purposes of National Security review (35 U.S.C. 181) and for review pursuant to the Atomic Energy Act (42 U.S.C. 218(c)).
7. A record from this system of records may be disclosed, as a routine use, to the Administrator, General Services, or his/her designee, during an inspection of records conducted by GSA as part of that agency's responsibility to recommend improvements in records management practices and programs, under authority of 44 U.S.C. 2904 and 2906. Such disclosure shall be made in accordance with the GSA regulations governing inspection of records for this purpose, and any other relevant (i.e., GSA or Commerce) directive. Such disclosure shall not be used to make determinations about individuals.
8. A record from this system of records may be disclosed, as a routine use, to the public after either publication of the application pursuant to 35 U.S.C. 122(b) or issuance of a patent pursuant to 35 U.S.C. 151. Further, a record may be disclosed, subject to the limitations of 37 CFR 1.14, as a routine use, to the public if the record was filed in an application which became abandoned or in which the proceedings were terminated and which application is referenced by either a published application, an application open to public inspections or an issued patent.
9. A record from this system of records may be disclosed, as a routine use, to a Federal, State, or local law enforcement agency, if the USPTO becomes aware of a violation or potential violation of law or regulation.

AOET, Ex. 1004

Page 180

**ALL REFERENCES CONSIDERED EXCEPT WHERE LINED THROUGH. /JJ/**



## EAST Search History

## EAST Search History (Prior Art)

Ref #	Hits	Search Query	DBs	Default Operator	Plurals	Time Stamp
S113	1749	S111 and S112	US-PGPUB; USPAT	OR	ON	2014/11/03 11:23
S212	105	(first near3 lens) near10 positive near10 paraxial.clm.	US-PGPUB; USPAT	OR	ON	2014/11/03 13:00
S213	1716	(second near3 lens) near10 positive near10 convex.clm.	US-PGPUB; USPAT	OR	ON	2014/11/03 13:00
S214	933	(third near3 lens) near10 negative near10 convex.clm.	US-PGPUB; USPAT	OR	ON	2014/11/03 13:00
S215	1804	(fourth near3 lens) near10 convex.clm.	US-PGPUB; USPAT	OR	ON	2014/11/03 13:00
S217	1782	(third near4 lens) same positive same convex same aspheric	US-PGPUB; USPAT	OR	ON	2014/11/03 13:24
S218	1383	(fourth near4 lens) same negative same convex same aspheric	US-PGPUB; USPAT	OR	ON	2014/11/03 13:29
S219	1025	S111 and S112 and S217 and S218	US-PGPUB; USPAT	OR	ON	2014/11/03 13:29
S220	1007	S219 and (diaphragm aperture stop)	US-PGPUB; USPAT	OR	ON	2014/11/03 13:30
S222	586	359/715.ccls.	US-PGPUB; USPAT	OR	ON	2014/11/03 13:41
S239	5267	(first near3 lens near3 group) near5 positive	US-PGPUB; USPAT	OR	ON	2014/12/01 11:44
S240	5090	(second near3 lens near3 group) near5 negative	US-PGPUB; USPAT	OR	ON	2014/12/01 11:44
S241	4434	(third near3 lens near3 group) near5 positive	US-PGPUB; USPAT	OR	ON	2014/12/01 11:45
S242	2246	(fourth near3 lens near3 group) near5 negative	US-PGPUB; USPAT	OR	ON	2014/12/01 11:45
S243	1427	(fifth near3 lens near3 group) near5 positive	US-PGPUB; USPAT	OR	ON	2014/12/01 11:45
S244	28907	aperture near3 stop	US-PGPUB; USPAT	OR	ON	2014/12/01 11:45
S245	522	S239 and S240 and S241 and S242 and S243 and S244	US-PGPUB; USPAT	OR	ON	2014/12/01 11:46
S246	1409	359/649-652.ccls.	US-PGPUB; USPAT	OR	ON	2014/12/01 11:46
S250	7019	(second near4 lens) same positive same concave	US-PGPUB; USPAT	OR	ON	2014/12/01 11:47
S251	1772	(second near4 lens) same positive same concave same aspheric	US-PGPUB; USPAT	OR	ON	2014/12/01 11:47
S252	1772	S250 and S251	US-PGPUB; USPAT	OR	ON	2014/12/01 11:47
S254	454	359/717.ccls.	US-PGPUB; USPAT	OR	ON	2014/12/01 11:47

S255	698	((second near4 lens) near20 positive near20 concave near20 aspheric)	US-PGPUB; USPAT	OR	ON	2014/12/01 11:47
S256	698	S255 and S251	US-PGPUB; USPAT	OR	ON	2014/12/01 11:47
S257	688	S256 and (diaphragm aperture stop)	US-PGPUB; USPAT	OR	ON	2014/12/01 11:47
S261	12254	(second near3 lens) near5 positive	US-PGPUB; USPAT	OR	ON	2014/12/01 11:47
S262	9749	(third near3 lens) near5 positive	US-PGPUB; USPAT	OR	ON	2014/12/01 11:47
S263	4021	(fifth near3 lens) near5 positive	US-PGPUB; USPAT	OR	ON	2014/12/01 11:47
S264	2670	(fifth near3 lens) near9 convex	US-PGPUB; USPAT	OR	ON	2014/12/01 11:47
S266	1105	(sixth near3 lens) near10 concave	US-PGPUB; USPAT	OR	ON	2014/12/01 11:47
S267	1017	(fifth near3 lens) near10 aspheric	US-PGPUB; USPAT	OR	ON	2014/12/01 11:47
S268	179	S261 and S262 and S263 and S264 and S266 and S267	US-PGPUB; USPAT	OR	ON	2014/12/01 11:47
S271	511	359/714.ccls.	US-PGPUB; USPAT	OR	ON	2014/12/01 11:47
S272	768	(G02B13/0045).CPC.	US-PGPUB; USPAT	OR	ON	2014/12/01 11:47
S274	9767	(first near3 lens) near5 negative	US-PGPUB; USPAT	OR	ON	2014/12/01 11:47
S275	9158	(second near3 lens) near5 convex	US-PGPUB; USPAT	OR	ON	2014/12/01 11:47
S276	3299	(third near3 lens) near5 concave	US-PGPUB; USPAT	OR	ON	2014/12/01 11:47
S277	3282	(fourth near3 lens) near5 convex	US-PGPUB; USPAT	OR	ON	2014/12/01 11:47
S278	1376	(fifth near3 lens) near5 concave	US-PGPUB; USPAT	OR	ON	2014/12/01 11:47
S279	370	S274 and S275 and S276 and S277 and S278	US-PGPUB; USPAT	OR	ON	2014/12/01 11:47
S284	25686	lens near3 barrel	US-PGPUB; USPAT	OR	ON	2014/12/01 11:47
S285	9767	(first near3 lens) near5 negative	US-PGPUB; USPAT	OR	ON	2014/12/01 11:47
S286	9158	(second near3 lens) near5 convex	US-PGPUB; USPAT	OR	ON	2014/12/01 11:47
S287	3299	(third near3 lens) near5 concave	US-PGPUB; USPAT	OR	ON	2014/12/01 11:47
S288	3282	(fourth near3 lens) near5 convex	US-PGPUB; USPAT	OR	ON	2014/12/01 11:47
S289	1376	(fifth near3 lens) near5 concave	US-PGPUB; USPAT	OR	ON	2014/12/01 11:47
S290	370	S285 and S286 and S287 and S288 and S289	US-PGPUB; USPAT	OR	ON	2014/12/01 11:47
S292	27030	lens near3 housing	US-PGPUB; USPAT	OR	ON	2014/12/01 11:47
S295	7992	(first near3 lens) near5 negative	FPRS; EPO;	OR	ON	2014/12/01

			JPO; DERWENT			11:47
S296	3967	(second near3 lens) near5 convex	FPRS; EPO; JPO; DERWENT	OR	ON	2014/12/01 11:47
S297	1723	(third near3 lens) near5 concave	FPRS; EPO; JPO; DERWENT	OR	ON	2014/12/01 11:47
S298	1380	(fourth near3 lens) near5 convex	FPRS; EPO; JPO; DERWENT	OR	ON	2014/12/01 11:47
S299	731	(fifth near3 lens) near5 concave	FPRS; EPO; JPO; DERWENT	OR	ON	2014/12/01 11:47
S300	26	S295 and S296 and S297 and S298 and S299	FPRS; EPO; JPO; DERWENT	OR	ON	2014/12/01 11:47
S301	5952	(first near3 lens) near5 negative.clm.	US-PGPUB; USPAT	OR	ON	2014/12/01 11:47
S302	3649	(second near3 lens) near5 convex.clm.	US-PGPUB; USPAT	OR	ON	2014/12/01 11:47
S303	1925	(third near3 lens) near5 convex.clm.	US-PGPUB; USPAT	OR	ON	2014/12/01 11:47
S304	1324	(fourth near3 lens) near5 convex.clm.	US-PGPUB; USPAT	OR	ON	2014/12/01 11:47
S305	341	(fifth near3 lens) near10 plastic.clm.	US-PGPUB; USPAT	OR	ON	2014/12/01 11:47
S307	37929	distance near10 image.clm.	US-PGPUB; USPAT	OR	ON	2014/12/01 11:47
S310	818	(axial near3 distance) same (first near3 lens) same (second near3 lens)	US-PGPUB; USPAT	OR	ON	2014/12/01 11:47
S315	9767	(first near3 lens) near5 negative	US-PGPUB; USPAT	OR	ON	2014/12/01 11:47
S316	9158	(second near3 lens) near5 convex	US-PGPUB; USPAT	OR	ON	2014/12/01 11:47
S317	3299	(third near3 lens) near5 concave	US-PGPUB; USPAT	OR	ON	2014/12/01 11:47
S318	3282	(fourth near3 lens) near5 convex	US-PGPUB; USPAT	OR	ON	2014/12/01 11:47
S319	1376	(fifth near3 lens) near5 concave	US-PGPUB; USPAT	OR	ON	2014/12/01 11:47
S320	370	S315 and S316 and S317 and S318 and S319	US-PGPUB; USPAT	OR	ON	2014/12/01 11:47
S325	11890	(first near3 lens) near5 positive	US-PGPUB; USPAT	OR	ON	2014/12/01 11:47
S326	7087	(second near3 lens) near5 (concave biconcave bi-concave)	US-PGPUB; USPAT	OR	ON	2014/12/01 11:47
S327	4779	(third near3 lens) near5 (convex)	US-PGPUB; USPAT	OR	ON	2014/12/01 11:47
S328	3282	(fourth near3 lens) near5 convex	US-PGPUB; USPAT	OR	ON	2014/12/01 11:47
S329	3749	(fifth near3 lens) near7 negative	US-PGPUB; USPAT	OR	ON	2014/12/01 11:47
S330	511	S325 and S326 and S327 and	US-PGPUB;	OR	ON	2014/12/01

		S328 and S329	USPAT			11:47
S331	36	((fifth near3 lens) near7 negative) near10 inflection	US-PGPUB; USPAT	OR	ON	2014/12/01 11:47
S334	7530	(second near3 lens) near5 positive.clm.	US-PGPUB; USPAT	OR	ON	2014/12/01 11:47
S335	6761	(third near3 lens) near5 positive.clm.	US-PGPUB; USPAT	OR	ON	2014/12/01 11:47
S336	2018	(fifth near3 lens) near5 positive.clm.	US-PGPUB; USPAT	OR	ON	2014/12/01 11:47
S337	903	(fifth near3 lens) near9 convex.clm.	US-PGPUB; USPAT	OR	ON	2014/12/01 11:47
S338	388	(fifth near3 lens) near5 aspheric.clm.	US-PGPUB; USPAT	OR	ON	2014/12/01 11:47
S339	4351	(inflection near2 point).clm.	US-PGPUB; USPAT	OR	ON	2014/12/01 11:47
S340	366	(sixth near3 lens) near10 concave.clm.	US-PGPUB; USPAT	OR	ON	2014/12/01 11:47
S342	337	(first near5 lens) near7 convex near5 plastic	US-PGPUB; USPAT	OR	ON	2014/12/01 11:47
S343	424	(second near5 lens) near7 aspheric near5 plastic	US-PGPUB; USPAT	OR	ON	2014/12/01 11:47
S344	230	(third near5 lens) near7 concave near5 plastic	US-PGPUB; USPAT	OR	ON	2014/12/01 11:47
S345	27787	(fourth lens near5 lens) near10 concave	US-PGPUB; USPAT	OR	ON	2014/12/01 11:47
S346	17229	(fourth lens near5 lens) near10 plastic	US-PGPUB; USPAT	OR	ON	2014/12/01 11:47
S347	965	(fourth lens near5 lens) near10 inflection	US-PGPUB; USPAT	OR	ON	2014/12/01 11:47
S351	109	(first near3 lens) near10 positive near10 paraxial.clm.	US-PGPUB; USPAT	OR	ON	2014/12/01 11:47
S352	1726	(second near3 lens) near10 positive near10 convex.clm.	US-PGPUB; USPAT	OR	ON	2014/12/01 11:47
S353	939	(third near3 lens) near10 negative near10 convex.clm.	US-PGPUB; USPAT	OR	ON	2014/12/01 11:47
S354	1832	(fourth near3 lens) near10 convex.clm.	US-PGPUB; USPAT	OR	ON	2014/12/01 11:47
S356	1811	(third near4 lens) same positive same convex same aspheric	US-PGPUB; USPAT	OR	ON	2014/12/01 11:47
S357	1410	(fourth near4 lens) same negative same convex same aspheric	US-PGPUB; USPAT	OR	ON	2014/12/01 11:47
S358	1045	S250 and S251 and S356 and S357	US-PGPUB; USPAT	OR	ON	2014/12/01 11:47
S359	1027	S358 and (diaphragm aperture stop)	US-PGPUB; USPAT	OR	ON	2014/12/01 11:47
S361	598	359/715.ccls.	US-PGPUB; USPAT	OR	ON	2014/12/01 11:47
S391	34219	inspection near3 system	US-PGPUB; USPAT	OR	ON	2014/12/29 09:21
S392	108481	variation near3 system	US-PGPUB; USPAT	OR	ON	2014/12/29 09:21
S393	761	fifth near3 lens same infinity	US-PGPUB; USPAT	OR	ON	2014/12/29 09:21
S394	8743	(first near4 lens) same positive	US-PGPUB;	OR	ON	2014/12/29

		same convex	USPAT			09:22
S395	7073	(second near4 lens) same positive same concave	US-PGPUB; USPAT	OR	ON	2014/12/29 09:22
S396	1794	(second near4 lens) same positive same concave same aspheric	US-PGPUB; USPAT	OR	ON	2014/12/29 09:22
S397	1794	S395 and S396	US-PGPUB; USPAT	OR	ON	2014/12/29 09:22
S398	1747	S397 and (diaphragm aperture stop)	US-PGPUB; USPAT	OR	ON	2014/12/29 09:22
S399	460	359/717.ccls.	US-PGPUB; USPAT	OR	ON	2014/12/29 09:22
S400	707	((second near4 lens) near20 positive near20 concave near20 aspheric)	US-PGPUB; USPAT	OR	ON	2014/12/29 09:22
S401	707	S400 and S396	US-PGPUB; USPAT	OR	ON	2014/12/29 09:22
S402	697	S401 and (diaphragm aperture stop)	US-PGPUB; USPAT	OR	ON	2014/12/29 09:22
S404	1	"13970832"	US-PGPUB; USPAT	OR	ON	2014/12/29 09:22
S405	601	359/715.ccls.	US-PGPUB; USPAT	OR	ON	2014/12/29 09:22
S406	12339	(second near3 lens) near5 positive	US-PGPUB; USPAT	OR	ON	2014/12/29 09:22
S407	9817	(third near3 lens) near5 positive	US-PGPUB; USPAT	OR	ON	2014/12/29 09:22
S408	4065	(fifth near3 lens) near5 positive	US-PGPUB; USPAT	OR	ON	2014/12/29 09:22
S409	2706	(fifth near3 lens) near9 convex	US-PGPUB; USPAT	OR	ON	2014/12/29 09:22
S410	897	(fifth near3 lens) near5 aspheric	US-PGPUB; USPAT	OR	ON	2014/12/29 09:22
S411	1122	(sixth near3 lens) near10 concave	US-PGPUB; USPAT	OR	ON	2014/12/29 09:22
S412	1038	(fifth near3 lens) near10 aspheric	US-PGPUB; USPAT	OR	ON	2014/12/29 09:22
S413	183	S406 and S407 and S408 and S409 and S411 and S412	US-PGPUB; USPAT	OR	ON	2014/12/29 09:22
S415	1	(14/049234).APP.	US-PGPUB; USPAT; USOCR	OR	OFF	2014/12/29 09:22
S416	527	359/714.ccls.	US-PGPUB; USPAT	OR	ON	2014/12/29 09:22
S417	820	(G02B13/0045).CPC.	US-PGPUB; USPAT	OR	ON	2014/12/29 09:22
S419	9831	(first near3 lens) near5 negative	US-PGPUB; USPAT	OR	ON	2014/12/29 09:22
S420	9208	(second near3 lens) near5 convex	US-PGPUB; USPAT	OR	ON	2014/12/29 09:22
S421	3333	(third near3 lens) near5 concave	US-PGPUB; USPAT	OR	ON	2014/12/29 09:22
S422	3310	(fourth near3 lens) near5 convex	US-PGPUB; USPAT	OR	ON	2014/12/29 09:22
S423	1400	(fifth near3 lens) near5 concave	US-PGPUB;	OR	ON	2014/12/29

			USPAT			09:22
S424	375	S419 and S420 and S421 and S422 and S423	US-PGPUB; USPAT	OR	ON	2014/12/29 09:22
S426	124	S417 and S424	US-PGPUB; USPAT	OR	ON	2014/12/29 09:22
S427	3646	(first near3 lens) near5 thickness	US-PGPUB; USPAT	OR	ON	2014/12/29 09:22
S428	1394	(third near3 lens) near5 thickness	US-PGPUB; USPAT	OR	ON	2014/12/29 09:22
S429	25814	lens near3 barrel	US-PGPUB; USPAT	OR	ON	2014/12/29 09:22
S430	9831	(first near3 lens) near5 negative	US-PGPUB; USPAT	OR	ON	2014/12/29 09:22
S431	9208	(second near3 lens) near5 convex	US-PGPUB; USPAT	OR	ON	2014/12/29 09:22
S432	3333	(third near3 lens) near5 concave	US-PGPUB; USPAT	OR	ON	2014/12/29 09:22
S433	3310	(fourth near3 lens) near5 convex	US-PGPUB; USPAT	OR	ON	2014/12/29 09:22
S434	1400	(fifth near3 lens) near5 concave	US-PGPUB; USPAT	OR	ON	2014/12/29 09:22
S435	375	S430 and S431 and S432 and S433 and S434	US-PGPUB; USPAT	OR	ON	2014/12/29 09:22
S436	200	S435 and S429	US-PGPUB; USPAT	OR	ON	2014/12/29 09:22
S437	27193	lens near3 housing	US-PGPUB; USPAT	OR	ON	2014/12/29 09:22
S439	5979059	third n	US-PGPUB; USPAT	OR	ON	2014/12/29 09:22
S440	8214	(first near3 lens) near5 negative	FPRS; EPO; JPO; DERWENT	OR	ON	2014/12/29 09:22
S441	4131	(second near3 lens) near5 convex	FPRS; EPO; JPO; DERWENT	OR	ON	2014/12/29 09:22
S442	1777	(third near3 lens) near5 concave	FPRS; EPO; JPO; DERWENT	OR	ON	2014/12/29 09:22
S443	1448	(fourth near3 lens) near5 convex	FPRS; EPO; JPO; DERWENT	OR	ON	2014/12/29 09:22
S444	773	(fifth near3 lens) near5 concave	FPRS; EPO; JPO; DERWENT	OR	ON	2014/12/29 09:22
S445	27	S440 and S441 and S442 and S443 and S444	FPRS; EPO; JPO; DERWENT	OR	ON	2014/12/29 09:22
S446	5984	(first near3 lens) near5 negative.clm.	US-PGPUB; USPAT	OR	ON	2014/12/29 09:22
S447	3676	(second near3 lens) near5 convex.clm.	US-PGPUB; USPAT	OR	ON	2014/12/29 09:22
S448	1953	(third near3 lens) near5 convex.clm.	US-PGPUB; USPAT	OR	ON	2014/12/29 09:22
S449	1340	(fourth near3 lens) near5 convex.clm.	US-PGPUB; USPAT	OR	ON	2014/12/29 09:22

S450	350	(fifth near3 lens) near10 plastic.clm.	US-PGPUB; USPAT	OR	ON	2014/12/29 09:22
S452	38243	distance near10 image.clm.	US-PGPUB; USPAT	OR	ON	2014/12/29 09:22
S454	53783	axial near3 distance	US-PGPUB; USPAT	OR	ON	2014/12/29 09:22
S455	830	(axial near3 distance) same (first near3 lens) same (second near3 lens)	US-PGPUB; USPAT	OR	ON	2014/12/29 09:22
S456	0	S445 and S455	US-PGPUB; USPAT	OR	ON	2014/12/29 09:22
S457	0	S440 and S441	US-PGPUB; USPAT	OR	ON	2014/12/29 09:22
S458	9831	(first near3 lens) near5 negative	US-PGPUB; USPAT	OR	ON	2014/12/29 09:22
S459	9208	(second near3 lens) near5 convex	US-PGPUB; USPAT	OR	ON	2014/12/29 09:22
S460	9831	(first near3 lens) near5 negative	US-PGPUB; USPAT	OR	ON	2014/12/29 09:22
S461	9208	(second near3 lens) near5 convex	US-PGPUB; USPAT	OR	ON	2014/12/29 09:22
S462	3333	(third near3 lens) near5 concave	US-PGPUB; USPAT	OR	ON	2014/12/29 09:22
S463	3310	(fourth near3 lens) near5 convex	US-PGPUB; USPAT	OR	ON	2014/12/29 09:22
S464	1400	(fifth near3 lens) near5 concave	US-PGPUB; USPAT	OR	ON	2014/12/29 09:22
S465	375	S460 and S461 and S462 and S463 and S464	US-PGPUB; USPAT	OR	ON	2014/12/29 09:22
S466	49	S465 and S455	US-PGPUB; USPAT	OR	ON	2014/12/29 09:22
S467	4	Tatsuyuki near3 Ogino.inv.	US-PGPUB; USPAT	OR	ON	2014/12/29 09:22
S468	92	Michio near3 cho.inv.	US-PGPUB; USPAT	OR	ON	2014/12/29 09:22
S470	11983	(first near3 lens) near5 positive	US-PGPUB; USPAT	OR	ON	2014/12/29 09:22
S471	7133	(second near3 lens) near5 (concave biconcave bi-concave)	US-PGPUB; USPAT	OR	ON	2014/12/29 09:22
S472	4820	(third near3 lens) near5 (convex)	US-PGPUB; USPAT	OR	ON	2014/12/29 09:22
S473	3310	(fourth near3 lens) near5 convex	US-PGPUB; USPAT	OR	ON	2014/12/29 09:22
S474	3799	(fifth near3 lens) near7 negative	US-PGPUB; USPAT	OR	ON	2014/12/29 09:22
S475	523	S470 and S471 and S472 and S473 and S474	US-PGPUB; USPAT	OR	ON	2014/12/29 09:22
S476	38	((fifth near3 lens) near7 negative) near10 inflection	US-PGPUB; USPAT	OR	ON	2014/12/29 09:22
S479	7577	(second near3 lens) near5 positive.clm.	US-PGPUB; USPAT	OR	ON	2014/12/29 09:22
S480	6810	(third near3 lens) near5 positive.clm.	US-PGPUB; USPAT	OR	ON	2014/12/29 09:22
S481	2044	(fifth near3 lens) near5	US-PGPUB;	OR	ON	2014/12/29

		positive.clm.	USPAT			09:22
S482	929	(fifth near3 lens) near9 convex.clm.	US-PGPUB; USPAT	OR	ON	2014/12/29 09:22
S483	403	(fifth near3 lens) near5 aspheric.clm.	US-PGPUB; USPAT	OR	ON	2014/12/29 09:22
S484	4390	(inflection near2 point).clm.	US-PGPUB; USPAT	OR	ON	2014/12/29 09:22
S485	378	(sixth near3 lens) near10 concave.clm.	US-PGPUB; USPAT	OR	ON	2014/12/29 09:22
S487	340	(first near5 lens) near7 convex near5 plastic	US-PGPUB; USPAT	OR	ON	2014/12/29 09:22
S488	428	(second near5 lens) near7 aspheric near5 plastic	US-PGPUB; USPAT	OR	ON	2014/12/29 09:22
S489	233	(third near5 lens) near7 concave near5 plastic	US-PGPUB; USPAT	OR	ON	2014/12/29 09:22
S490	27922	(fourth lens near5 lens) near10 concave	US-PGPUB; USPAT	OR	ON	2014/12/29 09:22
S491	17327	(fourth lens near5 lens) near10 plastic	US-PGPUB; USPAT	OR	ON	2014/12/29 09:22
S492	983	(fourth lens near5 lens) near10 inflection	US-PGPUB; USPAT	OR	ON	2014/12/29 09:22
S493	174247	S487 and S488 and S489 and 4a and S491 and S492	US-PGPUB; USPAT	OR	ON	2014/12/29 09:22
S495	244	(first near3 lens) near10 positive near10 paraxial	US-PGPUB; USPAT	OR	ON	2014/12/29 09:22
S496	112	(first near3 lens) near10 positive near10 paraxial.clm.	US-PGPUB; USPAT	OR	ON	2014/12/29 09:22
S497	1736	(second near3 lens) near10 positive near10 convex.clm.	US-PGPUB; USPAT	OR	ON	2014/12/29 09:22
S498	946	(third near3 lens) near10 negative near10 convex.clm.	US-PGPUB; USPAT	OR	ON	2014/12/29 09:22
S499	1855	(fourth near3 lens) near10 convex.clm.	US-PGPUB; USPAT	OR	ON	2014/12/29 09:22
S500	1	S496 and S497 and S498 and S499	US-PGPUB; USPAT	OR	ON	2014/12/29 09:22
S501	1829	(third near4 lens) same positive same convex same aspheric	US-PGPUB; USPAT	OR	ON	2014/12/29 09:22
S502	1426	(fourth near4 lens) same negative same convex same aspheric	US-PGPUB; USPAT	OR	ON	2014/12/29 09:22
S503	1060	S395 and S396 and S501 and S502	US-PGPUB; USPAT	OR	ON	2014/12/29 09:22
S504	1042	S503 and (diaphragm aperture stop)	US-PGPUB; USPAT	OR	ON	2014/12/29 09:22
S506	601	359/715.ccls.	US-PGPUB; USPAT	OR	ON	2014/12/29 09:22
S508	5300	(first near3 lens near3 group) near5 positive	US-PGPUB; USPAT	OR	ON	2014/12/29 09:22
S509	5120	(second near3 lens near3 group) near5 negative	US-PGPUB; USPAT	OR	ON	2014/12/29 09:22
S510	4456	(third near3 lens near3 group) near5 positive	US-PGPUB; USPAT	OR	ON	2014/12/29 09:22
S511	2263	(fourth near3 lens near3 group) near5 negative	US-PGPUB; USPAT	OR	ON	2014/12/29 09:22
S512	1440	(fifth near3 lens near3 group)	US-PGPUB;	OR	ON	2014/12/29



		near5 positive	USPAT			09:22
S513	29059	aperture near3 stop	US-PGPUB; USPAT	OR	ON	2014/12/29 09:22
S514	531	S508 and S509 and S510 and S511 and S512 and S513	US-PGPUB; USPAT	OR	ON	2014/12/29 09:22
S515	1415	359/649-652.ccls.	US-PGPUB; USPAT	OR	ON	2014/12/29 09:22
S517	51	S514 and S515	US-PGPUB; USPAT	OR	ON	2014/12/29 09:22
S518	8743	(first near4 lens) same positive same convex	US-PGPUB; USPAT	OR	ON	2014/12/29 09:22
S519	7073	(second near4 lens) same positive same concave	US-PGPUB; USPAT	OR	ON	2014/12/29 09:22
S520	1794	(second near4 lens) same positive same concave same aspheric	US-PGPUB; USPAT	OR	ON	2014/12/29 09:22
S521	1794	S519 and S520	US-PGPUB; USPAT	OR	ON	2014/12/29 09:22
S522	1747	S521 and (diaphragm aperture stop)	US-PGPUB; USPAT	OR	ON	2014/12/29 09:22
S523	460	359/717.ccls.	US-PGPUB; USPAT	OR	ON	2014/12/29 09:22
S524	707	((second near4 lens) near20 positive near20 concave near20 aspheric)	US-PGPUB; USPAT	OR	ON	2014/12/29 09:22
S525	707	S524 and S520	US-PGPUB; USPAT	OR	ON	2014/12/29 09:22
S526	697	S525 and (diaphragm aperture stop)	US-PGPUB; USPAT	OR	ON	2014/12/29 09:22
S528	1	"13970832"	US-PGPUB; USPAT	OR	ON	2014/12/29 09:22
S529	601	359/715.ccls.	US-PGPUB; USPAT	OR	ON	2014/12/29 09:22
S530	12339	(second near3 lens) near5 positive	US-PGPUB; USPAT	OR	ON	2014/12/29 09:22
S531	9817	(third near3 lens) near5 positive	US-PGPUB; USPAT	OR	ON	2014/12/29 09:22
S532	4065	(fifth near3 lens) near5 positive	US-PGPUB; USPAT	OR	ON	2014/12/29 09:22
S533	2706	(fifth near3 lens) near9 convex	US-PGPUB; USPAT	OR	ON	2014/12/29 09:22
S534	897	(fifth near3 lens) near5 aspheric	US-PGPUB; USPAT	OR	ON	2014/12/29 09:22
S535	1122	(sixth near3 lens) near10 concave	US-PGPUB; USPAT	OR	ON	2014/12/29 09:22
S536	1038	(fifth near3 lens) near10 aspheric	US-PGPUB; USPAT	OR	ON	2014/12/29 09:22
S537	183	S530 and S531 and S532 and S533 and S535 and S536	US-PGPUB; USPAT	OR	ON	2014/12/29 09:22
S539	1	(14/049234).APP.	US-PGPUB; USPAT; USOCR	OR	OFF	2014/12/29 09:22
S540	527	359/714.ccls.	US-PGPUB; USPAT	OR	ON	2014/12/29 09:22
S541	820	(G02B13/0045).CPC.	US-PGPUB;	OR	ON	2014/12/29

			USPAT			09:22
S543	9831	(first near3 lens) near5 negative	US-PGPUB; USPAT	OR	ON	2014/12/29 09:22
S544	9208	(second near3 lens) near5 convex	US-PGPUB; USPAT	OR	ON	2014/12/29 09:22
S545	3333	(third near3 lens) near5 concave	US-PGPUB; USPAT	OR	ON	2014/12/29 09:22
S546	3310	(fourth near3 lens) near5 convex	US-PGPUB; USPAT	OR	ON	2014/12/29 09:22
S547	1400	(fifth near3 lens) near5 concave	US-PGPUB; USPAT	OR	ON	2014/12/29 09:22
S548	375	S543 and S544 and S545 and S546 and S547	US-PGPUB; USPAT	OR	ON	2014/12/29 09:22
S550	124	S541 and S548	US-PGPUB; USPAT	OR	ON	2014/12/29 09:22
S551	3646	(first near3 lens) near5 thickness	US-PGPUB; USPAT	OR	ON	2014/12/29 09:22
S552	1394	(third near3 lens) near5 thickness	US-PGPUB; USPAT	OR	ON	2014/12/29 09:22
S553	25814	lens near3 barrel	US-PGPUB; USPAT	OR	ON	2014/12/29 09:22
S554	9831	(first near3 lens) near5 negative	US-PGPUB; USPAT	OR	ON	2014/12/29 09:22
S555	9208	(second near3 lens) near5 convex	US-PGPUB; USPAT	OR	ON	2014/12/29 09:22
S556	3333	(third near3 lens) near5 concave	US-PGPUB; USPAT	OR	ON	2014/12/29 09:22
S557	3310	(fourth near3 lens) near5 convex	US-PGPUB; USPAT	OR	ON	2014/12/29 09:22
S558	1400	(fifth near3 lens) near5 concave	US-PGPUB; USPAT	OR	ON	2014/12/29 09:22
S559	375	S554 and S555 and S556 and S557 and S558	US-PGPUB; USPAT	OR	ON	2014/12/29 09:22
S560	200	S559 and S553	US-PGPUB; USPAT	OR	ON	2014/12/29 09:22
S561	27193	lens near3 housing	US-PGPUB; USPAT	OR	ON	2014/12/29 09:22
S590	2	("5659426"   "6335833").PN.	US-PGPUB; USPAT	OR	ON	2014/12/29 09:31
S591	609	359/715.ccls.	US-PGPUB; USPAT	OR	ON	2015/01/08 16:06
S592	4822	((first near3 lens) near10 (positive) near15 (convex))	US-PGPUB; USPAT	OR	ON	2015/01/08 16:09
S593	5240	((second near3 lens) near10 (positive) near15 (convex))	US-PGPUB; USPAT	OR	ON	2015/01/08 16:09
S594	1972	(third near3 lens) near5 negative near15 (concave)	US-PGPUB; USPAT	OR	ON	2015/01/08 16:10
S595	1904	(fourth near3 lens) near10 positive near10 concave	US-PGPUB; USPAT	OR	ON	2015/01/08 16:13
S596	566	S592 and S593 and S594 and S595	US-PGPUB; USPAT	OR	ON	2015/01/08 16:13
S597	2639777	(diaphragm stop aperture)	US-PGPUB; USPAT	OR	ON	2015/01/08 16:14
S598	547	S596 and S597	US-PGPUB;	OR	ON	2015/01/08

			USPAT			16:14
S599	177	S598 and (inflection near3 point)	US-PGPUB; USPAT	OR	ON	2015/01/08 16:14
S600	1621	maximum near3 angle near3 view	US-PGPUB; USPAT	OR	ON	2015/01/08 18:20
S601	4822	((first near3 lens) near10 (positive) near15 (convex))	US-PGPUB; USPAT	OR	ON	2015/01/08 18:54
S602	5240	((second near3 lens) near10 (positive) near15 (convex))	US-PGPUB; USPAT	OR	ON	2015/01/08 18:54
S603	1972	(third near3 lens) near5 negative near15 (concave)	US-PGPUB; USPAT	OR	ON	2015/01/08 18:54
S604	1904	(fourth near3 lens) near10 positive near10 concave	US-PGPUB; USPAT	OR	ON	2015/01/08 18:54
S605	566	S601 and S602 and S603 and S604	US-PGPUB; USPAT	OR	ON	2015/01/08 18:54
S606	2639777	(diaphragm stop aperture)	US-PGPUB; USPAT	OR	ON	2015/01/08 18:54
S607	547	S605 and S606	US-PGPUB; USPAT	OR	ON	2015/01/08 18:54
S608	177	S607 and (inflection near3 point)	US-PGPUB; USPAT	OR	ON	2015/01/08 18:54
S609	23	S608 and S600	US-PGPUB; USPAT	OR	ON	2015/01/08 18:54
S610	832	HFOV	US-PGPUB; USPAT	OR	ON	2015/01/08 19:10
S611	19	S609 and S610	US-PGPUB; USPAT	OR	ON	2015/01/08 19:10
S612	2	("20130321920"   "20140036133").PN.	US-PGPUB; USPAT	OR	ON	2015/01/08 20:13
S613	168	wei-yu near3 chen.inv.	US-PGPUB; USPAT	OR	ON	2015/01/08 20:17
S614	9418	((first near3 lens) near10 positive).clm.	US-PGPUB; USPAT	OR	ON	2015/01/08 20:20
S615	8426	(second near3 lens) near10 positive.clm.	US-PGPUB; USPAT	OR	ON	2015/01/08 20:22
S616	7376	third near3 lens near10 positive.clm.	US-PGPUB; USPAT	OR	ON	2015/01/08 20:23
S617	189	paraxial near3 region.clm.	US-PGPUB; USPAT	OR	ON	2015/01/08 20:23
S618	3793	fourth near3 lens near10 negative.clm.	US-PGPUB; USPAT	OR	ON	2015/01/08 20:25
S619	6706	aspheric.clm.	US-PGPUB; USPAT	OR	ON	2015/01/08 20:25
S620	13	S614 and S615 and S616 and S617 and S618 and S619	US-PGPUB; USPAT	OR	ON	2015/01/08 20:25

## EAST Search History (Interference)

Ref #	Hits	Search Query	DBs	Default Operator	Plurals	Time Stamp
S224	5730	(first near3 lens) near5 negative	USPAT; UPAD	OR	ON	2014/11/03 13:00
S225	5174	(second near3 lens) near5 convex	USPAT; UPAD	OR	ON	2014/11/03 13:00

S226	2690	(third near3 lens) near5 convex	USPAT; UPAD	OR	ON	2014/11/03 13:00
S227	1785	(fourth near3 lens) near5 convex	USPAT; UPAD	OR	ON	2014/11/03 13:00
S228	331	(fifth near3 lens) near10 plastic	USPAT; UPAD	OR	ON	2014/11/03 13:00
S229	82073	distance near10 image	USPAT; UPAD	OR	ON	2014/11/03 13:00
S231	7176	(second near3 lens) near5 positive	USPAT; UPAD	OR	ON	2014/11/03 13:00
S232	5637	(third near3 lens) near5 positive	USPAT; UPAD	OR	ON	2014/11/03 13:00
S233	2165	(fifth near3 lens) near5 positive	USPAT; UPAD	OR	ON	2014/11/03 13:00
S234	1408	(fifth near3 lens) near9 convex	USPAT; UPAD	OR	ON	2014/11/03 13:00
S235	386	(fifth near3 lens) near5 aspheric	USPAT; UPAD	OR	ON	2014/11/03 13:00
S236	12679	(inflection near2 point)	USPAT; UPAD	OR	ON	2014/11/03 13:00
S375	5769	(first near3 lens) near5 negative	USPAT; UPAD	OR	ON	2014/12/01 11:47
S376	5200	(second near3 lens) near5 convex	USPAT; UPAD	OR	ON	2014/12/01 11:47
S377	2708	(third near3 lens) near5 convex	USPAT; UPAD	OR	ON	2014/12/01 11:47
S378	1808	(fourth near3 lens) near5 convex	USPAT; UPAD	OR	ON	2014/12/01 11:47
S379	337	(fifth near3 lens) near10 plastic	USPAT; UPAD	OR	ON	2014/12/01 11:47
S380	82743	distance near10 image	USPAT; UPAD	OR	ON	2014/12/01 11:47
S382	7219	(second near3 lens) near5 positive	USPAT; UPAD	OR	ON	2014/12/01 11:47
S383	5675	(third near3 lens) near5 positive	USPAT; UPAD	OR	ON	2014/12/01 11:47
S384	2186	(fifth near3 lens) near5 positive	USPAT; UPAD	OR	ON	2014/12/01 11:47
S385	1424	(fifth near3 lens) near9 convex	USPAT; UPAD	OR	ON	2014/12/01 11:47
S386	396	(fifth near3 lens) near5 aspheric	USPAT; UPAD	OR	ON	2014/12/01 11:47
S387	12773	(inflection near2 point)	USPAT; UPAD	OR	ON	2014/12/01 11:47
S563	5798	(first near3 lens) near5 negative	USPAT; UPAD	OR	ON	2014/12/29 09:22
S564	5227	(second near3 lens) near5 convex	USPAT; UPAD	OR	ON	2014/12/29 09:22
S565	2730	(third near3 lens) near5 convex	USPAT; UPAD	OR	ON	2014/12/29 09:22
S566	1823	(fourth near3 lens) near5 convex	USPAT; UPAD	OR	ON	2014/12/29 09:22
S567	350	(fifth near3 lens) near10 plastic	USPAT; UPAD	OR	ON	2014/12/29 09:22

S568	83302	distance near10 image	USPAT; UPAD	OR	ON	2014/12/29 09:22
S569	7255	(second near3 lens) near5 positive	USPAT; UPAD	OR	ON	2014/12/29 09:22
S570	5704	(third near3 lens) near5 positive	USPAT; UPAD	OR	ON	2014/12/29 09:22
S571	2204	(fifth near3 lens) near5 positive	USPAT; UPAD	OR	ON	2014/12/29 09:22
S572	1440	(fifth near3 lens) near9 convex	USPAT; UPAD	OR	ON	2014/12/29 09:22
S573	404	(fifth near3 lens) near5 aspheric	USPAT; UPAD	OR	ON	2014/12/29 09:22
S574	12849	(inflection near2 point)	USPAT; UPAD	OR	ON	2014/12/29 09:22
S575	5798	(first near3 lens) near5 negative	USPAT; UPAD	OR	ON	2014/12/29 09:22
S576	5227	(second near3 lens) near5 convex	USPAT; UPAD	OR	ON	2014/12/29 09:22
S577	2730	(third near3 lens) near5 convex	USPAT; UPAD	OR	ON	2014/12/29 09:22
S578	1823	(fourth near3 lens) near5 convex	USPAT; UPAD	OR	ON	2014/12/29 09:22
S579	350	(fifth near3 lens) near10 plastic	USPAT; UPAD	OR	ON	2014/12/29 09:22
S580	83302	distance near10 image	USPAT; UPAD	OR	ON	2014/12/29 09:22
S581	45	S575 and S576 and S577 and S578 and S579 and S580	USPAT; UPAD	OR	ON	2014/12/29 09:22
S582	7255	(second near3 lens) near5 positive	USPAT; UPAD	OR	ON	2014/12/29 09:22
S583	5704	(third near3 lens) near5 positive	USPAT; UPAD	OR	ON	2014/12/29 09:22
S584	2204	(fifth near3 lens) near5 positive	USPAT; UPAD	OR	ON	2014/12/29 09:22
S585	1440	(fifth near3 lens) near9 convex	USPAT; UPAD	OR	ON	2014/12/29 09:22
S586	404	(fifth near3 lens) near5 aspheric	USPAT; UPAD	OR	ON	2014/12/29 09:22
S587	12849	(inflection near2 point)	USPAT; UPAD	OR	ON	2014/12/29 09:22
S588	610	(sixth near3 lens) near10 concave	USPAT; UPAD	OR	ON	2014/12/29 09:22
S589	56	S582 and S583 and S584 and S585 and S586 and S587	USPAT; UPAD	OR	ON	2014/12/29 09:22
S621	7913	((first near3 lens) near10 positive)	USPAT; UPAD	OR	ON	2015/01/08 20:25
S622	7882	(second near3 lens) near10 positive	USPAT; UPAD	OR	ON	2015/01/08 20:26
S623	6096	third near3 lens near10 positive	USPAT; UPAD	OR	ON	2015/01/08 20:26
S624	494	paraxial near3 region	USPAT; UPAD	OR	ON	2015/01/08 20:26
S625	4083	fourth near3 lens near10 negative	USPAT; UPAD	OR	ON	2015/01/08 20:26

S626	12175	aspheric	USPAT; UPAD	OR	ON	2015/01/08 20:27
S627	98	S621 and S622 and S623 and S624 and S625 and S626	USPAT; UPAD	OR	ON	2015/01/08 20:27

**1/9/2015 11:25:28 PM**

**C:\Users\jjones4\Documents\EAST\Workspaces\14175290.wsp**

<b>Search Notes</b>  	<b>Application/Control No.</b>  14141665	<b>Applicant(s)/Patent Under Reexamination</b>  YU ET AL.
	<b>Examiner</b>  JAMES JONES	<b>Art Unit</b>  2872

CPC- SEARCHED		
Symbol	Date	Examiner

CPC COMBINATION SETS - SEARCHED		
Symbol	Date	Examiner

US CLASSIFICATION SEARCHED			
Class	Subclass	Date	Examiner
359	715	1/9/2015	JCJ

SEARCH NOTES		
Search Notes	Date	Examiner
359/715 class search and text search	1/9/2015	JCJ
east text search	1/9/2015	JCJ

INTERFERENCE SEARCH			
US Class/ CPC Symbol	US Subclass / CPC Group	Date	Examiner

	/JAMES JONES/ Primary Examiner.Art Unit 2872
AOET, Ex. 1004	

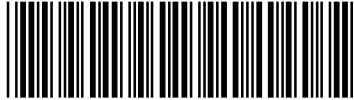
<b><i>Index of Claims</i></b>  	<b>Application/Control No.</b>  14141665	<b>Applicant(s)/Patent Under Reexamination</b>  YU ET AL.
	<b>Examiner</b>  JAMES JONES	<b>Art Unit</b>  2872

✓	<b>Rejected</b>	-	<b>Cancelled</b>	N	<b>Non-Elected</b>	A	<b>Appeal</b>
=	<b>Allowed</b>	÷	<b>Restricted</b>	I	<b>Interference</b>	O	<b>Objected</b>

Claims renumbered in the same order as presented by applicant
  CPA
  T.D.
  R.1.47

CLAIM		DATE							
Final	Original	01/09/2015							
	1	✓							
	2	✓							
	3	✓							
	4	○							
	5	○							
	6	✓							
	7	✓							



**UNITED STATES PATENT AND TRADEMARK OFFICE**

UNITED STATES DEPARTMENT OF COMMERCE  
**United States Patent and Trademark Office**  
 Address: COMMISSIONER FOR PATENTS  
 P.O. Box 1450  
 Alexandria, Virginia 22313-1450  
 www.uspto.gov

**BIB DATA SHEET**
**CONFIRMATION NO. 9554**

SERIAL NUMBER	FILING or 371(c) DATE	CLASS	GROUP ART UNIT	ATTORNEY DOCKET NO.		
14/141,665	12/27/2013	359	2872	SIIP.201299		
<b>APPLICANTS</b> ABILITY OPTO-ELECTRONICS TECHNOLOGY CO., LTD., Taichung City, TAIWAN, Assignee (with 37 CFR 1.172 Interest);						
<b>INVENTORS</b> Hung-Kuo Yu, Taichung City, TAIWAN; Chao-Hsiang Yang, Taichung City, TAIWAN;						
<b>** CONTINUING DATA *****</b>						
<b>** FOREIGN APPLICATIONS *****</b> TAIWAN 10213525 09/02/2013						
<b>** IF REQUIRED, FOREIGN FILING LICENSE GRANTED **</b> 01/09/2014						
Foreign Priority claimed <input checked="" type="checkbox"/> Yes <input type="checkbox"/> No	35 USC 119(a-d) conditions met <input checked="" type="checkbox"/> Yes <input type="checkbox"/> No	<input type="checkbox"/> Met after Allowance Initials	<b>STATE OR COUNTRY</b> TAIWAN	<b>SHEETS DRAWINGS</b> 9	<b>TOTAL CLAIMS</b> 7	<b>INDEPENDENT CLAIMS</b> 1
<b>ADDRESS</b> SHOOK, HARDY & BACON LLP INTELLECTUAL PROPERTY DEPARTMENT 2555 GRAND BLVD KANSAS CITY, MO 64108-2613 UNITED STATES						
<b>TITLE</b> LENS ASSEMBLY						
<b>FILING FEE RECEIVED</b> 1600	FEES: Authority has been given in Paper No. _____ to charge/credit DEPOSIT ACCOUNT No. _____ for following:			<input type="checkbox"/> All Fees <input type="checkbox"/> 1.16 Fees (Filing) <input type="checkbox"/> 1.17 Fees (Processing Ext. of time) <input type="checkbox"/> 1.18 Fees (Issue) <input type="checkbox"/> Other _____ <input type="checkbox"/> Credit		



UNITED STATES PATENT AND TRADEMARK OFFICE

UNITED STATES DEPARTMENT OF COMMERCE
United States Patent and Trademark Office
Address: COMMISSIONER FOR PATENTS
P.O. Box 1450
Alexandria, Virginia 22313-1450
www.uspto.gov

Table with 4 columns: APPLICATION NUMBER (14/141,665), FILING OR 371(C) DATE (12/27/2013), FIRST NAMED APPLICANT (Hung-Kuo Yu), ATTY. DOCKET NO./TITLE (SIIP.201299)

CONFIRMATION NO. 9554

PUBLICATION NOTICE

5251
SHOOK, HARDY & BACON LLP
INTELLECTUAL PROPERTY DEPARTMENT
2555 GRAND BLVD
KANSAS CITY, MO 64108-2613



Title:LENS ASSEMBLY

Publication No.US-2015-0062724-A1
Publication Date:03/05/2015

NOTICE OF PUBLICATION OF APPLICATION

The above-identified application will be electronically published as a patent application publication pursuant to 37 CFR 1.211, et seq. The patent application publication number and publication date are set forth above.

The publication may be accessed through the USPTO's publically available Searchable Databases via the Internet at www.uspto.gov. The direct link to access the publication is currently http://www.uspto.gov/patft/.

The publication process established by the Office does not provide for mailing a copy of the publication to applicant. A copy of the publication may be obtained from the Office upon payment of the appropriate fee set forth in 37 CFR 1.19(a)(1). Orders for copies of patent application publications are handled by the USPTO's Office of Public Records. The Office of Public Records can be reached by telephone at (703) 308-9726 or (800) 972-6382, by facsimile at (703) 305-8759, by mail addressed to the United States Patent and Trademark Office, Office of Public Records, Alexandria, VA 22313-1450 or via the Internet.

In addition, information on the status of the application, including the mailing date of Office actions and the dates of receipt of correspondence filed in the Office, may also be accessed via the Internet through the Patent Electronic Business Center at www.uspto.gov using the public side of the Patent Application Information and Retrieval (PAIR) system. The direct link to access this status information is currently http://pair.uspto.gov/. Prior to publication, such status information is confidential and may only be obtained by applicant using the private side of PAIR.

Further assistance in electronically accessing the publication, or about PAIR, is available by calling the Patent Electronic Business Center at 1-866-217-9197.

Office of Data Management, Application Assistance Unit (571) 272-4000, or (571) 272-4200, or 1-888-786-0101

<b>INFORMATION DISCLOSURE STATEMENT BY APPLICANT</b> ( Not for submission under 37 CFR 1.99)	Application Number		14141665	
	Filing Date		2013-12-27	
	First Named Inventor	Hung-Kuo YU		
	Art Unit		2872	
	Examiner Name	James Jones		
	Attorney Docket Number		48261.1270	

U.S.PATENTS						
Examiner Initial*	Cite No	Patent Number	Kind Code <sup>1</sup>	Issue Date	Name of Patentee or Applicant of cited Document	Pages,Columns,Lines where Relevant Passages or Relevant Figures Appear
	1	8014080	B1	2011-09-06	Chun Shan CHEN, et al.	

If you wish to add additional U.S. Patent citation information please click the Add button.

U.S.PATENT APPLICATION PUBLICATIONS						
Examiner Initial*	Cite No	Publication Number	Kind Code <sup>1</sup>	Publication Date	Name of Patentee or Applicant of cited Document	Pages,Columns,Lines where Relevant Passages or Relevant Figures Appear
	1	20120044403	A1	2012-02-23	Hsiang-Chi Tang, et al.	
	2	20130070347	A1	2013-03-21	Hsiang-Chi Tang, et al.	

If you wish to add additional U.S. Published Application citation information please click the Add button.

FOREIGN PATENT DOCUMENTS								
Examiner Initial*	Cite No	Foreign Document Number <sup>3</sup>	Country Code <sup>2</sup>	Kind Code <sup>4</sup>	Publication Date	Name of Patentee or Applicant of cited Document	Pages,Columns,Lines where Relevant Passages or Relevant Figures Appear	T <sup>5</sup>
	1	201215941	TW	A1	2012-04-16	Largan Precision Co., Ltd.		<input checked="" type="checkbox"/>

If you wish to add additional Foreign Patent Document citation information please click the Add button

NON-PATENT LITERATURE DOCUMENTS								
---------------------------------	--	--	--	--	--	--	--	--

<b>INFORMATION DISCLOSURE STATEMENT BY APPLICANT</b> ( Not for submission under 37 CFR 1.99)	Application Number	14141665
	Filing Date	2013-12-27
	First Named Inventor	Hung-Kuo YU
	Art Unit	2872
	Examiner Name	James Jones
	Attorney Docket Number	48261.1270

Examiner Initials*	Cite No	Include name of the author (in CAPITAL LETTERS), title of the article (when appropriate), title of the item (book, magazine, journal, serial, symposium, catalog, etc), date, pages(s), volume-issue number(s), publisher, city and/or country where published.	T <sup>5</sup>
	1		<input type="checkbox"/>

If you wish to add additional non-patent literature document citation information please click the Add button

**EXAMINER SIGNATURE**

Examiner Signature	Date Considered
--------------------	-----------------

\*EXAMINER: Initial if reference considered, whether or not citation is in conformance with MPEP 609. Draw line through a citation if not in conformance and not considered. Include copy of this form with next communication to applicant.

<sup>1</sup> See Kind Codes of USPTO Patent Documents at [www.USPTO.GOV](http://www.USPTO.GOV) or MPEP 901.04. <sup>2</sup> Enter office that issued the document, by the two-letter code (WIPO Standard ST.3). <sup>3</sup> For Japanese patent documents, the indication of the year of the reign of the Emperor must precede the serial number of the patent document. <sup>4</sup> Kind of document by the appropriate symbols as indicated on the document under WIPO Standard ST.16 if possible. <sup>5</sup> Applicant is to place a check mark here if English language translation is attached.

**INFORMATION DISCLOSURE  
STATEMENT BY APPLICANT**  
( Not for submission under 37 CFR 1.99)

Application Number	14141665
Filing Date	2013-12-27
First Named Inventor	Hung-Kuo YU
Art Unit	2872
Examiner Name	James Jones
Attorney Docket Number	48261.1270

**CERTIFICATION STATEMENT**

Please see 37 CFR 1.97 and 1.98 to make the appropriate selection(s):

That each item of information contained in the information disclosure statement was first cited in any communication from a foreign patent office in a counterpart foreign application not more than three months prior to the filing of the information disclosure statement. See 37 CFR 1.97(e)(1).

**OR**

That no item of information contained in the information disclosure statement was cited in a communication from a foreign patent office in a counterpart foreign application, and, to the knowledge of the person signing the certification after making reasonable inquiry, no item of information contained in the information disclosure statement was known to any individual designated in 37 CFR 1.56(c) more than three months prior to the filing of the information disclosure statement. See 37 CFR 1.97(e)(2).

- See attached certification statement.
- The fee set forth in 37 CFR 1.17 (p) has been submitted herewith.
- A certification statement is not submitted herewith.

**SIGNATURE**

A signature of the applicant or representative is required in accordance with CFR 1.33, 10.18. Please see CFR 1.4(d) for the form of the signature.

Signature	/Thomas T. Moga/	Date (YYYY-MM-DD)	2015-04-10
Name/Print	Thomas T. Moga	Registration Number	34881

This collection of information is required by 37 CFR 1.97 and 1.98. The information is required to obtain or retain a benefit by the public which is to file (and by the USPTO to process) an application. Confidentiality is governed by 35 U.S.C. 122 and 37 CFR 1.14. This collection is estimated to take 1 hour to complete, including gathering, preparing and submitting the completed application form to the USPTO. Time will vary depending upon the individual case. Any comments on the amount of time you require to complete this form and/or suggestions for reducing this burden, should be sent to the Chief Information Officer, U.S. Patent and Trademark Office, U.S. Department of Commerce, P.O. Box 1450, Alexandria, VA 22313-1450. **DO NOT SEND FEES OR COMPLETED FORMS TO THIS ADDRESS. SEND TO: Commissioner for Patents, P.O. Box 1450, Alexandria, VA 22313-1450.**

## Privacy Act Statement

The Privacy Act of 1974 (P.L. 93-579) requires that you be given certain information in connection with your submission of the attached form related to a patent application or patent. Accordingly, pursuant to the requirements of the Act, please be advised that: (1) the general authority for the collection of this information is 35 U.S.C. 2(b)(2); (2) furnishing of the information solicited is voluntary; and (3) the principal purpose for which the information is used by the U.S. Patent and Trademark Office is to process and/or examine your submission related to a patent application or patent. If you do not furnish the requested information, the U.S. Patent and Trademark Office may not be able to process and/or examine your submission, which may result in termination of proceedings or abandonment of the application or expiration of the patent.

The information provided by you in this form will be subject to the following routine uses:

1. The information on this form will be treated confidentially to the extent allowed under the Freedom of Information Act (5 U.S.C. 552) and the Privacy Act (5 U.S.C. 552a). Records from this system of records may be disclosed to the Department of Justice to determine whether the Freedom of Information Act requires disclosure of these records.
2. A record from this system of records may be disclosed, as a routine use, in the course of presenting evidence to a court, magistrate, or administrative tribunal, including disclosures to opposing counsel in the course of settlement negotiations.
3. A record in this system of records may be disclosed, as a routine use, to a Member of Congress submitting a request involving an individual, to whom the record pertains, when the individual has requested assistance from the Member with respect to the subject matter of the record.
4. A record in this system of records may be disclosed, as a routine use, to a contractor of the Agency having need for the information in order to perform a contract. Recipients of information shall be required to comply with the requirements of the Privacy Act of 1974, as amended, pursuant to 5 U.S.C. 552a(m).
5. A record related to an International Application filed under the Patent Cooperation Treaty in this system of records may be disclosed, as a routine use, to the International Bureau of the World Intellectual Property Organization, pursuant to the Patent Cooperation Treaty.
6. A record in this system of records may be disclosed, as a routine use, to another federal agency for purposes of National Security review (35 U.S.C. 181) and for review pursuant to the Atomic Energy Act (42 U.S.C. 218(c)).
7. A record from this system of records may be disclosed, as a routine use, to the Administrator, General Services, or his/her designee, during an inspection of records conducted by GSA as part of that agency's responsibility to recommend improvements in records management practices and programs, under authority of 44 U.S.C. 2904 and 2906. Such disclosure shall be made in accordance with the GSA regulations governing inspection of records for this purpose, and any other relevant (i.e., GSA or Commerce) directive. Such disclosure shall not be used to make determinations about individuals.
8. A record from this system of records may be disclosed, as a routine use, to the public after either publication of the application pursuant to 35 U.S.C. 122(b) or issuance of a patent pursuant to 35 U.S.C. 151. Further, a record may be disclosed, subject to the limitations of 37 CFR 1.14, as a routine use, to the public if the record was filed in an application which became abandoned or in which the proceedings were terminated and which application is referenced by either a published application, an application open to public inspections or an issued patent.
9. A record from this system of records may be disclosed, as a routine use, to a Federal, State, or local law enforcement agency, if the USPTO becomes aware of a violation or potential violation of law or regulation.



(19) 中華民國智慧財產局

(12) 發明說明書公開本

(11) 公開編號：TW 201215941 A1

(43) 公開日：中華民國 101 (2012) 年 04 月 16 日

(21) 申請案號：099134902

(22) 申請日：中華民國 99 (2010) 年 10 月 13 日

(51) Int. Cl. : G02B9/34 (2006.01)  
G02B13/18 (2006.01)

G02B11/22 (2006.01)

(71) 申請人：大立光電股份有限公司 (中華民國) LARGAN PRECISION CO., LTD. (TW)  
臺中市南屯區精科路 11 號

(72) 發明人：陳俊杉 CHEN, CHUN SHAN (TW) ; 蔡宗翰 TSAI, TSUNG HAN (TW) ; 黃歆璇 HUANG, HSIN HSUAN (TW)

(74) 代理人：郭雨嵐；林發立

申請實體審查：有 申請專利範圍項數：21 項 圖式數：22 共 74 頁

(54) 名稱

光學攝像系統

OPTICAL PHOTOGRAPHING SYSTEM

(57) 摘要

本發明提供一種光學攝像系統，包含四枚具屈折力的透鏡，由物側至像側依序為：一第一透鏡；一具正屈折力的第二透鏡，其物側表面與像側表面中至少一表面為非球面；一具負屈折力的第三透鏡，其物側表面為凹面及像側表面為凸面，該物側表面與像側表面皆為非球面；及一具正屈折力的第四透鏡，其物側表面與像側表面皆為非球面；其中，該光學攝像系統另包含有一光圈，該光圈係設置於被攝物與該第二透鏡之間。藉由上述的鏡組配置方式，可有效縮短鏡頭的總長度、提供較大的視角，且能獲得良好的成像品質。

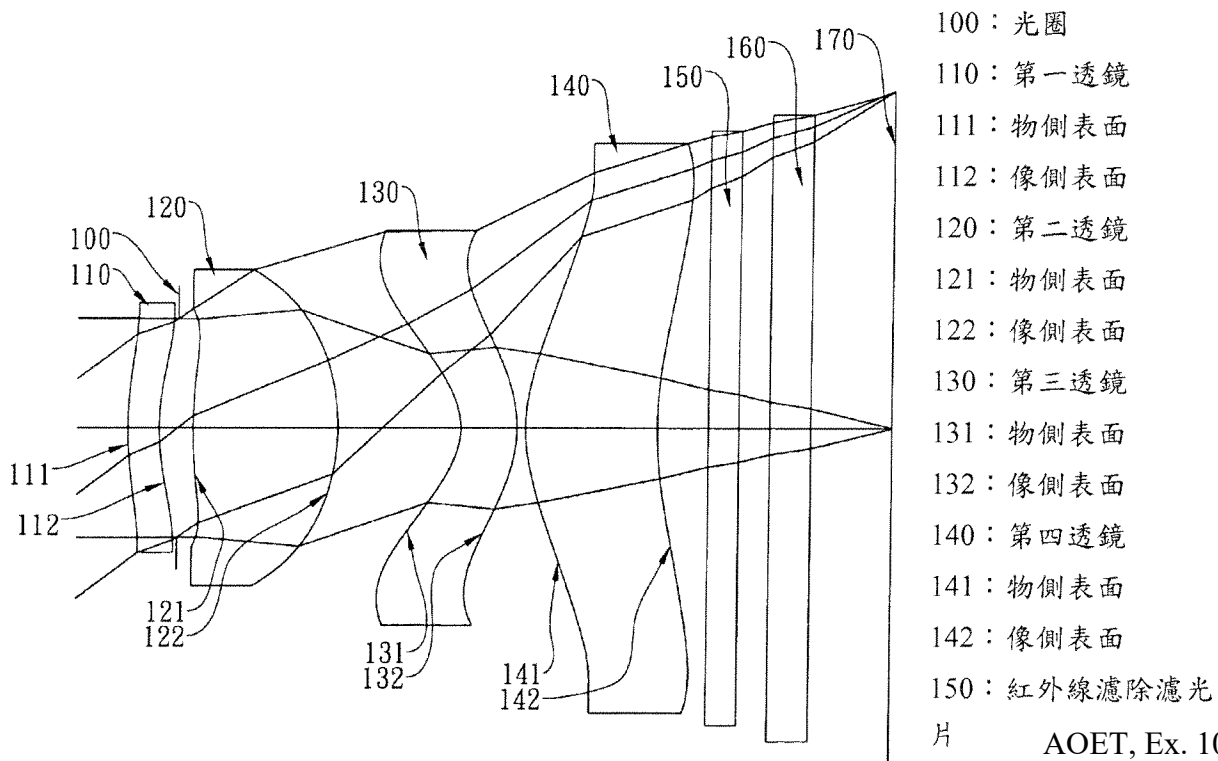

- 100：光圈
- 110：第一透鏡
- 111：物側表面
- 112：像側表面
- 120：第二透鏡
- 121：物側表面
- 122：像側表面
- 130：第三透鏡
- 131：物側表面
- 132：像側表面
- 140：第四透鏡
- 141：物側表面
- 142：像側表面
- 150：紅外線濾除濾光片





## 發明專利說明書

(本說明書格式、順序，請勿任意更動，※記號部分請勿填寫)

※申請案號：

99174902

※申請日：

99.10.13

G02B 9/34 (2006.01)

※IPC 分類：G02B 11/22 (2006.01)

G02B 13/18 (2006.01)

一、發明名稱：(中文/英文)

光學攝像系統 / Optical Photographing System

二、中文發明摘要：

本發明提供一種光學攝像系統，包含四枚具屈折力的透鏡，由物側至像側依序為：一第一透鏡；一具正屈折力的第二透鏡，其物側表面與像側表面中至少一表面為非球面；一具負屈折力的第三透鏡，其物側表面為凹面及像側表面為凸面，該物側表面與像側表面皆為非球面；及一具正屈折力的第四透鏡，其物側表面與像側表面皆為非球面；其中，該光學攝像系統另包含有一光圈，該光圈係設置於被攝物與該第二透鏡之間。藉由上述的鏡組配置方式，可有效縮短鏡頭的總長度、提供較大的視角，且能獲得良好的成像品質。

### 三、英文發明摘要

This invention provides an optical photographing system comprising four lens elements with refractive power, in order from an object side to an image side: a first lens element; a second lens element with positive refractive power, and at least one of the object-side and image-side surfaces thereof being aspheric; a third lens element with negative refractive power having a concave object-side surface and a convex image-side surface, and both of the object-side and image-side surfaces thereof being aspheric; a fourth lens element with positive refractive power, and both of the object-side and image-side surfaces thereof being aspheric; wherein the optical photographing system further comprises an aperture stop positioned between an imaged object and the second lens element. By such arrangement, total track length of the optical photographing system can be effectively reduced. Wide view-angle and high image resolution are also obtained.

四、指定代表圖：

(一)本案指定代表圖為：第(一A)圖。

(二)本代表圖之元件符號簡單說明：

光圈	100		
第一透鏡	110		
物側表面	111	像側表面	112
第二透鏡	120		
物側表面	121	像側表面	122
第三透鏡	130		
物側表面	131	像側表面	132
第四透鏡	140		
物側表面	141	像側表面	142
紅外線濾除濾光片	150		
保護玻璃	160		
成像面	170		

五、本案若有化學式時，請揭示最能顯示發明特徵的化學式：

無

六、發明說明：

【發明所屬之技術領域】

本發明係關於一種光學攝像系統；特別是關於一種應用於電子產品的小型化光學攝像系統。

【先前技術】

近年來，隨著小型化攝影鏡頭的蓬勃發展，微型取像模組的需求日漸提高，而一般攝影鏡頭的感光元件不外乎是感光耦合元件(Charge Coupled Device, CCD)或互補性氧化金屬半導體元件(Complementary Metal-Oxide Semiconductor Sensor, CMOS Sensor)兩種，且隨著半導體製程技術的精進，使得感光元件的畫素尺寸縮小，再加上現今電子產品以功能佳且輕薄短小的外型為發展趨勢，因此，具備良好成像品質的小型化攝影鏡頭儼然成為目前市場上的主流。

習見的高解像力攝影鏡頭，多採用前置光圈且為四枚式的透鏡組，其中，第一透鏡及第二透鏡常以二枚玻璃球面鏡互相黏合而成為 doublet，用以消除色差，如美國專利第 7,365,920 號所示，但此方法有其缺點，其一，過多的球面鏡配置使得系統自由度不足，導致系統的光學總長度不易縮短，其二，玻璃鏡片黏合的製程不易，造成製造上的困難。此外，隨著取像鏡頭的尺寸愈做愈小，且規格愈做愈高，在有限的空間裡作緊密的鏡片組立將容易造成不必要的光線在鏡筒內多次反射而影響鏡頭成像，因此，該非

必要的光線應避免進入成像區域以維持成像品質。

有鑑於此，急需一種適用於輕薄、可攜式電子產品上，成像品質佳且不至於使鏡頭總長度過長的光學攝像系統。

### 【發明內容】

本發明提供一種光學攝像系統，包含四枚具屈折力的透鏡，由物側至像側依序為：一第一透鏡；一具正屈折力的第二透鏡，其物側表面與像側表面中至少一表面為非球面；一具負屈折力的第三透鏡，其物側表面為凹面及像側表面為凸面，該物側表面與像側表面皆為非球面；及一具正屈折力的第四透鏡，其物側表面與像側表面皆為非球面；其中，該光學攝像系統另包含有一光圈及一於成像面上的電子感光元件供被攝物成像，該光圈係設置於被攝物與該第二透鏡之間；該第一透鏡物側表面至該第四透鏡像側表面於光軸上的距離為  $T_d$ ，該電子感光元件有效畫素區域對角線長的一半為  $ImgH$ ，該第一透鏡與該第二透鏡於光軸上的間隔距離為  $T_{12}$ ，該第三透鏡與該第四透鏡於光軸上的間隔距離為  $T_{34}$ ，該第二透鏡與該第三透鏡於光軸上的間隔距離為  $T_{23}$ ，該第二透鏡的像側表面曲率半徑為  $R_4$ ，該第二透鏡的物側表面曲率半徑為  $R_3$ ，該光圈至該成像面於光軸上的距離為  $SL$ ，該第一透鏡的物側表面至該成像面於光軸上的距離為  $TTL$ ，係滿足下列關係式： $0.7 < T_d / ImgH < 2.0$ ； $0.15 < (T_{12} + T_{34}) / T_{23} < 1.20$ ； $0.0 < |R_4 / R_3| < 1.55$ ；及  $0.8 < SL / TTL < 1.2$ 。

另一方面，本發明提供一種光學攝像系統，包含四枚

具屈折力的透鏡，由物側至像側依序為：一第一透鏡，其物側表面為凸面及像側表面為凹面；一具正屈折力的第二透鏡，其像側表面為凸面，且該第二透鏡的物側表面與像側表面中至少一表面為非球面；一具負屈折力的第三透鏡，其物側表面為凹面及像側表面為凸面，該第三透鏡的物側表面與像側表面皆為非球面，且該第三透鏡的材質為塑膠；及一具正屈折力的第四透鏡，其物側表面為凸面及像側表面為凹面，該第四透鏡的物側表面與像側表面皆為非球面，該第四透鏡的材質為塑膠，且該第四透鏡的物側表面與像側表面中至少一表面設置有至少一反曲點；其中，該光學攝像系統另包含有一光圈及一於成像面上的電子感光元件供被攝物成像，該光圈係設置於被攝物與該第二透鏡之間；該第一透鏡物側表面至該第四透鏡像側表面於光軸上的距離為  $T_d$ ，該電子感光元件有效畫素區域對角線長的一半為  $ImgH$ ，該光圈至該成像面於光軸上的距離為  $SL$ ，該第一透鏡的物側表面至該成像面於光軸上的距離為  $TTL$ ，該第一透鏡與該第二透鏡於光軸上的間隔距離為  $T_{12}$ ，該第二透鏡與該第三透鏡於光軸上的間隔距離為  $T_{23}$ ，係滿足下列關係式： $0.7 < T_d / ImgH < 2.0$ ； $0.8 < SL / TTL < 1.2$ ；及  $0.1 < T_{12} / T_{23} < 1.0$ 。

本發明藉由上述的鏡組配置方式，可有效縮短鏡頭的總長度、提供較大的視角，且能獲得良好的成像品質。

本發明光學攝像系統中，該光圈可置於被攝物與該第一透鏡之間或該第一透鏡與該第二透鏡之間。

藉由該第一透鏡提供正屈折力，並且將該光圈置於接

近該光學攝像系統的被攝物側時，可以有效縮短該光學攝像系統的光學總長度。

另外，上述的配置可使該光學攝像系統的出射瞳(Exit Pupil)遠離成像面，因此，光線將以接近垂直入射的方式入射在感光元件上，此即為像側的遠心(Telecentric)特性，遠心特性對於固態電子感光元件的感光能力極為重要，可使得電子感光元件的感光敏感度提高，減少系統產生暗角的可能性。此外，該第一、第三或第四透鏡上可設置有反曲點，將可更有效地壓制離軸視場的光線入射於感光元件上的角度，並且可進一步修正離軸視場的像差。另一方面，當將該光圈置於愈接近該第二透鏡處，可有利於廣視場角的特性，有助於對歪曲(Distortion)及倍率色收差(Chromatic Aberration of Magnification)的修正，且如此的配置可有效降低系統的敏感度。

因此，本發明光學攝像系統中該光圈係設置於被攝物與該第二透鏡之間，其目的係欲在遠心特性與廣視場角中取得平衡。

本發明光學攝像系統中，該第一透鏡可具有正或負屈折力；當第一透鏡具正屈折力，可提供系統部分屈折力，有助於縮短系統的光學總長度。當第一透鏡具負屈折力，係可利於擴大該系統的視場角；當第一透鏡具正屈折力及第二透鏡具正屈折力時，該第二透鏡正屈折力可分配第一透鏡的屈折力，且降低系統的敏感度。當第一透鏡具負屈折力及第二透鏡具正屈折力時，該第二透鏡提供系統主要的屈折力，可縮短系統的光學總長度。該第三透鏡具負屈

折力，可有效對具第二透鏡正屈折力所產生的像差做補正，且同時助於修正系統的色差。該第四透鏡具正屈折力，可進一步縮短系統的光學總長度，以維持鏡頭的小型化。

本發明光學攝像系統中，當該第一透鏡的物側表面為凸面及像側表面為凹面，如該第一透鏡具負屈折力，係可利於擴大該系統的視場角；當該第一透鏡的物側表面為凹面及像側表面為凸面，對於修正系統的像散(Astigmatism)較為有利，有助於提升系統的成像品質。當該第二透鏡的物側表面為凸面及像側表面為凸面，可加強第二透鏡的正屈折力，有助於縮短系統的光學總長度。當該第二透鏡的物側表面為凹面及像側表面為凸面，可利於修正系統的像散。當該第三透鏡的物側表面為凹面及像側表面為凸面，可有效修正系統的像差，且有助於修正系統的色差。當該第四透鏡的物側表面為凸面及像側表面為凹面，可有助於修正系統的像散與高階像差。

### 【實施方式】

本發明提供一種光學攝像系統，包含四枚具屈折力的透鏡，由物側至像側依序為：一第一透鏡；一具正屈折力的第二透鏡，其物側表面與像側表面中至少一表面為非球面；一具負屈折力的第三透鏡，其物側表面為凹面及像側表面為凸面，該物側表面與像側表面皆為非球面；及一具正屈折力的第四透鏡，其物側表面與像側表面皆為非球面；其中，該光學攝像系統另包含有一光圈及一於成像面上的電子感光元件供被攝物成像，該光圈係設置於被攝物



與該第二透鏡之間；該第一透鏡物側表面至該第四透鏡像側表面於光軸上的距離為  $T_d$ ，該電子感光元件有效畫素區域對角線長的一半為  $ImgH$ ，該第一透鏡與該第二透鏡於光軸上的間隔距離為  $T_{12}$ ，該第三透鏡與該第四透鏡於光軸上的間隔距離為  $T_{34}$ ，該第二透鏡與該第三透鏡於光軸上的間隔距離為  $T_{23}$ ，該第二透鏡的像側表面曲率半徑為  $R_4$ ，該第二透鏡的物側表面曲率半徑為  $R_3$ ，該光圈至該成像面於光軸上的距離為  $SL$ ，該第一透鏡的物側表面至該成像面於光軸上的距離為  $TTL$ ，係滿足下列關係式： $0.7 < T_d / ImgH < 2.0$ ； $0.15 < (T_{12} + T_{34}) / T_{23} < 1.20$ ； $0.0 < |R_4 / R_3| < 1.55$ ；及  $0.8 < SL / TTL < 1.2$ 。

當前述光學攝像系統滿足下列關係式： $0.7 < T_d / ImgH < 2.0$ ，有利於縮短光學總長度，以維持系統的小型化。當前述光學攝像系統滿足下列關係式： $0.15 < (T_{12} + T_{34}) / T_{23} < 1.20$ ，各鏡片的配置較合適，有利於鏡頭組裝與可以維持適當的光學總長度，較佳係滿足下列關係式： $0.2 < (T_{12} + T_{34}) / T_{23} < 0.6$ 。當前述光學攝像系統滿足下列關係式： $0.0 < |R_4 / R_3| < 1.55$ ，該第二透鏡的曲率不至於太彎曲，有利於提供系統適當的像散補正，較佳係滿足下列關係式： $0.0 < |R_4 / R_3| < 0.8$ 。當前述光學攝像系統滿足下列關係式： $0.8 < SL / TTL < 1.2$ ，該光圈的位置，可在遠心與廣角特性中取得最好的平衡，較佳係滿足下列關係式： $0.84 < SL / TTL < 0.97$ 。

本發明前述光學攝像系統中，較佳地，該第三透鏡及該第四透鏡的材質為塑膠，塑膠材質透鏡的使用可有效減

低鏡組的重量，更可有效降低生產成本。

本發明前述光學攝像系統中，該整體光學攝像系統的焦距為  $f$ ，該第一透鏡的焦距為  $f_1$ ，較佳地，當前述光學攝像系統滿足下列關係式： $0.0 < |f / f_1| < 0.5$ ，該第一透鏡的屈折力較為合適，得以避免敏感度過高。

本發明前述光學攝像系統中，該第一透鏡於光軸上的厚度為  $CT_1$ ，該第二透鏡於光軸上的厚度為  $CT_2$ ，較佳地，當前述光學攝像系統滿足下列關係式： $0.2 < CT_1 / CT_2 < 0.5$ ，該第一透鏡與第二透鏡的厚度配置較合適，有利於鏡片的製造與組裝。

本發明前述光學攝像系統中，該整體光學攝像系統的焦距為  $f$ ，該第二透鏡的焦距為  $f_2$ ，較佳地，當前述光學攝像系統滿足下列關係式： $1.0 < f / f_2 < 2.5$ ，該第二透鏡的屈折力較合適，可有效縮短系統的光學總長度。

本發明前述光學攝像系統中，該第三透鏡的物側表面曲率半徑為  $R_5$ ，該第三透鏡的像側表面曲率半徑為  $R_6$ ，較佳地，當前述光學攝像系統滿足下列關係式： $-5.0 < (R_5 + R_6) / (R_5 - R_6) < -2.0$ ，該第三透鏡的曲率，有助於修正系統的像散與像差。

本發明前述光學攝像系統中，該整體光學攝像系統的焦距為  $f$ ，該第三透鏡的焦距為  $f_3$ ，較佳地，當前述光學攝像系統滿足下列關係式： $-2.5 < f / f_3 < -1.0$ ，該第三透鏡的作用如同補正透鏡，其功能為平衡及修正系統所產生的各項像差，進而可使系統獲得更高的成像品質。

本發明前述光學攝像系統中，該第四透鏡的色散係數

為  $V4$ ，該第三透鏡的色散係數為  $V3$ ，較佳地，當前述光學攝像系統滿足下列關係式： $25 < V4 - V3 < 42$ ，有利於該攝像用光學鏡頭中色差的修正。

另一方面，本發明提供一種光學攝像系統，包含四枚具屈折力的透鏡，由物側至像側依序為：一第一透鏡，其物側表面為凸面及像側表面為凹面；一具正屈折力的第二透鏡，其像側表面為凸面，且該第二透鏡的物側表面與像側表面中至少一表面為非球面；一具負屈折力的第三透鏡，其物側表面為凹面及像側表面為凸面，該第三透鏡的物側表面與像側表面皆為非球面，且該第三透鏡的材質為塑膠；及一具正屈折力的第四透鏡，其物側表面為凸面及像側表面為凹面，該第四透鏡的物側表面與像側表面皆為非球面，該第四透鏡的材質為塑膠，且該第四透鏡的物側表面與像側表面中至少一表面設置有至少一反曲點；其中，該光學攝像系統另包含有一光圈及一於成像面上的電子感光元件供被攝物成像，該光圈係設置於被攝物與該第二透鏡之間；該第一透鏡物側表面至該第四透鏡像側表面於光軸上的距離為  $Td$ ，該電子感光元件有效畫素區域對角線長的一半為  $ImgH$ ，該光圈至該成像面於光軸上的距離為  $SL$ ，該第一透鏡的物側表面至該成像面於光軸上的距離為  $TTL$ ，該第一透鏡與該第二透鏡於光軸上的間隔距離為  $T12$ ，該第二透鏡與該第三透鏡於光軸上的間隔距離為  $T23$ ，係滿足下列關係式： $0.7 < Td / ImgH < 2.0$ ； $0.8 < SL / TTL < 1.2$ ；及  $0.1 < T12 / T23 < 1.0$ 。

當前述光學攝像系統滿足下列關係式： $0.7 < Td / ImgH$

$< 2.0$ ，有利於縮短光學總長度，以維持系統的小型化。當前述光學攝像系統滿足下列關係式： $0.8 < SL / TTL < 1.2$ ，該光圈的位置，可在遠心與廣角特性中取得最好的平衡，較佳係滿足下列關係式： $0.84 < SL / TTL < 0.97$ 。當前述光學攝像系統滿足下列關係式： $0.1 < T12 / T23 < 1.0$ ，該第一透鏡、第二透鏡至第三透鏡的配置較合適，有利於鏡頭組裝。

本發明前述光學攝像系統中，該整體光學攝像系統的焦距為  $f$ ，該第二透鏡的焦距為  $f_2$ ，較佳地，當前述光學攝像系統滿足下列關係式： $1.0 < f / f_2 < 2.5$ ，該第二透鏡的屈折力較合適，可有效縮短系統的光學總長度。

本發明前述光學攝像系統中，該整體光學攝像系統的焦距為  $f$ ，該第一透鏡的焦距為  $f_1$ ，較佳地，當前述光學攝像系統滿足下列關係式： $0 < f / f_1 < 0.5$ ，該第一透鏡的屈折力大小配置較為平衡，可有效控制系統的光學總長度，維持小型化的特性，並且可同時避免高階球差(High Order Spherical Aberration)的過度增大，進而提升成像品質。

本發明前述光學攝像系統中，該第二透鏡的像側表面曲率半徑為  $R_4$ ，該第二透鏡的物側表面曲率半徑為  $R_3$ ，較佳地，當前述光學攝像系統滿足下列關係式： $0.0 < |R_4 / R_3| < 0.8$ ，該第二透鏡的曲率不至於太彎曲，有利於提供系統適當的像散補正。

本發明前述光學攝像系統中，該第一透鏡於光軸上的厚度為  $CT_1$ ，該第二透鏡於光軸上的厚度為  $CT_2$ ，較佳地，當前述光學攝像系統滿足下列關係式： $0.2 < CT_1 / CT_2 <$

0.5，該第一透鏡與第二透鏡的厚度配置較合適，有利於鏡片的製造與組裝。

本發明光學攝像系統中，透鏡的材質可為玻璃或塑膠，若透鏡的材質為玻璃，則可以增加該光學攝像系統屈折力配置的自由度，若透鏡材質為塑膠，則可以有效降低生產成本。此外，可於鏡面上設置非球面，非球面可以容易製作成球面以外的形狀，獲得較多的控制變數，用以消減像差，進而縮減透鏡使用的數目，因此可以有效降低本發明光學攝像系統的總長度。

本發明光學攝像系統中，若透鏡表面係為凸面，則表示該透鏡表面於近軸處為凸面；若透鏡表面係為凹面，則表示該透鏡表面於近軸處為凹面。

本發明光學攝像系統將藉由以下具體實施例配合所附圖式予以詳細說明。

#### 《第一實施例》

本發明第一實施例請參閱第一 A 圖，第一實施例之像差曲線請參閱第一 B 圖。第一實施例之光學攝像系統主要由四片透鏡構成，由物側至像側依序包含：

一具負屈折力的第一透鏡(110)，其物側表面(111)為凸面及像側表面(112)為凹面，其材質為塑膠，該第一透鏡(110)的物側表面(111)及像側表面(112)皆為非球面，且該第一透鏡(110)的物側表面(111)及像側表面(112)皆設置有至少一個反曲點；

一具正屈折力的第二透鏡(120)，其物側表面(121)為凸面及像側表面(122)為凸面，其材質為塑膠，該第二透鏡(120)

的物側表面(121)及像側表面(122)皆為非球面；

一具負屈折力的第三透鏡(130)，其物側表面(131)為凹面及像側表面(132)為凸面，其材質為塑膠，該第三透鏡(130)的物側表面(131)及像側表面(132)皆為非球面，且該第三透鏡(130)的物側表面(131)及像側表面(132)皆設置有至少一個反曲點；及

一具正屈折力的第四透鏡(140)，其物側表面(141)為凸面及像側表面(142)為凹面，其材質為塑膠，該第四透鏡(140)的物側表面(141)及像側表面(142)皆為非球面，且該第四透鏡(140)的物側表面(141)及像側表面(142)皆設置有至少一個反曲點；

其中，該光學攝像系統另設置有一光圈(100)置於被攝物與該第二透鏡(120)之間；

另包含有一紅外線濾除濾光片(IR-filter)(150)置於該第四透鏡(140)的像側表面(142)與一成像面(170)之間；及一保護玻璃(Cover-glass)(160)置於該紅外線濾除濾光片(150)與該成像面(170)之間；另設置有一電子感光元件於該成像面(170)上；該紅外線濾除濾光片(150)的材質為玻璃且其不影響本發明該光學攝像系統的焦距。

上述之非球面曲線的方程式表示如下：

$$X(Y)=(Y^2/R)/(1+\text{sqrt}(1-(1+k)*(Y/R)^2))+\sum_i(A_i)*(Y^i)$$

其中：

X：非球面上距離光軸為 Y 的點，其與相切於非球面光軸上頂點之切面的相對高度；

Y：非球面曲線上的點與光軸的距離；

k：錐面係數；

$A_i$ ：第 i 階非球面係數。

第一實施例光學攝像系統中，整體光學攝像系統的焦距為 f，其關係式為： $f = 4.54$ (毫米)。

第一實施例光學攝像系統中，整體光學攝像系統的光圈值(f-number)為  $F_{no}$ ，其關係式為： $F_{no} = 2.07$ 。

第一實施例光學攝像系統中，整體光學攝像系統中最大視角的一半為 HFOV，其關係式為： $HFOV = 37.1$ (度)。

第一實施例光學攝像系統中，該第四透鏡(140)的色散係數為  $V_4$ ，該第三透鏡(130)的色散係數為  $V_3$ ，其關係式為： $V_4 - V_3 = 32.5$ 。

第一實施例光學攝像系統中，該第一透鏡(110)與該第二透鏡(120)於光軸上的間隔距離為  $T_{12}$ ，該第三透鏡(130)與該第四透鏡(140)於光軸上的間隔距離為  $T_{34}$ ，該第二透鏡(120)與該第三透鏡(130)於光軸上的間隔距離為  $T_{23}$ ，其關係式為： $(T_{12} + T_{34}) / T_{23} = 0.35$ 。

第一實施例光學攝像系統中，該第一透鏡(110)與該第二透鏡(120)於光軸上的間隔距離為  $T_{12}$ ，該第二透鏡(120)與該第三透鏡(130)於光軸上的間隔距離為  $T_{23}$ ，其關係式為： $T_{12} / T_{23} = 0.28$ 。

第一實施例光學攝像系統中，該第一透鏡(110)於光軸上的厚度為  $CT_1$ ，該第二透鏡(120)於光軸上的厚度為  $CT_2$ ，其關係式為： $CT_1 / CT_2 = 0.22$ 。

第一實施例光學攝像系統中，該第二透鏡(120)的像側

表面曲率半徑為  $R4$  及物側表面曲率半徑為  $R3$ ，其關係式為： $|R4 / R3| = 0.54$ 。

第一實施例光學攝像系統中，該第三透鏡(130)的物側表面曲率半徑為  $R5$  及像側表面曲率半徑為  $R6$ ，其關係式為： $(R5 + R6) / (R5 - R6) = -3.17$ 。

第一實施例光學攝像系統中，整體光學攝像系統的焦距為  $f$ ，該第一透鏡(110)的焦距為  $f1$ ，其關係式為： $f / f1 = -0.33$ 。

第一實施例光學攝像系統中，整體光學攝像系統的焦距為  $f$ ，該第二透鏡(120)的焦距為  $f2$ ，其關係式為： $f / f2 = 1.55$ 。

第一實施例光學攝像系統中，整體光學攝像系統的焦距為  $f$ ，該第三透鏡(130)的焦距為  $f3$ ，其關係式為： $f / f3 = -1.32$ 。

第一實施例光學攝像系統中，該光圈(100)至該成像面(170)於光軸上的距離為  $SL$ ，該第一透鏡(110)的物側表面(111)至該成像面(170)於光軸上的距離為  $TTL$ ，其關係式為： $SL / TTL = 0.93$ 。

第一實施例光學攝像系統中，該第一透鏡(110)物側表面(111)至該第四透鏡(140)像側表面(142)於光軸上的距離為  $Td$ ，該電子感光元件有效畫素區域對角線長的一半為  $ImgH$ ，其關係式為： $Td / ImgH = 1.55$ 。

第一實施例詳細的光學數據如第八圖表一所示，其非球面數據如第九圖的表二所示，其中曲率半徑、厚度及焦距的單位為  $mm$ ，HFOV 定義為最大視角的一半。



《第二實施例》

本發明第二實施例請參閱第二 A 圖，第二實施例之像差曲線請參閱第二 B 圖。第二實施例之光學攝像系統主要由四片透鏡構成，由物側至像側依序包含：

一具負屈折力的第一透鏡(210)，其物側表面(211)為凸面及像側表面(212)為凹面，其材質為塑膠，該第一透鏡(210)的物側表面(211)及像側表面(212)皆為非球面，且該第一透鏡(210)的物側表面(211)及像側表面(212)皆設置有至少一個反曲點；

一具正屈折力的第二透鏡(220)，其物側表面(221)為凹面及像側表面(222)為凸面，其材質為塑膠，該第二透鏡(220)的物側表面(221)及像側表面(222)皆為非球面；

一具負屈折力的第三透鏡(230)，其物側表面(231)為凹面及像側表面(232)為凸面，其材質為塑膠，該第三透鏡(230)的物側表面(231)及像側表面(232)皆為非球面，且該第三透鏡(230)的物側表面(231)及像側表面(232)皆設置有至少一個反曲點；及

一具正屈折力的第四透鏡(240)，其物側表面(241)為凸面及像側表面(242)為凹面，其材質為塑膠，該第四透鏡(240)的物側表面(241)及像側表面(242)皆為非球面，且該第四透鏡(240)的物側表面(241)及像側表面(242)皆設置有至少一個反曲點；

其中，該光學攝像系統另設置有一光圈(200)置於被攝物與該第二透鏡(220)之間；

另包含有一紅外線濾除濾光片(250)置於該第四透鏡

(240)的像側表面(242)與一成像面(270)之間；及一保護玻璃(260)置於該紅外線濾除濾光片(250)與該成像面(270)之間；另設置有一電子感光元件於該成像面(270)上；該紅外線濾除濾光片(250)的材質為玻璃且其不影響本發明該光學攝像系統的焦距。

第二實施例非球面曲線方程式的表示如同第一實施例的形式。

第二實施例光學攝像系統中，整體光學攝像系統的焦距為  $f$ ，其關係式為： $f = 4.11$ (毫米)。

第二實施例光學攝像系統中，整體光學攝像系統的光圈值(f-number)為  $Fno$ ，其關係式為： $Fno = 2.40$ 。

第二實施例光學攝像系統中，整體光學攝像系統中最大視角的一半為  $HFOV$ ，其關係式為： $HFOV = 39.1$ (度)。

第二實施例光學攝像系統中，該第四透鏡(240)的色散係數為  $V4$ ，該第三透鏡(230)的色散係數為  $V3$ ，其關係式為： $V4 - V3 = 34.5$ 。

第二實施例光學攝像系統中，該第一透鏡(210)與該第二透鏡(220)於光軸上的間隔距離為  $T12$ ，該第三透鏡(230)與該第四透鏡(240)於光軸上的間隔距離為  $T34$ ，該第二透鏡(220)與該第三透鏡(230)於光軸上的間隔距離為  $T23$ ，其關係式為： $(T12 + T34) / T23 = 0.22$ 。

第二實施例光學攝像系統中，該第一透鏡(210)與該第二透鏡(220)於光軸上的間隔距離為  $T12$ ，該第二透鏡(220)與該第三透鏡(230)於光軸上的間隔距離為  $T23$ ，其關係式為： $T12 / T23 = 0.18$ 。

第二實施例光學攝像系統中，該第一透鏡(210)於光軸上的厚度為 CT1，該第二透鏡(220)於光軸上的厚度為 CT2，其關係式為： $CT1 / CT2 = 0.43$ 。

第二實施例光學攝像系統中，該第二透鏡(220)的像側表面曲率半徑為 R4 及物側表面曲率半徑為 R3，其關係式為： $|R4 / R3| = 0.05$ 。

第二實施例光學攝像系統中，該第三透鏡(230)的物側表面曲率半徑為 R5 及像側表面曲率半徑為 R6，其關係式為： $(R5 + R6) / (R5 - R6) = -3.37$ 。

第二實施例光學攝像系統中，整體光學攝像系統的焦距為 f，該第一透鏡(210)的焦距為 f1，其關係式為： $f / f1 = -0.12$ 。

第二實施例光學攝像系統中，整體光學攝像系統的焦距為 f，該第二透鏡(220)的焦距為 f2，其關係式為： $f / f2 = 1.32$ 。

第二實施例光學攝像系統中，整體光學攝像系統的焦距為 f，該第三透鏡(230)的焦距為 f3，其關係式為： $f / f3 = -1.06$ 。

第二實施例光學攝像系統中，該光圈(200)至該成像面(270)於光軸上的距離為 SL，該第一透鏡(210)的物側表面(211)至該成像面(270)於光軸上的距離為 TTL，其關係式為： $SL / TTL = 0.93$ 。

第二實施例光學攝像系統中，該第一透鏡(210)物側表面(211)至該第四透鏡(240)像側表面(242)於光軸上的距離為 Td，該電子感光元件有效畫素區域對角線長的一半為

ImgH，其關係式為： $Td / \text{ImgH} = 1.35$ 。

第二實施例詳細的光學數據如第十圖表三所示，其非球面數據如第十一圖的表四所示，其中曲率半徑、厚度及焦距的單位為 mm，HFOV 定義為最大視角的一半。

### 《第三實施例》

本發明第三實施例請參閱第三 A 圖，第三實施例之像差曲線請參閱第三 B 圖。第三實施例之光學攝像系統主要由四片透鏡構成，由物側至像側依序包含：

一具負屈折力的第一透鏡(310)，其物側表面(311)為凸面及像側表面(312)為凹面，其材質為塑膠，該第一透鏡(310)的物側表面(311)及像側表面(312)皆為非球面，且該第一透鏡(310)的物側表面(311)及像側表面(312)皆設置有至少一個反曲點；

一具正屈折力的第二透鏡(320)，其物側表面(321)為凸面及像側表面(322)為凸面，其材質為塑膠，該第二透鏡(320)的物側表面(321)及像側表面(322)皆為非球面；

一具負屈折力的第三透鏡(330)，其物側表面(331)為凹面及像側表面(332)為凸面，其材質為塑膠，該第三透鏡(330)的物側表面(331)及像側表面(332)皆為非球面，且該第三透鏡(330)的物側表面(331)及像側表面(332)皆設置有至少一個反曲點；及

一具正屈折力的第四透鏡(340)，其物側表面(341)為凸面及像側表面(342)為凹面，其材質為塑膠，該第四透鏡(340)的物側表面(341)及像側表面(342)皆為非球面，且該第四透鏡(340)的像側表面(342)設置有至少一個反曲點；

其中，該光學攝像系統另設置有一光圈(300)置於被攝物與該第二透鏡(320)之間；

另包含有一紅外線濾除濾光片(350)置於該第四透鏡(340)的像側表面(342)與一成像面(370)之間；及一保護玻璃(360)置於該紅外線濾除濾光片(350)與該成像面(370)之間；另設置有一電子感光元件於該成像面(370)上；該紅外線濾除濾光片(350)的材質為玻璃且其不影響本發明該光學攝像系統的焦距。

第三實施例非球面曲線方程式的表示如同第一實施例的形式。

第三實施例光學攝像系統中，整體光學攝像系統的焦距為  $f$ ，其關係式為： $f = 4.34$ (毫米)。

第三實施例光學攝像系統中，整體光學攝像系統的光圈值(f-number)為  $Fno$ ，其關係式為： $Fno = 2.40$ 。

第三實施例光學攝像系統中，整體光學攝像系統中最大視角的一半為  $HFOV$ ，其關係式為： $HFOV = 38.2$ (度)。

第三實施例光學攝像系統中，該第四透鏡(340)的色散係數為  $V4$ ，該第三透鏡(330)的色散係數為  $V3$ ，其關係式為： $V4 - V3 = 32.5$ 。

第三實施例光學攝像系統中，該第一透鏡(310)與該第二透鏡(320)於光軸上的間隔距離為  $T12$ ，該第三透鏡(330)與該第四透鏡(340)於光軸上的間隔距離為  $T34$ ，該第二透鏡(320)與該第三透鏡(330)於光軸上的間隔距離為  $T23$ ，其關係式為： $(T12 + T34) / T23 = 0.34$ 。

第三實施例光學攝像系統中，該第一透鏡(310)與該第

二透鏡(320)於光軸上的間隔距離為  $T_{12}$ ，該第二透鏡(320)與該第三透鏡(330)於光軸上的間隔距離為  $T_{23}$ ，其關係式為： $T_{12} / T_{23} = 0.23$ 。

第三實施例光學攝像系統中，該第一透鏡(310)於光軸上的厚度為  $CT_1$ ，該第二透鏡(320)於光軸上的厚度為  $CT_2$ ，其關係式為： $CT_1 / CT_2 = 0.25$ 。

第三實施例光學攝像系統中，該第二透鏡(320)的像側表面曲率半徑為  $R_4$  及物側表面曲率半徑為  $R_3$ ，其關係式為： $|R_4 / R_3| = 0.78$ 。

第三實施例光學攝像系統中，該第三透鏡(330)的物側表面曲率半徑為  $R_5$  及像側表面曲率半徑為  $R_6$ ，其關係式為： $(R_5 + R_6) / (R_5 - R_6) = -3.03$ 。

第三實施例光學攝像系統中，整體光學攝像系統的焦距為  $f$ ，該第一透鏡(310)的焦距為  $f_1$ ，其關係式為： $f / f_1 = -0.35$ 。

第三實施例光學攝像系統中，整體光學攝像系統的焦距為  $f$ ，該第二透鏡(320)的焦距為  $f_2$ ，其關係式為： $f / f_2 = 1.63$ 。

第三實施例光學攝像系統中，整體光學攝像系統的焦距為  $f$ ，該第三透鏡(330)的焦距為  $f_3$ ，其關係式為： $f / f_3 = -1.36$ 。

第三實施例光學攝像系統中，該光圈(300)至該成像面(370)於光軸上的距離為  $SL$ ，該第一透鏡(310)的物側表面(311)至該成像面(370)於光軸上的距離為  $TTL$ ，其關係式為： $SL / TTL = 1.01$ 。

第三實施例光學攝像系統中，該第一透鏡(310)物側表面(311)至該第四透鏡(340)像側表面(342)於光軸上的距離為  $T_d$ ，該電子感光元件有效畫素區域對角線長的一半為  $ImgH$ ，其關係式為： $T_d / ImgH = 1.47$ 。

第三實施例詳細的光學數據如第十二圖表五所示，其非球面數據如第十三圖的表六所示，其中曲率半徑、厚度及焦距的單位為 mm，HFOV 定義為最大視角的一半。

#### 《第四實施例》

本發明第四實施例請參閱第四 A 圖，第四實施例之像差曲線請參閱第四 B 圖。第四實施例之光學攝像系統主要由四片透鏡構成，由物側至像側依序包含：

一具負屈折力的第一透鏡(410)，其物側表面(411)為凸面及像側表面(412)為凹面，其材質為塑膠，該第一透鏡(410)的物側表面(411)及像側表面(412)皆為非球面，且該第一透鏡(410)的物側表面(411)及像側表面(412)皆設置有至少一個反曲點；

一具正屈折力的第二透鏡(420)，其物側表面(421)為凸面及像側表面(422)為凸面，其材質為塑膠，該第二透鏡(420)的物側表面(421)及像側表面(422)皆為非球面；

一具負屈折力的第三透鏡(430)，其物側表面(431)為凹面及像側表面(432)為凸面，其材質為塑膠，該第三透鏡(430)的物側表面(431)及像側表面(432)皆為非球面，且該第三透鏡(430)的物側表面(431)及像側表面(432)皆設置有至少一個反曲點；及

一具正屈折力的第四透鏡(440)，其物側表面(441)為凸

面及像側表面(442)為凹面，其材質為塑膠，該第四透鏡(440)的物側表面(441)及像側表面(442)皆為非球面，且該第四透鏡(440)的物側表面(441)及像側表面(442)皆設置有至少一個反曲點；

其中，該光學攝像系統另設置有一光圈(400)置於被攝物與該第二透鏡(420)之間；

另包含有一紅外線濾除濾光片(450)置於該第四透鏡(440)的像側表面(442)與一成像面(470)之間；及一保護玻璃(460)置於該紅外線濾除濾光片(450)與該成像面(470)之間；另設置有一電子感光元件於該成像面(470)上；該紅外線濾除濾光片(450)的材質為玻璃且其不影響本發明該光學攝像系統的焦距。

第四實施例非球面曲線方程式的表示如同第一實施例的形式。

第四實施例光學攝像系統中，整體光學攝像系統的焦距為  $f$ ，其關係式為： $f = 5.06$ (毫米)。

第四實施例光學攝像系統中，整體光學攝像系統的光圈值(f-number)為  $Fno$ ，其關係式為： $Fno = 1.85$ 。

第四實施例光學攝像系統中，整體光學攝像系統中最大視角的一半為  $HFOV$ ，其關係式為： $HFOV = 33.4$ (度)。

第四實施例光學攝像系統中，該第四透鏡(440)的色散係數為  $V4$ ，該第三透鏡(430)的色散係數為  $V3$ ，其關係式為： $V4 - V3 = 33.0$ 。

第四實施例光學攝像系統中，該第一透鏡(410)與該第二透鏡(420)於光軸上的間隔距離為  $T12$ ，該第三透鏡(430)



與該第四透鏡(440)於光軸上的間隔距離為  $T_{34}$ ，該第二透鏡(420)與該第三透鏡(430)於光軸上的間隔距離為  $T_{23}$ ，其關係式為： $(T_{12} + T_{34}) / T_{23} = 0.25$ 。

第四實施例光學攝像系統中，該第一透鏡(410)與該第二透鏡(420)於光軸上的間隔距離為  $T_{12}$ ，該第二透鏡(420)與該第三透鏡(430)於光軸上的間隔距離為  $T_{23}$ ，其關係式為： $T_{12} / T_{23} = 0.21$ 。

第四實施例光學攝像系統中，該第一透鏡(410)於光軸上的厚度為  $CT_1$ ，該第二透鏡(420)於光軸上的厚度為  $CT_2$ ，其關係式為： $CT_1 / CT_2 = 0.27$ 。

第四實施例光學攝像系統中，該第二透鏡(420)的像側表面曲率半徑為  $R_4$  及物側表面曲率半徑為  $R_3$ ，其關係式為： $|R_4 / R_3| = 1.53$ 。

第四實施例光學攝像系統中，該第三透鏡(430)的物側表面曲率半徑為  $R_5$  及像側表面曲率半徑為  $R_6$ ，其關係式為： $(R_5 + R_6) / (R_5 - R_6) = -4.15$ 。

第四實施例光學攝像系統中，整體光學攝像系統的焦距為  $f$ ，該第一透鏡(410)的焦距為  $f_1$ ，其關係式為： $f / f_1 = -0.42$ 。

第四實施例光學攝像系統中，整體光學攝像系統的焦距為  $f$ ，該第二透鏡(420)的焦距為  $f_2$ ，其關係式為： $f / f_2 = 1.48$ 。

第四實施例光學攝像系統中，整體光學攝像系統的焦距為  $f$ ，該第三透鏡(430)的焦距為  $f_3$ ，其關係式為： $f / f_3 = -1.26$ 。

第四實施例光學攝像系統中，該光圈(400)至該成像面(470)於光軸上的距離為 SL，該第一透鏡(410)的物側表面(411)至該成像面(470)於光軸上的距離為 TTL，其關係式為： $SL / TTL = 0.89$ 。

第四實施例光學攝像系統中，該第一透鏡(410)物側表面(411)至該第四透鏡(440)像側表面(442)於光軸上的距離為 Td，該電子感光元件有效畫素區域對角線長的一半為 ImgH，其關係式為： $Td / ImgH = 1.69$ 。

第四實施例詳細的光學數據如第十四圖表七所示，其非球面數據如第十五圖的表八所示，其中曲率半徑、厚度及焦距的單位為 mm，HFOV 定義為最大視角的一半。

#### 《第五實施例》

本發明第五實施例請參閱第五 A 圖，第五實施例之像差曲線請參閱第五 B 圖。第五實施例之光學攝像系統主要由四片透鏡構成，由物側至像側依序包含：

一具負屈折力的第一透鏡(510)，其物側表面(511)為凸面及像側表面(512)為凹面，其材質為塑膠，該第一透鏡(510)的物側表面(511)及像側表面(512)皆為非球面；

一具正屈折力的第二透鏡(520)，其物側表面(521)為凸面及像側表面(522)為凸面，其材質為塑膠，該第二透鏡(520)的物側表面(521)及像側表面(522)皆為非球面；

一具負屈折力的第三透鏡(530)，其物側表面(531)為凹面及像側表面(532)為凸面，其材質為塑膠，該第三透鏡(530)的物側表面(531)及像側表面(532)皆為非球面，且該第三透鏡(530)的物側表面(531)及像側表面(532)皆設置有至少一

個反曲點；及

一具正屈折力的第四透鏡(540)，其物側表面(541)為凸面及像側表面(542)為凹面，其材質為塑膠，該第四透鏡(540)的物側表面(541)及像側表面(542)皆為非球面，且該第四透鏡(540)的物側表面(541)及像側表面(542)皆設置有至少一個反曲點；

其中，該光學攝像系統另設置有一光圈(500)置於被攝物與該第二透鏡(520)之間；

另包含有一紅外線濾除濾光片(550)置於該第四透鏡(540)的像側表面(542)與一成像面(570)之間；及一保護玻璃(560)置於該紅外線濾除濾光片(550)與該成像面(570)之間；另設置有一電子感光元件於該成像面(570)上；該紅外線濾除濾光片(550)的材質為玻璃且其不影響本發明該光學攝像系統的焦距。

第五實施例非球面曲線方程式的表示如同第一實施例的形式。

第五實施例光學攝像系統中，整體光學攝像系統的焦距為  $f$ ，其關係式為： $f = 3.44$ (毫米)。

第五實施例光學攝像系統中，整體光學攝像系統的光圈值(f-number)為  $Fno$ ，其關係式為： $Fno = 2.81$ 。

第五實施例光學攝像系統中，整體光學攝像系統中最大視角的一半為  $HFOV$ ，其關係式為： $HFOV = 37.6$ (度)。

第五實施例光學攝像系統中，該第四透鏡(540)的色散係數為  $V4$ ，該第三透鏡(530)的色散係數為  $V3$ ，其關係式為： $V4 - V3 = 25.6$ 。

第五實施例光學攝像系統中，該第一透鏡(510)與該第二透鏡(520)於光軸上的間隔距離為  $T_{12}$ ，該第三透鏡(530)與該第四透鏡(540)於光軸上的間隔距離為  $T_{34}$ ，該第二透鏡(520)與該第三透鏡(530)於光軸上的間隔距離為  $T_{23}$ ，其關係式為： $(T_{12} + T_{34}) / T_{23} = 0.88$ 。

第五實施例光學攝像系統中，該第一透鏡(510)與該第二透鏡(520)於光軸上的間隔距離為  $T_{12}$ ，該第二透鏡(520)與該第三透鏡(530)於光軸上的間隔距離為  $T_{23}$ ，其關係式為： $T_{12} / T_{23} = 0.67$ 。

第五實施例光學攝像系統中，該第一透鏡(510)於光軸上的厚度為  $CT_1$ ，該第二透鏡(520)於光軸上的厚度為  $CT_2$ ，其關係式為： $CT_1 / CT_2 = 0.44$ 。

第五實施例光學攝像系統中，該第二透鏡(520)的像側表面曲率半徑為  $R_4$  及物側表面曲率半徑為  $R_3$ ，其關係式為： $|R_4 / R_3| = 0.37$ 。

第五實施例光學攝像系統中，該第三透鏡(530)的物側表面曲率半徑為  $R_5$  及像側表面曲率半徑為  $R_6$ ，其關係式為： $(R_5 + R_6) / (R_5 - R_6) = -2.26$ 。

第五實施例光學攝像系統中，整體光學攝像系統的焦距為  $f$ ，該第一透鏡(510)的焦距為  $f_1$ ，其關係式為： $f / f_1 = -0.02$ 。

第五實施例光學攝像系統中，整體光學攝像系統的焦距為  $f$ ，該第二透鏡(520)的焦距為  $f_2$ ，其關係式為： $f / f_2 = 1.97$ 。

第五實施例光學攝像系統中，整體光學攝像系統的焦

距為  $f$ ，該第三透鏡(530)的焦距為  $f_3$ ，其關係式為： $f / f_3 = -1.91$ 。

第五實施例光學攝像系統中，該光圈(500)至該成像面(570)於光軸上的距離為  $SL$ ，該第一透鏡(510)的物側表面(511)至該成像面(570)於光軸上的距離為  $TTL$ ，其關係式為： $SL / TTL = 0.88$ 。

第五實施例光學攝像系統中，該第一透鏡(510)物側表面(511)至該第四透鏡(540)像側表面(542)於光軸上的距離為  $Td$ ，該電子感光元件有效畫素區域對角線長的一半為  $ImgH$ ，其關係式為： $Td / ImgH = 1.47$ 。

第五實施例詳細的光學數據如第十六圖表九所示，其非球面數據如第十七圖的表十所示，其中曲率半徑、厚度及焦距的單位為  $mm$ ，HFOV 定義為最大視角的一半。

#### 《第六實施例》

本發明第六實施例請參閱第六 A 圖，第六實施例之像差曲線請參閱第六 B 圖。第六實施例之光學攝像系統主要由四片透鏡構成，由物側至像側依序包含：

一具正屈折力的第一透鏡(610)，其物側表面(611)為凹面及像側表面(612)為凸面，其材質為塑膠，該第一透鏡(610)的物側表面(611)及像側表面(612)皆為非球面；

一具正屈折力的第二透鏡(620)，其物側表面(621)為凸面及像側表面(622)為凸面，其材質為塑膠，該第二透鏡(620)的物側表面(621)及像側表面(622)皆為非球面；

一具負屈折力的第三透鏡(630)，其物側表面(631)為凹面及像側表面(632)為凸面，其材質為塑膠，該第三透鏡(630)

的物側表面(631)及像側表面(632)皆為非球面，且該第三透鏡(630)的物側表面(631)及像側表面(632)皆設置有至少一個反曲點；及

一具正屈折力的第四透鏡(640)，其物側表面(641)為凸面及像側表面(642)為凹面，其材質為塑膠，該第四透鏡(640)的物側表面(641)及像側表面(642)皆為非球面，且該第四透鏡(640)的物側表面(641)及像側表面(642)皆設置有至少一個反曲點；

其中，該光學攝像系統另設置有一光圈(600)置於被攝物與該第二透鏡(620)之間；

另包含有一紅外線濾除濾光片(650)置於該第四透鏡(640)的像側表面(642)與一成像面(670)之間；及一保護玻璃(660)置於該紅外線濾除濾光片(650)與該成像面(670)之間；另設置有一電子感光元件於該成像面(670)上；該紅外線濾除濾光片(650)的材質為玻璃且其不影響本發明該光學攝像系統的焦距。

第六實施例非球面曲線方程式的表示如同第一實施例的形式。

第六實施例光學攝像系統中，整體光學攝像系統的焦距為  $f$ ，其關係式為： $f = 4.28$ (毫米)。

第六實施例光學攝像系統中，整體光學攝像系統的光圈值(f-number)為  $Fno$ ，其關係式為： $Fno = 2.40$ 。

第六實施例光學攝像系統中，整體光學攝像系統中最大視角的一半為  $HFOV$ ，其關係式為： $HFOV = 37.9$ (度)。

第六實施例光學攝像系統中，該第四透鏡(640)的色散

係數為  $V4$ ，該第三透鏡(630)的色散係數為  $V3$ ，其關係式為： $V4 - V3 = 34.5$ 。

第六實施例光學攝像系統中，該第一透鏡(610)與該第二透鏡(620)於光軸上的間隔距離為  $T12$ ，該第三透鏡(630)與該第四透鏡(640)於光軸上的間隔距離為  $T34$ ，該第二透鏡(620)與該第三透鏡(630)於光軸上的間隔距離為  $T23$ ，其關係式為： $(T12 + T34) / T23 = 0.54$ 。

第六實施例光學攝像系統中，該第一透鏡(610)與該第二透鏡(620)於光軸上的間隔距離為  $T12$ ，該第二透鏡(620)與該第三透鏡(630)於光軸上的間隔距離為  $T23$ ，其關係式為： $T12 / T23 = 0.46$ 。

第六實施例光學攝像系統中，該第一透鏡(610)於光軸上的厚度為  $CT1$ ，該第二透鏡(620)於光軸上的厚度為  $CT2$ ，其關係式為： $CT1 / CT2 = 0.26$ 。

第六實施例光學攝像系統中，該第二透鏡(620)的像側表面曲率半徑為  $R4$  及物側表面曲率半徑為  $R3$ ，其關係式為： $|R4 / R3| = 0.18$ 。

第六實施例光學攝像系統中，該第三透鏡(630)的物側表面曲率半徑為  $R5$  及像側表面曲率半徑為  $R6$ ，其關係式為： $(R5 + R6) / (R5 - R6) = -2.87$ 。

第六實施例光學攝像系統中，整體光學攝像系統的焦距為  $f$ ，該第一透鏡(610)的焦距為  $f1$ ，其關係式為： $f / f1 = 0.25$ 。

第六實施例光學攝像系統中，整體光學攝像系統的焦距為  $f$ ，該第二透鏡(620)的焦距為  $f2$ ，其關係式為： $f / f2 =$

1.11。

第六實施例光學攝像系統中，整體光學攝像系統的焦距為  $f$ ，該第三透鏡(630)的焦距為  $f_3$ ，其關係式為： $f / f_3 = -1.36$ 。

第六實施例光學攝像系統中，該光圈(600)至該成像面(670)於光軸上的距離為  $SL$ ，該第一透鏡(610)的物側表面(611)至該成像面(670)於光軸上的距離為  $TTL$ ，其關係式為： $SL / TTL = 0.94$ 。

第六實施例光學攝像系統中，該第一透鏡(610)物側表面(611)至該第四透鏡(640)像側表面(642)於光軸上的距離為  $T_d$ ，該電子感光元件有效畫素區域對角線長的一半為  $ImgH$ ，其關係式為： $T_d / ImgH = 1.81$ 。

第六實施例詳細的光學數據如第十八圖表十一所示，其非球面數據如第十九圖的表十二所示，其中曲率半徑、厚度及焦距的單位為  $mm$ ，HFOV 定義為最大視角的一半。

《第七實施例》

本發明第七實施例請參閱第七 A 圖，第七實施例之像差曲線請參閱第七 B 圖。第七實施例之光學攝像系統主要由四片透鏡構成，由物側至像側依序包含：

一具正屈折力的第一透鏡(710)，其物側表面(711)為凸面及像側表面(712)為凹面，其材質為塑膠，該第一透鏡(710)的物側表面(711)及像側表面(712)皆為非球面；

一具正屈折力的第二透鏡(720)，其物側表面(721)為凹面及像側表面(722)為凸面，其材質為塑膠，該第二透鏡(720)的物側表面(721)及像側表面(722)皆為非球面；



一具負屈折力的第三透鏡(730)，其物側表面(731)為凹面及像側表面(732)為凸面，其材質為塑膠，該第三透鏡(730)的物側表面(731)及像側表面(732)皆為非球面，且該第三透鏡(730)的物側表面(731)及像側表面(732)皆設置有至少一個反曲點；及

一具正屈折力的第四透鏡(740)，其物側表面(741)為凸面及像側表面(742)為凹面，其材質為塑膠，該第四透鏡(740)的物側表面(741)及像側表面(742)皆為非球面，且該第四透鏡(740)的物側表面(741)及像側表面(742)皆設置有至少一個反曲點；

其中，該光學攝像系統另設置有一光圈(700)置於被攝物與該第二透鏡(720)之間；

另包含有一紅外線濾除濾光片(750)置於該第四透鏡(740)的像側表面(742)與一成像面(770)之間；及一保護玻璃(760)置於該紅外線濾除濾光片(750)與該成像面(770)之間；另設置有一電子感光元件於該成像面(770)上；該紅外線濾除濾光片(750)的材質為玻璃且其不影響本發明該光學攝像系統的焦距。

第七實施例非球面曲線方程式的表示如同第一實施例的形式。

第七實施例光學攝像系統中，整體光學攝像系統的焦距為  $f$ ，其關係式為： $f = 3.46$ (毫米)。

第七實施例光學攝像系統中，整體光學攝像系統的光圈值( $f$ -number)為  $F_{no}$ ，其關係式為： $F_{no} = 2.81$ 。

第七實施例光學攝像系統中，整體光學攝像系統中最

大視角的一半為 HFOV，其關係式為： $HFOV = 37.5(\text{度})$ 。

第七實施例光學攝像系統中，該第四透鏡(740)的色散係數為  $V_4$ ，該第三透鏡(730)的色散係數為  $V_3$ ，其關係式為： $V_4 - V_3 = 26.3$ 。

第七實施例光學攝像系統中，該第一透鏡(710)與該第二透鏡(720)於光軸上的間隔距離為  $T_{12}$ ，該第三透鏡(730)與該第四透鏡(740)於光軸上的間隔距離為  $T_{34}$ ，該第二透鏡(720)與該第三透鏡(730)於光軸上的間隔距離為  $T_{23}$ ，其關係式為： $(T_{12} + T_{34}) / T_{23} = 1.18$ 。

第七實施例光學攝像系統中，該第一透鏡(710)與該第二透鏡(720)於光軸上的間隔距離為  $T_{12}$ ，該第二透鏡(720)與該第三透鏡(730)於光軸上的間隔距離為  $T_{23}$ ，其關係式為： $T_{12} / T_{23} = 0.93$ 。

第七實施例光學攝像系統中，該第一透鏡(710)於光軸上的厚度為  $CT_1$ ，該第二透鏡(720)於光軸上的厚度為  $CT_2$ ，其關係式為： $CT_1 / CT_2 = 0.62$ 。

第七實施例光學攝像系統中，該第二透鏡(720)的像側表面曲率半徑為  $R_4$  及物側表面曲率半徑為  $R_3$ ，其關係式為： $|R_4 / R_3| = 0.02$ 。

第七實施例光學攝像系統中，該第三透鏡(730)的物側表面曲率半徑為  $R_5$  及像側表面曲率半徑為  $R_6$ ，其關係式為： $(R_5 + R_6) / (R_5 - R_6) = -2.38$ 。

第七實施例光學攝像系統中，整體光學攝像系統的焦距為  $f$ ，該第一透鏡(710)的焦距為  $f_1$ ，其關係式為： $f / f_1 = 0.40$ 。

第七實施例光學攝像系統中，整體光學攝像系統的焦距為  $f$ ，該第二透鏡(720)的焦距為  $f_2$ ，其關係式為： $f / f_2 = 1.70$ 。

第七實施例光學攝像系統中，整體光學攝像系統的焦距為  $f$ ，該第三透鏡(730)的焦距為  $f_3$ ，其關係式為： $f / f_3 = -1.79$ 。

第七實施例光學攝像系統中，該光圈(700)至該成像面(770)於光軸上的距離為  $SL$ ，該第一透鏡(710)的物側表面(711)至該成像面(770)於光軸上的距離為  $TTL$ ，其關係式為： $SL / TTL = 0.86$ 。

第七實施例光學攝像系統中，該第一透鏡(710)物側表面(711)至該第四透鏡(740)像側表面(742)於光軸上的距離為  $T_d$ ，該電子感光元件有效畫素區域對角線長的一半為  $ImgH$ ，其關係式為： $T_d / ImgH = 1.62$ 。

第七實施例詳細的光學數據如第二十圖表十三所示，其非球面數據如第二十一圖的表十四所示，其中曲率半徑、厚度及焦距的單位為  $mm$ ，HFOV 定義為最大視角的一半。

表一至表十四(分別對應第八圖至第二十一圖)所示為本發明光學攝像系統實施例的不同數值變化表，然本發明各個實施例的數值變化皆屬實驗所得，即使使用不同數值，相同結構的產品仍應屬於本發明的保護範疇，故以上的說明所描述的及圖式僅做為例示性，非用以限制本發明的申請專利範圍。表十五(對應第二十二圖)為各個實施例對應本發明相關關係式的數值資料。

【圖式簡單說明】

- 第一 A 圖係本發明第一實施例的光學系統示意圖。  
第一 B 圖係本發明第一實施例之像差曲線圖。  
第二 A 圖係本發明第二實施例的光學系統示意圖。  
第二 B 圖係本發明第二實施例之像差曲線圖。  
第三 A 圖係本發明第三實施例的光學系統示意圖。  
第三 B 圖係本發明第三實施例之像差曲線圖。  
第四 A 圖係本發明第四實施例的光學系統示意圖。  
第四 B 圖係本發明第四實施例之像差曲線圖。  
第五 A 圖係本發明第五實施例的光學系統示意圖。  
第五 B 圖係本發明第五實施例之像差曲線圖。  
第六 A 圖係本發明第六實施例的光學系統示意圖。  
第六 B 圖係本發明第六實施例之像差曲線圖。  
第七 A 圖係本發明第七實施例的光學系統示意圖。  
第七 B 圖係本發明第七實施例之像差曲線圖。  
第八圖係表一，為本發明第一實施例的光學數據。  
第九圖係表二，為本發明第一實施例的非球面數據。  
第十圖係表三，為本發明第二實施例的光學數據。  
第十一圖係表四，為本發明第二實施例的非球面數據。  
第十二圖係表五，為本發明第三實施例的光學數據。  
第十三圖係表六，為本發明第三實施例的非球面數據。  
第十四圖係表七，為本發明第四實施例的光學數據。  
第十五圖係表八，為本發明第四實施例的非球面數據。  
第十六圖係表九，為本發明第五實施例的光學數據。  
第十七圖係表十，為本發明第五實施例的非球面數據。

第十八圖係表十一，為本發明第六實施例的光學數據。  
 第十九圖係表十二，為本發明第六實施例的非球面數據。  
 第二十圖係表十三，為本發明第七實施例的光學數據。  
 第二十一圖係表十四，為本發明第七實施例的非球面數據。  
 第二十二圖係表十五，為本發明第一實施例至第七實施例  
 相關關係式的數值資料。

【主要元件符號說明】

● 光圈	100、200、300、400、500、600、700
第一透鏡	110、210、310、410、510、610、710
物側表面	111、211、311、411、511、611、711
像側表面	112、212、312、412、512、612、712
第二透鏡	120、220、320、420、520、620、720
物側表面	121、221、321、421、521、621、721
像側表面	122、222、322、422、522、622、722
第三透鏡	130、230、330、430、530、630、730
物側表面	131、231、331、431、531、631、731
● 像側表面	132、232、332、432、532、632、732
第四透鏡	140、240、340、440、540、640、740
物側表面	141、241、341、441、541、641、741
像側表面	142、242、342、442、542、642、742
紅外線濾除濾光片	150、250、350、450、550、650、750
保護玻璃	160、260、360、460、560、660、760
成像面	170、270、370、470、570、670、770
整體光學攝像系統的焦距為	$f$

第一透鏡的焦距為  $f_1$

第二透鏡的焦距為  $f_2$

第三透鏡的焦距為  $f_3$

第三透鏡的色散係數為  $V_3$

第四透鏡的色散係數為  $V_4$

第二透鏡的物側表面曲率半徑為  $R_3$

第二透鏡的像側表面曲率半徑為  $R_4$

第三透鏡的物側表面曲率半徑為  $R_5$

第三透鏡的像側表面曲率半徑為  $R_6$

第一透鏡與第二透鏡於光軸上的間隔距離為  $T_{12}$

第二透鏡與第三透鏡於光軸上的間隔距離為  $T_{23}$

第三透鏡與第四透鏡於光軸上的間隔距離為  $T_{34}$

第一透鏡於光軸上的厚度為  $CT_1$

第二透鏡於光軸上的厚度為  $CT_2$

光圈至成像面於光軸上的距離為  $SL$

第一透鏡的物側表面至成像面於光軸上的距離為  $TTL$

第一透鏡物側表面至第四透鏡像側表面於光軸上的距離為  
 $T_d$

電子感光元件有效畫素區域對角線長的一半為  $ImgH$

## 七、申請專利範圍：

1. 一種光學攝像系統，包含四枚具屈折力的透鏡，由物側至像側依序為：

一第一透鏡；

一具正屈折力的第二透鏡，其物側表面與像側表面中至少一表面為非球面；

一具負屈折力的第三透鏡，其物側表面為凹面及像側表面為凸面，該物側表面與像側表面皆為非球面；及

一具正屈折力的第四透鏡，其物側表面與像側表面皆為非球面；

其中，該光學攝像系統另包含有一光圈及一於成像面上的電子感光元件供被攝物成像，該光圈係設置於被攝物與該第二透鏡之間；該第一透鏡物側表面至該第四透鏡像側表面於光軸上的距離為  $T_d$ ，該電子感光元件有效畫素區域對角線長的一半為  $ImgH$ ，該第一透鏡與該第二透鏡於光軸上的間隔距離為  $T_{12}$ ，該第三透鏡與該第四透鏡於光軸上的間隔距離為  $T_{34}$ ，該第二透鏡與該第三透鏡於光軸上的間隔距離為  $T_{23}$ ，該第二透鏡的像側表面曲率半徑為  $R_4$ ，該第二透鏡的物側表面曲率半徑為  $R_3$ ，該光圈至該成像面於光軸上的距離為  $SL$ ，該第一透鏡的物側表面至該成像面於光軸上的距離為  $TTL$ ，係滿足下列關係式：

$$0.7 < T_d / ImgH < 2.0 ;$$

$$0.15 < (T_{12} + T_{34}) / T_{23} < 1.20 ;$$

$$0.0 < |R_4 / R_3| < 1.55 ; \text{ 及}$$

$$0.8 < SL / TTL < 1.2 .$$

2. 如申請專利範圍第 1 項所述之光學攝像系統，其中該第二透鏡的像側表面為凸面，且該第四透鏡的物側表面為凸面。

3. 如申請專利範圍第 2 項所述之光學攝像系統，其中該第三透鏡的物側表面與像側表面中至少一表面設置有至少一反曲點，且該第四透鏡的物側表面與像側表面中至少一表面設置有至少一反曲點。

4. 如申請專利範圍第 3 項所述之光學攝像系統，其中該第三透鏡的材質為塑膠，且該第四透鏡的材質為塑膠。

5. 如申請專利範圍第 4 項所述之光學攝像系統，其中該第一透鏡的物側表面為凸面。

6. 如申請專利範圍第 5 項所述之光學攝像系統，其中該整體光學攝像系統的焦距為  $f$ ，該第一透鏡的焦距為  $f_1$ ，係滿足下列關係式：

$$0.0 < |f / f_1| < 0.5。$$

7. 如申請專利範圍第 6 項所述之光學攝像系統，其中該第一透鏡與該第二透鏡於光軸上的間隔距離為  $T_{12}$ ，該第三透鏡與該第四透鏡於光軸上的間隔距離為  $T_{34}$ ，該第二透鏡與該第三透鏡於光軸上的間隔距離為  $T_{23}$ ，係滿足下列關係式：

$$0.2 < (T_{12} + T_{34}) / T_{23} < 0.6。$$

8. 如申請專利範圍第 6 項所述之光學攝像系統，其中該第一透鏡於光軸上的厚度為  $CT_1$ ，該第二透鏡於光軸上的厚度為  $CT_2$ ，係滿足下列關係式：

$$0.2 < CT_1 / CT_2 < 0.5。$$



9. 如申請專利範圍第 6 項所述之光學攝像系統，其中該第二透鏡的像側表面曲率半徑為  $R_4$ ，該第二透鏡的物側表面曲率半徑為  $R_3$ ，係滿足下列關係式：

$$0.0 < |R_4 / R_3| < 0.8。$$

10. 如申請專利範圍第 4 項所述之光學攝像系統，其中該整體光學攝像系統的焦距為  $f$ ，該第二透鏡的焦距為  $f_2$ ，該光圈至該成像面於光軸上的距離為  $SL$ ，該第一透鏡的物側表面至該成像面於光軸上的距離為  $TTL$ ，係滿足下列關係式：

$$1.0 < f / f_2 < 2.5；及$$

$$0.84 < SL / TTL < 0.97。$$

11. 如申請專利範圍第 10 項所述之光學攝像系統，其中該第三透鏡的物側表面曲率半徑為  $R_5$ ，該第三透鏡的像側表面曲率半徑為  $R_6$ ，係滿足下列關係式：

$$-5.0 < (R_5 + R_6) / (R_5 - R_6) < -2.0。$$

12. 如申請專利範圍第 10 項所述之光學攝像系統，其中該整體光學攝像系統的焦距為  $f$ ，該第三透鏡的焦距為  $f_3$ ，係滿足下列關係式：

$$-2.5 < f / f_3 < -1.0。$$

13. 如申請專利範圍第 10 項所述之光學攝像系統，其中該第一透鏡的物側表面與像側表面中至少一表面設置有至少一反曲點。

14. 如申請專利範圍第 3 項所述之光學攝像系統，其中該第四透鏡的色散係數為  $V_4$ ，該第三透鏡的色散係數為  $V_3$ ，係滿足下列關係式：

$$25 < V4 - V3 < 42。$$

15. 如申請專利範圍第 14 項所述之光學攝像系統，其中該第一透鏡於光軸上的厚度為 CT1，該第二透鏡於光軸上的厚度為 CT2，係滿足下列關係式：

$$0.2 < CT1 / CT2 < 0.5。$$

16. 如申請專利範圍第 15 項所述之光學攝像系統，其中該第一透鏡與該第二透鏡於光軸上的間隔距離為 T12，該第三透鏡與該第四透鏡於光軸上的間隔距離為 T34，該第二透鏡與該第三透鏡於光軸上的間隔距離為 T23，係滿足下列關係式：

$$0.2 < (T12 + T34) / T23 < 0.6。$$

17. 一種光學攝像系統，包含四枚具屈折力的透鏡，由物側至像側依序為：

一第一透鏡，其物側表面為凸面及像側表面為凹面；

一具正屈折力的第二透鏡，其像側表面為凸面，且該第二透鏡的物側表面與像側表面中至少一表面為非球面；

一具負屈折力的第三透鏡，其物側表面為凹面及像側表面為凸面，該第三透鏡的物側表面與像側表面皆為非球面，且該第三透鏡的材質為塑膠；及

一具正屈折力的第四透鏡，其物側表面為凸面及像側表面為凹面，該第四透鏡的物側表面與像側表面皆為非球面，該第四透鏡的材質為塑膠，且該第四透鏡的物側表面與像側表面中至少一表面設置有至少一反曲點；

其中，該光學攝像系統另包含有一光圈及一於成像面上的電子感光元件供被攝物成像，該光圈係設置於被攝物

與該第二透鏡之間；該第一透鏡物側表面至該第四透鏡像側表面於光軸上的距離為  $T_d$ ，該電子感光元件有效畫素區域對角線長的一半為  $ImgH$ ，該光圈至該成像面於光軸上的距離為  $SL$ ，該第一透鏡的物側表面至該成像面於光軸上的距離為  $TTL$ ，該第一透鏡與該第二透鏡於光軸上的間隔距離為  $T12$ ，該第二透鏡與該第三透鏡於光軸上的間隔距離為  $T23$ ，係滿足下列關係式：

$$0.7 < T_d / ImgH < 2.0 ;$$

$$0.8 < SL / TTL < 1.2 ; \text{ 及}$$

$$0.1 < T12 / T23 < 1.0 .$$

18. 如申請專利範圍第 17 項所述之光學攝像系統，其中整體光學攝像系統的焦距為  $f$ ，該第二透鏡的焦距為  $f_2$ ，係滿足下列關係式：

$$1.0 < f / f_2 < 2.5 .$$

19. 如申請專利範圍第 18 項所述之光學攝像系統，其中整體光學攝像系統的焦距為  $f$ ，該第一透鏡的焦距為  $f_1$ ，係滿足下列關係式：

$$0 < f / f_1 < 0.5 .$$

20. 如申請專利範圍第 18 項所述之光學攝像系統，其中該第二透鏡的像側表面曲率半徑為  $R_4$ ，該第二透鏡的物側表面曲率半徑為  $R_3$ ，係滿足下列關係式：

$$0.0 < |R_4 / R_3| < 0.8 .$$

21. 如申請專利範圍第 18 項所述之光學攝像系統，其中該第一透鏡於光軸上的厚度為  $CT_1$ ，該第二透鏡於光軸上的厚度為  $CT_2$ ，係滿足下列關係式：

$$0.2 < CT_1 / CT_2 < 0.5 .$$

八、圖式：

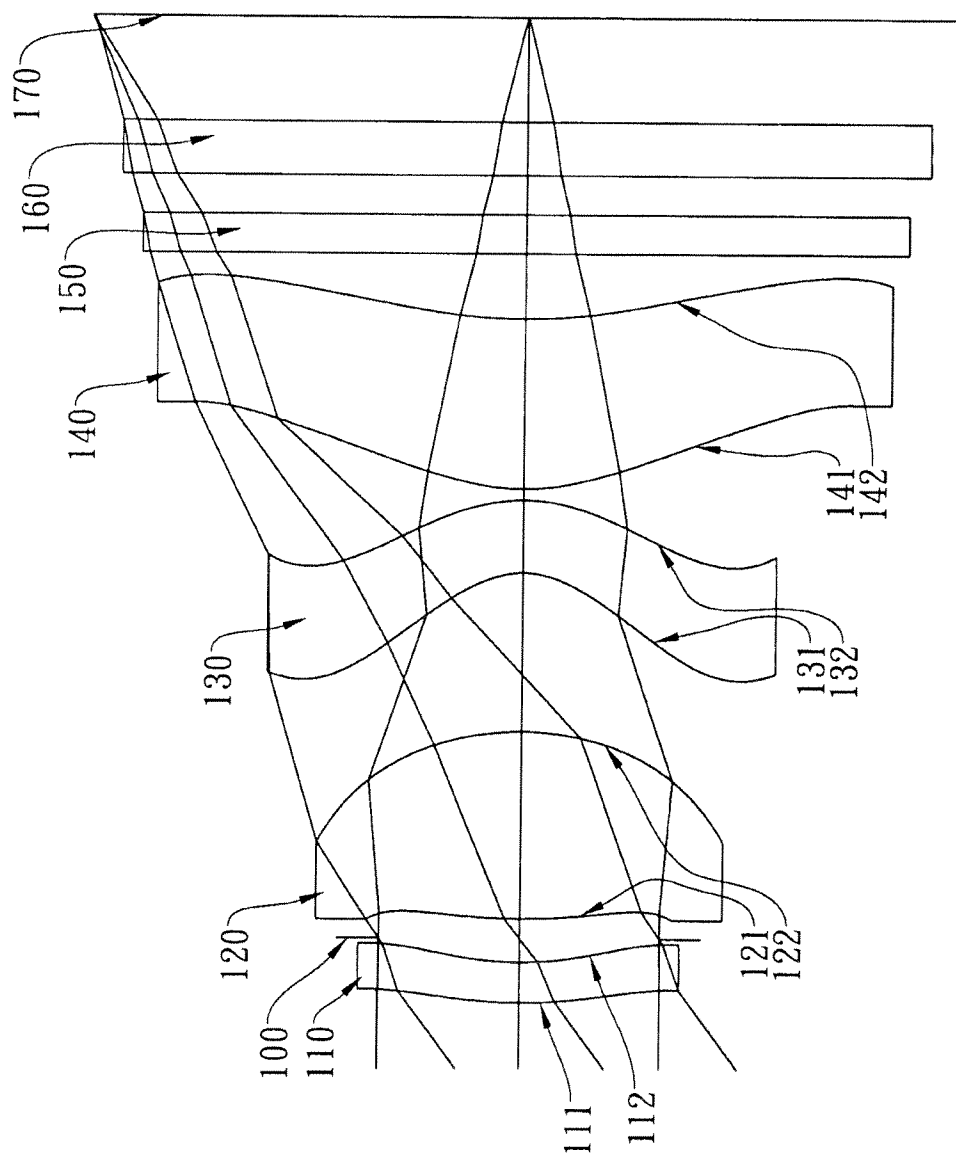

第一A圖

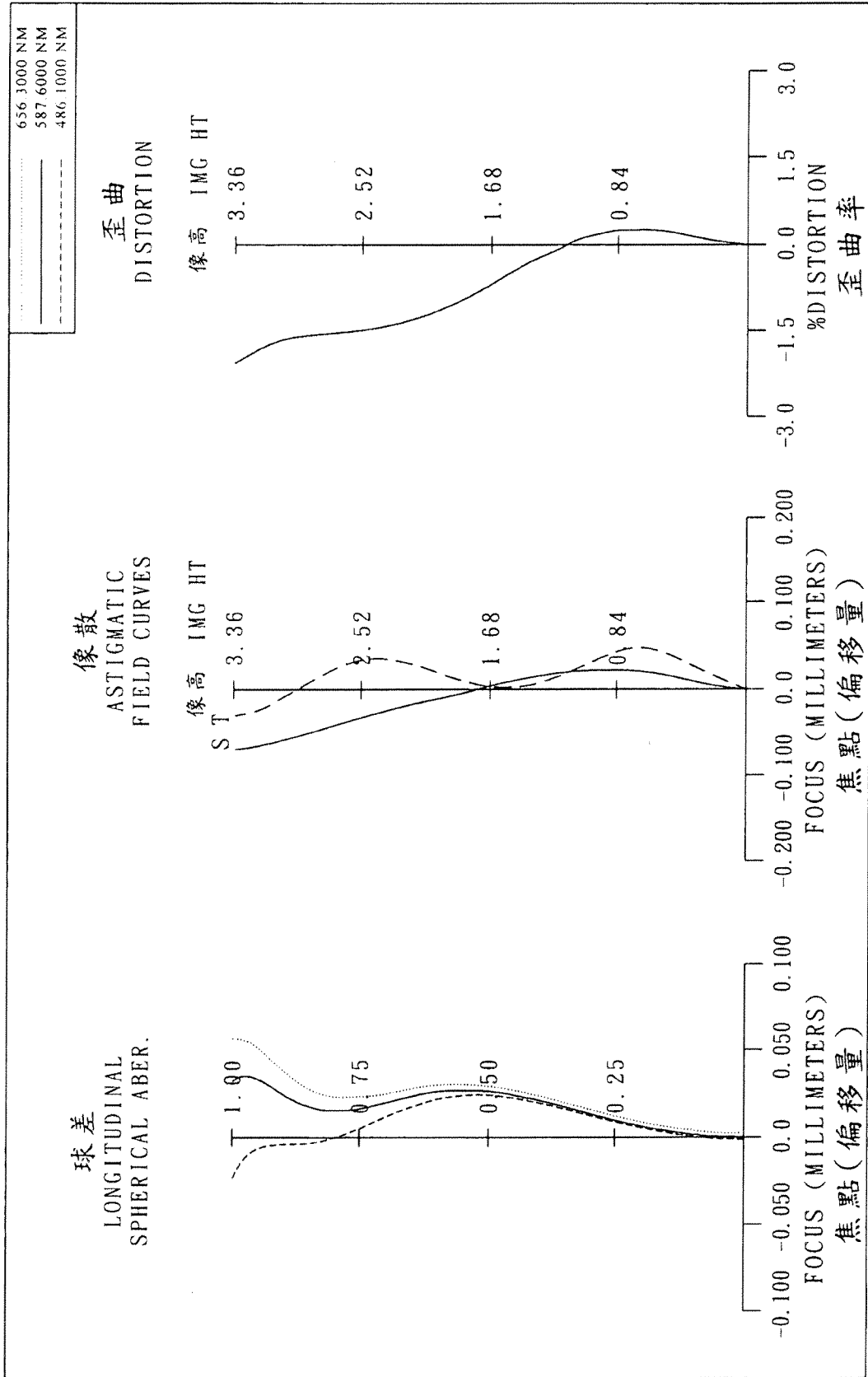

第一B圖

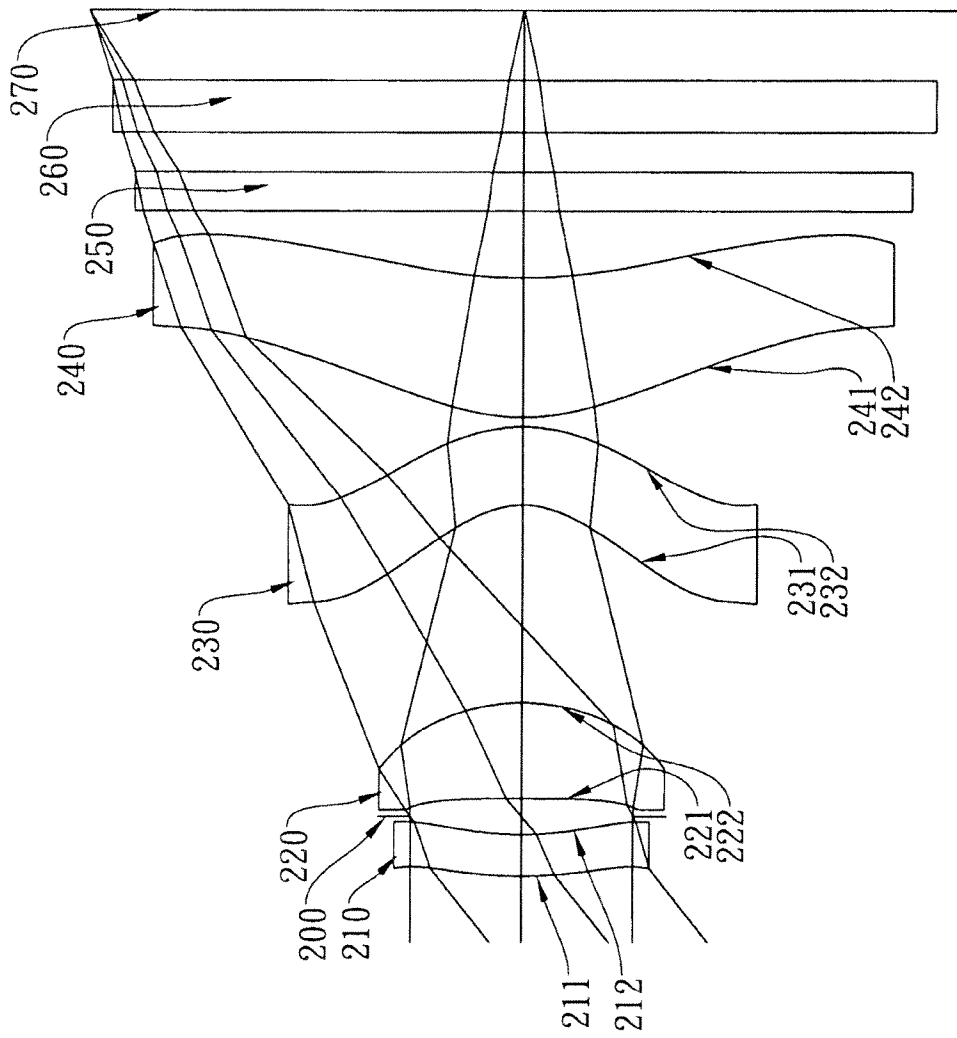

第二A圖

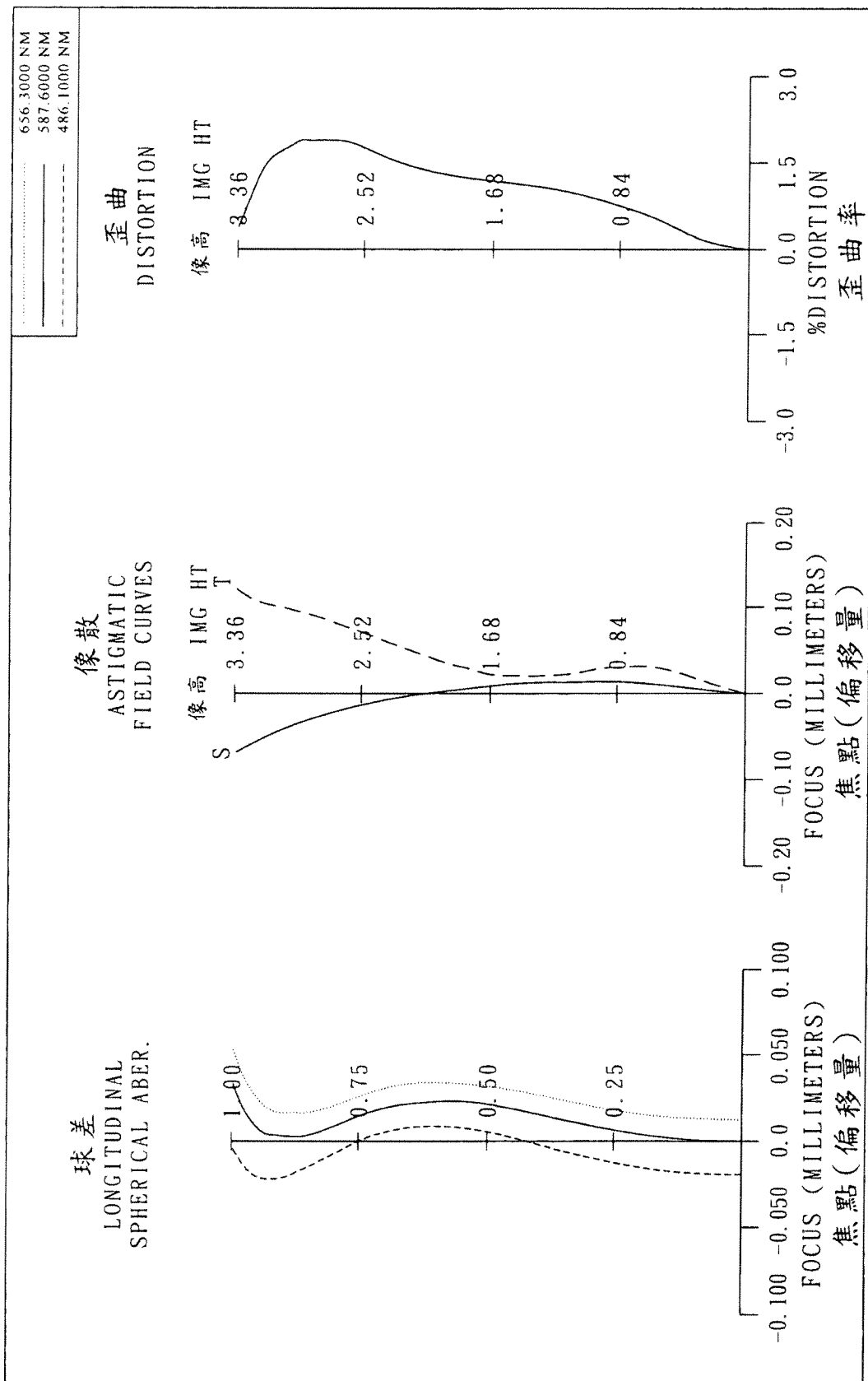

第二B圖

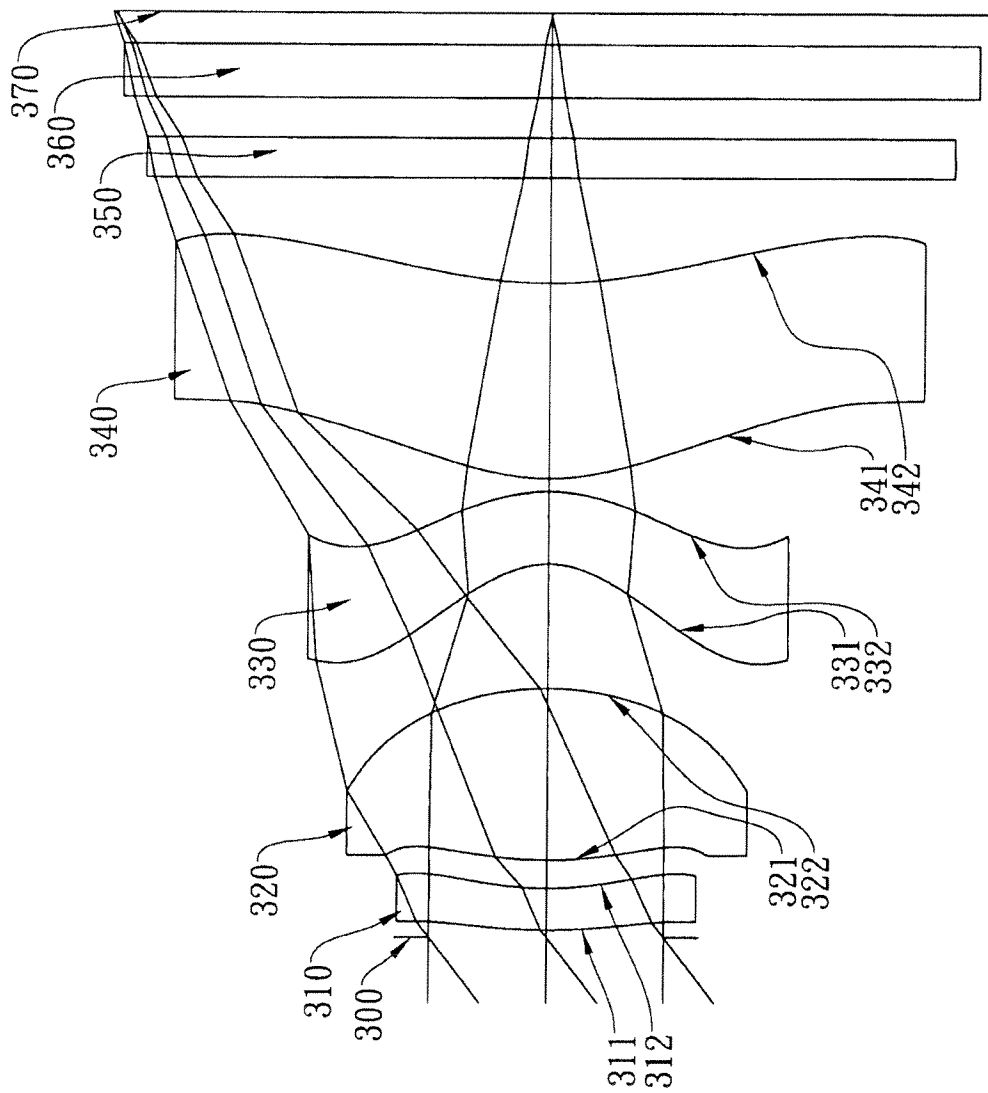

第三A圖



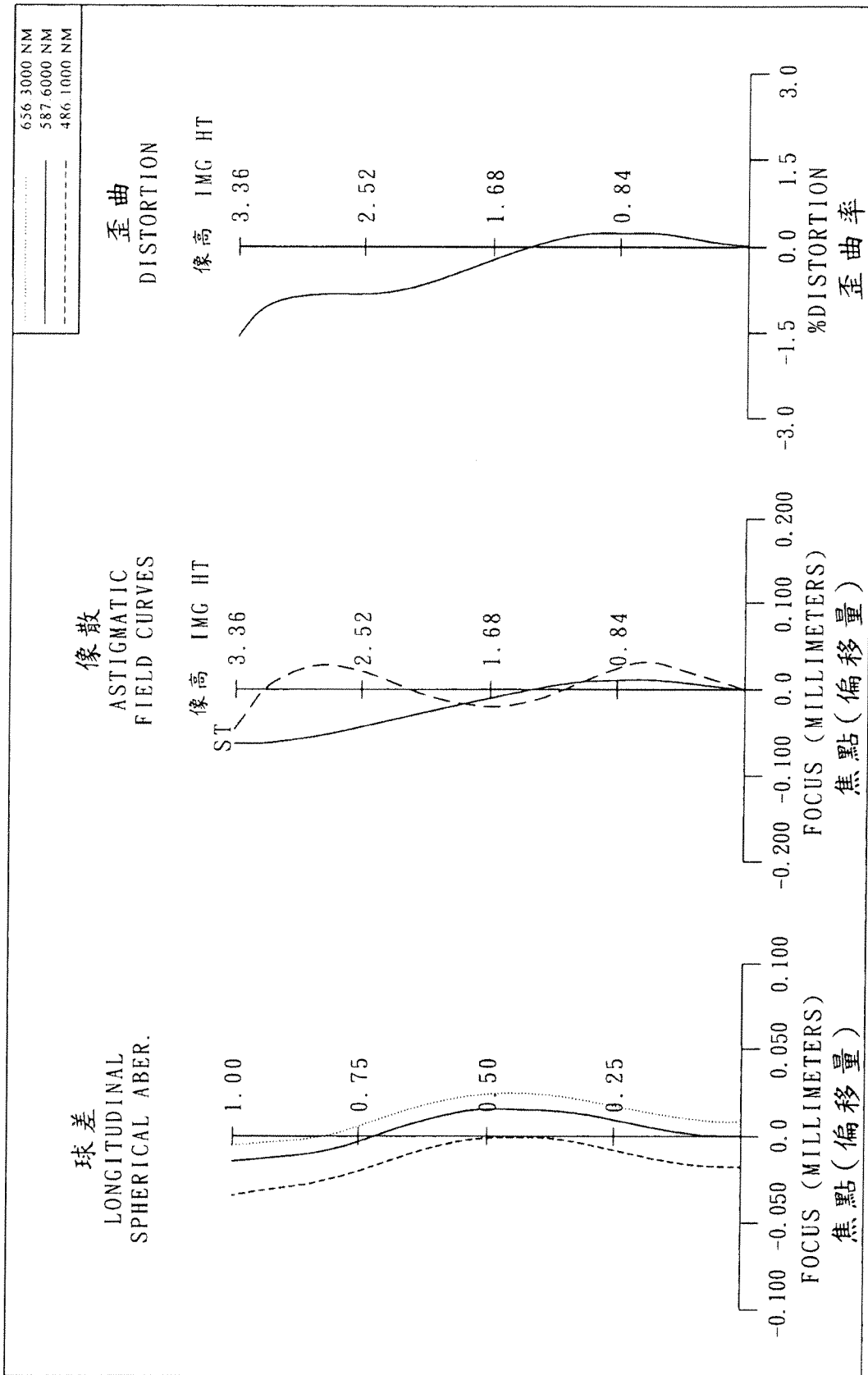

第三B圖

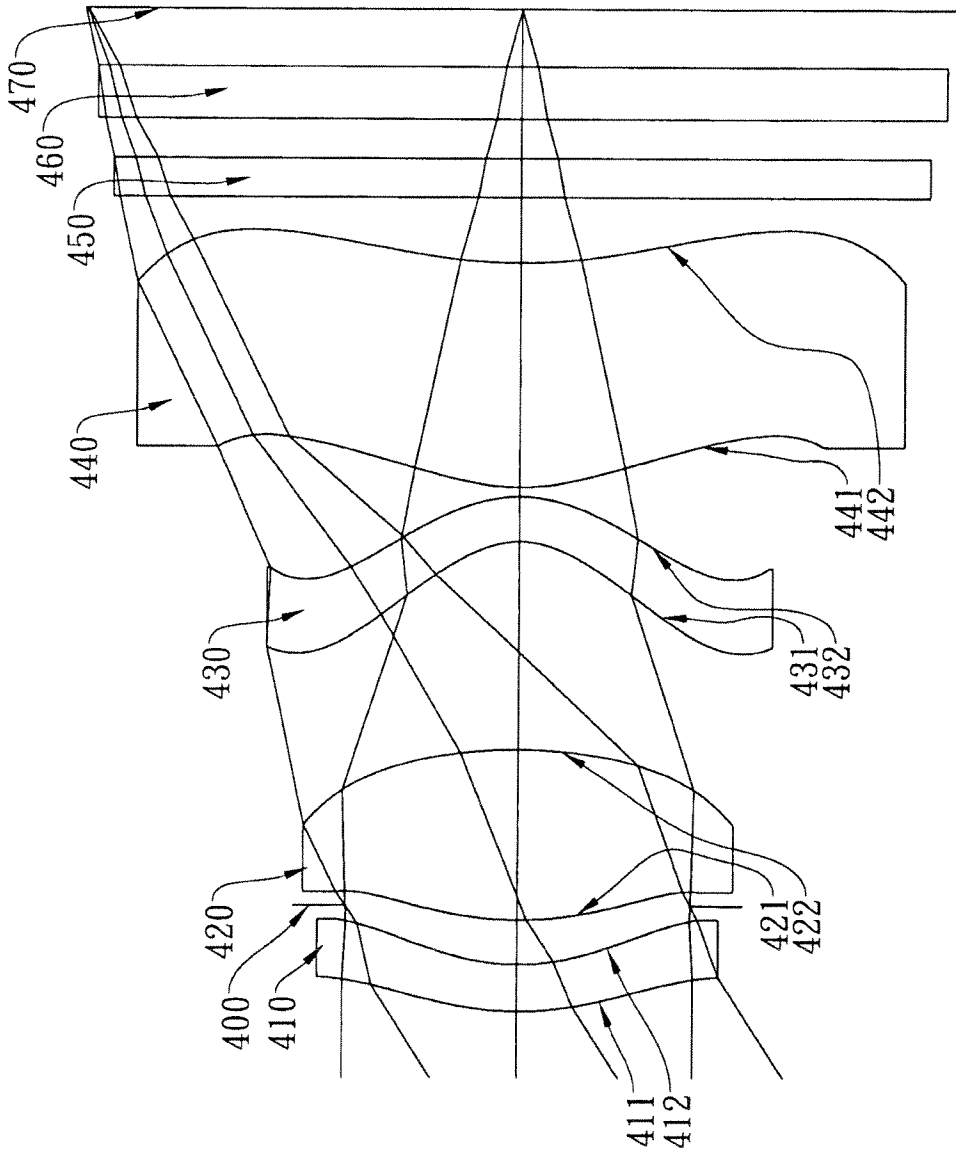

第四A圖

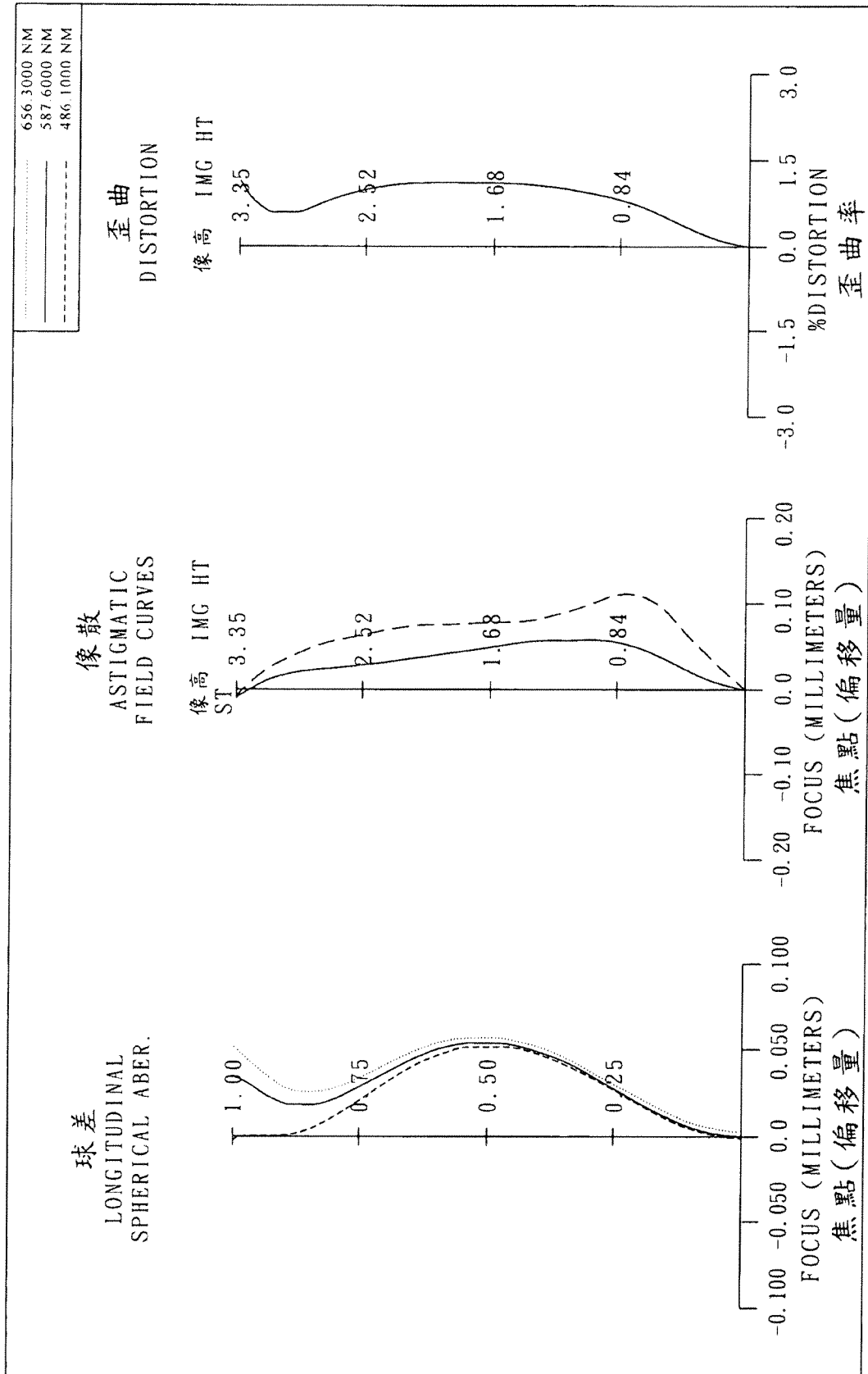

第四B圖

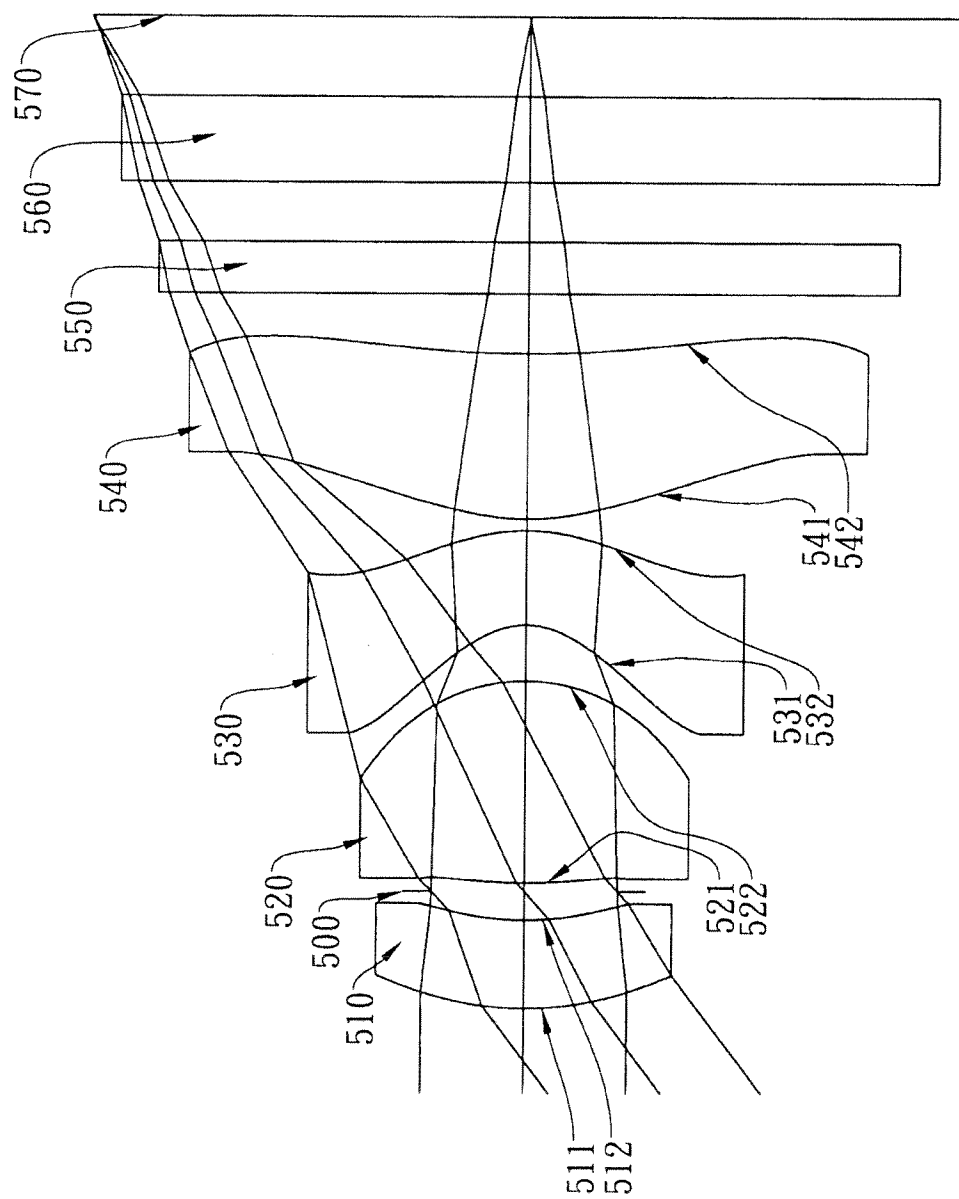

第五A圖

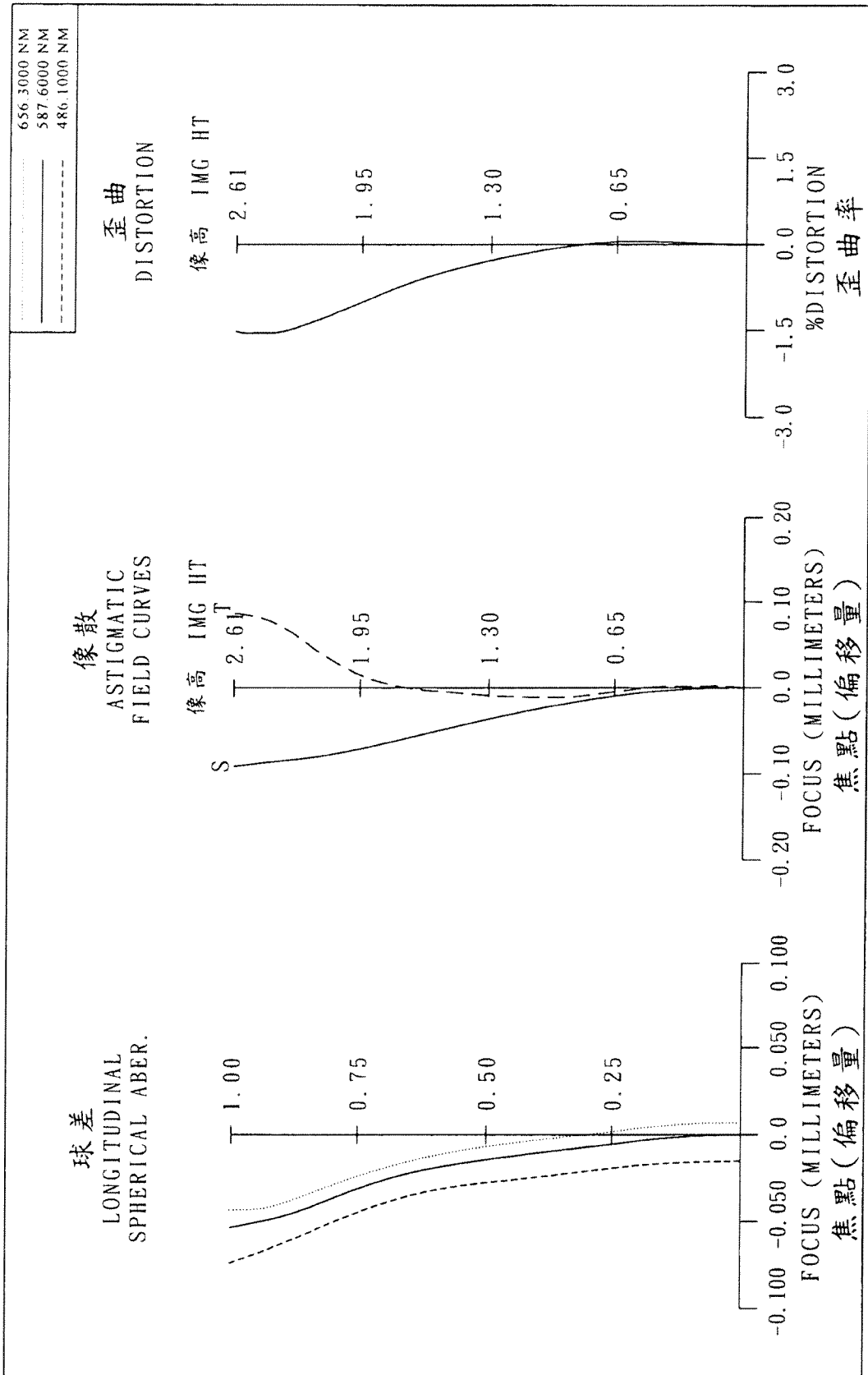

第五B圖

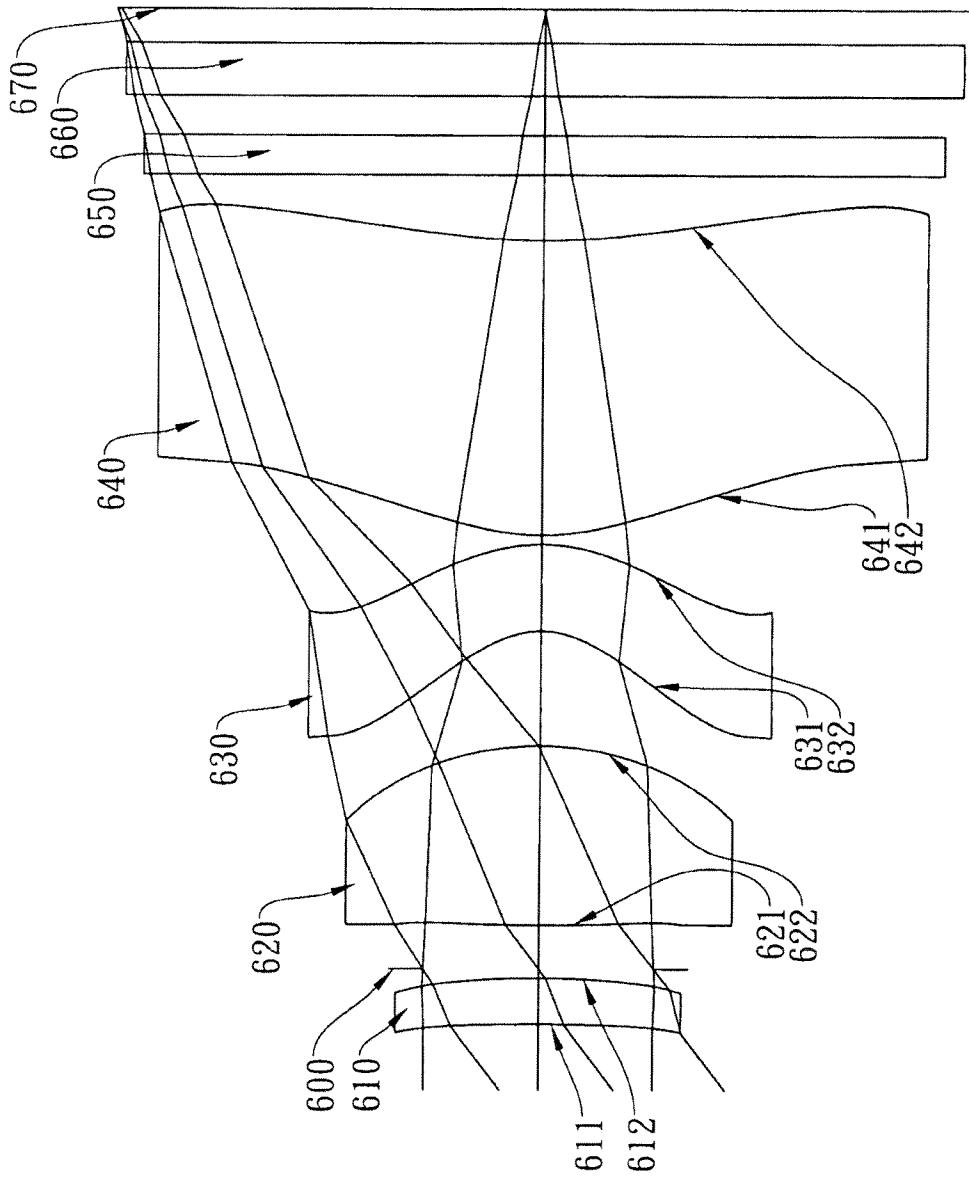

第六A圖

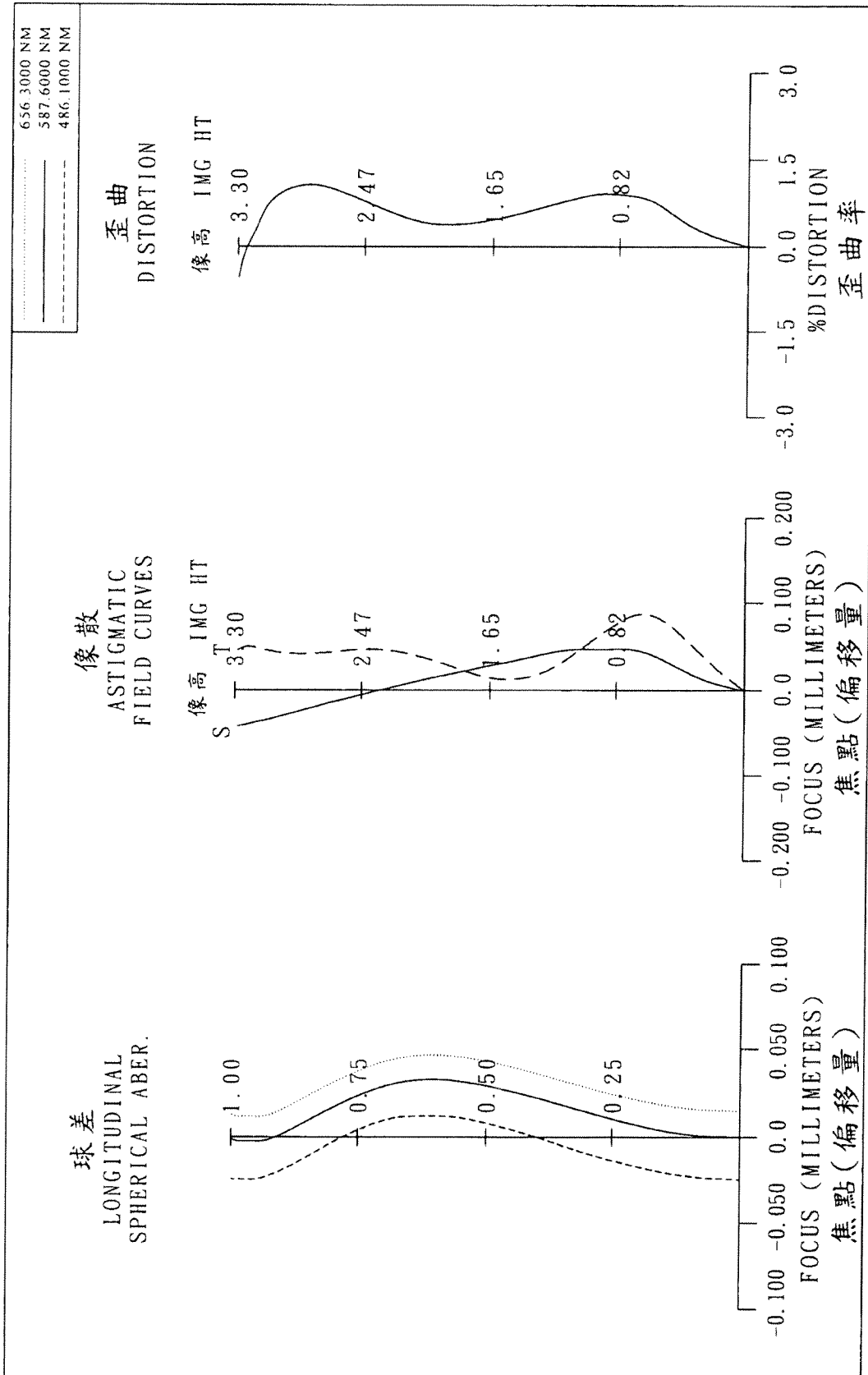

第六B圖

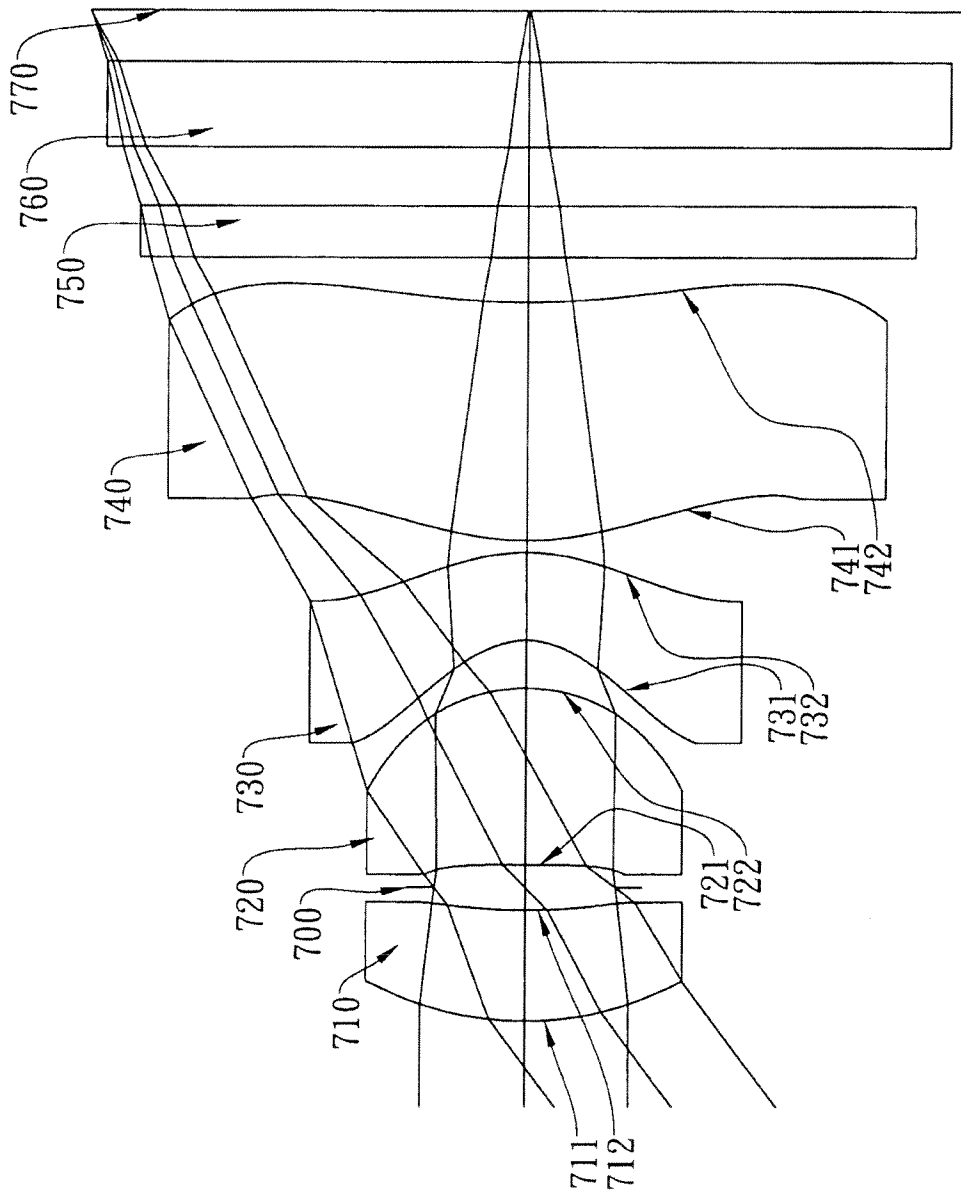

第七A圖



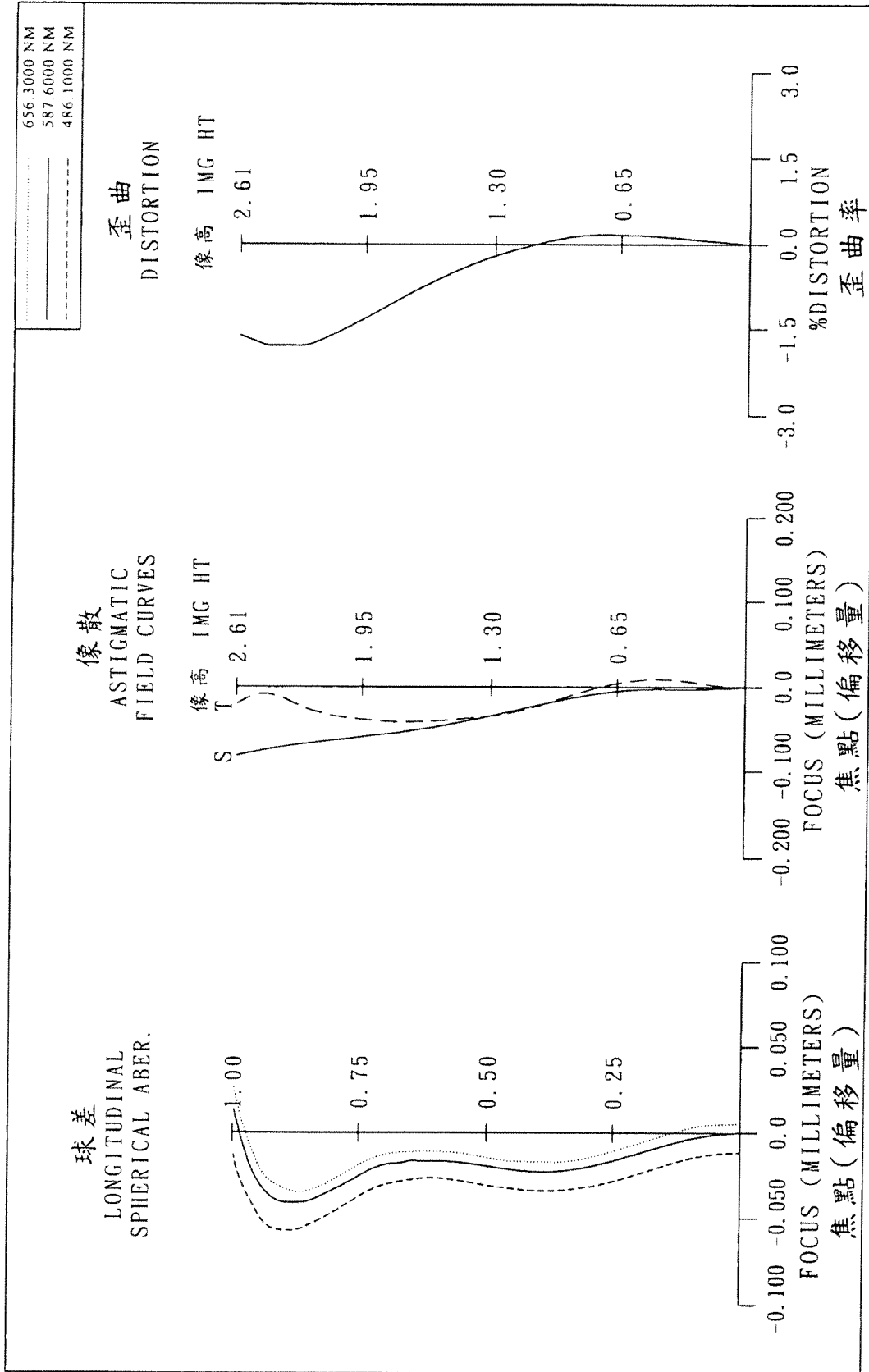

第七B圖

表一							
(第一實施例)							
f(焦距) = 4.54 mm, Fno = 2.07, HFOV(半視角) = 37.1 deg.							
Surface # 表面		Curvature Radius 曲率半徑	Thickness 厚度	Material 材質	Index 折射率	Abbe # 色散係數	Focal length 焦距
0	Object 物體	Plano 平面	Infinity 無限				
1	Lens 1 第一透鏡	3.28710 (ASP)	0.309	Plastic 塑膠	1.632	23.4	-13.56
2		2.28940 (ASP)	0.182				
3	Ape. Stop 光圈	Plano 平面	0.151				
4	Lens 2 第二透鏡	4.19080 (ASP)	1.420	Plastic 塑膠	1.544	55.9	2.93
5		-2.26608 (ASP)	1.202				
6	Lens 3 第三透鏡	-0.68837 (ASP)	0.557	Plastic 塑膠	1.632	23.4	-3.45
7		-1.32175 (ASP)	0.087				
8	Lens 4 第四透鏡	1.66390 (ASP)	1.299	Plastic 塑膠	1.544	55.9	4.45
9		3.86450 (ASP)	0.500				
10	IR-filter 紅外線濾 除濾光片	Plano 平面	0.300	Glass 玻璃	1.517	64.2	-
11		Plano 平面	0.300				
12	Cover-glass 保護玻璃	Plano 平面	0.400	Glass 玻璃	1.517	64.2	-
13		Plano 平面	0.786				
14	Image 成像面	Plano 平面	-				

註：參考波長為 d-line 587.6nm

## 第八圖

表二				
Aspheric Coefficients 非球面係數				
Surface # 表面	1	2	4	5
k =	-5.01259E+00	-1.41213E+00	-5.93643E+00	-7.53769E-02
A4 =	-4.75726E-02	-7.92436E-02	-3.32669E-02	-1.67292E-02
A6 =	6.04726E-03	9.62429E-03	-2.17666E-02	-2.13748E-03
A8 =	-3.10597E-03	-9.48463E-03	3.93610E-03	-2.07349E-03
A10 =	1.10855E-04	1.17155E-03	-9.52133E-03	
Surface # 表面	6	7	8	9
k =	-1.94431E+00	-6.75445E-01	-6.25837E+00	-6.15613E+00
A4 =	1.56500E-02	8.27291E-02	-3.53666E-03	-1.34584E-02
A6 =	9.40933E-03	6.48221E-03	2.85482E-05	2.31506E-03
A8 =	2.73102E-03	-1.55081E-03	5.24336E-05	-2.22626E-04
A10 =	-1.30245E-03	2.58073E-04	-1.22582E-05	4.54896E-06
A12 =	1.21890E-04			

第九圖

表三							
(第二實施例)							
$f$ (焦距) = 4.11 mm, $Fno$ = 2.40, HFOV(半視角) = 39.1 deg.							
Surface # 表面		Curvature Radius 曲率半徑	Thickness 厚度	Material 材質	Index 折射率	Abbe # 色散係數	Focal length 焦距
0	Object 物體	Plano 平面	Infinity 無限				
1	Lens 1 第一透鏡	3.02870 (ASP)	0.314	Plastic 塑膠	1.650	21.4	-33.05
2		2.54590 (ASP)	0.134				
3	Ape. Stop 光圈	Plano 平面	0.135				
4	Lens 2 第二透鏡	-31.84710 (ASP)	0.724	Plastic 塑膠	1.544	55.9	3.11
5		-1.61988 (ASP)	1.508				
6	Lens 3 第三透鏡	-0.67510 (ASP)	0.602	Plastic 塑膠	1.650	21.4	-3.88
7		-1.24557 (ASP)	0.070				
8	Lens 4 第四透鏡	1.58670 (ASP)	1.054	Plastic 塑膠	1.544	55.9	4.36
9		3.67710 (ASP)	0.500				
10	IR-filter 紅外線濾 除濾光片	Plano 平面	0.300	Glass 玻璃	1.517	64.2	-
11		Plano 平面	0.300				
12	Cover-glass 保護玻璃	Plano 平面	0.400	Glass 玻璃	1.517	64.2	-
13		Plano 平面	0.532				
14	Image 成像面	Plano 平面	-				

註：參考波長為 d-line 587.6nm

## 第十圖

表四				
Aspheric Coefficients 非球面係數				
Surface # 表面	1	2	4	5
k =	-3.83366E+00	6.05012E-01	1.00000E+00	-1.77487E-01
A4 =	-5.52609E-02	-6.59567E-02	-4.85937E-02	-2.43758E-02
A6 =	-2.08091E-02	-2.79863E-02	-4.07813E-02	-3.83364E-03
A8 =	-2.33961E-02	-5.06215E-02	-9.66708E-03	-1.99388E-02
A10 =	1.60933E-05	1.71676E-02	-4.56392E-02	
Surface # 表面	6	7	8	9
k =	-1.97398E+00	-6.32950E-01	-5.20422E+00	-7.30414E+00
A4 =	1.68154E-02	7.92064E-02	-6.71620E-03	-9.59159E-03
A6 =	1.45861E-02	8.17551E-03	-2.65346E-06	8.19770E-04
A8 =	3.70781E-03	-7.72460E-04	5.87614E-05	-1.92988E-05
A10 =	-1.94445E-03	3.68100E-04	-5.69372E-06	-4.31819E-06
A12 =	9.61498E-05			

第十一圖

表五							
(第三實施例)							
$f$ (焦距) = 4.34 mm, $Fno$ = 2.40, HFOV(半視角) = 38.2 deg.							
Surface # 表面		Curvature Radius 曲率半徑	Thickness 厚度	Material 材質	Index 折射率	Abbe # 色散係數	Focal length 焦距
0	Object 物體	Plano 平面	Infinity 無限				
1	Ape. Stop 光圈	Plano 平面	0.056				
2	Lens 1 第一透鏡	3.92330 (ASP)	0.320	Plastic 塑膠	1.544	55.9	-12.42
3		2.41081 (ASP)	0.215				
4	Lens 2 第二透鏡	3.04410 (ASP)	1.297	Plastic 塑膠	1.544	55.9	2.67
5		-2.35946 (ASP)	0.941				
6	Lens 3 第三透鏡	-0.68946 (ASP)	0.551	Plastic 塑膠	1.632	23.4	-3.20
7		-1.37018 (ASP)	0.101				
8	Lens 4 第四透鏡	1.66445 (ASP)	1.500	Plastic 塑膠	1.544	55.9	4.46
9		3.62180 (ASP)	0.800				
10	IR-filter 紅外線濾 除濾光片	Plano 平面	0.300	Glass 玻璃	1.517	64.2	-
11		Plano 平面	0.300				
12	Cover-glass 保護玻璃	Plano 平面	0.400	Glass 玻璃	1.517	64.2	-
13		Plano 平面	0.242				
14	Image 成像面	Plano 平面	-				

註：參考波長為 d-line 587.6nm

## 第十二圖

表六				
Aspheric Coefficients 非球面係數				
Surface # 表面	2	3	4	5
k =	-6.76700E+00	-1.01052E+00	-1.03686E-01	-1.99515E-01
A4 =	-5.23581E-02	-8.32662E-02	-3.89545E-02	-1.70087E-02
A6 =	7.20618E-03	-7.90233E-03	-1.95494E-02	-1.83603E-04
A8 =	-1.28690E-02	-5.38373E-04	4.83933E-04	-3.75427E-03
A10 =	5.01300E-03	-2.39390E-03	-8.00467E-03	
Surface # 表面	6	7	8	9
k =	-1.96195E+00	-6.45592E-01	-6.41005E+00	-1.41260E+00
A4 =	2.08276E-02	8.38468E-02	-6.84028E-03	-1.96256E-02
A6 =	1.18565E-02	9.60184E-03	1.76627E-04	1.96244E-03
A8 =	2.48625E-03	-1.08187E-03	9.26531E-05	-1.00720E-04
A10 =	-1.51480E-03	2.62214E-05	-1.48661E-05	-1.49358E-06
A12 =	1.45973E-04			

## 第十三圖

表七							
(第四實施例)							
$f(\text{焦距}) = 5.06 \text{ mm}$ , $F_{no} = 1.85$ , $HFOV(\text{半視角}) = 33.4 \text{ deg.}$							
Surface # 表面		Curvature Radius 曲率半徑	Thickness 厚度	Material 材質	Index 折射率	Abbe # 色散係數	Focal length 焦距
0	Object 物體	Plano 平面	Infinity 無限				
1	Lens 1 第一透鏡	2.35200 (ASP)	0.350	Plastic 塑膠	1.634	23.8	-12.16
2		1.69828 (ASP)	0.438				
3	Ape. Stop 光圈	Plano 平面	-0.105				
4	Lens 2 第二透鏡	2.71541 (ASP)	1.288	Plastic 塑膠	1.514	56.8	3.41
5		-4.14840 (ASP)	1.592				
6	Lens 3 第三透鏡	-0.69230 (ASP)	0.340	Plastic 塑膠	1.634	23.8	-4.02
7		-1.13210 (ASP)	0.070				
8	Lens 4 第四透鏡	1.60707 (ASP)	1.700	Plastic 塑膠	1.514	56.8	4.24
9		3.93250 (ASP)	0.500				
10	IR-filter 紅外線濾 除濾光片	Plano 平面	0.300	Glass 玻璃	1.517	64.2	-
11		Plano 平面	0.300				
12	Cover-glass 保護玻璃	Plano 平面	0.400	Glass 玻璃	1.517	64.2	-
13		Plano 平面	0.441				
14	Image 成像面	Plano 平面	-				

註：參考波長為 d-line 587.6nm

## 第十四圖



表八				
Aspheric Coefficients 非球面係數				
Surface # 表面	1	2	4	5
k =	-2.04930E+00	-9.38907E-01	-8.91863E-01	-2.58667E-01
A4 =	-4.08180E-02	-7.20292E-02	-1.79948E-02	-1.59706E-02
A6 =	5.90936E-03	1.15276E-02	-7.75708E-03	-7.01760E-04
A8 =	-2.58995E-03	-5.70934E-03	1.44145E-03	-1.63897E-03
A10 =	4.36183E-04	9.83188E-04	-1.69273E-03	
Surface # 表面	6	7	8	9
k =	-2.05071E+00	-7.37743E-01	-9.35451E+00	-1.20555E+00
A4 =	-1.50671E-03	9.36444E-02	-4.80539E-03	-2.06466E-02
A6 =	1.00183E-02	6.24022E-03	-8.47331E-04	2.17685E-03
A8 =	3.13244E-03	-1.06120E-03	1.36880E-04	-2.58306E-04
A10 =	-1.15842E-03	3.54869E-04	-3.65520E-05	7.81732E-06
A12 =	9.30516E-05			

第十五圖

表九							
(第五實施例)							
$f(\text{焦距}) = 3.44 \text{ mm}$ , $Fno = 2.81$ , $HFOV(\text{半視角}) = 37.6 \text{ deg.}$							
Surface # 表面		Curvature Radius 曲率半徑	Thickness 厚度	Material 材質	Index 折射率	Abbe # 色散係數	Focal length 焦距
0	Object 物體	Plano 平面	Infinity 無限				
1	Lens 1 第一透鏡	1.93853 (ASP)	0.516	Plastic	1.543	56.5	-171.12
2		1.72098 (ASP)	0.168				
3	Ape. Stop 光圈	Plano 平面	0.050				
4	Lens 2 第二透鏡	3.12360 (ASP)	1.175	Plastic	1.530	55.8	1.75
5		-1.14442 (ASP)	0.327				
6	Lens 3 第三透鏡	-0.46527 (ASP)	0.556	Plastic	1.583	30.2	-1.80
7		-1.20526 (ASP)	0.070				
8	Lens 4 第四透鏡	1.50364 (ASP)	0.981	Plastic	1.530	55.8	3.48
9		6.27330 (ASP)	0.350				
10	IR-filter 紅外線濾 除濾光片	Plano 平面	0.300	Glass 玻璃	1.517	64.2	-
11		Plano 平面	0.350				
12	Cover-glass 保護玻璃	Plano 平面	0.500	Glass 玻璃	1.517	64.2	-
13		Plano 平面	0.473				
14	Image 成像面	Plano 平面	-				

註：參考波長為 d-line 587.6nm

## 第十六圖

表十				
Aspheric Coefficients 非球面係數				
Surface # 表面	1	2	4	5
k =	-2.01374E+00	-1.17612E+00	-8.47976E-01	-2.00000E-01
A4 =	1.95052E-02	-3.11311E-02	-9.57531E-02	-9.27608E-02
A6 =	-1.62817E-02	-1.95406E-01	-3.83492E-01	3.68639E-02
A8 =	3.74820E-02	3.35823E-01	7.31622E-01	-2.38756E-03
A10 =	-4.44690E-02	-7.29540E-01	-1.76544E+00	-6.83017E-03
A12 =	4.19729E-08	4.38783E-09	4.30310E-09	4.29504E-09
Surface # 表面	6	7	8	9
k =	-1.55866E+00	-5.15252E-01	-6.65581E+00	-1.50139E+01
A4 =	4.37000E-02	1.98671E-01	-1.26285E-02	-7.25624E-03
A6 =	2.10531E-02	2.38394E-02	3.36034E-03	-8.54376E-04
A8 =	7.27488E-02	-2.07147E-02	-1.36899E-03	-2.41043E-04
A10 =	1.75148E-02	5.93938E-03	8.06300E-05	1.16484E-05
A12 =	-2.75238E-02	-6.93998E-05	-3.11537E-06	-4.50028E-06

第十七圖

表十一							
(第六實施例)							
$f$ (焦距) = 4.28 mm, $F_{no}$ = 2.40, HFOV(半視角) = 37.9 deg.							
Surface # 表面		Curvature Radius 曲率半徑	Thickness 厚度	Material 材質	Index 折射率	Abbe # 色散係數	Focal length 焦距
0	Object 物體	Plano 平面	Infinity 無限				
1	Lens 1 第一透鏡	-26.92460 (ASP)	0.349	Plastic 塑膠	1.632	23.4	17.13
2		-7.76000 (ASP)	0.070				
3	Ape. Stop 光圈	Plano 平面	0.331				
4	Lens 2 第二透鏡	13.36520 (ASP)	1.365	Plastic 塑膠	1.544	55.9	3.86
5		-2.40053 (ASP)	0.871				
6	Lens 3 第三透鏡	-0.68248 (ASP)	0.654	Plastic 塑膠	1.650	21.4	-3.15
7		-1.41052 (ASP)	0.070				
8	Lens 4 第四透鏡	1.80185 (ASP)	2.250	Plastic 塑膠	1.544	55.9	4.09
9		5.31320 (ASP)	0.500				
10	IR-filter 紅外線濾 除濾光片	Plano 平面	0.300	Glass 玻璃	1.517	64.2	-
11		Plano 平面	0.300				
12	Cover-glass 保護玻璃	Plano 平面	0.400	Glass 玻璃	1.517	64.2	-
13		Plano 平面	0.257				
14	Image 成像面	Plano 平面	-				

註：參考波長為 d-line 587.6nm

## 第十八圖

表十二				
Aspheric Coefficients 非球面係數				
Surface # 表面	1	2	4	5
k =	-5.00000E+01	-1.00000E+00	1.00000E+00	-1.12777E+00
A4 =	-1.79378E-02	-6.21780E-03	-4.13793E-04	-1.32423E-02
A6 =	4.60822E-03	1.76896E-03	-1.68136E-02	-8.86491E-06
A8 =	-1.13722E-02	-2.06358E-02	4.18349E-03	-1.98930E-03
A10 =	6.45520E-04	5.58703E-03	-6.80524E-03	
Surface # 表面	6	7	8	9
k =	-1.92618E+00	-6.40774E-01	-7.40744E+00	-1.42429E+01
A4 =	1.94221E-02	6.77887E-02	-4.04693E-03	-6.10683E-03
A6 =	8.32022E-03	5.73241E-03	-4.79945E-04	8.21498E-04
A8 =	2.77527E-03	-1.09407E-03	1.53952E-04	-4.21778E-05
A10 =	-1.17540E-03	3.12511E-04	-1.66159E-05	-2.55245E-06
A12 =	1.01566E-04			

第十九圖

表十三							
(第七實施例)							
$f$ (焦距) = 3.46 mm, $F_{no}$ = 2.81, HFOV(半視角) = 37.5 deg.							
Surface # 表面		Curvature Radius 曲率半徑	Thickness 厚度	Material 材質	Index 折射率	Abbe # 色散係數	Focal length 焦距
0	Object 物體	Plano 平面	Infinity 無限				
1	Lens 1 第一透鏡	2.05307 (ASP)	0.644	Plastic 塑膠	1.543	56.5	8.58
2		3.26380 (ASP)	0.132				
3	Ape. Stop 光圈	Plano 平面	0.132				
4	Lens 2 第二透鏡	-55.55560 (ASP)	1.033	Plastic 塑膠	1.543	56.5	2.03
5		-1.08909 (ASP)	0.284				
6	Lens 3 第三透鏡	-0.48542 (ASP)	0.518	Plastic 塑膠	1.583	30.2	-1.93
7		-1.18926 (ASP)	0.070				
8	Lens 4 第四透鏡	1.58136 (ASP)	1.400	Plastic 塑膠	1.543	56.5	3.77
9		4.76400 (ASP)	0.260				
10	IR-filter 紅外線濾除濾光片	Plano 平面	0.300	Glass 玻璃	1.517	64.2	-
11		Plano 平面	0.350				
12	Cover-glass 保護玻璃	Plano 平面	0.500	Glass 玻璃	1.517	64.2	-
13		Plano 平面	0.303				
14	Image 成像面	Plano 平面	-				

註：參考波長為 d-line 587.6nm

## 第二十圖

表十四				
Aspheric Coefficients 非球面係數				
Surface # 表面	1	2	4	5
k =	-5.21652E-01	-1.44236E+00	-1.00000E+00	-2.11626E-01
A4 =	3.42739E-02	-3.06847E-02	-1.56347E-01	-1.84664E-01
A6 =	-3.60103E-02	1.13551E-01	-7.52809E-01	5.85665E-02
A8 =	9.98894E-02	-1.18089E+00	1.93452E+00	7.73039E-02
A10 =	-9.77043E-02	1.13757E+00	-5.27109E+00	-1.07831E-01
A12 =	3.68301E-04	6.66863E-06	2.03567E-07	-1.26758E-04
Surface # 表面	6	7	8	9
k =	-1.47631E+00	-5.08750E-01	-6.91662E+00	-4.05107E+00
A4 =	5.67021E-02	2.14440E-01	-2.29662E-02	-1.93654E-02
A6 =	3.94413E-02	9.65001E-03	-1.35877E-04	-1.76530E-03
A8 =	8.33093E-02	-2.15921E-02	-1.40839E-03	1.47706E-04
A10 =	1.43449E-03	6.49944E-03	9.19278E-04	4.43112E-05
A12 =	-2.76244E-02	2.79487E-04	-2.61662E-04	-1.25490E-05

## 第二十一圖

表十五							
	第一實施例	第二實施例	第三實施例	第四實施例	第五實施例	第六實施例	第七實施例
f	4.54	4.11	4.34	5.06	3.44	4.28	3.46
Fno	2.07	2.40	2.40	1.85	2.81	2.40	2.81
HFOV	37.1	39.1	38.2	33.4	37.6	37.9	37.5
V4-V3	32.5	34.5	32.5	33.0	25.6	34.5	26.3
(T12+T34)/T23	0.35	0.22	0.34	0.25	0.88	0.54	1.18
T12/T23	0.28	0.18	0.23	0.21	0.67	0.46	0.93
CT1/CT2	0.22	0.43	0.25	0.27	0.44	0.26	0.62
R4/R3	0.54	0.05	0.78	1.53	0.37	0.18	0.02
(R5+R6)/(R5-R6)	-3.17	-3.37	-3.03	-4.15	-2.26	-2.87	-2.38
f/f1	-0.33	-0.12	-0.35	-0.42	-0.02	0.25	0.40
f/f2	1.55	1.32	1.63	1.48	1.97	1.11	1.70
f/f3	-1.32	-1.06	-1.36	-1.26	-1.91	-1.36	-1.79
SL/TTL	0.93	0.93	1.01	0.89	0.88	0.94	0.86
Td/ImgH	1.55	1.35	1.47	1.69	1.47	1.81	1.62

第二十二圖



## Electronic Patent Application Fee Transmittal

<b>Application Number:</b>	14141665
<b>Filing Date:</b>	27-Dec-2013
<b>Title of Invention:</b>	LENS ASSEMBLY
<b>First Named Inventor/Applicant Name:</b>	Hung-Kuo Yu
<b>Filer:</b>	Thomas Moga/Sandra Lewis
<b>Attorney Docket Number:</b>	SIIP.201299

Filed as Large Entity

**Filing Fees for Utility under 35 USC 111(a)**

Description	Fee Code	Quantity	Amount	Sub-Total in USD(\$)
<b>Basic Filing:</b>				
<b>Pages:</b>				
<b>Claims:</b>				
<b>Miscellaneous-Filing:</b>				
<b>Petition:</b>				
<b>Patent-Appeals-and-Interference:</b>				
<b>Post-Allowance-and-Post-Issuance:</b>				
<b>Extension-of-Time:</b>				

Description	Fee Code	Quantity	Amount	Sub-Total in USD(\$)
<b>Miscellaneous:</b>				
Submission- Information Disclosure Stmt	1806	1	180	180
<b>Total in USD (\$)</b>				<b>180</b>

## Electronic Acknowledgement Receipt

<b>EFS ID:</b>	22023583
<b>Application Number:</b>	14141665
<b>International Application Number:</b>	
<b>Confirmation Number:</b>	9554
<b>Title of Invention:</b>	LENS ASSEMBLY
<b>First Named Inventor/Applicant Name:</b>	Hung-Kuo Yu
<b>Customer Number:</b>	5251
<b>Filer:</b>	Thomas Moga/Sandra Lewis
<b>Filer Authorized By:</b>	Thomas Moga
<b>Attorney Docket Number:</b>	SIIP.201299
<b>Receipt Date:</b>	10-APR-2015
<b>Filing Date:</b>	27-DEC-2013
<b>Time Stamp:</b>	09:57:11
<b>Application Type:</b>	Utility under 35 USC 111(a)

### Payment information:

Submitted with Payment	yes
Payment Type	Deposit Account
Payment was successfully received in RAM	\$180
RAM confirmation Number	7065
Deposit Account	505409
Authorized User	

The Director of the USPTO is hereby authorized to charge indicated fees and credit any overpayment as follows:

Charge any Additional Fees required under 37 C.F.R. Section 1.21 (Miscellaneous fees and charges)

**File Listing:**

Document Number	Document Description	File Name	File Size(Bytes)/ Message Digest	Multi Part /.zip	Pages (if appl.)
1	Information Disclosure Statement (IDS) Form (SB08)	482611270InformationDisclosur eStatement.pdf	31699 82a81a30ee76c87ad808e4c09594b93942b9bac0	no	4

**Warnings:**

**Information:**

This is not an USPTO supplied IDS fillable form

2	Foreign Reference	TW201215941A1.pdf	2709498 843ffb192775f29cff16ac211ebd35795bedd2cb	no	74
---	-------------------	-------------------	---	----	----

**Warnings:**

**Information:**

3	Fee Worksheet (SB06)	fee-info.pdf	30427 9de5a972b38779d326efc021d6b276eeebd733b	no	2
---	----------------------	--------------	--	----	---

**Warnings:**

**Information:**

**Total Files Size (in bytes):** 2771624

This Acknowledgement Receipt evidences receipt on the noted date by the USPTO of the indicated documents, characterized by the applicant, and including page counts, where applicable. It serves as evidence of receipt similar to a Post Card, as described in MPEP 503.

**New Applications Under 35 U.S.C. 111**

If a new application is being filed and the application includes the necessary components for a filing date (see 37 CFR 1.53(b)-(d) and MPEP 506), a Filing Receipt (37 CFR 1.54) will be issued in due course and the date shown on this Acknowledgement Receipt will establish the filing date of the application.

**National Stage of an International Application under 35 U.S.C. 371**

If a timely submission to enter the national stage of an international application is compliant with the conditions of 35 U.S.C. 371 and other applicable requirements a Form PCT/DO/EO/903 indicating acceptance of the application as a national stage submission under 35 U.S.C. 371 will be issued in addition to the Filing Receipt, in due course.

**New International Application Filed with the USPTO as a Receiving Office**

If a new international application is being filed and the international application includes the necessary components for an international filing date (see PCT Article 11 and MPEP 1810), a Notification of the International Application Number and of the International Filing Date (Form PCT/RO/105) will be issued in due course, subject to prescriptions concerning national security, and the date shown on this Acknowledgement Receipt will establish the international filing date of the application.

## IN THE UNITED STATES PATENT AND TRADEMARK OFFICE

Appl. No. : 14/141,665 Confirmation No. 9554  
Applicant : Hung-Kuo Yu *al.*  
Filed : 12/27/2013  
Title : LENS ASSEMBLY  
Group Art Unit : 2872  
Examiner : James Jones  
Docket No. : SIIP.201299  
Customer No. : 13161

### VIA EFS

Commissioner for Patents  
P. O. Box 1450  
Alexandria, VA 22313-1450

## AMENDMENT AND RESPONSE

Madam:

In response to the non-final Office Action mailed January 15, 2015, please amend the above-identified application as follows:

**Amendments to the Claims** are reflected in the listing of claims that begins on page 2 of this paper; and

**Remarks/Arguments** begin on page 5 of this paper.

### **Amendments to the Claims:**

*This listing of claims will replace all prior versions, and listings, of claims in the application.*

### **Listing of Claims:**

Claim 1. (currently amended) A lens assembly comprising:

a lens set which includes a first lens, a second lens, a third lens and a fourth lens arranged in sequence from an object side to an image side along an optical axis of said lens assembly, wherein

said first lens has a positive optical power adjacent to the optical axis, and has a convex object-side surface which faces the object side, and an image-side surface which faces the image side, at least one of said object-side surface and said image-side surface of said first lens being an aspherical surface,

said second lens has a positive optical power adjacent to the optical axis, and has a convex image-side surface which faces the image side, and ~~an a~~ **concave** object-side surface which faces the object side, at least one of said object-side surface and said image-side surface of said second lens being an aspherical surface,

said third lens has a negative optical power adjacent to the optical axis, and has a concave object-side surface which faces the object side, and a convex image-side surface which faces the image side, at least one of said object-side surface and said image-side surface of said third lens being an aspherical surface,

said fourth lens has a positive optical power adjacent to the optical axis, and has an image-side surface which faces the image side and which has a concave portion around the optical axis, an object-side surface which faces the object side, and a peripheral surface which interconnects said object-side surface and said image-side surface, each of said object-side surface and said image-side surface of said fourth lens being an aspherical surface, at least one

of said object-side surface and said image-side surface of said fourth lens having an inflection point located between the optical axis and said peripheral surface; and

a non-adjustable diaphragm located between the object side and said second lens of said lens set;

wherein said lens assembly satisfies

$$15 < \text{HFOV}/f < 50,$$

in which, HFOV represents one half of a maximum angle of view of said lens assembly and has a unit of degree, and f represents a focal length of said lens assembly and has a unit of millimeter.

Claim 2. (currently amended) The lens assembly as claimed in Claim 1, further satisfying:

$$\text{HFOV} > 35^\circ$$

$$\underline{\text{HFOV} > 41^\circ}.$$

Claim 3. (currently amended) The lens assembly as claimed in Claim 1, further satisfying:

$$f < 2.7 \text{ mm},$$

$$\underline{f/f_4 > 0.54},$$

in which,  $f_4$  is a focal length of said fourth lens and has a unit of millimeter.

Claim 4. (original) The lens assembly as claimed in Claim 1, further satisfying:

$$N_{d3} > 1.56, \text{ and}$$

$$V_3 < 29,$$

in which,  $N_{d3}$  is a refractive index of said third lens for light with a wavelength equal to 587 nanometers, and  $V_3$  is a coefficient of dispersion of said third lens for light with a wavelength equal to 587 nanometers.

Claim 5. (original) The lens assembly as claimed in Claim 4, further

satisfying:

$$Nd2 < 1.56, \text{ and}$$

$$V2 > 29,$$

in which, Nd2 is a refractive index of said second lens for light with a wavelength equal to 587 nanometers, and V2 is a coefficient of dispersion of said second lens for light with a wavelength equal to 587 nanometers.

Claim 6. (original) The lens assembly as claimed in Claim 1, further satisfying:

$$0.8 < |f/f3| < 2.5,$$

in which, f3 is a focal length of said third lens and has a unit of millimeter.

Claim 7. (currently amended) The lens assembly as claimed in Claim 1, further satisfying:

$$0.3 < ct1/ct2 < 2.0$$

$$\underline{0.67 < ct1/ct2 < 2.0}, \text{ and}$$

$$0 < ct3/ct4 < 1.0,$$

in which, ct1 represents a center thickness of said first lens, ct2 represents a center thickness of said second lens, ct3 represents a center thickness of said third lens, ct4 represents a center thickness of said fourth lens, and each of ct1, ct2, ct3 and ct4 has a unit of millimeter.



## **REMARKS**

The present Amendment and Response is in response to the non-final Office Action mailed January 15, 2015, in which Claims 1 – 3, 6 and 7 were rejected and Claims 4 and 5 were objected to.

Independent Claim 1 and dependent Claims 2, 3 and 7 are amended. No new claim is added. No claim is cancelled. Accordingly, Claims 1 – 7 remain pending.

All changes made are for clarification and are based on the application as originally filed. It is respectfully submitted that no new matter is added.

Favorable reconsideration is respectfully requested.

## **ALLOWABLE SUBJECT MATTER**

With respect to Paragraph 6 of the Office Action, the Examiner stated that Claims 4 and 5 were objected to as being dependent upon a rejected base claim but would be allowable if rewritten in independent form including all of the limitations of the base claim and any intervening claims. Applicants appreciate the Examiner's finding.

## **CLAIM AMENDMENTS, CANCELLATIONS AND ADDITIONS**

### **Claim Amendments**

Claim amendments, cancellations and additions in the present response are as follows:

- Independent Claim 1 has been amended for clarification by changing "and an object-side surface" to -- and a concave object-side surface--.
- Dependent Claim 2 has been amended for clarification by changing "HFOV>35°" to --HFOV>41°--.
- Dependent Claim 3 has been amended for clarification by adding --  $f/f_4 > 0.54$ , in which,  $f_4$  is a focal length of said fourth lens and has a unit of millimeter--.
- Dependent Claim 7 has been amended for clarification by changing " $0.3 < ct_1/ct_2 < 2.0$ " to -- $0.67 < ct_1/ct_2 < 2.0$ --.

*Applicants respectfully submit that no new matter has been added by any of these claim amendments or additions.*

**CLAIM REJECTIONS  
UNDER 35 USC SECTION 102(a)(1)**

With respect to Paragraphs 4 and 5 of the Office Action, the Examiner rejected Claims 1 – 3, 6 and 7 under 35 USC Section 102(a)(1) as being anticipated by Huang (8,189,272; hereinafter “Huang”). Claim 1 is independent while Claims 2 – 7 are dependent.

Applicants respectfully traverse these rejections.

Regarding the rejection of Claim 1, this claim has been amended herein for clarification as noted above by limiting the object-side surface of the second lens to be concave, thus more clearly distinguishing the claimed invention from Huang.

Particularly, in Fig. 4A of Huang, the second lens 420 has an object-side surface 421 which faces the object side and which is convex toward the object side. Furthermore, the second lens of each of the other lens assemblies illustrated in Figs. 1A, 2A, 3A, 5A, 6A and 7A also includes a convex object-side surface. On the other hand, in Figs 1, 4 and 7 of the present invention as embodied in the application as filed, the second lens of each of the lens assemblies has a concave object-side surface. Therefore, the lens assembly of the claimed invention that includes a concave object-side surface of the second lens is not anticipated by Huang.

Accordingly, Applicants respectfully submit that independent Claim 1 as now presented is allowable over Huang.

In addition to the clarifying amendment to independent Claim 1 as set forth above, dependent Claims 2, 3 and 7 have also been amended for clarification as set forth above, also to further distinguish the claimed invention from the cited reference. The reasons and support for these amendments are provided hereinafter and can be found in the following comparison table.

Embodi- ment	Cited reference Huang							The present invention		
	1	2	3	4	5	6	7	1	2	3
HFOV/F	11.46	11.17	17.98	9.29	9.43	10.73	8.45	27.50	27.50	39.00
HFOV	33.7	32.5	41	30	30	38.2	29	44.00	44.00	44.00
F	2.94	2.91	2.28	3.23	3.18	3.56	3.43	1.6	1.6	1.13
Nd3	1.633	1.634	1.633	1.614	1.614	1.586	1.633	1.636	1.636	1.636
V3	23.4	23.8	23.4	25.6	25.6	30.2	23.4	23.89	23.89	23.89
Nd2	1.53	1.543	1.543	1.544	1.544	1.801	1.728	1.535	1.535	1.535
V2	55.8	56.5	56.5	55.9	55.9	35	28.5	56.07	56.07	56.07
f/f3	0.89	0.58	0.75	1.11	1.16	0.34	0.96	1.38	1.1	1.85
ct1/ct2	0.67	0.63	0.55	0.56	0.65	0.45	0.67	0.77	0.7	0.9
ct3/ct4	0.51	0.73	0.14	0.17	0.16	0.13	0.10	0.4	0.45	0.44
f/f4	0.32	0.04	0.5	0.44	0.52	0.54	0.41	1.05	0.87	1.15

As disclosed in the embodiments 1 to 7 of Huang, the HFOV ranges between 29 and 41. On the other hand, in the embodiments 1 to 3 of the present invention, the HFOV is 44. Therefore, in amended dependent Claim 2, the recitation of the HFOV>35° is replaced by the HFOV>41°. In other words, the lens assembly of the claimed invention has a relatively wide angle of view with a compact dimension.

Further, in embodiments 1 to 7 of Huang, f/f4 ranges between 0.04 and 0.54. On the other hand, in embodiments 1 to 3 of the present invention, f/f4 ranges between 0.87 and 1.15, and is greater than 0.54. Therefore, in amended dependent Claim 3, a limitation of f/f4>0.54 is added, in which f4 is a focal length of the fourth lens and has a unit of millimeter. In other words, the lens assembly of the claimed invention has a relatively compact design.

Finally, in embodiments 1 to 7 of Huang, ct1/ct2 ranges between 0.45 and 0.67. On the other hand, in embodiments 1 to 3 of the present invention, ct1/ct2 ranges between 0.7 and 0.9, and is greater than 0.67. Therefore, in amended dependent Claim 7, the recitation of 0.3<ct1/ct2<2.0 is replaced by 0.67<ct1/ct2<2.0. In other words, the lens assembly of the claimed invention has a relatively compact design.

Applicants respectfully submit that dependent Claims 2, 3, 6 and 7 as currently presented are also allowable over Huang.

Reconsideration and withdrawal of the rejection of Claims 1 – 3, 6 and 7 under 35 USC Section 102(a)(1) are respectfully requested.

### **CONCLUSION**

For the reasons stated above, it is respectfully submitted that Claims 1 – 7 as currently pending are in condition for allowance. Applicants respectfully requests withdrawal of the pending rejections and allowance of the claims. If any issues remain that would prevent issuance of this application, the Examiner is urged to contact the undersigned at 313-583-5956 or [Thomas.Moga@LeClairRyan.com](mailto:Thomas.Moga@LeClairRyan.com) (such communication via e-mail is herein expressly granted) – to resolve any remaining problems.

The Commissioner is hereby authorized to charge any additional amount required (or to credit any overpayment) to Deposit Account No. 50-5409.

Respectfully submitted,

/Thomas T. Moga/

Thomas T. Moga  
Registration No. 34,881  
Attorney for Applicants

Dated: **April 15, 2015**

TTM/hs

#### **LECLAIRRYAN**

Fairlane Plaza North  
290 Town Center Drive, Fourth Floor  
Dearborn, Michigan 48126  
(313) 583-5956 Direct  
(313) 583-6966 Fax

## Electronic Acknowledgement Receipt

<b>EFS ID:</b>	22041422
<b>Application Number:</b>	14141665
<b>International Application Number:</b>	
<b>Confirmation Number:</b>	9554
<b>Title of Invention:</b>	LENS ASSEMBLY
<b>First Named Inventor/Applicant Name:</b>	Hung-Kuo Yu
<b>Customer Number:</b>	5251
<b>Filer:</b>	Thomas Moga/Sandra Lewis
<b>Filer Authorized By:</b>	Thomas Moga
<b>Attorney Docket Number:</b>	SIIP.201299
<b>Receipt Date:</b>	13-APR-2015
<b>Filing Date:</b>	27-DEC-2013
<b>Time Stamp:</b>	14:14:27
<b>Application Type:</b>	Utility under 35 USC 111(a)

### Payment information:

Submitted with Payment	no
------------------------	----

### File Listing:

Document Number	Document Description	File Name	File Size(Bytes)/ Message Digest	Multi Part /.zip	Pages (if appl.)
1	Applicant Arguments/Remarks Made in an Amendment	482611270AmendmentandResponse.pdf	58536 <small>793b2d711fdc800cf1a0f16ca43d9349266c8b9f</small>	no	8

### Warnings:

### Information:

**This Acknowledgement Receipt evidences receipt on the noted date by the USPTO of the indicated documents, characterized by the applicant, and including page counts, where applicable. It serves as evidence of receipt similar to a Post Card, as described in MPEP 503.**

**New Applications Under 35 U.S.C. 111**

**If a new application is being filed and the application includes the necessary components for a filing date (see 37 CFR 1.53(b)-(d) and MPEP 506), a Filing Receipt (37 CFR 1.54) will be issued in due course and the date shown on this Acknowledgement Receipt will establish the filing date of the application.**

**National Stage of an International Application under 35 U.S.C. 371**

**If a timely submission to enter the national stage of an international application is compliant with the conditions of 35 U.S.C. 371 and other applicable requirements a Form PCT/DO/EO/903 indicating acceptance of the application as a national stage submission under 35 U.S.C. 371 will be issued in addition to the Filing Receipt, in due course.**

**New International Application Filed with the USPTO as a Receiving Office**

**If a new international application is being filed and the international application includes the necessary components for an international filing date (see PCT Article 11 and MPEP 1810), a Notification of the International Application Number and of the International Filing Date (Form PCT/RO/105) will be issued in due course, subject to prescriptions concerning national security, and the date shown on this Acknowledgement Receipt will establish the international filing date of the application.**

Under the Paperwork Reduction Act of 1995, no persons are required to respond to a collection of information unless it displays a valid OMB control number.

<b>PATENT APPLICATION FEE DETERMINATION RECORD</b> Substitute for Form PTO-875	Application or Docket Number <b>14/141,665</b>	Filing Date <b>12/27/2013</b>	<input type="checkbox"/> To be Mailed
---	---	----------------------------------	---------------------------------------

ENTITY:  LARGE  SMALL  MICRO

**APPLICATION AS FILED – PART I**

FOR	NUMBER FILED	NUMBER EXTRA	RATE (\$)	FEE (\$)
<input type="checkbox"/> BASIC FEE <small>(37 CFR 1.16(a), (b), or (c))</small>	N/A	N/A	N/A	
<input type="checkbox"/> SEARCH FEE <small>(37 CFR 1.16(k), (l), or (m))</small>	N/A	N/A	N/A	
<input type="checkbox"/> EXAMINATION FEE <small>(37 CFR 1.16(o), (p), or (q))</small>	N/A	N/A	N/A	
TOTAL CLAIMS <small>(37 CFR 1.16(i))</small>	minus 20 =	*	X \$ =	
INDEPENDENT CLAIMS <small>(37 CFR 1.16(h))</small>	minus 3 =	*	X \$ =	
<input type="checkbox"/> APPLICATION SIZE FEE <small>(37 CFR 1.16(s))</small>	If the specification and drawings exceed 100 sheets of paper, the application size fee due is \$310 (\$155 for small entity) for each additional 50 sheets or fraction thereof. See 35 U.S.C. 41(a)(1)(G) and 37 CFR 1.16(s).			
<input type="checkbox"/> MULTIPLE DEPENDENT CLAIM PRESENT <small>(37 CFR 1.16(j))</small>				
* If the difference in column 1 is less than zero, enter "0" in column 2.			TOTAL	

**APPLICATION AS AMENDED – PART II**

	(Column 1)	(Column 2)	(Column 3)	PRESENT EXTRA	RATE (\$)	ADDITIONAL FEE (\$)
<b>AMENDMENT</b>	<b>04/13/2015</b>	CLAIMS REMAINING AFTER AMENDMENT	HIGHEST NUMBER PREVIOUSLY PAID FOR			
	Total <small>(37 CFR 1.16(i))</small>	* 7	Minus	** 20	= 0	X \$80 = 0
	Independent <small>(37 CFR 1.16(h))</small>	* 1	Minus	***3	= 0	X \$420 = 0
	<input type="checkbox"/> Application Size Fee <small>(37 CFR 1.16(s))</small>					
	<input type="checkbox"/> FIRST PRESENTATION OF MULTIPLE DEPENDENT CLAIM <small>(37 CFR 1.16(j))</small>					
					TOTAL ADD'L FEE	<b>0</b>

	(Column 1)	(Column 2)	(Column 3)	PRESENT EXTRA	RATE (\$)	ADDITIONAL FEE (\$)
<b>AMENDMENT</b>		CLAIMS REMAINING AFTER AMENDMENT	HIGHEST NUMBER PREVIOUSLY PAID FOR			
	Total <small>(37 CFR 1.16(i))</small>	*	Minus	**	=	X \$ =
	Independent <small>(37 CFR 1.16(h))</small>	*	Minus	***	=	X \$ =
	<input type="checkbox"/> Application Size Fee <small>(37 CFR 1.16(s))</small>					
	<input type="checkbox"/> FIRST PRESENTATION OF MULTIPLE DEPENDENT CLAIM <small>(37 CFR 1.16(j))</small>					
					TOTAL ADD'L FEE	

\* If the entry in column 1 is less than the entry in column 2, write "0" in column 3.  
 \*\* If the "Highest Number Previously Paid For" IN THIS SPACE is less than 20, enter "20".  
 \*\*\* If the "Highest Number Previously Paid For" IN THIS SPACE is less than 3, enter "3".

The "Highest Number Previously Paid For" (Total or Independent) is the highest number found in the appropriate box in column 1.

LIE  
/SHARAIN MORELAND/

This collection of information is required by 37 CFR 1.16. The information is required to obtain or retain a benefit by the public which is to file (and by the USPTO to process) an application. Confidentiality is governed by 35 U.S.C. 122 and 37 CFR 1.14. This collection is estimated to take 12 minutes to complete, including gathering, preparing, and submitting the completed application form to the USPTO. Time will vary depending upon the individual case. Any comments on the amount of time you require to complete this form and/or suggestions for reducing this burden, should be sent to the Chief Information Officer, U.S. Patent and Trademark Office, U.S. Department of Commerce, P.O. Box 1450, Alexandria, VA 22313-1450. DO NOT SEND FEES OR COMPLETED FORMS TO THIS ADDRESS. **SEND TO: Commissioner for Patents, P.O. Box 1450, Alexandria, VA 22313-1450.**

If you need assistance in completing the form, call 1-800-PTO-9199 and select option 2.



NOTICE OF ALLOWANCE AND FEE(S) DUE

5251 7590 06/01/2015
SHOOK, HARDY & BACON LLP
INTELLECTUAL PROPERTY DEPARTMENT
2555 GRAND BLVD
KANSAS CITY, MO 64108-2613

Table with 2 columns: EXAMINER (JONES, JAMES), ART UNIT (2872), PAPER NUMBER (9554)

DATE MAILED: 06/01/2015

Table with 5 columns: APPLICATION NO., FILING DATE, FIRST NAMED INVENTOR, ATTORNEY DOCKET NO., CONFIRMATION NO.

14/141,665 12/27/2013 Hung-Kuo Yu SIIP.201299 9554
TITLE OF INVENTION: LENS ASSEMBLY

Table with 7 columns: APPLN. TYPE, ENTITY STATUS, ISSUE FEE DUE, PUBLICATION FEE DUE, PREV. PAID ISSUE FEE, TOTAL FEE(S) DUE, DATE DUE

THE APPLICATION IDENTIFIED ABOVE HAS BEEN EXAMINED AND IS ALLOWED FOR ISSUANCE AS A PATENT. PROSECUTION ON THE MERITS IS CLOSED. THIS NOTICE OF ALLOWANCE IS NOT A GRANT OF PATENT RIGHTS. THIS APPLICATION IS SUBJECT TO WITHDRAWAL FROM ISSUE AT THE INITIATIVE OF THE OFFICE OR UPON PETITION BY THE APPLICANT. SEE 37 CFR 1.313 AND MPEP 1308.

THE ISSUE FEE AND PUBLICATION FEE (IF REQUIRED) MUST BE PAID WITHIN THREE MONTHS FROM THE MAILING DATE OF THIS NOTICE OR THIS APPLICATION SHALL BE REGARDED AS ABANDONED. THIS STATUTORY PERIOD CANNOT BE EXTENDED. SEE 35 U.S.C. 151. THE ISSUE FEE DUE INDICATED ABOVE DOES NOT REFLECT A CREDIT FOR ANY PREVIOUSLY PAID ISSUE FEE IN THIS APPLICATION. IF AN ISSUE FEE HAS PREVIOUSLY BEEN PAID IN THIS APPLICATION (AS SHOWN ABOVE), THE RETURN OF PART B OF THIS FORM WILL BE CONSIDERED A REQUEST TO REAPPLY THE PREVIOUSLY PAID ISSUE FEE TOWARD THE ISSUE FEE NOW DUE.

HOW TO REPLY TO THIS NOTICE:

I. Review the ENTITY STATUS shown above. If the ENTITY STATUS is shown as SMALL or MICRO, verify whether entitlement to that entity status still applies.
If the ENTITY STATUS is the same as shown above, pay the TOTAL FEE(S) DUE shown above.
If the ENTITY STATUS is changed from that shown above, on PART B - FEE(S) TRANSMITTAL, complete section number 5 titled "Change in Entity Status (from status indicated above)".
For purposes of this notice, small entity fees are 1/2 the amount of undiscounted fees, and micro entity fees are 1/2 the amount of small entity fees.

II. PART B - FEE(S) TRANSMITTAL, or its equivalent, must be completed and returned to the United States Patent and Trademark Office (USPTO) with your ISSUE FEE and PUBLICATION FEE (if required). If you are charging the fee(s) to your deposit account, section "4b" of Part B - Fee(s) Transmittal should be completed and an extra copy of the form should be submitted. If an equivalent of Part B is filed, a request to reapply a previously paid issue fee must be clearly made, and delays in processing may occur due to the difficulty in recognizing the paper as an equivalent of Part B.

III. All communications regarding this application must give the application number. Please direct all communications prior to issuance to Mail Stop ISSUE FEE unless advised to the contrary.

IMPORTANT REMINDER: Utility patents issuing on applications filed on or after Dec. 12, 1980 may require payment of maintenance fees. It is patentee's responsibility to ensure timely payment of maintenance fees when due.



**PART B - FEE(S) TRANSMITTAL**

**Complete and send this form, together with applicable fee(s), to: Mail Mail Stop ISSUE FEE  
 Commissioner for Patents  
 P.O. Box 1450  
 Alexandria, Virginia 22313-1450  
 or Fax (571)-273-2885**

**INSTRUCTIONS:** This form should be used for transmitting the ISSUE FEE and PUBLICATION FEE (if required). Blocks 1 through 5 should be completed where appropriate. All further correspondence including the Patent, advance orders and notification of maintenance fees will be mailed to the current correspondence address as indicated unless corrected below or directed otherwise in Block 1, by (a) specifying a new correspondence address; and/or (b) indicating a separate "FEE ADDRESS" for maintenance fee notifications.

Note: A certificate of mailing can only be used for domestic mailings of the Fee(s) Transmittal. This certificate cannot be used for any other accompanying papers. Each additional paper, such as an assignment or formal drawing, must have its own certificate of mailing or transmission.

CURRENT CORRESPONDENCE ADDRESS (Note: Use Block 1 for any change of address)

5251 7590 06/01/2015  
**SHOOK, HARDY & BACON LLP**  
 INTELLECTUAL PROPERTY DEPARTMENT  
 2555 GRAND BLVD  
 KANSAS CITY, MO 64108-2613

**Certificate of Mailing or Transmission**

I hereby certify that this Fee(s) Transmittal is being deposited with the United States Postal Service with sufficient postage for first class mail in an envelope addressed to the Mail Stop ISSUE FEE address above, or being facsimile transmitted to the USPTO (571) 273-2885, on the date indicated below.

(Depositor's name)
(Signature)
(Date)

APPLICATION NO.	FILING DATE	FIRST NAMED INVENTOR	ATTORNEY DOCKET NO.	CONFIRMATION NO.
14/141,665	12/27/2013	Hung-Kuo Yu	SIIP.201299	9554

TITLE OF INVENTION: LENS ASSEMBLY

APPLN. TYPE	ENTITY STATUS	ISSUE FEE DUE	PUBLICATION FEE DUE	PREV. PAID ISSUE FEE	TOTAL FEE(S) DUE	DATE DUE
nonprovisional	UNDISCOUNTED	\$960	\$0	\$0	\$960	09/01/2015

EXAMINER	ART UNIT	CLASS-SUBCLASS
JONES, JAMES	2872	359-715000

<p>1. Change of correspondence address or indication of "Fee Address" (37 CFR 1.363).</p> <p><input type="checkbox"/> Change of correspondence address (or Change of Correspondence Address form PTO/SB/122) attached.</p> <p><input type="checkbox"/> "Fee Address" indication (or "Fee Address" Indication form PTO/SB/47; Rev 03-02 or more recent) attached. <b>Use of a Customer Number is required.</b></p>	<p>2. For printing on the patent front page, list</p> <p>(1) The names of up to 3 registered patent attorneys or agents OR, alternatively, _____ 1</p> <p>(2) The name of a single firm (having as a member a registered attorney or agent) and the names of up to 2 registered patent attorneys or agents. If no name is listed, no name will be printed. _____ 2</p> <p>_____ 3</p>
---	---

3. ASSIGNEE NAME AND RESIDENCE DATA TO BE PRINTED ON THE PATENT (print or type)

PLEASE NOTE: Unless an assignee is identified below, no assignee data will appear on the patent. If an assignee is identified below, the document has been filed for recordation as set forth in 37 CFR 3.11. Completion of this form is NOT a substitute for filing an assignment.

(A) NAME OF ASSIGNEE \_\_\_\_\_ (B) RESIDENCE: (CITY and STATE OR COUNTRY) \_\_\_\_\_

Please check the appropriate assignee category or categories (will not be printed on the patent) :  Individual  Corporation or other private group entity  Government

<p>4a. The following fee(s) are submitted:</p> <p><input type="checkbox"/> Issue Fee</p> <p><input type="checkbox"/> Publication Fee (No small entity discount permitted)</p> <p><input type="checkbox"/> Advance Order - # of Copies _____</p>	<p>4b. Payment of Fee(s): (<b>Please first reapply any previously paid issue fee shown above</b>)</p> <p><input type="checkbox"/> A check is enclosed.</p> <p><input type="checkbox"/> Payment by credit card. Form PTO-2038 is attached.</p> <p><input type="checkbox"/> The director is hereby authorized to charge the required fee(s), any deficiency, or credits any overpayment, to Deposit Account Number _____ (enclose an extra copy of this form).</p>
---	--

5. **Change in Entity Status** (from status indicated above)

Applicant certifying micro entity status. See 37 CFR 1.29

Applicant asserting small entity status. See 37 CFR 1.27

Applicant changing to regular undiscounted fee status.

**NOTE:** Absent a valid certification of Micro Entity Status (see forms PTO/SB/15A and 15B), issue fee payment in the micro entity amount will not be accepted at the risk of application abandonment.

**NOTE:** If the application was previously under micro entity status, checking this box will be taken to be a notification of loss of entitlement to micro entity status.

**NOTE:** Checking this box will be taken to be a notification of loss of entitlement to small or micro entity status, as applicable.

**NOTE:** This form must be signed in accordance with 37 CFR 1.31 and 1.33. See 37 CFR 1.4 for signature requirements and certifications.

Authorized Signature \_\_\_\_\_ Date \_\_\_\_\_

Typed or printed name \_\_\_\_\_ Registration No. \_\_\_\_\_



UNITED STATES PATENT AND TRADEMARK OFFICE

UNITED STATES DEPARTMENT OF COMMERCE
United States Patent and Trademark Office
Address: COMMISSIONER FOR PATENTS
P.O. Box 1450
Alexandria, Virginia 22313-1450
www.uspto.gov

Table with 5 columns: APPLICATION NO., FILING DATE, FIRST NAMED INVENTOR, ATTORNEY DOCKET NO., CONFIRMATION NO.
14/141,665 12/27/2013 Hung-Kuo Yu SIIP.201299 9554

5251 7590 06/01/2015
SHOOK, HARDY & BACON LLP
INTELLECTUAL PROPERTY DEPARTMENT
2555 GRAND BLVD
KANSAS CITY, MO 64108-2613

EXAMINER

JONES, JAMES

ART UNIT PAPER NUMBER

2872

DATE MAILED: 06/01/2015

Determination of Patent Term Adjustment under 35 U.S.C. 154 (b)
(Applications filed on or after May 29, 2000)

The Office has discontinued providing a Patent Term Adjustment (PTA) calculation with the Notice of Allowance.

Section 1(h)(2) of the AIA Technical Corrections Act amended 35 U.S.C. 154(b)(3)(B)(i) to eliminate the requirement that the Office provide a patent term adjustment determination with the notice of allowance. See Revisions to Patent Term Adjustment, 78 Fed. Reg. 19416, 19417 (Apr. 1, 2013). Therefore, the Office is no longer providing an initial patent term adjustment determination with the notice of allowance. The Office will continue to provide a patent term adjustment determination with the Issue Notification Letter that is mailed to applicant approximately three weeks prior to the issue date of the patent, and will include the patent term adjustment on the patent. Any request for reconsideration of the patent term adjustment determination (or reinstatement of patent term adjustment) should follow the process outlined in 37 CFR 1.705.

Any questions regarding the Patent Term Extension or Adjustment determination should be directed to the Office of Patent Legal Administration at (571)-272-7702. Questions relating to issue and publication fee payments should be directed to the Customer Service Center of the Office of Patent Publication at 1-(888)-786-0101 or (571)-272-4200.

## OMB Clearance and PRA Burden Statement for PTOL-85 Part B

The Paperwork Reduction Act (PRA) of 1995 requires Federal agencies to obtain Office of Management and Budget approval before requesting most types of information from the public. When OMB approves an agency request to collect information from the public, OMB (i) provides a valid OMB Control Number and expiration date for the agency to display on the instrument that will be used to collect the information and (ii) requires the agency to inform the public about the OMB Control Number's legal significance in accordance with 5 CFR 1320.5(b).

The information collected by PTOL-85 Part B is required by 37 CFR 1.311. The information is required to obtain or retain a benefit by the public which is to file (and by the USPTO to process) an application. Confidentiality is governed by 35 U.S.C. 122 and 37 CFR 1.14. This collection is estimated to take 12 minutes to complete, including gathering, preparing, and submitting the completed application form to the USPTO. Time will vary depending upon the individual case. Any comments on the amount of time you require to complete this form and/or suggestions for reducing this burden, should be sent to the Chief Information Officer, U.S. Patent and Trademark Office, U.S. Department of Commerce, P.O. Box 1450, Alexandria, Virginia 22313-1450. DO NOT SEND FEES OR COMPLETED FORMS TO THIS ADDRESS. SEND TO: Commissioner for Patents, P.O. Box 1450, Alexandria, Virginia 22313-1450. Under the Paperwork Reduction Act of 1995, no persons are required to respond to a collection of information unless it displays a valid OMB control number.

### Privacy Act Statement

**The Privacy Act of 1974 (P.L. 93-579)** requires that you be given certain information in connection with your submission of the attached form related to a patent application or patent. Accordingly, pursuant to the requirements of the Act, please be advised that: (1) the general authority for the collection of this information is 35 U.S.C. 2(b)(2); (2) furnishing of the information solicited is voluntary; and (3) the principal purpose for which the information is used by the U.S. Patent and Trademark Office is to process and/or examine your submission related to a patent application or patent. If you do not furnish the requested information, the U.S. Patent and Trademark Office may not be able to process and/or examine your submission, which may result in termination of proceedings or abandonment of the application or expiration of the patent.

The information provided by you in this form will be subject to the following routine uses:

1. The information on this form will be treated confidentially to the extent allowed under the Freedom of Information Act (5 U.S.C. 552) and the Privacy Act (5 U.S.C. 552a). Records from this system of records may be disclosed to the Department of Justice to determine whether disclosure of these records is required by the Freedom of Information Act.
2. A record from this system of records may be disclosed, as a routine use, in the course of presenting evidence to a court, magistrate, or administrative tribunal, including disclosures to opposing counsel in the course of settlement negotiations.
3. A record in this system of records may be disclosed, as a routine use, to a Member of Congress submitting a request involving an individual, to whom the record pertains, when the individual has requested assistance from the Member with respect to the subject matter of the record.
4. A record in this system of records may be disclosed, as a routine use, to a contractor of the Agency having need for the information in order to perform a contract. Recipients of information shall be required to comply with the requirements of the Privacy Act of 1974, as amended, pursuant to 5 U.S.C. 552a(m).
5. A record related to an International Application filed under the Patent Cooperation Treaty in this system of records may be disclosed, as a routine use, to the International Bureau of the World Intellectual Property Organization, pursuant to the Patent Cooperation Treaty.
6. A record in this system of records may be disclosed, as a routine use, to another federal agency for purposes of National Security review (35 U.S.C. 181) and for review pursuant to the Atomic Energy Act (42 U.S.C. 218(c)).
7. A record from this system of records may be disclosed, as a routine use, to the Administrator, General Services, or his/her designee, during an inspection of records conducted by GSA as part of that agency's responsibility to recommend improvements in records management practices and programs, under authority of 44 U.S.C. 2904 and 2906. Such disclosure shall be made in accordance with the GSA regulations governing inspection of records for this purpose, and any other relevant (i.e., GSA or Commerce) directive. Such disclosure shall not be used to make determinations about individuals.
8. A record from this system of records may be disclosed, as a routine use, to the public after either publication of the application pursuant to 35 U.S.C. 122(b) or issuance of a patent pursuant to 35 U.S.C. 151. Further, a record may be disclosed, subject to the limitations of 37 CFR 1.14, as a routine use, to the public if the record was filed in an application which became abandoned or in which the proceedings were terminated and which application is referenced by either a published application, an application open to public inspection or an issued patent.
9. A record from this system of records may be disclosed, as a routine use, to a Federal, State, or local law enforcement agency, if the USPTO becomes aware of a violation or potential violation of law or regulation.

<b>Notice of Allowability</b>	<b>Application No.</b> 14/141,665	<b>Applicant(s)</b> YU ET AL.	
	<b>Examiner</b> JAMES JONES	<b>Art Unit</b> 2872	<b>AIA (First Inventor to File) Status</b> Yes

**-- The MAILING DATE of this communication appears on the cover sheet with the correspondence address--**

All claims being allowable, PROSECUTION ON THE MERITS IS (OR REMAINS) CLOSED in this application. If not included herewith (or previously mailed), a Notice of Allowance (PTOL-85) or other appropriate communication will be mailed in due course. **THIS NOTICE OF ALLOWABILITY IS NOT A GRANT OF PATENT RIGHTS.** This application is subject to withdrawal from issue at the initiative of the Office or upon petition by the applicant. See 37 CFR 1.313 and MPEP 1308.

1.  This communication is responsive to amendments filed 4/13/2015.  
 A declaration(s)/affidavit(s) under **37 CFR 1.130(b)** was/were filed on \_\_\_\_\_.
2.  An election was made by the applicant in response to a restriction requirement set forth during the interview on \_\_\_\_\_; the restriction requirement and election have been incorporated into this action.
3.  The allowed claim(s) is/are 1-7. As a result of the allowed claim(s), you may be eligible to benefit from the **Patent Prosecution Highway** program at a participating intellectual property office for the corresponding application. For more information, please see [http://www.uspto.gov/patents/init\\_events/oph/index.jsp](http://www.uspto.gov/patents/init_events/oph/index.jsp) or send an inquiry to [PPHfeedback@uspto.gov](mailto:PPHfeedback@uspto.gov).
4.  Acknowledgment is made of a claim for foreign priority under 35 U.S.C. § 119(a)-(d) or (f).

**Certified copies:**

- a)  All    b)  Some    \*c)  None of the:
1.  Certified copies of the priority documents have been received.
  2.  Certified copies of the priority documents have been received in Application No. \_\_\_\_\_.
  3.  Copies of the certified copies of the priority documents have been received in this national stage application from the International Bureau (PCT Rule 17.2(a)).

\* Certified copies not received: \_\_\_\_\_.

Applicant has THREE MONTHS FROM THE "MAILING DATE" of this communication to file a reply complying with the requirements noted below. Failure to timely comply will result in ABANDONMENT of this application.

**THIS THREE-MONTH PERIOD IS NOT EXTENDABLE.**

5.  CORRECTED DRAWINGS ( as "replacement sheets") must be submitted.  
 including changes required by the attached Examiner's Amendment / Comment or in the Office action of Paper No./Mail Date \_\_\_\_\_.  
**Identifying indicia such as the application number (see 37 CFR 1.84(c)) should be written on the drawings in the front (not the back) of each sheet. Replacement sheet(s) should be labeled as such in the header according to 37 CFR 1.121(d).**
6.  DEPOSIT OF and/or INFORMATION about the deposit of BIOLOGICAL MATERIAL must be submitted. Note the attached Examiner's comment regarding REQUIREMENT FOR THE DEPOSIT OF BIOLOGICAL MATERIAL.

**Attachment(s)**

- |  |  |
|--|--|
| <ol style="list-style-type: none"> <li>1. <input type="checkbox"/> Notice of References Cited (PTO-892)</li> <li>2. <input checked="" type="checkbox"/> Information Disclosure Statements (PTO/SB/08),<br/>Paper No./Mail Date <u>4/10/2015</u></li> <li>3. <input type="checkbox"/> Examiner's Comment Regarding Requirement for Deposit of Biological Material</li> <li>4. <input type="checkbox"/> Interview Summary (PTO-413),<br/>Paper No./Mail Date _____.</li> </ol> | <ol style="list-style-type: none"> <li>5. <input type="checkbox"/> Examiner's Amendment/Comment</li> <li>6. <input checked="" type="checkbox"/> Examiner's Statement of Reasons for Allowance</li> <li>7. <input type="checkbox"/> Other _____.</li> </ol> |
|--|--|

/JAMES JONES/  
Primary Examiner, Art Unit 2872

### **REASONS FOR ALLOWANCE**

1. Claims 1-7 are allowed.
2. The following is an examiner's statement of reasons for allowance: the prior art does not disclose the claimed combination of limitations to warrant a rejection under 35 USC 102 or 103.

Claims 1-7 are considered allowable for the reasons set forth on pages 6 and 7 of the remarks filed by applicant on 4/13/2015.

Any comments considered necessary by applicant must be submitted no later than the payment of the issue fee and, to avoid processing delays, should preferably accompany the issue fee. Such submissions should be clearly labeled "Comments on Statement of Reasons for Allowance."

### **EXAMINER'S COMMENTS**

3. The information disclosure statement (IDS) submitted on 4/13/2015 is in compliance with the provisions of 37 CFR 1.97. Accordingly, the information disclosure statement is being considered by the examiner.

Any inquiry concerning this communication or earlier communications from the examiner should be directed to JAMES JONES whose telephone number is (571)270-1278. The examiner can normally be reached on Monday thru Friday, 9 a.m. to 6:00 p.m. est. time.

Art Unit: 2872

If attempts to reach the examiner by telephone are unsuccessful, the examiner's supervisor, Thomas Pham can be reached on (571) 272-3689. The fax phone number for the organization where this application or proceeding is assigned is 571-273-8300.

Information regarding the status of an application may be obtained from the Patent Application Information Retrieval (PAIR) system. Status information for published applications may be obtained from either Private PAIR or Public PAIR. Status information for unpublished applications is available through Private PAIR only. For more information about the PAIR system, see <http://pair-direct.uspto.gov>. Should you have questions on access to the Private PAIR system, contact the Electronic Business Center (EBC) at 866-217-9197 (toll-free). If you would like assistance from a USPTO Customer Service Representative or access to the automated information system, call 800-786-9199 (IN USA OR CANADA) or 571-272-1000.

/JAMES JONES/  
Primary Examiner, Art Unit 2872  
5/6/2015

## EAST Search History

## EAST Search History (Prior Art)

Ref #	Hits	Search Query	DBs	Default Operator	Plurals	Time Stamp
L1	1792	((first near3 lens) near5 positive near7 convex).clm.	US-PGPUB; USPAT	OR	ON	2015/05/07 09:27
L2	1175	((second near3 lens) near5 positive near7 convex).clm.	US-PGPUB; USPAT	OR	ON	2015/05/07 09:27
L3	1084	((fourth near3 lens) near5 positive same concave).clm.	US-PGPUB; USPAT	OR	ON	2015/05/07 09:28
L4	58334	diaphragm.clm.	US-PGPUB; USPAT	OR	ON	2015/05/07 09:28
L5	9658	maximum near3 angle.clm.	US-PGPUB; USPAT	OR	ON	2015/05/07 09:29
L6	26506	focal near3 length.clm.	US-PGPUB; USPAT	OR	ON	2015/05/07 09:29
L7	1	1 and 2 and 3 and 4 and 5 and 6	US-PGPUB; USPAT	OR	ON	2015/05/07 09:30
L8	303821	th	US-PGPUB; USPAT	OR	ON	2015/05/07 09:31
L9	41426	thi	US-PGPUB; USPAT; FPRS; EPO; JPO; DERWENT	OR	ON	2015/05/07 09:31
S113	1749	S111 and S112	US-PGPUB; USPAT	OR	ON	2014/11/03 11:23
S250	7019	(second near4 lens) same positive same concave	US-PGPUB; USPAT	OR	ON	2014/12/01 11:47
S251	1772	(second near4 lens) same positive same concave same aspheric	US-PGPUB; USPAT	OR	ON	2014/12/01 11:47
S254	454	359/717.ccls.	US-PGPUB; USPAT	OR	ON	2014/12/01 11:47
S295	7992	(first near3 lens) near5 negative	FPRS; EPO; JPO; DERWENT	OR	ON	2014/12/01 11:47
S296	3967	(second near3 lens) near5 convex	FPRS; EPO; JPO; DERWENT	OR	ON	2014/12/01 11:47
S297	1723	(third near3 lens) near5 concave	FPRS; EPO; JPO; DERWENT	OR	ON	2014/12/01 11:47
S298	1380	(fourth near3 lens) near5 convex	FPRS; EPO; JPO; DERWENT	OR	ON	2014/12/01 11:47
S299	731	(fifth near3 lens) near5 concave	FPRS; EPO; JPO; DERWENT	OR	ON	2014/12/01 11:47
S300	26	S295 and S296 and S297 and S298 and S299	FPRS; EPO; JPO;	OR	ON	2014/12/01 11:47

			DERWENT			
S301	5952	(first near3 lens) near5 negative.clm.	US-PGPUB; USPAT	OR	ON	2014/12/01 11:47
S302	3649	(second near3 lens) near5 convex.clm.	US-PGPUB; USPAT	OR	ON	2014/12/01 11:47
S303	1925	(third near3 lens) near5 convex.clm.	US-PGPUB; USPAT	OR	ON	2014/12/01 11:47
S304	1324	(fourth near3 lens) near5 convex.clm.	US-PGPUB; USPAT	OR	ON	2014/12/01 11:47
S305	341	(fifth near3 lens) near10 plastic.clm.	US-PGPUB; USPAT	OR	ON	2014/12/01 11:47
S307	37929	distance near10 image.clm.	US-PGPUB; USPAT	OR	ON	2014/12/01 11:47
S310	818	(axial near3 distance) same (first near3 lens) same (second near3 lens)	US-PGPUB; USPAT	OR	ON	2014/12/01 11:47
S315	9767	(first near3 lens) near5 negative	US-PGPUB; USPAT	OR	ON	2014/12/01 11:47
S316	9158	(second near3 lens) near5 convex	US-PGPUB; USPAT	OR	ON	2014/12/01 11:47
S317	3299	(third near3 lens) near5 concave	US-PGPUB; USPAT	OR	ON	2014/12/01 11:47
S318	3282	(fourth near3 lens) near5 convex	US-PGPUB; USPAT	OR	ON	2014/12/01 11:47
S319	1376	(fifth near3 lens) near5 concave	US-PGPUB; USPAT	OR	ON	2014/12/01 11:47
S320	370	S315 and S316 and S317 and S318 and S319	US-PGPUB; USPAT	OR	ON	2014/12/01 11:47
S325	11890	(first near3 lens) near5 positive	US-PGPUB; USPAT	OR	ON	2014/12/01 11:47
S326	7087	(second near3 lens) near5 (concave biconcave bi-concave)	US-PGPUB; USPAT	OR	ON	2014/12/01 11:47
S327	4779	(third near3 lens) near5 (convex)	US-PGPUB; USPAT	OR	ON	2014/12/01 11:47
S328	3282	(fourth near3 lens) near5 convex	US-PGPUB; USPAT	OR	ON	2014/12/01 11:47
S329	3749	(fifth near3 lens) near7 negative	US-PGPUB; USPAT	OR	ON	2014/12/01 11:47
S330	511	S325 and S326 and S327 and S328 and S329	US-PGPUB; USPAT	OR	ON	2014/12/01 11:47
S331	36	((fifth near3 lens) near7 negative) near10 inflection	US-PGPUB; USPAT	OR	ON	2014/12/01 11:47
S334	7530	(second near3 lens) near5 positive.clm.	US-PGPUB; USPAT	OR	ON	2014/12/01 11:47
S335	6761	(third near3 lens) near5 positive.clm.	US-PGPUB; USPAT	OR	ON	2014/12/01 11:47
S336	2018	(fifth near3 lens) near5 positive.clm.	US-PGPUB; USPAT	OR	ON	2014/12/01 11:47
S337	903	(fifth near3 lens) near9 convex.clm.	US-PGPUB; USPAT	OR	ON	2014/12/01 11:47
S338	388	(fifth near3 lens) near5 aspheric.clm.	US-PGPUB; USPAT	OR	ON	2014/12/01 11:47
S339	4351	(inflection near2 point).clm.	US-PGPUB; USPAT	OR	ON	2014/12/01 11:47



S340	366	(sixth near3 lens) near10 concave.clm.	US-PGPUB; USPAT	OR	ON	2014/12/01 11:47
S342	337	(first near5 lens) near7 convex near5 plastic	US-PGPUB; USPAT	OR	ON	2014/12/01 11:47
S343	424	(second near5 lens) near7 aspheric near5 plastic	US-PGPUB; USPAT	OR	ON	2014/12/01 11:47
S344	230	(third near5 lens) near7 concave near5 plastic	US-PGPUB; USPAT	OR	ON	2014/12/01 11:47
S345	27787	(fourth lens near5 lens) near10 concave	US-PGPUB; USPAT	OR	ON	2014/12/01 11:47
S346	17229	(fourth lens near5 lens) near10 plastic	US-PGPUB; USPAT	OR	ON	2014/12/01 11:47
S347	965	(fourth lens near5 lens) near10 inflection	US-PGPUB; USPAT	OR	ON	2014/12/01 11:47
S351	109	(first near3 lens) near10 positive near10 paraxial.clm.	US-PGPUB; USPAT	OR	ON	2014/12/01 11:47
S352	1726	(second near3 lens) near10 positive near10 convex.clm.	US-PGPUB; USPAT	OR	ON	2014/12/01 11:47
S353	939	(third near3 lens) near10 negative near10 convex.clm.	US-PGPUB; USPAT	OR	ON	2014/12/01 11:47
S354	1832	(fourth near3 lens) near10 convex.clm.	US-PGPUB; USPAT	OR	ON	2014/12/01 11:47
S356	1811	(third near4 lens) same positive same convex same aspheric	US-PGPUB; USPAT	OR	ON	2014/12/01 11:47
S357	1410	(fourth near4 lens) same negative same convex same aspheric	US-PGPUB; USPAT	OR	ON	2014/12/01 11:47
S358	1045	S250 and S251 and S356 and S357	US-PGPUB; USPAT	OR	ON	2014/12/01 11:47
S359	1027	S358 and (diaphragm aperture stop)	US-PGPUB; USPAT	OR	ON	2014/12/01 11:47
S361	598	359/715.ccls.	US-PGPUB; USPAT	OR	ON	2014/12/01 11:47
S399	460	359/717.ccls.	US-PGPUB; USPAT	OR	ON	2014/12/29 09:22
S402	697	S401 and (diaphragm aperture stop)	US-PGPUB; USPAT	OR	ON	2014/12/29 09:22
S413	183	S406 and S407 and S408 and S409 and S411 and S412	US-PGPUB; USPAT	OR	ON	2014/12/29 09:22
S416	527	359/714.ccls.	US-PGPUB; USPAT	OR	ON	2014/12/29 09:22
S424	375	S419 and S420 and S421 and S422 and S423	US-PGPUB; USPAT	OR	ON	2014/12/29 09:22
S435	375	S430 and S431 and S432 and S433 and S434	US-PGPUB; USPAT	OR	ON	2014/12/29 09:22
S437	27193	lens near3 housing	US-PGPUB; USPAT	OR	ON	2014/12/29 09:22
S446	5984	(first near3 lens) near5 negative.clm.	US-PGPUB; USPAT	OR	ON	2014/12/29 09:22
S447	3676	(second near3 lens) near5 convex.clm.	US-PGPUB; USPAT	OR	ON	2014/12/29 09:22
S448	1953	(third near3 lens) near5 convex.clm.	US-PGPUB; USPAT	OR	ON	2014/12/29 09:22
S449	1340	(fourth near3 lens) near5 convex.clm.	US-PGPUB; USPAT	OR	ON	2014/12/29 09:22

S450	350	(fifth near3 lens) near10 plastic.clm.	US-PGPUB; USPAT	OR	ON	2014/12/29 09:22
S452	38243	distance near10 image.clm.	US-PGPUB; USPAT	OR	ON	2014/12/29 09:22
S475	523	S470 and S471 and S472 and S473 and S474	US-PGPUB; USPAT	OR	ON	2014/12/29 09:22
S476	38	((fifth near3 lens) near7 negative) near10 inflection	US-PGPUB; USPAT	OR	ON	2014/12/29 09:22
S479	7577	(second near3 lens) near5 positive.clm.	US-PGPUB; USPAT	OR	ON	2014/12/29 09:22
S480	6810	(third near3 lens) near5 positive.clm.	US-PGPUB; USPAT	OR	ON	2014/12/29 09:22
S481	2044	(fifth near3 lens) near5 positive.clm.	US-PGPUB; USPAT	OR	ON	2014/12/29 09:22
S482	929	(fifth near3 lens) near9 convex.clm.	US-PGPUB; USPAT	OR	ON	2014/12/29 09:22
S483	403	(fifth near3 lens) near5 aspheric.clm.	US-PGPUB; USPAT	OR	ON	2014/12/29 09:22
S484	4390	(inflection near2 point).clm.	US-PGPUB; USPAT	OR	ON	2014/12/29 09:22
S485	378	(sixth near3 lens) near10 concave.clm.	US-PGPUB; USPAT	OR	ON	2014/12/29 09:22
S487	340	(first near5 lens) near7 convex near5 plastic	US-PGPUB; USPAT	OR	ON	2014/12/29 09:22
S488	428	(second near5 lens) near7 aspheric near5 plastic	US-PGPUB; USPAT	OR	ON	2014/12/29 09:22
S489	233	(third near5 lens) near7 concave near5 plastic	US-PGPUB; USPAT	OR	ON	2014/12/29 09:22
S490	27922	(fourth lens near5 lens) near10 concave	US-PGPUB; USPAT	OR	ON	2014/12/29 09:22
S491	17327	(fourth lens near5 lens) near10 plastic	US-PGPUB; USPAT	OR	ON	2014/12/29 09:22
S492	983	(fourth lens near5 lens) near10 inflection	US-PGPUB; USPAT	OR	ON	2014/12/29 09:22
S504	1042	S503 and (diaphragm aperture stop)	US-PGPUB; USPAT	OR	ON	2014/12/29 09:22
S506	601	359/715.ccls.	US-PGPUB; USPAT	OR	ON	2014/12/29 09:22
S523	460	359/717.ccls.	US-PGPUB; USPAT	OR	ON	2014/12/29 09:22
S526	697	S525 and (diaphragm aperture stop)	US-PGPUB; USPAT	OR	ON	2014/12/29 09:22
S537	183	S530 and S531 and S532 and S533 and S535 and S536	US-PGPUB; USPAT	OR	ON	2014/12/29 09:22
S540	527	359/714.ccls.	US-PGPUB; USPAT	OR	ON	2014/12/29 09:22
S548	375	S543 and S544 and S545 and S546 and S547	US-PGPUB; USPAT	OR	ON	2014/12/29 09:22
S559	375	S554 and S555 and S556 and S557 and S558	US-PGPUB; USPAT	OR	ON	2014/12/29 09:22
S561	27193	lens near3 housing	US-PGPUB; USPAT	OR	ON	2014/12/29 09:22
S653	1207	359/687.ccls.	US-PGPUB; USPAT	OR	ON	2015/01/25 12:46

S655	6851	(wide-angle "wide angle" wideangle) same condition	US-PGPUB; USPAT	OR	ON	2015/01/25 13:03
S657	2819	(wide-angle "wide angle" wideangle) same condition same (focal near3 length)	US-PGPUB; USPAT	OR	ON	2015/01/25 13:03
S659	2558	(focal near3 length near3 first adj lens adj4 group)	US-PGPUB; USPAT	OR	ON	2015/01/25 13:15
S660	6934	(focal near3 length near3 first adj lens)	US-PGPUB; USPAT	OR	ON	2015/01/25 13:15
S661	2558	S659 with S660	US-PGPUB; USPAT	OR	ON	2015/01/25 13:15
S663	281	359/773.ccls.	US-PGPUB; USPAT	OR	ON	2015/01/25 17:49
S664	12058	(first near3 lens near5 positive)	US-PGPUB; USPAT	OR	ON	2015/01/25 17:50
S665	9885	(third near3 lens near5 positive)	US-PGPUB; USPAT	OR	ON	2015/01/25 17:50
S666	11697	(second near3 lens near5 negative)	US-PGPUB; USPAT	OR	ON	2015/01/25 17:51
S667	5799	(fourth near3 lens near5 negative)	US-PGPUB; USPAT	OR	ON	2015/01/25 17:51
S668	4645	S664 and S665 and S666 and S667	US-PGPUB; USPAT	OR	ON	2015/01/25 17:53
S669	2558	(focal near3 length near3 first adj lens adj4 group)	US-PGPUB; USPAT	OR	ON	2015/01/25 17:54
S670	6934	(focal near3 length near3 first adj lens)	US-PGPUB; USPAT	OR	ON	2015/01/25 17:54
S671	2558	S669 and S670	US-PGPUB; USPAT	OR	ON	2015/01/25 17:54
S673	15	S671 and S663	US-PGPUB; USPAT	OR	ON	2015/01/25 17:55
S674	266	S663 not S673	US-PGPUB; USPAT	OR	ON	2015/01/25 18:10
S675	3142	(focal near3 length near10 zoom near10 (telephoto tele-photo))	US-PGPUB; USPAT	OR	ON	2015/01/25 18:11
S676	8	S674 and S675	US-PGPUB; USPAT	OR	ON	2015/01/25 18:11
S677	258	S674 not S676	US-PGPUB; USPAT	OR	ON	2015/01/25 18:17
S678	163	f1/ft	US-PGPUB; USPAT	OR	ON	2015/01/25 18:26
S679	530	f1/f	US-PGPUB; USPAT	OR	ON	2015/01/25 18:26
S684	539	f/f1	US-PGPUB; USPAT	OR	ON	2015/01/25 18:44
S686	1207	359/687.ccls.	US-PGPUB; USPAT	OR	ON	2015/01/25 18:45
S949	578	S945 and S946 and S947 and S948	US-PGPUB; USPAT	OR	ON	2015/02/05 13:38
S950	2652353	(diaphragm stop aperture)	US-PGPUB; USPAT	OR	ON	2015/02/05 13:38
S951	559	S949 and S950	US-PGPUB; USPAT	OR	ON	2015/02/05 13:38
S953	1638	maximum near3 angle near3 view	US-PGPUB;	OR	ON	2015/02/05

			USPAT			13:38
S954	4858	((first near3 lens) near10 (positive) near15 (convex))	US-PGPUB; USPAT	OR	ON	2015/02/05 13:38
S955	5275	((second near3 lens) near10 (positive) near15 (convex))	US-PGPUB; USPAT	OR	ON	2015/02/05 13:38
S956	1992	(third near3 lens) near5 negative near15 (concave)	US-PGPUB; USPAT	OR	ON	2015/02/05 13:38
S957	1927	(fourth near3 lens) near10 positive near10 concave	US-PGPUB; USPAT	OR	ON	2015/02/05 13:38
S958	578	S954 and S955 and S956 and S957	US-PGPUB; USPAT	OR	ON	2015/02/05 13:38
S959	2652353	(diaphragm stop aperture)	US-PGPUB; USPAT	OR	ON	2015/02/05 13:38
S960	559	S958 and S959	US-PGPUB; USPAT	OR	ON	2015/02/05 13:38
S961	185	S960 and (inflection near3 point)	US-PGPUB; USPAT	OR	ON	2015/02/05 13:38
S963	850	HFOV	US-PGPUB; USPAT	OR	ON	2015/02/05 13:38
S967	9474	((first near3 lens) near10 positive).clm.	US-PGPUB; USPAT	OR	ON	2015/02/05 13:38
S968	8475	(second near3 lens) near10 positive.clm.	US-PGPUB; USPAT	OR	ON	2015/02/05 13:38
S969	7414	third near3 lens near10 positive.clm.	US-PGPUB; USPAT	OR	ON	2015/02/05 13:38
S970	197	paraxial near3 region.clm.	US-PGPUB; USPAT	OR	ON	2015/02/05 13:38
S971	3820	fourth near3 lens near10 negative.clm.	US-PGPUB; USPAT	OR	ON	2015/02/05 13:38
S972	6754	aspheric.clm.	US-PGPUB; USPAT	OR	ON	2015/02/05 13:38
S975	2700	first near3 lens near3 unit near5 positive	US-PGPUB; USPAT	OR	ON	2015/02/05 13:38
S976	2661	second near3 lens near3 unit near5 negative	US-PGPUB; USPAT	OR	ON	2015/02/05 13:38
S977	9482	reflecting near3 unit	US-PGPUB; USPAT	OR	ON	2015/02/05 13:38
S978	3873	rear near3 lens near3 group	US-PGPUB; USPAT	OR	ON	2015/02/05 13:38
S981	2002	first near3 lens near3 unit near5 positive.clm.	US-PGPUB; USPAT	OR	ON	2015/02/05 13:38
S982	1833	second near3 lens near3 unit near5 negative.clm.	US-PGPUB; USPAT	OR	ON	2015/02/05 13:38
S983	3344	reflecting near3 unit.clm.	US-PGPUB; USPAT	OR	ON	2015/02/05 13:38
S984	1326	rear near3 lens near3 group.clm.	US-PGPUB; USPAT	OR	ON	2015/02/05 13:38
S1049	300	fixing near3 diaphragm.clm.	US-PGPUB; USPAT	OR	ON	2015/02/05 13:56
S1050	15694	optical near3 set.clm.	US-PGPUB; USPAT	OR	ON	2015/02/05 13:56
S1051	54097	first near3 lens.clm.	US-PGPUB; USPAT	OR	ON	2015/02/05 13:56
S1052	50432	second near3 lens.clm.	US-PGPUB; USPAT	OR	ON	2015/02/05

			USPAT			13:57
S1053	15816	third near3 lens.d.m.	US-PGPUB; USPAT	OR	ON	2015/02/05 13:57
S1054	8456	fourth near3 lens.d.m.	US-PGPUB; USPAT	OR	ON	2015/02/05 13:57
S1055	49310	convex near3 surface.d.m.	US-PGPUB; USPAT	OR	ON	2015/02/05 13:57
S1119	7204	(second near4 lens) same positive same concave	US-PGPUB; USPAT	OR	ON	2015/03/09 08:17
S1120	1837	(second near4 lens) same positive same concave same aspheric	US-PGPUB; USPAT	OR	ON	2015/03/09 08:17
S1164	12177	(first near3 lens) near5 positive	US-PGPUB; USPAT	OR	ON	2015/03/09 08:17
S1165	7263	(second near3 lens) near5 (concave biconcave bi-concave)	US-PGPUB; USPAT	OR	ON	2015/03/09 08:17
S1166	4924	(third near3 lens) near5 (convex)	US-PGPUB; USPAT	OR	ON	2015/03/09 08:17
S1167	3393	(fourth near3 lens) near5 convex	US-PGPUB; USPAT	OR	ON	2015/03/09 08:17
S1168	3899	(fifth near3 lens) near7 negative	US-PGPUB; USPAT	OR	ON	2015/03/09 08:17
S1188	1878	(third near4 lens) same positive same convex same aspheric	US-PGPUB; USPAT	OR	ON	2015/03/09 08:17
S1189	1467	(fourth near4 lens) same negative same convex same aspheric	US-PGPUB; USPAT	OR	ON	2015/03/09 08:17
S1190	1096	S1119 and S1120 and S1188 and S1189	US-PGPUB; USPAT	OR	ON	2015/03/09 08:17
S1193	5359	(first near3 lens near3 group) near5 positive	US-PGPUB; USPAT	OR	ON	2015/03/09 08:17
S1194	5180	(second near3 lens near3 group) near5 negative	US-PGPUB; USPAT	OR	ON	2015/03/09 08:17
S1195	4504	(third near3 lens near3 group) near5 positive	US-PGPUB; USPAT	OR	ON	2015/03/09 08:17
S1196	2294	(fourth near3 lens near3 group) near5 negative	US-PGPUB; USPAT	OR	ON	2015/03/09 08:17
S1197	1460	(fifth near3 lens near3 group) near5 positive	US-PGPUB; USPAT	OR	ON	2015/03/09 08:17
S1198	29453	aperture near3 stop	US-PGPUB; USPAT	OR	ON	2015/03/09 08:17
S1201	7204	(second near4 lens) same positive same concave	US-PGPUB; USPAT	OR	ON	2015/03/09 08:17
S1202	1837	(second near4 lens) same positive same concave same aspheric	US-PGPUB; USPAT	OR	ON	2015/03/09 08:17
S1205	720	((second near4 lens) near20 positive near20 concave near20 aspheric)	US-PGPUB; USPAT	OR	ON	2015/03/09 08:17
S1206	720	S1205 and S1202	US-PGPUB; USPAT	OR	ON	2015/03/09 08:17
S1208	12519	(second near3 lens) near5 positive	US-PGPUB; USPAT	OR	ON	2015/03/09 08:17
S1209	9987	(third near3 lens) near5 positive	US-PGPUB; USPAT	OR	ON	2015/03/09 08:17
S1210	4162	(fifth near3 lens) near5 positive	US-PGPUB; USPAT	OR	ON	2015/03/09 08:17

S1211	2789	(fifth near3 lens) near9 convex	US-PGPUB; USPAT	OR	ON	2015/03/09 08:17
S1212	1164	(sixth near3 lens) near10 concave	US-PGPUB; USPAT	OR	ON	2015/03/09 08:17
S1213	1081	(fifth near3 lens) near10 aspheric	US-PGPUB; USPAT	OR	ON	2015/03/09 08:17
S1217	9964	(first near3 lens) near5 negative	US-PGPUB; USPAT	OR	ON	2015/03/09 08:17
S1218	9361	(second near3 lens) near5 convex	US-PGPUB; USPAT	OR	ON	2015/03/09 08:17
S1219	3419	(third near3 lens) near5 concave	US-PGPUB; USPAT	OR	ON	2015/03/09 08:17
S1220	3393	(fourth near3 lens) near5 convex	US-PGPUB; USPAT	OR	ON	2015/03/09 08:17
S1221	1468	(fifth near3 lens) near5 concave	US-PGPUB; USPAT	OR	ON	2015/03/09 08:17
S1224	9964	(first near3 lens) near5 negative	US-PGPUB; USPAT	OR	ON	2015/03/09 08:17
S1225	9361	(second near3 lens) near5 convex	US-PGPUB; USPAT	OR	ON	2015/03/09 08:17
S1226	3419	(third near3 lens) near5 concave	US-PGPUB; USPAT	OR	ON	2015/03/09 08:17
S1227	3393	(fourth near3 lens) near5 convex	US-PGPUB; USPAT	OR	ON	2015/03/09 08:17
S1228	1468	(fifth near3 lens) near5 concave	US-PGPUB; USPAT	OR	ON	2015/03/09 08:17
S1231	4894	((first near3 lens) near10 (positive) near15 (convex))	US-PGPUB; USPAT	OR	ON	2015/03/09 08:17
S1232	5301	((second near3 lens) near10 (positive) near15 (convex))	US-PGPUB; USPAT	OR	ON	2015/03/09 08:17
S1233	2011	(third near3 lens) near5 negative near15 (concave)	US-PGPUB; USPAT	OR	ON	2015/03/09 08:17
S1234	1943	(fourth near3 lens) near10 positive near10 concave	US-PGPUB; USPAT	OR	ON	2015/03/09 08:17
S1235	581	S1231 and S1232 and S1233 and S1234	US-PGPUB; USPAT	OR	ON	2015/03/09 08:17
S1236	2666338	(diaphragm stop aperture)	US-PGPUB; USPAT	OR	ON	2015/03/09 08:17
S1238	1652	maximum near3 angle near3 view	US-PGPUB; USPAT	OR	ON	2015/03/09 08:17
S1239	4894	((first near3 lens) near10 (positive) near15 (convex))	US-PGPUB; USPAT	OR	ON	2015/03/09 08:17
S1240	5301	((second near3 lens) near10 (positive) near15 (convex))	US-PGPUB; USPAT	OR	ON	2015/03/09 08:17
S1241	2011	(third near3 lens) near5 negative near15 (concave)	US-PGPUB; USPAT	OR	ON	2015/03/09 08:17
S1242	1943	(fourth near3 lens) near10 positive near10 concave	US-PGPUB; USPAT	OR	ON	2015/03/09 08:17
S1243	581	S1239 and S1240 and S1241 and S1242	US-PGPUB; USPAT	OR	ON	2015/03/09 08:17
S1244	2666338	(diaphragm stop aperture)	US-PGPUB; USPAT	OR	ON	2015/03/09 08:17
S1245	562	S1243 and S1244	US-PGPUB; USPAT	OR	ON	2015/03/09 08:17

S1246	187	S1245 and (inflection near3 point)	US-PGPUB; USPAT	OR	ON	2015/03/09 08:17
S1266	2579	(focal near3 length near3 first adj lens adj4 group)	US-PGPUB; USPAT	OR	ON	2015/03/09 08:17
S1267	7008	(focal near3 length near3 first adj lens)	US-PGPUB; USPAT	OR	ON	2015/03/09 08:17
S1269	283	359/773.ccls.	US-PGPUB; USPAT	OR	ON	2015/03/09 08:17
S1270	12177	(first near3 lens near5 positive)	US-PGPUB; USPAT	OR	ON	2015/03/09 08:17
S1271	9987	(third near3 lens near5 positive)	US-PGPUB; USPAT	OR	ON	2015/03/09 08:17
S1272	11809	(second near3 lens near5 negative)	US-PGPUB; USPAT	OR	ON	2015/03/09 08:17
S1273	5872	(fourth near3 lens near5 negative)	US-PGPUB; USPAT	OR	ON	2015/03/09 08:17
S1275	2579	(focal near3 length near3 first adj lens adj4 group)	US-PGPUB; USPAT	OR	ON	2015/03/09 08:17
S1276	7008	(focal near3 length near3 first adj lens)	US-PGPUB; USPAT	OR	ON	2015/03/09 08:17
S1277	2579	S1275 and S1276	US-PGPUB; USPAT	OR	ON	2015/03/09 08:17
S1279	268	S1269 not S1278	US-PGPUB; USPAT	OR	ON	2015/03/09 08:17
S1280	3166	(focal near3 length near10 zoom near10 (telephoto tele-photo))	US-PGPUB; USPAT	OR	ON	2015/03/09 08:17
S1288	7204	(second near4 lens) same positive same concave	US-PGPUB; USPAT	OR	ON	2015/03/09 08:17
S1289	1837	(second near4 lens) same positive same concave same aspheric	US-PGPUB; USPAT	OR	ON	2015/03/09 08:17
S1295	1878	(third near4 lens) same positive same convex same aspheric	US-PGPUB; USPAT	OR	ON	2015/03/09 08:17
S1296	1467	(fourth near4 lens) same negative same convex same aspheric	US-PGPUB; USPAT	OR	ON	2015/03/09 08:17
S1297	1096	S1288 and S1289 and S1295 and S1296	US-PGPUB; USPAT	OR	ON	2015/03/09 08:17
S1300	5359	(first near3 lens near3 group) near5 positive	US-PGPUB; USPAT	OR	ON	2015/03/09 08:17
S1301	5180	(second near3 lens near3 group) near5 negative	US-PGPUB; USPAT	OR	ON	2015/03/09 08:17
S1302	4504	(third near3 lens near3 group) near5 positive	US-PGPUB; USPAT	OR	ON	2015/03/09 08:17
S1303	2294	(fourth near3 lens near3 group) near5 negative	US-PGPUB; USPAT	OR	ON	2015/03/09 08:17
S1304	1460	(fifth near3 lens near3 group) near5 positive	US-PGPUB; USPAT	OR	ON	2015/03/09 08:17
S1305	29453	aperture near3 stop	US-PGPUB; USPAT	OR	ON	2015/03/09 08:17
S1308	7204	(second near4 lens) same positive same concave	US-PGPUB; USPAT	OR	ON	2015/03/09 08:17
S1309	1837	(second near4 lens) same positive same concave same aspheric	US-PGPUB; USPAT	OR	ON	2015/03/09 08:17
S1312	720	((second near4 lens) near20 positive near20 concave near20	US-PGPUB; USPAT	OR	ON	2015/03/09 08:17

		aspheric)				
S1313	720	S1312 and S1309	US-PGPUB; USPAT	OR	ON	2015/03/09 08:17
S1315	12519	(second near3 lens) near5 positive	US-PGPUB; USPAT	OR	ON	2015/03/09 08:17
S1316	9987	(third near3 lens) near5 positive	US-PGPUB; USPAT	OR	ON	2015/03/09 08:17
S1317	4162	(fifth near3 lens) near5 positive	US-PGPUB; USPAT	OR	ON	2015/03/09 08:17
S1318	2789	(fifth near3 lens) near9 convex	US-PGPUB; USPAT	OR	ON	2015/03/09 08:17
S1319	1164	(sixth near3 lens) near10 concave	US-PGPUB; USPAT	OR	ON	2015/03/09 08:17
S1320	1081	(fifth near3 lens) near10 aspheric	US-PGPUB; USPAT	OR	ON	2015/03/09 08:17
S1324	9964	(first near3 lens) near5 negative	US-PGPUB; USPAT	OR	ON	2015/03/09 08:17
S1325	9361	(second near3 lens) near5 convex	US-PGPUB; USPAT	OR	ON	2015/03/09 08:17
S1326	3419	(third near3 lens) near5 concave	US-PGPUB; USPAT	OR	ON	2015/03/09 08:17
S1327	3393	(fourth near3 lens) near5 convex	US-PGPUB; USPAT	OR	ON	2015/03/09 08:17
S1328	1468	(fifth near3 lens) near5 concave	US-PGPUB; USPAT	OR	ON	2015/03/09 08:17
S1331	9964	(first near3 lens) near5 negative	US-PGPUB; USPAT	OR	ON	2015/03/09 08:17
S1332	9361	(second near3 lens) near5 convex	US-PGPUB; USPAT	OR	ON	2015/03/09 08:17
S1333	3419	(third near3 lens) near5 concave	US-PGPUB; USPAT	OR	ON	2015/03/09 08:17
S1334	3393	(fourth near3 lens) near5 convex	US-PGPUB; USPAT	OR	ON	2015/03/09 08:17
S1335	1468	(fifth near3 lens) near5 concave	US-PGPUB; USPAT	OR	ON	2015/03/09 08:17
S1338	8361	(first near3 lens) near5 negative	FPRS; EPO; JPO; DERWENT	OR	ON	2015/03/09 08:17
S1339	4246	(second near3 lens) near5 convex	FPRS; EPO; JPO; DERWENT	OR	ON	2015/03/09 08:17
S1340	1831	(third near3 lens) near5 concave	FPRS; EPO; JPO; DERWENT	OR	ON	2015/03/09 08:17
S1341	1501	(fourth near3 lens) near5 convex	FPRS; EPO; JPO; DERWENT	OR	ON	2015/03/09 08:17
S1342	802	(fifth near3 lens) near5 concave	FPRS; EPO; JPO; DERWENT	OR	ON	2015/03/09 08:17
S1351	9964	(first near3 lens) near5 negative	US-PGPUB; USPAT	OR	ON	2015/03/09 08:17
S1352	9361	(second near3 lens) near5 convex	US-PGPUB; USPAT	OR	ON	2015/03/09 08:17



S1353	3419	(third near3 lens) near5 concave	US-PGPUB; USPAT	OR	ON	2015/03/09 08:17
S1354	3393	(fourth near3 lens) near5 convex	US-PGPUB; USPAT	OR	ON	2015/03/09 08:17
S1355	1468	(fifth near3 lens) near5 concave	US-PGPUB; USPAT	OR	ON	2015/03/09 08:17
S1357	12177	(first near3 lens) near5 positive	US-PGPUB; USPAT	OR	ON	2015/03/09 08:17
S1358	7263	(second near3 lens) near5 (concave biconcave bi-concave)	US-PGPUB; USPAT	OR	ON	2015/03/09 08:17
S1359	4924	(third near3 lens) near5 (convex)	US-PGPUB; USPAT	OR	ON	2015/03/09 08:17
S1360	3393	(fourth near3 lens) near5 convex	US-PGPUB; USPAT	OR	ON	2015/03/09 08:17
S1361	3899	(fifth near3 lens) near7 negative	US-PGPUB; USPAT	OR	ON	2015/03/09 08:17
S1381	1878	(third near4 lens) same positive same convex same aspheric	US-PGPUB; USPAT	OR	ON	2015/03/09 08:17
S1382	1467	(fourth near4 lens) same negative same convex same aspheric	US-PGPUB; USPAT	OR	ON	2015/03/09 08:17
S1383	1096	S1308 and S1309 and S1381 and S1382	US-PGPUB; USPAT	OR	ON	2015/03/09 08:17
S1390	7204	(second near4 lens) same positive same concave	US-PGPUB; USPAT	OR	ON	2015/03/09 08:17
S1391	1837	(second near4 lens) same positive same concave same aspheric	US-PGPUB; USPAT	OR	ON	2015/03/09 08:17
S1392	1837	S1390 and S1391	US-PGPUB; USPAT	OR	ON	2015/03/09 08:17
S1395	720	((second near4 lens) near20 positive near20 concave near20 aspheric)	US-PGPUB; USPAT	OR	ON	2015/03/09 08:17
S1396	720	S1395 and S1391	US-PGPUB; USPAT	OR	ON	2015/03/09 08:17
S1400	12519	(second near3 lens) near5 positive	US-PGPUB; USPAT	OR	ON	2015/03/09 08:17
S1401	9987	(third near3 lens) near5 positive	US-PGPUB; USPAT	OR	ON	2015/03/09 08:17
S1402	4162	(fifth near3 lens) near5 positive	US-PGPUB; USPAT	OR	ON	2015/03/09 08:17
S1403	2789	(fifth near3 lens) near9 convex	US-PGPUB; USPAT	OR	ON	2015/03/09 08:17
S1405	1164	(sixth near3 lens) near10 concave	US-PGPUB; USPAT	OR	ON	2015/03/09 08:17
S1406	1081	(fifth near3 lens) near10 aspheric	US-PGPUB; USPAT	OR	ON	2015/03/09 08:17
S1410	887	(G02B13/0045).CPC.	US-PGPUB; USPAT	OR	ON	2015/03/09 08:17
S1411	9964	(first near3 lens) near5 negative	US-PGPUB; USPAT	OR	ON	2015/03/09 08:17
S1412	9361	(second near3 lens) near5 convex	US-PGPUB; USPAT	OR	ON	2015/03/09 08:17
S1413	3419	(third near3 lens) near5 concave	US-PGPUB; USPAT	OR	ON	2015/03/09 08:17
S1414	3393	(fourth near3 lens) near5 convex	US-PGPUB;	OR	ON	2015/03/09

			USPAT			08:17
S1415	1468	(fifth near3 lens) near5 concave	US-PGPUB; USPAT	OR	ON	2015/03/09 08:17
S1416	392	S1411 and S1412 and S1413 and S1414 and S1415	US-PGPUB; USPAT	OR	ON	2015/03/09 08:17
S1420	26186	lens near3 barrel	US-PGPUB; USPAT	OR	ON	2015/03/09 08:17
S1421	9964	(first near3 lens) near5 negative	US-PGPUB; USPAT	OR	ON	2015/03/09 08:17
S1422	9361	(second near3 lens) near5 convex	US-PGPUB; USPAT	OR	ON	2015/03/09 08:17
S1423	3419	(third near3 lens) near5 concave	US-PGPUB; USPAT	OR	ON	2015/03/09 08:17
S1424	3393	(fourth near3 lens) near5 convex	US-PGPUB; USPAT	OR	ON	2015/03/09 08:17
S1425	1468	(fifth near3 lens) near5 concave	US-PGPUB; USPAT	OR	ON	2015/03/09 08:17
S1426	392	S1421 and S1422 and S1423 and S1424 and S1425	US-PGPUB; USPAT	OR	ON	2015/03/09 08:17
S1430	8361	(first near3 lens) near5 negative	FPRS; EPO; JPO; DERWENT	OR	ON	2015/03/09 08:17
S1431	4246	(second near3 lens) near5 convex	FPRS; EPO; JPO; DERWENT	OR	ON	2015/03/09 08:17
S1432	1831	(third near3 lens) near5 concave	FPRS; EPO; JPO; DERWENT	OR	ON	2015/03/09 08:17
S1433	1501	(fourth near3 lens) near5 convex	FPRS; EPO; JPO; DERWENT	OR	ON	2015/03/09 08:17
S1434	802	(fifth near3 lens) near5 concave	FPRS; EPO; JPO; DERWENT	OR	ON	2015/03/09 08:17
S1435	29	S1430 and S1431 and S1432 and S1433 and S1434	FPRS; EPO; JPO; DERWENT	OR	ON	2015/03/09 08:17
S1443	850	(axial near3 distance) same (first near3 lens) same (second near3 lens)	US-PGPUB; USPAT	OR	ON	2015/03/09 08:17
S1448	9964	(first near3 lens) near5 negative	US-PGPUB; USPAT	OR	ON	2015/03/09 08:17
S1449	9361	(second near3 lens) near5 convex	US-PGPUB; USPAT	OR	ON	2015/03/09 08:17
S1450	3419	(third near3 lens) near5 concave	US-PGPUB; USPAT	OR	ON	2015/03/09 08:17
S1451	3393	(fourth near3 lens) near5 convex	US-PGPUB; USPAT	OR	ON	2015/03/09 08:17
S1452	1468	(fifth near3 lens) near5 concave	US-PGPUB; USPAT	OR	ON	2015/03/09 08:17
S1453	392	S1448 and S1449 and S1450 and S1451 and S1452	US-PGPUB; USPAT	OR	ON	2015/03/09 08:17
S1457	12177	(first near3 lens) near5 positive	US-PGPUB; USPAT	OR	ON	2015/03/09 08:17
S1458	7263	(second near3 lens) near5	US-PGPUB;	OR	ON	2015/03/09

		(concave biconcave bi-concave)	USPAT			08:17
S1459	4924	(third near3 lens) near5 (convex)	US-PGPUB; USPAT	OR	ON	2015/03/09 08:17
S1460	3393	(fourth near3 lens) near5 convex	US-PGPUB; USPAT	OR	ON	2015/03/09 08:17
S1461	3899	(fifth near3 lens) near7 negative	US-PGPUB; USPAT	OR	ON	2015/03/09 08:17
S1471	349	(first near5 lens) near7 convex near5 plastic	US-PGPUB; USPAT	OR	ON	2015/03/09 08:17
S1472	441	(second near5 lens) near7 aspheric near5 plastic	US-PGPUB; USPAT	OR	ON	2015/03/09 08:17
S1473	240	(third near5 lens) near7 concave near5 plastic	US-PGPUB; USPAT	OR	ON	2015/03/09 08:17
S1475	17566	(fourth lens near5 lens) near10 plastic	US-PGPUB; USPAT	OR	ON	2015/03/09 08:17
S1476	1015	(fourth lens near5 lens) near10 inflection	US-PGPUB; USPAT	OR	ON	2015/03/09 08:17
S1479	126	(first near3 lens) near10 positive near10 paraxial.clm.	US-PGPUB; USPAT	OR	ON	2015/03/09 08:17
S1480	1761	(second near3 lens) near10 positive near10 convex.clm.	US-PGPUB; USPAT	OR	ON	2015/03/09 08:17
S1481	957	(third near3 lens) near10 negative near10 convex.clm.	US-PGPUB; USPAT	OR	ON	2015/03/09 08:17
S1482	1921	(fourth near3 lens) near10 convex.clm.	US-PGPUB; USPAT	OR	ON	2015/03/09 08:17
S1484	1878	(third near4 lens) same positive same convex same aspheric	US-PGPUB; USPAT	OR	ON	2015/03/09 08:17
S1485	1467	(fourth near4 lens) same negative same convex same aspheric	US-PGPUB; USPAT	OR	ON	2015/03/09 08:17
S1486	1096	S1390 and S1391 and S1484 and S1485	US-PGPUB; USPAT	OR	ON	2015/03/09 08:17
S1489	5359	(first near3 lens near3 group) near5 positive	US-PGPUB; USPAT	OR	ON	2015/03/09 08:17
S1490	5180	(second near3 lens near3 group) near5 negative	US-PGPUB; USPAT	OR	ON	2015/03/09 08:17
S1491	4504	(third near3 lens near3 group) near5 positive	US-PGPUB; USPAT	OR	ON	2015/03/09 08:17
S1492	2294	(fourth near3 lens near3 group) near5 negative	US-PGPUB; USPAT	OR	ON	2015/03/09 08:17
S1493	1460	(fifth near3 lens near3 group) near5 positive	US-PGPUB; USPAT	OR	ON	2015/03/09 08:17
S1494	29453	aperture near3 stop	US-PGPUB; USPAT	OR	ON	2015/03/09 08:17
S1495	542	S1489 and S1490 and S1491 and S1492 and S1493 and S1494	US-PGPUB; USPAT	OR	ON	2015/03/09 08:17
S1496	1420	359/649-652.ccls.	US-PGPUB; USPAT	OR	ON	2015/03/09 08:17
S1499	7204	(second near4 lens) same positive same concave	US-PGPUB; USPAT	OR	ON	2015/03/09 08:17
S1500	1837	(second near4 lens) same positive same concave same aspheric	US-PGPUB; USPAT	OR	ON	2015/03/09 08:17
S1501	1837	S1499 and S1500	US-PGPUB; USPAT	OR	ON	2015/03/09 08:17
S1504	720	((second near4 lens) near20	US-PGPUB;	OR	ON	2015/03/09

		positive near20 concave near20 aspheric)	USPAT			08:17
S1505	720	S1504 and S1500	US-PGPUB; USPAT	OR	ON	2015/03/09 08:17
S1509	12519	(second near3 lens) near5 positive	US-PGPUB; USPAT	OR	ON	2015/03/09 08:17
S1510	9987	(third near3 lens) near5 positive	US-PGPUB; USPAT	OR	ON	2015/03/09 08:17
S1511	4162	(fifth near3 lens) near5 positive	US-PGPUB; USPAT	OR	ON	2015/03/09 08:17
S1512	2789	(fifth near3 lens) near9 convex	US-PGPUB; USPAT	OR	ON	2015/03/09 08:17
S1514	1164	(sixth near3 lens) near10 concave	US-PGPUB; USPAT	OR	ON	2015/03/09 08:17
S1515	1081	(fifth near3 lens) near10 aspheric	US-PGPUB; USPAT	OR	ON	2015/03/09 08:17
S1519	887	(G02B13/0045).CPC.	US-PGPUB; USPAT	OR	ON	2015/03/09 08:17
S1520	9964	(first near3 lens) near5 negative	US-PGPUB; USPAT	OR	ON	2015/03/09 08:17
S1521	9361	(second near3 lens) near5 convex	US-PGPUB; USPAT	OR	ON	2015/03/09 08:17
S1522	3419	(third near3 lens) near5 concave	US-PGPUB; USPAT	OR	ON	2015/03/09 08:17
S1523	3393	(fourth near3 lens) near5 convex	US-PGPUB; USPAT	OR	ON	2015/03/09 08:17
S1524	1468	(fifth near3 lens) near5 concave	US-PGPUB; USPAT	OR	ON	2015/03/09 08:17
S1525	392	S1520 and S1521 and S1522 and S1523 and S1524	US-PGPUB; USPAT	OR	ON	2015/03/09 08:17
S1529	26186	lens near3 barrel	US-PGPUB; USPAT	OR	ON	2015/03/09 08:17
S1530	9964	(first near3 lens) near5 negative	US-PGPUB; USPAT	OR	ON	2015/03/09 08:17
S1531	9361	(second near3 lens) near5 convex	US-PGPUB; USPAT	OR	ON	2015/03/09 08:17
S1532	3419	(third near3 lens) near5 concave	US-PGPUB; USPAT	OR	ON	2015/03/09 08:17
S1533	3393	(fourth near3 lens) near5 convex	US-PGPUB; USPAT	OR	ON	2015/03/09 08:17
S1534	1468	(fifth near3 lens) near5 concave	US-PGPUB; USPAT	OR	ON	2015/03/09 08:17
S1535	392	S1530 and S1531 and S1532 and S1533 and S1534	US-PGPUB; USPAT	OR	ON	2015/03/09 08:17
S1539	4894	((first near3 lens) near10 (positive) near15 (convex))	US-PGPUB; USPAT	OR	ON	2015/03/09 08:17
S1540	5301	((second near3 lens) near10 (positive) near15 (convex))	US-PGPUB; USPAT	OR	ON	2015/03/09 08:17
S1541	2011	(third near3 lens) near5 negative near15 (concave)	US-PGPUB; USPAT	OR	ON	2015/03/09 08:17
S1542	1943	(fourth near3 lens) near10 positive near10 concave	US-PGPUB; USPAT	OR	ON	2015/03/09 08:17
S1543	1	("20130057967").PN.	US-PGPUB; USPAT;	OR	OFF	2015/04/23 11:09

			USOCR			
S1544	11329	((first near3 lens) near7 negative)	US-PGPUB; USPAT	OR	ON	2015/04/23 11:35
S1545	6129	((second near3 lens) near7 positive) same convex)	US-PGPUB; USPAT	OR	ON	2015/04/23 11:38
S1546	4997	(third near3 lens) near10 concave	US-PGPUB; USPAT	OR	ON	2015/04/23 11:38
S1547	4965	(fourth near3 lens) near10 convex	US-PGPUB; USPAT	OR	ON	2015/04/23 11:39
S1548	2172	(fifth near3 lens) near10 concave	US-PGPUB; USPAT	OR	ON	2015/04/23 11:41
S1549	736	S1544 and S1545 and S1546 and S1547 and S1548	US-PGPUB; USPAT	OR	ON	2015/04/23 11:42
S1550	590	359/714.ccls.	US-PGPUB; USPAT	OR	ON	2015/04/23 11:42
S1551	1098	359/659,746,753,764-766.ccls.	US-PGPUB; USPAT	OR	ON	2015/04/23 11:44
S1552	150	S1549 and S1550	US-PGPUB; USPAT	OR	ON	2015/04/23 11:44
S1553	150	S1544 and S1552	US-PGPUB; USPAT	OR	ON	2015/04/23 12:32
S1554	1	"14175290"	US-PGPUB; USPAT	OR	ON	2015/04/23 13:08
S1555	7328	(second near4 lens) same positive same concave	US-PGPUB; USPAT	OR	ON	2015/04/23 13:43
S1556	1885	(second near4 lens) same positive same concave same aspheric	US-PGPUB; USPAT	OR	ON	2015/04/23 13:43
S1557	1885	S1555 and S1556	US-PGPUB; USPAT	OR	ON	2015/04/23 13:43
S1558	7328	(second near4 lens) same positive same concave	US-PGPUB; USPAT	OR	ON	2015/04/23 13:43
S1559	1885	(second near4 lens) same positive same concave same aspheric	US-PGPUB; USPAT	OR	ON	2015/04/23 13:43
S1560	466	359/717.ccls.	US-PGPUB; USPAT	OR	ON	2015/04/23 13:43
S1561	8448	(first near3 lens) near5 negative	FPRS; EPO; JPO; DERWENT	OR	ON	2015/04/23 13:43
S1562	4321	(second near3 lens) near5 convex	FPRS; EPO; JPO; DERWENT	OR	ON	2015/04/23 13:43
S1563	1863	(third near3 lens) near5 concave	FPRS; EPO; JPO; DERWENT	OR	ON	2015/04/23 13:43
S1564	1527	(fourth near3 lens) near5 convex	FPRS; EPO; JPO; DERWENT	OR	ON	2015/04/23 13:43
S1565	819	(fifth near3 lens) near5 concave	FPRS; EPO; JPO; DERWENT	OR	ON	2015/04/23 13:43
S1566	29	S1561 and S1562 and S1563 and S1564 and S1565	FPRS; EPO; JPO; DERWENT	OR	ON	2015/04/23 13:43
S1567	6143	(first near3 lens) near5 negative.clm.	US-PGPUB; USPAT	OR	ON	2015/04/23 13:43

S1568	3821	(second near3 lens) near5 convex.clm.	US-PGPUB; USPAT	OR	ON	2015/04/23 13:43
S1569	2040	(third near3 lens) near5 convex.clm.	US-PGPUB; USPAT	OR	ON	2015/04/23 13:43
S1570	1419	(fourth near3 lens) near5 convex.clm.	US-PGPUB; USPAT	OR	ON	2015/04/23 13:43
S1571	383	(fifth near3 lens) near10 plastic.clm.	US-PGPUB; USPAT	OR	ON	2015/04/23 13:43
S1572	39643	distance near10 image.clm.	US-PGPUB; USPAT	OR	ON	2015/04/23 13:43
S1573	871	(axial near3 distance) same (first near3 lens) same (second near3 lens)	US-PGPUB; USPAT	OR	ON	2015/04/23 13:43
S1574	10098	(first near3 lens) near5 negative	US-PGPUB; USPAT	OR	ON	2015/04/23 13:43
S1575	9511	(second near3 lens) near5 convex	US-PGPUB; USPAT	OR	ON	2015/04/23 13:43
S1576	3484	(third near3 lens) near5 concave	US-PGPUB; USPAT	OR	ON	2015/04/23 13:43
S1577	3470	(fourth near3 lens) near5 convex	US-PGPUB; USPAT	OR	ON	2015/04/23 13:43
S1578	1523	(fifth near3 lens) near5 concave	US-PGPUB; USPAT	OR	ON	2015/04/23 13:43
S1579	404	S1574 and S1575 and S1576 and S1577 and S1578	US-PGPUB; USPAT	OR	ON	2015/04/23 13:43
S1580	12354	(first near3 lens) near5 positive	US-PGPUB; USPAT	OR	ON	2015/04/23 13:43
S1581	7377	(second near3 lens) near5 (concave biconcave bi-concave)	US-PGPUB; USPAT	OR	ON	2015/04/23 13:43
S1582	5017	(third near3 lens) near5 (convex)	US-PGPUB; USPAT	OR	ON	2015/04/23 13:43
S1583	3470	(fourth near3 lens) near5 convex	US-PGPUB; USPAT	OR	ON	2015/04/23 13:43
S1584	3996	(fifth near3 lens) near7 negative	US-PGPUB; USPAT	OR	ON	2015/04/23 13:43
S1585	575	S1580 and S1581 and S1582 and S1583 and S1584	US-PGPUB; USPAT	OR	ON	2015/04/23 13:43
S1586	45	((fifth near3 lens) near7 negative) near10 inflection	US-PGPUB; USPAT	OR	ON	2015/04/23 13:43
S1587	7786	(second near3 lens) near5 positive.clm.	US-PGPUB; USPAT	OR	ON	2015/04/23 13:43
S1588	7030	(third near3 lens) near5 positive.clm.	US-PGPUB; USPAT	OR	ON	2015/04/23 13:43
S1589	2128	(fifth near3 lens) near5 positive.clm.	US-PGPUB; USPAT	OR	ON	2015/04/23 13:43
S1590	1015	(fifth near3 lens) near9 convex.clm.	US-PGPUB; USPAT	OR	ON	2015/04/23 13:43
S1591	453	(fifth near3 lens) near5 aspheric.clm.	US-PGPUB; USPAT	OR	ON	2015/04/23 13:43
S1592	4600	(inflection near2 point).clm.	US-PGPUB; USPAT	OR	ON	2015/04/23 13:43
S1593	419	(sixth near3 lens) near10 concave.clm.	US-PGPUB; USPAT	OR	ON	2015/04/23 13:43
S1594	354	(first near5 lens) near7 convex	US-PGPUB;	OR	ON	2015/04/23

		near5 plastic	USPAT			13:43
S1595	451	(second near5 lens) near7 aspheric near5 plastic	US-PGPUB; USPAT	OR	ON	2015/04/23 13:43
S1596	245	(third near5 lens) near7 concave near5 plastic	US-PGPUB; USPAT	OR	ON	2015/04/23 13:43
S1597	28691	(fourth lens near5 lens) near10 concave	US-PGPUB; USPAT	OR	ON	2015/04/23 13:43
S1598	17736	(fourth lens near5 lens) near10 plastic	US-PGPUB; USPAT	OR	ON	2015/04/23 13:43
S1599	1040	(fourth lens near5 lens) near10 inflection	US-PGPUB; USPAT	OR	ON	2015/04/23 13:43
S1600	130	(first near3 lens) near10 positive near10 paraxial.clm.	US-PGPUB; USPAT	OR	ON	2015/04/23 13:43
S1601	1786	(second near3 lens) near10 positive near10 convex.clm.	US-PGPUB; USPAT	OR	ON	2015/04/23 13:43
S1602	967	(third near3 lens) near10 negative near10 convex.clm.	US-PGPUB; USPAT	OR	ON	2015/04/23 13:43
S1603	1978	(fourth near3 lens) near10 convex.clm.	US-PGPUB; USPAT	OR	ON	2015/04/23 13:43
S1604	1925	(third near4 lens) same positive same convex same aspheric	US-PGPUB; USPAT	OR	ON	2015/04/23 13:43
S1605	1511	(fourth near4 lens) same negative same convex same aspheric	US-PGPUB; USPAT	OR	ON	2015/04/23 13:43
S1606	1132	S1558 and S1559 and S1604 and S1605	US-PGPUB; USPAT	OR	ON	2015/04/23 13:43
S1607	1114	S1606 and (diaphragm aperture stop)	US-PGPUB; USPAT	OR	ON	2015/04/23 13:43
S1608	637	359/715.ccls.	US-PGPUB; USPAT	OR	ON	2015/04/23 13:43
S1609	7328	(second near4 lens) same positive same concave	US-PGPUB; USPAT	OR	ON	2015/04/23 13:43
S1610	1885	(second near4 lens) same positive same concave same aspheric	US-PGPUB; USPAT	OR	ON	2015/04/23 13:43
S1611	466	359/717.ccls.	US-PGPUB; USPAT	OR	ON	2015/04/23 13:43
S1612	0	"S400" and S1610	US-PGPUB; USPAT	OR	ON	2015/04/23 13:43
S1613	0	S1612 and (diaphragm aperture stop)	US-PGPUB; USPAT	OR	ON	2015/04/23 13:43
S1614	12704	(second near3 lens) near5 positive	US-PGPUB; USPAT	OR	ON	2015/04/23 13:43
S1615	10143	(third near3 lens) near5 positive	US-PGPUB; USPAT	OR	ON	2015/04/23 13:43
S1616	4245	(fifth near3 lens) near5 positive	US-PGPUB; USPAT	OR	ON	2015/04/23 13:43
S1617	2874	(fifth near3 lens) near9 convex	US-PGPUB; USPAT	OR	ON	2015/04/23 13:43
S1618	1193	(sixth near3 lens) near10 concave	US-PGPUB; USPAT	OR	ON	2015/04/23 13:43
S1619	1126	(fifth near3 lens) near10 aspheric	US-PGPUB; USPAT	OR	ON	2015/04/23 13:43
S1620	201	S1614 and S1615 and S1616 and S1617 and S1618 and S1619	US-PGPUB; USPAT	OR	ON	2015/04/23 13:43
S1621	590	359/714.ccls.	US-PGPUB;	OR	ON	2015/04/23

			USPAT			13:43
S1622	10098	(first near3 lens) near5 negative	US-PGPUB; USPAT	OR	ON	2015/04/23 13:43
S1623	9511	(second near3 lens) near5 convex	US-PGPUB; USPAT	OR	ON	2015/04/23 13:43
S1624	3484	(third near3 lens) near5 concave	US-PGPUB; USPAT	OR	ON	2015/04/23 13:43
S1625	3470	(fourth near3 lens) near5 convex	US-PGPUB; USPAT	OR	ON	2015/04/23 13:43
S1626	1523	(fifth near3 lens) near5 concave	US-PGPUB; USPAT	OR	ON	2015/04/23 13:43
S1627	404	S1622 and S1623 and S1624 and S1625 and S1626	US-PGPUB; USPAT	OR	ON	2015/04/23 13:43
S1628	10098	(first near3 lens) near5 negative	US-PGPUB; USPAT	OR	ON	2015/04/23 13:43
S1629	9511	(second near3 lens) near5 convex	US-PGPUB; USPAT	OR	ON	2015/04/23 13:43
S1630	3484	(third near3 lens) near5 concave	US-PGPUB; USPAT	OR	ON	2015/04/23 13:43
S1631	3470	(fourth near3 lens) near5 convex	US-PGPUB; USPAT	OR	ON	2015/04/23 13:43
S1632	1523	(fifth near3 lens) near5 concave	US-PGPUB; USPAT	OR	ON	2015/04/23 13:43
S1633	404	S1628 and S1629 and S1630 and S1631 and S1632	US-PGPUB; USPAT	OR	ON	2015/04/23 13:43
S1634	27926	lens near3 housing	US-PGPUB; USPAT	OR	ON	2015/04/23 13:43
S1635	6143	(first near3 lens) near5 negative.clm.	US-PGPUB; USPAT	OR	ON	2015/04/23 13:43
S1636	3821	(second near3 lens) near5 convex.clm.	US-PGPUB; USPAT	OR	ON	2015/04/23 13:43
S1637	2040	(third near3 lens) near5 convex.clm.	US-PGPUB; USPAT	OR	ON	2015/04/23 13:43
S1638	1419	(fourth near3 lens) near5 convex.clm.	US-PGPUB; USPAT	OR	ON	2015/04/23 13:43
S1639	383	(fifth near3 lens) near10 plastic.clm.	US-PGPUB; USPAT	OR	ON	2015/04/23 13:43
S1640	39643	distance near10 image.clm.	US-PGPUB; USPAT	OR	ON	2015/04/23 13:43
S1641	12354	(first near3 lens) near5 positive	US-PGPUB; USPAT	OR	ON	2015/04/23 13:43
S1642	7377	(second near3 lens) near5 (concave biconcave bi-concave)	US-PGPUB; USPAT	OR	ON	2015/04/23 13:43
S1643	5017	(third near3 lens) near5 (convex)	US-PGPUB; USPAT	OR	ON	2015/04/23 13:43
S1644	3470	(fourth near3 lens) near5 convex	US-PGPUB; USPAT	OR	ON	2015/04/23 13:43
S1645	3996	(fifth near3 lens) near7 negative	US-PGPUB; USPAT	OR	ON	2015/04/23 13:43
S1646	575	S1641 and S1642 and S1643 and S1644 and S1645	US-PGPUB; USPAT	OR	ON	2015/04/23 13:43
S1647	45	((fifth near3 lens) near7 negative) near10 inflection	US-PGPUB; USPAT	OR	ON	2015/04/23 13:43
S1648	7786	(second near3 lens) near5	US-PGPUB;	OR	ON	2015/04/23



		positive.clm.	USPAT			13:43
S1649	7030	(third near3 lens) near5 positive.clm.	US-PGPUB; USPAT	OR	ON	2015/04/23 13:43
S1650	2128	(fifth near3 lens) near5 positive.clm.	US-PGPUB; USPAT	OR	ON	2015/04/23 13:43
S1651	1015	(fifth near3 lens) near9 convex.clm.	US-PGPUB; USPAT	OR	ON	2015/04/23 13:43
S1652	453	(fifth near3 lens) near5 aspheric.clm.	US-PGPUB; USPAT	OR	ON	2015/04/23 13:43
S1653	4600	(inflection near2 point).clm.	US-PGPUB; USPAT	OR	ON	2015/04/23 13:43
S1654	419	(sixth near3 lens) near10 concave.clm.	US-PGPUB; USPAT	OR	ON	2015/04/23 13:43
S1655	354	(first near5 lens) near7 convex near5 plastic	US-PGPUB; USPAT	OR	ON	2015/04/23 13:43
S1656	451	(second near5 lens) near7 aspheric near5 plastic	US-PGPUB; USPAT	OR	ON	2015/04/23 13:43
S1657	245	(third near5 lens) near7 concave near5 plastic	US-PGPUB; USPAT	OR	ON	2015/04/23 13:43
S1658	28691	(fourth lens near5 lens) near10 concave	US-PGPUB; USPAT	OR	ON	2015/04/23 13:43
S1659	17736	(fourth lens near5 lens) near10 plastic	US-PGPUB; USPAT	OR	ON	2015/04/23 13:43
S1660	1040	(fourth lens near5 lens) near10 inflection	US-PGPUB; USPAT	OR	ON	2015/04/23 13:43
S1661	1925	(third near4 lens) same positive same convex same aspheric	US-PGPUB; USPAT	OR	ON	2015/04/23 13:43
S1662	1511	(fourth near4 lens) same negative same convex same aspheric	US-PGPUB; USPAT	OR	ON	2015/04/23 13:43
S1663	1132	S1609 and S1610 and S1661 and S1662	US-PGPUB; USPAT	OR	ON	2015/04/23 13:43
S1664	1114	S1663 and (diaphragm aperture stop)	US-PGPUB; USPAT	OR	ON	2015/04/23 13:43
S1665	637	359/715.ccls.	US-PGPUB; USPAT	OR	ON	2015/04/23 13:43
S1666	5423	(first near3 lens near3 group) near5 positive	US-PGPUB; USPAT	OR	ON	2015/04/23 13:43
S1667	5244	(second near3 lens near3 group) near5 negative	US-PGPUB; USPAT	OR	ON	2015/04/23 13:43
S1668	4562	(third near3 lens near3 group) near5 positive	US-PGPUB; USPAT	OR	ON	2015/04/23 13:43
S1669	2323	(fourth near3 lens near3 group) near5 negative	US-PGPUB; USPAT	OR	ON	2015/04/23 13:43
S1670	1481	(fifth near3 lens near3 group) near5 positive	US-PGPUB; USPAT	OR	ON	2015/04/23 13:43
S1671	29778	aperture near3 stop	US-PGPUB; USPAT	OR	ON	2015/04/23 13:43
S1672	7328	(second near4 lens) same positive same concave	US-PGPUB; USPAT	OR	ON	2015/04/23 13:43
S1673	1885	(second near4 lens) same positive same concave same aspheric	US-PGPUB; USPAT	OR	ON	2015/04/23 13:43
S1674	466	359/717.ccls.	US-PGPUB; USPAT	OR	ON	2015/04/23 13:43
S1675	738	((second near4 lens) near20	US-PGPUB;	OR	ON	2015/04/23

		positive near20 concave near20 aspheric)	USPAT			13:43
S1676	738	S1675 and S1673	US-PGPUB; USPAT	OR	ON	2015/04/23 13:43
S1677	728	S1676 and (diaphragm aperture stop)	US-PGPUB; USPAT	OR	ON	2015/04/23 13:43
S1678	12704	(second near3 lens) near5 positive	US-PGPUB; USPAT	OR	ON	2015/04/23 13:43
S1679	10143	(third near3 lens) near5 positive	US-PGPUB; USPAT	OR	ON	2015/04/23 13:43
S1680	4245	(fifth near3 lens) near5 positive	US-PGPUB; USPAT	OR	ON	2015/04/23 13:43
S1681	2874	(fifth near3 lens) near9 convex	US-PGPUB; USPAT	OR	ON	2015/04/23 13:43
S1682	1193	(sixth near3 lens) near10 concave	US-PGPUB; USPAT	OR	ON	2015/04/23 13:43
S1683	1126	(fifth near3 lens) near10 aspheric	US-PGPUB; USPAT	OR	ON	2015/04/23 13:43
S1684	201	S1678 and S1679 and S1680 and S1681 and S1682 and S1683	US-PGPUB; USPAT	OR	ON	2015/04/23 13:43
S1685	590	359/714.ccls.	US-PGPUB; USPAT	OR	ON	2015/04/23 13:43
S1686	10098	(first near3 lens) near5 negative	US-PGPUB; USPAT	OR	ON	2015/04/23 13:43
S1687	9511	(second near3 lens) near5 convex	US-PGPUB; USPAT	OR	ON	2015/04/23 13:43
S1688	3484	(third near3 lens) near5 concave	US-PGPUB; USPAT	OR	ON	2015/04/23 13:43
S1689	3470	(fourth near3 lens) near5 convex	US-PGPUB; USPAT	OR	ON	2015/04/23 13:43
S1690	1523	(fifth near3 lens) near5 concave	US-PGPUB; USPAT	OR	ON	2015/04/23 13:43
S1691	404	S1686 and S1687 and S1688 and S1689 and S1690	US-PGPUB; USPAT	OR	ON	2015/04/23 13:43
S1692	10098	(first near3 lens) near5 negative	US-PGPUB; USPAT	OR	ON	2015/04/23 13:43
S1693	9511	(second near3 lens) near5 convex	US-PGPUB; USPAT	OR	ON	2015/04/23 13:43
S1694	3484	(third near3 lens) near5 concave	US-PGPUB; USPAT	OR	ON	2015/04/23 13:43
S1695	3470	(fourth near3 lens) near5 convex	US-PGPUB; USPAT	OR	ON	2015/04/23 13:43
S1696	1523	(fifth near3 lens) near5 concave	US-PGPUB; USPAT	OR	ON	2015/04/23 13:43
S1697	404	S1692 and S1693 and S1694 and S1695 and S1696	US-PGPUB; USPAT	OR	ON	2015/04/23 13:43
S1698	27926	lens near3 housing	US-PGPUB; USPAT	OR	ON	2015/04/23 13:43
S1699	4982	((first near3 lens) near10 (positive) near15 (convex))	US-PGPUB; USPAT	OR	ON	2015/04/23 13:43
S1700	5384	((second near3 lens) near10 (positive) near15 (convex))	US-PGPUB; USPAT	OR	ON	2015/04/23 13:43
S1701	2056	(third near3 lens) near5 negative near15 (concave)	US-PGPUB; USPAT	OR	ON	2015/04/23 13:43

S1702	1986	(fourth near3 lens) near10 positive near10 concave	US-PGPUB; USPAT	OR	ON	2015/04/23 13:43
S1703	599	S1699 and S1700 and S1701 and S1702	US-PGPUB; USPAT	OR	ON	2015/04/23 13:43
S1704	2690860	(diaphragm stop aperture)	US-PGPUB; USPAT	OR	ON	2015/04/23 13:43
S1705	1686	maximum near3 angle near3 view	US-PGPUB; USPAT	OR	ON	2015/04/23 13:43
S1706	4982	((first near3 lens) near10 (positive) near15 (convex))	US-PGPUB; USPAT	OR	ON	2015/04/23 13:43
S1707	5384	((second near3 lens) near10 (positive) near15 (convex))	US-PGPUB; USPAT	OR	ON	2015/04/23 13:43
S1708	2056	(third near3 lens) near5 negative near15 (concave)	US-PGPUB; USPAT	OR	ON	2015/04/23 13:43
S1709	1986	(fourth near3 lens) near10 positive near10 concave	US-PGPUB; USPAT	OR	ON	2015/04/23 13:43
S1710	599	S1706 and S1707 and S1708 and S1709	US-PGPUB; USPAT	OR	ON	2015/04/23 13:43
S1711	2690860	(diaphragm stop aperture)	US-PGPUB; USPAT	OR	ON	2015/04/23 13:43
S1712	580	S1710 and S1711	US-PGPUB; USPAT	OR	ON	2015/04/23 13:43
S1713	191	S1712 and (inflection near3 point)	US-PGPUB; USPAT	OR	ON	2015/04/23 13:43
S1714	1224	359/687.ccls.	US-PGPUB; USPAT	OR	ON	2015/04/23 13:43
S1715	6972	(wide-angle "wide angle" wideangle) same condition	US-PGPUB; USPAT	OR	ON	2015/04/23 13:43
S1716	2863	(wide-angle "wide angle" wideangle) same condition same (focal near3 length)	US-PGPUB; USPAT	OR	ON	2015/04/23 13:43
S1717	2619	(focal near3 length near3 first adj lens adj4 group)	US-PGPUB; USPAT	OR	ON	2015/04/23 13:43
S1718	7129	(focal near3 length near3 first adj lens)	US-PGPUB; USPAT	OR	ON	2015/04/23 13:43
S1719	2619	S1717 with S1718	US-PGPUB; USPAT	OR	ON	2015/04/23 13:43
S1720	288	359/773.ccls.	US-PGPUB; USPAT	OR	ON	2015/04/23 13:43
S1721	12354	(first near3 lens near5 positive)	US-PGPUB; USPAT	OR	ON	2015/04/23 13:43
S1722	10143	(third near3 lens near5 positive)	US-PGPUB; USPAT	OR	ON	2015/04/23 13:43
S1723	11978	(second near3 lens near5 negative)	US-PGPUB; USPAT	OR	ON	2015/04/23 13:43
S1724	5982	(fourth near3 lens near5 negative)	US-PGPUB; USPAT	OR	ON	2015/04/23 13:43
S1725	4793	S1721 and S1722 and S1723 and S1724	US-PGPUB; USPAT	OR	ON	2015/04/23 13:43
S1726	2619	(focal near3 length near3 first adj lens adj4 group)	US-PGPUB; USPAT	OR	ON	2015/04/23 13:43
S1727	7129	(focal near3 length near3 first adj lens)	US-PGPUB; USPAT	OR	ON	2015/04/23 13:43
S1728	2619	S1726 and S1727	US-PGPUB; USPAT	OR	ON	2015/04/23 13:43

			USPAT			13:43
S1730	273	S1720 not S1729	US-PGPUB; USPAT	OR	ON	2015/04/23 13:43
S1731	3207	((focal near3 length near10 zoom near10 (telephoto tele-photo))	US-PGPUB; USPAT	OR	ON	2015/04/23 13:43
S1734	170	f1/ft	US-PGPUB; USPAT	OR	ON	2015/04/23 13:43
S1735	556	f1/f	US-PGPUB; USPAT	OR	ON	2015/04/23 13:43
S1736	557	f/f1	US-PGPUB; USPAT	OR	ON	2015/04/23 13:43
S1737	1224	359/687.ccls.	US-PGPUB; USPAT	OR	ON	2015/04/23 13:43
S1738	7328	(second near4 lens) same positive same concave	US-PGPUB; USPAT	OR	ON	2015/04/23 13:43
S1739	1885	(second near4 lens) same positive same concave same aspheric	US-PGPUB; USPAT	OR	ON	2015/04/23 13:43
S1740	1925	(third near4 lens) same positive same convex same aspheric	US-PGPUB; USPAT	OR	ON	2015/04/23 13:43
S1741	1511	(fourth near4 lens) same negative same convex same aspheric	US-PGPUB; USPAT	OR	ON	2015/04/23 13:43
S1742	1132	S1738 and S1739 and S1740 and S1741	US-PGPUB; USPAT	OR	ON	2015/04/23 13:43
S1743	5423	((first near3 lens near3 group) near5 positive	US-PGPUB; USPAT	OR	ON	2015/04/23 13:43
S1744	5244	((second near3 lens near3 group) near5 negative	US-PGPUB; USPAT	OR	ON	2015/04/23 13:43
S1745	4562	((third near3 lens near3 group) near5 positive	US-PGPUB; USPAT	OR	ON	2015/04/23 13:43
S1746	2323	((fourth near3 lens near3 group) near5 negative	US-PGPUB; USPAT	OR	ON	2015/04/23 13:43
S1747	1481	((fifth near3 lens near3 group) near5 positive	US-PGPUB; USPAT	OR	ON	2015/04/23 13:43
S1748	29778	aperture near3 stop	US-PGPUB; USPAT	OR	ON	2015/04/23 13:43
S1749	7328	(second near4 lens) same positive same concave	US-PGPUB; USPAT	OR	ON	2015/04/23 13:43
S1750	1885	(second near4 lens) same positive same concave same aspheric	US-PGPUB; USPAT	OR	ON	2015/04/23 13:43
S1751	738	((second near4 lens) near20 positive near20 concave near20 aspheric)	US-PGPUB; USPAT	OR	ON	2015/04/23 13:43
S1752	738	S1751 and S1750	US-PGPUB; USPAT	OR	ON	2015/04/23 13:43
S1753	12704	(second near3 lens) near5 positive	US-PGPUB; USPAT	OR	ON	2015/04/23 13:43
S1754	10143	(third near3 lens) near5 positive	US-PGPUB; USPAT	OR	ON	2015/04/23 13:43
S1755	4245	(fifth near3 lens) near5 positive	US-PGPUB; USPAT	OR	ON	2015/04/23 13:43
S1756	2874	(fifth near3 lens) near9 convex	US-PGPUB; USPAT	OR	ON	2015/04/23 13:43
S1757	1193	(sixth near3 lens) near10 concave	US-PGPUB; USPAT	OR	ON	2015/04/23 13:43

S1758	1126	(fifth near3 lens) near10 aspheric	US-PGPUB; USPAT	OR	ON	2015/04/23 13:43
S1759	10098	(first near3 lens) near5 negative	US-PGPUB; USPAT	OR	ON	2015/04/23 13:43
S1760	9511	(second near3 lens) near5 convex	US-PGPUB; USPAT	OR	ON	2015/04/23 13:43
S1761	3484	(third near3 lens) near5 concave	US-PGPUB; USPAT	OR	ON	2015/04/23 13:43
S1762	3470	(fourth near3 lens) near5 convex	US-PGPUB; USPAT	OR	ON	2015/04/23 13:43
S1763	1523	(fifth near3 lens) near5 concave	US-PGPUB; USPAT	OR	ON	2015/04/23 13:43
S1764	10098	(first near3 lens) near5 negative	US-PGPUB; USPAT	OR	ON	2015/04/23 13:43
S1765	9511	(second near3 lens) near5 convex	US-PGPUB; USPAT	OR	ON	2015/04/23 13:43
S1766	3484	(third near3 lens) near5 concave	US-PGPUB; USPAT	OR	ON	2015/04/23 13:43
S1767	3470	(fourth near3 lens) near5 convex	US-PGPUB; USPAT	OR	ON	2015/04/23 13:43
S1768	1523	(fifth near3 lens) near5 concave	US-PGPUB; USPAT	OR	ON	2015/04/23 13:43
S1769	8448	(first near3 lens) near5 negative	FPRS; EPO; JPO; DERWENT	OR	ON	2015/04/23 13:43
S1770	4321	(second near3 lens) near5 convex	FPRS; EPO; JPO; DERWENT	OR	ON	2015/04/23 13:43
S1771	1863	(third near3 lens) near5 concave	FPRS; EPO; JPO; DERWENT	OR	ON	2015/04/23 13:43
S1772	1527	(fourth near3 lens) near5 convex	FPRS; EPO; JPO; DERWENT	OR	ON	2015/04/23 13:43
S1773	819	(fifth near3 lens) near5 concave	FPRS; EPO; JPO; DERWENT	OR	ON	2015/04/23 13:43
S1774	10098	(first near3 lens) near5 negative	US-PGPUB; USPAT	OR	ON	2015/04/23 13:43
S1775	9511	(second near3 lens) near5 convex	US-PGPUB; USPAT	OR	ON	2015/04/23 13:43
S1776	3484	(third near3 lens) near5 concave	US-PGPUB; USPAT	OR	ON	2015/04/23 13:43
S1777	3470	(fourth near3 lens) near5 convex	US-PGPUB; USPAT	OR	ON	2015/04/23 13:43
S1778	1523	(fifth near3 lens) near5 concave	US-PGPUB; USPAT	OR	ON	2015/04/23 13:43
S1779	12354	(first near3 lens) near5 positive	US-PGPUB; USPAT	OR	ON	2015/04/23 13:43
S1780	7377	(second near3 lens) near5 (concave biconcave bi-concave)	US-PGPUB; USPAT	OR	ON	2015/04/23 13:43
S1781	5017	(third near3 lens) near5 (convex)	US-PGPUB; USPAT	OR	ON	2015/04/23 13:43
S1782	3470	(fourth near3 lens) near5 convex	US-PGPUB; USPAT	OR	ON	2015/04/23 13:43

S1783	3996	(fifth near3 lens) near7 negative	US-PGPUB; USPAT	OR	ON	2015/04/23 13:43
S1784	1925	(third near4 lens) same positive same convex same aspheric	US-PGPUB; USPAT	OR	ON	2015/04/23 13:43
S1785	1511	(fourth near4 lens) same negative same convex same aspheric	US-PGPUB; USPAT	OR	ON	2015/04/23 13:43
S1786	1132	S1749 and S1750 and S1784 and S1785	US-PGPUB; USPAT	OR	ON	2015/04/23 13:43
S1787	7328	(second near4 lens) same positive same concave	US-PGPUB; USPAT	OR	ON	2015/04/23 13:43
S1788	1885	(second near4 lens) same positive same concave same aspheric	US-PGPUB; USPAT	OR	ON	2015/04/23 13:43
S1789	1885	S1787 and S1788	US-PGPUB; USPAT	OR	ON	2015/04/23 13:43
S1790	738	((second near4 lens) near20 positive near20 concave near20 aspheric)	US-PGPUB; USPAT	OR	ON	2015/04/23 13:43
S1791	738	S1790 and S1788	US-PGPUB; USPAT	OR	ON	2015/04/23 13:43
S1792	12704	(second near3 lens) near5 positive	US-PGPUB; USPAT	OR	ON	2015/04/23 13:43
S1793	10143	(third near3 lens) near5 positive	US-PGPUB; USPAT	OR	ON	2015/04/23 13:43
S1794	4245	(fifth near3 lens) near5 positive	US-PGPUB; USPAT	OR	ON	2015/04/23 13:43
S1795	2874	(fifth near3 lens) near9 convex	US-PGPUB; USPAT	OR	ON	2015/04/23 13:43
S1796	1193	(sixth near3 lens) near10 concave	US-PGPUB; USPAT	OR	ON	2015/04/23 13:43
S1797	1126	(fifth near3 lens) near10 aspheric	US-PGPUB; USPAT	OR	ON	2015/04/23 13:43
S1798	956	(G02B13/0045).CPC.	US-PGPUB; USPAT	OR	ON	2015/04/23 13:43
S1799	10098	(first near3 lens) near5 negative	US-PGPUB; USPAT	OR	ON	2015/04/23 13:43
S1800	9511	(second near3 lens) near5 convex	US-PGPUB; USPAT	OR	ON	2015/04/23 13:43
S1801	3484	(third near3 lens) near5 concave	US-PGPUB; USPAT	OR	ON	2015/04/23 13:43
S1802	3470	(fourth near3 lens) near5 convex	US-PGPUB; USPAT	OR	ON	2015/04/23 13:43
S1803	1523	(fifth near3 lens) near5 concave	US-PGPUB; USPAT	OR	ON	2015/04/23 13:43
S1804	404	S1799 and S1800 and S1801 and S1802 and S1803	US-PGPUB; USPAT	OR	ON	2015/04/23 13:43
S1805	26472	lens near3 barrel	US-PGPUB; USPAT	OR	ON	2015/04/23 13:43
S1806	10098	(first near3 lens) near5 negative	US-PGPUB; USPAT	OR	ON	2015/04/23 13:43
S1807	9511	(second near3 lens) near5 convex	US-PGPUB; USPAT	OR	ON	2015/04/23 13:43
S1808	3484	(third near3 lens) near5 concave	US-PGPUB; USPAT	OR	ON	2015/04/23 13:43
S1809	3470	(fourth near3 lens) near5 convex	US-PGPUB;	OR	ON	2015/04/23

			USPAT			13:43
S1810	1523	(fifth near3 lens) near5 concave	US-PGPUB; USPAT	OR	ON	2015/04/23 13:43
S1811	404	S1806 and S1807 and S1808 and S1809 and S1810	US-PGPUB; USPAT	OR	ON	2015/04/23 13:43
S1812	8448	(first near3 lens) near5 negative	FPRS; EPO; JPO; DERWENT	OR	ON	2015/04/23 13:43
S1813	4321	(second near3 lens) near5 convex	FPRS; EPO; JPO; DERWENT	OR	ON	2015/04/23 13:43
S1814	1863	(third near3 lens) near5 concave	FPRS; EPO; JPO; DERWENT	OR	ON	2015/04/23 13:43
S1815	1527	(fourth near3 lens) near5 convex	FPRS; EPO; JPO; DERWENT	OR	ON	2015/04/23 13:43
S1816	819	(fifth near3 lens) near5 concave	FPRS; EPO; JPO; DERWENT	OR	ON	2015/04/23 13:43
S1817	29	S1812 and S1813 and S1814 and S1815 and S1816	FPRS; EPO; JPO; DERWENT	OR	ON	2015/04/23 13:43
S1818	871	(axial near3 distance) same (first near3 lens) same (second near3 lens)	US-PGPUB; USPAT	OR	ON	2015/04/23 13:43
S1819	10098	(first near3 lens) near5 negative	US-PGPUB; USPAT	OR	ON	2015/04/23 13:43
S1820	9511	(second near3 lens) near5 convex	US-PGPUB; USPAT	OR	ON	2015/04/23 13:44
S1821	3484	(third near3 lens) near5 concave	US-PGPUB; USPAT	OR	ON	2015/04/23 13:44
S1822	3470	(fourth near3 lens) near5 convex	US-PGPUB; USPAT	OR	ON	2015/04/23 13:44
S1823	1523	(fifth near3 lens) near5 concave	US-PGPUB; USPAT	OR	ON	2015/04/23 13:44
S1824	404	S1819 and S1820 and S1821 and S1822 and S1823	US-PGPUB; USPAT	OR	ON	2015/04/23 13:44
S1825	12354	(first near3 lens) near5 positive	US-PGPUB; USPAT	OR	ON	2015/04/23 13:44
S1826	7377	(second near3 lens) near5 (concave biconcave bi-concave)	US-PGPUB; USPAT	OR	ON	2015/04/23 13:44
S1827	5017	(third near3 lens) near5 (convex)	US-PGPUB; USPAT	OR	ON	2015/04/23 13:44
S1828	3470	(fourth near3 lens) near5 convex	US-PGPUB; USPAT	OR	ON	2015/04/23 13:44
S1829	3996	(fifth near3 lens) near7 negative	US-PGPUB; USPAT	OR	ON	2015/04/23 13:44
S1830	354	(first near5 lens) near7 convex near5 plastic	US-PGPUB; USPAT	OR	ON	2015/04/23 13:44
S1831	451	(second near5 lens) near7 aspheric near5 plastic	US-PGPUB; USPAT	OR	ON	2015/04/23 13:44
S1832	245	(third near5 lens) near7 concave near5 plastic	US-PGPUB; USPAT	OR	ON	2015/04/23 13:44
S1833	17736	(fourth lens near5 lens) near10	US-PGPUB;	OR	ON	2015/04/23

		plastic	USPAT			13:44
S1834	1040	(fourth lens near5 lens) near10 inflection	US-PGPUB; USPAT	OR	ON	2015/04/23 13:44
S1835	130	(first near3 lens) near10 positive near10 paraxial.clm.	US-PGPUB; USPAT	OR	ON	2015/04/23 13:44
S1836	1786	(second near3 lens) near10 positive near10 convex.clm.	US-PGPUB; USPAT	OR	ON	2015/04/23 13:44
S1837	967	(third near3 lens) near10 negative near10 convex.clm.	US-PGPUB; USPAT	OR	ON	2015/04/23 13:44
S1838	1978	(fourth near3 lens) near10 convex.clm.	US-PGPUB; USPAT	OR	ON	2015/04/23 13:44
S1839	1925	(third near4 lens) same positive same convex same aspheric	US-PGPUB; USPAT	OR	ON	2015/04/23 13:44
S1840	1511	(fourth near4 lens) same negative same convex same aspheric	US-PGPUB; USPAT	OR	ON	2015/04/23 13:44
S1841	1132	S1787 and S1788 and S1839 and S1840	US-PGPUB; USPAT	OR	ON	2015/04/23 13:44
S1842	5423	(first near3 lens near3 group) near5 positive	US-PGPUB; USPAT	OR	ON	2015/04/23 13:44
S1843	5244	(second near3 lens near3 group) near5 negative	US-PGPUB; USPAT	OR	ON	2015/04/23 13:44
S1844	4562	(third near3 lens near3 group) near5 positive	US-PGPUB; USPAT	OR	ON	2015/04/23 13:44
S1845	2323	(fourth near3 lens near3 group) near5 negative	US-PGPUB; USPAT	OR	ON	2015/04/23 13:44
S1846	1481	(fifth near3 lens near3 group) near5 positive	US-PGPUB; USPAT	OR	ON	2015/04/23 13:44
S1847	29778	aperture near3 stop	US-PGPUB; USPAT	OR	ON	2015/04/23 13:44
S1848	555	S1842 and S1843 and S1844 and S1845 and S1846 and S1847	US-PGPUB; USPAT	OR	ON	2015/04/23 13:44
S1849	1427	359/649-652.ccls.	US-PGPUB; USPAT	OR	ON	2015/04/23 13:44
S1850	7328	(second near4 lens) same positive same concave	US-PGPUB; USPAT	OR	ON	2015/04/23 13:44
S1851	1885	(second near4 lens) same positive same concave same aspheric	US-PGPUB; USPAT	OR	ON	2015/04/23 13:44
S1852	1885	S1850 and S1851	US-PGPUB; USPAT	OR	ON	2015/04/23 13:44
S1853	738	((second near4 lens) near20 positive near20 concave near20 aspheric)	US-PGPUB; USPAT	OR	ON	2015/04/23 13:44
S1854	738	S1853 and S1851	US-PGPUB; USPAT	OR	ON	2015/04/23 13:44
S1855	12704	(second near3 lens) near5 positive	US-PGPUB; USPAT	OR	ON	2015/04/23 13:44
S1856	10143	(third near3 lens) near5 positive	US-PGPUB; USPAT	OR	ON	2015/04/23 13:44
S1857	4245	(fifth near3 lens) near5 positive	US-PGPUB; USPAT	OR	ON	2015/04/23 13:44
S1858	2874	(fifth near3 lens) near9 convex	US-PGPUB; USPAT	OR	ON	2015/04/23 13:44
S1859	1193	(sixth near3 lens) near10 concave	US-PGPUB; USPAT	OR	ON	2015/04/23 13:44



S1860	1126	(fifth near3 lens) near10 aspheric	US-PGPUB; USPAT	OR	ON	2015/04/23 13:44
S1861	956	(G02B13/0045).CPC.	US-PGPUB; USPAT	OR	ON	2015/04/23 13:44
S1862	10098	(first near3 lens) near5 negative	US-PGPUB; USPAT	OR	ON	2015/04/23 13:44
S1863	9511	(second near3 lens) near5 convex	US-PGPUB; USPAT	OR	ON	2015/04/23 13:44
S1864	3484	(third near3 lens) near5 concave	US-PGPUB; USPAT	OR	ON	2015/04/23 13:44
S1865	3470	(fourth near3 lens) near5 convex	US-PGPUB; USPAT	OR	ON	2015/04/23 13:44
S1866	1523	(fifth near3 lens) near5 concave	US-PGPUB; USPAT	OR	ON	2015/04/23 13:44
S1867	404	S1862 and S1863 and S1864 and S1865 and S1866	US-PGPUB; USPAT	OR	ON	2015/04/23 13:44
S1868	26472	lens near3 barrel	US-PGPUB; USPAT	OR	ON	2015/04/23 13:44
S1869	10098	(first near3 lens) near5 negative	US-PGPUB; USPAT	OR	ON	2015/04/23 13:44
S1870	9511	(second near3 lens) near5 convex	US-PGPUB; USPAT	OR	ON	2015/04/23 13:44
S1871	3484	(third near3 lens) near5 concave	US-PGPUB; USPAT	OR	ON	2015/04/23 13:44
S1872	3470	(fourth near3 lens) near5 convex	US-PGPUB; USPAT	OR	ON	2015/04/23 13:44
S1873	1523	(fifth near3 lens) near5 concave	US-PGPUB; USPAT	OR	ON	2015/04/23 13:44
S1874	404	S1869 and S1870 and S1871 and S1872 and S1873	US-PGPUB; USPAT	OR	ON	2015/04/23 13:44
S1875	4982	((first near3 lens) near10 (positive) near15 (convex))	US-PGPUB; USPAT	OR	ON	2015/04/23 13:44
S1876	5384	((second near3 lens) near10 (positive) near15 (convex))	US-PGPUB; USPAT	OR	ON	2015/04/23 13:44
S1877	2056	(third near3 lens) near5 negative near15 (concave)	US-PGPUB; USPAT	OR	ON	2015/04/23 13:44
S1878	1986	(fourth near3 lens) near10 positive near10 concave	US-PGPUB; USPAT	OR	ON	2015/04/23 13:44
S1879	599	S1875 and S1876 and S1877 and S1878	US-PGPUB; USPAT	OR	ON	2015/04/23 13:44
S1880	2690860	(diaphragm stop aperture)	US-PGPUB; USPAT	OR	ON	2015/04/23 13:44
S1881	580	S1879 and S1880	US-PGPUB; USPAT	OR	ON	2015/04/23 13:44
S1882	1686	maximum near3 angle near3 view	US-PGPUB; USPAT	OR	ON	2015/04/23 13:44
S1883	4982	((first near3 lens) near10 (positive) near15 (convex))	US-PGPUB; USPAT	OR	ON	2015/04/23 13:44
S1884	5384	((second near3 lens) near10 (positive) near15 (convex))	US-PGPUB; USPAT	OR	ON	2015/04/23 13:44
S1885	2056	(third near3 lens) near5 negative near15 (concave)	US-PGPUB; USPAT	OR	ON	2015/04/23 13:44
S1886	1986	(fourth near3 lens) near10 positive near10 concave	US-PGPUB; USPAT	OR	ON	2015/04/23 13:44

S1887	599	S1883 and S1884 and S1885 and S1886	US-PGPUB; USPAT	OR	ON	2015/04/23 13:44
S1888	2690860	(diaphragm stop aperture)	US-PGPUB; USPAT	OR	ON	2015/04/23 13:44
S1889	580	S1887 and S1888	US-PGPUB; USPAT	OR	ON	2015/04/23 13:44
S1890	191	S1889 and (inflection near3 point)	US-PGPUB; USPAT	OR	ON	2015/04/23 13:44
S1891	909	HFOV	US-PGPUB; USPAT	OR	ON	2015/04/23 13:44
S1892	9689	((first near3 lens) near10 positive).clm.	US-PGPUB; USPAT	OR	ON	2015/04/23 13:44
S1893	8642	(second near3 lens) near10 positive.clm.	US-PGPUB; USPAT	OR	ON	2015/04/23 13:44
S1894	7584	third near3 lens near10 positive.clm.	US-PGPUB; USPAT	OR	ON	2015/04/23 13:44
S1895	220	paraxial near3 region.clm.	US-PGPUB; USPAT	OR	ON	2015/04/23 13:44
S1896	3919	fourth near3 lens near10 negative.clm.	US-PGPUB; USPAT	OR	ON	2015/04/23 13:44
S1897	6884	aspheric.clm.	US-PGPUB; USPAT	OR	ON	2015/04/23 13:44
S1898	2746	first near3 lens near3 unit near5 positive	US-PGPUB; USPAT	OR	ON	2015/04/23 13:44
S1899	2703	second near3 lens near3 unit near5 negative	US-PGPUB; USPAT	OR	ON	2015/04/23 13:44
S1900	9637	reflecting near3 unit	US-PGPUB; USPAT	OR	ON	2015/04/23 13:44
S1901	3920	rear near3 lens near3 group	US-PGPUB; USPAT	OR	ON	2015/04/23 13:44
S1902	2040	first near3 lens near3 unit near5 positive.clm.	US-PGPUB; USPAT	OR	ON	2015/04/23 13:44
S1903	1865	second near3 lens near3 unit near5 negative.clm.	US-PGPUB; USPAT	OR	ON	2015/04/23 13:44
S1904	3397	reflecting near3 unit.clm.	US-PGPUB; USPAT	OR	ON	2015/04/23 13:44
S1905	1346	rear near3 lens near3 group.clm.	US-PGPUB; USPAT	OR	ON	2015/04/23 13:44
S1906	306	fixing near3 diaphragm.clm.	US-PGPUB; USPAT	OR	ON	2015/04/23 13:44
S1907	15865	optical near3 set.clm.	US-PGPUB; USPAT	OR	ON	2015/04/23 13:44
S1908	55050	first near3 lens.clm.	US-PGPUB; USPAT	OR	ON	2015/04/23 13:44
S1909	51278	second near3 lens.clm.	US-PGPUB; USPAT	OR	ON	2015/04/23 13:44
S1910	16152	third near3 lens.clm.	US-PGPUB; USPAT	OR	ON	2015/04/23 13:44
S1911	8685	fourth near3 lens.clm.	US-PGPUB; USPAT	OR	ON	2015/04/23 13:44
S1912	50102	convex near3 surface.clm.	US-PGPUB; USPAT	OR	ON	2015/04/23 13:44
S1913	7328	(second near4 lens) same positive same concave	US-PGPUB; USPAT	OR	ON	2015/04/23 13:44

S1914	1885	(second near4 lens) same positive same concave same aspheric	US-PGPUB; USPAT	OR	ON	2015/04/23 13:44
S1915	1885	S1913 and S1914	US-PGPUB; USPAT	OR	ON	2015/04/23 13:44
S1916	7328	(second near4 lens) same positive same concave	US-PGPUB; USPAT	OR	ON	2015/04/23 13:44
S1917	1885	(second near4 lens) same positive same concave same aspheric	US-PGPUB; USPAT	OR	ON	2015/04/23 13:44
S1918	466	359/717.ccls.	US-PGPUB; USPAT	OR	ON	2015/04/23 13:44
S1919	8448	(first near3 lens) near5 negative	FPRS; EPO; JPO; DERWENT	OR	ON	2015/04/23 13:44
S1920	4321	(second near3 lens) near5 convex	FPRS; EPO; JPO; DERWENT	OR	ON	2015/04/23 13:44
S1921	1863	(third near3 lens) near5 concave	FPRS; EPO; JPO; DERWENT	OR	ON	2015/04/23 13:44
S1922	1527	(fourth near3 lens) near5 convex	FPRS; EPO; JPO; DERWENT	OR	ON	2015/04/23 13:44
S1923	819	(fifth near3 lens) near5 concave	FPRS; EPO; JPO; DERWENT	OR	ON	2015/04/23 13:44
S1924	29	S1919 and S1920 and S1921 and S1922 and S1923	FPRS; EPO; JPO; DERWENT	OR	ON	2015/04/23 13:44
S1925	6143	(first near3 lens) near5 negative.clm.	US-PGPUB; USPAT	OR	ON	2015/04/23 13:44
S1926	3821	(second near3 lens) near5 convex.clm.	US-PGPUB; USPAT	OR	ON	2015/04/23 13:44
S1927	2040	(third near3 lens) near5 convex.clm.	US-PGPUB; USPAT	OR	ON	2015/04/23 13:44
S1928	1419	(fourth near3 lens) near5 convex.clm.	US-PGPUB; USPAT	OR	ON	2015/04/23 13:44
S1929	383	(fifth near3 lens) near10 plastic.clm.	US-PGPUB; USPAT	OR	ON	2015/04/23 13:44
S1930	39643	distance near10 image.clm.	US-PGPUB; USPAT	OR	ON	2015/04/23 13:44
S1931	871	(axial near3 distance) same (first near3 lens) same (second near3 lens)	US-PGPUB; USPAT	OR	ON	2015/04/23 13:44
S1932	10098	(first near3 lens) near5 negative	US-PGPUB; USPAT	OR	ON	2015/04/23 13:44
S1933	9511	(second near3 lens) near5 convex	US-PGPUB; USPAT	OR	ON	2015/04/23 13:44
S1934	3484	(third near3 lens) near5 concave	US-PGPUB; USPAT	OR	ON	2015/04/23 13:44
S1935	3470	(fourth near3 lens) near5 convex	US-PGPUB; USPAT	OR	ON	2015/04/23 13:44
S1936	1523	(fifth near3 lens) near5 concave	US-PGPUB; USPAT	OR	ON	2015/04/23 13:44
S1937	404	S1932 and S1933 and S1934 and S1935 and S1936	US-PGPUB; USPAT	OR	ON	2015/04/23 13:44

S1938	12354	(first near3 lens) near5 positive	US-PGPUB; USPAT	OR	ON	2015/04/23 13:44
S1939	7377	(second near3 lens) near5 (concave biconcave bi-concave)	US-PGPUB; USPAT	OR	ON	2015/04/23 13:44
S1940	5017	(third near3 lens) near5 (convex)	US-PGPUB; USPAT	OR	ON	2015/04/23 13:44
S1941	3470	(fourth near3 lens) near5 convex	US-PGPUB; USPAT	OR	ON	2015/04/23 13:44
S1942	3996	(fifth near3 lens) near7 negative	US-PGPUB; USPAT	OR	ON	2015/04/23 13:44
S1943	575	S1938 and S1939 and S1940 and S1941 and S1942	US-PGPUB; USPAT	OR	ON	2015/04/23 13:44
S1944	45	((fifth near3 lens) near7 negative) near10 inflection	US-PGPUB; USPAT	OR	ON	2015/04/23 13:44
S1945	7786	(second near3 lens) near5 positive.clm.	US-PGPUB; USPAT	OR	ON	2015/04/23 13:44
S1946	7030	(third near3 lens) near5 positive.clm.	US-PGPUB; USPAT	OR	ON	2015/04/23 13:44
S1947	2128	(fifth near3 lens) near5 positive.clm.	US-PGPUB; USPAT	OR	ON	2015/04/23 13:44
S1948	1015	(fifth near3 lens) near9 convex.clm.	US-PGPUB; USPAT	OR	ON	2015/04/23 13:44
S1949	453	(fifth near3 lens) near5 aspheric.clm.	US-PGPUB; USPAT	OR	ON	2015/04/23 13:44
S1950	4600	(inflection near2 point).clm.	US-PGPUB; USPAT	OR	ON	2015/04/23 13:44
S1951	419	(sixth near3 lens) near10 concave.clm.	US-PGPUB; USPAT	OR	ON	2015/04/23 13:44
S1952	354	(first near5 lens) near7 convex near5 plastic	US-PGPUB; USPAT	OR	ON	2015/04/23 13:44
S1953	451	(second near5 lens) near7 aspheric near5 plastic	US-PGPUB; USPAT	OR	ON	2015/04/23 13:44
S1954	245	(third near5 lens) near7 concave near5 plastic	US-PGPUB; USPAT	OR	ON	2015/04/23 13:44
S1955	28691	(fourth lens near5 lens) near10 concave	US-PGPUB; USPAT	OR	ON	2015/04/23 13:44
S1956	17736	(fourth lens near5 lens) near10 plastic	US-PGPUB; USPAT	OR	ON	2015/04/23 13:44
S1957	1040	(fourth lens near5 lens) near10 inflection	US-PGPUB; USPAT	OR	ON	2015/04/23 13:44
S1958	130	(first near3 lens) near10 positive near10 paraxial.clm.	US-PGPUB; USPAT	OR	ON	2015/04/23 13:44
S1959	1786	(second near3 lens) near10 positive near10 convex.clm.	US-PGPUB; USPAT	OR	ON	2015/04/23 13:44
S1960	967	(third near3 lens) near10 negative near10 convex.clm.	US-PGPUB; USPAT	OR	ON	2015/04/23 13:44
S1961	1978	(fourth near3 lens) near10 convex.clm.	US-PGPUB; USPAT	OR	ON	2015/04/23 13:44
S1962	1925	(third near4 lens) same positive same convex same aspheric	US-PGPUB; USPAT	OR	ON	2015/04/23 13:44
S1963	1511	(fourth near4 lens) same negative same convex same aspheric	US-PGPUB; USPAT	OR	ON	2015/04/23 13:44
S1964	1132	S1916 and S1917 and S1962 and S1963	US-PGPUB; USPAT	OR	ON	2015/04/23 13:44

S1965	1114	S1964 and (diaphragm aperture stop)	US-PGPUB; USPAT	OR	ON	2015/04/23 13:44
S1966	637	359/715.ccls.	US-PGPUB; USPAT	OR	ON	2015/04/23 13:44
S1967	7328	(second near4 lens) same positive same concave	US-PGPUB; USPAT	OR	ON	2015/04/23 13:44
S1968	1885	(second near4 lens) same positive same concave same aspheric	US-PGPUB; USPAT	OR	ON	2015/04/23 13:44
S1969	466	359/717.ccls.	US-PGPUB; USPAT	OR	ON	2015/04/23 13:44
S1970	0	"S400" and S1968	US-PGPUB; USPAT	OR	ON	2015/04/23 13:44
S1971	0	S1970 and (diaphragm aperture stop)	US-PGPUB; USPAT	OR	ON	2015/04/23 13:44
S1972	12704	(second near3 lens) near5 positive	US-PGPUB; USPAT	OR	ON	2015/04/23 13:44
S1973	10143	(third near3 lens) near5 positive	US-PGPUB; USPAT	OR	ON	2015/04/23 13:44
S1974	4245	(fifth near3 lens) near5 positive	US-PGPUB; USPAT	OR	ON	2015/04/23 13:44
S1975	2874	(fifth near3 lens) near9 convex	US-PGPUB; USPAT	OR	ON	2015/04/23 13:44
S1976	1193	(sixth near3 lens) near10 concave	US-PGPUB; USPAT	OR	ON	2015/04/23 13:44
S1977	1126	(fifth near3 lens) near10 aspheric	US-PGPUB; USPAT	OR	ON	2015/04/23 13:44
S1978	201	S1972 and S1973 and S1974 and S1975 and S1976 and S1977	US-PGPUB; USPAT	OR	ON	2015/04/23 13:44
S1979	590	359/714.ccls.	US-PGPUB; USPAT	OR	ON	2015/04/23 13:44
S1980	10098	(first near3 lens) near5 negative	US-PGPUB; USPAT	OR	ON	2015/04/23 13:44
S1981	9511	(second near3 lens) near5 convex	US-PGPUB; USPAT	OR	ON	2015/04/23 13:44
S1982	3484	(third near3 lens) near5 concave	US-PGPUB; USPAT	OR	ON	2015/04/23 13:44
S1983	3470	(fourth near3 lens) near5 convex	US-PGPUB; USPAT	OR	ON	2015/04/23 13:44
S1984	1523	(fifth near3 lens) near5 concave	US-PGPUB; USPAT	OR	ON	2015/04/23 13:44
S1985	404	S1980 and S1981 and S1982 and S1983 and S1984	US-PGPUB; USPAT	OR	ON	2015/04/23 13:44
S1986	10098	(first near3 lens) near5 negative	US-PGPUB; USPAT	OR	ON	2015/04/23 13:44
S1987	9511	(second near3 lens) near5 convex	US-PGPUB; USPAT	OR	ON	2015/04/23 13:44
S1988	3484	(third near3 lens) near5 concave	US-PGPUB; USPAT	OR	ON	2015/04/23 13:44
S1989	3470	(fourth near3 lens) near5 convex	US-PGPUB; USPAT	OR	ON	2015/04/23 13:44
S1990	1523	(fifth near3 lens) near5 concave	US-PGPUB; USPAT	OR	ON	2015/04/23 13:44
S1991	404	S1986 and S1987 and S1988 and S1989 and S1990	US-PGPUB; USPAT	OR	ON	2015/04/23 13:44

S1992	27926	lens near3 housing	US-PGPUB; USPAT	OR	ON	2015/04/23 13:44
S1993	8448	(first near3 lens) near5 negative	FPRS; EPO; JPO; DERWENT	OR	ON	2015/04/23 13:44
S1994	4321	(second near3 lens) near5 convex	FPRS; EPO; JPO; DERWENT	OR	ON	2015/04/23 13:44
S1995	1863	(third near3 lens) near5 concave	FPRS; EPO; JPO; DERWENT	OR	ON	2015/04/23 13:44
S1996	1527	(fourth near3 lens) near5 convex	FPRS; EPO; JPO; DERWENT	OR	ON	2015/04/23 13:44
S1997	819	(fifth near3 lens) near5 concave	FPRS; EPO; JPO; DERWENT	OR	ON	2015/04/23 13:44
S1998	29	S1993 and S1994 and S1995 and S1996 and S1997	FPRS; EPO; JPO; DERWENT	OR	ON	2015/04/23 13:44
S1999	6143	(first near3 lens) near5 negative.clm.	US-PGPUB; USPAT	OR	ON	2015/04/23 13:44
S2000	3821	(second near3 lens) near5 convex.clm.	US-PGPUB; USPAT	OR	ON	2015/04/23 13:44
S2001	2040	(third near3 lens) near5 convex.clm.	US-PGPUB; USPAT	OR	ON	2015/04/23 13:44
S2002	1419	(fourth near3 lens) near5 convex.clm.	US-PGPUB; USPAT	OR	ON	2015/04/23 13:44
S2003	383	(fifth near3 lens) near10 plastic.clm.	US-PGPUB; USPAT	OR	ON	2015/04/23 13:44
S2004	39643	distance near10 image.clm.	US-PGPUB; USPAT	OR	ON	2015/04/23 13:44
S2005	871	(axial near3 distance) same (first near3 lens) same (second near3 lens)	US-PGPUB; USPAT	OR	ON	2015/04/23 13:44
S2006	10098	(first near3 lens) near5 negative	US-PGPUB; USPAT	OR	ON	2015/04/23 13:44
S2007	9511	(second near3 lens) near5 convex	US-PGPUB; USPAT	OR	ON	2015/04/23 13:44
S2008	3484	(third near3 lens) near5 concave	US-PGPUB; USPAT	OR	ON	2015/04/23 13:44
S2009	3470	(fourth near3 lens) near5 convex	US-PGPUB; USPAT	OR	ON	2015/04/23 13:44
S2010	1523	(fifth near3 lens) near5 concave	US-PGPUB; USPAT	OR	ON	2015/04/23 13:44
S2011	404	S2006 and S2007 and S2008 and S2009 and S2010	US-PGPUB; USPAT	OR	ON	2015/04/23 13:44
S2012	12354	(first near3 lens) near5 positive	US-PGPUB; USPAT	OR	ON	2015/04/23 13:44
S2013	7377	(second near3 lens) near5 (concave biconcave bi-concave)	US-PGPUB; USPAT	OR	ON	2015/04/23 13:44
S2014	5017	(third near3 lens) near5 (convex)	US-PGPUB; USPAT	OR	ON	2015/04/23 13:44
S2015	3470	(fourth near3 lens) near5 convex	US-PGPUB; USPAT	OR	ON	2015/04/23 13:44

S2016	3996	(fifth near3 lens) near7 negative	US-PGPUB; USPAT	OR	ON	2015/04/23 13:44
S2017	575	S2012 and S2013 and S2014 and S2015 and S2016	US-PGPUB; USPAT	OR	ON	2015/04/23 13:44
S2018	45	((fifth near3 lens) near7 negative) near10 inflection	US-PGPUB; USPAT	OR	ON	2015/04/23 13:44
S2019	7786	(second near3 lens) near5 positive.clm.	US-PGPUB; USPAT	OR	ON	2015/04/23 13:44
S2020	7030	(third near3 lens) near5 positive.clm.	US-PGPUB; USPAT	OR	ON	2015/04/23 13:44
S2021	2128	(fifth near3 lens) near5 positive.clm.	US-PGPUB; USPAT	OR	ON	2015/04/23 13:44
S2022	1015	(fifth near3 lens) near9 convex.clm.	US-PGPUB; USPAT	OR	ON	2015/04/23 13:44
S2023	453	(fifth near3 lens) near5 aspheric.clm.	US-PGPUB; USPAT	OR	ON	2015/04/23 13:44
S2024	4600	(inflection near2 point).clm.	US-PGPUB; USPAT	OR	ON	2015/04/23 13:44
S2025	419	(sixth near3 lens) near10 concave.clm.	US-PGPUB; USPAT	OR	ON	2015/04/23 13:44
S2026	354	(first near5 lens) near7 convex near5 plastic	US-PGPUB; USPAT	OR	ON	2015/04/23 13:44
S2027	451	(second near5 lens) near7 aspheric near5 plastic	US-PGPUB; USPAT	OR	ON	2015/04/23 13:44
S2028	245	(third near5 lens) near7 concave near5 plastic	US-PGPUB; USPAT	OR	ON	2015/04/23 13:44
S2029	28691	(fourth lens near5 lens) near10 concave	US-PGPUB; USPAT	OR	ON	2015/04/23 13:44
S2030	17736	(fourth lens near5 lens) near10 plastic	US-PGPUB; USPAT	OR	ON	2015/04/23 13:44
S2031	1040	(fourth lens near5 lens) near10 inflection	US-PGPUB; USPAT	OR	ON	2015/04/23 13:44
S2032	130	(first near3 lens) near10 positive near10 paraxial.clm.	US-PGPUB; USPAT	OR	ON	2015/04/23 13:44
S2033	1786	(second near3 lens) near10 positive near10 convex.clm.	US-PGPUB; USPAT	OR	ON	2015/04/23 13:44
S2034	967	(third near3 lens) near10 negative near10 convex.clm.	US-PGPUB; USPAT	OR	ON	2015/04/23 13:44
S2035	1978	(fourth near3 lens) near10 convex.clm.	US-PGPUB; USPAT	OR	ON	2015/04/23 13:44
S2036	1925	(third near4 lens) same positive same convex same aspheric	US-PGPUB; USPAT	OR	ON	2015/04/23 13:44
S2037	1511	(fourth near4 lens) same negative same convex same aspheric	US-PGPUB; USPAT	OR	ON	2015/04/23 13:44
S2038	1132	S1967 and S1968 and S2036 and S2037	US-PGPUB; USPAT	OR	ON	2015/04/23 13:44
S2039	1114	S2038 and (diaphragm aperture stop)	US-PGPUB; USPAT	OR	ON	2015/04/23 13:44
S2040	637	359/715.ccls.	US-PGPUB; USPAT	OR	ON	2015/04/23 13:44
S2041	5423	(first near3 lens near3 group) near5 positive	US-PGPUB; USPAT	OR	ON	2015/04/23 13:44
S2042	5244	(second near3 lens near3 group) near5 negative	US-PGPUB; USPAT	OR	ON	2015/04/23 13:44

S2043	4562	(third near3 lens near3 group) near5 positive	US-PGPUB; USPAT	OR	ON	2015/04/23 13:44
S2044	2323	(fourth near3 lens near3 group) near5 negative	US-PGPUB; USPAT	OR	ON	2015/04/23 13:44
S2045	1481	(fifth near3 lens near3 group) near5 positive	US-PGPUB; USPAT	OR	ON	2015/04/23 13:44
S2046	29778	aperture near3 stop	US-PGPUB; USPAT	OR	ON	2015/04/23 13:44
S2047	555	S2041 and S2042 and S2043 and S2044 and S2045 and S2046	US-PGPUB; USPAT	OR	ON	2015/04/23 13:44
S2048	1427	359/649-652.ccls.	US-PGPUB; USPAT	OR	ON	2015/04/23 13:44
S2049	7328	(second near4 lens) same positive same concave	US-PGPUB; USPAT	OR	ON	2015/04/23 13:44
S2050	1885	(second near4 lens) same positive same concave same aspheric	US-PGPUB; USPAT	OR	ON	2015/04/23 13:44
S2051	1885	S2049 and S2050	US-PGPUB; USPAT	OR	ON	2015/04/23 13:44
S2052	466	359/717.ccls.	US-PGPUB; USPAT	OR	ON	2015/04/23 13:44
S2053	738	((second near4 lens) near20 positive near20 concave near20 aspheric)	US-PGPUB; USPAT	OR	ON	2015/04/23 13:44
S2054	738	S2053 and S2050	US-PGPUB; USPAT	OR	ON	2015/04/23 13:44
S2055	728	S2054 and (diaphragm aperture stop)	US-PGPUB; USPAT	OR	ON	2015/04/23 13:44
S2056	12704	(second near3 lens) near5 positive	US-PGPUB; USPAT	OR	ON	2015/04/23 13:44
S2057	10143	(third near3 lens) near5 positive	US-PGPUB; USPAT	OR	ON	2015/04/23 13:44
S2058	4245	(fifth near3 lens) near5 positive	US-PGPUB; USPAT	OR	ON	2015/04/23 13:44
S2059	2874	(fifth near3 lens) near9 convex	US-PGPUB; USPAT	OR	ON	2015/04/23 13:44
S2060	1193	(sixth near3 lens) near10 concave	US-PGPUB; USPAT	OR	ON	2015/04/23 13:44
S2061	1126	(fifth near3 lens) near10 aspheric	US-PGPUB; USPAT	OR	ON	2015/04/23 13:44
S2062	201	S2056 and S2057 and S2058 and S2059 and S2060 and S2061	US-PGPUB; USPAT	OR	ON	2015/04/23 13:44
S2063	590	359/714.ccls.	US-PGPUB; USPAT	OR	ON	2015/04/23 13:44
S2064	956	(G02B13/0045).CPC.	US-PGPUB; USPAT	OR	ON	2015/04/23 13:44
S2065	10098	(first near3 lens) near5 negative	US-PGPUB; USPAT	OR	ON	2015/04/23 13:44
S2066	9511	(second near3 lens) near5 convex	US-PGPUB; USPAT	OR	ON	2015/04/23 13:44
S2067	3484	(third near3 lens) near5 concave	US-PGPUB; USPAT	OR	ON	2015/04/23 13:44
S2068	3470	(fourth near3 lens) near5 convex	US-PGPUB; USPAT	OR	ON	2015/04/23 13:44
S2069	1523	(fifth near3 lens) near5 concave	US-PGPUB;	OR	ON	2015/04/23



			USPAT			13:44
S2070	404	S2065 and S2066 and S2067 and S2068 and S2069	US-PGPUB; USPAT	OR	ON	2015/04/23 13:44
S2071	26472	lens near3 barrel	US-PGPUB; USPAT	OR	ON	2015/04/23 13:44
S2072	10098	(first near3 lens) near5 negative	US-PGPUB; USPAT	OR	ON	2015/04/23 13:44
S2073	9511	(second near3 lens) near5 convex	US-PGPUB; USPAT	OR	ON	2015/04/23 13:44
S2074	3484	(third near3 lens) near5 concave	US-PGPUB; USPAT	OR	ON	2015/04/23 13:44
S2075	3470	(fourth near3 lens) near5 convex	US-PGPUB; USPAT	OR	ON	2015/04/23 13:44
S2076	1523	(fifth near3 lens) near5 concave	US-PGPUB; USPAT	OR	ON	2015/04/23 13:44
S2077	404	S2072 and S2073 and S2074 and S2075 and S2076	US-PGPUB; USPAT	OR	ON	2015/04/23 13:44
S2078	27926	lens near3 housing	US-PGPUB; USPAT	OR	ON	2015/04/23 13:44
S2079	4982	((first near3 lens) near10 (positive) near15 (convex))	US-PGPUB; USPAT	OR	ON	2015/04/23 13:44
S2080	5384	((second near3 lens) near10 (positive) near15 (convex))	US-PGPUB; USPAT	OR	ON	2015/04/23 13:44
S2081	2056	(third near3 lens) near5 negative near15 (concave)	US-PGPUB; USPAT	OR	ON	2015/04/23 13:44
S2082	1986	(fourth near3 lens) near10 positive near10 concave	US-PGPUB; USPAT	OR	ON	2015/04/23 13:44
S2083	599	S2079 and S2080 and S2081 and S2082	US-PGPUB; USPAT	OR	ON	2015/04/23 13:44
S2084	2690860	(diaphragm stop aperture)	US-PGPUB; USPAT	OR	ON	2015/04/23 13:44
S2085	580	S2083 and S2084	US-PGPUB; USPAT	OR	ON	2015/04/23 13:44
S2086	1686	maximum near3 angle near3 view	US-PGPUB; USPAT	OR	ON	2015/04/23 13:44
S2087	4982	((first near3 lens) near10 (positive) near15 (convex))	US-PGPUB; USPAT	OR	ON	2015/04/23 13:44
S2088	5384	((second near3 lens) near10 (positive) near15 (convex))	US-PGPUB; USPAT	OR	ON	2015/04/23 13:44
S2089	2056	(third near3 lens) near5 negative near15 (concave)	US-PGPUB; USPAT	OR	ON	2015/04/23 13:44
S2090	1986	(fourth near3 lens) near10 positive near10 concave	US-PGPUB; USPAT	OR	ON	2015/04/23 13:44
S2091	599	S2087 and S2088 and S2089 and S2090	US-PGPUB; USPAT	OR	ON	2015/04/23 13:44
S2092	2690860	(diaphragm stop aperture)	US-PGPUB; USPAT	OR	ON	2015/04/23 13:44
S2093	580	S2091 and S2092	US-PGPUB; USPAT	OR	ON	2015/04/23 13:44
S2094	191	S2093 and (inflection near3 point)	US-PGPUB; USPAT	OR	ON	2015/04/23 13:44
S2095	909	HFOV	US-PGPUB; USPAT	OR	ON	2015/04/23 13:44
S2096	9689	((first near3 lens) near10	US-PGPUB;	OR	ON	2015/04/23

		positive).clm.	USPAT			13:44
S2097	8642	(second near3 lens) near10 positive.clm.	US-PGPUB; USPAT	OR	ON	2015/04/23 13:44
S2098	7584	third near3 lens near10 positive.clm.	US-PGPUB; USPAT	OR	ON	2015/04/23 13:44
S2099	220	paraxial near3 region.clm.	US-PGPUB; USPAT	OR	ON	2015/04/23 13:44
S2100	3919	fourth near3 lens near10 negative.clm.	US-PGPUB; USPAT	OR	ON	2015/04/23 13:44
S2101	6884	aspheric.clm.	US-PGPUB; USPAT	OR	ON	2015/04/23 13:44
S2102	2746	first near3 lens near3 unit near5 positive	US-PGPUB; USPAT	OR	ON	2015/04/23 13:44
S2103	2703	second near3 lens near3 unit near5 negative	US-PGPUB; USPAT	OR	ON	2015/04/23 13:44
S2104	9637	reflecting near3 unit	US-PGPUB; USPAT	OR	ON	2015/04/23 13:44
S2105	3920	rear near3 lens near3 group	US-PGPUB; USPAT	OR	ON	2015/04/23 13:44
S2106	2040	first near3 lens near3 unit near5 positive.clm.	US-PGPUB; USPAT	OR	ON	2015/04/23 13:44
S2107	1865	second near3 lens near3 unit near5 negative.clm.	US-PGPUB; USPAT	OR	ON	2015/04/23 13:44
S2108	3397	reflecting near3 unit.clm.	US-PGPUB; USPAT	OR	ON	2015/04/23 13:44
S2109	1346	rear near3 lens near3 group.clm.	US-PGPUB; USPAT	OR	ON	2015/04/23 13:44
S2110	1224	359/687.ccls.	US-PGPUB; USPAT	OR	ON	2015/04/23 13:44
S2111	6972	(wide-angle "wide angle" wideangle) same condition	US-PGPUB; USPAT	OR	ON	2015/04/23 13:44
S2112	2863	(wide-angle "wide angle" wideangle) same condition same (focal near3 length)	US-PGPUB; USPAT	OR	ON	2015/04/23 13:44
S2113	2619	(focal near3 length near3 first adj lens adj4 group)	US-PGPUB; USPAT	OR	ON	2015/04/23 13:44
S2114	7129	(focal near3 length near3 first adj lens)	US-PGPUB; USPAT	OR	ON	2015/04/23 13:44
S2115	2619	S2113 with S2114	US-PGPUB; USPAT	OR	ON	2015/04/23 13:44
S2116	288	359/773.ccls.	US-PGPUB; USPAT	OR	ON	2015/04/23 13:44
S2117	12354	(first near3 lens near5 positive)	US-PGPUB; USPAT	OR	ON	2015/04/23 13:44
S2118	10143	(third near3 lens near5 positive)	US-PGPUB; USPAT	OR	ON	2015/04/23 13:44
S2119	11978	(second near3 lens near5 negative)	US-PGPUB; USPAT	OR	ON	2015/04/23 13:44
S2120	5982	(fourth near3 lens near5 negative)	US-PGPUB; USPAT	OR	ON	2015/04/23 13:44
S2121	4793	S2117 and S2118 and S2119 and S2120	US-PGPUB; USPAT	OR	ON	2015/04/23 13:44
S2122	2619	(focal near3 length near3 first adj lens adj4 group)	US-PGPUB; USPAT	OR	ON	2015/04/23 13:44

S2123	7129	(focal near3 length near3 first adj lens)	US-PGPUB; USPAT	OR	ON	2015/04/23 13:44
S2124	2619	S2122 and S2123	US-PGPUB; USPAT	OR	ON	2015/04/23 13:44
S2125	15	S2124 and S2116	US-PGPUB; USPAT	OR	ON	2015/04/23 13:44
S2126	273	S2116 not S2125	US-PGPUB; USPAT	OR	ON	2015/04/23 13:44
S2127	3207	(focal near3 length near10 zoom near10 (telephoto tele-photo))	US-PGPUB; USPAT	OR	ON	2015/04/23 13:44
S2128	170	f1/ft	US-PGPUB; USPAT	OR	ON	2015/04/23 13:44
S2129	556	f1/f	US-PGPUB; USPAT	OR	ON	2015/04/23 13:44
S2130	557	f/f1	US-PGPUB; USPAT	OR	ON	2015/04/23 13:44
S2131	1224	359/687.ccls.	US-PGPUB; USPAT	OR	ON	2015/04/23 13:44
S2132	111	359/715.ccls. and @pd>="20140311"	US-PGPUB; USPAT	OR	ON	2015/04/23 13:44
S2133	7328	(second near4 lens) same positive same concave	US-PGPUB; USPAT	OR	ON	2015/04/23 13:44
S2134	1885	(second near4 lens) same positive same concave same aspheric	US-PGPUB; USPAT	OR	ON	2015/04/23 13:44
S2135	1885	S2133 and S2134	US-PGPUB; USPAT	OR	ON	2015/04/23 13:44
S2136	130	(first near3 lens) near10 positive near10 paraxial.clm.	US-PGPUB; USPAT	OR	ON	2015/04/23 13:44
S2137	1786	(second near3 lens) near10 positive near10 convex.clm.	US-PGPUB; USPAT	OR	ON	2015/04/23 13:44
S2138	967	(third near3 lens) near10 negative near10 convex.clm.	US-PGPUB; USPAT	OR	ON	2015/04/23 13:44
S2139	1978	(fourth near3 lens) near10 convex.clm.	US-PGPUB; USPAT	OR	ON	2015/04/23 13:44
S2140	1925	(third near4 lens) same positive same convex same aspheric	US-PGPUB; USPAT	OR	ON	2015/04/23 13:44
S2141	1511	(fourth near4 lens) same negative same convex same aspheric	US-PGPUB; USPAT	OR	ON	2015/04/23 13:44
S2142	1132	S2133 and S2134 and S2140 and S2141	US-PGPUB; USPAT	OR	ON	2015/04/23 13:44
S2143	1114	S2142 and (diaphragm aperture stop)	US-PGPUB; USPAT	OR	ON	2015/04/23 13:44
S2144	637	359/715.ccls.	US-PGPUB; USPAT	OR	ON	2015/04/23 13:44
S2145	5423	(first near3 lens near3 group) near5 positive	US-PGPUB; USPAT	OR	ON	2015/04/23 13:44
S2146	5244	(second near3 lens near3 group) near5 negative	US-PGPUB; USPAT	OR	ON	2015/04/23 13:44
S2147	4562	(third near3 lens near3 group) near5 positive	US-PGPUB; USPAT	OR	ON	2015/04/23 13:44
S2148	2323	(fourth near3 lens near3 group) near5 negative	US-PGPUB; USPAT	OR	ON	2015/04/23 13:44
S2149	1481	(fifth near3 lens near3 group) near5 positive	US-PGPUB; USPAT	OR	ON	2015/04/23 13:44

S2150	29778	aperture near3 stop	US-PGPUB; USPAT	OR	ON	2015/04/23 13:44
S2151	555	S2145 and S2146 and S2147 and S2148 and S2149 and S2150	US-PGPUB; USPAT	OR	ON	2015/04/23 13:44
S2152	1427	359/649-652.ccls.	US-PGPUB; USPAT	OR	ON	2015/04/23 13:44
S2153	7328	(second near4 lens) same positive same concave	US-PGPUB; USPAT	OR	ON	2015/04/23 13:44
S2154	1885	(second near4 lens) same positive same concave same aspheric	US-PGPUB; USPAT	OR	ON	2015/04/23 13:44
S2155	1885	S2153 and S2154	US-PGPUB; USPAT	OR	ON	2015/04/23 13:44
S2156	466	359/717.ccls.	US-PGPUB; USPAT	OR	ON	2015/04/23 13:44
S2157	738	((second near4 lens) near20 positive near20 concave near20 aspheric)	US-PGPUB; USPAT	OR	ON	2015/04/23 13:44
S2158	738	S2157 and S2154	US-PGPUB; USPAT	OR	ON	2015/04/23 13:44
S2159	728	S2158 and (diaphragm aperture stop)	US-PGPUB; USPAT	OR	ON	2015/04/23 13:44
S2160	12704	(second near3 lens) near5 positive	US-PGPUB; USPAT	OR	ON	2015/04/23 13:44
S2161	10143	(third near3 lens) near5 positive	US-PGPUB; USPAT	OR	ON	2015/04/23 13:44
S2162	4245	(fifth near3 lens) near5 positive	US-PGPUB; USPAT	OR	ON	2015/04/23 13:44
S2163	2874	(fifth near3 lens) near9 convex	US-PGPUB; USPAT	OR	ON	2015/04/23 13:44
S2164	1193	(sixth near3 lens) near10 concave	US-PGPUB; USPAT	OR	ON	2015/04/23 13:44
S2165	1126	(fifth near3 lens) near10 aspheric	US-PGPUB; USPAT	OR	ON	2015/04/23 13:44
S2166	201	S2160 and S2161 and S2162 and S2163 and S2164 and S2165	US-PGPUB; USPAT	OR	ON	2015/04/23 13:44
S2167	590	359/714.ccls.	US-PGPUB; USPAT	OR	ON	2015/04/23 13:44
S2168	956	(G02B13/0045).CPC.	US-PGPUB; USPAT	OR	ON	2015/04/23 13:44
S2169	10098	(first near3 lens) near5 negative	US-PGPUB; USPAT	OR	ON	2015/04/23 13:44
S2170	9511	(second near3 lens) near5 convex	US-PGPUB; USPAT	OR	ON	2015/04/23 13:44
S2171	3484	(third near3 lens) near5 concave	US-PGPUB; USPAT	OR	ON	2015/04/23 13:44
S2172	3470	(fourth near3 lens) near5 convex	US-PGPUB; USPAT	OR	ON	2015/04/23 13:44
S2173	1523	(fifth near3 lens) near5 concave	US-PGPUB; USPAT	OR	ON	2015/04/23 13:44
S2174	404	S2169 and S2170 and S2171 and S2172 and S2173	US-PGPUB; USPAT	OR	ON	2015/04/23 13:44
S2175	26472	lens near3 barrel	US-PGPUB; USPAT	OR	ON	2015/04/23 13:44
S2176	10098	(first near3 lens) near5 negative	US-PGPUB;	OR	ON	2015/04/23

			USPAT			13:44
S2177	9511	(second near3 lens) near5 convex	US-PGPUB; USPAT	OR	ON	2015/04/23 13:44
S2178	3484	(third near3 lens) near5 concave	US-PGPUB; USPAT	OR	ON	2015/04/23 13:44
S2179	3470	(fourth near3 lens) near5 convex	US-PGPUB; USPAT	OR	ON	2015/04/23 13:44
S2180	1523	(fifth near3 lens) near5 concave	US-PGPUB; USPAT	OR	ON	2015/04/23 13:44
S2181	404	S2176 and S2177 and S2178 and S2179 and S2180	US-PGPUB; USPAT	OR	ON	2015/04/23 13:44
S2182	27926	lens near3 housing	US-PGPUB; USPAT	OR	ON	2015/04/23 13:44
S2183	8448	(first near3 lens) near5 negative	FPRS; EPO; JPO; DERWENT	OR	ON	2015/04/23 13:44
S2184	4321	(second near3 lens) near5 convex	FPRS; EPO; JPO; DERWENT	OR	ON	2015/04/23 13:44
S2185	1863	(third near3 lens) near5 concave	FPRS; EPO; JPO; DERWENT	OR	ON	2015/04/23 13:44
S2186	1527	(fourth near3 lens) near5 convex	FPRS; EPO; JPO; DERWENT	OR	ON	2015/04/23 13:44
S2187	819	(fifth near3 lens) near5 concave	FPRS; EPO; JPO; DERWENT	OR	ON	2015/04/23 13:44
S2188	29	S2183 and S2184 and S2185 and S2186 and S2187	FPRS; EPO; JPO; DERWENT	OR	ON	2015/04/23 13:44
S2189	6143	(first near3 lens) near5 negative.clm.	US-PGPUB; USPAT	OR	ON	2015/04/23 13:44
S2232	1	("20120087020").PN.	US-PGPUB; USPAT; USOCR	OR	OFF	2015/04/23 19:22
S2233	0	("(firstnear3lens)withpositive").PN.	US-PGPUB; USPAT; USOCR	OR	OFF	2015/04/23 20:13
S2234	15016	(first near3 lens) with positive	US-PGPUB; USPAT	OR	ON	2015/04/23 20:13
S2235	13134	(first near3 lens) near7 positive	US-PGPUB; USPAT	OR	ON	2015/04/23 20:13
S2236	6107	(third near3 lens) near7 convex	US-PGPUB; USPAT	OR	ON	2015/04/23 20:14
S2237	3996	(fifth near3 lens) near7 negative	US-PGPUB; USPAT	OR	ON	2015/04/23 20:19
S2238	1907	S2235 and S2236 and S2237	US-PGPUB; USPAT	OR	ON	2015/04/23 20:19
S2239	557	f/f1	US-PGPUB; USPAT	OR	ON	2015/04/23 20:19
S2240	86	S2238 and S2239	US-PGPUB; USPAT	OR	ON	2015/04/23 20:19
S2241	3	("20130033765"   "8310768"   "20120087020").PN.	US-PGPUB; USPAT	OR	ON	2015/04/23 20:58

S2242	25	("20100253829"   "20110310494"   "7365920"   "7643225").PN. OR ("8310768").URPN.	US-PGPUB; USPAT; USOCR	OR	ON	2015/04/24 07:41
S2243	1	"14226172"	US-PGPUB; USPAT; USOCR	OR	ON	2015/04/26 09:00
S2244	13169	(first near3 lens) near7 positive	US-PGPUB; USPAT	OR	ON	2015/05/04 12:19
S2245	11208	(second near lens) near7 negative	US-PGPUB; USPAT	OR	ON	2015/05/04 12:20
S2246	10482	(third near3 lens) near7 positive	US-PGPUB; USPAT	OR	ON	2015/05/04 12:20
S2247	8392	(fourth near3 lens) near7 (positive negative)	US-PGPUB; USPAT	OR	ON	2015/05/04 12:20
S2248	3310	(fourth near3 lens near3 group) near7 (positive negative)	US-PGPUB; USPAT	OR	ON	2015/05/04 12:20
S2249	5885	(first near3 lens near3 group) near7 positive	US-PGPUB; USPAT	OR	ON	2015/05/04 12:20
S2250	2759	S2245 and S2246 and S2248 and S2249	US-PGPUB; USPAT	OR	ON	2015/05/04 12:21
S2251	1226	359/687.ccls.	US-PGPUB; USPAT	OR	ON	2015/05/04 12:21
S2252	470	359/773,774.ccls.	US-PGPUB; USPAT	OR	ON	2015/05/04 12:22
S2253	601	S2250 and S2251	US-PGPUB; USPAT	OR	ON	2015/05/04 12:22
S2254	83	S2250 and S2252	US-PGPUB; USPAT	OR	ON	2015/05/04 12:22
S2255	7660	camera near3 (shake vibrate)	US-PGPUB; USPAT	OR	ON	2015/05/04 12:34
S2256	80	S2254 and "14"	US-PGPUB; USPAT	OR	ON	2015/05/04 12:34
S2257	15	S2254 and S2255	US-PGPUB; USPAT	OR	ON	2015/05/04 12:34
S2258	2673	correct\$3 near4 image near5 shake	US-PGPUB; USPAT	OR	ON	2015/05/04 12:39
S2259	2002	(third near3 lens near3 group) near7 fixed	US-PGPUB; USPAT	OR	ON	2015/05/04 12:44
S2260	3906	lens same moving same perpendicular same (optical adj axis)	US-PGPUB; USPAT	OR	ON	2015/05/04 12:45
S2261	91	S2258 and S2259 and S2260	US-PGPUB; USPAT	OR	ON	2015/05/04 12:45
S2262	76	S2255 and S2261	US-PGPUB; USPAT	OR	ON	2015/05/04 12:45
S2263	45	S2250 and S2262	US-PGPUB; USPAT	OR	ON	2015/05/04 12:46
S2264	3164	first near3 lens near group near3 positive.clm.	US-PGPUB; USPAT	OR	ON	2015/05/04 12:47
S2265	2869	third near3 lens near group near3 positive.clm.	US-PGPUB; USPAT	OR	ON	2015/05/04 12:47
S2266	1795	fourth near3 lens near group near3 positive.clm.	US-PGPUB; USPAT	OR	ON	2015/05/04 12:47
S2267	828	camera near3 shake.clm.	US-PGPUB;	OR	ON	2015/05/04

			USPAT			12:47
S2268	21	S2264 and S2265 and S2266 and S2267	US-PGPUB; USPAT	OR	ON	2015/05/04 12:47
S2269	1	("6650475").PN.	US-PGPUB; USPAT	OR	ON	2015/05/04 13:08
S2270	3537	(G02B15/173 OR G02B9/34).CPC.	US-PGPUB; USPAT	OR	ON	2015/05/04 13:16
S2271	0	Daki near3 Kawamura.inv.	US-PGPUB; USPAT	OR	ON	2015/05/04 13:19
S2277	24041	(first near3 lens) near5 positive	US-PGPUB; USPAT; FPRS; EPO; JPO; DERWENT	OR	ON	2015/05/04 14:09
S2278	20786	(third near3 lens) near5 positive	US-PGPUB; USPAT; FPRS; EPO; JPO; DERWENT	OR	ON	2015/05/04 14:10
S2279	24346	(second near3 lens) near5 negative	US-PGPUB; USPAT; FPRS; EPO; JPO; DERWENT	OR	ON	2015/05/04 14:10
S2280	0	(fourth near3 lens) near5 meniscus	US-PGPUB; USPAT; FPRS; EPO; JPO; DERWENT	OR	ON	2015/05/04 14:10
S2281	2248	(fourth near3 lens) near7 aspheric	US-PGPUB; USPAT; FPRS; EPO; JPO; DERWENT	OR	ON	2015/05/04 14:11
S2282	482	(fourth near3 lens) near7 aspheric near7 convex	US-PGPUB; USPAT; FPRS; EPO; JPO; DERWENT	OR	ON	2015/05/04 14:11
S2283	309	(fifth near3 lens) near7 aspheric near7 concave	US-PGPUB; USPAT; FPRS; EPO; JPO; DERWENT	OR	ON	2015/05/04 14:11
S2284	141	S2282 and S2283	US-PGPUB; USPAT; FPRS; EPO; JPO; DERWENT	OR	ON	2015/05/04 14:11
S2285	3	("20120019706").PN.	US-PGPUB; USPAT; FPRS; EPO; JPO; DERWENT	OR	ON	2015/05/04 14:12
S2286	88	S2284 and S2277 and S2278 and S2279	US-PGPUB; USPAT; FPRS; EPO; JPO; DERWENT	OR	ON	2015/05/04 14:16

S2287	1	"14242967"	US-PGPUB; USPAT; FPRS; EPO; JPO; DERWENT	OR	ON	2015/05/04 14:22
S2288	899	359/714.ccls.	US-PGPUB; USPAT; FPRS; EPO; JPO; DERWENT	OR	ON	2015/05/04 14:47
S2289	2741	(G02B13/0045 OR G02B9/60).CPC.	US-PGPUB; USPAT; FPRS; EPO; JPO; DERWENT	OR	ON	2015/05/04 14:47
S2290	354	masaya near3 hashimoto.inv.	US-PGPUB; USPAT; FPRS; EPO; JPO; DERWENT	OR	ON	2015/05/04 14:51
S2291	8558	(first near3 lens) near5 positive.clm.	US-PGPUB; USPAT; FPRS; EPO; JPO; DERWENT	OR	ON	2015/05/04 14:51
S2292	7046	(third near3 lens) near5 positive.clm.	US-PGPUB; USPAT; FPRS; EPO; JPO; DERWENT	OR	ON	2015/05/04 14:51
S2293	8082	(second near3 lens) near5 negative.clm.	US-PGPUB; USPAT; FPRS; EPO; JPO; DERWENT	OR	ON	2015/05/04 14:51
S2294	77	(fourth near3 lens) near7 aspheric near7 convex.clm.	US-PGPUB; USPAT; FPRS; EPO; JPO; DERWENT	OR	ON	2015/05/04 14:51
S2295	51	(fifth near3 lens) near7 aspheric near7 concave.clm.	US-PGPUB; USPAT; FPRS; EPO; JPO; DERWENT	OR	ON	2015/05/04 14:51
S2296	8	S2291 and S2292 and S2293 and S2294 and S2295	US-PGPUB; USPAT; FPRS; EPO; JPO; DERWENT	OR	ON	2015/05/04 14:52
S2297	1	("20130044381").FN.	US-PGPUB; USPAT; USOCR	OR	OFF	2015/05/05 11:31
S2298	6	359/717.ccls. and &pd>="20150109"	US-PGPUB; USPAT	OR	ON	2015/05/06 18:02
S2299	3279	((first near3 lens) near5 positive near7 convex)	US-PGPUB; USPAT	OR	ON	2015/05/06 18:12
S2300	3217	((second near3 lens) near5 positive near7 convex)	US-PGPUB; USPAT	OR	ON	2015/05/06 18:12



S2301	1944	((third near3 lens) near5 negative near7 convex)	US-PGPUB; USPAT	OR	ON	2015/05/06 18:13
S2303	3440	((second near3 lens) near5 positive same (convex and concave))	US-PGPUB; USPAT	OR	ON	2015/05/06 18:14
S2304	2758	((fourth near3 lens) near5 positive same concave)	US-PGPUB; USPAT	OR	ON	2015/05/06 18:15
S2305	1447	S2303 and S2304	US-PGPUB; USPAT	OR	ON	2015/05/06 18:15
S2306	467	359/717.ccls.	US-PGPUB; USPAT	OR	ON	2015/05/06 18:15
S2307	25	S2305 and S2306	US-PGPUB; USPAT	OR	ON	2015/05/06 18:15

## EAST Search History (Interference)

Ref #	Hits	Search Query	DBs	Default Operator	Plurals	Time Stamp
L10	1878	((first near3 lens) near5 positive near7 convex)	USPAT; UPAD	OR	ON	2015/05/07 09:31
L11	1878	((first near3 lens) near5 positive near7 convex)	USPAT; UPAD	OR	ON	2015/05/07 09:31
L12	1878	((first near3 lens) near5 positive near7 convex)	USPAT; UPAD	OR	ON	2015/05/07 09:31
L13	1881	((second near3 lens) near5 positive near7 convex)	USPAT; UPAD	OR	ON	2015/05/07 09:31
L14	1555	((fourth near3 lens) near5 positive same concave)	USPAT; UPAD	OR	ON	2015/05/07 09:31
L15	132575	diaphragm	USPAT; UPAD	OR	ON	2015/05/07 09:31
L16	38520	maximum near3 angle	USPAT; UPAD	OR	ON	2015/05/07 09:31
L17	61120	focal near3 length	USPAT; UPAD	OR	ON	2015/05/07 09:31
L18	17	12 and 13 and 14 and 15 and 16 and 17	USPAT; UPAD	OR	ON	2015/05/07 09:33
S375	5769	(first near3 lens) near5 negative	USPAT; UPAD	OR	ON	2014/12/01 11:47
S376	5200	(second near3 lens) near5 convex	USPAT; UPAD	OR	ON	2014/12/01 11:47
S377	2708	(third near3 lens) near5 convex	USPAT; UPAD	OR	ON	2014/12/01 11:47
S378	1808	(fourth near3 lens) near5 convex	USPAT; UPAD	OR	ON	2014/12/01 11:47
S379	337	(fifth near3 lens) near10 plastic	USPAT; UPAD	OR	ON	2014/12/01 11:47
S380	82743	distance near10 image	USPAT; UPAD	OR	ON	2014/12/01 11:47
S382	7219	(second near3 lens) near5 positive	USPAT; UPAD	OR	ON	2014/12/01 11:47
S383	5675	(third near3 lens) near5 positive	USPAT; UPAD	OR	ON	2014/12/01 11:47
S384	2186	(fifth near3 lens) near5 positive	USPAT; UPAD	OR	ON	2014/12/01 11:47
S385	1424	(fifth near3 lens) near9 convex	USPAT;	OR	ON	2014/12/01

			UPAD			11:47
S386	396	(fifth near3 lens) near5 aspheric	USPAT; UPAD	OR	ON	2014/12/01 11:47
S387	12773	(inflection near2 point)	USPAT; UPAD	OR	ON	2014/12/01 11:47
S647	1663	first near3 lens near3 unit near5 positive	USPAT; UPAD	OR	ON	2015/01/10 11:17
S648	1643	second near3 lens near3 unit near5 negative	USPAT; UPAD	OR	ON	2015/01/10 11:17
S649	4765	reflecting near3 unit	USPAT; UPAD	OR	ON	2015/01/10 11:17
S650	2549	rear near3 lens near3 group	USPAT; UPAD	OR	ON	2015/01/10 11:17
S1027	5833	(first near3 lens) near5 negative	USPAT; UPAD	OR	ON	2015/02/05 13:38
S1028	5265	(second near3 lens) near5 convex	USPAT; UPAD	OR	ON	2015/02/05 13:38
S1029	2760	(third near3 lens) near5 convex	USPAT; UPAD	OR	ON	2015/02/05 13:38
S1030	1845	(fourth near3 lens) near5 convex	USPAT; UPAD	OR	ON	2015/02/05 13:38
S1031	358	(fifth near3 lens) near10 plastic	USPAT; UPAD	OR	ON	2015/02/05 13:38
S1032	84112	distance near10 image	USPAT; UPAD	OR	ON	2015/02/05 13:38
S1034	7304	(second near3 lens) near5 positive	USPAT; UPAD	OR	ON	2015/02/05 13:38
S1035	5753	(third near3 lens) near5 positive	USPAT; UPAD	OR	ON	2015/02/05 13:38
S1036	2226	(fifth near3 lens) near5 positive	USPAT; UPAD	OR	ON	2015/02/05 13:38
S1037	1459	(fifth near3 lens) near9 convex	USPAT; UPAD	OR	ON	2015/02/05 13:38
S1038	414	(fifth near3 lens) near5 aspheric	USPAT; UPAD	OR	ON	2015/02/05 13:38
S1039	12971	(inflection near2 point)	USPAT; UPAD	OR	ON	2015/02/05 13:38
S1042	7945	((first near3 lens) near10 positive)	USPAT; UPAD	OR	ON	2015/02/05 13:38
S1043	7911	(second near3 lens) near10 positive	USPAT; UPAD	OR	ON	2015/02/05 13:38
S1044	6123	third near3 lens near10 positive	USPAT; UPAD	OR	ON	2015/02/05 13:38
S1045	505	paraxial near3 region	USPAT; UPAD	OR	ON	2015/02/05 13:38
S1046	4102	fourth near3 lens near10 negative	USPAT; UPAD	OR	ON	2015/02/05 13:38
S1047	12222	aspheric	USPAT; UPAD	OR	ON	2015/02/05 13:38
S1057	679	fixing near3 diaphragm	USPAT; UPAD	OR	ON	2015/02/05 14:00
S1058	39988	optical near3 set	USPAT; UPAD	OR	ON	2015/02/05 14:00
S1059	64927	first near3 lens	USPAT;	OR	ON	2015/02/05

			UPAD			14:00
S1060	59898	second near3 lens	USPAT; UPAD	OR	ON	2015/02/05 14:00
S1061	21737	third near3 lens	USPAT; UPAD	OR	ON	2015/02/05 14:00
S1062	12320	fourth near3 lens	USPAT; UPAD	OR	ON	2015/02/05 14:00
S1063	82891	convex near3 surface	USPAT; UPAD	OR	ON	2015/02/05 14:00
S2191	5927	(first near3 lens) near5 negative	USPAT; UPAD	OR	ON	2015/04/23 13:43
S2192	5380	(second near3 lens) near5 convex	USPAT; UPAD	OR	ON	2015/04/23 13:43
S2193	2816	(third near3 lens) near5 convex	USPAT; UPAD	OR	ON	2015/04/23 13:43
S2194	1889	(fourth near3 lens) near5 convex	USPAT; UPAD	OR	ON	2015/04/23 13:43
S2195	378	(fifth near3 lens) near10 plastic	USPAT; UPAD	OR	ON	2015/04/23 13:43
S2196	85927	distance near10 image	USPAT; UPAD	OR	ON	2015/04/23 13:43
S2197	7423	(second near3 lens) near5 positive	USPAT; UPAD	OR	ON	2015/04/23 13:43
S2198	5862	(third near3 lens) near5 positive	USPAT; UPAD	OR	ON	2015/04/23 13:43
S2199	2286	(fifth near3 lens) near5 positive	USPAT; UPAD	OR	ON	2015/04/23 13:43
S2200	1504	(fifth near3 lens) near9 convex	USPAT; UPAD	OR	ON	2015/04/23 13:43
S2201	436	(fifth near3 lens) near5 aspheric	USPAT; UPAD	OR	ON	2015/04/23 13:43
S2202	13231	(inflection near2 point)	USPAT; UPAD	OR	ON	2015/04/23 13:43
S2203	1694	first near3 lens near3 unit near5 positive	USPAT; UPAD	OR	ON	2015/04/23 13:43
S2204	1672	second near3 lens near3 unit near5 negative	USPAT; UPAD	OR	ON	2015/04/23 13:43
S2205	4868	reflecting near3 unit	USPAT; UPAD	OR	ON	2015/04/23 13:43
S2206	2575	rear near3 lens near3 group	USPAT; UPAD	OR	ON	2015/04/23 13:43
S2207	5927	(first near3 lens) near5 negative	USPAT; UPAD	OR	ON	2015/04/23 13:44
S2208	5380	(second near3 lens) near5 convex	USPAT; UPAD	OR	ON	2015/04/23 13:44
S2209	2816	(third near3 lens) near5 convex	USPAT; UPAD	OR	ON	2015/04/23 13:44
S2210	1889	(fourth near3 lens) near5 convex	USPAT; UPAD	OR	ON	2015/04/23 13:44
S2211	378	(fifth near3 lens) near10 plastic	USPAT; UPAD	OR	ON	2015/04/23 13:44
S2212	85927	distance near10 image	USPAT; UPAD	OR	ON	2015/04/23 13:44
S2213	7423	(second near3 lens) near5 positive	USPAT;	OR	ON	2015/04/23

			UPAD			13:44
S2214	5862	(third near3 lens) near5 positive	USPAT; UPAD	OR	ON	2015/04/23 13:44
S2215	2286	(fifth near3 lens) near5 positive	USPAT; UPAD	OR	ON	2015/04/23 13:44
S2216	1504	(fifth near3 lens) near9 convex	USPAT; UPAD	OR	ON	2015/04/23 13:44
S2217	436	(fifth near3 lens) near5 aspheric	USPAT; UPAD	OR	ON	2015/04/23 13:44
S2218	13231	(inflection near2 point)	USPAT; UPAD	OR	ON	2015/04/23 13:44
S2219	8072	((first near3 lens) near10 positive)	USPAT; UPAD	OR	ON	2015/04/23 13:44
S2220	8039	(second near3 lens) near10 positive	USPAT; UPAD	OR	ON	2015/04/23 13:44
S2221	6241	third near3 lens near10 positive	USPAT; UPAD	OR	ON	2015/04/23 13:44
S2222	531	paraxial near3 region	USPAT; UPAD	OR	ON	2015/04/23 13:44
S2223	4201	fourth near3 lens near10 negative	USPAT; UPAD	OR	ON	2015/04/23 13:44
S2224	12417	aspheric	USPAT; UPAD	OR	ON	2015/04/23 13:44
S2225	689	fixing near3 diaphragm	USPAT; UPAD	OR	ON	2015/04/23 13:44
S2226	40519	optical near3 set	USPAT; UPAD	OR	ON	2015/04/23 13:44
S2227	65846	first near3 lens	USPAT; UPAD	OR	ON	2015/04/23 13:44
S2228	60721	second near3 lens	USPAT; UPAD	OR	ON	2015/04/23 13:44
S2229	22058	third near3 lens	USPAT; UPAD	OR	ON	2015/04/23 13:44
S2230	12529	fourth near3 lens	USPAT; UPAD	OR	ON	2015/04/23 13:44
S2231	84085	convex near3 surface	USPAT; UPAD	OR	ON	2015/04/23 13:44
S2272	2795	first near3 lens near group near3 positive	USPAT; UPAD	OR	ON	2015/05/04 13:50
S2273	2327	third near3 lens near group near3 positive	USPAT; UPAD	OR	ON	2015/05/04 13:50
S2274	1505	fourth near3 lens near group near3 positive	USPAT; UPAD	OR	ON	2015/05/04 13:50
S2275	3488	camera near3 shake	USPAT; UPAD	OR	ON	2015/05/04 13:50
S2276	138	S2272 and S2273 and S2274 and S2275	USPAT; UPAD	OR	ON	2015/05/04 13:50

5/7/2015 9:33:58 AM

C:\Users\jjones4\Documents\EAST\Workspaces\14175290.wsp

**UNITED STATES PATENT AND TRADEMARK OFFICE**

UNITED STATES DEPARTMENT OF COMMERCE  
**United States Patent and Trademark Office**  
 Address: COMMISSIONER FOR PATENTS  
 P.O. Box 1450  
 Alexandria, Virginia 22313-1450  
 www.uspto.gov

**BIB DATA SHEET**
**CONFIRMATION NO. 9554**

SERIAL NUMBER	FILING or 371(c) DATE	CLASS	GROUP ART UNIT	ATTORNEY DOCKET NO.		
14/141,665	12/27/2013	359	2872	SIIP.201299		
<b>APPLICANTS</b> ABILITY OPTO-ELECTRONICS TECHNOLOGY CO., LTD., Taichung City, TAIWAN, Assignee (with 37 CFR 1.172 Interest);						
<b>INVENTORS</b> Hung-Kuo Yu, Taichung City, TAIWAN; Chao-Hsiang Yang, Taichung City, TAIWAN;						
<b>** CONTINUING DATA *****</b>						
<b>** FOREIGN APPLICATIONS *****</b> TAIWAN 10213525 09/02/2013						
<b>** IF REQUIRED, FOREIGN FILING LICENSE GRANTED **</b> 01/09/2014						
Foreign Priority claimed	<input checked="" type="checkbox"/> Yes <input type="checkbox"/> No	<input type="checkbox"/> Met after Allowance	<b>STATE OR COUNTRY</b>	<b>SHEETS DRAWINGS</b>	<b>TOTAL CLAIMS</b>	<b>INDEPENDENT CLAIMS</b>
35 USC 119(a-d) conditions met	<input checked="" type="checkbox"/> Yes <input type="checkbox"/> No	Initials	TAIWAN	9	7	1
Verified and Acknowledged	/James Jones/ Examiner's Signature					
<b>ADDRESS</b> SHOOK, HARDY & BACON LLP INTELLECTUAL PROPERTY DEPARTMENT 2555 GRAND BLVD KANSAS CITY, MO 64108-2613 UNITED STATES						
<b>TITLE</b> LENS ASSEMBLY						
<b>FILING FEE RECEIVED</b> 1600	FEES: Authority has been given in Paper No. _____ to charge/credit DEPOSIT ACCOUNT No. _____ for following:			<input type="checkbox"/> All Fees <input type="checkbox"/> 1.16 Fees (Filing) <input type="checkbox"/> 1.17 Fees (Processing Ext. of time) <input type="checkbox"/> 1.18 Fees (Issue) <input type="checkbox"/> Other _____ <input type="checkbox"/> Credit		

<b><i>Index of Claims</i></b>  	<b>Application/Control No.</b> 14141665	<b>Applicant(s)/Patent Under Reexamination</b> YU ET AL.
	<b>Examiner</b> JAMES JONES	<b>Art Unit</b> 2872

✓	<b>Rejected</b>
=	<b>Allowed</b>

-	<b>Cancelled</b>
÷	<b>Restricted</b>

N	<b>Non-Elected</b>
I	<b>Interference</b>

A	<b>Appeal</b>
O	<b>Objected</b>

Claims renumbered in the same order as presented by applicant
  CPA
  T.D.
  R.1.47

CLAIM		DATE							
Final	Original	01/09/2015	05/06/2015						
	1	✓	=						
	2	✓	=						
	3	✓	=						
	4	○	=						
	5	○	=						
	6	✓	=						
	7	✓	=						

Receipt date: 04/10/2015

14141665 - GAI: 2872

Doc code: IDS

Doc description: Information Disclosure Statement (IDS) Filed

Approved for use through 07/31/2012. OMB 0651-0031  
U.S. Patent and Trademark Office; U.S. DEPARTMENT OF COMMERCE

Under the Paperwork Reduction Act of 1995, no persons are required to respond to a collection of information unless it contains a valid OMB control number.

<b>INFORMATION DISCLOSURE STATEMENT BY APPLICANT</b> ( Not for submission under 37 CFR 1.99)	Application Number		14141665	
	Filing Date		2013-12-27	
	First Named Inventor	Hung-Kuo YU		
	Art Unit		2872	
	Examiner Name	James Jones		
	Attorney Docket Number		48261.1270	

U.S.PATENTS						
Examiner Initial*	Cite No	Patent Number	Kind Code <sup>1</sup>	Issue Date	Name of Patentee or Applicant of cited Document	Pages,Columns,Lines where Relevant Passages or Relevant Figures Appear
	1	8014080	B1	2011-09-06	Chun Shan CHEN, et al.	

If you wish to add additional U.S. Patent citation information please click the Add button.

U.S.PATENT APPLICATION PUBLICATIONS						
Examiner Initial*	Cite No	Publication Number	Kind Code <sup>1</sup>	Publication Date	Name of Patentee or Applicant of cited Document	Pages,Columns,Lines where Relevant Passages or Relevant Figures Appear
	1	20120044403	A1	2012-02-23	Hsiang-Chi Tang, et al.	
	2	20130070347	A1	2013-03-21	Hsiang-Chi Tang, et al.	

If you wish to add additional U.S. Published Application citation information please click the Add button.

FOREIGN PATENT DOCUMENTS								
Examiner Initial*	Cite No	Foreign Document Number <sup>3</sup>	Country Code <sup>2</sup>	Kind Code <sup>4</sup>	Publication Date	Name of Patentee or Applicant of cited Document	Pages,Columns,Lines where Relevant Passages or Relevant Figures Appear	T <sup>5</sup>
	1	201215941	TW	A1	2012-04-16	Largan Precision Co., Ltd.		<input checked="" type="checkbox"/>

If you wish to add additional Foreign Patent Document citation information please click the Add button

NON-PATENT LITERATURE DOCUMENTS								
---------------------------------	--	--	--	--	--	--	--	--

AOET, Ex. 1004

Page 347

<b>Receipt date: 04/10/2015</b>  <b>INFORMATION DISCLOSURE STATEMENT BY APPLICANT</b> ( Not for submission under 37 CFR 1.99)	Application Number		14141665	14141665 - GAU: 2872
	Filing Date		2013-12-27	
	First Named Inventor	Hung-Kuo YU		
	Art Unit		2872	
	Examiner Name	James Jones		
	Attorney Docket Number		48261.1270	

Examiner Initials*	Cite No	Include name of the author (in CAPITAL LETTERS), title of the article (when appropriate), title of the item (book, magazine, journal, serial, symposium, catalog, etc), date, pages(s), volume-issue number(s), publisher, city and/or country where published.	T <sup>5</sup>
	1		<input type="checkbox"/>

If you wish to add additional non-patent literature document citation information please click the Add button

**EXAMINER SIGNATURE**

Examiner Signature	/James Jones/	Date Considered	05/07/2015
--------------------	---------------	-----------------	------------

\*EXAMINER: Initial if reference considered, whether or not citation is in conformance with MPEP 609. Draw line through a citation if not in conformance and not considered. Include copy of this form with next communication to applicant.

<sup>1</sup> See Kind Codes of USPTO Patent Documents at [www.USPTO.GOV](http://www.USPTO.GOV) or MPEP 901.04. <sup>2</sup> Enter office that issued the document, by the two-letter code (WIPO Standard ST.3). <sup>3</sup> For Japanese patent documents, the indication of the year of the reign of the Emperor must precede the serial number of the patent document. <sup>4</sup> Kind of document by the appropriate symbols as indicated on the document under WIPO Standard ST.16 if possible. <sup>5</sup> Applicant is to place a check mark here if English language translation is attached.



<b>Receipt date: 04/10/2015</b>  <b>INFORMATION DISCLOSURE STATEMENT BY APPLICANT</b> ( Not for submission under 37 CFR 1.99)	Application Number	14141665	14141665 - GAU: 2872
	Filing Date	2013-12-27	
	First Named Inventor	Hung-Kuo YU	
	Art Unit	2872	
	Examiner Name	James Jones	
	Attorney Docket Number	48261.1270	

**CERTIFICATION STATEMENT**

Please see 37 CFR 1.97 and 1.98 to make the appropriate selection(s):

That each item of information contained in the information disclosure statement was first cited in any communication from a foreign patent office in a counterpart foreign application not more than three months prior to the filing of the information disclosure statement. See 37 CFR 1.97(e)(1).

**OR**

That no item of information contained in the information disclosure statement was cited in a communication from a foreign patent office in a counterpart foreign application, and, to the knowledge of the person signing the certification after making reasonable inquiry, no item of information contained in the information disclosure statement was known to any individual designated in 37 CFR 1.56(c) more than three months prior to the filing of the information disclosure statement. See 37 CFR 1.97(e)(2).

- See attached certification statement.
- The fee set forth in 37 CFR 1.17 (p) has been submitted herewith.
- A certification statement is not submitted herewith.

**SIGNATURE**

A signature of the applicant or representative is required in accordance with CFR 1.33, 10.18. Please see CFR 1.4(d) for the form of the signature.

Signature	/Thomas T. Moga/	Date (YYYY-MM-DD)	2015-04-10
Name/Print	Thomas T. Moga	Registration Number	34881

This collection of information is required by 37 CFR 1.97 and 1.98. The information is required to obtain or retain a benefit by the public which is to file (and by the USPTO to process) an application. Confidentiality is governed by 35 U.S.C. 122 and 37 CFR 1.14. This collection is estimated to take 1 hour to complete, including gathering, preparing and submitting the completed application form to the USPTO. Time will vary depending upon the individual case. Any comments on the amount of time you require to complete this form and/or suggestions for reducing this burden, should be sent to the Chief Information Officer, U.S. Patent and Trademark Office, U.S. Department of Commerce, P.O. Box 1450, Alexandria, VA 22313-1450. **DO NOT SEND FEES OR COMPLETED FORMS TO THIS ADDRESS. SEND TO: Commissioner for Patents, P.O. Box 1450, Alexandria, VA 22313-1450.**

**Privacy Act Statement**

The Privacy Act of 1974 (P.L. 93-579) requires that you be given certain information in connection with your submission of the attached form related to a patent application or patent. Accordingly, pursuant to the requirements of the Act, please be advised that: (1) the general authority for the collection of this information is 35 U.S.C. 2(b)(2); (2) furnishing of the information solicited is voluntary; and (3) the principal purpose for which the information is used by the U.S. Patent and Trademark Office is to process and/or examine your submission related to a patent application or patent. If you do not furnish the requested information, the U.S. Patent and Trademark Office may not be able to process and/or examine your submission, which may result in termination of proceedings or abandonment of the application or expiration of the patent.

The information provided by you in this form will be subject to the following routine uses:

1. The information on this form will be treated confidentially to the extent allowed under the Freedom of Information Act (5 U.S.C. 552) and the Privacy Act (5 U.S.C. 552a). Records from this system of records may be disclosed to the Department of Justice to determine whether the Freedom of Information Act requires disclosure of these records.
2. A record from this system of records may be disclosed, as a routine use, in the course of presenting evidence to a court, magistrate, or administrative tribunal, including disclosures to opposing counsel in the course of settlement negotiations.
3. A record in this system of records may be disclosed, as a routine use, to a Member of Congress submitting a request involving an individual, to whom the record pertains, when the individual has requested assistance from the Member with respect to the subject matter of the record.
4. A record in this system of records may be disclosed, as a routine use, to a contractor of the Agency having need for the information in order to perform a contract. Recipients of information shall be required to comply with the requirements of the Privacy Act of 1974, as amended, pursuant to 5 U.S.C. 552a(m).
5. A record related to an International Application filed under the Patent Cooperation Treaty in this system of records may be disclosed, as a routine use, to the International Bureau of the World Intellectual Property Organization, pursuant to the Patent Cooperation Treaty.
6. A record in this system of records may be disclosed, as a routine use, to another federal agency for purposes of National Security review (35 U.S.C. 181) and for review pursuant to the Atomic Energy Act (42 U.S.C. 218(c)).
7. A record from this system of records may be disclosed, as a routine use, to the Administrator, General Services, or his/her designee, during an inspection of records conducted by GSA as part of that agency's responsibility to recommend improvements in records management practices and programs, under authority of 44 U.S.C. 2904 and 2906. Such disclosure shall be made in accordance with the GSA regulations governing inspection of records for this purpose, and any other relevant (i.e., GSA or Commerce) directive. Such disclosure shall not be used to make determinations about individuals.
8. A record from this system of records may be disclosed, as a routine use, to the public after either publication of the application pursuant to 35 U.S.C. 122(b) or issuance of a patent pursuant to 35 U.S.C. 151. Further, a record may be disclosed, subject to the limitations of 37 CFR 1.14, as a routine use, to the public if the record was filed in an application which became abandoned or in which the proceedings were terminated and which application is referenced by either a published application, an application open to public inspections or an issued patent.
9. A record from this system of records may be disclosed, as a routine use, to a Federal, State, or local law enforcement agency, if the USPTO becomes aware of a violation or potential violation of law or regulation.

AOET, Ex. 1004

Page 350

**ALL REFERENCES CONSIDERED EXCEPT WHERE LINED THROUGH. /JJ/**





<b>Issue Classification</b> 	<b>Application/Control No.</b> 14141665	<b>Applicant(s)/Patent Under Reexamination</b> YU ET AL.
	<b>Examiner</b> JAMES JONES	<b>Art Unit</b> 2872

<input checked="" type="checkbox"/> <b>Claims renumbered in the same order as presented by applicant</b> <input type="checkbox"/> <b>CPA</b> <input type="checkbox"/> <b>T.D.</b> <input type="checkbox"/> <b>R.1.47</b>															
Final	Original	Final	Original	Final	Original	Final	Original	Final	Original	Final	Original	Final	Original	Final	Original
	1														
	2														
	3														
	4														
	5														
	6														
	7														

NONE		<b>Total Claims Allowed:</b>	
		7	
(Assistant Examiner)	(Date)	O.G. Print Claim(s)	O.G. Print Figure
/JAMES JONES/ Primary Examiner. Art Unit 2872	05/07/2015	1	1
(Primary Examiner)	(Date)		

<b>Search Notes</b>  	<b>Application/Control No.</b>  14141665	<b>Applicant(s)/Patent Under Reexamination</b>  YU ET AL.
	<b>Examiner</b>  JAMES JONES	<b>Art Unit</b>  2872

CPC- SEARCHED		
Symbol	Date	Examiner
G02B13/0045	5/7/2015	JCJ

CPC COMBINATION SETS - SEARCHED		
Symbol	Date	Examiner

US CLASSIFICATION SEARCHED			
Class	Subclass	Date	Examiner
359	715	5/7/2015	JCJ

SEARCH NOTES		
Search Notes	Date	Examiner
359/715 class search and text search	5/7/2015	JCJ
east text search	5/7/2015	JCJ

INTERFERENCE SEARCH			
US Class/ CPC Symbol	US Subclass / CPC Group	Date	Examiner

	/JAMES JONES/ Primary Examiner. Art Unit 2872	AOET, Ex. 1004 Page 354
--	--	----------------------------



UNITED STATES PATENT AND TRADEMARK OFFICE

UNITED STATES DEPARTMENT OF COMMERCE
United States Patent and Trademark Office
Address: COMMISSIONER FOR PATENTS
P.O. Box 1450
Alexandria, Virginia 22313-1450
www.uspto.gov

Table with 7 columns: APPLICATION NUMBER, FILING or 371(c) DATE, GRP ART UNIT, FIL FEE REC'D, ATTY. DOCKET NO, TOT CLAIMS, IND CLAIMS. Row 1: 14/141,665, 12/27/2013, 2872, 1600, SIIP.201299, 7, 1

CONFIRMATION NO. 9554
CORRECTED FILING RECEIPT

5251
SHOOK, HARDY & BACON LLP
INTELLECTUAL PROPERTY DEPARTMENT
2555 GRAND BLVD
KANSAS CITY, MO 64108-2613



Date Mailed: 06/17/2015

Receipt is acknowledged of this non-provisional patent application. The application will be taken up for examination in due course. Applicant will be notified as to the results of the examination. Any correspondence concerning the application must include the following identification information: the U.S. APPLICATION NUMBER, FILING DATE, NAME OF APPLICANT, and TITLE OF INVENTION. Fees transmitted by check or draft are subject to collection. Please verify the accuracy of the data presented on this receipt. If an error is noted on this Filing Receipt, please submit a written request for a Filing Receipt Correction. Please provide a copy of this Filing Receipt with the changes noted thereon. If you received a "Notice to File Missing Parts" for this application, please submit any corrections to this Filing Receipt with your reply to the Notice. When the USPTO processes the reply to the Notice, the USPTO will generate another Filing Receipt incorporating the requested corrections

Inventor(s)

Hung-Kuo Yu, Taichung City, TAIWAN;
Chao-Hsiang Yang, Taichung City, TAIWAN;

Applicant(s)

ABILITY OPTO-ELECTRONICS TECHNOLOGY CO., LTD., Taichung City, TAIWAN;

Assignment For Published Patent Application

ABILITY OPTO-ELECTRONICS TECHNOLOGY CO., LTD., Taichung City, TAIWAN

Power of Attorney: The patent practitioners associated with Customer Number 05251

Domestic Applications for which benefit is claimed - None.

A proper domestic benefit claim must be provided in an Application Data Sheet in order to constitute a claim for domestic benefit. See 37 CFR 1.76 and 1.78.

Foreign Applications (You may be eligible to benefit from the Patent Prosecution Highway program at the USPTO. Please see http://www.uspto.gov for more information.)

TAIWAN 102131525 09/02/2013

Permission to Access - A proper Authorization to Permit Access to Application by Participating Offices (PTO/SB/39 or its equivalent) has been received by the USPTO.

If Required, Foreign Filing License Granted: 01/09/2014

The country code and number of your priority application, to be used for filing abroad under the Paris Convention, is US 14/141,665

Projected Publication Date: Not Applicable

Non-Publication Request: No

**Early Publication Request: No  
Title**

LENS ASSEMBLY

**Preliminary Class**

359

**Statement under 37 CFR 1.55 or 1.78 for AIA (First Inventor to File) Transition Applications: No**

## **PROTECTING YOUR INVENTION OUTSIDE THE UNITED STATES**

Since the rights granted by a U.S. patent extend only throughout the territory of the United States and have no effect in a foreign country, an inventor who wishes patent protection in another country must apply for a patent in a specific country or in regional patent offices. Applicants may wish to consider the filing of an international application under the Patent Cooperation Treaty (PCT). An international (PCT) application generally has the same effect as a regular national patent application in each PCT-member country. The PCT process **simplifies** the filing of patent applications on the same invention in member countries, but **does not result** in a grant of "an international patent" and does not eliminate the need of applicants to file additional documents and fees in countries where patent protection is desired.

Almost every country has its own patent law, and a person desiring a patent in a particular country must make an application for patent in that country in accordance with its particular laws. Since the laws of many countries differ in various respects from the patent law of the United States, applicants are advised to seek guidance from specific foreign countries to ensure that patent rights are not lost prematurely.

Applicants also are advised that in the case of inventions made in the United States, the Director of the USPTO must issue a license before applicants can apply for a patent in a foreign country. The filing of a U.S. patent application serves as a request for a foreign filing license. The application's filing receipt contains further information and guidance as to the status of applicant's license for foreign filing.

Applicants may wish to consult the USPTO booklet, "General Information Concerning Patents" (specifically, the section entitled "Treaties and Foreign Patents") for more information on timeframes and deadlines for filing foreign patent applications. The guide is available either by contacting the USPTO Contact Center at 800-786-9199, or it can be viewed on the USPTO website at <http://www.uspto.gov/web/offices/pac/doc/general/index.html>.

For information on preventing theft of your intellectual property (patents, trademarks and copyrights), you may wish to consult the U.S. Government website, <http://www.stopfakes.gov>. Part of a Department of Commerce initiative, this website includes self-help "toolkits" giving innovators guidance on how to protect intellectual property in specific countries such as China, Korea and Mexico. For questions regarding patent enforcement issues, applicants may call the U.S. Government hotline at 1-866-999-HALT (1-866-999-4258).



**LICENSE FOR FOREIGN FILING UNDER**  
**Title 35, United States Code, Section 184**  
**Title 37, Code of Federal Regulations, 5.11 & 5.15**

**GRANTED**

The applicant has been granted a license under 35 U.S.C. 184, if the phrase "IF REQUIRED, FOREIGN FILING LICENSE GRANTED" followed by a date appears on this form. Such licenses are issued in all applications where the conditions for issuance of a license have been met, regardless of whether or not a license may be required as set forth in 37 CFR 5.15. The scope and limitations of this license are set forth in 37 CFR 5.15(a) unless an earlier license has been issued under 37 CFR 5.15(b). The license is subject to revocation upon written notification. The date indicated is the effective date of the license, unless an earlier license of similar scope has been granted under 37 CFR 5.13 or 5.14.

This license is to be retained by the licensee and may be used at any time on or after the effective date thereof unless it is revoked. This license is automatically transferred to any related applications(s) filed under 37 CFR 1.53(d). This license is not retroactive.

The grant of a license does not in any way lessen the responsibility of a licensee for the security of the subject matter as imposed by any Government contract or the provisions of existing laws relating to espionage and the national security or the export of technical data. Licensees should apprise themselves of current regulations especially with respect to certain countries, of other agencies, particularly the Office of Defense Trade Controls, Department of State (with respect to Arms, Munitions and Implements of War (22 CFR 121-128)); the Bureau of Industry and Security, Department of Commerce (15 CFR parts 730-774); the Office of Foreign Assets Control, Department of Treasury (31 CFR Parts 500+) and the Department of Energy.

**NOT GRANTED**

No license under 35 U.S.C. 184 has been granted at this time, if the phrase "IF REQUIRED, FOREIGN FILING LICENSE GRANTED" DOES NOT appear on this form. Applicant may still petition for a license under 37 CFR 5.12, if a license is desired before the expiration of 6 months from the filing date of the application. If 6 months has lapsed from the filing date of this application and the licensee has not received any indication of a secrecy order under 35 U.S.C. 181, the licensee may foreign file the application pursuant to 37 CFR 5.15(b).

---

***SelectUSA***

The United States represents the largest, most dynamic marketplace in the world and is an unparalleled location for business investment, innovation, and commercialization of new technologies. The U.S. offers tremendous resources and advantages for those who invest and manufacture goods here. Through SelectUSA, our nation works to promote and facilitate business investment. SelectUSA provides information assistance to the international investor community; serves as an ombudsman for existing and potential investors; advocates on behalf of U.S. cities, states, and regions competing for global investment; and counsels U.S. economic development organizations on investment attraction best practices. To learn more about why the United States is the best country in the world to develop technology, manufacture products, deliver services, and grow your business, visit <http://www.SelectUSA.gov> or call +1-202-482-6800.

**PART B - FEE(S) TRANSMITTAL**

Complete and send this form, together with applicable fee(s), to: **Mail** **Mail Stop ISSUE FEE**  
**Commissioner for Patents**  
**P.O. Box 1450**  
**Alexandria, Virginia 22313-1450**  
**or Fax** **(571)-273-2885**

**INSTRUCTIONS:** This form should be used for transmitting the ISSUE FEE and PUBLICATION FEE (if required). Blocks 1 through 5 should be completed where appropriate. All further correspondence including the Patent, advance orders and notification of maintenance fees will be mailed to the current correspondence address as indicated unless corrected below or directed otherwise in Block 1, by (a) specifying a new correspondence address; and/or (b) indicating a separate "FEE ADDRESS" for maintenance fee notifications.

Note: A certificate of mailing can only be used for domestic mailings of the Fee(s) Transmittal. This certificate cannot be used for any other accompanying papers. Each additional paper, such as an assignment or formal drawing, must have its own certificate of mailing or transmission.

CURRENT CORRESPONDENCE ADDRESS (Note: Use Block 1 for any change of address)

5251 7590 05/01/2015  
**SHOOK, HARDY & BACON LLP**  
**INTELLECTUAL PROPERTY DEPARTMENT**  
**2555 GRAND BLVD**  
**KANSAS CITY, MO 64108-2613**

**Certificate of Mailing or Transmission**

I hereby certify that this Fee(s) Transmittal is being deposited with the United States Postal Service with sufficient postage for first class mail in an envelope addressed to the Mail Stop ISSUE FEE address above, or being facsimile transmitted to the USPTO (571) 273-2885, on the date indicated below.

<b>Sandra M. Lewis</b>	<small>(Depositor's name)</small>
<b>/Sandra M. Lewis/</b>	<small>(Signature)</small>
<b>June 26, 2015</b>	<small>(Date)</small>

APPLICATION NO.	FILING DATE	FIRST NAMED INVENTOR	ATTORNEY DOCKET NO.	CONFIRMATION NO.
14/141,665	12/27/2013	Hung-Kuo Yu	SHIP.201299	9554

TITLE OF INVENTION: LENS ASSEMBLY

APPLN. TYPE	ENTITY STATUS	ISSUE FEE DUE	PUBLICATION FEE DUE	PREV. PAID ISSUE FEE	TOTAL FEE(S) DUE	DATE DUE
nonprovisional	UNDISCOUNTED	\$960	\$0	\$0	\$960	09/01/2015

EXAMINER	ART UNIT	CLASS-SUBCLASS
JONES, JAMES	2872	359-715000

1. Change of correspondence address or indication of "Fee Address" (37 CFR 1.363).

Change of correspondence address (or Change of Correspondence Address form PTO/SB/122) attached.

"Fee Address" indication (or "Fee Address" Indication form PTO/SB/47; Rev 03-02 or more recent) attached. Use of a **Customer Number is required.**

2. For printing on the patent front page, list

(1) The names of up to 3 registered patent attorneys or agents OR, alternatively, 1 LeClairRyan

(2) The name of a single firm (having as a member a registered attorney or agent) and the names of up to 2 registered patent attorneys or agents. If no name is listed, no name will be printed. 2 \_\_\_\_\_

3 \_\_\_\_\_

3. ASSIGNEE NAME AND RESIDENCE DATA TO BE PRINTED ON THE PATENT (print or type)

PLEASE NOTE: Unless an assignee is identified below, no assignee data will appear on the patent. If an assignee is identified below, the document has been filed for recordation as set forth in 37 CFR 3.11. Completion of this form is NOT a substitute for filing an assignment.

(A) NAME OF ASSIGNEE **Ability Opto-Electronics Technology Co., LTD.**

(B) RESIDENCE: (CITY and STATE OR COUNTRY) **Taichung City, Taiwan 42881**

Please check the appropriate assignee category or categories (will not be printed on the patent):  Individual  Corporation or other private group entity  Government

4a. The following fee(s) are submitted:

Issue Fee

Publication Fee (No small entity discount permitted)

Advance Order - # of Copies \_\_\_\_\_

4b. Payment of Fee(s): (Please first reapply any previously paid issue fee shown above)

A check is enclosed.

Payment by credit card. Form PTO-2038 is attached.

The director is hereby authorized to charge the required fee(s), any deficiency, or credits any overpayment, to Deposit Account Number **50-5409** (enclose an extra copy of this form).

5. Change in Entity Status (from status indicated above)

Applicant certifying micro entity status. See 37 CFR 1.29

Applicant asserting small entity status. See 37 CFR 1.27

Applicant changing to regular undiscounted fee status.

NOTE: Absent a valid certification of Micro Entity Status (see forms PTO/SB/15A and 15B), issue fee payment in the micro entity amount will not be accepted at the risk of application abandonment.

NOTE: If the application was previously under micro entity status, checking this box will be taken to be a notification of loss of entitlement to micro entity status.

NOTE: Checking this box will be taken to be a notification of loss of entitlement to small or micro entity status, as applicable.

NOTE: This form must be signed in accordance with 37 CFR 1.31 and 1.33. See 37 CFR 1.4 for signature requirements and certifications.

Authorized Signature /Thomas T. Moga/ Date June 26, 2015

Typed or printed name Thomas T. Moga Registration No. 34,881

## Electronic Patent Application Fee Transmittal

<b>Application Number:</b>	14141665
<b>Filing Date:</b>	27-Dec-2013
<b>Title of Invention:</b>	LENS ASSEMBLY
<b>First Named Inventor/Applicant Name:</b>	Hung-Kuo Yu
<b>Filer:</b>	Thomas Moga/Sandra Lewis
<b>Attorney Docket Number:</b>	SIIP.201299

Filed as Large Entity

**Filing Fees for Utility under 35 USC 111(a)**

Description	Fee Code	Quantity	Amount	Sub-Total in USD(\$)
<b>Basic Filing:</b>				
<b>Pages:</b>				
<b>Claims:</b>				
<b>Miscellaneous-Filing:</b>				
<b>Petition:</b>				
<b>Patent-Appeals-and-Interference:</b>				
<b>Post-Allowance-and-Post-Issuance:</b>				
Utility Appl Issue Fee	1501	1	960	960

Description	Fee Code	Quantity	Amount	Sub-Total in USD(\$)
<b>Extension-of-Time:</b>				
<b>Miscellaneous:</b>				
<b>Total in USD (\$)</b>				<b>960</b>

## Electronic Acknowledgement Receipt

<b>EFS ID:</b>	22752402
<b>Application Number:</b>	14141665
<b>International Application Number:</b>	
<b>Confirmation Number:</b>	9554
<b>Title of Invention:</b>	LENS ASSEMBLY
<b>First Named Inventor/Applicant Name:</b>	Hung-Kuo Yu
<b>Customer Number:</b>	5251
<b>Filer:</b>	Thomas Moga/Sandra Lewis
<b>Filer Authorized By:</b>	Thomas Moga
<b>Attorney Docket Number:</b>	SIIP.201299
<b>Receipt Date:</b>	26-JUN-2015
<b>Filing Date:</b>	27-DEC-2013
<b>Time Stamp:</b>	12:42:25
<b>Application Type:</b>	Utility under 35 USC 111(a)

### Payment information:

Submitted with Payment	yes
Payment Type	Deposit Account
Payment was successfully received in RAM	\$960
RAM confirmation Number	14387
Deposit Account	505409
Authorized User	MOGA, THOMAS T.

The Director of the USPTO is hereby authorized to charge indicated fees and credit any overpayment as follows:

Charge any Additional Fees required under 37 C.F.R. Section 1.21 (Miscellaneous fees and charges)

**File Listing:**

Document Number	Document Description	File Name	File Size(Bytes)/ Message Digest	Multi Part /.zip	Pages (if appl.)
1	Issue Fee Payment (PTO-85B)	482611270IssueFeeTransmittal.pdf	391269 0218c7bb10e365d800b91514e33bb446e0469d4f	no	1

**Warnings:**

**Information:**

2	Fee Worksheet (SB06)	fee-info.pdf	30359 017b39e357528fb0c3d72c2810c8cd24f570ab2e	no	2
---	----------------------	--------------	---	----	---

**Warnings:**

**Information:**

<b>Total Files Size (in bytes):</b>			421628		
-------------------------------------	--	--	--------	--	--

**This Acknowledgement Receipt evidences receipt on the noted date by the USPTO of the indicated documents, characterized by the applicant, and including page counts, where applicable. It serves as evidence of receipt similar to a Post Card, as described in MPEP 503.**

**New Applications Under 35 U.S.C. 111**

**If a new application is being filed and the application includes the necessary components for a filing date (see 37 CFR 1.53(b)-(d) and MPEP 506), a Filing Receipt (37 CFR 1.54) will be issued in due course and the date shown on this Acknowledgement Receipt will establish the filing date of the application.**

**National Stage of an International Application under 35 U.S.C. 371**

**If a timely submission to enter the national stage of an international application is compliant with the conditions of 35 U.S.C. 371 and other applicable requirements a Form PCT/DO/EO/903 indicating acceptance of the application as a national stage submission under 35 U.S.C. 371 will be issued in addition to the Filing Receipt, in due course.**

**New International Application Filed with the USPTO as a Receiving Office**

**If a new international application is being filed and the international application includes the necessary components for an international filing date (see PCT Article 11 and MPEP 1810), a Notification of the International Application Number and of the International Filing Date (Form PCT/RO/105) will be issued in due course, subject to prescriptions concerning national security, and the date shown on this Acknowledgement Receipt will establish the international filing date of the application.**



APPLICATION NO.	ISSUE DATE	PATENT NO.	ATTORNEY DOCKET NO.	CONFIRMATION NO.
14/141,665	08/04/2015	9097860	SIIP.201299	9554

5251                      7590                      07/15/2015  
 SHOOK, HARDY & BACON LLP  
 INTELLECTUAL PROPERTY DEPARTMENT  
 2555 GRAND BLVD  
 KANSAS CITY, MO 64108-2613

### ISSUE NOTIFICATION

The projected patent number and issue date are specified above.

**Determination of Patent Term Adjustment under 35 U.S.C. 154 (b)**  
 (application filed on or after May 29, 2000)

The Patent Term Adjustment is 0 day(s). Any patent to issue from the above-identified application will include an indication of the adjustment on the front page.

If a Continued Prosecution Application (CPA) was filed in the above-identified application, the filing date that determines Patent Term Adjustment is the filing date of the most recent CPA.

Applicant will be able to obtain more detailed information by accessing the Patent Application Information Retrieval (PAIR) WEB site (<http://pair.uspto.gov>).

Any questions regarding the Patent Term Extension or Adjustment determination should be directed to the Office of Patent Legal Administration at (571)-272-7702. Questions relating to issue and publication fee payments should be directed to the Application Assistance Unit (AAU) of the Office of Data Management (ODM) at (571)-272-4200.

APPLICANT(s) (Please see PAIR WEB site <http://pair.uspto.gov> for additional applicants):

ABILITY OPTO-ELECTRONICS TECHNOLOGY CO., LTD., Taichung City, TAIWAN;  
 Hung-Kuo Yu, Taichung City, TAIWAN;  
 Chao-Hsiang Yang, Taichung City, TAIWAN;

The United States represents the largest, most dynamic marketplace in the world and is an unparalleled location for business investment, innovation, and commercialization of new technologies. The USA offers tremendous resources and advantages for those who invest and manufacture goods here. Through SelectUSA, our nation works to encourage and facilitate business investment. To learn more about why the USA is the best country in the world to develop technology, manufacture products, and grow your business, visit [SelectUSA.gov](http://SelectUSA.gov).