

Drug Delivery Technology[®]

May 2009 Vol 9 No 5

www.drugdeliverytech.com

Intelligent TDD Via a Selective Barrier Membrane



PROPERTY OF THE
NATIONAL
LIBRARY OF
MEDICINE

The science & business of drug development in specialty pharma, biotechnology, and drug delivery



Arno Fries, PhD
Drug Delivery of Sensitive Biopharmaceuticals With Prefilled Syringes



Emma A. Durand
Successful, Sustained-Release Using a Selective Charged Barrier Membrane



Cheng-ju Kim, PhD
A New Process Producing Biodegradable Microspheres of Peptide Drugs: Suspension-Encapsulation

IN THIS ISSUE

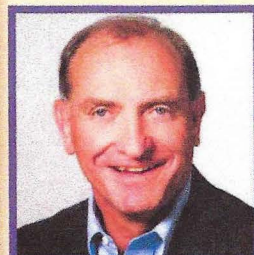

INTERVIEW WITH
SYMIX TECHNOLOGIES'
PRESIDENT

RICHARD BOEHNER

Characterization Services 20
Derek G. Hennecke, MBA

Inhaled Formulations 32
M.W. Samaha, PhD

Biopharmaceutical Development 40
Dave Mead, PhD

Particle Size Distribution 44
Philo Morse, MS

FEATURING

SPECIALTY PHARMA
Strategies For Business Development

Protein/Peptide Manufacturing 66
Cindy H. Dubin

Winning Partnerships 69
Matt Siefert, MBA

Get the most out of your resources with a single outsourcing partner!

Azopharma Product Development Group offers bundled services from key sections of the drug development process including the Preclinical, CMC and Clinical phases that extend your financial resources by maximizing communication and minimizing downtime! Contact Azopharma to develop a comprehensive solution for your product development needs.

AZOPHARMA PRODUCT DEVELOPMENT GROUP OF COMPANIES:

Azopharma™
Contract Pharmaceutical Services

Integrated product development including synthesis, analysis, formulation and CTM manufacturing for all dosage forms

AVIVOCLIN™
Clinical Services

Human clinical pharmacology and monitoring services for Phase I-III clinical trials.

AniClin™
PRECLINICAL SERVICES

Preclinical services in support of early product development.

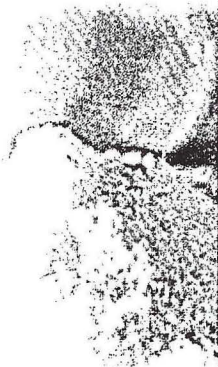

954-241-4340 | development@azopdogroup.com | www.azopdogroup.com/DDT

PUBLISHER/PRESIDENT
Ralph Vitaro

EXECUTIVE EDITORIAL DIRECTOR
Dan Marino, MSc
dmarino@drugdeliverytech.com

CREATIVE DIRECTOR
Shalamar Q. Eagel

CONTROLLER
Debbie Carrillo

CONTRIBUTING EDITORS
Cindy H. Dubin
Debra Bingham
Jason McKinnie

TECHNICAL OPERATIONS
Mark Newland

EDITORIAL SUPPORT
Nicholas D. Vitaro

ADMINISTRATIVE SUPPORT
Kathleen Kenny

Corporate/Editorial Office
219 Changebridge Road, Montville, NJ 07045
Tel: (973)299-1200
Fax: (973) 299-7937
www.drugdeliverytech.com

Advertising Sales Offices

East & Midwest

Victoria Geis - Account Executive
Cheryl S. Stratos - Account Executive
103 Oronoco Street, Suite 200
Alexandria, VA 22314
Tel: (703) 212-7735
Fax: (703) 548-3733
E-mail: vgeis@drugdeliverytech.com
E-mail: cstratos@drugdeliverytech.com

West Coast

Warren De Graff
Western Regional Manager
818 5th Avenue, Suite 301
San Rafael, CA 94901
Tel: (415) 721-0644
Fax: (415) 721-0665
E-mail: wjdegaff@drugdeliverytech.com

International

Ralph Vitaro
219 Changebridge Road
Montville, NJ 07045
Tel: (973) 299-1200
Fax: (973) 299-7937
E-mail: rvitaro@drugdeliverytech.com

Mailing List Rental

Candy Brecht
Tel: (703) 706-0383
Fax: (703) 549-6057
E-mail: cbrecht@mgilists.com

Drug Delivery Technology **FREE** SUBSCRIPTION OFFER

Keep abreast of the marketplace with the industry's only publication entirely devoted to drug delivery and development.

Go to www.drugdeliverytech.com and click on Subscription Services

Once on the website you can also subscribe to our eNewsletter!

For more information contact Ralph Vitaro at 973-299-1200 or e-mail him at rvitaro@drugdeliverytech.com

All editorial submissions are handled with reasonable care, but the publishers assume no responsibility for the safety of artwork, photographs, or manuscripts. Every precaution is taken to ensure accuracy, but publishers cannot accept responsibility for the accuracy of information supplied herein or for any opinion expressed. Drug Delivery Technology (ISSN 1944-818X) is published 10 times in 2009, January, February, March, April, May, June, July/August, September, October, and November/December by Drug Delivery Technology LLC, 219 Changebridge Road, Montville NJ 07045. Subscription rates: \$99.00 for 1 year in the United States, Canada, and Mexico. \$153.00 for 1 year outside the United States, Canada, and Mexico. All subscriptions are payable in US funds, drawn on US banks. Send payment to: Drug Delivery Technology LLC subscription Department, 219 Changebridge Road, Montville NJ 07045. Single copies (prepaid) \$15.00, US, Canada, and Mexico; \$24.00 in all other countries. Add \$5.00 per order for shipping and handling. Periodicals Postage Paid at Montville, NJ 07045-9998 and additional mailing offices. Postmaster: please send address changes to Drug Delivery Technology, 219 Changebridge Road, Montville NJ 07045. All rights reserved under the US International and Pan-American Copyright Conventions. All rights reserved. No part of this publication may be reproduced or transmitted in any form or by any means, electronic or mechanical, including by photocopy, recording, or information storage and retrieval system, without written permission from the publisher. Authorization to photocopy items for internal or personal use, or the internal or personal use of specific clients, is granted by Drug Delivery Technology LLC for libraries and other users registered with the Copyright Clearance, 222 Rosewood Drive, Danvers, MA 01923; phone: (978) 750-8400, fax: (978) 750-4470.

This material was copied at the NLM and may be

Drug Delivery of Sensitive Biopharmaceuticals With Prefilled Syringes

By: Arno Fries, PhD

Recombinant proteins, monoclonal antibodies, and other biopharmaceuticals offer medication for life-threatening diseases. However, these products consist of sensitive molecules. Among the causes for chemical and physical instability are leachables in container closure systems.¹⁻⁵ Interactions of leached contaminants with therapeutic proteins can result in aggregation, particulate formation, and loss of native protein tertiary structures.^{6,7} Even small fractions of aggregated proteins might reduce biological activity and enhance immunogenicity.⁸ For these reasons, strategies to prevent aggregation pathways and monitor aggregate levels in biopharmaceutical formulations are important elements of product development.⁹

BIOMOLECULES RAISE THE BAR

Strength, efficacy, and safety of active molecules are closely related to their chemical and physical properties. Most biopharmaceuticals are more sensitive toward product contact materials from container closure systems than small molecules. The difference can be attributed to several reasons.^{3,10} Biomolecules contain, due to their large size, a high number of functional groups that are prone to react with other compounds. This opens a wide range of pathways for undesirable reactions with leachables. In addition, the stability of biopharmaceutical products hinges on the three-dimensional orientation of the molecules (eg, native folding

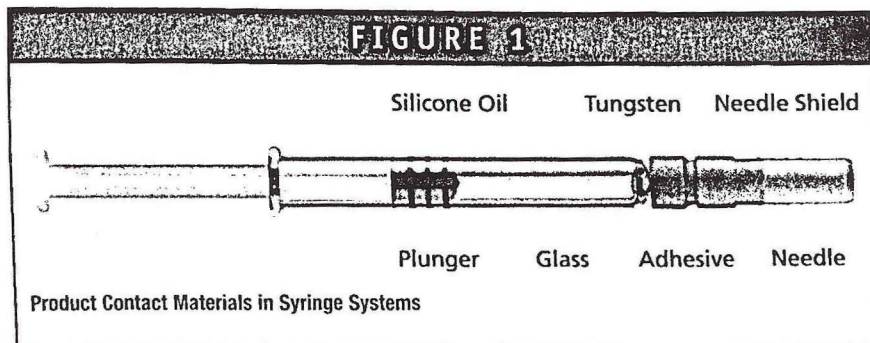

of proteins). Biopharmaceuticals are primarily administered as injectables, and liquid formulations increase the risk posed by leachables. Because these products often contain the active molecule in low concentrations, trace amounts of contaminants might interact with the whole quantity.

PREFILLED SYRINGES

Both for the ultimate end-users and biopharmaceutical companies, prefilled syringes offer advantages over traditional container systems.¹¹⁻¹⁵ Medical staff and patients prefer ready-to-use injection solutions in syringes because they are convenient and prevent medication errors. The industry is utilizing these benefits with life cycle strategies to gain competitive advantages and increase market shares.^{16,17} When molecules are expensive to manufacture, prefilled syringes increase revenues and earnings as they reduce product overfill compared to vials. Due to these benefits, the use of prefilled syringes grows at double-digit rates. The trend is predicted to continue over the coming years.^{18,19} However, for stability reasons, a number of biotherapeutics is

commercialized in vials as lyophilized formulations. This means the advantages of ready-to-use injection solutions in prefilled syringes are not leveraged.

THE PROCESS IS THE PRODUCT

Container closure compatibility is a regulatory requirement to protect the potency, efficacy, and safety of therapeutics. In glass-based syringe systems, a range of materials gets in immediate contact with active ingredients: silicone oil, tungsten, closure, plunger, glass, and (for staked needle syringes) adhesive and needle (Figure 1). The fact that closures are considered product contact materials is reflected by change control procedures in the biopharmaceutical industry. When the rubber formulation of an established needle shield is modified by the supplier, 93.3% of the companies run complete stability studies.²⁰

An evolving trend among biopharmaceutical companies is to enter closer partnerships with syringe suppliers and to scrutinize all aspects of their processes. The paradigm from biopharmaceutical

This material was copied at the NLM and may be

manufacturing, "the process is the product," is being transferred to the production of prefilled syringes. The rationale behind this shift in attention is that all substances used during glass cutting, forming, printing, needle staking, washing, siliconization, assembly, packaging, and sterilization are potential contact materials with sensitive biomolecules. Biopharmaceutical companies want to catalog these materials and understand how syringe suppliers control their processes.

The following outlines recent advances in the field of prefilled syringes. Strategies to mitigate stability risks for sensitive biopharmaceuticals are discussed. Special focus is placed on alkalinity, tungsten, and silicone oil as sources of incompatibilities.

pH RANGE

When sensitive products are applied in glass syringes, the pH value of the formulation needs to be considered.¹⁹ Elevated pH might trigger oxidation and hydrolysis of biopharmaceuticals.

For the production of syringe barrels, glass tubing from Type I borosilicate glass according to USP, EP, and JP is used. Standard glass tubing has an extension coefficient of 51-52 and consists of 70% to 80% SiO₂, 15% B₂O₃/Al₂O₃, and up to 7% Na₂O. The role of sodium is to lower the forming temperatures of glass to 1,000°C to 1,200°C, a prerequisite for industrial converting processes. Glass is a well-characterized material, and Type I borosilicate has excellent hydrolytic resistance.²¹ However, the material is being heated during the syringe manufacturing cycle, and at temperatures above 800°C, sodium cations are migrating from inside the glass barrel to the surface. Each single syringe-forming step increases the quantity of sodium oxide on the glass surface by 15% to 30%.²² When an aqueous formulation is filled and stored in a syringe, sodium cations are being leached from the glass surface into solution. This causes in unbuffered solutions an increase in pH.

How can alkali ion leachables in glass syringes be reduced? The principal strategies are use of glass material with lower sodium content, treatment of the glass surface, and a combination of both. Figure 2 compares analytical results with 1-ml long Luer cone syringes manufactured with these methods.

Syringe barrels from Type I borosilicate glass with extension coefficient 51-52 (EC 51-52) contain on average 2.3 ppm residual sodium oxide on the interior surface. Quantitative analysis is achieved by flame atom emission spectrometry according to ISO 4802-2.²³ When the barrels are manufactured from Type I borosilicate glass of extension coefficient 33 (EC 33), analysis shows a significantly reduced sodium oxide level of 1.2 ppm. This result is in line with data according to EP testing by equivalence titration with 0.01 M hydrochloric acid (EC 33: 0.46 ml HCl, EC 51-52: 0.90 ml HCl) and pH measurement with pH meter (EC 33: pH 6.1, EC 51-52: pH 6.6, aqua bi-dist.: pH 5.5).²⁴ Syringes from EC 33 glass increase the pH value of aqueous solutions by 0.6 units, whereas EC 51-52 glass barrels increase the pH by

1.1 units.²⁵ These data reflect that EC 33 glass tubing contains lower quantities of sodium oxide (4%) than EC 51-52 glass.

Syringe barrels produced from EC 51-52 glass and treated with ammonium sulfate (AST) contain on average 1.0 ppm sodium oxide in accordance to ISO 4802-2 testing. EP titration (AST: 0.44 ml HCl, untreated barrels: 0.90 ml HCl) and pH measurement (AST: pH 6.0, untreated barrels: pH 6.6) confirm this result. The increase in pH of surface-treated barrels is 0.5 units, which is 0.6 units lower than in untreated barrels. For ammonium sulfate treatment, dosing pumps are used to spray an aqueous solution of the agent onto the inner surface of syringe barrels. During the annealing step of the syringe manufacturing process, residual sodium oxide is converted under heat into the much better water-soluble sodium sulfate as follows: Na₂O + (NH₄)₂SO₄ → Na₂SO₄ + 2 NH₃ + H₂O. Removal of sodium sulfate is achieved downstream during washing of the syringe barrels and reduces significantly the amount of alkali ions on the glass surface.

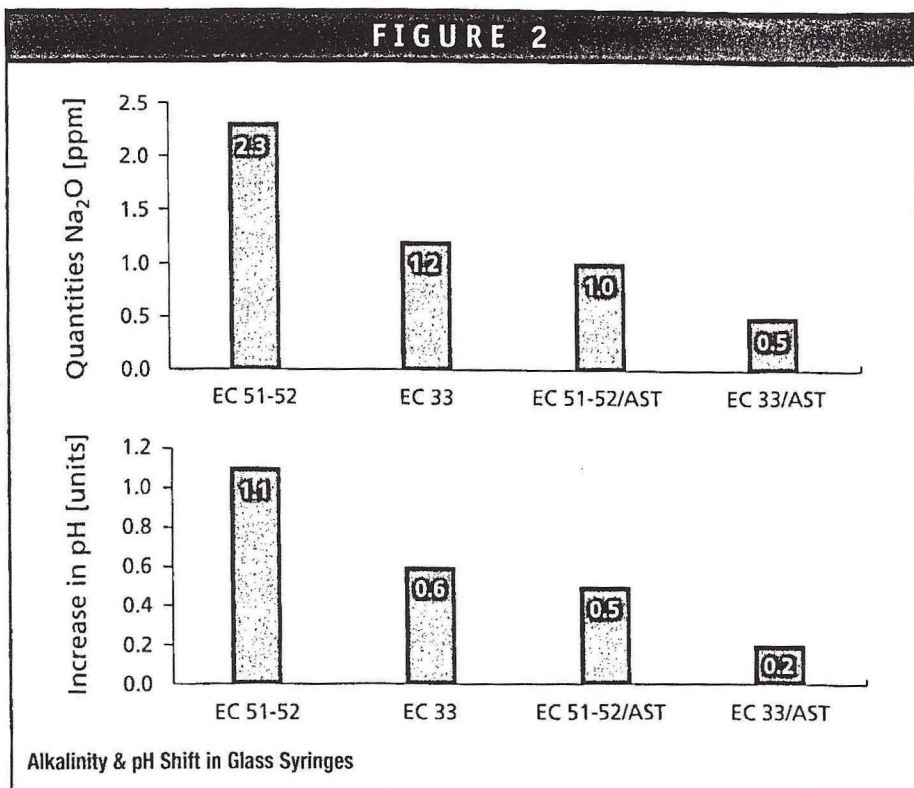

This material was copied at the NLM and may be

Quantitative analysis according to ISO 4802-2 shows that syringes manufactured from EC 33 glass and treated with ammonium sulfate contain merely 0.5 ppm residual sodium oxide on the interior surface. This is 78% lower than in untreated syringes from EC 51-52 glass. The pH of aqueous solutions in barrels from EC 33 tubing that are ammonium sulfate treated increases by 0.2 units, a decrease of 82% compared to standard syringes. The combination of both methods (EC 33 glass and AST) effects the strongest reduction of alkali leachables. This provides an efficient strategy to control alkalinity and pH-related interactions between sensitive biopharmaceuticals and glass-based prefilled syringes.

TUNGSTEN LEACHABLES

Transition metals are known as a cause for instability of sensitive products.¹ Tungsten can undergo interactions with protein therapeutics, leading to oxidation, aggregation, and degradation.²⁶⁻³⁰

In manufacturing processes of glass syringes, tungsten metal is commonly used due to its heat resistance. Pins from this material are keeping the bore open while the cone is being mechanically shaped with forming wheels (Figure 3).

Tungsten is well characterized and stands out among all metals with the highest melting point (3,422°C), the highest tensile strength at elevated temperatures, and the lowest vapor pressure.³¹ Even though tungsten is very wear-resistant, the metal is prone to oxidation under the conditions of syringe forming with temperatures up to 1,250°C. On the surface of tungsten pins, tungsten (IV) oxide (WO₂) can be formed at temperatures under 400°C and tungsten (VI) oxide (WO₃) between 500°C and 800°C. In aqueous solution, tungsten (VI) oxide produces a mixture of soluble mono, oligo, and polytungstates, which are stabilized at low pH.^{32,33} These large anions are highly charged species. They can interact with bipolar protein molecules through electrostatic attraction and induce formation of

colloidal solutions and aggregates.^{32,33} Tungsten compounds can also react with hydrocarbons to organometallic complexes and with molecules containing donor atoms to chelate complexes under formation of O-W-O, O-W-S, O-W-N, S-W-N, and S-W-S bonds. The metal and its compounds are also known as heterogeneous and homogeneous catalysts that convert high quantities of substrates through non-stoichiometric reactions.³⁴ Other metal leachables occasionally found in drug products (eg, Fe³⁺, Ni²⁺, and Mnⁿ⁺ from stainless steel tanks used in manufacturing equipment) are known for similar interactions with active molecules.¹

Prefilled syringes formed with tungsten pins contain trace amounts of tungsten compounds in the cone section, which is part of the product contact surface. Syringe filling processes with plunger placement under vacuum intensify the contact between active molecules and tungsten because air bubbles in the cone of the syringe are pulled out.³⁵

Proprietary methods for the extraction of tungsten from syringe barrels and the subsequent quantitative physicochemical analysis have been developed. Extractable tungsten concentrations are typically below 500 ppb and can be lower than 100 ppb, depending on manufacturing cycle and washing process. Staked needle syringes contain the lowest amount of extractable tungsten as most

of the bore is covered by the needle.

Incorporation of tungsten in syringe barrels can be further reduced by controlling the abrasion of tungsten pins or through substitution of tungsten with other materials. Wear of forming pins can be lowered by horizontal barrel-forming technology. This manufacturing process is using lower temperatures compared to vertical-forming techniques. Other methods are directed at controlling the physical properties of the forming pins. As a substitute for tungsten, alloys from group 9-10 transition metals can be employed. This approach allows tungsten-free syringe forming. However, intake of material from substitute pins into syringe barrels cannot be ruled out. Some biopharmaceutical companies prefer the use of tungsten pins because potential effects of tungsten on their products are better understood than for most other transition metals. Forming pins from non-metallic materials and alternative techniques of syringe forming are at an experimental stage.

To evaluate product stability of biopharmaceutical formulations, spiking studies in early phase development with material extracted from used tungsten (metal) pins are recommended. Subsequent stability studies in prefilled syringes verify the preliminary data and specify accepted tungsten (metal) levels. Advanced manufacturing methods for prefilled syringes together with targeted

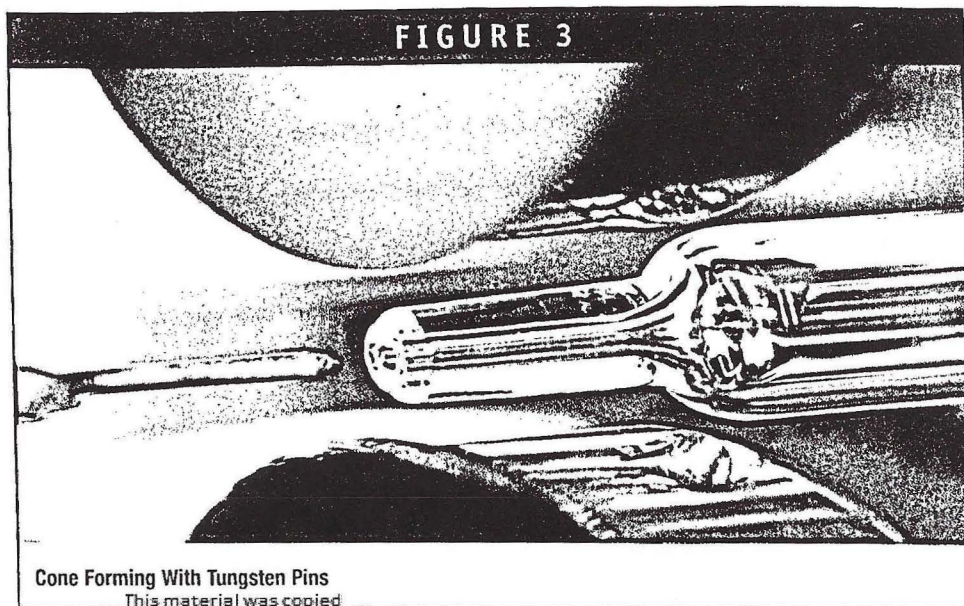

FIGURE 3
Cone Forming With Tungsten Pins
This material was copied

Explore Litigation Insights

Docket Alarm provides insights to develop a more informed litigation strategy and the peace of mind of knowing you're on top of things.

Real-Time Litigation Alerts



Keep your litigation team up-to-date with **real-time alerts** and advanced team management tools built for the enterprise, all while greatly reducing PACER spend.

Our comprehensive service means we can handle Federal, State, and Administrative courts across the country.

Advanced Docket Research



With over 230 million records, Docket Alarm's cloud-native docket research platform finds what other services can't. Coverage includes Federal, State, plus PTAB, TTAB, ITC and NLRB decisions, all in one place.

Identify arguments that have been successful in the past with full text, pinpoint searching. Link to case law cited within any court document via Fastcase.

Analytics At Your Fingertips



Learn what happened the last time a particular judge, opposing counsel or company faced cases similar to yours.

Advanced out-of-the-box PTAB and TTAB analytics are always at your fingertips.

API

Docket Alarm offers a powerful API (application programming interface) to developers that want to integrate case filings into their apps.

LAW FIRMS

Build custom dashboards for your attorneys and clients with live data direct from the court.

Automate many repetitive legal tasks like conflict checks, document management, and marketing.

FINANCIAL INSTITUTIONS

Litigation and bankruptcy checks for companies and debtors.

E-DISCOVERY AND LEGAL VENDORS

Sync your system to PACER to automate legal marketing.