

EP 0 879 611 A2

Example 1 and Comparative Examples 1 and 2

In the following Example and Comparative Examples, a rubber sheet having an excellent gas permeability resistance of Compounding Example 2 in Table 3 was used. According to the compounding formulation, the mixture was kneaded using an open roll, aged for 24 hours and heated to obtain an unvulcanized rubber sheet. The resulting rubber sheet and D-1, D-2 and D-3 films with a thickness of 20 μm, obtained in the foregoing Reference Examples, were placed on a metallic mold for shaping, corresponding to a cross-sectional shape of a stopper shown in Fig. 3 (a), pressing at a mold-fastening pressure of 150 kg/cm² depending on the vulcanization conditions of at 150 to 180 °C, vulcanized for 10 minutes, and the whole body of the rubber stopper was laminated with PTFE or ETFE film to prepare a sealing stopper with a cross-sectional shape as shown in Fig. 3 (a). The size of the sealing stopper was allowed to correspond to that of an injection cylinder used in each test described hereinafter.

Measurement of Sliding Resistance Value

Injection cylinders each having a volume of 5 ml and 100 ml, made of plastic (polypropylene), and sealing stoppers having sizes shown in Table 5, corresponding to these injection cylinders were prepared and each of the sealing stoppers was thrust and set into the injection cylinder. The sealing stopper was slowly thrust therein in such a manner that the end of the sealing stopper reached a position for defining a specified volume, thus preparing a sample injection cylinder. Then, a commercially available disposable injection needle having a determined size was firmly inserted into the end of the sample injection cylinder. Using a commercially available syringe fitted with an injection needle, on the other hand, distilled water with the specified volume of the injection cylinder was charged in the end of the sample injection cylinder, during which care was taken so that air was not allowed to enter therein. The end of the injection cylinder was directed downwards, inserted in a metallic jig and the sealing stopper was thrust into the end side at a rate of 100 mm/sec by a compression test disk of spherical seat type of a pressure sensor-fitted measurement device [Autograph AG-1KND -commercial name- manufactured by Shimazu Seisakujo KK], during which a sliding resistance value was measured. The maximum value was read from the thus resulting sliding measured chart to define this as the sliding resistance value. In general, there was a tendency such that a value at the start of sliding, i.e. static friction resistance value F_s was smaller than a value during sliding (kinematic friction resistance value) F_d. The results are shown in Table 5, from which it is evident that in Comparative Example 3 in which FTFE was laminated, the slidability is too low to measure the sliding resistance value and it is difficult to set in the injection cylinder.

Table 5

		Example 1	Comparative Example 2	3
Injection Cylinder Volume (ml)	Diameter of Sealing Stopper (mm)	PTFE Coated Sealing Stopper by Casting Method	PTFE Coated Sealing Stopper by Skiving Method	ETFE Coated Seal-Stopper by Extrusion Method
5	12.89	21.1 N*	20.4 N	not measurable
100	32.58	68.8 N	59.3 N	not measurable

(Note): * Newton (1 N = 9.8 kg)

Test for Estimation of Sealing Property for Long time

(Alternative Test for Estimation of Presence or Absence of Invasion of Microorganisms)

Using sealing stoppers of Example 1 and Comparative Examples 2 and 3 each having a size corresponding to an injection cylinder with a volume of 5 ml, the following procedure was carried out.

A plastic injection cylinder (volume 5 ml) having a cross-sectional shape shown in Fig. 1 (c) was washed and dried, followed by sealing the end thereof by a rubber cap. Water with a predetermined volume was then poured therein and each of the above described sealing stoppers was slowly inserted into the opening part. In the case of Comparative Example 2, the sealing stopper was forcedly thrust therein. The whole weight (initial weight) of the sample cylinder was precisely weighed and then subjected to storage under an accelerating condition of a temperature of 40 °C and relative humidity of 75 % for at least 6 months, during which every one month, each sample injection cylinder was taken and the surface thereof was dried for 30 minutes in a desiccator, followed by precisely weighing each sample (at least five measurement points). The resulting data of weight change was treated in statistical manner to calculate as a regression function and a numerical value corresponding to three years is extrapolated in the time term to estimate

EP 0 879 611 A2

and assess the sealing property for a long time after formulation of a medicament. In order to correspond to the real formulation, seventy samples were respectively prepared and investigated as to both plunger fitted- and plunger-free sealing stoppers.

A reduction curve Y for the time term X of each sample, $Y = -K + \alpha \ln X$, obtained by the above described statistical procedure can be represented in Example 1, as follows:

When fitting a plunger:

$$Y = -1.896 + 1.087 \times \ln X \tag{a}$$

When not fitting a plunger:

$$Y = -4.200 + 1.594 \times \ln X \tag{b}$$

When into the time term X of the above described regression function formulas (a) and (b) are extrapolated two years (17,520 hours) and three years (26,280 hours) to estimate weight reductions after two years and three years under normal state of water for injection in each sample, the weight reductions are 5.27 mg after two years and 5.71 mg after three years in the case of (a). The reduction ratios when the initial weight is 100 % are 0.11 % in two years and 0.11 % in three years. Similarly, the estimated values of the reduction and reduction ratio in the case of (b) are 6.31 mg and 0.12 % in two years and 6.96 mg and 0.13 % in three years.

The similar procedure to that of Example 1 was also carried out as to Comparative Example 1 (D-2) and Comparative Example 2 (D-3) to obtain reduction curves, and reductions and reduction ratios after two years and three years, obtained by extrapolation of the reduction curves. The results are shown in Table 6.

As shown in Table 6, the sealing property of the film (ETFE) of D-3 is more excellent, but the sealing stopper of Comparative Example 2 having this film laminated is inferior in slidability between the film and inner wall of the injection cylinder because of much higher sliding resistance so that it cannot be put to practical use. Even when using the same PTFE film, Example 1, in which the film by the casting method was laminated, is more excellent in slidable property and sealing property than Comparative Example 1, in which the film by the skiving method was laminated.

Table 6

Example	Laminated Resin (Reference Example) : Production Process	Plunger	Reduction Curve (Regression Function) $Y = -\alpha + K \cdot \ln X$	Reduction and Reduction Ratio After 2 Years	Reduction and Reduction Ratio After 3 Years
Example 1	PTFE (D-1) : Casting Method	yes no	$Y = -1.896 + 1.087 \ln X$ $Y = -4.200 + 1.594 \ln X$	5.27 mg 0.11 % 6.31 mg 0.12 %	5.71 mg 0.11 % 6.96 mg 0.13 %
Comparative Example 1	PTFE (D-2) : Skiving Method	yes no	$Y = -6.357 + 3.518 \ln X$ $Y = -6.676 + 3.617 \ln X$	16.84 mg 0.32 % 17.17 mg 0.32 %	17.79 mg 0.34 % 18.64 mg 0.35 %
Comparative Example 2	ETFE (D-3) : Extrusion Method	yes no	$Y = -7.379 + 2.683 \ln X$ $Y = -7.214 + 2.658 \ln X$	10.31 mg 0.19 % 10.31 mg 0.19 %	11.40 mg 0.22 % 11.39 mg 0.21 %

Example 2

This Example was carried out as to a sealing stopper having an UHMWPE film laminated within the scope of the present invention, prepared by the extrusion method, and another sealing stopper having an UHMWPE film laminated (D-4) in an analogous manner to Example 1, Comparative Example 1 or 2, thus obtaining similar good results to Example 1.

From the foregoing tests, it could be confirmed that the present invention was very excellent in sealing property as well as slidable property.

Results of various tests effected as a sealing stopper for a syringe will be shown using the sealing stopper, as a typical example, of the type of Example 1 using the film of D-1.

Test for Liquid Sealing Property

(a) Dynamic Loading Conditions

Compressing Test according to Notification No. 442 of the Ministry of Health and Welfare, Standard of Device for Medical Treatment, "Standard of Disposal Injection Cylinder", December 28, 1970, and British Standard.

Ten samples of clean plastic injection cylinders each having a specified volume were prepared, the end (lure part) of the injection cylinder being sealed by applying a rubber cap thereto. An aqueous Methylene Blue solution of 0.1 weight/volume % concentration in only a determined volume was poured in the injection cylinder. A rubber sealing stopper having a resin film laminated on the surface thereof according to the present invention or a comparative rubber stopper was slowly thrust from the flange part of the injection cylinder and while turning up the head of the cylinder, the rubber cap was taken off at the lure part. A plastic plunger was screwed in a threaded part at the opening side of the sealing stopper and slowly pushed up upwards in such a manner that the liquid in the cylinder was not leaked, thus pushing out air in the end part of the cylinder. A rubber cap was again applied to the lure part and mounted on a measurement device for pressure test. After a pressure defined for medical treatment as shown in Table 7 was added for 10 seconds, the injection cylinder was taken off from the measurement device and an interface between the sealing stopper and injection cylinder was observed with magnifying ten times to confirm whether there was a leakage of the above described blue aqueous Methylene Blue solution through the interface part or not (Compressing Test ①). The measured results are shown in Table 8, from which it is apparent that the sealing stopper of the present invention exhibits no leakage in any size of injection cylinders. In addition, Table 8 shows simultaneously the compressibility and sliding resistance of sealing stoppers, which teaches that even a sealing stopper having a larger compressibility (higher sealing property) has a higher sliding property.

When a further larger pressure was added to investigate presence or absence of leakage in addition to the above described defined Compressing Test (Compressing Test ②), there was found no leakage as shown in Table 8.

Table 7

Application	Volume for Injection Cylinder	Pressure (10 sec.)
General Medical Treatment	less than 3 ml	4.0 kg/cm ²
	at least 3 ml less than 10 ml	3.5 kg/cm ²
	at least 10 ml less than 20 ml	3.0 kg/cm ²
	at least 20 ml less than 30 ml	2.5 kg/cm ²
	at least 30 ml	2.0 kg/cm ²
Very Small Amount	less than 2 ml	5.0 kg/cm ²
	at least 2 ml	4.0 kg/cm ²
Insulin	long	5.0 kg/cm ²
	short	4.0 kg/cm ²

Table 8

Injection Cylinder Volume (mm)	Injection Cylinder Inner Diameter(mm)	Sealing Stopper Outer Diameter (mm)	Compressibility (%)	Sliding Resistance (N)	Compressing Test ①		Compressing Test ②	
					Pressure (kg/cm ²) (Observation)	Results	Pressure (kg/cm ²)	Test Results
1	6.8	7.1	4.8	11.4	4.0	no leakage	6.9	no leakage
3	8.7	9.1	4.5	20.7	3.5	no leakage	5.9	no leakage
5	12.4	12.9	3.8	21.1	3.5	no leakage	3.7	no leakage
10	15.0	15.5	3.3	16.3	3.0	no leakage	3.5	no leakage
20	20.0	21.0	2.1	13.5	2.5	no leakage	3.5	no leakage
50	29.5	30.2	2.4	11.9	2.0	no leakage	2.6	no leakage
100	32.2	32.9	1.2	68.1	2.0	no leakage	2.5	no leakage

[note] Compressibility = [(Stopper Outer Diameter - Cylinder Inner Diameter)/Stopper Outer Diameter] × 100 %

EP 0 879 611 A2

Test for Liquid Sealing Property

(b) Accelerated Conditions

5 Plastic injection cylinders having various volumes ten by ten and sealing stoppers having sizes corresponding thereto and end caps ten by ten were prepared. In a plastic injection cylinder whose end was covered with a cap was poured a 1 % aqueous Methylene Blue solution of a determined volume and then the sealing stopper of the present invention and that for comparison were slowly inserted respectively from the opening part of the injection cylinder. After passage of at least six months under accelerating conditions of a temperature of 40 °C and a relative humidity of 75 %
 10 %, it was confirmed by visual observation whether there was leakage of the above described aqueous Methylene Blue solution at the interface between the plastic injection cylinder and sealing stopper. This method was carried out as a test method for proving that in the case of formulation of a liquid injection agent through a sterile formulation step, there was no leakage of the liquid medicament nor invasion of a liquid material from the outside.

15 Test for Liquid Sealing Property

(c) Severer Conditions

20 Each of samples prepared in an analogous manner to the above described accelerating test was subjected to confirmation of the presence or absence of leakage of the above described aqueous Methylene Blue solution at the interface between the plastic injection cylinder and sealing stopper by heating at 121 °C for 30 minutes using an autoclave. This method is a method for estimating sealing property in a formulation step, which comprises adding a stress similar to a formulation step of a part of a liquid injection agent, sterilized after the formulation. The results of the foregoing (b) and (c) are shown in Table 9.

25

Gas Sealing Property Test (Invasion of Steam: Test according to "Moisture Permeability Test of US Pharmacopoeia", 22nd Edition)

30 Injection Cylinders each having a volume of 1 to 100 ml (ten by ten) as shown in Table 8 were precisely weighed, a drying agent was charged in the injection cylinder, maintained stood, in such a manner that the thickness (height) be 13 mm, and the sealing stopper was fixed at a scale of the injection cylinder, representing a specified volume. As the drying agent, there was preferably used calcium chloride passing through a 4-mesh sieve, dried at 110 °C for 1 hour and then cooled in a desiccator. After precisely weighing the weight (Ti) of each sample, the sample was preserved at a temperature of 20 °C and a humidity of 75 % RH, and after passage of 14 days, the weight (Tf) was precisely weighed again. An increment of weight for a period of 14 days (Tf - Ti) was sought. On the other hand, for control, the initial weight (Ci) and the weight (Cf) after passage of 14 days were precisely weighed concerning dried glass beads-charged samples instead of the calcium chloride to obtain the increment of weight (Cf - Ci) for control for a period of 14 days. When the volume of the injection cylinder is V, the moisture permeability can be given by the following formula. The results are shown in Table 9.

40

$$\text{Moisture Permeability} = (100/14 V)[(Tf - Ti) - (Cf - Ci)]$$

45

Table 9

Injection Cylinder Volume (ml)	Liquid Sealing Property Test ¹⁾ Results	Liquid Sealing Property Test ²⁾ Results	Gas Sealing Property Test ³⁾ Results (mg/day · l)
1	no leakage of MB ⁴⁾	no leakage of MB	-1
3	no leakage of MB	no leakage of MB	-1
5	no leakage of MB	no leakage of MB	2
10	no leakage of MB	no leakage of MB	22
20	no leakage of MB	no leakage of MB	25

50

(Note) 1) accelerating condition: 40 °C, 75 % RH, 6 months

55

2) severer condition: 121 °C, 1 hour

3) moisture permeability test : 20°C, 75 % RH, 14 days

4) MB: Methylene Blue

EP 0 879 611 A2

Table 9 (continued)

Injection Cylinder Volume (ml)	Liquid Sealing Property Test ¹⁾ Results	Liquid Sealing Property Test ²⁾ Results	Gas Sealing Property Test ³⁾ Results (mg/day · l)
50	no leakage of MB	no leakage of MB	30
100	no leakage of MB	no leakage of MB	2.8

(Note) 1) accelerating condition: 40 °C, 75 % RH, 6 months

2) severer condition: 121 °C, 1 hour

3) moisture permeability test : 20°C, 75 % RH, 14 days

In the moisture permeability test, a sealing property to gas (steam) at a setting part of a plastic injection cylinder and sealing stopper is estimated, but this test can be considered to be an alternative test for estimating possibility of invasion of microorganisms. The results of the moisture permeability within a range of -1 to 30 mg/day · liter according to the present invention, as shown in Table 9, teach very high sealing property.

Substantially similar good results could be obtained in an estimation test as to the sealing stopper having UHMWPE laminated in Example 2.

Advantages of the Invention

As illustrated above, according to the present invention, there can be obtained a sealing stopper for a syringe, which has more improved slidability as well as sealing property, to such a degree that even if the compressibility of a rubber stopper is rendered higher, smooth sliding can be obtained, by laminating a PTFE film or UHMWPE film with a very excellent surface property. In particular, the sealing property in a formulation step (high temperature or pressure condition) as well as the sealing property during storage for a long time are higher and moreover, during use, administration of an injection medicament can be carried out in easy and rapid manner because of the higher sliding property, so that requirements in the real medical scenes may be satisfied. The above described advantages can similarly be obtained in the case of the prefilled syringe according to the present invention.

Claims

1. A sealing stopper for a syringe, in which a surface of the rubber body is laminated with a tetrafluoroethylene resin film or ultra-high molecular weight polyethylene film having an average roughness Ra on the central line of the surface in a range of at most 0.05 μm and a kinematic friction coefficient of at most 0.2.
2. The sealing stopper for a syringe, as claimed in Claim 1, wherein the tetrafluoroethylene resin film is prepared by a casting shaping method comprising using, as a raw material, a suspension containing tetrafluoroethylene resin powder having a grain diameter of at most 0.01 to 1.0 μm, a dispersing agent and a solvent.
3. The sealing stopper for a syringe, as claimed in Claim 1, wherein the ultra-high molecular weight polyethylene film is prepared by an inflation shaping method or extrusion shaping method.
4. A prefilled syringe, in which a medicament is enclosed and sealed in an injection cylinder or two-component cylinder by the use of the sealing stopper for a syringe, and in which a surface of the rubber body is laminated with a tetrafluoroethylene resin film or ultrahigh molecular weight polyethylene film having an average roughness Ra on the central line of the surface in a range of at most 0.05 μm and a kinematic friction coefficient of at most 0.2.
5. A process for the production of a sealing stopper for a syringe, which comprises preparing a suspension of polytetrafluoroethylene fine grains having a maximum grain diameter in a range of 0.01 to 1.0 μm with a concentration of 40 to 50 % in a suitable solvent containing a dispersing agent, coating the resulting suspension onto a metallic belt, heating and drying the coating at a temperature of higher than the melting point of polytetrafluoroethylene to form a thin film, repeating this procedure to obtain a sintered cast film with a suitable thickness and then laminating a rubber body with the cast film.
6. The process for the production of a sealing stopper for a syringe, as claimed in Claim 5, wherein the thin film has a thickness of 5 to 20 μm and the sintered cast film has a thickness of 10 to 60 μm.

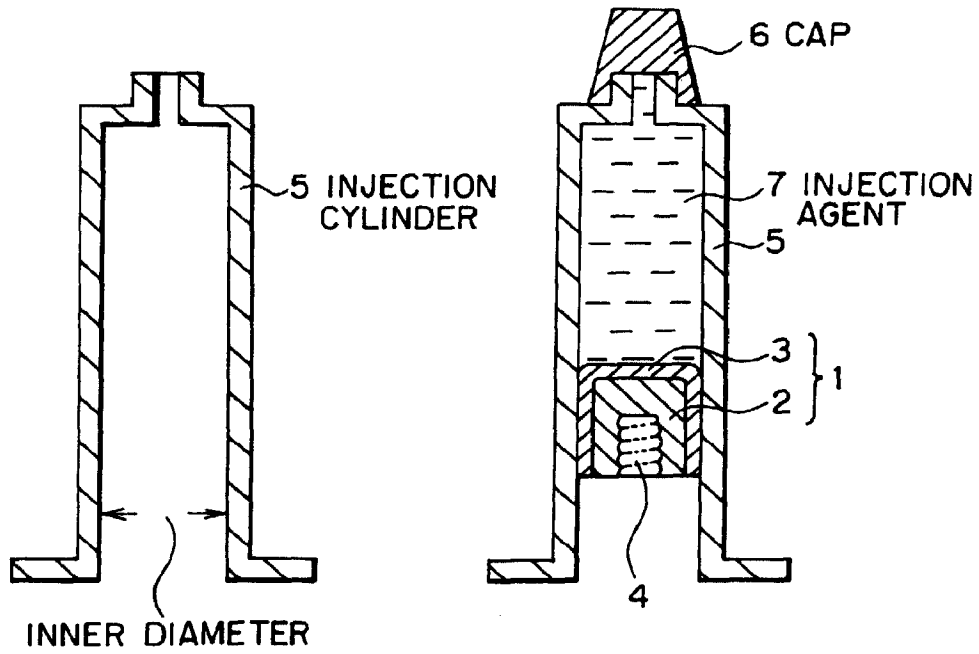

(b)

(c)

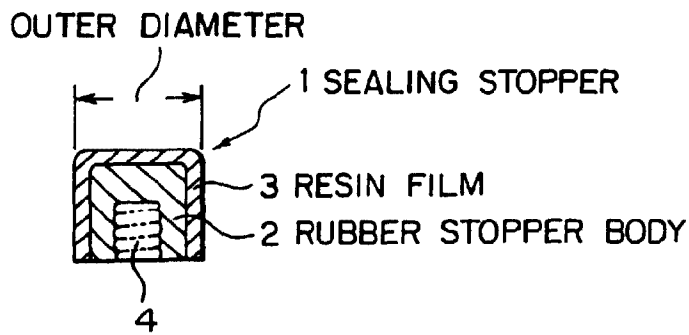

(a)

FIG. 1

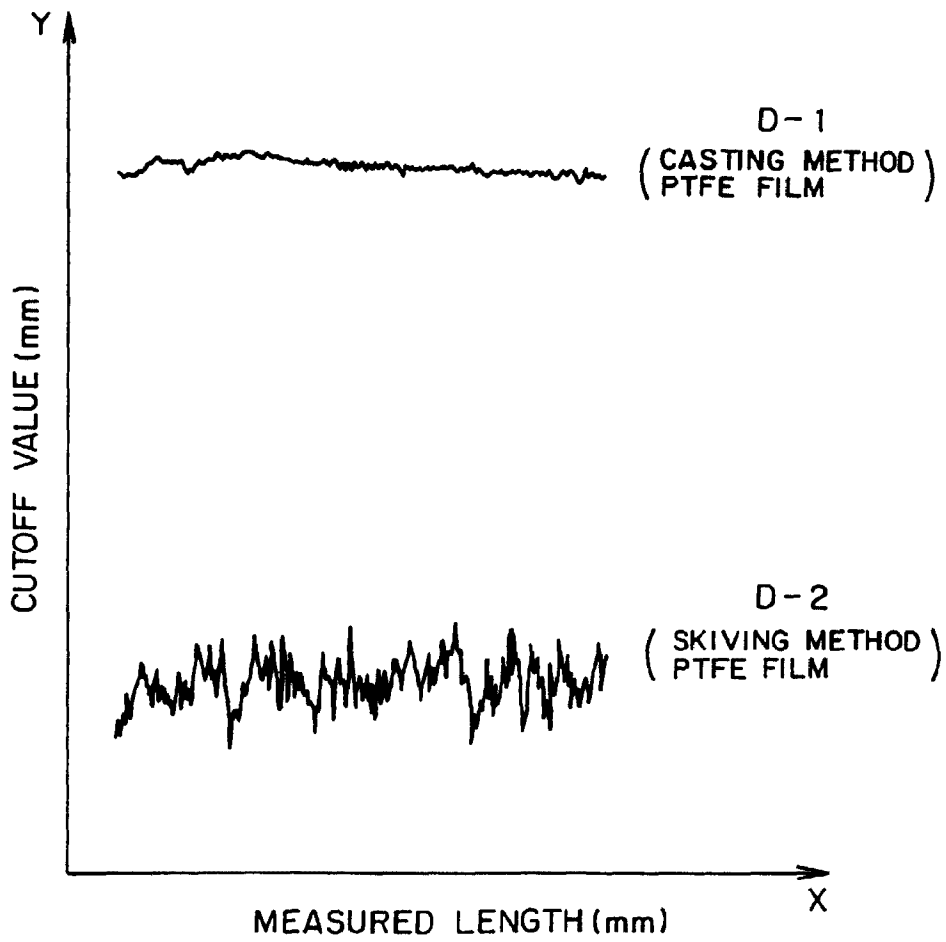

FIG. 2

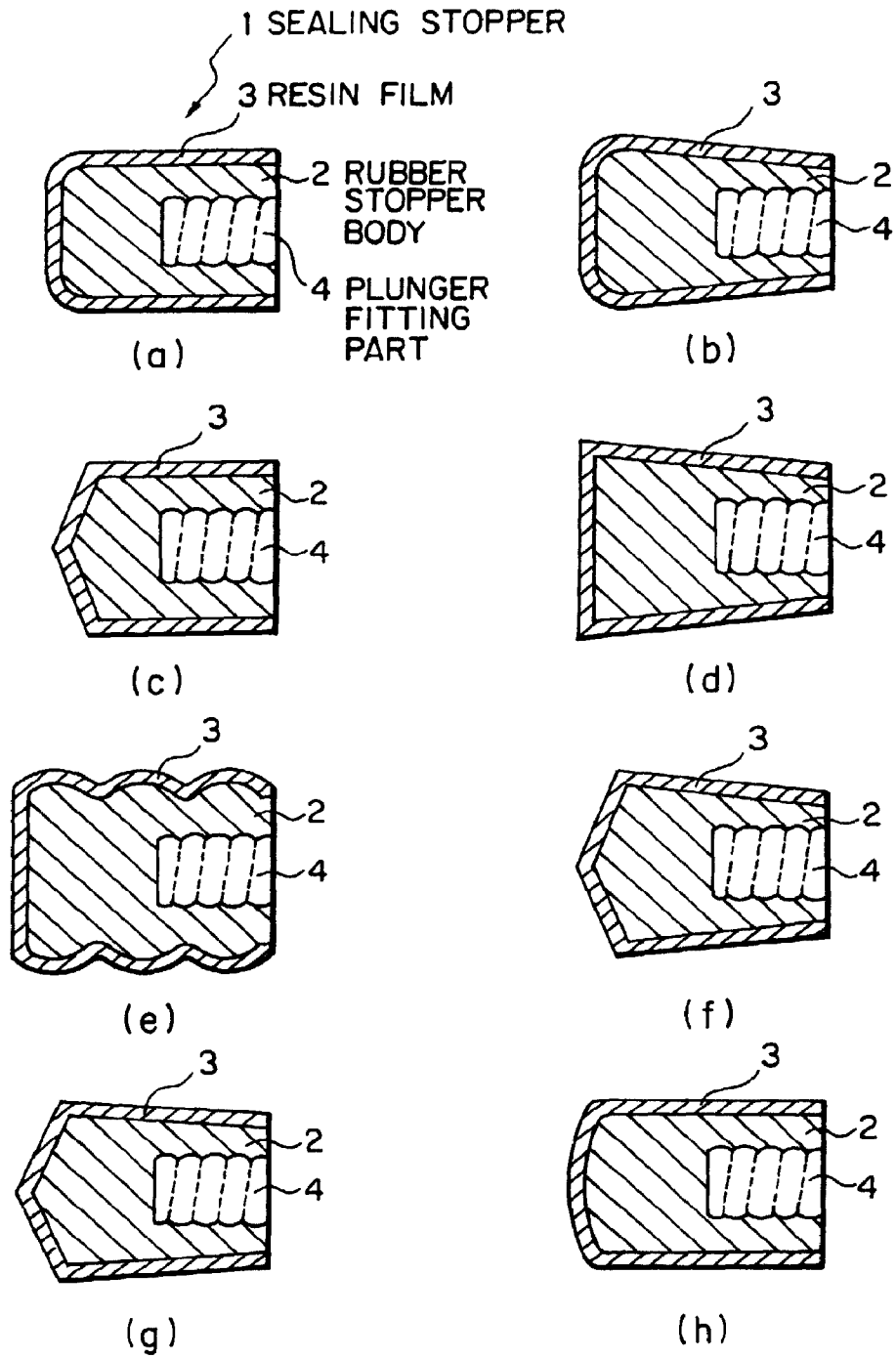

FIG. 3

PATENT ABSTRACTS OF JAPAN

(11)Publication number : 2002-241264

(43)Date of publication of application : 28.08.2002

(51)Int.Cl. A61K 9/08
 A61K 38/23
 A61P 3/14
 A61P 19/08
 A61P 19/10
 // A61M 5/28

(21)Application number : 2001-042590

(71)Applicant : ASAHI KASEI CORP

(22)Date of filing : 19.02.2001

(72)Inventor : HITOMI KOJI
 ENDO TAKESHI

(54) PREFILLED SYRINGE PHARMACEUTICAL PREPARATION OF ELCATONIN

(57)Abstract:

PROBLEM TO BE SOLVED: To obtain a prefilled syringe pharmaceutical preparation of elcatonin having stability and safe for human bodies.

SOLUTION: This prefilled syringe pharmaceutical preparation of the elcatonin is filled with an aqueous solution containing the elcatonin as an active ingredient and is characterized in that the amount of elution into the aqueous solution is $\leq 2\%$ expressed in terms of area ratio measured by high-performance liquid chromatography. The prefilled syringe pharmaceutical preparation of the elcatonin is filled with the aqueous solution containing the elcatonin as the active ingredient and is characterized in that the volume of a gap part is ≤ 0.2 when the volume occupied by the aqueous solution is 1. The prefilled syringe pharmaceutical preparation of the elcatonin comprises the syringe having a silicone at ≤ 3 wt./vol.% concentration applied to the inner surface and filled with the aqueous solution containing the elcatonin as the active ingredient.

Electronic Acknowledgement Receipt

EFS ID:	17242821
Application Number:	13750352
International Application Number:	
Confirmation Number:	5306
Title of Invention:	SYRINGE
First Named Inventor/Applicant Name:	Juergen Sigg
Customer Number:	1095
Filer:	James L Lynch/Denise Cooper
Filer Authorized By:	James L Lynch
Attorney Docket Number:	PAT055157-US-NP
Receipt Date:	28-OCT-2013
Filing Date:	25-JAN-2013
Time Stamp:	15:04:49
Application Type:	Utility under 35 USC 111(a)

Payment information:

Submitted with Payment	no
------------------------	----

File Listing:

Document Number	Document Description	File Name	File Size(Bytes)/ Message Digest	Multi Part /.zip	Pages (if appl.)
1	Information Disclosure Statement (IDS) Form (SB08)	PAT055157-US-NP-IDS.pdf	1730783 <small>57d366ea02e39a359a3fdca211020b7e578b272d</small>	no	3

Warnings:

Information:

This is not an USPTO supplied IDS fillable form					
2	Foreign Reference	EP0264273A2.pdf	616316 476f4646f8d6bc1b2b94db68bd123bb4e2747598	no	13
Warnings:					
Information:					
3	Foreign Reference	EP0879611A2.pdf	1043361 15b9f1841ad264fda02238fb642d3b63d387ce3d	no	20
Warnings:					
Information:					
4	Foreign Reference	JP2002241264_Abs.pdf	306347 ae5486bd2223ef9b5c6aee1bd9fe4fbc085d3d50	no	1
Warnings:					
Information:					
Total Files Size (in bytes):			3696807		
<p>This Acknowledgement Receipt evidences receipt on the noted date by the USPTO of the indicated documents, characterized by the applicant, and including page counts, where applicable. It serves as evidence of receipt similar to a Post Card, as described in MPEP 503.</p> <p><u>New Applications Under 35 U.S.C. 111</u> If a new application is being filed and the application includes the necessary components for a filing date (see 37 CFR 1.53(b)-(d) and MPEP 506), a Filing Receipt (37 CFR 1.54) will be issued in due course and the date shown on this Acknowledgement Receipt will establish the filing date of the application.</p> <p><u>National Stage of an International Application under 35 U.S.C. 371</u> If a timely submission to enter the national stage of an international application is compliant with the conditions of 35 U.S.C. 371 and other applicable requirements a Form PCT/DO/EO/903 indicating acceptance of the application as a national stage submission under 35 U.S.C. 371 will be issued in addition to the Filing Receipt, in due course.</p> <p><u>New International Application Filed with the USPTO as a Receiving Office</u> If a new international application is being filed and the international application includes the necessary components for an international filing date (see PCT Article 11 and MPEP 1810), a Notification of the International Application Number and of the International Filing Date (Form PCT/RO/105) will be issued in due course, subject to prescriptions concerning national security, and the date shown on this Acknowledgement Receipt will establish the international filing date of the application.</p>					



Bescheinigung

Die angehefteten Unterlagen stimmen mit der als ursprünglich eingereicht geltenden Fassung der auf dem nächsten Blatt bezeichneten europäischen Patentanmeldung überein.

Certificate

The attached documents are exact copies of the text in which the European patent application described on the following page is deemed to have been filed.

Attestation

Les documents joints à la présente attestation sont conformes au texte, considéré comme initialement déposé, de la demande de brevet européen qui est spécifiée à la page suivante.

Patentanmeldung Nr.

Patent application No.

Demande de brevet n°

12189649.2 / EP12189649

The organization code and number of your priority application, to be used for filing abroad under the Paris Convention, is EP12189649.

Der Präsident des Europäischen Patentamts;
Im Auftrag
For the President of the European Patent Office
Le Président de l'Office européen des brevets
p.o.

U. Ingmann

Anmeldung Nr:
Application no.: 12189649.2
Demande no :

Anmeldetag:
Date of filing: 23.10.12
Date de dépôt :

Anmelder / Applicant(s) / Demander(s):

Novartis AG
Lichtstrasse 35
4056 Basel/CH

Bezeichnung der Erfindung / Title of the invention / Titre de l'invention:

(Falls die Bezeichnung der Erfindung nicht angegeben ist, oder falls die Anmeldung in einer Nicht-Amtssprache des EPA eingereicht wurde, siehe Beschreibung bezüglich ursprünglicher Bezeichnung.

If no title is shown, or if the application has been filed in a non-EPO language, please refer to the description for the original title.

Si aucun titre n'est indiqué, ou si la demande a été déposée dans une langue autre qu'une langue officielle de l'OEB, se référer à la description pour le titre original.)

Syringe

In Anspruch genommene Priorität(en) / Priority(Priorities) claimed / Priorité(s) revendiquée(s)
Staat/Tag/Aktenzeichen / State/Date/File no. / Pays/Date/Numéro de dépôt:

Am Anmeldetag benannte Vertragsstaaten / Contracting States designated at date of filing / Etats contractants désignées lors du dépôt:

AL AT BE BG CH CY CZ DE DK EE ES FI FR GB GR HR HU IE IS IT LI LT LU LV MC MK MT NL NO PL
PT RO RS SE SI SK SM TR

SYRINGE

TECHNICAL FIELD

The present invention relates to a syringe, particularly to a small volume syringe such as a syringe suitable for ophthalmic injections.

5 BACKGROUND ART

Many medicaments are delivered to a patient in a syringe from which the user can dispense the medicament. If medicament is delivered to a patient in a syringe it is often to enable the patient, or a caregiver, to inject the medicament. It is important for patient safety and medicament integrity that the syringe and the contents of that syringe are sufficiently sterile to avoid
10 infection, or other, risks for patients. Sterilisation can be achieved by terminal sterilisation in which the assembled product, typically already in its associated packaging, is sterilised using heat or a sterilising gas.

For small volume syringes, for example those for injections into the eye in which it is intended that about 0.1ml or less of liquid is to be injected the sterilisation can pose difficulties that are
15 not necessarily associated with larger syringes. Changes in pressure, internal or external to the syringe, can cause parts of the syringe to move unpredictably, which may alter sealing characteristics and potentially compromise sterility. Incorrect handling of the syringe can also pose risks to product sterility.

Furthermore, certain therapeutics such as biologic molecules are particularly sensitive to
20 sterilisation, be it cold gas sterilisation, thermal sterilisation, or irradiation. Thus, a careful balancing act is required to ensure that while a suitable level of sterilisation is carried out, the syringe remains suitably sealed, such that the therapeutic is not compromised.

There is therefore a need for a new syringe construct which provides a robust seal for its content, but which maintains ease of use.

25 DISCLOSURE OF THE INVENTION

The present invention provides a pre-filled syringe, the syringe comprising a body, a stopper and a plunger, the body comprising an outlet at an outlet end and the stopper being arranged within the body such that a front surface of the stopper and the body define a variable volume chamber from which a fluid can be expelled through the outlet, the plunger comprising a plunger contact
30 surface at a first end and a rod extending between the plunger contact surface and a rear portion,

PAT055157-EP-EPA

the plunger contact surface arranged to contact the stopper, such that the plunger can be used to force the stopper towards the outlet end of the body, reducing the volume of the variable volume chamber, characterised in that the fluid comprises an ophthalmic solution. In one embodiment, the ophthalmic solution comprises a VEGF-antagonist.

5 In one embodiment, the syringe is suitable for ophthalmic injections, more particularly intravitreal injections, and as such has a suitably small volume. The syringe may also be silicone oil free, or substantially silicone oil free, or may comprise a low level of silicone oil as lubricant.

For ophthalmic injections, it is particularly important for the ophthalmic solution to have particularly low particle content. In one embodiment, the syringe meets US Pharmacopeia
10 standard 789 (USP789).

Syringe

The body of the syringe may be a substantially cylindrical shell, or may include a substantially cylindrical bore with a non circular outer shape. The outlet end of the body includes an outlet through which a fluid housed within the variable volume chamber can be expelled as the volume
15 of said chamber is reduced. The outlet may comprise a projection from the outlet end through which extends a channel having a smaller diameter than that of the variable volume chamber. The outlet may be adapted, for example via a luer lock type connection, for connection to a needle or other accessory such as a sealing device which is able to seal the variable volume chamber, but can be operated, or removed, to unseal the variable volume chamber and allow
20 connection of the syringe to another accessory, such as a needle. Such a connection may be made directly between the syringe and accessory, or via the sealing device. The body extends along a first axis from the outlet end to a rear end.

The body may be made from a plastic material (e.g. a cyclic olefin polymer) or from glass and may include indicia on a surface thereof to act as an injection guide. In one embodiment the
25 body may comprise a priming mark. This allows the physician to align a pre-determined part of the stopper (such as the tip of the front surface or one of the circumferential ribs, discussed later) with the mark, thus expelling excess ophthalmic solution and any air bubbles from the syringe. The priming process ensures that an exact, pre-determined dosage is administered to the patient.

The stopper may be made from rubber, silicone or other suitable resiliently deformable material.
30 The stopper may be substantially cylindrical and the stopper may include one or more circumferential ribs around an outer surface of the stopper, the stopper and ribs being

PAT055157-EP-EPA

dimensioned such that the ribs form a substantially fluid tight seal with an internal surface of the syringe body. The front surface of the stopper may be any suitable shape, for example substantially planar, substantially conical or of a domed shape. The rear surface of the stopper may include a substantially central recess. Such a central recess could be used to connect a plunger to the stopper using a snap fit feature or thread connection in a known manner. The stopper may be substantially rotationally symmetric about an axis through the stopper.

The plunger comprises a plunger contact surface and extending from that a rod extends from the plunger contact surface to a rear portion. The rear portion may include a user contact portion adapted to be contacted by a user during an injection event. The user contact portion may comprise a substantially disc shaped portion, the radius of the disc extending substantially perpendicular to the axis along which the rod extends. The user contact portion could be any suitable shape. The axis along which the rod extends may be the first axis, or may be substantially parallel with the first axis.

The syringe may include a backstop arranged at a rear portion of the body. The backstop may be removable from the syringe. If the syringe body includes terminal flanges at the end opposite the outlet end the backstop may be configured to substantially sandwich terminal flanges of the body as this prevent movement of the backstop in a direction parallel to the first axis.

The rod may comprise at least one rod shoulder directed away from the outlet end and the backstop may include a backstop shoulder directed towards the outlet end to cooperate with the rod shoulder to substantially prevent movement of the rod away from the outlet end when the backstop shoulder and rod shoulder are in contact. Restriction of the movement of the rod away from the outlet end can help to maintain sterility during terminal sterilisation operations, or other operations in which the pressure within the variable volume chamber or outside the chamber may change. During such operations any gas trapped within the variable volume chamber, or bubbles that may form in a liquid therein, may change in volume and thereby cause the stopper to move. Movement of the stopper away from the outlet could result in the breaching of a sterility zone created by the stopper. This is particularly important for low volume syringes where there are much lower tolerances in the component sizes and less flexibility in the stopper. The term sterility zone as used herein is used to refer to the area within the syringe that is sealed by the stopper from access from either end of the syringe. This may be the area between a seal of the stopper, for example a circumferential rib, closest to the outlet and a seal of the stopper, for example a circumferential rib, furthest from the outlet. The distance between these two seals

PAT055157-EP-EPA

defines the sterility zone of the stopper since the stopper is installed into the syringe barrel in a sterile environment.

To further assist in maintaining sterility during the operations noted above the stopper may comprise at a front circumferential rib and a rear circumferential rib and those ribs may be separated in a direction along the first axis by at least 3mm, by at least 3.5 mm, by at least 3.75mm or by 4mm or more. One or more additional ribs (for example 2, 3, 4 or 5 additional ribs, or between 1-10, 2-8, 3-6 or 4-5 additional ribs) may be arranged between the front and rear ribs. In one embodiment there are a total of three circumferential ribs.

A stopper with such an enhanced sterility zone can also provide protection for the injectable medicament during a terminal sterilisation process. More ribs on the stopper, or a greater distance between the front and rear ribs can reduce the potential exposure of the medicament to the sterilising agent. However, increasing the number of ribs can increase the friction between the stopper and syringe body, reducing ease of use. While this may be overcome by increasing the siliconisation of the syringe, such an increase in silicone oil levels is particularly undesirable for syringes for ophthalmic use.

The rod shoulder may be arranged within the external diameter of the rod, or may be arranged outside the external diameter of the rod. By providing a shoulder that extends beyond the external diameter of the rod, but still fits within the body, the shoulder can help to stabilise the movement of the rod within the body by reducing movement of the rod perpendicular to the first axis. The rod shoulder may comprise any suitable shoulder forming elements on the rod, but in one embodiment the rod shoulder comprises a substantially disc shaped portion on the rod.

In one embodiment of the syringe, when arranged with the plunger contact surface in contact with the stopper and the variable volume chamber is at its intended maximum volume there is a clearance of no more than about 2mm between the rod shoulder and backstop shoulder. In some embodiments there is a clearance of less than about 1.5 mm and in some less than about 1mm. This distance is selected to substantially limit or prevent excessive rearward (away from the outlet end) movement of the stopper.

In one embodiment the variable volume chamber has an internal diameter greater than 5mm or 6mm, or less than 3mm or 4mm. The internal diameter may be between 3mm and 6mm, or between 4mm and 5mm.

PAT055157-EP-EPA

In another embodiment the syringe is dimensioned so as to have a nominal maximum fill volume of between about 0.1ml and about 1.5ml. In certain embodiments the nominal maximum fill volume is between about 0.5ml and about 1ml. In certain embodiments the nominal maximum fill volume is about 0.5ml or about 1ml, or about 1.5ml.

5 The length of the body of the syringe may be less than 70mm, less than 60mm or less than 50mm. In one embodiment the length of the syringe body is between 45mm and 50mm.

In one embodiment, the syringe is filled with between about 0.01ml and about 1.5ml (for example between about 0.05ml and about 1ml, between about 0.1ml and about 0.5ml, between about 0.15ml and about 0.175ml) of a VEGF antagonist solution. In one embodiment, the syringe is filled with 0.165ml of a VEGF antagonist solution. Of course, typically a syringe is
10 filled with more than the desired dose to be administered to the patient, to take into account wastage due to “dead space” within the syringe and needle. There may also be a certain amount of wastage when the syringe is primed by the physician, so that it is ready to inject the patient.

Thus, in one embodiment, the syringe is filled with a dosage volume (i.e. the volume of medicament intended for delivery to the patient) of between about 0.01ml and about 1.5ml (e.g.
15 between about 0.05ml and about 1ml, between about 0.1ml and about 0.5ml) of a VEGF antagonist solution. In one embodiment, the dosage volume is between about 0.03ml and about 0.05ml. For example, for Lucentis, the dosage volume is 0.05ml or 0.03ml (0.5mg or 0.3mg) of a 10mg/ml injectable medicament solution; for Eylea, the dosage volume is 0.05ml of a 40mg/ml
20 injectable medicament solution.

In one embodiment the length of the syringe body is between about 45mm and about 50mm, the internal diameter is between about 4mm and about 5mm, the fill volume is between about 0.12 and about 0.3ml and the dosage volume is between about 0.03ml and about 0.05ml.

As the syringe contains a medicament solution, the outlet may be reversibly sealed to maintain
25 sterility of the medicament. This sealing may be achieved through the use of a sealing device as is known in the art. For example the OVSTM system which is available from Vetter Pharma International GmbH.

It is typical to siliconise the syringe in order to allow ease of use, i.e. to apply silicone oil to the inside of the barrel, which decreases the force required to move the stopper. However, for
30 ophthalmic use, it is desirable to decrease the likelihood of silicone oil droplets being injected into the eye. Furthermore, silicone oil can cause proteins to aggregate. A typical 1ml syringe

PAT055157-EP-EPA

comprises 100-800µg silicone oil in the barrel. Thus, in one embodiment, a syringe according to the invention comprises less than about 800µg (i.e. about less than about 500µg, less than about 300µg, less than about 200µg, less than about 100µg, less than about 75µg, less than about 50µg, less than about 25µg, less than about 15µg, less than about 10µg) silicone oil in the barrel.

5 Methods for measuring the amount of silicone oil in such a syringe barrel are known in the art and include, for example, differential weighing methods and quantitation by infrared-spectroscopy of the oil diluted in a suitable solvent. Various types of silicone oil are available, but typically either DC360 (Dow Corning®; with a viscosity of 1000cP) or DC365 emulsion (Dow Corning®; DC360 oil with a viscosity of 350cP) are used for syringe siliconisation. In one
10 embodiment, the pre-filled syringe of the invention comprises DC365 emulsion.

During testing it was found that, for syringes having small dimensions, such as those discussed above, and particularly those described in conjunction with the Figures below, the break loose and sliding forces for the stopper within the syringe are substantially unaffected by reducing the siliconisation levels far below the current standard to the levels discussed here. This is in contrast
15 to conventional thinking that would suggest that if you decrease the silicone oil level, the forces required would increase. Having too great a force required to move the stopper can cause problems during use for some users, for example accurate dose setting or smooth dose delivery may be made more difficult if significant strength is required to move, and/or keep in motion, the stopper. Break loose and slide forces for pre-filled syringes known in the art are typically in the
20 region of less than 20N, but where the pre-filled syringes contain about 100µg-about 800µg silicone oil. In one embodiment the glide/slide force for the stopper within the pre-filled syringe is less than about 11N or less than 9N, less than 7N, less than 5N or between about 3N to 5N. In one embodiment, the break loose force is less than about 11N or less than 9N, less than 7N, less than 5N or between about 2N to 5N. Note that such measurements are for a filled syringe, rather
25 than an empty syringe. The forces are typically measured at a stopper travelling speed of 190mm/min. In one embodiment, the syringe has a nominal maximal fill volume of between about 0.5ml and 1ml, contains less than about 100µg silicone oil and has a break loose force between about 2N to 5N.

In one embodiment the syringe barrel has an internal coating of silicone oil that has an average
30 thickness of about 450nm or less (i.e. 400nm or less, 350nm or less, 300nm or less, 200nm or less, 100nm or less, 50nm or less, 20nm or less). Methods to measure the thickness of silicone oil in a syringe are known in the art and include the rap.ID Layer Explorer® Application, which can also be used to measure the mass of silicone oil inside a syringe barrel.

PAT055157-EP-EPA

In one embodiment, the syringe is silicone oil free, or substantially silicone oil free. Such low silicone oil levels can be achieved by using uncoated syringe barrels and/or by avoiding the use of silicone oil as a lubricant for product contacting machine parts, or pumps in the syringe assembly and fill line.

5 The syringe according to the invention may also meet certain requirements for particulate content. In one embodiment, the ophthalmic solution comprises no more than 2 particles $\geq 50\mu\text{m}$ in diameter per ml. In one embodiment, the ophthalmic solution comprises no more than 5 particles $\geq 25\mu\text{m}$ in diameter per ml. In one embodiment, the ophthalmic solution comprises no more than 50 particles $\geq 10\mu\text{m}$ in diameter per ml. In one embodiment, the ophthalmic solution
10 comprises no more than 2 particles $\geq 50\mu\text{m}$ in diameter per ml, no more than 5 particles $\geq 25\mu\text{m}$ in diameter per ml and no more than 50 particles $\geq 10\mu\text{m}$ in diameter per ml. In one embodiment, a syringe according to the invention meets USP789. In one embodiment the syringe has low levels of silicone oil sufficient for the syringe to meet USP789.

VEGF Antagonists

15 *Antibody VEGF antagonists*

VEGF is a well-characterised signal protein which stimulates angiogenesis. Two antibody VEGF antagonists have been approved for human use, namely ranibizumab (Lucentis®) and bevacizumab (Avastin®).

Non-Antibody VEGF antagonists

20 In one aspect of the invention, the non-antibody VEGF antagonist is an immunoadhesin. One such immunoadhesin is aflibercept (Eylea®), which has recently been approved for human use and is also known as VEGF-trap (Holash *et al.* (2002) *PNAS USA* 99:11393-98; Ricly & Miller (2007) *Clin Cancer Res* 13:4623-7s). Aflibercept is the preferred non-antibody VEGF antagonist for use with the invention. Aflibercept is a recombinant human soluble VEGF receptor fusion
25 protein consisting of portions of human VEGF receptors 1 and 2 extracellular domains fused to the Fc portion of human IgG1. It is a dimeric glycoprotein with a protein molecular weight of 97 kilodaltons (kDa) and contains glycosylation, constituting an additional 15% of the total molecular mass, resulting in a total molecular weight of 115 kDa. It is conveniently produced as a glycoprotein by expression in recombinant CHO K1 cells. Each monomer can have the
30 following amino acid sequence (SEQ ID NO: 1):

PAT055157-EP-EPA

SDTGRPFVEMYSEIPEIIHMTEGRELVI PCRVTSPNITVTLKKFPLDTLIPDGKRIIWDSRKGFIISNATY
KEIGLLTCEATVNGHLYKTNYLTHRQTNTIIDVVLSPSHGIELSVGEKLVLNCTARTELVGIDFNWEYPS
SKHQHKKLVNRDLKTQSGSEMKKFLSTLTIDGVTRSDQGLYTCAASSGLMTKKNSTFVRVHEKDKTHTCPP
CPAPELLGGPSVFLFPPKPKDTLMISRTPEVTCVVVDVSHEDPEVKFNWYVDGVEVHNAKTKPREEQYNST
5 YRVVSVLTVLHQDWLNGKEYKCKVSNKALPAPIEKTISKAKGQPREPQVYITLPPSRDELTKNQVSLTCLVK
GFYPSDIAVEWESNGQPENNYKTPPVLDSDGSFFLYSKLTVDKSRWQQGNVFCSCVMHEALHNHYTQKSL
SLSPG

and disulfide bridges can be formed between residues 30-79, 124-185, 246-306 and 352-410 within each monomer, and between residues 211-211 and 214-214 between the monomers.

10 Another non-antibody VEGF antagonist immunoadhesin currently in pre-clinical development is a recombinant human soluble VEGF receptor fusion protein similar to VEGF-trap containing extracellular ligand-binding domains 3 and 4 from VEGFR2/KDR, and domain 2 from VEGFR1/Flt-1; these domains are fused to a human IgG Fc protein fragment (Li et al., 2011 *Molecular Vision* 17:797-803). This antagonist binds to isoforms VEGF-A, VEGF-B and VEGF-
15 C. The molecule is prepared using two different production processes resulting in different glycosylation patterns on the final proteins. The two glycoforms are referred to as KH902 (conbercept) and KH906. The fusion protein can have the following amino acid sequence (SEQ ID NO:2):

MVSYWDTGVLLCALLSCLLLTGSSSGGRPFVEMYSEIPEIIHMTEGRELVI PCRVTSPNITVTLKKFPLDT
20 LIPDGKRIIWDSRKGFIISNATYKEIGLLTCEATVNGHLYKTNYLTHRQTNTIIDVVLSPSHGIELSVGEK
LVLNCTARTELVGIDFNWEYPSKQHQHKKLVNRDLKTQSGSEMKKFLSTLTIDGVTRSDQGLYTCAASSG
LMTKKNSTFVRVHEKPFVAFSGMESLVEATVGERVRLPAKYLGYPPEIKWYKNGIPLESNHTIKAGHVL
TIMEVSRDTGNYTVILTNPISKEKQSHVSVLVVYVPPGPGDKTHTCPLCPAPELLGGPSVFLFPPKPKDT
LMISRTPEVTCVVVDVSHEDPEVKFNWYVDGVEVHNAKTKPREEQYNSTYRVVSVLTVLHQDWLNGKEYKC
25 KVSNKALPAPIEKTISKAKGQPREPQVYITLPPSRDELTKNQVSLTCLVKGFYPSDIAVEWESNGQPENNYK
ATPPVLDSDGSFFLYSKLTVDKSRWQQGNVFCSCVMHEALHNHYTQKSLSLSPGK

and, like VEGF-trap, can be present as a dimer. This fusion protein and related molecules are further characterized in EP1767546.

Other non-antibody VEGF antagonists include antibody mimetics (e.g. Affibody® molecules, 30 affilins, affitins, anticalins, avimers, Kunitz domain peptides, and monobodies) with VEGF antagonist activity. This includes recombinant binding proteins comprising an ankyrin repeat domain that binds VEGF-A and prevents it from binding to VEGFR-2. One example for such a molecule is DARPin® MP0112. The ankyrin binding domain may have the following amino acid sequence (SEQ ID NO: 3):

PAT055157-EP-EPA

GSDLGKKLLEAARAGQDDEVRI LMANGADVNTADSTGWTPLHLAVPWGHLEIVEVLLKYGADVNAKDFQGW
TPLHLAAAIGHQEIIVEVLLKNGADVNAQDKFGKTAFDISIDNGNEDLAEILQKAA

Recombinant binding proteins comprising an ankyrin repeat domain that binds VEGF-A and prevents it from binding to VEGFR-2 are described in more detail in WO2010/060748 and
5 WO2011/135067.

Further specific antibody mimetics with VEGF antagonist activity are the 40 kD pegylated anticalin PRS-050 and the monobody angiocept (CT-322).

The afore-mentioned non-antibody VEGF antagonist may be modified to further improve their pharmacokinetic properties or bioavailability. For example, a non-antibody VEGF antagonist
10 may be chemically modified (e.g., pegylated) to extend its *in vivo* half-life. Alternatively or in addition, it may be modified by glycosylation or the addition of further glycosylation sites not present in the protein sequence of the natural protein from which the VEGF antagonist was derived.

Variants of the above-specified VEGF antagonists that have improved characteristics for the
15 desired application may be produced by the addition or deletion of amino acids. Ordinarily, these amino acid sequence variants will have an amino acid sequence having at least 60% amino acid sequence identity with the amino acid sequences of SEQ ID NO: 1, SEQ ID NO: 2 or SEQ ID NO: 3, preferably at least 80%, more preferably at least 85%, more preferably at least 90%, and most preferably at least 95%, including for example, 80%, 81%, 82%, 83%, 84%, 85%, 86%,
20 87%, 88%, 89%, 90%, 91%, 92%, 93%, 94%, 95%, 96%, 97%, 98%, 99%, and 100%. Identity or homology with respect to this sequence is defined herein as the percentage of amino acid residues in the candidate sequence that are identical with SEQ ID NO: 1, SEQ ID NO: 2 or SEQ ID NO: 3, after aligning the sequences and introducing gaps, if necessary, to achieve the maximum percent sequence identity, and not considering any conservative substitutions as part
25 of the sequence identity.

Sequence identity can be determined by standard methods that are commonly used to compare the similarity in position of the amino acids of two polypeptides. Using a computer program such as BLAST or FASTA, two polypeptides are aligned for optimal matching of their
30 respective amino acids (either along the full length of one or both sequences or along a pre-determined portion of one or both sequences). The programs provide a default opening penalty and a default gap penalty, and a scoring matrix such as PAM 250 [a standard scoring matrix; see Dayhoff et al., in Atlas of Protein Sequence and Structure, vol. 5, supp. 3 (1978)] can be used in

PAT055157-EP-EPA

conjunction with the computer program. For example, the percent identity can then be calculated as: the total number of identical matches multiplied by 100 and then divided by the sum of the length of the longer sequence within the matched span and the number of gaps introduced into the longer sequences in order to align the two sequences.

- 5 Preferably, the non-antibody VEGF antagonist of the invention binds to VEGF via one or more protein domain(s) that are not derived from the antigen-binding domain of an antibody. The non-antibody VEGF antagonist of the invention are preferably proteinaceous, but may include modifications that are non-proteinaceous (e.g., pegylation, glycosylation).

Therapy

- 10 The syringe of the invention may be used to treat an ocular disease, including but not limited to choroidal neovascularisation, age-related macular degeneration (both wet and dry forms), macular edema secondary to retinal vein occlusion (RVO) including both branch RVO (bRVO) and central RVO (cRVO), choroidal neovascularisation secondary to pathologic myopia (PM), diabetic macular edema (DME), diabetic retinopathy, and proliferative retinopathy.

- 15 Thus the invention provides a method of treating a patient suffering from of an ocular disease selected from choroidal neovascularisation, wet age-related macular degeneration, macular edema secondary to retinal vein occlusion (RVO) including both branch RVO (bRVO) and central RVO (cRVO), choroidal neovascularisation secondary to pathologic myopia (PM), diabetic macular edema (DME), diabetic retinopathy, and proliferative retinopathy, comprising
20 the step of administering an ophthalmic solution to the patient using a pre-filled syringe of the invention. This method preferably further comprises an initial priming step in which the physician depresses the plunger of the pre-filled syringe to align the pre-determined part of the stopper with the priming mark.

- In one embodiment, the invention provides a method of treating an ocular disease selected from
25 choroidal neovascularisation, wet age-related macular degeneration, macular edema secondary to retinal vein occlusion (RVO) including both branch RVO (bRVO) and central RVO (cRVO), choroidal neovascularisation secondary to pathologic myopia (PM), diabetic macular edema (DME), diabetic retinopathy, and proliferative retinopathy, comprising administering a non-antibody VEGF antagonist with a pre-filled syringe of the invention, wherein the patient has
30 previously received treatment with an antibody VEGF antagonist.

Kits

Also provided are kits comprising the pre-filled syringes of the invention. In one embodiment, such a kit comprises a pre-filled syringe of the invention in a blister pack. The blister pack may itself be sterile on the inside. In one embodiment, syringes according to the invention may be
5 placed inside such blister packs prior to undergoing sterilisation, for example terminal sterilisation.

Such a kit may further comprise a needle for administration of the VEGF antagonist. If the VEGF antagonist is to be administered intravitreally, it is typical to use a 30-gauge x ½ inch needle, though 31-gauge and 32-gauge needles may be used. For intravitreal administration,
10 33-gauge or 34-gauge needles could alternatively be used. Such kits may further comprise instructions for use. In one embodiment, the invention provides a carton containing a pre-filled syringe according to the invention contained within a blister pack, a needle and optionally instructions for administration.

Sterilisation

15 As noted above, a terminal sterilisation process may be used to sterilise the syringe and such a process may use a known process such as an ethylene oxide or a hydrogen peroxide sterilisation process. Needles to be used with the syringe may be sterilised by the same method, as may kits according to the invention.

The package is exposed to the sterilising gas until the outside of the syringe is sterile. Following
20 such a process, the outer surface of the syringe may remain sterile (whilst in its blister pack) for up to 6 months, 9 months, 12 months, 15 months, 18 months or longer. In one embodiment, less than one syringe in a million has detectable microbial presence on the outside of the syringe after 18 months of storage. In one embodiment, the pre-filled syringe has been sterilised using EtO with a Sterility Assurance Level of at least 10^{-6} . In one embodiment, the pre-filled syringe has
25 been sterilised using hydrogen peroxide with a Sterility Assurance Level of at least 10^{-6} . Of course, it is a requirement that significant amounts of the sterilising gas should not enter the variable volume chamber of the syringe. The term “significant amounts” as used herein refers to an amount of gas that would cause unacceptable modification of the ophthalmic solution within the variable volume chamber. In one embodiment, the sterilisation process causes $\leq 10\%$
30 (preferably $\leq 5\%$, $\leq 3\%$, $\leq 1\%$) alkylation of the VEGF antagonist. In one embodiment, the pre-filled syringe has been sterilised using EtO, but the outer surface of the syringe has $\leq 1\text{ppm}$, preferably $\leq 0.2\text{ppm}$ EtO residue. In one embodiment, the pre-filled syringe has been sterilised

PAT055157-EP-EPA

using hydrogen peroxide, but the outer surface of the syringe has ≤ 1 ppm, preferably ≤ 0.2 ppm hydrogen peroxide residue. In another embodiment, the pre-filled syringe has been sterilised using EtO, and the total EtO residue found on the outside of the syringe and inside of the blister pack is ≤ 0.1 mg. In another embodiment, the pre-filled syringe has been sterilised using hydrogen peroxide, and the total hydrogen peroxide residue found on the outside of the syringe and inside of the blister pack is ≤ 0.1 mg.

General

The term “comprising” means “including” as well as “consisting” *e.g.* a composition “comprising” X may consist exclusively of X or may include something additional *e.g.* X + Y.

The term “about” in relation to a numerical value x means, for example, $x \pm 10\%$.

References to a percentage sequence identity between two amino acid sequences means that, when aligned, that percentage of amino acids are the same in comparing the two sequences. This alignment and the percent homology or sequence identity can be determined using software programs known in the art, for example those described in section 7.7.18 of *Current Protocols in Molecular Biology* (F.M. Ausubel *et al.*, eds., 1987) Supplement 30. A preferred alignment is determined by the Smith-Waterman homology search algorithm using an affine gap search with a gap open penalty of 12 and a gap extension penalty of 2, BLOSUM matrix of 62. The Smith-Waterman homology search algorithm is disclosed in Smith & Waterman (1981) *Adv. Appl. Math.* 2: 482-489

BRIEF DESCRIPTION OF THE FIGURES

Figure 1 shows a side view of a syringe

Figure 2 shows a cross section of a top down view of a syringe

Figure 3 shows a view of a plunger

Figure 4 shows a cross section through a plunger

Figure 5 shows a stopper

MODES FOR CARRYING OUT THE INVENTION

The invention will now be further described, by way of example only, with reference to the drawings.

5 Figure 1 shows a view from a side of a syringe 1 comprising a body 2, plunger 4, backstop 6 and a sealing device 8.

Figure 2 shows a cross section through the syringe 1 of Figure 1 from above. The syringe 1 is suitable for use in an ophthalmic injection. The syringe 1 comprises a body 2, a stopper 10 and a plunger 4. The syringe 1 extends along a first axis A. The body 2 comprises an outlet 12 at an outlet end 14 and the stopper 10 is arranged within the body 2 such that a front surface 16 of the stopper 10 and the body 2 define a variable volume chamber 18. The variable volume chamber 18 contains an injectable medicament 20 comprising an ophthalmic solution comprising a VEGF antagonist such as ranibizumab. The injectable fluid 20 can be expelled through the outlet 12 by movement of the stopper 10 towards the outlet end 14 thereby reducing the volume of the variable volume chamber 18. The plunger 4 comprises a plunger contact surface 22 at a first end 24 and a rod 26 extending between the plunger contact surface 22 and a rear portion 25. The plunger contact surface 22 is arranged to contact the stopper 10, such that the plunger 4 can be used to move the stopper 10 towards the outlet end 14 of the body 2. Such movement reduces the volume of the variable volume chamber 18 and causes fluid therein to be expelled through the outlet.

20 The backstop 6 is attached to the body 2 by coupling to a terminal flange 28 of the body 2. The backstop 6 includes sandwich portion 30 which is adapted to substantially sandwich at least some of the terminal flange 28 of the body 2. The backstop 6 is adapted to be coupled to the body 2 from the side by leaving one side of the backstop 6 open so that the backstop 6 can be fitted to the syringe 2.

25 The body 2 defines a substantially cylindrical bore 36 which has a bore radius. The rod 26 comprises a rod shoulder 32 directed away from the outlet end 14. The rod shoulder 32 extends from to a rod shoulder radius from the first axis A which is such that it is slightly less than the bore radius so that the shoulder fits within the bore 36. The backstop 6 includes a backstop shoulder 34 directed towards the outlet end 14. The shoulders 32, 34 are configured to cooperate to substantially prevent movement of the rod 26 away from the outlet end 14 when the backstop shoulder 34 and rod shoulder 32 are in contact. The backstop shoulder 34 extends from outside the

PAT055157-EP-EPA

bore radius to a radius less than the rod shoulder radius so that the rod shoulder 32 cannot pass the backstop shoulder 34 by moving along the first axis A. In this case the rod shoulder 32 is substantially disc, or ring, shaped and the backstop shoulder 34 includes an arc around a rear end 38 of the body 2.

5 The backstop 6 also includes two finger projections 40 which extend in opposite directions away from the body 2 substantially perpendicular to the first axis A to facilitate manual handling of the syringe 1 during use.

In this example the syringe comprises a 0.5ml body 2 filled with between about 0.1 and 0.3 ml of an injectable medicament 20 comprising a 10mg/ml injectable solution comprising ranibizumab. The
10 syringe body 2 has an internal diameter of about between about 4.5mm and 4.8mm, a length of between about 45mm and 50mm.

The plunger 4 and stopper 10 will be described in more detail with reference to later figures.

Figure 3 shows a perspective view of the plunger 4 of Figure 1 showing the plunger contact surface 22 at the first end 24 of the plunger 4. The rod 26 extends from the first end 24 to the rear portion
15 25. The rear portion 25 includes a disc shaped flange 42 to facilitate user handling of the device. The flange 42 provides a larger surface area for contact by the user than a bare end of the rod 26.

Figure 4 shows a cross section through a syringe body 2 and rod 26. The rod 26 includes four longitudinal ribs 44 and the angle between the ribs is 90°.

Figure 5 shows a detailed view of a stopper 10 showing a conical shaped front surface 16 and three
20 circumferential ribs 52,54,56 around a substantially cylindrical body 58. The axial gap between the first rib 52 and the last rib 56 is about 3mm. The rear surface 60 of the stopper 10 includes a substantially central recess 62. The central recess 62 includes an initial bore 64 having a first diameter. The initial bore 64 leading from the rear surface 60 into the stopper 10 to an inner recess 66 having a second diameter, the second diameter being larger than the first diameter.

25

Stopper forces

0.5ml syringes siliconised with <100µg silicone oil, filled with Lucentis, comprising one of two different stopper designs were tested for maximal and average break out and slide force. Prior to testing, 30G x 0.5” needles were attached to the syringes. The testing was carried out at a stopper
30 speed of 190mm/min over a travel length of 10.9mm.

		Stopper design 1			Stopper design 2	
		Batch A	Batch B	Batch C	Batch D	Batch E
Break loose force of syringes	Average of 10 syringes	2.2N	2.3N	1.9N	2.1N	2.5N
	Max individual value	2.5N	2.5N	2.3N	2.6N	2.7N
Sliding force	Average of 10 syringes	3.1N	3.2N	3.1N	4.1N	4.6N
	Max individual value	3.5N	3.5N	3.6N	4.7N	4.8N

For both stopper designs, average and maximum break out force remained below 3N. For both stopper designs, average and maximum sliding force remained below 5N.

It will be understood that the invention has been described by way of example only and
 5 modifications may be made whilst remaining within the scope and spirit of the invention.

CLAIMS

1. A pre-filled syringe, the syringe comprising a body, a stopper and a plunger, the body comprising an outlet at an outlet end and the stopper being arranged within the body such that a front surface of the stopper and the body define a variable volume chamber from which a fluid
5 can be expelled though the outlet, the plunger comprising a plunger contact surface at a first end and a rod extending between the plunger contact surface and a rear portion, the plunger contact surface arranged to contact the stopper, such that the plunger can be used to force the stopper towards the outlet end of the body, reducing the volume of the variable volume chamber, characterised in that the fluid is an ophthalmic solution which comprises a VEGF-antagonist.
- 10 2. A pre-filled syringe according to claim 1, wherein the syringe has a nominal maximum fill volume of between about 0.1ml and about 1.5ml.
3. A pre-filled syringe according to claim 1 or claim 2, wherein the syringe has a nominal maximum fill volume of between about 0.5ml and about 1ml.
4. A pre-filled syringe according to any previous claim, wherein the syringe is filled with
15 between about 0.01ml and about 1.5ml of a VEGF antagonist solution.
5. A pre-filled syringe according to any previous claim, wherein the syringe is filled with between about 0.15ml and about 0.175ml of a VEGF antagonist solution.
6. A pre-filled syringe according to any previous claim, wherein the syringe is filled with a dosage volume of between about 0.03ml and about 0.05ml of a VEGF antagonist solution.
- 20 7. A pre-filled syringe according to any previous claim, wherein the syringe is filled with dosage volume of about 0.05ml of a VEGF antagonist solution.
8. A pre-filled syringe according to any previous claim, wherein the syringe barrel has an internal coating of silicone oil that has an average thickness of about 450nm or less.
9. A pre-filled syringe according to any previous claim, wherein the syringe barrel has an
25 internal coating of less than about 500µg silicone oil, preferably less than about 50µg silicone oil, preferably less than about 25µg silicone oil.
10. A pre-filled syringe according to any previous claim, wherein the silicone oil is DC365 emulsion.
11. A pre-filled syringe according to any previous claim, wherein the syringe is silicone oil free.

PAT055157-EP-EPA

12. A pre-filled syringe according to any previous claim, wherein the VEGF antagonist solution comprises one or more of (i) no more than 2 particles $\geq 50\mu\text{m}$ in diameter per ml, (ii) no more than 5 particles $\geq 25\mu\text{m}$ in diameter per ml, and (iii) no more than 50 particles $\geq 10\mu\text{m}$ in diameter per ml.
- 5 13. A pre-filled syringe according to any previous claim, wherein the VEGF antagonist solution meets USP789.
14. A pre-filled syringe according to any previous claim, wherein the VEGF antagonist is an anti-VEGF antibody.
15. A pre-filled syringe according to claim 14, wherein the anti-VEGF antibody is ranibizumab.
- 10 16. A pre-filled syringe according to any one of claims 1-13, wherein the VEGF antagonist is a non-antibody VEGF antagonist.
17. A pre-filled syringe according to claim 16, wherein the non-antibody VEGF antagonist is aflibercept or conbercept.
18. A pre-filled syringe according to claim 17, wherein the non-antibody VEGF antagonist is
15 aflibercept at a concentration of 40mg/ml.
19. A pre-filled syringe according to claim 18, wherein:
- (i) the syringe has a nominal maximum fill volume of between about 0.5ml and about 1ml,
 - (ii) the syringe is filled with between about 0.15ml and about 0.175ml of aflibercept,
 - 20 (iii) the syringe is filled with dosage volume of about 0.05ml,
 - (iv) the syringe barrel has an internal coating of less than about 500 μg silicone oil, and
 - (v) the VEGF antagonist solution comprises no more than 2 particles $\geq 50\mu\text{m}$ in diameter per ml.
20. A pre-filled syringe according to any previous claim, wherein the syringe has a stopper break
25 loose force of less than about 11N.
21. A pre-filled syringe according to claim 20, wherein the syringe has a stopper break loose force of less than about 5N.

PAT055157-EP-EPA

22. A pre-filled syringe according to any previous claim, wherein the syringe has a stopper slide force of less than about 11N.
23. A pre-filled syringe according to claim 22, wherein the syringe has a stopper slide force of less than about 5N.
- 5 24. A blister pack comprising a pre-filled syringe according to any previous claim, wherein the syringe has been sterilised using H₂O₂ or EtO.
25. A blister pack comprising a pre-filled syringe according to claim 24, wherein the outer surface of the syringe has \leq 1ppm EtO or hydrogen peroxide residue.
26. A blister pack comprising a pre-filled syringe according to claim 24, wherein the syringe has
10 been sterilised using EtO or hydrogen peroxide and the total EtO or hydrogen peroxide residue found on the outside of the syringe and inside of the blister pack is \leq 0.1mg.
27. A blister pack comprising a pre-filled syringe according to any one of claims 24-26, wherein \leq 5% of the VEGF antagonist is alkylated.
28. A blister pack comprising a pre-filled syringe according to any of claims 24-27, wherein the
15 syringe has been sterilised using EtO or hydrogen peroxide with a Sterility Assurance Level of at least 10⁻⁶.
29. A kit comprising: (i) a pre-filled syringe according to any one of claims 1-23, or a blister pack comprising a pre-filled syringe according to any one of claims 24-28, (ii) a needle, and optionally (iii) instructions for administration.
- 20 30. A kit according to claim 29, wherein the needle is a 30-gauge x ½ inch needle.
31. A pre-filled syringe according to any one of claims 1-23 for use in therapy.
32. A pre-filled syringe according to any one of claims 1-23 for use in the treatment of an ocular disease selected from choroidal neovascularisation, wet age-related macular degeneration, macular edema secondary to retinal vein occlusion (RVO) including both branch RVO (bRVO)
25 and central RVO (cRVO), choroidal neovascularisation secondary to pathologic myopia (PM), diabetic macular edema (DME), diabetic retinopathy, and proliferative retinopathy.
33. A method of treating a patient suffering from of an ocular disease selected from choroidal neovascularisation, wet age-related macular degeneration, macular edema secondary to retinal vein occlusion (RVO) including both branch RVO (bRVO) and central RVO (cRVO), choroidal

PAT055157-EP-EPA

neovascularisation secondary to pathologic myopia (PM), diabetic macular edema (DME), diabetic retinopathy, and proliferative retinopathy, comprising the step of administering an ophthalmic solution to the patient using a pre-filled syringe according to any one of claims 1-23.

34. The method of claim 33, further comprising an initial priming step in which the physician
5 depresses the plunger of the pre-filled syringe to align the pre-determined part of the stopper with the priming mark.

35. A method according to claim 33 or 34, wherein the VEGF antagonist administered is a non-antibody VEGF antagonist and wherein the patient has previously received treatment with an antibody VEGF antagonist.

10

1/1

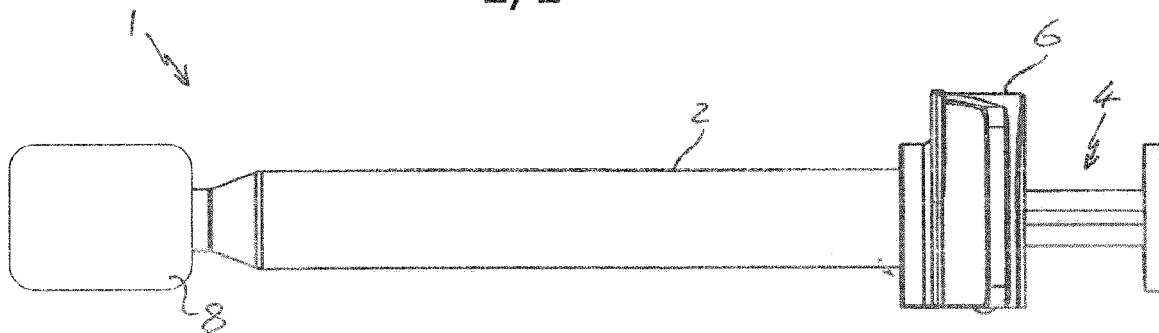

Fig 1

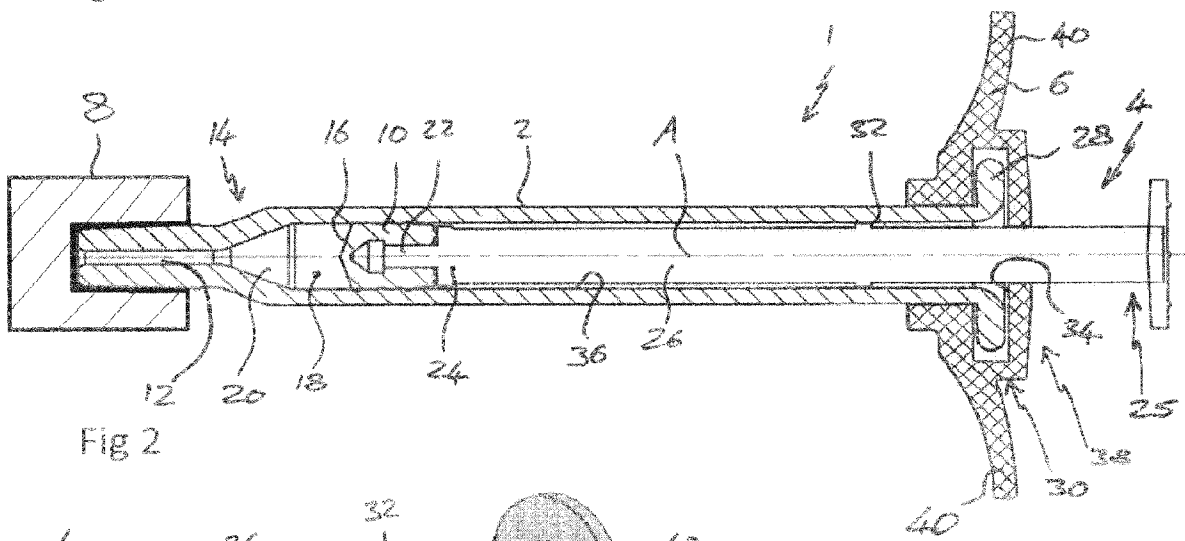

Fig 2

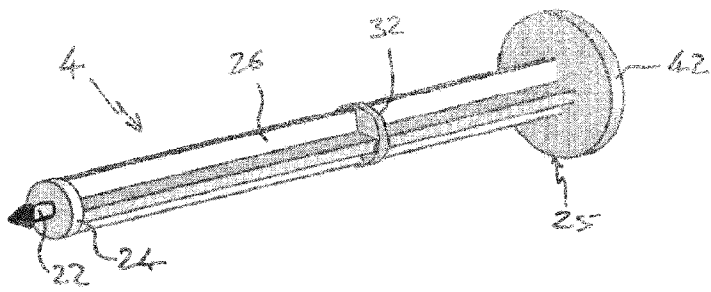

Fig 3

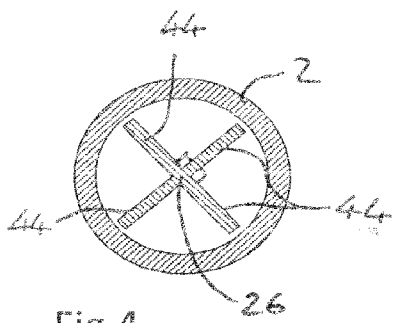

Fig 4

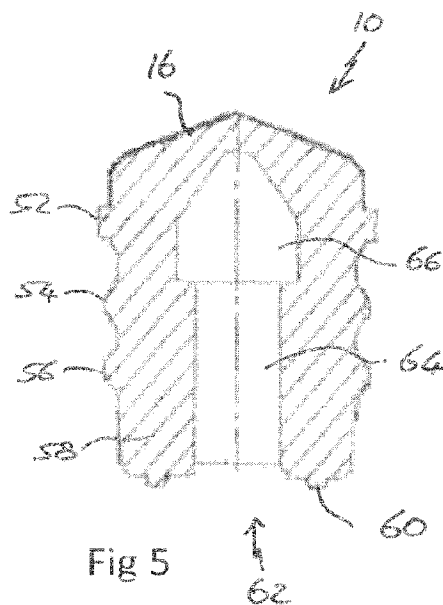

Fig 5

PAT055157-EP-EPA

ABSTRACT

The present invention relates to a syringe, particularly to a small volume syringe such as a syringe suitable for ophthalmic injections.



Bescheinigung

Die angehefteten Unterlagen stimmen mit der als ursprünglich eingereicht geltenden Fassung der auf dem nächsten Blatt bezeichneten europäischen Patentanmeldung überein.

Certificate

The attached documents are exact copies of the text in which the European patent application described on the following page is deemed to have been filed.

Attestation

Les documents joints à la présente attestation sont conformes au texte, considéré comme initialement déposé, de la demande de brevet européen qui est spécifiée à la page suivante.

Patentanmeldung Nr.

Patent application No.

Demande de brevet n°

12174860.2 / EP12174860

The organization code and number of your priority application, to be used for filing abroad under the Paris Convention, is EP12174860.

Der Präsident des Europäischen Patentamts;
Im Auftrag

For the President of the European Patent Office

Le Président de l'Office européen des brevets
p.o.

U. Ingmann

Anmeldung Nr:
Application no.: 12174860.2
Demande no. :

Anmeldetag:
Date of filing: 03.07.12
Date de dépôt :

Anmelder / Applicant(s) / Demander(s):

Novartis AG
Lichtstrasse 35
4056 Basel/CH

Bezeichnung der Erfindung / Title of the invention / Titre de l'invention:

(Falls die Bezeichnung der Erfindung nicht angegeben ist, oder falls die Anmeldung in einer Nicht-Amtssprache des EPA eingereicht wurde, siehe Beschreibung bezüglich ursprünglicher Bezeichnung.

If no title is shown, or if the application has been filed in a non-EPO language, please refer to the description for the original title.

Si aucun titre n'est indiqué, ou si la demande a été déposée dans une langue autre qu'une langue officielle de l'OEB, se référer à la description pour le titre original.)

Syringe

In Anspruch genommene Priorität(en) / Priority(Priorities) claimed / Priorité(s) revendiquée(s)
Staat/Tag/Aktenzeichen / State/Date/File no. / Pays/Date/Numéro de dépôt:

Am Anmeldetag benannte Vertragsstaaten / Contracting States designated at date of filing / Etats contractants désignées lors du dépôt:

AL AT BE BG CH CY CZ DE DK EE ES FI FR GB GR HR HU IE IS IT LI LT LU LV MC MK MT NL NO PL
PT RO RS SE SI SK SM TR

SYRINGE

TECHNICAL FIELD

The present invention relates to a syringe, particularly to a small volume syringe such as a syringe suitable for ophthalmic injections.

5 BACKGROUND ART

Many medicaments are delivered to a patient in a syringe from which the user can dispense the medicament. If medicament is delivered to a patient in a syringe it is often to enable the patient, or a caregiver, to inject the medicament. It is important for patient safety and medicament integrity that the syringe and the contents of that syringe are sufficiently sterile to avoid
10 infection, or other, risks for patients. Sterilisation can be achieved by terminal sterilisation in which the assembled product, typically already in its associated packaging, is sterilised using heat or a sterilising gas.

For small volume syringes, for example those for injections into the eye in which it is intended that about 0.1ml or less of liquid is to be injected the sterilisation can pose difficulties that are
15 not necessarily associated with larger syringes. Changes in pressure, internal or external to the syringe, can cause parts of the syringe to move unpredictably, which may alter sealing characteristics and potentially compromise sterility. Incorrect handling of the syringe can also pose risks to product sterility.

Furthermore, certain therapeutics such as biologic molecules are particularly sensitive to
20 sterilisation, be it cold gas sterilisation, thermal sterilisation, or irradiation. Thus, a careful balancing act is required to ensure that while a suitable level of sterilisation is carried out, the syringe remains suitably sealed, such that the therapeutic is not compromised.

There is therefore a need for a new syringe construct which provides a robust seal for its content, but which maintains ease of use.

25 DISCLOSURE OF THE INVENTION

The present invention provides a pre-filled syringe, the syringe comprising a body, a stopper and a plunger, the body comprising an outlet at an outlet end and the stopper being arranged within the body such that a front surface of the stopper and the body define a variable volume chamber from which a fluid can be expelled through the outlet, the plunger comprising a plunger contact
30 surface at a first end and a rod extending between the plunger contact surface and a rear portion,

PAT055157-EP-EPA

the plunger contact surface arranged to contact the stopper, such that the plunger can be used to force the stopper towards the outlet end of the body, reducing the volume of the variable volume chamber, characterised in that the fluid comprises an ophthalmic solution. In one embodiment, the ophthalmic solution comprises a VEGF-antagonist.

- 5 In one embodiment, the syringe is suitable for ophthalmic injections, more particularly intravitreal injections, and as such has a suitably small volume. The syringe may also be silicone free, or substantially silicone free, or may comprise a low level of silicone oil as lubricant.

For ophthalmic injections, it is particularly important for the ophthalmic solution to have particularly low particle content. In one embodiment, the syringe meets US Pharmacopeia
10 standard 789 (USP789).

Syringe

The body of the syringe may be a substantially cylindrical shell, or may include a substantially cylindrical bore with a non circular outer shape. The outlet end of the body includes an outlet through which a fluid housed within the variable volume chamber can be expelled as the volume
15 of said chamber is reduced. The outlet may comprise a projection from the outlet end through which extends a channel having a smaller diameter than that of the variable volume chamber. The outlet may be adapted, for example via a luer lock type connection, for connection to a needle or other accessory such as a sealing device which is able to seal the variable volume chamber, but can be operated, or removed, to unseal the variable volume chamber and allow
20 connection of the syringe to another accessory, such as a needle. Such a connection may be made directly between the syringe and accessory, or via the sealing device. The body extends along a first axis from the outlet end to a rear end.

The body may be made from a plastic material (e.g. a cyclic olefin polymer) or from glass and may include indicia on a surface thereof to act as an injection guide. In one embodiment the
25 body may comprise a priming mark. This allows the physician to align a pre-determined part of the stopper (such as the tip of the front surface or one of the circumferential ribs, discussed later) with the mark, thus expelling excess ophthalmic solution and any air bubbles from the syringe. The priming process ensures that an exact, pre-determined dosage is administered to the patient.

The stopper may be made from rubber, silicone or other suitable resiliently deformable material.
30 The stopper may be substantially cylindrical and the stopper may include one or more circumferential ribs around an outer surface of the stopper, the stopper and ribs being

PAT055157-EP-EPA

dimensioned such that the ribs form a substantially fluid tight seal with an internal surface of the syringe body. The front surface of the stopper may be any suitable shape, for example substantially planar, substantially conical or of a domed shape. The rear surface of the stopper may include a substantially central recess. Such a central recess could be used to connect a plunger to the stopper using a snap fit feature or thread connection in a known manner. The stopper may be substantially rotationally symmetric about an axis through the stopper.

The plunger comprises a plunger contact surface and extending from that a rod extends from the plunger contact surface to a rear portion. The rear portion may include a user contact portion adapted to be contacted by a user during an injection event. The user contact portion may comprise a substantially disc shaped portion, the radius of the disc extending substantially perpendicular to the axis along which the rod extends. The user contact portion could be any suitable shape. The axis along which the rod extends may be the first axis, or may be substantially parallel with the first axis.

The syringe may include a backstop arranged at a rear portion of the body. The backstop may be removable from the syringe. If the syringe body includes terminal flanges at the end opposite the outlet end the backstop may be configured to substantially sandwich terminal flanges of the body as this prevent movement of the backstop in a direction parallel to the first axis.

The rod may comprise at least one rod shoulder directed away from the outlet end and the backstop may include a backstop shoulder directed towards the outlet end to cooperate with the rod shoulder to substantially prevent movement of the rod away from the outlet end when the backstop shoulder and rod shoulder are in contact. Restriction of the movement of the rod away from the outlet end can help to maintain sterility during terminal sterilisation operations, or other operations in which the pressure within the variable volume chamber or outside the chamber may change. During such operations any gas trapped within the variable volume chamber, or bubbles that may form in a liquid therein, may change in volume and thereby cause the stopper to move. Movement of the stopper away from the outlet could result in the breaching of a sterility zone created by the stopper. This is particularly important for low volume syringes where there are much lower tolerances in the component sizes and less flexibility in the stopper. The term sterility zone as used herein is used to refer to the area within the syringe that is sealed by the stopper from access from either end of the syringe. This may be the area between a seal of the stopper, for example a circumferential rib, closest to the outlet and a seal of the stopper, for example a circumferential rib, furthest from the outlet. The distance between these two seals

PAT055157-EP-EPA

defines the sterility zone of the stopper since the stopper is installed into the syringe barrel in a sterile environment.

To further assist in maintaining sterility during the operations noted above the stopper may comprise at a front circumferential rib and a rear circumferential rib and those ribs may be separated in a direction along the first axis by at least 3mm, by at least 3.5 mm, by at least 3.75mm or by 4mm or more. One or more additional ribs (for example 2, 3, 4 or 5 additional ribs, or between 1-10, 2-8, 3-6 or 4-5 additional ribs) may be arranged between the front and rear ribs. In one embodiment there are a total of three circumferential ribs.

A stopper with such an enhanced sterility zone can also provide protection for the injectable medicament during a terminal sterilisation process. More ribs on the stopper, or a greater distance between the front and rear ribs can reduce the potential exposure of the medicament to the sterilising agent. However, increasing the number of ribs can increase the friction between the stopper and syringe body, reducing ease of use. While this may be overcome by increasing the siliconisation of the syringe, such an increase in silicone levels is particularly undesirable for syringes for ophthalmic use.

The rod shoulder may be arranged within the external diameter of the rod, or may be arranged outside the external diameter of the rod. By providing a shoulder that extends beyond the external diameter of the rod, but still fits within the body, the shoulder can help to stabilise the movement of the rod within the body by reducing movement of the rod perpendicular to the first axis. The rod shoulder may comprise any suitable shoulder forming elements on the rod, but in one embodiment the rod shoulder comprises a substantially disc shaped portion on the rod.

In one embodiment of the syringe, when arranged with the plunger contact surface in contact with the stopper and the variable volume chamber is at its intended maximum volume there is a clearance of no more than about 2mm between the rod shoulder and backstop shoulder. In some embodiments there is a clearance of less than about 1.5 mm and in some less than about 1mm. This distance is selected to substantially limit or prevent excessive rearward (away from the outlet end) movement of the stopper.

In one embodiment the variable volume chamber has an internal diameter greater than 5mm or 6mm and less than 3mm or 4mm. The internal diameter may be between 3mm and 6mm, or between 4mm and 5mm.

PAT055157-EP-EPA

In another embodiment the syringe is dimensioned so as to have a nominal maximum fill volume of between about 0.1ml and about 1.5ml. In certain embodiments the nominal maximum fill volume is between about 0.5ml and about 1ml. In certain embodiments the nominal maximum fill volume is about 0.5ml or about 1ml, or about 1.5ml.

5 The length of the body of the syringe may be less than 70mm, less than 60mm or less than 50mm. In one embodiment the length of the syringe body is between 45mm and 50mm.

In one embodiment, the syringe is filled with between about 0.01ml and about 1.5ml (for example between about 0.05ml and about 1ml, between about 0.1ml and about 0.5ml, between about 0.15ml and about 0.175ml) of a VEGF antagonist solution. In one embodiment, the syringe is filled with 0.165ml of a VEGF antagonist solution. Of course, typically a syringe is filled with more than the desired dose to be administered to the patient, to take into account wastage due to “dead space” within the syringe and needle. There may also be a certain amount of wastage when the syringe is primed by the physician, so that it is ready to inject the patient.

10 Thus, in one embodiment, the syringe is filled with a dosage volume (i.e. the volume of medicament intended for delivery to the patient) of between about 0.01ml and about 1.5ml (e.g. between about 0.05ml and about 1ml, between about 0.1ml and about 0.5ml) of a VEGF antagonist solution. In one embodiment, the dosage volume is between about 0.03ml and about 0.05ml. For example, for Lucentis, the dosage volume is 0.05ml or 0.03ml (0.5mg or 0.3mg) of a 10mg/ml injectable medicament solution; for Eylea, the dosage volume is 0.05ml of a 40mg/ml injectable medicament solution.

15 In one embodiment the length of the syringe body is between about 45mm and about 50mm, the internal diameter is between about 4mm and about 5mm, the fill volume is between about 0.12 and about 0.3ml and the dosage volume is between about 0.03ml and about 0.05ml.

20 As the syringe contains a medicament solution, the outlet may be reversibly sealed to maintain sterility of the medicament. This sealing may be achieved through the use of a sealing device as is known in the art. For example the OVSTM system which is available from Vetter Pharma International GmbH.

25 It is typical to siliconise the syringe in order to allow ease of use, i.e. to apply silicone to the inside of the barrel, which decreases the force required to move the stopper. However, for ophthalmic use, it is desirable to decrease the likelihood of silicone droplets being injected into the eye. Furthermore, silicone can cause proteins to aggregate. A typical 1ml syringe comprises

PAT055157-EP-EPA

100-800µg silicone in the barrel. Thus, in one embodiment, a syringe according to the invention comprises less than about 800µg (i.e. about less than about 500µg, less than about 300µg, less than about 200µg, less than about 100µg, less than about 75µg, less than about 50µg, less than about 25µg, less than about 15µg, less than about 10µg) silicone in the barrel. Methods for
5 measuring the amount of silicone in such a syringe barrel are known in the art and include, for example, differential weighing methods and quantitation by infrared-spectroscopy of the oil diluted in a suitable solvent.

During testing it was found that, for syringes having small dimensions, such as those discussed above, and particularly those described in conjunction with the Figures below, the break loose
10 and sliding forces for the stopper within the syringe are substantially unaffected by reducing the siliconisation levels far below the current standard to the levels discussed here. In one embodiment the glide force for the stopper within the pre-filled syringe is less than about 11N or less than 9N, less than 7N, less than 5N or between about 3N to 5N. Having too great a force required to move the stopper can cause problems during use for some users, for example
15 accurate dose setting or smooth dose delivery may be made more difficult if significant strength is required to move, and/or keep in motion, the stopper.

In one embodiment the syringe barrel has an internal coating of silicone that has an average thickness of about 450nm or less (i.e. 400nm or less, 350nm or less, 300nm or less, 200nm or less, 100nm or less, 50nm or less, 20nm or less). Methods to measure the thickness of silicone in
20 a syringe are known in the art and include the rap.ID Layer Explorer® Application, which can also be used to measure the mass of silicone inside a syringe barrel.

In one embodiment, the syringe is silicone free, or substantially silicone free. Such low silicone levels can be achieved by using uncoated syringe barrels and/or by avoiding the use of silicone as a lubricant for product contacting machine parts, or pumps in the syringe assembly and fill
25 line.

The syringe according to the invention may also meet certain requirements for particulate content. In one embodiment, the ophthalmic solution comprises no more than 2 particles $\geq 50\mu\text{m}$ in diameter per ml. In one embodiment, the ophthalmic solution comprises no more than 5 particles $\geq 25\mu\text{m}$ in diameter per ml. In one embodiment, the ophthalmic solution comprises no
30 more than 50 particles $\geq 10\mu\text{m}$ in diameter per ml. In one embodiment, the ophthalmic solution comprises no more than 2 particles $\geq 50\mu\text{m}$ in diameter per ml, no more than 5 particles $\geq 25\mu\text{m}$ in diameter per ml and no more than 50 particles $\geq 10\mu\text{m}$ in diameter per ml. In one embodiment,

PAT055157-EP-EPA

a syringe according to the invention meets USP789. In one embodiment the syringe has low levels of silicone sufficient for the syringe to meet USP789.

VEGF Antagonists

Antibody VEGF antagonists

5 VEGF is a well-characterised signal protein which stimulates angiogenesis. Two antibody VEGF antagonists have been approved for human use, namely ranibizumab (Lucentis®) and bevacizumab (Avastin®).

Non-Antibody VEGF antagonists

In one aspect of the invention, the non-antibody VEGF antagonist is an immunoadhesin. One
10 such immunoadhesin is aflibercept (Eylea®), which has recently been approved for human use and is also known as VEGF-trap (Holash *et al.* (2002) *PNAS USA* 99:11393-98; Riely & Miller (2007) *Clin Cancer Res* 13:4623-7s). Aflibercept is the preferred non-antibody VEGF antagonist for use with the invention. Aflibercept is a recombinant human soluble VEGF receptor fusion protein consisting of portions of human VEGF receptors 1 and 2 extracellular domains fused to
15 the Fc portion of human IgG1. It is a dimeric glycoprotein with a protein molecular weight of 97 kilodaltons (kDa) and contains glycosylation, constituting an additional 15% of the total molecular mass, resulting in a total molecular weight of 115 kDa. It is conveniently produced as a glycoprotein by expression in recombinant CHO K1 cells. Each monomer can have the following amino acid sequence (SEQ ID NO: 1):

20 SDTGRPFVEMYSEIPEIIHMTEGRELVIPCRVTSFNITVTLKKFPLDTLIPDGKRIIWDNRKGFIIISNATY
KEIGLLTCEATVNGHLYKTNYLTHRQTNTIIDVVLSPSHGIELSVGEKLVLNCTARTELVNVIDFNWEYPS
SKHQHKKLVNRDLKTQSGSEMKKFLSTLTIDGVTRSDQGLYTCAASSGLMTKKNSTFVRVHEKDKTHTCPP
CPAPELLGGPSVFLFPPKPKDITLMSRTEPVTVCVVVDVSHEDPEVKFNWYVDGVEVHNAKTKPREEQYNST
YRVVSVLTVLHQDWLNGKEYKCKVSNKALPAPIEKTISKAKGQPREPQVYTLPPSRDELTKNQVSLTCLVK
25 GFYPSDIAVEWESNGQPENNYKTTTPVLDSDGSFFLYSKLTVDKSRWQQGNVFCSSVMHEALHNHYTQKSL
SLSPG

and disulfide bridges can be formed between residues 30-79, 124-185, 246-306 and 352-410 within each monomer, and between residues 211-211 and 214-214 between the monomers.

Another non-antibody VEGF antagonist immunoadhesin currently in pre-clinical development is
30 a recombinant human soluble VEGF receptor fusion protein similar to VEGF-trap containing extracellular ligand-binding domains 3 and 4 from VEGFR2/KDR, and domain 2 from VEGFR1/Flt-1; these domains are fused to a human IgG Fc protein fragment (Li et al., 2011

PAT055157-EP-EPA

Molecular Vision 17:797-803). This antagonist binds to isoforms VEGF-A, VEGF-B and VEGF-C. The molecule is prepared using two different production processes resulting in different glycosylation patterns on the final proteins. The two glycoforms are referred to as KH902 (conbercept) and KH906. The fusion protein can have the following amino acid sequence (SEQ

5 ID NO:2):

MVSYWDTGVLLCALLSCLLLTGSSSGGRPFVEMYSEIPEIIHMTEGRELVI PCRVTSPNITVTLKKFPLDT
LIPDGKRIIWDSRKGFIISNATYKEIGLLTCEATVNGHLYKTNYLTHRQTNTIIDVVLSPSHGIELSVGEK
LVLNCTARTELVNGIDFNWEYPSSKHQHKLVNRDLKTQSGSEMKKFLSTLTIDGVTRSDQGLYTCAASSG
LMTKKNSTFVRVHEKPFVAFGSGMESLVEATVGERVRLPAKYLGYPPEIKWYKNGI PLESNHTIKAGHVL
10 TIMEVSRDGTGNYTVILTNPISKEKQSHVVSLVVYVPPGPGDKTHTCPLCPAPELLGGPSVFLFPPKPKDT
LMISRTPEVTCVVVDVSHEDPEVKFNWYVDGVEVHNAKTKPREEQYNSTYRVVSVLTVLHQDWLNGKEYKC
KVSNAKALPAIEKTIKAKGQPREPQVYTLPPSRDELTKNQVSLTCLVKGFYPSDIAVEWESNGQPENNYK
ATPPVLDSDGSFFLYSKLTVDKSRWQQGNV FSCSVMEALHNHYTQKSLSLSPGK

and, like VEGF-trap, can be present as a dimer. This fusion protein and related molecules are
15 further characterized in EP1767546.

Other non-antibody VEGF antagonists include antibody mimetics (e.g. Affibody® molecules, affilins, affitins, anticalins, avimers, Kunitz domain peptides, and monobodies) with VEGF antagonist activity. This includes recombinant binding proteins comprising an ankyrin repeat domain that binds VEGF-A and prevents it from binding to VEGFR-2. One example for such a
20 molecule is DARPin® MP0112. The ankyrin binding domain may have the following amino acid sequence (SEQ ID NO: 3):

GSDLGKKLLEAARAGQDDEVRI LMANGADVNTADSTGWTPLHLAVPWGHLEIVEVLLKYGADVNAKDFQGW
TPLHLAAAIGHQEIVEVLLKNGADVNAQDKFGKTAFDISIDNGNEDLAEILQKAA

Recombinant binding proteins comprising an ankyrin repeat domain that binds VEGF-A and
25 prevents it from binding to VEGFR-2 are described in more detail in WO2010/060748 and WO2011/135067.

Further specific antibody mimetics with VEGF antagonist activity are the 40 kD pegylated anticalin PRS-050 and the monobody angiocept (CT-322).

The afore-mentioned non-antibody VEGF antagonist may be modified to further improve their
30 pharmacokinetic properties or bioavailability. For example, a non-antibody VEGF antagonist may be chemically modified (e.g., pegylated) to extend its *in vivo* half-life. Alternatively or in addition, it may be modified by glycosylation or the addition of further glycosylation sites not

PAT055157-EP-EPA

present in the protein sequence of the natural protein from which the VEGF antagonist was derived.

Variants of the above-specified VEGF antagonists that have improved characteristics for the desired application may be produced by the addition or deletion of amino acids. Ordinarily, these amino acid sequence variants will have an amino acid sequence having at least 60% amino acid sequence identity with the amino acid sequences of SEQ ID NO: 1, SEQ ID NO: 2 or SEQ ID NO: 3, preferably at least 80%, more preferably at least 85%, more preferably at least 90%, and most preferably at least 95%, including for example, 80%, 81%, 82%, 83%, 84%, 85%, 86%, 87%, 88%, 89%, 90%, 91%, 92%, 93%, 94%, 95%, 96%, 97%, 98%, 99%, and 100%. Identity or homology with respect to this sequence is defined herein as the percentage of amino acid residues in the candidate sequence that are identical with SEQ ID NO: 1, SEQ ID NO: 2 or SEQ ID NO: 3, after aligning the sequences and introducing gaps, if necessary, to achieve the maximum percent sequence identity, and not considering any conservative substitutions as part of the sequence identity.

Sequence identity can be determined by standard methods that are commonly used to compare the similarity in position of the amino acids of two polypeptides. Using a computer program such as BLAST or FASTA, two polypeptides are aligned for optimal matching of their respective amino acids (either along the full length of one or both sequences or along a pre-determined portion of one or both sequences). The programs provide a default opening penalty and a default gap penalty, and a scoring matrix such as PAM 250 [a standard scoring matrix; see Dayhoff et al., in Atlas of Protein Sequence and Structure, vol. 5, supp. 3 (1978)] can be used in conjunction with the computer program. For example, the percent identity can then be calculated as: the total number of identical matches multiplied by 100 and then divided by the sum of the length of the longer sequence within the matched span and the number of gaps introduced into the longer sequences in order to align the two sequences.

Preferably, the non-antibody VEGF antagonist of the invention binds to VEGF via one or more protein domain(s) that are not derived from the antigen-binding domain of an antibody. The non-antibody VEGF antagonist of the invention are preferably proteinaceous, but may include modifications that are non-proteinaceous (e.g., pegylation, glycosylation).

30 *Therapy*

The syringe of the invention may be used to treat an ocular disease, including but not limited to choroidal neovascularisation, age-related macular degeneration (both wet and dry forms),

PAT055157-EP-EPA

macular edema secondary to retinal vein occlusion (RVO) including both branch RVO (bRVO) and central RVO (cRVO), choroidal neovascularisation secondary to pathologic myopia (PM), diabetic macular edema (DME), diabetic retinopathy, and proliferative retinopathy.

Thus the invention provides a method of treating a patient suffering from of an ocular disease selected from choroidal neovascularisation, wet age-related macular degeneration, macular edema secondary to retinal vein occlusion (RVO) including both branch RVO (bRVO) and central RVO (cRVO), choroidal neovascularisation secondary to pathologic myopia (PM), diabetic macular edema (DME), diabetic retinopathy, and proliferative retinopathy, comprising the step of administering an ophthalmic solution to the patient using a pre-filled syringe of the invention. This method preferably further comprises an initial priming step in which the physician depresses the plunger of the pre-filled syringe to align the pre-determined part of the stopper with the priming mark.

Kits

Also provided are kits comprising the pre-filled syringes of the invention. In one embodiment, such a kit comprises a pre-filled syringe of the invention in a blister pack. The blister pack may itself be sterile on the inside. In one embodiment, syringes according to the invention may be placed inside such blister packs prior to undergoing sterilisation, for example terminal sterilisation.

Such a kit may further comprise a needle for administration of the VEGF antagonist. If the VEGF antagonist is to be administered intravitreally, it is typical to use a 30-gauge x ½ inch needle, though 31-gauge and 32-gauge needles may be used. Such kits may further comprise instructions for use. In one embodiment, the invention provides a carton containing a pre-filled syringe according to the invention contained within a blister pack, a needle and optionally instructions for administration.

Sterilisation

As noted above, a terminal sterilisation process may be used to sterilise the syringe and such a process may use a known process such as an ethylene oxide or a hydrogen peroxide sterilisation process. Needles to be used with the syringe may be sterilised by the same method, as may kits according to the invention.

The package is exposed to the sterilising gas until the outside of the syringe is sterile. Following such a process, the outer surface of the syringe may remain sterile (whilst in its blister pack) for

PAT055157-EP-EPA

up to 6 months, 9 months, 12 months, 15 months, 18 months or longer. In one embodiment, less than one syringe in a million has detectable microbial presence on the outside of the syringe after 18 months of storage. In one embodiment, the pre-filled syringe has been sterilised using EtO with a Sterility Assurance Level of at least 10^{-6} . Of course, it is a requirement that significant amounts of the sterilising gas should not enter the variable volume chamber of the syringe. The term “significant amounts” as used herein refers to an amount of gas that would cause unacceptable modification of the ophthalmic solution within the variable volume chamber. In one embodiment, the sterilisation process causes $\leq 10\%$ (preferably $\leq 5\%$, $\leq 3\%$, $\leq 1\%$) alkylation of the VEGF antagonist. In one embodiment, the pre-filled syringe has been sterilised using EtO, but the outer surface of the syringe has $\leq 1\text{ppm}$, preferably $\leq 0.2\text{ppm}$ EtO residue.

General

The term “comprising” means “including” as well as “consisting” *e.g.* a composition “comprising” X may consist exclusively of X or may include something additional *e.g.* X + Y.

The term “about” in relation to a numerical value x means, for example, $x \pm 10\%$.

References to a percentage sequence identity between two amino acid sequences means that, when aligned, that percentage of amino acids are the same in comparing the two sequences. This alignment and the percent homology or sequence identity can be determined using software programs known in the art, for example those described in section 7.7.18 of *Current Protocols in Molecular Biology* (F.M. Ausubel *et al.*, eds., 1987) Supplement 30. A preferred alignment is determined by the Smith-Waterman homology search algorithm using an affine gap search with a gap open penalty of 12 and a gap extension penalty of 2, BLOSUM matrix of 62. The Smith-Waterman homology search algorithm is disclosed in Smith & Waterman (1981) *Adv. Appl. Math.* 2: 482-489

25 BRIEF DESCRIPTION OF THE FIGURES

Figure 1 shows a side view of a syringe

Figure 2 shows a cross section of a top down view of a syringe

Figure 3 shows a view of a plunger

Figure 4 shows a cross section through a plunger

Figure 5 shows a stopper

MODES FOR CARRYING OUT THE INVENTION

The invention will now be further described, by way of example only, with reference to the drawings.

5 Figure 1 shows a view from a side of a syringe 1 comprising a body 2, plunger 4, backstop 6 and a sealing device 8.

Figure 2 shows a cross section through the syringe 1 of Figure 1 from above. The syringe 1 is suitable for use in an ophthalmic injection. The syringe 1 comprises a body 2, a stopper 10 and a plunger 4. The syringe 1 extends along a first axis A. The body 2 comprises an outlet 12 at an outlet end 14 and the stopper 10 is arranged within the body 2 such that a front surface 16 of the stopper 10 and the body 2 define a variable volume chamber 18. The variable volume chamber 18 contains an injectable medicament 20 comprising an ophthalmic solution comprising a VEGF antagonist such as ranibizumab. The injectable fluid 20 can be expelled through the outlet 12 by movement of the stopper 10 towards the outlet end 14 thereby reducing the volume of the variable volume chamber 18. The plunger 4 comprises a plunger contact surface 22 at a first end 24 and a rod 26 extending between the plunger contact surface 22 and a rear portion 25. The plunger contact surface 22 is arranged to contact the stopper 10, such that the plunger 4 can be used to move the stopper 10 towards the outlet end 14 of the body 2. Such movement reduces the volume of the variable volume chamber 18 and causes fluid therein to be expelled through the outlet.

20 The backstop 6 is attached to the body 2 by coupling to a terminal flange 28 of the body 2. The backstop 6 includes sandwich portion 30 which is adapted to substantially sandwich at least some of the terminal flange 28 of the body 2. The backstop 6 is adapted to be coupled to the body 2 from the side by leaving one side of the backstop 6 open so that the backstop 6 can be fitted to the syringe 2.

25 The body 2 defines a substantially cylindrical bore 36 which has a bore radius. The rod 26 comprises a rod shoulder 32 directed away from the outlet end 14. The rod shoulder 32 extends from to a rod shoulder radius from the first axis A which is such that it is slightly less than the bore radius so that the shoulder fits within the bore 36. The backstop 6 includes a backstop shoulder 34 directed towards the outlet end 14. The shoulders 32, 34 are configured to cooperate to substantially prevent movement of the rod 26 away from the outlet end 14 when the backstop shoulder 34 and rod shoulder 32 are in contact. The backstop shoulder 34 extends from outside the

30

PAT055157-EP-EPA

bore radius to a radius less than the rod shoulder radius so that the rod shoulder 32 cannot pass the backstop shoulder 34 by moving along the first axis A. In this case the rod shoulder 32 is substantially disc, or ring, shaped and the backstop shoulder 34 includes an arc around a rear end 38 of the body 2.

5 The backstop 6 also includes two finger projections 40 which extend in opposite directions away from the body 2 substantially perpendicular to the first axis A to facilitate manual handling of the syringe 1 during use.

In this example the syringe comprises a 0.5ml body 2 filled with between about 0.1 and 0.3 ml of an injectable medicament 20 comprising a 10mg/ml injectable solution comprising ranibizumab. The
10 syringe body 2 has an internal diameter of about between about 4.5mm and 4.8mm, a length of between about 45mm and 50mm.

The plunger 4 and stopper 10 will be described in more detail with reference to later figures.

Figure 3 shows a perspective view of the plunger 4 of Figure 1 showing the plunger contact surface 22 at the first end 24 of the plunger 4. The rod 26 extends from the first end 24 to the rear portion
15 25. The rear portion 25 includes a disc shaped flange 42 to facilitate user handling of the device. The flange 42 provides a larger surface area for contact by the user than a bare end of the rod 26.

Figure 4 shows a cross section through a syringe body 2 and rod 26. The rod 26 includes four longitudinal ribs 44 and the angle between the ribs is 90°.

Figure 5 shows a detailed view of a stopper 10 showing a conical shaped front surface 16 and three
20 circumferential ribs 52,54,56 around a substantially cylindrical body 58. The axial gap between the first rib 52 and the last rib 56 is about 3mm. The rear surface 60 of the stopper 10 includes a substantially central recess 62. The central recess 62 includes an initial bore 64 having a first diameter. The initial bore 64 leading from the rear surface 60 into the stopper 10 to an inner recess 66 having a second diameter, the second diameter being larger than the first diameter.

25

It will be understood that the invention has been described by way of example only and modifications may be made whilst remaining within the scope and spirit of the invention.

30

CLAIMS

1. A pre-filled syringe, the syringe comprising a body, a stopper and a plunger, the body comprising an outlet at an outlet end and the stopper being arranged within the body such that a front surface of the stopper and the body define a variable volume chamber from which a fluid
5 can be expelled though the outlet, the plunger comprising a plunger contact surface at a first end and a rod extending between the plunger contact surface and a rear portion, the plunger contact surface arranged to contact the stopper, such that the plunger can be used to force the stopper towards the outlet end of the body, reducing the volume of the variable volume chamber, characterised in that the fluid is an ophthalmic solution which comprises a VEGF-antagonist.
- 10 2. A pre-filled syringe according to claim 1, wherein the syringe has a nominal maximum fill volume of between about 0.1ml and about 1.5ml.
3. A pre-filled syringe according to claim 1 or claim 2, wherein the syringe has a nominal maximum fill volume of between about 0.5ml and about 1ml.
4. A pre-filled syringe according to any previous claim, wherein the syringe is filled with
15 between about 0.01ml and about 1.5ml of a VEGF antagonist solution.
5. A pre-filled syringe according to any previous claim, wherein the syringe is filled with between about 0.15ml and about 0.175ml of a VEGF antagonist solution.
6. A pre-filled syringe according to any previous claim, wherein the syringe is filled with dosage volume of between about 0.03ml and about 0.05ml of a VEGF antagonist solution.
- 20 7. A pre-filled syringe according to any previous claim, wherein the syringe is filled with dosage volume of about 0.05ml of a VEGF antagonist solution.
8. A pre-filled syringe according to any previous claim, wherein the syringe barrel has an internal coating of silicone that has an average thickness of about 450nm or less.
8. A pre-filled syringe according to any previous claim, wherein the syringe barrel has an
25 internal coating of less than about 500µg silicone.
9. A pre-filled syringe according to any previous claim, wherein the syringe is silicone free.
10. A pre-filled syringe according to any previous claim, wherein the VEGF antagonist solution comprises one or more of (i) no more than 2 particles $\geq 50\mu\text{m}$ in diameter per ml, (ii) no more

PAT055157-EP-EPA

than 5 particles $\geq 25\mu\text{m}$ in diameter per ml, and (iii) no more than 50 particles $\geq 10\mu\text{m}$ in diameter per ml.

11. A pre-filled syringe according to any previous claim, wherein the VEGF antagonist solution meets USP789.

5 12. A pre-filled syringe according to any previous claim, wherein the VEGF antagonist is an anti-VEGF antibody.

13. A pre-filled syringe according to claim 12, wherein the anti-VEGF antibody is ranibizumab.

14. A pre-filled syringe according to claim 11, wherein the VEGF antagonist is a non-antibody VEGF antagonist.

10 15. A pre-filled syringe according to claim 14, wherein the non-antibody VEGF antagonist is aflibercept or conbercept.

16. A pre-filled syringe according to claim 15, wherein the non-antibody VEGF antagonist is aflibercept at a concentration of 40mg/ml.

17. A pre-filled syringe according to claim 16, wherein:

15 (i) the syringe has a nominal maximum fill volume of between about 0.5ml and about 1ml,

(ii) the syringe is filled with between about 0.15ml and about 0.175ml of aflibercept,

(iii) the syringe is filled with dosage volume of about 0.05ml,

(iv) the syringe barrel has an internal coating of less than about 500 μg silicone, and

20 (v) the VEGF antagonist solution comprises no more than 2 particles $\geq 50\mu\text{m}$ in diameter per ml.

18. A blister pack comprising a pre-filled syringe according to any previous claim, wherein the syringe has been sterilised using H_2O_2 or EtO.

25 19. A blister pack comprising a pre-filled syringe according to claim 18, wherein the outer surface of the syringe has $\leq 1\text{ppm}$ EtO residue.

20. A blister pack comprising a pre-filled syringe according to claim 18 or claim 19, wherein $\leq 5\%$ of the VEGF antagonist is alkylated.

PAT055157-EP-EPA

21. A blister pack comprising a pre-filled syringe according to any of claims 18-21, wherein the syringe has been sterilised using EtO with a Sterility Assurance Level of at least 10^{-6} .
22. A kit comprising: (i) a pre-filled syringe according to any one of claims 1-17, or a blister pack comprising a pre-filled syringe according to any one of claims 18-21, (ii) a needle, and
5 optionally (iii) instructions for administration.
23. A kit according to claim 22, wherein the needle is a 30-gauge x $\frac{1}{2}$ inch needle.
24. A pre-filled syringe according to any one of claims 1-17 for use in therapy.
25. A pre-filled syringe according to any one of claims 1-17 for use in the treatment of an ocular disease selected from choroidal neovascularisation, wet age-related macular degeneration,
10 macular edema secondary to retinal vein occlusion (RVO) including both branch RVO (bRVO) and central RVO (cRVO), choroidal neovascularisation secondary to pathologic myopia (PM), diabetic macular edema (DME), diabetic retinopathy, and proliferative retinopathy.
26. A method of treating a patient suffering from of an ocular disease selected from choroidal neovascularisation, wet age-related macular degeneration, macular edema secondary to retinal
15 vein occlusion (RVO) including both branch RVO (bRVO) and central RVO (cRVO), choroidal neovascularisation secondary to pathologic myopia (PM), diabetic macular edema (DME), diabetic retinopathy, and proliferative retinopathy, comprising the step of administering an ophthalmic solution to the patient using a pre-filled syringe of the invention.
27. The method of claim 26, further comprising an initial priming step in which the physician
20 depresses the plunger of the pre-filled syringe to align the pre-determined part of the stopper with the priming mark.

1/1

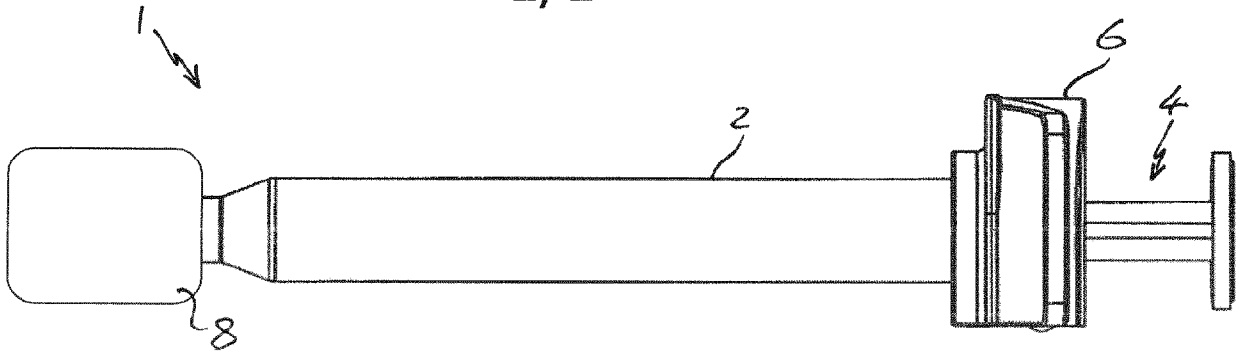

Fig 1

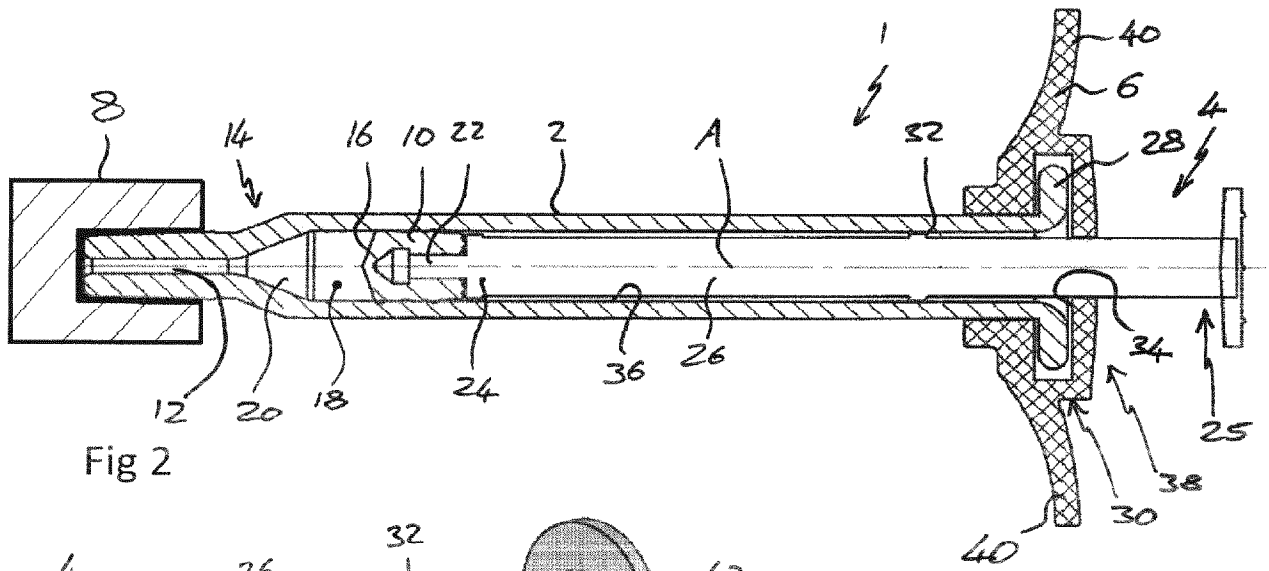

Fig 2

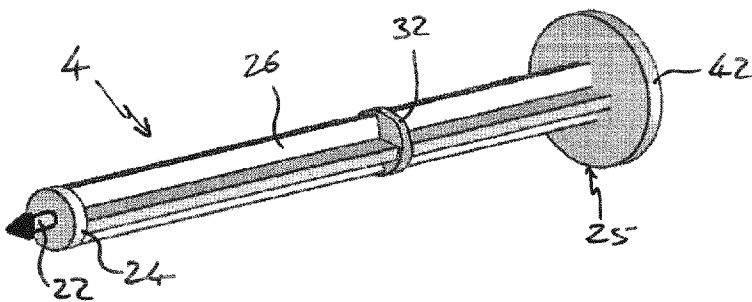

Fig 3

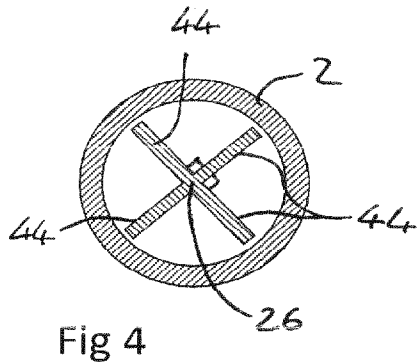

Fig 4

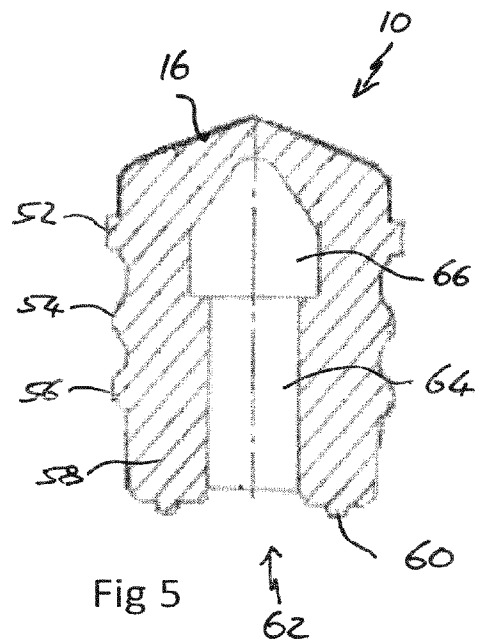

Fig 5

PAT055157-EP-EPA

ABSTRACT

The present invention relates to a syringe, particularly to a small volume syringe such as a syringe suitable for ophthalmic injections.



Bescheinigung

Certificate

Attestation

Die angehefteten
Unterlagen stimmen mit der
als ursprünglich eingereicht
geltenden Fassung der auf
dem nächsten Blatt
bezeichneten europäischen
Patentanmeldung überein.

The attached documents are
exact copies of the text in
which the European patent
application described on the
following page is deemed to
have been filed.

Les documents joints à la
présente attestation sont
conformes au texte,
considéré comme
initialement déposé, de la
demande de brevet
européen qui est spécifiée à
la page suivante.

Patentanmeldung Nr.

Patent application No.

Demande de brevet n°

12195360.8 / EP12195360

The organization code and number of your priority application, to be used for filing abroad under the Paris Convention, is EP12195360.

Der Präsident des Europäischen Patentamts;
Im Auftrag
For the President of the European Patent Office
Le Président de l'Office européen des brevets
p.o.

U. Ingmann

Anmeldung Nr:
Application no.: 12195360.8
Demande no :

Anmeldetag:
Date of filing: 03.12.12
Date de dépôt :

Anmelder / Applicant(s) / Demander(s):

Novartis AG
Lichtstrasse 35
4056 Basel/CH

Bezeichnung der Erfindung / Title of the invention / Titre de l'invention:

(Falls die Bezeichnung der Erfindung nicht angegeben ist, oder falls die Anmeldung in einer Nicht-Amtssprache des EPA eingereicht wurde, siehe Beschreibung bezüglich ursprünglicher Bezeichnung.

If no title is shown, or if the application has been filed in a non-EPO language, please refer to the description for the original title.

Si aucun titre n'est indiqué, ou si la demande a été déposée dans une langue autre qu'une langue officielle de l'OEB, se référer à la description pour le titre original.)

Syringe

In Anspruch genommene Priorität(en) / Priority(Priorities) claimed / Priorité(s) revendiquée(s)
Staat/Tag/Aktenzeichen / State/Date/File no. / Pays/Date/Numéro de dépôt:

Am Anmeldetag benannte Vertragsstaaten / Contracting States designated at date of filing / Etats contractants désignées lors du dépôt:

AL AT BE BG CH CY CZ DE DK EE ES FI FR GB GR HR HU IE IS IT LI LT LU LV MC MK MT NL NO PL
PT RO RS SE SI SK SM TR

SYRINGE

TECHNICAL FIELD

The present invention relates to a syringe, particularly to a small volume syringe such as a syringe suitable for ophthalmic injections.

5 BACKGROUND ART

Many medicaments are delivered to a patient in a syringe from which the user can dispense the medicament. If medicament is delivered to a patient in a syringe it is often to enable the patient, or a caregiver, to inject the medicament. It is important for patient safety and medicament integrity that the syringe and the contents of that syringe are sufficiently sterile to avoid
10 infection, or other, risks for patients. Sterilisation can be achieved by terminal sterilisation in which the assembled product, typically already in its associated packaging, is sterilised using heat or a sterilising gas.

For small volume syringes, for example those for injections into the eye in which it is intended that about 0.1ml or less of liquid is to be injected the sterilisation can pose difficulties that are
15 not necessarily associated with larger syringes. Changes in pressure, internal or external to the syringe, can cause parts of the syringe to move unpredictably, which may alter sealing characteristics and potentially compromise sterility. Incorrect handling of the syringe can also pose risks to product sterility.

Furthermore, certain therapeutics such as biologic molecules are particularly sensitive to
20 sterilisation, be it cold gas sterilisation, thermal sterilisation, or irradiation. Thus, a careful balancing act is required to ensure that while a suitable level of sterilisation is carried out, the syringe remains suitably sealed, such that the therapeutic is not compromised. Of course, the syringe must also remain easy to use, in that the force required to depress the plunger to administer the medicament must not be too high.

25 There is therefore a need for a new syringe construct which provides a robust seal for its content, but which maintains ease of use.

DISCLOSURE OF THE INVENTION

The present invention provides a pre-filled syringe, the syringe comprising a body, a stopper and a plunger, the body comprising an outlet at an outlet end and the stopper being arranged within
30 the body such that a front surface of the stopper and the body define a variable volume chamber

from which a fluid can be expelled through the outlet, the plunger comprising a plunger contact surface at a first end and a rod extending between the plunger contact surface and a rear portion, the plunger contact surface arranged to contact the stopper, such that the plunger can be used to force the stopper towards the outlet end of the body, reducing the volume of the variable volume chamber, characterised in that the fluid comprises an ophthalmic solution. In one embodiment, the ophthalmic solution comprises a VEGF-antagonist.

In one embodiment, the syringe is suitable for ophthalmic injections, more particularly intravitreal injections, and as such has a suitably small volume. The syringe may also be silicone oil free, or substantially silicone oil free, or may comprise a low level of silicone oil as lubricant. In one embodiment, despite the low silicone oil level, the stopper break loose and slide force is less than 20N.

For ophthalmic injections, it is particularly important for the ophthalmic solution to have particularly low particle content. In one embodiment, the syringe meets US Pharmacopeia standard 789 (USP789).

15 *Syringe*

The body of the syringe may be a substantially cylindrical shell, or may include a substantially cylindrical bore with a non circular outer shape. The outlet end of the body includes an outlet through which a fluid housed within the variable volume chamber can be expelled as the volume of said chamber is reduced. The outlet may comprise a projection from the outlet end through which extends a channel having a smaller diameter than that of the variable volume chamber. The outlet may be adapted, for example via a luer lock type connection, for connection to a needle or other accessory such as a sealing device which is able to seal the variable volume chamber, but can be operated, or removed, to unseal the variable volume chamber and allow connection of the syringe to another accessory, such as a needle. Such a connection may be made directly between the syringe and accessory, or via the sealing device. The body extends along a first axis from the outlet end to a rear end.

The body may be made from a plastic material (e.g. a cyclic olefin polymer) or from glass and may include indicia on a surface thereof to act as an injection guide. In one embodiment the body may comprise a priming mark. This allows the physician to align a pre-determined part of the stopper (such as the tip of the front surface or one of the circumferential ribs, discussed later) or plunger with the mark, thus expelling excess ophthalmic solution and any air bubbles from the

syringe. The priming process ensures that an exact, pre-determined dosage is administered to the patient.

The stopper may be made from rubber, silicone or other suitable resiliently deformable material. The stopper may be substantially cylindrical and the stopper may include one or more
5 circumferential ribs around an outer surface of the stopper, the stopper and ribs being dimensioned such that the ribs form a substantially fluid tight seal with an internal surface of the syringe body. The front surface of the stopper may be any suitable shape, for example substantially planar, substantially conical or of a domed shape. The rear surface of the stopper may include a substantially central recess. Such a central recess could be used to connect a
10 plunger to the stopper using a snap fit feature or thread connection in a known manner. The stopper may be substantially rotationally symmetric about an axis through the stopper.

The plunger comprises a plunger contact surface and extending from that a rod extends from the plunger contact surface to a rear portion. The rear portion may include a user contact portion adapted to be contacted by a user during an injection event. The user contact portion may
15 comprise a substantially disc shaped portion, the radius of the disc extending substantially perpendicular to the axis along which the rod extends. The user contact portion could be any suitable shape. The axis along which the rod extends may be the first axis, or may be substantially parallel with the first axis.

The syringe may include a backstop arranged at a rear portion of the body. The backstop may be
20 removable from the syringe. If the syringe body includes terminal flanges at the end opposite the outlet end the backstop may be configured to substantially sandwich terminal flanges of the body as this prevent movement of the backstop in a direction parallel to the first axis.

The rod may comprise at least one rod shoulder directed away from the outlet end and the backstop may include a backstop shoulder directed towards the outlet end to cooperate with the
25 rod shoulder to substantially prevent movement of the rod away from the outlet end when the backstop shoulder and rod shoulder are in contact. Restriction of the movement of the rod away from the outlet end can help to maintain sterility during terminal sterilisation operations, or other operations in which the pressure within the variable volume chamber or outside the chamber may change. During such operations any gas trapped within the variable volume chamber, or
30 bubbles that may form in a liquid therein, may change in volume and thereby cause the stopper to move. Movement of the stopper away from the outlet could result in the breaching of a sterility zone created by the stopper. This is particularly important for low volume syringes

where there are much lower tolerances in the component sizes and less flexibility in the stopper. The term sterility zone as used herein is used to refer to the area within the syringe that is sealed by the stopper from access from either end of the syringe. This may be the area between a seal of the stopper, for example a circumferential rib, closest to the outlet and a seal of the stopper, for example a circumferential rib, furthest from the outlet. The distance between these two seals defines the sterility zone of the stopper since the stopper is installed into the syringe barrel in a sterile environment.

To further assist in maintaining sterility during the operations noted above the stopper may comprise at a front circumferential rib and a rear circumferential rib and those ribs may be separated in a direction along the first axis by at least 3mm, by at least 3.5 mm, by at least 3.75mm or by 4mm or more. One or more additional ribs (for example 2, 3, 4 or 5 additional ribs, or between 1-10, 2-8, 3-6 or 4-5 additional ribs) may be arranged between the front and rear ribs. In one embodiment there are a total of three circumferential ribs.

A stopper with such an enhanced sterility zone can also provide protection for the injectable medicament during a terminal sterilisation process. More ribs on the stopper, or a greater distance between the front and rear ribs can reduce the potential exposure of the medicament to the sterilising agent. However, increasing the number of ribs can increase the friction between the stopper and syringe body, reducing ease of use. While this may be overcome by increasing the siliconisation of the syringe, such an increase in silicone oil levels is particularly undesirable for syringes for ophthalmic use.

The rod shoulder may be arranged within the external diameter of the rod, or may be arranged outside the external diameter of the rod. By providing a shoulder that extends beyond the external diameter of the rod, but still fits within the body, the shoulder can help to stabilise the movement of the rod within the body by reducing movement of the rod perpendicular to the first axis. The rod shoulder may comprise any suitable shoulder forming elements on the rod, but in one embodiment the rod shoulder comprises a substantially disc shaped portion on the rod.

In one embodiment of the syringe, when arranged with the plunger contact surface in contact with the stopper and the variable volume chamber is at its intended maximum volume there is a clearance of no more than about 2mm between the rod shoulder and backstop shoulder. In some embodiments there is a clearance of less than about 1.5 mm and in some less than about 1mm. This distance is selected to substantially limit or prevent excessive rearward (away from the outlet end) movement of the stopper.

In one embodiment the variable volume chamber has an internal diameter greater than 5mm or 6mm, or less than 3mm or 4mm. The internal diameter may be between 3mm and 6mm, or between 4mm and 5mm.

5 In another embodiment the syringe is dimensioned so as to have a nominal maximum fill volume of between about 0.1ml and about 1.5ml. In certain embodiments the nominal maximum fill volume is between about 0.5ml and about 1ml. In certain embodiments the nominal maximum fill volume is about 0.5ml or about 1ml, or about 1.5ml.

The length of the body of the syringe may be less than 70mm, less than 60mm or less than 50mm. In one embodiment the length of the syringe body is between 45mm and 50mm.

10 In one embodiment, the syringe is filled with between about 0.01ml and about 1.5ml (for example between about 0.05ml and about 1ml, between about 0.1ml and about 0.5ml, between about 0.15ml and about 0.175ml) of a VEGF antagonist solution. In one embodiment, the syringe is filled with 0.165ml of a VEGF antagonist solution. Of course, typically a syringe is filled with more than the desired dose to be administered to the patient, to take into account
15 wastage due to "dead space" within the syringe and needle. There may also be a certain amount of wastage when the syringe is primed by the physician, so that it is ready to inject the patient.

Thus, in one embodiment, the syringe is filled with a dosage volume (i.e. the volume of medicament intended for delivery to the patient) of between about 0.01ml and about 1.5ml (e.g. between about 0.05ml and about 1ml, between about 0.1ml and about 0.5ml) of a VEGF
20 antagonist solution. In one embodiment, the dosage volume is between about 0.03ml and about 0.05ml. For example, for Lucentis, the dosage volume is 0.05ml or 0.03ml (0.5mg or 0.3mg) of a 10mg/ml injectable medicament solution; for Eylea, the dosage volume is 0.05ml of a 40mg/ml injectable medicament solution. Although unapproved for ophthalmic indications, bevacizumab is used off-label in such ophthalmic indications at a concentration of 25mg/ml; typically at a
25 dosage volume of 0.05ml (1.25mg).

In one embodiment the length of the syringe body is between about 45mm and about 50mm, the internal diameter is between about 4mm and about 5mm, the fill volume is between about 0.12 and about 0.3ml and the dosage volume is between about 0.03ml and about 0.05ml.

As the syringe contains a medicament solution, the outlet may be reversibly sealed to maintain
30 sterility of the medicament. This sealing may be achieved through the use of a sealing device as

is known in the art. For example the OVSTM system which is available from Vetter Pharma International GmbH.

5 It is typical to siliconise the syringe in order to allow ease of use, i.e. to apply silicone oil to the inside of the barrel, which decreases the force required to move the stopper. However, for ophthalmic use, it is desirable to decrease the likelihood of silicone oil droplets being injected into the eye. With multiple injections, the amount of silicone droplets can build up in the eye, causing potential adverse effects. Furthermore, silicone oil can cause proteins to aggregate. A typical 1ml syringe comprises 100-800µg silicone oil in the barrel, though a survey of manufacturers reported that 500-1000µg was typically used in pre-filled syringes (Badkar *et al.* 10 2011, AAPS PharmaSciTech, 12(2):564-572). Thus, in one embodiment, a syringe according to the invention comprises less than about 800µg (i.e. about less than about 500µg, less than about 300µg, less than about 200µg, less than about 100µg, less than about 75µg, less than about 50µg, less than about 25µg, less than about 15µg, less than about 10µg) silicone oil in the barrel. Methods for measuring the amount of silicone oil in such a syringe barrel are known in the art and include, for example, differential weighing methods and quantitation by infrared- 15 spectroscopy of the oil diluted in a suitable solvent. Various types of silicone oil are available, but typically either DC360 (Dow Corning[®]; with a viscosity of 1000cP) or DC365 emulsion (Dow Corning[®]; DC360 oil with a viscosity of 350cP) are used for syringe siliconisation. In one embodiment, the pre-filled syringe of the invention comprises DC365 emulsion.

20 During testing it was surprisingly found that, for syringes having small dimensions, such as those discussed above, and particularly those described in conjunction with the Figures below, the break loose and sliding forces for the stopper within the syringe are substantially unaffected by reducing the siliconisation levels far below the current standard to the levels discussed here. This is in contrast to conventional thinking that would suggest that if you decrease the silicone oil level, the forces required would increase (see e.g. Schoenknecht, AAPS National Biotechnology 25 Conference 2007 – Abstract no. NBC07-000488, which indicates that while 400µg silicone oil is acceptable, usability improves when increased to 800µg). Having too great a force required to move the stopper can cause problems during use for some users, for example accurate dose setting or smooth dose delivery may be made more difficult if significant strength is required to 30 move, and/or keep in motion, the stopper. Smooth administration is particularly important in sensitive tissues such as the eye, where movement of the syringe during administration could cause local tissue damage. Break loose and slide forces for pre-filled syringes known in the art are typically in the region of less than 20N, but where the pre-filled syringes contain about

- 100µg-about 800µg silicone oil. In one embodiment the glide/slide force for the stopper within the pre-filled syringe is less than about 11N or less than 9N, less than 7N, less than 5N or between about 3N to 5N. In one embodiment, the break loose force is less than about 11N or less than 9N, less than 7N, less than 5N or between about 2N to 5N. Note that such measurements are
- 5 for a filled syringe, rather than an empty syringe. The forces are typically measured at a stopper travelling speed of 190mm/min. In one embodiment, the forces are measured with a 30G x 0.5 inch needle attached to the syringe. In one embodiment, the syringe has a nominal maximal fill volume of between about 0.5ml and 1ml, contains less than about 100µg silicone oil and has a break loose force between about 2N to 5N.
- 10 In one embodiment the syringe barrel has an internal coating of silicone oil that has an average thickness of about 450nm or less (i.e. 400nm or less, 350nm or less, 300nm or less, 200nm or less, 100nm or less, 50nm or less, 20nm or less). Methods to measure the thickness of silicone oil in a syringe are known in the art and include the rap.ID Layer Explorer® Application, which can also be used to measure the mass of silicone oil inside a syringe barrel.
- 15 In one embodiment, the syringe is silicone oil free, or substantially silicone oil free. Such low silicone oil levels can be achieved by using uncoated syringe barrels and/or by avoiding the use of silicone oil as a lubricant for product contacting machine parts, or pumps in the syringe assembly and fill line. A further way to reduce silicone oil and inorganic silica levels in a pre-filled syringe is to avoid the use of silicone tubing in filling lines, for example between storage
- 20 tanks and pumps.
- The syringe according to the invention may also meet certain requirements for particulate content. In one embodiment, the ophthalmic solution comprises no more than 2 particles $\geq 50\mu\text{m}$ in diameter per ml. In one embodiment, the ophthalmic solution comprises no more than 5 particles $\geq 25\mu\text{m}$ in diameter per ml. In one embodiment, the ophthalmic solution comprises no
- 25 more than 50 particles $\geq 10\mu\text{m}$ in diameter per ml. In one embodiment, the ophthalmic solution comprises no more than 2 particles $\geq 50\mu\text{m}$ in diameter per ml, no more than 5 particles $\geq 25\mu\text{m}$ in diameter per ml and no more than 50 particles $\geq 10\mu\text{m}$ in diameter per ml. In one embodiment, a syringe according to the invention meets USP789 (United States Pharmacopoeia: Particulate Matter in Ophthalmic Solutions). In one embodiment the syringe has low levels of silicone oil
- 30 sufficient for the syringe to meet USP789.

VEGF Antagonists

Antibody VEGF antagonists

VEGF is a well-characterised signal protein which stimulates angiogenesis. Two antibody VEGF antagonists have been approved for human use, namely ranibizumab (Lucentis®) and
5 bevacizumab (Avastin®).

Non-Antibody VEGF antagonists

In one aspect of the invention, the non-antibody VEGF antagonist is an immunoadhesin. One such immuoadhesin is aflibercept (Eylea®), which has recently been approved for human use and is also known as VEGF-trap (Holash *et al.* (2002) *PNAS USA* 99:11393-98; Riely & Miller
10 (2007) *Clin Cancer Res* 13:4623-7s). Aflibercept is the preferred non-antibody VEGF antagonist for use with the invention. Aflibercept is a recombinant human soluble VEGF receptor fusion protein consisting of portions of human VEGF receptors 1 and 2 extracellular domains fused to the Fc portion of human IgG1. It is a dimeric glycoprotein with a protein molecular weight of 97 kilodaltons (kDa) and contains glycosylation, constituting an additional 15% of the total
15 molecular mass, resulting in a total molecular weight of 115 kDa. It is conveniently produced as a glycoprotein by expression in recombinant CHO K1 cells. Each monomer can have the following amino acid sequence (SEQ ID NO: 1):

SDTGRPFVEMYSEIPEIIHMTEGRELVI PCRVTSPNITVTLKKFPLDTLIPDGKRIIWDSRKGFIISNATY
KEIGLLTCEATVNGHLYKTNYLTHRQTNTIIDVVLSPSHGIELSVGEKLVLNCTARTELVNVDGIDFNWEYPS
20 SKHQHKLVNRDLKTQSGSEMKKFLSTLTIDGVTRSDQGLYTCAASSGLMTPKKNSTFVRVHEKDKTHTCPP
CPAPELLGGPSVFLFPPKPKDTLMI SRTPEVTCVVVDVSHEDPEVKFNWYVDGVEVHNAKTKPREEQYNST
YRVVSVLTVLHQDWLNGKEYKCKVSNKALPAPIEKTISKAKGQPREPQVYTLPPSRDELTKNQVSLTCLVK
GFYPSDIAVEWESNGQPENNYKTTTPVLDSDGSFFLYSKLTVDKSRWQQGNVFCSCVMHEALHNHYTQKSL
SLSPG

25 and disulfide bridges can be formed between residues 30-79, 124-185, 246-306 and 352-410 within each monomer, and between residues 211-211 and 214-214 between the monomers.

Another non-antibody VEGF antagonist immunoadhesin currently in pre-clinical development is a recombinant human soluble VEGF receptor fusion protein similar to VEGF-trap containing extracellular ligand-binding domains 3 and 4 from VEGFR2/KDR, and domain 2 from
30 VEGFR1/Flt-1; these domains are fused to a human IgG Fc protein fragment (Li et al., 2011 *Molecular Vision* 17:797-803). This antagonist binds to isoforms VEGF-A, VEGF-B and VEGF-C. The molecule is prepared using two different production processes resulting in different

glycosylation patterns on the final proteins. The two glycoforms are referred to as KH902 (conbercept) and KH906. The fusion protein can have the following amino acid sequence (SEQ ID NO:2):

5 MVSYWDTGVLCCALLSCLLLTGSSSGGRPFVEMYSEIPEIIHMTEGRELVIPCRVTSFNITVTLKFFPLDT
LIPDGKRIWDSRKGFIISNATYKEIGLLTCEATVNGHLYKTNYLTHRQTNTIIDVVLSPSHGIELSVGEK
LVLNCTARTELVGIDFNWEYPSSKHQHKLVNRDLKTQSGSEMKKFLSTLTIDGVTRSDQGLYTCAASSG
LMTKKNSTFVRVHEKPFVAFGSGMESLVEATVGERVRLPAKYLGYPPEIKWYKNGIPLSNHTIKAGHVL
TIMEVSEKDTGNYTVILTNPISKEKQSHVVSLVVYVPPGPGDKTHTCPLCPAPELLGGPSVFLFPPKPKDT
10 LMISRTPEVTCVVVDVSHEDPEVKFNWYVDGVEVHNAKTKPREEQYNSTYRVVSVLTVLHQDWLNGKEYKC
KVSNAKALPAIEKTIKAKGQPREPQVYTLPPSRDELTKNQVSLTCLVKGFYPSDIAVEWESNGQPENNYK
ATPPVLDSDGSFFLYSKLTVDKSRWQQGNVFCFSVMHEALHNHYTQKSLSLSPGK

and, like VEGF-trap, can be present as a dimer. This fusion protein and related molecules are further characterized in EP1767546.

15 Other non-antibody VEGF antagonists include antibody mimetics (e.g. Affibody® molecules, affilins, affitins, anticalins, avimers, Kunitz domain peptides, and monobodies) with VEGF antagonist activity. This includes recombinant binding proteins comprising an ankyrin repeat domain that binds VEGF-A and prevents it from binding to VEGFR-2. One example for such a molecule is DARPin® MP0112. The ankyrin binding domain may have the following amino acid sequence (SEQ ID NO: 3):

20 GSDLGKKLLEAARAGQDDEVRIILMANGADVNTADSTGWTPLHLAVPWGHLEIVEVLLKYGADVNAKDFQGW
TPLHLAAAIGHQEIIVEVLLKNGADVNAQDKFGKTAFDISIDNGNEDLAEILQKAA

Recombinant binding proteins comprising an ankyrin repeat domain that binds VEGF-A and prevents it from binding to VEGFR-2 are described in more detail in WO2010/060748 and WO2011/135067.

25 Further specific antibody mimetics with VEGF antagonist activity are the 40 kD pegylated anticalin PRS-050 and the monobody angiocept (CT-322).

The afore-mentioned non-antibody VEGF antagonist may be modified to further improve their pharmacokinetic properties or bioavailability. For example, a non-antibody VEGF antagonist may be chemically modified (e.g., pegylated) to extend its *in vivo* half-life. Alternatively or in
30 addition, it may be modified by glycosylation or the addition of further glycosylation sites not present in the protein sequence of the natural protein from which the VEGF antagonist was derived.

Variants of the above-specified VEGF antagonists that have improved characteristics for the desired application may be produced by the addition or deletion of amino acids. Ordinarily, these amino acid sequence variants will have an amino acid sequence having at least 60% amino acid sequence identity with the amino acid sequences of SEQ ID NO: 1, SEQ ID NO: 2 or SEQ ID NO: 3, preferably at least 80%, more preferably at least 85%, more preferably at least 90%, and most preferably at least 95%, including for example, 80%, 81%, 82%, 83%, 84%, 85%, 86%, 87%, 88%, 89%, 90%, 91%, 92%, 93%, 94%, 95%, 96%, 97%, 98%, 99%, and 100%. Identity or homology with respect to this sequence is defined herein as the percentage of amino acid residues in the candidate sequence that are identical with SEQ ID NO: 1, SEQ ID NO: 2 or SEQ ID NO: 3, after aligning the sequences and introducing gaps, if necessary, to achieve the maximum percent sequence identity, and not considering any conservative substitutions as part of the sequence identity.

Sequence identity can be determined by standard methods that are commonly used to compare the similarity in position of the amino acids of two polypeptides. Using a computer program such as BLAST or FASTA, two polypeptides are aligned for optimal matching of their respective amino acids (either along the full length of one or both sequences or along a pre-determined portion of one or both sequences). The programs provide a default opening penalty and a default gap penalty, and a scoring matrix such as PAM 250 [a standard scoring matrix; see Dayhoff et al., in Atlas of Protein Sequence and Structure, vol. 5, supp. 3 (1978)] can be used in conjunction with the computer program. For example, the percent identity can then be calculated as: the total number of identical matches multiplied by 100 and then divided by the sum of the length of the longer sequence within the matched span and the number of gaps introduced into the longer sequences in order to align the two sequences.

Preferably, the non-antibody VEGF antagonist of the invention binds to VEGF via one or more protein domain(s) that are not derived from the antigen-binding domain of an antibody. The non-antibody VEGF antagonist of the invention are preferably proteinaceous, but may include modifications that are non-proteinaceous (e.g., pegylation, glycosylation).

Therapy

The syringe of the invention may be used to treat an ocular disease, including but not limited to choroidal neovascularisation, age-related macular degeneration (both wet and dry forms), macular edema secondary to retinal vein occlusion (RVO) including both branch RVO (bRVO)

and central RVO (cRVO), choroidal neovascularisation secondary to pathologic myopia (PM), diabetic macular edema (DME), diabetic retinopathy, and proliferative retinopathy.

Thus the invention provides a method of treating a patient suffering from of an ocular disease selected from choroidal neovascularisation, wet age-related macular degeneration, macular edema secondary to retinal vein occlusion (RVO) including both branch RVO (bRVO) and central RVO (cRVO), choroidal neovascularisation secondary to pathologic myopia (PM), diabetic macular edema (DME), diabetic retinopathy, and proliferative retinopathy, comprising the step of administering an ophthalmic solution to the patient using a pre-filled syringe of the invention. This method preferably further comprises an initial priming step in which the physician depresses the plunger of the pre-filled syringe to align the pre-determined part of the stopper with the priming mark.

In one embodiment, the invention provides a method of treating an ocular disease selected from choroidal neovascularisation, wet age-related macular degeneration, macular edema secondary to retinal vein occlusion (RVO) including both branch RVO (bRVO) and central RVO (cRVO), choroidal neovascularisation secondary to pathologic myopia (PM), diabetic macular edema (DME), diabetic retinopathy, and proliferative retinopathy, comprising administering a non-antibody VEGF antagonist with a pre-filled syringe of the invention, wherein the patient has previously received treatment with an antibody VEGF antagonist.

Kits

Also provided are kits comprising the pre-filled syringes of the invention. In one embodiment, such a kit comprises a pre-filled syringe of the invention in a blister pack. The blister pack may itself be sterile on the inside. In one embodiment, syringes according to the invention may be placed inside such blister packs prior to undergoing sterilisation, for example terminal sterilisation.

Such a kit may further comprise a needle for administration of the VEGF antagonist. If the VEGF antagonist is to be administered intravitreally, it is typical to use a 30-gauge x ½ inch needle, though 31-gauge and 32-gauge needles may be used. For intravitreal administration, 33-gauge or 34-gauge needles could alternatively be used. Such kits may further comprise instructions for use. In one embodiment, the invention provides a carton containing a pre-filled syringe according to the invention contained within a blister pack, a needle and optionally instructions for administration.

Sterilisation

As noted above, a terminal sterilisation process may be used to sterilise the syringe and such a process may use a known process such as an ethylene oxide (EtO) or a hydrogen peroxide (H₂O₂) sterilisation process. Needles to be used with the syringe may be sterilised by the same method, as may kits according to the invention.

The package is exposed to the sterilising gas until the outside of the syringe is sterile. Following such a process, the outer surface of the syringe may remain sterile (whilst in its blister pack) for up to 6 months, 9 months, 12 months, 15 months, 18 months, 24 months or longer. Thus, in one embodiment, a syringe according to the invention (whilst in its blister pack) may have a shelf life of up to 6 months, 9 months, 12 months, 15 months, 18 months, 24 months or longer. In one embodiment, less than one syringe in a million has detectable microbial presence on the outside of the syringe after 18 months of storage. In one embodiment, the pre-filled syringe has been sterilised using EtO with a Sterility Assurance Level of at least 10⁻⁶. In one embodiment, the pre-filled syringe has been sterilised using hydrogen peroxide with a Sterility Assurance Level of at least 10⁻⁶. Of course, it is a requirement that significant amounts of the sterilising gas should not enter the variable volume chamber of the syringe. The term "significant amounts" as used herein refers to an amount of gas that would cause unacceptable modification of the ophthalmic solution within the variable volume chamber. In one embodiment, the sterilisation process causes ≤10% (preferably ≤5%, ≤3%, ≤1%) alkylation of the VEGF antagonist. In one embodiment, the pre-filled syringe has been sterilised using EtO, but the outer surface of the syringe has ≤1ppm, preferably ≤0.2ppm EtO residue. In one embodiment, the pre-filled syringe has been sterilised using hydrogen peroxide, but the outer surface of the syringe has ≤1ppm, preferably ≤0.2ppm hydrogen peroxide residue. In another embodiment, the pre-filled syringe has been sterilised using EtO, and the total EtO residue found on the outside of the syringe and inside of the blister pack is ≤0.1mg. In another embodiment, the pre-filled syringe has been sterilised using hydrogen peroxide, and the total hydrogen peroxide residue found on the outside of the syringe and inside of the blister pack is ≤0.1mg.

General

The term "comprising" means "including" as well as "consisting" *e.g.* a composition "comprising" X may consist exclusively of X or may include something additional *e.g.* X + Y.

The term "about" in relation to a numerical value x means, for example, $x \pm 10\%$.

References to a percentage sequence identity between two amino acid sequences means that, when aligned, that percentage of amino acids are the same in comparing the two sequences. This alignment and the percent homology or sequence identity can be determined using software
5 programs known in the art, for example those described in section 7.7.18 of *Current Protocols in Molecular Biology* (F.M. Ausubel *et al.*, eds., 1987) Supplement 30. A preferred alignment is determined by the Smith-Waterman homology search algorithm using an affine gap search with a gap open penalty of 12 and a gap extension penalty of 2, BLOSUM matrix of 62. The Smith-Waterman homology search algorithm is disclosed in Smith & Waterman (1981) *Adv. Appl.*
10 *Math.* 2: 482-489

BRIEF DESCRIPTION OF THE FIGURES

Figure 1 shows a side view of a syringe

Figure 2 shows a cross section of a top down view of a syringe

Figure 3 shows a view of a plunger

15 Figure 4 shows a cross section through a plunger

Figure 5 shows a stopper

MODES FOR CARRYING OUT THE INVENTION

The invention will now be further described, by way of example only, with reference to the
20 drawings.

Figure 1 shows a view from a side of a syringe 1 comprising a body 2, plunger 4, backstop 6 and a sealing device 8.

Figure 2 shows a cross section through the syringe 1 of Figure 1 from above. The syringe 1 is suitable for use in an ophthalmic injection. The syringe 1 comprises a body 2, a stopper 10 and a
25 plunger 4. The syringe 1 extends along a first axis A. The body 2 comprises an outlet 12 at an outlet end 14 and the stopper 10 is arranged within the body 2 such that a front surface 16 of the stopper 10 and the body 2 define a variable volume chamber 18. The variable volume chamber 18 contains an injectable medicament 20 comprising an ophthalmic solution comprising a VEGF

antagonist such as ranibizumab. The injectable fluid 20 can be expelled through the outlet 12 by movement of the stopper 10 towards the outlet end 14 thereby reducing the volume of the variable volume chamber 18. The plunger 4 comprises a plunger contact surface 22 at a first end 24 and a rod 26 extending between the plunger contact surface 22 and a rear portion 25. The plunger contact surface 22 is arranged to contact the stopper 10, such that the plunger 4 can be used to move the stopper 10 towards the outlet end 14 of the body 2. Such movement reduces the volume of the variable volume chamber 18 and causes fluid therein to be expelled through the outlet.

The backstop 6 is attached to the body 2 by coupling to a terminal flange 28 of the body 2. The backstop 6 includes sandwich portion 30 which is adapted to substantially sandwich at least some of the terminal flange 28 of the body 2. The backstop 6 is adapted to be coupled to the body 2 from the side by leaving one side of the backstop 6 open so that the backstop 6 can be fitted to the syringe 2.

The body 2 defines a substantially cylindrical bore 36 which has a bore radius. The rod 26 comprises a rod shoulder 32 directed away from the outlet end 14. The rod shoulder 32 extends from to a rod shoulder radius from the first axis A which is such that it is slightly less than the bore radius so that the shoulder fits within the bore 36. The backstop 6 includes a backstop shoulder 34 directed towards the outlet end 14. The shoulders 32, 34 are configured to cooperate to substantially prevent movement of the rod 26 away from the outlet end 14 when the backstop shoulder 34 and rod shoulder 32 are in contact. The backstop shoulder 34 extends from outside the bore radius to a radius less than the rod shoulder radius so that the rod shoulder 32 cannot pass the backstop shoulder 34 by moving along the first axis A. In this case the rod shoulder 32 is substantially disc, or ring, shaped and the backstop shoulder 34 includes an arc around a rear end 38 of the body 2.

The backstop 6 also includes two finger projections 40 which extend in opposite directions away from the body 2 substantially perpendicular to the first axis A to facilitate manual handling of the syringe 1 during use.

In this example the syringe comprises a 0.5ml body 2 filled with between about 0.1 and 0.3 ml of an injectable medicament 20 comprising a 10mg/ml injectable solution comprising ranibizumab. The syringe body 2 has an internal diameter of about between about 4.5mm and 4.8mm, a length of between about 45mm and 50mm.

The plunger 4 and stopper 10 will be described in more detail with reference to later figures.

Figure 3 shows a perspective view of the plunger 4 of Figure 1 showing the plunger contact surface 22 at the first end 24 of the plunger 4. The rod 26 extends from the first end 24 to the rear portion 25. The rear portion 25 includes a disc shaped flange 42 to facilitate user handling of the device. The flange 42 provides a larger surface area for contact by the user than a bare end of the rod 26.

5 Figure 4 shows a cross section through a syringe body 2 and rod 26. The rod 26 includes four longitudinal ribs 44 and the angle between the ribs is 90°.

Figure 5 shows a detailed view of a stopper 10 showing a conical shaped front surface 16 and three circumferential ribs 52,54,56 around a substantially cylindrical body 58. The axial gap between the first rib 52 and the last rib 56 is about 3mm. The rear surface 60 of the stopper 10 includes a substantially central recess 62. The central recess 62 includes an initial bore 64 having a first diameter. The initial bore 64 leading from the rear surface 60 into the stopper 10 to an inner recess 66 having a second diameter, the second diameter being larger than the first diameter.

Stopper movement forces

15 0.5ml syringes siliconised with <100µg silicone oil, filled with Lucentis, comprising one of two different stopper designs were tested for maximal and average break out and slide force. Prior to testing, 30G x 0.5” needles were attached to the syringes. The testing was carried out at a stopper speed of 190mm/min over a travel length of 10.9mm. Stopper design 2 had a 45% increase in the distance between the front circumferential rib and rear circumferential rib.

		Stopper design 1			Stopper design 2	
		Batch A	Batch B	Batch C	Batch D	Batch E
Break loose force of syringes	Average of 10 syringes	2.2N	2.3N	1.9N	2.1N	2.5N
	Max individual value	2.5N	2.5N	2.3N	2.6N	2.7N
Sliding force	Average of 10 syringes	3.1N	3.2N	3.1N	4.1N	4.6N
	Max individual value	3.5N	3.5N	3.6N	4.7N	4.8N

20

For both stopper designs, average and maximum break out force remained below 3N. For both stopper designs, average and maximum sliding force remained below 5N.

It will be understood that the invention has been described by way of example only and modifications may be made whilst remaining within the scope and spirit of the invention.

5

CLAIMS

1. A pre-filled syringe, the syringe comprising a body, a stopper and a plunger, the body comprising an outlet at an outlet end and the stopper being arranged within the body such that a front surface of the stopper and the body define a variable volume chamber from which a fluid
5 can be expelled through the outlet, the plunger comprising a plunger contact surface at a first end and a rod extending between the plunger contact surface and a rear portion, the plunger contact surface arranged to contact the stopper, such that the plunger can be used to force the stopper towards the outlet end of the body, reducing the volume of the variable volume chamber, characterised in that the fluid is an ophthalmic solution which comprises a VEGF-antagonist
10 wherein:
- (a) the syringe has a nominal maximum fill volume of between about 0.5ml and about 1ml,
 - (b) the syringe is filled with between about 0.15ml and about 0.175ml of said VEGF antagonist solution which comprises a dosage volume of between about 0.03ml and about 0.05ml of said VEGF antagonist solution,
 - 15 (c) the syringe barrel comprises less than about 500µg silicone oil, and
 - (d) the VEGF antagonist solution comprises no more than 2 particles $\geq 50\mu\text{m}$ in diameter per ml.
2. A pre-filled syringe according to any previous claim, wherein the syringe is filled with dosage volume of about 0.05ml of a VEGF antagonist solution.
3. A pre-filled syringe according to any previous claim, in which the dosage volume is
20 determined by the volume of the variable volume chamber when a predetermined part of the stopper is aligned with a priming mark on the syringe.
4. A pre-filled syringe according to any previous claim, wherein the syringe barrel has an internal coating of silicone oil that has an average thickness of about 450nm or less.
5. A pre-filled syringe according to any previous claim, wherein the syringe barrel has an
25 internal coating of less than about 500µg silicone oil, preferably less than about 50µg silicone oil, preferably less than about 25µg silicone oil, preferably less than about 10µg silicone oil.
6. A pre-filled syringe according to any previous claim, wherein the silicone oil is DC365 emulsion.
7. A pre-filled syringe according to any previous claim, wherein the syringe is silicone oil free.

8. A pre-filled syringe according to any previous claim, wherein the VEGF antagonist solution further comprises one or more of (i) no more than 5 particles $\geq 25\mu\text{m}$ in diameter per ml, and (ii) no more than 50 particles $\geq 10\mu\text{m}$ in diameter per ml.
9. A pre-filled syringe according to any previous claim, wherein the VEGF antagonist solution
5 meets USP789.
10. A pre-filled syringe according to any previous claim, wherein the VEGF antagonist is an anti-VEGF antibody.
11. A pre-filled syringe according to claim 10, wherein the anti-VEGF antibody is ranibizumab.
12. A pre-filled syringe according to claim 11, wherein the ranibizumab is at a concentration of
10 10mg/ml.
13. A pre-filled syringe according to any one of claims 1-9, wherein the VEGF antagonist is a non-antibody VEGF antagonist.
14. A pre-filled syringe according to claim 13, wherein the non-antibody VEGF antagonist is aflibercept or conbercept.
- 15 15. A pre-filled syringe according to claim 14, wherein the non-antibody VEGF antagonist is aflibercept at a concentration of 40mg/ml.
16. A pre-filled syringe according to any previous claim, wherein the syringe has a stopper break loose force of less than about 11N.
17. A pre-filled syringe according to claim 16, wherein the syringe has a stopper break loose
20 force of less than about 5N.
18. A pre-filled syringe according to any previous claim, wherein the syringe has a stopper slide force of less than about 11N.
19. A pre-filled syringe according to claim 18, wherein the syringe has a stopper slide force of less than about 5N.
- 25 20. A pre-filled syringe according to any of claims 16-19, wherein the stopper break loose force or stopper slide force is measured using a filled syringe, at a stopper travelling speed of 190mm/min, with a 30G x 0.5 inch needle attached to the syringe.

21. A blister pack comprising a pre-filled syringe according to any previous claim, wherein the syringe has been sterilised using H₂O₂ or EtO.
22. A blister pack comprising a pre-filled syringe according to claim 21, wherein the outer surface of the syringe has ≤ 1 ppm EtO or H₂O₂ residue.
- 5 23. A blister pack comprising a pre-filled syringe according to claim 21, wherein the syringe has been sterilised using EtO or H₂O₂ and the total EtO or H₂O₂ residue found on the outside of the syringe and inside of the blister pack is ≤ 0.1 mg.
24. A blister pack comprising a pre-filled syringe according to any one of claims 21-23, wherein $\leq 5\%$ of the VEGF antagonist is alkylated.
- 10 25. A blister pack comprising a pre-filled syringe according to any of claims 21-24, wherein the syringe has been sterilised using EtO or H₂O₂ with a Sterility Assurance Level of at least 10⁻⁶.
26. A blister pack according to any of claims 21-25, wherein the pre-filled syringe has a shelf life of up to 6 months, 9 months, 12 months, 15 months, 18 months, 24 months or longer.
27. A kit comprising: (i) a pre-filled syringe according to any one of claims 1-20, or a blister
15 pack comprising a pre-filled syringe according to any one of claims 21-26, (ii) a needle, and optionally (iii) instructions for administration.
28. A kit according to claim 27, wherein the needle is a 30-gauge x ½ inch needle.
29. A pre-filled syringe according to any one of claims 1-20 for use in therapy.
30. A pre-filled syringe according to any one of claims 1-20 for use in the treatment of an ocular
20 disease selected from choroidal neovascularisation, wet age-related macular degeneration, macular edema secondary to retinal vein occlusion (RVO) including both branch RVO (bRVO) and central RVO (cRVO), choroidal neovascularisation secondary to pathologic myopia (PM), diabetic macular edema (DME), diabetic retinopathy, and proliferative retinopathy.
31. A method of treating a patient suffering from of an ocular disease selected from choroidal
25 neovascularisation, wet age-related macular degeneration, macular edema secondary to retinal vein occlusion (RVO) including both branch RVO (bRVO) and central RVO (cRVO), choroidal neovascularisation secondary to pathologic myopia (PM), diabetic macular edema (DME), diabetic retinopathy, and proliferative retinopathy, comprising the step of administering an ophthalmic solution to the patient using a pre-filled syringe according to any one of claims 1-20.

32. The method of claim 31, further comprising an initial priming step in which the physician depresses the plunger of the pre-filled syringe to align the pre-determined part of the stopper with the priming mark.

5 33. A method according to claim 31 or 32, wherein the VEGF antagonist administered is a non-antibody VEGF antagonist and wherein the patient has previously received treatment with an antibody VEGF antagonist.

1/1

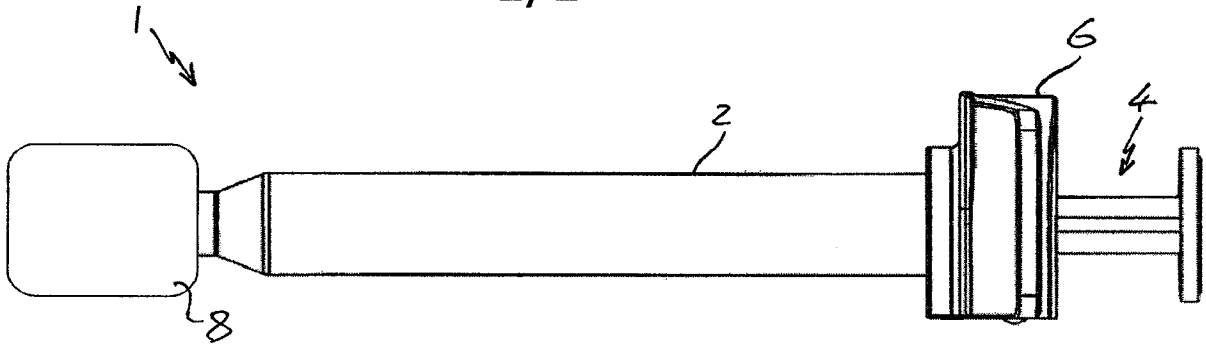

Fig 1

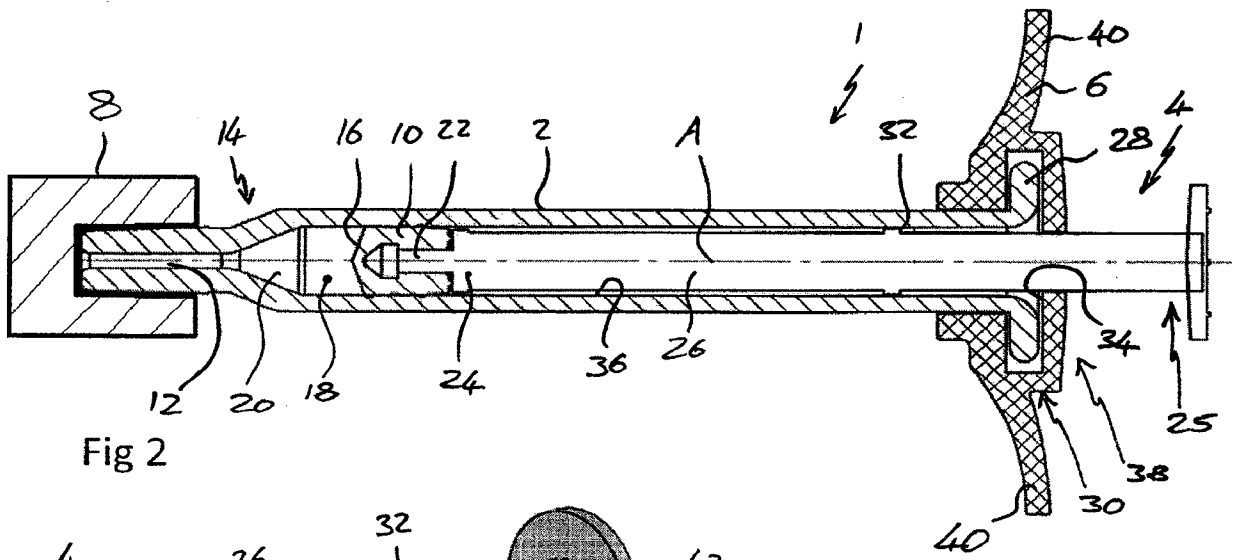

Fig 2

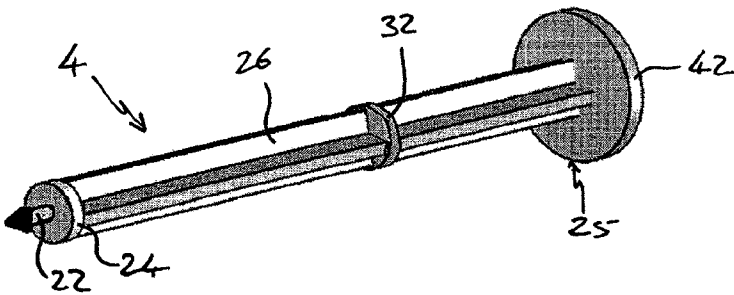

Fig 3

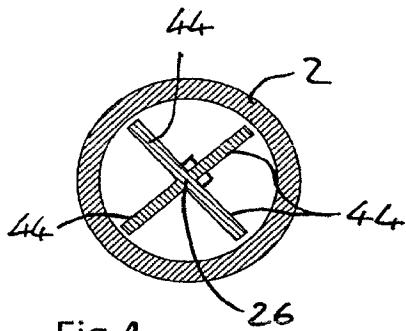

Fig 4

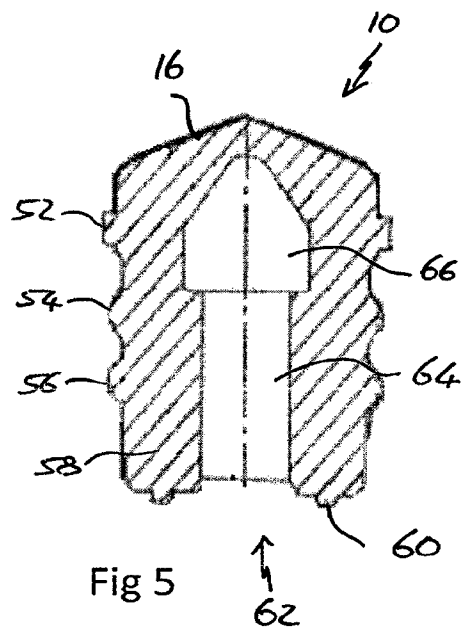

Fig 5

ABSTRACT

The present invention relates to a syringe, particularly to a small volume syringe such as a syringe suitable for ophthalmic injections.



UNITED STATES PATENT AND TRADEMARK OFFICE

UNITED STATES DEPARTMENT OF COMMERCE
United States Patent and Trademark Office
Address: COMMISSIONER FOR PATENTS
P.O. Box 1450
Alexandria, Virginia 22313-1450
www.uspto.gov

PRIORITY DOCUMENT EXCHANGE

FAILURE STATUS REPORT

An attempt by the Office to electronically retrieve, under the Priority Document Exchange programs (PDX and DAS), 2012101677 to which priority is claimed has FAILED on 12/04/2013.

For further questions or assistance, please contact our EBC Customer Support Center at

1-866-217-9197 (toll-free)

571-272-4100 (local)

M-F 6AM - Midnight (Eastern Time)



UNITED STATES PATENT AND TRADEMARK OFFICE

UNITED STATES DEPARTMENT OF COMMERCE
United States Patent and Trademark Office
Address: COMMISSIONER FOR PATENTS
P.O. Box 1450
Alexandria, Virginia 22313-1450
www.uspto.gov

PRIORITY DOCUMENT EXCHANGE

FAILURE STATUS REPORT

An attempt by the Office to electronically retrieve, under the Priority Document Exchange programs (PDX and DAS), 2012101678 to which priority is claimed has FAILED on 12/04/2013.

For further questions or assistance, please contact our EBC Customer Support Center at

1-866-217-9197 (toll-free)

571-272-4100 (local)

M-F 6AM - Midnight (Eastern Time)



UNITED STATES PATENT AND TRADEMARK OFFICE

UNITED STATES DEPARTMENT OF COMMERCE
United States Patent and Trademark Office
Address: COMMISSIONER FOR PATENTS
P.O. Box 1450
Alexandria, Virginia 22313-1450
www.uspto.gov

PRIORITY DOCUMENT EXCHANGE

FAILURE STATUS REPORT

An attempt by the Office to electronically retrieve, under the Priority Document Exchange programs (PDX and DAS), 2013100071 to which priority is claimed has FAILED on 12/04/2013.

For further questions or assistance, please contact our EBC Customer Support Center at

1-866-217-9197 (toll-free)

571-272-4100 (local)

M-F 6AM - Midnight (Eastern Time)



UNITED STATES PATENT AND TRADEMARK OFFICE

UNITED STATES DEPARTMENT OF COMMERCE
United States Patent and Trademark Office
Address: COMMISSIONER FOR PATENTS
P.O. Box 1450
Alexandria, Virginia 22313-1450
www.uspto.gov

PRIORITY DOCUMENT EXCHANGE

FAILURE STATUS REPORT

An attempt by the Office to electronically retrieve, under the Priority Document Exchange programs (PDX and DAS), 2013100070 to which priority is claimed has FAILED on 12/04/2013.

For further questions or assistance, please contact our EBC Customer Support Center at

1-866-217-9197 (toll-free)

571-272-4100 (local)

M-F 6AM - Midnight (Eastern Time)



UNITED STATES PATENT AND TRADEMARK OFFICE

UNITED STATES DEPARTMENT OF COMMERCE
United States Patent and Trademark Office
Address: COMMISSIONER FOR PATENTS
P.O. Box 1450
Alexandria, Virginia 22313-1450
www.uspto.gov

APPLICATION NUMBER	FILING OR 371(C) DATE	FIRST NAMED APPLICANT	ATTY. DOCKET NO./TITLE
13/750,352	01/25/2013	Juergen Sigg	PAT055157-US-NP

CONFIRMATION NO. 5306

PUBLICATION NOTICE

1095
NOVARTIS PHARMACEUTICAL CORPORATION
INTELLECTUAL PROPERTY DEPARTMENT
ONE HEALTH PLAZA 101/2
EAST HANOVER, NJ 07936-1080



Title:SYRINGE

Publication No.:US-2014-0012227-A1

Publication Date:01/09/2014

NOTICE OF PUBLICATION OF APPLICATION

The above-identified application will be electronically published as a patent application publication pursuant to 37 CFR 1.211, et seq. The patent application publication number and publication date are set forth above.

The publication may be accessed through the USPTO's publically available Searchable Databases via the Internet at www.uspto.gov. The direct link to access the publication is currently <http://www.uspto.gov/patft/>.

The publication process established by the Office does not provide for mailing a copy of the publication to applicant. A copy of the publication may be obtained from the Office upon payment of the appropriate fee set forth in 37 CFR 1.19(a)(1). Orders for copies of patent application publications are handled by the USPTO's Office of Public Records. The Office of Public Records can be reached by telephone at (703) 308-9726 or (800) 972-6382, by facsimile at (703) 305-8759, by mail addressed to the United States Patent and Trademark Office, Office of Public Records, Alexandria, VA 22313-1450 or via the Internet.

In addition, information on the status of the application, including the mailing date of Office actions and the dates of receipt of correspondence filed in the Office, may also be accessed via the Internet through the Patent Electronic Business Center at www.uspto.gov using the public side of the Patent Application Information and Retrieval (PAIR) system. The direct link to access this status information is currently <http://pair.uspto.gov/>. Prior to publication, such status information is confidential and may only be obtained by applicant using the private side of PAIR.

Further assistance in electronically accessing the publication, or about PAIR, is available by calling the Patent Electronic Business Center at 1-866-217-9197.

Office of Data Management, Application Assistance Unit (571) 272-4000, or (571) 272-4200, or 1-888-786-0101



UNITED STATES PATENT AND TRADEMARK OFFICE

Commissioner for Patents
United States Patent and Trademark Office
P.O. Box 1450
Alexandria, VA 22313-1450
www.uspto.gov

NOVARTIS PHARMACEUTICAL
CORPORATION
INTELLECTUAL PROPERTY
DEPARTMENT
ONE HEALTH PLAZA 101/2
EAST HANOVER NJ 07936-1080

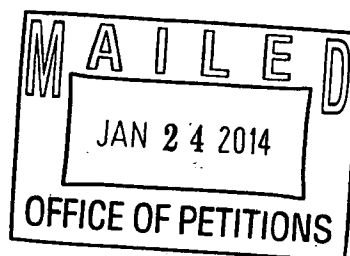

In re Application of
SIGG, et al.
Application No.: 13/750,352
Filed: 25 January 2013
Attorney Docket No.: PAT055157-US-NP
For: SYRINGE

: DECISION ON REQUEST TO
: PARTICIPATE IN THE PATENT
: PROSECUTION HIGHWAY
: PROGRAM AND PETITION
: TO MAKE SPECIAL UNDER
: 37 CFR 1.102(a)

This is a decision on the request to participate in the Patent Prosecution Highway (PPH) program and the petition under 37 CFR 1.102(a), filed 16 August 2013, to make the above-identified application special.

The request and petition are **GRANTED**.

DISCUSSION

A grantable request to participate in the PPH pilot program and petition to make special require:

1. The U.S. application and the corresponding application filed in the PPH 2.0 participating office (with the allowable/patentable claim(s)) must have the same priority/filing date. In particular, the U.S. application (including national stage entry of a PCT application and a so-called bypass application filed under 35 U.S.C. 111 which validly claims benefit under 35 U.S.C. 120 to a PCT application):
 - a. is an application that validly claims priority under 35 U.S.C. § 119(a) and 37 CFR 1.55 to one or more applications filed with the PPH 2.0 participating office, or
 - b. is an application which is the basis of a valid priority claim under the Paris Convention for the application filed in the PPH 2.0 participating office, or
 - c. is an application which shares a common priority document with the application filed in the PPH 2.0 participating office, or

- d. the application filed in the PPH 2.0 participating office are derived from/related to a PCT application having no priority claim.
2. Applicant must:
 - a. Ensure all the claims in the U.S. application must sufficiently correspond or be amended to sufficiently correspond to the allowable/patentable claim(s) in the PPH 2.0 participating office application(s) and
 - b. Submit a claims correspondence table in English;
3. Examination of the U.S. application has not begun;
4. Applicant must submit:
 - a. Documentation of prior office action:
 - i. a copy of the office action(s) just prior to the "Decision to Grant a Patent" from each of the PPH 2.0 participating office application(s) containing the allowable/patentable claim(s) or
 - ii. if the allowable/patentable claims(s) are from a "Notification of Reasons for Refusal" then the Notification of Reasons for Refusal or
 - iii. if the PPH 2.0 participating office application is a first action allowance then no office action from the PPH 2.0 participating office is necessary should be indicated on the request/petition form;
 - b. An English language translation of the PPH 2.0 participating office action from (4)(a)(i)-(ii) above
5. Applicant must submit:
 - a. An IDS listing the documents cited by the PPH 2.0 participating office examiner in the PPH 2.0 participating office action (unless already submitted in this application)
 - b. Copies of the documents except U.S. patents or U.S. patent application publications (unless already submitted in this application);

The request to participate in the PPH pilot program and petition comply with the above requirements. Accordingly, the above-identified application has been accorded "special" status.

Telephone inquiries concerning this decision should be directed to Cheryl Gibson-Baylor at (571) 272-3213.

All other inquiries concerning the examination or status of the application is accessible in the PAIR system at <http://www.uspto.gov/ebc.index.html>.

This application will be forwarded to the examiner for action on the merits commensurate with this decision once this application's formality reviews have been completed.

David Bucci
Petitions Examiner
Office of Petitions

INFORMATION DISCLOSURE STATEMENT BY APPLICANT (Not for submission under 37 CFR 1.99)	Application Number		13750352	
	Filing Date		2013-01-25	
	First Named Inventor	Juergen Sigg		
	Art Unit			
	Examiner Name			
	Attorney Docket Number		PAT055157-US-NP	

U.S.PATENTS						Remove
Examiner Initial*	Cite No	Patent Number	Kind Code ¹	Issue Date	Name of Patentee or Applicant of cited Document	Pages,Columns,Lines where Relevant Passages or Relevant Figures Appear
	1					

If you wish to add additional U.S. Patent citation information please click the Add button. Add

U.S.PATENT APPLICATION PUBLICATIONS						Remove
Examiner Initial*	Cite No	Publication Number	Kind Code ¹	Publication Date	Name of Patentee or Applicant of cited Document	Pages,Columns,Lines where Relevant Passages or Relevant Figures Appear
	1					

If you wish to add additional U.S. Published Application citation information please click the Add button. Add

FOREIGN PATENT DOCUMENTS								Remove
Examiner Initial*	Cite No	Foreign Document Number ³	Country Code ² i	Kind Code ⁴	Publication Date	Name of Patentee or Applicant of cited Document	Pages,Columns,Lines where Relevant Passages or Relevant Figures Appear	T ⁵
	1							<input type="checkbox"/>

If you wish to add additional Foreign Patent Document citation information please click the Add button Add

NON-PATENT LITERATURE DOCUMENTS			Remove
Examiner Initials*	Cite No	Include name of the author (in CAPITAL LETTERS), title of the article (when appropriate), title of the item (book, magazine, journal, serial, symposium, catalog, etc), date, pages(s), volume-issue number(s), publisher, city and/or country where published.	T ⁵

INFORMATION DISCLOSURE STATEMENT BY APPLICANT (Not for submission under 37 CFR 1.99)	Application Number	13750352
	Filing Date	2013-01-25
	First Named Inventor	Juergen Sigg
	Art Unit	
	Examiner Name	
	Attorney Docket Number	PAT055157-US-NP

1	Badkar et al., "Development of biotechnology products in pre-filled syringes: technical considerations and approaches", AAPS PharmaSciTech, Vol. 12, No. 2, pp. 564-572, (June 2011)	<input type="checkbox"/>
---	--------------------------------------------------------------------------------------------------------------------------------------------------------------------------------------	--------------------------

If you wish to add additional non-patent literature document citation information please click the Add button **Add**

EXAMINER SIGNATURE

Examiner Signature	Date Considered
--------------------	-----------------

*EXAMINER: Initial if reference considered, whether or not citation is in conformance with MPEP 609. Draw line through a citation if not in conformance and not considered. Include copy of this form with next communication to applicant.

¹ See Kind Codes of USPTO Patent Documents at www.USPTO.GOV or MPEP 901.04. ² Enter office that issued the document, by the two-letter code (WIPO Standard ST.3). ³ For Japanese patent documents, the indication of the year of the reign of the Emperor must precede the serial number of the patent document. ⁴ Kind of document by the appropriate symbols as indicated on the document under WIPO Standard ST.16 if possible. ⁵ Applicant is to place a check mark here if English language translation is attached.

INFORMATION DISCLOSURE STATEMENT BY APPLICANT (Not for submission under 37 CFR 1.99)	Application Number	13750352
	Filing Date	2013-01-25
	First Named Inventor	Juergen Sigg
	Art Unit	
	Examiner Name	
	Attorney Docket Number	PAT055157-US-NP

CERTIFICATION STATEMENT

Please see 37 CFR 1.97 and 1.98 to make the appropriate selection(s):

That each item of information contained in the information disclosure statement was first cited in any communication from a foreign patent office in a counterpart foreign application not more than three months prior to the filing of the information disclosure statement. See 37 CFR 1.97(e)(1).

OR

That no item of information contained in the information disclosure statement was cited in a communication from a foreign patent office in a counterpart foreign application, and, to the knowledge of the person signing the certification after making reasonable inquiry, no item of information contained in the information disclosure statement was known to any individual designated in 37 CFR 1.56(c) more than three months prior to the filing of the information disclosure statement. See 37 CFR 1.97(e)(2).

- See attached certification statement.
- The fee set forth in 37 CFR 1.17 (p) has been submitted herewith.
- A certification statement is not submitted herewith.

SIGNATURE

A signature of the applicant or representative is required in accordance with CFR 1.33, 10.18. Please see CFR 1.4(d) for the form of the signature.

Signature	/Jim Lynch/	Date (YYYY-MM-DD)	2014-03-28
Name/Print	Jim Lynch	Registration Number	54,763

This collection of information is required by 37 CFR 1.97 and 1.98. The information is required to obtain or retain a benefit by the public which is to file (and by the USPTO to process) an application. Confidentiality is governed by 35 U.S.C. 122 and 37 CFR 1.14. This collection is estimated to take 1 hour to complete, including gathering, preparing and submitting the completed application form to the USPTO. Time will vary depending upon the individual case. Any comments on the amount of time you require to complete this form and/or suggestions for reducing this burden, should be sent to the Chief Information Officer, U.S. Patent and Trademark Office, U.S. Department of Commerce, P.O. Box 1450, Alexandria, VA 22313-1450. **DO NOT SEND FEES OR COMPLETED FORMS TO THIS ADDRESS. SEND TO: Commissioner for Patents, P.O. Box 1450, Alexandria, VA 22313-1450.**

Privacy Act Statement

The Privacy Act of 1974 (P.L. 93-579) requires that you be given certain information in connection with your submission of the attached form related to a patent application or patent. Accordingly, pursuant to the requirements of the Act, please be advised that: (1) the general authority for the collection of this information is 35 U.S.C. 2(b)(2); (2) furnishing of the information solicited is voluntary; and (3) the principal purpose for which the information is used by the U.S. Patent and Trademark Office is to process and/or examine your submission related to a patent application or patent. If you do not furnish the requested information, the U.S. Patent and Trademark Office may not be able to process and/or examine your submission, which may result in termination of proceedings or abandonment of the application or expiration of the patent.

The information provided by you in this form will be subject to the following routine uses:

1. The information on this form will be treated confidentially to the extent allowed under the Freedom of Information Act (5 U.S.C. 552) and the Privacy Act (5 U.S.C. 552a). Records from this system of records may be disclosed to the Department of Justice to determine whether the Freedom of Information Act requires disclosure of these records.
2. A record from this system of records may be disclosed, as a routine use, in the course of presenting evidence to a court, magistrate, or administrative tribunal, including disclosures to opposing counsel in the course of settlement negotiations.
3. A record in this system of records may be disclosed, as a routine use, to a Member of Congress submitting a request involving an individual, to whom the record pertains, when the individual has requested assistance from the Member with respect to the subject matter of the record.
4. A record in this system of records may be disclosed, as a routine use, to a contractor of the Agency having need for the information in order to perform a contract. Recipients of information shall be required to comply with the requirements of the Privacy Act of 1974, as amended, pursuant to 5 U.S.C. 552a(m).
5. A record related to an International Application filed under the Patent Cooperation Treaty in this system of records may be disclosed, as a routine use, to the International Bureau of the World Intellectual Property Organization, pursuant to the Patent Cooperation Treaty.
6. A record in this system of records may be disclosed, as a routine use, to another federal agency for purposes of National Security review (35 U.S.C. 181) and for review pursuant to the Atomic Energy Act (42 U.S.C. 218(c)).
7. A record from this system of records may be disclosed, as a routine use, to the Administrator, General Services, or his/her designee, during an inspection of records conducted by GSA as part of that agency's responsibility to recommend improvements in records management practices and programs, under authority of 44 U.S.C. 2904 and 2906. Such disclosure shall be made in accordance with the GSA regulations governing inspection of records for this purpose, and any other relevant (i.e., GSA or Commerce) directive. Such disclosure shall not be used to make determinations about individuals.
8. A record from this system of records may be disclosed, as a routine use, to the public after either publication of the application pursuant to 35 U.S.C. 122(b) or issuance of a patent pursuant to 35 U.S.C. 151. Further, a record may be disclosed, subject to the limitations of 37 CFR 1.14, as a routine use, to the public if the record was filed in an application which became abandoned or in which the proceedings were terminated and which application is referenced by either a published application, an application open to public inspections or an issued patent.
9. A record from this system of records may be disclosed, as a routine use, to a Federal, State, or local law enforcement agency, if the USPTO becomes aware of a violation or potential violation of law or regulation.

Electronic Acknowledgement Receipt

EFS ID:	18612556
Application Number:	13750352
International Application Number:	
Confirmation Number:	5306
Title of Invention:	SYRINGE
First Named Inventor/Applicant Name:	Juergen Sigg
Customer Number:	1095
Filer:	James L Lynch/Andrea Jacquin
Filer Authorized By:	James L Lynch
Attorney Docket Number:	PAT055157-US-NP
Receipt Date:	28-MAR-2014
Filing Date:	25-JAN-2013
Time Stamp:	13:55:55
Application Type:	Utility under 35 USC 111(a)

Payment information:

Submitted with Payment	no
------------------------	----

File Listing:

Document Number	Document Description	File Name	File Size(Bytes)/ Message Digest	Multi Part /.zip	Pages (if appl.)
1	Information Disclosure Statement (IDS) Form (SB08)	____55157-US-NP_IDS_sb08_2014Mar28_SIG NED.pdf	612189 <small>d5ebd840f6158e1d00f6240cbd0b770c0848452</small>	no	4

Warnings:

Information:

A U.S. Patent Number Citation or a U.S. Publication Number Citation is required in the Information Disclosure Statement (IDS) form for autoloading of data into USPTO systems. You may remove the form to add the required data in order to correct the Informational Message if you are citing U.S. References. If you chose not to include U.S. References, the image of the form will be processed and be made available within the Image File Wrapper (IFW) system. However, no data will be extracted from this form. Any additional data such as Foreign Patent Documents or Non Patent Literature will be manually reviewed and keyed into USPTO systems.

2	Other Reference-Patent/App/Search documents	__05_Badkar.pdf	324368 8ee4a481b3da8d198e40574e12c6185c173c370b	no	9
---	---------------------------------------------	-----------------	--------------------------------------------------------	----	---

Warnings:

Information:

Total Files Size (in bytes):	936557
-------------------------------------	--------

This Acknowledgement Receipt evidences receipt on the noted date by the USPTO of the indicated documents, characterized by the applicant, and including page counts, where applicable. It serves as evidence of receipt similar to a Post Card, as described in MPEP 503.

New Applications Under 35 U.S.C. 111

If a new application is being filed and the application includes the necessary components for a filing date (see 37 CFR 1.53(b)-(d) and MPEP 506), a Filing Receipt (37 CFR 1.54) will be issued in due course and the date shown on this Acknowledgement Receipt will establish the filing date of the application.

National Stage of an International Application under 35 U.S.C. 371

If a timely submission to enter the national stage of an international application is compliant with the conditions of 35 U.S.C. 371 and other applicable requirements a Form PCT/DO/EO/903 indicating acceptance of the application as a national stage submission under 35 U.S.C. 371 will be issued in addition to the Filing Receipt, in due course.

New International Application Filed with the USPTO as a Receiving Office

If a new international application is being filed and the international application includes the necessary components for an international filing date (see PCT Article 11 and MPEP 1810), a Notification of the International Application Number and of the International Filing Date (Form PCT/RO/105) will be issued in due course, subject to prescriptions concerning national security, and the date shown on this Acknowledgement Receipt will establish the international filing date of the application.

FILING BY "EXPRESS MAIL" UNDER 37 CFR 1.10	
Express Mail Label Number	Date of Deposit

IN THE UNITED STATES PATENT AND TRADEMARK OFFICE

IN RE APPLICATION OF

Art Unit: 3763

Sigg, Juergen et al.

Examiner:

APPLICATION NO: 13/750352

Conf. No.: 5306

FILED: January 25, 2013

FOR: SYRINGE

Commissioner for Patents
PO Box 1450
Alexandria, VA 22313-1450

COMMUNICATION

Sir:

Applicants are submitting herewith an updated Application Data Sheet. This is being submitted to add the application number (202013000688.9) for the German priority application that was filed on January 23, 2013. The correction is reflected in the attached updated Application Data Sheet by underlining the application number that needs to be added. Please note, priority was claimed for this German application when this case was filed however, applicants did not have the application number at the time of filing. Furthermore, on March 13, 2013, the PTO had received all priority documents including German application No. 202013000688.9.

Please issue a corrected filing receipt.

If it is deemed there is a fee required, the Commissioner is hereby authorized to charge any fees under 37 CFR §1.17 which may be required, or credit any overpayment, to Account No. 19-0134 in the name of Novartis.

Respectfully submitted,

/Jim Lynch /

One Health Plaza
East Hanover, NJ 07936-1080
USA
+18627783423

Jim Lynch
Attorney for Applicant
Reg. No. 54,763

Date: April 11, 2014

Under the Paperwork Reduction Act of 1995, no persons are required to respond to a collection of information unless it contains a valid OMB control number.

Application Data Sheet 37 CFR 1.76		Attorney Docket Number	55157-US-NP
		Application Number	
Title of Invention	Syringe		
<p>The application data sheet is part of the provisional or nonprovisional application for which it is being submitted. The following form contains the bibliographic data arranged in a format specified by the United States Patent and Trademark Office as outlined in 37 CFR 1.76. This document may be completed electronically and submitted to the Office in electronic format using the Electronic Filing System (EFS) or the document may be printed and included in a paper filed application.</p>			

Secrecy Order 37 CFR 5.2

Portions or all of the application associated with this Application Data Sheet may fall under a Secrecy Order pursuant to 37 CFR 5.2. (Paper filers only. Applications that fall under Secrecy Order may not be filed electronically.)

Inventor Information:

Inventor 1 Remove				
Legal Name				
Prefix	Given Name	Middle Name	Family Name	Suffix
	Juergen		SIGG	
Residence Information (Select One) <input type="radio"/> US Residency <input checked="" type="radio"/> Non US Residency <input type="radio"/> Active US Military Service				
City	Loerrach	Country of Residence ¹	DE	
Mailing Address of Inventor:				
Address 1	Novartis Pharma AG			
Address 2	Postfach			
City	Basel	State/Province		
Postal Code	4002	Country ¹	CH	
Inventor 2 Remove				
Legal Name				
Prefix	Given Name	Middle Name	Family Name	Suffix
	Christopher		Royer	
Residence Information (Select One) <input type="radio"/> US Residency <input checked="" type="radio"/> Non US Residency <input type="radio"/> Active US Military Service				
City	Munich	Country of Residence ¹	DE	
Mailing Address of Inventor:				
Address 1	Novartis Pharma AG			
Address 2	Postfach			
City	Basel	State/Province		
Postal Code	4002	Country ¹	CH	
Inventor 3 Remove				
Legal Name				

Under the Paperwork Reduction Act of 1995, no persons are required to respond to a collection of information unless it contains a valid OMB control number.

Application Data Sheet 37 CFR 1.76		Attorney Docket Number	55157-US-NP	
		Application Number		
Title of Invention	Syringe			
Prefix	Given Name	Middle Name	Family Name	Suffix
	Andrew	Mark	BRYANT	
Residence Information (Select One) <input type="radio"/> US Residency <input checked="" type="radio"/> Non US Residency <input type="radio"/> Active US Military Service				
City	Reinach, Basel Land	Country of Residence ¹	CH	
Mailing Address of inventor:				
Address 1	Novartis Pharma AG			
Address 2	Postfach			
City	Basel	State/Province		
Postal Code	4002	Country ¹	CH	
Inventor 4 Remove				
Legal Name				
Prefix	Given Name	Middle Name	Family Name	Suffix
	Heinrich	Martin	BLUETTGEN	
Residence Information (Select One) <input type="radio"/> US Residency <input checked="" type="radio"/> Non US Residency <input type="radio"/> Active US Military Service				
City	Rheinfelden	Country of Residence ¹	CH	
Mailing Address of inventor:				
Address 1	Novartis Pharma AG			
Address 2	Postfach			
City	Basel	State/Province		
Postal Code	4002	Country ¹	CH	
Inventor 5 Remove				
Legal Name				
Prefix	Given Name	Middle Name	Family Name	Suffix
	Marie		PICCI	
Residence Information (Select One) <input type="radio"/> US Residency <input checked="" type="radio"/> Non US Residency <input type="radio"/> Active US Military Service				
City	Ranspack-le-bas	Country of Residence ¹	FR	
Mailing Address of inventor:				
Address 1	Novartis Pharma AG			
Address 2	Postfach			
City	Basel	State/Province		
Postal Code	4002	Country ¹	CH	

Under the Paperwork Reduction Act of 1995, no persons are required to respond to a collection of information unless it contains a valid OMB control number.

Application Data Sheet 37 CFR 1.76		Attorney Docket Number	55157-US-NP
		Application Number	
Title of Invention	Syringe		

All Inventors Must Be Listed - Additional inventor information blocks may be generated within this form by selecting the Add button.

Add

Correspondence Information:

Enter either Customer Number or complete the Correspondence Information section below. For further information see 37 CFR 1.33(a).

An Address is being provided for the correspondence information of this application.

Customer Number 01095

Email Address

Add Email

Remove Email

Application Information:

Title of the Invention	Syringe		
Attorney Docket Number	55157-US-NP	Small Entity Status Claimed	<input type="checkbox"/>
Application Type	Nonprovisional		
Subject Matter	Utility		
Total Number of Drawing Sheets (if any)		Suggested Figure for Publication (if any)	

Filing By Reference :

Only complete this section when filing an application by reference under 35 U.S.C. 111(c) and 37 CFR 1.57(a). Do not complete this section if application papers including a specification and any drawings are being filed. Any domestic benefit or foreign priority information must be provided in the appropriate section(s) below (i.e., "Domestic Benefit/National Stage Information" and "Foreign Priority Information").

For the purposes of a filing date under 37 CFR 1.53(b), the description and any drawings of the present application are replaced by this reference to the previously filed application, subject to conditions and requirements of 37 CFR 1.57(a).

Application number of the previously filed application	Filing date (YYYY-MM-DD)	Intellectual Property Authority or Country

Publication Information:

Request Early Publication (Fee required at time of Request 37 CFR 1.219)

Request Not to Publish. I hereby request that the attached application not be published under 35 U.S.C. 122(b) and certify that the invention disclosed in the attached application has not and will not be the subject of an application filed in another country, or under a multilateral international agreement, that requires publication at eighteen months after filing.

Representative Information:

Representative information should be provided for all practitioners having a power of attorney in the application. Providing this information in the Application Data Sheet does not constitute a power of attorney in the application (see 37 CFR 1.32). Either enter Customer Number or complete the Representative Name section below. If both sections are completed the customer Number will be used for the Representative Information during processing.

Under the Paperwork Reduction Act of 1995, no persons are required to respond to a collection of information unless it contains a valid OMB control number.

Application Data Sheet 37 CFR 1.76		Attorney Docket Number	55157-US-NP
		Application Number	
Title of Invention	Syringe		
Please Select One: <input checked="" type="radio"/> Customer Number <input type="radio"/> US Patent Practitioner <input type="radio"/> Limited Recognition (37 CFR 11.9)			
Customer Number	01095		

Domestic Benefit/National Stage Information:

This section allows for the applicant to either claim benefit under 35 U.S.C. 119(e), 120, 121, or 365(c) or indicate National Stage entry from a PCT application. Providing this information in the application data sheet constitutes the specific reference required by 35 U.S.C. 119(e) or 120, and 37 CFR 1.78.

When referring to the current application, please leave the application number blank.

Prior Application Status			Remove
Application Number	Continuity Type	Prior Application Number	Filing Date (YYYY-MM-DD)
Additional Domestic Benefit/National Stage Data may be generated within this form by selecting the Add button.			

Foreign Priority Information:

This section allows for the applicant to claim priority to a foreign application. Providing this information in the application data sheet constitutes the claim for priority as required by 35 U.S.C. 119(b) and 37 CFR 1.55(d). When priority is claimed to a foreign application that is eligible for retrieval under the priority document exchange program (PDX) the information will be used by the Office to automatically attempt retrieval pursuant to 37 CFR 1.55(h)(1) and (2). Under the PDX program, applicant bears the ultimate responsibility for ensuring that a copy of the foreign application is received by the Office from the participating foreign intellectual property office, or a certified copy of the foreign priority application is filed, within the time period specified in 37 CFR 1.55(g)(1).

			Remove
Application Number	Country	Filing Date (YYYY-MM-DD)	Access Code (if applicable)
12174860.2	EP	2012-07-03	
			Remove
Application Number	Country	Filing Date (YYYY-MM-DD)	Access Code (if applicable)
12189649.2	EP	2012-10-23	
			Remove
Application Number	Country	Filing Date (YYYY-MM-DD)	Access Code (if applicable)
202012011016.0	DE	2012-11-16	
			Remove
Application Number	Country	Filing Date (YYYY-MM-DD)	Access Code (if applicable)
2012101677	AU	2012-11-16	
			Remove
Application Number	Country	Filing Date (YYYY-MM-DD)	Access Code (if applicable)
2012101678	AU	2012-11-16	

Under the Paperwork Reduction Act of 1995, no persons are required to respond to a collection of information unless it contains a valid OMB control number.

Application Data Sheet 37 CFR 1.76		Attorney Docket Number	55157-US-NP
		Application Number	
Title of Invention	Syringe		

Application Number	Country	Filing Date (YYYY-MM-DD)	Access Code (if applicable)
202012011260.0	DE	2012-11-23	Remove
202012011259.7	DE	2012-11-23	Remove
12195360.8	EP	2012-12-03	Remove
2013100071	AU	2013-01-23	Remove
2013100070	AU	2013-01-23	Remove
202013000688.9	DE	2013-01-23	Remove

Additional Foreign Priority Data may be generated within this form by selecting the Add button.

Statement under 37 CFR 1.55 or 1.78 for AIA (First Inventor to File) Transition Applications

This application (1) claims priority to or the benefit of an application filed before March 16, 2013 and (2) also contains, or contained at any time, a claim to a claimed invention that has an effective filing date on or after March 16, 2013.

NOTE: By providing this statement under 37 CFR 1.55 or 1.78, this application, with a filing date on or after March 16, 2013, will be examined under the first inventor to file provisions of the AIA.

Authorization to Permit Access:

Authorization to Permit Access to the Instant Application by the Participating Offices

Under the Paperwork Reduction Act of 1996, no persons are required to respond to a collection of information unless it contains a valid OMB control number.

Application Data Sheet 37 CFR 1.76		Attorney Docket Number	55157-US-NP
		Application Number	
Title of Invention	Syringe		

If checked, the undersigned hereby grants the USPTO authority to provide the European Patent Office (EPO), the Japan Patent Office (JPO), the Korean Intellectual Property Office (KIPO), the World Intellectual Property Office (WIPO), and any other intellectual property offices in which a foreign application claiming priority to the instant patent application is filed access to the instant patent application. See 37 CFR 1.14(c) and (h). This box should not be checked if the applicant does not wish the EPO, JPO, KIPO, WIPO, or other intellectual property office in which a foreign application claiming priority to the instant patent application is filed to have access to the instant patent application.

In accordance with 37 CFR 1.14(h)(3), access will be provided to a copy of the instant patent application with respect to: 1) the instant patent application-as-filed; 2) any foreign application to which the instant patent application claims priority under 35 U.S.C. 119(a)-(d) if a copy of the foreign application that satisfies the certified copy requirement of 37 CFR 1.55 has been filed in the instant patent application; and 3) any U.S. application-as-filed from which benefit is sought in the instant patent application.

In accordance with 37 CFR 1.14(c), access may be provided to information concerning the date of filing this Authorization.

Applicant Information:

Providing assignment information in this section does not substitute for compliance with any requirement of part 3 of Title 37 of CFR to have an assignment recorded by the Office.

Applicant 1

If the applicant is the inventor (or the remaining joint inventor or inventors under 37 CFR 1.45), this section should not be completed. The information to be provided in this section is the name and address of the legal representative who is the applicant under 37 CFR 1.43; or the name and address of the assignee, person to whom the inventor is under an obligation to assign the invention, or person who otherwise shows sufficient proprietary interest in the matter who is the applicant under 37 CFR 1.46. If the applicant is an applicant under 37 CFR 1.46 (assignee, person to whom the inventor is obligated to assign, or person who otherwise shows sufficient proprietary interest) together with one or more joint inventors, then the joint inventor or inventors who are also the applicant should be identified in this section.

- Assignee
 Legal Representative under 35 U.S.C. 117
 Joint Inventor
 Person to whom the inventor is obligated to assign.
 Person who shows sufficient proprietary interest

If applicant is the legal representative, indicate the authority to file the patent application, the inventor is:

Name of the Deceased or Legally Incapacitated Inventor :

If the Applicant is an Organization check here.

Organization Name

Mailing Address Information For Applicant:

Address 1

Address 2

City

State/Province

Country

Postal Code

Phone Number

Fax Number

Under the Paperwork Reduction Act of 1995, no persons are required to respond to a collection of information unless it contains a valid OMB control number.

Application Data Sheet 37 CFR 1.76		Attorney Docket Number	55157-US-NP
		Application Number	
Title of Invention	Syringe		
Email Address			
Additional Applicant Data may be generated within this form by selecting the Add button.			

Assignee Information including Non-Applicant Assignee Information:

Providing assignment information in this section does not substitute for compliance with any requirement of part 3 of Title 37 of CFR to have an assignment recorded by the Office.				
Assignee 1				
Complete this section if assignee information, including non-applicant assignee information, is desired to be included on the patent application publication. An assignee-applicant identified in the "Applicant Information" section will appear on the patent application publication as an applicant. For an assignee-applicant, complete this section only if identification as an assignee is also desired on the patent application publication.				
If the Assignee or Non-Applicant Assignee is an Organization check here. <input type="checkbox"/>				
Prefix	Given Name	Middle Name	Family Name	Suffix
Mailing Address Information For Assignee including Non-Applicant Assignee:				
Address 1				
Address 2				
City		State/Province		
Country ¹		Postal Code		
Phone Number		Fax Number		
Email Address				
Additional Assignee or Non-Applicant Assignee Data may be generated within this form by selecting the Add button.				

Signature:

NOTE: This form must be signed in accordance with 37 CFR 1.33. See 37 CFR 1.4 for signature requirements and certifications.				
Signature	/Jim Lynch/		Date (YYYY-MM-DD)	2014-04-11
First Name	Jim	Last Name	Lynch	Registration Number 54763
Additional Signature may be generated within this form by selecting the Add button.				

Under the Paperwork Reduction Act of 1995, no persons are required to respond to a collection of information unless it contains a valid OMB control number.

Application Data Sheet 37 CFR 1.76		Attorney Docket Number	55157-US-NP
		Application Number	
Title of Invention	Syringe		

This collection of information is required by 37 CFR 1.76. The information is required to obtain or retain a benefit by the public which is to file (and by the USPTO to process) an application. Confidentiality is governed by 35 U.S.C. 122 and 37 CFR 1.14. This collection is estimated to take 23 minutes to complete, including gathering, preparing, and submitting the completed application data sheet form to the USPTO. Time will vary depending upon the individual case. Any comments on the amount of time you require to complete this form and/or suggestions for reducing this burden, should be sent to the Chief Information Officer, U.S. Patent and Trademark Office, U.S. Department of Commerce, P.O. Box 1450, Alexandria, VA 22313-1450. **DO NOT SEND FEES OR COMPLETED FORMS TO THIS ADDRESS. SEND TO: Commissioner for Patents, P.O. Box 1450, Alexandria, VA 22313-1450.**

Electronic Acknowledgement Receipt

EFS ID:	18742976
Application Number:	13750352
International Application Number:	
Confirmation Number:	5306
Title of Invention:	SYRINGE
First Named Inventor/Applicant Name:	Juergen Sigg
Customer Number:	1095
Filer:	James L Lynch/Andrea Jacquin
Filer Authorized By:	James L Lynch
Attorney Docket Number:	PAT055157-US-NP
Receipt Date:	11-APR-2014
Filing Date:	25-JAN-2013
Time Stamp:	16:02:58
Application Type:	Utility under 35 USC 111(a)

Payment information:

Submitted with Payment	no
------------------------	----

File Listing:

Document Number	Document Description	File Name	File Size(Bytes)/ Message Digest	Multi Part /.zip	Pages (if appl.)
1		55157-US- NP_Updated_ADS_to_add_Ger man_Priority_2014Apr11.pdf	2297127 b2c98e926eb1329f7d920ca1d905e015f9b eb259	yes	9

Multipart Description/PDF files in .zip description			
	Document Description	Start	End
	Miscellaneous Incoming Letter	1	1
	Application Data Sheet	2	9
Warnings:			
Information:			
Total Files Size (in bytes):		2297127	
<p>This Acknowledgement Receipt evidences receipt on the noted date by the USPTO of the indicated documents, characterized by the applicant, and including page counts, where applicable. It serves as evidence of receipt similar to a Post Card, as described in MPEP 503.</p> <p><u>New Applications Under 35 U.S.C. 111</u> If a new application is being filed and the application includes the necessary components for a filing date (see 37 CFR 1.53(b)-(d) and MPEP 506), a Filing Receipt (37 CFR 1.54) will be issued in due course and the date shown on this Acknowledgement Receipt will establish the filing date of the application.</p> <p><u>National Stage of an International Application under 35 U.S.C. 371</u> If a timely submission to enter the national stage of an international application is compliant with the conditions of 35 U.S.C. 371 and other applicable requirements a Form PCT/DO/EO/903 indicating acceptance of the application as a national stage submission under 35 U.S.C. 371 will be issued in addition to the Filing Receipt, in due course.</p> <p><u>New International Application Filed with the USPTO as a Receiving Office</u> If a new international application is being filed and the international application includes the necessary components for an international filing date (see PCT Article 11 and MPEP 1810), a Notification of the International Application Number and of the International Filing Date (Form PCT/RO/105) will be issued in due course, subject to prescriptions concerning national security, and the date shown on this Acknowledgement Receipt will establish the international filing date of the application.</p>			



UNITED STATES PATENT AND TRADEMARK OFFICE

UNITED STATES DEPARTMENT OF COMMERCE
United States Patent and Trademark Office
Address: COMMISSIONER FOR PATENTS
P.O. Box 1450
Alexandria, Virginia 22313-1450
www.uspto.gov

Table with 5 columns: APPLICATION NO., FILING DATE, FIRST NAMED INVENTOR, ATTORNEY DOCKET NO., CONFIRMATION NO.
13/750,352 01/25/2013 Juergen Sigg PAT055157-US-NP 5306

1095 7590 05/14/2014
NOVARTIS PHARMACEUTICAL CORPORATION
INTELLECTUAL PROPERTY DEPARTMENT
ONE HEALTH PLAZA 433/2
EAST HANOVER, NJ 07936-1080

EXAMINER

BERDICHEVSKY, AARTI

ART UNIT PAPER NUMBER

3763

NOTIFICATION DATE DELIVERY MODE

05/14/2014

ELECTRONIC

Please find below and/or attached an Office communication concerning this application or proceeding.

The time period for reply, if any, is set in the attached communication.

Notice of the Office communication was sent electronically on above-indicated "Notification Date" to the following e-mail address(es):

phip.patents@novartis.com

Office Action Summary	Application No. 13/750,352	Applicant(s) SIGG ET AL.	
	Examiner Aarti Bhatia Berdichevsky	Art Unit 3763	AIA (First Inventor to File) Status No

-- The MAILING DATE of this communication appears on the cover sheet with the correspondence address --

Period for Reply

A SHORTENED STATUTORY PERIOD FOR REPLY IS SET TO EXPIRE 3 MONTHS FROM THE MAILING DATE OF THIS COMMUNICATION.

- Extensions of time may be available under the provisions of 37 CFR 1.136(a). In no event, however, may a reply be timely filed after SIX (6) MONTHS from the mailing date of this communication.
- If NO period for reply is specified above, the maximum statutory period will apply and will expire SIX (6) MONTHS from the mailing date of this communication.
- Failure to reply within the set or extended period for reply will, by statute, cause the application to become ABANDONED (35 U.S.C. § 133). Any reply received by the Office later than three months after the mailing date of this communication, even if timely filed, may reduce any earned patent term adjustment. See 37 CFR 1.704(b).

Status

- 1) Responsive to communication(s) filed on _____.
 A declaration(s)/affidavit(s) under **37 CFR 1.130(b)** was/were filed on _____.
- 2a) This action is **FINAL**. 2b) This action is non-final.
- 3) An election was made by the applicant in response to a restriction requirement set forth during the interview on _____; the restriction requirement and election have been incorporated into this action.
- 4) Since this application is in condition for allowance except for formal matters, prosecution as to the merits is closed in accordance with the practice under *Ex parte Quayle*, 1935 C.D. 11, 453 O.G. 213.

Disposition of Claims*

- 5) Claim(s) 1-32 is/are pending in the application.
5a) Of the above claim(s) _____ is/are withdrawn from consideration.
- 6) Claim(s) _____ is/are allowed.
- 7) Claim(s) 1-32 is/are rejected.
- 8) Claim(s) _____ is/are objected to.
- 9) Claim(s) _____ are subject to restriction and/or election requirement.

* If any claims have been determined allowable, you may be eligible to benefit from the **Patent Prosecution Highway** program at a participating intellectual property office for the corresponding application. For more information, please see http://www.uspto.gov/patents/init_events/pph/index.jsp or send an inquiry to PPHfeedback@uspto.gov.

Application Papers

- 10) The specification is objected to by the Examiner.
- 11) The drawing(s) filed on _____ is/are: a) accepted or b) objected to by the Examiner.
Applicant may not request that any objection to the drawing(s) be held in abeyance. See 37 CFR 1.85(a).
Replacement drawing sheet(s) including the correction is required if the drawing(s) is objected to. See 37 CFR 1.121(d).

Priority under 35 U.S.C. § 119

- 12) Acknowledgment is made of a claim for foreign priority under 35 U.S.C. § 119(a)-(d) or (f).

Certified copies:

- a) All b) Some** c) None of the:
1. Certified copies of the priority documents have been received.
 2. Certified copies of the priority documents have been received in Application No. _____.
 3. Copies of the certified copies of the priority documents have been received in this National Stage application from the International Bureau (PCT Rule 17.2(a)).

** See the attached detailed Office action for a list of the certified copies not received.

Attachment(s)

- 1) Notice of References Cited (PTO-892)
- 2) Information Disclosure Statement(s) (PTO/SB/08a and/or PTO/SB/08b)
Paper No(s)/Mail Date 1.25.13, 1.29.13, 3.19.13, 6.04.13, 10.28.13, 3.28.14.
- 3) Interview Summary (PTO-413)
Paper No(s)/Mail Date. _____.
- 4) Other: _____.

DETAILED ACTION

This is the initial Office Action based on the 13/750,352 application filed on 1/25/2013. Claims 1-32, as amended on 8/16/2013, are currently pending and have been considered below.

Notice of Pre-AIA or AIA Status

1. The present application is being examined under the pre-AIA first to invent provisions.

Claim Rejections - 35 USC § 112

2. The following is a quotation of 35 U.S.C. 112(b):
(b) CONCLUSION.—The specification shall conclude with one or more claims particularly pointing out and distinctly claiming the subject matter which the inventor or a joint inventor regards as the invention.

The following is a quotation of 35 U.S.C. 112 (pre-AIA), second paragraph:
The specification shall conclude with one or more claims particularly pointing out and distinctly claiming the subject matter which the applicant regards as his invention.

3. Claim 10 is rejected under 35 U.S.C. 112(b) or 35 U.S.C. 112 (pre-AIA), second paragraph, as being indefinite for failing to particularly point out and distinctly claim the subject matter which the inventor or a joint inventor, or for pre-AIA the applicant regards as the invention.
4. Claim 10 recites the limitation "the silicone oil is a DC365 emulsion". There is insufficient antecedent basis for this limitation in the claim, since silicone oil has not yet been positively recited.

Art Unit: 3763

5. The following is a quotation of 35 U.S.C. 112(d):

(d) REFERENCE IN DEPENDENT FORMS.—Subject to subsection (e), a claim in dependent form shall contain a reference to a claim previously set forth and then specify a further limitation of the subject matter claimed. A claim in dependent form shall be construed to incorporate by reference all the limitations of the claim to which it refers.

The following is a quotation of 35 U.S.C. 112 (pre-AIA), fourth paragraph:

Subject to the [fifth paragraph of 35 U.S.C. 112 (pre-AIA)], a claim in dependent form shall contain a reference to a claim previously set forth and then specify a further limitation of the subject matter claimed. A claim in dependent form shall be construed to incorporate by reference all the limitations of the claim to which it refers.

6. Claims 2 and 3 are rejected under 35 U.S.C. 112(d) or pre-AIA 35 U.S.C. 112, 4th paragraph, as being of improper dependent form for failing to further limit the subject matter of the claim upon which it depends, or for failing to include all the limitations of the claim upon which it depends. Claims 2 and 3 require more solution than is already limited by Claim 1, on which these claims depend. Applicant may cancel the claims, amend the claims to place the claims in proper dependent form, rewrite the claims in independent form, or present a sufficient showing that the dependent claims comply with the statutory requirements.

Claim Rejections - 35 USC § 102

7. The following is a quotation of the appropriate paragraphs of pre-AIA 35 U.S.C. 102 that form the basis for the rejections under this section made in this Office action:

A person shall be entitled to a patent unless –

(b) the invention was patented or described in a printed publication in this or a foreign country or in public use or on sale in this country, more than one year prior to the date of application for patent in the United States.

Art Unit: 3763

8. Claims 1, 4, 11, 12, 13, 14, 15, 17, 30 rejected under pre-AIA 35 U.S.C. 102b as being anticipated by WO 2007/035621 to Scypinski et al.

Scypinski discloses the following:

1. A pre-filled syringe for intravitreal injection, the syringe comprising a glass body forming a barrel, a stopper and a plunger (page 9, lines 13-20) and containing an ophthalmic solution which comprises a VEGF-antagonist, wherein: (a) the syringe has a nominal maximum fill volume of between about 0.5 ml and about 1 ml (page 9, lines 13-20), (b) the syringe is filled with a dosage volume of between about 0.03 ml and about 0.05 ml of said VEGF antagonist solution (50 μ l, page 10, line 12), (c) the syringe barrel comprises less than about 500 μ g silicone oil (Scypinski teaches a barrel without any silicone oil), and (d) the VEGF antagonist solution comprises no more than 2 particles \geq 50 μ m in diameter per ml (see table 1).

4. A pre-filled syringe according to claim 1, wherein the syringe is filled with dosage volume of about 0.05 ml of a VEGF antagonist solution (100 μ L or less, page 10, lines 4-12).

11. A pre-filled syringe according to claim 1, wherein the syringe is silicone oil free.

12. A pre-filled syringe according to claim 1, wherein the VEGF antagonist solution further comprises one or more of (i) no more than 5 particles \geq 25 μ m in diameter per ml, and (ii) no more than 50 particles \geq 10 μ m in diameter per ml (table 1).

13. A pre-filled syringe according to claim 1, wherein the VEGF antagonist solution meets USP789 (page 11).

14. A pre-filled syringe according to claim 1, wherein the VEGF antagonist is an anti-VEGF antibody (pages 1 and 18).

15. A pre-filled syringe according to claim 14, wherein the anti-VEGF antibody is ranibizumab (page 1).

17. A pre-filled syringe according to claim 1 wherein the VEGF antagonist is a non-antibody VEGF antagonist (pages 18-22).

30. A method of treating a patient suffering from of an ocular disease selected from choroidal neovascularisation, wet age-related macular degeneration, macular edema secondary to retinal vein occlusion (RVO) including both branch RVO (bRVO) and central RVO (cRVO), choroidal neovascularisation secondary to pathologic myopia (PM), diabetic macular edema (DME), diabetic retinopathy, and proliferative retinopathy (pages 1 and 18) comprising the step of administering an ophthalmic solution to the patient using a pre-filled syringe according to claim 1.

Claim Rejections - 35 USC § 103

9. The following is a quotation of pre-AIA 35 U.S.C. 103(a) which forms the basis for all obviousness rejections set forth in this Office action:

(a) A patent may not be obtained though the invention is not identically disclosed or described as set forth in section 102 of this title, if the differences between the subject matter sought to be patented and the prior art are such that the subject matter as a whole would have been obvious at the time the invention was made to a person having ordinary skill in the art to which said subject matter pertains. Patentability shall not be negated by the manner in which the invention was made.

10. The factual inquiries set forth in *Graham v. John Deere Co.*, 383 U.S. 1, 148 USPQ 459 (1966), that are applied for establishing a background for determining obviousness under pre-AIA 35 U.S.C. 103(a) are summarized as follows:

Art Unit: 3763

1. Determining the scope and contents of the prior art.
2. Ascertaining the differences between the prior art and the claims at issue.
3. Resolving the level of ordinary skill in the pertinent art.
4. Considering objective evidence present in the application indicating obviousness or nonobviousness.

11. This application currently names joint inventors. In considering patentability of the claims under pre-AIA 35 U.S.C. 103(a), the examiner presumes that the subject matter of the various claims was commonly owned at the time any inventions covered therein were made absent any evidence to the contrary. Applicant is advised of the obligation under 37 CFR 1.56 to point out the inventor and invention dates of each claim that was not commonly owned at the time a later invention was made in order for the examiner to consider the applicability of pre-AIA 35 U.S.C. 103(c) and potential pre-AIA 35 U.S.C. 102(e), (f) or (g) prior art under pre-AIA 35 U.S.C. 103(a).

12. Claims 2, 3, 5, 16, 18, 19, 25-29, 31 and 35 are rejected under pre-AIA 35 U.S.C. 103(a) as being unpatentable over WO 2007/035621 to Scypinski et al.

With respect to claims 2, 3, and 16, it would have been obvious to one having ordinary skill in the art at the time the invention was made to vary the amount of solution delivered by Scypinski, based on the needs of the patient.

With respect to claims 5 and 31, it would have been obvious to determine the dosage volume using a priming mark on the syringe, and use that mark to deliver the dose, since Scypinski teaches the use of graduations on the syringe barrel (page 9).

With respect to claims 18-19, it would have been obvious to one having ordinary skill in the art to use any known VEGF antagonist, including aflibercept or conbercept.

With respect to claims 25-29, Scypinski teaches the use of foil pouch packaging. It would have been within the level of ordinary skill in the art to use known packaging materials including known blister packs which are similar.

With respect to claim 32, it would have been within the level of ordinary skill in the art to deliver one treatment after a previous different treatment, as a matter of common sense, especially if the first treatment did not produce the desired result.

13. Claims 6-10 and 20-24 are rejected under pre-AIA 35 U.S.C. 103(a) as being unpatentable over WO 2007/035621 to Scypinski et al. in view of US2011/0276005 to Hioki et al.

Scypinski teaches the pre-filled syringe according to claim 1, but is silent to an internal silicone coating on the syringe barrel.

Hioki teaches applying silicone oil to the inner surface of a syringe barrel (paragraph 0021). It would have been obvious to one having ordinary skill in the art at the time the invention was made to include silicone oil in the syringe barrel of Scypinski as taught by Hioki, since this will increase the slidability of the plunger within the barrel. It would have been within the level of ordinary skill in the art to find the optimum value of silicone oil to use, and to find the optimum amount to achieve the desired slide force and break loose force.

Conclusion

The prior art made of record and not relied upon is considered pertinent to applicant's disclosure. See PTO-892.

Any inquiry concerning this communication or earlier communications from the examiner should be directed to Aarti Bhatia Berdichevsky whose telephone number is 571-270-5033. The examiner can normally be reached M-F 9 AM to 5 PM.

If attempts to reach the examiner by telephone are unsuccessful, the examiner's supervisor, Bhisma Mehta can be reached on 571-272-3383. The fax phone number for the organization where this application is assigned is 571-273-8300.

Information regarding the status of an application may be obtained from the Patent Application Information Retrieval (PAIR) system. Status information for published applications may be obtained from either Private PAIR or Public PAIR. Status information for unpublished applications is available through Private PAIR only. For more information about the PAIR system, see <http://pair-direct.uspto.gov>. Should you have questions on access to the Private PAIR system, contact the Electronic Business Center (EBC) at 866-217-9197 (toll-free). If you would like assistance from a USPTO Customer Service Representative or access to the automated information system, call 800-786-9199 (IN USA OR CANADA) or 571-272-1000.

/Aarti Bhatia Berdichevsky/
Primary Examiner, Art Unit 3763

Notice of References Cited	Application/Control No. 13/750,352	Applicant(s)/Patent Under Reexamination SIGG ET AL.	
	Examiner Aarti Bhatia Berdichevsky	Art Unit 3763	Page 1 of 1

U.S. PATENT DOCUMENTS

*	Document Number Country Code-Number-Kind Code	Date MM-YYYY	Name	Classification
*	A US-6,090,081 A	07-2000	Sudo et al.	604/230
*	B US-2006/0172944 A1	08-2006	Wiegand et al.	514/012
*	C US-7,141,042 B2	11-2006	Lubrecht, Thea E.	604/230
*	D US-2007/0190058 A1	08-2007	Shams, Naveed	424/145.1
*	E US-7,303,748 B2	12-2007	Wiegand et al.	424/134.1
*	F US-2008/0312607 A1	12-2008	Delmotte et al.	604/230
*	G US-2011/0276005 A1	11-2011	Hioki et al.	604/187
	H US-			
	I US-			
	J US-			
	K US-			
	L US-			
	M US-			

FOREIGN PATENT DOCUMENTS

*	Document Number Country Code-Number-Kind Code	Date MM-YYYY	Country	Name	Classification
	N				
	O				
	P				
	Q				
	R				
	S				
	T				

NON-PATENT DOCUMENTS

*	Document Number Country Code-Number-Kind Code	Date MM-YYYY	Country	Name	Classification
	Include as applicable: Author, Title Date, Publisher, Edition or Volume, Pertinent Pages)				
	U				
	V				
	W				
	X				

*A copy of this reference is not being furnished with this Office action. (See MPEP § 707.05(a).)
Dates in MM-YYYY format are publication dates. Classifications may be US or foreign.

Receipt date: 03/28/2014

13750352 - GAIL 3763

Doc code: IDS

Doc description: Information Disclosure Statement (IDS) Filed

Approved for use through 07/31/2012. OMB 0651-0031
 U.S. Patent and Trademark Office; U.S. DEPARTMENT OF COMMERCE

Under the Paperwork Reduction Act of 1995, no persons are required to respond to a collection of information unless it contains a valid OMB control number.

INFORMATION DISCLOSURE STATEMENT BY APPLICANT (Not for submission under 37 CFR 1.99)	Application Number		13750352	
	Filing Date		2013-01-25	
	First Named Inventor	Juergen Sigg		
	Art Unit			
	Examiner Name			
	Attorney Docket Number		PAT055157-US-NP	

U.S.PATENTS						Remove
Examiner Initial*	Cite No	Patent Number	Kind Code ¹	Issue Date	Name of Patentee or Applicant of cited Document	Pages,Columns,Lines where Relevant Passages or Relevant Figures Appear
	1					

If you wish to add additional U.S. Patent citation information please click the Add button. Add

U.S.PATENT APPLICATION PUBLICATIONS						Remove
Examiner Initial*	Cite No	Publication Number	Kind Code ¹	Publication Date	Name of Patentee or Applicant of cited Document	Pages,Columns,Lines where Relevant Passages or Relevant Figures Appear
	1					

If you wish to add additional U.S. Published Application citation information please click the Add button. Add

FOREIGN PATENT DOCUMENTS								Remove
Examiner Initial*	Cite No	Foreign Document Number ³	Country Code ² i	Kind Code ⁴	Publication Date	Name of Patentee or Applicant of cited Document	Pages,Columns,Lines where Relevant Passages or Relevant Figures Appear	T ⁵
	1							<input type="checkbox"/>

If you wish to add additional Foreign Patent Document citation information please click the Add button Add

NON-PATENT LITERATURE DOCUMENTS			Remove
Examiner Initials*	Cite No	Include name of the author (in CAPITAL LETTERS), title of the article (when appropriate), title of the item (book, magazine, journal, serial, symposium, catalog, etc), date, pages(s), volume-issue number(s), publisher, city and/or country where published.	T ⁵

INFORMATION DISCLOSURE STATEMENT BY APPLICANT (Not for submission under 37 CFR 1.99)	Application Number	13750352	13750352 - GAU: 3763
	Filing Date	2013-01-25	
	First Named Inventor	Juergen Sigg	
	Art Unit		
	Examiner Name		
	Attorney Docket Number	PAT055157-US-NP	

1	Badkar et al., "Development of biotechnology products in pre-filled syringes: technical considerations and approaches", AAPS PharmaSciTech, Vol. 12, No. 2, pp. 564-572, (June 2011)	<input type="checkbox"/>
---	--------------------------------------------------------------------------------------------------------------------------------------------------------------------------------------	--------------------------

If you wish to add additional non-patent literature document citation information please click the Add button **Add**

EXAMINER SIGNATURE

Examiner Signature	/Aarti Bhatia Berdichevsky/	Date Considered	05/07/2014
--------------------	-----------------------------	-----------------	------------

*EXAMINER: Initial if reference considered, whether or not citation is in conformance with MPEP 609. Draw line through a citation if not in conformance and not considered. Include copy of this form with next communication to applicant.

¹ See Kind Codes of USPTO Patent Documents at www.USPTO.GOV or MPEP 901.04. ² Enter office that issued the document, by the two-letter code (WIPO Standard ST.3). ³ For Japanese patent documents, the indication of the year of the reign of the Emperor must precede the serial number of the patent document. ⁴ Kind of document by the appropriate symbols as indicated on the document under WIPO Standard ST.16 if possible. ⁵ Applicant is to place a check mark here if English language translation is attached.

Receipt date: 03/19/2013

13750352/GB/01/0701/3763

Approved for use through 12/31/2012. OMB control number: U.S. Patent and Trademark Office, U.S. DEPARTMENT OF COMMERCE

Under the Paperwork Reduction Act of 1995, no persons are required to respond to a collection of information unless it contains a valid OMB control number.

Substitute for form 1449/PTO		Complete if Known	
INFORMATION DISCLOSURE STATEMENT BY APPLICANT <i>(Use as many sheets as necessary)</i>		Application Number	13/750352
		Filing Date	January 25, 2013
		First Named Inventor	Sigg, Juergen et al.
		Art unit	3783
		Examiner Name	
		Attorney Docket Number	PAT055157-US-NP
Sheet	1	of	1

U.S. PATENT DOCUMENTS						
Examiner Initials*	Cite No. ¹	Document Number		Publication Date MM-DD-YYYY	Name of Patentee or Applicant of Cited Document	Pages, Columns, Lines, Where Relevant Passages or Relevant Figures Appear
		Number	Kind Code ² (if known)			
		US-				
		US-				
		US-				
		US-				
		US-				
		US-				
		US-				
		US-				

FOREIGN PATENT DOCUMENTS								
Examiner Initials*	Cite No. ¹	Foreign Patent Document			Publication Date MM-DD-YYYY	Name of Patentee or Applicant of Cited Document	Pages, Columns, Lines, Where Relevant Passages or Relevant Figures Appear	†*
		Country Code ³	Number ³	Kind Code ² (if known)				
		WO	2011/123722	A1	10-06-2011	OCUJECT, LLC		<input type="checkbox"/>
		WO	2012/149040	A2	11-01-2012	WONG, VERNON, G.		<input type="checkbox"/>
		WO	2007/149334	A2	12-27-2007	REGENERON PHARMACEUTICALS, INC		<input type="checkbox"/>
		WO	2012/134528	A1	10-04-2012	OCUJECT, LLC		<input type="checkbox"/>
								<input type="checkbox"/>
								<input type="checkbox"/>
								<input type="checkbox"/>
								<input type="checkbox"/>

Examiner Signature	/Aarti Bhatia Berdichevsky/	Date Considered	05/07/2014
--------------------	-----------------------------	-----------------	------------

*EXAMINER: Initial if reference considered, whether or not citation is in conformance with MPEP 609. Draw a line through citation if not in conformance and not considered. Include copy of this form with the next communication to applicant. ¹ Applicant's unique citation designation number (optional). ² See Kind Codes of USPTO Patent Documents at www.uspto.gov or MPEP 901.04. ³ Enter Office that issued the document, by the two-letter code (WIPO Standard ST.3). ⁴ For Japanese patent documents, the indication of the year of the reign of the Emperor must precede the serial number of the patent document. ⁵ Kind of document by the appropriate symbols as indicated on the document under WIPO Standard ST.16 if possible. ⁶ Applicant is to place a check mark here if English language Translation is attached. This collection of information is required by 37 CFR 1.97 and 1.98. The information is required to obtain or retain a benefit by the public which is to file (and by the USPTO to process) an application. Confidentiality is governed by 35 U.S.C. 122 and 37 CFR 1.14. This collection is estimated to take 2 hours to complete, including gathering, preparing, and submitting the completed application form to the USPTO. Time will vary depending upon the individual case. Any comments on the amount of time you require to complete this form and/or suggestions for reducing this burden, should be sent to the Chief Information Officer, U.S. Patent and Trademark Office, P.O. Box 1450, Alexandria, VA 22313-1450. DO NOT SEND FEES OR COMPLETED FORMS TO THIS ADDRESS. SEND TO: Commissioner for Patents, P.O. Box 1450, Alexandria, VA 22313-1450.

If you need assistance in completing the form, call 1-800-PTO-9199 (1-800-756-9199) and select option 2.

ALL REFERENCES CONSIDERED EXCEPT WHERE LINED THROUGH. /ABB/

Receipt date: 01/25/2013

13750252 PTO/SB/08a (07-09) 763

Approved for use through 07/31/2012. OMB 0651-0021
 U.S. Patent and Trademark Office: U.S. DEPARTMENT OF COMMERCE

Under the Paperwork Reduction Act of 1995, no persons are required to respond to a collection of information unless it contains a valid OMB control number.

Substitute for form 1449/PTO				Complete if Known	
INFORMATION DISCLOSURE STATEMENT BY APPLICANT <i>(Use as many sheets as necessary)</i>				Application Number	Not yet known
				Filing Date	Herewith
				First Named Inventor	Sigg, Juergen et al.
				Art unit	
				Examiner Name	
				Attorney Docket Number	PAT055157-US-NP
Sheet	1	of	1		

U.S. PATENT DOCUMENTS						
Examiner Initials*	Cite No. ¹	Document Number		Publication Date MM-DD-YYYY	Name of Patentee or Applicant of Cited Document	Pages, Columns, Lines, Where Relevant Passages or Relevant Figures Appear
		Number-Kind Code ² (If known)				
		US-				
		US-				

FOREIGN PATENT DOCUMENTS							
Examiner Initials*	Cite No. ¹	Foreign Patent Document		Publication Date MM-DD-YYYY	Name of Patentee or Applicant of Cited Document	Pages, Columns, Lines, Where Relevant Passages or Relevant Figures Appear	T ⁶
		Country Code ³ Number ⁴ Kind Code ⁵ (If known)					
		WO2010/060748		06-03-2010	Molecular Partners AG		<input type="checkbox"/>
		WO2011/135067		11-03-2011	Molecular Partners AG		<input type="checkbox"/>
							<input type="checkbox"/>

NON PATENT LITERATURE DOCUMENTS			
Examiner Initials*	Cite No. ¹	Include name of the author (in CAPITAL LETTERS), title of the article (when appropriate), title of the item (book, magazine, journal, serial, symposium, catalog, etc.), date, page(s), volume-issue number(s), publisher, city and/or country where published.	T ²
		Badkar et al., Analysis of Two Commercially Available Bortezomib Products : Differences in Assay of Active Agent and Impurity Profile » AAPS PharmaSciTech, Vol. 12, No. 2, pp. 564-572, (June 2011)	<input type="checkbox"/>
		Schoenknecht, "Requirements on pre-fillable glass syringes", AAPS National Biotechnology Conference 2007 – Abstract no. NBC07-000488, 2007	<input type="checkbox"/>
		Holash et al., "VEGF-Trap: A VEGF blocker with potent antitumor effects", PNAS USA, Vol. 99, No. 17, pp. 11393-11398, (August 20, 2002)	<input type="checkbox"/>
		Riely & Miller, "Vascular Endothelial Growth Factor Trap in Non-Small Cell lung Cancer", Clin Cancer Res, 13:4623-7s, (August 1, 2007)	<input type="checkbox"/>
		Li et al., "KH906, a recombinant human VEGF receptor fusion protein, is a new effective topical treatment for corneal neovascularization", Molecular Vision, 17:797-803,(March 25, 2011)	<input type="checkbox"/>
		Smith & Waterman, " Comparison of Biosequences", Adv Appl. Math, 2:482-489, (1981)	<input type="checkbox"/>
			<input type="checkbox"/>
			<input type="checkbox"/>

Examiner Signature	/Aarti Bhatia Berdichevsky/	Date Considered	05/07/2014
---------------------------	-----------------------------	------------------------	------------

*EXAMINER: Initial if reference considered, whether or not citation is in conformance with MPEP 609. Draw a line through citation if not in conformance and not considered. Include copy of this form with the next communication to applicant. ¹ Applicant's unique citation designation number (optional). ² See Kind Codes of USPTO Patent Documents at www.uspto.gov or MPEP 901.04. ³ Enter Office that issued the document, by the two-letter code (WIPO Standard ST.3). ⁴ For Japanese patent documents, the indication of the year of the reign of the Emperor must precede the serial number of the patent document. ⁵ Kind of document by the appropriate symbols as indicated on the document under WIPO Standard ST.16 if possible. ⁶ Applicant is to place a check mark here if English language Translation is attached.

This collection of information is required by 37 CFR 1.97 and 1.98. The information is required to obtain or retain a benefit by the public which is to file (and by the USPTO to process) an application. Confidentiality is governed by 35 U.S.C. 122 and 37 CFR 1.14. This collection is estimated to take 2 hours to complete, including gathering, preparing, and submitting the completed application form to the USPTO. Time will vary depending upon the individual case. Any comments on the amount of time you require to complete this form and/or suggestions for reducing this burden, should be sent to the Chief Information Officer, U.S. Patent and Trademark Office, P.O. Box 1450, Alexandria, VA 22313-1450. DO NOT SEND FEES OR COMPLETED FORMS TO THIS ADDRESS. SEND TO: Commissioner for Patents, P.O. Box 1450, Alexandria, VA 22313-1450.

If you need assistance in completing the form, call 1-800-PTO-9199 (1-800-786-9199) and select option 2.

PTO/SB/08a (07-09)

ALL REFERENCES CONSIDERED EXCEPT WHERE LINED THROUGH. /ABB/

Regeneron Exhibit 1002.1259

Receipt date: 06/04/2013

13750352 - GAI: 3768

Doc description: Information Disclosure Statement (IDS) Filed

Approved for use through 07/31/2012. OMB 0651-0031
U.S. Patent and Trademark Office; U.S. DEPARTMENT OF COMMERCE

Under the Paperwork Reduction Act of 1995, no persons are required to respond to a collection of information unless it contains a valid OMB control number.

INFORMATION DISCLOSURE STATEMENT BY APPLICANT (Not for submission under 37 CFR 1.99)	Application Number		13750352	
	Filing Date		2013-01-25	
	First Named Inventor	Juergen Sigg		
	Art Unit	3767		
	Examiner Name	Unknown		
	Attorney Docket Number	PAT055157-US-NP		

U.S.PATENTS						Remove
Examiner Initial*	Cite No	Patent Number	Kind Code ¹	Issue Date	Name of Patentee or Applicant of cited Document	Pages,Columns,Lines where Relevant Passages or Relevant Figures Appear
	1					

If you wish to add additional U.S. Patent citation information please click the Add button. Add

U.S.PATENT APPLICATION PUBLICATIONS						Remove
Examiner Initial*	Cite No	Publication Number	Kind Code ¹	Publication Date	Name of Patentee or Applicant of cited Document	Pages,Columns,Lines where Relevant Passages or Relevant Figures Appear
	1	2013012918	AA	2013-01-10	FOSTER GARY	
	2	2012078224	AA	2012-03-29	OCUJECT LLC	
	3	2006172944	AA	2006-08-03	WIEGAND STANLEY J	

If you wish to add additional U.S. Published Application citation information please click the Add button. Add

FOREIGN PATENT DOCUMENTS								Remove
Examiner Initial*	Cite No	Foreign Document Number ³	Country Code ²	Kind Code ⁴	Publication Date	Name of Patentee or Applicant of cited Document	Pages,Columns,Lines where Relevant Passages or Relevant Figures Appear	T ⁵
	1	2007084765	WO	A2	2007-07-26	POTENTIA		<input type="checkbox"/>

INFORMATION DISCLOSURE STATEMENT BY APPLICANT (Not for submission under 37 CFR 1.99)	Application Number		13750352	13750352 - GAU: 3763
	Filing Date		2013-01-25	
	First Named Inventor	Juergen Sigg		
	Art Unit		3767	
	Examiner Name	Unknown		
	Attorney Docket Number		PAT055157-US-NP	

	2	2006128564	WO	A1	2006-12-07	BAXTER INT		<input type="checkbox"/>
	3	2006047325	WO	A1	2006-05-04	SHAMS NAVEED		<input type="checkbox"/>
	4	201578690	CN	U	2010-09-15	JIANYOU WANG	English Abstract	<input type="checkbox"/>
	5	2371406	EP		2011-10-05	Taisei Kako Co., LTD	equivalent of WO2010/064667	<input type="checkbox"/>
	6	2001-104480	JP		2001-04-14	Daiko Seiko LTD	English Abstract	<input type="checkbox"/>
	7	2010136492	WO		2010-12-02	Glaxo Group Limited		<input type="checkbox"/>

If you wish to add additional Foreign Patent Document citation information please click the Add button **Add**

NON-PATENT LITERATURE DOCUMENTS

Remove

Examiner Initials*	Cite No	Include name of the author (in CAPITAL LETTERS), title of the article (when appropriate), title of the item (book, magazine, journal, serial, symposium, catalog, etc), date, pages(s), volume-issue number(s), publisher, city and/or country where published.	T ⁵
	1		<input type="checkbox"/>

If you wish to add additional non-patent literature document citation information please click the Add button **Add**

EXAMINER SIGNATURE

Examiner Signature	/Aarti Bhatia Berdichevsky/	Date Considered	05/07/2014
--------------------	-----------------------------	-----------------	------------

*EXAMINER: Initial if reference considered, whether or not citation is in conformance with MPEP 609. Draw line through a citation if not in conformance and not considered. Include copy of this form with next communication to applicant.

Receipt date: 10/28/2013

13750352 - GAU: 3763

Doc code: IDS

Doc description: Information Disclosure Statement (IDS) Filed

PTO/SB/08a (01-10)

Approved for use through 07/31/2012. OMB 0651-0031

U.S. Patent and Trademark Office: U.S. DEPARTMENT OF COMMERCE

Under the Paperwork Reduction Act of 1995, no persons are required to respond to a collection of information unless it contains a valid OMB control number.

INFORMATION DISCLOSURE STATEMENT BY APPLICANT (Not for submission under 37 CFR 1.99)	Application Number	13750352
	Filing Date	2013-01-25
	First Named Inventor	Juergen Sigg
	Art Unit	3763
	Examiner Name	N. D. Shah
	Attorney Docket Number	PAT055157-US-NP

U.S. PATENTS						
Examiner Initial*	Cite No	Patent Number	Kind Code ¹	Issue Date	Name of Patentee or Applicant of cited Document	Pages, Columns, Lines where Relevant Passages or Relevant Figures Appear
	1					

If you wish to add additional U.S. Patent citation information please click the Add button.

U.S. PATENT APPLICATION PUBLICATIONS						
Examiner Initial*	Cite No	Publication Number	Kind Code ¹	Publication Date	Name of Patentee or Applicant of cited Document	Pages, Columns, Lines where Relevant Passages or Relevant Figures Appear
	1					

If you wish to add additional U.S. Published Application citation information please click the Add button.

FOREIGN PATENT DOCUMENTS								
Examiner Initial*	Cite No	Foreign Document Number ³	Country Code ² i	Kind Code ⁴	Publication Date	Name of Patentee or Applicant of cited Document	Pages, Columns, Lines where Relevant Passages or Relevant Figures Appear	T ⁵
	1	2002241264	JP	A2	2002-08-28	HITOMI KOJI	Abstract	<input type="checkbox"/>
	2	0264273	EP	A2	1988-04-20	OKUDA TAMOTSU	eq SHO63-97173	<input type="checkbox"/>
	3	0879611	EP	A2	1998-11-25	SUDO MASAMICHI	eq HEI10-314305	<input type="checkbox"/>

ALL REFERENCES CONSIDERED EXCEPT WHERE LINED THROUGH. /ABB/

Receipt date: 10/28/2013

13750352 - GAU: 3763

INFORMATION DISCLOSURE STATEMENT BY APPLICANT (Not for submission under 37 CFR 1.99)	Application Number		13750352
	Filing Date		2013-01-25
	First Named Inventor	Juergen Sigg	
	Art Unit	3763	
	Examiner Name	N. D. Shah	
	Attorney Docket Number	PAT055157-US-NP	

If you wish to add additional Foreign Patent Document citation information please click the Add button

NON-PATENT LITERATURE DOCUMENTS

Examiner Initials*	Cite No	Include name of the author (in CAPITAL LETTERS), title of the article (when appropriate), title of the item (book, magazine, journal, serial, symposium, catalog, etc), date, pages(s), volume-issue number(s), publisher, city and/or country where published.	T ⁵
	1		<input type="checkbox"/>

If you wish to add additional non-patent literature document citation information please click the Add button

EXAMINER SIGNATURE

Examiner Signature	/Aarti Bhatia Berdichevsky/	Date Considered	05/07/2014
--------------------	-----------------------------	-----------------	------------

*EXAMINER: Initial if reference considered, whether or not citation is in conformance with MPEP 609. Draw line through a citation if not in conformance and not considered. Include copy of this form with next communication to applicant.

¹ See Kind Codes of USPTO Patent Documents at www.USPTO.GOV or MPEP 901.04. ² Enter office that issued the document, by the two-letter code (WIPO Standard ST.3). ³ For Japanese patent documents, the indication of the year of the reign of the Emperor must precede the serial number of the patent document. ⁴ Kind of document by the appropriate symbols as indicated on the document under WIPO Standard ST. 16 if possible. ⁵ Applicant is to place a check mark here if English language translation is attached.

Search Notes 	Application/Control No. 13750352	Applicant(s)/Patent Under Reexamination SIGG ET AL.
	Examiner AARTI B BERDICHEVSKY	Art Unit 3763

CPC- SEARCHED		
Symbol	Date	Examiner
A61K9/0048OR A61F9/008 OR A61M5178 OR A61M5/31	5/8/2014	ABB

CPC COMBINATION SETS - SEARCHED		
Symbol	Date	Examiner

US CLASSIFICATION SEARCHED			
Class	Subclass	Date	Examiner
604	218, 294	5/8/2014	ABB

SEARCH NOTES		
Search Notes	Date	Examiner
EAST search	5/8/2014	ABB
Inventor search	5/8/2014	ABB

INTERFERENCE SEARCH			
US Class/ CPC Symbol	US Subclass / CPC Group	Date	Examiner

--	--

EAST Search History

EAST Search History (Prior Art)

Ref #	Hits	Search Query	DBs	Default Operator	Plurals	Time Stamp
S1	13	sigg-juergen\$.in.	US-PGPUB; USPAT; USOCR; DERWENT	AND	ON	2014/05/08 09:18
S2	14	royer-chris\$.in.	US-PGPUB; USPAT; USOCR; DERWENT	AND	ON	2014/05/08 09:18
S3	73	bryant-andrew\$.in.	US-PGPUB; USPAT; USOCR; DERWENT	AND	ON	2014/05/08 09:18
S4	1	buettgen-heinrich\$.in.	US-PGPUB; USPAT; USOCR; DERWENT	AND	ON	2014/05/08 09:18
S5	5	picci-marie\$.in.	US-PGPUB; USPAT; USOCR; DERWENT	AND	ON	2014/05/08 09:18
S6	8	("20060293270" "20100310309" "20110257601" "3012918" "2078224" "6172944").PN.	US-PGPUB; USPAT; USOCR	AND	ON	2014/05/08 09:19
S7	1	"13750352"	US-PGPUB; USPAT; USOCR; DERWENT	AND	ON	2014/05/08 09:52
S8	11442	VEGF ophthalm\$	US-PGPUB; USPAT; USOCR; DERWENT	AND	ON	2014/05/08 11:12
S9	7642	VEGF antagonist ophthalm\$	US-PGPUB; USPAT; USOCR; DERWENT	AND	ON	2014/05/08 11:13
S10	714	VEGF antagonist ophthalm\$ syringe silicone oil solution	US-PGPUB; USPAT; USOCR; DERWENT	AND	ON	2014/05/08 11:13

EAST Search History

S11	5521	(A61K9/0048 OR A61F9/0008 OR A61M5/178 OR A61M5/31).CPC.	US-PGPUB; USPAT; USOCR; DERWENT	AND	ON	2014/05/08 11:16
S12	2553	604/218,294.ccls.	US-PGPUB; USPAT; USOCR; DERWENT	AND	ON	2014/05/08 12:06
S13	541	VEGF antagonist ophthalm\$ syringe glass silicone oil solution	US-PGPUB; USPAT; USOCR; DERWENT	AND	ON	2014/05/08 12:08
S14	535	VEGF antagonist ophthalm\$ syringe glass silicone oil solution volume	US-PGPUB; USPAT; USOCR; DERWENT	AND	ON	2014/05/08 12:08
S15	40	(VEGF near2 antagonist) ophthalm\$ syringe glass silicone oil solution volume	US-PGPUB; USPAT; USOCR; DERWENT	AND	ON	2014/05/08 12:09
S16	2	((glass with syringe) volume "silicone oil").clm.	US-PGPUB; USPAT; USOCR; DERWENT	AND	ON	2014/05/08 12:14
S17	448	(glass with syringe) volume "silicone oil"	US-PGPUB; USPAT; USOCR; DERWENT	AND	ON	2014/05/08 12:18
S18	2	"20130012918"	US-PGPUB; USPAT; USOCR; DERWENT	AND	ON	2014/05/08 12:28
S19	2	"20120078224"	US-PGPUB; USPAT; USOCR; DERWENT	AND	ON	2014/05/08 12:28
S20	3	"20060172944"	US-PGPUB; USPAT; USOCR; DERWENT	AND	ON	2014/05/08 12:29
S21	4	"2006047325"	US-PGPUB; USPAT; USOCR; DERWENT	AND	ON	2014/05/08 12:29
S22	2	"20070190058"	US-PGPUB; USPAT; USOCR; DERWENT	AND	ON	2014/05/08 12:30

EAST Search History

S23	2	"2007149334"	US-PGPUB; USPAT; USOCR; DERWENT	AND	ON	2014/05/08 12:30
S24	4	"2007084765"	US-PGPUB; USPAT; USOCR; DERWENT	AND	ON	2014/05/08 12:31
S25	3	"20070128654"	US-PGPUB; USPAT; USOCR; DERWENT	AND	ON	2014/05/08 12:32
S26	3	"20070238654"	US-PGPUB; USPAT; USOCR; DERWENT	AND	ON	2014/05/08 12:32
S27	4	"2007035621"	US-PGPUB; USPAT; USOCR; DERWENT	AND	ON	2014/05/08 12:33
S28	0	"11992110"	US-PGPUB; USPAT; USOCR; DERWENT	AND	ON	2014/05/08 12:34
S29	3	"2006128564"	US-PGPUB; USPAT; USOCR; DERWENT	AND	ON	2014/05/08 12:34
S30	2	"20080312607"	US-PGPUB; USPAT; USOCR; DERWENT	AND	ON	2014/05/08 12:35
S31	4	"2006047325"	US-PGPUB; USPAT; USOCR; DERWENT	AND	ON	2014/05/08 12:35
S32	1	"201578690"	US-PGPUB; USPAT; USOCR; DERWENT	AND	ON	2014/05/08 12:36
S33	44	(US-20140012227-\$ or US-20110257601-\$ or US-20060293270-\$ or US-20100310309-\$ or US-20070253985-\$ or US-20130338606-\$ or US-20130012918-\$ or US-20120078224-\$ or US-20060172944-\$ or US-20070190058-\$ or US-20070238654-\$ or US-20080312607-\$ or US-20130197451-\$ or US-20120171386-\$ or US-20120123345-\$ or US-20110276005-\$ or US-20020038111-	US-PGPUB; USPAT; USOCR; DERWENT	AND	ON	2014/05/08 13:06

EAST Search History

		\$.did. or (US-6172944-\$ or US-3012918-\$ or US-2078224-\$ or US-8668972-\$ or US-8603638-\$ or US-7303748-\$ or US-8168584-\$ or US-6689118-\$ or US-6569143-\$ or US-6494865-\$ or US-6189195-\$).did. or (US-3012918-\$ or US-2078224-\$).did. or (GB-2500092-\$ or WO-2006047325-\$ or US-20070293432-\$ or WO-03047244-\$ or WO-2007084765-\$ or WO-2007035621-\$ or WO-2006128564-\$ or CN-201578690-\$ or AU-2013100360-\$ or AU-2013100145-\$ or AU-2013100146-\$ or AU-2013100147-\$ or AU-2013100071-\$ or AU-2013100070-\$).did.				
S34	14	S33 and S8 ml	US-PGPUB; USPAT; USOCR; DERWENT	AND	ON	2014/05/08 13:19
S35	58	"6090081"	US-PGPUB; USPAT; USOCR; DERWENT	AND	ON	2014/05/08 13:30

EAST Search History (Interference)

< This search history is empty >

5/ 8/ 2014 1:34:46 PM

C:\Users\abhatia1\Documents\EAST\Workspaces\13750352.wsp

IN THE UNITED STATES PATENT AND TRADEMARK OFFICE

IN RE APPLICATION OF

Confirm No. 5306

Sigg, Juergen et al.

APPLICATION NO: 13/750,352

Examiner: Berdichevsky, Aarti

FILED: January 25, 2013

Art Unit: 3763

FOR: SYRINGE

Commissioner for Patents
PO Box 1450
Alexandria, VA 22313-1450

AMENDMENT AND RESPONSE TO OFFICE ACTION

Sir:

This Amendment and Response ("Response") is being submitted in reply to an Office Action mailed to Applicants' attorney on May 14, 2014 ("Office Action").

Amendments to the Claims are reflected in the listing of the claims which begins on page 2 of this paper.

Remarks/Arguments begin on page 5 of this paper.

Amendments to the Claims:

This listing of claims will replace all prior versions, and listings, of claims in the application:

Listing of Claims:

1.(Currently amended) A pre-filled syringe for intravitreal injection, the syringe comprising a glass body forming a barrel, a stopper and a plunger and containing an ophthalmic solution which comprises a VEGF-antagonist, wherein:

(a) the syringe has a nominal maximum fill volume of between about 0.5ml and about 1ml,

(b) the syringe is filled with a dosage volume of between about 0.03ml and about 0.05ml of said VEGF antagonist solution,

(c) the syringe barrel comprises ~~less than~~ from about 1µg to 500µg silicone oil, and

(d) the VEGF antagonist solution comprises no more than 2 particles >50µm in diameter per ml.

2.(Original) A pre-filled syringe according to claim 1, wherein the syringe is filled with between about 0.15ml and about 0.175ml of a VEGF antagonist solution.

3.(Original) A pre-filled syringe according to claim 1, wherein the syringe is filled with about 0.165ml of said VEGF antagonist solution.

4.(original) A pre-filled syringe according to claim 1, wherein the syringe is filled with dosage volume of about 0.05ml of a VEGF antagonist solution.

5.(original) A pre-filled syringe according to claim 1, in which the dosage volume is determined by the volume of the variable volume chamber when a predetermined part of the stopper is aligned with a priming mark on the syringe.

6.(Previously presented) A pre-filled syringe according to claim 1, wherein the syringe barrel has an internal coating of silicone oil that has an average thickness of about 450nm or less.

7.(Canceled).

8.(Canceled).

9.(Previously presented) A pre-filled syringe according to claim 1, wherein the syringe barrel has an internal coating of from about 3µg to about 200µg silicone oil.

10. (original) A pre-filled syringe according to claim 1, wherein the silicone oil is DC365 emulsion.

11. (Canceled).

12. (original) A pre-filled syringe according to claim 1, wherein the VEGF antagonist solution further comprises one or more of (i) no more than 5 particles $\geq 25\mu\text{m}$ in diameter per ml, and (ii) no more than 50 particles $\geq 10\mu\text{m}$ in diameter per ml.
13. (original) A pre-filled syringe according to claim 1, wherein the VEGF antagonist solution meets USP789.
14. (original) A pre-filled syringe according to claim 1, wherein the VEGF antagonist is an anti-VEGF antibody.
15. (original) A pre-filled syringe according to claim 14, wherein the anti-VEGF antibody is ranibizumab.
16. (original) A pre-filled syringe according to claim 15, wherein the ranibizumab is at a concentration of 10mg/ml.
17. (original) A pre-filled syringe according to claim 1 wherein the VEGF antagonist is a non-antibody VEGF antagonist.
18. (original) A pre-filled syringe according to claim 17, wherein the non-antibody VEGF antagonist is aflibercept or conbercept.
19. (original) A pre-filled syringe according to claim 18, wherein the non-antibody VEGF antagonist is aflibercept at a concentration of 40mg/ml.
20. (original) A pre-filled syringe according to claim 1, wherein the syringe has a stopper break loose force of less than about 11N.
21. (original) A pre-filled syringe according to claim 20, wherein the syringe has a stopper break loose force of less than about 5N.
22. (original) A pre-filled syringe according to claim 1, wherein the syringe has a stopper slide force of less than about 11N.
23. (original) A pre-filled syringe according to claim 22, wherein the syringe has a stopper slide force of less than about 5N.
24. (original) A pre-filled syringe according to claims 20, wherein the stopper break loose force or stopper slide force is measured using a filled syringe, at a stopper travelling speed of 190mm/min, with a 30G x 0.5 inch needle attached to the syringe.
25. (original) A blister pack comprising a pre-filled syringe according to claim 1, wherein the syringe has been sterilised using H_2O_2 or EtO.

26. (original) A blister pack comprising a pre-filled syringe according to claim 25, wherein the outer surface of the syringe has ≤ 1 ppm EtO or H₂O₂ residue.

27. (original) A blister pack comprising a pre-filled syringe according to claim 25, wherein the syringe has been sterilised using EtO or H₂O₂ and the total EtO or H₂O₂ residue found on the outside of the syringe and inside of the blister pack is ≤ 0.1 mg.

28. (original) A blister pack comprising a pre-filled syringe according to claims 25, wherein $\leq 5\%$ of the VEGF antagonist is alkylated.

29. (original) A blister pack comprising a pre-filled syringe according to claim 25, wherein the syringe has been sterilised using EtO or H₂O₂ with a Sterility Assurance Level of at least 10⁻⁶.

30. (original) A method of treating a patient suffering from of an ocular disease selected from choroidal neovascularisation, wet age-related macular degeneration, macular edema secondary to retinal vein occlusion (RVO) including both branch RVO (bRVO) and central RVO (cRVO), choroidal neovascularisation secondary to pathologic myopia (PM), diabetic macular edema (DME), diabetic retinopathy, and proliferative retinopathy, comprising the step of administering an ophthalmic solution to the patient using a pre-filled syringe according to claim 1.

31. (original) The method of claim 30, further comprising an initial priming step in which the physician depresses the plunger of the pre-filled syringe to align the pre-determined part of the stopper with the priming mark.

32. (original) A method according to claim 30, wherein the VEGF antagonist administered is a non-antibody VEGF antagonist and wherein the patient has previously received treatment with an antibody VEGF antagonist.

33. (New) A pre-filled syringe according to claim 1, wherein the syringe barrel has an internal coating of from about 1-100 μ g silicone oil.

34. (New) A pre-filled syringe according to claim 1, wherein the syringe barrel has an internal coating of from about 1-50 μ g silicone oil.

REMARKS/ARGUMENTS

Claim Status

Claims 1-32 were pending prior to the entry of this amendment. By way of this amendment, claim 1 has been amended to positively recite silicone oil by incorporating the elements from claim 8; claims 7, 8 and 11 have been canceled. New claims 33 and 34 have been added. Accordingly, claims 1-6, 9-10 and 12-34 are pending after entry of this amendment.

The Examiner's Objections and Rejections

The Examiner rejected claim 10 under 35 U.S.C. § 112 (b), second paragraph as being indefinites. More specifically, the Examiner found that the recitation of "the silicone oil is a DC365 emulsion" as lacking antecedent basis. The Examiner also rejected claims 2 and 3 under 35 U.S.C. § 112, fourth paragraph as being improper for failing to further limit the subject matter of claim 1 from which the claims each depend.

In addition the Examiner rejected claims 1, 4, 11, 12, 13, 14, 15, 17 and 20 under 35 U.S.C. § 102(b) as being anticipated by WO 2007/035621 to Scypinski et al. (hereinafter "the '621 publication"). More specifically, the Examiner contends that the '621 publication teaches all of the elements of the currently pending claims because, inter alia, the '621 publication teaches a barrel without any silicone oil.

The Examiner also rejected claims 2, 3, 5, 16, 18, 19, 25-29, 31 and 31 under 35 U.S.C. § 103 (a) as being obvious in view of the '621 publication. Claims 6-10 and 20-24 were rejected under 35 U.S.C. § 103 (a) as obvious under the '621 publication in further view of US2011/0276005 to Hioki et al (hereinafter "the '005 publication"). The Examiner admits that the '621 publication is silent to an internal silicone coating on the syringe barrel. However, to cure this deficiency, the Examiner relies on the teachings of the '005 publication. According to the Examiner, the '005 publication teaches coating the inner surface of a syringe barrel, and that the skilled artisan would have been motivated to include oil in the silicone barrel to increase the slidability of the plunger within the barrel, and that finding the optimum value of the silicone oil to use is well within the ordinary skill in the art.

Response

A. 35 U.S.C. § 112

Initially, the claims have been amended to positively recite the presence of silicone oil. As a result, there is now support for claim 10's recitation of a specific silicone oil type.

Accordingly, the Examiner's rejection of claim 10 under 35 U.S.C. §112 have been obviated and the applicants respectfully request that the rejection be withdrawn.

Claims 2 and 3 recite elements related to the **fill volume** of the VEGF solution to be utilized in the syringe. Claim 1 recites a specific **dosage volume**. As is known in the art and described on page 5 of the current specification the two terms are different. The fill volume refers to the actual volume of solution in the syringe. As stated on page 5 of the specification the fill volume of the syringe is between .01ml and 1.5ml. This is to be contrasted with the dosage volume. The dosage volume, as described on page 5, is the volume of medicament intended for delivery to the patient. Thus, the dosage volume can be equal to the fill volume if the volume in the syringe is intended to be delivered in one dose. However, the dosage volume can be much less than the fill volume if the syringe is intended to contain multiple dosages. Thus it is entirely consistent that the dosage volume is less than the fill volume. Accordingly the Examiner's rejection is improper and should be withdrawn.

B. 35 U.S.C. § 102

With regards to the 35 U.S.C. §102 rejection, the claims have been amended to positively recite the presence of silicone oil in the barrel. The Examiner admits that the '621 publication is silent as to the presence or amount of silicone oil. It is black letter law that a proper 35 U.S.C. §102 rejection must teach each and every element of the claims. Since the '621 publication does not teach at least the presence of silicone oil recited in the claims, the rejection is improper and should be withdrawn. Furthermore, the Examiner did not reject claim 8 under 35 U.S.C. §102. Since the elements of this claim have been incorporated into claim 1, the rejection is now moot for claim 1 and its dependent claims. Therefore the rejection should be withdrawn.

C. 35 U.S.C. § 103

The applicants note that the Examiner's first rejection under 35 U.S.C. §103 did not reject claim 8. Claim 1 has been amended to incorporate the elements from claim 1. Therefore the rejection is moot and should be withdrawn for claim 1 and its dependent claims. As such, the only remaining rejection is the rejection of claims 6-10 and 20-24 under the '621 publication in view of the '005 publication. For the reasons that follow, applicants respectfully traverse.

Initially, syringe barrels are typically comprised of either plastic or glass. Applicants concede that silicone-free plastic syringes are known in the art, However, plastic (or resin) syringes cannot be used as "pre-filled" syringes for biologics or sensitive drugs for a variety of reasons. First and foremost, the plastic and the biologic product may interact, corrupting the drug substance. In addition, the seal provided by plastic silicone free syringes are not tight

enough. Consequently, terminal sterilization of syringes is difficult. That is, because the seal is known to leak, it is possible for the sterilizing agent to leach into the syringe. For biologic products, this is critical as it is well known that they are particularly sensitive to terminal sterilizing agents such as hydrogen peroxide, which can oxidize the protein, and heat, which can denature the protein. As a result, syringes which are prefilled with biologics are comprised of glass barrels.

However, it is not possible to have silicone free glass barreled syringes. In glass barreled syringes, rubber stoppers are used to ensure suitable tightness of the seal. This eliminates the leaching of terminal sterilizing agents and eliminates biologic/plastic barrel interactions. However, there is a high friction level between the rubber and glass meaning that the break loose and slide forces are high. Without a lubricant such as silicone, the forces would be so high as to render the syringe unusable. To overcome this problem, the syringe barrels are siliconised.

As stated in the current specification, however, it is desirable to reduce the silicone content of a prefilled syringe as much as possible. With each injection, a small amount of silicone is injected into the eye with "standard" siliconised syringes known in the art. With drugs that are administered by repeated injection (such as VEGF antagonists), over time the droplets of silicone in the eye build up and can aggregate, causing "floaters" in the vision. By reducing the silicone levels as much as possible, the amount of silicone that detaches from the syringe barrel wall is minimized. With intravenous or intramuscular injections, this is less of a problem as the silicone droplets are less likely to localize and aggregate. A further issue is that silicone oil can cause aggregation of proteinaceous products.

The '621 publication teaches a dual barreled syringe useful in administering a combination of drugs simultaneously into a patient's eye. The '621 publication discloses that the syringe barrel can be either glass or plastic. As discussed above, plastic syringes are not useful as pre-filled syringes for biologic products. The '621 publication's disclosure of suitable glass needles are typical pre-filled syringes described on page 9 of the specification. There is absolutely no teaching or suggestion that the glass barrels described as useful in the '621 publication contain the amounts of silicone recited in the currently pending claims. Instead, as is known and described on page 6 of the current specification, typical glass prefilled syringes contain from 500-1000 micrograms of silicone.

The '005 publication exclusively describes resin syringes. It describes the addition of silicone at a thickness of 5-50 $\mu\text{g}/\text{cm}^2$ under the heading "Thickness of Silicone Film" at paragraphs [0074] and [0075]. As a result, there is no motivation to combine the references. At

best, the combination of the '621 publication and the '005 publication would lead to resin syringes comprising a silicone thickness of between 5-50 $\mu\text{g}/\text{cm}^2$. There are two problems with this. First, the current claims recite the use of a glass barrel and there is no teaching or suggestion in the references that the amount of silicone used in a resin barrel would be appropriate in a glass barrel. Second, as taught in the current specification on page 7, in order to maintain a low silicone content the silicone oil has a thickness of 450 nm or less. The thickness of silicone oil taught in the current specification is therefore 10-100 times less! As a result, the combination of the '621 publication and the '005 publication fails to teach or suggest the current invention.

The applicants have shown for the first time that you can reduce the silicone levels to far below previous standards and still obtain a usable syringe (see page 6, line 5 to page 7, line 16). Indeed, as shown in the test results on pages 15 and 16, the applicants have surprisingly found that the application of less silicone resulted in lowered sliding and break forces. This flies in the face of conventional wisdom, which suggests that the way to reduce these forces is to use more lubricant.

In sum, then, not only do the cited references fail to teach or suggest the currently claimed invention, but the applicants have surprisingly found that using less silicone actually leads to usable syringes. This is neither taught nor suggested by the cited references. Accordingly, the Examiner has not established a prima facie case of obviousness and the applicants respectfully request that it be withdrawn.

Conclusion

Applicants believe that the foregoing constitutes a complete and full response to the Office Action of record. They further submit that all pending claims, as amended, are patentable and in patentable form, and they respectfully request that such claims be allowed to issue. Should the Examiner have any outstanding issues, the undersigned representative invites the Examiner to contact him at his convenience.

Novartis Pharmaceuticals Corporation
One Health Plaza, Bldg. 101
East Hanover, NJ 07936
+1 8627783423

Respectfully submitted,
/ Jim Lynch /

Jim Lynch
Agent for Applicant
Reg. No. 54,763

Date: August 13, 2014

Electronic Acknowledgement Receipt

EFS ID:	19853954
Application Number:	13750352
International Application Number:	
Confirmation Number:	5306
Title of Invention:	SYRINGE
First Named Inventor/Applicant Name:	Juergen Sigg
Customer Number:	1095
Filer:	James L Lynch/Denise Cooper
Filer Authorized By:	James L Lynch
Attorney Docket Number:	PAT055157-US-NP
Receipt Date:	13-AUG-2014
Filing Date:	25-JAN-2013
Time Stamp:	13:55:26
Application Type:	Utility under 35 USC 111(a)

Payment information:

Submitted with Payment	no
------------------------	----

File Listing:

Document Number	Document Description	File Name	File Size(Bytes)/ Message Digest	Multi Part /.zip	Pages (if appl.)
1	Amendment/Req. Reconsideration-After Non-Final Reject	PAT055157-US-NP-ROA-14May2014.pdf	182986 <small>ece4183802e7183c7a0396aead2f4a7c1a8e d777</small>	no	8

Warnings:

Information:

This Acknowledgement Receipt evidences receipt on the noted date by the USPTO of the indicated documents, characterized by the applicant, and including page counts, where applicable. It serves as evidence of receipt similar to a Post Card, as described in MPEP 503.

New Applications Under 35 U.S.C. 111

If a new application is being filed and the application includes the necessary components for a filing date (see 37 CFR 1.53(b)-(d) and MPEP 506), a Filing Receipt (37 CFR 1.54) will be issued in due course and the date shown on this Acknowledgement Receipt will establish the filing date of the application.

National Stage of an International Application under 35 U.S.C. 371

If a timely submission to enter the national stage of an international application is compliant with the conditions of 35 U.S.C. 371 and other applicable requirements a Form PCT/DO/EO/903 indicating acceptance of the application as a national stage submission under 35 U.S.C. 371 will be issued in addition to the Filing Receipt, in due course.

New International Application Filed with the USPTO as a Receiving Office

If a new international application is being filed and the international application includes the necessary components for an international filing date (see PCT Article 11 and MPEP 1810), a Notification of the International Application Number and of the International Filing Date (Form PCT/RO/105) will be issued in due course, subject to prescriptions concerning national security, and the date shown on this Acknowledgement Receipt will establish the international filing date of the application.

Under the Paperwork Reduction Act of 1995, no persons are required to respond to a collection of information unless it displays a valid OMB control number.

PATENT APPLICATION FEE DETERMINATION RECORD Substitute for Form PTO-875	Application or Docket Number 13/750,352	Filing Date 01/25/2013	<input type="checkbox"/> To be Mailed
-----------------------------------------------------------------------------------	---------------------------------------------------	----------------------------------	---------------------------------------

ENTITY: LARGE SMALL MICRO

APPLICATION AS FILED – PART I

(Column 1) (Column 2)

FOR	NUMBER FILED	NUMBER EXTRA	RATE (\$)	FEE (\$)
<input type="checkbox"/> BASIC FEE (37 CFR 1.16(a), (b), or (c))	N/A	N/A	N/A	
<input type="checkbox"/> SEARCH FEE (37 CFR 1.16(k), (l), or (m))	N/A	N/A	N/A	
<input type="checkbox"/> EXAMINATION FEE (37 CFR 1.16(o), (p), or (q))	N/A	N/A	N/A	
TOTAL CLAIMS (37 CFR 1.16(j))	minus 20 =	*	X \$ =	
INDEPENDENT CLAIMS (37 CFR 1.16(h))	minus 3 =	*	X \$ =	
<input type="checkbox"/> APPLICATION SIZE FEE (37 CFR 1.16(s))	If the specification and drawings exceed 100 sheets of paper, the application size fee due is \$310 (\$155 for small entity) for each additional 50 sheets or fraction thereof. See 35 U.S.C. 41(a)(1)(G) and 37 CFR 1.16(s).			
<input type="checkbox"/> MULTIPLE DEPENDENT CLAIM PRESENT (37 CFR 1.16(j))				
* If the difference in column 1 is less than zero, enter "0" in column 2.			TOTAL	

APPLICATION AS AMENDED – PART II

(Column 1) (Column 2) (Column 3)

AMENDMENT	08/13/2014	CLAIMS REMAINING AFTER AMENDMENT		HIGHEST NUMBER PREVIOUSLY PAID FOR	PRESENT EXTRA	RATE (\$)	ADDITIONAL FEE (\$)
	Total (37 CFR 1.16(i))	* 31	Minus	** 32	= 0	X \$80 =	0
	Independent (37 CFR 1.16(h))	* 1	Minus	***3	= 0	X \$420 =	0
	<input type="checkbox"/> Application Size Fee (37 CFR 1.16(s))						
<input type="checkbox"/> FIRST PRESENTATION OF MULTIPLE DEPENDENT CLAIM (37 CFR 1.16(j))							
TOTAL ADD'L FEE						0	

(Column 1) (Column 2) (Column 3)

AMENDMENT		CLAIMS REMAINING AFTER AMENDMENT		HIGHEST NUMBER PREVIOUSLY PAID FOR	PRESENT EXTRA	RATE (\$)	ADDITIONAL FEE (\$)
	Total (37 CFR 1.16(i))	*	Minus	**	=	X \$ =	
	Independent (37 CFR 1.16(h))	*	Minus	***	=	X \$ =	
	<input type="checkbox"/> Application Size Fee (37 CFR 1.16(s))						
<input type="checkbox"/> FIRST PRESENTATION OF MULTIPLE DEPENDENT CLAIM (37 CFR 1.16(j))							
TOTAL ADD'L FEE							

* If the entry in column 1 is less than the entry in column 2, write "0" in column 3.
 ** If the "Highest Number Previously Paid For" IN THIS SPACE is less than 20, enter "20".
 *** If the "Highest Number Previously Paid For" IN THIS SPACE is less than 3, enter "3".
 The "Highest Number Previously Paid For" (Total or Independent) is the highest number found in the appropriate box in column 1.

LIE
 /ALLYSON PURNELL/

This collection of information is required by 37 CFR 1.16. The information is required to obtain or retain a benefit by the public which is to file (and by the USPTO to process) an application. Confidentiality is governed by 35 U.S.C. 122 and 37 CFR 1.14. This collection is estimated to take 12 minutes to complete, including gathering, preparing, and submitting the completed application form to the USPTO. Time will vary depending upon the individual case. Any comments on the amount of time you require to complete this form and/or suggestions for reducing this burden, should be sent to the Chief Information Officer, U.S. Patent and Trademark Office, U.S. Department of Commerce, P.O. Box 1450, Alexandria, VA 22313-1450. DO NOT SEND FEES OR COMPLETED FORMS TO THIS ADDRESS. **SEND TO: Commissioner for Patents, P.O. Box 1450, Alexandria, VA 22313-1450.**

If you need assistance in completing the form, call 1-800-PTO-9199 and select option 2.



UNITED STATES PATENT AND TRADEMARK OFFICE

UNITED STATES DEPARTMENT OF COMMERCE
United States Patent and Trademark Office
Address: COMMISSIONER FOR PATENTS
P.O. Box 1450
Alexandria, Virginia 22313-1450
www.uspto.gov

Table with 5 columns: APPLICATION NO., FILING DATE, FIRST NAMED INVENTOR, ATTORNEY DOCKET NO., CONFIRMATION NO.
13/750,352 01/25/2013 Juergen Sigg PAT055157-US-NP 5306

1095 7590 08/26/2014
NOVARTIS PHARMACEUTICAL CORPORATION
INTELLECTUAL PROPERTY DEPARTMENT
ONE HEALTH PLAZA 433/2
EAST HANOVER, NJ 07936-1080

EXAMINER

BERDICHEVSKY, AARTI

ART UNIT PAPER NUMBER

3763

NOTIFICATION DATE DELIVERY MODE

08/26/2014

ELECTRONIC

Please find below and/or attached an Office communication concerning this application or proceeding.

The time period for reply, if any, is set in the attached communication.

Notice of the Office communication was sent electronically on above-indicated "Notification Date" to the following e-mail address(es):

phip.patents@novartis.com

DETAILED ACTION

This is the second Office Action based on the 13/750,352 application filed on 1/25/2013. Claims 1-6, 9-10 and 12-34, as amended on 8/13/2014, are currently pending and have been considered below.

Notice of Pre-AIA or AIA Status

1. The present application is being examined under the pre-AIA first to invent provisions.

Response to Amendment

2. The rejection of claim 10 under the second paragraph of 35 USC § 112 has been withdrawn in view of the amendments made by the Applicant.

Claim Rejections - 35 USC § 112

3. The following is a quotation of 35 U.S.C. 112(b):

(b) CONCLUSION.—The specification shall conclude with one or more claims particularly pointing out and distinctly claiming the subject matter which the inventor or a joint inventor regards as the invention.

The following is a quotation of 35 U.S.C. 112 (pre-AIA), second paragraph:
The specification shall conclude with one or more claims particularly pointing out and distinctly claiming the subject matter which the applicant regards as his invention.

4. Claims 1-6, 9-10 and 12-34 are rejected under 35 U.S.C. 112(b) or 35 U.S.C. 112 (pre-AIA), second paragraph, as being indefinite for failing to particularly point out

and distinctly claim the subject matter which the inventor or a joint inventor, or for pre-AIA the applicant regards as the invention.

5. Claim 1 recites “the syringe is filled with a dosage volume of between about 0.03ml and about 0.05ml of said VEGF antagonist solution”. It is unclear whether there is more than one intended dosage volume filled inside the syringe. As the claim is currently worded, it appears that there is only a single dosage volume filled in the syringe. Clarification is requested.

6. The following is a quotation of 35 U.S.C. 112(d):

(d) REFERENCE IN DEPENDENT FORMS.—Subject to subsection (e), a claim in dependent form shall contain a reference to a claim previously set forth and then specify a further limitation of the subject matter claimed. A claim in dependent form shall be construed to incorporate by reference all the limitations of the claim to which it refers.

The following is a quotation of 35 U.S.C. 112 (pre-AIA), fourth paragraph:

Subject to the [fifth paragraph of 35 U.S.C. 112 (pre-AIA)], a claim in dependent form shall contain a reference to a claim previously set forth and then specify a further limitation of the subject matter claimed. A claim in dependent form shall be construed to incorporate by reference all the limitations of the claim to which it refers.

7. Claims 2 and 3 are rejected under 35 U.S.C. 112(d) or pre-AIA 35 U.S.C. 112, 4th paragraph, as being of improper dependent form for failing to further limit the subject matter of the claim upon which it depends, or for failing to include all the limitations of the claim upon which it depends. Claims 2 and 3 require more solution than is already limited by Claim 1, on which these claims depend. Applicant may cancel the claims, amend the claims to place the claims in proper dependent form, rewrite the claims in independent form, or present a sufficient showing that the dependent claims comply with the statutory requirements. Additionally, claim recites “a VEGF antagonist

Art Unit: 3763

solution”, the Examiner is interpreting this as the same solution claimed in claim 1, clarification is requested.

Claim Rejections - 35 USC § 103

8. The text of those sections of Title 35, U.S. Code not included in this action can be found in a prior Office action.

9. Claims 1-6, 9-10 and 12-34 are rejected under pre-AIA 35 U.S.C. 103(a) as being unpatentable over WO 2007/035621 to Scypinski et al. in view of US2011/0276005 to Hioki et al.

Scypinski discloses a pre-filled syringe for intravitreal injection, the syringe comprising a glass body forming a barrel, a stopper and a plunger (page 9, lines 13-20) and containing an ophthalmic solution which comprises a VEGF-antagonist, wherein: (a) the syringe has a nominal maximum fill volume of between about 0.5 ml and about 1 ml (page 9, lines 13-20), (b) the syringe is filled with a dosage volume of between about 0.03 ml and about 0.05 ml of said VEGF antagonist solution (50 μ l, page 10, line 12), (c) the syringe barrel comprises less than about 500 μ g silicone oil, and (d) the VEGF antagonist solution comprises no more than 2 particles \geq 50 μ m in diameter per ml (see table 1); wherein the syringe is filled with dosage volume of about 0.05 ml of a VEGF antagonist solution (100 μ L or less, page 10, lines 4-12); wherein the VEGF antagonist solution further comprises one or more of (i) no more than 5 particles \geq 25 μ m in diameter per ml, and (ii) no more than 50 particles \geq 10 μ m in diameter per ml (table 1); wherein the VEGF antagonist solution meets USP789 (page 11); wherein the VEGF

Art Unit: 3763

antagonist is an anti-VEGF antibody (pages 1 and 18); wherein the anti-VEGF antibody is ranibizumab (page 1); wherein the VEGF antagonist is a non-antibody VEGF antagonist (pages 18-22). Scypinski additionally teaches the method of treating a patient suffering from of an ocular disease selected from choroidal neovascularisation, wet age-related macular degeneration, macular edema secondary to retinal vein occlusion (RVO) including both branch RVO (bRVO) and central RVO (cRVO), choroidal neovascularisation secondary to pathologic myopia (PM), diabetic macular edema (DME), diabetic retinopathy, and proliferative retinopathy (pages 1 and 18) comprising the step of administering an ophthalmic solution to the patient using a pre-filled syringe.

Scypinski is silent to an internal silicone coating on the syringe barrel.

Hioki teaches applying silicone oil to the inner surface of a syringe barrel (paragraph 0021). It would have been obvious to one having ordinary skill in the art at the time the invention was made to include silicone oil in the syringe barrel of Scypinski as taught by Hioki, since this will increase the slidability of the plunger within the barrel. It would have been within the level of ordinary skill in the art to find the optimum value of silicone oil to use, and to find the optimum amount to achieve the desired slide force and break loose force.

Additionally, it would have been obvious to one having ordinary skill in the art at the time the invention was made to vary the amount of solution delivered by Scypinski, based on the needs of the patient.

Additionally, it would have been obvious to determine the dosage volume using a priming mark on the syringe, and use that mark to deliver the dose, since Scypinski teaches the use of graduations on the syringe barrel (page 9).

Additionally, it would have been obvious to one having ordinary skill in the art to use any known VEGF antagonist, including aflibercept or conbercept.

Additionally, Scypinski teaches the use of foil pouch packaging. It would have been within the level of ordinary skill in the art to use known packaging materials including known blister packs which are similar.

Additionally, it would have been within the level of ordinary skill in the art to deliver one treatment after a previous different treatment, as a matter of common sense, especially if the first treatment did not produce the desired result.

Response to Arguments

10. Applicant's arguments filed 8/13/2014 have been fully considered but they are not persuasive.

11. The Applicant argues that Claim 1 recites a specific dosage volume and that Claims 2 and 3 describe the fill volume. The Examiner understands and appreciates the differences between these terms, however, Claim 1 recites that the syringe is filled with a specific volume. It does not describe the syringe as containing multiple dosage volumes. The Examiner suggests the Applicant more clearly describe how much solution is being claimed in claim 1.

Art Unit: 3763

12. In response to applicant's argument that there is no teaching, suggestion, or motivation to combine the references, the examiner recognizes that obviousness may be established by combining or modifying the teachings of the prior art to produce the claimed invention where there is some teaching, suggestion, or motivation to do so found either in the references themselves or in the knowledge generally available to one of ordinary skill in the art. See *In re Fine*, 837 F.2d 1071, 5 USPQ2d 1596 (Fed. Cir. 1988), *In re Jones*, 958 F.2d 347, 21 USPQ2d 1941 (Fed. Cir. 1992), and *KSR International Co. v. Teleflex, Inc.*, 550 U.S. 398, 82 USPQ2d 1385 (2007). In this case, as the Applicant argues, it is well known to use silicone oil in glass barrels, therefore it would have been within the level of ordinary skill in the art at the time the invention was made to use the silicone oil levels as generally described by Hioki with the glass barrel syringe of Scypinski, and further within the level of ordinary skill to optimize the amount of silicone.

Conclusion

THIS ACTION IS MADE FINAL. Applicant is reminded of the extension of time policy as set forth in 37 CFR 1.136(a).

A shortened statutory period for reply to this final action is set to expire THREE MONTHS from the mailing date of this action. In the event a first reply is filed within TWO MONTHS of the mailing date of this final action and the advisory action is not mailed until after the end of the THREE-MONTH shortened statutory period, then the shortened statutory period will expire on the date the advisory action is mailed, and any

Art Unit: 3763

extension fee pursuant to 37 CFR 1.136(a) will be calculated from the mailing date of the advisory action. In no event, however, will the statutory period for reply expire later than SIX MONTHS from the mailing date of this final action.

Any inquiry concerning this communication or earlier communications from the examiner should be directed to Aarti Bhatia Berdichevsky whose telephone number is 571-270-5033. The examiner can normally be reached M-F 9 AM to 5 PM.

If attempts to reach the examiner by telephone are unsuccessful, the examiner's supervisor, Bhisma Mehta can be reached on 571-272-3383. The fax phone number for the organization where this application is assigned is 571-273-8300.

Information regarding the status of an application may be obtained from the Patent Application Information Retrieval (PAIR) system. Status information for published applications may be obtained from either Private PAIR or Public PAIR. Status information for unpublished applications is available through Private PAIR only. For more information about the PAIR system, see <http://pair-direct.uspto.gov>. Should you have questions on access to the Private PAIR system, contact the Electronic Business Center (EBC) at 866-217-9197 (toll-free). If you would like assistance from a USPTO Customer Service Representative or access to the automated information system, call 800-786-9199 (IN USA OR CANADA) or 571-272-1000.

/Aarti Bhatia Berdichevsky/
Primary Examiner, Art Unit 3763

Search Notes 	Application/Control No. 13750352	Applicant(s)/Patent Under Reexamination SIGG ET AL.
	Examiner AARTI B BERDICHEVSKY	Art Unit 3763

CPC- SEARCHED		
Symbol	Date	Examiner
A61K9/0048OR A61F9/008 OR A61M5178 OR A61M5/31	5/8/2014	ABB
above updated	8/21/2014	ABB

CPC COMBINATION SETS - SEARCHED		
Symbol	Date	Examiner

US CLASSIFICATION SEARCHED			
Class	Subclass	Date	Examiner
604	218, 294	5/8/2014	ABB
above	updated	8/21/2014	ABB

SEARCH NOTES		
Search Notes	Date	Examiner
EAST search	5/8/2014	ABB
Inventor search	5/8/2014	ABB

INTERFERENCE SEARCH			
US Class/ CPC Symbol	US Subclass / CPC Group	Date	Examiner

	/AARTI B BERDICHEVSKY/ Primary Examiner.Art Unit 3763
--	----------------------------------------------------------

**REQUEST FOR CONTINUED EXAMINATION(RCE)TRANSMITTAL
 (Submitted Only via EFS-Web)**

Application Number	13750352	Filing Date	2013-01-25	Docket Number (if applicable)	PAT055157-US-NP	Art Unit	3763
First Named Inventor	Sigg, Jergen, et al			Examiner Name	Berdichevsky, Aarti		

This is a Request for Continued Examination (RCE) under 37 CFR 1.114 of the above-identified application.
 Request for Continued Examination (RCE) practice under 37 CFR 1.114 does not apply to any utility or plant application filed prior to June 8, 1995, or to any design application. The Instruction Sheet for this form is located at WWW.USPTO.GOV

SUBMISSION REQUIRED UNDER 37 CFR 1.114

Note: If the RCE is proper, any previously filed unentered amendments and amendments enclosed with the RCE will be entered in the order in which they were filed unless applicant instructs otherwise. If applicant does not wish to have any previously filed unentered amendment(s) entered, applicant must request non-entry of such amendment(s).

- Previously submitted. If a final Office action is outstanding, any amendments filed after the final Office action may be considered as a submission even if this box is not checked.
- Consider the arguments in the Appeal Brief or Reply Brief previously filed on _____
- Other _____
- Enclosed
- Amendment/Reply
- Information Disclosure Statement (IDS)
- Affidavit(s)/ Declaration(s)
- Other _____

MISCELLANEOUS

- Suspension of action on the above-identified application is requested under 37 CFR 1.103(c) for a period of months _____
 (Period of suspension shall not exceed 3 months; Fee under 37 CFR 1.17(i) required)
- Other _____

FEES

- The RCE fee under 37 CFR 1.17(e) is required by 37 CFR 1.114 when the RCE is filed.**
- The Director is hereby authorized to charge any underpayment of fees, or credit any overpayments, to Deposit Account No 190134

SIGNATURE OF APPLICANT, ATTORNEY, OR AGENT REQUIRED

- Patent Practitioner Signature
- Applicant Signature

Doc code: RCEX
Doc description: Request for Continued Examination (RCE)

PTO/SB/30EFS (07-09)
Approved for use through 07/31/2012. OMB 0651-0031
U.S. Patent and Trademark Office; U.S. DEPARTMENT OF COMMERCE

Under the Paperwork Reduction Act of 1995, no persons are required to respond to a collection of information unless it contains a valid OMB control number.

Signature of Registered U.S. Patent Practitioner			
Signature	/Jim Lynch/	Date (YYYY-MM-DD)	2014-11-24
Name	Jim Lynch	Registration Number	54763

This collection of information is required by 37 CFR 1.114. The information is required to obtain or retain a benefit by the public which is to file (and by the USPTO to process) an application. Confidentiality is governed by 35 U.S.C. 122 and 37 CFR 1.11 and 1.14. This collection is estimated to take 12 minutes to complete, including gathering, preparing, and submitting the completed application form to the USPTO. Time will vary depending upon the individual case. Any comments on the amount of time you require to complete this form and/or suggestions for reducing this burden, should be sent to the Chief Information Officer, U.S. Patent and Trademark Office, U.S. Department of Commerce, P.O. Box 1450, Alexandria, VA 22313-1450.

If you need assistance in completing the form, call 1-800-PTO-9199 and select option 2.

Privacy Act Statement

The Privacy Act of 1974 (P.L. 93-579) requires that you be given certain information in connection with your submission of the attached form related to a patent application or patent. Accordingly, pursuant to the requirements of the Act, please be advised that: (1) the general authority for the collection of this information is 35 U.S.C. 2(b)(2); (2) furnishing of the information solicited is voluntary; and (3) the principal purpose for which the information is used by the U.S. Patent and Trademark Office is to process and/or examine your submission related to a patent application or patent. If you do not furnish the requested information, the U.S. Patent and Trademark Office may not be able to process and/or examine your submission, which may result in termination of proceedings or abandonment of the application or expiration of the patent.

The information provided by you in this form will be subject to the following routine uses:

1. The information on this form will be treated confidentially to the extent allowed under the Freedom of Information Act (5 U.S.C. 552) and the Privacy Act (5 U.S.C. 552a). Records from this system of records may be disclosed to the Department of Justice to determine whether the Freedom of Information Act requires disclosure of these records.
2. A record from this system of records may be disclosed, as a routine use, in the course of presenting evidence to a court, magistrate, or administrative tribunal, including disclosures to opposing counsel in the course of settlement negotiations.
3. A record in this system of records may be disclosed, as a routine use, to a Member of Congress submitting a request involving an individual, to whom the record pertains, when the individual has requested assistance from the Member with respect to the subject matter of the record.
4. A record in this system of records may be disclosed, as a routine use, to a contractor of the Agency having need for the information in order to perform a contract. Recipients of information shall be required to comply with the requirements of the Privacy Act of 1974, as amended, pursuant to 5 U.S.C. 552a(m).
5. A record related to an International Application filed under the Patent Cooperation Treaty in this system of records may be disclosed, as a routine use, to the International Bureau of the World Intellectual Property Organization, pursuant to the Patent Cooperation Treaty.
6. A record in this system of records may be disclosed, as a routine use, to another federal agency for purposes of National Security review (35 U.S.C. 181) and for review pursuant to the Atomic Energy Act (42 U.S.C. 218(c)).
7. A record from this system of records may be disclosed, as a routine use, to the Administrator, General Services, or his/her designee, during an inspection of records conducted by GSA as part of that agency's responsibility to recommend improvements in records management practices and programs, under authority of 44 U.S.C. 2904 and 2906. Such disclosure shall be made in accordance with the GSA regulations governing inspection of records for this purpose, and any other relevant (i.e., GSA or Commerce) directive. Such disclosure shall not be used to make determinations about individuals.
8. A record from this system of records may be disclosed, as a routine use, to the public after either publication of the application pursuant to 35 U.S.C. 122(b) or issuance of a patent pursuant to 35 U.S.C. 151. Further, a record may be disclosed, subject to the limitations of 37 CFR 1.14, as a routine use, to the public if the record was filed in an application which became abandoned or in which the proceedings were terminated and which application is referenced by either a published application, an application open to public inspections or an issued patent.
9. A record from this system of records may be disclosed, as a routine use, to a Federal, State, or local law enforcement agency, if the USPTO becomes aware of a violation or potential violation of law or regulation.

IN THE UNITED STATES PATENT AND TRADEMARK OFFICE

IN RE APPLICATION OF

Confirm No. 5306

Sigg, Juergen et al.

APPLICATION NO: 13/750,352

Examiner: Berdichevsky, Aarti

FILED: January 25, 2013

Art Unit: 3763

FOR: SYRINGE

Commissioner for Patents
PO Box 1450
Alexandria, VA 22313-1450

AMENDMENT AND RESPONSE TO FINAL OFFICE ACTION

Sir:

This Amendment and Response to Final Office Action ("Response") is being submitted in reply to a Final Office Action mailed to Applicants' attorney on August 26, 2014 ("Office Action").

Amendments to the Claims are reflected in the listing of the claims which begins on page 2 of this paper.

Remarks/Arguments begin on page 5 of this paper.

Amendments to the Claims:

This listing of claims will replace all prior versions, and listings, of claims in the application:

Listing of Claims:

1.(Currently amended) A pre-filled syringe for intravitreal injection, the syringe comprising a glass body forming a barrel, a stopper and a plunger and containing an ophthalmic solution which comprises a VEGF-antagonist, wherein:

(a) the syringe has a nominal maximum fill volume of between about 0.5ml and about 1ml,

~~(b) the syringe is filled with a dosage volume of between about 0.03ml and about 0.05ml of said VEGF antagonist solution,~~

~~(b) (e)~~ the syringe barrel comprises from about 1µg to 100µg ~~500µg~~ silicone oil, ~~and~~

~~(c) (d)~~ the VEGF antagonist solution comprises no more than 2 particles >50µm in diameter per ml and

wherein the syringe has a stopper break loose force of less than about 11N.

2.(Canceled)

3.(Canceled)

4.(Canceled)

5.(Canceled)

6.(Previously presented) A pre-filled syringe according to claim 1, wherein the syringe barrel has an internal coating of silicone oil that has an average thickness of about 450nm or less.

7.(Canceled)

8.(Canceled)

9.(Currently amended) A pre-filled syringe according to claim 1, wherein the syringe barrel has an internal coating of from about 3µg to about ~~200µg~~ 100µg silicone oil.

10. (Original) A pre-filled syringe according to claim 1, wherein the silicone oil is DC365 emulsion.

11. (Canceled)

12. (Original) A pre-filled syringe according to claim 1, wherein the VEGF antagonist solution further comprises one or more of (i) no more than 5 particles $\geq 25\mu\text{m}$ in diameter per ml, and (ii) no more than 50 particles $\geq 10\mu\text{m}$ in diameter per ml.
13. (Original) A pre-filled syringe according to claim 1, wherein the VEGF antagonist solution meets USP789.
14. (Original) A pre-filled syringe according to claim 1, wherein the VEGF antagonist is an anti-VEGF antibody.
15. (Original) A pre-filled syringe according to claim 14, wherein the anti-VEGF antibody is ranibizumab.
16. (Original) A pre-filled syringe according to claim 15, wherein the ranibizumab is at a concentration of 10mg/ml.
17. (Original) A pre-filled syringe according to claim 1 wherein the VEGF antagonist is a non-antibody VEGF antagonist.
18. (Original) A pre-filled syringe according to claim 17, wherein the non-antibody VEGF antagonist is aflibercept or conbercept.
19. (Original) A pre-filled syringe according to claim 18, wherein the non-antibody VEGF antagonist is aflibercept at a concentration of 40mg/ml.
20. (Canceled)
21. (Original) A pre-filled syringe according to claim 20, wherein the syringe has a stopper break loose force of less than about 5N.
22. (Original) A pre-filled syringe according to claim 1, wherein the syringe has a stopper slide force of less than about 11N.
23. (Original) A pre-filled syringe according to claim 22, wherein the syringe has a stopper slide force of less than about 5N.
24. (Original) A pre-filled syringe according to claim 20, wherein the stopper break loose force or stopper slide force is measured using a filled syringe, at a stopper travelling speed of 190mm/min, with a 30G x 0.5 inch needle attached to the syringe.
25. (Original) A blister pack comprising a pre-filled syringe according to claim 1, wherein the syringe has been sterilised using H_2O_2 or EtO.

26. (Original) A blister pack comprising a pre-filled syringe according to claim 25, wherein the outer surface of the syringe has ≤ 1 ppm EtO or H₂O₂ residue.
27. (Original) A blister pack comprising a pre-filled syringe according to claim 25, wherein the syringe has been sterilised using EtO or H₂O₂ and the total EtO or H₂O₂ residue found on the outside of the syringe and inside of the blister pack is ≤ 0.1 mg.
28. (Original) A blister pack comprising a pre-filled syringe according to claim 25, wherein $\leq 5\%$ of the VEGF antagonist is alkylated.
29. (Original) A blister pack comprising a pre-filled syringe according to claim 25, wherein the syringe has been sterilised using EtO or H₂O₂ with a Sterility Assurance Level of at least 10⁻⁶.
30. (Original) A method of treating a patient suffering from of an ocular disease selected from choroidal neovascularisation, wet age-related macular degeneration, macular edema secondary to retinal vein occlusion (RVO) including both branch RVO (bRVO) and central RVO (cRVO), choroidal neovascularisation secondary to pathologic myopia (PM), diabetic macular edema (DME), diabetic retinopathy, and proliferative retinopathy, comprising the step of administering an ophthalmic solution to the patient using a pre-filled syringe according to claim 1.
31. (Original) The method of claim 30, further comprising an initial priming step in which the physician depresses the plunger of the pre-filled syringe to align the pre-determined part of the stopper with the priming mark.
32. (Original) A method according to claim 30, wherein the VEGF antagonist administered is a non-antibody VEGF antagonist and wherein the patient has previously received treatment with an antibody VEGF antagonist.
33. (Canceled)
34. (Previously presented) A pre-filled syringe according to claim 1, wherein the syringe barrel has an internal coating of from about 1-50 μ g silicone oil.

REMARKS/ARGUMENTS

Claim Status

Claims 1-6, 9, 10 and 12-34 were pending prior to the entry of this amendment. By way of this amendment, claims 1 and 9 have been amended; claims 2-5, 7-8, 11, 20 and 33 have been canceled. Accordingly, claims 1, 6, 9-10, 12-19, 21-32, and 34 are pending after entry of this amendment.

The Examiner's Rejections

The Examiner rejected claims 1-6, 9-10 and 12-34 under 35 U.S.C. § 112 (b), second paragraph as being indefinite. More specifically, the Examiner found that the recitation of dosage volume of between about 0.03ml and 0.05ml as unclear as to whether there is more than one intended dosage volume filled inside the syringe. In addition, claims 2 and 3 were rejected under 35 U.S.C. § 112 (d) as failing to further limit the claim.

The Examiner rejected claims 1-6, 9-10 and 12-34 under 35 U.S.C. § 103(a) as being obvious in view of WO 2007/035621 to Scypinski et al. (hereinafter "the '621 publication") in further view of US2011/0276005 to Hioki et al (hereinafter "the '005 publication"). The Examiner admits that the '621 publication is silent to an internal silicone coating on the syringe barrel. However, to cure this deficiency, the Examiner relies on the teachings of the '005 publication. According to the Examiner, the '005 publication teaches coating the inner surface of a syringe barrel, and that the skilled artisan would have been motivated to include oil in the silicone barrel to increase the slidability of the plunger within the barrel, and that finding the optimum value of the silicone oil to use is well within the ordinary skill in the art.

Response

A. 35 U.S.C. § 112

Initially, the Applicants thank the Examiner for withdrawing the rejection of claim 10 under 35 U.S.C. § 112 (d). Claims 2-3 have been canceled, rendering the rejection of those claims moot. With regards to the element related to the dosage volume, the element has been removed to clarify the claims. Applicants therefore respectfully request that this rejection be withdrawn.

B. 35 U.S.C. § 103

In response to the Applicants previous arguments, the Examiner stated that it is well known to use silicone in glass barreled syringes, and that therefore it would have been well within the level of ordinary skill in the art to use silicone oil levels as generally described by the '005 publication as it amounts to no more than an optimization of the amount of silicone into a glass barreled syringe. Applicants respectfully disagree.

Initially, syringe barrels are typically comprised of either plastic or glass. Applicants concede that silicone-free plastic syringes are known in the art. However, it is not possible to have silicone free glass barreled syringes due to the high friction level between the glass and the rubber stopper of the plunger. As a result the break loose and slide forces are high. Without a lubricant such as silicone, the forces would be so high as to render the syringe unusable. To overcome this problem, syringe barrels are siliconised.

The '621 publication teaches a dual barreled syringe useful in administering a combination of drugs simultaneously into a patient's eye. The '621 publication discloses that the syringe barrel can be either glass or plastic. As discussed above, plastic syringes are not useful as pre-filled syringes for biologic products. The '621 publication's disclosure of suitable glass needles are typical pre-filled syringes described on page 9 of the specification. There is absolutely no teaching or suggestion that the glass barrels described as useful in the '621 publication contain the amounts of silicone recited in the currently pending claims. Instead, as is known and described on page 6 of the current specification, typical glass prefilled syringes contain from 500-1000 micrograms of silicone.

The '005 publication exclusively describes resin syringes. It describes the addition of silicone at a thickness of 5-50 $\mu\text{g}/\text{cm}^2$ to resin syringes. It does not teach or suggest that these levels of silicone can be applied to glass barreled syringes. Indeed, as stated above and described in the current specification, prior to the date of the current invention the art taught that much higher levels of lubricant were needed with regards to glass barreled syringes. Simply put, the skilled artisan recognized the distinction between plastic/resin barreled syringes and glass barreled syringes. Nowhere in either reference cited by the Examiner is it suggested or taught that the levels of silicone used in the current invention can be applied to glass barreled syringes.

The applicants have shown for the first time that you can reduce the silicone levels to far below previous standards and still obtain a usable syringe (see page 6, line 5 to page 7, line 16). Indeed, as shown in the test results on pages 15 and 16, the applicants have surprisingly found that

the application of less silicone resulted in lowered sliding and break forces. This flies in the face of conventional wisdom, which suggests that the way to reduce these forces is to use more lubricant.

In sum, then, not only do the cited references fail to teach or suggest the currently claimed invention, but the applicants have surprisingly found that using less silicone actually leads to usable syringes. This is neither taught nor suggested by the cited references. Accordingly, the Examiner has not established a prima facie case of obviousness and the applicants respectfully request that it be withdrawn.

Conclusion

Applicants believe that the foregoing constitutes a complete and full response to the Office Action of record. They further submit that all pending claims, as amended, are patentable and in patentable form, and they respectfully request that such claims be allowed to issue. Should the Examiner have any outstanding issues, the undersigned representative invites the Examiner to contact him at his convenience.

Novartis Pharmaceuticals Corporation
One Health Plaza, Bldg. 433
East Hanover, NJ 07936
+1 8627783423

Date: November 24, 2014

Respectfully submitted,

/ Jim Lynch /

Jim Lynch
Agent for Applicant
Reg. No. 54,763

Electronic Patent Application Fee Transmittal

Application Number:	13750352			
Filing Date:	25-Jan-2013			
Title of Invention:	SYRINGE			
First Named Inventor/Applicant Name:	Juergen Sigg			
Filer:	James L Lynch/Linda Adams			
Attorney Docket Number:	PAT055157-US-NP			
Filed as Large Entity				
Utility under 35 USC 111(a) Filing Fees				
Description	Fee Code	Quantity	Amount	Sub-Total in USD(\$)
Basic Filing:				
Pages:				
Claims:				
Miscellaneous-Filing:				
Petition:				
Patent-Appeals-and-Interference:				
Post-Allowance-and-Post-Issuance:				
Extension-of-Time:				

Description	Fee Code	Quantity	Amount	Sub-Total in USD(\$)
Miscellaneous:				
Request for Continued Examination	1801	1	1200	1200
Total in USD (\$)				1200

Electronic Acknowledgement Receipt

EFS ID:	20777373
Application Number:	13750352
International Application Number:	
Confirmation Number:	5306
Title of Invention:	SYRINGE
First Named Inventor/Applicant Name:	Juergen Sigg
Customer Number:	1095
Filer:	James L Lynch/Linda Adams
Filer Authorized By:	James L Lynch
Attorney Docket Number:	PAT055157-US-NP
Receipt Date:	24-NOV-2014
Filing Date:	25-JAN-2013
Time Stamp:	11:23:41
Application Type:	Utility under 35 USC 111(a)

Payment information:

Submitted with Payment	yes
Payment Type	Deposit Account
Payment was successfully received in RAM	\$1200
RAM confirmation Number	9539
Deposit Account	190134
Authorized User	

File Listing:

Document Number	Document Description	File Name	File Size(Bytes)/ Message Digest	Multi Part /.zip	Pages (if appl.)
-----------------	----------------------	-----------	-------------------------------------	------------------	------------------

1	Request for Continued Examination (RCE)	RCE_fill_signed.pdf	697799 0e4d8c57ff32df98ef2065745646e512059567f	no	3
Warnings:					
Information:					
2	Amendment Submitted/Entered with Filing of CPA/RCE	2014_24_11_PAT055157-US_resopnse_to_OA_dated_26_August_2014.pdf	116651 0440d250ae7357d186e2629c38966909c7db293c	no	7
Warnings:					
Information:					
3	Fee Worksheet (SB06)	fee-info.pdf	29712 12b20dd0a55ec1cb92236ad328601bdd0aa63fd1	no	2
Warnings:					
Information:					
Total Files Size (in bytes):				844162	
<p>This Acknowledgement Receipt evidences receipt on the noted date by the USPTO of the indicated documents, characterized by the applicant, and including page counts, where applicable. It serves as evidence of receipt similar to a Post Card, as described in MPEP 503.</p> <p><u>New Applications Under 35 U.S.C. 111</u> If a new application is being filed and the application includes the necessary components for a filing date (see 37 CFR 1.53(b)-(d) and MPEP 506), a Filing Receipt (37 CFR 1.54) will be issued in due course and the date shown on this Acknowledgement Receipt will establish the filing date of the application.</p> <p><u>National Stage of an International Application under 35 U.S.C. 371</u> If a timely submission to enter the national stage of an international application is compliant with the conditions of 35 U.S.C. 371 and other applicable requirements a Form PCT/DO/EO/903 indicating acceptance of the application as a national stage submission under 35 U.S.C. 371 will be issued in addition to the Filing Receipt, in due course.</p> <p><u>New International Application Filed with the USPTO as a Receiving Office</u> If a new international application is being filed and the international application includes the necessary components for an international filing date (see PCT Article 11 and MPEP 1810), a Notification of the International Application Number and of the International Filing Date (Form PCT/RO/105) will be issued in due course, subject to prescriptions concerning national security, and the date shown on this Acknowledgement Receipt will establish the international filing date of the application.</p>					

Under the Paperwork Reduction Act of 1995, no persons are required to respond to a collection of information unless it displays a valid OMB control number.

PATENT APPLICATION FEE DETERMINATION RECORD Substitute for Form PTO-875	Application or Docket Number 13/750,352	Filing Date 01/25/2013	<input type="checkbox"/> To be Mailed
-----------------------------------------------------------------------------------	---------------------------------------------------	----------------------------------	---------------------------------------

ENTITY: LARGE SMALL MICRO

APPLICATION AS FILED – PART I

FOR	NUMBER FILED	NUMBER EXTRA	RATE (\$)	FEE (\$)
<input type="checkbox"/> BASIC FEE (37 CFR 1.16(a), (b), or (c))	N/A	N/A	N/A	
<input type="checkbox"/> SEARCH FEE (37 CFR 1.16(k), (l), or (m))	N/A	N/A	N/A	
<input type="checkbox"/> EXAMINATION FEE (37 CFR 1.16(o), (p), or (q))	N/A	N/A	N/A	
TOTAL CLAIMS (37 CFR 1.16(j))	minus 20 =	*	X \$ =	
INDEPENDENT CLAIMS (37 CFR 1.16(h))	minus 3 =	*	X \$ =	
<input type="checkbox"/> APPLICATION SIZE FEE (37 CFR 1.16(s))	If the specification and drawings exceed 100 sheets of paper, the application size fee due is \$310 (\$155 for small entity) for each additional 50 sheets or fraction thereof. See 35 U.S.C. 41(a)(1)(G) and 37 CFR 1.16(s).			
<input type="checkbox"/> MULTIPLE DEPENDENT CLAIM PRESENT (37 CFR 1.16(j))				
* If the difference in column 1 is less than zero, enter "0" in column 2.			TOTAL	

APPLICATION AS AMENDED – PART II

	(Column 1)	(Column 2)	(Column 3)	(Column 3)	RATE (\$)	ADDITIONAL FEE (\$)
AMENDMENT	11/24/2014	CLAIMS REMAINING AFTER AMENDMENT	HIGHEST NUMBER PREVIOUSLY PAID FOR	PRESENT EXTRA		
	Total (37 CFR 1.16(i))	* 25	Minus	** 31	= 0	X \$80 = 0
	Independent (37 CFR 1.16(h))	* 1	Minus	***3	= 0	X \$420 = 0
	<input type="checkbox"/> Application Size Fee (37 CFR 1.16(s))					
	<input type="checkbox"/> FIRST PRESENTATION OF MULTIPLE DEPENDENT CLAIM (37 CFR 1.16(j))					
					TOTAL ADD'L FEE	0

	(Column 1)	(Column 2)	(Column 3)	(Column 3)	RATE (\$)	ADDITIONAL FEE (\$)
AMENDMENT		CLAIMS REMAINING AFTER AMENDMENT	HIGHEST NUMBER PREVIOUSLY PAID FOR	PRESENT EXTRA		
	Total (37 CFR 1.16(i))	*	Minus	**	=	X \$ =
	Independent (37 CFR 1.16(h))	*	Minus	***	=	X \$ =
	<input type="checkbox"/> Application Size Fee (37 CFR 1.16(s))					
	<input type="checkbox"/> FIRST PRESENTATION OF MULTIPLE DEPENDENT CLAIM (37 CFR 1.16(j))					
					TOTAL ADD'L FEE	

* If the entry in column 1 is less than the entry in column 2, write "0" in column 3.
 ** If the "Highest Number Previously Paid For" IN THIS SPACE is less than 20, enter "20".
 *** If the "Highest Number Previously Paid For" IN THIS SPACE is less than 3, enter "3".

LIE
/ERNEST MARFO/

The "Highest Number Previously Paid For" (Total or Independent) is the highest number found in the appropriate box in column 1.

This collection of information is required by 37 CFR 1.16. The information is required to obtain or retain a benefit by the public which is to file (and by the USPTO to process) an application. Confidentiality is governed by 35 U.S.C. 122 and 37 CFR 1.14. This collection is estimated to take 12 minutes to complete, including gathering, preparing, and submitting the completed application form to the USPTO. Time will vary depending upon the individual case. Any comments on the amount of time you require to complete this form and/or suggestions for reducing this burden, should be sent to the Chief Information Officer, U.S. Patent and Trademark Office, U.S. Department of Commerce, P.O. Box 1450, Alexandria, VA 22313-1450. DO NOT SEND FEES OR COMPLETED FORMS TO THIS ADDRESS. **SEND TO: Commissioner for Patents, P.O. Box 1450, Alexandria, VA 22313-1450.**

If you need assistance in completing the form, call 1-800-PTO-9199 and select option 2.



UNITED STATES PATENT AND TRADEMARK OFFICE

UNITED STATES DEPARTMENT OF COMMERCE
United States Patent and Trademark Office
Address: COMMISSIONER FOR PATENTS
P.O. Box 1450
Alexandria, Virginia 22313-1450
www.uspto.gov

Table with 5 columns: APPLICATION NO., FILING DATE, FIRST NAMED INVENTOR, ATTORNEY DOCKET NO., CONFIRMATION NO.
13/750,352 01/25/2013 Juergen Sigg PAT055157-US-NP 5306

1095 7590 12/12/2014
NOVARTIS PHARMACEUTICAL CORPORATION
INTELLECTUAL PROPERTY DEPARTMENT
ONE HEALTH PLAZA 433/2
EAST HANOVER, NJ 07936-1080

EXAMINER

BERDICHEVSKY, AARTI

ART UNIT PAPER NUMBER

3763

NOTIFICATION DATE DELIVERY MODE

12/12/2014

ELECTRONIC

Please find below and/or attached an Office communication concerning this application or proceeding.

The time period for reply, if any, is set in the attached communication.

Notice of the Office communication was sent electronically on above-indicated "Notification Date" to the following e-mail address(es):

phip.patents@novartis.com

Office Action Summary	Application No. 13/750,352	Applicant(s) SIGG ET AL.	
	Examiner Aarti Bhatia Berdichevsky	Art Unit 3763	AIA (First Inventor to File) Status No

-- The MAILING DATE of this communication appears on the cover sheet with the correspondence address --

Period for Reply

A SHORTENED STATUTORY PERIOD FOR REPLY IS SET TO EXPIRE 3 MONTHS FROM THE MAILING DATE OF THIS COMMUNICATION.

- Extensions of time may be available under the provisions of 37 CFR 1.136(a). In no event, however, may a reply be timely filed after SIX (6) MONTHS from the mailing date of this communication.
- If NO period for reply is specified above, the maximum statutory period will apply and will expire SIX (6) MONTHS from the mailing date of this communication.
- Failure to reply within the set or extended period for reply will, by statute, cause the application to become ABANDONED (35 U.S.C. § 133). Any reply received by the Office later than three months after the mailing date of this communication, even if timely filed, may reduce any earned patent term adjustment. See 37 CFR 1.704(b).

Status

- 1) Responsive to communication(s) filed on 11/24/2014.
 A declaration(s)/affidavit(s) under **37 CFR 1.130(b)** was/were filed on _____.
- 2a) This action is **FINAL**. 2b) This action is non-final.
- 3) An election was made by the applicant in response to a restriction requirement set forth during the interview on _____; the restriction requirement and election have been incorporated into this action.
- 4) Since this application is in condition for allowance except for formal matters, prosecution as to the merits is closed in accordance with the practice under *Ex parte Quayle*, 1935 C.D. 11, 453 O.G. 213.

Disposition of Claims*

- 5) Claim(s) 1,6,9,10,12-19,21-32 and 34 is/are pending in the application.
5a) Of the above claim(s) _____ is/are withdrawn from consideration.
- 6) Claim(s) _____ is/are allowed.
- 7) Claim(s) 1,6,9,10,12-19,21-32 and 34 is/are rejected.
- 8) Claim(s) _____ is/are objected to.
- 9) Claim(s) _____ are subject to restriction and/or election requirement.

* If any claims have been determined allowable, you may be eligible to benefit from the **Patent Prosecution Highway** program at a participating intellectual property office for the corresponding application. For more information, please see http://www.uspto.gov/patents/init_events/pph/index.jsp or send an inquiry to PPHfeedback@uspto.gov.

Application Papers

- 10) The specification is objected to by the Examiner.
- 11) The drawing(s) filed on _____ is/are: a) accepted or b) objected to by the Examiner.
Applicant may not request that any objection to the drawing(s) be held in abeyance. See 37 CFR 1.85(a).
Replacement drawing sheet(s) including the correction is required if the drawing(s) is objected to. See 37 CFR 1.121(d).

Priority under 35 U.S.C. § 119

- 12) Acknowledgment is made of a claim for foreign priority under 35 U.S.C. § 119(a)-(d) or (f).

Certified copies:

- a) All b) Some** c) None of the:
1. Certified copies of the priority documents have been received.
2. Certified copies of the priority documents have been received in Application No. _____.
3. Copies of the certified copies of the priority documents have been received in this National Stage application from the International Bureau (PCT Rule 17.2(a)).

** See the attached detailed Office action for a list of the certified copies not received.

Attachment(s)

- 1) Notice of References Cited (PTO-892)
- 2) Information Disclosure Statement(s) (PTO/SB/08a and/or PTO/SB/08b)
Paper No(s)/Mail Date _____
- 3) Interview Summary (PTO-413)
Paper No(s)/Mail Date _____
- 4) Other: _____

DETAILED ACTION

This is the third Office Action based on the 13/750,352 application filed on 1/25/2013. Claims 1, 6, 9, 10, 12-19, 21-32 and 34, as amended on 11/24/2014, are currently pending and have been considered below.

Notice of Pre-AIA or AIA Status

1. The present application is being examined under the pre-AIA first to invent provisions.

Continued Examination Under 37 CFR 1.114

2. A request for continued examination under 37 CFR 1.114, including the fee set forth in 37 CFR 1.17(e), was filed in this application after final rejection. Since this application is eligible for continued examination under 37 CFR 1.114, and the fee set forth in 37 CFR 1.17(e) has been timely paid, the finality of the previous Office action has been withdrawn pursuant to 37 CFR 1.114. Applicant's submission filed on 11/24/2014 has been entered.

Response to Amendment

3. The rejection of claim 1 under the second paragraph of 35 USC § 112 has been withdrawn in view of the amendments made by the Applicant.

Claim Rejections - 35 USC § 103

4. The text of those sections of Title 35, U.S. Code not included in this action can be found in a prior Office action.

Art Unit: 3763

5. Claims 1,6, 9-10, 12-19, 21-32 and 34 are rejected under pre-AIA 35 U.S.C. 103(a) as being unpatentable over WO 2007/035621 to Scypinski et al. in view of US2011/0276005 to Hioki et al.

Scypinski discloses a pre-filled syringe for intravitreal injection, the syringe comprising a glass body forming a barrel, a stopper and a plunger (page 9, lines 13-20) and containing an ophthalmic solution which comprises a VEGF-antagonist, wherein: (a) the syringe has a nominal maximum fill volume of between about 0.5 ml and about 1 ml (page 9, lines 13-20), (c) the VEGF antagonist solution comprises no more than 2 particles $\geq 50 \mu\text{m}$ in diameter per ml (see table 1); wherein the syringe is filled with dosage volume of about 0.05 ml of a VEGF antagonist solution (100 μL or less, page 10, lines 4-12); wherein the VEGF antagonist solution further comprises one or more of (i) no more than 5 particles $\geq 25 \mu\text{m}$ in diameter per ml, and (ii) no more than 50 particles $\geq 10 \mu\text{m}$ in diameter per ml (table 1); wherein the VEGF antagonist solution meets USP789 (page 11); wherein the VEGF antagonist is an anti-VEGF antibody (pages 1 and 18); wherein the anti-VEGF antibody is ranibizumab (page 1); wherein the VEGF antagonist is a non-antibody VEGF antagonist (pages 18-22). Scypinski additionally teaches the method of treating a patient suffering from of an ocular disease selected from choroidal neovascularisation, wet age-related macular degeneration, macular edema secondary to retinal vein occlusion (RVO) including both branch RVO (bRVO) and central RVO (cRVO), choroidal neovascularisation secondary to pathologic myopia (PM), diabetic macular edema (DME), diabetic retinopathy, and proliferative

Art Unit: 3763

retinopathy (pages 1 and 18) comprising the step of administering an ophthalmic solution to the patient using a pre-filled syringe.

Scypinski is silent to an internal silicone coating on the syringe barrel.

Hioki teaches applying silicone oil to the inner surface of a syringe barrel (paragraph 0021). It would have been obvious to one having ordinary skill in the art at the time the invention was made to include silicone oil in the syringe barrel of Scypinski as taught by Hioki, since this will increase the slidability of the plunger within the barrel. It would have been within the level of ordinary skill in the art to find the optimum value of silicone oil to use, and to find the optimum amount to achieve the desired slide force and break loose force.

Additionally, it would have been obvious to one having ordinary skill in the art at the time the invention was made to vary the amount of solution delivered by Scypinski, based on the needs of the patient.

Additionally, it would have been obvious to determine the dosage volume using a priming mark on the syringe, and use that mark to deliver the dose, since Scypinski teaches the use of graduations on the syringe barrel (page 9).

Additionally, it would have been obvious to one having ordinary skill in the art to use any known VEGF antagonist, including aflibercept or conbercept.

Additionally, Scypinski teaches the use of foil pouch packaging. It would have been within the level of ordinary skill in the art to use known packaging materials including known blister packs which are similar.

Additionally, it would have been within the level of ordinary skill in the art to deliver one treatment after a previous different treatment, as a matter of common sense, especially if the first treatment did not produce the desired result.

Response to Arguments

6. Applicant's arguments filed 11/24/2014 have been fully considered but they are not persuasive.

7. In response to applicant's argument that there is no teaching, suggestion, or motivation to combine the references, the examiner recognizes that obviousness may be established by combining or modifying the teachings of the prior art to produce the claimed invention where there is some teaching, suggestion, or motivation to do so found either in the references themselves or in the knowledge generally available to one of ordinary skill in the art. See *In re Fine*, 837 F.2d 1071, 5 USPQ2d 1596 (Fed. Cir. 1988), *In re Jones*, 958 F.2d 347, 21 USPQ2d 1941 (Fed. Cir. 1992), and *KSR International Co. v. Teleflex, Inc.*, 550 U.S. 398, 82 USPQ2d 1385 (2007). In this case, as the Applicant argues, it is well known to use silicone oil in glass barrels, therefore it would have been within the level of ordinary skill in the art at the time the invention was made to use the silicone oil levels as generally described by Hioki with the glass barrel syringe of Scypinski, and further within the level of ordinary skill to optimize the amount of silicone. The Applicant claims the unexpected result of using less silicone actually leads to useable syringes, however the Examiner finds that it would be obvious to one having ordinary skill in the art to try and use less silicone, since it is common sense to

Art Unit: 3763

use as little as possible to achieve the desired effect. The rejection as previously set forth is maintained.

Conclusion

Any inquiry concerning this communication or earlier communications from the examiner should be directed to Aarti Bhatia Berdichevsky whose telephone number is 571-270-5033. The examiner can normally be reached M-F 9 AM to 5 PM.

If attempts to reach the examiner by telephone are unsuccessful, the examiner's supervisor, Bhisma Mehta can be reached on 571-272-3383. The fax phone number for the organization where this application is assigned is 571-273-8300.

Information regarding the status of an application may be obtained from the Patent Application Information Retrieval (PAIR) system. Status information for published applications may be obtained from either Private PAIR or Public PAIR. Status information for unpublished applications is available through Private PAIR only. For more information about the PAIR system, see <http://pair-direct.uspto.gov>. Should you have questions on access to the Private PAIR system, contact the Electronic Business Center (EBC) at 866-217-9197 (toll-free). If you would like assistance from a USPTO Customer Service Representative or access to the automated information system, call 800-786-9199 (IN USA OR CANADA) or 571-272-1000.

/Aarti Bhatia Berdichevsky/
Primary Examiner, Art Unit 3763

Search Notes 	Application/Control No. 13750352	Applicant(s)/Patent Under Reexamination SIGG ET AL.
	Examiner AARTI B BERDICHEVSKY	Art Unit 3763

CPC- SEARCHED		
Symbol	Date	Examiner
A61K9/0048OR A61F9/008 OR A61M5178 OR A61M5/31	5/8/2014	ABB
above updated	8/21/2014	ABB
above updated	12/8/2014	ABB

CPC COMBINATION SETS - SEARCHED		
Symbol	Date	Examiner

US CLASSIFICATION SEARCHED			
Class	Subclass	Date	Examiner
604	218, 294	5/8/2014	ABB
above	updated	8/21/2014	ABB
above	updated	12/8/2014	ABB

SEARCH NOTES		
Search Notes	Date	Examiner
EAST search	5/8/2014	ABB
Inventor search	5/8/2014	ABB

INTERFERENCE SEARCH			
US Class/ CPC Symbol	US Subclass / CPC Group	Date	Examiner

	/AARTI B BERDICHEVSKY/ Primary Examiner.Art Unit 3763
--	----------------------------------------------------------

INFORMATION DISCLOSURE STATEMENT BY APPLICANT (Not for submission under 37 CFR 1.99)	Application Number		13750352	
	Filing Date		2013-01-25	
	First Named Inventor	Juergen Sigg		
	Art Unit	3763		
	Examiner Name	Berdichevsky, Aarti		
	Attorney Docket Number	PAT055157-US-NP		

U.S.PATENTS						Remove
Examiner Initial*	Cite No	Patent Number	Kind Code ¹	Issue Date	Name of Patentee or Applicant of cited Document	Pages,Columns,Lines where Relevant Passages or Relevant Figures Appear
	1					

If you wish to add additional U.S. Patent citation information please click the Add button. Add

U.S.PATENT APPLICATION PUBLICATIONS						Remove
Examiner Initial*	Cite No	Publication Number	Kind Code ¹	Publication Date	Name of Patentee or Applicant of cited Document	Pages,Columns,Lines where Relevant Passages or Relevant Figures Appear
	1					

If you wish to add additional U.S. Published Application citation information please click the Add button. Add

FOREIGN PATENT DOCUMENTS								Remove
Examiner Initial*	Cite No	Foreign Document Number ³	Country Code ² i	Kind Code ⁴	Publication Date	Name of Patentee or Applicant of cited Document	Pages,Columns,Lines where Relevant Passages or Relevant Figures Appear	T ⁵
	1	97/44068	WO	A1	1997-11-27	SCHERING AG	Abstract	<input type="checkbox"/>

If you wish to add additional Foreign Patent Document citation information please click the Add button Add

NON-PATENT LITERATURE DOCUMENTS			Remove
Examiner Initials*	Cite No	Include name of the author (in CAPITAL LETTERS), title of the article (when appropriate), title of the item (book, magazine, journal, serial, symposium, catalog, etc), date, pages(s), volume-issue number(s), publisher, city and/or country where published.	T ⁵

INFORMATION DISCLOSURE STATEMENT BY APPLICANT (Not for submission under 37 CFR 1.99)	Application Number	13750352
	Filing Date	2013-01-25
	First Named Inventor	Juergen Sigg
	Art Unit	3763
	Examiner Name	Berdichevsky, Aarti
	Attorney Docket Number	PAT055157-US-NP

	1		<input type="checkbox"/>
--	---	--	--------------------------

If you wish to add additional non-patent literature document citation information please click the Add button Add

EXAMINER SIGNATURE

Examiner Signature		Date Considered	
--------------------	--	-----------------	--

*EXAMINER: Initial if reference considered, whether or not citation is in conformance with MPEP 609. Draw line through a citation if not in conformance and not considered. Include copy of this form with next communication to applicant.

¹ See Kind Codes of USPTO Patent Documents at www.USPTO.GOV or MPEP 901.04. ² Enter office that issued the document, by the two-letter code (WIPO Standard ST.3). ³ For Japanese patent documents, the indication of the year of the reign of the Emperor must precede the serial number of the patent document. ⁴ Kind of document by the appropriate symbols as indicated on the document under WIPO Standard ST.16 if possible. ⁵ Applicant is to place a check mark here if English language translation is attached.

INFORMATION DISCLOSURE STATEMENT BY APPLICANT (Not for submission under 37 CFR 1.99)	Application Number	13750352
	Filing Date	2013-01-25
	First Named Inventor	Juergen Sigg
	Art Unit	3763
	Examiner Name	Berdichevsky, Aarti
	Attorney Docket Number	PAT055157-US-NP

CERTIFICATION STATEMENT

Please see 37 CFR 1.97 and 1.98 to make the appropriate selection(s):

That each item of information contained in the information disclosure statement was first cited in any communication from a foreign patent office in a counterpart foreign application not more than three months prior to the filing of the information disclosure statement. See 37 CFR 1.97(e)(1).

OR

That no item of information contained in the information disclosure statement was cited in a communication from a foreign patent office in a counterpart foreign application, and, to the knowledge of the person signing the certification after making reasonable inquiry, no item of information contained in the information disclosure statement was known to any individual designated in 37 CFR 1.56(c) more than three months prior to the filing of the information disclosure statement. See 37 CFR 1.97(e)(2).

- See attached certification statement.
- The fee set forth in 37 CFR 1.17 (p) has been submitted herewith.
- A certification statement is not submitted herewith.

SIGNATURE

A signature of the applicant or representative is required in accordance with CFR 1.33, 10.18. Please see CFR 1.4(d) for the form of the signature.

Signature	/Jim Lynch/	Date (YYYY-MM-DD)	2015-03-11
Name/Print	Jim Lynch	Registration Number	54,763

This collection of information is required by 37 CFR 1.97 and 1.98. The information is required to obtain or retain a benefit by the public which is to file (and by the USPTO to process) an application. Confidentiality is governed by 35 U.S.C. 122 and 37 CFR 1.14. This collection is estimated to take 1 hour to complete, including gathering, preparing and submitting the completed application form to the USPTO. Time will vary depending upon the individual case. Any comments on the amount of time you require to complete this form and/or suggestions for reducing this burden, should be sent to the Chief Information Officer, U.S. Patent and Trademark Office, U.S. Department of Commerce, P.O. Box 1450, Alexandria, VA 22313-1450. **DO NOT SEND FEES OR COMPLETED FORMS TO THIS ADDRESS. SEND TO: Commissioner for Patents, P.O. Box 1450, Alexandria, VA 22313-1450.**

Privacy Act Statement

The Privacy Act of 1974 (P.L. 93-579) requires that you be given certain information in connection with your submission of the attached form related to a patent application or patent. Accordingly, pursuant to the requirements of the Act, please be advised that: (1) the general authority for the collection of this information is 35 U.S.C. 2(b)(2); (2) furnishing of the information solicited is voluntary; and (3) the principal purpose for which the information is used by the U.S. Patent and Trademark Office is to process and/or examine your submission related to a patent application or patent. If you do not furnish the requested information, the U.S. Patent and Trademark Office may not be able to process and/or examine your submission, which may result in termination of proceedings or abandonment of the application or expiration of the patent.

The information provided by you in this form will be subject to the following routine uses:

1. The information on this form will be treated confidentially to the extent allowed under the Freedom of Information Act (5 U.S.C. 552) and the Privacy Act (5 U.S.C. 552a). Records from this system of records may be disclosed to the Department of Justice to determine whether the Freedom of Information Act requires disclosure of these records.
2. A record from this system of records may be disclosed, as a routine use, in the course of presenting evidence to a court, magistrate, or administrative tribunal, including disclosures to opposing counsel in the course of settlement negotiations.
3. A record in this system of records may be disclosed, as a routine use, to a Member of Congress submitting a request involving an individual, to whom the record pertains, when the individual has requested assistance from the Member with respect to the subject matter of the record.
4. A record in this system of records may be disclosed, as a routine use, to a contractor of the Agency having need for the information in order to perform a contract. Recipients of information shall be required to comply with the requirements of the Privacy Act of 1974, as amended, pursuant to 5 U.S.C. 552a(m).
5. A record related to an International Application filed under the Patent Cooperation Treaty in this system of records may be disclosed, as a routine use, to the International Bureau of the World Intellectual Property Organization, pursuant to the Patent Cooperation Treaty.
6. A record in this system of records may be disclosed, as a routine use, to another federal agency for purposes of National Security review (35 U.S.C. 181) and for review pursuant to the Atomic Energy Act (42 U.S.C. 218(c)).
7. A record from this system of records may be disclosed, as a routine use, to the Administrator, General Services, or his/her designee, during an inspection of records conducted by GSA as part of that agency's responsibility to recommend improvements in records management practices and programs, under authority of 44 U.S.C. 2904 and 2906. Such disclosure shall be made in accordance with the GSA regulations governing inspection of records for this purpose, and any other relevant (i.e., GSA or Commerce) directive. Such disclosure shall not be used to make determinations about individuals.
8. A record from this system of records may be disclosed, as a routine use, to the public after either publication of the application pursuant to 35 U.S.C. 122(b) or issuance of a patent pursuant to 35 U.S.C. 151. Further, a record may be disclosed, subject to the limitations of 37 CFR 1.14, as a routine use, to the public if the record was filed in an application which became abandoned or in which the proceedings were terminated and which application is referenced by either a published application, an application open to public inspections or an issued patent.
9. A record from this system of records may be disclosed, as a routine use, to a Federal, State, or local law enforcement agency, if the USPTO becomes aware of a violation or potential violation of law or regulation.



PCT WELTORGANISATION FÜR GEISTIGES EIGENTUM
Internationales Büro
INTERNATIONALE ANMELDUNG VERÖFFENTLICHT NACH DEM VERTRAG ÜBER DIE
INTERNATIONALE ZUSAMMENARBEIT AUF DEM GEBIET DES PATENTWESENS (PCT)

<p>(51) Internationale Patentklassifikation ⁶ : A61L 2/04, 2/06, 2/12, 2/20, A61M 5/00</p>	<p>A1</p>	<p>(11) Internationale Veröffentlichungsnummer: WO 97/44068 (43) Internationales Veröffentlichungsdatum: 27. November 1997 (27.11.97)</p>
<p>(21) Internationales Aktenzeichen: PCT/EP97/02641 (22) Internationales Anmeldedatum: 23. Mai 1997 (23.05.97) (30) Prioritätsdaten: 196 22 283.4 23. Mai 1996 (23.05.96) DE (71) Anmelder (für alle Bestimmungsstaaten ausser US): SCHERING AG [DE/DE]; D-13342 Berlin (DE). (72) Erfinder; und (75) Erfinder/Anmelder (nur für US): TACK, Johannes [DE/DE]; Tharsanderweg 42, D-13595 Berlin (DE). SCHURREIT, Thomas [DE/DE]; Matterhornstrasse 18, D-14163 Berlin (DE). ZÜRCHER, Jörg [DE/DE]; Bergstrasse 36, D-15711 Deutsch Wusterhausen (DE).</p>	<p>(81) Bestimmungsstaaten: AL, AM, AT, AU, AZ, BA, BB, BG, BR, BY, CA, CH, CN, CU, CZ, DK, EE, ES, FI, GB, GE, HU, IL, IS, JP, KE, KG, KP, KR, KZ, LC, LK, LR, LS, LT, LU, LV, MD, MG, MK, MN, MW, MX, NO, NZ, PL, PT, RO, RU, SD, SE, SG, SI, SK, TJ, TM, TR, TT, UA, UG, US, eurasisches Patent (AM, AZ, BY, KG, KZ, MD, RU, TJ, TM), europäisches Patent (AT, BE, CH, DE, DK, ES, FI, FR, GB, GR, IE, IT, LU, MC, NL, PT, SE). Veröffentlicht <i>Mit internationalem Recherchenbericht. Vor Ablauf der für Änderungen der Ansprüche zugelassenen Frist. Veröffentlichung wird wiederholt falls Änderungen eintreffen.</i></p>	
<p>(54) Title: METHOD OF TERMINALLY STERILIZING FILLED SYRINGES (54) Bezeichnung: VERFAHREN ZUR TERMINALEN STERILISIERUNG VON BEFÜLLTEN SPRITZEN (57) Abstract <p>The invention concerns a method of producing a pre-filled sterile syringe. The syringe comprises a syringe body with a proximal end and a distal end, a syringe-outlet part at the distal end, a seal, a stopper, a fluid medium and a gaseous medium, the fluid medium being a liquid. The method comprises the following steps: preparing the syringe body, seal and stopper which is/are free from germs and/or endotoxins and low in particles; a lubricant is applied; the proximal end is sealed by inserting the stopper into the syringe body; the syringe is filled through the distal end; the syringe outlet part is sealed with the seal; the syringe is sterilized in a sterilizing chamber; the syringe is then packaged and the package container is then sterilized once again.</p></p> <p>(57) Zusammenfassung <p>Die Erfindung besteht aus einem Herstellungsverfahren einer vorgefüllten, sterilen Spritze. Die Spritze umfaßt einem Spritzenkörper mit einem proximalen und distalen Ende, ein Spritzenauslaßstück am distalen Ende, einen Verschuß, einen Stopfen und ein flüdes und ein gasförmiges Medium. Das flüde Medium ist eine Flüssigkeit. Das Verfahren umfaßt die folgenden Schritte: Bereitstellen von dem Spritzenkörper, Verschuß und Stopfen, der oder die von Keimen und/oder Endotoxinen befreit sowie partikelarm sind. Ein Gleitmittel wird aufgetragen. Das proximale Ende wird durch Einführen des Stopfens in den Spritzenkörper abgedichtet. Die Spritze wird durch das distale Ende befüllt. Das Spritzenauslaßstück wird mit dem Verschuß abgedichtet. In einer Sterilisationskammer wird die Spritze sterilisiert, anschließend verpackt und der Verpackungsbehälter danach noch einmal sterilisiert.</p></p>		

LEDIGLICH ZUR INFORMATION

Codes zur Identifizierung von PCT-Vertragsstaaten auf den Kopfbögen der Schriften, die internationale Anmeldungen gemäss dem PCT veröffentlichen.

AL	Albanien	ES	Spanien	LS	Lesotho	SI	Slowenien
AM	Armenien	FI	Finnland	LT	Litauen	SK	Slowakei
AT	Österreich	FR	Frankreich	LU	Luxemburg	SN	Senegal
AU	Australien	GA	Gabun	LV	Lettland	SZ	Swasiland
AZ	Aserbaidschan	GB	Vereinigtes Königreich	MC	Monaco	TD	Tschad
BA	Bosnien-Herzegowina	GE	Georgien	MD	Republik Moldau	TG	Togo
BB	Barbados	GH	Ghana	MG	Madagaskar	TJ	Tadschikistan
BE	Belgien	GN	Guinea	MK	Die ehemalige jugoslawische Republik Mazedonien	TM	Turkmenistan
BF	Burkina Faso	GR	Griechenland	ML	Mali	TR	Türkei
BG	Bulgarien	HU	Ungarn	MN	Mongolei	TT	Trinidad und Tobago
BJ	Benin	IE	Irland	MR	Mauretanien	UA	Ukraine
BR	Brasilien	IL	Israel	MW	Malawi	UG	Uganda
BY	Belarus	IS	Island	MX	Mexiko	US	Vereinigte Staaten von Amerika
CA	Kanada	IT	Italien	NE	Niger	UZ	Usbekistan
CF	Zentralafrikanische Republik	JP	Japan	NL	Niederlande	VN	Vietnam
CG	Kongo	KE	Kenia	NO	Norwegen	YU	Jugoslawien
CH	Schweiz	KG	Kirgisistan	NZ	Neuseeland	ZW	Zimbabwe
CI	Côte d'Ivoire	KP	Demokratische Volksrepublik Korea	PL	Polen		
CM	Kamerun	KR	Republik Korea	PT	Portugal		
CN	China	KZ	Kasachstan	RO	Rumänien		
CU	Kuba	LC	St. Lucia	RU	Russische Föderation		
CZ	Tschechische Republik	LI	Liechtenstein	SD	Sudan		
DE	Deutschland	LK	Sri Lanka	SE	Schweden		
DK	Dänemark	LR	Liberia	SG	Singapur		
EE	Estland						

Verfahren zur terminalen Sterilisierung von befüllten Spritzen

- Die Erfindung betrifft ein Verfahren zur terminalen Sterilisierung von befüllten
5 Spritzen. Dabei wird insbesondere auf eine pyrogenfreie und keimfreie Ober-
fläche der Spritzen abgestellt. Diese Spritzen sind bevorzugt für den Einsatz
von injizierbaren Diagnostika, insbesondere Kontrastmitteln vorgesehen, die
zum Beispiel in Blutgefäße, Organe, Organteile, Höhlungen und andere Gefäße
gespritzt werden oder dort bildgebende Wirkung entfalten.
- 10 In der Patentschrift AT-E 68 979 wird ein Verfahren zum Herstellen einer gefüll-
ten, terminal sterilisierten Spritze beschrieben. Die Spritze besteht aus Kunst-
stoff. Die Spritze weist einen Zylinder auf mit einem distalen Ende mit einem
Spritzenauslaßstück. Das Spritzenauslaßstück wird durch einen Verschuß ab-
15 gedichtet. Die Spritze wird nach dem Befüllen mit einem flexiblen Gummi-
stopfen verschlossen, der in dem Zylinder gleitfähig ist. Das Verfahren beginnt
damit, daß Abfallteilchen oder andere Verunreinigungen von dem Verschuß
und dem Kolben entfernt werden. Mikrobielle Verunreinigungen auf dem Ver-
schluß und dem Kolben werden zerstört. Der Zylinder wird mit einer Vielzahl
20 von Wasserstrahlen gewaschen, um Pyrogene und Abfallteilchen zu entfernen.
Anschließend wird Silikonöl auf die Innenwandung der Spritze aufgetragen.
Der Verschuß wird daraufhin auf das Spritzenauslaßstück aufgesteckt. Durch
das proximale Ende der Spritze wird das Kontrastmittel in die Spritze gefüllt.
Die Spritze wird anschließend mit dem Stopfen verschlossen. Diese zusam-
25 mengesetzte und befüllte Spritze wird in einem Autoklaven sterilisiert. Dabei
wird neben dem üblichen Autoklavendruck noch ein zusätzlicher Stützdruck in
dem Autoklaven erzeugt. Dadurch wird der Druck auf der Außenoberfläche der
Spritze gleich oder größer als der Druck auf der Innenoberfläche der Spritze.
- 30 Aus der Publikation von Venten und Hoppert (E. VENTEN und J. HOPPERT
(1978) Pharm. Ind. Vol. 40, Nr. 6, Seiten 665 bis 671) ist ein terminales Sterili-
sieren von vorgefüllten Spritzampullen bekannt. Die Spritzampullen, die einen
Stopfen am proximalen Ende aufweisen, werden distal durch den Rollrand be-
füllt. Der Rollrand wird anschließend durch eine Dichtscheibe abgedichtet, wo-
35 bei eine Bördelkappe die Dichtscheibe auf dem Rollrand fixiert. (M. JUNGA
(1973) Pharm. Ind. Vol. 35, Nr. 11a, Seiten 824 bis 829) Die vorgefüllten
Spritzampullen werden dann in einen Autoklaven überführt. Dieser Autoklav ist
bezüglich der Temperatur und des Druckes regelbar. Damit die Dichtscheibe

- sich nicht von der Spritzampulle löst wird in dem Autoklav ein Stützdruck erzeugt. Der Stützdruck wird durch ein zusätzliches Gas aufgebaut. Dadurch ist es möglich, den Druck auf der Innenseite der Dichtscheibe annähernd gleich dem Druck auf der Außenseite der Dichtscheibe zu halten. Hierdurch wird
- 5 auch eine Bewegung des eingesetzten Kolbens vermieden. Infolge der guten Regelung ist es selbst möglich, Zweikammerspritzampullen, die mit zwei Lösungen gefüllt sind, terminal zu sterilisieren, ohne daß eine unzulässige Stopfenbewegung oder Dichtscheibenundichtigkeit auftritt.
- 10 In der finnischen Patentanmeldung FI 93 0405 wird ein Verfahren zum terminalen Sterilisieren einer vorgefüllten Plastikspritze oder Glasspritze beschrieben, wobei die Spritze ein Kontrastmittel enthält. Die Spritze besteht aus einem Spritzenzylinder, der ein Spritzenauslaßstück am distalen Ende aufweist. Daneben werden Spritzampullen in der zuvor schon bei Venten und Hoppert
- 15 beschriebenen Form angeführt. Die Spritzen weisen ein offenes proximales Ende auf, welches durch einem in der Spritze gleitfähigen Stopfen verschließbar ist. Der Stopfen wird mit einem Stempel verbunden.
- Wenn die Spritze oder Spritzampulle befüllt wird, wird zuerst der Stopfen in das proximale Ende der Spritze oder Spritzampulle eingeführt. Danach wird über
- 20 das distale Ende befüllt. Das distale Ende wird anschließend durch einen Verschuß abgedichtet. Bei den Spritzampullen wird eine Dichtscheibe mit einer Bördelkappe am Rollrand fixiert. Die Spritzen oder Spritzampullen werden anschließend sterilisiert, wobei ein Stützdruck verwendet wird. Dadurch wird der Druck auf der Außenoberfläche der Spritze kleiner als der Druck auf der Innen-
- 25 oberfläche der Spritze oder Spritzampulle gehalten. Bei den Spritzampullen ist der Druck in dem Autoklaven gleich, größer oder kleiner als der Druck in der Spritzampulle.
- In der WO 95/12418 wird ein terminales Sterilisationsverfahren für vorgefüllte
- 30 Spritzen beschreiben, bei dem kein Autoklav verwendet wird, sondern lediglich eine druckfeste Sterilisationskammer zum Einsatz gelangt. In diese Sterilisationskammer wird die distal oder proximal befüllte Spritze eingebracht. Die Kammer wird mittels Heizgas erwärmt. Zugleich sorgt dieses Heizgas auch für einen Druck, der den Druckanstieg in der Spritze kompensieren soll. Um ein
- 35 Verdampfen von Flüssigkeit, die durch den Kunststoff dringt, zu vermeiden, wird neben dem Heizgas auch Wasserdampf eingebracht. Es wird in dem Schutzrecht beschrieben, daß dieselbe Sicherheit wie bei einem Autoklavieren erzielt werden soll.

Die WO 95/12482 beschreibt ein Verfahren zur Herstellung von vorgefüllten Kunststoffspritzen, die mit einem Kontrastmittel gefüllt sind. Die Spritzen bestehen aus einem Zylinder, einem Spritzenauslaßstück am distalen Ende, welches für einen Kanülenansatz vorbereitet ist. Weiterhin umfaßt die Spritze einen Stopfen, der in dem Zylinder gleiten kann. Er dichtet das proximale Ende der Spritze ab. Die Spritze ist nach einem Verfahren hergestellt worden, das zu pyrogenfreien Objekten führt. Ebenso liegen keine Partikel mehr vor. Die Spritze wird durch das proximale Ende befüllt, dabei ist das Spritzenauslaßstück mit einem Verschuß abgedichtet. Die befüllte Spritze wird mit dem Stopfen verschlossen. Der Partikelstatus der Räumlichkeiten entspricht den Bedingungen der Klasse 100.

Nachdem die Spritzenteile aus der Gußform kommen, werden sie mit Gas abgeblasen, um Partikel zu entfernen. Die Spritze wird anschließend gewaschen. Die Spritze wird danach sterilisiert, so daß die Spritze wahlweise weiterverarbeitet, gelagert oder transportiert werden kann.

Es stellt sich die Aufgabe, eine Spritze anzubieten, welche mit einem Medium vorgefüllt wird, wobei sich das Medium dauerhaft ohne Qualitätseinbußen in der Spritze befindet. Besonders hohe Ansprüche sollen an die Sicherheit bezüglich Sterilität und Partikelarmut innerhalb und außerhalb der Spritze gestellt werden.

Die Aufgabe wird gelöst durch ein Herstellungsverfahren einer vorgefüllten, sterilen Spritze aus Glas oder Kunststoff oder eine Mischung aus Glas und Kunststoff, weiterhin einer Glasspritze mit einer damit verbundenen Kunststoffolie und einer Kunststoffspritze mit einer damit verbundenen Glasbeschichtung, dabei umfaßt die Spritze

einen zylinderförmigen Spritzenkörper mit einem verschließbaren proximalen und einem verschließbaren distalen Ende,
ein Spritzenauslaßstück am distalen Ende,
ein das Spritzenauslaßstück abdichtenden Verschuß,
einen Stopfen, der in dem Spritzenkörper gleitfähig ist,
dabei ist der Stopfen durch einen Stempel bewegbar,
und
ein fluides und ein gasförmiges Medium,
wobei das fluide Medium eine Flüssigkeit, eine Lösung, eine Suspension oder eine Emulsion ist,

wobei das Verfahren die folgenden Schritte umfaßt:

- Bereitstellen von dem Spritzenkörper, der von Keimen, Pyrogenen und/oder Endotoxinen befreit, sowie partikelarm ist,
 - Bereitstellen von dem Verschuß, der von Keimen, Pyrogenen und/oder Endotoxinen befreit, sowie partikelarm ist,
 - 5 - Bereitstellen von dem Stopfen, der von Keimen, Pyrogenen und/oder Endotoxinen befreit, sowie partikelarm ist,
 - Auftragen eines Gleitmittels,
 - Abdichten des proximalen Endes durch Einführen des Stopfens in den Spritzenkörper und Befüllen der Spritze durch das distale Ende und
 - 10 Verschließen des Spritzenauslaßstückes mit dem Verschuß oder Verschweißen des Spritzenauslaßstückes,
oder alternativ
Abdichten des distalen Endes durch den Verschuß oder Verschweißen des Spritzenauslaßstückes und Befüllen der Spritze durch das proximale
 - 15 Ende und Abdichten des proximalen Endes durch Einführen des Stopfens in den Spritzenkörper,
- thermisches Sterilisieren in einer Sterilisationskammer, insbesondere einem Autoklaven oder Sterilisator, mit Dampf, Heißluft und / oder Mikrowelle,
 - 20 - gegebenenfalls Aufbau von einem Stützdruck durch ein Gas in der Sterilisationskammer, wobei der Druck auf die Außenoberfläche der Spritze gleich, größer oder kleiner als der Druck auf die Innenoberfläche der Spritze ist.
 - Verpacken der sterilisierten Spritze in einem Behälter, insbesondere einem Sekundärpackmittel, und
 - 25 - Sterilisieren der verpackten Spritze mit einer Substanz, die mindestens Teile des Behälters, insbesondere des Sekundärpackmittels, permeiert.
- 30 Der Begriff Spritze umfaßt die Begriffe Kartusche (großvolumige Spritze mit mindestens 100 ml Volumen), Ampullenspritzen, Einmalspritzen, Einmalspritzampullen, Einwegspritzampullen, Einwegspritzen, Injektionsampullen, Spritzampullen, spritzfertige Ampulle, Zylinderampulle, Doppelkammer-Spritzampulle, Zweikammer-Spritze, Zweikammer-Spritzampulle, Zweikammer-Einmalspritze
- 35 und Sofortspritze.

Glasspritzen und Kunststoffspritzen sind in der Publikation von Junga (M. JUNGA (1973) Pharm. Ind. Vol. 35, Nr. 11a, Seiten 824 bis 829) ausführlich

beschrieben. Eine Mischung aus Glas und Kunststoff wird in WO 96/00098 (Anmeldetag 23.6.1995) dargestellt.

5 Kunststoffe werden ausführlich in Römpp - Chemie - Lexikon, Herausgeber Jürgen FALBE und Manfred REGITZ, 9. Auflage, Stuttgart, 1990 auf den Seiten 2398 ff dargestellt. Bevorzugt sind COC, PP und Polymethylpenten. [COC = Cycloolefincopolymer mit den Markennamen CZ (Hersteller: Nihon Zeon) und TOPAS (Hersteller: Mitsui Chemicals und Hoechst)] Diese Kunststoffe sind
10 besonders für den Einsatz bei vorgefüllten, terminal sterilisierten Spritzen geeignet, weil deren hoher Schmelzpunkt (mindestens 130 °C) eine Dampfsterilisation (Standardverfahren 121 °C) zulassen. Darüber hinaus sind die optischen Eigenschaften für eine arzneibuchgemäße visuelle einhundertprozentige Inspektion ausreichend.

15 Die Begriffe proximal und distal definieren sich aus Sicht des behandelnden Arztes. Am distalen Ende befindet sich das Spritzenauslaßstück, an dem zum Beispiel die Kanüle oder ein Schlauch, der zu einer Kanüle führt, angeschlossen ist. Am proximalen Ende befindet sich der Stopfen, der das Medium durch das distale Ende bei der Applikation drückt. Die Bewegung des Stopfens kann
20 manuell oder auch mechanisch erfolgen. Der Ausdruck Stopfen umfaßt auch Kolben. Für die manuelle Betätigung der Spritze ist es für das Bedienungspersonal hilfreich, wenn die Spritze am proximalen Ende Fingerhalterungen trägt. Dabei weisen die Fingerhalterungen üblicherweise mindestens eine Fläche als Widerlager für den Zeigefinger und Mittelfinger auf, wobei die Fläche der Fingerhalterung im wesentlichen senkrecht zu der Achse des Spritzenzylinders steht.
25 Bei mechanischen Pumpvorrichtungen sind verschiedene Modelle bekannt. Eine Spritze trägt dann bevorzugt eine oder mehrere Gerätehalterungen am vorzugsweise proximalen Ende. Besonders gut ist eine solche mechanische Pumpe in der EP 0 584 531 (Reilly et al. Anmeldetag 21. 07. 1993) beschrieben. Auch Mischformen aus Fingerhalterung und Gerätehalterung sind möglich.
30

Die Spritzen sind üblicherweise drehsymmetrisch, lediglich die Fingerhalterungen und Gerätehalterungen und bisweilen auch das Spritzenauslaßstück weichen von der Symmetrie ab. So kann das Spritzenauslaßstück exzentrisch angeordnet sein. Besonders bevorzugt ist der Luer - Lock, da er ausschließlich bei der Applikation von Kontrastmitteln dann zum Tragen kommt, wenn mechanische Pumpvorrichtungen eingesetzt werden. Auch bei der manuellen Appli-
35

kation vermeidet der Luer - Lock und der damit verbundene Schlauch, daß nicht beabsichtigte Bewegungen des Arztes auf die Kanüle direkt übertragen werden. Weiterhin sind der einfache Luer-Ansatz und auch der Record-Ansatz bekannt.

- 5 Es ist auch möglich, das Spritzenauslaßstück zu verschweißen und dadurch abzudichten. Vorteilhaft ist dann, daß ein Spritzenauslaßstück eine Sollbruchstelle aufweist, die problemlos ein Öffnen des Spritzenauslaßstückes vor dem Benutzen erlaubt.
- 10 Die proximale und das distale Ende der Spritze muß verschließbar sein. Das distale Ende wird durch einen Verschuß abgedichtet, der auf das Spritzenauslaßstück aufsetzbar ist. Das Spritzenauslaßstück umfaßt in diesem Schutzrecht die Decke des Spritzenzylinders. Weiterhin umfaßt das Spritzenauslaßstück eine Röhre, die zu der Nadel oder dem Schlauch führt, ein Endstück, welches mit der Nadel oder dem Schlauch in Kontakt steht und einem Zylinder mit Gewinde auf der Innenseite, wobei der Zylinder das Endstück umgibt und ein Gewinde für einen zum Beispiel Luer - Lock trägt. Dabei kann das Spritzenauslaßstück einstückig oder mehrstückig sein. Die Decke kann gewölbt, eben oder pyramidenförmig sein. Auch Mischformen sind denkbar.
- 15 20 Der Stopfen verschließt das proximale Ende der Spritze. Er muß in dem Zylinder gleitfähig sein und muß das Medium sicher von der Umgebung zurückhalten. Er soll möglichst wenig für Gase und Flüssigkeiten permeabel sein. Auch Temperaturschwankungen müssen ohne Funktionsstörung aufzufangen sein. Üblicherweise ist der Stopfen bei dem mechanischen Entleeren der Spritzen nicht mit einem eigenen Stempel versehen. Vielmehr greift ein Stempel, der Teil der Pumpvorrichtung ist, in einen Verschuß im Inneren des Stopfens ein, so daß eine Bewegung des Stopfens problemlos möglich ist. (vgl. EP 0 584 531)
- 25 30 Das Medium in der befüllten Spritze ist eine Mischung aus einem fluiden Medium und mindestens einem Gas. Das Medium kann eine Flüssigkeit, eine Lösung, eine Suspension oder eine Emulsion sein. Diese Erscheinungsformen sind in W. SCHRÖTER et al., (1987) Chemie; Fakten und Gesetze, 14. Auflage, Leipzig auf den Seiten 23 und folgende beschrieben.
- 35 Bevorzugt ist ein fluides Medium, welches ein Kontrastmittel ist. Hierbei handelt es sich um die folgenden Kontrastmittel mit den generischen Namen: Ami-

dotrizesäure, Gadopentetsäure, Gadobutrol, Gadolinium EOB-DTPA, Iopamidol, Iopromid, Iotrolan und Iotroxinsäure.

5 Eine Spritze muß von Fremdkörpern gereinigt werden. Fremdkörper sind alle die Partikel, die nicht aus dem Material der Spritze und dem Medium und die losgelöste Bruchstücke der Spritze sind.

Pyrogene sind Substanzen, die als Fragmente der Bakterien eine Immunantwort des Menschen provozieren. Insbesondere handelt es sich um Lipopolysaccharide.

10

Sterile und reine Produktionsprozesse sind in DAB 1996 oder Ph.Eur. beschrieben.

15 Publikationen zum Sterilisieren und zur Keimzahlreduktion sind in den folgenden Fundstellen angeführt:

K.H. WALLHÄUSSER (1990) Die mikrobielle Reinheit von Arzneimittelrohstoffen und Arzneimitteln, Pharma Technologie, Vol 11, Nr. 4, Seiten 2 - 9;

20

H. SEYFARTH (1990) Kritische Anmerkungen zu den Hygieneanforderungen des EG-Leitfadens einer guten Herstellpraxis für Arzneimittel, Pharma Technologie, Vol 11, Nr. 4, Seiten 10 - 19;

W. Hecker und R. MEIER (1990) Bestimmung der Luftkeimzahl im Produktionsbereich mit neueren Geräten, Pharma Technologie, Vol 11, Nr. 4, Seiten 20 - 28;

25

G. SPICHER (1990) Möglichkeiten und Grenzen der Sterilisation mit Gasen und ionisierenden Strahlen im Vergleich mit den klassischen Sterilisationsverfahren, Pharma Technologie, Vol 11, Nr. 4, Seiten 50 - 56;

30

Als chemische Sterilisierungsverfahren sind die Behandlung mit Ethylenoxid, Propan-3-oxid und Diethyldikarbonat, weiterhin Wasserstoffperoxid und ein Ozon/Dampfgemisch bekannt. Solche Verfahren werden beschrieben in:

G. SPICHER (1990) Möglichkeiten und Grenzen der Sterilisation mit Gasen und ionisierenden Strahlen im Vergleich mit den klassischen Sterilisationsverfahren, Pharma Technologie, Vol 11, Nr. 4, Seiten 50 - 56;

35

H. HÖRATH (1990) Rechtliche Rahmenbedingungen der Sterilisation mit Ethylenoxid und Formaldehyd, Pharma Technologie, Vol 11, Nr. 4, Seiten 57 - 64;

5 J. SCHUSTER (1990) Die Praxis der betrieblichen Ethylenoxid-Sterilisation und Versuche zu ihrer Optimierung, Pharma Technologie, Vol 11, Nr. 4, Seiten 65 - 71;

M. MARCZINOWSKI (1990) Praktische Durchführung der Formaldehyd-Sterilisation, Pharma Technologie, Vol 11, Nr. 4, Seiten 72 - 76;

10 Besonders bevorzugt ist das Verfahren mit Wasserstoffperoxid.

Ebenso ist ein Sterilisieren mit energiereicher Strahlung möglich. Hier sind Gamma-Strahlen und Röntgenstrahlen bekannt. Ebenso werden Neutronenstrahlen, Beta-Strahlen und Alpha-Strahlen eingesetzt.

15

Gleitmittel dienen dazu, daß der Stopfen ohne größeren Kraftaufwand innerhalb des Zylinders bewegt werden kann. Bevorzugt ist Silikonöl, welches folgende Eigenschaften aufweist: Viskosität mindestens 1000 cSt; Qualität: medical grade.

20

Nachdem die Spritze teilweise zusammengesetzt worden ist, ist es eventuell möglich, die Spritze erneut von Fremdkörpern zu reinigen. Fremdkörper sind all die Partikel, die nicht aus dem Material der Spritze und dem Medium sind und die losgelöste Bruchstücke der Spritze sind.

25 Als Sterilisationsverfahren sind besonders geeignet: Strahlensterilisation beziehungsweise chemische Sterilisationsverfahren.

30 Als chemische Sterilisierungsverfahren sind die Behandlung mit Ethylenoxid, Propan-3-olid und Diethyldikarbonat, weiterhin Wasserstoffperoxid und ein Ozon/Dampfgemisch bekannt.

Ebenso ist ein Sterilisieren mit energiereicher Strahlung möglich. Hier sind Gamma-Strahlen und Röntgenstrahlen bekannt.

35 Gegebenenfalls werden die Teile der Spritze in bakteriendichte, aber gasdurchlässige Folie oder Aluminium sterilverpackt. Die Sterilisation erfolgt mit Hilfe von thermischem und/oder chemischem Sterilisieren, mit Gamma-Strahlen oder Röntgenstrahlen, Neutronenstrahlen oder Beta-Strahlen oder einem Gemisch

der zuvor genannten Strahlen. Bevorzugt ist die Behandlung mit Wasserstoffperoxid oder Ozon/Dampfgemisch.

5 Anschließend wird der Spritzenkörper durch das distale oder proximale Ende befüllt, wobei entweder der Stopfen oder der Verschuß das entgegengesetzte Ende abdichten. Anschließend wird die Befüllungsöffnung durch den Verschuß oder den Stopfen verschlossen.

10 Das distale Ende wird mit einem Verschuß oder durch Verschweißen des distalen Endes verschlossen. Bei dem Verschweißen weist das distale Ende eine Sollbruchstelle proximal zur Verschweißung auf. Dadurch kann das distale Ende problemlos nach dem Verschweißen geöffnet werden.

15 Im nächsten Schritt wird die Spritze oder Kartusche im Autoklaven oder Sterilisator mit Heißluft oder mittels Mikrowelle thermisch sterilisiert.

Damit der Stopfen nicht innerhalb des Zylinders wandert, ist es vorteilhaft, wenn der Stopfen während des Sterilisierens fixiert ist.

20 Gegebenenfalls ist es möglich, einen Stützdruck in dem Sterilisationsraum des Autoklaven oder der Sterilkammer durch ein Gas in dem Sterilisationsraum aufzubauen, wobei der Druck auf die Außenoberfläche der Spritze größer, gleich oder geringer als der Druck auf der Innenoberfläche der Spritze ist. Der Stützdruck ist zu definieren als der Druck, welcher der Summe der Partialdrücke im Sterilisationsraum minus dem Partialdruck des Dampfes entspricht.

25 Vorteilhaft ist, wenn der Stopfen nach dem Sterilisieren rejustiert wird. Hierdurch wird gewährleistet, daß der Stopfen sich in einer optimalen Position befindet. Bisweilen ist die Reibung zwischen Stopfen und Zylinder so groß, daß ein Einstellen des Stopfens in die stabile Position, bei der keine Druckdifferenz zwischen Innenseite und Außenseite der Spritze besteht, nicht selbständig erfolgt.
30

An dieser Stelle ist eine optische Kontrolle vorteilhaft. Dadurch wird gewährleistet, daß Partikel, die sich in der Spritze befinden, aufgefunden werden. Spritzen mit Partikel sind dabei zu verwerfen.

35 Besonders wesentlich ist das Verpacken der sterilisierten Spritze in einem Behälter und das Sterilisieren des gefüllten Behälters. Dieser Vorgang kann in einem Sterilraum erfolgen. Dieser Schritt ist besonders vorteilhaft, weil da-

- durch allein eine Sicherheit gegeben ist, dem behandelnden Arzt eine Spritze anzubieten, die auch äußerlich steril ist. Hierdurch kann die Kontaminationsgefahr verringert werden. Auch bei den mechanisch zu entleerenden Spritzen kommt dieser Vorteil zur Geltung, da der Arzt auch hier die Spritze berührt.
- 5 Häufig werden die mechanisch zu entleerenden Spritzen in sterilen Operationsräumen angewendet. In diese Räume dürfen nur sterile oder desinfizierte Materialien eingebracht werden. Somit muß auch eine mechanisch zu entleerende Spritze äußerlich unbedingt steril sein.
- 10 Vorteilhaft ist weiterhin, daß die gefüllte und terminal gefüllte Spritze in sterile Kunststoffolie und / oder Aluminiumfolie unter gegebenenfalls aseptischen Bedingungen verpackt wird. Vorteilhaft ist dabei, daß die Spritze in möglicherweise sterile Blister eingepackt wird, wobei gegebenenfalls aseptische Bedingungen vorherrschen.
- 15 Anschließend wird die Spritze, die in dem Behälter liegt, äußerlich erneut sterilisiert, indem die Spritze mit Ethylenoxid, Propan-3-olid und/oder Diethyldikarbonat behandelt wird. Weiterhin sind Wasserstoffperoxid und ein Ozon/Dampfgemisch bekannt.

Eine bevorzugte Ausführungsform wird beispielhaft im weiteren dargestellt.

Eine Spritze gemäß der Erfindung wird in der Figur 1 als perspektivische Zeichnung abgebildet.

In der Figur 2 wird eine Schnittzeichnung der Spritze abgebildet.

- 5 In der Figur 3 ist ein Flußdiagramm zu sehen, in dem das Verfahren der Herstellung, Sterilisation, Befüllung und des terminalen Sterilisierens dargestellt ist.

Die Figur 1 und 2 zeigen eine Kunststoffspritze 100, die aus einem Spritzenkörper 1 mit einem Spritzenzylinder 2 besteht. Die Spritze 100 weist ein proximales Ende 3 auf, welches durch einen Stopfen 4 verschlossen ist. Der Stopfen weist ein pyramidenförmigen distalen Stopfenteil 5 und einen zylinderförmigen proximalen Stopfenteil 6 auf, der der Innenwandung des Spritzenzylinders 2 dichtend anliegt. Der Kontakt zwischen dem proximalen Stopfenteil 6 und der Zylinderinnenwandung erfolgt über mehrere Gummiwülste 7.

15 Am proximalen Ende sind Gerätehalterungen 8 an der Außenwand des Spritzenzylinders angeordnet, die aus einem Gerätehalterungsring 9 und zwei Gerätehalterungsvorsprünge 10 und 10' bestehen. Die Gerätehalterungen 8 dienen zum Einspannen der Spritze in eine mechanische Pumpvorrichtung.

Am distalen Ende 11 der Spritze befindet sich ein pyramidenförmige Spritzenauslaßstück 12, welches eine Röhre 13 und ein Endstück 14 umfaßt. Der pyramidenförmige distale Stopfenteil 5 paßt komplementär in das pyramidenförmige Spritzenauslaßstück 12. Zentrisch von dem Spritzenauslaßstück 12 ist die konisch zulaufende Röhre 13 angeordnet, die in dem Endstück 14 endet. Dieses Endstück 14 ist von einem Zylinder 15 umgeben, der auf der Innenseite ein Gewinde 16 für einen Luer - Lock trägt. Das Endstück 14 ist entweder durch ein Spritzenverschlußteil in Form eines Tip - Cap oder durch ein Spritzenverschlußteil mit Luer - Lock verschließbar. Das Spritzenverschlußteil ist in der Zeichnung nicht abgebildet.

30 In der Figur 3 ist ein Flußdiagramm abgebildet.

51414AWOM1XX00-P 21.5.1997

Patentansprüche

1. Herstellungsverfahren einer vorgefüllten, sterilen Spritze aus Glas oder
5 Kunststoff oder eine Mischung aus Glas und Kunststoff, weiterhin einer Glas-
spritze mit einer damit verbundenen Kunststoffolie und einer Kunststoffspritze
mit einer damit verbundenen Glasbeschichtung,
dabei umfaßt die Spritze
- 10 einen zylinderförmigen Spritzenkörper mit einem verschließbaren proxi-
malen und einem verschließbaren distalen Ende,
ein Spritzenauslaßstück am distalen Ende,
ein das Spritzenauslaßstück abdichtenden Verschuß,
einen Stopfen, der in dem Spritzenkörper gleitfähig ist,
15 dabei ist der Stopfen durch einen Stempel bewegbar,
und
ein fluides und ein gasförmiges Medium,
wobei das fluide Medium eine Flüssigkeit, eine Lösung, eine
Suspension oder eine Emulsion ist,
wobei das Verfahren die folgenden Schritte umfaßt:
- 20 - Bereitstellen von dem Spritzenkörper, der von Keimen, Pyrogenen
und/oder Endotoxinen befreit, sowie partikelarm ist,
- Bereitstellen von dem Verschuß, der von Keimen, Pyrogenen
und/oder Endotoxinen befreit, sowie partikelarm ist,
- Bereitstellen von dem Stopfen, der von Keimen, Pyrogenen
25 und/oder Endotoxinen befreit, sowie partikelarm ist,
- Auftragen eines Gleitmittels,
- Abdichten des proximalen Endes durch Einführen des Stopfens in
den Spritzenkörper und Befüllen der Spritze durch das distale Ende und
Verschließen des Spritzenauslaßstückes mit dem Verschuß oder Ver-
30 schweißen des Spritzenauslaßstückes,
oder alternativ
Abdichten des distalen Endes durch den Verschuß oder Verschweißen
des Spritzenauslaßstückes und Befüllen der Spritze durch das proximale
Ende und Abdichten des proximalen Endes durch Einführen des
35 Stopfens in den Spritzenkörper,
- thermisches Sterilisieren in einer Sterilisationskammer,
- Verpacken der sterilisierten Spritze in einem Behälter und

- Sterilisieren der verpackten Spritze mit einer Substanz, die mindestens Teile des Behälters permeiert..
2. Herstellungsverfahren nach Anspruch 1, wobei die Sterilisationskammer
5 ein Autoklav oder Sterilisator, mit Dampf, Heißluft und / oder Mikrowelle ist.
3. Herstellungsverfahren nach einem der vorherigen Ansprüche, wobei ein
Stützdruck durch ein Gas in der Sterilisationskammer aufgebaut wird, wobei der
10 Druck auf die Außenoberfläche der Spritze gleich, größer oder kleiner als der
Druck auf die Innenoberfläche der Spritze ist.
4. Herstellungsverfahren nach einem der vorherigen Ansprüche, wobei die
Spritzen umfassen: Kartuschen, Ampullenspritzen, Einmalspritzen, Einmal-
15 spritzampullen, Einwegspritzenampullen, Einwegspritzen, Injektionsampullen,
Spritzenampullen, spritzfertige Ampullen, Zylinderampullen, Doppelkammer-
Spritzenampullen, Zweikammer-Spritzen, Zweikammer-Spritzenampullen, Zwei-
kammer-Einmalspritzen oder Sofortspritzen.
5. Herstellungsverfahren nach einem der vorherigen Ansprüche, wobei der
20 Kunststoff der Polyolefine aus der Gruppe COC, Polymethylpenten und PP ist.
6. Herstellungsverfahren nach einem der vorherigen Ansprüche, wobei die
Spritze einen Luer - Lock am distalen Ende aufweist.
- 25 7. Herstellungsverfahren nach einem der vorherigen Ansprüche, wobei das
Medium in der befüllten Spritze eine Mischung aus einem fluiden Medium und
mindestens einem Gas ist.
8. Herstellungsverfahren nach Anspruch 7, wobei das Medium eine Flüssig-
30 keit, eine Lösung, eine Suspension oder eine Emulsion ist.
9. Herstellungsverfahren nach Anspruch 8, wobei das Medium ein Kon-
trastmittel ist.
- 35 10. Herstellungsverfahren nach Anspruch 9, wobei das Kontrastmittel eine
Substanz oder eine Mischung aus der Gruppe der folgenden Substanzen um-
faßt: Amidotrizoesäure, Gadopentetsäure, Gadobutrol, Gadolinium EOB-DTPA,
Iopamidol, Iopromid, Iotrolan und Iotroxinsäure

11. Herstellungsverfahren nach einem der vorherigen Ansprüche, wobei das Sterilisationsverfahren mit Gas die Behandlung mit Ethylenoxid, Propan-3-olid und Diethyldikarbonat, weiterhin Wasserstoffperoxid und ein
5 Ozon/Dampfgemisch umfaßt.
12. Herstellungsverfahren nach Anspruch 11, wobei die Behandlung Wasserstoffperoxid umfaßt.
- 10 13. Herstellungsverfahren nach einem der vorherigen Ansprüche, wobei der Stopfen während des Sterilisierens fixiert ist.
14. Herstellungsverfahren nach einem der vorherigen Ansprüche, wobei der Stopfen nach dem Sterilisieren rejustiert wird.
15
15. Herstellungsverfahren nach einem der vorherigen Ansprüche, wobei die gefüllte und terminal gefüllte Spritze in sterile Kunststoffolie und / oder Aluminiumfolie unter gegebenenfalls aseptischen Bedingungen verpackt wird.
- 20 16. Herstellungsverfahren nach Anspruch 15, wobei die Spritze, die in dem Behälter liegt, äußerlich erneut sterilisiert wird, indem die Spritze mit Ethylenoxid, Propan-3-olid, Wasserstoffperoxid, ein Ozon/Dampfgemisch und/oder Diethyldikarbonat behandelt wird. Weiterhin sind bekannt.

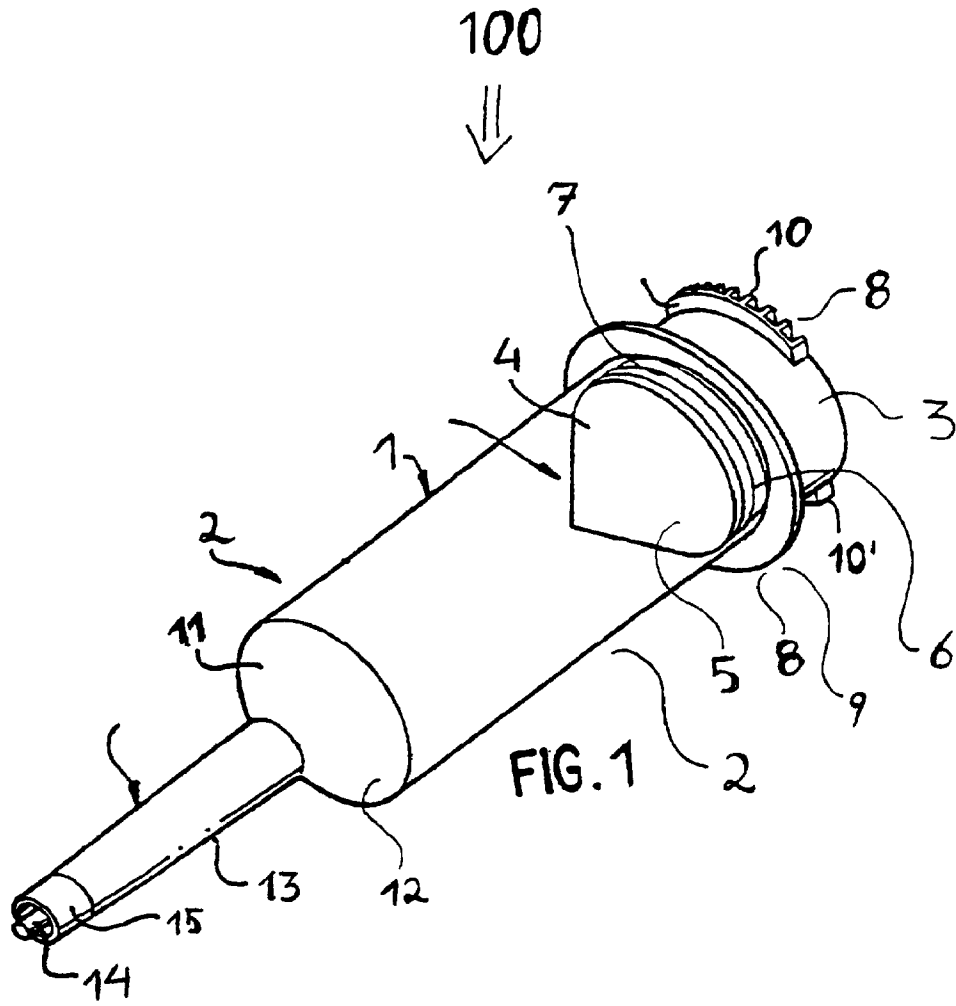

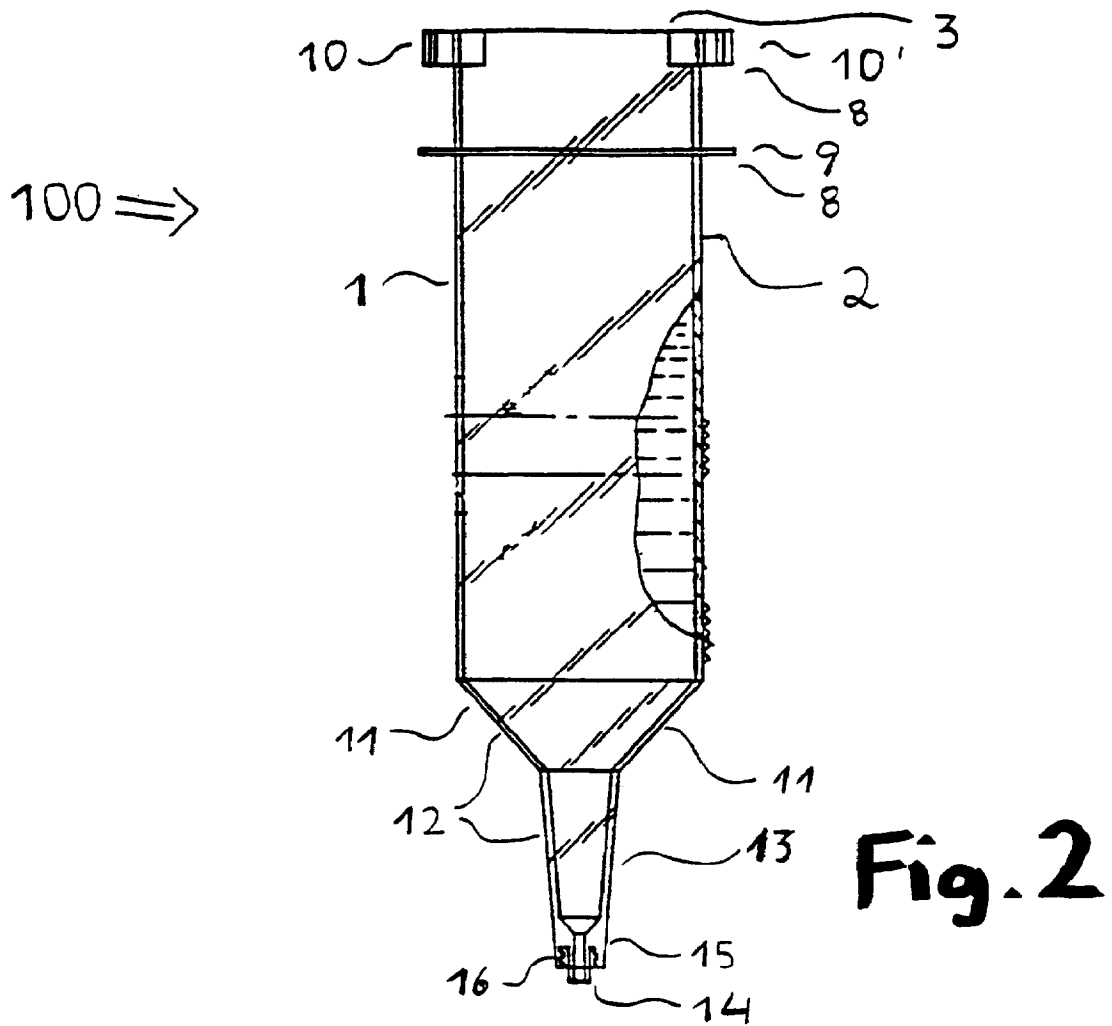

Figur 3

Herstellung von	Spritzenzylinder mit Spritzenauslaßstück (pyrogenfrei)	Kolben	Verschuß	Medium
	---	Autoklavieren	Autoklavieren	Sterilfiltriert
Einführen des Kolbens in den Spritzenkörper			---	---
Sterilisieren des Kolbens und des Spritzenkörpers			---	---
Weiterverarbeiten, Verpacken und Lagern oder Verpacken und Transportieren				---

Befüllen der Spritze durch das distale Ende
Verschließen der Spritze mit dem Verschuß
Autoklavieren der gefüllten Spritze unter Stützdruck
Abkühlen der Spritze unter Stützdruck
Verpacken der gefüllten Spritze in Behälter
Verschließen der Behälter
Sterilisieren der Behälter mit Gas

INTERNATIONAL SEARCH REPORT

International Application No
PCT/EP 97/02641

A. CLASSIFICATION OF SUBJECT MATTER IPC 6 A61L2/04 A61L2/06 A61L2/12 A61L2/20 A61M5/00		
According to International Patent Classification (IPC) or to both national classification and IPC		
B. FIELDS SEARCHED Minimum documentation searched (classification system followed by classification symbols) IPC 6 A61L A61M		
Documentation searched other than minimum documentation to the extent that such documents are included in the fields searched		
Electronic data base consulted during the international search (name of data base and, where practical, search terms used)		
C. DOCUMENTS CONSIDERED TO BE RELEVANT		
Category *	Citation of document, with indication, where appropriate, of the relevant passages	Relevant to claim No.
X	WO 94 13328 A (MALLINCKRODT MEDICAL INC) 23 June 1994 see abstract see page 4, line 5 - line 9 see page 4, line 15 - line 24 see claims 1-13 see figure 1 ---	1,2,4-16
X Y	WO 95 00180 A (FARCO PHARMA GES MIT BESCHRAEN ;WOLF ERICH (DE)) 5 January 1995 see page 3, line 24 - page 4, line 13 see page 6, line 28 - line 32 see claims 1,4-6 --- -/--	1-8, 13-15 9,10
<input checked="" type="checkbox"/> Further documents are listed in the continuation of box C. <input checked="" type="checkbox"/> Patent family members are listed in annex.		
* Special categories of cited documents :		
A document defining the general state of the art which is not considered to be of particular relevance *E* earlier document but published on or after the international filing date *L* document which may throw doubts on priority claim(s) or which is cited to establish the publication date of another citation or other special reason (as specified) *O* document referring to an oral disclosure, use, exhibition or other means *P* document published prior to the international filing date but later than the priority date claimed *T* later document published after the international filing date or priority date and not in conflict with the application but cited to understand the principle or theory underlying the invention *X* document of particular relevance; the claimed invention cannot be considered novel or cannot be considered to involve an inventive step when the document is taken alone *Y* document of particular relevance; the claimed invention cannot be considered to involve an inventive step when the document is combined with one or more other such documents, such combination being obvious to a person skilled in the art. *&* document member of the same patent family		
Date of the actual completion of the international search <p align="center">10 October 1997</p>		Date of mailing of the international search report <p align="center">17 -10- 1997</p>
Name and mailing address of the ISA European Patent Office, P.B. 5818 Patentlaan 2 NL - 2280 HV Rijswijk Tel. (+31-70) 340-2040, Tx. 31 651 eponl, Fax: (+31-70) 340-3016		Authorized officer <p align="center">Heck, G</p>

INTERNATIONAL SEARCH REPORT

 International Application No
 PCT/EP 97/02641

C.(Continuation) DOCUMENTS CONSIDERED TO BE RELEVANT

Category ^o	Citation of document, with indication, where appropriate, of the relevant passages	Relevant to claim No.
Y	US 4 628 969 A (JURGENS JR RAYMOND W ET AL) 16 December 1986 see column 1, line 38 - line 64 see column 2, line 24 - line 39 see claims 1-3 ---	9,10
A	US 5 207 983 A (LIEBERT RICHARD T ET AL) 4 May 1993 see column 2, line 8 - line 28 see claims 1,3,4,7,8 ---	1,2,4, 7-9
A	EP 0 496 633 A (EISAI CO LTD ;MICRO DENSHI CO LTD (JP)) 29 July 1992 see abstract ---	2
A	US 5 370 861 A (KLAVENESS JO ET AL) 6 December 1994 see abstract see column 3, line 12 - line 19 -----	10

1

INTERNATIONAL SEARCH REPORT

Information on patent family members

International Application No
PCT/EP 97/02641

Patent document cited in search report	Publication date	Patent family member(s)	Publication date
WO 9413328 A	23-06-94	AU 5898794 A	04-07-94
		EP 0673261 A	27-09-95
		JP 8504350 T	14-05-96
		MX 9307952 A	31-08-94

WO 9500180 A	05-01-95	EP 0703793 A	03-04-96

US 4628969 A	16-12-86	AU 583967 B	11-05-89
		AU 6656286 A	25-06-87
		CA 1289737 A	01-10-91
		DE 3682260 A	05-12-91
		EP 0227401 A	01-07-87
		JP 6034827 B	11-05-94
		JP 62194866 A	27-08-87
		JP 8224303 A	03-09-96
		JP 8224302 A	03-09-96
		US 4718463 A	12-01-88

US 5207983 A	04-05-93	AT 145339 T	15-12-96
		AU 650186 B	09-06-94
		AU 3022392 A	05-08-93
		BR 9300277 A	03-08-93
		CA 2088331 A	30-07-93
		CZ 278610 B	16-03-94
		DE 69306006 D	02-01-97
		DE 69306006 T	22-05-97
		EP 0553926 A	04-08-93
		ES 2094456 T	16-01-97
		HU 65109 A	28-04-94
		IL 104543 A	10-01-97
		JP 6181968 A	05-07-94
		MX 9300441 A	01-07-93
		NO 300956 B	25-08-97
		NZ 245779 A	26-10-95
		RU 2070056 C	10-12-96
SK 4993 A	09-09-93		

EP 0496633 A	29-07-92	AT 128685 T	15-10-95
		DE 69205180 D	09-11-95
		DE 69205180 T	04-04-96

INTERNATIONAL SEARCH REPORT

Information on patent family members

International Application No PCT/EP 97/02641

Patent document cited in search report	Publication date	Patent family member(s)	Publication date
EP 0496633 A		JP 5277166 A US 5279788 A	26-10-93 18-01-94

US 5370861 A	06-12-94	US 5416223 A US 5559266 A DE 69012796 D EP 0452377 A NO 300968 B AT 111889 T AU 631837 B AU 4814290 A CA 2045543 A WO 9007491 A ES 2060138 T IE 64500 B JP 4502617 T	16-05-95 24-09-96 27-10-94 23-10-91 25-08-97 15-10-94 10-12-92 01-08-90 10-07-90 12-07-90 16-11-94 09-08-95 14-05-92

INTERNATIONALER RECHERCHENBERICHT

Internationaler Aktenzeichen
PCT/EP 97/02641

A. KLASSIFIZIERUNG DES ANMELDUNGSGEGENSTANDES IPK 6 A61L2/04 A61L2/06 A61L2/12 A61L2/20 A61M5/00		
Nach der Internationalen Patentklassifikation (IPK) oder nach der nationalen Klassifikation und der IPK		
B. RECHERCHIERTE GEBIETE		
Recherchierter Mindestprüfstoff (Klassifikationssystem und Klassifikationssymbole) IPK 6 A61L A61M		
Recherchierte aber nicht zum Mindestprüfstoff gehörende Veröffentlichungen, soweit diese unter die recherchierten Gebiete fallen		
Während der internationalen Recherche konsultierte elektronische Datenbank (Name der Datenbank und evtl. verwendete Suchbegriffe)		
C. ALS WESENTLICH ANGESEHENE UNTERLAGEN		
Kategorie*	Bezeichnung der Veröffentlichung, soweit erforderlich unter Angabe der in Betracht kommenden Teile	Betr. Anspruch Nr.
X	WO 94 13328 A (MALLINCKRODT MEDICAL INC) 23.Juni 1994 siehe Zusammenfassung siehe Seite 4, Zeile 5 - Zeile 9 siehe Seite 4, Zeile 15 - Zeile 24 siehe Ansprüche 1-13 siehe Abbildung 1 ---	1,2,4-16
X	WO 95 00180 A (FARCO PHARMA GES MIT BESCHRAEN ;WOLF ERICH (DE)) 5.Januar 1995 siehe Seite 3, Zeile 24 - Seite 4, Zeile 13 siehe Seite 6, Zeile 28 - Zeile 32 siehe Ansprüche 1,4-6 ---	1-8, 13-15 9,10
Y		
	-/--	
<input checked="" type="checkbox"/> Weitere Veröffentlichungen sind der Fortsetzung von Feld C zu entnehmen		<input checked="" type="checkbox"/> Siehe Anhang Patentfamilie
<p>* Besondere Kategorien von angegebenen Veröffentlichungen</p> <p>*A* Veröffentlichung, die den allgemeinen Stand der Technik definiert, aber nicht als besonders bedeutsam anzusehen ist</p> <p>*E* Älteres Dokument, das jedoch erst am oder nach dem internationalen Anmeldedatum veröffentlicht worden ist</p> <p>*L* Veröffentlichung, die geeignet ist, einen Prioritätsanspruch zweifelhaft erscheinen zu lassen, oder durch die das Veröffentlichungsdatum einer anderen im Recherchenbericht genannten Veröffentlichung belegt werden soll oder die aus einem anderen besonderen Grund angegeben ist (wie ausgeführt)</p> <p>*O* Veröffentlichung, die sich auf eine mündliche Offenbarung, eine Benutzung, eine Ausstellung oder andere Maßnahmen bezieht</p> <p>*P* Veröffentlichung, die vor dem internationalen Anmeldedatum, aber nach dem beanspruchten Prioritätsdatum veröffentlicht worden ist</p>		<p>*T* Spätere Veröffentlichung, die nach dem internationalen Anmeldedatum oder dem Prioritätsdatum veröffentlicht worden ist und mit der Anmeldung nicht kollidiert, sondern nur zum Verständnis des der Erfindung zugrundeliegenden Prinzips oder der ihr zugrundeliegenden Theorie angegeben ist</p> <p>*X* Veröffentlichung von besonderer Bedeutung; die beanspruchte Erfindung kann allein aufgrund dieser Veröffentlichung nicht als neu oder auf erfinderischer Tätigkeit beruhend betrachtet werden</p> <p>*Y* Veröffentlichung von besonderer Bedeutung; die beanspruchte Erfindung kann nicht als auf erfinderischer Tätigkeit beruhend betrachtet werden, wenn die Veröffentlichung mit einer oder mehreren anderen Veröffentlichungen dieser Kategorie in Verbindung gebracht wird und diese Verbindung für einen Fachmann naheliegend ist</p> <p>*Z* Veröffentlichung, die Mitglied derselben Patentfamilie ist</p>
Datum des Abschlusses der internationalen Recherche 10. Oktober 1997		Absendedatum des internationalen Recherchenberichts 17-10-1997
Name und Postanschrift der Internationalen Recherchenbehörde Europäisches Patentamt, P.B. 5818 Patentlaan 2 NL - 2280 HV Rijswijk Tel. (+31-70) 340-2040, Tx. 31 651 epo nl, Fax: (+31-70) 340-3016		Bevollmächtigter Bediensteter Heck, G

INTERNATIONALER RECHERCHENBERICHT

Internation: Aktenzeichen
PCT/EP 97/02641

C.(Fortsetzung) ALS WESENTLICH ANGESEHENE UNTERLAGEN		
Kategorie*	Bezeichnung der Veröffentlichung, soweit erforderlich unter Angabe der in Betracht kommenden Teile	Betr. Anspruch Nr.
Y	US 4 628 969 A (JURGENS JR RAYMOND W ET AL) 16.Dezember 1986 siehe Spalte 1, Zeile 38 - Zeile 64 siehe Spalte 2, Zeile 24 - Zeile 39 siehe Ansprüche 1-3 ---	9,10
A	US 5 207 983 A (LIEBERT RICHARD T ET AL) 4.Mai 1993 siehe Spalte 2, Zeile 8 - Zeile 28 siehe Ansprüche 1,3,4,7,8 ---	1,2,4, 7-9
A	EP 0 496 633 A (EISAI CO LTD ;MICRO DENSHI CO LTD (JP)) 29.Juli 1992 siehe Zusammenfassung ---	2
A	US 5 370 861 A (KLAVENESS JO ET AL) 6.Dezember 1994 siehe Zusammenfassung siehe Spalte 3, Zeile 12 - Zeile 19 -----	10

1

INTERNATIONALER RECHERCHENBERICHT

Angaben zu Veröffentlichungen, die zur selben Patentfamilie gehören

Internationale Patentzeichen
PCT/EP 97/02641

Im Recherchenbericht angeführtes Patentdokument	Datum der Veröffentlichung	Mitglied(er) der Patentfamilie	Datum der Veröffentlichung
WO 9413328 A	23-06-94	AU 5898794 A	04-07-94
		EP 0673261 A	27-09-95
		JP 8504350 T	14-05-96
		MX 9307952 A	31-08-94

WO 9500180 A	05-01-95	EP 0703793 A	03-04-96

US 4628969 A	16-12-86	AU 583967 B	11-05-89
		AU 6656286 A	25-06-87
		CA 1289737 A	01-10-91
		DE 3682260 A	05-12-91
		EP 0227401 A	01-07-87
		JP 6034827 B	11-05-94
		JP 62194866 A	27-08-87
		JP 8224303 A	03-09-96
		JP 8224302 A	03-09-96
		US 4718463 A	12-01-88

US 5207983 A	04-05-93	AT 145339 T	15-12-96
		AU 650186 B	09-06-94
		AU 3022392 A	05-08-93
		BR 9300277 A	03-08-93
		CA 2088331 A	30-07-93
		CZ 278610 B	16-03-94
		DE 69306006 D	02-01-97
		DE 69306006 T	22-05-97
		EP 0553926 A	04-08-93
		ES 2094456 T	16-01-97
		HU 65109 A	28-04-94
		IL 104543 A	10-01-97
		JP 6181968 A	05-07-94
		MX 9300441 A	01-07-93
		NO 300956 B	25-08-97
		NZ 245779 A	26-10-95
RU 2070056 C	10-12-96		
SK 4993 A	09-09-93		

EP 0496633 A	29-07-92	AT 128685 T	15-10-95
		DE 69205180 D	09-11-95
		DE 69205180 T	04-04-96

INTERNATIONALER RECHERCHENBERICHT

Angaben zu Veröffentlichungen, die zur selben Patentfamilie gehören

Internationales Patentzeichen
PCT/EP 97/02641

Im Recherchenbericht angeführtes Patentedokument	Datum der Veröffentlichung	Mitglied(er) der Patentfamilie	Datum der Veröffentlichung
EP 0496633 A		JP 5277166 A US 5279788 A	26-10-93 18-01-94
US 5370861 A	06-12-94	US 5416223 A US 5559266 A DE 69012796 D EP 0452377 A NO 300968 B AT 111889 T AU 631837 B AU 4814290 A CA 2045543 A WO 9007491 A ES 2060138 T IE 64500 B JP 4502617 T	16-05-95 24-09-96 27-10-94 23-10-91 25-08-97 15-10-94 10-12-92 01-08-90 10-07-90 12-07-90 16-11-94 09-08-95 14-05-92

Electronic Patent Application Fee Transmittal

Application Number:	13750352			
Filing Date:	25-Jan-2013			
Title of Invention:	SYRINGE			
First Named Inventor/Applicant Name:	Juergen Sigg			
Filer:	James L Lynch/Denise Cooper			
Attorney Docket Number:	PAT055157-US-NP			
Filed as Large Entity				
Filing Fees for Utility under 35 USC 111(a)				
Description	Fee Code	Quantity	Amount	Sub-Total in USD(\$)
Basic Filing:				
Pages:				
Claims:				
Miscellaneous-Filing:				
Petition:				
Patent-Appeals-and-Interference:				
Post-Allowance-and-Post-Issuance:				
Extension-of-Time:				

Description	Fee Code	Quantity	Amount	Sub-Total in USD(\$)
Miscellaneous:				
Submission- Information Disclosure Stmt	1806	1	180	180
Total in USD (\$)				180

Electronic Acknowledgement Receipt

EFS ID:	21740968
Application Number:	13750352
International Application Number:	
Confirmation Number:	5306
Title of Invention:	SYRINGE
First Named Inventor/Applicant Name:	Juergen Sigg
Customer Number:	1095
Filer:	James L Lynch/Denise Cooper
Filer Authorized By:	James L Lynch
Attorney Docket Number:	PAT055157-US-NP
Receipt Date:	11-MAR-2015
Filing Date:	25-JAN-2013
Time Stamp:	16:20:23
Application Type:	Utility under 35 USC 111(a)

Payment information:

Submitted with Payment	yes
Payment Type	Deposit Account
Payment was successfully received in RAM	\$180
RAM confirmation Number	2807
Deposit Account	190134
Authorized User	

The Director of the USPTO is hereby authorized to charge indicated fees and credit any overpayment as follows:

Charge any Additional Fees required under 37 C.F.R. Section 1.21 (Miscellaneous fees and charges)

File Listing:

Document Number	Document Description	File Name	File Size(Bytes)/ Message Digest	Multi Part /.zip	Pages (if appl.)
1	Amendment/Req. Reconsideration-After Non-Final Reject	PAT055157-US-NP-ResonseOA-2015March11.pdf	134000 2dee4e17b87d609ec3308c51c200568c7eabe80b	no	7
Warnings:					
Information:					
2	Information Disclosure Statement (IDS) Form (SB08)	PAT055157-US-NP_IDS_sb08_2015Mar11.pdf	612209 c976383b6bcd74dbbbe8e8a68a44ae91aa929c442	no	4
Warnings:					
Information:					
A U.S. Patent Number Citation or a U.S. Publication Number Citation is required in the Information Disclosure Statement (IDS) form for autoloading of data into USPTO systems. You may remove the form to add the required data in order to correct the Informational Message if you are citing U.S. References. If you chose not to include U.S. References, the image of the form will be processed and be made available within the Image File Wrapper (IFW) system. However, no data will be extracted from this form. Any additional data such as Foreign Patent Documents or Non Patent Literature will be manually reviewed and keyed into USPTO systems.					
3	Foreign Reference	WO9744068A1.pdf	1062327 dc92d9a13ce4c089a0c7ba40c9646b350d079fd0	no	27
Warnings:					
Information:					
4	Fee Worksheet (SB06)	fee-info.pdf	30253 4d510f42ef32b29863341915f1f40c86ccad5573	no	2
Warnings:					
Information:					
Total Files Size (in bytes):			1838789		

This Acknowledgement Receipt evidences receipt on the noted date by the USPTO of the indicated documents, characterized by the applicant, and including page counts, where applicable. It serves as evidence of receipt similar to a Post Card, as described in MPEP 503.

New Applications Under 35 U.S.C. 111

If a new application is being filed and the application includes the necessary components for a filing date (see 37 CFR 1.53(b)-(d) and MPEP 506), a Filing Receipt (37 CFR 1.54) will be issued in due course and the date shown on this Acknowledgement Receipt will establish the filing date of the application.

National Stage of an International Application under 35 U.S.C. 371

If a timely submission to enter the national stage of an international application is compliant with the conditions of 35 U.S.C. 371 and other applicable requirements a Form PCT/DO/EO/903 indicating acceptance of the application as a national stage submission under 35 U.S.C. 371 will be issued in addition to the Filing Receipt, in due course.

New International Application Filed with the USPTO as a Receiving Office

If a new international application is being filed and the international application includes the necessary components for an international filing date (see PCT Article 11 and MPEP 1810), a Notification of the International Application Number and of the International Filing Date (Form PCT/RO/105) will be issued in due course, subject to prescriptions concerning national security, and the date shown on this Acknowledgement Receipt will establish the international filing date of the application.

IN THE UNITED STATES PATENT AND TRADEMARK OFFICE

IN RE APPLICATION OF

Confirm No. 5306

Sigg, Juergen et al.

APPLICATION NO: 13/750,352

Examiner: Berdichevsky, Aarti

FILED: January 25, 2013

Art Unit: 3763

FOR: SYRINGE

Commissioner for Patents
PO Box 1450
Alexandria, VA 22313-1450

RESPONSE TO OFFICE ACTION

Sir:

This Response to Office Action ("Response") is being submitted in reply to an Office Action mailed to Applicants' attorney on December 12, 2014 ("Office Action").

Listing of the Claims are reflected in the listing of the claims which begins on page 2 of this paper.

Remarks/Arguments begin on page 5 of this paper.

Amendments to the Claims:

This listing of claims will replace all prior versions, and listings, of claims in the application:

Listing of Claims:

1. (Previously presented) A pre-filled syringe for intravitreal injection, the syringe comprising a glass body forming a barrel, a stopper and a plunger and containing an ophthalmic solution which comprises a VEGF-antagonist, wherein:

(a) the syringe has a nominal maximum fill volume of between about 0.5ml and about 1ml,

(b) the syringe barrel comprises from about 1 μ g to 100ug silicone oil,

(c) the VEGF antagonist solution comprises no more than 2 particles >50 μ m in diameter per ml and

wherein the syringe has a stopper break loose force of less than about 11N.

2.(Canceled)

3.(Canceled)

4.(Canceled)

5.(Canceled)

6.(Previously presented) A pre-filled syringe according to claim 1, wherein the syringe barrel has an internal coating of silicone oil that has an average thickness of about 450nm or less.

7.(Canceled)

8.(Canceled)

9.(Previously presented) A pre-filled syringe according to claim 1, wherein the syringe barrel has an internal coating of from about 3 μ g to about 100ug silicone oil.

10. (Original) A pre-filled syringe according to claim 1, wherein the silicone oil is DC365 emulsion.

11. (Canceled)

12. (Original) A pre-filled syringe according to claim 1, wherein the VEGF antagonist solution further comprises one or more of (i) no more than 5 particles \geq 25 μ m in diameter per ml, and (ii) no more than 50 particles \geq 10 μ m in diameter per ml.

13. (Original) A pre-filled syringe according to claim 1, wherein the VEGF antagonist solution meets USP789.
14. (Original) A pre-filled syringe according to claim 1, wherein the VEGF antagonist is an anti-VEGF antibody.
15. (Original) A pre-filled syringe according to claim 14, wherein the anti-VEGF antibody is ranibizumab.
16. (Original) A pre-filled syringe according to claim 15, wherein the ranibizumab is at a concentration of 10mg/ml.
17. (Original) A pre-filled syringe according to claim 1 wherein the VEGF antagonist is a non-antibody VEGF antagonist.
18. (Original) A pre-filled syringe according to claim 17, wherein the non-antibody VEGF antagonist is aflibercept or conbercept.
19. (Original) A pre-filled syringe according to claim 18, wherein the non-antibody VEGF antagonist is aflibercept at a concentration of 40mg/ml.
20. (Canceled)
21. (Original) A pre-filled syringe according to claim 20, wherein the syringe has a stopper break loose force of less than about 5N.
22. (Original) A pre-filled syringe according to claim 1, wherein the syringe has a stopper slide force of less than about 11N.
23. (Original) A pre-filled syringe according to claim 22, wherein the syringe has a stopper slide force of less than about 5N.
24. (Original) A pre-filled syringe according to claim 20, wherein the stopper break loose force or stopper slide force is measured using a filled syringe, at a stopper travelling speed of 190mm/min, with a 30G x 0.5 inch needle attached to the syringe.
- 25.(Original) A blister pack comprising a pre-filled syringe according to claim 1, wherein the syringe has been sterilised using H₂O₂ or EtO.
26. (Original) A blister pack comprising a pre-filled syringe according to claim 25, wherein the outer surface of the syringe has ≤ 1 ppm EtO or H₂O₂ residue.
27. (Original) A blister pack comprising a pre-filled syringe according to claim 25, wherein the syringe has been sterilised using EtO or H₂O₂ and the total EtO or H₂O₂ residue found on the outside of the syringe and inside of the blister pack is ≤ 0.1 mg.

28. (Original) A blister pack comprising a pre-filled syringe according to claim 25, wherein $\leq 5\%$ of the VEGF antagonist is alkylated.

29. (Original) A blister pack comprising a pre-filled syringe according to claim 25, wherein the syringe has been sterilised using EtO or H₂O₂ with a Sterility Assurance Level of at least 10⁻⁶.

30. (Original) A method of treating a patient suffering from of an ocular disease selected from choroidal neovascularisation, wet age-related macular degeneration, macular edema secondary to retinal vein occlusion (RVO) including both branch RVO (bRVO) and central RVO (cRVO), choroidal neovascularisation secondary to pathologic myopia (PM), diabetic macular edema (DME), diabetic retinopathy, and proliferative retinopathy, comprising the step of administering an ophthalmic solution to the patient using a pre-filled syringe according to claim 1.

31. (Original) The method of claim 30, further comprising an initial priming step in which the physician depresses the plunger of the pre-filled syringe to align the pre-determined part of the stopper with the priming mark.

32. (Original) A method according to claim 30, wherein the VEGF antagonist administered is a non-antibody VEGF antagonist and wherein the patient has previously received treatment with an antibody VEGF antagonist.

33. (Canceled)

34. (Previously presented) A pre-filled syringe according to claim 1, wherein the syringe barrel has an internal coating of from about 1-50 μ g silicone oil.

REMARKS/ARGUMENTS

Claim Status

Claims 1,6, 9, 10, 12-19, 21-32 and 34 were pending prior to the entry of this response. No claim amendments have been made. Accordingly, claims 1, 6, 9-10, 12-19, 21-32, and 34 are pending after entry of this amendment.

The Examiner's Rejections

The Examiner rejected claims 1, 6, 9-10 and 12-19, 21-32 and 34 under 35 U.S.C. § 103(a) as being obvious in view of WO 2007/035621 to Scypinski et al. (hereinafter "the '621 publication") in further view of US2011/0276005 to Hioki et al (hereinafter "the '005 publication"). The Examiner admits that the '621 publication is silent to an internal silicone coating on the syringe barrel. However, to cure this deficiency, the Examiner relies on the teachings of the '005 publication. According to the Examiner, the '005 publication teaches coating the inner surface of a syringe barrel, and that the skilled artisan would have been motivated to include oil in the silicone barrel to increase the slidability of the plunger within the barrel, and that finding the optimum value of the silicone oil to use is well within the ordinary skill in the art.

Response

Initially, the Applicants thank the Examiner for withdrawing the rejection of the claims under 35 U.S.C. § 112.

35 U.S.C. § 103

We respectfully disagree with the Examiner's objection regarding obviousness. Applicant does not agree that the subject matter of the present application would simply be an improvement or optimization of the usability of a syringe. For patient safety and the hygiene of the drug it is vital that the syringe and its contents are sufficiently sterile to avoid infection and other risks for the patients. To this end, not only the solution to be filled in is treated, but the prefilled syringe is terminally sterilized as well, whereby the syringe is typically already located in its package. The sterilization of the syringe is carried out with the aid of heat or chemically by means of a sterilizing gas. In case of syringes with low volume, for example those for injections into the eye, the sterilization of the syringes and their contents can lead to problems that do not necessarily occur at larger syringes. Changes in pressure, which may occur for instance after heating, may cause air bubbles contained in the syringe to extend and parts of the syringe to move. This can change tightness properties and may compromise sterility of the prefilled syringe. The tightness of the pre-filled syringe is not only relevant for maintaining the sterility of the syringe and its content, but it also protects the content of the syringe from the sterilizing gas. If the pre-filled syringe is not appropriately sealed, significant amounts of the gas may intrude

into the volume chamber of the syringe and have a detrimental effect on the drug. Ethylene oxide, for instance, alkylates proteins and may in such a manner inactivate proteinogenic substances. Overall, it is therefore not true that the general teaching for syringes can simply be adjusted to the present situation.

Claim 1 refers to a syringe that is pre-filled with an ophthalmic solution. The term "pre-filled" indicates that the syringe is not administered shortly after filling. Between the filling and the administration of the solution the syringe is sterilized and transported or stored. The syringes reach the user or patient already in the pre-filled condition. Silicone oil applied to the inner syringe surface can migrate into the solution, especially during storage, which is undesired, since silicone oil droplets injected into the eye cause potentially adverse effects. Silicone oil can also migrate from the lubricated stopper setting tube into the drug solution. Silicone oil can cause proteins, like the active agent Ranibizumab, to aggregate. Silicone may also induce denaturation of the protein adsorbed at the surface of silicone droplets.

Scypinski does not contain any data regarding the amount of lubricant that is contained in the syringe cylinder. Consequently, the skilled person could not draw conclusions from that regarding a silicone oil content of less than those recited in the current claims.

It is known that siliconization of pre-filled syringes is often irregular and specific regions of the inner surface of the cylinder of the syringes are not siliconized. The distribution of silicone oil in PFS is often non-uniform, leaving some bare glass surfaces without silicone oil. This particularly occurs when smaller amounts of silicone oils are used. Such insufficient siliconization may already lead to the situation that the adhesive forces and the frictional forces of the stopper are too high to safeguard the functioning of the pre-filled syringe. When using a smaller amount of silicone oil, the skilled person would thus have expected that the drug is incompletely administered. This would have prevented him from attempting to develop a prefilled syringe with a silicone level below the recommended threshold amount.

Hioki refers to pre-filled syringes that are not specifically designed for ophthalmic purposes. The barrel of the syringe disclosed in Hioki is made of resin. There are substantial different material properties of plastic (resin) and glass. Different are for example the interactions of the active substance contained in an injection solution with plastic and glass. The intensity of a bond of e.g. proteins to a certain surface depends on the nature of the used surface and also on the kind of the used protein. Moreover, containers made of glass and plastic (resin) differ in the way and amount of the substances that can go through the material of the container into the injection solution.

The skilled person facing the objective of developing a syringe prefilled with ophthalmic solution is not given any stimulation from both citations, Scypinski and Hioki, that the threshold value for the silicone amount used in the syringe cylinder to below those cited in the current claims.

There is no teaching in the cited prior nor can any suggestion be derived from the combination of Scypinski and Hioki that a pre-filled syringe with a glass body of the claimed size (maximum fill volume between about 0.5 ml and about 1 ml) could be obtained with such small break loose and sliding forces and having at the same time such a small silicone oil content within the barrel. The surprising finding that the silicone oil content of a pre-filled syringe for ophthalmic use can be decreased without increasing the break loose and sliding forces cannot be found anywhere in the cited prior art, nor can it be deduced. The subject matter of claim 1 is therefore inventive.

According to the Applicant's knowledge, there does not exist any pre-filled syringe for ophthalmic use, with a glass body and a maximum fill volume between about 0.5 ml and about 1 ml, with a silicone oil content of 1 μg to 100 μg that has break loose and sliding forces $<11\text{ N}$ (or even within the range of 2 to 5 N).

In total it has to be noticed that the cited prior art does not contain any suggestion whatsoever regarding a silicone content of less than about 500 μg in the glass cylinder of pre-filled syringes for ophthalmic use, as it is determined in the claims. The lack of any suggestion in order to reach this value shows that the current invention is not obvious in view of the documents cited by the Examiner.

Conclusion

Applicants believe that the foregoing constitutes a complete and full response to the Office Action of record. They further submit that all pending claims, as amended, are patentable and in patentable form, and they respectfully request that such claims be allowed to issue. Should the Examiner have any outstanding issues, the undersigned representative invites the Examiner to contact him at his convenience.

Novartis Pharmaceuticals Corporation
One Health Plaza, Bldg. 101
East Hanover, NJ 07936
+1 8627783423

Respectfully submitted,

/ Jim Lynch /

Jim Lynch
Agent for Applicant
Reg. No. 54,763

Date: March 11, 2015



UNITED STATES PATENT AND TRADEMARK OFFICE

UNITED STATES DEPARTMENT OF COMMERCE
United States Patent and Trademark Office
Address: COMMISSIONER FOR PATENTS
P.O. Box 1450
Alexandria, Virginia 22313-1450
www.uspto.gov

Table with 5 columns: APPLICATION NO., FILING DATE, FIRST NAMED INVENTOR, ATTORNEY DOCKET NO., CONFIRMATION NO.
13/750,352 01/25/2013 Juergen Sigg PAT055157-US-NP 5306

1095 7590 03/20/2015
NOVARTIS PHARMACEUTICAL CORPORATION
INTELLECTUAL PROPERTY DEPARTMENT
ONE HEALTH PLAZA 433/2
EAST HANOVER, NJ 07936-1080

EXAMINER

BERDICHEVSKY, AARTI

ART UNIT PAPER NUMBER

3763

NOTIFICATION DATE DELIVERY MODE

03/20/2015

ELECTRONIC

Please find below and/or attached an Office communication concerning this application or proceeding.

The time period for reply, if any, is set in the attached communication.

Notice of the Office communication was sent electronically on above-indicated "Notification Date" to the following e-mail address(es):

phip.patents@novartis.com

DETAILED ACTION

This is the fourth Office Action based on the 13/750,352 application filed on 1/25/2013. Claims 1, 6, 9, 10, 12-19, 21-32 and 34, as amended on 3/11/2015, are currently pending and have been considered below.

Notice of Pre-AIA or AIA Status

1. The present application is being examined under the pre-AIA first to invent provisions.

Claim Rejections - 35 USC § 103

2. The text of those sections of Title 35, U.S. Code not included in this action can be found in a prior Office action.

3. Claims 1,6, 9-10, 12-19, 21-32 and 34 are rejected under pre-AIA 35 U.S.C. 103(a) as being unpatentable over WO 2007/035621 to Scypinski et al. in view of US2011/0276005 to Hioki et al. as set forth in the Office Action dated 12/12/2014.

Response to Arguments

4. Applicant's arguments filed 3/11/2015 have been fully considered but they are not persuasive.

5. In response to applicant's argument that the references fail to show certain features of applicant's invention, it is noted that the features upon which applicant relies (i.e., the prefilled syringe is terminally sterilized) are not recited in the rejected claim(s).

Although the claims are interpreted in light of the specification, limitations from the specification are not read into the claims. See *In re Van Geuns*, 988 F.2d 1181, 26 USPQ2d 1057 (Fed. Cir. 1993).

6. The Examiner finds that the prior art meets the claims as currently presented as set forth in the previous Office Action. The Examiner does appreciate the differences between the present invention and the prior art, those differences are not reflected in the claims as currently presented.

Conclusion

THIS ACTION IS MADE FINAL. Applicant is reminded of the extension of time policy as set forth in 37 CFR 1.136(a).

A shortened statutory period for reply to this final action is set to expire THREE MONTHS from the mailing date of this action. In the event a first reply is filed within TWO MONTHS of the mailing date of this final action and the advisory action is not mailed until after the end of the THREE-MONTH shortened statutory period, then the shortened statutory period will expire on the date the advisory action is mailed, and any extension fee pursuant to 37 CFR 1.136(a) will be calculated from the mailing date of the advisory action. In no event, however, will the statutory period for reply expire later than SIX MONTHS from the mailing date of this final action.

Any inquiry concerning this communication or earlier communications from the examiner should be directed to Aarti Bhatia Berdichevsky whose telephone number is 571-270-5033. The examiner can normally be reached M-F 9 AM to 5 PM.

If attempts to reach the examiner by telephone are unsuccessful, the examiner's supervisor, Bhisma Mehta can be reached on 571-272-3383. The fax phone number for the organization where this application is assigned is 571-273-8300.

Information regarding the status of an application may be obtained from the Patent Application Information Retrieval (PAIR) system. Status information for published applications may be obtained from either Private PAIR or Public PAIR. Status information for unpublished applications is available through Private PAIR only. For more information about the PAIR system, see <http://pair-direct.uspto.gov>. Should you have questions on access to the Private PAIR system, contact the Electronic Business Center (EBC) at 866-217-9197 (toll-free). If you would like assistance from a USPTO Customer Service Representative or access to the automated information system, call 800-786-9199 (IN USA OR CANADA) or 571-272-1000.

/Aarti Bhatia Berdichevsky/
Primary Examiner, Art Unit 3763

Receipt date: 03/11/2015

13750352 - GAIL 3763

Doc code: IDS

Doc description: Information Disclosure Statement (IDS) Filed

Approved for use through 07/31/2012. OMB 0651-0031
U.S. Patent and Trademark Office; U.S. DEPARTMENT OF COMMERCE

Under the Paperwork Reduction Act of 1995, no persons are required to respond to a collection of information unless it contains a valid OMB control number.

INFORMATION DISCLOSURE STATEMENT BY APPLICANT (Not for submission under 37 CFR 1.99)	Application Number		13750352	
	Filing Date		2013-01-25	
	First Named Inventor	Juergen Sigg		
	Art Unit	3763		
	Examiner Name	Berdichevsky, Aarti		
	Attorney Docket Number	PAT055157-US-NP		

U.S.PATENTS						Remove
Examiner Initial*	Cite No	Patent Number	Kind Code ¹	Issue Date	Name of Patentee or Applicant of cited Document	Pages,Columns,Lines where Relevant Passages or Relevant Figures Appear
	1					

If you wish to add additional U.S. Patent citation information please click the Add button.

Add

U.S.PATENT APPLICATION PUBLICATIONS						Remove
Examiner Initial*	Cite No	Publication Number	Kind Code ¹	Publication Date	Name of Patentee or Applicant of cited Document	Pages,Columns,Lines where Relevant Passages or Relevant Figures Appear
	1					

If you wish to add additional U.S. Published Application citation information please click the Add button.

Add

FOREIGN PATENT DOCUMENTS								Remove
Examiner Initial*	Cite No	Foreign Document Number ³	Country Code ² i	Kind Code ⁴	Publication Date	Name of Patentee or Applicant of cited Document	Pages,Columns,Lines where Relevant Passages or Relevant Figures Appear	T ⁵
/ABB/	1	97/44068	WO	A1	1997-11-27	SCHERING AG	Abstract	<input type="checkbox"/>

If you wish to add additional Foreign Patent Document citation information please click the Add button

Add

NON-PATENT LITERATURE DOCUMENTS		Remove	
Examiner Initials*	Cite No	Include name of the author (in CAPITAL LETTERS), title of the article (when appropriate), title of the item (book, magazine, journal, serial, symposium, catalog, etc), date, pages(s), volume-issue number(s), publisher, city and/or country where published.	T ⁵

INFORMATION DISCLOSURE STATEMENT BY APPLICANT (Not for submission under 37 CFR 1.99)	Application Number		13750352	13750352 - GAU: 3763
	Filing Date		2013-01-25	
	First Named Inventor	Juergen Sigg		
	Art Unit		3763	
	Examiner Name	Berdichevsky, Aarti		
	Attorney Docket Number	PAT055157-US-NP		

	1		<input type="checkbox"/>
--	---	--	--------------------------

If you wish to add additional non-patent literature document citation information please click the Add button **Add**

EXAMINER SIGNATURE

Examiner Signature	/Aarti Bhatia Berdichevsky/	Date Considered	03/15/2015
--------------------	-----------------------------	-----------------	------------

*EXAMINER: Initial if reference considered, whether or not citation is in conformance with MPEP 609. Draw line through a citation if not in conformance and not considered. Include copy of this form with next communication to applicant.

¹ See Kind Codes of USPTO Patent Documents at www.USPTO.GOV or MPEP 901.04. ² Enter office that issued the document, by the two-letter code (WIPO Standard ST.3). ³ For Japanese patent documents, the indication of the year of the reign of the Emperor must precede the serial number of the patent document. ⁴ Kind of document by the appropriate symbols as indicated on the document under WIPO Standard ST.16 if possible. ⁵ Applicant is to place a check mark here if English language translation is attached.

Search Notes 	Application/Control No. 13750352	Applicant(s)/Patent Under Reexamination SIGG ET AL.
	Examiner AARTI B BERDICHEVSKY	Art Unit 3763

CPC- SEARCHED		
Symbol	Date	Examiner
A61K9/0048OR A61F9/008 OR A61M5178 OR A61M5/31	5/8/2014	ABB
above updated	8/21/2014	ABB
above updated	12/8/2014	ABB
above updated	3/15/2015	ABB

CPC COMBINATION SETS - SEARCHED		
Symbol	Date	Examiner

US CLASSIFICATION SEARCHED			
Class	Subclass	Date	Examiner
604	218, 294	5/8/2014	ABB
above	updated	8/21/2014	ABB
above	updated	12/8/2014	ABB

SEARCH NOTES		
Search Notes	Date	Examiner
EAST search	5/8/2014	ABB
Inventor search	5/8/2014	ABB

INTERFERENCE SEARCH			
US Class/ CPC Symbol	US Subclass / CPC Group	Date	Examiner

	/AARTI B BERDICHEVSKY/ Primary Examiner.Art Unit 3763
--	----------------------------------------------------------

INFORMATION DISCLOSURE STATEMENT BY APPLICANT (Not for submission under 37 CFR 1.99)	Application Number	13750352
	Filing Date	2013-01-25
	First Named Inventor	Juergen Sigg
	Art Unit	3763
	Examiner Name	Aarti Berdichevsky
	Attorney Docket Number	PAT055157-US-NP

U.S.PATENTS						Remove
Examiner Initial*	Cite No	Patent Number	Kind Code ¹	Issue Date	Name of Patentee or Applicant of cited Document	Pages,Columns,Lines where Relevant Passages or Relevant Figures Appear
	1					

If you wish to add additional U.S. Patent citation information please click the Add button.

Add

U.S.PATENT APPLICATION PUBLICATIONS						Remove
Examiner Initial*	Cite No	Publication Number	Kind Code ¹	Publication Date	Name of Patentee or Applicant of cited Document	Pages,Columns,Lines where Relevant Passages or Relevant Figures Appear
	1					

If you wish to add additional U.S. Published Application citation information please click the Add button.

Add

FOREIGN PATENT DOCUMENTS								Remove
Examiner Initial*	Cite No	Foreign Document Number ³	Country Code ² j	Kind Code ⁴	Publication Date	Name of Patentee or Applicant of cited Document	Pages,Columns,Lines where Relevant Passages or Relevant Figures Appear	T ⁵
	1	2014/005728	WO	A1	2014-01-09	NOVARTIS AG		<input type="checkbox"/>
	2	2012101678	AU	A4	2012-12-20	JUERGEN SIGG ET AL		<input type="checkbox"/>
	3	2012101677	AU	A4	2012-12-13	JUERGEN SIGG ET AL		<input type="checkbox"/>

INFORMATION DISCLOSURE STATEMENT BY APPLICANT (Not for submission under 37 CFR 1.99)	Application Number	13750352
	Filing Date	2013-01-25
	First Named Inventor	Juergen Sigg
	Art Unit	3763
	Examiner Name	Aarti Berdichevsky
	Attorney Docket Number	PAT055157-US-NP

If you wish to add additional Foreign Patent Document citation information please click the Add button **Add**

NON-PATENT LITERATURE DOCUMENTS Remove

Examiner Initials*	Cite No	Include name of the author (in CAPITAL LETTERS), title of the article (when appropriate), title of the item (book, magazine, journal, serial, symposium, catalog, etc), date, pages(s), volume-issue number(s), publisher, city and/or country where published.	T ⁵
	1	CHAN ET AL: "Syringe Siliconization Process Investigation and Optimization" Journal of Pharmaceutical Science and Technology, Issue 66, pp.137, 147-148, March 2012	<input type="checkbox"/>
	2	LANKERS: "The Relationship Between Silicone Layer Thickness, Free Silicone Oil and Protein Aggregation In Prefilled Syringes" 2010 AAPS National Biotechnology Conference San Francisco, Slides 25, 39, 46, MAY 19, 2010	<input type="checkbox"/>
	3	MAJUMDAR ET AL: " Evaluation of the Effect of Syringe Surfaces on Protein Formulations" Journal of Pharmaceutical Sciences, Issue 100, pp.2563-2573, July 2011	<input type="checkbox"/>
	4	BAKRI AND EKDAWI: "Intravitreal Silicone Oil Droplets after Intravitreal Drug Injections" Retina, Issue 28, pp.996-1001, July 2008	<input type="checkbox"/>
	5	DAIKYO RU Crystal Zenith Insert Needle Syringe System, West Delivering Innovative Solutions, 2010	<input type="checkbox"/>
	6	MEYER ET AL: "Steps for a Safe Intravitreal Injection Technique", Meyer et al. "Steps for a Safe Intravitreal Injection Technique" Retinal Physician, p.3, July 1, 2009	<input type="checkbox"/>

If you wish to add additional non-patent literature document citation information please click the Add button **Add**

EXAMINER SIGNATURE

Examiner Signature	Date Considered
--------------------	-----------------

*EXAMINER: Initial if reference considered, whether or not citation is in conformance with MPEP 609. Draw line through a citation if not in conformance and not considered. Include copy of this form with next communication to applicant.

¹ See Kind Codes of USPTO Patent Documents at www.USPTO.GOV or MPEP 901.04. ² Enter office that issued the document, by the two-letter code (WIPO Standard ST.3). ³ For Japanese patent documents, the indication of the year of the reign of the Emperor must precede the serial number of the patent document. ⁴ Kind of document by the appropriate symbols as indicated on the document under WIPO Standard ST.16 if possible. ⁵ Applicant is to place a check mark here if English language translation is attached.

**INFORMATION DISCLOSURE
STATEMENT BY APPLICANT**
(Not for submission under 37 CFR 1.99)

Application Number	13750352
Filing Date	2013-01-25
First Named Inventor	Juergen Sigg
Art Unit	3763
Examiner Name	Aarti Berdichevsky
Attorney Docket Number	PAT055157-US-NP

CERTIFICATION STATEMENT

Please see 37 CFR 1.97 and 1.98 to make the appropriate selection(s):

That each item of information contained in the information disclosure statement was first cited in any communication from a foreign patent office in a counterpart foreign application not more than three months prior to the filing of the information disclosure statement. See 37 CFR 1.97(e)(1).

OR

That no item of information contained in the information disclosure statement was cited in a communication from a foreign patent office in a counterpart foreign application, and, to the knowledge of the person signing the certification after making reasonable inquiry, no item of information contained in the information disclosure statement was known to any individual designated in 37 CFR 1.56(c) more than three months prior to the filing of the information disclosure statement. See 37 CFR 1.97(e)(2).

See attached certification statement.

The fee set forth in 37 CFR 1.17 (p) has been submitted herewith.

A certification statement is not submitted herewith.

SIGNATURE

A signature of the applicant or representative is required in accordance with CFR 1.33, 10.18. Please see CFR 1.4(d) for the form of the signature.

Signature	/Michael Mazza/	Date (YYYY-MM-DD)	2015-07-16
Name/Print	Michael Mazza	Registration Number	30775

This collection of information is required by 37 CFR 1.97 and 1.98. The information is required to obtain or retain a benefit by the public which is to file (and by the USPTO to process) an application. Confidentiality is governed by 35 U.S.C. 122 and 37 CFR 1.14. This collection is estimated to take 1 hour to complete, including gathering, preparing and submitting the completed application form to the USPTO. Time will vary depending upon the individual case. Any comments on the amount of time you require to complete this form and/or suggestions for reducing this burden, should be sent to the Chief Information Officer, U.S. Patent and Trademark Office, U.S. Department of Commerce, P.O. Box 1450, Alexandria, VA 22313-1450. **DO NOT SEND FEES OR COMPLETED FORMS TO THIS ADDRESS. SEND TO: Commissioner for Patents, P.O. Box 1450, Alexandria, VA 22313-1450.**

Privacy Act Statement

The Privacy Act of 1974 (P.L. 93-579) requires that you be given certain information in connection with your submission of the attached form related to a patent application or patent. Accordingly, pursuant to the requirements of the Act, please be advised that: (1) the general authority for the collection of this information is 35 U.S.C. 2(b)(2); (2) furnishing of the information solicited is voluntary; and (3) the principal purpose for which the information is used by the U.S. Patent and Trademark Office is to process and/or examine your submission related to a patent application or patent. If you do not furnish the requested information, the U.S. Patent and Trademark Office may not be able to process and/or examine your submission, which may result in termination of proceedings or abandonment of the application or expiration of the patent.

The information provided by you in this form will be subject to the following routine uses:

1. The information on this form will be treated confidentially to the extent allowed under the Freedom of Information Act (5 U.S.C. 552) and the Privacy Act (5 U.S.C. 552a). Records from this system of records may be disclosed to the Department of Justice to determine whether the Freedom of Information Act requires disclosure of these records.
2. A record from this system of records may be disclosed, as a routine use, in the course of presenting evidence to a court, magistrate, or administrative tribunal, including disclosures to opposing counsel in the course of settlement negotiations.
3. A record in this system of records may be disclosed, as a routine use, to a Member of Congress submitting a request involving an individual, to whom the record pertains, when the individual has requested assistance from the Member with respect to the subject matter of the record.
4. A record in this system of records may be disclosed, as a routine use, to a contractor of the Agency having need for the information in order to perform a contract. Recipients of information shall be required to comply with the requirements of the Privacy Act of 1974, as amended, pursuant to 5 U.S.C. 552a(m).
5. A record related to an International Application filed under the Patent Cooperation Treaty in this system of records may be disclosed, as a routine use, to the International Bureau of the World Intellectual Property Organization, pursuant to the Patent Cooperation Treaty.
6. A record in this system of records may be disclosed, as a routine use, to another federal agency for purposes of National Security review (35 U.S.C. 181) and for review pursuant to the Atomic Energy Act (42 U.S.C. 218(c)).
7. A record from this system of records may be disclosed, as a routine use, to the Administrator, General Services, or his/her designee, during an inspection of records conducted by GSA as part of that agency's responsibility to recommend improvements in records management practices and programs, under authority of 44 U.S.C. 2904 and 2906. Such disclosure shall be made in accordance with the GSA regulations governing inspection of records for this purpose, and any other relevant (i.e., GSA or Commerce) directive. Such disclosure shall not be used to make determinations about individuals.
8. A record from this system of records may be disclosed, as a routine use, to the public after either publication of the application pursuant to 35 U.S.C. 122(b) or issuance of a patent pursuant to 35 U.S.C. 151. Further, a record may be disclosed, subject to the limitations of 37 CFR 1.14, as a routine use, to the public if the record was filed in an application which became abandoned or in which the proceedings were terminated and which application is referenced by either a published application, an application open to public inspections or an issued patent.
9. A record from this system of records may be disclosed, as a routine use, to a Federal, State, or local law enforcement agency, if the USPTO becomes aware of a violation or potential violation of law or regulation.

IN THE UNITED STATES PATENT AND TRADEMARK OFFICE

IN RE APPLICATION OF

Sigg, Juergen et al.

APPLICATION NO: 13/750352

FILED: January 25, 2013

FOR: SYRINGE

Art Unit: 3763

Examiner: Berdichevsky, Aarti

Conf. No.: 5306

Commissioner for Patents
PO Box 1450
Alexandria, VA 22313-1450

PETITION FOR EXTENSION OF TIME

Sir:

The Office Action of March 20, 2015 has a shortened statutory time set to expire on June 20, 2015. A one-month extension is hereby requested pursuant to 37 CFR §1.136(a).

Please charge Deposit Account No. 19-0134 in the name of Novartis in the amount of \$200 for payment of the extension fee. The Commissioner is hereby authorized to charge any additional fees under 37 CFR §1.17 which may be required, or credit any overpayment, to Account No. 19-0134 in the name of Novartis.

Respectfully submitted,

/Michael Mazza/

Novartis Pharmaceuticals Corporation
One Health Plaza, Bldg. 433
East Hanover, NJ 07936
+15108799666

Michael Mazza
Attorney for Applicant
Reg. No. 30,775

Date: 14 July 2015

IN THE UNITED STATES PATENT AND TRADEMARK OFFICE

IN RE APPLICATION OF

Confirm No. 5306

Sigg, Juergen et al.

APPLICATION NO: 13/750,352

Examiner: Berdichevsky, Aarti

FILED: January 25, 2013

Art Unit: 3763

FOR: SYRINGE

Commissioner for Patents
PO Box 1450
Alexandria, VA 22313-1450

AMENDMENT AND RESPONSE TO FINAL OFFICE ACTION

Sir:

This Amendment and Response together with a petition and fee for a one-month extension, is submitted in response to the Final Office Action mailed on 20 March, 2015.

Amendments to the Claims are reflected in the listing of the claims which begins on page 2 of this paper.

Remarks/Arguments begin on page 5 of this paper.

Amendments to the Claims:

This listing of claims will replace all prior versions, and listings, of claims in the application:

Listing of Claims:

1.(Currently amended) A pre-filled, terminally sterilized syringe for intravitreal injection, the syringe comprising a glass body forming a barrel, a stopper and a plunger and containing an ophthalmic solution which comprises a VEGF-antagonist, wherein:

(a) the syringe has a nominal maximum fill volume of between about 0.5ml and about 1ml,

(b) the syringe barrel comprises from about 1 μ g to 100ug silicone oil,

(c) the VEGF antagonist solution comprises no more than 2 particles >50 μ m in diameter per ml and wherein the syringe has a stopper break loose force of less than about 11N.

2. – 5 (Canceled)

6. (Previously presented) A pre-filled syringe according to claim 1, wherein the syringe barrel has an internal coating of silicone oil that has an average thickness of about 450nm or less.

7. – 8 (Canceled)

9. (Previously presented) A pre-filled syringe according to claim 1, wherein the syringe barrel has an internal coating of from about 3 μ g to about 100ug silicone oil.

10. (Original) A pre-filled syringe according to claim 1, wherein the silicone oil is DC365 emulsion.

11. (Canceled)

12. (Original) A pre-filled syringe according to claim 1, wherein the VEGF antagonist solution further comprises one or more of (i) no more than 5 particles \geq 25 μ m in diameter per ml, and (ii) no more than 50 particles \geq 10 μ m in diameter per ml.

13. (Original) A pre-filled syringe according to claim 1, wherein the VEGF antagonist solution meets USP789.

14. (Original) A pre-filled syringe according to claim 1, wherein the VEGF antagonist is an anti-VEGF antibody.

15. (Original) A pre-filled syringe according to claim 14, wherein the anti-VEGF antibody is ranibizumab.

16. (Original) A pre-filled syringe according to claim 15, wherein the ranibizumab is at a concentration of 10mg/ml.
17. (Original) A pre-filled syringe according to claim 1 wherein the VEGF antagonist is a non-antibody VEGF antagonist.
18. (Original) A pre-filled syringe according to claim 17, wherein the non-antibody VEGF antagonist is aflibercept or conbercept.
19. (Original) A pre-filled syringe according to claim 18, wherein the non-antibody VEGF antagonist is aflibercept at a concentration of 40mg/ml.
20. (Canceled)
21. (Currently amended) A pre-filled syringe according to claim ~~[[20]]~~ 1, wherein the syringe has a stopper break loose force of less than about 5N, and wherein the syringe has a stopper slide force of less than about 5N.
22. (Original) A pre-filled syringe according to claim 1, wherein the syringe has a stopper slide force of less than about 11N.
23. (Cancel)
24. (Original) A pre-filled syringe according to claim 20, wherein the stopper break loose force or stopper slide force is measured using a filled syringe, at a stopper travelling speed of 190mm/min, with a 30G x 0.5 inch needle attached to the syringe.
- 25.(Original) A blister pack comprising a pre-filled syringe according to claim 1, wherein the syringe has been sterilised using H₂O₂ or EtO.
26. (Original) A blister pack comprising a pre-filled syringe according to claim 25, wherein the outer surface of the syringe has ≤ 1 ppm EtO or H₂O₂ residue.
27. (Original) A blister pack comprising a pre-filled syringe according to claim 25, wherein the syringe has been sterilised using EtO or H₂O₂ and the total EtO or H₂O₂ residue found on the outside of the syringe and inside of the blister pack is ≤ 0.1 mg.
28. (Original) A blister pack comprising a pre-filled syringe according to claim 25, wherein $\leq 5\%$ of the VEGF antagonist is alkylated.
29. (Original) A blister pack comprising a pre-filled syringe according to claim 25, wherein the syringe has been sterilised using EtO or H₂O₂ with a Sterility Assurance Level of at least 10⁻⁶.

30. (Original) A method of treating a patient suffering from of an ocular disease selected from choroidal neovascularisation, wet age-related macular degeneration, macular edema secondary to retinal vein occlusion (RVO) including both branch RVO (bRVO) and central RVO (cRVO), choroidal neovascularisation secondary to pathologic myopia (PM), diabetic macular edema (DME), diabetic retinopathy, and proliferative retinopathy, comprising the step of administering an ophthalmic solution to the patient using a pre-filled syringe according to claim 1.

31. (Original) The method of claim 30, further comprising an initial priming step in which the physician depresses the plunger of the pre-filled syringe to align the pre-determined part of the stopper with the priming mark.

32. (Original) A method according to claim 30, wherein the VEGF antagonist administered is a non-antibody VEGF antagonist and wherein the patient has previously received treatment with an antibody VEGF antagonist.

33. (Canceled)

34. (Previously presented) A pre-filled syringe according to claim 1, wherein the syringe barrel has an internal coating of from about 1-50 μ g silicone oil.

35 (New) A pre-filled syringe according to claim 1, wherein the silicone oil has a viscosity of about 350 cP.

36. (New) A pre-filled syringe according to claim 15, wherein the silicone oil has a viscosity of about 350 cP, and the VEGF antagonist solution further comprises one or more of (i) no more than 5 particles $\geq 25\mu$ m in diameter per ml, and (ii) no more than 50 particles $\geq 10\mu$ m in diameter per ml.

REMARKS/ARGUMENTS

Claim Status

By way of this amendment, claims 1 and 21 have been amended; claim 23 has been canceled, and its subject matter incorporated into claim 21. Support for the amendments is found in applicants published specification US 2014/0012227, at paragraph 0046 and in the originally filed claims. New claims 35 and 36 have been added. Support for new claim 35 is found in the specification at paragraph 0026. Support for new claim 36 is found in the claims as originally presented.

Claims 1, 6, 9-10, 12-19, 21-22, 24-32, and 34-36 are pending after entry of this amendment.

Rejection under 35 U.S.C. § 103

Claims 1-6, 9-10, 12-19, 21-32 and 34 were rejected under 35 U.S.C. § 103(a) as allegedly over WO 2007/035621 to Scypinski et al. (hereinafter "Scypinski") in view of US2011/0276005 to Hioki et al (hereinafter "Hioki"). While it is admitted that Scypinski is silent to an internal silicone coating on the syringe barrel, the Examiner contends that Hioki teaches coating the inner surface of a syringe barrel, and that the skilled artisan would have been motivated to include oil in the silicone barrel to increase the slidability of the plunger within the barrel, and that finding the optimum value of the silicone oil to use is well within the ordinary skill in the art.

Response

While applicants respectfully continue to disagree with this characterization and application of the art, applicants also appreciate the Examiner's comment in paragraph 6 of the Action that the Examiner understands and recognizes the differences between the present invention and the cited art, but that those differences were not previously incorporated into the claims. Accordingly, applicants have hereby amended claims 1 and 21 solely to expedite prosecution and allowance. As amended, independent claim 1 now recites that the prefilled syringe is terminally sterilized. Note that while claim 1 states this explicitly, at least claims 25 – 27 and 29 recite that the prefilled syringe has been sterilized and comprises a blister pack i.e. a prefilled syringe which is terminally sterilized.

In the prior responses, applicants have argued the novelty and non-obviousness of the invention comprising a syringe having a glass barrel, and which is adequately and operationally lubricated with low levels of a silicone oil. Applicants have amended claim 21 to clarify that this low

level of silicone oil results in both a low break-loose in a low slide force. These features collectively are not taught by either cited reference. Applicant wishes to reiterate the position that while the '621 publication teaches a dual barreled syringe useful in administering a combination of drugs simultaneously into a patient's eye, it also discloses that the syringe barrel can be either glass or plastic. Plastic syringes are not useful as pre-filled syringes for biologic products. Hence the '621 publication does not teach or suggest a glass barrel syringe which contain the low amounts of silicone, together with the break-loose force and which is sterilized in packaged form, all as recited in the currently pending claims.

The '005 publication exclusively describes resin syringes, hence does not and cannot teach or suggest levels of silicone applicable to glass barreled syringes. Nowhere in either reference cited by the Examiner is it suggested or taught that the levels of silicone used in the current invention can be applied to glass barreled syringes.

Moreover, applicants have amended claim 21 to clarify that the reduced levels of silicone oils in conjunction with a glass barreled syringe afford not only a low break loose force but also a low slide force. Applicants have further added new claims 35 and 36 which explicitly describe a viscosity of the silicone oil in one embodiment (claim 35), and further relate the embodiment of viscosity of the silicone oil to a particle size distribution (claim 36). Nowhere does the cited references teach or suggest the combination of elements recited in claims 35 and 36 and the independent claims from which they depend, including specifically the low slide and break loose forces, low levels of silicone oil, and low levels of particulates within a glass barreled syringe for ophthalmic purposes. As note in the prior response, silicone oils can cause proteins, such as ranibizumab, to aggregate, and also to denaturate. Hence, new claim 36, which depends from claim 15, is further distinct form the art, which teaches neither the problem nor the solution.

Accordingly, a prima facie case of obviousness has not been established and the applicants respectfully request that it be withdrawn.

Moreover, claims 6, 9-10, 12-19, 21-22, 24-32, and 34-36 are dependent claims. With further regard to these claims, and dependent claims generally, as independent claim 1 is contended to be allowable over the prior art of record, then its dependent claims are allowable as a matter of law, because these dependent claims contain all features/elements/steps of the independent claim. *In re Fine*, 837 F.2d 1071 (Fed. Cir. 1988).

Additionally and notwithstanding the foregoing reasons for the allowability of amended independent claims 1 and 20, the dependent claims recite further features/steps and/or combinations of features/steps (as is apparent by examination of the claims themselves) that are patentably distinct from the prior art of record. Hence, there are other reasons why these dependent claims are allowable.

Conclusion

The claims are allowable for the reasons given above. Therefore, the applicants respectfully request the Examiner reconsider the present rejections and allow the presently pending claims. Should the Examiner have any questions, the Examiner is asked to call the undersigned at the number given below.

Novartis Pharmaceuticals Corporation
One Health Plaza, Bldg. 433
East Hanover, NJ 07936
510-879-9666

Date: 16 July 2015

Respectfully submitted,

/Michael J. Mazza/

Michael J. Mazza
Agent for Applicant
Reg. No. 30,775

(12) INTERNATIONAL APPLICATION PUBLISHED UNDER THE PATENT COOPERATION TREATY (PCT)

(19) World Intellectual Property
Organization
International Bureau



(43) International Publication Date
9 January 2014 (09.01.2014)

(10) International Publication Number
WO 2014/005728 A1

- (51) **International Patent Classification:**
A61K 9/00 (2006.01) *A61M 5/31* (2006.01)
A61M 5/28 (2006.01) *A61M 5/315* (2006.01)
- (21) **International Application Number:**
PCT/EP2013/051491
- (22) **International Filing Date:**
25 January 2013 (25.01.2013)
- (25) **Filing Language:** English
- (26) **Publication Language:** English
- (30) **Priority Data:**
- | | | |
|-------------------|-------------------------------|----|
| 12174860.2 | 3 July 2012 (03.07.2012) | EP |
| 12189649.2 | 23 October 2012 (23.10.2012) | EP |
| 20 2012 011 016.0 | 16 November 2012 (16.11.2012) | DE |
| 2012101677 | 16 November 2012 (16.11.2012) | AU |
| 2012101678 | 16 November 2012 (16.11.2012) | AU |
| 20 2012 011 260.0 | 23 November 2012 (23.11.2012) | DE |
| 20 2012 011 259.7 | 23 November 2012 (23.11.2012) | DE |
| 12195360.8 | 3 December 2012 (03.12.2012) | EP |
| 20 2013 000 688.9 | 23 January 2013 (23.01.2013) | DE |
| 2013100071 | 23 January 2013 (23.01.2013) | AU |
| 2013100070 | 23 January 2013 (23.01.2013) | AU |
- (71) **Applicant (for all designated States except US):** **NOVARTIS AG** [CH/CH]; Lichtstrasse 35, CH-4056 Basel (CH).
- (72) **Inventors; and**
- (71) **Applicants (for US only):** **SIGG, Juergen** [DE/CH]; Novartis Pharma AG, Postfach, CH-4002 Basel (CH). **ROY-ER, Christophe** [FR/DE]; Novartis Pharma AG, Postfach, CH-4002 Basel (CH). **BRYANT, Andrew Mark** [GB/CH]; Novartis Pharma AG, Postfach, CH-4002 Basel (CH). **BUETTGEN, Heinrich Martin** [DE/CH]; Novartis Pharma AG, Postfach, CH-4002 Basel (CH). **PICCI, Marie** [FR/FR]; Novartis Pharma AG, Postfach, CH-4002 Basel (CH).
- (74) **Agent:** **SPINNER, David Richard**; Novartis Pharma AG, Patent Department, CH-4002 Basel (CH).
- (81) **Designated States (unless otherwise indicated, for every kind of national protection available):** AE, AG, AL, AM, AO, AT, AU, AZ, BA, BB, BG, BH, BN, BR, BW, BY, BZ, CA, CH, CL, CN, CO, CR, CU, CZ, DE, DK, DM, DO, DZ, EC, EE, EG, ES, FI, GB, GD, GE, GH, GM, GT, HN, HR, HU, ID, IL, IN, IS, JP, KE, KG, KM, KN, KP, KR, KZ, LA, LC, LK, LR, LS, LT, LU, LY, MA, MD, ME, MG, MK, MN, MW, MX, MY, MZ, NA, NG, NI, NO, NZ, OM, PA, PE, PG, PH, PL, PT, QA, RO, RS, RU, RW, SC, SD, SE, SG, SK, SL, SM, ST, SV, SY, TH, TJ, TM, TN, TR, TT, TZ, UA, UG, US, UZ, VC, VN, ZA, ZM, ZW.
- (84) **Designated States (unless otherwise indicated, for every kind of regional protection available):** ARIPO (BW, GH, GM, KE, LR, LS, MW, MZ, NA, RW, SD, SL, SZ, TZ, UG, ZM, ZW), Eurasian (AM, AZ, BY, KG, KZ, RU, TJ, TM), European (AL, AT, BE, BG, CH, CY, CZ, DE, DK, EE, ES, FI, FR, GB, GR, HR, HU, IE, IS, IT, LT, LU, LV, MC, MK, MT, NL, NO, PL, PT, RO, RS, SE, SI, SK, SM, TR), OAPI (BF, BJ, CF, CG, CI, CM, GA, GN, GQ, GW, ML, MR, NE, SN, TD, TG).
- Published:**
- with international search report (Art. 21(3))
 - with sequence listing part of description (Rule 5.2(a))



WO 2014/005728 A1

(54) **Title:** SYRINGE

(57) **Abstract:** The present invention relates to a syringe, particularly to a small volume syringe such as a syringe suitable for ophthalmic injections.

SYRINGE

TECHNICAL FIELD

The present invention relates to a syringe, particularly to a small volume syringe such as a syringe suitable for ophthalmic injections.

5 BACKGROUND ART

Many medicaments are delivered to a patient in a syringe from which the user can dispense the medicament. If medicament is delivered to a patient in a syringe it is often to enable the patient, or a caregiver, to inject the medicament. It is important for patient safety and medicament integrity that the syringe and the contents of that syringe are sufficiently sterile to avoid
10 infection, or other, risks for patients. Sterilisation can be achieved by terminal sterilisation in which the assembled product, typically already in its associated packaging, is sterilised using heat or a sterilising gas.

For small volume syringes, for example those for injections into the eye in which it is intended that about 0.1ml or less of liquid is to be injected the sterilisation can pose difficulties that are
15 not necessarily associated with larger syringes. Changes in pressure, internal or external to the syringe, can cause parts of the syringe to move unpredictably, which may alter sealing characteristics and potentially compromise sterility. Incorrect handling of the syringe can also pose risks to product sterility.

Furthermore, certain therapeutics such as biologic molecules are particularly sensitive to
20 sterilisation, be it cold gas sterilisation, thermal sterilisation, or irradiation. Thus, a careful balancing act is required to ensure that while a suitable level of sterilisation is carried out, the syringe remains suitably sealed, such that the therapeutic is not compromised. Of course, the syringe must also remain easy to use, in that the force required to depress the plunger to administer the medicament must not be too high.

25 There is therefore a need for a new syringe construct which provides a robust seal for its content, but which maintains ease of use.

DISCLOSURE OF THE INVENTION

The present invention provides a pre-filled syringe, the syringe comprising a body, a stopper and a plunger, the body comprising an outlet at an outlet end and the stopper being arranged within
30 the body such that a front surface of the stopper and the body define a variable volume chamber

from which a fluid can be expelled through the outlet, the plunger comprising a plunger contact surface at a first end and a rod extending between the plunger contact surface and a rear portion, the plunger contact surface arranged to contact the stopper, such that the plunger can be used to force the stopper towards the outlet end of the body, reducing the volume of the variable volume chamber, characterised in that the fluid comprises an ophthalmic solution. In one embodiment, the ophthalmic solution comprises a VEGF-antagonist.

In one embodiment, the syringe is suitable for ophthalmic injections, more particularly intravitreal injections, and as such has a suitably small volume. The syringe may also be silicone oil free, or substantially silicone oil free, or may comprise a low level of silicone oil as lubricant. In one embodiment, despite the low silicone oil level, the stopper break loose and slide force is less than 20N.

For ophthalmic injections, it is particularly important for the ophthalmic solution to have particularly low particle content. In one embodiment, the syringe meets US Pharmacopeia standard 789 (USP789).

15 *Syringe*

The body of the syringe may be a substantially cylindrical shell, or may include a substantially cylindrical bore with a non circular outer shape. The outlet end of the body includes an outlet through which a fluid housed within the variable volume chamber can be expelled as the volume of said chamber is reduced. The outlet may comprise a projection from the outlet end through which extends a channel having a smaller diameter than that of the variable volume chamber. The outlet may be adapted, for example via a luer lock type connection, for connection to a needle or other accessory such as a sealing device which is able to seal the variable volume chamber, but can be operated, or removed, to unseal the variable volume chamber and allow connection of the syringe to another accessory, such as a needle. Such a connection may be made directly between the syringe and accessory, or via the sealing device. The body extends along a first axis from the outlet end to a rear end.

The body may be made from a plastic material (e.g. a cyclic olefin polymer) or from glass and may include indicia on a surface thereof to act as an injection guide. In one embodiment the body may comprise a priming mark. This allows the physician to align a pre-determined part of the stopper (such as the tip of the front surface or one of the circumferential ribs, discussed later) or plunger with the mark, thus expelling excess ophthalmic solution and any air bubbles from the

syringe. The priming process ensures that an exact, pre-determined dosage is administered to the patient.

The stopper may be made from rubber, silicone or other suitable resiliently deformable material. The stopper may be substantially cylindrical and the stopper may include one or more
5 circumferential ribs around an outer surface of the stopper, the stopper and ribs being dimensioned such that the ribs form a substantially fluid tight seal with an internal surface of the syringe body. The front surface of the stopper may be any suitable shape, for example substantially planar, substantially conical or of a domed shape. The rear surface of the stopper may include a substantially central recess. Such a central recess could be used to connect a
10 plunger to the stopper using a snap fit feature or thread connection in a known manner. The stopper may be substantially rotationally symmetric about an axis through the stopper.

The plunger comprises a plunger contact surface and extending from that a rod extends from the plunger contact surface to a rear portion. The rear portion may include a user contact portion adapted to be contacted by a user during an injection event. The user contact portion may
15 comprise a substantially disc shaped portion, the radius of the disc extending substantially perpendicular to the axis along which the rod extends. The user contact portion could be any suitable shape. The axis along which the rod extends may be the first axis, or may be substantially parallel with the first axis.

The syringe may include a backstop arranged at a rear portion of the body. The backstop may be
20 removable from the syringe. If the syringe body includes terminal flanges at the end opposite the outlet end the backstop may be configured to substantially sandwich terminal flanges of the body as this prevent movement of the backstop in a direction parallel to the first axis.

The rod may comprise at least one rod shoulder directed away from the outlet end and the backstop may include a backstop shoulder directed towards the outlet end to cooperate with the
25 rod shoulder to substantially prevent movement of the rod away from the outlet end when the backstop shoulder and rod shoulder are in contact. Restriction of the movement of the rod away from the outlet end can help to maintain sterility during terminal sterilisation operations, or other operations in which the pressure within the variable volume chamber or outside the chamber may change. During such operations any gas trapped within the variable volume chamber, or
30 bubbles that may form in a liquid therein, may change in volume and thereby cause the stopper to move. Movement of the stopper away from the outlet could result in the breaching of a sterility zone created by the stopper. This is particularly important for low volume syringes

where there are much lower tolerances in the component sizes and less flexibility in the stopper. The term sterility zone as used herein is used to refer to the area within the syringe that is sealed by the stopper from access from either end of the syringe. This may be the area between a seal of the stopper, for example a circumferential rib, closest to the outlet and a seal of the stopper, for example a circumferential rib, furthest from the outlet. The distance between these two seals defines the sterility zone of the stopper since the stopper is installed into the syringe barrel in a sterile environment.

To further assist in maintaining sterility during the operations noted above the stopper may comprise at a front circumferential rib and a rear circumferential rib and those ribs may be separated in a direction along the first axis by at least 3mm, by at least 3.5 mm, by at least 3.75mm or by 4mm or more. One or more additional ribs (for example 2, 3, 4 or 5 additional ribs, or between 1-10, 2-8, 3-6 or 4-5 additional ribs) may be arranged between the front and rear ribs. In one embodiment there are a total of three circumferential ribs.

A stopper with such an enhanced sterility zone can also provide protection for the injectable medicament during a terminal sterilisation process. More ribs on the stopper, or a greater distance between the front and rear ribs can reduce the potential exposure of the medicament to the sterilising agent. However, increasing the number of ribs can increase the friction between the stopper and syringe body, reducing ease of use. While this may be overcome by increasing the siliconisation of the syringe, such an increase in silicone oil levels is particularly undesirable for syringes for ophthalmic use.

The rod shoulder may be arranged within the external diameter of the rod, or may be arranged outside the external diameter of the rod. By providing a shoulder that extends beyond the external diameter of the rod, but still fits within the body, the shoulder can help to stabilise the movement of the rod within the body by reducing movement of the rod perpendicular to the first axis. The rod shoulder may comprise any suitable shoulder forming elements on the rod, but in one embodiment the rod shoulder comprises a substantially disc shaped portion on the rod.

In one embodiment of the syringe, when arranged with the plunger contact surface in contact with the stopper and the variable volume chamber is at its intended maximum volume there is a clearance of no more than about 2mm between the rod shoulder and backstop shoulder. In some embodiments there is a clearance of less than about 1.5 mm and in some less than about 1mm. This distance is selected to substantially limit or prevent excessive rearward (away from the outlet end) movement of the stopper.

In one embodiment the variable volume chamber has an internal diameter greater than 5mm or 6mm, or less than 3mm or 4mm. The internal diameter may be between 3mm and 6mm, or between 4mm and 5mm.

5 In another embodiment the syringe is dimensioned so as to have a nominal maximum fill volume of between about 0.1ml and about 1.5ml. In certain embodiments the nominal maximum fill volume is between about 0.5ml and about 1ml. In certain embodiments the nominal maximum fill volume is about 0.5ml or about 1ml, or about 1.5ml.

The length of the body of the syringe may be less than 70mm, less than 60mm or less than 50mm. In one embodiment the length of the syringe body is between 45mm and 50mm.

10 In one embodiment, the syringe is filled with between about 0.01ml and about 1.5ml (for example between about 0.05ml and about 1ml, between about 0.1ml and about 0.5ml, between about 0.15ml and about 0.175ml) of a VEGF antagonist solution. In one embodiment, the syringe is filled with 0.165ml of a VEGF antagonist solution. Of course, typically a syringe is filled with more than the desired dose to be administered to the patient, to take into account
15 wastage due to “dead space” within the syringe and needle. There may also be a certain amount of wastage when the syringe is primed by the physician, so that it is ready to inject the patient.

Thus, in one embodiment, the syringe is filled with a dosage volume (i.e. the volume of medicament intended for delivery to the patient) of between about 0.01ml and about 1.5ml (e.g. between about 0.05ml and about 1ml, between about 0.1ml and about 0.5ml) of a VEGF
20 antagonist solution. In one embodiment, the dosage volume is between about 0.03ml and about 0.05ml. For example, for Lucentis, the dosage volume is 0.05ml or 0.03ml (0.5mg or 0.3mg) of a 10mg/ml injectable medicament solution; for Eylea, the dosage volume is 0.05ml of a 40mg/ml injectable medicament solution. Although unapproved for ophthalmic indications, bevacizumab is used off-label in such ophthalmic indications at a concentration of 25mg/ml; typically at a
25 dosage volume of 0.05ml (1.25mg). In one embodiment, the extractable volume from the syringe (that is the amount of product obtainable from the syringe following filling, taking into account loss due to dead space in the syringe and needle) is about 0.09ml.

In one embodiment the length of the syringe body is between about 45mm and about 50mm, the internal diameter is between about 4mm and about 5mm, the fill volume is between about 0.12
30 and about 0.3ml and the dosage volume is between about 0.03ml and about 0.05ml.

As the syringe contains a medicament solution, the outlet may be reversibly sealed to maintain sterility of the medicament. This sealing may be achieved through the use of a sealing device as is known in the art. For example the OVS™ system which is available from Vetter Pharma International GmbH.

5 It is typical to siliconise the syringe in order to allow ease of use, i.e. to apply silicone oil to the inside of the barrel, which decreases the force required to move the stopper. However, for ophthalmic use, it is desirable to decrease the likelihood of silicone oil droplets being injected into the eye. With multiple injections, the amount of silicone droplets can build up in the eye, causing potential adverse effects, including “floaters” and an increase in intra-ocular pressure.

10 Furthermore, silicone oil can cause proteins to aggregate. A typical 1ml syringe comprises 100-800µg silicone oil in the barrel, though a survey of manufacturers reported that 500-1000µg was typically used in pre-filled syringes (Badkar *et al.* 2011, AAPS PharmaSciTech, 12(2):564-572). Thus, in one embodiment, a syringe according to the invention comprises less than about 800µg (i.e. about less than about 500µg, less than about 300µg, less than about 200µg, less than about

15 100µg, less than about 75µg, less than about 50µg, less than about 25µg, less than about 15µg, less than about 10µg) silicone oil in the barrel. If the syringe comprises a low level of silicone oil, this may be more than about 1µg, more than about 3µg, more than about 5µg, more than about 7µg or more than about 10µg silicone oil in the barrel. Thus, in one embodiment, the syringe may comprise about 1µg-about 500µg, about 3µg-about 200µg, about 5µg-about 100µg

20 or about 10µg-about 50µg silicone oil in the barrel. Methods for measuring the amount of silicone oil in such a syringe barrel are known in the art and include, for example, differential weighing methods and quantitation by infrared-spectroscopy of the oil diluted in a suitable solvent. Various types of silicone oil are available, but typically either DC360 (Dow Corning®; with a viscosity of 1000cP) or DC365 emulsion (Dow Corning®; DC360 oil with a viscosity of

25 350cP) are used for syringe siliconisation. In one embodiment, the pre-filled syringe of the invention comprises DC365 emulsion.

During testing it was surprisingly found that, for syringes having small dimensions, such as those discussed above, and particularly those described in conjunction with the Figures below, the break loose and sliding forces for the stopper within the syringe are substantially unaffected by

30 reducing the siliconisation levels far below the current standard to the levels discussed here. This is in contrast to conventional thinking that would suggest that if you decrease the silicone oil level, the forces required would increase (see e.g. Schoenknecht, AAPS National Biotechnology Conference 2007 – Abstract no. NBC07-000488, which indicates that while 400µg silicone oil is

acceptable, usability improves when increased to 800 μ g). Having too great a force required to move the stopper can cause problems during use for some users, for example accurate dose setting or smooth dose delivery may be made more difficult if significant strength is required to move, and/or keep in motion, the stopper. Smooth administration is particularly important in sensitive tissues such as the eye, where movement of the syringe during administration could cause local tissue damage. Break loose and slide forces for pre-filled syringes known in the art are typically in the region of less than 20N, but where the pre-filled syringes contain about 100 μ g-about 800 μ g silicone oil. In one embodiment the glide/slide force for the stopper within the pre-filled syringe is less than about 11N or less than 9N, less than 7N, less than 5N or between about 3N to 5N. In one embodiment, the break loose force is less than about 11N or less than 9N, less than 7N, less than 5N or between about 2N to 5N. Note that such measurements are for a filled syringe, rather than an empty syringe. The forces are typically measured at a stopper travelling speed of 190mm/min. In one embodiment, the forces are measured with a 30G x 0.5 inch needle attached to the syringe. In one embodiment, the syringe has a nominal maximal fill volume of between about 0.5ml and 1ml, contains less than about 100 μ g silicone oil and has a break loose force between about 2N to 5N.

In one embodiment the syringe barrel has an internal coating of silicone oil that has an average thickness of about 450nm or less (i.e. 400nm or less, 350nm or less, 300nm or less, 200nm or less, 100nm or less, 50nm or less, 20nm or less). Methods to measure the thickness of silicone oil in a syringe are known in the art and include the rap.ID Layer Explorer[®] Application, which can also be used to measure the mass of silicone oil inside a syringe barrel.

In one embodiment, the syringe is silicone oil free, or substantially silicone oil free. Such low silicone oil levels can be achieved by using uncoated syringe barrels and/or by avoiding the use of silicone oil as a lubricant for product contacting machine parts, or pumps in the syringe assembly and fill line. A further way to reduce silicone oil and inorganic silica levels in a pre-filled syringe is to avoid the use of silicone tubing in filling lines, for example between storage tanks and pumps.

The syringe according to the invention may also meet certain requirements for particulate content. In one embodiment, the ophthalmic solution comprises no more than 2 particles \geq 50 μ m in diameter per ml. In one embodiment, the ophthalmic solution comprises no more than 5 particles \geq 25 μ m in diameter per ml. In one embodiment, the ophthalmic solution comprises no more than 50 particles \geq 10 μ m in diameter per ml. In one embodiment, the ophthalmic solution

comprises no more than 2 particles $\geq 50\mu\text{m}$ in diameter per ml, no more than 5 particles $\geq 25\mu\text{m}$ in diameter per ml and no more than 50 particles $\geq 10\mu\text{m}$ in diameter per ml. In one embodiment, a syringe according to the invention meets USP789 (United States Pharmacopoeia: Particulate Matter in Ophthalmic Solutions). In one embodiment the syringe has low levels of silicone oil
 5 sufficient for the syringe to meet USP789.

VEGF Antagonists

Antibody VEGF antagonists

VEGF is a well-characterised signal protein which stimulates angiogenesis. Two antibody VEGF antagonists have been approved for human use, namely ranibizumab (Lucentis®) and
 10 bevacizumab (Avastin®).

Non-Antibody VEGF antagonists

In one aspect of the invention, the non-antibody VEGF antagonist is an immunoadhesin. One such immuoadhesin is aflibercept (Eylea®), which has recently been approved for human use and is also known as VEGF-trap (Holash *et al.* (2002) *PNAS USA* 99:11393-98; Riely & Miller
 15 (2007) *Clin Cancer Res* 13:4623-7s). Aflibercept is the preferred non-antibody VEGF antagonist for use with the invention. Aflibercept is a recombinant human soluble VEGF receptor fusion protein consisting of portions of human VEGF receptors 1 and 2 extracellular domains fused to the Fc portion of human IgG1. It is a dimeric glycoprotein with a protein molecular weight of 97 kilodaltons (kDa) and contains glycosylation, constituting an additional 15% of the total
 20 molecular mass, resulting in a total molecular weight of 115 kDa. It is conveniently produced as a glycoprotein by expression in recombinant CHO K1 cells. Each monomer can have the following amino acid sequence (SEQ ID NO: 1):

SDTGRPFVEMYSEIPEIIHMTREGRELVIPCRVTSPNITVTLKKFPLDTLIPDGKRIIWDSRKGFIIISNATY
 KEIGLLTCEATVNGHLYKTNYLTHRQTNTIIDVVLSPSHGIELSVGEKLVLNCTARTELNVGIDFNWEYPS
 25 SKHQHKKLVNRDLKTQSGSEMKKFLSTLTIDGVTRSDQGLYTCAASSGLMTKKNSTFVRVHEKDKTHTCPC
 CPAPPELLGGPSVFLFPPKPKDTLMI SRTPEVTCVVVDVSHEDPEVKFNWYVDGVEVHNAKTKPREEQYNST
 YRVVSVLTVLHQDWLNGKEYKCKVSNKALPAPIEKTISKAKGQPREPQVYTLPPSRDELTKNQVSLTCLVK
 GFYPSDIAVEWESNGQPENNYKTPPPVLDSDGSFFLYSKLTVDKSRWQQGNVFSCSVMEALHNHYTQKSL
 SLSPG

30 and disulfide bridges can be formed between residues 30-79, 124-185, 246-306 and 352-410 within each monomer, and between residues 211-211 and 214-214 between the monomers.

Another non-antibody VEGF antagonist immunoadhesin currently in pre-clinical development is a recombinant human soluble VEGF receptor fusion protein similar to VEGF-trap containing extracellular ligand-binding domains 3 and 4 from VEGFR2/KDR, and domain 2 from VEGFR1/Flt-1; these domains are fused to a human IgG Fc protein fragment (Li et al., 2011
 5 *Molecular Vision* 17:797-803). This antagonist binds to isoforms VEGF-A, VEGF-B and VEGF-C. The molecule is prepared using two different production processes resulting in different glycosylation patterns on the final proteins. The two glycoforms are referred to as KH902 (conbercept) and KH906. The fusion protein can have the following amino acid sequence (SEQ ID NO:2):

10 MVSYWDTGVLLCALLSCLLLTGSSSGRPFVEMYSEIPEIIHMTEGRELVI PCRVTSPNITVTLKFFPLDT
 LIPDGKRIIWDSRKGFIISNATYKEIGLLTCEATVNGHLYKTNYLTHRQTNTIIDVVLSPSHGIELSVGEK
 LVLNCTARTELVNGIDFNWEYPPSSKHQHKLVNRDLKTQSGSEMKKFLSTLTIDGVTRSDQGLYTCAASSG
 LMTKKNSTFVRVHEKPFVAFSGMESLVEATVGERVRLPAKYLGYPPPEIKWYKNGI PLESNHTIKAGHVL
 TIMEVSRDGTGNYTVILTNPISKEKQSHVVSLLVVYVPPGPGDKTHTCPLCPAPELLGGPSVFLFPPKPKDT
 15 LMISRTPEVTCVVVDVSHEDPEVKFNWYVDGVEVHNAKTKPREEQYNSTYRVVSVLTVLHQDWLNGKEYKC
 KVSNAKALPAPIEKTISKAKGQPREPQVYTLPPSRDELTKNQVSLTCLVKGFYPSDIAVEWESNGQPENNYK
 ATPPVLDSDGSFFLYSKLTVDKSRWQQGNV FSCSVMHEALHNHYTQKSLSLSPGK

and, like VEGF-trap, can be present as a dimer. This fusion protein and related molecules are further characterized in EP1767546.

20 Other non-antibody VEGF antagonists include antibody mimetics (e.g. Affibody® molecules, affilins, affitins, anticalins, avimers, Kunitz domain peptides, and monobodies) with VEGF antagonist activity. This includes recombinant binding proteins comprising an ankyrin repeat domain that binds VEGF-A and prevents it from binding to VEGFR-2. One example for such a molecule is DARPin® MP0112. The ankyrin binding domain may have the following amino
 25 acid sequence (SEQ ID NO: 3):

GSDLGKKLLEAARAGQDDEVRIILMANGADVNTADSTGWTPLHLAVPWGHLEIVEVLLKYGADVNAKDFQGW
 TPLHLAAAIGHQEIVEVLLKNGADVNAQDKFGKTAFDISIDNGNEDLAEILQKAA

Recombinant binding proteins comprising an ankyrin repeat domain that binds VEGF-A and prevents it from binding to VEGFR-2 are described in more detail in WO2010/060748 and
 30 WO2011/135067.

Further specific antibody mimetics with VEGF antagonist activity are the 40 kD pegylated anticalin PRS-050 and the monobody angiocept (CT-322).

The afore-mentioned non-antibody VEGF antagonist may be modified to further improve their pharmacokinetic properties or bioavailability. For example, a non-antibody VEGF antagonist may be chemically modified (e.g., pegylated) to extend its *in vivo* half-life. Alternatively or in addition, it may be modified by glycosylation or the addition of further glycosylation sites not present in the protein sequence of the natural protein from which the VEGF antagonist was derived.

Variants of the above-specified VEGF antagonists that have improved characteristics for the desired application may be produced by the addition or deletion of amino acids. Ordinarily, these amino acid sequence variants will have an amino acid sequence having at least 60% amino acid sequence identity with the amino acid sequences of SEQ ID NO: 1, SEQ ID NO: 2 or SEQ ID NO: 3, preferably at least 80%, more preferably at least 85%, more preferably at least 90%, and most preferably at least 95%, including for example, 80%, 81%, 82%, 83%, 84%, 85%, 86%, 87%, 88%, 89%, 90%, 91%, 92%, 93%, 94%, 95%, 96%, 97%, 98%, 99%, and 100%. Identity or homology with respect to this sequence is defined herein as the percentage of amino acid residues in the candidate sequence that are identical with SEQ ID NO: 1, SEQ ID NO: 2 or SEQ ID NO: 3, after aligning the sequences and introducing gaps, if necessary, to achieve the maximum percent sequence identity, and not considering any conservative substitutions as part of the sequence identity.

Sequence identity can be determined by standard methods that are commonly used to compare the similarity in position of the amino acids of two polypeptides. Using a computer program such as BLAST or FASTA, two polypeptides are aligned for optimal matching of their respective amino acids (either along the full length of one or both sequences or along a predetermined portion of one or both sequences). The programs provide a default opening penalty and a default gap penalty, and a scoring matrix such as PAM 250 [a standard scoring matrix; see Dayhoff et al., in Atlas of Protein Sequence and Structure, vol. 5, supp. 3 (1978)] can be used in conjunction with the computer program. For example, the percent identity can then be calculated as: the total number of identical matches multiplied by 100 and then divided by the sum of the length of the longer sequence within the matched span and the number of gaps introduced into the longer sequences in order to align the two sequences.

Preferably, the non-antibody VEGF antagonist of the invention binds to VEGF via one or more protein domain(s) that are not derived from the antigen-binding domain of an antibody. The non-

antibody VEGF antagonist of the invention are preferably proteinaceous, but may include modifications that are non-proteinaceous (e.g., pegylation, glycosylation).

Therapy

The syringe of the invention may be used to treat an ocular disease, including but not limited to
5 choroidal neovascularisation, age-related macular degeneration (both wet and dry forms), macular edema secondary to retinal vein occlusion (RVO) including both branch RVO (bRVO) and central RVO (cRVO), choroidal neovascularisation secondary to pathologic myopia (PM), diabetic macular edema (DME), diabetic retinopathy, and proliferative retinopathy.

Thus the invention provides a method of treating a patient suffering from of an ocular disease
10 selected from choroidal neovascularisation, wet age-related macular degeneration, macular edema secondary to retinal vein occlusion (RVO) including both branch RVO (bRVO) and central RVO (cRVO), choroidal neovascularisation secondary to pathologic myopia (PM), diabetic macular edema (DME), diabetic retinopathy, and proliferative retinopathy, comprising the step of administering an ophthalmic solution to the patient using a pre-filled syringe of the
15 invention. This method preferably further comprises an initial priming step in which the physician depresses the plunger of the pre-filled syringe to align the pre-determined part of the stopper with the priming mark.

In one embodiment, the invention provides a method of treating an ocular disease selected from
20 choroidal neovascularisation, wet age-related macular degeneration, macular edema secondary to retinal vein occlusion (RVO) including both branch RVO (bRVO) and central RVO (cRVO), choroidal neovascularisation secondary to pathologic myopia (PM), diabetic macular edema (DME), diabetic retinopathy, and proliferative retinopathy, comprising administering a non-antibody VEGF antagonist with a pre-filled syringe of the invention, wherein the patient has previously received treatment with an antibody VEGF antagonist.

25 *Kits*

Also provided are kits comprising the pre-filled syringes of the invention. In one embodiment, such a kit comprises a pre-filled syringe of the invention in a blister pack. The blister pack may itself be sterile on the inside. In one embodiment, syringes according to the invention may be placed inside such blister packs prior to undergoing sterilisation, for example terminal
30 sterilisation.

Such a kit may further comprise a needle for administration of the VEGF antagonist. If the VEGF antagonist is to be administered intravitreally, it is typical to use a 30-gauge x ½ inch needle, though 31-gauge and 32-gauge needles may be used. For intravitreal administration, 33-gauge or 34-gauge needles could alternatively be used. Such kits may further comprise instructions for use. In one embodiment, the invention provides a carton containing a pre-filled syringe according to the invention contained within a blister pack, a needle and optionally instructions for administration.

Sterilisation

As noted above, a terminal sterilisation process may be used to sterilise the syringe and such a process may use a known process such as an ethylene oxide (EtO) or a hydrogen peroxide (H₂O₂) sterilisation process. Needles to be used with the syringe may be sterilised by the same method, as may kits according to the invention.

The package is exposed to the sterilising gas until the outside of the syringe is sterile. Following such a process, the outer surface of the syringe may remain sterile (whilst in its blister pack) for up to 6 months, 9 months, 12 months, 15 months, 18 months, 24 months or longer. Thus, in one embodiment, a syringe according to the invention (whilst in its blister pack) may have a shelf life of up to 6 months, 9 months, 12 months, 15 months, 18 months, 24 months or longer. In one embodiment, less than one syringe in a million has detectable microbial presence on the outside of the syringe after 18 months of storage. In one embodiment, the pre-filled syringe has been sterilised using EtO with a Sterility Assurance Level of at least 10⁻⁶. In one embodiment, the pre-filled syringe has been sterilised using hydrogen peroxide with a Sterility Assurance Level of at least 10⁻⁶. Of course, it is a requirement that significant amounts of the sterilising gas should not enter the variable volume chamber of the syringe. The term “significant amounts” as used herein refers to an amount of gas that would cause unacceptable modification of the ophthalmic solution within the variable volume chamber. In one embodiment, the sterilisation process causes ≤10% (preferably ≤5%, ≤3%, ≤1%) alkylation of the VEGF antagonist. In one embodiment, the pre-filled syringe has been sterilised using EtO, but the outer surface of the syringe has ≤1ppm, preferably ≤0.2ppm EtO residue. In one embodiment, the pre-filled syringe has been sterilised using hydrogen peroxide, but the outer surface of the syringe has ≤1ppm, preferably ≤0.2ppm hydrogen peroxide residue. In another embodiment, the pre-filled syringe has been sterilised using EtO, and the total EtO residue found on the outside of the syringe and inside of the blister pack is ≤0.1mg. In another embodiment, the pre-filled syringe has been sterilised using hydrogen

peroxide, and the total hydrogen peroxide residue found on the outside of the syringe and inside of the blister pack is ≤ 0.1 mg.

General

The term “comprising” means “including” as well as “consisting” *e.g.* a composition
5 “comprising” X may consist exclusively of X or may include something additional *e.g.* X + Y.

The term “about” in relation to a numerical value x means, for example, $x \pm 10\%$.

References to a percentage sequence identity between two amino acid sequences means that, when aligned, that percentage of amino acids are the same in comparing the two sequences. This alignment and the percent homology or sequence identity can be determined using software
10 programs known in the art, for example those described in section 7.7.18 of *Current Protocols in Molecular Biology* (F.M. Ausubel *et al.*, eds., 1987) Supplement 30. A preferred alignment is determined by the Smith-Waterman homology search algorithm using an affine gap search with a gap open penalty of 12 and a gap extension penalty of 2, BLOSUM matrix of 62. The Smith-Waterman homology search algorithm is disclosed in Smith & Waterman (1981) *Adv. Appl.*
15 *Math.* 2: 482-489

BRIEF DESCRIPTION OF THE FIGURES

Figure 1 shows a side view of a syringe

Figure 2 shows a cross section of a top down view of a syringe

20 Figure 3 shows a view of a plunger

Figure 4 shows a cross section through a plunger

Figure 5 shows a stopper

MODES FOR CARRYING OUT THE INVENTION

The invention will now be further described, by way of example only, with reference to the drawings.

Figure 1 shows a view from a side of a syringe 1 comprising a body 2, plunger 4, backstop 6 and a sealing device 8.

Figure 2 shows a cross section through the syringe 1 of Figure 1 from above. The syringe 1 is suitable for use in an ophthalmic injection. The syringe 1 comprises a body 2, a stopper 10 and a plunger 4. The syringe 1 extends along a first axis A. The body 2 comprises an outlet 12 at an outlet end 14 and the stopper 10 is arranged within the body 2 such that a front surface 16 of the stopper 10 and the body 2 define a variable volume chamber 18. The variable volume chamber 18 contains an injectable medicament 20 comprising an ophthalmic solution comprising a VEGF antagonist such as ranibizumab. The injectable fluid 20 can be expelled through the outlet 12 by movement of the stopper 10 towards the outlet end 14 thereby reducing the volume of the variable volume chamber 18. The plunger 4 comprises a plunger contact surface 22 at a first end 24 and a rod 26 extending between the plunger contact surface 22 and a rear portion 25. The plunger contact surface 22 is arranged to contact the stopper 10, such that the plunger 4 can be used to move the stopper 10 towards the outlet end 14 of the body 2. Such movement reduces the volume of the variable volume chamber 18 and causes fluid therein to be expelled through the outlet.

The backstop 6 is attached to the body 2 by coupling to a terminal flange 28 of the body 2. The backstop 6 includes a sandwich portion 30 which is adapted to substantially sandwich at least some of the terminal flange 28 of the body 2. The backstop 6 is adapted to be coupled to the body 2 from the side by leaving one side of the backstop 6 open so that the backstop 6 can be fitted to the syringe 2.

The body 2 defines a substantially cylindrical bore 36 which has a bore radius. The rod 26 comprises a rod shoulder 32 directed away from the outlet end 14. The rod shoulder 32 extends from to a rod shoulder radius from the first axis A which is such that it is slightly less than the bore radius so that the shoulder fits within the bore 36. The backstop 6 includes a backstop shoulder 34 directed towards the outlet end 14. The shoulders 32, 34 are configured to cooperate to substantially prevent movement of the rod 26 away from the outlet end 14 when the backstop shoulder 34 and rod shoulder 32 are in contact. The backstop shoulder 34 extends from outside the bore radius to a radius less than the rod shoulder radius so that the rod shoulder 32 cannot pass the

backstop shoulder 34 by moving along the first axis A. In this case the rod shoulder 32 is substantially disc, or ring, shaped and the backstop shoulder 34 includes an arc around a rear end 38 of the body 2.

The backstop 6 also includes two finger projections 40 which extend in opposite directions away
5 from the body 2 substantially perpendicular to the first axis A to facilitate manual handling of the syringe 1 during use.

In this example the syringe comprises a 0.5ml body 2 filled with between about 0.1 and 0.3 ml of an injectable medicament 20 comprising a 10mg/ml injectable solution comprising ranibizumab. The syringe body 2 has an internal diameter of about between about 4.5mm and 4.8mm, a length of
10 between about 45mm and 50mm.

The plunger 4 and stopper 10 will be described in more detail with reference to later figures.

Figure 3 shows a perspective view of the plunger 4 of Figure 1 showing the plunger contact surface 22 at the first end 24 of the plunger 4. The rod 26 extends from the first end 24 to the rear portion 25. The rear portion 25 includes a disc shaped flange 42 to facilitate user handling of the device.
15 The flange 42 provides a larger surface area for contact by the user than a bare end of the rod 26.

Figure 4 shows a cross section through a syringe body 2 and rod 26. The rod 26 includes four longitudinal ribs 44 and the angle between the ribs is 90°.

Figure 5 shows a detailed view of a stopper 10 showing a conical shaped front surface 16 and three circumferential ribs 52,54,56 around a substantially cylindrical body 58. The axial gap between the
20 first rib 52 and the last rib 56 is about 3mm. The rear surface 60 of the stopper 10 includes a substantially central recess 62. The central recess 62 includes an initial bore 64 having a first diameter. The initial bore 64 leading from the rear surface 60 into the stopper 10 to an inner recess 66 having a second diameter, the second diameter being larger than the first diameter.

25 *Stopper movement forces*

0.5ml syringes siliconised with <100µg silicone oil, filled with Lucentis, comprising one of two different stopper designs were tested for maximal and average break out and slide force. Prior to testing, 30G x 0.5" needles were attached to the syringes. The testing was carried out at a stopper speed of 190mm/min over a travel length of 10.9mm. Stopper design 2 had a 45% increase in the
30 distance between the front circumferential rib and rear circumferential rib.

		Stopper design 1			Stopper design 2	
		Batch A	Batch B	Batch C	Batch D	Batch E
Break loose force of syringes	Average of 10 syringes	2.2N	2.3N	1.9N	2.1N	2.5N
	Max individual value	2.5N	2.5N	2.3N	2.6N	2.7N
Sliding force	Average of 10 syringes	3.1N	3.2N	3.1N	4.1N	4.6N
	Max individual value	3.5N	3.5N	3.6N	4.7N	4.8N

For both stopper designs, average and maximum break out force remained below 3N. For both stopper designs, average and maximum sliding force remained below 5N.

It will be understood that the invention has been described by way of example only and modifications may be made whilst remaining within the scope and spirit of the invention.

5

CLAIMS

1. A pre-filled syringe, the syringe comprising a glass body, a stopper and a plunger, the body comprising an outlet at an outlet end and the stopper being arranged within the body such that a front surface of the stopper and the body define a variable volume chamber from which a fluid
5 can be expelled through the outlet, the plunger comprising a plunger contact surface at a first end and a rod extending between the plunger contact surface and a rear portion, the plunger contact surface arranged to contact the stopper, such that the plunger can be used to force the stopper towards the outlet end of the body, reducing the volume of the variable volume chamber, characterised in that the fluid is an ophthalmic solution which comprises a VEGF-antagonist
10 wherein:
- (a) the syringe has a nominal maximum fill volume of between about 0.5ml and about 1ml,
 - (b) the syringe is filled a dosage volume of between about 0.03ml and about 0.05ml of said VEGF antagonist solution,
 - (c) the syringe barrel comprises less than about 500µg silicone oil, and
15 (d) the VEGF antagonist solution comprises no more than 2 particles $\geq 50\mu\text{m}$ in diameter per ml.
2. A pre-filled syringe according to claim 1, wherein the syringe is filled with between about 0.15ml and about 0.175ml of a VEGF antagonist solution.
3. A pre-filled syringe according to claim 1 or claim 2, wherein the syringe is filled with about 0.165ml of said VEGF antagonist solution.
- 20 4. A pre-filled syringe according to any previous claim, wherein the syringe is filled with dosage volume of about 0.05ml of a VEGF antagonist solution.
5. A pre-filled syringe according to any previous claim, in which the dosage volume is determined by the volume of the variable volume chamber when a predetermined part of the stopper is aligned with a priming mark on the syringe.
- 25 6. A pre-filled syringe according to any previous claim, wherein the syringe barrel has an internal coating of silicone oil that has an average thickness of about 450nm or less, preferably 400nm or less, preferably 350nm or less, preferably 300nm or less, preferably 200nm or less, preferably 100nm or less, preferably 50nm or less, preferably 20nm or less.

7. A pre-filled syringe according to any previous claim, wherein the syringe barrel has an internal coating of less than about 500 μ g silicone oil, preferably less than about 100 μ g silicone oil, preferably less than about 50 μ g silicone oil, preferably less than about 25 μ g silicone oil, preferably less than about 10 μ g silicone oil.
- 5 8. A pre-filled syringe according to any previous claim, wherein the syringe barrel has an internal coating of more than about 1 μ g, more than about 3 μ g, more than about 5 μ g, more than about 7 μ g or more than about 10 μ g silicone oil.
9. A pre-filled syringe according to any previous claim, wherein the syringe barrel has an internal coating of about 1 μ g-about 500 μ g, about 3 μ g-about 200 μ g, about 5 μ g-about 100 μ g or
10 about 10 μ g-about 50 μ g silicone oil.
10. A pre-filled syringe according to any previous claim, wherein the silicone oil is DC365 emulsion.
11. A pre-filled syringe according to any one of claims 1-5, wherein the syringe is silicone oil free.
- 15 12. A pre-filled syringe according to any previous claim, wherein the VEGF antagonist solution further comprises one or more of (i) no more than 5 particles $\geq 25\mu$ m in diameter per ml, and (ii) no more than 50 particles $\geq 10\mu$ m in diameter per ml.
13. A pre-filled syringe according to any previous claim, wherein the VEGF antagonist solution meets USP789.
- 20 14. A pre-filled syringe according to any previous claim, wherein the VEGF antagonist is an anti-VEGF antibody.
15. A pre-filled syringe according to claim 14, wherein the anti-VEGF antibody is ranibizumab.
16. A pre-filled syringe according to claim 15, wherein the ranibizumab is at a concentration of 10mg/ml.
- 25 17. A pre-filled syringe according to any one of claims 1-13 wherein the VEGF antagonist is a non-antibody VEGF antagonist.
18. A pre-filled syringe according to claim 17, wherein the non-antibody VEGF antagonist is aflibercept or conbercept.

19. A pre-filled syringe according to claim 18, wherein the non-antibody VEGF antagonist is aflibercept at a concentration of 40mg/ml.
20. A pre-filled syringe according to any previous claim, wherein the syringe has a stopper break loose force of less than about 11N.
- 5 21. A pre-filled syringe according to claim 20, wherein the syringe has a stopper break loose force of less than about 5N.
22. A pre-filled syringe according to any previous claim, wherein the syringe has a stopper slide force of less than about 11N.
23. A pre-filled syringe according to claim 22, wherein the syringe has a stopper slide force of
10 less than about 5N.
24. A pre-filled syringe according to any of claims 20-23, wherein the stopper break loose force or stopper slide force is measured using a filled syringe, at a stopper travelling speed of 190mm/min, with a 30G x 0.5 inch needle attached to the syringe.
25. A blister pack comprising a pre-filled syringe according to any previous claim, wherein the
15 syringe has been sterilised using H₂O₂ or EtO.
26. A blister pack comprising a pre-filled syringe according to claim 25, wherein the outer surface of the syringe has ≤ 1 ppm EtO or H₂O₂ residue.
27. A blister pack comprising a pre-filled syringe according to claim 25, wherein the syringe has been sterilised using EtO or H₂O₂ and the total EtO or H₂O₂ residue found on the outside of the
20 syringe and inside of the blister pack is ≤ 0.1 mg.
28. A blister pack comprising a pre-filled syringe according to any one of claims 25-27, wherein $\leq 5\%$ of the VEGF antagonist is alkylated.
29. A blister pack comprising a pre-filled syringe according to any of claims 25-28, wherein the syringe has been sterilised using EtO or H₂O₂ with a Sterility Assurance Level of at least 10⁻⁶.
- 25 30. A blister pack according to any of claims 25-29, wherein the pre-filled syringe has a shelf life of up to 6 months, 9 months, 12 months, 15 months, 18 months, 24 months or longer.

31. A kit comprising: (i) a pre-filled syringe according to any one of claims 1-24, or a blister pack comprising a pre-filled syringe according to any one of claims 25-30, (ii) a needle, and optionally (iii) instructions for administration.
32. A kit according to claim 31, wherein the needle is a 30-gauge x ½ inch needle.
- 5 33. A pre-filled syringe according to any one of claims 1-24 for use in therapy.
34. A pre-filled syringe according to any one of claims 1-24 for use in the treatment of an ocular disease selected from choroidal neovascularisation, wet age-related macular degeneration, macular edema secondary to retinal vein occlusion (RVO) including both branch RVO (bRVO) and central RVO (cRVO), choroidal neovascularisation secondary to pathologic myopia (PM),
10 diabetic macular edema (DME), diabetic retinopathy, and proliferative retinopathy.
35. A method of treating a patient suffering from of an ocular disease selected from choroidal neovascularisation, wet age-related macular degeneration, macular edema secondary to retinal vein occlusion (RVO) including both branch RVO (bRVO) and central RVO (cRVO), choroidal neovascularisation secondary to pathologic myopia (PM), diabetic macular edema (DME),
15 diabetic retinopathy, and proliferative retinopathy, comprising the step of administering an ophthalmic solution to the patient using a pre-filled syringe according to any one of claims 1-24.
36. The method of claim 35, further comprising an initial priming step in which the physician depresses the plunger of the pre-filled syringe to align the pre-determined part of the stopper with the priming mark.
- 20 37. A method according to claim 35 or 36, wherein the VEGF antagonist administered is a non-antibody VEGF antagonist and wherein the patient has previously received treatment with an antibody VEGF antagonist.

1/1

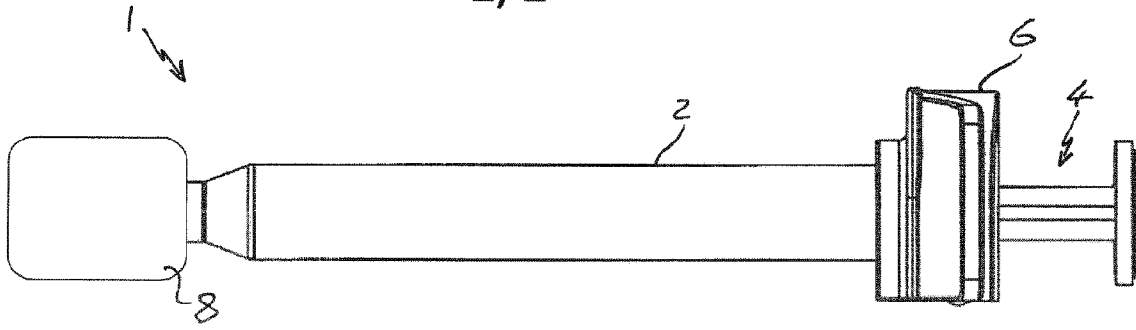

Fig 1

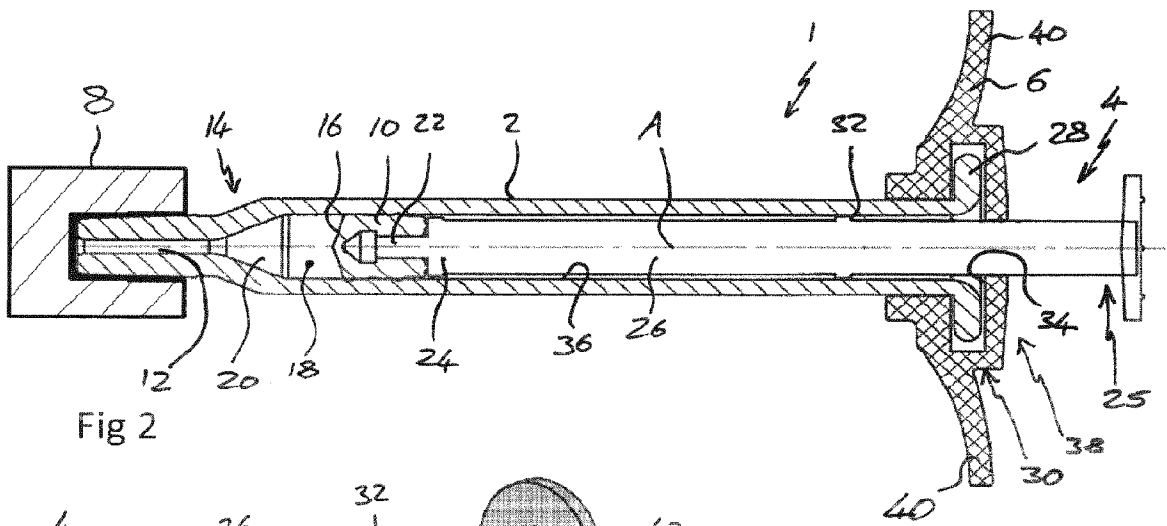

Fig 2

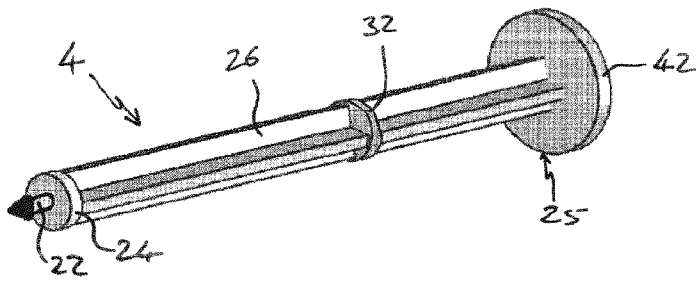

Fig 3

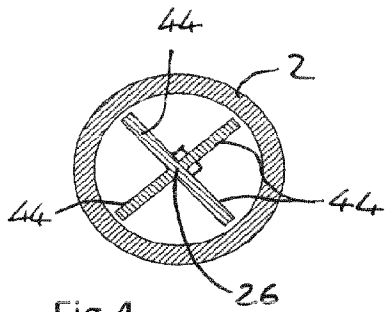

Fig 4

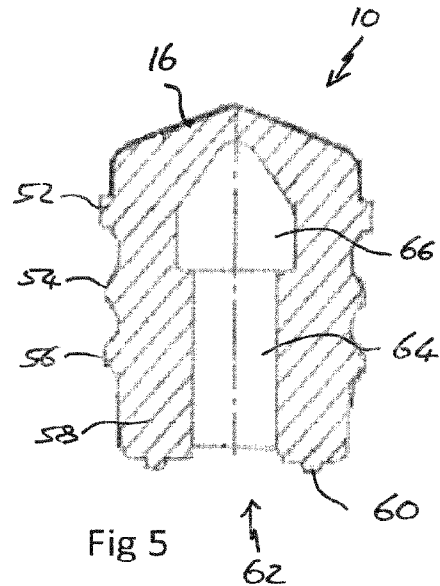

Fig 5

INTERNATIONAL SEARCH REPORT

International application No PCT/EP2013/051491

A. CLASSIFICATION OF SUBJECT MATTER		
INV. A61K9/00	A61M5/28	A61M5/31
ADD.		A61M5/315
According to International Patent Classification (IPC) or to both national classification and IPC		
B. FIELDS SEARCHED		
Minimum documentation searched (classification system followed by classification symbols) A61M A61K		
Documentation searched other than minimum documentation to the extent that such documents are included in the fields searched		
Electronic data base consulted during the international search (name of data base and, where practicable, search terms used) EPO-Internal, WPI Data, EMBASE, BIOSIS		
C. DOCUMENTS CONSIDERED TO BE RELEVANT		
Category*	Citation of document, with indication, where appropriate, of the relevant passages	Relevant to claim No.
X	WO 2007/035621 A1 (OSI EYETECH INC [US]; SCYPINSKI STEPHEN [US]; CALIAS PERRY [US]; EVERE) 29 March 2007 (2007-03-29) page 1, lines 7-9 page 5, lines 10-18 page 6, lines 15,16 page 9, lines 12-20 page 10, line 3 - page 11, line 13 page 18, lines 6-12 page 18, line 21 - page 19, line 18 examples 1,2 figures 3-5	1-34
X	----- US 2006/293270 A1 (ADAMIS ANTHONY P [US] ET AL) 28 December 2006 (2006-12-28) paragraphs [0002], [0026], [0043] - [0046], [0055] - [0065] examples ----- -/--	1-34
<input checked="" type="checkbox"/> Further documents are listed in the continuation of Box C. <input checked="" type="checkbox"/> See patent family annex.		
* Special categories of cited documents :		
"A" document defining the general state of the art which is not considered to be of particular relevance "E" earlier application or patent but published on or after the international filing date "L" document which may throw doubts on priority claim(s) or which is cited to establish the publication date of another citation or other special reason (as specified) "O" document referring to an oral disclosure, use, exhibition or other means "P" document published prior to the international filing date but later than the priority date claimed	"T" later document published after the international filing date or priority date and not in conflict with the application but cited to understand the principle or theory underlying the invention "X" document of particular relevance; the claimed invention cannot be considered novel or cannot be considered to involve an inventive step when the document is taken alone "Y" document of particular relevance; the claimed invention cannot be considered to involve an inventive step when the document is combined with one or more other such documents, such combination being obvious to a person skilled in the art "&" document member of the same patent family	
Date of the actual completion of the international search	Date of mailing of the international search report	
8 April 2013	19/04/2013	
Name and mailing address of the ISA/ European Patent Office, P.B. 5818 Patentlaan 2 NL - 2280 HV Rijswijk Tel. (+31-70) 340-2040, Fax: (+31-70) 340-3016	Authorized officer López García, Mónica	

INTERNATIONAL SEARCH REPORT

International application No PCT/EP2013/051491

C(Continuation). DOCUMENTS CONSIDERED TO BE RELEVANT		
Category*	Citation of document, with indication, where appropriate, of the relevant passages	Relevant to claim No.
X	US 2011/257601 A1 (FURFINE ERIC [US] ET AL) 20 October 2011 (2011-10-20) paragraphs [0003], [0008], [0009], [0039], [0050] claims 1-15 examples 4,6	1-34
A	----- DE 10 2008 005938 A1 (VETTER & CO APOTHEKER [DE]) 30 July 2009 (2009-07-30) paragraphs [0002], [0005] figures 1-3 -----	1-34

INTERNATIONAL SEARCH REPORT

International application No.
PCT/EP2013/051491

Box No. II Observations where certain claims were found unsearchable (Continuation of item 2 of first sheet)

This international search report has not been established in respect of certain claims under Article 17(2)(a) for the following reasons:

- 1. Claims Nos.: 35-37
because they relate to subject matter not required to be searched by this Authority, namely:
see FURTHER INFORMATION sheet PCT/ISA/210
- 2. Claims Nos.:
because they relate to parts of the international application that do not comply with the prescribed requirements to such an extent that no meaningful international search can be carried out, specifically:
- 3. Claims Nos.:
because they are dependent claims and are not drafted in accordance with the second and third sentences of Rule 6.4(a).

Box No. III Observations where unity of invention is lacking (Continuation of item 3 of first sheet)

This International Searching Authority found multiple inventions in this international application, as follows:

- 1. As all required additional search fees were timely paid by the applicant, this international search report covers all searchable claims.
- 2. As all searchable claims could be searched without effort justifying an additional fees, this Authority did not invite payment of additional fees.
- 3. As only some of the required additional search fees were timely paid by the applicant, this international search report covers only those claims for which fees were paid, specifically claims Nos.:
- 4. No required additional search fees were timely paid by the applicant. Consequently, this international search report is restricted to the invention first mentioned in the claims; it is covered by claims Nos.:

Remark on Protest

- The additional search fees were accompanied by the applicant's protest and, where applicable, the payment of a protest fee.
- The additional search fees were accompanied by the applicant's protest but the applicable protest fee was not paid within the time limit specified in the invitation.
- No protest accompanied the payment of additional search fees.

FURTHER INFORMATION CONTINUED FROM PCT/ISA/ 210

Continuation of Box II.1

Claims Nos.: 35-37

Independent claim 35 refers to " A method of treating a patient ... comprising the step of administering an ophthalmic solution to the patient using a pre-filled syringe according to any one of claims 1-24". Therefore, independent claim 35 and dependent claims 36 and 37 relate to a subject-matter considered by this Authority to be covered by the provision of rule 39.1(iv)/67.1(iv) PCT. Consequently, no examination will be carried out on the subject-matter of claims 35-37.

INTERNATIONAL SEARCH REPORT

Information on patent family members

International application No

PCT/EP2013/051491

Patent document cited in search report	Publication date	Patent family member(s)	Publication date
WO 2007035621 A1	29-03-2007	CA 2622573 A1 EP 1924309 A1 JP 2009508593 A WO 2007035621 A1	29-03-2007 28-05-2008 05-03-2009 29-03-2007

US 2006293270 A1	28-12-2006	NONE	

US 2011257601 A1	20-10-2011	AU 2007261536 A1 BR PI0713749 A2 CA 2654510 A1 CN 101478949 A EP 2029103 A2 EP 2364691 A1 JP 2009540001 A KR 20090018807 A RU 2009101226 A US 2007293432 A1 US 2010075903 A1 US 2011257601 A1 US 2012087929 A1 WO 2007149334 A2	27-12-2007 06-11-2012 27-12-2007 08-07-2009 04-03-2009 14-09-2011 19-11-2009 23-02-2009 27-07-2010 20-12-2007 25-03-2010 20-10-2011 12-04-2012 27-12-2007

DE 102008005938 A1	30-07-2009	NONE	

(12) INNOVATION PATENT
(19) AUSTRALIAN PATENT OFFICE

(11) Application No. **AU 2012101678 A4**

(54) Title
USE OF DEVICE

(51) International Patent Classification(s)
A61M 5/315 (2006.01)

(21) Application No: **2012101678** (22) Date of Filing: **2012.11.16**

(30) Priority Data

(31) Number	(32) Date	(33) Country
EP12189649	2012.10.23	EP
EP12174860	2012.07.03	EP

(45) Publication Date: **2012.12.20**

(45) Publication Journal Date: **2012.12.20**

(45) Granted Journal Date: **2012.12.20**

(71) Applicant(s)
Novartis AG

(72) Inventor(s)
Sigg, Juergen;Royer, Christophe;Buettgen, Heinrich;Bryant, Andrew Mark;Picci, Marie

(74) Agent / Attorney
Pizzeys Patent and Trade Mark Attorneys, GPO Box 1374, BRISBANE, QLD, 4001

2012101678 16 Nov 2012

PAT055157-AU-Innovation2

ABSTRACT

The present invention relates to a device and in particular a syringe, particularly to a small volume syringe such as a syringe suitable for ophthalmic injections. The present invention also relates to uses of the device and methods.

5

1/1

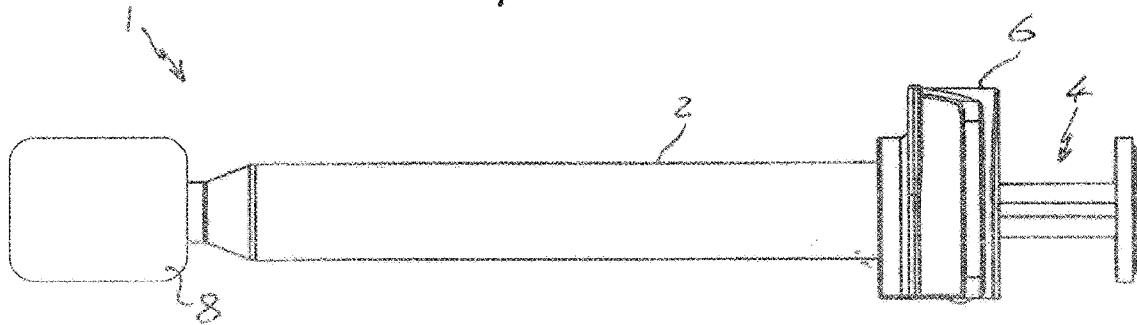

Fig 1

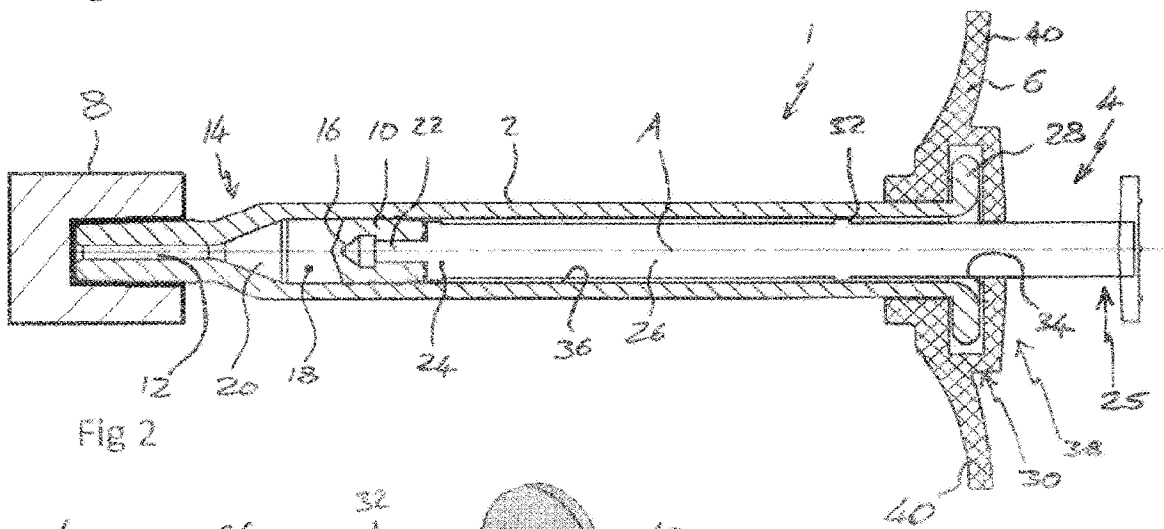

Fig 2

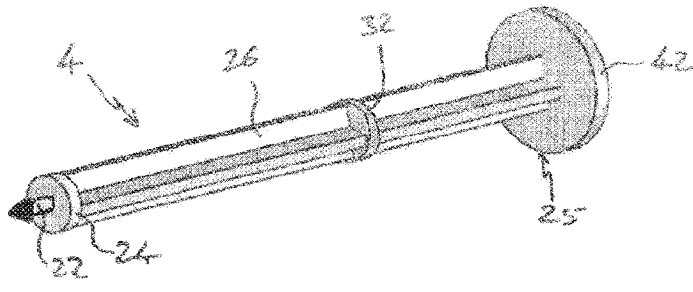

Fig 3

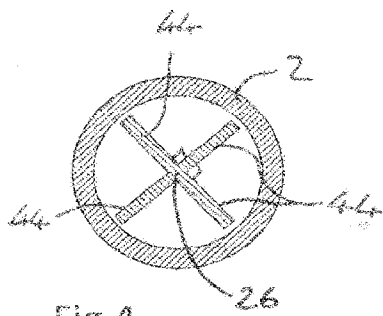

Fig 4

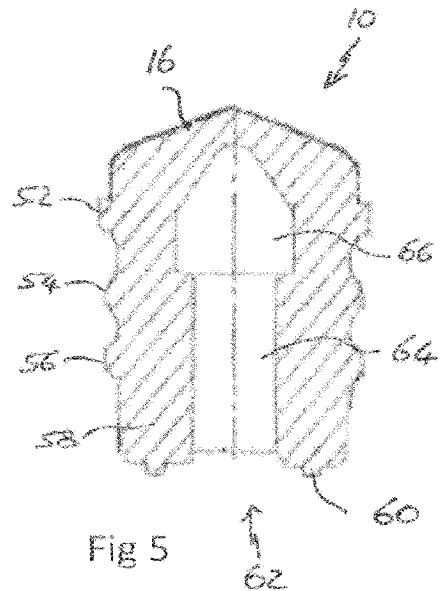

Fig 5

USE OF DEVICE

TECHNICAL FIELD

The present invention relates to a syringe, particularly to a small volume syringe such as a syringe suitable for ophthalmic injections.

BACKGROUND ART

Many medicaments are delivered to a patient in a syringe from which the user can dispense the medicament. If medicament is delivered to a patient in a syringe it is often to enable the patient, or a caregiver, to inject the medicament. It is important for patient safety and medicament integrity that the syringe and the contents of that syringe are sufficiently sterile to avoid infection, or other, risks for patients. Sterilisation can be achieved by terminal sterilisation in which the assembled product, typically already in its associated packaging, is sterilised using heat or a sterilising gas.

For small volume syringes, for example those for injections into the eye in which it is intended that about 0.1ml or less of liquid is to be injected the sterilisation can pose difficulties that are not necessarily associated with larger syringes. Changes in pressure, internal or external to the syringe, can cause parts of the syringe to move unpredictably, which may alter sealing characteristics and potentially compromise sterility. Incorrect handling of the syringe can also pose risks to product sterility.

Furthermore, certain therapeutics such as biologic molecules are particularly sensitive to sterilisation, be it cold gas sterilisation, thermal sterilisation, or irradiation. Thus, a careful balancing act is required to ensure that while a suitable level of sterilisation is carried out, the syringe remains suitably sealed, such that the therapeutic is not compromised.

There is therefore a need for a new syringe construct which provides a robust seal for its content, but which maintains ease of use.

DISCLOSURE OF THE INVENTION

The present invention provides a pre-filled syringe, the syringe comprising a body, a stopper and a plunger, the body comprising an outlet at an outlet end and the stopper being arranged within the body such that a front surface of the stopper and the body define a variable volume chamber from which a fluid can be expelled through the outlet, the plunger comprising a plunger contact surface at a first end and a rod extending between the plunger contact surface and a rear portion,

16 Nov 2012

2012101678

5

0

5

20

25

30

PAT055157-AU-Innovation2

the plunger contact surface arranged to contact the stopper, such that the plunger can be used to force the stopper towards the outlet end of the body, reducing the volume of the variable volume chamber, characterised in that the fluid comprises an ophthalmic solution. In one embodiment, the ophthalmic solution comprises a VEGF-antagonist.

5 In one embodiment, the syringe is suitable for ophthalmic injections, more particularly intravitreal injections, and as such has a suitably small volume. The syringe may also be silicone oil free, or substantially silicone oil free, or may comprise a low level of silicone oil as lubricant.

For ophthalmic injections, it is particularly important for the ophthalmic solution to have particularly low particle content. In one embodiment, the syringe meets US Pharmacopeia
0 standard 789 (USP789).

Syringe

The body of the syringe may be a substantially cylindrical shell, or may include a substantially cylindrical bore with a non circular outer shape. The outlet end of the body includes an outlet through which a fluid housed within the variable volume chamber can be expelled as the volume
5 of said chamber is reduced. The outlet may comprise a projection from the outlet end through which extends a channel having a smaller diameter than that of the variable volume chamber. The outlet may be adapted, for example via a luer lock type connection, for connection to a needle or other accessory such as a sealing device which is able to seal the variable volume chamber, but can be operated, or removed, to unseal the variable volume chamber and allow
0 connection of the syringe to another accessory, such as a needle. Such a connection may be made directly between the syringe and accessory, or via the sealing device. The body extends along a first axis from the outlet end to a rear end.

The body may be made from a plastic material (e.g. a cyclic olefin polymer) or from glass and may include indicia on a surface thereof to act as an injection guide. In one embodiment the
25 body may comprise a priming mark. This allows the physician to align a pre-determined part of the stopper (such as the tip of the front surface or one of the circumferential ribs, discussed later) with the mark, thus expelling excess ophthalmic solution and any air bubbles from the syringe. The priming process ensures that an exact, pre-determined dosage is administered to the patient.

The stopper may be made from rubber, silicone or other suitable resiliently deformable material.
30 The stopper may be substantially cylindrical and the stopper may include one or more circumferential ribs around an outer surface of the stopper, the stopper and ribs being

2012101678 16 Nov 2012

PAT055157-AU-Innovation2

5 dimensioned such that the ribs form a substantially fluid tight seal with an internal surface of the syringe body. The front surface of the stopper may be any suitable shape, for example substantially planar, substantially conical or of a domed shape. The rear surface of the stopper may include a substantially central recess. Such a central recess could be used to connect a plunger to the stopper using a snap fit feature or thread connection in a known manner. The stopper may be substantially rotationally symmetric about an axis through the stopper.

0 The plunger comprises a plunger contact surface and extending from that a rod extends from the plunger contact surface to a rear portion. The rear portion may include a user contact portion adapted to be contacted by a user during an injection event. The user contact portion may comprise a substantially disc shaped portion, the radius of the disc extending substantially perpendicular to the axis along which the rod extends. The user contact portion could be any suitable shape. The axis along which the rod extends may be the first axis, or may be substantially parallel with the first axis.

5 The syringe may include a backstop arranged at a rear portion of the body. The backstop may be removable from the syringe. If the syringe body includes terminal flanges at the end opposite the outlet end the backstop may be configured to substantially sandwich terminal flanges of the body as this prevent movement of the backstop in a direction parallel to the first axis.

0 The rod may comprise at least one rod shoulder directed away from the outlet end and the backstop may include a backstop shoulder directed towards the outlet end to cooperate with the rod shoulder to substantially prevent movement of the rod away from the outlet end when the backstop shoulder and rod shoulder are in contact. Restriction of the movement of the rod away from the outlet end can help to maintain sterility during terminal sterilisation operations, or other operations in which the pressure within the variable volume chamber or outside the chamber may change. During such operations any gas trapped within the variable volume chamber, or
25 bubbles that may form in a liquid therein, may change in volume and thereby cause the stopper to move. Movement of the stopper away from the outlet could result in the breaching of a sterility zone created by the stopper. This is particularly important for low volume syringes where there are much lower tolerances in the component sizes and less flexibility in the stopper. The term sterility zone as used herein is used to refer to the area within the syringe that is sealed
30 by the stopper from access from either end of the syringe. This may be the area between a seal of the stopper, for example a circumferential rib, closest to the outlet and a seal of the stopper, for example a circumferential rib, furthest from the outlet. The distance between these two seals

PAT055157-AU-Innovation2

defines the sterility zone of the stopper since the stopper is installed into the syringe barrel in a sterile environment.

To further assist in maintaining sterility during the operations noted above the stopper may comprise at a front circumferential rib and a rear circumferential rib and those ribs may be separated in a direction along the first axis by at least 3mm, by at least 3.5 mm, by at least 3.75mm or by 4mm or more. One or more additional ribs (for example 2, 3, 4 or 5 additional ribs, or between 1-10, 2-8, 3-6 or 4-5 additional ribs) may be arranged between the front and rear ribs. In one embodiment there are a total of three circumferential ribs.

A stopper with such an enhanced sterility zone can also provide protection for the injectable medicament during a terminal sterilisation process. More ribs on the stopper, or a greater distance between the front and rear ribs can reduce the potential exposure of the medicament to the sterilising agent. However, increasing the number of ribs can increase the friction between the stopper and syringe body, reducing ease of use. While this may be overcome by increasing the siliconisation of the syringe, such an increase in silicone oil levels is particularly undesirable for syringes for ophthalmic use.

The rod shoulder may be arranged within the external diameter of the rod, or may be arranged outside the external diameter of the rod. By providing a shoulder that extends beyond the external diameter of the rod, but still fits within the body, the shoulder can help to stabilise the movement of the rod within the body by reducing movement of the rod perpendicular to the first axis. The rod shoulder may comprise any suitable shoulder forming elements on the rod, but in one embodiment the rod shoulder comprises a substantially disc shaped portion on the rod.

In one embodiment of the syringe, when arranged with the plunger contact surface in contact with the stopper and the variable volume chamber is at its intended maximum volume there is a clearance of no more than about 2mm between the rod shoulder and backstop shoulder. In some embodiments there is a clearance of less than about 1.5 mm and in some less than about 1mm. This distance is selected to substantially limit or prevent excessive rearward (away from the outlet end) movement of the stopper.

In one embodiment the variable volume chamber has an internal diameter greater than 5mm or 6mm, or less than 3mm or 4mm. The internal diameter may be between 3mm and 6mm, or between 4mm and 5mm.

PAT055157-AU-Innovation2

In another embodiment the syringe is dimensioned so as to have a nominal maximum fill volume of between about 0.1ml and about 1.5ml. In certain embodiments the nominal maximum fill volume is between about 0.5ml and about 1ml. In certain embodiments the nominal maximum fill volume is about 0.5ml or about 1ml, or about 1.5ml.

5 The length of the body of the syringe may be less than 70mm, less than 60mm or less than 50mm. In one embodiment the length of the syringe body is between 45mm and 50mm.

In one embodiment, the syringe is filled with between about 0.01ml and about 1.5ml (for example between about 0.05ml and about 1ml, between about 0.1ml and about 0.5ml, between about 0.15ml and about 0.175ml) of a VEGF antagonist solution. In one embodiment, the
0 syringe is filled with 0.165ml of a VEGF antagonist solution. Of course, typically a syringe is filled with more than the desired dose to be administered to the patient, to take into account wastage due to "dead space" within the syringe and needle. There may also be a certain amount of wastage when the syringe is primed by the physician, so that it is ready to inject the patient.

Thus, in one embodiment, the syringe is filled with a dosage volume (i.e. the volume of
5 medicament intended for delivery to the patient) of between about 0.01ml and about 1.5ml (e.g. between about 0.05ml and about 1ml, between about 0.1ml and about 0.5ml) of a VEGF antagonist solution. In one embodiment, the dosage volume is between about 0.03ml and about 0.05ml. For example, for Lucentis, the dosage volume is 0.05ml or 0.03ml (0.5mg or 0.3mg) of a
0 10mg/ml injectable medicament solution; for Eylea, the dosage volume is 0.05ml of a 40mg/ml injectable medicament solution. In one embodiment, the extractable volume from the syringe (that is the amount of product obtainable from the syringe following filling, taking into account loss due to dead space in the syringe and needle) is about 0.09ml.

In one embodiment the length of the syringe body is between about 45mm and about 50mm, the
25 internal diameter is between about 4mm and about 5mm, the fill volume is between about 0.12 and about 0.3ml and the dosage volume is between about 0.03ml and about 0.05ml.

As the syringe contains a medicament solution, the outlet may be reversibly sealed to maintain sterility of the medicament. This sealing may be achieved through the use of a sealing device as is known in the art. For example the OVSTM system which is available from Vetter Pharma International GmbH.

30 It is typical to siliconise the syringe in order to allow ease of use, i.e. to apply silicone oil to the inside of the barrel, which decreases the force required to move the stopper. However, for

PAT055157-AU-Innovation2

ophthalmic use, it is desirable to decrease the likelihood of silicone oil droplets being injected into the eye. Furthermore, silicone oil can cause proteins to aggregate. A typical 1ml syringe comprises 100-800µg silicone oil in the barrel. Thus, in one embodiment, a syringe according to the invention comprises less than about 800µg (i.e. about less than about 500µg, less than about 300µg, less than about 200µg, less than about 100µg, less than about 75µg, less than about 50µg, less than about 25µg, less than about 15µg, less than about 10µg) silicone oil in the barrel. Methods for measuring the amount of silicone oil in such a syringe barrel are known in the art and include, for example, differential weighing methods and quantitation by infrared-spectroscopy of the oil diluted in a suitable solvent. Various types of silicone oil are available, but typically either DC360 (Dow Corning®; with a viscosity of 1000cP) or DC365 emulsion (Dow Corning®; DC360 oil with a viscosity of 350cP) are used for syringe siliconisation. In one embodiment, the pre-filled syringe of the invention comprises DC365 emulsion.

During testing it was found that, for syringes having small dimensions, such as those discussed above, and particularly those described in conjunction with the Figures below, the break loose and sliding forces for the stopper within the syringe are substantially unaffected by reducing the siliconisation levels far below the current standard to the levels discussed here. This is in contrast to conventional thinking that would suggest that if you decrease the silicone oil level, the forces required would increase. Having too great a force required to move the stopper can cause problems during use for some users, for example accurate dose setting or smooth dose delivery may be made more difficult if significant strength is required to move, and/or keep in motion, the stopper. Break loose and slide forces for pre-filled syringes known in the art are typically in the region of less than 20N, but where the pre-filled syringes contain about 100µg-about 800µg silicone oil. In one embodiment the glide/slide force for the stopper within the pre-filled syringe is less than about 11N or less than 9N, less than 7N, less than 5N or between about 3N to 5N. In one embodiment, the break loose force is less than about 11N or less than 9N, less than 7N, less than 5N or between about 2N to 5N. Note that such measurements are for a filled syringe, rather than an empty syringe. The forces are typically measured at a stopper travelling speed of 190mm/min. In one embodiment, the syringe has a nominal maximal fill volume of between about 0.5ml and 1ml, contains less than about 100µg silicone oil and has a break loose force between about 2N to 5N.

In one embodiment the syringe barrel has an internal coating of silicone oil that has an average thickness of about 450nm or less (i.e. 400nm or less, 350nm or less, 300nm or less, 200nm or less, 100nm or less, 50nm or less, 20nm or less). Methods to measure the thickness of silicone oil

PAT055157-AU-Innovation2

in a syringe are known in the art and include the rap.ID Layer Explorer® Application, which can also be used to measure the mass of silicone oil inside a syringe barrel.

In one embodiment, the syringe is silicone oil free, or substantially silicone oil free. Such low silicone oil levels can be achieved by using uncoated syringe barrels and/or by avoiding the use of silicone oil as a lubricant for product contacting machine parts, or pumps in the syringe assembly and fill line.

The syringe according to the invention may also meet certain requirements for particulate content. In one embodiment, the ophthalmic solution comprises no more than 2 particles $\geq 50\mu\text{m}$ in diameter per ml. In one embodiment, the ophthalmic solution comprises no more than 5 particles $\geq 25\mu\text{m}$ in diameter per ml. In one embodiment, the ophthalmic solution comprises no more than 50 particles $\geq 10\mu\text{m}$ in diameter per ml. In one embodiment, the ophthalmic solution comprises no more than 2 particles $\geq 50\mu\text{m}$ in diameter per ml, no more than 5 particles $\geq 25\mu\text{m}$ in diameter per ml and no more than 50 particles $\geq 10\mu\text{m}$ in diameter per ml. In one embodiment, a syringe according to the invention meets USP789. In one embodiment the syringe has low levels of silicone oil sufficient for the syringe to meet USP789.

VEGF Antagonists

Antibody VEGF antagonists

VEGF is a well-characterised signal protein which stimulates angiogenesis. Two antibody VEGF antagonists have been approved for human use, namely ranibizumab (Lucentis®) and bevacizumab (Avastin®).

Non-Antibody VEGF antagonists

In one aspect of the invention, the non-antibody VEGF antagonist is an immunoadhesin. One such immunoadhesin is aflibercept (Eylea®), which has recently been approved for human use and is also known as VEGF-trap (Holash *et al.* (2002) *PNAS USA* 99:11393-98; Riely & Miller (2007) *Clin Cancer Res* 13:4623-7s). Aflibercept is the preferred non-antibody VEGF antagonist for use with the invention. Aflibercept is a recombinant human soluble VEGF receptor fusion protein consisting of portions of human VEGF receptors 1 and 2 extracellular domains fused to the Fc portion of human IgG1. It is a dimeric glycoprotein with a protein molecular weight of 97 kilodaltons (kDa) and contains glycosylation, constituting an additional 15% of the total molecular mass, resulting in a total molecular weight of 115 kDa. It is conveniently produced as

2012101678 16 Nov 2012

PAT055157-AU-Innovation2

a glycoprotein by expression in recombinant CHO K1 cells. Each monomer can have the following amino acid sequence (SEQ ID NO: 1):

SDTGRPFVEMYSEIPEIIHMTEGRELVIPCRVTSPNITVTLKKFPLDTLIPDGKRIIWDSRKGFIISNATY
KEIGLLTCEATVNGHLYKTNYLTHRQTNTIIDVVLSPSHGIELSVGEKLVLNCTARTELVNGIDFNWEYPS
SKHQHKKLVNRDLKTQSGSEMKKFLSTLTIDGVTRSDQGLYTCAASSGLMTKKNSTFVVRVHEKDKTHTCPP
CPAPELLGGPSVFLFPPKPKDTLMI SRTPEVTCVVVDVSHEDPEVKFNWYVDGVEVHNAKTKPREEQYNST
YRVVSVLTVLHQDWLNGKEYKCKVSNKALPAPIEKTISKAKGQPREPQVYTLPPSRDELTKNQVSLTCLVK
GFYPSDIAVEWESNGQPENNYKTPPVLDSDGSFFLYSKLTVDKSRWQQGNVVFSCSVMEALHNHYTQKSL
SLSPG

and disulfide bridges can be formed between residues 30-79, 124-185, 246-306 and 352-410 within each monomer, and between residues 211-211 and 214-214 between the monomers.

Another non-antibody VEGF antagonist immunoadhesin currently in pre-clinical development is a recombinant human soluble VEGF receptor fusion protein similar to VEGF-trap containing extracellular ligand-binding domains 3 and 4 from VEGFR2/KDR, and domain 2 from VEGFR1/Flt-1; these domains are fused to a human IgG Fc protein fragment (Li et al., 2011 *Molecular Vision* 17:797-803). This antagonist binds to isoforms VEGF-A, VEGF-B and VEGF-C. The molecule is prepared using two different production processes resulting in different glycosylation patterns on the final proteins. The two glycoforms are referred to as KH902 (conbercept) and KH906. The fusion protein can have the following amino acid sequence (SEQ ID NO:2):

MVSYWDTGVLLCALLSCLLLTGSSSGRPFVEMYSEIPEIIHMTEGRELVIPCRVTSPNITVTLKKFPLDT
LIPDGKRIIWDSRKGFIISNATYKEIGLLTCEATVNGHLYKTNYLTHRQTNTIIDVVLSPSHGIELSVGEK
LVLNCTARTELVNGIDFNWEYPSKHKQHKKLVNRDLKTQSGSEMKKFLSTLTIDGVTRSDQGLYTCAASSG
LMTKKNSTFVVRVHEKPFVAFGSGMESLVEATVGERVRLPAKYLGYPPEIKWYKNGIPLSNHTIKAGHVL
IMEVSRDGTGNYTVILTNPISKEKQSHVVSLVVYVPPGPGDKTHTCPLCPAPELLGGPSVFLFPPKPKDT
LMI SRTPEVTCVVVDVSHEDPEVKFNWYVDGVEVHNAKTKPREEQYNSTYRVVSVLTVLHQDWLNGKEYK
KVSNAKALPAPIEKTISKAKGQPREPQVYTLPPSRDELTKNQVSLTCLVKGFYPSDIAVEWESNGQPENNYK
ATPPVLDSDGSFFLYSKLTVDKSRWQQGNVVFSCSVMEALHNHYTQKSLSLSPGK

and, like VEGF-trap, can be present as a dimer. This fusion protein and related molecules are further characterized in EP1767546.

Other non-antibody VEGF antagonists include antibody mimetics (e.g. Affibody® molecules, affilins, affitins, anticalins, avimers, Kunitz domain peptides, and monobodies) with VEGF antagonist activity. This includes recombinant binding proteins comprising an ankyrin repeat domain that binds VEGF-A and prevents it from binding to VEGFR-2. One example for such a

2012101678 16 Nov 2012

PAT055157-AU-Innovation2

molecule is DARPin® MP0112. The ankyrin binding domain may have the following amino acid sequence (SEQ ID NO: 3):

```
GSDLGKKLLEAARAGQDDEVRIILMANGADVNTADSTGWTPHLHAVPWGHLEIVEVLLKYGADVNAKDFQGW  
EPLHLAAAIHQEIVEVLLKNGADVNAQDKFGKTAFDISIDNGNEDLAEILQKAA
```

5 Recombinant binding proteins comprising an ankyrin repeat domain that binds VEGF-A and prevents it from binding to VEGFR-2 are described in more detail in WO2010/060748 and WO2011/135067.

Further specific antibody mimetics with VEGF antagonist activity are the 40 kD pegylated anticalin PRS-050 and the monobody angicept (CT-322).

0 The afore-mentioned non-antibody VEGF antagonist may be modified to further improve their pharmacokinetic properties or bioavailability. For example, a non-antibody VEGF antagonist may be chemically modified (e.g., pegylated) to extend its *in vivo* half-life. Alternatively or in addition, it may be modified by glycosylation or the addition of further glycosylation sites not present in the protein sequence of the natural protein from which the VEGF antagonist was
5 derived.

Variants of the above-specified VEGF antagonists that have improved characteristics for the desired application may be produced by the addition or deletion of amino acids. Ordinarily, these amino acid sequence variants will have an amino acid sequence having at least 60% amino acid sequence identity with the amino acid sequences of SEQ ID NO: 1, SEQ ID NO: 2 or SEQ ID
10 NO: 3, preferably at least 80%, more preferably at least 85%, more preferably at least 90%, and most preferably at least 95%, including for example, 80%, 81%, 82%, 83%, 84%, 85%, 86%, 87%, 88%, 89%, 90%, 91%, 92%, 93%, 94%, 95%, 96%, 97%, 98%, 99%, and 100%. Identity or homology with respect to this sequence is defined herein as the percentage of amino acid residues in the candidate sequence that are identical with SEQ ID NO: 1, SEQ ID NO: 2 or SEQ
25 ID NO: 3, after aligning the sequences and introducing gaps, if necessary, to achieve the maximum percent sequence identity, and not considering any conservative substitutions as part of the sequence identity.

Sequence identity can be determined by standard methods that are commonly used to compare the similarity in position of the amino acids of two polypeptides. Using a computer program
30 such as BLAST or FASTA, two polypeptides are aligned for optimal matching of their respective amino acids (either along the full length of one or both sequences or along a pre-

PAT055157-AU-Innovation2

determined portion of one or both sequences). The programs provide a default opening penalty and a default gap penalty, and a scoring matrix such as PAM 250 [a standard scoring matrix; see Dayhoff et al., in Atlas of Protein Sequence and Structure, vol. 5, supp. 3 (1978)] can be used in conjunction with the computer program. For example, the percent identity can then be calculated as: the total number of identical matches multiplied by 100 and then divided by the sum of the length of the longer sequence within the matched span and the number of gaps introduced into the longer sequences in order to align the two sequences.

Preferably, the non-antibody VEGF antagonist of the invention binds to VEGF via one or more protein domain(s) that are not derived from the antigen-binding domain of an antibody. The non-antibody VEGF antagonist of the invention are preferably proteinaceous, but may include modifications that are non-proteinaceous (e.g., pegylation, glycosylation).

Therapy

The syringe of the invention may be used to treat an ocular disease, including but not limited to choroidal neovascularisation, age-related macular degeneration (both wet and dry forms), macular edema secondary to retinal vein occlusion (RVO) including both branch RVO (bRVO) and central RVO (cRVO), choroidal neovascularisation secondary to pathologic myopia (PM), diabetic macular edema (DME), diabetic retinopathy, and proliferative retinopathy.

Thus the invention provides a method of treating a patient suffering from of an ocular disease selected from choroidal neovascularisation, wet age-related macular degeneration, macular edema secondary to retinal vein occlusion (RVO) including both branch RVO (bRVO) and central RVO (cRVO), choroidal neovascularisation secondary to pathologic myopia (PM), diabetic macular edema (DME), diabetic retinopathy, and proliferative retinopathy, comprising the step of administering an ophthalmic solution to the patient using a pre-filled syringe of the invention. This method preferably further comprises an initial priming step in which the physician depresses the plunger of the pre-filled syringe to align the pre-determined part of the stopper with the priming mark.

In one embodiment, the invention provides a method of treating an ocular disease selected from choroidal neovascularisation, wet age-related macular degeneration, macular edema secondary to retinal vein occlusion (RVO) including both branch RVO (bRVO) and central RVO (cRVO), choroidal neovascularisation secondary to pathologic myopia (PM), diabetic macular edema (DME), diabetic retinopathy, and proliferative retinopathy, comprising administering a non-

PAT055157-AU-Innovation2

antibody VEGF antagonist with a pre-filled syringe of the invention, wherein the patient has previously received treatment with an antibody VEGF antagonist.

Kits

Also provided are kits comprising the pre-filled syringes of the invention. In one embodiment, such a kit comprises a pre-filled syringe of the invention in a blister pack. The blister pack may itself be sterile on the inside. In one embodiment, syringes according to the invention may be placed inside such blister packs prior to undergoing sterilisation, for example terminal sterilisation.

Such a kit may further comprise a needle for administration of the VEGF antagonist. If the VEGF antagonist is to be administered intravitreally, it is typical to use a 30-gauge x ½ inch needle, though 31-gauge and 32-gauge needles may be used. For intravitreal administration, 33-gauge or 34-gauge needles could alternatively be used. Such kits may further comprise instructions for use. In one embodiment, the invention provides a carton containing a pre-filled syringe according to the invention contained within a blister pack, a needle and optionally instructions for administration.

Sterilisation

As noted above, a terminal sterilisation process may be used to sterilise the syringe and such a process may use a known process such as an ethylene oxide or a hydrogen peroxide sterilisation process. Needles to be used with the syringe may be sterilised by the same method, as may kits according to the invention.

The package is exposed to the sterilising gas until the outside of the syringe is sterile. Following such a process, the outer surface of the syringe may remain sterile (whilst in its blister pack) for up to 6 months, 9 months, 12 months, 15 months, 18 months or longer. In one embodiment, less than one syringe in a million has detectable microbial presence on the outside of the syringe after 18 months of storage. In one embodiment, the pre-filled syringe has been sterilised using EtO with a Sterility Assurance Level of at least 10^{-6} . In one embodiment, the pre-filled syringe has been sterilised using hydrogen peroxide with a Sterility Assurance Level of at least 10^{-6} . Of course, it is a requirement that significant amounts of the sterilising gas should not enter the variable volume chamber of the syringe. The term “significant amounts” as used herein refers to an amount of gas that would cause unacceptable modification of the ophthalmic solution within the variable volume chamber. In one embodiment, the sterilisation process causes $\leq 10\%$

2012101678 16 Nov 2012

PAT055157-AU-Innovation2

(preferably $\leq 5\%$, $\leq 3\%$, $\leq 1\%$) alkylation of the VEGF antagonist. In one embodiment, the pre-filled syringe has been sterilised using EtO, but the outer surface of the syringe has $\leq 1\text{ppm}$, preferably $\leq 0.2\text{ppm}$ EtO residue. In one embodiment, the pre-filled syringe has been sterilised using hydrogen peroxide, but the outer surface of the syringe has $\leq 1\text{ppm}$, preferably $\leq 0.2\text{ppm}$ hydrogen peroxide residue. In another embodiment, the pre-filled syringe has been sterilised using EtO, and the total EtO residue found on the outside of the syringe and inside of the blister pack is $\leq 0.1\text{mg}$. In another embodiment, the pre-filled syringe has been sterilised using hydrogen peroxide, and the total hydrogen peroxide residue found on the outside of the syringe and inside of the blister pack is $\leq 0.1\text{mg}$.

General

The term “comprising” means “including” as well as “consisting” *e.g.* a composition “comprising” X may consist exclusively of X or may include something additional *e.g.* X + Y.

The term “about” in relation to a numerical value x means, for example, $x \pm 10\%$.

References to a percentage sequence identity between two amino acid sequences means that, when aligned, that percentage of amino acids are the same in comparing the two sequences. This alignment and the percent homology or sequence identity can be determined using software programs known in the art, for example those described in section 7.7.18 of *Current Protocols in Molecular Biology* (F.M. Ausubel *et al.*, eds., 1987) Supplement 30. A preferred alignment is determined by the Smith-Waterman homology search algorithm using an affine gap search with a gap open penalty of 12 and a gap extension penalty of 2, BLOSUM matrix of 62. The Smith-Waterman homology search algorithm is disclosed in Smith & Waterman (1981) *Adv. Appl. Math.* 2: 482-489

BRIEF DESCRIPTION OF THE FIGURES

Figure 1 shows a side view of a syringe

Figure 2 shows a cross section of a top down view of a syringe

Figure 3 shows a view of a plunger

Figure 4 shows a cross section through a plunger

Figure 5 shows a stopper

2012101678 16 Nov 2012

MODES FOR CARRYING OUT THE INVENTION

The invention will now be further described, by way of example only, with reference to the drawings.

5 Figure 1 shows a view from a side of a syringe 1 comprising a body 2, plunger 4, backstop 6 and a sealing device 8.

Figure 2 shows a cross section through the syringe 1 of Figure 1 from above. The syringe 1 is suitable for use in an ophthalmic injection. The syringe 1 comprises a body 2, a stopper 10 and a plunger 4. The syringe 1 extends along a first axis A. The body 2 comprises an outlet 12 at an outlet end 14 and the stopper 10 is arranged within the body 2 such that a front surface 16 of the stopper 10 and the body 2 define a variable volume chamber 18. The variable volume chamber 18 contains an injectable medicament 20 comprising an ophthalmic solution comprising a VEGF antagonist such as ranibizumab. The injectable fluid 20 can be expelled though the outlet 12 by movement of the stopper 10 towards the outlet end 14 thereby reducing the volume of the variable volume chamber 18. The plunger 4 comprises a plunger contact surface 22 at a first end 24 and a rod 26 extending between the plunger contact surface 22 and a rear portion 25. The plunger contact surface 22 is arranged to contact the stopper 10, such that the plunger 4 can be used to move the stopper 10 towards the outlet end 14 of the body 2. Such movement reduces the volume of the variable volume chamber 18 and causes fluid therein to be expelled though the outlet.

20 The backstop 6 is attached to the body 2 by coupling to a terminal flange 28 of the body 2. The backstop 6 includes sandwich portion 30 which is adapted to substantially sandwich at least some of the terminal flange 28 of the body 2. The backstop 6 is adapted to be coupled to the body 2 from the side by leaving one side of the backstop 6 open so that the backstop 6 can be fitted to the syringe 2.

25 The body 2 defines a substantially cylindrical bore 36 which has a bore radius. The rod 26 comprises a rod shoulder 32 directed away from the outlet end 14. The rod shoulder 32 extends from to a rod shoulder radius from the first axis A which is such that it is slightly less than the bore radius so that the shoulder fits within the bore 36. The backstop 6 includes a backstop shoulder 34 directed towards the outlet end 14. The shoulders 32, 34 are configured to cooperate to substantially prevent movement of the rod 26 away from the outlet end 14 when the backstop shoulder 34 and rod shoulder 32 are in contact. The backstop shoulder 34 extends from outside the

PAT055157-AU-Innovation2

bore radius to a radius less than the rod shoulder radius so that the rod shoulder 32 cannot pass the backstop shoulder 34 by moving along the first axis A. In this case the rod shoulder 32 is substantially disc, or ring, shaped and the backstop shoulder 34 includes an arc around a rear end 38 of the body 2.

5 The backstop 6 also includes two finger projections 40 which extend in opposite directions away from the body 2 substantially perpendicular to the first axis A to facilitate manual handling of the syringe 1 during use.

In this example the syringe comprises a 0.5ml body 2 filled with between about 0.1 and 0.3 ml of an injectable medicament 20 comprising a 10mg/ml injectable solution comprising ranibizumab. The syringe body 2 has an internal diameter of about between about 4.5mm and 4.8mm, a length of between about 45mm and 50mm.

The plunger 4 and stopper 10 will be described in more detail with reference to later figures.

Figure 3 shows a perspective view of the plunger 4 of Figure 1 showing the plunger contact surface 22 at the first end 24 of the plunger 4. The rod 26 extends from the first end 24 to the rear portion 25. The rear portion 25 includes a disc shaped flange 42 to facilitate user handling of the device. The flange 42 provides a larger surface area for contact by the user than a bare end of the rod 26.

Figure 4 shows a cross section through a syringe body 2 and rod 26. The rod 26 includes four longitudinal ribs 44 and the angle between the ribs is 90°.

Figure 5 shows a detailed view of a stopper 10 showing a conical shaped front surface 16 and three circumferential ribs 52,54,56 around a substantially cylindrical body 58. The axial gap between the first rib 52 and the last rib 56 is about 3mm. The rear surface 60 of the stopper 10 includes a substantially central recess 62. The central recess 62 includes an initial bore 64 having a first diameter. The initial bore 64 leading from the rear surface 60 into the stopper 10 to an inner recess 66 having a second diameter, the second diameter being larger than the first diameter.

25

Stopper forces

0.5ml syringes siliconised with <100µg silicone oil, filled with Lucentis, comprising one of two different stopper designs were tested for maximal and average break out and slide force. Prior to testing, 30G x 0.5” needles were attached to the syringes. The testing was carried out at a stopper speed of 190mm/min over a travel length of 10.9mm.

30

		Stopper design 1			Stopper design 2	
		Batch A	Batch B	Batch C	Batch D	Batch E
Break loose force of syringes	Average of 10 syringes	2.2N	2.3N	1.9N	2.1N	2.5N
	Max individual value	2.5N	2.5N	2.3N	2.6N	2.7N
Sliding force	Average of 10 syringes	3.1N	3.2N	3.1N	4.1N	4.6N
	Max individual value	3.5N	3.5N	3.6N	4.7N	4.8N

For both stopper designs, average and maximum break out force remained below 3N. For both stopper designs, average and maximum sliding force remained below 5N.

5 It will be understood that the invention has been described by way of example only and modifications may be made whilst remaining within the scope and spirit of the invention.

CLAIMS

1. Use of a pre-filled syringe in the treatment of wet age-related macular degeneration, wherein the syringe comprises a body, a stopper and a plunger, the body comprising an outlet at an outlet end and the stopper being arranged within the body such that a front surface of the stopper and the body define a variable volume chamber from which a fluid can be expelled though the outlet, the plunger comprising a plunger contact surface at a first end and a rod extending between the plunger contact surface and a rear portion, the plunger contact surface arranged to contact the stopper, such that the plunger can be used to force the stopper towards the outlet end of the body, reducing the volume of the variable volume chamber, characterised in that the fluid is an ophthalmic solution which comprises a VEGF-antagonist, wherein:

- (a) the syringe has a nominal maximum fill volume of between about 0.5ml and about 1ml,
- (b) the syringe is filled with between about 0.15ml and about 0.175ml of said VEGF antagonist solution which comprises a dosage volume of about 0.05ml of said VEGF antagonist solution,
- (c) the syringe barrel comprises less than about 500µg silicone oil,
- (d) the VEGF antagonist solution comprises no more than 2 particles $\geq 50\mu\text{m}$ in diameter per ml, and
- (e) the VEGF antagonist is the non-antibody VEGF antagonist aflibercept at a concentration of 40mg/ml.

2. A method of treating a patient suffering from wet age-related macular degeneration, comprising the step of administering an ophthalmic solution to the patient using a pre-filled syringe as defined in claim 1.

3. The method of claim 2, further comprising an initial priming step in which a user depresses the plunger of the pre-filled syringe to align the pre-determined part of the stopper with a priming mark.

4. A method according to claim 3, wherein the patient has previously received treatment with an antibody VEGF antagonist.

2012101678 16 Nov 2012

PAT055157-AU-Innovation2

5. The use according to claim 1, or method according to any one of claims 2 to 4, wherein the VEGF antagonist solution further comprises (i) no more than 5 particles $\geq 25\mu\text{m}$ in diameter per ml, (ii) no more than 50 particles $\geq 10\mu\text{m}$ in diameter per ml; or a combination of both (i) and (ii).

1/1

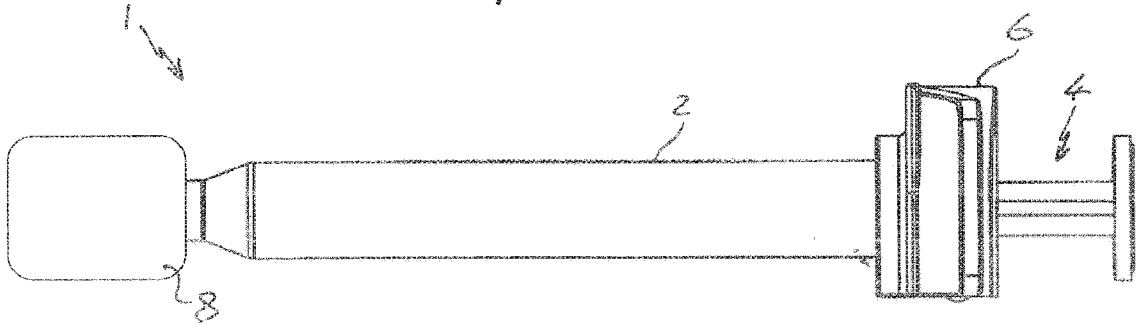

Fig 1

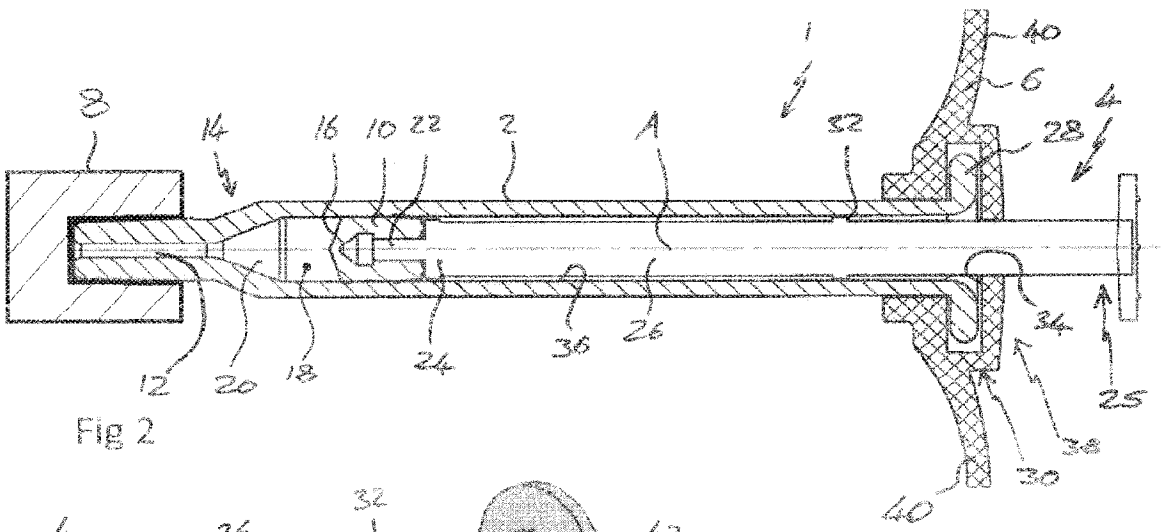

Fig 2

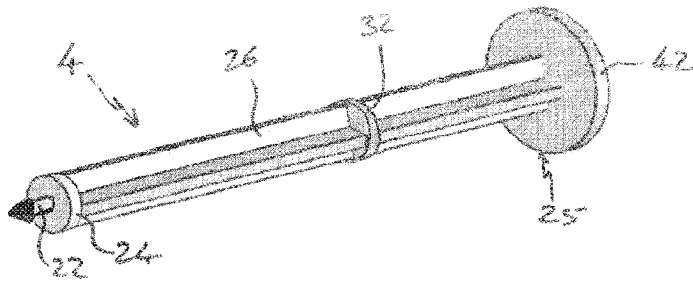

Fig 3

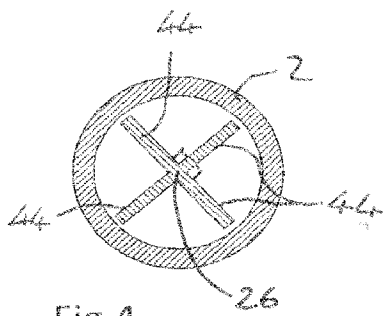

Fig 4

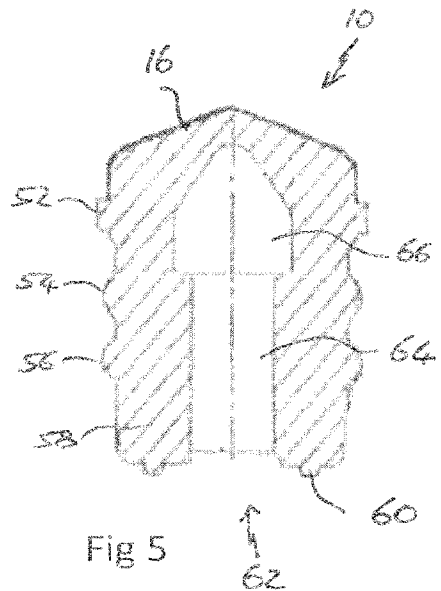

Fig 5

(12) INNOVATION PATENT
(19) AUSTRALIAN PATENT OFFICE

(11) Application No. **AU 2012101677 A4**

(54) Title
DEVICE

(51) International Patent Classification(s)
A61M 3/00 (2006.01)

(21) Application No: **2012101677** (22) Date of Filing: **2012.11.16**

(30) Priority Data

(31) Number	(32) Date	(33) Country
EP12174860	2012.07.03	EP
EP12189649	2012.10.23	EP

(45) Publication Date: **2012.12.13**

(45) Publication Journal Date: **2012.12.13**

(45) Granted Journal Date: **2012.12.13**

(71) Applicant(s)
Novartis AG

(72) Inventor(s)
Sigg, Juergen;Royer, Christophe;Buettgen, Heinrich;Bryant, Andrew Mark;Picci, Marie

(74) Agent / Attorney
Pizzeys Patent and Trade Mark Attorneys, GPO Box 1374, BRISBANE, QLD, 4001

2012101677 16 Nov 2012

PAT055157-AU-Innovation1

ABSTRACT

The present invention relates to a device and in particular a syringe, more particularly to a small volume syringe such as a syringe suitable for ophthalmic injections.

DEVICE

TECHNICAL FIELD

The present invention relates to a syringe, particularly to a small volume syringe such as a syringe suitable for ophthalmic injections.

BACKGROUND ART

Many medicaments are delivered to a patient in a syringe from which the user can dispense the medicament. If medicament is delivered to a patient in a syringe it is often to enable the patient, or a caregiver, to inject the medicament. It is important for patient safety and medicament integrity that the syringe and the contents of that syringe are sufficiently sterile to avoid infection, or other, risks for patients. Sterilisation can be achieved by terminal sterilisation in which the assembled product, typically already in its associated packaging, is sterilised using heat or a sterilising gas.

For small volume syringes, for example those for injections into the eye in which it is intended that about 0.1ml or less of liquid is to be injected the sterilisation can pose difficulties that are not necessarily associated with larger syringes. Changes in pressure, internal or external to the syringe, can cause parts of the syringe to move unpredictably, which may alter sealing characteristics and potentially compromise sterility. Incorrect handling of the syringe can also pose risks to product sterility.

Furthermore, certain therapeutics such as biologic molecules are particularly sensitive to sterilisation, be it cold gas sterilisation, thermal sterilisation, or irradiation. Thus, a careful balancing act is required to ensure that while a suitable level of sterilisation is carried out, the syringe remains suitably sealed, such that the therapeutic is not compromised.

There is therefore a need for a new syringe construct which provides a robust seal for its content, but which maintains ease of use.

DISCLOSURE OF THE INVENTION

The present invention provides a pre-filled syringe, the syringe comprising a body, a stopper and a plunger, the body comprising an outlet at an outlet end and the stopper being arranged within the body such that a front surface of the stopper and the body define a variable volume chamber from which a fluid can be expelled through the outlet, the plunger comprising a plunger contact surface at a first end and a rod extending between the plunger contact surface and a rear portion,

16 Nov 2012

2012101677

5

0

5

20

25

30

PAT055157-AU-Innovation1

the plunger contact surface arranged to contact the stopper, such that the plunger can be used to force the stopper towards the outlet end of the body, reducing the volume of the variable volume chamber, characterised in that the fluid comprises an ophthalmic solution. In one embodiment, the ophthalmic solution comprises a VEGF-antagonist.

5 In one embodiment, the syringe is suitable for ophthalmic injections, more particularly intravitreal injections, and as such has a suitably small volume. The syringe may also be silicone oil free, or substantially silicone oil free, or may comprise a low level of silicone oil as lubricant.

For ophthalmic injections, it is particularly important for the ophthalmic solution to have particularly low particle content. In one embodiment, the syringe meets US Pharmacopeia
0 standard 789 (USP789).

Syringe

The body of the syringe may be a substantially cylindrical shell, or may include a substantially cylindrical bore with a non circular outer shape. The outlet end of the body includes an outlet through which a fluid housed within the variable volume chamber can be expelled as the volume
5 of said chamber is reduced. The outlet may comprise a projection from the outlet end through which extends a channel having a smaller diameter than that of the variable volume chamber. The outlet may be adapted, for example via a luer lock type connection, for connection to a needle or other accessory such as a sealing device which is able to seal the variable volume chamber, but can be operated, or removed, to unseal the variable volume chamber and allow
0 connection of the syringe to another accessory, such as a needle. Such a connection may be made directly between the syringe and accessory, or via the sealing device. The body extends along a first axis from the outlet end to a rear end.

The body may be made from a plastic material (e.g. a cyclic olefin polymer) or from glass and may include indicia on a surface thereof to act as an injection guide. In one embodiment the
25 body may comprise a priming mark. This allows the physician to align a pre-determined part of the stopper (such as the tip of the front surface or one of the circumferential ribs, discussed later) with the mark, thus expelling excess ophthalmic solution and any air bubbles from the syringe. The priming process ensures that an exact, pre-determined dosage is administered to the patient.

The stopper may be made from rubber, silicone or other suitable resiliently deformable material.
30 The stopper may be substantially cylindrical and the stopper may include one or more circumferential ribs around an outer surface of the stopper, the stopper and ribs being

2012101677 16 Nov 2012

PAT055157-AU-Innovation1

5 dimensioned such that the ribs form a substantially fluid tight seal with an internal surface of the syringe body. The front surface of the stopper may be any suitable shape, for example substantially planar, substantially conical or of a domed shape. The rear surface of the stopper may include a substantially central recess. Such a central recess could be used to connect a plunger to the stopper using a snap fit feature or thread connection in a known manner. The stopper may be substantially rotationally symmetric about an axis through the stopper.

0 The plunger comprises a plunger contact surface and extending from that a rod extends from the plunger contact surface to a rear portion. The rear portion may include a user contact portion adapted to be contacted by a user during an injection event. The user contact portion may comprise a substantially disc shaped portion, the radius of the disc extending substantially perpendicular to the axis along which the rod extends. The user contact portion could be any suitable shape. The axis along which the rod extends may be the first axis, or may be substantially parallel with the first axis.

5 The syringe may include a backstop arranged at a rear portion of the body. The backstop may be removable from the syringe. If the syringe body includes terminal flanges at the end opposite the outlet end the backstop may be configured to substantially sandwich terminal flanges of the body as this prevent movement of the backstop in a direction parallel to the first axis.

0 The rod may comprise at least one rod shoulder directed away from the outlet end and the backstop may include a backstop shoulder directed towards the outlet end to cooperate with the rod shoulder to substantially prevent movement of the rod away from the outlet end when the backstop shoulder and rod shoulder are in contact. Restriction of the movement of the rod away from the outlet end can help to maintain sterility during terminal sterilisation operations, or other operations in which the pressure within the variable volume chamber or outside the chamber may change. During such operations any gas trapped within the variable volume chamber, or
25 bubbles that may form in a liquid therein, may change in volume and thereby cause the stopper to move. Movement of the stopper away from the outlet could result in the breaching of a sterility zone created by the stopper. This is particularly important for low volume syringes where there are much lower tolerances in the component sizes and less flexibility in the stopper. The term sterility zone as used herein is used to refer to the area within the syringe that is sealed
30 by the stopper from access from either end of the syringe. This may be the area between a seal of the stopper, for example a circumferential rib, closest to the outlet and a seal of the stopper, for example a circumferential rib, furthest from the outlet. The distance between these two seals

PAT055157-AU-Innovation1

defines the sterility zone of the stopper since the stopper is installed into the syringe barrel in a sterile environment.

To further assist in maintaining sterility during the operations noted above the stopper may comprise at a front circumferential rib and a rear circumferential rib and those ribs may be separated in a direction along the first axis by at least 3mm, by at least 3.5 mm, by at least 3.75mm or by 4mm or more. One or more additional ribs (for example 2, 3, 4 or 5 additional ribs, or between 1-10, 2-8, 3-6 or 4-5 additional ribs) may be arranged between the front and rear ribs. In one embodiment there are a total of three circumferential ribs.

A stopper with such an enhanced sterility zone can also provide protection for the injectable medicament during a terminal sterilisation process. More ribs on the stopper, or a greater distance between the front and rear ribs can reduce the potential exposure of the medicament to the sterilising agent. However, increasing the number of ribs can increase the friction between the stopper and syringe body, reducing ease of use. While this may be overcome by increasing the siliconisation of the syringe, such an increase in silicone oil levels is particularly undesirable for syringes for ophthalmic use.

The rod shoulder may be arranged within the external diameter of the rod, or may be arranged outside the external diameter of the rod. By providing a shoulder that extends beyond the external diameter of the rod, but still fits within the body, the shoulder can help to stabilise the movement of the rod within the body by reducing movement of the rod perpendicular to the first axis. The rod shoulder may comprise any suitable shoulder forming elements on the rod, but in one embodiment the rod shoulder comprises a substantially disc shaped portion on the rod.

In one embodiment of the syringe, when arranged with the plunger contact surface in contact with the stopper and the variable volume chamber is at its intended maximum volume there is a clearance of no more than about 2mm between the rod shoulder and backstop shoulder. In some embodiments there is a clearance of less than about 1.5 mm and in some less than about 1mm. This distance is selected to substantially limit or prevent excessive rearward (away from the outlet end) movement of the stopper.

In one embodiment the variable volume chamber has an internal diameter greater than 5mm or 6mm, or less than 3mm or 4mm. The internal diameter may be between 3mm and 6mm, or between 4mm and 5mm.

PAT055157-AU-Innovation1

In another embodiment the syringe is dimensioned so as to have a nominal maximum fill volume of between about 0.1ml and about 1.5ml. In certain embodiments the nominal maximum fill volume is between about 0.5ml and about 1ml. In certain embodiments the nominal maximum fill volume is about 0.5ml or about 1ml, or about 1.5ml.

5 The length of the body of the syringe may be less than 70mm, less than 60mm or less than 50mm. In one embodiment the length of the syringe body is between 45mm and 50mm.

In one embodiment, the syringe is filled with between about 0.01ml and about 1.5ml (for example between about 0.05ml and about 1ml, between about 0.1ml and about 0.5ml, between about 0.15ml and about 0.175ml) of a VEGF antagonist solution. In one embodiment, the
0 syringe is filled with 0.165ml of a VEGF antagonist solution. Of course, typically a syringe is filled with more than the desired dose to be administered to the patient, to take into account wastage due to "dead space" within the syringe and needle. There may also be a certain amount of wastage when the syringe is primed by the physician, so that it is ready to inject the patient.

Thus, in one embodiment, the syringe is filled with a dosage volume (i.e. the volume of
5 medicament intended for delivery to the patient) of between about 0.01ml and about 1.5ml (e.g. between about 0.05ml and about 1ml, between about 0.1ml and about 0.5ml) of a VEGF antagonist solution. In one embodiment, the dosage volume is between about 0.03ml and about 0.05ml. For example, for Lucentis, the dosage volume is 0.05ml or 0.03ml (0.5mg or 0.3mg) of a
0 10mg/ml injectable medicament solution; for Eylea, the dosage volume is 0.05ml of a 40mg/ml injectable medicament solution. In one embodiment, the extractable volume from the syringe (that is the amount of product obtainable from the syringe following filling, taking into account loss due to dead space in the syringe and needle) is about 0.09ml.

In one embodiment the length of the syringe body is between about 45mm and about 50mm, the
25 internal diameter is between about 4mm and about 5mm, the fill volume is between about 0.12 and about 0.3ml and the dosage volume is between about 0.03ml and about 0.05ml.

As the syringe contains a medicament solution, the outlet may be reversibly sealed to maintain sterility of the medicament. This sealing may be achieved through the use of a sealing device as is known in the art. For example the OVSTM system which is available from Vetter Pharma International GmbH.

30 It is typical to siliconise the syringe in order to allow ease of use, i.e. to apply silicone oil to the inside of the barrel, which decreases the force required to move the stopper. However, for

2012101677 16 Nov 2012

PAT055157-AU-Innovation1

ophthalmic use, it is desirable to decrease the likelihood of silicone oil droplets being injected into the eye. Furthermore, silicone oil can cause proteins to aggregate. A typical 1ml syringe comprises 100-800µg silicone oil in the barrel. Thus, in one embodiment, a syringe according to the invention comprises less than about 800µg (i.e. about less than about 500µg, less than about 300µg, less than about 200µg, less than about 100µg, less than about 75µg, less than about 50µg, less than about 25µg, less than about 15µg, less than about 10µg) silicone oil in the barrel. Methods for measuring the amount of silicone oil in such a syringe barrel are known in the art and include, for example, differential weighing methods and quantitation by infrared-spectroscopy of the oil diluted in a suitable solvent. Various types of silicone oil are available, but typically either DC360 (Dow Corning®; with a viscosity of 1000cP) or DC365 emulsion (Dow Corning®; DC360 oil with a viscosity of 350cP) are used for syringe siliconisation. In one embodiment, the pre-filled syringe of the invention comprises DC365 emulsion.

During testing it was found that, for syringes having small dimensions, such as those discussed above, and particularly those described in conjunction with the Figures below, the break loose and sliding forces for the stopper within the syringe are substantially unaffected by reducing the siliconisation levels far below the current standard to the levels discussed here. This is in contrast to conventional thinking that would suggest that if you decrease the silicone oil level, the forces required would increase. Having too great a force required to move the stopper can cause problems during use for some users, for example accurate dose setting or smooth dose delivery may be made more difficult if significant strength is required to move, and/or keep in motion, the stopper. Break loose and slide forces for pre-filled syringes known in the art are typically in the region of less than 20N, but where the pre-filled syringes contain about 100µg-about 800µg silicone oil. In one embodiment the glide/slide force for the stopper within the pre-filled syringe is less than about 11N or less than 9N, less than 7N, less than 5N or between about 3N to 5N. In one embodiment, the break loose force is less than about 11N or less than 9N, less than 7N, less than 5N or between about 2N to 5N. Note that such measurements are for a filled syringe, rather than an empty syringe. The forces are typically measured at a stopper travelling speed of 190mm/min. In one embodiment, the syringe has a nominal maximal fill volume of between about 0.5ml and 1ml, contains less than about 100µg silicone oil and has a break loose force between about 2N to 5N.

In one embodiment the syringe barrel has an internal coating of silicone oil that has an average thickness of about 450nm or less (i.e. 400nm or less, 350nm or less, 300nm or less, 200nm or less, 100nm or less, 50nm or less, 20nm or less). Methods to measure the thickness of silicone oil

PAT055157-AU-Innovation1

in a syringe are known in the art and include the rap.ID Layer Explorer® Application, which can also be used to measure the mass of silicone oil inside a syringe barrel.

In one embodiment, the syringe is silicone oil free, or substantially silicone oil free. Such low silicone oil levels can be achieved by using uncoated syringe barrels and/or by avoiding the use of silicone oil as a lubricant for product contacting machine parts, or pumps in the syringe assembly and fill line.

The syringe according to the invention may also meet certain requirements for particulate content. In one embodiment, the ophthalmic solution comprises no more than 2 particles $\geq 50\mu\text{m}$ in diameter per ml. In one embodiment, the ophthalmic solution comprises no more than 5 particles $\geq 25\mu\text{m}$ in diameter per ml. In one embodiment, the ophthalmic solution comprises no more than 50 particles $\geq 10\mu\text{m}$ in diameter per ml. In one embodiment, the ophthalmic solution comprises no more than 2 particles $\geq 50\mu\text{m}$ in diameter per ml, no more than 5 particles $\geq 25\mu\text{m}$ in diameter per ml and no more than 50 particles $\geq 10\mu\text{m}$ in diameter per ml. In one embodiment, a syringe according to the invention meets USP789. In one embodiment the syringe has low levels of silicone oil sufficient for the syringe to meet USP789.

VEGF Antagonists

Antibody VEGF antagonists

VEGF is a well-characterised signal protein which stimulates angiogenesis. Two antibody VEGF antagonists have been approved for human use, namely ranibizumab (Lucentis®) and bevacizumab (Avastin®).

Non-Antibody VEGF antagonists

In one aspect of the invention, the non-antibody VEGF antagonist is an immunoadhesin. One such immunoadhesin is aflibercept (Eylea®), which has recently been approved for human use and is also known as VEGF-trap (Holash *et al.* (2002) *PNAS USA* 99:11393-98; Riely & Miller (2007) *Clin Cancer Res* 13:4623-7s). Aflibercept is the preferred non-antibody VEGF antagonist for use with the invention. Aflibercept is a recombinant human soluble VEGF receptor fusion protein consisting of portions of human VEGF receptors 1 and 2 extracellular domains fused to the Fc portion of human IgG1. It is a dimeric glycoprotein with a protein molecular weight of 97 kilodaltons (kDa) and contains glycosylation, constituting an additional 15% of the total molecular mass, resulting in a total molecular weight of 115 kDa. It is conveniently produced as

2012101677 16 Nov 2012

PAT055157-AU-Innovation1

a glycoprotein by expression in recombinant CHO K1 cells. Each monomer can have the following amino acid sequence (SEQ ID NO: 1):

SDTGRPFVEMYSEIPEIIHMTEGRELVIPCRVTSPNITVTLKKFPLDTLIPDGKRIIWDSRKGFIISNATY
KEIGLLTCEATVNGHLYKTNYLTHRQTNTIIDVVLSPSHGIELSVGEKLVLNCTARTELVNGIDFNWEYPS
SKHQHKKLVNRDLKTQSGSEMKKFLSTLTIDGVTRSDQGLYTCAASSGLMTKKNSTFVVRVHEKDKTHTCPP
CPAPELLGGPSVFLFPPKPKDTLMI SRTPEVTCVVVDVSHEDPEVKFNWYVDGVEVHNAKTKPREEQYNST
YRVVSVLTVLHQDWLNGKEYKCKVSNKALPAPIEKTISKAKGQPREPQVYTLPPSRDELTKNQVSLTCLVK
GFYPSDIAVEWESNGQPENNYKTPPVLDSDGSFFLYSKLTVDKSRWQQGNVVFSCSVMEALHNHYTQKSL
SLSPG

and disulfide bridges can be formed between residues 30-79, 124-185, 246-306 and 352-410 within each monomer, and between residues 211-211 and 214-214 between the monomers.

Another non-antibody VEGF antagonist immunoadhesin currently in pre-clinical development is a recombinant human soluble VEGF receptor fusion protein similar to VEGF-trap containing extracellular ligand-binding domains 3 and 4 from VEGFR2/KDR, and domain 2 from VEGFR1/Flt-1; these domains are fused to a human IgG Fc protein fragment (Li et al., 2011 *Molecular Vision* 17:797-803). This antagonist binds to isoforms VEGF-A, VEGF-B and VEGF-C. The molecule is prepared using two different production processes resulting in different glycosylation patterns on the final proteins. The two glycoforms are referred to as KH902 (conbercept) and KH906. The fusion protein can have the following amino acid sequence (SEQ ID NO:2):

MVSYWDTGVLLCALLSCLLLTGSSSGRPFVEMYSEIPEIIHMTEGRELVIPCRVTSPNITVTLKKFPLDT
LIPDGKRIIWDSRKGFIISNATYKEIGLLTCEATVNGHLYKTNYLTHRQTNTIIDVVLSPSHGIELSVGEK
LVLNCTARTELVNGIDFNWEYPSKHKQHKKLVNRDLKTQSGSEMKKFLSTLTIDGVTRSDQGLYTCAASSG
LMTKKNSTFVVRVHEKPFVAFGSGMESLVEATVGERVRLPAKYLGYPPEIKWYKNGIPLSNHTIKAGHVL
IMEVSRDGTGNYTVILTNPISKEKQSHVVSLVVYVPPGPGDKTHTCPLCPAPELLGGPSVFLFPPKPKDT
LMI SRTPEVTCVVVDVSHEDPEVKFNWYVDGVEVHNAKTKPREEQYNSTYRVVSVLTVLHQDWLNGKEYK
KVSNAKALPAPIEKTISKAKGQPREPQVYTLPPSRDELTKNQVSLTCLVKGFYPSDIAVEWESNGQPENNYK
ATPPVLDSDGSFFLYSKLTVDKSRWQQGNVVFSCSVMEALHNHYTQKSLSLSPGK

and, like VEGF-trap, can be present as a dimer. This fusion protein and related molecules are further characterized in EP1767546.

Other non-antibody VEGF antagonists include antibody mimetics (e.g. Affibody® molecules, affilins, affitins, anticalins, avimers, Kunitz domain peptides, and monobodies) with VEGF antagonist activity. This includes recombinant binding proteins comprising an ankyrin repeat domain that binds VEGF-A and prevents it from binding to VEGFR-2. One example for such a

2012101677 16 Nov 2012

PAT055157-AU-Innovation1

molecule is DARPin® MP0112. The ankyrin binding domain may have the following amino acid sequence (SEQ ID NO: 3):

```
GSDLGKKLLEAARAGQDDEVRIILMANGADVNTADSTGWTPHLHAVPWGHLEIVEVLLKYGADVNAKDFQGW  
EPLHLAAAIIGHQEIVEVLLKNGADVNAQDKFGKTAFDISIDNGNEDLAEILQKAA
```

5 Recombinant binding proteins comprising an ankyrin repeat domain that binds VEGF-A and prevents it from binding to VEGFR-2 are described in more detail in WO2010/060748 and WO2011/135067.

Further specific antibody mimetics with VEGF antagonist activity are the 40 kD pegylated anticalin PRS-050 and the monobody angicept (CT-322).

0 The afore-mentioned non-antibody VEGF antagonist may be modified to further improve their pharmacokinetic properties or bioavailability. For example, a non-antibody VEGF antagonist may be chemically modified (e.g., pegylated) to extend its *in vivo* half-life. Alternatively or in addition, it may be modified by glycosylation or the addition of further glycosylation sites not present in the protein sequence of the natural protein from which the VEGF antagonist was
5 derived.

Variants of the above-specified VEGF antagonists that have improved characteristics for the desired application may be produced by the addition or deletion of amino acids. Ordinarily, these amino acid sequence variants will have an amino acid sequence having at least 60% amino acid sequence identity with the amino acid sequences of SEQ ID NO: 1, SEQ ID NO: 2 or SEQ ID
10 NO: 3, preferably at least 80%, more preferably at least 85%, more preferably at least 90%, and most preferably at least 95%, including for example, 80%, 81%, 82%, 83%, 84%, 85%, 86%, 87%, 88%, 89%, 90%, 91%, 92%, 93%, 94%, 95%, 96%, 97%, 98%, 99%, and 100%. Identity or homology with respect to this sequence is defined herein as the percentage of amino acid residues in the candidate sequence that are identical with SEQ ID NO: 1, SEQ ID NO: 2 or SEQ
25 ID NO: 3, after aligning the sequences and introducing gaps, if necessary, to achieve the maximum percent sequence identity, and not considering any conservative substitutions as part of the sequence identity.

Sequence identity can be determined by standard methods that are commonly used to compare the similarity in position of the amino acids of two polypeptides. Using a computer program
30 such as BLAST or FASTA, two polypeptides are aligned for optimal matching of their respective amino acids (either along the full length of one or both sequences or along a pre-

PAT055157-AU-Innovation1

5 determined portion of one or both sequences). The programs provide a default opening penalty and a default gap penalty, and a scoring matrix such as PAM 250 [a standard scoring matrix; see Dayhoff et al., in Atlas of Protein Sequence and Structure, vol. 5, supp. 3 (1978)] can be used in conjunction with the computer program. For example, the percent identity can then be calculated as: the total number of identical matches multiplied by 100 and then divided by the sum of the length of the longer sequence within the matched span and the number of gaps introduced into the longer sequences in order to align the two sequences.

0 Preferably, the non-antibody VEGF antagonist of the invention binds to VEGF via one or more protein domain(s) that are not derived from the antigen-binding domain of an antibody. The non-antibody VEGF antagonist of the invention are preferably proteinaceous, but may include modifications that are non-proteinaceous (e.g., pegylation, glycosylation).

Therapy

5 The syringe of the invention may be used to treat an ocular disease, including but not limited to choroidal neovascularisation, age-related macular degeneration (both wet and dry forms), macular edema secondary to retinal vein occlusion (RVO) including both branch RVO (bRVO) and central RVO (cRVO), choroidal neovascularisation secondary to pathologic myopia (PM), diabetic macular edema (DME), diabetic retinopathy, and proliferative retinopathy.

0 Thus the invention provides a method of treating a patient suffering from of an ocular disease selected from choroidal neovascularisation, wet age-related macular degeneration, macular edema secondary to retinal vein occlusion (RVO) including both branch RVO (bRVO) and central RVO (cRVO), choroidal neovascularisation secondary to pathologic myopia (PM), diabetic macular edema (DME), diabetic retinopathy, and proliferative retinopathy, comprising the step of administering an ophthalmic solution to the patient using a pre-filled syringe of the invention. This method preferably further comprises an initial priming step in which the
25 physician depresses the plunger of the pre-filled syringe to align the pre-determined part of the stopper with the priming mark.

30 In one embodiment, the invention provides a method of treating an ocular disease selected from choroidal neovascularisation, wet age-related macular degeneration, macular edema secondary to retinal vein occlusion (RVO) including both branch RVO (bRVO) and central RVO (cRVO), choroidal neovascularisation secondary to pathologic myopia (PM), diabetic macular edema (DME), diabetic retinopathy, and proliferative retinopathy, comprising administering a non-

PAT055157-AU-Innovation1

antibody VEGF antagonist with a pre-filled syringe of the invention, wherein the patient has previously received treatment with an antibody VEGF antagonist.

Kits

Also provided are kits comprising the pre-filled syringes of the invention. In one embodiment, such a kit comprises a pre-filled syringe of the invention in a blister pack. The blister pack may itself be sterile on the inside. In one embodiment, syringes according to the invention may be placed inside such blister packs prior to undergoing sterilisation, for example terminal sterilisation.

Such a kit may further comprise a needle for administration of the VEGF antagonist. If the VEGF antagonist is to be administered intravitreally, it is typical to use a 30-gauge x ½ inch needle, though 31-gauge and 32-gauge needles may be used. For intravitreal administration, 33-gauge or 34-gauge needles could alternatively be used. Such kits may further comprise instructions for use. In one embodiment, the invention provides a carton containing a pre-filled syringe according to the invention contained within a blister pack, a needle and optionally instructions for administration.

Sterilisation

As noted above, a terminal sterilisation process may be used to sterilise the syringe and such a process may use a known process such as an ethylene oxide or a hydrogen peroxide sterilisation process. Needles to be used with the syringe may be sterilised by the same method, as may kits according to the invention.

The package is exposed to the sterilising gas until the outside of the syringe is sterile. Following such a process, the outer surface of the syringe may remain sterile (whilst in its blister pack) for up to 6 months, 9 months, 12 months, 15 months, 18 months or longer. In one embodiment, less than one syringe in a million has detectable microbial presence on the outside of the syringe after 18 months of storage. In one embodiment, the pre-filled syringe has been sterilised using EtO with a Sterility Assurance Level of at least 10^{-6} . In one embodiment, the pre-filled syringe has been sterilised using hydrogen peroxide with a Sterility Assurance Level of at least 10^{-6} . Of course, it is a requirement that significant amounts of the sterilising gas should not enter the variable volume chamber of the syringe. The term “significant amounts” as used herein refers to an amount of gas that would cause unacceptable modification of the ophthalmic solution within the variable volume chamber. In one embodiment, the sterilisation process causes $\leq 10\%$

2012101677 16 Nov 2012 5 0

PAT055157-AU-Innovation1

(preferably $\leq 5\%$, $\leq 3\%$, $\leq 1\%$) alkylation of the VEGF antagonist. In one embodiment, the pre-filled syringe has been sterilised using EtO, but the outer surface of the syringe has $\leq 1\text{ppm}$, preferably $\leq 0.2\text{ppm}$ EtO residue. In one embodiment, the pre-filled syringe has been sterilised using hydrogen peroxide, but the outer surface of the syringe has $\leq 1\text{ppm}$, preferably $\leq 0.2\text{ppm}$ hydrogen peroxide residue. In another embodiment, the pre-filled syringe has been sterilised using EtO, and the total EtO residue found on the outside of the syringe and inside of the blister pack is $\leq 0.1\text{mg}$. In another embodiment, the pre-filled syringe has been sterilised using hydrogen peroxide, and the total hydrogen peroxide residue found on the outside of the syringe and inside of the blister pack is $\leq 0.1\text{mg}$.

General

The term “comprising” means “including” as well as “consisting” *e.g.* a composition “comprising” X may consist exclusively of X or may include something additional *e.g.* X + Y.

The term “about” in relation to a numerical value *x* means, for example, $x \pm 10\%$.

5 References to a percentage sequence identity between two amino acid sequences means that, when aligned, that percentage of amino acids are the same in comparing the two sequences. This alignment and the percent homology or sequence identity can be determined using software programs known in the art, for example those described in section 7.7.18 of *Current Protocols in Molecular Biology* (F.M. Ausubel *et al.*, eds., 1987) Supplement 30. A preferred alignment is
20 determined by the Smith-Waterman homology search algorithm using an affine gap search with a gap open penalty of 12 and a gap extension penalty of 2, BLOSUM matrix of 62. The Smith-Waterman homology search algorithm is disclosed in Smith & Waterman (1981) *Adv. Appl. Math.* 2: 482-489

BRIEF DESCRIPTION OF THE FIGURES

- 25 Figure 1 shows a side view of a syringe
- Figure 2 shows a cross section of a top down view of a syringe
- Figure 3 shows a view of a plunger
- Figure 4 shows a cross section through a plunger
- Figure 5 shows a stopper

2012101677 16 Nov 2012

MODES FOR CARRYING OUT THE INVENTION

The invention will now be further described, by way of example only, with reference to the drawings.

5 Figure 1 shows a view from a side of a syringe 1 comprising a body 2, plunger 4, backstop 6 and a sealing device 8.

Figure 2 shows a cross section through the syringe 1 of Figure 1 from above. The syringe 1 is suitable for use in an ophthalmic injection. The syringe 1 comprises a body 2, a stopper 10 and a plunger 4. The syringe 1 extends along a first axis A. The body 2 comprises an outlet 12 at an outlet end 14 and the stopper 10 is arranged within the body 2 such that a front surface 16 of the stopper 10 and the body 2 define a variable volume chamber 18. The variable volume chamber 18 contains an injectable medicament 20 comprising an ophthalmic solution comprising a VEGF antagonist such as ranibizumab. The injectable fluid 20 can be expelled through the outlet 12 by movement of the stopper 10 towards the outlet end 14 thereby reducing the volume of the variable volume chamber 18. The plunger 4 comprises a plunger contact surface 22 at a first end 24 and a rod 26 extending between the plunger contact surface 22 and a rear portion 25. The plunger contact surface 22 is arranged to contact the stopper 10, such that the plunger 4 can be used to move the stopper 10 towards the outlet end 14 of the body 2. Such movement reduces the volume of the variable volume chamber 18 and causes fluid therein to be expelled through the outlet.

20 The backstop 6 is attached to the body 2 by coupling to a terminal flange 28 of the body 2. The backstop 6 includes sandwich portion 30 which is adapted to substantially sandwich at least some of the terminal flange 28 of the body 2. The backstop 6 is adapted to be coupled to the body 2 from the side by leaving one side of the backstop 6 open so that the backstop 6 can be fitted to the syringe 2.

25 The body 2 defines a substantially cylindrical bore 36 which has a bore radius. The rod 26 comprises a rod shoulder 32 directed away from the outlet end 14. The rod shoulder 32 extends from to a rod shoulder radius from the first axis A which is such that it is slightly less than the bore radius so that the shoulder fits within the bore 36. The backstop 6 includes a backstop shoulder 34 directed towards the outlet end 14. The shoulders 32, 34 are configured to cooperate to substantially prevent movement of the rod 26 away from the outlet end 14 when the backstop shoulder 34 and rod shoulder 32 are in contact. The backstop shoulder 34 extends from outside the

30

PAT055157-AU-Innovation1

bore radius to a radius less than the rod shoulder radius so that the rod shoulder 32 cannot pass the backstop shoulder 34 by moving along the first axis A. In this case the rod shoulder 32 is substantially disc, or ring, shaped and the backstop shoulder 34 includes an arc around a rear end 38 of the body 2.

5 The backstop 6 also includes two finger projections 40 which extend in opposite directions away from the body 2 substantially perpendicular to the first axis A to facilitate manual handling of the syringe 1 during use.

In this example the syringe comprises a 0.5ml body 2 filled with between about 0.1 and 0.3 ml of an injectable medicament 20 comprising a 10mg/ml injectable solution comprising ranibizumab. The syringe body 2 has an internal diameter of about between about 4.5mm and 4.8mm, a length of between about 45mm and 50mm.

The plunger 4 and stopper 10 will be described in more detail with reference to later figures.

Figure 3 shows a perspective view of the plunger 4 of Figure 1 showing the plunger contact surface 22 at the first end 24 of the plunger 4. The rod 26 extends from the first end 24 to the rear portion 25. The rear portion 25 includes a disc shaped flange 42 to facilitate user handling of the device. The flange 42 provides a larger surface area for contact by the user than a bare end of the rod 26.

Figure 4 shows a cross section through a syringe body 2 and rod 26. The rod 26 includes four longitudinal ribs 44 and the angle between the ribs is 90°.

Figure 5 shows a detailed view of a stopper 10 showing a conical shaped front surface 16 and three circumferential ribs 52,54,56 around a substantially cylindrical body 58. The axial gap between the first rib 52 and the last rib 56 is about 3mm. The rear surface 60 of the stopper 10 includes a substantially central recess 62. The central recess 62 includes an initial bore 64 having a first diameter. The initial bore 64 leading from the rear surface 60 into the stopper 10 to an inner recess 66 having a second diameter, the second diameter being larger than the first diameter.

25

Stopper forces

0.5ml syringes siliconised with <100µg silicone oil, filled with Lucentis, comprising one of two different stopper designs were tested for maximal and average break out and slide force. Prior to testing, 30G x 0.5” needles were attached to the syringes. The testing was carried out at a stopper speed of 190mm/min over a travel length of 10.9mm.

30

2012101677 16 Nov 2012

		Stopper design 1			Stopper design 2	
		Batch A	Batch B	Batch C	Batch D	Batch E
Break loose force of syringes	Average of 10 syringes	2.2N	2.3N	1.9N	2.1N	2.5N
	Max individual value	2.5N	2.5N	2.3N	2.6N	2.7N
Sliding force	Average of 10 syringes	3.1N	3.2N	3.1N	4.1N	4.6N
	Max individual value	3.5N	3.5N	3.6N	4.7N	4.8N

For both stopper designs, average and maximum break out force remained below 3N. For both stopper designs, average and maximum sliding force remained below 5N.

5 It will be understood that the invention has been described by way of example only and modifications may be made whilst remaining within the scope and spirit of the invention.

CLAIMS

1. A pre-filled syringe, the syringe comprising a body, a stopper and a plunger, the body comprising an outlet at an outlet end and the stopper being arranged within the body such that a front surface of the stopper and the body define a variable volume chamber from which a fluid can be expelled though the outlet, the plunger comprising a plunger contact surface at a first end and a rod extending between the plunger contact surface and a rear portion, the plunger contact surface arranged to contact the stopper, such that the plunger can be used to force the stopper towards the outlet end of the body, reducing the volume of the variable volume chamber, characterised in that the fluid is an ophthalmic solution which comprises a VEGF-antagonist, wherein:

- (a) the syringe has a nominal maximum fill volume of between about 0.5ml and about 1ml,
 - (b) the syringe is filled with between about 0.15ml and about 0.175ml of said VEGF antagonist solution which comprises a dosage volume of about 0.05ml of said VEGF antagonist solution,
 - (c) the syringe barrel comprises less than about 500µg silicone oil,
 - (d) the VEGF antagonist solution comprises no more than 2 particles $\geq 50\mu\text{m}$ in diameter per ml.
- and
- (e) the VEGF antagonist is the non-antibody VEGF antagonist aflibercept at a concentration of 40mg/ml.

2. A pre-filled syringe according to claim 1, wherein the syringe barrel comprises less than about 100µg silicone oil.

3. A pre-filled syringe according to claim 1 or 2, wherein the syringe has a stopper break loose force of less than about 11N.

4. A pre-filled syringe according to any one of the previous claims, wherein the VEGF antagonist solution further comprises (i) no more than 5 particles $\geq 25\mu\text{m}$ in diameter per ml, (ii) no more than 50 particles $\geq 10\mu\text{m}$ in diameter per ml, or a combination of both (i) and (ii).

5. A blister pack comprising a pre-filled syringe according to any one of the previous claims, wherein the syringe has been sterilised using H₂O₂ to a Sterility Assurance Level of at least 10⁻⁶.

1/1

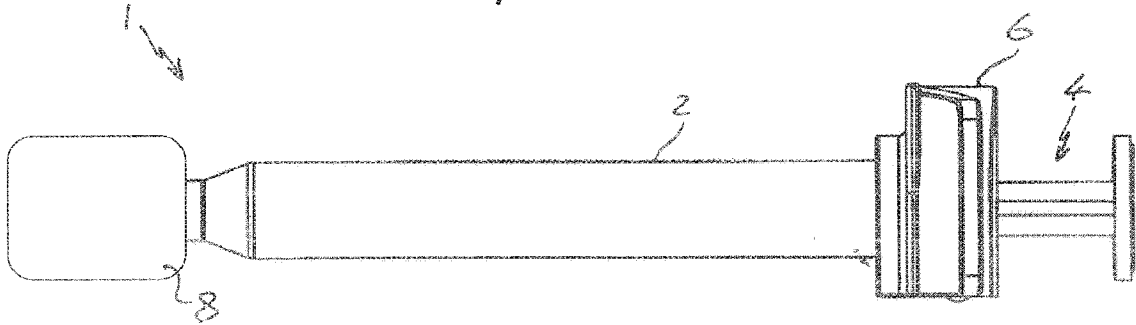

Fig 1

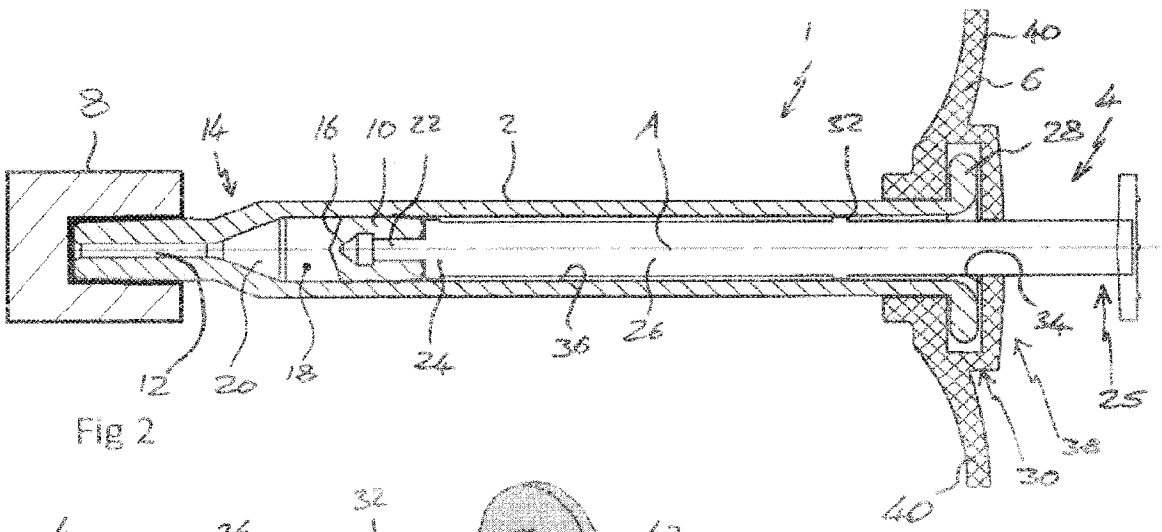

Fig 2

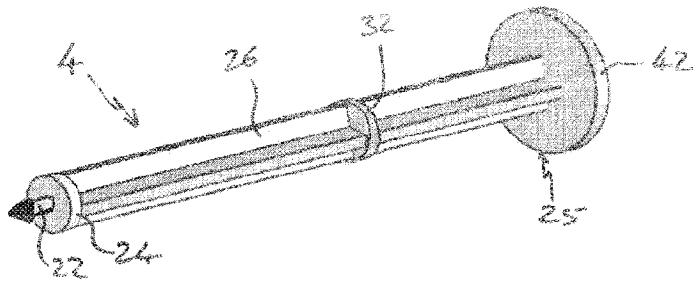

Fig 3

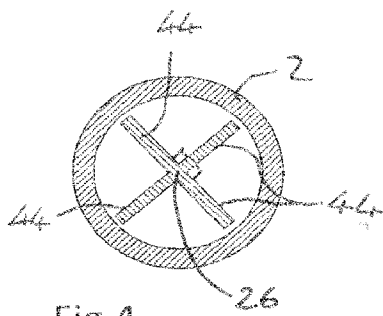

Fig 4

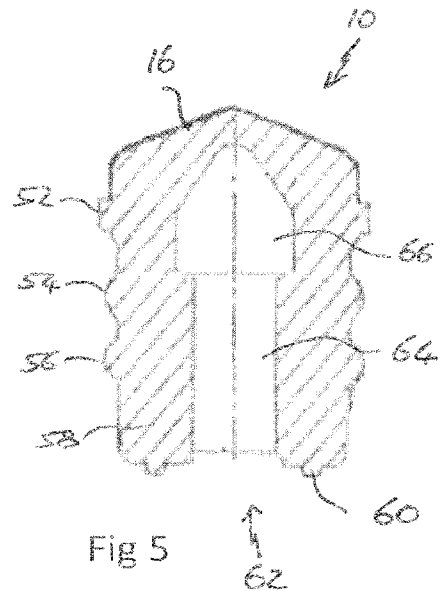

Fig 5

Electronic Patent Application Fee Transmittal

Application Number:	13750352			
Filing Date:	25-Jan-2013			
Title of Invention:	SYRINGE			
First Named Inventor/Applicant Name:	Juergen Sigg			
Filer:	Michael J. Mazza/Linda Adams			
Attorney Docket Number:	PAT055157-US-NP			
Filed as Large Entity				
Filing Fees for Utility under 35 USC 111(a)				
Description	Fee Code	Quantity	Amount	Sub-Total in USD(\$)
Basic Filing:				
Pages:				
Claims:				
Miscellaneous-Filing:				
Petition:				
Patent-Appeals-and-Interference:				
Post-Allowance-and-Post-Issuance:				
Extension-of-Time:				

Description	Fee Code	Quantity	Amount	Sub-Total in USD(\$)
Extension - 1 month with \$0 paid	1251	1	200	200
Miscellaneous:				
RCE- 2nd and Subsequent Request	1820	1	1700	1700
Total in USD (\$)				1900

Electronic Acknowledgement Receipt

EFS ID:	22946179
Application Number:	13750352
International Application Number:	
Confirmation Number:	5306
Title of Invention:	SYRINGE
First Named Inventor/Applicant Name:	Juergen Sigg
Customer Number:	1095
Filer:	Michael J. Mazza/Linda Adams
Filer Authorized By:	Michael J. Mazza
Attorney Docket Number:	PAT055157-US-NP
Receipt Date:	17-JUL-2015
Filing Date:	25-JAN-2013
Time Stamp:	10:50:46
Application Type:	Utility under 35 USC 111(a)

Payment information:

Submitted with Payment	yes
Payment Type	Deposit Account
Payment was successfully received in RAM	\$1900
RAM confirmation Number	8167
Deposit Account	190134
Authorized User	MAZZA, MICHAEL J.

The Director of the USPTO is hereby authorized to charge indicated fees and credit any overpayment as follows:

Charge any Additional Fees required under 37 C.F.R. Section 1.17 (Patent application and reexamination processing fees)

File Listing:					
Document Number	Document Description	File Name	File Size(Bytes)/ Message Digest	Multi Part /.zip	Pages (if appl.)
1	Request for Continued Examination (RCE)	55157_RCE_signed.pdf	1350090 695e50d3310fd7e442643e418de942d4eab2832d	no	3
Warnings:					
Information:					
2	Information Disclosure Statement (IDS) Form (SB08)	updated_IDS_SIGNED.pdf	1036058 94117a65e6cfefbab464958d990a4dffa339514f	no	4
Warnings:					
Information:					
A U.S. Patent Number Citation or a U.S. Publication Number Citation is required in the Information Disclosure Statement (IDS) form for autoloading of data into USPTO systems. You may remove the form to add the required data in order to correct the Informational Message if you are citing U.S. References. If you chose not to include U.S. References, the image of the form will be processed and be made available within the Image File Wrapper (IFW) system. However, no data will be extracted from this form. Any additional data such as Foreign Patent Documents or Non Patent Literature will be manually reviewed and keyed into USPTO systems.					
3	Extension of Time	55157_US_NP-extension_signed.pdf	57540 4209e430550ad5417227f2812469e13e610851bd	no	1
Warnings:					
Information:					
4	Amendment Submitted/Entered with Filing of CPA/RCE	PAT055157-US_resopnse_to_OA_MJMv2.pdf	159006 214f7254c1d30fe66707966bf054dac7c829eb68	no	7
Warnings:					
Information:					
5	Foreign Reference	D12_WO2014005728.pdf	2207457 330b2052176de3bb771ad68875bfe192f57c6a4b	no	27
Warnings:					
Information:					
6	Foreign Reference	D13_AU2012101678A4.pdf	1128011 94e0d9b4742fd2920f75037edb84e6a7dcb80d6a	no	21
Warnings:					
Information:					
7	Foreign Reference	D12_AU2012101677A4.pdf	1009826 5906cb6de6faa58f41ee11ec63bff864cb287be8	no	19

Warnings:					
Information:					
8	Non Patent Literature	1_D5_Chan.pdf	1785996 e36c0b42f5496f7d6ba26763bcd75c52c785 c7f	no	17
Warnings:					
Information:					
9	Non Patent Literature	2_D6_Lankers.pdf	7524624 0a0777a3d6f15c0d85e7d95b7632c59552 ba511	no	46
Warnings:					
Information:					
10	Non Patent Literature	3_D8-Majumdar.pdf	1526569 30a56a62147a12fe82841bcfd4f41502cce4f f52	no	11
Warnings:					
Information:					
11	Non Patent Literature	4_D9-Bakri.pdf	695344 a0a4e5b7e2ee3a7df213adedb4d775ae457 cd73d	no	6
Warnings:					
Information:					
12	Non Patent Literature	7_D7_future.pdf	902542 6a13e663d5302a46ddc56f601d7bec473d 9f5a1	no	3
Warnings:					
Information:					
13	Non Patent Literature	6_D15-Meyer.pdf	573093 2491651d12c32af931f7c0ab220bef697ed5 505c	no	5
Warnings:					
Information:					
14	Fee Worksheet (SB06)	fee-info.pdf	32201 f1b2338133004bc9b672d7366c08cb1e01f 35630	no	2
Warnings:					
Information:					
Total Files Size (in bytes):				19988357	

This Acknowledgement Receipt evidences receipt on the noted date by the USPTO of the indicated documents, characterized by the applicant, and including page counts, where applicable. It serves as evidence of receipt similar to a Post Card, as described in MPEP 503.

New Applications Under 35 U.S.C. 111

If a new application is being filed and the application includes the necessary components for a filing date (see 37 CFR 1.53(b)-(d) and MPEP 506), a Filing Receipt (37 CFR 1.54) will be issued in due course and the date shown on this Acknowledgement Receipt will establish the filing date of the application.

National Stage of an International Application under 35 U.S.C. 371

If a timely submission to enter the national stage of an international application is compliant with the conditions of 35 U.S.C. 371 and other applicable requirements a Form PCT/DO/EO/903 indicating acceptance of the application as a national stage submission under 35 U.S.C. 371 will be issued in addition to the Filing Receipt, in due course.

New International Application Filed with the USPTO as a Receiving Office

If a new international application is being filed and the international application includes the necessary components for an international filing date (see PCT Article 11 and MPEP 1810), a Notification of the International Application Number and of the International Filing Date (Form PCT/RO/105) will be issued in due course, subject to prescriptions concerning national security, and the date shown on this Acknowledgement Receipt will establish the international filing date of the application.

**REQUEST FOR CONTINUED EXAMINATION(RCE)TRANSMITTAL
 (Submitted Only via EFS-Web)**

Application Number	13750352	Filing Date	2013-01-25	Docket Number (if applicable)	PAT055157-US-NP	Art Unit	3763
First Named Inventor	Juergen Sigg			Examiner Name	Aarti Berdichevsky		

This is a Request for Continued Examination (RCE) under 37 CFR 1.114 of the above-identified application.
 Request for Continued Examination (RCE) practice under 37 CFR 1.114 does not apply to any utility or plant application filed prior to June 8, 1995, to any international application that does not comply with the requirements of 35 U.S.C. 371, or to any design application. The Instruction Sheet for this form is located at WWW.USPTO.GOV.

SUBMISSION REQUIRED UNDER 37 CFR 1.114

Note: If the RCE is proper, any previously filed unentered amendments and amendments enclosed with the RCE will be entered in the order in which they were filed unless applicant instructs otherwise. If applicant does not wish to have any previously filed unentered amendment(s) entered, applicant must request non-entry of such amendment(s).

- Previously submitted. If a final Office action is outstanding, any amendments filed after the final Office action may be considered as a submission even if this box is not checked.
- Consider the arguments in the Appeal Brief or Reply Brief previously filed on _____
- Other _____

- Enclosed
- Amendment/Reply
- Information Disclosure Statement (IDS)
- Affidavit(s)/ Declaration(s)
- Other _____

MISCELLANEOUS

- Suspension of action on the above-identified application is requested under 37 CFR 1.103(c) for a period of months _____
 (Period of suspension shall not exceed 3 months; Fee under 37 CFR 1.17(i) required)
- Other _____
 Request for Extension of Time

FEEES

- The RCE fee under 37 CFR 1.17(e) is required by 37 CFR 1.114 when the RCE is filed.**
- The Director is hereby authorized to charge any underpayment of fees, or credit any overpayments, to Deposit Account No 190134

SIGNATURE OF APPLICANT, ATTORNEY, OR AGENT REQUIRED

- Patent Practitioner Signature
- Applicant Signature

Doc code: RCEX
Doc description: Request for Continued Examination (RCE)

PTO/SB/30EFS (07-14)
Approved for use through 07/31/2016. OMB 0651-0031
U.S. Patent and Trademark Office; U.S. DEPARTMENT OF COMMERCE

Under the Paperwork Reduction Act of 1995, no persons are required to respond to a collection of information unless it contains a valid OMB control number.

Signature of Registered U.S. Patent Practitioner			
Signature	/Michael Mazza/	Date (YYYY-MM-DD)	2015-07-16
Name	Michael Mazza	Registration Number	30775

This collection of information is required by 37 CFR 1.114. The information is required to obtain or retain a benefit by the public which is to file (and by the USPTO to process) an application. Confidentiality is governed by 35 U.S.C. 122 and 37 CFR 1.11 and 1.14. This collection is estimated to take 12 minutes to complete, including gathering, preparing, and submitting the completed application form to the USPTO. Time will vary depending upon the individual case. Any comments on the amount of time you require to complete this form and/or suggestions for reducing this burden, should be sent to the Chief Information Officer, U.S. Patent and Trademark Office, U.S. Department of Commerce, P.O. Box 1450, Alexandria, VA 22313-1450.

If you need assistance in completing the form, call 1-800-PTO-9199 and select option 2.

Privacy Act Statement

The Privacy Act of 1974 (P.L. 93-579) requires that you be given certain information in connection with your submission of the attached form related to a patent application or patent. Accordingly, pursuant to the requirements of the Act, please be advised that: (1) the general authority for the collection of this information is 35 U.S.C. 2(b)(2); (2) furnishing of the information solicited is voluntary; and (3) the principal purpose for which the information is used by the U.S. Patent and Trademark Office is to process and/or examine your submission related to a patent application or patent. If you do not furnish the requested information, the U.S. Patent and Trademark Office may not be able to process and/or examine your submission, which may result in termination of proceedings or abandonment of the application or expiration of the patent.

The information provided by you in this form will be subject to the following routine uses:

1. The information on this form will be treated confidentially to the extent allowed under the Freedom of Information Act (5 U.S.C. 552) and the Privacy Act (5 U.S.C. 552a). Records from this system of records may be disclosed to the Department of Justice to determine whether the Freedom of Information Act requires disclosure of these records.
2. A record from this system of records may be disclosed, as a routine use, in the course of presenting evidence to a court, magistrate, or administrative tribunal, including disclosures to opposing counsel in the course of settlement negotiations.
3. A record in this system of records may be disclosed, as a routine use, to a Member of Congress submitting a request involving an individual, to whom the record pertains, when the individual has requested assistance from the Member with respect to the subject matter of the record.
4. A record in this system of records may be disclosed, as a routine use, to a contractor of the Agency having need for the information in order to perform a contract. Recipients of information shall be required to comply with the requirements of the Privacy Act of 1974, as amended, pursuant to 5 U.S.C. 552a(m).
5. A record related to an International Application filed under the Patent Cooperation Treaty in this system of records may be disclosed, as a routine use, to the International Bureau of the World Intellectual Property Organization, pursuant to the Patent Cooperation Treaty.
6. A record in this system of records may be disclosed, as a routine use, to another federal agency for purposes of National Security review (35 U.S.C. 181) and for review pursuant to the Atomic Energy Act (42 U.S.C. 218(c)).
7. A record from this system of records may be disclosed, as a routine use, to the Administrator, General Services, or his/her designee, during an inspection of records conducted by GSA as part of that agency's responsibility to recommend improvements in records management practices and programs, under authority of 44 U.S.C. 2904 and 2906. Such disclosure shall be made in accordance with the GSA regulations governing inspection of records for this purpose, and any other relevant (i.e., GSA or Commerce) directive. Such disclosure shall not be used to make determinations about individuals.
8. A record from this system of records may be disclosed, as a routine use, to the public after either publication of the application pursuant to 35 U.S.C. 122(b) or issuance of a patent pursuant to 35 U.S.C. 151. Further, a record may be disclosed, subject to the limitations of 37 CFR 1.14, as a routine use, to the public if the record was filed in an application which became abandoned or in which the proceedings were terminated and which application is referenced by either a published application, an application open to public inspections or an issued patent.
9. A record from this system of records may be disclosed, as a routine use, to a Federal, State, or local law enforcement agency, if the USPTO becomes aware of a violation or potential violation of law or regulation.

Under the Paperwork Reduction Act of 1995, no persons are required to respond to a collection of information unless it displays a valid OMB control number.

PATENT APPLICATION FEE DETERMINATION RECORD Substitute for Form PTO-875	Application or Docket Number 13/750,352	Filing Date 01/25/2013	<input type="checkbox"/> To be Mailed
-----------------------------------------------------------------------------------	---------------------------------------------------	----------------------------------	---------------------------------------

ENTITY: LARGE SMALL MICRO

APPLICATION AS FILED – PART I

FOR	NUMBER FILED	NUMBER EXTRA	RATE (\$)	FEE (\$)
<input type="checkbox"/> BASIC FEE (37 CFR 1.16(a), (b), or (c))	N/A	N/A	N/A	
<input type="checkbox"/> SEARCH FEE (37 CFR 1.16(k), (l), or (m))	N/A	N/A	N/A	
<input type="checkbox"/> EXAMINATION FEE (37 CFR 1.16(o), (p), or (q))	N/A	N/A	N/A	
TOTAL CLAIMS (37 CFR 1.16(j))	minus 20 =	*	X \$ =	
INDEPENDENT CLAIMS (37 CFR 1.16(h))	minus 3 =	*	X \$ =	
<input type="checkbox"/> APPLICATION SIZE FEE (37 CFR 1.16(s))	If the specification and drawings exceed 100 sheets of paper, the application size fee due is \$310 (\$155 for small entity) for each additional 50 sheets or fraction thereof. See 35 U.S.C. 41(a)(1)(G) and 37 CFR 1.16(s).			
<input type="checkbox"/> MULTIPLE DEPENDENT CLAIM PRESENT (37 CFR 1.16(j))				
* If the difference in column 1 is less than zero, enter "0" in column 2.			TOTAL	

APPLICATION AS AMENDED – PART II

	(Column 1)	(Column 2)	(Column 3)	(Column 3)	RATE (\$)	ADDITIONAL FEE (\$)
AMENDMENT	07/17/2015	CLAIMS REMAINING AFTER AMENDMENT	HIGHEST NUMBER PREVIOUSLY PAID FOR	PRESENT EXTRA		
	Total (37 CFR 1.16(i))	* 26	Minus ** 31	= 0	X \$80 =	0
	Independent (37 CFR 1.16(h))	* 1	Minus ***3	= 0	X \$420 =	0
	<input type="checkbox"/> Application Size Fee (37 CFR 1.16(s))					
<input type="checkbox"/> FIRST PRESENTATION OF MULTIPLE DEPENDENT CLAIM (37 CFR 1.16(j))						
					TOTAL ADD'L FEE	0

	(Column 1)	(Column 2)	(Column 3)	(Column 3)	RATE (\$)	ADDITIONAL FEE (\$)
AMENDMENT		CLAIMS REMAINING AFTER AMENDMENT	HIGHEST NUMBER PREVIOUSLY PAID FOR	PRESENT EXTRA		
	Total (37 CFR 1.16(i))	*	Minus **	=	X \$ =	
	Independent (37 CFR 1.16(h))	*	Minus ***	=	X \$ =	
	<input type="checkbox"/> Application Size Fee (37 CFR 1.16(s))					
<input type="checkbox"/> FIRST PRESENTATION OF MULTIPLE DEPENDENT CLAIM (37 CFR 1.16(j))						
					TOTAL ADD'L FEE	

* If the entry in column 1 is less than the entry in column 2, write "0" in column 3.
 ** If the "Highest Number Previously Paid For" IN THIS SPACE is less than 20, enter "20".
 *** If the "Highest Number Previously Paid For" IN THIS SPACE is less than 3, enter "3".

LIE
/ANGELONA JONES/

The "Highest Number Previously Paid For" (Total or Independent) is the highest number found in the appropriate box in column 1.

This collection of information is required by 37 CFR 1.16. The information is required to obtain or retain a benefit by the public which is to file (and by the USPTO to process) an application. Confidentiality is governed by 35 U.S.C. 122 and 37 CFR 1.14. This collection is estimated to take 12 minutes to complete, including gathering, preparing, and submitting the completed application form to the USPTO. Time will vary depending upon the individual case. Any comments on the amount of time you require to complete this form and/or suggestions for reducing this burden, should be sent to the Chief Information Officer, U.S. Patent and Trademark Office, U.S. Department of Commerce, P.O. Box 1450, Alexandria, VA 22313-1450. DO NOT SEND FEES OR COMPLETED FORMS TO THIS ADDRESS. **SEND TO: Commissioner for Patents, P.O. Box 1450, Alexandria, VA 22313-1450.**

If you need assistance in completing the form, call 1-800-PTO-9199 and select option 2.



UNITED STATES PATENT AND TRADEMARK OFFICE

UNITED STATES DEPARTMENT OF COMMERCE
United States Patent and Trademark Office
Address: COMMISSIONER FOR PATENTS
P.O. Box 1450
Alexandria, Virginia 22313-1450
www.uspto.gov

NOTICE OF ALLOWANCE AND FEE(S) DUE

1095 7590 08/19/2015
NOVARTIS PHARMACEUTICAL CORPORATION
INTELLECTUAL PROPERTY DEPARTMENT
ONE HEALTH PLAZA 433/2
EAST HANOVER, NJ 07936-1080

EXAMINER

BERDICHEVSKY, AARTI

ART UNIT PAPER NUMBER

3763

DATE MAILED: 08/19/2015

Table with 5 columns: APPLICATION NO., FILING DATE, FIRST NAMED INVENTOR, ATTORNEY DOCKET NO., CONFIRMATION NO.
13/750,352 01/25/2013 Juergen Sigg PAT055157-US-NP 5306

TITLE OF INVENTION: SYRINGE

Table with 7 columns: APPLN. TYPE, ENTITY STATUS, ISSUE FEE DUE, PUBLICATION FEE DUE, PREV. PAID ISSUE FEE, TOTAL FEE(S) DUE, DATE DUE
nonprovisional UNDISCOUNTED \$960 \$0 \$0 \$960 11/19/2015

THE APPLICATION IDENTIFIED ABOVE HAS BEEN EXAMINED AND IS ALLOWED FOR ISSUANCE AS A PATENT. PROSECUTION ON THE MERITS IS CLOSED. THIS NOTICE OF ALLOWANCE IS NOT A GRANT OF PATENT RIGHTS. THIS APPLICATION IS SUBJECT TO WITHDRAWAL FROM ISSUE AT THE INITIATIVE OF THE OFFICE OR UPON PETITION BY THE APPLICANT. SEE 37 CFR 1.313 AND MPEP 1308.

THE ISSUE FEE AND PUBLICATION FEE (IF REQUIRED) MUST BE PAID WITHIN THREE MONTHS FROM THE MAILING DATE OF THIS NOTICE OR THIS APPLICATION SHALL BE REGARDED AS ABANDONED. THIS STATUTORY PERIOD CANNOT BE EXTENDED. SEE 35 U.S.C. 151. THE ISSUE FEE DUE INDICATED ABOVE DOES NOT REFLECT A CREDIT FOR ANY PREVIOUSLY PAID ISSUE FEE IN THIS APPLICATION. IF AN ISSUE FEE HAS PREVIOUSLY BEEN PAID IN THIS APPLICATION (AS SHOWN ABOVE), THE RETURN OF PART B OF THIS FORM WILL BE CONSIDERED A REQUEST TO REAPPLY THE PREVIOUSLY PAID ISSUE FEE TOWARD THE ISSUE FEE NOW DUE.

HOW TO REPLY TO THIS NOTICE:

I. Review the ENTITY STATUS shown above. If the ENTITY STATUS is shown as SMALL or MICRO, verify whether entitlement to that entity status still applies.

If the ENTITY STATUS is the same as shown above, pay the TOTAL FEE(S) DUE shown above.

If the ENTITY STATUS is changed from that shown above, on PART B - FEE(S) TRANSMITTAL, complete section number 5 titled "Change in Entity Status (from status indicated above)".

For purposes of this notice, small entity fees are 1/2 the amount of undiscounted fees, and micro entity fees are 1/2 the amount of small entity fees.

II. PART B - FEE(S) TRANSMITTAL, or its equivalent, must be completed and returned to the United States Patent and Trademark Office (USPTO) with your ISSUE FEE and PUBLICATION FEE (if required). If you are charging the fee(s) to your deposit account, section "4b" of Part B - Fee(s) Transmittal should be completed and an extra copy of the form should be submitted. If an equivalent of Part B is filed, a request to reapply a previously paid issue fee must be clearly made, and delays in processing may occur due to the difficulty in recognizing the paper as an equivalent of Part B.

III. All communications regarding this application must give the application number. Please direct all communications prior to issuance to Mail Stop ISSUE FEE unless advised to the contrary.

IMPORTANT REMINDER: Utility patents issuing on applications filed on or after Dec. 12, 1980 may require payment of maintenance fees. It is patentee's responsibility to ensure timely payment of maintenance fees when due.

PART B - FEE(S) TRANSMITTAL

**Complete and send this form, together with applicable fee(s), to: Mail Mail Stop ISSUE FEE
 Commissioner for Patents
 P.O. Box 1450
 Alexandria, Virginia 22313-1450
 or Fax (571)-273-2885**

INSTRUCTIONS: This form should be used for transmitting the ISSUE FEE and PUBLICATION FEE (if required). Blocks 1 through 5 should be completed where appropriate. All further correspondence including the Patent, advance orders and notification of maintenance fees will be mailed to the current correspondence address as indicated unless corrected below or directed otherwise in Block 1, by (a) specifying a new correspondence address; and/or (b) indicating a separate "FEE ADDRESS" for maintenance fee notifications.

CURRENT CORRESPONDENCE ADDRESS (Note: Use Block 1 for any change of address)

Note: A certificate of mailing can only be used for domestic mailings of the Fee(s) Transmittal. This certificate cannot be used for any other accompanying papers. Each additional paper, such as an assignment or formal drawing, must have its own certificate of mailing or transmission.

1095 7590 08/19/2015
NOVARTIS PHARMACEUTICAL CORPORATION
INTELLECTUAL PROPERTY DEPARTMENT
ONE HEALTH PLAZA 433/2
EAST HANOVER, NJ 07936-1080

Certificate of Mailing or Transmission

I hereby certify that this Fee(s) Transmittal is being deposited with the United States Postal Service with sufficient postage for first class mail in an envelope addressed to the Mail Stop ISSUE FEE address above, or being facsimile transmitted to the USPTO (571) 273-2885, on the date indicated below.

_____ (Depositor's name)
_____ (Signature)
_____ (Date)

APPLICATION NO.	FILING DATE	FIRST NAMED INVENTOR	ATTORNEY DOCKET NO.	CONFIRMATION NO.
13/750,352	01/25/2013	Juergen Sigg	PAT055157-US-NP	5306

TITLE OF INVENTION: SYRINGE

APPLN. TYPE	ENTITY STATUS	ISSUE FEE DUE	PUBLICATION FEE DUE	PREV. PAID ISSUE FEE	TOTAL FEE(S) DUE	DATE DUE
nonprovisional	UNDISCOUNTED	\$960	\$0	\$0	\$960	11/19/2015

EXAMINER	ART UNIT	CLASS-SUBCLASS
BERDICHEVSKY, AARTI	3763	604-218000

<p>1. Change of correspondence address or indication of "Fee Address" (37 CFR 1.363).</p> <p><input type="checkbox"/> Change of correspondence address (or Change of Correspondence Address form PTO/SB/122) attached.</p> <p><input type="checkbox"/> "Fee Address" indication (or "Fee Address" Indication form PTO/SB/47; Rev 03-02 or more recent) attached. Use of a Customer Number is required.</p>	<p>2. For printing on the patent front page, list</p> <p>(1) The names of up to 3 registered patent attorneys or agents OR, alternatively, 1 _____</p> <p>(2) The name of a single firm (having as a member a registered attorney or agent) and the names of up to 2 registered patent attorneys or agents. If no name is listed, no name will be printed. 2 _____</p> <p>3 _____</p>
-------------------------------------------------------------------------------------------------------------------------------------------------------------------------------------------------------------------------------------------------------------------------------------------------------------------------------------------------------------------------------------------------------------------	---------------------------------------------------------------------------------------------------------------------------------------------------------------------------------------------------------------------------------------------------------------------------------------------------------------------------------------------------------------------------------------

3. ASSIGNEE NAME AND RESIDENCE DATA TO BE PRINTED ON THE PATENT (print or type)

PLEASE NOTE: Unless an assignee is identified below, no assignee data will appear on the patent. If an assignee is identified below, the document has been filed for recordation as set forth in 37 CFR 3.11. Completion of this form is NOT a substitute for filing an assignment.

(A) NAME OF ASSIGNEE _____ (B) RESIDENCE: (CITY and STATE OR COUNTRY) _____

Please check the appropriate assignee category or categories (will not be printed on the patent) : Individual Corporation or other private group entity Government

<p>4a. The following fee(s) are submitted:</p> <p><input type="checkbox"/> Issue Fee</p> <p><input type="checkbox"/> Publication Fee (No small entity discount permitted)</p> <p><input type="checkbox"/> Advance Order - # of Copies _____</p>	<p>4b. Payment of Fee(s): (Please first reapply any previously paid issue fee shown above)</p> <p><input type="checkbox"/> A check is enclosed.</p> <p><input type="checkbox"/> Payment by credit card. Form PTO-2038 is attached.</p> <p><input type="checkbox"/> The director is hereby authorized to charge the required fee(s), any deficiency, or credits any overpayment, to Deposit Account Number _____ (enclose an extra copy of this form).</p>
-------------------------------------------------------------------------------------------------------------------------------------------------------------------------------------------------------------------------------------------------	-----------------------------------------------------------------------------------------------------------------------------------------------------------------------------------------------------------------------------------------------------------------------------------------------------------------------------------------------------------------------------------------------------------------------------------------------------------

5. **Change in Entity Status** (from status indicated above)

Applicant certifying micro entity status. See 37 CFR 1.29

Applicant asserting small entity status. See 37 CFR 1.27

Applicant changing to regular undiscounted fee status.

NOTE: Absent a valid certification of Micro Entity Status (see forms PTO/SB/15A and 15B), issue fee payment in the micro entity amount will not be accepted at the risk of application abandonment.

NOTE: If the application was previously under micro entity status, checking this box will be taken to be a notification of loss of entitlement to micro entity status.

NOTE: Checking this box will be taken to be a notification of loss of entitlement to small or micro entity status, as applicable.

NOTE: This form must be signed in accordance with 37 CFR 1.31 and 1.33. See 37 CFR 1.4 for signature requirements and certifications.

Authorized Signature _____ Date _____

Typed or printed name _____ Registration No. _____



UNITED STATES PATENT AND TRADEMARK OFFICE

UNITED STATES DEPARTMENT OF COMMERCE
United States Patent and Trademark Office
Address: COMMISSIONER FOR PATENTS
P.O. Box 1450
Alexandria, Virginia 22313-1450
www.uspto.gov

Table with 5 columns: APPLICATION NO., FILING DATE, FIRST NAMED INVENTOR, ATTORNEY DOCKET NO., CONFIRMATION NO.
Row 1: 13/750,352, 01/25/2013, Juergen Sigg, PAT055157-US-NP, 5306
Row 2: 1095, 7590, 08/19/2015, [Empty], [Empty]
Row 3: [Empty], [Empty], [Empty], EXAMINER, [Empty]
Row 4: [Empty], [Empty], [Empty], BERDICHEVSKY, AARTI, [Empty]
Row 5: [Empty], [Empty], [Empty], ART UNIT, PAPER NUMBER
Row 6: [Empty], [Empty], [Empty], 3763, [Empty]

NOVARTIS PHARMACEUTICAL CORPORATION
INTELLECTUAL PROPERTY DEPARTMENT
ONE HEALTH PLAZA 433/2
EAST HANOVER, NJ 07936-1080

DATE MAILED: 08/19/2015

Determination of Patent Term Adjustment under 35 U.S.C. 154 (b)
(Applications filed on or after May 29, 2000)

The Office has discontinued providing a Patent Term Adjustment (PTA) calculation with the Notice of Allowance.

Section 1(h)(2) of the AIA Technical Corrections Act amended 35 U.S.C. 154(b)(3)(B)(i) to eliminate the requirement that the Office provide a patent term adjustment determination with the notice of allowance. See Revisions to Patent Term Adjustment, 78 Fed. Reg. 19416, 19417 (Apr. 1, 2013). Therefore, the Office is no longer providing an initial patent term adjustment determination with the notice of allowance. The Office will continue to provide a patent term adjustment determination with the Issue Notification Letter that is mailed to applicant approximately three weeks prior to the issue date of the patent, and will include the patent term adjustment on the patent. Any request for reconsideration of the patent term adjustment determination (or reinstatement of patent term adjustment) should follow the process outlined in 37 CFR 1.705.

Any questions regarding the Patent Term Extension or Adjustment determination should be directed to the Office of Patent Legal Administration at (571)-272-7702. Questions relating to issue and publication fee payments should be directed to the Customer Service Center of the Office of Patent Publication at 1-(888)-786-0101 or (571)-272-4200.

OMB Clearance and PRA Burden Statement for PTOL-85 Part B

The Paperwork Reduction Act (PRA) of 1995 requires Federal agencies to obtain Office of Management and Budget approval before requesting most types of information from the public. When OMB approves an agency request to collect information from the public, OMB (i) provides a valid OMB Control Number and expiration date for the agency to display on the instrument that will be used to collect the information and (ii) requires the agency to inform the public about the OMB Control Number's legal significance in accordance with 5 CFR 1320.5(b).

The information collected by PTOL-85 Part B is required by 37 CFR 1.311. The information is required to obtain or retain a benefit by the public which is to file (and by the USPTO to process) an application. Confidentiality is governed by 35 U.S.C. 122 and 37 CFR 1.14. This collection is estimated to take 12 minutes to complete, including gathering, preparing, and submitting the completed application form to the USPTO. Time will vary depending upon the individual case. Any comments on the amount of time you require to complete this form and/or suggestions for reducing this burden, should be sent to the Chief Information Officer, U.S. Patent and Trademark Office, U.S. Department of Commerce, P.O. Box 1450, Alexandria, Virginia 22313-1450. DO NOT SEND FEES OR COMPLETED FORMS TO THIS ADDRESS. SEND TO: Commissioner for Patents, P.O. Box 1450, Alexandria, Virginia 22313-1450. Under the Paperwork Reduction Act of 1995, no persons are required to respond to a collection of information unless it displays a valid OMB control number.

Privacy Act Statement

The Privacy Act of 1974 (P.L. 93-579) requires that you be given certain information in connection with your submission of the attached form related to a patent application or patent. Accordingly, pursuant to the requirements of the Act, please be advised that: (1) the general authority for the collection of this information is 35 U.S.C. 2(b)(2); (2) furnishing of the information solicited is voluntary; and (3) the principal purpose for which the information is used by the U.S. Patent and Trademark Office is to process and/or examine your submission related to a patent application or patent. If you do not furnish the requested information, the U.S. Patent and Trademark Office may not be able to process and/or examine your submission, which may result in termination of proceedings or abandonment of the application or expiration of the patent.

The information provided by you in this form will be subject to the following routine uses:

1. The information on this form will be treated confidentially to the extent allowed under the Freedom of Information Act (5 U.S.C. 552) and the Privacy Act (5 U.S.C. 552a). Records from this system of records may be disclosed to the Department of Justice to determine whether disclosure of these records is required by the Freedom of Information Act.
2. A record from this system of records may be disclosed, as a routine use, in the course of presenting evidence to a court, magistrate, or administrative tribunal, including disclosures to opposing counsel in the course of settlement negotiations.
3. A record in this system of records may be disclosed, as a routine use, to a Member of Congress submitting a request involving an individual, to whom the record pertains, when the individual has requested assistance from the Member with respect to the subject matter of the record.
4. A record in this system of records may be disclosed, as a routine use, to a contractor of the Agency having need for the information in order to perform a contract. Recipients of information shall be required to comply with the requirements of the Privacy Act of 1974, as amended, pursuant to 5 U.S.C. 552a(m).
5. A record related to an International Application filed under the Patent Cooperation Treaty in this system of records may be disclosed, as a routine use, to the International Bureau of the World Intellectual Property Organization, pursuant to the Patent Cooperation Treaty.
6. A record in this system of records may be disclosed, as a routine use, to another federal agency for purposes of National Security review (35 U.S.C. 181) and for review pursuant to the Atomic Energy Act (42 U.S.C. 218(c)).
7. A record from this system of records may be disclosed, as a routine use, to the Administrator, General Services, or his/her designee, during an inspection of records conducted by GSA as part of that agency's responsibility to recommend improvements in records management practices and programs, under authority of 44 U.S.C. 2904 and 2906. Such disclosure shall be made in accordance with the GSA regulations governing inspection of records for this purpose, and any other relevant (i.e., GSA or Commerce) directive. Such disclosure shall not be used to make determinations about individuals.
8. A record from this system of records may be disclosed, as a routine use, to the public after either publication of the application pursuant to 35 U.S.C. 122(b) or issuance of a patent pursuant to 35 U.S.C. 151. Further, a record may be disclosed, subject to the limitations of 37 CFR 1.14, as a routine use, to the public if the record was filed in an application which became abandoned or in which the proceedings were terminated and which application is referenced by either a published application, an application open to public inspection or an issued patent.
9. A record from this system of records may be disclosed, as a routine use, to a Federal, State, or local law enforcement agency, if the USPTO becomes aware of a violation or potential violation of law or regulation.

Notice of Allowability	Application No. 13/750,352	Applicant(s) SIGG ET AL.	
	Examiner Aarti Bhatia Berdichevsky	Art Unit 3763	AIA (First Inventor to File) Status No

-- The MAILING DATE of this communication appears on the cover sheet with the correspondence address--

All claims being allowable, PROSECUTION ON THE MERITS IS (OR REMAINS) CLOSED in this application. If not included herewith (or previously mailed), a Notice of Allowance (PTOL-85) or other appropriate communication will be mailed in due course. **THIS NOTICE OF ALLOWABILITY IS NOT A GRANT OF PATENT RIGHTS.** This application is subject to withdrawal from issue at the initiative of the Office or upon petition by the applicant. See 37 CFR 1.313 and MPEP 1308.

1. This communication is responsive to 7/17/2015.
 A declaration(s)/affidavit(s) under **37 CFR 1.130(b)** was/were filed on _____.
2. An election was made by the applicant in response to a restriction requirement set forth during the interview on _____; the restriction requirement and election have been incorporated into this action.
3. The allowed claim(s) is/are 1,6,9,10,12-19,21,22,24-32 and 34-36. As a result of the allowed claim(s), you may be eligible to benefit from the **Patent Prosecution Highway** program at a participating intellectual property office for the corresponding application. For more information, please see http://www.uspto.gov/patents/init_events/pph/index.jsp or send an inquiry to PPHfeedback@uspto.gov.
4. Acknowledgment is made of a claim for foreign priority under 35 U.S.C. § 119(a)-(d) or (f).

Certified copies:

- a) All b) Some *c) None of the:
1. Certified copies of the priority documents have been received.
 2. Certified copies of the priority documents have been received in Application No. _____.
 3. Copies of the certified copies of the priority documents have been received in this national stage application from the International Bureau (PCT Rule 17.2(a)).
- * Certified copies not received: _____.

Applicant has THREE MONTHS FROM THE "MAILING DATE" of this communication to file a reply complying with the requirements noted below. Failure to timely comply will result in ABANDONMENT of this application.
THIS THREE-MONTH PERIOD IS NOT EXTENDABLE.

5. CORRECTED DRAWINGS (as "replacement sheets") must be submitted.
 including changes required by the attached Examiner's Amendment / Comment or in the Office action of Paper No./Mail Date _____.
Identifying indicia such as the application number (see 37 CFR 1.84(c)) should be written on the drawings in the front (not the back) of each sheet. Replacement sheet(s) should be labeled as such in the header according to 37 CFR 1.121(d).
6. DEPOSIT OF and/or INFORMATION about the deposit of BIOLOGICAL MATERIAL must be submitted. Note the attached Examiner's comment regarding REQUIREMENT FOR THE DEPOSIT OF BIOLOGICAL MATERIAL.

Attachment(s)

- | | |
|-------------------------------------------------------------------------------------------------------------------------------|--------------------------------------------------------------------------------------|
| 1. <input checked="" type="checkbox"/> Notice of References Cited (PTO-892) | 5. <input checked="" type="checkbox"/> Examiner's Amendment/Comment |
| 2. <input checked="" type="checkbox"/> Information Disclosure Statements (PTO/SB/08),
Paper No./Mail Date <u>7/17/2015</u> | 6. <input checked="" type="checkbox"/> Examiner's Statement of Reasons for Allowance |
| 3. <input type="checkbox"/> Examiner's Comment Regarding Requirement for Deposit
of Biological Material | 7. <input type="checkbox"/> Other _____. |
| 4. <input type="checkbox"/> Interview Summary (PTO-413),
Paper No./Mail Date _____. | |

/Aarti Bhatia Berdichevsky/
Primary Examiner, Art Unit 3763

EXAMINER'S AMENDMENT

1. An examiner's amendment to the record appears below. Should the changes and/or additions be unacceptable to applicant, an amendment may be filed as provided by 37 CFR 1.312. To ensure consideration of such an amendment, it **MUST** be submitted no later than the payment of the issue fee.

Authorization for this examiner's amendment was given in a telephone interview with Jim Lynch on 8/10/2015.

The application has been amended as follows:

In claim 24: "claim 20" is replaced with --claim 21--.

Allowable Subject Matter

2. Claims 1, 6, 9, 10, 12-19, 21-22, 24-32, and 34-36 are allowed.

3. The following is an examiner's statement of reasons for allowance:

Claim 1 has been indicated allowable because the prior art of record fails to disclose either singly or in combination the claimed device of a prefilled glass syringe with 1-100 ug of silicone oil that is prefilled with a VEGF antagonist and is terminally sterilized as successfully amended and argued by the Applicant in the response of 7/17/2015.

Any comments considered necessary by applicant must be submitted no later than the payment of the issue fee and, to avoid processing delays, should preferably accompany the issue fee. Such submissions should be clearly labeled "Comments on Statement of Reasons for Allowance."

Conclusion

The prior art made of record and not relied upon is considered pertinent to applicant's disclosure. See PTO-892.

Any inquiry concerning this communication or earlier communications from the examiner should be directed to Aarti Bhatia Berdichevsky whose telephone number is 571-270-5033. The examiner can normally be reached M-F 9 AM to 5 PM.

If attempts to reach the examiner by telephone are unsuccessful, the examiner's supervisor, Bhisma Mehta can be reached on 571-272-3383. The fax phone number for the organization where this application is assigned is 571-273-8300.

Information regarding the status of an application may be obtained from the Patent Application Information Retrieval (PAIR) system. Status information for published applications may be obtained from either Private PAIR or Public PAIR. Status information for unpublished applications is available through Private PAIR only. For more information about the PAIR system, see <http://pair-direct.uspto.gov>. Should you have questions on access to the Private PAIR system, contact the Electronic Business Center (EBC) at 866-217-9197 (toll-free). If you would like assistance from a USPTO Customer Service Representative or access to the automated information system, call 800-786-9199 (IN USA OR CANADA) or 571-272-1000.

/Aarti Bhatia Berdichevsky/
Primary Examiner, Art Unit 3763

Notice of References Cited	Application/Control No. 13/750,352	Applicant(s)/Patent Under Reexamination SIGG ET AL.	
	Examiner Aarti Bhatia Berdichevsky	Art Unit 3763	Page 1 of 1

U.S. PATENT DOCUMENTS

*	Document Number Country Code-Number-Kind Code	Date MM-YYYY	Name	Classification
*	A US-2014/0249484 A1	09-2014	Jones et al.	604/230
	B US-			
	C US-			
	D US-			
	E US-			
	F US-			
	G US-			
	H US-			
	I US-			
	J US-			
	K US-			
	L US-			
	M US-			

FOREIGN PATENT DOCUMENTS

*	Document Number Country Code-Number-Kind Code	Date MM-YYYY	Country	Name	Classification
	N				
	O				
	P				
	Q				
	R				
	S				
	T				

NON-PATENT DOCUMENTS

*	Document Number Country Code-Number-Kind Code	Date MM-YYYY	Country	Name	Classification
	Include as applicable: Author, Title Date, Publisher, Edition or Volume, Pertinent Pages)				
	U				
	V				
	W				
	X				

*A copy of this reference is not being furnished with this Office action. (See MPEP § 707.05(a).)
Dates in MM-YYYY format are publication dates. Classifications may be US or foreign.

Receipt date: 07/17/2015

13750352 - GAU: 3763

Doc code: IDS

PTO/SB/08a (03-15)

Doc description: Information Disclosure Statement (IDS) Filed

Approved for use through 07/31/2016. OMB 0651-0031

U.S. Patent and Trademark Office; U.S. DEPARTMENT OF COMMERCE

Under the Paperwork Reduction Act of 1995, no persons are required to respond to a collection of information unless it contains a valid OMB control number.

INFORMATION DISCLOSURE STATEMENT BY APPLICANT (Not for submission under 37 CFR 1.99)	Application Number		13750352	
	Filing Date		2013-01-25	
	First Named Inventor	Juergen Sigg		
	Art Unit	3763		
	Examiner Name	Aarti Berdichevsky		
	Attorney Docket Number	PAT055157-US-NP		

U.S.PATENTS						Remove
Examiner Initial*	Cite No	Patent Number	Kind Code ¹	Issue Date	Name of Patentee or Applicant of cited Document	Pages,Columns,Lines where Relevant Passages or Relevant Figures Appear
	1					

If you wish to add additional U.S. Patent citation information please click the Add button. Add

U.S.PATENT APPLICATION PUBLICATIONS						Remove
Examiner Initial*	Cite No	Publication Number	Kind Code ¹	Publication Date	Name of Patentee or Applicant of cited Document	Pages,Columns,Lines where Relevant Passages or Relevant Figures Appear
	1					

If you wish to add additional U.S. Published Application citation information please click the Add button. Add

FOREIGN PATENT DOCUMENTS								Remove
Examiner Initial*	Cite No	Foreign Document Number ³	Country Code ² i	Kind Code ⁴	Publication Date	Name of Patentee or Applicant of cited Document	Pages,Columns,Lines where Relevant Passages or Relevant Figures Appear	T ⁵
	1	2014/005728	WO	A1	2014-01-09	NOVARTIS AG		<input type="checkbox"/>
	2	2012101678	AU	A4	2012-12-20	JUERGEN SIGG ET AL		<input type="checkbox"/>
	3	2012101677	AU	A4	2012-12-13	JUERGEN SIGG ET AL		<input type="checkbox"/>

Receipt date: 07/17/2015

13750352 - GAU: 3763

INFORMATION DISCLOSURE STATEMENT BY APPLICANT (Not for submission under 37 CFR 1.99)	Application Number		13750352
	Filing Date		2013-01-25
	First Named Inventor	Juergen Sigg	
	Art Unit		3763
	Examiner Name	Aarti Berdichevsky	
	Attorney Docket Number		PAT055157-US-NP

If you wish to add additional Foreign Patent Document citation information please click the Add button **Add**

NON-PATENT LITERATURE DOCUMENTS Remove

Examiner Initials*	Cite No	Include name of the author (in CAPITAL LETTERS), title of the article (when appropriate), title of the item (book, magazine, journal, serial, symposium, catalog, etc), date, pages(s), volume-issue number(s), publisher, city and/or country where published.	T ⁵
	1	CHAN ET AL: "Syringe Siliconization Process Investigation and Optimization" Journal of Pharmaceutical Science and Technology, Issue 66, pp.137, 147-148, March 2012	<input type="checkbox"/>
	2	LANKERS: "The Relationship Between Silicone Layer Thickness, Free Silicone Oil and Protein Aggregation In Prefilled Syringes" 2010 AAPS National Biotechnology Conference San Francisco, Slides 25, 39, 46, MAY 19, 2010	<input type="checkbox"/>
	3	MAJUMDAR ET AL: " Evaluation of the Effect of Syringe Surfaces on Protein Formulations" Journal of Pharmaceutical Sciences, Issue 100, pp.2563-2573, July 2011	<input type="checkbox"/>
	4	BAKRI AND EKDAWI: "Intravitreal Silicone Oil Droplets after Intravitreal Drug Injections" Retina, Issue 28, pp.996-1001, July 2008	<input type="checkbox"/>
	5	DAIKYO RU Crystal Zenith Insert Needle Syringe System, West Delivering Innovative Solutions, 2010	<input type="checkbox"/>
	6	MEYER ET AL: "Steps for a Safe Intravitreal Injection Technique", Meyer et al. "Steps for a Safe Intravitreal Injection Technique" Retinal Physician, p.3, July 1, 2009	<input type="checkbox"/>

If you wish to add additional non-patent literature document citation information please click the Add button **Add**

EXAMINER SIGNATURE

Examiner Signature	/Aarti Bhatia Berdichevsky/ (08/06/2015)	Date Considered	08/06/2015
--------------------	------------------------------------------	-----------------	------------

*EXAMINER: Initial if reference considered, whether or not citation is in conformance with MPEP 609. Draw line through a citation if not in conformance and not considered. Include copy of this form with next communication to applicant.

¹ See Kind Codes of USPTO Patent Documents at www.USPTO.GOV or MPEP 901.04. ² Enter office that issued the document, by the two-letter code (WIPO Standard ST.3). ³ For Japanese patent documents, the indication of the year of the reign of the Emperor must precede the serial number of the patent document. ⁴ Kind of document by the appropriate symbols as indicated on the document under WIPO Standard ST.16 if possible. ⁵ Applicant is to place a check mark here if English language translation is attached.

UNITED STATES PATENT AND TRADEMARK OFFICE

UNITED STATES DEPARTMENT OF COMMERCE
United States Patent and Trademark Office
 Address: COMMISSIONER FOR PATENTS
 P.O. Box 1450
 Alexandria, Virginia 22313-1450
 www.uspto.gov

BIB DATA SHEET
CONFIRMATION NO. 5306

SERIAL NUMBER	FILING or 371(c) DATE	CLASS	GROUP ART UNIT	ATTORNEY DOCKET NO.	
13/750,352	01/25/2013	604	3763	PAT055157-US-NP	
APPLICANTS NOVARTIS AG, Basel, SWITZERLAND INVENTORS Juergen Sigg, Loerrach, GERMANY; Christopher Royer, Munich, GERMANY; Andrew Mark Bryant, Reinach, SWITZERLAND; Heinrich Martin Buettgen, Rheinfelden, SWITZERLAND; Marie Picci, Ranspack-le-bas, FRANCE;					
** CONTINUING DATA *****					
** FOREIGN APPLICATIONS ***** EUROPEAN PATENT OFFICE (EPO) 12174860.2 07/03/2012 EUROPEAN PATENT OFFICE (EPO) 12189649.2 10/23/2012 GERMANY 202012011016.0 11/16/2012 AUSTRALIA 2012101677 11/16/2012 AUSTRALIA 2012101678 11/16/2012 GERMANY 202012011260.0 11/23/2012 GERMANY 202012011259.7 11/23/2012 EUROPEAN PATENT OFFICE (EPO) 12195360.8 12/03/2012 AUSTRALIA 2013100071 01/23/2013 AUSTRALIA 2013100070 01/23/2013					
** IF REQUIRED, FOREIGN FILING LICENSE GRANTED ** 02/05/2013					
Foreign Priority claimed <input checked="" type="checkbox"/> Yes <input type="checkbox"/> No 35 USC 119(a-d) conditions met <input checked="" type="checkbox"/> Yes <input type="checkbox"/> No Verified and /AARTI B BERDICHEVSKY/ Acknowledged Examiner's Signature	<input type="checkbox"/> Met after Allowance Initials	STATE OR COUNTRY GERMANY	SHEETS DRAWINGS 1	TOTAL CLAIMS 32	INDEPENDENT CLAIMS 2
ADDRESS NOVARTIS PHARMACEUTICAL CORPORATION INTELLECTUAL PROPERTY DEPARTMENT ONE HEALTH PLAZA 433/2 EAST HANOVER, NJ 07936-1080 UNITED STATES					
TITLE SYRINGE					
FILING FEE RECEIVED	FEES: Authority has been given in Paper No. _____ to charge/credit DEPOSIT ACCOUNT		<input type="checkbox"/> All Fees <input type="checkbox"/> 1.16 Fees (Filing) <input type="checkbox"/> 1.17 Fees (Processing Ext. of time) <input type="checkbox"/> 1.18 Fees (Issue)		

Issue Classification 	Application/Control No. 13750352	Applicant(s)/Patent Under Reexamination SIGG ET AL.	
	Examiner AARTI B BERDICHEVSKY	Art Unit 3763	

CPC						
Symbol					Type	Version
A61F		9		0008	F	2013-01-01
A61M		5		178	I	2013-01-01
A61M		5		31505	I	2013-01-01
A61M		5		31513	A	2013-01-01
A61M		2005		3104	A	2013-01-01
A61M		2005		3139	A	2013-01-01
A61M		5		002	I	2013-01-01
A61K		9		0019	I	2013-01-01
A61K		9		0048	I	2013-01-01
A61K		38		179	I	2013-01-01
A61M		5		28	I	2013-01-01
A61M		5		31	I	2013-01-01
A61M		5		315	I	2013-01-01

CPC Combination Sets				
Symbol	Type	Set	Ranking	Version

NONE		Total Claims Allowed:	
(Assistant Examiner)	(Date)	26	
/AARTI B BERDICHEVSKY/ Primary Examiner. Art Unit 3763	08/08/2015	O.G. Print Claim(s)	O.G. Print Figure
(Primary Examiner)	(Date)	1	2

Issue Classification 	Application/Control No. 13750352	Applicant(s)/Patent Under Reexamination SIGG ET AL.
	Examiner AARTI B BERDICHEVSKY	Art Unit 3763

<input type="checkbox"/> Claims renumbered in the same order as presented by applicant		<input type="checkbox"/> CPA		<input type="checkbox"/> T.D.		<input type="checkbox"/> R.1.47									
Final	Original	Final	Original	Final	Original	Final	Original	Final	Original	Final	Original	Final	Original	Final	Original
1	1	17	25												
2	6	18	26												
3	9	19	27												
4	10	20	28												
5	12	21	29												
6	13	22	34												
7	14	23	35												
8	15	24	30												
9	16	25	31												
10	36	26	32												
11	17														
12	18														
13	19														
14	21														
15	24														
16	22														

NONE		Total Claims Allowed:	
		26	
(Assistant Examiner)	(Date)		
/AARTI B BERDICHEVSKY/ Primary Examiner. Art Unit 3763	08/08/2015	O.G. Print Claim(s)	O.G. Print Figure
(Primary Examiner)	(Date)	1	2

Search Notes 	Application/Control No. 13750352	Applicant(s)/Patent Under Reexamination SIGG ET AL.
	Examiner AARTI B BERDICHEVSKY	Art Unit 3763

CPC- SEARCHED		
Symbol	Date	Examiner
A61K9/0048 A61F9/008 A61M5178 A61M5/31	5/8/2014	
above updated	8/21/2014	ABB
above updated	12/8/2014	ABB
above updated	3/15/2015	ABB
above updated	8/8/2015	ABB

CPC COMBINATION SETS - SEARCHED		
Symbol	Date	Examiner

US CLASSIFICATION SEARCHED			
Class	Subclass	Date	Examiner
604	218, 294	5/8/2014	ABB
above	updated	8/21/2014	ABB
above	updated	12/8/2014	ABB

SEARCH NOTES		
Search Notes	Date	Examiner
EAST search	5/8/2014	ABB
Inventor search	5/8/2014	ABB

INTERFERENCE SEARCH			
US Class/ CPC Symbol	US Subclass / CPC Group	Date	Examiner
claims text search		8/8/2015	ABB

	/AARTI B BERDICHEVSKY/ Primary Examiner.Art Unit 3763
--	----------------------------------------------------------

EAST Search History

EAST Search History (Prior Art)

Ref #	Hits	Search Query	DBs	Default Operator	Plurals	Time Stamp
L1	0	(A61K9/0048 OR A61F9/0008 OR A61M5/178 OR A61M5/31).CPC. @pd>"20150808"	US-PGPUB; USPAT; USOCR; DERWENT	AND	ON	2015/08/08 20:29
L2	717	(A61K9/0048 OR A61F9/0008 OR A61M5/178 OR A61M5/31).CPC. @pd>"20150301"	US-PGPUB; USPAT; USOCR; DERWENT	AND	ON	2015/08/08 20:30
L3	817612	((prefilled or pre-filled) terminally sterilized syringe intravitreal injection glass barrel stopper plunger silicone oil break loose force).clm.	USPAT	OR	OFF	2015/08/08 20:37

EAST Search History (Interference)

Ref #	Hits	Search Query	DBs	Default Operator	Plurals	Time Stamp
L4	0	((prefilled or pre-filled) terminally sterilized syringe intravitreal injection glass barrel stopper plunger silicone oil break loose force).clm.	US-PGPUB; USPAT; UPAD	AND	OFF	2015/08/08 20:37
L5	0	((prefilled or pre-filled)sterilized syringe intravitreal injection glass barrel stopper plunger silicone oil break loose force).clm.	US-PGPUB; USPAT; UPAD	AND	OFF	2015/08/08 20:37
L6	1	((prefilled or pre-filled) syringe intravitreal injection glass barrel stopper plunger silicone oil break loose force).clm.	US-PGPUB; USPAT; UPAD	AND	OFF	2015/08/08 20:37
L7	1	((prefilled or pre-filled) syringe injection glass barrel stopper plunger silicone oil break loose force).clm.	US-PGPUB; USPAT; UPAD	AND	OFF	2015/08/08 20:38
L8	1	((prefilled or pre-filled) syringe injection glass barrel stopper plunger silicone oil break force).clm.	US-PGPUB; USPAT; UPAD	AND	OFF	2015/08/08 20:38
L9	1	((prefilled or pre-filled) syringe injection glass barrel stopper plunger silicone oil force).clm.	US-PGPUB; USPAT; UPAD	AND	OFF	2015/08/08 20:38
L10	1	((prefilled or pre-filled) syringe injection glass barrel stopper plunger silicone force).clm.	US-PGPUB; USPAT; UPAD	AND	OFF	2015/08/08 20:38
L11	1	((prefilled or pre-filled) syringe injection glass barrel stopper plunger silicone).clm.	US-PGPUB; USPAT; UPAD	AND	OFF	2015/08/08 20:38

EAST Search History

L12	2	((prefilled or pre-filled) syringe injection glass barrel plunger silicone).clm.	US-PGPUB; USPAT; UPAD	AND	OFF	2015/08/08 20:38
L13	6	(syringe injection glass barrel plunger silicone).clm.	US-PGPUB; USPAT; UPAD	AND	OFF	2015/08/08 20:39

8/ 8/ 2015 8:40:49 PM

C:\Users\abhatia1\Documents\EAST\Workspaces\13750352.wsp



UNITED STATES PATENT AND TRADEMARK OFFICE

UNITED STATES DEPARTMENT OF COMMERCE
United States Patent and Trademark Office
Address: COMMISSIONER FOR PATENTS
P.O. Box 1450
Alexandria, Virginia 22313-1450
www.uspto.gov

Table with 7 columns: APPLICATION NUMBER, FILING or 371(c) DATE, GRP ART UNIT, FIL FEE REC'D, ATTY. DOCKET NO, TOT CLAIMS, IND CLAIMS. Row 1: 13/750,352, 01/25/2013, 3763, 2274, PAT055157-US-NP, 32, 2

CONFIRMATION NO. 5306
CORRECTED FILING RECEIPT

1095
NOVARTIS PHARMACEUTICAL CORPORATION
INTELLECTUAL PROPERTY DEPARTMENT
ONE HEALTH PLAZA 433/2
EAST HANOVER, NJ 07936-1080



Date Mailed: 08/28/2015

Receipt is acknowledged of this non-provisional patent application. The application will be taken up for examination in due course. Applicant will be notified as to the results of the examination. Any correspondence concerning the application must include the following identification information: the U.S. APPLICATION NUMBER, FILING DATE, NAME OF APPLICANT, and TITLE OF INVENTION. Fees transmitted by check or draft are subject to collection. Please verify the accuracy of the data presented on this receipt. If an error is noted on this Filing Receipt, please submit a written request for a Filing Receipt Correction. Please provide a copy of this Filing Receipt with the changes noted thereon. If you received a "Notice to File Missing Parts" for this application, please submit any corrections to this Filing Receipt with your reply to the Notice. When the USPTO processes the reply to the Notice, the USPTO will generate another Filing Receipt incorporating the requested corrections

Inventor(s)

Juergen Sigg, Loerrach, GERMANY;
Christopher Royer, Munich, GERMANY;
Andrew Mark Bryant, Reinach, SWITZERLAND;
Heinrich Martin Buettgen, Rheinfelden, SWITZERLAND;
Marie Picci, Ranspack-le-bas, FRANCE;

Applicant(s)

NOVARTIS AG, Basel, SWITZERLAND

Assignment For Published Patent Application

Novartis AG, Basel, SWITZERLAND

Power of Attorney: The patent practitioners associated with Customer Number 01095

Domestic Applications for which benefit is claimed - None.

A proper domestic benefit claim must be provided in an Application Data Sheet in order to constitute a claim for domestic benefit. See 37 CFR 1.76 and 1.78.

Foreign Applications (You may be eligible to benefit from the Patent Prosecution Highway program at the USPTO. Please see http://www.uspto.gov for more information.)

- EUROPEAN PATENT OFFICE (EPO) 12174860.2 07/03/2012
EUROPEAN PATENT OFFICE (EPO) 12189649.2 10/23/2012
GERMANY 202012011016.0 11/16/2012
AUSTRALIA 2012101677 11/16/2012 No Access Code Provided
AUSTRALIA 2012101678 11/16/2012 No Access Code Provided
GERMANY 202012011260.0 11/23/2012
GERMANY 202012011259.7 11/23/2012
EUROPEAN PATENT OFFICE (EPO) 12195360.8 12/03/2012

AUSTRALIA 2013100071 01/23/2013 No Access Code Provided
AUSTRALIA 2013100070 01/23/2013 No Access Code Provided
GERMANY 202013000688.9 01/23/2013

Permission to Access - A proper **Authorization to Permit Access to Application by Participating Offices** (PTO/SB/39 or its equivalent) has been received by the USPTO.

Request to Retrieve - This application either claims priority to one or more applications filed in an intellectual property Office that participates in the Priority Document Exchange (PDX) program or contains a proper **Request to Retrieve Electronic Priority Application(s)** (PTO/SB/38 or its equivalent). Consequently, the USPTO will attempt to electronically retrieve these priority documents.

If Required, Foreign Filing License Granted: 02/05/2013

The country code and number of your priority application, to be used for filing abroad under the Paris Convention, is **US 13/750,352**

Projected Publication Date: Not Applicable

Non-Publication Request: No

Early Publication Request: No

Title

SYRINGE

Preliminary Class

604

Statement under 37 CFR 1.55 or 1.78 for AIA (First Inventor to File) Transition Applications:

PROTECTING YOUR INVENTION OUTSIDE THE UNITED STATES

Since the rights granted by a U.S. patent extend only throughout the territory of the United States and have no effect in a foreign country, an inventor who wishes patent protection in another country must apply for a patent in a specific country or in regional patent offices. Applicants may wish to consider the filing of an international application under the Patent Cooperation Treaty (PCT). An international (PCT) application generally has the same effect as a regular national patent application in each PCT-member country. The PCT process **simplifies** the filing of patent applications on the same invention in member countries, but **does not result** in a grant of "an international patent" and does not eliminate the need of applicants to file additional documents and fees in countries where patent protection is desired.

Almost every country has its own patent law, and a person desiring a patent in a particular country must make an application for patent in that country in accordance with its particular laws. Since the laws of many countries differ in various respects from the patent law of the United States, applicants are advised to seek guidance from specific foreign countries to ensure that patent rights are not lost prematurely.

Applicants also are advised that in the case of inventions made in the United States, the Director of the USPTO must issue a license before applicants can apply for a patent in a foreign country. The filing of a U.S. patent application serves as a request for a foreign filing license. The application's filing receipt contains further information and guidance as to the status of applicant's license for foreign filing.

Applicants may wish to consult the USPTO booklet, "General Information Concerning Patents" (specifically, the section entitled "Treaties and Foreign Patents") for more information on timeframes and deadlines for filing foreign patent applications. The guide is available either by contacting the USPTO Contact Center at 800-786-9199, or it can be viewed on the USPTO website at <http://www.uspto.gov/web/offices/pac/doc/general/index.html>.

For information on preventing theft of your intellectual property (patents, trademarks and copyrights), you may wish to consult the U.S. Government website, <http://www.stopfakes.gov>. Part of a Department of Commerce initiative, this website includes self-help "toolkits" giving innovators guidance on how to protect intellectual property in specific countries such as China, Korea and Mexico. For questions regarding patent enforcement issues, applicants may call the U.S. Government hotline at 1-866-999-HALT (1-866-999-4258).

LICENSE FOR FOREIGN FILING UNDER
Title 35, United States Code, Section 184
Title 37, Code of Federal Regulations, 5.11 & 5.15

GRANTED

The applicant has been granted a license under 35 U.S.C. 184, if the phrase "IF REQUIRED, FOREIGN FILING LICENSE GRANTED" followed by a date appears on this form. Such licenses are issued in all applications where the conditions for issuance of a license have been met, regardless of whether or not a license may be required as set forth in 37 CFR 5.15. The scope and limitations of this license are set forth in 37 CFR 5.15(a) unless an earlier license has been issued under 37 CFR 5.15(b). The license is subject to revocation upon written notification. The date indicated is the effective date of the license, unless an earlier license of similar scope has been granted under 37 CFR 5.13 or 5.14.

This license is to be retained by the licensee and may be used at any time on or after the effective date thereof unless it is revoked. This license is automatically transferred to any related applications(s) filed under 37 CFR 1.53(d). This license is not retroactive.

The grant of a license does not in any way lessen the responsibility of a licensee for the security of the subject matter as imposed by any Government contract or the provisions of existing laws relating to espionage and the national security or the export of technical data. Licensees should apprise themselves of current regulations especially with respect to certain countries, of other agencies, particularly the Office of Defense Trade Controls, Department of State (with respect to Arms, Munitions and Implements of War (22 CFR 121-128)); the Bureau of Industry and Security, Department of Commerce (15 CFR parts 730-774); the Office of Foreign Assets Control, Department of Treasury (31 CFR Parts 500+) and the Department of Energy.

NOT GRANTED

No license under 35 U.S.C. 184 has been granted at this time, if the phrase "IF REQUIRED, FOREIGN FILING LICENSE GRANTED" DOES NOT appear on this form. Applicant may still petition for a license under 37 CFR 5.12, if a license is desired before the expiration of 6 months from the filing date of the application. If 6 months has lapsed from the filing date of this application and the licensee has not received any indication of a secrecy order under 35 U.S.C. 181, the licensee may foreign file the application pursuant to 37 CFR 5.15(b).

SelectUSA

The United States represents the largest, most dynamic marketplace in the world and is an unparalleled location for business investment, innovation, and commercialization of new technologies. The U.S. offers tremendous resources and advantages for those who invest and manufacture goods here. Through SelectUSA, our nation works to promote and facilitate business investment. SelectUSA provides information assistance to the international investor community; serves as an ombudsman for existing and potential investors; advocates on behalf of U.S. cities, states, and regions competing for global investment; and counsels U.S. economic development organizations on investment attraction best practices. To learn more about why the United States is the best country in the world to develop technology, manufacture products, deliver services, and grow your business, visit <http://www.SelectUSA.gov> or call +1-202-482-6800.

IN THE UNITED STATES PATENT AND TRADEMARK OFFICE

IN RE APPLICATION OF

Sigg, Juergen et al.

APPLICATION NO: 13/750352

FILED: January 25, 2013

FOR: SYRINGE

Art Unit: 3763

Examiner: Aarti Berkichevsky

Conf. No. 5306

Commissioner for Patents
PO Box 1450
Alexandria, VA 22313-1450

LETTER CORRECTING NAME OF INVENTOR

Sir:

The official filing receipt received in the above-identified application erroneously lists one of the inventors. An Application Data Sheet showing the correct name of the inventor, Christophe Royer, is enclosed. Please issue a corrected filing receipt listing the inventors as follows:

--Juergen Sigg, Loerrach, GERMANY
Christophe Royer, Munich, GERMANY
Andrew Mark Bryant, Reinach, SWITZERLAND
Heinrich Martin Buettgen, Rheinfelden, SWITZERLAND
Marie Picci, Ranspack-le-bas, FRANCE--

It should be noted that the Inventor, Christophe Royer, was correctly identified on the Declaration. A copy of the executed Declaration is attached.

Please charge Deposit Account No. 19-0134 in the name of Novartis in the amount of \$140 for payment of the applicable fee. The Commissioner is hereby authorized to charge any additional fees under 37 CFR §1.17 which may be required, or credit any overpayment, to Account No. 19-0134 in the name of Novartis.

Respectfully submitted,

/Michael Mazza/

Novartis Pharmaceuticals Corporation
One Health Plaza, Bldg. 433
East Hanover, NJ 07936
+15108799666

Michael Mazza
Attorney for Applicant
Reg. No. 30,775

Date: 1 September 2015

Under the Paperwork Reduction Act of 1995, no persons are required to respond to a collection of information unless it contains a valid OMB control number.

Application Data Sheet 37 CFR 1.76		Attorney Docket Number	55157-US-NP
		Application Number	13/750,352
Title of Invention	Syringe		
<p>The application data sheet is part of the provisional or nonprovisional application for which it is being submitted. The following form contains the bibliographic data arranged in a format specified by the United States Patent and Trademark Office as outlined in 37 CFR 1.76.</p> <p>This document may be completed electronically and submitted to the Office in electronic format using the Electronic Filing System (EFS) or the document may be printed and included in a paper filed application.</p>			

Secrecy Order 37 CFR 5.2

Portions or all of the application associated with this Application Data Sheet may fall under a Secrecy Order pursuant to 37 CFR 5.2 (Paper filers only. Applications that fall under Secrecy Order may not be filed electronically.)

Inventor Information:

Inventor 1 Remove				
Legal Name				
Prefix	Given Name	Middle Name	Family Name	Suffix
	Juergen		SIGG	
Residence Information (Select One) <input type="radio"/> US Residency <input checked="" type="radio"/> Non US Residency <input type="radio"/> Active US Military Service				
City	Loerrach	Country of Residence ¹	DE	
Mailing Address of Inventor:				
Address 1	Novartis Pharma AG			
Address 2	Postfach			
City	Basel	State/Province		
Postal Code	4002	Country ¹	CH	
Inventor 2 Remove				
Legal Name				
Prefix	Given Name	Middle Name	Family Name	Suffix
	Christopher Christophe		Royer	
Residence Information (Select One) <input type="radio"/> US Residency <input checked="" type="radio"/> Non US Residency <input type="radio"/> Active US Military Service				
City	Munich	Country of Residence ¹	DE	
Mailing Address of Inventor:				
Address 1	Novartis Pharma AG			
Address 2	Postfach			
City	Basel	State/Province		
Postal Code	4002	Country ¹	CH	
Inventor 3 Remove				
Legal Name				

Under the Paperwork Reduction Act of 1995, no persons are required to respond to a collection of information unless it contains a valid OMB control number.

Application Data Sheet 37 CFR 1.76		Attorney Docket Number	55157-US-NP
		Application Number	13/750,352
Title of Invention	Syringe		

Prefix	Given Name	Middle Name	Family Name	Suffix
	Andrew	Mark	BRYANT	
Residence Information (Select One) <input type="radio"/> US Residency <input checked="" type="radio"/> Non US Residency <input type="radio"/> Active US Military Service				

City	Reinach, Basel Land	Country of Residence ⁱ	CH
-------------	---------------------	------------------------------------------	----

Mailing Address of Inventor:

Address 1	Novartis Pharma AG		
Address 2	Postfach		
City	Basel	State/Province	
Postal Code	4002	Country ⁱ	CH

Inventor 4

Remove

Legal Name

Prefix	Given Name	Middle Name	Family Name	Suffix
	Heinrich	Martin	BUETTGEN	
Residence Information (Select One) <input type="radio"/> US Residency <input checked="" type="radio"/> Non US Residency <input type="radio"/> Active US Military Service				

City	Rheinfelden	Country of Residence ⁱ	CH
-------------	-------------	------------------------------------------	----

Mailing Address of Inventor:

Address 1	Novartis Pharma AG		
Address 2	Postfach		
City	Basel	State/Province	
Postal Code	4002	Country ⁱ	CH

Inventor 5

Remove

Legal Name

Prefix	Given Name	Middle Name	Family Name	Suffix
	Marie		PICCI	
Residence Information (Select One) <input type="radio"/> US Residency <input checked="" type="radio"/> Non US Residency <input type="radio"/> Active US Military Service				

City	Ranspack-le-bas	Country of Residence ⁱ	FR
-------------	-----------------	------------------------------------------	----

Mailing Address of Inventor:

Address 1	Novartis Pharma AG		
Address 2	Postfach		
City	Basel	State/Province	
Postal Code	4002	Country ⁱ	CH

Under the Paperwork Reduction Act of 1995, no persons are required to respond to a collection of information unless it contains a valid OMB control number.

Application Data Sheet 37 CFR 1.76		Attorney Docket Number	55157-US-NP
		Application Number	13/750,352
Title of Invention	Syringe		

All Inventors Must Be Listed - Additional Inventor Information blocks may be generated within this form by selecting the **Add** button.

Correspondence Information:

Enter either Customer Number or complete the Correspondence Information section below.
For further information see 37 CFR 1.33(a).

An Address is being provided for the correspondence information of this application.

Customer Number 01095

Email Address

Application Information:

Title of the Invention	Syringe		
Attorney Docket Number	55157-US-NP	Small Entity Status Claimed	<input type="checkbox"/>
Application Type	Nonprovisional		
Subject Matter	Utility		
Total Number of Drawing Sheets (if any)		Suggested Figure for Publication (if any)	

Filing By Reference :

Only complete this section when filing an application by reference under 35 U.S.C. 111(c) and 37 CFR 1.57(a). Do not complete this section if application papers including a specification and any drawings are being filed. Any domestic benefit or foreign priority information must be provided in the appropriate section(s) below (i.e., "Domestic Benefit/National Stage Information" and "Foreign Priority Information").

For the purposes of a filing date under 37 CFR 1.53(b), the description and any drawings of the present application are replaced by this reference to the previously filed application, subject to conditions and requirements of 37 CFR 1.57(a).

Application number of the previously filed application	Filing date (YYYY-MM-DD)	Intellectual Property Authority or Country

Publication Information:

Request Early Publication (Fee required at time of Request 37 CFR 1.219)

Request Not to Publish. I hereby request that the attached application not be published under 35 U.S.C. 122(b) and certify that the invention disclosed in the attached application **has not and will not** be the subject of an application filed in another country, or under a multilateral international agreement, that requires publication at eighteen months after filing.

Representative Information:

Representative information should be provided for all practitioners having a power of attorney in the application. Providing this information in the Application Data Sheet does not constitute a power of attorney in the application (see 37 CFR 1.32). Either enter Customer Number or complete the Representative Name section below. If both sections are completed the customer Number will be used for the Representative Information during processing.

Under the Paperwork Reduction Act of 1995, no persons are required to respond to a collection of information unless it contains a valid OMB control number.

Application Data Sheet 37 CFR 1.76		Attorney Docket Number	55157-US-NP	
		Application Number	13/750,352	
Title of Invention	Syringe			
Please Select One:	<input checked="" type="radio"/> Customer Number	<input type="radio"/> US Patent Practitioner	<input type="radio"/> Limited Recognition (37 CFR 11.9)	
Customer Number	01095			

Domestic Benefit/National Stage Information:

This section allows for the applicant to either claim benefit under 35 U.S.C. 119(e), 120, 121, or 365(c) or indicate National Stage entry from a PCT application. Providing this information in the application data sheet constitutes the specific reference required by 35 U.S.C. 119(e) or 120, and 37 CFR 1.78.

When referring to the current application, please leave the application number blank.

Prior Application Status			Remove
Application Number	Continuity Type	Prior Application Number	Filing Date (YYYY-MM-DD)
Additional Domestic Benefit/National Stage Data may be generated within this form by selecting the Add button.			

Foreign Priority Information:

This section allows for the applicant to claim priority to a foreign application. Providing this information in the application data sheet constitutes the claim for priority as required by 35 U.S.C. 119(b) and 37 CFR 1.55(d). When priority is claimed to a foreign application that is eligible for retrieval under the priority document exchange program (PDX)ⁱ the information will be used by the Office to automatically attempt retrieval pursuant to 37 CFR 1.55(h)(1) and (2). Under the PDX program, applicant bears the ultimate responsibility for ensuring that a copy of the foreign application is received by the Office from the participating foreign intellectual property office, or a certified copy of the foreign priority application is filed, within the time period specified in 37 CFR 1.55(g)(1).

			Remove
Application Number	Country ⁱ	Filing Date (YYYY-MM-DD)	Access Code ⁱ (if applicable)
12174860.2	EP	2012-07-03	
			Remove
Application Number	Country ⁱ	Filing Date (YYYY-MM-DD)	Access Code ⁱ (if applicable)
12189649.2	EP	2012-10-23	
			Remove
Application Number	Country ⁱ	Filing Date (YYYY-MM-DD)	Access Code ⁱ (if applicable)
202012011016.0	DE	2012-11-16	
			Remove
Application Number	Country ⁱ	Filing Date (YYYY-MM-DD)	Access Code ⁱ (if applicable)
2012101677	AU	2012-11-16	
			Remove
Application Number	Country ⁱ	Filing Date (YYYY-MM-DD)	Access Code ⁱ (if applicable)
2012101678	AU	2012-11-16	

Under the Paperwork Reduction Act of 1995, no persons are required to respond to a collection of information unless it contains a valid OMB control number.

Application Data Sheet 37 CFR 1.76		Attorney Docket Number	55157-US-NP
		Application Number	13 / 750 , 352
Title of Invention	Syringe		

Application Number	Country ⁱ	Filing Date (YYYY-MM-DD)	Access Code ⁱ (if applicable)
202012011260.0	DE	2012-11-23	<input type="button" value="Remove"/>
202012011259.7	DE	2012-11-23	<input type="button" value="Remove"/>
12195360.8	EP	2012-12-03	<input type="button" value="Remove"/>
2013100071	AU	2013-01-23	<input type="button" value="Remove"/>
2013100070	AU	2013-01-23	<input type="button" value="Remove"/>
202013000688.9	DE	2013-01-23	<input type="button" value="Remove"/>

Additional Foreign Priority Data may be generated within this form by selecting the **Add** button.

Statement under 37 CFR 1.55 or 1.78 for AIA (First Inventor to File) Transition Applications

<p>This application (1) claims priority to or the benefit of an application filed before March 16, 2013 and (2) also contains, or contained at any time, a claim to a claimed invention that has an effective filing date on or after March 16, 2013.</p> <p><input type="checkbox"/> NOTE: By providing this statement under 37 CFR 1.55 or 1.78, this application, with a filing date on or after March 16, 2013, will be examined under the first inventor to file provisions of the AIA.</p>

Authorization to Permit Access:

<input checked="" type="checkbox"/> Authorization to Permit Access to the Instant Application by the Participating Offices

Under the Paperwork Reduction Act of 1995, no persons are required to respond to a collection of information unless it contains a valid OMB control number.

Application Data Sheet 37 CFR 1.76		Attorney Docket Number	55157-US-NP
		Application Number	13 / 750 , 352
Title of Invention	Syringe		

If checked, the undersigned hereby grants the USPTO authority to provide the European Patent Office (EPO), the Japan Patent Office (JPO), the Korean Intellectual Property Office (KIPO), the World Intellectual Property Office (WIPO), and any other intellectual property offices in which a foreign application claiming priority to the instant patent application is filed access to the instant patent application. See 37 CFR 1.14(c) and (h). This box should not be checked if the applicant does not wish the EPO, JPO, KIPO, WIPO, or other intellectual property office in which a foreign application claiming priority to the instant patent application is filed to have access to the instant patent application.

In accordance with 37 CFR 1.14(h)(3), access will be provided to a copy of the instant patent application with respect to: 1) the instant patent application-as-filed; 2) any foreign application to which the instant patent application claims priority under 35 U.S.C. 119(a)-(d) if a copy of the foreign application that satisfies the certified copy requirement of 37 CFR 1.55 has been filed in the instant patent application; and 3) any U.S. application-as-filed from which benefit is sought in the instant patent application.

In accordance with 37 CFR 1.14(c), access may be provided to information concerning the date of filing this Authorization.

Applicant Information:

Providing assignment information in this section does not substitute for compliance with any requirement of part 3 of Title 37 of CFR to have an assignment recorded by the Office.

Applicant 1

If the applicant is the inventor (or the remaining joint inventor or inventors under 37 CFR 1.45), this section should not be completed. The information to be provided in this section is the name and address of the legal representative who is the applicant under 37 CFR 1.43; or the name and address of the assignee, person to whom the inventor is under an obligation to assign the invention, or person who otherwise shows sufficient proprietary interest in the matter who is the applicant under 37 CFR 1.46. If the applicant is an applicant under 37 CFR 1.46 (assignee, person to whom the inventor is obligated to assign, or person who otherwise shows sufficient proprietary interest) together with one or more joint inventors, then the joint inventor or inventors who are also the applicant should be identified in this section.

- Assignee
 Legal Representative under 35 U.S.C. 117
 Joint Inventor
 Person to whom the inventor is obligated to assign.
 Person who shows sufficient proprietary interest

If applicant is the legal representative, indicate the authority to file the patent application, the inventor is:

Name of the Deceased or Legally Incapacitated Inventor :

If the Applicant is an Organization check here.

Organization Name Novartis AG

Mailing Address Information For Applicant:

Address 1	Lichtstrasse 35		
Address 2			
City	Basel	State/Province	
Country	CH	Postal Code	4056
Phone Number		Fax Number	

Under the Paperwork Reduction Act of 1995, no persons are required to respond to a collection of information unless it contains a valid OMB control number.

Application Data Sheet 37 CFR 1.76		Attorney Docket Number	55157-US-NP
		Application Number	13/750,352
Title of Invention	Syringe		

Email Address	
---------------	--

Additional Applicant Data may be generated within this form by selecting the Add button.

Assignee Information including Non-Applicant Assignee Information:

Providing assignment information in this section does not substitute for compliance with any requirement of part 3 of Title 37 of CFR to have an assignment recorded by the Office.

Assignee 1				
Complete this section if assignee information, including non-applicant assignee information, is desired to be included on the patent application publication. An assignee-applicant identified in the "Applicant Information" section will appear on the patent application publication as an applicant. For an assignee-applicant, complete this section only if identification as an assignee is also desired on the patent application publication.				
If the Assignee or Non-Applicant Assignee is an Organization check here. <input type="checkbox"/>				
Prefix	Given Name	Middle Name	Family Name	Suffix

Mailing Address Information For Assignee including Non-Applicant Assignee:

Address 1				
Address 2				
City		State/Province		
Country ⁱ		Postal Code		
Phone Number		Fax Number		
Email Address				

Additional Assignee or Non-Applicant Assignee Data may be generated within this form by selecting the Add button.

Signature:

NOTE: This form must be signed in accordance with 37 CFR 1.33. See 37 CFR 1.4 for signature requirements and certifications.					
Signature	/Michael Mazza/			Date (YYYY-MM-DD)	2014-04-11
First Name	Michael	Last Name	Mazza	Registration Number	30775
Additional Signature may be generated within this form by selecting the Add button.					

Under the Paperwork Reduction Act of 1995, no persons are required to respond to a collection of information unless it contains a valid OMB control number.

Application Data Sheet 37 CFR 1.76		Attorney Docket Number	55157-US-NP
		Application Number	1/750,352
Title of Invention	Syringe		

This collection of information is required by 37 CFR 1.76. The information is required to obtain or retain a benefit by the public which is to file (and by the USPTO to process) an application. Confidentiality is governed by 35 U.S.C. 122 and 37 CFR 1.14. This collection is estimated to take 23 minutes to complete, including gathering, preparing, and submitting the completed application data sheet form to the USPTO. Time will vary depending upon the individual case. Any comments on the amount of time you require to complete this form and/or suggestions for reducing this burden, should be sent to the Chief Information Officer, U.S. Patent and Trademark Office, U.S. Department of Commerce, P.O. Box 1450, Alexandria, VA 22313-1450. DO NOT SEND FEES OR COMPLETED FORMS TO THIS ADDRESS. **SEND TO: Commissioner for Patents, P.O. Box 1450, Alexandria, VA 22313-1450.**

Privacy Act Statement

The Privacy Act of 1974 (P.L. 93-579) requires that you be given certain information in connection with your submission of the attached form related to a patent application or patent. Accordingly, pursuant to the requirements of the Act, please be advised that: (1) the general authority for the collection of this information is 35 U.S.C. 2(b)(2); (2) furnishing of the information solicited is voluntary; and (3) the principal purpose for which the information is used by the U.S. Patent and Trademark Office is to process and/or examine your submission related to a patent application or patent. If you do not furnish the requested information, the U.S. Patent and Trademark Office may not be able to process and/or examine your submission, which may result in termination of proceedings or abandonment of the application or expiration of the patent.

The information provided by you in this form will be subject to the following routine uses:

1. The information on this form will be treated confidentially to the extent allowed under the Freedom of Information Act (5 U.S.C. 552) and the Privacy Act (5 U.S.C. 552a). Records from this system of records may be disclosed to the Department of Justice to determine whether the Freedom of Information Act requires disclosure of these records.
2. A record from this system of records may be disclosed, as a routine use, in the course of presenting evidence to a court, magistrate, or administrative tribunal, including disclosures to opposing counsel in the course of settlement negotiations.
3. A record in this system of records may be disclosed, as a routine use, to a Member of Congress submitting a request involving an individual, to whom the record pertains, when the individual has requested assistance from the Member with respect to the subject matter of the record.
4. A record in this system of records may be disclosed, as a routine use, to a contractor of the Agency having need for the information in order to perform a contract. Recipients of information shall be required to comply with the requirements of the Privacy Act of 1974, as amended, pursuant to 5 U.S.C. 552a(m).
5. A record related to an International Application filed under the Patent Cooperation Treaty in this system of records may be disclosed, as a routine use, to the International Bureau of the World Intellectual Property Organization, pursuant to the Patent Cooperation Treaty.
6. A record in this system of records may be disclosed, as a routine use, to another federal agency for purposes of National Security review (35 U.S.C. 181) and for review pursuant to the Atomic Energy Act (42 U.S.C. 218(c)).
7. A record from this system of records may be disclosed, as a routine use, to the Administrator, General Services, or his/her designee, during an inspection of records conducted by GSA as part of that agency's responsibility to recommend improvements in records management practices and programs, under authority of 44 U.S.C. 2904 and 2906. Such disclosure shall be made in accordance with the GSA regulations governing inspection of records for this purpose, and any other relevant (i.e., GSA or Commerce) directive. Such disclosure shall not be used to make determinations about individuals.
8. A record from this system of records may be disclosed, as a routine use, to the public after either publication of the application pursuant to 35 U.S.C. 122(b) or issuance of a patent pursuant to 35 U.S.C. 151. Further, a record may be disclosed, subject to the limitations of 37 CFR 1.14, as a routine use, to the public if the record was filed in an application which became abandoned or in which the proceedings were terminated and which application is referenced by either a published application, an application open to public inspections or an issued patent.
9. A record from this system of records may be disclosed, as a routine use, to a Federal, State, or local law enforcement agency, if the USPTO becomes aware of a violation or potential violation of law or regulation.

DECLARATION (37 CFR 1.63) FOR UTILITY OR DESIGN APPLICATION USING AN APPLICATION DATA SHEET (37 CFR 1.76)

Title of Invention

SYRINGE

As the below named inventor, I hereby declare that:

This declaration is directed to: The attached application, or
 United States application or PCT international application number PCT/EP2013/051491
 filed on 25 January 2013.

The above-identified application was made or authorized to be made by me.

I believe that I am the original inventor or an original joint inventor of a claimed invention in the application.

I hereby acknowledge that any willful false statement made in this declaration is punishable under 18 U.S.C. 1001 by fine or imprisonment of not more than five (5) years, or both.

WARNING:

Petitioner/applicant is cautioned to avoid submitting personal information in documents filed in a patent application that may contribute to identity theft. Personal information such as social security numbers, bank account numbers, or credit card numbers (other than a check or credit card authorization form PTO-2038 submitted for payment purposes) is never required by the USPTO to support a petition or an application. If this type of personal information is included in documents submitted to the USPTO, petitioners/applicants should consider redacting such personal information from the documents before submitting them to the USPTO. Petitioner/applicant is advised that the record of a patent application is available to the public after publication of the application (unless a non-publication request in compliance with 37 CFR 1.213(a) is made in the application) or issuance of a patent. Furthermore, the record from an abandoned application may also be available to the public if the application is referenced in a published application or an issued patent (see 37 CFR 1.14). Checks and credit card authorization forms PTO-2038 submitted for payment purposes are not retained in the application file and therefore are not publicly available.

LEGAL NAME OF INVENTOR

Inventor: Christophe Royer Date (Optional): 02 Feb 2013Signature: 

Note: An application data sheet (PTO/AIA/14 or equivalent), including naming the entire inventive entity, must accompany this form. Use an additional PTO/SB/AIA01 form for each additional inventor.

This collection of information is required by 35 U.S.C. 115 and 37 CFR 1.63. The information is required to obtain or retain a benefit by the public which is to file (and by the USPTO to process) an application. Confidentiality is governed by 35 U.S.C. 122 and 37 CFR 1.11 and 1.14. This collection is estimated to take 1 minute to complete, including gathering, preparing, and submitting the completed application form to the USPTO. Time will vary depending upon the individual case. Any comments on the amount of time you require to complete this form and/or suggestions for reducing this burden, should be sent to the Chief Information Officer, U.S. Patent and Trademark Office, U.S. Department of Commerce, P.O. Box 1450, Alexandria, VA 22313-1450. DO NOT SEND FEES OR COMPLETED FORMS TO THIS ADDRESS. SEND TO: Commissioner for Patents, P.O. Box 1450, Alexandria, VA 22313-1450.

If you need assistance in completing the form, call 1-800-PTO-9199 and select option 2.

Electronic Patent Application Fee Transmittal

Application Number:	13750352			
Filing Date:	25-Jan-2013			
Title of Invention:	SYRINGE			
First Named Inventor/Applicant Name:	Juergen Sigg			
Filer:	Michael J. Mazza/Linda Adams			
Attorney Docket Number:	PAT055157-US-NP			
Filed as Large Entity				
Filing Fees for Utility under 35 USC 111(a)				
Description	Fee Code	Quantity	Amount	Sub-Total in USD(\$)
Basic Filing:				
Pages:				
Claims:				
Miscellaneous-Filing:				
PROCESSING FEE, EXCEPT PROV. APPLS.	1830	1	140	140
Petition:				
Patent-Appeals-and-Interference:				
Post-Allowance-and-Post-Issuance:				

Description	Fee Code	Quantity	Amount	Sub-Total in USD(\$)
Extension-of-Time:				
Miscellaneous:				
Total in USD (\$)				140

Electronic Acknowledgement Receipt

EFS ID:	23370550
Application Number:	13750352
International Application Number:	
Confirmation Number:	5306
Title of Invention:	SYRINGE
First Named Inventor/Applicant Name:	Juergen Sigg
Customer Number:	1095
Filer:	Michael J. Mazza/Linda Adams
Filer Authorized By:	Michael J. Mazza
Attorney Docket Number:	PAT055157-US-NP
Receipt Date:	01-SEP-2015
Filing Date:	25-JAN-2013
Time Stamp:	14:43:59
Application Type:	Utility under 35 USC 111(a)

Payment information:

Submitted with Payment	yes
Payment Type	Deposit Account
Payment was successfully received in RAM	\$140
RAM confirmation Number	936
Deposit Account	190134
Authorized User	MAZZA, MICHAEL J.

The Director of the USPTO is hereby authorized to charge indicated fees and credit any overpayment as follows:

File Listing:					
Document Number	Document Description	File Name	File Size(Bytes)/ Message Digest	Multi Part /.zip	Pages (if appl.)
1	Miscellaneous Incoming Letter	Inventor_ltr.pdf	58679	no	2
			542003a5d440fbbd0014108d52b5b5881c4dd733		
Warnings:					
Information:					
2	Application Data Sheet	55157_ADS_signed_2.pdf	323275	no	9
			4d39da07914151676ec6fd641ea9e55ee48e55f		
Warnings:					
Information:					
This is not an USPTO supplied ADS fillable form					
3	Oath or Declaration filed	Royer_Dec.pdf	215658	no	1
			1ed2dc027520e250afbcabaa1d71c85a59bb6fde		
Warnings:					
Information:					
4	Fee Worksheet (SB06)	fee-info.pdf	30176	no	2
			ef2cd9b18a036557a36c722af215645df0b6d7c4		
Warnings:					
Information:					
Total Files Size (in bytes):			627788		

This Acknowledgement Receipt evidences receipt on the noted date by the USPTO of the indicated documents, characterized by the applicant, and including page counts, where applicable. It serves as evidence of receipt similar to a Post Card, as described in MPEP 503.

New Applications Under 35 U.S.C. 111

If a new application is being filed and the application includes the necessary components for a filing date (see 37 CFR 1.53(b)-(d) and MPEP 506), a Filing Receipt (37 CFR 1.54) will be issued in due course and the date shown on this Acknowledgement Receipt will establish the filing date of the application.

National Stage of an International Application under 35 U.S.C. 371

If a timely submission to enter the national stage of an international application is compliant with the conditions of 35 U.S.C. 371 and other applicable requirements a Form PCT/DO/EO/903 indicating acceptance of the application as a national stage submission under 35 U.S.C. 371 will be issued in addition to the Filing Receipt, in due course.

New International Application Filed with the USPTO as a Receiving Office

If a new international application is being filed and the international application includes the necessary components for an international filing date (see PCT Article 11 and MPEP 1810), a Notification of the International Application Number and of the International Filing Date (Form PCT/RO/105) will be issued in due course, subject to prescriptions concerning national security, and the date shown on this Acknowledgement Receipt will establish the international filing date of the application.



UNITED STATES PATENT AND TRADEMARK OFFICE

UNITED STATES DEPARTMENT OF COMMERCE
United States Patent and Trademark Office
Address: COMMISSIONER FOR PATENTS
P.O. Box 1450
Alexandria, Virginia 22313-1450
www.uspto.gov

Table with 7 columns: APPLICATION NUMBER, FILING or 371(c) DATE, GRP ART UNIT, FIL FEE REC'D, ATTY. DOCKET NO, TOT CLAIMS, IND CLAIMS. Row 1: 13/750,352, 01/25/2013, 3763, 2274, PAT055157-US-NP, 32, 2

CONFIRMATION NO. 5306

CORRECTED FILING RECEIPT



1095
NOVARTIS PHARMACEUTICAL CORPORATION
INTELLECTUAL PROPERTY DEPARTMENT
ONE HEALTH PLAZA 433/2
EAST HANOVER, NJ 07936-1080

Date Mailed: 09/04/2015

Receipt is acknowledged of this non-provisional patent application. The application will be taken up for examination in due course. Applicant will be notified as to the results of the examination. Any correspondence concerning the application must include the following identification information: the U.S. APPLICATION NUMBER, FILING DATE, NAME OF APPLICANT, and TITLE OF INVENTION. Fees transmitted by check or draft are subject to collection. Please verify the accuracy of the data presented on this receipt. If an error is noted on this Filing Receipt, please submit a written request for a Filing Receipt Correction. Please provide a copy of this Filing Receipt with the changes noted thereon. If you received a "Notice to File Missing Parts" for this application, please submit any corrections to this Filing Receipt with your reply to the Notice. When the USPTO processes the reply to the Notice, the USPTO will generate another Filing Receipt incorporating the requested corrections

Inventor(s)

Juergen Sigg, Loerrach, GERMANY;
Christophe Royer, Munich, GERMANY;
Andrew Mark Bryant, Reinach, SWITZERLAND;
Heinrich Martin Buettgen, Rheinfelden, SWITZERLAND;
Marie Picci, Ranspack-le-bas, FRANCE;

Applicant(s)

NOVARTIS AG, Basel, SWITZERLAND

Assignment For Published Patent Application

Novartis AG, Basel, SWITZERLAND

Power of Attorney: The patent practitioners associated with Customer Number 01095

Domestic Applications for which benefit is claimed - None.

A proper domestic benefit claim must be provided in an Application Data Sheet in order to constitute a claim for domestic benefit. See 37 CFR 1.76 and 1.78.

Foreign Applications (You may be eligible to benefit from the Patent Prosecution Highway program at the USPTO. Please see http://www.uspto.gov for more information.)

- EUROPEAN PATENT OFFICE (EPO) 12174860.2 07/03/2012
EUROPEAN PATENT OFFICE (EPO) 12189649.2 10/23/2012
GERMANY 202012011016.0 11/16/2012
AUSTRALIA 2012101677 11/16/2012 No Access Code Provided
AUSTRALIA 2012101678 11/16/2012 No Access Code Provided
GERMANY 202012011260.0 11/23/2012
GERMANY 202012011259.7 11/23/2012
EUROPEAN PATENT OFFICE (EPO) 12195360.8 12/03/2012

AUSTRALIA 2013100071 01/23/2013 No Access Code Provided
AUSTRALIA 2013100070 01/23/2013 No Access Code Provided
GERMANY 202013000688.9 01/23/2013

Permission to Access - A proper **Authorization to Permit Access to Application by Participating Offices** (PTO/SB/39 or its equivalent) has been received by the USPTO.

Request to Retrieve - This application either claims priority to one or more applications filed in an intellectual property Office that participates in the Priority Document Exchange (PDX) program or contains a proper **Request to Retrieve Electronic Priority Application(s)** (PTO/SB/38 or its equivalent). Consequently, the USPTO will attempt to electronically retrieve these priority documents.

If Required, Foreign Filing License Granted: 02/05/2013

The country code and number of your priority application, to be used for filing abroad under the Paris Convention, is **US 13/750,352**

Projected Publication Date: Not Applicable

Non-Publication Request: No

Early Publication Request: No

Title

SYRINGE

Preliminary Class

604

Statement under 37 CFR 1.55 or 1.78 for AIA (First Inventor to File) Transition Applications:

PROTECTING YOUR INVENTION OUTSIDE THE UNITED STATES

Since the rights granted by a U.S. patent extend only throughout the territory of the United States and have no effect in a foreign country, an inventor who wishes patent protection in another country must apply for a patent in a specific country or in regional patent offices. Applicants may wish to consider the filing of an international application under the Patent Cooperation Treaty (PCT). An international (PCT) application generally has the same effect as a regular national patent application in each PCT-member country. The PCT process **simplifies** the filing of patent applications on the same invention in member countries, but **does not result** in a grant of "an international patent" and does not eliminate the need of applicants to file additional documents and fees in countries where patent protection is desired.

Almost every country has its own patent law, and a person desiring a patent in a particular country must make an application for patent in that country in accordance with its particular laws. Since the laws of many countries differ in various respects from the patent law of the United States, applicants are advised to seek guidance from specific foreign countries to ensure that patent rights are not lost prematurely.

Applicants also are advised that in the case of inventions made in the United States, the Director of the USPTO must issue a license before applicants can apply for a patent in a foreign country. The filing of a U.S. patent application serves as a request for a foreign filing license. The application's filing receipt contains further information and guidance as to the status of applicant's license for foreign filing.

Applicants may wish to consult the USPTO booklet, "General Information Concerning Patents" (specifically, the section entitled "Treaties and Foreign Patents") for more information on timeframes and deadlines for filing foreign patent applications. The guide is available either by contacting the USPTO Contact Center at 800-786-9199, or it can be viewed on the USPTO website at <http://www.uspto.gov/web/offices/pac/doc/general/index.html>.

For information on preventing theft of your intellectual property (patents, trademarks and copyrights), you may wish to consult the U.S. Government website, <http://www.stopfakes.gov>. Part of a Department of Commerce initiative, this website includes self-help "toolkits" giving innovators guidance on how to protect intellectual property in specific countries such as China, Korea and Mexico. For questions regarding patent enforcement issues, applicants may call the U.S. Government hotline at 1-866-999-HALT (1-866-999-4258).

LICENSE FOR FOREIGN FILING UNDER
Title 35, United States Code, Section 184
Title 37, Code of Federal Regulations, 5.11 & 5.15

GRANTED

The applicant has been granted a license under 35 U.S.C. 184, if the phrase "IF REQUIRED, FOREIGN FILING LICENSE GRANTED" followed by a date appears on this form. Such licenses are issued in all applications where the conditions for issuance of a license have been met, regardless of whether or not a license may be required as set forth in 37 CFR 5.15. The scope and limitations of this license are set forth in 37 CFR 5.15(a) unless an earlier license has been issued under 37 CFR 5.15(b). The license is subject to revocation upon written notification. The date indicated is the effective date of the license, unless an earlier license of similar scope has been granted under 37 CFR 5.13 or 5.14.

This license is to be retained by the licensee and may be used at any time on or after the effective date thereof unless it is revoked. This license is automatically transferred to any related applications(s) filed under 37 CFR 1.53(d). This license is not retroactive.

The grant of a license does not in any way lessen the responsibility of a licensee for the security of the subject matter as imposed by any Government contract or the provisions of existing laws relating to espionage and the national security or the export of technical data. Licensees should apprise themselves of current regulations especially with respect to certain countries, of other agencies, particularly the Office of Defense Trade Controls, Department of State (with respect to Arms, Munitions and Implements of War (22 CFR 121-128)); the Bureau of Industry and Security, Department of Commerce (15 CFR parts 730-774); the Office of Foreign Assets Control, Department of Treasury (31 CFR Parts 500+) and the Department of Energy.

NOT GRANTED

No license under 35 U.S.C. 184 has been granted at this time, if the phrase "IF REQUIRED, FOREIGN FILING LICENSE GRANTED" DOES NOT appear on this form. Applicant may still petition for a license under 37 CFR 5.12, if a license is desired before the expiration of 6 months from the filing date of the application. If 6 months has lapsed from the filing date of this application and the licensee has not received any indication of a secrecy order under 35 U.S.C. 181, the licensee may foreign file the application pursuant to 37 CFR 5.15(b).

SelectUSA

The United States represents the largest, most dynamic marketplace in the world and is an unparalleled location for business investment, innovation, and commercialization of new technologies. The U.S. offers tremendous resources and advantages for those who invest and manufacture goods here. Through SelectUSA, our nation works to promote and facilitate business investment. SelectUSA provides information assistance to the international investor community; serves as an ombudsman for existing and potential investors; advocates on behalf of U.S. cities, states, and regions competing for global investment; and counsels U.S. economic development organizations on investment attraction best practices. To learn more about why the United States is the best country in the world to develop technology, manufacture products, deliver services, and grow your business, visit <http://www.SelectUSA.gov> or call +1-202-482-6800.



UNITED STATES PATENT AND TRADEMARK OFFICE

UNITED STATES DEPARTMENT OF COMMERCE
United States Patent and Trademark Office
Address: COMMISSIONER FOR PATENTS
P.O. Box 1450
Alexandria, Virginia 22313-1450
www.uspto.gov

Table with 7 columns: APPLICATION NUMBER, FILING or 371(c) DATE, GRP ART UNIT, FIL FEE REC'D, ATTY. DOCKET NO, TOT CLAIMS, IND CLAIMS. Row 1: 13/750,352, 01/25/2013, 3763, 2274, PAT055157-US-NP, 32, 2

CONFIRMATION NO. 5306

CORRECTED FILING RECEIPT



1095
NOVARTIS PHARMACEUTICAL CORPORATION
INTELLECTUAL PROPERTY DEPARTMENT
ONE HEALTH PLAZA 433/2
EAST HANOVER, NJ 07936-1080

Date Mailed: 09/04/2015

Receipt is acknowledged of this non-provisional patent application. The application will be taken up for examination in due course. Applicant will be notified as to the results of the examination. Any correspondence concerning the application must include the following identification information: the U.S. APPLICATION NUMBER, FILING DATE, NAME OF APPLICANT, and TITLE OF INVENTION. Fees transmitted by check or draft are subject to collection. Please verify the accuracy of the data presented on this receipt. If an error is noted on this Filing Receipt, please submit a written request for a Filing Receipt Correction. Please provide a copy of this Filing Receipt with the changes noted thereon. If you received a "Notice to File Missing Parts" for this application, please submit any corrections to this Filing Receipt with your reply to the Notice. When the USPTO processes the reply to the Notice, the USPTO will generate another Filing Receipt incorporating the requested corrections

Inventor(s)

Juergen Sigg, Loerrach, GERMANY;
Christopher Royer, Munich, GERMANY;
Andrew Mark Bryant, Reinach, SWITZERLAND;
Heinrich Martin Buettgen, Rheinfelden, SWITZERLAND;
Marie Picci, Ranspack-le-bas, FRANCE;

Applicant(s)

NOVARTIS AG, Basel, SWITZERLAND

Assignment For Published Patent Application

Novartis AG, Basel, SWITZERLAND

Power of Attorney: The patent practitioners associated with Customer Number 01095

Domestic Applications for which benefit is claimed - None.

A proper domestic benefit claim must be provided in an Application Data Sheet in order to constitute a claim for domestic benefit. See 37 CFR 1.76 and 1.78.

Foreign Applications (You may be eligible to benefit from the Patent Prosecution Highway program at the USPTO. Please see http://www.uspto.gov for more information.)

- EUROPEAN PATENT OFFICE (EPO) 12174860.2 07/03/2012
EUROPEAN PATENT OFFICE (EPO) 12189649.2 10/23/2012
GERMANY 202012011016.0 11/16/2012
AUSTRALIA 2012101677 11/16/2012 No Access Code Provided
AUSTRALIA 2012101678 11/16/2012 No Access Code Provided
GERMANY 202012011260.0 11/23/2012
GERMANY 202012011259.7 11/23/2012
EUROPEAN PATENT OFFICE (EPO) 12195360.8 12/03/2012

AUSTRALIA 2013100071 01/23/2013 No Access Code Provided
AUSTRALIA 2013100070 01/23/2013 No Access Code Provided
GERMANY 202013000688.9 01/23/2013

Permission to Access - A proper **Authorization to Permit Access to Application by Participating Offices** (PTO/SB/39 or its equivalent) has been received by the USPTO.

Request to Retrieve - This application either claims priority to one or more applications filed in an intellectual property Office that participates in the Priority Document Exchange (PDX) program or contains a proper **Request to Retrieve Electronic Priority Application(s)** (PTO/SB/38 or its equivalent). Consequently, the USPTO will attempt to electronically retrieve these priority documents.

If Required, Foreign Filing License Granted: 02/05/2013

The country code and number of your priority application, to be used for filing abroad under the Paris Convention, is **US 13/750,352**

Projected Publication Date: Not Applicable

Non-Publication Request: No

Early Publication Request: No

Title

SYRINGE

Preliminary Class

604

Statement under 37 CFR 1.55 or 1.78 for AIA (First Inventor to File) Transition Applications:

PROTECTING YOUR INVENTION OUTSIDE THE UNITED STATES

Since the rights granted by a U.S. patent extend only throughout the territory of the United States and have no effect in a foreign country, an inventor who wishes patent protection in another country must apply for a patent in a specific country or in regional patent offices. Applicants may wish to consider the filing of an international application under the Patent Cooperation Treaty (PCT). An international (PCT) application generally has the same effect as a regular national patent application in each PCT-member country. The PCT process **simplifies** the filing of patent applications on the same invention in member countries, but **does not result** in a grant of "an international patent" and does not eliminate the need of applicants to file additional documents and fees in countries where patent protection is desired.

Almost every country has its own patent law, and a person desiring a patent in a particular country must make an application for patent in that country in accordance with its particular laws. Since the laws of many countries differ in various respects from the patent law of the United States, applicants are advised to seek guidance from specific foreign countries to ensure that patent rights are not lost prematurely.

Applicants also are advised that in the case of inventions made in the United States, the Director of the USPTO must issue a license before applicants can apply for a patent in a foreign country. The filing of a U.S. patent application serves as a request for a foreign filing license. The application's filing receipt contains further information and guidance as to the status of applicant's license for foreign filing.

Applicants may wish to consult the USPTO booklet, "General Information Concerning Patents" (specifically, the section entitled "Treaties and Foreign Patents") for more information on timeframes and deadlines for filing foreign patent applications. The guide is available either by contacting the USPTO Contact Center at 800-786-9199, or it can be viewed on the USPTO website at <http://www.uspto.gov/web/offices/pac/doc/general/index.html>.

For information on preventing theft of your intellectual property (patents, trademarks and copyrights), you may wish to consult the U.S. Government website, <http://www.stopfakes.gov>. Part of a Department of Commerce initiative, this website includes self-help "toolkits" giving innovators guidance on how to protect intellectual property in specific countries such as China, Korea and Mexico. For questions regarding patent enforcement issues, applicants may call the U.S. Government hotline at 1-866-999-HALT (1-866-999-4258).

LICENSE FOR FOREIGN FILING UNDER
Title 35, United States Code, Section 184
Title 37, Code of Federal Regulations, 5.11 & 5.15

GRANTED

The applicant has been granted a license under 35 U.S.C. 184, if the phrase "IF REQUIRED, FOREIGN FILING LICENSE GRANTED" followed by a date appears on this form. Such licenses are issued in all applications where the conditions for issuance of a license have been met, regardless of whether or not a license may be required as set forth in 37 CFR 5.15. The scope and limitations of this license are set forth in 37 CFR 5.15(a) unless an earlier license has been issued under 37 CFR 5.15(b). The license is subject to revocation upon written notification. The date indicated is the effective date of the license, unless an earlier license of similar scope has been granted under 37 CFR 5.13 or 5.14.

This license is to be retained by the licensee and may be used at any time on or after the effective date thereof unless it is revoked. This license is automatically transferred to any related applications(s) filed under 37 CFR 1.53(d). This license is not retroactive.

The grant of a license does not in any way lessen the responsibility of a licensee for the security of the subject matter as imposed by any Government contract or the provisions of existing laws relating to espionage and the national security or the export of technical data. Licensees should apprise themselves of current regulations especially with respect to certain countries, of other agencies, particularly the Office of Defense Trade Controls, Department of State (with respect to Arms, Munitions and Implements of War (22 CFR 121-128)); the Bureau of Industry and Security, Department of Commerce (15 CFR parts 730-774); the Office of Foreign Assets Control, Department of Treasury (31 CFR Parts 500+) and the Department of Energy.

NOT GRANTED

No license under 35 U.S.C. 184 has been granted at this time, if the phrase "IF REQUIRED, FOREIGN FILING LICENSE GRANTED" DOES NOT appear on this form. Applicant may still petition for a license under 37 CFR 5.12, if a license is desired before the expiration of 6 months from the filing date of the application. If 6 months has lapsed from the filing date of this application and the licensee has not received any indication of a secrecy order under 35 U.S.C. 181, the licensee may foreign file the application pursuant to 37 CFR 5.15(b).

SelectUSA

The United States represents the largest, most dynamic marketplace in the world and is an unparalleled location for business investment, innovation, and commercialization of new technologies. The U.S. offers tremendous resources and advantages for those who invest and manufacture goods here. Through SelectUSA, our nation works to promote and facilitate business investment. SelectUSA provides information assistance to the international investor community; serves as an ombudsman for existing and potential investors; advocates on behalf of U.S. cities, states, and regions competing for global investment; and counsels U.S. economic development organizations on investment attraction best practices. To learn more about why the United States is the best country in the world to develop technology, manufacture products, deliver services, and grow your business, visit <http://www.SelectUSA.gov> or call +1-202-482-6800.

PART B - FEE(S) TRANSMITTAL

Complete and send this form, together with applicable fee(s), to: **Mail Stop ISSUE FEE
Commissioner for Patents
P.O. Box 1450
Alexandria, Virginia 22313-1450**
or Fax (571)-273-2885

INSTRUCTIONS: This form should be used for transmitting the ISSUE FEE and PUBLICATION FEE (if required). Blocks 1 through 5 should be completed where appropriate. All further correspondence including the Patent, advance orders and notification of maintenance fees will be mailed to the current correspondence address as indicated unless corrected below or directed otherwise in Block 1, by (a) specifying a new correspondence address, and/or (b) indicating a separate "FEE ADDRESS" for maintenance fee notification.

CURRENT CORRESPONDENCE ADDRESS (Note: Use Block 1 for any change of address)

Note: A certificate of mailing can only be used for domestic mailings of the Fee(s) Transmittal. This certificate cannot be used for any other accompanying papers. Each additional paper, such as an assignment or formal drawing, must have its own certificate of mailing or transmission.

Certificate of Mailing or Transmission

I hereby certify that this Fee(s) Transmittal is being deposited with the United States Postal Service with sufficient postage for first class mail in an envelope addressed to the Mail Stop ISSUE FEE address above, or being facsimile transmitted to the USPTO (571) 273-2885, on the date indicated below.

Depositor's name
Signature
Date

0166 7530 08140715
**NOVARTIS PHARMACEUTICAL CORPORATION
INTELLECTUAL PROPERTY DEPARTMENT
ONE HEALTH PLAZA 433/2
EAST HANOVER, NJ 07936-1080**

APPLICATION NO.	FILING DATE	FIRST NAME INVENTOR	ATTORNEY DOCKET NO.	CONFIRMATION NO.
13/750,351	01/25/2013	Jorge J. Sigg	PAT099157-1'S-NP	5306

TITLE OF INVENTION: SYRINGE

APPL. TYPE	ENTITY STATUS	ISSUE FEE DUE	PUBLICATION FEE DUE	PREV. PAID ISSUE FEE	TOTAL FEES DUE	DATE DUE
nonprovisional	UNDISCOUNTED	5960	50	50	5960	11/19/2015

EXAMINER	ART UNIT	CLASS-SUBCLASS
BERDICHEVSKY, AAKU	3763	064-218000

1. Change of correspondence address or indication of "Fee Address" (37 CFR 1.363):

- Change of correspondence address (or Change of Correspondence Address form PTO/SB/122) attached.
- "Fee Address" indication (or "Fee Address" Indication form PTO/SB/47, Rev. 03-02 or more recent) attached. Use of a Customer Number is required.

2. For printing on the patent from page, list:

- (1) The names of up to 3 registered patent attorneys or agents OR, alternatively,
- (2) The name of a single firm (having as a member a registered attorney or agent) and the names of up to 2 registered patent attorneys or agents. If no name is listed, no name will be printed.

Michael Mazza

3. ASSIGNEE NAME AND RESIDENCE DATA TO BE PRINTED ON THE PATENT (print or type)

PLEASE NOTE: Unless an assignee is identified below, no assignee data will appear on the patent. If an assignee is identified below, the document has been filed for recordation as set forth in 37 CFR 3.11. Completion of this form is NOT a substitute for filing an assignment.

(A) NAME OF ASSIGNEE
Novartis AG

(B) RESIDENCE (CITY AND STATE OR COUNTRY)
Basel, SWITZERLAND

Please check the appropriate assignee category or categories (will not be printed on the patent): Individual Corporation or other private group entity Government

4a. The following fee(s) are submitted:

- Issue Fee
- Publication Fee (No small entity discount permitted)
- Advance Order - # of Copies

4b. Payment of Fee(s): (Please first reapply any previously paid issue fee shown above)

- A check is enclosed.
- Payment by credit card. Form PTO-2038 is attached.
- The director is hereby authorized to charge the required fee(s), any deficiency, or credits any overpayment, to Deposit Account Number 190134. (enclose an exact copy of this form).

5. Change in Entity Status (from status indicated above)

- Applicant certifying micro entity status. See 37 CFR 1.29
- Applicant asserting small entity status. See 37 CFR 1.27
- Applicant changing to regular undiscounted fee status.

NOTE: Absent a valid certification of Micro Entity Status (see forms PTO/SB/15A and 1531), issue fee payment in the micro entity amount will not be accepted at the risk of application abandonment.

NOTE: If the application was previously under micro entity status, checking this box will be taken to be a notification of loss of entitlement to micro entity status.

NOTE: Checking this box will be taken to be a notification of loss of entitlement to small or micro entity status, as applicable.

NOTE: This form must be signed in accordance with 37 CFR 1.31 and 1.33. See 37 CFR 1.4 for signature requirements and certifications.

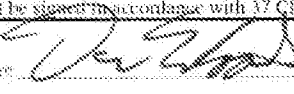
Authorized Signature: 
Typed or printed name: Daniel Woods

Date: November 17, 2015
Registration No.: 59664

Electronic Patent Application Fee Transmittal

Application Number:	13750352			
Filing Date:	25-Jan-2013			
Title of Invention:	SYRINGE			
First Named Inventor/Applicant Name:	Juergen Sigg			
Filer:	Daniel J. Woods/Linda Adams			
Attorney Docket Number:	PAT055157-US-NP			
Filed as Large Entity				
Filing Fees for Utility under 35 USC 111(a)				
Description	Fee Code	Quantity	Amount	Sub-Total in USD(\$)
Basic Filing:				
Pages:				
Claims:				
Miscellaneous-Filing:				
Petition:				
Patent-Appeals-and-Interference:				
Post-Allowance-and-Post-Issuance:				

Description	Fee Code	Quantity	Amount	Sub-Total in USD(\$)
Utility Appl Issue Fee	1501	1	960	960
Publ. Fee- Early, Voluntary, or Normal	1504	1	0	0
Extension-of-Time:				
Miscellaneous:				
Total in USD (\$)				960

Electronic Acknowledgement Receipt

EFS ID:	24103238
Application Number:	13750352
International Application Number:	
Confirmation Number:	5306
Title of Invention:	SYRINGE
First Named Inventor/Applicant Name:	Juergen Sigg
Customer Number:	1095
Filer:	Daniel J. Woods/Linda Adams
Filer Authorized By:	Daniel J. Woods
Attorney Docket Number:	PAT055157-US-NP
Receipt Date:	17-NOV-2015
Filing Date:	25-JAN-2013
Time Stamp:	11:17:18
Application Type:	Utility under 35 USC 111(a)

Payment information:

Submitted with Payment	yes
Payment Type	Deposit Account
Payment was successfully received in RAM	\$960
RAM confirmation Number	9332
Deposit Account	190134
Authorized User	WOODS, DANIEL JOSEPH

The Director of the USPTO is hereby authorized to charge indicated fees and credit any overpayment as follows:

--	--	--	--	--	--

File Listing:

Document Number	Document Description	File Name	File Size(Bytes)/ Message Digest	Multi Part /.zip	Pages (if appl.)
1	Issue Fee Payment (PTO-85B)	Issue_Fee_Woods.pdf	239717	no	1
			ae6c03384f75e12992d6e41705b0c9f48d3d044		

Warnings:

Information:

2	Fee Worksheet (SB06)	fee-info.pdf	31913	no	2
			f51ac8f10adca62cfab6a2669a8b84faabfd01c		

Warnings:

Information:

Total Files Size (in bytes):	271630
-------------------------------------	--------

This Acknowledgement Receipt evidences receipt on the noted date by the USPTO of the indicated documents, characterized by the applicant, and including page counts, where applicable. It serves as evidence of receipt similar to a Post Card, as described in MPEP 503.

New Applications Under 35 U.S.C. 111

If a new application is being filed and the application includes the necessary components for a filing date (see 37 CFR 1.53(b)-(d) and MPEP 506), a Filing Receipt (37 CFR 1.54) will be issued in due course and the date shown on this Acknowledgement Receipt will establish the filing date of the application.

National Stage of an International Application under 35 U.S.C. 371

If a timely submission to enter the national stage of an international application is compliant with the conditions of 35 U.S.C. 371 and other applicable requirements a Form PCT/DO/EO/903 indicating acceptance of the application as a national stage submission under 35 U.S.C. 371 will be issued in addition to the Filing Receipt, in due course.

New International Application Filed with the USPTO as a Receiving Office

If a new international application is being filed and the international application includes the necessary components for an international filing date (see PCT Article 11 and MPEP 1810), a Notification of the International Application Number and of the International Filing Date (Form PCT/RO/105) will be issued in due course, subject to prescriptions concerning national security, and the date shown on this Acknowledgement Receipt will establish the international filing date of the application.

INFORMATION DISCLOSURE STATEMENT BY APPLICANT (Not for submission under 37 CFR 1.99)	Application Number	13750352
	Filing Date	2013-01-25
	First Named Inventor	Juergen Sigg
	Art Unit	3763
	Examiner Name	Berdichevsky, Aarti
	Attorney Docket Number	PAT055157-US-NP

U.S. PATENTS						
Examiner Initial*	Cite No	Patent Number	Kind Code ¹	Issue Date	Name of Patentee or Applicant of cited Document	Pages, Columns, Lines where Relevant Passages or Relevant Figures Appear
	1					

If you wish to add additional U.S. Patent citation information please click the Add button.

U.S. PATENT APPLICATION PUBLICATIONS						
Examiner Initial*	Cite No	Publication Number	Kind Code ¹	Publication Date	Name of Patentee or Applicant of cited Document	Pages, Columns, Lines where Relevant Passages or Relevant Figures Appear
	1					

If you wish to add additional U.S. Published Application citation information please click the Add button.

FOREIGN PATENT DOCUMENTS								
Examiner Initial*	Cite No	Foreign Document Number ³	Country Code ²	Kind Code ⁴	Publication Date	Name of Patentee or Applicant of cited Document	Pages, Columns, Lines where Relevant Passages or Relevant Figures Appear	T ⁵
	1							<input type="checkbox"/>

If you wish to add additional Foreign Patent Document citation information please click the Add button.

NON-PATENT LITERATURE DOCUMENTS			
Examiner Initials*	Cite No	Include name of the author (in CAPITAL LETTERS), title of the article (when appropriate), title of the item (book, magazine, journal, serial, symposium, catalog, etc), date, page(s), volume-issue number(s), publisher, city and/or country where published.	T ⁵

**INFORMATION DISCLOSURE
STATEMENT BY APPLICANT**
(Not for submission under 37 CFR 1.99)

Application Number	13750352
Filing Date	2013-01-25
First Named Inventor	Juergen Sigg
Art Unit	3763
Examiner Name	Berdichevsky, Aarti
Attorney Docket Number	PAT055157-US-NP

1	"Biopharmaceuticals - SPE applications"; RapID Particle Systems, Single Particle Explore, D6a, 28-09-2015; http://www.particle-explorer.com/yourapplications/biopharmaceuticals/index.html [16.09.2015 11:23:45]	<input type="checkbox"/>
2	Email dated September 9, 2015 from Elizabeth Scuderi, Senior meetings Manager, AAPS to Teresa Hornrich re Inquiry about publication of conference abstract.	<input type="checkbox"/>
3	Tibor Hlobik: "Reducing quality risks to drug products and meeting needs of patients with enhanced components for prefilled syringe systems", West Delivering Innovative Solutions, www.ondrugdelivery.com , 2012 No. 33, pp. 32-34	<input type="checkbox"/>
4	Summary of Product Characteristics - Zaltrap (undated)	<input type="checkbox"/>
5	"Ranibizumab", Scientific Discussion, EMEA, 2007, pp. 1-54	<input type="checkbox"/>
6	"Avastin", Scientific Discussion, EMEA, 2005, pp. 1-61	<input type="checkbox"/>
7	Mehmet Selim Kocabora, et al: "Intravitreal silicone oil droplets following pegaptanib injection", <i>Acta Ophthalmologica</i> , 2010 e44-345	<input type="checkbox"/>
8	N. Clunas, et al: "Ranibizumab pre-filled syringe: recently approved innovation in the European Union with the potential to reduce infection risk, improve dose accuracy, and enhance efficient treatment administration", <i>Congress on Controversies in Ophthalmology, Abstract, 2014</i>	<input type="checkbox"/>
9	"COPHy Poster List - Group A" (Poster 17), The 5th World congress on Controversies in Ophthalmology (COPHy) March 20-23-2014, Lisbon, Portugal	<input type="checkbox"/>

If you wish to add additional non-patent literature document citation information please click the Add button

EXAMINER SIGNATURE

Examiner Signature		Date Considered	
--------------------	--	-----------------	--

*EXAMINER: Initial if reference considered, whether or not citation is in conformance with MPEP 609. Draw line through a citation if not in conformance and not considered. Include copy of this form with next communication to applicant.

**INFORMATION DISCLOSURE
STATEMENT BY APPLICANT**
(Not for submission under 37 CFR 1.99)

Application Number	13750352
Filing Date	2013-01-25
First Named Inventor	Jsergen Sigg
Art Unit	3753
Examiner Name	Berdichevsky, Aarti
Attorney Docket Number	PAT055157-US-NP

¹ See Kind Codes of USPTO Patent Documents at www.USPTO.GOV or MPEP 901.04. ² Enter office that issued the document, by the two-letter code (WIPO Standard ST.3). ³ For Japanese patent documents, the indication of the year of the reign of the Emperor must precede the serial number of the patent document. ⁴ Kind of document by the appropriate symbols as indicated on the document under WIPO Standard ST.18 if possible. ⁵ Applicant is to place a check mark here if English language translation is attached.

**INFORMATION DISCLOSURE
STATEMENT BY APPLICANT**
(Not for submission under 37 CFR 1.99)

Application Number	13750352
Filing Date	2013-01-25
First Named Inventor	Juergen Sigg
Art Unit	3763
Examiner Name	Berdichevsky, Aarti
Attorney Docket Number	PAT055157-US-NP

CERTIFICATION STATEMENT

Please see 37 CFR 1.97 and 1.98 to make the appropriate selection(s):

That each item of information contained in the information disclosure statement was first cited in any communication from a foreign patent office in a counterpart foreign application not more than three months prior to the filing of the information disclosure statement. See 37 CFR 1.97(e)(1).

OR

That no item of information contained in the information disclosure statement was cited in a communication from a foreign patent office in a counterpart foreign application, and, to the knowledge of the person signing the certification after making reasonable inquiry, no item of information contained in the information disclosure statement was known to any individual designated in 37 CFR 1.56(c) more than three months prior to the filing of the information disclosure statement. See 37 CFR 1.97(e)(2).

See attached certification statement.

The fee set forth in 37 CFR 1.17 (p) has been submitted herewith.

A certification statement is not submitted herewith.

SIGNATURE

A signature of the applicant or representative is required in accordance with CFR 1.33, 10.18. Please see CFR 1.4(d) for the form of the signature.

Signature		Date (YYYY-MM-DD)	2015-11-17
Name/Print	Daniel Woods	Registration Number	59864

This collection of information is required by 37 CFR 1.97 and 1.98. The information is required to obtain or retain a benefit by the public which is to file (and by the USPTO to process) an application. Confidentiality is governed by 35 U.S.C. 122 and 37 CFR 1.14. This collection is estimated to take 1 hour to complete, including gathering, preparing and submitting the completed application form to the USPTO. Time will vary depending upon the individual case. Any comments on the amount of time you require to complete this form and/or suggestions for reducing this burden, should be sent to the Chief Information Officer, U.S. Patent and Trademark Office, U.S. Department of Commerce, P.O. Box 1450, Alexandria, VA 22313-1450. DO NOT SEND FEES OR COMPLETED FORMS TO THIS ADDRESS. SEND TO: Commissioner for Patents, P.O. Box 1450, Alexandria, VA 22313-1450.

Electronic Patent Application Fee Transmittal

Application Number:	13750352			
Filing Date:	25-Jan-2013			
Title of Invention:	SYRINGE			
First Named Inventor/Applicant Name:	Juergen Sigg			
Filer:	Daniel J. Woods/Linda Adams			
Attorney Docket Number:	PAT055157-US-NP			
Filed as Large Entity				
Filing Fees for Utility under 35 USC 111(a)				
Description	Fee Code	Quantity	Amount	Sub-Total in USD(\$)
Basic Filing:				
Pages:				
Claims:				
Miscellaneous-Filing:				
Petition:				
Patent-Appeals-and-Interference:				
Post-Allowance-and-Post-Issuance:				
Extension-of-Time:				

Description	Fee Code	Quantity	Amount	Sub-Total in USD(\$)
Miscellaneous:				
Submission- Information Disclosure Stmt	1806	1	180	180
Total in USD (\$)				180

Electronic Acknowledgement Receipt

EFS ID:	24103202
Application Number:	13750352
International Application Number:	
Confirmation Number:	5306
Title of Invention:	SYRINGE
First Named Inventor/Applicant Name:	Juergen Sigg
Customer Number:	1095
Filer:	Daniel J. Woods/Linda Adams
Filer Authorized By:	Daniel J. Woods
Attorney Docket Number:	PAT055157-US-NP
Receipt Date:	17-NOV-2015
Filing Date:	25-JAN-2013
Time Stamp:	11:14:47
Application Type:	Utility under 35 USC 111(a)

Payment information:

Submitted with Payment	yes
Payment Type	Deposit Account
Payment was successfully received in RAM	\$180
RAM confirmation Number	9288
Deposit Account	190134
Authorized User	WOODS, DANIEL JOSEPH

The Director of the USPTO is hereby authorized to charge indicated fees and credit any overpayment as follows:

File Listing:					
Document Number	Document Description	File Name	File Size(Bytes)/ Message Digest	Multi Part /.zip	Pages (if appl.)
1	Information Disclosure Statement (IDS) Form (SB08)	IDS_Woods.pdf	697021 fa864253409296e837688fe1b9eeddd448b3334aa	no	4
Warnings:					
Information:					
This is not an USPTO supplied IDS fillable form					
2	Non Patent Literature	51_RapID_2015-1088048.pdf	439235 78c49752fad9eb8423e645dad43089d9368d9fd9	no	4
Warnings:					
Information:					
3	Non Patent Literature	52_EMail_2015-1088050.pdf	76559 dd4b27f8451b66ceffe1790be964e8a997fed1a	no	1
Warnings:					
Information:					
4	Non Patent Literature	53_Hlobik_2012-1088053.pdf	1001043 7e0f34207a20a7b10e0a8bae21f70c34dc923c3	no	4
Warnings:					
Information:					
5	Non Patent Literature	54_Zaltrap_Summary_of_Product-1088055.pdf	576445 9155aa9ed55ab225510f5416cabcb9d5f880afc8	no	44
Warnings:					
Information:					
6	Non Patent Literature	55_EMEA_2007-1088056.pdf	4861500 c5e581bc709b12de2c4060538ff00b78902f405f	no	54
Warnings:					
Information:					
7	Non Patent Literature	56_EMEA_2005-1088058.pdf	6183478 71b118dd1e1b94b27b00384dde713ad8be2c5e29	no	61
Warnings:					
Information:					

8	Non Patent Literature	57_Kocabora_2010-1088063.pdf	258466 da05bea161ac298014ad92c8c16625ff629e1223	no	2
Warnings:					
Information:					
9	Non Patent Literature	58_Clunas_2014-1088061.pdf	78173 76f03aeb28ea7e2f783f9aa2b6b4e4545649b1ac	no	1
Warnings:					
Information:					
10	Non Patent Literature	59_COPHy_2014-1088064.pdf	1097672 5db4ef41cf2b0a764e0d11e4427b997f47a29ebc	no	6
Warnings:					
Information:					
11	Fee Worksheet (SB06)	fee-info.pdf	30173 f2489257bbb5e0b1639a6c5f7b70588632da3cfd	no	2
Warnings:					
Information:					
Total Files Size (in bytes):			15299765		
<p>This Acknowledgement Receipt evidences receipt on the noted date by the USPTO of the indicated documents, characterized by the applicant, and including page counts, where applicable. It serves as evidence of receipt similar to a Post Card, as described in MPEP 503.</p> <p><u>New Applications Under 35 U.S.C. 111</u> If a new application is being filed and the application includes the necessary components for a filing date (see 37 CFR 1.53(b)-(d) and MPEP 506), a Filing Receipt (37 CFR 1.54) will be issued in due course and the date shown on this Acknowledgement Receipt will establish the filing date of the application.</p> <p><u>National Stage of an International Application under 35 U.S.C. 371</u> If a timely submission to enter the national stage of an international application is compliant with the conditions of 35 U.S.C. 371 and other applicable requirements a Form PCT/DO/EO/903 indicating acceptance of the application as a national stage submission under 35 U.S.C. 371 will be issued in addition to the Filing Receipt, in due course.</p> <p><u>New International Application Filed with the USPTO as a Receiving Office</u> If a new international application is being filed and the international application includes the necessary components for an international filing date (see PCT Article 11 and MPEP 1810), a Notification of the International Application Number and of the International Filing Date (Form PCT/RO/105) will be issued in due course, subject to prescriptions concerning national security, and the date shown on this Acknowledgement Receipt will establish the international filing date of the application.</p>					

Receipt date: 11/17/2015

13750352 - GAU: 3763

Doc code: IDS

Doc description: Information Disclosure Statement (IDS) Filed

PTO/SB/03a (03-15)

Approved for use through 07/31/2015. OMB 0551-0031

U.S. Patent and Trademark Office, U.S. DEPARTMENT OF COMMERCE

Under the Paperwork Reduction Act of 1995, no persons are required to respond to a collection of information unless it contains a valid OMB control number.

INFORMATION DISCLOSURE STATEMENT BY APPLICANT (Not for submission under 37 CFR 1.99)	Application Number	13750352
	Filing Date	2013-01-25
	First Named Inventor	Juergen Sigg
	Art Unit	3763
	Examiner Name	Berdichevsky, Aarti
	Attorney Docket Number	PAT055157-US-NP

U.S. PATENTS						
Examiner Initial*	Cite No	Patent Number	Kind Code ¹	Issue Date	Name of Patentee or Applicant of cited Document	Pages, Columns, Lines where Relevant Passages or Relevant Figures Appear
	1					

If you wish to add additional U.S. Patent citation information please click the Add button.

U.S. PATENT APPLICATION PUBLICATIONS						
Examiner Initial*	Cite No	Publication Number	Kind Code ¹	Publication Date	Name of Patentee or Applicant of cited Document	Pages, Columns, Lines where Relevant Passages or Relevant Figures Appear
	1					

If you wish to add additional U.S. Published Application citation information please click the Add button.

FOREIGN PATENT DOCUMENTS								
Examiner Initial*	Cite No	Foreign Document Number ³	Country Code ²	Kind Code ⁴	Publication Date	Name of Patentee or Applicant of cited Document	Pages, Columns, Lines where Relevant Passages or Relevant Figures Appear	T ⁵
	1							<input type="checkbox"/>

If you wish to add additional Foreign Patent Document citation information please click the Add button

NON-PATENT LITERATURE DOCUMENTS			
Examiner Initials*	Cite No	Include name of the author (in CAPITAL LETTERS), title of the article (when appropriate), title of the item (book, magazine, journal, serial, symposium, catalog, etc), date, page(s), volume-issue number(s), publisher, city and/or country where published.	T ⁵

Receipt date: 11/17/2015

13750352 - GAU: 3763

**INFORMATION DISCLOSURE
STATEMENT BY APPLICANT**
(Not for submission under 37 CFR 1.99)

Application Number	13750352
Filing Date	2013-01-25
First Named Inventor	Juergen Sigg
Art Unit	3763
Examiner Name	Berdichevsky, Aarti
Attorney Docket Number	PAT055157-US-NP

1	"Biopharmaceuticals - SPE applications"; RapID Particle Systems, Single Particle Explore, D6a, 28-09-2015; http://www.particle-explorer.com/yourapplications/biopharmaceuticals/index.html [16.09.2015 11:23:45]	<input type="checkbox"/>
2	Email dated September 9, 2015 from Elizabeth Scuderi, Senior meetings Manager, AAPS to Teresa Hornrich re Inquiry about publication of conference abstract.	<input type="checkbox"/>
3	Tibor Hlobik: "Reducing quality risks to drug products and meeting needs of patients with enhanced components for prefilled syringe systems", West Delivering Innovative Solutions, www.ondrugdelivery.com , 2012 No. 33, pp. 32-34	<input type="checkbox"/>
4	Summary of Product Characteristics - Zaltrap (undated)	<input type="checkbox"/>
5	"Ranibizumab", Scientific Discussion, EMEA, 2007, pp. 1-54	<input type="checkbox"/>
6	"Avastin", Scientific Discussion, EMEA, 2005, pp. 1-61	<input type="checkbox"/>
7	Mehmet Selim Kocabora, et al: "Intravitreal silicone oil droplets following pegaptanib injection", <i>Acta Ophthalmologica</i> , 2010 e44-345	<input type="checkbox"/>
8	N. Clunas, et al: "Ranibizumab pre-filled syringe: recently approved innovation in the European Union with the potential to reduce infection risk, improve dose accuracy, and enhance efficient treatment administration", <i>Congress on Controversies in Ophthalmology, Abstract, 2014</i>	<input type="checkbox"/>
9	"COPHy Poster List - Group A" (Poster 17), The 5th World congress on Controversies in Ophthalmology (COPHy) March 20-23-2014, Lisbon, Portugal	<input type="checkbox"/>

If you wish to add additional non-patent literature document citation information please click the Add button

EXAMINER SIGNATURE

Examiner Signature	/Aarti Bhatia Berdichevsky/ (11/23/2015)	Date Considered	
--------------------	------------------------------------------	-----------------	--

*EXAMINER: Initial if reference considered, whether or not citation is in conformance with MPEP 609. Draw line through a citation if not in conformance and not considered. Include copy of this form with next communication to applicant.

APPROVED: /ABB/ (11/23/2015)

CASE PAT055157-US-NP

IN THE UNITED STATES PATENT AND TRADEMARK OFFICE

IN RE APPLICATION OF

Sigg, Juergen et al.

APPLICATION NO: 13/750352

FILED: January 25, 2013

FOR: SYRINGE

Art Unit: 3763

Examiner: Aarti Berkichevsky

Conf. No. 5306

Commissioner for Patents
PO Box 1450
Alexandria, VA 22313-1450

LETTER CORRECTING NAME OF INVENTOR

Sir:

The official filing receipt received in the above-identified application erroneously lists one of the inventors. An Application Data Sheet showing the correct name of the inventor, Christophe Royer, is enclosed. Please issue a corrected filing receipt listing the inventors as follows:

--Juergen Sigg, Loerrach, GERMANY
Christophe Royer, Munich, GERMANY
Andrew Mark Bryant, Reinach, SWITZERLAND
Heinrich Martin Buettgen, Rheinfelden, SWITZERLAND
Marie Picci, Ranspack-le-bas, FRANCE--

It should be noted that the Inventor, Christophe Royer, was correctly identified on the Declaration. A copy of the executed Declaration is attached.

Please charge Deposit Account No. 19-0134 in the name of Novartis in the amount of \$140 for payment of the applicable fee. The Commissioner is hereby authorized to charge any additional fees under 37 CFR §1.17 which may be required, or credit any overpayment, to Account No. 19-0134 in the name of Novartis.

Respectfully submitted,

/Michael Mazza/

Novartis Pharmaceuticals Corporation
One Health Plaza, Bldg. 433
East Hanover, NJ 07936
+15108799666

Michael Mazza
Attorney for Applicant
Reg. No. 30,775

Date: 1 September 2015



UNITED STATES PATENT AND TRADEMARK OFFICE

UNITED STATES DEPARTMENT OF COMMERCE
United States Patent and Trademark Office
Address: COMMISSIONER FOR PATENTS
P.O. Box 1450
Alexandria, Virginia 22313-1450
www.uspto.gov

Table with 5 columns: APPLICATION NO., FILING DATE, FIRST NAMED INVENTOR, ATTORNEY DOCKET NO., CONFIRMATION NO.
13/750,352 01/25/2013 Juergen Sigg PAT055157-US-NP 5306

1095 7590 11/30/2015
NOVARTIS PHARMACEUTICAL CORPORATION
INTELLECTUAL PROPERTY DEPARTMENT
ONE HEALTH PLAZA 433/2
EAST HANOVER, NJ 07936-1080

EXAMINER

BERDICHEVSKY, AARTI

ART UNIT PAPER NUMBER

3763

NOTIFICATION DATE DELIVERY MODE

11/30/2015

ELECTRONIC

Please find below and/or attached an Office communication concerning this application or proceeding.

The time period for reply, if any, is set in the attached communication.

Notice of the Office communication was sent electronically on above-indicated "Notification Date" to the following e-mail address(es):

phip.patents@novartis.com

**Corrected
Notice of Allowability**

Application No. 13/750,352	Applicant(s) SIGG ET AL.	
Examiner Aarti Bhatia Berdichevsky	Art Unit 3763	AIA (First Inventor to File) Status No

-- The MAILING DATE of this communication appears on the cover sheet with the correspondence address--

All claims being allowable, PROSECUTION ON THE MERITS IS (OR REMAINS) CLOSED in this application. If not included herewith (or previously mailed), a Notice of Allowance (PTOL-85) or other appropriate communication will be mailed in due course. **THIS NOTICE OF ALLOWABILITY IS NOT A GRANT OF PATENT RIGHTS.** This application is subject to withdrawal from issue at the initiative of the Office or upon petition by the applicant. See 37 CFR 1.313 and MPEP 1308.

1. This communication is responsive to 11/17/2015.
 A declaration(s)/affidavit(s) under **37 CFR 1.130(b)** was/were filed on _____.
2. An election was made by the applicant in response to a restriction requirement set forth during the interview on _____; the restriction requirement and election have been incorporated into this action.
3. The allowed claim(s) is/are 1,6,9,10,12-19,21,22,24-32 and 34-36. As a result of the allowed claim(s), you may be eligible to benefit from the **Patent Prosecution Highway** program at a participating intellectual property office for the corresponding application. For more information, please see http://www.uspto.gov/patents/init_events/pph/index.jsp or send an inquiry to PPHfeedback@uspto.gov.
4. Acknowledgment is made of a claim for foreign priority under 35 U.S.C. § 119(a)-(d) or (f).

Certified copies:

- a) All b) Some *c) None of the:
1. Certified copies of the priority documents have been received.
 2. Certified copies of the priority documents have been received in Application No. _____.
 3. Copies of the certified copies of the priority documents have been received in this national stage application from the International Bureau (PCT Rule 17.2(a)).
- * Certified copies not received: _____.

Applicant has THREE MONTHS FROM THE "MAILING DATE" of this communication to file a reply complying with the requirements noted below. Failure to timely comply will result in ABANDONMENT of this application.
THIS THREE-MONTH PERIOD IS NOT EXTENDABLE.

5. CORRECTED DRAWINGS (as "replacement sheets") must be submitted.
 including changes required by the attached Examiner's Amendment / Comment or in the Office action of Paper No./Mail Date _____.
Identifying indicia such as the application number (see 37 CFR 1.84(c)) should be written on the drawings in the front (not the back) of each sheet. Replacement sheet(s) should be labeled as such in the header according to 37 CFR 1.121(d).
6. DEPOSIT OF and/or INFORMATION about the deposit of BIOLOGICAL MATERIAL must be submitted. Note the attached Examiner's comment regarding REQUIREMENT FOR THE DEPOSIT OF BIOLOGICAL MATERIAL.

Attachment(s)

- | | |
|--------------------------------------------------------------------------------------------------------------------------------|---------------------------------------------------------------------------------------|
| 1. <input type="checkbox"/> Notice of References Cited (PTO-892) | 5. <input type="checkbox"/> Examiner's Amendment/Comment |
| 2. <input checked="" type="checkbox"/> Information Disclosure Statements (PTO/SB/08),
Paper No./Mail Date <u>11/17/2015</u> | 6. <input type="checkbox"/> Examiner's Statement of Reasons for Allowance |
| 3. <input type="checkbox"/> Examiner's Comment Regarding Requirement for Deposit of Biological Material | 7. <input checked="" type="checkbox"/> Other <u>Request to correct inventorship</u> . |
| 4. <input type="checkbox"/> Interview Summary (PTO-413),
Paper No./Mail Date _____. | |

/Aarti Bhatia Berdichevsky/
Primary Examiner, Art Unit 3763

Receipt date: 06/04/2013

13750352 - GAI: 3768

Doc code: IDS
 Doc description: Information Disclosure Statement (IDS) Filed

Approved for use through 07/31/2012. OMB 0651-0031
 U.S. Patent and Trademark Office; U.S. DEPARTMENT OF COMMERCE

Under the Paperwork Reduction Act of 1995, no persons are required to respond to a collection of information unless it contains a valid OMB control number.

INFORMATION DISCLOSURE STATEMENT BY APPLICANT (Not for submission under 37 CFR 1.99)	Application Number		13750352	
	Filing Date		2013-01-25	
	First Named Inventor	Juergen Sigg		
	Art Unit	3767		
	Examiner Name	Unknown		
	Attorney Docket Number	PAT055157-US-NP		

U.S.PATENTS						Remove
Examiner Initial*	Cite No	Patent Number	Kind Code ¹	Issue Date	Name of Patentee or Applicant of cited Document	Pages,Columns,Lines where Relevant Passages or Relevant Figures Appear
	1					

If you wish to add additional U.S. Patent citation information please click the Add button.

Add

U.S.PATENT APPLICATION PUBLICATIONS						Remove
Examiner Initial*	Cite No	Publication Number	Kind Code ¹	Publication Date	Name of Patentee or Applicant of cited Document	Pages,Columns,Lines where Relevant Passages or Relevant Figures Appear
	1	2013012918	AA	2013-01-10	FOSTER GARY	
Change(s) applied to document,	2	2012078224	AA	2012-03-29	OCUJECT LLO	Lerner et al.
/N.B.H./ 8/28/2015	3	2006172944	AA	2006-08-03	WIEGAND STANLEY J	

If you wish to add additional U.S. Published Application citation information please click the Add button.

Add

FOREIGN PATENT DOCUMENTS								Remove
Examiner Initial*	Cite No	Foreign Document Number ³	Country Code ²	Kind Code ⁴	Publication Date	Name of Patentee or Applicant of cited Document	Pages,Columns,Lines where Relevant Passages or Relevant Figures Appear	T ⁵
	1	2007084765	WO	A2	2007-07-26	POTENTIA		<input type="checkbox"/>



UNITED STATES PATENT AND TRADEMARK OFFICE

UNITED STATES DEPARTMENT OF COMMERCE
United States Patent and Trademark Office
Address: COMMISSIONER FOR PATENTS
P. O. Box 1450
Alexandria, Virginia 22313-1450
www.uspto.gov

APPLICATION NO.	ISSUE DATE	PATENT NO.	ATTORNEY DOCKET NO.	CONFIRMATION NO.
13/750,352	12/29/2015	9220631	PAT055157-US-NP	5306

1095 7590 12/09/2015
NOVARTIS PHARMACEUTICAL CORPORATION
INTELLECTUAL PROPERTY DEPARTMENT
ONE HEALTH PLAZA 433/2
EAST HANOVER, NJ 07936-1080

ISSUE NOTIFICATION

The projected patent number and issue date are specified above.

Determination of Patent Term Adjustment under 35 U.S.C. 154 (b)
(application filed on or after May 29, 2000)

The Patent Term Adjustment is 0 day(s). Any patent to issue from the above-identified application will include an indication of the adjustment on the front page.

If a Continued Prosecution Application (CPA) was filed in the above-identified application, the filing date that determines Patent Term Adjustment is the filing date of the most recent CPA.

Applicant will be able to obtain more detailed information by accessing the Patent Application Information Retrieval (PAIR) WEB site (<http://pair.uspto.gov>).

Any questions regarding the Patent Term Extension or Adjustment determination should be directed to the Office of Patent Legal Administration at (571)-272-7702. Questions relating to issue and publication fee payments should be directed to the Application Assistance Unit (AAU) of the Office of Data Management (ODM) at (571)-272-4200.

APPLICANT(s) (Please see PAIR WEB site <http://pair.uspto.gov> for additional applicants):

Juergen Sigg, Loerrach, GERMANY;
Christophe Royer, Munich, GERMANY;
Andrew Mark Bryant, Reinach, SWITZERLAND;
Heinrich Martin Buettgen, Rheinfelden, SWITZERLAND;
Marie Picci, Ranspack-le-bas, FRANCE;
NOVARTIS AG, Basel, SWITZERLAND

The United States represents the largest, most dynamic marketplace in the world and is an unparalleled location for business investment, innovation, and commercialization of new technologies. The USA offers tremendous resources and advantages for those who invest and manufacture goods here. Through SelectUSA, our nation works to encourage and facilitate business investment. To learn more about why the USA is the best country in the world to develop technology, manufacture products, and grow your business, visit SelectUSA.gov.