

(19) **United States**

(12) **Patent Application Publication**
Hato

(10) **Pub. No.: US 2005/0182370 A1**

(43) **Pub. Date: Aug. 18, 2005**

(54) **PREFILLED SYRINGE WITH PLUNGER
BACKWARD MOVEMENT LIMITING
MECHANISM**

Publication Classification

(51) **Int. Cl.⁷ A61M 5/178**

(52) **U.S. Cl. 604/213**

(76) **Inventor: Seiichi Hato, Kanagawa (JP)**

Correspondence Address:
**DAVID W. HIGHET VP & CHIEF IP
COUNSEL
BECTION DICKINSON AND COMPANY
1 BECTON DRIVE MC 110
FRANKLIN LAKES, NJ 07417-1880 (US)**

(57) **ABSTRACT**

A risk of injection liquid contamination due to contact of injection liquid in an injection-liquid filled area in a barrel with the surface in an injection-liquid unfilled area in the barrel by causing a plunger of a prefilled syringe to be inadvertently withdrawn by mishandling which may leads to medical malpractice, is eliminated by the invention. Withdrawal of a plunger 14 is limited by engagement of a barrel 12 in which a withdrawal-limiting member 48 is provided and a the plunger 14 in which a withdrawal-limiting member 54 is provided. As a result of this, contact of the injection liquid L prefilled to a liquid-filled area 32 in the barrel 12 with the surface of a liquid-unfilled area 34 in the barrel by withdrawal of the plunger 14 is prevented.

(21) **Appl. No.: 10/507,767**

(22) **PCT Filed: Mar. 11, 2003**

(86) **PCT No.: PCT/JP03/02851**

(30) **Foreign Application Priority Data**

Mar. 15, 2002 (JP) 2002-72083

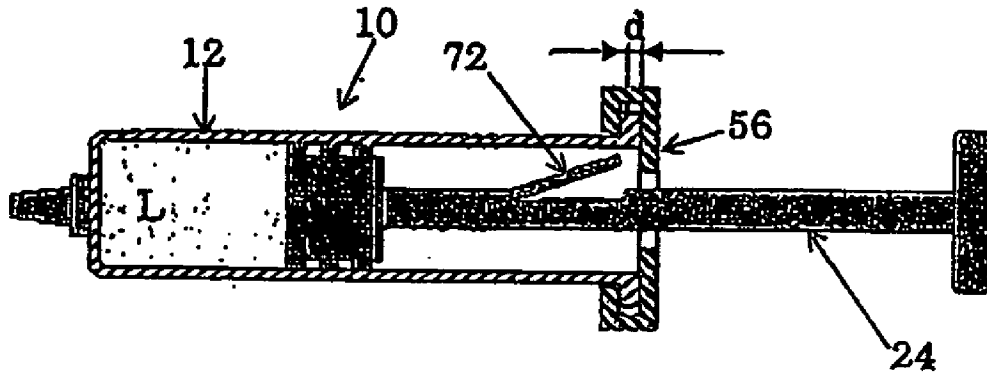

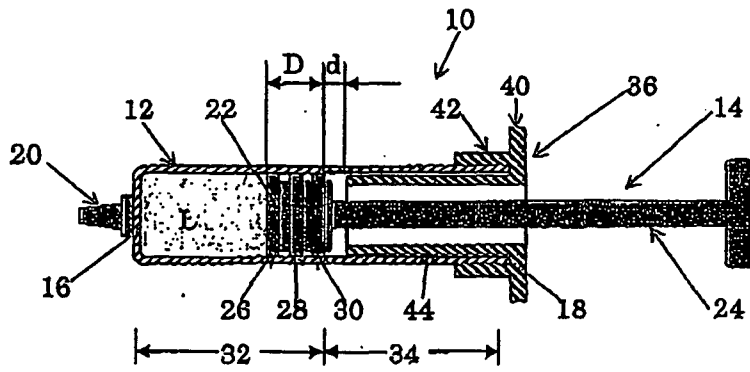

Fig. 2

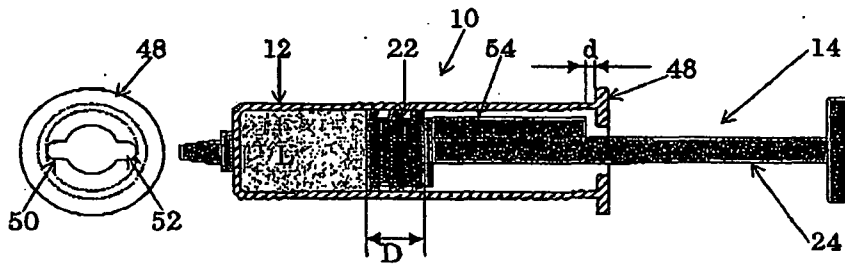

Fig. 3

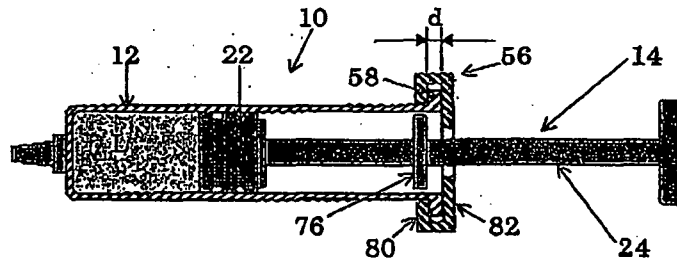

Fig. 4

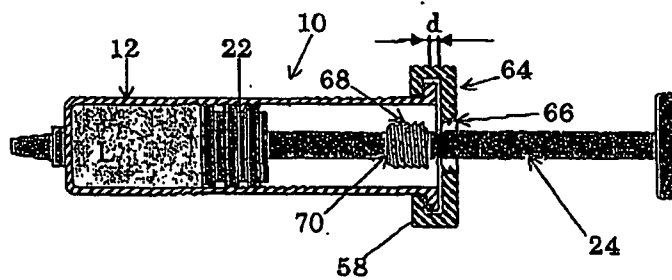

Fig. 5

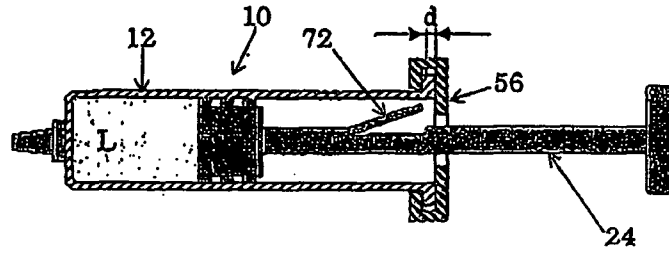
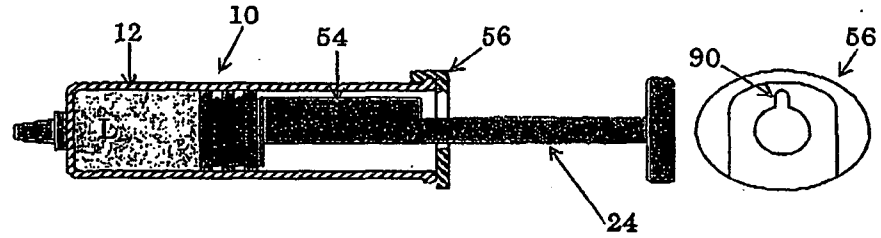

Fig. 6



PREFILLED SYRINGE WITH PLUNGER BACKWARD MOVEMENT LIMITING MECHANISM

TECHNICAL FIELD

[0001] The present invention relates to a syringe in which injection liquid is prefilled (prefilled syringe), and more particularly, the prefilled syringe which is provided with a means for preventing contamination of the prefilled injection liquid.

BACKGROUND TECHNIQUE

[0002] For a conventional type of prefilled syringe, injection liquid is filled into the syringe barrel and a sliding plug (of the liquid-injecting plunger) is inserted in the barrel, usually under a sterilized condition, and thereafter, a plunger rod is fixed to the sliding plug and works such as labeling and packaging are done for shipment under a non-sterilized condition.

[0003] A syringe in which some specific injection liquid is prefilled may be finally sterilized by heating using an autoclave etc. after packaging. However, in other type of syringe in which injection liquid unable to be sterilized by heating is prefilled, bacteria or other microorganisms are considered to have started to adhere to the syringe immediately after it was brought out from the sterilized condition. Namely, in such condition, only the liquid-filled space sealed by the sliding plug (of the plunger) in the barrel is kept sterilized, and there is a possibility that microorganisms adhere to the backward area of the sliding plug, even if the backward area is inside the barrel, before the prefilled syringe is used.

[0004] Consequently, in case of the above-mentioned syringe, when the sliding plug is withdrawn backward, there is a risk that bacteria or other microorganisms adhering to the inner surface of the barrel may contaminate injection liquid and the syringe is therefore hazardous. The control of such risk has been depending on the careful handling of the prefilled syringe by care providers such as physicians and nurses, but their mishandling has been reasonably anticipated. However, in reality, injection liquid was contaminated due to the mishandling, that may result in medical malpractice. Even if such contamination of injection liquid and medical malpractice due to it occur, it was difficult to determine that such malpractice was attributable to the mishandling of the prefilled syringe and the problem has therefore not been clearly recognized.

[0005] The invention is intended to clarify where the problem exists and to provide a prefilled syringe entirely free from a risk of injection liquid contamination due to mishandling and resultant medical malpractice.

DISCLOSURE OF THE INVENTION

[0006] The invention provides the prefilled syringe comprising a barrel having a closed front-end wall with a small passageway through which injection liquid is discharged and a rear opening, a plunger including a sliding plug liquid-tightly contacting with the inner surface of the barrel and partitioning the inside of the barrel into a liquid-filled area which is formed between the plunger and the closed front-end wall and in which injection liquid is filled and sealed and

a liquid-unfilled area in the back of the liquid-filled area and a plunger rod extending backward from the sliding plug through the rear opening of the barrel, and a plunger withdrawal-limiting member fixed to the barrel, which limits withdrawal of the plunger by engaging the plunger and prevents injection liquid from contacting with the surface of the liquid-unfilled area in the barrel.

[0007] Referring more particularly, the plunger withdrawal-limiting member which is provided at the rear opening of the barrel and extends from the rear opening to the inside of the barrel for a certain length, can contact with the backward-moving sliding plug of the plunger so that withdrawal of the plunger is limited.

[0008] It is also possible that the plunger withdrawal-limiting member provided at the rear opening of the barrel is in the form of an annular withdrawal-limiting flange comprising an opening for the plunger rod which extends inwardly in the radial direction from the periphery of the rear opening of the barrel and is sized to allow the plunger rod to pass therethrough, while a stopper member extending outwardly in the radial direction from the plunger rod is provided. As a result of this, withdrawal of the plunger is limited by engagement of the stopper member with the withdrawal-limiting flange.

[0009] In the above case, it is possible to stably push and handle the plunger by allowing at least a portion of the outer peripheral surface of the withdrawal-limiting member to closely contact with the inner peripheral surface of the barrel. It is also possible that the position in which the withdrawal-limiting member is fixed to the plunger rod is adjusted at needs in accordance with the quantity of injection liquid to be prefilled.

[0010] In other form of embodiment, the withdrawal-limiting member may be made in the form of a cylindrical member in which a male screw is provided on the outer peripheral surface thereof, and on the other hand, the plunger withdrawal-limiting member may be formed in the form of an annular flange in which the inner peripheral surface of the flange defines an opening having a size corresponding to the plunger withdrawal-limiting member, the annular flange being provided at the rear end opening of the barrel and extending inwardly in a radial direction from the peripheral edge of the opening and a female screw to be mated with the male screw is formed on the inner peripheral surface of the flange. In this form of syringe, when the plunger is withdrawn for a predetermined distance over a predetermined position, the stopper member engages the withdrawal-limiting member, thus preventing withdrawal of the plunger. If the male screw of the stopper member is further turned and fitted into the female screw on the plunger withdrawal-limiting member the plunger can be further withdrawn.

[0011] Additionally, it is possible that the stopper member is formed in the form of a leaf spring shaped member which extends diagonally backward from a predetermined location in the plunger rod so that when the plunger rod is inserted into the barrel through the opening for the plunger rod the leaf spring is deflected by the surface of the opening for the plunger rod and after passing through the same opening the leaf spring returned to its original shape to act the function to limit plunger withdrawal.

[0012] Furthermore, it is possible that the stopper member is formed in a member projecting radially outward from the

plunger rod and a notch through which the stopper member passes may be formed at the opening of the withdrawal-limiting flange so that the function of plunger withdrawal can be released.

BRIEF EXPLANATION OF THE DRAWINGS

[0013] FIG. 1 is a sectional side elevational view of a prefilled syringe arrangement in accordance with the first embodiment of the invention;

[0014] FIG. 2 is a sectional side elevational view of a prefilled syringe arrangement in accordance with the second embodiment of the invention;

[0015] FIG. 3 is a sectional side elevational view of a prefilled syringe arrangement in accordance with the third embodiment of the invention;

[0016] FIG. 4 is a schematic illustration view of a prefilled syringe arrangement in accordance with the fourth embodiment of the invention;

[0017] FIG. 5 is a schematic illustration view of a prefilled syringe arrangement in accordance with the fifth embodiment of the invention; and

[0018] FIG. 6 is a schematic illustration view of the prefilled syringe according to the sixth embodiment of the invention in which the side view of the withdrawal-limiting flange is also shown.

BEST MODE FOR CARRYING OUT THE INVENTION

[0019] The mode for carrying out the prefilled syringe according to the invention is explained below, referring to the attached drawings.

[0020] FIG. 1 shows the first mode for carrying out the prefilled syringe 10 according to the invention. As illustrated, the prefilled syringe 10 has a barrel 12 in a cylindrical form and the plunger 14 to be inserted into the barrel. The barrel has the front-end wall 16, the tip of which has a small passageway (not shown in the FIG. 1) through which the injection liquid is discharged, and the rear opening 18 through which the plunger 14 is received. A barrel tip cover 20 is mounted on the outer surface of the tip of the front-end wall 16. The plunger 14 has a sliding plug 22 at its tip which is able to slidably move along the inner surface of the barrel 12 and a plunger rod 24 which extends outwardly from the sliding plug 22 to the outside of the barrel through the rear opening 18 at the rear end of the barrel. FIG. 1 shows the completed prefilled syringe before use. In this state, the sliding plug 22 partitions the inside of the barrel 12 into a liquid-filled area 32 where the injection liquid L is filled and sealed and a liquid-unfilled area 34 in the back of the area 32. In the illustrative embodiment shown in the FIG. 1, the sliding plug 22 has a generally cylindrical form and three ring-shaped ribs 26, 28 and 30 are provided around the outer surface of the sliding plug with keeping predetermined spaces in the axial direction therebetween. As the ribs liquid-tightly contact with the inner surface of the barrel 12, so that the liquid-filled area 32 in which the injection liquid is filled and sealed is formed between the front-end wall 16 of the barrel and the sliding plug 16. Namely, in this state, the liquid-filled area 32 is formed between the front-end wall

16 and the right side rib 30 and the liquid-unfilled area 34 is formed between the right side rib 30 and the rear opening 18 of the barrel.

[0021] As illustrated in the FIG. 1, a withdrawal-limiting member 36 to limit withdrawal of the plunger 14 is provided around the rear opening 18 of the barrel. The withdrawal-limiting member has a base plate 40 in an annular form, which is abutted to the end edge of the rear opening 18, a outer cylindrical portion 42 which extends from the base plate toward the tip of the barrel along the outer surface of the barrel and an inner cylindrical portion 44 which extends longer than the outer cylindrical portion 42 from the base plate toward the tip of the barrel around the inner surface of the barrel. These outer and inner cylindrical portions are secured to the barrel by pinching the side wall of the barrel.

[0022] The front-end of the inner cylindrical portion 44 is spaced from the rear end of the sliding plug 22 for a distance of d. Therefore, the sliding plug 22 is able to move rearward by the distance d from the predetermined position shown in FIG. 1 and when the sliding plug is moved rearward for the distance d it abuts or engages the front end of the inner cylindrical portion 44 of the withdrawal-limiting member 36, thus further withdrawal being prevented. The distance d is determined to be shorter than a distance D between the front-end of the sliding plug (more accurately, the position where the left side rib 26 liquid-tightly contacts with the inner surface of the barrel) and the position where the rear end of the right side rib 30 liquid-tightly contacts with the inner surface of the barrel so that when the sliding plug is withdrawn no contact between injection liquid L and the inner surface in the liquid-unfilled area in the barrel.

[0023] For the above-mentioned prefilled syringe, the plunger 14 and the withdrawal-limiting member 36 may be formed from a general-purpose resin such as polypropylene and polyethylene using injection molding and the sliding plug 22 is preferably be made from rubber or similar materials.

[0024] FIG. 2 shows other mode for carrying out the prefilled syringe 10 according to the invention.

[0025] In this type of prefilled syringe, an annular withdrawal-limiting flange 48 is integrally molded with the cylindrical barrel 12 in the rear end therefore and an opening through which the plunger rod 24 passes is provided in the central portion of the withdrawal-limiting flange 48. In addition, a pair of notches 50 and 52 are formed diametrically in the diameter of the inner peripheral edge of the flange 48. On the other hand, on the surface of the plunger rod 24, a withdrawal-limiting member 54 extends backward from the rear-end of the sliding plug 22. The withdrawal-limiting member 54 has a shape and a size corresponding to that of the notches 50 and 52 so that the member 54 is able to pass through the notches. Therefore, after injection liquid is prefilled and the sliding plug 22 is loaded, the plunger rod 24 is inserted into the barrel with the withdrawal-limiting part 54 passing through the notch 50 or 52, and then the front-end of the plunger rod can be connected to the sliding plug 22. Between the rear-end of the withdrawal-limiting member 54 and the inner surface of the withdrawal-limiting flange 48, the space d keeping the same relation of $D > d$ as shown in the embodiment in FIG. 1 is provided.

[0026] FIG. 3 shows the third mode for carrying out the prefilled syringe according to the invention.

Explore Litigation Insights

Docket Alarm provides insights to develop a more informed litigation strategy and the peace of mind of knowing you're on top of things.

Real-Time Litigation Alerts



Keep your litigation team up-to-date with **real-time alerts** and advanced team management tools built for the enterprise, all while greatly reducing PACER spend.

Our comprehensive service means we can handle Federal, State, and Administrative courts across the country.

Advanced Docket Research



With over 230 million records, Docket Alarm's cloud-native docket research platform finds what other services can't. Coverage includes Federal, State, plus PTAB, TTAB, ITC and NLRB decisions, all in one place.

Identify arguments that have been successful in the past with full text, pinpoint searching. Link to case law cited within any court document via Fastcase.

Analytics At Your Fingertips



Learn what happened the last time a particular judge, opposing counsel or company faced cases similar to yours.

Advanced out-of-the-box PTAB and TTAB analytics are always at your fingertips.

API

Docket Alarm offers a powerful API (application programming interface) to developers that want to integrate case filings into their apps.

LAW FIRMS

Build custom dashboards for your attorneys and clients with live data direct from the court.

Automate many repetitive legal tasks like conflict checks, document management, and marketing.

FINANCIAL INSTITUTIONS

Litigation and bankruptcy checks for companies and debtors.

E-DISCOVERY AND LEGAL VENDORS

Sync your system to PACER to automate legal marketing.