

(19) **United States**

(12) **Patent Application Publication** (10) **Pub. No.: US 2003/0167316 A1**

Bramnick et al.

(43) **Pub. Date:**

Sep. 4, 2003

(54) **DATA STORAGE SERVICE FOR USERS OF DATA COMMUNICATION NETWORKS**

(76) Inventors: **Arnold H. Bramnick**, Boca Raton, FL (US); **Mark A. Sehorne**, Round Rock, FL (US)

Correspondence Address:
IBM Corporation
Intellectual Property Law
Internal Zip 4042
8051 Congress Avenue
Boca Raton, FL 33487 (US)

(21) Appl. No.: **10/086,390**

(22) Filed: **Mar. 1, 2002**

Publication Classification

(51) **Int. Cl.⁷** **G06F 15/16**

(52) **U.S. Cl.** **709/219; 709/203**

(57) **ABSTRACT**

The presently contemplated file transfer service, for users of data communication networks like the Internet, operates as agent of respective subscribing clients to retrieve and store

data files that clients are unable to instantly download to workstations currently used by them. Files stored by the transfer service are made available to respective clients when the latter are able to receive them. In one application of this, a client is unable to instantly download a large file because the computer workstation the client is then using operates at a low speed unsuited for that purpose. In other applications, the client is unable to download a file because the client's workstation is behind a firewall that effectively blocks that action. In these applications, the transfer service is useful to effectively either circumvent restrictions of the firewall, or to deliver the file to the client at a workstation that is not behind the firewall. The contemplated service retrieves and stores data files at source locations designated by client workstations, and confirms completion of these operations to the client (e.g. via an e-mail message). When the client is at a workstation able to receive files stored by the service, the client connects to the service and requests transmittal of respective files. Upon authenticating the client's identity and subscription, the transfer service makes the file accessible to the requesting client. A group of clients may use a single subscription to effectively allow any member of the group to initiate a file retrieval and storage operation and/or to request access to a previously retrieved and stored file.

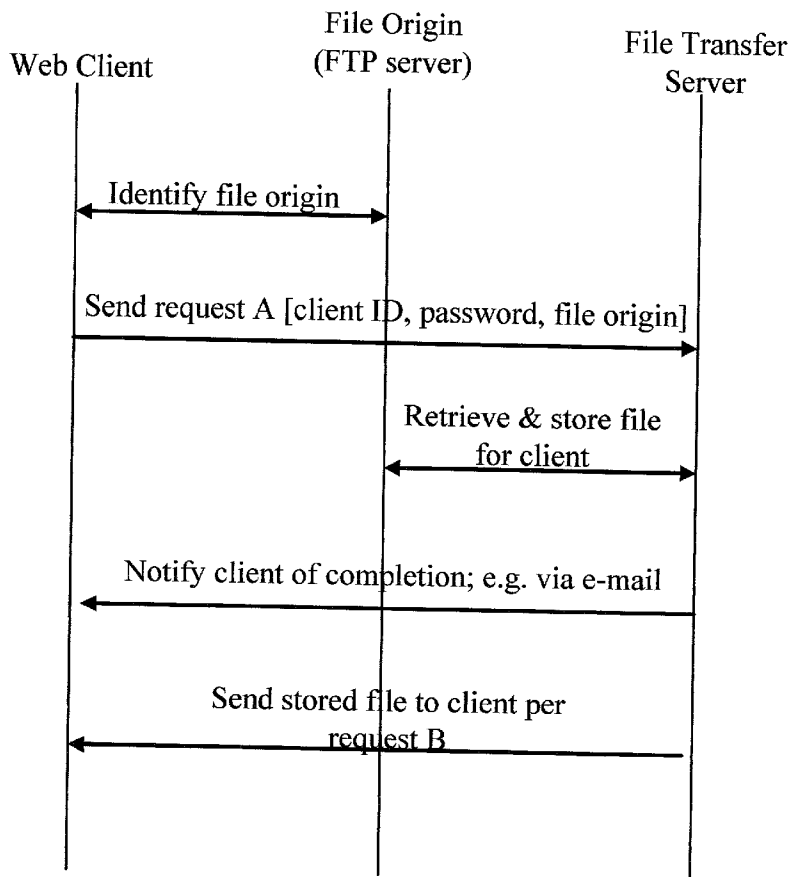

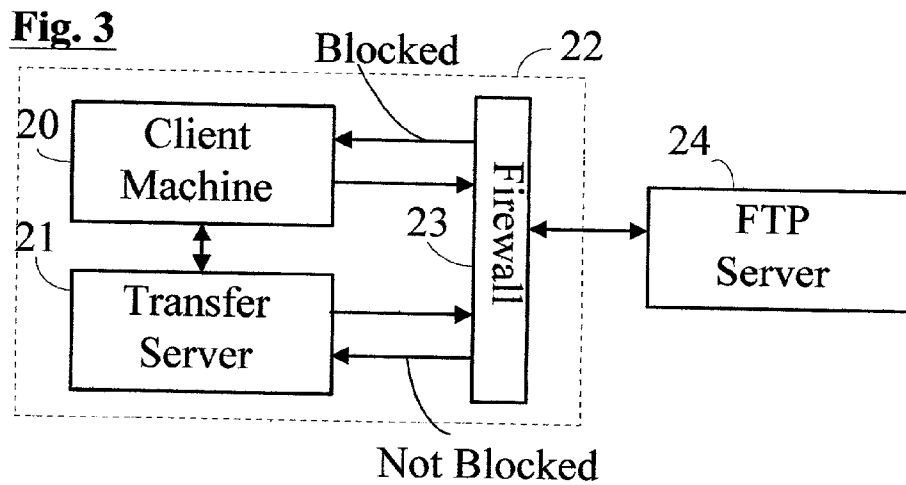
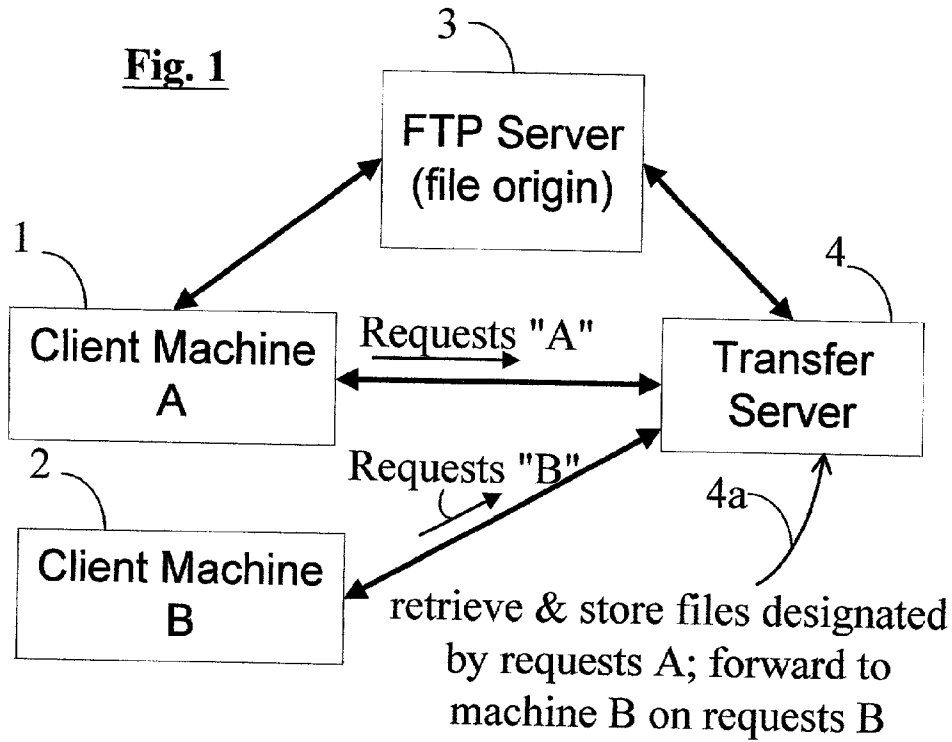

Fig. 2

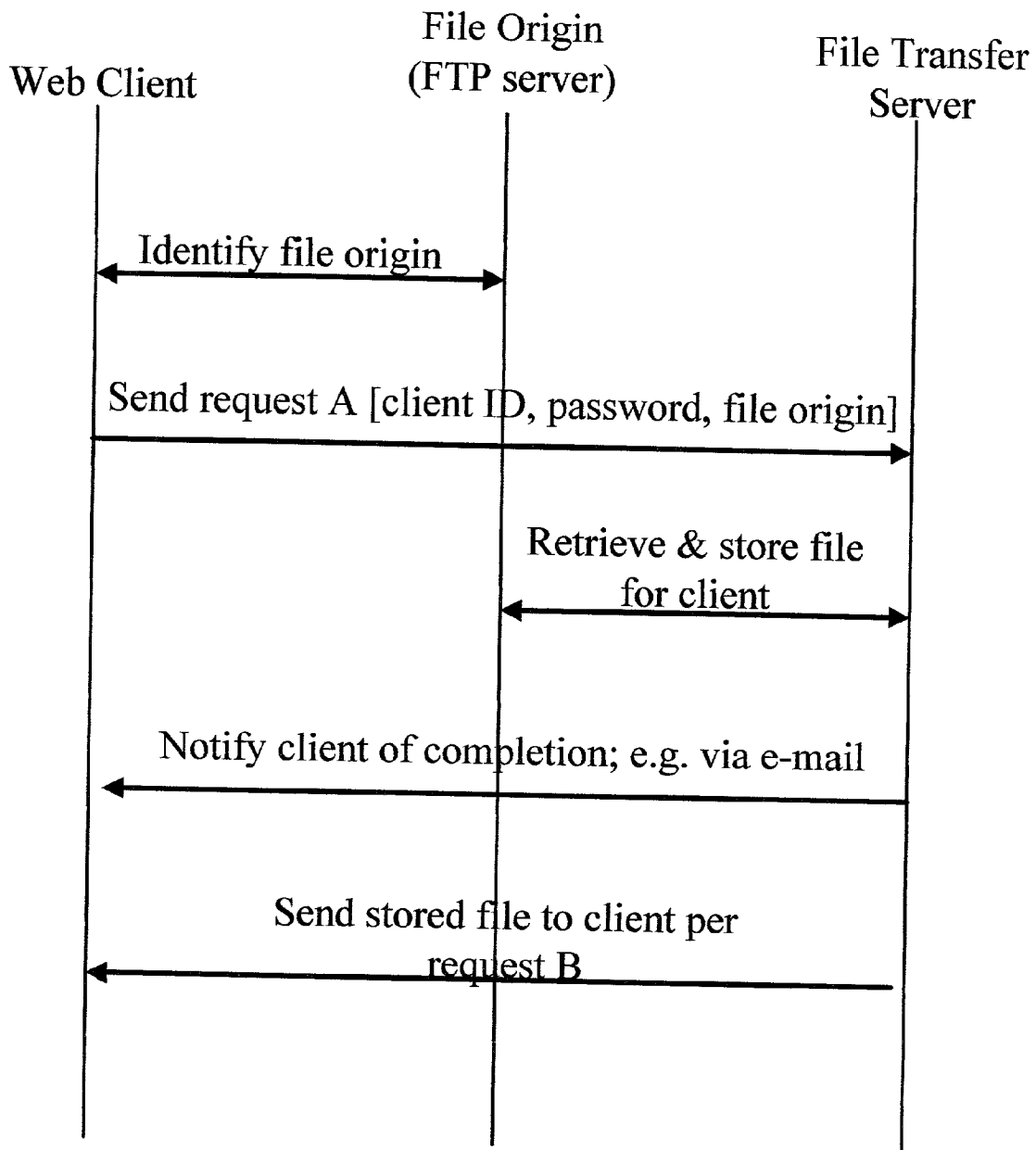

Fig. 4

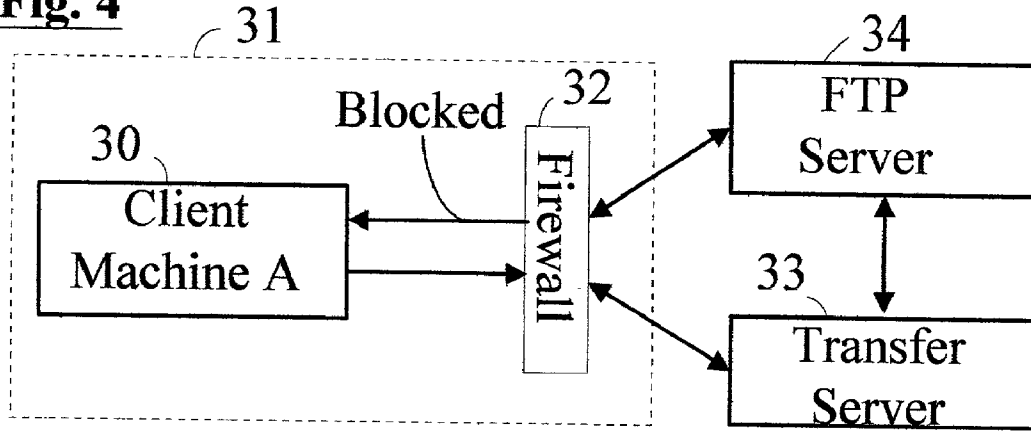
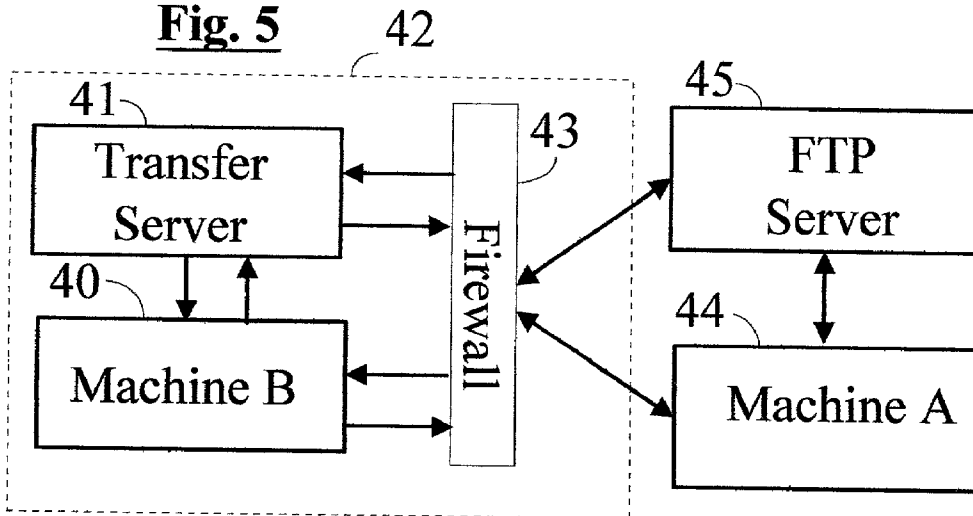

Fig. 5



DATA STORAGE SERVICE FOR USERS OF DATA COMMUNICATION NETWORKS

BACKGROUND OF THE INVENTION

[0001] This invention relates to a service for users of high speed links to data communication networks such as the Internet. These users may need to download data files from a remote location on the network, but are unable to do so because of conditions existing at their workstations making it either impractical or impossible to directly download data from remote sources to respective workstations. In such circumstances, the presently contemplated service is useful to retrieve and store data files from remote sources designated by its clients, and to make the stored data available to its clients when conditions at respective client workstations do not prevent receipt of data from the service.

SUMMARY OF THE INVENTION

[0002] In one application of the invention, a client of the file transfer service presently contemplated has workstations operating at different speeds relative to a network (e.g. the Internet) connecting to the service. While using the slow workstation (e.g. while on a business trip and using a slow laptop computer with a conventional dial-up modem), the client locates a data file too large for practical direct retrieval at that workstation, and requests the service to retrieve and store the file. The request identifies the location of the file source on the network, and the service—acting as agent for the client—retrieves and stores the file for the client, and sends confirmation to the client, e.g. via e-mail. Later, while using the fast workstation (e.g. a desktop computer with broadband cable or DSL connection to the same network), the client connects to the transfer service and requests that the stored file be forwarded. In response to the latter request, the service transmits the stored file to the client's workstation at a transmission speed at which the transfer is accomplished in a practical interval of time.

[0003] In other applications, the client uses the service to effectively overcome security restrictions preventing transfer of data to a client workstation from an arbitrary remote source.

[0004] In one such application, both client workstation(s) and a transfer server operated by the transfer service (which, in this case, could be a facility controlled by the client's employer) are behind a firewall restricting transmission of data from arbitrary sources on a network to the workstation(s). In this instance, the firewall is programmed to allow the transfer server to download data from arbitrary sources on the external network. Thus, the client can use the transfer server to retrieve and store data that could not be transmitted directly to the client's workstation(s). The transfer server can be programmed to inspect retrieved data for viruses or other problems (e.g. relevance to a business enterprise maintaining that server and the firewall) and discard data which is considered flawed or unsuitable.

[0005] In a similar application, a client workstation is behind the firewall and the transfer server and remote source of data are both outside the firewall. In this situation, the firewall prevents direct transfer of data from the remote source to the client workstation, but allows transfer of data from the transfer server to the client. Accordingly, if the client locates a remote source of data that can not be sent

through the firewall, the client workstation sends a request to the (external) transfer server and the latter operates to effectively bypass the firewall.

[0006] More specific applications of the foregoing security circumvention use are as follows:

[0007] Associated clients A and B are located behind a firewall, and the transfer server is located outside of the firewall (on the internet for example). The associated clients may be a single client having two workstations behind the firewall or two different clients having a sharing association relative to data retrievable by the transfer server. The firewall is programmed to permit transmission of file retrieval requests from either client to the transfer server, and to deny transmission of such requests to any other computer outside the firewall. The firewall also is programmed to allow the transfer server to transmit acknowledgments and data to either client. Now assume client A locates a file or files that he wants to download from a source outside the firewall. Since the firewall will not permit a direct transfer, client A, using the aforementioned plug-in, makes a request to the transfer server to retrieve the desired files. The transfer server schedules retrieval of the specified files, stores the retrieved files, and notifies either client when these functions have been completed. Thereafter, upon receipt of a file transfer request from either client, the transfer server transmits the stored file to the workstation issuing that request.

[0008] In the other application, associated clients A and B and the transfer server are all behind the firewall. The firewall is programmed to permit transmission of file retrieval/transfer requests between the transfer server and any source on the external networks (e.g. the internet), and to deny transmissions of similar requests between the clients external sources. The firewall allows transmissions of browsing requests between the clients and external sources. Now assume client A locates a file (or files) that he wishes to download from outside the firewall. Since the firewall will not permit a direct transfer, client A, using the aforementioned plug-in, makes a request to the transfer server to retrieve the desired files. The transfer server then schedules the file transfer, stores the retrieved files and, upon completing these functions, notifies client A (or B) that the file or files has been retrieved. Client A (or B) then sends a transfer request to the transfer server and the latter transmits the stored data to the requesting workstation.

[0009] In a third application of these security restriction avoidance uses, workstations A and B used by the same person/client are located respectively outside the firewall and inside the firewall (e.g. A at the client's home and B at the client's workplace), and the transfer server is situated inside the firewall. In this instance, while using (external) workstation A, the client locates a remote source of data that the client wants downloaded to (inside) workstation B. The firewall, which prevents direct downloading of that data from its source to workstation B, is programmed to allow communications from any external source to the transfer server. Accordingly, workstation A is operated to request the transfer server to retrieve the data from the remote source. The server retrieves and stores the file and confirms completion of that to workstation A. The file is later retrieved at workstation B; via either secure or unsecured communications between it and the transfer server as permitted or required by the enterprise operating the firewall (e.g. the client's employer).

Explore Litigation Insights

Docket Alarm provides insights to develop a more informed litigation strategy and the peace of mind of knowing you're on top of things.

Real-Time Litigation Alerts



Keep your litigation team up-to-date with **real-time alerts** and advanced team management tools built for the enterprise, all while greatly reducing PACER spend.

Our comprehensive service means we can handle Federal, State, and Administrative courts across the country.

Advanced Docket Research



With over 230 million records, Docket Alarm's cloud-native docket research platform finds what other services can't. Coverage includes Federal, State, plus PTAB, TTAB, ITC and NLRB decisions, all in one place.

Identify arguments that have been successful in the past with full text, pinpoint searching. Link to case law cited within any court document via Fastcase.

Analytics At Your Fingertips



Learn what happened the last time a particular judge, opposing counsel or company faced cases similar to yours.

Advanced out-of-the-box PTAB and TTAB analytics are always at your fingertips.

API

Docket Alarm offers a powerful API (application programming interface) to developers that want to integrate case filings into their apps.

LAW FIRMS

Build custom dashboards for your attorneys and clients with live data direct from the court.

Automate many repetitive legal tasks like conflict checks, document management, and marketing.

FINANCIAL INSTITUTIONS

Litigation and bankruptcy checks for companies and debtors.

E-DISCOVERY AND LEGAL VENDORS

Sync your system to PACER to automate legal marketing.