

EXHIBIT P

EXHIBIT P

Obviousness of U.S. Patent No. 8,630,761 Claims 1-12 over Severinsky '970 in View of One or More Secondary References

To the extent Severinsky '970 does not disclose any particular limitation below, or aspects thereof, expressly or by implication, such limitation(s) would have been known to a person of skill in the art and/or it would have been obvious to combine such limitation(s) with one or more of the prior art references identified and cited herein, including Adler, Drozd, Farrall, Frank, Hosaka '083, Hosaka '697, Moroto, Nii, Onari, Probst, and Quigley.

U.S. Patent No. 8,630,761	Severinsky '970 ¹ + One or More of Secondary References ²
1[pre]. A method of operation of a hybrid vehicle, comprising steps of:	Severinsky '970 discloses a "Hybrid Electric Vehicle" and a "An improved electric vehicle includes an internal combustion engine and an electric motor." Severinsky '970 at Abstract. <i>See also</i> 1:6-14; 5:25-37; 7:45-46; 9:37-40. Figure 3 illustrates the "schematic diagram of the principal components of a ... hybrid vehicle drive system." Severinsky '970 at 7:45-46. Severinsky '970 at Fig. 3:

¹ U.S. Patent No. 5,343,970 ("Severinsky '970")

² U.S. Patent No. 5,533,583 ("Adler"); U.S. Patent No. 5,898,282 ("Drozd"); U.S. Patent No. 5,656,921 ("Farrall"); U.S. Patent No. 6,116,363 ("Frank"); U.S. Patent No. 5,788,004 ("Friedmann"); U.S. Patent No. 6,188,945 ("Graf"); U.S. Patent No. 5,697,466 ("Hosaka '083"); U.S. Patent No. 4,625,697 ("Hosaka '697"); U.S. Patent No. 5,697,466 ("Moroto"); U.S. Patent No. 5,189,621 ("Nii"); U.S. Patent No. 5,189,621 ("Onari"); UK Patent Application No. GB 2,318,105 ("Probst"); C.P. Quigley, *Use of a Hybrid Electric Vehicle*, IFAC Workshop on Intelligent Components for Autonomous and Semi-Autonomous Systems (1996) 129-134 ("Quigley")

EXHIBIT P

Obviousness of U.S. Patent No. 8,630,761 Claims 1-12 over Severinsky '970 in View of One or More Secondary References

U.S. Patent No. 8,630,761	Severinsky '970 ¹ + One or More of Secondary References
	 <p>FIG. 3</p> <p>Figures 4-9 refer to “schematic diagrams of the hybrid drive system of the invention operating in different modes and showing flow of energy, of electrical energy or fossil fuel, and of power, as torque from either the internal combustion engine.” Severinsky '970 at 7:47-52; <i>see also</i> [23.1][23.4] Engine, Hybrid Vehicle, [23.3] Motor</p> <p>“Like claim 23, Severinsky [‘970] discloses the essential components of a hybrid vehicle, including an internal combustion engine, an electric motor, a battery, and a microprocessor for controlling the vehicle’s mode of operation in electric mode, an engine-only mode, or a hybrid mode.” IPR2014-001 Decision, page 14.</p>
<p>[a] storing and supplying electrical power from a battery bank,</p>	<p>Severinsky '970 discloses a “battery 22.” Severinsky '970 at 9:65-66. Severinsky '970 discloses that “battery 22 is charged by power generated by the motor 20 as a generator, that is, when driven by the engine 40 by way of the controllable torque transfer unit 28, or in a regenerative braking mode.” Severinsky '970 at 10:53-54. Severinsky also discloses that the electric motor 20 will be “powered by a relatively large, high voltage battery pack 22.” BMW 1013 at 10:53-54.</p>

EXHIBIT P

Obviousness of U.S. Patent No. 8,630,761 Claims 1-12 over Severinsky '970 in View of One or More Secondary References

U.S. Patent No. 8,630,761	Severinsky '970 ¹ + One or More of Secondary References
	Further, the '761 Patent itself acknowledges that Severinsky '970 discloses an "electric motor powered by electrical energy stored in a substantial battery pack in the vehicle." '761 Patent at 24:23-40.
[b] applying torque to road wheels of said hybrid vehicle from one or both of an internal combustion engine and at least one traction motor, and	<p>Severinsky '970 discloses an "engine 40" and relates to a hybrid vehicle such that the "relative power outputs of the internal combustion engine and the electric motor are sized such that the engine is operated only within its most efficient operating range." Severinsky '970 at 9:40-46. Severinsky '970 is able to restrict operation of the internal combustion engine to its most efficient range by sizing the "internal combustion engine of the vehicle to supply adequate power for highway cruising, preferably with some reserve power in reverse, so that the internal combustion engine operates only in its most efficient operating range." Severinsky '970 at 9:47-52.</p> <p>With reference to Figure 3, Severinsky '970 explains that "both the electric motor 20 and the internal combustion engine 40 provide torque to the drive wheels 34 by way of the control unit 28." Severinsky '970 at 10:24-26; Fig. 3.</p> <p>Severinsky '970 also discloses "the internal combustion engine is operated only under most efficient conditions of output power and speed." Severinsky '970 at 9:40-46. Severinsky '970 further recognizes that these conditions of "output power and speed" are met when the "internal combustion engine is run only in the near vicinity of its most efficient operational point, that is, such that it produces 60-90% of its maximum power whenever operated." Severinsky '970 at 20:63-66, 7:8-16.</p> <p>Severinsky '970 discloses an "electric motor 20." Severinsky '970 at 10:24-26. Severinsky '970 also discloses that the "electric motor 20" is capable of providing "output torque from motor 20 [] transmitted by way of torque transfer means to a conventional differential 32 to the vehicle drive wheels 34." Severinsky '970 at 10:52-11:6.</p> <p>The '761 patent itself states that "an important aspect of the invention is that the '970 patent, substantially improved efficiency is afforded by operating the internal combustion engine only within its most efficient operating range."</p>

EXHIBIT P

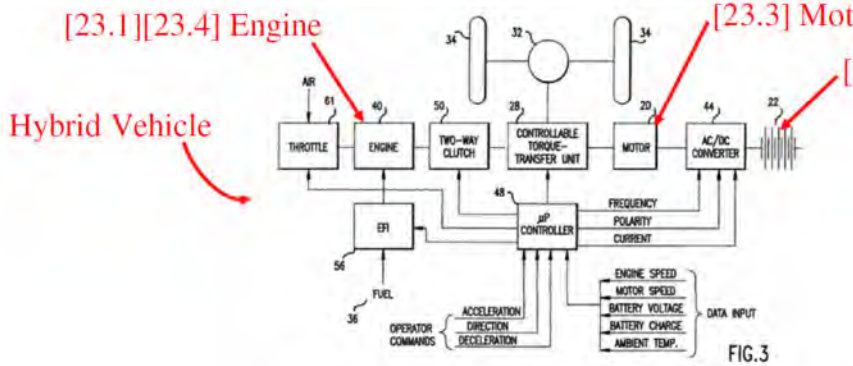
Obviousness of U.S. Patent No. 8,630,761 Claims 1-12 over Severinsky '970 in View of One or More Secondary References

U.S. Patent No. 8,630,761	Severinsky '970 ¹ + One or More of Secondary References
	<p>combustion engine only at relatively high torque output levels, typically preferably at least 50% of peak torque. When the vehicle operating at this torque of this approximate magnitude, the engine is used to propel the vehicle. When more torque is required, an electric motor powered by electrical energy stored in a battery bank drives the vehicle; when more power is required than provided by the engine or the motor, both are operated simultaneously.” ‘761 patent at 9:61-65.</p>
<p>[c] controlling flow of torque between said internal combustion engine, said at least one traction motor, and said road wheels, and</p>	<p>Severinsky '970 discloses that the “torque transfer unit 28 receives torque from and/or from alternating current electric motor 20 and transmits this torque to the wheels 34 of the vehicle by way of a conventional differential 32.” Severinsky '970 at 9:61-65.</p> <p>With reference to Figure 3, Severinsky '970 discloses that “microprocessor 48 controls the flow of torque between the motor 20, the engine 40, and the wheels 34 in various modes of operation of the vehicle. For example, when the vehicle is operating on a highway, all torque is preferably supplied from the engine 40. However, when the vehicle starts down a hill, and the operator lifts his foot from the accelerator pedal, the energy of the vehicle and the engine's excess torque may be used to drive a generator so as to charge the batteries. If the vehicle then starts to accelerate, motor 20 is used to supplement the output torque of engine 40. Similar to the engine 40, motor 20 can be used to start the engine 40, e.g., when accelerating in traffic or in various modes of operation of the system will be described below in FIGS. 4-9, after which further details of the various elements of the system are described. Severinsky '970 at 10:28-43.</p> <p>Severinsky '970 discloses a “microprocessor controller 48” that controls the directional flow of power between the battery 22 and the motor 20.” Severinsky '970 at 9:58-10:23. The “microprocessor controller 48” also controls the torque of the engine and “electric motor 20” to the road wheels using the “control unit 28.” Severinsky '970 at 12:64-13:2, 22:19-28.</p>

Explore Litigation Insights

Docket Alarm provides insights to develop a more informed litigation strategy and the peace of mind of knowing you're on top of things.

Real-Time Litigation Alerts



Keep your litigation team up-to-date with **real-time alerts** and advanced team management tools built for the enterprise, all while greatly reducing PACER spend.

Our comprehensive service means we can handle Federal, State, and Administrative courts across the country.

Advanced Docket Research



With over 230 million records, Docket Alarm's cloud-native docket research platform finds what other services can't. Coverage includes Federal, State, plus PTAB, TTAB, ITC and NLRB decisions, all in one place.

Identify arguments that have been successful in the past with full text, pinpoint searching. Link to case law cited within any court document via Fastcase.

Analytics At Your Fingertips



Learn what happened the last time a particular judge, opposing counsel or company faced cases similar to yours.

Advanced out-of-the-box PTAB and TTAB analytics are always at your fingertips.

API

Docket Alarm offers a powerful API (application programming interface) to developers that want to integrate case filings into their apps.

LAW FIRMS

Build custom dashboards for your attorneys and clients with live data direct from the court.

Automate many repetitive legal tasks like conflict checks, document management, and marketing.

FINANCIAL INSTITUTIONS

Litigation and bankruptcy checks for companies and debtors.

E-DISCOVERY AND LEGAL VENDORS

Sync your system to PACER to automate legal marketing.