

[54] AUTOMOTIVE ENGINE CONTROL SYSTEM CAPABLE OF DETECTING SPECIFIC ENGINE OPERATING CONDITIONS AND PROJECTING SUBSEQUENT ENGINE OPERATING PATTERNS

[75] Inventor: Aldo Hosaka, Yokohama, Japan

[73] Assignee: Nissan Motor Company, Limited, Kanagawa, Japan

[21] Appl. No.: 666,367

[22] Filed: Oct. 30, 1984

[30] Foreign Application Priority Data

Nov. 4, 1983	[JP]	Japan	58-205927
Nov. 4, 1983	[JP]	Japan	58-205928
Nov. 4, 1983	[JP]	Japan	58-205929

[51] Int. Cl.⁴ F02M 51/00

[52] U.S. Cl. 123/478; 123/480; 123/486; 123/339

[58] Field of Search 123/440, 478, 486, 349, 123/339, 395,417,489,479,480

[56] References Cited

U.S. PATENT DOCUMENTS

Re. 31,582	5/1984	Hosaka et al.	364/431.04
4,130,095	12/1978	Bowler et al.	123/440
4,235,234	11/1980	Rice	123/486
4,319,327	3/1982	Higashiyama et al.	364/431.05
4,344,398	8/1982	Ikeura	123/339
4,345,557	8/1982	Ikeura	123/339
4,376,428	3/1983	Hata et al.	123/417
4,402,217	9/1983	Higashiyama et al.	73/117.3
4,402,289	9/1983	Ikeura	123/339
4,406,261	9/1983	Ikeura	123/339
4,406,262	9/1983	Ikeura	123/339
4,459,670	7/1984	Yamaguchi et al.	364/431.10

FOREIGN PATENT DOCUMENTS

0058826	9/1982	European Pat. Off.
0081648	6/1983	European Pat. Off.
0084116	7/1983	European Pat. Off.
0085909	8/1983	European Pat. Off.
2949988	7/1980	Fed. Rep. of Germany

3333392	3/1984	Fed. Rep. of Germany
49-40886	11/1974	Japan
2125578	3/1984	United Kingdom

OTHER PUBLICATIONS

SAE Technical Paper Series, 800825, Digital Engine Controller (date unavailable).

Ser. No. 655,554 filed 9/28/84, by Hara.

Ser. No. 445,552 filed 11/30/82, by Ito.

SAE Paper 800056 of Feb. '80, "Microprocessor Control Brings About Better Fuel Economy With Good Drivability".

Primary Examiner-Raymond A. Nelli

Attorney, Agent, or Firm-Schwartz, Jeffery, Schwaab, Mack, Blumenthal & Evans

[57] ABSTRACT

An engine control system monitors engine operation by periodically sampling engine operating parameters and records variation patterns of the engine operating parameters as engine operation pattern data whenever any of a number of preselected specific engine operating conditions occur, such as engine stalling, acceleration, or deceleration. The control system normally controls the engine according to conventional engine control procedures and adjusts the control procedures in response to preselected engine operating conditions in accordance with a projected engine operation pattern derived from prerecorded engine operation pattern data and the detected specific engine operating condition. The engine operation pattern data may be repeatedly updated and/or accumulated during engine operation and may be held in a memory of the control system even after the engine is turned off. The engine operating parameters may include the operation state of one or more vehicle components influencing engine operation, such as an air conditioner with a compressor driver by the engine and so acting as an additional load on the engine, or a transmission, the gear position of which can change engine operation significantly.

27 Claims, 26 Drawing Figures

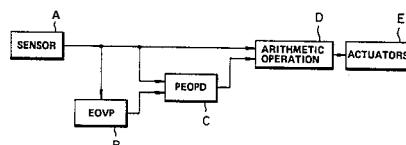

FIG. 1

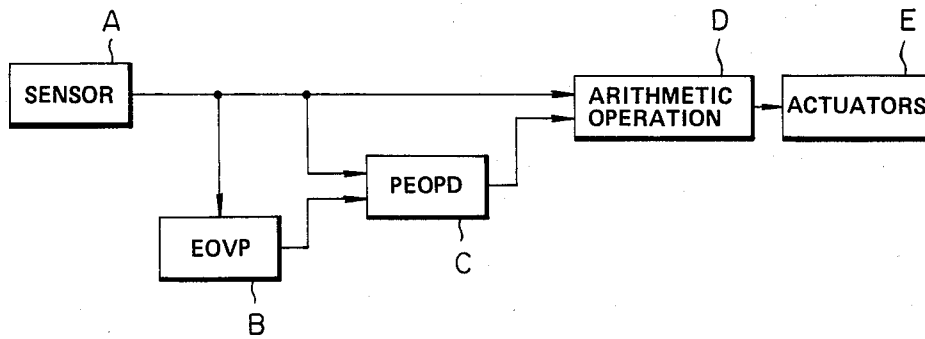

FIG. 2

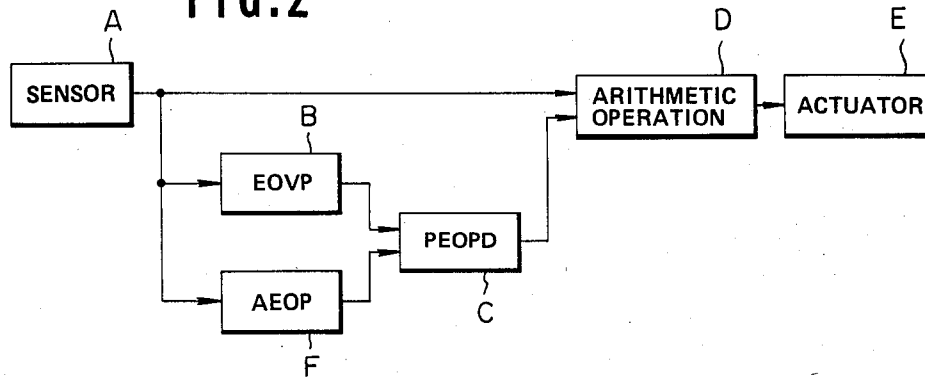

FIG. 3

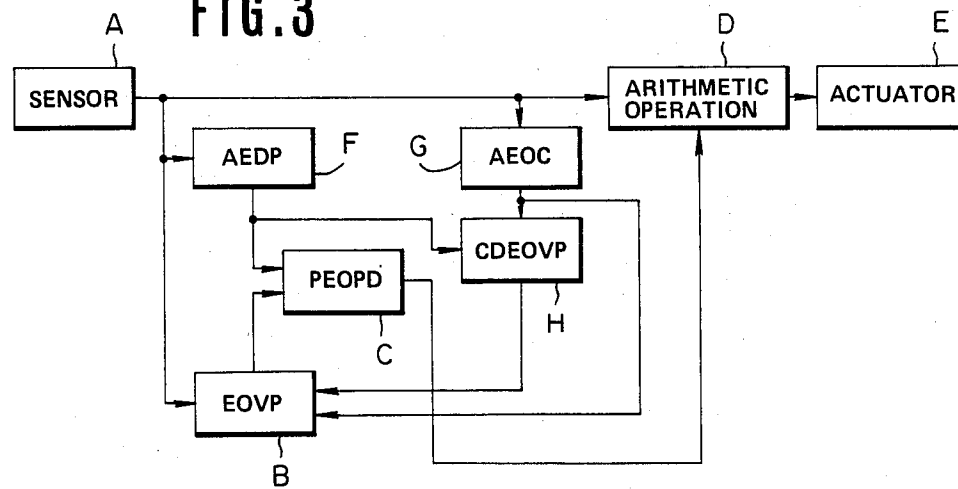

FIG. 4

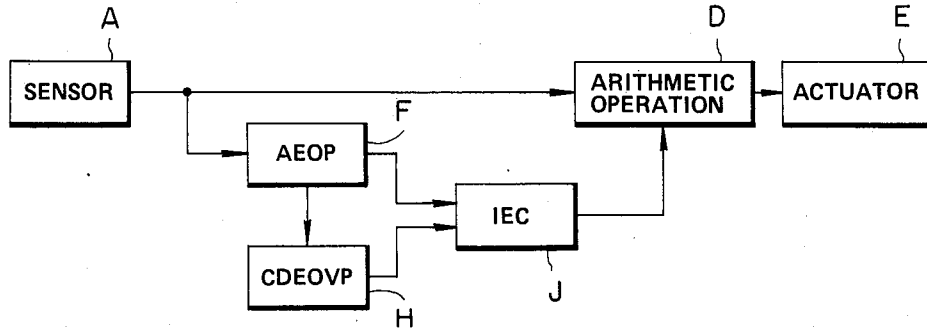

FIG. 5

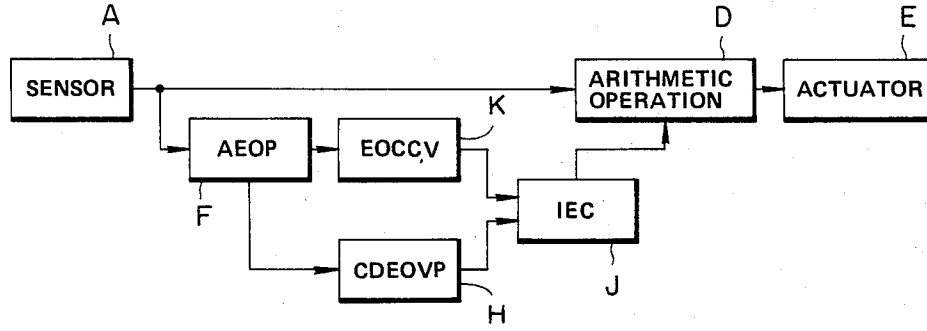

FIG. 6

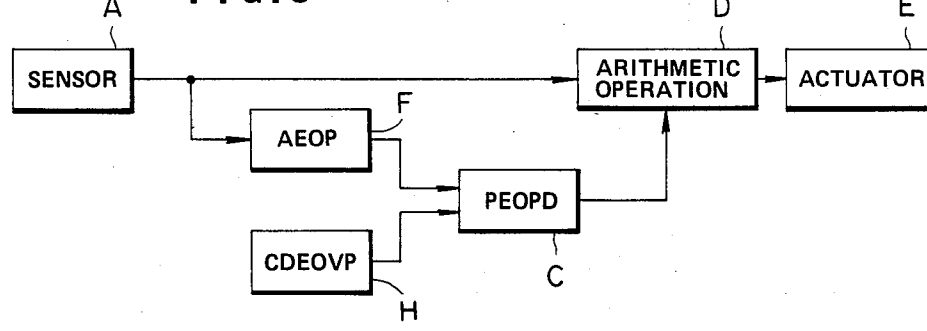
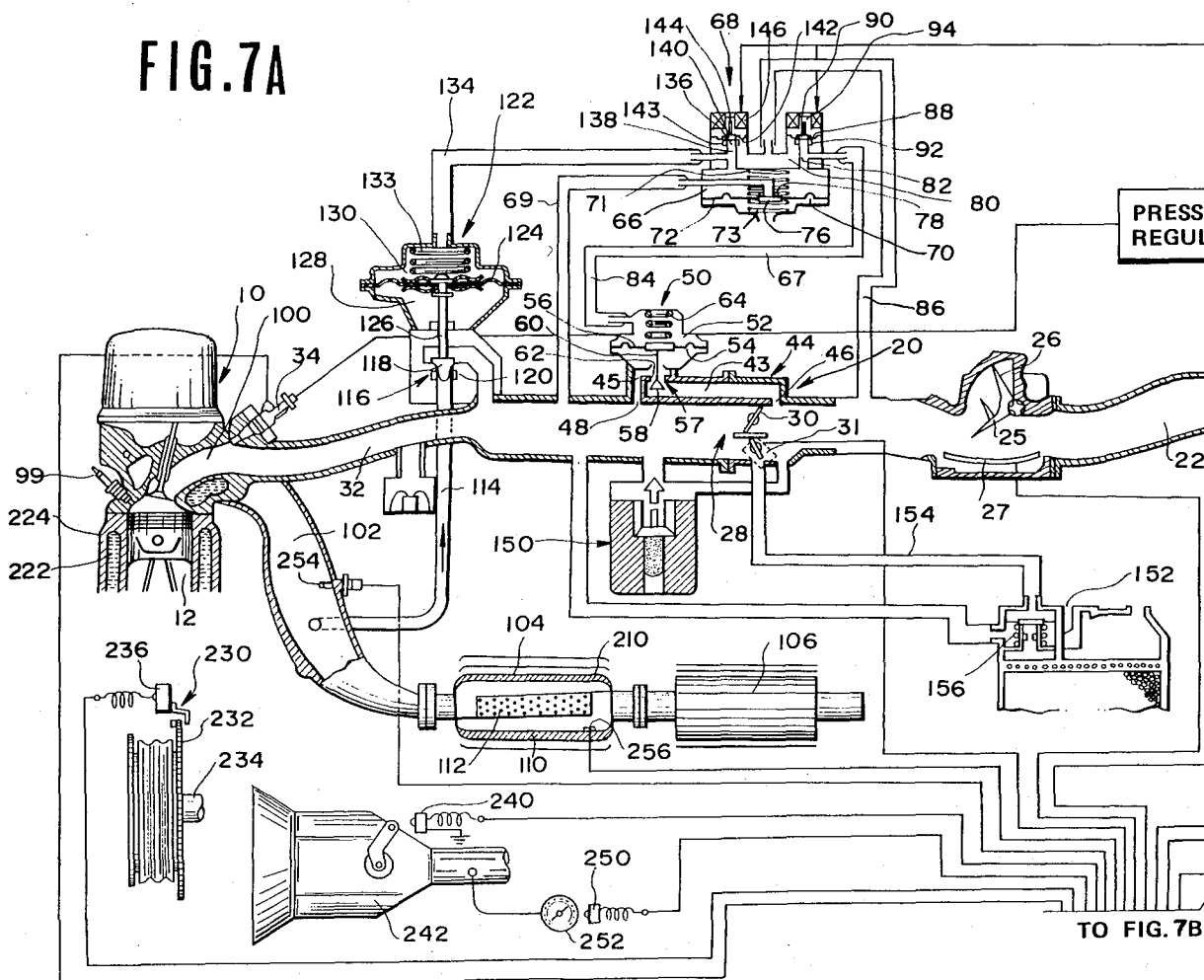
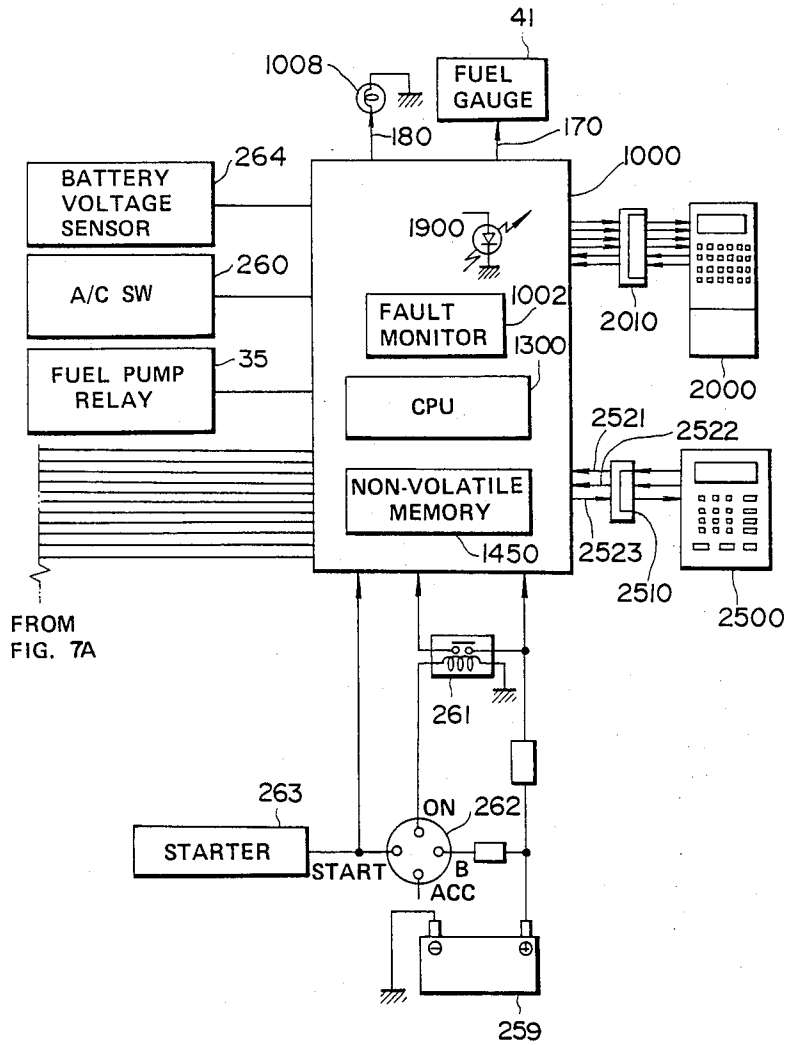

FIG. 7A



TO FIG. 7B

FIG. 7B



FROM FIG. 7A

Explore Litigation Insights

Docket Alarm provides insights to develop a more informed litigation strategy and the peace of mind of knowing you're on top of things.

Real-Time Litigation Alerts



Keep your litigation team up-to-date with **real-time alerts** and advanced team management tools built for the enterprise, all while greatly reducing PACER spend.

Our comprehensive service means we can handle Federal, State, and Administrative courts across the country.

Advanced Docket Research



With over 230 million records, Docket Alarm's cloud-native docket research platform finds what other services can't. Coverage includes Federal, State, plus PTAB, TTAB, ITC and NLRB decisions, all in one place.

Identify arguments that have been successful in the past with full text, pinpoint searching. Link to case law cited within any court document via Fastcase.

Analytics At Your Fingertips



Learn what happened the last time a particular judge, opposing counsel or company faced cases similar to yours.

Advanced out-of-the-box PTAB and TTAB analytics are always at your fingertips.

API

Docket Alarm offers a powerful API (application programming interface) to developers that want to integrate case filings into their apps.

LAW FIRMS

Build custom dashboards for your attorneys and clients with live data direct from the court.

Automate many repetitive legal tasks like conflict checks, document management, and marketing.

FINANCIAL INSTITUTIONS

Litigation and bankruptcy checks for companies and debtors.

E-DISCOVERY AND LEGAL VENDORS

Sync your system to PACER to automate legal marketing.