



(19) **United States**

(12) **Patent Application Publication** (10) **Pub. No.: US 2003/0150352 A1**

**Kumar**

(43) **Pub. Date: Aug. 14, 2003**

(54) **HYBRID ENERGY OFF HIGHWAY VEHICLE  
ELECTRIC POWER STORAGE SYSTEM  
AND METHOD**

(57) **ABSTRACT**

(75) Inventor: **Ajith Kumar**, Erie, PA (US)

Correspondence Address:  
**SENNIGER POWERS LEAVITT AND  
ROEDEL  
ONE METROPOLITAN SQUARE  
16TH FLOOR  
ST LOUIS, MO 63102 (US)**

(73) Assignee: **General Electric Company**

(21) Appl. No.: **10/378,335**

(22) Filed: **Mar. 3, 2003**

**Related U.S. Application Data**

(63) Continuation-in-part of application No. 10/033,347, filed on Dec. 26, 2001.

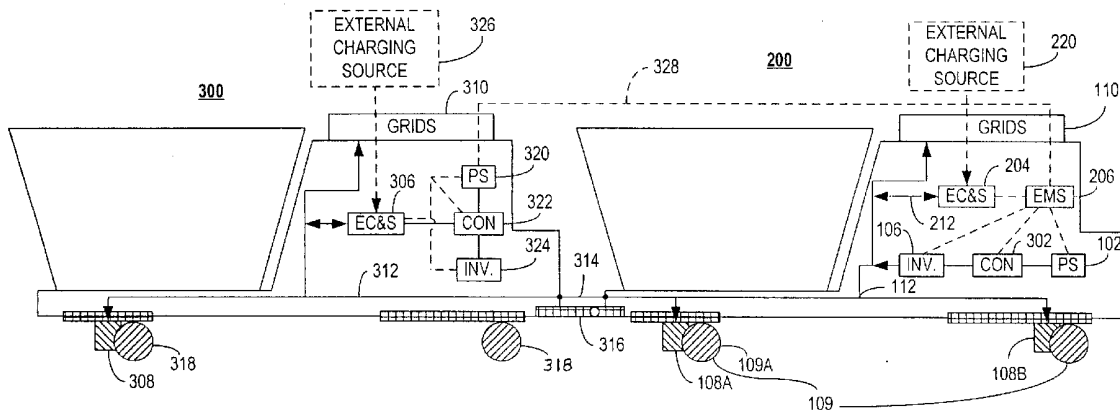
(60) Provisional application No. 60/278,975, filed on Mar. 27, 2001.

**Publication Classification**

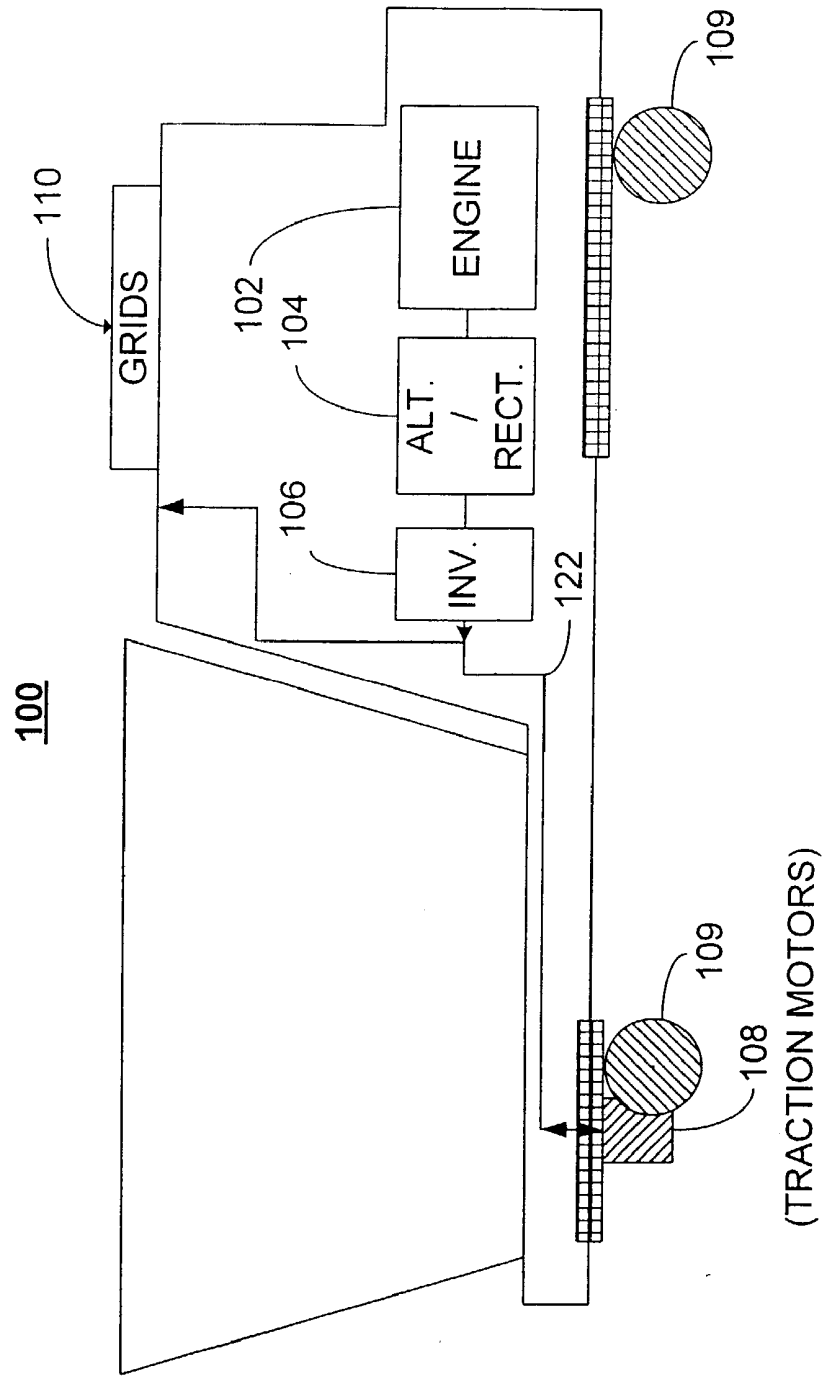
(51) **Int. Cl.<sup>7</sup> ..... B61C 3/00; B61C 7/04**

(52) **U.S. Cl. .... 105/35**

An electrical energy capture system for use in connection with a hybrid energy off highway vehicle system of a off highway vehicle. The hybrid energy off highway vehicle system includes an off highway vehicle, a primary power source, and an off highway vehicle traction motor propelling the off highway vehicle in response to the primary electric power. The off highway vehicle traction motor has a dynamic braking mode of operation generating electrical energy. The electrical energy capture system includes an energy management processor carried on the off highway vehicle. The capture system also includes an off highway vehicle electric generator connected to and driven by the primary power source for selectively supplying primary electric power, wherein the generator is responsive to said processor. An electrical energy storage device is carried on a off highway vehicle and is in electrical communication with the off highway vehicle traction motor. The storage device is responsive to the processor, selectively stores electrical energy generated in the dynamic braking mode, and selectively provides secondary electric power from said stored electricity electrical energy to the off highway vehicle traction motor. The off highway vehicle traction motor is responsive to the secondary electric power. The processor provides a first control signal to the electrical energy storage device to control the selective storing of the electrical energy generated in the dynamic braking mode, and to control the selective providing of secondary electric power to the off highway vehicle traction motor. The processor also provides a second control signal to the generator for controlling the selective supplying of primary electric power to the off highway vehicle traction motor.

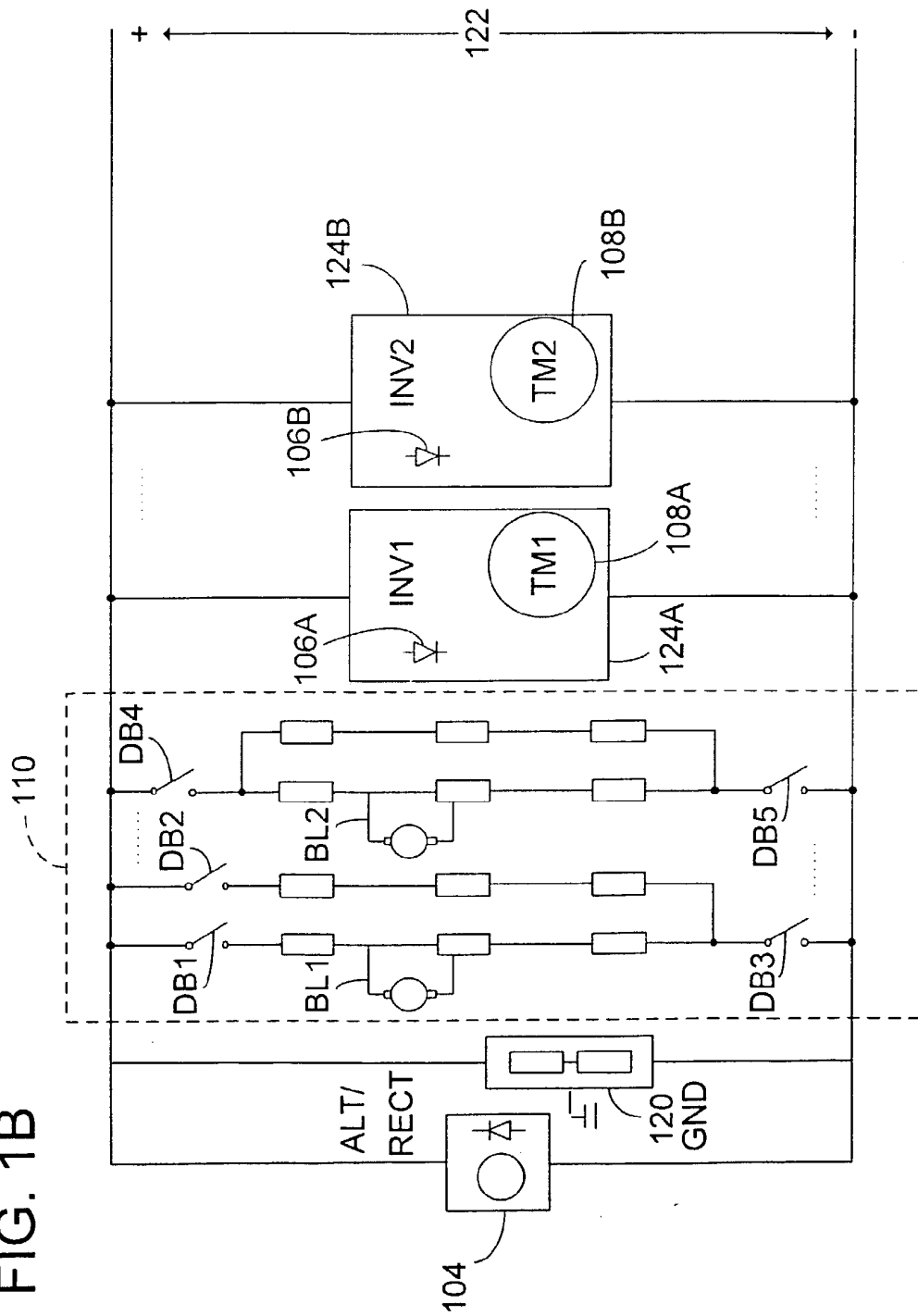


**FIG. 1A**  
PRIOR ART



PRIOR ART

FIG. 1B



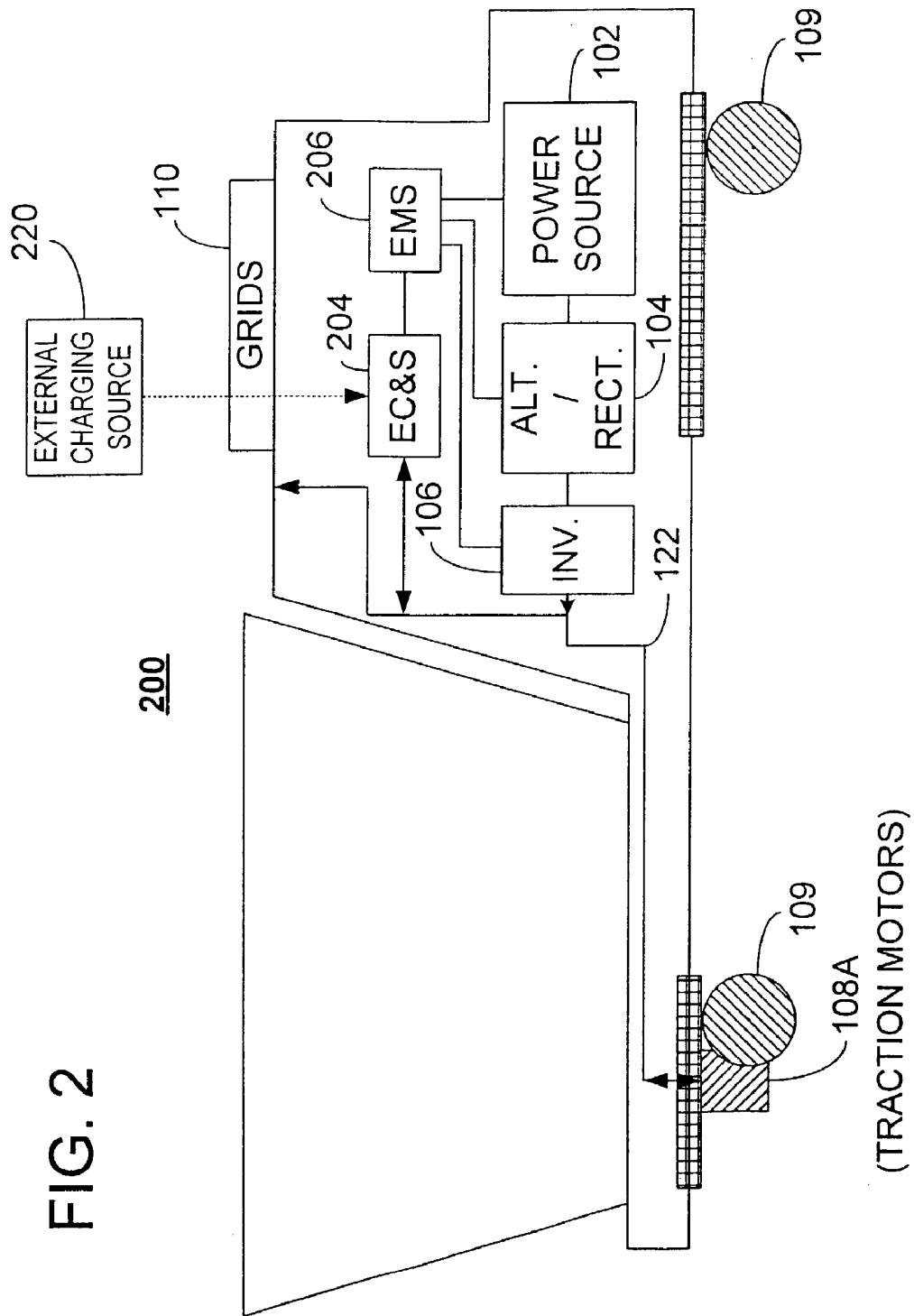
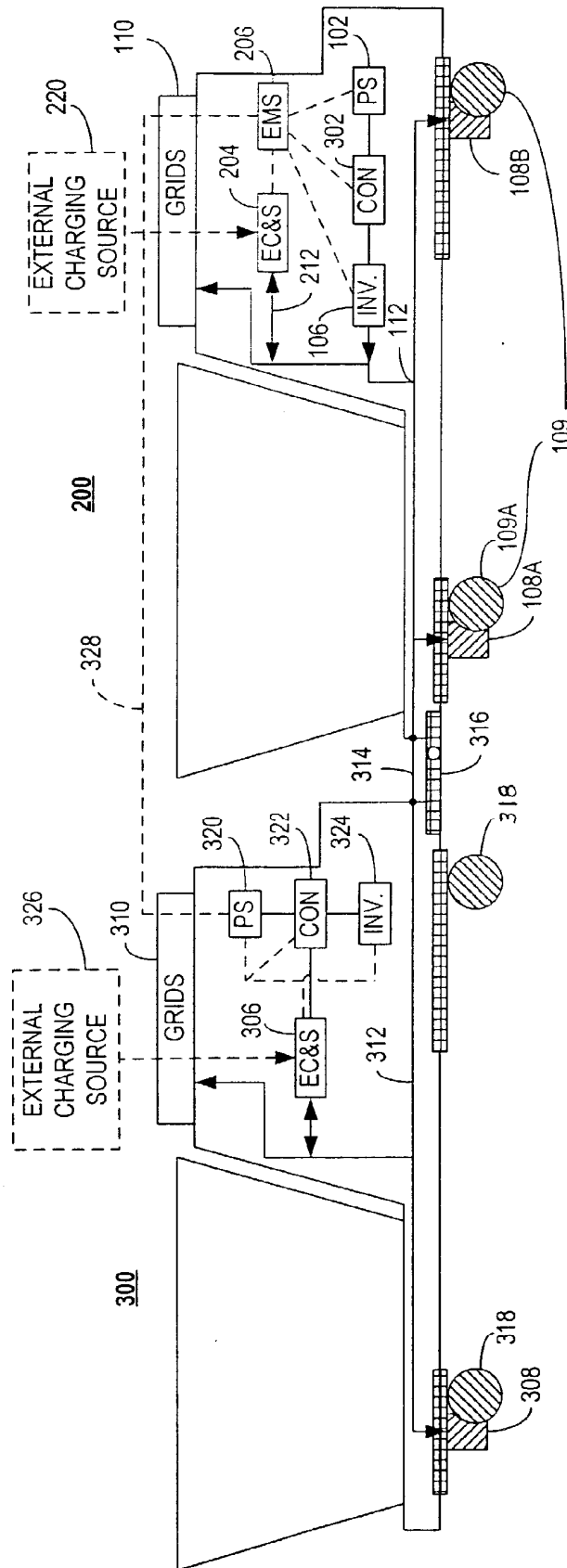


FIG. 3



# Explore Litigation Insights

Docket Alarm provides insights to develop a more informed litigation strategy and the peace of mind of knowing you're on top of things.

## Real-Time Litigation Alerts



Keep your litigation team up-to-date with **real-time alerts** and advanced team management tools built for the enterprise, all while greatly reducing PACER spend.

Our comprehensive service means we can handle Federal, State, and Administrative courts across the country.

## Advanced Docket Research



With over 230 million records, Docket Alarm's cloud-native docket research platform finds what other services can't. Coverage includes Federal, State, plus PTAB, TTAB, ITC and NLRB decisions, all in one place.

Identify arguments that have been successful in the past with full text, pinpoint searching. Link to case law cited within any court document via Fastcase.

## Analytics At Your Fingertips



Learn what happened the last time a particular judge, opposing counsel or company faced cases similar to yours.

Advanced out-of-the-box PTAB and TTAB analytics are always at your fingertips.

## API

Docket Alarm offers a powerful API (application programming interface) to developers that want to integrate case filings into their apps.

## LAW FIRMS

Build custom dashboards for your attorneys and clients with live data direct from the court.

Automate many repetitive legal tasks like conflict checks, document management, and marketing.

## FINANCIAL INSTITUTIONS

Litigation and bankruptcy checks for companies and debtors.

## E-DISCOVERY AND LEGAL VENDORS

Sync your system to PACER to automate legal marketing.