



(12) **United States Patent**
Kaplan et al.

(10) **Patent No.:** **US 7,349,710 B2**
(45) **Date of Patent:** **Mar. 25, 2008**

(54) **SYSTEM AND METHOD FOR WIRELESS
DEVICE CONFIGURATION**

(75) Inventors: **Diego Kaplan**, San Diego, CA (US);
Bilhan Kirbas, La Jolla, CA (US)

(73) Assignee: **Kyocera Wireless Corp.**, San Diego,
CA (US)

(*) Notice: Subject to any disclaimer, the term of this
patent is extended or adjusted under 35
U.S.C. 154(b) by 163 days.

(21) Appl. No.: **11/382,122**

(22) Filed: **May 8, 2006**

(65) **Prior Publication Data**
US 2006/0195517 A1 Aug. 31, 2006

Related U.S. Application Data
(63) Continuation of application No. 10/120,956, filed on
Apr. 11, 2002, now Pat. No. 7,043,263.

(51) **Int. Cl.**
H04Q 7/20 (2006.01)

(52) **U.S. Cl.** **455/466; 455/418; 455/419;**
455/420; 455/517

(58) **Field of Classification Search** **455/418,**
455/419, 420, 466, 517
See application file for complete search history.

(56) **References Cited**

U.S. PATENT DOCUMENTS

6,029,065	A	2/2000	Shah	
6,223,028	B1	4/2001	Chang et al.	
6,275,693	B1	8/2001	Lin et al.	
6,292,833	B1	9/2001	Liao et al.	
2002/0144151	A1*	10/2002	Shell et al.	713/201
2003/0186721	A1	10/2003	Kanazawa et al.	

* cited by examiner

Primary Examiner—Joseph Feild
Assistant Examiner—S. Smith

(57) **ABSTRACT**

A system and method for configuring, or provisioning, mobile communication devices **10** by an administrator **12**. Administrator **12** comprises a computer, or second mobile device **18**. Feature codes for configuring a device **10** are encrypted into a Short Message System (SMS) message or an Internet protocol-based Over-the-Air (IOTA) protocol message and transmitted to mobile device **10**. The message further contains a mobile identifier and a set/reset bit to indicate whether the features are to be set or reset. The encrypted message is communicated to mobile device **10** over communications channel **14** of a mobile communication network.

10 Claims, 2 Drawing Sheets

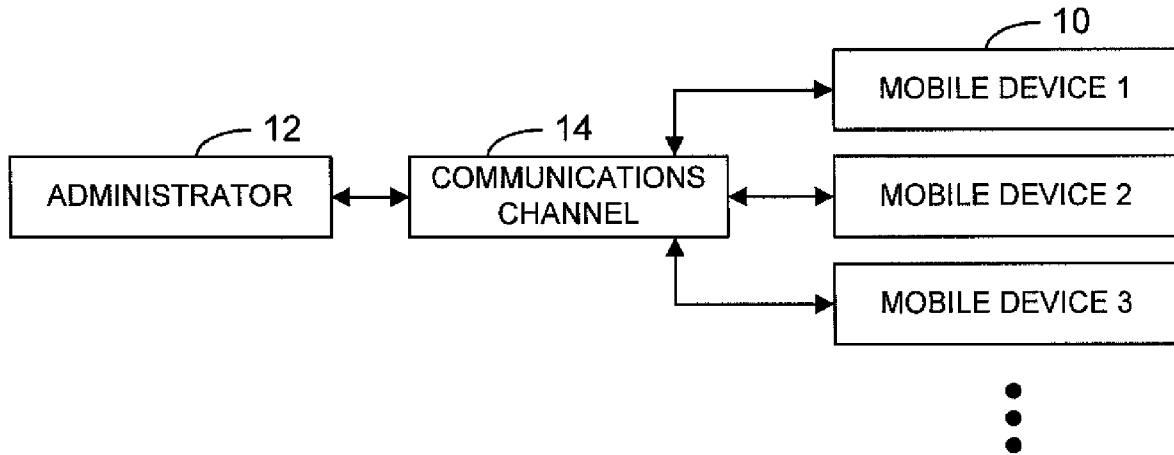

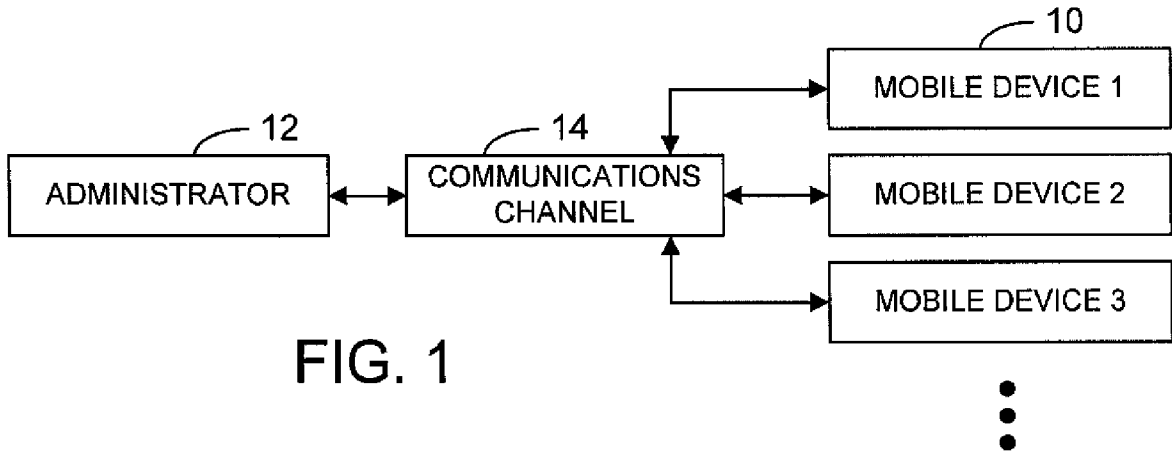

FIG. 1

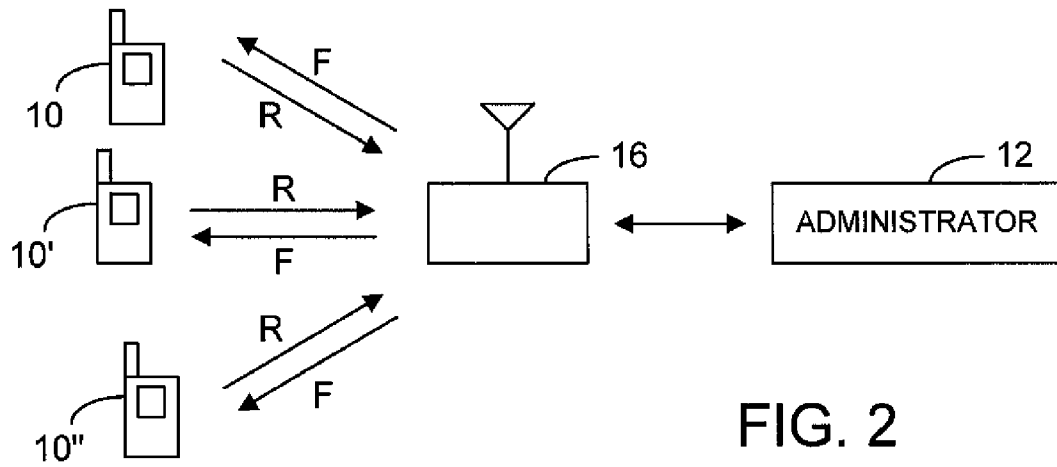

FIG. 2

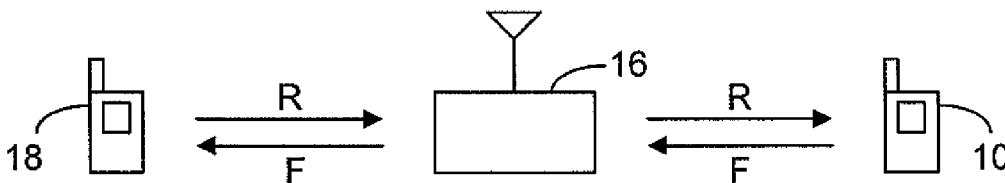

FIG. 4

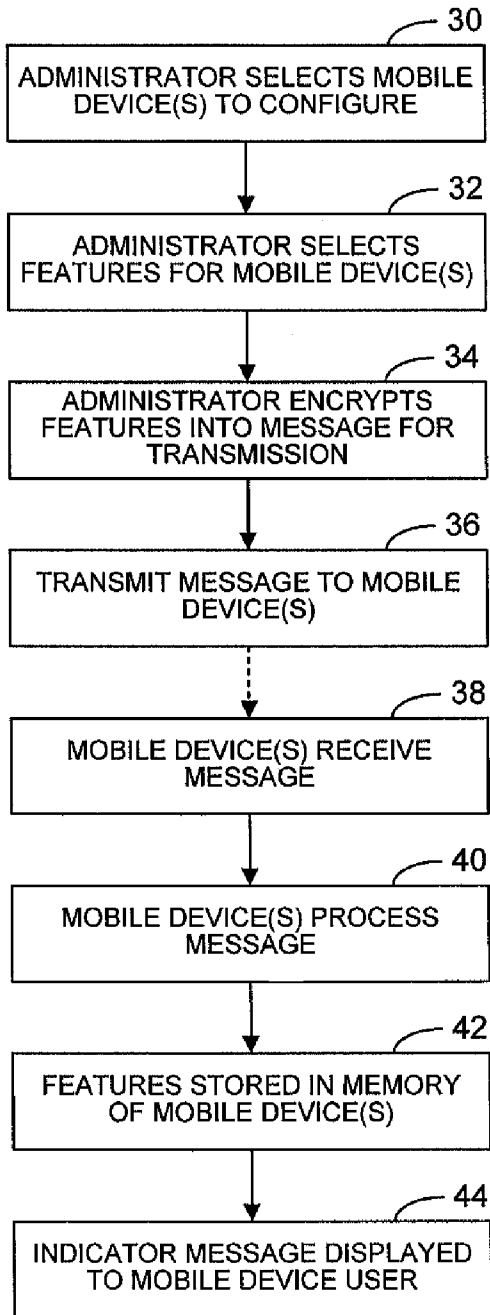

FIG. 3

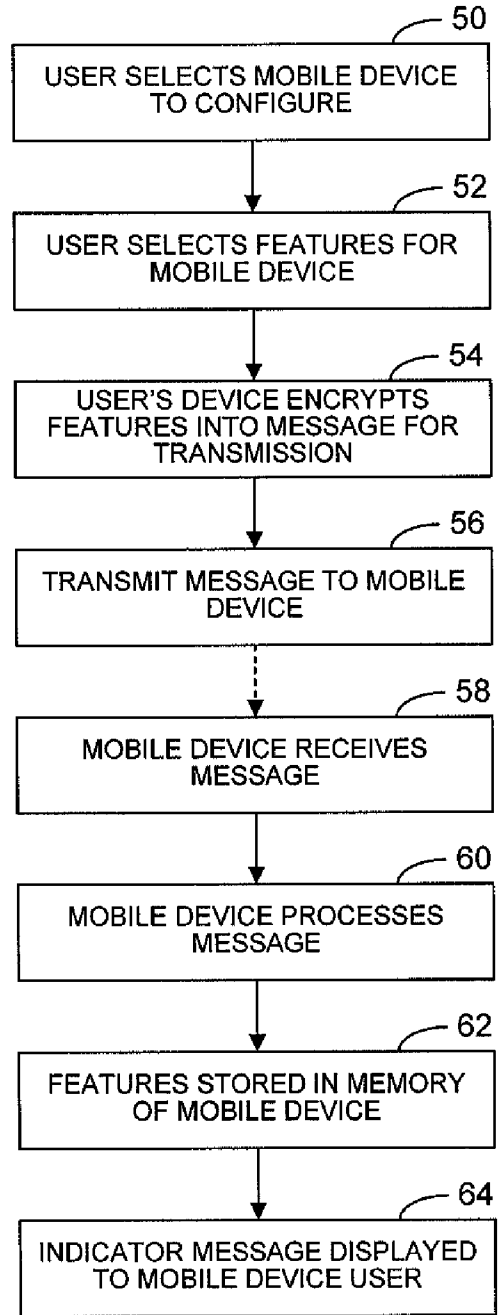

FIG. 5

SYSTEM AND METHOD FOR WIRELESS DEVICE CONFIGURATION

RELATED APPLICATIONS

This is a continuation application of U.S. application No. 10/120,956 filed on Apr. 11, 2002, and issuing as U.S. Patent No. 7,043,263 on May 9, 2006.

FIELD OF THE INVENTION

The present invention relates to wireless communications devices, in particular to configuring or reconfiguring a wireless device by transmitting a configuration message from another wireless device or a computer to the wireless device to be configured.

BACKGROUND OF THE INVENTION

There are a variety of wireless communication devices (also referred to herein as mobile communication devices and mobile devices) available for wireless or remote communications including mobile cellular and satellite telephones, pagers, personal digital assistants (PDAs), and the like. These wireless communication devices typically comprise a rigid housing enclosing a printed circuit board, an associated microprocessor, electronic and electro-acoustic components, and a portable power supply such as a battery. Wireless communication devices communicate through a variety of means, including antennas that transmit and receive radio frequency (RF) signals, infrared (IR) emitters and receivers, or cable connections to input/output ports of computers and other mobile devices.

The user of the mobile device interfaces with the circuitry and microprocessor of the device through a keypad, or touchpad, located on the front outer surface of the housing. Keys on the keypad are pressed by the user to temporarily close an internal switch and send a signal to the microprocessor where an appropriate routine processes the input and operates the device. On mobile telephones, graphical elements, such as alphanumeric characters and icons, are located on or near the keys of the keypad to guide the user in interfacing with the mobile device. A display on the housing of the device provides a readout of data input by the user, access to spatially navigated menu trees, includes a graphical user interface (GUIs), windows, and messages.

Wireless communication devices are configured, or "provisioned", for various modes of operation. The configuration determines how basic functions of the wireless device will operate, such as setting or resetting wireless voice and data exchange protocol parameters, parameters used to enable or disable communication features, and local network services available to the mobile device. Examples of communication features include, but are not limited to, call forwarding, call waiting, caller identification, automatic callback, conference calling, message waiting notification, call encryption, voice mail, cost of call notification, enhanced vocoder (voice encoder), and the ability to transmit and receive textual messages.

Mobile devices are also configured so that communications occur through the appropriate service provider and are invoiced properly. A telephone number and a binary mobile identification number (MIN), e.g., a 34-bit MIN, for analog communications, (international mobile subscriber identity (IMSI) for CDMA communications), used to identify a

device in a number assignment module (NAM) within non-volatile memory of the mobile device. The NAM is also used to indicate whether the mobile functions in the personal communication service (PCS) band (1.9 GHz) or the cellular band (800 MHz). Other configuration information can include an electronic serial number (ESN), network identification (NID), system identification (SID), a home registration indicator, a preferred roaming list (PRL), and other information that allows the network base station to locate and determine the operating characteristics and capabilities of the mobile device. The configuration can be preset in the mobile device, set into the mobile device upon entering an appropriate access code, or set after connection to the wireless carrier network through which the mobile device operates.

Typically, the configuration is established after connection to the wireless carrier network, commonly referred to as over-the-air service provisioning (OTASP). A specification for OTASP operation can be found in "Over-the-Air Service Provisioning of Mobile Stations in Spread Spectrum Systems", TIA/EIA/IS-683-A, incorporated herein by reference. Local service parameters are acquired from and set by the carrier network via the over-the-air function/customer service center (OTAF/CSC) through a particular server, typically that of the communication service provider. The mobile device requests configuration information from a network server and is then configured "over the air" in accordance with the information acquired from the server. The information obtained from the server is executable or binary code containing interfaces, data, and operational parameters that modify local service parameters to set or alter mobile functions, such as communication features, including whether the mobile device will support cellular or personal communication service, dual-band or single band transmission, analog or digital transmission protocol, etc.

Users are not directly provided the information necessary to configure, or reconfigure, a mobile device. However, most mobile devices can be reconfigured by accessing a "hidden" menu within the mobile processor. To do so, the communications service provider must either contact the user, or subscriber, in order to instruct the user how to reconfigure the mobile device. Alternatively, the mobile device must be taken to a service provider service center. The mobile device cannot be reconfigured for a particular feature until the appropriate access code has been entered into the mobile device to access the appropriate configuration menu. Particular communication features require a feature code in order to set or reset the feature.

Once configured, information is exchanged between mobile devices or between mobile devices and other devices, such as computers, via RF signals, or cable connections sometimes referred to as "connectivity kits". Wireless RF transmission provides the longest transmission range currently available and is often more flexible than cable transmission.

As mobile designs have advanced over time, more features are available to the user, such as the ability to program, store, and transmit data. Mobile devices store contact information, for example, names, telephone numbers, addresses, e-mail addresses, web site addresses, and scheduling information such as meetings and appointments. Many mobile devices are capable of transmitting textual data as well as voice information to other mobile devices, computers, servers, or over the Internet by means such as short messaging systems (SMS), discussed below, and Internet protocol-

In order to transmit data and text messages between mobile devices or between mobile devices and computers, servers, or the Internet, spatially navigated menus shown on the display are typically implemented to aid the user in inputting messages and data, and also to aid the user in accessing data for revision or transmission. To improve the efficiency of text message transmission between mobile devices, a variety of SMS have been designed for rapid text entry. Early applications of SMS were used by telephone operators to alert subscribers to newly received voice mail messages or stored facsimiles by displaying a simple message on the mobile display that the user saw once the mobile was turned on. Later applications of SMS provide users with a list of default messages that are chosen by a single keystroke in order to be sent, for example, "please call home." Upon choosing the predefined message, the sending mobile would automatically send it to the receiving mobile. One advantage of an SMS is that it does not require the receiving mobile to be powered on in order to receive the message. The sent message is stored in the communication system until the receiving mobile is powered on. The message is then automatically received, stored on the receiving mobile, and displayed on the mobile display.

With increasing reliance on wireless communication, particularly via mobile devices, it is desirable for individuals or organizations to be able to control the configuration of a particular mobile, and to be able to monitor the current configuration status of the mobile. Currently, mobile devices are constrained by the service provider to the configuration provided under the service plan and can only be configured, or reconfigured, by the carrier network, or by accessing the appropriate configuration menu by secret code.

Accordingly, a method is needed whereby mobile devices can be configured or reconfigured for particular features in a user-friendly manner to enhance communication efficiency and to minimize communication costs.

SUMMARY OF THE INVENTION

In an exemplary embodiment of the present invention a mobile device is directly configured with features selected by a user via another mobile device or from a computer. In an exemplary embodiment, the mobile device is configured over wireless means so that communication distance does not inhibit the process. In another exemplary embodiment of the present invention, the configuration status of a mobile device is retrieved from the mobile device by communication from another mobile or a computer. The present invention overcomes the limitations existing in the prior art by implementing a conventional SMS or IOTA protocol to configure and reconfigure features of mobile devices.

BRIEF DESCRIPTION OF THE DRAWINGS

The accompanying drawings, which are incorporated into and form a part of the specification, illustrate preferred embodiments of the present invention and, together with the description, serve to explain the principles of the invention. The drawings are only for the purpose of illustrating exemplary embodiments of the invention and are not to be construed as limiting the invention.

FIG. 1 is a block diagram illustrating an exemplary embodiment of the present invention for configuring a mobile device, depicting communication between a plurality of mobile devices and an organization administrator.

FIG. 3 is a flow diagram of the method of configuring a mobile device according to an exemplary embodiment of the present invention.

FIG. 4 is a block diagram illustrating another exemplary embodiment of the present invention for configuring a mobile device, wherein a second mobile device operates as the administrator to configure the first mobile device.

FIG. 5 is a flow diagram of the method of configuring a mobile device according to the embodiment of FIG. 4.

DETAILED DESCRIPTION

An exemplary embodiment of the present invention is a method and system for configuring a mobile device. The method and system allows an administrator, operating independently, yet within the parameters set by a carrier network, to use an SMS or an IOTA protocol to communicate feature codes to a mobile device, as well as to retrieve the current configuration status of the mobile device. As used herein the phrase "feature codes" refers to codes depicting a variety of communication features available to a typical mobile device, including wireless voice and data exchange protocol parameters, parameters used to enable or disable communication features, and local network services available to the mobile device. Such features may include but are not limited to call blocking, call forwarding, call waiting, caller identification, automatic callback, conference calling, message waiting notification, call encryption, voice mail, cost of call notification, enhanced vocoder (voice encoder), and the ability to transmit and receive textual messages.

Features also include such capabilities as whether the mobile device can support cellular or personal communication service, IS 95 or CDMA 2000 modulation protocol, dual-band or single band transmission, analog or digital transmission protocol, etc. The term "administrator" as used herein refers to the device through which the user or individual within a business organization controls the configuration of a mobile device. Such a device can include a second mobile device, a computer, or a server.

Referring to FIG. 1, a block diagram depicts an exemplary embodiment of the present invention. A plurality of mobile devices **10** used within an organization, such as a particular business environment, communicate with an organization administrator **12** through communications channel **14**. Communications channel **14** can comprise RF or other wireless transmission means between mobile devices **10** and administrator **12**. Communications channel **14** can operate via the Internet Protocol (IP), Wireless Application Protocol (WAP), or other suitable transmission protocol. Preferably the communications channel is wireless, so that distance and flexibility of communication is maximized. In this system, administrator **12** operates as a mobile communications administrator for the organization, capable of communicating feature codes to mobile devices **10** and retrieving configuration data from mobile devices **10**. It will be understood in this embodiment of the invention that administrator **12** comprises a computer, a server for a particular organization, or other equivalent device.

Referring to FIG. 2, a diagram illustrates a mobile cellular telephone communications system within which an embodiment of the present invention as described above can be implemented. Three mobile devices **10**, **10'**, and **10''** are shown with a single base transceiver station **16** within a cellular communications site, or cell. A cell is generally defined as a particular RF coverage area. As a mobile device

Explore Litigation Insights

Docket Alarm provides insights to develop a more informed litigation strategy and the peace of mind of knowing you're on top of things.

Real-Time Litigation Alerts



Keep your litigation team up-to-date with **real-time alerts** and advanced team management tools built for the enterprise, all while greatly reducing PACER spend.

Our comprehensive service means we can handle Federal, State, and Administrative courts across the country.

Advanced Docket Research



With over 230 million records, Docket Alarm's cloud-native docket research platform finds what other services can't. Coverage includes Federal, State, plus PTAB, TTAB, ITC and NLRB decisions, all in one place.

Identify arguments that have been successful in the past with full text, pinpoint searching. Link to case law cited within any court document via Fastcase.

Analytics At Your Fingertips



Learn what happened the last time a particular judge, opposing counsel or company faced cases similar to yours.

Advanced out-of-the-box PTAB and TTAB analytics are always at your fingertips.

API

Docket Alarm offers a powerful API (application programming interface) to developers that want to integrate case filings into their apps.

LAW FIRMS

Build custom dashboards for your attorneys and clients with live data direct from the court.

Automate many repetitive legal tasks like conflict checks, document management, and marketing.

FINANCIAL INSTITUTIONS

Litigation and bankruptcy checks for companies and debtors.

E-DISCOVERY AND LEGAL VENDORS

Sync your system to PACER to automate legal marketing.