

I.	Appendix B-1: Exemplary Evidence And Discussions Relating To The Invalidity Of The '068 Patent In View Of Shin, International Publication WO 2004/090853 (“Shin”).....	2
A.	Independent Claim 1	2
1.	[1pre]—“1. A transistor array substrate comprising:”	2
2.	[1a]—“a substrate”	9
3.	[1b]—“a plurality of driving transistors which are arrayed in a matrix on the substrate, each of the driving transistors having a gate, a source, and a drain, and a gate insulating film inserted between the gate, and the source and drain;”	9
4.	[1c]—“a plurality of signal lines which are patterned together with the gates of said plurality of driving transistors and arrayed to run in a predetermined direction on the substrate”	20
5.	[1d]—“a plurality of supply lines which are patterned together with the sources and drains of said plurality of driving transistors and arrayed to cross said plurality of signal lines via the gate insulating film, one of the source and the drain of each of the driving transistors being electrically connected to the supply lines”	30
6.	[1e]—“a plurality of feed interconnections which are formed on said plurality of supply lines along said plurality of supply lines, respectively.”.....	50
B.	Dependent Claim 5 – “A substrate according to claim 1, further comprising a plurality of light-emitting elements each of which is connected to one of the source and drain of a corresponding one of the driving transistors.”.....	65
C.	Dependent Claim 10 – “A substrate according to claim 1, wherein the feed interconnections have a width of 7.45 to 44.00 um.”	68
D.	Independent Claim 13	68
1.	[13pre]—“A display panel comprising:”	68
2.	Limitations [13a]-[13d] are disclosed for the same reasons as [1a]-[1d].....	70
3.	[13e]—“a plurality of feed interconnections which are connected to said plurality of supply lines along said plurality of supply lines;”	70
4.	[13f]—“a plurality of pixel electrodes each of which is electrically connected to the other of the source and the drain of a corresponding one of said plurality of driving transistors;”	72
5.	[13g]—“a plurality of light-emitting layers which are formed on said plurality of pixel electrodes, respectively; and”	79
6.	[13h]—“a counter electrode which covers said plurality of light-emitting layers.”	86

I. APPENDIX B-1: EXEMPLARY EVIDENCE AND DISCUSSIONS RELATING TO THE INVALIDITY OF THE '068 PATENT IN VIEW OF SHIN, INTERNATIONAL PUBLICATION WO 2004/090853 (“SHIN”)

1. The following includes exemplary evidence and discussions from Shin relating to the asserted claims of the '068 patent.

2. In addition to the exemplary evidence and discussions below, the body of my report contains additional narrative descriptions and exemplary evidence as to Shin that supplements the disclosures below and should be considered part of this Appendix, and vice versa for this and all other appendices.

3. I have reviewed Solas's responses to Defendants' Interrogatory No. 14, and understand that Solas contends that Defendants have failed to show that any limitation of the asserted claims of the '068 patent is disclosed or rendered obvious by Shin, but has not explained any of those positions or provided facts supporting its contentions. Thus, it is not possible to understand or rebut Solas's contentions, which amount to mere conclusions lacking factual support or explanation. However, to the extent that Solas or its expert allege any facts or opinions supporting its contentions that Shin does not disclose and/or render obvious any one or more limitations of the asserted claims of the '068 patent, I may supplement my opinions below to cite additional evidence from Shin, other references, or to supplement or modify my opinions regarding the obviousness of the asserted claims in view of Shin and one or more references.

A. Independent Claim 1

1. [1pre]—“1. A transistor array substrate comprising:”

4. To the extent the preamble is limiting, Shin discloses and/or renders obvious [1pre].

5. For example, Shin discloses “an OELD panel capable of decreasing a cross-talk.”

Shin, Abstract. Shin's OELD panel, like any OELD panel, is composed of a plurality of pixels

Appendix B-1 to the Expert Report of Douglas R. Holberg Regarding The Invalidity of the '891 patent, '068 patent, and '137 patent

arranged in an array of rows and columns, wherein each pixel has multiple transistors (such as “a driving transistor QD” and a “switching transistor QS”). The claimed transistor array substrate is disclosed throughout the Shin reference, for example:

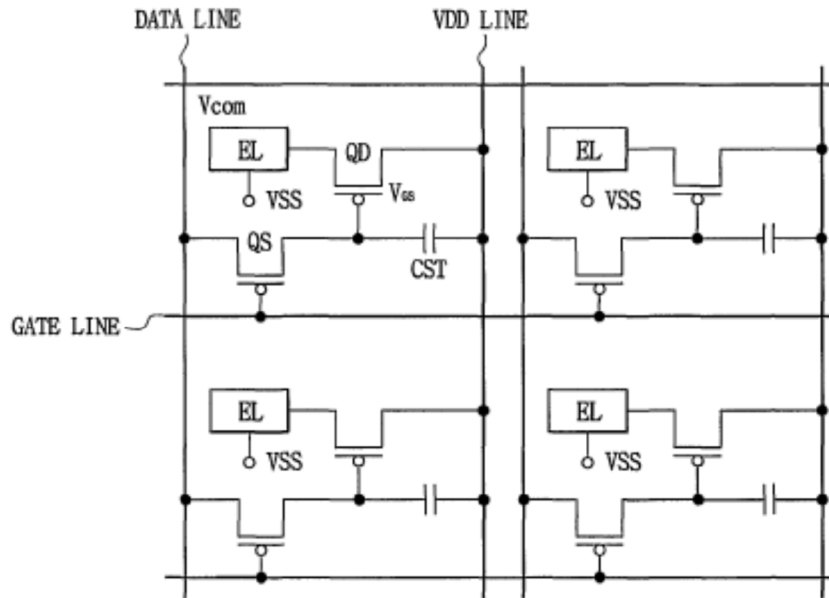

Shin, Fig. 1;

FIG. 3

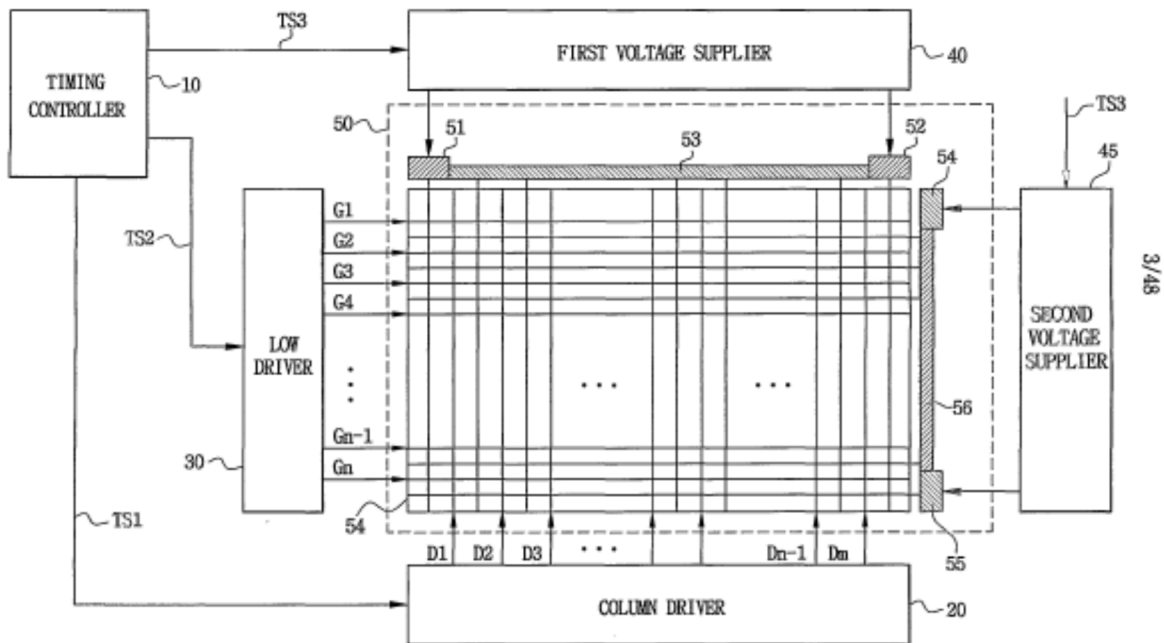

Shin, Fig. 3;

In addition, the organic electro luminescent panel 50 includes a plurality of data lines, a plurality of first current supply lines, a plurality of scan lines and a plurality of second current supply lines. Numbers of the data lines, the first current supply lines, the scan lines and the second current supply lines are 'm', 'm', 'n' and 'n', respectively, wherein 'm' and 'n' are positive numbers and are independent from each other. The organic electro luminescent panel 50 displays an image using the image signal that is provided from the column driver 20 in response to the scan signals that are provided from the low driver 30. A switching element (QS, not shown), a driving element (QD, not shown), an organic electro luminescent element (not shown) and a storage capacitor (Cst, not shown) are formed in a region defined by two adjacent data lines and two adjacent scan lines

Shin, 9:8-18;

The organic electro luminescent display apparatus may include a plurality of the pixels, a plurality of the scan lines, a plurality of the horizontal current supply lines, a plurality of the data lines and a plurality of the longitudinal current supply lines. The number of the

pixels that are electrically connected to each of the longitudinal current supply lines may be equal to that of the scan lines.

The p-th longitudinal current supply line (H-Vddp) is extended in the horizontal direction that is substantially in parallel with the scan line. The horizontal current supply line (H-Vddp) is electrically connected to the longitudinal current supply lines (V-Vddg and V-Vddg+1).

Shin, 25:15-23;

FIG. 19 is a plan view showing a unit pixel of an organic electro luminescent display apparatus in accordance with another exemplary embodiment of the present invention. FIG. 20 is a cross-sectional view taken along the line A1-A1' of FIG. 19.

Referring to FIGS. 19 and 20, the organic electro luminescent panel includes a scan line N10, a horizontal current supply line N30, a switching transistor (QS), a driving transistor (QD), a longitudinal current supply line N33, a first ITO pattern N40, a second ITO pattern N42, a partition wall N50, an organic electro luminescent layer N60, a counter electrode layer N70 and a protection layer N80. The organic electro luminescent panel may include a plurality of the scan lines, a plurality of the horizontal current supply lines, a plurality of the switching transistors, a plurality of the driving transistors, a plurality of the longitudinal current supply lines, a plurality of the first ITO patterns, a plurality of the second ITO patterns, a plurality of the partition walls and a plurality of the organic electro luminescent layers.

Shin, 25:24-26:10; *see also id.*, Figs. 1, 7-48 (showing transistors), claim 9 (“plurality of the unit pixels”).

6. With respect to the embodiment described with respect to Figures 18-22, the pixels and their respective transistors are formed on a “substrate N05 including an insulating material, for example, such as a glass, a ceramic, etc.”

Explore Litigation Insights

Docket Alarm provides insights to develop a more informed litigation strategy and the peace of mind of knowing you're on top of things.

Real-Time Litigation Alerts



Keep your litigation team up-to-date with **real-time alerts** and advanced team management tools built for the enterprise, all while greatly reducing PACER spend.

Our comprehensive service means we can handle Federal, State, and Administrative courts across the country.

Advanced Docket Research



With over 230 million records, Docket Alarm's cloud-native docket research platform finds what other services can't. Coverage includes Federal, State, plus PTAB, TTAB, ITC and NLRB decisions, all in one place.

Identify arguments that have been successful in the past with full text, pinpoint searching. Link to case law cited within any court document via Fastcase.

Analytics At Your Fingertips



Learn what happened the last time a particular judge, opposing counsel or company faced cases similar to yours.

Advanced out-of-the-box PTAB and TTAB analytics are always at your fingertips.

API

Docket Alarm offers a powerful API (application programming interface) to developers that want to integrate case filings into their apps.

LAW FIRMS

Build custom dashboards for your attorneys and clients with live data direct from the court.

Automate many repetitive legal tasks like conflict checks, document management, and marketing.

FINANCIAL INSTITUTIONS

Litigation and bankruptcy checks for companies and debtors.

E-DISCOVERY AND LEGAL VENDORS

Sync your system to PACER to automate legal marketing.