

FORM PTO-1380 (REV. 12-2004)		U.S. DEPARTMENT OF COMMERCE PATENT AND TRADEMARK OFFICE		ATTORNEY'S DOCKET NUMBER	
TRANSMITTAL LETTER TO THE UNITED STATES DESIGNATED/ELECTED OFFICE (DO/EO/US) CONCERNING A FILING UNDER 35 U.S.C. 371				RUF-11-1270	
				U.S. APPLICATION NO. (If known, see 37 CFR 1.5)	
INTERNATIONAL APPLICATION NO. PCT/EP2010/000787		INTERNATIONAL FILING DATE 09 February 2010 (09.02.10)		PRIORITY DATE CLAIMED 09 February 2009 (09.02.09)	
TITLE OF INVENTION BUTTON CELLS AND METHOD FOR PRODUCING SAME					
APPLICANTS FOR DO/EO/US Eduard Pytlík, Jürgen Lindner, Ulrich Barenthin and Winfried Gaugler					
Applicant herewith submits to the United States Designated/Elected Office (DO/EO/US) the following items and other information:					
<ol style="list-style-type: none"> 1. <input checked="" type="checkbox"/> This is a FIRST submission of items concerning a filing under 35 U.S.C. 371. 2. <input type="checkbox"/> This is a SECOND or SUBSEQUENT submission of items concerning a filing under 35 U.S.C. 371. 3. <input type="checkbox"/> This is an express request to begin national examination procedures (35 U.S.C. 371(f)). The submission must include items (5), (6), (9) and (21) indicated below. 4. <input type="checkbox"/> The US has been elected (Article 31). 5. <input checked="" type="checkbox"/> A copy of the International Application as filed (35 U.S.C. 371(c)(2)) <ol style="list-style-type: none"> a. <input type="checkbox"/> is attached hereto (required only if not communicated by the International Bureau). b. <input checked="" type="checkbox"/> has been communicated by the International Bureau. c. <input type="checkbox"/> is not required, as the application was filed in the United States Receiving Office (RO/US). 6. <input checked="" type="checkbox"/> An English language translation of the International Application as filed (35 U.S.C. 371(c)(2)) <ol style="list-style-type: none"> a. <input checked="" type="checkbox"/> is attached hereto. b. <input type="checkbox"/> has been previously submitted under 35 U.S.C. 154(d)(4). 7. <input type="checkbox"/> Amendments to the claims of the International Application under PCT Article 19 (35 U.S.C. 371(e)(3)) <ol style="list-style-type: none"> a. <input type="checkbox"/> are attached hereto (required only if not communicated by the International Bureau). b. <input type="checkbox"/> have been communicated by the International Bureau. c. <input type="checkbox"/> have not been made; however, the time limit for making such amendments has NOT expired. d. <input type="checkbox"/> have not been made and will not be made. 8. <input type="checkbox"/> An English language translation of the amendments to the claims under PCT Article 19 (35 U.S.C. 371(e)(3)). 9. <input type="checkbox"/> An oath or declaration of the inventor(s) (35 U.S.C. 371(c)(4)). 10. <input type="checkbox"/> An English language translation of the annexes of the International Preliminary Examination Report under PCT Article 36 (35 U.S.C. 371(c)(5)). <p>Items 11 to 20 below concern document(s) or information included:</p> <ol style="list-style-type: none"> 11. <input checked="" type="checkbox"/> An Information Disclosure Statement under 37 C.F.R. 1.97 and 1.98 with Form PTO-1449 and nine (9) publications. 12. <input type="checkbox"/> An assignment document for recording. A separate cover sheet in compliance with 37 C.F.R. 3.28 and 3.31 is included. 13. <input checked="" type="checkbox"/> A preliminary amendment. 14. <input checked="" type="checkbox"/> An Application Data Sheet under 37 C.F.R. 1.76. 15. <input checked="" type="checkbox"/> A substitute specification (marked-up and clean copies) and clean Abstract. 16. <input type="checkbox"/> A power of attorney and/or change of address letter. 17. <input type="checkbox"/> A computer-readable form of the sequence listing in accordance with PCT Rule 13ter.2 and 37 C.F.R. 1.821 - 1.825. 18. <input type="checkbox"/> A second copy of the published international application under 35 U.S.C. 154(d)(4). 19. <input type="checkbox"/> A second copy of the English language translation of the international application under 35 U.S.C. 154(d)(4). 20. <input checked="" type="checkbox"/> Other items or information: PCT/RO/101 (4 pgs), PCT/IB/306, WO 2010/089152 A1 (2 pgs), PCT/ISA/210 (2 pgs) & German Search Report (4 pgs) 					

21. The following fees are submitted:				
<input checked="" type="checkbox"/> a) Basic national fee.....	\$ 330.00		\$ 330.00	
<input checked="" type="checkbox"/> b) Examination fee.....	\$ 220.00		\$ 220.00	
<input checked="" type="checkbox"/> c) Search fee.....	\$ 430.00		\$ 430.00	
TOTAL OF ABOVE CALCULATIONS =	\$ 980.00		\$ 980.00	

Additional fee for specification and drawings filed in paper over 100 sheets (excluding sequence listing or computer program listing filed in an electronic medium). The fee is \$270.00 for each additional 50 sheets of paper or fraction thereof.

Total Sheets	Extra Sheets	Number of each additional 50 or fraction thereof (round up to a whole number)	Rate	
- 100 =	/50 =		x \$270.00	\$

Surcharge of \$130.00 for furnishing the oath or declaration later than 30 months from the earliest claimed priority date (37 CFR 1.492(e)).

CLAIMS	NUMBER FILED	NUMBER EXTRA	RATE	
Total Claims	14 - 20 =	0	x \$ 52.00	\$
Independent claims	1 - 3 =	0	x \$220.00	\$
MULTIPLE DEPENDENT CLAIM(S) (if applicable)			+ \$390.00	\$
TOTAL OF ABOVE CALCULATIONS =				\$ 980.00

Applicant claims small entity status. See 37 CFR 1.27. The fees indicated above are reduced by 1/2.

SUBTOTAL = \$ 980.00

Processing fee of \$130.00 for furnishing the English translation later than 30 months from the earliest claimed priority date (37 CFR 1.492(f)).

TOTAL NATIONAL FEE = \$ 980.00

Fee for recording the enclosed assignment (37 CFR 1.21(h)). The assignment must be accompanied by an appropriate cover sheet (37 CFR 3.28, 3.31). \$40.00 per property.

TOTAL FEES ENCLOSED = \$ 980.00

	Amount to be refunded:	\$
	Amount to be charged:	\$

- a. A check in the amount of \$ _____ to cover the above fees is enclosed.
- b. Please charge my Deposit Account No. 50-2719 in the amount of \$980.00 to cover the above fees.
- c. The Commissioner is hereby authorized to charge any additional fees which may be required, or credit any overpayment to Deposit Account No. 50-2719.
- d. Fees are to be charged to a credit card. **WARNING:** Information on this form may become public. Credit card information should not be included on this form. Provide credit card information and authorization on PTO-2038.

NOTE: Where an appropriate time limit under 37 CFR 1.494 or 1.495 has not been met, a petition to revive (37 CFR 1.137(a) or (b)) must be filed and granted to restore the application to pending status.

SEND ALL CORRESPONDENCE TO:

 T. Daniel Christenbury, Reg. No. 31,750
 Date: July 28, 2011

Customer No. 035811, whose contact information is:
IP Group of DLA Piper LLP (US)
One Liberty Place, Suite 4900
1650 Market Street
Philadelphia, PA 19103
(215) 656-3381

Under the Paperwork Reduction Act of 1995, no persons are required to respond to a collection of information unless it contains a valid OMB control number.

Application Data Sheet 37 CFR 1.76		Attorney Docket Number	RUF-11-1270
		Application Number	
Title of Invention	BUTTON CELLS AND METHOD FOR PRODUCING SAME		
The application data sheet is part of the provisional or nonprovisional application for which it is being submitted. The following form contains the bibliographic data arranged in a format specified by the United States Patent and Trademark Office as outlined in 37 CFR 1.76. This document may be completed electronically and submitted to the Office in electronic format using the Electronic Filing System (EFS) or the document may be printed and included in a paper filed application.			

Secrecy Order 37 CFR 5.2

<input type="checkbox"/>	Portions or all of the application associated with this Application Data Sheet may fall under a Secrecy Order pursuant to 37 CFR 5.2 (Paper filers only. Applications that fall under Secrecy Order may not be filed electronically.)
--------------------------	---

Applicant Information:

Applicant 1					<input type="button" value="Remove"/>		
Applicant Authority		<input checked="" type="radio"/> Inventor		<input type="radio"/> Legal Representative under 35 U.S.C. 117		<input type="radio"/> Party of Interest under 35 U.S.C. 118	
Prefix	Given Name	Middle Name	Family Name		Suffix		
	Eduard		Pytlík				
Residence Information (Select One)		<input type="radio"/> US Residency		<input checked="" type="radio"/> Non US Residency		<input type="radio"/> Active US Military Service	
City	Ellwangen	Country Of Residenceⁱ	DE				
Citizenship under 37 CFR 1.41(b)ⁱ		DE					
Mailing Address of Applicant:							
Address 1		Alemannenstraße 7					
Address 2							
City	Ellwangen	State/Province					
Postal Code	73479	Countryⁱ	DE				
Applicant 2					<input type="button" value="Remove"/>		
Applicant Authority		<input checked="" type="radio"/> Inventor		<input type="radio"/> Legal Representative under 35 U.S.C. 117		<input type="radio"/> Party of Interest under 35 U.S.C. 118	
Prefix	Given Name	Middle Name	Family Name		Suffix		
	Jürgen		Lindner				
Residence Information (Select One)		<input type="radio"/> US Residency		<input checked="" type="radio"/> Non US Residency		<input type="radio"/> Active US Military Service	
City	Ellwangen	Country Of Residenceⁱ	DE				
Citizenship under 37 CFR 1.41(b)ⁱ		DE					
Mailing Address of Applicant:							
Address 1		Kottenwiesen 9					
Address 2							
City	Ellwangen	State/Province					
Postal Code	73479	Countryⁱ	DE				
Applicant 3					<input type="button" value="Remove"/>		
Applicant Authority		<input checked="" type="radio"/> Inventor		<input type="radio"/> Legal Representative under 35 U.S.C. 117		<input type="radio"/> Party of Interest under 35 U.S.C. 118	
Prefix	Given Name	Middle Name	Family Name		Suffix		
	Ulrich		Barenthin				
Residence Information (Select One)		<input type="radio"/> US Residency		<input checked="" type="radio"/> Non US Residency		<input type="radio"/> Active US Military Service	
City	Ellwangen	Country Of Residenceⁱ	DE				

Under the Paperwork Reduction Act of 1995, no persons are required to respond to a collection of information unless it contains a valid OMB control number.

Application Data Sheet 37 CFR 1.76		Attorney Docket Number	RUF-11-1270	
		Application Number		
Title of Invention	BUTTON CELLS AND METHOD FOR PRODUCING SAME			
Citizenship under 37 CFR 1.41(b) i	DE			
Mailing Address of Applicant:				
Address 1	Bahnhofstraße 6/1			
Address 2				
City	Ellwangen	State/Province		
Postal Code	73479	Country ⁱ	DE	
Applicant 4				<input type="button" value="Remove"/>
Applicant Authority	<input checked="" type="radio"/> Inventor	<input type="radio"/> Legal Representative under 35 U.S.C. 117	<input type="radio"/> Party of Interest under 35 U.S.C. 118	
Prefix	Given Name	Middle Name	Family Name	Suffix
	Winfried		Gaugler	
Residence Information (Select One) <input type="radio"/> US Residency <input checked="" type="radio"/> Non US Residency <input type="radio"/> Active US Military Service				
City	Ellwangen	Country Of Residence ⁱ	DE	
Citizenship under 37 CFR 1.41(b) i	DE			
Mailing Address of Applicant:				
Address 1	Birklen 26			
Address 2				
City	Ellwangen	State/Province		
Postal Code	73479	Country ⁱ	DE	
All Inventors Must Be Listed - Additional Inventor Information blocks may be generated within this form by selecting the Add button.				<input type="button" value="Add"/>

Correspondence Information:

Enter either Customer Number or complete the Correspondence Information section below. For further information see 37 CFR 1.33(a).	
<input type="checkbox"/> An Address is being provided for the correspondence information of this application.	
Customer Number	35811
Email Address	pto.phil@dlapiper.com <input type="button" value="Add Email"/> <input type="button" value="Remove Email"/>

Application Information:

Title of the Invention	BUTTON CELLS AND METHOD FOR PRODUCING SAME		
Attorney Docket Number	RUF-11-1270	Small Entity Status Claimed	<input type="checkbox"/>
Application Type	Nonprovisional		
Subject Matter	Utility		
Suggested Class (if any)		Sub Class (if any)	
Suggested Technology Center (if any)			
Total Number of Drawing Sheets (if any)	3	Suggested Figure for Publication (if any)	1

Under the Paperwork Reduction Act of 1995, no persons are required to respond to a collection of information unless it contains a valid OMB control number.

Application Data Sheet 37 CFR 1.76		Attorney Docket Number	RUF-11-1270
		Application Number	
Title of Invention	BUTTON CELLS AND METHOD FOR PRODUCING SAME		

Publication Information:

<input type="checkbox"/>	Request Early Publication (Fee required at time of Request 37 CFR 1.219)
<input type="checkbox"/>	Request Not to Publish. I hereby request that the attached application not be published under 35 U.S.C. 122(b) and certify that the invention disclosed in the attached application has not and will not be the subject of an application filed in another country, or under a multilateral international agreement, that requires publication at eighteen months after filing.

Representative Information:

Representative information should be provided for all practitioners having a power of attorney in the application. Providing this information in the Application Data Sheet does not constitute a power of attorney in the application (see 37 CFR 1.32). Enter either Customer Number or complete the Representative Name section below. If both sections are completed the Customer Number will be used for the Representative Information during processing.			
Please Select One:	<input checked="" type="radio"/> Customer Number	<input type="radio"/> US Patent Practitioner	<input type="radio"/> Limited Recognition (37 CFR 11.9)
Customer Number	35811		

Domestic Benefit/National Stage Information:

This section allows for the applicant to either claim benefit under 35 U.S.C. 119(e), 120, 121, or 365(c) or indicate National Stage entry from a PCT application. Providing this information in the application data sheet constitutes the specific reference required by 35 U.S.C. 119(e) or 120, and 37 CFR 1.78(a)(2) or CFR 1.78(a)(4), and need not otherwise be made part of the specification.			
Prior Application Status	Pending	<input type="button" value="Remove"/>	
Application Number	Continuity Type	Prior Application Number	Filing Date (YYYY-MM-DD)
	a 371 of international	PCT/EP2010/000787	2010-02-09
Additional Domestic Benefit/National Stage Data may be generated within this form by selecting the Add button.			<input type="button" value="Add"/>

Foreign Priority Information:

This section allows for the applicant to claim benefit of foreign priority and to identify any prior foreign application for which priority is not claimed. Providing this information in the application data sheet constitutes the claim for priority as required by 35 U.S.C. 119(b) and 37 CFR 1.55(a).			
<input type="button" value="Remove"/>			
Application Number	Country ⁱ	Parent Filing Date (YYYY-MM-DD)	Priority Claimed
10 2009 008 859.8	DE	2009-02-09	<input checked="" type="radio"/> Yes <input type="radio"/> No
<input type="button" value="Remove"/>			
Application Number	Country ⁱ	Parent Filing Date (YYYY-MM-DD)	Priority Claimed
10 2009 030 359.6	DE	2009-06-18	<input checked="" type="radio"/> Yes <input type="radio"/> No
<input type="button" value="Remove"/>			
Application Number	Country ⁱ	Parent Filing Date (YYYY-MM-DD)	Priority Claimed
10 2009 060 788.9	DE	2009-12-22	<input checked="" type="radio"/> Yes <input type="radio"/> No

Under the Paperwork Reduction Act of 1995, no persons are required to respond to a collection of information unless it contains a valid OMB control number.

Application Data Sheet 37 CFR 1.76		Attorney Docket Number	RUF-11-1270
		Application Number	
Title of Invention	BUTTON CELLS AND METHOD FOR PRODUCING SAME		

Additional Foreign Priority Data may be generated within this form by selecting the **Add** button.

Add

Assignee Information:

Providing this information in the application data sheet does not substitute for compliance with any requirement of part 3 of Title 37 of the CFR to have an assignment recorded in the Office.

Assignee 1

Remove

If the Assignee is an Organization check here.

Organization Name VARTA Microbattery GmbH

Mailing Address Information:

Address 1 Daimlerstraße 1

Address 2

City Ellwangen

State/Province

Country ⁱ DE

Postal Code

73479

Phone Number

Fax Number

Email Address

Additional Assignee Data may be generated within this form by selecting the **Add** button.

Add

Signature:

A signature of the applicant or representative is required in accordance with 37 CFR 1.33 and 10.18. Please see 37 CFR 1.4(d) for the form of the signature.

Signature	/TDC/	Date (YYYY-MM-DD)	2011-07-28
First Name	T. Daniel	Last Name	Christenbury
		Registration Number	31750

This collection of information is required by 37 CFR 1.76. The information is required to obtain or retain a benefit by the public which is to file (and by the USPTO to process) an application. Confidentiality is governed by 35 U.S.C. 122 and 37 CFR 1.14. This collection is estimated to take 23 minutes to complete, including gathering, preparing, and submitting the completed application data sheet form to the USPTO. Time will vary depending upon the individual case. Any comments on the amount of time you require to complete this form and/or suggestions for reducing this burden, should be sent to the Chief Information Officer, U.S. Patent and Trademark Office, U.S. Department of Commerce, P.O. Box 1450, Alexandria, VA 22313-1450. DO NOT SEND FEES OR COMPLETED FORMS TO THIS ADDRESS. **SEND TO: Commissioner for Patents, P.O. Box 1450, Alexandria, VA 22313-1450.**

Privacy Act Statement

The Privacy Act of 1974 (P.L. 93-579) requires that you be given certain information in connection with your submission of the attached form related to a patent application or patent. Accordingly, pursuant to the requirements of the Act, please be advised that: (1) the general authority for the collection of this information is 35 U.S.C. 2(b)(2); (2) furnishing of the information solicited is voluntary; and (3) the principal purpose for which the information is used by the U.S. Patent and Trademark Office is to process and/or examine your submission related to a patent application or patent. If you do not furnish the requested information, the U.S. Patent and Trademark Office may not be able to process and/or examine your submission, which may result in termination of proceedings or abandonment of the application or expiration of the patent.

The information provided by you in this form will be subject to the following routine uses:

1. The information on this form will be treated confidentially to the extent allowed under the Freedom of Information Act (5 U.S.C. 552) and the Privacy Act (5 U.S.C. 552a). Records from this system of records may be disclosed to the Department of Justice to determine whether the Freedom of Information Act requires disclosure of these records.
2. A record from this system of records may be disclosed, as a routine use, in the course of presenting evidence to a court, magistrate, or administrative tribunal, including disclosures to opposing counsel in the course of settlement negotiations.
3. A record in this system of records may be disclosed, as a routine use, to a Member of Congress submitting a request involving an individual, to whom the record pertains, when the individual has requested assistance from the Member with respect to the subject matter of the record.
4. A record in this system of records may be disclosed, as a routine use, to a contractor of the Agency having need for the information in order to perform a contract. Recipients of information shall be required to comply with the requirements of the Privacy Act of 1974, as amended, pursuant to 5 U.S.C. 552a(m).
5. A record related to an International Application filed under the Patent Cooperation Treaty in this system of records may be disclosed, as a routine use, to the International Bureau of the World Intellectual Property Organization, pursuant to the Patent Cooperation Treaty.
6. A record in this system of records may be disclosed, as a routine use, to another federal agency for purposes of National Security review (35 U.S.C. 181) and for review pursuant to the Atomic Energy Act (42 U.S.C. 218(c)).
7. A record from this system of records may be disclosed, as a routine use, to the Administrator, General Services, or his/her designee, during an inspection of records conducted by GSA as part of that agency's responsibility to recommend improvements in records management practices and programs, under authority of 44 U.S.C. 2904 and 2906. Such disclosure shall be made in accordance with the GSA regulations governing inspection of records for this purpose, and any other relevant (i.e., GSA or Commerce) directive. Such disclosure shall not be used to make determinations about individuals.
8. A record from this system of records may be disclosed, as a routine use, to the public after either publication of the application pursuant to 35 U.S.C. 122(b) or issuance of a patent pursuant to 35 U.S.C. 151. Further, a record may be disclosed, subject to the limitations of 37 CFR 1.14, as a routine use, to the public if the record was filed in an application which became abandoned or in which the proceedings were terminated and which application is referenced by either a published application, an application open to public inspections or an issued patent.
9. A record from this system of records may be disclosed, as a routine use, to a Federal, State, or local law enforcement agency, if the USPTO becomes aware of a violation or potential violation of law or regulation.

Description

Button cells and method for producing same

[0001] The present invention relates to button cells comprising two metallic housing half-parts, which are separated from one another by an electrically insulating seal and which form a housing with a flat bottom area and a flat top area parallel to it, as well as within the housing, an electrode-separator assembly comprising at least one positive and at least one negative electrode, which are in the form of flat layers and are connected to one another by at least one flat separator, and to a method for producing such button cells.

[0002] Button cells normally have a housing consisting of two housing half-parts, a cell cup and a cell top. By way of example, these may be produced from nickel-plated deep-drawn metal sheet as stamped and drawn parts. The cell cup normally has positive polarity, and the housing top negative polarity. The housing may contain widely differing electrochemical systems, for example zinc/MnO₂, primary and secondary lithium systems, or secondary systems such as nickel/cadmium or nickel/metal hydride.

[0003] By way of example, rechargeable button cells based on nickel/metal hydride or lithium-ion systems are in widespread use. In the case of lithium-ion button cells, the electrochemically active materials are normally not arranged within the button cell housing in the form of individual electrodes, in the form of tablets, separated from one another by a separator. Instead of this, prefabricated electrode-separator assemblies are preferably inserted flat into the housing. In this case, a porous plastic film is preferably used as a separator, onto which the electrodes are laminated or adhesively bonded flat. The entire assembly comprising the separator and the electrodes in this case generally has a maximum thickness of a few hundred

µm. In order to allow button cell housings of normal dimensions to be filled, a plurality of such assemblies are therefore frequently placed flat one on top of the other. This allows stacks of any desired height, in principle, to be produced, in each case matched to the available dimensions of the button cell housing into which the stack is intended to be installed. This ensures optimum utilization of the available area within the housing.

[0004] By virtue of the design, however, various problems also occur in the case of button cells which contain such stacks of electrode-separator assemblies. On the one hand, it is necessary, of course, for the electrodes of the same polarity each to be connected to one another within the stack, and then each to make contact with the corresponding pole of the button cell housing. The required electrical contacts result in material costs, and the space occupied by them is, furthermore, no longer available for active material. In addition, the production of the electrode stacks is complicated and expensive since faults can easily occur when the assemblies make contact with one another, increasing the scrap rate. On the other hand, it has been found that button cells having a stack of electrodes and separators very quickly start to leak.

[0005] Traditionally, button cells have been closed in a liquid-tight manner by beading the edge of the cell cup over the edge of the cell top in conjunction with a plastic ring, which is arranged between the cell cup and the cell top and at the same time acts as a sealing element and for electrical insulation of the cell cup and of the cell top. Button cells such as these are described, for example, in DE 31 13 309.

[0006] However, alternatively, it is also possible to manufacture button cells in which the cell cup and the cell top are held together in the axial direction exclusively by a force-fitting connection, and which do not have a beaded-over cup edge. Button cells such as these and methods for their production are described in the still unpublished German patent application

with the file reference 10 2009 017 514.8. Irrespective of the various advantages which button cells such as these without beading may have, they can, however, not be loaded as heavily in the axial direction as comparable button cells with a beaded-over cup edge, in particular with respect to axial mechanical loads which are caused in the interior of the button cell. For example, the electrodes of rechargeable lithium-ion systems are continually subject to volume changes during charging and discharging processes. The axial forces which occur in this case can, of course, lead to leaks more readily in the case of button cells without beading than in the case of button cells with beading.

[0007] The present invention was based on the object of providing a button cell in which the problems mentioned above do not occur, or occur only to a greatly reduced extent. In particular, the button cell is intended to be more resistant to mechanical loads which occur in the axial direction than conventional button cells, in particular even when they are manufactured as button cells without a beaded-over cup edge.

[0008] This object is achieved by the button cell having the features of claim 1. Preferred embodiments of the button cell according to the invention are defined in the dependent claims 2 to 10. The method according to claim 11 also contributes to the solution of the problem according to the invention. Preferred embodiments of the method according to the invention are defined in dependent claims 12 to 14. The wording of all the claims is hereby included by reference to the content of this description.

[0009] A button cell according to the invention always comprises two metallic housing half-parts, which are separated from one another by an electrically insulating seal and form a housing with a flat bottom area and a flat top area parallel to it. As already mentioned initially, the two housing half-parts are generally a so-called housing cup and a housing top. In particular, parts

composed of nickel-plated steel or metal sheet are preferred as housing half-parts. Furthermore, trimetals, for example with the sequence of nickel, steel (or stainless steel) and copper (with the nickel layer preferably forming the outer layer and the copper layer preferably forming the inside of the button cell housing) are particularly suitable for use as the metallic material.

[0010] By way of example, an injection-molded or film seal can be used as a seal. The latter are described, for example, in DE 196 47 593.

[0011] Within the housing, a button cell according to the invention comprises an electric-separator assembly with at least one positive and at least one negative electrode. These are each in the form of flat electrode layers. The electrodes are connected to one another via a flat separator. The electrodes are preferably laminated or adhesively bonded onto this separator. The electrodes and the separator generally each have thicknesses only in the μm range. In general, a porous plastic film is used as the separator.

[0012] In contrast to the button cells mentioned initially, the button cell according to the invention is distinguished in particular by the electrode layers having a very particular orientation, specifically being aligned essentially at right angles to the flat bottom and top areas. While button cells known from the prior art with stacked electrode-separator assemblies always contain these assemblies inserted flat, such that the electrode layers are aligned essentially parallel to the flat bottom and top areas, the situation in a button cell according to the invention is the opposite of this.

[0013] The right-angled alignment of the electrode layers has an unexpectedly considerable advantage, specifically because it has been found that this alignment results in a considerable improvement in the sealing characteristics of a button cell according to the invention, particularly for button cells based on lithium-ion systems. The electrodes of rechargeable lithium-ion

systems are continually subject to volume changes during charging and discharging processes. Volume changes such as these also occur, of course, in the electrodes of a button cell according to the invention. However, the mechanical forces which are created during this process no longer act primarily axially, as in the case of a stack of electrode-separator assemblies which are inserted flat. Because of the right-angled alignment of the electrodes, they in fact act radially. Radial forces can be absorbed very much better than axial forces by the housing of a button cell. The improved sealing characteristics are presumably a result of this.

[0014] Particularly preferably, the electrodes and the flat separator of a button cell according to the invention are each in the form of strips or ribbons. By way of example, the production of a button cell according to the invention can be based on a separator material in the form of an endless ribbon, onto which the electrodes are applied, in particular laminated, once again in particular in the form of strips or at least rectangles.

[0015] In the housing of a button cell according to the invention, this assembly is particularly preferably in the form of a winding, in particular in the form of a spiral winding. Windings such as these can be produced very easily using known methods (see for example DE 36 38 793), by applying the electrodes flat, in particular in the form of strips, to a separator which is in the form of an endless ribbon, in particular by laminating them on. In this case, the assembly comprising electrodes and separators is generally wound onto a so-called winding mandrel. Once the winding has been removed from the winding mandrel an axial cavity remains in the center of the winding. This allows the winding to expand into this cavity, if necessary. However, in some circumstances, this can lead to problems in making electrical contact between the electrodes and the metallic housing half-parts, and this will be described in more detail in the following text.

[0016] The electrode winding is preferably arranged within a button cell according to the invention (in order that the electrode layers of the winding are aligned at right angles to the flat bottom area and top area of the housing), such that the end faces of the winding face in the direction of the flat bottom area and of the flat top area.

[0017] According to the present invention, preferred embodiments of the button cell according to the invention have a fixed winding core in the center of the winding, which at least partially fills the axial cavity in the center of the winding. A winding core such as this fixes the electrode winding in the radial direction and prevents possible implosion of the winding into the axial cavity. When the winding expands in this way, this also results in the reduction in the pressure which the end faces of the winding exert in the axial direction, and therefore in the direction of output conductors which may be arranged there (this is described in more detail further below). If this is prevented, then there are generally also no problems with making electrical contact between the electrodes and the metallic housing half-parts.

[0018] In addition, a winding core such as this also makes the button cell according to the invention more robust against external mechanical influences. In general, it is no longer possible for the electrode winding in the button cell to be damaged by external mechanical pressure in the axial direction.

[0019] According to the preferred embodiment of the electrode winding as a spiral electrode winding, the axial cavity which has been mentioned in the center of the winding is preferably essentially cylindrical (in particular circular-cylindrical). On the casing side, it is bounded by the winding, and at the end it is bounded by corresponding surfaces of the bottom area and of the top area of the button cell housing.

[0020] Correspondingly, the winding core which is contained in a button cell according to the invention is preferably also in the form of a cylinder, in particular a hollow cylinder. The height of a cylinder such as this preferably corresponds to the respective distance between the flat bottom area and the flat top area, which is parallel to it.

[0021] In particularly preferred embodiments, the winding core may have radially self-expanding characteristics. For example, it is possible for the winding core to be inserted in a radially compressed configuration into the axial cavity in the winding of a button cell according to the invention. When the radially compressed winding core expands, it exerts a radial pressure on the electrode winding surrounding it, thus ensuring a contact pressure in the axial direction as well.

[0022] By way of example, an axially slotted hollow cylinder may be used as a radially self-expanding winding core. However, alternatively, it is also conceivable to use other radially self-expanding materials, for example based on plastic.

[0023] Particularly preferably, the winding core is composed of a metal such as stainless steel or plastic.

[0024] Particularly preferably, the assembly comprising electrodes and a separator in a button cell according to the invention has one of the following layer sequences:

- negative electrode/separator/positive electrode/separator
- or
- positive electrode/separator/negative electrode/separator.

[0025] Assemblies such as these can be produced and wound very easily without short circuits occurring between electrodes of opposite polarity.

[0026] The separators which can be used in a button cell according to the invention are preferably films composed of at least one plastic, in particular of at least one polyolefin. By way of example, the at least one polyolefin may be polyethylene. However, it is also possible to use multilayer separators, for example separators composed of a sequence of different polyolefin layers, for example with the sequence polyethylene/polypropylene/polyethylene.

[0027] It is not essential to use a plurality of separate separators in order to produce assemblies with the abovementioned sequence. In fact, a separator can also be looped around the end of one of the electrodes, thus resulting in both sides of this electrode being covered by the separator.

[0028] The separators which can preferably be used in a button cell according to the invention preferably have a thickness of between 3 μm and 100 μm , in particular of between 10 μm and 50 μm .

[0029] The electrodes of a button cell according to the invention preferably have a thickness of between 10 μm and 1000 μm , in particular of between 30 μm and 500 μm .

[0030] In preferred embodiments of a button cell according to the invention, the negative electrode and the positive electrode in the electrode-separator assembly are arranged offset with respect to one another within the assembly. In this case, an offset arrangement is intended to mean that the electrodes are arranged such that this results in a respectively different separation between the electrodes and the flat bottom and top areas in the button cell according to the invention. In the simplest case, for example, a positive and a negative electrode can be slightly offset as strips of the same width applied to the opposite sides of a separator ribbon, as a result of which the distance between the positive electrode and the upper separator edge is greater than the

comparable distance measured from the negative electrode. This then applies in the opposite sense, of course, to the distance from the lower separator edge.

[0031] In particularly preferred embodiments, preferably as a result of this offset arrangement, the positive electrode, in particular an edge of the positive electrode, rests directly on the cup part, in particular in the flat bottom area of the cup part, while the negative electrode, in particular an edge of the negative electrode, rests directly on the top part, in particular in the flat top area of the top part. In this embodiment, a direct electrical and mechanical contact is made between the electrodes and the cup and top parts. The offset arrangement of the electrodes with respect to one another therefore makes it possible for the electrodes to make contact with the respective housing parts, without any need to use additional electrical contacts and connecting means.

[0032] However, in alternative preferred embodiments, it is also preferable for at least one of the electrodes, preferably both the at least one negative electrode and the at least one positive electrode, in a button cell according to the invention, to be connected to the flat bottom and top areas via one or more output conductors. By way of example, the output conductors may be output-conductor lugs composed of copper or some other suitable metal. On the electrode side, the output conductors may, for example, be connected to a current collector. The output conductors can be connected to the housing and/or to the current collectors by, for example, welding or via an clamped joint.

[0033] In the simplest case, the current collectors of the positive and negative electrodes can also themselves act as output conductors. Collectors such as these are generally metallic films or meshes which are embedded in the respective electrode material. Uncovered subareas, in

particular end pieces, of collectors such as these can be bent around and can be brought into contact with the button cell housing.

[0034] The use of output conductors may be particularly advantageous if the negative electrode and the positive electrode within the assembly are arranged with respect to one another such that this results in the electrodes each being at the same distance from the flat bottom and top areas. Or, in other words, if the electrodes are not arranged offset with respect to one another within the electrode-separator assembly, as has been described above.

[0035] However, if the distance between electrodes of opposite polarity and the flat bottom and top areas is the same, this results in the risk of a positive and a negative electrode touching the metallic cup or top part at the same time, thus resulting in a short circuit. In preferred embodiments, the button cell according to the invention may therefore comprise at least one insulating means, which prevents a direct mechanical and electrical contact between the end faces of the winding and the flat bottom and top areas.

[0036] In one development, it is preferable for the electrodes in a button cell according to the invention such as this to be connected via the already mentioned separate output conductors to the flat bottom and top areas. These ensure the electrical contact between the electrodes and the housing.

[0037] In this case, it is preferable for at least a subsection of the output conductor or conductors in the bottom area and in the top area of the housing to rest flat on the inside of the housing half-parts. Ideally, the output conductors naturally make electrical contact with the insides of the housing when they are at least slightly pressed against the housing (if they are not welded to it in any case). This can be achieved surprisingly efficiently by a suitable arrangement of the winding core that has been mentioned, in a button cell according to the invention.

[0038] By way of example, the insulating means may be a flat layer composed of plastic, for example a plastic film, which is arranged between the end faces of the winding and the flat bottom and top areas of the housing of a button cell according to the invention.

[0039] Corresponding to the above statements, the button cell according to the invention is, in particular, a rechargeable button cell. A button cell according to the invention particularly preferably has at least one lithium-intercalating electrode.

[0040] The ratio of the height to the diameter of button cells is, by definition, less than 1. For a button cell according to the invention, this ratio is particularly preferably between 0.1 and 0.9, in particular between 0.15 and 0.7. In this case, the height means the distance between the flat bottom area and the flat top area parallel to it. The diameter means the maximum distance between two points on the casing area of the button cell.

[0041] The button cell according to the invention is particularly preferably a button cell which is not beaded over, as is described in the patent application with the file reference 10 2009 017 514.8, which has already been mentioned in the introduction. Correspondingly, there is preferably an exclusively force-fitting connection between the housing half-parts. Therefore, the button cell according to the invention does not have a beaded-over cup edge, as is always the case with button cells known from the prior art. The button cell is closed without being beaded over.

[0042] Button cells such as these which are not beaded over generally make use of conventional cell cups and cell tops, which each have a bottom area and a top area, a casing area, an edge area which is arranged between the bottom and top areas and the casing area, and a cut edge. Together, the cell cup and cell top form a housing, which forms a receptacle for the conventional internal components of a button cell, such as electrodes, separator etc. As in the

normal way, the bottom area of the cell cup and the top area of the cell top are aligned essentially parallel to one another in this housing. The casing areas of the cell cup and cell top in the finished button cell are aligned essentially at right angles to the bottom and top areas, and preferably have an essentially cylindrical geometry. The internal and external radii of the cell cup and cell top are preferably essentially constant in the casing areas. The edge areas, which have been mentioned, of the cell cup and cell top form the transition between the casing areas and the top and bottom areas. They are preferably therefore bounded on the one hand by essentially flat bottom and top areas, and on the other hand by the essentially cylindrical casing areas, which are arranged at right angles to them. By way of example, the edge areas may be in the form of a sharp edge, or else may be rounded.

[0043] The procedure for producing a button cell which is not beaded over is generally to first of all apply a seal to the casing area of a cell top. In a further step, the cell top is then inserted, with the seal fitted, into a cell cup thus resulting in an area in which the casing areas of the cell cup and cell top overlap. The size of the overlap area and the ratio of the overlapping area to the non-overlapping areas are in this case governed by the respective height of the casing areas of the cell cup and cell top, and by the depth of the insertion. With regard to the casing area of the cell top, it is preferable for between 20% and 99%, in particular between 30% and 99%, particularly preferably between 50% and 99%, to overlap the casing area of the cell cup (the percentages each relate to the height of the casing or of the casing area). Before being inserted into the housing cup and/or the housing top, the other conventional components of a button cell (electrodes, separator, electrolyte etc.) are inserted. After the cell top has been inserted completely into the cell cup a pressure is exerted on the casing area of the cell cup, in particular in the area of the cut edge, in order to seal the housing. In this case, a joined-together

housing part should as far as possible not be subjected to any loads, or only to very small loads, in the axial direction. Therefore, the pressure is applied in particular radially. Apart from the sealing of the housing which has already been mentioned the external diameter of the cell housing can therefore also be calibrated.

[0044] It is particularly important for the heights of the casing areas of the cell cup and cell top to be matched to one another such that the cut edge of the cell cup is pressed against the casing area of the cell top by the pressure on the casing area of the cell cup. The heights of the casing areas are therefore preferably chosen such that it is impossible to bend the cut edge of the cell cup around inward over the edge area of the cell top which has been completely inserted into the cell cup. Correspondingly, the edge of the cell cup is not beaded over the edge area of the cell top. In consequence, the cell cup of a button cell manufactured using the method according to the invention has a casing area with an essentially constant radius in the direction of the cut edge.

[0045] In the case of button cells produced using a method such as this, there is preferably an exclusively force-fitting connection between the housing components comprising the cell cup, the cell top and the seal. This ensures that the components are therefore held together in a preferred manner, essentially only by static-friction force.

[0046] Button cells without any beading over are particularly preferably produced using a cell cup which is conical at least in one subarea of its casing, such that at least its internal diameter increases in the direction of the cut edge. This makes it considerably easier to insert the cell top into the cell cup. The dimensions of the cell cup and cell top are preferably matched to one another such that relatively large opposing forces preferably do not occur until the top has

been inserted virtually completely into the cup. The cone angle in this case is preferably between 10 minutes and 3°, in particular between 30 minutes and 1° 30 minutes.

[0047] The cell top, which is inserted into the cell cup with the applied seal, is cylindrical, at least in a part of the casing area, in preferred embodiments. This may relate in particular to that part of the casing area which overlaps the conical subarea of the cell cup casing that has been mentioned, after the cell top has been inserted into the cell cup. The casing of the cell top, and therefore also the casing area, is particularly preferably entirely cylindrical. The cell top therefore preferably has a constant external radius in the casing area. This may relate in particular to that part which overlaps the conical part of the casing area of the cell cup after the cell top has been inserted.

[0048] When a cell top with a cylindrical casing area is being inserted into a cell cup which is conical at least in one subarea of its casing, as has been described above, a gap which is open at the top is generally created between the cell cup and the cell top. This gap is generally closed again by the pressure on the casing area of the cell cup. Thus, the pressure on the casing area of the cell cup may be chosen such that the conical part of the casing area of the cell cup is pushed inward until the inside of the cell cup and the outside of the cell top are essentially at the same distance from one another in the overlapping area. The resultant button cell has casing areas which are aligned parallel to one another, in particular in the overlapping area.

[0049] One important aspect in this case is the choice of the seal which connects the cell cup to the cell top. The seal is preferably a plastic seal which connects the cell cup to the cell top. The seal is preferably a plastic seal composed of a thermoplastic.

[0050] The plastic seal is particularly preferably a film seal, for example as is described in the already cited DE 196 47 593, in particular a film seal composed of a thermoplastic.

[0051] Film seals can be produced with a very uniform thickness. When a suitable pressure is applied to the casing area of the cell cup, this results in an interference fit, as a consequence of which the button cell that has been produced has highly excellent sealing characteristics. Not least, the use of film seals makes it possible to dispense with the edge of the cell cup being beaded over without this on the other hand resulting in a need to accept disadvantages in other important characteristics.

[0052] It is very particularly preferable to use plastic seals, in particular plastic films, based on polyamide or based on polyether ether ketones in the present case.

[0053] It is preferable for the seal for a cell which is not beaded over to have an initial thickness in the range between 50 μm and 250 μm , particularly preferably between 70 μm and 150 μm , in particular about 100 μm . The term "initial thickness" is in this case intended to mean the thickness of the seal before it is applied to the casing of the cell top. In contrast to this, the term "final thickness" is intended to mean the thickness of the seal in the finished cell. It is clear that, at least in the overlapping area, this generally corresponds to the distance between the inside of the cell cup and the outside of the cell top.

[0054] In order to allow a sufficiently large amount of friction to be produced between the cell cup and the cell top, both the external and internal radii of the cup and top should be matched to one another and to the thickness of the film seal. This is the only way to create a sufficiently high contact pressure to hold the two individual parts together. It is preferable for the parts used in this case for the difference between the external radius of the cell top, which is to be inserted into the cell cup, on the cut edge of the cell top and the smallest internal radius of the cell cup in that part of the casing area which overlaps the casing area of the cell top to be less than the initial thickness of the seal that is used. The difference is particularly preferably

between 10% and 90% of the initial thickness, in particular between 30% and 70%, and very particularly preferably about 50%.

[0055] After the cell top has been inserted into the cell cup, a part of the casing area of the cell cup can be drawn radially inward. In particular, this relates to that part of the casing area which does not overlap the casing area of the cell top.

[0056] It has been found that this process of drawing in radially makes it possible to achieve considerably better sealing characteristics. Drawing in the cup casing results in a radial pressure being exerted on the edge section which rests on the inner wall of the housing cup and on the seal which is arranged between the housing top and the housing cup, with the seal in consequence being compressed in this area.

[0057] The drawing-in process can be carried out at the same time as the already mentioned exertion of pressure on the casing area of the cell cup, although the drawing-in process is preferably carried out in a subsequent, separate step.

[0058] The method according to the invention for producing a button cell can be used in particular to produce button cells as have been described above, that is to say button cells having a housing with a flat bottom area and a flat top area parallel to it. It is suitable for producing not only button cells which are not beaded over, but also for those which are beaded over.

[0059] With respect to the preferred embodiments of the individual components which are used in the method according to the invention (housing parts and dimensions, electrodes, separator etc.), reference can therefore be made to the above statements and explanations in their entirety.

[0060] In general, the housing is assembled from a metallic cup part (housing cup) and a metallic top part (housing top), with an electrode-separator assembly with electrodes in the form

of a flat layer being inserted into the housing such that the electrodes are aligned at right angles to the flat bottom area and top area.

[0061] As already mentioned, the electrode-separator assembly is preferably installed in the form of a winding, in particular a spiral winding.

[0062] In general, the method according to the invention always comprises the following steps:

- insertion of the winding into the metallic top part, and
- insertion of the metallic top part with the winding into a metallic cup part.

[0063] The edge of the cup part is then optionally beaded over the edge of the top part.

[0064] When a button cell which is not beaded over is produced, the corresponding steps as described above are carried out.

[0065] Before the housing is closed, the electrodes are normally also impregnated with electrolyte solution.

[0066] For the insertion process, the winding is preferably rolled up on a winding mandrel. After or during the insertion process, the winding mandrel can then be removed. If required, the winding core that has been mentioned above is then inserted. Alternatively, the electrode-separator assembly can also be wound directly onto a core such as this.

[0067] The spiral winding is particularly preferably heat-treated on its end faces before being installed. In this case, it is at least briefly subjected to a temperature at which the separator in the winding is thermoplastically deformable. In general, the separator projects somewhat on the end faces of the winding, and this is itself subject to the precondition that the electrodes are arranged with the offset with respect to one another, as described above. The heat treatment allows the

separator to be shrunk together somewhat, therefore, if required, even exposing the edge of an adjacent electrode, such that this can rest directly on the button cell housing.

[0068] The stated advantages and further advantages of the invention will become evident from the description which now follows of the drawings in conjunction with the dependent claims. In this case, the individual features of the invention may be implemented on their own or in combination with one another. The described embodiments are intended only for explanation and for better understanding of the invention, and should in no way be understood as being restrictive.

Description of the figures

[0069] Figure 1 schematically illustrates the cross section through one preferred embodiment of a button cell according to the invention.

[0070] Figure 2 illustrates the effect of heat treatment of a wound-up electrode-separator assembly, which is used in preferred embodiments of the method according to the invention.

[0071] Figure 3 shows an electrode-separator assembly in the form of a winding, as can be installed in a button cell according to the invention.

[0072] Figure 4 shows a section illustration of a further preferred embodiment of a button cell according to the invention.

[0073] Figure 5 schematically illustrates the cross section through one preferred embodiment of a button cell according to the invention, in which the edge of the cell cup is not beaded over the edge of the cell top.

[0074] Figure 1 schematically illustrates the cross section through one preferred embodiment of a button cell 100 according to the invention. This has a metallic cup part 101 and metallic top part 102. The two parts are connected to one another, sealed by means of a seal 109. Together,

they form a housing with a flat bottom area 103 and a flat top area 104 parallel to it. When in use, these flat areas 103 and 104 form the poles of the button cell, from which current can be drawn by a load. The edge 110 of the cell cup 101 is beaded inward over the edge of the cell top 102.

[0075] An arrangement comprising an electrode 105 in the form of a strip, an electrode 106 in the form of a strip, and the separators 107 in the form of strips is arranged in the interior of the electrode. The assembly comprising the electrodes 105 and 106 as well as the separators 107 is in this case in the form of a winding, whose end faces abut against the flat bottom area 103 and the flat top area 104, which is parallel to it. The assembly is wound up on the core 108 in the center of the button cell 100. Both the core 108 as well as the electrodes and separators which are wound around it are aligned at right angles to the flat bottom and top areas 104 and 103. When the volume of the electrodes increases or decreases during a charging or discharging process, the mechanical forces which result in this case act predominantly radially, and can be absorbed by the casing area of the button cell 100.

[0076] It should be stressed that the positive electrode 105 and the negative electrode 106 respectively rest directly on the cup part 101 and on the top part 102 of the button cell 100. There is no need for a separate output conductor for connecting the electrodes to the top part 102 and to the cup part 101.

[0077] Figure 2 shows the effect of the heat treatment of an electrode-separator winding 200, which is provided in preferred embodiments of the method according to the invention for producing a button cell. The illustration schematically shows a winding 200 comprising an assembly of a positive electrode 201 (bar with cross strips), a negative electrode 202 (white bar) and the separators 203 (detail). The positive and the negative electrodes 201 and 202 are in each

case arranged offset with respect to one another. The separators 203 are composed of a thermoplastically deformable material.

[0078] When the separator edges which are located on the end faces 204 and 205 of the winding 200 are subjected to a high temperature (for example of 250°C, as illustrated), then these separator edges shrink. The separators are drawn in at least partially between adjacent electrodes. In the process, the edges of the negative electrode 202 are exposed on the end face 204, while the edges of the positive electrode 201 are covered. The edges of the positive electrode 201 on the end face 205 are exposed, while the edges of the negative electrode 202 are covered.

[0079] When a winding that has been treated in this way is in use, this ensures that electrodes of the same polarity can each rest directly only on the housing cup or on the housing top. There is no need for separate electrical connections between the electrodes and the housing parts.

[0080] Figure 3 shows an electrode-separator assembly for button cells according to the invention, in the form of a winding 300, with the illustration A depicting a plan view vertically from above at one of the end faces 301 of the winding 300, while the illustration B shows the winding 300 in a view obliquely from above. In both cases, this shows that the assembly comprises two layers; separators 302 and 303 as well as two electrode layers 304 and 305 (a positive and a negative electrode). The assembly is wound up in a spiral shape and is held together by an adhesive tape 306 on its outside.

[0081] Figure 4 shows a sectioned illustration of one preferred embodiment of a button cell 400 according to the invention. The figure shows the housing of the button cell comprising the cup part 401 and the top part 402, between which the seal 403 is arranged. An assembly of electrodes and separators, as is illustrated in Figure 3, is contained as a spiral winding 404

(illustrated schematically in the cross section) within the housing. The separator layers 405 and 406 as well as the electrodes 407 and 408 of opposite polarity can also be seen well here. In this case, the electrode 407 is connected via the output conductor 410 to the top part 402, while the electrode 408 is connected via the output conductor 409 to the cup part 402. The output conductor 410 is preferably welded to the top part 402. In contrast, the output conductor 409 is connected to the cup part 402 via a clamping connection (it is clamped inbetween the supporting ring 413, on which the edge of the cell top rests, and the bottom of the cell cup). The insulating means 411 and 412 are arranged between the end faces of the winding and the cup part 401 and the top part 402, and are each in the form of thin plastic disks. This prevents electrodes of opposite polarity from being able to come into contact with the cup part 401 or the top part 402 at the same time. This prevents any short circuit.

[0082] Figure 5 schematically illustrates the cross section through one preferred embodiment of a button cell 500 according to the invention.

[0083] This button cell 500 has a metallic cup part 501 and a metallic top part 502. The two parts are connected to one another, sealed by means of a seal 510. Together, they form a housing with a flat bottom area 503 and a flat top area 504 parallel to it. When in use, these flat areas 503 and 504 form the poles of the button cell, from which current can be drawn by a load.

[0084] The cell top 502 is inserted into the cell cup 501 such that the casing areas of the cell top and of the cell cup overlap, with the internal radius of the cell cup 501 in the overlapping area being essentially constant in the direction of the cut edge. Therefore, the edge of the cell cup 501 is not beaded over the edge 511 of the cell top 502, and the preferred embodiment described above for a button cell 500 according to the invention is therefore a button cell which is not beaded over.

[0085] An assembly comprising an electrode 508 in the form of a strip, an electrode 509 in the form of a strip and separators 507 in the form of strips is arranged in the interior of the electrode. The assembly comprising the electrodes 508 and 509 as well as the separators 507 is in this case in the form of a winding, whose end faces face in the direction of the flat bottom area 503 and of the flat top area 504 which is parallel to it. The assembly is wound up on the winding core 512 in the center of the button cell 500. Both the core 512 and the electrodes and separators which are wound around it are aligned at right angles to the flat bottom and top areas 504 and 503. If the volume of the electrodes increases or decreases during a charging or discharging process, the mechanical forces which result in this case act predominantly radially, and can be absorbed by the casing area of the button cell 500.

[0086] The positive and the negative electrodes make contact with the housing half-part comprising the cup and top via the output conductor 505 and the output conductor 506. The output conductor 505 is composed of aluminum, and the output conductor 506 is composed of nickel (or alternatively of copper). Both output conductors are thin films, which rest flat between the end faces of the winding and the flat top and bottom areas 503 and 504. A continuous slight contact pressure is maintained on the output conductors by the winding core 512. The output conductors are preferably separated from the end faces of the winding by a separate insulator arrangement (not illustrated in the drawing), for example by a thin film.

Patent Claims

1. A button cell (100; 400; 500), comprising
 - two metallic housing half-parts (101, 102; 401, 402; 501, 502), which are separated from one another by an electrically insulating seal (109; 403; 510) and which form a housing with a flat bottom area (103; 503) and a flat top area (104; 504) parallel to it, as well as
 - within the housing, an electrode-separator assembly comprising at least one positive and at least one negative electrode (105, 106; 201, 202; 304, 305; 407, 408; 508, 509), which are in the form of flat layers and are connected to one another by at least one flat separator (107; 203; 302, 303; 405, 406; 507),
with the electrode layers being aligned essentially at right angles to the flat bottom and top areas.

2. The button cell as claimed in claim 1, characterized in that the electrodes and/or the separator are/is in the form of strips or ribbons.

3. The button cell as claimed in claim 1 or claim 2, characterized in that the electrode-separator assembly is in the form of a winding (200; 300; 404), in particular a spiral winding, whose end faces (204, 205; 301) face in the direction of the flat bottom area and the flat top area.

4. The button cell as claimed in claim 3, characterized in that the winding has an axial cavity in its center, which axial cavity is at least partially filled by a winding core (108; 512).

5. The button cell as claimed in one of the preceding claims, characterized in that the electrode-separator assembly has one of the following layer sequences:

- negative electrode/separator/positive electrode/separator
- positive electrode/separator/negative electrode/separator

6. The button cell as claimed in one of the preceding claims, characterized in that the positive electrode (408; 509) and/or the negative electrode (407; 508) are/is connected via an output conductor (409, 410; 505, 506) to the housing in the area of the flat bottom area and/or of the flat top area.

7. The button cell as claimed in one of claims 3 to 6, characterized in that the button cell comprises at least one insulating means (413, 414), which prevents direct mechanical and electrical contact between the end faces of the winding and the flat bottom and top areas.

8. The button cell as claimed in claim 7, characterized in that the at least one insulating means (413, 414) is a flat layer composed of plastic, for example a plastic film, which is arranged between the end faces of the winding and the flat bottom and top areas.

9. The button cell as claimed in one of the preceding claims, characterized in that the button cell is rechargeable.

10. The button cell as claimed in one of the preceding claims, characterized in that the button cell has a height:diameter ratio of < 1 , preferably between 0.1 and 0.9, in particular between 0.15 and 0.7.

11. A method for producing a button cell, in particular a button cell (100; 400; 500) according to one of the preceding claims, with a housing being fitted which is composed of metallic housing half-parts, in particular a metallic cup part (101; 401; 501) and a metallic top part (102; 402; 502), said housing having a flat bottom area (103; 503) and a flat top area (104; 504) parallel to it, and with an electrode-separator assembly with electrodes (105, 106; 201, 202; 304, 305; 407, 408; 508, 509) in the form of a flat layer being inserted into the housing such that the electrode layers are aligned essentially at right angles to the flat bottom and top areas (103, 104; 503, 504).

12. The method as claimed in claim 11, characterized in that the electrode-separator assembly is inserted as a winding (200; 300; 404), in particular as a spiral winding.

13. The method as claimed in claim 12, comprising the following steps:
- insertion of the winding (200; 300; 404) into the metallic top part (102; 402; 502),
 - insertion of the metallic top part with the winding into a metallic cup part (101; 401; 501),
 - possibly, beading over the edge of the cup part.

14. The method as claimed in claim 12 or 13, characterized in that the winding (200; 300; 404) is heat-treated on its end faces (204, 205; 301) before being installed, with it being at least greatly subjected to a temperature at which the separator (107; 203; 302, 303; 405, 406; 507) is thermoplastically deformable.

Abstract

A button cell (100; 400; 500) is described, comprising two metallic housing half-parts (101, 102; 401, 402; 501, 502), which are connected to one another forming a seal, and form a housing with a flat bottom area (103; 503) and a flat top area (104; 504) parallel to it, with positive and negative electrodes (105, 106; 201, 202; 304, 305; 407, 408; 508, 509) in the form of flat layers being arranged within the housing and being connected to one another via a flat separator (107; 203; 302, 303; 405, 406; 507), with the electrode layers being aligned essentially at right angles to the flat bottom and top areas. A method is also described for producing a button cell such as this.

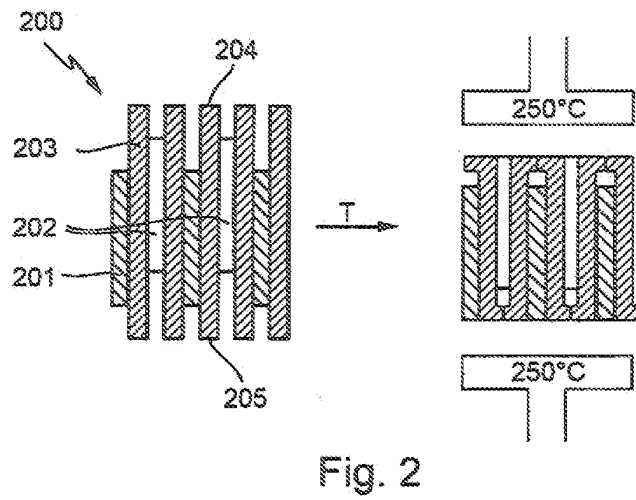
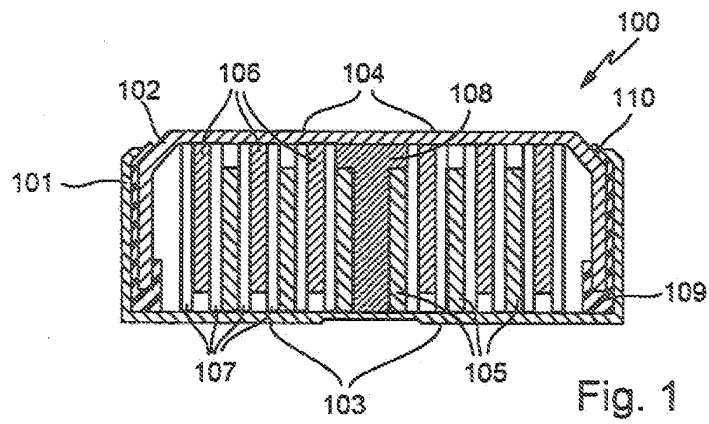

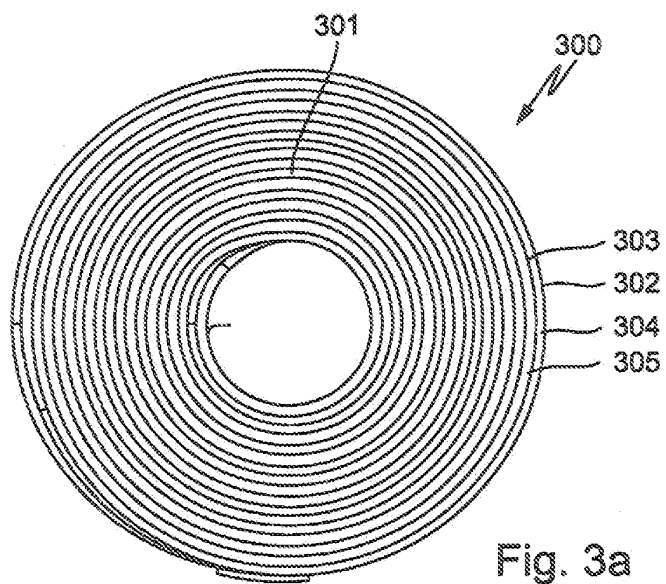

Fig. 3a

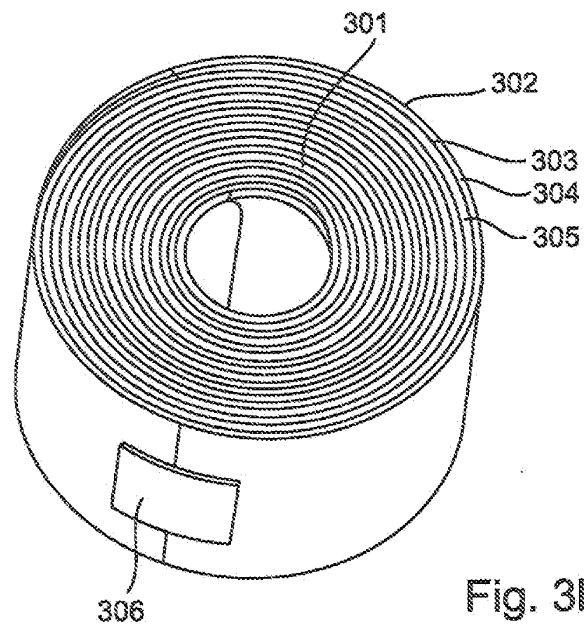

Fig. 3b

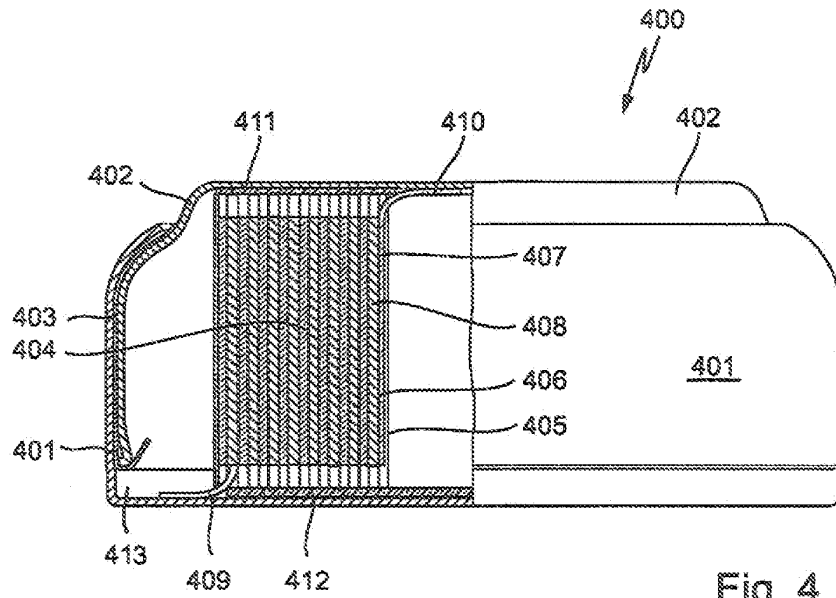

Fig. 4

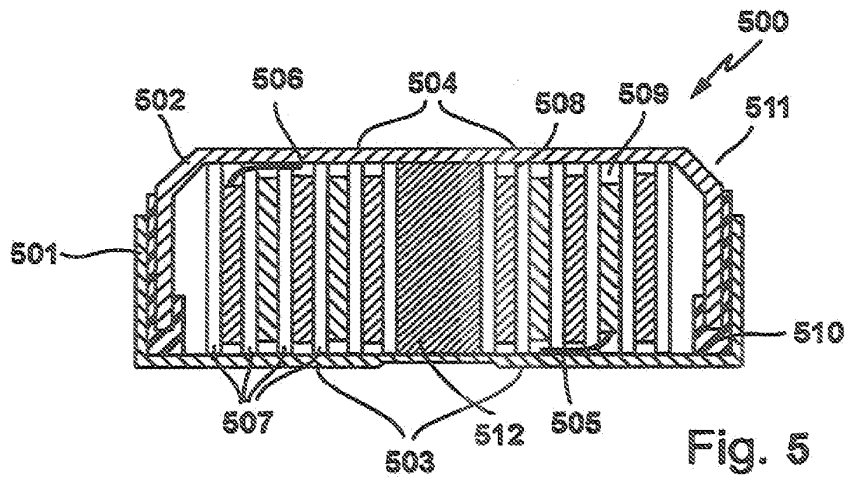

Fig. 5

IN THE UNITED STATES PATENT AND TRADEMARK OFFICE

Art Unit : Customer No.: 035811
Examiner :
Serial No. :
Filed : Herewith
PCT No. : PCT/EP2010/000787
PCT Filed : February 9, 2010
Inventors : Eduard Pytlik Docket No.: RUF-11-1270
 : Jürgen Lindner Confirmation No.:
 : Ulrich Barenthin
 : Winfried Gaugler
Title : BUTTON CELLS AND METHOD
 : FOR PRODUCING SAME
Dated: July 28, 2011

PRELIMINARY AMENDMENT

Mail Stop PCT
Commissioner for Patents
P.O. Box 1450
Alexandria, VA 22313-1450

Sir:

Prior to action on the merits, the Applicants respectfully request consideration of the following amendments and remarks:

Remarks

The Applicants have amended the Title and have amended the Specification to provide related application information and to place the Application into proper condition for examination. No new matter has been added. A Substitute Specification (marked-up and clean copies) is enclosed. Also, the Abstract (clean copy attached) has been amended and the Claims have been amended to remove improper multiple dependencies and to place them into proper form. Entry of the amendments into the Official File and consideration on the merits is respectfully requested.

Passage to the appropriate art unit for examination on the merits is respectfully requested.

Respectfully submitted,

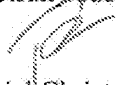

T. Daniel Christenbury
Reg. No. 31,750
Attorney for Applicants

TDC/lh
(215) 656-3381

SUBSTITUTE SPECIFICATION (Marked-Up)

Description

~~Button cells and method for producing same~~BUTTON CELLS AND METHOD FOR PRODUCING SAME

Related Applications

[0001] This is a §371 of International Application No. PCT/EP2010/000787, with an international filing date of February 9, 2010 (WO 2010/089152 A1, published August 12, 2010), which is based on German Patent Application Nos. 10 2009 008 859.8, filed February 9, 2009, 10 2009 030 359.6, filed June 18, 2009, and 10 2009 060 788.9, filed December 22, 2009, the subject matter of which is incorporated by reference.

Technical Field

[0002] ~~The present invention~~This disclosure relates to button cells comprising two metallic housing half-parts, ~~which are separated from one another by an electrically insulating seal and which form a housing with a flat bottom area and a flat top area parallel to it, as well as within the housing, an electrode-separator assembly comprising at least one positive and at least one negative electrode, which are in the form of flat layers and are connected to one another by at least one flat separator, and to a method for producing such button cells.~~

Background

[0003] Button cells normally have a housing consisting of two housing half-parts, a cell cup and a cell top. By way of example, these may be produced from nickel-plated deep-drawn metal sheet as stamped and drawn parts. The cell cup normally has positive polarity, and the housing

top negative polarity. The housing may contain widely differing electrochemical systems, for example, zinc/MnO₂, primary and secondary lithium systems, or secondary systems such as nickel/cadmium or nickel/metal hydride.

[0004] By way of example, rechargeable button cells based on nickel/metal hydride or lithium-ion systems are in widespread use. In the case of lithium-ion button cells, the electrochemically active materials are normally not arranged within the button cell housing in the form of individual electrodes, in the form of tablets, separated from one another by a separator. Instead of this, prefabricated electrode-separator assemblies are preferably inserted flat into the housing. In ~~this~~that case, a porous plastic film is preferably used as a separator, onto which the electrodes are laminated or adhesively bonded flat. The entire assembly comprising the separator and the electrodes ~~in this case~~ generally ~~[[has]]~~have a maximum thickness of a few hundred µm. ~~In order to~~To allow button cell housings of normal dimensions to be filled, a plurality of such assemblies are therefore frequently placed flat one on top of the other. This allows stacks of any desired height, in principle, to be produced, in each case matched to the available dimensions of the button cell housing into which the stack is intended to be installed. This ensures optimum utilization of the available area within the housing.

[0005] By virtue of the design, however, various problems also occur in the case of button cells which contain such stacks of electrode-separator assemblies. On the one hand, it is necessary, of course, for the electrodes of the same polarity each to be connected to one another within the stack, and then each to make contact with the corresponding pole of the button cell housing. The required electrical contacts result in material costs, and the space occupied by them is, furthermore, no longer available for active material. In addition, the production of the electrode stacks is complicated and expensive since faults can easily occur when the assemblies

make contact with one another, increasing the scrap rate. On the other hand, it has been found that button cells having a stack of electrodes and separators very quickly start to leak.

[0006] Traditionally, button cells have been closed in a liquid-tight manner by beading the edge of the cell cup over the edge of the cell top in conjunction with a plastic ring, which is arranged between the cell cup and the cell top and at the same time acts as a sealing element and for electrical insulation of the cell cup and of the cell top. Button cells such as these are described, for example, in DE 31 13 309.

[0007] However, alternatively, it is also possible to manufacture button cells in which the cell cup and the cell top are held together in the axial direction exclusively by a force-fitting connection, and which do not have a beaded-over cup edge. Button cells such as these and methods for their production are described in ~~the still unpublished German~~ Patent Application with the file reference 10 2009 017 514[[.8]]. Irrespective of the various advantages which button cells such as these without beading may have, they can, however, not be loaded as heavily in the axial direction as comparable button cells with a beaded-over cup edge, in particular with respect to axial mechanical loads which are caused in the interior of the button cell. For example, the electrodes of rechargeable lithium-ion systems are continually subject to volume changes during charging and discharging processes. The axial forces which occur in this case can, of course, lead to leaks more readily in the case of button cells without beading than in the case of button cells with beading.

[0008] ~~The present invention was based on the object of providing~~It could therefore be helpful to provide a button cell in which the problems mentioned above do not occur, or occur only to a greatly reduced extent. In particular, it could be helpful to provide a button cell that is

resistant to mechanical loads which occur in the axial direction than conventional button cells, in particular even when they are manufactured as button cells without a beaded-over cup edge.

[0009] ~~This object is achieved by the button cell having the features of claim 1. Preferred embodiments of the button cell according to the invention are defined in the dependent claims 2 to 10. The method according to claim 11 also contributes to the solution of the problem according to the invention. Preferred embodiments of the method according to the invention are defined in dependent claims 12 to 14. The wording of all the claims is hereby included by reference to the content of this description.~~

Summary

[0010] We provide a button cell including a housing cup and a housing top separated from one another by an electrically insulating seal and which form a housing with a flat bottom area and a flat top area parallel to it, and an electrode-separator assembly within the housing including at least one positive and at least one negative electrode in the form of flat layers and connected to one another by at least one flat separator, wherein the electrode layers are aligned essentially at right angles to the flat bottom and top areas and the button cell is closed without being beaded over.

[0011] We also provide a method for producing the button cell including inserting an electrode-separator assembly with electrodes in the form of a flat layer into the housing such that the electrode layers are aligned essentially at right angles to the flat bottom and top areas, wherein the housing includes a metallic cup part and a metallic top part.

Brief Description of the Drawings

[0012] Fig. 1 schematically illustrates the cross section through one preferred example of a button cell.

[0013] Fig. 2 illustrates the effect of heat treatment of a wound-up electrode-separator assembly, which is used in preferred examples of our method.

[0014] Fig. 3 shows an electrode-separator assembly in the form of a winding, as can be installed in a button cell.

[0015] Fig. 4 shows a section illustration of a further preferred example of a button cell.

[0016] Fig. 5 schematically illustrates the cross section through one preferred example of a button cell in which the edge of the cell cup is not beaded over the edge of the cell cop.

Detailed Description

[0017] ~~[[A]]~~Our button cell ~~according to the invention always~~ comprises two metallic housing half-parts, ~~which are~~ separated from one another by an electrically insulating seal and form a housing with a flat bottom area and a flat top area parallel to it. As already mentioned initially, the two housing half-parts are generally a so-called “housing cup” and a “housing top.” In particular, parts composed of nickel-plated steel or metal sheet are preferred as housing half-parts. Furthermore, trimetals, for example, with the sequence of nickel, steel (or stainless steel) and copper (with the nickel layer preferably forming the outer layer and the copper layer preferably forming the inside of the button cell housing) are particularly suitable for use as the metallic material.

[0018] By way of example, an injection-molded or film seal can be used as a seal. The latter are described, for example, in DE 196 47 593.

[0019] Within the housing, a button cell ~~according to the invention~~ comprises an electric-separator assembly with at least one positive and at least one negative electrode. These are each in the form of flat electrode layers. The electrodes are connected to one another via a flat separator. The electrodes are preferably laminated or adhesively bonded onto this separator. The electrodes and the separator generally each have thicknesses only in the μm range. In general, a porous plastic film is used as the separator.

[0020] In contrast to the button cells mentioned initially, ~~the invention~~ our button cell ~~according to the invention~~ is distinguished in particular by the electrode layers having a very particular orientation, specifically being aligned essentially at right angles to the flat bottom and top areas. While button cells known from the prior art with stacked electrode-separator assemblies always contain these assemblies inserted flat~~[,]~~ such that the electrode layers are aligned essentially parallel to the flat bottom and top areas, the situation in our button cell ~~according to the invention~~ is the opposite of this.

[0021] The right-angled alignment of the electrode layers has an unexpectedly considerable advantage, specifically because it has been found that this alignment results in a considerable improvement in the sealing characteristics of our button cell ~~according to the invention~~, particularly for button cells based on lithium-ion systems. The electrodes of rechargeable lithium-ion systems are continually subject to volume changes during charging and discharging processes. Volume changes such as these also occur, of course, in the electrodes of our button cell ~~according to the invention~~. However, the mechanical forces which are created during this process no longer act primarily axially, as in the case of a stack of electrode-separator assemblies which are inserted flat. Because of the right-angled alignment of the electrodes, they

in fact act radially. Radial forces can be absorbed very much better than axial forces by the housing of a button cell. The improved sealing characteristics are presumably a result of this.

[0022] Particularly preferably, the electrodes and the flat separator of ~~[[a]]our~~ button cell ~~according to the invention~~ are each in the form of strips or ribbons. By way of example, the production of ~~[[a]]our~~ button cell ~~according to the invention~~ can be based on a separator material in the form of an endless ribbon, onto which the electrodes are applied, in particular laminated, once again in particular in the form of strips or at least rectangles.

[0023] In the housing of ~~[[a]]our~~ button cell ~~according to the invention~~, this assembly is particularly preferably in the form of a winding, in particular in the form of a spiral winding. Windings such as these can be produced very easily using known methods (see, for example, DE 36 38 793), by applying the electrodes flat, in particular in the form of strips, to a separator which is in the form of an endless ribbon, in particular by laminating them on. In this case, the assembly comprising electrodes and separators is generally wound onto a so-called "winding mandrel." Once the winding has been removed from the winding mandrel an axial cavity remains in the center of the winding. This allows the winding to expand into this cavity, if necessary. However, in some circumstances, this can lead to problems in making electrical contact between the electrodes and the metallic housing half-parts, and this will be described in more detail in the following text.

[0024] The electrode winding is preferably arranged within a button cell ~~according to the invention~~ ~~(in order so~~ that the electrode layers of the winding are aligned at right angles to the flat bottom area and top area of the housing)~~][,]~~ such that the end faces of the winding face in the direction of the flat bottom area and of the flat top area.

[0025] ~~According to the present invention, preferred embodiments of the~~Preferably, our button cells ~~according to the invention~~ have a fixed winding core in the center of the winding, which at least partially fills the axial cavity in the center of the winding. A winding core such as this fixes the electrode winding in the radial direction and prevents possible implosion of the winding into the axial cavity. When the winding expands in this way, this also results in the reduction in the pressure which the end faces of the winding exert in the axial direction, and therefore in the direction of output conductors which may be arranged there (this is described in more detail further below). If this is prevented, then there are generally also no problems with making electrical contact between the electrodes and the metallic housing half-parts.

[0026] In addition, a winding core such as this also makes the button cell ~~according to the invention~~ more robust against external mechanical influences. In general, it is no longer possible for the electrode winding in the button cell to be damaged by external mechanical pressure in the axial direction.

[0027] ~~According to the preferred embodiment of~~Preferably, the electrode winding ~~[[as]]~~ is a spiral electrode winding, the axial cavity which has been mentioned in the center of the winding is preferably essentially cylindrical (in particular circular-cylindrical). On the casing side, it is bounded by the winding, and at the end it is bounded by corresponding surfaces of the bottom area and of the top area of the button cell housing.

[0028] Correspondingly, the winding core which is contained in ~~[[a]]~~our button cell ~~according to the invention~~ is preferably also in the form of a cylinder, in particular a hollow cylinder. The height of a cylinder such as this preferably corresponds to the respective distance between the flat bottom area and the flat top area, which is parallel to it.

[0029] ~~In particularly preferred embodiments~~Particularly preferably, the winding core may have radially self-expanding characteristics. For example, it is possible for the winding core to be inserted in a radially compressed configuration into the axial cavity in the winding of a button cell ~~according to the invention~~. When the radially compressed winding core expands, it exerts a radial pressure on the electrode winding surrounding it, thus ensuring a contact pressure in the axial direction as well.

[0030] By way of example, an axially slotted hollow cylinder may be used as a radially self-expanding winding core. However, alternatively, it is also conceivable to use other radially self-expanding materials, for example, based on plastic.

[0031] Particularly preferably, the winding core is composed of a metal such as stainless steel or plastic.

[0032] Particularly preferably, the assembly comprising electrodes and a separator in [[a]]our button cell ~~according to the invention~~ has one of the following layer sequences:

[[•]] negative electrode/separator/positive electrode/separator

or

[[•]] positive electrode/separator/negative electrode/separator.

[0033] Assemblies such as these can be produced and wound very easily without short circuits occurring between electrodes of opposite polarity.

[0034] The separators which can be used in [[a]]our button cell ~~according to the invention~~ are preferably films composed of at least one plastic, in particular of at least one polyolefin. By way of example, the at least one polyolefin may be polyethylene. However, it is also possible to use multilayer separators, for example, separators composed of a sequence of different polyolefin layers, for example, with the sequence polyethylene/polypropylene/polyethylene.

[0035] It is not essential to use a plurality of separate separators ~~in order to~~ produce assemblies with the abovementioned sequence. In fact, a separator can also be looped around the end of one of the electrodes, thus resulting in both sides of this electrode being covered by the separator.

[0036] The separators which can preferably be used in ~~our~~ button cell ~~according to the invention~~ preferably have a thickness of between 3 μm and 100 μm , in particular of between 10 μm and 50 μm .

[0037] The electrodes ~~of a button cell according to the invention~~ preferably have a thickness of between 10 μm and 1000 μm , in particular of between 30 μm and 500 μm .

[0038] ~~In preferred embodiments of a button cell according to the invention~~ Preferably, the negative electrode and the positive electrode in the electrode-separator assembly are arranged offset with respect to one another within the assembly. In this case, an offset arrangement is intended to mean that the electrodes are arranged such that this results in a respectively different separation between the electrodes and the flat bottom and top areas in the button cell ~~according to the invention~~. In the simplest case, for example, a positive and a negative electrode can be slightly offset as strips of the same width applied to the opposite sides of a separator ribbon, as a result of which the distance between the positive electrode and the upper separator edge is greater than the comparable distance measured from the negative electrode. This then applies in the opposite sense, of course, to the distance from the lower separator edge.

[0039] ~~In particularly preferred embodiments~~ Particularly preferably, preferably as a result of this offset arrangement, the positive electrode, in particular an edge of the positive electrode, rests directly on the cup part, in particular in the flat bottom area of the cup part, while the negative electrode, in particular an edge of the negative electrode, rests directly on the top part,

in particular in the flat top area of the top part. In this ~~embodiment~~example, a direct electrical and mechanical contact is made between the electrodes and the cup and top parts. The offset arrangement of the electrodes with respect to one another therefore makes it possible for the electrodes to make contact with the respective housing parts, without any need to use additional electrical contacts and connecting means.

[0040] However, ~~in alternative preferred embodiments~~alternatively, it is also preferable for at least one of the electrodes, preferably both the at least one negative electrode and the at least one positive electrode[[,]] in [[a]]our button cell ~~according to the invention~~, to be connected to the flat bottom and top areas via one or more output conductors. By way of example, the output conductors may be output-conductor lugs composed of copper or some other suitable metal. On the electrode side, the output conductors may, for example, be connected to a current collector. The output conductors can be connected to the housing and/or to the current collectors by, for example, welding or via an clamped joint.

[0041] In the simplest case, the current collectors of the positive and negative electrodes can also themselves act as output conductors. Collectors such as these are generally metallic films or meshes which are embedded in the respective electrode material. Uncovered subareas, in particular end pieces, of collectors such as these can be bent around and can be brought into contact with the button cell housing.

[0042] The use of output conductors may be particularly advantageous if the negative electrode and the positive electrode within the assembly are arranged with respect to one another such that this results in the electrodes each being at the same distance from the flat bottom and top areas. Or, in other words, if the electrodes are not arranged offset with respect to one another within the electrode-separator assembly, as has been described above.

[0043] However, if the distance between electrodes of opposite polarity and the flat bottom and top areas is the same, this results in the risk of a positive and a negative electrode touching the metallic cup or top part at the same time, thus resulting in a short circuit. ~~In preferred embodiments~~ Preferably, the button cell ~~according to the invention~~ may therefore comprise at least one insulating means, which prevents a direct mechanical and electrical contact between the end faces of the winding and the flat bottom and top areas.

[0044] In one development, it is preferable for the electrodes in ~~[[a]]our~~ button cell ~~according to the invention~~ such as this to be connected via the already mentioned separate output conductors to the flat bottom and top areas. These ensure the electrical contact between the electrodes and the housing.

[0045] In this case, it is preferable for at least a subsection of the output conductor or conductors in the bottom area and in the top area of the housing to rest flat on the inside of the housing half-parts. Ideally, the output conductors naturally make electrical contact with the insides of the housing when they are at least slightly pressed against the housing (if they are not welded to it in any case). This can be achieved surprisingly efficiently by a suitable arrangement of the winding core that has been mentioned, in ~~[[a]]our~~ button cell ~~according to the invention~~.

[0046] By way of example, the insulating means may be a flat layer composed of plastic, for example, a plastic film, which is arranged between the end faces of the winding and the flat bottom and top areas of the housing of ~~[[a]]our~~ button cell ~~according to the invention~~.

[0047] Corresponding to the above statements, the button cell ~~according to the invention~~ is, in particular, a rechargeable button cell. ~~[[A]]Our~~ button cell ~~according to the invention~~ particularly preferably has at least one lithium-intercalating electrode.

[0048] The ratio of the height to the diameter of button cells is, by definition, less than 1. For ~~[[a]]our button cell according to the invention~~, this ratio is particularly preferably between 0.1 and 0.9, in particular between 0.15 and 0.7. In this case, the height means the distance between the flat bottom area and the flat top area parallel to it. The diameter means the maximum distance between two points on the casing area of the button cell.

[0049] The button cell ~~according to the invention~~ is particularly preferably a button cell which is not beaded over, as is described in ~~the patent application with the file reference~~ DE Patent Application 10 2009 017 514.8, ~~which has already been mentioned in the introduction above~~. Correspondingly, there is preferably an exclusively force-fitting connection between the housing half-parts. Therefore, ~~[[the]]our button cell according to the invention~~ does not have a beaded-over cup edge, as is always the case with known button cells ~~known from the prior art~~. The button cell is closed without being beaded over.

[0050] Button cells such as these which are not beaded over generally make use of conventional cell cups and cell tops, which each have a bottom area and a top area, a casing area, an edge area which is arranged between the bottom and top areas and the casing area, and a cut edge. Together, the cell cup and cell top form a housing, which forms a receptacle for the conventional internal components of a button cell, such as electrodes, separator ~~[[etc]]and the like~~. As in the normal way, the bottom area of the cell cup and the top area of the cell top are aligned essentially parallel to one another in this housing. The casing areas of the cell cup and cell top in the finished button cell are aligned essentially at right angles to the bottom and top areas, and preferably have an essentially cylindrical geometry. The internal and external radii of the cell cup and cell top are preferably essentially constant in the casing areas. The edge areas, which have been mentioned, of the cell cup and cell top form the transition between the casing

areas and the top and bottom areas. They are preferably therefore bounded on the one hand by essentially flat bottom and top areas, and on the other hand by the essentially cylindrical casing areas, which are arranged at right angles to them. By way of example, the edge areas may be in the form of a sharp edge, or else may be rounded.

[0051] The procedure for producing a button cell which is not beaded over is generally to first of all apply a seal to the casing area of a cell top. In a further step, the cell top is then inserted, with the seal fitted, into a cell cup thus resulting in an area in which the casing areas of the cell cup and cell top overlap. The size of the overlap area and the ratio of the overlapping area to the non-overlapping areas are in this case governed by the respective height of the casing areas of the cell cup and cell top, and by the depth of the insertion. With regard to the casing area of the cell top, it is preferable for between 20% and 99%, in particular between 30% and 99%, particularly preferably between 50% and 99%, to overlap the casing area of the cell cup (the percentages each relate to the height of the casing or of the casing area). Before being inserted into the housing cup and/or the housing top, the other conventional components of a button cell (electrodes, separator, electrolyte ~~etc.~~ etc. and the like) are inserted. After the cell top has been inserted completely into the cell cup a pressure is exerted on the casing area of the cell cup, in particular in the area of the cut edge, ~~in order~~ to seal the housing. In this case, a joined-together housing part should as far as possible not be subjected to any loads, or only to very small loads, in the axial direction. Therefore, the pressure is applied in particular radially. Apart from the sealing of the housing which has already been mentioned the external diameter of the cell housing can therefore also be calibrated.

[0052] It is particularly important for the heights of the casing areas of the cell cup and cell top to be matched to one another such that the cut edge of the cell cup is pressed against the

casing area of the cell top by the pressure on the casing area of the cell cup. The heights of the casing areas are therefore preferably chosen such that it is impossible to bend the cut edge of the cell cup around inward over the edge area of the cell top which has been completely inserted into the cell cup. Correspondingly, the edge of the cell cup is not beaded over the edge area of the cell top. In consequence, the cell cup of a button cell manufactured using ~~our~~ method ~~according to the invention~~ has a casing area with an essentially constant radius in the direction of the cut edge.

[0053] In the case of button cells produced using a method such as this, there is preferably an exclusively force-fitting connection between the housing components comprising the cell cup, the cell top and the seal. This ensures that the components are therefore held together in a preferred manner, essentially only by static-friction force.

[0054] Button cells without any beading over are particularly preferably produced using a cell cup which is conical at least in one subarea of its casing, such that at least its internal diameter increases in the direction of the cut edge. This makes it considerably easier to insert the cell top into the cell cup. The dimensions of the cell cup and cell top are preferably matched to one another such that relatively large opposing forces preferably do not occur until the top has been inserted virtually completely into the cup. The cone angle in this case is preferably between 10 minutes and 3°, in particular between 30 minutes and 1° 30 minutes.

[0055] The cell top, which is inserted into the cell cup with the applied seal, is preferably cylindrical, at least in a part of the casing area, ~~in preferred embodiments~~. This may relate in particular to that part of the casing area which overlaps the conical subarea of the cell cup casing that has been mentioned, after the cell top has been inserted into the cell cup. The casing of the cell top, and therefore also the casing area, is particularly preferably entirely cylindrical. The

cell top therefore preferably has a constant external radius in the casing area. This may relate in particular to that part which overlaps the conical part of the casing area of the cell cup after the cell top has been inserted.

[0056] When a cell top with a cylindrical casing area is being inserted into a cell cup which is conical at least in one subarea of its casing, as has been described above, a gap which is open at the top is generally created between the cell cup and the cell top. This gap is generally closed again by the pressure on the casing area of the cell cup. Thus, the pressure on the casing area of the cell cup may be chosen such that the conical part of the casing area of the cell cup is pushed inward until the inside of the cell cup and the outside of the cell top are essentially at the same distance from one another in the overlapping area. The resultant button cell has casing areas which are aligned parallel to one another, in particular in the overlapping area.

[0057] One important aspect in this case is the choice of the seal which connects the cell cup to the cell top. The seal is preferably a plastic seal which connects the cell cup to the cell top. The seal is preferably a plastic seal composed of a thermoplastic.

[0058] The plastic seal is particularly preferably a film seal, for example, as is described in ~~the~~ already cited DE 196 47 593, in particular a film seal composed of a thermoplastic.

[0059] Film seals can be produced with a very uniform thickness. When a suitable pressure is applied to the casing area of the cell cup, this results in an interference fit, as a consequence of which the button cell that has been produced has highly excellent sealing characteristics. ~~Not~~ at least, the use of film seals makes it possible to dispense with the edge of the cell cup being beaded over without this on the other hand resulting in a need to accept disadvantages in other important characteristics.

[0060] It is very particularly preferable to use plastic seals, in particular plastic films, based on polyamide or based on polyether ether ketones in the present case.

[0061] It is preferable for the seal for a cell which is not beaded over to have an initial thickness in the range between 50 μm and 250 μm , particularly preferably between 70 μm and 150 μm , in particular about 100 μm . The term "initial thickness" is in this case intended to mean the thickness of the seal before it is applied to the casing of the cell top. In contrast to this, the term "final thickness" is intended to mean the thickness of the seal in the finished cell. It is clear that, at least in the overlapping area, this generally corresponds to the distance between the inside of the cell cup and the outside of the cell top.

[0062] ~~In order to~~To allow a sufficiently large amount of friction to be produced between the cell cup and the cell top, both the external and internal radii of the cup and top should be matched to one another and to the thickness of the film seal. This is the only way to create a sufficiently high contact pressure to hold the two individual parts together. It is preferable for the parts used in this case for the difference between the external radius of the cell top, which is to be inserted into the cell cup, on the cut edge of the cell top and the smallest internal radius of the cell cup in that part of the casing area which overlaps the casing area of the cell top to be less than the initial thickness of the seal that is used. The difference is particularly preferably between 10% and 90% of the initial thickness, in particular between 30% and 70%, and very particularly preferably about 50%.

[0063] After the cell top has been inserted into the cell cup, a part of the casing area of the cell cup can be drawn radially inward. In particular, this relates to that part of the casing area which does not overlap the casing area of the cell top.

[0064] It has been found that this process of drawing in radially makes it possible to achieve considerably better sealing characteristics. Drawing in the cup casing results in a radial pressure being exerted on the edge section which rests on the inner wall of the housing cup and on the seal which is arranged between the housing top and the housing cup, with the seal in consequence being compressed in this area.

[0065] The drawing-in process can be carried out at the same time as the already mentioned exertion of pressure on the casing area of the cell cup, although the drawing-in process is preferably carried out in a subsequent, separate step.

[0066] ~~[[The]]~~Our method ~~according to the invention~~ for producing a button cell can be used in particular to produce button cells as have been described above, that is to say button cells having a housing with a flat bottom area and a flat top area parallel to it. It is suitable for producing not only button cells which are not beaded over, but also for those which are beaded over.

[0067] With respect to the preferred ~~embodiments~~examples of the individual components which are used in ~~[[the]]~~our method ~~according to the invention~~ (housing parts and dimensions, electrodes, separator ~~etc. and the like~~), reference can therefore be made to the above statements and explanations in their entirety.

[0068] In general, the housing is assembled from a metallic cup part (housing cup) and a metallic top part (housing top), with an electrode-separator assembly with electrodes in the form of a flat layer being inserted into the housing such that the electrodes are aligned at right angles to the flat bottom area and top area.

[0069] As already mentioned, the electrode-separator assembly is preferably installed in the form of a winding, in particular a spiral winding.

[0070] In general, ~~[[the]]our method according to the invention~~ always comprises the following steps:

[[•]] insertion of the winding into the metallic top part, and

[[•]] insertion of the metallic top part with the winding into a metallic cup part.

[0071] The edge of the cup part is then optionally beaded over the edge of the top part.

[0072] When a button cell which is not beaded over is produced, the corresponding steps as described above are carried out.

[0073] Before the housing is closed, the electrodes are normally also impregnated with electrolyte solution.

[0074] For the insertion process, the winding is preferably rolled up on a winding mandrel. After or during the insertion process, the winding mandrel can then be removed. If required, the winding core that has been mentioned above is then inserted. Alternatively, the electrode-separator assembly can also be wound directly onto a core such as this.

[0075] The spiral winding is particularly preferably heat-treated on its end faces before being installed. In this case, it is at least briefly subjected to a temperature at which the separator in the winding is thermoplastically deformable. In general, the separator projects somewhat on the end faces of the winding, and this is itself subject to the precondition that the electrodes are arranged with the offset with respect to one another, as described above. The heat treatment allows the separator to be shrunk together somewhat, therefore, if required, even exposing the edge of an adjacent electrode, such that this can rest directly on the button cell housing.

[0076] The stated advantages and further advantages ~~of the invention~~ will become evident from the description which now follows of the drawings ~~in conjunction with the dependent claims~~. In this case, ~~the individual features of the invention~~ may be implemented on their own or

in combination with one another. The described ~~embodiments~~examples are intended only for explanation and ~~for better understanding of the invention~~, and should in no way be understood as being restrictive.

Description of the figures

[0077] — ~~Figure 1 schematically illustrates the cross section through one preferred embodiment of a button cell according to the invention.~~

[0078] — ~~Figure 2 illustrates the effect of heat treatment of a wound-up electrode separator assembly, which is used in preferred embodiments of the method according to the invention.~~

[0079] — ~~Figure 3 shows an electrode separator assembly in the form of a winding, as can be installed in a button cell according to the invention.~~

[0080] — ~~Figure 4 shows a section illustration of a further preferred embodiment of a button cell according to the invention.~~

[0081] — ~~Figure 5 schematically illustrates the cross section through one preferred embodiment of a button cell according to the invention, in which the edge of the cell cup is not beaded over the edge of the cell top.~~

[0082] Fig[[ure]]. 1 schematically illustrates the cross section through one preferred ~~embodiment~~example of a button cell 100 ~~according to the invention~~. This has a metallic cup part 101 and metallic top part 102. The two parts are connected to one another, sealed by means of a seal 109. Together, they form a housing with a flat bottom area 103 and a flat top area 104 parallel to it. When in use, these flat areas 103 and 104 form the poles of the button cell, from which current can be drawn by a load. The edge 110 of the cell cup 101 is beaded inward over the edge of the cell top 102.

[0083] An arrangement comprising an electrode 105 in the form of a strip, an electrode 106 in the form of a strip, and the separators 107 in the form of strips is arranged in the interior of the electrode. The assembly comprising the electrodes 105 and 106 as well as the separators 107 is in this case in the form of a winding, whose end faces abut against the flat bottom area 103 and the flat top area 104, which is parallel to it. The assembly is wound up on the core 108 in the center of the button cell 100. Both the core 108 as well as the electrodes and separators which are wound around it are aligned at right angles to the flat bottom and top areas 104 and 103. When the volume of the electrodes increases or decreases during a charging or discharging process, the mechanical forces which result in this case act predominantly radially, and can be absorbed by the casing area of the button cell 100.

[0084] It should be stressed that the positive electrode 105 and the negative electrode 106 respectively rest directly on the cup part 101 and on the top part 102 of the button cell 100. There is no need for a separate output conductor for connecting the electrodes to the top part 102 and to the cup part 101.

[0085] Fig[[ure]]. 2 shows the effect of the heat treatment of an electrode-separator winding 200, which is provided in preferred ~~embodiments~~examples of the method ~~according to the invention~~ for producing a button cell. The illustration schematically shows a winding 200 comprising an assembly of a positive electrode 201 (bar with cross strips), a negative electrode 202 (white bar) and the separators 203 (detail). The positive and the negative electrodes 201 and 202 are in each case arranged offset with respect to one another. The separators 203 are composed of a thermoplastically deformable material.

[0086] When the separator edges which are located on the end faces 204 and 205 of the winding 200 are subjected to a high temperature (for example, of 250°C, as illustrated), then

these separator edges shrink. The separators are drawn in at least partially between adjacent electrodes. In the process, the edges of the negative electrode 202 are exposed on the end face 204, while the edges of the positive electrode 201 are covered. The edges of the positive electrode 201 on the end face 205 are exposed, while the edges of the negative electrode 202 are covered.

[0087] When a winding that has been treated in this way is in use, this ensures that electrodes of the same polarity can each rest directly only on the housing cup or on the housing top. There is no need for separate electrical connections between the electrodes and the housing parts.

[0088] Fig[[ure]]. 3 shows an electrode-separator assembly for button cells ~~according to the invention~~, in the form of a winding 300, with the illustration A depicting a plan view vertically from above at one of the end faces 301 of the winding 300, while the illustration B shows the winding 300 in a view obliquely from above. In both cases, this shows that the assembly comprises two layers; separators 302 and 303 as well as two electrode layers 304 and 305 (a positive and a negative electrode). The assembly is wound up in a spiral shape and is held together by an adhesive tape 306 on its outside.

[0089] Fig[[ure]]. 4 shows a sectioned illustration of one preferred ~~embodiment~~example of a button cell 400 ~~according to the invention~~. The figure shows the housing of the button cell comprising the cup part 401 and the top part 402, between which the seal 403 is arranged. An assembly of electrodes and separators, as is illustrated in Fig[[ure]]. 3, is contained as a spiral winding 404 (illustrated schematically in the cross section) within the housing. The separator layers 405 and 406 as well as the electrodes 407 and 408 of opposite polarity can also be seen well here. In this case, the electrode 407 is connected via the output conductor 410 to the top part 402, while the electrode 408 is connected via the output conductor 409 to the cup part 402.

The output conductor 410 is preferably welded to the top part 402. In contrast, the output conductor 409 is connected to the cup part 402 via a clamping connection (it is clamped inbetween the supporting ring 413, on which the edge of the cell top rests, and the bottom of the cell cup). The insulating means 411 and 412 are arranged between the end faces of the winding and the cup part 401 and the top part 402, and are each in the form of thin plastic disks. This prevents electrodes of opposite polarity from being able to come into contact with the cup part 401 or the top part 402 at the same time. This prevents any short circuit.

[0090] Fig[[ure]]. 5 schematically illustrates the cross section through one preferred ~~embodiment~~example of a button cell 500 ~~according to the invention~~.

[0091] This button cell 500 has a metallic cup part 501 and a metallic top part 502. The two parts are connected to one another, sealed by means of a seal 510. Together, they form a housing with a flat bottom area 503 and a flat top area 504 parallel to it. When in use, these flat areas 503 and 504 form the poles of the button cell, from which current can be drawn by a load.

[0092] The cell top 502 is inserted into the cell cup 501 such that the casing areas of the cell top and of the cell cup overlap, with the internal radius of the cell cup 501 in the overlapping area being essentially constant in the direction of the cut edge. Therefore, the edge of the cell cup 501 is not beaded over the edge 511 of the cell top 502, and the preferred ~~embodiment~~example described above for a button cell 500 ~~according to the invention~~ is therefore a button cell which is not beaded over.

[0093] An assembly comprising an electrode 508 in the form of a strip, an electrode 509 in the form of a strip and separators 507 in the form of strips is arranged in the interior of the electrode. The assembly comprising the electrodes 508 and 509 as well as the separators 507 is in this case in the form of a winding, whose end faces face in the direction of the flat bottom area

503 and of the flat top area 504 which is parallel to it. The assembly is wound up on the winding core 512 in the center of the button cell 500. Both the core 512 and the electrodes and separators which are wound around it are aligned at right angles to the flat bottom and top areas 504 and 503. If the volume of the electrodes increases or decreases during a charging or discharging process, the mechanical forces which result in this case act predominantly radially, and can be absorbed by the casing area of the button cell 500.

[0094] The positive and the negative electrodes make contact with the housing half-part comprising the cup and top via the output conductor 505 and the output conductor 506. The output conductor 505 is composed of aluminum, and the output conductor 506 is composed of nickel (or alternatively of copper). Both output conductors are thin films, which rest flat between the end faces of the winding and the flat top and bottom areas 503 and 504. A continuous slight contact pressure is maintained on the output conductors by the winding core 512. The output conductors are preferably separated from the end faces of the winding by a separate insulator arrangement (not illustrated in the drawing), for example, by a thin film.

SUBSTITUTE SPECIFICATION (Clean Copy)

BUTTON CELLS AND METHOD FOR PRODUCING SAME

Related Applications

[0001] This is a §371 of International Application No. PCT/EP2010/000787, with an international filing date of February 9, 2010 (WO 2010/089152 A1, published August 12, 2010), which is based on German Patent Application Nos. 10 2009 008 859.8, filed February 9, 2009, 10 2009 030 359.6, filed June 18, 2009, and 10 2009 060 788.9, filed December 22, 2009, the subject matter of which is incorporated by reference.

Technical Field

[0002] This disclosure relates to button cells comprising two metallic housing half-parts separated from one another by an electrically insulating seal and which form a housing with a flat bottom area and a flat top area parallel to it, as well as within the housing, an electrode-separator assembly comprising at least one positive and at least one negative electrode, which are in the form of flat layers and are connected to one another by at least one flat separator, and to a method for producing such button cells.

Background

[0003] Button cells normally have a housing consisting of two housing half-parts, a cell cup and a cell top. By way of example, these may be produced from nickel-plated deep-drawn metal sheet as stamped and drawn parts. The cell cup normally has positive polarity, and the housing top negative polarity. The housing may contain widely differing electrochemical systems, for

example, zinc/MnO₂, primary and secondary lithium systems, or secondary systems such as nickel/cadmium or nickel/metal hydride.

[0004] By way of example, rechargeable button cells based on nickel/metal hydride or lithium-ion systems are in widespread use. In the case of lithium-ion button cells, the electrochemically active materials are normally not arranged within the button cell housing in the form of individual electrodes, in the form of tablets, separated from one another by a separator. Instead, prefabricated electrode-separator assemblies are preferably inserted flat into the housing. In that case, a porous plastic film is preferably used as a separator, onto which the electrodes are laminated or adhesively bonded flat. The entire assembly comprising the separator and the electrodes generally have a maximum thickness of a few hundred μm . To allow button cell housings of normal dimensions to be filled, a plurality of such assemblies are therefore frequently placed flat one on top of the other. This allows stacks of any desired height, in principle, to be produced, in each case matched to the available dimensions of the button cell housing into which the stack is intended to be installed. This ensures optimum utilization of the available area within the housing.

[0005] By virtue of the design, however, various problems also occur in the case of button cells which contain such stacks of electrode-separator assemblies. On the one hand, it is necessary, of course, for the electrodes of the same polarity each to be connected to one another within the stack, and then each to make contact with the corresponding pole of the button cell housing. The required electrical contacts result in material costs, and the space occupied by them is, furthermore, no longer available for active material. In addition, the production of the electrode stacks is complicated and expensive since faults can easily occur when the assemblies

make contact with one another, increasing the scrap rate. On the other hand, it has been found that button cells having a stack of electrodes and separators very quickly start to leak.

[0006] Traditionally, button cells have been closed in a liquid-tight manner by beading the edge of the cell cup over the edge of the cell top in conjunction with a plastic ring, which is arranged between the cell cup and the cell top and at the same time acts as a sealing element and for electrical insulation of the cell cup and of the cell top. Button cells such as these are described, for example, in DE 31 13 309.

[0007] However, alternatively, it is also possible to manufacture button cells in which the cell cup and the cell top are held together in the axial direction exclusively by a force-fitting connection, and which do not have a beaded-over cup edge. Button cells such as these and methods for their production are described in German Patent Application 10 2009 017 514. Irrespective of the various advantages which button cells such as these without beading may have, they can, however, not be loaded as heavily in the axial direction as comparable button cells with a beaded-over cup edge, in particular with respect to axial mechanical loads which are caused in the interior of the button cell. For example, the electrodes of rechargeable lithium-ion systems are continually subject to volume changes during charging and discharging processes. The axial forces which occur in this case can, of course, lead to leaks more readily in the case of button cells without beading than in the case of button cells with beading.

[0008] It could therefore be helpful to provide a button cell in which the problems mentioned above do not occur, or occur only to a greatly reduced extent. In particular, it could be helpful to provide a button cell that is resistant to mechanical loads which occur in the axial direction than conventional button cells, in particular even when they are manufactured as button cells without a beaded-over cup edge.

Summary

[0009] We provide a button cell including a housing cup and a housing top separated from one another by an electrically insulating seal and which form a housing with a flat bottom area and a flat top area parallel to it, and an electrode-separator assembly within the housing including at least one positive and at least one negative electrode in the form of flat layers and connected to one another by at least one flat separator, wherein the electrode layers are aligned essentially at right angles to the flat bottom and top areas and the button cell is closed without being beaded over.

[0010] We also provide a method for producing the button cell including inserting an electrode-separator assembly with electrodes in the form of a flat layer into the housing such that the electrode layers are aligned essentially at right angles to the flat bottom and top areas, wherein the housing includes a metallic cup part and a metallic top part.

Brief Description of the Drawings

[0011] Fig. 1 schematically illustrates the cross section through one preferred example of a button cell.

[0012] Fig. 2 illustrates the effect of heat treatment of a wound-up electrode-separator assembly, which is used in preferred examples of our method.

[0013] Fig. 3 shows an electrode-separator assembly in the form of a winding, as can be installed in a button cell.

[0014] Fig. 4 shows a section illustration of a further preferred example of a button cell.

[0015] Fig. 5 schematically illustrates the cross section through one preferred example of a button cell in which the edge of the cell cup is not beaded over the edge of the cell cop.

Detailed Description

[0016] Our button cell comprises two metallic housing half-parts separated from one another by an electrically insulating seal and form a housing with a flat bottom area and a flat top area parallel to it. As already mentioned initially, the two housing half-parts are generally a so-called “housing cup” and a “housing top.” In particular, parts composed of nickel-plated steel or metal sheet are preferred as housing half-parts. Furthermore, trimetals, for example, with the sequence of nickel, steel (or stainless steel) and copper (with the nickel layer preferably forming the outer layer and the copper layer preferably forming the inside of the button cell housing) are particularly suitable for use as the metallic material.

[0017] By way of example, an injection-molded or film seal can be used as a seal. The latter are described, for example, in DE 196 47 593.

[0018] Within the housing, a button cell comprises an electric-separator assembly with at least one positive and at least one negative electrode. These are each in the form of flat electrode layers. The electrodes are connected to one another via a flat separator. The electrodes are preferably laminated or adhesively bonded onto this separator. The electrodes and the separator generally each have thicknesses only in the μm range. In general, a porous plastic film is used as the separator.

[0019] In contrast to the button cells mentioned initially, our button cell is distinguished in particular by the electrode layers having a very particular orientation, specifically being aligned essentially at right angles to the flat bottom and top areas. While button cells known from the prior art with stacked electrode-separator assemblies always contain these assemblies inserted flat such that the electrode layers are aligned essentially parallel to the flat bottom and top areas, the situation in our button cell is the opposite of this.

[0020] The right-angled alignment of the electrode layers has an unexpectedly considerable advantage, specifically because it has been found that this alignment results in a considerable improvement in the sealing characteristics of our button cell, particularly for button cells based on lithium-ion systems. The electrodes of rechargeable lithium-ion systems are continually subject to volume changes during charging and discharging processes. Volume changes such as these also occur, of course, in the electrodes of our button cell. However, the mechanical forces which are created during this process no longer act primarily axially, as in the case of a stack of electrode-separator assemblies which are inserted flat. Because of the right-angled alignment of the electrodes, they in fact act radially. Radial forces can be absorbed very much better than axial forces by the housing of a button cell. The improved sealing characteristics are presumably a result of this.

[0021] Particularly preferably, the electrodes and the flat separator of our button cell are each in the form of strips or ribbons. By way of example, the production of our button cell can be based on a separator material in the form of an endless ribbon, onto which the electrodes are applied, in particular laminated, once again in particular in the form of strips or at least rectangles.

[0022] In the housing of our button cell, this assembly is particularly preferably in the form of a winding, in particular in the form of a spiral winding. Windings such as these can be produced very easily using known methods (see, for example, DE 36 38 793), by applying the electrodes flat, in particular in the form of strips, to a separator which is in the form of an endless ribbon, in particular by laminating them on. In this case, the assembly comprising electrodes and separators is generally wound onto a so-called "winding mandrel." Once the winding has been removed from the winding mandrel an axial cavity remains in the center of the winding. This allows the winding to expand into this cavity, if necessary. However, in some circumstances,

this can lead to problems in making electrical contact between the electrodes and the metallic housing half-parts, and this will be described in more detail in the following text.

[0023] The electrode winding is preferably arranged within a button cell (so that the electrode layers of the winding are aligned at right angles to the flat bottom area and top area of the housing) such that the end faces of the winding face in the direction of the flat bottom area and of the flat top area.

[0024] Preferably, our button cells have a fixed winding core in the center of the winding, which at least partially fills the axial cavity in the center of the winding. A winding core such as this fixes the electrode winding in the radial direction and prevents possible implosion of the winding into the axial cavity. When the winding expands in this way, this also results in the reduction in the pressure which the end faces of the winding exert in the axial direction, and therefore in the direction of output conductors which may be arranged there (this is described in more detail further below). If this is prevented, then there are generally also no problems with making electrical contact between the electrodes and the metallic housing half-parts.

[0025] In addition, a winding core such as this also makes the button cell more robust against external mechanical influences. In general, it is no longer possible for the electrode winding in the button cell to be damaged by external mechanical pressure in the axial direction.

[0026] Preferably, the electrode winding is a spiral electrode winding, the axial cavity which has been mentioned in the center of the winding is preferably essentially cylindrical (in particular circular-cylindrical). On the casing side, it is bounded by the winding, and at the end it is bounded by corresponding surfaces of the bottom area and of the top area of the button cell housing.

[0027] Correspondingly, the winding core which is contained in our button cell is preferably also in the form of a cylinder, in particular a hollow cylinder. The height of a cylinder such as

this preferably corresponds to the respective distance between the flat bottom area and the flat top area, which is parallel to it.

[0028] Particularly preferably, the winding core may have radially self-expanding characteristics. For example, it is possible for the winding core to be inserted in a radially compressed configuration into the axial cavity in the winding of a button cell. When the radially compressed winding core expands, it exerts a radial pressure on the electrode winding surrounding it, thus ensuring a contact pressure in the axial direction as well.

[0029] By way of example, an axially slotted hollow cylinder may be used as a radially self-expanding winding core. However, alternatively, it is also conceivable to use other radially self-expanding materials, for example, based on plastic.

[0030] Particularly preferably, the winding core is composed of a metal such as stainless steel or plastic.

[0031] Particularly preferably, the assembly comprising electrodes and a separator in our button cell has one of the following layer sequences:

negative electrode/separator/positive electrode/separator

or

positive electrode/separator/negative electrode/separator.

[0032] Assemblies such as these can be produced and wound very easily without short circuits occurring between electrodes of opposite polarity.

[0033] The separators which can be used in our button cell are preferably films composed of at least one plastic, in particular of at least one polyolefin. By way of example, the at least one polyolefin may be polyethylene. However, it is also possible to use multilayer separators, for

example, separators composed of a sequence of different polyolefin layers, for example, with the sequence polyethylene/polypropylene/polyethylene.

[0034] It is not essential to use a plurality of separate separators to produce assemblies with the abovementioned sequence. In fact, a separator can also be looped around the end of one of the electrodes, thus resulting in both sides of this electrode being covered by the separator.

[0035] The separators which can preferably be used in our button cell preferably have a thickness of between 3 μm and 100 μm , in particular of between 10 μm and 50 μm .

[0036] The electrodes preferably have a thickness of between 10 μm and 1000 μm , in particular of between 30 μm and 500 μm .

[0037] Preferably, the negative electrode and the positive electrode in the electrode-separator assembly are arranged offset with respect to one another within the assembly. In this case, an offset arrangement is intended to mean that the electrodes are arranged such that this results in a respectively different separation between the electrodes and the flat bottom and top areas in the button cell. In the simplest case, for example, a positive and a negative electrode can be slightly offset as strips of the same width applied to the opposite sides of a separator ribbon, as a result of which the distance between the positive electrode and the upper separator edge is greater than the comparable distance measured from the negative electrode. This then applies in the opposite sense, of course, to the distance from the lower separator edge.

[0038] Particularly preferably, preferably as a result of this offset arrangement, the positive electrode, in particular an edge of the positive electrode, rests directly on the cup part, in particular in the flat bottom area of the cup part, while the negative electrode, in particular an edge of the negative electrode, rests directly on the top part, in particular in the flat top area of the top part. In this example, a direct electrical and mechanical contact is made between the

electrodes and the cup and top parts. The offset arrangement of the electrodes with respect to one another therefore makes it possible for the electrodes to make contact with the respective housing parts, without any need to use additional electrical contacts and connecting means.

[0039] However, alternatively, it is also preferable for at least one of the electrodes, preferably both the at least one negative electrode and the at least one positive electrode in our button cell, to be connected to the flat bottom and top areas via one or more output conductors. By way of example, the output conductors may be output-conductor lugs composed of copper or some other suitable metal. On the electrode side, the output conductors may, for example, be connected to a current collector. The output conductors can be connected to the housing and/or to the current collectors by, for example, welding or via an clamped joint.

[0040] In the simplest case, the current collectors of the positive and negative electrodes can also themselves act as output conductors. Collectors such as these are generally metallic films or meshes which are embedded in the respective electrode material. Uncovered subareas, in particular end pieces, of collectors such as these can be bent around and can be brought into contact with the button cell housing.

[0041] The use of output conductors may be particularly advantageous if the negative electrode and the positive electrode within the assembly are arranged with respect to one another such that this results in the electrodes each being at the same distance from the flat bottom and top areas. Or, in other words, if the electrodes are not arranged offset with respect to one another within the electrode-separator assembly, as has been described above.

[0042] However, if the distance between electrodes of opposite polarity and the flat bottom and top areas is the same, this results in the risk of a positive and a negative electrode touching the metallic cup or top part at the same time, thus resulting in a short circuit. Preferably, the but-

ton cell may therefore comprise at least one insulating means, which prevents a direct mechanical and electrical contact between the end faces of the winding and the flat bottom and top areas.

[0043] In one development, it is preferable for the electrodes in our button cell such as this to be connected via the already mentioned separate output conductors to the flat bottom and top areas. These ensure the electrical contact between the electrodes and the housing.

[0044] In this case, it is preferable for at least a subsection of the output conductor or conductors in the bottom area and in the top area of the housing to rest flat on the inside of the housing half-parts. Ideally, the output conductors naturally make electrical contact with the insides of the housing when they are at least slightly pressed against the housing (if they are not welded to it in any case). This can be achieved surprisingly efficiently by a suitable arrangement of the winding core that has been mentioned, in our button cell.

[0045] By way of example, the insulating means may be a flat layer composed of plastic, for example, a plastic film, which is arranged between the end faces of the winding and the flat bottom and top areas of the housing of our button cell.

[0046] Corresponding to the above statements, the button cell is, in particular, a rechargeable button cell. Our button cell particularly preferably has at least one lithium-intercalating electrode.

[0047] The ratio of the height to the diameter of button cells is, by definition, less than 1. For our button cell, this ratio is particularly preferably between 0.1 and 0.9, in particular between 0.15 and 0.7. In this case, the height means the distance between the flat bottom area and the flat top area parallel to it. The diameter means the maximum distance between two points on the casing area of the button cell.

[0048] The button cell is particularly preferably a button cell which is not beaded over, as is described in DE Patent Application 10 2009 017 514.8, mentioned above. Correspondingly, there is preferably an exclusively force-fitting connection between the housing half-parts. Therefore, our button cell does not have a beaded-over cup edge, as is always the case with known button cells. The button cell is closed without being beaded over.

[0049] Button cells such as these which are not beaded over generally make use of conventional cell cups and cell tops, which each have a bottom area and a top area, a casing area, an edge area which is arranged between the bottom and top areas and the casing area, and a cut edge. Together, the cell cup and cell top form a housing, which forms a receptacle for the conventional internal components of a button cell, such as electrodes, separator and the like. As in the normal way, the bottom area of the cell cup and the top area of the cell top are aligned essentially parallel to one another in this housing. The casing areas of the cell cup and cell top in the finished button cell are aligned essentially at right angles to the bottom and top areas, and preferably have an essentially cylindrical geometry. The internal and external radii of the cell cup and cell top are preferably essentially constant in the casing areas. The edge areas, which have been mentioned, of the cell cup and cell top form the transition between the casing areas and the top and bottom areas. They are preferably therefore bounded on the one hand by essentially flat bottom and top areas, and on the other hand by the essentially cylindrical casing areas, which are arranged at right angles to them. By way of example, the edge areas may be in the form of a sharp edge, or else may be rounded.

[0050] The procedure for producing a button cell which is not beaded over is generally to first of all apply a seal to the casing area of a cell top. In a further step, the cell top is then inserted, with the seal fitted, into a cell cup thus resulting in an area in which the casing areas of

the cell cup and cell top overlap. The size of the overlap area and the ratio of the overlapping area to the non-overlapping areas are in this case governed by the respective height of the casing areas of the cell cup and cell top, and by the depth of the insertion. With regard to the casing area of the cell top, it is preferable for between 20% and 99%, in particular between 30% and 99%, particularly preferably between 50% and 99%, to overlap the casing area of the cell cup (the percentages each relate to the height of the casing or of the casing area). Before being inserted into the housing cup and/or the housing top, the other conventional components of a button cell (electrodes, separator, electrolyte and the like) are inserted. After the cell top has been inserted completely into the cell cup a pressure is exerted on the casing area of the cell cup, in particular in the area of the cut edge, to seal the housing. In this case, a joined-together housing part should as far as possible not be subjected to any loads, or only to very small loads, in the axial direction. Therefore, the pressure is applied in particular radially. Apart from the sealing of the housing which has already been mentioned the external diameter of the cell housing can therefore also be calibrated.

[0051] It is particularly important for the heights of the casing areas of the cell cup and cell top to be matched to one another such that the cut edge of the cell cup is pressed against the casing area of the cell top by the pressure on the casing area of the cell cup. The heights of the casing areas are therefore preferably chosen such that it is impossible to bend the cut edge of the cell cup around inward over the edge area of the cell top which has been completely inserted into the cell cup. Correspondingly, the edge of the cell cup is not beaded over the edge area of the cell top. In consequence, the cell cup of a button cell manufactured using our method has a casing area with an essentially constant radius in the direction of the cut edge.

[0052] In the case of button cells produced using a method such as this, there is preferably an exclusively force-fitting connection between the housing components comprising the cell cup, the cell top and the seal. This ensures that the components are therefore held together in a preferred manner, essentially only by static-friction force.

[0053] Button cells without any beading over are particularly preferably produced using a cell cup which is conical at least in one subarea of its casing, such that at least its internal diameter increases in the direction of the cut edge. This makes it considerably easier to insert the cell top into the cell cup. The dimensions of the cell cup and cell top are preferably matched to one another such that relatively large opposing forces preferably do not occur until the top has been inserted virtually completely into the cup. The cone angle in this case is preferably between 10 minutes and 3°, in particular between 30 minutes and 1° 30 minutes.

[0054] The cell top, which is inserted into the cell cup with the applied seal, is preferably cylindrical, at least in a part of the casing area. This may relate in particular to that part of the casing area which overlaps the conical subarea of the cell cup casing that has been mentioned, after the cell top has been inserted into the cell cup. The casing of the cell top, and therefore also the casing area, is particularly preferably entirely cylindrical. The cell top therefore preferably has a constant external radius in the casing area. This may relate in particular to that part which overlaps the conical part of the casing area of the cell cup after the cell top has been inserted.

[0055] When a cell top with a cylindrical casing area is being inserted into a cell cup which is conical at least in one subarea of its casing, as has been described above, a gap which is open at the top is generally created between the cell cup and the cell top. This gap is generally closed again by the pressure on the casing area of the cell cup. Thus, the pressure on the casing area of the cell cup may be chosen such that the conical part of the casing area of the cell cup is pushed

inward until the inside of the cell cup and the outside of the cell top are essentially at the same distance from one another in the overlapping area. The resultant button cell has casing areas which are aligned parallel to one another, in particular in the overlapping area.

[0056] One important aspect in this case is the choice of the seal which connects the cell cup to the cell top. The seal is preferably a plastic seal which connects the cell cup to the cell top. The seal is preferably a plastic seal composed of a thermoplastic.

[0057] The plastic seal is particularly preferably a film seal, for example, as is described in already cited DE 196 47 593, in particular a film seal composed of a thermoplastic.

[0058] Film seals can be produced with a very uniform thickness. When a suitable pressure is applied to the casing area of the cell cup, this results in an interference fit, as a consequence of which the button cell that has been produced has highly excellent sealing characteristics. The use of film seals makes it possible to dispense with the edge of the cell cup being beaded over without this on the other hand resulting in a need to accept disadvantages in other important characteristics.

[0059] It is very particularly preferable to use plastic seals, in particular plastic films, based on polyamide or based on polyether ether ketones in the present case.

[0060] It is preferable for the seal for a cell which is not beaded over to have an initial thickness in the range between 50 μm and 250 μm , particularly preferably between 70 μm and 150 μm , in particular about 100 μm . The term "initial thickness" is in this case intended to mean the thickness of the seal before it is applied to the casing of the cell top. In contrast to this, the term "final thickness" is intended to mean the thickness of the seal in the finished cell. It is clear that, at least in the overlapping area, this generally corresponds to the distance between the inside of the cell cup and the outside of the cell top.

[0061] To allow a sufficiently large amount of friction to be produced between the cell cup and the cell top, both the external and internal radii of the cup and top should be matched to one another and to the thickness of the film seal. This is the only way to create a sufficiently high contact pressure to hold the two individual parts together. It is preferable for the parts used in this case for the difference between the external radius of the cell top, which is to be inserted into the cell cup, on the cut edge of the cell top and the smallest internal radius of the cell cup in that part of the casing area which overlaps the casing area of the cell top to be less than the initial thickness of the seal that is used. The difference is particularly preferably between 10% and 90% of the initial thickness, in particular between 30% and 70%, and very particularly preferably about 50%.

[0062] After the cell top has been inserted into the cell cup, a part of the casing area of the cell cup can be drawn radially inward. In particular, this relates to that part of the casing area which does not overlap the casing area of the cell top.

[0063] It has been found that this process of drawing in radially makes it possible to achieve considerably better sealing characteristics. Drawing in the cup casing results in a radial pressure being exerted on the edge section which rests on the inner wall of the housing cup and on the seal which is arranged between the housing top and the housing cup, with the seal in consequence being compressed in this area.

[0064] The drawing-in process can be carried out at the same time as the already mentioned exertion of pressure on the casing area of the cell cup, although the drawing-in process is preferably carried out in a subsequent, separate step.

[0065] Our method for producing a button cell can be used in particular to produce button cells as have been described above, that is to say button cells having a housing with a flat bottom

area and a flat top area parallel to it. It is suitable for producing not only button cells which are not beaded over, but also for those which are beaded over.

[0066] With respect to the preferred examples of the individual components which are used in our method (housing parts and dimensions, electrodes, separator and the like), reference can therefore be made to the above statements and explanations in their entirety.

[0067] In general, the housing is assembled from a metallic cup part (housing cup) and a metallic top part (housing top), with an electrode-separator assembly with electrodes in the form of a flat layer being inserted into the housing such that the electrodes are aligned at right angles to the flat bottom area and top area.

[0068] As already mentioned, the electrode-separator assembly is preferably installed in the form of a winding, in particular a spiral winding.

[0069] In general, our method always comprises the following steps:

insertion of the winding into the metallic top part, and

insertion of the metallic top part with the winding into a metallic cup part.

[0070] The edge of the cup part is then optionally beaded over the edge of the top part.

[0071] When a button cell which is not beaded over is produced, the corresponding steps as described above are carried out.

[0072] Before the housing is closed, the electrodes are normally also impregnated with electrolyte solution.

[0073] For the insertion process, the winding is preferably rolled up on a winding mandrel. After or during the insertion process, the winding mandrel can then be removed. If required, the winding core that has been mentioned above is then inserted. Alternatively, the electrode-separator assembly can also be wound directly onto a core such as this.

[0074] The spiral winding is particularly preferably heat-treated on its end faces before being installed. In this case, it is at least briefly subjected to a temperature at which the separator in the winding is thermoplastically deformable. In general, the separator projects somewhat on the end faces of the winding, and this is itself subject to the precondition that the electrodes are arranged with the offset with respect to one another, as described above. The heat treatment allows the separator to be shrunk together somewhat, therefore, if required, even exposing the edge of an adjacent electrode, such that this can rest directly on the button cell housing.

[0075] The stated advantages and further advantages will become evident from the description which now follows of the drawings. In this case, individual features may be implemented on their own or in combination with one another. The described examples are intended only for explanation and better understanding, and should in no way be understood as being restrictive.

[0076] Fig. 1 schematically illustrates the cross section through one preferred example of a button cell 100. This has a metallic cup part 101 and metallic top part 102. The two parts are connected to one another, sealed by means of a seal 109. Together, they form a housing with a flat bottom area 103 and a flat top area 104 parallel to it. When in use, these flat areas 103 and 104 form the poles of the button cell, from which current can be drawn by a load. The edge 110 of the cell cup 101 is beaded inward over the edge of the cell top 102.

[0077] An arrangement comprising an electrode 105 in the form of a strip, an electrode 106 in the form of a strip, and the separators 107 in the form of strips is arranged in the interior of the electrode. The assembly comprising the electrodes 105 and 106 as well as the separators 107 is in this case in the form of a winding, whose end faces abut against the flat bottom area 103 and the flat top area 104, which is parallel to it. The assembly is wound up on the core 108 in the center of the button cell 100. Both the core 108 as well as the electrodes and separators which

are wound around it are aligned at right angles to the flat bottom and top areas 104 and 103. When the volume of the electrodes increases or decreases during a charging or discharging process, the mechanical forces which result in this case act predominantly radially, and can be absorbed by the casing area of the button cell 100.

[0078] It should be stressed that the positive electrode 105 and the negative electrode 106 respectively rest directly on the cup part 101 and on the top part 102 of the button cell 100. There is no need for a separate output conductor for connecting the electrodes to the top part 102 and to the cup part 101.

[0079] Fig. 2 shows the effect of the heat treatment of an electrode-separator winding 200, which is provided in preferred examples of the method for producing a button cell. The illustration schematically shows a winding 200 comprising an assembly of a positive electrode 201 (bar with cross strips), a negative electrode 202 (white bar) and the separators 203 (detail). The positive and the negative electrodes 201 and 202 are in each case arranged offset with respect to one another. The separators 203 are composed of a thermoplastically deformable material.

[0080] When the separator edges which are located on the end faces 204 and 205 of the winding 200 are subjected to a high temperature (for example, of 250°C, as illustrated), then these separator edges shrink. The separators are drawn in at least partially between adjacent electrodes. In the process, the edges of the negative electrode 202 are exposed on the end face 204, while the edges of the positive electrode 201 are covered. The edges of the positive electrode 201 on the end face 205 are exposed, while the edges of the negative electrode 202 are covered.

[0081] When a winding that has been treated in this way is in use, this ensures that electrodes of the same polarity can each rest directly only on the housing cup or on the housing top. There is no need for separate electrical connections between the electrodes and the housing parts.

[0082] Fig. 3 shows an electrode-separator assembly for button cells in the form of a winding 300, with the illustration A depicting a plan view vertically from above at one of the end faces 301 of the winding 300, while the illustration B shows the winding 300 in a view obliquely from above. In both cases, this shows that the assembly comprises two layers; separators 302 and 303 as well as two electrode layers 304 and 305 (a positive and a negative electrode). The assembly is wound up in a spiral shape and is held together by an adhesive tape 306 on its outside.

[0083] Fig. 4 shows a sectioned illustration of one preferred example of a button cell 400. The figure shows the housing of the button cell comprising the cup part 401 and the top part 402, between which the seal 403 is arranged. An assembly of electrodes and separators, as is illustrated in Fig. 3, is contained as a spiral winding 404 (illustrated schematically in the cross section) within the housing. The separator layers 405 and 406 as well as the electrodes 407 and 408 of opposite polarity can also be seen well here. In this case, the electrode 407 is connected via the output conductor 410 to the top part 402, while the electrode 408 is connected via the output conductor 409 to the cup part 402. The output conductor 410 is preferably welded to the top part 402. In contrast, the output conductor 409 is connected to the cup part 402 via a clamping connection (it is clamped inbetween the supporting ring 413, on which the edge of the cell top rests, and the bottom of the cell cup). The insulating means 411 and 412 are arranged between the end faces of the winding and the cup part 401 and the top part 402, and are each in the form of thin plastic disks. This prevents electrodes of opposite polarity from being able to come into contact with the cup part 401 or the top part 402 at the same time. This prevents any short circuit.

[0084] Fig. 5 schematically illustrates the cross section through one preferred example of a button cell 500.

[0085] This button cell 500 has a metallic cup part 501 and a metallic top part 502. The two parts are connected to one another, sealed by means of a seal 510. Together, they form a housing with a flat bottom area 503 and a flat top area 504 parallel to it. When in use, these flat areas 503 and 504 form the poles of the button cell, from which current can be drawn by a load.

[0086] The cell top 502 is inserted into the cell cup 501 such that the casing areas of the cell top and of the cell cup overlap, with the internal radius of the cell cup 501 in the overlapping area being essentially constant in the direction of the cut edge. Therefore, the edge of the cell cup 501 is not beaded over the edge 511 of the cell top 502, and the preferred example described above for a button cell 500 is therefore a button cell which is not beaded over.

[0087] An assembly comprising an electrode 508 in the form of a strip, an electrode 509 in the form of a strip and separators 507 in the form of strips is arranged in the interior of the electrode. The assembly comprising the electrodes 508 and 509 as well as the separators 507 is in this case in the form of a winding, whose end faces face in the direction of the flat bottom area 503 and of the flat top area 504 which is parallel to it. The assembly is wound up on the winding core 512 in the center of the button cell 500. Both the core 512 and the electrodes and separators which are wound around it are aligned at right angles to the flat bottom and top areas 504 and 503. If the volume of the electrodes increases or decreases during a charging or discharging process, the mechanical forces which result in this case act predominantly radially, and can be absorbed by the casing area of the button cell 500.

[0088] The positive and the negative electrodes make contact with the housing half-part comprising the cup and top via the output conductor 505 and the output conductor 506. The out-

put conductor 505 is composed of aluminum, and the output conductor 506 is composed of nickel (or alternatively of copper). Both output conductors are thin films, which rest flat between the end faces of the winding and the flat top and bottom areas 503 and 504. A continuous slight contact pressure is maintained on the output conductors by the winding core 512. The output conductors are preferably separated from the end faces of the winding by a separate insulator arrangement (not illustrated in the drawing), for example, by a thin film.

Abstract (Clean)

A button cell includes a housing cup and a housing top separated from one another by an electrically insulating seal and which form a housing with a flat bottom area and a flat top area parallel to it and an electrode-separator assembly within the housing including at least one positive and at least one negative electrode in the form of flat layers and connected to one another by at least one flat separator, wherein the electrode layers are aligned essentially at right angles to the flat bottom and top areas and the button cell is closed without being beaded over.

Vorab per Telefax

PCT

ANTRAG

Der Unterzeichnete beantragt, daß die vorliegende internationale Anmeldung nach dem Vertrag über die internationale Zusammenarbeit auf dem Gebiet des Patentwesens behandelt wird.

Vom Anmeldeamt auszufüllen

PCT/EP2010 / 000787 Internationales Aktenzeichen
09 FEB 2010 (09. 02. 10) Internationales Anmeldedatum
RO/EP Name des Anmeldeamts und "PCT International Application"
Aktenzeichen des Anmelders oder Anwahls (falls gewünscht) (max. 12 Zeichen) P 49226 WO

Feld Nr. I BEZEICHNUNG DER ERFINDUNG	
Knopfzellen und Verfahren zu ihrer Herstellung	
Feld Nr. II ANMELDER <input type="checkbox"/> Diese Person ist gleichzeitig Erfinder	
Name und Anschrift: (Familienname, Vorname; bei juristischen Personen vollständige amtliche Bezeichnung. Bei der Anschrift sind die Postleitzahl und der Name des Staats anzugeben. Der in diesem Feld in der Anschrift angegebene Staat ist der Staat des Sitzes oder Wohnsitzes des Anmelders, sofern nachstehend kein Staat des Sitzes oder Wohnsitzes angegeben ist.)	Telefonnr.:
VARTA Microbattery GmbH Am Leineufer 51 30419 Hannover	Telefaxnr.:
	Registrierungsnr. des Anmelders beim Amt:
<input type="checkbox"/> E-Mail-Ermächtigung: Durch Ankreuzen dieses Kästchens werden das Anmeldeamt, die Internationale Recherchenbehörde, das Internationale Büro und die mit der internationalen vorläufigen Prüfung beauftragte Behörde ermächtigt, die in diesem Feld angegebene E-Mail-Adresse zu benutzen, um Vorkopien von Mitteilungen bezüglich dieser internationalen Anmeldung zu übersenden, soweit das Amt oder die Behörde dazu bereit ist (s. auch die Anmerkungen zu den Feldern Nr. II und Nr. III).	E-Mail-Adresse
Staatsangehörigkeit (Staat):	Sitz oder Wohnsitz (Staat):
	Deutschland
Diese Person ist Anmelder für folgende Staaten: <input type="checkbox"/> alle Bestimmungsstaaten <input checked="" type="checkbox"/> alle Bestimmungsstaaten mit Ausnahme der Vereinigten Staaten von Amerika <input type="checkbox"/> nur die Vereinigten Staaten von Amerika <input type="checkbox"/> die im Zusatzfeld angegebenen Staaten	
Feld Nr. III WEITERE ANMELDER UND/ODER (WEITERE) ERFINDER	
<input checked="" type="checkbox"/> Weitere Anmelder und/oder (weitere) Erfinder sind auf einem Fortsetzungsblatt angegeben.	
Feld Nr. IV ANWALT ODER GEMEINSAMER VERTRETER; ODER ZUSTELLANSCHRIFT	
Die folgende Person wird (hiermit) bestellt/ist bestellt worden, um für den (die) Anmelder vor den zuständigen internationalen Behörden in folgender Eigenschaft zu handeln als:	<input checked="" type="checkbox"/> Anwalt <input type="checkbox"/> gemeinsamer Vertreter
Name und Anschrift: (Familienname, Vorname; bei juristischen Personen vollständige amtliche Bezeichnung. Bei der Anschrift sind die Postleitzahl und der Name des Staats anzugeben.)	Telefonnr.:
Dr. Michael Eberle Patentanwälte Ruff, Wilhelm, Beier, Dauster & Partner Postfach 10 40 36 D-70035 Stuttgart	0711 / 22 29 76 - 0
	Telefaxnr.:
	0711 / 22 29 76 76
	Registrierungsnr. des Anwalts beim Amt:
	Zusammenschluss-Nr. 16
<input type="checkbox"/> E-Mail-Ermächtigung: Durch Ankreuzen dieses Kästchens werden das Anmeldeamt, die Internationale Recherchenbehörde, das Internationale Büro und die mit der internationalen vorläufigen Prüfung beauftragte Behörde ermächtigt, die in diesem Feld angegebene E-Mail-Adresse zu benutzen, um Vorkopien von Mitteilungen bezüglich dieser internationalen Anmeldung zu übersenden, soweit das Amt oder die Behörde dazu bereit ist (s. auch die Anmerkungen zu den Feldern Nr. II und Nr. III).	E-Mail-Adresse
	mail@kronenpat.de
<input type="checkbox"/> Zustellanschrift: Dieses Kästchen ist anzukreuzen, wenn kein Anwalt oder gemeinsamer Vertreter bestellt ist und statt dessen im obigen Feld eine spezielle Zustellanschrift angegeben ist.	

Formblatt PCT/RO/101 (Blatt 1) (Juli 2008)

Siehe Anmerkungen zu diesem Antragsformular

BESTÄTIGUNGSKOPIE

Feld Nr. III WEITERE ANMELDER UND/ODER (WEITERE) ERFINDER	
<i>Wird keines der folgenden Felder benutzt, so sollte dieses Blatt dem Antrag nicht beigelegt werden.</i>	
Name und Anschrift: (Familienname, Vorname; bei juristischen Personen vollständige amtliche Bezeichnung. Bei der Anschrift sind die Postleitzahl und der Name des Staats anzugeben. Der in diesem Feld in der Anschrift angegebene Staat ist der Staat des Sitzes oder Wohnsitzes des Anmelders, sofern nachstehend kein Staat des Sitzes oder Wohnsitzes angegeben ist.) Eduard Pytlík Alemannenstraße 7 73479 Ellwangen	Diese Person ist: <input type="checkbox"/> nur Anmelder <input checked="" type="checkbox"/> Anmelder und Erfinder <input type="checkbox"/> nur Erfinder (Wird dieses Kästchen angekreuzt, so sind die nachstehenden Angaben nicht nötig.) Registrierungsnr. des Anmelders beim Amt:
Staatsangehörigkeit (Staat): DE	Sitz oder Wohnsitz (Staat): DE
Diese Person ist Anmelder für folgende Staaten: <input type="checkbox"/> alle Bestimmungsstaaten <input type="checkbox"/> alle Bestimmungsstaaten mit Ausnahme der Vereinigten Staaten von Amerika <input checked="" type="checkbox"/> nur die Vereinigten Staaten von Amerika <input type="checkbox"/> die im Zusatzfeld angegebenen Staaten	
Name und Anschrift: (Familienname, Vorname; bei juristischen Personen vollständige amtliche Bezeichnung. Bei der Anschrift sind die Postleitzahl und der Name des Staats anzugeben. Der in diesem Feld in der Anschrift angegebene Staat ist der Staat des Sitzes oder Wohnsitzes des Anmelders, sofern nachstehend kein Staat des Sitzes oder Wohnsitzes angegeben ist.) Jürgen Lindner Kottenwiesen 9 73479 Ellwangen	Diese Person ist: <input type="checkbox"/> nur Anmelder <input checked="" type="checkbox"/> Anmelder und Erfinder <input type="checkbox"/> nur Erfinder (Wird dieses Kästchen angekreuzt, so sind die nachstehenden Angaben nicht nötig.) Registrierungsnr. des Anmelders beim Amt:
Staatsangehörigkeit (Staat): DE	Sitz oder Wohnsitz (Staat): DE
Diese Person ist Anmelder für folgende Staaten: <input type="checkbox"/> alle Bestimmungsstaaten <input type="checkbox"/> alle Bestimmungsstaaten mit Ausnahme der Vereinigten Staaten von Amerika <input checked="" type="checkbox"/> nur die Vereinigten Staaten von Amerika <input type="checkbox"/> die im Zusatzfeld angegebenen Staaten	
Name und Anschrift: (Familienname, Vorname; bei juristischen Personen vollständige amtliche Bezeichnung. Bei der Anschrift sind die Postleitzahl und der Name des Staats anzugeben. Der in diesem Feld in der Anschrift angegebene Staat ist der Staat des Sitzes oder Wohnsitzes des Anmelders, sofern nachstehend kein Staat des Sitzes oder Wohnsitzes angegeben ist.) Ulrich Barenthin Bahnhofstraße 6/1 73479 Ellwangen	Diese Person ist: <input type="checkbox"/> nur Anmelder <input checked="" type="checkbox"/> Anmelder und Erfinder <input type="checkbox"/> nur Erfinder (Wird dieses Kästchen angekreuzt, so sind die nachstehenden Angaben nicht nötig.) Registrierungsnr. des Anmelders beim Amt:
Staatsangehörigkeit (Staat): DE	Sitz oder Wohnsitz (Staat): DE
Diese Person ist Anmelder für folgende Staaten: <input type="checkbox"/> alle Bestimmungsstaaten <input type="checkbox"/> alle Bestimmungsstaaten mit Ausnahme der Vereinigten Staaten von Amerika <input checked="" type="checkbox"/> nur die Vereinigten Staaten von Amerika <input type="checkbox"/> die im Zusatzfeld angegebenen Staaten	
Name und Anschrift: (Familienname, Vorname; bei juristischen Personen vollständige amtliche Bezeichnung. Bei der Anschrift sind die Postleitzahl und der Name des Staats anzugeben. Der in diesem Feld in der Anschrift angegebene Staat ist der Staat des Sitzes oder Wohnsitzes des Anmelders, sofern nachstehend kein Staat des Sitzes oder Wohnsitzes angegeben ist.) Winfried Gaugier Birklen 26 73479 Ellwangen	Diese Person ist: <input type="checkbox"/> nur Anmelder <input checked="" type="checkbox"/> Anmelder und Erfinder <input type="checkbox"/> nur Erfinder (Wird dieses Kästchen angekreuzt, so sind die nachstehenden Angaben nicht nötig.) Registrierungsnr. des Anmelders beim Amt:
Staatsangehörigkeit (Staat): DE	Sitz oder Wohnsitz (Staat): DE
Diese Person ist Anmelder für folgende Staaten: <input type="checkbox"/> alle Bestimmungsstaaten <input type="checkbox"/> alle Bestimmungsstaaten mit Ausnahme der Vereinigten Staaten von Amerika <input checked="" type="checkbox"/> nur die Vereinigten Staaten von Amerika <input type="checkbox"/> die im Zusatzfeld angegebenen Staaten	
<input type="checkbox"/> Weitere Anmelder und/oder (weitere) Erfinder sind auf einem zusätzlichen Fortsetzungsblatt angegeben.	

Feld Nr. V BESTIMMUNGEN				
Die Einreichung dieses Antrags umfasst gemäß Regel 4.9 Absatz a die Bestimmung aller Vertragsstaaten, für die der PCT am internationalen Anmeldedatum verbindlich ist, und insoweit verfügbar, für jede Art von Schutzrecht und sowohl für ein regionales als auch für ein nationales Patent.				
Dennoch wird				
<input type="checkbox"/> DE Deutschland nicht für ein nationales Schutzrecht bestimmt				
<input type="checkbox"/> JP Japan nicht für ein nationales Schutzrecht bestimmt				
<input type="checkbox"/> KR Republik Korea nicht für ein nationales Schutzrecht bestimmt				
<input type="checkbox"/> RU Russische Föderation nicht für ein nationales Schutzrecht bestimmt				
<i>(Obstehende Kästchen können nur angekreuzt werden, um die betreffenden Bestimmungen (unwiderruflich) auszuschließen, falls die internationale Anmeldung, zum Zeitpunkt ihrer Einreichung oder nachträglich gemäß Regel 26bis.1, in Feld Nr. VI die Priorität einer in dem betreffenden Staat eingereichten früheren nationalen Anmeldung beansprucht, um zu vermeiden, daß diese frühere nationale Anmeldung nach nationalem Recht ihre Wirkung verliert).</i>				
Feld Nr. VI PRIORITÄTSANSPRUCH				
Die Priorität der folgenden früheren Anmeldung(en) wird hiermit in Anspruch genommen:				
Anmeldedatum der früheren Anmeldung (Tag/Monat/Jahr)	Aktenzeichen der früheren Anmeldung	Ist die frühere Anmeldung eine:		
		nationale Anmeldung: Staat oder Mitglied der WTO	regionale Anmeldung: regionales Amt	internationale Anmeldung: Anmeldeamt
Zeile (1) 09.02.2009	102009008859.8	Deutschland		
Zeile (2) 18.06.2009	102009030359.6	Deutschland		
Zeile (3) 22.12.2009	102009060788.9	Deutschland		
Zeile (4)				
<input type="checkbox"/> Weitere Prioritätsansprüche sind im Zusatzfeld angegeben.				
Übermittlung einer beglaubigten Abschrift: Das Anmeldeamt wird ersucht, eine beglaubigte Abschrift der oben bezeichneten früheren Anmeldung(en) zu erstellen und dem internationalen Büro zu übermitteln (nur falls die frühere Anmeldung(en) bei dem Amt eingereicht worden ist (sind), das für die Zwecke dieser internationalen Anmeldung Anmeldeamt ist):				
<input type="checkbox"/> sämtliche Zeilen <input type="checkbox"/> Zeile (1) <input type="checkbox"/> Zeile (2) <input type="checkbox"/> Zeile (3) <input type="checkbox"/> Zeile (4) <input type="checkbox"/> weitere, siehe Zusatzfeld				
Wiederherstellung des Prioritätsrechts: Das Anmeldeamt wird ersucht, das Prioritätsrecht der oben bezeichneten oder im Zusatzfeld unter Punkt(e) (.....) angegebenen früheren Anmeldung(en) wiederherzustellen. (Siehe auch die Anmerkungen zu Feld Nr. VI; weitere Angaben zur Begründung des Antrags auf Wiederherstellung des Prioritätsrechts sind einzureichen.)				
Einbeziehung durch Verweis: Ist ein in Artikel 11 Absatz 1 Ziffer iii Buchstabe d oder e genannter Bestandteil der internationalen Anmeldung oder ein in Regel 20.5 Absatz a genannter Teil der Beschreibung, der Ansprüche oder der Zeichnungen nicht anderswo in der internationalen Anmeldung, aber vollständig in einer früheren Anmeldung enthalten, deren Priorität, zu dem Datum, an dem ein oder mehrere in Artikel 11 Absatz 1 Ziffer iii genannte Bestandteile zuerst beim Anmeldeamt eingegangen sind, beansprucht wird, so wird dieser Bestandteil oder Teil, vorbehaltlich der Bestätigung nach Regel 20.6, für die Zwecke der Regel 20.6 in diese internationale Anmeldung einbezogen.				
Feld Nr. VII INTERNATIONALE RECHERCHENBEHÖRDE				
Wahl der internationalen Recherchenbehörde (ISA) (falls mehr als eine internationale Recherchenbehörden für die Ausführung der internationalen Recherche zuständig ist, gehen Sie die von Ihnen gewählte Behörde an; der Zweibuchstaben-Code kann benutzt werden):				
ISA / EP				

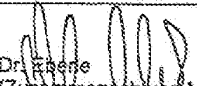
Feld Nr. IX KONTROLLISTE; EINREICHUNGSSPRACHE		Anzahl
Diese internationale Anmeldung enthält:		
(a) auf Papier, die folgende Anzahl Blätter:		
Antrag (inklusive Erklärungs- und Zusatzblätter) :	4	
Beschreibung (ohne Sequenzprotokoll und/oder diesbezügliche Tabellen) :	23	
Ansprüche :	3	
Zusammenfassung :	1	
Zeichnungen :	3	
Teilanzahl :	34	
Sequenzprotokoll :		
diesbezügliche Tabellen :		
<i>(für beide, Anzahl der Blätter, soweit auf Papier eingereicht wird, unabhängig davon, ob zusätzlich auch in elektronischer Form eingereicht wird; siehe unter (c))</i>		
Gesamtanzahl :	34	
(b) <input type="checkbox"/> ausschließlich in elektronischer Form (Abschnitt 801(a)(i))		
(i) <input type="checkbox"/> Sequenzprotokoll		
(ii) <input type="checkbox"/> diesbezügliche Tabellen		
(c) <input type="checkbox"/> auch in elektronischer Form (Abschnitt 801(a)(ii))		
(i) <input type="checkbox"/> Sequenzprotokoll		
(ii) <input type="checkbox"/> diesbezügliche Tabellen		
Art und Anzahl der Datenträger (Diskette, CD-ROM, CD-R oder sonstige) auf denen sich befinden		
(i) <input type="checkbox"/> Sequenzprotokoll:		
(ii) <input type="checkbox"/> diesbezügliche Tabellen:		
<i>(zusätzliche eingereichte Kopien unter Punkt 9(ii) und/oder 10(ii) in der rechten Spalte angeben)</i>		
Abbildung der Zeichnungen, die mit der Zusammenfassung veröffentlicht werden soll (Nr.):		5
Sprache, in der die internationale Anmeldung eingereicht wird:		Deutsch
Feld Nr. X UNTERSCHRIFT DES ANMELDERS, DES ANWALTS ODER DES GEMEINSAMEN VERTRETERS		
<i>Der Name jeder unterzeichnenden Person ist neben der Unterschrift zu wiederholen, und es ist anzugeben, sofern sich dies nicht eindeutig aus dem Antrag ergibt, in welcher Eigenschaft die Person unterzeichnet.</i>		
 Dr. Ebene (Zusatzunterschrift Nr. 16)		
Vom Anmeldeamt auszufüllen		
1. Datum des tatsächlichen Eingangs dieser internationalen Anmeldung:		09 FEB 2010 (09. 02. 10)
3. Geändertes Eingangsdatum aufgrund nachträglich, jedoch fristgerecht eingegangener Unterlagen oder Zeichnungen zur Vervollständigung dieser internationalen Anmeldung:		<input checked="" type="checkbox"/> eingegangen:
4. Datum des fristgerechten Eingangs der angeforderten Richtigstellungen nach Artikel 11(2) PCT:		<input type="checkbox"/> nicht eingegangen:
5. Internationale Recherchenbehörde (falls zwei oder mehr zuständig sind):	ISA /	
6. <input type="checkbox"/> Übermittlung des Recherchenexemplars bis zur Zahlung der Recherchegebühr aufgeschoben		
Vom Internationalen Büro auszufüllen		
Datum des Eingangs des Aktenexemplars beim Internationalen Büro:		

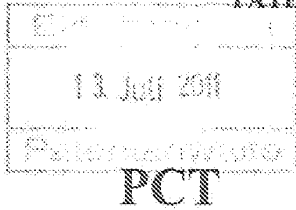

From the INTERNATIONAL BUREAU

NOTIFICATION OF THE RECORDING
OF A CHANGE

(PCT Rule 92bis.1 and
Administrative Instructions, Section 422)

To:
EBERLE, Michael
Ruff, Wilhelm, Beier, Dauster & Partner
Postfach 10 40 36
70035 Stuttgart
ALLEMAGNE

Date of mailing (day/month/year) 01 July 2011 (01.07.2011)	IMPORTANT NOTIFICATION
Applicant's or agent's file reference P 49226 WO	
International application No. PCT/EP2010/000787	International filing date (day/month/year) 09 February 2010 (09.02.2010)

1. The following indications appeared on record concerning:

the applicant the inventor the agent the common representative

Name and Address VARTA MICROBATTERY GMBH Am Leinufer 51 30419 Hannover Germany	State of Nationality DE	State of Residence DE
	Telephone No.	
	Facsimile No.	
	E-mail address	

2. The international Bureau hereby notifies the applicant that the following change has been recorded concerning:

the person the name the address the nationality the residence

Name and Address VARTA MICROBATTERY GMBH Daimlerstraße 1 73479 Ellwangen Germany	State of Nationality DE	State of Residence DE
	Telephone No.	
	Facsimile No.	
	E-mail address <input type="checkbox"/> Notifications by e-mail authorized	

3. Further observations, if necessary:

4. A copy of this notification has been sent to:

the receiving Office the International Preliminary Examining Authority
 the International Searching Authority the designated Offices concerned
 the Authority(ies) specified for supplementary search the elected Offices concerned
 other:

The International Bureau of WIPO 34, chemin des Colombettes 1211 Geneva 20, Switzerland	Authorized officer Happe Isabel e-mail pt06.pct@wipo.int Telephone No. +41 22 338 74 06
---	--

(12) NACH DEM VERTRAG ÜBER DIE INTERNATIONALE ZUSAMMENARBEIT AUF DEM GEBIET DES PATENTWESENS (PCT) VERÖFFENTLICHTE INTERNATIONALE ANMELDUNG

(19) Weltorganisation für geistiges Eigentum
Internationales Büro



(43) Internationales Veröffentlichungsdatum
12. August 2010 (12.08.2010)

(10) Internationale Veröffentlichungsnummer
WO 2010/089152 A1

- (51) Internationale Patentklassifikation:
H01M 10/04 (2006.01) *H01M 2/02* (2006.01)
- (21) Internationales Aktenzeichen: PCT/EP2010/000787
- (22) Internationales Anmeldedatum:
9. Februar 2010 (09.02.2010)
- (25) Einreichungssprache: Deutsch
- (26) Veröffentlichungssprache: Deutsch
- (30) Angaben zur Priorität:
10 2009 008 859.8
9. Februar 2009 (09.02.2009) DE
10 2009 030 359.6 18. Juni 2009 (18.06.2009) DE
10 2009 060 788.9
22. Dezember 2009 (22.12.2009) DE
- (71) Anmelder (für alle Bestimmungsstaaten mit Ausnahme von US): VARTA MICROBATTERY GMBH [DE/DE]; Am Leinulfert 51, 30419 Hannover (DE).
- (72) Erfinder; und
- (75) Erfinder/Anmelder (nur für US): FYLIK, Eduard [DE/DE]; Alemannenstrasse 7, 73479 Ellwangen (DE). LINDNER, Jürgen [DE/DE]; Kottenwiesen 9, 73479 Ellwangen (DE). BARENTHIN, Ulrich [DE/DE]; Bahm-
- hofstrasse 6/1, 73479 Ellwangen (DE). GAUGLER, Winfried [DE/DE]; Birken 26, 73479 Ellwangen (DE).
- (74) Anwalt: EBERLE, Michael; Ruff, Wilhelm, Beier, Dauster & Partner, Postfach 10 40 36, 70035 Stuttgart (DE).
- (81) Bestimmungsstaaten (soweit nicht anders angegeben, für jede verfügbare nationale Schutzrechtsart): AE, AG, AL, AM, AO, AT, AU, AZ, BA, BB, BG, BH, BR, BW, BY, BZ, CA, CH, CL, CN, CO, CR, CU, CZ, DE, DK, DM, DO, DZ, EC, EE, EG, ES, FI, GB, GD, GE, GH, GM, GT, HN, HR, HU, ID, IL, IN, IS, JP, KE, KG, KM, KN, KP, KR, KZ, LA, LC, LK, LR, LS, LT, LU, LY, MA, MD, ME, MG, MK, MN, MW, MX, MY, MZ, NA, NG, NI, NO, NZ, OM, PE, PG, PH, PL, PT, RO, RS, RU, SC, SD, SE, SG, SK, SL, SM, ST, SV, SY, TH, TJ, TM, TN, TR, TT, TZ, UA, UG, US, UZ, VC, VN, ZA, ZM, ZW.
- (84) Bestimmungsstaaten (soweit nicht anders angegeben, für jede verfügbare regionale Schutzrechtsart): ARIPO (BW, GH, GM, KE, LS, MW, MZ, NA, SD, SL, SZ, TZ, UG, ZM, ZW), eurasisches (AM, AZ, BY, KG, KZ, MD, RU, TJ, TM), europäisches (AT, BE, BG, CH, CY, CZ, DE, DK, EE, ES, FI, FR, GB, GR, HR, HU, IE, IS, IT, LT, LU, LV, MC, MK, MT, NL, NO, PL, PT, RO, SE, SI, SK, SM, TR), OAPI (BF, BJ, CF, CG, CI, CM, GA, GN, GQ, GW, ML, MR, NE, SN, TD, TG).

[Fortsetzung auf der nächsten Seite]

(54) Title: BUTTON CELLS AND METHOD FOR PRODUCING SAME

(54) Bezeichnung : KNOPFZELLEN UND VERFAHREN ZU IHRER HERSTELLUNG

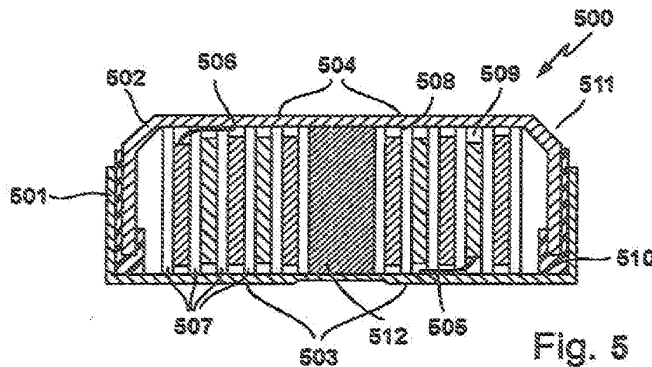

Fig. 5

(57) Abstract: A button cell (100; 400; 500) is described, comprising two metal housing halves (101, 102; 401, 402; 501, 502), which are sealingly connected to each other and form a housing having a planar base area (103; 503) and a planar cover area (104; 504) parallel thereto, wherein positive and negative electrodes (105, 106; 201, 202; 304, 305; 407, 408; 508, 509) are arranged as flat layers inside the housing and are connected to each other via an areal separator (107; 203; 302, 303; 403, 406; 507), wherein the electrode layers have an orthogonal orientation relative to the planar base and cover areas. Furthermore, a method for producing such a button cell is described.

(57) Zusammenfassung:

[Fortsetzung auf der nächsten Seite]

WO 2010/089152 A1

Veröffentlicht:

— mit internationalem Recherchenbericht (Artikel 21 Absatz 3)

Beschrieben wird eine Knopfzelle (100; 400; 500), umfassend zwei metallische Gehäuseteile (101, 102; 401, 402; 501, 502), welche dichtend miteinander verbunden sind und ein Gehäuse mit einem ebenen Bodenbereich (103; 503) und einem dazu parallelen ebenen Deckelbereich (104; 504) ausbilden, wobei innerhalb des Gehäuses als flache Schichten ausgebildete positive und negative Elektroden (105, 106; 201, 202; 304, 305; 407, 408; 508, 509) angeordnet sind, die über einen flächigen Separator (107; 203; 302, 303; 405, 406; 507) miteinander verbunden sind, wobei die Elektrodenschichten orthogonal zu dem ebenen Boden- und Deckelbereich ausgerichtet sind. Weiterhin wird ein Verfahren zur Herstellung einer solchen Knopfzelle beschrieben.

INTERNATIONAL SEARCH REPORT

International application No
PCT/EP2010/000787

<p>A. CLASSIFICATION OF SUBJECT MATTER INV. HOIM10/04 HOIM2/02 ADD.</p>		
<p>According to international Patent Classification (IPC) or to both national classification and IPC</p>		
<p>B. FIELDS SEARCHED</p>		
<p>Minimum documentation searched (classification system followed by classification symbols): HOIM</p>		
<p>Documentation searched other than minimum documentation to the extent that such documents are included in the fields searched</p>		
<p>Electronic data base consulted during the international search (name of data base and, where practicable, search terms used): EPO-Internal</p>		
<p>C. DOCUMENTS CONSIDERED TO BE RELEVANT</p>		
Category*	Citation of document, with indication, where appropriate, of the relevant passages	Relevant to claim No.
X	US 6 265 100 B1 (SAASKI ELRIC W [US] ET AL) 24 July 2001 (2001-07-24) column 5, lines 31-60 column 24, line 9 - column 26, line 18 column 26, line 35 - column 29, line 57	1-13
A	DE 198 57 638 A1 (VARTA GERAETEBATTERIE GMBH [DE]) 15 June 2000 (2000-06-15) the whole document	1-14
<p><input type="checkbox"/> Further documents are listed in the continuation of Box C. <input checked="" type="checkbox"/> See patent family annex.</p>		
<p>* Special categories of cited documents:</p> <p>"A" document defining the general state of the art which is not considered to be of particular relevance "E" earlier document but published on or after the international filing date "L" document which may throw doubts on priority claim(s) or which is cited to establish the publication date of another citation or other special reason (as specified) "O" document referring to an oral disclosure, use, exhibition or other means "P" document published prior to the international filing date but later than the priority date claimed</p> <p>"T" later document published after the international filing date or priority date and not in conflict with the application but cited to understand the principle or theory underlying the invention "X" document of particular relevance: the claimed invention cannot be considered novel or cannot be considered to involve an inventive step when the document is taken alone "Y" document of particular relevance: the claimed invention cannot be considered to involve an inventive step when the document is combined with one or more other such documents, such combination being obvious to a person skilled in the art. "&" document member of the same patent family</p>		
<p>Date of the actual completion of the international search</p> <p>11 May 2010</p>		<p>Date of mailing of the international search report</p> <p>19/05/2010</p>
<p>Name and mailing address of the ISA/ European Patent Office, P.B. 5815 Patentlaan 2 NL - 2280 HV Rijswijk Tel: (+31-70) 340-2040 Fax: (+31-70) 340-3016</p>		<p>Authorized officer</p> <p>Panitz, J</p>

INTERNATIONAL SEARCH REPORT

Information on patent family members

International application No
PCT/EP2010/000787

Patent document cited in search report	Publication date	Patent family member(s)	Publication date
US 6265100	B1	24-07-2001	US 6310960 B1 30-10-2001
DE 19857638	A1	15-06-2000	AT 246404 T 15-08-2003
			BR 9908650 A 17-10-2000
			CA 2292108 A1 14-06-2000
			CN 1264185 A 23-08-2000
			EP 1011163 A1 21-06-2000
			JP 2000182659 A 30-06-2000
			KR 20000047704 A 25-07-2000
			US 6312848 B1 06-11-2001

Deutsches Patent- und Markenamt

München, den 08.10.2009
Telefon: (0 89) 2195 3756
Anmelder/inhaber: VARTA Microbattery GmbH

Ihr Zeichen: P 49 226 DE

Deutsches Patent- und Markenamt · 80297 München

Ihr Antrag vom: 09.02.2009
auf Recherche gemäß §43 Patentgesetz

Herren Patentanwälte
Ruff, Wilhelm, Beier, Dauster
& Partner
Kronenstr. 30
70174 Stuttgart

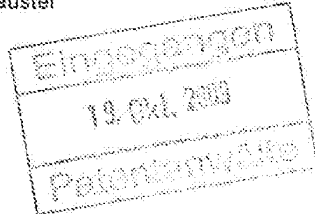

Bitte Aktenzeichen und Anmelder/inhaber bei
allen Eingaben und Zahlungen angeben

Aktenzeichen: 10 2009 008 859.8

Recherchebericht

A. Klassifizierung des Anmeldegegenstandes nach der Internationalen Patentklassifikation (IPC)

IPC 08
H 01 M 10/38 01.01.2006
H 01 M 10/40 01.01.2006

B. Recherchierte Gebiete

Klasse/Gruppe	Prüfer	Patentabteilung
H 01 M 10/38	Fred Spann	45

Die Recherche im Deutschen Patent- und Markenamt stützt sich auf die in der Recherchedatenbank von DEPATIS verfügbare Patentliteratur
(siehe hierzu die Informationen im Internet www.depatinet.de-Information>Datenbestand).

Recherchiert wurde in folgenden Datenbanken:

Name der Datenbank und des Hosts

DOKIDX

Klassen/Gruppen, die in Abschnitt A aufgeführt sind, jedoch in Abschnitt B nicht ausdrücklich erwähnt werden, wurden entweder durch eine IPC-übergreifende Datenbankrecherche erfasst oder dienen lediglich der Dokumentation und Information. In Klassen/Gruppen, die in Abschnitt B aufgeführt sind, jedoch nicht in Abschnitt A genannt sind, wurde mit dem im Abschnitt C angegebenen Ergebnis recherchiert.

Dokumentenaufnahme und Nachbriefkasten nur Zweibrückenstraße 12	Hauptgebäude: Zweibrückenstraße 12 Markenabteilungen: Cincinnatistr. 64 81534 München	Hausadresse (für Fracht): Deutsches Patent- und Markenamt Zweibrückenstraße 12 80331 München	Telefon: (089) 2195-0 Telefax: (089) 2195-2221 Internet: http://www.dpma.de	Zahlungsempfänger: Bundeskasse Weiden BSK München Kto.Nr.: 700 010 54 BLZ: 700 200 00 BIC (SWIFT-Code): MARKDEF1700 IBAN: DE84 7000 0000 0070 0010 54
S-Bahnanschluss im Münchner Verkehrs- u. Tarifverbund (MUV):	Zweibrückenstr. 12 (Hauptgebäude): S1 - S8 Haltestelle Isartor	Schwab-Röhrer-Straße 37 Cincinnatistr. 34		

C. Ergebnis der Druckschriftenermittlung

Kat.	Ermittelte Druckschriften	Erfäuterungen	Betr. Ansprüche	IPC / Fundstellen	IPC-Datum
X	DE 14 71 758 A	S. 5, letzter Abs., Anspr. 7	1-4, 7, 9, 10		
Y	EP 697 00 312 T2	Fig. 1, 2	5		
Y	EP 02 02 857 B1	Fig. 1 Fig. 5, Anspr. 1, Sp. 4, Z. 26- Z. 44	1, 2, 4, 9		

D. Folgende Literatur und Zitate liegen dem Deutschen Patent- und Markenamt nicht vor:

Die Recherche kann sich auf den vom Anmelder/von der Anmelderin selbstgenannten Stand der Technik nicht erstrecken, der dem Deutschen Patent- und Markenamt nicht vorliegt. Wenn beabsichtigt ist, einen Prüfungsantrag nach § 44 PatG zu stellen, wird der Anmelder/die Anmelderin aufgefordert, diese Literatur in Kopie zur Prüfungsakte zu reichen.

□

E. Datum des Abschlusses der Recherche 05.10.2009

Vollständigkeit der Ermittlung:

Eine Gewähr für die Vollständigkeit der Ermittlung der einschlägigen Druckschriften und für die Richtigkeit der angegebenen Kategorien wird nicht geleistet (§43 Abs. 7 Satz 1 Patentgesetz bzw. §7 Abs. 2 Gebrauchsmustergesetz i.V.m. §43 Abs. 7 Satz 1 Patentgesetz).

Absenddatum des Rechercheberichtes

Anlagen: 3

Patentabteilung 1.45
Rechercheleitstelle



Erläuterungen zu Abschnitt C. Ergebnis der Druckschriftenermittlung

Spalte: Kat(egorie)

Es bedeutet:

- X: Druckschriften, die Neuheit oder das Vorliegen einer erfinderischen Tätigkeit (§ 43 PatG) / eines erfinderischen Schritts (§ 7 GebrMG) allein in Frage stellen
- Y: Druckschriften, die das Vorliegen einer erfinderischen Tätigkeit (§ 43 PatG) / eines erfinderischen Schrittes (§ 7 GebrMG) einer beanspruchten Erfindung in **Kombination** mit einer oder mehreren solchen Druckschriften in Frage stellt, wobei die Kombination der Druckschriften für einen Fachmann nahe liegen muss
- A: Allgemein zum Stand der Technik, technologischer Hintergrund
- O: Nicht-schriftliche Offenbarung, z.B. ein in einer nachveröffentlichten Druckschrift abgedruckter Vortrag, der vor dem Anmelde- oder Prioritätstag öffentlich gehalten wurde
- P: Im Prioritätsintervall veröffentlichte Druckschriften
- T: Nachveröffentlichte, nicht kollidierende Druckschriften, die die Theorie der angemeldeten Erfindung betreffen und für ein besseres Verständnis der angemeldeten Erfindung nützlich sein können oder zeigen, dass der angemeldeten Erfindung zugrunde liegende Gedankengänge oder Sachverhalte falsch sein könnten
- E: Ältere Anmeldungen gemäß § 3 Abs. 2 PatG (bei Recherchen nach § 43 PatG) / frühere Patent- oder Gebrauchsmusteranmeldungen gemäß § 15 GebrMG (bei Recherchen nach § 7 GebrMG)
- D: Druckschriften, die bereits in der Patentanmeldung genannt sind (bei Recherchen nach § 43 PatG) / Druckschriften, die bereits in der Anmeldung oder dem Gebrauchsmuster genannt sind (bei Recherchen nach § 7 GebrMG)
- L: Aus besonderen Gründen genannte Druckschriften, z.B. zum Veröffentlichungstag einer Entgegenhaltung oder bei Zweifeln an der Priorität.

Spalte: Erläuterungen

Die im Rechercheverfahren angegebenen Erläuterungen und relevanten Stellen sind in dieser Spalte von der zitierten Druckschrift getrennt angegeben. Die verwendeten Abkürzungen und Symbole bei Nennung einer Druckschrift bedeuten:

Veröff.: Veröffentlichungstag einer Druckschrift im Prioritätsintervall

=: Druckschriften, die auf dieselbe Ursprungsanmeldung zurückgehen („Patentfamilien“) oder auf die sich Referate oder Abstracts beziehen

Bei Klassen-/Gruppenangabe ohne Nennung von Druckschriften bedeutet das Symbol:

*-: Nichts ermittelt

Spalte: Betr(offene) Ansprüche

Hier sind die Ansprüche unter Zuordnung zu den in Spalte „Erläuterungen“ genannten Anmerkungen angegeben.

Hinweis zur Patentliteratur:

Die angegebene Patentliteratur kann in den Ausleihhallen des Deutschen Patent- und Markenamts, 80331 München, Zweibrückenstraße 12 oder 10969 Berlin, Gitschiner Str. 97 eingesehen werden; deutsche Patentschriften, Auslegeschriften oder Offenlegungsschriften und teilweise auch Patentliteratur anderer Länder auch in den Patentinformationszentren. Ein Verzeichnis über diese Patentinformationszentren kann vom Deutschen Patent- und Markenamt sowie von einigen Privatfirmen bezogen werden.

Online-Recherchen zu Patentveröffentlichungen aus aller Welt, die sich im Datenbestand des amtsinternen deutschen Patentinformationssystems DEPATIS befinden, sind kostenlos möglich unter <http://www.depatinet.de>

IN THE UNITED STATES PATENT AND TRADEMARK OFFICE

Art Unit : Customer No.: 035811
Examiner :
Serial No. :
Filed : Herewith
PCT No. : PCT/EP2010/000787
PCT Filed : February 9, 2010
Inventors : Eduard Pytlik Docket No.: RUF-11-1270
: Jürgen Lindner Confirmation No.:
: Ulrich Barenthin
: Winfried Gaugler
Title : BUTTON CELLS AND METHOD
: FOR PRODUCING SAME
Dated: July 28, 2011

INFORMATION DISCLOSURE STATEMENT

Mail Stop PCT
Commissioner for Patents
P.O. Box 1450
Alexandria, VA 22313-1450

Sir:

The Applicants enclose Form PTO-1449 together with a copy of each of the nine (9) listed non-US publications. The documents are identified in the International Search Report attached to the PCT Application as published under No. WO 2010/089152 A1 and in the Specification. The documents are submitted under 37 C.F.R. §1.56 and are believed to be related to this application.

The Applicants respectfully request that this Information Disclosure Statement be officially entered into the file and that appropriate notification be made that it was considered by the Examiner.

Respectfully submitted,

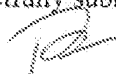
T. Daniel Christenbury
Reg. No. 31,750
Attorney for Applicants

TDC/lh
(215) 656-3381

Form PTO-1449 U.S. DEPARTMENT OF COMMERCE PATENT AND TRADEMARK OFFICE LIST OF PUBLICATIONS CITED BY APPLICANT <i>(Use several sheets if necessary)</i>	ATTY. DOCKET NO. RUF-11-1270	SERIAL NO.
APPLICANTS Eduard Pytlik et al.		
FILING DATE Herewith		GROUP

U.S. PATENT DOCUMENTS

EXAMINER INITIAL.*	DOCUMENT NUMBER	DATE	NAME	CLASS	SUBCLASS	FILING DATE IF APPROPRIATE
AA	US 6,265,100 B1	07/24/2001	Elric W. Saaski et al.			
AB						
AC						
AD						
AE						
AF						
AG						
AH						
AI						

FOREIGN PATENT DOCUMENTS

EXAMINER INITIAL.*	DOCUMENT NUMBER	DATE	COUNTRY	CLASS	SUBCLASS	TRANSLATION	
						YES	NO
AJ	1,088,271 A (DE '758)	10/25/1967	United Kingdom				
AK	1 471 758 A1 (GB 1,088,271 A)	05/08/1969	Germany			X	
AL	31 13 309 A1	10/21/1982	Germany			Abstract only	
AM	36 38 793 A1	05/26/1988	Germany			Abstract only	
AN	0 202 857 B1	07/31/1991	Europe				
AO	196 47 593 A1	05/20/1998	Germany			Abstract only	
AP	697 00 312 T2	02/24/2000	Germany			Abstract only	
AQ	198 57 638 A1	06/15/2000	Germany			Abstract only	
AR	10 2009 017 514 A1	10/07/2010	Germany			Abstract only	
AS							
AT							
AU							

OTHER PUBLICATIONS (Including Author, Title, Date, Pertinent Pages, Etc.)

AV	
AW	
AX	

EXAMINER

DATE CONSIDERED

*EXAMINER: Initial if publication considered, whether or not citation is in conformance with MPEP 609; Draw line through citation if not in conformance and not considered. Include copy of this form with next communication to Applicant.

PATENT SPECIFICATION

DRAWINGS ATTACHED

1,088,271

1,088,271



Inventor: ALFRED LINTON.

Date of filing Complete Specification: April 7, 1964.

Application Date: April 4, 1963.

No. 3904/63

Complete Specification Published: October 25, 1967.

© Crown Copyright 1967.

Index at Acceptance:—**H1 B** (D10A, S1A5, S1A6, S1A10, S1A14, S1A15, S1A16, S1A18, S1C3, S1C4, S3A1).

Int. Cl.:—H 01 m 43/04.

COMPLETE SPECIFICATION

Electric Cells

We, BURNEDEPT LIMITED, of Canada Road, Oyster Lane, Byfleet, Surrey, a British Company, do hereby declare the invention, for which we pray that a Patent may be granted to us, and the method by which it is to be performed, to be particularly described in and by the following statement:—

The invention relates to the construction of sealed alkaline electrolyte secondary electric cells having finely divided cadmium in the negative electrode. It is particularly applicable to sealed nickel cadmium cells but it may be used in cells having active materials other than nickel hydroxide in the positive electrode.

It has previously been proposed in Specification No. 685,341 to make a cell of this type with a negative electrode of higher capacity than the positive electrode, the negative electrode being at the moment of sealing more charged than the positive electrode and the difference between the charges being smaller than the difference between the capacities of the electrodes. This Specification was, however, mainly concerned with overcoming problems of gas evolution due to overdischarge of one cell in a battery of cells, and the larger quoted difference between the charges on the two electrodes was 25% of the smaller capacity.

Our invention on the other hand is concerned with the solution of problems which arise in the production of cells which are designed to deliver substantially all their theoretical capacity at a high rate of discharge. The term "high rate" is used throughout this Specification to denote a discharge rate in which the whole capacity of the cell is discharged within a maximum time of two hours, that is to say the average discharge current in amperes is equal to at least half the capacity of the cell in ampere hours (Ah).

[Price 4s. 6d.]

It has been established that the negative, cadmium electrodes of these secondary cells are less efficient in the electrochemical sense than the corresponding positive electrodes and that they tend to become even less efficient when the cell is charged and discharged for the first few cycles.

We have now discovered that this relative inefficiency of the negative electrodes is much more pronounced in cells which are to be discharged at high rates and we have observed that the efficiency of a typical cadmium oxide electrode material may fall from 100% of the theoretical capacity at extremely low discharge rate to 60% at an average discharge current in amperes equal to its capacity in Ah and to as little as 45% at a rate in amperes of 4 times its capacity in Ah. The corresponding figures for a typical cadmium hydroxide material are 80% and 65%.

Specification No. 685,341 gives no information about the rate of discharge for which the cell was designed but in the light of our observations it appears that, if discharged at a high rate the quoted reserve of charged negative material would be insufficient to accomplish the stated objects of that invention.

Proceeding from these observations a high rate cell in accordance with the invention is made with a negative, cadmium, electrode system of substantially greater theoretical capacity than the positive electrode system. At the moment of sealing the cell the positive electrode system is to have material in the uncharged state and the negative electrode is to have a main body of material in the uncharged, cadmium oxide or hydroxide, state. In addition to this main body of uncharged material the negative electrode system is to have such a reserve of charged material at the moment

of sealing that the total charge on the negative electrode system exceeds that on the positive electrode system and the sealed and charged cell can be discharged at a high rate at an overall efficiency at least substantially equal to that of the positive electrode system.

The quantity of charged material incorporated as a reserve in the negative electrode system is determined mainly by the maximum discharge rate for which the cell is designed, but preferably includes an addition for the anticipated deterioration of the electrode during its expected lifetime.

To obviate the risk of dangerous rises in pressure upon overcharging it is already the practice in the manufacture of this sort of cell to make the negative electrode of a higher capacity than the positive electrode and to ensure that, at the moment of sealing the cell, the negative electrode has a greater capacity to accept charge than the positive electrode.

The correct required balance of charge between the electrodes is currently attained by one of three procedures. The cell may be sealed with both electrodes completely uncharged; the electrodes may be given a carefully controlled partial charge before the cell is sealed; or both electrodes may be fully precharged and the negative electrode subjected to a carefully controlled partial discharge. Each of the three procedures present difficulties, the latter two being most inconvenient in mass production where it is highly desirable to carry out any precharging steps on the electrode material before it is cut to form individual electrodes.

We have discovered that the amount of active material which has to be incorporated in the negative electrode so that it may possess the required electrical capacity and the extent to which it needs to be precharged must depend upon the quality of the materials employed and that it may vary from batch to batch in the course of the manufacturing run. This raises the problem of varying the amount and precharge of the negative electrode. This problem can be avoided in the manufacture of a cell in accordance with the invention by disposing the additional mass of charged negative electrode material, constituting the reserve mentioned above, in an auxiliary negative electrode in direct electrical connection with the main negative electrode and by fully precharging the auxiliary electrode before the cell is assembled and sealed. In such a construction there is no need to vary the mass of the main negative electrode in accordance with variations in material quality and there is no problem in determining the precise degree of precharge which has been given to the negative elec-

trode assembly.

Preferably the electrodes of a cell in accordance with the invention comprise active materials mixed with conductive materials in powder form and bound with an elastomeric binder such as high molecular weight polyisobutylene, for instance "Vistanex" (registered Trade Mark) L. 140 or a still higher molecular weight polyisobutylene. Other strong elastomers can be used. If the elastomer is mixed with the powdered materials as a solution it is an advantage to use one which shrinks as it dries because this will have the effect of compressing the powdered material slightly, thus helping to ensure electrical contacts between the particles, thus helping to ensure electrical contacts between the particles. Such electrodes are described in greater detail in the specification of our copending application number 29846/59 (Serial No. 970638).

Alternatively the electrodes may be of the construction in which a porous sintered mass of nickel powder is impregnated with active materials. Electrodes of more than one type of structure may be used in a single cell.

Where a cylindrical cell is to be made with plastic bonded electrodes a particularly convenient mode of assembly is to prepare the pack of electrodes and separators in the form of strips gripped at one end by a split mandrel and then to wind the pack around the mandrel to form a roll. The roll thus formed is then removed from the mandrel and placed inside a suitable cylindrical can. This method of winding facilitates the handling of the components and helps to produce an accurate roll even where the diameter is large in proportion to its length. In making cells of relatively large diameter we have found it preferable to apply the mandrel at the middle of the length of the pack and to wind from the centre and that technique forms the subject of our Application No. 13302/67 (Serial No. 1088272), divided from the present Application.

In order that the invention may be thoroughly understood the preparation and assembly of three cells in accordance with it will be described in some detail, by way of example, with reference to the accompanying drawings, in which:—

Figure 1 is a vertical section on the line I-I of Figure 2, through a cylindrical cell with wound strip electrodes;

Figure 2 is a cross-section on the line II-II of Figure 1, through the same cell;

Figure 3 is a vertical section on the line III-III of Figure 4, through another cylindrical cell with strip electrodes wound from the centre;

Figure 4 is a cross-section on the line 130

IV-IV of Figure 3, through the cell shown in Figure 3; and

Figure 5 is a vertical section through a button cell having flat electrodes.

5 The cell shown in Figures 1 and 2 comprises main positive and negative electrodes 10 and 12 respectively and an auxiliary cadmium negative 14 with porous separators 16 and 18 between the two electrode
10 systems. The three electrodes and the separators are in strip form and wound into a spiral in a manner to be described below.

The two separators 16 and 18 may conveniently be made from a single strip of
15 material turned over the positive electrode, as shown in Figure 2, at the inner end 17.

The electrodes and separators are enclosed in a cylindrical can 20 between
20 insulating end discs 22 and 24 at top and bottom respectively.

The end discs 22 and 24 are suitably apertured to allow positive and negative contact strips 26 and 28, 29 respectively to be connected between the electrode systems
25 and the terminals. The positive terminal is constituted by a top cap 30 insulated by a plastics material grommet 32 from the can 20 which constitutes the negative terminal.

30 The cell shown in Figures 3 and 4 is generally similar but the whole system of electrodes and separators is folded back on itself at the inner end 34, so as to form a double spiral in a manner to be described
35 below. The several parts are given the same numbers as the corresponding parts of the cell shown in Figures 1 and 2.

The positive electrodes of the cells shown in the drawings may advantageously
40 comprise a mixture of 36.77% by weight of nickel hydroxide and 1.93% by weight of cobalt hydroxide as the active materials, admixed with 58.1% by weight of nickel powder as a conductive material, bound in
45 3.2% by weight of polyisobutylene binder in the form of "Vistanex" L.140.

Specific proportions have been quoted for the several materials of the positive electrode. These proportions (all of which relate
50 to the total weight of the electrode in question) can be varied and it is possible to include some graphite as a conductive material in proportions up to 30% by weight. The total of active ingredients should
55 preferably be between 30 and 70% by weight and if cobalt hydroxide is included it may be present in a proportion up to 30% of the weight of nickel hydroxide. The nickel powder should be present in
60 proportion between 25 and 70% by weight and there should be between 2 and 5% by weight of elastomeric binder.

The negative electrodes are made from a mixture of 62.2% by weight of cadmium
65 oxide as the active material, 35% by weight

of nickel powder as the conductive material, and 2.8% of "Vistanex" L.140 as the elastomeric binder. The proportion of cadmium oxide may be varied between 45% and 70% by weight, the proportion of
70 nickel powder may be between 25% and 50% by weight and up to 10% by weight graphite and 20% by weight of iron oxide may also be included as conductive materials. The proportion of elastomeric
75 binder should be between 2% and 5% by weight.

Strips of electrode material are made by coating the respective mixtures onto nickel gauze or expanded foil. This coating can
80 conveniently be achieved by passing the gauze or foil through the mix in a box with a slot in the base to admit the strip and by doctoring off excess mixture at the top of the box so as to produce a strip
85 of the required thickness.

If a positive electrode of sintered construction is to be used the nickel powder will be mixed with the binder solution, coated onto gauze or foil and then sintered,
90 for example by furnacing at about 800°C to 900°C for five to fifteen minutes, oxidation being prevented by the restriction of access of air to the furnace. The sintered strip will then be impregnated in the usual
95 way.

The negative electrode material is preferably prepared in strips of two thicknesses, the thicker of which will serve for the main
100 negative electrodes 12 and the thinner of which will serve for auxiliary negative electrodes 14.

Contacts 26, 28 and 29 are spot-welded to the positive electrode 10 and to the main and auxiliary negative electrodes 12 and 14,
105 respectively. These contacts are attached approximately mid-way along one edge of the strip which is to form the electrode. Placing the contacts centrally is advantageous because it cuts down voltage drop
110 through the material of the electrode.

The strip which is to form auxiliary negative electrodes is fully precharged in electrolyte, washed and dried, under non-oxidising
115 conditions in one piece, and thereafter cut to form individual electrodes.

Strips of separator material are cut from a suitable material for use as separators. The separator strips should be somewhat
120 wider than the electrode strips to avoid the risk of short circuiting when the electrodes 10, 12, 14 and separators 16, 18 are assembled.

Electrode and separator strips are then laid up alternately into a pack within guides
125 in a locating fixture. The strips are carefully located so that the separators 16 and 18 overlap the electrodes along both edges.

The pack is then wound onto a slotted mandrel. In the construction shown in
130

Figures 1 and 2 the mandrel is applied to one end of the pack and in that shown in Figures 3 and 4 it is applied to the middle of the strip. Care must be taken to ensure accurate positioning, the tightness is achieved by applying pressure by means of rollers and turning the mandrel several times after the assembly is wound on. The mandrel is then withdrawn, and after bending the negative contacts 28, 29 across the central hole 34 and arranging the bottom end disc 24, the assembly is inserted into the cylindrical steel can 20. The negative contacts 28, 29 are electrically welded to the base of the steel can 20 by means of a welding electrode inserted down the central hole 34.

The top end disc 22 is placed over the assembly, the can is then rilled at 36, the grommet 32 put into position to insulate the top cap 30 from the can 20, and the positive contact 26 is welded to the top cap. Only then may the electrolyte be added to the electrodes and as soon as this has been done, the cell must be sealed to avoid self-discharge of the charged auxiliary negative electrode 14.

In the button cell construction shown in Figure 5 there are two sets of positive, main negative and auxiliary negative, electrodes 50 50', 52 52' and 54 54' respectively of the same composition as those of the cells described above, but in the form of flat plates. The electrodes and separators 56 and 56' and 58 are cut into the shape of round discs. After welding positive and negative contacts, 66 66' and 68 68' respectively to the electrodes 50 50', 52 52' and 54 54' the electrodes and separators are stacked into a pile which is bound with insulating tapes 72 73 covering the contact strips and placed within the can 60. The electrolyte is added and the can tightly sealed by a top cap 80 insulated from the can by a grommet 82.

A plate spring 86 between the pile of electrodes and the top cap assures good contact between the electrodes and separators, between the positive contacts 66 66' and the can 60 and between the negative contacts 68 68' and the top cap 80.

The positive electrode 50', has a segmental cut out at 88 to allow for passage of the negative contact 68 and the negative electrodes 52 and 54 are similarly cut away at 90 for the positive contact 66'.

If it is thought necessary to add a mechanical safety device to ensure that under no circumstances can an explosion be caused by excessive gas pressure within the sealed cell, this can conveniently be done by stretching a diaphragm across the top of the can immediately below the top cap 30 and by forming an inturned pointed lug on the top cap. By a suitable choice of material and thickness for the diaphragm

matters can be arranged so that any excess gas pressure, even though it be well below that which the can is designed to withstand, will so distort the diaphragm as to cause it to be pierced by the inturned lug on the top cap. If the diaphragm is of metal the contact 26 from the positive electrode can be welded to it.

If it is required to provide a reserve against over-discharge, so that batteries of more than two cells can be made successfully without the weaker cells being over-discharged by their more powerful neighbours, this can be done by a second type of auxiliary electrode of uncharged negative material having just sufficient capacity to absorb a reserve charge equivalent to the difference in capacity between the worst and the best possible cells in a battery, and connected to the positive electrode.

WHAT WE CLAIM IS:—

1. A sealed alkaline electrolyte secondary electric cell designed to deliver substantially all its theoretical capacity at a high rate of discharge as hereinbefore defined and having finely divided cadmium in the negative electrode which is of substantially greater theoretical capacity than the positive electrode system, and in which cell, at the moment of sealing the positive electrode system has material in the uncharged state, while the negative electrode system has a main body of material in the uncharged, cadmium oxide or hydroxide, state, and, in addition such a reserve of material in the charged, cadmium metal state that the total charge on the negative electrode system exceeds that on the positive electrode system and the sealed and charged cell can be discharged at a high rate at an overall efficiency at least substantially equal to that of the positive electrode system.

2. A cell according to claim 1, in which the reserve of charged material in the negative electrode system includes an addition for the anticipated deterioration of the electrode during the expected lifetime of the cell.

3. A cell according to claim 1 or claim 2, in which the additional mass of charged negative electrode material constituting the said reserve is disposed in an auxiliary negative electrode in direct electrical connection with the main negative electrode, the said auxiliary electrode being fully precharged before the cell is assembled and sealed.

4. A cell according to any preceding claim, having an electrode which comprises active material in powder form and bound with an elastomeric binder, such as high molecular weight polyisobutylene.

5. A cell according to any of claims 1 to 3, having an electrode of the construction in which a porous sintered mass of nickel powder is impregnated with active

- material.
6. A cell according to claim 4, comprising a cylindrical roll of electrodes and separators in strip form in a cylindrical can.
- 5 7. A cell according to any of claims 1 to 5, comprising electrodes and separators in the form of flat plates layed up in a stack in a cylindrical can having a diameter large in proportion to its length.
- 10 8. A method for the construction of a sealed alkaline electrolyte secondary electric cell as claimed in claim 1, which comprises preparing a positive electrode system with material in the uncharged state and a negative electrode system of substantially greater theoretical capacity than the positive system partially precharging the negative electrode assembling and sealing the electrodes with separators in a suitable container, so that
- 20 at the moment of sealing the negative electrode system has, in addition to a main body of material in the uncharged cadmium oxide or hydroxide, state such a reserve of material in the charged, cadmium metal state that the total charge on the negative electrode system exceeds that on the positive electrode system and the sealed and charged cell can be discharged at a high rate at an overall efficiency at least substantially equal to that of the positive electrode system.
- 25 9. A method according to claim 8, in which the said reserve includes an addition for the anticipated deterioration of the electrode during the expected lifetime of the cell.
- 30 10. A method according to claim 8 or claim 9, in which the additional material constituting the said reserve is disposed in an auxiliary negative electrode in direct electrical connection with the main negative electrode and in which the auxiliary electrode is fully precharged at the moment of sealing the cell.
- 35 11. A sealed alkaline electrolyte secondary cell according to claim 1, having a negative electrode of the composition quoted herein.
- 40 12. A sealed alkaline electrolyte secondary cell according to claim 1 or claim 11, having a positive electrode of the composition quoted herein.
- 45 13. A sealed alkaline electrolyte secondary cell substantially as described with reference to Figures 1 and 2, or Figure 5 of the accompanying drawings.
- 50 14. A method for the construction of a sealed alkaline electrolyte cell substantially as described with reference to Figures 1 and 2, or Figure 5 of the accompanying drawings.
- 55 60

SEFTON-JONES, O'DELL &
STEPHENS,

Chartered Patent Agents,
15 Great James Street,
London, W.C.1.
Agents for the Applicants.

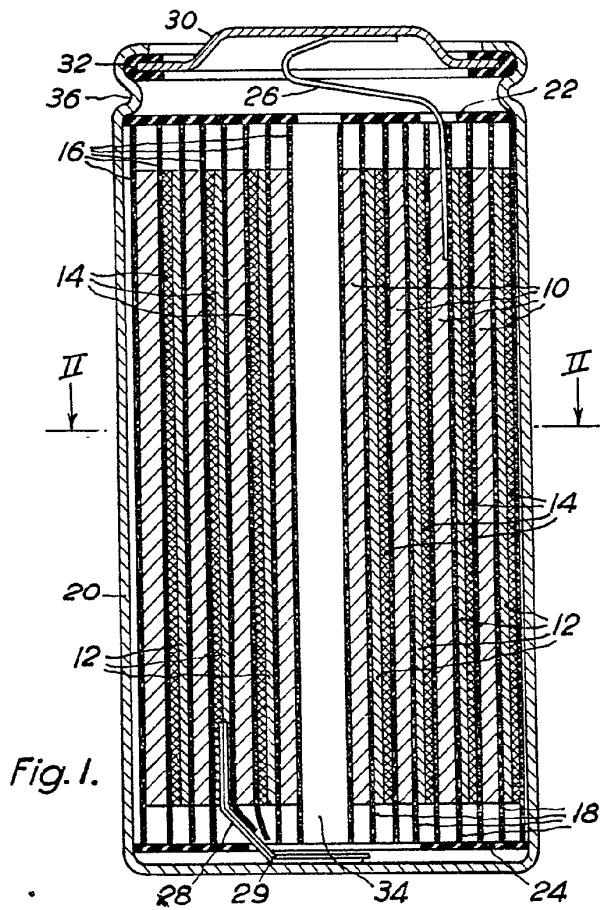

Fig. 1.

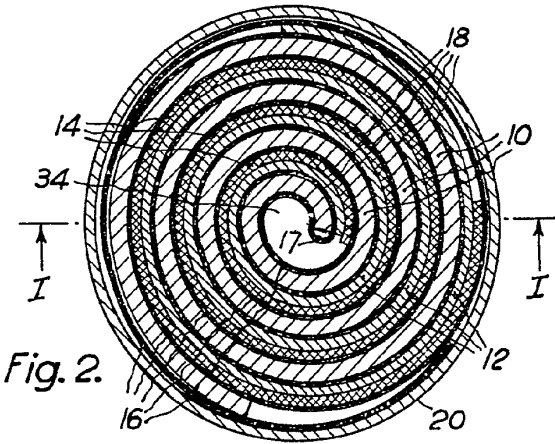
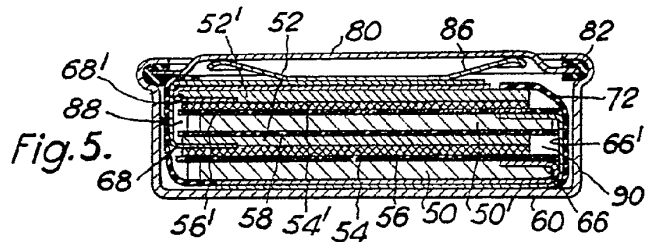
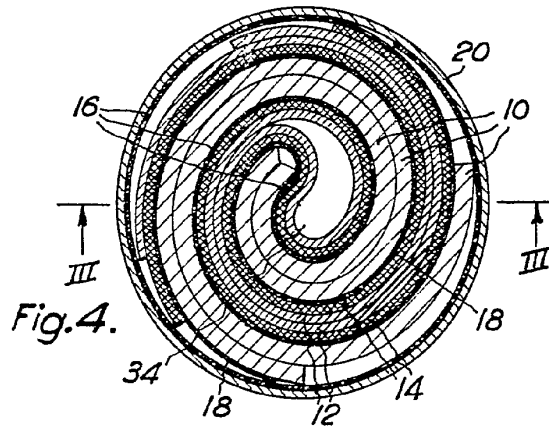
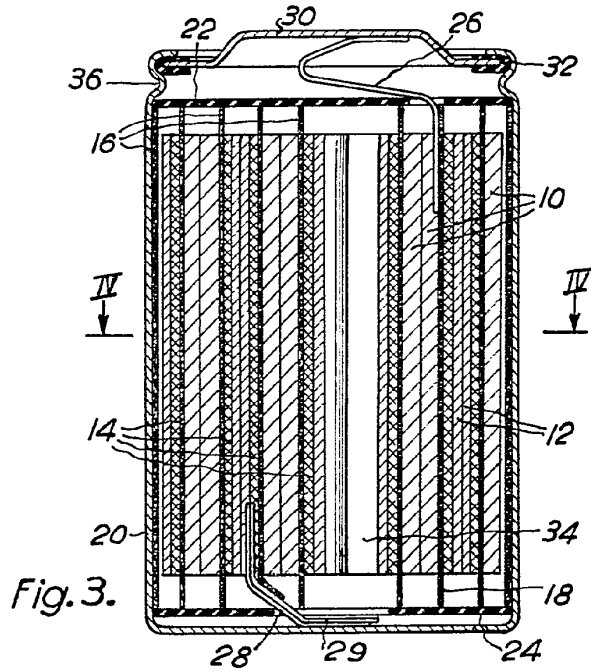

Fig. 2.



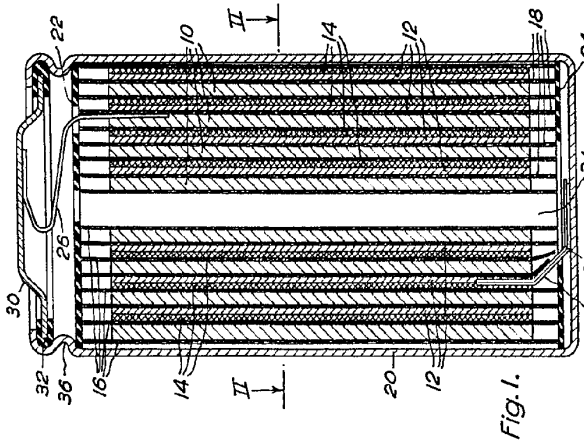

Fig. 1.

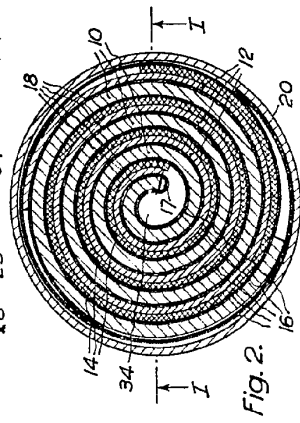

Fig. 2.

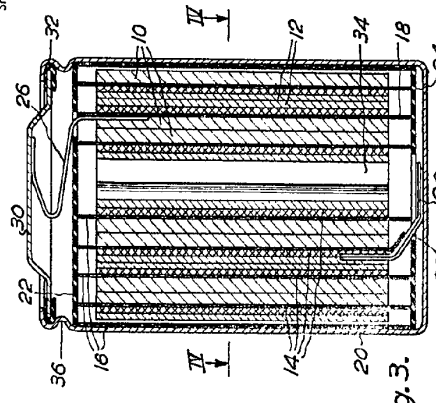

Fig. 3.

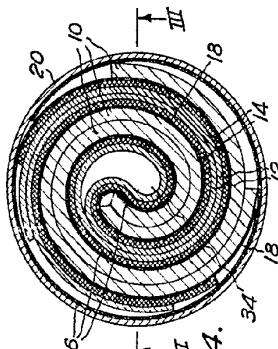

Fig. 4.

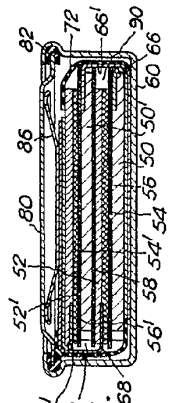

Fig. 5.



Espacenet

Bibliographic data: DE 1471758 (A1)

Gekapselter,alkalischer Akkumulator

Publication date: 1969-05-08
Inventor(s): LINTON ALFRED; DUNDEE ANGUS +
Applicant(s): BURNDPT LTD +
Classification:
 - **international:** H01M10/34; H01M4/24; H01M10/42; H01M8/10
 - **European:** H01M10/34; H01M4/24; Y02E60/12D
Application number: DE19641471758 19640403
Priority number(s): GB19630003904 19630404

Also published as:
 • GB 1388271 (A)
 • CH 465023 (A)

Abstract not available for DE 1471758 (A1)

Last updated: 26.04.2011 Worldwide Database 5.7.23; 92p



Espacenet

Bibliographic data: DE 3113309 (A1)

Galvanic element

Publication date: 1982-10-21
Inventor(s): KUEHL THOMAS DIPL ING DR [DE]; LAIG-HOERSTEBROCK HELMUT DIPL [DE]; NIENTIEDT HEINZ-WERNER DIPL CH [DE] +
Applicant(s): VARTA BATTERIE [DE] +
Classification:
 - **international:** *H01M2/04; H01M2/08*; (IPC1-7): H01M10/28; H01M2/02
 - **European:** H01M2/04B2B; H01M2/08; Y02E60/12D
Application number: DE19813113309 19810402
Priority number (s): DE19813113309 19810402

Abstract of DE 3113309 (A1)

A galvanic element of the button cell type is protected more effectively against leakage of electrolyte by that part of the two components (2, 3) of its metal casing which are of opposite polarity and electrically insulated against one another, which is of negative polarity (3) being enamelled in the region of the sealing zone. In this arrangement, the enamel coating (1) may function on its own as a seal or may be compression-bonded to a conventional plastic seal (4). The enamel particularly inhibits the creepage of alkali, which occurs to a greater extent on negative output conductor bushings for electrochemical reasons, by keeping, as an insulator, the boundary zone enamel-sealing plastic free of the potential of the base metal, as well as, owing to its strong chemical bond to the base metal, precluding a transmigration of liquid even in this boundary region.

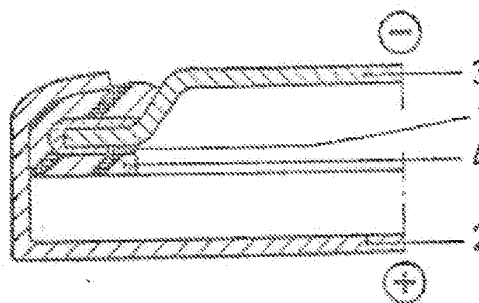

Last updated: 25.04.2011 Worldwide Database 5.7.23; 52p



Espacenet

Bibliographic data: DE 3638793 (A1)

Electrode winding for electrochemical round cells (button cells), and a method for its production

Publication date: 1988-05-26
Inventor(s): SPRENGEL DIETRICH DIPL PHYS DR [DE]; PRANGE ROLF [DE] +
Applicant(s): VARTA BATTERIE [DE] +
Classification: - **International:** H01M6/10; H01M10/04; (IPC1-7): C25D3/26; H01M10/28; H01M2/14; H01M6/10
 - **European:** H01M6/10; Y02E60/12D
Application number: DE19863638793 19861113
Priority number (s): DE19863638793 19861113
Also published as: • DE 3638793 (C2)
Cited documents: DE911506 (C) DE2221818 (B2) [View all](#)

Abstract of DE 3638793 (A1)

An electrode winding which is formed from two strip electrodes and two separators and has a free core hole which is intrinsically firm and can easily be removed from the winding needle is produced in a manner such that the free ends of a first separator (1), which is looped around the winding needle (4), and a first electrode (3) - for example the negative electrode - are permanently connected on their underneath along (a), for example by welding, and that an adjacent separator section (b), whose length corresponds to the circumference of the winding needle, is provided with an adhesive agent coating which results in the separator being bonded to the electrode over the strip length (b) (along which it forms the wall of the subsequent free core hole) during insertion of the electrode into the spacing gap (6) between the winding needle and winding rail (5) and when rolling in starts. Once the first turn of the first electrode has been completed (not illustrated), the second strip electrode (positive) is pushed into the gap (6) together with the second separator, whose end is fastened to this electrode in an analogous manner to the first separator.

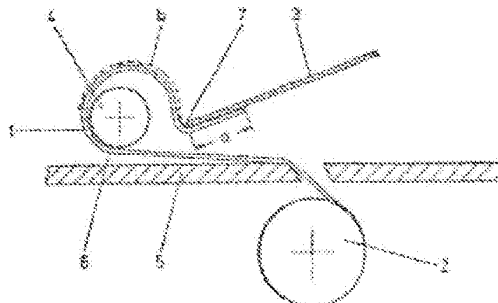

Last updated: 26.04.2011 Worldwide Database 5.7.23: 92p



⑫ **EUROPEAN PATENT SPECIFICATION**

④ Date of publication of patent specification: **31.07.91** ⑤ Int. Cl.⁵: **H01M 6/10, H01M 6/16**

⑥ Application number: **86303664.6**

⑦ Date of filing: **14.05.86**

⑧ **Electrode assembly.**

⑨ Priority: **17.05.85 US 735406**

⑩ Date of publication of application:
26.11.86 Bulletin 86/48

⑪ Publication of the grant of the patent:
31.07.91 Bulletin 91/31

⑫ Designated Contracting States:
DE FR GB NL

⑬ References cited:
FR-A- 1 174 278
FR-A- 1 505 285
GB-A- 1 088 272
GB-A- 2 060 983

PATENT ABSTRACTS OF JAPAN, vol. 4, no.
137 (E-27)[619], 25th September 1980; & JP-
A-55 88 277 (SANYO DENKI K.K.) 03-07-1980

⑭ Proprietor: **EASTMAN KODAK COMPANY (a**
New Jersey corporation)
343 State Street
Rochester New York 14650(US)

⑮ Inventor: **Bakos, Vincent William**
Kodak Park
Rochester New York 14650(US)
Inventor: **Martin, Thomas William**
Kodak Park
Rochester New York 14650(US)

⑯ Representative: **Phillips, Margaret Dawn et al**
Kodak Limited Patent Department Headstone
Drive
Harrow, Middlesex HA1 4TY(GB)

EP 0 202 857 B1

Note: Within nine months from the publication of the mention of the grant of the European patent, any person may give notice to the European Patent Office of opposition to the European patent granted. Notice of opposition shall be filed in a written reasoned statement. It shall not be deemed to have been filed until the opposition fee has been paid (Art. 99(1) European patent convention).

Description

The invention relates to an electrode assembly, a method for making the electrode assembly and electrochemical cells in which the electrode assembly is used.

Various configurations of electrode assemblies consisting of an anode and a cathode have been disclosed. The configuration and the arrangement of such electrode assemblies in a particular housing is important in that the assembly and configuration impacts upon the 1) amount of active electrode material that can be included in each cell, 2) electrical performance, and 3) the ease of manufacturing.

A useful electrode assembly configuration is disclosed in U.S. Patent 3,663,721. Therein, an electrochemical cell is disclosed in which the lithium anode comprises a unitary and continuous length of zig-zag pleated lithium of a selected width. Individual cathode plates are positioned between pairs of the pleated anode. A separator is placed between the cathode and the anode to prevent electrical contact between the anode and the cathode.

While this electrode assembly is useful, it is disadvantageous in that it requires 1) the manufacturing step of placing separate cathode plates between the zig-zag pleated anode, and 2) a series of electrical connections to be made between the various cathode plates and the external electrical contact with the cathode thereby increasing the opportunities for short circuits to occur.

The present invention provides an electrode assembly comprising an anode, a cathode and insulating separator positioned between the cathode and the anode, the anode, the separator and the cathode being folded to form an accordian fold;

characterized in that the anode and separator are approximately twice the length of the cathode and are folded in half over the cathode prior to forming the accordian fold. An accordian fold comprises two or more "V" folds.

The electrode assembly of this invention is advantageous in that it avoids 1) the need for the manufacturing steps involved in making separate cathode plates and subsequently inserting such plates into the pleats of a zig-zag anode and 2) the need to make a series of electrical connections between individual cathode plates. Since the cathode is itself continuous, only one electrical contact need be made to the cathode.

In one useful embodiment, the electrode assembly of this invention comprises a three piece laminate comprising, in the following order:

- a) a metal foil current collector;
- b) a layer of a malleable anode-active material;
- and

c) the insulating separator.

The present invention also provides an electrochemical cell comprising an electrolyte, and an electrode assembly of the present invention.

In the above embodiment, the electrochemical cell constructed with the accordian folded electrode assembly of this invention has 1) decreased internal resistance and 2) better utilization of the anode-active material compared to electrochemical cells in which the anode is coated on a metal grid current collector.

The present invention further provides a method of making an electrochemical cell comprising:

forming an anode by covering a metal foil current collector with a layer of anode-active material;

placing an insulating separator over the anode-active material to form a laminate;

forming a cathode by coating at least one side of a metal foil grid current collector with a cathode-active material;

folding the laminate approximately in half to sandwich the cathode therebetween;

folding the assembly so formed into accordian folds;

inserting the accordian folds into a housing; and

filling the housing with an electrolyte.

The present invention will now be described by way of example with reference to the accompanying drawings, in which:-

Fig. 1 is a schematic drawing of the anode assembly.

Fig. 2 is a schematic drawing of a typical cathode assembly.

Fig. 3 shows the anode and cathode being laminated together prior to the accordian fold.

Fig. 4 shows the laminate of Fig. 3 in an accordian fold.

Fig. 5 shows an electrochemical cell comprising an electrode assembly of the invention.

Applicants will now proceed to describe the anode and cathode construction, the separator and the technique by which they are brought together in a laminate structure and subsequently accordian folded. In this description of the invention, lithium anodes and MnO₂ cathodes are used. It will be recognized that the invention will work with most electrode assemblies using solid fuel.

The anode assembly in Fig. 1 is a three piece laminate comprised of an anode-active material 12 such as lithium coated on a .0254 mm (1 mil) metal foil current collector 13 such as stainless steel. A portion of the stainless steel foil 13 is left uncoated and trimmed to form the anode terminal 14. A separator 15 such as Celgard® 4510 (available from Celanese) and/or non-woven polypropylene is rolled over the entire lithium anode 11 formed of

the anode-active material 12 and the current collector 13. The separator is a porous electrically-insulating material which prevents electrical contact between the anode and the cathode but allows movement of ions.

Other useful anode-active materials include any malleable anode material such as alkali metals (Na and K), Li-Al alloys, Li-Si alloys, Li-B alloys and the metals of Groups Ia and IIa of the periodic table of elements. Malleable anode-active materials are coatable on metal foil. Also, the separator can be coated onto the surface of the active material with considerable adherence of the separator to the anode layer. Metal foils which can be used as the current collector include metals such as nickel, stainless steel, aluminum and titanium.

While this embodiment of the invention is exemplified by having the insulating separator placed over the anode, it is clear that the invention works equally well when the separator is placed over the cathode. In any case, a small excess of separator is left relative to the sides of the electrode. The total length and thickness of the anode will be dictated by the fuel loading requirements of the electrochemical cell or battery specification under consideration.

The cathode 1 is a laminate as shown in Fig. 2. In the embodiment shown it is made with MnO₂. The MnO₂ cathode 1 comprises a grid current collector 22 such as stainless steel coated on one or both sides with a mixture of MnO₂, carbon and Teflon® 23. A small portion of the stainless steel current collector 22 is left uncoated and shaped at one end to function as a cathode terminal 24.

The wide variety of cathode-active materials which would also be useful in the electrode assemblies of this invention include the various forms of polyfluorocarbons, i.e. (CF_x)_n x < 4 and n is some indeterminate large number, FeS₂, FeS, CuO and Bi₂O₃.

A complete electrode assembly is shown in Fig. 3. It is made by positioning the cathode 1 on top of the separator 15 attached to the anode 11 so that the cathode terminal 24 and the anode terminal 14 are side by side but are not in electrical contact. The cathode, in this embodiment of the invention, is about one-half the length of the anode. The entire anode 11 is then folded over the entire cathode 1 to form a laminate structure in which the cathode 1 is sandwiched between the folds of the anode 11.

Next, the complete electrode assembly of Fig. 3 is then accordian folded as shown in Fig. 4. The accordian folded electrode assembly of Fig. 4 is a series of connected "V" folds. The accordian folded electrode assemblies of this invention comprise two or more "V" folds. The length of each leg in the fold and the number of folds and legs will, of

course, be determined by the dimensions of the container in which the electrode assembly is to be inserted. Obviously, electrode assemblies having more than two "V" folds or four legs are possible, depending upon the fuel loading requirements of the intended power application and the specific anode and cathode materials used.

One method for folding the electrode assembly of this invention, referring to Fig. 3, is to make sequential folds beginning at the end away from the contacts 14 and 24. As each fold is made, the loose ends of the separate components are thus free to shift enough to reduce stresses and strains at the fold thereby preventing pinching, cracking, breaking, delamination, shorting, or the like.

After checking for internal electrical shorts with an ohmmeter, the electrode assembly is made into an electrochemical cell or battery by first inserting the assembly into a container 25 such as shown in Fig. 5. An electrolyte comprising, for example, a solvent mixture of a propylene carbonate and dimethoxyethane or butyrolactone and dimethoxyethane, with a lithium salt such as lithium perchlorate or lithium tetrafluoroborate, is added to the container 25.

The electrode assembly is inserted in the container so that electrode terminals 14 and 24 protrude upward forming a complete electrochemical cell or battery. The cell can be sealed with a cap if desired. Such caps and methods of sealing the cap to the container are well known in the battery art.

In the accordian folded electrode assembly of Fig. 4, electrical contact between each leg of the anode is achieved when the legs of the assembly are pressed together and inserted into the container of Fig. 5. This electrical contact is achieved through the physical contact of the current collectors 13 of the anode assembly 11. This electrical contact between each leg of metal foiled back anode decreased the internal resistance of electrochemical cells because electrons have a shorter path to travel to reach the anode terminal compared to anodes and electrode assemblies having a different configuration.

Moreover, the anode construction of Fig. 1 facilitates greater utilization of the anode-active material since substantially all of the anode-active material is in direct electrical contact with the metal foil current collector. This is in contrast to metal grid collectors in which much of the anode-active material is only indirectly in electrical contact with the grid current collector.

'Celgard' and 'Teflon', referred to above, are trade marks.

Claims

1. An electrode assembly comprising an anode

- (11), a cathode (1) and insulating separator (15) positioned between the cathode (1) and the anode (11), the anode (11), the separator (15) and the cathode (1) being folded to form an accordian fold;
- characterized in that the anode (11) and separator (15) are approximately twice the length of the cathode (1) and are folded in half over the cathode (1) prior to forming the accordian fold.
2. An assembly according to claim 1, wherein the anode (11) comprises a three-piece laminate including, in the following order:
 - a) a metal foil current collector (13);
 - b) a layer (12) of a malleable anode-active material; and
 - c) the insulating separator (15).
 3. An assembly according to claim 2, wherein the anode-active material of the anode is a malleable metal.
 4. An assembly according to claim 3, wherein the cathode (1) comprises a layer (23) of cathode-active material coated onto a metal grid current collector (22).
 5. An assembly according to claim 4, wherein the cathode-active material is a polyfluorocarbon, FeS_2 , FeS , CuO , MnO_2 or Bi_2O_3 .
 6. An assembly according to claim 5, wherein the anode-active material is lithium and the cathode-active material is MnO_2 .
 7. An assembly according to claim 4, wherein the metal grid current collector (23) is made of stainless steel and is coated on both sides with the cathode-active material.
 8. An electrochemical cell comprising an electrolyte, and an electrode assembly according to any one of the previous claims.
 9. An electrochemical cell according to claim 8, wherein the electrolyte comprises a solvent mixture of propylene carbonate and dimethoxyethane and a lithium salt.
 10. An electrochemical cell according to claim 8, wherein the electrolyte comprises a solvent mixture of dimethoxyethane and butyrolactone and a lithium salt.
 11. A method of making an electrochemical cell comprising:

- forming an anode (11) by covering a metal foil current collector (13) with a layer (12) of anode-active material;
- placing an insulating separator (15) over the anode-active material to form a laminate;
- forming a cathode (1) by coating at least one side of a metal foil grid current collector (22) with a cathode-active material;
- folding the laminate approximately in half to sandwich the cathode (1) therebetween;
- folding the assembly so formed into accordian folds;
- inserting the accordian folds into a housing; and
- filling the housing with an electrolyte.

Revendications

1. Assemblage d'électrodes comprenant une anode (11) une cathode (1) et un séparateur (15) placé entre la cathode (1) et l'anode (11), l'anode (11), le séparateur (15) et la cathode (1) étant pliés en accordéon ; caractérisé en ce que l'anode (11) et le séparateur (15) ont une longueur approximativement du double de la longueur de la cathode (1) et sont pliés en deux autour de la cathode (1) avant de former le pliage en accordéon.
2. Assemblage selon la revendication 1, dans lequel l'anode (11) comprend un laminé formé de trois pièces comprenant, dans l'ordre suivant :
 - a) un collecteur de courant en feuille métallique (13)
 - b) une couche (12) d'un matériau malléable à activité anodique ; et
 - c) un séparateur isolant (15)
3. Assemblage selon la revendication 2, dans lequel le matériau à activité anodique de l'anode est un métal malléable.
4. Assemblage selon la revendication 3, dans lequel la cathode (1) comprend une couche (23) d'un matériau à activité cathodique couché sur une grille métallique collectrice de courant (22).
5. Assemblage selon la revendication 4, dans lequel le matériau à activité cathodique est du polyfluorocarbonate, FeS_2 , FeS , CuO , MnO_2 ou Bi_2O_3 .
6. Assemblage selon la revendication 5, dans lequel le matériau à activité anodique est du lithium et le matériau à activité cathodique est MnO_2 .

7. Assemblage selon la revendication 4, dans lequel la grille métallique collectrice de courant (23) est en acier inoxydable et est appliquée sur les deux faces du matériau à activité cathodique.
8. Cellule électrochimique comprenant un électrolyte et un assemblage d'électrodes selon l'une quelconque des revendications précédentes.
9. Cellule électrochimique selon la revendication 8, dans laquelle l'électrolyte comprend un mélange solvant de carbonate de propylène et de diméthoxyéthane et un sel de lithium.
10. Cellule électrochimique selon la revendication 8, dans laquelle l'électrolyte comprend un mélange solvant de diméthoxyéthane et de butyrolactone et un sel de lithium.
11. Procédé de fabrication de cellule électrochimique consistant
à former une anode (11) en recouvrant une feuille collectrice de courant (13) avec une couche (12) d'un matériau à activité anodique ;
placer un séparateur isolant (15) sur le matériau à activité anodique pour former un laminé ;
former une cathode (1) en appliquant un matériau à activité cathodique sur au moins une face de la grille collectrice de courant métallique (22).
plier le laminé approximativement en deux pour placer la cathode (1) en sandwich à l'intérieur ;
plier l'assemblage ainsi formé en accordéon ;
insérer les plis en accordéon dans une cuve ; et
remplir la cuve avec un électrolyte.

Patentansprüche

1. Elektrodensystem mit einer Anode (11), einer Kathode (1) und einem zwischen Kathode (1) und Anode (11) angeordneten isolierenden Trennelement (15), wobei die Anode (11), das Trennelement (15) und die Kathode (1) ziehharmonikaförmig zusammengefaltet sind, **dadurch gekennzeichnet**, daß die Anode (11) und das Trennelement (15) etwa zweimal so lang sind wie die Kathode (1) und zur Hälfte gefaltet um die Kathode (1) herumgelegt werden, bevor die ziehharmonikaförmige Faltung erfolgt.
2. System nach Anspruch 1, dadurch gekennzeichnet, daß die Anode (11) ein dreiteiliges

Laminat umfaßt, das der Reihe nach aus
a) einem aus einer Metallfolie bestehenden Stromabnehmer (13),
b) einer aus einem formbaren anodisch aktiven Material bestehenden Schicht (12) und
c) dem isolierenden Trennelement (15) aufgebaut ist.

3. System nach Anspruch 2, dadurch gekennzeichnet, daß das anodisch aktive Material der Anode ein formbares Metall ist.
4. System nach Anspruch 3, dadurch gekennzeichnet, daß die Kathode (1) eine Schicht (23) aus einem kathodisch aktiven Material aufweist, die auf einen aus einem Metallgitter bestehenden Stromabnehmer (22) aufgetragen ist.
5. System nach Anspruch 4, dadurch gekennzeichnet, daß das kathodisch aktive Material aus einem Polyfluorkohlenstoff, FeS₂, FeS, CuO, MnO₂ oder Bi₂O₃ besteht.
6. System nach Anspruch 5, dadurch gekennzeichnet, daß das anodisch aktive Material aus Lithium und das kathodisch aktive Material aus MnO₂ bestehen.
7. System nach Anspruch 4, dadurch gekennzeichnet, daß der aus einem Metallgitter aufgebaute Stromabnehmer (22) aus Edelstahl besteht und auf beiden Seiten mit dem kathodisch aktiven Material beschichtet ist.
8. Elektrochemische Zelle, gekennzeichnet durch einen Elektrolyten sowie ein Elektrodensystem nach einem der vorhergehenden Ansprüche.
9. Elektrochemische Zelle nach Anspruch 8, dadurch gekennzeichnet, daß der Elektrolyt aus einem Lösungsmittelgemisch aus Propylenkarbonat und Dimethoxyäthan sowie einem Lithiumsalz besteht.
10. Elektrochemische Zelle nach Anspruch 8, dadurch gekennzeichnet, daß der Elektrolyt aus einem Lösungsmittelgemisch aus Dimethoxyäthan und Butyrolacton sowie einem Lithiumsalz besteht.
11. Verfahren zur Herstellung einer elektrochemischen Zelle, dadurch gekennzeichnet, daß
durch Aufbringen einer Schicht (12) aus einem anodisch aktiven Material auf einen aus einer Metallfolie bestehenden Stromabnehmer (13) eine Anode (11) hergestellt wird,

über dem anodisch aktiven Material ein isolierendes Trennelement (15) aufgebracht und damit ein Laminat erzeugt wird,

5

durch Beschichten mindestens einer Seite eines aus einem Metallfoliengitter bestehenden Stromabnehmers (22) mit einem kathodisch aktiven Material eine Kathode (1) hergestellt wird,

10

das Laminat auf etwa die Hälfte so zusammengefaltet wird, daß es die Kathode (1) umschließt,

15

der so entstandene Verband ziehharmonikaförmig zusammengefaltet wird,

der so gefaltete Verband in ein Gehäuse eingesetzt wird und

20

das Gehäuse mit einem Elektrolyten gefüllt wird.

25

30

35

40

45

50

55

6

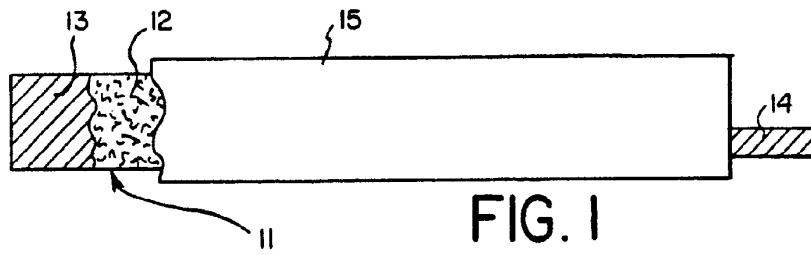

FIG. 1

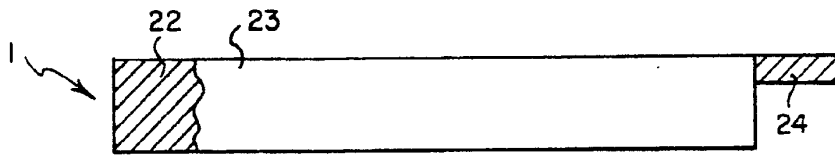

FIG. 2

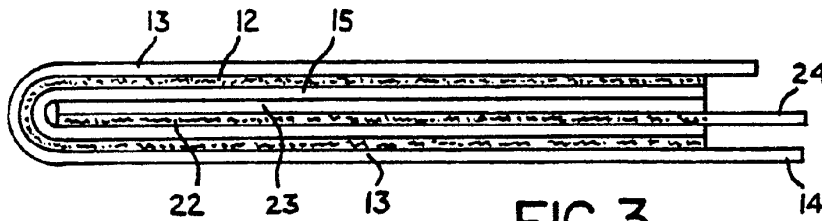

FIG. 3

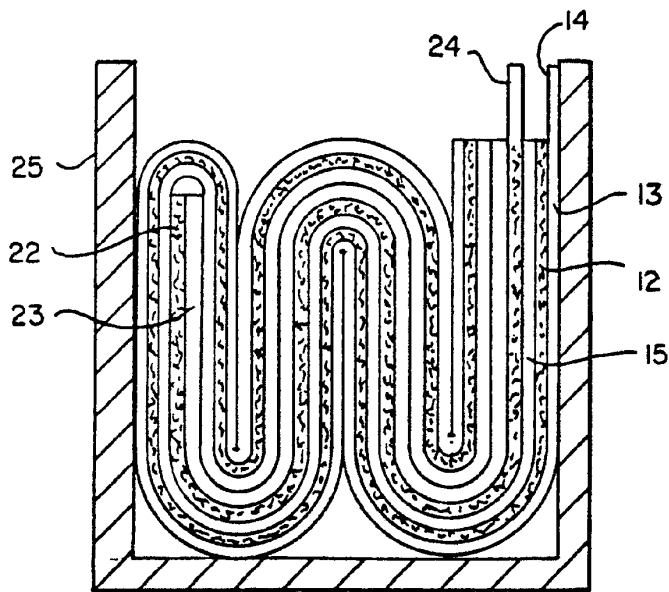
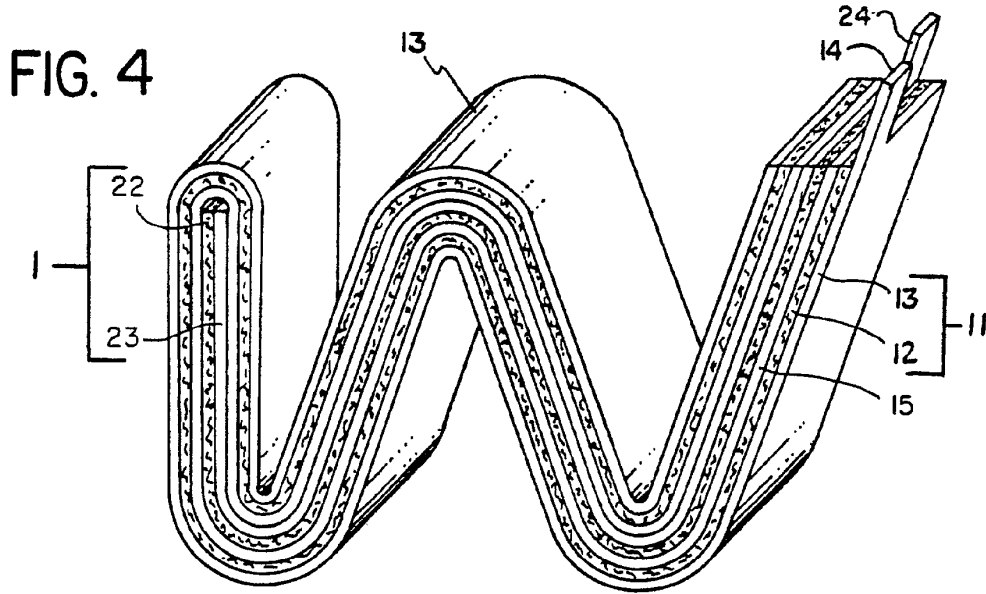

FIG. 5



Espacenet

Bibliographic data: DE 19647593 (A1)

Galvanic element in round cell form

Publication date: 1998-05-20
Inventor(s): BRENNER ROLF [DE] +
Applicant(s): VARTA BATTERIE [DE] +
Classification:
- **International:** *H01M2/02; H01M2/08; (IPC1-7): H01M2/08*
- **European:** *H01M2/02B6B2; H01M2/08; Y02E60/12*
Application number: DE19961047593 19961118
Priority number(s): DE19961047593 19961118
Also published as: * US 6056184 (A)

Abstract of DE 19647593 (A1)

A galvanic element in round cell form has a closed fluid-tight housing comprising a cell cup and a lid insulated from it by a seal. The seal is formed from a sealing blank made by deep drawing from a plastic foil. The sealing mould is shrink-fitted on the edge of the cell lid. Its thickness is between 0.1 and 0.3 millimetres and it is made from a polyamide. Before the deep-drawing process the plastic foil is heated to a temperature of 100 to 120 degC. The drawing is done in a vacuum.

Last updated: 26.04.2011 Worldwide Database 5.7.23; 92p



Espacenet

Bibliographic data: DE 69700312 (T2)

Use of B2O3 additive in non-aqueous electrolytes of rechargeable lithium batteries

Publication date: 2000-02-24
Inventor(s): MAO HUANYU [CA]; REIMERS JAN NAESS [CA] +
Applicant(s): MOLI ENERGY 1990 LTD [CA] +
Classification:
 - international: *H01M10/40; H01M2/16; H01M4/02; H01M4/52; H01M6/10; H01M6/18; (IPC1-7): H01M10/26; H01M10/40*
 - European: H01M10/40E5; H01M4/52; Y02E60/12B
Application number: DE19976000312T 19970416
Priority number (s): CA19962175755 19960503

Also published as:

- EP 0805504 (A1)
- EP 0805504 (B1)
- US 5964002 (A)
- JP 10040958 (A)
- CA 2175755 (A1)

Abstract not available for DE 69700312 (T2)

Abstract of corresponding document: EP 0805504 (A1)

The loss in delivered capacity upon cycling nonaqueous rechargeable lithium batteries can be reduced by incorporating a small amount of B2O3 additive in the electrolyte. The B2O3 additive is preferably dissolved in the electrolyte prior to assembling the battery. The invention is particularly suited to lithium ion rechargeable batteries.

Last updated: 26.04.2011 Worldwide Database 5 7.23; 92p



Espacenet

Bibliographic data: DE 19857638 (A1)

Elektrischer Akkumulator in Form einer Knopfzelle

Publication date: 2000-06-15
Inventor(s): KILB MANFRED [DE]; ILIC DEJAN [DE]; PYTLIK EDUARD [DE]; WEITBRECHT SIEGFRIED [DE] +
Applicant(s): VARTA GERAETEBATTERIE GMBH [DE] +
Classification:
 - **international:** H01M10/04; H01M10/30; H01M2/28; H01M4/64; H01M4/80; H01M10/34; H01M2/02; (IPC1-7): H01M10/36; H01M4/06; H01M4/24; H01M6/12
 - **European:** H01M2/28D; Y02E60/12D
Application number: DE19981057638 19981214
Priority number (s): DE19981057638 19981214

Also published as:

- US 8312848 (B1)
- KR 20000047704 (A)
- KR 100822199 (B1)
- JP 2000192659 (A)
- EP 1011163 (A1)
- EP 1011163 (B1)
- CN 1264185 (A)
- CN 1178325 (C)
- CA 2292108 (A1)
- BR 9908650 (A)
- AT 245404 (T)
- iess

Abstract of DE 19857638 (A1)

Die Erfindung betrifft einen elektrischen Akkumulator mit einem Gehäuse in Form einer gasdicht verschlossenen Knopfzelle, bestehend aus einem Gehäusedeckel (2) und einem Gehäusenapf (1), mit zwischenliegender elektrisch isolierender Dichtung (3), die einen Elektrodenstanz aus positiven und negativen Elektroden (5, 6) sowie zwischenliegenden Separatoren (7) enthält, wobei mindestens zwei Elektroden einer Polarität an mindestens zwei Stellen ihres Umfangs derart mechanisch und elektrisch verbunden sind, dass sich ein mechanisch stabiles Elektrodenpaket (9) ergibt. Die Erfindung betrifft weiterhin ein Verfahren zur Herstellung eines solchen Akkumulators.

Last updated: 26.04.2011 Worldwide Database 5.7.23; 92p



Notice

This automatic translation cannot guarantee full intelligibility, completeness and accuracy. [Terms of use](#), [Legal notice](#)

Abstract DE19657638

The invention relates to an electric storage battery with a housing in the form of a gas-tight coin cell, consisting of a housing cover (2) and a Gehäusestapf (1), with intermediate electrically insulating gasket (3), a set of electrodes of positive and negative electrodes (5, 6) and intermediate separators (7) included, with at least two electrodes, a polarity of at least two points of the scale are so connected mechanically and electrically that a mechanically stable electrode package (8) gives. The invention relates to a method for producing such a battery.



Espacenet

Bibliographic data: DE 102009017514 (A1)

Knopfzelle ohne Bördelung

Publication date: 2010-10-07
Inventor(s): BRENNER ROLF [DE] +
Applicant(s): VARTA MICROBATTERY GMBH [DE] +
Classification: - International: **H01M2/02**
 - European: H01M10/04C2; H01M2/02B6B2; H01M2/04B; Y02E60/12
Application number: DE200910017514 20090404
Priority number(s): DE200910017514 20090404
Also published as: • WO 2010112332 (A1)

Cited documents: DE102008018172 (A1) DE2823888 (A1) DE69603653T (T2) WO2007062238 (A1) [View all](#)

Abstract of DE 102009017514 (A1)

Beschrieben wird ein Verfahren zur Herstellung einer Knopfzelle mit einem Gehäuse (1) aus einem Zellenbecher (2) mit einem Bodenbereich (2a), einem Mantelbereich (2b), einem dazwischen liegenden Randbereich (2c) und einer Schnittkante (2d) sowie einem Zellendeckel (3) mit einem Deckelbereich (3a), einem Mantelbereich (3b), einem dazwischen liegenden Randbereich (3c) und einer Schnittkante (3d), die über eine Dichtung (4) miteinander verbunden sind. Das Verfahren umfasst zumindest ein Aufbringen der Dichtung (4) auf den Mantelbereich (3b), ein Einschleiben des Zellenbeckers (2) mit der Dichtung (4) in den Zellenbecher (3), wobei sich ein Bereich (5) ergibt, in dem die Mantelbereiche (2b) und (3b) überlappen, und das Ausüben eines Drucks auf den Mantelbereich (2b) des Zellenbeckers (2). Die Höhen der Mantelbereiche (2b) und (3b) sind dabei derart aufeinander abgestimmt, dass die Schnittkante (2d) durch den Druck gegen den Mantelbereich (3b) gepresst wird. Bei so hergestellten Knopfzellen ist der Innenradius des Zellenbeckers (2) im Bereich (5) in Richtung der Schnittkante (2d) im Wesentlichen konstant.

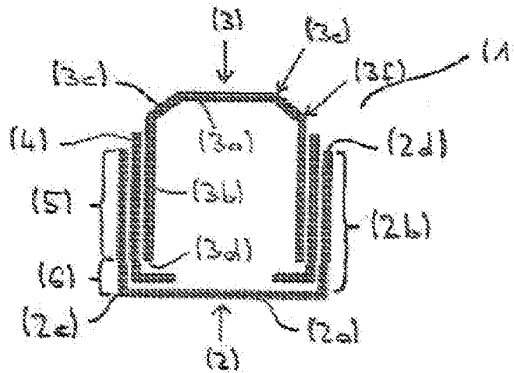

Last updated: 26.04.2011 Worldwide Database 6.7.23; 92p



Notice

This automatic translation cannot guarantee full intelligibility, completeness and accuracy. [Terms of Use](#), [Legal notice](#)

Abstract DE102009017514

Disclosed is a method of manufacturing a button cell having a housing (1) from a cell cup (2) with a floor area (2a), a cladding layer (2b), an intermediate boundary region (2c) and a cutting edge (2d) and a cell cover (3) with a lid section (3a), a cladding layer (3b), an intermediate boundary region (3c) and a cutting edge (3d), which are connected via a seal (4) together. The method comprises at least one application of the seal (4) on the cladding region (2b), insertion of the cell cover (3) with the seal (4) in the cell cup (2), resulting in a field (5), in which the cladding regions (2b) and (3b) overlap, and exerting a pressure on the cladding layer (2b) of the cell cup (2).

The heights of the cladding regions (2b) and (3b) are matched so that the cutting edge (2d) by the pressure against the sheath region (3c) is pressed. When prepared in this way button cells, the inner radius of the cell cup (2) in (5) in the direction of the cut edge (2d) is essentially constant.

Electronic Patent Application Fee Transmittal

Application Number:				
Filing Date:				
Title of Invention:	BUTTON CELLS AND METHOD FOR PRODUCING SAME			
First Named Inventor/Applicant Name:	Eduard Pytlik			
Filer:	Thomas Daniel Christenbury/Leslie Hood			
Attorney Docket Number:	RUF-11-1270 (308875-139)			
Filed as Large Entity				
U.S. National Stage under 35 USC 371 Filing Fees				
Description	Fee Code	Quantity	Amount	Sub-Total in USD(\$)
Basic Filing:				
National Stage Fee	1631	1	330	330
Natl Stage Search Fee - Report provided	1642	1	430	430
National Stage Exam - all other cases	1633	1	220	220
Pages:				
Claims:				
Miscellaneous-Filing:				
Petition:				
Patent-Appeals-and-Interference:				

Description	Fee Code	Quantity	Amount	Sub-Total in USD(\$)
Post-Allowance-and-Post-Issuance:				
Extension-of-Time:				
Miscellaneous:				
Total in USD (\$)				980

Electronic Acknowledgement Receipt

EFS ID:	10615154
Application Number:	13146669
International Application Number:	PCT/EP10/00787
Confirmation Number:	6273
Title of Invention:	BUTTON CELLS AND METHOD FOR PRODUCING SAME
First Named Inventor/Applicant Name:	Eduard Pytlik
Customer Number:	35811
Filer:	Thomas Daniel Christenbury/Leslie Hood
Filer Authorized By:	Thomas Daniel Christenbury
Attorney Docket Number:	RUF-11-1270 (308875-139)
Receipt Date:	28-JUL-2011
Filing Date:	
Time Stamp:	10:14:00
Application Type:	U.S. National Stage under 35 USC 371

Payment information:

Submitted with Payment	yes
Payment Type	Deposit Account
Payment was successfully received in RAM	\$980
RAM confirmation Number	9771
Deposit Account	502719
Authorized User	

The Director of the USPTO is hereby authorized to charge indicated fees and credit any overpayment as follows:
 Charge any Additional Fees required under 37 C.F.R. 1.492 (National application filing, search, and examination fees)
 Charge any Additional Fees required under 37 C.F.R. Section 1.17 (Patent application and reexamination processing fees)

Charge any Additional Fees required under 37 C.F.R. Section 1.19 (Document supply fees)
 Charge any Additional Fees required under 37 C.F.R. Section 1.20 (Post Issuance fees)
 Charge any Additional Fees required under 37 C.F.R. Section 1.21 (Miscellaneous fees and charges)

File Listing:

Document Number	Document Description	File Name	File Size(Bytes)/ Message Digest	Multi Part /.zip	Pages (if appl.)
1	Transmittal of New Application	FormPTO1390.pdf	593624	no	2
			7da28f82bafd9e398efef000752f49c18856598e		
Warnings:					
Information:					
2	Application Data Sheet	ApplicationDataSheet.pdf	837105	no	5
			4e9bfcbed00999e24cb5b4c71e5aa609f1ce1b9		
Warnings:					
Information:					
3		Application.pdf	119950	yes	27
			52044129bd37997f4ac200b247e7651feb967fbc		
	Multipart Description/PDF files in .zip description				
	Document Description		Start	End	
	Specification		1	22	
	Claims		23	26	
	Abstract		27	27	
Warnings:					
Information:					
4	Drawings-only black and white line drawings	Drawings.pdf	903151	no	3
			628a9b09942dfe12ea327a4fb3ac16c49b47499d		
Warnings:					
Information:					
5		PreliminaryAmendment.pdf	1344911	yes	9
			6d5c483fd38719079dae193211374704e3a83b00		
	Multipart Description/PDF files in .zip description				
	Document Description		Start	End	
	Preliminary Amendment		1	2	
	Specification		3	3	

	Claims		4		7
	Abstract		8		8
	Applicant Arguments/Remarks Made in an Amendment		9		9
Warnings:					
Information:					
6	Specification	SubSpecMarkedUp.pdf	138007 c8c725ced3d905eea6f0ffa769ce868cae978960	no	24
Warnings:					
Information:					
7	Specification	SubSpecCleanCopy.pdf	122387 d81d7d4bbb15165678540b6a293b4145cb9dd25	no	22
Warnings:					
Information:					
8	Abstract	AbstractClean.pdf	51389 9641be3e35e370500521ae02d4b9873bf305fce6	no	1
Warnings:					
Information:					
9	Documents submitted with 371 Applications	371Documents.pdf	2982446 790f61abe004eb1e9e99cfcb231924b2a766a8bd	no	13
Warnings:					
Information:					
10	Transmittal Letter	IDSTL.pdf	185949 1d750c162087a6d9401c59c23d1f520a21922879	no	1
Warnings:					
Information:					
11	Information Disclosure Statement (IDS) Form (SB08)	IDS.pdf	72105 ecd4cf1ec9a3a9e4a04fbd947b793ab0ae4a0634	no	1
Warnings:					
Information:					
This is not an USPTO supplied IDS fillable form					
12	Foreign Reference	ReferenceAJ.pdf	696948 1e9eb154a02219033f95bb39a23f7562410f6c3c	no	8
Warnings:					
Information:					

13	Foreign Reference	ReferenceAK.pdf	161557	no	1
			7077f68aeddb59aafbb4c93dad9fb67eb12462d7		
Warnings:					
Information:					
14	Foreign Reference	ReferenceAL.pdf	251729	no	1
			4db646c6373b7e5613c4c65d587928e615138f56		
Warnings:					
Information:					
15	Foreign Reference	ReferenceAM.pdf	280649	no	1
			1b7edb15a380359b07df394f8ba1bdd6d9c7f29f		
Warnings:					
Information:					
16	Foreign Reference	ReferenceAN.pdf	451782	no	8
			9cf813703a98f643f946878b1952f5d912455d8a		
Warnings:					
Information:					
17	Foreign Reference	ReferenceAO.pdf	149345	no	1
			c251bed6a32085ab2d46df2dc982fecdf712405a		
Warnings:					
Information:					
18	Foreign Reference	ReferenceAP.pdf	160465	no	1
			6d928b2de160cc320f543e2279744c4bb74cfb23		
Warnings:					
Information:					
19	Foreign Reference	ReferenceAQ.pdf	294964	no	2
			c25ea7d4bf43505571d4cfd8d26c296bc7f90aad		
Warnings:					
Information:					
20	Foreign Reference	ReferenceAR.pdf	326008	no	2
			f1btd499856ac6e0b2fa3dab72755632ab9009bf		
Warnings:					
Information:					
21	Fee Worksheet (SB06)	fee-info.pdf	33607	no	2
			cf9b6e016ce7c9b1ccc366027d760727f56388d9		
Warnings:					
Information:					

Total Files Size (in bytes):

10158078

This Acknowledgement Receipt evidences receipt on the noted date by the USPTO of the indicated documents, characterized by the applicant, and including page counts, where applicable. It serves as evidence of receipt similar to a Post Card, as described in MPEP 503.

New Applications Under 35 U.S.C. 111

If a new application is being filed and the application includes the necessary components for a filing date (see 37 CFR 1.53(b)-(d) and MPEP 506), a Filing Receipt (37 CFR 1.54) will be issued in due course and the date shown on this Acknowledgement Receipt will establish the filing date of the application.

National Stage of an International Application under 35 U.S.C. 371

If a timely submission to enter the national stage of an international application is compliant with the conditions of 35 U.S.C. 371 and other applicable requirements a Form PCT/DO/EO/903 indicating acceptance of the application as a national stage submission under 35 U.S.C. 371 will be issued in addition to the Filing Receipt, in due course.

New International Application Filed with the USPTO as a Receiving Office

If a new international application is being filed and the international application includes the necessary components for an international filing date (see PCT Article 11 and MPEP 1810), a Notification of the International Application Number and of the International Filing Date (Form PCT/RO/105) will be issued in due course, subject to prescriptions concerning national security, and the date shown on this Acknowledgement Receipt will establish the international filing date of the application.

In the Title

Kindly replace the Title with the following:

Description

~~Button cells and method for producing same~~ **BUTTON CELLS AND METHOD FOR
PRODUCING SAME**

In the Specification

A Substitute Specification (Marked-Up) is enclosed with the amendments to the Specification, together with a Substitute Specification (Clean Copy).

In the Claims

Patent Claims

1. (Currently Amended) A button cell (~~100; 400; 500~~), comprising:
[[~~-~~]] ~~two metallic housing half parts (101, 102; 401, 402; 501, 502), which are~~
housing cup and a housing top separated from one another by an electrically insulating
seal (~~109; 403; 510~~) and which form a housing with a flat bottom area (~~103; 503~~) and a
flat top area (~~104; 504~~) parallel to it, ~~as well as and~~
[[~~-~~]] ~~within the housing,~~ an electrode-separator assembly within the housing
comprising at least one positive and at least one negative electrode (~~105, 106; 201, 202;~~
~~304, 305; 407, 408; 508, 509~~), ~~which are~~ in the form of flat layers and ~~are~~ connected to
one another by at least one flat separator (~~107; 203; 302, 303; 405, 406; 507~~),
~~with~~wherein the electrode layers ~~being~~are aligned essentially at right angles to the flat
bottom and top areas and the button cell is closed without being beaded over.
2. (Currently Amended) The button cell as claimed in claim 1, ~~characterized in~~
~~that~~wherein the electrodes and/or the separator are/is in the form of strips or ribbons.
3. (Currently Amended) The button cell as claimed in claim 1 ~~or claim 2~~,
~~characterized in that~~wherein the electrode-separator assembly is in the form of a winding (~~200;~~
~~300; 404~~), ~~in particular a spiral winding~~[[~~,~~]] whose end faces (~~204, 205; 301~~) face in [[~~the~~]]a
direction of the flat bottom area and the flat top area.
4. (Currently Amended) The button cell as claimed in claim 3, ~~characterized in~~
~~that~~wherein the winding has an axial cavity in its center, which axial cavity is at least partially
filled by a winding core (~~108; 512~~).

5. (Currently Amended) The button cell as claimed in ~~one of the preceding~~ claim[[s]]_1, ~~characterized in that~~wherein the electrode-separator assembly has one of the following layer sequences:

[[-]] negative electrode/separator/positive electrode/separator and

[[-]] positive electrode/separator/negative electrode/separator.

6. (Currently Amended) The button cell as claimed in ~~one of the preceding~~ claim[[s]]_1, ~~characterized in that~~wherein the positive electrode (408; 509) and/or the negative electrode (407; 508) are/is connected via an output conductor (409; 410; 505; 506) to the housing in ~~[[the]]~~an area of the flat bottom area and/or of the flat top area.

7. (Currently Amended) The button cell as claimed in ~~one of claim[[s]] 3 to 6,~~ ~~characterized in that the button cell comprises~~further comprising at least one ~~insulating means~~ (413; 414), insulator which prevents direct mechanical and electrical contact between the end faces of the winding and the flat bottom and top areas.

8. (Currently Amended) The button cell as claimed in claim 7, ~~characterized in that~~wherein the at least one ~~insulating means~~ (413; 414) insulator is a flat layer composed of plastic, ~~for example a plastic film, which is arranged between the end faces of the winding and the flat bottom and top areas.~~

9. (Currently Amended) The button cell as claimed in ~~one of the preceding~~ claim[[s]]_1, ~~characterized in that the button cell~~which is rechargeable.

10. (Currently Amended) The button cell as claimed in ~~one of the preceding~~ claim[[s]]_1, ~~characterized in that the button cell has~~having a height:diameter ratio of < 1 ; ~~preferably between 0.1 and 0.9, in particular between 0.15 and 0.7.~~

11. (Currently Amended) A method for producing a button cell, ~~in particular a button cell (100; 400; 500) according to one of the preceding claim[[s]] 1, with a housing being fitted which is composed of metallic housing half parts, in particular a metallic cup part (101; 401; 501) and a metallic top part (102; 402; 502), said housing having a flat bottom area (103; 503) and a flat top area (104; 504) parallel to it, and with an electrode separator assembly with electrodes (105; 106; 201, 202; 304, 305; 407, 408; 508, 509) in the form of a flat layer being inserted~~comprising inserting an electrode-separator assembly with electrodes in the form of a flat layer into the housing such that the electrode layers are aligned essentially at right angles to the flat bottom and top areas ~~(103, 104; 503, 504), wherein the housing comprises a metallic cup part and a metallic top part.~~

12. (Currently Amended) The method as claimed in claim 11, ~~characterized in that~~wherein the electrode-separator assembly is inserted as a winding ~~(200; 300; 404), in particular as a spiral winding.~~

13. (Currently Amended) The method as claimed in claim 12, further ~~comprising the following steps:~~

[[-]] ~~insertion of~~inserting the winding ~~(200; 300; 404) into the metallic top part (102; 402; 502), and~~

[[-]] ~~insertion of~~inserting the metallic top part with the winding into a metallic cup part ~~(101; 401; 501),~~

~~possibly, beading over the edge of the cup part.~~

14. (Currently Amended) The method as claimed in claim 12 ~~or 13, characterized in that~~wherein the winding ~~(200; 300; 404) is heat-treated on its end faces (204, 205; 301) before~~

being installed, with it being at least ~~greatly~~for a short time subjected to a temperature at which the separator (107; 203; 302; 303; 405; 406; 507) is thermoplastically deformable.

In the Abstract

Kindly replace the Abstract with the following:

A button cell (~~100; 400; 500~~) ~~is described, comprising two metallic~~includes a housing half parts (~~101, 102; 401, 402; 501, 502~~), ~~which are connected to~~cup and a housing top separated ~~from one another forming~~aby an electrically insulating seal[[,]] and which form a housing with a flat bottom area (~~103; 503~~) and a flat top area (~~104; 504~~) parallel to it, ~~with~~and an electrode- ~~separator assembly within the housing including at least one positive and at least one negative~~ electrodes (~~105, 106; 201, 202; 304, 305; 407, 408; 508, 509~~) in the form of flat layers ~~being~~ arranged within the housing and ~~being~~ connected to one another ~~via~~aby at least one flat separator (~~107; 203; 302, 303; 405, 406; 507~~), ~~with~~wherein the electrode layers ~~being~~are aligned essentially at right angles to the flat bottom and top areas. ~~A method is also described for producing a~~and the button cell ~~such as this~~is closed without being beaded over.

(12) NACH DEM VERTRAG ÜBER DIE INTERNATIONALE ZUSAMMENARBEIT AUF DEM GEBIET DES PATENTWESENS (PCT) VERÖFFENTLICHTE INTERNATIONALE ANMELDUNG

(19) Weltorganisation für geistiges Eigentum
Internationales Büro



(43) Internationales Veröffentlichungsdatum
12. August 2010 (12.08.2010)

(10) Internationale Veröffentlichungsnummer
WO 2010/089152 A1

- (51) **Internationale Patentklassifikation:**
H01M 10/04 (2006.01) *H01M 2/02* (2006.01)
- (21) **Internationales Aktenzeichen:** PCT/EP2010/000787
- (22) **Internationales Anmeldedatum:**
9. Februar 2010 (09.02.2010)
- (25) **Einreichungssprache:** Deutsch
- (26) **Veröffentlichungssprache:** Deutsch
- (30) **Angaben zur Priorität:**
10 2009 008 859.8
9. Februar 2009 (09.02.2009) DE
10 2009 030 359.6 18. Juni 2009 (18.06.2009) DE
10 2009 060 788.9
22. Dezember 2009 (22.12.2009) DE
- (71) **Anmelder** (für alle Bestimmungsstaaten mit Ausnahme von US): **VARTA MICROBATTERY GMBH** [DE/DE]; Am Leinufer 51, 30419 Hannover (DE).
- (72) **Erfinder; und**
- (75) **Erfinder/Anmelder** (nur für US): **PYTLIK, Eduard** [DE/DE]; Alemannenstrasse 7, 73479 Ellwangen (DE). **LINDNER, Jürgen** [DE/DE]; Kottenwiesen 9, 73479 Ellwangen (DE). **BARENTHIN, Ulrich** [DE/DE]; Bahn-
- hofstrasse 6/1, 73479 Ellwangen (DE). **GAUGLER, Winfried** [DE/DE]; Birklen 26, 73479 Ellwangen (DE).
- (74) **Anwalt:** **EBERLE, Michael**; Ruff, Wilhelm, Beier, Dauster & Partner, Postfach 10 40 36, 70035 Stuttgart (DE).
- (81) **Bestimmungsstaaten** (soweit nicht anders angegeben, für jede verfügbare nationale Schutzrechtsart): AE, AG, AL, AM, AO, AT, AU, AZ, BA, BB, BG, BH, BR, BW, BY, BZ, CA, CH, CL, CN, CO, CR, CU, CZ, DE, DK, DM, DO, DZ, EC, EE, EG, ES, FI, GB, GD, GE, GH, GM, GT, HN, HR, HU, ID, IL, IN, IS, JP, KE, KG, KM, KN, KP, KR, KZ, LA, LC, LK, LR, LS, LT, LU, LY, MA, MD, ME, MG, MK, MN, MW, MX, MY, MZ, NA, NG, NI, NO, NZ, OM, PE, PG, PH, PL, PT, RO, RS, RU, SC, SD, SE, SG, SK, SL, SM, ST, SV, SY, TH, TJ, TM, TN, TR, TT, TZ, UA, UG, US, UZ, VC, VN, ZA, ZM, ZW.
- (84) **Bestimmungsstaaten** (soweit nicht anders angegeben, für jede verfügbare regionale Schutzrechtsart): ARIPO (BW, GH, GM, KE, LS, MW, MZ, NA, SD, SL, SZ, TZ, UG, ZM, ZW), eurasisches (AM, AZ, BY, KG, KZ, MD, RU, TJ, TM), europäisches (AT, BE, BG, CH, CY, CZ, DE, DK, EE, ES, FI, FR, GB, GR, HR, HU, IE, IS, IT, LT, LU, LV, MC, MK, MT, NL, NO, PL, PT, RO, SE, SI, SK, SM, TR), OAPI (BF, BJ, CF, CG, CI, CM, GA, GN, GQ, GW, ML, MR, NE, SN, TD, TG).

[Fortsetzung auf der nächsten Seite]

(54) **Title:** BUTTON CELLS AND METHOD FOR PRODUCING SAME

(54) **Bezeichnung:** KNOPFZELLEN UND VERFAHREN ZU IHRER HERSTELLUNG

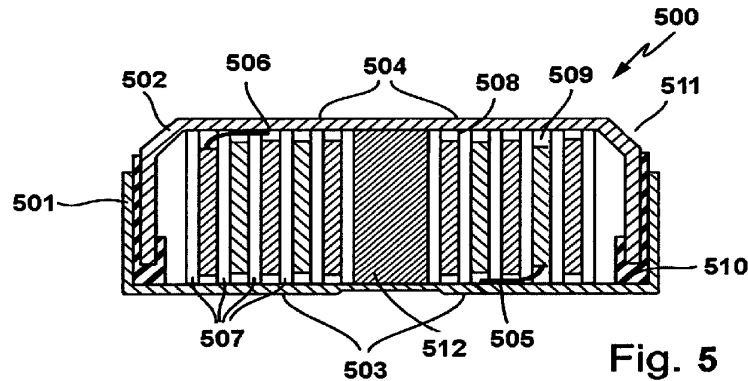

Fig. 5

(57) **Abstract:** A button cell (100; 400; 500) is described, comprising two metal housing halves (101, 102; 401, 402; 501, 502), which are sealingly connected to each other and form a housing having a planar base area (103; 503) and a planar cover area (104; 504) parallel thereto, wherein positive and negative electrodes (105, 106; 201, 202; 304, 305; 407, 408; 508, 509) are arranged as flat layers inside the housing and are connected to each other via an areal separator (107; 203; 302, 303; 405, 406; 507), wherein the electrode layers have an orthogonal orientation relative to the planar base and cover areas. Furthermore, a method for producing such a button cell is described.

(57) **Zusammenfassung:**

[Fortsetzung auf der nächsten Seite]

WO 2010/089152 A1



Veröffentlicht:

- mit internationalem Recherchenbericht (Artikel 21 Absatz 3)

Beschrieben wird eine Knopfzelle (100; 400; 500), umfassend zwei metallische Gehäusehalbteile (101, 102; 401, 402; 501, 502), welche dichtend miteinander verbunden sind und ein Gehäuse mit einem ebenen Bodenbereich (103; 503) und einem dazu parallelen ebenen Deckelbereich (104; 504) ausbilden, wobei innerhalb des Gehäuses als flache Schichten ausgebildete positive und negative Elektroden (105, 106; 201, 202; 304, 305; 407, 408; 508, 509) angeordnet sind, die über einen flächigen Separator (107; 203; 302, 303; 405, 406; 507) miteinander verbunden sind, wobei die Elektrodenschichten orthogonal zu dem ebenen Boden- und Deckelbereich ausgerichtet sind. Weiterhin wird ein Verfahren zur Herstellung einer solchen Knopfzelle beschrieben.

Knopfzellen und Verfahren zu ihrer Herstellung

5

Die vorliegende Erfindung betrifft Knopfzellen umfassend zwei metallische Gehäusehalbteile, die durch eine elektrisch isolierende Dichtung voneinander getrennt sind und die ein Gehäuse mit einem ebenen Bodenbereich und einem dazu parallelen ebenen Deckelbereich ausbilden
10 sowie innerhalb des Gehäuses mit einem Elektroden-Separator-Verbund, umfassend mindestens eine positive und mindestens eine negative Elektrode, die als flache Schichten ausgebildet und über mindestens einen flächigen Separator miteinander verbunden sind, sowie ein Verfahren zur Herstellung von solchen Knopfzellen.

15

Knopfzellen weisen üblicherweise ein Gehäuse aus zwei Gehäusehalbteilen, einem Zellenbecher und einem Zellendeckel, auf. Diese können beispielsweise aus vernickeltem Tiefziehblech als Stanzziehteile hergestellt werden. Gewöhnlich ist der Zellenbecher positiv und der Gehäuse-
20 deckel negativ gepolt. In dem Gehäuse können die verschiedensten elektrochemischen Systeme enthalten sein, beispielsweise Zink/MnO₂, primäre und sekundäre Lithium-Systeme oder sekundäre Systeme wie Nickel/Cadmium oder Nickel/Metallhydrid.

25 Sehr verbreitet sind z.B. wiederaufladbare Knopfzellen auf Basis von Nickel-Metallhydrid- oder Lithium-Ionen-Systemen. Bei Lithium-Ionen-Knopfzellen werden die elektrochemisch aktiven Materialien innerhalb des Knopfzelligehäuses üblicherweise nicht in Form von einzelnen, durch einen Separator voneinander getrennten, tablettenförmigen Elektroden
30 angeordnet. Stattdessen werden bevorzugt vorgefertigte Elektroden-Separator-Verbünde flach in das Gehäuse eingelegt. Als Separator dient dabei bevorzugt eine poröse Kunststofffolie, auf welche die Elektroden flächig auflaminiert oder aufgeklebt sind. Der Gesamtverbund aus Separator und Elektroden ist dabei in der Regel maximal wenige 100 µm

BESTÄTIGUNGSKOPIE

dick. Um Knopfzelligegehäuse üblicher Dimensionen ausfüllen zu können, werden daher häufig mehrere solcher Verbände flach übereinander gelegt. Auf diese Weise lassen sich Stapel in grundsätzlich beliebiger Höhe erhalten, jeweils abgestimmt auf die zur Verfügung stehenden Dimensionen des Knopfzelligegehäuses, in das der Stapel verbaut werden soll. So wird eine optimale Ausnutzung des zur Verfügung stehenden Gehäuseinnenraumes gewährleistet.

Konstruktionsbedingt treten bei Knopfzellen, die solche Stapel aus Elektroden-Separator-Verbänden enthalten, allerdings auch diverse Probleme auf. Zum einen ist es natürlich erforderlich, Elektroden von jeweils gleicher Polarität innerhalb des Stapels miteinander zu verbinden und dann jeweils mit dem entsprechenden Pol des Knopfzelligegehäuses zu kontaktieren. Die erforderlichen elektrischen Kontakte verursachen Materialkosten, der durch sie eingenommene Raum steht zudem für Aktivmaterial nicht mehr zur Verfügung. Die Herstellung der Elektrodenstapel ist darüber hinaus kompliziert und teuer, da bei der Kontaktierung der Verbände untereinander leicht Fehler auftreten können, die die Ausschussrate erhöhen. Zum anderen wurde festgestellt, dass Knopfzellen mit einem Stapel aus Elektroden und Separatoren sehr schnell undicht werden.

Der flüssigkeitsdichte Verschluss von Knopfzellen erfolgt klassisch durch Umbördeln des Randes des Zellenbechers über den Rand des Zellendeckels in Verbindung mit einem Kunststoffring, der zwischen Zellenbecher und Zellendeckel angeordnet ist und der gleichzeitig als Dichtungselement sowie zur elektrischen Isolierung des Zellenbechers und des Zellendeckels dient. Derartige Knopfzellen sind beispielsweise in der DE 31 13 309 beschrieben.

Alternativ ist es jedoch auch möglich, Knopfzellen zu fertigen, bei denen Zellenbecher und Zellendeckel in axialer Richtung ausschließlich durch eine kraftschlüssige Verbindung zusammengehalten werden und die keinen umgebördelten Becherrand aufweisen. Derartige Knopfzellen

sowie ein Verfahren zu ihrer Herstellung sind in der noch unveröffentlichten deutschen Patentanmeldung mit dem Aktenzeichen 10 2009 017 514.8 beschrieben. Ungeachtet der diversen Vorteile, die solche Knopfzellen ohne Bördelung aufweisen können, sind sie in axialer Richtung
5 jedoch weniger belastbar als vergleichbare Knopfzellen mit umgebördeltem Becherrand, insbesondere was axiale mechanische Belastungen angeht, die ihre Ursache im Inneren der Knopfzelle haben. So sind zum Beispiel die Elektroden von wiederaufladbaren Lithium-Ionen-Systemen bei Lade- und Entladevorgängen stets Volumenänderungen ausgesetzt.
10 Die dabei auftretenden axialen Kräfte können bei Knopfzellen ohne Bördelung natürlich vergleichsweise leichter zu Undichtigkeiten führen als bei Knopfzellen mit Bördelung.

Der vorliegenden Erfindung lag die Aufgabe zugrunde, eine Knopfzelle
15 bereitzustellen, bei der die oben angesprochenen Probleme nicht oder nur in stark verringertem Maß auftreten. Die Knopfzelle soll insbesondere gegenüber in axialer Richtung auftretenden mechanischen Belastungen widerstandsfähiger sein als herkömmliche Knopfzellen, insbesondere auch dann, wenn sie als Knopfzelle ohne umgebördelten Becherrand
20 gefertigt wird.

Diese Aufgabe wird gelöst durch die Knopfzelle mit den Merkmalen des Anspruchs 1. Bevorzugte Ausführungsformen der erfindungsgemäßen Knopfzelle sind in den abhängigen Ansprüchen 2 bis 10 definiert. Auch
25 das Verfahren gemäß Anspruch 11 trägt zur Lösung der erfindungsgemäßen Aufgabe bei. Bevorzugte Ausführungsformen des erfindungsgemäßen Verfahrens sind in den abhängigen Ansprüchen 12 bis 14 definiert. Der Wortlaut sämtlicher Ansprüche wird hiermit durch Bezugnahme zum Inhalt dieser Beschreibung gemacht.

30

Eine erfindungsgemäße Knopfzelle umfasst stets zwei metallische Gehäusehalbteile, die durch eine elektrisch isolierende Dichtung voneinander getrennt sind und die ein Gehäuse mit einem ebenen Bodenbereich und einem dazu parallelen ebenen Deckelbereich ausbilden. Bei den

beiden Gehäusehalbteilen handelt es sich, wie eingangs bereits erwähnt, in der Regel um einen sogenannten Gehäusebecher und einen Gehäusedeckel. Als Gehäusehalbteile sind insbesondere Teile aus vernickeltem Stahl oder Blech bevorzugt. Weiterhin als metallischer Werkstoff geeignet sind insbesondere Trimetalle, beispielsweise mit der Abfolge Nickel, Stahl (oder Edelstahl) und Kupfer (wobei die Nickelschicht bevorzugt die Außen- und die Kupferschicht bevorzugt die Innenseite des Knopfzellegehäuses bildet).

- 5
- 10 Als Dichtung kann beispielsweise eine Spritzguß- oder eine Foliendichtung zum Einsatz kommen. Letztere sind beispielsweise in der DE 196 47 593 beschrieben.

Innerhalb des Gehäuses umfasst eine erfindungsgemäße Knopfzelle einen Elektroden-Separator-Verbund mindestens eine positive und mindestens eine negative Elektrode. Diese liegen jeweils in Form von flachen Elektrodenschichten vor. Miteinander verbunden sind die Elektroden über einen flächigen Separator. Bevorzugt sind die Elektroden auf diesen Separator auflaminiert oder aufgeklebt. Die Elektroden und der Separator weisen in der Regel jeweils nur Dicken im μm -Bereich auf. Als Separator dient in der Regel eine poröse Kunststoffolie.

Im Gegensatz zu den eingangs erwähnten Knopfzellen zeichnet sich die erfindungsgemäße Knopfzelle insbesondere dadurch aus, dass die Elektrodenschichten eine ganz besondere Orientierung aufweisen, sie sind nämlich im wesentlichen orthogonal zu dem ebenen Boden- und Deckelbereich ausgerichtet. Während aus dem Stand der Technik bekannte Knopfzellen mit gestapelten Elektroden-Separator-Verbänden diese stets flach eingelegt enthalten, so dass die Elektrodenschichten im wesentlichen parallel zu den ebenen Boden- und Deckelbereichen ausgerichtet sind, ist bei einer erfindungsgemäßen Knopfzelle das Gegenteil der Fall.

Die orthogonale Ausrichtung der Elektrodenschichten hat einen unerwartet deutlichen Vorteil, es wurde nämlich festgestellt, dass diese Ausrichtung mit einer deutlichen Verbesserung der Dichtigkeitseigenschaften einer erfindungsgemäßen Knopfzelle einhergeht, insbesondere bei

5 Knopfzellen auf Basis von Lithium-Ionen-Systemen. Die Elektroden von wiederaufladbaren Lithium-Ionen-Systemen sind bei Lade- und Entladevorgängen stets Volumenänderungen ausgesetzt. Zu solchen Volumenänderungen kann es natürlich auch bei den Elektroden einer erfindungsgemäßen Knopfzelle kommen. Die dabei entstehenden mechanischen Kräfte wirken jedoch nicht mehr primär axial, wie das im Falle eines flach eingelegten Stapels aus Elektroden-Separator-Verbänden der Fall ist. Aufgrund der orthogonalen Ausrichtung der Elektroden wirken sie vielmehr radial. Radiale Kräfte können von dem Gehäuse einer Knopfzelle sehr viel besser aufgenommen werden als axiale. Vermutlich

10 lassen sich darauf die verbesserten Dichtigkeitseigenschaften zurückführen.

Besonders bevorzugt sind die Elektroden und der flächige Separator einer erfindungsgemäßen Knopfzelle jeweils streifen- oder bandförmig ausgebildet. So kann zur Herstellung einer erfindungsgemäßen Knopfzelle beispielsweise von einem als Endlosband vorliegenden Separatormaterial ausgegangen werden, auf das die Elektroden flächig, insbesondere wieder in Form von Streifen oder zumindest von Rechtecken, aufgebracht, insbesondere auf laminiert, werden.

25 Im Gehäuse einer erfindungsgemäßen Knopfzelle liegt dieser Verbund besonders bevorzugt in Form eines Wickels, insbesondere in Form eines spiralförmigen Wickels, vor. Derartige Wickel lassen sich nach bekannten Verfahren (s. z.B. DE 36 38 793) recht einfach herstellen, indem auf einen als Endlosband vorliegenden Separator die Elektroden

30 flächig, insbesondere in Form von Streifen, aufgebracht, insbesondere auf laminiert, werden. Aufgewickelt wird der Verbund aus Elektroden und Separatoren dabei in der Regel auf einen sogenannten Wickeldorn. Nach Abstreifen des Wickels vom Wickeldorn bleibt im Zentrum des Wi-

ckels ein axialer Hohlraum zurück. Das hat zur Folge, dass sich der Wickel gegebenenfalls in diesen Hohlraum hinein entspannen kann. Dies kann jedoch unter Umständen zu Problemen bei der elektrischen Kontaktierung der Elektroden mit den metallischen Gehäusehalbteilen führen, was im Folgenden noch genauer beschrieben wird.

Der Elektrodenwickel ist innerhalb einer erfindungsgemäßen Knopfzelle (damit die Elektrodenschichten des Wickels orthogonal zu dem ebenen Boden- und Deckelbereich des Gehäuses ausgerichtet sind) bevorzugt derart angeordnet, dass die Stirnseiten des Wickels in Richtung des ebenen Bodenbereichs und des ebenen Deckelbereichs weisen.

Gemäß der vorliegenden Erfindung ist es vorgesehen, dass eine erfindungsgemäße Knopfzelle in bevorzugten Ausführungsformen einen festen Wickelkern im Zentrum des Wickels aufweist, der den axialen Hohlraum im Zentrum des Wickels mindestens teilweise ausfüllt. Ein solcher Wickelkern fixiert den Elektrodenwickel in radialer Richtung und verhindert eine mögliche Implosion des Wickels in den axialen Hohlraum. Bei einer derartigen Entspannung des Wickels lässt auch der Druck nach, den die Stirnseiten des Wickels in axialer Richtung und damit in Richtung dort gegebenenfalls angeordneter Ableiter (hierzu unten noch mehr) ausüben. Wird dies unterbunden, so resultieren in der Regel auch keine Probleme mit der elektrischen Kontaktierung der Elektroden und der metallischen Gehäusehalbteile.

Daneben verbessert ein solcher Wickelkern auch die Stabilität der erfindungsgemäßen Knopfzelle gegenüber äußeren mechanischen Einflüssen. Eine Beschädigung des Elektrodenwickels in der Knopfzelle durch einen äußeren mechanischen Druck in axialer Richtung ist in der Regel nicht mehr möglich.

Gemäß der bevorzugten Ausführungsform des Elektrodenwickels als spiralförmiger Elektrodenwickel ist der erwähnte axiale Hohlraum im Zentrum des Wickels vorzugsweise im Wesentlichen zylindrisch (insbe-

sondere kreiszylindrisch) ausgebildet. Mantelseitig wird er durch den Wickel begrenzt, stirnseitig durch entsprechende Flächen des Boden- bzw. des Deckelbereichs des Knopfzellegehäuses.

5 Entsprechend ist auch der in einer erfindungsgemäßen Knopfzelle enthaltene Wickelkern bevorzugt als Zylinder, insbesondere als Hohlzylinder, ausgebildet. Die Höhe eines solchen Zylinders entspricht bevorzugt dem jeweiligen Abstand des ebenen Bodenbereichs von dem dazu parallelen ebenen Deckelbereich.

10

In besonders bevorzugten Ausführungsformen kann der Wickelkern radial selbstexpandierende Eigenschaften aufweisen. Es ist zum Beispiel möglich, den Wickelkern in einer radial komprimierten Konfiguration in den axialen Hohlraum des Wickels einer erfindungsgemäßen Knopfzelle einzuführen. Bei Entspannung des radial komprimierten Wickelkerns übt dieser einen radialen Druck auf den ihn umgebenden Elektrodenwickel aus und gewährleistet so einen Anpressdruck auch in axialer Richtung.

15 Als radial selbstexpandierender Wickelkern kann beispielsweise ein axial geschlitzter Hohlzylinder zum Einsatz kommen. Alternativ sind jedoch auch andere radial selbstexpandierende Materialien, beispielsweise auf Kunststoffbasis, denkbar.

25 Besonders bevorzugt besteht der Wickelkern aus einem Metall wie Edelstahl oder aus Kunststoff.

Besonders bevorzugt weist der Verbund aus Elektroden und Separator in einer erfindungsgemäßen Knopfzelle eine der folgenden Schichtabfolgen auf:

30

- negative Elektrode / Separator / positive Elektrode / Separator

oder

- positive Elektrode / Separator / negative Elektrode / Separator.

Derartige Verbände lassen sich sehr einfach herstellen und aufwickeln, ohne dass es zu Kurzschlüssen zwischen entgegengesetzt gepolten
5 Elektroden kommt.

Bei den in einer erfindungsgemäßen Knopfzelle einsetzbaren Separatoren handelt es sich vorzugsweise um Folien aus mindestens einem Kunststoff, insbesondere aus mindestens einem Polyolefin. Bei dem
10 mindestens einen Polyolefin kann es sich beispielsweise um Polyethylen handeln. Es können aber auch mehrlagige Separatoren verwendet werden, beispielsweise Separatoren aus einer Abfolge verschiedener Polyolefinschichten, z.B. mit der Sequenz Polyethylen/Polypropylen/Polyethylen.

15

Zur Herstellung von Verbänden der oben genannten Abfolge müssen nicht zwingend mehrere separate Separatoren zum Einsatz kommen. Vielmehr kann ein Separator auch um das Ende einer der Elektroden umgeschlagen werden, so dass im Ergebnis beide Seiten dieser Elektrode von dem Separator bedeckt werden.
20

Die in einer erfindungsgemäßen Knopfzelle bevorzugt einsetzbaren Separatoren weisen bevorzugt eine Dicke zwischen 3 μm und 100 μm , insbesondere zwischen 10 μm und 50 μm , auf.

25

Die Elektroden einer erfindungsgemäßen Knopfzelle weisen bevorzugt eine Dicke zwischen 10 μm und 1000 μm , insbesondere zwischen 30 μm und 500 μm , auf.

30 In bevorzugten Ausführungsformen einer erfindungsgemäßen Knopfzelle sind die negative Elektrode und die positive Elektrode im Elektroden-Separator-Verbund innerhalb des Verbundes versetzt zueinander angeordnet. Unter einer versetzten Anordnung soll dabei verstanden werden, dass die Elektroden derart angeordnet sind, dass in der erfindungsge-

mäßigen Knopfzelle eine jeweils unterschiedliche Beabstandung der Elektroden zu den ebenen Boden- und Deckelbereichen resultiert. Im einfachsten Fall können z.B. eine positive und eine negative Elektrode als gleich breite Streifen leicht versetzt auf die gegenüberliegenden Seiten
5 eines Separatorbandes aufgebracht werden, so dass der Abstand der positiven Elektrode zum oberen Separatorrand größer ist als der vergleichbare Abstand von der negativen Elektrode aus gemessen. Umgekehrtes gilt dann natürlich im Hinblick auf den Abstand zum unteren Separatorrand.

10

In besonders bevorzugten Ausführungsformen liegt, vorzugsweise als Resultat dieser versetzten Anordnung, die positive Elektrode, insbesondere ein Rand der positiven Elektrode, unmittelbar am Becherteil an, insbesondere im ebenen Bodenbereich des Becherteils, während die
15 negative Elektrode, insbesondere ein Rand der negativen Elektrode, unmittelbar am Deckelteil, insbesondere im ebenen Deckelbereich des Deckelteils, anliegt. In dieser Ausführungsform besteht ein unmittelbarer elektrischer und mechanischer Kontakt zwischen den Elektroden und dem Becher- bzw. Deckelteil. Die versetzte Anordnung der Elektroden
20 zueinander ermöglicht also eine Kontaktierung der Elektroden mit den jeweiligen Gehäuseteilen, ohne dass zusätzliche elektrische Kontakte und Verbindungsmittel zum Einsatz kommen müssen.

In alternativen bevorzugten Ausführungsformen kann es allerdings auch
25 bevorzugt sein, dass zumindest eine der Elektroden, vorzugsweise sowohl die mindestens eine negative als auch die mindestens eine positive Elektrode in einer erfindungsgemäßen Knopfzelle, über einen oder mehrere Ableiter mit den ebenen Boden- und Deckelbereichen verbunden sind. Bei den Ableitern kann es sich beispielsweise um Ableiterfahnen
30 aus Kupfer oder einem anderen geeigneten Metall handeln. Elektrodenseitig können die Ableiter z.B. an einen Stromkollektor angebunden sein. Eine Anbindung der Ableiter ans Gehäuse und/oder an die Stromkollektoren kann z.B. über Verschweissung oder über eine Klemmverbindung erfolgen.

Im einfachsten Fall können als Ableiter auch die Stromkollektoren von positiver und negativer Elektrode selbst fungieren. Bei solchen Kollektoren handelt es sich in der Regel um metallische Folien oder Netze, die in das jeweilige Elektrodenmaterial eingebettet sind. Unbedeckte Teilbereiche, insbesondere Endstücke, solcher Kollektoren können umgebogen und in Kontakt mit dem Knopfzallengehäuse gebracht werden.

Die Verwendung von Ableitern kann insbesondere dann vorteilhaft sein, wenn die negative Elektrode und die positive Elektrode innerhalb des Verbundes derart zueinander angeordnet sind, dass für die Elektroden eine jeweils gleiche Beabstandung zu den ebenen Boden- und Deckelbereichen resultiert. Oder mit anderen Worten, wenn die Elektroden innerhalb des Elektroden-Separator-Verbundes nicht versetzt zueinander angeordnet sind, wie es oben beschrieben wurde.

Allerdings besteht bei gleicher Beabstandung entgegengesetzt gepolter Elektroden zu den ebenen Boden- und Deckelbereichen die Gefahr, dass eine positive und eine negative Elektrode gleichzeitig das metallische Becher- oder Deckelteil berühren, so dass ein Kurzschluss entsteht. In bevorzugten Ausführungsformen kann die erfindungsgemäße Knopfzelle deshalb mindestens ein Isoliermittel umfassen, das einen direkten und unmittelbaren mechanischen und elektrischen Kontakt zwischen den Stirnseiten des Wickels und den ebenen Boden- und Deckelbereichen unterbindet.

In Weiterbildung ist es bevorzugt, wenn die Elektroden in einer solchen erfindungsgemäßen Knopfzelle über die bereits erwähnten separaten Ableiter mit den ebenen Boden- und Deckelbereichen verbunden sind. Diese gewährleisten den elektrischen Kontakt zwischen den Elektroden und dem Gehäuse.

Dabei ist es bevorzugt, dass zumindest ein Teilabschnitt des oder der Ableiter im Boden- bzw. im Deckelbereich des Gehäuses flach an der

Innenseite der Gehäusehalbteile anliegt. Ideal ist die elektrische Kontaktierung der Ableiter mit den Innenseiten des Gehäuses natürlich dann, wenn sie zumindest leicht an das Gehäuse angepresst werden (falls sie nicht ohnehin angeschweisst sind). Überraschend effizient kann dies
5 durch geeignete Anordnung des oben erwähnten Wickelkerns in einer erfindungsgemäßen Knopfzelle erreicht werden.

Bei dem Isoliermittel kann es sich z.B. um eine flache Schicht aus Kunststoff, beispielsweise um eine Kunststofffolie handeln, die zwischen
10 den Stirnseiten des Wickels und den ebenen Boden- und Deckelbereichen des Gehäuses einer erfindungsgemäßen Knopfzelle angeordnet ist.

Bei der erfindungsgemäßen Knopfzelle handelt es sich entsprechend
15 den obigen Ausführungen insbesondere um eine wiederaufladbare Knopfzelle. Besonders bevorzugt weist eine erfindungsgemäße Knopfzelle mindestens eine Lithium-interkalierende Elektrode auf.

Das Verhältnis von Höhe zu Durchmesser liegt bei Knopfzellen definiti-
20 onsgemäß unterhalb von 1. Besonders bevorzugt liegt dieses Verhältnis bei einer erfindungsgemäßen Knopfzelle zwischen 0.1 und 0.9, insbesondere zwischen 0.15 und 0.7. Unter der Höhe soll dabei der Abstand zwischen dem ebenen Bodenbereich und dem dazu parallelen ebenen Deckelbereich verstanden werden. Der Durchmesser meint die maxima-
25 le Entfernung zweier Punkte auf dem Mantelbereich der Knopfzelle.

Besonders bevorzugt handelt es sich bei der erfindungsgemäßen Knopfzelle um eine Knopfzelle ohne Bördelung, wie sie in der eingangs bereits erwähnten Patentanmeldung mit dem Aktenzeichen 10 2009 017
30 514.8 beschrieben ist. Entsprechend besteht zwischen den Gehäusehalbteilen bevorzugt eine ausschließlich kraftschlüssige Verbindung. Die erfindungsgemäße Knopfzelle weist also keinen umgebördelten Becher-
rand auf, wie dies bei aus dem Stand der Technik bekannten Knopfzellen stets der Fall ist. Die Knopfzelle ist bördelfrei verschlossen.

Für solche bördelfreien Knopfzellen greift man in der Regel auf übliche Zellenbecher und Zellendeckel zurück, die jeweils einen Boden- bzw. einen Deckelbereich, einen Mantelbereich, einen zwischen Boden- bzw. 5 Deckelbereich und Mantelbereich angeordneten Randbereich und eine Schnittkante aufweisen. Zusammen bilden Zellenbecher und Zellendeckel ein Gehäuse, das eine Aufnahme für die üblichen Innenkomponenten einer Knopfzelle wie Elektroden, Separator etc. bildet. Wie üblich sind in diesem Gehäuse der Bodenbereich des Zellenbechers und der 10 Deckelbereich des Zellendeckels im wesentlichen parallel zueinander ausgerichtet. Die Mantelbereiche von Zellenbecher und Zellendeckel sind in der fertigen Knopfzelle im wesentlichen orthogonal zum Boden- bzw. zum Deckelbereich ausgerichtet und weisen bevorzugt eine im wesentlichen zylindrische Geometrie auf. Vorzugsweise sind Innen- und 15 Außenradius von Zellenbecher und Zellendeckel in den Mantelbereichen im wesentlichen konstant. Die erwähnten Randbereiche von Zellenbecher und Zellendeckel bilden den Übergang zwischen den Mantelbereichen und dem Deckelbereich bzw. dem Bodenbereich. Sie sind also bevorzugt zum einen begrenzt durch die im wesentlichen eben ausgebildeten Boden- und Deckelbereiche, zum anderen durch die orthogonal zu diesen angeordneten im wesentlichen zylindrischen Mantelbereiche. Die 20 Randbereiche können beispielsweise als scharfe Kante oder auch abgerundet ausgebildet sein.

25 Zur Herstellung einer bördelfreien Knopfzelle geht man in der Regel so vor, dass zunächst eine Dichtung auf den Mantelbereich eines Zellendeckels aufgebracht wird. In einem weiteren Schritt wird dann der Zellendeckel mit der aufgetragenen Dichtung in einen Zellenbecher eingeschoben, so dass sich ein Bereich ergibt, in dem die Mantelbereiche von 30 Zellenbecher und Zellendeckel überlappen. Die Größe des Überlappungsbereiches bzw. das Verhältnis von überlappendem Bereich zu nicht überlappendem Bereich ist dabei durch die jeweilige Höhe der Mantelbereiche von Zellenbecher und Zellendeckel sowie durch die Tiefe des Einschubs festgelegt. Hinsichtlich des Mantelbereichs des Zel-

lendeckels ist es bevorzugt, dass zwischen 20 % und 99 %, insbesondere zwischen 30 % und 99 %, besonders bevorzugt zwischen 50 % und 99 %, mit dem Mantelbereich des Zellenbechers überlappen (die Prozentzahlen beziehen sich jeweils auf die Höhe des Mantels bzw. des
5 Mantelbereichs). Vor dem Einschieben können in den Gehäusebecher und/oder in den Gehäusedeckel die sonstigen üblichen Bestandteile einer Knopfzelle (Elektroden, Separator, Elektrolyt etc.) eingesetzt werden. Nach dem vollständigen Einschieben des Zellendeckels in den Zellenbecher wird auf den Mantelbereich des Zellenbechers, insbesondere
10 im Bereich der Schnittkante, ein Druck ausgeübt, um das Gehäuse abzudichten. Dabei sollen die zusammengefügte Gehäuseteile möglichst keinen oder nur sehr geringen Belastungen in axialer Richtung unterliegen. Der Druck wird daher insbesondere radial angelegt. Abgesehen von der bereits erwähnten Abdichtung des Gehäuses kann so auch der
15 Außendurchmesser des Zellengehäuses kalibriert werden.

Besonders wichtig ist es dass die Höhen der Mantelbereiche von Zellenbecher und Zellendeckel derart aufeinander abgestimmt sind, dass die Schnittkante des Zellenbechers durch den Druck auf den Mantelbereich des Zellenbechers gegen den Mantelbereich des Zellendeckels
20 gepresst wird. Die Höhen der Mantelbereiche sind also bevorzugt so gewählt, dass ein Umbiegen der Schnittkante des Zellenbechers nach innen über den Randbereich des vollständig in den Zellenbecher eingeschobenen Zellendeckels nicht möglich ist. Es findet entsprechend keine
25 Umbördelung des Randes des Zellenbechers über den Randbereich des Zellendeckels statt. In Folge dessen weist der Zellenbecher einer nach dem erfindungsgemäßen Verfahren gefertigten Knopfzelle einen Mantelbereich mit einem im wesentlichen konstanten Radius in Richtung der Schnittkante auf.

30

Bei nach einem solchen Verfahren hergestellten Knopfzellen besteht zwischen den Gehäusekomponenten Zellenbecher, Zellendeckel und Dichtung vorzugsweise eine ausschließlich kraftschlüssige Verbindung.

Der Zusammenhalt der Komponenten wird also bevorzugt im wesentlichen nur durch Haftkraft gewährleistet.

Besonders bevorzugt wird zur Herstellung bördelfreier Knopfzellen ein
5 Zellenbecher verwendet, der zumindest in einem Teilbereich seines Mantels konisch ausgebildet ist, so dass zumindest sein Innendurchmesser in Richtung der Schnittkante zunimmt. Dadurch wird das Einschieben des Zellendeckels in den Zellenbecher deutlich erleichtert. Die Dimensionen von Zellenbecher und Zellendeckel sind bevorzugt so auf
10 einander abgestimmt, dass größere Gegenkräfte vorzugsweise erst bei nahezu vollständigem Einschub des Deckels in den Becher auftreten. Vorzugsweise liegt der Konuswinkel dabei zwischen 10 min und 3°, insbesondere zwischen 30 min und 1° 30 min.

15 Der Zellendeckel, der mit aufgebrachtener Dichtung in den Zellenbecher eingeschoben wird, ist in bevorzugten Ausführungsformen zumindest in einem Teil des Mantelbereiches zylindrisch ausgebildet. Dies betrifft gegebenenfalls insbesondere den Teil des Mantelbereiches, der nach dem Einschieben des Zellendeckels in den Zellenbecher mit dem erwähnten
20 konisch ausgebildeten Teilbereich des Zellenbechermantels überlappt. Besonders bevorzugt ist der Mantel des Zellendeckels und damit auch der Mantelbereich zur Gänze zylindrisch ausgebildet. Vorzugsweise weist der Zellendeckel im Mantelbereich also einen konstanten Außenradius auf. Dies betrifft gegebenenfalls insbesondere den Teil, der nach
25 dem Einschieben des Zellendeckels mit dem konisch ausgebildeten Teil des Mantelbereiches des Zellenbechers überlappt.

Beim Einschieben eines Zellendeckels mit zylindrischem Mantelbereich in einen zumindest in einem Teilbereich seines Mantels konisch ausgebildeten Zellenbecher, wie er oben beschrieben wurde, entsteht in der
30 Regel ein sich nach oben öffnender Spalt zwischen Zellenbecher und Zellendeckel. Dieser Spalt wird in der Regel durch den Druck auf den Mantelbereich des Zellenbechers wieder beseitigt. So wird der Druck auf den Mantelbereich des Zellenbechers gegebenenfalls so gewählt, dass

der konisch ausgebildete Teil des Mantelbereichs des Zellenbeckers nach innen gedrückt wird, bis die Innenseite des Zellenbeckers und die Außenseite des Zellendeckels im überlappenden Bereich im wesentlichen gleichmäßig voneinander beabstandet sind. Die resultierende

5 Knopfzelle weist Mantelbereiche auf, die parallel zueinander ausgerichtet sind, insbesondere im überlappenden Bereich.

Ein wichtiger Aspekt dabei ist die Wahl der Dichtung, die den Zellenbecher mit dem Zellendeckel verbindet. Bevorzugt handelt es sich bei der

10 Dichtung um eine Kunststoffdichtung aus einem Thermoplasten.

Besonders bevorzugt handelt es sich bei der Kunststoffdichtung um eine Foliendichtung, wie sie z.B. in der bereits genannten DE 196 47 593 beschrieben ist, insbesondere um eine Foliendichtung aus einem Thermo-

15 plasten.

Foliendichtungen können mit einer sehr gleichmäßigen Dicke hergestellt werden. Beim Anlegen eines geeigneten Drucks auf den Mantelbereich des Zellenbeckers ergibt sich eine Presspassung, infolge derer die her-

20 gestellte Knopfzelle ganz hervorragende Dichtigkeitseigenschaften aufweist. So ermöglicht nicht zuletzt die Verwendung von Foliendichtungen den Verzicht auf ein Umbördeln des Randes des Zellenbeckers, ohne im Gegenzug Nachteile bei sonstigen wichtigen Eigenschaften in Kauf nehmen zu müssen.

25 Ganz besonders bevorzugt kommen vorliegend Kunststoffdichtungen, insbesondere Kunststofffolien, auf Basis von Polyamid oder auf Basis von Polyetheretherketonen zum Einsatz.

30 Es ist bevorzugt, dass die Dichtung einer bördelfreien Zelle eine Ausgangsdicke im Bereich zwischen 50 µm und 250 µm, besonders bevorzugt zwischen 70 µm und 150 µm, insbesondere von ca. 100 µm, aufweist. Unter dem Begriff „Ausgangsdicke“ soll dabei die Dicke verstanden werden, die die Dichtung aufweist, bevor sie auf den Mantel des

Zellendeckels aufgebracht wird. Im Gegensatz dazu soll unter dem Begriff „Enddicke“ die Dicke der Dichtung in der fertigen Zelle verstanden werden. Es ist klar, dass diese zumindest im überlappenden Bereich in der Regel dem Abstand zwischen der Innenseite des Zellenbeckers und
5 der Außenseite des Zellendeckels entspricht.

Damit eine ausreichend hohe Reibung zwischen Zellenbecher und Zellendeckel entstehen kann, sollten sowohl die Außen- als auch die Innenradien von Becher und Deckel aufeinander sowie auf die Dicke der Fo-
10 liendichtung abgestimmt werden. Nur so kann ein ausreichend hoher Pressdruck entstehen, der die beiden Einzelteile zusammenhält. Für die dabei verwendeten Teile gilt bevorzugt, dass die Differenz zwischen dem Außenradius des in den Zellenbecher einzuschiebenden Zellendeckels an der Schnittkante des Zellendeckels und dem kleinsten Innenra-
15 dius des Zellenbeckers in dem Teil des Mantelbereichs, der mit dem Mantelbereich des Zellendeckels überlappt, kleiner ist als die Ausgangsdicke der verwendeten Dichtung. Besonders bevorzugt beträgt die Differenz zwischen 10 % und 90 % der Ausgangsdicke, insbesondere zwischen 30 % und 70 %, ganz besonders bevorzugt ca. 50 %.

20 Nach dem Einschieben des Zellendeckels in den Zellenbecher kann ein Teil des Mantelbereiches des Zellenbeckers radial nach innen eingezogen werden. Es handelt sich dabei insbesondere um den Teil des Mantelbereichs, der nicht mit dem Mantelbereich des Zellendeckels über-
25 lappt.

Es wurde gefunden, dass durch diesen radialen Einzug deutlich verbesserte Dichtigkeitseigenschaften erzielt werden können. Durch das Einziehen des Bechermantels wird ein radialer Druck auf den an der In-
30 nenwand des Gehäusebeckers anliegenden Randabschnitt bzw. auf die zwischen Gehäusedeckel und Gehäusebecher angeordnete Dichtung ausgeübt, die in der Folge in diesem Bereich zusammengepresst wird.

Das Einziehen kann zeitgleich zu der bereits erwähnten Druckausübung auf den Mantelbereich des Zellenbechers erfolgen, bevorzugt erfolgt das Einziehen aber in einem späteren separaten Schritt.

- 5 Das erfindungsgemäße Verfahren zur Herstellung einer Knopfzelle kann insbesondere zur Herstellung von Knopfzellen dienen, wie sie vorstehend beschrieben wurde, also von Knopfzellen mit einem Gehäuse mit einem ebenen Bodenbereich und einem dazu parallelen ebenen Deckelbereich. Es eignet sich sowohl zur Herstellung von bördelfreien
10 Knopfzellen als auch von solchen mit Bördelung.

Betreffend die bevorzugten Ausführungsformen der einzelnen in einem erfindungsgemäßen Verfahren verwendeten Komponenten (Gehäuseteile und -dimensionen, Elektroden, Separator etc.) kann somit vollumfänglich auf die obenstehenden Ausführungen und Erläuterungen Bezug
15 genommen und verwiesen werden.

Das Gehäuse wird in der Regel aus einem metallischen Becherteil (Gehäusebecher) und einem metallischen Deckelteil (Gehäusedeckel) zusammengefügt, wobei ein Elektroden-Separator-Verbund mit als flache Schicht ausgebildeten Elektroden derart in das Gehäuse eingesetzt
20 wird, dass die Elektroden orthogonal zu dem ebenen Boden- und Deckelbereich ausgerichtet sind.

25 Wie bereits erwähnt, wird der Elektroden-Separator-Verbund bevorzugt in Form eines Wickels verbaut, insbesondere als spiralförmiger Wickel.

In aller Regel umfasst das erfindungsgemäße Verfahren stets die Schritte

30

- Einsetzen des Wickels in das metallische Deckelteil und
- Einsetzen des metallischen Deckelteils mit dem Wickel in ein metallisches Becherteil.

Danach erfolgt optional das Umbördeln des Randes des Becherteils über den Rand des Deckelteils.

5 Sofern eine bördelfreie Knopfzelle hergestellt wird, werden die entsprechenden oben beschriebenen Schritte durchgeführt.

Vor dem Schließen des Gehäuses werden die Elektroden üblicherweise noch mit Elektrolytlösung getränkt.

10 Der Wickel befindet sich beim Einsetzen bevorzugt aufgerollt auf einem Wickeldorn. Nach dem oder beim Einsetzen kann der Wickeldorn dann entfernt werden. Gegebenenfalls wird dann der oben erwähnte Wickelkern eingesetzt. Alternativ kann der Elektroden-Separator-Verbund auch gleich unmittelbar auf einen solchen Kern aufgewickelt werden.

15

Besonders bevorzugt wird der spiralförmige Wickel vor dem Verbauen an seinen Stirnseiten wärmebehandelt. Dabei wird er zumindest kurzfristig einer Temperatur ausgesetzt, bei der der Separator in dem Wickel thermoplastisch verformbar ist. In der Regel steht der Separator an den
20 Stirnseiten des Wickels etwas über, selbst unter der Voraussetzung, dass die Elektroden mit dem oben beschriebenen Versatz zueinander angeordnet sind. Durch die Wärmebehandlung kann der Separator etwas zusammenschrumpfen und dadurch gegebenenfalls sogar den Rand einer benachbarten Elektroden freilegen, so dass dieser unmittel-
25 bar am Knopfzellegehäuse anliegen kann.

Die genannten und weitere Vorteile der Erfindung ergeben sich aus der nun folgenden Beschreibung der Zeichnungen in Verbindung mit den Unteransprüchen. Dabei können die einzelnen Merkmale der Erfindung
30 für sich allein oder in Kombination miteinander verwirklicht sein. Die beschriebenen Ausführungsformen dienen lediglich zur Erläuterung und zum besseren Verständnis der Erfindung und sind in keiner Weise einschränkend zu verstehen.

Figurenbeschreibung

- 5 Fig. 1 zeigt schematisch den Querschnitt einer bevorzugten Ausführungsform einer erfindungsgemäßen Knopfzelle.
- Fig. 2 illustriert den Effekt der Wärmebehandlung eines aufgewickelten Elektrode-Separator-Verbundes, welche bei bevorzugten Ausführungsformen des erfindungsgemäßen Verfahrens zum Einsatz kommt.
- 10 Fig. 3 zeigt einen Elektroden-Separator-Verbund in Form eines Wickels, wie er in einer erfindungsgemäßen Knopfzelle verbaut werden kann.
- 15 Fig. 4 zeigt eine geschnittene Darstellung einer weiteren bevorzugten Ausführungsform einer erfindungsgemäßen Knopfzelle.
- 20 Fig. 5 zeigt schematisch den Querschnitt einer bevorzugten Ausführungsform einer erfindungsgemäßen Knopfzelle, bei der der Rand des Zellenbechers nicht über den Rand des Zellendeckels gebördelt ist.

25

- Fig. 1** zeigt schematisch den Querschnitt einer bevorzugten Ausführungsform einer erfindungsgemäßen Knopfzelle **100**. Diese weist ein metallisches Becherteil **101** und ein metallisches Deckelteil **102** auf. Über eine Dichtung **109** sind die beiden Teile dichtend miteinander verbunden. Zusammen bilden sie ein Gehäuse mit einem ebenen Bodenbereich **103** und einem dazu parallelen ebenen Deckelbereich **104** aus. Im Gebrauchszustand bilden diese ebenen Bereiche **103** und **104** die Pole der Knopfzelle, an denen eine Stromabnahme durch einen Verbraucher
- 30

erfolgen kann. Der Rand **110** des Zellenbeckers **101** ist nach innen über den Rand des Zellendeckels **102** gebördelt.

Im Inneren der Elektrode ist ein Verbund aus einer streifenförmigen Elektrode **105**, einer streifenförmigen Elektrode **106** und den streifenförmigen Separatoren **107** angeordnet. Der Verbund aus den Elektroden **105** und **106** sowie den Separatoren **107** liegt dabei in Form eines Wickels vor, der mit seinen Stirnseiten an den ebenen Bodenbereich **103** und den dazu parallelen ebenen Deckelbereich **104** anstößt. Aufgewickelt ist der Verbund auf dem Kern **108** im Zentrum der Knopfzelle **100**. Sowohl der Kern **108** als auch die um ihn gewickelten Elektroden und Separatoren sind orthogonal zu den ebenen Boden- und Deckelbereichen **104** und **103** ausgerichtet. Sofern die Elektroden bei einem Lade- oder Entladevorgang an Volumen gewinnen oder verlieren, wirken die dabei resultierenden mechanischen Kräfte überwiegend radial und können vom Mantelbereich der Knopfzelle **100** aufgefangen werden.

Hervorzuheben ist, dass die positive Elektrode **105** und die negative Elektrode **106** jeweils unmittelbar an dem Becherteil **101** bzw. an dem Deckelteil **102** der Knopfzelle **100** anliegen. Ein separater Ableiter zum Verbinden der Elektroden mit dem Deckelteil **102** und dem Becherteil **101** ist nicht erforderlich.

Fig. 2 zeigt den Effekt der Wärmebehandlung eines Elektroden-Separator-Wickels **200**, die in bevorzugten Ausführungsformen des erfindungsgemäßen Verfahrens zur Herstellung einer Knopfzelle vorgesehen ist. Dargestellt ist schematisch ein Wickel **200** aus einem Verbund aus einer positiven Elektrode **201** (quergestreifte Balken), einer negativen Elektrode **202** (weisse Balken) und den Separatoren **203** (Ausschnitt). Die positive und die negative Elektroden **201** und **202** sind jeweils versetzt zueinander angeordnet. Die Separatoren **203** bestehen aus einem thermoplastisch verformbaren Material.

Setzt man die sich an den Stirnseiten **204** und **205** des Wickels **200** befindlichen Separatorränder einer hohen Temperatur aus (beispielsweise 250 °C, wie dargestellt), so schrumpfen diese Separatorränder. Die Separatoren ziehen sich zumindest teilweise zwischen benachbarte Elektroden zurück. Dabei werden an der Stirnseite **204** die Ränder der negativen Elektrode **202** freigelegt, während die Ränder der positiven Elektrode **201** abgedeckt werden. An der Stirnseite **205** werden die Ränder der positiven Elektrode **201** freigelegt, während die Ränder der negativen Elektrode **202** abgedeckt werden.

10

Beim Einsatz eines so behandelten Wickels ist gewährleistet, dass Elektroden gleicher Polarität jeweils nur am Gehäusebecher oder am Gehäusedeckel unmittelbar anliegen können. Separate elektrische Verbindungen zwischen den Elektroden und den Gehäuseteilen sind nicht erforderlich.

15

Fig. 3 zeigt einen Elektroden-Separator-Verbund für erfindungsgemäße Knopfzellen in Form eines Wickels **300**, wobei die Darstellung A eine Draufsicht senkrecht von oben auf eine der Stirnseiten **301** des Wickels **300** abbildet, während in der Darstellung B der Wickel **300** in einer Ansicht schräg von oben dargestellt ist. Zu erkennen ist in beiden Fällen, dass der Verbund zwei Lagen Separator **302** und **303** sowie zwei Elektroden-schichten **304** und **305** (eine positive und eine negative Elektrode) umfasst. Der Verbund ist spiralförmig aufgewickelt und wird durch ein Klebeband **306** auf seiner Außenseite zusammengehalten.

25

Fig. 4 zeigt eine geschnittene Darstellung einer bevorzugten Ausführungsform einer erfindungsgemäßen Knopfzelle **400**. Zu erkennen ist das Gehäuse der Knopfzelle aus dem Becherteil **401** und dem Deckelteil **402**, zwischen denen die Dichtung **403** angeordnet ist. Innerhalb des Gehäuses ist ein Verbund aus Elektroden und Separatoren, wie er in **Fig. 3** dargestellt ist, als spiralförmiger Wickel **404** (im Querschnitt schematisch dargestellt) enthalten. Gut zu erkennen sind auch hier die Separatorlagen **405** und **406** sowie die entgegengesetzt gepolten Elektroden

30

407 und **408**. Die Elektrode **407** ist dabei über den Ableiter **410** mit dem Deckelteil **402** verbunden, während die Elektrode **408** über den Ableiter **409** mit dem Becherteil **402** verbunden ist. Der Ableiter **410** ist vorzugsweise mit dem Deckelteil **402** verschweisst. Dagegen ist der Ableiter **409** mit dem Becherteil **402** über eine Klemmverbindung verbunden (er ist zwischen dem Stützring **413**, auf dem der Rand des Zellendeckels aufliegt, und dem Boden des Zellenbeckers eingeklemmt). Zwischen den Stirnseiten des Wickels und dem Becherteil **401** und dem Deckelteil **402** sind die Isoliermittel **411** und **412** angeordnet, bei denen es sich jeweils um dünne Kunststoffscheiben handelt. Durch diese wird verhindert, dass Elektroden entgegengesetzter Polarität gleichzeitig in Kontakt mit dem Becher- oder dem Deckelteil **401** und **402** kommen können. Einem Kurzschluss wird dadurch vorgebeugt.

Fig. 5 zeigt schematisch den Querschnitt einer bevorzugten Ausführungsform einer erfindungsgemäßen Knopfzelle **500**.

Diese weist ein metallisches Becherteil **501** und ein metallisches Deckelteil **502** auf. Über eine Dichtung **510** sind die beiden Teile dichtend miteinander verbunden. Zusammen bilden sie ein Gehäuse mit einem ebenen Bodenbereich **503** und einem dazu parallelen ebenen Deckelbereich **504** aus. Im Gebrauchszustand bilden diese ebenen Bereiche **503** und **504** die Pole der Knopfzelle, an denen eine Stromabnahme durch einen Verbraucher erfolgen kann.

Der Zellendeckel **502** ist in den Zellenbecher **501** eingeschoben, so dass die Mantelbereiche des Zellendeckels und des Zellenbeckers überlappen, wobei der Innenradius des Zellenbeckers **501** im überlappenden Bereich in Richtung der Schnittkante im wesentlichen konstant ist. Der Rand des Zellenbeckers **501** ist also nicht über den Rand **511** des Zellendeckels **502** gebördelt, bei der vorliegend beschriebenen bevorzugten Ausführungsform einer erfindungsgemäßen Knopfzelle **500** handelt es sich somit um eine bördelfreie Knopfzelle.

Im Inneren der Elektrode ist ein Verbund aus einer streifenförmigen Elektrode **508**, einer streifenförmigen Elektrode **509** und den streifenförmigen Separatoren **507** angeordnet. Der Verbund aus den Elektroden **508** und **509** sowie den Separatoren **507** liegt dabei in Form eines Wickels vor, dessen Stirnseiten in Richtung des ebenen Bodenbereichs **503** und des dazu parallelen ebenen Deckelbereichs **504** weisen. Aufgewickelt ist der Verbund auf dem Wickelkern **512** im Zentrum der Knopfzelle **500**. Sowohl der Kern **512** als auch die um ihn gewickelten Elektroden und Separatoren sind orthogonal zu den ebenen Boden- und Deckelbereichen **504** und **503** ausgerichtet. Sofern die Elektroden bei einem Lade- oder Entladevorgang an Volumen gewinnen oder verlieren, wirken die dabei resultierenden mechanischen Kräfte überwiegend radial und können vom Mantelbereich der Knopfzelle **500** aufgefangen werden.

Kontaktiert sind die positiven und die negativen Elektroden mit den Gehäusehalbteilen Becher und Deckel über den Ableiter **505** und den Ableiter **506**. Der Ableiter **505** besteht aus Aluminium, der Ableiter **506** aus Nickel (oder alternativ aus Kupfer). Bei beiden Ableitern handelt es sich um dünne Folien, die flach zwischen den Stirnseiten des Wickels und den ebenen Deckel- bzw. Bodenbereichen **503** und **504** zum Liegen kommen. Bedingt durch den Wickelkern **512** wird ein steter leichter Anpressdruck auf die Ableiter aufrechterhalten. Von den Stirnseiten des Wickels sind die Ableiter bevorzugt durch ein separates Isolatorelement (in der Zeichnung nicht dargestellt) getrennt, beispielsweise durch eine dünne Folie.

Patentansprüche

1. Knopfzelle (100; 400; 500), umfassend
 - zwei metallische Gehäusehalbteile (101, 102; 401, 402; 501, 502), die durch eine elektrisch isolierende Dichtung (109; 403; 510) voneinander getrennt sind und die ein Gehäuse mit einem ebenen Bodenbereich (103; 503) und einem dazu parallelen ebenen Deckelbereich (104; 504) ausbilden sowie
 - innerhalb des Gehäuses einen Elektroden-Separator-Verbund umfassend mindestens eine positive und mindestens eine negative Elektrode (105, 106; 201, 202; 304, 305; 407, 408; 508, 509), die als flache Schichten ausgebildet und über mindestens einen flächigen Separator (107; 203; 302, 303; 405, 406; 507) miteinander verbunden sind,

wobei die Elektrodenschichten im Wesentlichen orthogonal zu dem ebenen Boden- und Deckelbereich ausgerichtet sind.
2. Knopfzelle nach Anspruch 1, dadurch gekennzeichnet, dass die Elektroden und/oder der Separator streifen- oder bandförmig ausgebildet sind.
3. Knopfzelle nach Anspruch 1 oder Anspruch 2, dadurch gekennzeichnet, dass der Elektroden-Separator-Verbund als Wickel (200; 300; 404) vorliegt, insbesondere als spiralförmiger Wickel, dessen Stirnseiten (204, 205; 301) in Richtung des ebenen Bodenbereichs und des ebenen Deckelbereichs weisen.
4. Knopfzelle nach Anspruch 3, dadurch gekennzeichnet, dass der Wickel in seinem Zentrum einen axialen Hohlraum aufweist, der mindestens teilweise von einem Wickelkern (108; 512) ausgefüllt ist.

5. Knopfzelle nach einem der vorhergehenden Ansprüche, dadurch gekennzeichnet, dass der Elektroden-Separator-Verbund eine der folgenden Schichtabfolgen aufweist:
 - negative Elektrode / Separator / positive Elektrode / Separator
 - positive Elektrode / Separator / negative Elektrode / Separator
6. Knopfzelle nach einem der vorhergehenden Ansprüche, dadurch gekennzeichnet, dass die positive Elektrode (408; 509) und/oder die negative Elektrode (407; 508) über einen Ableiter (409, 410; 505, 506) mit dem Gehäuse im Bereich des ebenen Boden- und/oder des ebenen Deckelbereichs verbunden sind.
7. Knopfzelle nach einem der Ansprüche 3 bis 6, dadurch gekennzeichnet, dass sie mindestens ein Isoliermittel (413, 414) umfasst, das einen direkten mechanischen und elektrischen Kontakt zwischen den Stirnseiten des Wickels und den ebenen Boden- und Deckelbereichen unterbindet.
8. Knopfzelle nach Anspruch 7, dadurch gekennzeichnet, dass es sich bei dem mindestens einen Isoliermittel (413, 414) um eine flache Schicht aus Kunststoff, beispielsweise um eine Kunststoffolie handelt, die zwischen den Stirnseiten des Wickels und den ebenen Boden- und Deckelbereichen angeordnet ist.
9. Knopfzelle nach einem der vorhergehenden Ansprüche, dadurch gekennzeichnet, dass sie wiederaufladbar ist.
10. Knopfzelle nach einem der vorhergehenden Ansprüche, dadurch gekennzeichnet, dass sie ein Verhältnis Höhe : Durchmesser < 1 , vorzugsweise zwischen 0.1 und 0.9, insbesondere zwischen 0.15 und 0.7, aufweist.

11. Verfahren zur Herstellung einer Knopfzelle, insbesondere einer Knopfzelle (100; 400; 500) nach einem der vorhergehenden Ansprüche, wobei aus metallische Gehäusehalbteilen, insbesondere einem metallischen Becherteil (101; 401; 501) und einem metallischen Deckelteil (102; 402; 502), ein Gehäuse mit einem ebenen Bodenbereich (103; 503) und einem dazu parallelen ebenen Deckelbereich (104; 504) montiert wird und wobei ein Elektroden-Separator-Verbund mit als flache Schicht ausgebildeten Elektroden (105, 106; 201, 202; 304, 305; 407, 408; 508, 509) derart in das Gehäuse eingesetzt wird, dass die Elektrodenschichten im Wesentlichen orthogonal zu dem ebenen Boden- und Deckelbereich (103, 104; 503, 504) ausgerichtet sind.
12. Verfahren nach Anspruch 11, dadurch gekennzeichnet, dass der Elektroden-Separator-Verbund als Wickel (200; 300; 404) eingesetzt wird, insbesondere als spiralförmiger Wickel.
13. Verfahren nach Anspruch 12, umfassend die Schritte
 - Einsetzen des Wickels (200; 300; 404) in das metallische Deckelteil (102; 402; 502),
 - Einsetzen des metallischen Deckelteils mit dem Wickel in ein metallisches Becherteil (101; 401; 501),
 - Gegebenenfalls Umbördeln des Randes des Becherteils.
14. Verfahren nach Anspruch 12 oder 13, dadurch gekennzeichnet, dass der Wickel (200; 300; 404) vor dem Verbauen an seinen Stirnseiten (204, 205; 301) wärmebehandelt wird, wobei er zumindest kurzfristig einer Temperatur ausgesetzt wird, bei der der Separator (107; 203; 302, 303; 405, 406; 507) thermoplastisch verformbar ist.

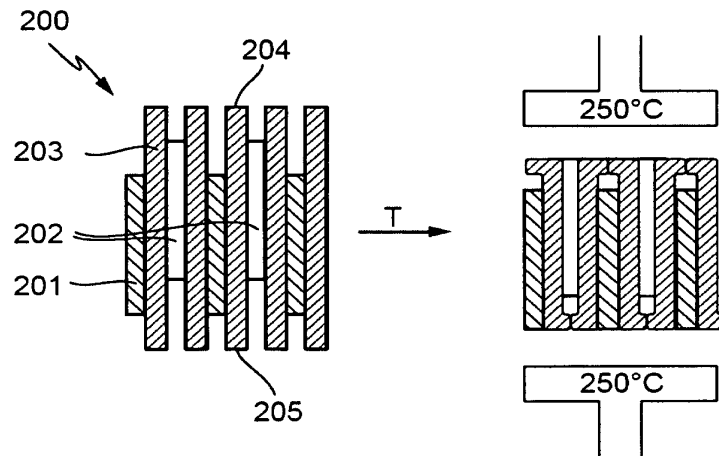
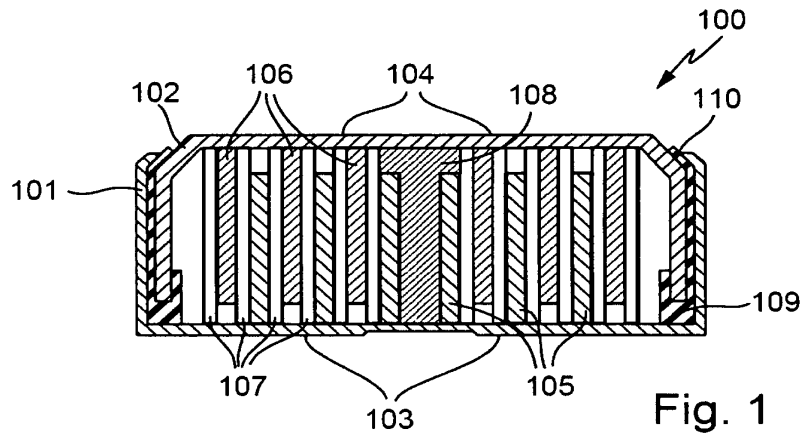

Fig. 2

2/3

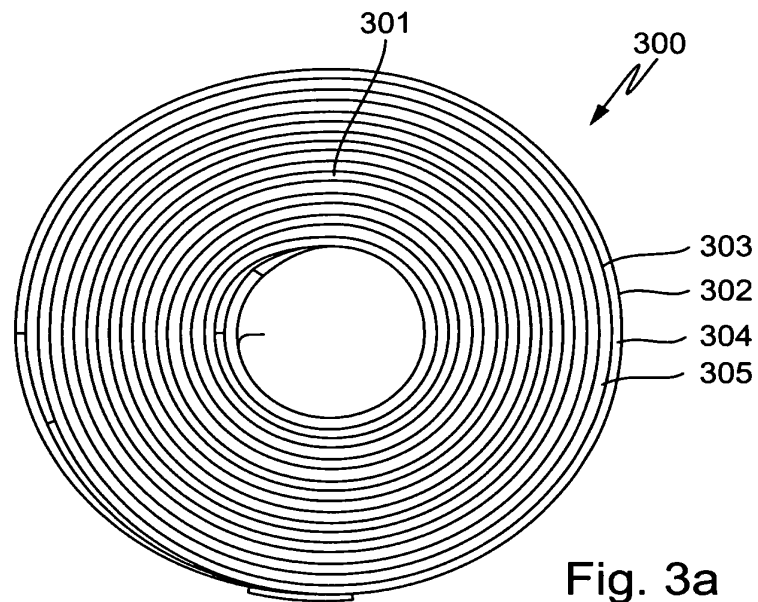

Fig. 3a

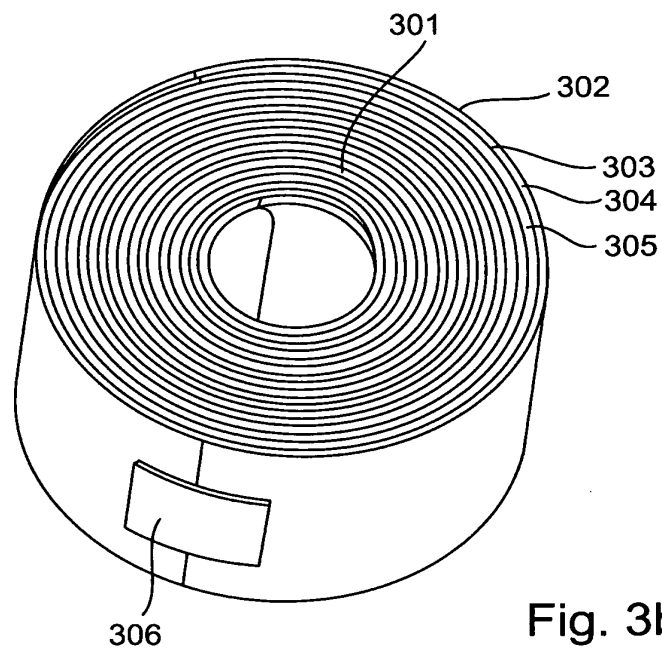

Fig. 3b

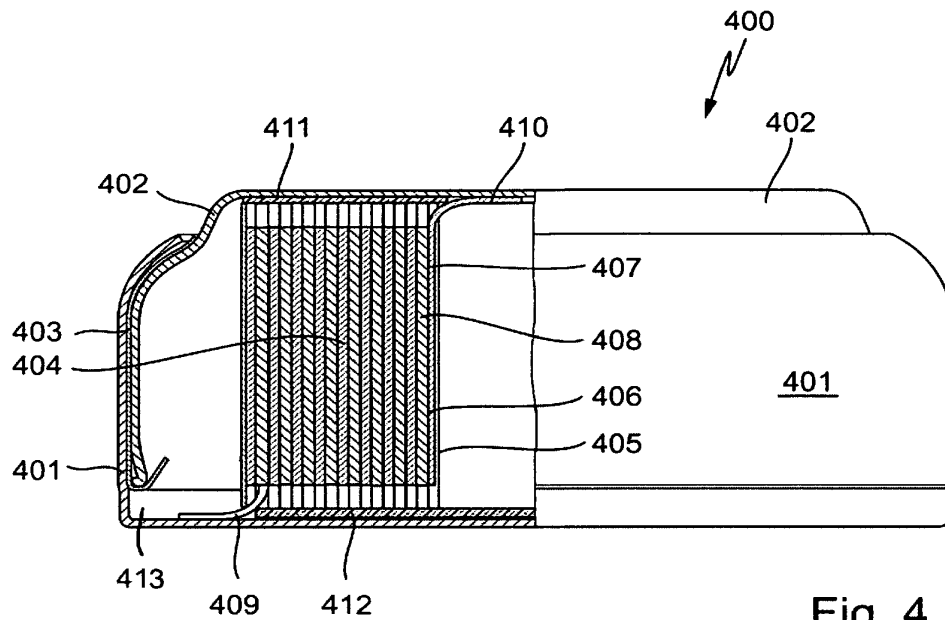

Fig. 4

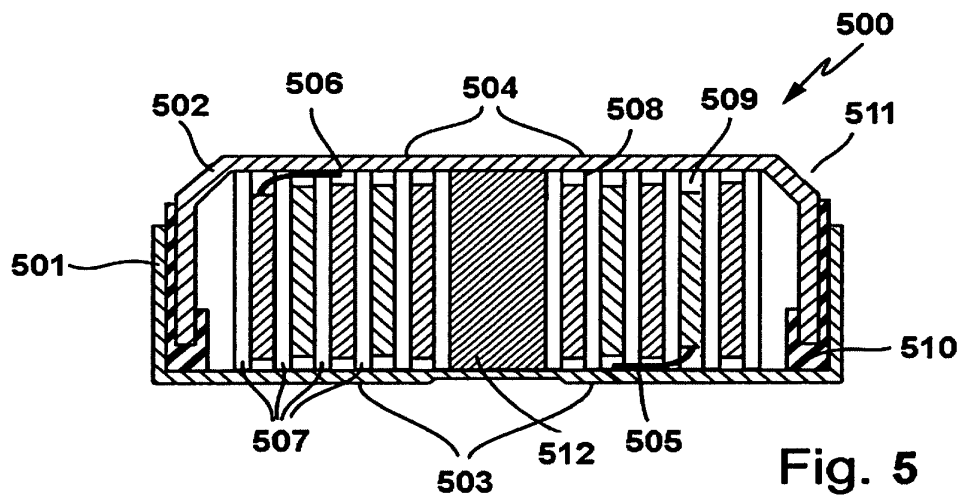

Fig. 5

INTERNATIONAL SEARCH REPORT

International application No
PCT/EP2010/000787

A. CLASSIFICATION OF SUBJECT MATTER
INV. H01M10/04 H01M2/02
ADD.

According to International Patent Classification (IPC) or to both national classification and IPC

B. FIELDS SEARCHED

Minimum documentation searched (classification system followed by classification symbols)
H01M

Documentation searched other than minimum documentation to the extent that such documents are included in the fields searched

Electronic data base consulted during the international search (name of data base and, where practical, search terms used)

EPO-Internal

C. DOCUMENTS CONSIDERED TO BE RELEVANT

Category*	Citation of document, with indication, where appropriate, of the relevant passages	Relevant to claim No.
X	US 6 265 100 B1 (SAASKI ELRIC W [US] ET AL) 24 July 2001 (2001-07-24) column 5, lines 31-60 column 24, line 9 - column 26, line 18 column 26, line 35 - column 29, line 57 -----	1-13
A	DE 198 57 638 A1 (VARTA GERAETEBATTERIE GMBH [DE]) 15 June 2000 (2000-06-15) the whole document -----	1-14

Further documents are listed in the continuation of Box C.

See patent family annex.

* Special categories of cited documents :

- "A" document defining the general state of the art which is not considered to be of particular relevance
- "E" earlier document but published on or after the international filing date
- "L" document which may throw doubts on priority claim(s) or which is cited to establish the publication date of another citation or other special reason (as specified)
- "O" document referring to an oral disclosure, use, exhibition or other means
- "P" document published prior to the international filing date but later than the priority date claimed

- "T" later document published after the international filing date or priority date and not in conflict with the application but cited to understand the principle or theory underlying the invention
- "X" document of particular relevance; the claimed invention cannot be considered novel or cannot be considered to involve an inventive step when the document is taken alone
- "Y" document of particular relevance; the claimed invention cannot be considered to involve an inventive step when the document is combined with one or more other such documents, such combination being obvious to a person skilled in the art.
- "&" document member of the same patent family

Date of the actual completion of the international search

11 May 2010

Date of mailing of the international search report

19/05/2010

Name and mailing address of the ISA/

European Patent Office, P.B. 5818 Patentlaan 2
NL - 2280 HV Rijswijk
Tel. (+31-70) 340-2040,
Fax: (+31-70) 340-3016

Authorized officer

Panitz, J

INTERNATIONAL SEARCH REPORT

Information on patent family members

International application No
PCT/EP2010/000787

Patent document cited in search report	Publication date	Patent family member(s)	Publication date
US 6265100	B1	24-07-2001	US 6310960 B1 30-10-2001
DE 19857638	A1	15-06-2000	AT 246404 T 15-08-2003
			BR 9908650 A 17-10-2000
			CA 2292108 A1 14-06-2000
			CN 1264185 A 23-08-2000
			EP 1011163 A1 21-06-2000
			JP 2000182659 A 30-06-2000
			KR 20000047704 A 25-07-2000
			US 6312848 B1 06-11-2001

INTERNATIONALER RECHERCHENBERICHT

Internationales Aktenzeichen
PCT/EP2010/000787

A. KLASSIFIZIERUNG DES ANMELDUNGSGEGENSTANDES INV. HO1M10/04 HO1M2/02 ADD.		
Nach der Internationalen Patentklassifikation (IPC) oder nach der nationalen Klassifikation und der IPC		
B. RECHERCHIERTE GEBIETE Recherchiertes Mindestprüfstoff (Klassifikationssystem und Klassifikationssymbole) HO1M		
Recherchierte, aber nicht zum Mindestprüfstoff gehörende Veröffentlichungen, soweit diese unter die recherchierten Gebiete fallen		
Während der internationalen Recherche konsultierte elektronische Datenbank (Name der Datenbank und evtl. verwendete Suchbegriffe) EPO-Internal		
C. ALS WESENTLICH ANGESEHENE UNTERLAGEN		
Kategorie*	Bezeichnung der Veröffentlichung, soweit erforderlich unter Angabe der in Betracht kommenden Teile	Betr. Anspruch Nr.
X	US 6 265 100 B1 (SAASKI ELRIC W [US] ET AL) 24. Juli 2001 (2001-07-24) Spalte 5, Zeilen 31-60 Spalte 24, Zeile 9 - Spalte 26, Zeile 18 Spalte 26, Zeile 35 - Spalte 29, Zeile 57 -----	1-13
A	DE 198 57 638 A1 (VARTA GERAETEBATTERIE GMBH [DE]) 15. Juni 2000 (2000-06-15) das ganze Dokument -----	1-14
<input type="checkbox"/> Weitere Veröffentlichungen sind der Fortsetzung von Feld C zu entnehmen <input checked="" type="checkbox"/> Siehe Anhang Patentfamilie		
* Besondere Kategorien von angegebenen Veröffentlichungen : "A" Veröffentlichung, die den allgemeinen Stand der Technik definiert, aber nicht als besonders bedeutsam anzusehen ist "E" älteres Dokument, das jedoch erst am oder nach dem internationalen Anmeldedatum veröffentlicht worden ist "L" Veröffentlichung, die geeignet ist, einen Prioritätsanspruch zweifelhaft erscheinen zu lassen, oder durch die das Veröffentlichungsdatum einer anderen im Recherchenbericht genannten Veröffentlichung belegt werden soll oder die aus einem anderen besonderen Grund angegeben ist (wie ausgeführt) "O" Veröffentlichung, die sich auf eine mündliche Offenbarung, eine Benutzung, eine Ausstellung oder andere Maßnahmen bezieht "P" Veröffentlichung, die vor dem internationalen Anmeldedatum, aber nach dem beanspruchten Prioritätsdatum veröffentlicht worden ist "T" Spätere Veröffentlichung, die nach dem internationalen Anmeldedatum oder dem Prioritätsdatum veröffentlicht worden ist und mit der Anmeldung nicht kollidiert, sondern nur zum Verständnis des der Erfindung zugrundeliegenden Prinzips oder der ihr zugrundeliegenden Theorie angegeben ist "X" Veröffentlichung von besonderer Bedeutung; die beanspruchte Erfindung kann allein aufgrund dieser Veröffentlichung nicht als neu oder auf erfinderscher Tätigkeit beruhend betrachtet werden "Y" Veröffentlichung von besonderer Bedeutung; die beanspruchte Erfindung kann nicht als auf erfinderscher Tätigkeit beruhend betrachtet werden, wenn die Veröffentlichung mit einer oder mehreren anderen Veröffentlichungen dieser Kategorie in Verbindung gebracht wird und diese Verbindung für einen Fachmann naheliegend ist "&" Veröffentlichung, die Mitglied derselben Patentfamilie ist		
Datum des Abschlusses der internationalen Recherche		Absenddatum des internationalen Recherchenberichts
11. Mai 2010		19/05/2010
Name und Postanschrift der internationalen Recherchenbehörde Europäisches Patentamt, P. B. 5818 Patentlaan 2 NL - 2280 HV Rijswijk Tel. (+31-70) 340-2040, Fax: (+31-70) 340-3016		Bevollmächtigter Bediensteter Panitz, J

INTERNATIONALER RECHERCHENBERICHT

Angaben zu Veröffentlichungen, die zur selben Patentfamilie gehören

Internationales Aktenzeichen

PCT/EP2010/000787

Im Recherchenbericht angeführtes Patentdokument	Datum der Veröffentlichung	Mitglied(er) der Patentfamilie	Datum der Veröffentlichung
US 6265100	B1	US 6310960 B1	30-10-2001
DE 19857638	A1	AT 246404 T	15-08-2003
		BR 9908650 A	17-10-2000
		CA 2292108 A1	14-06-2000
		CN 1264185 A	23-08-2000
		EP 1011163 A1	21-06-2000
		JP 2000182659 A	30-06-2000
		KR 20000047704 A	25-07-2000
		US 6312848 B1	06-11-2001

Document made available under the Patent Cooperation Treaty (PCT)

International application number: PCT/EP2010/000787

International filing date: 09 February 2010 (09.02.2010)

Document type: Certified copy of priority document

Document details: Country/Office: DE
Number: 10 2009 008 859.8
Filing date: 09 February 2009 (09.02.2009)

Date of receipt at the International Bureau: 06 April 2010 (06.04.2010)

Remark: Priority document submitted or transmitted to the International Bureau in compliance with Rule 17.1(a) or (b)



World Intellectual Property Organization (WIPO) - Geneva, Switzerland
Organisation Mondiale de la Propriété Intellectuelle (OMPI) - Genève, Suisse

BUNDESREPUBLIK DEUTSCHLAND



Prioritätsbescheinigung DE 10 2009 008 859.8 über die Einreichung einer Patentanmeldung

Aktenzeichen: 10 2009 008 859.8

Anmeldetag: 09. Februar 2009

Anmelder/Inhaber: VARTA Microbattery GmbH, 30419 Hannover/DE

Bezeichnung: Knopfzelle und Verfahren zu ihrer Herstellung

IPC: H 01 M 10/38, H 01 M 10/40

Die angehefteten Stücke sind eine richtige und genaue Wiedergabe der Teile der am 09. Februar 2009 eingereichten Unterlagen dieser Patentanmeldung unabhängig von gegebenenfalls durch das Kopierverfahren bedingten Farbabweichungen.

München, den 10. Dezember 2009
Deutsches Patent- und Markenamt
Die Präsidentin
Im Auftrag

Wunder

A 9101 (t1)
5.09

Anmelderin:

VARTA Microbattery GmbH
Am Leineufer 51

30419 Hannover

Unser Zeichen: P 49 226 DE

09. Februar 2009 ME/nz

Beschreibung

Knopfzelle und Verfahren zu ihrer Herstellung

Die vorliegende Erfindung betrifft eine Knopfzelle mit einem Gehäuse aus einem metallischen Becherteil und einem metallischen Deckerteil, die dichtend miteinander verbunden sind, sowie ein Verfahren zur Herstellung von solchen Knopfzellen.

Wiederaufladbare Knopfzellen können unterschiedliche elektrochemische Systeme enthalten. Sehr verbreitet sind z. B. Knopfzellen auf Basis von Nickel-Metallhydrid- sowie auf Basis von Lithium-Ionen-Systemen. Insbesondere bei Lithium-Ionen-Knopfzellen werden die elektrochemisch aktiven Materialien innerhalb des Knopfzellengehäuses üblicherweise nicht in Form von einzelnen, durch einen Separator voneinander getrennten, tablettenförmigen Elektroden angeordnet. Stattdessen werden bevorzugt vorgefertigte Elektroden-Separator-Verbünde flach in das Gehäuse eingelegt. Als Separator dient dabei bevorzugt eine poröse Kunststofffolie, auf welche die Elektroden flächig auflaminiert oder aufgeklebt sind. Der Gesamtverbund aus Separator und Elektroden ist dabei in der Regel maximal wenige 100 µm dick. Um Knopfzellengehäuse

üblicher Dimensionen ausfüllen zu können, werden daher häufig mehrere solcher Verbünde flach übereinander gelegt. Auf diese Weise lassen sich Stapel in grundsätzlich beliebiger Höhe erhalten, jeweils abgestimmt auf die zur Verfügung stehenden Dimensionen des Knopfzellegehäuses, in das der Stapel verbaut werden soll. So wird eine optimale Ausnutzung des zur Verfügung stehenden Gehäuseinnenraumes gewährleistet.

Konstruktionsbedingt treten bei Knopfzellen, die solche Stapel aus Elektroden-Separator-Verbänden enthalten, allerdings auch diverse Probleme auf. Zum einen ist es natürlich erforderlich, Elektroden von jeweils gleicher Polarität innerhalb des Stapels miteinander zu verbinden und dann jeweils mit dem entsprechenden Pol des Knopfzellegehäuses zu kontaktieren. Die erforderlichen elektrischen Kontakte verursachen Materialkosten, der durch sie eingenommene Raum steht zudem für Aktivmaterial nicht mehr zur Verfügung. Die Herstellung der Elektrodenstapel ist darüber hinaus kompliziert und teuer, da bei der Kontaktierung der Verbünde untereinander leicht Fehler auftreten können, die die Ausschußrate erhöhen. Zum anderen wurde festgestellt, dass Knopfzellen mit einem Stapel aus Elektroden und Separatoren sehr schnell undicht werden können.

Der vorliegenden Erfindung lag die Aufgabe zugrunde, Knopfzellen bereitzustellen, bei denen die genannten Probleme nicht auftreten. Die bereitzustellenden Knopfzellen sollten eine möglichst einfache Konstruktionsweise aufweisen, höchsten Anforderungen im Hinblick auf die Dichtigkeit im Betrieb genügen und sehr einfach herzustellen sein.

Diese Aufgabe wird gelöst durch die Knopfzelle mit den Merkmalen des Anspruchs 1 sowie das Verfahren mit den Merkmalen des Anspruchs 9. Bevorzugte Ausführungsformen der erfindungsgemäßen Knopfzelle sind in den abhängigen Ansprüchen 2 bis 8 angegeben. Bevorzugte Ausführungsformen sind in den abhängigen Ansprüchen 10 bis 15 angegeben.

rungsformen des erfindungsgemäßen Verfahrens finden sich in den Ansprüchen 10 bis 12. Der Wortlaut sämtlicher Ansprüche wird hiermit durch Bezugnahme zum Inhalt dieser Beschreibung gemacht.

Eine erfindungsgemäße Knopfzelle weist ein metallisches Becherteil und ein metallisches Deckelteil auf, die dichtend miteinander verbunden sind. Zusammen bilden die beiden Teile ein Gehäuse aus, das einen ebenen Bodenbereich und einen dazu parallelen ebenen Deckelbereich ausbildet. Als Becher- und Deckelteil sind insbesondere Teile aus vernickeltem Stahl oder Blech bevorzugt. Weiterhin als metallischer Werkstoff geeignet sind insbesondere Trimetalle, beispielsweise mit der Abfolge Nickel, Stahl (oder Edelstahl) und Kupfer (wobei dann die Nickelschicht bevorzugt die Außen- und die Kupferschicht bevorzugt die Innenseite des Knopfzelligehäuses bildet). Als Dichtung kann beispielsweise eine Spritzguss- oder eine Foliendichtung zum Einsatz kommen.

Innerhalb des Gehäuses sind mindestens eine positive und mindestens eine negative Elektrode angeordnet, und zwar jeweils in Form von flachen Elektrodenschichten. Die Elektroden sind dabei über einen flächigen Separator miteinander verbunden. Vorzugsweise sind die Elektroden auf diesen Separator auflaminiert oder aufgeklebt. Die Elektroden und der Separator weisen in der Regel jeweils nur Dicken im μm -Bereich auf. Sie bilden zusammen einen Elektroden-Separator-Verbund aus, wie er bereits eingangs erwähnt wurde.

Im Gegensatz zu den eingangs erwähnten Knopfzellen zeichnet sich die erfindungsgemäße Knopfzelle jedoch insbesondere dadurch aus, dass die Elektrodenschichten eine ganz besondere Orientierung aufweisen, sie sind nämlich im wesentlichen orthogonal zu dem ebenen Boden- und Deckelbereich ausgerichtet. Während aus dem Stand der Technik bekannte Knopfzellen mit gestapelten Elektroden-Separator-Verbänden diese stets flach eingelegt enthalten, so dass die Elektrodenschichten im

wesentlichen parallel zu den ebenen Boden- und Deckelbereichen ausgerichtet sind, ist bei einer erfindungsgemäßen Knopfzelle das Gegenteil der Fall.

Die orthogonale Ausrichtung der Elektrodenschichten hat einen unerwartet deutlichen Vorteil, es wurde nämlich festgestellt, dass diese Ausrichtung mit einer deutlichen Verbesserung der Dichtigkeitseigenschaften einer erfindungsgemäßen Knopfzelle einhergeht, insbesondere bei Knopfzellen auf Basis von Lithium-Ionen-Systemen. Die Elektroden von wiederaufladbaren Lithium-Ionen-Systemen sind bei Lade- und Entladevorgängen stets Volumenänderungen ausgesetzt. Zu solchen Volumenänderungen kann es natürlich auch bei den Elektroden einer erfindungsgemäßen Knopfzelle kommen. Die dabei entstehenden mechanischen Kräfte wirken jedoch nicht mehr primär axial, wie das im Falle eines flach eingelegten Stapels aus Elektroden-Separator-Verbänden der Fall ist. Aufgrund der orthogonalen Ausrichtung der Elektroden wirken sie stattdessen radial. Radiale Kräfte können von dem Gehäuse einer Knopfzelle allerdings sehr viel besser aufgenommen werden als axiale, worauf vermutlich die verbesserten Dichtigkeitseigenschaften zurückzuführen sind.

Besonders bevorzugt sind die Elektroden und der flächige Separator einer erfindungsgemäßen Knopfzelle jeweils streifen- oder bandförmig ausgebildet. So kann zur Herstellung einer erfindungsgemäßen Knopfzelle beispielsweise von einem als Endlosband vorliegenden Separatormaterial ausgegangen werden, auf das die Elektroden flächig, insbesondere wieder in Form von Streifen oder zumindest von Rechtecken, aufgebracht, insbesondere auf laminiert werden.

Wenn die Elektroden streifenförmig auf einen solchen Separator aufgebracht werden, so lässt sich der entstehende Verbund aus streifenförmigen Elektroden und streifenförmigem Separator gut aufwickeln. In be-

vorzugten Ausführungsformen enthält eine erfindungsgemäße Knopfzelle entsprechend den Verbund aus Elektroden und Separator als Wickel, besonders bevorzugt als spiralförmigen Wickel.

Besonders bevorzugt weist der Verbund aus Elektroden und Separator in einer erfindungsgemäßen Knopfzelle eine der folgenden Schichtabfolgen auf:

- negative Elektrode / Separator / positive Elektrode / Separator

oder

- positive Elektrode / Separator / negative Elektrode / Separator.

Derartige Verbände lassen sich sehr einfach herstellen und aufwickeln, ohne dass es zu Kurzschlüssen zwischen entgegengesetzt gepolten Elektroden kommt.

In besonders bevorzugten Ausführungsformen einer erfindungsgemäßen Knopfzelle sind die negative Elektrode und die positive Elektrode im Elektroden-Separator-Verbund innerhalb des Verbundes versetzt zueinander angeordnet. Unter einer versetzten Anordnung soll dabei verstanden werden, dass die Elektroden derart angeordnet sind, dass in der erfindungsgemäßen Knopfzelle eine jeweils unterschiedliche Beabstandung der Elektroden zu den ebenen Boden- und Deckelbereichen resultiert. Im einfachsten Fall können z.B. eine positive und eine negative Elektrode als gleich breite Streifen leicht versetzt auf die gegenüberliegenden Seiten eines Separatorbandes aufgebracht werden, so dass der Abstand der positiven Elektrode zum oberen Separatorrand größer ist als der vergleichbare Abstand von der negativen Elektrode aus gemessen. Umgekehrtes gilt dann natürlich im Hinblick auf den Abstand zum unteren Separatorrand.

In besonders bevorzugten Ausführungsformen liegt, vorzugsweise als Resultat dieser versetzten Anordnung, die positive Elektrode, insbesondere ein Rand der positiven Elektrode, unmittelbar am Becherteil an, insbesondere im ebenen Bodenbereich des Becherteils, während die negative Elektrode, insbesondere ein Rand der negativen Elektrode, unmittelbar am Deckelteil, insbesondere im ebenen Deckelbereich des Deckelteils, anliegt.

Die versetzte Anordnung der Elektroden zueinander ermöglicht also eine Kontaktierung der Elektroden mit den jeweiligen Gehäuseteilen, ohne dass zusätzliche elektrische Kontakte und Verbindungsmittel zum Einsatz kommen müssen.

Bei den in einer erfindungsgemäßen Knopfzelle einsetzbaren Separatoren handelt es sich vorzugsweise um Folien aus mindestens einem Kunststoff, insbesondere aus mindestens einem Polyolefin. Bei dem mindestens einen Polyolefin kann es sich beispielsweise um Polyethylen handeln. Es können aber auch mehrlagige Separatoren verwendet werden, beispielsweise Separatoren aus einer Abfolge verschiedener Polyolefinschichten, z.B. mit der Sequenz Polyethylen/Polypropylen/Polyethylen.

Die in einer erfindungsgemäßen Knopfzelle bevorzugt einsetzbaren Separatoren weisen bevorzugt eine Dicke zwischen 3 μm und 100 μm , insbesondere zwischen 10 μm und 50 μm , auf.

Die Elektroden einer erfindungsgemäßen Knopfzelle weisen bevorzugt eine Dicke zwischen 10 μm und 1000 μm , insbesondere zwischen 30 μm und 500 μm , auf.

Wie bereits eingangs erwähnt wurde, handelt es sich bei der erfindungsgemäßen Knopfzelle insbesondere um eine wiederaufladbare

Knopfzelle. Besonders bevorzugt weist eine erfindungsgemäße Knopfzelle mindestens eine Lithium interkalierende Elektrode auf.

Das Verhältnis Höhe : Durchmesser einer erfindungsgemäßen Knopfzelle beträgt vorzugsweise < 1 . Besonders bevorzugt liegt es zwischen 0.1 und 0.9, insbesondere zwischen 0.15 und 0.7. Unter der Höhe soll dabei der Abstand zwischen dem ebenen Bodenbereich und dem dazu parallelen ebenen Deckelbereich verstanden werden. Der Durchmesser meint die maximale Entfernung zweier Punkte auf dem Mantelbereich der Knopfzelle.

Das erfindungsgemäße Verfahren zur Herstellung einer Knopfzelle kann insbesondere auch zur Herstellung einer Knopfzelle dienen, wie sie vorstehend beschrieben wurde, also einer Knopfzelle mit einem Gehäuse mit einem ebenen Bodenbereich und einem dazu parallelen ebenen Deckelbereich. Betreffend die bevorzugten Ausführungsformen der einzelnen in einem erfindungsgemäßen Verfahren verwendeten Komponenten (Gehäuseteile und -dimensionen, Elektroden, Separator etc.) kann somit vollumfänglich auf die obenstehenden Ausführungen und Erläuterungen Bezug genommen und verwiesen werden.

Das Gehäuse wird aus einem metallischen Becherteil und einem metallischen Deckelteil zusammengefügt, wobei ein Elektroden-Separator-Verbund mit als flache Schicht ausgebildeten Elektroden derart in das Gehäuse eingesetzt wird, dass die Elektroden orthogonal zu dem ebenen Boden- und Deckelbereich ausgerichtet sind.

Wie bereits erwähnt, wird der Elektroden-Separator-Verbund in Form eines Wickels verbaut, insbesondere als spiralförmiger Wickel.

In aller Regel umfasst das erfindungsgemäße Verfahren stets die Schritte

- Einsetzen des Wickels in das metallische Deckelteil,
- Einsetzen des metallischen Deckelteils mit dem Wickel in ein metallisches Becherteil,
- Umbördeln des Randes des Becherteils.

Vor dem Schließen des Gehäuses werden die Elektroden üblicherweise noch mit Elektrolytlösung getränkt.

Der Wickel befindet sich beim Einsetzen bevorzugt aufgerollt auf einem Wickeldorn. Nach dem oder beim Einsetzen kann der Wickeldorn dann entfernt werden.

Besonders bevorzugt wird der spiralförmige Wickel vor dem Verbauen an seinen Stirnseiten wärmebehandelt. Dabei wird er zumindest kurzfristig einer Temperatur ausgesetzt, bei der der Separator in dem Wickel thermoplastisch verformbar ist. In der Regel steht der Separator an den Stirnseiten des Wickels etwas über, selbst unter der Voraussetzung, dass die Elektroden mit dem oben beschriebenen Versatz zueinander angeordnet sind. Durch die Wärmebehandlung kann der Separator etwas zusammenschrumpfen und dadurch gegebenenfalls sogar den Rand einer benachbarten Elektroden freilegen, so dass dieser unmittelbar am Knopfzelligegehäuse anliegen kann.

Die genannten und weitere Vorteile der Erfindung ergeben sich aus der nun folgenden Beschreibung der Zeichnungen in Verbindung mit den Unteransprüchen. Dabei können die einzelnen Merkmale der Erfindung für sich allein oder in Kombination miteinander verwirklicht sein. Die beschriebenen Ausführungsformen dienen lediglich zur Erläuterung und zum besseren Verständnis der Erfindung und sind in keiner Weise einschränkend zu verstehen.

Figurenbeschreibung

Fig. 1 zeigt schematisch den Querschnitt einer erfindungsgemäßen Knopfzelle.

Fig. 2 illustriert den Effekt der Wärmebehandlung eines aufgewickelten Elektrode-Separator-Verbundes, welche bei bevorzugten Ausführungsformen des erfindungsgemäßen Verfahrens zum Einsatz kommt.

Fig. 1 zeigt schematisch den Querschnitt einer erfindungsgemäßen Knopfzelle **100**. Diese weist ein metallisches Becherteil **101** und ein metallisches Deckelteil **102** auf. Über eine Dichtung **109** sind die beiden Teile dichtend miteinander verbunden. Zusammen bilden sich ein Gehäuse mit einem ebenen Bodenbereich **103** und einem dazu parallelen ebenen Deckelbereich **104** aus. Im Gebrauchszustand bilden diese ebenen Bereiche **103** und **104** die Pole der Knopfzelle, an denen eine Stromabnahme durch einen Verbraucher erfolgen kann. Der Rand **110** des Zellenbechers **101** ist nach innen über den Rand des Zellendeckels **102** gebördelt.

Im Inneren der Elektrode ist ein Verbund aus einer streifenförmigen Elektrode **105**, einer streifenförmigen Elektrode **106** und den streifenförmigen Separatoren **107** angeordnet. Der Verbund aus den Elektroden **105** und **106** sowie den Separatoren **107** liegt dabei in Form eines Wickels vor. Aufgewickelt ist der Verbund auf dem Kern **108** im Zentrum der Knopfzelle **100**. Sowohl der Kern **108** als auch die um ihn gewickelten Elektroden und Separatoren sind orthogonal zu den ebenen Boden- und Deckelbereichen **104** und **103** ausgerichtet. Sofern die Elektroden bei einem Lade- oder Entladevorgang an Volumen gewinnen oder verlie-

ren, wirken die dabei resultierenden mechanischen Kräfte radial und können vom Mantelbereich der Knopfzelle **100** aufgefangen werden.

Hervorzuheben ist, dass die positive Elektrode **105** und die negative Elektrode **106** jeweils unmittelbar an dem Becherteil **101** bzw. an dem Deckelteil **102** der Knopfzelle **100** anliegen. Ein separater Ableiter zum Verbinden der Elektroden mit dem Deckelteil **102** und dem Becherteil **101** ist nicht erforderlich.

Fig. 2 zeigt den Effekt der Wärmebehandlung eines Elektroden-Separator-Wickels **200**, die in bevorzugten Ausführungsformen des erfindungsgemäßen Verfahrens zur Herstellung einer Knopfzelle vorgesehen ist. Dargestellt ist schematisch ein Wickel **200** aus einem Verbund aus einer positiven Elektrode **201** (schwarze Balken), einer negativen Elektrode **202** (weisse Balken) und den (quergestreiften) Separatoren **203** (Ausschnitt). Die positive und die negative Elektroden **201** und **202** sind jeweils versetzt zueinander angeordnet. Die Separatoren **203** bestehen aus einem thermoplastisch verformbaren Material.

Setzt man die sich an den Stirnseiten **204** und **205** des Wickels **200** befindlichen Separatorränder einer hohen Temperatur aus (beispielsweise 250 °C, wie dargestellt), so schrumpfen diese Separatorränder. Die Separatoren ziehen sich zumindest teilweise zwischen benachbarte Elektroden zurück. Dabei werden an der Stirnseite **204** die Ränder der negativen Elektrode **202** freigelegt, während die Ränder der positiven Elektrode **201** abgedeckt werden. An der Stirnseite **205** werden die Ränder der positiven Elektrode **201** freigelegt, während die Ränder der negativen Elektrode **202** abgedeckt werden.

Beim Einsatz eines so behandelten Wickels ist gewährleistet, dass Elektroden gleicher Polarität jeweils nur am Gehäusebecher oder am

Gehäusedeckel unmittelbar anliegen können. Separate elektrische Verbindungen zwischen den Elektroden und den Gehäuseteilen sind nicht erforderlich.



Patentansprüche

1. Knopfzelle (100), umfassend ein metallisches Becherteil (101) und ein metallisches Deckelteil (102), welche dichtend miteinander verbunden sind und ein Gehäuse mit einem ebenen Bodenbereich (103) und einem dazu parallelen ebenen Deckelbereich (104) ausbilden, sowie innerhalb des Gehäuses als flache Schichten ausgebildete positive und negative Elektroden (105, 106; 201, 202), die über einen flächigen Separator (107; 203) miteinander verbunden sind, wobei die Elektrodenschichten (105, 106; 201, 202) im wesentlichen orthogonal zu dem ebenen Boden- und Deckelbereich (103, 104) ausgerichtet sind.
2. Knopfzelle nach Anspruch 1, dadurch gekennzeichnet, dass die Elektroden (105, 106; 201, 202) und/oder der Separator (107; 203) streifen- oder bandförmig ausgebildet sind.
3. Knopfzelle nach Anspruch 1 oder Anspruch 2, dadurch gekennzeichnet, dass sie den Elektroden-Separator-Verbund als Wickel (200) enthält, insbesondere als spiralförmigen Wickel.
4. Knopfzelle nach einem der vorhergehenden Ansprüche, dadurch gekennzeichnet, dass der Verbund eine der folgenden Schichtabfolgen aufweist:
 - negative Elektrode / Separator / positive Elektrode / Separator
 - positive Elektrode / Separator / negative Elektrode / Separator
5. Knopfzelle nach einem der vorhergehenden Ansprüche, dadurch gekennzeichnet, dass die negative Elektrode (106; 202) und die positive Elektrode (105; 201) innerhalb des Verbundes versetzt

zueinander angeordnet sind, so dass für die Elektroden eine jeweils unterschiedliche Beabstandung zu den ebenen Boden- und Deckelbereichen (103, 104) resultiert.

6. Knopfzelle nach einem der vorhergehenden Ansprüche, dadurch gekennzeichnet, dass die positive Elektrode (105; 201), insbesondere ein Rand der positiven Elektrode (105; 201), unmittelbar am Becherteil (101), insbesondere im ebenen Bodenbereich (103), und die negative Elektrode (106; 202), insbesondere ein Rand der negativen Elektrode (106; 202), unmittelbar am Deckelteil (102), insbesondere im ebenen Deckelbereich (104), anliegt.
7. Knopfzelle nach einem der vorhergehenden Ansprüche, dadurch gekennzeichnet, dass sie wiederaufladbar ist.
8. Knopfzelle nach einem der vorhergehenden Ansprüche, dadurch gekennzeichnet, dass sie ein Verhältnis Höhe : Durchmesser < 1 , vorzugsweise zwischen 0.1 und 0.9, insbesondere zwischen 0.15 und 0.7, aufweist.
9. Verfahren zur Herstellung einer Knopfzelle, insbesondere einer Knopfzelle (101) nach einem der vorhergehenden Ansprüche, wobei aus einem metallischen Becherteil (101) und einem metallischen Deckelteil (102) ein Gehäuse mit einem ebenen Bodenbereich (103) und einem dazu parallelen ebenen Deckelbereich (104) gebildet wird und wobei ein Elektroden-Separator-Verbund mit als flache Schicht ausgebildeten Elektroden (105, 106; 201, 202) derart in das Gehäuse eingesetzt wird, dass die Elektroden (105, 106; 201, 202) orthogonal zu dem ebenen Boden- und Deckelbereich (103, 104) ausgerichtet sind.

10. Verfahren nach Anspruch 9, dadurch gekennzeichnet, dass der Elektroden-Separator-Verbund als Wickel (200) eingesetzt wird, insbesondere als spiralförmiger Wickel.

11. Verfahren nach Anspruch 10, umfassend die Schritte
 - Einsetzen des Wickels (200) in das metallische Deckelteil (102),
 - Einsetzen des metallischen Deckelteils (102) mit dem Wickel (200) in ein metallisches Becherteil (101),
 - Umbördeln des Randes (110) des Becherteils (101).

12. Verfahren nach Anspruch 10 oder 11, dadurch gekennzeichnet, dass der Wickel (200) vor dem Verbauen an seinen Stirnseiten wärmebehandelt wird, wobei er zumindest kurzfristig einer Temperatur ausgesetzt wird, bei der der Separator (203) thermoplastisch verformbar ist.

Zusammenfassung

Beschrieben wird eine Knopfzelle (100), die ein metallisches Becherteil (101) und ein metallisches Deckelteil (102) aufweist, welche dichtend miteinander verbunden sind und ein Gehäuse mit einem ebenen Bodenbereich (103) und einem dazu parallelen ebenen Deckelbereich (104) ausbilden, wobei innerhalb des Gehäuses als flache Schichten ausgebildete positive und negative Elektroden (105, 106; 201, 202) angeordnet sind, die über einen flächigen Separator (107; 203) miteinander verbunden sind, wobei die Elektrodenschichten (105, 106; 201, 202) im wesentlichen orthogonal zu dem ebenen Boden- und Deckelbereich (103, 104) ausgerichtet sind. Weiterhin wird ein Verfahren zur Herstellung einer solchen Knopfzelle beschrieben.

Fig. 1

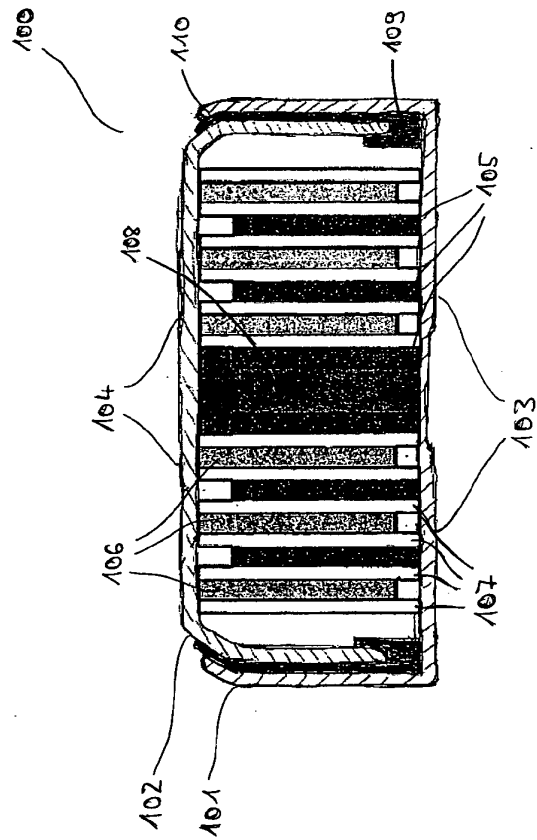

Document made available under the Patent Cooperation Treaty (PCT)

International application number: PCT/EP2010/000787

International filing date: 09 February 2010 (09.02.2010)

Document type: Certified copy of priority document

Document details: Country/Office: DE
Number: 10 2009 030 359.6
Filing date: 18 June 2009 (18.06.2009)

Date of receipt at the International Bureau: 06 April 2010 (06.04.2010)

Remark: Priority document submitted or transmitted to the International Bureau in compliance with Rule 17.1(a) or (b)



World Intellectual Property Organization (WIPO) - Geneva, Switzerland
Organisation Mondiale de la Propriété Intellectuelle (OMPI) - Genève, Suisse

BUNDESREPUBLIK DEUTSCHLAND



Prioritätsbescheinigung DE 10 2009 030 359.6 über die Einreichung einer Patentanmeldung

Aktenzeichen: 10 2009 030 359.6

Anmeldetag: 18. Juni 2009

Anmelder/Inhaber: VARTA Microbattery GmbH, 30419 Hannover/DE

Bezeichnung: Knopfzelle und Verfahren zu ihrer Herstellung

IPC: H 01 M 2/02, H 01 M 2/18

Die angehefteten Stücke sind eine richtige und genaue Wiedergabe der Teile der am 18. Juni 2009 eingereichten Unterlagen dieser Patentanmeldung unabhängig von gegebenenfalls durch das Kopierverfahren bedingten Farbabweichungen.

München, den 10. Dezember 2009
Deutsches Patent- und Markenamt
Die Präsidentin
Im Auftrag

Wunder

Anmelderin:

VARTA Microbattery GmbH
Am Leineufer 51

30419 Hannover

Unser Zeichen: P 49226 DE1

18. Juni 2009 ME/ME

Beschreibung

Knopfzelle und Verfahren zu ihrer Herstellung

Die vorliegende Erfindung betrifft eine Knopfzelle umfassend ein Gehäuse mit einem metallischen Becherteil und einem metallischen Deckelteil, die dichtend miteinander verbunden sind, sowie innerhalb des Gehäuses mit einer positiven und einer negativen Elektrode, die als flache Schichten ausgebildet und über mindestens einen flächigen Separator miteinander verbunden sind, sowie ein Verfahren zur Herstellung von solchen Knopfzellen.

Wiederaufladbare Knopfzellen können unterschiedliche elektrochemische Systeme enthalten. Sehr verbreitet sind z. B. Knopfzellen auf Basis von Nickel-Metallhydrid- oder Lithium-Ionen-Systemen. Insbesondere bei Lithium-Ionen-Knopfzellen werden die elektrochemisch aktiven Materialien innerhalb des Knopfzellegehäuses üblicherweise nicht in Form von einzelnen, durch einen Separator voneinander getrennten, tablettenförmigen Elektroden angeordnet. Stattdessen werden bevorzugt vorgefertigte Elektroden-Separator-Verbünde flach in das Gehäuse eingelegt. Als Separator dient dabei bevorzugt eine poröse Kunststoffolie, auf wel-

che die Elektroden flächig auflaminiert oder aufgeklebt sind. Der Gesamtverbund aus Separator und Elektroden ist dabei in der Regel maximal wenige 100 µm dick. Um Knopfzelligegehäuse üblicher Dimensionen ausfüllen zu können, werden daher häufig mehrere solcher Verbünde flach übereinander gelegt. Auf diese Weise lassen sich Stapel in grundsätzlich beliebiger Höhe erhalten, jeweils abgestimmt auf die zur Verfügung stehenden Dimensionen des Knopfzelligegehäuses, in das der Stapel verbaut werden soll. So wird eine optimale Ausnutzung des zur Verfügung stehenden Gehäuseinnenraumes gewährleistet.

Konstruktionsbedingt treten bei Knopfzellen, die solche Stapel aus Elektroden-Separator-Verbänden enthalten, allerdings auch diverse Probleme auf. Zum einen ist es natürlich erforderlich, Elektroden von jeweils gleicher Polarität innerhalb des Stapels miteinander zu verbinden und dann jeweils mit dem entsprechenden Pol des Knopfzelligegehäuses zu kontaktieren. Die erforderlichen elektrischen Kontakte verursachen Materialkosten, der durch sie eingenommene Raum steht zudem für Aktivmaterial nicht mehr zur Verfügung. Die Herstellung der Elektrodenstapel ist darüber hinaus kompliziert und teuer, da bei der Kontaktierung der Verbünde untereinander leicht Fehler auftreten können, die die Ausschussrate erhöhen. Zum anderen wurde festgestellt, dass Knopfzellen mit einem Stapel aus Elektroden und Separatoren sehr schnell undicht werden können.

Der vorliegenden Erfindung lag die Aufgabe zugrunde, Knopfzellen bereitzustellen, bei denen die genannten Probleme nicht auftreten. Die bereitzustellenden Knopfzellen sollten eine möglichst einfache Konstruktionsweise aufweisen, höchsten Anforderungen im Hinblick auf die Dichtigkeit im Betrieb genügen und sehr einfach herzustellen sein.

Diese Aufgabe wird gelöst durch die Knopfzelle mit den Merkmalen des Anspruchs 1 sowie das Verfahren mit den Merkmalen des Anspruchs 13. Bevorzugte Ausführungsformen der erfindungsgemäßen Knopfzelle

sind in den abhängigen Ansprüchen 2 bis 12 angegeben. Bevorzugte Ausführungsformen des erfindungsgemäßen Verfahrens finden sich in den Ansprüchen 14 bis 16. Der Wortlaut sämtlicher Ansprüche wird hiermit durch Bezugnahme zum Inhalt dieser Beschreibung gemacht.

Eine erfindungsgemäße Knopfzelle weist ein metallisches Becherteil und ein metallisches Deckelteil auf, die dichtend miteinander verbunden sind. Zusammen bilden die beiden Teile ein Gehäuse aus, das einen ebenen Bodenbereich und einen dazu parallelen ebenen Deckelbereich aufweist. Als Becher- und Deckelteil sind insbesondere Teile aus vernickeltem Stahl oder Blech bevorzugt. Weiterhin als metallischer Werkstoff geeignet sind insbesondere Trimetalle, beispielsweise mit der Abfolge Nickel, Stahl (oder Edelstahl) und Kupfer (wobei dann die Nickelschicht bevorzugt die Außen- und die Kupferschicht bevorzugt die Innenseite des Knopfzellengehäuses bildet). Als Dichtung kann beispielsweise eine Spritzguss- oder eine Foliendichtung zum Einsatz kommen.

Innerhalb des Gehäuses sind mindestens eine positive und mindestens eine negative Elektrode angeordnet, und zwar jeweils in Form von flachen Elektrodenschichten. Die Elektroden sind dabei über einen flächigen Separator miteinander verbunden. Vorzugsweise sind die Elektroden auf diesen Separator auflaminiert oder aufgeklebt. Die Elektroden und der Separator weisen in der Regel jeweils nur Dicken im μm -Bereich auf. In bevorzugten Ausführungsformen bilden sie zusammen einen Elektroden-Separator-Verbund aus, wie er bereits eingangs erwähnt wurde.

Im Gegensatz zu den eingangs erwähnten Knopfzellen zeichnet sich die erfindungsgemäße Knopfzelle jedoch insbesondere dadurch aus, dass die Elektrodenschichten eine ganz besondere Orientierung aufweisen, sie sind nämlich im wesentlichen orthogonal zu dem ebenen Boden- und Deckelbereich ausgerichtet. Während aus dem Stand der Technik bekannte Knopfzellen mit gestapelten Elektroden-Separator-Verbänden

diese stets flach eingelegt enthalten, so dass die Elektrodenschichten im wesentlichen parallel zu den ebenen Boden- und Deckelbereichen ausgerichtet sind, ist bei einer erfindungsgemäßen Knopfzelle das Gegenteil der Fall.

Die orthogonale Ausrichtung der Elektrodenschichten hat einen unerwartet deutlichen Vorteil, es wurde nämlich festgestellt, dass diese Ausrichtung mit einer deutlichen Verbesserung der Dichtigkeitseigenschaften einer erfindungsgemäßen Knopfzelle einhergeht, insbesondere bei Knopfzellen auf Basis von Lithium-Ionen-Systemen. Die Elektroden von wiederaufladbaren Lithium-Ionen-Systemen sind bei Lade- und Entladevorgängen stets Volumenänderungen ausgesetzt. Zu solchen Volumenänderungen kann es natürlich auch bei den Elektroden einer erfindungsgemäßen Knopfzelle kommen. Die dabei entstehenden mechanischen Kräfte wirken jedoch nicht mehr primär axial, wie das im Falle eines flach eingelegten Stapels aus Elektroden-Separator-Verbänden der Fall ist. Aufgrund der orthogonalen Ausrichtung der Elektroden wirken sie vielmehr radial. Radiale Kräfte können von dem Gehäuse einer Knopfzelle sehr viel besser aufgenommen werden als axiale. Vermutlich lassen sich darauf die verbesserten Dichtigkeitseigenschaften zurückführen.

Besonders bevorzugt sind die Elektroden und der flächige Separator einer erfindungsgemäßen Knopfzelle jeweils streifen- oder bandförmig ausgebildet. So kann zur Herstellung einer erfindungsgemäßen Knopfzelle beispielsweise von einem als Endlosband vorliegenden Separatormaterial ausgegangen werden, auf das die Elektroden flächig, insbesondere wieder in Form von Streifen oder zumindest von Rechtecken, aufgebracht, insbesondere auflaminiert, werden.

Insbesondere wenn die Elektroden streifenförmig auf einen solchen Separator aufgebracht werden, so lässt sich der entstehende Verbund aus streifenförmigen Elektroden und streifenförmigem Separator gut aufwi-

ckeln. In bevorzugten Ausführungsformen enthält eine erfindungsgemäße Knopfzelle entsprechend den Verbund aus Elektroden und Separator als Wickel, besonders bevorzugt als spiralförmigen Wickel. In der erfindungsgemäßen Knopfzelle ist der Wickel bevorzugt derart ausgerichtet, dass er mit seinen Stirnseiten an dem ebenen Bodenbereich und dem dazu parallel ausgerichteten ebenen Deckelbereich des Gehäuses anliegt.

Besonders bevorzugt weist der Verbund aus Elektroden und Separator in einer erfindungsgemäßen Knopfzelle eine der folgenden Schichtabfolgen auf:

- negative Elektrode / Separator / positive Elektrode / Separator

oder

- positive Elektrode / Separator / negative Elektrode / Separator.

Derartige Verbände lassen sich sehr einfach herstellen und aufwickeln, ohne dass es zu Kurzschlüssen zwischen entgegengesetzt gepolten Elektroden kommt.

In besonders bevorzugten Ausführungsformen einer erfindungsgemäßen Knopfzelle sind die negative Elektrode und die positive Elektrode im Elektroden-Separator-Verbund innerhalb des Verbundes versetzt zueinander angeordnet. Unter einer versetzten Anordnung soll dabei verstanden werden, dass die Elektroden derart angeordnet sind, dass in der erfindungsgemäßen Knopfzelle eine jeweils unterschiedliche Beabstandung der Elektroden zu den ebenen Boden- und Deckelbereichen resultiert. Im einfachsten Fall können z.B. eine positive und eine negative Elektrode als gleich breite Streifen leicht versetzt auf die gegenüberliegenden Seiten eines Separatorbandes aufgebracht werden, so dass der Abstand der positiven Elektrode zum oberen Separatorrand größer ist

als der vergleichbare Abstand von der negativen Elektrode aus gemessen. Umgekehrtes gilt dann natürlich im Hinblick auf den Abstand zum unteren Separatorrand.

In besonders bevorzugten Ausführungsformen liegt, vorzugsweise als Resultat dieser versetzten Anordnung, die positive Elektrode, insbesondere ein Rand der positiven Elektrode, unmittelbar am Becherteil an, insbesondere im ebenen Bodenbereich des Becherteils, während die negative Elektrode, insbesondere ein Rand der negativen Elektrode, unmittelbar am Deckelteil, insbesondere im ebenen Deckelbereich des Deckelteils, anliegt. In dieser Ausführungsform besteht ein unmittelbarer elektrischer und mechanischer Kontakt zwischen den Elektroden und dem Becher- bzw. Deckelteil. Die versetzte Anordnung der Elektroden zueinander ermöglicht also eine Kontaktierung der Elektroden mit den jeweiligen Gehäuseteilen, ohne dass zusätzliche elektrische Kontakte und Verbindungsmittel zum Einsatz kommen müssen.

In weiteren bevorzugten Ausführungsformen kann es allerdings auch bevorzugt sein, dass zumindest eine der Elektroden, vorzugsweise sowohl die mindestens eine negative als auch die mindestens eine positive Elektrode in einer erfindungsgemäßen Knopfzelle, über einen oder mehrere separate Ableiter mit den ebenen Boden- und Deckelbereichen verbunden sind. Bei den Ableitern kann es sich beispielsweise um Ableiterfahnen aus Kupfer oder einem anderen geeigneten Metall handeln. Elektrodenseitig können die Ableiter z.B. an einen Stromkollektor angebunden sein. Eine Anbindung ans Gehäuse kann z.B. über Verschweißung oder eine Klemmverbindung erfolgen.

Separate Ableiter können insbesondere vorteilhaft sein, wenn die negative Elektrode und die positive Elektrode innerhalb des Verbundes derart zueinander angeordnet sind, dass für die Elektroden eine jeweils gleiche Beabstandung zu den ebenen Boden- und Deckelbereichen resultiert. Oder mit anderen Worten, wenn die Elektroden innerhalb des Elektro-

den-Separator-Verbundes nicht versetzt zueinander angeordnet sind, wie es oben beschrieben wurde.

Allerdings besteht bei gleicher Beabstandung entgegengesetzt gepolter Elektroden zu den ebenen Boden- und Deckelbereichen die Gefahr, dass eine positive und eine negative Elektrode gleichzeitig das metallische Becher- oder Deckelteil berühren, so dass ein Kurzschluss entsteht. In bevorzugten Ausführungsformen kann die erfindungsgemäße Knopfzelle deshalb mindestens ein Isoliermittel umfassen, das einen direkten und unmittelbaren mechanischen und elektrischen Kontakt zwischen den Stirnseiten des Wickels und den ebenen Boden- und Deckelbereichen unterbindet.

In Weiterbildung ist es bevorzugt, wenn die Elektroden in einer solchen erfindungsgemäßen Knopfzelle über die bereits erwähnten separaten Ableiter mit den ebenen Boden- und Deckelbereichen verbunden sind. Diese gewährleisten den elektrischen Kontakt zwischen den Elektroden und dem Gehäuse.

Bei dem Isoliermittel kann es sich z.B. um eine flache Schicht aus Kunststoff, beispielsweise um eine Kunststofffolie handeln, die zwischen den Stirnseiten des Wickels und den ebenen Boden- und Deckelbereichen des Gehäuses einer erfindungsgemäßen Knopfzelle angeordnet ist.

Bei den in einer erfindungsgemäßen Knopfzelle einsetzbaren Separatoren handelt es sich vorzugsweise um Folien aus mindestens einem Kunststoff, insbesondere aus mindestens einem Polyolefin. Bei dem mindestens einen Polyolefin kann es sich beispielsweise um Polyethylen handeln. Es können aber auch mehrlagige Separatoren verwendet werden, beispielsweise Separatoren aus einer Abfolge verschiedener Polyolefinschichten, z.B. mit der Sequenz Polyethylen/Polypropylen/Polyethylen.

Die in einer erfindungsgemäßen Knopfzelle bevorzugt einsetzbaren Separatoren weisen bevorzugt eine Dicke zwischen 3 μm und 100 μm , insbesondere zwischen 10 μm und 50 μm , auf.

Die Elektroden einer erfindungsgemäßen Knopfzelle weisen bevorzugt eine Dicke zwischen 10 μm und 1000 μm , insbesondere zwischen 30 μm und 500 μm , auf.

Wie bereits eingangs erwähnt wurde, handelt es sich bei der erfindungsgemäßen Knopfzelle insbesondere um eine wiederaufladbare Knopfzelle. Besonders bevorzugt weist eine erfindungsgemäße Knopfzelle mindestens eine Lithium interkalierende Elektrode auf.

Das Verhältnis Höhe : Durchmesser einer erfindungsgemäßen Knopfzelle beträgt vorzugsweise < 1 . Besonders bevorzugt liegt es zwischen 0.1 und 0.9, insbesondere zwischen 0.15 und 0.7. Unter der Höhe soll dabei der Abstand zwischen dem ebenen Bodenbereich und dem dazu parallelen ebenen Deckelbereich verstanden werden. Der Durchmesser meint die maximale Entfernung zweier Punkte auf dem Mantelbereich der Knopfzelle.

Das erfindungsgemäße Verfahren zur Herstellung einer Knopfzelle kann insbesondere zur Herstellung einer Knopfzelle dienen, wie sie vorstehend beschrieben wurde, also einer Knopfzelle mit einem Gehäuse mit einem ebenen Bodenbereich und einem dazu parallelen ebenen Deckelbereich.

Betreffend die bevorzugten Ausführungsformen der einzelnen in einem erfindungsgemäßen Verfahren verwendeten Komponenten (Gehäuseteile und -dimensionen, Elektroden, Separator etc.) kann somit vollumfänglich auf die obenstehenden Ausführungen und Erläuterungen Bezug genommen und verwiesen werden.

Das Gehäuse wird aus einem metallischen Becherteil und einem metallischen Deckelteil zusammengefügt, wobei ein Elektroden-Separator-Verbund mit als flache Schicht ausgebildeten Elektroden derart in das Gehäuse eingesetzt wird, dass die Elektroden orthogonal zu dem ebenen Boden- und Deckelbereich ausgerichtet sind.

Wie bereits erwähnt, wird der Elektroden-Separator-Verbund bevorzugt in Form eines Wickels verbaut, insbesondere als spiralförmiger Wickel.

In aller Regel umfasst das erfindungsgemäße Verfahren stets die Schritte

- Einsetzen des Wickels in das metallische Deckelteil,
- Einsetzen des metallischen Deckelteils mit dem Wickel in ein metallisches Becherteil,
- Umbördeln des Randes des Becherteils.

Vor dem Schließen des Gehäuses werden die Elektroden üblicherweise noch mit Elektrolytlösung getränkt.

Der Wickel befindet sich beim Einsetzen bevorzugt aufgerollt auf einem Wickeldorn. Nach dem oder beim Einsetzen kann der Wickeldorn dann entfernt werden.

Besonders bevorzugt wird der spiralförmige Wickel vor dem Verbauen an seinen Stirnseiten wärmebehandelt. Dabei wird er zumindest kurzfristig einer Temperatur ausgesetzt, bei der der Separator in dem Wickel thermoplastisch verformbar ist. In der Regel steht der Separator an den Stirnseiten des Wickels etwas über, selbst unter der Voraussetzung, dass die Elektroden mit dem oben beschriebenen Versatz zueinander angeordnet sind. Durch die Wärmebehandlung kann der Separator etwas zusammenschrumpfen und dadurch gegebenenfalls sogar den Rand einer benachbarten Elektroden freilegen, so dass dieser unmittelbar am Knopfzelligegehäuse anliegen kann.

Die genannten und weitere Vorteile der Erfindung ergeben sich aus der nun folgenden Beschreibung der Zeichnungen in Verbindung mit den Unteransprüchen. Dabei können die einzelnen Merkmale der Erfindung für sich allein oder in Kombination miteinander verwirklicht sein. Die beschriebenen Ausführungsformen dienen lediglich zur Erläuterung und zum besseren Verständnis der Erfindung und sind in keiner Weise einschränkend zu verstehen.

Figurenbeschreibung

Fig. 1 zeigt schematisch den Querschnitt einer bevorzugten Ausführungsform einer erfindungsgemäßen Knopfzelle.

Fig. 2 illustriert den Effekt der Wärmebehandlung eines aufgewickelten Elektrode-Separator-Verbundes, welche bei bevorzugten Ausführungsformen des erfindungsgemäßen Verfahrens zum Einsatz kommt.

Fig. 3 zeigt einen Elektroden-Separator-Verbund in Form eines Wickels, wie er in einer erfindungsgemäßen Knopfzelle verbaut werden kann.

Fig. 4 zeigt eine geschnittene Darstellung einer weiteren bevorzugten Ausführungsform einer erfindungsgemäßen Knopfzelle.

Fig. 1 zeigt schematisch den Querschnitt einer erfindungsgemäßen Knopfzelle **100**. Diese weist ein metallisches Becherteil **101** und ein metallisches Deckelteil **102** auf. Über eine Dichtung **109** sind die beiden Teile dichtend miteinander verbunden. Zusammen bilden sie ein Gehäuse mit einem ebenen Bodenbereich **103** und einem dazu parallelen ebenen Deckelbereich **104** aus. Im Gebrauchszustand bilden diese ebenen

Bereiche **103** und **104** die Pole der Knopfzelle, an denen eine Stromabnahme durch einen Verbraucher erfolgen kann. Der Rand **110** des Zellenbeckers **101** ist nach innen über den Rand des Zellendeckels **102** gebördelt.

Im Inneren der Elektrode ist ein Verbund aus einer streifenförmigen Elektrode **105**, einer streifenförmigen Elektrode **106** und den streifenförmigen Separatoren **107** angeordnet. Der Verbund aus den Elektroden **105** und **106** sowie den Separatoren **107** liegt dabei in Form eines Wickels vor, der mit seinen Stirnseiten an den ebenen Bodenbereich **103** und den dazu parallelen ebenen Deckelbereich **104** anstößt. Aufgewickelt ist der Verbund auf dem Kern **108** im Zentrum der Knopfzelle **100**. Sowohl der Kern **108** als auch die um ihn gewickelten Elektroden und Separatoren sind orthogonal zu den ebenen Boden- und Deckelbereichen **104** und **103** ausgerichtet. Sofern die Elektroden bei einem Lade- oder Entladevorgang an Volumen gewinnen oder verlieren, wirken die dabei resultierenden mechanischen Kräfte überwiegend radial und können vom Mantelbereich der Knopfzelle **100** aufgefangen werden.

Hervorzuheben ist, dass die positive Elektrode **105** und die negative Elektrode **106** jeweils unmittelbar an dem Becherteil **101** bzw. an dem Deckelteil **102** der Knopfzelle **100** anliegen. Ein separater Ableiter zum Verbinden der Elektroden mit dem Deckelteil **102** und dem Becherteil **101** ist nicht erforderlich.

Fig. 2 zeigt den Effekt der Wärmebehandlung eines Elektroden-Separator-Wickels **200**, die in bevorzugten Ausführungsformen des erfindungsgemäßen Verfahrens zur Herstellung einer Knopfzelle vorgesehen ist. Dargestellt ist schematisch ein Wickel **200** aus einem Verbund aus einer positiven Elektrode **201** (quergestreifte Balken), einer negativen Elektrode **202** (weisse Balken) und den Separatoren **203** (Ausschnitt). Die positive und die negative Elektroden **201** und **202** sind jeweils versetzt zu-

einander angeordnet. Die Separatoren **203** bestehen aus einem thermoplastisch verformbaren Material.

Setzt man die sich an den Stirnseiten **204** und **205** des Wickels **200** befindlichen Separatorränder einer hohen Temperatur aus (beispielsweise 250 °C, wie dargestellt), so schrumpfen diese Separatorränder. Die Separatoren ziehen sich zumindest teilweise zwischen benachbarte Elektroden zurück. Dabei werden an der Stirnseite **204** die Ränder der negativen Elektrode **202** freigelegt, während die Ränder der positiven Elektrode **201** abgedeckt werden. An der Stirnseite **205** werden die Ränder der positiven Elektrode **201** freigelegt, während die Ränder der negativen Elektrode **202** abgedeckt werden.

Beim Einsatz eines so behandelten Wickels ist gewährleistet, dass Elektroden gleicher Polarität jeweils nur am Gehäusebecher oder am Gehäusedeckel unmittelbar anliegen können. Separate elektrische Verbindungen zwischen den Elektroden und den Gehäuseteilen sind nicht erforderlich.

Fig. 3 zeigt einen Elektroden-Separator-Verbund in Form eines Wickels **300**, wobei die Darstellung A eine Draufsicht senkrecht von oben auf eine der Stirnseiten **301** des Wickels **300** abbildet, während in der Darstellung B der Wickel **300** in einer Ansicht schräg von oben dargestellt ist. Zu erkennen ist in beiden Fällen, dass der Verbund zwei Lagen Separator **302** und **303** sowie zwei Elektrodenschichten **304** und **305** (eine positive und eine negative Elektrode) umfasst. Der Verbund ist spiralförmig aufgewickelt und wird durch ein Klebeband **306** auf seiner Außenseite zusammengehalten.

Fig. 4 zeigt eine geschnittene Darstellung einer bevorzugten Ausführungsform einer erfindungsgemäßen Knopfzelle **400**. Zu erkennen ist das Gehäuse der Knopfzelle aus dem Becherteil **401** und dem Deckelteil **402**, zwischen denen die Dichtung **403** angeordnet ist. Innerhalb des

Gehäuses ist ein Verbund aus Elektroden und Separatoren, wie er in Fig. 3 dargestellt ist, als spiralförmiger Wickel **404** (im Querschnitt schematisch dargestellt) enthalten. Gut zu erkennen sind auch hier die Separatorlagen **405** und **406** sowie die entgegengesetzt gepolten Elektroden **407** und **408**. Die Elektrode **407** ist dabei über den Ableiter **410** mit dem Deckelteil **402** verbunden, während die Elektrode **408** über den Ableiter **409** mit dem Becherteil **402** verbunden ist. Der Ableiter **410** ist vorzugsweise mit dem Deckelteil **402** verschweisst. Dagegen ist der Ableiter **409** mit dem Becherteil **402** über eine Klemmverbindung verbunden (er ist zwischen dem Stützring **413**, auf dem der Rand des Zellendeckels aufliegt, und dem Boden des Zellenbechers eingeklemmt). Zwischen den Stirnseiten des Wickels und dem Becherteil **401** und dem Deckelteil **402** sind die Isoliermittel **411** und **412** angeordnet, bei denen es sich jeweils um dünne Kunststoffscheiben handelt. Durch diese wird verhindert, dass Elektroden entgegengesetzter Polarität gleichzeitig in Kontakt mit dem Becher- oder dem Deckelteil **401** und **402** kommen können. Einem Kurzschluss wird dadurch vorgebeugt.

Patentansprüche

1. Knopfzelle (100; 400), umfassend ein metallisches Becherteil (101, 401) und ein metallisches Deckelteil (102; 402), welche dichtend miteinander verbunden sind und ein Gehäuse mit einem ebenen Bodenbereich (103) und einem dazu parallelen ebenen Deckelbereich (104) ausbilden, sowie innerhalb des Gehäuses eine positive und eine negative Elektrode (105, 106; 201, 202; 304, 305; 407, 408), die als flache Schichten ausgebildet und über mindestens einen flächigen Separator (107; 203; 302, 303; 405, 406) miteinander verbunden sind, wobei die Elektrodenschichten (105, 106; 201, 202; 407, 408) im wesentlichen orthogonal zu dem ebenen Boden- und Deckelbereich (103, 104) ausgerichtet sind.
2. Knopfzelle nach Anspruch 1, dadurch gekennzeichnet, dass die Elektroden (105, 106; 201, 202; 304, 305; 407, 408) und/oder der Separator (107; 203; 302, 303; 405, 406) streifen- oder bandförmig ausgebildet sind.
3. Knopfzelle nach Anspruch 1 oder Anspruch 2, dadurch gekennzeichnet, dass sie den Elektroden-Separator-Verbund als Wickel (200; 300; 404) enthält, insbesondere als spiralförmigen Wickel, der mit seinen Stirnseiten an dem ebenen Bodenbereich und dem dazu parallelen ebenen Deckelbereich anliegt.
4. Knopfzelle nach einem der vorhergehenden Ansprüche, dadurch gekennzeichnet, dass der Verbund eine der folgenden Schichtabfolgen aufweist:
 - negative Elektrode / Separator / positive Elektrode / Separator
 - positive Elektrode / Separator / negative Elektrode / Separator

5. Knopfzelle nach einem der Ansprüche 3 oder 4, dadurch gekennzeichnet, dass die negative Elektrode (106) und die positive Elektrode (105) innerhalb des Verbundes derart zueinander angeordnet sind, dass für die Elektroden eine jeweils unterschiedliche Beabstandung zu den ebenen Boden- und Deckelbereichen (103, 104) resultiert.
6. Knopfzelle nach einem der vorhergehenden Ansprüche, dadurch gekennzeichnet, dass die positive Elektrode (105), insbesondere ein Rand der positiven Elektrode (105), unmittelbar am Becherteil (101), insbesondere im ebenen Bodenbereich (103), und die negative Elektrode (106), insbesondere ein Rand der negativen Elektrode (106), unmittelbar am Deckelteil (102), insbesondere im ebenen Deckelbereich (104), anliegt.
7. Knopfzelle nach einem der vorhergehenden Ansprüche, dadurch gekennzeichnet, dass die positive Elektrode (408) und/oder die negative Elektrode (407) über einen Ableiter (409, 410) mit den ebenen Boden- und/oder Deckelbereichen verbunden sind.
8. Knopfzelle nach einem der Ansprüche 3, 4 oder 7, dadurch gekennzeichnet, dass die negative Elektrode (407) und die positive Elektrode (408) innerhalb des Verbundes derart zueinander angeordnet sind, dass für die Elektroden eine im wesentlichen jeweils gleiche Beabstandung zu den ebenen Boden- und Deckelbereichen resultiert.
9. Knopfzelle nach einem der Ansprüche 3 bis 5, 7 oder 8, dadurch gekennzeichnet, dass sie mindestens ein Isoliermittel (413, 414) umfasst, das einen direkten mechanischen und elektrischen Kontakt zwischen den Stirnseiten des Wickels und den ebenen Boden- und Deckelbereichen unterbindet.

10. Knopfzelle nach Anspruch 9, dadurch gekennzeichnet, dass es sich bei dem mindestens einen Isoliermittel (413, 414) um eine flache Schicht aus Kunststoff, beispielsweise um eine Kunststoffolie handelt, die zwischen den Stirnseiten des Wickels und den ebenen Boden- und Deckelbereichen angeordnet ist.
11. Knopfzelle nach einem der vorhergehenden Ansprüche, dadurch gekennzeichnet, dass sie wiederaufladbar ist.
12. Knopfzelle nach einem der vorhergehenden Ansprüche, dadurch gekennzeichnet, dass sie ein Verhältnis Höhe : Durchmesser < 1 , vorzugsweise zwischen 0.1 und 0.9, insbesondere zwischen 0.15 und 0.7, aufweist.
13. Verfahren zur Herstellung einer Knopfzelle, insbesondere einer Knopfzelle (100; 400) nach einem der vorhergehenden Ansprüche, wobei aus einem metallischen Becherteil (101, 401) und einem metallischen Deckelteil (102; 402) ein Gehäuse mit einem ebenen Bodenbereich (103) und einem dazu parallelen ebenen Deckelbereich (104) montiert wird und wobei ein Elektroden-Separator-Verbund mit als flache Schicht ausgebildeten Elektroden (105, 106; 201, 202; 304, 305; 407, 408) derart in das Gehäuse eingesetzt wird, dass die Elektroden orthogonal zu dem ebenen Boden- und Deckelbereich (103, 104) ausgerichtet sind.
14. Verfahren nach Anspruch 13, dadurch gekennzeichnet, dass der Elektroden-Separator-Verbund als Wickel (200; 300; 404) eingesetzt wird, insbesondere als spiralförmiger Wickel.
15. Verfahren nach Anspruch 14, umfassend die Schritte
 - Einsetzen des Wickels (200; 300; 404) in das metallische Deckelteil (102; 402),

- Einsetzen des metallischen Deckelteils (102) mit dem Wickel (200) in ein metallisches Becherteil (101; 401),
 - Umbördeln des Randes des Becherteils.
16. Verfahren nach Anspruch 14 oder 15, dadurch gekennzeichnet, dass der Wickel (200; 300; 404) vor dem Verbauen an seinen Stirnseiten wärmebehandelt wird, wobei er zumindest kurzfristig einer Temperatur ausgesetzt wird, bei der der Separator (107; 203; 302, 303; 405, 406) thermoplastisch verformbar ist.

Zusammenfassung

Beschrieben wird eine Knopfzelle (100; 400), die ein metallisches Becherteil (101; 401) und ein metallisches Deckelteil (102; 402) aufweist, welche dichtend miteinander verbunden sind und ein Gehäuse mit einem ebenen Bodenbereich (103) und einem dazu parallelen ebenen Deckelbereich (104) ausbilden, wobei innerhalb des Gehäuses als flache Schichten ausgebildete positive und negative Elektroden (105, 106; 201, 202; 304, 305; 407, 408) angeordnet sind, die über einen flächigen Separator (107; 203; 302, 303; 405, 406) miteinander verbunden sind, wobei die Elektrodenschichten im wesentlichen orthogonal zu dem ebenen Boden- und Deckelbereich ausgerichtet sind. Weiterhin wird ein Verfahren zur Herstellung einer solchen Knopfzelle beschrieben.

P 49 226 DE1

Figur zur Zusammenfassung

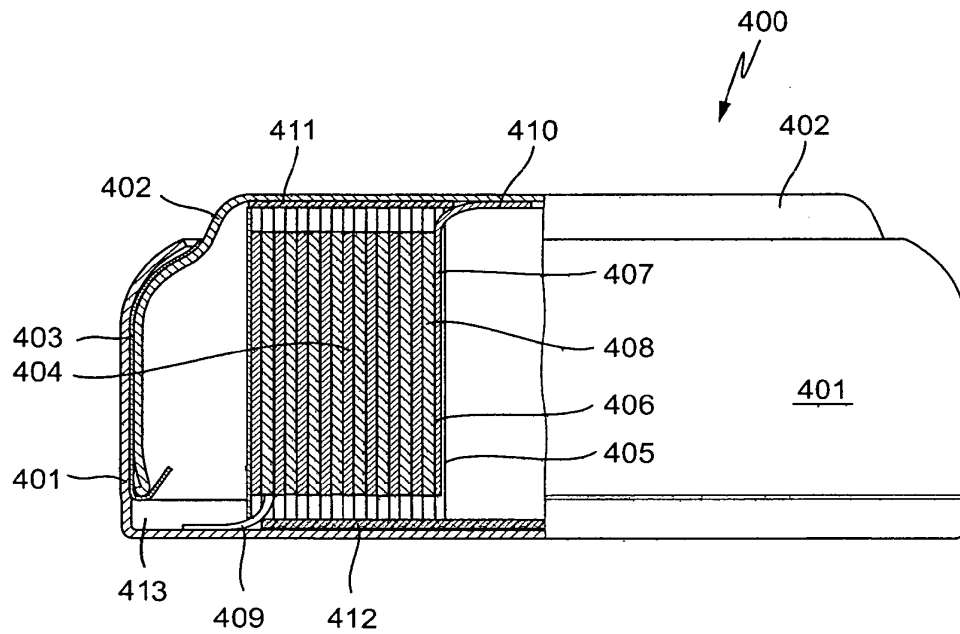

Fig. 4

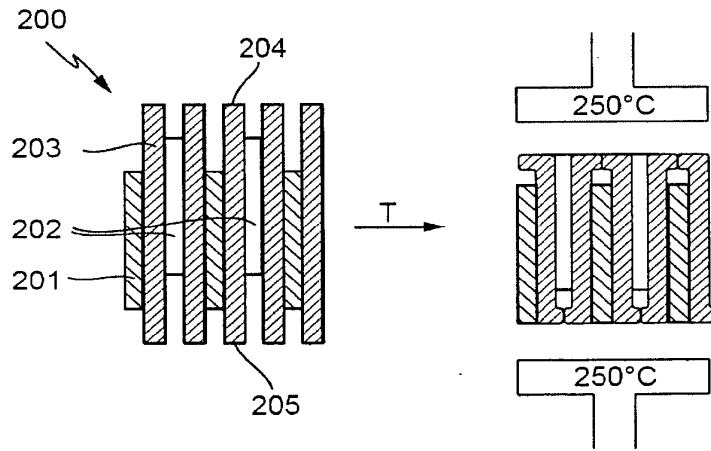
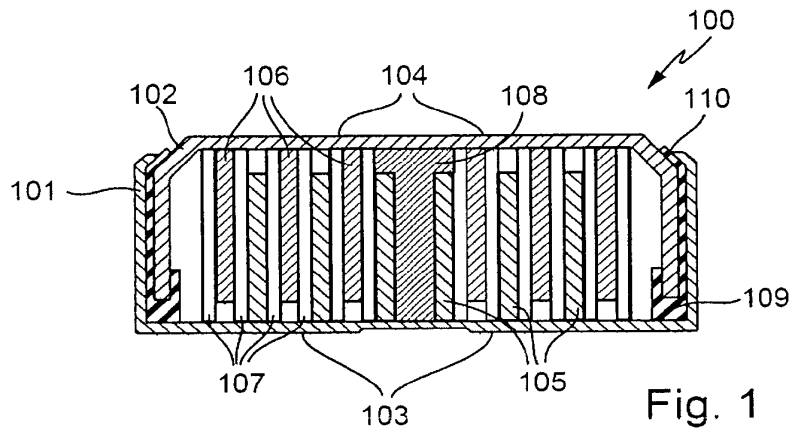

Fig. 2

2/3

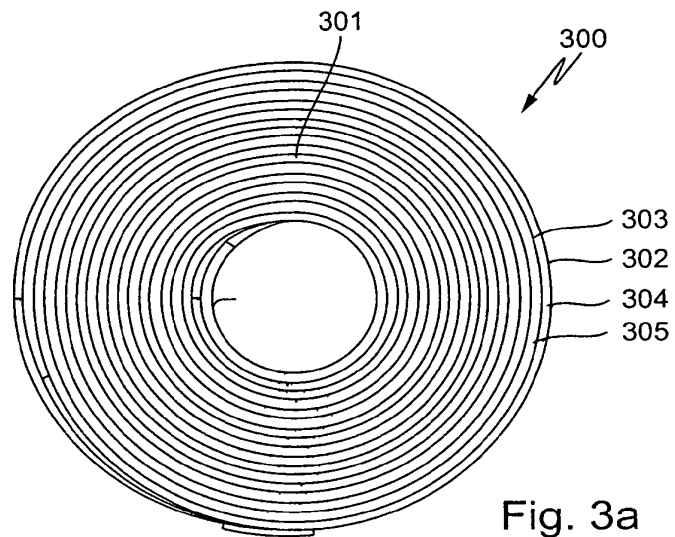

Fig. 3a

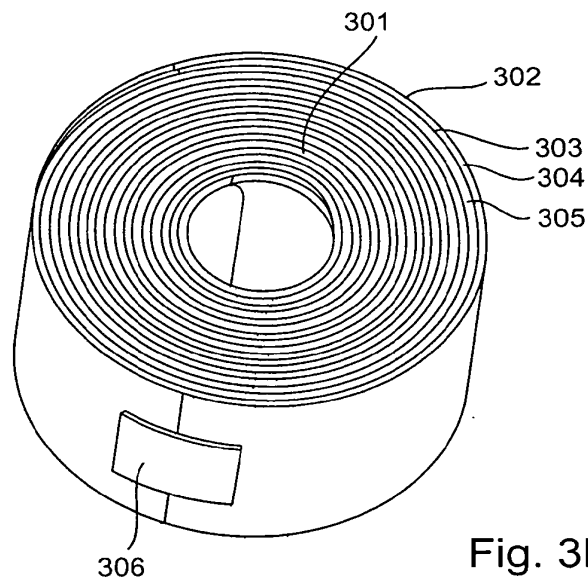

Fig. 3b

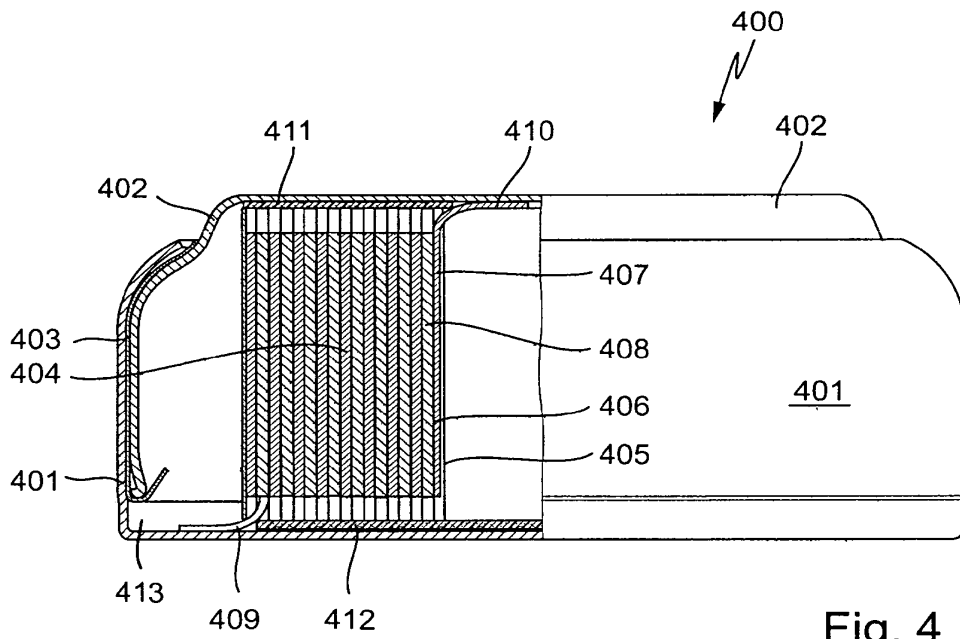

Fig. 4

Document made available under the Patent Cooperation Treaty (PCT)

International application number: PCT/EP2010/000787

International filing date: 09 February 2010 (09.02.2010)

Document type: Certified copy of priority document

Document details: Country/Office: DE
Number: 10 2009 060 788.9
Filing date: 22 December 2009 (22.12.2009)

Date of receipt at the International Bureau: 06 April 2010 (06.04.2010)

Remark: Priority document submitted or transmitted to the International Bureau in compliance with Rule 17.1(a) or (b)



World Intellectual Property Organization (WIPO) - Geneva, Switzerland
Organisation Mondiale de la Propriété Intellectuelle (OMPI) - Genève, Suisse

BUNDESREPUBLIK DEUTSCHLAND



Prioritätsbescheinigung DE 10 2009 060 788.9 über die Einreichung einer Patentanmeldung

Aktenzeichen: 10 2009 060 788.9

Anmeldetag: 22. Dezember 2009

Anmelder/Inhaber: VARTA Microbattery GmbH,
30419 Hannover/DE

Bezeichnung: Knopfzelle mit Elektrodenwickel

IPC: H 01 M 2/00, H 01 M 2/02

Die angehefteten Stücke sind eine richtige und genaue Wiedergabe der Teile der am 22. Dezember 2009 eingereichten Unterlagen dieser Patentanmeldung unabhängig von gegebenenfalls durch das Kopierverfahren bedingten Farbabweichungen.

München, den 22. März 2010
Deutsches Patent- und Markenamt
Die Präsidentin

Im Auftrag

A handwritten signature in black ink, appearing to read 'Dreer'.

Dreer

Anmelder:

VARTA Microbattery GmbH
Am Leineufer 51

30419 Hannover

Unser Zeichen: P 49 226 DE2

22. Dezember 2009 ME/mh

Beschreibung

Knopfzelle mit Elektrodenwickel

Die vorliegende Erfindung betrifft Knopfzellen mit einem Gehuse aus zwei metallischen Gehusehalbteilen, das einen gewickelten Elektroden-Separator-Verbund enthalt.

Knopfzellen weisen ublicherweise ein Gehuse aus zwei Gehusehalbteilen, einem Zellenbecher und einem Zellendeckel, auf. Diese konnen beispielsweise aus vernickeltem Tiefziehblech als Stanzziehteile hergestellt werden. Gewohnlich ist der Zellenbecher positiv und der Gehusedeckel negativ gepolt. In dem Gehuse konnen die verschiedensten elektrochemischen Systeme enthalten sein, beispielsweise Zink/MnO₂, primare und sekundare Lithium-Systeme oder sekundare Systeme wie Nickel/Cadmium oder Nickel/Metallhydrid.

Der flussigkeitsdichte Verschluss von Knopfzellen erfolgt klassisch durch Umbordeln des Randes des Zellenbechers uber den Rand des Zellendeckels in Verbindung mit einem Kunststoffring, der zwischen Zellenbecher und Zellendeckel angeordnet ist und der gleichzeitig als Dichtungs-

element sowie zur elektrischen Isolierung des Zellenbechers und des Zellendeckels dient. Derartige Knopfzellen sind beispielsweise in der DE 31 13 309 beschrieben.

Alternativ ist es jedoch auch möglich, Knopfzellen zu fertigen, bei denen Zellenbecher und Zellendeckel in axialer Richtung ausschließlich durch eine kraftschlüssige Verbindung zusammengehalten werden und die keinen umgebördelten Becherrand aufweisen. Derartige Knopfzellen sowie ein Verfahren zu ihrer Herstellung sind in der bislang noch unveröffentlichten deutschen Patentanmeldung mit dem Aktenzeichen 10 2009 017 514.8 beschrieben. Ungeachtet der diversen Vorteile, die solche Knopfzellen ohne Bördelung aufweisen können, sind sie in axialer Richtung jedoch weniger belastbar als vergleichbare Knopfzellen mit umgebördeltem Becherrand, insbesondere was axiale mechanische Belastungen angeht, die ihre Ursache im Inneren der Knopfzelle haben. So sind zum Beispiel die Elektroden von wiederaufladbaren Lithium-Ionen-Systemen bei Lade- und Entladevorgängen stets Volumenänderungen ausgesetzt. Die dabei auftretenden axialen Kräfte können bei Knopfzellen ohne Bördelung natürlich vergleichsweise leichter zu Undichtigkeiten führen als bei Knopfzellen mit Bördelung.

Der vorliegenden Erfindung lag die Aufgabe zugrunde, eine Knopfzelle bereitzustellen, bei der die oben angesprochenen Probleme nicht oder nur in stark verringertem Maß auftreten. Die Knopfzelle soll insbesondere gegenüber in axialer Richtung auftretenden mechanischen Belastungen widerstandsfähiger sein als herkömmliche Knopfzellen, insbesondere auch dann, wenn sie als Knopfzelle ohne umgebördelten Becherrand gefertigt wird.

Diese Aufgabe wird gelöst durch die Knopfzelle mit den Merkmalen des Anspruchs 1. Bevorzugte Ausführungsformen der erfindungsgemäßen Knopfzelle sind in den abhängigen Ansprüchen 2 bis 6 definiert. Der

Wortlaut sämtlicher Ansprüche wird hiermit durch Bezugnahme zum Inhalt dieser Beschreibung gemacht.

Eine erfindungsgemäße Knopfzelle umfasst stets zwei metallische Gehäusehalbteile, die durch eine elektrisch isolierende Dichtung voneinander getrennt sind und die ein Gehäuse mit einem ebenen Bodenbereich und einem dazu parallelen ebenen Deckelbereich ausbilden. Bei den beiden Gehäusehalbteilen handelt es sich, wie eingangs bereits erwähnt, in der Regel um einen sogenannten Gehäusebecher und einen Gehäusedeckel. Als Gehäusehalbteile sind insbesondere Teile aus vernickeltem Stahl oder Blech bevorzugt. Weiterhin als metallischer Werkstoff geeignet sind insbesondere Trimetalle, beispielsweise mit der Abfolge Nickel, Stahl (oder Edelstahl) und Kupfer (wobei die Nickelschicht bevorzugt die Außen- und die Kupferschicht bevorzugt die Innenseite des Knopfzelligehäuses bildet).

Als Dichtung kann beispielsweise eine Spritzguß- oder eine Foliendichtung zum Einsatz kommen. Letztere sind beispielsweise in der DE 196 47 593 beschrieben.

Innerhalb des Gehäuses sind mindestens eine positive und mindestens eine negative Elektrode angeordnet und zwar jeweils in Form von flachen Elektrodenschichten. Die Elektroden sind vorzugsweise über einen flächigen Separator miteinander verbunden. Bevorzugt sind die Elektroden auf diesen Separator auflaminiert oder aufgeklebt. Die Elektroden und der Separator weisen in der Regel jeweils nur Dicken im μm -Bereich auf. Als Separator dient in der Regel eine poröse Kunststoffolie.

Im Gehäuse einer erfindungsgemäßen Knopfzelle liegt dieser Verbund in Form eines Wickels, insbesondere in Form eines spiralförmigen Wickels, vor. Derartige Wickel lassen sich nach bekannten Verfahren (s. z.B. DE 36 38 793) recht einfach herstellen, indem auf einen als Endlos-

band vorliegenden Separator die Elektroden flächig, insbesondere in Form von Streifen, aufgebracht, insbesondere auflaminiert, werden. Aufgewickelt wird der Verbund aus Elektroden und Separatoren auf einen sogenannten Wickeldorn. Nach Abstreifen des Wickels vom Wickeldorn bleibt im Zentrum des Wickels ein axialer Hohlraum zurück, was zur Folge hat, dass sich der Wickel gegebenenfalls in diesen Hohlraum hinein entspannen kann. Dies kann jedoch unter Umständen zu Problemen bei der elektrischen Kontaktierung der Elektroden mit den metallischen Gehäusehalbteilen führen, was im Folgenden noch genauer beschrieben wird.

Der Elektrodenwickel ist innerhalb einer erfindungsgemäßen Knopfzelle nämlich derart angeordnet, dass die Stirnseiten des Wickels in Richtung des ebenen Bodenbereichs und des ebenen Deckelbereichs weisen. Die Elektrodenschichten des Wickels sind also im Wesentlichen orthogonal zu dem ebenen Boden- und Deckelbereich des Gehäuses ausgerichtet. Dadurch können radiale Kräfte, wie sie bei den erwähnten Lade- und Entladevorgängen von Lithium-Ionen-Systemen auftreten, grundsätzlich besser aufgefangen werden als bei klassischen Lithium-Ionen-Knopfzellen, in denen die Elektrodenschichten gestapelt in paralleler Ausrichtung zu den ebenen Boden- und Deckelbereichen angeordnet sind.

Dies ist detailliert in den bislang noch unveröffentlichten deutschen Patentanmeldungen mit den Aktenzeichen 10 2009 030 359.6 und 10 2009 008 859.8 beschrieben. Der Inhalt dieser Patentanmeldungen wird vollumfänglich durch Bezugnahme zum Inhalt dieser Beschreibung gemacht. Dies gilt insbesondere auch für die darin beschriebenen bevorzugten Ausführungsformen betreffend den Verbund aus Elektroden und Separator in einer erfindungsgemäßen Knopfzelle sowie die beschriebenen Ausführungsformen betreffend die elektrische Kontaktierung der

positiven und negativen Elektroden des Verbundes mit den Gehäusehalbteilen (Becher und Deckel).

Demgemäß weist auch der Verbund aus Elektroden und Separator in einer erfindungsgemäßen Knopfzelle bevorzugt eine der folgenden Schichtabfolgen auf:

- negative Elektrode / Separator / positive Elektrode / Separator

oder

- positive Elektrode / Separator / negative Elektrode / Separator.

Weiterhin weist entsprechend der DE 10 2009 030 359.6 auch die vorliegend beschriebene erfindungsgemäße Knopfzelle besonders bevorzugt einen oder mehrere separate Ableiter auf, die die Elektroden mit den Gehäusehalbteilen verbinden.

Dabei ist es bevorzugt, dass zumindest ein Teilabschnitt des oder der Ableiter im Boden- bzw. im Deckelbereich des Gehäuses flach an der Innenseite der Gehäusehalbteile anliegt. Ideal ist die elektrische Kontaktierung der Ableiter mit den Innenseiten des Gehäuses natürlich dann, wenn sie zumindest leicht an das Gehäuse angepresst werden. Überraschend effizient kann dies durch geeignete Anordnung eines Wickelkerns in einer erfindungsgemäßen Knopfzelle erreicht werden.

Gemäß der vorliegenden Erfindung ist es vorgesehen, dass eine erfindungsgemäße Knopfzelle einen festen Wickelkern im Zentrum des Wickels aufweist, der den axialen Hohlraum im Zentrum des Wickels mindestens teilweise ausfüllt. Ein solcher Wickelkern fixiert den Elektrodenwickel in radialer Richtung und verhindert eine mögliche Implosion des Wickels in den axialen Hohlraum. Bei einer derartigen Entspannung des

Wickels lässt auch der Druck nach, den die Stirnseiten des Wickels in axialer Richtung und damit in Richtung dort gegebenenfalls angeordneten Ableiter ausüben. Wird dies unterbunden, so resultieren auch keine Probleme mit der elektrischen Kontaktierung der Elektroden und den metallischen Gehäusehalbteilen.

Daneben verbessert ein solcher Wickelkern auch die Stabilität der erfindungsgemäßen Knopfzelle gegenüber äußeren mechanischen Einflüssen. Eine Beschädigung des Elektrodenwickels in der Knopfzelle durch einen äußeren mechanischen Druck in axialer Richtung ist in der Regel nicht mehr möglich.

Gemäß der bevorzugten Ausführungsform des Elektrodenwickels als spiralförmiger Elektrodenwickel ist der erwähnte axiale Hohlraum im Zentrum des Wickels vorzugsweise im Wesentlichen zylindrisch (insbesondere kreiszylindrisch) ausgebildet. Mantelseitig wird er durch den Wickel begrenzt, stirnseitig durch entsprechende Flächen des Boden- bzw. des Deckelbereichs des Knopfzellegehäuses.

Entsprechend ist auch der in einer erfindungsgemäßen Knopfzelle enthaltene Wickelkern bevorzugt als Zylinder, insbesondere als Hohlzylinder, ausgebildet. Die Höhe eines solchen Zylinders entspricht bevorzugt dem jeweiligen Abstand des ebenen Bodenbereichs von dem dazu parallelen ebenen Deckelbereich.

In besonders bevorzugten Ausführungsformen kann der Wickelkern radial selbstexpandierende Eigenschaften aufweisen. Es ist zum Beispiel möglich, den Wickelkern in einer radial komprimierten Konfiguration in den axialen Hohlraum des Wickels einer erfindungsgemäßen Knopfzelle einzuführen. Bei Entspannung des radial komprimierten Wickelkerns übt dieser einen radialen Druck auf den ihn umgebenden Elektrodenwickel aus und gewährleistet so einen Anpressdruck auch in axialer Richtung.

Als radial selbstexpandierender Wickelkern kann beispielsweise ein axial geschlitzter Hohlzylinder zum Einsatz kommen. Alternativ sind jedoch auch andere radial selbstexpandierende Materialien, beispielsweise auf Kunststoffbasis, denkbar.

Besonders bevorzugt besteht der Wickelkern aus einem Metall wie Edelstahl oder aus Kunststoff.

Bei der erfindungsgemäßen Knopfzelle handelt es sich entsprechend den obigen Ausführungen insbesondere um eine wiederaufladbare Knopfzelle. Besonders bevorzugt weist eine erfindungsgemäße Knopfzelle mindestens eine Lithium-interkalierende Elektrode auf.

Das Verhältnis von Höhe zu Durchmesser liegt bei Knopfzellen definitionsgemäß unterhalb von 1. Besonders bevorzugt liegt dieses Verhältnis bei einer erfindungsgemäßen Knopfzelle zwischen 0.1 und 0.9, insbesondere zwischen 0.15 und 0.7. Unter der Höhe soll dabei der Abstand zwischen dem ebenen Bodenbereich und dem dazu parallelen ebenen Deckelbereich verstanden werden. Der Durchmesser meint die maximale Entfernung zweier Punkte auf dem Mantelbereich der Knopfzelle.

Besonders bevorzugt handelt es sich bei der erfindungsgemäßen Knopfzelle um eine Knopfzelle ohne Bördelung, wie sie in der eingangs bereits erwähnten Patentanmeldung mit dem Aktenzeichen 10 2009 017 514.8 beschrieben ist. Entsprechend besteht zwischen den Gehäusehalbteilen bevorzugt eine ausschließlich kraftschlüssige Verbindung. Die erfindungsgemäße Knopfzelle weist also keinen umgebördelten Becher rand auf, wie dies bei aus dem Stand der Technik bekannten Knopfzellen stets der Fall ist. Die Knopfzelle ist bördelfrei verschlossen. Auch der Inhalt der DE 10 2009 017 514.8 wird vollumfänglich durch Bezugnahme zum Inhalt dieser Beschreibung gemacht.

Die genannten und weitere Vorteile der Erfindung ergeben sich aus der nun folgenden Beschreibung der Zeichnung in Verbindung mit den Unteransprüchen. Dabei können die einzelnen Merkmale der Erfindung für sich allein oder in Kombination miteinander verwirklicht sein. Die beschriebenen Ausführungsformen dienen lediglich zur Erläuterung und zum besseren Verständnis der Erfindung und sind in keiner Weise einschränkend zu verstehen.

Figurenbeschreibung

Fig. 1 zeigt schematisch den Querschnitt einer bevorzugten Ausführungsform einer erfindungsgemäßen Knopfzelle **100**.

Diese weist ein metallisches Becherteil **101** und ein metallisches Deckelteil **102** auf. Über eine Dichtung **110** sind die beiden Teile dichtend miteinander verbunden. Zusammen bilden sie ein Gehäuse mit einem ebenen Bodenbereich **103** und einem dazu parallelen ebenen Deckelbereich **104** aus. Im Gebrauchszustand bilden diese ebenen Bereiche **103** und **104** die Pole der Knopfzelle, an denen eine Stromabnahme durch einen Verbraucher erfolgen kann.

Der Zellendeckel **102** ist in den Zellenbecher **101** eingeschoben, so dass die Mantelbereiche des Zellendeckels und des Zellenbechers überlappen, wobei der Innenradius des Zellenbechers **101** im überlappenden Bereich in Richtung der Schnittkante im wesentlichen konstant ist. Der Rand des Zellenbechers **101** ist also nicht über den Rand **111** des Zellendeckels **102** gebördelt, bei der vorliegend beschriebenen bevorzugten Ausführungsform einer erfindungsgemäßen Knopfzelle **100** handelt es sich somit um eine bördelfreie Knopfzelle.

Im Inneren der Elektrode ist ein Verbund aus einer streifenförmigen Elektrode **108**, einer streifenförmigen Elektrode **109** und den streifenförmigen Separatoren **107** angeordnet. Der Verbund aus den Elektroden **108** und **109** sowie den Separatoren **107** liegt dabei in Form eines Wickels vor, dessen Stirnseiten in Richtung des ebenen Bodenbereichs **103** und des dazu parallelen ebenen Deckelbereichs **104** weisen. Aufgewickelt ist der Verbund auf dem Wickelkern **112** im Zentrum der Knopfzelle **100**. Sowohl der Kern **112** als auch die um ihn gewickelten Elektroden und Separatoren sind orthogonal zu den ebenen Boden- und Deckelbereichen **104** und **103** ausgerichtet. Sofern die Elektroden bei einem Lade- oder Entladevorgang an Volumen gewinnen oder verlieren, wirken die dabei resultierenden mechanischen Kräfte überwiegend radial und können vom Mantelbereich der Knopfzelle **100** aufgefangen werden.

Kontaktiert sind die positiven und die negativen Elektroden mit den Gehäusehalbteilen Becher und Deckel über den Ableiter **105** und den Ableiter **106**. Der Ableiter **105** besteht aus Aluminium, der Ableiter **106** aus Nickel (oder alternativ aus Kupfer). Bei beiden Ableitern handelt es sich um dünne Folien, die flach zwischen den Stirnseiten des Wickels und den ebenen Deckel- bzw. Bodenbereichen **103** und **104** zum Liegen kommen. Bedingt durch den Wickelkern **112** wird ein steter leichter Anpressdruck auf die Ableiter aufrechterhalten. Von den Stirnseiten des Wickels sind die Ableiter bevorzugt durch ein separates Isolatorelement (in der Zeichnung nicht dargestellt) getrennt, beispielsweise durch eine dünne Folie.

Patentansprüche

1. Knopfzelle, umfassend
 - zwei metallische Gehäusehalbteile, die durch eine elektrisch isolierende Dichtung voneinander getrennt sind und die ein Gehäuse mit einem ebenen Bodenbereich und einem dazu parallelen ebenen Deckelbereich ausbilden,
 - einen Elektroden-Separator-Verbund innerhalb des Gehäuses, wobei der Verbund in Form eines vorzugsweise spiralförmigen Wickels vorliegt, in dessen Zentrum sich ein axialer Hohlraum befindet und dessen Stirnseiten in Richtung des ebenen Bodenbereichs und des ebenen Deckelbereichs weisen und
 - einen Wickelkern im Zentrum des Wickels, der den axialen Hohlraum mindestens teilweise ausfüllt.
2. Knopfzelle nach Anspruch 1, dadurch gekennzeichnet, dass der Wickelkern als Hohlzylinder ausgebildet ist.
3. Knopfzelle nach Anspruch 1 oder Anspruch 2, dadurch gekennzeichnet, dass der Wickelkern radial selbstexpandierend ausgebildet ist.
4. Knopfzelle nach einem der vorhergehenden Ansprüche, dadurch gekennzeichnet, dass es sich bei dem Wickelkern um einen axial geschlitzten Hohlzylinder handelt.
5. Knopfzelle nach einem der vorhergehenden Ansprüche, dadurch gekennzeichnet, dass der Wickelkern aus Metall oder aus Kunststoff besteht.

6. Knopfzelle nach einem der vorhergehenden Ansprüche, dadurch gekennzeichnet, dass sie ein Verhältnis von Hülle zu Durchmesser zwischen 0.1 und 0.9 aufweist.

Zusammenfassung

Beschrieben wird eine Knopfzelle mit zwei metallischen Gehäusehälften, die durch eine elektrisch isolierende Dichtung voneinander getrennt sind und die ein Gehäuse mit einem ebenen Bodenbereich und einem dazu parallelen ebenen Deckelbereich ausbilden. In dem Gehäuse befinden sich ein Elektroden-Separator-Verbund, der in Form eines vorzugsweise spiralförmigen Wickels vorliegt, in dessen Zentrum sich ein axialer Hohlraum befindet, und ein Wickelkern, der den axialen Hohlraum mindestens teilweise ausfüllt.

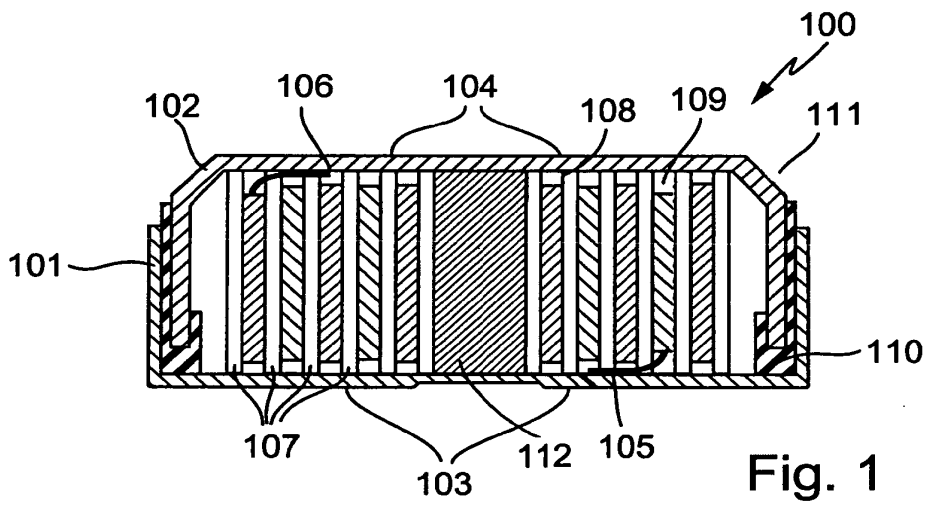

Fig. 1

Under the Paperwork Reduction Act of 1995, no persons are required to respond to a collection of information unless it displays a valid OMB control number.

PATENT APPLICATION FEE DETERMINATION RECORD Substitute for Form PTO-875				Application or Docket Number 13/146,669		Filing Date 09/07/2011		<input type="checkbox"/> To be Mailed				
APPLICATION AS FILED – PART I												
(Column 1)			(Column 2)			SMALL ENTITY <input type="checkbox"/>		OR		OTHER THAN SMALL ENTITY		
FOR		NUMBER FILED	NUMBER EXTRA		RATE (\$)	FEE (\$)	OR		RATE (\$)	FEE (\$)		
<input type="checkbox"/> BASIC FEE <small>(37 CFR 1.16(a), (b), or (c))</small>		N/A	N/A		N/A				N/A			
<input type="checkbox"/> SEARCH FEE <small>(37 CFR 1.16(k), (i), or (m))</small>		N/A	N/A		N/A		N/A					
<input type="checkbox"/> EXAMINATION FEE <small>(37 CFR 1.16(o), (p), or (q))</small>		N/A	N/A		N/A		N/A					
TOTAL CLAIMS <small>(37 CFR 1.16(j))</small>		minus 20 =	*		X \$ =		X \$ =					
INDEPENDENT CLAIMS <small>(37 CFR 1.16(h))</small>		minus 3 =	*		X \$ =		X \$ =					
<input type="checkbox"/> APPLICATION SIZE FEE <small>(37 CFR 1.16(s))</small>		If the specification and drawings exceed 100 sheets of paper, the application size fee due is \$250 (\$125 for small entity) for each additional 50 sheets or fraction thereof. See 35 U.S.C. 41(a)(1)(G) and 37 CFR 1.16(s).										
<input type="checkbox"/> MULTIPLE DEPENDENT CLAIM PRESENT <small>(37 CFR 1.16(j))</small>												
* If the difference in column 1 is less than zero, enter "0" in column 2.												
APPLICATION AS AMENDED – PART II												
(Column 1)			(Column 2)			SMALL ENTITY		OR		OTHER THAN SMALL ENTITY		
AMENDMENT	07/28/2011		CLAIMS REMAINING AFTER AMENDMENT		HIGHEST NUMBER PREVIOUSLY PAID FOR	PRESENT EXTRA	RATE (\$)	ADDITIONAL FEE (\$)		RATE (\$)	ADDITIONAL FEE (\$)	
	Total <small>(37 CFR 1.16(n))</small>		* 14	Minus	** 20	=	0	X \$ =		OR	X \$2=	0
	Independent <small>(37 CFR 1.16(h))</small>		* 1	Minus	***3	=	0	X \$ =		OR	X \$220=	0
	<input type="checkbox"/> Application Size Fee <small>(37 CFR 1.16(s))</small>											
	<input type="checkbox"/> FIRST PRESENTATION OF MULTIPLE DEPENDENT CLAIM <small>(37 CFR 1.16(j))</small>											
TOTAL ADD'L FEE							OR		TOTAL ADD'L FEE			0
AMENDMENT			CLAIMS REMAINING AFTER AMENDMENT		HIGHEST NUMBER PREVIOUSLY PAID FOR	PRESENT EXTRA	RATE (\$)	ADDITIONAL FEE (\$)		RATE (\$)	ADDITIONAL FEE (\$)	
	Total <small>(37 CFR 1.16(n))</small>		*	Minus	**	=	=	X \$ =		OR	X \$ =	
	Independent <small>(37 CFR 1.16(h))</small>		*	Minus	***	=	=	X \$ =		OR	X \$ =	
	<input type="checkbox"/> Application Size Fee <small>(37 CFR 1.16(s))</small>											
	<input type="checkbox"/> FIRST PRESENTATION OF MULTIPLE DEPENDENT CLAIM <small>(37 CFR 1.16(j))</small>											
TOTAL ADD'L FEE							OR		TOTAL ADD'L FEE			
* If the entry in column 1 is less than the entry in column 2, write "0" in column 3.												
** If the "Highest Number Previously Paid For" IN THIS SPACE is less than 20, enter "20".												
*** If the "Highest Number Previously Paid For" IN THIS SPACE is less than 3, enter "3".												
The "Highest Number Previously Paid For" (Total or Independent) is the highest number found in the appropriate box in column 1.												
Legal Instrument Examiner: /FRANCES FIELDS/												

This collection of information is required by 37 CFR 1.16. The information is required to obtain or retain a benefit by the public which is to file (and by the USPTO to process) an application. Confidentiality is governed by 35 U.S.C. 122 and 37 CFR 1.14. This collection is estimated to take 12 minutes to complete, including gathering, preparing, and submitting the completed application form to the USPTO. Time will vary depending upon the individual case. Any comments on the amount of time you require to complete this form and/or suggestions for reducing this burden, should be sent to the Chief Information Officer, U.S. Patent and Trademark Office, U.S. Department of Commerce, P.O. Box 1450, Alexandria, VA 22313-1450. DO NOT SEND FEES OR COMPLETED FORMS TO THIS ADDRESS. **SEND TO: Commissioner for Patents, P.O. Box 1450, Alexandria, VA 22313-1450.**

If you need assistance in completing the form, call 1-800-PTO-9199 and select option 2.



UNITED STATES PATENT AND TRADEMARK OFFICE

UNITED STATES DEPARTMENT OF COMMERCE
United States Patent and Trademark Office
Address: COMMISSIONER FOR PATENTS
P.O. Box 1450
Alexandria, Virginia 22313-1450
www.uspto.gov

Table with 3 columns: U.S. APPLICATION NUMBER NO. (13/146,669), FIRST NAMED APPLICANT (Eduard Pytlik), ATTY. DOCKET NO. (RUF-11-1270). Includes fields for INTERNATIONAL APPLICATION NO. (PCT/EP10/00787) and I.A. FILING DATE (02/09/2010) vs PRIORITY DATE (02/09/2009).

35811
IP GROUP OF DLA PIPER LLP (US)
ONE LIBERTY PLACE
1650 MARKET ST, SUITE 4900
PHILADELPHIA, PA 19103

CONFIRMATION NO. 6273
371 FORMALITIES LETTER



Date Mailed: 08/12/2011

NOTIFICATION OF MISSING REQUIREMENTS UNDER 35 U.S.C. 371
IN THE UNITED STATES DESIGNATED/ELECTED OFFICE (DO/EO/US)

The following items have been submitted by the applicant or the IB to the United States Patent and Trademark Office as a Designated Office (37 CFR 1.494):

- Priority Document
• Copy of the International Application filed on 07/28/2011
• English Translation of the IA filed on 07/28/2011
• Copy of the International Search Report filed on 07/28/2011
• Preliminary Amendments filed on 07/28/2011
• Information Disclosure Statements filed on 07/28/2011
• U.S. Basic National Fees filed on 07/28/2011
• Substitute Specification filed on 07/28/2011
• Assignee Statement for PGPUB filed on 07/28/2011
• Priority Documents filed on 07/28/2011

The applicant needs to satisfy supplemental fees problems indicated below.

The following items MUST be furnished within the period set forth below in order to complete the requirements for acceptance under 35 U.S.C. 371:

- Oath or declaration of the inventors, in compliance with 37 CFR 1.497(a) and (b), identifying the application by the International application number and international filing date.
• To avoid abandonment, a surcharge (for late submission of filing fee, search fee, examination fee or oath or declaration) as set forth in 37 CFR 1.492(h) of \$130 for a non-small entity, must be submitted with the missing items identified in this letter.

SUMMARY OF FEES DUE:

Total additional fees required for this application is \$130 for a Large Entity:

- \$130 Surcharge.

ALL OF THE ITEMS SET FORTH ABOVE MUST BE SUBMITTED WITHIN TWO (2) MONTHS FROM THE DATE OF THIS NOTICE OR BY 32 MONTHS FROM THE PRIORITY DATE FOR THE APPLICATION, WHICHEVER IS LATER. FAILURE TO PROPERLY RESPOND WILL RESULT IN ABANDONMENT.

The time period set above may be extended by filing a petition and fee for extension of time under the provisions of 37 CFR 1.136(a).

Applicant is reminded that any communications to the United States Patent and Trademark Office must be mailed to the address given in the heading and include the U.S. application no. shown above (37 CFR 1.5)

Registered users of EFS-Web may alternatively submit their reply to this notice via EFS-Web.

<https://sportal.uspto.gov/authenticate/AuthenticateUserLocalEPF.html>

For more information about EFS-Web please call the USPTO Electronic Business Center at **1-866-217-9197** or visit our website at <http://www.uspto.gov/ebc>.

If you are not using EFS-Web to submit your reply, you must include a copy of this notice.

DEBORAH A THOMAS

Telephone: (571) 272-7175

PATENT APPLICATION FEE DETERMINATION RECORD Substitute for Form PTO-875	Application or Docket Number 13/146,669
---	--

APPLICATION AS FILED - PART I			SMALL ENTITY		OR	OTHER THAN SMALL ENTITY	
	(Column 1)	(Column 2)					
FOR	NUMBER FILED	NUMBER EXTRA	RATE(\$)	FEE(\$)		RATE(\$)	FEE(\$)
BASIC FEE <small>(37 CFR 1.16(a), (b), or (c))</small>	N/A	N/A	N/A			N/A	330
SEARCH FEE <small>(37 CFR 1.16(k), (j), or (m))</small>	N/A	N/A	N/A			N/A	430
EXAMINATION FEE <small>(37 CFR 1.16(o), (p), or (q))</small>	N/A	N/A	N/A			N/A	220
TOTAL CLAIMS <small>(37 CFR 1.16(i))</small>	14	minus 20 = *			OR	x 52 =	0.00
INDEPENDENT CLAIMS <small>(37 CFR 1.16(h))</small>	1	minus 3 = *				x 220 =	0.00
APPLICATION SIZE FEE <small>(37 CFR 1.16(s))</small>	If the specification and drawings exceed 100 sheets of paper, the application size fee due is \$270 (\$135 for small entity) for each additional 50 sheets or fraction thereof. See 35 U.S.C. 41(a)(1)(G) and 37 CFR 1.16(s).						0.00
MULTIPLE DEPENDENT CLAIM PRESENT <small>(37 CFR 1.16(j))</small>							0.00
* If the difference in column 1 is less than zero, enter "0" in column 2.			TOTAL			TOTAL	980

APPLICATION AS AMENDED - PART II					SMALL ENTITY		OR	OTHER THAN SMALL ENTITY			
	(Column 1)	(Column 2)	(Column 3)								
AMENDMENT A	CLAIMS REMAINING AFTER AMENDMENT	HIGHEST NUMBER PREVIOUSLY PAID FOR	PRESENT EXTRA	RATE(\$)	ADDITIONAL FEE(\$)		RATE(\$)	ADDITIONAL FEE(\$)			
	Total <small>(37 CFR 1.16(i))</small>	*	Minus	**	=	x	=	OR	x	=	
	Independent <small>(37 CFR 1.16(h))</small>	*	Minus	***	=	x	=	OR	x	=	
	Application Size Fee <small>(37 CFR 1.16(s))</small>								OR		
	FIRST PRESENTATION OF MULTIPLE DEPENDENT CLAIM <small>(37 CFR 1.16(j))</small>								OR		
				TOTAL ADD'L FEE		OR	TOTAL ADD'L FEE				
AMENDMENT B	CLAIMS REMAINING AFTER AMENDMENT	HIGHEST NUMBER PREVIOUSLY PAID FOR	PRESENT EXTRA	RATE(\$)	ADDITIONAL FEE(\$)		RATE(\$)	ADDITIONAL FEE(\$)			
	Total <small>(37 CFR 1.16(i))</small>	*	Minus	**	=	x	=	OR	x	=	
	Independent <small>(37 CFR 1.16(h))</small>	*	Minus	***	=	x	=	OR	x	=	
	Application Size Fee <small>(37 CFR 1.16(s))</small>								OR		
	FIRST PRESENTATION OF MULTIPLE DEPENDENT CLAIM <small>(37 CFR 1.16(j))</small>								OR		
				TOTAL ADD'L FEE		OR	TOTAL ADD'L FEE				
<p>* If the entry in column 1 is less than the entry in column 2, write "0" in column 3.</p> <p>** If the "Highest Number Previously Paid For" IN THIS SPACE is less than 20, enter "20".</p> <p>*** If the "Highest Number Previously Paid For" IN THIS SPACE is less than 3, enter "3".</p> <p>The "Highest Number Previously Paid For" (Total or Independent) is the highest found in the appropriate box in column 1.</p>											

MULTIPLE DEPENDENT CLAIM FEE CALCULATION SHEET							Application Number		Filing Date	
Substitute for Form PTO-1360 (For use with Form PTO/SB/06)							13146669			
							Applicant(s) Eduard Pytlik			
							* May be used for additional claims or amendments			
CLAIMS	AS FILED		AFTER FIRST AMENDMENT		AFTER SECOND AMENDMENT		*		*	
	Indep	Depend	Indep	Depend	Indep	Depend	Indep	Depend	Indep	Depend
1			1							
2				1						
3				1						
4				1						
5				1						
6				1						
7				1						
8				1						
9				1						
10				1						
11				1						
12				1						
13				1						
14				1						
15										
16										
17										
18										
19										
20										
21										
22										
23										
24										
25										
26										
27										
28										
29										
30										
31										
32										
33										
34										
35										
36										
37										
38										
39										
40										
41										
42										
43										
44										
45										
46										
47										
48										
49										
50										
51										
52										
53										
54										
55										
56										
57										
58										
59										
60										
61										
62										
63										
64										
65										
66										
67										
68										
69										
70										
71										
72										
73										
74										
75										
76										
77										
78										
79										
80										
81										
82										
83										
84										
85										
86										
87										
88										
89										
90										
91										
92										
93										
94										
95										
96										
97										
98										
99										
100										
Total Indep	0		1		0					
Total Depend	0		13		0					
Total Claims	0		14		0					

IN THE UNITED STATES PATENT AND TRADEMARK OFFICE

Art Unit :
Examiner :
Serial No. : 13/146,669
Filed : July 28, 2011
PCT No. : PCT/EP2010/000787
PCT Filed : February 9, 2010
Inventors : Eduard Pytlik
 : Jürgen Lindner
 : Ulrich Barenthin
 : Winfried Gaugler
Title : BUTTON CELLS AND METHOD
 : FOR PRODUCING SAME

Customer No.: 035811
Docket No.: RUF-11-1270
Confirmation No.: 6273

Dated: September 7, 2011

TRANSMITTAL LETTER

Mail Stop Missing Parts
Commissioner for Patents
P.O. Box 1450
Alexandria, VA 22313-1450

Sir:

Applicants acknowledge receipt of the Notification of Missing Requirements dated August 12, 2011. Applicants submit an executed Combined Declaration, Power of Attorney and Petition and request that it be formally entered in the official file.

The Commissioner is authorized to charge the \$130.00 fee to Deposit Account No. 50-2719.

The Commissioner is authorized to charge any insufficiency or credit any overpayment to Deposit Account No. 50-2719.

Respectfully submitted,

T. Daniel Christenbury
Reg. No. 31,750

TDC/cc
(215) 656-3381

- Original Application
- PCT National Application
U.S. Designated Office
- Continuation or Divisional Application
- Continuation-in-Part Application

**COMBINED DECLARATION,
POWER OF ATTORNEY AND PETITION**

As a below named inventor, I hereby declare that:

My residence, post office address and citizenship are as stated below next to my name,

I believe I am the original, first and sole inventor (if only one name is listed below) or an original, first and joint inventor (if plural names are listed below) of the subject matter which is claimed and for which a patent is sought on the invention entitled **BUTTON CELLS AND METHOD FOR PRODUCING SAME**

which is described in the specification and claims

attached hereto.

filed on _____

Application Serial No. _____

and was amended on _____

(if applicable)

which is described in International Application No. PCT/EP2010/000787 filed 09 February 2010 and as amended on _____ (if any),

which I have reviewed and for which I solicit a United States patent.

I hereby state that I have reviewed and understand the contents of the above-identified specification, including the claims, as amended by any amendment referred to above.

I acknowledge the duty to disclose information which is material to patentability as defined in 37 C.F.R. §1.56, including for continuation-in-part applications, material information which became available between the filing date of the prior application and the national or PCT international filing date of the continuation-in-part application.

COMBINED DECLARATION, POWER OF ATTORNEY AND PETITION

(Page 2)

Attorney Docket No. RUF-11-1270

I hereby claim foreign priority benefits under Title 35, United States Code, §119(a)-(d) or §365(b) of any foreign application(s) for patent or inventor's certificate, or §365(a) of any PCT International Application which designated at least one country other than the United States of America, listed below and have also identified below any foreign application(s) for patent or inventor's certificate or of any PCT International Application having a filing date before that of the application on which priority is claimed:

Number	Country	Date of Filing (day,month,year)	Priority Claimed
10 2009 008 859.8	Germany	09 February 2009	<input checked="" type="checkbox"/> yes <input type="checkbox"/> no
10 2009 030 359.6	Germany	18 June 2009	<input checked="" type="checkbox"/> yes <input type="checkbox"/> no
10 2009 060 788.9	Germany	22 December 2009	<input checked="" type="checkbox"/> yes <input type="checkbox"/> no
			<input type="checkbox"/> yes <input type="checkbox"/> no
			<input type="checkbox"/> yes <input type="checkbox"/> no

I hereby claim the benefit under Title 35, United States Code, §119(e) or §120 (as applicable) of any United States application(s) or §365(c) of any PCT International Application designating the United States of America, listed below and, insofar as the subject matter of each of the claims of this application is not disclosed in the prior United States or PCT International Application(s) in the manner provided by the first paragraph of Title 35, United States Code, §112:

<u>PCT/EP2010/000787</u> <i>(Application Serial No.)</i>	<u>09 February 2010</u> <i>(Filing Date)</i>	<u>Pending</u> <i>(Status)(patented,pending,abandoned)</i>
 <i>(Application Serial No.)</i>	 <i>(Filing Date)</i>	 <i>(Status)(patented,pending,abandoned)</i>

POWER OF ATTORNEY: As a named inventor, I hereby appoint the following registered attorneys to prosecute this application and transact all business in the United States Patent and Trademark Office connected therewith:

T. Daniel Christenbury	Reg. No. 31,750	William L. Bartow	Reg. No. 54,981
Paul A. Taufer	Reg. No. 35,703	Erin Pacella	Reg. No. 56,239
Darius C. Gambino	Reg. No. 41,472	Michael L. Burns IV	Reg. No. 57,593
Richard L. Cruz	Reg. No. 52,783	Lisa M. Lint	Reg. No. 60,856



<p>SEND CORRESPONDENCE TO: Customer No. 035811, whose contact information is: IP Department of DLA Piper LLP (US) One Liberty Place, Suite 4900 1650 Market Street Philadelphia, PA 19103</p>	<p>DIRECT TELEPHONE CALLS TO ATTORNEY OF RECORD AT: (215) 656-3381</p>
---	---

COMBINED DECLARATION, POWER OF ATTORNEY AND PETITION
(Page 3)

Attorney Docket No. RUF-11-1270

I hereby petition for grant of a United States Letters Patent on this invention.

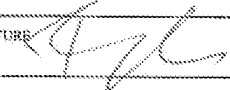
I hereby declare that all statements made herein of my own knowledge are true and that all statements made on information and belief are believed to be true; and further that these statements were made with the knowledge that willful false statements and the like so made are punishable by fine or imprisonment, or both, under Section 1001 of Title 18 of the United States Code and that such willful false statements may jeopardize the validity of the application or any patent issued thereon.

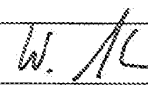
1. FULL NAME OF SOLE OR FIRST INVENTOR Eduard Pytlík		INVENTOR'S SIGNATURE 	DATE 18.06.11
RESIDENCE Ellwangen, Germany		CITIZENSHIP Germany	
POST OFFICE ADDRESS Esplanade #2 Alsmannstraße 7, 73479 Ellwangen, Germany			
2. FULL NAME OF JOINT INVENTOR, IF ANY Jürgen Lindner		INVENTOR'S SIGNATURE 	DATE 18.06.11
RESIDENCE Ellwangen, Germany		CITIZENSHIP Germany	
POST OFFICE ADDRESS Kottenwiesen 9, 73479 Ellwangen, Germany			
3. FULL NAME OF ADDITIONAL JOINT INVENTOR, IF ANY Ulrich Barenthin		INVENTOR'S SIGNATURE 	DATE 27.07.11
RESIDENCE Ellwangen, Germany		CITIZENSHIP Germany	
POST OFFICE ADDRESS Bahnhofstraße 6/1, 73479 Ellwangen, Germany			
4. FULL NAME OF ADDITIONAL JOINT INVENTOR, IF ANY Winfried Gaugler		INVENTOR'S SIGNATURE 	DATE 01.01.2011
RESIDENCE Ellwangen, Germany		CITIZENSHIP Germany	
POST OFFICE ADDRESS Birklen 26, 73479 Ellwangen, Germany			
5. FULL NAME OF ADDITIONAL JOINT INVENTOR, IF ANY		INVENTOR'S SIGNATURE	DATE
RESIDENCE		CITIZENSHIP	
POST OFFICE ADDRESS			
6. FULL NAME OF ADDITIONAL JOINT INVENTOR, IF ANY		INVENTOR'S SIGNATURE	DATE
RESIDENCE		CITIZENSHIP	
POST OFFICE ADDRESS			
7. FULL NAME OF ADDITIONAL JOINT INVENTOR, IF ANY		INVENTOR'S SIGNATURE	DATE
RESIDENCE		CITIZENSHIP	
POST OFFICE ADDRESS			

Electronic Patent Application Fee Transmittal

Application Number:	13146669				
Filing Date:					
Title of Invention:	BUTTON CELLS AND METHOD FOR PRODUCING SAME				
First Named Inventor/Applicant Name:	Eduard Pytlik				
Filer:	Thomas Daniel Christenbury/Carol Coney				
Attorney Docket Number:	RUF-11-1270				
Filed as Large Entity					
U.S. National Stage under 35 USC 371 Filing Fees					
Description	Fee Code	Quantity	Amount	Sub-Total in USD(\$)	
Basic Filing:					
Pages:					
Claims:					
Miscellaneous-Filing:					
Oath/decl > 30 months from priority date	1617	1	130	130	
Petition:					
Patent-Appeals-and-Interference:					
Post-Allowance-and-Post-Issuance:					
Extension-of-Time:					

Description	Fee Code	Quantity	Amount	Sub-Total in USD(\$)
Miscellaneous:				
Total in USD (\$)				130

Electronic Acknowledgement Receipt

EFS ID:	10894074
Application Number:	13146669
International Application Number:	
Confirmation Number:	6273
Title of Invention:	BUTTON CELLS AND METHOD FOR PRODUCING SAME
First Named Inventor/Applicant Name:	Eduard Pytlik
Customer Number:	35811
Filer:	Thomas Daniel Christenbury/Carol Coney
Filer Authorized By:	Thomas Daniel Christenbury
Attorney Docket Number:	RUF-11-1270
Receipt Date:	07-SEP-2011
Filing Date:	
Time Stamp:	15:03:17
Application Type:	U.S. National Stage under 35 USC 371

Payment information:

Submitted with Payment	yes
Payment Type	Deposit Account
Payment was successfully received in RAM	\$130
RAM confirmation Number	1401
Deposit Account	502719
Authorized User	

The Director of the USPTO is hereby authorized to charge indicated fees and credit any overpayment as follows:
 Charge any Additional Fees required under 37 C.F.R. 1.492 (National application filing, search, and examination fees)
 Charge any Additional Fees required under 37 C.F.R. Section 1.17 (Patent application and reexamination processing fees)

Charge any Additional Fees required under 37 C.F.R. Section 1.19 (Document supply fees)

Charge any Additional Fees required under 37 C.F.R. Section 1.20 (Post Issuance fees)

Charge any Additional Fees required under 37 C.F.R. Section 1.21 (Miscellaneous fees and charges)

File Listing:

Document Number	Document Description	File Name	File Size(Bytes)/ Message Digest	Multi Part /.zip	Pages (if appl.)
1	Transmittal Letter	transmittalletter1.pdf	196345	no	1
			a4ab8649e3c2aeb40c4c30fefa66e83a258128f		
Warnings:					
Information:					
2	Non Patent Literature	writtenopinion.pdf	2266483	no	8
			9dbc17cf19ff36ff8245974a17758454935129b3		
Warnings:					
Information:					
3	Miscellaneous Incoming Letter	transmittalletter2.pdf	237083	no	1
			c1cfadbc92de65c934a5c6368789ad0bc96262af		
Warnings:					
Information:					
4	Oath or Declaration filed	Declaration.pdf	954229	no	3
			9815a4277c40a33131eaa412bfaaa31e0e31a6cc		
Warnings:					
Information:					
5	Fee Worksheet (SB06)	fee-info.pdf	30164	no	2
			5e70da3e19d0467e32988cfebd44bd007ca0e3b		
Warnings:					
Information:					
Total Files Size (in bytes):			3684304		

This Acknowledgement Receipt evidences receipt on the noted date by the USPTO of the indicated documents, characterized by the applicant, and including page counts, where applicable. It serves as evidence of receipt similar to a Post Card, as described in MPEP 503.

New Applications Under 35 U.S.C. 111

If a new application is being filed and the application includes the necessary components for a filing date (see 37 CFR 1.53(b)-(d) and MPEP 506), a Filing Receipt (37 CFR 1.54) will be issued in due course and the date shown on this Acknowledgement Receipt will establish the filing date of the application.

National Stage of an International Application under 35 U.S.C. 371

If a timely submission to enter the national stage of an international application is compliant with the conditions of 35 U.S.C. 371 and other applicable requirements a Form PCT/DO/EO/903 indicating acceptance of the application as a national stage submission under 35 U.S.C. 371 will be issued in addition to the Filing Receipt, in due course.

New International Application Filed with the USPTO as a Receiving Office

If a new international application is being filed and the international application includes the necessary components for an international filing date (see PCT Article 11 and MPEP 1810), a Notification of the International Application Number and of the International Filing Date (Form PCT/RO/105) will be issued in due course, subject to prescriptions concerning national security, and the date shown on this Acknowledgement Receipt will establish the international filing date of the application.

IN THE UNITED STATES PATENT AND TRADEMARK OFFICE

Art Unit : Customer No.: 035811
Examiner :
Serial No. : 13/146,669
Filed : July 28, 2011
PCT No. : PCT/EP2010/000787
PCT Filed : February 9, 2010
Inventors : Eduard Pytlik Docket No.: RUF-11-1270
: Jürgen Lindner
: Ulrich Barenthin Confirmation No.: 6273
: Winfried Gaugler
Title : BUTTON CELLS AND METHOD
: FOR PRODUCING SAME Dated: September 7, 2011

TRANSMITTAL LETTER

Mail Stop PCT
Commissioner for Patents
P.O. Box 1450
Alexandria, VA 22313-1450

Sir:

The Applicants enclose a copy of an English translation of the Written Opinion of the International Searching Authority for the Examiner's convenience.

Respectfully submitted,



T. Daniel Christenbury
Reg. No. 31,750

TDC/cc
(215) 656-3381

PCT

NOTIFICATION OF TRANSMITTAL
OF COPIES OF TRANSLATION
OF THE INTERNATIONAL PRELIMINARY REPORT
ON PATENTABILITY
(CHAPTER I OR CHAPTER II)
(PCT Rules 44bis.3(c) and 72.2)

From the INTERNATIONAL BUREAU

Empfangen
22. Aug. 2011
Patentanwälte

To:

EBERLE, Michael
Ruff, Wilhelm, Beier, Dauster & Partner
Postfach 10 40 36
70035 Stuttgart
ALLEMAGNE

Date of mailing (day/month/year) 18 August 2011 (18.08.2011)	
Applicant's or agent's file reference P 49226 WO	IMPORTANT NOTIFICATION
International application No. PCT/EP2010/000787	International filing date (day/month/year) 09 February 2010 (09.02.2010)
Applicant VARTA MICROBATTERY GMBH et al	

1. Transmittal of the translation to the applicant.

- The International Bureau transmits herewith a copy of the English translation of the international preliminary report on patentability (Chapter I).
- The International Bureau transmits herewith a copy of the English translation of the international preliminary report on patentability (Chapter II).

2. Transmittal of the copy of the translation to the designated or elected Offices.

The International Bureau notifies the applicant that copies of that translation have been transmitted to the following designated or elected Offices requiring such translation:

None

The following designated or elected Offices, having waived the requirement for such a transmittal at this time, will receive copies of that translation from the International Bureau only upon their request:

AE, AG, AL, AM, AO, AP, AT, AU, AZ, BA, BB, BG, BH, BR, BW, BY, BZ, CA, CH, CL, CN, CO, CR, CU, CZ, DE, DK, DM, DO, DZ, EA, EC, EE, EG, EP, ES, FI, GB, GD, GE, GH, GM, GT, HN, HR, HU, ID, IL, IN, IS, JP, KE, KG, KM, KN, KP, KR, KZ, LA, LC, LK, LR, LS, LT, LU, LY, MA, MD, ME, MG, MK, MN, MW, MX, MY, MZ, NA, NG, NI, NO, NZ, OA, OM, PE, PG, PH, PL, PT, RO, RS, RU, SC, SD, SE, SG, SK, SL, SM, ST, SV, SY, TH, TJ, TM, TN, TR, TT, TZ, UA, UG, US, UZ, VC, VN, ZA, ZM, ZW

3. Reminder regarding translation into (one of) the official language(s) of the elected Office(s).

The applicant is reminded that, where a translation of the international application must be furnished to an elected Office, that translation must contain a translation of any annexes to the international preliminary report on patentability (Chapter II).

It is the applicant's responsibility to prepare and furnish such translation directly to each elected Office concerned within the applicable time limit (Rule 74.1). See Volume II of the PCT Applicant's Guide for further details.

The International Bureau of WIPO 34, chemin des Colombettes 1211 Geneva 20, Switzerland	Authorized officer Agnes Wittmann-Regis
---	--

PATENT COOPERATION TREATY

PCT

INTERNATIONAL PRELIMINARY REPORT ON PATENTABILITY
(Chapter I of the Patent Cooperation Treaty)

(PCT Rule 44bis)

Applicant's or agent's file reference P 49226 WO	FOR FURTHER ACTION		See item 4 below
International application No. PCT/EP2010/000787	International filing date (day/month/year) 09 February 2010 (09.02.2010)	Priority date (day/month/year) 09 February 2009 (09.02.2009)	
International Patent Classification (8th edition unless older edition indicated) See relevant information in Form PCT/ISA/237			
Applicant VARTA MICROBATTERY GMBH			

1. This international preliminary report on patentability (Chapter I) is issued by the International Bureau on behalf of the International Searching Authority under Rule 44 bis.1(a).

2. This REPORT consists of a total of 7 sheets, including this cover sheet.

In the attached sheets, any reference to the written opinion of the International Searching Authority should be read as a reference to the international preliminary report on patentability (Chapter I) instead.

3. This report contains indications relating to the following items:

<input checked="" type="checkbox"/>	Box No. I	Basis of the report
<input type="checkbox"/>	Box No. II	Priority
<input type="checkbox"/>	Box No. III	Non-establishment of opinion with regard to novelty, inventive step and industrial applicability
<input type="checkbox"/>	Box No. IV	Lack of unity of invention
<input checked="" type="checkbox"/>	Box No. V	Reasoned statement under Article 35(2) with regard to novelty, inventive step or industrial applicability; citations and explanations supporting such statement
<input type="checkbox"/>	Box No. VI	Certain documents cited
<input type="checkbox"/>	Box No. VII	Certain defects in the international application
<input checked="" type="checkbox"/>	Box No. VIII	Certain observations on the international application

4. The International Bureau will communicate this report to designated Offices in accordance with Rules 44bis.3(c) and 93bis.1 but not, except where the applicant makes an express request under Article 23(2), before the expiration of 30 months from the priority date (Rule 44bis .2).

The International Bureau of WIPO 34, chemin des Colombettes 1211 Geneva 20, Switzerland Facsimile No. +41 22 338 82 70	Date of issuance of this report 09 August 2011 (09.08.2011)
	Authorized officer Agnes Wittmann-Regis e-mail: pt06.pct@wipo.int

PATENT COOPERATION TREATY

TRANSLATION

From the
INTERNATIONAL SEARCHING AUTHORITY

PCT

WRITTEN OPINION OF THE
INTERNATIONAL SEARCHING AUTHORITY

(PCT Rule 43bis.1)

To:

Date of mailing
(day/month/year)

Applicant's or agent's file reference

P 49226 WO

FOR FURTHER ACTION

See paragraph 2 below

International application No.

PCT/EP2010/000787

International filing date (day/month/year)

09.02.2010

Priority date (day/month/year)

09.02.2009

International Patent Classification (IPC) or both national classification and IPC

H01M10/04 H01M2/02

Applicant

VARTA MICROBATTERY GMBH

1. This opinion contains indications relating to the following items:

- Box No. I Basis of the opinion
- Box No. II Priority
- Box No. III Non-establishment of opinion with regard to novelty, inventive step and industrial applicability
- Box No. IV Lack of unity of invention
- Box No. V Reasoned statement under Rule 43bis.1(a)(i) with regard to novelty, inventive step or industrial applicability; citations and explanations supporting such statement
- Box No. VI Certain documents cited
- Box No. VII Certain defects in the international application
- Box No. VIII Certain observations on the international application

2. FURTHER ACTION

If a demand for international preliminary examination is made, this opinion will be considered to be a written opinion of the International Preliminary Examining Authority ("IPEA") except that this does not apply where the applicant chooses an Authority other than this one to be the IPEA and the chosen IPEA has notified the International Bureau under Rule 66.1bis(b) that written opinions of this International Searching Authority will not be so considered.

If this opinion is, as provided above, considered to be a written opinion of the IPEA, the applicant is invited to submit to the IPEA a written reply together, where appropriate, with amendments, before the expiration of 3 months from the date of mailing of Form PCT/ISA/220 or before the expiration of 22 months from the priority date, whichever expires later.

For further options, see Form PCT/ISA/220.

3. For further details, see notes to Form PCT/ISA/220.

Name and mailing address of the ISA/EP

Date of completion of this opinion

Authorized officer

Facsimile No.

Telephone No.

WRITTEN OPINION OF THE
INTERNATIONAL SEARCHING AUTHORITY

International application No.

PCT/EP2010/000787

Box No. 1

Basis of this opinion

1. With regard to the language, this opinion has been established on the basis of:
 - the international application in the language in which it was filed
 - a translation of the international application into _____, which is the language of a translation furnished for the purposes of international search (Rules 12.3(a) and 23.1(b)).
2. This opinion has been established taking into account the rectification of an obvious mistake authorized by or notified to this Authority under Rule 91 (Rule 43bis.1(a)).
3. With regard to any nucleotide and/or amino acid sequence disclosed in the international application and necessary to the claimed invention, this opinion has been established on the basis of:
 - a. type of material
 - a sequence listing
 - table(s) related to the sequence listing
 - b. format of material
 - on paper
 - in electronic form
 - c. time of filing/furnishing
 - contained in the international application as filed
 - filed together with the international application in electronic form
 - furnished subsequently to this Authority for the purposes of search
4. In addition, in the case that more than one version or copy of a sequence listing and/or table(s) relating thereto has been filed or furnished, the required statements that the information in the subsequent or additional copies is identical to that in the application as filed or does not go beyond the application as filed, as appropriate, were furnished.
5. Additional comments:

WRITTEN OPINION OF THE
INTERNATIONAL SEARCHING AUTHORITY

International application No.

PCT/EP2010/000787

Box No. V Reasoned statement under Rule 43bis.1(a)(i) with regard to novelty, inventive step or industrial applicability; citations and explanations supporting such statement

1. Statement

Novelty (N)	Claims	14	YES
	Claims	1-13	NO
Inventive step (IS)	Claims	14	YES
	Claims	1-13	NO
Industrial applicability (IA)	Claims	1-14	YES
	Claims		NO

2. Citations and explanations:

1 CITED DOCUMENTS

D1 US 6 265 100 B1 (SAASKI ELRIC W [US] ET AL)
24 July 2001 (2001-07-24)

2 NOVELTY

Apart from the lack of clarity noted in Box VIII, the subject matter of claim 1 is also not novel (PCT Article 33(2)), and therefore the requirements of PCT Article 33(1) are not met.

D1 discloses a button cell comprising two metal housing halves which are separated from each other by an electrically insulating seal and that form a housing having a flat base area and a flat cover area parallel thereto, and an electrode separator unit within the housing comprising at least one positive and at least one negative electrode that are designed as planar layers and are bonded with each other by at least one planar separator, wherein the electrode layers are aligned substantially orthogonal to the flat base and cover areas (figures 13 to 15, column 27, line 1 to column 28, line 26 and column 29, lines 42 to 57).

WRITTEN OPINION OF THE
INTERNATIONAL SEARCHING AUTHORITY

International application No.

PCT/EP2010/000787

Box No. V

Reasoned statement under Rule 43bis.1(a)(i) with regard to novelty, inventive step or industrial applicability;
citations and explanations supporting such statement

D1 also discloses the subject matter of:

- Claim 2: (column 29, lines 42 to 57);
- Claim 3: (figures 13 to 15);
- Claim 4: (column 28, lines 15 to 26);
- Claim 5: (column 27, line 1 to column 28, line 26);
- Claim 6: (column 27, lines 1 to 17);
- Claims 7 and 8: (column 27, lines 18 to 26);
- Claim 9: (column 26, lines 35 to 38);
- Claim 10: (column 29, lines 42 to 57);
- Claims 11 and 12: (column 27, lines 1 to 26);
- Claim 13: (column 28, lines 15 to 26).

The subject matter of claims 1 to 13 is therefore not novel (PCT Article 33(2)).

In contrast, the subject matter of claim 14 cannot be found in the cited prior art, neither is it generally known, and therefore said claim satisfies the requirement of PCT Article 33(2) in respect of novelty.

3 INVENTIVE STEP

D1, which is considered to be the closest prior art, discloses a method for producing a button cell having an electrode separator unit as a winding in which the electrode layers are aligned orthogonal to the flat base and cover area from which the subject matter of claim 14 differs in that the front faces of the winding are heat-treated before installation, wherein the winding is exposed at least briefly to a temperature at which the separator is thermoplastically deformable.

The problem to be solved by the present invention can

WRITTEN OPINION OF THE
INTERNATIONAL SEARCHING AUTHORITY

International application No.

PCT/EP2010/000787

Box No. V

Reasoned statement under Rule 43bis.1(a)(i) with regard to novelty, inventive step or industrial applicability;
citations and explanations supporting such statement

therefore be considered that of providing a simplified and improved method for producing a button cell.

The solution proposed in claim 14 of the present application is considered inventive (PCT Article 33(3)) since a person skilled in the art, on the basis of D1, would neither consider the process step of a heat treatment to thermoplastically deform the separator before installing the winding to solve the stated problem, nor would he consider it a conventional procedure.

WRITTEN OPINION OF THE
INTERNATIONAL SEARCHING AUTHORITY

International application No.

PCT/EP2010/000787

Box No. VIII Certain observations on the international application

The following observations on the clarity of the claims, description, and drawings or on the question whether the claims are fully supported by the description, are made:

Clarity

The application does not meet the requirements of PCT Article 6 because claim 1 is unclear.

The expression "substantially orthogonal" in claim 1 is vague and unclear and leaves the reader uncertain as to the meaning of the technical feature in question. As a result, the subject matter of said claim is not clearly defined (PCT Article 6).



UNITED STATES PATENT AND TRADEMARK OFFICE

UNITED STATES DEPARTMENT OF COMMERCE
United States Patent and Trademark Office
Address: COMMISSIONER FOR PATENTS
P.O. Box 1450
Alexandria, Virginia 22313-1450
www.uspto.gov

Table with 3 columns: U.S. APPLICATION NUMBER NO. (13/146,669), FIRST NAMED APPLICANT (Eduard Pytlik), ATTY. DOCKET NO. (RUF-11-1270). Includes international application number (PCT/EP10/00787) and filing dates (02/09/2010 and 02/09/2009).

35811
IP GROUP OF DLA PIPER LLP (US)
ONE LIBERTY PLACE
1650 MARKET ST, SUITE 4900
PHILADELPHIA, PA 19103

CONFIRMATION NO. 6273
371 FORMALITIES LETTER



Date Mailed: 09/13/2011

NOTIFICATION OF DEFECTIVE RESPONSE

The following items have been submitted by the applicant or the IB to the United States Patent and Trademark Office as a Designated Office (37 CFR 1.494):

- Priority Document
• Copy of the International Application filed on 07/28/2011
• English Translation of the IA filed on 07/28/2011
• Copy of the International Search Report filed on 07/28/2011
• Preliminary Amendments filed on 07/28/2011
• Information Disclosure Statements filed on 07/28/2011
• Oath or Declaration filed on 09/07/2011
• U.S. Basic National Fees filed on 07/28/2011
• Substitute Specification filed on 07/28/2011
• Assignee Statement for PG PUB filed on 07/28/2011
• Priority Documents filed on 07/28/2011

Applicant's response filed 09/07/2011 is hereby acknowledged. The following requirements set forth in the NOTIFICATION of MISSING REQUIREMENTS mailed 08/12/2011 have not been completed.

The following items MUST be furnished within the period set forth below in order to complete the requirements for acceptance under 35 U.S.C. 371:

- Oath or declaration of the inventors, in compliance with 37 CFR 1.497(a) and (b), identifying the application by the International application number and international filing date. The current oath or declaration does not comply with 37 CFR 1.497(a) and (b) in that it:
• Applicant change the address on the oath and it's not legible, please initial changes.

Applicant is required to complete the response within a time limit of ONE MONTH from the date of this Notification or within the time remaining in the response set forth in the Notification of Missing Requirements, whichever is the longer. No extension of this time limit may be granted under 37 CFR 1.136, but the period for response set in the Notification of Missing Requirements may be extended under 37 CFR 1.136(a).

Applicant is reminded that any communications to the United States Patent and Trademark Office must be mailed to the address given in the heading and include the U.S. application no. shown above (37 CFR 1.5)

Registered users of EFS-Web may alternatively submit their reply to this notice via EFS-Web.
https://portal.uspto.gov/authenticate/AuthenticateUserLocalEPF.html

For more information about EFS-Web please call the USPTO Electronic Business Center at **1-866-217-9197** or visit our website at <http://www.uspto.gov/ebc>.

If you are not using EFS-Web to submit your reply, you must include a copy of this notice.

DEBORAH A THOMAS

Telephone: (571) 272-7175

PATENT APPLICATION FEE DETERMINATION RECORD

Substitute for Form PTO-875

Application or Docket Number
13/146,669

APPLICATION AS FILED - PART I

(Column 1)		(Column 2)	SMALL ENTITY		OR	OTHER THAN SMALL ENTITY	
FOR	NUMBER FILED	NUMBER EXTRA	RATE(\$)	FEE(\$)		RATE(\$)	FEE(\$)
BASIC FEE (37 CFR 1.16(a), (b), or (c))	N/A	N/A	N/A			N/A	330
SEARCH FEE (37 CFR 1.16(k), (j), or (m))	N/A	N/A	N/A			N/A	430
EXAMINATION FEE (37 CFR 1.16(o), (p), or (q))	N/A	N/A	N/A			N/A	220
TOTAL CLAIMS (37 CFR 1.16(i))	14 minus 20 =	*			OR	x 52 =	0.00
INDEPENDENT CLAIMS (37 CFR 1.16(h))	1 minus 3 =	*				x 220 =	0.00
APPLICATION SIZE FEE (37 CFR 1.16(s))	If the specification and drawings exceed 100 sheets of paper, the application size fee due is \$270 (\$135 for small entity) for each additional 50 sheets or fraction thereof. See 35 U.S.C. 41(a)(1)(G) and 37 CFR 1.16(s).						0.00
MULTIPLE DEPENDENT CLAIM PRESENT (37 CFR 1.16(j))							0.00
* If the difference in column 1 is less than zero, enter "0" in column 2.			TOTAL			TOTAL	980

APPLICATION AS AMENDED - PART II

(Column 1)		(Column 2)	(Column 3)	SMALL ENTITY		OR	OTHER THAN SMALL ENTITY		
AMENDMENT A		CLAIMS REMAINING AFTER AMENDMENT	HIGHEST NUMBER PREVIOUSLY PAID FOR	PRESENT EXTRA	RATE(\$)	ADDITIONAL FEE(\$)	RATE(\$)	ADDITIONAL FEE(\$)	
	Total (37 CFR 1.16(i))	*	Minus	**	=	x	=	x	=
	Independent (37 CFR 1.16(h))	*	Minus	***	=	x	=	x	=
	Application Size Fee (37 CFR 1.16(s))								
	FIRST PRESENTATION OF MULTIPLE DEPENDENT CLAIM (37 CFR 1.16(j))								
				TOTAL ADD'L FEE		OR	TOTAL ADD'L FEE		
AMENDMENT B		CLAIMS REMAINING AFTER AMENDMENT	HIGHEST NUMBER PREVIOUSLY PAID FOR	PRESENT EXTRA	RATE(\$)	ADDITIONAL FEE(\$)	RATE(\$)	ADDITIONAL FEE(\$)	
	Total (37 CFR 1.16(i))	*	Minus	**	=	x	=	x	=
	Independent (37 CFR 1.16(h))	*	Minus	***	=	x	=	x	=
	Application Size Fee (37 CFR 1.16(s))								
	FIRST PRESENTATION OF MULTIPLE DEPENDENT CLAIM (37 CFR 1.16(j))								
				TOTAL ADD'L FEE		OR	TOTAL ADD'L FEE		

* If the entry in column 1 is less than the entry in column 2, write "0" in column 3.
 ** If the "Highest Number Previously Paid For" IN THIS SPACE is less than 20, enter "20".
 *** If the "Highest Number Previously Paid For" IN THIS SPACE is less than 3, enter "3".
 The "Highest Number Previously Paid For" (Total or Independent) is the highest found in the appropriate box in column 1.

IN THE UNITED STATES PATENT AND TRADEMARK OFFICE

Art Unit : Customer No.: 035811
Examiner :
Serial No. : 13/146,669
Filed : July 28, 2011
PCT No. : PCT/EP2010/000787
PCT Filed : February 9, 2010
Inventors : Eduard Pytlik Docket No.: RUF-11-1270
 : Jürgen Lindner Confirmation No.: 6273
 : Ulrich Barenthin
 : Winfried Gaugler
Title : BUTTON CELLS AND METHOD
 : FOR PRODUCING SAME
Dated: September 28, 2011

TRANSMITTAL LETTER

Mail Stop Missing Parts
Commissioner for Patents
P.O. Box 1450
Alexandria, VA 22313-1450

Sir:

In response to the Notification of Defective Response dated September 13, 2011, applicants resubmit the executed Combined Declaration, Power of Attorney and Petition which has been initialed a second time and request that it be formally entered in the official file.

The fee was submitted on September 7, 2011 with the filing of the original Declaration. Therefore no fee is required at this time.

The Commissioner is authorized to charge any insufficiency or credit any overpayment to Deposit Account No. 50-2719.

Respectfully submitted,



T. Daniel Christenbury
Reg. No. 31,750

TDC/cc
(215) 656-3381

- Original Application
- PCT National Application
U.S. Designated Office
- Continuation or Divisional Application
- Continuation-in-Part Application

**COMBINED DECLARATION,
POWER OF ATTORNEY AND PETITION**

As a below named inventor, I hereby declare that:

My residence, post office address and citizenship are as stated below next to my name,

I believe I am the original, first and sole inventor (if only one name is listed below) or an original, first and joint inventor (if plural names are listed below) of the subject matter which is claimed and for which a patent is sought on the invention entitled **BUTTON CELLS AND METHOD FOR PRODUCING SAME**

which is described in the specification and claims

attached hereto.

filed on

Application Serial No.

and was amended on
(if applicable)

which is described in International Application No. PCT/EP2010/000787 filed 09 February 2010 and as amended on
..... (if any),

which I have reviewed and for which I solicit a United States patent.

I hereby state that I have reviewed and understand the contents of the above-identified specification, including the claims, as amended by any amendment referred to above.

I acknowledge the duty to disclose information which is material to patentability as defined in 37 C.F.R. §1.56, including for continuation-in-part applications, material information which became available between the filing date of the prior application and the national or PCT international filing date of the continuation-in-part application.

COMBINED DECLARATION, POWER OF ATTORNEY AND PETITION
(Page 2)

Attorney Docket No. RUF-11-1270

I hereby claim foreign priority benefits under Title 35, United States Code, §119(a)-(d) or §365(b) of any foreign application(s) for patent or inventor's certificate, or §365(a) of any PCT International Application which designated at least one country other than the United States of America, listed below and have also identified below any foreign application(s) for patent or inventor's certificate or of any PCT International Application having a filing date before that of the application on which priority is claimed:

Number	Country	Date of Filing (day,month,year)	Priority Claimed
10 2009 008 859.8	Germany	09 February 2009	<input checked="" type="checkbox"/> yes <input type="checkbox"/> no
10 2009 030 359.6	Germany	18 June 2009	<input checked="" type="checkbox"/> yes <input type="checkbox"/> no
10 2009 060 788.9	Germany	22 December 2009	<input checked="" type="checkbox"/> yes <input type="checkbox"/> no
			<input type="checkbox"/> yes <input type="checkbox"/> no
			<input type="checkbox"/> yes <input type="checkbox"/> no

I hereby claim the benefit under Title 35, United States Code, §119(e) or §120 (as applicable) of any United States application(s) or §365(c) of any PCT International Application designating the United States of America, listed below and, insofar as the subject matter of each of the claims of this application is not disclosed in the prior United States or PCT International Application(s) in the manner provided by the first paragraph of Title 35, United States Code, §112:

<u>PCT/EP2010/000787</u> <i>(Application Serial No.)</i>	<u>09 February 2010</u> <i>(Filing Date)</i>	<u>Pending</u> <i>(Status)(patented,pending,abandoned)</i>
 <i>(Application Serial No.)</i>	 <i>(Filing Date)</i>	 <i>(Status)(patented,pending,abandoned)</i>

POWER OF ATTORNEY: As a named inventor, I hereby appoint the following registered attorneys to prosecute this application and transact all business in the United States Patent and Trademark Office connected therewith:

T. Daniel Christenbury Reg. No. 31,750	William L. Bartow Reg. No. 54,981
Paul A. Taufer Reg. No. 35,703	Erin Pacella Reg. No. 56,239
Darius C. Gambino Reg. No. 41,472	Michael L. Burns IV Reg. No. 57,593
Richard L. Cruz Reg. No. 52,783	Lisa M. Lint Reg. No. 60,856

<p>SEND CORRESPONDENCE TO: Customer No. 035811, whose contact information is: IP Department of DLA Piper LLP (US) One Liberty Place, Suite 4900 1650 Market Street Philadelphia, PA 19103</p>	<p>DIRECT TELEPHONE CALLS TO ATTORNEY OF RECORD AT: (215) 656-3381</p>
---	--

COMBINED DECLARATION, POWER OF ATTORNEY AND PETITION
(Page 3)

Attorney Docket No. RUF-11-1270

I hereby petition for grant of a United States Letters Patent on this invention.

I hereby declare that all statements made herein of my own knowledge are true and that all statements made on information and belief are believed to be true; and further that these statements were made with the knowledge that willful false statements and the like so made are punishable by fine or imprisonment, or both, under Section 1001 of Title 18 of the United States Code and that such willful false statements may jeopardize the validity of the application or any patent issued thereon.

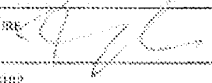
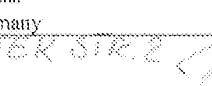
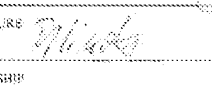
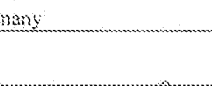
1 FULL NAME OF SOLE OR FIRST INVENTOR Eduard Pyltik		INVENTOR'S SIGNATURE 	DATE 18.06.2011
RESIDENCE Ellwangen, Germany		CITIZENSHIP Germany	
POST OFFICE ADDRESS -Altmannstraße-7, 73479 Ellwangen, Germany			
2 FULL NAME OF JOINT INVENTOR, IF ANY Jürgen Lindner		INVENTOR'S SIGNATURE 	DATE 18.06.2011
RESIDENCE Ellwangen, Germany		CITIZENSHIP Germany	
POST OFFICE ADDRESS Kottenwiesen 9, 73479 Ellwangen, Germany			
3 FULL NAME OF ADDITIONAL JOINT INVENTOR, IF ANY Ulrich Barenthin		INVENTOR'S SIGNATURE 	DATE 23.07.11
RESIDENCE Ellwangen, Germany		CITIZENSHIP Germany	
POST OFFICE ADDRESS Bahnhofstraße 6/1, 73479 Ellwangen, Germany			
4 FULL NAME OF ADDITIONAL JOINT INVENTOR, IF ANY Winfried Gaugler		INVENTOR'S SIGNATURE 	DATE 01.08.2011
RESIDENCE Ellwangen, Germany		CITIZENSHIP Germany	
POST OFFICE ADDRESS Birken 26, 73479 Ellwangen, Germany			
5 FULL NAME OF ADDITIONAL JOINT INVENTOR, IF ANY		INVENTOR'S SIGNATURE	DATE
RESIDENCE		CITIZENSHIP	
POST OFFICE ADDRESS			
6 FULL NAME OF ADDITIONAL JOINT INVENTOR, IF ANY		INVENTOR'S SIGNATURE	DATE
RESIDENCE		CITIZENSHIP	
POST OFFICE ADDRESS			
7 FULL NAME OF ADDITIONAL JOINT INVENTOR, IF ANY		INVENTOR'S SIGNATURE	DATE
RESIDENCE		CITIZENSHIP	
POST OFFICE ADDRESS			

Electronic Acknowledgement Receipt

EFS ID:	11068698
Application Number:	13146669
International Application Number:	
Confirmation Number:	6273
Title of Invention:	BUTTON CELLS AND METHOD FOR PRODUCING SAME
First Named Inventor/Applicant Name:	Eduard Pytlik
Customer Number:	35811
Filer:	Thomas Daniel Christenbury/Carol Coney
Filer Authorized By:	Thomas Daniel Christenbury
Attorney Docket Number:	RUF-11-1270
Receipt Date:	28-SEP-2011
Filing Date:	
Time Stamp:	15:14:43
Application Type:	U.S. National Stage under 35 USC 371

Payment information:

Submitted with Payment	no
------------------------	----

File Listing:

Document Number	Document Description	File Name	File Size(Bytes)/ Message Digest	Multi Part /.zip	Pages (if appl.)
1	Miscellaneous Incoming Letter	transmittalletter.pdf	245313 af12590745426d90cce6d84b48bc40a4526256b1f	no	1

Warnings:

Information:

2	Oath or Declaration filed	Declaration.pdf	918980 f5beb77e48c91f827c72780fd8338d9b1098fac	no	3
Warnings:					
Information:					
Total Files Size (in bytes):				1164293	
<p>This Acknowledgement Receipt evidences receipt on the noted date by the USPTO of the indicated documents, characterized by the applicant, and including page counts, where applicable. It serves as evidence of receipt similar to a Post Card, as described in MPEP 503.</p> <p><u>New Applications Under 35 U.S.C. 111</u> If a new application is being filed and the application includes the necessary components for a filing date (see 37 CFR 1.53(b)-(d) and MPEP 506), a Filing Receipt (37 CFR 1.54) will be issued in due course and the date shown on this Acknowledgement Receipt will establish the filing date of the application.</p> <p><u>National Stage of an International Application under 35 U.S.C. 371</u> If a timely submission to enter the national stage of an international application is compliant with the conditions of 35 U.S.C. 371 and other applicable requirements a Form PCT/DO/EO/903 indicating acceptance of the application as a national stage submission under 35 U.S.C. 371 will be issued in addition to the Filing Receipt, in due course.</p> <p><u>New International Application Filed with the USPTO as a Receiving Office</u> If a new international application is being filed and the international application includes the necessary components for an international filing date (see PCT Article 11 and MPEP 1810), a Notification of the International Application Number and of the International Filing Date (Form PCT/RO/105) will be issued in due course, subject to prescriptions concerning national security, and the date shown on this Acknowledgement Receipt will establish the international filing date of the application.</p>					



UNITED STATES PATENT AND TRADEMARK OFFICE

UNITED STATES DEPARTMENT OF COMMERCE
United States Patent and Trademark Office
Address: COMMISSIONER FOR PATENTS
P.O. Box 1450
Alexandria, Virginia 22313-1450
www.uspto.gov

Table with 7 columns: APPLICATION NUMBER, FILING or 371(c) DATE, GRP ART UNIT, FIL FEE REC'D, ATTY DOCKET NO, TOT CLAIMS, IND CLAIMS. Row 1: 13/146,669, 09/07/2011, 1110, RUF-11-1270, 14, 1

CONFIRMATION NO. 6273

FILING RECEIPT

35811
IP GROUP OF DLA PIPER LLP (US)
ONE LIBERTY PLACE
1650 MARKET ST, SUITE 4900
PHILADELPHIA, PA 19103



Date Mailed: 10/12/2011

Receipt is acknowledged of this non-provisional patent application. The application will be taken up for examination in due course. Applicant will be notified as to the results of the examination. Any correspondence concerning the application must include the following identification information: the U.S. APPLICATION NUMBER, FILING DATE, NAME OF APPLICANT, and TITLE OF INVENTION. Fees transmitted by check or draft are subject to collection. Please verify the accuracy of the data presented on this receipt. If an error is noted on this Filing Receipt, please submit a written request for a Filing Receipt Correction. Please provide a copy of this Filing Receipt with the changes noted thereon. If you received a "Notice to File Missing Parts" for this application, please submit any corrections to this Filing Receipt with your reply to the Notice. When the USPTO processes the reply to the Notice, the USPTO will generate another Filing Receipt incorporating the requested corrections

Applicant(s)

Eduard Pytlik, Ellwangen, GERMANY;
Jürgen Lindner, Ellwangen, GERMANY;
Ulrich Barenthin, Ellwangen, GERMANY;
Winfried Gaugler, Ellwangen, GERMANY;

Assignment For Published Patent Application

VARTA MICROBATTERY GMBH, Ellwangen, DE

Power of Attorney:

Thomas Christenbury--31750 Erin Pacella--56239
Paul Taufer--35703 Michael Burns--57593
Darius Gambino--41472 Lisa Lint--60856
Richard Cruz--52783
William Bartow--54981

Domestic Priority data as claimed by applicant

This application is a 371 of PCT/EP10/00787 02/09/2010

Foreign Applications (You may be eligible to benefit from the Patent Prosecution Highway program at the USPTO. Please see http://www.uspto.gov for more information.)

GERMANY 10 2009 008 859.8 02/09/2009
GERMANY 10 2009 060 788.9 12/22/2009
GERMANY 10 2009 030 359.6 06/18/2009

If Required, Foreign Filing License Granted: 10/06/2011

The country code and number of your priority application, to be used for filing abroad under the Paris Convention, is **US 13/146,669**

Projected Publication Date: 01/19/2012

Non-Publication Request: No

Early Publication Request: No
Title

BUTTON CELLS AND METHOD FOR PRODUCING SAME

Preliminary Class

PROTECTING YOUR INVENTION OUTSIDE THE UNITED STATES

Since the rights granted by a U.S. patent extend only throughout the territory of the United States and have no effect in a foreign country, an inventor who wishes patent protection in another country must apply for a patent in a specific country or in regional patent offices. Applicants may wish to consider the filing of an international application under the Patent Cooperation Treaty (PCT). An international (PCT) application generally has the same effect as a regular national patent application in each PCT-member country. The PCT process **simplifies** the filing of patent applications on the same invention in member countries, but **does not result** in a grant of "an international patent" and does not eliminate the need of applicants to file additional documents and fees in countries where patent protection is desired.

Almost every country has its own patent law, and a person desiring a patent in a particular country must make an application for patent in that country in accordance with its particular laws. Since the laws of many countries differ in various respects from the patent law of the United States, applicants are advised to seek guidance from specific foreign countries to ensure that patent rights are not lost prematurely.

Applicants also are advised that in the case of inventions made in the United States, the Director of the USPTO must issue a license before applicants can apply for a patent in a foreign country. The filing of a U.S. patent application serves as a request for a foreign filing license. The application's filing receipt contains further information and guidance as to the status of applicant's license for foreign filing.

Applicants may wish to consult the USPTO booklet, "General Information Concerning Patents" (specifically, the section entitled "Treaties and Foreign Patents") for more information on timeframes and deadlines for filing foreign patent applications. The guide is available either by contacting the USPTO Contact Center at 800-786-9199, or it can be viewed on the USPTO website at <http://www.uspto.gov/web/offices/pac/doc/general/index.html>.

For information on preventing theft of your intellectual property (patents, trademarks and copyrights), you may wish to consult the U.S. Government website, <http://www.stopfakes.gov>. Part of a Department of Commerce initiative, this website includes self-help "toolkits" giving innovators guidance on how to protect intellectual property in specific countries such as China, Korea and Mexico. For questions regarding patent enforcement issues, applicants may call the U.S. Government hotline at 1-866-999-HALT (1-866-999-4158).

LICENSE FOR FOREIGN FILING UNDER
Title 35, United States Code, Section 184
Title 37, Code of Federal Regulations, 5.11 & 5.15

GRANTED

The applicant has been granted a license under 35 U.S.C. 184, if the phrase "IF REQUIRED, FOREIGN FILING LICENSE GRANTED" followed by a date appears on this form. Such licenses are issued in all applications where the conditions for issuance of a license have been met, regardless of whether or not a license may be required as set forth in 37 CFR 5.15. The scope and limitations of this license are set forth in 37 CFR 5.15(a) unless an earlier license has been issued under 37 CFR 5.15(b). The license is subject to revocation upon written notification. The date indicated is the effective date of the license, unless an earlier license of similar scope has been granted under 37 CFR 5.13 or 5.14.

This license is to be retained by the licensee and may be used at any time on or after the effective date thereof unless it is revoked. This license is automatically transferred to any related applications(s) filed under 37 CFR 1.53(d). This license is not retroactive.

The grant of a license does not in any way lessen the responsibility of a licensee for the security of the subject matter as imposed by any Government contract or the provisions of existing laws relating to espionage and the national security or the export of technical data. Licensees should apprise themselves of current regulations especially with respect to certain countries, of other agencies, particularly the Office of Defense Trade Controls, Department of State (with respect to Arms, Munitions and Implements of War (22 CFR 121-128)); the Bureau of Industry and Security, Department of Commerce (15 CFR parts 730-774); the Office of Foreign Assets Control, Department of Treasury (31 CFR Parts 500+) and the Department of Energy.

NOT GRANTED

No license under 35 U.S.C. 184 has been granted at this time, if the phrase "IF REQUIRED, FOREIGN FILING LICENSE GRANTED" DOES NOT appear on this form. Applicant may still petition for a license under 37 CFR 5.12, if a license is desired before the expiration of 6 months from the filing date of the application. If 6 months has lapsed from the filing date of this application and the licensee has not received any indication of a secrecy order under 35 U.S.C. 181, the licensee may foreign file the application pursuant to 37 CFR 5.15(b).

PATENT APPLICATION FEE DETERMINATION RECORD Substitute for Form PTO-875	Application or Docket Number 13/146,669
---	--

APPLICATION AS FILED - PART I			SMALL ENTITY		OR	OTHER THAN SMALL ENTITY	
	(Column 1)	(Column 2)					
FOR	NUMBER FILED	NUMBER EXTRA	RATE(\$)	FEE(\$)		RATE(\$)	FEE(\$)
BASIC FEE <small>(37 CFR 1.16(a), (b), or (c))</small>	N/A	N/A	N/A			N/A	380
SEARCH FEE <small>(37 CFR 1.16(k), (j), or (m))</small>	N/A	N/A	N/A			N/A	490
EXAMINATION FEE <small>(37 CFR 1.16(o), (p), or (q))</small>	N/A	N/A	N/A			N/A	250
TOTAL CLAIMS <small>(37 CFR 1.16(i))</small>	14	minus 20 = *			OR	x 60 =	0.00
INDEPENDENT CLAIMS <small>(37 CFR 1.16(h))</small>	1	minus 3 = *				x 250 =	0.00
APPLICATION SIZE FEE <small>(37 CFR 1.16(s))</small>	If the specification and drawings exceed 100 sheets of paper, the application size fee due is \$310 (\$155 for small entity) for each additional 50 sheets or fraction thereof. See 35 U.S.C. 41(a)(1)(G) and 37 CFR 1.16(s).						0.00
MULTIPLE DEPENDENT CLAIM PRESENT <small>(37 CFR 1.16(j))</small>							0.00
* If the difference in column 1 is less than zero, enter "0" in column 2.			TOTAL			TOTAL	1120

APPLICATION AS AMENDED - PART II					SMALL ENTITY		OR	OTHER THAN SMALL ENTITY		
	(Column 1)	(Column 2)	(Column 3)							
AMENDMENT A	CLAIMS REMAINING AFTER AMENDMENT	MINUS	HIGHEST NUMBER PREVIOUSLY PAID FOR	PRESENT EXTRA	RATE(\$)	ADDITIONAL FEE(\$)		RATE(\$)	ADDITIONAL FEE(\$)	
	Total <small>(37 CFR 1.16(i))</small>	*	Minus	**	=		OR	x	=	
	Independent <small>(37 CFR 1.16(h))</small>	*	Minus	***	=		OR	x	=	
	Application Size Fee <small>(37 CFR 1.16(s))</small>							OR		
	FIRST PRESENTATION OF MULTIPLE DEPENDENT CLAIM <small>(37 CFR 1.16(j))</small>							OR		
					TOTAL ADD'L FEE		OR	TOTAL ADD'L FEE		
AMENDMENT B	CLAIMS REMAINING AFTER AMENDMENT	MINUS	HIGHEST NUMBER PREVIOUSLY PAID FOR	PRESENT EXTRA	RATE(\$)	ADDITIONAL FEE(\$)		RATE(\$)	ADDITIONAL FEE(\$)	
	Total <small>(37 CFR 1.16(i))</small>	*	Minus	**	=		OR	x	=	
	Independent <small>(37 CFR 1.16(h))</small>	*	Minus	***	=		OR	x	=	
	Application Size Fee <small>(37 CFR 1.16(s))</small>							OR		
	FIRST PRESENTATION OF MULTIPLE DEPENDENT CLAIM <small>(37 CFR 1.16(j))</small>							OR		
					TOTAL ADD'L FEE		OR	TOTAL ADD'L FEE		
<p>* If the entry in column 1 is less than the entry in column 2, write "0" in column 3.</p> <p>** If the "Highest Number Previously Paid For" IN THIS SPACE is less than 20, enter "20".</p> <p>*** If the "Highest Number Previously Paid For" IN THIS SPACE is less than 3, enter "3".</p> <p>The "Highest Number Previously Paid For" (Total or Independent) is the highest found in the appropriate box in column 1.</p>										



UNITED STATES PATENT AND TRADEMARK OFFICE

UNITED STATES DEPARTMENT OF COMMERCE
United States Patent and Trademark Office
Address: COMMISSIONER FOR PATENTS
P.O. Box 1450
Alexandria, Virginia 22313-1450
www.uspto.gov

Table with 3 columns: U.S. APPLICATION NUMBER NO. (13/146,669), FIRST NAMED APPLICANT (Eduard Pytlik), ATTY. DOCKET NO. (RUF-11-1270). Includes international application number (PCT/EP10/00787) and filing dates (02/09/2010, 02/09/2009).

35811
IP GROUP OF DLA PIPER LLP (US)
ONE LIBERTY PLACE
1650 MARKET ST, SUITE 4900
PHILADELPHIA, PA 19103

CONFIRMATION NO. 6273
371 ACCEPTANCE LETTER



Date Mailed: 10/12/2011

NOTICE OF ACCEPTANCE OF APPLICATION UNDER 35 U.S.C 371 AND 37 CFR 1.495

The applicant is hereby advised that the United States Patent and Trademark Office in its capacity as a Designated / Elected Office (37 CFR 1.495), has determined that the above identified international application has met the requirements of 35 U.S.C. 371, and is ACCEPTED for national patentability examination in the United States Patent and Trademark Office.

The United States Application Number assigned to the application is shown above and the relevant dates are:

09/07/2011 DATE OF RECEIPT OF 35 U.S.C. 371(c)(1), (c)(2) and (c)(4) REQUIREMENTS
09/07/2011 DATE OF COMPLETION OF ALL 35 U.S.C. 371 REQUIREMENTS

A Filing Receipt (PTO-103X) will be issued for the present application in due course. THE DATE APPEARING ON THE FILING RECEIPT AS THE " FILING DATE" IS THE DATE ON WHICH THE LAST OF THE 35 U.S.C. 371 (c)(1), (c)(2) and (c)(4) REQUIREMENTS HAS BEEN RECEIVED IN THE OFFICE. THIS DATE IS SHOWN ABOVE. The filing date of the above identified application is the international filing date of the international application (Article 11(3) and 35 U.S.C. 363). Once the Filing Receipt has been received, send all correspondence to the Group Art Unit designated thereon.

The following items have been received:

- Copy of the International Application filed on 07/28/2011
• English Translation of the IA filed on 07/28/2011
• Copy of the International Search Report filed on 07/28/2011
• Preliminary Amendments filed on 07/28/2011
• Information Disclosure Statements filed on 07/28/2011
• Oath or Declaration filed on 09/07/2011
• U.S. Basic National Fees filed on 07/28/2011
• Substitute Specification filed on 07/28/2011
• Assignee Statement for PG PUB filed on 07/28/2011
• Priority Documents filed on 07/28/2011

Applicant is reminded that any communications to the United States Patent and Trademark Office must be mailed to the address given in the heading and include the U.S. application no. shown above (37 CFR 1.5)

DEBORAH A THOMAS

Telephone: (571) 272-7175



UNITED STATES PATENT AND TRADEMARK OFFICE

UNITED STATES DEPARTMENT OF COMMERCE
United States Patent and Trademark Office
Address: COMMISSIONER FOR PATENTS
P.O. Box 1450
Alexandria, Virginia 22313-1450
www.uspto.gov

Table with 4 columns: APPLICATION NUMBER (13/146,669), FILING OR 371(C) DATE (09/07/2011), FIRST NAMED APPLICANT (Eduard Pytlik), ATTY. DOCKET NO./TITLE (RUF-11-1270)

CONFIRMATION NO. 6273

PUBLICATION NOTICE

35811
IP GROUP OF DLA PIPER LLP (US)
ONE LIBERTY PLACE
1650 MARKET ST, SUITE 4900
PHILADELPHIA, PA 19103



Title:BUTTON CELLS AND METHOD FOR PRODUCING SAME

Publication No.US-2012-0015224-A1

Publication Date:01/19/2012

NOTICE OF PUBLICATION OF APPLICATION

The above-identified application will be electronically published as a patent application publication pursuant to 37 CFR 1.211, et seq. The patent application publication number and publication date are set forth above.

The publication may be accessed through the USPTO's publically available Searchable Databases via the Internet at www.uspto.gov. The direct link to access the publication is currently http://www.uspto.gov/patft/.

The publication process established by the Office does not provide for mailing a copy of the publication to applicant. A copy of the publication may be obtained from the Office upon payment of the appropriate fee set forth in 37 CFR 1.19(a)(1). Orders for copies of patent application publications are handled by the USPTO's Office of Public Records. The Office of Public Records can be reached by telephone at (703) 308-9726 or (800) 972-6382, by facsimile at (703) 305-8759, by mail addressed to the United States Patent and Trademark Office, Office of Public Records, Alexandria, VA 22313-1450 or via the Internet.

In addition, information on the status of the application, including the mailing date of Office actions and the dates of receipt of correspondence filed in the Office, may also be accessed via the Internet through the Patent Electronic Business Center at www.uspto.gov using the public side of the Patent Application Information and Retrieval (PAIR) system. The direct link to access this status information is currently http://pair.uspto.gov/. Prior to publication, such status information is confidential and may only be obtained by applicant using the private side of PAIR.

Further assistance in electronically accessing the publication, or about PAIR, is available by calling the Patent Electronic Business Center at 1-866-217-9197.

Office of Data Management, Application Assistance Unit (571) 272-4000, or (571) 272-4200, or 1-888-786-0101

Form PTO-1449 US DEPARTMENT OF COMMERCE PATENT AND TRADEMARK OFFICE				ATTY. DOCKET NO. RUF-11-1270		SERIAL NO. 13/146,669		
LIST OF PUBLICATIONS CITED BY APPLICANT <i>(Use several sheets if necessary)</i>				APPLICANT Eduard Pytlik, et al.				
				FILING DATE July 28, 2011		GROUP		
US PATENT DOCUMENTS								
EXAMINER INITIAL*		DOCUMENT NUMBER	DATE	NAME	CLASS	SUBCLASS	FILING DATE IF APPROPRIATE	
	AA	7,488,553 B2	02/10/09	Tsukamoto et al.				
	AB							
	AC							
	AD							
	AE							
	AF							
	AG							
	AH							
	AI							
	AJ							
	AK							
FOREIGN PATENT DOCUMENTS								
		DOCUMENT NUMBER	DATE	COUNTRY	CLASS	SUBCLASS	TRANSLATION	
							YES	NO
	AL	2008-262825	10/30/08	JP			x	
	AM	1 968 134 A1	09/10/08	EP				
	AN							
	AO							
	AP							
OTHER PUBLICATIONS (Including Author, Title, Date, Pertinent Pages, Etc.)								
	AR							
	AS							
	AT							
EXAMINER				DATE CONSIDERED				
*EXAMINER: Initial if publication considered, whether or not citation is in conformance with MPEP 609; Draw line through citation if not in conformance and not considered. Include copy of this form with next communication to Applicant.								

I. DESCRIPTION JP 2008-262825

The present invention relates to a secondary battery coin-shaped non-aqueous electrolyte solution discharge load characteristics are enhanced.

Secondary battery coin non-aqueous electrolyte solution represented by the secondary battery lithium coin-ion, also known as secondary batteries flat type non-aqueous electrolyte solution or a button type, a headphone set, a watch-type communication device, a body-mounted medical it has attracted attention as a small battery of heavy load support to be used in the so-called wearable equipment like used person of equipment is worn.

The secondary battery lithium coin conventional ion, for example, those using an electrode formed by laminating through one by one the separator and positive electrode and a negative electrode was punched into a circle.

However, the battery of this type, the problem that the electrode is increased, there is a disadvantage that the diffusion resistance of the lithium ion to the direction of the thickness of the electrode is increased, the discharge load characteristics is lowered and can not be used only for applications in low power I have a.

(E.g., patent literature method by which to solve the above problems, the use of an electrode material are wound through the separator strip, and the positive electrode of the strip, and a negative electrode of the strip, to reduce the electrode is proposed 1, Patent Document 2, Patent Document 3, 4 references. Patent Document 1).

11-354150 Patent Publication No. 11-345626 JP JP 2003-77543 2005-310578 JP-JP

The battery has been proposed in Patent Document 2 and Patent Document 1, to form an electrode body by winding via a separator strip, the positive electrode of the strip, and a negative electrode of band, and then formed into a flat shape and the electrode assembly in the state that later, and (in the thickness direction) are orthogonal to the height direction of the battery can and direction of the winding axis electrode body, I have inserted into a battery can electrode body.

In this case, the electrode body of the battery can, because it is formed in a square shape when seen in the height direction of the battery, there is a problem that a gap is formed between the battery can and the electrode member, the volume loss occurs.

In addition, this electrode structure, because the expansion and contraction direction of the electrode due to the charging and discharging of the battery matches the height direction of the battery can, there is a possibility that the battery is deformed in the direction of height when repeatedly charged and discharged.

Meanwhile, the battery has been proposed in Patent Document 3 and Patent Document 4, since the direction of winding axis of the electrode body, and the height direction of the battery can is the same, the gap between the battery can and electrode assembly In addition, not occur, since the expansion and contraction direction of the electrode due to charging and discharging of the battery coincides with the radial direction of the battery can, there is no possibility that the battery is deformed even after repeated charging and discharging.

However, in Patent Documents 3 and 4, the electrode structure is only disclosed merely specific configuration for improvement in heavy load characteristics is not disclosed at all.

Of course, the specific configuration for improvement in heavy load characteristics is not disclosed at all in Patent Document 2 and Patent Document 1.

The present invention has solved the above problems, and is intended to provide a secondary battery coin-shaped non-aqueous electrolyte solution discharge load characteristics are enhanced.

Secondary battery coin non-aqueous electrolyte solution of the present invention is a secondary battery coin-shaped non-aqueous electrolyte solution comprising a positive electrode of the strip, and the negative electrode of the strip, the separator strip, and a battery can of a coin type. The positive electrode and the negative electrode, to constitute a wound body in a cylindrical shape are wound through the separator, the direction winding axis of the wound body wherein is the same as the height direction of the battery can. The ratio D/H and the outer diameter D of the wound body, and the height H of the winding axis direction of the wound body is 1 to 25, and the area A of the upper surface portion of the wound body, wherein The ratio R/A and the effective reaction area R and the said negative electrode and positive electrode faces is characterized in that it is 9-25.

In accordance with the present invention, it is possible to provide a secondary battery coin-shaped non-aqueous electrolyte solution discharge load characteristics is high, no deformation of the battery due to charging and discharging.

Following, I will explain the embodiment of the secondary battery coin-shaped non-aqueous electrolyte solution of the present invention.

Comprising a positive electrode of the strip, and the negative electrode of the strip, the separator strip, and a battery can of a coin type, the positive electrode and the negative electrode, a secondary battery coin-shaped non-aqueous electrolytic solution of the present invention, spirally wound with the separator and constitutes a wound body of cylindrical shape is.

With this structure, it is possible to reduce the electrode, can be improved to some extent the discharge load characteristics.

The direction winding axis of the wound body above is the same as the height direction of the battery can.

It is possible to prevent deformation of the battery by this structure, the expansion and contraction direction of the electrode, the diameter direction of the battery can strong in strength is the same, even after repeated charging and discharging.

The ratio D/H and the outer diameter D of the wound body, and the height H of the winding axis direction of the winder (flatness) is set to 1 to 25.

In less than 1, it can not be said that coin-shaped battery, D/H is not suitable for secondary battery coin-shaped non-aqueous electrolyte of wearable equipment for high capacity is required in a small thin.

In addition, D/H is more than 25, I will depart from the acceptable range of normal cell design.

That is, since the electrode width to withstand the manufacturing process for winding the electrode is required about 2mm at least, the minimum value of the height H of the winding axis direction of the wound body is 2mm.

Also, I believed from the size of the device to be equipped with a battery, the maximum value of the outer diameter D of the winder and 50mm.

Therefore, the maximum value of D/H is 25.

Further, D/H is 1 in consideration of the battery capacity required for equipment to be mounted battery.

5-23 is more preferable.

Further, in the secondary battery coin-shaped non-aqueous electrolytic solution of the present invention, the ratio R/A and the effective reaction area R of the area A of the upper surface portion of the wound body above, and the negative electrode and the positive electrode is opposed to , and is set to 15 to 20, more preferably, is set to 9-25.

Thus, it is possible to further improve the discharge load characteristics, it is optimal as a battery for various equipment for heavy load characteristics are required.

Here, means the area of the active material layer between the cathode and anode that are wound are opposite, in the secondary battery typically lithium ion, lithium dendrite is not generated during charging, effective reaction area R is, the negative electrode active Because larger than the area of the positive electrode active material layer to the area of the material layer, the entire surface of the positive electrode active material layer faces the anode active material layer, effective reaction surface area is provided with a positive electrode active material layer is substantially it is the area of the portion is.

The volume of the secondary battery coin-shaped non-aqueous electrolytic solution of the present invention is preferably at least 1cm^3 7cm^3 less.

When it is within this range, it is optimal as a secondary battery coin-shaped non-aqueous electrolyte solution for a wearable device for high capacity is required in the thin compact.

Further, the two battery coin non-aqueous electrolyte solution of the present invention, the outer diameter of the battery can is at least 20mm 50mm or less.

When it is within this range, it is optimal as a secondary battery coin-shaped non-aqueous electrolyte solution for a wearable device for high capacity is required in thin small as described above.

Next, I will be described with reference to the drawings an example of a secondary battery coin-shaped non-aqueous electrolytic solution of the present invention.

However, in Figures 1-10, there may be omitted will be denoted by the same symbols, and overlapping the same portions.

Figure 1 is a perspective view of a wound body used in the present invention.

In Figure 1, the wound body 10 is fabricated by winding via a separator strip, and a negative electrode of the strip-shaped positive electrode and the strip.

The mixture containing the positive electrode active material, positive electrode conductive additive and Seikyoku-yo binder or the like, the positive electrode was coated on both surfaces of the cathode current collector, a positive electrode mixture paste was obtained by kneading sufficiently by adding the solvent can be formed by, after drying, is controlled to a predetermined electrode density and a predetermined thickness of the positive electrode mixture layer.

As the positive electrode active material, for example, lithium nickel oxide such as lithium manganese oxide, lithium cobalt oxide LiCoO_2 , etc., of LiMn_2O_4 , etc., of the LiNiO_2 and the like can be used, and these, if capable of absorbing and desorbing lithium ions but are not limited to.

Examples of the positive electrode current collector is not particularly limited as long as the electron conductor chemically stable substantially in the fabricated battery.

The positive electrode current collector, for example, aluminum foil or the like.

Exposed collector surface that are not coated with the mixture paste on the one end of the positive electrode current collector is provided by folding the exposed collector surface, the cathode lead 11 is formed.

Further, the collector-exposed portion, may electrode lead may also be provided at both ends of the current collector can be provided at both ends of the current collector.

Further, instead of the positive electrode lead that is formed by folding the collector-exposed portion, it may be the positive electrode lead by welding tabs as a separate component in one or both ends of the cathode current collector.

To a mixture comprising active material, a negative electrode conductive auxiliary agent, a negative electrode binder and the like, the negative electrode was coated on both surfaces of the negative electrode current collector, a negative electrode mixture paste was obtained by kneading sufficiently by adding the solvent can be formed by, after drying, is controlled to a predetermined electrode density and a predetermined thickness of the negative electrode mixture layer.

As the negative electrode active material, for example, a carbon material artificial graphite such as bulk graphite or natural graphite, flake graphite and amorphous graphite and the like can be used, but is not limited thereto as long as capable of absorbing and desorbing lithium ions.

Examples of the negative electrode current collector is not particularly limited as long as the electron conductor chemically stable substantially in the fabricated battery.

As the negative electrode current collector, for example, copper foil or the like.

Exposed collector surface that are not coated with the mixture paste on one end of the anode current collector is provided by folding the collector-exposed portion, the negative electrode lead 12 is formed.

Further, the collector-exposed portion, may be the negative electrode lead may be provided at both ends of the current collector can be provided at both ends of the current collector.

Further, in place of the negative electrode lead is formed by folding the collector-exposed portion may be a negative electrode lead by welding tabs as a separate component in one or both ends of the anode current collector.

In Figure 1, it is provided on the outer peripheral side of the winder 10 the cathode lead 11, is provided on the inner peripheral side of the winder 10 and the anode lead 12, but is provided on the inner peripheral side of the winder 10 the cathode lead 11. Also, well, may be provided on the outer peripheral side of the wound body 10, both the anode lead 12 and the cathode lead 11 can be provided on the outer periphery of the winder 10 and anode lead 12.

As the separator, microporous insulating thin film having a predetermined mechanical strength and ion permeability larger are used.

Further, one obtained by closing the micropores in (100 ~ 140 °C) predetermined temperature or higher, and has a function to increase the resistance, from the viewpoint of improving safety of the battery.

Specifically, as the separator, were adhesively bonded particles of olefin polypropylene having hydrophobic and organic solvent resistance, a sheet made of glass fibers or olefin polymers such as polyethylene, nonwoven or woven fabric, porous layer and the like are used.

FIG 2 is a perspective view showing a process that is inserted into the battery can 13 of the cylindrical winder 10.

Kai-jiku the direction N and winding to be the same as the direction M height of the battery can 13, wound body 10 is inserted into the battery can 13.

The material of the battery can 13 to be used is aluminum.

In the bottom of the battery can 13 (and not shown). Lower insulating plate

But it is disposed.

The material of the lower insulating plate is not particularly limited, and a polymer material is used polyphenylene sulfide (PPS) and the like.

FIG 3 is a perspective view after inserting the battery can 13 and winder 10, showing a process that is disposed an upper insulating plate 14 on the winder 10.

The material of the upper insulating plate 14 may be used a material similar to the lower insulating plate.

Figure 4 is a perspective view of a state where welded to the anode lead 12 and the back portion of the negative electrode terminal 16 that is placed on a 10 winder upper insulating plate 14, which is disposed in the central portion of the lid 15.

The negative electrode terminal 16 and the cover 15, and is insulated by the insulating packing 17.

The material of the lid 15 to be used is aluminum or the like in the same manner as the battery can 13.

The material of the negative electrode terminal 16 to be used is nickel.

Material of the insulating packing 17 can be used polymeric materials polypropylene (PP) or the like.

Figure 5A is a perspective view of a state where joined by laser welding or the like and the lid 15 and the battery can 13.

5B is a cross-sectional view of line B-B in FIG 5A.

In Figure 5B, the winder 10 is housed in a sealed container formed by the battery can 13 and the lid 15, the lower insulating plate 19 is disposed at the bottom of the battery can 13.

However, in Figure 5B, the portion of the inner peripheral side of the wound body 10 is not in section.

As described above, wound body 10 has a structure that is spirally wound with the separator 3 of the strip, and a negative electrode 2 of the strip-shaped positive electrode 1 and the strip.

Further, the positive electrode lead 11 is joined in a state of being sandwiched between the cover 15 and the battery can 13.

Thus, the lid 15 and the battery can 13 functions as a positive terminal.

However, depending on the material of the battery can 13, in some cases the lid 15 and the battery can 13 become negative.

Finally, the injection port 18, and an electrolyte is poured, and (not shown). Sealing cover the injection port 18

Secondary battery coin-shaped non-aqueous electrolyte is completed if sealed by mouth.

For example, the electrolyte solution, vinylene carbonate (VC), propylene carbonate (PC), ethylene carbonate (EC), butylene carbonate (BC), dimethyl carbonate (DMC), diethyl carbonate (DEC), methyl ethyl carbonate (MEC), in a mixed solvent of one or two or more organic solvent of γ -butyrolactone, for example, is using an electrolytic solution obtained by dissolving a lithium salt of at least one selected from LiClO₄, LiPF₆, LiBF₄, LiAsF₆, LiSbF₆, LiCF₃SO₃ etc. Bayoi.

Concentration of Li ions in the electrolytic solution, 0.

It may be set to 5 ~ 1.5mol / L.

Figure 6 is a schematic diagram of the winder 10.

In Figure 6, it is not shown in the positive and negative electrode leads.

Outer diameter D of the winder 10 and (mm), the ratio D / H of the (mm) H height direction of the winding axis wound body 10 is set to 1 to 25.

The ratio R / A effective reaction area R in which the area A of the upper surface portion of the winder 10 and (mm²), and the positive electrode and the negative electrode are opposed to each other and (mm²), is set to 9-25.

Figure 7 is a schematic diagram of the positive electrode for describing the parameters of the present invention.

In Figure 7, on both sides of the cathode current collector 21 of the positive electrode 20 of the strip, and a second positive electrode active material layer 23 and the first positive electrode active material layer 22, is formed shorter than the first positive electrode active material layer 22 is formed have been.

end of the cathode current collector 21 of the positive electrode active material layer is not formed is formed on the cathode lead 24 is bent.

Assuming that W (mm) is the width J (mm), the cathode current collector 21 L (mm), the length of the second positive electrode active material layer 23 and the length of the first positive electrode active material layer 22, effective reaction area R (mm²) becomes $R = (L + J) \times W$.

Further, assuming that n is the number (mm²), the positive electrode lead B the cross-sectional area of the positive electrode 20 including 22 21 positive electrode current collector, the first positive electrode active material layer, a second electrode active material layer 23, the ratio L thereof / 2000-8000 is preferable that the (B × n).

Figure 8 is a cross-sectional view of line I-I in FIG.

Further, Figure 9 is a cross-sectional view of line II-II of FIG.

Here, assuming that S is the cross-sectional area of the positive electrode current collector 21 (mm²), the positive electrode lead C cross-sectional area of the cathode lead 24, the ratio thereof $(C \times n) / S$ be at or more.

FIG 10 is a perspective view showing another embodiment of the positive lead of FIG.

In Figure 10, to form a cathode lead 25 by welding a tab on the end of the cathode current collector 21.

Be in the form of Figure 10, the ratio $L / (B \times n)$ referred to above, the preferred range of the ratio $(C \times n) / S$ are the same.

Hereinafter, the present invention will be described with reference to Examples, but the present invention is not intended to be limited to the following examples.

(Example 1) LiCoO₂ positive electrode active material is a <Production of Positive Electrode>: 80 parts by weight of acetylene black as a conductive auxiliary agent; 10 parts by weight of polyvinylidene fluoride as a binder (PVDF); in 5 parts by weight, N-methyl-2-pyrrolidone (NMP), to prepare a positive electrode mixture-containing paste is mixed until uniform.

To both sides of an aluminum foil with 20 μ m in thickness as the positive electrode current collector, the active material coating length 1221mm, the back side is applied in a 1155mm active material coating length on the front side, the positive electrode mixture-containing paste, dry.

Then, by performing the calender process to adjust the thickness of the electrode total thickness so as to 134 μ m, and is cut so that the width of 3.0mm, thereby preparing a positive electrode of the strip.

At both ends of the positive electrode of the strip was made, the active material uncoated portion is formed.

Here, the surface of the positive electrode current collector refers to the outer peripheral side of the case of forming a wound body, and the back side, a negative electrode refers to the inner peripheral side of the case of forming a wound body, will be described later. The same applies to the current collector.

Graphite negative-electrode active material <Preparation of Negative Electrode>: 90 parts by weight, PVDF as the binder; and the 5 parts by weight, by adding a solvent NMP, and prepare a negative electrode mixture-containing paste is mixed to form a uniform were.

To both sides of a copper foil with 12 μ m in thickness as a negative electrode current collector, the active material coating length 1207mm, the back side is applied in a 1207mm active material coating length on the front side, the negative electrode mixture-containing paste, dry.

Then, by performing the calender process to adjust the thickness of the electrode total thickness so as to 142 μ m, and is cut so that the width of 3.5mm, thereby preparing a negative electrode of the strip.

At both ends of the negative electrode strip was prepared, the active material uncoated portion is formed.

Between the positive and negative electrode of the strip was made as described above <Preparation of the wound body>, by winding by placing 20 μ m in thickness, a separator made of a microporous polyethylene film of width 4.3mm, I was making a winder.

Wound body was formed so as to face the negative electrode active material coating portion all of the positive electrode active material coating portion on both sides of the positive electrode.

Then removed from the folded end portion of the outer peripheral side of the wound body, the aluminum foil of the active material uncoated portion of the positive electrode, to form a single electrode lead.

Further, the taken out from the folded end portion (center side) inner peripheral side of the wound body, a copper foil of the active material uncoated portion of the negative electrode, to form a single anode lead.

The outer diameter D of the winding body, which was manufactured height, H 23.5mm, the winder is 6 3.7mm, the ratio D / H thereof.

Was 4.

In addition, 398mm², effective reaction area R is 7128mm², 17 the ratio R / A These area A of the upper surface portion of the winder.

Was 9.

Mixed solvent (EC) and diethyl carbonate (DEC) <Preparation of electrolyte> ethylene carbonate (EC: mixing volume ratio of DEC 1:2) preparing an electrolytic solution was 1.2mol / L LiPF₆ dissolved in were.

The battery can of aluminum outer diameter 24mm <manufacture of battery>, 5.0mm height, 0.25mm thickness aspect, of 0.3mm thick bottom, the lid of the aluminum diameter 24mm, thickness of 0.4mm was prepared.

The center of the lid, the negative electrode terminal made of nickel having a diameter of 6mm is fitted through a packing made of polypropylene.

Then, the bottom of the battery can, and placed the lower insulating plate made of PPS of 0.05mm thick, the direction of the winding axis winder becomes the same as the height direction of the battery can, the I was inserted into the battery can the winder.

Then, after placing an upper insulating plate made of PPS of 0.05mm thickness on top of the wound body was welded to the back side of the negative electrode terminal and the negative lead.

Were then joined by laser welding a lid and the battery can while sandwiched between the lid and the battery can and the positive electrode lead.

Finally, after which it is poured in the electrolyte solution from the injection port with a diameter of 1.5mm provided in the cap and impregnated sufficiently electrolyte solution to the electrode body, and the laser is inserted into the injection port sealing pin by sealing by welding, cell volume secondary battery was produced coin-type lithium ion 2.3cm³.

(Example 2) except that 162μm total thickness surface 678mm, rear side 624mm, calendar treatment, and was 2.0mm width 25μm, the active material coated length the thickness of the positive electrode current collector <Preparation of Positive Electrode> and thereby producing a positive electrode in the same manner as in Example 1.

Except that the 177μm total thickness surface 667mm, rear side 667mm, calendar treatment, and was 2.5mm width 20μm, the active material coated length the thickness of the negative electrode current collector <Preparation of Negative Electrode>, Example 1 thereby producing a negative electrode in the same manner as.

Was used instead of the negative electrode and the positive electrode, and a 3.3mm width of the separator, using the battery can outer diameter 20mm, the 4.0mm height, in the same manner as in Example 1, a battery volume of 1.3cm³ secondary battery was produced in coin-shaped non-aqueous electrolyte solution.

The outer diameter D of the winding body of the present embodiment, H height 19.5mm, the winder is 7 2.7mm, the ratio D / H thereof.

Was 2.

In addition, 269mm², effective reaction area R is 2604mm², 9 the ratio R / A These area A of the upper surface portion of the winder.

Was 7.

(Example 3) except that the 115 μ m total thickness surface 3146mm, back side 3047mm, calendar treatment, and the 3.5mm width of the active material coating length <Preparation of Positive Electrode>, the cathode in the same manner as in Example 1 I was prepared.

Except that the 122 μ m total thickness surface 3121mm, back side 3121mm, the calendar treatment, to obtain a 4.0mm width of the active material coating length <Preparation of Negative Electrode>, in the same manner as in Example 1 to prepare a negative electrode.

Was used instead of the negative electrode and the positive electrode, and a 4.8mm width of the separator, using the battery can outer diameter 35mm, the 5.5mm height, in the same manner as in Example 1, a battery volume of 5.3cm³ l secondary battery was produced in coin-shaped non-aqueous electrolyte solution.

The outer diameter D of the winding body of the present embodiment, H height 34.5mm, the winder is 8 4.2mm, the ratio D / H thereof.

Was 2.

In addition, 881mm², effective reaction area R is 21676mm², 24 the ratio R / A These area A of the upper surface portion of the winder.

Was 6.

(Comparative Example 1) except for using 89 μ m total thickness surface 1750mm, back side 1685mm, the calendar treatment after the active material coating length <Preparation of Positive Electrode>, and a positive electrode was prepared in the same manner as in Example 1.

Except for using 91 μ m total thickness surface 1735mm, back side 1735mm, the calendar treatment after the active material coating length <Preparation of Negative Electrode>, to produce a negative electrode in the same manner as in Example 1.

But using the negative electrode and the positive electrode, in the same manner as in Example 1, cell volume secondary battery was manufactured coin-type non-aqueous electrolyte solution of 2.3cm³.

The outer diameter D of the winding body of the present Comparative Example, H height 23.5mm, the winder is 6 3.7mm, the ratio D / H thereof.

Was 4.

In addition, 398mm², effective reaction area R is 10305mm², 25 the ratio R / A These area A of the upper surface portion of the winder.

Was 9.

(Comparative Example 2) except that 185 μ m total thickness surface 603mm, rear side 548mm, calendar treatment, and was 2.0mm width 25 μ m, the active material coated length the thickness of the positive electrode current collector <Preparation of Positive Electrode> and thereby producing a positive electrode in the same manner as in Example 1.

Except that the 203 μ m total thickness surface 592mm, rear side 592mm, calendar treatment, and was 2.5mm width 20 μ m, the active material coated length the thickness of the negative electrode current collector <Preparation of Negative Electrode>, Example 1 thereby producing a negative electrode in the same manner as.

Was used instead of the negative electrode and the positive electrode, and a 3.3mm width of the separator, using the battery can outer diameter 20mm, the 4.0mm height, in the same manner as in Example 1, a battery volume of 1.3cm³ l secondary battery was produced in coin-shaped non-aqueous electrolyte solution.

The outer diameter D of the winding body of the present Comparative Example, H height 19.5mm, the winder is 7 2.7mm, the ratio D / H thereof.

Was 2.

In addition, 269mm², effective reaction area R is 2302mm², 8 the ratio R / A These area A of the upper surface portion of the winder.

Was 6.

Are shown in Table 1 and Table 2 the size of the positive and negative electrodes 1 and 2 and Comparative Examples 1 to 3.

I also shown in Table 3 and Table 4 winder battery parameters and parameters of Comparative Examples 1 and 2 and Examples 1 to 3.

For each battery of Comparative Examples 1 and 2 and 1-3 Example <Evaluation of battery characteristics>, 0.

4 2C.

3V to perform the constant current charging, then the current value is 0.

Was subjected to constant voltage charging until the 0.2C.

Then, 0.

3 2C.

I asked (a) initial capacity 0V to perform the constant current discharge.

The "C" means the current value when it is discharged in one hour design capacity of the battery.

Subsequently, to 0 each battery.

4 2C.

3V to perform the constant current charging, then the current value is 0.

Was subjected to constant voltage charging until the 0.2C.

Then, 3 2C.

I asked (b) heavy load capacity 0V to perform the constant current discharge.

Is determined from the following equation capacity retention ratio Z (%) From the above results, it was evaluated as the discharge load characteristics.

$$Z = (b / a) \times 100$$

I are shown in Table 5 along with the parameters R / A parameters and D / H, and the battery characteristics.

I went to then charge-discharge cycle test <evaluation cycle characteristics>.

For each battery, charging 0.

4 5C.

3V to perform the constant current charging, then the current value is 0.

Was subjected to constant voltage charging until the 0.2C.

Discharge, 3 1C.

I was subjected to constant current discharge to 0V.

I repeated up to 200 cycles of charge and discharge this.

Next, the visually observed appearance of the battery, it was confirmed whether or not the deformation of the battery.

I are shown in Table 5.

From Table 5, Examples 1 to 3 in the range of 9-25 parameters R / A and that (heavy load characteristics) high capacity retention ratio Z as compared with Comparative Examples 1 and 2 is in the range understand.

Further, there was no any deformation of the battery can be repeated 200 times to charge and discharge in the batteries of Comparative Examples 1 and 2 and Examples 1 to 3.

As described above, the present invention can provide a secondary battery coin-shaped non-aqueous electrolyte solution discharge load characteristics is high, no deformation of the battery due to charging and discharging.

Not only the power of the wearable device for secondary battery coin-shaped non-aqueous electrolyte solution, can be widely used as power sources for various equipment.

It is a perspective view of the wound body used in the present invention.

Is a perspective view showing a step of being inserted into a battery can of a cylindrical winder.

Is a perspective view after it is inserted into the battery can winder, showing the steps that are disposed an upper insulating plate on a winder.

Is a perspective view of a state where welded to the anode lead and the back portion of the negative terminal is placed on the wound body and insulating plate, which is disposed in the central portion of the lid.

5A is a perspective view of a state joined by laser welding or the like and the lid and battery can, FIG 5B is a cross-sectional view of line B-B in FIG 5A.

And is a schematic diagram of the winder.

Is a schematic diagram of the positive electrode for describing the parameters of the present invention.

Is a cross-sectional view of line I-I in FIG.

Is a cross-sectional view of line II-II of FIG.

Is a perspective view showing another embodiment of the positive lead of FIG.

18 injection port 19 lower insulating plate 20 positive electrode 21 positive electrode current collector 22 first positive electrode 17 insulating packing the positive electrode 1 2 3 negative electrode separator 10 winder 11 positive electrode lead 12 negative electrode lead 13 battery can 14 upper insulating plate 15 cover the negative electrode terminal 16 active material layer 23 second positive electrode active material layer 24 cathode lead 25 positive lead

II. CLAIMS JP 2008-262825

(1).

A secondary battery coin-shaped non-aqueous electrolyte solution comprising a positive electrode of the strip, and the strip-shaped negative electrode, a separator strip, the battery can of the coin,

The positive electrode and the negative electrode, to constitute a wound body of the cylindrically wound through the separator,

Direction winding axis of the wound body is, is the same as the direction of the height of the battery can,

Outer diameter D of the Kai-tai and (mm), the ratio D / H of the (mm) H height direction winding axis of the winding wound body, wherein the 1 to 25.

The ratio R / A effective reaction area R in which the area A of the upper surface portion of the Kai-tai and (mm²), the positive electrode and the negative electrode winding the faces and (mm²) is a feature that is 9-25 secondary battery coin non-aqueous electrolyte solution to be.

(2).

The ratio D / H is 1.

Secondary battery coin non-aqueous electrolyte solution according to claim 1 is 5 to 23.

(3).

The volume of the secondary battery of the coin-shaped non-aqueous electrolyte secondary battery coin-shaped non-aqueous electrolyte solution according to claim 1, wherein at least 1cm³ 7cm³ less.

(4).

Outer diameter of the battery can, two battery coin non-aqueous electrolyte solution according to claim 1, wherein at least 20mm 50mm or less.

(5).

The negative electrode and the positive electrode, a secondary battery coin-shaped non-aqueous electrolyte solution according to claim 1 which is capable of absorbing and desorbing lithium ions.

(19)



JAPANESE PATENT OFFICE

PATENT ABSTRACTS OF JAPAN

(11) Publication number: 2008262825 A

(43) Date of publication of application: 30.10.08

(51) Int. Cl.	H01M 10/36	20060101
	H01M 2/02	20060101

(21) Application number: 2007105148

(22) Date of filing: 12.04.07

(71) Applicant: HITACHI MAXELL LTD

(72) Inventor: HIGUCHI ISATO
NAKAZAWA KAZUYUKI
SANO KENICHI

(54) COIN-SHAPED NONAQUEOUS ELECTROLYTIC SOLUTION SECONDARY BATTERY 9-25.

COPYRIGHT: (C)2009,JPO&INPIT

(57) Abstract:

PROBLEM TO BE SOLVED: To provide a coin-shaped nonaqueous electrolytic solution secondary battery high in discharge load characteristics and free of deformation of the battery accompanied with charge and discharge.

SOLUTION: As for the coin-shaped nonaqueous electrolytic solution secondary battery, a cylindrical wound-around body 10 is constituted by means that a belt form positive electrode 1 and a belt form negative electrode 2 are wound via a belt form separator 3, a wound-around shaft direction of the wound-around body 10 is the same as the height direction of a battery can 13, the ratio D/H between the outer diameter D (mm) of the wound body 10 and the height H (mm) of the wound-around shaft direction of the wound body 10 is 1-25, and the ratio R/A between the area A (mm²) of the upper face part of the wound body 10 and the reaction effective area R (mm²) where the positive electrode 1 and the negative electrode 2 are opposed is

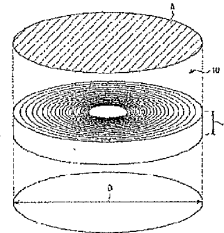

(19) 日本国特許庁(JP)

(12) 公開特許公報(A)

(11) 特許出願公開番号

特開2008-262825

(P2008-262825A)

(43) 公開日 平成20年10月30日(2008.10.30)

(51) Int. Cl.	F 1	テーマコード (参考)
HO 1M 10/36 (2006.01)	HO 1M 10/00 118	5HO11
HO 1M 2/02 (2006.01)	HO 1M 10/00 103	5HO29
	HO 1M 2/02 J	
	HO 1M 10/00 111	

審査請求 未請求 請求項の数 5 O L (全 14 頁)

(21) 出願番号	特願2007-105148 (P2007-105148)	(71) 出願人	000005810 日立マクセル株式会社 大阪府茨木市丑寅1丁目1番88号
(22) 出願日	平成19年4月12日 (2007.4.12)	(74) 代理人	110000040 特許業務法人池内・佐藤アンドパートナーズ
		(72) 発明者	樋口 勇人 大阪府茨木市丑寅1丁目1番88号 日立マクセル株式会社内
		(72) 発明者	中澤 一幸 大阪府茨木市丑寅1丁目1番88号 日立マクセル株式会社内
		(72) 発明者	佐野 健一 大阪府茨木市丑寅1丁目1番88号 日立マクセル株式会社内

最終頁に続く

(54) 【発明の名称】 コイン形非水電解液二次電池

(57) 【要約】

【課題】 放電負荷特性が高く、充放電に伴う電池の変形もないコイン形非水電解液二次電池を提供する。

【解決手段】 本発明のコイン形非水電解液二次電池は、帯状の正極1と帯状の負極2とが、帯状のセパレータ3を介して捲回されて円筒状の捲回体10を構成し、捲回体10の捲回軸方向は、電池缶13の高さ方向と同一であり、捲回体10の外径D (mm) と、捲回体10の捲回軸方向の高さH (mm) との比D/Hは、1~2.5であり、捲回体10の上表面の面積A (mm²) と、正極1と負極2とが対向している反応有効面積R (mm²) との比R/Aは、9~2.5であることを特徴とする。

【選択図】 図6

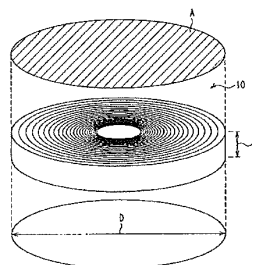

【特許請求の範囲】

【請求項 1】

帯状の正極と、帯状の負極と、帯状のセパレータと、コイン形の電池缶とを含むコイン形非水電解液二次電池であって、

前記正極と前記負極とは、前記セパレータを介して捲回されて円筒状の捲回体を構成し

、前記捲回体の捲回軸方向が、前記電池缶の高さ方向と同一であり、

前記捲回体の外径 D (mm) と、前記捲回体の捲回軸方向の高さ H (mm) との比 D/H が、 $1 \sim 2.5$ であり、

前記捲回体の上面部の面積 A (mm²) と、前記正極と前記負極とが対向している反応有効面積 R (mm²) との比 R/A が、 $9 \sim 2.5$ であることを特徴とするコイン形非水電解液二次電池。 10

【請求項 2】

前記比 D/H が、 $1.5 \sim 2.3$ である請求項 1 に記載のコイン形非水電解液二次電池。

【請求項 3】

前記コイン形非水電解液二次電池の体積が、 1 cm^3 以上 7 cm^3 以下である請求項 1 に記載のコイン形非水電解液二次電池。

【請求項 4】

前記電池缶の外径が、 20 mm 以上 50 mm 以下である請求項 1 に記載のコイン形非水電解液二次電池。 20

【請求項 5】

前記正極及び前記負極は、リチウムイオンを吸蔵・放出可能である請求項 1 に記載のコイン形非水電解液二次電池。

【発明の詳細な説明】

【技術分野】

【0001】

本発明は、放電負荷特性が高いコイン形非水電解液二次電池に関する。

【背景技術】

【0002】

コイン形リチウムイオン二次電池に代表されるコイン形非水電解液二次電池は、ボタン形又は扁平形非水電解液二次電池とも呼ばれ、ヘッドホンセット、時計型通信機器、身体取付型医療機器等の人が身につけて使用するいわゆるウェアラブル機器等に用いる重負荷対応の小型電池として注目されている。 30

【0003】

従来のコイン形リチウムイオン二次電池としては、例えば、円形に打ち抜いた正極と負極とを 1 枚づつセパレータを介して積層した電極体を用いたものがある。しかし、このタイプの電池では、電極が厚くなるため、電極の厚さ方向に対するリチウムイオンの拡散抵抗が増加して、放電負荷特性が低下する欠点があり、低出力の用途にしか使用できないという問題がある。

【0004】

上記問題を解決するために、帯状の正極と、帯状の負極とを、帯状のセパレータを介して捲回した電極体を用いることにより、電極を薄くする方法が提案されている（例えば、特許文献 1、特許文献 2、特許文献 3、特許文献 4 参照。）。 40

【特許文献 1】特開 2003-77543 号公報

【特許文献 2】特開 2005-310578 号公報

【特許文献 3】特開平 11-345626 号公報

【特許文献 4】特開平 11-354150 号公報

【発明の開示】

【発明が解決しようとする課題】

【0005】

50

特許文献1及び特許文献2に提案されている電池では、帯状の正極と、帯状の負極とを、帯状のセパレータを介して捲回して電極体を形成し、その電極体を扁平状に成形した後、電極体の捲回軸方向と電池缶の高さ方向（厚さ方向）とが直交した状態で、電極体を電池缶に挿入している。この場合、電池缶内の電極体は、電池の高さ方向から見て四角状に形成されているため、電極体と電池缶との間に隙間が生じ、容積ロスが生じる問題がある。また、この電極構造では、電池の充放電に伴う電極の膨張・収縮方向が電池缶の高さ方向と一致するため、充放電を繰り返すと電池が高さ方向に変形するおそれもある。

【0006】

一方、特許文献3及び特許文献4に提案されている電池では、電極体の捲回軸方向と、電池缶の高さ方向とが同一であるため、電極体と電池缶との間に隙間が生ぜず、また、電池の充放電に伴う電極の膨張・収縮方向が電池缶の径方向と一致するため、充放電を繰り返しても電池が変形するおそれもない。

【0007】

しかし、特許文献3及び特許文献4では、単に電極構造が開示されているのみであり、重負荷特性の向上のための具体的構成が一切開示されていない。もちろん、特許文献1及び特許文献2にも重負荷特性の向上のための具体的構成は一切開示されていない。

【0008】

本発明は上記問題を解決したもので、放電負荷特性が高いコイン形非水電解液二次電池を提供するものである。

【課題を解決するための手段】

【0009】

本発明のコイン形非水電解液二次電池は、帯状の正極と、帯状の負極と、帯状のセパレータと、コイン形の電池缶とを含むコイン形非水電解液二次電池であって、前記正極と前記負極とは、前記セパレータを介して捲回されて円筒状の捲回体を構成し、前記捲回体の捲回軸方向が、前記電池缶の高さ方向と同一であり、前記捲回体の外径Dと、前記捲回体の捲回軸方向の高さHとの比D/Hが、1～2.5であり、前記捲回体の上面部の面積Aと、前記正極と前記負極とが対向している反応有効面積Rとの比R/Aが、9～2.5であることを特徴とする。

【発明の効果】

【0010】

本発明によると、放電負荷特性が高く、充放電に伴う電池の変形もないコイン形非水電解液二次電池を提供できる。

【発明を実施するための最良の形態】

【0011】

以下、本発明のコイン形非水電解液二次電池の実施形態を説明する。

【0012】

本発明のコイン形非水電解液二次電池は、帯状の正極と、帯状の負極と、帯状のセパレータと、コイン形の電池缶とを備え、正極と負極とは、セパレータを介して捲回されて円筒状の捲回体を構成している。この構造により、電極を薄くでき、放電負荷特性をある程度向上できる。

【0013】

また、上記捲回体の捲回軸方向は、電池缶の高さ方向と同一とされている。この構造により、電極の膨張・収縮方向と、強度的に強固な電池缶の径方向とが一致し、充放電を繰り返しても電池の変形を防止できる。

【0014】

また、上記捲回体の外径Dと、捲回体の捲回軸方向の高さHとの比D/H（扁平度）は、1～2.5に設定されている。D/Hが1未満では、コイン形電池とはいえ、薄型小型で高容量が要求されるウェアラブル機器用のコイン形非水電解液二次電池には適さない。

【0015】

また、D/Hが2.5を超えると、通常の電池設計の許容範囲を逸脱する。即ち、電極を

捲回する製造工程に耐え得る電極幅は最低でも約2mmは必要であるため、捲回体の捲回軸方向の高さHの最小値は2mmである。また、電池を搭載する機器の大きさから、捲回体の外径Dの最大値は50mmと考えられる。このため、D/Hの最大値は2.5となる。さらに、電池を搭載する機器に必要な電池容量を考慮するとD/Hは1.5~2.3がより好ましい。

【0016】

また、本発明のコイン形非水電解液二次電池では、上記捲回体の上面部の面積Aと、上記正極と上記負極とが対向している反応有効面積Rとの比R/Aは、9~2.5に設定され、より好ましくは1.5~2.0に設定される。これにより、放電負荷特性をさらに向上でき、重負荷特性が要求される各種機器用の電池として最適となる。ここで、反応有効面積Rは、捲回された正極と負極の活物質層同士が対向している面積をいい、通常リチウムイオン二次電池では、充電時にリチウムデンドライトが生じないように、負極活物質層の面積を正極活物質層の面積よりも大きくし、正極活物質層の全面が負極活物質層に対向しているため、反応有効面積は、実質的には正極活物質層が設けられている部分の面積となる。

10

【0017】

また、本発明のコイン形非水電解液二次電池の体積は、1cm³以上7cm³以下であることが好ましい。この範囲内であれば、薄型小型で高容量が要求されるウェアラブル機器用のコイン形非水電解液二次電池として最適となる。

【0018】

さらに、本発明のコイン形非水電解液二次電池は、電池缶の外径が、2.0mm以上5.0mm以下であることが好ましい。この範囲内であれば、上記と同様に薄型小型で高容量が要求されるウェアラブル機器用のコイン形非水電解液二次電池として最適となる。

20

【0019】

次に、本発明のコイン形非水電解液二次電池の一例を図面に基づき説明する。但し、図1~図10では、同一部分には同一の符号を付し、重複した説明は省略する場合がある。

【0020】

図1は、本発明に用いる捲回体の斜視図である。図1において、捲回体10は、帯状の正極と帯状の負極とを、帯状のセパレータを介して捲回して作製されている。

【0021】

上記正極は、正極活物質、正極用導電助剤、正極用バインダ等を含む混合物に、溶剤を加えて十分に混練して得た正極合剤ペーストを、正極集電体の両面に塗布して乾燥した後、その正極合剤層を所定の厚さ及び所定の電極密度に制御することにより形成できる。

30

【0022】

上記正極活物質としては、例えば、LiCoO₂等のリチウムコバルト酸化物、LiMn₂O₄等のリチウムマンガン酸化物、LiNiO₂等のリチウムニッケル酸化物等が使用できるが、リチウムイオンを吸蔵・放出可能であればこれらに限定はされない。

【0023】

上記正極集電体としては、構成された電池において実質的に化学的に安定な電子伝導体であれば特に限定されない。正極集電体としては、例えば、アルミニウム箔等が用いられる。

40

【0024】

正極集電体の一端部には正極合剤ペーストを塗布していない集電体露出部が設けられ、集電体露出部を折り返すことにより、正極リード11が形成されている。また、集電体露出部は、集電体の両端部に設けてもよく、正極リードも集電体の両端部に設けてもよい。さらに、集電体露出部を折り返して形成する上記正極リードに代えて、正極集電体の一端部又は両端部に別部品としてのタブを溶接して正極リードとしてもよい。

【0025】

上記負極は、負極活物質、負極用導電助剤、負極用バインダ等を含む混合物に、溶剤を加えて十分に混練して得た負極合剤ペーストを、負極集電体の両面に塗布して乾燥した後、その負極合剤層を所定の厚さ及び所定の電極密度に制御することにより形成できる。

50

【0026】

上記負極活物質としては、例えば、天然黒鉛又は塊状黒鉛、鱗片状黒鉛、土状黒鉛等の人造黒鉛等の炭素材料が用いられるが、リチウムイオンを吸蔵・放出可能であればこれらに限定はされない。

【0027】

上記負極集電体としては、構成された電池において実質的に化学的に安定な電子伝導体であれば特に限定されない。負極集電体としては、例えば、銅箔等が用いられる。

【0028】

負極集電体の一端部には負極合剤ペーストを塗布していない集電体露出部が設けられ、集電体露出部を折り返すことにより、負極リード12が形成されている。また、集電体露出部は、集電体の両端部に設けてもよく、負極リードも集電体の両端部に設けてもよい。さらに、集電体露出部を折り返して形成する上記負極リードに代えて、負極集電体の一端部又は両端部に別部品としてのタブを溶接して負極リードとしてもよい。

10

【0029】

図1では、正極リード11を捲回体10の外周側に設け、負極リード12を捲回体10の内周側に設けたが、正極リード11を捲回体10の内周側に設け、負極リード12を捲回体10の外周側に設けてもよく、また、正極リード11及び負極リード12をともに捲回体10の外周側に設けてもよい。

【0030】

上記セパレータとしては、大きなイオン透過度及び所定の機械的強度を有する絶縁性の微多孔性薄膜が用いられる。また、一定温度以上(100~140℃)で微孔を閉塞し、抵抗を上げる機能を有するものが、電池の安全性向上の点から好ましい。具体的には、上記セパレータとしては、耐有機溶剤性及び疎水性を有するポリプロピレン、ポリエチレン等のオレフィン系ポリマー又はガラス繊維からなるシート、不織布、織布、又はオレフィン系の粒子を接着剤で固着した多孔質体層等が用いられる。

20

【0031】

図2は、捲回体10を円筒状の電池缶13に挿入している工程を示す斜視図である。捲回体10は、その捲回軸方向Nが電池缶13の高さ方向Mと同一となるように、電池缶13に挿入される。電池缶13の材質は、アルミニウム等が用いられる。また、電池缶13の底部には、下部絶縁板(図示せず。)が配置されている。下部絶縁板の材質は特に限定されず、ポリフェニレンサルファイド(PPS)等の高分子材料を用いることができる。

30

【0032】

図3は、捲回体10を電池缶13に挿入した後に、捲回体10の上に上部絶縁板14を配置している工程を示す斜視図である。上部絶縁板14の材質は、上記下部絶縁板と同様の材質が使用できる。

【0033】

図4は、上部絶縁板14を捲回体10の上に載置し、蓋15の中央部に配置された負極端子16の裏部と負極リード12とを溶接した状態の斜視図である。蓋15と負極端子16とは、絶縁パッキング17によって絶縁されている。蓋15の材質は、電池缶13と同様にアルミニウム等が用いられる。負極端子16の材質は、ニッケル等が用いられる。絶縁パッキング17の材質は、ポリプロピレン(PP)等の高分子材料を用いることができる。

40

【0034】

図5Aは、電池缶13と蓋15とをレーザー溶接等により接合した状態の斜視図である。図5Bは、図5AのB-B線の断面図である。図5Bにおいて、蓋15と電池缶13とで形成された密閉容器内に捲回体10が収納され、電池缶13の底部には下部絶縁板19が配置されている。但し、図5Bでは、捲回体10の内周側の部分は断面にしていない。捲回体10は、前述のとおり、帯状の正極1と帯状の負極2とを、帯状のセパレータ3を介して渦巻状に捲回した構造を有している。また、正極リード11は、電池缶13と蓋15との間に挟まれた状態で接合されている。これにより、電池缶13及び蓋15が正極端

50

子として機能する。但し、電池缶 13 の材質によっては、電池缶 13 及び蓋 15 が負極となる場合もある。最後に、注液口 18 から、電解液を注液し、注液口 18 を封口体（図示せず。）によって封口すればコイン形非水電解液二次電池が完成する。

【0035】

上記電解液は、例えば、ビニレンカーボネート（VC）、プロピレンカーボネート（PC）、エチレンカーボネート（EC）、ブチレンカーボネート（BC）、ジメチルカーボネート（DMC）、ジエチルカーボネート（DEC）、メチルエチルカーボネート（MEC）、γ-ブチロラクトン等の有機溶媒を 1 種類又は 2 種類以上混合した溶媒に、例えば、 LiClO_4 、 LiPF_6 、 LiBF_4 、 LiAsF_6 、 LiSbF_6 、 LiCF_3SO_3 等から選ばれる少なくとも 1 種類のリチウム塩を溶解させた電解液を用いればよい。この電解液中の Li イオンの濃度は、 $0.5 \sim 1.5 \text{ mol/L}$ とすればよい。

10

【0036】

図 6 は、捲回体 10 の模式図である。図 6 では、正極リード及び負極リードの図示を省略している。捲回体 10 の外径 D (mm) と、捲回体 10 の捲回軸方向の高さ H (mm) との比 D/H は、 $1 \sim 2.5$ に設定されている。また、捲回体 10 の上面部の面積 A (mm^2) と、正極と負極とが対向している反応有効面積 R (mm^2) との比 R/A は、 $9 \sim 2.5$ に設定されている。

【0037】

図 7 は、本発明のパラメータを説明するための正極の模式図である。図 7 において、帯状の正極 20 の正極集電体 21 の両面には、第 1 正極活物質層 22 と、第 1 正極活物質層 22 より短く形成された第 2 正極活物質層 23 とが形成されている。正極活物質層が形成されていない正極集電体 21 の端部は折り曲げられて正極リード 24 を形成している。ここで、第 1 正極活物質層 22 の長さを L (mm)、第 2 正極活物質層 23 の長さを J (mm)、正極集電体 21 の幅を W (mm) とすると、反応有効面積 R (mm^2) は、 $R = (L + J) \times W$ となる。

20

【0038】

また、正極集電体 21、第 1 正極活物質層 22、第 2 正極活物質層 23 を含む正極 20 の断面積を B (mm^2)、正極リードの数を n とすると、これらの比 $L / (B \times n)$ は $2000 \sim 8000$ が好ましい。

【0039】

図 8 は、図 7 の I-I 線の断面図である。また、図 9 は、図 7 の II-II 線の断面図である。ここで、正極リード 24 の断面積を C (mm^2)、正極リードの数を n 、正極集電体 21 の断面積を S (mm^2) とすると、これらの比 $(C \times n) / S$ は 1 以上であることが好ましい。

30

【0040】

図 10 は、図 7 の正極リードの他の形態を示す斜視図である。図 10 では、正極集電体 21 の端部にタブを溶接することにより正極リード 25 を形成している。図 10 の形態であっても、上記した比 $L / (B \times n)$ 、比 $(C \times n) / S$ の好適範囲は同様である。

【実施例】

【0041】

以下、実施例に基づき本発明を説明するが、本発明は以下の実施例に限定されるものではない。

40

【0042】

(実施例 1)

<正極の作製>

正極活物質である LiCoO_2 : 80 重量部と、導電助剤であるアセチレンブラック: 10 重量部と、バインダであるポリフッ化ビニリデン (PVDF): 5 重量部とに、N-メチル-2-ピロリドン (NMP) を溶剤として加えて、均一になるように混合して正極合剤含有ペーストを調製した。この正極合剤含有ペーストを、正極集電体となる厚さ $20 \mu\text{m}$ のアルミニウム箔の両面に、表面側の活物質塗布長が 1221 mm 、裏面側の活物質

50

塗布長が1155mmになるように塗布し、乾燥した。その後、カレンダー処理を行って、全厚が134 μ mになるように電極の厚さを調整し、幅3.0mmになるように切断して、帯状の正極を作製した。作製した帯状の正極の両端部には、活物質未塗布部が形成されている。

【0043】

ここで、上記正極集電体の表面側とは、捲回体を形成した場合の外周側をいい、その裏面側とは、捲回体を形成した場合の内周側をいい、後述する負極集電体の場合も同様である。

【0044】

<負極の作製>

負極活物質である黒鉛：90重量部と、バインダであるPVDF：5重量部とに、NMPを溶剤として加えて、均一になるように混合して負極合剤含有ペーストを調製した。この負極合剤含有ペーストを、負極集電体となる厚さ12 μ mの銅箔の両面に、表面側の活物質塗布長が1207mm、裏面側の活物質塗布長が1207mmになるように塗布し、乾燥した。その後、カレンダー処理を行って、全厚が142 μ mになるように電極の厚さを調整し、幅3.5mmになるように切断して、帯状の負極を作製した。作製した帯状の負極の両端部には、活物質未塗布部が形成されている。

【0045】

<捲回体の作製>

上記のように作製した帯状の正極と負極との間に、厚さ20 μ m、幅4.3mmのポリエチレン製の微多孔性フィルムよりなるセパレータを配置して捲回して、捲回体を作製した。捲回体は、正極の両面の正極活物質塗布部が全て負極活物質塗布部と対向するように形成した。次に、正極の活物質未塗布部のアルミニウム箔を、捲回体の外周部側の端部より折り返して取り出し、正極リードを1本形成した。また、負極の活物質未塗布部の銅箔を、捲回体の内周部側（中心側）の端部より折り返して取り出し、負極リードを1本形成した。

【0046】

作製した捲回体の外径Dは、23.5mm、捲回体の高さHは3.7mm、これらの比D/Hは6.4であった。また、捲回体の上面部の面積Aは398mm²、反応有効面積Rは7128mm²、これらの比R/Aは17.9であった。

【0047】

<電解液の調製>

エチレンカーボネート（EC）とジエチルカーボネート（DEC）との混合溶媒（EC：DECの混合体積比は1：2）中にLiPF₆を1.2mol/L溶解させた電解液を調製した。

【0048】

<電池の作製>

外径24mm、高さ5.0mm、側面厚さ0.25mm、底面厚さ0.3mmのアルミニウム製の電池缶と、直径24mm、厚さ0.4mmのアルミニウム製の蓋を準備した。蓋の中央には、直径6mmのニッケル製の負極端子がポリプロピレン製のパッキングを介して嵌合されている。次に、上記電池缶の底部に、厚さ0.05mmのPPS製の下部絶縁板を配置した後、捲回体の捲回軸方向が電池缶の高さ方向と同一となるように、上記捲回体を電池缶内に挿入した。次に、捲回体の上部に厚さ0.05mmのPPS製の上部絶縁板を配置した後、負極リードを負極端子の裏側に溶接した。その後、正極リードを電池缶と蓋との間に挟んだまま電池缶と蓋とをレーザー溶接により接合した。

【0049】

最後に、蓋に設けられた直径1.5mmの注液口から上記電解液を注液し、電極体に電解液を十分に浸透させた後、封止ピンを注液口に挿入してレーザー溶接することにより封口して、電池体積が2.3cm³のコイン形リチウムイオン二次電池を作製した。

【0050】

(実施例 2)

<正極の作製>

正極集電体の厚さを $25 \mu\text{m}$ 、活物質塗布長を表面側 678mm 、裏面側 624mm 、カレンダー処理後の全厚を $162 \mu\text{m}$ 、幅を 2.0mm とした以外は、実施例 1 と同様にして正極を作製した。

【0051】

<負極の作製>

負極集電体の厚さを $20 \mu\text{m}$ 、活物質塗布長を表面側 667mm 、裏面側 667mm 、カレンダー処理後の全厚を $177 \mu\text{m}$ 、幅を 2.5mm とした以外は、実施例 1 と同様にして負極を作製した。

10

【0052】

上記正極及び上記負極を用い、セパレータの幅を 3.3mm とし、外径 20mm 、高さ 4.0mm の電池缶を用いた以外は、実施例 1 と同様にして、電池体積が 1.3cm^3 のコイン形非水電解液二次電池を作製した。

【0053】

本実施例の捲回体の外径 D は、 19.5mm 、捲回体の高さ H は 2.7mm 、これらの比 D/H は 7.2 であった。また、捲回体の上面部の面積 A は 269mm^2 、反応有効面積 R は 2604mm^2 、これらの比 R/A は 9.7 であった。

【0054】

(実施例 3)

<正極の作製>

活物質塗布長を表面側 3146mm 、裏面側 3047mm 、カレンダー処理後の全厚を $115 \mu\text{m}$ 、幅を 3.5mm とした以外は、実施例 1 と同様にして正極を作製した。

20

【0055】

<負極の作製>

活物質塗布長を表面側 3121mm 、裏面側 3121mm 、カレンダー処理後の全厚を $122 \mu\text{m}$ 、幅を 4.0mm とした以外は、実施例 1 と同様にして、負極を作製した。

【0056】

上記正極及び上記負極を用い、セパレータの幅を 4.8mm とし、外径 35mm 、高さ 5.5mm の電池缶を用いた以外は、実施例 1 と同様にして、電池体積が 5.3cm^3 のコイン形非水電解液二次電池を作製した。

30

【0057】

本実施例の捲回体の外径 D は、 34.5mm 、捲回体の高さ H は 4.2mm 、これらの比 D/H は 8.2 であった。また、捲回体の上面部の面積 A は 881mm^2 、反応有効面積 R は 21676mm^2 、これらの比 R/A は 24.6 であった。

【0058】

(比較例 1)

<正極の作製>

活物質塗布長を表面側 1750mm 、裏面側 1685mm 、カレンダー処理後の全厚を $89 \mu\text{m}$ とした以外は、実施例 1 と同様にして正極を作製した。

40

【0059】

<負極の作製>

活物質塗布長を表面側 1735mm 、裏面側 1735mm 、カレンダー処理後の全厚を $91 \mu\text{m}$ とした以外は、実施例 1 と同様にして負極を作製した。

【0060】

上記正極及び上記負極を用いた以外は、実施例 1 と同様にして、電池体積が 2.3cm^3 のコイン形非水電解液二次電池を作製した。

【0061】

本比較例の捲回体の外径 D は、 23.5mm 、捲回体の高さ H は 3.7mm 、これらの比 D/H は 6.4 であった。また、捲回体の上面部の面積 A は 398mm^2 、反応有効面

50

積Rは10305 mm²、これらの比R/Aは25.9であった。

【0062】

(比較例2)

<正極の作製>

正極集電体の厚さを25 μm、活物質塗布長を表面側603 mm、裏面側548 mm、カレンダー処理後の全厚を185 μm、幅を2.0 mmとした以外は、実施例1と同様にして正極を作製した。

【0063】

<負極の作製>

負極集電体の厚さを20 μm、活物質塗布長を表面側592 mm、裏面側592 mm、カレンダー処理後の全厚を203 μm、幅を2.5 mmとした以外は、実施例1と同様にして負極を作製した。

【0064】

上記正極及び上記負極を用い、セパレータの幅を3.3 mmとし、外径20 mm、高さ4.0 mmの電池缶を用いた以外は、実施例1と同様にして、電池体積が1.3 cm³のコイン形非水電解液二次電池を作製した。

【0065】

本比較例の捲回体の外径Dは、19.5 mm、捲回体の高さHは2.7 mm、これらの比D/Hは7.2であった。また、捲回体の上面部の面積Aは269 mm²、反応有効面積Rは2302 mm²、これらの比R/Aは8.6であった。

【0066】

実施例1～3及び比較例1、2の正極及び負極の各寸法を表1及び表2にまとめて示す。

【0067】

【表1】

	正極寸法 (mm)			
	幅	活物質塗布長 (表面側/裏面側)	電極厚さ	集電体厚さ
実施例1	3.0	1221/1155	0.134	0.02
実施例2	2.0	678/624	0.162	0.025
実施例3	3.5	3146/3047	0.115	0.02
比較例1	3.0	1750/1685	0.089	0.02
比較例2	2.0	603/548	0.185	0.025

【0068】

【表2】

	負極寸法 (mm)			
	幅	活物質塗布長 (表面側/裏面側)	電極厚さ	集電体厚さ
実施例1	3.5	1207/1207	0.142	0.012
実施例2	2.5	667/667	0.177	0.02
実施例3	4.0	3121/3121	0.122	0.012
比較例1	3.5	1735/1735	0.091	0.012
比較例2	2.5	592/592	0.203	0.02

【0069】

また、実施例1～3及び比較例1、2の電池パラメータ及び捲回体パラメータを表3及び表4に示す。

【0070】

【表 3】

	電池パラメータ					
	電池外径 (mm)	電池高さ (mm)	電池体積 (cm ³)	捲回体外径D (mm)	捲回体高さH (mm)	D/H
実施例1	24	5.0	2.3	23.5	3.7	6.4
実施例2	20	4.0	1.3	19.5	2.7	7.2
実施例3	35	5.5	5.3	34.5	4.2	8.2
比較例1	24	5.0	2.3	23.5	3.7	6.4
比較例2	20	4.0	1.3	19.5	2.7	7.2

10

【0071】

【表 4】

	捲回体パラメータ		
	捲回体上面部面積A (mm ²)	反応有効面積R (mm ²)	R/A
実施例1	398	7128	17.9
実施例2	269	2604	9.7
実施例3	881	21676	24.6
比較例1	398	10305	25.9
比較例2	269	2302	8.6

20

【0072】

＜電池特性の評価＞

実施例1～3及び比較例1、2の各電池について、0.2Cで4.3Vまで定電流充電を行い、その後、電流値が0.02Cとなるまで定電圧充電を行った。次に、0.2Cで3.0Vまで定電流放電を行って初期容量(a)を求めた。なお、「C」とは、電池の設計容量を1時間で放電する場合の電流値を意味する。

【0073】

続いて、各電池を0.2Cで4.3Vまで定電流充電を行い、その後、電流値が0.02Cとなるまで定電圧充電を行った。次に、2Cで3.0Vまで定電流放電を行って重負荷容量(b)を求めた。

【0074】

上記結果から容量維持率Z(%)を下記式から求め、放電負荷特性として評価した。

【0075】

$$Z = (b/a) \times 100$$

【0076】

上記電池特性を、パラメータD/H及びパラメータR/Aとともに表5に示す。

【0077】

＜サイクル特性の評価＞

充放電サイクル試験を次に行なった。充電は各電池について、0.5Cで4.3Vまで定電流充電を行い、その後、電流値が0.02Cとなるまで定電圧充電を行った。放電は、1Cで3.0Vまで定電流放電を行った。この充放電を1サイクルとして200サイクルまで繰り返した。次に、電池の外観を目視により観察し、電池の変形の有無を確認した。その結果を表5に示す。

【0078】

30

40

【表 5】

	パラメータ		電池特性		サイクル特性
	D/H	R/A	初期容量 (mA h)	容量維持率Z (%)	電池変形の有無
実施例 1	6.4	17.9	220	90	無し
実施例 2	7.2	9.7	96	86	無し
実施例 3	8.2	24.6	585	87	無し
比較例 1	6.4	25.9	180	67	無し
比較例 2	7.2	8.6	99	56	無し

10

【0079】

表 5 から、パラメータ R/A が 9 ~ 25 の範囲内にある実施例 1 ~ 3 は、その範囲外にある比較例 1、2 に比べて容量維持率 Z (重負荷特性) が高いことが分かる。また、実施例 1 ~ 3 及び比較例 1、2 の各電池では充放電を 200 回繰り返しても電池の変形は一切認められなかった。

【産業上の利用可能性】

【0080】

以上説明したように、本発明は、放電負荷特性が高く、充放電に伴う電池の変形もないコイン形非水電解液二次電池を提供できる。このコイン形非水電解液二次電池は、ウェアラブル機器用の電源だけでなく、様々な機器の電源として広く利用できる。

20

【図面の簡単な説明】

【0081】

【図 1】本発明に用いる捲回体の斜視図である。

【図 2】捲回体を円筒状の電池缶に挿入している工程を示す斜視図である。

【図 3】捲回体を電池缶に挿入した後に、捲回体の上に上部絶縁板を配置している工程を示す斜視図である。

【図 4】上部絶縁板を捲回体の上に載置し、蓋の中央部に配置された負極端子の裏部と負極リードとを溶接した状態の斜視図である。

【図 5】図 5 A は、電池缶と蓋とをレーザー溶接等により接合した状態の斜視図であり、図 5 B は、図 5 A の B-B 線の断面図である。

30

【図 6】捲回体の模式図である。

【図 7】本発明のパラメータを説明するための正極の模式図である。

【図 8】図 7 の I-I 線の断面図である。

【図 9】図 7 の II-II 線の断面図である。

【図 10】図 7 の正極リードの他の形態を示す斜視図である。

【符号の説明】

【0082】

- 1 正極
- 2 負極
- 3 セパレータ
- 10 捲回体
- 11 正極リード
- 12 負極リード
- 13 電池缶
- 14 上部絶縁板
- 15 蓋
- 16 負極端子
- 17 絶縁パッキング
- 18 注液口

40

50

- 1 9 下部絶縁板
- 2 0 正極
- 2 1 正極集電体
- 2 2 第1正極活物質層
- 2 3 第2正極活物質層
- 2 4 正極リード
- 2 5 正極リード

【図1】

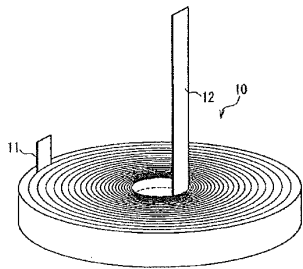

【図2】

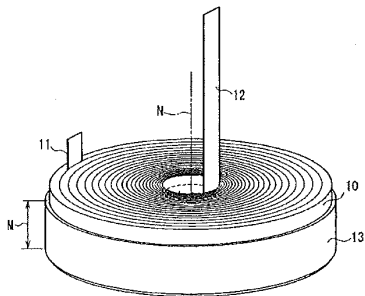

【図3】

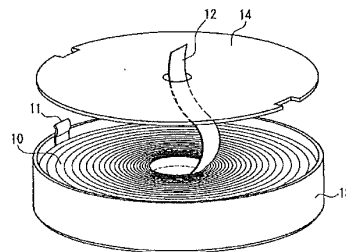

【図4】

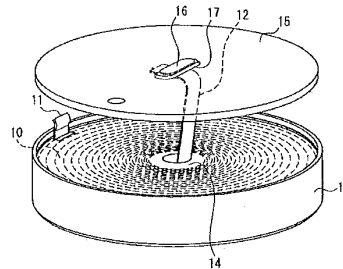

【 図 5 】

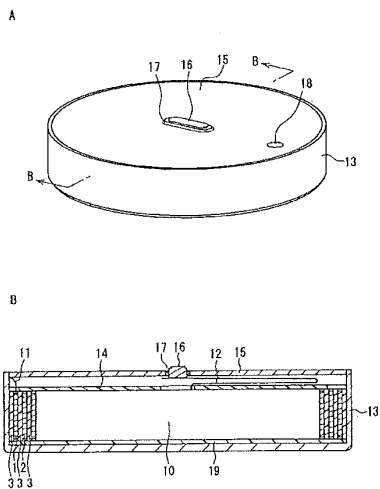

【 図 6 】

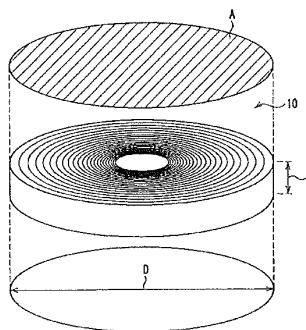

【 図 7 】

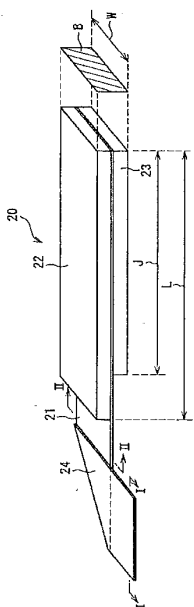

【 図 9 】

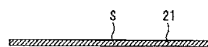

【 図 10 】

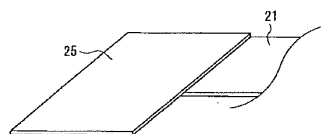

【 図 8 】

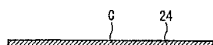

フロントページの続き

Fターム(参考) 5H011 AA03 CC06 KK01
5H029 AJ02 AK03 AL07 AM03 AM05 AM07 BJ03 BJ14 DJ02 EJ01
HJ00 HJ04 HJ07



(11) **EP 1 968 134 A1**

(12) **EUROPEAN PATENT APPLICATION**

(43) Date of publication:
10.09.2008 Bulletin 2008/37

(51) Int Cl.:
H01M 2/00 (2006.01) H01M 10/40 (2006.01)

(21) Application number: **08154358.9**

(22) Date of filing: **27.04.2006**

(84) Designated Contracting States:
DE FR GB

(30) Priority: **27.04.2005 KR 20050035301**
18.05.2005 KR 20050041422

(62) Document number(s) of the earlier application(s) in accordance with Art. 76 EPC:
06113177.7 / 1 717 878

(71) Applicant: **Samsung SDI Co., Ltd.**
Suwon-si
Gyeonggi-do (KR)

(72) Inventors:

- **Kim, Jongku**
Gyeonggi-do (KR)
- **Woo, Soonki**
Gyeonggi-do (KR)

- **Kim, Jinwook**
Gyeonggi-do (KR)
- **Chang, Younhan**
Gyeonggi-do (KR)
- **Nam, Sangbong**
Gyeonggi-do (KR)

(74) Representative: **Hengelhaupt, Jürgen et al**
Anwaltskanzlei
Gulde Hengelhaupt Ziebig & Schneider
Wallstrasse 58/59
10179 Berlin (DE)

Remarks:
This application was filed on 11-04-2008 as a divisional application to the application mentioned under INID code 62.

(54) **Core member for a cylindrical lithium secondary battery**

(57) The invention is directed to a cylindrical lithium secondary battery (200) comprising:
 an electrode assembly (300) which has a first electrode plate (310), a second electrode plate (320), and a separator (330) provided between the first electrode plate (310) and the second electrode plate (320), and has a central space at the center of winding;
 a core member (800, 900) which is formed in a tube shape having a cut-groove (810, 910) along a longitudinal direction, and includes at least one notch (830, 930) formed in a longitudinal direction at an inner lateral surface of the tube shape;
 a case (400) which has a space for containing the electrode assembly (300) and including an open portion; and
 a cap assembly (500) which is connected to the open portion of the case (400) so as to seal the case (400).

FIG. 4B

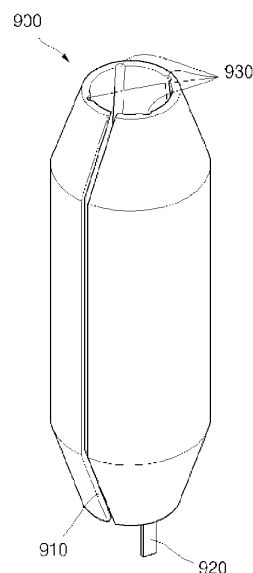

EP 1 968 134 A1

Description

BACKGROUND OF THE INVENTION

1. Field of the Invention

[0001] Aspects of the present invention relate to a cylindrical lithium ion secondary battery, and more particularly, to a cylindrical lithium ion secondary battery having an improved stability with respect to external pressure.

2. Description of the Related Art

[0002] In general, a cylindrical lithium ion secondary battery includes an electrode assembly that is wound substantially in the form of a cylinder, a cylindrical can that is connected to the electrode assembly, an electrolytic solution that is infused inside the can to allow lithium ions to move, and a cap assembly that is connected to one side of the can and prevents the electrolytic solution from leaking and prevents the electrode assembly from separating.

[0003] The cylindrical lithium ion secondary battery typically has a capacity of approximately 2000 to 2400mA, and thus is mainly used in electronic devices requiring high power such as notebook PCs, digital cameras, or camcorders. For example, a required number of cylindrical lithium ion secondary batteries may be connected in series or parallel, may include a protection circuit, and may be assembled in a specific shape in a hard pack to be used as a power source connected to an electronic device.

[0004] The cylindrical lithium ion secondary battery is manufactured by the following method.

[0005] First, a negative electrode plate that includes an active material and a positive electrode plate that includes a separator and the active material are laminated together. One end thereof is then connected to a pole-shaped wind-axis, and is then wound in a substantial cylindrical shape, thereby forming an electrode assembly. Thereafter, the electrode assembly is inserted into a cylindrical can, an electrolytic solution is then infused therein, and a cap assembly is welded at an upper portion of the cylindrical can, thereby forming a lithium ion secondary battery having a substantial cylindrical shape.

[0006] Recently, a core member 100 having a substantial pole shape as shown in FIG. 1 has been inserted in the center of the electrode assembly, so that the electrode assembly is not deformed when the cylindrical lithium ion secondary battery is charged or discharged. The core member 100 is generally formed by winding a material that initially has a form of a plate, so that a tube shape having a circular cross-section is formed. A portion thereof is cut along a longitudinal direction.

[0007] However, in the cylindrical lithium ion secondary battery above, the core member 100 may move due to an external impact such as a drop. The movement of the core member 100 may affect the cap assembly lo-

cated at an upper portion of the core member 100. In particular, when the core member 100 collides with a safety belt of the cap assembly, the safety belt may be inverted or damaged. If the safety belt is inverted or damaged, it may severely affect a safety of a lithium secondary battery.

[0008] Further, when the core member 100 rotates, a lower end of the electrode assembly may come in contact with the core member 100, and thus a short may occur at the lower end of the electrode assembly.

[0009] Furthermore, when the core member 100 is deformed or damaged, the separator of the electrode assembly may be damaged, and the damage to the separator may lead to a short between the positive electrode plate and the negative electrode plate, which may produce even greater damage or an explosion of the cylindrical lithium ion secondary battery. In particular, when external pressure is applied, the core member 100 may be deformed in a specific direction at a point where the external pressure is concentrated. The electrode assembly receives the pressure in the specific direction, thereby producing a short between the electrode plates.

SUMMARY OF THE INVENTION

[0010] Aspects of the present invention provide a cylindrical lithium ion secondary battery having an improved safety with respect to an external pressure.

[0011] According to the present invention, a core member insertable into a central space of an electrode assembly of a cylindrical lithium secondary battery has a tubular shape, has a cut-groove along a longitudinal direction, and includes at least one notch formed in a longitudinal direction at an inner lateral surface of the core member. More precisely, the cylindrical lithium secondary battery comprising:

an electrode assembly which has a first electrode plate, a second electrode plate, and a separator provided between the first electrode plate and the second electrode plate, and

has a central space at the center of winding;

a core member which is formed in a tube shape having a cut-groove along a longitudinal direction, and includes at least one notch formed in a longitudinal direction at an inner lateral surface of the tube shape;

a case which has a space for containing the electrode assembly and including an open portion; and

a cap assembly which is connected to an open portion of the case so as to seal the case.

BRIEF DESCRIPTION OF THE DRAWINGS

[0012] These and/or other aspects and advantages of

the invention will become apparent and more readily appreciated from the following description of the embodiments, taken in conjunction with the accompanying drawings of which:

FIG. 1 is a perspective view of a conventional core member;

FIG. 2A is a perspective view of a cylindrical lithium secondary battery;

FIG. 2B is a cross-sectional view along the A-A line of FIG. 2A;

FIG. 2C is a cross-sectional view along the B-B line of FIG. 2A;

FIG. 3A is a vertical cross-sectional view illustrating a cylindrical lithium secondary battery according to the present invention;

FIG. 3B is a horizontal cross-sectional view illustrating a cylindrical lithium secondary battery according to the embodiment of FIG. 5A; and

FIGS. 4A and 4B are perspective views illustrating core members of a cylindrical lithium secondary battery according to the present invention.

DETAILED DESCRIPTION OF THE EMBODIMENTS

[0013] Reference will now be made in detail to the present embodiments of the present invention, examples of which are illustrated in the accompanying drawings, wherein like reference numerals refer to the like elements throughout. The embodiments are described below in order to explain the present invention by referring to the figures.

[0014] FIG. 2A is a perspective view of a cylindrical lithium secondary battery. FIG. 2B is a cross-sectional view along the A-A line of FIG. 2A. FIG. 2C is a cross-sectional view along the B-B line of FIG. 2A.

[0015] Referring to FIGS. 2A to 2C, a cylindrical lithium ion secondary battery 200 includes an electrode assembly 300 which generates a voltage difference at charging/discharging time, a cylindrical case 400 which contains the electrode assembly 300, a cap assembly 500 which is assembled at an upper portion of the cylindrical case 400 and prevents the electrode assembly 300 from separation, and a core member 600 which is located at a central space of the electrode assembly 300.

[0016] The electrode assembly 300 includes a positive (or negative) active material, such as, for example, a first electrode plate 310 coated with the positive active material, and a negative (or positive) active material, such as, for example, a second electrode plate 320 coated with the negative active material. In addition, a separator 330 is located between the first electrode plate 310 and

the second electrode plate 320. The separator 330 prevents the first and second electrode plates 310 and 320 from shorting and allows only lithium ions to move. Further, the first electrode plate 310, the second electrode plate 320, and the separator 330 are wound in a spiral shape, have a specific space at the center of winding, and are contained in the cylindrical case 400. The first electrode plate 310 is generally made of aluminum (Al), and is bonded with a first electrode tab 315 that protrudes upwards in a specific length. The second electrode plate 320 is generally made of nickel (Ni), and is bonded with a second electrode tab 325 that protrudes downwards in a specific length. However, the present invention is not limited thereto. Moreover, upper and lower isolating plates 341 and 345 are further included at upper and lower portions of the electrode assembly 300, respectively, in order to avoid a direct contact with a cap assembly 500 or the cylindrical case 400.

[0017] In the cylindrical case 400, a cylindrical surface 410 defines a specific space with a specific diameter. A bottom surface 420 is formed at a lower portion of the cylindrical surface 410 to block a lower space of the cylindrical surface 410, and an upper portion of the cylindrical surface 410 is open so that the electrode assembly 300 can be inserted. Either the first electrode tab 315 of the electrode plate 310 or the second electrode tab 325 of the second electrode plate 320 is bonded at the center of the bottom surface 420 of the cylindrical case 400, and thus, the cylindrical case 400 itself functions as an extension of the first electrode plate 310 or second electrode plate 320. For example, the second electrode tab 325 may be bonded at the center of the bottom surface 420 of the cylindrical case 400 so that the cylindrical case functions as part of the negative electrode. The cylindrical case 400 is generally made of aluminum (Al), steel (Fe), or an alloy of Al and Fe. Further, in the upper portion of the cylindrical case 400, a crimping portion 430 is curved in one direction so as to press the cap assembly 500, and a beading portion 440 is concaved inwards to press the cap assembly 500 from bottom to top.

[0018] The cap assembly 500 includes a conductive safety belt 510 which is welded to the first electrode tab 315 and which is inverted in the case of over-charging or abnormal heating, a printed circuit board (PCB) 520 which is electrically or mechanically connected to an upper portion of the safety belt 510 and cuts a circuit when the safety belt 510 is inverted, a positive temperature element 530 which is electrically and mechanically connected to an upper portion of the PCB 520 and cuts a circuit at a specific temperature and a higher temperature, a conductive electrode cap 540 which is electrically and mechanically connected to an upper portion of the positive temperature element 530 and applies a practical current to an external side, and a gasket 550 which encloses lateral circumferences of the safety belt 510, the PCB 520, the positive temperature element 530, and the electrode cap 540, to isolate them from the cylindrical case 400. Here, the electrode cap 540 may be bonded

to either the first electrode 315 of the electrode assembly 300 or the second electrode tab 325 thereof. For example, the electrode cap 540 may be bonded to the first electrode tab 315 and may function as part of the same electrode along with the first electrode plate 310, which may be, for example, the positive electrode.

[0019] The core member 600 is inserted into the center portion of the wound type electrode assembly 300. The core member 600 prevents the wound type electrode assembly 300 from releasing and loosening, and also prevents the wound type electrode assembly 300 from deforming due to external pressure.

[0020] The core member 600 is formed by winding a metal plate into a substantially tubular shape. Further, a cut-groove, gap, or slit opening 630 is formed along a longitudinal direction of the core member 600. Both lateral ends of the cut-groove 630 of the core member 600 are bent to face inwards, and the both lateral ends thereof are bent again so that the edges thereof face outwards with respect to the core member 600.

[0021] Preferably, but not necessarily, diameters of the core member 600 are smaller at the first and second tube end portions than at the center portion. In other words, the core member 600 may be tapered at the first tube end and the second tube end.

[0022] Although not shown, an electrolytic solution is infused into the cylindrical case 400 so that a lithium ion can move between the electrodes. The electrolytic solution functions as a medium for moving lithium (Li) ions generated by an electrochemical reaction that occurs in positive and negative electrode inside a battery during charging/discharging. The electrolytic solution may be a non-aqueous type organic electrolytic solution which is a mixture of a lithium salt and an organic solvent with high purity. Further, the electrolytic solution may be a polymer using a polymer electrolyte, but the type of the electrolytic solution material is not limited thereto.

[0023] FIG. 3A is a vertical cross-sectional view illustrating a cylindrical lithium secondary battery according to another embodiment of the present invention. FIG. 3B is a horizontal cross-sectional view illustrating a cylindrical lithium secondary battery according to this embodiment of the present invention.

[0024] Overall structures of the cylindrical lithium secondary battery illustrated in FIGS. 3A to 3B are similar to those of the cylindrical lithium secondary battery illustrated in FIGS. 2A to 2C.

[0025] The only difference can be seen in the structure of a core member. The core member 800 is inserted into a central space of the wound type electrode assembly 300, prevents the wound type electrode assembly 300 from releasing and loosening, and also prevents the wound type electrode assembly 300 from deforming due to an external pressure. The core member 800 has a substantially tubular shape. A cut-groove 810 is formed along a longitudinal direction of the core member 800. The cut-groove 810 is bonded when the core member 800 is joined with the electrode assembly 300. In some

cases, the cut-groove 810 may be separated to maintain a specific distance.

[0026] Further, the core member 800 includes a protrusion 820 that protrudes by a specific length at a lower portion of the core member 800, that is, at the tube end portion of the core member 800 that faces the bottom or closed end of the case, and at least one notch 830 is formed at an inner lateral surface of the tube shaped core member 800 along a longitudinal direction of the core member 800.

[0027] In addition, the height of the core member 800 is 90 to 110% of the height of the electrode assembly 300 when a tube end portion of the core member 800 is located on the second electrode tab 325. If the height of the core member 800 is equal to or less than 90% of the height of the electrode assembly 300, the core member 800 lacks sufficient strength for fixing and supporting the electrode assembly 300. In addition, if the height of the core member 800 is equal to or greater than 110% of the height of the electrode assembly 300, the core member 600 may come into contact with an element of the cap assembly 500, thereby creating problems.

[0028] Although not shown, an electrolytic solution is infused into the cylindrical case 400 so that lithium ions can move between the electrodes. The electrolytic solution functions as a medium for moving lithium (Li) ions generated by an electrochemical reaction that occurs in positive and negative electrodes inside a battery during charging/discharging. The electrolytic solution may be a non-aqueous type organic electrolytic solution which is a mixture of a lithium salt and an organic solvent with high purity. Further, the electrolytic solution may be a polymer using a polymer electrolyte, but the type of the electrolytic solution material is not limited thereto.

[0029] FIGS. 4A and 4B are perspective views illustrating core members of a cylindrical lithium secondary battery according to additional embodiments of the present invention.

[0030] Referring to FIGS. 4A and 4B, core members 800 and 900 of the cylindrical lithium secondary battery 200 have a substantially tubular shape, and cut-grooves 810 and 910 are formed along longitudinal directions of the core members 800 and 900. As used herein, the term "cut-groove" refers to any longitudinal gap in the wound core members 800 and 900. The cut-groove may be formed by cutting the core member after it has been formed into a tubular shape, or may be formed by cutting the plate from which the core member is formed so that when the core member is formed, the plate material does not extend in an entire circumference.

[0031] The core members 800 and 900 each include a protrusion 820 and 920 that protrudes by a specific length from the lower portion, of the core member 800 or 900. The core members 800 and 900 each have a tubular shape in which diameters at edges of upper and lower portions of the core members 800 and 900 are smaller than diameters at center portions thereof. This prevents lower portions of elements of the electrode assembly

300, for example, the first electrode plate 310, the second electrode plate 320, and the separator 330, from being damaged by the cut-grooves 810 and 910, when the core member 800 and 900 rotate due to an external pressure.

[0032] Further, one or more notches 830 and 930 are formed at an inner lateral surface of the tube-shaped core members 800 and 900 along a longitudinal direction of the core members 800 and 900. Through the notches 830 and 930, a deformation direction of the core members 800 and 900 can be predetermined, so that when an external pressure equal to or greater than a specific pressure is applied, the core members 800 and 900 can be deformed in a predetermined direction, and thus a short of the electrode assembly 300 can be prevented which may otherwise occur when the core members 800 and 900 are deformed.

[0033] The notches 830 and 930 formed at the inner lateral surface of the core members 800 and 900 may be disposed in various forms.

[0034] For example, as shown in FIG. 4A, in an inner lateral surface of the core member 800, the core member 800 may include a pair of notches 830 formed along a longitudinal direction of the core member 800. Here, the notches 830 may be located in a symmetrical manner on left and right sides of the cut-groove 810, and may be located on a circumference with an angle of 45° from left and right sides of the cut-groove 810. In other words, the notches 830 may be located at the left and right sides of the cut-groove 810 at the same distance from the cut-groove.

[0035] As shown in FIG. 4B, the core member 900 may include four notches 930 formed along a longitudinal direction of the core member 900 at an inner lateral surface of the core member 900. The four notches 930 may be respectively located in pairs at left and right sides with respect to the cut-groove 910 in a symmetrical manner, and may be located on the circumference of the core member at 45°, 135°, 225°, and 315° with respect to the cut-groove 910. In other words, in the four notches 930 formed on the inner lateral circumferential surface of the core member 800, imaginary lines connecting each adjacent notch may form a trapezoid. In particular, the four notches 930 formed on the circumference of the core member 900 may be located so that the imaginary lines connecting each adjacent notch form a square.

[0036] As described above, the cylindrical lithium secondary battery 200 according to the present invention includes the protrusions 820 and 920 at lower portions of the core members 800 and 900 and the notches 830 and 930 formed in a longitudinal direction at the inner lateral surface of the core members 800 and 900, thereby improving the stability of the cylindrical lithium secondary battery 200.

[0037] In particular, the protrusions 820 and 920 formed at the lower portions of the core members 800 and 900 may prevent damage to the lower portion of the electrode assembly 300 when the core members 800 and 900 rotate.

[0038] Further, when an external pressure equal to or greater than a specific pressure is applied to the core members 800 and 900, the notches 830 and 930 may allow for the core members 800 and 900 to be deformed to a spiral shape in a central direction thereof. Thus, a short of the electrode assembly caused by deformation of the core members 800 and 900 can be prevented.

[0039] Accordingly, the present invention provides a cylindrical lithium secondary battery having improved stability with respect to an external pressure.

Claims

1. A cylindrical lithium secondary battery (200) comprising:
 - an electrode assembly (300) which has a first electrode plate (310), a second electrode plate (320), and a separator (330) provided between the first electrode plate (310) and the second electrode plate (320), and has a central space at the center of winding;
 - a core member (800, 900) which is formed in a tube shape having a cut-groove (810, 910) along a longitudinal direction, and includes at least one notch (830, 930) formed in a longitudinal direction at an inner lateral surface of the tube shape;
 - a case (400) which has a space for containing the electrode assembly (300) and including an open portion; and
 - a cap assembly (500) which is connected to the open portion of the case (400) so as to seal the case (400).
2. The cylindrical lithium secondary battery of claim 1, wherein the at least one notch (830, 930) allows the core member (800, 900) to deform in a predetermined direction when an external pressure is applied to the case (400).
3. The cylindrical lithium secondary battery according to claim 1, wherein the core member (900) comprises four notches (930) on a circumference, and wherein imaginary lines connecting adjacent notches (930) together form a trapezoid.
4. The cylindrical lithium secondary battery according to claim 3, wherein, in the four notches (930) formed on an inner lateral circumferential surface of the core member (900), the imaginary lines connecting adjacent notches (930) form a square.
5. The cylindrical lithium secondary battery according to claim 1, wherein the core member (830, 930) further com-

prises a protrusion (820, 920) which is protruded from a lower portion by a specific length.

6. The cylindrical lithium secondary battery according to claim 1, wherein diameters at upper and lower portions of the core member (830, 930) are smaller than a diameter at a center portion.

5

10

15

20

25

30

35

40

45

50

55

6

FIG. 1

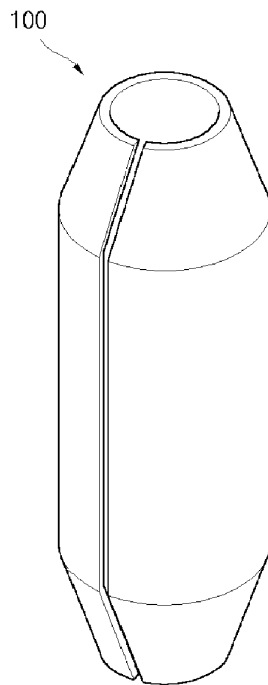

FIG. 2A

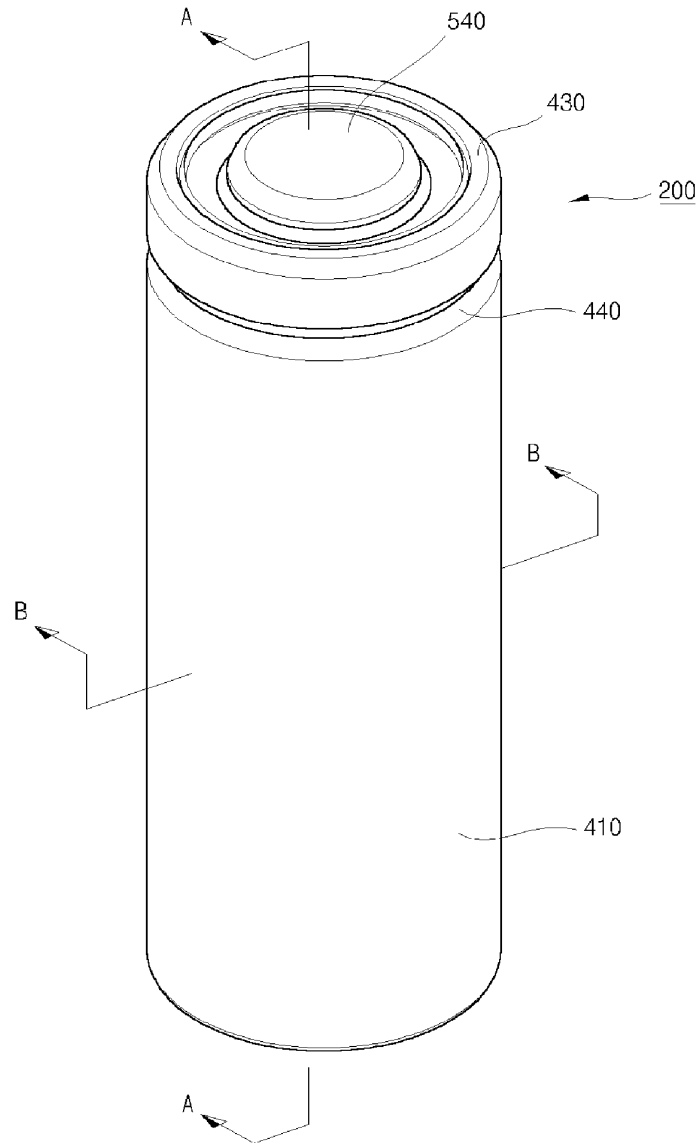

FIG. 2B

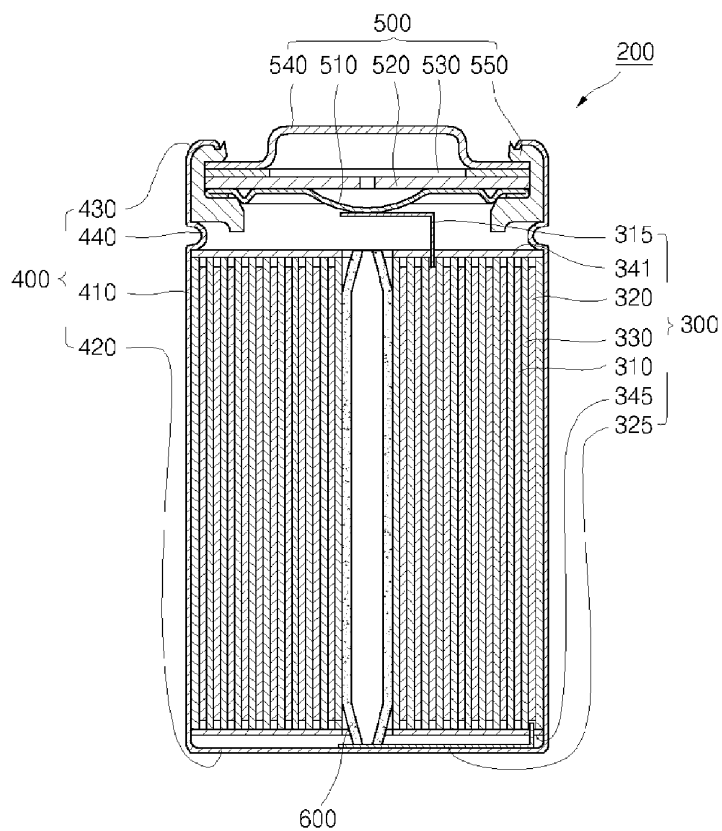

FIG. 2C

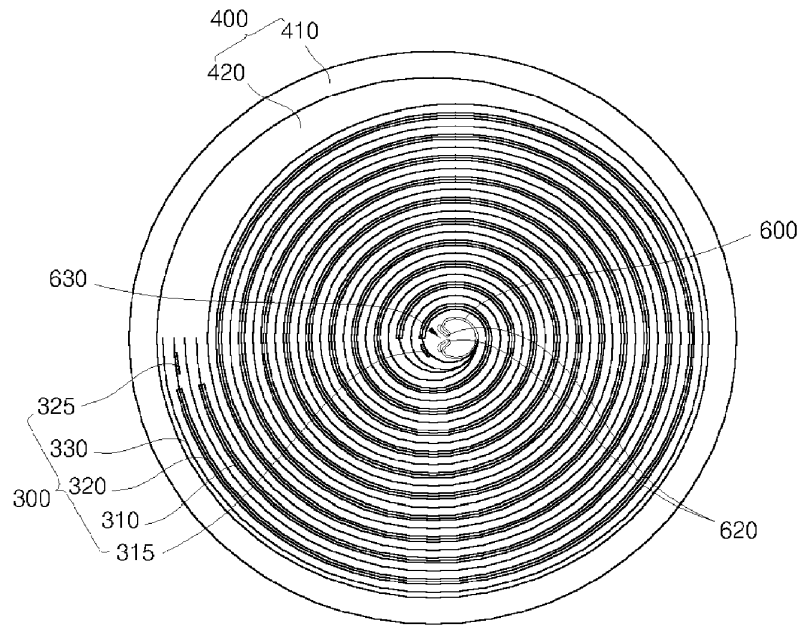

FIG. 3A

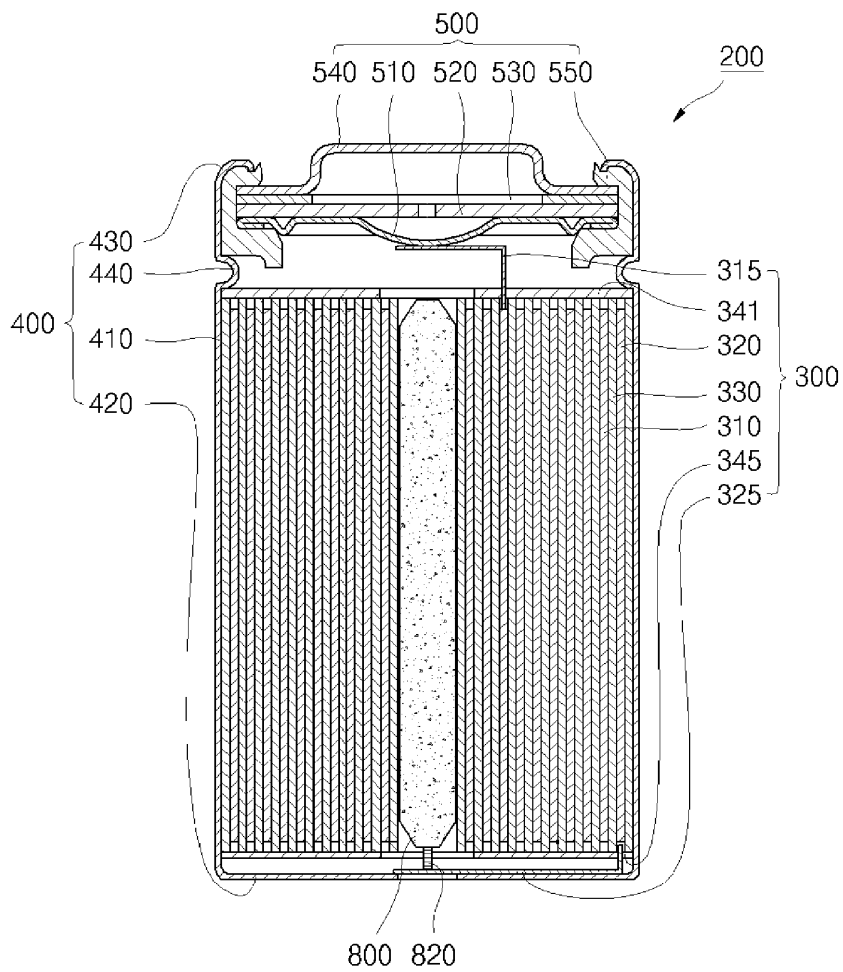

FIG. 3B

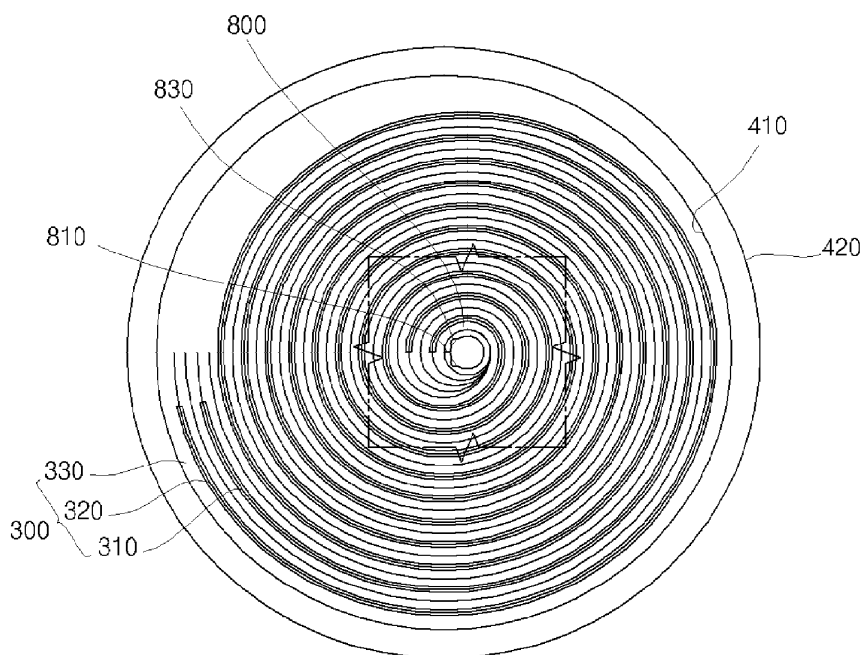

FIG. 4A

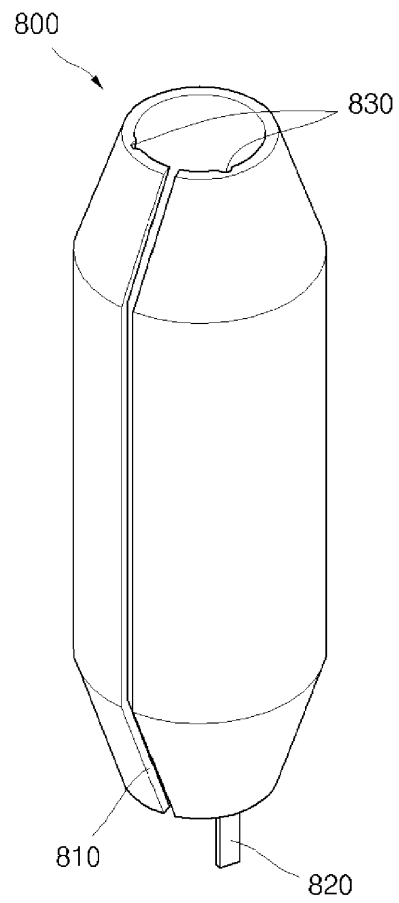
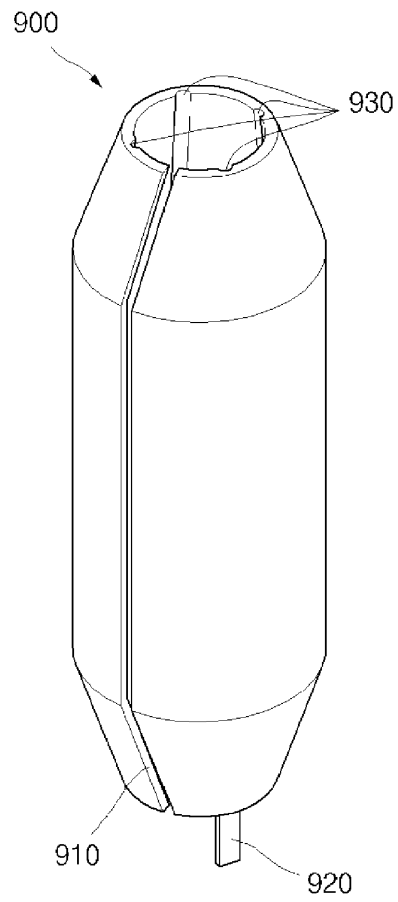

FIG. 4B





DOCUMENTS CONSIDERED TO BE RELEVANT			
Category	Citation of document with indication, where appropriate, of relevant passages	Relevant to claim	CLASSIFICATION OF THE APPLICATION (IPC)
X	US 5 925 482 A (YAMASHITA MASAYA [JP]) 20 July 1999 (1999-07-20)	1-4,6	INV. H01M2/00 H01M10/40
Y	* column 8, line 1 - column 12, line 4; figures 5,6,9-11 *	5	
X	US 2003/198863 A1 (MURASHIGE SHINJI ET AL) 23 October 2003 (2003-10-23)	1-4,6	
Y	* paragraphs [0045], [0046]; figures 1,3; example 1 *	5	
Y	EP 1 139 458 A (NGK INSULATORS, LTD) 4 October 2001 (2001-10-04)	5	
A	US 2003/148175 A1 (IWANAGA MASATO ET AL) 7 August 2003 (2003-08-07)	1-6	TECHNICAL FIELDS SEARCHED (IPC) H01M
A	* page 2, paragraph 35 - page 4, paragraph 68; claims 1-10; figures 1-4; examples 1,2 *	1	
The present search report has been drawn up for all claims			
Place of search Munich		Date of completion of the search 17 July 2008	Examiner Fitzpatrick, John
<p>CATEGORY OF CITED DOCUMENTS</p> <p>X : particularly relevant if taken alone Y : particularly relevant if combined with another document of the same category A : technological background O : non-written disclosure P : intermediate document</p> <p>T : theory or principle underlying the invention E : earlier patent document, but published on, or after the filing date D : document cited in the application L : document cited for other reasons & : member of the same patent family, corresponding document</p>			

EPO FORM 1503 (03.02) (P/M/C01)

EP 1 968 134 A1

**ANNEX TO THE EUROPEAN SEARCH REPORT
ON EUROPEAN PATENT APPLICATION NO.**

EP 08 15 4358

This annex lists the patent family members relating to the patent documents cited in the above-mentioned European search report. The members are as contained in the European Patent Office EDP file on The European Patent Office is in no way liable for these particulars which are merely given for the purpose of information.

17-07-2008

Patent document cited in search report	Publication date	Patent family member(s)	Publication date
US 5925482 A	20-07-1999	CA 2211615 A1	01-08-1996
		CN 1176023 A	11-03-1998
		DE 69636345 T2	28-06-2007
		EP 0872909 A1	21-10-1998
		WO 9623324 A1	01-08-1996

US 2003198863 A1	23-10-2003	JP 2003317805 A	07-11-2003

EP 1139458 A	04-10-2001	CA 2342123 A1	30-09-2001
		JP 3683181 B2	17-08-2005
		JP 2001345084 A	14-12-2001
		US 2002006540 A1	17-01-2002

US 2003148175 A1	07-08-2003	CN 1423361 A	11-06-2003
		HK 1055017 A1	06-07-2007
		JP 2003229177 A	15-08-2003
		KR 20030043745 A	02-06-2003
		TW 595032 B	21-06-2004

JP 2001283894 A	12-10-2001	NONE	

EPO FORM P0459

For more details about this annex : see Official Journal of the European Patent Office, No. 12/82

Electronic Acknowledgement Receipt

EFS ID:	18061871
Application Number:	13146669
International Application Number:	
Confirmation Number:	6273
Title of Invention:	BUTTON CELLS AND METHOD FOR PRODUCING SAME
First Named Inventor/Applicant Name:	Eduard Pytlik
Customer Number:	35811
Filer:	Paul A. Taufer/Nancy Nunez
Filer Authorized By:	Paul A. Taufer
Attorney Docket Number:	RUF-11-1270
Receipt Date:	29-JAN-2014
Filing Date:	07-SEP-2011
Time Stamp:	17:14:37
Application Type:	U.S. National Stage under 35 USC 371

Payment information:

Submitted with Payment	no
------------------------	----

File Listing:

Document Number	Document Description	File Name	File Size(Bytes)/ Message Digest	Multi Part /.zip	Pages (if appl.)
1		SIDS.pdf	179163 <small>e73f8e7d55fd4cf26efaab6674c4d8825fd6bd7b</small>	yes	2

Multipart Description/PDF files in .zip description					
Document Description			Start	End	
Transmittal Letter			1	1	
Information Disclosure Statement (IDS) Form (SB08)			2	2	
Warnings:					
Information:					
2	Foreign Reference	JP825.pdf	2312672	no	26
			e56a9c18c1a70a9364ad1633d9d6188a30a131cd		
Warnings:					
Information:					
3	Foreign Reference	EP1968134A1.pdf	658579	no	16
			d88c3f840386f5855f1f6a43feaaeb5a2d505fa2		
Warnings:					
Information:					
Total Files Size (in bytes):			3150414		
<p>This Acknowledgement Receipt evidences receipt on the noted date by the USPTO of the indicated documents, characterized by the applicant, and including page counts, where applicable. It serves as evidence of receipt similar to a Post Card, as described in MPEP 503.</p> <p><u>New Applications Under 35 U.S.C. 111</u> If a new application is being filed and the application includes the necessary components for a filing date (see 37 CFR 1.53(b)-(d) and MPEP 506), a Filing Receipt (37 CFR 1.54) will be issued in due course and the date shown on this Acknowledgement Receipt will establish the filing date of the application.</p> <p><u>National Stage of an International Application under 35 U.S.C. 371</u> If a timely submission to enter the national stage of an international application is compliant with the conditions of 35 U.S.C. 371 and other applicable requirements a Form PCT/DO/EO/903 indicating acceptance of the application as a national stage submission under 35 U.S.C. 371 will be issued in addition to the Filing Receipt, in due course.</p> <p><u>New International Application Filed with the USPTO as a Receiving Office</u> If a new international application is being filed and the international application includes the necessary components for an international filing date (see PCT Article 11 and MPEP 1810), a Notification of the International Application Number and of the International Filing Date (Form PCT/RO/105) will be issued in due course, subject to prescriptions concerning national security, and the date shown on this Acknowledgement Receipt will establish the international filing date of the application.</p>					

IN THE UNITED STATES PATENT AND TRADEMARK OFFICE

Art Unit : **Customer No.: 035811**
Examiner :
Serial No. : 13/146,669
Filed : July 28, 2011
Inventors : Eduard Pytlik Docket No.: RUF-11-1270
: Jürgen Lindner
: Ulrich Barenthin Confirmation No.: 6273
: Winfried Gaugler
Title : BUTTON CELLS AND METHOD
: FOR PRODUCING SAME Dated: January 29, 2014

SUPPLEMENTAL INFORMATION DISCLOSURE STATEMENT

Commissioner for Patents
P.O. Box 1450
Alexandria, VA 22313-1450

Sir:

The Applicants enclose Form PTO-1449 which lists two (2) relevant non-US publications. The documents were first cited by a third party on November 29, 2013 in the corresponding German Application No. 10 2009 060 788.9. The publications are submitted under 37 CFR §1.56 and is believed related to this application for the reasons stated.

The Applicants certify that each item of information contained in the Supplemental Information Disclosure Statement was first cited in any communication from any foreign patent office in a counterpart foreign application not more than three months ago.

The Applicants respectfully request that this Supplemental Information Disclosure Statement be officially entered into the file and that appropriate notification be made that it was considered by the Examiner.

Respectfully submitted,



T. Daniel Christenbury
Reg. No. 31,750

TDC/mn
(215) 656-3381



UNITED STATES PATENT AND TRADEMARK OFFICE

UNITED STATES DEPARTMENT OF COMMERCE
United States Patent and Trademark Office
Address: COMMISSIONER FOR PATENTS
P.O. Box 1450
Alexandria, Virginia 22313-1450
www.uspto.gov

Table with 5 columns: APPLICATION NO., FILING DATE, FIRST NAMED INVENTOR, ATTORNEY DOCKET NO., CONFIRMATION NO.

13/146,669 09/07/2011 Eduard Pytlik RUF-11-1270 6273

35811 7590 03/27/2014
IP GROUP OF DLA PIPER LLP (US)
ONE LIBERTY PLACE
1650 MARKET ST, SUITE 4900
PHILADELPHIA, PA 19103

Table with 1 column: EXAMINER

ANTHONY, JULIAN

Table with 2 columns: ART UNIT, PAPER NUMBER

1726

Table with 2 columns: NOTIFICATION DATE, DELIVERY MODE

03/27/2014 ELECTRONIC

Please find below and/or attached an Office communication concerning this application or proceeding.

The time period for reply, if any, is set in the attached communication.

Notice of the Office communication was sent electronically on above-indicated "Notification Date" to the following e-mail address(es):

pto.phil@dlapiper.com

Office Action Summary	Application No. 13/146,669	Applicant(s) PYTLIK ET AL.	
	Examiner JULIAN ANTHONY	Art Unit 1726	AIA (First Inventor to File) Status No

-- The MAILING DATE of this communication appears on the cover sheet with the correspondence address --

Period for Reply

A SHORTENED STATUTORY PERIOD FOR REPLY IS SET TO EXPIRE 3 MONTHS FROM THE MAILING DATE OF THIS COMMUNICATION.

- Extensions of time may be available under the provisions of 37 CFR 1.136(a). In no event, however, may a reply be timely filed after SIX (6) MONTHS from the mailing date of this communication.
- If NO period for reply is specified above, the maximum statutory period will apply and will expire SIX (6) MONTHS from the mailing date of this communication.
- Failure to reply within the set or extended period for reply will, by statute, cause the application to become ABANDONED (35 U.S.C. § 133). Any reply received by the Office later than three months after the mailing date of this communication, even if timely filed, may reduce any earned patent term adjustment. See 37 CFR 1.704(b).

Status

- 1) Responsive to communication(s) filed on _____.
 A declaration(s)/affidavit(s) under **37 CFR 1.130(b)** was/were filed on _____.
- 2a) This action is **FINAL**. 2b) This action is non-final.
- 3) An election was made by the applicant in response to a restriction requirement set forth during the interview on _____; the restriction requirement and election have been incorporated into this action.
- 4) Since this application is in condition for allowance except for formal matters, prosecution as to the merits is closed in accordance with the practice under *Ex parte Quayle*, 1935 C.D. 11, 453 O.G. 213.

Disposition of Claims*

- 5) Claim(s) 1-14 is/are pending in the application.
5a) Of the above claim(s) _____ is/are withdrawn from consideration.
- 6) Claim(s) _____ is/are allowed.
- 7) Claim(s) 1-14 is/are rejected.
- 8) Claim(s) _____ is/are objected to.
- 9) Claim(s) _____ are subject to restriction and/or election requirement.

* If any claims have been determined allowable, you may be eligible to benefit from the **Patent Prosecution Highway** program at a participating intellectual property office for the corresponding application. For more information, please see http://www.uspto.gov/patents/init_events/pph/index.jsp or send an inquiry to PPHfeedback@uspto.gov.

Application Papers

- 10) The specification is objected to by the Examiner.
- 11) The drawing(s) filed on 7-28-2011 is/are: a) accepted or b) objected to by the Examiner.
Applicant may not request that any objection to the drawing(s) be held in abeyance. See 37 CFR 1.85(a).
Replacement drawing sheet(s) including the correction is required if the drawing(s) is objected to. See 37 CFR 1.121(d).

Priority under 35 U.S.C. § 119

- 12) Acknowledgment is made of a claim for foreign priority under 35 U.S.C. § 119(a)-(d) or (f).

Certified copies:

- a) All b) Some** c) None of the:
1. Certified copies of the priority documents have been received.
 2. Certified copies of the priority documents have been received in Application No. _____.
 3. Copies of the certified copies of the priority documents have been received in this National Stage application from the International Bureau (PCT Rule 17.2(a)).

** See the attached detailed Office action for a list of the certified copies not received.

Attachment(s)

- 1) Notice of References Cited (PTO-892)
- 2) Information Disclosure Statement(s) (PTO/SB/08a and/or PTO/SB/08b)
Paper No(s)/Mail Date 7-28-2011, 1-29-2014
- 3) Interview Summary (PTO-413)
Paper No(s)/Mail Date. _____
- 4) Other: _____

DETAILED ACTION

Notice of Pre-AIA or AIA Status

The present application is being examined under the pre-AIA first to invent provisions.

Information Disclosure Statement

The IDS filed on July 28, 2011 has been considered by the examiner, except for citation AK which is presently lined-through. Only one page of the cited document is present in the application file, which also appears to be merely the bibliographic data.

The IDS filed on January 29, 2014 has been considered by the examiner.

Drawings

The drawings are objected to under 37 CFR 1.83(a). The drawings must show every feature of the invention specified in the claims. Therefore, the claimed insulator which prevents direct mechanical and electrical contact between the end faces of the winding and the flat bottom and top areas must be shown or the feature(s) canceled from the claim(s). No new matter should be entered.

Corrected drawing sheets in compliance with 37 CFR 1.121(d) are required in reply to the Office action to avoid abandonment of the application. Any amended replacement drawing sheet should include all of the figures appearing on the immediate prior version of the sheet, even if only one figure is being amended. The figure or figure number of an amended drawing should not be labeled as "amended." If a drawing figure is to be canceled, the appropriate figure

must be removed from the replacement sheet, and where necessary, the remaining figures must be renumbered and appropriate changes made to the brief description of the several views of the drawings for consistency. Additional replacement sheets may be necessary to show the renumbering of the remaining figures. Each drawing sheet submitted after the filing date of an application must be labeled in the top margin as either "Replacement Sheet" or "New Sheet" pursuant to 37 CFR 1.121(d). If the changes are not accepted by the examiner, the applicant will be notified and informed of any required corrective action in the next Office action. The objection to the drawings will not be held in abeyance.

Claim Rejections - 35 USC § 102

The following is a quotation of the appropriate paragraphs of pre-AIA 35 U.S.C. 102 that form the basis for the rejections under this section made in this Office action:

A person shall be entitled to a patent unless –

(b) the invention was patented or described in a printed publication in this or a foreign country or in public use or on sale in this country, more than one year prior to the date of application for patent in the United States.

Claims 1, 2, 6, 10 and 11 are rejected under pre-AIA 35 U.S.C. 102(b) as being anticipated by Nakayama (US 4,224,387).

Nakayama teaches a button cell comprising a housing cup [14] and a housing top [20] separated from one another by an electrically insulating seal [26] and which form a housing with a flat bottom area and a flat top area parallel to it, i.e. the vertical flat part of the housing top and the vertical flat part of the housing cup. An electrode-separator assembly is within the housing and comprises strips or rectangular sections of a positive electrode [12] and a negative [10] electrode in the form of flat layers and are connected to one another by a flat separator [16]. The

electrode layers are aligned essentially at right angles to the flat bottom area and flat top area as defined previously. Furthermore, the button cell is closed without being beaded over. (Figure 1) See col. 1 line 59 et seq. Thus, Nakayama also teaches a method for producing a button cell such that the electrode layers are aligned essentially at right angles to the flat bottom and top areas as defined previously.

Claim Rejections - 35 USC § 103

The following is a quotation of pre-AIA 35 U.S.C. 103(a) which forms the basis for all obviousness rejections set forth in this Office action:

(a) A patent may not be obtained though the invention is not identically disclosed or described as set forth in section 102 of this title, if the differences between the subject matter sought to be patented and the prior art are such that the subject matter as a whole would have been obvious at the time the invention was made to a person having ordinary skill in the art to which said subject matter pertains. Patentability shall not be negated by the manner in which the invention was made.

Claims 3-5, 9, 12 and 13 are rejected under pre-AIA 35 U.S.C. 103(a) as being unpatentable over Nakayama (US 4,224,387) in view of Suzuki et al. (US 7,566,515)

The teachings of Nakayama are discussed above.

Nakayama does not explicitly teach a spiral winding. However, Suzuki teaches electrode assemblies both in flat sheet form (Fig. 1) and in flat spiral windings form. (col. 6 line 43 et seq.) The prior art as a whole is considered to recognize the equivalence of flat electrode assemblies (as disclosed in Nakayama and Suzuki) with spiral electrode assemblies (as disclosed in Suzuki). The prior art's clear recognition of mutual equivalence of these components, independent of applicant's disclosure, is herein relied upon as the rationale to support an obviousness rejection. *In re Ruff*, 256 F.2d 590, 118 USPQ 340 (CCPA 1958) Furthermore, the claims would have been obvious because the substitution of one known element for another would have yielded

predictable results to one of ordinary skill in the art at the time the invention was made.

Additionally, Suzuki teaches that spiral windings “have the advantage that they are firmly wound and excellent in adhesion.” (col. 6 line 61 et seq.)

Nakayama does not explicitly teach a rechargeable battery. However, Suzuki teaches a rechargeable battery, which the skilled artisan would find as an obvious modification in view of secondary cells having the benefit of renewable energy.

Claims 7, 8 and 14 are rejected under pre-AIA 35 U.S.C. 103(a) as being unpatentable over Nakayama (US 4,224,387) in view of Suzuki et al. (US 7,566,515), and further in view of Cantave et al. (US 6,443,999)

The teachings of Nakayama and Suzuki are discussed above.

Nakayama does not explicitly teach an insulator which prevents direct mechanical and electrical contact between the end faces of the winding and the flat bottom and top areas. However, Cantave teaches an insulator [74] to line the end of the battery casing. (col. 5 line 59 et seq.) Furthermore, improved insulation is accomplished by reshaping an edge of the separator layer, as by heat forming, and using said reshaped portion of the separator layer to also function as a continuous electrical insulation layer between the positive cathode sheet and the cell casing, particularly at the closed end of the casing. (col. 2 line 66 et seq.) The skilled artisan would find obvious to further modify Nakayama’s invention in the manner claimed. The motivation for such a modification is to improve the electrical insulation of the cell.

Conclusion

Any inquiry concerning this communication or earlier communications from the examiner should be directed to Julian Anthony whose telephone number is (571) 272-1289. The examiner can normally be reached on Monday through Friday.

If attempts to reach the examiner by telephone are unsuccessful, the examiner's supervisor, Patrick J. Ryan, can be reached on (571) 272-1292. The fax phone number for the organization where this application or proceeding is assigned is 703-872-9306.

Information regarding the status of an application may be obtained from the Patent Application Information Retrieval (PAIR) system. Status information for published applications may be obtained from either Private PAIR or Public PAIR. Status information for unpublished applications is available through Private PAIR only. For more information about the PAIR system, see <http://pair-direct.uspto.gov>. Should you have questions on access to the Private PAIR system, contact the Electronic Business Center (EBC) at 866-217-9197 (toll-free).

Any inquiry of a general nature or relating to the status of this application or proceeding should be directed to the receptionist whose telephone number is (703) 308-0661.

/Julian Anthony/
Examiner, Art Unit 1726

/PATRICK RYAN/
Supervisory Patent Examiner, Art Unit 1726