

UNITED STATES PATENT AND TRADEMARK OFFICE

---

BEFORE THE PATENT TRIAL AND APPEAL BOARD

---

PEAG LLC (d/b/a JLab Audio), Audio Partnership LLC and  
Audio Partnership PLC (d/b/a Cambridge Audio)  
Petitioners,

v.

VARTA Microbattery GmbH,  
Patent Owner

---

Case No. IPR2020-01211  
U.S. Patent No. 9,496,581

Case No. IPR2020-01212  
U.S. Patent No. 9,153,835

Case No. IPR2020-01213  
U.S. Patent No. 9,799,858

Case No. IPR2020-01214  
U.S. Patent No. 9,799,913

---

**DECLARATION OF MARTIN C. PECKERAR, PH.D.**

## Table of Contents

DECLARATION OF MARTIN C. PECKERAR, PH.D. ....	I
I. INTRODUCTION .....	1
II. QUALIFICATIONS .....	2
III. MATERIALS CONSIDERED .....	5
IV. LEGAL PRINCIPLES.....	6
A. Level of Ordinary Skill in the Art .....	6
B. Claim Construction.....	7
C. Anticipation .....	8
D. Obviousness.....	9
E. Written Description .....	11
V. LEVEL OF SKILL IN THE ART .....	12
VI. TECHNOLOGICAL BACKGROUND OF THE CHALLENGED PATENTS.....	12
VII. THE CHALLENGED PATENTS .....	17
A. U.S. Patent 9,153,835 (“the ’835 Patent”) .....	18
B. U.S. Patents 9,496,581 and 9,799,913 (“the ‘581 and ’913 Patents”) .....	27
C. U.S. Patent No. 9,799,858 (“the ’858 Patent”) .....	27
VIII. CLAIM CONSTRUCTION .....	30
A. “button cell” (all challenged claims).....	30
B. “insulating means” (’835 and ’913 patents).....	33
C. “button cell is closed without being beaded over” (’835 patent).....	36
D. “connected to one another by at least one flat separator” (’835 ,’581, and ’913 patents) .....	42
IX. OVERVIEW OF THE PRIOR ART .....	44
A. JP 2007-294111 (Kobayashi) .....	44
B. U.S. Publication No. 2005/0233212 (“Kaun”).....	59
C. EP 1 886 364 B1 (“Ryou”).....	71
D. KR Publication No. 10-2003-0087316 (“Kwon”).....	74

X. THE CHALLENGED '835 PATENT CLAIMS ARE PATENTABLE OVER KOBAYASHI, KAUN, AND RYOU .....77

A. The Combination of Kaun in view of Kobayashi Fails to Render Obvious the Claims of the '835 Patent .....77

1. A POSA Would Not Have a Reason to Combine Kaun with Kobayashi 77

2. Kobayashi Would Decrease Energy Capacity in Kaun and Render Kaun Less Efficient.....81

3. Kaun Teaches Away from Using Additional Current Collectors that Are Necessary in Kobayashi .....84

4. The Proposed Modification Would Require a Complete Rebuild of Kaun .....88

5. Kaun and Kobayashi Fail to Disclose or Suggest “Button Cell,” “Insulating Means,” and “Closed Without Being Beaded Over” .....91

B. The Combination of Kobayashi in view of Kaun Fails to Render Obvious the Claims of the '835 Patent .....98

1. There Is No Motivation to Combine Kobayashi with Kaun .....98

2. A POSA Would Not Have a Reasonable Expectation of Success in Modifying Kobayashi with Kaun.....108

3. Kobayashi Teaches Away from the Direct and Continuous Edge Contact of Kaun .....110

4. Kobayashi and Kaun Fail to Disclose or Suggest “Insulation Means” and “Closed Without Being “Beaded Over” .....112

C. The Combination of Kobayashi in view of Ryou Fails to Render Obvious the Claims of the '835 Patent .....116

1. A POSA Would Not Have a Reason to Combine Kobayashi and Ryou .....116

2. The Combination of Kobayashi and Ryou Does Not Provide a Cell that is “Closed” without Being Beaded Over .....121

XI. THE CHALLENGED '581 PATENT AND'913 PATENT CLAIMS ARE PATENTABLE OVER KOBAYASHI, KAUN, AND THE KNOWLEDGE OF A POSA .....122

A. The Combination of Kobayashi in View of the Knowledge of a POSA Fails to Render Obvious the Challenged Claims of the '581 and '913 Patents.....122

1. Kobayashi Does Not Teach “An Output Conductor Comprising a Foil” .....	122
2. A POSA Would Not Be Motivated to Make the Terminal Plates of Kobayashi to Be Foils .....	124
3. A POSA Would Not Have Been Motivated to Modify Kobayashi’s with General Knowledge .....	128
4. Kobayashi Will Not Operate With a Foil Conductor.....	133
5. The Proposed Modification Would Render Kobayashi Inoperable for its Intended Purpose .....	135
6. A POSA Would Not Have Reasonably Expected to Successfully Achieve the Claimed Invention .....	136
B. The Combination of Kaun in View of the Knowledge of a POSA Fails to Render Obvious the Challenged Claims of the ’581 Patent.....	137
1. Kaun Does Not Disclose or Suggest “a Button Cell” or “an Output Conductor Comprising a Foil Resting Flat Between an End Face of the Spiral Winding” .....	137
2. A POSA Would Not Have Reasonably Expected a Foil Conductor to Work with Kaun .....	144
3. Kaun Could Not Be Modified With a Foil.....	145
C. The Combination of Kaun in View of Kobayashi and the Knowledge of a POSA Fails to Render Obvious the Challenged Claims of the ’581 and ’913 Patents .....	147
1. Kaun in View of Kobayashi and the Knowledge of a POSA Does Not Disclose or Suggest “Button Cell,” “an Output Conductor Comprising a Foil Resting Flat Between and End Face of the Spiral Winding,” or “at Least One Insulator” .....	147
2. A POSA Would Not Have a Reason to Combine Kaun with Kobayashi .....	156
3. Kobayashi Would Render Kaun Less Efficient .....	160
4. Kaun Teaches Away from Using Additional Current Collectors that Are Necessary in Kobayashi .....	162
5. The Proposed Modification Would Require a Complete Rebuild of Kaun. .....	167

XII. THE CHALLENGED '858 PATENT CLAIMS ARE PATENTABLE OVER KOBAYASHI, KWON, KAUN AND THE PURPORTED KNOWLEDGE OF A POSA .....170

A. The '858 Patent Is Not Rendered Obvious Over the Asserted Combination of Kobayashi and Kwon .....170

1. Kobayashi and Kwon do not Disclose “Metal Foil” Output Conductors .....170

2. A POSA Would Have No Reason to Modify Kobayashi with Kwon ...174

3. Kobayashi Will Not Operate with a Foil Conductor.....179

4. The Proposed Modification Would Render Kobayashi Inoperable .....182

5. The Proposed Modification Would Require a Complete Rebuild of Kobayashi .....182

6. Kobayashi and Kwon Do Not Disclose the Additional Features of Dependent Claims 6 and 8 .....183

B. The '858 Patent Is Not Rendered Obvious Over the Asserted Combination of Kaun with Kobayashi and Kwon .....185

1. Kaun in view of Kobayashi and Kwon Does Not Disclose or Suggest a “Button Cell,” and “Metal [Conductor] . . . is a Metal Foil,” or “Insulating Elements” .....186

2. A POSA Would Not Have Had a Reason to Combine Kaun with Kobayashi .....194

3. Kobayashi Would Render Kaun Less Efficient. ....198

4. Kaun Teaches Away From Using Additional Current Collectors that are Necessary in Kobayashi .....201

5. The Proposed Modification Would Require a Complete Rebuild of Kaun .....205

6. Kaun also Teaches Away from Kwon.....208

7. The Proposed Modification Would Require a Complete Rebuild of Kaun .....209

8. Kaun in view of Kobayashi and Kwon Does Not Disclose or Suggest the Features of Dependent Claims 6 and 8 .....212

C. The '858 Patent Claims Are Not Obvious Over the Combination of Kobayashi, Kwon and the Knowledge of a POSA.....213

1. Kobayashi, Kwon and the Knowledge of a POSA Fail to Disclose or Suggest a “Metal Foil” Conductor .....	213
2. A POSA Would Not Have Been Motivated to Make the Terminal Plates of Kobayashi to Be Foils .....	214
3. A POSA Would Not Have Been Motivated to Modify Kobayashi with General Knowledge .....	217
4. Kobayashi Will Not Operator with a Foil Conductor .....	222
5. The Proposed Modification Would Render Kobayashi Inoperable for its Intended Purpose .....	224
6. A POSA Would Not Have Reasonably Expected to Successfully Achieve the Claimed Invention .....	225
7. Kobayashi Does Not Disclose or Suggest the Features of Dependent Claims 6 and 8 .....	226
<b>XIII. SECONDARY CONSIDERATIONS CONFIRM THAT THE CHALLENGED PATENTS ARE NOT OBVIOUS.....</b>	<b>229</b>
<b>A. The VARTA CoinPower® Button Cells Practice the Inventions of the Challenged Patents .....</b>	<b>229</b>
1. The VARTA CoinPower® Batteries Practice the ’835 Patent .....	233
2. The VARTA CoinPower® Batteries Practice the ’581 Patent .....	236
3. The VARTA CoinPower® Batteries Practice the ’913 Patent .....	239
4. The VARTA CoinPower® Batteries Practice the ’858 Patent .....	243
<b>B. Unexpected Results .....</b>	<b>247</b>
<b>C. Copying by Others.....</b>	<b>248</b>
1. The Eve and Mic-Power Batteries Are Covered by the ’835 Patent .....	250
2. The Eve and Mic-Power Batteries Are Covered by the ’581 Patent .....	252
3. The Eve and Mic-Power Batteries Are Covered by the ’913 Patent .....	254
4. The Eve and Mic-Power Batteries Are Covered by the ’858 Patent .....	257
<b>XIV. THE SUBSTITUTE CLAIMS OF THE CHALLENGED PATENTS ARE PATENTABLE.....</b>	<b>259</b>
<b>A. Kaun, Kobayashi, Ryou, and Kwon Fail to Disclose a Button Cell Closed at “Overlapping Sides” of a Housing by “a Radial Seal” or “a Force-Fit Connection” .....</b>	<b>259</b>

B. Kaun, Kobayashi, Ryou, and Kwon Fail to Disclose “a Metal Foil” with  
“a Bend Portion” and “a Flat Portion” .....264

XV. CONCLUSION.....271

I, Martin C. Peckerar, Ph.D., declare as follows:

**I. INTRODUCTION**

1. I have been retained by Patent Owner VARTA Microbattery GmbH (“VARTA” or “Patent Owner”) as an expert in the relevant art.

2. I understand that Petitioners PEAG LLC (d/b/a JLab Audio), Audio Partnership LLC and Audio Partnership PLC (d/b/a Cambridge Audio) (“Petitioners”) seek cancellation of claims 1-12 of U.S. Patent No. 9,153,835 (“the ’835 patent”), claims 1-12 of U.S. Patent No. 9,496,581 (“the ’581 patent”), claims 1-8 of U.S. Patent No. 9,799,913 (“the ’913 patent”), and claims 1-8 of U.S. Patent 9,799,858 (“the ’858 patent) (collectively “the Challenged Claims”). In particular, I have been asked to provide my opinion on whether the Challenged Claims are unpatentable for alleged obviousness based on combinations of Kobayashi (Ex. 1006), Kaun (Ex. 1005), Ryou (Ex. 1007), Kwon (Ex. 1008) and the knowledge of a person of ordinary skill in the art (“POSA”). In my opinion, the various combinations proposed by Petitioners do not render any of the Challenged Claims obvious.

3. I am being compensated at my standard consulting rate of \$525 per hour for my work, plus reimbursement for my expenses. My compensation has not influenced any of my opinions in this matter and does not depend on the outcome of the proceeding or any issue in it.



4. My opinions are based on (i) the material described in Section III of this declaration including Petitioners' Petitions for *inter partes* review and the Decisions on Institution; and (ii) my own education, training, teaching and experience in the relevant art.

5. The full extent of my opinions and the underlying reasoning for these opinions are set forth below.

## **II. QUALIFICATIONS**

6. My qualifications for forming the opinions given in this expert declaration are summarized here and are addressed more fully in my curriculum vitae, which is attached as Exhibit 2044. Exhibit 2044 also includes a list of cases in which I have testified at trial or in a deposition for the past four years.

7. I received a Bachelor's of Science in Physics from Stony Brook University in 1968. I then received a Master's of Science in Physics from the University of Maryland in 1971 and a Ph.D. in Electrical Engineering from the University of Maryland in 1975.

8. In 1981, I became head of the Nanoelectronics Processing Facility at the Naval Research Laboratory (NRL) and, subsequently, head of the Surface and Interface Sciences Branch. There, I developed devices for deep-UV imaging and was a co-inventor of the laser-plasma source for x-ray lithography. This source became the primary radiation source used by the Intel-led EUV lithography

consortium developing advanced patterning tools enabling modern day microelectronics. I was also in charge of process development for integrated circuit test structures for radiation hardening studies. These test structures mirrored state of the art VLSI process and design.

9. I was the Principal Navy Technical Officer on the DARPA Advanced Lithography Program from 1989 to 2003. I was also assigned the role of U.S. Navy consultant to the State Department on issues relating to strategic arms control for electronic weapons systems.

10. From 1981 to 2002, I was a part-time professor in The Department of Electrical & Computer Engineering at the University of Maryland. In 2002, I became a tenured professor full time at the University of Maryland, where I am currently a Professor Emeritus of Microelectronic Engineering.

11. My university research has centered on analog and mixed signal design. In the course of my work, I have incorporated new materials systems and processes into the system-on-a-chip toolset. I have also developed algorithms for e-beam proximity control, which are essential for e-beam mask manufacture. I have also been active in various imaging technologies. I have also developed instruments for improvement of e-beam pattern placement using local-fiducial networks. I am also an expert in the area of imaging system technologies, including the development of a maximum-entropy image reconstruction chip and

development of fast-Fourier chips based on neural net principles and a tomographic imager chip (also based on maximum entropy principles).

12. For the last decade or so my research has been primarily in the area of low power electronics, particularly in the development of power sources (batteries and super-capacitors) for low power systems. I have developed “super-capacitor” power sources for distributed ad hoc sensor arrays. In addition, I have developed flexible batteries whose form, fit and function are tailored to the specific requirements of the empowered system. These systems include drones, ad hoc sensor networks and a host of internet-of-things (IOT) devices. In 2008, I received the University of Maryland’s outstanding inventor of the year award for a flexible thin-film battery cell.

13. My work in battery development has led to the formation of two companies: FlexE1, LLC and VersaVolt, LLC. FlexE1 was involved in empowering a variety of special-purpose devices such as e-cigarettes and blink-controlled ocular prosthetics using a patented flexible battery technology. My work in connection with FlexE1 led to the 2013 University of Maryland System Entrepreneur of the Year Award. VersaVolt was a consulting company, primarily in the area of underwater batteries for flight data recorder applications as well as a host of IOT projects.

14. Over the course of my career, I designed and made button cell batteries for testing and validating battery chemistry and for other purposes. I also designed and made cells containing “jelly-roll” or spiral wound assemblies, although these assemblies were not incorporated into the button cell type batteries of which I am aware.

15. I am a co-author of several textbooks, including *Electronic Materials: Science And Technology*, which is a standard textbook used worldwide in semiconductor process technology. I am also an editor of several widely cited books, including *Synthetic Microstructures in Biological Research*, and an author of over 100 journal articles and other publications.

16. I have received several awards during my career, including my election as a Fellow of the IEEE in 1993 for contributions to and leadership in x-ray and microlithography, and my receipt of the 2008 award for Outstanding Invention of the Year in physical sciences, presented by the Maryland Office of Technology Commercialization for a ruthenium based super-capacitor.

17. I am a named inventor on approximately twenty-nine United States patents which have issued between 1980 and 2011.

### **III. MATERIALS CONSIDERED**

18. In forming the opinions set forth in this declaration, I have reviewed and/or considered the materials listed in the Appendix to this Declaration (as well

as any other material or information referenced herein) in addition to my years of experience and education.

#### **IV. LEGAL PRINCIPLES**

19. In forming my opinions and considering the patentability of the Challenged Claims, I am relying upon certain legal principles that counsel has explained to me.

20. I understand that for an invention claimed in a patent to be patentable, it must be, among other things, new and not obvious in light of what came before it. Patents and publications which predated the invention are generally known as “prior art.”

##### **A. Level of Ordinary Skill in the Art**

21. I understand that the claims and specification of a patent are to be read and construed from the perspective of a person of ordinary skill in the art (“POSA”) at the time the invention was made. In determining the level of ordinary skill in the art at the relevant time frame, I understand that the following factors may be considered: (i) the types of problems encountered in the art; (ii) the existing and proposed solutions to those problems; (iii) the sophistication of the technology, and the rapidity with which innovations occur in the field; and (iv) the education level of active workers in the field.

**B. Claim Construction**

22. I understand that, in order to assess whether the prior art satisfies a certain claim element in an invalidity analysis, the claim element must first be construed, and then the prior art must be evaluated to determine whether it satisfies the properly-construed element of the claim. I understand that claim construction is the process of interpreting the meaning of the words and/or terms in the patent claims. I understand that the terms of a claim are to be construed in accordance with their ordinary and customary meaning as understood by a POSA at the time of the invention.

23. I understand that claim construction should begin with the language of the claims as the claims may provide substantial guidance to the meaning of a term. I further understand the claim terms are usually used consistently throughout a patent and throughout related patents.

24. I understand the specification should also be referred to, as it is the best guide to understand the meaning of a term. However, I understand that claim terms are usually not limited to the specific examples in the specification.

25. I understand that the prosecution history may also be consulted in construing the meaning of a term, although the prosecution history may lack the clarity of the specification.

26. I understand that the preamble of a claim may limit the scope of a claim if it recites essential structure or if it is necessary to give life, meaning, vitality to the claim.

27. I understand that certain claim terms may be expressed as a means or step for performing a specified function without the recital in the body of the claim of a corresponding structure, material or act for accomplishing the function. I understand that use of the term “means for” in a claim raises a presumption that that the term should be interpreted under 35 U.S.C. § 112(b) and that such claim elements are called “means-plus-function” terms.

28. I understand that the construction of a ‘means-plus-function’ element is a two-step process. First, the function of the element is identified. The specification is then reviewed to determine the corresponding structure for performing the function that is claimed.

**C. Anticipation**

29. I understand that a patent claim is invalid as being anticipated if each limitation of the claim is disclosed explicitly or inherently in a single prior art reference. I further understand that a limitation is disclosed inherently if it is necessarily present in the prior art reference or is the natural result flowing from the disclosure of the prior art reference.

**D. Obviousness**

30. I understand that a patent claim may be “obvious” and therefore unpatentable if the claimed subject matter as a whole would have been obvious to a POSA at the time of the invention in light of the teachings and the disclosure of the prior art.

31. I understand that the determination of whether a claim is obvious is based on several factors including (i) the scope and content of the prior art; (ii) the differences between the prior art and the claimed invention; and (iii) the level of ordinary skill in the art. I further understand that objective evidence of non-obviousness, sometimes referred to as “secondary considerations,” are to be considered if present.

32. I understand the Petitioner has the burden of proving the obviousness of a claim by the “preponderance of the evidence,” which means “more likely than not” and requires that a fact finder be reasonably convinced that the existence of a specific material fact is more probable than the non-existence of that fact.

33. I understand that the relevant time frame for considering whether a claim would have been obvious is the time at which the invention was made, which would have been the 2009 time-frame.

34. I understand that the first inquiry in a nonobviousness analysis is whether the prior art, including the knowledge of one skilled in the art at that time,



discloses each and every element of the recited claim. When combining two or more references, one should consider whether there was a teaching or suggestion, or whether there was a motivation to combine the references, so as to avoid impermissible hindsight.

35. I have also been informed that the claimed invention must be considered as a whole in analyzing obviousness or non-obviousness. In determining the differences between the prior art and the claims, the question under the obviousness inquiry is not whether the differences themselves would have been obvious, but whether the claimed invention as a whole would have been obvious.

36. I understand that an indicator of the non-obviousness of a claim is when the prior art is found to “teach away” from making the proposed combination of references. For example, a prior art reference teaches away from the particular combination if it leads in a different direction or discourages that combination, recommends steps or structures that would not lead to the patent claims, or otherwise indicated that an inoperative device would be produced. Further, the proposed modification cannot render the prior art unsatisfactory for its intended purpose or change the principles of operation of a reference.

37. I have been informed that the objective indicia of non-obviousness, the so called secondary factors, include whether there exists: (i) a long-felt need in

the industry; (ii) any unexpected results; (iii) skepticism of the invention; (iv) commercial success; (vi) praise by others for the invention; (vii) failure of others and (viii) copying by others.

38. I understand that when assessing the obviousness or non-obviousness of a claim, it is impermissible to rely on hindsight derived from the patent being considered. More specifically, one should take care not to use the claimed invention as a roadmap or template to find its components in the prior art, and pick and choose some disclosures in the prior art but not others to fit the parameters of the invention.

#### **E. Written Description**

39. I understand that a patent claim has adequate written description when the original disclosure reasonably conveys to a POSA that the inventor had possession of the claimed subject matter as of the filing date of the application for patent. Stated another way, a patent specification satisfies the written description requirement if a POSA would recognize that the specification describes what is claimed. In order to satisfy the written description requirement, the patent specification must describe every claim limitation, although the exact words used in the claim need not be used in the specification.

## **V. LEVEL OF SKILL IN THE ART**

40. It is my opinion that a POSA relevant to the challenged patents would have had a good working understanding of the design and manufacture of batteries and cells, and would possess a Bachelor's degree in electrical, mechanical or chemical engineering or an equivalent degree. A POSA would also have two to three years of experience working in a related technology. Alternatively, a POSA could have a Ph.D. or a Master's degree or its equivalent and less experience, but would have at least some experience in battery design and manufacture.

41. I understand that Petitioners' expert, Mr. Gardner provides a different definition of the skill level of a POSA. My opinions set forth herein would be the same under the standard provided by Mr. Gardner.

## **VI. TECHNOLOGICAL BACKGROUND OF THE CHALLENGED PATENTS**

42. The patents here at issue are directed generally to small button cell batteries. In general, different battery technologies are used in a wide range of applications. A cell is the basic unit in which an electrochemical reaction occurs. One or more cells electrically together make up a battery. Ex. 1009 p. 20. Batteries and cells are classified as either primary (non-rechargeable), which can be discharged once and is discarded thereafter, or secondary (rechargeable) which can be discharged and recharged over many cycles. *Id.* p. 21.

43. The basic components of a cell include positive and negative electrodes, a separator that prevents contact between the electrodes, electrolyte which may be combined with the separator, terminals that can be connected to an external circuit, and a container or housing. *Id.* p. 20. The components of the cell are arranged to carry out an electrochemical reaction that converts chemical energy into electrical power. The basic construction and operation of a secondary cell during discharging and charging are shown schematically below.

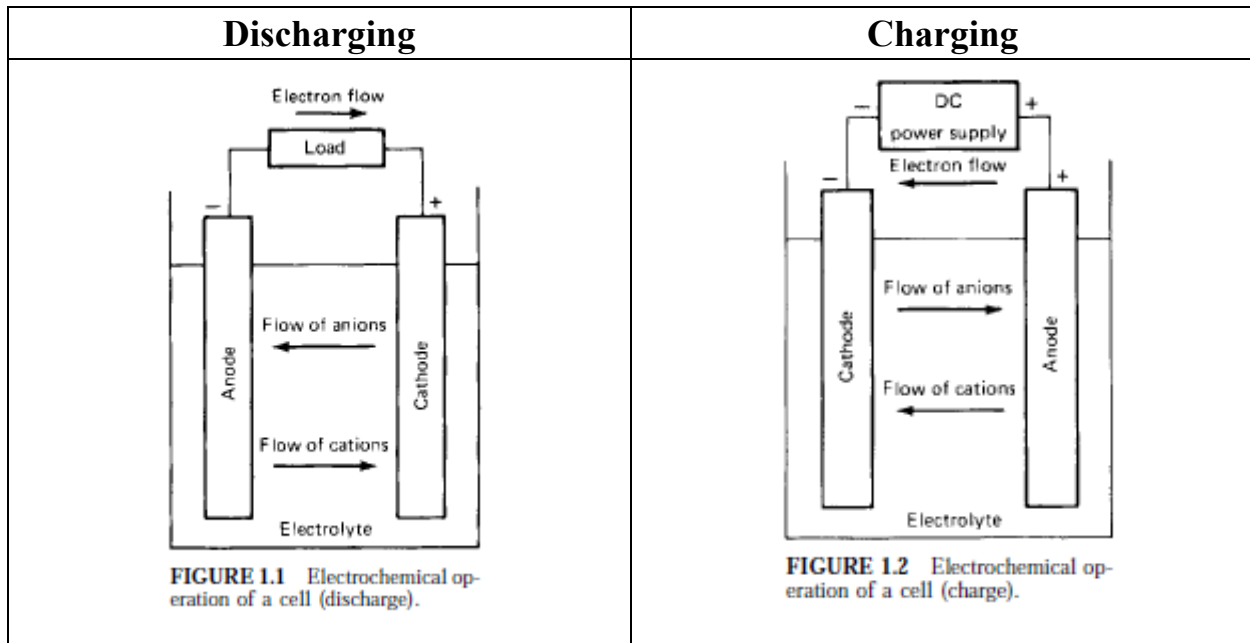

44. The electrodes are the components which cause the electrochemical reaction to take place. *Id.* p. 1378. A negative electrode, or anode, typically generates current including electrons that may be delivered to an external circuit. Current flows from the anode to a positive electrode, or cathode, to complete the circuit. *Id.* pp. 1374, 1375. The electrodes may be fabricated of metal on to which

an active material is coated. *Id.* p. 1074. Active materials are the substances which actively take part in the electrochemical reaction during charging and discharging of the cell. *Id.* p. 1374. An electrolyte surrounds and separates the electrodes. The electrolyte is a material that can transport ions between the positive and negative electrodes. *Id.* p 1378.

45. When the cell is connected to an external load via an electrically conductive circuit, part of the chemical reaction occurs at the anode that causes electrons to flow to the load. Ex. 1009 p. 24. To provide the electrons, the anode absorbs electrons from molecules in the electrolyte. Those molecules thus become positively charged ions. *Id.* A corresponding part of the chemical reaction occurs at the cathode towards which electrons flow from the load. *Id.* The molecules in the electrolyte can accept electrons from the cathode, thereby becoming negatively charged ions. To balance the reaction, the positively and negatively charged ions travel through the electrolyte to the oppositely charged electrode.

46. The electrodes and the electrolyte have complementary material properties to facilitate the electrochemical reaction. Many different electrochemical combinations of materials can perform the reaction and characterize the cell. Common electrochemical systems for rechargeable secondary cells include nickel-metal hydride cells and lithium-ion cells. Ex. 1001 ('835 patent) 1:37:39, Ex. 1009 pp. 841-875, 1074-1167.

47. During the charging and discharging process in lithium-ion cells, the electrodes are subject to volume changes. Ex. 1001 ('835 patent), 2:23-25. The volume change is due to the intercalation process where lithium ions are alternatively absorbed into or removed from the active material. Ex. 1009 pp. 1077-78. In a secondary cell, the volume change of the electrodes will occur with each charge and discharge cycle generating cyclic internal loading and force within the cell.

48. "Button" or "coin" cells derive their name from their relatively small form factor and low height with respect to their diameter, i.e., similar to that of a button or coin. Button cells and coin cells are used to power small, often portable electronic devices like watches and hearing aids. See EP 1 318 561 at Ex. 1002 ('858 patent file history) pp. 853. Examples of a conventional button cells at the time the inventions of the Challenged Patents were made are shown below.

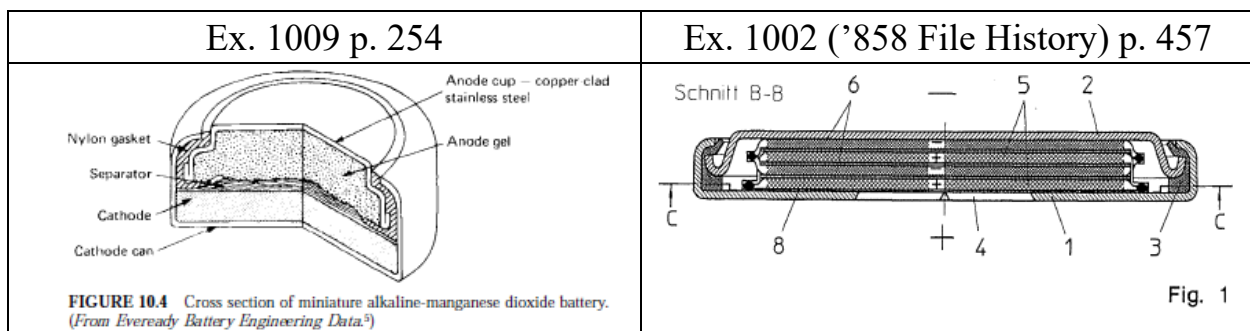

49. The electrodes of conventional commercial button cells were formed in a "tablet" or "pellet" configuration where the active material of the electrode is compressed into a tablet or pellet. Ex. 1009 p, 299-300; Ex. 1006 ¶ [0004]. Button

cells are also available in a “stacked” configuration in which the electrodes and separators are flat layers that are alternately stacked one on top of the other and inserted into the housing. Ex. 1001 ('835 patent), 1:39-49. Button cells and coin cells were used in light load applications and were capable of producing discharge currents of about a few  $\mu\text{A}$  to a few dozen  $\mu\text{A}$ . Ex. 1006 ¶ [0003].

50. At the time of the inventions of the Challenged Patents, commercial buttons cells did not incorporate a jelly roll style electrode configuration. The art at the time discouraged the use of the jelly roll configuration in button cells. See, e.g., Ex. 1006 (“[S]ize reduction is extremely difficult for these rechargeable [wound electrode] batteries, and the limit has currently substantially been reached.”). Indeed, Kobayashi (Ex. 1006), teaches that “it was thought impossible to store the [wound] electrode group structure within a small battery such as a button cell or coin cell.” *Id.* ¶ [0014].

51. One reason preventing the use of jelly rolls especially in secondary button cell was the cyclic swelling and contraction of the electrodes during charging and discharging. In larger cylindrical cells, there is sufficient internal volume to accommodate the volume change of the electrodes. However, in the small sized button cells, the electrode volume change becomes more significant ( $\Delta V/V$ ). These mechanical forces tend to shorten the life of the battery.

52. Prior to the invention of the Challenged Claims which led to the introduction of VARTA's Coin-Power® button cells into the marketplace, there were no commercially available button cells using a jelly roll configuration of which I was aware, and there were no commercially available button cells (microbatteries) with the current density, performance rate, and mechanical forces provided by the patented VARTA button cells with its jelly roll configuration.

## **VII. THE CHALLENGED PATENTS**

53. The inventions covered in the Challenged Patents represent a fundamental departure from the conventional button cell design at the time that used tablet or stacked plate electrodes. The patented button cell provides a battery which provides for greater levels of energy and longer battery life by efficiently packing the available interior volume of the housing that can be sealed closed without beading over the mating housing components.

54. An electrode-separator assembly consisting of a positive electrode, negative electrode and a separator in between the electrodes can be formed as a spiral winding ("a jelly roll") and inserted into the housing so that the electrodes are at right angles to the flat bottom and top areas of the housing cup and the housing top, respectively. Insulating means can be provided to separate the electrode-separator assembly from the flat top and flat bottom areas of the housing. Output conductors can be in the form of metal foils resting flat between an end



face of the spiral winding and the flat top or the flat bottom area to which it is connected, taking up very little space inside the housing. The metal foil conductors are thin and flexible to accommodate the changes in volume of the jelly roll (expansion and contraction) that the jelly roll undergoes during charging and discharging cycles. The housing cup and top may be closed without being beaded over.

55. Various combinations of these combined features provide for a stable, resilient button cell with excellent energy density and life, which VARTA now makes and sells under the tradename CoinPower®.

**A. U.S. Patent 9,153,835 (“the ’835 Patent”)**

56. The ’835 Patent, titled “Button Cell and Method of Producing Same,” relates to microbatteries and particularly button cells as described in the Technical Background above. I understand that the application leading to the ’858 Patent was filed from international application PCT/EP2010/000787 which was filed on February 9, 2010.

57. The Background of the ’835 Patent describes the state of conventional lithium ion button cells at the time. The Background notes that the electrodes of lithium ion button cells are normally not in the “form of tablets, separated from one another by a separator.” Ex. 1001 ’835 Patent 1:39-43. The conventional lithium ion cell typically includes “prefabricated electrode-separator assemblies [that] are

preferably inserted flat into the housing.” *Id.* 1:43-44. The prefabricated assembly has the electrode laminated or bonded flat onto a porous plastic film used as the separator. *Id.* 1:44-45. “The entire assembly comprising the separator and the electrodes generally have a maximum thickness of a few hundred  $\mu\text{m}$ .” *Id.* 1:45-49. The Background notes that multiple assemblies may be inserted into the same housing to fill the cell. *Id.* 1:49-51.

58. The ’835 Patent makes note of a drawback with this stacked configuration:

On the one hand, it is necessary, of course, for the electrodes of the same polarity each to be connected to one another within the stack, and then each to make contact with the corresponding pole of the button cell housing. The required electrical contacts result in material costs, and the space occupied by them is, furthermore, no longer available for active material.

Ex. 1001 ’835 Patent 1:59-65.

59. The ’835 Patent notes that manufacture of these stacked-configuration button cells is complicated and prone to faults and leaks. *Id.* 1:65-2:3.

60. In contrast to the stacked electrode configuration, the ’835 Patent utilizes an electrode separator assembly in the configuration of a jelly roll that includes a positive electrode and a negative electrode in the form of flat layers that are laminated or bonded to one another by a flat separator. Ex. 1001 ’835 Patent 3:22-27. “The electrodes and the flat separator . . . are each in the form of strips or ribbons.” *Id.* 3:56-57. The thickness of the electrode layers and the separator layer

is on the order of micrometers, with the preferred thickness of the electrodes between 30 $\mu\text{m}$  and 500  $\mu\text{m}$  and the preferred thickness of the separator between 10 $\mu\text{m}$  and 50  $\mu\text{m}$ . Id. 5:17-22.

61. The electrode separator assembly can be fabricated from flat electrode and separator layers and be in the form of a winding and “in particular in the form of a spiral winding.” Ex. 1001 '835 Patent 3:63-65. The “electrode winding is a spiral electrode winding” and is shaped as a squat cylinder. Id. 4:35-38. The compact jelly roll configuration maximizes the amount of active material in the electrode separator assembly, and thus energy density of the cell, and increases the interfacial surface area between electrodes to ensure the electrochemical reaction occurs quickly. The prefabricated electrode separator assembly is inserted in a button cell housing including a cell cup and a cell top. Id. 4:12-16, 6:54-58.

62. FIGS. 4 and 3(b) illustrate an exemplary electrode separator spiral winding and button cell per the disclosure.

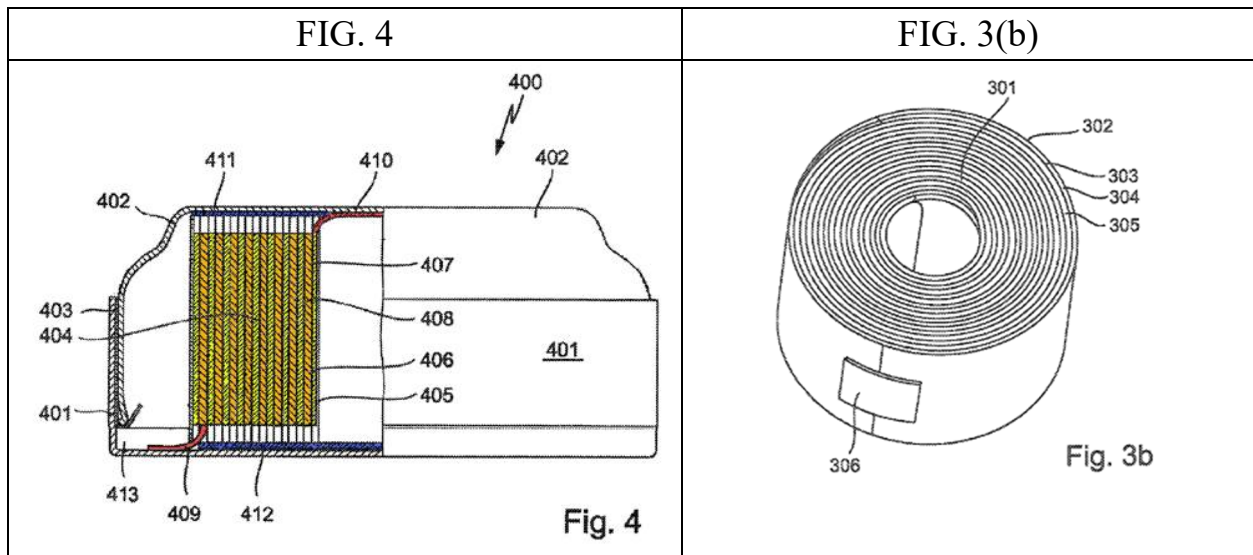

63. As described in the patent specification, “[b]utton cells normally have a housing consisting of two housing half-parts, a cell cup and a cell top.” Ex. 1001 ’835 Patent 1:28-29. The housing cup and housing top are fitted together to create a sealed (liquid-tight) interior volume. *Id.* 2:4-6. The housing top is typically inserted into the housing cup and separated from the housing cup by a seal. *Id.* 3:7-12. Unlike conventional button cells, the VARTA “button cell is particularly preferably a button cell which is not beaded over.” *Id.* 6:46-48.

64. “Within the housing, a button cell comprises an electrode-separator assembly with at least one positive and one negative electrode.” *Id.* 3:22-24. The positive and negative electrodes (colored above in red and green) are in contact with two opposing surfaces of a film-like separator. *Id.* 3:24-27. As shown in FIG. 4, electrodes and separator layers generally appear relatively flat when

viewed from the side. The electrode-separator assembly produces electrical power when connected to a circuit. The connections to the external circuit can occur through the housing, wherein “[t]he cell cup normally has positive polarity and the housing top negative polarity.” *Id.* 1:31-33.

65. A feature of the ’835 Patent is the orientation of the electrode-separator assembly in the housing. The ’835 Patent explains that, in prior art button cells, the electrode-separator assemblies are “frequently placed flat one on top of the other” such that the “electrode layers are aligned essentially parallel to the flat bottom and top areas” of the housing. *Id.* 1:49-53 and 3:34-38. The ’835 Patent notes that various problems can occur with such prior art designs. For one, “the electrodes of rechargeable . . . systems are continually subject to volume changes during charging and discharging processes.” *Id.* 2:23-25. Expansion of the electrodes results in axial forces directed upward toward the cell top and downward toward the cell cup which tends to force the two apart damaging the integrity of the microbattery. *Id.* 2:25-28.

66. To address this problem, the ’835 Patent provides that the electrode-separator assembly in which electrodes with a separator interposed between the electrodes is wound into a cylindrically-shaped spiral winding, i.e., a jelly roll, and is located in the housing so that the electrodes are disposed essentially at right angles to the flat bottom and flat top of the housing cup and housing top

respectively. *Id.* 3:24-27, 2:40-49, and 3:63-4:4. The axial end faces of the spiral wound jelly roll are therefore directed towards the flat bottom and flat top of the housing. (Ex. 1001 '835 Patent 4:12-16.)

67. The result is that expansion and/or contraction of the electrode-separator jelly roll during charging and discharging is generally directed radially outward and/or inward, rather than axially upward and downward. The '835 Patent specifically states:

[T]he mechanical forces which are created during this process no longer act primarily axially, as in the case of a stack of electrode-separator assemblies which are inserted flat. Because of the right-angled alignment of the electrodes, they in fact act radially. Radial forces can be absorbed very much better than axial forces by the housing of a button cell. The improved sealing characteristics are presumably a result of this. Ex. 1001 '835 Patent, 3:47-55.

68. Expansion and contraction of the jelly roll with respect to the housing “can lead to problems in making electrical contact between the electrode and the metallic housing half-parts.” *Id.* 4:6-11. To connect the expanding and contracting electrodes to the flat top and bottom areas of the housing, output conductors are included. *Id.* 6:17-30. The output conductors can be metal foils such as copper and rest flat on the end faces of the spiral wound electrode separator assembly and “rest flat on the inside of the housing half parts.” *Id.* 5:50-56, 6:22-30. The flat output conductors are connected to and pressed against the flat top and bottom areas of the housing making electrical contact with the housing in highly space-

efficient manner. *Id.* 6:22-30. The flexible output conductors can accommodate movement of the electrode separator assembly as it expands and contracts, directing and relieving pressure in the radial and axial directions, to avoid “problems with making electrical contact between the electrodes and the metallic housing half-parts.” *Id.* 4:23-29.

69. Another feature of the '835 Patent is that, to prevent positive and negative electrodes from short circuiting the button cell, insulating means can be included “which prevents a direct mechanical and electrical contact between the end faces of the winding and the flat bottom and top areas.” Ex. 1001 '835 Patent 6:9-16. The insulating means may be plastic, which in certain embodiments is one or more films or discs. *Id.* 6:31-34 and 11:17-19, 64-67. The use of a flat plastic insulating means inside the button cell makes further efficient use of the internal volume that can leave more space available to accommodate more active material.

70. Another feature of the '835 Patent is the manner in which the housing top and housing cup are fitted together without being beaded over. The '835 Patent describes that “[t]raditionally, button cells have been closed in a liquid-tight manner by beading the edge of the cell cup over the edge of the cell top . . . .” Ex. 1001 '835 Patent 2:4-6; *see also* FIG. 1. The '835 Patent states that in contrast to traditional button cells, the housing top and cup of the disclosed button cells are preferably fitted together without beading over.

The button cell is particularly preferably a button cell which is not beaded over . . . Correspondingly, there is preferably an exclusively force-fitting connection between the housing half-parts. Ex. 1001 '835 Patent 6:46-50.

71. The '835 Patent describes a particular method of making a cell without beading over:

The procedure for producing a button cell which is not beaded over is generally to first of all apply a seal to the casing area of a cell top. In a further step, the cell top is then inserted, with the seal fitted, into a cell cup thus resulting in an area in which the casing areas of the cell cup and cell top overlap. The size of the overlap area and the ratio of the overlapping area to the non-overlapping areas are in this case governed by the respective height of the casing areas of the cell cup and cell top, and by the depth of the insertion. With regard to the casing area of the cell top, it is preferable for between 20% and 99%, in particular between 30% and 99%, particularly preferably between 50% and 99%, to overlap the casing area of the cell cup (the percentages each relate to the height of the casing or of the casing area). Before being inserted into the housing cup and/or the housing top, the other conventional components of a button cell (electrodes, separator, electrolyte and the like) are inserted. After the cell top has been inserted completely into the cell cup a pressure is exerted on the casing area of the cell cup, in particular in the area of the cut edge, to seal the housing. In this case, a joined-together housing part should as far as possible not be subjected to any loads, or only to very small loads, in the axial direction. Therefore, the pressure is applied in particular radially. Apart from the sealing of the housing which has already been mentioned the external diameter of the cell housing can therefore also be calibrated.

It is particularly important for the heights of the casing areas of the cell cup and cell top to be matched to one another such that the cut edge of the cell cup is pressed against the casing area of the cell top by the pressure on the casing area of the cell cup. The heights of the casing areas are therefore preferably chosen such that it is impossible to bend the cut edge of the cell cup around inward over the edge area of the cell top which has been completely inserted into the cell cup.



Correspondingly, the edge of the cell cup is not beaded over the edge area of the cell top. In consequence, the cell cup of a button cell manufactured using our method has a casing area with an essentially constant radius in the direction of the cut edge.

In the case of button cells produced using a method such as this, there is preferably an exclusively force-fitting connection between the housing components comprising the cell cup, the cell top and the seal. This ensures that the components are therefore held together in a preferred manner, essentially only by static-friction force.

Button cells without any beading over are particularly preferably produced using a cell cup which is conical at least in one subarea of its casing, such that at least its internal diameter increases in the direction of the cut edge. This makes it considerably easier to insert the cell top into the cell cup.

Ex. 1001 '835 Patent 7:10-59.

72. A result of closing the housing cup and housing top without beading them over is that interior region has an “essentially cylindrical geometry” with the internal radii being essentially constant. Ex.1001 '835 Patent 6:63-7:9. The absence of a beaded over edge helps provide a cylindrical interior that conforms the interior of the housing to the corresponding cylindrical shape of the spiral wound electrode separator assembly so that essentially all the interior volume is packed with active material maximizing the energy density of the cell. That optimizes the efficient use of internal space to accommodate active materials, i.e. the electrodes and separator.

73. The unique arrangement of the jelly roll inside the housing utilizes the expansion and contraction forces generated during charging and discharging cycles

to the best advantage that provides “considerable improvement in the sealing characteristics of our button cell.” *Id.* 3:39-42. The mechanical forces generated by expansion and contraction of the electrodes are directed radially and can be withstood by the housing much better than if the forces were directed axially. *Id.* 3:47-55. The non-beaded over design conforms to the jelly roll electrode separator assembly as it swells and contracts and efficiently dissipates the repetitive forces and loads occurring during charging and discharging so that the patented button cell has excellent cycle life.

**B. U.S. Patents 9,496,581 and 9,799,913 (“the ‘581 and ‘913 Patents”)**

74. The ‘581 and ‘913 Patents are related to the ‘835 Patent. The ‘581 Patent is a divisional of the ‘835 Patent, and the ‘913 Patent is a continuation of the ‘581 Patent. The specifications and figures of the ‘581 and ‘913 Patents are substantially the same as the ‘835 Patent.

**C. U.S. Patent No. 9,799,858 (“the ‘858 Patent”)**

75. The ‘858 Patent is also directed to a button cell and is titled “Button Cell Having Winding Electrode and Method for Production Thereof.” The application for the ‘858 Patent was filed on December 14, 2011, as a national stage application of international application PCT/EP2010/058637. The ‘858 Patent is based on prior German applications DE 10 2009 030 359, filed on June 18, 2009, and DE 10 2009 060 800, filed on December 31, 2009.

76. The specification of the '858 Patent describes “a button cell including two metal housing halves separated from one another by an electrically insulating seal forming a housing having a plane bottom region and a plane top region parallel thereto.” Ex. 1001 '858 Patent 2:28-31. The '858 Patent describes a jelly roll style electrode-separator assembly in the “form of a winding, end sides of which face in the direction of the plane bottom region and the plane top region.” *Id.* 6:66-7:4. The electrode separator assembly includes “[a]t least one positive electrode and at least one negative electrode . . . each in the form of flat electrode layers.” *Id.* 3:14-16. The electrodes are preferably connected to one another by a flat separator that may be a porous plastic film. *Id.* 3:16-22.

77. To establish an electrical connection between the electrodes and the housing, the '858 Patent states that the “button cell is distinguished particularly in that at least one of the conductors is welded to the respective housing half, preferably both the conductor connected to the at least one positive electrode and the conductor connected to the at least one negative electrode.” Ex. '858 Patent 4:10-14.

78. The '858 Patent describes the conventional state of the art regarding welding with respect to connecting a conductor to the housing:

Particularly preferably, the conductor or conductors are welded onto the inner side of the housing in the plane bottom region or the plane top region, respectively, of the housing. For this purpose, according to conventional methods the welding process must be carried out before

the housing is assembled, which is very difficult to achieve in terms of production technology. Welded connections have therefore been regarded as highly disadvantageous for bonding the conductors to the inner side of the housing halves. Ex. 1001 '858 Patent 4:22-33.

79. To address the foregoing disadvantages, the '858 Patent describes a preferred embodiment for welding the conductors to the housing. That embodiment involves first assembling the components including the winding inside the housing and then welding the conductors to the housing. Ex. 1001 '858 Patent 5:46-6:6.

This means that the at least one conductor is welded to the inner side of the housing when the housing is closed. The welding must correspondingly be carried out from the outside through the housing wall of one or both housing halves.

*Id.* 6:2-6.

80. In a specific example, the '858 Patent discloses that “[w]elding the conductors and the housing is preferably carried out by a laser.” *Id.* 6:13-14.

81. To prevent the button cell from electrically shorting due to contact between the positive and/or negative electrodes in the electrode-separator assembly and housing halves of opposite polarity, the '858 Patent states “the button cell therefore comprises at least one separate insulating means which prevents direct electrical contact between the end sides of the winding and the conductors. *Id.* 5:9-14. The insulating means can be a thin plastic film. Ex. *Id.* 5:14-17.

## VIII. CLAIM CONSTRUCTION

### A. “button cell” (all challenged claims)

82. The phrase “button cell” appears in each of the challenged claims of the Challenged Patents. In my opinion, a POSA would understand the term “button cell” to mean a “small, generally round and flat battery typically used in small electronic devices.”

83. I initially note that the title of each Challenged Patent includes the term “button cell.” Further, the term “button cell” is used repeatedly throughout the specification of the Challenged Patents to refer to the subject matter of concern. The specification however does not otherwise define a button cell. Accordingly, a POSA would understand that “button cell” should be attributed its plain and ordinary meaning at the time of the invention.

84. At the time of the inventions of the Challenged Patents, a POSA would recognize that a “button cell” refers to a small, round and relatively flat battery (e.g., generally the size of a button). Button cells were well known at the time the applications for the Challenged Patents were filed and a POSA would recognize that the term “button cell” as used in the claims places requirements on the type and size of the claimed batteries as compared to other types of batteries including those that are substantially larger. Button cells had diameters of about 30 mm or less and heights of about 6 mm or less.

85. The prosecution history of the '858 Patent confirms the understanding that “button cell” relates to a specific type of battery characterized by its small size.

To overcome a reference during prosecution of the '858 Patent, VARTA stated:

However, Fig. 15 [of Saaski] does not show a button cell. It shows a cylindrical round cell. This interpretation is confirmed in Applicant's substitute specification in para. [0029], wherein the general definition of a button cell is found. It is defined as having a ratio of height to diameter of preferably less than one. This is further confirmed by the attached definition from “Electropedia” (4/2004). This definition distinguishes the claimed button cell over the round cell shown in Fig. 15 of Saaski.

It is also well known that round cells regularly have (much) larger dimension than button cells. Therefore, generation of electrical contacts between different components of round cells, for example, of welding connections is much easier. For example, in Fig. 15 of Saaski, a massive metal nail 196 has to be connected to a housing part 178a. In comparison, the connect of the Applicant's button cell have a thickness of only a few micrometers. It is far more difficult to generate welding connections between connectors as shown, for example, in the Applicant's FIG. 3A and the bottom of cup-shaped housing parts.

Ex. 1002 in IPR2020-01213, p. 270-271.

86. The definition from the referenced Electropedia website for a button cell is “cell with a cylindrical shape in which the overall height is less than the diameter e.g. in the shape of a button or a coin.”

[www.electropedia.org/iev/iev.nsf/display?openform&ievref=482-02-40](http://www.electropedia.org/iev/iev.nsf/display?openform&ievref=482-02-40). This definition thus confirms that the form factor of a button cell is on the order of a button or coin.

87. The International Electrochemical Commission published an International Standard IEC 62133-1 regarding safety requirements for secondary batteries that defines “button cell” as a “small round cell or battery in which the overall height is less than the diameter.” Ex. 2025 § 3.21.

88. Other evidence confirms that the meaning of a “button cell” is a small, generally round and flat battery. See, e.g., Ex. 2026 (Wikipedia Entry for Button Cell [https://en.wikipedia.org/wiki/Button\\_cell](https://en.wikipedia.org/wiki/Button_cell)) (“a small single cell battery shaped as a squat cylinder typically 5 to 25 mm (0.197 to 0.984 in) in diameter and 1 to 6 mm (0.039 to 0.236 in) high — resembling a button”); Ex. 2027 at 2 (“The term ‘button cell battery’ means . . . a cell battery that is 32 millimeters or less in diameter and less than its diameter in length”). Petitioners’ cited reference Kobayashi also describes a “button cell” as “a small battery.” Ex. 1006 ¶ [0001].

89. The term “button cell” places restrictions on the shape and size of the claimed cell that would be readily apparent to a POSA and essential to understanding the nature of the invention.

90. Accordingly, in view of the consistent use of the term in the Challenged Patents, the intrinsic evidence, and the term’s well-known meaning in the art, it is my opinion that a POSA would understand “button cell” to refer to a small, generally round and flat battery typically used in small electronic devices

and further that inclusion of the term in the claims of the Challenged Patents places restrictions on the type and sizes of the batteries being claimed.

**B. “insulating means” (’835 and ’913 patents)**

91. The term “insulating means” appears in independent claim 1 of the ’835 Patent and in independent claims 1 and 6 and dependent claims 2 and 7 of the ’913 Patent. I understand that the Board has preliminarily interpreted “insulating means” to be a means-plus-function term and adopted Petitioners’ construction for purposes of instituting this proceeding. *See* IPR2020-01212 (’835 patent), Paper No. 8 at 25.

92. In my opinion, a POSA would construe “insulating means” as including plural layers, i.e., “layer(s) composed of plastic, plastic disc(s) or structural equivalents” to correspond to the plural structures disclosed in the patent specification. *See, e.g.*, Ex. 1001 ’835 patent at FIG. 4 (showing insulator arrangements 411, 412); 11:17-19 (“The insulating means 411 and 412 are arranged between the end faces of the winding and the cup part 401 and the top part 402, and are each in the form of thin plastic disks.”); 11:64-67 (describing the output conductors 505, 506 as being separated from the winding by “a separate insulator arrangement”).



93. I understand that to interpret a means-plus-function term, one should determine the function performed by the term and then identify the corresponding structure disclosed in the specification.

94. The term “insulating” itself has a well-understood meaning in the battery art as meaning preventing the conduction of electricity. Accordingly, in my opinion, a POSA would identify the function of the “insulating means” to include “electrically insulating.” Furthermore, I note in the district court cases involving the Challenged Patents, Petitioners agreed that the function of the “insulating means” is “electrically insulating.” (Ex. 2014 at 5, 16, 20.)

95. The specifications of the '835 and '913 patents describe examples of corresponding materials and structures that perform the electrically insulating function of the claimed “insulating means.” These disclosed structures include:

By way of example, the insulating means may be a flat layer composed of plastic, for example, a plastic film, which is arranged between the end faces of the winding and the flat bottom and top areas of the housing of our button cell.

*See, e.g.,* Ex. 1001 '835 Patent 6:31-34.

The insulating means 411 and 412 are arranged between the end faces of the winding and the cup part 401 and the top part 402, and are each in the form of thin plastic disks.

*See, e.g.,* Ex. 1001 '835 Patent 11:17-19.

The output conductors are preferably separated from the end faces of the winding by a separate insulator arrangement (not illustrated in the drawing), for example, by a thin film.

*See, e.g.,* '835 Patent, 11:64-67.



The insulating means 411 and 412 are arranged between the end faces of the winding and the cup part 401 and the top part 402, and are each in the form of thin plastic disks. This prevents electrodes of opposite polarity from being able to come into contact with the cup part 401 or the top part at the same time. This prevent any short circuit. (Ex. 1001 '835 Patent 11:17-22.)

100. Accordingly, I disagree with Petitioners' and Mr. Gardner's proposed construction to the extent it implies the insulating means is only a single layer and excludes embodiments explicitly disclosed in the specification.

**C. "button cell is closed without being beaded over" ('835 patent)**

101. The phrase "the button cell is closed without being beaded over" appears in independent claim 1 of the '835 Patent. A POSA would understand that the phrase "closed without being beaded over" describes the way by which the housing cup and the housing top are joined and closed to form the housing of the button cell. In my opinion, a POSA would understand that the phrase "the button cell is closed without being beaded over" to mean that the button cell is "closed at overlapping sides of the housing cup and top without a bend in the cut end of the housing extending over a top edge area of the housing top."

102. Claim 1 of the '835 Patent states that the button cell includes "a housing cup and a housing top which form . . . a housing." The specification confirms that that these two housing halves to be closed must be joined in an overlapping manner.

103. The specification notes that “[t]raditionally, button cells have been closed in a liquid-tight manner by beading the edge of the cell cup over the edge of the cell top.” Ex. 1001 ’835 Patent 2:4-9. The construction of a beaded over cell is shown in FIG. 1 of the ’835 Patent reproduced below wherein the “edge of the cell cup 101 [highlight in red] is beaded inward over the edge of the cell top 102.” *Id.* 10:11-12.

104. As described above, the ’835 patent solves the problem of axial forces produced by the electrode-separator assembly by forming the electrode separator assembly as a spiral winding and locating the spiral winding in the housing so that the electrode and separator layer are “aligned at essentially right angles to the flat bottom and top areas.” *Id.* 3:30-34. When the electrodes are subject to volume changes when charging and discharging, “[b]ecause of the right-angled alignment of the electrodes, [the expansive forces] act radially. Radial forces can be absorbed very much better than axial forces by the housing of a button cell.” *Id.* at 3:44-55.

105. The right-angled orientation of the electrode-separator assembly enables production of a button cell that is closed without being beaded over. An embodiment of the ’835 Patent is therefore directed to such a button cell.

106. The specification describes that “alternatively, it is also possible to manufacture button cells in which the cell cup and the cell top are held together in the axial direction exclusively by a force-fitting connection, and which do not have

a beaded-over cup edge. *Id.* 2:11-15. An example of the non-beaded over construction is shown in FIG. 4 of the '835 Patent also reproduced below wherein “the edge of the cell cup 501 [highlight in blue] is not beaded over the edge 511 of the cell top 502, and the preferred example described above for a button cell 500 is therefore a button cell which is not beaded over.” *Id.* 11:36-39.

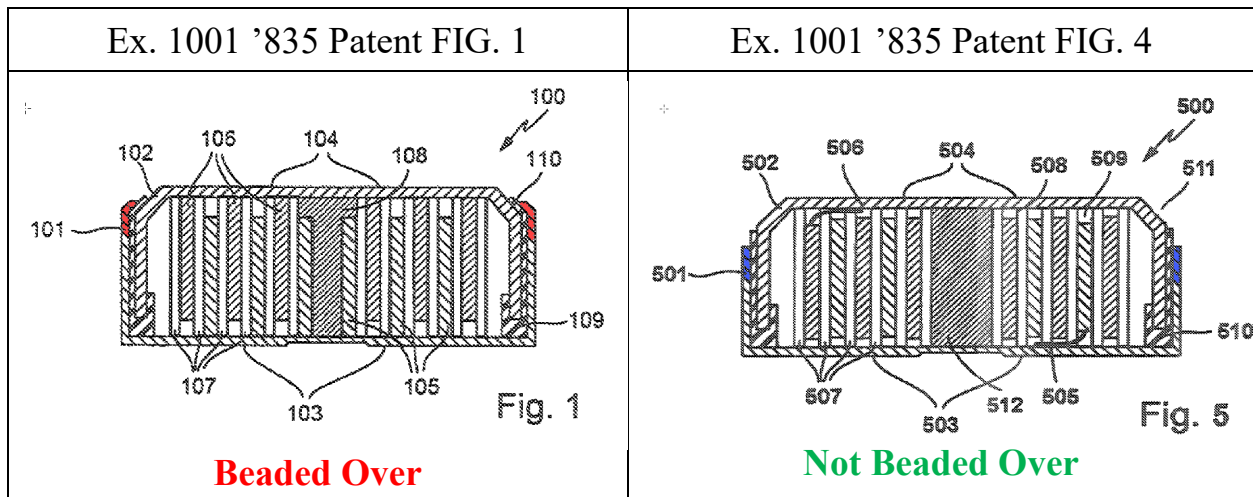

107. The '835 Patent also describes how to assemble a button cell that is closed without being beaded over:

Button cells such as these which are not beaded over generally make use of conventional cell cups and cell tops, which each have a bottom area and a top area, a casing area, an edge area which is arranged between the bottom and top areas and the casing area, and a cut edge. Ex. 1001 '835 Patent 6:54-58.

[T]he cell top is then inserted, with the seal fitted, into a cell cup thus resulting in an area in which the casing areas of the cell cup and cell top overlap. The size of the overlap area and the ratio of the overlapping area to the non-overlapping areas are in this case governed by the respective height of the casing areas of the cell cup and cell top, and by the depth of the insertion.

Ex. 1001 '835 Patent 7:12-18.

After the cell top has been inserted completely into the cell cup a pressure is exerted on the casing area of the cell cup, in particular in the area of the cut edge, to seal the housing.

Ex. 1001 '835 Patent 7:26-30.

It is particularly important for the heights of the casing areas of the cell cup and cell top to be matched to one another such that the cut edge of the cell cup is pressed against the casing area of the cell top by the pressure on the casing area of the cell cup. The heights of the casing areas are therefore preferably chosen such that it is impossible to bend the cut edge of the cell cup around inward over the edge area of the cell top which has been completely inserted into the cell cup. Correspondingly, the edge of the cell cup is not beaded over the edge area of the cell top.

Ex. 1001 '835 Patent 7:36-45.

108. The '835 Patent also describes that in the button cells produced by the above method “there is a preferably an exclusively force-fitting connection between the housing component” that “ensures that the components are therefore held together in a preferred manner, essentially only by static friction force.” (Ex. 1001 '835 Patent 7:49-54.) The static friction force is present between the vertically oriented casing areas of the housing cup and housing top that overlap parallel to each other without the uppermost cut edge of the housing cup being bent over an adjacent edge of the housing top.

109. Based on the guidance of the specification describing alternate examples of a beaded over cell versus a non-beaded over cell and the described construction of a non-beaded over cell in the '835 Patent, a POSA would have understood the term “without being beaded over” to mean a button cell that is

“closed at overlapping sides of the housing cup and top without a bend in the cut end of the housing cup extending over a top edge area of the housing top.”

110. I disagree with Petitioners’ and Mr. Gardner’s proposed construction of the phrase “the button cell is closed without being beaded over” as “the button cell is closed without any portion of the housing cup edge being deformed or crimped radially inward such that the housing top cannot be vertically displaced without outwardly deforming the housing cup edge.” Paper 1 IPR2020-01212 at 20; *see also* Ex. 1003 ¶¶ 93-98. In my opinion, such a construction would completely remove the requirement from the term “beaded over” that the housing component is crimped or bent “over” another component.

111. In addition, Petitioners’ and Mr. Gardner’s proposed construction that “without beading over” requires that “the button cell is closed *without any portion of the housing cup edge being deformed or crimped radially inward*” is contrary to the disclosure in the specification that the non-beaded over button cell may be closed by applying radial pressure to the overlapping casing areas of the housing cup and top to produce a force-fitting connection. Ex. 1001 ’835 Patent 7:26-32, 7:49-54. In my opinion, a POSA would have understood that the application of such radial pressure would deform/crimp the housing components.

112. Petitioners’ and Mr. Gardner’s proposed construction also sets forth a test that must be conducted to determine whether a button cell is closed without

being beaded over, namely that “the housing top cannot be vertically displaced without outwardly deforming the housing cup edge.” According to this test, the housing top is vertically displaced, and then the housing cup is examined for signs of deformation.

113. In my opinion, the specification does not refer to such a test for determining whether a button cell is “closed without being beaded over.” There is no information or protocol for this proposed test set forth in the specification. Petitioners and Mr. Gardner do not point out where such test is set forth in the ’835 patent and fail to provide clear guidance on how one could ascertain whether this test was satisfied. For example, Petitioners and Mr. Gardner fail to make clear whether the vertical displacement mentioned in this test must be a relative displacement between the housing top and the housing cup and, if so, the amount such relative displacement must be.

114. Petitioners and Mr. Gardner also fail to quantify or characterize the outward deformation of the housing cup edge that would lead one to conclude that the housing is beaded over. For example, it is unclear whether the deformation must be permanent or can be temporary.

115. In view of the reasons above, I disagree with Petitioners’ and Mr. Gardner’s proposed construction because it does not explain how a POSA would



determine from the intrinsic record with any reasonable certainty whether a given construction is or is not “beaded over.”

**D. “connected to one another by at least one flat separator”  
(’835 ,’581, and ’913 patents)**

116. The term “connected to one another by at least one flat separator” appears in independent claim 1 of the ’835 Patent, independent claim 1 of the ’581 Patent, and in independent claims 1, 4, and 6 of the ’913 Patent. In my opinion, this term should be attributed its plain and ordinary meaning and that no further construction is necessary or helpful to the resolution of the IPRs.

117. The independent claims each require “at least one positive and at least one negative electrode in the form of flat layers.” The independent claims further state the electrodes are in the form of flat layers “connected to one another by at least one flat separator.” See, e.g., Ex. 1001 ’835 Patent 12:7-10; Ex. 1001 ’581 Patent 12:21-24; Ex. 1001 ’913 Patent 13:12-15. From this disclosure, a POSA would have understood that the electrodes may be connected to one another via separators. In particular, they are connected (joined together) by interposing a flat separator in between them.

118. In my opinion, the specifications are consistent with the conclusion that the plain and ordinary meaning of this phrase applies and that there is no special meaning that should be given.

119. The Patent specifications state that the button cell includes at least one positive and at least one negative electrode that “are each in the form of flat electrode layers. The electrodes are connected to one another via a flat separator.” See, e.g., Ex. 1001 ’835 Patent 3:24-26. From this disclosure, a POSA would have understood that the electrodes may be connected to one another via separators. In particular, they are connected (joined together) by interposing a flat separator in between them.

120. In my opinion, a POSA would have understood these disclosures as not limiting the manner of connection of the various electrode layers to lamination or gluing. To the contrary, a POSA would have understood the specification to include other types of connection so long as the layers allow ionic transfer between the positive and negative electrodes.

121. Rather than apply the plain and ordinary meaning to the term “connected to one another by at least one flat separator,” Petitioners and Mr. Gardner improperly seek to limit the term to a preferred embodiment whereby the electrodes and separator must be laminated, adhesively bonded or otherwise bonded. (Ex. 1003 ¶ [0099], [0106].)

122. The specifications of the ’835, ’581, and ’913 patent discloses these are only preferred embodiments:

The electrodes are connected to one another via a flat separator. The electrodes are preferably laminated or adhesively bonded onto this

separator. Ex. 1001 '835 Patent 3:25-26; Ex. 1001 '581 3:26-27; Ex. 1001 '913 Patent 4:17-19.

123. It is my understanding that a claim term is not limited to preferred examples but rather receives its plain and ordinary meaning except under specific circumstances where the patentee shows an intent to so limit the claims.

124. Had the Patentee intended to limit the scope of the term “connected to one another by at least one flat separator” to require lamination or adhesion, a POSA would have expected the specific language from the specification to be used the claim. Instead, the preferred method for connecting the layers together, which are provided in the specification, are absent from the claims. Instead, the claims state the manner of connection, i.e., by at least one flat the separator. The claim language mandates nothing more and the specification does not include any disclosure to the contrary.

## **IX. OVERVIEW OF THE PRIOR ART**

### **A. JP 2007-294111 (Kobayashi)**

125. Kobayashi relates to “a small battery provided with a winding electrode group (for example, a button cell or a coin cell)” that is “capable of improving heavy load characteristics without impairing productivity.” Ex. 1006 Abstract, ¶ [0001]. Kobayashi is also a detailed account of the difficulties encountered and the solutions created to enable the construction of a button cell with a wound electrode group or jelly roll.

126. The Kobayashi publication includes an illustration of the then state-of-the-art button cell in FIG. 10 which is the “typical structure for these small rechargeable batteries such as button cells and coin cells.” Ex. 6 ¶ [0004]. The conventional button cell included “a positive electrode case 21 doubling as a positive electrode terminal and a metal negative electrode case 22 doubling as a negative electrode.” Id. Contained within and connected to the case halves of the correct polarity are “one each of a tablet shaped positive electrode 23 and negative electrode 25.” Id. Button cells having internal electrodes in the form of solid tablets or pellets were common at the time of the Kobayashi publication in part, as Kobayashi notes, because of their “simple structure, they have excellent mass producibility and the characteristic of being capable of size reduction.” Ex. 1006 ¶ [0005]. However, Kobayashi also notes that because of their size and structure, prior art button cells “have insufficient properties when discharging at high currents.” Ex. 1006 ¶ [0006].

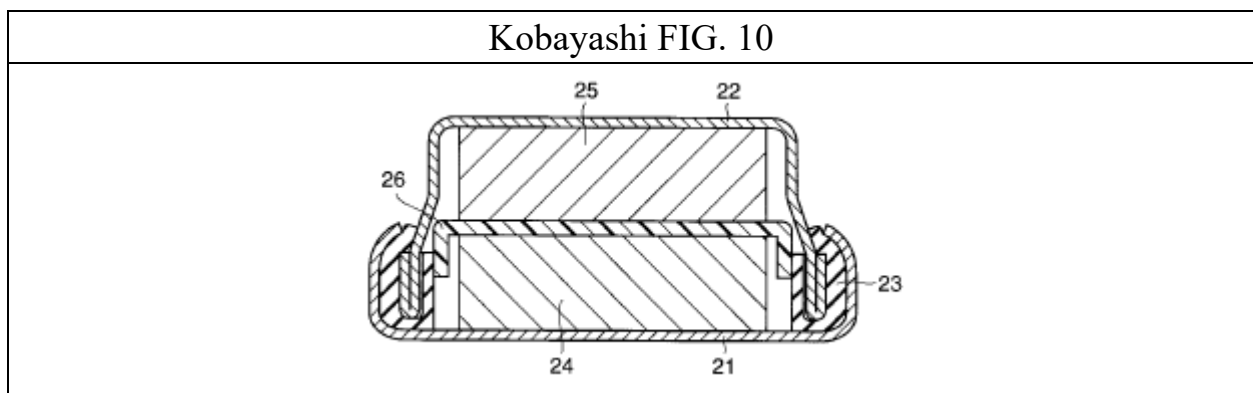

127. Kobayashi also describes larger cylindrical and prismatic batteries including lithium ion batteries that existed at the time. To manufacture the battery, “[f]irst an active material layer is applied or filled on a current collector composed of a metal foil or metal net to form electrodes.” Ex. 1006 ¶ [0007]. “After welding current-collecting tab terminals to the formed electrodes, these electrodes are wound or laminated to form an electrode group.” The wound electrodes are in the form of a jelly roll as I have described herein.

128. Kobayashi, however, notes reasons why the jelly rolls of conventional cylindrical batteries were incompatible with button cells. Kobayashi states that an important detriment is that “[m]anufacture of these rechargeable batteries requires such complicated manufacturing steps, and the work is complicated.” Ex. 1006 ¶ [0007]. Among the difficult manufacturing steps is the complication that “the current collecting tab terminals taken out from the electrode group are bent in a complicated manner and welded to . . . an electrode can . . . to manufacture the battery.” Ex. 1006 ¶ [0007]. In addition, “in order to prevent short-circuiting of the tab terminals, it is necessary to provide a space or part within the battery or to incorporate many parts such as safety elements within the battery.” *Id.* Kobayashi states that because of these factors “size reduction is extremely difficult for these rechargeable batteries, and the limit has currently substantially been reached.” *Id.* At the time of the Kobayashi publication, “it was thought that it was impossible to

store the electrode group structure within a small battery such as a button cell or a coin cell.” Ex. 1006 ¶ [0014].

129. To solve the foregoing obstacles, Kobayashi explains that “the present inventors attempted to change the approach away from conventional art, and by incorporating at least a winding axis core into the electrode group structure, and as needed, an insulation plate and contacting terminals between electrodes and external terminals” they were able to “enabled efficient storage of an electrode group in which a positive electrode, a negative electrode, and a separator are wound in a few layers to a few dozen layers within a case of a small battery such as a button cell or a coin cell.” Ex. 1006 ¶ [0015]. The winding axis core is “formed from an insulating material such as polyethylene, polypropylene, resin, glass or ceramic.” Id. ¶ [0017] “[T]he flat electrode group is integrated with a winding axis core by spirally winding the laminate while at least one of the positive electrode and the negative electrode is fixed to the winding axis core.” Ex. 1006 ¶ [0009].

130. The winding axis core therefore becomes the key element in Kobayashi because only “by incorporating the winding axis core into the electrode group while being integrated with the negative electrode and/or the positive electrode, it was possible to manufacture a wound electrode group capable of being housed in a case of a small battery such as a button cell or a coin cell.” Ex. 1006 ¶ [0017].

131. The winding axis core 7 is illustrated below is part of a larger spool-like structure extending between upper and lower insulating members 8, 9. Kobayashi states that it is “desirable to establish an insulating member between the electrode group and the battery case to prevent short-circuiting.” Ex. 1006 ¶ [0019]. Kobayashi further describes the “insulating member may be integrated with the winding axis core” and that doing so is desirable because the “stability of the electrode group is improved by integrating the insulating member and the winding axis core.” Ex. 1006 ¶ [0020].

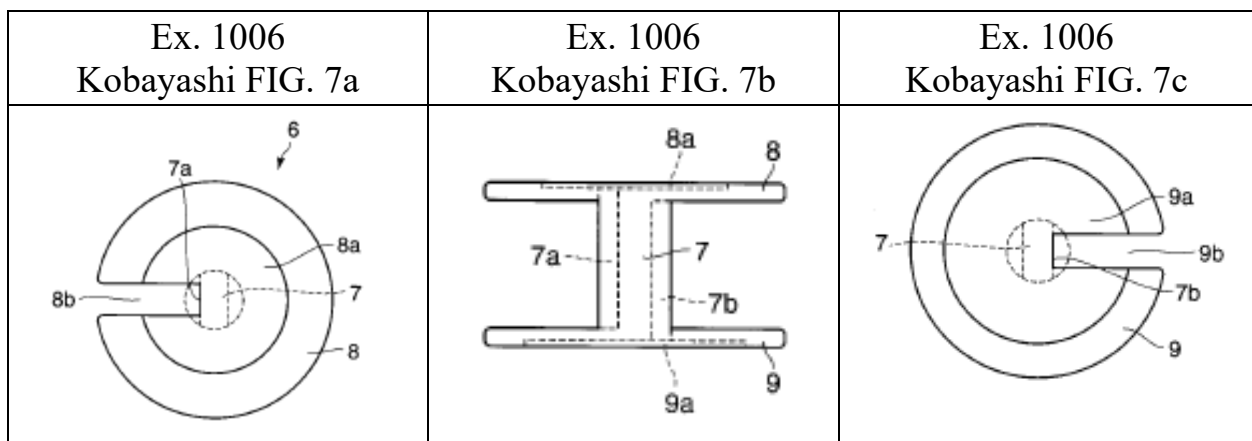

132. The winding axis core is to be “formed from an insulating material such as polyethylene, polypropylene resin, glass or ceramic.” Ex. 1006 ¶ [0017]. As illustrated in FIGS. 7a-7c above, the winding axis core 7 is part of a winding member 6 with the insulating plates 8 and 9 “integrated with the upper end and the lower end of the winding axis core 7.” Ex. 1006 ¶ [0030]. When assembled as illustrated in FIG. 1 above, the winding axis core 7 extending between the upper

and lower insulating plates 8 and 9 becomes the central core structure about which the remainder of the Kobayashi cell is built.

133. The remaining structure includes, for example, “an electrode group having a laminate including a positive electrode and a negative electrode wound in a spiral.” Ex. 1006 ¶ [0013]. Similar to the electrode separator configuration used in larger cylindrical cells, the positive and negative electrodes are in the form of ribbons or strips shown below in FIGS. 2 and 3. In particular, FIG. 2 shows “a positive electrode 1 having a positive electrode active substance containing material layer 1b laminated on both surfaces of a positive electrode current collector.” Ex. 1006 ¶ [0026]. The current collector 1a is disclosed as being “composed of a metal foil or metal net.” Ex. 1006 ¶ [0007]. The active substance containing layer 1b is “removed from both ends of the positive electrode” to expose the current collector and form a current carrying part 1c. Ex. 1006 ¶ [0026]. The negative electrode 2 is formed in the same manner.



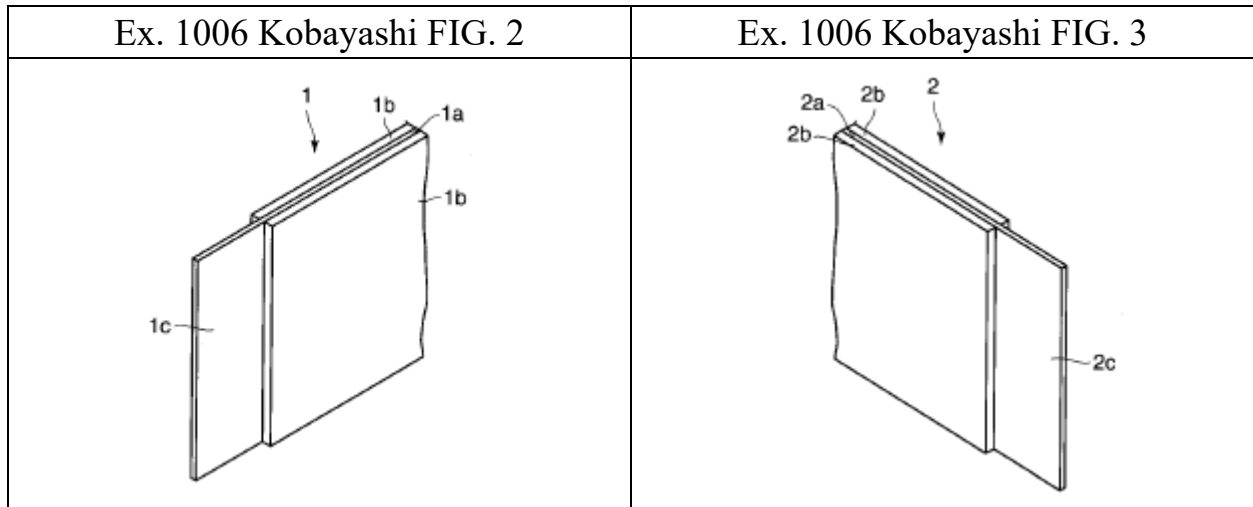

134. Kobayashi also confronted challenges in connecting the positive and negative electrodes to the top and bottom housing cases doubling as the external positive and negative terminals of the cell. According to Kobayashi, in comparatively larger cylindrical and prismatic batteries, “tab terminals are welded to the central part of the electrode group . . . and after bending this [tab terminal] it is welded” to the external terminal. Ex. 1006 ¶ [0018]. Kobayashi particularly notes that the “tab terminals taken out from the electrode group are bent in a complicated manner.” Ex. 1006 ¶ [0007]. Kobayashi contends the manufacturability of bent tab terminals to connect internal electrodes to external terminals “is poor because the bending process is complicated.” Ex. 1006 ¶ [0018]. Furthermore, the necessity of providing a space or safety elements to “prevent the short circuiting of tab terminals” prevents reducing the structural size to scale of a button cell. Ex. 1006 ¶ [0007].

135. To overcome the difficulties in connecting the electrodes to the terminal casings, Kobayashi developed a solution whereby “it was possible to simplify the structure by installing a terminal on the winding axis core to be incorporated into the electrode group to connect the electrode and the metal case doubling as an external terminal.” Ex. 1006 ¶ [0018]. As shown in FIGS. 4 and 5 and as described in Kobayashi:

The positive electrode terminal 4 has a disc-shaped positive electrode 20 terminal plate 4a (positive electrode terminal part), a bar-shaped terminal connection part 4b (positive electrode lead part) electrically connected to the positive electrode terminal plate 4a, and a slit 4c formed on the terminal connection part 4b. This positive electrode terminal 4 is formed, for example, from aluminum. Ex. 1006 ¶ [0028]

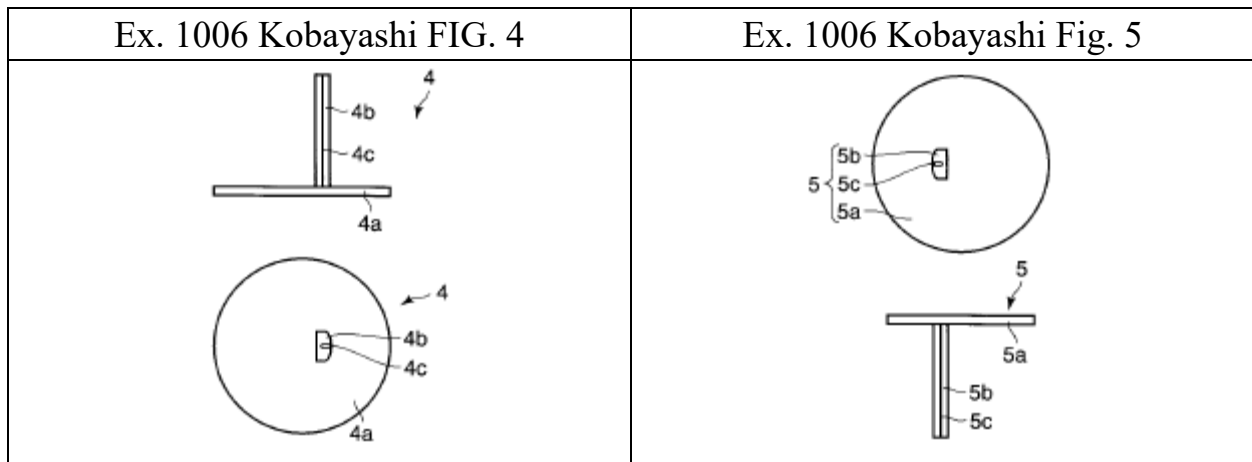

136. The negative electrode terminal 5 is similarly formed with a disc-shaped negative electrode terminal plate 5a integrated perpendicularly to a bar-shaped terminal connection part 5b. Ex. 1006 ¶ [0018].

137. To incorporate the positive electrode 1 with the positive terminal 4, Kobayashi instructs that “the current-carrying part 1c of the positive electrode 1

was inserted into the slit 4c in the terminal connection part 4b of the positive electrode terminal 4.” Ex. 1006 ¶ [0029]. To secure the connection, Kobayashi further instructs that “pressure [is] applied to the terminal connection part 4b from the outside, and the current-carrying part 1c [is] crimped to the terminal connection part 4b.” Ex. 1006 ¶ [0029]. This process is illustrated in FIG. 6 below.

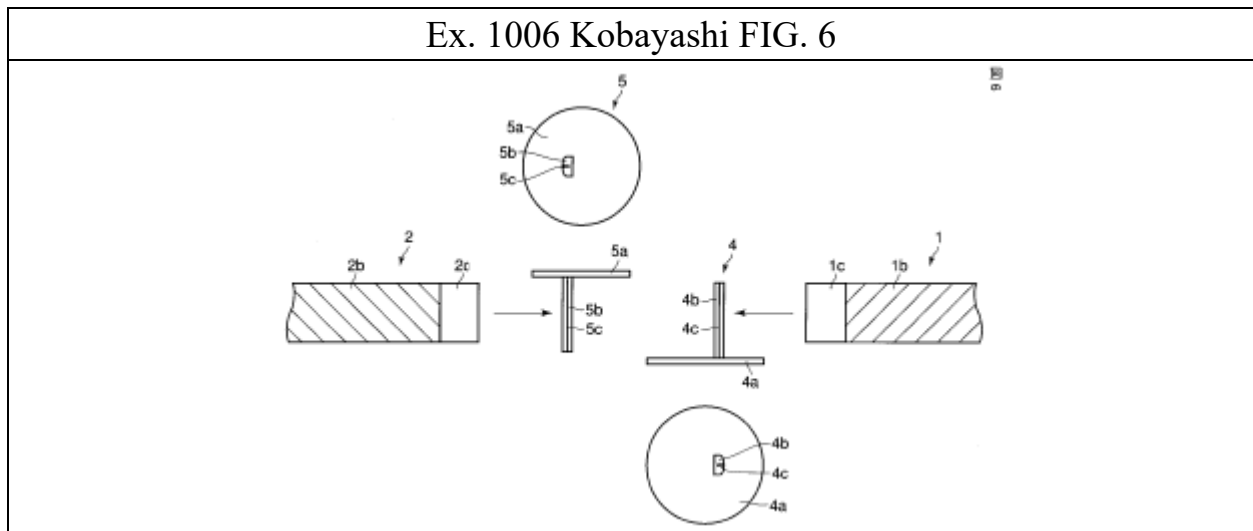

138. Kobayashi next describes how the positive and negative terminals 4, 5 are integrated with the winding axis core 7 to the winding member 6 described above. To accommodate and register with the bar-shaped terminal connection parts 4b, 5b, the winding axis core 7 is provided with a first notch part 7a and a second notch part 7b that extend the vertical extension of the winding axis core 7 between the upper and lower insulation plates 8 and 9. Ex. 1006 ¶ [0030]. To communicate with the notch part 7a of the winding axis core 7, “a slit 8b is also formed on the insulation plate 8.” Ex. 1006 ¶ [0030]. As shown, the slit 8b

extends radially outward from the central winding axis core 7 to the circumferential edge of the insulation plate 8. “Furthermore, a slit 9b is also formed on the insulation plate 9 so as to communicate with the notch part 7b of the winding axis core 7.” Ex. 1006 ¶ [0030].

139. As illustrated in FIG. 8, reproduced below, “the terminal connection part 4b of the positive electrode terminal 4 was inserted into the notch part 7b of the winding axis core 7.” Ex. 1006 ¶ [0031]. Inserting the bar-shaped terminal connection part 4b into the winding axis core 7 serves to register the positive and negative electrodes 1, 2 radially with respect to the winding member 6. Furthermore, “for accommodating the positive electrode terminal plate 4a, [a circular groove part 9a] is formed on the insulation plate.” Ex. 1006 ¶ [0030]. To integrate with the negative electrode terminal 5, “the terminal connection part 5b . . . [is] inserted into the notch part 7a of the winding axis core 7, and the negative electrode terminal plate 5a [is] disposed in the groove part 8a of the insulation plate 8.” Ex. 1006 ¶ [0031].

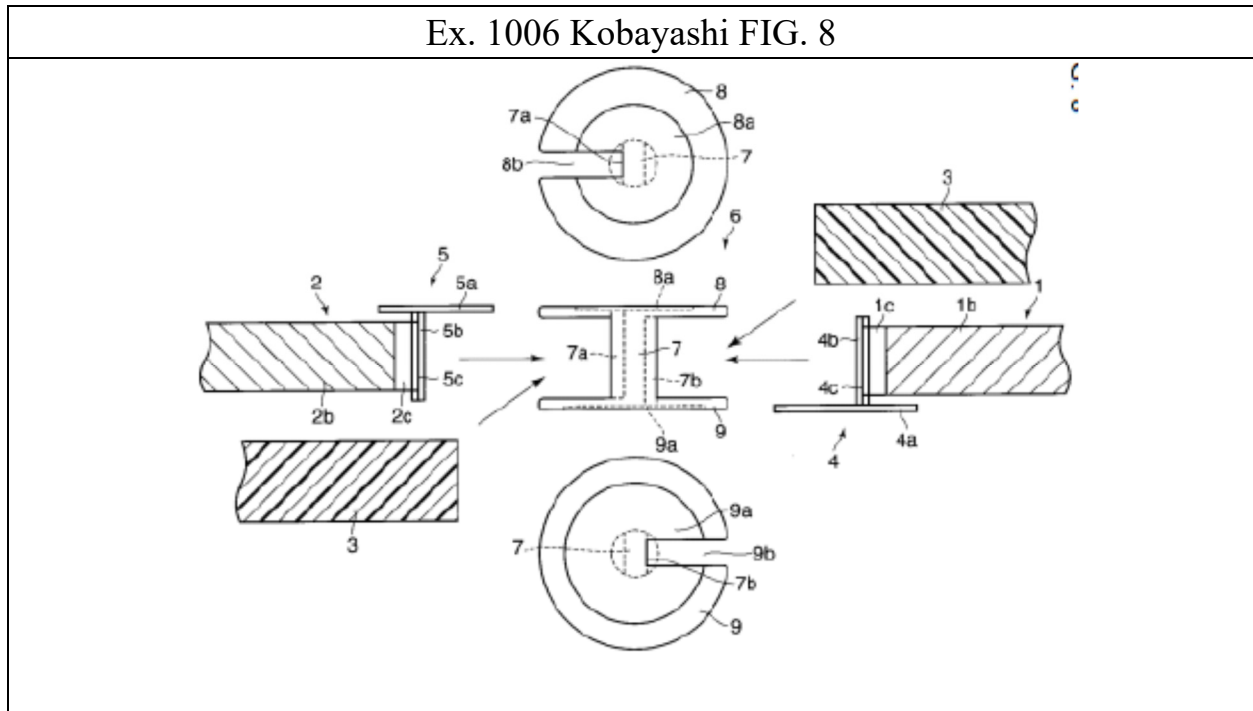

140. To electrically separate the electrodes, “a separator 3 composed of a polyethylene microporous film . . . was sandwiched and fixed between the winding axis core 7 and the positive electrode 1, and between the winding axis core 7 and the negative electrode 2.” Ex. 1006 ¶ [0032]. “[T]he positive electrode 1 and the negative electrode 2 are spirally wound with the separator 3 interposed” and the wound electrode group is complete. Ex. 1006 ¶ [0032].

141. The assembled electrode group is illustrated in FIG. 9 which shows “the winding axis core 7 wherein the terminal connection part 4b (positive electrode lead part) of the positive electrode terminal 4 and the terminal connection part 5b (negative electrode lead part) of the negative electrode terminal 5 are integrated is located at the center portion of the wound 10 electrode group.” Ex.

1006 ¶ [0032]. The disc-like negative terminal plate 5a (blue) is disposed on the upper insulation plate 8 (green) and the disc-like negative terminal plate 5b (blue) is disposed on the lower insulation plate 9 (green) thereby integrating the terminal plates with the winding core axis 7. Id.

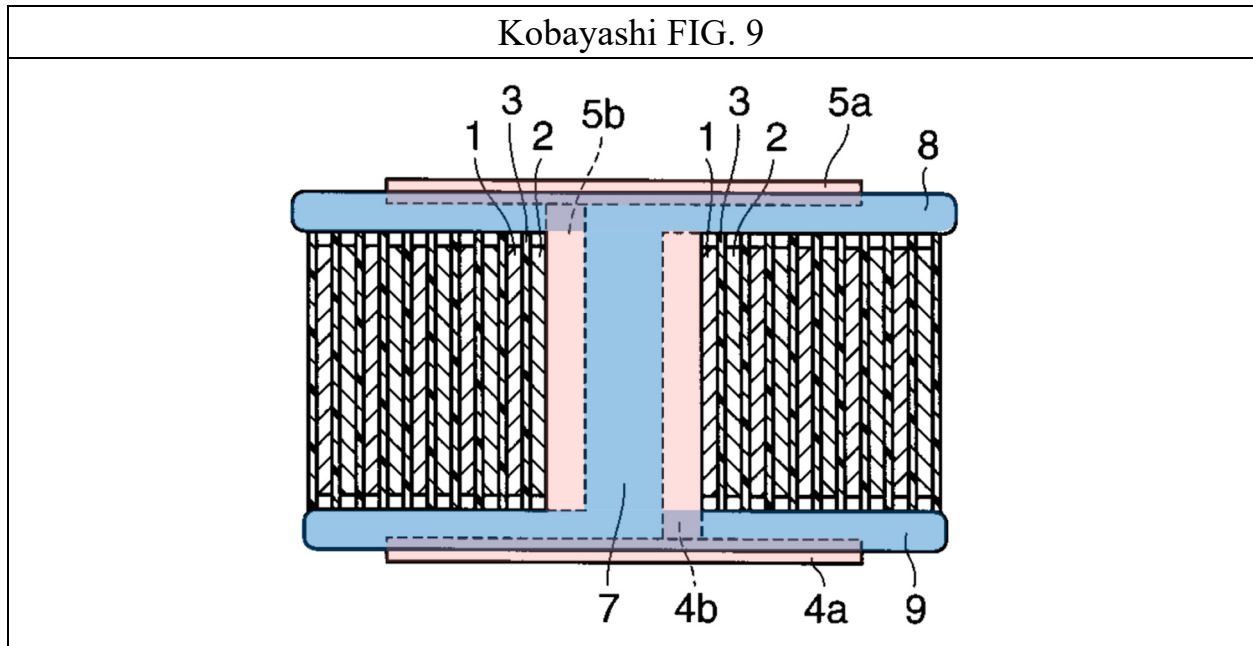

142. In the assembled electrode group, the current flow spirals through the winding along the lengths of the positive electrode 1 and negative electrode 2 wound about the winding axis core 7 to the centrally located, positive and negative terminal connection parts 4b, 5b, then moves axially upward and downward to the respective positive electrode plate 4a and negative electrode plate 5a. Because the positive and negative electrodes 1, 2 are spirally wound, the current flow must circumnavigate, or circle around, the wound electrode group to reach the centrally located positive and negative terminal connection parts 4b, 5b. Depending upon

the number of wound layers, the current may circumnavigate the wound electrode group many times.

143. Kobayashi also describes how to integrate the wound electrode group into the button cell. A metal container 11 is formed by a drawing process to have the shape illustrated in FIG. 1 reproduced below. “The electrode group was inserted into the negative electrode case 11 so that the negative electrode terminal plate 5a thereof was in contact with the inner surface of the negative electrode case 11, and the negative electrode terminal plate 5a and the negative electrode case 11 were resistance-welded.” Ex. 1006 ¶ [0033]. Similarly, the portion of the electrode group that remains uncovered by the container 11 is inserted into a positive electrode case 13 so that the positive electrode terminal plate 4a contacts the inner surface of the positive electrode terminal case 13. Ex. 1006, ¶ [0034].

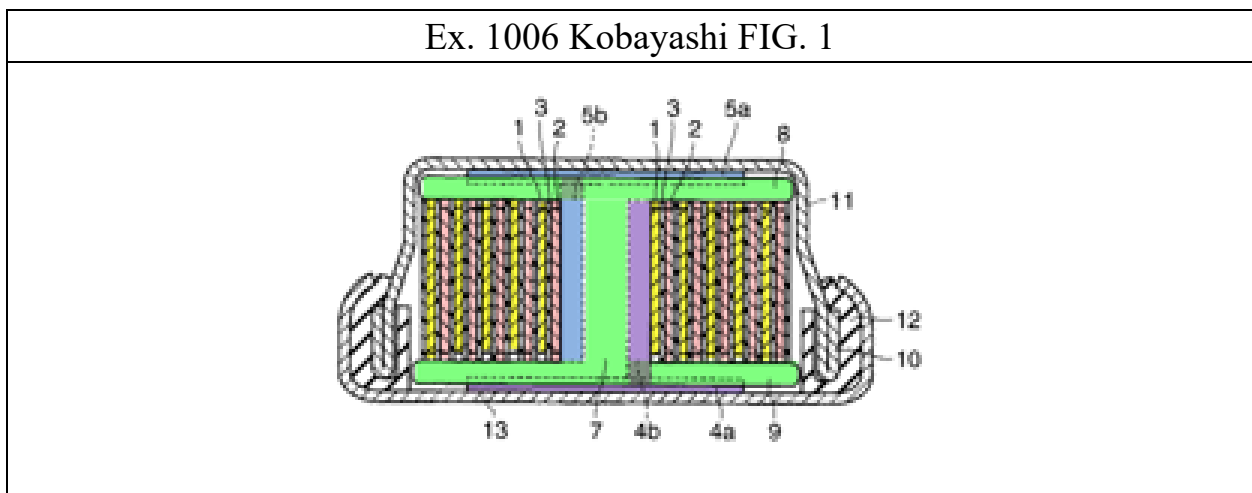

144. Welding the positive terminal plate 4a and the negative terminal plate 5a to the respective positive electrode case 13 and negative electrode case 11

further results in fitting the positive and negative electrode cases together. Ex. 1006 ¶ [0035]. The positive and negative electrode cases 11, 13 are sealed together by “implanting swaging.” Ex. 1006 ¶ [0035]. To prevent electrical shorting between the positive electrode case 13 and the negative electrode case 11, a ring shaped insulation gasket is fitted between the cases. Ex. 1006 ¶ [0032].

145. Closing the positive and negative electrode cases 11, 13 by “swaging” as shown in FIG. 1 is the same as closing the cases with a beading-over arrangement. The lower electrode case 11 is bent radially inwards over a corresponding radially outward edge of the upper electrode case 13 about the mid-axial circumference of the housing. Because of conductive contact between the electrodes 1, 2, the rod-like terminal connection parts 4b, 5b, and the terminal plates 4a, 4b that are connected axially through the winding axis core 7 and the upper and lower insulation plates 8, 9 of the winding member 6, the beading-over arrangement is necessary.

146. Specifically, any movement of the conductive components in the axial direction would likely result in detachment between the electrodes 1, 2, and the rod-like terminal connection parts 4b, 5b, between the terminal connection parts 4b, 5b, and the terminal plates 4a, 5a, or between the terminal plates and the electrode cases 11, 13, resulting in an open circuit condition. The “swaging” or beading-over of the electrode cases furthers the “structural stability” provided by



the winding member 6 to prevent relative axial movement and detachment of the internal components.

147. The winding member 6 also functions to register and align the other components during the winding process. Prior to winding electrode group is interlocked because the electrodes 1, 2 are crimped in the terminal connection parts 4b, 5b, the terminal connection parts 4b, 5b are retained in the winding axis core 7, and the terminal plates 4a, 5a integral with the terminal connection parts 4b, 5b are nested in the insulation plates 8, 9 at upper and lower ends of the winding axis core 7. The components are prevented from displacement due to the tension forces generated as the electrodes and separator are wound about the winding axis core.

148. Kobayashi describes the final construction and finished structure as follows:

[T]he winding axis core 7 wherein the terminal connection part 4b (positive electrode lead part) of the positive electrode terminal 4 and the terminal connection part 5b (negative electrode lead part) of the negative electrode terminal 5 are integrated is located at the center portion of the wound 10 electrode group in which the positive electrode 1 and the negative electrode 2 are spirally wound with the separator 3 interposed. The insulation plate 8, as the second insulating member, is disposed on the top surface of the wound electrode group. The negative electrode terminal plate 5a (negative electrode terminal part) integrated with the terminal connection part 5b is disposed on the insulation plate 8. Furthermore, the insulation plate 9, as the first insulating member, is disposed on the bottom surface of the wound electrode group. The positive electrode terminal plate 4a (positive electrode terminal part) integrated with the terminal connection part 4b is laminated on the insulation plate 9. Ex. 1006 ¶ [0032].

**B. U.S. Publication No. 2005/0233212 (“Kaun”)**

149. Kaun is directed to providing an ideal electrochemical cell for high power applications requiring kilowatts and hundreds of amps that “will provide high current density, decrease internal resistance, and effectively manage thermal output.” Ex. 1005 ¶¶ [0004], [0021]. Kaun is directed to improving energy and power output in a battery with substantial energy density at kilowatt levels of power for high pulse-power requirement applications like hybrid electric vehicles. Id. ¶¶ [0004], [0021], [0079]. “[T]he present invention can release close to 100% of theoretical power of the Li/organic electrolyte cell chemistry in substantially larger cells of 5-10 Ah capacity with pulse currents of 100-200 A from a single cell.” Ex. 1005 ¶ [0094]. To generate even greater power, Kaun discloses that these large cells can be stacked and electrically coupled together in housings and have intercell contact area on the order of 125 cm<sup>2</sup>. Id. ¶ [0094].

150. To achieve a sufficiently high specific energy, Kaun proposes to use “as the preferred embodiments electrochemical devices are related to the ‘jellyroll’ configuration [wherein] the cell preassembly 10 can be layered or coiled on itself, such as into a spiral.” Ex. 1005 ¶ [0108]. The reason for using a jellyroll, as Kaun notes, is “to increase the interfacial contact area ‘A’ between the electrode elements and the electrolyte” which is related to increasing the output energy of the cell. Ex. 1005 ¶ [0015].

A "jellyroll" cell can be formed by coiling a preformed assembly of cathode and anode electrodes and a separator on itself to yield a cylindrically shaped electrochemical device, wherein the face-to-face electrodes and sandwiched electrolyte and separator structures increase the interfacial contact area "A" between the electrodes. Ex. 1005 ¶ [0017].

151. Kaun identifies a problem with traditional jellyroll configurations, though, in which "isolated conductors are generally connected to the electrodes and routed along extended paths independently of the electrodes to the external terminals." Ex. 1005 ¶ [0018].

152. To reduce the resistance introduced by the current collectors and thus the power loss due to decreased current, "[t]hese conductors should carry the full cell current, and thus should be of sufficient mass and cross-section to keep internal resistance manageably low." Ex. 1005 ¶ [0018]. Kaun notes that "[g]enerally, massive connectors are used to avoid power loss for high powered batteries." *Id.* Because of the added contact area "A" between electrodes and the added current collectors, any gains in energy density "are typically offset by increased electrode thickness 'I' and the weight and volume of the current collectors reduce specific energy and power outputs." Ex. 1005 ¶ [0020].

153. To overcome the problem caused by the current collectors, Kaun proposes a solution that eliminates the current collectors in favor of directly connecting the positive and negative electrodes to the housing cups functioning as the external terminals. Kaun's cell is shown below wherein "[o]ne cup acts as a

positive terminal and the other cup acts as a negative terminal and, together with the electrode assembly [22], the cups form a cell. Ex. 1005 ¶ [0085].

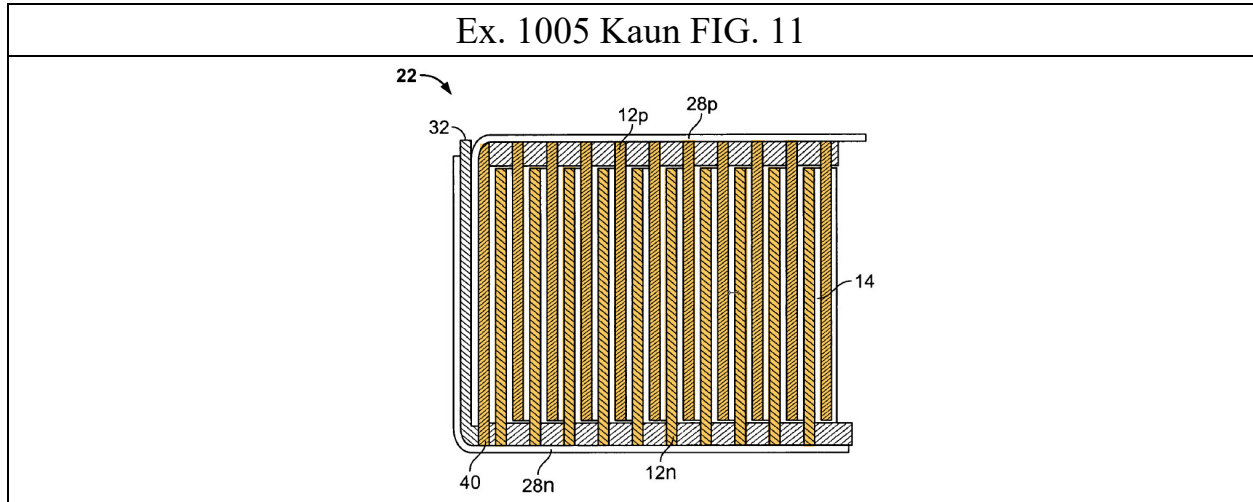
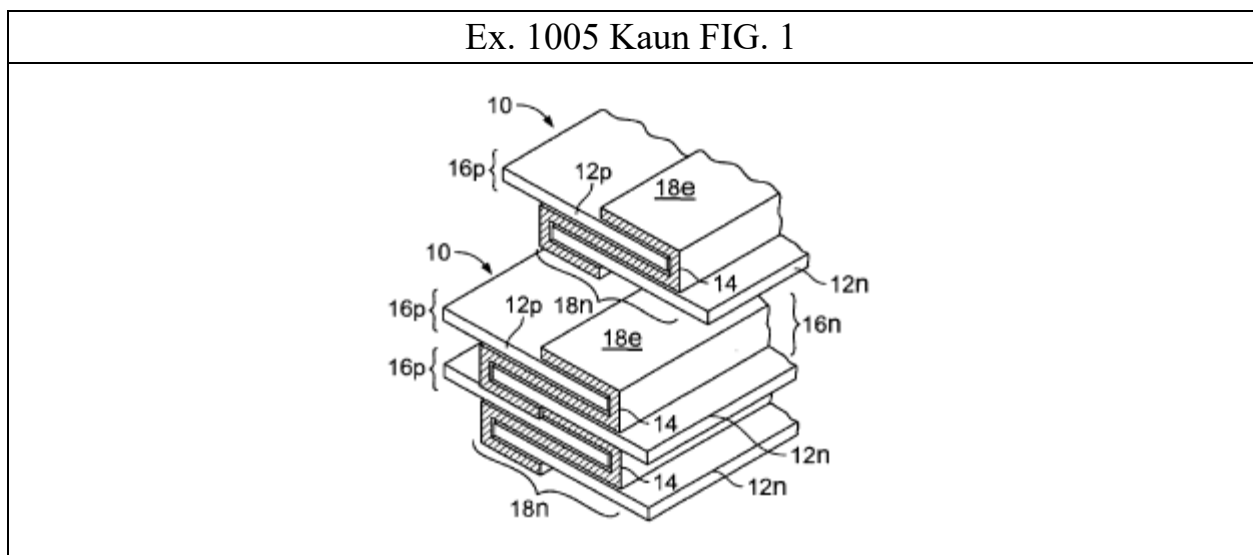

FIG. 11 illustrates positive and negative electrodes 12p and 12n that have surface configurations generally opposed to one another and extend in axial directions primarily transverse to the paired current collectors, and the separator/electrolyte 14 follows a serpentine configuration having portions generally elongated in the axial direction transverse to the paired current collectors. . . The positive and negative electrodes 12p and 12n are alternately arranged across the cell membrane, and respectively are electrically common with only one of the terminals of the paired cups 28p and 28n. Ex. 1005 ¶ [0115].

154. As illustrated, the positive and negative electrodes are “sandwiched between plate-like current collectors [28p, 28n] with the electrode interfaces primarily perpendicular to the current collectors” along the entire length of the spiral edges of the electrodes. Ex. 1005 ¶ [0078], *see also* ¶ [0133] (“The positive and negative electrodes are alternatively arranged whereby each is electrically common with only one of the paired current collectors respectively and is extended

primarily transverse or even perpendicular thereto.”). This type of interface can be considered to create a direct and continuous edge contact between staggered electrodes 12p, 12n and the housing cups 28p, 28n.

155. Kaun discloses that the “improved cell arrangement in an exemplary embodiment uses a ribbon-like cell assembly with coated foil electrode strips extending beyond the edge of the folded separator.” Ex. 1005 ¶ [0080]. A cross-section of the electrode-separator assembly, referred to by Kaun as a cell preassembly 10, for the rolled ribbon configuration is shown below.



156. “The cell preassembly 10 specifically includes alternatively arranged generally parallel positive electrode 12p and negative electrode 12n, and a separator or electrolyte layer 14 interposed therebetween.” Ex. 1005 ¶ [0095]. “As can be seen in FIG. 1, the positive and negative electrodes 12p and 12n extend beyond the edge of the separator layer 14. Preferably, the electrodes extend

beyond the edge of the separator layer 0.1 to 1.0 mm, particularly 0.5 to 1.0 mm, or more.” Ex. 1005 ¶ [0097].

157. “The electrodes [12p, 12n] are generally metal foils coated with particles of the active electrode material.” Ex. 1005 ¶ [0095]. To electrically contact the housing cups, “the extended electrode areas can have less or no active electrode material.” Ex. 1005 ¶ [0080].

158. To prevent electrical shorting between the alternately arranged positive and negative electrodes, a “separator layer and/or electrolyte formed of a very thin ionic-conductive ribbon-like layer configured in a tight serpentine manner and [is] physically interposed between the electrodes.” Ex. 1005 ¶ [0078]. The folding of the separator layer 14 about the positive and negative electrodes is shown in FIGS. 4 and 5 and a process for folding the separator is shown and described with respect to FIG. 3.

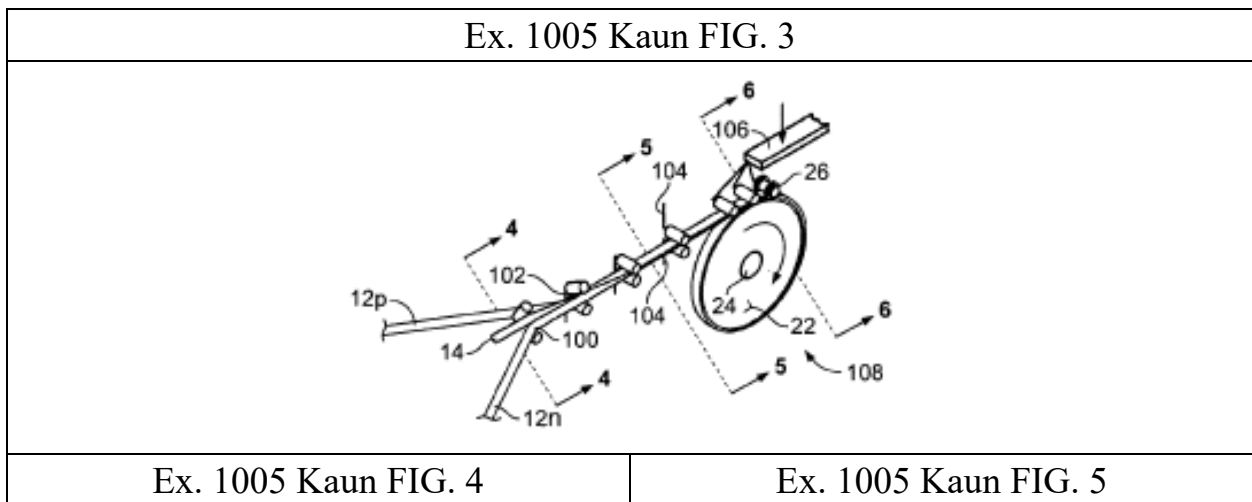



Forming of the cell preassembly 10, in an exemplary embodiment, can be performed as depicted in FIG. 3 by folding a strip of separator 14 into the shape of a Z, and sliding the electrodes 12p and 12n into opposite folds of the separator 14. Ex. 1005 ¶ [0102]

159. An advantage of direct and continuous edge contact between the positive and negative electrodes and the housing cups functioning as external terminals is the reduction in electrical resistance and resulting power loss as current flows between the electrodes and terminals:

The majority of electron transfer takes place in the axial direction along the flattened electrodes and the adjacent electrode material layers or normal to the current collectors. As noted above, the positive and negative electrodes 12p and 12n are electrically continuous at opposite open ends thereof respectively with the positive and negative material layers 28p and 28n of each cell. Resistance to electron passage via the electrodes will generally be negligible compared to ionic resistance. Ex. 1005 ¶ [0125].

160. Kaun further states the “electron passage through the terminal of the cups 28p and 28n is in the axial direction transverse thereto” such that “[i]nternal resistance due to the current collectors will also negligible.” Ex. 1005 ¶ [0126].

Kaun states that:

The greater concern is electrode contact onto the face of the current collector. Facial conductivity can be preserved or enhanced with a non-oxidizing conductive paste. Ex. 1005 ¶ [0126].

161. Described another way, the direct and continuous edge contact between the positive and negative electrodes 12p, 12n and the terminals 28p, 28n results in a “short electronic current flow paths along the lengths of the electrodes (less than 10 mm) [and] do not require a highly conductive electrode current collector supplementing or paralleling the electrodes.” Ex. 1005 ¶ [0128]. Shortening the electrically conductive path between electrodes 12p, 12n and external terminals 28p, 28n, decreases the internal resistance and improves power output of the Kaun cell.

162. The direct and continuous edge contact between the positive and negative electrodes 12p, 12n and the inner surfaces of the terminal cups 28p, 28n, which results in a significant amount of direct contact between the electrodes and cup, enables high energy pulse discharges. In other words, the Kaun configuration can deliver a large amount of energy instantaneously.

163. Direct and continuous edge contact between the positive and negative electrodes 12p, 12n and the external terminals 28p, 28n also improves heat transfer and thermal management of the cell during operation. “For the conventional jelly-rolled cell, the most direct path for heat loss is across the layers of heat sensitive microporous polymer.” Ex. 1005 ¶ [0005]. However, excessive temperatures internally in the cell can breakdown the microporous polymer comprising the



electrolyte separator impairing operation and possibly resulting in cell failure. Ex. 1005 ¶ [0005].

164. In the Kaun cell:

Unlike the prismatic, jelly-rolled cells, internally generated heat from the rolled-ribbon cell can be drawn out from the cell via short conduction paths without crossing the heat sensitive microporous polyethylene/polypropylene separator. Accordingly, the present cells can be operated without the need for active thermal management.” Ex. 1005 ¶ [0094].

165. Another advantage of the axial orientation of the electrodes and the separator in the rolled ribbon configuration “relates to its durability, and thereby allows the separator/ electrolyte 14 to be made with a very small thickness "I", for further reducing the ion resistance.” Ex. 1005 ¶ [0128].

166. The advantages of the direct continuous edge contact provided by Kaun’s rolled ribbon configuration over conventional wound tab cell structures are further explained with respect to the commercial embodiment of Kaun’s cell (I understand that Mr. Kaun is the President of the Rolled Ribbon Battery Company). The website associated with the company includes the following webpages:

EX 2029 <<http://www.rolled-ribbon.com/technology.html>>

### Rolled-Ribbon Cell Structure

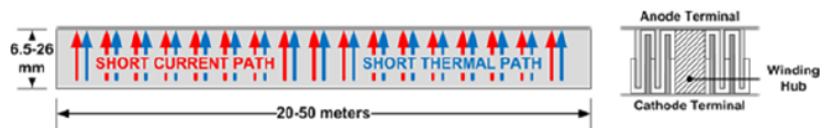

Rolled-Ribbon cells have narrow electrodes (typically 13-26 mm). One edge of each electrode is in direct contact along its entire length (typically 20-50 meters) with its associated cell terminal. From an electrical perspective, this creates a very short, low impedance path to the cell terminal. From a thermal perspective, this creates a very short path with very low thermal resistance to the very large cell terminal. This is because heat travels along the electrode foil rather than through multiple layers of electrode material, foil and separator. The thermal resistance along an electrode foil is on the order of 100-200 times lower than that for crossing electrode layers. ^

### Conventional Wound-Tabbed Cell Structure

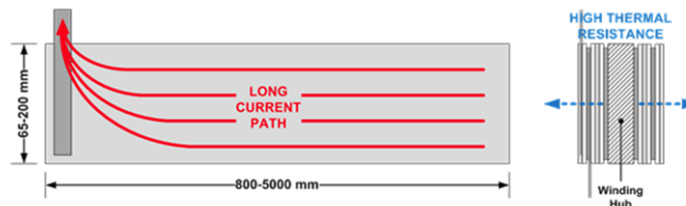

These cells have long current paths (typically 800-5000 mm). This long path length result in much higher impedance. Further, the heat generated from this impedance will not be uniformly distributed across the electrode. There will be much more current flowing as you approach the tab on the left-side than on the right-side in the illustration, so there will be much more heat generated on the left than the right. Next, you have very poor thermal properties. Heat generated at the core must travel along a long longitudinal path of electrode foil through the highest heat portion of the electrode or overcome high thermal resistance through layers of electrode, including the highest heat portion of the electrode. This causes hotspots and thermal gradients that accelerate aging and can lead to unsafe conditions.

167. The public statements on the commercial website that criticize the “conventional wound-tabbed structure” due to their “long current paths” are consistent with the disclosure in the Kaun patent that criticizes conventional “current collectors [that] reduce specific energy and power outputs” of the battery due to their weight and volume. Ex. 1005 ¶ [0020]. The webpage explains that long conventional windings generate more heat and have very poor thermal

management, which results in hotspots and undesirable thermal gradients that accelerate aging and can lead to unsafe condition. Ex. 2029.

168. Another important aspect of the Kaun disclosure is the housing of the cell. “[T]he present invention provides a housing for an electrochemical device comprising a first cup, a second cup, a fastener, and a gasket.” Ex. 1005 ¶ [0024].

169. Kaun is also directed to a particular style of housing and that “[t]he invention also provides a button-type cell housing.” Ex. 1005 ¶ [0084]. This passage refers to the style of the housing disclosed in Kaun, which is circular and wider than it is tall, and a POSA would not understand the passage as conveying any teaching or suggestion regarding the cell size, power output, or technical classification.

170. FIG. 7D illustrates the housing 28 which includes first and second cups 28p, 28n joined together and “electrically isolated from each other with a gasket 32 located around the periphery of the cups 28p and 28n.” Ex. 1005 ¶ [0109].

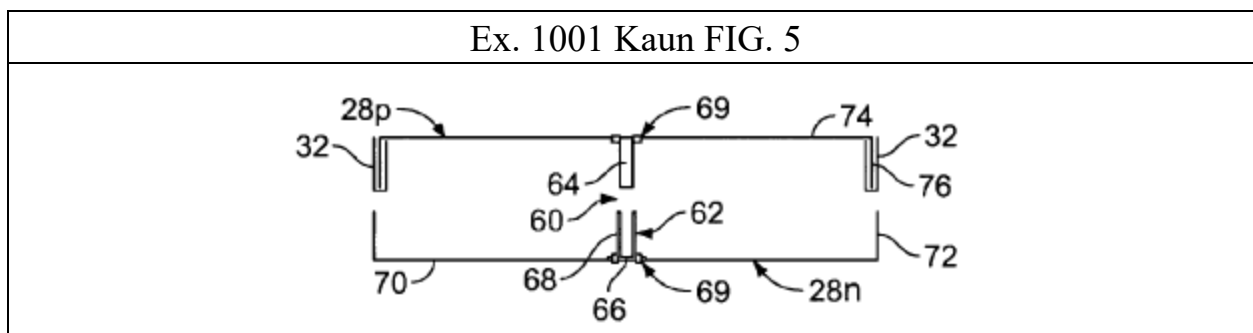

171. Kaun notes that cells should be designed to “withstand[] thermal expansion and contraction forces of the cell components during operational temperature changes.” Ex. 1005 ¶ [0017]. Kaun further notes this may be a particular problem in Lithium-ion batteries for high power applications “[b]ecause there is an internal gas pressure generated during battery operation and battery degradation conditions.” Ex. 1005 ¶ [0023].

172. Kaun discloses that:

An improved housing for a rolled-ribbon electrochemical device is provided. The housing comprises a fastener that aligns first and second cups during assembly and maintains electrode contact independent of external pressure on the housing eliminating the possibility of an open circuit state for a cell. Ex. 1005 Abstract.

\*\*\*\*

In exemplary embodiments, the housing for the electrode assembly further comprises a fastener that aligns the first and second cups during assembly and maintains electrode contact with the appropriate cup independent of external pressure on the housing, helping to eliminate the possibility of an open circuit state for a cell. Ex. 1005 ¶ [0086].

173. In view of the dimensions described in Kaun, especially the large diameters of the housing, and high power output, the fastener is an essential component that “holds the housing, including the enclosed electrode assembly, together independent of the external pressure on the housing thereby providing consistent contact between the cups and the electrodes.” Ex. 1005 ¶ [0088].

174. A POSA would understand that the cell described in Kaun requires a central fastener to close the housing and maintain direct continuous edge contact between the positive and negative electrodes and the first and second cups functioning as the external terminals.

175. Kaun also provides for managing heat generation and internal pressurization of the cell. In lithium ion batteries for high power applications, Kaun states that a completely sealed closure would be problematic because “internal gas pressure may be generated during operation.” Ex. 1005 ¶ [0023]. Kaun discloses that it would be desirable to incorporate “non-catastrophic, cost effective means to relieve the gas pressure.” Id. Accordingly, Kaun describes that as a safety measure the peripheral gasket that is disposed between the peripheral edges of the positive and negative cups 28p, 28n that form the housing can relax in the event of over pressurization inside a cell to act as a vent to release the internal pressure. Ex. 1005 ¶¶ [0091] (“The specified limit for internal pressure is handled by release via the peripheral gasket which can reseal after an event.”).

176. To relieve internal pressure, Kaun describes that the positive and negative cups 28p, 28n can be externally loaded by springs to urge the cups together. Ex. 1005 ¶ [0130]. “If a single cell produced internal pressure exceeding the 10-20 psi limit, the end spring would slightly compress and the peripheral gasket of the over pressurized cell would subsequently relax to relieve the

overpressure. This cell would then reseal itself under the spring force.” Id. When releasing gas, the positive and negative electrode cases 28p, 28n must vertically displace with respect to each other to relieve the gasket 32.

### C. EP 1 886 364 B1 (“Ryou”)

177. Ryou particularly relates to a primary zinc-air battery. Ex. 1007 ¶ [0001] (“the invention relates to a method of manufacturing a standardized cylindrical zinc-air battery”); ¶ [0003] (“conventional batteries include a primary battery such as a . . . zinc-air battery”); ¶ [0034] (“according to another aspect, there is provided a zinc-air battery”); FIG. 6 (below). It is well-known that zinc-air batteries are primary batteries because once the active material is exposed to air the electrochemical activity cannot be readily reversed. Ex. 1009 Ch. 13.

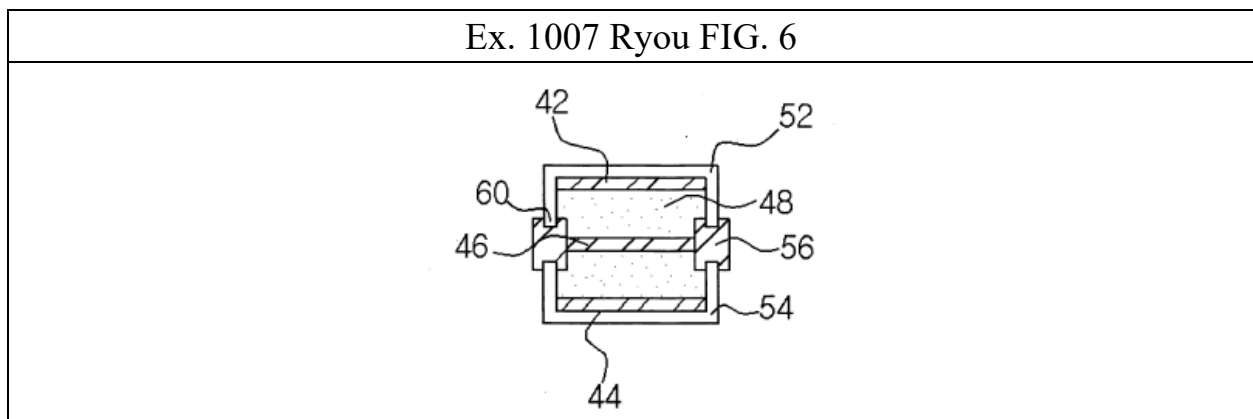

178. As a primary zinc-air battery, the Ryou cell does not undergo successive discharge and recharge cycles that a secondary battery would. Any evolved gases created during the electrochemical reaction would vent to the atmosphere and not result in internal pressure. Thus, the Ryou cell does not

experience the successive expansion and contraction cycles associated with the successive discharge and recharge cycles of a second battery. Furthermore, in the Ryou cell, there is no axial forces and loads, radially forces and loads, or other directional forces and loads that the housing must contend with.

179. Conventional zinc-air batteries like the Ryou cell do not use a jelly-roll design. As described in Ryou, “the conventional button type zinc-air battery includes an oxygen admitting membrane at the cathode 14 and a zinc gel as an anode 12, and a separator 15 interposed between the membrane and the zinc gel.” Ex.1007 ¶ [0013]. The zinc gel contains zinc powder and an aqueous electrolyte. Ex. 1007 ¶ [0019]. The membrane is an air permeable membrane and may contain water vapor. Ex. 1007 ¶ [0014]. Moreover, because the chemical reaction in a zinc-air battery requires oxygen, the membrane must be exposed to an air hole in the housing. Ex. 1007 ¶ [0016]. In my experience, these structural and functional requirements of a zinc-air battery, especially in a button cell, are incompatible with an electrolytic jelly-roll configuration.

180. Ryou exclusively uses fusion bonding to seal the cathode can and the anode can. Ryou in particular describes that “hermetical sealing of the battery may be carried out by fusion-bonding of the cans 52 and 54 and the body 56. The body 56 is made of an insulation resin and insulates the first and second cans 52 and 54 from each other and also is fused at the end portion 60 of the cans 52 and 54 to seal

the inside of the battery.” Ex. 1007 ¶ [0071]. As shown in FIG. 4, after the body 56 has been fusion bonded between the end portions 60 of the U-shaped cans 52, 54, the cans are held together in tension by the body. In every embodiment described in Ryou, the button cell is closed by fusion bonding the cans together in tension.

181. Fusion bonding as described in Ryou involves the application of heat to melt a resin body 56 into which the edge portions of the cathode can and the anode can are inserted and joined with the resin body. For example, Ryou states “both ends of the body 56 are melted and, after the end portions of the cans 52 and 54 are inserted into the inside of the body 56, the body 56 is cooled and cured to fusion-bond the body 56 with the cans 52 and 54.” Ex. 1007 ¶ [0086]. Ryou describes elsewhere that “the fusion-bonding of the second can 54 and the body 56 may be performed after the body 56 is first melted.” Ex. 1007 ¶ [0077].

182. Ryou describes that heat may be applied to melt the resin body 56 and the “heating temperature of the can 54 may be determined according to the melting temperature of the body 56, the inserting pressure, or the like.” Ex. 1007 ¶ [0080]. Ryou also describes that “[a]lthough the body 56 generally is melted by heating, pressurization or ultrasonic radiation can be used. The melting method may be selected depending on the body 56 material.” Ex. 1007 ¶ [0077]. Ryou also



describes an embodiment where “a resin may be injected and the body injection molded, thereby forming a fusion bonded assembly.” Ex. 1007 ¶ [0081].

**D. KR Publication No. 10-2003-0087316 (“Kwon”)**

183. The Kwon reference is actually not directed to a battery or a cell but instead states that its inventive objective “is to provide the coin-type electric double layer capacitor having excellent coupling capability and electrical performance.” Ex. 1008 p. 6. A POSA would recognize that a capacitor is a different device than a battery and operates on different electrical principles to achieve different results.

184. Kwon describes a prior art embodiment of a capacitor in which polarized electrodes (5)(5’) are formed and were welded and coupled to the metal cases (4)(4’) of the capacitor by spot welding. Ex. 1008 p. 5. Kwon criticized this method because, due to the mechanical pressure and heat applied by the welding tool, “the electrode (5) (5’) is easily damaged by resulting shock and its electrical performance is deteriorated.” Id.

185. To address this problem, Kwon describes a double layered capacitor that is assembled by “laser welding the metal case and polarized electrode” and that the “laser beam is injected from outside the metal case (20).” Ex. 1008 pp. 6, 7.

186. Kwon does not disclose or suggest an electrode separator assembly in the form of a spiral winding. In Kwon, as shown below, the polarized electrodes including an anode 10 and a cathode 10a are manufactured by fixing powdered carbon slurry 14, 14' to a current collector 12, 12' with a knife which is then dried to produce the disc-like electrodes shown in FIG. 5a below. The anode 10 and cathode 10' are separately fitted within individual metal cases 20, 20' and welded thereto using a laser R. After welding, the first metal case 20 and second metal case 20' are fitted together with a separator located between the bodies of the anode 10 and cathode 10' and a gasket 40 is placed in the inner circumference of the cathode case 20' to lock to cases together.

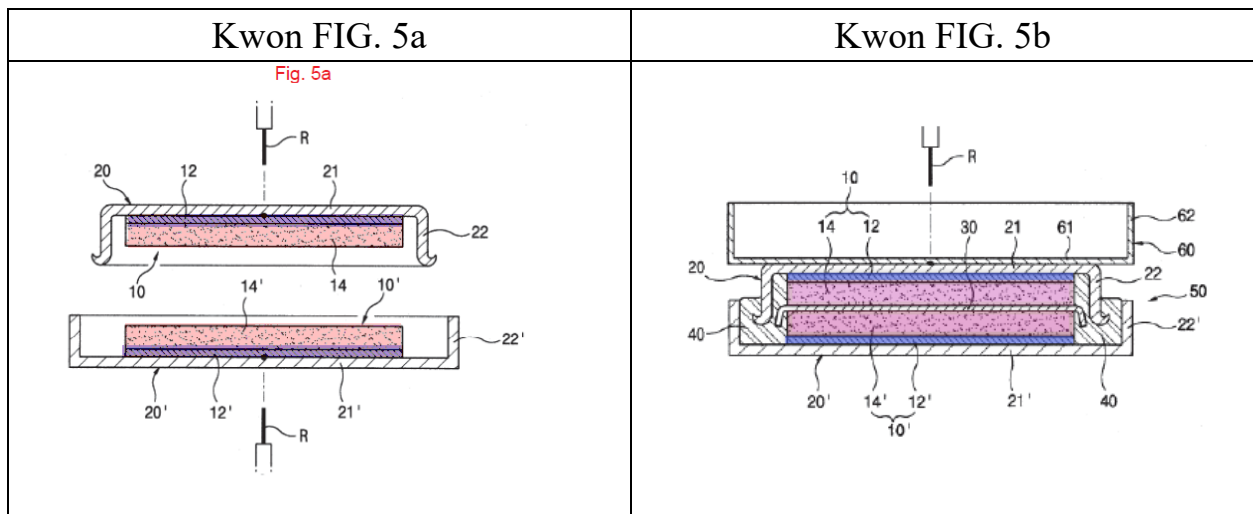

187. The electrodes 10, 10' of Kaun are thick objects similar to the flat, stacked tablet cells described in the Technology Background. The electrodes 10, 10' and the separator 30 are not “provided in the form of a winding” and cannot be modified to be in the form of a winding. Further, Kaun does not disclose or

suggest that metals foils (other than etched metal foils) are used to electrically connect an electrode-separator assembly to the metal cases.

188. Kwon describes a fabrication process by which the polarized electrodes (10) (10') prior to assembly in the capacitor are prepared by coating and fixing "powder activated carbon slurry (14) (14') on the metal current collector (12) (12') in a foil form." Ex. 1008 p. 4. The interface between the powdered activated slurry 14, 14' and the foil current collectors 12, 12' act as a boundary where opposite polarity charges build up and increases the internal resistance or impedance of the capacitor. To reduce resistance and impedance, Kwon describes that the current collectors 12, 12' can be "an etching foil furnished with a number of recessed parts (12a) which are formed by etching or pitting the surface on which powder activated carbon slurry (14) (14') is fixed." Id. pp. 6-7.

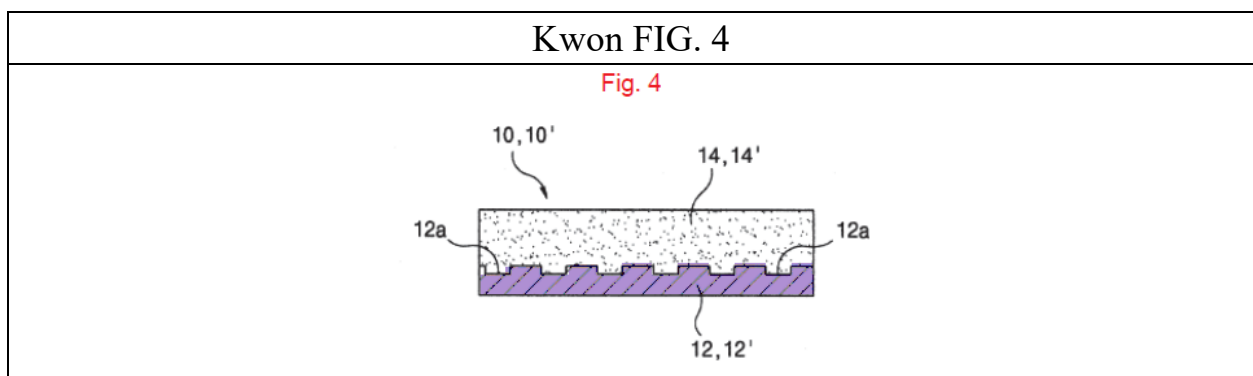

189. Etching the foil "increases the contact surface area between the powder activated carbon slurry (14) (14') and the metal current collector (12) (12') due to its recessed parts (12a) to improve on the electrical conductivity between the

components.” Id. The etched foils in Kwon are therefore an integral part of the electrode and are quite different than using metal foil conductors taken out of the wound electrode separator assembly, or jelly roll, to electrically connect the wound electrode separator assembly with the housing halves of the button cell.

**X. THE CHALLENGED '835 PATENT CLAIMS ARE PATENTABLE OVER KOBAYASHI, KAUN, AND RYOU**

190. I understand that Petitioners and Mr. Gardner allege that claims 1-12 of the '835 Patent are invalid as obvious over the following combinations of prior art references: (1) Kaun in view of Kobayashi; (2) Kobayashi in view of Kaun; and (3) Kobayashi in view of Ryou. I disagree that any of the purported combinations renders claims 1-12 invalid and provide my analysis and opinions as follows.

**A. The Combination of Kaun in view of Kobayashi Fails to Render Obvious the Claims of the '835 Patent**

191. It would not have been obvious for a POSA to combine Kaun and Kobayashi to arrive at the inventions of the Challenged Claims of the '835 patent.

**1. A POSA Would Not Have a Reason to Combine Kaun with Kobayashi**

192. I disagree with Mr. Gardner's that there is motivation to combine Kobayashi and Kaun.

193. Initially, Mr. Gardner contends that Kobayashi and Kaun are directed to “similar” subject matter. I disagree. Kobayashi is directed to a small button cell battery, e.g., on the order of  $\mu\text{A}$  and  $\text{mA}$ . Ex. 1006. Kobayashi is further directed

to a solution of using a wound electrode assembly in a small cell with a diameter of about 12 mm. Kaun, on the other hand is directed to high power, multi-cell battery that delivers kW levels of power with tens or even hundreds of amps of current. Kaun's solution offers a way to manage resistance and heat in a cell that can deliver close to 100% theoretical power. Ex. 1005. Neither the problems nor solutions described in Kaun and Kobayashi are similar. To the contrary, they are quite different.

194. I also disagree with Mr. Gardner's opinion that the thickness of Kaun's separator material or its Z-shaped separator provides any motivation to modify the structure described therein.

195. Kaun mentions that high interfacial area "A" of a "jelly roll" electrode requires a minimum separator thickness for cell durability and cycle life. He explains that in conventional jelly roll arrangements, the increased interfacial contact area "A" is generally offset by the need for increased thickness "I" of the separator. Ex. 1005 at [0017].

196. Kaun describes his solution as providing a "large interfacial electrode area 'A', compared to the cross section of the cell, [which] reduces internal resistance against ion transfer in the electrochemical device." *Id.* at [0127]. Kaun states that his invention solves the problem in a way that "allows the separator/electrolyte 14 to be made with a very small thickness 'I', for further

reducing the ion resistance.” *See* Ex. 1005 at [0128]. Kaun also states “a separator layer and/or electrolyte formed of a very thin ionic-conductive ribbon-like layer configured in a tight serpentine manner and physically interposed between the electrodes.” *Id.* at [0078].

197. Thus, as the disclosure of Kaun confirms, his device uses a “very thin” separator layer. Mr. Gardner appears to rely on the fact that Kaun states separator material can be less than 0.1 mm while Kobayashi refers to a separator having a thickness of 22  $\mu\text{m}$ . This does not provide a basis to conclude that Kobayashi provides a thinner separator. 22  $\mu\text{m}$  is merely an approximate range provided by Kaun. Moreover, Kaun is directed to a larger cell with much higher power characteristics than the cell of Kobayashi. The comparison is, therefore, inappropriate.

198. Mr. Gardner also incorrectly asserts that there is “an inherent weakness in the electrode assembly of Kaun” in which the Z-shaped separator results in thickness variances that would reduce the useable volume of the electrode-separator assembly. Ex. 1003 ¶¶ 136-137. In reaching this conclusion, Mr. Gardner appears to take the view that the Z-shaped separator in Kaun would necessarily require overlapping edges. I disagree.

199. The disclosure of Kaun, which explicitly describes non-overlapping butt joints, contradicts Mr. Gardner’s position that overlapping edges are required.

Kaun's non-overlapping butt-joints are described with respect to FIG. 6 of Kaun and are circled in red below:

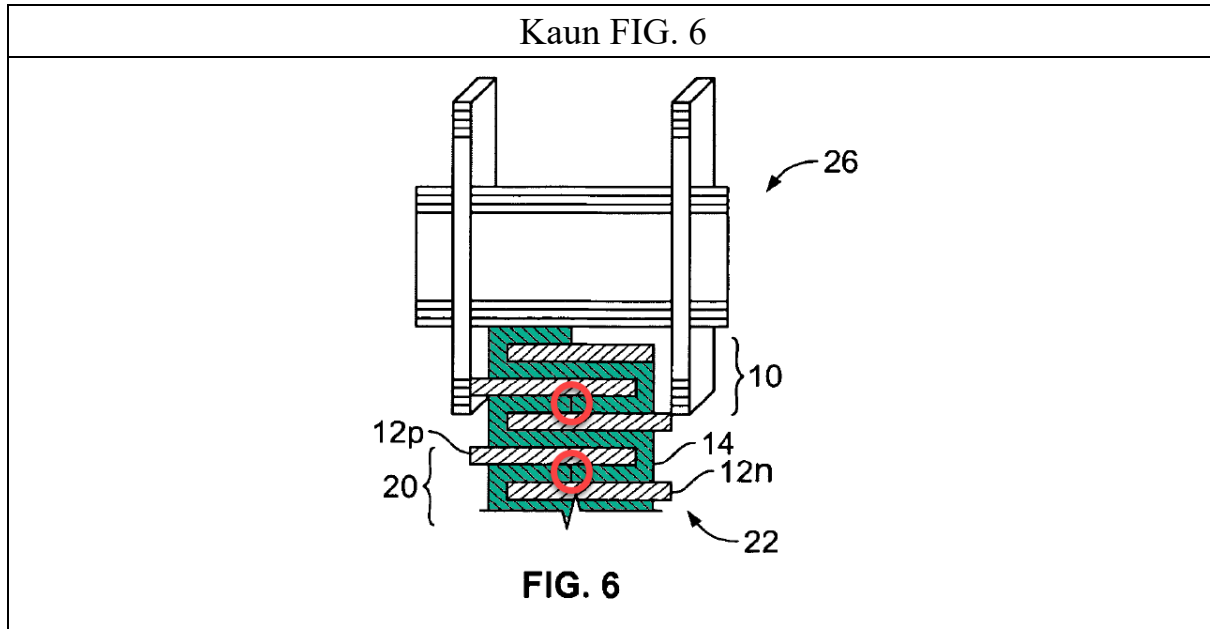

200. The figures of the Kaun application do not show an “overlap” between separator edges or a “thickness variation” at the butt joints. They do show a perfectly formed butt joint. Kaun does not mention or disclose a “thickness variation.” To the contrary, Kaun states “[t]he separator edges can form a butt-joint to separate the successive electrode layers.” Ex. 1005 ¶ [0108]. Thus, while Kaun does describe that separator edges “can overlap,” abutting edges are specifically disclosed as an alternative.

201. Furthermore, interpreting Kaun’s disclosure that separator edges “can overlap” (*Id.*) to require a thickness variation in the separator layer is contrary to the entirety of Kaun’s remaining disclosure. Kaun explicitly recognizes that

“[d]esigners of electrochemical devices thus strive to reduce electrolyte thickness ‘I.’” *Id.* ¶ [0015]. Kaun proposes a configuration and orientation for a rolled-ribbon jelly roll that “allows the separator/electrolyte 14 to be made with a very small thickness ‘I’” and that also allows “the electrode structure and the separator/electrolyte to made of substantially uniform thickness.” *Id.* ¶ [0128]. Kaun discloses a manufacturing and assembly technique that produces butt joints without a thickness variation. *Id.* Figs. 1 and 6, ¶ [0103]. A POSA would not be motivated to look beyond the disclosure of Kaun to solve a problem regarding thickness variations.

202. I also disagree with Mr. Gardner that there can be “no gap between the edges of the separator” in Kaun. A relatively small gap would simply form a void to be filled by electrolyte, adhesive, or by separator material squeezed and compressed into the gap. *See, e.g., Id.* ¶ [0103].

## **2. Kobayashi Would Decrease Energy Capacity in Kaun and Render Kaun Less Efficient**

203. A POSA would also not look to the electrode assembly in Kobayashi to increase the amount of usable power as Petitioners argue. *Pet.* at 37. To the contrary, the assembly in Kaun is far more efficient than that of Kobayashi.

204. Kaun repeatedly teaches that “the weight and volume of current collectors reduce specific energy and power outputs.” *Ex.* 1005 ¶ [0020], *see also* ¶ [0018] (“Current collectors used in these cell arrangements add significant



weight and thus reduce specific cell energy and power outputs.”). Kaun teaches that it is desirable to eliminate the “current collector supplementing and paralleling the electrodes” in favor of direct and continuous edge contact between the positive and negative electrodes 12p, 12n and the terminal cups 28p, 28n that results in “short electronic current flow paths.” Ex. 1005 ¶ [0128]. Kaun thus results in the electrode-separator jelly roll that can be densely packed by utilizing substantially all the internal volume. As shown below, the electrode assembly of Kaun utilizes almost all of the available space.

205. Kobayashi, on the other hand, teaches the desirability of incorporating a winding member 6 with a winding axis core 7 because it was only “by incorporating the winding axis core into the electrode group while being integrated with the negative electrode and/or the positive electrode, it was possible to manufacture a wound electrode group capable of being housed in a case of a small battery such as a button cell or a coin cell.” Ex. 1006 ¶ [0017]. Kobayashi claims to have “change[d] the approach away from conventional art, and by incorporating at least a winding axis core into the electrode group structure” it succeeded in “storing a wound electrode group within a case of a small battery such as a button cell or a coin cell.” Ex. 1006 ¶¶ [0012], [0015].

206. However, as shown below in contrast with Kaun, the winding axis core 7 and integrated insulating plates 8, 9 around which the positive and negative

electrodes 1, 2 and separator 3 are wound take up considerable internal space. The space occupied by the winding core 7 and insulating plates 8, 9 cannot include electrochemically active material and cannot contribute to the energy density or power capacity of the cell.

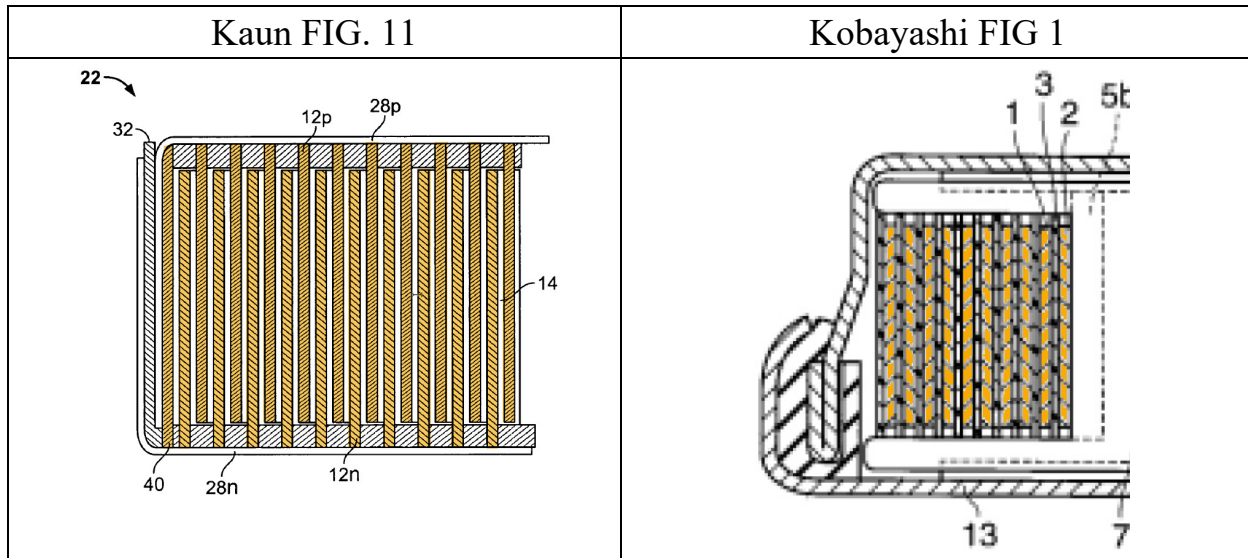

207. The lost volume in Kobayashi due to its winding axis core and insulating plates is about 30% of the total volume of the cell. I understand that patent figures are not necessarily to scale. However, in arriving at this percentage, I assumed the drawing was roughly to scale for a cell having a diameter on the order of 12 mm and a height of 5.3 mm as described in Kobayashi. In my opinion, the size of the Kobayashi's winding axis core and insulating plates under that assumption are reasonable

### 3. Kaun Teaches Away from Using Additional Current Collectors that Are Necessary in Kobayashi

208. Kaun's solution eliminates intermediate current collectors in favor of direct and continuous edge contact between the housing and the electrodes in a "rolled-ribbon" assembly. Kaun explains that "the weight and volume of the current collectors reduce specific energy and power outputs." Ex. 1005 ¶ [0020]. Kaun notes that for a typical battery design, these additional conductors "can account for a 50% reduction in battery power output from theoretical capability." *Id.* ¶ [0018].

209. Kaun states:

Current collectors used in these cell arrangements add significant weight, and thus reduced specific cell energy and power outputs. For example, isolated conductors are generally connected to the electrodes and routed along extended paths independently of the electrodes to the external terminals. Ex. 1005 ¶ [0018]

210. Instead, in Kaun, separate conductors are eliminated and current flows in the axial direction from the positive and negative electrodes 12p, 12n directly to the positive and negative cups 28p, 28n:

The majority of electron transfer takes place in the axial direction along the flattened electrodes and the adjacent electrode material layers or normal to the current collectors. As noted above, the positive and negative electrodes 12p and 12n are electrically continuous at opposite open ends thereof respectively with the positive and negative material layers 28p and 28n of each cell. Resistance to electron passage via the electrodes will generally be negligible compared to ionic resistance. Ex. 1005 ¶ [0125].

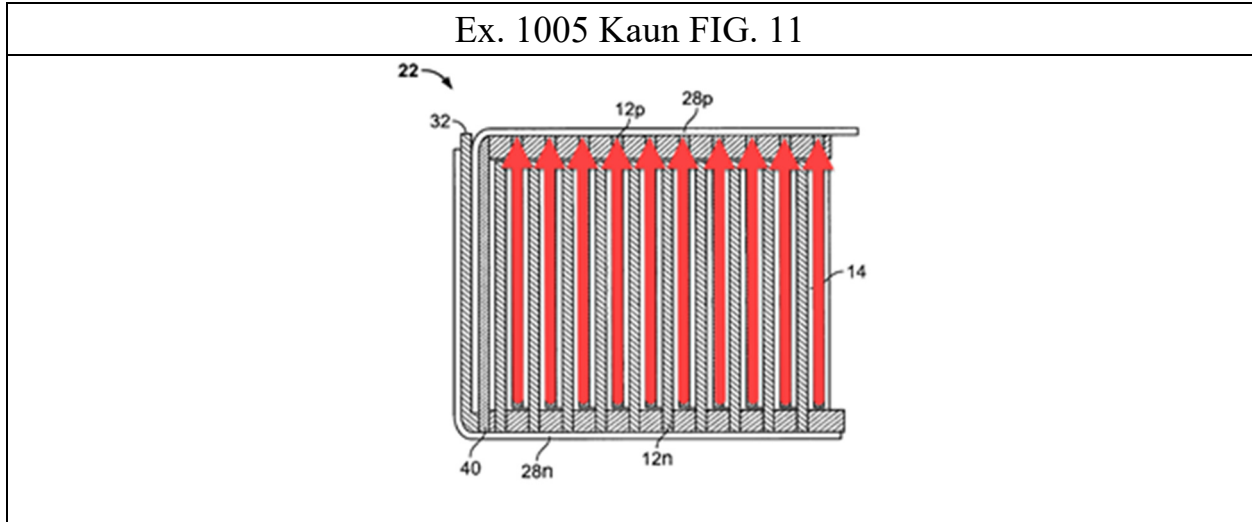

211. The diagram above illustrates the current flow for the set of electrodes in contact with the housing top.

212. A benefit of the direct and continuous edge contact between the electrodes and external terminal is the resulting “short electronic current flow paths along the lengths of the electrodes” [that] “do not require a highly conductive electrode current collectors supplement or paralleling the electrodes.” Ex. 1005 ¶ [0128].

213. Another benefit is improved thermal heat management in which internally generated heat from the rolled-ribbon cell can be drawn out from the cell via short conduction paths without crossing the heat sensitive microporous polyethylene/polypropylene separator” thereby avoiding degradation of the separator. Ex. 1005 ¶ [0094].

214. In contrast to Kaun, Kobayashi teaches that “the present inventors attempted to change the approach away from conventional art, and by

incorporating at least a winding axis core into the electrode group structure, and as needed, an insulation plate and contacting terminals between electrodes and external terminals.” Ex. 1006 ¶ [0015]. Kobayashi states that only “by incorporating the winding axis core into the electrode group while being integrated with the negative electrode and/or the positive electrode, it was possible to manufacture a wound electrode group capable of being housed in a case of a small battery such as a button cell or a coin cell.” Ex. 1006 ¶ [0017].

215. Because of the presence of the winding core axis 7 integrated into the winding core member 6 and with “insulation plates 8 and 9 (first and second insulating members) integrated with the upper end and the lower end of the winding core 7” which the electrode group is wound around, the electrodes cannot directly contact the electrode cases forming the housing. See Ex. 1006 ¶ [0030]. To establish electrical contact, Kobayashi creates an electrically conductive path “by installing a terminal on the winding axis core to be incorporated into the electrode group to connect the electrode and the metal case doubling as an external terminal.” Ex. 1006 ¶ [0018].

216. The electrical path through the winding axis core requires a bar-shaped terminal connection part 4b, 5b integrated to the disc-shaped terminal connection plates 4a, 5a for both the positive and negative electrode terminals 4, 5. Ex. 1006 ¶ [0028]. Kobayashi teaches that “the terminal connection part 4b of the

positive electrode terminal 4 [is] inserted into the notch part 7b of the winding axis core 7” and that “the terminal connection part 5b of the negative electrode terminal 5 [is] inserted into the notch part 7a of the winding axis core 7.” Ex. 1006 ¶ [0031]. The assembled electrode group is shown in FIG. 9 below.

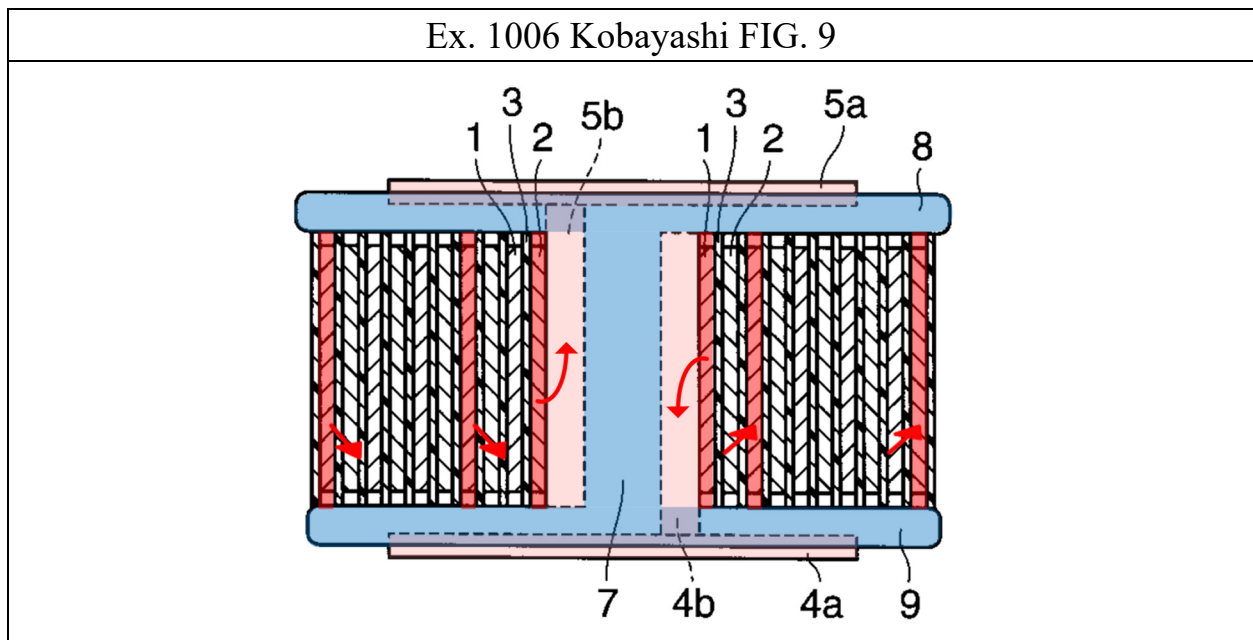

217. As indicated by the red arrows, the current flow in the cell of Kobayashi moves horizontally and radially inward through the positive and negative electrode windings 1, 2 to the central rod-like terminal connection parts 4b, 5a then vertically upwards and downwards to the disc-like positive and negative terminal plates 4a, 5a that contact the positive and negative electrode cases 11, 13. Moreover, the current flow must circumnavigate and spiral inwardly through the wound electrodes windings 1, 2, possibly many times, to reach the central contact point with the terminal connection parts 4b, 5b located in the

winding axis core 7. This is an exceeding long current path compared to the direct and continuous edge contact between the electrodes and the positive and negative cups that form the housing.

218. From the foregoing, Kobayashi differs from Kaun in two principle respects: (1) Kobayashi does not include direct and continuous edge contact in which the majority of electron flow is axial and (2) Kobayashi uses additional terminal connection parts to conductively connect the electrodes to the plates welded to the electrode cases, extra conductive components which Kaun teaches not to use. A POSA would have fully appreciated these fundamental differences and, because the structure of Kobayashi is directly contrary to Kaun's teachings, would not have been motivated to modify Kaun's cell to include Kobayashi's electrode assembly.

#### **4. The Proposed Modification Would Require a Complete Rebuild of Kaun**

219. The proposed modifications to Kaun to use the Kobayashi wound electrode group is such a significant change in design and application that a POSA would not have reasonably expected that it could be successfully done.

Furthermore, because many of these changes are contrary to the disclosure of Kaun, a POSA would have been discouraged from attempting to do so.

220. Kaun is directed to a multi-cell battery for delivering power on the order of hundreds of amps for high powered applications like hybrid vehicles and

power tools. Ex. 1005 ¶¶ [0004], [0021], [0007]. A POSA contemplating using Kaun's housing with Kobayashi's electrode assembly need to make significant modifications for the combination to work, for which Mr. Gardner has not provided any details.

221. A POSA would, for example, have had to redesign the Kaun housing to incorporate the electrode group of Kobayashi. That would involve including the winding axis core 7 and the disc-like terminal plates 4a, 5a and bar-like terminal connection parts 4b, 5b integrated with the winding axis core. This is all contrary to Kaun's teaching of a battery that does "not require a highly conductive electrode current collector." Ex. 1005 [0128].

222. A POSA would also have had to eliminate the direct and continuous edge contact, which is the essential feature of Kaun, and changing the direction of current flow from that of Kaun, where "[t]he majority of electron transfer takes place in the axial direction along the flattened electrodes" to that of Kobayashi, where current spirals along wound up lengths of the electrodes 1, 2 before passing to the terminal connection parts 4b, 5b in the winding axis core 7 and then flowing vertically to terminal plates 4a, 5a at either end of the winding core. *Id.* ¶ [0018]; Ex. 1006 ¶ [0032]. For reference, the different current flow paths are annotated below:



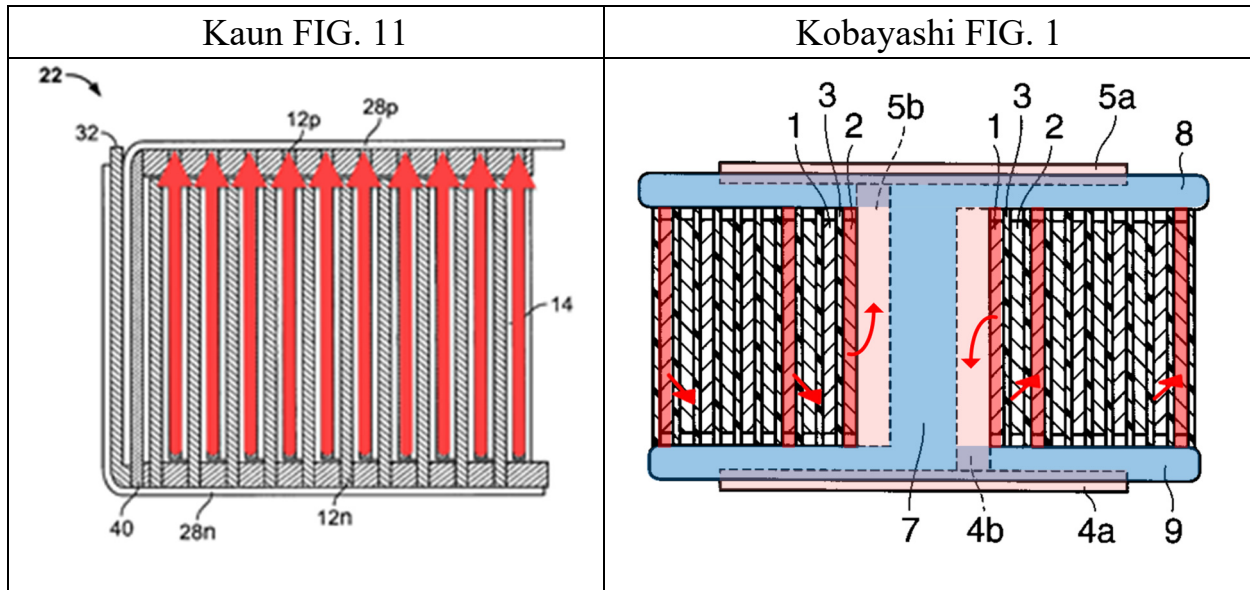

223. The change in flow direction is contrary to the Kaun's preference for "short electronic current paths along the lengths of the electrode," and would dramatically increase impedance beyond what Kaun teaches would be acceptable for high pulse power discharge. Ex. 1005 ¶¶ [0018], [0128].

224. A POSA would further have to redesign the closing mechanism in Kaun and eliminate the safety mechanism that vents to relieve overpressure inside the battery. *Id.* ¶ [0130]. This is contrary to Kaun's direction that "there needs to be non-catastrophic, cost effective means to relieve the gas pressure." *Id.* ¶ [0023].

225. Finally, a POSA would need to incorporate two mutually exclusive structures: the central fastener, an essential element in Kaun, with the winding axis core in Kobayashi, an essential component of that reference. The fastener of Kaun, however configured, is impractical for the small microbattery button cell of Kobayashi. No guidance is provided by Mr. Gardner on how that can be done.

226. In my opinion, the above issues would lead a POSA to conclude that Kaun could not be modified in view of Kobayashi as proposed by Mr. Gardner. There is no element that could be usefully imported from Kobayashi into Kaun, nor from Kaun into Kobayashi, given the disparity of the cells described in those two references.

**5. Kaun and Kobayashi Fail to Disclose or Suggest “Button Cell,” “Insulating Means,” and “Closed Without Being Beaded Over”**

**a. “Button Cell”**

227. In my opinion, any combination of Kaun with Kobayashi would not result in a button cell. As stated earlier in my report, a POSA would understand a button cell to be “a small, generally round and flat battery typically used in electronic devices.”

228. Kaun relates to a battery for “high-pulse power requirements, such as for hybrid electric vehicles and for power tools.” *Id.* ¶ [0021]. Kaun notes that “[f]or hybrid electric vehicles, the current [required] is on the order of 100 A at 200-400 volts (equivalent to 20-40 kW).” *Id.* Kaun claims its “technology provides high pulse power devices . . . producing kW levels of power.” *Id.* ¶ [0079]. The Kaun cell achieves these power requirements with a “rolled-ribbon cell configuration according to the present invention [that] can release close to 100% of theoretical power of the Li/organic electrolyte cell chemistry in

substantially larger cells of 5-10 Ah capacity with pulse currents of 100-200 A from a single cell.” *Id.* ¶ [0094]. The same passage notes that cells of this type preferably have a contact area of 125 cm<sup>2</sup>. *Id.*

229. A POSA would not consider a battery providing these levels of wattage and amperage to be a “button cell.” Rather, a POSA would understand Kaun relates to a significantly larger cell and would have significantly larger dimensions such as a cylindrical or prismatic cell.

230. Kaun does state that “[t]he invention also provides a button-type cell housing.” Ex. 1005 ¶ [0084]. A POSA would understand this passage refers to the style of the housing disclosed in Kaun, which is circular and wider than it is tall, and does not convey any teaching or suggestion regarding the cell size, power output, or technical classification.

231. The Petitioners’ and Mr. Gardner do not contend the cell disclosed in Kaun could be miniaturized to a “button cell,” nor does it appear that it could. If the wattage and amperage stated in Kaun were drawn from a button cell, i.e. a cell less than 25 mm in diameter and 6 mm in height, the internal components would quickly burn out. Kaun includes a central fastener to hold the housing cups 28p, 28n together, a component fundamentally incompatible with a miniature button cell and which is incompatible with Kobayashi’s winding axis core particularly on the scale of Kobayashi’s microcell.

232. Kobayashi itself is evidence that miniaturization of Kaun is not possible. Kobayashi states that, with respect to rechargeable batteries providing power and current on levels required by small mobile devices (i.e. devices with significantly lower power requirements than the electric vehicles contemplated by Kaun), “size reduction is extremely difficult . . . and the limit has currently substantially been reached.” Ex. 1006 ¶ [0007]. Kobayashi further states that, with respect to the jelly rolls used in larger cylindrical batteries, “it was thought that it was impossible to store the electrode group structure within a small battery such as a button cell or a coin cell.” *Id.* ¶ [0014]. These statements would discourage a POSA from trying to modify rechargeable batteries for small mobile devices—much less the high power cells of Kaun—into a button cell.

233. Kaun teaches that for a lithium based battery for ‘high power applications, such as for hybrid electric vehicles,’ “internal gas pressure may be generated during operation.” Ex. 1005 ¶ [0023]. Kaun discloses that it would be desirable to incorporate “non-catastrophic, cost effective means to relieve the gas pressure.” *Id.* Accordingly, Kaun describes in an embodiment that the peripheral gasket that is disposed between the peripheral edges of the positive and negative cups 28p, 28n that form the housing can relax in the event of over pressurization inside a cell to act as a vent to release the internal pressure. *Id.* ¶¶ [0091], [0130]. Kaun’s cell is also designed to be stacked in a larger, external housing, along with

multiple other cells to form a battery assembly (*Id.* ¶ [0130]), while Kobayashi's cell is completely closed and intended for use as a stand-alone cell. To combine Kaun with Kobayashi, Kaun's venting system would need to be eliminated. Mr. Gardner provides no details on how this would be done, and no such instructions are provided in Kaun.

234. For the above reasons, Kaun—even as modified by Kobayashi—would not be a button cell.

**b. “Insulating Means”**

235. Independent claim 1 of the '835 Patent has “an insulating means” and further indicates “wherein the insulating means is arranged between the end faces of the spiral winding and the housing cup and the housing top.” As stated in my discussion of claim construction above, “insulating means” is “layer(s) composed of plastic, plastic disc(s) or structural equivalents.” In my opinion, Kaun combined with Kobayashi would not result in a cell with the claimed insulating means.

236. Initially, I note that while Mr. Gardner has offered explanation (with which I disagree) as to why a POSA would consider Kaun's separator thickness to be an issue and would therefore turn to Kobayashi, Mr. Gardner has not offered a reason why a POSA would turn to Kobayashi for the purpose of using its insulating plates. In my opinion, a POSA would not consider importing Kobayashi's insulating plates into the structure of Kaun.

237. As described above, the consistent teaching of Kaun is to eliminate intermediate current collectors so that “each respective electrode 12p and 12n is electrically common with cups 28p and 28n, respectively.” Ex. 1005 ¶ [0122], see also ¶ [0125] (“positive and negative electrodes 12p and 12n are electrically continuous at opposite open ends thereof respectively with the positive and negative material layers 28p and 28n of each cell.”). This direct and continuous edge contact results in “short electronic current flow paths along the lengths of the electrodes [and] do not require a highly conductive electrode current collector supplementing or paralleling the electrodes” such that “[r]esistance to electron passage via the electrodes will generally be negligible.” Ex. 1005 ¶¶ [0125], [0128].

238. Another key consideration of Kaun’s design is improved thermal management. Due to the direct and continuous edge contact between the electrodes and external terminal, internally generated heat from the rolled-ribbon cell “can be drawn out from the cell via short conduction paths without crossing the heat sensitive microporous polyethylene/polypropylene separator.” *Id.* ¶ [0094]. Kaun teaches that “[t]hermal management is important to the long life of Li-ion batteries,” particularly for high power applications, as “[e]xcessive temperatures will destroy (e.g. melt the microporous polymer separator or autoignite the flammable organic electrolyte) or significantly shorten the useful life

of the Li-ion cell.” *Id.* ¶ [0005]. Kaun further cautions that poor thermal management can contribute to thermal gradients in the cell, i.e. “[e]xcessive temperature within the cell will locally shutdown the microporous polymer resulting in still higher temperatures.” *Id.*

239. In my opinion, a POSA would not consider importing Kobayashi’s insulating plates into the structure of Kaun in an attempt address any issue concerning separator thickness because Kobayashi’s insulating plates would eliminate the key design features of Kaun’s rolled-ribbon configuration: short, axial conduction paths by which electrical current and internally generated heat can flow out of the interior of the cell.

240. A POSA seeking to eliminate overlap of separators in Kaun would have followed Kaun’s own teaching: “[a]lthough the preferred configuration of the separator 14 is Z-shaped, the separator 14 can encompass other embodiments envisioned by those skilled in the art as long as the separator adequately isolates the successive electrodes from one another in the contemplated device.” *Id.* ¶ at [0107].

241. Following Kaun’s teaching, a POSA looking to modify Kaun would employ a continuous non-overlapping separator between the electrode material (as Petitioners allege is shown in Kobayashi), while maintaining offset electrodes that directly connect the electrodes to the housing top and cup in Kaun. This

modification would have eliminated any issue with separator thickness without disregarding Kaun's core teachings: maintaining direct contact between the electrodes and housing to provide the shortest possible conduction paths for both electrical current and internally-generated heat, thereby reducing impedance and providing adequate thermal management for high power applications.

**c. "Closed without Being Beaded Over"**

242. As stated in my discussion on claim construction above, in my opinion, the term "the button cell is closed without being beaded over" should be construed to mean that the button cell is closed at overlapping sides of the housing cup and top without a bend in the cut end of the housing extending over a top edge area of the housing top. Kaun and Kobayashi do not describe a cell housing that meets this construction.

243. In Kobayashi, the positive electrode case 12 and the negative electrode case 11 are "sealed by implementing swaging," which is used by Kobayashi to describe a housing that is beaded over.

244. An essential feature of Kaun is "a fastener that aligns the first and second cups during assembly and maintains electrode contact with the appropriate cup independent of external pressure on the housing, helping to eliminate the possibility of an open circuit state for a cell." Ex. 1005 ¶ [0086]. Kaun specifically notes that "the present invention provides a housing for an



electrochemical device comprising a first cup, a second cup, a fastener, and a gasket.” Ex. 1005 ¶ [0024]. The fastener is an essential element to hold the housing cups together.

245. Kaun does disclose a u-shaped peripheral gasket 26 that “extends along at least of the wall of one of the two opposing cups.” *Id.* ¶ [0084]. Kaun states that the peripheral gasket relaxes in the event of over pressurization inside a cell to act as a vent to release the internal pressure. *Id.* ¶¶ [0091], [0130]. A POSA would understand Kaun’s venting system means that the Kaun housing is not “closed” in the sense of the ’835 Patent where, for example, it is imperative to prevent the extremely reactive lithium ions from encountering moisture.

**B. The Combination of Kobayashi in view of Kaun Fails to Render Obvious the Claims of the ’835 Patent**

246. It would not have been obvious for a POSA to combine Kobayashi and Kaun to arrive at the inventions of the Challenged Claims of the ’835 patent. A POSA would not have been motivated to combine Kobayashi with the Kaun reference for several reasons including the fundamental differences between the references and because there is no benefit that would result from combining them.

**1. There Is No Motivation to Combine Kobayashi with Kaun**

**a. A POSA Would Not Eliminate the Beaded Over Closure of Kobayashi**

247. I disagree with Mr. Gardner’s conclusion that a POSA would be motivated to modify Kobayashi’s housing. I further disagree with Mr. Gardner’s

conclusion that a POSA would be motivated to remove the beaded over housing of Kobayashi in view of Kaun “in order to prevent damage to the interior of the cell which could occur during beading over of the cell edge.” Ex. 1003 ¶ 139.

248. In Kobayashi, the positive electrode case 13 and the negative electrode case 11 are “sealed by implementing swaging”. Ex. 1006 ¶ [0035]. Closing by “swaging” in the context of Kobayashi means closed by beading over. Such a method of closing in Kobayashi is beneficial because it maintains conductive contact and physical registration between the electrodes 1, 2, the rod-like terminal connection parts 4b, 5b, and the terminal plates 4a, 4b. Kobayashi was designed in this manner where “a ring-shaped insulation gasket was fitted into the reverse part 10 of this negative electrode case 11” prior to swaging. Ex. 1006 ¶ [0033].

249. Axial movement between the positive and negative electrode cases 11, 13 would likely compromise attachment of the electrodes 1, 2 from the rod-like terminal parts 4b, 5b or result in detachment between the terminal plates 4a, 5a and the electrode cases 11, 13, either one resulting in an open circuit condition. This will be apparent from the figure below. Relative axial movement of the electrode cases 11, 13 would also likely result in leakage of the electrolyte.

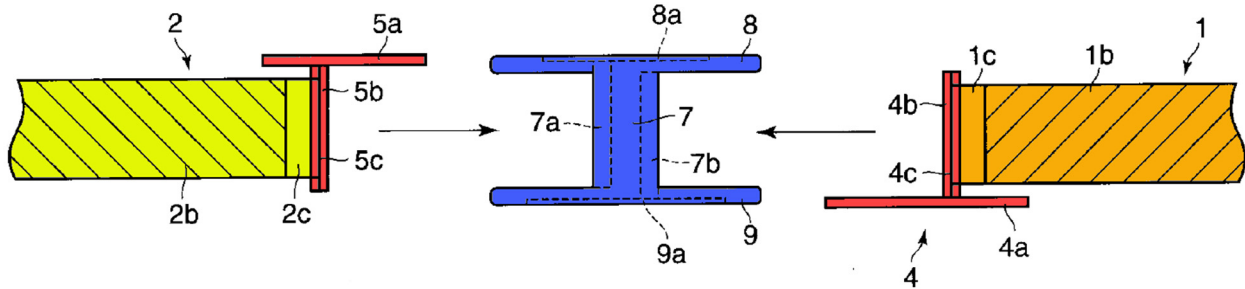

250. It is especially desirable in lithium-ion chemistry that the cell housing is tightly sealed to prevent moisture from leaking into the cell. Lithium is highly reactive with water vapor and even very small amounts of moisture can significantly hamper performance and lead to potentially hazardous conditions. A POSA would recognize that, with respect to Kobayashi, the beaded over connection between the positive and negative electrodes 11, 13 with the ring-shaped gasket there between is actually beneficial and advantageous. As shown in Kobayashi FIG. 1, a result of swaging or beading over the housing cup and the housing top about the gasket is that a leak-tight seal is formed as a result of the long and narrow path formed by beading over and the seal between the housing cup and housing top.

251. For these reasons, I believe Kobayashi requires a method of closing its housing that involves a positive lock, that is in a manner prevents vertical displacement of the housing bottom from the housing top and that sufficiently closes at the side seals to prevent leakage.

252. I also disagree with Mr. Gardner's apparent presumption that beading can cause damage to a cell housing and/or its internal components regardless of the cell's underlying structure.

253. Closing a cell housing by beading over is a well-known method for closing the housing cup and housing top when assembling button cells and is a conventional way of creating a leak-tight enclosure for a button cell. The '835 Patent itself notes "[t]raditionally, button cells have been closed in a liquid-tight manner by beading the edge of the cell cup over the edge of the cell top." Ex. 1001 '835 Patent 2:4-9.

254. A review of the button cell prior art, in Linden Handbook, demonstrates that closing the housing halves by beading them over was a conventional practice with button cells. *See, e.g.*, Ex. 1009 at 254, 279, 280, 281, 300, 310-12, 400, 421, 810, 845. It is still widely used today because it is a secure and easy method of closing a cell.

255. A POSA would understand that "beading over" the cut end edge of a housing cup and a housing top only possibly results in damage to the interior of the cell in certain arrangements. In my opinion, in the design of Kobayashi and several of the other button cells referenced above, where the lower electrode case 11 is bent radially inwards over a corresponding radially outward edge of the upper electrode case 11 about the mid-axial circumference of the housing, the potential

for damage to the interior of the cell is reduced or eliminated. In this case, force is not applied over the entire axial height or directly upon the electrode separator or other internal components such that the button cell is not being squeezed or compressed over its entire height and the beading over forces can be better dissipated.

256. Further, Kobayashi includes the internal winding member 6 about which “the positive electrode 1 and the negative electrode 2 are spirally wound with the separator 3 interposed.” Ex. 1006 ¶ [0032]. “The insulation plate 8 as the second insulating member, is disposed on the top surface of the wound electrode” and “the insulation plate 9, as the first insulating member, is disposed on the bottom surface of the wound electrode group.” Id. The winding member 6 including the winding axis core 7 and insulation plates 8, 9, space apart and brace the positive and negative electrode cases 11, 13 and protect the spiral wound foil electrodes 1, 2 and pliable separator 3. A POSA would recognize inclusion of the winding member 6 in Kobayashi further resists damage due to beading over and renders the beading process safe.

257. A POSA would recognize that beading over the electrode case 11 to the electrode case 13 about the mid-axial circumference maintain axial compression on the terminals 4, 5 integrated in the winding member 6 without

damaging the cell. In this case a POSA would not have a reason to eliminate the bead over connection in favor the housing arrangement described in Kaun.

**b. Kaun's Housing is Incompatible with Kobayashi**

258. It is my opinion that if a POSA would have been motivated to modify the housing of Kobayashi, a POSA would not have turned to the housing of Kaun. Kaun's housing, designed for a high power cell that is intended to be stacked with other high power cells in an additional, external housing, is not compatible with Kobayashi's microcell architecture.

259. Kaun discloses a lithium based battery for 'high power applications, such as for hybrid electric vehicles,' "internal gas pressure may be generated during operation." Ex. 1005 ¶ [0023]. Kaun discloses that it would be desirable to incorporate "non-catastrophic, cost effective means to relieve the gas pressure." Id. Accordingly, Kaun describes that as a safety measure the peripheral gasket that is disposed between the peripheral edges of the positive and negative cups 28p, 28n can relax in the event of over pressurization inside a cell to act as a vent to release the internal pressure. Ex. 1005 ¶¶ [0130].

260. To relieve internal pressure, Kaun describes that the positive and negative cups 28p, 28n can be externally loaded by springs to urge the cups together. Ex. 1005 ¶ [0130]. "If a single cell produced internal pressure exceeding the 10-20 psi limit, the end spring would slightly compress and the peripheral

gasket of the over pressurized cell would subsequently relax to relieve the overpressure. This cell would then reseal itself under the spring force.” Id.

261. Mr. Gardner does not explain how he would adapt the pressure relief gaskets in Kaun if the housing were to be adapted and miniaturized to work with Kaun’s cell which must be completely closed.

262. An essential element of Kaun is the central fastener. The fastener “aligns the first and second cups during assembly and maintains electrode contact with the appropriate cup independent of external pressure on the housing, helping to eliminate the possibility of an open circuit state for a cell.” Ex. 1005 ¶ [0086]. It is only “[i]n combination with the gasket, the fastener holds the housing, including the enclosed electrode assembly, together independent of the external pressure on the housing thereby providing consistent contact between the cups and the electrodes.” Ex. 1005 ¶ [0088].

263. In my opinion, the fastener in Kaun’s housing is fundamentally incompatible with the winding axis core of Kobayashi.

264. Kobayashi includes the winding axis core 7 at the center of the wound electrode group and it serves as the central element around which the remainder of the Kobayashi cell is constructed:

As illustrated in FIG. 9, the winding axis core 7 wherein the terminal connection part 4b (positive electrode lead part) of the positive electrode terminal 4 and the terminal connection part 5b (negative electrode lead part) of the negative electrode terminal 5 are integrated

is located at the center portion of the wound 10 electrode group in which the positive electrode 1 and the negative electrode 2 are spirally wound with the separator 3 interposed. Ex. 1006 ¶ [0032].

265. Only “by incorporating the winding axis core into the electrode group while being integrated with the negative electrode and/or the positive electrode, [] was [it] possible to manufacture a wound electrode group capable of being housed in a case of a small battery such as a button cell or a coin cell.” Ex. 1005 ¶ [0017]. The wind axis core 7 is integrated with upper and lower insulating plates 8, 9 because “stability of the electrode group is improved by integrating the insulating member and the winding axis core.” Ex. 1006 ¶ [0020]. The winding axis core registers and connects the electrodes 1, 2 with the rod-like terminal connection parts 4b, 5b that are conductively integrated with the positive and negative terminal plates 4a, 5a. Ex. 1006, ¶ [0031]. Thus the winding axis core is an essential element to register and connect the electrodes, terminal rods, terminal plates, and insulation plates, while maintaining structural rigidity and is the fundamental component about which the integrated button cell is built.

266. Mr. Gardner states “[i]t would be well within the skill of a POSA to include within the winding axis of Kobayashi the additional fastener of Kaun.” Ex. 1003 ¶ 141. However, he does not provide any details of how a POSA would have modified Kobayashi to accommodate Kaun’s center fastener.



267. Mr. Gardner states “inclusion of the fastener would not take away existing room within the cell.” I disagree. The winding core axis and the fastener occupy the same central location in the cells and would compete for the same internal volume. Any modification of the winding core axis to accommodate a fastener would involve increasing the volume of the winding core axis beyond what is otherwise minimally necessary. This would in turn cause a corresponding decrease in space for active material and/or it would displace the bar-like terminal connection parts. This tradeoff is contrary to the supposed benefit of using the Kaun housing “to provide greater volume within the housing cell.” Ex. 1003 ¶ 141.

268. Mr. Gardner states “a POSA could adopt a through hole in the winding axis core of Kobayashi” to accommodate the fastener. In the absence of further modification, a through hole through the winding axis core would weaken the core structure thereby risking failure. To prevent this, size of the core structure would need to be increased, which would decrease the space available and thereby undermine the rationale for turning to Kaun’s housing in the first instance. Further, any center fastener would need to be designed to avoid shorting top and bottom conductor plates, and it would need to be designed to avoid creating a point of leakage. These are all significant issues—particularly in context of a button cell such as Kobayashi’s—yet they are left unaddressed by Mr. Gardner.

269. Mr. Gardner also states that a POSA would look to Kaun's housing because its center fastener can help maintain contact with the electrodes. *Id.* ¶ 140. Mr. Gardner loses sight of the fact that this stated advantage is with reference to Kaun's electrode assembly, not Kobayashi's. Kobayashi's electrode winding is not designed to contact the housing directly. Moreover, the beaded over housing of Kobayashi already provides the requisite axial pressure to maintain contact between the conductor plates and the housing.

270. Mr. Gardner states it may be possible to attach the "housing parts to winding axis of Kobayashi using clips or other fittings." *Id.* ¶ 141. Kobayashi and Kaun do not disclose or suggest clips or fittings, and Mr. Gardner does not otherwise explain how this could be done.

271. Yet further, in a button cell, any fasteners would need to be somehow integrated in a way that maintains a relatively flat top and bottom. This is yet another issue that Mr. Gardner simply does not address.

272. Given the above considerations, it is my opinion that the housing of Kaun would not improve Kobayashi's cell at all. At a minimum, given the many challenges that would need to be overcome in order to modify Kaun's housing to work with a microcell, a POSA would not have been motivated to look to Kaun even if modification of Kobayashi's housing were desired.

**2. A POSA Would Not Have a Reasonable Expectation of Success in Modifying Kobayashi with Kaun**

273. It is my opinion that a POSA, even if looking to improve Kobayashi, would not have had a reasonable expectation of success in modifying Kobayashi with Kaun's housing.

274. The Kobayashi reference, which is directed to button cells, states that, with respect to larger cells, "size reduction is extremely difficult for these rechargeable batteries, and the limit has currently substantially been reached." Ex. 1006 ¶ [0007]. Therefore, Kobayashi had to "change the approach away from conventional art." *Id.* ¶ [0014]. Kobayashi states that it was only "by incorporating at least a winding axis core into the electrode group structure, and as needed, an insulation plate and contacting terminals between electrodes and external terminals" were they able to produce a small battery such as a button cell or a coin cell. *Id.* And Kobayashi discloses that the positive and negative electrode cases of the housing should be "swaged" or beaded over to prevent axial movement and maintain conductive contact of the internal components.

275. These statements and disclosures in Kobayashi teach a POSA away from looking to cylindrical cells for small mobile devices—or to cells for electric vehicles as contemplated by Kaun, contrary to Petitioners' and Mr. Gardner's approach.

276. For his part, Kaun is directed to improving energy and power output in a battery with substantial energy density at kilowatt levels of power for high pulse-power requirement applications like hybrid electric vehicles and power tools. Ex. 1005 ¶¶ [0004], [0021], [0079]. “[T]he present invention can release close to 100% of theoretical power of the Li/organic electrolyte cell chemistry in substantially larger cells of 5-10 Ah capacity with pulse currents of 100-200 A from a single cell.” *Id.* ¶ [0094], see also FIGS. 14-15. Kaun is precisely a type of battery for which Kobayashi indicates further size reduction would be extremely difficult.

277. Kaun includes “a fastener that aligns the first and second cups during assembly and maintains electrode contact with the appropriate cup independent of external pressure on the housing, helping to eliminate the possibility of an open circuit state for a cell.” *Id.* ¶ [0086]. As discussed, a center fastener disposed through the cell is not a viable closure mechanism for a button cell due to its small size, for example, on the order 12 mm. Moreover, the center fastener of Kaun and the winding axis core of Kobayashi are mutually exclusive elements and a POSA would not have a reason or motivation to attempt to combine the elements. A POSA attempting to use a “through hole” in Kobayashi’s winding axis core, per Mr. Gardner’s suggestion, would, for example, risk weakening the core structure, which is critical to Kobayashi’s battery structure, or require the core to be widened

thereby defeating the alleged purpose of turning to Kaun's housing in the first instance.

278. Moreover, Kaun's cell is designed with a complex structure to relieve overpressure. *Id.* ¶ [0130]. These structures would need to be redesigned to provide a completely closed cell as required by Kobayashi. Mr. Gardner does not address this issue.

279. In my opinion, given Kobayashi's teaching of the difficulty of further miniaturization of cells and the design challenges that would be attendant to any attempt to adopt Kaun's high power cell housing, a POSA would not have had a reasonable expectation of modifying Kobayashi with Kaun.

### **3. Kobayashi Teaches Away from the Direct and Continuous Edge Contact of Kaun**

280. Kobayashi and Kaun have different current flow paths for different purposes. Kobayashi states that "by incorporating the winding axis core into the electrode group while being integrated with the negative electrode and/or the positive electrode, it was possible to manufacture a wound electrode group capable of being housed in a case of a small battery such as a button cell or a coin cell." Ex. 1006 ¶ [0017]. Because of the presence of the winding axis core 7 and the need to facilitate winding of the electrodes 1, 2 and separator 3 between the insulation plates 8,9, the electrodes cannot directly contact the electrode cases 11, 13. Instead, Kobayashi discloses that conductive path should be established

between the wound electrodes 1, 2, to the rod-like terminal connection parts 4b, 5b in the winding axis core 7, between the terminal connection parts 4b, 5b, and the disc-like terminal plates 4a, 5a, and between the terminal plates 4b, 5b and the positive and negative electrode case 11, 13. The current flow circumnavigates and spirals radially inward through the wound electrodes 1, 2 to the winding axis core 7, then axially up or down through the rod-like terminal parts 4b, 5b to the disc-like terminal plates 4a, 5a. The extended current flow path is acceptable to facilitate manufacturing a wound electrode group in a small battery such as a button cell. *Id.* ¶ [0017].

281. Kaun teaches direct and continuous edge contact between the positive and negative electrodes 12p, 12n and the positive and negative electrode cups 28p, 28n respectively. According to Kaun, “[t]he majority of electron transfer takes place in the axial direction along the flattened electrodes . . . normal to the current collectors.” Ex. 1005 ¶ [0018]. “[T]he short electronic current flow paths along the lengths of the electrodes (less than 10 mm) do not require a highly conductive electrode current collector,” thus reducing the internal resistance and resulting impedance to current flow. *Id.* ¶ [0128]. The direct and continuous edge contact and axial current flow path is the primary design feature employed in the battery of Kaun for delivery of high pulse power and currents up to hundreds of amps.

282. For reference, the different current flow paths are annotated below:

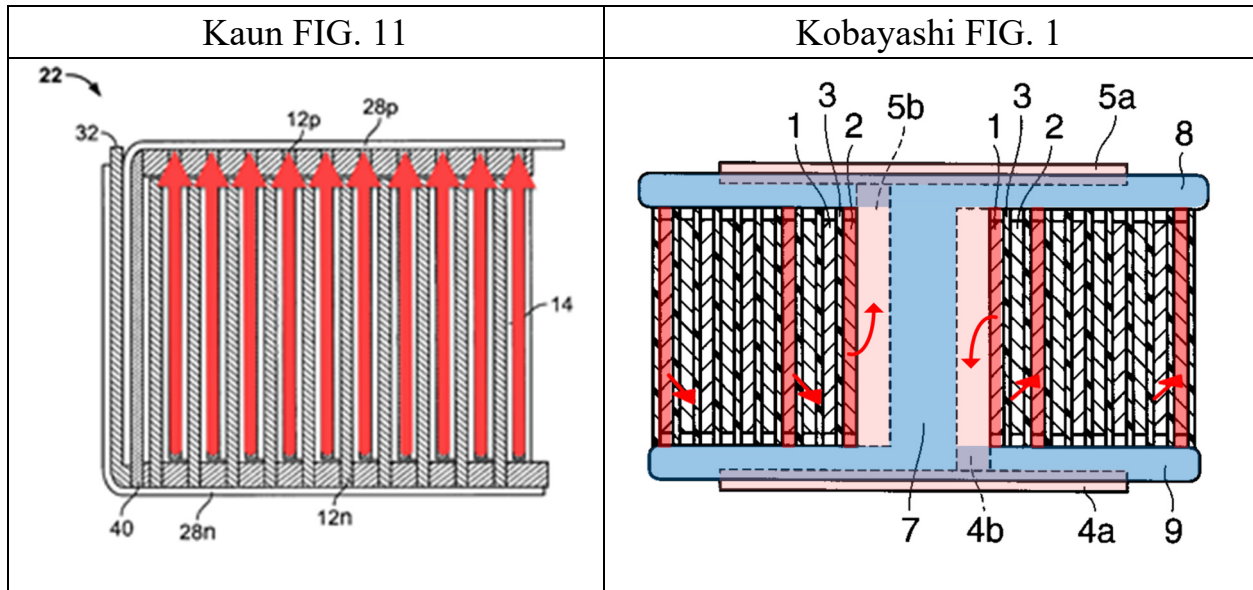

283. Because of these fundamentally different current flow paths, and the different components and connections to establish the flow paths, a POSA would view Kobayashi and Kaun as teaching away from each other. As stated above, Petitioners and Mr. Gardner do not reconcile these divergent teachings. A POSA would not have combined Kobayashi and Kaun.

#### 4. Kobayashi and Kaun Fail to Disclose or Suggest “Insulation Means” and “Closed Without Being “Beaded Over”

##### a. “Insulation Means”

284. Independent claim 1 of the ’835 Patent recites “insulating means” and further recites its location in the button cell “wherein the insulating means is arranged between the end faces of the spiral winding and the housing cup and the housing top.” A POSA would not have considered the combined teachings of Kobayashi and Kaun to provide a button cell with the claimed insulation means.

285. As discussed above in Section IX.A., the key feature of the Kaun reference is to eliminate intermediate current collectors in favor of direct and continuous edge contact between the electrodes 12p, 12n and the positive and negative terminal cups 28p, 28n. “[E]ach respective electrode 12p and 12n is electrically common with cups 28p and 28n, respectively.” Ex. 1005 ¶ [0122], see also ¶ [0125] (“positive and negative electrodes 12p and 12n are electrically continuous at opposite open ends thereof respectively with the positive and negative material layers 28p and 28n of each cell.”).

286. This direct and continuous edge contact results in “short electronic current flow paths along the lengths of the electrodes [and] do not require a highly conductive electrode current collector supplementing or paralleling the electrodes” such that “[r]esistance to electron passage via the electrodes will generally be negligible.” Ex. 1005 ¶¶ [0125], [0128]. “The majority of electron transfer takes place in the axial direction along the flattened electrodes and the adjacent electrode material layers or normal to the current collectors.” Id. ¶ [0125].

287. Another key consideration of Kaun’s design is the improved thermal management afforded by the direct and continuous edge contact between the electrodes and external terminal. Internally generated heat from the rolled-ribbon cell “can be drawn out from the cell via short conduction paths without crossing



the heat sensitive microporous polyethylene/polypropylene separator.” *Id.* ¶ [0094].

288. In addition, Mr. Gardner states “the button cell of Kaun, which is sealed without being beaded over, allows for greater internal space to contain the electrode assembly.” Ex. 1003 ¶ 138. Mr. Gardner claims this means more electrode layers can be included in a button cell that is not beaded over (i.e. according to Kaun) than with one that is closed by being beaded over (i.e. according to Kobayashi). Mr. Gardner states this would motivate a POSA to combine the housing taught in Kaun with the cell of Kobayashi.

289. Accepting, Mr. Gardner’s logic, a POSA would abandon the insulating plates 8, 9 of Kobayashi and incorporated the direct and continuous edge contact between electrodes and the housing cases of Kaun. The insulating plates 8, 9 prevent the direct and continuous edge contact between the electrodes and inner surfaces of the casing. Given the advantages of direct and continuous edge contact with the inner surfaces of the housing in providing lower internal resistance and lowering internal resistance, a POSA would include that feature in Kobayashi and eliminate the insulation plates.

290. Moreover, to the extent a POSA is motivated to use the Kaun housing because it “allows for greater internal space to contain the electrode assembly,” as Mr. Gardner alleges, a POSA would be further motivated to abandon the insulator

plates 8, 9 in favor of the direct and continuous edge contact. As illustrated below, the insulating plates 8, 9 and winding axis core 7 that are inactive materials take up a significant amount of the internal volume of the cell between the spiral wound electrodes 1, 2, and the inner surfaces of the positive and negative electrode cases 11, 13. A POSA, therefore, would have adopted Kaun's winding—not Kobayashi's. The result would be a cell without an insulator between the windings and housing.

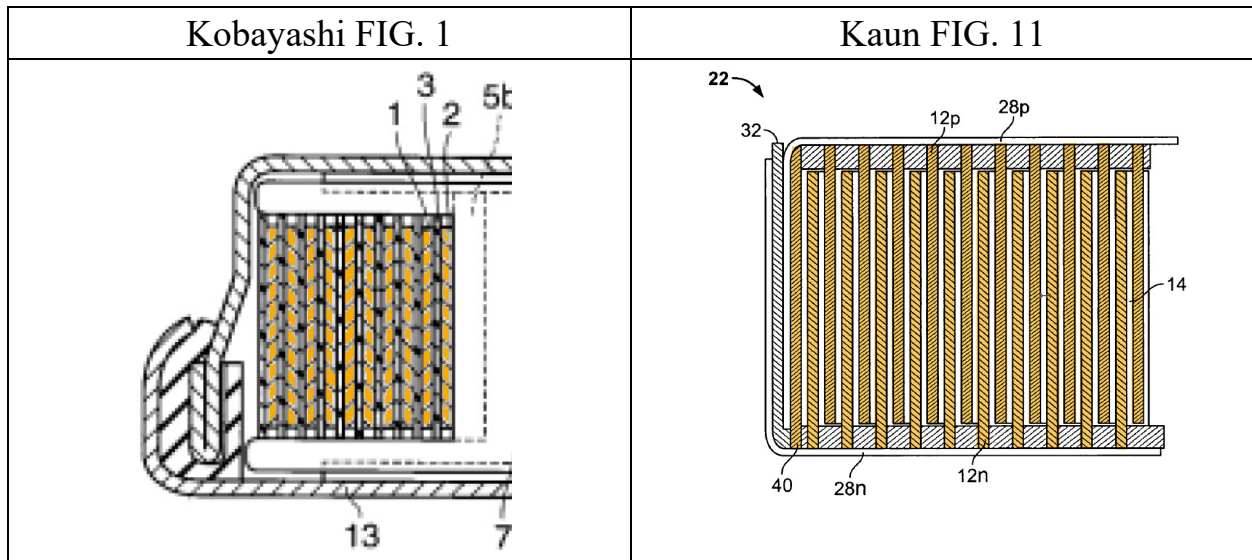

### b. “Closed Without Being Beaded Over”

291. Neither Kobayashi nor Kaun disclose a button cell where the housing is “closed” without being beaded over.

292. The positive and negative electrode casings 13, 11 in Kobayashi are “sealed by implementing swaging,” i.e. are beaded over. Ex. 1006 ¶ [0035].

293. Kaun includes a central fastener as an essential element to hold the housing cups together. Ex. 1005 ¶ [0086]. Furthermore, as a safety measure, Kaun provides a peripheral gasket that can, in the event of over pressurization inside the cell, relax in order to vent the cell and release internal pressure. *Id.* ¶¶ [0091], [0130]. Because of its over pressurization venting, Kaun is not closed.

294. Accordingly, it is my opinion that Kaun and Kobayashi cannot be combined to teach the limitation of closed without being over.

**C. The Combination of Kobayashi in view of Ryou Fails to Render Obvious the Claims of the '835 Patent**

295. It would not have been obvious for a POSA to combine Kaun and Ryou to arrive at the inventions of the Challenged Claims of the '835 patent. A POSA would not have been motivated to combine Kobayashi with the Ryou reference for several reasons including the significant differences between the references and because there is no benefit that would result from combining them.

**1. A POSA Would Not Have a Reason to Combine Kobayashi and Ryou**

296. Petitioners and Mr. Gardner state that a POSA would recognize a potential advantage of replacing the housing of Kobayashi with the housing of Ryou “since crimping or beading can cause damage to the overall structure of the cell.” Ex. 1003 ¶ 210. I disagree that a POSA would have such a motivation.

297. Initially, I note that there are fundamental differences between the battery described in Kobayashi as compared to the battery in Ryou. Kobayashi is a rechargeable lithium ion battery with a jelly roll electrode winding. Its battery is sealed and would be subject to various forces of expansion. Ryou is a primary battery that does not include a jelly roll. Furthermore, the zinc-air battery of Ryou is necessarily vented. These differences alone would suggest to a POSA that Ryou would be an unlikely source of any teaching relevant a POSA attempting to improve the housing of Kobayashi.

298. As I discussed in the proposed combination of Kobayashi with Kaun, a POSA would not have been modified to modify the housing of Kobayashi for a number of reasons. Those reasons apply equally here. For example, closing button cells such as Kobayashi has been known for years and has been used successfully and continues to be used successfully. Notably, there is nothing about Kobayashi that would have caused to POSA to believe its cell would be subject to failure when closed by beading over. To the contrary, the fixed and rigid structure of Kobayashi would be capable of withstanding beading over without any risk of damage to its cell components.

299. As also discussed in connection with the combination of Kobayashi and Kaun, a POSA would have understood that the positive lock provided by Kobayashi's housing was essential in view of the configuration of its electrode

assembly (winding axis core, electrodes, insulating plates, etc.) and the need to protect against an open circuit and leaking cell. These reasons also apply to the proposed combination of Kobayashi with Ryou.

300. In my opinion, and in view of the foregoing, a POSA would not have been motivated to modify Kobayashi's housing at all.

301. It is further my opinion that, if a POSA had sought to modify Kobayashi's housing, a POSA would not have considered the housing of Ryou.

302. Ryou is directed to a primary battery, i.e. a vented zinc-air battery, and does not generate successive expansion and contraction forces and loads, especially those encountered with an expanding and contracting jelly roll. In the Ryou cell, there are no radial forces or loads, axial forces or loads, or other directional forces or loads that the housing must contend with. While the closure mechanism of Ryou may be sufficient for a primary zinc-air battery, it would likely fail under cyclical loading conditions associated with a lithium ion rechargeable battery.

303. Ryou does not describe the material used to form the fusion bond between the cathode can and the anode can. Ryou states:

[H]ermetical sealing of the battery may be carried out by fusion-bonding of the cans 52 and 54 and the body 56. The body 56 is made of an insulation resin and insulates the first and second cans 52 and 54 from each other and also is fused at the end portion 60 of the cans 52 and 54 to seal the inside of the battery. Ex. 1007 ¶ [0071].

304. Mr. Gardner does not provide any analysis whether a fusion bonded resin that makes a hermetic seal and electrically isolates conductive cans would provide the same restraint and structural integrity against axial movement as provided by the beaded over arrangement of Kobayashi. In my opinion it would not.

305. Further, the fusion bonded body 56 is merely disposed between the spaced apart edges of the can 52, 54 and there is no structure containing the body at that location. The upper cup and lower cup do not overlap but are spaced apart from each other. There is no affirmative locking arrangement such as created by displacing the cut edge of the negative electrode casing 11 radially inward and over the cut edge of the positive electrode casing 13.

306. Due to the lack of a positive lock in Ryou, any axial forces vertically displacing the cans 52, 54 would place the fusion body 56 in tension and the cans would slip apart from the body. The resin of the body 56 would not have the strength to constrain the axial forces and maintain the terminal plates, terminal connecting parts, and electrodes in contact. A POSA would be discouraged from using the fusion bonded body 56 disclosed in Ryou in a secondary lithium ion battery particularly in the configuration of Kobayashi.

307. A POSA would have concluded that the fusion bonded body 56 of Ryou would not likely withstand the radially outward directed force cause by

expansion and contraction of the wound electrode separator assembly in Kobayashi. There is no overlap between the cut edges of the cans 52, 54 that reinforces the cut edges against expansion and contraction and the body 56 would slip apart from the cut edges.

308. Due to the inherent weakness of fusion bonded body 56, a POSA would not have any reason to modify Kobayashi in view of the button cell in Ryou. Indeed, a POSA would have concluded that the seals in the Ryou battery would likely fail resulting in a battery that leaks and that likely would cause open circuit conditions.

309. Another reasons why the housing in Ryou would not have been considered appropriate by a POSA for use with Kobayashi's electrolytic cell is that the sealing mechanism does not provide sufficient protection against moisture entering the cell.

310. As shown in the illustration below, beading over of the lower case and the upper case about the ring-shaped gasket of Kobayashi produces narrow, somewhat winding, and relatively lengthy path moisture would have to migrate to enter the cell. This provides a good seal making it unlikely moisture will enter the cell. The seal in Ryou is quite different. It provides a very a short path the moisture must travel making it far more likely moisture will enter the cell.

Moisture entering an electrolytic cell will destroy the battery thus making Ryou an entirely inappropriate choice for Kobayashi's electrolytic cell.

311. In fact, the housing of Ryou is not only inappropriate, it is incompatible with Kobayashi's cell.

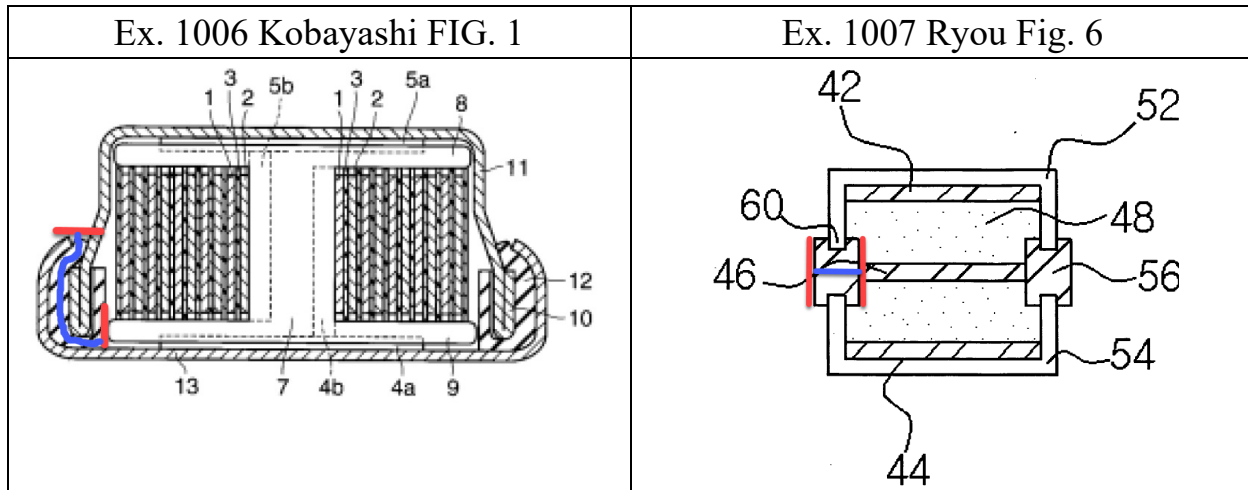

## 2. The Combination of Kobayashi and Ryou Does Not Provide a Cell that is “Closed” without Being Beaded Over

312. I understand that Petitioners rely on the Ryou reference provide the element “closed without being beaded over.” In my opinion Ryou does not meet this claim element for at least two reasons.

313. First, Ryou is not closed at all. Ryou is directed to a zinc-air battery that is vented. As such, the cell of Ryou is not closed at all.

314. Second, as set forth in my discussion of claim construction, a POSA would understand “closed without being beaded over” to mean “closed at overlapping sides of the housing cup and top without a bend in the cut end of the



housing cup extending over a top edge area of the housing top.” Ryou does not meet this definition because the housing in Ryou does not have overlapping sides.

**XI. THE CHALLENGED '581 PATENT AND '913 PATENT CLAIMS ARE PATENTABLE OVER KOBAYASHI, KAUN, AND THE KNOWLEDGE OF A POSA**

**A. The Combination of Kobayashi in View of the Knowledge of a POSA Fails to Render Obvious the Challenged Claims of the '581 and '913 Patents**

315. It would not have been obvious for a POSA to combine Kobayashi and general knowledge in the art to arrive at the inventions of the Challenged Claims of the '581 patent and the '913 patent.

**1. Kobayashi Does Not Teach “An Output Conductor Comprising a Foil”**

316. The independent claims of the '581 and '913 patents recite that “one of the electrodes connects to the flat bottom area or flat top area [of the housing] via an output conductor comprising a foil resting flat between the end face of the spiral winding and the flat top or the flat bottom area.” The specifications state that the “output conductors are thin films, which rest between the end faces of the winding and the flat top and bottom areas 503 and 504.” Ex. 1001 '581 Patent 12:6-8; Ex. 1001 '913 Patent 12:65-67. FIG. 4 shown below illustrates the output conductors 409, 410 (red) that extend from the spiral wound electrode-separator assembly 404 (yellow). They rest flat between the end faces of the electrode-

separator assembly and the flat top and bottom areas of the housing cup 403 and housing top 404.

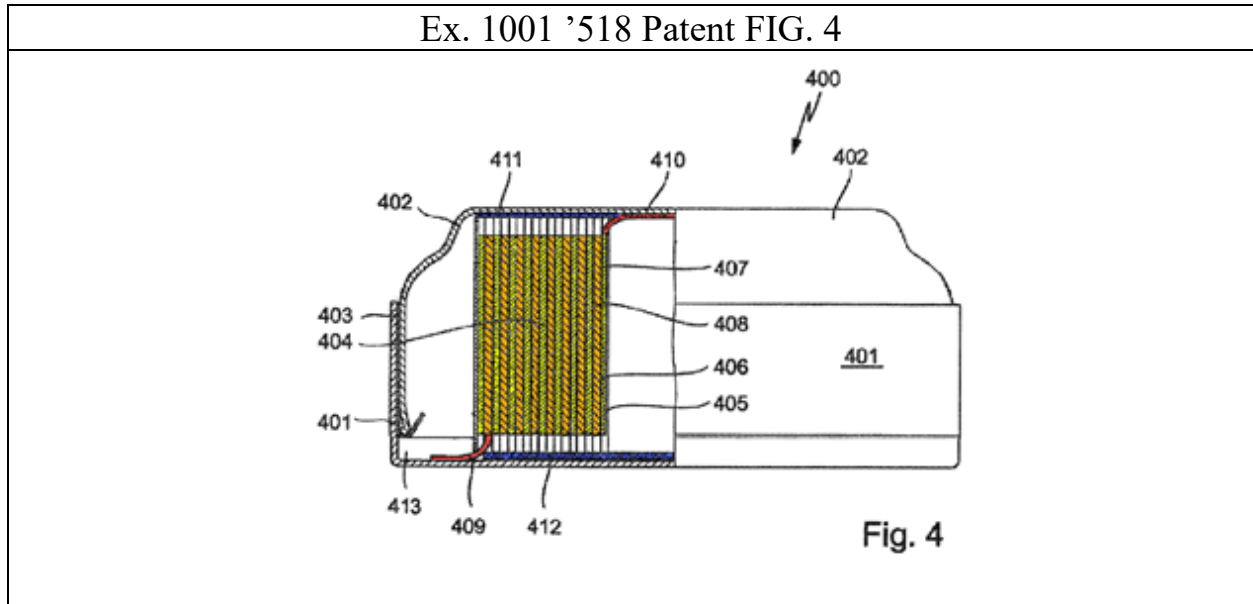

317. Kobayashi does not teach “an output conductor comprising a foil.” To connect the positive electrode 1 to the respective positive casing 11, Kobayashi teaches “a disc-shaped positive electrode terminal plate 4a” and “bar-shaped terminal connection part 4b . . . electrically connected to the positive electrode terminal plate 4a.” Ex. 1006 ¶ [0028]. Likewise, Kobayashi discloses a negative “disc-shaped negative electrode plate 5a” and a “bar-shaped terminal connection part 5b” to connect the negative electrode to the negative housing casing 13. These are shown in FIG. 1 of Kobayashi below in which the positive and negative terminal plates 4, 5 are red.

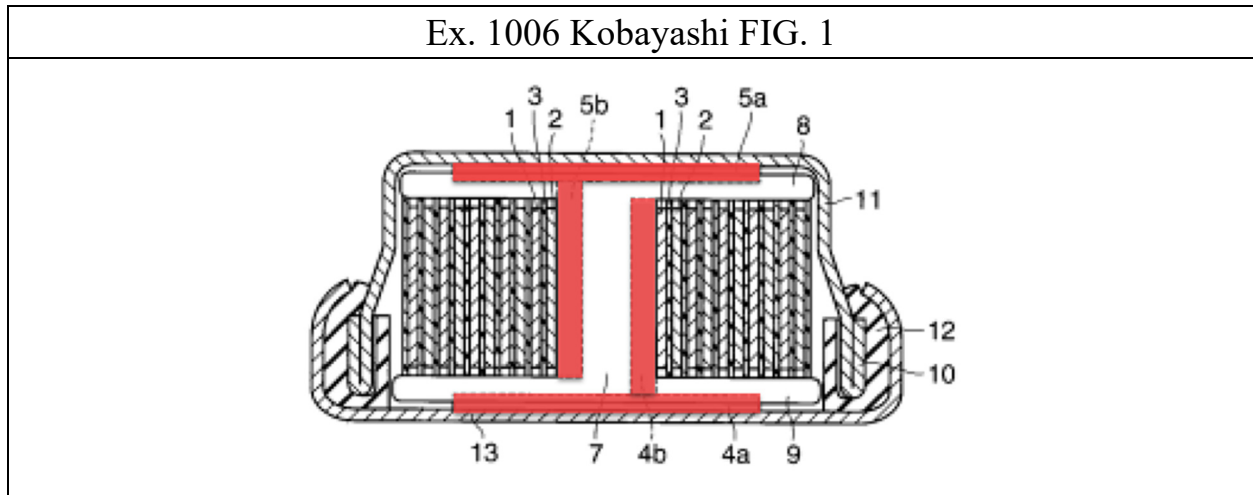

318. A POSA would have understood a rigid “disc-like terminal plate” to be different from a foil output conductor. A “plate” would necessarily involve or impart a sense of structural rigidity. The foil output conductors in the ‘581 and ‘913 patents, by contrast, are flexible in order to (a) provide resilience in the button cell to accommodate mechanical forces generated during charge and discharge cycles and withstand external mechanical influences, and (b) facilitate assembly of the button cell in which the foils are folded and rest flat between the end faces of the spiral winding and the flat top and bottom areas of the housing.

## 2. A POSA Would Not Be Motivated to Make the Terminal Plates of Kobayashi to Be Foils

319. I disagree with Mr. Gardner that it would have been obvious to modify Kobayashi to use foils in place of the metal plates, as he states at Ex. 1003 ¶¶ 249-250 for example.

320. Mr. Gardner does not cite any evidence supporting his conclusion, and the references he cites throughout his report do not teach foil output conductors to connect electrodes to respective terminals in button cells. Those references also do not teach foil output conductors folded flat between the end faces of a spiral winding and flat areas of a button cell housing cup and top.

321. Mr. Gardner states “[a] POSA would further recognize that the output conductor can be comprised of various different materials” and a “POSA would recognize a number of shapes which would fit between the electrode assembly and the housing.” *Id.* ¶¶ 255, 322. He does not explain why a POSA would be led, from among the numerous shapes and materials, to select a metal foil for Kobayashi’s output conductor.

322. Mr. Gardner relies on a very general proposition that a POSA would have been motivated to reduce the size of the inactive components so that “the active materials have as much space in the cell as they can.” *Id.* ¶ 256. This is one general factor of numerous factors that would have been considered, many of which are unique to button cell design.

323. Mr. Gardner’s citations to the Linden Handbook concern conventional cylindrical or prismatic batteries with NiMH and sodium-beta chemistries and are not button cells. Ex. 1009 pp.1285, 1294. The teachings regarding conventional batteries were not readily applicable to miniature rechargeable button cells. His

citations also concern the effect of electrode thickness on battery performance, which does not apply to output conductors (See *id.* at 1294: “The structure and thickness of the positive electrode can have a substantial effect . . . . The thickness of the negative electrode is not an electrical factor . . . .”).

324. The factors a POSA would have considered in designing or modifying the internal components of a button cell would have included an evaluation of the purpose and function of the components already present in the button cell. A POSA would have needed to balance the quantity of active electrode material that could be placed in the cell with safety requirements with requirements stemming from the application for which the end battery product is to be employed. The structural integrity of the battery and whether any changes would compromise that integrity would also need to be considered. All of these design factors would dictate whether a POSA would have modified Kobayashi as proposed by Mr. Gardner. I have not seen where Mr. Gardner has considered any of them.

325. The size and manufacturability of the button cell would also have been a critical factor. A POSA would have considered Kobayashi’s teachings “that size reduction is extremely difficult . . . and the limit has currently substantially been reached.” Ex. 1006 ¶ [0007].

326. Kobayashi addresses the difficulties in manufacturing a miniature button cell having a “flat electrode group in which . . . a positive electrode and a

negative electrode is spirally wound,” the type of cell that was previously thought impossible to make. *Id.* ¶¶ [0009], [0014]. Kobayashi attempts to “simplify the structure by installing a terminal on the winding axis core to be incorporated into the electrode group to connect the electrode and the metal case doubling as an external terminal.” *Id.* ¶ [0018]. By integrating the electrode terminals 4, 5 including the disc-like terminal plates 4a, 5a, with the winding core, Kobayashi provides enhanced manufacturability of the button cell.

327. Kaun also discourages the use of current collectors that “add significant weight, and thus reduce specific cell energy and power outputs.” Ex. 1005 ¶ [0018]. Kaun teaches eliminating current collectors and other connective elements between the electrodes and terminals in favor of direct and continuous edge contact. *Id.* ¶¶ [0018], [0128] (“the short electron current flow paths along the lengths of the electrodes . . . do not require a highly conductive electrode current collector.”)

328. A POSA would not have modified Kobayashi’s metal plates to be foils without assessing these concerns and considerations.

**3. A POSA Would Not Have Been Motivated to Modify Kobayashi's with General Knowledge**

**a. The Proposed Modification Would Eliminate Kobayashi's Winding Axis Core**

329. Kobayashi's teachings would have discouraged a POSA from replacing Kobayashi's metal plates with foils. Kobayashi's metal plates are critical elements in his winding axis core. Replacing Kobayashi's metal plates with foils would render the Kobayashi cell non-functional.

330. The winding axis core and its interaction with the electrode assembly are critical aspects of Kobayashi. According to Kobayashi, "by incorporating at least a winding axis core into the electrode group structure, and as needed, an insulation plate and contacting terminals between electrodes and external terminals" the Kobayashi structure overcame an alleged "impossibility." Ex. 1006 ¶ [0015]. His structure "enabled efficient storage of the electrode group in which a positive electrode, a negative electrode, and a separator are wound in a few layers to a few dozen layers within a case of a small battery."

331. The metal conductor plates 4a, 5a on the top and bottom of the winding axis core function to route current to the casings 11, 13. They also maintain the structural integrity of the electrode assembly. The core teaching of Kobayashi, i.e. integration of the winding core with the electrodes, is achieved by integrating conductor terminals 4, 5 into the winding core by seating the metal

conductor plates 4a, 5a into the grooves formed in the insulation plates 8, 9. The metal plates are also connected to terminal posts (elements 4b, 5b) in the notches in the winding axis core 7, the components register in alignment and are rigidly interlocked with respect to each other.

332. The integration and interaction of the components enables the winding of the electrode assembly, and it maintains the resulting electrode assembly and additional structure in place inside the housing. The electrode assembly is wound by placing the terminal connection rods into notches (7a, 7b) so the electrodes can be crimped around slits (4c, 5c) formed in the terminal posts, registering metal conductor plates (5a, 4a) into recesses (8a, 9a) formed in winding core insulating members (8, 9), and then coiling the electrodes around the winding axis core 7. *See id.* ¶¶ [0030]-[0031]. Once the conductive terminals 4, 5 and the winding member 6 are integrated, “the positive electrode 1 and the negative electrode 2 are spirally wound with the separator 3, thereby preparing a flat electrode group.” *Id.* ¶ [0032].

333. A POSA would have understood that the electrodes 1, 2, are placed in tension as they are wound around the winding axis core. A POSA would also have understood that the integrated assembly of the disc-like terminal plates 4a, 5a within the insulation plates 8, 9, which register and secure the terminal posts 4b, 5b in the winding axis core, stabilizes the assembly when winding the electrode and



separator. A POSA would additionally have understood that the insulation plates 8, 9 and terminal plates 4a, 5a would serve to provide a guide during the winding of the electrodes 1, 2 about the winding core, and that such guide would prevent the electrodes from telescoping during the winding process. Therefore, a POSA would understand that the combination of the insulation plates 8, 9 and the terminal plates 4a, 5a would function to improve the quality of the electrode winding realized by winding the electrodes 1, 2 about the winding core.

334. A POSA would also have understood that winding the electrodes 1, 2, and separator 3 about the winding axis core 7 would be difficult and perhaps impossible without the integrated assembly of the terminals 4, 5 and terminal plates 4a, 5a registered with respect to the winding member 6. Mr. Gardner did not consider this benefit of the disc-like terminal connection plates 4a, 5a. Their removal would eliminate a prominent feature of Kobayashi.

335. The metal conducting plates 4a, 5a also present a sufficient surface in order to make reliable contact with the housing. They extend axially beyond the planar insulating plates 8 and 9 of the winding member 6 to expose the plates. A POSA would understand that if the metal plates did not so extend, the cell would be inoperative because there would be an open circuit between electrode and housing.

336. The thickness of the terminal plates 4a, 5a and depth of the grooves in the insulation plates 8, 9 ensures the plates are exposed to contact the casings 11, 13, thereby improving service life and ensuring reliable manufacturability of the Kobayashi button cell due to the reliable contact between the metal conducting plates and the housing.

**b. A POSA Would Not Be Motivate to Use Foils**

337. I also disagree with Mr. Gardner that a POSA would be motivated to use foils in the Kobayashi design rather than the disc-like terminal plates “in order to increase overall volume in the cell that is available for active components.” Ex. 1003, ¶¶ 250, 323. As can be seen in the annotated FIG. 1 of Kobayashi below, the available volume overall would only be very slightly improved by replacing the metal plates with foils. The terminal plates 4a, 5a (red) are already recessed in the insulation plates 8, 9; there is minimum clearance between the insulator plates and the inner surfaces of the casings 11, 13. Some portion of the metal plates must be exposed, as is already shown by Kobayashi, to complete the electrical connection from the terminal connecting rods 4b, 5b (which secure the electrodes) in the winding axis core to casings 11, 13. A POSA would not eliminate the metal conducting plates 4a, 5a and the associated advantages in the Kobayashi design.

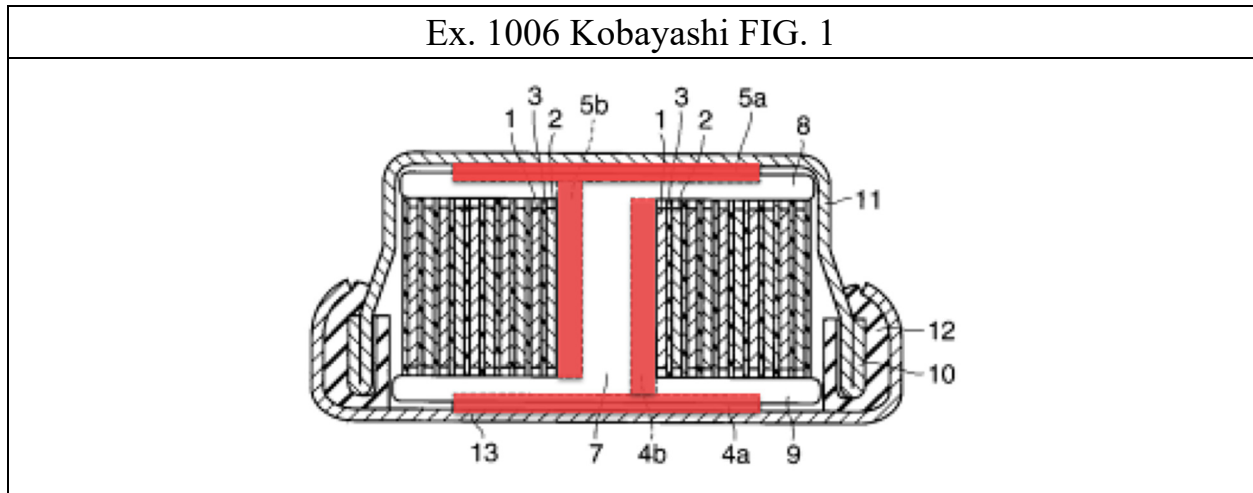

338. A POSA would have been discouraged from modifying the metal plates to be foils because it would result in an unsatisfactory electrical connection. Mr. Gardner does not explain what, if any, further modifications he would have made to maintain the structural stability of Kobayashi's winding axis core, while deploying metal foils.

339. A POSA would have also understood that metal foils would have been difficult to attach to other components of Kobayashi's cell. For example, it would have been difficult, if not impossible, to reliably attach a flexible metal foil to the terminal connecting rods 4b, 5b due to the relative thickness of these different components. By contrast, a POSA would have understood that a rigid metal plate would be much easier to attach reliably to the connecting rods. Such knowledge would also have discouraged a POSA from modifying Kobayashi's metal plates to be foils.

340. At the heart of Kobayashi's invention is a unitary winding axis core made as a rigid connection system, including metal terminal plates rigidly connected to terminal rods holding the electrode ends, which are integrated into a unitary winding core. A POSA would not have modified Kobayashi in the manner proposed by Mr. Gardner, as doing so would be contrary to Kobayashi's teachings.

#### **4. Kobayashi Will Not Operate With a Foil Conductor**

341. Kobayashi teaches that the insulation plates 8, 9 include respective circular grooves to accommodate "the positive electrode terminal plate 4a" and a "the negative electrode terminal plate 5a." Ex. 1006 ¶ [0030]. The winding axis core is integrated when the metal conducting plates are registered in the grooves formed in the insulation plates. Id. ¶ [0031].

342. The metal conductor plates 4a, 5a are thus partially recessed in the notches 8a, 9a formed in the insulation plates 8, 9. This serves to register the rod-like terminal connector posts 4b, 5b to which the metal conductor plates 4a, 5a are integrated within the winding axis core 7 so that the electrodes 1, 2, and separator 3 can be wound about the winding assembly 6. Petitioners and Mr. Gardner do not address how a POSA would modify Kobayashi to incorporate foils in the same manner that could be integrated with and registered within the notches 8a, 9a in the insulation plates 8, 9.

343. A metal foil would lack the necessary surrounding structure to hold the terminal connector posts firmly in place. It would be unable to register, i.e. interlock with, the terminal connector posts and the winding axis core such that there would no longer be an electrode group integrated with a unitary winding core, which a POSA would understand to be the essence of Kobayashi. A metal foil would also be unable to provide the rigidity required to enable winding of the electrodes.

344. It is unclear to me how a POSA would have understood the foils to be “integrated” with the terminal connector posts 4b, 5b in the same manner that the metal conductor plates 4a, 5a can be integrated with the connector posts. The metal conductor plates 4a, 5a and terminal connector rods 4b, 5b can be fairly easily joined prior to integration with the winding axis core. Electrically connecting the terminal connector posts 4b, 5b to a thin foil cannot be easily or reliably done, either by a rigid attachment or by simple abutting contact.

345. Further, the foil would presumably be recessed in the notches 8a, 9a formed in the insulation plates. It would not electrically contact the surfaces of the positive and negative electrode casings 11, 13. This would likely result in an open circuit condition and an inoperable cell. Mr. Gardner did not consider that a thin foil recessed in the notches 8a, 9a of the insulation plates 8a, 9a would not provide a reliable connection between the terminal connector rods 4b, 5b in the winding

axis core and the inner surfaces of the casing 11, 13. The proposed combination would result in an inoperable button cell.

346. In this arrangement, the thickness of the terminal plates 4a, 5a and depth of the grooves in the insulation plates 8, 9 ensures contact with the casings 11, 13 thereby prolonging service life and ensuring reliable manufacturability of the Kobayashi button cell. A POSA would be not be motivated to eliminate the terminal plates and lose this manufacturing advantage.

347. Kobayashi describes the method for “electronically connecting the terminal to the metal case doubling as an external terminal includes welding such as resistance welding and ultrasonic welding.” *Id.* ¶ [0018]. A POSA would recognize the benefit of welding the disc-like terminal plate, with a large surface area and substantial thickness, to the inner surface of the electrode casings over the comparative difficulty in welding a thin metal film, which could experience alignment problems or burn through. This is an additional reason a POSA would be discouraged from using a foil in Kobayashi.

## **5. The Proposed Modification Would Render Kobayashi Inoperable for its Intended Purpose**

348. The metal conducting plates 4a, 5a are partially recessed in the notches 8a, 9a formed in the insulation plates 8, 9. *Id.* ¶¶ [0031]-[0032]. This serves to register the terminal connection rods 4b, 5b within the winding axis core 7 to allow the electrodes and separator to be wound. A POSA would understand

the integration of these components to stabilize the assembly, which would be impossible using metal foils.

349. A POSA would have understood that a metal foil would lack the necessary rigidity to support the components of the winding axis core. This would be the case for both winding the electrodes and stabilizing the structure within the housing.

**6. A POSA Would Not Have Reasonably Expected to Successfully Achieve the Claimed Invention**

350. The use of foils for the terminal plates 4a, 5a of the electrode terminals in Kobayashi is such a significant change that a POSA would not have reasonably expected to successfully arrive at what is claimed in the VARTA patents. Kobayashi's metal conducting plates are critical elements that perform an important function regarding the assembly and structural stability of the electrode group. In their absence, a POSA would need to completely redesign the Kobayashi cell.

351. A POSA would have understood that the design of Kobayashi's winding axis core would need to be completely changed. The winding axis core relies on the interlocked structure of the metal conducting plates 4, 5 to wind the electrodes 1, 2 and separator 3.

352. If the metal conducting plates 4a, 5a were made to be foils, a POSA would be required to rearrange all remaining components that securely anchor the

spiral wound electrodes and separator, including the winding axis core itself. A POSA would have had to redesign the terminal connection posts 4b, 5b received in the winding axis core 7 because they would no longer be securely held in place. A POSA would also have had to redesign the insulating plates 8, 9 because they would not allow metal foils to easily or reliably contact the housing. A POSA would likely have to abandon the concept of integrating the electrodes and separator with the winding axis core—i.e. abandon the core teaching of Kobayashi.

**B. The Combination of Kaun in View of the Knowledge of a POSA Fails to Render Obvious the Challenged Claims of the '581 Patent<sup>1</sup>**

353. It would not have been obvious for a POSA to combine Kaun and the knowledge of a POSA to arrive at the inventions of the Challenged Claims of the '581 patent. The use of a foil output conductor with Kaun is contrary to Kaun's teaching.

**1. Kaun Does Not Disclose or Suggest “a Button Cell” or “an Output Conductor Comprising a Foil Resting Flat Between an End Face of the Spiral Winding”**

**a. “Button Cell”**

354. In my opinion, a combination of Kaun with Knowledge of a POSA would not result in a button cell. As stated earlier in my report, a POSA would

---

<sup>1</sup> Petitioners did not assert that any of the claims of the '913 Patent are invalid over Kaun in view of the Knowledge of a POSA.



understand a button cell to be “a small, generally round and flat battery typically used in electronic devices.”

355. Kaun relates to a battery for “high-pulse power requirements, such as for hybrid electric vehicles and for power tools.” Ex. 1005 ¶ [0021]. Kaun notes that “[f]or hybrid electric vehicles, the current [required] is on the order of 100 A at 200-400 volts (equivalent to 20-40 kW).” *Id.* Kaun claims its “technology provides high pulse power devices . . . producing kW levels of power.” *Id.* ¶ [0079]. The Kaun cell achieves these power requirements with a “rolled-ribbon cell configuration . . . [that] can release close to 100% of theoretical power of the Li/organic electrolyte cell chemistry in substantially larger cells of 5-10 Ah capacity with pulse currents of 100-200 A from a single cell.” *Id.* ¶ [0094]. The same passage notes that cells of this type preferably have a contact area of 125 cm<sup>2</sup>. *Id.*

356. A POSA would not consider a battery providing these levels of power and current to be a “button cell.” Rather, a POSA would understand Kaun relates to a significantly larger cell.

357. Kaun does state that “[t]he invention also provides a button-type cell housing.” *Id.* ¶ [0084]. A POSA would understand this passage refers to the style of the housing disclosed in Kaun, which is circular and wider than it is tall, and

does not convey any teaching or suggestion regarding the cell size, power output, or technical classification.

358. The Petitioners' and Mr. Gardner do not contend the cell disclosed in Kaun could be miniaturized to a "button cell," nor does it appear that it could. If the wattage and amperage stated in Kaun were drawn from a button cell, i.e. a cell less than 25 mm in diameter and 6 mm in height, the internal components would quickly burn out. Kaun includes a central fastener to hold the housing cups 28p, 28n together, a component fundamentally incompatible with a miniature button cell. As the radius of a fastener becomes smaller, the force it could exert to hold two components together would be reduced. In the volume allotted by a button cell, a center fastener such as described by Kaun would only be able to exert a minimal holding force on the housing components.

359. Kobayashi (relied on by Mr. Gardner in other Grounds) itself is evidence that miniaturization of Kaun is not possible. Kobayashi states that, with respect to rechargeable batteries providing power and current on levels required by small mobile devices (i.e. devices with significantly lower power requirements than the electric vehicles contemplated by Kaun), "size reduction is extremely difficult for these rechargeable batteries, and the limit has currently substantially been reached." Ex. 1006 ¶ [0007]. Kobayashi further states that, with respect to the jelly rolls used in larger cylindrical batteries, "it was thought that it was

impossible to store the electrode group structure within a small battery such as a button cell or a coin cell.” *Id.* ¶ [0014]. These statements would discourage a POSA from trying to modify rechargeable batteries for small mobile devices—much less the high power cells of Kaun—into a button cell.

360. Kaun teaches that for a lithium based battery for “high power applications, such as for hybrid electric vehicles,” “internal gas pressure may be generated during operation.” Ex. 1005 ¶ [0023]. Kaun discloses that it would be desirable to incorporate “non-catastrophic, cost effective means to relieve the gas pressure.” *Id.* Accordingly, Kaun describes in an embodiment that the peripheral gasket that is disposed between the peripheral edges of the positive and negative cups 28p, 28n that form the housing can relax in the event of over pressurization inside a cell to act as a vent to release the internal pressure. *Id.* ¶¶ [0091], [0130]. Mr. Gardner provides no details on how this feature would be modified in a button cell arrangement.

361. Kaun does not disclose a button cell even in view of the Knowledge of POSA.

**b. “An Output Conductor Comprising a Foil Resting Flat Between an End Face of the Spiral Winding”**

362. Independent claim 1 of the ’581 Patent requires “one of the electrodes connects to the flat bottom area or flat top area [of the housing] via an output

conductor comprising a foil resting flat between the end face of the spiral winding and the flat top or the flat bottom area.”

363. Mr. Gardner identifies “two possible output conductors which connect the electrode layers to the flat bottom or flat top area of the cell housing.” Ex. 1003 at ¶ 286. First, he refers to “electrode layers which extend beyond the end faces of the electrode assembly.” Id. citing Ex. 1005 at [0095]. Second, he refers to “a piece of conductive material can be interposed between the electrodes 12p and 12n and cups 28p and 28n.” Id. citing Ex. 1005 at [0122]. In my opinion, neither of those structures is a foil resting flat between an end face of the spiral winding and flat top or bottom as stated in the claims.

364. Kaun does indicate that the electrodes 12p and 12n can be metal foils. However, Kaun does not indicate that the electrodes are connected to the housing by a foil conductor resting flat between the spiral winding and the housing top and bottom.

365. Kaun also references an “additional piece of conductive material.” This reference, however, cannot reasonably be considered to a reference to a foil conductor or even suggesting that a foil conductor could be used. The only “conductive material” disclosed by Kaun is conductive paste: “Facial conductivity can be preserved or enhanced with a non-oxidizing conductive paste”. Ex. 1005 at [0125]. A conductive paste is plainly not a foil resting flat.

366. Kaun teaches that separate conductors “used in these [prior art] cell arrangements add significant weight, and thus reduced specific cell energy and power outputs.” *Id.* ¶ [0018]. He states that “isolated conductors are generally connected to the electrodes and routed along extended paths independently of the electrodes to the external terminals” and these conductors can account for substantial resistance, heat, and reduction in power output. *Id.* To solve this problem, Kaun proposes a design where additional conductors are not used. *Id.* ¶ [0122] (“the open end of each respective electrode 12p and 12n is electrically common with cups 28p and 28n, respectively.”), [0128] (“The short electronic current flow paths along the lengths of the electrodes . . . do not require a highly conductive electrode current collector supplementing or paralleling the electrodes.”). Current is distributed to each electrode winding and travels vertically and directly from each electrode winding to the housing top and bottom (terminals). *Id.* at [0125]-[0128]. The direction of current flow in Kaun’s electrodes (red arrows) is shown below.

Ex. 1005 FIG. 11
------------------

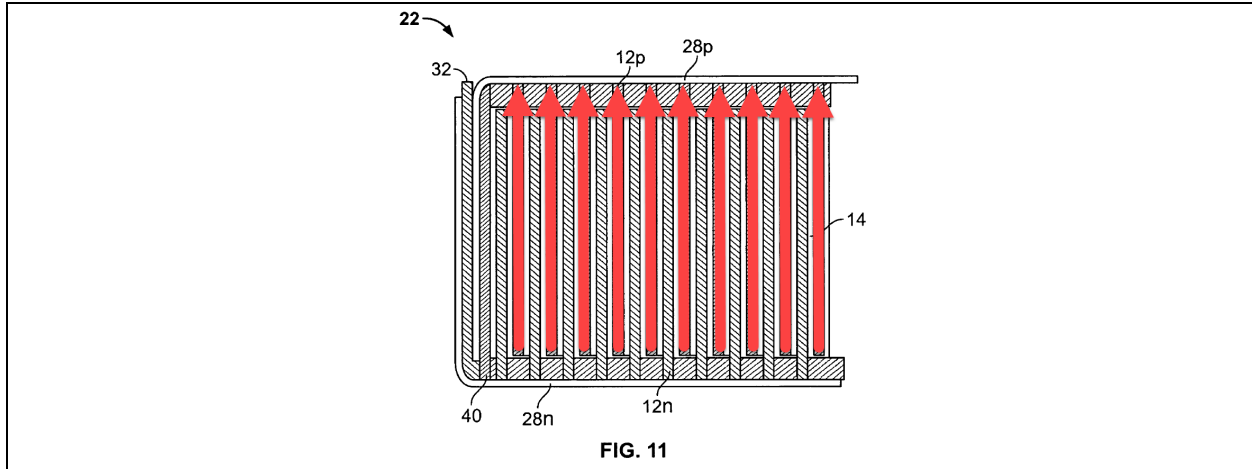

367. In my opinion, nothing in Kaun suggests that a foil output conductor resting flat should be used. Nor would a POSA have considered using a foil conductor with Kaun given Kaun's teaching to avoid separate conductors.

368. Mr. Gardner states that a POSA would be motivated to include foil conductors to increase the overall volume available for active components and to reduce size and weight of output conductors. Ex. 1003 at ¶¶ 281, 283, 288. Mr. Gardner, however, fails to reconcile his statement with the fact that one of the principal teachings of Kaun is to eliminate the output conductor entirely. Ex. 1005 at [0128]. Mr. Gardner also does not explain how adding an unnecessary output conductor to Kaun's design would somehow decrease size or weight or increase the overall volume of output conductors. His position does not make sense.

369. In my opinion, a POSA would not have considered placing a foil between the electrodes and Kaun's housing as Mr. Gardner appears to suggest. Kaun depends on good contact between the electrodes and housing to provide for

consistent vertical current flow, i.e., the shortest current path possible. Foil is thin flexible metal inherently susceptible to bending, thereby creating an uneven surface area. A foil interposed between the electrode winding and housing would likely result in inconsistent contact between the electrode windings and housing. This would, in addition to being contrary to Kaun's design goal of making current flow paths as short as possible, inhibit rather than facilitate contact between the electrodes and the housing.

**2. A POSA Would Not Have Reasonably Expected a Foil Conductor to Work with Kaun**

370. Kaun teaches that separate output conductors add weight and reduce the specific energy of the cell. *Id.* ¶ [0018]. He describes that output conductors add significant resistance and can greatly reduce battery power. *Id.* To solve these problems, Kaun's avoids using an output conductor by directly contacting the electrodes to the housing top and bottom. *Id.* ¶¶ [0125], [0128]. This arrangement allows for relatively thin and lightweight housing and electrode materials to be used as well as for very thin separator material to be employed. *Id.* Resistance is minimized contributing the cell's ability to release close to 100% of its theoretical power. *Id.* ¶¶ [0094], [0126].

371. A POSA would not consider adding an output conductor to Kaun given Kaun's teachings. But even if I were to assume that POSA would have added an output conductor, a POSA would not have considered using a foil for that

conductor. In his discussion of the prior art, Kaun indicates that when output conductors are used they must be “massive conductors to avoid power loss for high powered batteries.” *Id.* ¶ [0018]. This is because the output conductor must typically carry current for the entire winding. Foils are thin metals with much higher resistance than the massive conductors referenced in Kaun. Given the high-power applications discussed in Kaun, a POSA would have understood that a foil output conductor would be unable to handle the currents contemplated by Kaun’s cell. Moreover, even if a foil conductor could handle the currents in Kaun’s cell, it would be at the expense of high resistance, heat generation and significant power loss, which Kaun teaches are to be avoided. A POSA, therefore, would have concluded that a foil output conductor was incompatible with Kaun’s cell.

### **3. Kaun Could Not Be Modified With a Foil**

372. Kaun teaches that it is desirable to eliminate the “current collector supplementing and paralleling the electrodes” in favor of direct and continuous edge contact between the positive and negative electrodes 12p, 12n and the terminal cups 28p, 28n that results in “short electronic current flow paths.” *Id.* ¶ [0128]. Kaun avoided the use of current collectors that “add significant weight, and thus reduce specific cell energy and power outputs.” *Id.* ¶¶ [0018], [0128]. The direct and continuous edge contact results in “short electronic current flow paths along the lengths of the electrodes . . . [that] do not require a highly



conductive electrode current collector supplementing or paralleling the electrodes.” *Id.* ¶ [0128]. A POSA would therefore be discouraged by Kaun from attempting to add additional conductors to a cell.

373. Assuming a POSA were to add conductors based on the teachings of Kaun, they would not be thin, flexible foils per the '581 Patent. The Kaun battery delivers power on the order of hundreds of amps for high powered applications like hybrid vehicles and power tools. *Id.* ¶¶ [0004], [0021], [0007]. The thin film conductors configured to rest flat between the end faces of the spiral winding and the flat top and bottom areas of the housing are not suitable for such large current.

374. In the types of batteries Kaun is directed to, “massive connectors are used to avoid power loss for high powered batteries.” *Id.* ¶ [0018]. Kaun notes “[t]hese conductors should carry the full cell current, and thus should be of sufficient mass and cross-section to keep internal resistance manageably low.” *Id.* A thin metal foil would have much higher resistance than the types of conductors referenced in Kaun.

375. A POSA would not have a reasonable likelihood of success in trying to incorporate a thin foil output conductor in the high amperage cell for high pulse power applications described in Kaun.

**C. The Combination of Kaun in View of Kobayashi and the Knowledge of a POSA Fails to Render Obvious the Challenged Claims of the '581 and '913 Patents**

376. It would not have been obvious for a POSA to combine Kaun and Kobayashi in view of the knowledge of a POSA to arrive at the inventions of the Challenged Claims of the '581 and '913 patents.

377. Mr. Gardner proposes that the electrode assembly of Kobayashi be placed in Kaun's cell and further that Kobayashi's conductive plates be replaced with metal foils. I disagree with Mr. Gardner's position that such combination could be made to make the claims obvious. Kaun and Kobayashi cannot be combined because of the stark differences in those cells. Nor does the combination properly teach an output conductor comprising a foil resting flat. Further, even if the combination were made, the conductive plates in Kobayashi could not be made into foils without entirely eviscerating the structure of Kobayashi's cell.

- 1. Kaun in View of Kobayashi and the Knowledge of a POSA Does Not Disclose or Suggest "Button Cell," "an Output Conductor Comprising a Foil Resting Flat"**

**Between and End Face of the Spiral Winding,” or  
“at Least One Insulator”**

**a. “Button Cell”**

378. In my opinion, any combination of Kaun with Kobayashi and Knowledge of POSA would not result in a button cell. As stated earlier in my report, a POSA would understand a button cell to be “a small, generally round and flat battery typically used in electronic devices.”

379. Kaun relates to a battery for “high-pulse power requirements, such as for hybrid electric vehicles and for power tools.” Ex. 1005 ¶ [0021]. Kaun notes that battery of the type “[f]or hybrid electric vehicles, the current is on the order of 100 A at 200-400 volts (equivalent to 20-40 kW).” *Id.* Kaun claims its “technology provides high pulse power devices . . . producing kW levels of power.” *Id.* ¶ [0079]. The Kaun cell achieves such performance with a “rolled-ribbon cell configuration . . . [that] can release close to 100% of theoretical power of the Li/organic electrolyte cell chemistry in substantially larger cells of 5-10 Ah capacity with pulse currents of 100-200 A from a single cell.” *Id.* ¶ [0094]. The same passage notes that cells of this type preferably have a contact area of 125 cm<sup>2</sup>. *Id.*

380. A POSA would not consider a battery providing these levels of wattage and amperage to be a “button cell.” Rather, a POSA would understand Kaun relates to a significantly larger cell.

381. Kaun does state that “[t]he invention also provides a button-type cell housing.” *Id.* ¶ [0084]. A POSA would understand this passage refers to the style of the housing disclosed in Kaun, which is circular and wider than it is tall, and does not convey any teaching or suggestion regarding the cell size, power output, or technical classification.

382. The Petitioners’ and Mr. Gardner do not contend the cell disclosed in Kaun could be miniaturized to a “button cell,” nor does it appear that it could. If the wattage and amperage stated in Kaun were drawn from a button cell, i.e. a cell less than 25 mm in diameter and 6 mm in height, the internal components would quickly burn out. Kaun includes a central fastener to hold the housing cups 28p, 28n together, a component fundamentally incompatible with a miniature button cell and which is incompatible with Kobayashi’s winding axis core—particularly on the scale of Kobayashi’s microcell.

383. Kobayashi itself is evidence that miniaturization of Kaun is not possible. Kobayashi states that, with respect to rechargeable batteries providing power and current on the levels of Kaun, “size reduction is extremely difficult for these rechargeable batteries, and the limit has currently substantially been reached.” Ex. 1006 ¶ [0007]. Kobayashi further states that, with respect to the jelly rolls used in larger cylindrical batteries, “it was thought that it was impossible to store the electrode group structure within a small battery such as a button cell or

a coin cell.” *Id.* ¶ [0014]. These statements would discourage a POSA from trying to modify Kaun into a button cell.

384. Kaun discloses that a lithium based battery for ‘high power applications, such as for hybrid electric vehicles,’ “internal gas pressure may be generated during operation.” Ex. 1005 ¶ [0023]. Kaun discloses that it would be desirable to incorporate “non-catastrophic, cost effective means to relieve the gas pressure.” *Id.* Accordingly, Kaun describes in an embodiment that the peripheral gasket disposed between the peripheral edges of the positive and negative cups 28p, 28n that form the housing can relax in the event of over pressurization inside a cell to act as a vent to release the internal pressure. Ex. 1005 ¶¶ [0091], [0130]. Kobayashi’s cell is completely closed. To combine Kaun with Kobayashi, Kaun’s venting system would need to be disabled. Mr. Gardner provides no details on how this would be done, nor are such instructions provided in Kaun.

385. For the above reasons, Kaun, even as modified by Kobayashi, would not be a button cell.

**b. “An Output Conductor Comprising a Foil Resting Flat Between an End Face of the Spiral Winding”**

386. The independent claims of the ’581 and ’913 patents recite that “one of the electrodes connects to the flat bottom area or flat top area [of the housing] via an output conductor comprising a foil resting flat between the end face of the spiral winding and the flat top or the flat bottom area.” The specifications state

that the “output conductors are thin films, which rest between the end faces of the winding and the flat top and bottom areas 503 and 504.” Ex. 1001 ’581 Patent 12:6-8; Ex. 1001 ’913 Patent 12:65-67. FIG. 4 shown below illustrates the output conductors 409, 410 (red) that extend from the spiral wound electrode-separator assembly 404 (yellow). They rest flat between the end faces of the electrode-separator assembly and the flat top and bottom areas of the housing cup 403 and housing top 404.

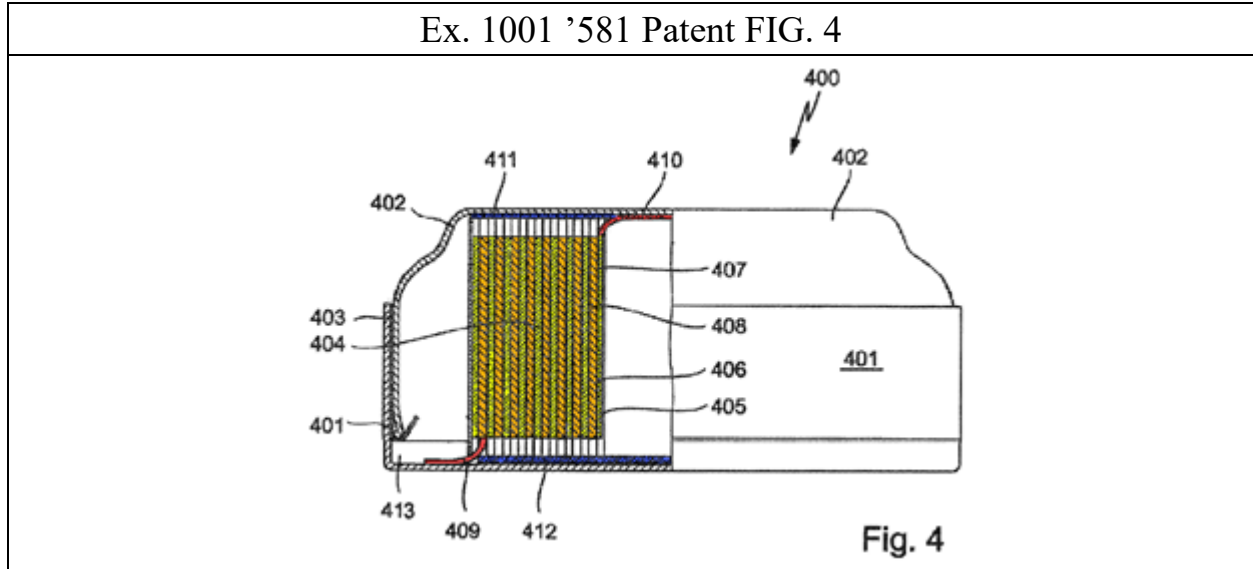

387. Kobayashi does not teach “an output conductor comprising a foil.” To connect the positive electrode 1 to the respective positive casing 13, Kobayashi teaches “a disc-shaped positive electrode terminal plate 4a” and “bar-shaped terminal connection part 4b . . . electrically connected to the positive electrode terminal plate 4a.” Ex. 1006 ¶ [0028]. Likewise, Kobayashi discloses a negative “disc-shaped negative electrode plate 5a” and a “bar-shaped terminal connection

part 5b” to connect the negative electrode 2 to the negative housing casing 11.

These are shown in FIG. 1 of Kobayashi below in which the positive and negative terminals 4, 5 are red.

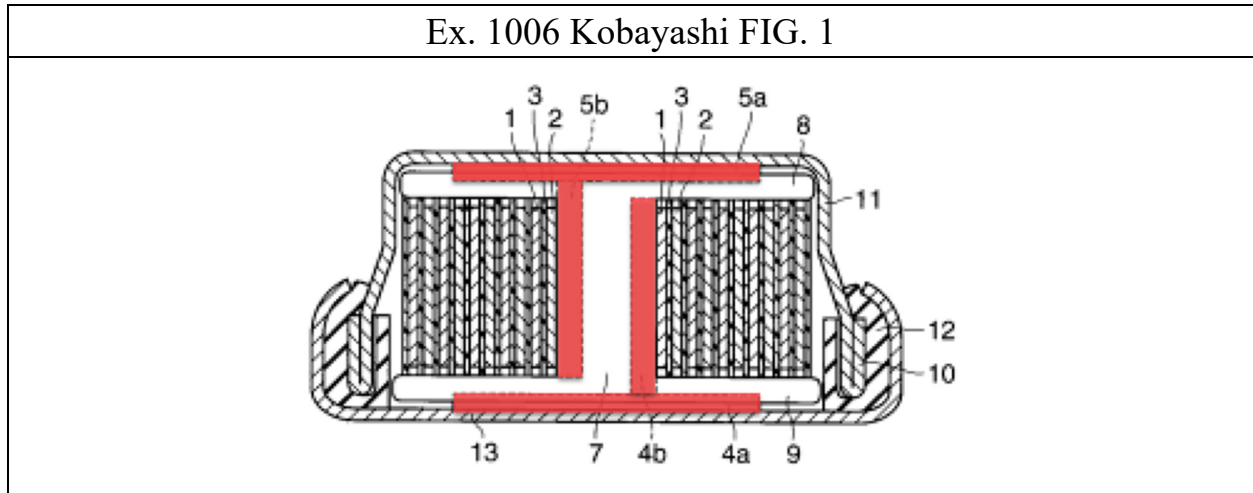

388. A POSA would have understood a rigid “disc-like terminal plate” to be different from a foil output conductor. A “plate” would necessarily involve or impart a sense of structural rigidity. The foil output conductors in the ‘581 and ‘913 patents, by contrast, are flexible in order to (a) provide resilience in the button cell to accommodate mechanical forces generated during charge and discharge cycles and withstand external mechanical influences, and (b) facilitate assembly of the button cell in which the foils are folded and rest flat between the end faces of the spiral winding and the flat top and bottom areas of the housing.

- c. **“At Least One Insulator” (claim 6 ‘581 Patent)**  
**“At Least One Insulating Means” (claims 1 and 6 ‘913 Patent)**

**“At Least One Flat Layer Composed of Plastic”  
(claim 4 '913 Patent)**

389. The independent claims of the '913 Patent claim “at least one insulating means” or “at least one flat layer composed of plastic.” Dependent claim 6 of the '581 Patent claims that “further comprising at least one insulator which prevents direct mechanical and electrical contact between the end faces of the winding and the flat bottom and top areas.” The specification discloses that the insulating means or elements “may, for example, be a film, for example, a plastic adhesive film, by which the side of the conductor or conductors remote from the inner side of the button cell housing is covered.” Ex. 1001 '585 Patent 5:14-17; Ex. 1001 '913 Patent 7:27-30.

390. I disagree that combining Kobayashi with Kaun and knowledge of POSA would result in a button cell with insulating elements.

391. Mr. Gardner suggests that a POSA reviewing Kaun would turn to Kobayashi to solve a problem unrelated to the claimed insulators. Specifically, Mr. Gardner suggests importing the winding structure of Kobayashi into Kaun to address an alleged concern stemming from overlap of the separator in Kaun and/or supposed thickness variances in the edges of Kaun's Z-shaped separator. As I have stated, I disagree with Mr. Gardner's conclusions surrounding separator thickness. Nonetheless, even assuming Mr. Gardner were correct, I note that he has not



provided any reason why a POSA would have turned to Kobayashi for its insulator plates.

392. To the extent Petitioners purport to provide a motivation as to why a POSA would have looked to Kobayashi to resolve issues surrounding separator thickness variances, Petitioners utterly fail to explain any reason why a POSA would have looked to Kobayashi for the purpose of incorporating insulating plates into Kaun's cell.

393. In my opinion, a POSA would not incorporate the insulating plates into the housing of Kaun even if it were combined with Kobayashi. Assuming, Kaun presented the challenges stated by Mr. Gardner, a POSA reading Kaun would also have understood the importance of eliminating additional conductors and for this reason would avoid the terminal connecting rods integrated into the winding axis of Kobayashi. Importantly, a POSA would have recognized the criticality of maintaining the short current paths provided by the direct and continuous edge contact between the electrodes and external terminal in Kaun and, for that reason, would not have incorporated the insulating plates from Kobayashi.

394. Another key consideration of Kaun's design is improved thermal management. Due to the direct and continuous edge contact between the electrodes and external terminal, internally generated heat from the rolled-ribbon cell "can be drawn out from the cell via short conduction paths without crossing

the heat sensitive microporous polyethylene/polypropylene separator.” Ex. 1005 ¶ [0094]. Kaun teaches that “[t]hermal management is important to the long life of Li-ion batteries,” particularly for high power applications, as “[e]xcessive temperatures will destroy (e.g. melt the microporous polymer separator or autoignite the flammable organic electrolyte) or significantly shorten the useful life of the Li-ion cell.” *Id.* ¶ [0005]. Kaun further cautions that poor thermal management can contribute to thermal gradients in the cell, i.e. “[e]xcessive temperature within the cell will locally shutdown the microporous polymer resulting in still higher temperatures.” *Id.*

395. Rather than ignore Kaun’s teachings as Petitioners propose, a POSA seeking to eliminate overlap of separator in Kaun would have simply followed Kaun’s own teaching: “[a]lthough the preferred configuration of the separator 14 is Z-shaped, the separator 14 can encompass other embodiments envisioned by those skilled in the art as long as the separator adequately isolates the successive electrodes from one another in the contemplated device.” Ex. 1005 at [0107].

396. Following Kaun’s teaching, a POSA looking to modify Kaun would, for example, have simply employed a continuous non-overlapping separator between the electrode material (as Petitioners allege is shown in Kobayashi), while maintaining offset electrodes that directly connect the electrodes to the housing top and cup in Kaun. That combination would have eliminated the supposed problems

in Kaun, while remaining true to the teachings of Kaun, e.g., maintaining direct contact between the electrodes and housing to provide the shortest current path possible thereby reducing electrical resistance and adequately managing the heat generated by high power applications. *Id.* ¶¶ [0107], [0125]-[0126].

397. Because any modified version of Kaun based on Kobayashi would not include Kobayashi's winding axis core (including insulating plates), the combination of references would not result in the claimed insulator between the winding and housing.

**2. A POSA Would Not Have a Reason to Combine Kaun with Kobayashi**

398. I disagree with Mr. Gardner that a POSA would have had a motivation to combine Kobayashi and Kaun.

399. Initially, Mr. Gardner contends that Kobayashi and Kaun are directed to "similar" subject matter. I disagree. Kobayashi is directed to a small button cell battery, e.g., on the order of  $\mu\text{A}$  and mA. Ex. 1006. Kobayashi is further directed to a solution of using a wound electrode assembly in a small cell with a diameter of about 12 mm. Kaun, on the other hand is directed to high power, multi-cell battery that delivers kW levels of power with tens or even hundreds of amps of current. Kaun's solution offers a way to manage resistance and heat in a cell that can deliver close to 100% theoretical power. Ex. 1005. Neither the problems nor

solutions described in Kaun and Kobayashi are similar. To the contrary, they are quite different.

400. I also disagree with Mr. Gardner's opinion that the thickness of Kaun's separator material or its Z-shaped separator provides any motivation to modify the structure described therein.

401. Kaun mentions that high interfacial area "A" of a "jelly roll" electrode requires a minimum separator thickness for cell durability and cycle life. He explains that in conventional jelly roll arrangements, the increased interfacial contact area "A" is generally offset by the need for increased thickness "T" of the separator. *Id.* ¶ [0017].

402. Kaun describes his solution as providing a "large interfacial electrode area 'A', compared to the cross section of the cell, [which] reduces internal resistance against ion transfer in the electrochemical device." *Id.* at [0127]. Kaun states that his invention solves the problem in a way that "allows the separator/electrolyte 14 to be made with a very small thickness 'T', for further reducing the ion resistance." *See id.* ¶ [0128]. Kaun also states "a separator layer and/or electrolyte formed of a very thin ionic-conductive ribbon-like layer configured in a tight serpentine manner and physically interposed between the electrodes." *Id.* ¶ [0078].

403. Thus, as the disclosure of Kaun confirms, his device uses a “very thin” separator layer. Mr. Gardner appears to rely on the fact that Kaun states separator material can be less than 0.1 mm while Kobayashi refers to a separator having a thickness of 22  $\mu\text{m}$ . This does not provide a basis to conclude that Kobayashi provides a thinner separator. 22  $\mu\text{m}$  is merely an approximate range provided by Kaun. Moreover, Kaun is directed a larger cell with much higher power characteristics than the cell of Kobayashi. The comparison is, therefore, inappropriate.

404. Mr. Gardner also incorrectly asserts that there is “an inherent weakness in the electrode assembly of Kaun” in which the Z-shaped separator results in thickness variances that would reduce the useable volume of the electrode-separator assembly. Ex. 1003 ¶¶ 136-137. In reaching this conclusion, Mr. Gardner appears to take the view that the Z-shaped separator in Kaun would necessarily require overlapping edges. I disagree.

405. The disclosure of Kaun, which explicitly describes non-overlapping butt joints, contradicts Mr. Gardner’s position that overlapping edges are required. Kaun’s non-overlapping butt-joints are described with respect to FIG. 6 of Kaun and are circled in red below:

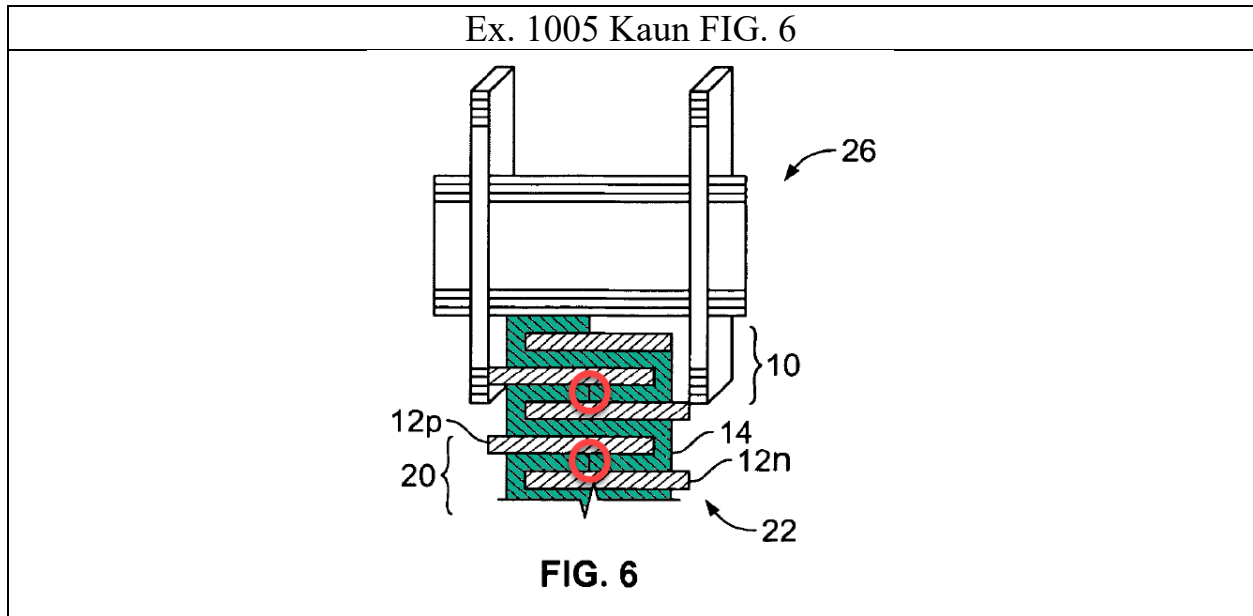

406. The figures of the Kaun application do not show an “overlap” between separator edges or a “thickness variation” at the butt joints. They do show a perfectly formed butt joint. Kaun does not mention or disclose a “thickness variation.” To the contrary, Kaun states “[t]he separator edges can form a butt-joint to separate the successive electrode layers.” Ex. 1005 ¶ [0108]. Thus, while Kaun does describe that separator edges “can overlap,” abutting edges are specifically disclosed as an alternative.

407. Furthermore, interpreting Kaun’s disclosure that separator edges “can overlap” (*Id.*) to require a thickness variation in the separator layer is contrary to the entirety of Kaun’s remaining disclosure. Kaun explicitly recognizes that “[d]esigners of electrochemical devices thus strive to reduce electrolyte thickness ‘I.’” *Id.* ¶ [0015]. Kaun proposes a configuration and orientation for a rolled-

ribbon jelly roll that “allows the separator/electrolyte 14 to be made with a very small thickness ‘I’” and that also allows “the electrode structure and the separator/electrolyte to made of substantially uniform thickness.” *Id.* ¶ [0128].

Kaun discloses a manufacturing and assembly technique that produces butt joints without a thickness variation. *Id.* Figs. 1 and 6, ¶ [0103]. A POSA would not be motivated to look beyond the disclosure of Kaun to solve a problem regarding thickness variations.

408. I also disagree that Mr. Gardner that there can be “no gap between the edges of the separator” in Kaun. A relatively small gap would simply form a void to be filled by electrolyte, adhesive, or by separator material squeezed and compressed into the gap. *See, e.g., id.* ¶ [0103].

### **3. Kobayashi Would Render Kaun Less Efficient**

409. A POSA would also not have looked to the electrode assembly in Kobayashi to increase the amount of usable power as Petitioners argue. *Pet.* at 37. To the contrary, the assembly in Kaun is far more efficient than that of Kobayashi.

410. Kaun repeatedly teaches that “the weight and volume of current collectors reduce specific energy and power outputs.” *Ex.* 1005 ¶ [0020], *see also* ¶ [0018] (“Current collectors used in these cell arrangements add significant weight and thus reduce specific cell energy and power outputs.”). Kaun teaches that it is desirable to eliminate the “current collector supplementing and paralleling

the electrodes” in favor of direct and continuous edge contact between the positive and negative electrodes 12p, 12n and the terminal cups 28p, 28n that results in “short electronic current flow paths.” *Id.* ¶ [0128]. Kaun thus results in the electrode-separator jelly roll can be densely packed by utilizing substantially all the internal volume. As shown below, the electrode assembly of Kaun utilizes almost all of the available space.

411. Kobayashi, on the other hand, teaches the desirability of incorporating a winding member 6 with a winding axis core 7 because it was only “by incorporating the winding axis core into the electrode group while being integrated with the negative electrode and/or the positive electrode, it was possible to manufacture a wound electrode group capable of being housed in a case of a small battery such as a button cell or a coin cell.” Ex. 1006 ¶ [0017]. Kobayashi claims to have “change[d] the approach away from conventional art, and by incorporating at least a winding axis core into the electrode group structure” it succeeded in “storing a wound electrode group within a case of a small battery such as a button cell or a coin cell.” *Id.* ¶¶ [0012], [0015].

412. However, as shown below in contrast with Kaun, the winding axis core 7 and integrated insulating plates 8, 9 around which the positive and negative electrodes 1, 2 and separator 3 are wound, take up considerable internal space. The space occupied by the winding core 7 and insulating plates 8, 9 cannot include



electrochemically active material and cannot contribute to the energy density or power capacity of the cell.

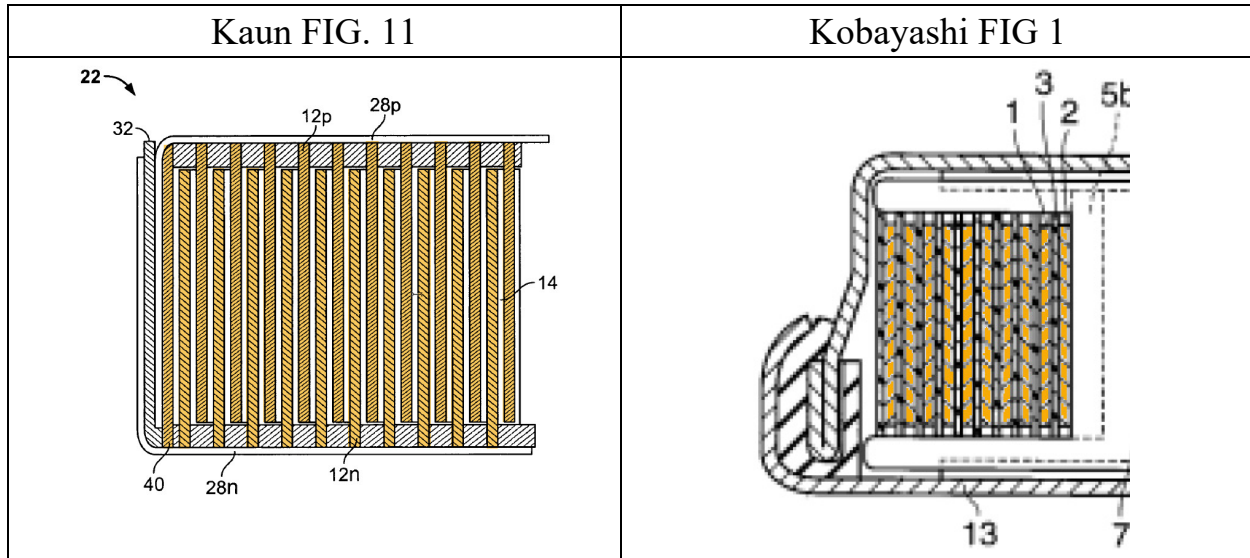

413. The lost volume in Kobayashi due to its winding axis core and insulating plates is about 30% of the total volume of the cell. I understand that patent figures are not necessarily to scale. However, in arriving at this percentage, I assumed the drawing was roughly to scale for a cell having a diameter on the order of 12 mm and a height of 5.3 mm as described in Kobayashi. In my opinion, the size of the Kobayashi's winding axis core and insulating plates under that assumption are reasonable.

#### 4. Kaun Teaches Away from Using Additional Current Collectors that Are Necessary in Kobayashi

414. Kaun's solution eliminates intermediate current collectors in favor of direct and continuous edge contact between the housing and the electrodes in a "rolled-ribbon" assembly. Kaun explains that "the weight and volume of the

current collectors reduce specific energy and power outputs.” Ex. 1005 ¶ [0020].

Kaun notes that for a typical battery design, these additional conductors “can account for a 50% reduction in battery power output from theoretical capability.”

*Id.* ¶ [0018].

415. Kaun states:

Current collectors used in these cell arrangements add significant weight, and thus reduced specific cell energy and power outputs. For example, isolated conductors are generally connected to the electrodes and routed along extended paths independently of the electrodes to the external terminals. Ex. 1005 ¶ [0018].

416. Instead, in Kaun, current flows in the axial direction from the positive and negative electrodes 12p, 12n directly to the positive and negative cups 28p,

28n:

The majority of electron transfer takes place in the axial direction along the flattened electrodes and the adjacent electrode material layers or normal to the current collectors. As noted above, the positive and negative electrodes 12p and 12n are electrically continuous at opposite open ends thereof respectively with the positive and negative material layers 28p and 28n of each cell. Resistance to electron passage via the electrodes will generally be negligible compared to ionic resistance.

*Id.* ¶ [0125].

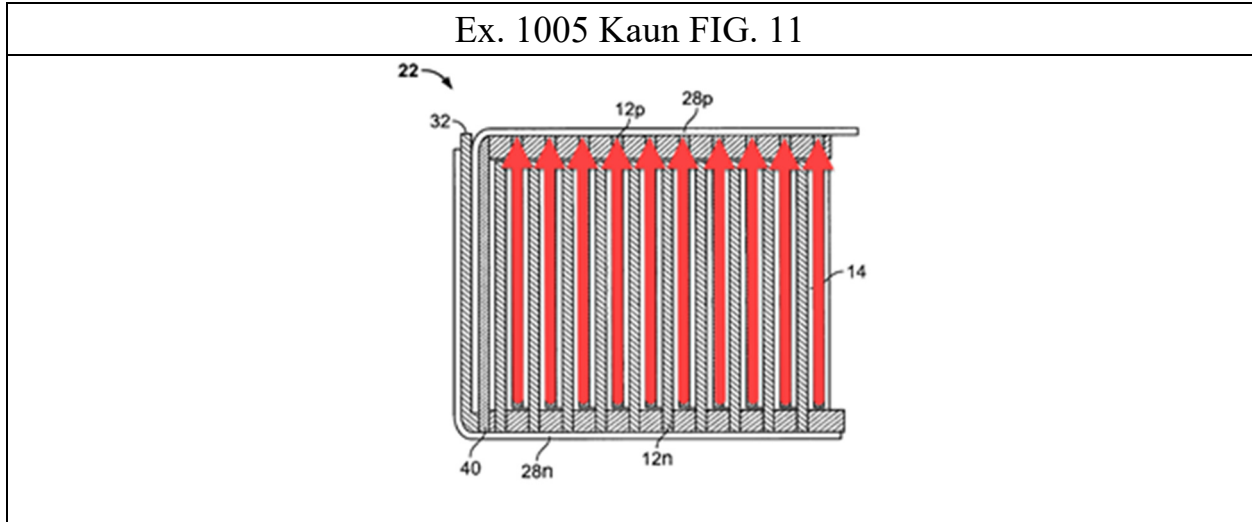

417. The diagram above illustrates the current flow for the set of electrodes in contact with the housing top.

418. The direct and continuous edge contact between the electrodes and external terminal provides the benefit of “short electronic current flow paths” that “do not require a highly conductive electrode current collector supplementing or paralleling the electrodes.” *Id.* ¶ [0128].

419. In contrast to Kaun, Kobayashi teaches that “the present inventors attempted to change the approach away from conventional art, and by incorporating at least a winding axis core into the electrode group structure, and as needed, an insulation plate and contacting terminals between electrodes and external terminals.” Ex. 1006 ¶ [0015]. Kobayashi states that only “by incorporating the winding axis core into the electrode group while being integrated with the negative electrode and/or the positive electrode, it was possible to

manufacture a wound electrode group capable of being housed in a case of a small battery such as a button cell or a coin cell.” *Id.* ¶ [0017].

420. Because of the presence of the winding core axis 7 integrated into the winding core member 6 and with “insulation plates 8 and 9 (first and second insulating members) integrated with the upper end and the lower end of the winding core 7” which the electrode group is wound around, the electrodes cannot directly contact the electrode cases forming the housing. See *id.* ¶ [0030]. To establish electrical contact, Kobayashi creates an electrically conductive path “by installing a terminal on the winding axis core to be incorporated into the electrode group to connect the electrode and the metal case doubling as an external terminal.” *Id.* ¶ [0018].

421. The electrical path through the winding axis core requires a bar-shaped terminal connection part 4b, 5b integrated to the disc-shaped terminal connection plates 4a, 5a for both the positive and negative electrode terminals 4, 5. *Id.* ¶ [0028]. Kobayashi teaches that “the terminal connection part 4b of the positive electrode terminal 4 [is] inserted into the notch part 7b of the winding axis core 7” and that “the terminal connection part 5b of the negative electrode terminal 5 [is] inserted into the notch part 7a of the winding axis core 7.” *Id.* ¶ [0031]. The assembled electrode group is shown in FIG. 9 below.

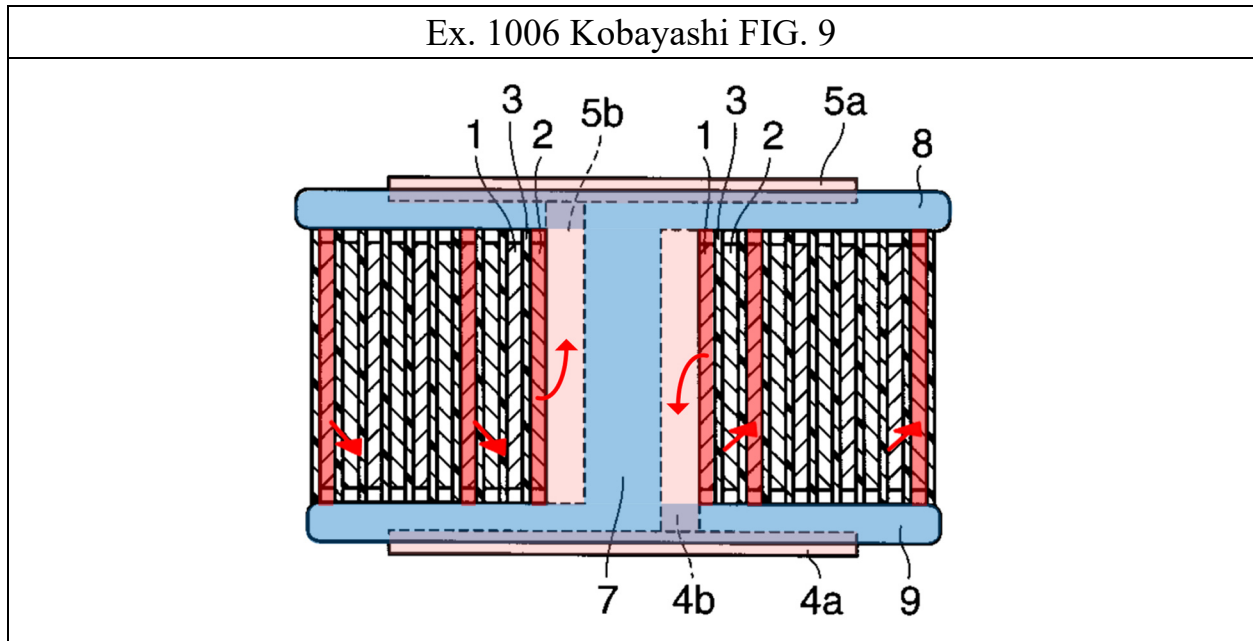

422. As indicated by the red arrows, the current flow in the cell of Kobayashi spirals around the wound lengths of the positive and negative electrodes 1, 2 to the central rod-like terminal connection parts 4b, 5a then vertically upwards and downwards to the disc-like positive and negative terminal plates 4a, 5a that contact the positive and negative electrode cases 11, 13. Moreover, the current flow must circumnavigate and spiral through the wound electrodes windings 1, 2, possibly many times, to reach the central contact point with the terminal connection parts 4b, 5b located in the winding axis core 7. This is an exceeding long current path compared to the direct and continuous edge contact between the electrodes and the positive and negative cups that form the housing.

423. From the foregoing, Kobayashi differs from Kaun in two principle respects: (1) Kobayashi does not include direct and continuous edge contact in which the majority of electron flow is axial and (2) Kobayashi uses additional

terminal connection parts to conductively connect the electrodes to the plates welded to the electrode cases, extra conductive components which Kaun teaches not to use. A POSA would have fully appreciated these fundamental differences and, because the structure of Kobayashi is directly contrary to Kaun's teachings, would not have been motivated to modify Kaun's cell to include Kobayashi's electrode assembly.

**5. The Proposed Modification Would Require a Complete Rebuild of Kaun.**

424. The proposed modifications to Kaun to use the Kobayashi wound electrode group is such a significant change in design and application that a POSA would not have reasonably expected that it could be successfully done. Furthermore, because many of these changes are contrary to the disclosure of Kaun, a POSA would have been discouraged from attempting to do so.

425. Kaun is directed to a multi-cell battery for delivering power on the order of hundreds of amps for high powered applications like hybrid vehicles and power tools. Ex. 1005 ¶¶ [0004], [0021], [0007]. A POSA contemplating using Kaun's housing with Kobayashi's electrode assembly would need to make significant modifications for the combination to work, for which Mr. Gardner has not provided any details.

426. A POSA would, for example, have had to redesign the Kaun housing to incorporate the electrode group of Kobayashi. That would involve including the

winding axis core 7 and the disc-like terminal plates 4a, 5a and bar-like terminal connection parts 4b, 5b integrated with the winding axis core. This is all contrary Kaun's teaching of a battery that does "not require a highly conductive electrode current collector." *Id.* ¶ [0128].

427. A POSA would also have had to eliminate the direct and continuous edge contact, which is the essential feature of Kaun, and changing the direction of current flow from that of Kaun, where "[t]he majority of electron transfer takes place in the axial direction along the flattened electrodes" to that of Kobayashi, where current spirals along wound up lengths of the electrodes 1, 2 before passing to the terminal connection parts 4b, 5b in the winding axis core 7 and then flowing vertically to terminal plates 4a, 5a at either end of the winding core. *Id.* ¶ [0018]; Ex. 1006 ¶ [0032]. For reference, the different current flow paths are annotated below:

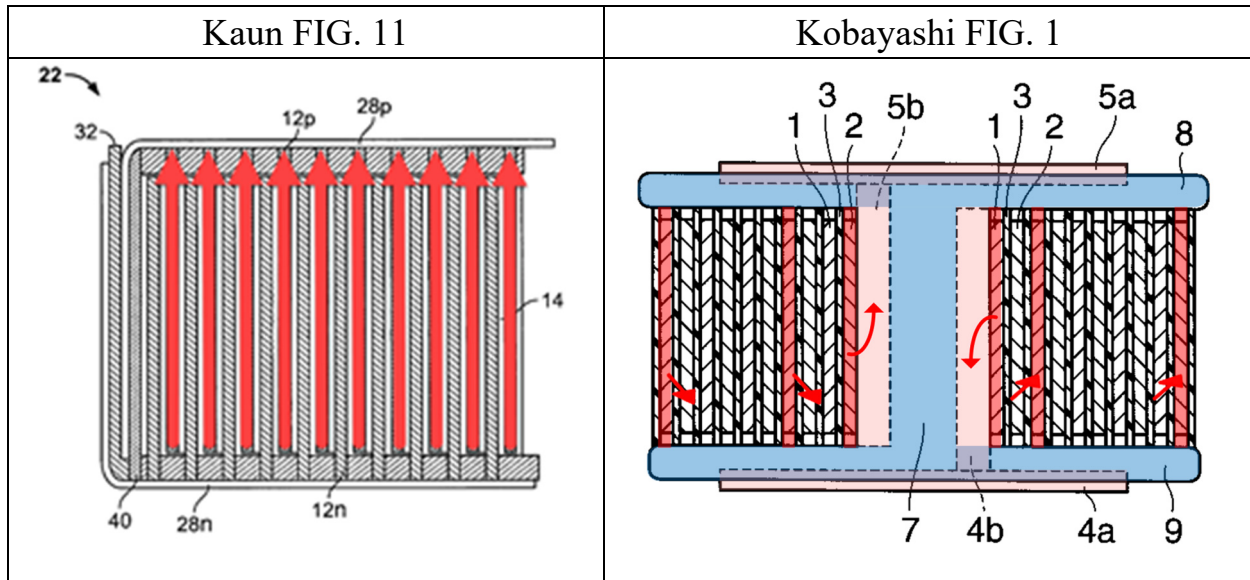

428. The change in flow direction is contrary to the Kaun’s preference for “short electronic current paths along the lengths of the electrode,” and would dramatically increase impedance beyond what Kaun teaches would be acceptable for high pulse power discharge. Ex. 1005 ¶¶ [0018], [0128].

429. A POSA would further have to redesign the closing mechanism in Kaun and eliminate the safety mechanism that vents to relieve overpressure inside the battery. *Id.* ¶ [0130]. This is contrary to Kaun’s direction that “there needs to be non-catastrophic, cost effective means to relieve the gas pressure.” *Id.* ¶ [0023].

430. Finally, a POSA would need to incorporate two mutually exclusive structures: the central fastener, an essential element in Kaun, with the winding axis core in Kobayashi, an essential component of that reference. The fastener of Kaun, however configured, is impractical for the small microbattery button cell of Kobayashi. No guidance is provided by Mr. Gardner on how that can be done.



431. In my opinion, the above issues would lead a POSA to conclude that Kaun could not be modified in view of Kobayashi as proposed by Mr. Gardner. There is no element that could be usefully imported from Kobayashi into Kaun, nor from Kaun into Kobayashi, given the disparity of the cells described in those two references.

**XII. THE CHALLENGED '858 PATENT CLAIMS ARE PATENTABLE OVER KOBAYASHI, KWON, KAUN AND THE PURPORTED KNOWLEDGE OF A POSA**

**A. The '858 Patent Is Not Rendered Obvious Over the Asserted Combination of Kobayashi and Kwon**

432. It would not have been obvious for a POSA to combine Kobayashi and Kwon to arrive at the inventions of the Challenged Claims of the '858 patent.

**1. Kobayashi and Kwon do not Disclose “Metal Foil” Output Conductors**

433. Claim 1 of the '858 Patent recites “metal conductors” that are “electrically connected to the at least one positive electrode and the at least one negative electrode, and respectively, to one of the housing halves,” and that “at least one of the conductors is a metal foil.” The metal foil “bears flat on one of lateral end sides of the electrode separator assembly winding, and the metal foils are shielded from lateral end sides of the winding by insulating elements.”

434. The '858 Patent discloses metal foil conductors and insulating elements that isolate the metal conductors from the lateral end sides of the winding.

435. FIG. 3B shows the electrode separator assembly, which includes conductor foils 301, 302 that are disposed transverse to the winding direction by folding them to bear flat on the lateral end sides 303, 304 of the electrode winding. Ex. 1001 '858 Patent 7:56-65. FIG. 3B also shows insulating elements 305, 306 that “prevent direct electrical contact between the conductors 301 and 302 and the end sides 303 and 304 of the electrode winding.” *Id.* 7:65-8:2.

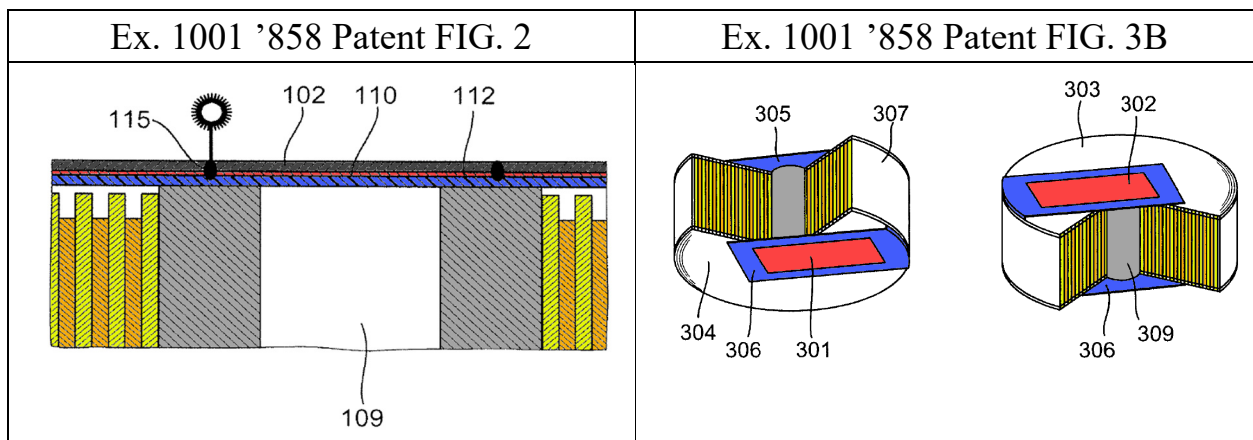

436. Kobayashi does not disclose metal foil output conductors. Kobayashi instead discloses metal plate conductors (disc-shaped electrode terminal plates 4a, 5a) and terminal connection posts (4b, 5b). Ex. 1006 ¶ [0028]. These items are shown below.

Ex. 1006 Kobayashi FIG. 5

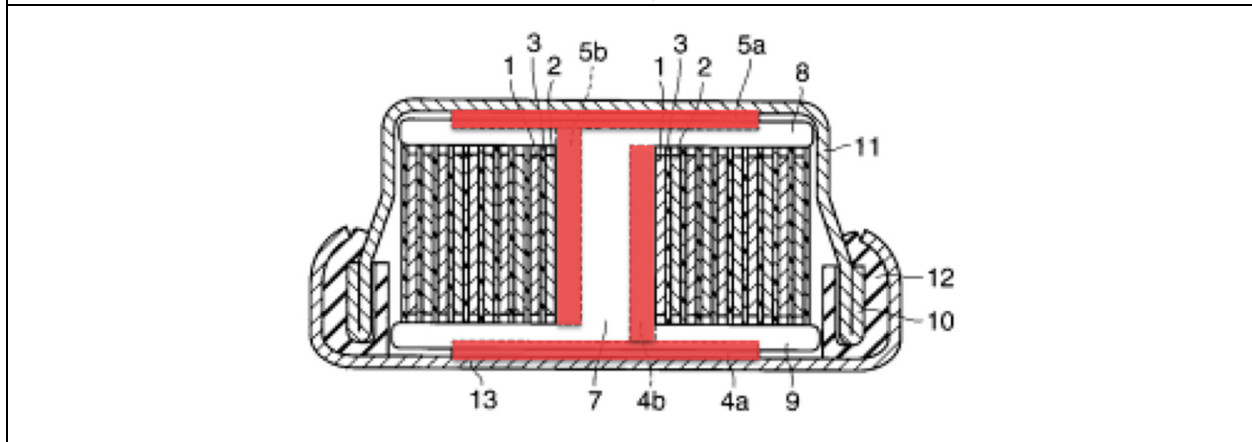

437. A POSA would understand that the metal conducting plates are not a metal foil output conductor. They are very different. Kobayashi's metal conducting plates are rigid and inflexible because they also provide structural support for Kobayashi's winding core.

438. I disagree with Mr. Gardner's contention that Kobayashi's electrodes can be considered as metal foil output conductors. They are coated with active material, and do not connect the electrodes to the housing halves. *Id.* ¶ [0026].

439. Kwon also does not disclose a metal foil output conductor. Claim 1 requires that the "metal conductors [are] electrically connected to the at least one positive electrode and the one at least negative electrode, and respectively, to one of the housing halves." The metal conductors in claim 1 are not the electrode layers in the electrode separator assembly, which are indicated as at least one positive electrode and at least one negative electrode. The metal foil output conductor is distinct from the electrode.

440. Kwon discloses polarized electrode layers (10) (10') of a double-layer capacitor. The polarized electrodes (10) (10') are formed by coating a "powder activated carbon slurry (14) (14') onto a metal current collector (12) (12')." Ex. 1008 p. 4. The current collector is an electrode that forms part of the active device. To increase the capacitance, the current collectors are made of an etching foil to increase the interface with the coating layers: "[A]n etching foil furnished with a number of recessed parts (12a) which are formed by etching or pitting the surface on which powder activated carbon slurry (14) (14') is fixed." Ex. 1008 pp. 6-7.

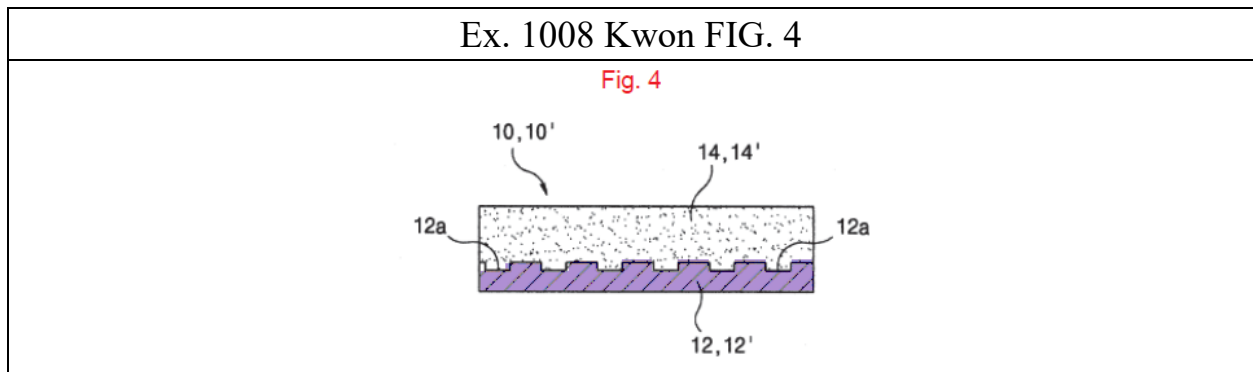

441. The etching foils in Kwon, which are an integral part of the electrodes (10) (10'), are not metal foil output conductors that pass current from a wound electrode separator assembly, or jelly roll, to housing halves of a button cell.

442. The current collectors (12), (12') are not shielded from the lateral end sides of the winding by insulating elements. Because they are a part of the

electrodes (10) (10'), they are in direct electrical contact with the capacitor housing and the carbon slurry.

443. As a result of their being coated with a carbon slurry, the current collectors (12), (12') of Kwon have a structure that is more rigid than a metal foil output conductor that rests on an insulator element. The electrode structure in Kwon's dual capacitor is therefore easier to handle during various manufacturing steps as compared to the metal output conductor in the claims.

**2. A POSA Would Have No Reason to Modify Kobayashi with Kwon**

**a. The Proposed Combination Eliminates the Primary Goal of Kobayashi**

444. Kobayashi would have directed a POSA away from using metal foils rather than metal conducting places. Kobayashi addresses the "impossibility" of placing a spiral wound electrode into a button cell "by incorporating the winding axis core into the electrode group while being integrated with the negative electrode and/or the positive electrode, it was possible to manufacture a wound electrode group capable of being housed in a case of a small battery such as a button cell or a coin cell." Ex. 1006 ¶ [0017]. By integrating the winding into the winding axis core, Kobayashi "change[d] the approach away from conventional art" relating to button cells. *Id.* ¶¶ [0012], [0015].

445. The metal conducting plates 4a, 5a on the top and bottom of the winding member conduct electricity to the housing, and they maintain the structural integrity of the assembly. By integrating the electrode terminals 4, 5 and winding member 6, for example, by disposing the metal terminal plates in the grooves on the insulation plates 8, 9 and the terminal posts 4b, 5b in the notches in the winding axis core 7, the components register in alignment with respect to each other. These components and their interaction with each other are all necessary to allow the winding of the electrode assembly and its placement within the housing. See *id.* [0015].

446. Once the terminal conductor plates 4a, 5a and the terminal posts 4b, 5b are integrated with the winding core, “the positive electrode 1 and the negative electrode 2 are spirally wound with the separator 3.” *Id.* ¶ [0032]. Winding the electrodes 1, 2, and separator 3 around the winding core places the electrodes and separator in tension. A POSA would have understood the metal conductor plates 4a, 5a are located in the insulation plates 8, 9, to register and secure the terminal connecting rods, or terminal posts, 4b, 5b in the winding core. A POSA would have understood this structure stabilizes the assembly when winding the electrode and separator. A POSA would also have understood that winding the electrodes 1, 2, and separator 3 about the winding core would be difficult if not impossible

without Kobayashi's integrated assembly, including metal conductor plates 4a, 5a registered within the insulating plates 8, 9.

447. A POSA would also have understood that the Kobayashi assembly would securely hold the electrodes after they are wound. The metal conductor plates are nested in the insulation plates to positively interlock and hold the winding assembly in place. Replacement of the metal conductor plates with metal foils would have eliminated the most prominent features of Kobayashi, the structural integration of the electrodes with the winding core and the ability to wind the electrodes.

448. The metal conductor plates 4a, 5a also ensure reliable electrical contact with the housing. The metal conductor plates 4a, 5a extend axially beyond the planar surfaces of the insulating plates 8 and 9 of the winding member 6 to expose the plates for electrical contact with the housing.

449. In this arrangement, the thickness of the metal conductor plates 4a, 5a and depth of the grooves in the insulation plates 8, 9 ensures the plates are exposed to contact the casings 11, 13 thereby prolonging service life and ensuring reliable manufacture of the Kobayashi button cell. If the terminal plates were not exposed, the cell would not work.

450. Kobayashi teaches that the metal conductor plates are connected to the metal case by resistance or ultrasonic welding. *Id.* ¶ [0018]. A POSA would

recognize the benefit of welding the disc-like terminal plate, having a large surface area and substantial thickness, to the inner surface of the electrode casings over the comparative difficulty in welding a thin metal film, which could experience alignment problems or burn through. This is an additional reason a POSA would be discouraged from using a foil in Kobayashi.

**b. A POSA Would Not Have Been Motivated to Use Foils for Thickness Reduction**

451. I disagree with Mr. Gardner that a POSA would be motivated to use foils in the Kobayashi design rather than the disc-like terminal plates to reduce cell weight or volume. As can be seen in the annotated FIG. 1 of Kobayashi below, the available volume overall would only be very slightly improved by replacing the metal plates with foils. It is unclear that the available volume would be improved at all. The weight reduction would also be slight.

452. The terminal plates 4a, 5a (red) are already recessed in the insulation plates 8, 9; there is minimum clearance between the insulator plates and the inner surfaces of the casings 11, 13. Some portion of the metal plates must be exposed, as is already shown by Kobayashi, to complete the electrical connection from the terminal connecting rods 4b, 5b (which secure the electrodes) in the winding axis core to casings 11, 13. A POSA would have not eliminated the metal conducting plates 4a, 5a because the associated advantages in the Kobayashi design would have been lost.



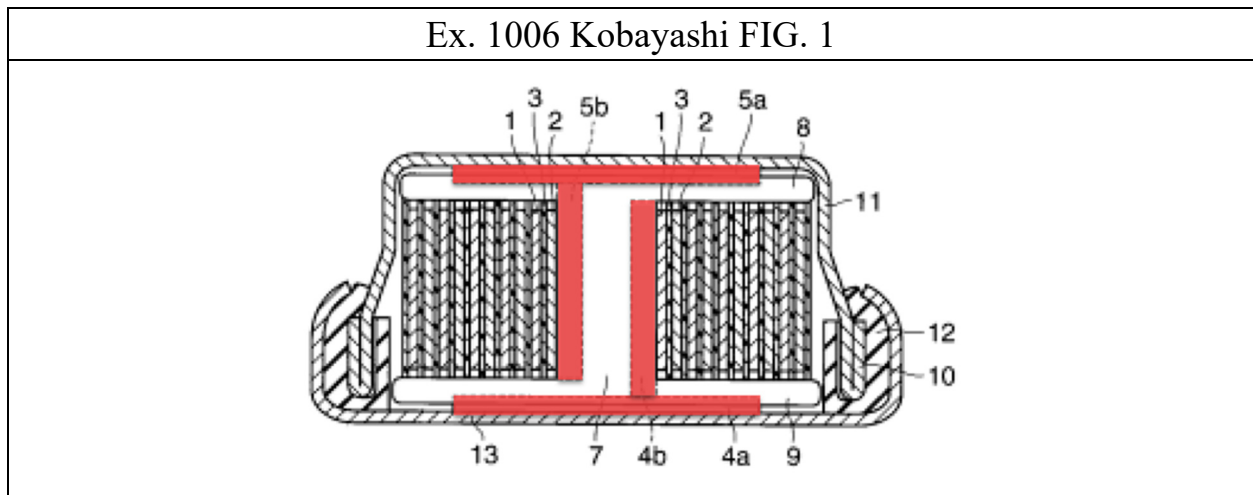

453. A POSA would have been discouraged from modifying the metal plates to be foils because it would result in an unsatisfactory electrical connection. Mr. Gardner does not explain what, if any, further modifications he would have made to maintain the structural stability of Kobayashi's winding axis core, while deploying metal foils.

454. A POSA would have also understood that metal foils would have been difficult to attach to other components of Kobayashi's cell. For example, it would have been difficult, if not impossible, to reliably attach a flexible metal foil to the terminal connecting rods 4b, 5b due to the relative thickness of these different components. By contrast, a POSA would have understood that a rigid metal plate would be much easier to attach reliably to the connecting rods. Such knowledge would have discouraged a POSA from modifying Kobayashi's metal plates to be foils.

455. At the heart of Kobayashi's invention is a unitary winding axis core made as a rigid connection system, including metal terminal plates rigidly connected to terminal rods holding the electrode ends, which are integrated into a unitary winding core. A POSA would not have modified Kobayashi in the manner proposed by Mr. Gardner, as doing so would be contrary to Kobayashi's teachings.

456. A POSA would not have looked to Kwon's double layer capacitor structure or laser welding technique to modify Kobayashi. Kobayashi's metal conducting plates provide an advantage in relative ease of welding as compared to metal foils. There would have been no reason to modify Kobayashi's metal conducting plates for the reasons provided above.

### **3. Kobayashi Will Not Operate with a Foil Conductor**

457. Kobayashi teaches that the insulation plates 8, 9 include grooves to accommodate "the positive electrode terminal plate 4a" and a "the negative electrode terminal plate 5a." Ex. 1006 ¶ [0030]. The metal conducting plates are registered in the grooves formed in the insulation plates to integrate the winding axis core. *Id.* ¶ [0031].

458. The metal conductor plates 4a, 5a are partially recessed in the grooves 8a, 9a formed in the insulation plates 8, 9, which serves to register the rod-like terminal connector posts 4b, 5b to which the metal conductor plates 4a, 5a are integrated within the winding axis core 7 so that the electrodes 1, 2, and separator 3

can be wound about the winding assembly 6. Petitioners and Mr. Gardner do not address how a POSA would modify Kobayashi to incorporate foils in the same manner that could be integrated with and registered within the notches 8a, 9a in the insulation plates 8, 9.

459. A metal foil would lack the necessary surrounding structure to hold the terminal connector posts firmly in place. It would be unable to register, i.e. interlock with, the terminal connector posts and the winding axis core such that there would no longer be an integrated electrode group disposed about a unitary winding core. This would also prevent winding of the electrodes, which a POSA would understand to be the essence of Kobayashi.

460. It is unclear to me how a POSA would have understood the foils to be “integrated” with the terminal connector posts 4b, 5b in the same manner that the metal conductor plates 4a, 5a can be integrated with the connector posts. The metal conductor plates 4a, 5a and terminal connector rods 4b, 5b can be fairly easily joined prior to integration with the winding axis core. Electrically connecting the terminal connector posts 4b, 5b to a thin foil cannot be easily or reliably done, either by a rigid attachment or by simple abutting contact.

461. Further, the foil would presumably be recessed in the notches 8a, 9a formed the insulation plates. It would not electrically contact the surfaces of the positive and negative electrode casings 11, 13. This would likely result in an open

circuit condition and an inoperable cell. Mr. Gardner did not consider that a thin foil recessed in the notches 8a, 9a of the insulation plates 8a, 9a would not provide a reliable connection between the terminal connector rods 4b, 5b in the winding axis core and the inner surfaces of the casing 11, 13. The proposed combination would result in an inoperable button cell.

462. In this arrangement, the thickness of the terminal plates 4a, 5a and depth of the grooves in the insulation plates 8, 9 ensures contact with the casings 11, 13 thereby prolonging service life and ensuring reliable manufacturability of the Kobayashi button cell. A POSA would not be motivated to eliminate the terminal plates and lose this manufacturing advantage.

463. Kobayashi describes that method for “electronically connecting the terminal to the metal case doubling as an external terminal includes welding such as resistance welding and ultrasonic welding.” *Id.* ¶ [0018]. A POSA would recognize the benefit of welding the disc-like terminal plate with a large surface area and substantial thickness to the inner surface of the electrode casings over the comparative difficulty in welding a thin metal film, which could experience alignment problems or burn through. This is an additional reason a POSA would be discouraged from using a foil in Kobayashi.

#### **4. The Proposed Modification Would Render Kobayashi Inoperable**

464. The metal conducting plates 4a, 5a are partially recessed in the notches 8a, 9a formed in the insulation plates 8, 9. *Id.* ¶¶ [0031]-[0032]. This serves to register the terminal connection rods 4b, 5b within the winding axis core 7 to allow the electrodes and separator to be wound. A POSA would understand the integration of these components to stabilize the assembly, which would be impossible using metal foils.

465. A POSA would have understood that a metal foil would lack the necessary rigidity to support the components of the winding axis core. This would be the case for both winding the electrodes and stabilizing the structure within the housing.

#### **5. The Proposed Modification Would Require a Complete Rebuild of Kobayashi**

466. The use of foils for the terminal plates 4a, 5a of the electrode terminals in Kobayashi is such a significant change, that a POSA would not have reasonably expected to successfully arrive at what is claimed in the VARTA patents. Kobayashi's metal conducting plates are critical elements that perform an important function regarding the assembly and structural stability of the electrode group. In their absence, a POSA would need to completely redesign the Kobayashi cell.

467. A POSA would have understood that the design of Kobayashi's winding axis core would need to be completely changed. The winding axis core relies on the interlocked structure of the metal conducting plates 4, 5 to wind the electrodes 1, 2 and separator 3.

468. If the metal conducting plates 4a, 5a were made to be foils, a POSA would be required to rearrange all remaining components that securely anchor the spiral wound electrodes and separator, including the winding axis core itself. A POSA would have had to redesign the terminal connection posts 4b, 5b received in the winding axis core 7 because they would no longer be securely held in place. A POSA would also have had to redesign the insulating plates 8, 9 because they would not allow metal foils to easily or reliably contact the housing. A POSA would likely have to abandon the concept of integrating the electrodes and separator with the winding axis core—i.e. abandon the core teaching of Kobayashi.

## **6. Kobayashi and Kwon Do Not Disclose the Additional Features of Dependent Claims 6 and 8**

469. Claim 6 depends from claim 1 and further recites “at least one separate insulator which prevents direct electrical contact between the lateral end side of the winding and the conductor.” A POSA would understand that “one separate insulator” refers to an insulator in addition to the insulating elements in claim 1.

470. The specification discloses two type of insulators. In respect to FIG. 1, the specification describes that the “conductors are shielded from the end sides of the winding by the insulating elements 112 and 113. The latter are thin plastic films.” Ex. 1001 ’858 Patent 7:12-14. With respect to FIG. 3A and 3b, the ’858 specification also describes insulating tapes 207, 208 that are adhesively bonded to the conductors 203, 204. Id. 7:45-52.

471. Claim 8 depends from claim 1 and further recites “the winding comprises at its center an . . . cylindrical axial cavity delimited laterally by the winding and on lateral end sides by a subregion of the bottom or top region, respectively, and at least one of the conductors contains a weld with a corresponding housing half in the subregion.” The specification explains that “welding the conductors to the housing is particularly preferably carried out in the subregion of the bottom or top region, which delimits the axial cavity at the center of the winding.” Ex. 1001 ’858 Patent 6:28-39. A POSA would understand from these teachings that welding from the outside of the housing may preferably be performed in the housing subregion proximate to the axial cavity to protect the active elements in the button cell.

472. Kwon discloses welding a solid “polarized electrode” to the capacitor housing. Kwon teaches no electrode that defines a cavity and does not disclose

welding at any particular subregion or location in the capacitor housing relative to any cavity.

473. Kobayashi also does not disclose or suggest welding at a subregion with respect to the axial cavity. Kobayashi should be not considered as disclosing an axial cavity at all. As shown in FIG. 8, Kobayashi connects the electrodes to the terminal connection posts, which are placed into and become a part of the winding axis core. Specifically, Kobayashi teaches that “the current-carrying part 1c of the positive electrode 1 was inserted into the slit 4c in the terminal connection part 4b of the positive electrode terminal 4, pressure was applied to the terminal connection part 4b from the outside, and the current-carrying part 1c was crimped to the terminal connection part 4b.” Ex. 1006 ¶ [0028]. The negative electrode 2 and the negative electrode terminal 5 are similarly assembled. The shape of winding axis core becomes cylindrical only when terminal connection posts are located in the winding axis core. *Id.* ¶ [0031]. Therefore, the electrodes are present in the “central cylindrical axle” (Ex. 1003, ¶¶ 404-406) of Kobayashi.

**B. The '858 Patent Is Not Rendered Obvious Over the Asserted Combination of Kaun with Kobayashi and Kwon**

474. Petitioners' and Mr. Gardner' proposed combination of Kaun in view of Kobayashi and Kwon does not suggest or disclose all of the elements of the claims, is not supported by a reasoned or rational basis, and runs contrary to the



disclosure of the references themselves. Accordingly, a POSA would not find the claims of the '858 Patent obvious over Kaun, Kobayashi and Kwon.

**1. Kaun in view of Kobayashi and Kwon Does Not Disclose or Suggest a “Button Cell,” and “Metal [Conductor] . . . is a Metal Foil,” or “Insulating Elements”**

**a. “Button Cell”**

475. The term “button cell” means “a small, generally round and flat battery typically used in electronic devices.”

476. Kaun relates to a battery for “high-pulse power requirements, such as for hybrid electric vehicles and for power tools.” Ex. 1005 ¶ [0021]. Kaun notes that battery of the type “[f]or hybrid electric vehicles, the current is on the order of 100 A at 200-400 volts (equivalent to 20-40 kW).” *Id.* Kaun claims its “technology provides high pulse power devices . . . producing kW levels of power.” *Id.* ¶ [0079]. The Kaun cell achieves these power requirements with a “rolled-ribbon cell configuration according to the present invention [that] can release close to 100% of theoretical power of the Li/organic electrolyte cell chemistry in substantially larger cells of 5-10 Ah capacity with pulse currents of 100-200 A from a single cell.” *Id.* ¶ [0094]. The same passage notes that cells of this type preferably have a contact area of 125 cm<sup>2</sup>. *Id.*

477. A POSA would not consider a battery providing these levels of power and current to be a “button cell.” Rather, a POSA would understand Kaun relates

to a significantly larger cell and would have significantly larger dimensions such as a cylindrical or prismatic cell.

478. Kaun does state that “[t]he invention also provides a button-type cell housing.” Ex. 1005 ¶ [0084]. A POSA would understand this passage refers to the style of the housing disclosed in Kaun, which is circular and wider than it is tall, and does not convey any teaching or suggestion regarding the cell size, power output, or technical classification.

479. The Petitioners’ and Mr. Gardner do not contend the cell disclosed in Kaun could be miniaturized to a “button cell,” nor does it appear that it could. If the wattage and amperage stated in Kaun were drawn from a button cell, i.e. a cell less than 25 mm in diameter and 6 mm in height, the internal components would quickly burn out. Kaun includes a central fastener to hold the housing cups 28p, 28n together, a component fundamentally incompatible with a miniature button cell.

480. Kobayashi (relied on by Mr. Gardner in other Grounds) itself is evidence that miniaturization of Kaun is not possible. Kobayashi states that, with respect to rechargeable batteries providing power and current on levels required by small mobile devices (i.e. devices with significantly lower power requirements than the electric vehicles contemplated by Kaun), “size reduction is extremely difficult for these rechargeable batteries, and the limit has currently substantially

been reached.” Ex. 1006 ¶ [0007]. Kobayashi further states that, with respect to the jelly rolls used in larger cylindrical batteries, “it was thought that it was impossible to store the electrode group structure within a small battery such as a button cell or a coin cell.” *Id.* ¶ [0014]. These statements would discourage a POSA from trying to modify rechargeable batteries for small mobile devices—much less the high power cells of Kaun—into a button cell.

481. Kaun teaches that in a lithium based battery for “high power applications, such as for hybrid electric vehicles,” “internal gas pressure may be generated during operation.” Ex. 1005 ¶ [0023]. Kaun discloses that it would be desirable to incorporate “non-catastrophic, cost effective means to relieve the gas pressure.” *Id.* Accordingly, Kaun describes in an embodiment that the peripheral gasket that is disposed between the peripheral edges of the positive and negative cups 28p, 28n that form the housing can relax in the event of over pressurization inside a cell to act as a vent to release the internal pressure. *Id.* ¶¶ [0091], [0130]. Mr. Gardner provides no details on how this feature would be modified in a button cell arrangement.

#### **b. “Metal Foil” Output Conductor**

482. Mr. Gardner contends that Kaun and Kobayashi disclose metal conductors as is claimed in the ’858 Patent. Ex. 1003 ¶ 385. Mr. Gardner also contends Kwon discloses an output conductor which can be a foil; therefore, he

contends it would have been obvious to replace Kobayashi's metal conducting plates with metal foils. *Id.* ¶ 386. These references do not disclose a "metal foil" output conductor as claimed in the '858 Patent.

483. Kaun criticizes the use of current collectors and additional elements for establishing electrical contact between the electrodes in the electrode assembly and the housing. Instead, Kaun teaches direct and continuous edge contact between the positive and negative electrodes 12p, 12n and the positive and negative cups 28p, 28n that serve as terminals. The Kaun design provides "short electronic current flow paths along the lengths of the electrodes (less than 10 mm)" that allow for the elimination of any "highly conductive electrode current collector supplementing or paralleling the electrodes." Ex. 1005 ¶ [0128]. Accordingly, it would not be obvious to use an additional metal foil conductor in Kaun.

484. Kobayashi also does not disclose or suggest a metal foil. To connect the positive electrode 1 to the respective positive and negative electrode case 13, Kobayashi discloses use of electrode terminals that include "a disc-shaped positive electrode terminal plate 4a" and "bar-shaped terminal connection part 4b . . . electrically connected to the positive electrode terminal plate 4a." Ex. 1006 ¶ [0028]. Likewise, Kobayashi discloses a negative electrode terminal having "disc-shaped negative electrode plate 5a" and a "bar-shaped terminal connection part 5b" are used to connect the negative electrode to the negative housing casing 11.

Ex. 1006 Kobayashi FIG. 5

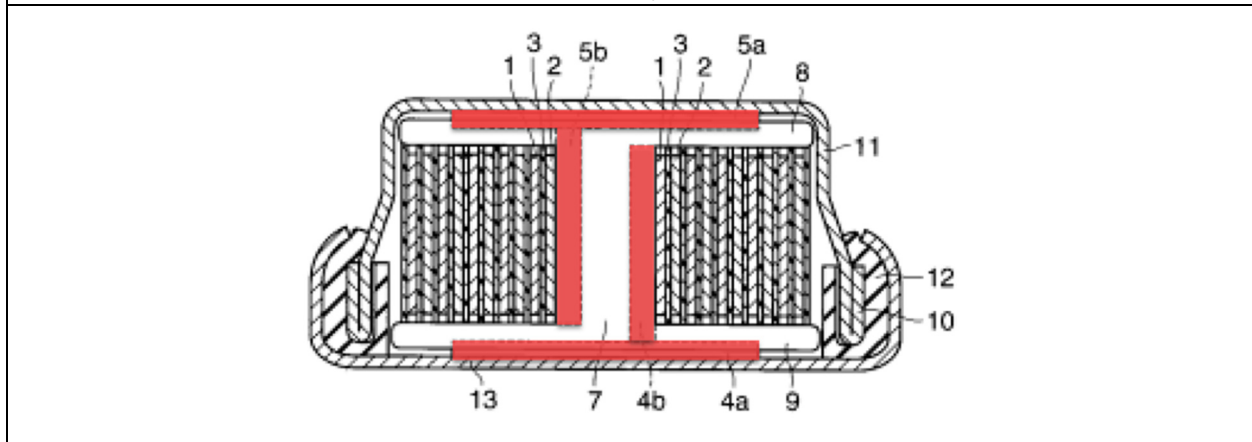

485. A POSA would understand that a rigid “disc-like terminal plate” and an output foil conductor are different. In the context of the ’581 Patent, a “plate” would necessarily involve or impart a sense of rigidity or inflexibility. The claimed output conductors, by contrast, are pliable and flexible to facilitate assembly of the button cell. In particular, the flexible characteristic of the foil output conductors enables them to be folded and rest flat between the end faces of the spiral winding and the flat top and bottom areas of the housing.

486. Kwon also does not disclose or suggest a “metal foil” output conductor. Kwon instead discloses a multi-layer electrode assembly in which the electrode itself is attached to the housing.

487. In Kwon, polarized electrodes (10) (10’) are prepared by coating and fixing “powder activated carbon slurry (14) (14’) on the metal current collector (12) (12’).” Ex. 1008 p. 4. The current collectors (12) (12’) can be “an etching foil furnished with a number of recessed parts (12a) which are formed by etching

or pitting the surface on which powder activated carbon slurry (14) (14') is fixed.”

Id. pp. 6-7.

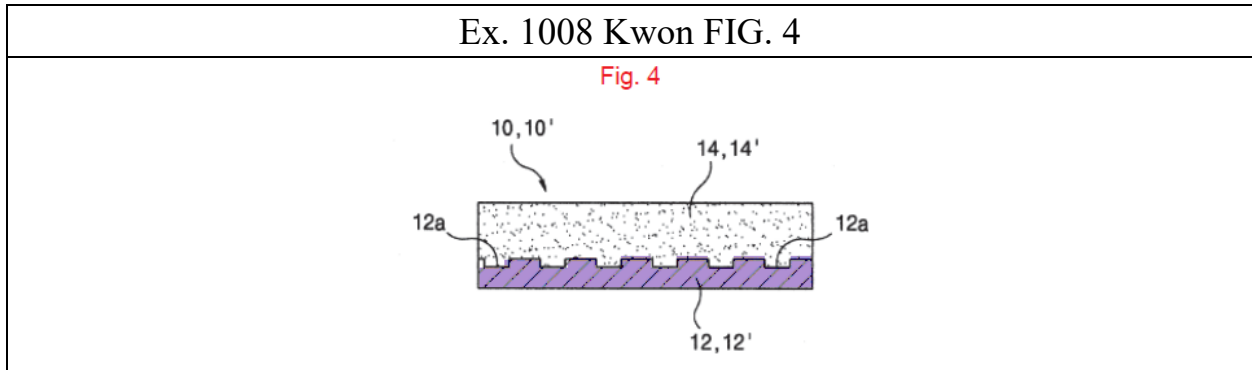

488. Etching the foil “increases the contact surface area between the powder activated carbon slurry (14) (14’) and the metal current collector (12) (12’) due to its recessed parts (12a) to improve on the electrical conductivity between the components.” Id. The etching foils in Kwon therefore form an integral part of the electrodes (10) (10’). They are not a metal foil used as an output conductor that takes current from a wound electrode separator assembly, or jelly roll, to one of the housing halves.

489. The electrode in Kwon also does not bear flat on the one of lateral end sides of the electrode separator assembly. Kwon does not disclose or suggest an electrode separator assembly at all.

### c. “Insulating Elements”

490. Claim 1 requires “insulating elements” that prevent direct mechanical and electrical contact between the end sides of the winding and the conductors.

Ex. 1001 '858 Patent 5:9-14. Combining Kaun with Kobayashi (or Kwon) would not result in a button cell with insulating elements.

491. Mr. Gardner suggests that a POSA reviewing Kaun would turn to Kobayashi to solve a problem unrelated to the claimed insulators concerning overlap of the separator in Kaun and/or supposed thickness variances in the edges of Kaun's Z-shaped separator. As I have stated, I disagree with Mr. Gardner's conclusions surrounding separator thickness. Nonetheless, even assuming Mr. Gardner were correct, I note that he has not provided any reason why a POSA would have turned to Kobayashi for its insulator plates.

492. To the extent Petitioners purport to provide a motivation as to why a POSA would have looked to Kobayashi to resolve issues surrounding separator thickness variances, Petitioners utterly fail to explain any reason why a POSA would have looked to Kobayashi for the purpose of incorporating insulating plates into Kaun's cell.

493. In my opinion, a POSA would not incorporate the insulating plates into the housing of Kaun even if it were combined with Kobayashi. Assuming, Kaun presented the challenges stated by Mr. Gardner, a POSA reading Kaun would also have understood the importance of eliminating additional conductors and for this reason would avoid the terminal connecting rods integrated into the winding axis core of Kobayashi. Importantly, a POSA would have recognized the

criticality of maintaining the short current paths provided by the direct and continuous edge contact between the electrodes and external terminal in Kaun and, for that reason, would not have incorporated the insulating plates from Kobayashi.

494. Another key consideration of Kaun's design is improved thermal management. Due to the direct and continuous edge contact between the electrodes and external terminal, internally generated heat from the rolled-ribbon cell "can be drawn out from the cell via short conduction paths without crossing the heat sensitive microporous polyethylene/polypropylene separator." Ex. 1005 ¶ [0094]. Kaun teaches that "[t]hermal management is important to the long life of Li-ion batteries," particularly for high power applications, as "[e]xcessive temperatures will destroy (e.g. melt the microporous polymer separator or autoignite the flammable organic electrolyte) or significantly shorten the useful life of the Li-ion cell." *Id.* ¶ [0005]. Kaun further cautions that poor thermal management can contribute to thermal gradients in the cell, i.e. "[e]xcessive temperature within the cell will locally shutdown the microporous polymer resulting in still higher temperatures." *Id.*

495. Rather than ignore Kaun's teachings as Petitioners propose, a POSA seeking to eliminate overlap of separator in Kaun would have simply followed Kaun's own teaching: "[a]lthough the preferred configuration of the separator 14 is Z-shaped, the separator 14 can encompass other embodiments envisioned by those



skilled in the art as long as the separator adequately isolates the successive electrodes from one another in the contemplated device.” Ex. 1005 at [0107].

496. Following Kaun’s teaching, a POSA looking to modify Kaun would, for example, have simply employed a continuous non-overlapping separator between the electrode material (as Petitioners allege is shown in Kobayashi), while maintaining offset electrodes that directly connect the electrodes to the housing top and cup in Kaun. That combination would have eliminated the supposed problems in Kaun, while remaining true to the teachings of Kaun, e.g., maintaining direct contact between the electrodes and housing to provide the shortest current path possible thereby reducing electrical resistance and adequately managing the heat generated by high power applications. *Id.* ¶¶ [0107], [0125]-[0126].

497. Because any modified version of Kaun based on Kobayashi would not include Kobayashi’s winding axis core (including insulating plates), the combination of references would not result in the claimed insulator between the winding and housing.

## **2. A POSA Would Not Have Had a Reason to Combine Kaun with Kobayashi**

498. It would not have been obvious for a POSA to combine Kaun and Kobayashi to arrive at the inventions of the Challenged Claims of the ’858 patent.

499. I disagree with Mr. Gardner that Kobayashi and Kaun are directed to “similar” subject matter. Kobayashi is directed to a small button cell battery, e.g.,

on the order of  $\mu\text{A}$  and  $\text{mA}$ . Ex. 1006. Kobayashi is further directed to a solution of using a wound electrode assembly in a small cell with a diameter of about 12 mm. Kaun, on the other hand is directed to a high power, multi-cell battery that delivers kW levels of power with tens or even hundreds of amps of current. Kaun's solution offers a way to manage resistance and heat in a cell that can deliver close to 100% theoretical power. Ex. 1005. Neither the problems nor solutions described in Kaun and Kobayashi are similar. To the contrary, they are quite different.

500. I also disagree with Mr. Gardner's opinion that the thickness of Kaun's separator material or its Z-shaped separator provides any motivation to modify the structure described therein.

501. Kaun mentions that high interfacial area "A" of a "jelly roll" electrode requires a minimum separator thickness for cell durability and cycle life. He explains that in conventional jelly roll arrangements, the increased interfacial contact area "A" is generally offset by the need for increased thickness "I" of the separator. *Id.* ¶ [0017].

502. Kaun describes his solution as providing a "large interfacial electrode area 'A', compared to the cross section of the cell, [which] reduces internal resistance against ion transfer in the electrochemical device." *Id.* at [0127]. Kaun states that his invention solves the problem in a way that "allows the

separator/electrolyte 14 to be made with a very small thickness ‘I’, for further reducing the ion resistance.” *See id.* ¶ [0128]. Kaun also states “a separator layer and/or electrolyte formed of a very thin ionic-conductive ribbon-like layer configured in a tight serpentine manner and physically interposed between the electrodes.” *Id.* ¶ [0078].

503. Thus, as the disclosure of Kaun confirms, his device uses a “very thin” separator layer. Mr. Gardner appears to rely on the fact that Kaun states separator material can be less than 0.1 mm while Kobayashi refers to a separator having a thickness of 22  $\mu\text{m}$ . This does not provide a basis to conclude that Kobayashi provides a thinner separator. 22  $\mu\text{m}$  is merely an approximate range provided by Kaun. Moreover, Kaun is directed a larger cell with much higher power characteristics than the cell of Kobayashi. The comparison is, therefore, inappropriate.

504. Mr. Gardner also incorrectly asserts that there is “an inherent weakness in the electrode assembly of Kaun” in which the Z-shaped separator results in thickness variances that would reduce the useable volume of the electrode-separator assembly. Ex. 1003 ¶¶ 136-137. In reaching this conclusion, Mr. Gardner appears to take the view that the Z-shaped separator in Kaun would necessarily require overlapping edges. I disagree.

505. The disclosure of Kaun, which explicitly describes non-overlapping butt joints, contradicts Mr. Gardner’s position that overlapping edges are required. Kaun’s non-overlapping butt-joints are described with respect to FIG. 6 of Kaun and are circled in red below:

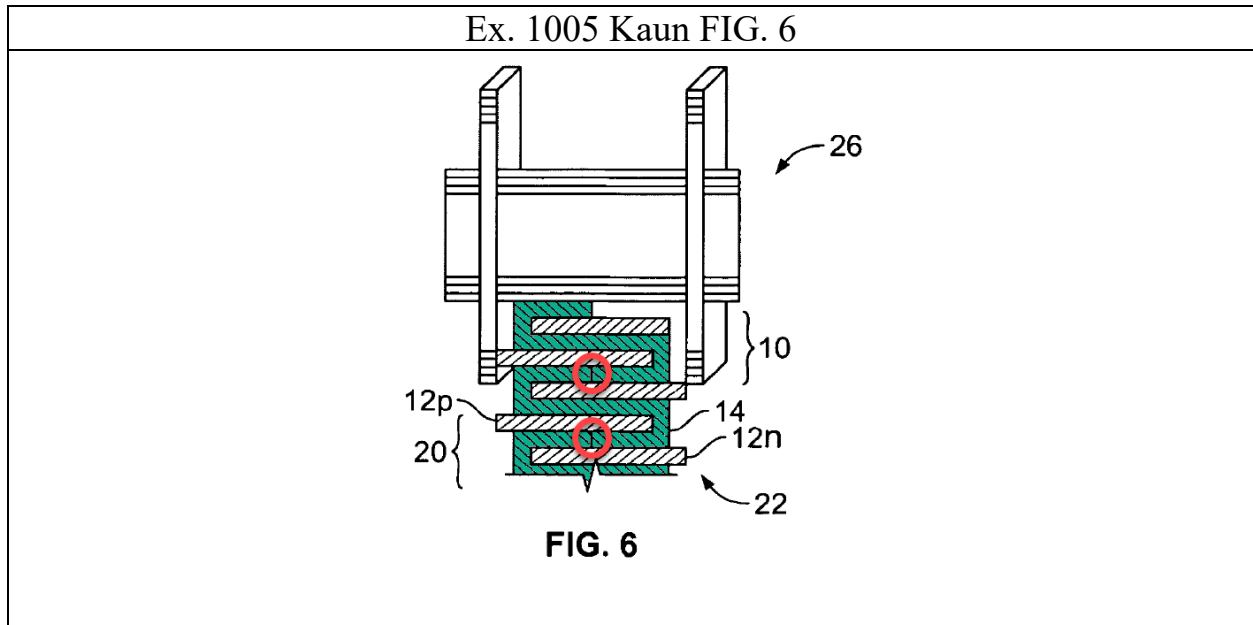

506. The figures of the Kaun application do not show an “overlap” between separator edges or a “thickness variation” at the butt joints. They do show a perfectly formed butt joint. Kaun does not mention or disclose a “thickness variation.” To the contrary, Kaun states “[t]he separator edges can form a butt-joint to separate the successive electrode layers.” Ex. 1005 ¶ [0108]. Thus, while Kaun does describe that separator edges “can overlap,” abutting edges are specifically disclosed as an alternative.

507. Furthermore, interpreting Kaun’s disclosure that separator edges “can overlap” (*Id.*) to require a thickness variation in the separator layer is contrary to the entirety of Kaun’s remaining disclosure. Kaun explicitly recognizes that “[d]esigners of electrochemical devices thus strive to reduce electrolyte thickness ‘I.’” *Id.* ¶ [0015]. Kaun proposes a configuration and orientation for a rolled-ribbon jelly roll that “allows the separator/electrolyte 14 to be made with a very small thickness ‘I’” and that also allows “the electrode structure and the separator/electrolyte to made of substantially uniform thickness.” *Id.* ¶ [0128]. Kaun discloses a manufacturing and assembly technique that produces butt joints without a thickness variation. *Id.* Figs. 1 and 6, ¶ [0103]. A POSA would not be motivated to look beyond the disclosure of Kaun to solve a problem regarding thickness variations.

508. I also disagree that Mr. Gardner that there can be “no gap between the edges of the separator” in Kaun. A relatively small gap would simply form a void to be filled by electrolyte, adhesive, or by separator material squeezed and compressed into the gap. *See, e.g.*, Ex. 1005 at [0103].

### **3. Kobayashi Would Render Kaun Less Efficient.**

509. A POSA would also not look to the electrode assembly in Kobayashi to increase the amount of usable power as Petitioners argue. *Pet.* at 37. To the contrary, the assembly in Kaun is far more efficient than that of Kobayashi.

510. Kaun repeatedly teaches that “the weight and volume of current collectors reduce specific energy and power outputs.” Ex. 1005 ¶ [0020], see also ¶ [0018] (“Current collectors used in these cell arrangements add significant weight and thus reduce specific cell energy and power outputs.”). Kaun teaches that it is desirable to eliminate the “current collector supplementing and paralleling the electrodes” in favor of direct and continuous edge contact between the positive and negative electrodes 12p, 12n and the terminal cups 28p, 28n that results in “short electronic current flow paths.” Ex. 1005 ¶ [0128]. Kaun thus results in the electrode-separator jelly roll can be densely packed by utilizing substantially all the internal volume. As shown below, the electrode assembly of Kaun utilizes almost all of the available space.

511. Kobayashi, on the other hand, teaches the desirability of incorporating a winding member 6 with a winding axis core 7 because it was only “by incorporating the winding axis core into the electrode group while being integrated with the negative electrode and/or the positive electrode, it was possible to manufacture a wound electrode group capable of being housed in a case of a small battery such as a button cell or a coin cell.” Ex. 1006 ¶ [0017]. Kobayashi claims to have “change[d] the approach away from conventional art, and by incorporating at least a winding axis core into the electrode group structure” it succeeded in

“storing a wound electrode group within a case of a small battery such as a button cell or a coin cell.” Ex. 1006 ¶¶ [0012], [0015].

512. However, as shown below in contrast with Kaun, the winding axis core 7 and integrated insulating plates 8, 9 around which the positive and negative electrodes 1, 2 and separator 3 are wound takes up considerable internal space.

The space occupied by the winding core 7 and insulating plates 8, 9 cannot include electrochemically active material and cannot contribute to the energy density or power capacity of the cell.

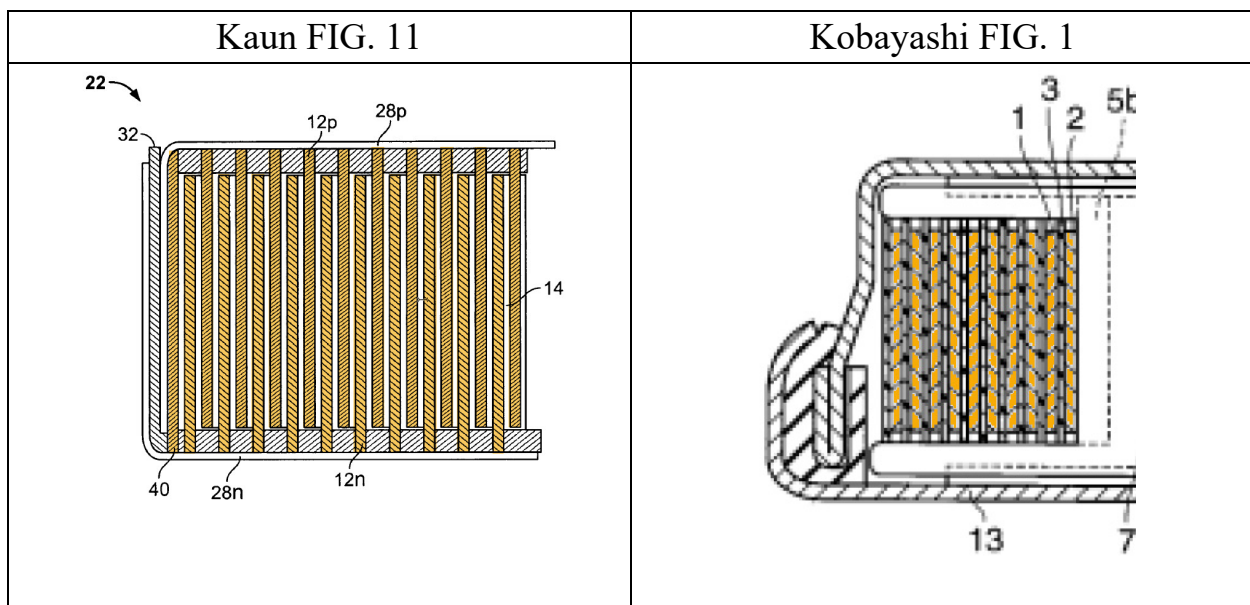

513. The lost volume in Kobayashi due to its winding axis core and insulating plates is about 30% of the total volume of the cell. I understand that patent figures are not necessarily to scale. However, in arriving at this percentage, I assumed the drawing was roughly to scale for a cell having a diameter on the order of 12 mm and a height of 5.3 mm as described in Kobayashi. In my opinion,

the size of the Kobayashi's winding axis core and insulating plates under that assumption are reasonable.

#### **4. Kaun Teaches Away From Using Additional Current Collectors that are Necessary in Kobayashi**

514. Kaun's solution eliminates intermediate current collectors in favor of direct and continuous edge contact between the housing and the electrodes in a "rolled-ribbon" assembly. Kaun explains that "the weight and volume of the current collectors reduce specific energy and power outputs." Ex. 1005 ¶ [0020]. Kaun notes that for a typical battery design, these additional conductors "can account for a 50% reduction in battery power output from theoretical capability." *Id.* ¶ [0018].

515. Kaun states:

Current collectors used in these cell arrangements add significant weight, and thus reduced specific cell energy and power outputs. For example, isolated conductors are generally connected to the electrodes and routed along extended paths independently of the electrodes to the external terminals. Ex. 1005 ¶ [0018].

516. Instead, in Kaun, current flows in the axial direction from the positive and negative electrodes 12p, 12n directly to the positive and negative cups 28p, 28n:

The majority of electron transfer takes place in the axial direction along the flattened electrodes and the adjacent electrode material layers or normal to the current collectors. As noted above, the positive and negative electrodes 12p and 12n are electrically continuous at opposite open ends thereof respectively with the positive and negative



material layers 28p and 28n of each cell. Resistance to electron passage via the electrodes will generally be negligible compared to ionic resistance.

Ex. 1005 ¶ [0125].

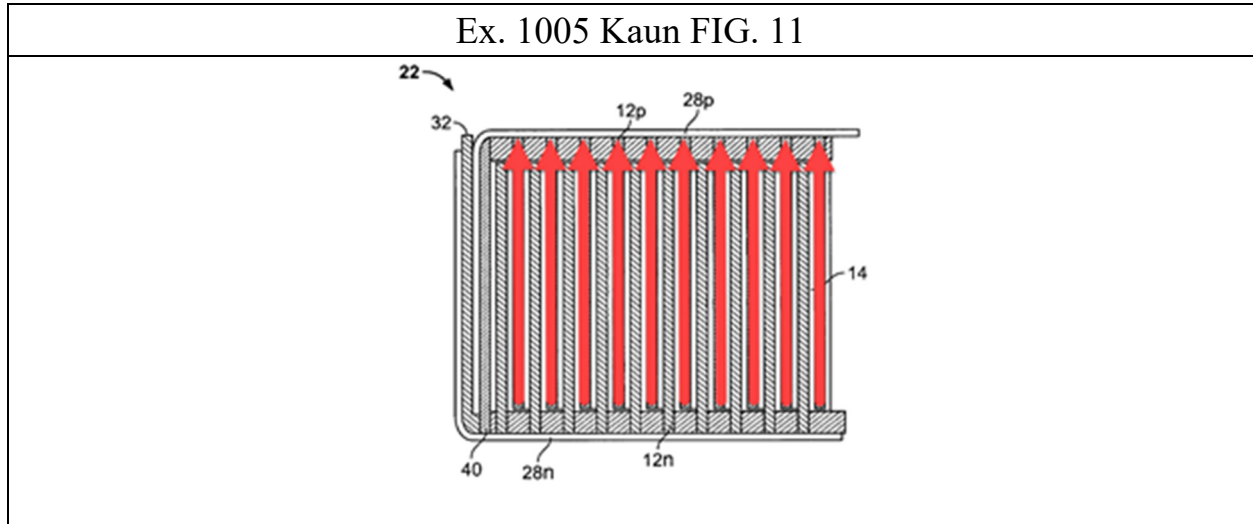

517. The diagram above illustrates the current flow for the set of electrodes in contact with the housing top.

518. The direct and continuous edge contact between the electrodes and external terminal provides the benefit of “short electronic current flow paths” that “do not require a highly conductive electrode current collector supplementing or paralleling the electrodes.” *Id.* ¶ [0128].

519. Another benefit is improved thermal heat management in which internally generated heat from the rolled-ribbon cell can be drawn out from the cell via short conduction paths without crossing the heat sensitive microporous

polyethylene/polypropylene separator” thereby avoiding degradation of the separator. Ex. 1005 ¶ [0094].

520. In contrast to Kaun, Kobayashi teaches that “the present inventors attempted to change the approach away from conventional art, and by incorporating at least a winding axis core into the electrode group structure, and as needed, an insulation plate and contacting terminals between electrodes and external terminals.” Ex. 1006 ¶ [0015]. Kobayashi states that only “by incorporating the winding axis core into the electrode group while being integrated with the negative electrode and/or the positive electrode, it was possible to manufacture a wound electrode group capable of being housed in a case of a small battery such as a button cell or a coin cell.” Ex. 1006 ¶ [0017].

521. Because of the presence of the winding core axis 7 integrated into the winding core member 6 and with “insulation plates 8 and 9 (first and second insulating members) integrated with the upper end and the lower end of the winding core 7” which the electrode group is wound around, the electrodes cannot directly contact the electrode cases forming the housing. See Ex. 1006 ¶ [0030]. To establish electrical contact, Kobayashi creates an electrically conductive path “by installing a terminal on the winding axis core to be incorporated into the electrode group to connect the electrode and the metal case doubling as an external terminal.” Ex. 1006 ¶ [0018].

522. The electrical path through the winding axis core requires a bar-shaped terminal connection part 4b, 5b integrated to the disc-shaped terminal connection plates 4a, 5a for both the positive and negative electrode terminals 4, 5. Ex. 1006 ¶ [0028]. Kobayashi teaches that “the terminal connection part 4b of the positive electrode terminal 4 [is] inserted into the notch part 7b of the winding axis core 7” and that “the terminal connection part 5b of the negative electrode terminal 5 [is] inserted into the notch part 7a of the winding axis core 7.” Ex. 1006 ¶ [0031]. The assembled electrode group is shown in FIG. 9 below.

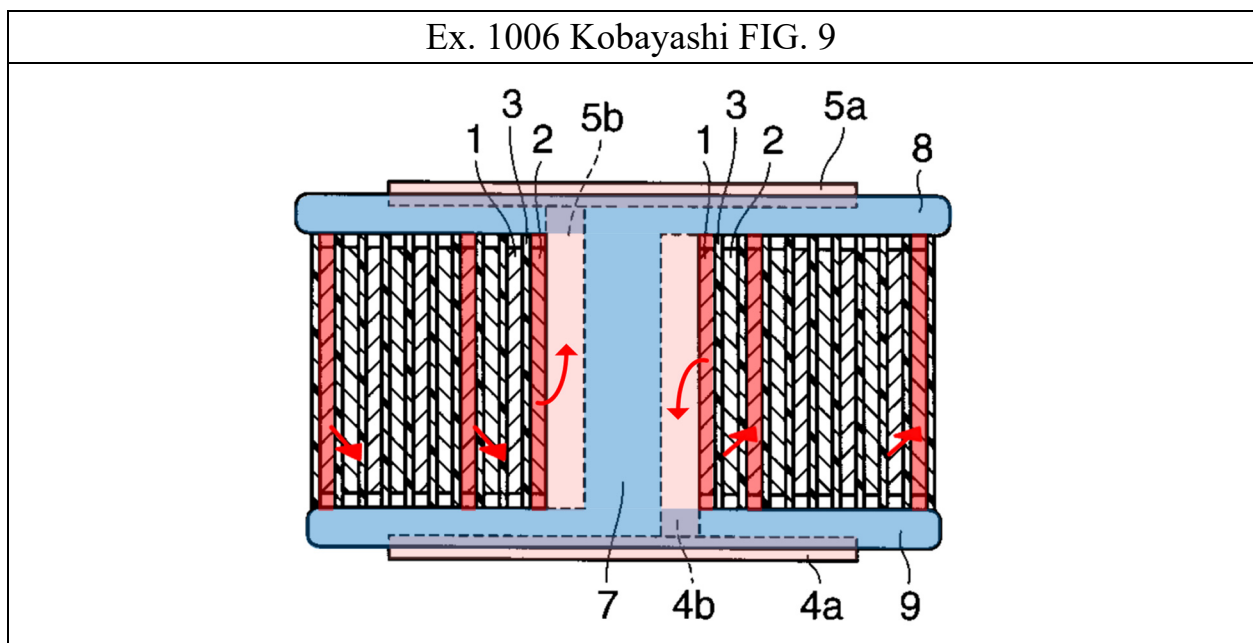

523. As indicated by the red arrows, the current flow in the cell of Kobayashi spirals around the wound lengths of the positive and negative electrodes 1, 2 to the central rod-like terminal connection parts 4b, 5a then vertically upwards and downwards to the disc-like positive and negative terminal plates 4a, 5a that contact the positive and negative electrode cases 11, 13. Moreover, the current

flow must circumnavigate and spiral through the wound electrodes windings 1, 2, possibly many times, to reach the central contact point with the terminal connection parts 4b, 5b located in the winding axis core 7. This is an exceeding long current path compared to the direct and continuous edge contact between the electrodes and the positive and negative cups that form the housing.

524. From the foregoing, Kobayashi differs from Kaun in two principle respects: (1) Kobayashi does not include direct and continuous edge contact in which the majority of electron flow is axial and (2) Kobayashi uses additional terminal connection parts to conductively connect the electrodes to the plates welded to the electrode cases, extra conductive components which Kaun teaches not to use. A POSA would have fully appreciated these fundamental differences and because the structure of Kobayashi is directly contrary to Kaun's teachings, a POSA would not have been motivated to modify Kaun's cell to include Kobayashi's electrode assembly.

#### **5. The Proposed Modification Would Require a Complete Rebuild of Kaun**

525. The proposed modifications to Kaun to use the Kobayashi wound electrode group is such a significant change in design and application that a POSA would not have reasonably expected that it could be successfully done. Furthermore, because many of these changes are contrary to the disclosure of Kaun, a POSA would have been discouraged from attempting to do so.

526. Kaun is directed to a battery for delivering power on the order of hundreds of amps for high powered applications like hybrid vehicles and power tools. Ex. 1005 ¶¶ [0004], [0021], [0007]. A POSA contemplating using Kaun's housing with Kobayashi's electrode assembly need to make significant modifications for the combination to work, for which Mr. Gardner has not provided any details.

527. A POSA would, for example, have had to redesign the Kaun housing to incorporate the electrode group of Kobayashi. That would involve including the winding axis core 7 and the disc-like terminal plates 4a, 5a and bar-like terminal connection parts 4b, 5b integrated with the winding axis core. This is all contrary Kaun's teaching of a battery that does "not require a highly conductive electrode current collector." *Id.* ¶ [0128].

528. A POSA would also have had to eliminate the direct and continuous edge contact, which is the essential feature of Kaun, and changing the direction of current flow from that of Kaun, where "[t]he majority of electron transfer takes place in the axial direction along the flattened electrodes" to that of Kobayashi, where current spirals along wound up lengths of the electrodes 1, 2 before passing to the terminal connection parts 4b, 5b in the winding axis core 7 and then flowing vertically to terminal plates 4a, 5a at either end of the winding core. *Id.* ¶ [0018];

Ex. 1006 ¶ [0032]. For reference, the different current flow paths are annotated below:

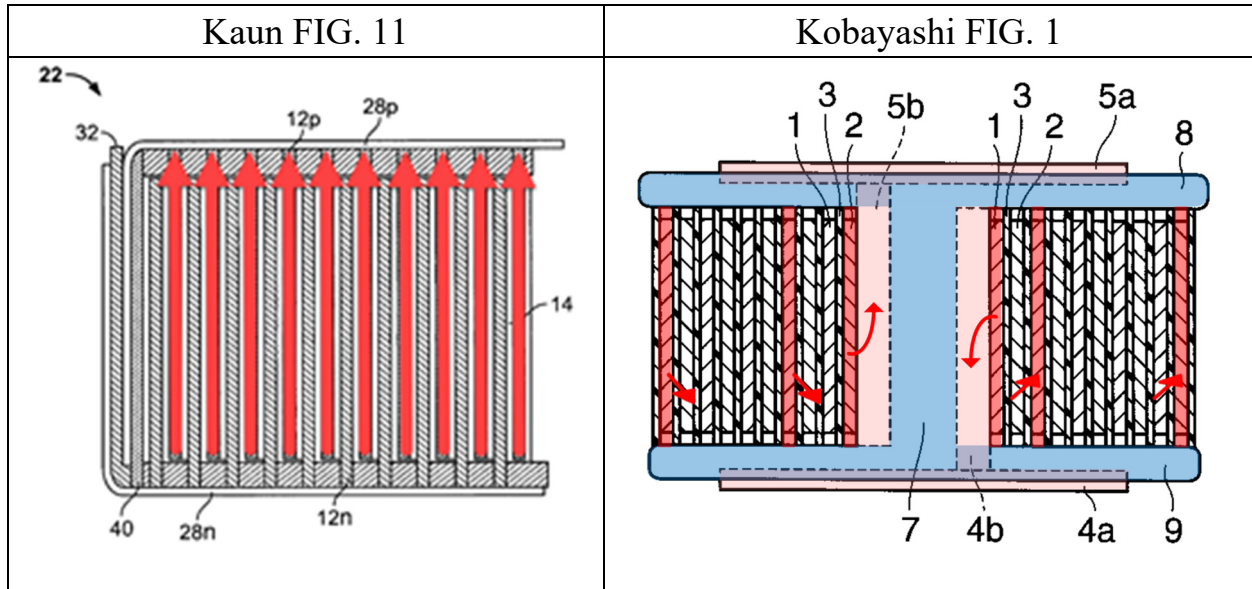

529. The change in flow direction is contrary to the Kaun’s preference for “short electronic current paths along the lengths of the electrode,” and would dramatically increase impedance beyond what Kaun teaches would be acceptable for high pulse power discharge. Ex. 1005 ¶¶ [0018], [0128].

530. A POSA would further have to redesign the closing mechanism in Kaun and eliminate the safety mechanism that vents to relieve overpressure inside the battery. *Id.* ¶ [0130]. This is contrary to Kaun’s direction that “there needs to be non-catastrophic, cost effective means to relieve the gas pressure.” *Id.* ¶ [0023].

531. Finally, a POSA would need to incorporate two mutually exclusive structures: the central fastener, an essential element in Kaun, with the winding axis core in Kobayashi, an essential component of that reference. The fastener of Kaun,

however configured, is impractical for the small microbattery button cell of Kobayashi. No guidance is provided by Mr. Gardner on how that can be done.

532. In my opinion, the above issue would lead a POSA to conclude that Kaun could not be modified in view of Kobayashi as proposed by Mr. Gardner. There is no element that could be usefully imported from Kobayashi into Kaun nor Kaun into Kobayashi given the disparity of the cells described in those two references.

#### **6. Kaun also Teaches Away from Kwon**

533. The Kaun reference is related to another patent application published at U.S. 2003/0013007 A1 (“Kaun ’007, Ex. 2013). The Kaun ’007 publication is directed to the same direct and continuous edge contact between the electrode separator assembly and the electrode casings. The Kaun ’007 publication lauds the same advantages of direct and continuous edge contact that provide “the short electronic current flow paths along the lengths of the electrodes (less than 10 mm) do not require highly conductive electrode current collector supplementing or paralleling the electrodes.” Ex. 2013 ¶ [0094].

534. The Kaun publication also states that the direct and continuous edge contact between electrodes and separators and the electrode cases occurs without welding.

The electrode layers extend beyond the periphery of the separator layers providing superior contact between the electrodes and battery

terminals, eliminating the need for welding the electrode to the terminal. Electrical resistance within the battery is decreased and thermal conductivity of the cell is increased allowing for superior heat removal from the battery and increased efficiency. Ex. 2013 Abstract.

535. A POSA would have considered the teachings of this related publication in consider modifications to Kaun. A POSA would have concluded that the electrode layers directly abut the inner surface of the casing to establish direct and continuous edge contact “eliminating the need for welding the electrode to the terminal.” Accordingly, a POSA would not look to the Kwon reference “wherein the metal cases (20) (20’) and polarized electrodes (10) (10’) are welded by laser.” Ex. 1008 Abstract.

#### **7. The Proposed Modification Would Require a Complete Rebuild of Kaun**

536. The proposed modifications to Kaun to use the Kobayashi wound electrode group is such a significant change in design and application that a POSA would not reasonably expect that it could be successfully done. Furthermore, because many of these changes are contrary to the disclosure of Kaun, a POSA would actually be discouraged from the attempt.

537. Kaun is directed to a battery for delivering power on the order of hundreds of amps for high powered applications like hybrid vehicles and power tools. Ex. 1005 ¶¶ [0004], [0021], [0007]. As initial matter, to be comparable to the invention of the Challenged Patent, a POSA would have to miniaturize the



entire structure of Kaun. Mr. Gardner does not provide guidance on how this initial step can be accomplished.

538. A POSA would then have to redesign the Kaun housing to incorporate the electrode group of Kobayashi. That would involve including the winding axis core 7 and the disc-like terminal plates 4a, 5a and bar-like terminal connection parts 4b, 5b integrated with the winding axis core. This is contrary to the teachings of Kaun's battery, which does "not require a highly conductive electrode current collector." Ex. 1005 [0128].

539. Those changes would also involve eliminating the direct and continuous edge contact, which is the essential feature of Kaun, and changing the direction of current flow from where "[t]he majority of electron transfer takes place in the axial direction along the flattened electrodes" to that of Kobayashi, where current spirals along wound up lengths of the electrodes 1, 2 before passing to the terminal connection parts 4b, 5b in the winding axis core 7 and then flowing vertically to terminal plates 4a, 5a at either end of the winding core. Ex. 1005 ¶ [0018]; Ex. 1006 ¶ [0032]. For reference, the different current flow paths are annotated below:

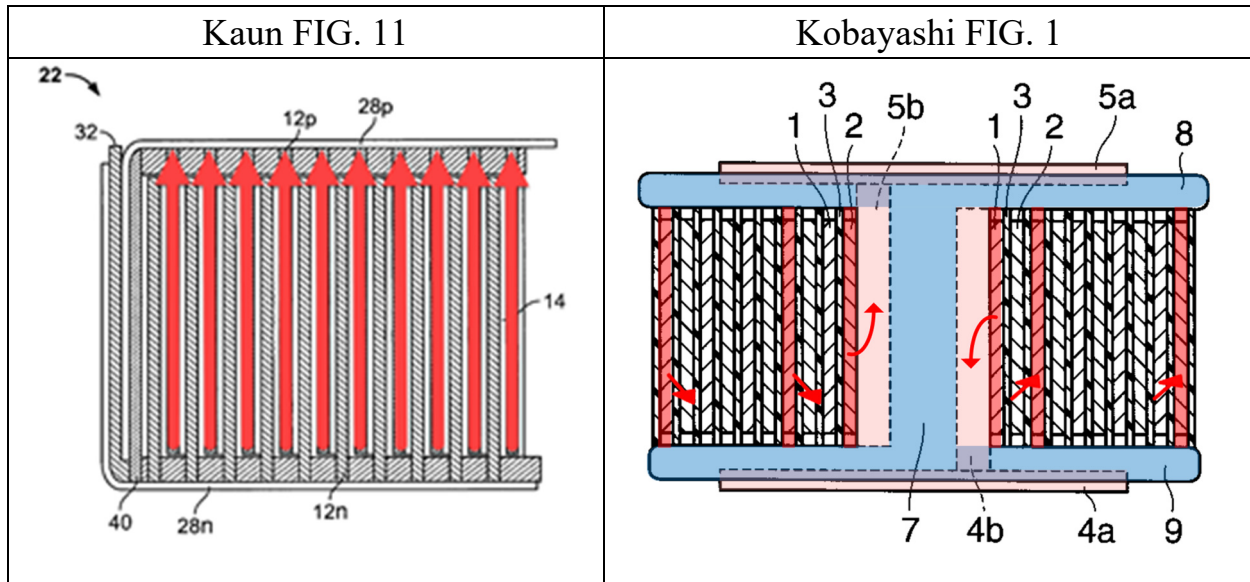

540. The change in flow direction is contrary to the Kaun’s preference for “short electronic current paths along the lengths of the electrode,” and would dramatically increase impedance beyond what Kaun teaches would be acceptable for high pulse power discharge. Ex. 1005 ¶¶ [0018], [0128].

541. A POSA would further have to redesign the closing mechanism in Kaun and eliminate the safety mechanism that vents to relieve overpressure inside the battery. Ex. 1005 ¶ [0130]. This is contrary to Kaun’s direction that “there needs to be non-catastrophic, cost effective means to relieve the gas pressure.” Id. ¶ [0023].

542. Finally, a POSA would need to incorporate two mutually exclusive structures: the central fastener, an essential element in Kaun, with the winding axis core in Kobayashi, an essential component of that reference. The fastener of Kaun,

however configured, is impractical for the small microbattery button cell of Kobayashi. No guidance is provided by Mr. Gardner on how that can be done.

543. All these issues would lead a POSA to reasonably question whether Kaun could possibly be modified in view of Kobayashi. There is no element that could be usefully imported from Kobayashi into Kaun nor Kaun into Kobayashi.

**8. Kaun in view of Kobayashi and Kwon Does Not Disclose or Suggest the Features of Dependent Claims 6 and 8**

544. As discussed at ¶¶ \_\_\_, Kobayashi does not disclose or suggest “at least one separate insulator which prevents direct electrical contact between the lateral end sides of the winding and the conductor.” Petitioners and Mr. Gardner do not allege that Kaun or Kwon discloses or suggests this feature. Accordingly, a POSA would understand that claim 6 is patentable over the references.

545. As discussed at ¶¶ \_\_\_, Kobayashi and Kwon do not disclose or suggest the winding comprises at its center an . . . cylindrical axial cavity delimited laterally by the winding and on lateral end sides by a subregion of the bottom or top region, respectively, and at least one of the conductors contains a weld with a corresponding housing half in the subregion.” Petitioners and Mr. Gardner do not allege that Kaun or Kwon discloses or suggests this feature. Accordingly, a POSA would understand that claim 8 is patentable over the references.

**C. The '858 Patent Claims Are Not Obvious Over the Combination of Kobayashi, Kwon and the Knowledge of a POSA**

**1. Kobayashi, Kwon and the Knowledge of a POSA Fail to Disclose or Suggest a “Metal Foil” Conductor**

546. Independent claim 1 of the '858 Patent requires a metal foil that “bears flat” on one of the lateral end sides of the electrode winding. In the patent specification, “the conductors of a button cell are flat conductors, in particular metal foils, particularly preferably rectangular, strip- or band-shaped metal foils.” Ex. 1001 '858 Patent 4:22-24. “[T]he conductor or conductors bears flat on the inner side of the housing half or halves” and “are welded onto the inner side of the housing in the plane bottom region or the plane top region.” Id. 4:51-54, 4:65-5:5.

547. Kobayashi does not teach a metal foil that “bears flat” on one of the lateral end sides of the electrode winding. Kobayashi instead discloses “a disc-shaped positive electrode terminal plate 4a” and “bar-shaped terminal connection part 4b . . . electrically connected to the positive electrode terminal plate 4a.” Ex. 1006 ¶ [0028]. Likewise, Kobayashi discloses a negative “disc-shaped negative electrode plate 5a” and a “bar-shaped terminal connection part 5b” to connect the negative electrode to the negative housing casing 13. These are shown in FIG. 1 of Kobayashi below in which the positive and negative terminal plates 4, 5 are red.

Ex. 1006 Kobayashi FIG. 5

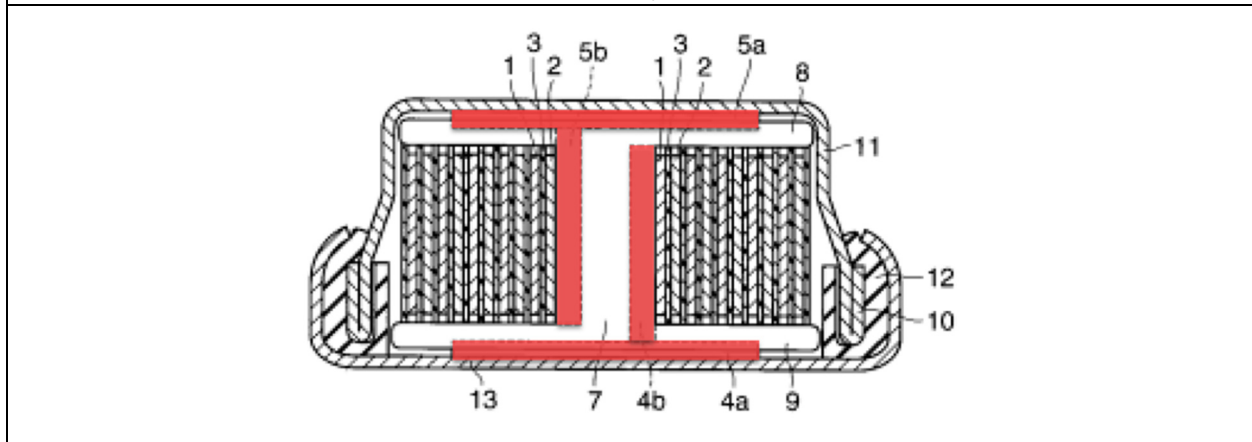

548. A POSA would have understood a rigid “disc-like terminal plate” to be different from a metal foil conductor. A “plate” would necessarily involve or impart a sense of structural rigidity. The metal foil conductors in the ‘858 patent claims, by contrast, are flexible in order to (a) provide resilience in the button cell to accommodate mechanical forces generated during charge and discharge cycles and withstand external mechanical influences, and (b) facilitate assembly of the button cell in which the foils are folded and rest flat between the end faces of the spiral winding and the flat top and bottom areas of the housing.

## 2. A POSA Would Not Have Been Motivated to Make the Terminal Plates of Kobayashi to Be Foils

549. I disagree with Mr. Gardner that it would have been obvious to modify Kobayashi to use foils in place of the metal plates. The references he cites throughout his report do not teach metal foil conductors to connect electrodes to respective terminal halves in button cells. They also do not teach metal foil

conductors that bear flat between the end faces of a spiral winding and flat areas of a button cell housing cup and top.

550. Mr. Gardner relies on a very general proposition that a POSA would have been motivated to reduce the size of the inactive components in the cell. Ex. 1003 ¶ 323, citing Ex. 1009 (Linden) at 35, 879, 1294. These citations are directed to cylindrical and prismatic NiMH battery designs (at 879), or to Sodium-Beta batteries for large-scale energy storage applications (at 1294). In that context, the citations relate to considerations regarding the electrodes, which are not the same as for output conductors which route current from the electrodes to the housing. *See* Ex. 1009, at 1294. In any event, reduction of the size and/or weight of inactive component in the battery cell would be one general factor of numerous factors that would have been considered a POSA, many of which are unique to button cell design.

551. Mr. Gardner's citations to the Linden Handbook concern conventional cylindrical or prismatic batteries with NiMH and sodium-beta chemistries and are not button cells. Ex. 1009 pp.1285, 1294. The teachings regarding conventional batteries were not readily applicable to miniature rechargeable button cells. His citations also concern the effect of electrode thickness on battery performance, which does not apply to output conductors. (See *id.* at 1294: "The structure and

thickness of the positive electrode can have a substantial effect . . . . The thickness of the negative electrode is not an electrical factor . . . .”).

552. The factors a POSA would have considered in designing or modifying the internal components of a button cell would have included an evaluation of the purpose and function of the components already present in the button cell. A POSA would have needed to balance the quantity of active electrode material as compared to inactive material that could be placed in the cell based on requirements of safety, and application of the end battery product. The structural integrity of the battery and whether any changes would compromise that integrity would also need to be considered. All of these design factors would dictate whether a POSA would have modified Kobayashi as proposed by Mr. Gardner. I have not seen where Mr. Gardner has considered any of them.

553. The size and manufacturability of the button would also have been a critical factor. A POSA would have considered Kobayashi’s teachings “that size reduction extremely difficult . . . and the limit has currently substantially been reached. Ex. 1006 ¶ [0007].

554. Kobayashi addresses the difficulties in manufacturing a miniature button cell having a “flat electrode group in which containing a positive electrode and a negative electrode is spirally wound,” the type of cell that was previously thought impossible. Ex. 1006 ¶¶ [0009], [0014]. Kobayashi attempts to “simplify

the structure installing a terminal on the winding axis core to be incorporated into the electrode group to connect the electrode and the metal case doubling as an external terminal.” Id. ¶¶ [0018]. By integrating the electrode terminals 4, 5 including the disc-like terminal plates 4a, 5a to the winding core, Kobayashi provides enhanced manufacturability of the button cell.

555. Kaun also discourages the use of current collectors that “add significant weight, and thus reduce specific cell energy and power outputs.” Ex. 1005 ¶ [0018]. Kaun teaches eliminating current collectors and other connective elements between the electrodes and terminals in favor of direct edge contact. Id. ¶¶ [0018], [0128] (“the short electron current flow paths along the lengths of the electrodes . . . do not require a highly conductive electrode current collector supplementing or paralleling the electrodes.”)

556. A POSA would not have modified Kobayashi’s metal plates to be foils without assessing these concerns and considerations.

**3. A POSA Would Not Have Been Motivated to Modify Kobayashi with General Knowledge**

**a. The Proposed Modification Would Eliminate Kobayashi’s Winding Axis Core**

557. Kobayashi would have discouraged a POSA from replacing Kobayashi’s metal plates with foils. Kobayashi’s metal plates are critical elements



in to his winding axis core. Replacing Kobayashi's metal plates with foils would render the Kobayashi cell non-functional.

558. The winding axis core and its interaction with the electrode assembly are critical aspects of Kobayashi. According to Kobayashi, "by incorporating at least a winding axis core into the electrode group structure, and as needed, an insulation plate and contacting terminals between electrodes and external terminals" the Kobayashi structure overcame an alleged "impossibility." Ex. 1006 ¶ [0015]. His structure "enabled efficient storage of the electrode group in which a positive electrode, a negative electrode, and a separator are wound in a few layers to a few dozen layers within a case of a small battery."

559. The metal conductor plates 4a, 5a on the top and bottom of the winding axis core function to route current to the casings 11, 13. They also maintain the structural integrity of the electrode assembly. At its heart, Kobayashi integrates the conductor terminals 4, 5 into the winding core by seating the metal conductor plates 4a, 5a into the grooves formed in the insulation plates 8, 9. The metal plates are also connected to terminal posts (elements 4b, 5b) in the notches in the winding core axis 7, the components register in alignment and are rigidly interlocked with respect to each other.

560. The integration and interaction of the components enables the winding of the electrode assembly, and it maintains the resulting electrode assembly and

additional structure in place inside the housing. The electrode assembly is wound by placing the terminal connection rods into notches (7a, 7b) so the electrodes can be crimped around slits (4c, 5c) formed in the connecting rods, registering metal conductor plates (5a, 4a) into recesses (8a, 9a) formed in winding core insulating members (8, 9), and then coiling the electrodes around the winding core. *See id.*: Once the conductive terminals 4, 5 and the winding member 6 are integrated, “the positive electrode 1 and the negative electrode 2 are spirally wound with the separator 3, thereby preparing a flat electrode group.”

561. A POSA would have understood that the electrodes 1, 2, are placed in tension as they are wound around the winding axis core. A POSA would also have understood that the integrated assembly of the disc-like terminal plates 4a, 5a within the insulation plates 8, 9, which register and secure the terminal posts 4b, 5b in the winding axis core, stabilizes the assembly when winding the electrode and separator.

562. A POSA would also have understood that winding the electrodes 1, 2, and separator 3 about the winding axis core 7 would be difficult and perhaps impossible without the integrated assembly of the terminals 4, 5 and terminal plates 4a, 5a registered with respect to the winding member 6. Mr. Gardner did not consider this benefit of the disc-like terminal connection plates 4a, 5a and their removal would eliminate a prominent feature of Kobayashi.

563. The metal conducting plates 4a, 5a also present a sufficient surface in order to make reliable contact with the housing. They extend axially beyond the planar insulating plates 8 and 9 of the winding member 6 to expose the plates. A POSA would understand that if the metal plates did not so extend, cell would be inoperative because there would be an open circuit between electrode and housing.

564. The thickness of the terminal plates 4a, 5a and depth of the grooves in the insulation plates 8, 9 ensures the plates are exposed to contact the casings 11, 13, thereby improving service life and ensuring reliable manufacturability of the Kobayashi button cell due to the reliable contact between the metal conducting plates and the housing

**b. A POSA Would Not Have Been Motivated to Use Foils**

565. I also disagree with Mr. Gardner that a POSA would be motivated to use foils in the Kobayashi design rather than the disc-like terminal plates “in order to increase overall volume in the cell that is available for active components.” Ex. 1003, ¶¶ 250, 323. As can be seen in the annotated FIG. 1 of Kobayashi below, the available volume overall would only be very slightly improved by replacing the metal plates with foils. The terminal plates 4a, 5a (red) are already recessed in the insulation plates 8, 9; there is minimum clearance between the insulator plates and the inner surfaces of the casings 11, 13. Some portion of the metal plates must be exposed, as is already shown by Kobayashi, to complete the electrical connection

from the terminal connecting rods 4b, 5b (which secure the electrodes) in the winding axis core to casings 11, 13. A POSA would not eliminate the metal conducting plates 4a, 5a and the associated advantages in the Kobayashi design.

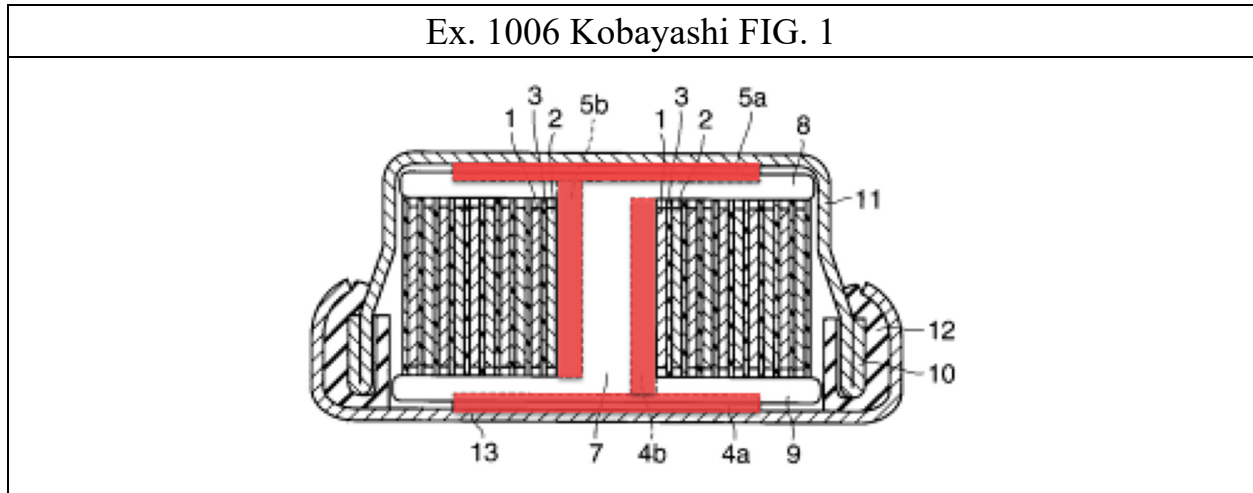

566. A POSA would have been discouraged from modifying the metal plates to be foils because it would result in an unsatisfactory electrical connection. Mr. Gardner does not explain what, if any, further modifications he would have made to maintain the structural stability of Kobayashi's winding axis core, while deploying metal foils.

567. A POSA would have also understood that metal foils would have been difficult to attach to other components of Kobayashi's cell. For example, it would have been difficult, if not impossible, to reliably attach a flexible metal foil to the terminal connecting rods 4b, 5b due to the relative thickness of these different components. By contrast, a POSA would have understood that a rigid metal plate would be much easier to attach reliably to the connecting rods. Such knowledge

would also have discouraged a POSA from modifying Kobayashi's metal plates to be foils.

568. At the heart of Kobayashi's invention is a unitary winding axis core made as a rigid connection system, including metal terminal plates rigidly connected to terminal rods holding the electrode ends, which are integrated into a unitary winding core. A POSA would not have modified Kobayashi in the manner proposed by Mr. Gardner, which are contrary to Kobayashi's teachings.

#### **4. Kobayashi Will Not Operator with a Foil Conductor**

569. Kobayashi teaches that the insulation plates 8, 9 include respective circular grooves to accommodate "the positive electrode terminal plate 4a" and a "the negative electrode terminal plate 5a." Ex. 1006 ¶ [0030]. The winding axis core is integrated when the metal conducting plates are registered in the grooves formed in the insulation plates. Id. ¶ [0031].

570. The metal conductor plates 4a, 5a are thus partially recessed in the notches 8a, 9a formed in the insulation plates 8, 9. This serves to register the rod-like terminal connector posts 4b, 5b to which the metal conductor plates 4a, 5a are integrated within the winding axis core 7 so that the electrodes 1, 2, and separator 3 can be wound about the winding assembly 6. Petitioners and Mr. Gardner do not address how a POSA would modify Kobayashi to incorporate foils in a manner

that could be integrated with and registered within the notches 8a, 9a in the insulation plates 8, 9.

571. A metal foil would lack the necessary surrounding structure to hold the terminal connector posts firmly in place. It would be unable to register, i.e. interlock with, the terminal connector posts and the winding axis core such that there would no longer be an integrated electrode group disposed about a unitary winding core. This would also prevent winding of the electrodes about a winding core with which they are integrated, which a POSA would understand to be the essence of Kobayashi.

572. It is unclear to me how a POSA would have understood the foils to be “integrated” with the terminal connector posts 4b, 5b in the same manner that the metal conductor plates 4a, 5a can be integrated with the connector posts. The metal conductor plates 4a, 5a and terminal connector rods 4b, 5b can be fairly easily joined prior to integration with the winding axis core. Electrically connecting the terminal connector posts 4b, 5b to a thin foil cannot be easily or reliably done, either by a rigid attachment or by simple abutting contact.

573. Further, the foil would presumably be recessed in the notches 8a, 9a formed the insulation plates. It would not electrically contact the surfaces of the positive and negative electrode casings 11, 13. This would likely result in an open circuit condition and an inoperable cell. Mr. Gardner did not consider that a thin

foil recessed in the notches 8a, 9a of the insulation plates 8a, 9a would not provide a reliable connection between the terminal connector rods 4b, 5b in the winding axis core and the inner surfaces of the casing 11, 13. The proposed combination would result in an inoperable button cell.

574. In this arrangement, the thickness of the terminal plates 4a, 5a and depth of the grooves in the insulation plates 8, 9 ensures contact with the casings 11, 13 thereby prolonging service life and ensuring reliable manufacturability of the Kobayashi button cell. A POSA would be not be motivated to eliminate the terminal plates and lose this manufacturing advantage.

575. Kobayashi describes that method for “electronically connecting the terminal to the metal case doubling as an external terminal includes welding such as resistance welding and ultrasonic welding.” Ex. 1006 ¶ [0018]. A POSA would recognize the benefit of welding the disc-like terminal plate with a large surface area and thick to the inner surface of the electrode casings over the comparative difficulty in welding a thin metal film, which could experience alignment problems or burn through. This is an additional reason a POSA would be discouraged from using a foil in Kobayashi.

##### **5. The Proposed Modification Would Render Kobayashi Inoperable for its Intended Purpose**

576. The metal conducting plates 4a, 5a are partially recessed in the notches 8a, 9a formed in the insulation plates 8, 9. Ex. 1006 ¶¶ [0031]-[0032].

This serves to register the terminal connection rods 4b, 5b within the winding axis core 7 to allow the electrodes and separator to be wound. A POSA would understand this integrated assembly to stabilize the assembly, which would be impossible using metal foils.

577. A POSA would have understood that a metal foil would lack the necessary rigidity to support the components of the winding axis core. This would be the case for both winding the electrodes and stabilizing the structure within the housing.

**6. A POSA Would Not Have Reasonably Expected to Successfully Achieve the Claimed Invention**

578. The use of foils for the terminal plates 4a, 5a of the electrode terminals in Kobayashi is such a significant change, that a POSA would not have reasonably expected to successfully arrive at what is claimed in the VARTA patents. Kobayashi's metal conducting plates are critical elements that perform an important function regarding the assembly and structural stability of the electrode group. In their absence, a POSA would need to completely redesign the Kobayashi cell.

579. A POSA would have understood that the design of Kobayashi's winding axis core would need to be completely changed. The winding axis core relies on the interlocked structure of the metal conducting plates 4, 5 to wind the electrodes 1, 2 and separator.



580. If the metal conducting plates 4a, 5a were made to be foils, a POSA be required to rearrange all remaining components that securely anchor the spiral wound electrodes and separator, including the winding axis core itself. A POSA would have had to redesign the terminal connection posts 4b, 5b received in the winding axis core 7 because they would no longer be securely held in place. A POSA would also have had to redesign the insulating plates 8, 9 because they would not allow metal foils to easily or reliably contact the housing. A POSA would likely have to abandon the concept of integrating the electrodes and separator with the winding axis core.

**7. Kobayashi Does Not Disclose or Suggest the Features of Dependent Claims 6 and 8**

581. Dependent claim 6 further recites “at least one separate insulator which prevents direct electrical contact between the lateral end side of the winding and the conductor.” This “one separate insulator” is in addition to the insulating elements that shield the metal foils from the lateral end side of the winding. Petitioners, however, identify the insulation plates 8, 9 (first and second insulating 40 members) integrated with the upper end and lower end of the winding axis core 7” as satisfying both the insulation elements of claim 1 and one separator insulator of claim 6. Ex. 1003 ¶¶ 388, 399. This is wrong.

582. The specification discloses two type of insulators. For example, with respect to FIG. 1, the '858 specification describes that the “conductors are shielded

from the end sides of the winding by the insulating elements 112 and 113. The latter are thin plastic films.” Ex. 1001 ’858 Patent 7:12-14. With respect to FIG. 3A and 3b, the ’858 specification also describes insulating tapes 207, 208 that are adhesively bonded to the conductors 203, 204. Id. 7:45-52. Mr. Gardner does not explain why or how the same insulating plates 8, 9 in Kobayashi discloses or suggest two different elements in the disclosure of the ’858 Patent, and accordingly has not shown this claim to be invalid.

583. Dependent claim 8 further recites “the winding comprises at its center an . . . cylindrical axial cavity delimited laterally by the winding and on lateral end sides by a subregion of the bottom or top region, respectively, and at least one of the conductors contains a weld with a corresponding housing half in the subregion.” The specification states that “welding the conductors to the housing is particularly preferably carried out in the subregion of the bottom or top region, which delimits the axial cavity at the center of the winding.” Ex. 1001 ’858 Patent 6:28-39. The reason for welding the housing and the conductor in the region of the axial cavity is to protect the button cell and activate components and avoid possible damage if the laser preferred for welding is too strong.

584. Kwon discloses welding a solid “polarized electrode” to the capacitor housing and does not disclose or suggest a jelly roll that might have an axial cavity and does not disclose welding at any particular subregion or location with respect

to the capacitor housing and solid electrode therein. Kwon has nothing to disclose with respect to dependent claim 8

585. Kobayashi also does not disclose or suggest welding at a subregion with respect to the axial cavity and in fact does not disclose or suggest an axial cavity. As shown in FIG. 8, and with respect to the positive electrode, Kobayashi directs that “the current-carrying part 1c of the positive electrode 1 was inserted into the slit 30 4c in the terminal connection part 4b of the positive electrode terminal 4, pressure was applied to the terminal connection part 4b from the outside, and the current-carrying part 1c was crimped to the terminal connection part 4b.” Ex. 1006 ¶ [0028]. The negative electrode 2 and the negative terminal are similar assembly. The bar-like terminal connection parts 4b, 5b are then inserted into the notches in winding axis core 7. *Id.* ¶ [0031]. The current carrying parts of the electrodes, i.e., the metal foils, and the termination connection parts are necessarily present in the winding core axis

586. A POSA would not understand Kobayashi as disclosing or suggesting “winding comprises at its center an essentially cylindrical axial cavity delimited laterally by the winding” per claim 8. The winding axis core of Kobayashi contains the bar-like terminal connection parts 4b, 5b, the current carrying electrode 1c, 2c, and other features and is not “delimited by the winding” or

“essentially cylindrical.” The winding axis core is filled with other components and is not a cavity.

### **XIII. SECONDARY CONSIDERATIONS CONFIRM THAT THE CHALLENGED PATENTS ARE NOT OBVIOUS**

#### **A. The VARTA CoinPower® Button Cells Practice the Inventions of the Challenged Patents**

587. VARTA manufactures and sells commercial embodiments of the patented button cells under the tradename CoinPower® in various models, including CP1254, CP1454, and CP1654 (“the VARTA CoinPower® button cells”). The VARTA CoinPower® button cells typically have an overall height less than their diameter and typically having heights of about 5.4 mm and diameters between 12 mm and 16 mm and, therefore, are a “button cell.” The first two numbers in the model name denote the diameter of the button cell (e.g., a CP1254 has a 12mm diameter) and the last two numbers the height of the button cell (e.g., a CP1654 has a 5.4mm height).

588. I have conducted physical examination of the VARTA CoinPower® button cell and studied information, such as engineering drawings and graphical depictions (including photographs) of the VARTA CoinPower® button cells. Below are CoinPower® button cells that I understand are often used in True Wireless Stereo (TWS) applications

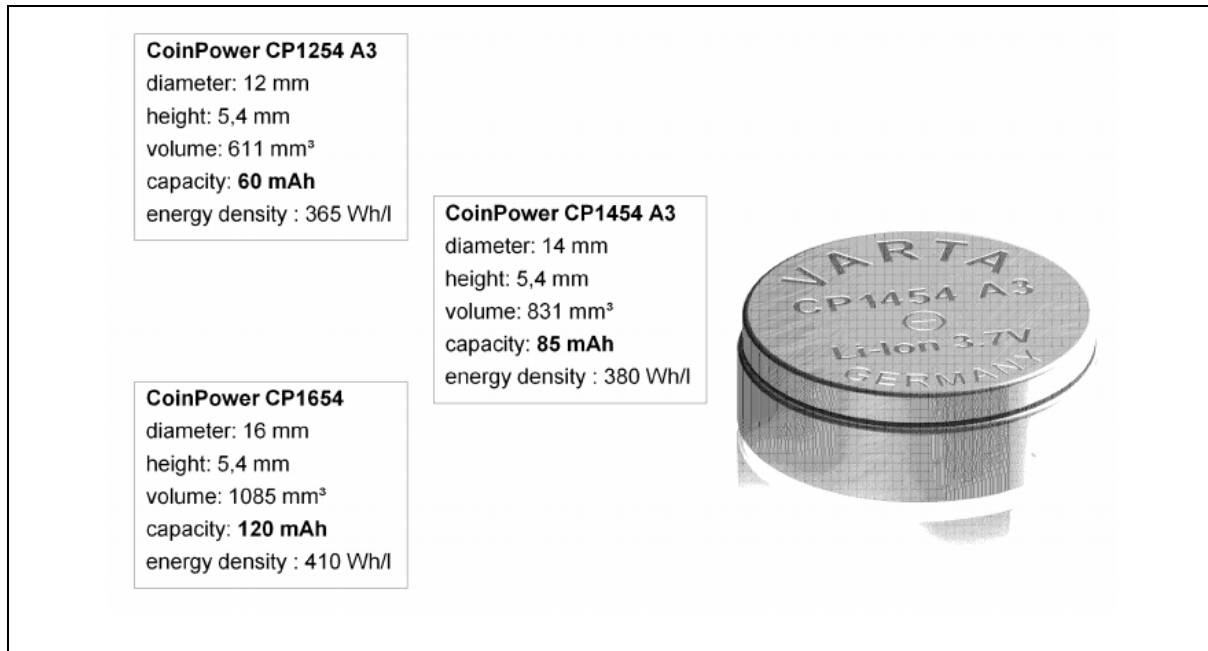

589. Based on public information, I understand that the VARTA CoinPower<sup>®</sup> button cells are used by original equipment manufacturers such as Apple, Samsung, Jabra, and Bose, among others. Ex. 2031 (Forbes) at 3.

590. The VARTA CoinPower<sup>®</sup> button cells are constructed using the patented features to pack as much active material into the small form factors associated with microcells. The positive and negative electrodes and the ion permeable separator of the VARTA CoinPower<sup>®</sup> button cells are formed as long continuous flat strips and are spiral wound into a compact jelly roll to maximize the amount of active material in the button cell. The spiral wound jelly roll configuration is also advantageous for its high rated performance. The winding of the positive and negative electrodes in the jelly roll configuration provide a large interfacial surface area between the electrodes for the electrochemical reaction to

take place in a short amount of time. The parasitic ionic resistance offered by the separator to charge transport between the cathode and anode plates in the cell is minimized by increasing this interfacial area.

591. The jelly roll is positioned in the housing with the electrode layers of the jelly roll aligned at right angles to the planar top and planar bottom areas of the cell cup and cover. As the volume of the electrodes changes due to intercalation during discharging and charging cycles, the forces and loads arising from the volume change are largely directed radially with respect to the overlapped cut edges of the housing cup and top.

592. The right-angled orientation of the jelly roll inside the housing considerably improves the sealing of the button cell in which the housing cup and housing top of the VARTA CoinPower<sup>®</sup> button cells may be closed without being beaded over. The orientation of the jelly roll in the housing helps improve the mechanical connection of the housing component and represents a significant breakthrough in button cell design. The wound jelly roll is contained in a housing fabricated from a conductive housing cup and a housing cover that are inserted together and closed by a static friction fit between overlapping cut edges.

593. Metal foils are used in the VARTA CoinPower<sup>®</sup> button cells as output conductors to conduct electric current between the positive and negative electrodes in the jelly roll and the housing cup and housing top of the correct polarity. When

the button cell is discharging and charging, the flexible foil conductors allow the jelly roll to “breathe,” i.e., expand and contract relative to the housing as the volume of the electrodes changes during charge/discharge cycles. The foil conductors of the VARTA CoinPower<sup>®</sup> button cells rest flat between one of the faces of the spiral wound jelly roll and the housing top and housing cup, respectively, to permit the jelly roll to essentially fill the internal volume of the housing.

594. To protect the output conductors from shorting against electrodes of opposite polarities (particularly during swelling and shrinking of the jelly roll during charging and discharging), insulation layers in the form of non-conductive plastic films are placed flat between the conductors and the jelly roll. These thin insulating elements perform their electrical isolating function but are located only at critical areas inside the button cell to permit the space inside the housing to be almost fully occupied by the jelly roll.

595. The VARTA CoinPower<sup>®</sup> button cells embody the claimed features of the Challenged patents and are coextensive with them. These points are elaborated on below.

596. The features of the VARTA CoinPower<sup>®</sup> button cells are coextensive with the Challenged Patents in that the features that distinguish them from conventional button cells are features covered by the Challenged Patents. For

example, the construction and arrangement of the jelly-roll electrode separator assembly in the button cell housing along with at least one other of the foregoing features has enabled the VARTA CoinPower® button cells to obtain its unprecedented performance advantages, including maximizing the active material and energy density while advantageously directing expansion and contraction loads to improve cycling characteristics and prolong service life.

597. I show below particular depictions of the CP1254 model of the VARTA CoinPower® Batteries, which I consider to be representative of all of the VARTA CoinPower® button cells in general.

**1. The VARTA CoinPower® Batteries Practice the '835 Patent**

598. In my opinion, the VARTA CoinPower® button cells practice at least claim 1 of the '835 patent.

599. The VARTA CoinPower® button cells embody the claimed features of the '835 patent and are coextensive with them. The VARTA CoinPower® button cells not only contain the patented features, but those products are to a substantial extent made up of them. These claimed features provide increased energy density to be packed in the cell housing while maintaining improved cycling ability. In the specific context of the claims of the '835 patent, these features include: a jelly roll configuration that facilitates optimal use of limited space in the housing because it is perpendicular to flat top and bottom portions of the housing; a non-beaded over



housing helps maximize space for active material; and the jelly roll is protected by an insulating layer to avoid short circuits, particularly during swelling and shrinking of the jelly roll during charging and discharging. This structure also provides greater stability of the button cell, representing a significant breakthrough in button cell design.

600. With respect to independent claim 1 of the '835 Patent, the CoinPower® button cells include a housing formed from a housing cup and a housing top separated from each other by an electrical insulating seal. The housing cup and housing top can be made from nickel plated stainless steel and the insulating seal can be injection molded from a non-conductive thermoplastic material. The housing cup has a flat bottom area and the housing top has a flat top area that is parallel to the flat bottom area as shown below.

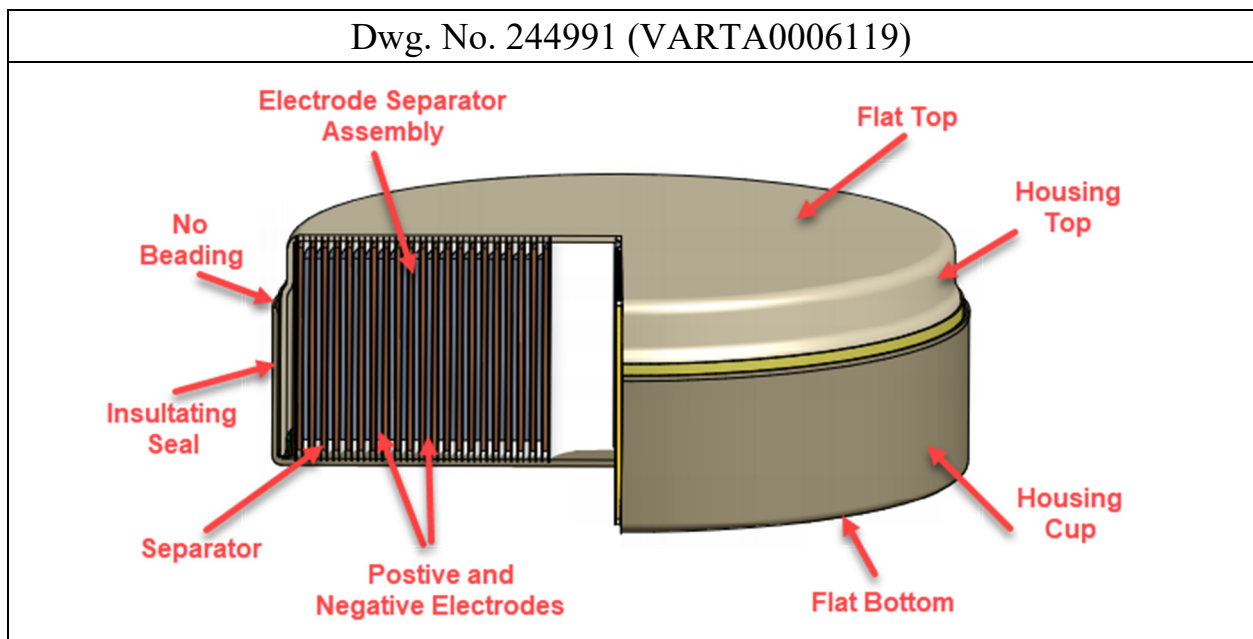

601. The CoinPower® button cells include an electrode-separator assembly within the housing that has a positive electrode and a negative electrode in the form of flat layers and that are connected to one another by a flat separator. The positive and negative electrodes are made from conductive foils coated with an active material and the separator can include an ion permeable electrolyte. The electrode layers are aligned at right angles to the flat bottom area and the flat top area of the housing cup and the housing top respectively. The housing cup and housing top are closed by a static friction fit at overlapping cut edges without being beaded over. The electrode separator assembly is in the form of a spiral winding or jelly roll and is contained in the housing with end faces that face in an axial direction relative to flat bottom area and the flat top area.

602. To prevent the positive and negative electrodes in the electrode separator assembly from creating an electrical short by contacting the flat bottom or flat top areas of opposite polarity, the CoinPower® button cells also include an insulation means in the form of flat plastic disks that are arranged between the jelly rolled spiral winding and the housing cup and the housing top.

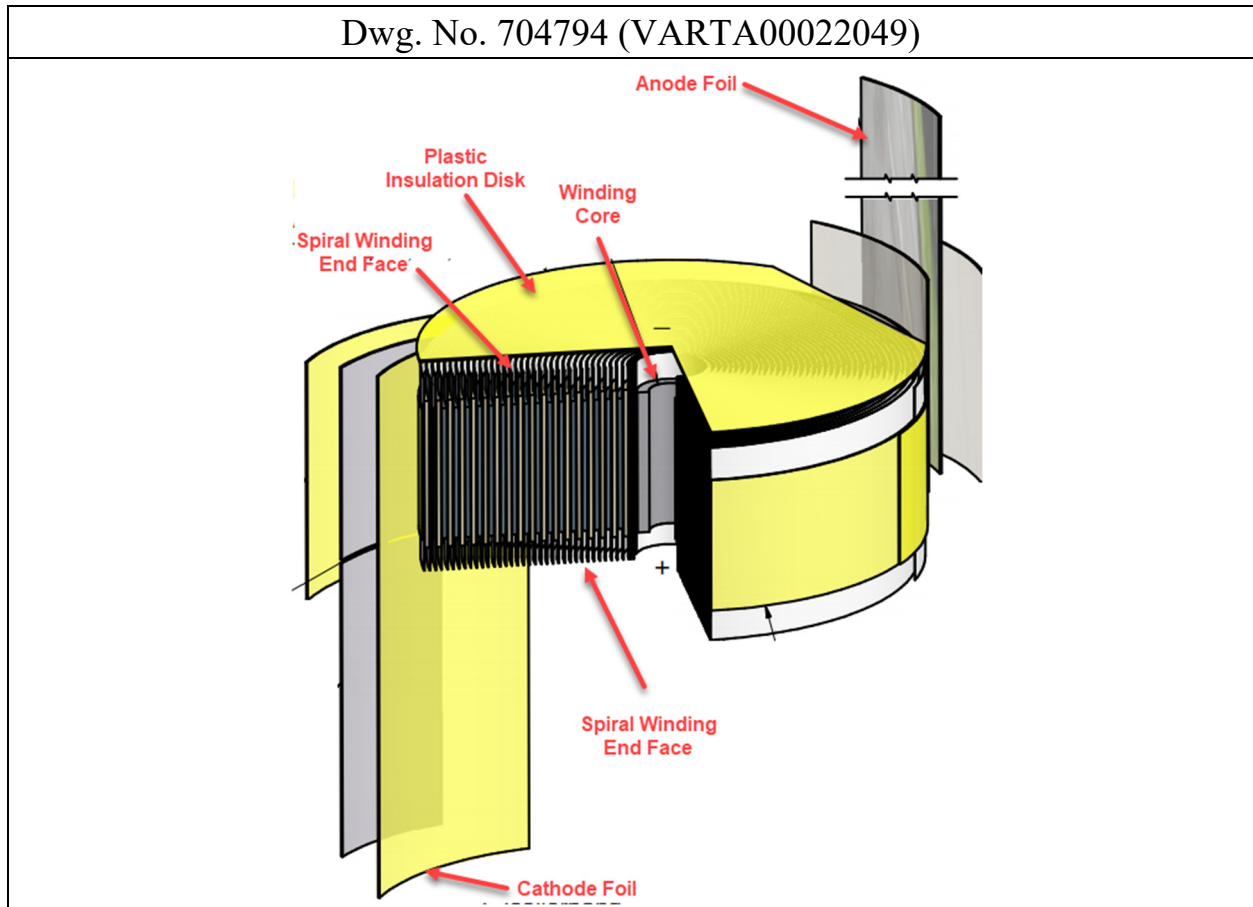

## 2. The VARTA CoinPower® Batteries Practice the '581 Patent

603. In my opinion, the VARTA CoinPower® button cells practice at least claim 1 of the '581 patent.

604. The VARTA CoinPower® button cells embody the claimed features of the '581 patent and are coextensive with them. The VARTA CoinPower® button cells not only contain the patented features, but those products are to a substantial extent made up of them. These claimed features provide increased energy density to be packed in the cell housing while maintaining improved cycling ability. In the specific context of the claims of the '581 patent, these features include: a right-

angle jelly roll configuration that facilitates optimal use of limited space in the housing; a flat foil output conductor that connects one of the jelly roll electrodes to the housing and consumes essentially no space because it rests between the spiral winding and the housing, thereby making volume available for electrode material. This structure also provides greater stability of the button cell, representing a significant breakthrough in button cell design.

605. With respect to independent claim 1 of the '581 Patent, it is directed to a small round battery with a structure that allows increased electrode material to be placed inside the housing. The VARTA CoinPower® button cells include a housing formed from a housing cup and a housing top separated from each other by an electrical insulating seal. The housing cup and housing top can be made from nickel plated stainless steel and the insulating seal can be injection molded from a non-conductive thermoplastic material. The housing cup has a flat bottom area and the housing top has a flat top area that is parallel to the flat bottom area.

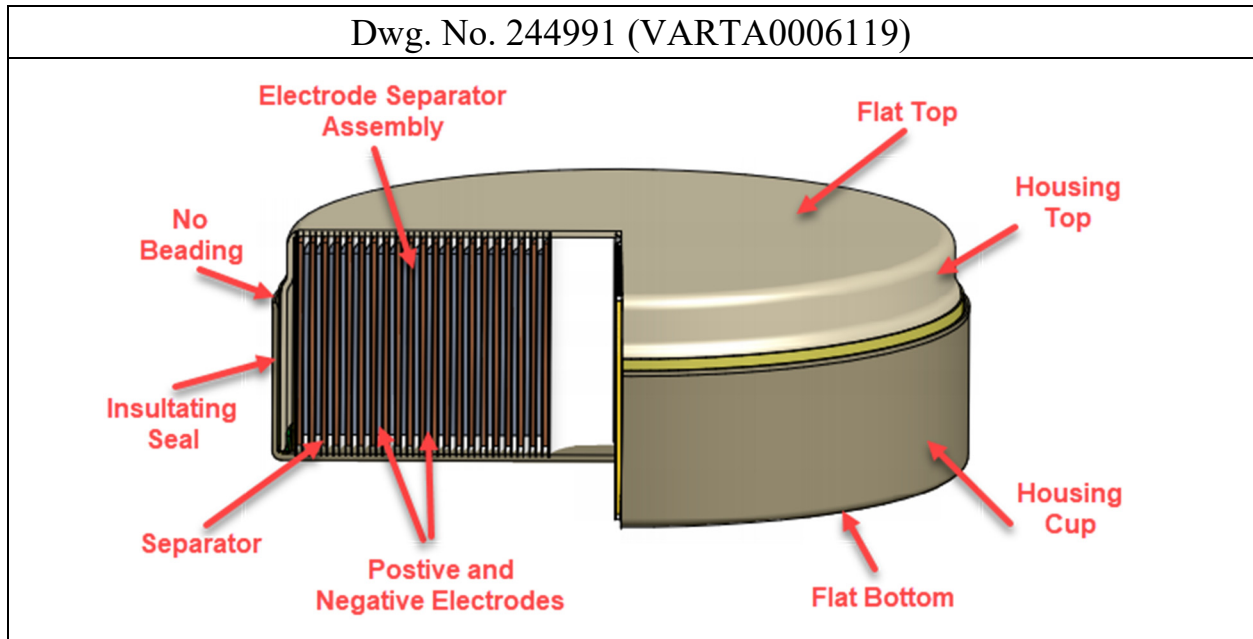

606. The CoinPower® button cells include an electrode separator assembly within the housing that has a positive electrode and a negative electrode in the form of flat layers and that are connected to one another by a flat separator. The positive and negative electrodes are made from conductive foils coated with an active material and the separator can include an ion permeable electrolyte. The electrode layers are aligned at right angles to the flat bottom area and the flat top area respectively. The electrode separator assembly is in the form of a spiral winding or jelly roll having end faces facing in an axial direction relative to the flat bottom area and the flat top area.

607. In the CoinPower® button cells, the positive and negative electrodes are connected to the flat bottom area or the flat top area, respectively, by an output conductor in the form of a conductive foil that extends from the electrode separator

assembly. When assembled in the housing, the output conductor is bent over and rests flat between the end faces of the spiral winding and the flat top area or flat bottom area of the housing to which the output conductor is connected.

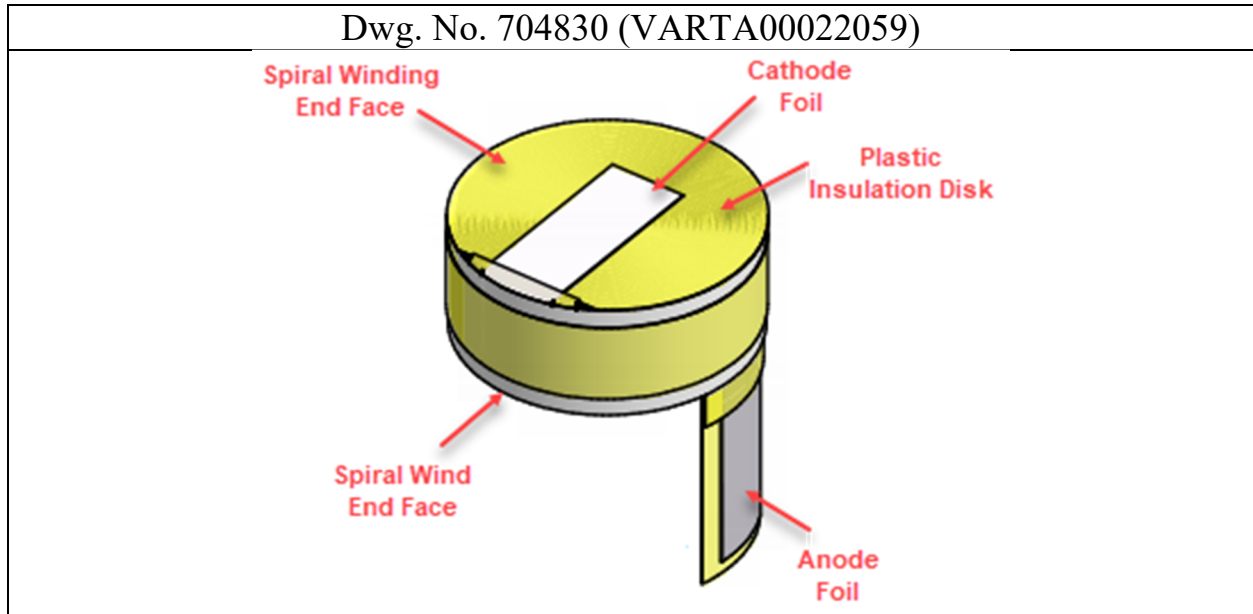

608. With respect to dependent claim 6, the CoinPower® button cells include an insulator that prevent direct mechanical and electrical contact between the end face of the spiral winding and the output conductor.

### 3. The VARTA CoinPower® Batteries Practice the '913 Patent

609. In my opinion, the VARTA CoinPower® button cells practice at least claims 1, 4, and 6 of the '913 patent.

610. The VARTA CoinPower® button cells embody the claimed features of the '913 patent and are coextensive with them. The VARTA CoinPower® button cells not only contain the patented features, but those products are to a substantial extent made up of them. These claimed features provide high energy and good

recycling characteristics. In the specific context of the claims of the '913 patent, these features include the winding axis of the jelly roll is perpendicular to the vector normal to the cathode and anode plates; the output conductor is a conductive foil linking the cathode and anode plates to their respective external contacts; the foil is made to lie flat between the jelly roll and the housing. This structure also provides greater stability of the button cell, representing a significant breakthrough in button cell design.

611. With respect to independent claims 1, 4, and 6 of the '913 Patent, the CoinPower® button cells include a housing formed from a housing cup and a housing top separated from each other by an electrical insulating seal. The housing cup and housing top can be made from nickel plated stainless steel and the insulating seal can be injection molded from a non-conductive thermoplastic material. The housing cup has a flat bottom area and the housing top has a flat top area that is parallel to the flat bottom area.

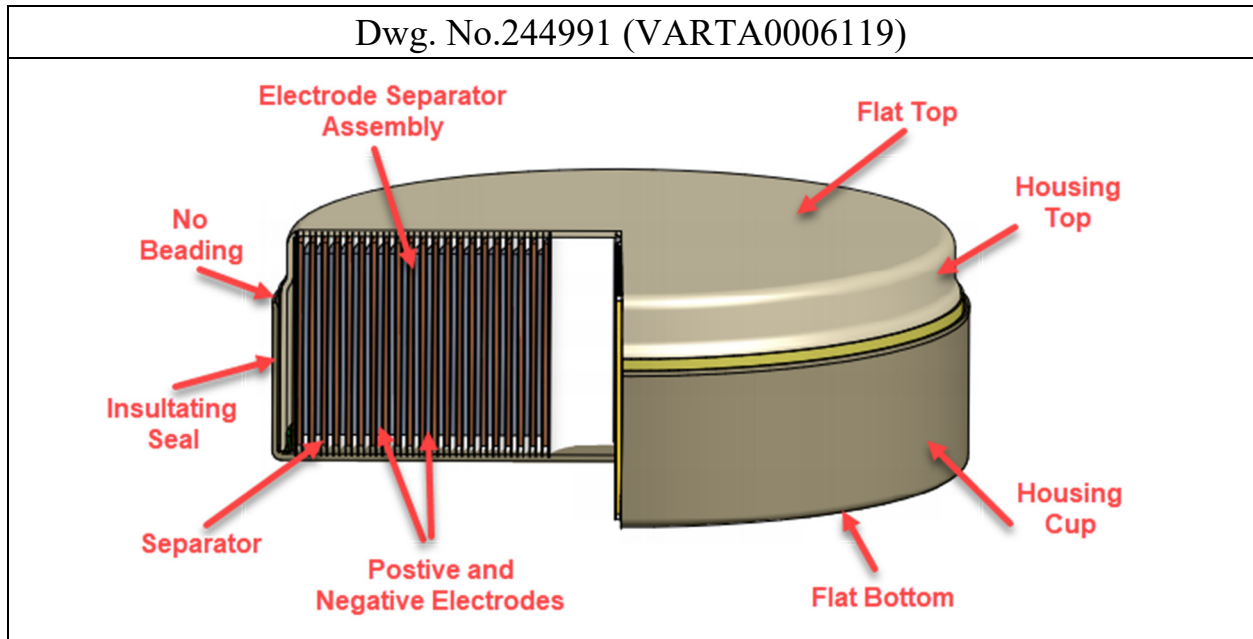

612. The CoinPower® button cells include an electrode separator assembly within the housing that has a positive electrode and a negative electrode in the form of flat layers and that are connected to one another by a flat separator. The electrode layers are aligned at right angles to the flat bottom area and the flat top area respectively. The positive and negative electrodes are made from conductive foils coated with an active material and the separator can include an ion permeable electrolyte. The electrode separator assembly is in the form of a spiral winding having end faces that face in an axial direction relative to the flat bottom area and the flat top area.

613. In the CoinPower® button cells, the positive and negative electrodes are connected to the flat bottom area or the flat top area respectively by an output conductor in the form of a conductive foil that extends from the electrode separator



assembly. When assembled in the housing, the output conductor rests flat between the end faces of the spiral winding and the flat bottom area or flat top area of the housing to which the output conductor is connected.

614. To prevent the positive and negative electrodes in the electrode separator assembly from creating an electrical short by contacting the housing cup or housing top of opposite polarity, the CoinPower® batteries also include an insulation means in the form of flat plastic disks between the end faces of the winding and the flat bottom area and the flat top area. Further, with respect to independent claim 6, the flat plastic disks also prevent direct electrical and mechanical connection between the upper end face of the spiral winding and the flat top area of the housing and the lower end face of the spiral winding and the flat bottom area of the housing.

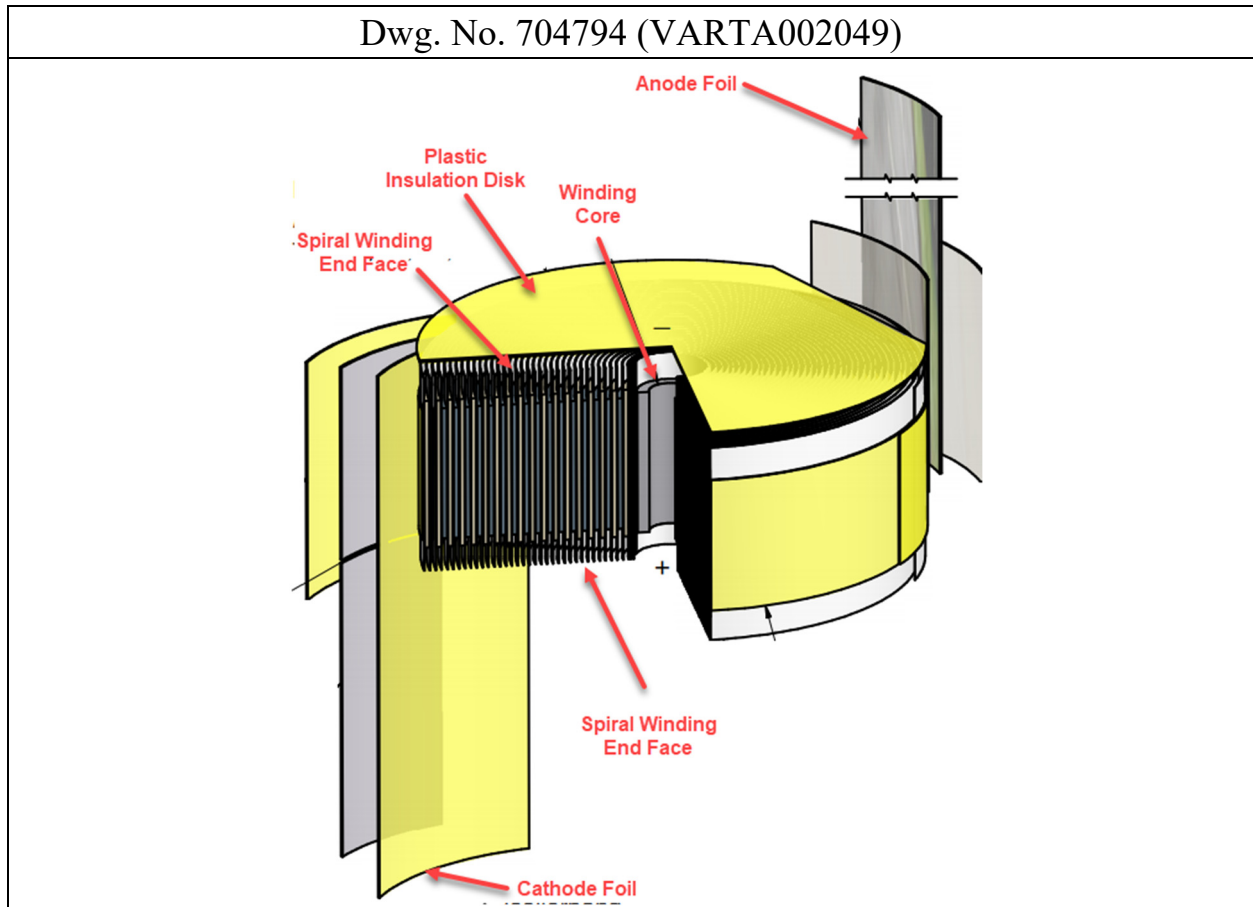

#### 4. The VARTA CoinPower® Batteries Practice the '858 Patent

615. It is my opinion that the VARTA CoinPower® button cells practice at least claim 1 of the '858 patent.

616. The VARTA CoinPower® button cells embody the claimed features of the '913 patent and are coextensive with them. The VARTA CoinPower® button cells not only contain the patented features, but those products are to a substantial extent made up of them. These claimed features provide increased energy density to be packed in the cell housing while maintaining improved cycling ability. In the specific context of the claims of the '913 patent, these features include the winding

axis of the jelly roll is perpendicular to the vector normal to the cathode and anode plates that facilitates optimal use of limited space in the housing; the jelly roll is protected by an insulating layer to avoid short circuits, particularly during swelling and shrinking of the jelly roll during charging and discharging; and a flat foil output conductor connects one of the jelly roll electrodes to the housing which consumes essentially no space because it rests between the spiral winding and the housing, thereby freeing more space for the jelly roll. These claimed features provide increased energy density and enhanced stability characteristics.

617. With respect to independent claim 1 of the '858 Patent, the CoinPower® button cells include a housing formed from two metal housing halves separated from each other by an electrical insulating seal. The metal housing halves have a respective plane bottom region and plane top region that are parallel to each other.

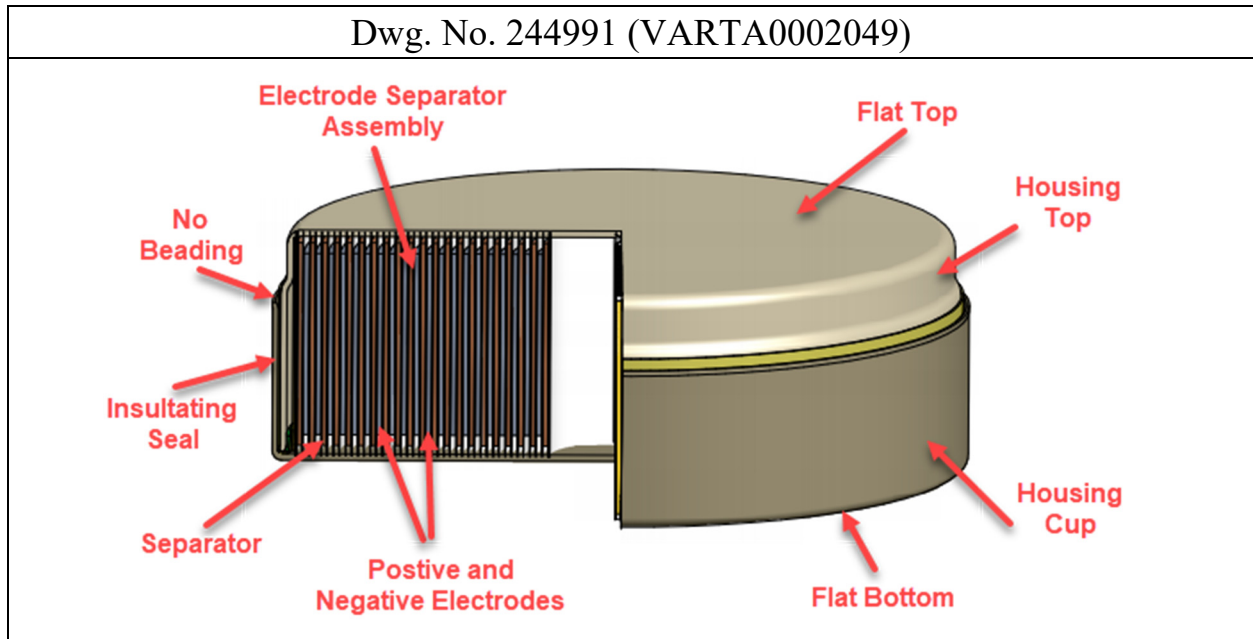

618. The CoinPower® button cells include an electrode separator assembly including a positive electrode and a negative electrode in the form of a winding or jelly roll. The winding is located inside the housing with its lateral end sides facing in the direction of the plane bottom region or plane top region of the housing so that the electrode layers of the winding are oriented orthogonally to the plane bottom region and plane top region.

619. The CoinPower® button cells have a height to diameter ratio of less than one.

620. The CoinPower® button cells use metal conductors to electrically connect the positive electrodes and the negative electrodes to the respective housing halves. The conductors are metal foils that are connected during the

assembly process to the respective housing halves by a weld bead and/or weld spot that pass through the housing and that originate from an outer side of the housing.

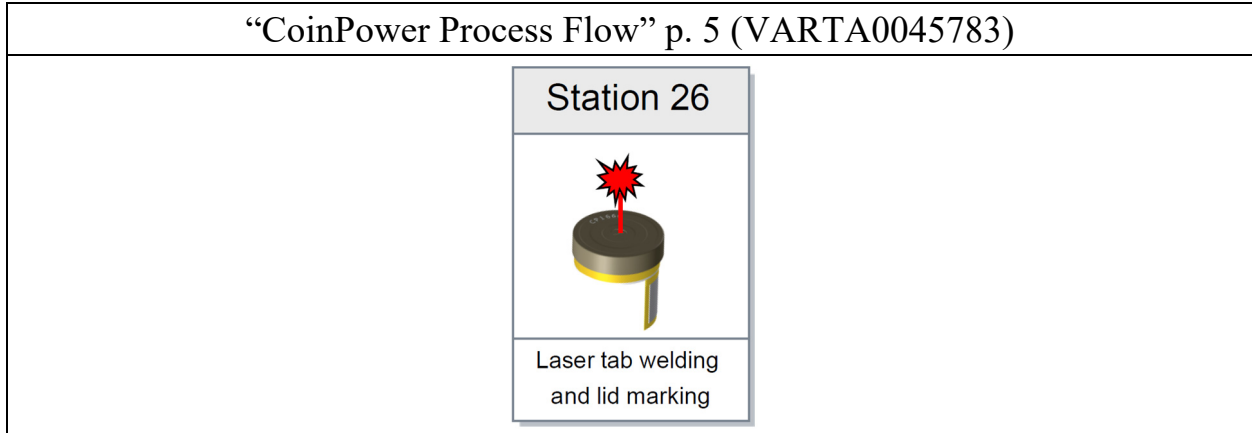

621. After welding, the metal foils bear flat on the lateral end sides of the electrode separator assembly and are shielded from the lateral end sides by insulating elements in the form of thermoplastic discs.

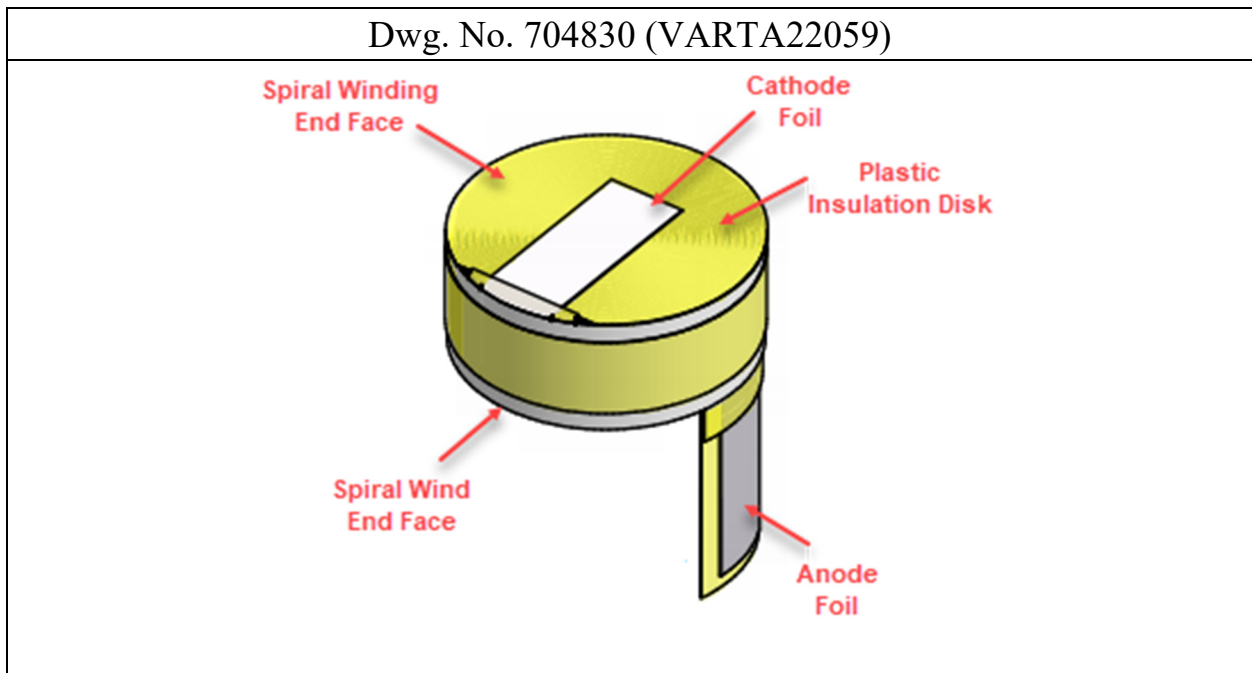

**B. Unexpected Results**

622. As stated in the Technology Background, prior to the inventions contained in the Challenged Patents, the commercially available button cells that I was familiar with were of the tablet configuration with tablet-shaped positive and negative electrodes separated by an electrolytic separator or were of the stacked electrode configuration. These conventional button cells had energy densities in the range of 100-200 Wh/L and capacities typically around 50 mAh and below.

623. Kobayashi stated that “it was thought that it was impossible to store the electrode group structure within a small battery such as a button cell or a coin cell.” *Id.* Kobayashi found that “size reduction is extremely difficult . . . and the limit has currently been substantially reached.” Ex. 1006 ¶ [0007].

624. The combination of features recited in the Challenged Claims of the Challenged Patents are not present in the prior art. Kobayashi dealt with the issue of charging and discharging by teaching a fixed core structure to integrate the electrode assembly with a winding core. This core structure included solid metal connecting plates held in place by a crimped over cell housing. According to Kobayashi, this structure enabled winding of the electrode assembly for a small button cell. Contrary to this conventional belief, the invention contained in the Challenged Claims of the Challenged Patents surprisingly obtained a stable connection that withstood mechanical stresses experienced over the battery life.

The flexibility and resilience of the combination of elements of the invention allows the electrode assembly to “breathe” from its charged to discharged states, while providing excellent stability over its lifetime. The achievements represent a striking advancement in the field.

### **C. Copying by Others**

625. I have studied button cell microbatteries manufactured by EVE Energy and Guangdong Mic-Power New Energy Co., Ltd., both of China, that are strikingly similar to the VARTA CoinPower® button cells. I understand that the VARTA CoinPower® button cells had been commercially available long before the EVE and Mic-Power button cells appeared in the marketplace. In my opinion, these similarities are so pervasive that the EVE and Mic-Power batteries were constructed to be copies of the VARTA CoinPower® button cells.

626. The EVE and Mic-Power button cells are similar to the commercially available VARTA CoinPower® button cells to the extent that they appear to be as to be clones. The Eve and Mic-Power copies are made in the same size ranges as the VARTA CoinPower® button cells, specifically having a height of 5.4 mm and diameters between 12 and 16 mm. I understand that the EVE and Mic-Power button cells are being targeted to the same applications and even the same customers as the CoinPower® button cells, specifically, manufacturers of true wireless stereo headphones.

627. The EVE and Mic-Power copies include the same combination of features and their arrangement that VARTA developed so that the CoinPower® microbatteries would have such an exemplary electrical performance and improved cyclic service life. It is very improbable in my opinion that one competitor, much less two different competitors, would arrive at the some unique and novel combination of features as are found in the VARTA CoinPower® button cells without setting out to copy the patented features found in the VARTA CoinPower® button cells.

628. The EVE and Mic-Power copies include an electrode separator assembly comprised of positive and negative electrode layers and an interposed separator layer that are spirally wound into a jelly roll. The jelly roll is located inside a small cylindrical housing so that the electrode layers are aligned at right angles to the planer top and bottom areas of the housing. The jelly roll designs of the Eve and Mic-Power copies are different from the tablet electrode and stacked electrode configurations of other commercially available button cells.

629. The small cylindrical housing is fabricated from a housing cup into which the housing top is inserted and closed by a static friction fit without being beaded over. Moreover, the right angled orientation of the electrode layers in the housing and non-beaded over closure harness the cyclic expansion and contraction



forces from the electrodes to improve the sealing characteristics in the same way as the VARTA CoinPower® button cells.

630. The EVE and Mic-Power copies use thin, flexible foils as current collectors to conduct electric current between the jelly roll and the housing cup or housing cover of the proper polarity. The use of thin flexible foils as current collectors allows the jelly roll to move within the housing as the electrodes expand and contract when discharging and charging, the same way the foil conductors in CoinPower® button cells function. Moreover, the EVE and Mic-Power copies include insulating means in the form of thin plastic films at precisely the same locations as included in the CoinPower® button cells.

631.

**1. The Eve and Mic-Power Batteries Are Covered by the '835 Patent**

632. In my opinion, the EVE and Mic-Power button cells are covered by at least claim 1 of the '835 patent.

633. Regarding claim 1 of the '835 Patent, the button cell copies include a housing cup and a housing top that are separated from one other by an electrical insulating seal. The housing cup has a flat bottom area and the housing top has a flat top area that is parallel to the flat bottom area.

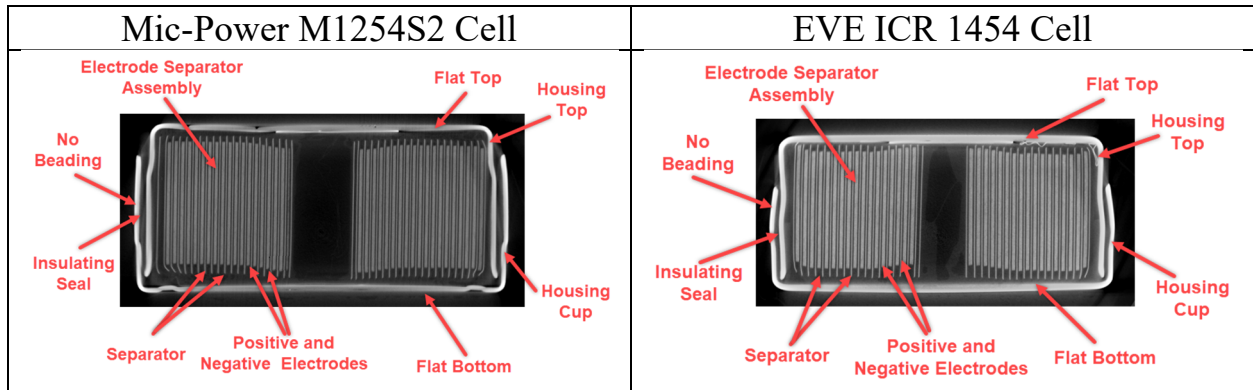

634. The Eve and Mic-Power copies include an electrode separator assembly within the housing that has a positive electrode and a negative electrode in the form of flat layers that are connected to one another by a flat separator. The electrode layers of the electrode separator assembly are aligned at right angles to the flat bottom area of the housing cup and the flat top area of the housing top respectively.

635. The housing cup and the housing top are closed by a static friction fit without being beaded over.

636. The electrode separator assembly is in the form of a spiral winding that is contained in the housing with the end faces of the spiral winding facing in the axial direction relative to the flat bottom area and the flat top area.

637. The Eve and Mic-Power copies include an insulating means arranged between the end faces of the spiral winding and the housing cup and the housing top respectively.

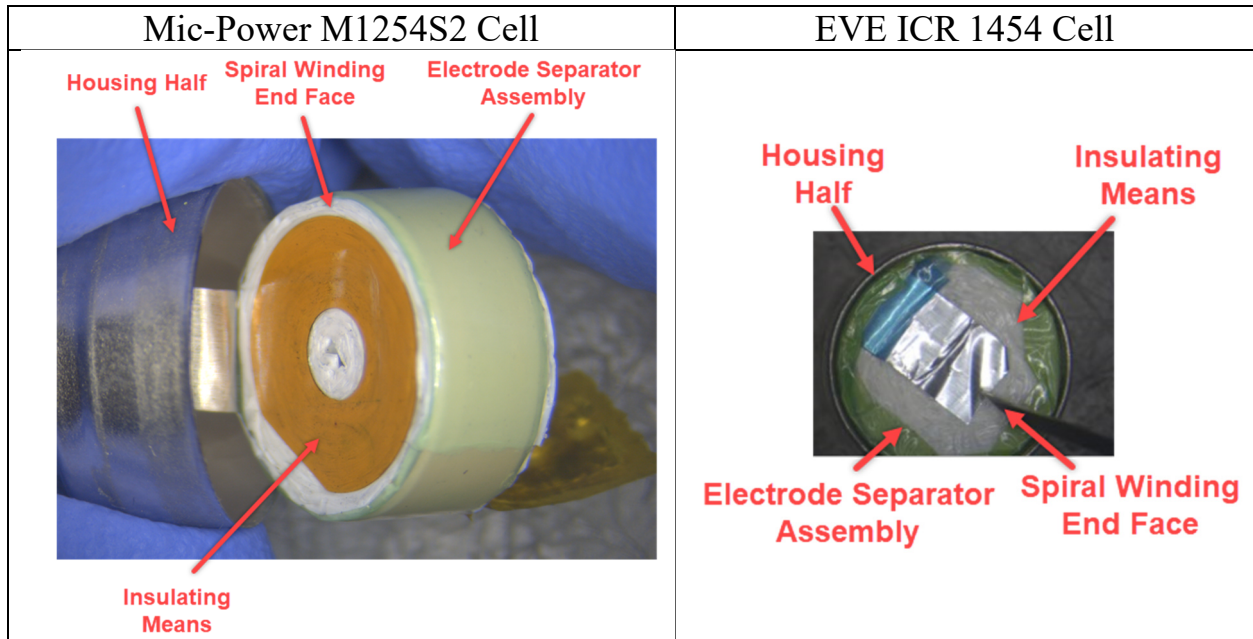

## 2. The Eve and Mic-Power Batteries Are Covered by the '581 Patent

638. In my opinion, the EVE and Mic-Power button cells are covered by at least claim 1 of the '581 patent.

639. With respect to independent claim 1 of the '581 Patent, the Eve and Mic-Power copies include a housing formed from a housing cup and a housing top separated from each other by an electrical insulating seal. The housing cup has a flat bottom area and the housing top has a flat top area that is parallel to the flat bottom area.

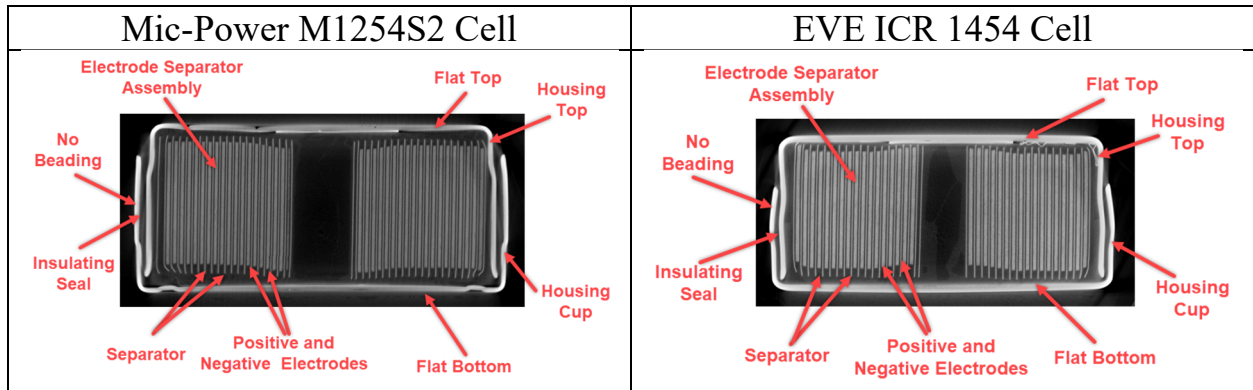

640. The Eve and Mic-Power copies include an electrode separator assembly within the housing that has a positive electrode and a negative electrode in the form of flat layers and that are connected to one another by a flat separator. The electrode separator assembly is in the form of a spiral winding having end faces that face in an axial direction relative to the flat bottom area and the flat top area.

641. In the Eve and Mic-Power copies, the positive and negative electrodes are connected to the flat bottom area or to the flat top area, respectively, by an output conductor in the form of a conductive foil that extends from the electrode separator assembly. When assembled in the housing, the output conductor is bent over and rests flat between the end faces of the spiral winding and the flat top area or the flat bottom area of the housing to which the output conductor is connected.

642. With respect to dependent claim 6, the Eve and Mic-Power copies also include an insulator to prevent direct mechanical and electrical contact

between the end faces of the electrode separator assembly and the output conductors.

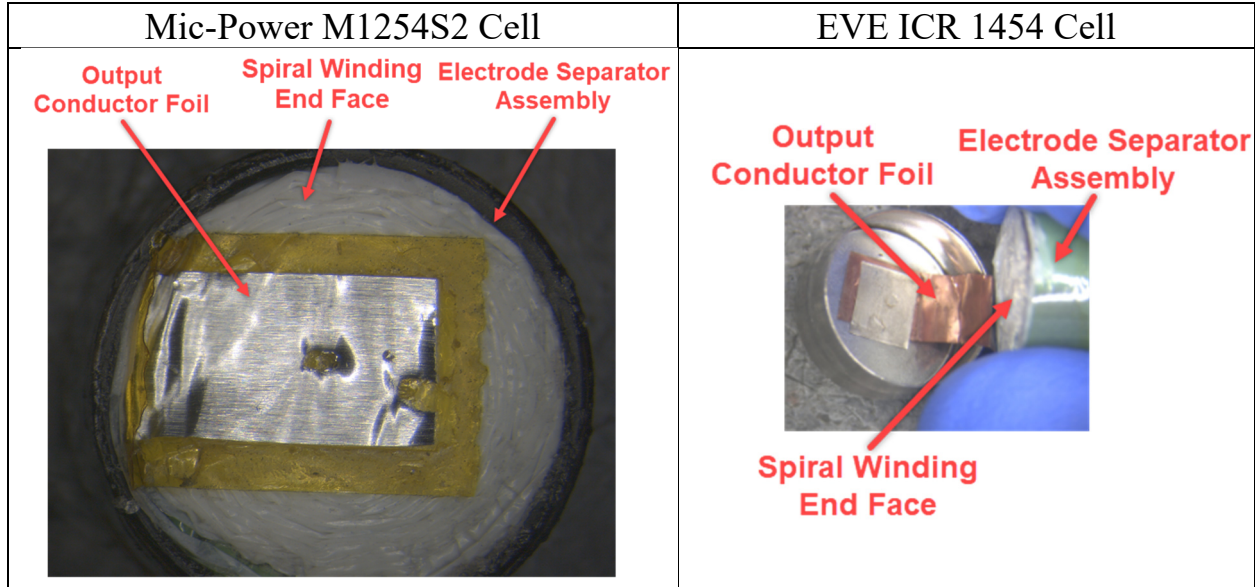

**3. The Eve and Mic-Power Batteries Are Covered by the '913 Patent**

643. In my opinion, the EVE and Mic-Power button cells are covered by at least claims 1, 4, and 6 of the '913 patent.

644. With respect to independent claims 1, 4, and 6 of the '913 Patent, the EVE and Mic-Power copies include a housing formed from a housing cup and a housing top separated from each other by an electrical insulating seal. The housing cup has a flat bottom area and the housing top has a flat top area that is parallel to flat bottom area.

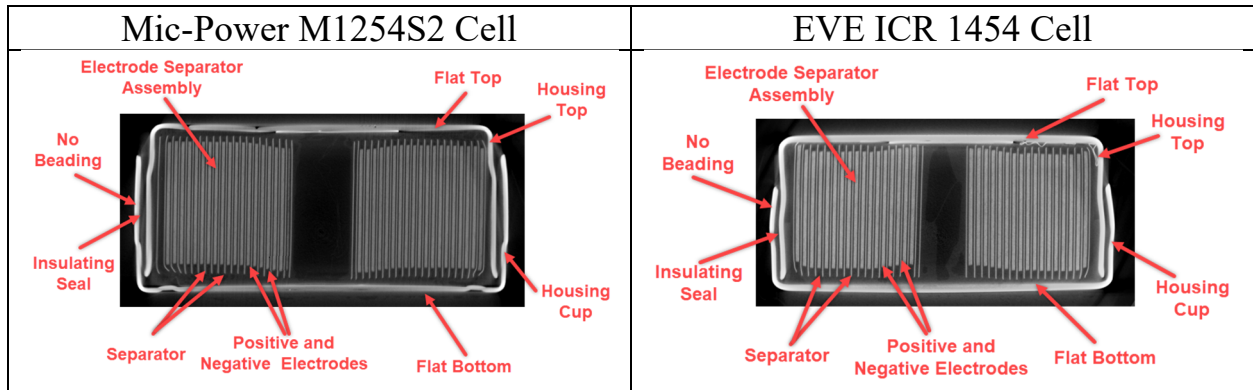

645. The EVE and Mic-Power copies include an electrode separator assembly within the housing that has a positive electrode and a negative electrode in the form of flat layers and that are connected to one another by a flat separator. The electrode layers are aligned at right angles to the flat bottom area and the flat top area respectively. The electrode separator assembly is in the form of a spiral winding having end faces that face in an axial direction relative to the flat bottom area and to the flat top area.

646. In the EVE and Mic-Power copies, the positive and negative electrodes are connected to the flat bottom area or to the flat top area, respectively, by an output conductor that is in the form of a conductive foil that extends from the electrode separator assembly. When assembled in the housing, the output conductor rests flat between the end faces of the spiral winding and the flat bottom area or the flat top area of the housing to which the output conductor is connected.

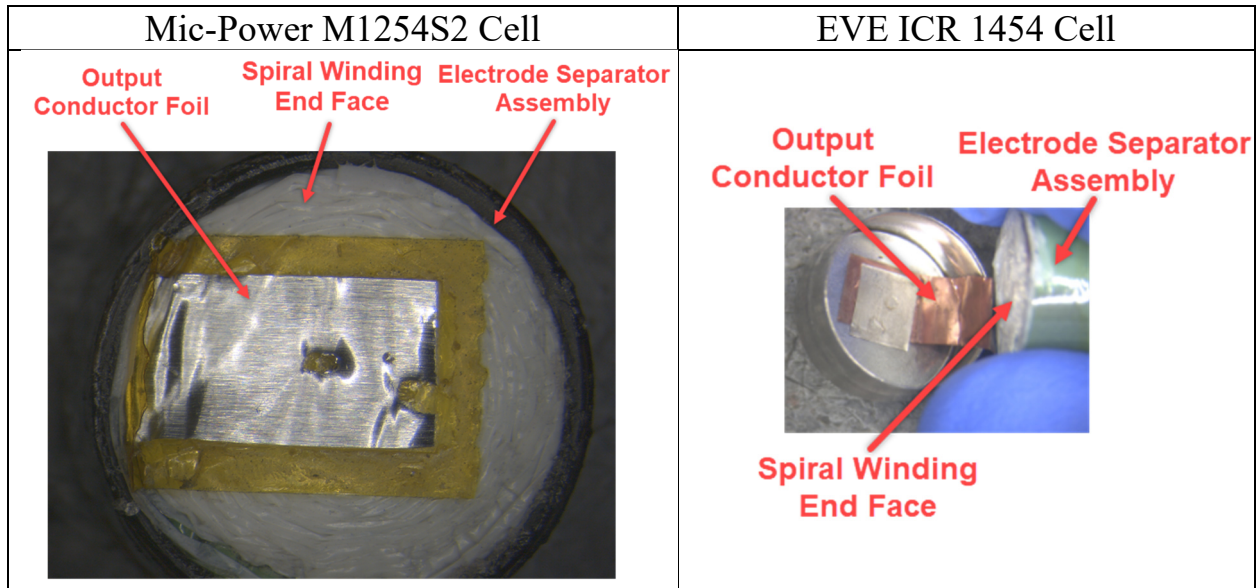

647. With respect to claim 1 of the '913 Patent, the EVE and Mic-Power copies include an insulating means in the form of non-conductive film arranged between the end faces of the spiral winding and the housing cup and the housing top. With respect to claim 4, the EVE and Mic-Power copies include a flat layer composed of plastic that prevents direct mechanical and electrical contact between the end faces of the winding and the flat bottom area and the flat top area. With respect to claim 6, the EVE and Mic-Power copies include an insulating means that prevents direct mechanical and electrical contact between 1) the upper end faces of the winding and the flat top area or 2) the end faces of the winding and the flat bottom area.

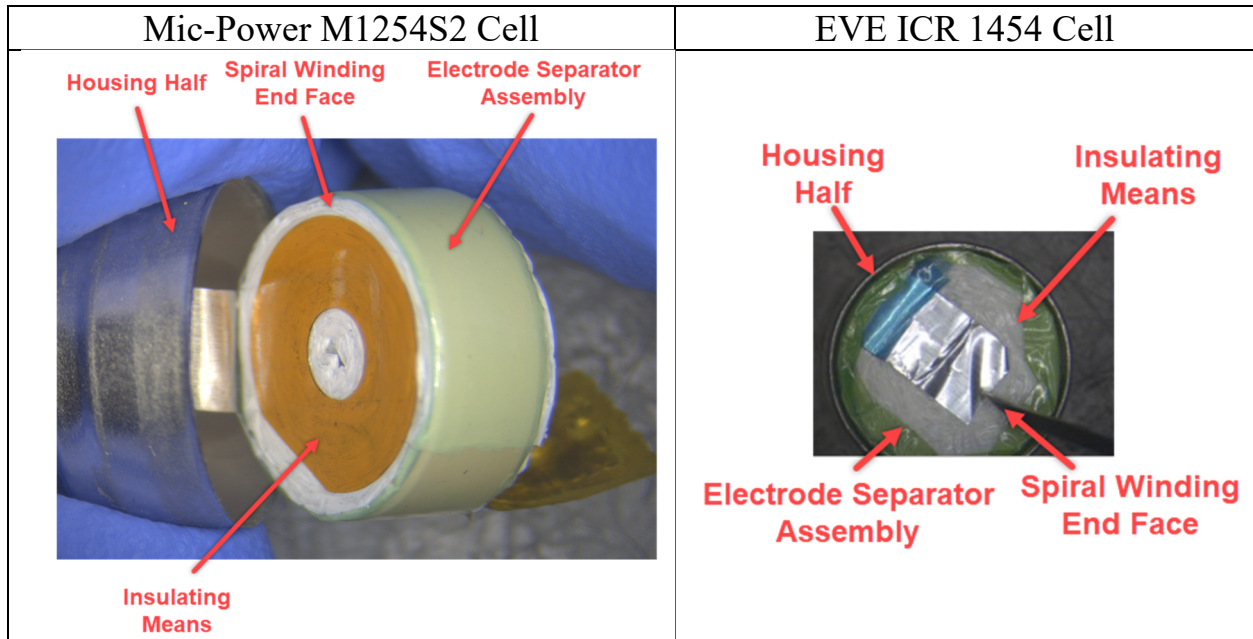

#### 4. The Eve and Mic-Power Batteries Are Covered by the '858 Patent

648. In my opinion, the EVE and Mic-Power button cells are covered by at least claim 1 of the '858 patent.

649. With respect to independent claim 1 of the '858 Patent, the Mic-Power copies include a housing formed from two metal housing halves separated from each other by an electrical insulating seal. The housing halves form a housing having a respective plane bottom region and a plane top region that are parallel to each other.



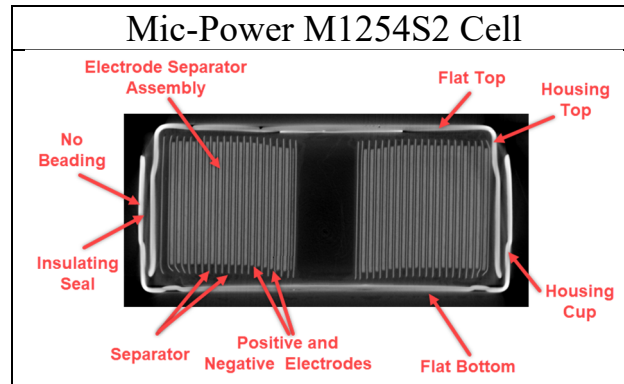

650. The Mic-Power copies include an electrode separator assembly including a positive electrode and a negative electrode in the form of a winding. The winding is inside the housing with lateral end sides that face in the direction of the plane bottom region and plane top region of the housing so that the electrode layers of the winding are oriented orthogonally to the plane bottom region and plane top region.

651. The Mic-Power copies have a height to diameter ratio of less than one.

652. The Mic-Power copies use metal conductors to electrically connect the positive electrodes and the negative electrodes to the respective housing halves. The conductors are metal foils that are connected during the assembly process to the respective housing halves by a weld bead and/or weld spot that passes through the housing and that originates from an outer side of the housing.

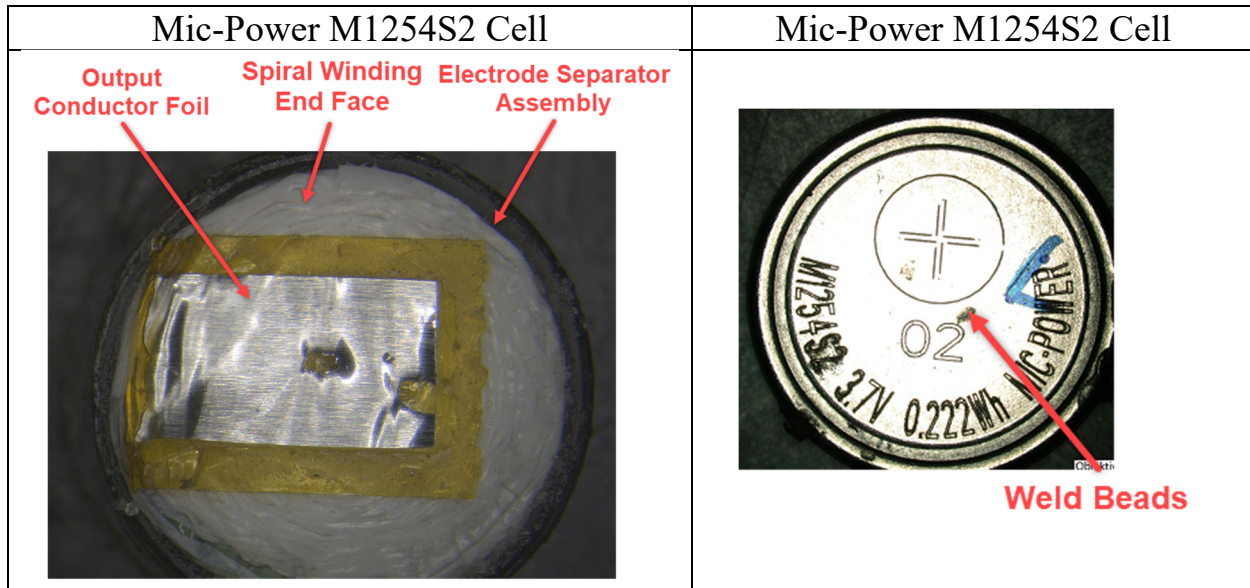

653. The metal foils bear flat on the lateral end sides of the electrode separator assembly and are shielded from the lateral end sides by insulating elements in the form of non-conductive film.

#### **XIV. THE SUBSTITUTE CLAIMS OF THE CHALLENGED PATENTS ARE PATENTABLE**

654. In my opinion, the references Petitioners rely upon do not disclose or render obvious the additional features found in the substitute claims VARTA has presented, nor the combinations of these features with other elements present in the original claims.

##### **A. Kaun, Kobayashi, Ryou, and Kwon Fail to Disclose a Button Cell Closed at “Overlapping Sides” of a Housing by “a Radial Seal” or “a Force-Fit Connection”**

655. The substitute claims submitted by VARTA recite additional features of the patented button cell, such as, a button cell “closed at overlapping sides of the housing cup and the housing top by a radial seal without being beaded over,” (see,

e.g., Substitute Claim 14 of the '835 Patent), a button cell having “an electrically insulating seal at least partially interposed between overlapping sides of the housing cup and the housing top to provide a radial seal therebetween,” (see, e.g., Substitute Claim 14 of the '581 Patent and Substitute Independent Claim 12 of the '913 Patent), and a button cell having “lateral surface regions of the housing halves at least partially overlapping each other and . . . providing a force-fit connection therebetween to form a leak-tight housing” (see, e.g., Substitute Claim 10 of the '858 Patent).

656. None of Kaun, Kobayashi, Ryou, or Kwon, either alone or in combination, or in view of the knowledge of a POSA, discloses or suggests a button cell closed at overlapping sides of a housing by either a radial seal or a force-fit connection.

657. Kaun does not disclose a cell that is closed by a radial seal or force-fit connection between overlapping sides of a housing. Instead Kaun provides a venting mechanism at the periphery of his cell that allows for gas pressure to escape. Kaun discloses that a lithium based battery for ‘high power applications, such as for hybrid electric vehicles,” “internal gas pressure may be generated during operation.” Ex. 1005 at ¶ [0023]. Kaun discloses that it would be desirable to incorporate “non-catastrophic, cost effective means to relieve the gas pressure.” Id. Accordingly, Kaun describes in an embodiment that the peripheral gasket that

is disposed between the peripheral edges of the positive and negative cups 28p, 28n that form the housing can relax in the event of over pressurization inside a cell to act as a vent to release the internal pressure. Id. at ¶¶ [0091], [0130]. Providing either a radial seal or a force-fit connection between peripheral edges of the positive and negative cups 28p, 28n would disable Kaun's venting system.

658. Kobayashi also does not disclose a radial seal or force-fit connection between overlapping sides of a housing. Instead, Kobayashi discloses an axial seal in which metal housing parts overlap in an axial direction. In particular, Kobayashi discloses "a small battery provided with a winding electrode group (for example, a button cell or a coin cell)" housed in positive and negative electrode cases 11, 13 that are sealed together by "implementing swaging." Ex. 1006 ¶¶ [0001], [0035]. Closing the positive and negative electrode cases 11, 13 by "swaging" as shown in FIG. 1 is the same as closing the cases with a beading-over arrangement. The lower electrode case 11 is bent radially inwards over a corresponding radially outward edge of the upper electrode case 13 about the mid-axial circumference of the housing. In Kobayashi, swaging is critical to prevent axial movement and maintain the conductive path from the electrodes 1, 2, to the terminal connection parts 4b, 5b to the terminal plates 4a, 5a.

659. Ryou discloses a housing formed from a cup and a top part that do not overlap at all. Ryou, which particularly relates to a primary zinc-air battery,

describes that “hermetical sealing of the battery may be carried out by fusion-bonding of the cans 52 and 54 and the body 56.” Ex. 1007 ¶ [0071]. The body 56 of Ryou is made of an insulation resin and is fused at the end portions of the cans 52 and 54 to seal the inside of the battery. Id. In every embodiment described in Ryou, the button cell is closed by fusion bonding the cans together without any radial overlap thereof.

660. Kwon, which is not directed to a battery or a cell but instead to a coin-type electric double layer capacitor, also does not disclose a radial seal or force-fit connection between overlapping sides of a housing.

661. A POSA would not have modified Kaun so as to provide a housing with a radial seal or force-fit connection between overlapping sides. In particular, a POSA would have understood that, if Kaun’s venting system were disabled by incorporating a radial seal or a force-fit connection between peripheral edges of the positive and negative cups 28p, 28n, the resulting cell would not be suitable for the high power applications for which Kaun is designed.

662. Kaun teaches that “[a] Li/organic-based electrolyte battery for high power applications . . . needs . . . non-catastrophic, cost effective means to relieve the gas pressure.” Ex. 1005 ¶ [0023]. Accordingly, Kaun describes that as a safety measure the peripheral gasket that is disposed between the peripheral edges of the positive and negative cups 28p, 28n that form the housing can relax in the event of

over pressurization inside a cell to act as a vent to release the internal pressure. Ex. 1005 ¶¶ [0091] (“The specified limit for internal pressure is handled by release via the peripheral gasket which can reseal after an event.”). To relieve internal pressure, Kaun describes that the positive and negative cups 28p, 28n can be externally loaded by springs to urge the cups together. Ex. 1005 ¶ [0130]. “If a single cell produced internal pressure exceeding the 10-20 psi limit, the end spring would slightly compress and the peripheral gasket of the over pressurized cell would subsequently relax to relieve the overpressure. This cell would then reseal itself under the spring force.” Id. Accordingly, forming a radial seal or a force-fit connection between peripheral edges of the positive and negative cups 28p, 28n would eliminate the venting functionality that Kaun teaches is needed for lithium based batteries designed for high power applications.

663. A POSA would also not have modified Kobayashi so as to provide a housing with a radial seal or force-fit connection between overlapping sides. The beading over closure process taught by Kobayashi is a well-known method for closing the housing cup and housing top when assembling button cells and is a conventional way of creating a leak-tight enclosure for a button cell. It is especially desirable for batteries based on lithium-ion chemistry that the cell housing is tightly sealed to prevent moisture from leaking into the cell. Lithium is highly reactive with water and even small amounts of water vapor can be

catastrophic to the function of a cell. A POSA would have expected that, with respect to Kobayashi, the beaded over connection between the positive and negative electrodes 11, 13 with the ring-shaped gasket there between was necessary both for the specific structure described by Kobayashi as well as to ensure a sufficiently tight seal for a lithium-based battery.

664. As another example, none of Kaun, Kobayashi, Ryou, or Kwon, either alone or in combination, or in view of the knowledge of a POSA, discloses or suggests a metal foil output conductor which includes a bend portion and a flat portion and by which an electrode is connected to the housing.

**B. Kaun, Kobayashi, Ryou, and Kwon Fail to Disclose “a Metal Foil” with “a Bend Portion” and “a Flat Portion”**

665. The substitute claims also recite a button cell, in which an electrode is connected to a housing “via a metal foil output conductor including a (i) a bend portion . . . (ii) a weld portion connected to [the housing] . . . and (iii) a flat portion, extending in a radial direction . . . , from the bend portion to the weld portion,” (*see, e.g.,* Substitute Claim 14 of the ‘835 Patent), a button cell in which an electrode is connected to a housing via a “metal foil output conductor comprising a bend portion [connected to the electrode] . . . and a flat portion extending from the bend portion in a radial direction,” the flat portion being connected to the housing, (*see, e.g.,* Substitute Claim 14 of the ‘581 Patent, Substitute Claims 9, 12, and 14 of the ‘913 Patent), and a button cell in which a “metal foil strip connects, at a first end,

to [an electrode,] . . . [and] at a second end [to the housing], . . . wherein the metal foil strip includes a bend portion proximate the first end thereof and a length portion proximate the second end thereof that bears flat” on an end side of an electrode winding, (*see, e.g.*, Substitute Claim 10 of the ‘858 Patent).

666. None of Kaun, Kobayashi, Ryou, or Kwon, either alone or in combination, or in view of the knowledge of a POSA, discloses or suggests a button cell in which an electrode is connected to a housing via a metal foil output conductor or metal foil.

667. Kaun does not disclose a button cell in which an electrode is connected to a housing via a distinct metal foil output conductor or metal foil strip. Instead, Kaun criticizes the use of an output conductor distinct from the electrodes and instead teaches direct and continuous edge contact between the positive and negative electrodes 12p, 12n and the positive and negative cups 28p, 28n that serve as the terminals. Kaun highlights that such edge contact results in “short electronic current flow paths” and allows for internally generated heat to be drawn out from the cell via short conduction paths without crossing the heat sensitive separator layer. Ex. 1005 ¶¶ [0094], [0128].

668. Kobayashi also does not disclose a button cell in which an electrode is connected to a housing via a metal foil output conductor or metal foil strip. Kobayashi instead teaches “a disc-shaped positive electrode terminal plate 4a” and



“bar-shaped terminal connection part 4b . . . electrically connected to the positive electrode terminal plate 4a” as well as a “disc-shaped negative electrode plate 5a” and a “bar-shaped terminal connection part 5b” to connect the positive and negative electrodes to the housing. Ex. Such terminal plates and bar-shaped posts would necessarily involve or impart structural rigidity.

669. Neither Ryou, which particularly relates to a primary zinc-air battery, nor Kwon, which is not directed to a battery or a cell but instead to a coin-type electric double layer capacitor, includes an electrode connected to a housing via a distinct metal foil output conductor or metal foil strip.

670. A POSA would not have modified Kaun to connect an electrode to a housing via a distinct metal foil output conductor or metal foil strip. Kaun’s solution to providing a battery for high current density and high pulse power requirements is to eliminate intermediate output conductors in favor of direct and continuous edge contact between electrodes in the rolled-ribbon electrode assembly and the housing cups serving as external terminals.

671. Kaun notes that for a typical battery design, additional conductors “can account for a 50% reduction in battery power output from theoretical capability.” Ex. 1005 ¶ [0018]. To solve this problem, Kaun avoids using an output conductor by directly contacting the electrodes to the housing top and bottom. Id. at [0125], [0128]. This arrangement allows relatively thin and

lightweight housing and electrode material to be used as well as for very thin separator material to be employed. *Id.* Resistance is minimized contributing the cell's ability to release close to 100% of its theoretical power. *Id.* at [0094], [0126].

672. A POSA would not consider adding an output conductor to Kaun given Kaun's teachings. But even if I were to assume that POSA would have added an output conductor, a POSA would not have considered using a foil for that conductor. In his discussion of the prior art, Kaun indicates that when output conductors are used, the conductors must be "massive conductors to avoid power loss for high powered batteries." *Id.* at [0018]. This is because the output conductor must typically carry current for the entire winding. Foils are thin metals with much higher resistance than the massive conductors referenced in Kaun. Given the high-power applications discussed in Kaun, a POSA would have understood that a foil output conductor would be unable to handle the currents contemplated by Kaun's cell. Moreover, even if a foil conductor could handle the currents in Kaun's cell, it would be at the expense of high resistance, heat generation and significant power loss, which Kaun teaches are to be avoided. A POSA, therefore, would have concluded that a foil output conductor was incompatible with Kaun's cell.

673. A POSA would also not have modified Kobayashi to connect an electrode to a housing via a metal foil output conductor or metal foil strip. The factors a POSA would have considered in designing or modifying the internal components of Kobayashi's button cell would have included an evaluation of the purpose and function of the components already present therein. The structural integrity of the battery and whether any changes would compromise that integrity would need to be considered. The size and manufacturability of the button would also have been a critical factor. A POSA would have considered Kobayashi's teachings "that size reduction extremely difficult . . . and the limit has currently substantially been reached. Ex. 1006 ¶ [0007].

674. Kobayashi would have discouraged a POSA from replacing Kobayashi's metal plates with foils. Kobayashi's metal plates are critical elements in his winding core, and the interaction between the winding core and the electrode assembly are critical aspects of Kobayashi. According to Kobayashi, "by incorporating at least a winding axis core into the electrode group structure, and as needed, an insulation plate and contacting terminals between electrodes and external terminals" the Kobayashi structure overcame an alleged "impossibility." Ex. 1006 ¶ [0015]. His structure "enabled efficient storage of the electrode group in which a positive electrode, a negative electrode, and a separator are wound in a few layers to a few dozen layers within a case of a small battery."

675. Replacing Kobayashi's metal plates with foils would render the Kobayashi cell non-functional. The metal conductor plates 4a, 5a on the top and bottom of the winding axis core function to route current to the casings 11, 13. They also maintain the structural integrity of the electrode assembly. At its heart, Kobayashi integrates the conductor terminals 4, 5 into the winding core by seating the metal conductor plates 4a, 5a into the grooves formed in the insulation plates 8, 9. The metal plates are also connected to terminal posts (elements 4b, 5b) in the notches in the winding core axis 7, the components register in alignment and are rigidly interlocked with respect to each other.

676. The integration and interaction of the components enables the winding of the electrode assembly, and it maintains the resulting electrode assembly and additional structure in place inside the housing. The electrode assembly is wound by placing the terminal connection rods into notches (7a, 7b) so the electrodes can be crimped around slits (8b, 9b) formed in the connecting rods, registering metal conductor plates (5a, 4a) into recesses (8a, 9a) formed in winding core insulating members (8, 9), and then coiling the electrodes around the winding axis core 7. *See id.*: Once the conductive terminals 4, 5 and the winding member 6 are integrated, "the positive electrode 1 and the negative electrode 2 are spirally wound with the separator 3, thereby preparing a flat electrode group."

677. A POSA would have understood that the electrodes 1, 2, are placed in tension as they are wound around the winding axis core. A POSA would also have understood that the integrated assembly of the disc-like terminal plates 4a, 5a within the insulation plates 8, 9, which register and secure the terminal posts 4b, 5b in the winding axis core, stabilizes the assembly when winding the electrode and separator. A POSA would also have understood that winding the electrodes 1, 2, and separator 3 about the winding axis core 7 would be difficult and perhaps impossible without the integrated assembly of the terminals 4, 5 and terminal plates 4a, 5a registered with respect to the winding member 6.

678. The metal conducting plates 4a, 5a also present a sufficient surface in order to make reliable contact with the housing. They extend axially beyond the planar insulating plates 8 and 9 of the winding member 6 to expose the plates. The thickness of the terminal plates 4a, 5a and depth of the grooves in the insulation plates 8, 9 ensures the plates are exposed to contact the casings 11, 13 with the aim of ensuring good service life and reliable manufacturability of the Kobayashi button cell due to the positive contact between the metal conducting plates and the housing. Accordingly, a POSA would not have modified Kobayashi so as to replace Kobayashi's metal plates with foils.

**XV. CONCLUSION**

679. This declaration is based on information currently available to me. I expressly reserve the right to supplement, amend, or modify my opinions in response to any new information or documents that become available to me, in response to any new statements or contentions raised by Petitioners, and to any new declarations or opinions provided by Petitioners' Expert.

680. I declare that all statements made herein of my own knowledge are true and that all statements made on information and belief are believed to be true. I further declare that these statements are made with knowledge that willful false statements and the like so made are punishable by fine or imprisonment or both under 18 U.S.C. § 1001.

I, Martin C. Peckerar, Ph.D., declare under penalty of perjury under the laws of the United States that the foregoing is true and correct.

Date: March 31, 2021



/Martin Peckerar/  
Martin C. Peckerar, Ph.D.

APPENDIX TO DECLARATION OF  
Dr. MARTIN PECKERAR Ph.D

APPENDIX  
INFORMATION CONSIDERED

<b>Document</b>	<b>Description of Document</b>
Paper 1 in IPR2020- 01212	Petition for Inter Partes Review of U.S. Patent 9,153,835
Paper 7 in IPR2020-1212	Patent Owner Preliminary Response in IPR2020-01212
Paper 8 in IPR2020- 01212	Decision Granting Institution of Inter Partes Review in IPR2020-01212
Paper 1 in IPR2020- 01211	Petition for Inter Partes Review of U.S. Patent 9,496,581
Paper 7 in IPR2020- 01211	Patent Owner Preliminary Response in IRP2020-01211
Paper 8 in IPR2020-1211	Decision Granting Institution of Inter Partes Review in IPR2020-01211
Paper 1 in IPR2020- 01213	Petition for Inter Partes Review of U.S. Patent 9,799,858
Paper 8 in IPR2020- 01213	Patent Owner Preliminary Response in IRP2020-01213



APPENDIX  
INFORMATION CONSIDERED

<b>Document</b>	<b>Description of Document</b>
Paper 9 in IPR2020- 01213	Decision Granting Inter Partes Review in IPR2020-01213
Paper 1 in IPR2020- 01214	Petition for Inter Partes Review of U.S. Patent 9,799,913
Paper 7 in IPR2020- 01214	Patent Owner's Preliminary Response in IPR2020-01214
Paper 8 in IPR2020- 01214	Decision Granting Inter Partes Review in IPR2020-01214
Ex. 1001 in IPR2020-01212	U.S. Patent No. 9,153,835 ("835Patent")
Ex. 1002 in IPR2020-01212	File History of U.S. Patent No. 9,153,835 (Application No. 13/146,669)
Ex. 1001 in IPR2020-01211	U.S. Patent No. 9,496,581 ("the '581 Patent)
Ex. 1002 in IPR2020-01211	File History of U.S Patent No. 9,496,581 (Application No. 14/827,387)
Ex. 1001 in IPR2020-01213	U.S. Patent No. 9,799,858 ("the '858 Patent)
Ex. 1002 in IPR2020-01213	File History of U.S Patent No. 9,799,858 (Application No. 13/378,117)

APPENDIX  
INFORMATION CONSIDERED

<b>Document</b>	<b>Description of Document</b>
Ex.1001 in IPR2020-01214	U.S. Patent No. 9,799,913 (“the ’913 Patent”)
Ex. 1002 in IRP2020-01214	File History of U.S Patent No. 9,799,913 (Application No. 15/283,568)
1003	Expert Report of William Gardner (“Gardner”)
1004	<i>Curriculum Vitae</i> of William Gardner
1005	U.S. Patent Publication No. 2005/0233212 to Kaun (“Kaun”)
1006	Japanese Patent Publication No. 2007-294111 to Kobayashi (“Kobayashi”)
1007	E.P. Patent No. 1886364B1 to Ryou (“Ryou”)
1008	Korean Patent Publication No. 10-2003-0087316A to Kwon (“Kwon”)
1009	David Linden & Thomas B. Reddy, <i>Handbook of Batteries</i> 91 (3d ed. 2002) (“Linden”)
1010	U.S. Patent No. 6,287,719 to Bailey (“Bailey”)
1011	U.S. Patent No. 6,723,466 to Oogami (“Oogami”)
1012	EP Patent No. 1,315,220 B1 to Masakatsu (“Masakatsu”)
1013	U.S. Patent No. 7,566,515 to Suzuki (“Suzuki”)
1014	U.S. Patent No. 8,236,441 to Gardner (“Gardner Patent”)
1015	U.S. Patent No. 4,224,387 to Nakayama (“Nakayama”)
1016	U.S Patent No. 6,443,999 to Cantave (“Cantave”)
1017	U.S. Patent No. 5,470,357 to Schmutz (“Schmutz”)

APPENDIX  
INFORMATION CONSIDERED

<b>Document</b>	<b>Description of Document</b>
1018	U.S. Patent Number 6,379,839 to Inoue (“Inoue”)
1019	U.S. Patent No. 5,432,027 to Tuttle (“Tuttle”)
1020	U.S. Patent No. 8,703,327 to Kim (“Kim”)
1021	U.S. Patent Publication No. 2005/042506 to Tomimoto (“Tomimoto”)
1022	U.S. Patent No. 6,265,100 to Saaski (“Saaski”)
1023	U.S. Publication No. 2005/0271938 to Suzuki (“Suzuki II”)
1024	U.S. Publication No. 2008/0003500 to Issaev (“Issaev”)
1025	Japanese Patent No. 2008-262826 to Higuchi (“Higuchi”)
1026	U.S. Publication No. 2001/0009737 to Lane (“Lane”)
1027	Table comparing issued claims of '858 Patent and claims of PCT application
1028	U.S. Patent No. 4,487,819 to Koga (“Koga”)
1029	Abstract of DE 3638793A1 (“Sprengel”)
1030	Laminated Lithium Ion Batteries with improved fast charging capability (“Frankenberger”)
2012	Defendants’ P.R. 3-3 Invalidity Contentions, 2:20-cv-00051-JRG, (E.D. Tex., July 10, 2020)
2025	IEC-62133-2 Standard
2026	<i>Button Cell</i> , WIKIPEDIA (Dec. 3, 2020, 11:24 AM), <a href="https://en.wikipedia.org/wiki/Button_cell">https://en.wikipedia.org/wiki/Button_cell</a>
2027	Button Cell Battery Safety Act, S. 1165, 112th Cong. (2011)

APPENDIX  
INFORMATION CONSIDERED

Document	Description of Document
2029	Rolled-Ribbon Cell Design, Rolled-Ribbon Battery Company, <a href="http://www.rolled-ribbon.com/downloads/D-RRBC_Cell%20Design_20190827_11x17.pdf">http://www.rolled-ribbon.com/downloads/D-RRBC_Cell%20Design_20190827_11x17.pdf</a> (last visited Mar. 28, 2021)
2030	William H. Gardner Deposition Testimony – Days 1-2 (Mar. 3-4, 2021) and Exhibits
2031	Iain Martin, The Tiny Batter Powering AirPods Built a \$1.9 Billion Fortune, FORBES (Apr. 9, 2020), <a href="https://www.forbes.com/sites/iainmartin/2020/04/09/how-a-tiny-battery-thanks-apple-built-a-new-19-billion-fortune/?sh=6aabf9063d72">https://www.forbes.com/sites/iainmartin/2020/04/09/how-a-tiny-battery-thanks-apple-built-a-new-19-billion-fortune/?sh=6aabf9063d72</a>
	Plaintiff’s Infringement Contentions and related pleadings and papers in <i>VARTA Microbattery GmbH v. Samsung Electronics North America</i> , C.A. No. 20-cv-00029 (E.D. Tx.)
	Plaintiff’s Infringement Contentions and related pleadings and papers in <i>VARTA Microbattery GmbH v. Costco Wholesale Corp.</i> , C.A. No. 20-cv-00051 (E.D. Tx.)
	Plaintiff’s Infringement Contentions and related pleadings and papers in <i>VARTA Microbattery GmbH v. Amazon.com, Inc.</i> , C.A. No. 20-cv-00052 (E.D. Tx.)
	Plaintiff’s Infringement Contentions and related pleadings and papers in <i>VARTA Microbattery GmbH v. Best Buy Co. Inc.</i> , C.A. No. 20-cv-00054 (E.D. Tx.)

APPENDIX  
INFORMATION CONSIDERED

<b>Document</b>	<b>Description of Document</b>
	Plaintiff's Infringement Contentions and related pleadings and papers in <i>VARTA Microbattery GmbH v. PEAG</i> , C.A. No. 20-cv-00071 (E.D. Tx.)
	Plaintiff's Infringement Contentions and related pleadings and papers in <i>VARTA Microbattery GmbH v. Audio Partnership et al.</i> , C.A. No. 20-cv-00138 (E.D. Tx.)
	VARTA Production Documents from <i>Microbattery GmbH v. Costco Wholesale Corp.</i> , C.A. No. 20-cv-00051 (E.D. Tx.) concerning development of CoinPower® button cells including VARTA0006119, VARTA00022049, VARTA00022059, VARTA0006119
	Photos, CT Scans and samples of button cell batteries from VARTA Microbattery GmbH, Eve Energy of China, and Mic-Power