

(12) **United States Patent**
Wang et al.

(10) **Patent No.:** **US 7,439,907 B2**
(45) **Date of Patent:** **Oct. 21, 2008**

(54) **NAVIGATION SIGNAL RECEIVER
TRAJECTORY DETERMINATION**

(75) **Inventors:** **Chi-Shin Wang**, Half Moon Bay, CA (US); **David Wang**, Belmont, CA (US); **Wentao Zhang**, Mountain View, CA (US); **Jun Mo**, San Jose, CA (US); **Lei Dong**, Cupertino, CA (US)

(73) **Assignee:** **SIRF Technology Holdings, Inc.**, San Jose, CA (US)

(*) **Notice:** Subject to any disclaimer, the term of this patent is extended or adjusted under 35 U.S.C. 154(b) by 38 days.

(21) **Appl. No.:** **11/561,758**

(22) **Filed:** **Nov. 20, 2006**

(65) **Prior Publication Data**

US 2008/0117100 A1 May 22, 2008

(51) **Int. Cl.**
G01S 3/14 (2006.01)

(52) **U.S. Cl.** **342/357.02; 342/357.13**

(58) **Field of Classification Search** **342/357.02, 342/357.06, 357.13**

See application file for complete search history.

(56) **References Cited**

U.S. PATENT DOCUMENTS

6,225,945 B1 5/2001 Loomis

6,429,809 B1	8/2002	Vayanos	
6,559,793 B1 *	5/2003	Eschenbach	342/357.03
6,570,530 B2	5/2003	Gaal	
6,707,420 B2	3/2004	Vayanos	
6,727,848 B2	4/2004	Eschenbach	
6,930,635 B2	8/2005	Vayanos	
2007/0152878 A1 *	7/2007	Wang et al.	342/357.06

* cited by examiner

Primary Examiner—Thomas H. Tarcaza

Assistant Examiner—Fred H. Mull

(74) *Attorney, Agent, or Firm*—Orrick, Herrington & Sutcliffe, LLP

(57) **ABSTRACT**

The present invention provides methods and systems that enable a mobile navigation receiver to accurately determine its trajectory with non-current ephemeris in stand-alone mode. In an embodiment, the receiver computes the position for the same location using non-current ephemeris and current ephemeris at different time instances. The receiver then determines a position correction by finding the difference between these two computed positions, and applies this correction to the trajectory generated with non-current ephemeris to obtain a more accurate trajectory. In another embodiment, the receiver computes an initial position of the receiver using non-current ephemeris and finds the difference between the computed initial position and an accurate approximation of the initial position. The receiver then shifts the subsequent receiver trajectory computed using non-current ephemeris by the difference to obtain a more accurate trajectory.

18 Claims, 5 Drawing Sheets

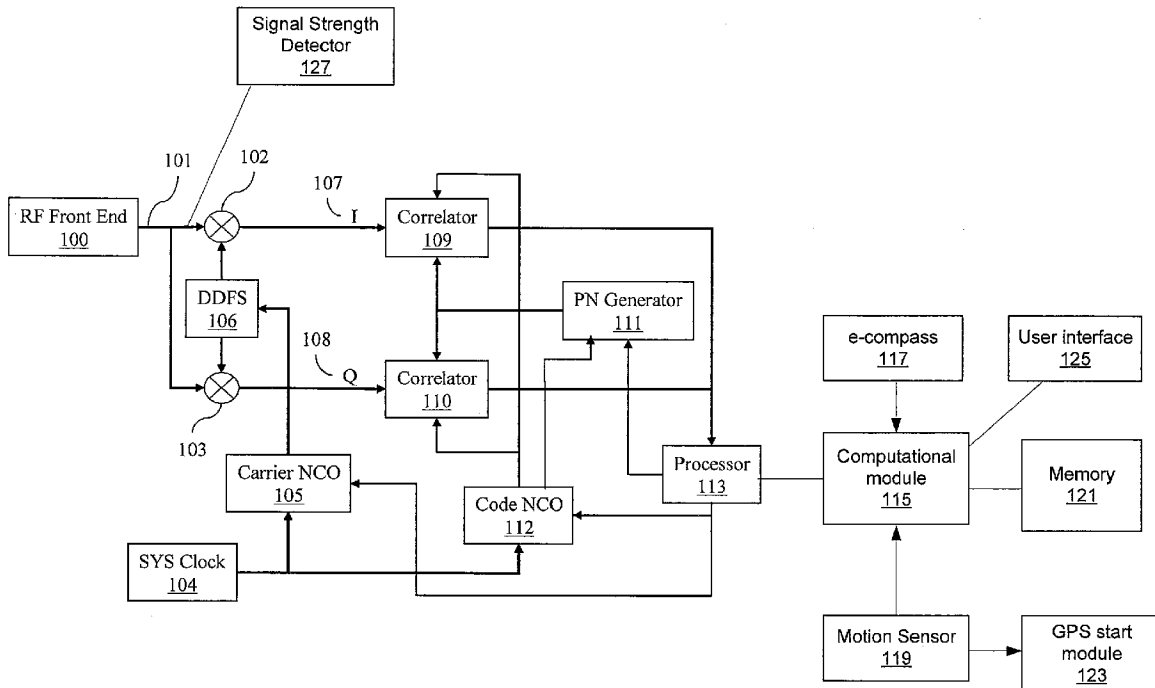

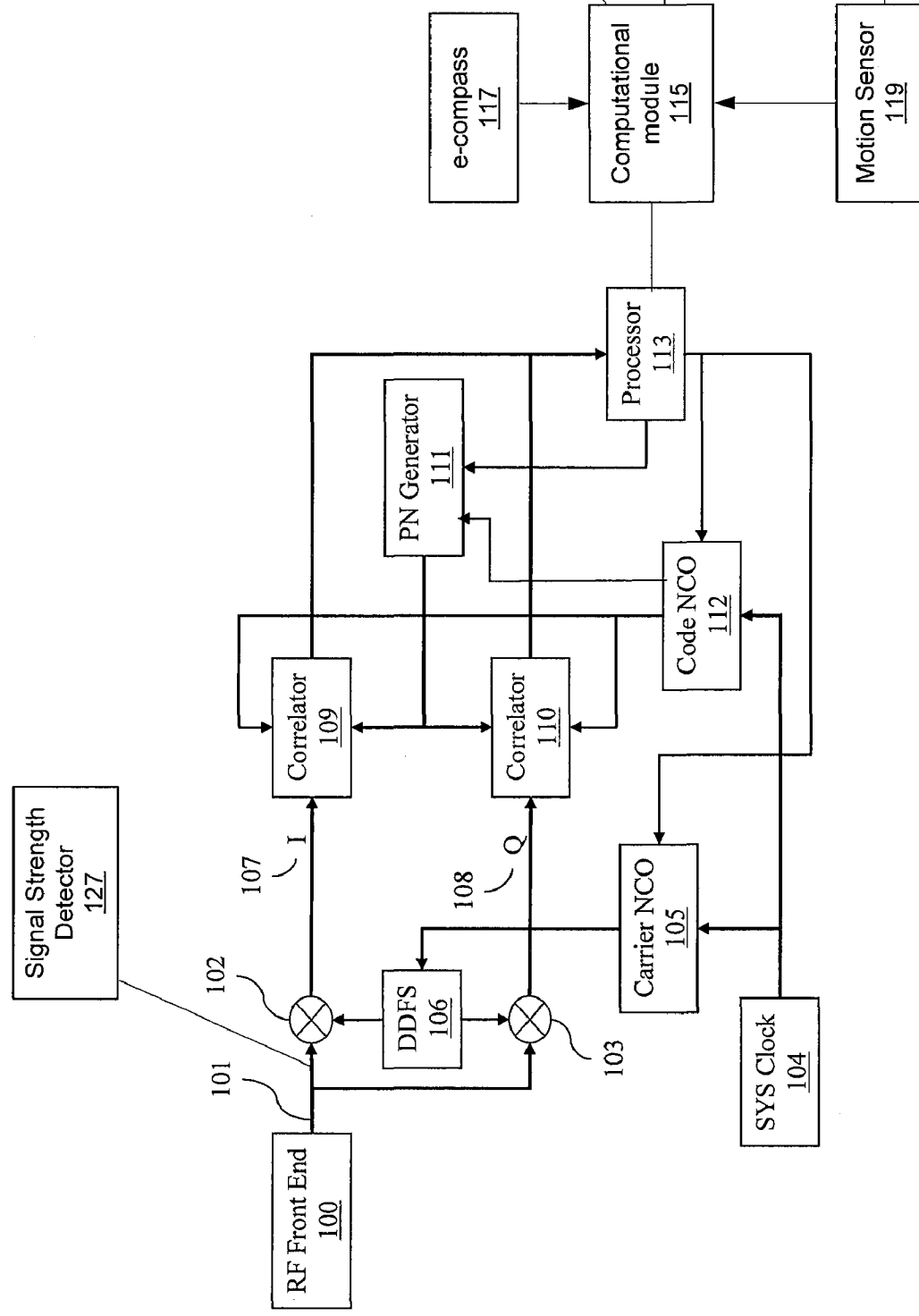

FIG. 1A GPS Receiver

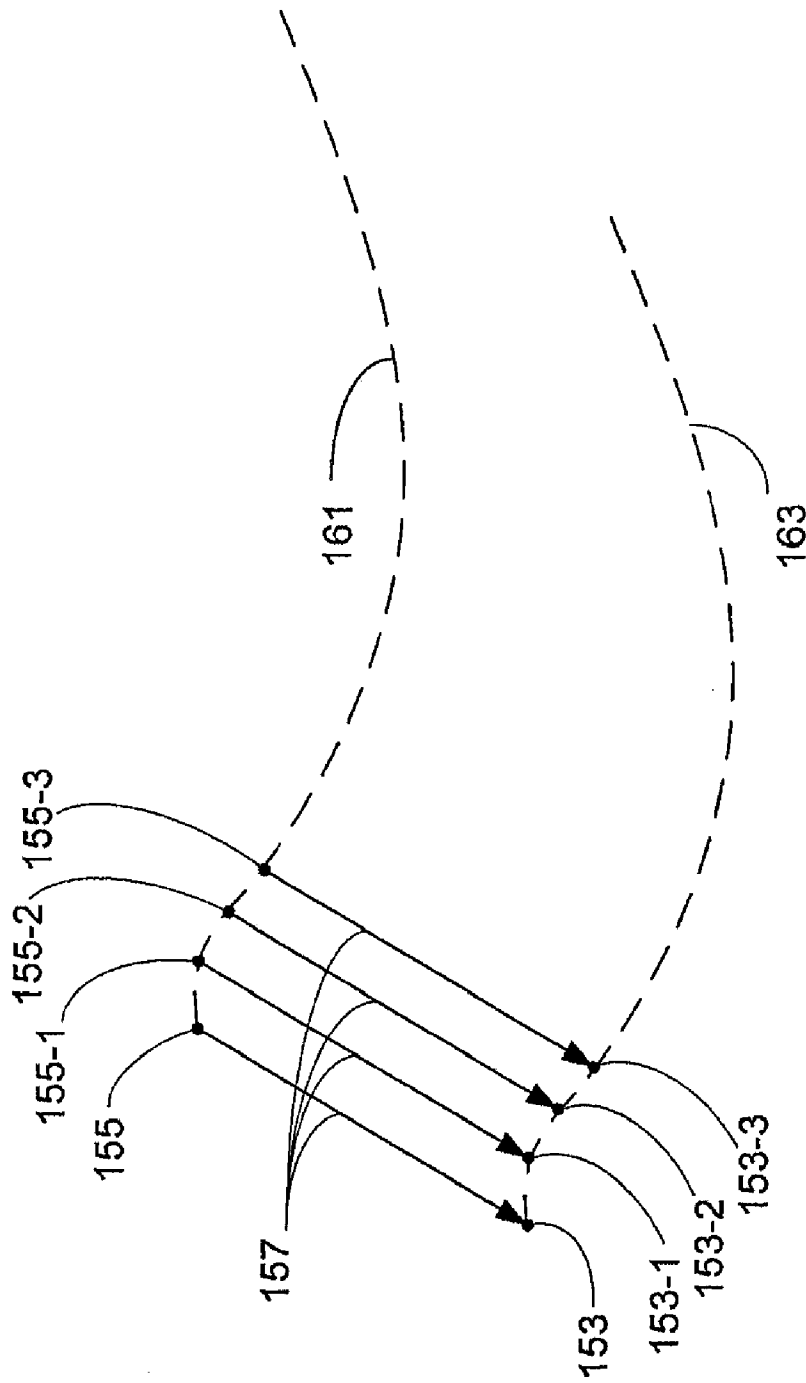

FIG. 1B

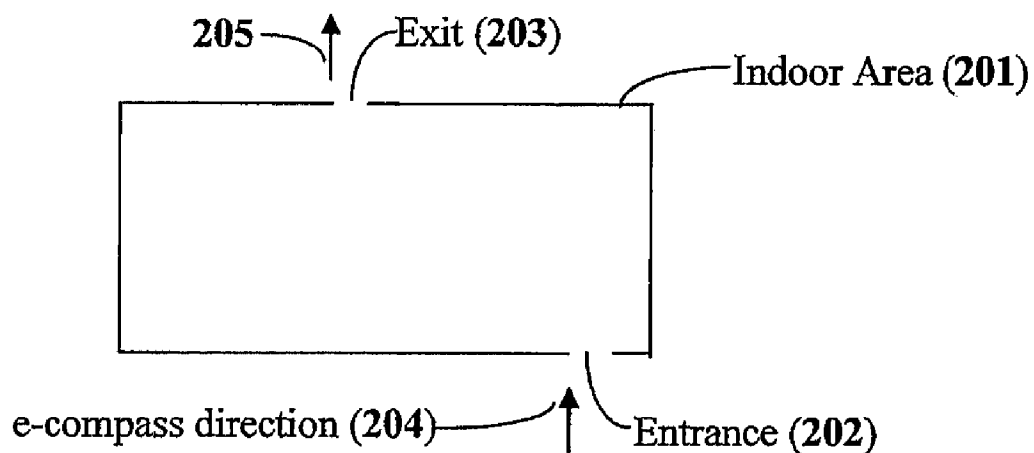

FIG. 2 USE OF E-COMPASS IN LARGE INDOOR AREA

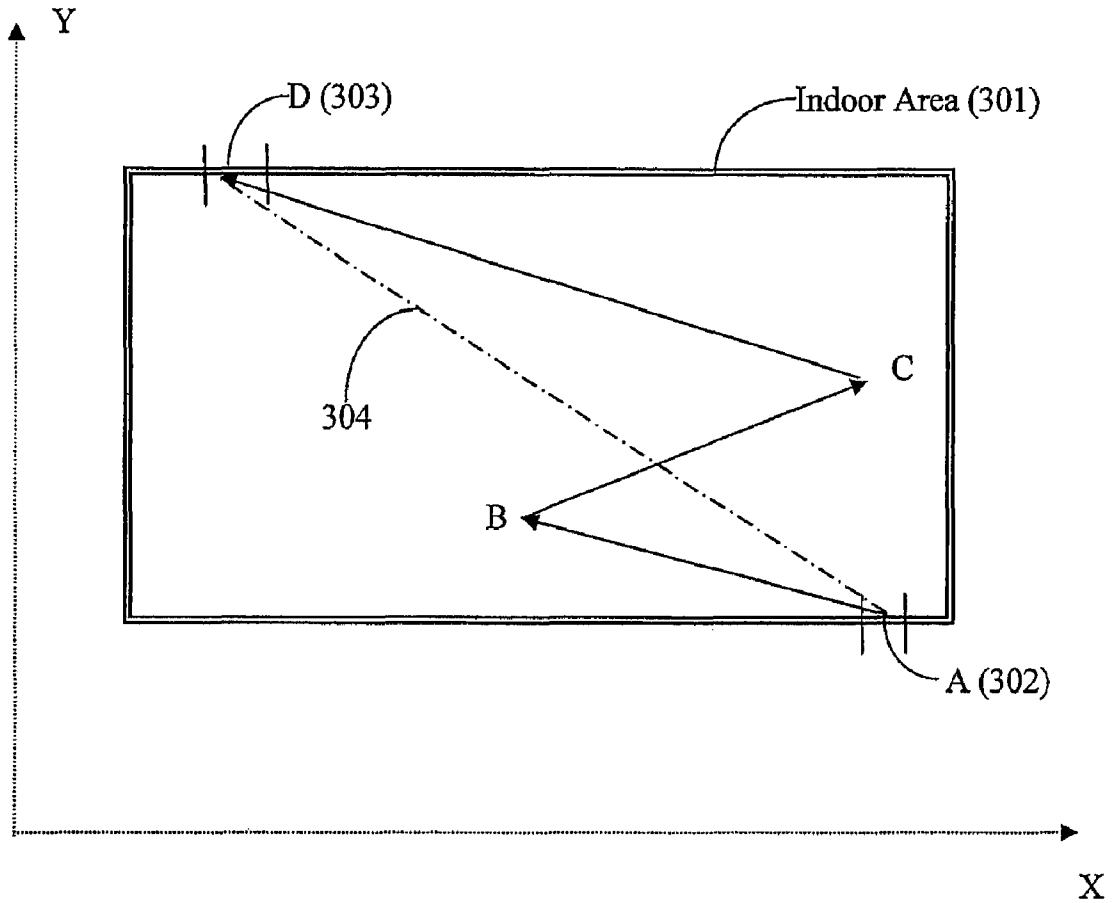

FIG 3 USE OF MOTION SENSORS FOR INITIAL POSITION

Explore Litigation Insights

Docket Alarm provides insights to develop a more informed litigation strategy and the peace of mind of knowing you're on top of things.

Real-Time Litigation Alerts



Keep your litigation team up-to-date with **real-time alerts** and advanced team management tools built for the enterprise, all while greatly reducing PACER spend.

Our comprehensive service means we can handle Federal, State, and Administrative courts across the country.

Advanced Docket Research



With over 230 million records, Docket Alarm's cloud-native docket research platform finds what other services can't. Coverage includes Federal, State, plus PTAB, TTAB, ITC and NLRB decisions, all in one place.

Identify arguments that have been successful in the past with full text, pinpoint searching. Link to case law cited within any court document via Fastcase.

Analytics At Your Fingertips



Learn what happened the last time a particular judge, opposing counsel or company faced cases similar to yours.

Advanced out-of-the-box PTAB and TTAB analytics are always at your fingertips.

API

Docket Alarm offers a powerful API (application programming interface) to developers that want to integrate case filings into their apps.

LAW FIRMS

Build custom dashboards for your attorneys and clients with live data direct from the court.

Automate many repetitive legal tasks like conflict checks, document management, and marketing.

FINANCIAL INSTITUTIONS

Litigation and bankruptcy checks for companies and debtors.

E-DISCOVERY AND LEGAL VENDORS

Sync your system to PACER to automate legal marketing.