

**APPARATUS AND METHOD FOR ADJUSTING REFRESH RATE OF  
LOCATION COORDINATES OF A TRACKING DEVICE**

5 *Priority and Related Applications*

This application is a continuation-in-part and claims priority to U.S. patent application number 11/969,905 entitled “Apparatus and Method for Determining Location and Tracking Coordinates of a Tracking Device” that was filed on January 6, 2008, and incorporates by reference in their entirety and claims priority to U.S. patent application Serial No. 11/753,979 filed on May 25, 2007, entitled “Apparatus and Method for Providing Location Information on Individuals and Objects Using Tracking Devices”; U.S. patent application Serial No. 11/933,024 filed on October 31, 2007, entitled “Apparatus and Method for Manufacturing an Electronic Package”; US patent application Serial No. 11/784,400 filed on April 5, 2007, entitled “Communication System and Method Including Dual Mode Capability”; US patent application Serial No. 11/784,318 filed on April 5, 2007, entitled “Communication System and Method Including Communication Billing Options”; and US patent application Serial No. 11/935,901 filed on November 6, 2007, entitled “System and Method for Creating and Managing a Personalized Web Interface for Monitoring Location Information on Individuals and Objects Using Tracking Devices.”

*Background of the Invention*

1. Field of the Invention

The invention relates generally to the field of location and tracking communication systems. More particularly, the present invention relates in one embodiment to a power conservation methodology and apparatus incorporated as part of portable electronic tracking device for individuals and objects to improve battery life by a wireless location and tracking system and/or wireless communication system (WCS).

30

## 2. Description of Related Technology

Accelerometers are conventionally integrated into electronics systems that are part of a vehicle, vessel, and airplane to detect, measure, and monitor deflections, vibrations, and acceleration. Accelerometers, for example, may include one or more  
5 Micro Electro-Mechanical System (MEMS) devices. In particular, MEMS devices include one or more suspended cantilever beams (e.g., single-axis, dual-axis, and three-axis models), as well as deflection sensing circuitry. Accelerometers are utilized by a multitude of electronics manufacturers.

For instance, electronics gaming manufacturers exploit an accelerometer's  
10 deflection sensing capability, for instance, to measure device tilt and control game functionality. In another instance, consumer electronics manufacturers, e.g., Apple, Ericsson, and Nike, incorporate accelerometers in personal electronic devices, e.g., Apple iPhone to provide a changeable screen display orientation that toggles between portrait and landscape layout window settings; to manage human inputs through a human  
15 interface, e.g., Apple iPod® touch screen interface; and to measure game movement and tilt, e.g., Wii gaming remotes. Still others including automobile electronics circuitry manufacturers utilize MEMS accelerometers to initiate airbag deployment in accordance with a detected collision severity level by measuring negative vehicle acceleration.

Other electronics manufacturer products, e.g., Nokia 5500 sport, count step  
20 motions using a 3D accelerometer, and translate user information via user's taps or shaking motion to select song titles and to enable mp3 player track switching. In another instance, portable or laptop computers include hard-disk drives integrated with an accelerometer to detect displacement or falling incidents. For instance, when a hard-disk accelerometer detects a low-g condition, e.g., indicating free-fall and expected shock, a  
25 hard-disk write feature may be temporarily disabled to avoid accidental data overwriting and prevent stored data corruption. After free-fall and expected shock, the hard-disk write feature is enabled to allow data to be written to one or more hard-disk tracks. Still others including medical product manufacturers utilize accelerometers to measure depth of Cardio Pulmonary Resuscitation (CPR) chest compressions. Sportswear  
30 manufacturers, e.g., Nike sports watches and footwear, incorporate accelerometers to feedback speed and distance to a runner via a connected iPod® Nano.

Still others including manufacturers of conventional inertial navigation systems deploy one or more accelerometers as part of, for instance, on-board electronics of a vehicle, vessel, train and/or airplane. In addition to accelerometer measurements, conventional inertial navigation systems integrate one or more gyroscopes with the on-board electronics to assist tracking including performing various measurements, e.g., tilt, angle, and roll. More specifically, gyroscopes measure angular velocity, for instance, of a vehicle, vessel, train, and/or airplane in an inertial reference frame. The inertial reference frame, provided, for instance, by a human operator, a GPS receiver, or position and velocity measurements from one or more motion sensors.

More specifically, integration of measured inertial accelerations commences with, for instance, original velocity, for instance, of a vehicle, vessel, train, and/or airplane to yield updated inertial system velocities. Another integration of updated inertial system velocities yields an updated inertial system orientation, e.g., tilt, angle, and roll, within a system limited positioning accuracy. In one instance to improve positioning accuracy, conventional inertial navigation systems utilize GPS system outputs. In another instance to improve positioning accuracy, conventional inertial navigation systems intermittently reset to zero inertial tracking velocity, for instance, by stopping the inertial navigation system. In yet other examples, control theory and Kalman filtering provide a framework to combine motion sensor information in attempts to improve positional accuracy of the updated inertial system orientation.

Potential drawbacks of many conventional inertial navigation systems include electrical and mechanical hardware occupying a large real estate footprint and requiring complex electronic measurement and control circuitry with limited applicability to changed environmental conditions. Furthermore, many conventional inertial navigation system calculations are prone to accumulated acceleration and velocity measurement errors. For instance, many conventional inertial navigation acceleration and velocity measurement errors are on the order of 0.6 nautical miles per hour in position and tenths of a degree per hour in orientation.

In contrast to conventional inertial navigation systems, a conventional Global Positioning Satellite (GPS) system uses Global Positioning Signals (GPS) to monitor and track location coordinates communicated between location coordinates monitoring

satellites and an individual or an object having a GPS transceiver. In this system, GPS monitoring of location coordinates is practical when a GPS transceiver receives at least a minimal GPS signal level. However, a minimal GPS signal level may not be detectable when an individual or object is not located in a skyward position. For instance, when an individual or object carrying a GPS transceiver enters a covered structure, e.g., a garage, a parking structure, or a large building, GPS satellite communication signals may be obstructed or partially blocked, hindering tracking and monitoring capability. Not only is a GPS transceiver receiving a weak GPS signal, but also the GPS transceiver is depleting battery power in failed attempts to acquire communication signals from one or more location coordinates monitoring satellites, e.g., GPS satellites, or out-of-range location coordinates reference towers. Furthermore, weak GPS communication signals may introduce errors in location coordinates information.

In addition during the acquisition of signaling and or other information, a conventional GPS transceiver has limited functionality or capabilities associated with control and monitoring of battery power usage. For instance, a conventional GPS transceiver may have some indication battery charge level such as a power level bar but have very few or any ability or capability to control or reduce power usage. Furthermore, often users do not realize or are only alerted when their GPS transceiver is using reserve power or about to suddenly involuntarily shut-down to prevent data loss and loss of other user information such as personal GPS settings, screen color displays, and user recreational or pleasure settings.

More specifically, users of conventional GPS transceivers typically are unprepared for such a sudden loss of GPS transceiver service. Generally, within minutes of an initial warning indication, e.g., beeping, vibration, voice, alarms or combination thereof, the GPS transceiver shuts off. As such, a user may suddenly experience loss of location determination or location based capabilities or monitoring or being monitored capabilities and not prepared for such sudden outage. Furthermore, even if a user could reduce battery power usage, a result, within the last few minutes of battery power, a user has little or no incentive or capability to alter battery usage of a conventional GPS transceiver due to low power level GPS transceivers may suddenly become non-operational without any warning to or recourse to a user. Thus, when a conventional

GPS transceiver is low in power level, a user's most viable alternative would be locating an electrical outlet to recharge their conventional GPS transceiver.

5 In summary, electronic tracking device and methodology that provides additional advantages over conventional systems such as improved power management, e.g., efficient use of battery power and provide other improvements include supplementing conventional electronic tracking device monitoring, e.g., increased measurement accuracy of location coordinates of objects and individuals traveling into and/or through a structure, e.g., a partially covered building, a parking structure, or a substantially enclosed structure, such as a basement or a storage area in a high-rise office building.

10

#### Summary of the Invention

In a first aspect of the present invention, a portable electronic apparatus for a tracking device is disclosed. In one embodiment, the tracking device includes a battery having a battery charge level, transceiver circuitry, processor circuitry, and a battery power monitor. In one embodiment, the battery power monitor measures in real-time the battery charge level and makes a prediction of an estimated remaining battery charge level in response to the battery charge level.

15 In one variant, a local battery power adjustment mechanism generates in substantially real-time an updated set of network communication signaling protocols associated with at least one of a request rate of location coordinate packets to be communicated to a target host and a listen rate of the location coordinate packets. In yet another variant, the updated set of network communication signaling protocols has a value that is responsive to a user input request. In yet another embodiment, the local battery power adjustment mechanism activates or deactivates one or more portions of the transceiver circuitry to conserve the battery charge level. In yet another embodiment, the local battery power adjustment mechanism activates or deactivates the processor to conserve the battery charge level in response to the value having the value responsive to a user input request.

25 In a second aspect of the present invention, a local charging management device is disclosed to manage electrical resource capability for an electronic tracking device that is tracked by at least one other tracking device. In one embodiment, local charging

30

management device includes a battery power monitor, a charging unit; and an electrical power resource management component. In one variant, the power resource management component adjusts cycle timing of a request rate of location coordinate packets communicated to a target host responsive to an estimate charge level of the charging unit.

5 In another variant, the power resource management component adjusts a listen rate of location coordinate packets responsive to an estimated charge level of the charging unit. In yet another variant, the power resource management component adjusts one or more of request rate of location coordinate packets to a target host and a listen rate of location coordinate packets responsive to an estimated charge level of the charging unit.

10 In another aspect of the present invention, a method is disclosed to control power usage. In one embodiment, the method includes measurement of charging unit power level of a tracking device communicated by a location coordinate tracking system, and adjustment of charging unit power level of the tracking device in response to a substantially-real life estimate of the unit power level of a charge unit of the tracking  
15 device. In one variant, the method includes creation of an initial timing schedule for communication of signaling parameters associated with a request rate communicated with location coordinate information and listen rate communicated with the location coordinate information, the initial time schedule being at least partially automatically and responsive to an estimated power level of the charge unit. In yet another variant, the  
20 method includes readjustment of the initial timing schedule for communication of signaling parameters in accordance with a local request by a remote user using an Internet accessible icon that displays user viewable tradeoffs between the estimated charge unit life and charge unit update rate.

25 These and other embodiments, aspects, advantages, and features of the present invention will be set forth in part in the description which follows, and in part will become apparent to those skilled in the art by reference to the following description of the invention and referenced drawings or by practice of the invention. The aspects, advantages and features of the invention are realized and attained by means of the instrumentalities, procedures, and combinations particularly pointed out in the appended  
30 claims.

### Brief Description of the Drawings

Figure 1 illustrates a schematic of an electronic tracking device in accordance with an embodiment of the present invention.

5 Figure 2 illustrates a location tracking system associated with the electronic tracking device and the wireless network in accordance with an embodiment of the present invention.

Figure 3 illustrates a flow diagram to manage and control circuitry associated with the electronic tracking device of Figures 1 and 2 in accordance with an embodiment of the present invention.

10 Figure 4 illustrates a screen display including a user definable adjustable power level monitor in accordance with an embodiment of the present invention.

Figure 5 illustrates a location coordinate navigational system utilizing user definable power level monitor of Figure 4 in accordance with an embodiment of the present invention.

15 Figure 6 illustrates a location coordinate navigation system utilizing a user definable power level monitor of Figure 4 in accordance with an embodiment of the present invention.

Figure 7 illustrates a flow diagram of a user definable adjustable power level monitor in accordance with an embodiment of the present invention.

20

### Detailed Description

Reference is now made to the drawings wherein like numerals refer to like parts throughout.

25 As used herein, the terms “location coordinates” refer without limitation to any set or partial set of integer, real and/or complex location data or information such as longitudinal, latitudinal, and elevational positional coordinates.

As used herein, the terms “tracking device” and “electronic tracking device” refers to without limitation to any hybrid electronic circuit, integrated circuit (IC), chip, chip set, system-on-a-chip, microwave integrated circuit (MIC), Monolithic Microwave  
30 Integrated Circuit (MMIC), low noise amplifier, power amplifier, transceiver, receiver, transmitter and Application Specific Integrated Circuit (ASIC) that may be constructed

and/or fabricated. The chip or IC may be constructed (“fabricated”) on a small rectangle (a “die”) cut from, for example, a Silicon (or special applications, Sapphire), Gallium Arsenide, or Indium Phosphide wafer. The IC may be classified, for example, into analogue, digital, or hybrid (both analogue and digital on the same chip and/or analog-to-digital converter). Digital integrated circuits may contain anything from one to millions of logic gates, invertors, and, or, nand, and nor gates, flipflops, multiplexors, etc. on a few square millimeters. The small size of these circuits allows high speed, low power dissipation, and reduced manufacturing cost compared with board-level integration.

As used herein, the terms “data transfer”, “tracking and location system”, “location and tracking system”, “location tracking system”, and “positioning system,” refer to without limitation to any system that transfers and/or determines location coordinates using one or more devices, such as Global Positioning System (GPS).

As used herein, the terms “Global Positioning System” refer to without limitation to any services, methods or devices that utilize GPS technology to determine position of a GPS receiver based on measuring a signal transfer time of signals communicated between satellites having known positions and the GPS receiver. A signal transfer time is proportional to a distance of a respective satellite from the GPS receiver. The distance between a satellite and a GPS receiver may be converted, utilizing signal propagation velocity, into a respective signal transfer time. The positional information of the GPS receiver is calculated based on distance calculations from at least four satellites to determine positional information of the GPS receiver.

As used herein, the terms “wireless network”, “wireless communication”, “wireless link”, and “wireless transmission” refers to, without limitation, any digital, analog, microwave, and millimeter wave communication networks that transfer signals from one location to another location, such as, but not limited to IEEE 802.11g, Bluetooth, WiMax, IS-95, GSM, IS-95, CGM, CDMA, wCDMA, PDC, UMTS, TDMA, and FDMA, or combinations thereof.

### *Major Features*

In one aspect, the present invention discloses an apparatus and method to provide an improved capability electronic tracking device. In one embodiment, the device



provides electronic circuitry including an accelerometer to measure location coordinates without requiring GPS signaling. In this embodiment, location coordinates of an electronic tracking device are measured when the electronic tracking device is located in a partially enclosed structure, e.g., a building or parking lot, up to a fully enclosed structure. In one embodiment, the electronic tracking device conserves battery power when the device is partially or fully blocked access to location coordinates from one or more GPS satellites, e.g., a primary location tracking system. In yet another embodiment, accelerometer measures force applied to the electronic tracking device and provides an alert message to a guardian or other responsible person. In one embodiment, the alert message includes location coordinates of the electronic tracking device and other information, e.g., magnitude or nature of force, as well as possibility of injury of an object or individual having the electronic tracking device. As described though out the following specification, the present invention generally provides a portable electronic device configuration for locating and tracking an individual or an object.

15

#### *Exemplary Apparatus*

Referring now to Figs. 1-2 and 4-6 exemplary embodiments of the electronic tracking device of the invention are described in detail. Please note that the following discussions of electronics and components for an electronic tracking device to monitor and locate individuals are non-limiting; thus, the present invention may be useful in other electronic signal transferring and communication applications, such as electronics modules included in items such as: watches, calculators, clocks, computer keyboards, computer mice, and/or mobile phones to location and track trajectory of movement and current location of these items within boundaries of or proximity to a room, building, city, state, and country.

20  
25

Furthermore, it will be appreciated that while described primarily in the context of tracking individuals or objects, at least portions of the apparatus and methods described herein may be used in other applications, such as, utilized, without limitation, for control systems that monitor components such as transducers, sensors, and electrical and/or optical components that are part of an assembly line process. Moreover, it will be recognized that the present invention may find utility beyond purely tracking and

30

monitoring concerns. Myriad of other functions will be recognized by those of ordinary skill in the art given the present disclosure.

*Electronic Tracking Device*

5 Referring to Figure 1, tracking device 100 contains various electronic components 101 such as transceiver 102, signal processing circuitry 104 (e.g., a microprocessor or other signal logic circuitry), and accelerometer 130. In one non-limiting example, the electronic components 101 are disposed, deposited, or mounted on a substrate 107 (e.g., Printed Circuit Board (PCB)). The PCB 107, for example, may be manufactured from:  
10 polyacrylic (PA), polycarbonate (PC), composite material, and arylonitrile-butadiene-styrene (ABS) substrates, blends or combinations thereof, or the like (as described in more detail in incorporated by reference US patent application Serial No. 11/933,024 filed on October 31, 2007). The signal processing circuitry 104, in one example, associated with the tracking device 100 configured to store a first identification code,  
15 produce a second identification code, determine location coordinates, and generate a positioning signal that contains location data (as described in more detail in incorporated by reference US patent application Serial No. 11/753,979 filed on May 25, 2007). For instance, the location data includes longitudinal, latitudinal, and elevational position of a tracking device, current address or recent address of the tracking device, a nearby  
20 landmark to the tracking device, and the like. In one example, electronic tracking device 100 is portable, mobile and fits easily within a compact volume, such as standard shirt pocket having approximate dimensions of 1.5 inch by 2.5 inch by 1.0 inch. In yet another example, electronic tracking device 100 may be one integrated circuit having dimensionality in the mm range in all directions (or even smaller).

25 In one embodiment, location tracking circuitry 114, calculates location data received and sends the data to signal processing circuitry 104. Memory 112 stores operating software and data, for instance, communicated to and from signal processing circuit 104 and/or location tracking circuitry 114, e.g., GPS logic circuitry. In one embodiment, a signal detecting circuitry 115 detects and measures signal power level. In  
30 another embodiment, the signal processing circuitry 104 processes and measures signal power level. Battery level detection circuitry (e.g., battery level monitor 116) detects a

battery level of battery 118, which contains one or more individual units or grouped as a single unit.

In one non-limiting example, antennas 122a, 122b electrically couple to transceiver 102. In one variant, transceiver 102 includes one integrated circuit or, in another embodiment, may be multiple individual circuits or integrated circuits. Transceiver 102 communicates a signal including location data between tracking device 100 and the monitoring station 110, for example, by any of the following including: wireless network, wireless data transfer station, wired telephone, and Internet channel. A demodulator circuit 126 extracts baseband signals, for instance at 100 KHz, including tracking device configuration and software updates, as well as converts a low-frequency AC signal to a DC voltage level. The DC voltage level, in one example, is supplied to battery charging circuitry 128 to recharge a battery level of the battery 118. In one embodiment, a user of monitoring station 110, e.g., a mobile personal digital assistant, mobile phone, or the like, by listening (or downloading) one or more advertisements to reduce and/or shift usage charges to another user, account, or database (as described in more detail in previous incorporated by reference US patent applications Serial No. 11/784,400 and 11/784,318 each filed on April 5, 2007).

In another embodiment, an accelerometer 130, for example, a dual-axis accelerometer 130, e.g. ADXL320 integrated circuit manufactured by Analog Devices having two substantially orthogonal beams, may be utilized. The data sheet ADXH320L from Analog Devices is incorporated by reference. In one embodiment, the accelerometer 130 activates upon one or more designated antenna(s), e.g., antennas 122a, 122b, detecting a first signal level, e.g., a low signal level or threshold value, as specified by, for instance, a user or system administrator. In one variant of this embodiment, electrical circuitry associated with GPS signal acquisition, e.g., all or a portion of amplifier block 120, may be, for instance, placed on standby or in a sleep mode. In another embodiment, the accelerometer 130 remains in a standby mode until, for instance, a system administrator, a specified time period, or a user activates the accelerometer 130. In one embodiment, the amplifier block 120 includes multiple electronic functions and blocks including a low noise amplifier, a power amplifier, a RF

power switch, or the like, placed in a sleep or standby mode, for instance, to conserve a battery level of the battery 118.

In another variant of this embodiment, circuitry, such as amplifier block 120 or location tracking circuitry 114, may be placed in a sleep or standby mode to conserve a battery level of the battery 118. In one variant, the tracking device 100 periodically  
5 checks availability of GPS signal, e.g., performs a GPS signal acquisition to determine if a receive communication signal is above a first signal level. Referring to embodiment depicted in Figure 2, electronic tracking device 100 exits an opening 150 in partially enclosed structure 210; thus, electronic tracking device 100 may resume GPS signal  
10 acquisition using GPS satellite 143 (e.g., in response to a periodic check by the tracking device 100 of a receive communication signal level above a first signal level).

In one embodiment, system administrator selects a signal noise bandwidth, e.g., within a range of 3 to 500 Hz, of the accelerator 130 to measure dynamic acceleration (e.g., due to vibration forces applied to electronic tracking device 100). In another  
15 embodiment, system administrator selects a signal noise bandwidth, e.g., within a range of 3 to 500 Hz, to measure static acceleration (due to gravitational forces applied to electronic tracking device 100). In particular, external forces on electronic tracking device 100 cause, for example, internal structural movements, e.g., deflection of dual-axis beams, of the accelerometer 130. The deflection of dual-axis beams generates  
20 differential voltage(s).

Differential voltage(s) are proportional to acceleration measurements, e.g., discrete acceleration measurements, of electronic tracking device 100, for instance in x, y, and z directions. Differential voltage(s), in one instance, are relative to, for instance, a last known GPS location coordinates of electronic tracking device 100. By performing  
25 electronic device proximity measurements, e.g., measuring acceleration vectors of electronic tracking device 100 at time intervals, e.g., T1, T2, T3 . . . TN, monitoring station 110 computes electronic tracking device velocity at time intervals, e.g., T1, T2, T3 . . . TN. In one embodiment, time intervals, e.g., T1, T2, and T3 . . . TN are measured in accordance with instructions by a system administrator or user. In one embodiment,  
30 time intervals are selected within a range of one micro-second to several minutes.

In one embodiment, the monitoring station 110 performs an integration of the acceleration measurements as a function of time to compute electronic tracking device velocity at time intervals, e.g., T1, T2, and T3 . . . TN. By referencing prior location coordinates, e.g., last known accurate location data of the electronic tracking device 100 or last known location data of nearby electronic tracking device (e.g., second tracking device 101 in proximity to electronic tracking device 100), monitoring station 110 computes a current location of electronic tracking device 100 utilizing electronic tracking device velocity computations. Advantageously, monitoring station 110, in an above described embodiment, uses above described device proximity measurements to monitor current location data of electronic tracking device 100 without connectivity to receive communication signals from GPS satellites.

In one embodiment, the monitoring station 110 may include a mobile phone having connectivity to wireless network 140 electrically coupled to electronic tracking device 100 (Figure 2). In this variant, the wireless network 140 resides or circulates within at least a portion of a semi-enclosed, partially-enclosed, or fully enclosed structure, e.g., building, parking structure, closet, storage room, or the like (e.g., structure 210 in Figure 2). Furthermore, in one embodiment, the present invention conserves battery power by placing on standby, low power mode, or disabling entirely GPS signal acquisition circuitry and other associated devices, e.g., all or a portion of amplifier block 120 including power amplifiers, LNAs, switches, and the like. Furthermore, during supplemental location coordinates tracking, e.g., electronic device proximity measurements, the transceiver circuitry (e.g., transceiver 102, location tracking circuitry 114, and signal processing circuitry 104) consumes reduced battery power for GPS circuitry while the electronic tracking device 100 communicates displacement vectors (e.g., differential location coordinates) to monitoring station 110 (e.g., a mobile phone, a personal digital assistant) through a wireless network 140. As described above, when GPS signaling is not practicable, electronic device proximity measurements provide differential location coordinate information to calculate current location coordinate information.

In one embodiment, accelerometer, e.g., accelerometer 130, determines if electronic tracking device 100 in a stationary position for a period, for instance,

designated by system administrator or user. For example, electronic tracking device 100 may be, for example, located on a counter top, within a pocket of clothing, or inside a suitcase, not being moved, or not currently in use. Continuing with this embodiment, electronic tracking device 100 communicates a code, e.g., a stationary acknowledgement  
5 code, to communication network, e.g., wireless network 140. In one variant, when or if monitoring station 110 requests location data through communication network, electronic tracking device 100 determines located in a stationary or substantially stationary position and electronic tracking device 100 communicates its last-known location to the monitoring station 110 without accessing or requiring GPS signaling or active GPS  
10 circuitry, e.g., location tracking circuitry 114. Advantageously, in this embodiment, when electronic tracking device 100 does not utilize and require GPS circuitry, e.g., location tracking circuitry 114, or functionality, the power resources are preserved of battery 118 in contrast to many conventional GPS communication system continuing power-on GPS circuitry. In one embodiment, electronic tracking device 130 associated  
15 with a person or object remains at a substantially stationary position approximately one-fourth to one-third of a calendar day; thus, this feature of not accessing GPS circuitry preserves battery power.

In another embodiment, an accelerometer, such as accelerometer 130, detects tapping against electronic tracking device 100. For instance, upon wake-up, user prompt,  
20 system administrator prompt, or active, accelerometer 130 detects a person or object tapping a sequence on electronic tracking device 100. In one embodiment, electronic tracking device 100 includes digital signal programming circuitry (such as of signal processing circuitry 104). The digital signal programming circuitry recognizes programmed motions received by accelerometer, such as accelerometer 130, and  
25 transmits an alert message to the monitoring station 110 upon receiving a recognized motion pattern. For example, electronic tracking device 100 may be programmed to recognize an “SOS tap cadence”. Thus, if electronic tracking device 100 is repeatedly tapped, for instance, in a “dot-dot-dot, dash-dash-dash, dot-dot-dot” pattern, signal processing circuitry 104 recognizes a motion pattern and transmit an alert message to  
30 wireless network 114 to monitoring station 110. In one instance, alert message may be associated as a distress pattern and will require an appropriate response. In one variant,

the accelerometer may recognize when an object or individual spins or turns motion of electronic tracking device 100. Continuing with this embodiment, signal processing circuitry 104 recognizes programmed motions, and transceiver 102 transmits an alert message to wireless network 114 associated with programmed motions. In another  
5 variant, electronic tracking device 100 is programmed to recognize other motion patterns, such as, when it is tumbled or flipped. Depending upon on duration, time, or cadence of these movements or motion patterns, electronic tracking device 100 communicates an alert message to the wireless network 114. In one variant, wireless network 114 performs an appropriate action, such as communicating information signal to monitoring station  
10 110.

In another example, physical impacts on electronic tracking device 100 are measured to determine if an individual or object may be injured. In one embodiment, magnitude of displacement vectors may be measured by one or more accelerometers, such as accelerometer 130, disposed at various inclinations and orientations, e.g.,  
15 disposed substantially orthogonal to one another. Continuing with this embodiment, when a measured physical impact is above a predetermined level, an object or individual associated with electronic tracking device 100 may have suffered a fall or be in need of medical attention. In one variant of this embodiment, a user (e.g., a system administrator, or person located in a contact book) at monitoring station 110 becomes alerted, e.g., by  
20 text message, email, or voice mail (as more fully described in previously incorporated by reference U.S. patent application Serial No. 11/935,901 filed on November 6, 2007, entitled “System and Method for Creating and Managing a Personalized Web Interface for Monitoring Location Information on Individuals and Objects Using Tracking Devices”). In one variant of this embodiment, if a user does not affirmatively respond,  
25 another individual, guardian, medical personnel, or law enforcement officer is contacted by monitoring station 110 (as more fully described in Serial No. 11/935,901). In yet another variant of this embodiment, monitoring station 110 continues to contact individuals until the alert message is affirmatively answered.

30 *Battery Conservation*

Referring to Figure 3, a flow chart 300 illustrates battery conservation for electronic tracking device 100 as described in Figures 1, 2 in accordance with one embodiment of the present invention. In step 302, antenna 122a associated with electronic tracking device 100 acquires a snapshot of receive communication signal including location coordinates data. In step 304, processing unit 104 processes the snapshot of receive communication signal including location coordinates data. In step 306, processing unit 104 determines a power level of receive communication signal. In step 308, accelerometer 130 activates if a power level of the receive communication signal is insufficient for processing. In one variant of step 308, accelerometer 130 measures acceleration of electronic tracking device 100 at time intervals, e.g., T1, T2, T3 . . . TN.

In step 310, processing unit 104 computes current location coordinates using acceleration measurements. In step 312, all or a portion of amplifier block 120 and associated circuitry, e.g., location tracking circuitry, are activated at selected time intervals to determine if receive communication signal is of sufficient signal strength. In one variation of step 312, upon determining receive communication signal of sufficient signal strength, location tracking circuitry 114 are activated, and processing unit 104 determines location coordinates from the receive communication signal. In another variation of step 312, upon determining receive communication signal of sufficient signal strength, accelerometer 130 is deactivated and location tracking circuitry 114 are activated, and processing unit 104 determines location coordinates from the receive communication signal.

#### *User Adjustable Location Coordinate Refresh Rate*

Referring to Figures 4, screen display 400 illustrates a user definable adjustable location coordinate refresh rate in one embodiment of the present invention. As best illustrated in Figure 5, schematic 500 illustrates communication of location coordinate refresh rate between portable electronic tracking device 402 and satellite navigation system 403 in accordance with an embodiment of the present invention.

In one embodiment, portable electronic tracking device 402 monitors location coordinates of one or more individuals and objects using satellite navigation system 403.



Portable electronic tracking device 402 includes battery 118 having battery charge level 406 displayed on screen display 400 of personal communication device 404 (e.g., mobile phone, wireless digital assistant, laptop computer, personal computer and the like). Other components of portable electronic tracking device 402 include transceiver 102, signal processing circuitry 104, battery level monitor 116, signal processing circuitry 104, location tracking circuitry 114, adj 416, and battery charging circuitry 128.

In one example, battery level monitor 116 measures in real-time battery charge level 406. In one embodiment, battery level monitor 116 predicts, for instance, estimated remaining battery charge life 414 in response to battery charge level 406. This estimation or prediction may be based on standard techniques know by those skilled in the art at the time of this disclosure including measurement of time average amperage draw and voltage level (over a given period) to estimate remaining battery charge life 414.

In one embodiment, local battery power adjustment mechanism 416 generates in substantially real-time updated set of network communication signaling protocols. In one variant, updated set of network communication signaling protocols communicated, for instance, includes an update rate (e.g., refresh rate) of location coordinate packets 446. In one example, update rate of location coordinate packets 446 includes request rate 420 of location coordinate packets 422 by target host 452 (e.g., a computer server) and/or listen rate 425 of location coordinate packets 422 by portable electronic tracking device 402. Updated set of network communication signaling protocols, for instance, has value (e.g., X Y Z) responsive to user input request 430.

In one embodiment, to conserve battery power when communicating messages between target host 452 and portable electronic tracking device 402, local battery power adjustment mechanism 416, for instance, remotely by personal communication device 404 communicates a message to active or deactivate a portion of transceiver circuitry 102 or processor circuitry 104 or location tracking circuitry 114 to conserve battery charge level 406 responsive to value 419 (e.g., a user input screen control or mouse adjustable cursor value). In one variant, local battery adjustment mechanism 416 includes user adjustable screen icon 432 to graphically display in substantially real-time trade-off relationships between remaining battery charge level 414 and update rate 446 (e.g., refresh rate) of location coordinate packets 422. Advantageously as compared to

conventional tracking devices, user input request 430 adjusts value 419 to select an appropriate update set of network communication signaling protocols to achieve a desired user defined battery operating environment, e.g., obtain optimal battery life, obtain optimal update rate, tradeoffs between them. In one embodiment, when user adjusts  
5 slider 432 to value 419, a message is sent to target host 452, which communicates an updated set of network communication to portable location tracking device 402.

In response to receipt of updated set of network communication signaling protocols, portable location tracking device 402 adjusts settings (an internal time schedule) and acknowledges receipt of the message to target host 452. Portable location  
10 tracking device 402 checks internal time schedule to determine if it should listen for (perform a location lookup of) location coordinates 422 from satellite navigation system 403 or an adjacent portable location coordinate tracking device (as shown in Fig. 6) as more fully described in, for instance, U.S. patent application Serial No. 11/753,979 filed on May 25, 2007, which has been previously incorporated by referenced and claimed  
15 priority to. Portable location tracking device 402 obtains location coordinates 422 and stores, for instance, in one or more internal breadcrumb memory location(s). Based on the internal time schedule, portable location tracking device 402 determines whether to transmit contents of the one or more breadcrumb memory location(s) to target host 452.

Upon transmission of contents, target host 452 acknowledges receipt of contents  
20 of one or more breadcrumb memory locations. In one variant, target host 452 issues a command to flush one or more breadcrumb memory locations. In this same variant, portable electronic tracking device 402 flushes its internal breadcrumb memory and acknowledges completion of the command to the target host 452. In another variant, target host 452 issues a stack pointer adjustment command to acknowledge receipt of  
25 previously submitted contents of breadcrumb memory locations and to move stack pointer to an adjacent or an alternative breadcrumb memory location to signal that these memory location have been uploaded by target host 452.

In another embodiment, local battery adjustment mechanism 416 includes timing adjustment mechanism 446 adjusting, for instance, request rate 420 of location coordinate  
30 packets 422 to target host 452 and listen rate 425 of location coordinates 422 in accordance with a current location coordinate position of portable tracking device 402.

In one variant, local battery adjustment mechanism 416 includes user adjustable electronic display 432 that indicates current level of battery 406 and allows user a capability to adjust power level thereof. In one variant of this embodiment, local battery adjustment mechanism 416 includes automatic or semi-automatic sleep mode 448. In one  
5 embodiment, automatic or semi-automatic sleep mode 448 sets to a minimal level request rate 420 of location coordinate packets 422 to target host 452 and listen rate 425 of location coordinates 422 until battery power monitor 116 measures, for instance, a sustainable battery charge level to sustain operation of portable electronic tracking device 402.

10 In one embodiment, local battery adjustment mechanism 416 includes charge control management (e.g., adj 416) of portable electronic tracking device 402 that estimates charge capability (e.g., battery charge remaining 414) and adjusts cycling of one or more of request rate 420 of location coordinate packets 422 to target host 452 and listen rate 425 of location coordinate packets 422 to maximize charge capability. In one  
15 alternative embodiment, local battery adjustment mechanism (e.g., adj 416) includes cycle management apparatus 416 to set up, for example, timing schedule (e.g., refresh rate 446) to maximize effectiveness of request rate 420 and listen rate 425 in response to substantially real-time measured velocity of travel of portable electronic tracking device 402.

20 Referring to Figures 5 and 6, system 500 and system 600 respectively include local charging management device (e.g. local battery adjustment mechanism 416) manages electrical resource capability for an electronic tracking device 402 that is tracked by at least one other tracking device (e.g., devices 403, 405, 407, 409). In one embodiment, tracking device (e.g., portable electronic tracking device 402) includes a  
25 battery level monitor 116 remotely located for charging unit (e.g., battery charging circuitry 128), adj 416 (e.g., electrical power resource management component, local battery adjustment mechanism 416). In one variant, electrical power resource management component adjusts cycle timing of request rate 420 of location coordinate packets 422 to target host 452 and listen rate 425 of location coordinate packets 422 from  
30 satellite navigation system 403 responsive to estimated charge level of charging unit (e.g., battery charge level 406).

In one embodiment, electrical power resource management component (e.g., local battery adjustment mechanism 416) includes a substantially real-time user viewable display icon 432 that indicates estimate charge level (e.g., battery level 406) and provides an on-line user adjustable cursor display 432 (see Figure 4). In one example, on-line  
5 cursor display 432 adjusts one or more of: request rate 420 of location coordinate packets 422 to target host 452 and listen rate 425 and gives substantially automatic updated estimated charge level of the charging unit (e.g., battery charging circuitry or unit 128). In one variant, local battery management device 416 includes charge control management of electronic tracking device 402 that estimates charge capability and adjust cycling of  
10 request rate 420 of location coordinate packets 422 to host target 428 and listen rate 425 of location coordinate packets 422 from satellite navigation system 403 or alternatively an adjacent portable location tracking device to maximize charge capability.

In yet another embodiment, local charging management device 416 includes cycle management apparatus to set up timing schedule 446 to maximize effectiveness of  
15 request rate 420 and listen rate 425 in response to measured velocity of travel portable electronic tracking device 402. In one variant, local charging management device 416 electrically coupled through personal communication device 404 sets up timing schedule 446 between one or more than one wireless communication networks to communicate information between portable electronic tracking device 402. In one example of this  
20 embodiment, listen rate 425 of location coordinate packets 422 to the host target 428 and response rate 425 includes global positioning system (GPS) system refresh rate 446.

Advantageously as compared to prior global positioning systems having manufactured defined power settings, the current invention power charging monitor (e.g., battery level monitor 116) measures a power level (e.g., battery power level 406) of the  
25 power charging unit (e.g., battery level monitor 116) and substantially automatically adjusts power usage responsive to available power of power charging unit to maximize power life.

In yet another advantage, the present invention power charging monitor (e.g., battery level monitor 116) measures a power level (e.g., battery power level 406) of  
30 power charging unit (e.g., battery 118) and adjusts a power level (e.g., battery power level 406) applied to, for example, location tracking circuitry (e.g., location tracking

circuitry 114) or transceiver 102 responsive to one or more signal levels. In contrast to previous manufacturer tracking device power level settings, the present invention has the capability of power level (e.g., battery power level 406) adjustments include multitude of threshold values (see active display 432 of Figure 4) that is determined by user or system administrator to intermittently activate or deactivate location tracking circuitry (e.g., location tracking circuitry 114) to conserve power of the power charging unit (e.g., battery 118) responsive to estimated charge level (e.g., battery charge level 406).

In a first example, a lost dog has portable location tracking device 402. Using the present invention, a user, e.g., a dog owner, will adjust a slider level, such as using on-line cursor display 432, to a high update rate interval. For instance, the high setting corresponds to 15 minute intervals for location and 15 minute intervals for transmission to target host, e.g., server. The server sends these settings to portable location tracking device 402 and portable location tracking device 402 adjusts its settings and acknowledges the message. As such, portable location tracking device 402 will perform frequent updates of its location coordinates from a satellite navigation system and will transmit frequently its location coordinates to a target host. Thus, advantageously, with this setting, a user will probably more rapidly locate a missing or lost pet. With this setting, battery life will be relatively short.

In a second example, a teenager borrows a parent's car having portable location tracking device 402. Using the present invention, users, e.g., parents, desire to know if their teenager is driving safely in designated areas or locations, but does not want to track the teenager's location in real-time. In this case, the parents adjust a slider level, such as using on-line cursor display 432, to a medium update rate interval. For instance, the medium setting corresponds to 15 minute intervals for location and 60 minute intervals for transmission to the target host, e.g., server. The server sends these settings to portable location tracking device 402 and portable location tracking device 402 adjusts its settings and acknowledges the message. As such, portable location tracking device 402 will perform frequent updates of its velocity and location coordinates from a satellite navigation system and will less frequently transmit its location coordinates to a target host. As long as the teenager remains in allowed areas and traveling at allowed speeds, the portable location tracking device will not transmit frequently. Fortunately, during

these infrequent transmissions, portable location tracking device will transmit its location history. Thus, advantageously, with this setting, parents can see history at many locations while still preserving battery life, e.g., longer life than first example.

In a third example, a provider of construction equipment having portable tracking device 402 rents the equipment to contractors. Using the present invention, a user, e.g., provider desires to know location of the equipment once per day. In this case, the provider adjusts a slider level, such as using on-line cursor display 432, to a low update rate interval. For instance, the low setting corresponds to 1440 minute intervals (24 hours) for location coordinates and 1440 minute intervals (24 hours) for transmission to the target host, e.g., server. The server sends these settings to portable location tracking device 402 and portable location tracking device 402 adjusts its settings and acknowledges the message. As such, portable location tracking device 402 will perform infrequent updates (once per day) of location coordinates from a satellite navigation system and will less frequently transmission (once per day) of its location coordinates to a target host. Thus, advantageously, with this setting, portable location coordinate device will realize increased battery life, e.g., longer life than first and second examples.

#### *User Adjustable Power Level Monitor Flow Chart*

Referring to Figure 7, flow chart 700 illustrates user definable adjustable conservation power level monitor for portable electronic tracking device 402 as described in Figures 4, 5, and 6 in accordance with one embodiment of the present invention.

In step 702, user receives measured charging unit power level of tracking device 402 communicated by a location coordinate tracking system 403. In step 704, system administrator, user, automatic or semi-automatic program software adjusts charging unit power level of tracking device 402 in response to a substantially-real life estimate of the unit power level 406 of a charge unit 118 of tracking device 402.

In step 706, system administrator, user, automatic or semi-automatic power monitoring software program creates an initial timing schedule 446 including communication of signaling parameters associated with a request rate 420 communicated with location coordinate information 422 and listen rate 425 of location coordinate information 422. In one variant of step 706, initial timing schedule 446 was at least

partially automatically and responsive to an estimated power level 414 of the charge unit 118.

5 In step 708, user readjusts the initial timing schedule 446 for communication of signaling parameters in accordance with a local request by remote user using an Internet accessible icon 432 that displays user viewable tradeoffs between the estimated charge unit life and charge unit update rate. In one variant of step 708, remote user uses a mouse to enter an on screen cursor value 419 that is associated with a tradeoff of estimated charge life 414 and an update rate 446 of location coordinate information 422.

10 It is noted that many variations of the methods described above may be utilized consistently with the present invention. Specifically, certain steps are optional and may be performed or deleted as desired. Similarly, other steps (such as additional data sampling, processing, filtration, calibration, or mathematical analysis for example) may be added to the foregoing embodiments. Additionally, the order of performance of certain steps may be permuted, or performed in parallel (or series) if desired. Hence, the  
15 foregoing embodiments are merely illustrative of the broader methods of the invention disclosed herein.

20 While the above detailed description has shown, described, and pointed out novel features of the invention as applied to various embodiments, it will be understood that various omissions, substitutions and changes in the form and details of the device or process illustrated may be made by those skilled in the art without departing from the spirit of the invention. The foregoing description is of the best mode presently contemplated of carrying out the invention. This description is in no way meant to be limiting, but rather should be taken as illustrative of the general principles of the invention. The scope of the invention should be determined with reference to the claims.

## WHAT IS CLAIMED IS:

1. A portable electronic tracking device to monitor location coordinates of one or more individuals and objects using a satellite navigation system, the portable electronic tracking device comprising:
  - 5 a battery having a battery charge level;
  - transceiver circuitry;
  - processor circuitry;
  - a battery power monitor to measure in real-time the battery charge level and to  
10 make a prediction of an estimated remaining battery charge level in response to the battery charge level;
  - local battery power adjustment mechanism to generate in substantially real-time an updated set of network communication signaling protocols associated with at least one of a request rate of location coordinate packets to be communicated to a target host and a  
15 listen rate of the location coordinate packets from a satellite navigation system, the updated set of network communication signaling protocols having a value that is responsive to a user input request;
  - wherein the local battery power adjustment mechanism activates or deactivates at least one portion of the transceiver circuitry or the processor to conserve the battery  
20 charge level in response to the value.
2. The device of claim 1, wherein the local battery adjustment mechanism comprises an adjustable screen icon to graphically display in substantially real-time a trade-off relationship between the remaining battery charge level and an update rate of the location  
25 coordinate packets that is response to the updated set of network communication signaling protocols.
3. The device of claim 1, wherein the local battery adjustment mechanism comprises a timing adjustment mechanism that adjust the at least one of the request rate of the  
30 location coordinate packets to the target host and the listen rate of the location coordinates from a satellite navigation system in accordance with a current position of the



tracking

device.

4. The device of claim 1, wherein the local battery adjustment mechanism comprises a user adjustable electronic display that indicates a current level of battery power and  
5 allows a user a capability to adjust power level thereof.

5. The device of claim 4, wherein the local battery adjustment mechanism comprises an automatic sleep mode to set at least one of the request rate of the location coordinate packets to the target host and the listen rate of the location coordinates from the satellite  
10 navigation system to a minimal level until the battery power monitor measures a sustainable battery charge level to process the at least one portion of an receive signal.

6. The device of claim 4, wherein the local battery adjustment mechanism comprises a charge control management of the portable electronic tracking device that estimates  
15 charge capability and adjust cycling of the at least one of a request rate of location coordinate packets to a target host and a listen rate of the location coordinate packets from the satellite navigation system to maximize charge capability.

7. The device of claim 1, wherein the local battery adjustment mechanism comprises a  
20 cycle management apparatus to set up a timing schedule to maximize effectiveness of the request rate and the response rate in response to substantially real-time measured velocity of the portable electronic tracking device.

8. A local charging management device to manage electrical resource capability for an  
25 electronic tracking device that is tracked by at least one other tracking device comprising:  
a battery power monitor;  
a charging unit; and  
an electrical power resource management component to adjust cycle timing of at  
least one of a request rate of location coordinate packets to a target host and a listen rate  
30 of the location coordinate packets responsive to an estimated charge level of the charging unit.

9. The apparatus of claim 8, wherein the electrical power resource management component comprises a substantially real-time user viewable display icon that indicates the estimate charge level and provides an on-line user adjustable cursor display that  
5 adjusts at least one of the request rate of the location coordinate packets to the target host and the listen rate of the location coordinate packets and gives substantially automatic updated estimated charge level of the charging unit.

10. The apparatus of claim 8, wherein the local device comprises a charge control  
10 management of the portable electronic tracking device that estimates charge capability and adjust cycling of the at least one of a request rate of location coordinate packets to a host target and a listen rate of the location coordinate packets to maximize charge capability.

15 11. The apparatus of claim 8, wherein the local device comprises a cycle management apparatus to set up a timing schedule to maximize effectiveness of the request rate and listen rate responsive to measured velocity of the portable electronic tracking device.

20 12. The apparatus of claim 11, wherein the local device electrically couples to a mobile phone to remote control the local apparatus to setup up a timing schedule from a multitude of wireless communication networks to communicate information between the electronic tracking device and the mobile phone.

25 13. The apparatus of claim 8, wherein the listen rate of the location coordinates comprises a global positioning system (GPS) system refresh rate of the location coordinates.

14. The apparatus of claim 8, wherein the request rate and the listen rate are set remotely  
30 by a user using a mobile phone or wireless communication device.

15. The apparatus of claim 8, wherein the power charging monitor measures a power level of the power charging unit and substantially automatically adjusts power usage responsive to available power of the power charging unit to maximize power unit life.
- 5 16. The apparatus of claim 8, wherein the power charging monitor measures a power level of the power charging unit and adjusts a power level applied to the location tracking circuitry responsive to the signal level.
17. The apparatus of claim 16, wherein the power level comprises a multitude of  
10 threshold value determined by a user or system administrator to intermittently activate or deactivate the location tracking circuitry to conserve power of the power charging unit in response to the estimated charge level of the power unit.
18. A method to control power usage comprising:
- 15       measuring charging unit power level of a tracking device communicated by a location coordinate tracking system;
- adjusting charging unit power level of the tracking device in response to a substantially-real life estimate of the unit power level of a charge unit of the tracking device;
- 20       creating an initial timing schedule for communication of signaling parameters associated with a target host request rate communicated with location coordinate information and listen rate of the location coordinate information, the initial time schedule being at least partially automatically and responsive to an estimated power level of the charge unit; and
- 25       readjusting the initial timing schedule for communication of signaling parameters in accordance with a local request by a remote user using an Internet accessible icon that displays user viewable tradeoffs between the estimated charge unit life and charge unit update rate.
- 30 19. The method of claim 18, wherein creating an initial timing schedule for communication of signaling parameters comprises creating a management schedule for

setting a rate at which messages are exchanged between the tracking device and a target host.

20. The method of claim 18, wherein creating an initial timing schedule for  
5 communication of signaling parameters comprises creating a management schedule for  
setting a rate at which messages are exchanged between the navigational satellite system  
and the tracking device to local device to maximize effectiveness of the request rate and  
the listen rate to the location coordinate information in response to measured velocity of  
the portable electronic tracking device.

10

21. The method of claim 18, wherein readjusting the timing schedule for communication  
of signaling parameters in accordance with a local request by a remote user comprise  
electrically coupling the tracking device to a mobile phone to remote control cycling the  
location coordinates to setup up a timing schedule between a multitude of wireless  
15 communication networks to communicate information between the electronic tracking  
device and the mobile phone.

20

**APPARATUS AND METHOD FOR ADJUSTING REFRESH RATE OF  
LOCATION COORDINATES OF A TRACKING DEVICE**

5

ABSTRACT

A local charging management device manages electrical resource capability for an electronic tracking device. In one embodiment, the electronic tracking device includes a battery power monitor, a charging unit; and an electrical power resource management component. The electrical power resource management component adjusts cycle timing of one or more of control parameters for the tracking device. Control parameters include request rate of location coordinate packets to a target host and a listen rate of the location coordinate packets. The adjustment is responsive to an estimated charge level of the charging unit, velocity of the device, and user desired inputs.

15

## Electronic Patent Application Fee Transmittal

<b>Application Number:</b>				
<b>Filing Date:</b>				
<b>Title of Invention:</b>	APPARATUS AND METHOD FOR ADJUSTING REFRESH RATE OF LOCATION COORDINATES OF A TRACKING DEVICE			
<b>First Named Inventor/Applicant Name:</b>	Joseph F. Scalisi			
<b>Filer:</b>	Robert E. Kasody			
<b>Attorney Docket Number:</b>	LBTECH.012CP1			
Filed as Small Entity				
<b>Utility under 35 USC 111(a) Filing Fees</b>				
<b>Description</b>	<b>Fee Code</b>	<b>Quantity</b>	<b>Amount</b>	<b>Sub-Total in USD(\$)</b>
<b>Basic Filing:</b>				
Utility filing Fee (Electronic filing)	4011	1	82	82
Utility Search Fee	2111	1	270	270
Utility Examination Fee	2311	1	110	110
<b>Pages:</b>				
<b>Claims:</b>				
Claims in excess of 20	2202	1	26	26
<b>Miscellaneous-Filing:</b>				
<b>Petition:</b>				

Description	Fee Code	Quantity	Amount	Sub-Total in USD(\$)
<b>Patent-Appeals-and-Interference:</b>				
<b>Post-Allowance-and-Post-Issuance:</b>				
<b>Extension-of-Time:</b>				
<b>Miscellaneous:</b>				
<b>Total in USD (\$)</b>				<b>488</b>

## Electronic Acknowledgement Receipt

<b>EFS ID:</b>	5109532
<b>Application Number:</b>	12419451
<b>International Application Number:</b>	
<b>Confirmation Number:</b>	1643
<b>Title of Invention:</b>	APPARATUS AND METHOD FOR ADJUSTING REFRESH RATE OF LOCATION COORDINATES OF A TRACKING DEVICE
<b>First Named Inventor/Applicant Name:</b>	Joseph F. Scalisi
<b>Customer Number:</b>	70515
<b>Filer:</b>	Robert E. Kasody
<b>Filer Authorized By:</b>	
<b>Attorney Docket Number:</b>	LBTECH.012CP1
<b>Receipt Date:</b>	07-APR-2009
<b>Filing Date:</b>	
<b>Time Stamp:</b>	12:50:24
<b>Application Type:</b>	Utility under 35 USC 111(a)

### Payment information:

Submitted with Payment	yes
Payment Type	Credit Card
Payment was successfully received in RAM	\$488
RAM confirmation Number	8443
Deposit Account	
Authorized User	

### File Listing:

Document Number	Document Description	File Name	File Size(Bytes)/ Message Digits	Multi Part (if appl.)	Pages (if appl.)



1	Drawings-only black and white line drawings	LBTECH_012CP1_dwgs_fnl.pdf	168802 7d64fc03f91f64d0f4a14a698bbc4eb7898c443b	no	7
<b>Warnings:</b>					
<b>Information:</b>					
2	Oath or Declaration filed	LBTECH_012CP1_declsnged.pdf	342651 0da19b6d56157ffdab774edbf9bf071625bd995d	no	2
<b>Warnings:</b>					
<b>Information:</b>					
3		LBTECH_012CP1_app_fnl.pdf	87164 a256595c6c0a333e79ea519bd5ac48ceca11e92	yes	29
	<b>Multipart Description/PDF files in .zip description</b>				
	<b>Document Description</b>		<b>Start</b>	<b>End</b>	
	Specification		1	23	
	Claims		24	28	
	Abstract		29	29	
<b>Warnings:</b>					
<b>Information:</b>					
4	Fee Worksheet (PTO-06)	fee-info.pdf	36704 086d2410523806fabf55fca06dcedef30bc98f85	no	2
<b>Warnings:</b>					
<b>Information:</b>					
<b>Total Files Size (in bytes):</b>			635321		

**This Acknowledgement Receipt evidences receipt on the noted date by the USPTO of the indicated documents, characterized by the applicant, and including page counts, where applicable. It serves as evidence of receipt similar to a Post Card, as described in MPEP 503.**

**New Applications Under 35 U.S.C. 111**

**If a new application is being filed and the application includes the necessary components for a filing date (see 37 CFR 1.53(b)-(d) and MPEP 506), a Filing Receipt (37 CFR 1.54) will be issued in due course and the date shown on this Acknowledgement Receipt will establish the filing date of the application.**

**National Stage of an International Application under 35 U.S.C. 371**

**If a timely submission to enter the national stage of an international application is compliant with the conditions of 35 U.S.C. 371 and other applicable requirements a Form PCT/DO/EO/903 indicating acceptance of the application as a national stage submission under 35 U.S.C. 371 will be issued in addition to the Filing Receipt, in due course.**

**New International Application Filed with the USPTO as a Receiving Office**

**If a new international application is being filed and the international application includes the necessary components for an international filing date (see PCT Article 11 and MPEP 1810), a Notification of the International Application Number and of the International Filing Date (Form PCT/RO/105) will be issued in due course, subject to prescriptions concerning national security, and the date shown on this Acknowledgement Receipt will establish the international filing date of the application.**

177

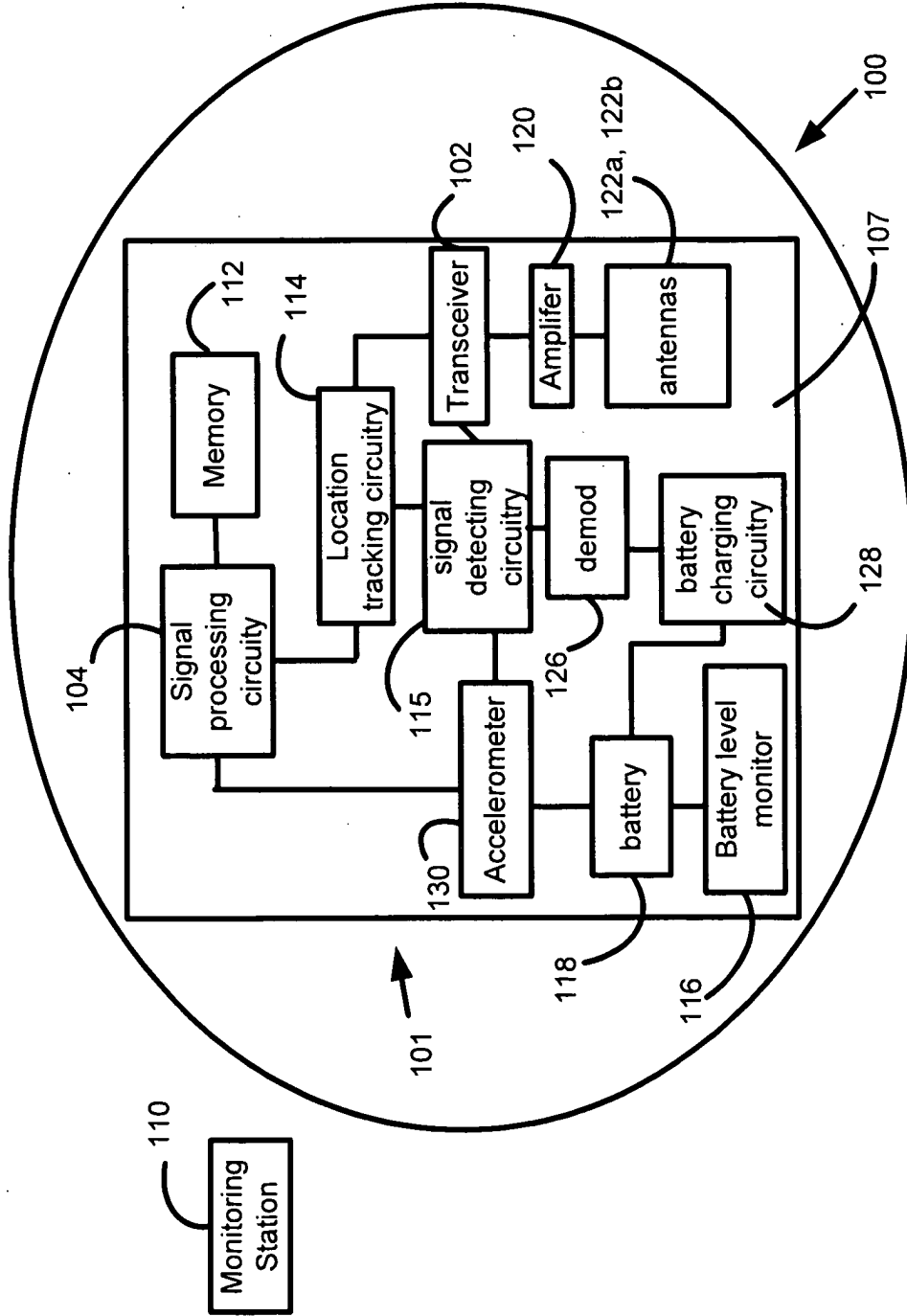

Figure 1

2/7

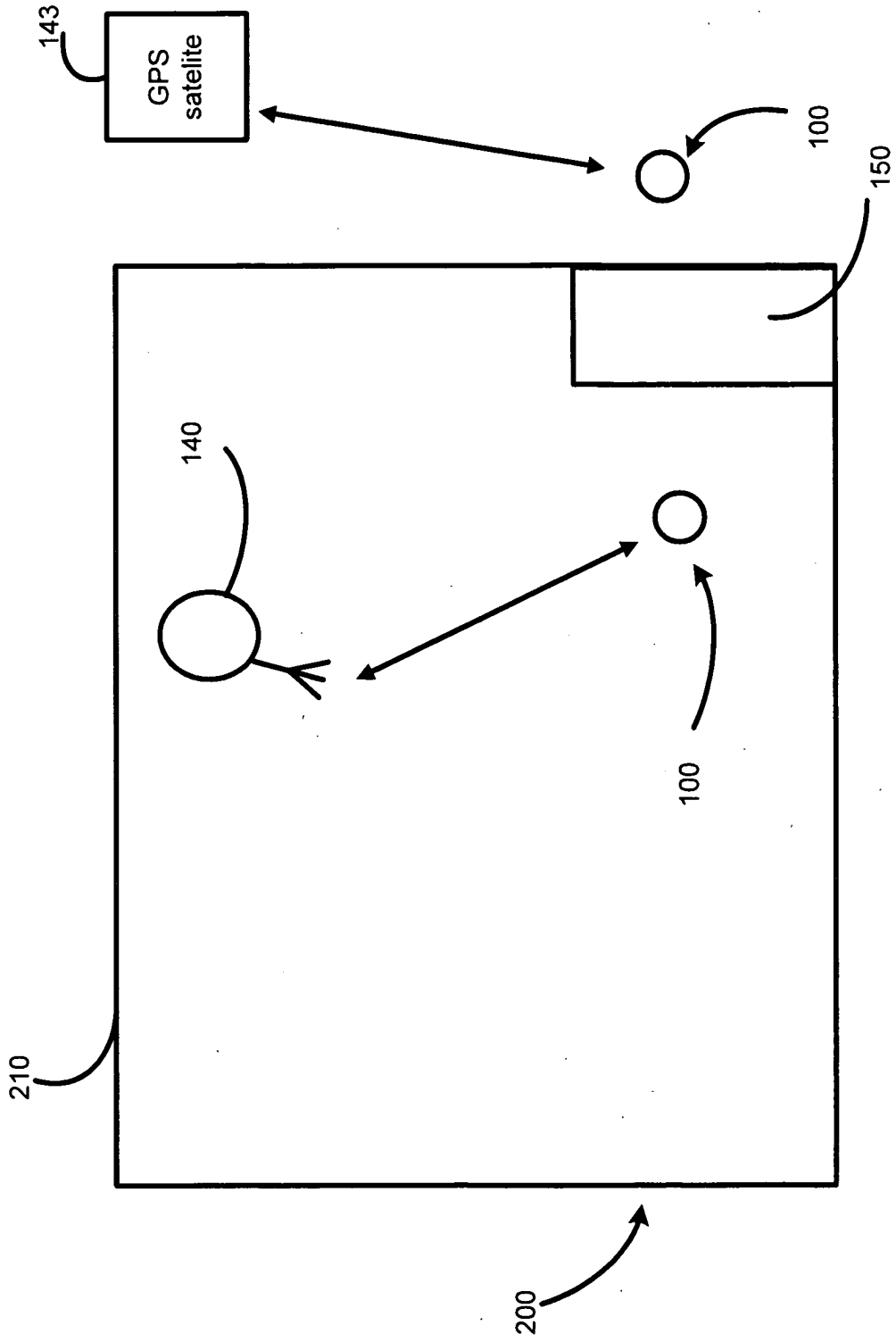

Figure 2

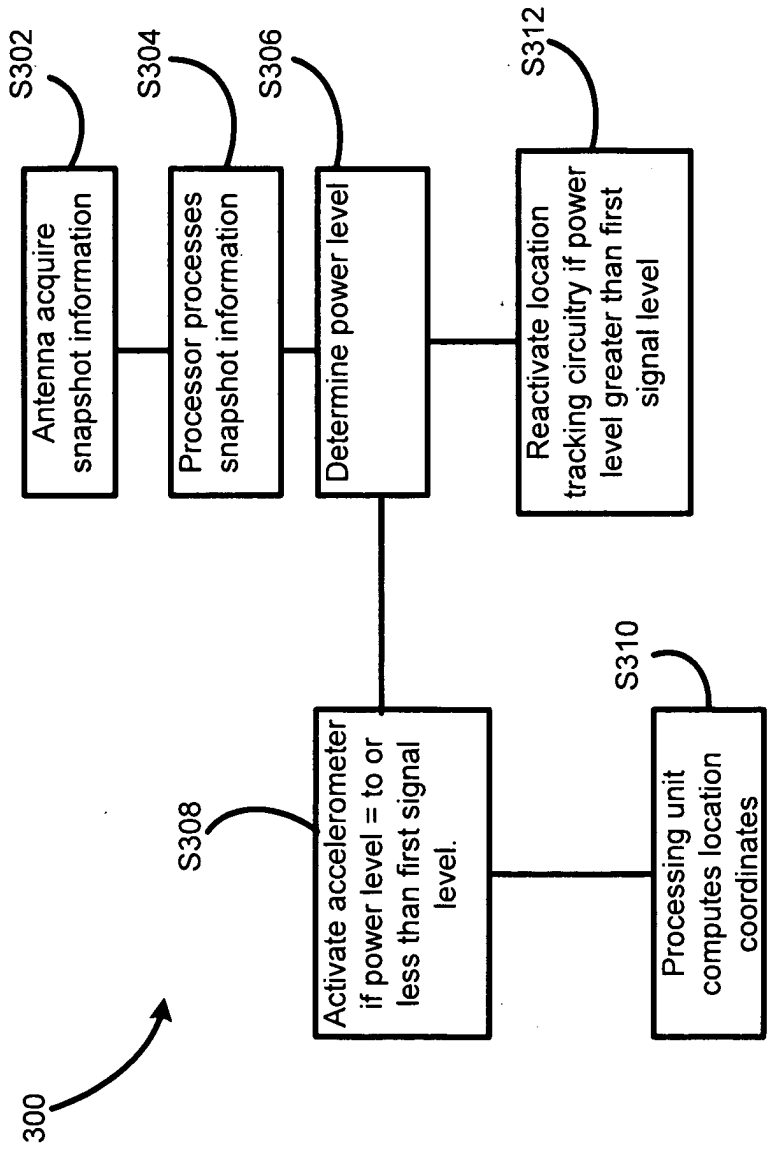

Figure 3

Locate By Phone 1-321-441-4254 44-161-660-6845 \* Beta Users: Please leave feedback or report a bug here. Home Log Out

**iwi pocketfinder**

Mom **Dashboard** **Users** **My Account**

Locate History Zones Power Identification

30 Speed Limit 65 HELLO MARIO

**Power Management**

Adjust the power settings for your device. Here you can see the current battery life, how much time is left before a charge is required and fine tune your update interval to obtain your optimal battery setting.

Adjust Battery Performance

less updates (+ battery) more updates (- battery)

Battery Life Mode Updates Every 3 Days 10 min

406 419 432 446 400

Leave a comment or report a bug. Site Credit Privacy Policy Terms and Conditions

This site is protected by copyright and trademark laws under US and International law. All rights reserved. © 2006-2008 Location Based Technologies

Figure 4

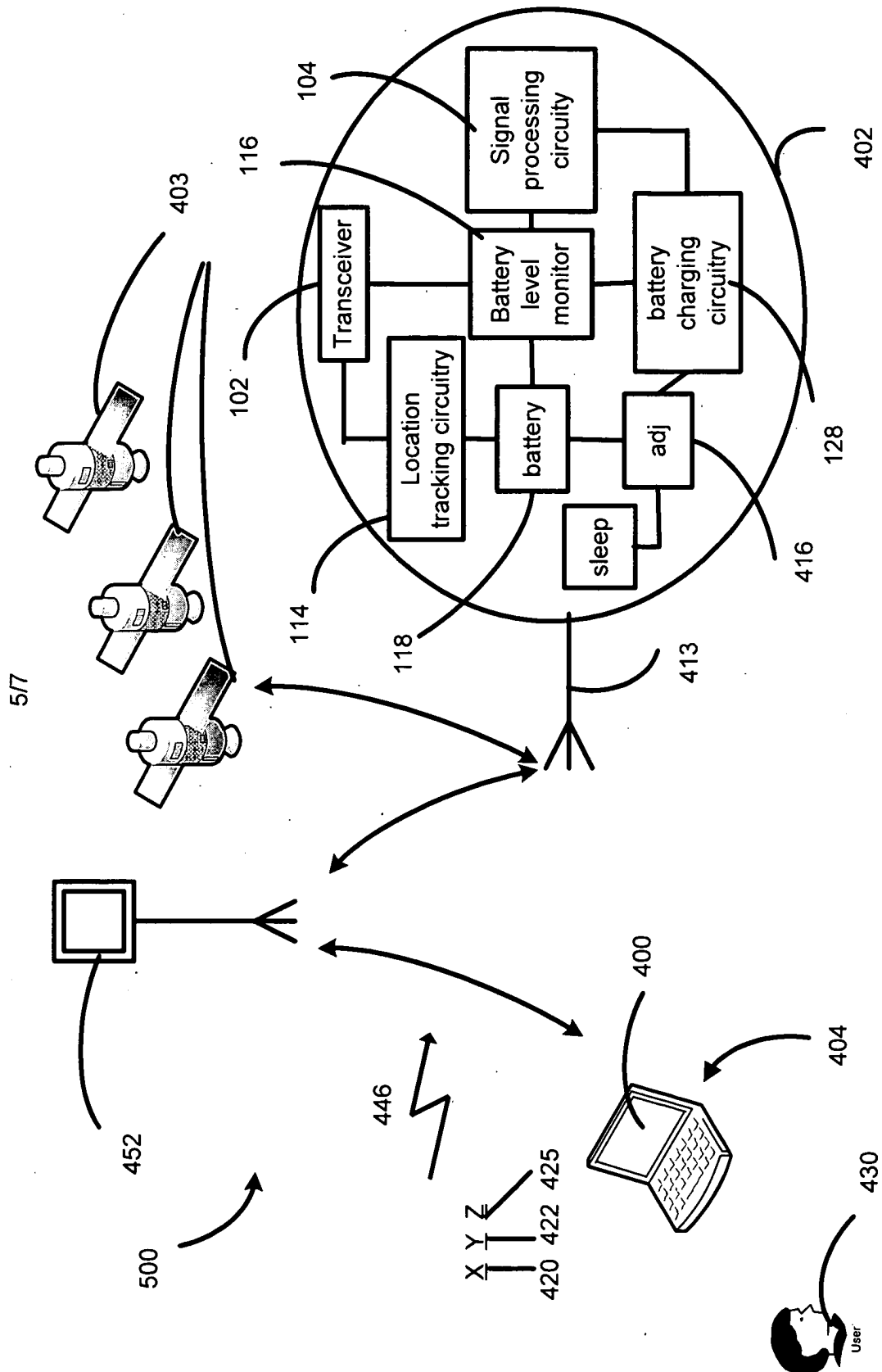

Figure 5

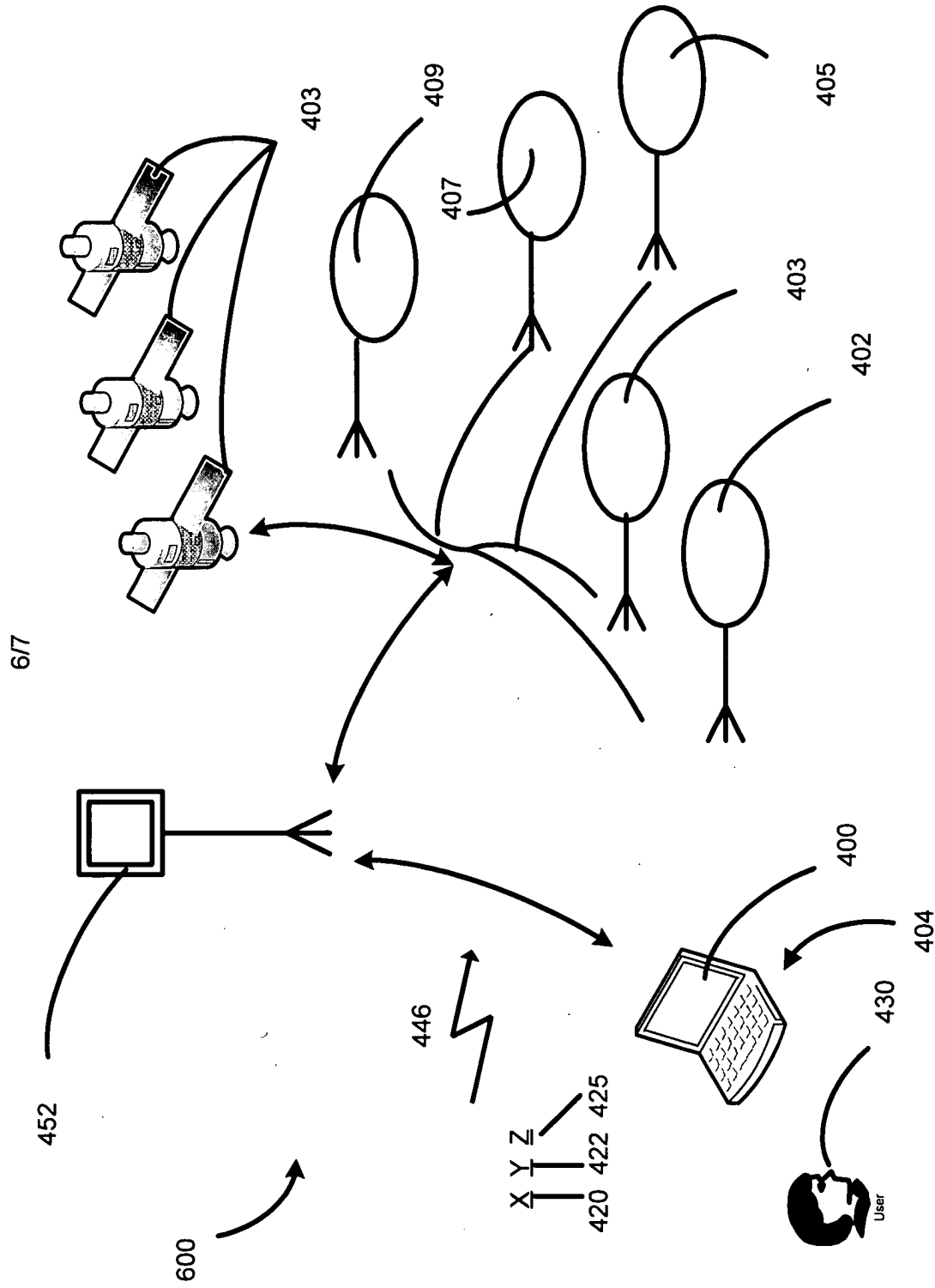

Figure 6



717

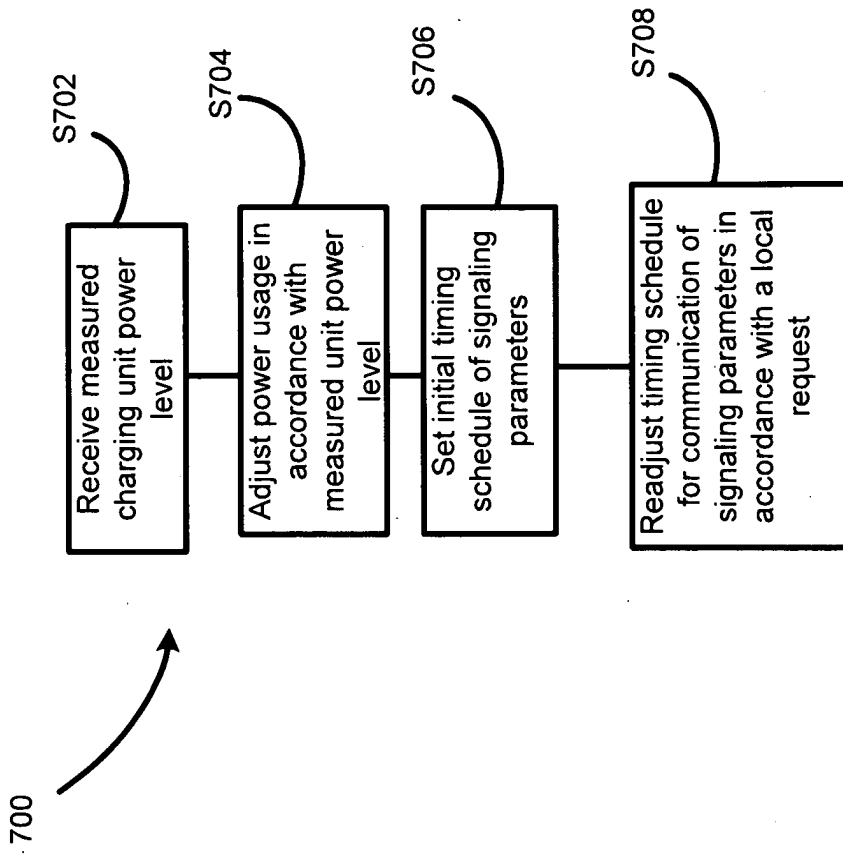

Figure 7

LBTECH.012CP1

**Declaration and Power of Attorney for Patent Application**

As a below named inventor, I hereby declare that:

My residence, post office address and citizenship are as stated below next to my name;

I believe I am the original, first and sole inventor (if only one name is listed below) or an original, first and joint inventor (if plural names are listed below) of the subject matter which is claimed and for which a patent is sought on the invention entitled:

**“APPARATUS AND METHOD FOR ADJUSTING REFRESH RATE OF LOCATION COORDINATES OF A TRACKING DEVICE”**

the specification of which  is attached hereto.  
 was filed on \_\_\_\_\_  
Application Serial No. \_\_\_\_\_  
and was amended on \_\_\_\_\_

I hereby state that I have reviewed and understand the contents of the above-identified specification, including the claims, as amended by any amendment referred to above.

I acknowledge the duty to disclose information which is material to the patentability of this application in accordance with Title 37, Code of Federal Regulations, Section 1.56(a).

I hereby claim foreign priority benefits under Title 35, United States Code, Section 119, of any foreign application(s) for patent or inventor's certificate listed below and have also identified below any foreign application for patent or inventor's certificate having a filing date before that of the application on which priority is claimed:

Prior Foreign Application(s) (Number/Country/Date Filed/Priority Claims: Yes/No)

No \_\_\_\_\_

I hereby claim the benefit under Title 35, United States Code, Section 120, of any United States application(s) listed below and, insofar as the subject matter of each of the claims of this application is not disclosed in the prior United States application in the manner provided by the first paragraph of Title 35, United States Code, Section 112, I acknowledge the duty to disclose material information as defined in Title 37, Code of Federal Regulations, Section 1.56(a), which occurred between the filing date of the prior application and the national or PCT international filing date of this application (list application Serial No./Filing Date/Status):  
Prior US/PCT Application(s) (Number/Date Filed/Priority Claims: Yes/No)

Yes, this application is a continuation-in-part and claims priority to U.S. patent application number 11/969,905 entitled “Apparatus and Method for Determining Location and

LBTECH.012CP1

Tracking Coordinates of a Tracking Device” that was filed on January 6, 2008, and incorporates by reference in their entirety and claims priority to U.S. patent application Serial No. 11/753,979 filed on May 25, 2007, entitled “Apparatus and Method for Providing Location Information on Individuals and Objects Using Tracking Devices”; U.S. patent application Serial No. 11/933,024 filed on October 31, 2007, entitled “Apparatus and Method for Manufacturing an Electronic Package”; US patent application Serial No. 11/784,400 filed on April 5, 2007, entitled “Communication System and Method Including Dual Mode Capability”; US patent application Serial No. 11/784,318 filed on April 5, 2007, entitled “Communication System and Method Including Communication Billing Options”; and US patent application Serial No. 11/935,901 filed on November 6, 2007, entitled “System and Method for Creating and Managing a Personalized Web Interface for Monitoring Location Information on Individuals and Objects Using Tracking Devices

POWER OF ATTORNEY: As a named inventor, I hereby revoke any previous power of attorney in the subject application, and hereby appoint the following to prosecute this application and transact all business in the Patent and Trademark Office connected therewith, with full power of substitution and revocation to prosecute this application and to transact all business in the U.S. Patent and Trademark Office connected herewith.

USPTO Customer No. 70,515  
Law Office of Robert E. Kasody, Professional Corporation  
6601 Center Drive West, Suite 500  
Los Angeles, CA 90045  
SEND CORRESPONDENCE TO:  
Law Office of Robert E. Kasody, Professional Corp.  
6601 Center Drive West, Suite 500  
Los Angeles, CA 90045

DIRECT TELEPHONE CALLS TO:  
Name: Robert E. Kasody  
Telephone: (310) 348-8195

I hereby declare that all statements made herein of my own knowledge are true and that all statements made on information and belief are believed to be true; and further that these statements were made with the knowledge that willful false statements and the like so made are punishable by fine or imprisonment, or both, under Section 1001 of Title 18 of the United States Code and that such willful false statements may jeopardize the validity of the application or any patent issued thereon.

Full name of 1st or joint inventor: Joseph F. Scalisi

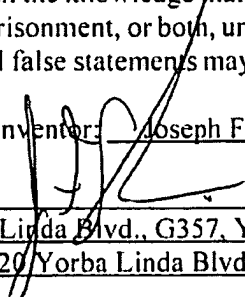
Inventor's Signature:   
Residence: 21520 Yorba Linda Blvd., G357, Yorba Linda, CA, 92887  
Post Office Address: 21520 Yorba Linda Blvd., G357, Yorba Linda, CA, 92887

Dated: April 2nd 2009  
Citizenship: USA

Full name of 2nd or joint inventor: Roger B. Anderson

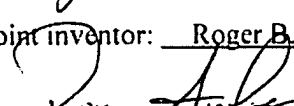
Inventor's Signature:   
Residence: 928 Othello St., Arcadia, CA, 91006  
Post Office Address: 713 W. Duarte Rd. #G-170, Arcadia, CA 91007

Dated: April 6, 2009  
Citizenship: USA

Filing Date: 04/07/09

Approved for use through 7/31/2006. OMB 0651-0032  
U.S. Patent and Trademark Office; U.S. DEPARTMENT OF COMMERCE

Under the Paperwork Reduction Act of 1995, no persons are required to respond to a collection of information unless it displays a valid OMB control number.

<b>PATENT APPLICATION FEE DETERMINATION RECORD</b> Substitute for Form PTO-875	Application or Docket Number <b>12/419,451</b>
---	---

APPLICATION AS FILED – PART I			SMALL ENTITY		OTHER THAN SMALL ENTITY	
	(Column 1)	(Column 2)				
FOR	NUMBER FILED	NUMBER EXTRA	RATE (\$)	FEE (\$)	RATE (\$)	FEE (\$)
BASIC FEE (37 CFR 1.16(a), (b), or (c))	N/A	N/A	N/A	<b>82</b>	N/A	
SEARCH FEE (37 CFR 1.16(k), (l), or (m))	N/A	N/A	N/A	<b>270</b>	N/A	
EXAMINATION FEE (37 CFR 1.16(o), (p), or (q))	N/A	N/A	N/A	<b>110</b>	N/A	
TOTAL CLAIMS (37 CFR 1.16(i))	<b>21</b>	minus 20 = <b>1</b>	x\$26	<b>26</b>	x\$52	
INDEPENDENT CLAIMS (37 CFR 1.16(h))	<b>3</b>	minus 3 = *	x\$110		x\$220	
APPLICATION SIZE FEE (37 CFR 1.16(s))	If the specification and drawings exceed 100 sheets of paper, the application size fee due is \$260 (\$130 for small entity) for each additional 50 sheets or fraction thereof. See 35 U.S.C. 41(a)(1)(G) and 37 CFR					
MULTIPLE DEPENDENT CLAIM PRESENT (37 CFR 1.16(j))			195		390	
			<b>TOTAL</b>	<b>488</b>	<b>TOTAL</b>	

\* If the difference in column 1 is less than zero, enter "0" in column 2.

APPLICATION AS AMENDED – PART II					SMALL ENTITY		OTHER THAN SMALL ENTITY	
	(Column 1)	(Column 2)	(Column 3)					
AMENDMENT A	CLAIMS REMAINING AFTER AMENDMENT	HIGHEST NUMBER PREVIOUSLY PAID FOR	PRESENT EXTRA	RATE (\$)	ADDITIONAL FEE (\$)	RATE (\$)	ADDITIONAL FEE (\$)	
Total (37 CFR 1.16(i))	*	Minus **	=	X =		X =		
Independent (37 CFR 1.16(h))	*	Minus ***	=	X =		X =		
Application Size Fee (37 CFR 1.16(s))								
FIRST PRESENTATION OF MULTIPLE DEPENDENT CLAIM (37 CFR 1.16(j))				N/A		N/A		
				<b>TOTAL ADD'T FEE</b>		<b>TOTAL ADD'T FEE</b>		

APPLICATION AS AMENDED – PART II					SMALL ENTITY		OTHER THAN SMALL ENTITY	
	(Column 1)	(Column 2)	(Column 3)					
AMENDMENT B	CLAIMS REMAINING AFTER AMENDMENT	HIGHEST NUMBER PREVIOUSLY PAID FOR	PRESENT EXTRA	RATE (\$)	ADDITIONAL FEE (\$)	RATE (\$)	ADDITIONAL FEE (\$)	
Total (37 CFR 1.16(i))	*	Minus **	=	X =		X =		
Independent (37 CFR 1.16(h))	*	Minus ***	=	X =		X =		
Application Size Fee (37 CFR 1.16(s))								
FIRST PRESENTATION OF MULTIPLE DEPENDENT CLAIM (37 CFR 1.16(j))				N/A		N/A		
				<b>TOTAL ADD'T FEE</b>		<b>TOTAL ADD'T FEE</b>		

\* If the entry in column 1 is less than the entry in column 2, write "0" in column 3.

\*\* If the "Highest Number Previously Paid For" IN THIS SPACE is less than 20, enter "20".

\*\*\* If the "Highest Number Previously Paid For" IN THIS SPACE is less than 3, enter "3".

The "Highest Number Previously Paid For" (Total or INDEPENDENT) is the highest number found in the appropriate box in column 1.

This collection of information is required by 37 CFR 1.16. The information is required to obtain or retain a benefit by the public which is to file (and by the USPTO to process) an application. Confidentiality is governed by 35 U.S.C. 122 and 37 CFR 1.14. This collection is estimated to take 12 minutes to complete, including gathering, preparing, and submitting the completed application form to the USPTO. Time will vary depending upon the individual case. Any comments on the amount of time you require to complete this form and/or suggestions for reducing this burden, should be sent to the Chief Information Officer, U.S. Patent and Trademark Office, U.S. Department of Commerce, P.O. Box 1450, Alexandria, VA 22313-1450. DO NOT SEND FEES OR COMPLETED FORMS TO THIS ADDRESS. SEND TO: Commissioner for Patents, P.O. Box 1450, Alexandria, VA 22313-1450.

If you need assistance in completing the form, call 1-800-PTO-9199 and select option 2.

1.8.18.

Filing Date: 04/07/09

Approved for use through 7/31/2006. OMB 0651-0032  
U.S. Patent and Trademark Office; U.S. DEPARTMENT OF COMMERCE

Under the Paperwork Reduction Act of 1995, no persons are required to respond to a collection of information unless it displays a valid OMB control number.

<b>PATENT APPLICATION FEE DETERMINATION RECORD</b> Substitute for Form PTO-875	Application or Docket Number <b>12/419,451</b>
---	---

APPLICATION AS FILED – PART I			SMALL ENTITY		OR		OTHER THAN SMALL ENTITY	
(Column 1) (Column 2)			RATE (\$)	FEE (\$)		RATE (\$)	FEE (\$)	
FOR	NUMBER FILED	NUMBER EXTRA	N/A			N/A	<b>330</b>	
BASIC FEE (37 CFR 1.16(a), (b), or (c))	N/A	N/A	N/A			N/A	<b>540</b>	
SEARCH FEE (37 CFR 1.16(k), (l), or (m))	N/A	N/A	N/A			N/A	<b>220</b>	
EXAMINATION FEE (37 CFR 1.16(o), (p), or (q))	N/A	N/A	N/A			N/A		
TOTAL CLAIMS (37 CFR 1.16(i))	<b>15</b>	minus 20 =	x\$26			x\$52		
INDEPENDENT CLAIMS (37 CFR 1.16(h))	<b>3</b>	minus 3 = *	x\$110			x\$220		
APPLICATION SIZE FEE (37 CFR 1.16(s))	If the specification and drawings exceed 100 sheets of paper, the application size fee due is \$260 (\$130 for small entity) for each additional 50 sheets or fraction thereof. See 35 U.S.C. 41(a)(1)(G) and 37 CFR							
MULTIPLE DEPENDENT CLAIM PRESENT (37 CFR 1.16(j))			195			390		
			TOTAL			TOTAL	<b>1090</b>	

\* If the difference in column 1 is less than zero, enter "0" in column 2.

APPLICATION AS AMENDED – PART II					SMALL ENTITY		OR		OTHER THAN SMALL ENTITY	
(Column 1) (Column 2) (Column 3)					RATE (\$)	ADDI-TIONAL FEE (\$)		RATE (\$)	ADDI-TIONAL FEE (\$)	
AMENDMENT A	CLAIMS REMAINING AFTER AMENDMENT		HIGHEST NUMBER PREVIOUSLY PAID FOR	PRESENT EXTRA	X =			X =		
	Total (37 CFR 1.16(i))	*	Minus **	=	X =			X =		
	Independent (37 CFR 1.16(h))	*	Minus ***	=				N/A		
	Application Size Fee (37 CFR 1.16(s))					N/A			N/A	
FIRST PRESENTATION OF MULTIPLE DEPENDENT CLAIM (37 CFR 1.16(j))					TOTAL ADD'T FEE			TOTAL ADD'T FEE		

(Column 1) (Column 2) (Column 3)					RATE (\$)	ADDI-TIONAL FEE (\$)		RATE (\$)	ADDI-TIONAL FEE (\$)
AMENDMENT B	CLAIMS REMAINING AFTER AMENDMENT		HIGHEST NUMBER PREVIOUSLY PAID FOR	PRESENT EXTRA	X =			X =	
	Total (37 CFR 1.16(i))	*	Minus **	=	X =			X =	
	Independent (37 CFR 1.16(h))	*	Minus ***	=				N/A	
	Application Size Fee (37 CFR 1.16(s))					N/A			N/A
FIRST PRESENTATION OF MULTIPLE DEPENDENT CLAIM (37 CFR 1.16(j))					TOTAL ADD'T FEE			TOTAL ADD'T FEE	

\* If the entry in column 1 is less than the entry in column 2, write "0" in column 3.

\*\* If the "Highest Number Previously Paid For" IN THIS SPACE is less than 20, enter "20".

\*\*\* If the "Highest Number Previously Paid For" IN THIS SPACE is less than 3, enter "3".

The "Highest Number Previously Paid For" (Total or Independent) is the highest number found in the appropriate box in column 1.

This collection of information is required by 37 CFR 1.16. The information is required to obtain or retain a benefit by the public which is to file (and by the USPTO to process) an application. Confidentiality is governed by 35 U.S.C. 122 and 37 CFR 1.14. This collection is estimated to take 12 minutes to complete, including gathering, preparing, and submitting the completed application form to the USPTO. Time will vary depending upon the individual case. Any comments on the amount of time you require to complete this form and/or suggestions for reducing this burden, should be sent to the Chief Information Officer, U.S. Patent and Trademark Office, U.S. Department of Commerce, P.O. Box 1450, Alexandria, VA 22313-1450. DO NOT SEND FEES OR COMPLETED FORMS TO THIS ADDRESS. SEND TO: Commissioner for Patents, P.O. Box 1450, Alexandria, VA 22313-1450.



UNITED STATES PATENT AND TRADEMARK OFFICE

UNITED STATES DEPARTMENT OF COMMERCE
United States Patent and Trademark Office
Address: COMMISSIONER FOR PATENTS
P.O. Box 1450
Alexandria, Virginia 22313-1450
www.uspto.gov

Table with 6 columns: APPLICATION NUMBER, FILING or 371(c) DATE, GRP ART UNIT, FIL FEE REC'D, ATTY. DOCKET NO, TOT CLAIMS, IND CLAIMS. Row 1: 12/419,451, 04/07/2009, 3661, 488, LBTECH.012CP1, 21, 3

CONFIRMATION NO. 1643

70515
Law Office Of Robert E. Kasody,
Professional Corporation
6601 Center Drive West, Suite #500
Los Angeles, CA 90045

FILING RECEIPT



Date Mailed: 04/22/2009

Receipt is acknowledged of this non-provisional patent application. The application will be taken up for examination in due course. Applicant will be notified as to the results of the examination. Any correspondence concerning the application must include the following identification information: the U.S. APPLICATION NUMBER, FILING DATE, NAME OF APPLICANT, and TITLE OF INVENTION. Fees transmitted by check or draft are subject to collection. Please verify the accuracy of the data presented on this receipt. If an error is noted on this Filing Receipt, please submit a written request for a Filing Receipt Correction. Please provide a copy of this Filing Receipt with the changes noted thereon. If you received a "Notice to File Missing Parts" for this application, please submit any corrections to this Filing Receipt with your reply to the Notice. When the USPTO processes the reply to the Notice, the USPTO will generate another Filing Receipt incorporating the requested corrections

Applicant(s)

Joseph F. Scalisi, Yorba Linda, CA;
Roger B. Anderson, Arcadia, CA;

Power of Attorney: The patent practitioners associated with Customer Number 70515

Domestic Priority data as claimed by applicant

This application is a CIP of 11/969,905 01/06/2008
and is a CIP of 11/753,979 05/25/2007
and is a CIP of 11/933,024 10/31/2007
and is a CIP of 11/784,400 04/05/2007
and is a CIP of 11/935,901 11/06/2007

Foreign Applications

If Required, Foreign Filing License Granted: 04/16/2009

The country code and number of your priority application, to be used for filing abroad under the Paris Convention, is US 12/419,451

Projected Publication Date: 07/30/2009

Non-Publication Request: No

Early Publication Request: No

\*\* SMALL ENTITY \*\*

**Title**

APPARATUS AND METHOD FOR ADJUSTING REFRESH RATE OF LOCATION COORDINATES  
OF A TRACKING DEVICE

**Preliminary Class**

701

**PROTECTING YOUR INVENTION OUTSIDE THE UNITED STATES**

Since the rights granted by a U.S. patent extend only throughout the territory of the United States and have no effect in a foreign country, an inventor who wishes patent protection in another country must apply for a patent in a specific country or in regional patent offices. Applicants may wish to consider the filing of an international application under the Patent Cooperation Treaty (PCT). An international (PCT) application generally has the same effect as a regular national patent application in each PCT-member country. The PCT process **simplifies** the filing of patent applications on the same invention in member countries, but **does not result** in a grant of "an international patent" and does not eliminate the need of applicants to file additional documents and fees in countries where patent protection is desired.

Almost every country has its own patent law, and a person desiring a patent in a particular country must make an application for patent in that country in accordance with its particular laws. Since the laws of many countries differ in various respects from the patent law of the United States, applicants are advised to seek guidance from specific foreign countries to ensure that patent rights are not lost prematurely.

Applicants also are advised that in the case of inventions made in the United States, the Director of the USPTO must issue a license before applicants can apply for a patent in a foreign country. The filing of a U.S. patent application serves as a request for a foreign filing license. The application's filing receipt contains further information and guidance as to the status of applicant's license for foreign filing.

Applicants may wish to consult the USPTO booklet, "General Information Concerning Patents" (specifically, the section entitled "Treaties and Foreign Patents") for more information on timeframes and deadlines for filing foreign patent applications. The guide is available either by contacting the USPTO Contact Center at 800-786-9199, or it can be viewed on the USPTO website at <http://www.uspto.gov/web/offices/pac/doc/general/index.html>.

For information on preventing theft of your intellectual property (patents, trademarks and copyrights), you may wish to consult the U.S. Government website, <http://www.stopfakes.gov>. Part of a Department of Commerce initiative, this website includes self-help "toolkits" giving innovators guidance on how to protect intellectual property in specific countries such as China, Korea and Mexico. For questions regarding patent enforcement issues, applicants may call the U.S. Government hotline at 1-866-999-HALT (1-866-999-4158).

**LICENSE FOR FOREIGN FILING UNDER****Title 35, United States Code, Section 184****Title 37, Code of Federal Regulations, 5.11 & 5.15****GRANTED**

The applicant has been granted a license under 35 U.S.C. 184, if the phrase "IF REQUIRED, FOREIGN FILING LICENSE GRANTED" followed by a date appears on this form. Such licenses are issued in all applications where

the conditions for issuance of a license have been met, regardless of whether or not a license may be required as set forth in 37 CFR 5.15. The scope and limitations of this license are set forth in 37 CFR 5.15(a) unless an earlier license has been issued under 37 CFR 5.15(b). The license is subject to revocation upon written notification. The date indicated is the effective date of the license, unless an earlier license of similar scope has been granted under 37 CFR 5.13 or 5.14.

This license is to be retained by the licensee and may be used at any time on or after the effective date thereof unless it is revoked. This license is automatically transferred to any related applications(s) filed under 37 CFR 1.53(d). This license is not retroactive.

The grant of a license does not in any way lessen the responsibility of a licensee for the security of the subject matter as imposed by any Government contract or the provisions of existing laws relating to espionage and the national security or the export of technical data. Licensees should apprise themselves of current regulations especially with respect to certain countries, of other agencies, particularly the Office of Defense Trade Controls, Department of State (with respect to Arms, Munitions and Implements of War (22 CFR 121-128)); the Bureau of Industry and Security, Department of Commerce (15 CFR parts 730-774); the Office of Foreign Assets Control, Department of Treasury (31 CFR Parts 500+) and the Department of Energy.

**NOT GRANTED**

No license under 35 U.S.C. 184 has been granted at this time, if the phrase "IF REQUIRED, FOREIGN FILING LICENSE GRANTED" DOES NOT appear on this form. Applicant may still petition for a license under 37 CFR 5.12, if a license is desired before the expiration of 6 months from the filing date of the application. If 6 months has lapsed from the filing date of this application and the licensee has not received any indication of a secrecy order under 35 U.S.C. 181, the licensee may foreign file the application pursuant to 37 CFR 5.15(b).





UNITED STATES PATENT AND TRADEMARK OFFICE

UNITED STATES DEPARTMENT OF COMMERCE
United States Patent and Trademark Office
Address: COMMISSIONER FOR PATENTS
P.O. Box 1450
Alexandria, Virginia 22313-1450
www.uspto.gov

Table with 4 columns: APPLICATION NUMBER (12/419,451), FILING OR 371(C) DATE (04/07/2009), FIRST NAMED APPLICANT (Joseph F. Scalisi), ATTY. DOCKET NO./TITLE (LBTECH.012CP1)

CONFIRMATION NO. 1643

PUBLICATION NOTICE



70515
Law Office Of Robert E. Kasody,
Professional Corporation
6601 Center Drive West, Suite #500
Los Angeles, CA 90045

Title: APPARATUS AND METHOD FOR ADJUSTING REFRESH RATE OF LOCATION COORDINATES OF A TRACKING DEVICE

Publication No. US-2009-0189807-A1

Publication Date: 07/30/2009

NOTICE OF PUBLICATION OF APPLICATION

The above-identified application will be electronically published as a patent application publication pursuant to 37 CFR 1.211, et seq. The patent application publication number and publication date are set forth above.

The publication may be accessed through the USPTO's publically available Searchable Databases via the Internet at www.uspto.gov. The direct link to access the publication is currently http://www.uspto.gov/patft/.

The publication process established by the Office does not provide for mailing a copy of the publication to applicant. A copy of the publication may be obtained from the Office upon payment of the appropriate fee set forth in 37 CFR 1.19(a)(1). Orders for copies of patent application publications are handled by the USPTO's Office of Public Records. The Office of Public Records can be reached by telephone at (703) 308-9726 or (800) 972-6382, by facsimile at (703) 305-8759, by mail addressed to the United States Patent and Trademark Office, Office of Public Records, Alexandria, VA 22313-1450 or via the Internet.

In addition, information on the status of the application, including the mailing date of Office actions and the dates of receipt of correspondence filed in the Office, may also be accessed via the Internet through the Patent Electronic Business Center at www.uspto.gov using the public side of the Patent Application Information and Retrieval (PAIR) system. The direct link to access this status information is currently http://pair.uspto.gov/. Prior to publication, such status information is confidential and may only be obtained by applicant using the private side of PAIR.

Further assistance in electronically accessing the publication, or about PAIR, is available by calling the Patent Electronic Business Center at 1-866-217-9197.

Office of Data Management, Application Assistance Unit (571) 272-4000, or (571) 272-4200, or 1-888-786-0101

(19) 日本国特許庁 (J P)

(12) 公開特許公報 (A)

(11) 特許出願公開番号

特開平10-325735

(43) 公開日 平成10年(1998)12月8日

(51) Int. Cl. <sup>4</sup>	識別記号	P I
G 0 1 C 22/00		G 0 1 C 22/00 E
	21/00	21/00 Z
G 0 1 S 5/14		G 0 1 S 5/14

審査請求 有 請求項の数 5 O L (全 12 頁)

(21) 出願番号	特願平9-169744	(71) 出願人	000002325 セイコーインスツルメンツ株式会社 千葉県千葉市美浜区中瀬1丁目8番地
(22) 出願日	平成9年(1997)6月26日	(72) 発明者	佐久本 和実 千葉県千葉市美浜区中瀬1丁目8番地 セイコー電子工業株式会社内
(31) 優先権主張番号	特願平8-273787	(72) 発明者	小田切 将之 千葉県千葉市美浜区中瀬1丁目8番地 セイコー電子工業株式会社内
(32) 優先日	平8(1996)10月16日	(72) 発明者	中村 千秋 千葉県千葉市美浜区中瀬1丁目8番地 セイコー電子工業株式会社内
(33) 優先権主張国	日本 (J P)	(74) 代理人	弁理士 林 徹之助
(31) 優先権主張番号	特願平9-72269		
(32) 優先日	平9(1997)3月25日		
(33) 優先権主張国	日本 (J P)		

最終頁に続く

(54) 【発明の名称】 携帯型GPS受信装置

(57) 【要約】

【課題】 人間の移動距離、移動速度を計測する携帯型GPS受信装置において、衛星が捕捉不能になると測定が出来なくなる。また、移動距離や移動速度を正確に求めるためには測定間隔を連続して測位動作を行う必要があり、GPS受信機の消費電力が大きくなってしまいう等の問題があった。

【解決手段】 一旦GPS受信装置600で搬送波のドップラー周波数から速度を求め、その速度から距離換算手段106で距離を求める。歩行検出手段100で歩行を検出し、歩数演算手段102で演算した歩数と、換算した距離からストライド演算手段104でストライドを求める。その後は、ストライドと検出積算される歩数から距離演算手段103で移動距離を速度演算手段105で移動速度を求める。また、定期的にGPS受信装置600で受信し、ストライドを更新する。

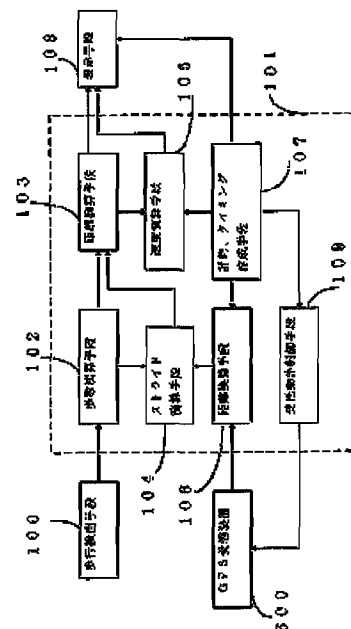

(2) 特開平10-325735

1

## 【特許請求の範囲】

【請求項1】 GPS衛星からの信号を受信し、受信装置の位置及び搬送波のドップラー周波数測定による速度を測定するGPS受信装置において、人体の歩行及び走行を検出する歩行検出手段と、前記歩行検出手段で検出した歩行信号を入力し歩数を演算する歩数演算手段と、時刻を計時すると共に基準タイミング信号を作成する計時、タイミング作成手段と、

前記GPS受信装置で測定した搬送波のドップラー周波数から測定した人体の速度データ信号と、前記計時、タイミング作成手段の出力する計時、タイミング信号を入力し、速度データから距離に換算する距離換算手段と、前記距離換算手段の出力する換算距離信号と、前記歩数演算手段の出力する歩数値信号を入力し、1歩あたりのストライドを演算するストライド演算手段と、前記歩数演算手段の出力する歩数値信号と、前記ストライド演算手段の出力するストライド信号を入力し、人体の移動距離を演算する距離演算手段と、

前記距離演算手段の出力する距離信号と、前記計時、タイミング作成手段の出力する計時、タイミング信号を入力し、人体の移動速度を演算する速度演算手段と、前記距離演算手段の出力する距離信号と、前記速度演算手段の出力する速度信号と、前記計時、タイミング作成手段の出力する時刻信号を表示する表示手段と、

前記計時、タイミング作成手段の出力する計時、タイミング信号を入力し、ある一定時間間隔で、前記GPS受信装置での受信動作を開始させ、一定時間後に受信動作を終了させるように制御する受信動作制御手段と、を有することを特徴とする携帯型GPS受信装置。

【請求項2】 GPS衛星からの信号を受信し、受信装置の位置及び搬送波のドップラー周波数測定による速度を測定するGPS受信装置において、人体の歩行及び走行を検出する歩行検出手段と、前記歩行検出手段で検出した歩行信号を入力し歩数を演算する歩数演算手段と、時刻を計時すると共に基準タイミング信号を作成する計時、タイミング作成手段と、

前記GPS受信装置で測定した搬送波のドップラー周波数から測定した人体の速度データ信号と、前記計時、タイミング作成手段の出力する計時、タイミング信号を入力し、速度データから距離に換算する距離換算手段と、前記距離換算手段の出力する換算距離信号と、前記歩数演算手段の出力する歩数値信号を入力し、1歩あたりのストライドを演算するストライド演算手段と、前記歩数演算手段の出力する歩数値信号と、前記ストライド演算手段の出力するストライド信号を入力し、人体の移動距離を演算する距離演算手段と、

前記距離演算手段の出力する距離信号と、前記計時、タイミング作成手段の出力する計時、タイミング信号を入力し、人体の移動速度を演算する速度演算手段と、前記距離演算手段の出力する距離信号と、前記速度演算

2

手段の出力する速度信号と、前記計時、タイミング作成手段の出力する時刻信号を表示する表示手段と、

前記歩数演算手段の出力する歩数値信号と、前記計時、タイミング作成手段の出力する計時、タイミング信号を入力し、単位時間当たりの歩数であるピッチを演算するピッチ演算手段と、

前記計時、タイミング作成手段の出力する計時、タイミング信号と、前記ピッチ演算手段の出力するピッチ信号を入力し、ある一定のピッチ信号の変化により、前記GPS受信装置での受信動作を開始させ、ある一定時間後に受信動作を終了させるように制御する受信動作制御手段と、を有することを特徴とする携帯型GPS受信装置。

【請求項3】 GPS衛星からの信号を受信し、受信装置の位置及び搬送波のドップラー周波数測定による速度を測定するGPS受信装置において、人体の歩行及び走行を検出する歩行検出手段と、前記歩行検出手段で検出した歩行信号を入力し歩数を演算する歩数演算手段と、時刻を計時すると共に基準タイミング信号を作成する計時、タイミング作成手段と、

前記GPS受信装置で測定した搬送波のドップラー周波数から測定した人体の速度データ信号と、前記計時、タイミング作成手段の出力する計時、タイミング信号を入力し、速度データから距離に換算する距離換算手段と、前記距離換算手段の出力する換算距離信号と、前記歩数演算手段の出力する歩数値信号を入力し、1歩あたりのストライドを演算するストライド演算手段と、前記歩数演算手段の出力する歩数値信号と、前記ストライド演算手段の出力するストライド信号を入力し、人体の移動距離を演算する距離演算手段と、

前記距離演算手段の出力する距離信号と、前記計時、タイミング作成手段の出力する計時、タイミング信号を入力し、人体の移動速度を演算する速度演算手段と、前記距離演算手段の出力する距離信号と、前記速度演算手段の出力する速度信号と、前記計時、タイミング作成手段の出力する時刻信号を表示する表示手段と、

前記歩行検出手段の出力する歩行信号の大きさを判断し、歩行の強度を検出する歩行強度検出手段と、前記計時、タイミング作成手段の出力する計時、タイミング信号と、前記歩行強度検出手段の出力する歩行強度判定信号を入力し、ある一定の歩行信号の強弱変化により、前記GPS受信装置での受信動作を開始させ、ある一定時間後に受信動作を終了させるように制御する受信動作制御手段と、を有することを特徴とする携帯型GPS受信装置。

【請求項4】 GPS衛星からの信号を受信し、受信装置の位置及び搬送波のドップラー周波数測定による速度を測定するGPS受信装置において、人体の歩行及び走行を検出する歩行検出手段と、前記歩行検出手段で検出した歩行信号を入力し歩数を演算する歩数演算手段と、

(3) 特開平10-325735

3

時刻を計時すると共に基準タイミング信号を作成する計時、タイミング作成手段と、

前記GPS受信装置で測定した搬送波のドップラー周波数から測定した人体の速度データ信号と、前記計時、タイミング作成手段の出力する計時、タイミング信号を入力し、速度データから距離に換算する距離換算手段と、前記距離換算手段の出力する換算距離信号と、前記歩数演算手段の出力する歩数値信号を入力し、1歩あたりのストライドを演算するストライド演算手段と、

前記歩数演算手段の出力する歩数値信号と、前記ストライド演算手段の出力するストライド信号を入力し、人体の移動距離を演算する距離演算手段と、

前記距離演算手段の出力する距離信号と、前記計時、タイミング作成手段の出力する計時、タイミング信号を入力し、人体の移動速度を演算する速度演算手段と、

前記距離演算手段の出力する距離信号と、前記速度演算手段の出力する速度信号と、前記計時、タイミング作成手段の出力する時刻信号を表示する表示手段と、

装置の周りの照度を測定し、照度の変化を検出する照度変化検出手段と、

前記計時、タイミング作成手段の出力する計時、タイミング信号と、前記照度変化検出手段の出力する、装置の周りの照度変化信号を入力し、ある一定の照度変化があった場合、前記GPS受信装置での受信動作を開始させ、ある一定時間後に受信動作を終了させるように制御する受信動作制御手段と、を有することを特徴とする携帯型GPS受信装置。

【請求項5】 GPS衛星からの信号を受信し、受信装置の位置及び搬送波のドップラー周波数測定による速度を測定するGPS受信装置において、人体の歩行及び走行を検出する歩行検出手段と、前記歩行検出手段で検出した歩行信号を入力し歩数を演算する歩数演算手段と、時刻を計時すると共に基準タイミング信号を作成する計時、タイミング作成手段と、

前記GPS受信装置で測定した搬送波のドップラー周波数から測定した人体の速度データ信号と、前記計時、タイミング作成手段の出力する計時、タイミング信号を入力し、速度データから距離に換算する距離換算手段と、前記距離換算手段の出力する換算距離信号と、前記歩数演算手段の出力する歩数値信号を入力し、1歩あたりのストライドを演算するストライド演算手段と、

前記歩数演算手段の出力する歩数値信号と、前記ストライド演算手段の出力するストライド信号を入力し、人体の移動距離を演算する距離演算手段と、

前記距離演算手段の出力する距離信号と、前記計時、タイミング作成手段の出力する計時、タイミング信号を入力し、人体の移動速度を演算する速度演算手段と、

前記距離演算手段の出力する距離信号と、前記速度演算手段の出力する速度信号と、前記計時、タイミング作成手段の出力する時刻信号を表示する表示手段と、

4

心臓の拍動に同期した、携帯者の脈拍数を検出する脈拍検出手段と、

前記計時、タイミング作成手段の出力する計時、タイミング信号と、前記脈拍検出手段の出力する脈拍数信号を入力し、ある一定の脈拍数信号の変化により、前記GPS受信装置での受信動作を開始させ、ある一定時間後に受信動作を終了させるように制御する受信動作制御手段と、を有することを特徴とする携帯型GPS受信装置。

【発明の詳細な説明】

【0001】

【発明の属する技術分野】本発明は、GPS (Global Positioning System: 全世界測位システム) 衛星からの信号を受信し、受信装置の位置、速度を測定するGPS受信装置に関する。とくに人間の腕での保持、装着が可能であり、人間の走行、歩行時の位置、移動距離、および移動速度を測定するGPS受信装置に関するものである。

【0002】

【従来の技術】従来、GPSシステムは、地球上約20、200Km、傾斜角5.5度の6つの軌道を1周約1.2時間で回る24個のGPS衛星のうち3~4個以上の衛星から測位に必要な航法データを地球上の受信機により受信して、受信機が装着された移動体の位置、移動速度等の測位演算を行うものである。また、搬送波のドップラー周波数を測定し、移動体の速度ベクトルを求めることもできる。GPS衛星の送信周波数には周波数が1,575.42GHzのL1と周波数が1,227.60GHzのL2の2つが有る。一般的な測位には、L1を用いる。L1は擬似雑音符号(衛星を識別するC/Aコード)と衛星の軌道と衛星の軌道情報、時刻情報等の航法データの合成波)でPSK (phase shift keying) 変調され、スペクトラム拡散されて衛星から送信されている。この電波を図6に示すGPS受信装置で受信する。アンテナ601で受信した1,575.42GHzの信号をL帯増幅回路602で増幅し、ダウンコンバータ部603で数十MHz~200MHzの第1のIF(中間周波)信号に変換し、さらに2MHz~5MHz程度の第2のIF信号に変換する。第2IF信号を電圧比較器604に入力し、IF信号の数倍のクロックで電圧比較器604を用いてデジタル変換する。この出力がスペクトラム拡散されたデータである。メッセージ解読手段605において、電圧比較器604の出力するデジタル信号にC/A符号発生回路606で発生する衛星と同じ擬似雑音符号であるC/Aコードを逆拡散することで航法データを得る。この動作を複数の衛星に対して行い通常は4つの衛星の航法データから測位演算手段607で測位データを求める。この様なGPS受信機の小型化に伴い、人間の走行や歩行時の移動距離や移動速度を求める目的で利用されることが考えられており、特開平6-118156等に開示されている。

5

【0003】

【発明が解決しようとする課題】しかし、従来のGPS受信機を人体の移動距離や移動速度の測定に利用しようとすると、色々な課題がある。車載用のGPS受信機であればトンネルやビルの谷間等の、測位し難い場所に於いては、マップマッチングなどの自立航法手段を用いてナビゲーション動作を続ける事が出来る。しかし、腕型のように小型のGPS受信機に於いては、CDROMによる地図情報を備えることはそのサイズから難しい。また、車であれば移動距離や移動速度を車載の計器から得る事が出来るが、腕型の場合、移動距離や移動速度そのものをGPS衛星から求めるため衛星が捕捉不能になると測定が出来なくなる。また、その移動距離や移動速度を正確に求めるためには測定間隔を連続して測位動作を行う必要があるため、GPS受信機の消費電力が大きくなってしまいう等の課題があった。

【0004】本発明は上述した課題に鑑みてなされたものであり、衛星が捕捉出来ない時も移動距離や移動速度の測定を可能とすると共に、連続受信をすること無く正確な移動距離や移動速度を測定できる携帯型GPS受信装置を得ることを目的とする。

【0005】

【課題を解決するための手段】上記課題を解決するため、本発明は第1に、一旦GPS受信装置で搬送波のドップラー周波数から速度を求め、その速度と時間から距離換算手段で距離を求める。速度計測中、歩行検出手段で歩行を検出し、歩数演算手段で演算した歩数と、換算した距離からストライド演算手段でストライドを求める。その後は、ストライドと検出演算される歩数から距離演算手段で移動距離を速度演算手段で移動スピードを求め、また、定期的にGPS受信装置で受信し、ストライドを更新する。

【0006】第2に、第1の構成に歩数演算手段で演算した歩数と、計時、タイミング手段の時間データとから単位時間当たりの歩数であるピッチを演算するピッチ演算手段を設け、ある一定のピッチ信号の変化によりGPS受信装置の受信動作開始を指示し、一定時間後に受信動作を終了させるように制御する受信動作制御手段とを設ける構成とした。

【0007】第3に、第1の構成に歩行の強弱を判定する歩行強度検出手段を設け、歩行強度のある一定の変化によりGPS受信装置の受信動作開始を指示し、一定時間後に受信動作を終了させるように制御する受信動作制御手段とを設ける構成とした。第4に、第1の構成に装置の回りの照度変化を検出する照度変化検出手段を設け、ある一定の照度変化があった場合にGPS受信装置の受信動作開始を指示し、一定時間後に受信動作を終了させるように制御する受信動作制御手段とを設ける構成とした。

【0008】第5に、第1の構成に携帯者の脈拍数を検

(4)

特開平10-325735

6

出する脈拍検出手段を設け、ある一定の脈拍数変化があった場合にGPS受信装置の受信動作開始を指示し、一定時間後に受信動作を終了させるように制御する受信動作制御手段とを設ける構成とした。

【0009】

【発明の実施の形態】図1は、本発明の構成を示す機能ブロック図である。計時、タイミング作成手段107は、時刻を計時するとともに基準タイミング信号を作成する。受信動作制御手段109は、基準タイミング信号によりある一定時間間隔で、GPS受信装置600での受信動作を開始させ、一定時間後に受信動作を終了させるように制御する。距離換算手段106は、その一定時間の受信動作中に測定した搬送波のドップラー周波数から求めた移動速度と、計時、タイミング作成手段107の時間データから距離を換算する。歩行検出手段100は、人体の歩行を検出する。歩数演算手段102は、歩行検出手段100で検出した信号を積算し歩数を演算する。ストライド演算手段104は、距離換算手段106で換算した距離とそのデータが得られる間に歩数演算手段102で演算した歩数とから歩あたりのストライドを演算する。距離演算手段103は、次の受信タイミングになるまで、ストライド演算手段104で求めたストライドと歩数演算手段102で演算した歩数とから歩行距離を演算する。速度演算手段105は、距離演算手段103で求めた歩行距離と、計時、タイミング作成手段107の時間データとから速度を演算する。

【0010】図2は、本発明の構成を示す他の機能ブロック図である。ピッチ演算手段200は、歩数演算手段102で演算した歩数と、計時、タイミング作成手段107の時間データとから単位時間当たりの歩数であるピッチを演算する。受信動作制御手段109は、ピッチ信号の変化によりGPS受信装置600の受信動作開始を指示し、一定時間後に受信動作を終了させるように制御する。

【0011】図3は、本発明の構成を示す他の機能ブロック図である。歩行強度検出手段300は、歩行検出手段100の出力する歩行信号の強弱を判定する。受信動作制御手段109は、歩行強度の変化によりGPS受信装置600の受信動作開始を指示し、一定時間後に受信動作を終了させるように制御する。図4は、本発明の構成を示す他の機能ブロック図である。照度変化検出手段400は、装置の回りの照度変化を検出する。受信動作制御手段109は、検出された照度信号の変化によりGPS受信装置600の受信動作開始を指示し、一定時間後に受信動作を終了させるように制御する。

【0012】図5は、本発明の構成を示す他の機能ブロック図である。脈拍検出手段500は、携帯者の脈拍数を検出する。受信動作制御手段109は、検出された脈拍数の変化によりGPS受信装置600の受信動作開始を指示し、一定時間後に受信動作を終了させるよう

7

に制御する。図7は、本発明の代表的な構成の1例を示す機能ブロック図である。

【0013】図7において、歩行検出手段100の加速度センサー700は、圧電素子を貼り付けた片持ち梁構造の加速度センサを用い歩行や走行に応じた振動変位を電荷として出力する。増幅回路701は、加速度センサー700の出力信号を増幅する。フィルター702は、商用周波数等雑音成分を除去する。矩形波変換回路703は、フィルター702の出力する信号をデジタル信号に変換する。基準電圧発生回路704は、歩行検出手段100の各回路に基準電圧を与える。矩形波変換回路703の出力する歩行に同期した信号は、CPU101に入力される。CPU101は、その動作ステップがプログラムされたROM710の内容にしたがって、歩数演算、距離演算等の動作を行う。RAM705は、CPU101が動作する際のデータのレジスタとしてCPU101に接続されている。GPS受信装置600は、CPU101により受信動作が制御され、図6で説明したアンテナ601から測位演算回路607までの機能を持ち、CPU101に位置データ、速度データを出力する。基準信号発生回路707は、CPU101の動作のための基準信号を発生させる。入力回路708は、機器の動作開始を指示するスイッチであり、CPU101に入力信号を伝送する。駆動回路709は、CPU101で演算された距離や速度及び、時刻信号を表示パネル108で表示させる信号に変換する。

【0014】図8は、本発明の動作を示すフローチャートである。図8において、入力回路708から、距離、速度の計測開始入力信号を待つ(S100)。SWが入力されると、計測開始信号であれば計測をスタートさせるが、その他の入力信号であれば、その他の処理を行う(S101、S115)。計測スタート信号であれば、GPS受信装置により、所定の数の衛星が捕捉され、データが揃うまで初期測定処理を行う(S102、S103)。初期測定処理が終了すると、搬送波のドップラー周波数測定による速度測定処理に移る(S104)。測定された速度データと時間データとから距離を換算する(S105)。速度、距離を表示する(S106)。搬送波のドップラー周波数測定による速度測定と並行して歩行検出手段100で歩行を検出し、歩数を積算する(S107)。定められた時間経過したら測定を終了し、経過していないのであれば、受信を続ける(S108)。一定時間が経過したならば、受信を終了し、歩数当たりの歩幅であるストライドを演算する(S109)。

【0015】図9、図10は、ストライド演算処理の動作を示すフローチャートである。図9において、歩行検出信号が入力されると歩数カウンタに2を加算する(S201、S202)。2を加算するのは、歩行検出信号は、腕の振りを検出しているの、腕の1周期中、歩数

(5)

特開平10-325735

8

は2歩であるからである。次に1分経過したかどうか判断し(S203)、1分経過したのであれば、現在の歩数カウンタの値、つまり1分間の歩数をピッチP (step/min)とする(S204)。この間の1分間の平均速度を求め、V (m/SEC)とする(S205)。次にストライドを求める(S206)。

【0016】図10は、その他のストライド演算の動作フローチャートである。図10において、歩行検出信号が入力されると、1回目の入力かどうか1回目フラグにより判断される(S301、S302)。1回目の入力であれば、1回目フラグをセットし、次の入力が2回目となるようにする(S311)。次に、周期計測用の時間カウンタをスタートさせる(S312)。歩行検出信号が2回目の入力である場合は、1回目フラグをリセットし、次の入力が1回目となるようにする(S303)。次に周期計測用時間カウンタをストップし、周期tを得る(S304、S305)。この周期tは、腕振りの周期であるので、単位秒当たりのピッチ周期に変換するには、 $t/2$ とする。つまりピッチの周波数は $p = 2/t$ となる(S306)。ここで、歩行検出信号の周波数を時間計測により求めたが、周波数分析により求めてもよい。次に単位秒当たりの速度 $v$  (m/sec)を求め(S307)、ストライド $S = v/p$ を求める(S308)。以上のような方法により、一旦GPS受信中にストライドを求める。その後は、GPS受信動作によらず、歩行を検出し、歩数を積算するとともに、歩数と、ストライドから、距離を演算する(S110、111)。また、演算した距離と、時間データから、速度を求め表示する(S112、113)。GPS受信動作停止中に、ある受信開始条件が成立すれば、GPS受信装置600により速度を測定し、新たなストライドを求める(S114)。ここで、受信開始条件の例は、例えば第1に計時、タイミング作成手段107によりタイマーで時間を監視し、一定時間までは、検出した歩数と、ストライドから距離と、速度を演算する。一定時間経過後受信を開始する。例えば第2に歩数演算手段102の歩数データと計時、タイミング作成手段107の時間データから単位時間当たりの歩数であるピッチを演算し、演算したピッチが前回まで求めたピッチの値に比べ、ある一定の変化があった場合、ストライドの変化が生じた可能性があるの、受信を開始する。例えば第3に歩行強度検出手段300で歩行強度の変化を検出し、ある一定の歩行強度の変化があった場合に、受信を開始する。

【0017】図11は、歩行強度検出手段300の実施形態を示す図である。図11において、歩行検出手段100の加速度センサー700は、圧電素子を貼り付けた片持ち梁構造の加速度センサを用い歩行や走行に応じた振動変位を電荷として出力する。増幅回路701は、加速度センサー700の出力信号を増幅する。フィルター702は、商用周波数等雑音成分を除去する。矩形波

9

換回路703は、フィルタ702の出力する信号をデジタル信号に変換する。基準電圧発生回路704は、歩行検出手段100の各回路に基準電圧を与える。

【0018】図12は、検出された歩行信号と矩形波変換回路の出力を示した波形図である。図12において、歩行検出信号は歩行の強度に応じて、その周期 $t$ と、波高値 $p_h$ が異なる。周期は、矩形変換した信号により、 $t$ で求まる。今、歩行の状態から、走行に移ると、波高値は $p_{h1}$ から $p_{h2}$ に、周期は $t1$ から $t2$ に変わる。この波高値の変化を図11に示すA/D変換器1100により検出する。検出した歩行信号の強度の変化率が、ある一定の値になった場合、ストライドの変化が生じた可能性があるため、受信を開始する。例えば第4に照度変化検出手段400により、装置の周りの照度変化を検出し、例えば長いトンネルから出た場合のように、ある一定の照度変化がある場合に受信を開始する。

【0019】図13は、照度変化検出手段400の実施形態を示す図である。図13において検出動作開始信号Kにより検出を開始する。フォトD1に外光が照射されると、外光の照射量に比例し負荷抵抗RLに流れるIRLが変化する。その電流変化をVRLの変化として、増幅回路1300で増幅し、A/D変換器1100でデジタルデータに変換し検出する。検出した外光の照度変化率がある一定の値になった場合、受信を開始する。例えば第5に脈拍検出手段500により、携帯者の脈拍数を検出して、運動の強度変化によるある一定の脈拍数の変化があった場合に、受信を開始する。

【0020】図14は、脈拍検出手段500の実施形態を示す図である。図14において、検出動作開始信号Kにより検出を開始する。LEDから出力された光は、指1202に照射され、反射光がフォトD1に入射する。入射光には脈拍の情報が含まれており、これを増幅回路1400で増幅し、フィルタ回路1401によりS/N比を高められ、A/D変換器によりデジタルデータに変換される。デジタルデータをCPU101に入力し、脈拍数に変換する。脈拍数の変化率がある一定の値になった場合に、運動の強度が変わり、ストライドの変化が生じた可能性があるため、受信を開始する。このようにいくつかの受信開始の条件によりストライドを更新し、より正確なストライドを求めておき、移動距離、速度計算

【0021】

【発明の効果】上述したように本発明によれば、一旦GPS受信装置で搬送波のドップラー周波数から速度を求め、その速度から距離を求め歩数演算手段で演算した歩数とからストライドを求める。その後は、ストライドと検出積算される歩数から移動距離、移動スピードを求める様にした事で、トンネルやビルの谷間等の測位の難しい場所での連続計測を可能にした。また、ストライド基準で距離、スピードを求める為、GPS受信装置の測位

(6)

特開平10-325735

10

を連続的に行う必要がなくなり低消費電力とする事が可能となる。

【図面の簡単な説明】

【図1】本発明に係わる携帯型GPS受信装置の1例を示す機能ブロック図である。

【図2】本発明に係わる携帯型GPS受信装置の1例を示す他の機能ブロック図である。

【図3】本発明に係わる携帯型GPS受信装置の1例を示す他の機能ブロック図である。

10 【図4】本発明に係わる携帯型GPS受信装置の1例を示す他の機能ブロック図である。

【図5】本発明に係わる携帯型GPS受信装置の1例を示す他の機能ブロック図である。

【図6】従来のGPS受信装置の構成を示す機能ブロック図である。

【図7】本発明に係わる携帯型GPS受信装置の実施形態を示す機能ブロック図である。

【図8】本発明に係わる携帯型GPS受信装置の動作フローを示す図である。

20 【図9】本発明に係わる携帯型GPS受信装置のストライド演算の動作フローを示す図である。

【図10】本発明に係わる携帯型GPS受信装置のストライド演算の動作フローを示すその他の図である。

【図11】本発明に係わる携帯型GPS受信装置の歩行強度検出手段の実施形態を示す図である。

【図12】本発明に係わる携帯型GPS受信装置の歩行強度検出手段の歩行信号と矩形波変換回路の出力を示した波形図である。

30 【図13】本発明に係わる携帯型GPS受信装置の照度変化検出手段の実施形態を示す図である。

【図14】本発明に係わる携帯型GPS受信装置の脈拍検出手段の実施形態を示す図である。

【符号の説明】

- 100 歩行検出手段
- 101 CPU
- 102 歩数演算手段
- 103 距離演算手段
- 104 ストライド演算手段
- 105 速度演算手段
- 40 106 距離換算手段
- 107 計時、タイミング作成手段
- 108 表示手段
- 109 受信動作制御手段
- 200 ピッチ演算手段
- 300 歩行強度検出手段
- 400 照度変化検出手段
- 500 脈拍検出手段
- 600 GPS受信装置
- 601 アンテナ
- 50 602 L帯増幅回路

(7)

特開平10-326735

- |                |              |
|----------------|--------------|
| 11             | 12           |
| 603 ダウンコンバータ回路 | *705 RAM     |
| 604 高圧比較回路     | 707 基準信号発生回路 |
| 605 メッセージ解読回路  | 708 入力回路     |
| 606 C/A符号発生回路  | 709 駆動回路     |
| 607 測位演算回路     | 710 ROM      |
| 700 加速度センサー    | 1100 A/D変換器  |
| 701 増幅回路       | 1300 増幅回路    |
| 702 フィルター      | 1400 増幅回路    |
| 703 矩形波変換回路    | 1401 フィルタ    |
| 704 基準電圧発生回路   |              |

\*10

【図1】

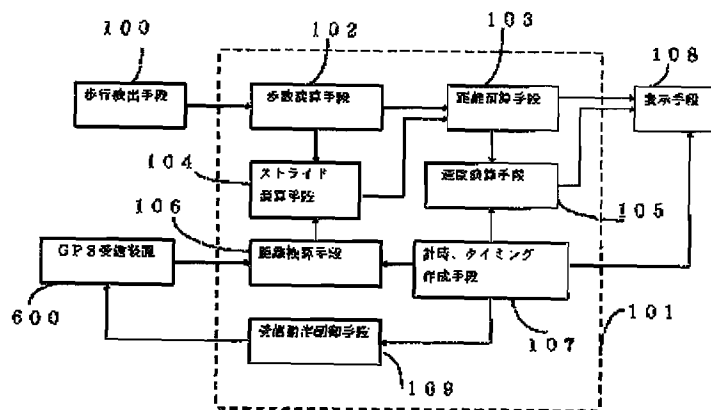

【図2】

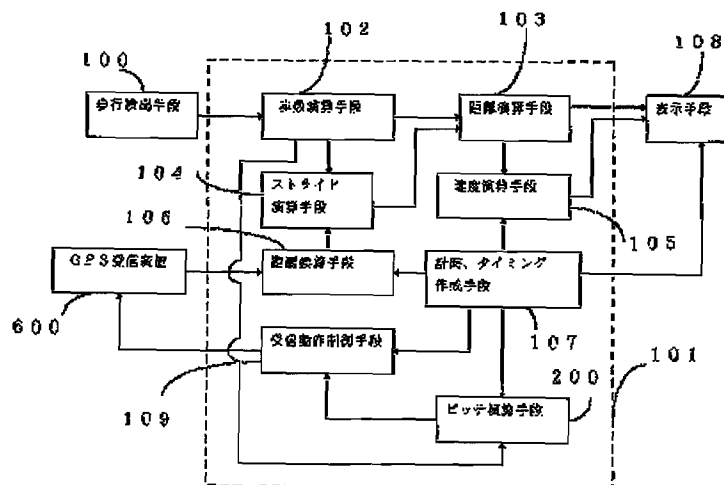



(8)

特開平10-326735

【図3】

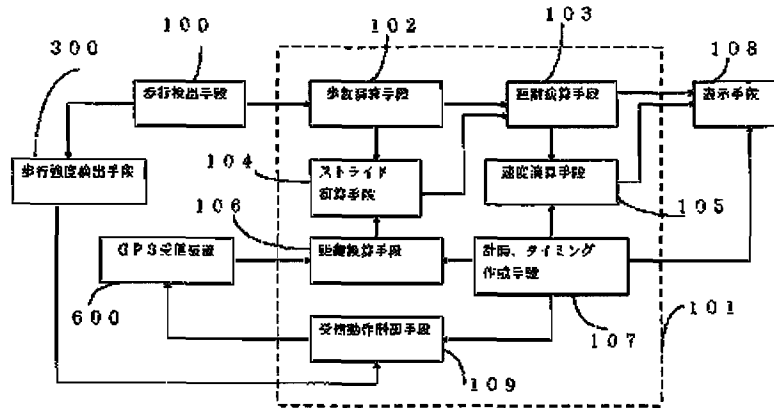

【図4】

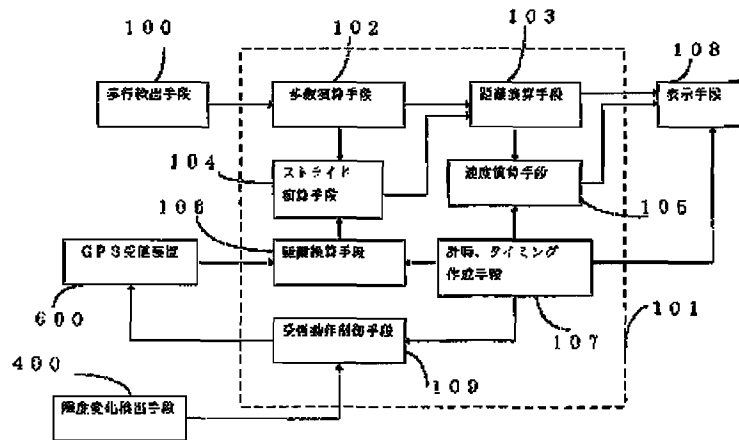

【図11】

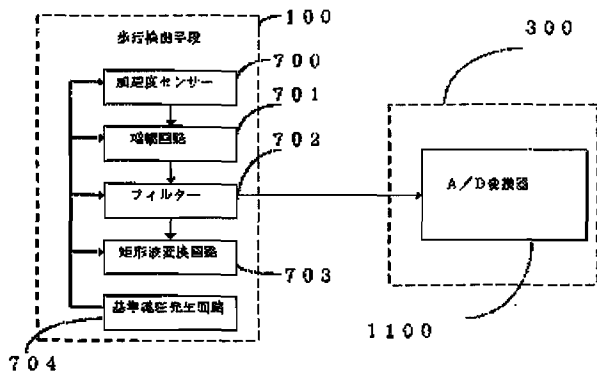

(9)

特開平10-325735

【図5】

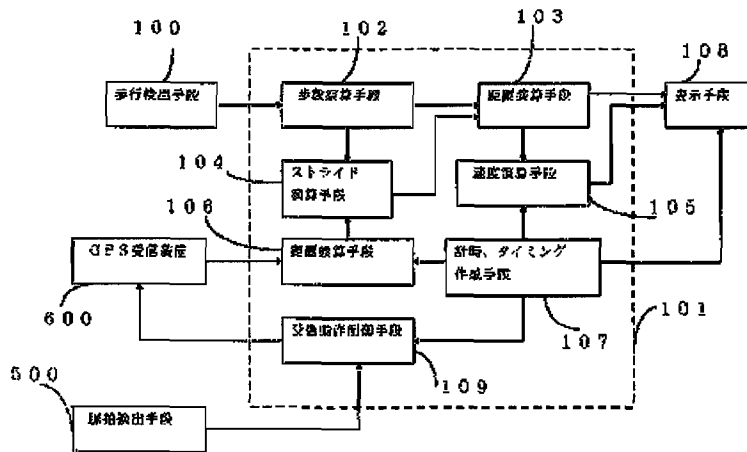

【図6】

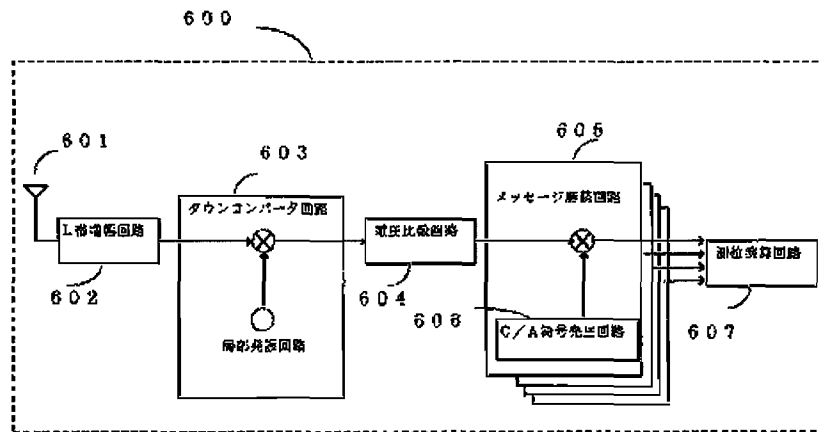

【図12】

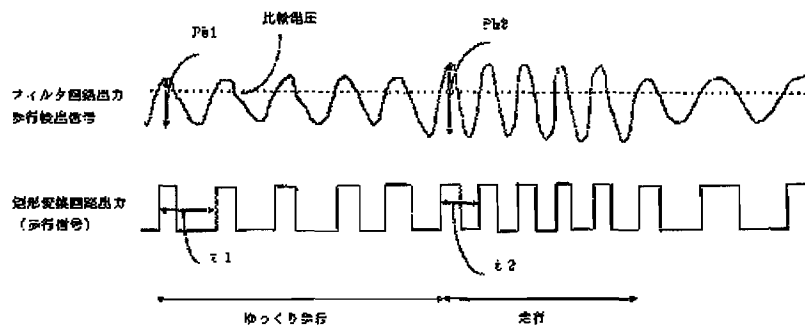

(10)

特開平10-325735

【図7】

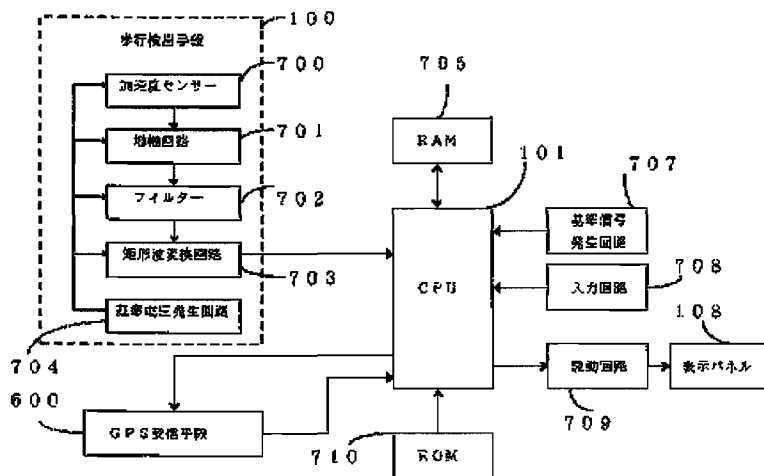

【図9】

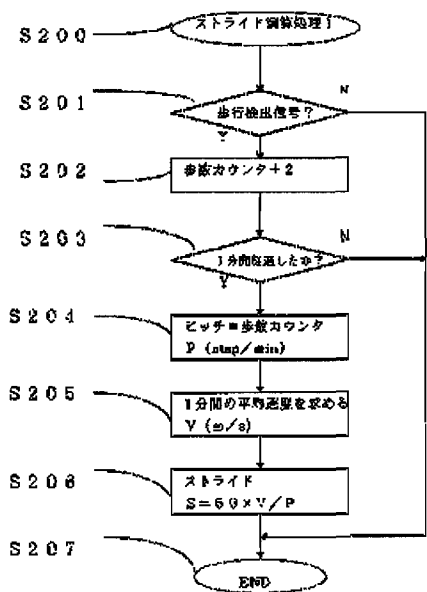

【図10】

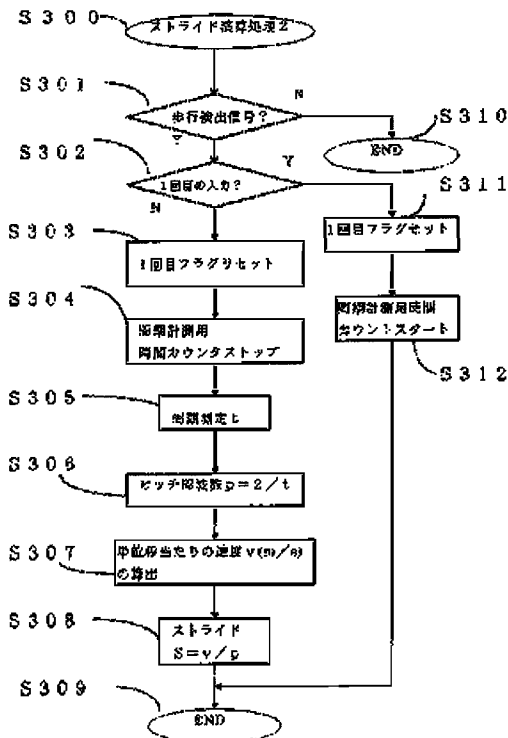

(11)

特開平10-325735

【図8】

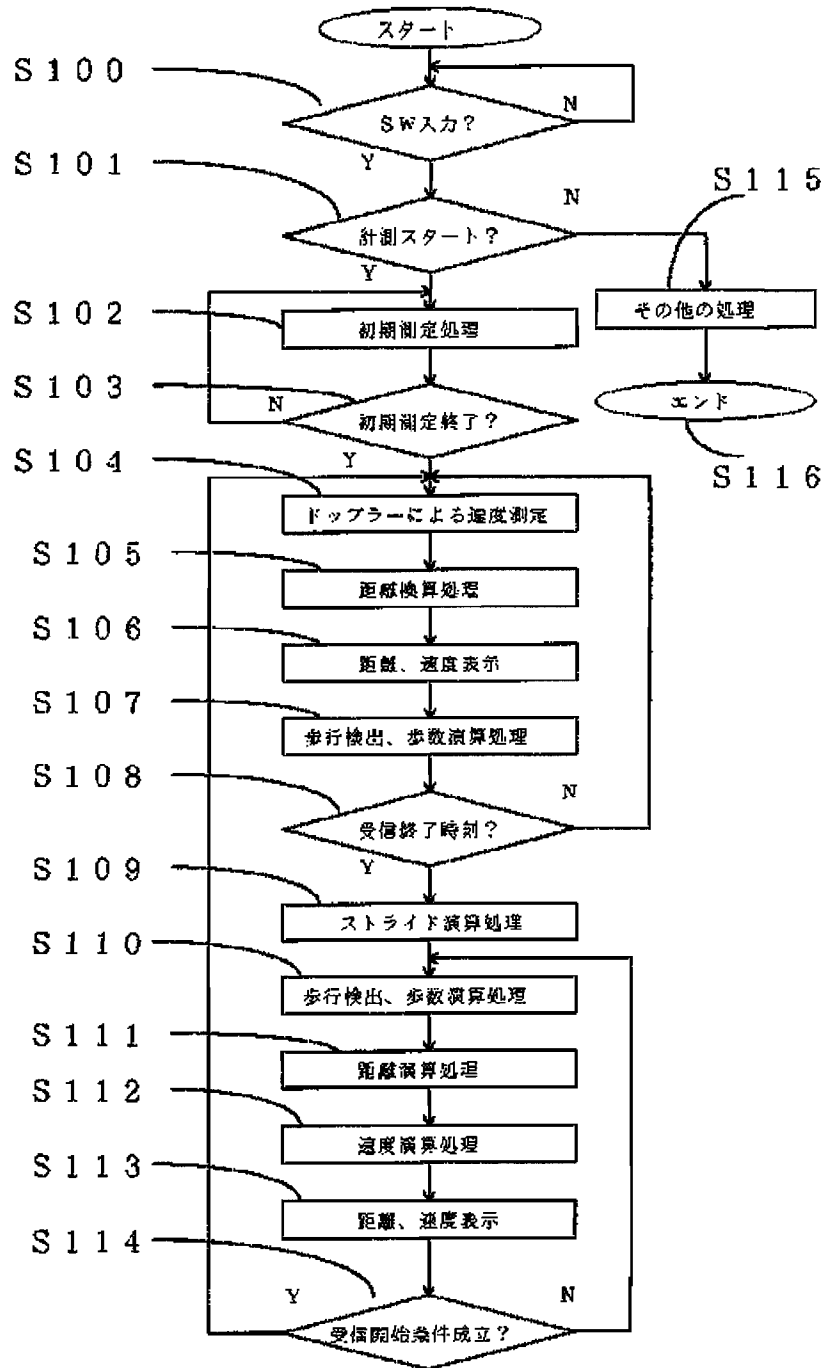

(12)

特開平10-325735

【図13】

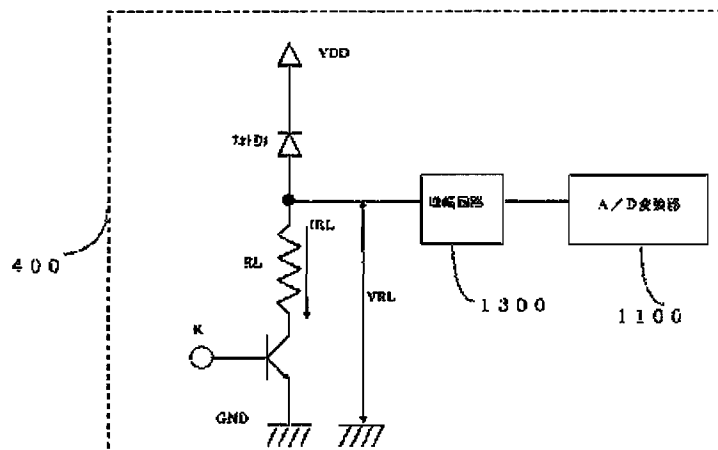

【図14】

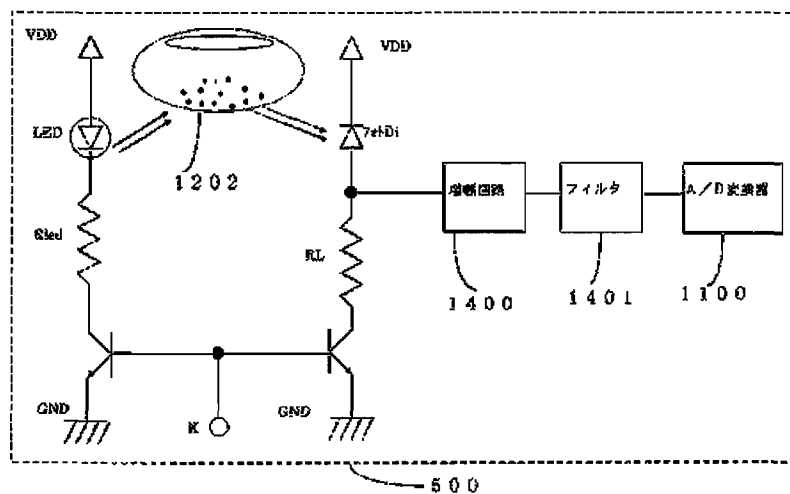

フロントページの続き

(72)発明者 津端 佳介  
 千葉県千葉市美浜区中瀬1丁目8番地 セ  
 イコー電子工業株式会社内

(19) 日本国特許庁 (J P)

(12) 公開特許公報 (A)

(11) 特許出願公開番号

特開平11-64480

(43) 公開日 平成11年(1999) 3月5日

(51) Int. Cl. <sup>5</sup>	識別記号	P I
G 0 1 S 5/14		G 0 1 S 5/14
5/02		5/02
		Z

審査請求 未請求 請求項の数 5 O L (全 7 頁)

(21) 出願番号	特願平9-21753d	(71) 出願人	000148623 株式会社ソニー
(22) 出願日	平成9年(1987) 8月12日		株式会社ソニー 東京都渋谷区宮ヶ谷1丁目1番1号
		(72) 発明者	宮原 一典 神奈川県厚木市長谷字柳町260-83 株式会社ソニー厚木工場内
		(74) 代理人	弁理士 松本 雅利

(54) 【発明の名称】 GPS受信機

(57) 【要約】

【課題】 GPS受信機の省電力化

【解決手段】 受信機1は、高周波増幅回路2、周波数変換回路3、A/D変換回路4、クロック信号を送出するシンセサイザ7、DSP復調回路10とを備えている。復調回路10は、それぞれの衛星に対応する1~Nチャンネルの信号処理部10a~10nと、これらの制御用のCPU12とを備えている。各信号処理部10a~10nには、スイッチング手段15がそれぞれ設けられている。スイッチング手段15は、アンドゲート15aとフリップフロップ回路15bから構成されていて、アンドゲート15aの一方の入力端子には、シンセサイザ7の出力側が接続されていて、シンセサイザ7から常時各信号処理回路14にクロック信号が供給される。アンドゲート15aの他方入力端子には、フリップフロップ15bの出力側が接続されていて、フリップフロップ15bから出力が送出されたときに、シンセサイザ7からのクロック信号の供給が停止される。

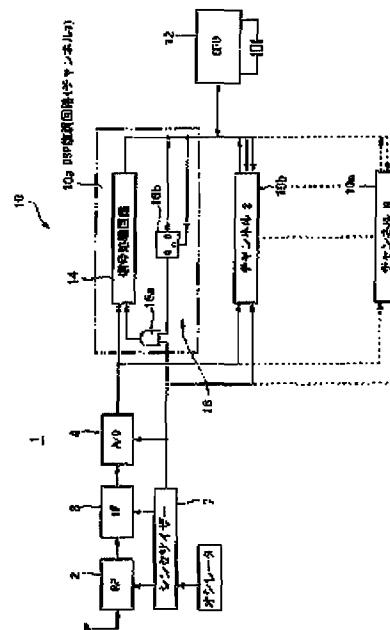

IPR2020-01189

(2) 特開平11-64480

1

2

## 【特許請求の範囲】

【請求項1】 複数の衛星から送信された電波信号を増幅する高周波増幅回路と、前記高周波増幅回路の出力信号を中間周波信号に変換する周波数変換回路と、前記中間周波信号に基づいて、前記衛星に対応したチャンネル数を備え、位相データとコードデータを復調する複数の信号処理部と、前記信号処理部の制御用演算処理部とを備えたGPS受信機において、前記信号処理部は、それぞれクロック信号の供給、停止を行なうスイッチング手段を有し、前記演算処理部は、前記信号処理部のいずれかが非指定状態ないしは前記送信電波の非受信状態であると判断したときに、前記スイッチング手段を作動させて、当該信号処理部へのクロック信号の供給を停止させることを特徴とするGPS受信機。

【請求項2】 前記演算処理部は、前記信号処理部のいずれかが前記送信電波の受信を回復したと判断したときに、前記スイッチング手段の作動を停止し、当該信号処理部に前記クロック信号を供給することを特徴とする請求項1記載のGPS受信機。

【請求項3】 前記演算処理部は、前記信号処理部の一部が前記送信電波の非受信状態であると判断したとき、または、受信動作を必要としない場合に、前記スイッチング手段を作動させて、前記信号処理部の一部または全部にクロック信号の供給を停止させるとともに、前記演算処理部自身に低電力機能がある場合は、受信しないチャンネルの制御に使用している間は、当該演算処理部を低電力状態とすることを特徴とする請求項1または2記載のGPS受信機。

【請求項4】 前記スイッチング手段は、前記信号処理部を構成するICパッケージ内に実装されるICスイッチで構成したことを特徴とする請求項1または2記載のGPS受信機。

【請求項5】 複数の衛星から送信された電波信号を増幅する高周波増幅回路と、前記高周波増幅回路の出力信号を中間周波信号に変換する周波数変換回路と、前記中間周波信号に基づいて、前記衛星に対応したチャンネル数を備え、位相データとコードデータを復調する複数の信号処理部と、前記信号処理部の制御用演算処理部とを備えたGPS受信機において、前記GPS受信機は、L1、L2波の受信が可能な2周波用のものであって、L2受信チャンネルへのクロック信号の供給を停止したときに、高周波増幅回路および周波数変換回路への電源供給を停止することを特徴とするGPS受信機。

## 【発明の詳細な説明】

【0001】

【発明の属する技術分野】本発明は、GPS受信機に関し、特に、その省電力化を図る技術に関するものである。

【0002】

【従来の技術】GPS受信機は、複数のGPS衛星から送られてくる電波を受信し、受信電波から地球上の二点間の距離の測定や、地球上の移動局の位置を測定するために用いられる。この種のGPS受信機には、受信電波から測定に必要なデジタルデータを抽出するためにDSP(Digital Signal Processor)復調回路が用いられている。

【0003】このDSP復調回路は、複数のGPS衛星のそれぞれに対応したデジタルデータを信号処理するために、複数チャンネルの信号処理部を備えている。各信号処理部には、受信電波に含まれている搬送波の位相データを復調するコードトラッキング回路と、スペクトラム拡散コードを復調するキャリアトラッキング回路とが含まれている。

【0004】図4には、この種のGPS受信機の基本的な構成が示されている。同図に示すGPS受信機は、衛星から送信された電波信号を受信するアンテナ1と、アンテナ1で受信された電波信号を増幅する高周波増幅回路2と、高周波増幅回路2の出力信号を中間周波数信号に変換する周波数変換回路3と、A/D変換回路4及びDSP復調回路5並びに各部にクロック信号を送出するシンセサイザ7とを備えている。

【0005】DSP復調回路5は、電波信号を受信しようとする衛星にそれぞれ割り当てられる1～Nチャンネルの信号処理部5a～5nと、PLLなどを設けた信号処理部5a～5nの制御用演算処理部、すなわちCPU6とを備えたもので、A/D変換回路4から送られるデジタル信号を処理して、各衛星毎の位相データとコードデータを復調する。

【0006】しかしながら、このような従来のGPS受信機には、以下に説明する技術的な課題が指摘されていた。

【0007】

【発明が解決しようとする課題】すなわち、図4に示したGPS受信機においては、実際に衛星からの電波を受信していない場合でも、複数の信号処理部5a～5nが復調動作し、その間に電力を消費続けるという問題があった。例えば、チャンネル数が8あった場合、視野内に測定情報の得られる衛星が4個しかなくとも、残りの4チャンネル分にも電源が供給されるため、電力が無駄に消費され、特に、バッテリーを主な電源とする携帯用受信機では、非常に不利となる。

【0008】また、測定情報が得られる衛星が、電波信号を受信できる範囲から消えてしまったときにも、予め割り当てられた信号処理部5a～5nには、電力が供給されていて、同様な問題があった。このような欠点を解決するために、本出願人は、特開平6-88867号公報に示すように、使われていないチャンネルに対して電源供給を停止するためにスイッチング手段を設けたGP

3

S受信機を開発した。

【0009】この受信機では、航法データに含まれるアルファナックデータから現在受信可能な衛星に対応したチャンネルを指定し、その指定されたチャンネル以外のチャンネルの電源スイッチをオフすることによって省電力化を図るものである。

【0010】しかし、この方式では、IC化された各信号処理部毎に、電源供給位置の前段にスイッチの接点を設けなければならず、しかも、電源の供給を停止するためには、スイッチの接点容量が比較的大きくなるため、機器を小型化する上で不利であった。つまり、復調回路の具体的な構成は、各信号処理部を個別のICパッケージとしてこれらを配線基板上に実装している。

【0011】ところが、電源スイッチを設けるためには、各信号処理部を構成するICパッケージのそれぞれに近接させてスイッチング回路を個別に配置しなければならないため、配線基板の大型化や、配線パターン複雑化につながるものとなっていた。

【0012】さらに、複数のチャンネルを有するICにおいて、チャンネル毎に電源のON/OFFをコントロールする機能を持たせることは難しい。

【0013】本発明は、このような従来の問題点に鑑みてなされたものであって、その目的とするところは、電源供給の遮断方式に代えて、使われていないチャンネルを休眠状態とすることにより、省電力化を図ることができるGPS受信機を提供することにある。

【0014】また、別の目的として、スイッチング手段を、各信号処理部のICパッケージ内に組込むことができるようにしたGPS受信機を提供することにある。

【0015】

【課題を解決するための手段】前記目的を達成するため、本発明は、複数の衛星から送信された電波信号を増幅する高周波増幅回路と、前記高周波増幅回路の出力信号を中間周波信号に変換する周波数変換回路と、前記中間周波信号に基づいて、前記衛星に対応したチャンネル数を備え、位相データとコードデータとを復調する複数の信号処理部と、前記信号処理部の制御用演算処理部とを備えたGPS受信機において、前記信号処理部は、それぞれクロック信号の供給、停止を行なうスイッチング手段を有し、前記演算処理部は、前記信号処理部のいずれかが非指定状態ないしは前記送信電波の非受信状態であると判断したときに、前記スイッチング手段を作動させて、当該信号処理部へのクロック信号の供給を停止させるようにした。この構成によれば、非指定状態ないしは非受信状態のチャンネルへのクロック信号の供給が停止されるので、これらのチャンネルの信号処理部が休眠状態となり、これにより省電力化を図ることができる。この場合、前記演算処理部は、前記信号処理部のいずれかが前記送信電波の受信を回復したと判断したときに、前記スイッチング手段の作動を停止し、当該信号処理部

(3)

特開平11-64480

4

に前記クロック信号を供給することができる。この構成によれば、例えば、GPS受信機の観測位置において、電波信号を受信していた衛星が、高度角条件内から外れた場合に、クロック信号を停止して省電力化を図ることができるとともに、軌道を周回して受信可能になった場合に、自動的に観測状態に復帰させることができる。また、前記演算処理部は、前記信号処理部の一部が前記送信電波の非受信状態であると判断したとき、または、受信動作を必要としない場合に、前記スイッチング手段を作動させて、前記信号処理部の一部または全部にクロック信号の供給を停止させるとともに、前記演算処理部自身に低電力機能がある場合は、各チャンネルの受信制御が終了し、受信制御が不要な間は、当該演算処理部を低電力状態とすることができる。この構成によれば、演算処理部自体へのクロック信号の供給を停止するので、より一層省電力化を図れる。さらに、前記スイッチング手段は、前記信号処理部を構成するICパッケージ内に実装されるICスイッチで構成することができる。この構成によれば、スイッチング手段と信号処理部とが1つのICパッケージになるので、配線パターンの簡略化を図れる。さらに、本発明は、複数の衛星から送信された電波信号を増幅する高周波増幅回路と、前記高周波増幅回路の出力信号を中間周波信号に変換する周波数変換回路と、前記中間周波信号に基づいて、前記衛星に対応したチャンネル数を備え、位相データとコードデータとを復調する複数の信号処理部と、前記信号処理部の制御用演算処理部とを備えたGPS受信機において、前記GPS受信機は、L1、L2波の受信が可能な2周波用のものであって、L2受信チャンネルへのクロック信号の供給を停止したときに、高周波増幅回路および周波数変換回路への電源供給を停止するようにした。この構成によれば、より一層の低電力化を図れる。

【0016】

【発明の実施の形態】以下、本発明の好ましい実施の形態について添付図面を参照にして詳細に説明する。図1は、本発明にかかるGPS受信機を示している。なお、同図に示したGPS受信機では、前述した従来例と同一もしくは相当する箇所には同一符号を付し、新たに付加された箇所のみ異なる符号を付して説明する。

【0017】同図に示すGPS受信機は、従来とほぼ同様に、衛星から送信された電波をアンテナ1と、このアンテナ1を介して受信した電波信号を増幅する高周波増幅回路2と、この出力信号を中間周波数信号に変換する周波数変換回路3と、A/D変換回路4と、DSP復調回路10と、オンレータからの発信信号を受けて、各部にクロック信号を送出するシンセサイザ7とを備えている。

【0018】DSP復調回路10は、複数の衛星に対応する1～Nチャンネルの信号処理部10a～10n及びPLLなどを設けた信号処理部10a～10nの制御用



5

CPU12とを備えている。各信号処理部10a~10nでは、受信電波信号を周波数変換した中間周波信号に基づいて、コードデータや搬送周波数の位相データおよび衛星の軌道データなどを、CPU12に内蔵されたソフトウェアのアーキテクチャに基づき復調する。

【0019】各信号処理部10a~10nは、例えば、コードデータを復調するコードトラッキング回路や、位相データを復調するキャリアトラッキング回路などを備えている。そして、各信号処理部10a~10nには、スイッチング手段16がそれぞれ設けられている。

【0020】このスイッチング手段16は、アンドゲート16aとフリップフロップ回路16bから構成されていて、アンドゲート16aの一方の入力端子には、シンセサイザ7の出力側が接続されていて、シンセサイザ7から常時各信号処理回路14にクロック信号が供給される。

【0021】アンドゲート16aの他方入力端子には、フリップフロップ16bの出力側が接続されていて、フリップフロップ16bから出力が送出されたときに、シンセサイザ7からのクロック信号の供給が停止される。

【0022】フリップフロップ16bの入力端子は、CPU12によりその作動が制御される。

【0023】図2は、CPU12で実行される各信号処理部10a~10nおよびスイッチング手段16の制御手順の一例を示している。同図に示す手順では、スタートすると、まず、ステップs1で初期設定が行なわれる。この初期設定では、受信処理の初期化が行われる。

【0024】続くステップs2では、衛星のアルファナックデータから軌道計算が行われ、ステップs3に移行する。ステップs3では、衛星の選択が行われる。この場合の衛星の選択条件は、例えば、高度角順やPDOPなどに従って、観測に使用する衛星を選択する。

【0025】次のステップs4では、選択した衛星の割当てが実行される。この割当てでは、選択された衛星を各信号処理部10a~10nに割当てることになるが、この時に、全ての信号処理部10a~10nに衛星が割当てられることはなく、ステップs3で選択された衛星の数に対応した数の信号処理部10a~10nにのみ割当てられる。

【0026】続くステップs5では、ステップs4で割当てられなかった信号処理部10a~10nについて、スイッチング手段16に制御信号を送出して、該当する信号処理部10a~10nへのクロック信号の供給を停止させ、休眠状態とする。

【0027】ステップs5が終了すると、ステップs6でCPU12は、一旦低電力状態となる。CPU12が低電力状態から脱する条件としては、衛星の割当てのあった信号処理部10a~10nの受信処理を行うタイミング（受信処理タイミング）又は、前記ステップs2~s5（各衛星を各チャンネルに割当てて処理）までの

(4)

特開平11-64480

6

処理を行うタイミング（衛星割当てタイミング）とがある。

【0028】前記タイミングのうち、受信処理タイミング（ステップs7）であれば、続くステップs8で衛星の割当てのあった信号処理部10a~10nに対して、それぞれ信号処理が行われる。

【0029】そして、続いてステップs9で衛星割当てタイミングであるか否かが判断され、衛星割当てタイミングであればステップs2に戻り、衛星割当てタイミングでなければステップs6に戻る。

【0030】さて、以上のように構成されたGPS受信機によれば、非指定状態ないしは非受信状態のチャンネルの信号処理部10a~10nへのクロック信号の供給が、CPU12により停止されるので、これらのチャンネルの信号処理部10a~10nが休眠状態となり、これにより省電力化を図ることができる。また、本実施例の場合には、GPS受信機の観測位置において、電波信号を受信していた衛星が高度角条件から外れた場合に、クロック信号を停止して省電力化を図ることができるとともに、軌道を周回して受信可能になった場合には、クロック信号を供給して、自動的に観測状態に復帰させることができる。

【0031】さらに、本実施例の場合には、CPU12自体低電力状態とするので、より一層省電力化を図れる。またさらに、本実施例の場合には、スイッチング手段16と信号処理部10a~10nとが1つのICパッケージ内に実装されているので、配線パターンの簡略化が図れる。

【0032】なお、上記実施例では、スイッチング手段16としてアンドゲート16aとフリップフロップ16bとを用いる場合を例示したが、この組合せに限ることはない。

【0033】図3は、この発明の他の実施例を示しており、上記実施例と同一もしくは相当する部分に同一符号を付してその説明を省略するとともに、以下にその特徴点についてのみ説明する。

【0034】同図に示した実施例では、2周波（L1、L2波）のGPS受信機に本発明を適用した例であって、各チャンネルの信号処理部10a'~10n'には、L1波受信チャンネル100と、L2波受信チャンネル101と、L1、L2受信チャンネル100、101にクロック信号を供給するクロック供給コントロール部102と、切替スイッチ103とが設けられている。

【0035】クロック供給コントロール部102および切替スイッチ103は、CPU12によりその作動が以下のように制御される。すなわち、まず、切替スイッチ103を作動させて、L2受信チャンネル101をすべてクロック停止状態にすると、2周波用の受信機であるが、1周波の測量精度でよい場合、低電力化の効果があり、バッテリーの持続時間が増加する。

(5) 特開平11-64480

7

8

【0036】また、2周波受信チャンネル101を付加価値と位置づけ、これをオプションまたはアップグレード対象とすることで、製造の効率化や製品のフレキシビリティが向上する。

【0037】なお、本実施例の場合には、L2受信チャンネル101へのクロック供給を停止したときに、RF回路2、IF回路3への電源供給を停止する機能を備えることによって、より一層低電力化が図れる。

【0038】

【発明の効果】以上、実施例で詳細に説明したように、本発明にかかるGPS受信機によれば、非指定状態または非受信状態のチャンネルを休眠状態とし、省電力化を達成することができるので、余分な電力消費がなく、特に携帯用受信機などに好適である。

【図面の簡単な説明】

【図1】この発明に係るGPS受信機の全体構成を示す回路ブロック図である。

【図2】同GPS受信機の演算処理部の処理手順の一例\*

\*を示すフローチャートである。

【図3】本発明に係るGPS受信機の他の実施例の全体構成を示す回路ブロック図である。

【図4】従来のGPS受信機の全体構成を示す回路ブロック図である。

【符号の説明】

- 1 アンテナ
- 2 高周波増幅回路
- 3 周波数変換回路
- 7 シンセサイザ（クロック信号発生手段）
- 10 DSP復調回路
- 10a~10n 信号処理部
- 12 CPU（演算処理部）
- 14 信号処理回路
- 16 スwitching手段
- 16a アンドゲート
- 16b フリップフロップ

【図1】

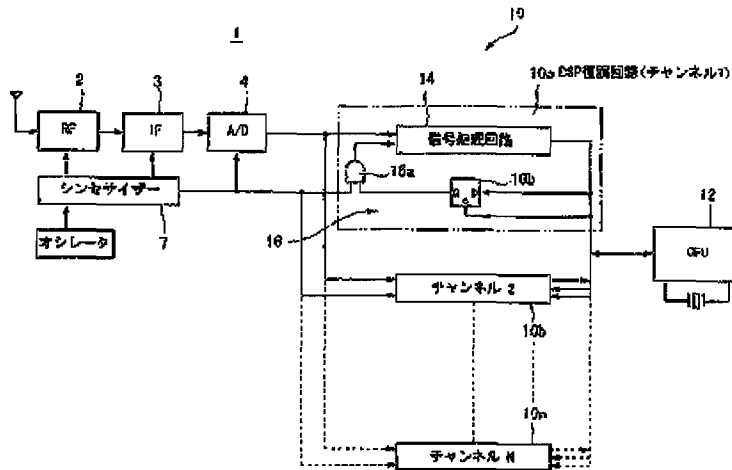

(5)

特開平11-64480

【図2】

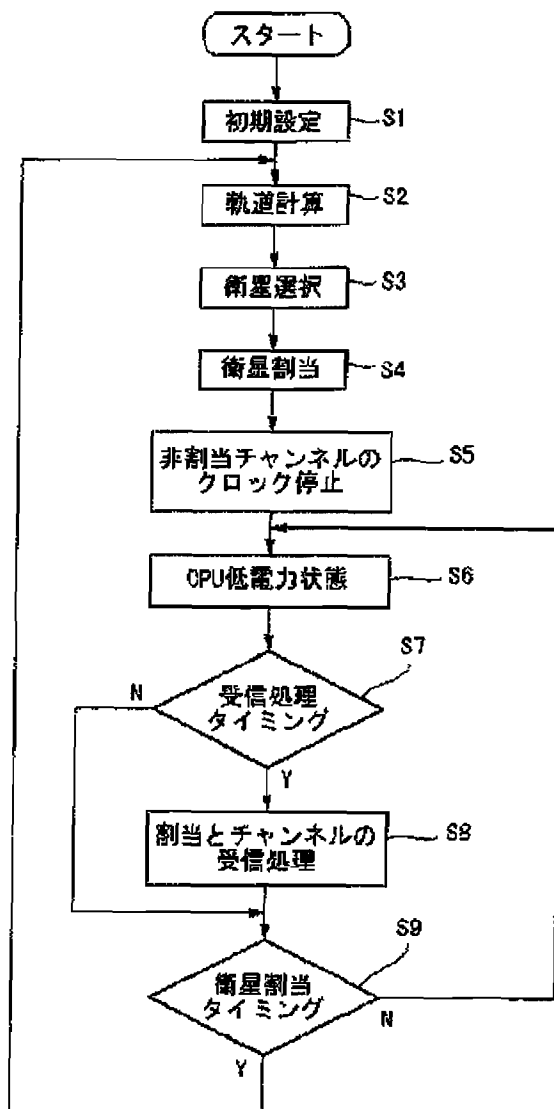



JP 1999-64480 A5 2005.6.2

【公報種別】 特許法第17条の2の規定による補正の掲載  
 【部門区分】 第6部門第1区分  
 【発行日】 平成17年6月2日(2005.6.2)

【公開番号】 特開平11-64480  
 【公開日】 平成11年3月5日(1999.3.5)  
 【出願番号】 特願平9-217534  
 【国際特許分類第7版】

G 0 1 S 5/14

G 0 1 S 5/02

【F I】

G 0 1 S 5/14

G 0 1 S 5/02 Z

【手続補正書】

【提出日】 平成16年8月10日(2004.8.10)

【手続補正1】

【補正対象書類名】 明細書

【補正対象項目名】 0024

【補正方法】 変更

【補正の内容】

【0024】

続くステップs2では、衛星のアルマナックデータから軌道計算が行われ、ステップs3に移行する、ステップs3では、衛星の選択が行われる。この場合の衛星の選択条件は、例えば、高度角順やPDQPなどによって、観測に使用する衛星を選択する。

# PATENT ABSTRACTS OF JAPAN

(11)Publication number : 11-064480

(43)Date of publication of application : 05.03.1999

(51)Int.Cl. G01S 5/14

G01S 5/02

(21)Application number : 09-217534

(71)Applicant : SOKKIA CO LTD

(22)Date of filing : 12.08.1997

(72)Inventor : MIYAHARA KAZUNORI

## (54) GPS RECEIVER

(57)Abstract:

**PROBLEM TO BE SOLVED:** To save power by turning off the power switch for a channel other than a channel corresponding to a currently receivable satellite designated from an almanac data contained in a navigation data.

**SOLUTION:** The Receiver 1 comprises a high frequency amplifier circuit 2, a frequency converter circuit 3, an A/D converter circuit 4, a synthesizer 7 delivering a clock signal, and a DSP demodulator circuit 10. The demodulator circuit 10 comprises signal processing sections 10a-10n for 1-N channels corresponding to respective satellites, and a control CPU 12 therefor. Each signal processing section 10a-10n is provided with a switching means 16 comprising an AND gate 16a and a flip-flop circuit 16b. The AND gate 16a has one input terminal connected with the output side of the synthesizer 7 which delivers a clock signal constantly to each signal processing circuit 14. The AND gate 16a has the other input terminal connected with the output side of the flip-flop 16b and delivery of clock signal from the synthesizer 7 is interrupted when an output is delivered from the flip-flop 16b.

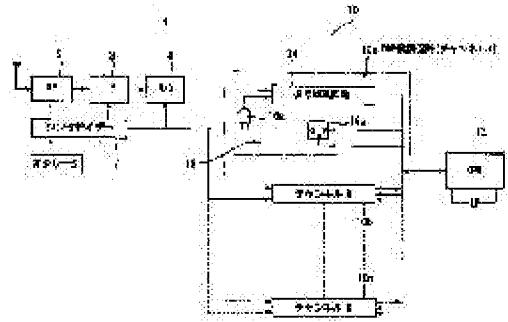

\* NOTICES \*

JPO and INPIT are not responsible for any damages caused by the use of this translation.

1.This document has been translated by computer. So the translation may not reflect the original precisely.

2.\*\*\* shows the word which can not be translated.

3.In the drawings, any words are not translated.

---

## TECHNICAL FIELD

---

[Field of the Invention]Especially this invention relates to the art of attaining the power-saving, about a GPS receiver.

---

[Translation done.]

### \* NOTICES \*

JPO and INPIT are not responsible for any damages caused by the use of this translation.

- 1.This document has been translated by computer. So the translation may not reflect the original precisely.
- 2.\*\*\*\* shows the word which can not be translated.
- 3.In the drawings, any words are not translated.

---

## PRIOR ART

---

[Description of the Prior Art]A GPS receiver receives the electric wave sent from two or more GPS Satellites, and it is used in order to measure the position of measurement of a point to point distance on the earth, and the mobile station on the earth from a reception radio wave. In order to extract digital data required for measurement from a reception radio wave, the DSP (Digital Signal Processor) demodulator circuit is used for this kind of GPS receiver.

[0003]This DSP demodulator circuit is provided with the signal processing part of two or more channels in order to carry out signal processing of the digital data corresponding to each of two or more GPS Satellites. In each signal processing part, the code tracking circuit which restores to the phase data of the subcarrier contained in the reception radio wave, and the carrier tracking circuit which restores to a spectrum spread code are included.

[0004]The fundamental composition of this kind of GPS receiver is shown in drawing 4. The antenna 1 with which the GPS receiver shown in the figure receives the radio wave signal transmitted from the satellite, It has the synthesizer 7 which sends out a clock signal to the high frequency amplifying circuit 2 which amplifies the radio wave signal received with the antenna 1, the frequency changing circuit 3 which changes the output signal of the high frequency amplifying circuit 2 into an intermediate frequency signal, the A/D conversion circuit 4 and the DSP demodulator circuit 5, and each part.

[0005]The signal processing parts 5a-5n of 1 - N channel which are assigned to the satellite with which the DSP demodulator circuit 5 tends to receive a radio wave signal, respectively, It is the signal processing parts [ which provided PLL etc. / 5a-5n ] arithmetic processing section for control, i.e., the thing provided with CPU6, and the digital signal sent out from the A/D conversion circuit 4 is processed, and it restores to the phase data and the coded data for every

satellite.

[0006]However, the technical technical problem explained below was pointed out to such a conventional GPS receiver.

---

[Translation done.]

\* NOTICES \*

**JPO and INPIT are not responsible for any damages caused by the use of this translation.**

- 1.This document has been translated by computer. So the translation may not reflect the original precisely.
- 2.\*\*\*\* shows the word which can not be translated.
- 3.In the drawings, any words are not translated.

---

## **EFFECT OF THE INVENTION**

[Effect of the Invention]As mentioned above, since according to the GPS receiver concerning this invention the channel of the state where it does not specify, or a non-receive state can be made idle and power-saving can be attained as the example explained in detail, there is no excessive power consumption and it is suitable for especially a portable receiver etc.

---

[Translation done.]

\* NOTICES \*

**JPO and INPIT are not responsible for any damages caused by the use of this translation.**

- 1.This document has been translated by computer. So the translation may not reflect the original precisely.
- 2.\*\*\*\* shows the word which can not be translated.
- 3.In the drawings, any words are not translated.

---

## **TECHNICAL PROBLEM**

[Problem(s) to be Solved by the Invention]That is, in the GPS receiver shown in drawing 4, even when the electric wave from a satellite was not actually received, two or more signal processing parts 5a-5n did demodulation operation, and the meantime had a problem of consumption



\*\*\*\*\* for electric power. For example, since a power supply is supplied also to four remaining channels even if there are only four satellites with which measurement information is acquired in a field of view, when there are the eight numbers of channels, electric power is consumed vainly and becomes very disadvantageous especially in the portable receiver which uses a battery as the main power supplies.

[0008]Also when the satellite with which measurement information is acquired had disappeared from the range which can receive a radio wave signal, electric power is supplied to the signal processing parts 5a-5n assigned beforehand, and they had the same problem. In order to suspend current supply to the channel which is not used as these people show JP,6-88867,A in order to solve such a fault, the GPS receiver which established the switching means was developed.

[0009]In this receiver, the channel corresponding to a satellite receivable now is specified from the almanac data contained in navigation data, and power-saving is attained by turning off the electric power switch of channels other than that specified channel.

[0010]However, since the contact capacity of a switch became comparatively large in order to have to provide the contact surface of a switch in the preceding paragraph of a current supply position and to suspend supply of a power supply moreover in this method for each [ by which the IC form was carried out ] signal processing part of every, it was disadvantageous when apparatus was miniaturized. That is, the concrete composition of a demodulator circuit mounts these for each signal processing part on a wiring board as an individual IC package.

[0011]however, since each of the IC package which constitutes each signal processing part in order to form an electric power switch was made to approach, and a switching circuit was arranged individually, and it would not become if there is no \*\*, it had led to enlargement of a wiring board, and complication of the circuit pattern.

[0012]In IC which has two or more channels, it is difficult to give the function to control ON/OFF of a power supply for every channel.

[0013]This invention is made in view of such a conventional problem, and there is a place made into the purpose in providing the GPS receiver which can attain power-saving by making idle the channel which is not used replacing with the interception method of current supply.

[0014]It is in providing the GPS receiver which enabled it to incorporate a switching means in the IC package of each signal processing part as another purpose.

---

[Translation done.]

\* NOTICES \*

**JPO and INPIT are not responsible for any damages caused by the use of this translation.**

- 1.This document has been translated by computer. So the translation may not reflect the original precisely.
- 2.\*\*\* shows the word which can not be translated.
- 3.In the drawings, any words are not translated.

---

**MEANS**

---

[Means for Solving the Problem]A high frequency amplifying circuit where this invention amplifies a radio wave signal transmitted from two or more satellites in order to attain said purpose, A frequency changing circuit which changes an output signal of said high frequency amplifying circuit into an intermediate frequency signal, In a GPS receiver which was provided with the number of channels corresponding to said satellite, and was provided with two or more signal processing parts which restore to phase data and coded data, and an arithmetic processing section for control of said signal processing part based on said intermediate frequency signal, Said signal processing part has a switching means which performs supply of a clock signal, and a stop, respectively, and said arithmetic processing section, When it judged that either of said signal processing parts is a state where it does not specify, or a non-receive state of said transmit radio wave, said switching means is operated and it was made to stop supply of a clock signal to the signal processing part concerned. Since supply of a clock signal to a channel of a state where it does not specify, or a non-receive state is suspended according to this composition, a signal processing part of these channels becomes idle, and, thereby, power-saving can be attained. In this case, when either of said signal processing parts judges that reception of said transmit radio wave was recovered, said arithmetic processing section can suspend an operation of said switching means, and can supply said clock signal to the signal processing part concerned. When a satellite which had received a radio wave signal separates out of an altitude condition, for example in an observation post of a GPS receiver according to this composition, while being able to stop a clock signal and being able to attain power-saving, When an orbit is gone around and it becomes ability ready for receiving, it can be made to return to an observational state automatically. When said arithmetic processing section judges that said some of signal processing parts are the non-receive states of said transmit radio wave, Or when you do not need receiving operation, while operating said switching means and making some or all of said signal processing part suspend supply of a clock signal, When said arithmetic processing section itself has a low-electric-power function, a reception control of each channel is completed, and while a reception control is unnecessary, the arithmetic processing section concerned can be made into a low power state. Since supply of a clock signal of the arithmetic processing section itself is suspended according to this composition, power-saving can be attained further. Said switching means can consist of IC switches mounted in an IC package which constitutes said signal processing part. Since a switching means and a signal processing part become an IC package of 1 \*\* according to this composition, simplification of a circuit pattern can be attained. A high frequency amplifying circuit where this invention amplifies a radio wave signal transmitted from two or more satellites, A frequency changing circuit which changes an output signal of said high frequency amplifying circuit into an intermediate frequency signal, In a GPS receiver which was provided with the number of channels corresponding to said satellite, and was provided with two or more signal processing parts which restore to phase data and coded data, and an arithmetic processing section for control of said signal processing part based on said intermediate frequency signal, Said GPS receiver was [ which can receive L1 and L2 wave ] for two cycles, and when supply of a clock signal to L2 receiving channel was suspended, it was made to suspend current supply to a high frequency amplifying circuit and a frequency changing circuit. According to this composition, much more low-electric-power-ization can be attained.

[0016]

[Embodiment of the Invention]Hereafter, about the desirable embodiment of this invention, an accompanying drawing is made reference and explained in detail. Drawing 1 shows the GPS

receiver concerning this invention. By the GPS receiver shown in the figure, identical codes are given to the part which is the same as that of the conventional example mentioned above, or corresponds, and numerals which are different only in the newly added part are attached and explained to it.

[0017]The GPS receiver shown in the figure is provided with the following.

It is the antenna 1 almost as usual about the electric wave transmitted from the satellite.

The high frequency amplifying circuit 2 which amplifies the radio wave signal received via this antenna 1.

The frequency changing circuit 3 which changes this output signal into an intermediate frequency signal.

The synthesizer 7 which sends out a clock signal to each part in response to the A/D conversion circuit 4, the DSP demodulator circuit 10, and the dispatch signal from an oscillator.

[0018]The DSP demodulator circuit 10 is provided with CPU12 [ signal processing parts / 10a-10n / which provided the signal processing parts 10a-10n, PLL, etc. of 1 - N channel corresponding to two or more satellites ] for control. In each signal processing parts 10a-10n, it gets over based on the architecture of the software in which coded data, the phase data of a carrier frequency, the orbit data of a satellite, etc. were built by CPU12 based on the intermediate frequency signal which carried out frequency conversion of the reception radio wave signal.

[0019]Each signal processing parts 10a-10n have the code tracking circuit which restores to coded data, the carrier tracking circuit which restores to phase data, etc., for example. And the switching means 16 is prepared for each signal processing parts 10a-10n, respectively.

[0020]This switching means 16 comprises AND gate 16a and the flip-flop circuit 16b, the output side of the synthesizer 7 is connected to one input terminal of AND gate 16a, and a clock signal is always supplied to each digital disposal circuit 14 from the synthesizer 7.

[0021]When the output side of the flip-flop 16b is connected and an output is sent out from the flip-flop 16b, supply of the clock signal from the synthesizer 7 is suspended by the another side input terminal of AND gate 16a.

[0022]As for the input terminal of the flip-flop 16b, the operation is controlled by CPU12.

[0023]Drawing 2 shows an example of the control procedure of each signal processing parts 10a-10n and the switching means 16 which are performed by CPU12. In the procedure shown in the figure, a start will perform initial setting at Step s1 first. Initialization of reception is performed in this initial setting.

[0024]Selection of a satellite is performed in Step s3 which orbital calculation is performed from the almanac data of a satellite, and shifts to Step s3 in continuing Step s2. The selection condition of the satellite in this case chooses the satellite used for observation, for example according to the order of an altitude, PDOP, etc.

[0025]Assignment of the selected satellite is performed in the following step s4. Although the selected satellite will be assigned to each signal processing parts 10a-10n in this assignment, a satellite is assigned to no signal processing parts 10a-10n at this time, and only the signal processing parts 10a-10n of the number corresponding to the number of the satellites selected at Step s3 are assigned.

[0026]In continuing Step s5, about the signal processing parts 10a-10n which were not assigned at Step s4, a control signal is sent out to the switching means 16, and the supply of a clock signal to the applicable signal processing parts 10a-10n is stopped, and suppose that it is idle.

[0027]After Step s5 is completed, CPU12 will once be in a low power state at Step s6. The

timing to which CPU12 performs signal processing parts [ which had assignment of a satellite as conditions which escape from a low power state / 10a-10n ] reception (reception timing). or said steps s2-s5 (processing which assigns each satellite to each channel) up to -- there is timing (satellite quota timing) which processes.

[0028]If it is reception timing (Step s7) among said timing, signal processing will be performed to the signal processing parts 10a-10n with assignment of a satellite, respectively at continuing Step s8.

[0029]And it is judged continuously whether it is satellite quota timing at Step s9, if it is satellite quota timing, it will return to Step s2, and if it is not satellite quota timing, it will return to Step s6.

[0030]Now, since the supply of a clock signal to the signal processing parts 10a-10n of the channel of the state where it does not specify, or a non-receive state is suspended by CPU12 according to the GPS receiver constituted as mentioned above, The signal processing parts 10a-10n of these channels become idle, and, thereby, power-saving can be attained. When the satellite which had received the radio wave signal separates from altitude conditions in the observation post of a GPS receiver in the case of this example, while being able to stop a clock signal and being able to attain power-saving, When an orbit is gone around and it becomes ability ready for receiving, a clock signal can be supplied and it can be made to return to an observational state automatically.

[0031]In the case of this example, since it is considered as CPU12 themselves low power state, power-saving can be attained further. In the case of this example, since the switching means 16 and the signal processing parts 10a-10n are mounted in the IC package of 1 \*\*, simplification of a circuit pattern can be attained.

[0032]Although the case where AND gate 16a and the flip-flop 16b were used as the switching means 16 was illustrated in the above-mentioned example, it does not restrict to this combination.

[0033]Drawing 3 shows other examples of this invention, and it explains only that focus below while it gives identical codes to the portion which is the same as that of the above-mentioned example, or corresponds and omits that explanation.

[0034]In the example shown in the figure, are the example which applied this invention to the GPS receiver of two cycles (L1, L2 wave), and in the signal processing parts 10a-10n of each channel. The clock supply control section 102 which supplies a clock signal to L1 wave receiving channel 100, L2 wave receiving channel 101, and L1 and the L2 receiving channel 100,101, and the changeover switch 103 are formed.

[0035]As for the clock supply concentrated roll part 102 and the changeover switch 103, the operation is controlled by CPU12 as follows. That is, when the changeover switch 103 is operated and the L2 receiving channel 101 is first made into a clock halt condition by a way, it is a receiver for two cycles, but when the survey precision of one cycle may be sufficient, there is an effect of low-electric-power-izing and the temporal duration of a battery increases.

[0036]2 cycle receiving channel 101 is regarded as added value, and the increase in efficiency of manufacture and the flexibility of a product improve by making this an option or applicable to upgrade.

[0037]In the case of this example, when the clock supply to the L2 receiving channel 101 is suspended, low-electric-power-ization can be further attained by having the function to suspend the current supply to RF circuit 2 and IF circuit 3.

---

[Translation done.]

\* NOTICES \*

**JPO and INPIT are not responsible for any damages caused by the use of this translation.**

1. This document has been translated by computer. So the translation may not reflect the original precisely.
2. \*\*\*\* shows the word which can not be translated.
3. In the drawings, any words are not translated.

---

## DESCRIPTION OF DRAWINGS

---

[Brief Description of the Drawings]

[Drawing 1] It is a circuit block figure showing the entire configuration of the GPS receiver concerning this invention.

[Drawing 2] It is a flow chart which shows an example of the procedure of the arithmetic processing section of the GPS receiver.

[Drawing 3] It is a circuit block figure showing the entire configuration of other examples of the GPS receiver concerning this invention.

[Drawing 4] It is a circuit block figure showing the entire configuration of the conventional GPS receiver.

[Description of Notations]

- 1 Antenna
- 2 High frequency amplifying circuit
- 3 Frequency changing circuit
- 7 synthesizer (clock signal generating means)
- 10 DSP demodulator circuit
- 10a-10n Signal processing part
- 12 CPU (arithmetic processing section)
- 14 Digital disposal circuit
- 16 Switching means
- 16a AND gate
- 16b Flip-flop

---

[Translation done.]

\* NOTICES \*

JPO and INPIT are not responsible for any damages caused by the use of this translation.

1. This document has been translated by computer. So the translation may not reflect the original precisely.
2. \*\*\*\* shows the word which can not be translated.
3. In the drawings, any words are not translated.

---

**DETAILED DESCRIPTION**

---

[Detailed Description of the Invention]

[0001]

[Field of the Invention] Especially this invention relates to the art of attaining the power-saving, about a GPS receiver.

[0002]

[Description of the Prior Art] A GPS receiver receives the electric wave sent from two or more GPS Satellites, and it is used in order to measure the position of measurement of a point to point distance on the earth, and the mobile station on the earth from a reception radio wave. In order to extract digital data required for measurement from a reception radio wave, the DSP (Digital Signal Processor) demodulator circuit is used for this kind of GPS receiver.

[0003] This DSP demodulator circuit is provided with the signal processing part of two or more channels in order to carry out signal processing of the digital data corresponding to each of two or more GPS Satellites. In each signal processing part, the code tracking circuit which restores to the phase data of the subcarrier contained in the reception radio wave, and the carrier tracking circuit which restores to a spectrum spread code are included.

[0004] The fundamental composition of this kind of GPS receiver is shown in drawing 4. The antenna 1 with which the GPS receiver shown in the figure receives the radio wave signal transmitted from the satellite, It has the synthesizer 7 which sends out a clock signal to the high frequency amplifying circuit 2 which amplifies the radio wave signal received with the antenna 1, the frequency changing circuit 3 which changes the output signal of the high frequency amplifying circuit 2 into an intermediate frequency signal, the A/D conversion circuit 4 and the DSP demodulator circuit 5, and each part.

[0005] The signal processing parts 5a-5n of 1 - N channel which are assigned to the satellite with which the DSP demodulator circuit 5 tends to receive a radio wave signal, respectively, It is the signal processing parts [ which provided PLL etc. / 5a-5n ] arithmetic processing section for control, i.e., the thing provided with CPU6, and the digital signal sent out from the A/D conversion circuit 4 is processed, and it restores to the phase data and the coded data for every satellite.

[0006] However, the technical technical problem explained below was pointed out to such a conventional GPS receiver.

[0007]

[Problem(s) to be Solved by the Invention] That is, in the GPS receiver shown in drawing 4, even

when the electric wave from a satellite was not actually received, two or more signal processing parts 5a-5n did demodulation operation, and the meantime had a problem of consumption \*\*\*\*\* for electric power. For example, since a power supply is supplied also to four remaining channels even if there are only four satellites with which measurement information is acquired in a field of view, when there are the eight numbers of channels, electric power is consumed vainly and becomes very disadvantageous especially in the portable receiver which uses a battery as the main power supplies.

[0008]Also when the satellite with which measurement information is acquired had disappeared from the range which can receive a radio wave signal, electric power is supplied to the signal processing parts 5a-5n assigned beforehand, and they had the same problem. In order to suspend current supply to the channel which is not used as these people show JP,6-88867,A in order to solve such a fault, the GPS receiver which established the switching means was developed.

[0009]In this receiver, the channel corresponding to a satellite receivable now is specified from the almanac data contained in navigation data, and power-saving is attained by turning off the electric power switch of channels other than that specified channel.

[0010]However, since the contact capacity of a switch became comparatively large in order to have to provide the contact surface of a switch in the preceding paragraph of a current supply position and to suspend supply of a power supply moreover in this method for each [ by which the IC form was carried out ] signal processing part of every, it was disadvantageous when apparatus was miniaturized. That is, the concrete composition of a demodulator circuit mounts these for each signal processing part on a wiring board as an individual IC package.

[0011]however, since each of the IC package which constitutes each signal processing part in order to form an electric power switch was made to approach, and a switching circuit was arranged individually, and it would not become if there is no \*\*, it had led to enlargement of a wiring board, and complication of the circuit pattern.

[0012]In IC which has two or more channels, it is difficult to give the function to control ON/OFF of a power supply for every channel.

[0013]This invention is made in view of such a conventional problem, and there is a place made into the purpose in providing the GPS receiver which can attain power-saving by making idle the channel which is not used replacing with the interception method of current supply.

[0014]It is in providing the GPS receiver which enabled it to incorporate a switching means in the IC package of each signal processing part as another purpose.

[0015]

[Means for Solving the Problem]A high frequency amplifying circuit where this invention amplifies a radio wave signal transmitted from two or more satellites in order to attain said purpose, A frequency changing circuit which changes an output signal of said high frequency amplifying circuit into an intermediate frequency signal, In a GPS receiver which was provided with the number of channels corresponding to said satellite, and was provided with two or more signal processing parts which restore to phase data and coded data, and an arithmetic processing section for control of said signal processing part based on said intermediate frequency signal, Said signal processing part has a switching means which performs supply of a clock signal, and a stop, respectively, and said arithmetic processing section, When it judged that either of said signal processing parts is a state where it does not specify, or a non-receive state of said transmit radio wave, said switching means is operated and it was made to stop supply of a clock signal to the signal processing part concerned. Since supply of a clock signal to a channel of a state where it does not specify, or a non-receive state is suspended according to this composition, a signal

processing part of these channels becomes idle, and, thereby, power-saving can be attained. In this case, when either of said signal processing parts judges that reception of said transmit radio wave was recovered, said arithmetic processing section can suspend an operation of said switching means, and can supply said clock signal to the signal processing part concerned. When a satellite which had received a radio wave signal separates out of an altitude condition, for example in an observation post of a GPS receiver according to this composition, while being able to stop a clock signal and being able to attain power-saving, When an orbit is gone around and it becomes ability ready for receiving, it can be made to return to an observational state automatically. When said arithmetic processing section judges that said some of signal processing parts are the non-receive states of said transmit radio wave, Or when you do not need receiving operation, while operating said switching means and making some or all of said signal processing part suspend supply of a clock signal, When said arithmetic processing section itself has a low-electric-power function, a reception control of each channel is completed, and while a reception control is unnecessary, the arithmetic processing section concerned can be made into a low power state. Since supply of a clock signal of the arithmetic processing section itself is suspended according to this composition, power-saving can be attained further. Said switching means can consist of IC switches mounted in an IC package which constitutes said signal processing part. Since a switching means and a signal processing part become an IC package of 1\*\* according to this composition, simplification of a circuit pattern can be attained. A high frequency amplifying circuit where this invention amplifies a radio wave signal transmitted from two or more satellites, A frequency changing circuit which changes an output signal of said high frequency amplifying circuit into an intermediate frequency signal, In a GPS receiver which was provided with the number of channels corresponding to said satellite, and was provided with two or more signal processing parts which restore to phase data and coded data, and an arithmetic processing section for control of said signal processing part based on said intermediate frequency signal, Said GPS receiver was [ which can receive L1 and L2 wave ] for two cycles, and when supply of a clock signal to L2 receiving channel was suspended, it was made to suspend current supply to a high frequency amplifying circuit and a frequency changing circuit. According to this composition, much more low-electric-power-ization can be attained.

[0016]

[Embodiment of the Invention]Hereafter, about the desirable embodiment of this invention, an accompanying drawing is made reference and explained in detail. Drawing 1 shows the GPS receiver concerning this invention. By the GPS receiver shown in the figure, identical codes are given to the part which is the same as that of the conventional example mentioned above, or corresponds, and numerals which are different only in the newly added part are attached and explained to it.

[0017]The GPS receiver shown in the figure is provided with the following.

It is the antenna 1 almost as usual about the electric wave transmitted from the satellite.

The high frequency amplifying circuit 2 which amplifies the radio wave signal received via this antenna 1.

The frequency changing circuit 3 which changes this output signal into an intermediate frequency signal.

The synthesizer 7 which sends out a clock signal to each part in response to the A/D conversion circuit 4, the DSP demodulator circuit 10, and the dispatch signal from an oscillator.

[0018]The DSP demodulator circuit 10 is provided with CPU12 [ signal processing parts / 10a-



10n / which provided the signal processing parts 10a-10n, PLL, etc. of 1 - N channel corresponding to two or more satellites ] for control. In each signal processing parts 10a-10n, it gets over based on the architecture of the software in which coded data, the phase data of a carrier frequency, the orbit data of a satellite, etc. were built by CPU12 based on the intermediate frequency signal which carried out frequency conversion of the reception radio wave signal.

[0019]Each signal processing parts 10a-10n have the code tracking circuit which restores to coded data, the carrier tracking circuit which restores to phase data, etc., for example. And the switching means 16 is prepared for each signal processing parts 10a-10n, respectively.

[0020]This switching means 16 comprises AND gate 16a and the flip-flop circuit 16b, the output side of the synthesizer 7 is connected to one input terminal of AND gate 16a, and a clock signal is always supplied to each digital disposal circuit 14 from the synthesizer 7.

[0021]When the output side of the flip-flop 16b is connected and an output is sent out from the flip-flop 16b, supply of the clock signal from the synthesizer 7 is suspended by the another side input terminal of AND gate 16a.

[0022]As for the input terminal of the flip-flop 16b, the operation is controlled by CPU12.

[0023]Drawing 2 shows an example of the control procedure of each signal processing parts 10a-10n and the switching means 16 which are performed by CPU12. In the procedure shown in the figure, a start will perform initial setting at Step s1 first. Initialization of reception is performed in this initial setting.

[0024]Selection of a satellite is performed in Step s3 which orbital calculation is performed from the almanac data of a satellite, and shifts to Step s3 in continuing Step s2. The selection condition of the satellite in this case chooses the satellite used for observation, for example according to the order of an altitude, PDOP, etc.

[0025]Assignment of the selected satellite is performed in the following step s4. Although the selected satellite will be assigned to each signal processing parts 10a-10n in this assignment, a satellite is assigned to no signal processing parts 10a-10n at this time, and only the signal processing parts 10a-10n of the number corresponding to the number of the satellites selected at Step s3 are assigned.

[0026]In continuing Step s5, about the signal processing parts 10a-10n which were not assigned at Step s4, a control signal is sent out to the switching means 16, and the supply of a clock signal to the applicable signal processing parts 10a-10n is stopped, and suppose that it is idle.

[0027]After Step s5 is completed, CPU12 will once be in a low power state at Step s6. The timing to which CPU12 performs signal processing parts [ which had assignment of a satellite as conditions which escape from a low power state / 10a-10n ] reception (reception timing). or said steps s2-s5 (processing which assigns each satellite to each channel) up to -- there is timing (satellite quota timing) which processes.

[0028]If it is reception timing (Step s7) among said timing, signal processing will be performed to the signal processing parts 10a-10n with assignment of a satellite, respectively at continuing Step s8.

[0029]And it is judged continuously whether it is satellite quota timing at Step s9, if it is satellite quota timing, it will return to Step s2, and if it is not satellite quota timing, it will return to Step s6.

[0030]Now, since the supply of a clock signal to the signal processing parts 10a-10n of the channel of the state where it does not specify, or a non-receive state is suspended by CPU12 according to the GPS receiver constituted as mentioned above, The signal processing parts 10a-10n of these channels become idle, and, thereby, power-saving can be attained. When the

satellite which had received the radio wave signal separates from altitude conditions in the observation post of a GPS receiver in the case of this example, while being able to stop a clock signal and being able to attain power-saving, When an orbit is gone around and it becomes ability ready for receiving, a clock signal can be supplied and it can be made to return to an observational state automatically.

[0031]In the case of this example, since it is considered as CPU12 themselves low power state, power-saving can be attained further. In the case of this example, since the switching means 16 and the signal processing parts 10a-10n are mounted in the IC package of 1 \*\*, simplification of a circuit pattern can be attained.

[0032]Although the case where AND gate 16a and the flip-flop 16b were used as the switching means 16 was illustrated in the above-mentioned example, it does not restrict to this combination.

[0033]Drawing 3 shows other examples of this invention, and it explains only that focus below while it gives identical codes to the portion which is the same as that of the above-mentioned example, or corresponds and omits that explanation.

[0034]In the example shown in the figure, are the example which applied this invention to the GPS receiver of two cycles (L1, L2 wave), and in the signal processing parts 10a-10n of each channel. The clock supply control section 102 which supplies a clock signal to L1 wave receiving channel 100, L2 wave receiving channel 101, and L1 and the L2 receiving channel 100,101, and the changeover switch 103 are formed.

[0035]As for the clock supply concentrated roll part 102 and the changeover switch 103, the operation is controlled by CPU12 as follows. That is, when the changeover switch 103 is operated and the L2 receiving channel 101 is first made into a clock halt condition by a way, it is a receiver for two cycles, but when the survey precision of one cycle may be sufficient, there is an effect of low-electric-power-izing and the temporal duration of a battery increases.

[0036]2 cycle receiving channel 101 is regarded as added value, and the increase in efficiency of manufacture and the flexibility of a product improve by making this an option or applicable to upgrade.

[0037]In the case of this example, when the clock supply to the L2 receiving channel 101 is suspended, low-electric-power-ization can be further attained by having the function to suspend the current supply to RF circuit 2 and IF circuit 3.

[0038]

[Effect of the Invention]As mentioned above, since according to the GPS receiver concerning this invention the channel of the state where it does not specify, or a non-receive state can be made idle and power-saving can be attained as the example explained in detail, there is no excessive power consumption and it is suitable for especially a portable receiver etc.

---

[Translation done.]

\* NOTICES \*

**JPO and INPIT are not responsible for any damages caused by the use of this translation.**

- 1.This document has been translated by computer. So the translation may not reflect the original precisely.
- 2.\*\*\* shows the word which can not be translated.
- 3.In the drawings, any words are not translated.

---

## CLAIMS

---

[Claim(s)]

[Claim 1]A high frequency amplifying circuit which amplifies a radio wave signal transmitted from two or more satellites.

A frequency changing circuit which changes an output signal of said high frequency amplifying circuit into an intermediate frequency signal.

Two or more signal processing parts which have the number of channels corresponding to said satellite, and restore to phase data and coded data based on said intermediate frequency signal.

An arithmetic processing section for control of said signal processing part.

Are the above the GPS receiver which it had and said signal processing part, Have a switching means which performs supply of a clock signal, and a stop, respectively, and said arithmetic processing section, When it judges that either of said signal processing parts is a state where it does not specify, or a non-receive state of said transmit radio wave, said switching means is operated and supply of a clock signal to the signal processing part concerned is stopped.

[Claim 2]The GPS receiver according to claim 1 when either of said signal processing parts judges that reception of said transmit radio wave was recovered, wherein said arithmetic processing section suspends an operation of said switching means and supplies said clock signal to the signal processing part concerned.

\* NOTICES \*

**JPO and INPIT are not responsible for any damages caused by the use of this translation.**

- 1.This document has been translated by computer. So the translation may not reflect the original precisely.
- 2.\*\*\* shows the word which can not be translated.
- 3.In the drawings, any words are not translated.

---

## CORRECTION OR AMENDMENT

---

[Kind of official gazette]Printing of amendment by the regulation of 2 of Article 17 of Patent Law

[Section classification] The 1st classification of the part VI gate  
[Publication date] June 2, Heisei 17 (2005.6.2)

[Publication No.] JP, 11-64480, A  
[Date of Publication] March 5, Heisei 11 (1999.3.5)  
[Application number] Japanese Patent Application No. 9-217534  
[The 7th edition of International Patent Classification]  
G01S 5/14

G01S 5/02

[FI]  
G01S 5/14

G01S 5/02 Z

[Written amendment]  
[Filing date] August 10, Heisei 16 (2004.8.10)  
[Amendment 1]  
[Document to be Amended] Specification  
[Item(s) to be Amended] 0024  
[Method of Amendment] Change  
[The contents of amendment]  
[0024]

Selection of a satellite is performed in Step s3 which orbital calculation is performed from the almanac data of a satellite, and shifts to Step s3 in continuing Step s2. The selection condition of the satellite in this case chooses the satellite used for observation, for example according to the order of an altitude, PDOP, etc.

---

[Translation done.]

\* NOTICES \*

JPO and INPIT are not responsible for any damages caused by the use of this translation.

- 1.This document has been translated by computer. So the translation may not reflect the original precisely.
- 2.\*\*\* shows the word which can not be translated.
- 3.In the drawings, any words are not translated.

DRAWINGS

[Drawing 1]

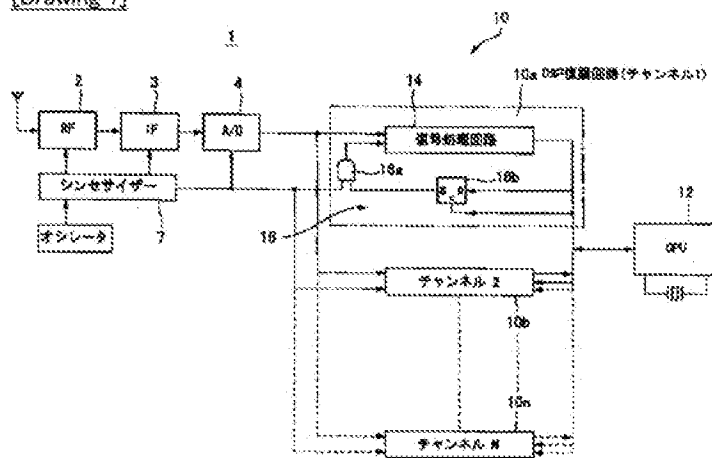

[Drawing 2]

[http://www4.ipdl.inpit.go.jp/cgi-bin/iran\\_web.cgi\\_ejje?atw\\_u=http%3A%2F%2Fwww4.ip...](http://www4.ipdl.inpit.go.jp/cgi-bin/iran_web.cgi_ejje?atw_u=http%3A%2F%2Fwww4.ip...) 7/28/2009

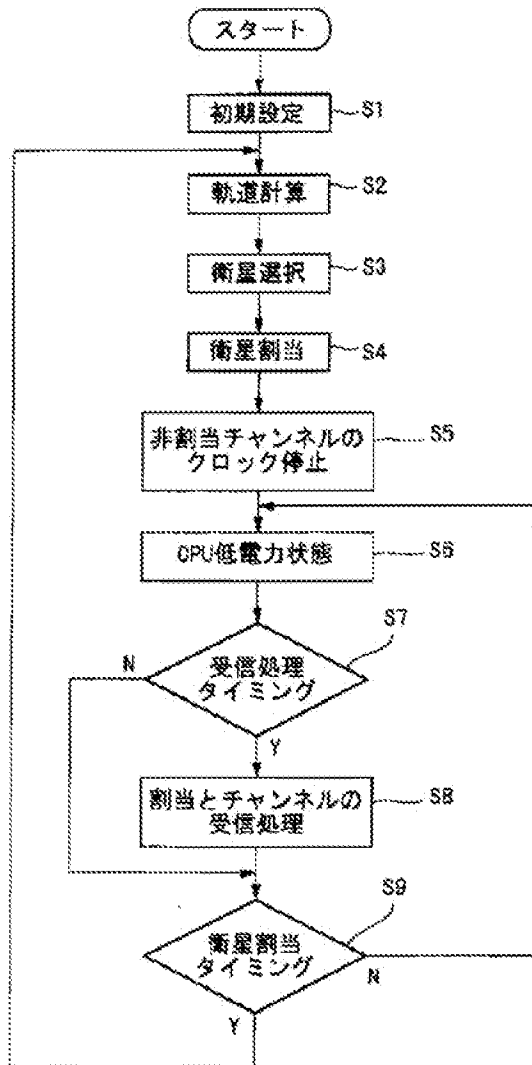

[Drawing 3]

[http://www4.ipdl.inpit.go.jp/egi-bin/tran\\_web.cgi\\_ejje?atw\\_u=http%3A%2F%2Fwww4.ip...](http://www4.ipdl.inpit.go.jp/egi-bin/tran_web.cgi_ejje?atw_u=http%3A%2F%2Fwww4.ip...) 7/28/2009

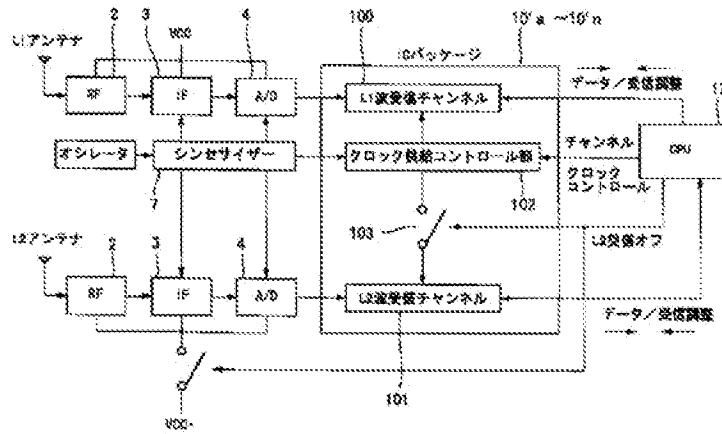

[Drawing 4]

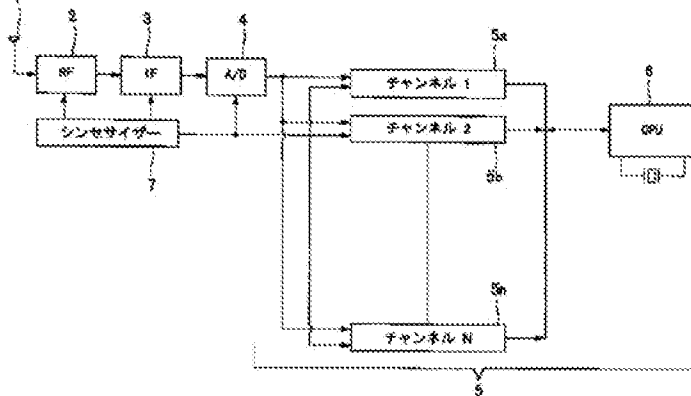

[Translation done.]

(19) 日本国特許庁 (J P)

(12) 公開特許公報 (A)

(11) 特許出願公開番号  
特開2001-74494  
(P2001-74494A)

(43) 公開日 平成13年3月23日 (2001.3.23)

(51) Int. Cl. <sup>7</sup>	識別記号	F I	7-コード*(参考)		
G 0 1 C	21/00	G 0 1 C	21/00	Z	2 F 0 2 9
G 0 1 S	5/14	G 0 1 S	5/14		5 J 0 6 2

審査請求 未請求 請求項の数 7 O L (全 8 頁)

(21) 出願番号	特願2000-14058(P2000-14058)	(71) 出願人	000002325 セイコーインスツルメンツ株式会社 千葉県千葉市美浜区中瀬1丁目8番地
(22) 出願日	平成12年1月19日(2000.1.19)	(72) 発明者	佐久本 和実 千葉県千葉市美浜区中瀬1丁目8番地 セイコーインスツルメンツ株式会社内
(31) 優先権主張番号	特願平11-190441	(72) 発明者	小田切 博之 千葉県千葉市美浜区中瀬1丁目8番地 セイコーインスツルメンツ株式会社内
(32) 優先日	平成11年7月5日(1998.7.5)	(74) 代理人	100090286 弁理士 林 敬之助
(33) 優先権主張国	日本 (J P)		

最終頁に続く

(54) 【発明の名称】 携帯型GPS受信機

(57) 【要約】

【課題】 消費電力を低減し、電源の消費を遅らせ、使用可能な時間を延ばすこと。

【解決手段】 電源電圧を検出する電源電圧検出部103と、電源電圧検出部103から電源電圧値を入力し、入力した電源電圧値に基づいてGPS受信部101の動作間隔を制御するGPS受信制御部105と、を備え、検出した電源電圧値に基づいて、GPS受信部101の動作間隔を制御することにより、常に連続的に受信動作を行わせるのではなく、電源電圧の状態に応じて受信動作を行い、消費電力を低減する。

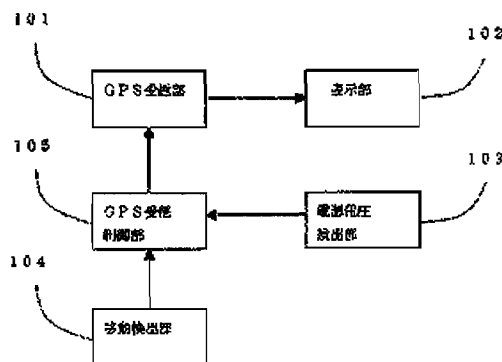



(2) 特開2001-74494

1

2

## 【特許請求の範囲】

【請求項1】 GPS衛星からの電波を受信し、GPS情報を生成する受信手段を備えた携帯型GPS受信機において、

電源電圧を検出する電源電圧検出手段と、前記電源電圧検出手段から電源電圧値を入力し、入力した電源電圧値に基づいて前記受信手段の動作間隔を制御する制御手段と、

を具備する携帯型GPS受信機。

【請求項2】 前記制御手段は、前記入力した電源電圧値が低下すると前記受信手段の動作間隔を長くするように制御する請求項1に記載の携帯型GPS受信機。

【請求項3】 GPS衛星からの電波を受信し、GPS情報を生成する受信手段を備えた携帯型GPS受信機において、

電源電圧を検出する電源電圧検出手段と、前記受信手段の動作の実行を命ずる命令信号を入力するための入力手段と、

前記電源電圧検出手段から電源電圧値を入力し、入力した電源電圧値が予め設定されている閾値より低い場合には、前記入力手段を介して命令信号が入力されたときのみ前記GPS情報を生成するように前記受信手段を制御する制御手段と、

を具備する携帯型GPS受信機。

【請求項4】 GPS衛星からの電波を受信し、GPS情報を生成する受信手段を備えた携帯型GPS受信機において、

自機が移動しているか否かを検出する移動検出手段と、前記移動検出手段で検出した検出信号を入力し、自機が移動していないと判断した場合に前記受信手段の動作を停止させる制御手段と、

を具備する携帯型GPS受信機。

【請求項5】 GPS衛星からの電波を受信し、GPS情報を生成する受信手段を備えた携帯型GPS受信機において、

自機が移動しているか否かを検出する移動検出手段と、前記移動検出手段で検出した検出信号を入力し、自機が移動していないと判断した場合に前記受信手段の動作間隔を制御する制御手段と、

を具備する携帯型GPS受信機。

【請求項6】 GPS衛星からの電波を受信し、GPS情報を生成する受信手段を備えた携帯型GPS受信機において、

自機の移動速度を検出する移動速度検出手段と、前記移動速度検出手段の検出結果に基づいて前記受信手段の動作間隔を制御する制御手段と、

を具備する携帯型GPS受信機。

【請求項7】 GPS衛星からの電波を受信し、GPS情報を生成する受信手段を備えた携帯型GPS受信機において、

前記受信手段の受信状態に基づいて前記受信手段の動作間隔を制御する制御手段を具備する携帯型GPS受信機。

【発明の詳細な説明】

【0001】

【発明の属する技術分野】本発明は、GPS衛星からの電波を受信し、位置情報等のGPS情報を生成する携帯型GPS受信機に関し、より詳細には、消費電力をセーブする機能を有する携帯型GPS受信機に関する。

【0002】

【従来の技術】従来の携帯型GPS受信機の一つとして、たとえば、GPS(Global Positioning System)アンテナと、GPSレシーバと、からなるGPS受信部を備えた腕時計がある。このような腕時計にあっては、GPSアンテナがGPS衛星からの電波を受信し、GPSレシーバが、毎秒、GPSアンテナで受信した受信信号から位置情報等のGPS情報を生成して出力する。ユーザは、この情報によりユーザ自身がいる位置等を知ることができる。

【0003】一般的に、上記腕時計のような携帯型GPS受信機では、電源がオンされている間、換言すれば、電源切れになるまで、毎秒、GPS情報を出力するための動作を行っている。

【0004】

【発明が解決しようとする課題】しかしながら、上記従来の技術によれば、毎秒、GPS情報を出力するための動作が行われるため、消費電力が大きく、電源を早く消費してしまい、使用可能な時間が短いという問題点があった。電源の容量を増やすことによって、使用可能な時間を長くすることが考えられるが、一般的に、上記腕時計のような携帯型GPS受信機は、その用途から自機の大きさや重さ等に制約があることから、電源の容量を簡単に増やすことができないという不具合がある。

【0005】本発明は上記に鑑みてなされたものであって、消費電力を低減し、電源の消費を遅らせ、使用可能な時間を延ばすことを目的とする。

【0006】

【課題を解決するための手段】上記の目的を達成するために、本発明の携帯型GPS受信機では、GPS衛星からの電波を受信し、GPS情報を生成する受信手段を備えた携帯型GPS受信機において、消費電力が少なくなるように、電源電圧を検出する電源電圧検出手段と、電源電圧検出手段から電源電圧値を入力し、入力した電源電圧値に基づいて受信手段の動作間隔を制御する制御手段と、を設けるようにした。

【0007】この携帯型GPS受信機にあっては、電源電圧を検出し、電源電圧値に基づいて受信手段の動作間隔を制御する。ここで、制御手段が、入力した電源電圧値が低下すると受信手段の動作間隔が長くなるように制御するようにしてもよい。また、本発明の携帯型GPS受信機は、GPS衛星からの電波を受信し、GPS情報を

(3) 特開2001-74494

3

生成する受信手段を備えた携帯型GPS受信機において、消費電力が少なくなるように、電源電圧を検出する電源電圧検出手段と、受信手段の動作の実行を命ずる命令信号を入力するための入力手段と、電源電圧検出手段から電源電圧値を入力し、入力した電源電圧値が予め設定されている閾値より低い場合には、入力手段を介して命令信号が入力されたときのみGPS情報を生成するように受信手段を制御する制御手段と、を設けるようにした。

【0008】この携帯型GPS受信機にあっては、電源電圧を検出し、電源電圧値が予め設定されている閾値より低い場合には、入力手段を介して命令信号が入力されたときのみGPS情報を生成するように受信手段を制御する。また、本発明の携帯型GPS受信機は、GPS衛星からの電波を受信し、GPS情報を生成する受信手段を備えた携帯型GPS受信機において、消費電力が少なくなるように、自機が移動しているか否かを検出する移動検出手段と、移動検出手段で検出した検出信号を入力し、自機が移動していない場合、受信手段の動作を停止させる制御手段と、を設けるようにした。

【0009】この携帯型GPS受信機にあっては、自機が移動しているか否かを検出し、自機が移動していない場合は、受信手段の動作を停止させる。また、本発明の携帯型GPS受信機は、GPS衛星からの電波を受信し、GPS情報を生成する受信手段を備えた携帯型GPS受信機において、消費電力が少なくなるように、自機が移動しているか否かを検出する移動検出手段と、移動検出手段で検出した検出信号を入力し、自機が移動していない場合、受信手段の動作間隔を制御する制御手段と、を設けるようにした。

【0010】この携帯型GPS受信機にあっては、自機が移動しているか否かを検出し、自機が移動していない場合は、受信手段の動作間隔を制御する。また、本発明の携帯型GPS受信機は、GPS衛星からの電波を受信し、GPS情報を生成する受信手段を備えた携帯型GPS受信機において、自機の移動速度を検出する移動速度検出手段と、この移動速度検出手段の検出結果に基づいて受信手段の動作間隔を制御する制御手段と、を設けるようにした。この携帯型GPS受信機にあっては、自機の移動速度を検出し、この検出結果に基づいて受信手段の動作間隔を制御する。

【0011】また、本発明の携帯型GPS受信機は、GPS衛星からの電波を受信し、GPS情報を生成する受信手段を備えた携帯型GPS受信機において、受信手段の受信状態に基づいて受信手段の動作間隔を制御する制御手段を設けるようにした。この携帯型GPS受信機にあっては、受信手段の受信状態を判断して、これに基づいて受信手段の動作間隔を制御する。

【0012】

【発明の実施の形態】以下に本発明の実施の形態を、実

4

施の形態1から実施の形態4の順で添付の図面を参照して詳細に説明する。

実施の形態1. 図1は、本発明の実施の形態1の携帯型GPS受信機の構成を示すブロック図である。実施の形態1の携帯型GPS受信機は、GPS衛星からの電波を受信し、位置データ等のGPSデータを生成して出力するGPS受信部101と、GPS受信部101からのGPSデータを表示する表示部102と、電源電圧を検出する電源電圧検出部103と、バッシュ素子である加速度センサーを有し、自機が移動しているか否かを検出する移動検出部104と、電源電圧検出部103から電源電圧値を入力するとともに移動検出部104で検出した検出信号を入力し、電源電圧値および検出信号に基づいてGPS受信部101の動作を制御するGPS受信制御部105と、を備えている。

【0013】実施の形態1の携帯型GPS受信機にあっては、電源電圧検出部103が電源電圧を検出し、移動検出部104が、自機が移動しているか否かを検出し、GPS受信制御部105が、電源電圧値および検出信号に基づいてGPS受信部101の動作を制御する。GPS受信部101は、GPS衛星からの電波を受信し、GPSデータを生成して出力し、表示部102が、出力されたGPSデータを表示する。

【0014】なお、GPS受信部101は本発明の受信手段に対応し、GPS受信制御部105は本発明の制御手段に対応する。以上の構成において、実施の形態1の動作をフローチャートを参照して説明する。図2は、実施の形態1のGPS受信制御部105の動作を示すフローチャートである。GPS受信制御部105は、まず、移動検出部104で検出した検出信号を入力して自機が移動中であるか否かを判定する(S201)。自機が移動中でない場合、換言すれば、自機が停止している場合は、通常の1秒ごとにGPSデータを出力するための動作よりも広い動作間隔、たとえば、10秒ごとにGPSデータを出力するような動作を行うようにGPS受信部101を制御し(S204)、ステップS201に戻る。

【0015】一方、自機が移動中である場合は、電源電圧検出部103から電源電圧値を入力し(S202)、入力した電源電圧値に基づいてGPS受信部101の動作間隔を制御し(S203)、ステップS201に戻る。ここで、電源電圧値が低下すると動作間隔が長くなるように制御してもよいし、電源電圧値の範囲を複数に分割し、分割された各電源電圧値の範囲のそれぞれに異なる動作間隔を対応させたテーブルを予め設定しておき、このテーブルに従って動作間隔を制御するようにしてもよい。

【0016】前述した様に実施の形態1によれば、自機が移動中であるか否かを検出し、自機が停止している場合、GPS受信部101の動作の間隔を広げるため、消

(4)

特開2001-74494

5

6

費電力を低減し、電源の消費を遅らせ、使用可能な時間を延ばすことができる。また、電源電圧を検出し、電源電圧値に基づいて、GPS受信部101の動作間隔を制御するため、消費電力を低減し、電源の消費を遅らせ、使用可能な時間を延ばすことができる。

【0017】実施の形態2。図3は、本発明の実施の形態2の携帯型GPS受信機の構成を示すブロック図である。なお、基本的な構成は、実施の形態1と同様につき、同一の部分は図1と同一の符号を付して説明を省略し、ここでは異なる部分のみを説明する。実施の形態2の携帯型GPS受信機が実施の形態1と異なる部分は、GPS受信制御部302の動作である。また、図1で示した実施の形態1の携帯型GPS受信機の構成に加え、GPS受信部101の動作の実行と停止を命ずる命令信号を入力するための入力部301を備えている。

【0018】GPS受信制御部302は、入力部301からのGPS受信開始命令の入力によって動作を開始する。電源電圧検出部103が電源電圧の低下を検出していないとき、GPS受信開始命令の入力にしたがって、ただちにGPS受信部101に対して動作開始を指示する信号を発生する。電源電圧検出部103が電源電圧の低下を検出しているときは、入力部301からGPS受信開始命令の入力があってもGPS受信は行わない。

【0019】電源電圧検出部103が電源電圧の低下を検出していないとき、GPS受信制御部302は、入力部301からGPS受信開始命令が入力される度にGPS受信部101に対して動作開始を指示する信号を発生する。また、GPS受信制御部302は、一度、入力部301からGPS受信開始命令入力があると、入力部301からGPS受信を停止する命令が入力されるまで、ある一定時間のタイマー間隔で、GPS受信部101に対して受信動作開始信号を発生し続ける様に構成されている。

【0020】以上の構成において、実施の形態2の動作をフローチャートを参照して説明する。図4は、実施の形態2のGPS受信制御部の動作を示すフローチャートである。入力部301からGPS受信開始命令入力（入力部301内の図示しないスイッチ）があると（S401）、その命令入力によって割り込みが発生しソフトウェアの動作が開始される。その割り込み信号が入力部301からのGPS受信開始命令であると認識されると（S402）、GPS受信制御部302は電源電圧検出部103の出力信号を参照し（S403）、電源電圧が低下していない場合、GPS受信制御部302は、GPS受信部101にGPS受信動作を開始させる開始指示信号を伝達する（S404）。GPS受信部101はGPS受信制御部302からの受信開始指示信号によって受信を開始し、受信したデータは表示部102で表示される。

【0021】GPS受信制御部302がGPS受信部1

01に受信開始指示信号を出力した後、タイマーをスタートさせる（S405）。スタートさせたタイマーがタイムアップすると（S406）、GPS受信制御部302は、移動検出部104の出力を参照し自機が移動中であるか否かを判断する（S407）。自機が移動していると判断すると、再び電源電圧検出部103の出力を参照し（S408）、電源電圧が低下していない場合には、再びGPS受信制御部302は受信開始指示信号をGPS受信部101へ出力する（S409）。

【0022】ステップS407の処理において自機が移動していないと判断したときは、GPS受信を行わずタイマースタート処理（S405）に戻る。この様にGPS受信制御部302を構成することによって、タイマー時間の間隔で自機の移動の有無を評価し、移動している場合、GPS受信部101に受信動作を行わせることができる。この動作は入力部301からGPS受信停止入力があるまで継続される。入力部301からGPS受信停止入力がGPS受信制御部302に入力されると、その命令入力によって割り込みが発生しソフトウェアの動作が開始される。その割り込み信号が受信停止入力と認識されると（S401）、ただちにタイマーがストップされ（S410）、ソフト動作が停止される。

【0023】前述したように実施の形態2によれば、一回のGPS受信開始の操作によって連続的にGPS受信を行わせることができる。また、連続的な受信動作であっても受信のつど、自機が移動中であるか否か、および、電源電圧値が予め設定された閾値以上であるか否かを判定し、自機が停止している場合、または、電源電圧値が予め設定された閾値未満の場合、GPS受信部101の動作を停止させる。この結果、消費電力を低減し、電源の消費を遅らせ、使用可能な時間を延ばすことができる。

【0024】なお、実施の形態2の動作説明では、タイマー動作で連続的な受信を可能にしたために、入力部からの受信開始信号が発生しても電源電圧が低下している場合は、受信しないように説明した。しかし、入力部からの受信開始信号に呼応して参照する電圧検出レベルと、タイマー動作で参照する電圧検出レベルを変換することで、入力部からの操作によって動作する電圧範囲を広げることができる。

【0025】実施の形態3。実施の形態3は、実施の形態2において、電源電圧が低くなった場合、ユーザからの命令信号があったときのみ受信動作を行うようにしたものである。なお、基本的な構成および動作は実施の形態2と同様であるので、異なる部分についてのみ説明する。この場合、GPS受信制御部302は、電源電圧検出部103から電源電圧値を入力し、入力した電源電圧値が予め設定された閾値未満の場合、GPS受信部101を制御してその動作を停止させる。また、GPS受信制御部302は、GPS受信部101の動作が停止して

(5) 特開2001-74494

7

8

いる場合には、ユーザのボタン操作等により、入力部301を介して命令信号が入力されたときのみ、予め設定された回数分のGPSデータを出力するようにGPS受信部101を制御する。

【0026】図5は、実施の形態3のGPS受信制御部302の動作を示すフローチャートである。GPS受信制御部302は、まず、GPS受信部101の動作が停止しており、かつ、入力部301を介して命令信号が入力されたか否かを判定する(S501)。GPS受信部101の動作が停止しており、かつ、入力部301を介して命令信号が入力されていた場合、予め設定された回数分のGPSデータを出力するようにGPS受信部101を制御し(S505)、ステップS501に戻る。

【0027】一方、GPS受信部101が動作しているか、または、入力部301を介して命令信号が入力されていなかった場合、移動検出部104で検出した検出信号を入力して自機が移動中であるか否かを判定する(S502)。自機が移動中でない場合、換言すれば、自機が停止している場合は、GPS受信部101を制御してその動作を停止させ(S506)、ステップS501に戻る。

【0028】一方、自機が移動中である場合は、電源電圧検出部103から電源電圧値を入力して電源電圧値が予め設定された閾値以上であるか否かを判定する(S503)。電源電圧値が予め設定された閾値未満である場合はステップS506に進み、電源電圧値が予め設定された閾値以上である場合はGPS受信部101が通常の動作を行うように制御し(S504)、ステップS501に戻る。

【0029】前述した様に実施の形態3によれば、自機が移動中であるか否か、および、電源電圧値が予め設定された閾値以上であるか否かを判定し、自機が停止している場合、または、電源電圧値が予め設定された閾値未満の場合、GPS受信部101の動作を停止し、入力部301を介して命令信号が入力された場合に限り、予め設定された回数分のGPSデータを出力するための動作を行うため、消費電力を低減し、電源の消費を遅らせ、使用可能な時間を延ばすことができる。

【0030】実施の形態4、図6は、本発明の実施の形態4の携帯型GPS受信機の構成を示すブロック図である。なお、基本的な構成は、実施の形態2と同様につき、同一の部分は図3と同一の符号を付して説明を省略し、ここでは異なる部分のみを説明する。実施の形態4の携帯型GPS受信機は、移動検出部104に代えて、GPS受信部101からの情報を入力して受信状態を判定する受信状態判定部601と、GPS受信部101からの情報を入力して移動速度を検出する移動速度検出部602と、を備えている。また、実施の形態2の制御部302に代えて、受信状態判定部601による判定結果、移動速度検出部602による検出結果および電源電

圧検出部103による検出結果に基づいてGPS受信部101を制御するGPS受信制御部603を備えている。

【0031】受信状態判定部601は、GPS受信部101での測位演算の結果得られる誤差情報、たとえば、位置の計算結果の精度や受信電波の強度などから受信状態を判定する。移動速度検出部602は、GPS受信部101からの速度情報や単位時間あたりの位置情報の変化から移動速度の値を得る。また、加速度センサを設けて速度を検出するようにしてもよい。

【0032】GPS受信制御部603は、受信状態判定部601による判定結果、移動速度検出部602による検出結果および電源電圧検出部103による検出結果に基づいてGPS受信部101を制御し、測位間隔(動作間隔)を変更する。たとえば、受信状態がわるい場合は、無駄な受信動作による電力消費を抑えるために測位間隔を広げる。また、移動速度が速い場合は、細かい測位が必要なので測位間隔を狭め、人が歩行する場合等、移動速度が遅い場合は、測位間隔は長くてもよいので測位間隔を広げる。

【0033】以上の構成において、実施の形態4の動作を、フローチャートを参照して説明する。図7、8は、実施の形態4のGPS受信制御部603の動作を示すフローチャートである。GPS受信制御部603は、ユーザからのキー入力により入力部301を介して受信開始指示があると、電源電圧検出部103を制御して電源電圧を測定する(S701)。つぎに、測定した電源電圧値が所定の値よりも高いか否かを判定する(S702)。測定した電源電圧値が所定の値よりも高い場合は、電源電圧値に応じて測位間隔データT<sub>1</sub>vを算出する(S703)。そして、算出したT<sub>1</sub>vによりGPS受信部101の測位間隔を設定し(S704)、受信動作を開始する(S705)。

【0034】たとえば、電源の電圧値が十分である場合は、T<sub>1</sub>vをGPS受信部101の最小測位間隔とする。最小測位間隔については多くの従来のGPS受信機が1秒を採用している。電圧値の低下により、測位間隔を10秒、1分と長くしていく。ステップS702で、電源電圧が所定の値よりも低ければ処理を終了する。すなわち、ある値よりも電源電圧が低くなれば、キー入力による測位指示がされても(受信開始指示があっても)受信動作を開始しない。電源電圧の測定は、受信動作がスタートした後も一定間隔で行われ、電源電圧値に応じた測位間隔データT<sub>1</sub>vが設定される。

【0035】受信動作がスタートすると、GPS受信制御部603は、設定された測位間隔ごとに自機の現在位置、速度、方位、現在時刻等を計算し、表示する(S801、S802)。また、受信状態判断部601を制御して、GPS受信部101での測位演算の結果得られる誤差情報、たとえば、位置精度劣化率(PDOP値)や受信電波の強度などから、現時点の受信状態を判定し

(6)

特開2001-74494

9

(S803)、判定結果から測位間隔データTipを設定(算出)する(S804)。受信状態がわるければ、測位間隔データTipを1秒、10秒、1分というように長くする。ここで、受信状態の判定は、連続した複数回の受信状態から行ってよい。

【0036】つぎに、移動速度検出部602を制御して、測位演算の結果得られる自機の移動速度を判定(検出)し(S805)、判定結果から測位間隔データTipを設定(算出)する(S806)。自機の移動速度が遅くなれば、測位間隔データTipは、1秒、10秒、1分というように長くする。ここで、移動速度は、連続した複数回の測位結果から算出するようにしてもよい。GPS受信制御部603は、電源電圧に応じて設定したTipと、受信状態に応じて設定したTipと、移動速度に応じて設定したTipと、からなる3つの設定値に基づき、GPS受信部101を制御して測位間隔を変更する(S807)。

【0037】測位間隔の決定方法は、どのようなものでもよい。たとえば、Tip、Tip、Tipのうち、一番長い測位間隔値を自機の測位間隔として採用し、この測位間隔で受信動作を続けるようにしてもよい。この場合、Tipが1分、Tipが10秒、Tipが1秒、だとすると、携帯型GPS受信機の測位間隔として1分が採用され、この測位間隔により受信動作が行われる。

【0038】前述したように実施の形態4によれば、自機の受信状態および移動速度を判定し、判定結果に基づいて測位間隔を変更するため、消費電力を低減し、電源の消費を遅らせ、使用可能な時間を延ばすことができる。また、受信状態がわるいときでも動作を終了させてしまわないため、受信動作を継続することができる。また、電源電圧が一定値以下となった場合は受信動作を行わないため、システムをダウンしてしまふことを防ぐことができる。

【0039】なお、実施の形態1から実施の形態4におけるGPS受信部101の動作間隔(測位間隔)の変更は、GPS受信部101への電源供給間隔を変えることにより行ってよいし、GPS受信部101における測位間隔を変えることにより行ってよい。

【0040】

【発明の効果】以上説明したように、本発明の携帯型GPS受信機は、電源電圧を検出し、電源電圧値に基づいて受信手段の動作間隔を制御するため、消費電力を低減し、電源の消費を遅らせ、使用可能な時間を延ばすことができる。また、本発明の携帯型GPS受信機は、電源電圧を検出し、電源電圧値が低下すると共に受信手段の動作間隔が長くなるように制御するため、電源電圧値の低下にあわせて消費電力を低減し、電源の消費を遅らせ、使用可能な時間を延ばすことができる。

10

【0041】また、本発明の携帯型GPS受信機は、電源電圧を検出し、電源電圧値が予め設定されている閾値より低い場合には、入力手段を介して命令信号が入力されたときのみGPS情報を生成するように受信手段を制御するため、消費電力を低減し、電源の消費を遅らせ、使用可能な時間を延ばすことができる。また、本発明の携帯型GPS受信機は、自機が移動しているか否かを検出し、自機が移動していない場合は、受信手段の動作を停止させるため、消費電力を低減し、電源の消費を遅らせ、使用可能な時間を延ばすことができる。

【0042】また、本発明の携帯型GPS受信機は、自機が移動しているか否かを検出し、自機が移動していない場合は、受信手段の動作間隔を制御するため、消費電力を低減し、電源の消費を遅らせ、使用可能な時間を延ばすことができる。また、本発明の携帯型GPS受信機は、自機の移動速度を検出し、この検出結果に基づいて受信手段の動作間隔を制御するため、消費電力を低減し、電源の消費を遅らせ、使用可能な時間を延ばすことができる。

【0043】また、携帯型GPS受信機は、受信手段の受信状態に基づいて受信手段の動作間隔を制御するため、消費電力を低減し、電源の消費を遅らせ、使用可能な時間を延ばすことができる。

【図面の簡単な説明】

【図1】本発明の実施の形態1の携帯型GPS受信機の構成を示すブロック図である。

【図2】実施の形態1のGPS受信制御部の動作を示すフローチャートである。

【図3】本発明の実施の形態2の携帯型GPS受信機の構成を示すブロック図である。

【図4】実施の形態2のGPS受信制御部の動作を示すフローチャートである。

【図5】本発明の実施の形態3のGPS受信制御部の動作を示すフローチャートである。

【図6】本発明の実施の形態4の携帯型GPS受信機の構成を示すブロック図である。

【図7】実施の形態4のGPS受信制御部の動作を示すフローチャートである。

【図8】実施の形態4のGPS受信制御部の動作を示すフローチャートである。

【符号の説明】

101 GPS受信部  
102 表示部  
103 電源電圧検出部  
104 移動検出部  
105、302 GPS受信制御部  
301 入力部

(7)

特開2001-74494

【図1】

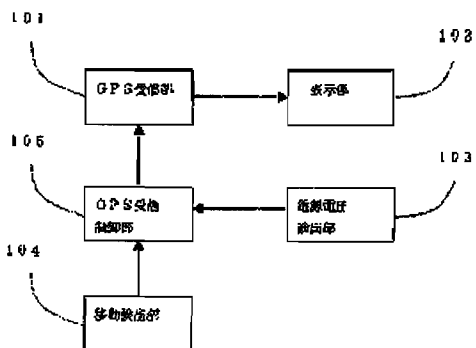

【図2】

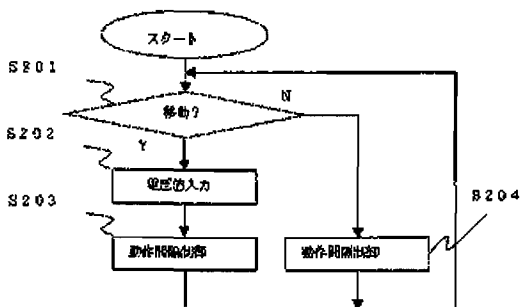

【図3】

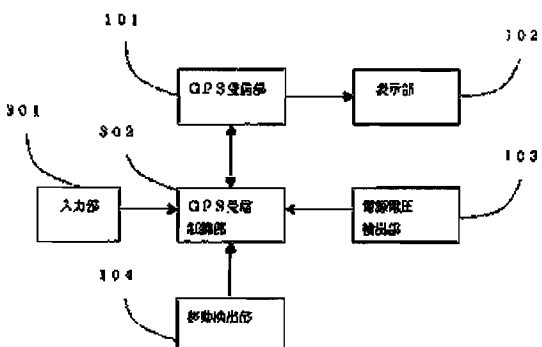

【図4】

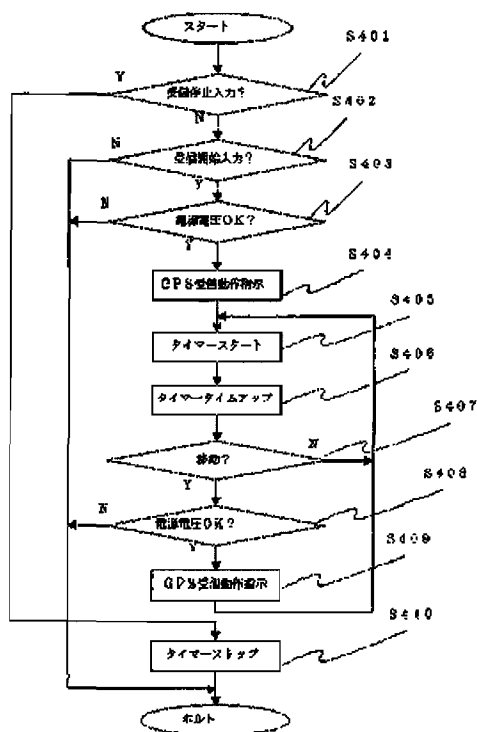

【図6】

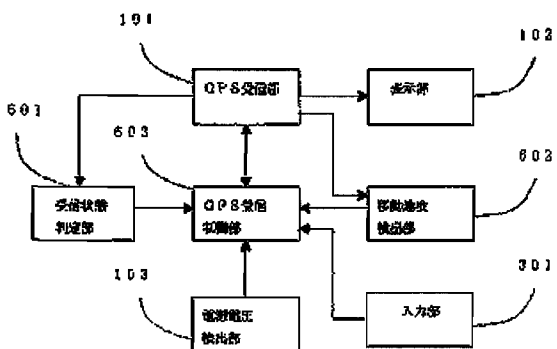

(8)

特開2001-74494

【図5】

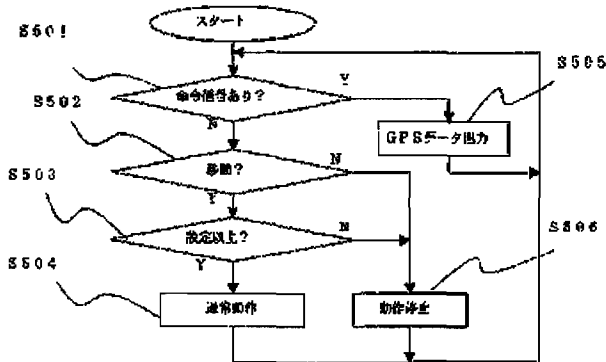

【図7】

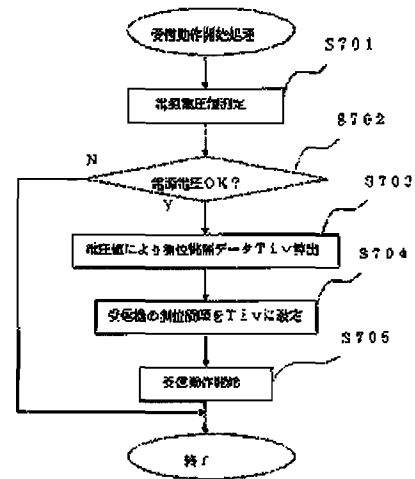

【図8】

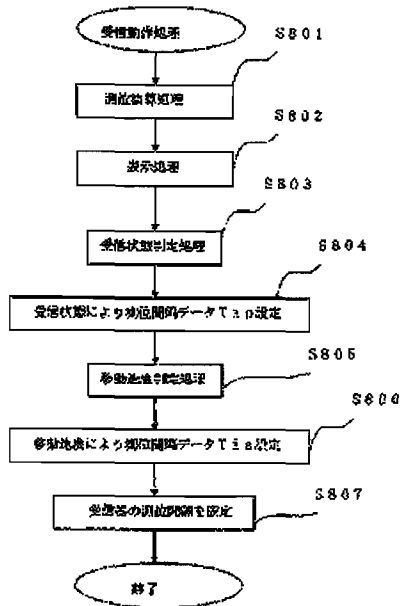

フロントページの続き

(72)発明者 長妻 英昭  
 千葉県千葉市美浜区中瀬1丁目8番地 株式会社エスアイアイ・オールディセンター  
 内

Fターム(参考) 2F029 AA07 AB07  
 5J062 AA00 BB05 CC07 DD21

# PATENT ABSTRACTS OF JAPAN

(11)Publication number : 2001-074494

(43)Date of publication of application : 23.03.2001

(51)Int.Cl. G01C 21/00

G01S 5/14

(21)Application number : 2000-014058 (71)Applicant : SEIKO INSTRUMENTS INC

(22)Date of filing : 19.01.2000 (72)Inventor : SAKUMOTO KAZUSANE  
ODAGIRI HIROYUKI  
NAGATSUMA HIDEAKI

(30)Priority

Priority number : 11190441 Priority date : 05.07.1999 Priority country : JP

## (54) PORTABLE GPS RECEIVER

(57)Abstract:

PROBLEM TO BE SOLVED: To extend a useable time for a receiver by reducing the consumption power and delaying consumption of a power source.

SOLUTION: This receiver has a source voltage detecting part 103 for detecting source voltage, and a GPS reception control part 105 to which a source voltage value is inputted from the source voltage detecting part 103 and which controls an operation interval of a GPS reception part 101, on the basis of the inputted source voltage value. The operation interval of the GPS reception part 101 is controlled on the basis of the detected source voltage value. Consequently a reception operation is not carried out continuously at all times but is executed in accordance with the state of the source voltage. The power consumed is reduced accordingly.

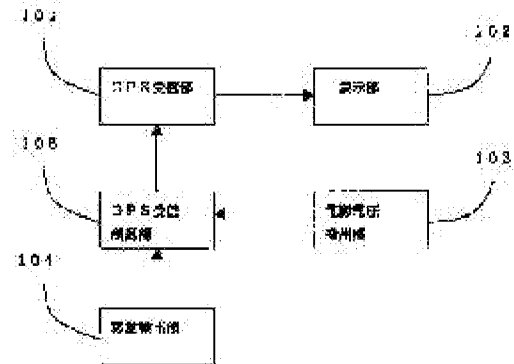

\* NOTICES \*

JPO and INPIT are not responsible for any damages caused by the use of this translation.

1. This document has been translated by computer. So the translation may not reflect the original precisely.



- 2.\*\*\* shows the word which can not be translated.
- 3.In the drawings, any words are not translated.

---

## TECHNICAL FIELD

---

[Field of the Invention]This invention receives the electric wave from a GPS Satellite, and relates to the portable GPS receiver which has a function which saves power consumption to details more about the portable GPS receiver which generates GPS information, such as position information.

---

[Translation done.]

\* NOTICES \*

**JPO and INPIT are not responsible for any damages caused by the use of this translation.**

- 1.This document has been translated by computer. So the translation may not reflect the original precisely.
- 2.\*\*\* shows the word which can not be translated.
- 3.In the drawings, any words are not translated.

---

## PRIOR ART

---

[Description of the Prior Art]As one of the conventional portable GPS receivers, there are a GPS (GlobalPositioning System) antenna, a GPS receiver, and a wrist watch provided with the GPS transmitting and receiving part, \*\* and others, for example. If it is in such a wrist watch, a GPS antenna receives the electric wave from a GPS Satellite, and a GPS receiver generates and outputs GPS information, such as position information, per second from the input signal received with the GPS antenna. The user can know the position etc. in which the user itself is using this information.

[0003]Generally, in a portable GPS receiver like the above-mentioned wrist watch, if it puts in another way while one [ the power supply ], operation for outputting GPS information per second is performed until it becomes a power supply piece.

---

[Translation done.]

\* NOTICES \*

**JPO and INPIT are not responsible for any damages caused by the use of this translation.**

1.This document has been translated by computer. So the translation may not reflect the original precisely.

2.\*\*\* shows the word which can not be translated.

3.In the drawings, any words are not translated.

---

## **EFFECT OF THE INVENTION**

---

[Effect of the Invention]As explained above, since the portable GPS receiver of this invention detects power supply voltage and controls the interval of a reception means of operation based on a supply voltage value, it can reduce power consumption, can delay consumption of a power supply, and can extend usable time. Since detect power supply voltage and a supply voltage value falls, and the portable GPS receiver of this invention is controlled so that the interval of a reception means of operation becomes long, it can reduce power consumption in accordance with the fall of a supply voltage value, can delay consumption of a power supply, and can extend usable time.

[0041]The portable GPS receiver of this invention detects power supply voltage, and when a supply voltage value is lower than the threshold set up beforehand, Since a reception means is controlled to generate GPS information only when an order signal is inputted via an input means, power consumption can be reduced, consumption of a power supply can be delayed, and usable time can be extended. Since the portable GPS receiver of this invention stops operation of a reception means when it detects whether the self-opportunity is moving and the self-opportunity is not moving, it can reduce power consumption, can delay consumption of a power supply, and can extend usable time.

[0042]Since the portable GPS receiver of this invention controls the interval of a reception means of operation when it detects whether the self-opportunity is moving and the self-opportunity is not moving, it can reduce power consumption, can delay consumption of a power supply, and can extend usable time. Since the portable GPS receiver of this invention detects the movement speed of a self-opportunity and controls the interval of a reception means of operation based on this detection result, it can reduce power consumption, can delay consumption of a power supply, and can extend usable time.

[0043]Since a portable GPS receiver controls the interval of a reception means of operation based on the receive state of a reception means, it can reduce power consumption, can delay consumption of a power supply, and can extend usable time.

---

[Translation done.]

\* NOTICES \*

**JPO and INPIT are not responsible for any damages caused by the use of this translation.**

1.This document has been translated by computer. So the translation may not reflect the original precisely.

- 2.\*\*\* shows the word which can not be translated.
- 3.In the drawings, any words are not translated.

---

## TECHNICAL PROBLEM

---

[Problem(s) to be Solved by the Invention]However, since operation for outputting GPS information per second was performed according to the above-mentioned conventional art, power consumption was large, the power supply was consumed early, and there was a problem that usable time was short. Although it is possible to lengthen usable time by increasing the capacity of a power supply, since a size, weight, etc. of a self-opportunity have restrictions from the use, generally a portable GPS receiver like the above-mentioned wrist watch has the fault that capacity of a power supply cannot be increased easily.

[0005]This invention was made in view of the above, and is \*\*\*\*. It is reducing the purpose, delaying consumption of a power supply and extending usable time.

---

[Translation done.]

\* NOTICES \*

**JPO and INPIT are not responsible for any damages caused by the use of this translation.**

- 1.This document has been translated by computer. So the translation may not reflect the original precisely.
- 2.\*\*\* shows the word which can not be translated.
- 3.In the drawings, any words are not translated.

---

## MEANS

---

[Means for Solving the Problem]In order to attain the above-mentioned purpose, in a portable GPS receiver of this invention. In a portable GPS receiver provided with a reception means which receives an electric wave from a GPS Satellite and generates GPS information, A source voltage detecting means which detects power supply voltage, and a control means which inputs a supply voltage value and controls an interval of a reception means of operation based on an inputted supply voltage value from a source voltage detecting means were established so that power consumption might decrease.

[0007]If it is in this portable GPS receiver, power supply voltage is detected and an interval of a reception means of operation is controlled based on a supply voltage value. If a supply voltage value which a control means inputted falls, it may be made to control here so that an interval of a reception means of operation becomes long. In a portable GPS receiver provided with a reception means which a portable GPS receiver of this invention receives an electric wave from a GPS Satellite, and generates GPS information, A source voltage detecting means which detects

power supply voltage so that power consumption may decrease, An input means for inputting an order signal which orders execution of operation of a reception means, A supply voltage value was inputted from a source voltage detecting means, and when an inputted supply voltage value was lower than a threshold set up beforehand, a control means which controls a reception means to generate GPS information only when an order signal is inputted via an input means was established.

[0008]If it is in this portable GPS receiver, power supply voltage is detected, and when a supply voltage value is lower than a threshold set up beforehand, a reception means is controlled to generate GPS information, only when an order signal is inputted via an input means. In a portable GPS receiver provided with a reception means which a portable GPS receiver of this invention receives an electric wave from a GPS Satellite, and generates GPS information, A shift detection means which detects whether a self-opportunity is moving, and a control means which stops operation of a reception means when a detecting signal detected by a shift detection means is inputted and a self-opportunity is not moving were established so that power consumption might decrease.

[0009]If it is in this portable GPS receiver, when it detects whether a self-opportunity is moving and a self-opportunity is not moving, operation of a reception means is stopped. In a portable GPS receiver provided with a reception means which a portable GPS receiver of this invention receives an electric wave from a GPS Satellite, and generates GPS information, A shift detection means which detects whether a self-opportunity is moving, and a control means which controls an interval of a reception means of operation when a detecting signal detected by a shift detection means is inputted and a self-opportunity is not moving were established so that power consumption might decrease.

[0010]If it is in this portable GPS receiver, when it detects whether a self-opportunity is moving and a self-opportunity is not moving, an interval of a reception means of operation is controlled. In a portable GPS receiver provided with a reception means which a portable GPS receiver of this invention receives an electric wave from a GPS Satellite, and generates GPS information, A travelling speed detection means which detects movement speed of a self-opportunity, and a control means which controls an interval of a reception means of operation based on a detection result of this travelling speed detection means were established. If it is in this portable GPS receiver, movement speed of a self-opportunity is detected and an interval of a reception means of operation is controlled based on this detection result.

[0011]A portable GPS receiver of this invention receives an electric wave from a GPS Satellite, and established a control means which controls an interval of a reception means of operation based on a receive state of a reception means in a portable GPS receiver provided with a reception means which generates GPS information. If it is in this portable GPS receiver, a receive state of a reception means is judged and an interval of a reception means of operation is controlled based on this.

[0012]

[Embodiment of the Invention]The order of Embodiment 1 to Embodiment 4 explains an embodiment of the invention in detail with reference to an attached drawing below.

Embodiment 1. drawing 1 is a block diagram showing the composition of the portable GPS receiver of the embodiment of the invention 1. GPS transmitting and receiving part 101 which the portable GPS receiver of Embodiment 1 receives the electric wave from a GPS Satellite, and generates and outputs GPS data, such as position data, The indicator 102 which displays the GPS data from GPS transmitting and receiving part 101, The power-supply-voltage primary detecting

element 103 which detects power supply voltage, and the move primary detecting element 104 which detects whether it has an acceleration sensor which is a passive element, and the self-opportunity is moving, While inputting the supply voltage value from the power-supply-voltage primary detecting element 103, the detecting signal detected in the move primary detecting element 104 was inputted, and it has the GPS reception control part 105 which controls operation of GPS transmitting and receiving part 101 based on a supply voltage value and a detecting signal.

[0013]If it is in the portable GPS receiver of Embodiment 1, the power-supply-voltage primary detecting element 103 detects power supply voltage, the move primary detecting element 104 detects whether the self-opportunity is moving, and the GPS reception control part 105 controls operation of GPS transmitting and receiving part 101 based on a supply voltage value and a detecting signal. GPS transmitting and receiving part 101 receives the electric wave from a GPS Satellite, and generates and outputs GPS data, and the indicator 102 displays the outputted GPS data.

[0014]GPS transmitting and receiving part 101 corresponds to the reception means of this invention, and the GPS reception control part 105 corresponds to the control means of this invention. In the above composition, operation of Embodiment 1 is explained with reference to a flow chart. Drawing 2 is a flow chart which shows operation of the GPS reception control part 105 of Embodiment 1. The GPS reception control part 105 judges whether the detecting signal detected in the move primary detecting element 104 is inputted first, and a self-opportunity is moving (S201). If it puts in another way when a self-opportunity is not moving, when the self-opportunity will have stopped, GPS transmitting and receiving part 101 is controlled to perform an interval of operation larger than the operation for outputting GPS data for usual every second, for example, operation which outputs GPS data every 10 seconds, (S204), and it returns to Step S201.

[0015]On the other hand, when a self-opportunity is moving, a supply voltage value is inputted from the power-supply-voltage primary detecting element 103 (S202), the interval of GPS transmitting and receiving part 101 of operation is controlled based on the inputted supply voltage value (S203), and it returns to Step S201. If a supply voltage value falls, may control here so that an interval of operation becomes long, and, The table to which an interval of operation which divided the range of a supply voltage value into plurality, and is different in each of the range of each divided supply voltage value was made to correspond is set up beforehand, and it may be made to control an interval of operation according to this table.

[0016]Since the interval of operation of GPS transmitting and receiving part 101 is extended when according to the Embodiment 1 it detects whether a self-opportunity is moving and the self-opportunity has stopped, as mentioned above, power consumption can be reduced, consumption of a power supply can be delayed, and usable time can be extended. Since power supply voltage is detected and the interval of GPS transmitting and receiving part 101 of operation is controlled based on a supply voltage value, power consumption can be reduced, consumption of a power supply can be delayed, and usable time can be extended.

[0017]Embodiment 2. drawing 3 is a block diagram showing the composition of the portable GPS receiver of the embodiment of the invention 2. Attaching fundamental composition like Embodiment 1, the same portion attaches the same numerals as drawing 1, omits explanation, and explains only a portion different here. The portion into which the portable GPS receiver of Embodiment 2 differs from Embodiment 1 is operation of the GPS reception control part 302. It has the input part 301 for inputting the order signal which orders execution of operation and stop

of GPS transmitting and receiving part 101 in addition to the composition of the portable GPS receiver of Embodiment 1 shown by drawing 1.

[0018]The GPS reception control part 302 starts operation by the input of the GPS receiving start command from the input part 301. When the power-supply-voltage primary detecting element 103 has not detected the fall of power supply voltage, according to the input of a GPS receiving start command, the signal which directs an operation start to GPS transmitting and receiving part 101 immediately is generated. When the power-supply-voltage primary detecting element 103 has detected the fall of power supply voltage, GPS reception is not performed even if there is an input of a GPS receiving start command from the input part 301.

[0019]When the power-supply-voltage primary detecting element 103 has not detected the fall of power supply voltage, the GPS reception control part 302 generates the signal which directs an operation start to GPS transmitting and receiving part 101 whenever a GPS receiving start command is inputted from the input part 301. Until the command which stops GPS reception from the input part 301 will be inputted, once the GPS reception control part 302 has a GPS receiving start command input from the input part 301, At intervals of the timer of a certain fixed time, it is constituted so that it may continue generating a receiving operation start signal to GPS transmitting and receiving part 101.

[0020]In the above composition, operation of Embodiment 2 is explained with reference to a flow chart. Drawing 4 is a flow chart which shows operation of the GPS reception control part of Embodiment 2. If there is a GPS receiving start command input from the input part 301 (S401) (switch in the input part 301 which is not illustrated), an interrupt will occur and operation of software will be started by the command input. If recognized as the interrupt signal being the GPS receiving start command from the input part 301 (S402), The GPS reception control part 302 transmits the start indication signal for which the GPS reception control part 302 makes GPS transmitting and receiving part 101 start GPS receiving operation, when power supply voltage is not falling with reference to the output signal of the power-supply-voltage primary detecting element 103 (S403) (S404). GPS transmitting and receiving part 101 starts reception with the receiving start indication signal from the GPS reception control part 302, and the received data is displayed by the indicator 102.

[0021]A timer is started after the GPS reception control part 302 outputs a receiving start indication signal to GPS transmitting and receiving part 101 (S405). If the started timer passes the deadline of (S406), the GPS reception control part 302 will judge whether a self-opportunity is moving with reference to the output of the move primary detecting element 104 (S407). If it judges that the self-opportunity is moving, when power supply voltage will not fall again with reference to the output of the power-supply-voltage primary detecting element 103 (S408), the GPS reception control part 302 outputs a receiving start indication signal to GPS transmitting and receiving part 101 again (S409).

[0022]When it judges that the self-opportunity is not moving in processing of Step S407, GPS reception is not performed but it returns to timer start processing (S405). Thus, when the interval of timer time is estimating the existence of movement of a self-opportunity and it is moving at it by constituting the GPS reception control part 302, receiving operation can be made to perform to GPS transmitting and receiving part 101. This operation is continued until there is a GPS blind input from the input part 301. If a GPS blind input is inputted into the GPS reception control part 302 from the input part 301, an interrupt will occur and operation of software will be started by the command input. If the interrupt signal is recognized to be a blind input (S401), a timer will stop immediately (S410) and soft operation will be suspended.

[0023]According to the Embodiment 2, operation of one GPS receiving start can be made to perform GPS reception continuously, as mentioned above. Even if it is continuous receiving operation, when it judges whether whether a self-opportunity's moving and a supply voltage value are beyond the threshold set up beforehand at every reception and the self-opportunity has stopped, or when a supply voltage value is less than the threshold set up beforehand, operation of GPS transmitting and receiving part 101 is stopped. As a result, power consumption can be reduced, consumption of a power supply can be delayed, and usable time can be extended.

[0024]By explanation of Embodiment 2 of operation, even if the reception start signal from an input part occurred to write continuous reception possible by timer operation, when power supply voltage was falling, it was explained that it did not receive. However, it can perform easily extending the voltage range which operates by operation from an input part by changing the voltage disregard level referred to in response to the reception start signal from an input part, and the voltage disregard level referred to by timer operation.

[0025]In Embodiment 2, the embodiment 3. embodiment 3 is made to perform receiving operation, only when power supply voltage becomes low, and there is an order signal from a user. Since fundamental composition and operation are the same as that of Embodiment 2, only a different portion is explained. In this case, the GPS reception control part 302 inputs a supply voltage value from the power-supply-voltage primary detecting element 103, when the inputted supply voltage value is less than the threshold set up beforehand, controls GPS transmitting and receiving part 101, and stops that operation. The GPS reception control part 302 controls GPS transmitting and receiving part 101 to output the GPS data for the number of times set up beforehand, only when operation of GPS transmitting and receiving part 101 has stopped and an order signal is inputted via the input part 301 by a user's button grabbing etc.

[0026]Drawing 5 is a flow chart which shows operation of the GPS reception control part 302 of Embodiment 3. The GPS reception control part 302 judges whether first, operation of GPS transmitting and receiving part 101 had stopped, and the order signal was inputted via the input part 301 (S501). When operation of GPS transmitting and receiving part 101 has stopped and the order signal is inputted via the input part 301, GPS transmitting and receiving part 101 is controlled to output the GPS data for the number of times set up beforehand (S505), and it returns to Step S501.

[0027]On the other hand, when GPS transmitting and receiving part 101 is operating or the order signal is not inputted via the input part 301, it is judged whether the detecting signal detected in the move primary detecting element 104 is inputted, and a self-opportunity is moving (S502). If it puts in another way when a self-opportunity is not moving, when the self-opportunity will have stopped, GPS transmitting and receiving part 101 is controlled, the operation is stopped (S506), and it returns to Step S501.

[0028]On the other hand, when a self-opportunity is moving, it is judged whether it is beyond the threshold to which the supply voltage value was inputted into from the power-supply-voltage primary detecting element 103, and the supply voltage value was set beforehand (S503). When a supply voltage value is less than the threshold set up beforehand, it progresses to Step S506, it controls so that GPS transmitting and receiving part 101 performs the usual operation, when a supply voltage value is beyond the threshold set up beforehand (S504), and it returns to Step S501.

[0029]When it judged whether whether a self-opportunity's moving and a supply voltage value were beyond the threshold set up beforehand according to the Embodiment 3 as mentioned above, and the self-opportunity has stopped, Or in order to perform operation for outputting the

GPS data for the number of times which suspended operation of GPS transmitting and receiving part 101 when a supply voltage value was less than the threshold set up beforehand, restricted when an order signal was inputted via the input part 301, and was set up beforehand, Power consumption can be reduced, consumption of a power supply can be delayed, and usable time can be extended.

[0030]Embodiment 4. drawing 6 is a block diagram showing the composition of the portable GPS receiver of the embodiment of the invention 4. Attaching fundamental composition like Embodiment 2, the same portion attaches the same numerals as drawing 3, omits explanation, and explains only a portion different here. The portable GPS receiver of Embodiment 4 was replaced with the move primary detecting element 104, and is provided with the receive state judgment part 601 which inputs the information from GPS transmitting and receiving part 101, and judges a receive state, and the movement speed primary detecting element 602 which inputs the information from GPS transmitting and receiving part 101, and detects movement speed. It replaced with the control section 302 of Embodiment 2, and has the GPS reception control part 603 which controls GPS transmitting and receiving part 101 based on the decision result by the receive state judgment part 601, the detection result by the movement speed primary detecting element 602, and the detection result by the power-supply-voltage primary detecting element 103.

[0031]The receive state judgment part 601 judges a receive state from the accuracy of the error information acquired as a result of the positioning computing in GPS transmitting and receiving part 101, for example, the calculation result of a position, the intensity of a reception radio wave, etc. The movement speed primary detecting element 602 gets the value of movement speed from change of the speed information from GPS transmitting and receiving part 101, or the position information per unit time. An acceleration sensor is formed and it may be made to detect speed.

[0032]The GPS reception control part 603 controls GPS transmitting and receiving part 101 based on the decision result by the receive state judgment part 601, the detection result by the movement speed primary detecting element 602, and the detection result by the power-supply-voltage primary detecting element 103, and changes a positioning interval (interval of operation). For example, when a receive state is bad, a positioning interval is extended in order to hold down the power consumption by useless receiving operation. Since positioning fine when movement speed is quick is required, when a positioning interval is narrowed, people walk and movement speed is slow, since a positioning interval may be long, it extends a positioning interval.

[0033]In the above composition, operation of Embodiment 4 is explained with reference to a flow chart. Drawing 7 and 8 are flow charts which show operation of the GPS reception control part 603 of Embodiment 4. If the GPS reception control part 603 has receiving start directions via the input part 301 by the keystroke from a user, it will control the power-supply-voltage primary detecting element 103, and will measure power supply voltage (S701). It is judged whether next the measured supply voltage value is higher than a predetermined value (S702). When the measured supply voltage value is higher than a predetermined value, the positioning interval data  $T_{iv}$  is computed according to a supply voltage value (S703). And the positioning interval of GPS transmitting and receiving part 101 is set up by computed  $T_{iv}$  (S704), and receiving operation is started (S705).

[0034]For example, the pressure value of a power supply comes out enough, and, in a certain case, let  $T_{iv}$  be the minimum positioning interval of GPS transmitting and receiving part 101. About the minimum positioning interval, many conventional GPS receivers have adopted 1 second. Due to the fall of the pressure value, the positioning interval is lengthened with 10



seconds and 1 minute. At Step S702, if power supply voltage is lower than a predetermined value, processing will be ended. That is, if power supply voltage becomes low rather than a certain value, receiving operation will not be started even if the positioning directions by keystroke are carried out (even if there are receiving start directions). Even after receiving operation starts measurement of power supply voltage, it is performed with a constant interval, and the positioning interval data Tiv according to a supply voltage value is set up.

[0035]If receiving operation starts, the GPS reception control part 603 will calculate and display the current position of a self-opportunity, speed, a direction, current time, etc. for every set-up positioning interval (S801, S802). The error information which controls the receive state judgment part 601 and is acquired as a result of the positioning computing in GPS transmitting and receiving part 101, For example, a receive state at present is judged from an accuracy-of-position degradation rate (PDOP value), the intensity of a reception radio wave, etc. (S803), and the positioning interval data Tip is set up from a decision result (S804). (calculation) If a receive state is bad, the positioning interval data Tip will be lengthened like 1 second, 10 seconds, and 1 minute. Here, the judgment of a receive state may be performed from the receive state of continuous multiple times.

[0036]Next, the movement speed primary detecting element 602 is controlled, the movement speed of the self-opportunity obtained as a result of positioning computing is judged (detection) (S805), and the positioning interval data Tis is set up from a decision result (S806). (calculation) If the movement speed of a self-opportunity becomes slow, the positioning interval data Tis will be lengthened like 1 second, 10 seconds, and 1 minute. It may be made to compute movement speed from the positioning result of continuous multiple times here. Based on Tiv set up according to power supply voltage, Tip set up according to the receive state, Tis set up according to movement speed, and three preset values, \*\* and others, the GPS reception control part 603 controls GPS transmitting and receiving part 101, and changes a positioning interval (S807).

[0037]What kind of thing may be sufficient as the deciding method of a positioning interval? For example, the longest positioning space value is adopted as a positioning interval of a self-opportunity among Tiv, Tip, and Tis, and it may be made to continue receiving operation at intervals of this positioning. In this case, if Tip considers it as 10 seconds by Tiv considering it as 1 minute and Tis considers it as \*\* for 1 second, 1 minute will be adopted as a positioning interval of a portable GPS receiver, and receiving operation will be performed by this positioning interval.

[0038]Since according to the Embodiment 4 the receive state and movement speed of a self-opportunity are judged and a positioning interval is changed based on a decision result as mentioned above, power consumption can be reduced, consumption of a power supply can be delayed, and usable time can be extended. Since operation is not terminated even when a receive state is bad, receiving operation is continuable. Since receiving operation is not performed when power supply voltage becomes below in constant value, it can prevent downing a system.

[0039]From Embodiment 1, a change of the interval (positioning interval) of GPS transmitting and receiving part 101 in Embodiment 4 of operation may be made by changing the current supply interval to GPS transmitting and receiving part 101, and may be performed by changing the positioning interval in GPS transmitting and receiving part 101.

---

[Translation done.]

\* NOTICES \*

JPO and INPIT are not responsible for any damages caused by the use of this translation.

- 1.This document has been translated by computer. So the translation may not reflect the original precisely.
- 2.\*\*\* shows the word which can not be translated.
- 3.In the drawings, any words are not translated.

---

## DESCRIPTION OF DRAWINGS

---

[Brief Description of the Drawings]

[Drawing 1]It is a block diagram showing the composition of the portable GPS receiver of the embodiment of the invention 1.

[Drawing 2]It is a flow chart which shows operation of the GPS reception control part of Embodiment 1.

[Drawing 3]It is a block diagram showing the composition of the portable GPS receiver of the embodiment of the invention 2.

[Drawing 4]It is a flow chart which shows operation of the GPS reception control part of Embodiment 2.

[Drawing 5]It is a flow chart which shows operation of the GPS reception control part of the embodiment of the invention 3.

[Drawing 6]It is a block diagram showing the composition of the portable GPS receiver of the embodiment of the invention 4.

[Drawing 7]It is a flow chart which shows operation of the GPS reception control part of Embodiment 4.

[Drawing 8]It is a flow chart which shows operation of the GPS reception control part of Embodiment 4.

[Description of Notations]

101 GPS transmitting and receiving part

102 Indicator

103 Power-supply-voltage primary detecting element

104 Move primary detecting element

105,302 GPS reception control part

301 Input part

---

[Translation done.]

\* NOTICES \*

JPO and INPIT are not responsible for any damages caused by the use of this translation.

1. This document has been translated by computer. So the translation may not reflect the original precisely.
2. \*\*\* shows the word which can not be translated.
3. In the drawings, any words are not translated.

**DRAWINGS**

[Drawing 1]

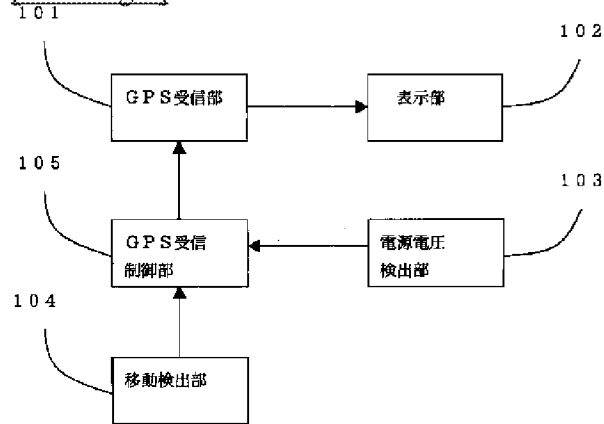

[Drawing 2]

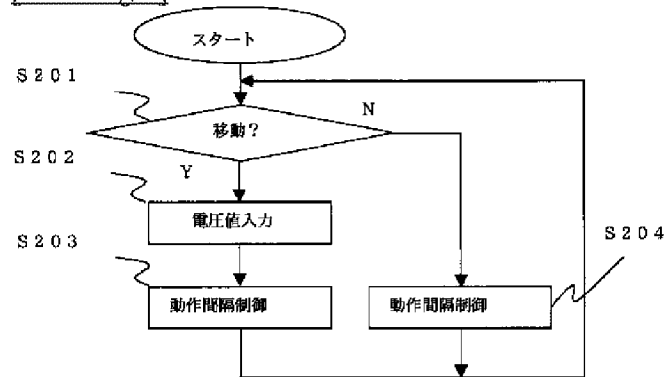

[Drawing 3]

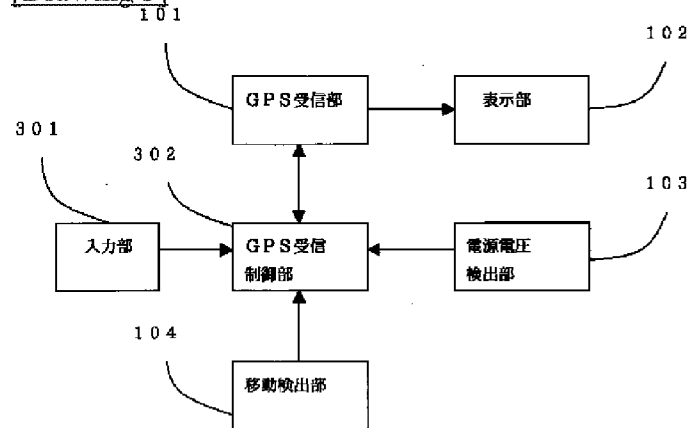

[Drawing 4]

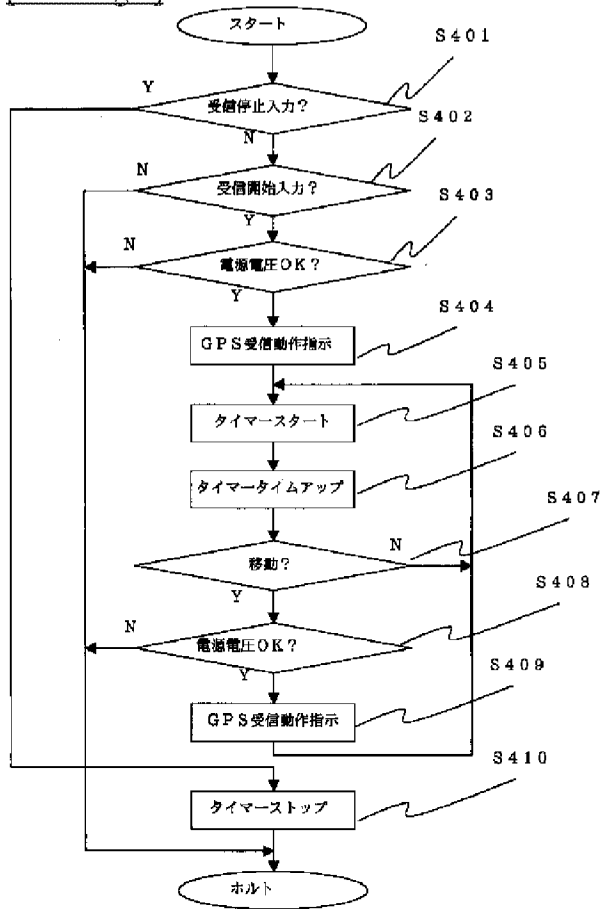

[Drawing 6]

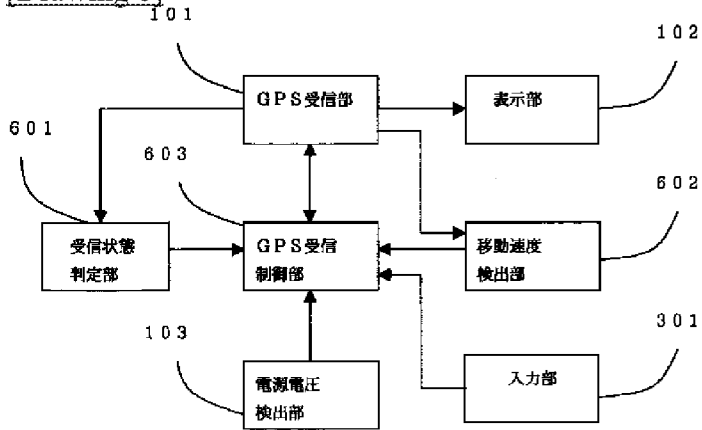

[Drawing 5]

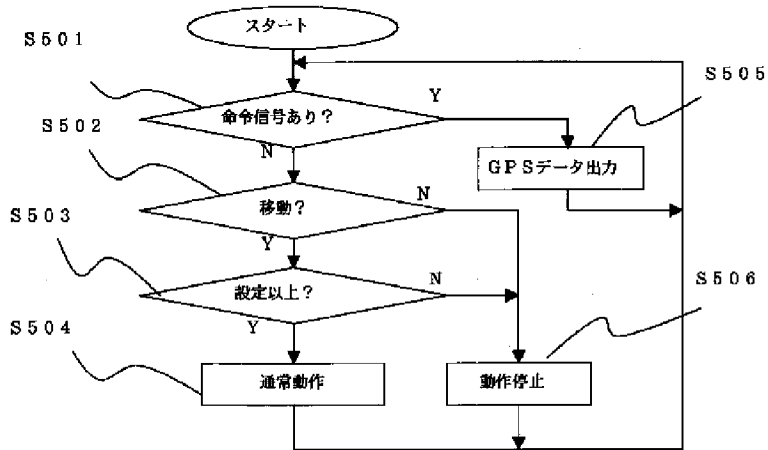

[Drawing 7]

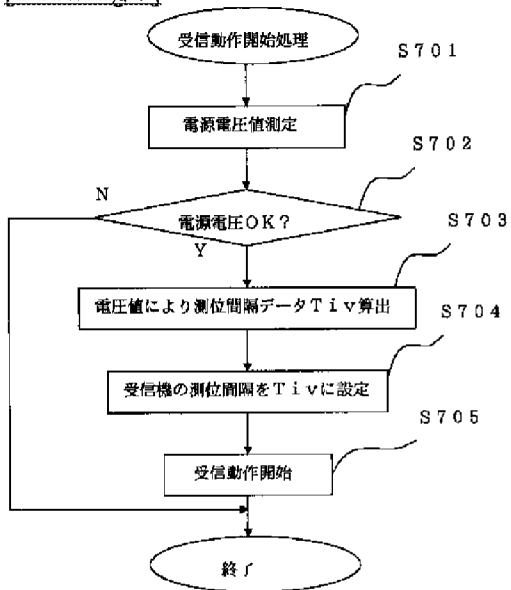

[Drawing 8]

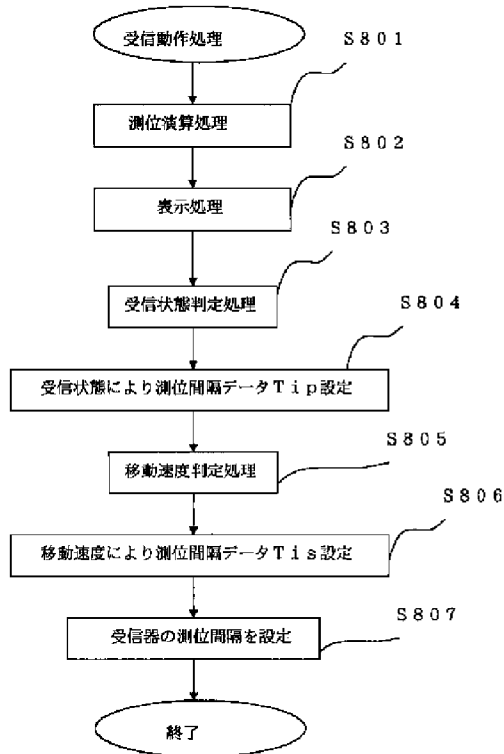

[Translation done.]

\* NOTICES \*

JPO and INPIT are not responsible for any damages caused by the use of this translation.

- 1.This document has been translated by computer. So the translation may not reflect the original precisely.
- 2.\*\*\*\* shows the word which can not be translated.
- 3.In the drawings, any words are not translated.

## DETAILED DESCRIPTION

[Detailed Description of the Invention]

[0001]

[Field of the Invention]This invention receives the electric wave from a GPS Satellite, and relates to the portable GPS receiver which has a function which saves power consumption to

details more about the portable GPS receiver which generates GPS information, such as position information.

[0002]

[Description of the Prior Art]As one of the conventional portable GPS receivers, there are a GPS (Global Positioning System) antenna, a GPS receiver, and a wrist watch provided with the GPS transmitting and receiving part, \*\* and others, for example. If it is in such a wrist watch, a GPS antenna receives the electric wave from a GPS Satellite, and a GPS receiver generates and outputs GPS information, such as position information, per second from the input signal received with the GPS antenna. The user can know the position etc. in which the user itself is using this information.

[0003]Generally, in a portable GPS receiver like the above-mentioned wrist watch, if it puts in another way while one [ the power supply ], operation for outputting GPS information per second is performed until it becomes a power supply piece.

[0004]

[Problem(s) to be Solved by the Invention]However, since operation for outputting GPS information per second was performed according to the above-mentioned conventional art, power consumption was large, the power supply was consumed early, and there was a problem that usable time was short. Although it is possible to lengthen usable time by increasing the capacity of a power supply, since a size, weight, etc. of a self-opportunity have restrictions from the use, generally a portable GPS receiver like the above-mentioned wrist watch has the fault that capacity of a power supply cannot be increased easily.

[0005]This invention was made in view of the above, and is \*\*\*\*. It is reducing the purpose, delaying consumption of a power supply and extending usable time.

[0006]

[Means for Solving the Problem]In order to attain the above-mentioned purpose, in a portable GPS receiver of this invention. In a portable GPS receiver provided with a reception means which receives an electric wave from a GPS Satellite and generates GPS information, A source voltage detecting means which detects power supply voltage, and a control means which inputs a supply voltage value and controls an interval of a reception means of operation based on an inputted supply voltage value from a source voltage detecting means were established so that power consumption might decrease.

[0007]If it is in this portable GPS receiver, power supply voltage is detected and an interval of a reception means of operation is controlled based on a supply voltage value. If a supply voltage value which a control means inputted falls, it may be made to control here so that an interval of a reception means of operation becomes long. In a portable GPS receiver provided with a reception means which a portable GPS receiver of this invention receives an electric wave from a GPS Satellite, and generates GPS information, A source voltage detecting means which detects power supply voltage so that power consumption may decrease, An input means for inputting an order signal which orders execution of operation of a reception means, A supply voltage value was inputted from a source voltage detecting means, and when an inputted supply voltage value was lower than a threshold set up beforehand, a control means which controls a reception means to generate GPS information only when an order signal is inputted via an input means was established.

[0008]If it is in this portable GPS receiver, power supply voltage is detected, and when a supply voltage value is lower than a threshold set up beforehand, a reception means is controlled to

generate GPS information, only when an order signal is inputted via an input means. In a portable GPS receiver provided with a reception means which a portable GPS receiver of this invention receives an electric wave from a GPS Satellite, and generates GPS information, A shift detection means which detects whether a self-opportunity is moving, and a control means which stops operation of a reception means when a detecting signal detected by a shift detection means is inputted and a self-opportunity is not moving were established so that power consumption might decrease.

[0009]If it is in this portable GPS receiver, when it detects whether a self-opportunity is moving and a self-opportunity is not moving, operation of a reception means is stopped. In a portable GPS receiver provided with a reception means which a portable GPS receiver of this invention receives an electric wave from a GPS Satellite, and generates GPS information, A shift detection means which detects whether a self-opportunity is moving, and a control means which controls an interval of a reception means of operation when a detecting signal detected by a shift detection means is inputted and a self-opportunity is not moving were established so that power consumption might decrease.

[0010]If it is in this portable GPS receiver, when it detects whether a self-opportunity is moving and a self-opportunity is not moving, an interval of a reception means of operation is controlled. In a portable GPS receiver provided with a reception means which a portable GPS receiver of this invention receives an electric wave from a GPS Satellite, and generates GPS information, A travelling speed detection means which detects movement speed of a self-opportunity, and a control means which controls an interval of a reception means of operation based on a detection result of this travelling speed detection means were established. If it is in this portable GPS receiver, movement speed of a self-opportunity is detected and an interval of a reception means of operation is controlled based on this detection result.

[0011]A portable GPS receiver of this invention receives an electric wave from a GPS Satellite, and established a control means which controls an interval of a reception means of operation based on a receive state of a reception means in a portable GPS receiver provided with a reception means which generates GPS information. If it is in this portable GPS receiver, a receive state of a reception means is judged and an interval of a reception means of operation is controlled based on this.

[0012]

[Embodiment of the Invention]The order of Embodiment 1 to Embodiment 4 explains an embodiment of the invention in detail with reference to an attached drawing below.

Embodiment 1. drawing 1 is a block diagram showing the composition of the portable GPS receiver of the embodiment of the invention 1. GPS transmitting and receiving part 101 which the portable GPS receiver of Embodiment 1 receives the electric wave from a GPS Satellite, and generates and outputs GPS data, such as position data, The indicator 102 which displays the GPS data from GPS transmitting and receiving part 101, The power-supply-voltage primary detecting element 103 which detects power supply voltage, and the move primary detecting element 104 which detects whether it has an acceleration sensor which is a passive element, and the self-opportunity is moving, While inputting the supply voltage value from the power-supply-voltage primary detecting element 103, the detecting signal detected in the move primary detecting element 104 was inputted, and it has the GPS reception control part 105 which controls operation of GPS transmitting and receiving part 101 based on a supply voltage value and a detecting signal.

[0013]If it is in the portable GPS receiver of Embodiment 1, the power-supply-voltage primary



detecting element 103 detects power supply voltage, the move primary detecting element 104 detects whether the self-opportunity is moving, and the GPS reception control part 105 controls operation of GPS transmitting and receiving part 101 based on a supply voltage value and a detecting signal. GPS transmitting and receiving part 101 receives the electric wave from a GPS Satellite, and generates and outputs GPS data, and the indicator 102 displays the outputted GPS data.

[0014]GPS transmitting and receiving part 101 corresponds to the reception means of this invention, and the GPS reception control part 105 corresponds to the control means of this invention. In the above composition, operation of Embodiment 1 is explained with reference to a flow chart. Drawing 2 is a flow chart which shows operation of the GPS reception control part 105 of Embodiment 1. The GPS reception control part 105 judges whether the detecting signal detected in the move primary detecting element 104 is inputted first, and a self-opportunity is moving (S201). If it puts in another way when a self-opportunity is not moving, when the self-opportunity will have stopped, GPS transmitting and receiving part 101 is controlled to perform an interval of operation larger than the operation for outputting GPS data for usual every second, for example, operation which outputs GPS data every 10 seconds, (S204), and it returns to Step S201.

[0015]On the other hand, when a self-opportunity is moving, a supply voltage value is inputted from the power-supply-voltage primary detecting element 103 (S202), the interval of GPS transmitting and receiving part 101 of operation is controlled based on the inputted supply voltage value (S203), and it returns to Step S201. If a supply voltage value falls, may control here so that an interval of operation becomes long, and, The table to which an interval of operation which divided the range of a supply voltage value into plurality, and is different in each of the range of each divided supply voltage value was made to correspond is set up beforehand, and it may be made to control an interval of operation according to this table.

[0016]Since the interval of operation of GPS transmitting and receiving part 101 is extended when according to the Embodiment 1 it detects whether a self-opportunity is moving and the self-opportunity has stopped, as mentioned above, power consumption can be reduced, consumption of a power supply can be delayed, and usable time can be extended. Since power supply voltage is detected and the interval of GPS transmitting and receiving part 101 of operation is controlled based on a supply voltage value, power consumption can be reduced, consumption of a power supply can be delayed, and usable time can be extended.

[0017]Embodiment 2. drawing 3 is a block diagram showing the composition of the portable GPS receiver of the embodiment of the invention 2. Attaching fundamental composition like Embodiment 1, the same portion attaches the same numerals as drawing 1, omits explanation, and explains only a portion different here. The portion into which the portable GPS receiver of Embodiment 2 differs from Embodiment 1 is operation of the GPS reception control part 302. It has the input part 301 for inputting the order signal which orders execution of operation and stop of GPS transmitting and receiving part 101 in addition to the composition of the portable GPS receiver of Embodiment 1 shown by drawing 1.

[0018]The GPS reception control part 302 starts operation by the input of the GPS receiving start command from the input part 301. When the power-supply-voltage primary detecting element 103 has not detected the fall of power supply voltage, according to the input of a GPS receiving start command, the signal which directs an operation start to GPS transmitting and receiving part 101 immediately is generated. When the power-supply-voltage primary detecting element 103 has detected the fall of power supply voltage, GPS reception is not performed even if there is an

input of a GPS receiving start command from the input part 301.

[0019]When the power-supply-voltage primary detecting element 103 has not detected the fall of power supply voltage, the GPS reception control part 302 generates the signal which directs an operation start to GPS transmitting and receiving part 101 whenever a GPS receiving start command is inputted from the input part 301. Until the command which stops GPS reception from the input part 301 will be inputted, once the GPS reception control part 302 has a GPS receiving start command input from the input part 301, At intervals of the timer of a certain fixed time, it is constituted so that it may continue generating a receiving operation start signal to GPS transmitting and receiving part 101.

[0020]In the above composition, operation of Embodiment 2 is explained with reference to a flow chart. Drawing 4 is a flow chart which shows operation of the GPS reception control part of Embodiment 2. If there is a GPS receiving start command input from the input part 301 (S401) (switch in the input part 301 which is not illustrated), an interrupt will occur and operation of software will be started by the command input. If recognized as the interrupt signal being the GPS receiving start command from the input part 301 (S402), The GPS reception control part 302 transmits the start indication signal for which the GPS reception control part 302 makes GPS transmitting and receiving part 101 start GPS receiving operation, when power supply voltage is not falling with reference to the output signal of the power-supply-voltage primary detecting element 103 (S403) (S404). GPS transmitting and receiving part 101 starts reception with the receiving start indication signal from the GPS reception control part 302, and the received data is displayed by the indicator 102.

[0021]A timer is started after the GPS reception control part 302 outputs a receiving start indication signal to GPS transmitting and receiving part 101 (S405). If the started timer passes the deadline of (S406), the GPS reception control part 302 will judge whether a self-opportunity is moving with reference to the output of the move primary detecting element 104 (S407). If it judges that the self-opportunity is moving, when power supply voltage will not fall again with reference to the output of the power-supply-voltage primary detecting element 103 (S408), the GPS reception control part 302 outputs a receiving start indication signal to GPS transmitting and receiving part 101 again (S409).

[0022]When it judges that the self-opportunity is not moving in processing of Step S407, GPS reception is not performed but it returns to timer start processing (S405). Thus, when the interval of timer time is estimating the existence of movement of a self-opportunity and it is moving at it by constituting the GPS reception control part 302, receiving operation can be made to perform to GPS transmitting and receiving part 101. This operation is continued until there is a GPS blind input from the input part 301. If a GPS blind input is inputted into the GPS reception control part 302 from the input part 301, an interrupt will occur and operation of software will be started by the command input. If the interrupt signal is recognized to be a blind input (S401), a timer will stop immediately (S410) and soft operation will be suspended.

[0023]According to the Embodiment 2, operation of one GPS receiving start can be made to perform GPS reception continuously, as mentioned above. Even if it is continuous receiving operation, when it judges whether whether a self-opportunity's moving and a supply voltage value are beyond the threshold set up beforehand at every reception and the self-opportunity has stopped, or when a supply voltage value is less than the threshold set up beforehand, operation of GPS transmitting and receiving part 101 is stopped. As a result, power consumption can be reduced, consumption of a power supply can be delayed, and usable time can be extended.

[0024]By explanation of Embodiment 2 of operation, even if the reception start signal from an

input part occurred to write continuous reception possible by timer operation, when power supply voltage was falling, it was explained that it did not receive. However, it can perform easily extending the voltage range which operates by operation from an input part by changing the voltage disregard level referred to in response to the reception start signal from an input part, and the voltage disregard level referred to by timer operation.

[0025]In Embodiment 2, the embodiment 3. embodiment 3 is made to perform receiving operation, only when power supply voltage becomes low, and there is an order signal from a user. Since fundamental composition and operation are the same as that of Embodiment 2, only a different portion is explained. In this case, the GPS reception control part 302 inputs a supply voltage value from the power-supply-voltage primary detecting element 103, when the inputted supply voltage value is less than the threshold set up beforehand, controls GPS transmitting and receiving part 101, and stops that operation. The GPS reception control part 302 controls GPS transmitting and receiving part 101 to output the GPS data for the number of times set up beforehand, only when operation of GPS transmitting and receiving part 101 has stopped and an order signal is inputted via the input part 301 by a user's button grabbing etc.

[0026]Drawing 5 is a flow chart which shows operation of the GPS reception control part 302 of Embodiment 3. The GPS reception control part 302 judges whether first, operation of GPS transmitting and receiving part 101 had stopped, and the order signal was inputted via the input part 301 (S501). When operation of GPS transmitting and receiving part 101 has stopped and the order signal is inputted via the input part 301, GPS transmitting and receiving part 101 is controlled to output the GPS data for the number of times set up beforehand (S505), and it returns to Step S501.

[0027]On the other hand, when GPS transmitting and receiving part 101 is operating or the order signal is not inputted via the input part 301, it is judged whether the detecting signal detected in the move primary detecting element 104 is inputted, and a self-opportunity is moving (S502). If it puts in another way when a self-opportunity is not moving, when the self-opportunity will have stopped, GPS transmitting and receiving part 101 is controlled, the operation is stopped (S506), and it returns to Step S501.

[0028]On the other hand, when a self-opportunity is moving, it is judged whether it is beyond the threshold to which the supply voltage value was inputted into from the power-supply-voltage primary detecting element 103, and the supply voltage value was set beforehand (S503). When a supply voltage value is less than the threshold set up beforehand, it progresses to Step S506, it controls so that GPS transmitting and receiving part 101 performs the usual operation, when a supply voltage value is beyond the threshold set up beforehand (S504), and it returns to Step S501.

[0029]When it judged whether whether a self-opportunity's moving and a supply voltage value were beyond the threshold set up beforehand according to the Embodiment 3 as mentioned above, and the self-opportunity has stopped, Or in order to perform operation for outputting the GPS data for the number of times which suspended operation of GPS transmitting and receiving part 101 when a supply voltage value was less than the threshold set up beforehand, restricted when an order signal was inputted via the input part 301, and was set up beforehand, Power consumption can be reduced, consumption of a power supply can be delayed, and usable time can be extended.

[0030]Embodiment 4. drawing 6 is a block diagram showing the composition of the portable GPS receiver of the embodiment of the invention 4. Attaching fundamental composition like Embodiment 2, the same portion attaches the same numerals as drawing 3, omits explanation,

and explains only a portion different here. The portable GPS receiver of Embodiment 4 was replaced with the move primary detecting element 104, and is provided with the receive state judgment part 601 which inputs the information from GPS transmitting and receiving part 101, and judges a receive state, and the movement speed primary detecting element 602 which inputs the information from GPS transmitting and receiving part 101, and detects movement speed. It replaced with the control section 302 of Embodiment 2, and has the GPS reception control part 603 which controls GPS transmitting and receiving part 101 based on the decision result by the receive state judgment part 601, the detection result by the movement speed primary detecting element 602, and the detection result by the power-supply-voltage primary detecting element 103.

[0031]The receive state judgment part 601 judges a receive state from the accuracy of the error information acquired as a result of the positioning computing in GPS transmitting and receiving part 101, for example, the calculation result of a position, the intensity of a reception radio wave, etc. The movement speed primary detecting element 602 gets the value of movement speed from change of the speed information from GPS transmitting and receiving part 101, or the position information per unit time. An acceleration sensor is formed and it may be made to detect speed.

[0032]The GPS reception control part 603 controls GPS transmitting and receiving part 101 based on the decision result by the receive state judgment part 601, the detection result by the movement speed primary detecting element 602, and the detection result by the power-supply-voltage primary detecting element 103, and changes a positioning interval (interval of operation). For example, when a receive state is bad, a positioning interval is extended in order to hold down the power consumption by useless receiving operation. Since positioning fine when movement speed is quick is required, when a positioning interval is narrowed, people walk and movement speed is slow, since a positioning interval may be long, it extends a positioning interval.

[0033]In the above composition, operation of Embodiment 4 is explained with reference to a flow chart. Drawing 7 and 8 are flow charts which show operation of the GPS reception control part 603 of Embodiment 4. If the GPS reception control part 603 has receiving start directions via the input part 301 by the keystroke from a user, it will control the power-supply-voltage primary detecting element 103, and will measure power supply voltage (S701). It is judged whether next the measured supply voltage value is higher than a predetermined value (S702). When the measured supply voltage value is higher than a predetermined value, the positioning interval data  $T_{iv}$  is computed according to a supply voltage value (S703). And the positioning interval of GPS transmitting and receiving part 101 is set up by computed  $T_{iv}$  (S704), and receiving operation is started (S705).

[0034]For example, the pressure value of a power supply comes out enough, and, in a certain case, let  $T_{iv}$  be the minimum positioning interval of GPS transmitting and receiving part 101. About the minimum positioning interval, many conventional GPS receivers have adopted 1 second. Due to the fall of the pressure value, the positioning interval is lengthened with 10 seconds and 1 minute. At Step S702, if power supply voltage is lower than a predetermined value, processing will be ended. That is, if power supply voltage becomes low rather than a certain value, receiving operation will not be started even if the positioning directions by keystroke are carried out (even if there are receiving start directions). Even after receiving operation starts measurement of power supply voltage, it is performed with a constant interval, and the positioning interval data  $T_{iv}$  according to a supply voltage value is set up.

[0035]If receiving operation starts, the GPS reception control part 603 will calculate and display the current position of a self-opportunity, speed, a direction, current time, etc. for every set-up

positioning interval (S801, S802). The error information which controls the receive state judgment part 601 and is acquired as a result of the positioning computing in GPS transmitting and receiving part 101, For example, a receive state at present is judged from an accuracy-of-position degradation rate (PDOP value), the intensity of a reception radio wave, etc. (S803), and the positioning interval data Tip is set up from a decision result (S804). (calculation) If a receive state is bad, the positioning interval data Tip will be lengthened like 1 second, 10 seconds, and 1 minute. Here, the judgment of a receive state may be performed from the receive state of continuous multiple times.

[0036]Next, the movement speed primary detecting element 602 is controlled, the movement speed of the self-opportunity obtained as a result of positioning computing is judged (detection) (S805), and the positioning interval data Tis is set up from a decision result (S806). (calculation) If the movement speed of a self-opportunity becomes slow, the positioning interval data Tis will be lengthened like 1 second, 10 seconds, and 1 minute. It may be made to compute movement speed from the positioning result of continuous multiple times here. Based on Tiv set up according to power supply voltage, Tip set up according to the receive state, Tis set up according to movement speed, and three preset values, \*\* and others, the GPS reception control part 603 controls GPS transmitting and receiving part 101, and changes a positioning interval (S807).

[0037]What kind of thing may be sufficient as the deciding method of a positioning interval? For example, the longest positioning space value is adopted as a positioning interval of a self-opportunity among Tiv, Tip, and Tis, and it may be made to continue receiving operation at intervals of this positioning. In this case, if Tip considers it as 10 seconds by Tiv considering it as 1 minute and Tis considers it as \*\* for 1 second, 1 minute will be adopted as a positioning interval of a portable GPS receiver, and receiving operation will be performed by this positioning interval.

[0038]Since according to the Embodiment 4 the receive state and movement speed of a self-opportunity are judged and a positioning interval is changed based on a decision result as mentioned above, power consumption can be reduced, consumption of a power supply can be delayed, and usable time can be extended. Since operation is not terminated even when a receive state is bad, receiving operation is continuable. Since receiving operation is not performed when power supply voltage becomes below in constant value, it can prevent downing a system.

[0039]From Embodiment 1, a change of the interval (positioning interval) of GPS transmitting and receiving part 101 in Embodiment 4 of operation may be made by changing the current supply interval to GPS transmitting and receiving part 101, and may be performed by changing the positioning interval in GPS transmitting and receiving part 101.

[0040]

[Effect of the Invention]As explained above, since the portable GPS receiver of this invention detects power supply voltage and controls the interval of a reception means of operation based on a supply voltage value, it can reduce power consumption, can delay consumption of a power supply, and can extend usable time. Since detect power supply voltage and a supply voltage value falls, and the portable GPS receiver of this invention is controlled so that the interval of a reception means of operation becomes long, it can reduce power consumption in accordance with the fall of a supply voltage value, can delay consumption of a power supply, and can extend usable time.

[0041]The portable GPS receiver of this invention detects power supply voltage, and when a supply voltage value is lower than the threshold set up beforehand, Since a reception means is controlled to generate GPS information only when an order signal is inputted via an input means,

power consumption can be reduced, consumption of a power supply can be delayed, and usable time can be extended. Since the portable GPS receiver of this invention stops operation of a reception means when it detects whether the self-opportunity is moving and the self-opportunity is not moving, it can reduce power consumption, can delay consumption of a power supply, and can extend usable time.

[0042]Since the portable GPS receiver of this invention controls the interval of a reception means of operation when it detects whether the self-opportunity is moving and the self-opportunity is not moving, it can reduce power consumption, can delay consumption of a power supply, and can extend usable time. Since the portable GPS receiver of this invention detects the movement speed of a self-opportunity and controls the interval of a reception means of operation based on this detection result, it can reduce power consumption, can delay consumption of a power supply, and can extend usable time.

[0043]Since a portable GPS receiver controls the interval of a reception means of operation based on the receive state of a reception means, it can reduce power consumption, can delay consumption of a power supply, and can extend usable time.

---

[Translation done.]

\* NOTICES \*

**JPO and INPIT are not responsible for any damages caused by the use of this translation.**

- 1.This document has been translated by computer. So the translation may not reflect the original precisely.
- 2.\*\*\* shows the word which can not be translated.
- 3.In the drawings, any words are not translated.

---

## CLAIMS

---

[Claim(s)]

[Claim 1]A portable GPS receiver comprising provided with a reception means which receives an electric wave from a GPS Satellite and generates GPS information:

A source voltage detecting means which detects power supply voltage.

A control means which inputs a supply voltage value and controls an interval of said reception means of operation based on an inputted supply voltage value from said source voltage detecting means.

[Claim 2]The portable GPS receiver according to claim 1 controlled so that an interval of said reception means of operation will be lengthened, if said control means falls [ said inputted supply voltage value ].

[Claim 3]A portable GPS receiver comprising provided with a reception means which receives

an electric wave from a GPS Satellite and generates GPS information:

A source voltage detecting means which detects power supply voltage.

An input means for inputting an order signal which orders execution of operation of said reception means, A control means which controls said reception means to input a supply voltage value from said source voltage detecting means, and to generate said GPS information only when an inputted supply voltage value is lower than a threshold set up beforehand, and an order signal is inputted via said input means.

[Claim 4]A portable GPS receiver comprising provided with a reception means which receives an electric wave from a GPS Satellite and generates GPS information:

A shift detection means which detects whether a self-opportunity is moving.

A control means which stops operation of said reception means when it is judged that a detecting signal detected by said shift detection means is inputted, and a self-opportunity is not moving.

[Claim 5]A portable GPS receiver comprising provided with a reception means which receives an electric wave from a GPS Satellite and generates GPS information:

A shift detection means which detects whether a self-opportunity is moving.

A control means which controls an interval of said reception means of operation when it is judged that a detecting signal detected by said shift detection means is inputted, and a self-opportunity is not moving.

[Claim 6]A portable GPS receiver comprising provided with a reception means which receives an electric wave from a GPS Satellite and generates GPS information:

A travelling speed detection means which detects movement speed of a self-opportunity.

A control means which controls an interval of said reception means of operation based on a detection result of said travelling speed detection means.

[Claim 7]A portable GPS receiver which possesses a control means which controls an interval of said reception means of operation based on a receive state of said reception means in a portable GPS receiver provided with a reception means which receives an electric wave from a GPS Satellite and generates GPS information.

---

[Translation done.]

**(19)대한민국특허청(KR)**  
**(12) 등록특허공보(B1)**

(51) Int. Cl.<sup>7</sup>  
H04B 7/26

(45) 공고일자 2005년12월01일  
(11) 등록번호 10-0532589  
(24) 등록일자 2005년11월24일

(21) 출원번호 10-2003-0097845  
(22) 출원일자 2003년12월26일

(65) 공개번호 10-2005-0066544  
(43) 공개일자 2005년06월30일

(73) 특허권자 한국전자통신연구원  
대전 유성구 가정동 161번지

(72) 발명자 김인준  
대전광역시서구가장동나르메아파트209-509

김재훈  
대전광역시유성구어은동한빛아파트109-1303

(74) 대리인 특허법인 신성

심사관 : 하은주

**(54) 무선인식/위성측위/관성항법을 결합한 통합 측위 장치 및 그 방법**

요약

1. 청구범위에 기재된 발명이 속하는 기술분야

본 발명은 무선인식/위성측위/관성항법을 결합한 통합 측위 장치 및 그 방법에 관한 것임.

2. 발명이 해결하려고 하는 기술적 과제

본 발명은, 불완전한 위성측위시스템(GPS: Global Positioning System)과 관성항법장치(INS:Inertial Navigation System)를 결합한 측위장치에 무선인식(RFID: Radio frequency identification) 측위기술을 결합함으로써, GPS 신호 단절시에도 RFID 측위정보와 INS 측위정보를 이용하여 안정적이고 연속적인 위치정보를 획득할 수 있게 하는, 무선인식/위성측위/관성항법을 결합한 통합 측위 장치 및 그 방법을 제공하는데 그 목적이 있음.

3. 발명의 해결 방법의 요지

본 발명은, 이동체에 탑재되어 상기 이동체의 위치를 측정하는 측위 장치에 있어서, 위성으로부터 GPS(Global Positioning System) 위성 신호를 수신하여 상기 이동체의 위치정보를 획득하기 위한 GPS 수신 수단; 상기 이동체의 이동에 따라 무선인식(RFID: Radio frequency identification) 태그로부터 송신되는 태그 식별정보(ID)를 수신하여 읽기 위한 RFID 리딩 수단; 다수의 가속도센서와 자이로센서를 이용하여 상기 이동체의 속도정보, 가속도정보, 및 방향정보를 획득하기 위한 INS센서 모듈; 상기 GPS 수신 수단으로부터 전달받은 GPS 위치정보의 사용여부와 상기 RFID 리딩 수단으로부터의 태그 식별정보의 획득여부에 따라, 측위 알고리즘의 유형에 대한 선택정보를 생성하기 위한 GPS/RFID 선택 수단; 및



상기 GPS/RFID 선택 수단의 선택정보에 따라 GPS/INS 결합 측위 알고리즘, RFID/INS 결합 측위 알고리즘, INS 단독 측위 알고리즘 중 어느 하나의 해당 측위 알고리즘을 수행하여 상기 이동체의 위치정보를 획득하기 위한 통합 측위 수단을 포함함.

4. 발명의 중요한 용도

본 발명은 측위 시스템 등에 이용됨.

대표도

도 2

색인어

RFID, GPS, 관성항법장치, INS, 통합 측위 장치, 이중결합 통합 측위, 단일결합 통합 측위, 강결합 측위필터, 칼만필터.

명세서

도면의 간단한 설명

도 1 은 본 발명에 따른 RFID/GPS/INS/DR이 결합된 텔레메틱스 측위 시스템에 대한 설명도.

도 2 는 본 발명에 따른 RFID/GPS/INS/DR이 결합된 통합 측위 장치의 일실시에 구성도.

도 3 은 본 발명에 따른 도 2 의 이중결합 방식으로 결합된 통합 측위 장치의 일실시에 구성도.

도 4 는 본 발명에 따른 도 2 의 단일결합 방식으로 결합된 통합 측위 장치의 일실시에 구성도.

도 5 는 본 발명에 따른 도 4 의 단일결합 방식으로 결합된 통합 측위 필터의 일실시에 상세구성도.

도 6 은 본 발명에 따른 RFID/GPS/INS/DR 이중결합 방식에 의한 통합 측위 방법에 대한 일실시에 흐름도.

도 7 은 본 발명에 따른 RFID/GPS/INS/DR 단일결합 방식에 의한 통합 측위 방법에 대한 일실시에 흐름도.

도 8a 및 도 8b 는 본 발명에 따른 GPS/RFID선택기의 측위 알고리즘 선택 방법에 대한 일실시에 흐름도.

\* 도면의 주요 부분에 대한 부호 설명

100: RFID/GPS/INS/DR 결합 통합 측위 장치 110: 위성

120: RFID 태그 210: RFID 리더기

220: GPS수신기 230: INS 센서 모듈

240: DR센서 모듈 250: 마이크로프로세서

260, 500: RFID 태그 ID별 위치정보DB 300, 400: GPS/RFID 선택기

310: 이중결합 통합 측위 필터

312: GPS/INS/DR 강결합측위 필터 410: 단일결합 통합 측위 필터

501: RFID 위치 필터 502: 스위치

503, 506: 결합기 504: 칼만 필터

505: INS/DR 센서 필터

발명의 상세한 설명

발명의 목적

발명이 속하는 기술 및 그 분야의 종래기술

본 발명은 측위장치 및 그 방법에 관한 것으로서, 더욱 상세하게는 불안정한 위성측위시스템(GPS: Global Positioning System)과 관성항법장치(INS:Inertial Navigation System)를 결합한 측위장치에 무선인식(RFID: Radio frequency identification) 측위기술을 결합함으로써, GPS 신호 단절시에도 RFID 측위정보와 INS 측위정보를 이용하여 안정적이고 연속적인 위치정보를 획득할 수 있게 하는, 무선인식, 위성측위, 및 관성항법을 결합한 통합 측위 장치 및 그 방법에 관한 것이다.

최근 이동통신 기술이 발달함에 따라 사용자의 위치를 파악하여 새로운 서비스를 제공하기 위한 위치결정 기술이 개발되고 있다. 일반적으로 위치정보를 활용한 서비스 분야를 위치기반서비스(LBS: Location based Service)라 부르며, 이는 텔레매틱스(Telematics)의 한 분야로서 차량의 위치추적 또는 항법 기술이 이에 포함된다.

종래의 위치 정보 획득 방법으로는, 위성측위시스템(GPS: Global Positioning System)만을 이용한 전통적인 방법, 이동통신단말기만을 이용한 방법, GPS와 관성항법장치(INS)를 결합한 방법, GPS와 이동통신단말기를 결합한 방법, GPS/이동통신단말기/INS를 결합한 방법 등이 주로 개발되고 있다.

GPS를 이용한 전통적인 방법은 GPS음영지역(예를 들면, 빌딩숲, 높은 가로수, 터널, 실내 등)에서의 GPS신호의 단절에 의해 측위가 불가능할 수 있으며, 이동통신망을 이용한 방법은 근원문제(Near-far problem), 가청성(Hearability), 다중경로(Multipath), 나쁜 정도(精度)열화(DOP: Dilution of Precision), 중계기 문제(Repeater problem) 등으로 인해 정확도 및 신뢰도가 떨어진다는 문제점이 있었다.

한편, 차량항법장치로 많이 사용되고 있는 GPS/INS 결합 방법은 GPS신호의 단절 및 INS의 시간에 따른 오차누적 문제로 장시간 동안 GPS신호를 받지 못하면 위치 오차가 발산하는 문제점이 있었고, GPS와 이동통신단말기의 결합 방법은 이동통신단말기의 특성상 짧은 순간의 위치정보만 서비스가 가능하며 역시 GPS신호의 단절시 이동통신단말기만으로 측위를 수행해야 하므로 부정확한 위치 획득과 많은 비용이 소모되는 문제점이 있었다.

최근에는 무선인식(RFID), 무선랜, UWB(Ultra-Wide Band)기술 등을 이용한 측위방법에 대한 연구가 활발하다.

앞에서 설명한 바와 같이, 종래의 기술들은 GPS신호의 단절에 크게 영향을 받고, 이동통신망을 이용한 측위기술도 기지국망의 배치 및 전파환경 등에 크게 영향을 받으며, 관성항법장치(INS) 등과의 통합 방법도 시간에 따른 오차 누적 가능성을 완전히 배제하지 못하므로 잠재적인 오차요인을 갖고 있다.

발명이 이루고자 하는 기술적 과제

본 발명은, 상기와 같은 문제점을 해결하기 위하여 제안된 것으로, 불안정한 위성측위시스템(GPS: Global Positioning System)/관성항법장치(INS:Inertial Navigation System) 결합 측위장치에 무선인식(RFID) 측위기술을 결합함으로써, GPS 신호 단절시에도 RFID 측위정보와 INS 측위정보를 이용하여 안정적이고 연속적인 위치정보를 획득할 수 있게 하는, 무선인식, 위성측위, 및 관성항법을 결합한 통합 측위 장치 및 그 방법을 제공하는데 그 목적이 있다.

발명의 구성 및 작용

상기의 목적을 달성하기 위한 본 발명은, 이동체에 탑재되어 상기 이동체의 위치를 측정하는 측위 장치에 있어서, 위성으로부터 GPS(Global Positioning System)위성 신호를 수신하여 상기 이동체의 위치정보를 획득하기 위한 GPS 수신 수단; 상기 이동체의 이동에 따라 무선인식(RFID: Radio frequency identification) 태그로부터 송신되는 태그 식별정보(ID)를 수신하여 읽기 위한 RFID 리더 수단; 다수의 가속도센서와 자이로센서를 이용하여 상기 이동체의 속도정보, 가속도정보,

및 방향정보를 획득하기 위한 INS센서 모듈; 상기 GPS 수신 수단으로부터 전달받은 GPS 위치정보의 사용여부와 상기 RFID 리더기 수단으로부터의 태그 식별정보의 획득여부에 따라, 측위 알고리즘의 유형에 대한 선택정보를 생성하기 위한 GPS/RFID 선택 수단; 및 상기 GPS/RFID 선택 수단의 선택정보에 따라 GPS/INS 결합 측위 알고리즘, RFID/INS 결합 측위 알고리즘, INS 단독 측위 알고리즘 중 어느 하나의 해당 측위 알고리즘을 수행하여 상기 이동체의 위치정보를 획득하기 위한 통합 측위 수단을 포함한다.

한편, 본 발명은, 이동체에 탑재되어 상기 이동체의 위치를 측정하는 측위 방법에 있어서, 위성으로부터 GPS(Global Positioning System) 위성 신호를 수신하여 상기 이동체의 위치정보를 획득하는 GPS 수신 단계; 상기 이동체의 이동에 따라 무선인식(RFID) 태그로부터 송신되는 태그 식별정보(ID)를 수신하여 읽는 RFID 리더기 단계; 다수의 가속도센서와 자이로센서를 이용하여 상기 이동체의 속도정보, 가속도정보, 및 방향정보를 획득하는 INS 운동정보 획득 단계; 상기 GPS 수신 단계에서 획득한 GPS 위치정보의 사용여부와 상기 RFID 태그 식별정보의 수신여부에 따라, 측위 알고리즘의 유형에 대한 선택정보를 생성하는 측위 알고리즘 선택 단계; 및 상기 선택정보에 따라 GPS/INS 결합 측위 알고리즘, RFID/INS 결합 측위 알고리즘, INS 단독 측위 알고리즘 중 어느 하나의 해당 측위 알고리즘을 수행하여 상기 이동체의 위치정보를 획득하는 통합 측위 단계를 포함한다.

본 발명은 RFID 기술을 GPS 및 INS와 결합하여 측위에 적용하는 기술로서, GPS신호 수신에 가능할 경우에는 GPS/INS(DR) 통합 측위 필터를 사용하여 측위를 수행하고, GPS신호의 단절시에는 RFID 위치정보를 INS(DR)와 결합하여 측위를 수행함으로써 측위의 연속성과 신뢰도를 확보할 수 있게 하는 것이다.

즉, 본 발명은, RFID 기술과 GPS, INS/DR 기술을 결합함으로써 연속측위를 가능하게 하는 위치 결정에 관한 기술로서, 특히 RFID 기술을 활용하여 GPS신호의 단절시에도 연속적인 측위가 가능하고, RFID 기술을 INS/DR기술과 결합하여 오랜 기간 동안 GPS신호를 수신하지 못하여도 안정적인 측위가 가능한 통합 측위 장치 및 그 방법에 관한 것이다.

상술한 목적, 특징들 및 장점은 첨부된 도면과 관련한 다음의 상세한 설명을 통하여 보다 분명해 질 것이다. 이하, 첨부된 도면을 참조하여 본 발명에 따른 바람직한 일실시예를 상세히 설명한다.

도 1은 본 발명에 따른 RFID/GPS/INS/DR이 결합된 텔레메틱스 측위 시스템에 대한 설명도이다.

무선인식(RFID: Radio frequency identification) 네트워크, 위성측위시스템 (GPS: Global Positioning System), 및 관성항법장치(INS: Inertial Navigation System)/추측(DR: Dead-Reckoning)항법장치를 결합한 텔레메틱스 측위 시스템에 해당하는 RFID/GPS/INS/DR 결합 통합 측위 장치(100)은 RFID 리더기, GPS 수신기, INS센서 모듈, 및 RFID 태그를 포함하여 이루어지며, 차량에 탑재된다.

RFID 태그(120)는 도로상에 있는 시설물 안에 내장되어 있으며, 위치좌표값 또는 데이터베이스(DB)로부터 위치를 조회할 수 있는 태그 식별정보(ID)를 저장한다. 여기서, RFID 태그(120)는 일정한 간격을 갖고 RFID 리더기의 전파범위 안에 포함되도록 배치되며, 중앙분리대, 가드레일, 신호등, 가로등, 가로수, 도로 위 등의 도로 시설물 안에 내장될 수 있다.

RFID 리더기는 지속적으로 전파를 발산하여 전파범위 안에 들어온 RFID 태그(140)로부터 데이터를 읽어 들여, RFID 태그(120)의 위치정보를 출력한다.

GPS 수신기는 위성(110)으로부터 GPS 위성 신호를 안테나를 통해 수신하여 사용자의 위치(Position), 속도(Velocity), 가속도(Acceleration), 방향각(Heading), 위성파 수신기사이의 거리인 의사거리(Pseudorange) 등을 출력한다.

INS센서 모듈은 다수의 자이로스코프(Gyroscope)라는 자이로 센서와 가속도계(Accelerometer)라는 가속도 센서로 구성된다.

한편, 측위 시스템이 차량에 적용할 경우에는, 차속계를 포함한 추측(DR: Dead-Reckoning)센서가 추가된다.

도 2는 본 발명에 따른 RFID/GPS/INS/DR이 결합된 통합 측위 장치의 일실시예 구성도이다.

GPS수신기(220)는 GPS 안테나를 통하여 GPS 위성 신호를 수신하여 사용자의 위치를 결정한다.

RFID 리더기(210)는 RFID 안테나를 통하여 지속적으로 전파를 발산하여 전파범위 안에 들어온 RFID 태그(120)로부터 데이터를 읽어 들여, RFID 태그(120)의 위치정보를 출력한다.

초소형정밀가공기술(MEMS: MicroElectroMechanical Systems)형 INS센서 모듈 (230)은 다수의 자이로스코프(Gyroscope)라는 자이로 센서와 가속도계 (Accelerometer)라는 가속도 센서로 구성된다.

한편, 측위장치는 이동가능한 단말기 등의 이동체에 장착되는데, 그 측위 장치가 차량에 적용할 경우에는, 차속계를 포함한 추측(DR: Dead-Reckoning) 센서(250)가 추가된다.

마이크로프로세서(250)는 디지털 신호처리된 RFID, GPS, INS/DR센서에서 얻은 정보를 통합하여 처리하며, 위치정보 데이터베이스(DB)(260)는 RFID 태그의 ID에 따른 위치좌표(위치정보)를 저장하고 있기 때문에 위치좌표 조회에 이용된다.

도 3 은 본 발명에 따른 도 2 의 이중결합 방식으로 결합된 통합 측위 장치의 일실시에 구성도이다.

이중결합(double coupled) 방식의 RFID/GPS/INS/DR 통합 측위 장치는, 도면에 도시된 바와 같이, RFID리더기(210), GPS수신기(220), INS센서 모듈(230), GPS/RFID 선택기(300), 및 이중결합 통합 측위 필터(310)로 구성된다.

한편, 측위장치는 이동가능한 단말기 등의 이동체에 장착되는데, 그 측위 장치가 차량에 적용할 경우에는 속도 필터로 속도정보를 제공하는(즉, 차량의 차속에 장착되어 차량의 바퀴의 반경에 따라 차량의 바퀴가 몇 바퀴 회전했는지 감지하여 차의 속도를 알아내는) 차속계를 포함하는 DR 센서 모듈(240)이 추가된다.

GPS/RFID 선택기(300)는 측위 신호자원인 GPS 정보(가시위성 개수, DOP)와 RFID 태그 ID를 인식하여 사용할 측위 알고리즘을 선택한다. 즉, GPS/RFID 선택 기(300)의 선택정보에 따라 GPS/INS/DR 강결합 측위 알고리즘, RFID/INS/DR 결합 측위알고리즘, INS/DR 단독 측위 알고리즘 중 어느 하나의 해당 측위 알고리즘을 수행하여 차량등의 위치정보를 획득한다.

GPS/INS/DR 강결합(tightly-coupled) 측위 필터(312)는 INS센서 모듈(230)과 DR 센서 모듈(240)로부터 가속도, 방향각, 속도 정보 등을 받아 오차 추정 및 보정을 수행하는 가속도 필터, 방향 필터, 속도 필터를 포함하며, 각 필터로부터 추정된 위치정보와 GPS 수신기로부터 전달된 위치관련정보(예를 들면, 가시위성위치, 의사거리, 의사거리변화율 등)를 이용하여 일반적인 GPS/INS/DR 강결합 추측방법(즉, GPS/INS/DR 측위 알고리즘)을 수행함으로써 위치를 추정한다.

이중결합 통합 측위 필터(310)는 GPS/RFID 선택기(300)가 결정한 측위 알고리즘에 따라 GPS/INS/DR 강결합 측위 필터(312)에서 계산한 위치정보를 출력하거나, 도 5 에서 ①로 스위칭되었을 때와 같은 RFID/INS/DR 통합 측위 필터를 구동하여 새로운 위치를 계산한다.

GPS/INS/DR 강결합 측위 필터(312)에서는 INS 센서 모듈(230)만 독립적으로 이용하여 항법해를 계산하며, GPS수신기(120)에서는 항법해를 직접 계산하지 않고 가시위성(Visible satellite)의 위치와 의사거리(Pseudorange), 의사거리변화율(Pseudorange rate)만을 제공한다.

GPS/RFID 선택기(300)에서 RFID정보를 이용한 측위 알고리즘(즉, RFID/INS 결합 측위 알고리즘)을 선택할 경우, 이중결합 통합 측위 필터(310)에서는 GPS/INS/DR 강결합 측위 필터(312)를 사용하지 않고, 단지 RFID 태그 ID를 이용한 RFID 위치정보와 INS/DR 센서 모듈 데이터(즉, 가속도, 방향, 속도 등)를 이용한 위치정보만을 결합하여 위치를 추정한다.

즉, RFID/INS 결합 측위 알고리즘은, RFID 리더기(210)로부터 전달되는 RFID태그 식별정보(ID)를 이용하여 RFID위치정보를 구하고, INS/DR센서 모듈(230, 240)로부터 전달되는 속도정보, 가속도정보, 및 방향정보를 이용하여 INS위치정보를 구한 후, RFID위치정보로 INS위치정보를 보정하여 차량 등의 이동체의 위치를 측정한다.

도 4 는 본 발명에 따른 도 2 의 단일결합 방식으로 결합된 통합 측위 장치의 일실시에 구성도이다.

단일결합(single coupled) 방식의 RFID/GPS/INS/DR 통합 측위 장치는 GPS/RFID 선택기(400)의 측위 알고리즘 선택에 따라, 단일결합 통합 측위 필터(410)에서 GPS수신기(220) 또는 RFID 리더기(210)에 의한 위치정보를 선택적으로 이용하여 새로운 위치를 추정하게 된다. 즉, GPS/RFID 선택기(400)는 측위 신호자원인 GPS 정보(가시 위성개수, DOP)와 RFID 태그 ID를 인식하여 사용할 측위 알고리즘을 선택한다.

GPS/RFID 선택기(400)의 선택정보에 따라 GPS/INS/DR 약(Loosely coupled)결합 측위 알고리즘, RFID/INS/DR 결합 측위 알고리즘, INS/DR 단독 측위 알고리즘 중 어느 하나의 해당 측위 알고리즘을 수행하여 차량등의 위치정보를 획득한다.

INS센서 모듈(230)과 DR센서 모듈(240)(차량의 경우에 추가됨)로부터 가속도, 방향각, 속도 정보가 단일결합 통합 측위 필터(410)로 보내지면, 단일결합 통합 측위 필터(410)는 GPS에 의한 위치정보 또는 RFID에 의한 위치정보와 함께 도 7의 측위 알고리즘을 수행하여 사용자의 위치를 추정한다.

만약, GPS/RFID 선택기(400)에 의하여 RFID/INS 결합 측위 알고리즘이 선택된 경우에는, RFID 리더기(210)로부터 전달되는 RFID태그 식별정보(ID)를 이용하여 RFID위치정보를 구하고, INS/DR센서 모듈(230, 240)로부터 전달되는 속도정보, 가속도정보, 및 방향정보를 이용하여 INS위치정보를 구한 후, RFID위치정보로 INS위치정보를 보정하여 차량 등의 이동체의 위치를 측정한다.

도 5는 본 발명에 따른 도 4의 단일결합 방식으로 결합된 통합 측위 필터의 일실시에 상세구성도로서, 기본적인 동작원리는 도 4에서와 같다.

GPS/RFID 선택기(400)의 선택에 따라 스위치(502)를 스위칭함으로써 적용될 측위알고리즘이 결정되게 된다. 스위치(502)가 ①로 연결되면, RFID/INS/DR 결합 측위 알고리즘이 수행되고, 스위치(502)가 ②로 연결되면 GPS/INS/DR 약결합(Loosely coupled) 측위 알고리즘이 수행되고, 스위치(502)가 ③으로 연결되면 INS 단독 측위 알고리즘이 수행된다. 여기서는 스위치를 이용하여 측위알고리즘을 선택하는 구성을 하였으나, 이것이 가능함은 물론이며, 또한 이와 달리 완전히 디지털 프로세서로 구현하여, GPS/RFID 선택기의 선택에 따라 해당 측위알고리즘을 수행하도록하는 것도 당연히 본 발명에 포함된다.

RFID 위치 필터(501)는 RFID 리더기(210)로부터 전달되는 RFID 태그ID를, RFID 태그 ID별 위치정보 데이터베이스(DB)(500)에서 검색하여 해당 태그의 위치정보를 획득한다. 여기서, RFID 위치 필터(501)는 RFID 태그 ID별 위치정보 데이터베이스(DB)(500)와 유선 또는 무선으로 연동된다.

INS/DR센서 필터(505)는 INS/DR센서 모듈(230, 240)로부터 입력된 INS/DR 데이터(예를 들면, 가속도, 방향, 속도 등)를 이용하여 사용자의 위치를 계산한다.

칼만필터(504)는 스위치(502)를 통하여 전달되는 위치정보(즉, RFID 위치정보 또는 GPS 위치정보(좌표정보) 중 하나)와 INS/DR센서 필터(505)로부터 전달되는 위치정보가 결합된(503) 신호를 이용하여 위치오차 보정치와 센서오차보정치를 생성하여, 그 중 센서오차보정치는 INS/DR센서 필터(505)로 전달한다.

INS/DR센서 필터(505)로부터 전달되는 위치정보에서 칼만필터(504)로부터 출력되는 위치오차 보정치를 빼면, 새로운 위치가 추정되는 것이다.

한편, 도면에는 도시하지 않았으나, 또 다른 실시예로서 이중결합구조인 경우에는, 스위치(502)에서 ②의 구조를 제거하고, GPS/INS/DR 강결합 측위 필터가 독립적으로 존재하여 새로운 추정위치를 계산하는 구조도 본 발명에 해당된다.

도 6는 본 발명에 따른 RFID/GPS/INS/DR 이중결합 방식에 의한 통합 측위 방법에 대한 일실시에 흐름도로서, 도 3에서의 이중결합 통합 측위 필터(310)에서 수행되는 이중결합 통합 알고리즘을 나타낸다.

GPS/RFID 선택기(300)의 선택에 따라 세가지의 측위 알고리즘으로 나뉘는데, 그 구체적인 과정은 다음과 같다.

먼저, 첫번째 경우로서, GPS/RFID 선택기(300)의 선택에 따라 스위치("502" 참조)가 스위칭되어, 이중결합 통합 측위 필터 내의 GPS/INS/DR 강결합 측위필터(312)에서 GPS정보를 전달받아 측위에 사용가능한 경우에는(601, 602), 일반적인 GPS/INS/DR 강결합 측위 필터(312)를 수행하여 새로운 위치정보를 획득하고(604), 새로이 획득한 위치정보로 위치정보를 갱신한다(612).

한편, 두번째 경우로서, GPS/RFID 선택기(300)의 선택에 따라 스위치("502" 참조)가 스위칭되어, 이중결합 통합 측위 필터(312)에서 GPS정보는 사용할 수 없고 RFID정보는 사용할 수 있는 경우에는(601, 602, 603), INS/DR센서 필터("505" 참조)는 INS/DR센서 모듈(230, 240) 내의 가속도 센서, 자이로 센서, 차속센서(DR 센서) 등으로부터 가속도, 속도,

방향 정보(간단히, INS/DR 센서 데이터라 함)를 획득하고(605), 그 획득된 INS/DR 센서 데이터를 이용하여 가속도, 속도, 방향각 필터링을 수행하여 위치정보를 획득하며, 칼만필터로부터 전달되는 센서오차보정치를 이용하여 각각의 센서 오차에 대한 보정을 수행한다(606).

또한, 이중결합 통합 측위 필터 내의 RFID 위치필터("501" 참조)은 RFID 리더기(210)로부터 전달되는 RFID태그 ID를 이용하여 위치정보를 획득한다(607).

칼만 필터("504" 참조)를 이용하여 위치오차 보정치 및 센서오차 보정치를 생성한 후(610), 위치오차 보정치 및 센서오차 보정치를 이용해 새로운 위치를 추정하고(611), 그 새로이 추정된 위치로 위치정보를 갱신한다(612)(도 5 참조).

한편, 세번째 경우로서, GPS/RFID 선택기(300)의 선택에 따라 스위치("502" 참조)가 스위칭되어, 이중결합 통합 측위 필터(312)에서 GPS와 RFID 정보를 모두 이용할 수 없는 경우에는(601, 602, 603), INS/DR센서 모듈(230, 240) 내의 가속도 센서, 자이로 센서, 차속센서(DR 센서) 등으로부터 가속도, 속도, 방향 정보(즉, INS/DR 센서 데이터)를 획득하고(608), 그 획득된 INS/DR 센서 데이터를 이용하여 가속도, 속도, 방향각 필터링을 수행하여 위치정보를 획득하며, 칼만필터로부터 전달되는 센서오차보정치를 이용하여 각각의 센서 오차에 대한 보정을 수행한다(609).

칼만 필터("504" 참조)를 이용하여 위치오차 보정치 및 센서오차 보정치를 생성한 후(610), 위치오차 보정치 및 센서오차 보정치를 이용해 새로운 위치를 추정하고(611), 그 새로이 추정된 위치로 위치정보를 갱신한다(612)(도 5 참조).

도 7 은 본 발명에 따른 RFID/GPS/INS/DR 단일결합 방식에 의한 통합 측위 방법에 대한 일실시에 흐름도로서, 도 4 에서의 단일결합 통합 측위 필터(410)에서 수행되는 단일결합 통합 알고리즘을 나타낸다.

GPS/RFID 선택기(300)의 선택에 따라 세가지의 측위 알고리즘으로 나뉘는데, 그 구체적인 과정은 다음과 같다.

첫번째 경우로서, GPS/RFID 선택기(400)의 선택에 따라 스위치(502)가 스위칭되어, 단일결합 통합 측위 필터(410)에서 GPS정보를 사용할 수 있는 경우라면(701, 702), INS/DR센서 모듈(230, 240) 내의 가속도 센서, 자이로 센서, 차속센서(DR 센서)등으로부터 가속도, 속도, 방향 정보(즉, INS/DR 센서 데이터)를 획득하고(704), 그 획득된 INS/DR 센서 데이터를 이용하여 가속도, 속도, 방향각 필터링을 수행하여 위치정보를 획득하며, 칼만필터로부터 전달되는 센서오차보정치를 이용하여 각각의 센서 오차에 대한 보정을 수행한다(705).

또한, GPS 수신기(220)으로부터 수신기 위치정보를 획득하여(706) 칼만 필터(504)로 전달하면, 칼만 필터(504)는 INS/DR에 의한 위치정보와 GPS에 의한 위치정보를 이용하여 위치오차 보정치 및 센서오차 보정치를 생성한다(712).

그러면, 단일결합 통합 측위 필터(410)는 위치오차 보정치 및 센서오차 보정치를 이용해 새로운 위치를 추정하고(713), 그 새로이 추정된 위치로 위치정보를 갱신한다(714)(도 5 참조).

두번째 경우로서, GPS/RFID 선택기(400)의 선택에 따라 스위치(502)가 스위칭되어, 단일결합 통합 측위 필터(410)에서 GPS정보는 사용할 수 없고 RFID정보는 이용가능하다면(701, 702, 703), INS/DR센서 모듈(230, 240) 내의 가속도 센서, 자이로 센서, 차속센서(DR 센서)등으로부터 가속도, 속도, 방향 정보(즉, INS/DR 센서 데이터)를 획득하고(707), 그 획득된 INS/DR 센서 데이터를 이용하여 가속도, 속도, 방향각 필터링을 수행하여 위치정보를 획득하며, 칼만필터로부터 전달되는 센서오차보정치를 이용하여 각각의 센서 오차에 대한 보정을 수행한다(708).

한편, RFID 위치필터(501)가 RFID 리더기(210)로부터 전달되는 태그 ID를 이용하여 위치정보를 획득하여(709), 칼만 필터(504)로 전달하면, 칼만 필터(504)는 INS/DR에 의한 위치정보와 RFID에 의한 위치정보를 이용하여 위치오차 보정치 및 센서오차 보정치를 생성한다(712).

그러면, 단일결합 통합 측위 필터(410)는 위치오차 보정치 및 센서오차 보정치를 이용해 새로운 위치를 추정하고(713), 그 새로이 추정된 위치로 위치정보를 갱신한다(714)(도 5 참조).

세번째 경우로서, GPS/RFID 선택기(400)의 선택에 따라 스위치(502)가 스위칭되어, 단일결합 통합 측위 필터(410)에서 GPS 위치정보와 RFID 위치정보를 모두 이용할 수 없는 경우에는(701, 702, 703), INS/DR센서 모듈(230, 240) 내의 가속도 센서, 자이로 센서, 차속센서(DR 센서)등으로부터 가속도, 속도, 방향 정보(즉, INS/DR 센서 데이터)를 획득하고(710), 그 획득된 INS/DR 센서 데이터를 이용하여 가속도, 속도, 방향각 필터링을 수행하여 위치정보를 획득하며, 칼만필터로부터 전달되는 센서오차보정치를 이용하여 각각의 센서 오차에 대한 보정을 수행한다(711).

칼만 필터(504)는 INS/DR에 의한 위치정보를 이용하여 위치오차 보정치 및 센서오차 보정치를 생성한다(712). 그러면, 단일결합 통합 측위 필터(410)는 위치오차 보정치 및 센서오차 보정치를 이용해 새로운 위치를 추정하고(713), 그 새로이 추정된 위치로 위치정보를 갱신한다(714)(도 5 참조).

도 8a 및 도 8b 는 본 발명에 따른 GPS/RFID선택기의 측위 알고리즘 선택 방법에 대한 일실시에 흐름도이다.

도 8a 는 단일결합방식에서의 GPS/RFID 선택기(400)의 선택 방법을 나타낸다.

GPS가시위성의 개수가 3개보다 큰지 여부(801)와 정도(精度)열화(DOP: Dilution of Precision)가 문턱값(Threshold)보다 작은지 여부(802)를 확인하여, GPS가시위성의 개수가 3개보다 크고 DOP가 문턱값보다 작으면 GPS/INS/DR 약결합(Loosely coupled) 측위 알고리즘 수행을 선택하는 신호(즉, 스위치가 ②로 연결하도록 하는 신호)를 생성한다(803).

한편, GPS가시위성의 개수가 3개 이하이거나, DOP가 문턱값 이상이면, RFID위치정보를 획득했는지 여부를 검사하여(804), 만약 RFID위치정보를 획득했으면 RFID/INS/DR 결합 측위 알고리즘의 수행을 선택하는 신호(즉, 스위치가 ①로 연결하도록 하는 신호)를 선택하고(805), 만약 RFID위치정보를 획득하지 못했으면 INS단독 측위 알고리즘의 수행을 선택하는 신호(즉, 스위치가 ③으로 연결하도록 하는 신호)를 생성한다(806).

한편, 도 8b 는 이중결합방식에서의 GPS/RFID 선택기(300)의 선택 방법을 나타낸다.

GPS가시위성의 개수가 1개 이상인지를 확인하여(810), 만약 GPS가시위성의 개수가 1개이상이면 GPS/INS/DR 강결합 측위 알고리즘의 수행을 선택하는 신호를 생성한다(811).

한편, GPS가시위성이 없으면, 다시 RFID위치정보의 획득여부를 검사하여(812), 만약 RFID위치정보를 획득했으면 RFID/INS/DR 결합 측위 알고리즘의 수행을 선택하는 신호를 생성하고(813), 만약 RFID위치정보를 획득하지 못했으면 INS단독 측위 알고리즘의 수행을 선택하는 신호를 생성한다(814).

상기와 같이 본 발명에 의하면, GPS/INS/DR의 결합 또는 RFID/INS/DR의 결합을 GPS신호의 수신여부에 따라 선택하여 측위를 수행할 수 있으며, 이때 결합방식은 이중결합 방식 또는 단일결합 방식으로 선택하여 구현할 수 있다.

따라서 GPS 신호의 수신여부에 관계없이 연속적인 측위가 가능하며, RFID 태그를 액세스할 수 있는 공간에서는 GPS에 의존하지 않고 INS와 결합하여 측위할 수 있다. DR센서는 차량에 RFID/GPS/INS/DR 결합 통합 측위 장치(100)를 설치할 경우에만 추가적인 센서로 활용할 수 있다.

상술한 바와 같은 본 발명의 방법은 프로그램으로 구현되어 컴퓨터로 읽을 수 있는 형태로 기록매체(씨디롬, 램, 롬, 플로피 디스크, 하드 디스크, 광자기 디스크 등)에 저장될 수 있다.

이상에서 설명한 본 발명은, 본 발명이 속하는 기술분야에서 통상의 지식을 가진 자에 있어 본 발명의 기술적 사상을 벗어나지 않는 범위내에서 여러 가지 치환, 변형 및 변경이 가능하므로 전술한 실시예 및 첨부된 도면에 의해 한정되는 것이 아니다.

#### 발명의 효과

상기와 같은 본 발명은, RFID 네트워크, GPS 및 관성항법장치(INS)를 결합한 측위장치 및 방법에 따르면, 관성항법장치(INS)를 RFID 또는 GPS와 결합하여 위치결정을 수행함으로써 GPS 신호를 수신할 수 없는 경우에도 연속적인 측위가 가능하며, 이때 RFID를 이용해 INS의 시간에 따른 오차누적 효과를 제거함으로써 안정적인 측위를 가능하게 하는 효과가 있다.

또한, 본 발명은, RFID와 INS를 결합한 측위장치를 구현함으로써 RFID 태그 네트워크의 배치간격을 더욱 넓게 배치할 수 있기 때문에, 공간적, 경제적인 효율성을 제공하는 효과가 있다.

또한, 본 발명에 따른 RFID 태그 네트워크는 모든 환경에서 구축가능하고, 서비스의 확장성 및 다양성, 적은 구축 및 유지 비용 등의 장점이 있기 때문에, 향후 유비쿼터스(Ubiquitous) 컴퓨팅 환경에서 사용자의 위치정보를 쉽게 획득할 수 있게 하며; 또한 RFID 태그에 저장되는 정보에는 위치결정에 요구되는 데이터뿐만 아니라 기타 지리정보 등이 포함될 수 있기 때문에, 다양한 형태의 데이터 제공을 통하여 부가 서비스를 활성화시킬 수 있는 효과가 있다.

또한, 본 발명에 따른 RFID/GPS/INS 복합 단말기는 소형화가 가능하기 때문에, 이동통신단말기와 통합되어 사용하면 개인 휴대용 통신측위 복합단말의 구현을 가능하게 하는 효과가 있다.

또한, 본 발명은, RFID네트워크와 GPS 및 INS를 사용함으로써, 종래의 이동통신신호를 측위에 활용하는 방법이 갖고 있던 전파환경의 문제, 기지국 배치 및 중계기 문제, 통신기능과 측위기능의 기술적 모순, 막대한 인프라 구축 비용, 만족스럽지 못한 측위성능 등의 문제를 해결하여, 측위의 연속성, 안정성, 가용성, 저비용을 이룰 수 있는 효과가 있다.

(57) 청구의 범위

**청구항 1.**

이동체에 탑재되어 상기 이동체의 위치를 측정하는 측위 장치에 있어서,

위성으로부터 GPS(Global Positioning System) 위성 신호를 수신하여 상기 이동체의 위치정보를 획득하기 위한 GPS 수신 수단;

상기 이동체의 이동에 따라 무선인식(RFID: Radio frequency identification) 태그로부터 송신되는 태그 식별정보(ID)를 수신하여 읽기 위한 RFID 리딩 수단;

다수의 가속도센서와 자이로센서를 이용하여 상기 이동체의 속도정보, 가속도정보, 및 방향정보를 획득하기 위한 INS 센서 모듈;

상기 GPS 수신 수단으로부터 전달받은 GPS 위치정보의 사용여부와 상기 RFID 리딩 수단으로부터의 태그 식별정보의 획득여부에 따라, 측위 알고리즘의 유형에 대한 선택정보를 생성하기 위한 GPS/RFID 선택 수단; 및

상기 GPS/RFID 선택 수단의 선택정보에 따라 GPS/INS 결합 측위 알고리즘, RFID/INS 결합 측위 알고리즘, INS 단독 측위 알고리즘 중 어느 하나의 해당 측위 알고리즘을 수행하여 상기 이동체의 위치정보를 획득하기 위한 통합 측위 수단

을 포함하는 무선인식/위성측위/관성항법을 결합한 통합 측위 장치.

**청구항 2.**

제 1 항에 있어서,

상기 GPS/RFID 선택 수단에서의 GPS 위치정보의 사용여부는,

상기 GPS 수신 수단으로부터 전달받은 가시위성 개수를 이용하여 판단하는 것을 특징으로 하는 무선인식/위성측위/관성항법을 결합한 통합 측위 장치.

**청구항 3.**

제 2 항에 있어서,

상기 GPS/RFID 선택 수단의 선택정보 생성은,



상기 GPS 위치정보가 사용 가능하면, GPS/INS 강결합(tightly-coupled) 측위 알고리즘이 수행되게 하는 선택정보를 생성하고; 상기 GPS 위치정보는 사용불가능하지만 상기 태그 식별정보가 획득된 경우이면, 상기 RFID/INS 결합 측위 알고리즘이 수행되게 하는 선택정보를 생성하고; 상기 GPS 위치정보도 사용불가능하고 상기 태그 식별정보도 획득하지 못한 경우이면, INS 단독 측위 알고리즘이 수행되게 하는 선택정보를 생성하는 것을 특징으로 하는 무선인식/위성측위/관성항법을 결합한 통합 측위 장치.

#### 청구항 4.

제 1 항에 있어서,

상기 GPS/RFID 선택 수단에서의 GPS 위치정보의 사용여부는,

상기 GPS 수신 수단으로부터 전달받은 가시위성 개수와 정도(精度)열화(DOP)를 이용하여 판단하는 것을 특징으로 하는 무선인식/위성측위/관성항법을 결합한 통합 측위 장치.

#### 청구항 5.

제 4 항에 있어서,

상기 GPS/RFID 선택 수단의 선택정보 생성은,

상기 GPS 위치정보가 사용 가능하면, GPS/INS 약결합(Loosely coupled) 측위 알고리즘이 수행되게 하는 선택정보를 생성하고; 상기 GPS 위치정보는 사용불가능하지만 상기 태그 식별정보가 획득된 경우이면, 상기 RFID/INS 결합 측위 알고리즘이 수행되게 하는 선택정보를 생성하고; 상기 GPS 위치정보도 사용불가능하고 상기 태그 식별정보도 획득하지 못한 경우이면, INS 단독 측위 알고리즘이 수행되게 하는 선택정보를 생성하는 것을 특징으로 하는 무선인식/위성측위/관성항법을 결합한 통합 측위 장치.

#### 청구항 6.

제 1 항 내지 제 5 항 중 어느 한 항에 있어서,

상기 INS센서 모듈은,

상기 이동체가 차량이면, 차속센서모듈을 더 포함하는 것을 특징으로 하는 무선인식/위성측위/관성항법을 결합한 통합 측위 장치.

#### 청구항 7.

제 6 항에 있어서,

상기 RFID/INS 결합 측위 알고리즘은,

상기 RFID 리더 수단으로부터 전달되는 RFID태그 식별정보(ID)를 이용하여 RFID위치정보를 구하고, 상기 INS센서 모듈로부터 전달되는 속도정보, 가속도정보, 및 방향정보를 이용하여 INS위치정보를 구한 후, 상기 RFID위치정보로 상기 INS위치정보를 보정하여 상기 이동체의 위치를 측정하는 것을 특징으로 하는 무선인식/위성측위/관성항법을 결합한 통합 측위 장치.

### 청구항 8.

제 6 항에 있어서,

상기 RFID 태그는,

상기 RFID 리딩 수단의 전파범위 안에 속하도록, 소정의 간격으로 도로시설물에 설치되는 것을 특징으로 하는 무선인식/위성측위/관성항법을 결합한 통합 측위 장치.

### 청구항 9.

이동체에 탑재되어 상기 이동체의 위치를 측정하는 측위 방법에 있어서,

위성으로부터 GPS(Global Positioning System) 위성 신호를 수신하여 상기 이동체의 위치정보를 획득하는 GPS 수신 단계;

상기 이동체의 이동에 따라 무선인식(RFID) 태그로부터 송신되는 태그 식별정보(ID)를 수신하여 읽는 RFID 리딩 단계;

다수의 가속도센서와 자이로센서를 이용하여 상기 이동체의 속도정보, 가속도정보, 및 방향정보를 획득하는 INS 운동정보 획득 단계;

상기 GPS 수신 단계에서 획득한 GPS 위치정보의 사용여부와 상기 RFID 태그 식별정보의 수신여부에 따라, 측위 알고리즘의 유형에 대한 선택정보를 생성하는 측위알고리즘 선택 단계; 및

상기 선택정보에 따라 GPS/INS 결합 측위 알고리즘, RFID/INS 결합 측위알고리즘, INS 단독 측위 알고리즘 중 어느 하나의 해당 측위 알고리즘을 수행하여 상기 이동체의 위치정보를 획득하는 통합 측위 단계

를 포함하는 무선인식/위성측위/관성항법을 결합한 통합 측위 방법.

### 청구항 10.

제 9 항에 있어서,

상기 측위알고리즘 선택 단계에서의 GPS 위치정보 사용여부는,

가시위성 개수를 이용하여 판단하는 것을 특징으로 하는 무선인식/위성측위/관성항법을 결합한 통합 측위 방법.

### 청구항 11.

제 10 항에 있어서,

상기 측위알고리즘 선택 단계는,

상기 GPS 위치정보의 사용여부와 상기 RFID 태그 식별정보의 수신여부를 확인하는 확인 단계;

상기 확인 단계의 확인 결과, 상기 GPS 위치정보가 사용 가능하면, GPS/INS 강결합(tightly-coupled) 측위 알고리즘이 수행되게 하는 선택정보를 생성하는 단계;

상기 확인 단계의 확인 결과, 상기 GPS 위치정보는 사용불가능하지만 상기 태그 식별정보가 획득된 경우이면, 상기 RFID/INS 결합 측위 알고리즘이 수행되게 하는 선택정보를 생성하는 단계; 및

상기 확인 단계의 확인 결과, 상기 GPS 위치정보도 사용불가능하고 상기 태그 식별정보도 획득하지 못한 경우이면, 상기 INS 단독 측위 알고리즘이 수행되게 하는 선택정보를 생성하는 단계

를 포함하는 무선인식/위성측위/관성항법을 결합한 통합 측위 방법.

### 청구항 12.

제 9 항에 있어서,

상기 측위알고리즘 선택 단계에서의 GPS 위치정보 사용여부는,

가시위성 개수와 정도(精度)열화(DOP)를 이용하여 판단하는 것을 특징으로 하는 무선인식/위성측위/관성항법을 결합한 통합 측위 방법.

### 청구항 13.

제 12 항에 있어서,

상기 측위알고리즘 선택 단계는,

상기 GPS 위치정보의 사용여부와 상기 RFID 태그 식별정보의 수신여부를 확인하는 확인 단계;

상기 확인 단계의 확인 결과, 상기 GPS 위치정보가 사용 가능하면, GPS/INS 약결합(Loosely coupled) 측위 알고리즘이 수행되게 하는 선택정보를 생성하는 단계;

상기 확인 단계의 확인 결과, 상기 GPS 위치정보는 사용불가능하지만 상기 태그 식별정보가 획득된 경우이면, 상기 RFID/INS 결합 측위 알고리즘이 수행되게 하는 선택정보를 생성하는 단계; 및

상기 확인 단계의 확인 결과, 상기 GPS 위치정보도 사용불가능하고 상기 태그 식별정보도 획득하지 못한 경우이면, 상기 INS 단독 측위 알고리즘이 수행되게 하는 선택정보를 생성하는 단계

를 포함하는 무선인식/위성측위/관성항법을 결합한 통합 측위 방법.

### 청구항 14.

제 9 항 내지 제 13 항 중 어느 한 항에 있어서,

상기 INS 운동정보 획득 단계는,

상기 이동체가 차량이면, 차속센서를 통한 차량 속도정보를 더 획득하는 것을 특징으로 하는 무선인식/위성측위/관성항법을 결합한 통합 측위 방법.

### 청구항 15.

제 14 항에 있어서,

상기 RFID/INS 결합 측위 알고리즘은,

상기 RFID태그 식별정보(ID)를 이용하여 RFID위치정보를 구하는 단계;

상기 INS 운동정보 획득 단계에서 획득한 속도정보, 가속도정보, 및 방향정보를 이용하여 INS위치정보를 구하는 단계; 및

칼만필터를 이용하여, 상기 RFID 위치정보로 상기 INS위치정보를 보정하여 상기 이동체의 위치를 추정하는 단계

를 포함하는 무선인식/위성측위/관성항법을 결합한 통합 측위 방법.

도면

도면1

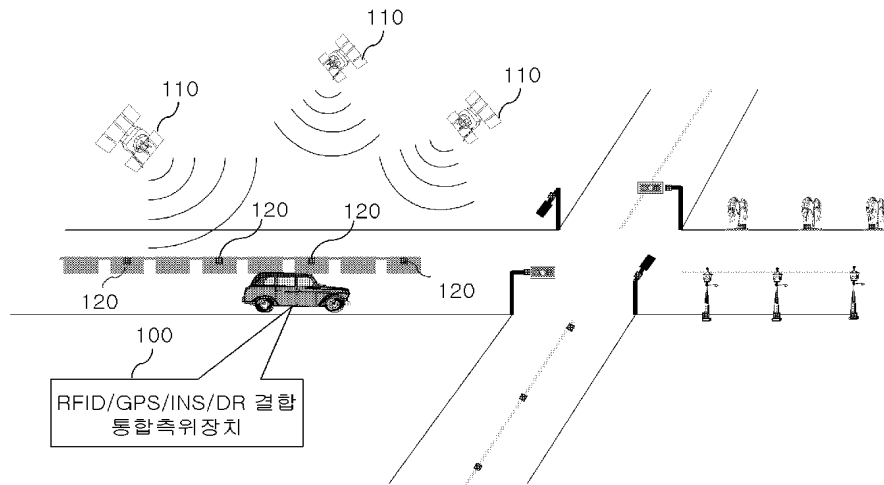

도면2

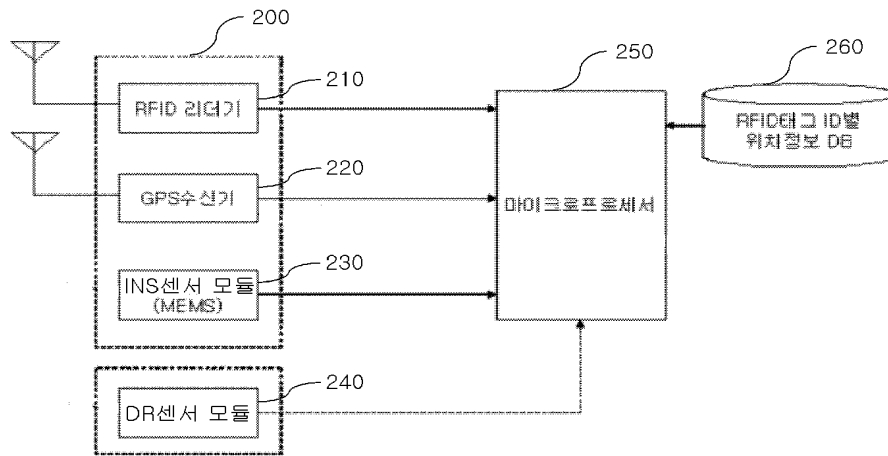

도면3

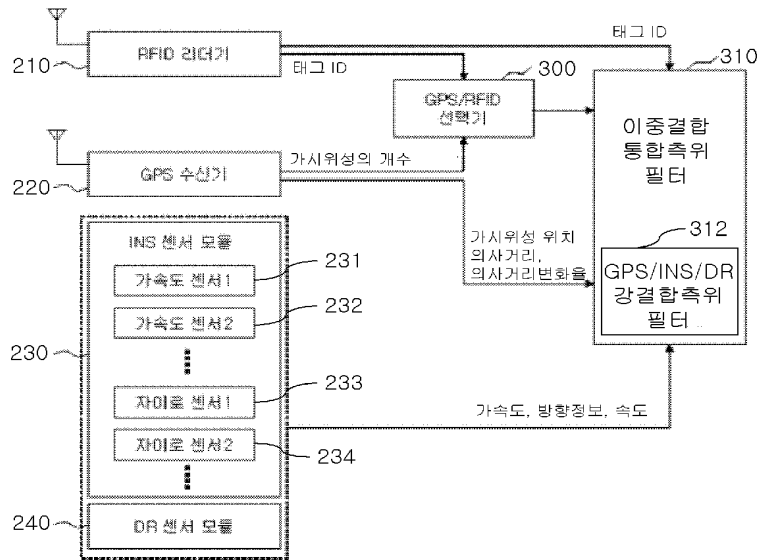

도면4

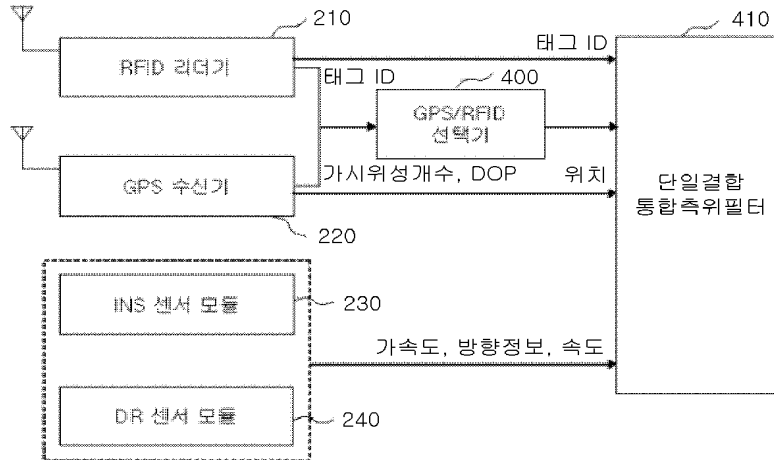

도면5

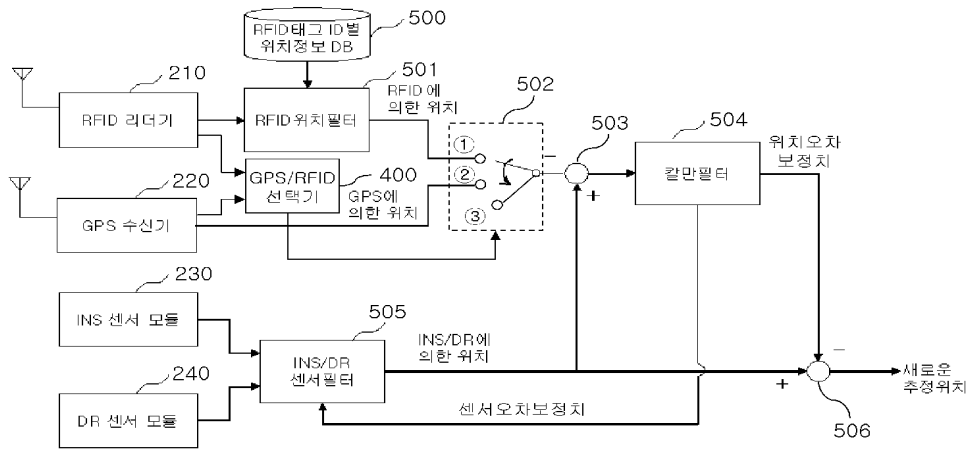

도면6

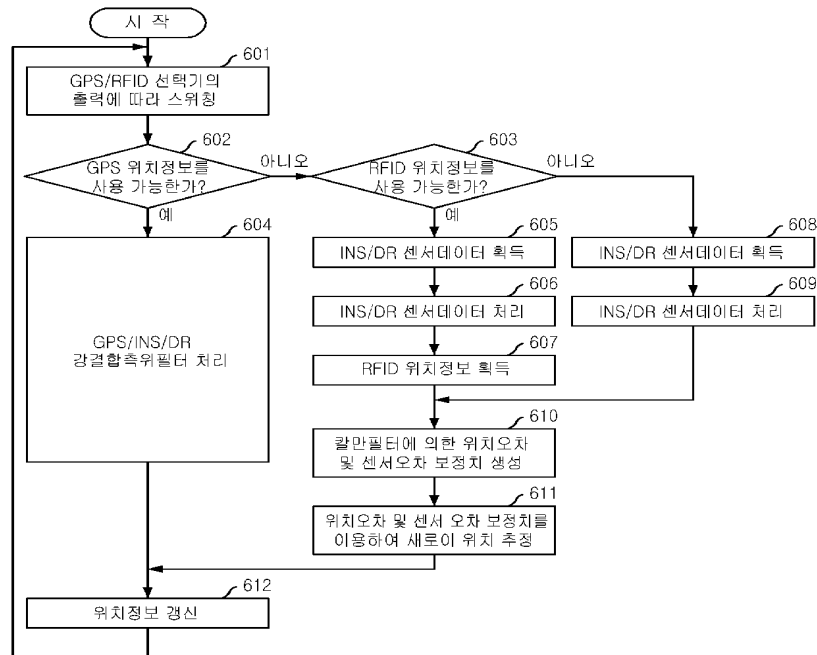

도면7

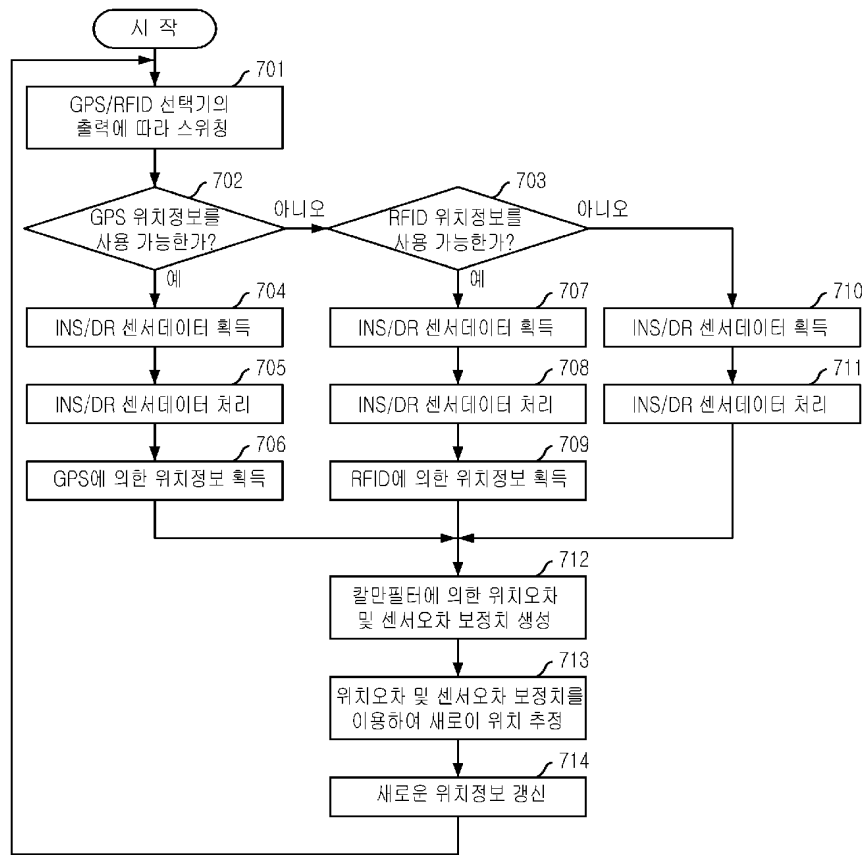

도면8a

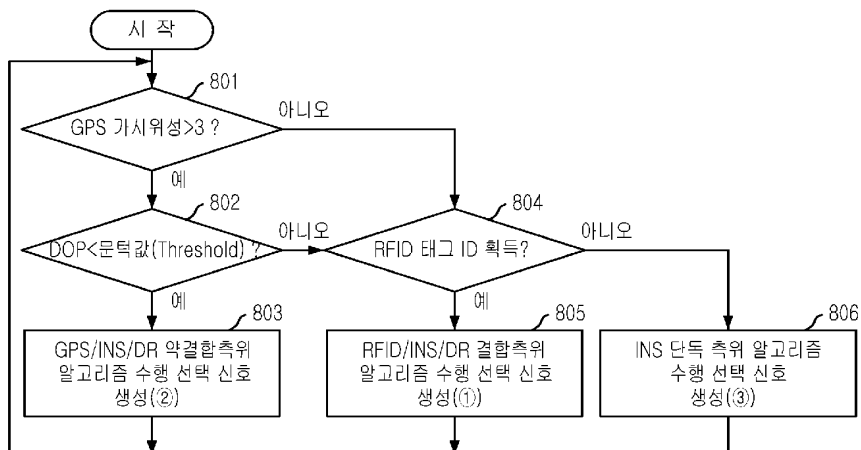

도면8b

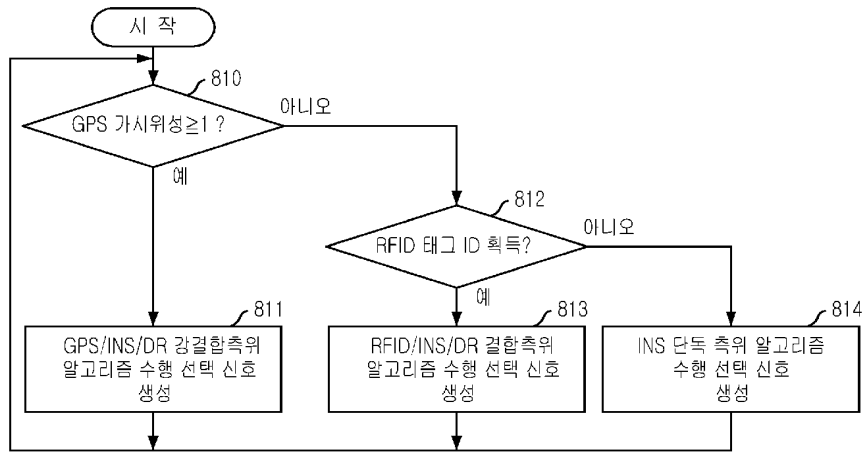





(19)대한민국특허청(KR)  
(12) 등록특허공보(B1)

(51) Int. Cl.	(45) 공고일자	2007년06월22일
<i>H04B 1/40</i> (2006.01)	(11) 등록번호	10-0730548
<i>H04B 1/16</i> (2006.01)	(24) 등록일자	2007년06월14일

(21) 출원번호	10-2005-7008007	(65) 공개번호	10-2005-0063802
(22) 출원일자	2005년05월04일	(43) 공개일자	2005년06월28일
심사청구일자	2005년06월23일		
번역문 제출일자	2005년05월04일		
(86) 국제출원번호	PCT/CA2003/000309	(87) 국제공개번호	WO 2004/042941
국제출원일자	2003년03월06일	국제공개일자	2004년05월21일

(30) 우선권주장                      60/423,372                      2002년11월04일                      미국(US)

(73) 특허권자                      리서치 인 모션 리미티드  
   캐나다 온타리오 워털루 필립 스트리트 295 (우편번호 엔2엘 3더블유8)

(72) 발명자                              호사인 아시프  
   캐나다 온타리오 케이2케이 3에이치9 카나타 플램보러프 웨이 163

   이슬람 칼레델 엠  
   캐나다 온타리오 케이2지 6지5 네벤 윈드허스트 드라이브 27

(74) 대리인                              김태홍  
   신정건

(56) 선행기술조사문헌  
   US2002/106997 A1

심사관 : 임태석

전체 청구항 수 : 총 59 항

**(54) 무선 장치 배터리 보존 방법 및 시스템**

(57) 요약

본 발명은 전반적으로 RF 조건을 탐지하고 RF 조건에 따라 배터리 전원을 절약하기 위해 상이한 슬립 모드 레벨 또는 단계로 진입하는 방법을 제공한다. 이동 장치가 열악한 RF 조건을 탐지하고 딥 슬립 모드의 동작으로 진입할 때에 이동 장치 배터리 수명이 보존될 수 있다. 이 딥 슬립 모드의 동작에서, 이동 장치는 RF 조건을 주기적으로 샘플링하고, RF 조건이 향상되지 못할 때에 샘플간의 주기를 점차적으로 증가시킨다. 우수한 RF 송수신 범위의 지역에서조차도 이동성이 무선 장치에 대한 RF 조건을 변화시킬 수 있기 때문에, 딥 슬립 모드로 작동하고 있는 이동 장치는 이 이동성을 탐지할 수 있고, 그에 따라 아이들 상태로 진입하거나 또는 이와 달리 장기적 전원 절약 모드로 진입하는 가능성을 향상시킬 수 있다. RF 조건이 향상될 때에, 이동 장치는 딥 슬립 모드에서 벗어나서 아이들 상태로 복귀한다.

대표도

도 4

**특허청구의 범위**

**청구항 1.**

이동 장치의 딥 슬립 모드에서 배터리 전원을 절약하는 방법에 있어서,

- a) 시스템의 RF 강도를 샘플링하기 위해 소정의 시간 간격 후에 딥 슬립 모드로부터 기동하는 단계와;
- b) 상기 샘플링된 RF 조건 강도를 소정의 레벨에 비교하는 단계와;
- c) 상기 샘플링된 RF 조건 강도가 상기 소정의 레벨 미만이라면 상기 시간 간격을 증가시키는 단계와;
- d) 상기 딥 슬립 모드에 진입하는 단계

를 포함하는 이동 장치의 배터리 전원 절약 방법.

**청구항 2.**

제1항에 있어서, 상기 이동 장치는 상기 시스템의 채널이 타임아웃 기간 내에서 소정의 횟수로 상실되는 때에 상기 딥 슬립 모드에 진입하는 것인 이동 장치의 배터리 전원 절약 방법.

**청구항 3.**

제1항에 있어서, 상기 딥 슬립 모드에 진입하는 단계는 상기 이동 장치를 제1, 제2 및 제3 레벨의 딥 슬립 모드 중의 하나로 전환하는 단계를 포함하는 것인 이동 장치의 배터리 전원 절약 방법.

**청구항 4.**

제3항에 있어서, 상기 전환 단계는 최대 루프 카운터 값을 상기 제1, 제2 및 제3 레벨의 딥 슬립 모드 중의 하나와 관련된 소정의 카운터 값으로 설정하는 단계를 포함하는 것인 이동 장치의 배터리 전원 절약 방법.

**청구항 5.**

제4항에 있어서, 상기 전환 단계는 상기 시간 간격을 상기 제1, 제2 및 제3 레벨의 딥 슬립 모드 중의 하나와 관련된 소정의 시간 값으로 설정하는 단계를 포함하는 것인 이동 장치의 배터리 전원 절약 방법.

**청구항 6.**

제5항에 있어서, 상기 제2 레벨의 딥 슬립 모드와 관련된 소정의 시간 값은 상기 제1 레벨의 딥 슬립 모드와 관련된 소정의 시간 값보다 큰 것인 이동 장치의 배터리 전원 절약 방법.

**청구항 7.**

제6항에 있어서, 상기 제3 레벨의 딥 슬립 모드와 관련된 소정의 시간 값은 상기 제2 레벨의 딥 슬립 모드와 관련된 소정의 시간 값보다 큰 것인 이동 장치의 배터리 전원 절약 방법.

**청구항 8.**

제3항에 있어서, 상기 기동 단계는 상기 제1, 제2 및 제3 레벨의 딥 슬립 모드 중의 하나와 관련된 시스템 리스트로부터 획득하기 위한 시스템을 결정하는 단계를 포함하는 것인 이동 장치의 배터리 전원 절약 방법.

**청구항 9.**

제8항에 있어서, 상기 시스템 리스트는 각각 상기 제1, 제2 및 제3 레벨의 딥 슬립 모드와 관련된 제1 시스템 리스트, 제2 시스템 리스트 및 제3 시스템 리스트를 포함하는 것인 이동 장치의 배터리 전원 절약 방법.

**청구항 10.**

제9항에 있어서, 상기 제1 시스템 리스트는 상기 제2 및 제3 시스템 리스트의 서브셋이고, 상기 제2 시스템 리스트는 상기 제3 시스템 리스트의 서브셋인 것인 이동 장치의 배터리 전원 절약 방법.

**청구항 11.**

제1항에 있어서, 상기 비교 단계는 상기 RF 조건의 신호대 잡음비를 소정의 값에 비교하는 단계를 포함하는 것인 이동 장치의 배터리 전원 절약 방법.

**청구항 12.**

제4항에 있어서, 상기 비교 단계는 상기 시스템의 의사 잡음이 알려져 있지 않다면 이동성 플래그를 참으로 설정하는 단계를 포함하는 것인 이동 장치의 배터리 전원 절약 방법.

**청구항 13.**

제4항에 있어서, 상기 비교 단계는 상기 이동 장치가 이동중이라면 이동성 플래그를 참으로 설정하는 단계를 포함하는 것인 이동 장치의 배터리 전원 절약 방법.

**청구항 14.**

제12항에 있어서, 상기 이동 장치의 이동성을 판정하기 위해 상기 의사 잡음의 상태를 모니터링하는 것인 이동 장치의 배터리 전원 절약 방법.

**청구항 15.**

제12항에 있어서, 상기 이동 장치는 상기 이동성 플래그가 참일 때에 아이들 상태와 상기 제1 레벨의 딥 슬립 모드 중의 하나로 복귀하는 것인 이동 장치의 배터리 전원 절약 방법.

**청구항 16.**

제15항에 있어서, 상기 비교 단계는,

- (i) 상기 이동성 플래그가 거짓일 때에 루프 카운터를 증분시키는 단계와;
- (ii) 상기 루프 카운터 값을 상기 최대 루프 카운터 값에 비교하는 단계와;
- (iii) 상기 루프 카운터 값이 상기 최대 루프 카운터 값과 동일할 때에 상기 이동 장치를 상기 제2 및 제3 레벨의 딥 슬립 모드 중의 하나로 전환하는 단계를 포함하는 것인 이동 장치의 배터리 전원 절약 방법.

**청구항 17.**

제16항에 있어서, 상기 전환 단계 (iii)은 상기 이동 장치가 상기 제1 레벨의 딥 슬립 모드에 있을 때에 상기 이동 장치를 상기 제2 레벨의 딥 슬립 모드로 전환하는 단계를 포함하는 것인 이동 장치의 배터리 전원 절약 방법.

**청구항 18.**

제16항에 있어서, 상기 전환 단계 (iii)은 상기 이동 장치가 상기 제2 레벨의 딥 슬립 모드에 있을 때에 상기 이동 장치를 상기 제3 레벨의 딥 슬립 모드로 전환하는 단계를 포함하는 것인 이동 장치의 배터리 전원 절약 방법.

**청구항 19.**

제3항에 있어서, 상기 전환 단계는 최대 타임아웃 기간을 상기 제1, 제2 및 제3 레벨의 딥 슬립 모드 중의 하나와 관련된 소정의 타임아웃 값으로 설정하는 단계를 포함하는 것인 이동 장치의 배터리 전원 절약 방법.

**청구항 20.**

제19항에 있어서, 상기 비교 단계는 상기 최대 타임아웃 기간이 만료될 때에 상기 이동 장치를 상기 제2 및 제3 레벨의 딥 슬립 모드 중의 하나로 전환하는 단계를 포함하는 것인 이동 장치의 배터리 전원 절약 방법.

**청구항 21.**

제3항에 있어서, 상기 이동 장치를 상기 제2 및 제3 레벨의 딥 슬립 모드 중의 하나로 전환하는 단계는 상기 이동 장치가 상기 제1 레벨의 딥 슬립 모드에 있을 때에 상기 이동 장치를 상기 제2 레벨의 딥 슬립 모드로 전환하는 단계를 포함하는 것인 이동 장치의 배터리 전원 절약 방법.

**청구항 22.**

제3항에 있어서, 상기 이동 장치를 상기 제2 및 제3 레벨의 딥 슬립 모드 중의 하나로 전환하는 단계는 상기 이동 장치가 상기 제2 레벨의 딥 슬립 모드에 있을 때에 상기 이동 장치를 상기 제3 레벨의 딥 슬립 모드로 전환하는 단계를 포함하는 것인 이동 장치의 배터리 전원 절약 방법.

### 청구항 23.

이동 장치의 배터리 전원 절약 시스템에 있어서,

- a) 시스템 채널의 상실을 나타내는 플래그 신호를 제공하는 채널 프로세서와;
- b) 상기 플래그 신호를 수신하고 시스템 상실 탈출 플래그를 제공하는 딥 슬립 컨트롤러와;
- c) 상기 시스템 상실 탈출 플래그에 응답하여 딥 슬립 모드 변수를 설정하고, 제어 신호에 응답하여 상기 딥 슬립 모드 변수를 조정하는 변수 설정 컨트롤러와;
- d) 상기 딥 슬립 모드 변수에 의해 정해진 시간 간격으로 RF 조건 파라미터를 반복적으로 샘플링하고, 상기 RF 조건이 향상되지 않을 때에 상기 변수 설정 컨트롤러에 상기 제어 신호를 제공하는 저전력 컨트롤러

를 포함하는 이동 장치의 배터리 전원 절약 시스템.

### 청구항 24.

제23항에 있어서, 상기 시스템 채널은 파일럿 채널 및 페이징 채널 중의 하나를 포함하는 것인 이동 장치의 배터리 전원 절약 시스템.

### 청구항 25.

제23항에 있어서, 상기 딥 슬립 모드 변수는 상기 시간 간격을 설정하기 위한 타이머 값과 반복의 횟수를 설정하기 위한 루프 카운트 값을 포함하는 것인 이동 장치의 배터리 전원 절약 시스템.

### 청구항 26.

제23항에 있어서, 상기 RF 조건 파라미터는 신호대 잡음 강도비를 포함하는 것인 이동 장치의 배터리 전원 절약 시스템.

### 청구항 27.

이동 장치를 딥 슬립 모드로 전환하는 방법에 있어서,

- a) 시스템 채널을 모니터링하는 단계와;
- b) 소정의 타임아웃 기간 내에서 상기 시스템 채널이 상실되는 횟수를 카운트하는 단계와;
- c) 상기 시스템 채널 카운트가 소정의 수와 동일할 때에 상기 딥 슬립 모드에 진입하는 단계

를 포함하는 이동 장치의 딥 슬립 모드 전환 방법.

**청구항 28.**

제27항에 있어서, 상기 모니터링 단계는 상기 시스템 채널의 파일럿 채널과 페이징 채널 중의 하나를 모니터링하는 단계를 포함하는 것인 이동 장치의 딥 슬립 모드 전환 방법.

**청구항 29.**

제27항에 있어서, 상기 모니터링 단계는 채널 상실 카운터와 채널 상실 개시 시간 값을 리셋하는 단계를 포함하는 것인 이동 장치의 딥 슬립 모드 전환 방법.

**청구항 30.**

제29항에 있어서, 상기 카운트 단계는 상기 시스템 채널이 상실될 때마다 상기 채널 상실 카운터를 증분시키는 단계를 포함하는 것인 이동 장치의 딥 슬립 모드 전환 방법.

**청구항 31.**

제30항에 있어서, 상기 증분 단계는 상기 채널 상실 카운터 값이 1일 때에 상기 채널 상실 개시 시간 값을 제1의 현재 GPS 시간으로 설정하는 단계를 포함하는 것인 이동 장치의 딥 슬립 모드 전환 방법.

**청구항 32.**

제31항에 있어서, 상기 증분 단계는 상기 채널 상실 카운터 값이 상기 소정의 수에 도달할 때에 채널 상실 최종 시간 값을 제2의 현재 GPS 시간으로 설정하는 단계를 포함하는 것인 이동 장치의 딥 슬립 모드 전환 방법.

**청구항 33.**

제32항에 있어서, 상기 이동 장치는 상기 채널 상실 최종 시간 값과 상기 채널 상실 개시 시간 값간의 차가 적어도 상기 타임아웃 기간일 때에 상기 딥 슬립 모드에 진입하는 것인 이동 장치의 딥 슬립 모드 전환 방법.

**청구항 34.**

제33항에 있어서, 상기 진입 단계는 상기 이동 장치가 상기 딥 슬립 모드에 진입한 후에 상기 채널 상실 카운터와 상기 채널 상실 개시 시간 값을 리셋하는 단계를 포함하는 것인 이동 장치의 딥 슬립 모드 전환 방법.

**청구항 35.**

딥 슬립 모드로 전환된 이동 장치의 배터리 전원을 절약하는 방법에 있어서,

- a) 시스템 채널을 모니터링하는 단계와;
- b) 소정의 타임아웃 기간 내에서 상기 시스템 채널이 상실되는 횟수를 카운트하는 단계와;
- c) 상기 시스템 채널 카운트가 소정의 수와 동일할 때에 상기 딥 슬립 모드에 진입하는 단계와;

- d) 시스템의 RF 강도를 샘플링하기 위해 소정의 시간 간격 후에 상기 딥 슬립 모드로부터 기동하는 단계와;
  - e) 상기 샘플링된 RF 조건 강도를 소정의 레벨에 비교하는 단계와;
  - f) 상기 샘플링된 RF 조건 강도가 상기 소정의 레벨 미만이라면 상기 시간 간격을 증가시키는 단계와;
  - g) 상기 딥 슬립 모드에 재진입하는 단계
- 를 포함하는 이동 장치의 배터리 전원 절약 방법.

### 청구항 36.

제35항에 있어서, 상기 딥 슬립 모드에 재진입하는 단계는 상기 이동 장치를 제1, 제2 및 제3 레벨의 딥 슬립 모드 중의 하나로 전환하는 단계를 포함하는 것인 이동 장치의 배터리 전원 절약 방법.

### 청구항 37.

제36항에 있어서, 상기 전환 단계는 최대 루프 카운터 값을 상기 제1, 제2 및 제3 레벨의 딥 슬립 모드 중의 하나와 관련된 소정의 카운터 값으로 설정하는 단계를 포함하는 것인 이동 장치의 배터리 전원 절약 방법.

### 청구항 38.

제37항에 있어서, 상기 전환 단계는 상기 시간 간격을 상기 제1, 제2 및 제3 레벨의 딥 슬립 모드 중의 하나와 관련된 소정의 시간 값으로 설정하는 단계를 포함하는 것인 이동 장치의 배터리 전원 절약 방법.

### 청구항 39.

제38항에 있어서, 상기 제2 레벨의 딥 슬립 모드와 관련된 소정의 시간 값은 상기 제1 레벨의 딥 슬립 모드와 관련된 소정의 시간 값보다 큰 것인 이동 장치의 배터리 전원 절약 방법.

### 청구항 40.

제39항에 있어서, 상기 제3 레벨의 딥 슬립 모드와 관련된 소정의 시간 값은 상기 제2 레벨의 딥 슬립 모드와 관련된 소정의 시간 값보다 큰 것인 이동 장치의 배터리 전원 절약 방법.

### 청구항 41.

제36항에 있어서, 상기 기동 단계는 상기 제1, 제2 및 제3 레벨의 딥 슬립 모드 중의 하나와 관련된 시스템 리스트로부터 획득하기 위한 시스템을 결정하는 단계를 포함하는 것인 이동 장치의 배터리 전원 절약 방법.

### 청구항 42.

제41항에 있어서, 상기 시스템 리스트는 각각 상기 제1, 제2 및 제3 레벨의 딥 슬립 모드와 관련된 제1 시스템 리스트, 제2 시스템 리스트 및 제3 시스템 리스트를 포함하는 것인 이동 장치의 배터리 전원 절약 방법.

**청구항 43.**

제42항에 있어서, 상기 제1 시스템 리스트는 상기 제2 및 제3 시스템 리스트의 서브셋이고, 상기 제2 시스템 리스트는 상기 제3 시스템 리스트의 서브셋인 것인 이동 장치의 배터리 전원 절약 방법.

**청구항 44.**

제35항에 있어서, 상기 비교 단계는 상기 RF 조건의 신호대 잡음비를 소정의 값에 비교하는 단계를 포함하는 것인 이동 장치의 배터리 전원 절약 방법.

**청구항 45.**

제37항에 있어서, 상기 비교 단계는 상기 시스템의 의사 잡음이 알려져 있지 않다면 이동성 플래그를 참으로 설정하는 단계를 포함하는 것인 이동 장치의 배터리 전원 절약 방법.

**청구항 46.**

제37항에 있어서, 상기 비교 단계는 상기 이동 장치가 이동중이라면 이동성 플래그를 참으로 설정하는 단계를 포함하는 것인 이동 장치의 배터리 전원 절약 방법.

**청구항 47.**

제45항에 있어서, 상기 이동 장치의 이동성을 판정하기 위해 상기 의사 잡음의 상태를 모니터링하는 것인 이동 장치의 배터리 전원 절약 방법.

**청구항 48.**

제45항에 있어서, 상기 이동 장치는 상기 이동성 플래그가 참일 때에 아이들 상태와 상기 제1 레벨의 딥 슬립 모드 중의 하나로 복귀하는 것인 이동 장치의 배터리 전원 절약 방법.

**청구항 49.**

제48항에 있어서, 상기 비교 단계는,

- (i) 상기 이동성 플래그가 거짓일 때에 루프 카운터를 증분시키는 단계와;
- (ii) 상기 루프 카운터 값을 상기 최대 루프 카운터 값에 비교하는 단계와;
- (iii) 상기 루프 카운터 값이 상기 최대 루프 카운터 값과 동일할 때에 상기 이동 장치를 상기 제2 및 제3 레벨의 딥 슬립 모드 중의 하나로 전환하는 단계를 포함하는 것인 이동 장치의 배터리 전원 절약 방법.

**청구항 50.**



제49항에 있어서, 상기 전환 단계 (iii)은 상기 이동 장치가 상기 제1 레벨의 딥 슬립 모드에 있을 때에 상기 이동 장치를 상기 제2 레벨의 딥 슬립 모드로 전환하는 단계를 포함하는 것인 이동 장치의 배터리 전원 절약 방법.

### 청구항 51.

제49항에 있어서, 상기 전환 단계 (iii)은 상기 이동 장치가 상기 제2 레벨의 딥 슬립 모드에 있을 때에 상기 이동 장치를 상기 제3 레벨의 딥 슬립 모드로 전환하는 단계를 포함하는 것인 이동 장치의 배터리 전원 절약 방법.

### 청구항 52.

제36항에 있어서, 상기 전환 단계는 최대 타임아웃 기간을 상기 제1, 제2 및 제3 레벨의 딥 슬립 모드 중의 하나와 관련된 소정의 타임아웃 값으로 설정하는 단계를 포함하는 것인 이동 장치의 배터리 전원 절약 방법.

### 청구항 53.

제52항에 있어서, 상기 비교 단계는 상기 최대 타임아웃 기간이 만료될 때에 상기 이동 장치를 상기 제2 및 제3 레벨의 딥 슬립 모드 중의 하나로 전환하는 단계를 포함하는 것인 이동 장치의 배터리 전원 절약 방법.

### 청구항 54.

제36항에 있어서, 상기 이동 장치를 상기 제2 및 제3 레벨의 딥 슬립 모드 중의 하나로 전환하는 단계는 상기 이동 장치가 상기 제1 레벨의 딥 슬립 모드에 있을 때에 상기 이동 장치를 상기 제2 레벨의 딥 슬립 모드로 전환하는 단계를 포함하는 것인 이동 장치의 배터리 전원 절약 방법.

### 청구항 55.

제36항에 있어서, 상기 이동 장치를 상기 제2 및 제3 레벨의 딥 슬립 모드 중의 하나로 전환하는 단계는 상기 이동 장치가 상기 제2 레벨의 딥 슬립 모드에 있을 때에 상기 이동 장치를 상기 제3 레벨의 딥 슬립 모드로 전환하는 단계를 포함하는 것인 이동 장치의 배터리 전원 절약 방법.

### 청구항 56.

이동 장치의 배터리 전원 절약 시스템에 있어서,

- a) 시스템 채널의 상실을 나타내는 플래그 신호를 제공하는 채널 프로세서와;
- b) 상기 플래그 신호를 수신하고, 소정의 타임아웃 기간 내에 상기 시스템 채널이 상실되는 횟수를 카운트하여, 상기 시스템 채널 카운트가 소정의 수와 동일할 때에 딥 슬립 모드에 진입하도록 시스템 상실 탈출 플래그를 제공하는 딥 슬립 컨트롤러와;
- c) 상기 시스템 상실 탈출 플래그에 응답하여 딥 슬립 모드 변수를 설정하고, 제어 신호에 응답하여 상기 딥 슬립 모드 변수를 조정하는 변수 설정 컨트롤러와;
- d) 상기 딥 슬립 모드 변수에 의해 정해진 시간 간격으로 RF 조건 파라미터를 반복적으로 샘플링하고, 상기 RF 조건이 향상되지 않을 때에 상기 변수 설정 컨트롤러에 상기 제어 신호를 제공하는 저전력 컨트롤러

를 포함하는 이동 장치의 배터리 전원 절약 시스템.

**청구항 57.**

제56항에 있어서, 상기 시스템 채널은 파일럿 채널 및 페이징 채널 중의 하나를 포함하는 것인 이동 장치의 배터리 전원 절약 시스템.

**청구항 58.**

제56항에 있어서, 상기 딥 슬립 모드 변수는 상기 시간 간격을 설정하기 위한 타이머 값과 반복의 횟수를 설정하기 위한 루프 카운트 값을 포함하는 것인 이동 장치의 배터리 전원 절약 시스템.

**청구항 59.**

제56항에 있어서, 상기 RF 조건 파라미터는 신호대 잡음 강도비를 포함하는 것인 이동 장치의 배터리 전원 절약 시스템.

명세서

기술분야

본 발명은 전반적으로 이동 무선 통신 장치에 관한 것으로, 보다 구체적으로는 열악한 송수신 범위의 지역에 있는 무선 통신 장치의 배터리 수명을 향상시키기 위한 방법 및 시스템에 관한 것이다.

배경기술

우수한 송수신 범위를 갖는 지역과 송수신 범위에서 벗어나 있는 지역 내에서 작동하는 동안 배터리 전원을 절약하기 위한 CDMA 이동 장치에서의 메카니즘이 존재한다. 우수한 송수신 범위를 갖는 지역 또는 비교적 강한 RF 신호가 나타나는 지역에서, 이동 장치 배터리 파워는 CDMA 표준에 기술된 바와 같은 슬롯 사이클 인덱스(slot cycle index)를 이용하여 슬립 모드(sleep mode)로 진입함으로써 보존되는 한편, 이동 장치는 아이들 상태에 있게 된다. 슬롯 사이클 인덱스는 본 기술 분야에 익숙한 사람에게는 널리 공지되어 있으며, 추후에 간략히 설명될 것이다. 송수신 범위에서 벗어나 있는 지역에서, 이동 장치는 딥 슬립 모드(deep sleep mode)에 진입할 수 있으며, 이 모드 동안에 이동 장치는 RF 신호의 존재를 체크하기 위해 간혹 "기동(wake up)"할 수 있다.

슬롯 사이클 인덱스의 설명에 앞서, 이동 장치의 획득 시퀀스(acquisition sequence)에 대해 간단히 설명한다. 이동 장치의 전원이 켜질 때, 이동 장치는 파일럿 채널(pilot channel)을 찾기 위해 탐색 모드에 진입한다. 파일럿 채널은 기지국과의 초기 통신 링크를 구축하기 위해 사용된다. 그리고 나서, 이동 장치는 시스템 및 네트워크 식별 정보와, 타이밍 정보와, 예를 들어 페이징 채널을 찾기 위한 정보 등의 셋업 데이터를 획득하기 위해 동기화 채널로 전환한다. 페이징 채널이 획득된 후, 이동 장치는 아이들 상태로 유지할 수 있고, 그에 후속하여 인입 호출을 수신하거나 인출 호출을 전송하거나 단문 메시지 서비스(SMS) 데이터 버스트 메시지를 송신하기 위해 네트워크에의 등록을 위한 액세스 상태에 진입할 수 있다. 이동 장치는 그리고 나서 인입 호출을 수신하거나 인출 호출을 전송하거나 SMS 데이터 버스트 메시지를 송신하기 위해 트래픽 상태에 진입할 수 있다.

슬롯 사이클 인덱스는 이동 장치의 페이징 채널에서 작동하며, 도 1에 그래픽으로 도시되어 있다. 슬롯화 모드(slotted mode)의 동작에서, 이동 장치는 예를 들어 매 5초마다와 같이 소정 구간(20)에서 슬립 모드로부터 기동하도록 설정된다. 이동 장치는 기지국으로부터 어떠한 메시지를 수신하기 위해 단기의 시간창(22) 동안 기동하며, 이 기지국은 이동 장치와 동기화된 이후에는 유일하게 이들 단기의 시간창(22) 동안에 메시지를 발송할 것이다. 이동 장치는 사용자에게 의해 턴오프 되지 않는다면 모든 시간 동안 기술적으로 "온" 상태에 있으면서 기동 기간(22) 동안보다 구간(20) 동안에 훨씬 더 적은 배터리 전원을 소비한다.

이동 장치가 우수한 RF 송수신 범위 지역 또는 RF 송수신 범위에서 완전히 벗어나 있는 지역에 있는 상황 외에도, RF 조건이 이상적인 것보다 더 적어 이동 장치로 하여금 페이징 채널을 반복적으로 상실할 수 있는 상황도 존재한다. 지리학적 위치 및 네트워크/시스템 송수신 범위는 RF 조건이 악화될 수 있는 상황의 예이다. 페이징 채널이 상실될 때, 이동 장치는 과일롯 채널, 동기화 채널 및 페이징 채널을 재획득하기 위해 탐색 모드로 진입한다. 그러나, 새로이 재획득된 신호가 원래 신호가 상실되었던 동일한 조건으로 인해 다시 상실될 수 있기 때문에, 이동 장치는 페이징 채널이 상실되지 않도록 RF 조건이 향상되거나 또는 이동 장치가 배터리의 과도한 고갈로 인해 사용이 불가능하게 될 때까지 이러한 재획득 과정을 지속적으로 반복한다. 그러므로, 슬롯 사이클 인덱스의 주기적 성질 및 그 성질이 제공하는 전원 절약이 유지될 수 없다. 따라서, 이동 장치는 그 대부분의 시간을 슬립 모드가 아닌 동작 모드에서 소비하며, 이 동작 모드에서 이동 장치는 페이징 채널이 빈번하게 얻어지고 상실될 때 귀중한 배터리 수명을 소비한다. 무선 신호가 더 긴 주기의 시간 동안 완전히 상실되지 않는 이러한 RF 조건에 있는 동안, 이동 장치는 배터리 소모를 절약하기 위해 어떠한 유형의 슬립 모드로도 진입할 수 없다.

따라서, RF 조건이 열악한 상황에서 이동 장치 배터리 전원을 보존하기 위한 방법을 제공하는 것이 요망된다.

### 발명의 상세한 설명

본 발명의 목적은 이전의 배터리 전원 보존 방법의 적어도 하나의 단점을 제거 또는 완화시키는 것이다. 특히, 본 발명의 목적은 배터리 전원이 보존되도록 열악한 RF 조건에서 작동하는 이동 장치를 제어하는 방법을 제공하는 것이다.

제1 특징으로, 본 발명은 이동 장치의 딥 슬립 모드에서 배터리 전원을 절약하는 방법을 제공한다. 본 방법은 시스템의 RF 강도를 샘플링하기 위해 소정의 시간 간격 후에 딥 슬립 모드로부터 기동하는 단계와, 샘플링된 RF 조건 강도를 소정 레벨에 비교하는 단계와, 샘플링된 RF 조건 강도가 소정 레벨 미만이라면 시간 간격을 증가시키는 단계와, 딥 슬립 모드로 진입하는 단계를 포함한다.

본 특징의 실시예에 따르면, 이동 장치는 시스템의 채널이 타임아웃 기간 내에서 소정의 횟수로 상실될 때 딥 슬립 모드로 진입하며, 비교 단계는 RF 조건의 신호대 잡음비를 소정의 값에 비교하는 단계를 포함하며, 비교 단계는 또한 시스템의 의사 잡음(Pseudo Noise)이 알려져 있지 않거나 또는 이동 장치가 이동중인 경우 이동성 플래그(mobility flag)를 "참"으로 설정하는 단계를 포함한다. 이동 장치의 이동성을 판정하기 위해 의사 잡음의 형태(phase)가 모니터링될 수 있다.

본 실시예의 특징으로, 이동 장치는 이동성 플래그가 "참"일 때에 아이들 상태와 제1 레벨의 딥 슬립 모드 중의 하나로 복귀하며, 비교 단계는 이동성 플래그가 "거짓"일 때에 루프 카운터를 증분시키는 단계와, 루프 카운터값을 최대 루프 카운터값에 비교하는 단계와, 루프 카운터값이 최대 루프 카운터값과 동일할 때에 이동 장치를 제2 및 제3 레벨의 딥 슬립 모드 중의 하나로 전환하는 단계를 포함한다. 이동 장치는 이동 장치가 제1 레벨의 딥 슬립 모드에 있을 때에 제2 레벨의 딥 슬립 모드로 전환할 수 있으며, 이동 장치가 제2 레벨의 딥 슬립 모드에 있을 때에 제3 레벨의 딥 슬립 모드로 전환할 수 있다.

본 실시예의 또다른 특징으로, 전환 단계는 최대 타임아웃 기간을 제1, 제2 및 제3 레벨의 딥 슬립 모드 중의 하나와 관련된 소정 타임아웃 값으로 설정하는 단계와, 최대 타임아웃 기간이 만료할 때에 이동 장치를 제2 및 제3 레벨의 딥 슬립 모드 중의 하나로 전환하는 단계를 포함한다. 이동 장치는 이동 장치가 제1 레벨의 딥 슬립 모드에 있을 때에 제2 레벨의 딥 슬립 모드로 전환하고, 이동 장치가 제2 레벨의 딥 슬립 모드에 있을 때에 제3 레벨의 딥 슬립 모드로 전환한다.

본 특징의 또다른 실시예에서, 딥 슬립 모드로 진입하는 단계는 이동 장치를 제1, 제2 및 제3 레벨의 딥 슬립 모드 중의 하나로 전환하는 단계를 포함하며, 전환 단계는 최대 루프 카운터 값을 제1, 제2 및 제3 레벨의 딥 슬립 모드 중의 하나와 관련된 소정 카운터 값으로 설정하는 단계와, 시간 간격을 제1, 제2 및 제3 레벨의 딥 슬립 모드 중의 하나와 관련된 소정 시간 값으로 설정하는 단계를 포함한다. 제2 레벨의 딥 슬립 모드와 관련된 소정 시간 값은 제1 레벨의 딥 슬립 모드와 관련된 소정 시간 값보다 더 크며, 제3 레벨의 딥 슬립 모드와 관련된 소정 시간 값은 제2 레벨의 딥 슬립 모드와 관련된 소정 시간 값보다 더 크다.

본 특징의 또다른 실시예에서, 기동 단계는 제1, 제2 및 제3 레벨의 딥 슬립 모드 중의 하나와 관련된 시스템 리스트로부터 획득하기 위한 시스템을 결정하는 단계를 포함한다. 시스템 리스트는 각각 제1, 제2 및 제3 레벨 슬립 모드와 관련된 제1 시스템 리스트, 제2 시스템 리스트 및 제3 시스템 리스트를 포함할 수 있다. 제1 시스템 리스트는 제2 시스템 리스트 및 제3 시스템 리스트의 서브셋이 될 수도 있으며, 제2 시스템 리스트는 제3 시스템 리스트의 서브셋이 될 수 있다.

제2 특징으로, 본 발명은 이동 장치 배터리 전원 절약 시스템을 제공한다. 이동 장치 배터리 전원 절약 시스템은 채널 프로세서, 딥 슬립 컨트롤러, 변수 설정 컨트롤러 및 저전원 컨트롤러를 포함한다. 채널 프로세서는 시스템 채널의 상실을 나타내는 플래그 신호를 제공한다. 딥 슬립 컨트롤러는 플래그 신호를 수신하고, 시스템 상실 탈출 플래그(system lost exit flag)를 제공한다. 변수 설정 컨트롤러는 시스템 상실 탈출 플래그에 응답하여 딥 슬립 모드 변수를 설정한다. 저전원 컨트롤러는 딥 슬립 모드 변수에 의해 정해진 시간 간격으로 RF 조건 파라미터를 반복적으로 샘플링하고, RF 조건이 향상되지 못할 때에 변수 설정 컨트롤러에 제어 신호를 제공한다.

이 특징의 실시예에 따르면, 시스템 채널은 파일럿 채널과 페이징 채널 중의 하나를 포함하며, 딥 슬립 모드 변수는 시간 간격을 설정하기 위한 타이머 값과 반복 횟수를 설정하기 위한 루프 카운트 값을 포함하며, RF 조건 파라미터는 신호대 잡음 강도 비율을 포함한다.

제3 특징으로, 본 발명은 이동 장치를 딥 슬립 모드로 전환하기 위한 방법을 제공한다. 본 방법은 시스템 채널을 모니터링하는 단계와, 시스템 채널이 타임아웃 기간 내에서 상실되는 횟수를 카운트하는 단계와, 시스템 채널 카운트가 소정의 수에 동일하게 될 때 딥 슬립 모드에 진입하는 단계를 포함한다.

본 특징의 일실시예에서, 모니터링 단계는 시스템 채널의 파일럿 채널 및 페이징 채널 중의 하나를 모니터링하는 단계를 포함한다.

본 특징의 다른 실시예에서, 모니터링 단계는 채널 상실 카운터 및 채널 상실 개시 시간 값을 리셋하는 단계와, 시스템 채널이 상실될 때마다 채널 상실 카운터를 증분시키는 단계를 포함한다. 증분 단계는 채널 상실 카운터값이 1일 때에 채널 상실 개시 시간 값을 제1의 현재 GPS(Global Positioning System) 시간으로 설정하는 단계와, 채널 상실 카운터값이 소정의 수에 도달할 때에 채널 상실 최종 시간 값을 제2의 현재 GPS 시간으로 설정하는 단계를 포함한다. 이동 장치는 채널 상실 최종 시간 값과 채널 상실 개시 시간 값간의 차가 적어도 타임아웃 기간일 때에 딥 슬립 모드로 진입하며, 이동 장치가 딥 슬립 모드에 진입한 후에 채널 상실 카운터 및 채널 상실 개시 시간 값을 리셋된다.

본 발명의 다른 측면 및 특징은 첨부 도면과 관련하여 본 발명의 특정 실시예에 대한 다음의 설명을 재검토함으로써 본 기술분야에 익숙한 사람들에게는 명백하게 이해될 것이다.

본 발명의 실시예는 첨부 도면을 참조하여 설명될 것이며, 이러한 실시예는 단지 예시를 위한 것임을 주지하기 바란다.

### 실시예

전반적으로, 본 발명은 열악한 RF 조건을 탐지하고, 배터리 전원을 절약하기 위해 RF 조건에 따라 상이한 슬립 모드 레벨 또는 단계에 진입하는 방법을 제공한다. 이동 장치 배터리 수명은 이동 장치가 열악한 RF 조건을 탐지하고 딥 슬립 모드의 동작에 진입할 때에 보존될 수 있다. 이 딥 슬립 모드의 동작에서, 이동 장치는 RF 조건을 주기적으로 샘플링하고, RF 조건이 향상되지 않을 때에 샘플링의 주기를 점차적으로 증가시킨다. 이동성이 우수한 RF 송수신 범위의 지역에서조차도 무선 장치에 대한 RF 조건을 변경시킬 수 있기 때문에, 딥 슬립 모드에서 동작하는 이동 장치는 이 이동성을 탐지할 수 있고, 그러므로 아이들 상태에 진입하거나 또는 이와 달리 장기적 전원 절약 모드에 진입하는 가능성을 향상시킬 수 있다. RF 조건이 향상될 때, 이동 장치는 딥 슬립 모드에서 빠져나와 아이들 상태로 복귀한다.

본 발명의 딥 슬립 모드에 따르면, 이동 장치는 열악한 RF 조건이 탐지될 때에 딥 슬립 모드로 전환하고, 가변 시간 간격에서의 RF 조건의 샘플링을 진행한다. RF 조건의 강도는 그리고나서 소정 레벨에 비교된다. RF 조건의 강도가 소정 레벨 미만이라면, 가변 시간 간격이 증가된다. 가변 시간 간격이 점차적으로 증가되기 때문에, 이동 장치는 더 많은 배터리 전원을 보존한다. 예를 들어 시스템이 아이들 상태 동안 이동 장치에 의해 상실되는 횟수와 같은 본 기술분야에 익숙한 사람에게 알려진 딥 슬립 모드에 진입하기 위한 다양한 조건이 사용될 수 있다. 본 기술분야에 익숙한 사람이라면, 소정의 샘플링 시도 실패 횟수에 도달된 후에 가변 시간 간격이 증가될 수 있고, 가변 시간 간격이 임의의 수의 시간으로 그리고 임의의 양으로 증가될 수 있다는 것을 이해할 수 있을 것이다.

본 발명의 바람직한 실시예에 따르면, 이동 장치는 먼저 처음에 상실된 신호보다 더 우수한 신호 강도로, 바람직한 로밍 리스트(PRL : Preferred Roaming List)의 일부인 가장 최근 사용의(MRU : Most Recently Used) 테이블 리스트로부터 시스템을 획득하려고 시도한다. 이동 장치가 시스템을 획득하기 위해 시스템의 알려진 주파수에 파장을 맞추고 CDMA 신호를 탐색한다는 것을 본 기술분야에 익숙한 사람이라면 이해할 수 있을 것이다. 성공적이라면, 이동 장치는 그 시스템에서 아이들 상태로 진행한다. 그렇지 않다면, 이동 장치는 즉각적으로 제1 레벨의 딥 슬립 모드로 진행한다. 제1 레벨의 딥 슬

럼 모드에 있는 동안, 이동 장치는 RF 조건을 샘플링하기 위해 주기적으로 기동한다. RF 조건이 수용 가능하다면, 이동 장치는 신호를 재획득하고, 아이들 상태에 진입한다. 열악한 RF 조건이 지속된다면, 이동 장치는 제2 레벨의 딥 슬립 모드에 진입하고, 그 후에 제3 레벨의 딥 슬립 모드에 진입한다. 이동 장치는 샘플간의 가변 시간 간격이 각각의 슬립 모드 레벨과 함께 증가되고 상이한 시스템이 획득하기 위해 시도된다는 점을 제외하고는 제2 및 제3 레벨 슬립 모드에 있는 동안 제1 레벨 슬립 모드에서와 동일한 기능을 수행한다. 구체적으로, 이동 장치는 제1 레벨에 있는 MRU 테이블 리스트로부터 시스템을 획득하도록 시도할 것이고, 그리고나서 PRL로부터의 현재의 지리적 영역(아이들 GEO 리스트)에 있는 시스템뿐만 아니라 MRU 테이블 리스트에 있는 시스템을 획득하도록 시도할 것이며, 그리고나서 PRL에 있는 모든 시스템으로부터 시스템을 획득하도록 시도할 것이다.

도 2는 앞의 단락에서 설명된 딥 슬립 모드 프로세스를 예시하며, 특히 열악한 RF 조건이 시스템 또는 페이징 채널의 상실의 결과로 나타나는 상황에서 이동 장치 배터리 전원을 절약하기 위한 일반적인 방법을 보여주고 있다. 페이징 채널이 상실될 때, 이동 장치는 이동 장치가 아이들 상태로 동작하려고 시도하고 있는 메인 루틴으로부터 시스템 상실 탈출을 개시한다. 도 2로부터, 프로세서는 이동 장치가 딥 슬립 모드의 동작에 진입되어 있는 것으로 가정되는 단계 "100"에서 개시한다. 단계 "102"에서, 이동 장치는 단계 "100"에서 딥 슬립 모드에 진입한 이후 지연 시간  $i$ 가 경과된 후에 RF 조건을 샘플링하기 위해 간략히 활성화되거나 또는 딥 슬립 모드로부터 기동(wake up)한다. 샘플링 반복 회수의 추적을 유지하기 위해 카운터가 사용되며, 단계 "104"에서 샘플링 반복의 수는 사전 설정된 최대 반복 수와 비교된다. 카운터가 최대 수미만이 라면, 프로세서는 단계 "108"로 진행할 것이다. 단계 "108"에서, 샘플링된 RF 조건의 상태가 판정된다. RF 조건이 열악하다면, 프로세서는 또다른 샘플을 위해 다시 단계 "102"로 복귀하며, 카운터는 증분된다. 단계 "102", "104" 및 "108"의 루프는 카운터 값이 최대 반복 수와 동일할 때까지 지속한다. 카운터가 최대값에 도달할 때, 프로세서는 단계 "106"으로 진행하여 지연 시간  $i$ 를 소정의 값만큼 증가시킨다. 카운터는 그리고나서 리셋되며, 단계 "102", "104" 및 "108"의 루프는 다시 동일한 또는 상이한 최대 반복 수 중의 하나 동안 지속한다. 샘플링된 RF 조건이 단계 "108"에서 우수한 것으로 판정된다면, 프로세서는 단계 "110"으로 진행하여 지연 시간  $i$ 를 리셋하며, 그리고나서 딥 슬립 모드의 동작이 종료되는 단계 "112"로 진행한다. 지연 시간  $i$ 는 최대 3회까지 증가되는 것이 바람직하지만, 어떠한 요구된 횟수로 증가될 수도 있다.

지연 시간  $i$ 를 변경하는 목적은 이동 장치의 이동성 상태를 캡처하기 위한 것이다. 도 2에 도시된 실시예에서, 초기 지연 시간  $i$ 는 제1 레벨의 딥 슬립 모드에 대응하며, 지연 시간  $i$ 에서의 최초 증가는 제2 레벨의 딥 슬립 모드에 대응하며, 지연 시간  $i$ 에서의 두번째 증가는 제3 레벨의 딥 슬립 모드에 대응한다. 더 높은 주파수의 RF 조건 샘플링은 지연 시간  $i$ 가 짧을 때 RF 조건이 급속하게 변화하는 상황을 캡처하고자 하기 위함이다. 예를 들어, 이동 장치는 이동중인 차량 내에 있거나 또는 이동중인 차량이 RF 조건을 변경시킬 수 있는 주차 시설 내에 있을 수 있다. 더 낮은 주파수의 RF 조건 샘플링은 지연 시간  $i$ 가 증가될 때 RF 조건이 저속으로 변경하고 있는 상황을 캡처하기 위함이다. 그 예는 도보중인 사용자가 이동 장치를 소지하고 있을 때이다. 저주파수의 RF 조건 샘플링은 지연 시간  $i$ 가 높을 때 RF 조건이 매우 저속으로 변하거나 또는 전혀 변하지 않는 상황을 캡처하기 위함이다. 그 예는 이동 장치가 열악한 RF 조건의 지역에서 정지하여 있을 때이다. 따라서, 샘플링 주파수를 점차적으로 단계적으로 하향시킴으로써, 이동 장치의 배터리 전원은 보존될 수 있다. 더욱이, 이러한 감소 시퀀스는 이동 장치에 대하여 가능한 한 즉시 시스템을 차지하도록 부지런하게 시도된다. 특히, 이동 장치가 이동중이라면, 향상된 RF 조건을 만나게 되거나 짧은 기간의 시간에 걸쳐 RF 신호가 없는 지역을 탐지할 더 높은 가능성이 존재한다. 이동 장치가 정지 상태라면, 더 긴 기간의 시간에 걸쳐 동일한 열악한 RF 조건을 가질 가능성이 더 높아진다.  $i$ 에 해당하는 특정 지연 시간은 초단위 또는 분단위의 어떠한 값으로 되도록 선택될 수 있음은 자명하다.

본 발명의 다음의 실시예는 열악한 RF 조건에서 배터리 전원을 절약하기 위해 이동 장치에 사용하기에 적합한 시스템 및 방법을 설명한다.

도 3은 본 발명의 실시예에 따른 딥 슬립 시스템의 블록도를 도시하고 있다. 도 3에 도시된 딥 슬립 시스템(200)은 통신 채널을 모니터링하고, 성공적인 통신이 가능하도록 하며, 딥 슬립 모드에 있는 이동 장치를 제어한다. 딥 슬립 시스템(200)은 채널 프로세서(202), 딥 슬립 컨트롤러(204), 변수 설정 컨트롤러(206) 및 저전원 컨트롤러(208)를 포함한다. 블록을 상호 연결하는 화살표는 한 블록에서 다른 블록으로의 순방향 공급 정보 또는 다른 블록으로의 역방향 공급 정보 중의 하나이다. 각각의 블록의 기능은 다른 이동 장치 기능과 함께 주문형 반도체(ASIC)로 구현될 수 있다. 각각의 블록의 전반적인 기능은 아래에 설명된다.

채널 프로세서(202)는 이동 장치를 슬롯화 모드의 동작으로 작동시키기 위한 표준 채널 획득 기능을 수행한다. 딥 슬립 컨트롤러(204)는 채널 프로세서(202)에 의한 파일럿 또는 페이징 채널의 상실을 나타내주는 플래그 신호를 수신하며, 사전 설정된 조건에 기초하여 시스템 상실 탈출을 개시한다. 본 실시예에서, 딥 슬립 컨트롤러(204)는 파일럿 또는 페이징 채널이 일정 기간의 시간 동안 상실되는 횟수를 카운트한다. 채널 프로세서(202)는 사전 설정된 조건이 충족되지 못한다면 시스템에 대한 탐색을 지속하도록 명령되지만, 사전 설정된 조건이 충족된다면 시스템 상실 탈출을 개시하도록 명령된다. 시스템 상실 탈출이 딥 슬립 컨트롤러(204)에 의해 개시된 후, 변수 설정 컨트롤러(206)는 제1, 제2 및 제3 레벨의 딥 슬립

모드의 각각에 대하여 적합한 딥 슬립 모드 변수를 설정한다. 저전원 콘트롤러(208)는 변수 설정 콘트롤러(206)에 의해 설정된 딥 슬립 모드 변수에 따라 RF 조건을 샘플링하며, 변수 설정 콘트롤러(206)에 제어 신호를 송신함으로써 이동 장치를 제2 및 제3 레벨의 딥 슬립 모드로 전환한다. 우수한 RF 조건의 존재시에, 저전원 콘트롤러(208)는 이동 장치의 제어를 정상 작동을 위해 채널 프로세서(202)에 돌려준다.

전술된 블록의 각각에 대한 제어 프로세스는 도 4 내지 도 7을 참조하여 설명된다.

도 4는 도 3에 도시된 시스템(200)의 채널 프로세서(202)에 대한 제어 프로세스를 도시하고 있다. 이 제어 프로세스는 통신 채널의 획득 및 이동 장치와 기기국간의 데이터 트래픽의 처리와 같은 슬롯화 모드의 동작과 관련된 표준 기능을 수행한다. 본 제어 프로세스는 시스템의 다른 블록과 상호 작용하여 이동 장치가 예를 들어 아이들 상태와 같은 정상 모드 동작으로 재진입하도록 한다. 단계 "300"에서, 이동 장치가 전원 공급되거나 무선 회로가 턴온된다. 채널 상실 카운터  $x$  및 채널 상실 개시 시간  $y$ 는 단계 "302"에서 제로 값으로 초기화되거나 리셋된다. 단계 "304"에서, 이동 장치는 시스템의 파일럿 채널 및 동기화 채널을 획득하도록 시도하는 시스템 결정 단계에 진입한다. 파일럿 채널 및 동기화 채널이 획득된 후, 단계 "306"에서 페이징 채널 처리로 진행하여, 이동 장치가 아이들 상태로 진입하여 파일럿 및 페이징 채널을 모니터링하면서 슬롯화 모드 또는 비슬롯화 모드 중의 하나로 작동한다. 이동 장치는 파일럿 채널을 모니터링하면서 단계 "308"에서 액세스 채널로 전환할 것이며, 액세스를 위한 이유가 트래픽 상태로 진행하기 위한 것이 아니라면 다시 페이징 채널을 모니터링하도록 되돌려질 것이다. 액세스를 위한 이유 중의 한 예는 네트워크에 등록하기 위해서이다. 프로세스는 단계 "310"으로 진행하고, 인출 호출이 이루어지거나 또는 인입 호출이 수신될 때 트래픽 채널로 전환한다. 그리고나서, 채널 상실 카운터 및 채널 상실 개시 시간이 모두 단계 "312"에서 리셋되며, 단계 "314"에서 호출이 완료된다. 성공적인 호출이 완료되었다면 변수  $x$  및  $y$ 는 단계 "312"에서 항상 리셋된다. 시스템이 단계 "306" 및 "308" 동안에 상실될 수도 있어서 프로세스가 시스템 상실에 대한 이유의 판정을 위한 단계 "316"으로 진행된다는 점에 유의하기 바란다. 시스템이 상실될 수 있는 다른 이유는 액세스 실패 또는 다른 시스템을 탐색하기 위한 기기국에 의한 이동 장치의 재지향(redirection)을 포함한다. 파일럿 또는 페이징 채널의 상실로 인해 시스템이 상실되었다면, 이 프로세스는 중간 단계 "A"로 진행하고, 그렇지 않다면 프로세스는 단계 "304"로 복귀한다.

도 5는 시스템이 파일럿 또는 페이징 채널의 상실로 인해 상실될 때에 도 4의 제어 프로세스로부터 수행되는 도 3의 딥 슬립 콘트롤러(204)에 대한 제어 프로세스를 도시하고 있다. 중간 단계 "A"에서 부터, 채널 상실 카운터  $x$ 는 단계 "318"에서 증분되며,  $x$ 가 정확히 1인지를 체크하기 위한 판정이 단계 "320"에서 이루어진다.  $x$ 가 정확히 1이라면, 단계 "322"에서는 채널 상실 개시 시간  $y$ 가 현재의 GPS 시간으로 설정되며, 프로세스는 중간 단계 "B"를 경유하여 도 4의 단계 "304"로 복귀한다. 단계 "320" 및 "322"는 파일럿 및 페이징 채널이 최초로 상실되는 상황을 캡처한다. 단계 "320"에서  $x$ 가 1보다 크다면, 프로세스는  $x$ 가 사전 설정된 값에 적어도 동일함을 체크하는 단계 "324"로 진입한다.  $x$ 가 사전 설정된 값과 동일하지 않다면, 프로세스는 중간 단계 "B"를 경유하여 도 4의 단계 "304"로 복귀한다. 그렇지 않다면, 프로세스는 변수  $z$ 에 의해 기록된 채널 상실 최종 시간이 현재의 GPS 시간으로 설정되는 단계 "326"으로 진행한다. 사전 설정된 값은 딥 슬립 모드로 진입하기 위한 하나의 조건을 형성하며, 이것은 파일럿 또는 페이징 채널이 이동 장치에 의해 상실되는 최대 횟수이다. 단계 "328"에서, 변수  $z$ 와  $y$ 간의 차는 사전 설정된 타임아웃 기간에 비교된다. 이 차이가 사전 설정된 타임아웃 기간에 적어도 동일하다면,  $x$  및  $y$ 는 단계 "330"에서 리셋되며, 프로세스는 중간 단계 "C"로 진행한다. 그렇지 않다면, 프로세스는 이동 장치가 시스템 상실 탈출을 수행한 횟수가 사전 정의된 타임아웃 기간 동안에 발생하지 않았다는 것을 나타내주는 중간 단계 "B"를 경유하여 도 4의 단계 "302"로 복귀한다. 그러므로, 딥 슬립 콘트롤러는 RF 조건이 딥 슬립 모드의 동작으로 진행되는 것을 보장할 정도로 매우 열악하지는 않다는 것으로 결정한다. 타임아웃 기간은 제1 조건과 조합하여 딥 슬립 모드로 진입하기 위한 제2 조건을 형성한다. 즉, 딥 슬립 모드는 파일럿 또는 페이징 채널이 적어도 최대 기간의 시간 내에서 최소 횟수로 상실될 때에만 진입된다.

도 6은 도 3의 변수 설정 콘트롤러(206)에 대한 제어 프로세스를 도시하고 있다. 이 제어 프로세스는 먼저 중간 단계 "C"를 통해 진입된다. 후술되는 바와 같이, 도 6의 제어 프로세스는 중간 단계 "D" 및 "E"를 통해 추후에 재진입된다. 중간 단계 "C"에서부터, 딥 슬립 모드에서의 획득을 위해 시도될 시스템을 나열하고 있는 가장 최근 사용의(MRU) 테이블이 단계 "332"에서 탐색된다. 본 실시예에서, 이동 장치는 자신이 마지막으로 획득한 최종의 10 내지 12개의 시스템을 자신의 MRU 테이블에 저장한다. 그리고나서, 변수 타이머  $T$ 가 단계 "334"에서 최초의 값  $t_1$ 로 설정되며, 변수 최대 루프 카운터 값  $n$ 은 단계 "336"에서 4로 설정되는 것이 바람직하다. 프로세스는 그리고나서 중간 단계 "Deep Nap"을 통해 딥 슬립 프로세스에 진입한다. 단계 "332" 내지 "336"은 제1 레벨 슬립 모드에 대한 변수를 형성한다. 중간 단계 "E"에서부터, 이동 장치의 현재 지리적 영역 및 MRU로부터의 시스템은 단계 "338"에서 획득 시도를 위해 탐색된다. 그리고나서, 가변 타이머  $T$ 가 단계 "340"에서 제2 값  $t_2$ 로 설정되며, 변수 최대 루프 카운터 값  $n$ 은 단계 "342"에서 4로 설정되는 것이 바람직하다. 중간 단계 "F"에서부터, PRL로부터의 모든 시스템은 단계 "344"에서 획득 시도를 위해 탐색된다. 가변 타이머  $T$ 는 그리고나서 단계 "346"에서 세번째 값  $t_3$ 로 설정되며, 변수 최대 루프 카운터 값  $n$ 은 단계 "348"에서 무한대로 설정되는 것이 바람직하다. 이것은 실제로  $n$ 을 최고의 허용 가능한 정수로 설정함으로써 또는 무한 루프를 구현함으로써 달성된다. 단계

"338" 내지 "342" 및 "344" 내지 "348"이 전반적으로 각각 단계 "332" 내지 "336"과 동일하기는 하지만, 단계 "338" 내지 "342"는 제2 레벨 슬립 모드에 대한 변수를 형성하고, 단계 "344" 내지 "348"은 제3 레벨 슬립 모드에 대한 변수를 형성한다. 구체적으로, 가변 타이머 T는 단계 "340"에서 t1보다 더 큰 것이 바람직 한 시간 t2로 설정되며, 변수 타이머 T는 단계 "346"에서 t2보다 더 큰 것이 바람직한 시간 t3로 설정된다. 최대 루프 카운터 값 n은 단계 "342"에서 4로 설정되는 것이 바람직하며, 그리고 나서 단계 "348"에서 무한대로 설정된다.

도 7은 도 3의 저전원 컨트롤러(208)에 대한 제어 프로세스를 도시하고 있으며, 이 프로세스는 가변 타이머 T 및 최대 루프 카운터 값 n이 도 6에서 설정된 후에 실행된다. 단계 "350"에서, 이동 장치는 전원을 보존하기 위한 시간 T 동안 딥 슬립으로 진행한다. 시간 T가 만료될 때, 이동 장치는 단계 "352"에서 기동하며, 단계 "354"로 진행한다. 단계 "354"에서, 이동 장치는 시스템 결정 단계에 진입하고, 도 6에 도시된 시스템 리스트에 의해 결정된 바와 같이 시스템을 순차적으로 획득하려고 시도한다. 시스템이 단계 "356"에서 획득되었다면, 단계 "358"에서 신호대 잡음비(S/N)가 평가된다. 그렇지 않다면, 프로세스는 단계 "364"로 진행한다. 단계 "358"에서, 획득된 시스템의 S/N이 사전 결정된 레벨에 비교된다. S/N 강도가 사전 결정된 레벨 이하라면, 프로세스는 단계 "360"로 진행하여 이동성 플래그가 참 또는 거짓 중의 하나로 설정된다. 이동성 플래그를 참으로 설정하기 위해서는 2가지의 조건 중의 하나가 사용된다. 먼저, 획득된 시스템 기지국의 의사 잡음(PN)이 이동 장치에 알려져 있다면, 이동성 플래그는 참으로 설정된다. 두번째로, PN 상태가 이동 장치가 이동중인 것으로 나타내고 있다면, 이동성 플래그는 참으로 설정된다. CDMA 시스템에서, 각각의 기지국은 그 자신의 고유한 PN 시퀀스에 의해 식별될 수 있다. 프로세스는 그리고 나서 신호대 잡음비가 만족스럽지 못하기 때문에 현재의 시스템을 "바람직하지 않음"으로 마킹하기 위해 단계 "362"로 진행한다. 따라서, 이동 장치는 도 7의 프로세스 내에서 작동하고 있는 동안에는 "바람직하지 않음"으로 마킹된 시스템의 획득을 재시도하지 않을 것이다. 단계 "364"에서, 프로세스는 획득 시도가 이루어지지 않은 도 6에서의 리스트로부터 어떠한 시스템에 대해 검사한다. 단계 "364"가 단계 "362"로부터 진입되었다면, 그 결과는 자동적으로 "아니오"이고, 프로세스는 단계 "366"으로 진행한다. 이에 의해 이동 장치는 리스트 내의 다른 시스템을 시도할 수 있게 되고 만족할만한 S/N비를 갖는 시스템을 찾게 된다. 단계 "364"가 단계 "356"으로부터 진입되고 획득 시도가 이루어지지 않은 시스템이 존재한다면, 프로세스는 도 6으로부터 리스트 내에서의 다음 시스템의 획득을 위해 단계 "354"로 복귀한다. 단계 "366"에서, 이동성 플래그가 체크되며, 거짓이라면, 루프 카운터가 단계 "368"에서 증분된다. 그렇지 않다면, 프로세스는 단계 "374"로 진행하여 이동 장치가 도 7의 제어 프로세스에서 빠져나오려고 준비한다. 단계 "350"이 초기에 도 6으로부터의 중간 단계 "C"를 경유하여 진입되었다면, 프로세스는 중간 단계 "D"를 경유하여 단계 "306"으로 복귀한다. 그렇지 않다면, 프로세스는 도 6의 단계 "C"로 복귀한다. 단계 "374"는 이동 장치로 하여금 현재의 제어 프로세스에서 빠져나오도록 한다. 구체적으로, 이동 장치는 단계 "350"이 도 6의 중간 단계 "E" 또는 "F" 중의 하나로부터 진입되었다면 정상 작동 모드 또는 제1 레벨의 딥 슬립 모드로 복귀한다. 그러므로, 이동 장치는 RF 조건이 향상되기 시작하고 급격하게 변화하는 상황에서 아이들 상태로 복귀할 더 높은 확율을 가질 수 있다. 루프 카운터가 단계 "368"에서 증분된 후, 이 루프 카운터는 단계 "370"에서 최대 루프 카운터 값과 비교된다. 루프 카운터가 최대 루프 카운터 값에 도달하지 않았다면, 프로세스는 단계 "350"으로 되돌아가 현재의 제어 프로세스의 또다른 반복을 개시한다. 한편, 최대 루프 카운터 값에 도달되었다면, 프로세스는 단계 "372"로 진행한다. 단계 "372"에서, 프로세스는 이동 장치가 현재 어느 딥 슬립 모드 레벨에 있는지를 판정한다. 이동 장치가 현재 단계 "332" 내지 "336"에 의해 설정된 바와 같은 제1 레벨의 딥 슬립 모드에 있다면, 프로세스는 도 6의 단계 "338" 내지 "342" 및 중간 단계 "E"를 경유하여 제2 레벨의 딥 슬립 모드로 진입할 것이다. 이동 장치가 현재 제2 레벨의 딥 슬립 모드에 있다면, 프로세스는 도 6의 단계 "344" 내지 "348" 및 중간 단계 "F"를 경유하여 제3 레벨의 딥 슬립 모드로 진입할 것이다. 이동 장치가 이미 제3 레벨의 딥 슬립 모드에 있다면, 이동 장치는 프로세스가 중간 단계 "F"를 경유하여 단계 "344" 내지 "348"로 복귀할 것이기 때문에 제3 레벨의 딥 슬립 모드를 유지할 것이다. 따라서, 도 7의 제어 프로세스는 도 3의 변수 설정 컨트롤러(206)에서 설정된 최대 루프 카운터 값에 기초하여 각각의 딥 슬립 모드 레벨에서 소정수의 시간 동안 순환하며, 여기서 시스템 S/N 강도가 각각의 루프에서 샘플링된다. 더욱이, 시간 T가 또한 변수 설정 컨트롤러(206)에서도 설정되기 때문에, 각각의 루프는 시간 T가 만료된 후에만 실행된다. RF 조건이 향상되지 못할 때, 도 7의 제어 프로세스는 점차적으로 이동 장치가 시스템을 샘플링하기 위해 점점 더 적게 주기적으로 기동하는 상이한 딥 슬립 모드 레벨에 진입할 것이다. 그러므로, 열악한 RF 조건 하에서도 배터리 수명이 보존된다.

바람직한 실시예에서, 도 7의 제어 프로세스는 제어 프로세스가 다음 슬립 모드 레벨에 진입해야만 할 때를 결정하기 위해 루프 카운터 대신에 타임아웃 기간을 사용한다. 타임아웃 기간은 도 6에서 루프 카운터가 설정되는 것과 동일한 방식으로 각각의 슬립 모드 레벨에 대해 가변적으로 설정될 수 있다.

또다른 바람직한 실시예에서, 값 t1으로는 30초가 가능하고, t2에 대한 값으로는 1분이 가능하며, t3에 대한 값으로는 3분이 가능하다.

본 발명의 딥 슬립 모드 실시예는 이동 장치의 이동성 상태를 캡처한다. 이동 장치가 더 고속으로 이동할수록, 이동 장치가 향상된 RF 조건으로 더 우수한 송수신 범위 지역에 진입하는 가능성이 더 높아져, 사용자가 호출을 송신/수신할 수 있게 된다. 송수신 범위가 지속적으로 열악할 때, 이동 장치는 회로가 한번에 수분 동안 전원 다운된 채로 유지되는 딥 슬립 모드에 진입할 수 있다.

본 발명의 전술된 실시예는 예를 위한 것이다. 본 기술분야에 익숙한 사람이라면 본 발명의 기술사상으로부터 벗어남이 없이도 특정 실시예에 대한 변경, 수정 및 변형이 가능할 것이며, 본 발명의 기술사상은 청구의 범위에 의해서만 한정될 것이다.

도면의 간단한 설명

도 1은 종래 기술의 슬롯 사이클 인덱스 타이밍도이다.

도 2는 본 발명의 실시예에 따른 이동 장치 제어 방법을 나타내는 흐름도이다.

도 3은 본 발명의 또다른 실시예에 따른 이동 장치 제어 시스템의 블록도이다.

도 4는 도 3의 채널 프로세서의 프로세스를 나타내는 흐름도이다.

도 5는 도 3의 전원 절약 컨트롤러의 프로세스를 나타내는 흐름도이다.

도 6은 도 3의 변수 설정 컨트롤러의 프로세스를 나타내는 흐름도이다.

도 7은 도 3의 저전원 컨트롤러의 프로세스를 나타내는 흐름도이다.

도면

도면 1

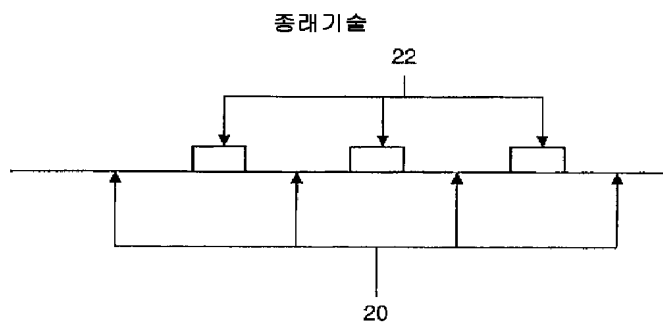



도면2

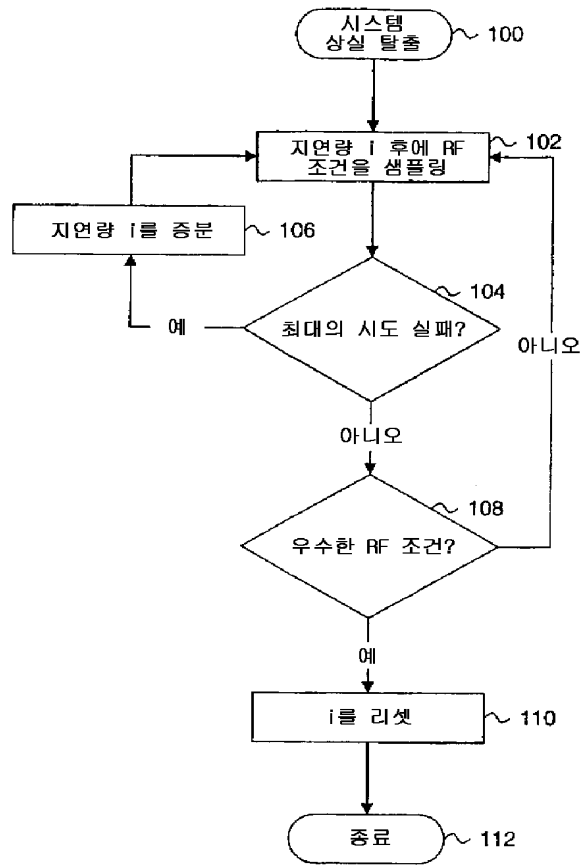

도면3

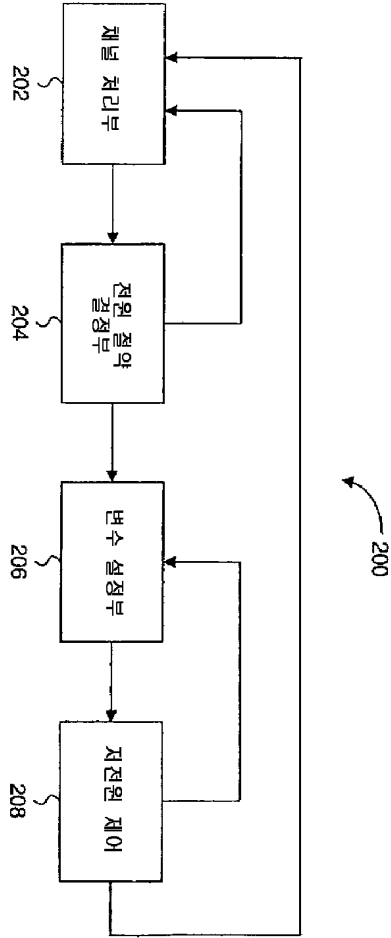

도면4

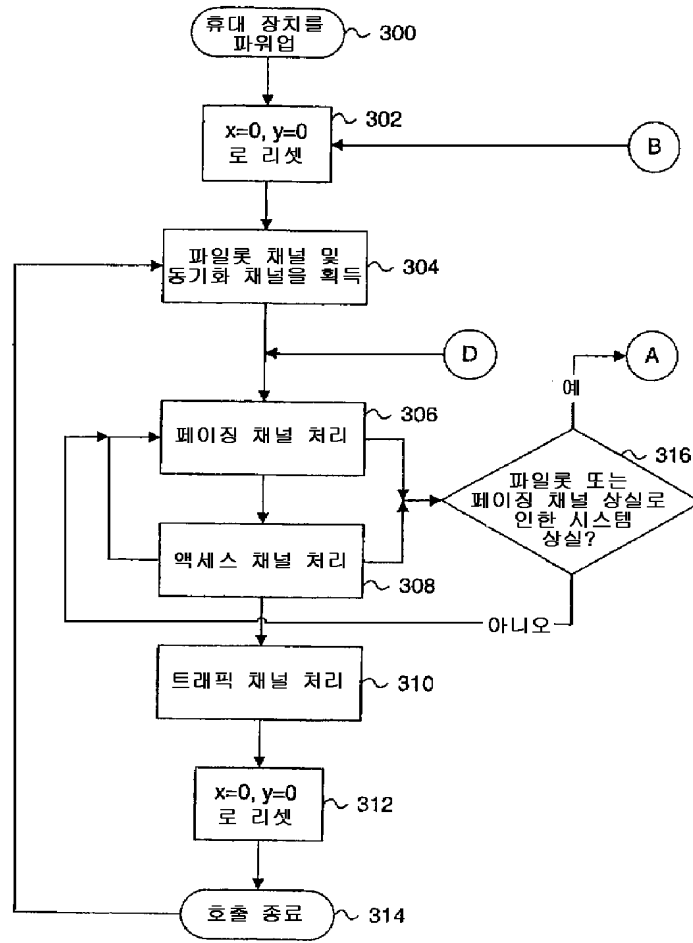

도면5

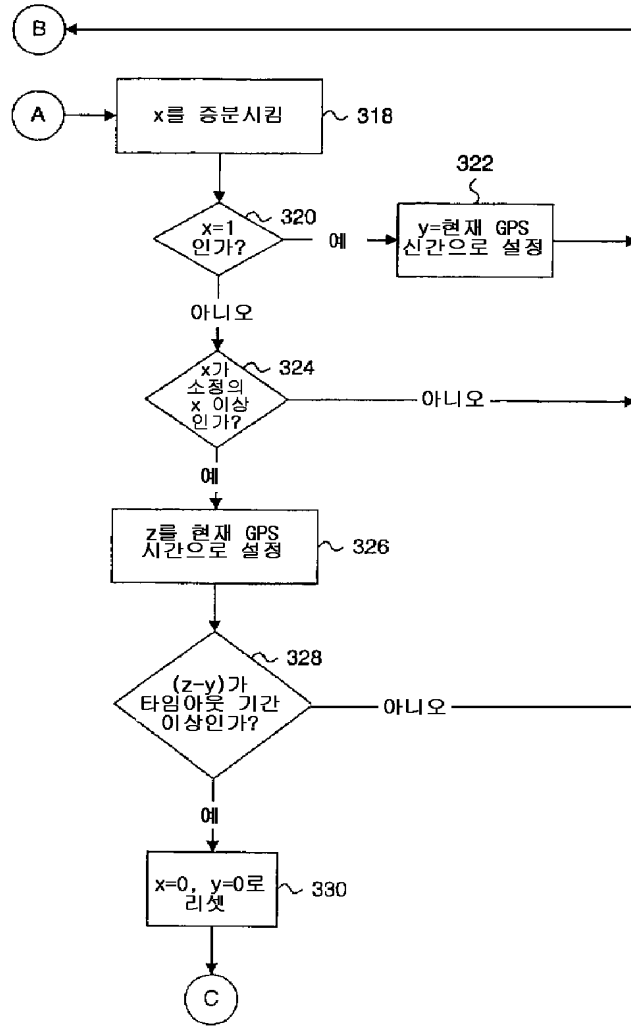

도면6

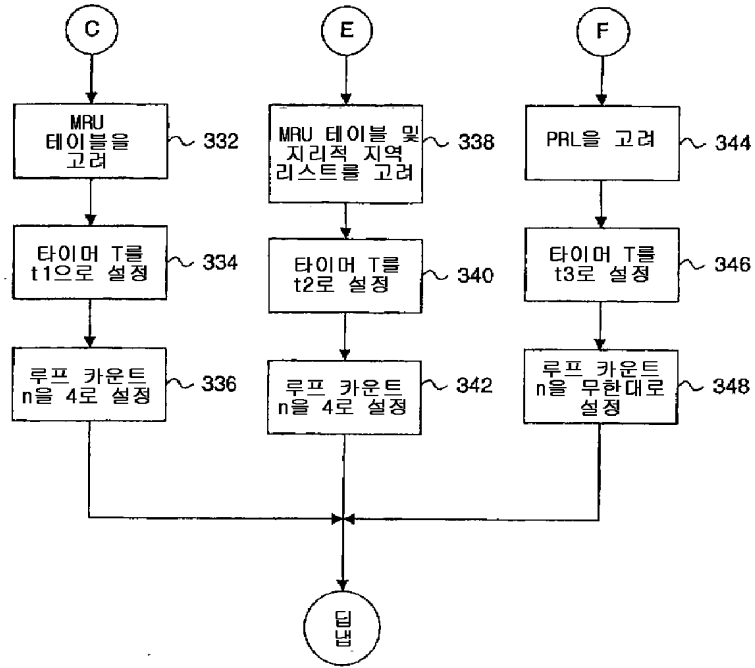

도면7

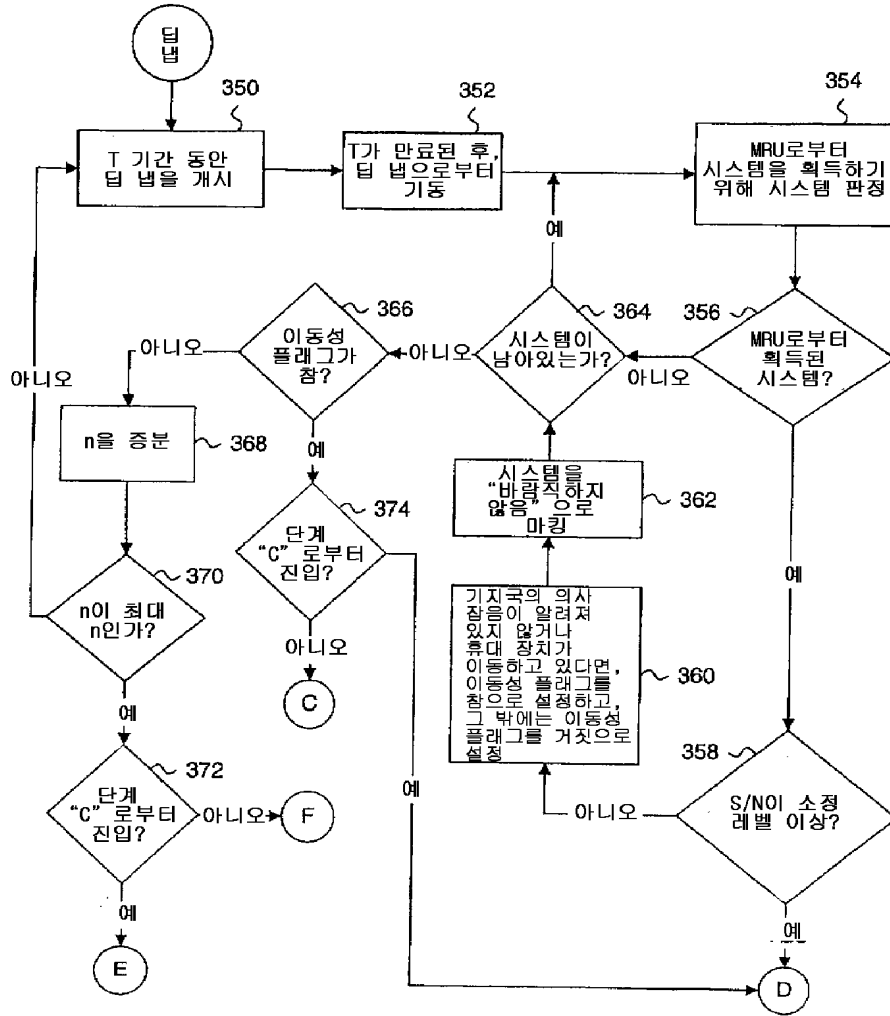

# PATENT ABSTRACTS OF JAPAN

(11)Publication number : **10-325735**

(43)Date of publication of application : **08.12.1998**

---

(51)Int.Cl.

**G01C 22/00**

**G01C 21/00**

**G01S 5/14**

---

(21)Application number : **09-169744**

(71)Applicant : **SEIKO INSTR INC**

(22)Date of filing : **26.06.1997**

(72)Inventor : **SAKUMOTO KAZUSANE  
ODAGIRI HIROYUKI  
NAKAMURA CHIAKI  
TSUBATA KEISUKE**

---

(30)Priority

Priority number : **08273787** Priority date : **16.10.1996** Priority country : **JP**  
**09 72269** **25.03.1997** **JP**

---

(54) **PORTABLE TYPE GPS RECEIVER**

(57)Abstract:

PROBLEM TO BE SOLVED: To obtain a GPS (global position measuring system) receiver which can accurately measure a moving distance and a moving speed without continuous reception while enabling measuring of the moving distance and the moving speed even when a satellite can not be caught.

SOLUTION: A speed is determined once from a Doppler frequency of a carrier by a GPS receiver 600 to obtain a distance by a distance conversion means 106 from the speed. A walking detection means 100 detects walking to determine a stride by a stride computing means 104 from the number of steps accumulated by a number of step computing means 102 and the distance converted. Thereafter, a moving distance is determined by a distance computing means 103 and a moving speed by a speed computing means 105 from the stride and the number of steps detected and accumulated. Signals are periodically received by the GPS receiver 600 to update the stride.

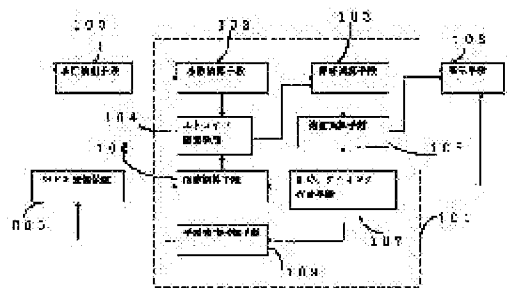

\* NOTICES \*

JPO and INPIT are not responsible for any damages caused by the use of this translation.

- 1.This document has been translated by computer. So the translation may not reflect the original precisely.
- 2.\*\*\* shows the word which can not be translated.
- 3.In the drawings, any words are not translated.

---

## PRIOR ART

---

[Description of the Prior Art]A GPS system receives navigation data required for positioning with the receiver on the earth from 3-4 or more satellites conventionally among 24 GPS Satellites which turn around about 20,200 km and six orbits of 55 angles of inclination 1 round on the earth in about 12 hours, Positioning computing, such as a position of the mobile equipped with the receiver and movement speed, is performed. The Doppler frequency of a subcarrier can be measured and it can also ask for the velocity vector of a mobile. There are two of L2 L1 whose frequency is 1.57542 GHz, and whose frequency are 1.22760 GHz in the transmit frequency of a GPS Satellite. L1 is used for general positioning. With pseudonoise numerals (synthetic wave of navigation data, such as a C/A code which identifies a satellite, an orbit of a satellite, trajectory information of a satellite, and time information), PSK (phase shift keying) abnormal conditions are carried out, spectrum spread of L1 is carried out, and it is transmitted



from the satellite. The GPS receiving set shown in drawing 6 receives this electric wave. The 1.57542-GHz signal received with the antenna 601 is amplified in L belt amplifying circuit 602, and it changes into 1st IF (intermediate frequency) signal (tens of MHz - 200 MHz) in the down converter part 603, and changes into the 2nd IF signal (2 more MHz - about 5 MHz). The 2nd IF signal is inputted into the voltage comparator 604, and digital conversion is carried out using the voltage comparator 604 with a several times as many clock as an IF signal. This output is the data by which spectrum spread was carried out. In the message decoding means 605, navigation data is obtained by carrying out back-diffusion of gas of the C/A code which is the same pseudonoise numerals as the satellite by which it is generated in the C/A numerals generation circuit 606 to the digital signal which the voltage comparator 604 outputs. This operation is performed to two or more satellites, and it usually asks for positioning data by the positioning computing means 607 from the navigation data of four satellites. It is possible to be used with the miniaturization of such a GPS receiver, in order to ask for the migration length and movement speed at the time of a run and a walk of human being, and is indicated by JP,6-118156,A etc.

---

[Translation done.]

\* NOTICES \*

**JPO and INPIT are not responsible for any damages caused by the use of this translation.**

- 1.This document has been translated by computer. So the translation may not reflect the original precisely.
- 2.\*\*\*\* shows the word which can not be translated.
- 3.In the drawings, any words are not translated.

---

## **EFFECT OF THE INVENTION**

[Effect of the Invention]As mentioned above, according to this invention, speed is once found from the Doppler frequency of a subcarrier with a GPS receiving set, and it asks for stride from the number of steps integrated by the number-of-steps calculating means in quest of distance from the speed. It is having asked for migration length and moving speed after that from the number of steps by which detection addition is carried out with stride, and continuation measurement at the difficult place of positioning of a tunnel, the valley of a building, etc. was enabled. In order to ask for distance and speed on a stride standard, it becomes possible to lose the necessity of positioning a GPS receiving set continuously, and to consider it as low power consumption.

\* NOTICES \*

**JPO and INPIT are not responsible for any damages caused by the use of this translation.**

- 1.This document has been translated by computer. So the translation may not reflect the original

precisely.

2.\*\*\* shows the word which can not be translated.

3.In the drawings, any words are not translated.

---

## DESCRIPTION OF DRAWINGS

---

[Brief Description of the Drawings]

[Drawing 1]It is a functional block diagram showing one example of the portable GPS receiving set concerning this invention.

[Drawing 2]They are other functional block diagrams showing one example of the portable GPS receiving set concerning this invention.

[Drawing 3]They are other functional block diagrams showing one example of the portable GPS receiving set concerning this invention.

[Drawing 4]They are other functional block diagrams showing one example of the portable GPS receiving set concerning this invention.

[Drawing 5]They are other functional block diagrams showing one example of the portable GPS receiving set concerning this invention.

[Drawing 6]It is a functional block diagram showing the composition of the conventional GPS receiving set.

[Drawing 7]It is a functional block diagram showing the embodiment of the portable GPS receiving set concerning this invention.

[Drawing 8]It is a figure showing the operation flow of the portable GPS receiving set concerning this invention.

[Drawing 9]It is a figure showing the operation flow of the stride operation of the portable GPS receiving set concerning this invention.

[Drawing 10]They are the other figures showing the operation flow of the stride operation of the portable GPS receiving set concerning this invention.

[Drawing 11]It is a figure showing the embodiment of the walk intensity detecting means of the portable GPS receiving set concerning this invention.

[Drawing 12]It is a wave form chart showing the walk signal of the walk intensity detecting means of a portable GPS receiving set and the output of a rectangular wave conversion circuit concerning this invention.

[Drawing 13]It is a figure showing the embodiment of the illuminance change detection means of the portable GPS receiving set concerning this invention.

[Drawing 14]It is a figure showing the embodiment of the pulse detection means of the portable GPS receiving set concerning this invention.

[Description of Notations]

100 Walk detection means

101 CPU

102 Number-of-steps calculating means

103 Distance calculating means

104 Stride calculating means

105 Speed arithmetic means

106 Distance conversion means

107 A time check, a timing preparing means

108 Displaying means

109 Receiving operation control means  
200 Pitch calculating means  
300 Walk intensity detecting means  
400 Illuminance change detection means  
500 Pulse detection means  
600 GPS receiving set  
601 Antenna  
602 L belt amplifying circuit  
603 Down converter circuit  
604 Voltage comparator circuit  
605 Message decipherment circuit  
606 C/A numerals generation circuit  
607 Positioning computing circuit  
700 Acceleration sensor  
701 Amplifying circuit  
702 Filter  
703 Rectangular wave conversion circuit  
704 Circuit generating reference voltage  
705 RAM  
707 Reference signal generating circuit  
708 Input circuit  
709 Drive circuit  
710 ROM  
1100 A/D converter  
1300 Amplifying circuit  
1400 Amplifying circuit  
1401 Filter

\* NOTICES \*

**JPO and INPIT are not responsible for any damages caused by the use of this translation.**

- 1.This document has been translated by computer. So the translation may not reflect the original precisely.
- 2.\*\*\*\* shows the word which can not be translated.
- 3.In the drawings, any words are not translated.

---

## **DRAWINGS**

---

[Drawing 1]

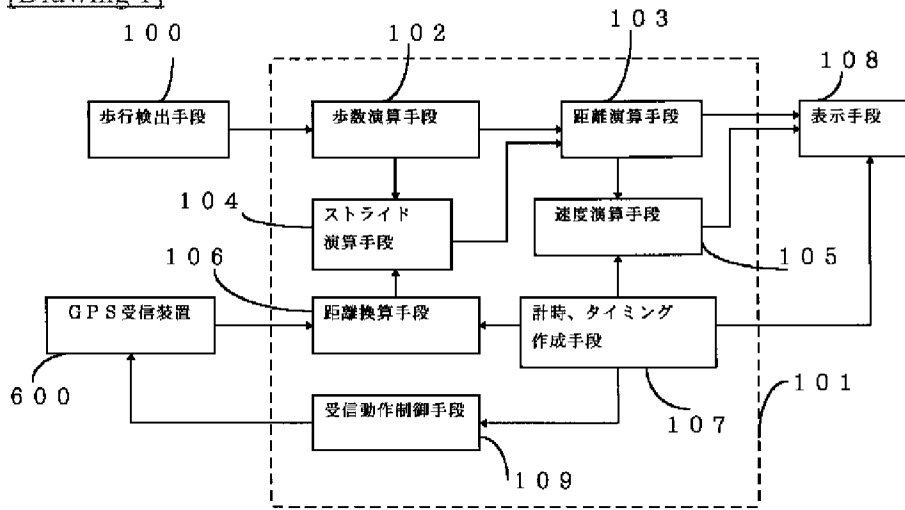

[Drawing 2]

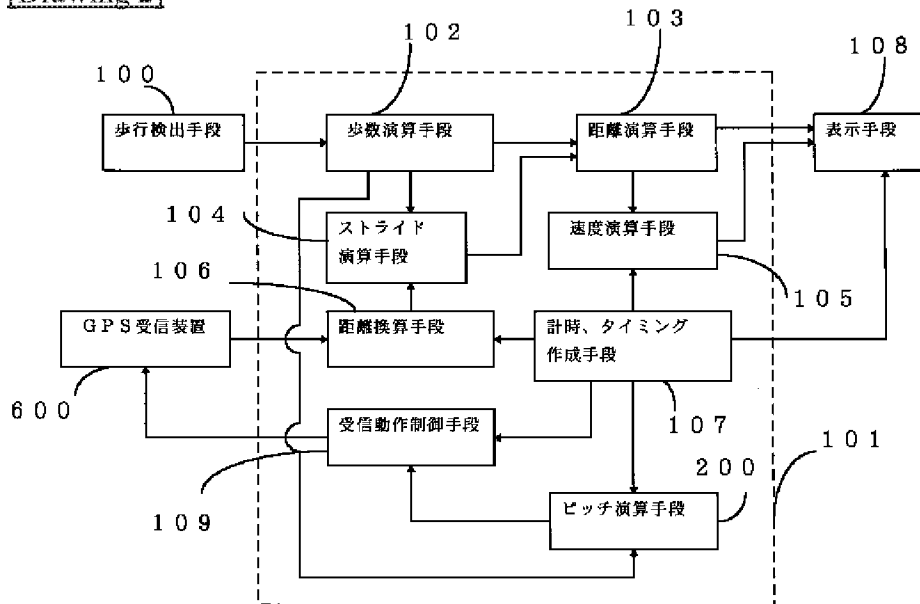

[Drawing 3]

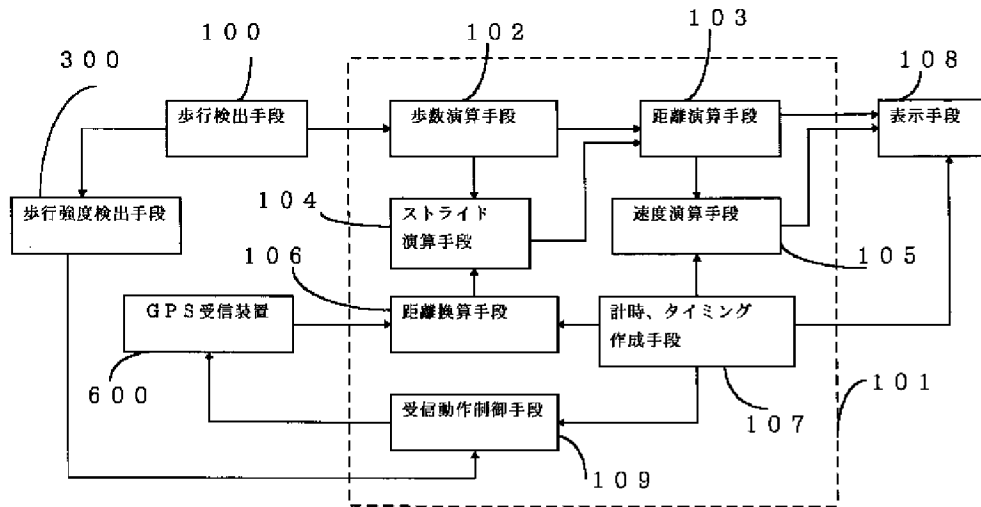

[Drawing 4]

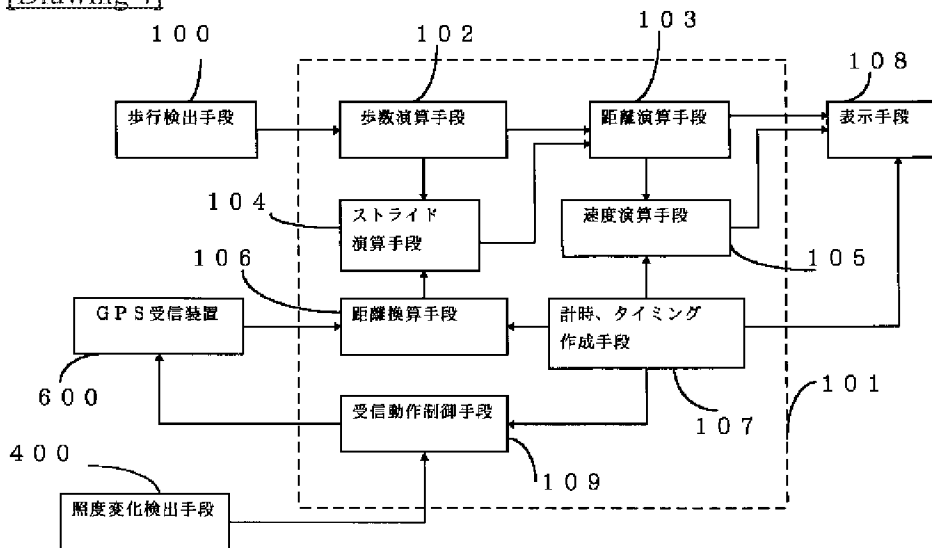

[Drawing 11]

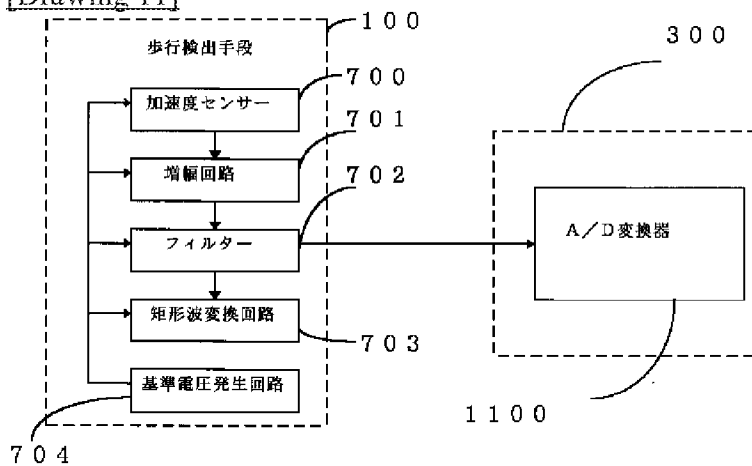

[Drawing 5]

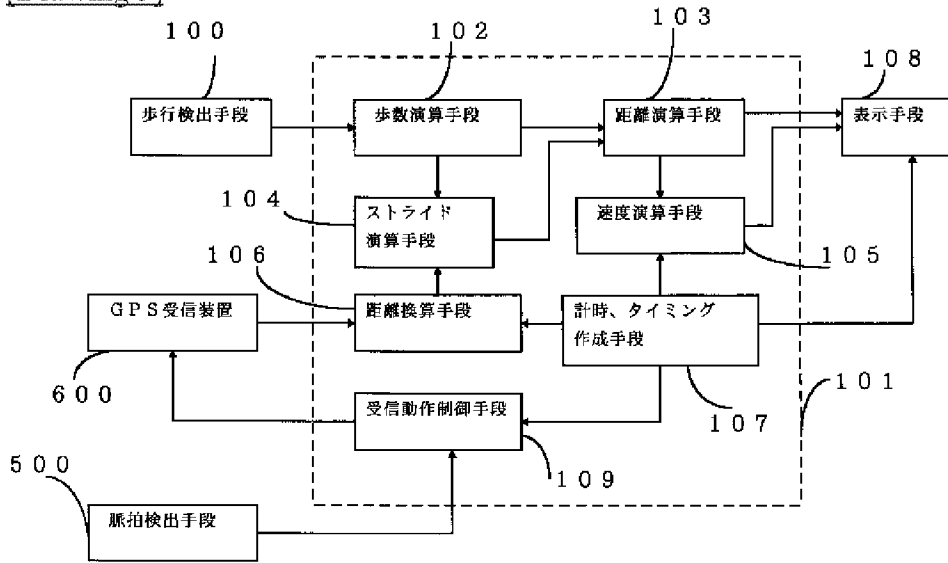

[Drawing 6]

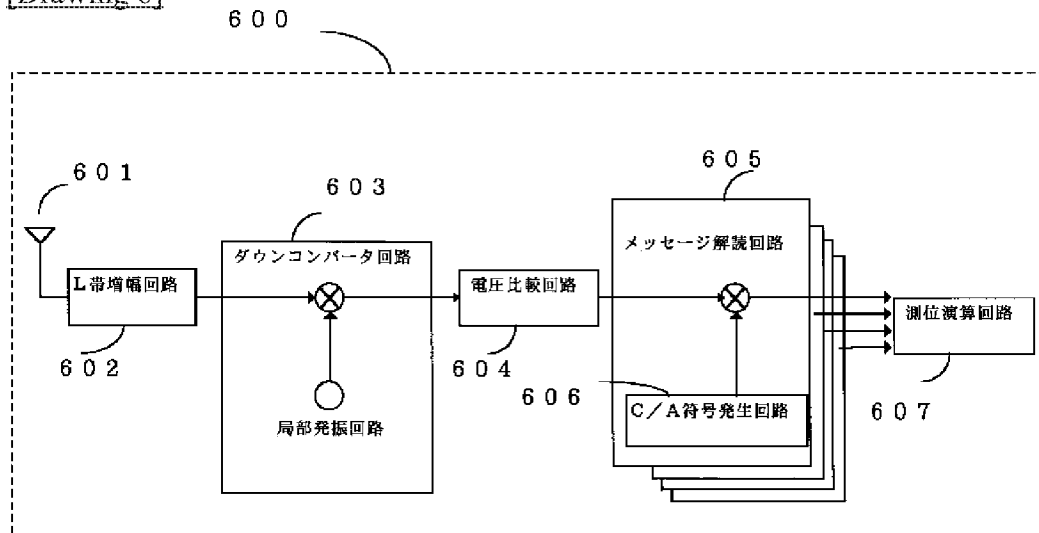

[Drawing 12]

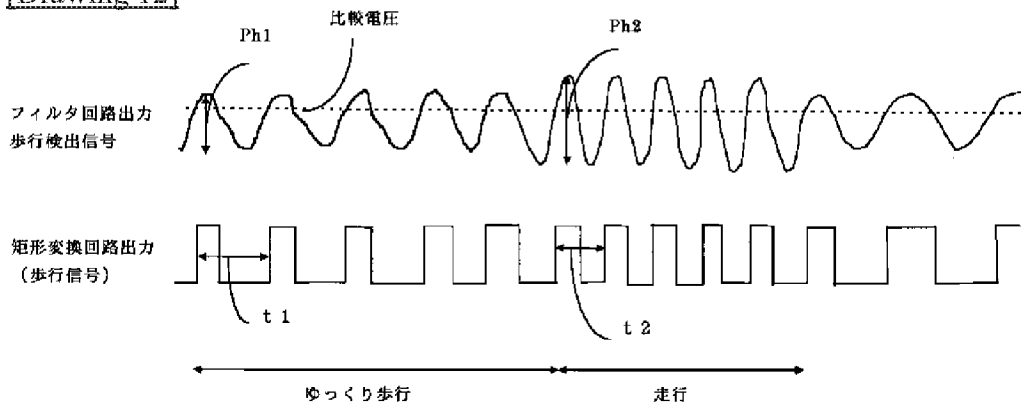

[Drawing 7]

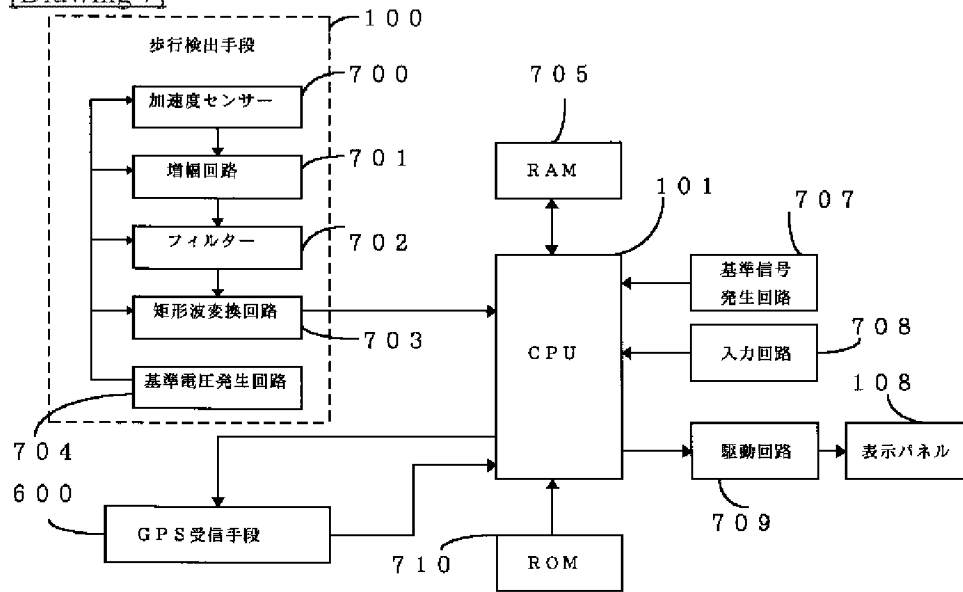

[Drawing 9]

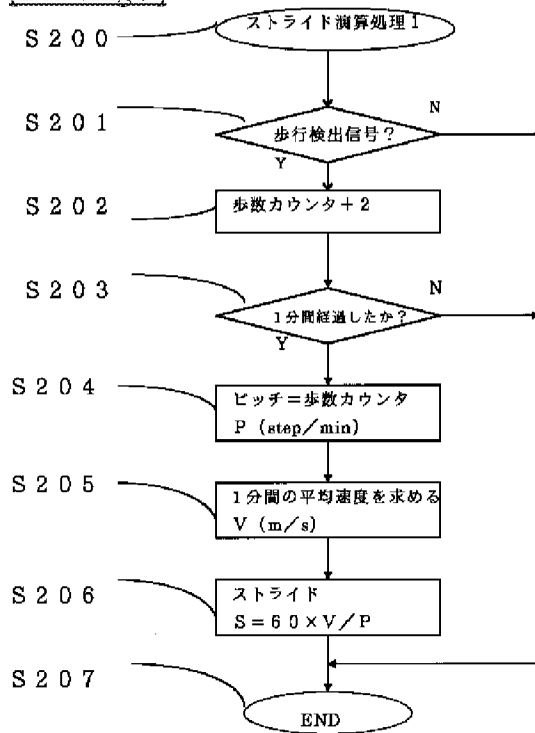

[Drawing 10]

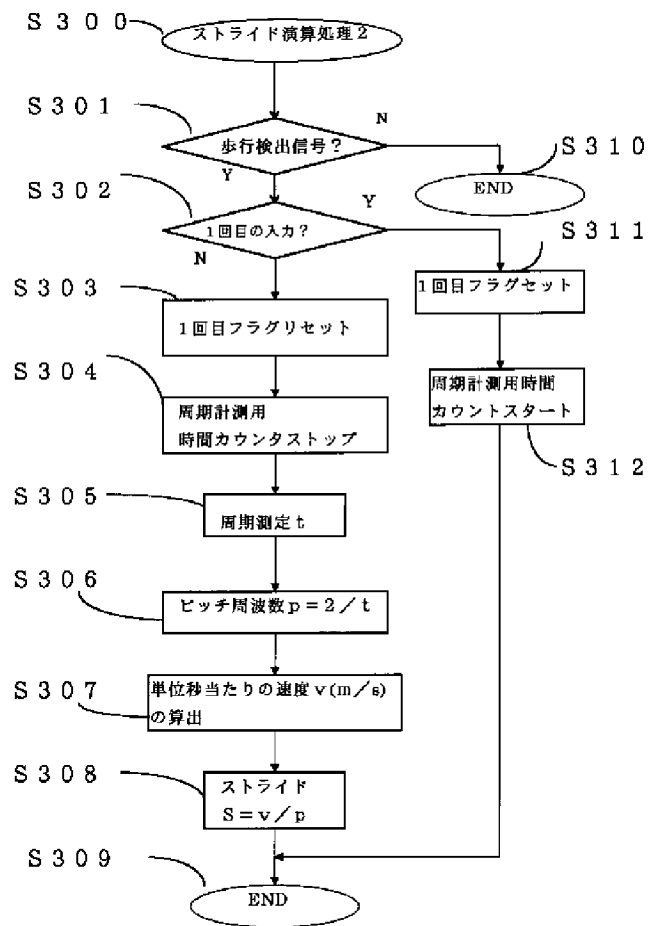

[Drawing 8]



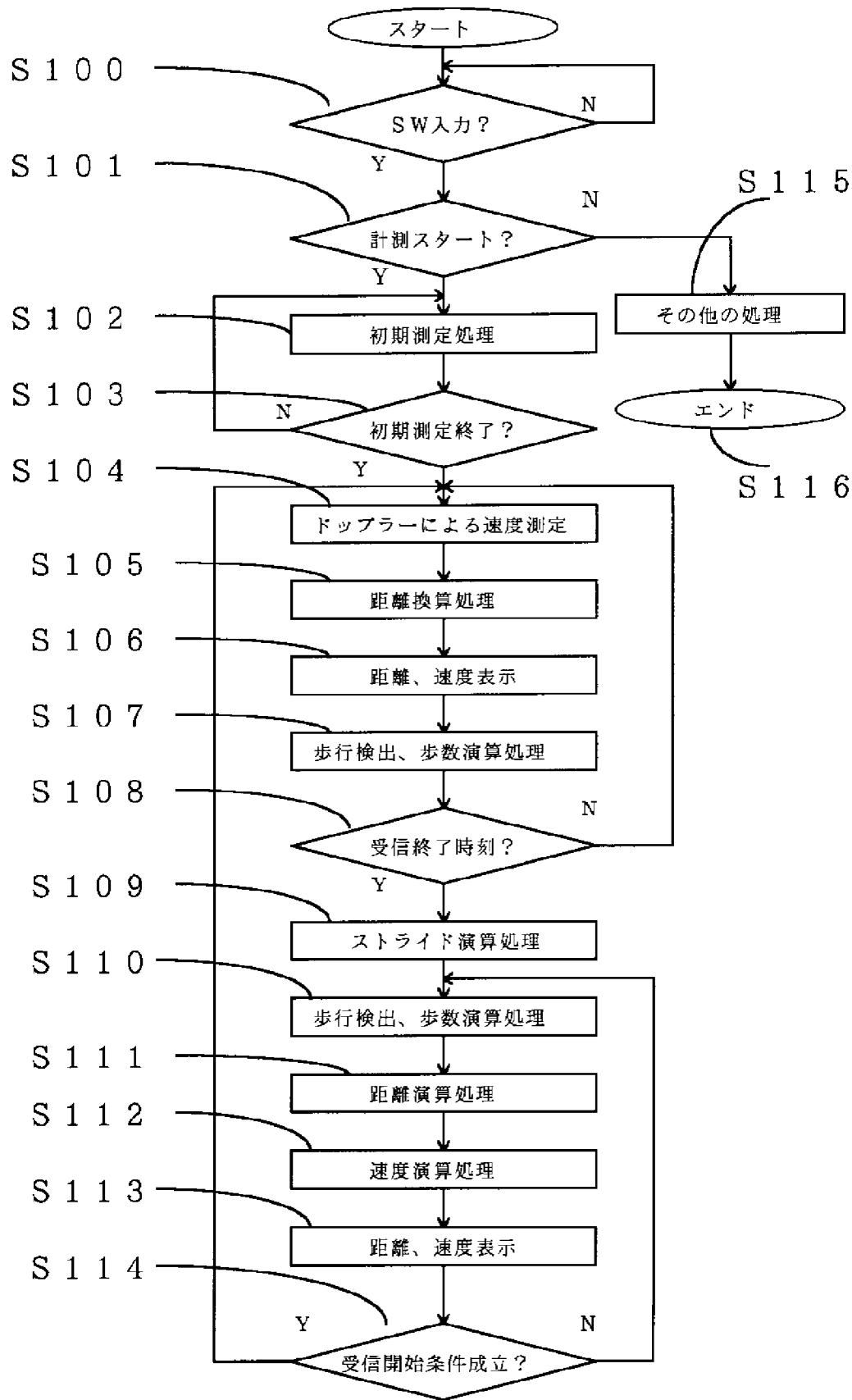

[Drawing 13]

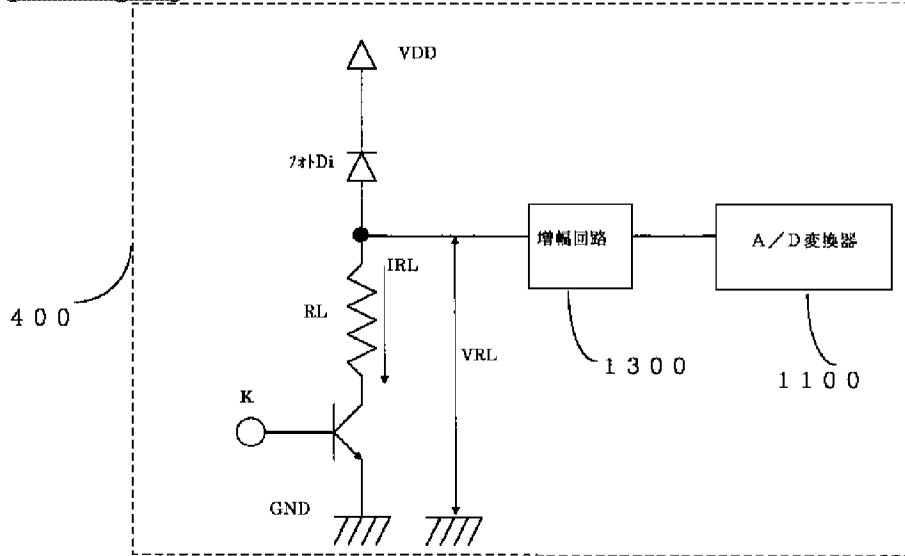

[Drawing 14]

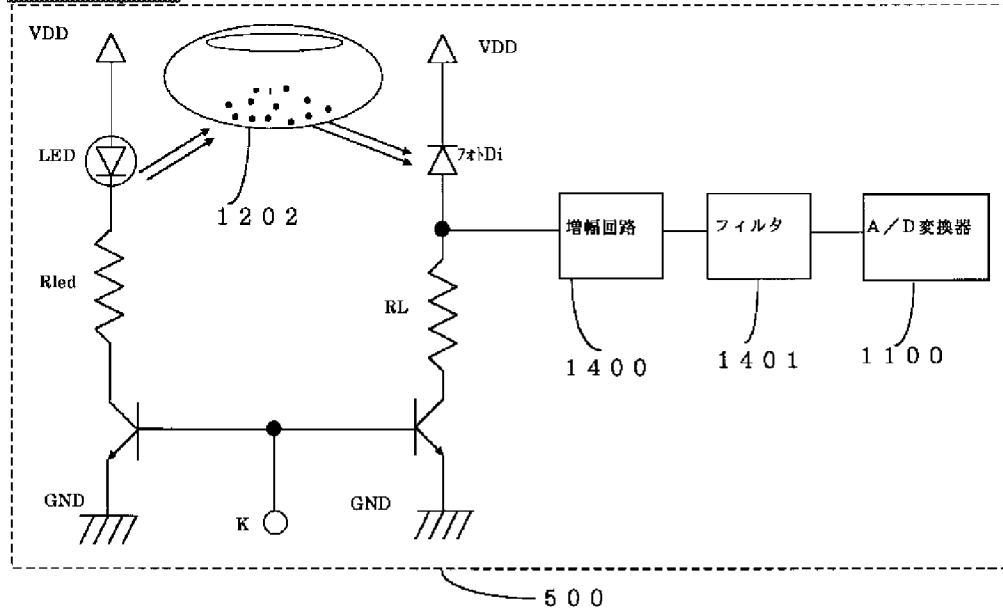

[Translation done.]

[Translation done.]

\* NOTICES \*

JPO and INPIT are not responsible for any damages caused by the use of this translation.

1. This document has been translated by computer. So the translation may not reflect the original precisely.
2. \*\*\*\* shows the word which can not be translated.
3. In the drawings, any words are not translated.

---

## DETAILED DESCRIPTION

---

[Detailed Description of the Invention]

[0001]

[Field of the Invention] This invention is GPS. The signal from a satellite (Global Positioning System: whole-world positioning system) is received, and it is related with the position of a receiving set, and the GPS receiving set which measures speed. Especially, maintenance with human being's arm and wearing are possible, and it is related with the position at the time of human being's run and a walk, migration length, and the GPS receiving set that measures movement speed.

[0002]

[Description of the Prior Art] A GPS system receives navigation data required for positioning with the receiver on the earth from 3-4 or more satellites conventionally among 24 GPS Satellites which turn around about 20,200 km and six orbits of 55 angles of inclination 1 round on the earth in about 12 hours, Positioning computing, such as a position of the mobile equipped with the receiver and movement speed, is performed. The Doppler frequency of a subcarrier can be measured and it can also ask for the velocity vector of a mobile. There are two of L2 L1 whose frequency is 1.57542 GHz, and whose frequency are 1.22760 GHz in the transmit frequency of a GPS Satellite. L1 is used for general positioning. With pseudonoise numerals (synthetic wave of navigation data, such as a C/A code which identifies a satellite, an orbit of a satellite, trajectory information of a satellite, and time information), PSK (phase shift keying) abnormal conditions are carried out, spectrum spread of L1 is carried out, and it is transmitted from the satellite. The GPS receiving set shown in drawing 6 receives this electric wave. The 1.57542-GHz signal received with the antenna 601 is amplified in L belt amplifying circuit 602, and it changes into 1st IF (intermediate frequency) signal (tens of MHz - 200 MHz) in the down converter part 603, and changes into the 2nd IF signal (2 more MHz - about 5 MHz). The 2nd IF signal is inputted into the voltage comparator 604, and digital conversion is carried out using the voltage comparator 604 with a several times as many clock as an IF signal. This output is the data by which spectrum spread was carried out. In the message decoding means 605, navigation data is obtained by carrying out back-diffusion of gas of the C/A code which is the same pseudonoise numerals as the satellite by which it is generated in the C/A numerals generation circuit 606 to the digital signal which the voltage comparator 604 outputs. This operation is performed to two or more satellites, and it usually asks for positioning data by the positioning computing means 607 from the navigation data of four satellites. It is possible to be used with the miniaturization of such a GPS receiver, in order to ask for the migration length and movement speed at the time of a run and a walk of human being, and is indicated by JP,6-118156,A etc.

[0003]

[Problem(s) to be Solved by the Invention] However, when it is going to use the conventional

GPS receiver for the migration length of a human body, or measurement of movement speed, various technical problems occur. If it is a GPS receiver for mount, at places which are hard to position, such as a tunnel and a valley of a building, navigation operation can be continued using self-contained navigation means, such as map matching. However, in a small GPS receiver, it is difficult [ it ] like an arm type to have the map information by CDROM from the size. In order to ask for migration length or the movement speed itself from a GPS Satellite, when it is an arm type, and a satellite becomes prehension impossible, measurement becomes impossible [ if it is a car, can obtain migration length and movement speed from a mounted meter, but ]. In order to ask for the migration length and movement speed correctly, there is the necessity of performing positioning operation continuously, about time between measurements, and there was a problem of the power consumption of a GPS receiver becoming large.

[0004]This invention was made in view of the technical problem mentioned above, and there is, and it aims at enabling measurement of migration length or movement speed, also when a satellite cannot be caught, and obtaining the portable GPS receiving set which can measure exact migration length and movement speed without carrying out continuous reception.

[0005]

[Means for Solving the Problem]In order to solve an aforementioned problem, this invention once asks the 1st for speed from the Doppler frequency of a subcarrier with a GPS receiving set, and asks it for distance by a distance conversion means from the speed and time. It asks for stride by a stride calculating means from the number of steps which detected a walk by a walk detection means among a tachography, and was integrated by a number-of-steps calculating means, and converted distance. After that, migration length is found by a distance calculating means from the number of steps by which detection addition is carried out with stride, and it asks for moving speed by a speed arithmetic means. A GPS receiving set receives periodically and stride is updated.

[0006]A pitch calculating means which calculates a pitch which is the number of steps per unit time is provided in the 2nd from the number of steps integrated by a number-of-steps calculating means in the 1st composition, and temporal data of a time check and a timing means, It pointed to a receiving operation start of a GPS receiving set by change of a certain fixed pitch signal, and had composition which establishes a receiving operation control means controlled to terminate receiving operation after fixed time.

[0007]A walk intensity detecting means which judges strength of a walk in the 1st composition was provided in the 3rd, and it pointed to a receiving operation start of a GPS receiving set by fixed change with walk intensity, and had composition which establishes a receiving operation control means controlled to terminate receiving operation after fixed time. When an illuminance change detection means to detect a surrounding device illuminance change was formed in the 1st composition and it had a certain fixed illuminance change the 4th, it pointed to a receiving operation start of a GPS receiving set, and it had composition which establishes a receiving operation control means controlled to terminate receiving operation after fixed time.

[0008]When a pulse detection means to detect person having's pulse rate was formed in the 1st composition and it had a certain fixed pulse rate change the 5th, it pointed to a receiving operation start of a GPS receiving set, and it had composition which establishes a receiving operation control means controlled to terminate receiving operation after fixed time.

[0009]

[Embodiment of the Invention]Drawing 1 is a functional block diagram showing the composition of this invention. A time check and the timing preparing means 107 create a reference timing

signal while clocking time. The receiving operation control means 109 is controlled to be a certain certain time interval, to make the receiving operation in the GPS receiving set 600 start with a reference timing signal, and to terminate receiving operation after fixed time. The distance conversion means 106 converts distance from the temporal data of the movement speed for which it asked from the Doppler frequency of the subcarrier measured during the receiving operation of the fixed time, and a time check and the timing preparing means 107. The walk detection means 100 detects the walk of a human body. The number-of-steps calculating means 102 integrates the signal detected by the walk detection means 100, and calculates the number of steps. The stride calculating means 104 calculates the stride per step from the number of steps calculated by the number-of-steps calculating means 102, while the distance converted by the distance conversion means 106 and its data are obtained. The distance calculating means 103 calculates walking distance from the stride for which it asked by the stride calculating means 104, and the number of steps calculated by the number-of-steps calculating means 102 until it becomes the following receiving timing. The speed arithmetic means 105 calculates speed from the walking distance found by the distance calculating means 103, and the temporal data of a time check and the timing preparing means 107.

[0010]Drawing 2 is the other functional block diagrams showing the composition of this invention. The pitch calculating means 200 calculates the pitch which is the number of steps per unit time from the number of steps integrated by the number-of-steps calculating means 102, and the temporal data of a time check and the timing preparing means 107. The receiving operation control means 109 points to the receiving operation start of the GPS receiving set 600 by change of a pitch signal, and controls it to terminate receiving operation after fixed time.

[0011]Drawing 3 is the other functional block diagrams showing the composition of this invention. The walk intensity detecting means 300 judges the strength of the walk signal which the walk detection means 100 outputs. The receiving operation control means 109 points to the receiving operation start of the GPS receiving set 600 by change of walk intensity, and controls it to terminate receiving operation after fixed time. Drawing 4 is the other functional block diagrams showing the composition of this invention. The illuminance change detection means 400 detects the surrounding illuminance change of a device. The receiving operation control means 109 points to the receiving operation start of the GPS receiving set 600 by change of the detected illumination signal, and controls it to terminate receiving operation after fixed time.

[0012]Drawing 5 is the other functional block diagrams showing the composition of this invention. The pulse detection means 500 detects person having's pulse rate. The receiving operation control means 109 points to the receiving operation start of the GPS receiving set 600 by change of the detected pulse rate, and controls it to terminate receiving operation after fixed time. Drawing 7 is a functional block diagram showing one example of the typical composition of this invention.

[0013]In drawing 7, the acceleration sensor 700 of the walk detection means 100 outputs the vibration displacement according to a walk or a run as an electric charge using the acceleration sensor of the cantilever structure which stuck the piezoelectric element. The amplifying circuit 701 amplifies the output signal of the acceleration sensor 700. The filter 702 removes noise components, such as commercial frequency. The rectangular wave conversion circuit 703 changes into a digital signal the signal which the filter 702 outputs. The circuit generating reference voltage 704 gives reference voltage to each circuit of the walk detection means 100. The signal in sync with the walk which the rectangular wave conversion circuit 703 outputs is inputted into CPU101. CPU101 operates a number-of-steps operation, a distance operation, etc.

according to the contents of ROM710 by which the operation step was programmed. RAM705 is connected to CPU101 as a register of the data at the time of CPU101 operating. Receiving operation is controlled by CPU101, and the GPS receiving set 600 has a function from the antenna 601 explained by drawing 6 to the positioning computing circuit 607, and outputs position data and speed data to CPU101. The reference signal generating circuit 707 generates the reference signal for operation of CPU101. The input circuit 708 is a switch which directs the operation start of apparatus, and transmits an input signal to CPU101. The drive circuit 709 is changed into the distance calculated by CPU101, speed, and the signal on which a time signal is displayed with the display panel 108.

[0014]Drawing 8 is a flow chart which shows operation of this invention. In drawing 8, it waits for the measurement start input signal of distance and speed from the input circuit 708 (S100). If SW is inputted, and it is a measurement start signal, measurement will be started, but others will be processed if it is other input signals (S101, S115). If it is a measurement start signal, a predetermined number of satellites are caught by a GPS receiving set, and initial measurement processing will be performed until data is assembled (S102, S103). After initial measurement processing is completed, it shifts to the rate measurement processing by the Doppler frequency measurement of a subcarrier (S104). Distance is converted from the speed data and temporal data which were measured (S105). Speed and distance are displayed (S106). In parallel to the rate measurement by the Doppler frequency measurement of a subcarrier, the walk detection means 100 detects a walk, and the number of steps is integrated (S107). If time progress is set and carried out, measurement is ended, and reception will be continued if it has not passed (S108). If fixed time passes, reception will be ended and the stride which is a step per step will be calculated (S109).

[0015]Drawing 9 and drawing 10 are flow charts which show operation of stride data processing. In drawing 9, an input of a walk detecting signal will add 2 to a number-of-steps counter (S201, S202). Since, as for adding 2, the walk detecting signal has detected the way of an arm, it is because the number of steps is two steps among 1 cycle of an arm. Next, if it judged whether 1 minute passed (S203) and 1 minute passed, let the value of the present number-of-steps counter, i.e., the number of steps for 1 minute, be the pitch P (step/min) (S204). It asks for the mean velocity for 1 minute during this period, and is referred to as V (m/SEC) (S205). Next, it asks for stride (S206).

[0016]Drawing 10 is an operation flow chart of other stride operations. In drawing 10, an input of a walk detecting signal will judge with the 1st flag whether it is the 1st input (S301, S302). If it is the 1st input, the 1st flag will be set and it will be made for a next input to be the 2nd time (S311). Next, the time counter for periodic measurement is started (S312). When a walk detecting signal is an input which is the 2nd time, the 1st flag is reset and it is made for a next input to be the 1st time (S303). Next, the time counter for periodic measurement is stopped and the cycle t is obtained (S304, S305). Since this cycle t is a cycle for the first time in an arm, in order to change into the pitch period per unit second, it may be  $t/2$ . That is, the frequency of a pitch is set to  $p = 2/t$  (S306). Here, although it asked for the frequency of the walk detecting signal by time measurement, it may ask by frequency analysis. Next, the speed v per unit second (m/sec) is found (S307), and stride  $S = v/p$  is calculated (S308). By the above methods, it once asks for stride during GPS reception. While not being based on GPS receiving operation, but detecting a walk and integrating the number of steps after that, distance is calculated from stride with the number of steps (S110, S111). In quest of speed, it is displayed as the calculated distance from temporal data (S112, S113). During a GPS receiving operation stop, if some receiving start

conditions are satisfied, speed will be measured with the GPS receiving set 600, and it will ask for new stride (S114). Here, the example of receiving start conditions supervises [ 1st ] time by a timer by a time check and the timing preparing means 107, for example, and calculates distance and speed from the detected number of steps and stride to fixed time. The reception after fixed time lapse is started. For example, the pitch which is the number of steps per unit time is calculated to the 2nd from the number-of-steps data of the number-of-steps calculating means 102, and the temporal data of a time check and the timing preparing means 107, Since change of stride may have arisen when there was a certain fixed change compared with the value of the pitch for which the calculated pitch asked to last time, reception is started. For example, when change of walk intensity was detected by the walk intensity detecting means 300 to the 3rd and there is change of a certain fixed walk intensity Reception is started.

[0017]Drawing 11 is a figure showing the embodiment of the walk intensity detecting means 300. In drawing 11, the acceleration sensor 700 of the walk detection means 100 outputs the vibration displacement according to a walk or a run as an electric charge using the acceleration sensor of the cantilever structure which stuck the piezoelectric element. The amplifying circuit 701 amplifies the output signal of the acceleration sensor 700. The filter 702 removes noise components, such as commercial frequency. The rectangular wave conversion circuit 703 changes into a digital signal the signal which the filter 702 outputs. The circuit generating reference voltage 704 gives reference voltage to each circuit of the walk detection means 100.

[0018]Drawing 12 is a wave form chart showing the output of the walk signal and rectangular wave conversion circuit which were detected. In drawing 12, a walk detecting signal differs in the cycle  $t$  and peak value  $ph$  according to the intensity of a walk. A cycle can be found in  $t$  with the signal which carried out rectangle conversion. If it shifts from the state of a walk to a run now, peak value will change to  $ph_2$  from  $Ph_1$ , and a cycle will change to  $t_2$  from  $t_1$ . A/D converter 1100 shown in drawing 11 detects change of this peak value. Since change of stride may have arisen when the rate of change in the intensity of the detected walk signal became a certain fixed value, reception is started. For example, like [ at the time of detecting the surrounding illuminance change of a device to the 4th, for example, appearing from a long tunnel in it by the illuminance change detection means 400, ], when a certain fixed illuminance change occurs, reception is started.

[0019]Drawing 13 is a figure showing the embodiment of the illuminance change detection means 400. In drawing 13, detection is started with the detecting operation start signal K. If outdoor daylight is irradiated by the photograph Di, IRL which is proportional to the dose of outdoor daylight and flows into the load resistance RL will change. As change of VRL, it amplifies in the amplifying circuit 1300, and the current change is changed into digital data, and A/D converter 1100 detects it. Reception is started when it becomes a fixed value with the rate of an illuminance change of the detected outdoor daylight. For example, by the pulse detection means 500, when person having's pulse rate is detected to the 5th and it has change of a certain fixed pulse rate by intensity change of movement, reception is started to it.

[0020]Drawing 14 is a figure showing the embodiment of the pulse detection means 500. In drawing 14, detection is started with the detecting operation start signal K. The light outputted from LED is irradiated by the finger 1202, and catoptric light enters into the photograph Di. The information on a pulse is included in incident light, this is amplified in the amplifying circuit 1400, a S/N ratio is raised by the filter circuit 1401, and it is changed into digital data by the A/D converter. Digital data is inputted into CPU101 and it changes into a pulse rate. Since the intensity of movement might change and change of stride may have arisen when it became a

fixed value with the rate of change of a pulse rate, reception is started. Thus, stride is updated by the conditions of some receiving starts, and it asks for more exact stride, and is used for migration length and speed calculation.

[0021]

[Effect of the Invention]As mentioned above, according to this invention, speed is once found from the Doppler frequency of a subcarrier with a GPS receiving set, and it asks for stride from the number of steps integrated by the number-of-steps calculating means in quest of distance from the speed. It is having asked for migration length and moving speed after that from the number of steps by which detection addition is carried out with stride, and continuation measurement at the difficult place of positioning of a tunnel, the valley of a building, etc. was enabled. In order to ask for distance and speed on a stride standard, it becomes possible to lose the necessity of positioning a GPS receiving set continuously, and to consider it as low power consumption.

---

[Translation done.]

\* NOTICES \*

**JPO and INPIT are not responsible for any damages caused by the use of this translation.**

- 1.This document has been translated by computer. So the translation may not reflect the original precisely.
- 2.\*\*\*\* shows the word which can not be translated.
- 3.In the drawings, any words are not translated.

---

## CLAIMS

[Claim(s)]

[Claim 1]A GPS receiving set which receives a signal from a GPS Satellite and measures speed by a position of a receiving set, and Doppler frequency measurement of a subcarrier, comprising:

A walk detection means to detect a walk and a run of a human body.

A number-of-steps calculating means which inputs a walk signal detected by said walk detection means, and calculates the number of steps.

A time check, a timing preparing means which time is clocked and create a reference timing signal.

A speed data signal of a human body measured from the Doppler frequency of a subcarrier measured with said GPS receiving set.

A distance conversion means to input said time check, a time check which a timing preparing means outputs, and a timing signal, and to convert into distance from speed data.

A scaled distance signal which said distance conversion means outputs.

A stride calculating means which inputs a step numeric signal which said number-of-steps calculating means outputs, and calculates stride per step, A distance calculating means which inputs a step numeric signal which said number-of-steps calculating means outputs, and a stride



signal which said stride calculating means outputs, and calculates migration length of a human body, A speed arithmetic means which inputs a distance signal which said distance calculating means outputs, and said time check, a time check which a timing preparing means outputs and a timing signal, and calculates movement speed of a human body, A distance signal which said distance calculating means outputs, and a speed signal which said speed arithmetic means outputs, Input a displaying means which displays a time signal which said time check and a timing preparing means output, said time check and a time check which a timing preparing means outputs, and a timing signal, and with a certain certain time interval. A receiving operation control means controlled to make receiving operation in said GPS receiving set start, and to terminate receiving operation after fixed time.

[Claim 2]A GPS receiving set which receives a signal from a GPS Satellite and measures speed by a position of a receiving set, and Doppler frequency measurement of a subcarrier, comprising: A walk detection means to detect a walk and a run of a human body.

A number-of-steps calculating means which inputs a walk signal detected by said walk detection means, and calculates the number of steps.

A time check, a timing preparing means which time is clocked and create a reference timing signal.

A speed data signal of a human body measured from the Doppler frequency of a subcarrier measured with said GPS receiving set.

A distance conversion means to input said time check, a time check which a timing preparing means outputs, and a timing signal, and to convert into distance from speed data.

A scaled distance signal which said distance conversion means outputs.

A stride calculating means which inputs a step numeric signal which said number-of-steps calculating means outputs, and calculates stride per step, A distance calculating means which inputs a step numeric signal which said number-of-steps calculating means outputs, and a stride signal which said stride calculating means outputs, and calculates migration length of a human body, A speed arithmetic means which inputs a distance signal which said distance calculating means outputs, and said time check, a time check which a timing preparing means outputs and a timing signal, and calculates movement speed of a human body, A distance signal which said distance calculating means outputs, and a speed signal which said speed arithmetic means outputs, A displaying means which displays a time signal which said time check and a timing preparing means output, A pitch calculating means which inputs a step numeric signal which said number-of-steps calculating means outputs, and said time check, a time check which a timing preparing means outputs and a timing signal, and calculates a pitch which is the number of steps per unit time, Input said time check, a time check which a timing preparing means outputs, a timing signal, and a pitch signal which said pitch calculating means outputs, and by change of a certain fixed pitch signal. A receiving operation control means controlled to make receiving operation in said GPS receiving set start, and to terminate receiving operation after a certain fixed time.

[Claim 3]A GPS receiving set which receives a signal from a GPS Satellite and measures speed by a position of a receiving set, and Doppler frequency measurement of a subcarrier, comprising: A walk detection means to detect a walk and a run of a human body.

A number-of-steps calculating means which inputs a walk signal detected by said walk detection means, and calculates the number of steps.

A time check, a timing preparing means which time is clocked and create a reference timing signal.

A speed data signal of a human body measured from the Doppler frequency of a subcarrier measured with said GPS receiving set.

A distance conversion means to input said time check, a time check which a timing preparing means outputs, and a timing signal, and to convert into distance from speed data.

A scaled distance signal which said distance conversion means outputs.

A stride calculating means which inputs a step numeric signal which said number-of-steps calculating means outputs, and calculates stride per step, A distance calculating means which inputs a step numeric signal which said number-of-steps calculating means outputs, and a stride signal which said stride calculating means outputs, and calculates migration length of a human body, A speed arithmetic means which inputs a distance signal which said distance calculating means outputs, and said time check, a time check which a timing preparing means outputs and a timing signal, and calculates movement speed of a human body, A distance signal which said distance calculating means outputs, and a speed signal which said speed arithmetic means outputs, A displaying means which displays a time signal which said time check and a timing preparing means output, A walk intensity detecting means which judges a size of a walk signal which said walk detection means outputs, and detects intensity of a walk, Input said time check, a time check which a timing preparing means outputs, a timing signal, and a walk intensity judgment signal which said walk intensity detecting means outputs, and by a certain fixed strength change of a walk signal. A receiving operation control means controlled to make receiving operation in said GPS receiving set start, and to terminate receiving operation after a certain fixed time.

[Claim 4]A GPS receiving set which receives a signal from a GPS Satellite and measures speed by a position of a receiving set, and Doppler frequency measurement of a subcarrier, comprising:

A walk detection means to detect a walk and a run of a human body.

A number-of-steps calculating means which inputs a walk signal detected by said walk detection means, and calculates the number of steps.

A time check, a timing preparing means which time is clocked and create a reference timing signal.

A speed data signal of a human body measured from the Doppler frequency of a subcarrier measured with said GPS receiving set.

A distance conversion means to input said time check, a time check which a timing preparing means outputs, and a timing signal, and to convert into distance from speed data.

A scaled distance signal which said distance conversion means outputs.

A stride calculating means which inputs a step numeric signal which said number-of-steps calculating means outputs, and calculates stride per step, A distance calculating means which inputs a step numeric signal which said number-of-steps calculating means outputs, and a stride signal which said stride calculating means outputs, and calculates migration length of a human body, A speed arithmetic means which inputs a distance signal which said distance calculating means outputs, and said time check, a time check which a timing preparing means outputs and a timing signal, and calculates movement speed of a human body, A distance signal which said distance calculating means outputs, and a speed signal which said speed arithmetic means outputs, A displaying means which displays a time signal which said time check and a timing preparing means output, An illuminance change detection means to measure surrounding

illumination of a device and to detect change of illumination, Said time check, a time check which a timing preparing means outputs, and a timing signal, A receiving operation control means controlled to make receiving operation in said GPS receiving set start, and to terminate receiving operation after a certain fixed time when a surrounding illuminance change signal of a device which said illuminance change detection means outputs is inputted and a certain fixed illuminance change occurs.

[Claim 5]A GPS receiving set which receives a signal from a GPS Satellite and measures speed by a position of a receiving set, and Doppler frequency measurement of a subcarrier, comprising: A walk detection means to detect a walk and a run of a human body.

A number-of-steps calculating means which inputs a walk signal detected by said walk detection means, and calculates the number of steps.

A time check, a timing preparing means which time is clocked and create a reference timing signal.

A speed data signal of a human body measured from the Doppler frequency of a subcarrier measured with said GPS receiving set.

A distance conversion means to input said time check, a time check which a timing preparing means outputs, and a timing signal, and to convert into distance from speed data.

A scaled distance signal which said distance conversion means outputs.

A stride calculating means which inputs a step numeric signal which said number-of-steps calculating means outputs, and calculates stride per step, A distance calculating means which

inputs a step numeric signal which said number-of-steps calculating means outputs, and a stride signal which said stride calculating means outputs, and calculates migration length of a human

body, A speed arithmetic means which inputs a distance signal which said distance calculating means outputs, and said time check, a time check which a timing preparing means outputs and a

timing signal, and calculates movement speed of a human body, A distance signal which said distance calculating means outputs, and a speed signal which said speed arithmetic means

outputs, A displaying means which displays a time signal which said time check and a timing preparing means output, A pulse detection means in sync with pulsation of the heart to detect

person having's pulse rate, Input said time check, a time check which a timing preparing means outputs, a timing signal, and a pulse rate signal which said pulse detection means outputs, and by

change of a certain fixed pulse rate signal. A receiving operation control means controlled to make receiving operation in said GPS receiving set start, and to terminate receiving operation after a certain fixed time.

---

[Translation done.]

\* NOTICES \*

**JPO and INPIT are not responsible for any damages caused by the use of this translation.**

1. This document has been translated by computer. So the translation may not reflect the original precisely.

- 2.\*\*\* shows the word which can not be translated.
- 3.In the drawings, any words are not translated.

---

## **TECHNICAL FIELD**

---

[Field of the Invention]This invention is GPS. The signal from a satellite (Global Positioning System: whole-world positioning system) is received, and it is related with the position of a receiving set, and the GPS receiving set which measures speed. Especially, maintenance with human being's arm and wearing are possible, and it is related with the position at the time of human being's run and a walk, migration length, and the GPS receiving set that measures movement speed.

---

[Translation done.]

(19) 대한민국특허청 (KR)  
(12) 공개특허공보 (A)

(51) 。 Int. Cl. 7  
G01S 5/04

(11) 공개번호 특2002 - 0001257  
(43) 공개일자 2002년01월09일

(21) 출원번호 10 - 2000 - 0035695  
(22) 출원일자 2000년06월27일

(71) 출원인 지규인  
경기 성남시 분당구 서현동 효자촌아파트 311동 1003호

(72) 발명자 지규인  
경기 성남시 분당구 서현동 효자촌아파트 311동 1003호  
윤선일  
서울특별시광진구화양동74 - 2  
홍진석  
서울특별시중구신당2동432 - 713

(74) 대리인 김성기

심사청구 : 있음

(54) G P S 와 관성센서를 이용한 개인 위치측정장치 및 방법

요약

본 발명은 GPS와 관성센서를 이용한 개인위치측정장치 및 방법에 관한 것으로, 피치 자이로 각속도, 초기 기울기, 가속도를 통해 기본 걸음 주파수, 평균보폭, 평균속도 등의 기본 변수값을 계산하고, 가속도계에서 얻은 가속도의 절대값이 임계값 이상이고 걸음주기가 설정된 시간 이상일 때 걸음으로 판단한 후 걸음을 상승부분과 하강부분으로 구분하여 이루어진 펄스를 세어 걸음을 검출한다. 또한, 중력의 영향이 제거된 가속도의 보정을 한 후 매 걸음마다 보정된 속도를 적분하여 보폭을 결정하며, GPS에서 제공하는 속도와 걸음 검출, 보폭 결정에 의한 속도 정보를 결합하여 개인의 속도를 추정하고, GPS와 자력계, 헤딩 자이로를 선택 조합하여 개인의 방향을 추정한 상태에서, 속도필터에서 추측항법에 필요한 속도 정보를 얻어 이동 거리를 계산한 후, 상기 추정된 방향과 더불어 GPS의 위치 정보와 결합하여 개인의 위치를 추정함으로써, 실내 및 도심과 같은 GPS의 수신이 불량한 곳에서도 연속적인 위치정보를 제공할 수 있으므로 레저, 군사작전, 개인 위치추적, 응급구조 등과 같이 광범위한 용도로 사용할 수 있다.

대표도  
도 1

명세서

도면의 간단한 설명

도 1은 본 발명에 적용되는 개인휴대 항법 시스템의 개략적인 블록도.

도 2는 걸음 검출과 보폭 보정을 하기 위한 보정(Calibration)과정을 나타낸 계통도.

도 3은 관성센서를 사용하여 걸음을 검출하는 방법과 보행 특징을 이용한 보폭 결정 알고리즘의 계통도.

도 4는 피치각(pitch angle)과 전진 방향 속도 결정에 적용되는 피치 각속도와 전진 방향 가속도의 최대값(peak to peak) 검출 알고리즘 계통도.

도 5는 GPS가 제공하는 속도와 추측항법 결과에서 얻어지는 속도를 GPS를 사용할 수 있는 경우에 따라 결합하는 속도 필터.

도 6은 위치 결정에 필요한 방향을 GPS 사용 가능 여부와 주변 자장의 왜곡을 고려하여 3가지의 모드를 설정하고 방향을 추정하는 계통도.

도 7은 칼만 필터를 이용한 GPS/DR 결합방식의 항법 알고리즘 계통도.

< 도면의 주요부분에 대한 설명 >

1 ; GPS 수신기 2 ; 가속도계

3 ; 피치 자이로 4 ; 자력계

5 ; 헤딩 자이로 6 ; 속도필터

7a,7b,7c ; 방향필터 8 ; 위치필터

발명의 상세한 설명

발명의 목적

발명이 속하는 기술 및 그 분야의 종래기술

본 발명은 GPS(Global Positioning System)와 관성센서를 이용한 개인 위치추정 장치 및 방법에 관한 것으로, 특히 사람이 도보로 이동하면서 사용할 수 있는 걸음 계수 방식의 새로운 추측항법을 이용하여 GPS와 결합한 형태의 새로운 개인 휴대 항법 시스템으로 군사작전, 등산, 실내보행 등 언제 어디서나 이동하는 사람의 위치를 추적할 수 있도록 한 것이다.

종래에 사용되어 온 항법기술은 통합위치시스템(GPS), 관성항법(INS:Inertial Navigation System), 추측항법(DR: Dead Reckoning) 등이 있다.

GPS는 어디서나 손쉽게 사용자의 위치와 속도 정보를 얻을 수 있고 시간에 따른 오차 누적이 없지만 위성신호를 수신할 수 없는 상황, 즉 도심이나 숲, 터널, 실내에서는 사용할 수 없는 문제점이 있다. 관성항법의 경우에는 고가의 센서를 사용하지 않는 한 시간에 따라 누적되는 오차로 인해 원하는 항법성능을 기대할 수 없다. 그리고 추측항법을 도보로 이동하는 사람에게 적용할 경우 차량과는 달리 이동거리를 알아내는 주행거리계(Odometer)를 부착할 수 없고 또한 저가의 센서를 이용하여 관성항법과 같은 방식으로 속도를 구해서는 큰 속도오차로 인하여 사용할 수 없는 문제점이 있다.

발명이 이루고자 하는 기술적 과제

본 발명은 이러한 종래 기술의 문제점을 해결하기 위한 것으로, 사람이 도보로 이동하면서 사용할 수 있는 걸음 계수 방식의 새로운 추측항법을 이용하여 GPS와 결합한 형태의 새로운 개인 휴대 항법 시스템을 개발, 사용자에게 위치 정보를 항상 제공할 수 있도록 한 GPS와 관성센서를 이용한 개인 위치측정 장치 및 방법을 제공하는데 그 목적이 있다.

상기 목적을 달성하기 위한 본 발명은 위성신호를 수신받아 개인의 절대위치와 방향, 속도에 대한 정보를 제공받는 GPS 수신기와, 걸음 검출과 보폭 결정을 얻을 수 있는 가속도계 및 피치 자이로와, 절대 방위각을 얻을 수 있는 자력계와, 각속도를 얻을 수 있는 헤딩 자이로와, 상기 GPS 수신기에서 얻은 속도 정보와 가속도계 및 피치 자이로로부터 검출된 걸음 및 보폭을 결합하여 속도를 보정하는 속도필터와, 상기 GPS 수신기로부터 얻은 방향 정보와 자력계 및 헤딩 자이로로부터 얻은 정보를 이용하여 개인의 방향을 보정하는 방향필터와, 상기 GPS 수신기의 위치정보와 속도필터 및 방향필터로부터 얻어진 정보를 이용하여 개인의 위치를 보정하는 위치필터를 포함하여 구성되는 것을 특징으로 한다.

또한, 상기 본 발명의 목적은 피치 자이로 각속도, 초기 기울기, 가속도를 통해 기본 걸음 주파수, 평균보폭, 평균속도 등의 기본 변수값을 계산하는 파라미터 결정 단계와; 가속도계에서 얻은 가속도의 절대값이 임계값 이상이고 걸음주기 가 설정된 시간 이상일 때 걸음으로 판단한 후 걸음을 상승부분과 하강부분으로 구분하여 이루어진 펄스를 세어 걸음을 검출하며, 중력의 영향이 제거된 가속도의 보정을 한 후 매 걸음마다 보정된 속도를 적분하여 보폭을 결정하는 보폭 결정 단계와; GPS에서 제공하는 속도와 걸음 검출, 보폭 결정에 의한 속도 정보를 결합하여 개인의 속도를 추정하는 속도 추정 단계와; GPS와 자력계, 헤딩 자이로를 선택 조합하여 개인의 방향을 추정하는 방향 추정 단계와; 속도필터에서 추측항법에 필요한 속도 정보를 얻어 이동 거리를 계산한 후, 상기 추정된 방향과 더불어 GPS의 위치 정보와 결합하여 개인의 위치를 추정하는 위치 추정 단계를 거침으로써 달성된다.

발명의 구성 및 작용

이하, 본 발명의 실시예에 대하여 첨부된 도면을 참조하면서 상세히 설명하기로 한다.

도 1은 본 발명의 개략적인 블록도로서, 본 발명의 개인휴대 항법 시스템은 GPS 수신기(1), 가속도계(2), 피치 자이로(pitch gyro)(3), 자력계(4), 헤딩 자이로(heading gyro)(5)로 구성되어 있으며 GPS, 자력계 데이터 획득은 RS232 직렬통신을 사용하고 관성센서인 가속도계(2), 자이로는 A/D 컨버터(Analog/Digital converter)를 사용한다. 이때, GPS 수신기(1)에서 절대 위치와 방향, 속도를 얻을 수 있다.

추측항법에서의 속도는 가속도계(2)와 피치 자이로(3)로부터 걸음을 검출과 보폭 결정을 통해 얻을 수 있다. 방향은 자력계(4)의 절대 방위각과, 헤딩 자이로(5)의 각속도를 결합한 형태의 방향 필터(7)를 통해 결정할 수 있다.

한편, 개인휴대 항법 시스템은 크게 속도필터(6)와 방향필터(7) 그리고 항법 해를 구하는 위치필터(8)로 구분할 수 있는데, 속도는 도 5에서와 같이 도 2의 캘리브레이션(Calibration), 도 3의 걸음검출/보폭결정을 통해 결정되고, 방향필터(7)는 도 6의 GPS/자력계 결합 방식, 자력계/자이로 결합방식, 제한보행 방식을 주변 상황에 맞게 선택하게 되며, 위치필터(8)는 도 7에서와 같이 GPS의 절대위치와 추측항법의 상대위치를 결합하는 방법을 적용한다.

도 2는 보폭 결정을 위한 속도계산 캘리브레이션 알고리즘의 계통도이다. 가속도를 적분하는 일반적인 방법으로 보폭을 계산하는 것은 많은 오차로 인해 적용하기 힘들다. 이러한 오차를 보정하기 위한 속도필터(6)에 앞서 기본적인 파라미터 값을 다음과 같은 순서에 의해 계산한다.

우선, 피치 자이로(3) 각속도를 측정하고(101), 초기 기울기( $\theta_0 = \arcsin(y_0/g)$ )를 계산(102)한 후, 가속도 FFT를 통해 peak 주파수, 즉 기본 걸음 주파수( $f_0$ )를 계산한다(103).

그후, 실험에 의한 평균보폭을 계산하고(평균보폭  $l_0 = \text{거리}/\text{걸음 수}$ ) (104), 이 평균보폭을 이용하여 평균 속도 계산한다(평균속도  $v_0 = f_0 * l_0$ ) (105).

도 3은 관성센서를 사용하여 걸음을 검출하는 방법과 보행 특징을 이용한 보폭 결정 방법 계통도로서, 개인휴대 항법은 GPS와 함께 걸음 계수 방식의 추측항법을 같이 결합하는 형태의 시스템으로 걸음은 수직방향 가속도를 이용하여 걸음을 상승과 하강으로 구분하여 검출하는 방법을 사용한다. 걸음 검출은 도 3의 (208)에서 (213)까지이며 각 부분은 다음과 같다.

수직 방향 가속도계(2)에서 A/D 컨버터를 통해 가속도를 획득하고(201), 걸음 검출 성능 향상을 위해 저역통과 필터링을 한다(208). 이때, 가속도계(2)는 중력의 영향을 받기 때문에 원하는 가속도를 얻기 위해 바이어스를 제귀평균식에 의해 보정한다(209).

가속도의 절대값이 임계값 이상일 때 걸음 구분 조건으로 판단하고(210), 걸음 주기가 최소 시간 이상일 때 걸음으로 판단하며(211), 걸음을 상승부분과 하강부분으로 구분하여 펄스형태로 만든다(212). 그후, 펄스를 세어 걸음을 센다(213).

이때, 걸음 검출만으로 보행인의 속도를 결정한다면 역동적인 걸음 특성상 고정 보폭으로 인해 오차가 누적된다. 그러므로 매 걸음마다 보폭을 결정하여 오차를 최소화할 수 있다. 즉, 보폭결정은 보정된 피치 앵글(pitch angle)을 이용한 중력 보상을 과정과 보행특징을 이용한 전진방향 가속도 보정으로 구성된다. 아래 과정은 피치 앵글 보정과 전진 방향 가속도 중력보상이다.

우선, 도 2의 보폭 결정을 위한 캘리브레이션 과정을 거쳐 초기 기울기, 기본 걸음 주파수, 평균 보폭, 평균 속도를 계산한다(100).

그리고 피치 자이로(3) 각속도를 A/D converter를 통해 측정하고(201), pitch angle(경사) ( $= \int \text{각속도} * dt$ )를 계산한다(202).

그후, 도 4에 나타낸 것과 같이 피치 앵글의 peak - to - peak를 검출하되(220), 피치 앵글의 저점을 한 걸음으로 판단하고 매 걸음마다 피치 앵글 보정을 하며(203), 보정값을 계산한다(보정값 = 정점과 저점 중간 기울기 - 초기 기울기( $\theta_0$ )) (204).

이때, 피치 앵글을 보정하고(보정된 pitch angle = pitch angle - 보정값) (205), 가속도에 대한 중력의 영향을 제거하기 위해 중력 가속도 보상( $f = y - g * \sin(\theta)$ )을 하며(206), 전진 방향 속도( $= \int f * dt$ )를 계산한다(207).

계산된 전진 방향 속도는 가속도계(2)의 바이어스 오차로 인해 시간에 따라 오차가 누적된다. 이러한 오차를 최소화하기 위해 가감속의 보행 특징을 이용한 보정 알고리즘을 다음과 같이 적용한다.

즉, 계산된 전진방향 속도의 peak - to - peak를 검출하고(220), 전진방향 속도의 저점을 한 걸음으로 판단하고 전진방향 속도 보정은 매 걸음마다 한다(214). 이때의 보정은 다음과 같다.

보정 속도 = 정점과 저점 중간속도 - 평균 속도( $v_0$ ) (215)

보정된 속도 = 전진방향 속도 - 보정 속도(216)

보폭 =  $\int$  보정된 속도 \* dt(217)

도 4는 피치 앵글, 전진 방향 속도의 peak - to - peak 검출 알고리즘의 계통도로서, 사람의 몸의 경사는 감소와 증가의 반복적인 특징을 가지고 있고, 전진 방향 가속도 또한 가속과 감속의 반복적인 특징을 가지며, 이러한 특징은 일반적인 보행 특징과 일치한다. 가속도의 중력보상에 필요한 보정된 경사, 전진 방향 속도 보정에 필요한 속도 보정은 아래의 peak - to - peak 검출과정을 필요로 한다.



즉, 보정된 피치 앵글 또는 전진 방향 속도 데이터를 획득하고(221), 정점과 저점을 검출하는데(222), 이때 정점은 이전 데이터와 이후 데이터보다 큰 값을 가진 데이터이고, 저점은 작은 값을 가진 데이터이다.

그리고 정점과 저점의 차가 임계값 이상인지 판단하고(223), 다음 정점과 저점을 검출하여(224) 저점을 다음 저점에 저장한다(225).

그후, 정점이 다음 정점보다 작은지 판단하여(226) 정점이 다음 정점보다 작으면 정점은 다음 정점이 되고(227), 정점의 주기가 일정 시간 이상일 때 정점으로 판단(228)하여 정점을 걸음 주기 정점에 저장한다(229).

그후, 다음 정점과 저점을 검출하고(230), 정점을 다음 정점으로 저장하며(231), 정점과 저점의 차가 임계값 이상인지 판단하여(232) 다음 정점과 저점을 검출함과 아울러(233) 다음 정점을 정점에 저장한다(234).

저점과 다음 저점을 비교하여(235) 저점이 다음 저점보다 작을 때 다음 저점을 저점으로 하고(236), 저점 주기가 최소 시간 이상일 때 저점으로 판단하여(237) 저점을 걸음 주기 저점에 저장한다(238).

도 5는 추측 항법에 필요한 속도 정보를 얻는 알고리즘에 관한 계통도로서, GPS 수신기(1)에서 제공하는 속도와 걸음 검출/보폭결정 방법에 의한 속도 정보를 칼만 필터(Kalman filter)를 사용하여 결합하면 안정적이면서 연속적으로 사용자의 속도를 추정할 수 있다.

이에 따르면, GPS 속도 정보를 사용할 수 있는지 판단한 후(301), GPS 속도( $V_{GPS}$ ) 정보를 획득한다(302). 보행 방식에 의한 속도( $V_{DR}$ )를 계산하고(207), 칼만 필터를 사용하여 두 속도 정보( $V_{GPS}$ ,  $V_{DR}$ )를 결합한다. 이때, 측정 방정식은  $Z = V_{GPS} - V_{DR} + w$  이다(303).

도 6은 추측 항법에 필요한 방향 정보를 얻는 알고리즘에 관한 계통도로서, 도 1에서와 같이 방향은 GPS 수신기(1), 자력계(4), 헤딩 자이로(5)로부터 얻을 수 있으며 주변 상황에 맞게 방향필터(7)의 모드를 선택하여 방향을 결정한다. GPS를 사용할 수 있는 실외에서는 GPS 수신기(1)와 자력계(4)를 결합한 제1방향필터(7a)를, GPS를 사용할 수 없고 주변 자장의 왜곡이 심하지 않은 실내에서는 자력계(4)와 헤딩 자이로(5)를 결합한 제2방향필터(7b)를, 주변 자장의 왜곡이 심한 실내에서는 헤딩 자이로(5)를 사용하는 제한 보행 방식의 제3방향필터(7c)를 사용하게 된다.

우선, GPS를 사용할 수 있는지 판단하는데(401), 실내, 도심, 터널, 숲 등에서는 GPS 신호를 수신할 수 없으므로 방향을 결정하기 위해서는 자력계(4)나 헤딩 자이로(5) 등을 사용한다.

제1방향필터(7a)는 실외에서 GPS를 사용할 수 있을 때 칼만 필터를 사용하여 GPS/자력계 결합 방식을 적용하여 방향을 추정한다(402).

그후, 실외 모드에서 GPS를 사용 가능한지 판단하고(403), GPS 방향(404) 및 자력계 방향을 측정하며(405), 칼만 필터를 사용하여 방향을 추정한다(406). 측정방정식은  $Z = H_{GPS} - H_{DR} + w$  이다.

그리고 실외 모드에서 GPS를 사용할 수 없을 때에는 자력계(4) 방향만으로 방향을 결정하며(407), 실내에서는 주변 자장의 왜곡여부를 자력계(4)를 통해서 판단한다(408).

제2방향필터(7b)는 실내에서 주변 자장이 일정 값 이상으로 왜곡되지 않았을 때 칼만 필터를 사용하여 자력계(4)와 헤딩 자이로(5)를 결합하여 방향을 추정하고(409), 헤딩 자이로(5) 출력, 즉 각속도를 적분하여 방향( $H_{Gyro}$ )을 계산하며(410), 자력계 방향( $H_{Mag}$ )을 측정한다(411).

그후, 칼만 필터를 사용하여 두 방향 정보를 결합한다(412). 측정방정식은  $Z = H_{Mag} - H_{Gyro} + w$  이다.

제3방향필터(7c)는 실내에서 주변 자장이 일정 값 이상으로 왜곡되었을 때 헤딩 자이로(5)만을 이용하여 직진과 회전으로 구성된 제한 보행 방식을 적용하여 방향을 추정한다(413).

자력계 방향을 측정하여 초기 방향 설정을 하고(414), 헤딩 자이로 각속도를 측정하여(415) 각속도가 임계값 이상이 면 회전 구간의 제1조건으로 판단하고 그 이하일 때는 직진 구간으로 판단한다(416).

회전 구간의 제1조건을 만족할 때 회전 연속 시간이 0.2초 이상이면 회전 구간의 제2조건으로 판단하고(417), 회전 구 간이 끝나면 회전 구간 동안의 각속도를 적분하여 회전각을 계산하며(418), 방향을 누적시킨다(419).

그후, 연속 직진 시간이 2초 이상인지 판단하고(421), 재귀 평균식을 이용하여 자이로 바이어스(gyro bias)를 추정하 며(422), 선택된 모드에서 추정된 방향을 결정한다(423).

도 7은 칼만 필터를 사용하여 걸음 계수 방식에 의한 추측항법의 위치와 GPS의 위치 정보를 결합하는 위치필터(8)이 다.

우선, 도 5의 속도필터(6)에서 추측항법에 필요한 속도 정보를 획득한다(300).

그리고 추측항법에서의 이동 거리를 속도와 시간의 곱으로 계산하고(501), 도 6의 방향필터(7)에서 (401), (408)의 조건을 고려하여 방향 모드를 판단한다(502).

그후, 제1방향필터(7a) 모드가 선택되었을 때 GPS/자력계 결합된 방향을 추정하고(503), 추측항법에 의해 추정된 위 치를 계산한다. 위치( $P_{DR}$ )는  $x=s*\sin(H)$ ,  $y=s*\cos(H)$  이다(504).

그후, GPS의 위치 정보( $P_{GPS}$ )를 획득하고(505), 칼만 필터를 사용하여 두 위치 정보를 결합한다(506). 측정 방정식 은  $z = P_{DR} + P_{GPS} + w$ 이다.

한편, GPS를 사용할 수 없는 제2방향필터(7b) 모드가 선택되었을 때 자력계/자이로 결합된 방향을 추정하고(508), G PS를 사용할 수 없는 제3방향필터(7c) 모드가 선택되었을 때 자이로만을 이용하여 직진과 회전으로 구성된 제한 보행 방식을 적용하여 방향을 추정한다(509).

그후, 추측항법에 의해 추정된 위치를 계산한다(510). 위치( $P_{DR}$ )는  $x = s*\sin(H)$ ,  $y = s*\cos(H)$  이다.

따라서, 이와 같은 위치추적장치 및 방법은 실내 및 도심과 같은 GPS의 수신이 불량한 곳에서도 연속적인 위치정보를 제공할 수 있으므로 레저, 군사작전, 개인 위치추적, 응급구조 등과 같이 광범위한 용도로 사용할 수 있다.

#### 발명의 효과

이상에서 설명한 바와 같이, 본 발명에 의하면 GPS와 추측항법을 결합하여 보행시 발의 움직임에 따라 전진 가속과 수 직 가감속, 전후의 기울임, 좌우의 흔들림을 가지는 보행 특징을 관성센서를 사용하여 측정하고 처리함으로써 걸음을 검출하고 보폭을 결정하여 일반적인 관성항법 방식에서 문제가 되는 급격한 오차 증가를 극소화시킬 수 있으므로 GPS 신호를 수신할 수 없는 경우에도 연속적으로 개인의 위치 및 속도정보를 제공할 수 있게 된다.

#### (57) 청구의 범위

##### 청구항 1.

위성신호를 수신받아 개인의 절대위치와 방향, 속도에 대한 정보를 제공받는 GPS 수신기;

걸음 검출과 보폭 결정을 얻을 수 있는 가속도계 및 피치 자이로;

절대 방위각을 얻을 수 있는 자력계;

각속도를 얻을 수 있는 헤딩 자이로;

상기 GPS 수신기에서 얻은 속도 정보와 가속도계 및 피치 자이로로부터 검출된 걸음 및 보폭을 결합하여 속도를 보정하는 속도필터;

상기 GPS 수신기로부터 얻은 방향 정보와 자력계 및 헤딩 자이로로부터 얻은 정보를 이용하여 개인의 방향을 보정하는 방향필터;

상기 GPS 수신기의 위치정보와 속도필터 및 방향필터로부터 얻어진 정보를 이용하여 개인의 위치를 보정하는 위치필터를 포함하여 구성되는 것을 특징으로 하는 GPS와 관성센서를 이용한 개인위치측정장치.

## 청구항 2.

제1항에 있어서, 상기 방향필터는

GPS 신호가 수신 가능한 장소에서는 GPS와 자력계를 결합하여 방향을 추정하는 제1방향필터와, GPS 신호의 수신 불가능하고 주변 자장의 왜곡이 일정 값 이하의 장소에서는 자력계와 헤딩 자이로를 결합하여 방향을 추정하는 제2방향필터와, 주변 자장의 왜곡이 일정 값 이상의 장소에서는 헤딩 자이로를 이용하여 방향을 추정하는 제3방향필터로 구성되는 것을 특징으로 하는 GPS와 관성센서를 이용한 개인위치측정장치.

## 청구항 3.

제1항 또는 제2항에 있어서, 상기 방향필터는 칼만 필터인 것을 특징으로 하는 GPS와 관성센서를 이용한 개인위치측정장치.

## 청구항 4.

피치 자이로 각속도, 초기 기울기, 가속도를 통해 기본 걸음 주파수, 평균보폭, 평균속도 등의 기본 변수값을 계산하는 파라미터 결정 단계;

가속도계에서 얻은 가속도의 절대값이 임계값 이상이고 걸음주기가 설정된 시간 이상일 때 걸음으로 판단한 후 걸음을 상승부분과 하강부분으로 구분하여 이루어진 펄스를 세어 걸음을 검출하며, 중력의 영향이 제거된 가속도의 보정을 한 후 매 걸음마다 보정된 속도를 적분하여 보폭을 결정하는 보폭 결정 단계;

GPS에서 제공하는 속도와 걸음 검출, 보폭 결정에 의한 속도 정보를 결합하여 개인의 속도를 추정하는 속도 추정 단계;

GPS와 자력계, 헤딩 자이로를 선택 조합하여 개인의 방향을 추정하는 방향 추정 단계;

속도필터에서 추측방법에 필요한 속도 정보를 얻어 이동 거리를 계산한 후, 상기 추정된 방향과 더불어 GPS의 위치 정보와 결합하여 개인의 위치를 추정하는 위치 추정 단계로 이루어지는 것을 특징으로 하는 GPS와 관성센서를 이용한 개인위치측정방법.

## 청구항 5.

제4항에 있어서, 상기 보폭 결정 단계는 보정된 피치 앵글을 이용한 중력 보상 과정과, 보행 특징을 이용한 전진 방향 가속도 보정 과정으로 이루어진 것을 특징으로 하는 GPS와 관성센서를 이용한 개인위치측정방법.

## 청구항 6.

제4항에 있어서, 상기 걸음 검출은 수직방향 가속도를 이용하여 걸음을 상승과 하강으로 구분하여 검출하는 것을 특징으로 하는 GPS와 관성센서를 이용한 개인위치측정방법.

청구항 7.

제4항에 있어서, 상기 방향 추정 단계는 GPS 신호를 수신 가능한 장소에서는 GPS와 자력계를 이용하고, GPS 신호의 수신 불가능하고 주변 자장의 왜곡이 비교적 적은 장소에서는 자력계와 헤딩 자이로를 이용하며, 주변 자장의 왜곡이 심한 장소에서는 헤딩 자이로를 이용하여 방향을 추정하는 것을 특징으로 하는 GPS와 관성센서를 이용한 개인위치측정방법.

도면

도면 1

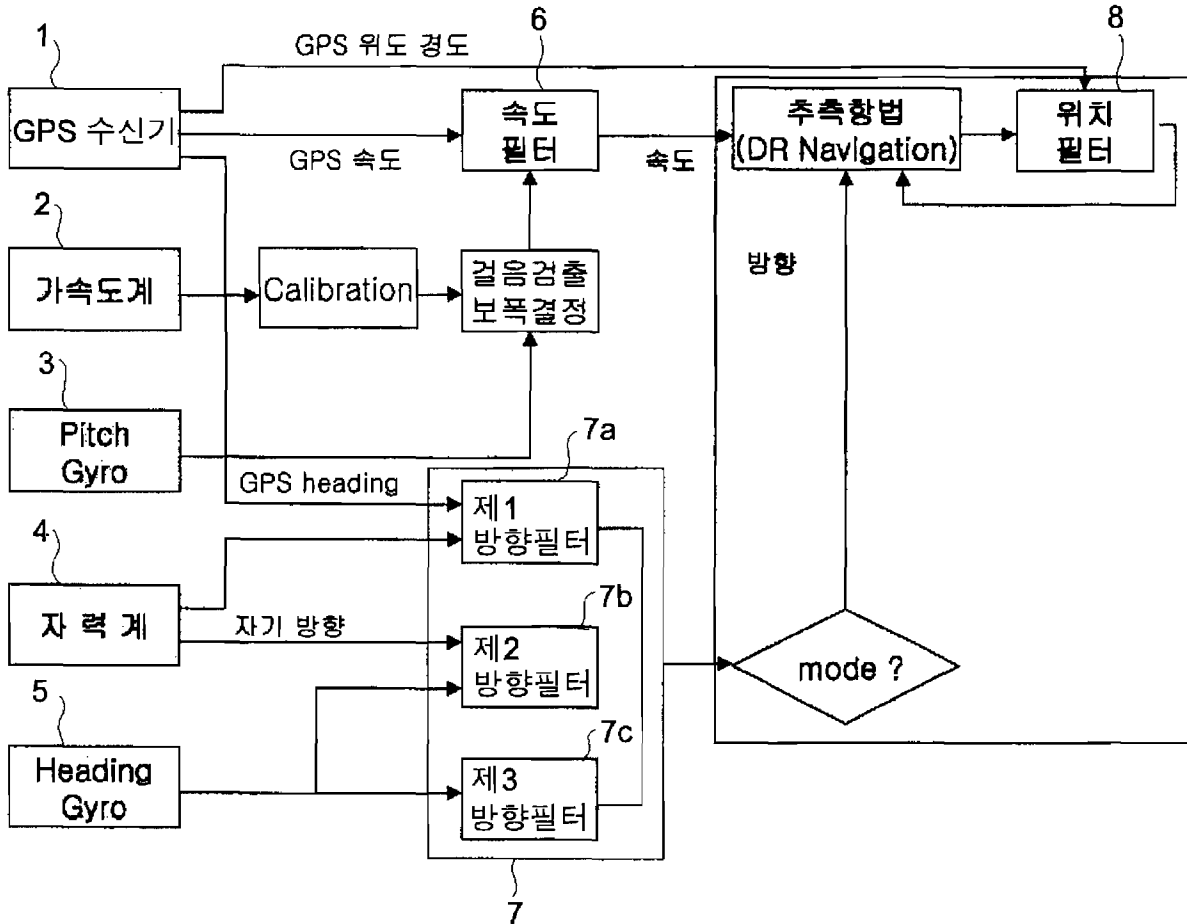

도면 2

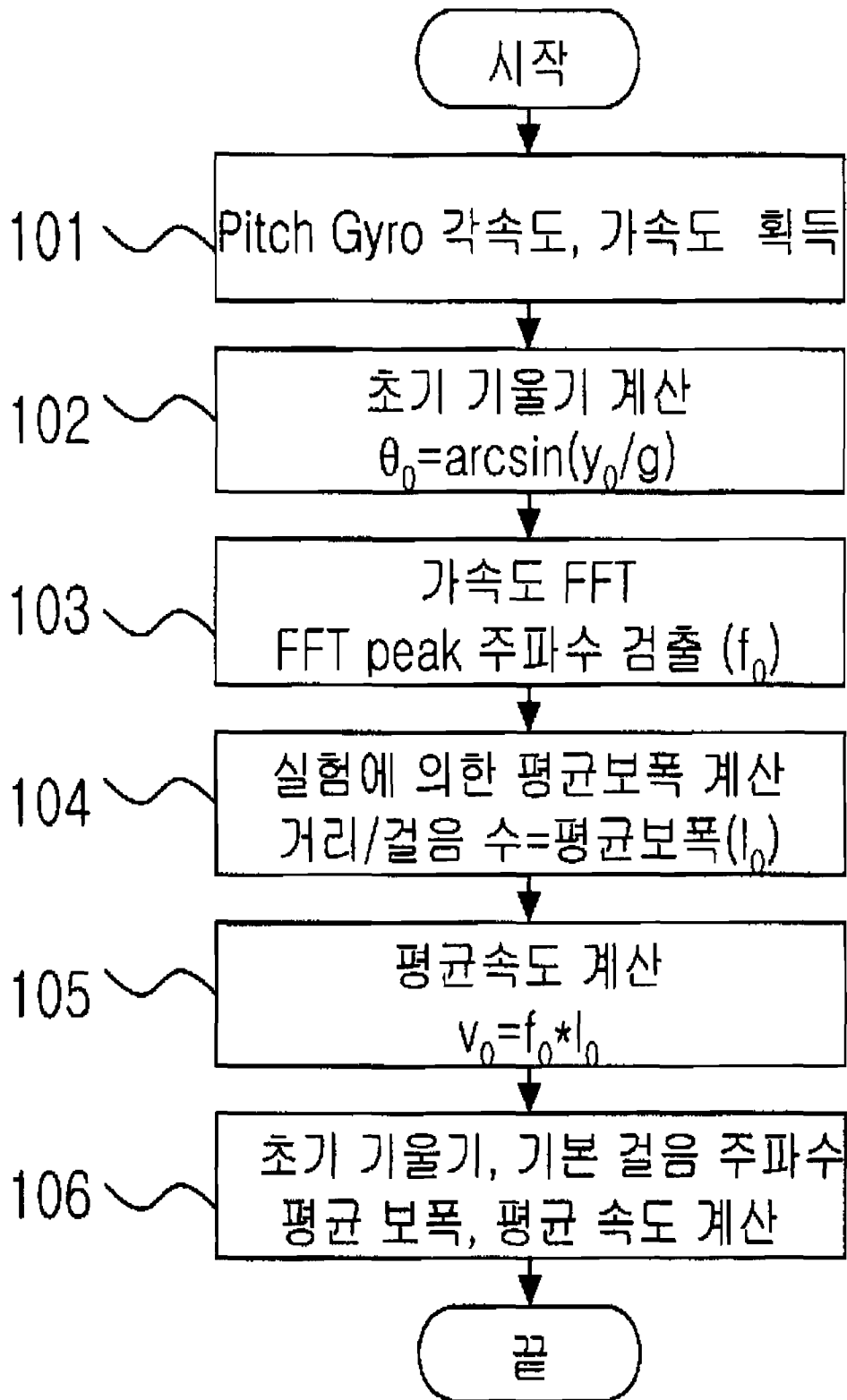

도면 3

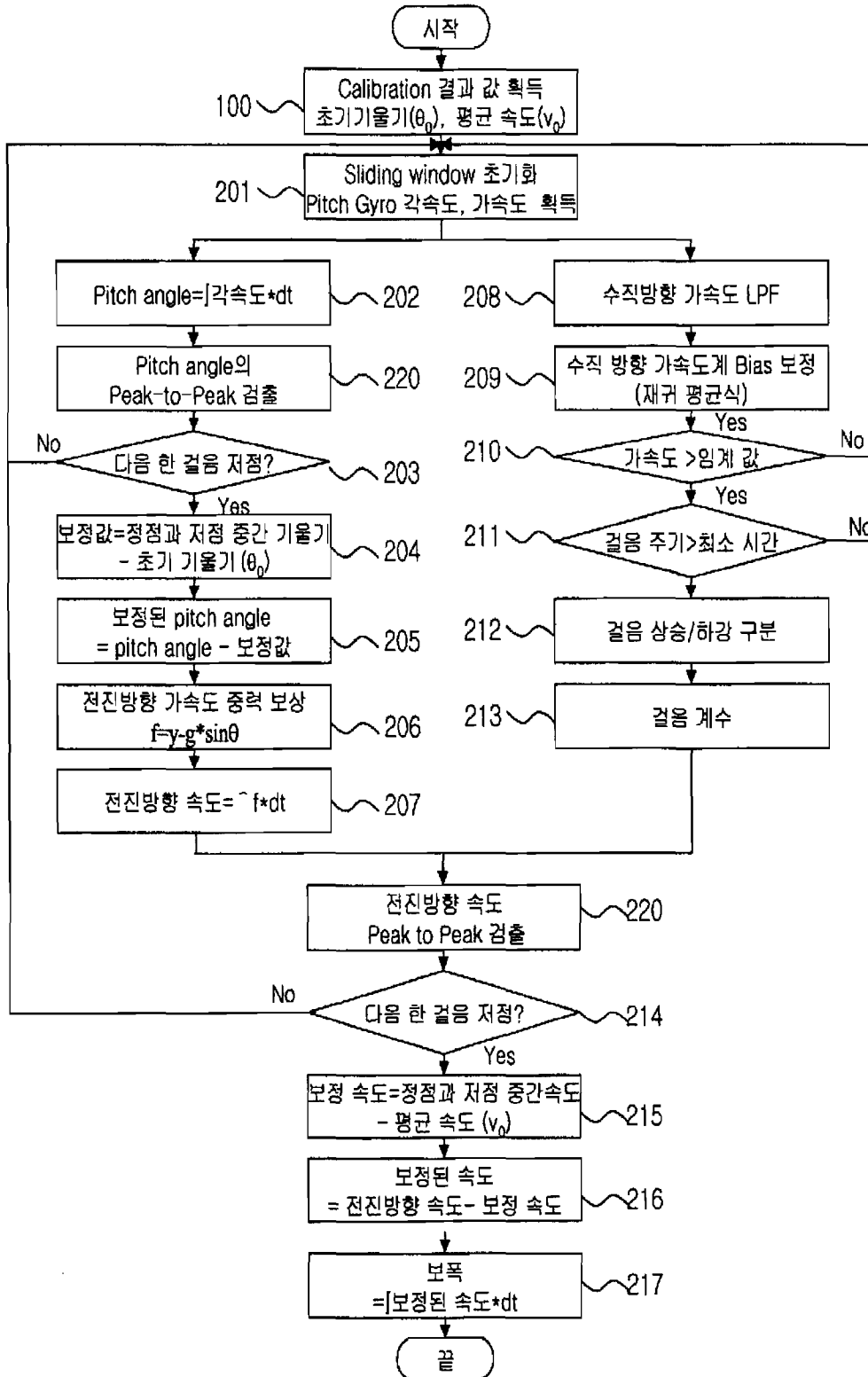

도면 4

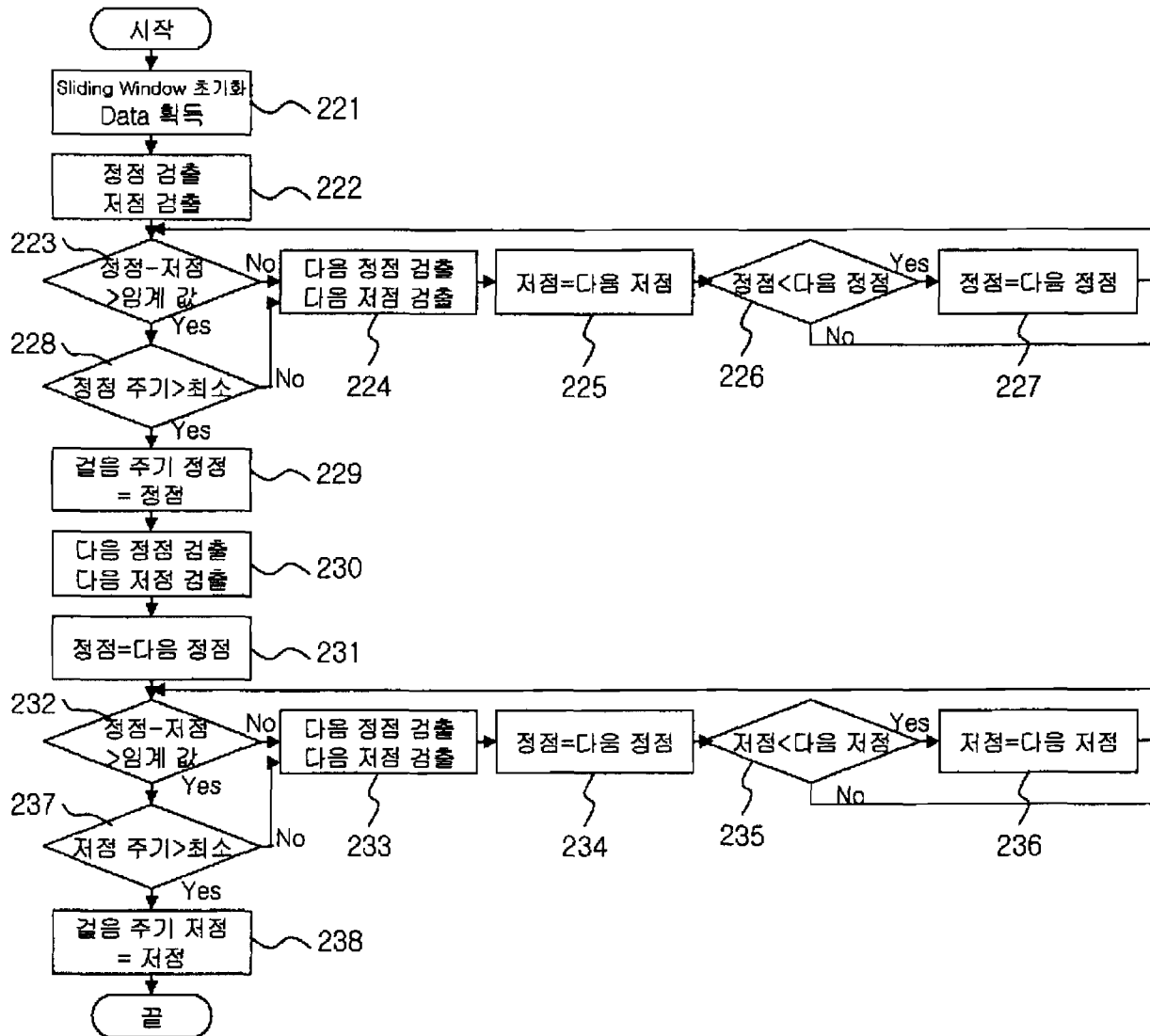

도면 5

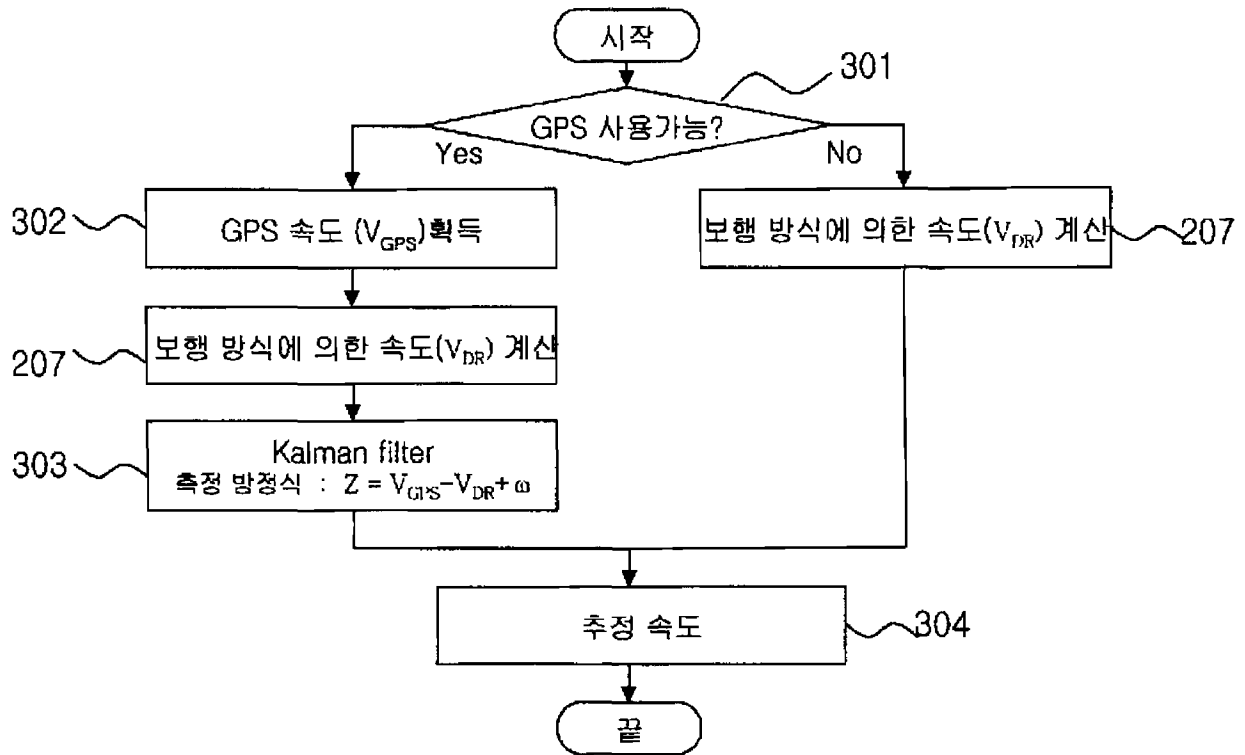



도 9

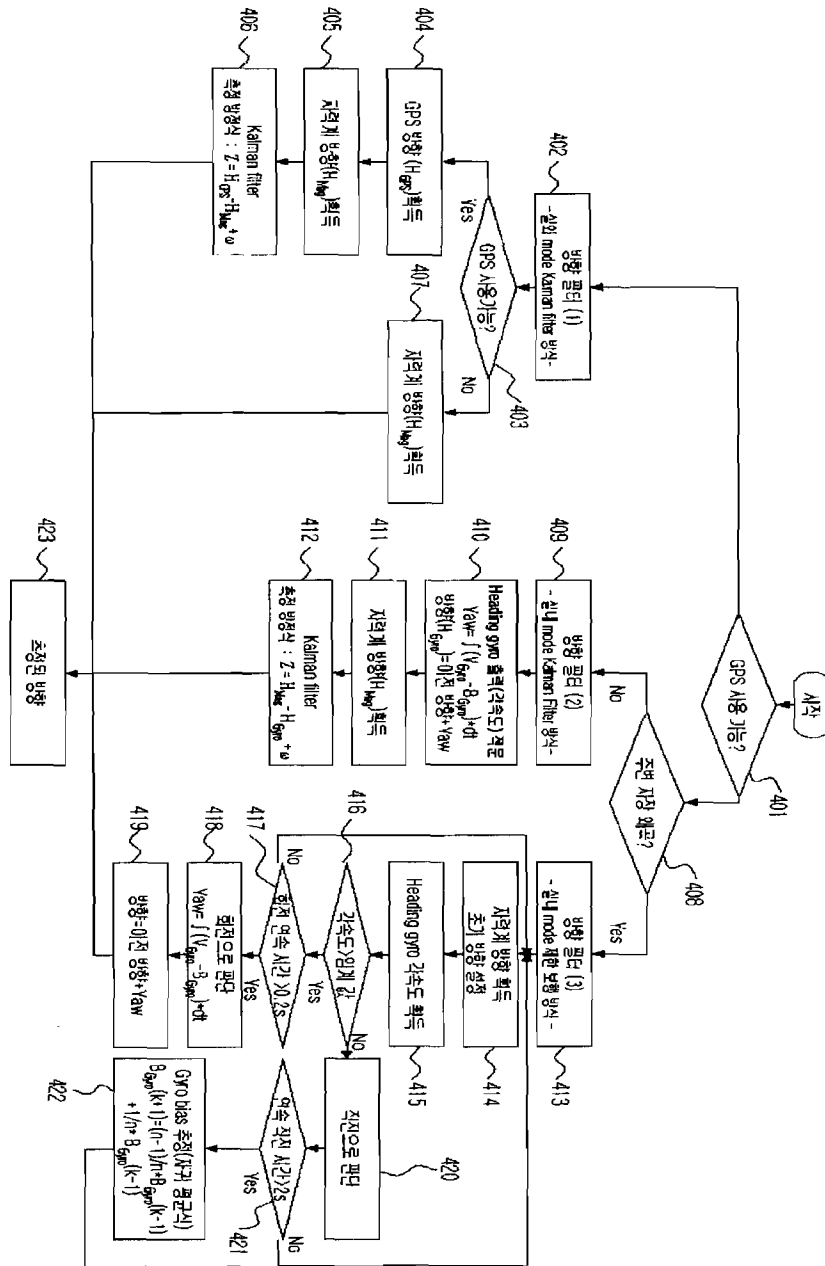

도면 7

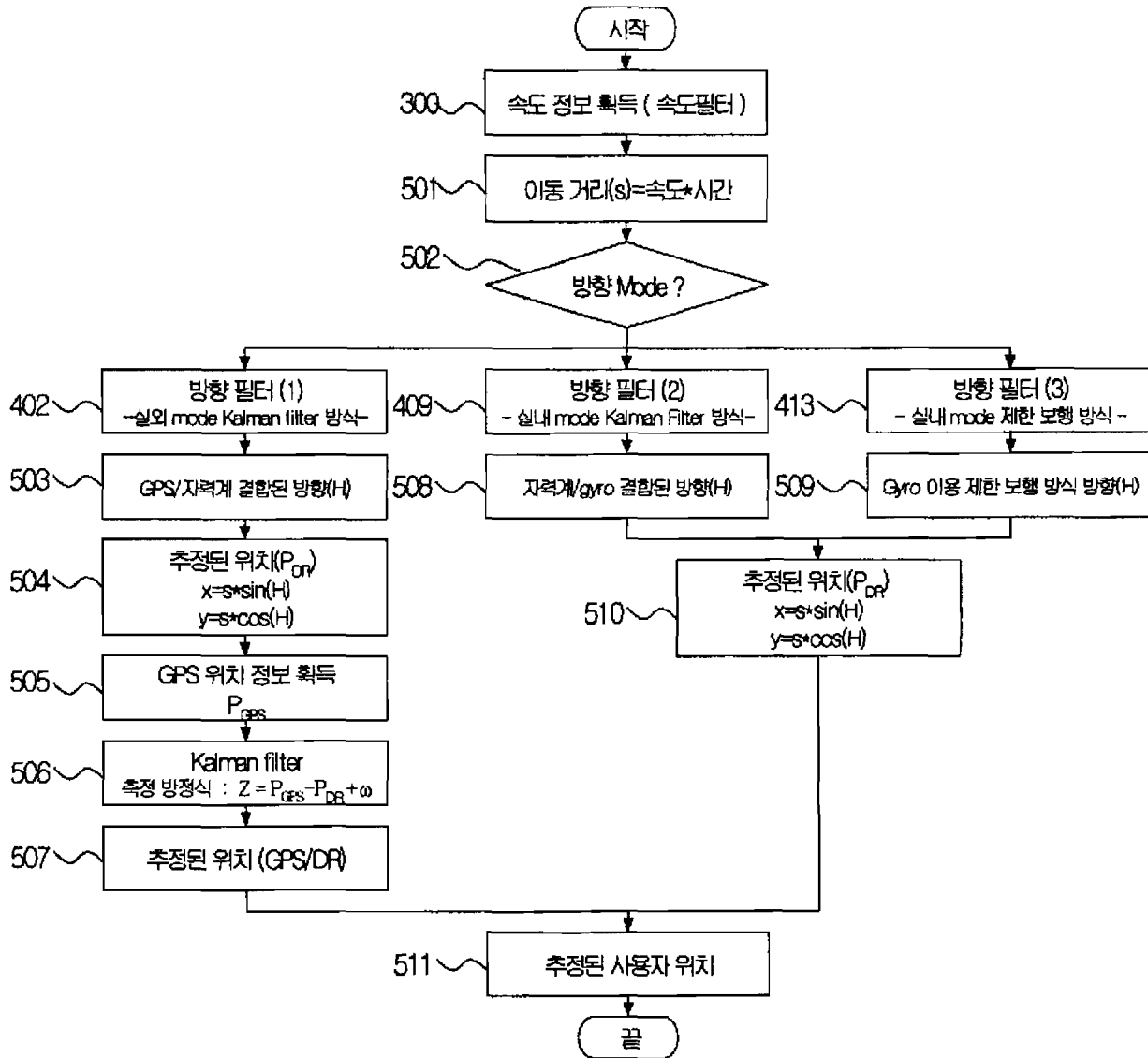



## Electronic Acknowledgement Receipt

<b>EFS ID:</b>	6023345
<b>Application Number:</b>	12419451
<b>International Application Number:</b>	
<b>Confirmation Number:</b>	1643
<b>Title of Invention:</b>	APPARATUS AND METHOD FOR ADJUSTING REFRESH RATE OF LOCATION COORDINATES OF A TRACKING DEVICE
<b>First Named Inventor/Applicant Name:</b>	Joseph F. Scalisi
<b>Customer Number:</b>	70515
<b>Filer:</b>	Robert E. Kasody
<b>Filer Authorized By:</b>	
<b>Attorney Docket Number:</b>	LBTECH.012CP1
<b>Receipt Date:</b>	05-SEP-2009
<b>Filing Date:</b>	07-APR-2009
<b>Time Stamp:</b>	16:18:23
<b>Application Type:</b>	Utility under 35 USC 111(a)

### Payment information:

Submitted with Payment	no
------------------------	----

### File Listing:

Document Number	Document Description	File Name	File Size(Bytes)/ Message Digest	Multi Part /.zip	Pages (if appl.)
1	Foreign Reference	JP10325735jap.pdf	313490 <small>ee483f6859be0713f28a8d99f39af8b0ed8a9d60</small>	no	12

### Warnings:

### Information:

IPR2020-01189

2	Foreign Reference	JP11064480jap.pdf	199147	no	8
			be7c1d63779bb604f168cec82e655f187614877a		
<b>Warnings:</b>					
<b>Information:</b>					
3	Foreign Reference	JP11064480sub.pdf	268919	no	18
			8259d1ab3721849755546a85ce5d1fc581e1ec67		
<b>Warnings:</b>					
<b>Information:</b>					
4	Foreign Reference	JP13074494jap.pdf	241043	no	8
			eeeb64d764335de5d51eb9544d4554f103385890		
<b>Warnings:</b>					
<b>Information:</b>					
5	Foreign Reference	JP13074494sub.pdf	137281	no	24
			f62f23bb678de8725e93e0e991c36982b7886419		
<b>Warnings:</b>					
<b>Information:</b>					
6	Foreign Reference	KR100532589B1kor.pdf	471288	no	17
			7d7e24703da54763bf013717e385c8b219dcf86e		
<b>Warnings:</b>					
<b>Information:</b>					
7	Foreign Reference	KR1020050063802kor.pdf	288618	no	22
			03544844736079add81e2217ba698dd1153aecdf		
<b>Warnings:</b>					
<b>Information:</b>					
8	Foreign Reference	JP10325735Asub.pdf	210322	no	22
			0bd5f020fd8ea6bc3b453a379e8dab35bba89ad2		
<b>Warnings:</b>					
<b>Information:</b>					
9	Foreign Reference	KR1020020001257korsub1.pdf	226585	no	14
			f322df7fdc7f8b06b38c344dd18814260ed4ff76		
<b>Warnings:</b>					
<b>Information:</b>					
10	Foreign Reference	IDS_patent_sub.pdf	468372	no	1
			ec6212ce08de15e4224097ac388301d2f6617da8		
<b>Warnings:</b>					
<b>Information:</b>					

**This Acknowledgement Receipt evidences receipt on the noted date by the USPTO of the indicated documents, characterized by the applicant, and including page counts, where applicable. It serves as evidence of receipt similar to a Post Card, as described in MPEP 503.**

**New Applications Under 35 U.S.C. 111**

**If a new application is being filed and the application includes the necessary components for a filing date (see 37 CFR 1.53(b)-(d) and MPEP 506), a Filing Receipt (37 CFR 1.54) will be issued in due course and the date shown on this Acknowledgement Receipt will establish the filing date of the application.**

**National Stage of an International Application under 35 U.S.C. 371**

**If a timely submission to enter the national stage of an international application is compliant with the conditions of 35 U.S.C. 371 and other applicable requirements a Form PCT/DO/EO/903 indicating acceptance of the application as a national stage submission under 35 U.S.C. 371 will be issued in addition to the Filing Receipt, in due course.**

**New International Application Filed with the USPTO as a Receiving Office**

**If a new international application is being filed and the international application includes the necessary components for an international filing date (see PCT Article 11 and MPEP 1810), a Notification of the International Application Number and of the International Filing Date (Form PCT/RO/105) will be issued in due course, subject to prescriptions concerning national security, and the date shown on this Acknowledgement Receipt will establish the international filing date of the application.**

Under the Paperwork Reduction Act of 1995, no persons are required to respond to a collection of information unless it contains a valid OMB control number.

Substitute for form 1449/PTO  <b>INFORMATION DISCLOSURE STATEMENT BY APPLICANT</b>  (Use as many sheets as necessary)		<b>Complete if Known</b>	
		Application Number	12/419,451
		Filing Date	04-07-2009
		First Named Inventor	Joseph F. Scalisi
		Art Unit	
		Examiner Name	
Sheet 1	of 1	Attorney Docket Number	LBTECH.012CP1

NON PATENT LITERATURE DOCUMENTS			
Examiner Initials*	Cite No. <sup>1</sup>	Include name of the author (in CAPITAL LETTERS), title of the article (when appropriate), title of the item (book, magazine, journal, serial, symposium, catalog, etc.), date, page(s), volume-issue number(s), publisher, city and/or country where published.	T <sup>2</sup>
	R1	Analog Devices Application Note AN-377 "Increase the Frequency Response of the ADXL Series Accelerometers" by Mike Shutster, et al.	
	R2	Analog Devices Small and Thin +-5 g Accelerometer ADXL320	
	R3	Timing Group Delay (TGD) Correction and GPS Timing Biases by Demetrios Matsakis	
	R4	GPS Compass Solutions Ceact Information Systems	
	R5	ET301 GPS-UAV Development Platform	
	R6	Surface Micromachined Sensor for Vehicle Navigation Systems by Christophe Lemaire and Bob Sulouff, Analog Devices, Inc. Micromachined Products Division	
	R7	Complementary Characteristics of GPS and Accelerometer in Monitoring Structural Deformation by Xiaojing Li, et al.	
	R8	Full-Scale structural monitoring using and integrated GPS and accelerometer system by Xianojing Li, et al.	

Examiner Signature		Date Considered	
--------------------	--	-----------------	--

\*EXAMINER: Initial if reference considered, whether or not citation is in conformance with MPEP 609. Draw line through citation if not in conformance and not considered. Include copy of this form with next communication to applicant.  
<sup>1</sup> Applicant's unique citation designation number (optional). <sup>2</sup> Applicant is to place a check mark here if English language Translation is attached.  
 This collection of information is required by 37 CFR 1.98. The information is required to obtain or retain a benefit by the public which is to file (and by the USPTO to process) an application. Confidentiality is governed by 35 U.S.C. 122 and 37 CFR 1.14. This collection is estimated to take 2 hours to complete, including gathering, preparing, and submitting the completed application form to the USPTO. Time will vary depending upon the individual case. Any comments on the amount of time you require to complete this form and/or suggestions for reducing this burden, should be sent to the Chief Information Officer, U.S. Patent and Trademark Office, P.O. Box 1450, Alexandria, VA 22313-1450. DO NOT SEND FEES OR COMPLETED FORMS TO THIS ADDRESS. SEND TO: Commissioner for Patents, P.O. Box 1450, Alexandria, VA 22313-1450.

If you need assistance in completing the form, call 1-800-PTO-9199 (1-800-786-9199) and select option 2.

## Electronic Acknowledgement Receipt

<b>EFS ID:</b>	6375323
<b>Application Number:</b>	12419451
<b>International Application Number:</b>	
<b>Confirmation Number:</b>	1643
<b>Title of Invention:</b>	APPARATUS AND METHOD FOR ADJUSTING REFRESH RATE OF LOCATION COORDINATES OF A TRACKING DEVICE
<b>First Named Inventor/Applicant Name:</b>	Joseph F. Scalisi
<b>Customer Number:</b>	70515
<b>Filer:</b>	Robert E. Kasody
<b>Filer Authorized By:</b>	
<b>Attorney Docket Number:</b>	LBTECH.012CP1
<b>Receipt Date:</b>	02-NOV-2009
<b>Filing Date:</b>	07-APR-2009
<b>Time Stamp:</b>	16:13:03
<b>Application Type:</b>	Utility under 35 USC 111(a)

### Payment information:

Submitted with Payment	no
------------------------	----

### File Listing:

Document Number	Document Description	File Name	File Size(Bytes)/ Message Digest	Multi Part /.zip	Pages (if appl.)
1	Information Disclosure Statement (IDS) Filed (SB/08)	IDS_012CP1_NONPAT.pdf	70131 <small>650093e28f3a11caa6fe68b82ad7c8f7ca45c025</small>	no	1

### Warnings:

### Information:

IPR2020-01189



This is not an USPTO supplied IDS fillable form					
2	NPL Documents	r2DataSheet1053sub.pdf	206164	no	16
			6452acaefc0d47974c38bc63b14928ec492675b4		
<b>Warnings:</b>					
<b>Information:</b>					
3	NPL Documents	r3gpstimingsub.pdf	313819	no	6
			8cf24a2ec80bbdea7a761cfd05f46a70923c191		
<b>Warnings:</b>					
<b>Information:</b>					
4	NPL Documents	r4gpscompassaccusub.pdf	260377	no	10
			a6149037faa9f8108158e2ec36a690666a86fdcf		
<b>Warnings:</b>					
<b>Information:</b>					
5	NPL Documents	r5gpsmanualsub.pdf	79259	no	11
			d62a0b8cd5c880dbf3f1b62482d78bb1e6aafcb		
<b>Warnings:</b>					
<b>Information:</b>					
6	NPL Documents	r6imems_accelsub.pdf	70342	no	4
			2c9f7f12c7c526c6d12ba8b17d8d7bade59e5a51		
<b>Warnings:</b>					
<b>Information:</b>					
7	NPL Documents	r7lix_etal2005asub.pdf	549947	no	9
			87a88745c01cb8075e7512c2f23efd3fa565856c		
<b>Warnings:</b>					
<b>Information:</b>					
8	NPL Documents	r8lix_etal2006bsub.pdf	4247497	no	15
			46d7abbf82c5e7c1a969ea8bfb11d6682d7192a		
<b>Warnings:</b>					
<b>Information:</b>					
<b>Total Files Size (in bytes):</b>			5797536		

**This Acknowledgement Receipt evidences receipt on the noted date by the USPTO of the indicated documents, characterized by the applicant, and including page counts, where applicable. It serves as evidence of receipt similar to a Post Card, as described in MPEP 503.**

**New Applications Under 35 U.S.C. 111**

**If a new application is being filed and the application includes the necessary components for a filing date (see 37 CFR 1.53(b)-(d) and MPEP 506), a Filing Receipt (37 CFR 1.54) will be issued in due course and the date shown on this Acknowledgement Receipt will establish the filing date of the application.**

**National Stage of an International Application under 35 U.S.C. 371**

**If a timely submission to enter the national stage of an international application is compliant with the conditions of 35 U.S.C. 371 and other applicable requirements a Form PCT/DO/EO/903 indicating acceptance of the application as a national stage submission under 35 U.S.C. 371 will be issued in addition to the Filing Receipt, in due course.**

**New International Application Filed with the USPTO as a Receiving Office**

**If a new international application is being filed and the international application includes the necessary components for an international filing date (see PCT Article 11 and MPEP 1810), a Notification of the International Application Number and of the International Filing Date (Form PCT/RO/105) will be issued in due course, subject to prescriptions concerning national security, and the date shown on this Acknowledgement Receipt will establish the international filing date of the application.**

## Electronic Acknowledgement Receipt

<b>EFS ID:</b>	6375908
<b>Application Number:</b>	12419451
<b>International Application Number:</b>	
<b>Confirmation Number:</b>	1643
<b>Title of Invention:</b>	APPARATUS AND METHOD FOR ADJUSTING REFRESH RATE OF LOCATION COORDINATES OF A TRACKING DEVICE
<b>First Named Inventor/Applicant Name:</b>	Joseph F. Scalisi
<b>Customer Number:</b>	70515
<b>Filer:</b>	Robert E. Kasody
<b>Filer Authorized By:</b>	
<b>Attorney Docket Number:</b>	LBTECH.012CP1
<b>Receipt Date:</b>	02-NOV-2009
<b>Filing Date:</b>	07-APR-2009
<b>Time Stamp:</b>	16:42:04
<b>Application Type:</b>	Utility under 35 USC 111(a)

### Payment information:

Submitted with Payment	no
------------------------	----

### File Listing:

Document Number	Document Description	File Name	File Size(Bytes)/ Message Digest	Multi Part /.zip	Pages (if appl.)
1	NPL Documents	r1AN377sub.pdf	20516 <small>4c575e97ac045c3da0672dcbced647766d1f1322</small>	no	1

### Warnings:

### Information:

IPR2020-01189

**This Acknowledgement Receipt evidences receipt on the noted date by the USPTO of the indicated documents, characterized by the applicant, and including page counts, where applicable. It serves as evidence of receipt similar to a Post Card, as described in MPEP 503.**

**New Applications Under 35 U.S.C. 111**

**If a new application is being filed and the application includes the necessary components for a filing date (see 37 CFR 1.53(b)-(d) and MPEP 506), a Filing Receipt (37 CFR 1.54) will be issued in due course and the date shown on this Acknowledgement Receipt will establish the filing date of the application.**

**National Stage of an International Application under 35 U.S.C. 371**

**If a timely submission to enter the national stage of an international application is compliant with the conditions of 35 U.S.C. 371 and other applicable requirements a Form PCT/DO/EO/903 indicating acceptance of the application as a national stage submission under 35 U.S.C. 371 will be issued in addition to the Filing Receipt, in due course.**

**New International Application Filed with the USPTO as a Receiving Office**

**If a new international application is being filed and the international application includes the necessary components for an international filing date (see PCT Article 11 and MPEP 1810), a Notification of the International Application Number and of the International Filing Date (Form PCT/RO/105) will be issued in due course, subject to prescriptions concerning national security, and the date shown on this Acknowledgement Receipt will establish the international filing date of the application.**

Under the Paperwork Reduction Act of 1995, no persons are required to respond to a collection of information unless it displays a valid OMB control number.

<b>REQUEST FOR WITHDRAWAL AS ATTORNEY OR AGENT AND CHANGE OF CORRESPONDENCE ADDRESS</b>	Application Number	12/419,451
	Filing Date	04-07-2009
	First Named Inventor	Joseph F. Scalisi
	Art Unit	2618
	Examiner Name	N/A
	Attorney Docket Number	LBTECH.012CP1

To: **Commissioner for Patents  
P.O. Box 1450  
Alexandria, VA 22313-1450**

Please withdraw me as attorney or agent for the above identified patent application, and

- all the practitioners of record;
- the practitioners (with registration numbers) of record listed on the attached paper(s); or
- the practitioners of record associated with Customer Number: 70,515

**NOTE:** The immediately preceding box should only be marked when the practitioners were appointed using the listed Customer Number.

The reason(s) for this request are those described in 37 CFR :

- |   |   |  |   |
|---|---|--|---|
| <input type="checkbox"/> 10.40(b)(1)    | <input type="checkbox"/> 10.40(b)(2)                | <input type="checkbox"/> 10.40(b)(3)                       | <input type="checkbox"/> 10.40(b)(4)                |
| <input type="checkbox"/> 10.40(c)(1)(i) | <input type="checkbox"/> 10.40(c)(1)(ii)            | <input type="checkbox"/> 10.40(c)(1)(iii)                  | <input checked="" type="checkbox"/> 10.40(c)(1)(iv) |
| <input type="checkbox"/> 10.40(c)(1)(v) | <input checked="" type="checkbox"/> 10.40(c)(1)(vi) | <input type="checkbox"/> 10.40(c)(2)                       | <input type="checkbox"/> 10.40(c)(3)                |
| <input type="checkbox"/> 10.40(c)(4)    | <input type="checkbox"/> 10.40(c)(5)                | <input type="checkbox"/> 10.40(c)(6) Please explain below: |   |

**Certifications**

**Check each box below that is factually correct. WARNING: If a box is left unchecked, the request will likely not be approved.**

1.  I/We have given reasonable notice to the client, prior to the expiration of the response period, that the practitioner(s) intend to withdraw from employment.
2.  I/We have delivered to the client or a duly authorized representative of the client all papers and property (including funds) to which the client is entitled.
3.  I/We have notified the client of any responses that may be due and the time frame within which the client must respond.

Please provide an explanation, if necessary:

[Page 1 of 2]

This collection of information is required by 37 CFR 1.36. The information is required to obtain or retain a benefit by the public which is to file (and by the USPTO to process) an application. Confidentiality is governed by 35 U.S.C. 122 and 37 CFR 1.11 and 1.14. This collection is estimated to take 12 minutes to complete, including gathering, preparing, and submitting the completed application form to the USPTO. Time will vary depending upon the individual case. Any comments on the amount of time you require to complete this form and/or suggestions for reducing this burden, should be sent to the Chief Information Officer, U.S. Patent and Trademark Office, U.S. Department of Commerce, P.O. Box 1450, Alexandria, VA 22313-1450. DO NOT SEND FEES OR COMPLETED FORMS TO THIS ADDRESS. **SEND TO: Commissioner for Patents, P.O. Box 1450, Alexandria, VA 22313-1450.**

If you need assistance in completing the form, call 1-800-PTO-9199 and select option 2.

Under the Paperwork Reduction Act of 1995, no persons are required to respond to a collection of information unless it displays a valid OMB control number.

## REQUEST FOR WITHDRAWAL AS ATTORNEY OR AGENT AND CHANGE OF CORRESPONDENCE ADDRESS

Complete the following section only when the correspondence address will change. Changes of address will only be accepted to an inventor or an assignee that has properly made itself of record pursuant to 37 CFR 3.71.

Change the correspondence address and direct all future correspondence to:

A.  The address of the inventor or assignee associated with Customer Number: \_\_\_\_\_

**OR**

B.  Inventor or Assignee name Joseph F. Scalisi

Address 38 Discovery, Suite 150

City Irvine State CA Zip 92618 Country USA

Telephone 888-600-1044 Email joseph@pocketfinder.com

I am authorized to sign on behalf of myself and all withdrawing practitioners.

Signature

Name Robert E. Kasody, Esq. Registration No. 50,268

Address 6601 Center Drive West, Suite 500

City Los Angeles State CA Zip 90045 Country USA

Date 9/2/2010 Telephone No. 310-348-8195

**NOTE: Withdrawal is effective when approved rather than when received.**

[Page 2 of 2]

This collection of information is required by 37 CFR 1.36. The information is required to obtain or retain a benefit by the public which is to file (and by the USPTO to process) an application. Confidentiality is governed by 35 U.S.C. 122 and 37 CFR 1.11 and 1.14. This collection is estimated to take 12 minutes to complete, including gathering, preparing, and submitting the completed application form to the USPTO. Time will vary depending upon the individual case. Any comments on the amount of time you require to complete this form and/or suggestions for reducing this burden, should be sent to the Chief Information Officer, U.S. Patent and Trademark Office, U.S. Department of Commerce, P.O. Box 1450, Alexandria, VA 22313-1450. DO NOT SEND FEES OR COMPLETED FORMS TO THIS ADDRESS. **SEND TO: Commissioner for Patents, P.O. Box 1450, Alexandria, VA 22313-1450.**

*If you need assistance in completing the form, call 1-800-PTO-9199 and select option 2.*

## Electronic Acknowledgement Receipt

<b>EFS ID:</b>	8344148
<b>Application Number:</b>	12419451
<b>International Application Number:</b>	
<b>Confirmation Number:</b>	1643
<b>Title of Invention:</b>	APPARATUS AND METHOD FOR ADJUSTING REFRESH RATE OF LOCATION COORDINATES OF A TRACKING DEVICE
<b>First Named Inventor/Applicant Name:</b>	Joseph F. Scalisi
<b>Customer Number:</b>	70515
<b>Filer:</b>	Robert E. Kasody
<b>Filer Authorized By:</b>	
<b>Attorney Docket Number:</b>	LBTECH.012CP1
<b>Receipt Date:</b>	02-SEP-2010
<b>Filing Date:</b>	07-APR-2009
<b>Time Stamp:</b>	13:09:12
<b>Application Type:</b>	Utility under 35 USC 111(a)

### Payment information:

Submitted with Payment	no
------------------------	----

### File Listing:

Document Number	Document Description	File Name	File Size(Bytes)/ Message Digest	Multi Part /.zip	Pages (if appl.)
1	Petition to withdraw attorney or agent (SB83)	12cp1_withdrawal.pdf	35912 <small>339a18eb23bf237b7226eed935ed6eac5e a091e</small>	no	2

### Warnings:

### Information:

IPR2020-01189

**This Acknowledgement Receipt evidences receipt on the noted date by the USPTO of the indicated documents, characterized by the applicant, and including page counts, where applicable. It serves as evidence of receipt similar to a Post Card, as described in MPEP 503.**

**New Applications Under 35 U.S.C. 111**

**If a new application is being filed and the application includes the necessary components for a filing date (see 37 CFR 1.53(b)-(d) and MPEP 506), a Filing Receipt (37 CFR 1.54) will be issued in due course and the date shown on this Acknowledgement Receipt will establish the filing date of the application.**

**National Stage of an International Application under 35 U.S.C. 371**

**If a timely submission to enter the national stage of an international application is compliant with the conditions of 35 U.S.C. 371 and other applicable requirements a Form PCT/DO/EO/903 indicating acceptance of the application as a national stage submission under 35 U.S.C. 371 will be issued in addition to the Filing Receipt, in due course.**

**New International Application Filed with the USPTO as a Receiving Office**

**If a new international application is being filed and the international application includes the necessary components for an international filing date (see PCT Article 11 and MPEP 1810), a Notification of the International Application Number and of the International Filing Date (Form PCT/RO/105) will be issued in due course, subject to prescriptions concerning national security, and the date shown on this Acknowledgement Receipt will establish the international filing date of the application.**





UNITED STATES PATENT AND TRADEMARK OFFICE

UNITED STATES DEPARTMENT OF COMMERCE  
United States Patent and Trademark Office  
Address: COMMISSIONER FOR PATENTS  
P.O. Box 1450  
Alexandria, Virginia 22313-1450  
www.uspto.gov

APPLICATION NUMBER	FILING OR 371(C) DATE	FIRST NAMED APPLICANT	ATTY. DOCKET NO./TITLE
12/419,451	04/07/2009	Joseph F. Scalisi	LBTECH.012CP1

**CONFIRMATION NO. 1643**

**POWER OF ATTORNEY NOTICE**



70515  
Law Office Of Robert E. Kasody,  
Professional Corporation  
6601 Center Drive West, Suite #500  
Los Angeles, CA 90045

Date Mailed: 10/01/2010

**NOTICE REGARDING CHANGE OF POWER OF ATTORNEY**

This is in response to the Power of Attorney filed 09/02/2010.

- The withdrawal as attorney in this application has been accepted. Future correspondence will be mailed to the new address of record. 37 CFR 1.33.

/magraves/

Office of Data Management, Application Assistance Unit (571) 272-4000, or (571) 272-4200, or 1-888-786-0101



Law Office Of Robert E. Kasody,  
Professional Corporation  
6601 Center Drive West, Suite #500  
Los Angeles, CA 90045

MAILED

OCT 01 2010

OFFICE OF PETITIONS

In re Application of  
**Joseph F. SCALISI, et al.**  
Application No. 12/419,451  
Filed: April 7, 2009  
Attorney Docket No. **LBTECH.012CP1**

DECISION ON PETITION TO  
WITHDRAW FROM RECORD

This is a decision on the Request to Withdraw as attorney or agent of record under 37 C.F.R. § 1.36(b), filed September 2, 2010.

The request is **APPROVED**.

A grantable request to withdraw as attorney/agent of record must be signed by every attorney/agent seeking to withdraw or contain a clear indication that one attorney is signing on behalf of another/others.

The request was signed by Robert E. Kasody. Robert E. Kasody has been withdrawn as attorney or agent of record. Applicant is reminded that there is no attorney of record at this time.

All future communications from the Office will be directed to the first named signing inventor at the address below until otherwise properly notified by the applicant.

Telephone inquiries concerning this decision should be directed to the undersigned at (571) 272-7253.

/Monica A. Graves/  
Petitions Examiner, Office of Petitions

cc: **JOSEPH F. SCALISI**  
**38 DISCOVERY, SUITE 150**  
**IRVINE, CA 92618**



UNITED STATES PATENT AND TRADEMARK OFFICE

UNITED STATES DEPARTMENT OF COMMERCE  
 United States Patent and Trademark Office  
 Address: COMMISSIONER FOR PATENTS  
 P.O. Box 1450  
 Alexandria, Virginia 22313-1450  
 www.uspto.gov



Bib Data Sheet

CONFIRMATION NO. 1643

<b>SERIAL NUMBER</b> 12/419,451	<b>FILING OR 371(c) DATE</b> 04/07/2009 <b>RULE</b>	<b>CLASS</b> 455	<b>GROUP ART UNIT</b> 2618	<b>ATTORNEY DOCKET NO.</b> LBTECH.012CP1
------------------------------------	---	---------------------	-------------------------------	---

**APPLICANTS**  
 Joseph F. Scalisi, Yorba Linda, CA;  
 Roger B. Anderson, Arcadia, CA;

**\*\* CONTINUING DATA \*\*\*\*\***  
 This application is a CIP of 11/969,905 01/06/2008  
 and is a CIP of 11/753,979 05/25/2007  
 and is a CIP of 11/933,024 10/31/2007  
 and is a CIP of 11/784,400 04/05/2007  
 and is a CIP of 11/935,901 11/06/2007

**\*\* FOREIGN APPLICATIONS \*\*\*\*\***

**IF REQUIRED, FOREIGN FILING LICENSE GRANTED\*\* SMALL ENTITY\*\***  
 \*\* 04/16/2009

Foreign Priority claimed <input type="checkbox"/> yes <input type="checkbox"/> no	<b>STATE OR COUNTRY</b> CA	<b>SHEETS DRAWING</b> 7	<b>TOTAL CLAIMS</b> 21	<b>INDEPENDENT CLAIMS</b> 3
35 USC 119 (a-d) conditions met <input type="checkbox"/> yes <input type="checkbox"/> no <input type="checkbox"/> Met after Allowance				
Verified and Acknowledged	Examiner's Signature	Initials		

**ADDRESS**  
 JOSEPH F. SCALISI  
 38 DISCOVERY, SUITE 150  
 IRVINE,, CA92618

**TITLE**  
 APPARATUS AND METHOD FOR ADJUSTING REFRESH RATE OF LOCATION COORDINATES OF A TRACKING DEVICE

<b>FILING FEE RECEIVED</b> 488	FEES: Authority has been given in Paper No. _____ to charge/credit DEPOSIT ACCOUNT No. _____ for following:	<input type="checkbox"/> All Fees <input type="checkbox"/> 1.16 Fees ( Filing ) <input type="checkbox"/> 1.17 Fees ( Processing Ext. of time ) <input type="checkbox"/> 1.18 Fees ( Issue ) <input type="checkbox"/> Other _____ <input type="checkbox"/> Credit
-----------------------------------	---	---

Under the Paperwork Reduction Act of 1995, no persons are required to respond to a collection of information unless it displays a valid OMB control number.

**POWER OF ATTORNEY TO PROSECUTE APPLICATIONS BEFORE THE USPTO**

I hereby revoke all previous powers of attorney given in the application identified in the attached statement under 37 CFR 3.73(b).

I hereby appoint:

 Practitioners associated with the Customer Number:

93892

OR

 Practitioner(s) named below (if more than ten patent practitioners are to be named, then a customer number must be used):

Name	Registration Number	Name	Registration Number

as attorney(s) or agent(s) to represent the undersigned before the United States Patent and Trademark Office (USPTO) in connection with any and all patent applications assigned only to the undersigned according to the USPTO assignment records or assignment documents attached to this form in accordance with 37 CFR 3.73(b).

Please change the correspondence address for the application identified in the attached statement under 37 CFR 3.73(b) to:

 The address associated with Customer Number:

93892

OR

<input type="checkbox"/> Firm or Individual Name			
Address			
City	State	Zip	
Country			
Telephone	Email		

Assignee Name and Address:

Location Based Technologies, Inc.  
38 Discovery Suite 150  
Irvine, CA 92618**A copy of this form, together with a statement under 37 CFR 3.73(b) (Form PTO/SB/96 or equivalent) is required to be filed in each application in which this form is used. The statement under 37 CFR 3.73(b) may be completed by one of the practitioners appointed in this form if the appointed practitioner is authorized to act on behalf of the assignee, and must identify the application in which this Power of Attorney is to be filed.****SIGNATURE of Assignee of Record**

The individual whose signature and title is supplied below is authorized to act on behalf of the assignee

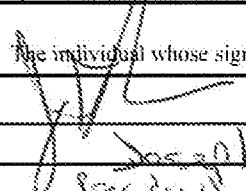
Signature		Date	1/19/11
Name	Joseph Scalis	Telephone	714583-867
Title	President		

This collection of information is required by 37 CFR 1.31, 1.32 and 1.33. The information is required to obtain or retain a benefit by the public which is to file (and by the USPTO to process) an application. Confidentiality is governed by 35 U.S.C. 122 and 37 CFR 1.11 and 1.14. This collection is estimated to take 3 minutes to complete, including gathering, preparing, and submitting the completed application form to the USPTO. Time will vary depending upon the individual case. Any comments on the amount of time you require to complete this form and/or suggestions for reducing this burden, should be sent to the Chief Information Officer, U.S. Patent and Trademark Office, U.S. Department of Commerce, P.O. Box 1450, Alexandria, VA 22313-1450. DO NOT SEND FEES OR COMPLETED FORMS TO THIS ADDRESS. **SEND TO: Commissioner for Patents, P.O. Box 1450, Alexandria, VA 22313-1450.**

If you need assistance in completing the form, call 1-800-PTO-9199 and select option 2.

Under the Paperwork Reduction Act of 1995, no persons are required to respond to a collection of information unless it displays a valid OMB control number.

**STATEMENT UNDER 37 CFR 3.73(b)**

Applicant/Patent Owner: Location Based Technologies, Inc.

Application No./Patent No.: 12/419,451 Filed/Issue Date: 7 Apr 2009

Titled: **APPARATUS AND METHOD FOR ADJUSTING REFRESH RATE OF LOCATION COORDINATES OF A TRACKING DEVICE**

Location Based Technologies, Inc., a Corporation  
(Name of Assignee) (Type of Assignee, e.g., corporation, partnership, university, government agency, etc.)

states that it is:

- 1.  the assignee of the entire right, title, and interest in;
  - 2.  an assignee of less than the entire right, title, and interest in  
(The extent (by percentage) of its ownership interest is \_\_\_\_\_ %); or
  - 3.  the assignee of an undivided interest in the entirety of (a complete assignment from one of the joint inventors was made)
- the patent application/patent identified above, by virtue of either:

A.  An assignment from the inventor(s) of the patent application/patent identified above. The assignment was recorded in the United States Patent and Trademark Office at Reel \_\_\_\_\_, Frame \_\_\_\_\_, or for which a copy therefore is attached.

**OR**

B.  A chain of title from the inventor(s), of the patent application/patent identified above, to the current assignee as follows:

1. From: Joseph F. Scalisi To: Location Based Technologies, Inc.

The document was recorded in the United States Patent and Trademark Office at  
Reel 022515, Frame 0451, or for which a copy thereof is attached.

2. From: Roger B. Anderson To: Location Based Technologies, Inc.

The document was recorded in the United States Patent and Trademark Office at  
Reel 022515, Frame 0575, or for which a copy thereof is attached.

3. From: \_\_\_\_\_ To: \_\_\_\_\_

The document was recorded in the United States Patent and Trademark Office at  
Reel \_\_\_\_\_, Frame \_\_\_\_\_, or for which a copy thereof is attached.

Additional documents in the chain of title are listed on a supplemental sheet(s).

As required by 37 CFR 3.73(b)(1)(i), the documentary evidence of the chain of title from the original owner to the assignee was, or concurrently is being, submitted for recordation pursuant to 37 CFR 3.11.

[NOTE: A separate copy (i.e., a true copy of the original assignment document(s)) must be submitted to Assignment Division in accordance with 37 CFR Part 3, to record the assignment in the records of the USPTO. See MPEP 302.08]

The undersigned (whose title is supplied below) is authorized to act on behalf of the assignee.

/Christopher W. Lattin, Reg. No. 56064/  
Signature

February 16, 2011  
Date

Christopher W. Lattin, Reg. No. 56064  
Printed or Typed Name

Attorney of Record  
Title

This collection of information is required by 37 CFR 3.73(b). The information is required to obtain or retain a benefit by the public which is to file (and by the USPTO to process) an application. Confidentiality is governed by 35 U.S.C. 122 and 37 CFR 1.11 and 1.14. This collection is estimated to take 12 minutes to complete, including gathering, preparing, and submitting the completed application form to the USPTO. Time will vary depending upon the individual case. Any comments on the amount of time you require to complete this form and/or suggestions for reducing this burden, should be sent to the Chief Information Officer, U.S. Patent and Trademark Office, U.S. Department of Commerce, P.O. Box 1450, Alexandria, VA 22313-1450. DO NOT SEND FEES OR COMPLETED FORMS TO THIS ADDRESS. **SEND TO: Commissioner for Patents, P.O. Box 1450, Alexandria, VA 22313-1450.**

IPR2020-01189

## Electronic Acknowledgement Receipt

<b>EFS ID:</b>	9490101
<b>Application Number:</b>	12419451
<b>International Application Number:</b>	
<b>Confirmation Number:</b>	1643
<b>Title of Invention:</b>	APPARATUS AND METHOD FOR ADJUSTING REFRESH RATE OF LOCATION COORDINATES OF A TRACKING DEVICE
<b>First Named Inventor/Applicant Name:</b>	Joseph F. Scalisi
<b>Correspondence Address:</b>	JOSEPH F. SCALISI - 38 DISCOVERY, SUITE 150 - IRVINE, CA 92618 US 8886001044 joseph@pocketfinder.com
<b>Filer:</b>	Christopher W. Lattin/Melissa Nelson
<b>Filer Authorized By:</b>	Christopher W. Lattin
<b>Attorney Docket Number:</b>	LBTECH.012CP1
<b>Receipt Date:</b>	22-FEB-2011
<b>Filing Date:</b>	07-APR-2009
<b>Time Stamp:</b>	13:01:39
<b>Application Type:</b>	Utility under 35 USC 111(a)

### Payment information:

Submitted with Payment	no
------------------------	----

### File Listing:

Document Number	Document Description	File Name	File Size(Bytes)/ Message Digest	Multi Part /.zip	Pages (if appl.)
1		LB1006USC1POA.pdf	431366 ee9589dd2b719f35931a66e25a409d470c01695d	yes	2
<b>Multipart Description/PDF files in .zip description</b>					
	<b>Document Description</b>		<b>Start</b>		<b>End</b>
	Power of Attorney		1		1
	Assignee showing of ownership per 37 CFR 3.73(b).		2		2
<b>Warnings:</b>					
<b>Information:</b>					
<b>Total Files Size (in bytes):</b>			431366		
<p><b>This Acknowledgement Receipt evidences receipt on the noted date by the USPTO of the indicated documents, characterized by the applicant, and including page counts, where applicable. It serves as evidence of receipt similar to a Post Card, as described in MPEP 503.</b></p> <p><b><u>New Applications Under 35 U.S.C. 111</u></b>  If a new application is being filed and the application includes the necessary components for a filing date (see 37 CFR 1.53(b)-(d) and MPEP 506), a Filing Receipt (37 CFR 1.54) will be issued in due course and the date shown on this Acknowledgement Receipt will establish the filing date of the application.</p> <p><b><u>National Stage of an International Application under 35 U.S.C. 371</u></b>  If a timely submission to enter the national stage of an international application is compliant with the conditions of 35 U.S.C. 371 and other applicable requirements a Form PCT/DO/EO/903 indicating acceptance of the application as a national stage submission under 35 U.S.C. 371 will be issued in addition to the Filing Receipt, in due course.</p> <p><b><u>New International Application Filed with the USPTO as a Receiving Office</u></b>  If a new international application is being filed and the international application includes the necessary components for an international filing date (see PCT Article 11 and MPEP 1810), a Notification of the International Application Number and of the International Filing Date (Form PCT/RO/105) will be issued in due course, subject to prescriptions concerning national security, and the date shown on this Acknowledgement Receipt will establish the international filing date of the application.</p>					



UNITED STATES PATENT AND TRADEMARK OFFICE

UNITED STATES DEPARTMENT OF COMMERCE  
United States Patent and Trademark Office  
Address: COMMISSIONER FOR PATENTS  
P.O. Box 1450  
Alexandria, Virginia 22313-1450  
www.uspto.gov

APPLICATION NUMBER	FILING OR 371(C) DATE	FIRST NAMED APPLICANT	ATTY. DOCKET NO./TITLE
12/419,451	04/07/2009	Joseph F. Scalisi	LBTECH.012CP1

**CONFIRMATION NO. 1643**

**POWER OF ATTORNEY NOTICE**



70515  
Law Office Of Robert E. Kasody,  
Professional Corporation  
6601 Center Drive West, Suite #500  
Los Angeles, CA 90045

Date Mailed: 03/02/2011

**NOTICE REGARDING CHANGE OF POWER OF ATTORNEY**

This is in response to the Power of Attorney filed 09/02/2010.

- The withdrawal as attorney in this application has been accepted. Future correspondence will be mailed to the new address of record. 37 CFR 1.33.

/magraves/

Office of Data Management, Application Assistance Unit (571) 272-4000, or (571) 272-4200, or 1-888-786-0101





UNITED STATES PATENT AND TRADEMARK OFFICE

UNITED STATES DEPARTMENT OF COMMERCE  
United States Patent and Trademark Office  
Address: COMMISSIONER FOR PATENTS  
P.O. Box 1450  
Alexandria, Virginia 22313-1450  
www.uspto.gov

APPLICATION NUMBER	FILING OR 371(C) DATE	FIRST NAMED APPLICANT	ATTY. DOCKET NO./TITLE
12/419,451	04/07/2009	Joseph F. Scalisi	LBTECH.012CP1

**CONFIRMATION NO. 1643**

**POA ACCEPTANCE LETTER**



93892  
Timberline Patent Law Group  
157 S. Howard St.  
Suite 516  
Spokane, WA 99203

Date Mailed: 03/02/2011

**NOTICE OF ACCEPTANCE OF POWER OF ATTORNEY**

This is in response to the Power of Attorney filed 02/22/2011.

The Power of Attorney in this application is accepted. Correspondence in this application will be mailed to the above address as provided by 37 CFR 1.33.

/magraves/

Office of Data Management, Application Assistance Unit (571) 272-4000, or (571) 272-4200, or 1-888-786-0101

Substitute for form 1449A/PTO  <b>INFORMATION DISCLOSURE STATEMENT BY APPLICANT</b>  (Use as many sheets as necessary)		<i>Complete if Known</i>	
		<b>Application Number</b>	12/419,451
		<b>Filing Date</b>	April 7, 2009
		<b>First Named Inventor</b>	Scalisi, Joseph
		<b>Art Unit</b>	2618
		<b>Examiner Name</b>	Unknown
	1	of	6
Attorney Docket No: LB1-006USC1			

US PATENT DOCUMENTS					
Examiner Initial *	Cite No	Document Number	Publication Date	Name of Patentee or Applicant of Cited Document	Filing Date If Appropriate
		US-20010030667	10/18/2001	Kelts, Brett R.	
		US-20010048364	12/06/2001	Kalthoff, Robert M., et al.	
		US-20020041328	04/11/2002	LeCompte, Malcolm et al.	
		US-20020067256	06/06/2002	Kail IV, Karl A.	
		US-20020077130	06/20/2002	Owensby, Craig A.	
		US-20020180602	12/05/2002	Yoakum, Jay	
		US-20020186135	12/12/2002	Wagner, Colleen	
		US-20020196123	12/26/2002	Diehl, Joseph R., et al.	
		US-20030043200	03/06/2003	Faieta, Baldo et al.	
		US-20030131073	07/10/2003	Lucovsky, Mark H., et al.	
		US-20030208518	11/06/2003	Gura, Nils et al.	
		US-20030210262	11/13/2003	Gahm, Thomas et al.	
		US-20030212729	11/13/2003	Eberle, Hans et al.	
		US-20040010689	01/15/2004	Vanstone, Scott A., et al.	
		US-20040165726	08/26/2004	Yamamichi, Masato et al.	
		US-20040166879	08/26/2004	Meadows, Vernon et al.	
		US-20040172403	09/02/2004	Steele, Rhea L., et al.	
		US-20040212493	10/28/2004	Stilp, Louis A.	
		US-20050012620	01/20/2005	Yoakum, Jay	
		US-20050071736	03/31/2006	Schneider, Tina F., et al.	
		US-20050099303	05/12/2005	Suckerman, Andrew M.	
		US-20050159883	07/21/2005	Humphries, Laymon S., et al.	
		US-20050181870	08/18/2005	Nguyen, Binh T., et al.	
		US-20050188403	08/25/2005	Kotzin, Michael D.	
		US-20050210260	09/22/2005	Venkatesan, Ramarathnam et al.	
		US-20050246647	11/03/2005	Beam, Tyler K., et al.	
		US-20050248459	11/10/2005	Bonalle, David S., et al.	
		US-20060009152	01/12/2006	Millard, Thomas A., et al.	
		US-20060206246	09/14/2006	Walker, Richard C.	
		US-20060211405	09/21/2006	Scalisi, Joseph F., et al.	
		US-20060232429	10/19/2006	Jain, Amit et al.	
		US-20060253590	11/09/2006	Nagy, David et al.	
		US-20060290497	12/28/2006	Sugata, T.	
		US-20070028088	02/01/2007	Bayrak, Coskun et al.	
		US-20070033531	02/08/2007	Marsh, Christopher	

**EXAMINER**

**DATE CONSIDERED**

Substitute Disclosure Statement Form (PTO-1449)  
\* EXAMINER: Initial if reference considered, whether or not citation is in conformance with MPEP 609. Draw line through citation if not in conformance and not considered. Include copy of this form with next communication to applicant. 1 Applicant's unique citation designation number (optional) 2 Applicant is to place a check mark here if English language Translation is attached

Substitute for form 1449A/PTO  <b>INFORMATION DISCLOSURE STATEMENT BY APPLICANT</b>  (Use as many sheets as necessary)		<table border="1" style="width: 100%; border-collapse: collapse;"> <tr> <td colspan="2" style="text-align: right;"><i>Complete if Known</i></td> </tr> <tr> <td style="width: 50%;"><b>Application Number</b></td> <td>12/419,451</td> </tr> <tr> <td><b>Filing Date</b></td> <td>April 7, 2009</td> </tr> <tr> <td><b>First Named Inventor</b></td> <td>Scalisi, Joseph</td> </tr> <tr> <td><b>Art Unit</b></td> <td>2618</td> </tr> <tr> <td><b>Examiner Name</b></td> <td>Unknown</td> </tr> </table>		<i>Complete if Known</i>		<b>Application Number</b>	12/419,451	<b>Filing Date</b>	April 7, 2009	<b>First Named Inventor</b>	Scalisi, Joseph	<b>Art Unit</b>	2618	<b>Examiner Name</b>	Unknown
<i>Complete if Known</i>															
<b>Application Number</b>	12/419,451														
<b>Filing Date</b>	April 7, 2009														
<b>First Named Inventor</b>	Scalisi, Joseph														
<b>Art Unit</b>	2618														
<b>Examiner Name</b>	Unknown														
Sheet	2	of	6	Attorney Docket No: LB1-006USC1											

US PATENT DOCUMENTS					
Examiner Initial *	Cite No	Document Number	Publication Date	Name of Patentee or Applicant of Cited Document	Filing Date If Appropriate
		US-20070053513	03/08/2007	Hoffberg, Steven M.	
		US-20070054530	03/08/2007	Bauer, Michael et al.	
		US-20070061303	03/15/2007	Ramer, Jorey et al.	
		US-20070073719	03/29/2007	Ramer, Jorey et al.	
		US-20070083819	04/12/2007	Shoemaker, Garth B.	
		US-20070159322	07/12/2007	Campbell, Garratt	
		US-20070229350	10/04/2007	Scalisi, Joseph F., et al.	
		US-20070255620	11/01/2007	Tumminaro, John et al.	
		US-20070288427	12/13/2007	Ramer, Jorey et al.	
		US-20080010585	01/10/2008	Schneider, Tina F.	
		US-20080059504	03/06/2008	Barbetta, Jackie et al.	
		US-20080059889	03/06/2008	Parker, Cheryl et al.	
		US-20080090550	04/17/2008	Scalisi, Joseph F., et al.	
		US-20080109762	05/08/2008	Hundal, Gurpal S., et al.	
		US-20080129491	06/05/2008	Ruperto, Netzer A., et al.	
		US-20080172173	07/17/2008	Chang, Eric et al.	
		US-20080252254	10/16/2008	Osada, Takeshi	
		US-20080252459	10/16/2008	Butler, Timothy P., et al.	
		US-20090098903	04/16/2009	Donaldson, Jesse E., et al.	
		US-20090103722	04/23/2009	Anderson, Roger B., et al.	
		US-20090111393	04/30/2009	Scalisi, Joseph F., et al.	
		US-20090117921	05/07/2009	Beydler, Michael L., et al.	
		US-20090119119	05/07/2009	Scalisi, Joseph F., et al.	
		US-20090174603	07/09/2009	Scalisi, Joseph F., et al.	
		US-20090201127	08/13/2009	Stobbe, Anatoli et al.	
		US-20090315706	12/24/2009	Scalisi, Joseph F., et al.	
		US-20090315767	12/24/2009	Scalisi, Joseph F., et al.	
		US-3924102	12/02/1975	Hanekom, Nicolaas W.	
		US-4379334	04/05/1983	Feagins, Jr., Thomas J., et al.	
		US-4807453	02/28/1989	Bernier, Denis et al.	
		US-4850007	07/18/1989	Marino, Patrick J., et al.	
		US-4885920	12/12/1989	Larson, Donna J.	
		US-5079541	01/07/1992	Moody, Thomas O.	
		US-5127042	06/30/1992	Gillig, Steven F., et al.	
		US-5353331	10/04/1994	Emery, Mark J., et al.	

**EXAMINER**

**DATE CONSIDERED**

Substitute Disclosure Statement Form (PTO-1449)  
 \* EXAMINER: Initial if reference considered, whether or not citation is in conformance with MPEP 609. Draw line through citation if not in conformance and not considered. Include copy of this form with next communication to applicant. 1 Applicant's unique citation designation number (optional) 2 Applicant is to place a check mark here if English language Translation is attached

Substitute for form 1449A/PTO  <b>INFORMATION DISCLOSURE STATEMENT BY APPLICANT</b>  (Use as many sheets as necessary)		<i>Complete if Known</i>	
		<b>Application Number</b>	12/419,451
		<b>Filing Date</b>	April 7, 2009
		<b>First Named Inventor</b>	Scalisi, Joseph
		<b>Art Unit</b>	2618
		<b>Examiner Name</b>	Unknown
Sheet	3	of	6
Attorney Docket No: LB1-006USC1			

US PATENT DOCUMENTS					
Examiner Initial *	Cite No	Document Number	Publication Date	Name of Patentee or Applicant of Cited Document	Filing Date If Appropriate
		US-5361612	11/08/1994	Voiculescu, Danut et al.	
		US-5386468	01/31/1995	Akiyama, Ryota et al.	
		US-5417092	05/23/1995	Iu, Chien-Chzh	
		US-5432542	07/11/1995	Thibadeau, Robert et al.	
		US-5490402	02/13/1996	Shieh, Jin-Ren	
		US-5541976	07/30/1996	Ghisler, Walter	
		US-5563579	10/08/1996	Carter, Ronald L.	
		US-5565909	10/15/1996	Thibadeau, Robert et al.	
		US-5768920	06/23/1998	DeBevoise, Bruce D.	
		US-5785181	07/28/1998	Quartarao, Jr., Peter J.	
		US-5876765	03/02/1999	Hinterlechner, Gerhard et al.	
		US-5967841	10/19/1999	Bianca, Giuseppe et al.	
		US-5973599	11/26/1999	Nicholson, Mark et al.	
		US-6088453	07/11/2000	Shimbo, Atsushi	
		US-6141356	10/31/2000	Gorman, Michael G.	
		US-6236365	05/22/2001	LeBlanc, Frederick W., et al.	
		US-6330817	12/18/2001	Frolov, George	
		US-6388612	05/14/2002	Neher, Timothy J.	
		US-6414629	07/02/2002	Curcio, Joseph A.	
		US-6441741	08/27/2002	Yoakum, Jay	
		US-6445921	09/03/2002	Bell, John R.	
		US-6453037	09/17/2002	Welter, Jr., William G.	
		US-6498797	12/24/2002	Anerousis, Nikolaos et al.	
		US-6546253	04/08/2003	Chow, Albert et al.	
		US-6611755	08/26/2003	Coffee, John R., et al.	
		US-6633835	10/14/2003	Moran, Mike et al.	
		US-6674368	01/06/2004	Hawkins, Dale K., et al.	
		US-6708028	03/16/2004	Byrne, John D.	
		US-6716101	04/06/2004	Meadows, Vernon	
		US-6731212	05/04/2004	Hirose, Yuuki et al.	
		US-6732090	05/04/2004	Shanahan, James G., et al.	
		US-6735630	05/11/2004	Gelvin, David C., et al.	
		US-6747561	06/08/2004	Reeves, William F., et al.	
		US-6754470	06/22/2004	Hendrickson, Keith et al.	
		US-6768942	07/27/2004	Chojnacki, Robert	

**EXAMINER**

**DATE CONSIDERED**

Substitute Disclosure Statement Form (PTO-1449)  
\* EXAMINER: Initial if reference considered, whether or not citation is in conformance with MPEP 609. Draw line through citation if not in conformance and not considered. Include copy of this form with next communication to applicant. 1 Applicant's unique citation designation number (optional) 2 Applicant is to place a check mark here if English language Translation is attached

Substitute for form 1449A/PTO  <b>INFORMATION DISCLOSURE STATEMENT BY APPLICANT</b>  (Use as many sheets as necessary)		<i>Complete if Known</i>	
		<b>Application Number</b>	12/419,451
		<b>Filing Date</b>	April 7, 2009
		<b>First Named Inventor</b>	Scalisi, Joseph
		<b>Art Unit</b>	2618
		<b>Examiner Name</b>	Unknown
Sheet	4	of	6
Attorney Docket No: LB1-006USC1			

US PATENT DOCUMENTS					
Examiner Initial *	Cite No	Document Number	Publication Date	Name of Patentee or Applicant of Cited Document	Filing Date If Appropriate
		US-6778089	08/17/2004	Yoakum, Jay	
		US-6812824	11/02/2004	Goldinger, James et al.	
		US-6819247	11/16/2004	Birnbach, Jeffrey M., et al.	
		US-6833787	12/21/2004	Levi, Andrew E.	
		US-6850252	02/01/2005	Hoffberg, Steven M.	
		US-6859533	02/22/2005	Wang, Xin et al.	
		US-6879244	04/12/2005	Scalisi, Joseph F.	
		US-6882897	04/19/2005	Fernandez, Dennis S.	
		US-6928280	08/09/2005	Xanthos, James et al.	
		US-6937726	08/30/2005	Wang, Xin	
		US-6952181	10/04/2005	Karr, Charles L., et al.	
		US-6975941	12/13/2005	Lau, Chung	
		US-6978021	12/20/2005	Chojnacki, Robert	
		US-6988026	01/17/2006	Breed, David S.	
		US-6992584	01/31/2006	Dooley, Saul R., et al.	
		US-6998985	02/14/2006	Reisman et al.	
		US-6998995	02/14/2006	Nakajima, Yutaka	
		US-7020701	03/28/2007	Gelvin, David C., et al.	
		US-7038590	05/02/2006	Hoffman, Mark et al.	
		US-7049957	05/23/2006	Watson, Mitchell L.	
		US-7064711	06/20/2006	Strickland, Stuart et al.	
		US-7065244	06/20/2006	Akimov, Vassili A.	
		US-7065348	06/20/2006	Aoki, Hidehiko et al.	
		US-7065370	06/20/2006	Ogaki, Tadao et al.	
		US-7079650	07/18/2006	Knudsen, Erik	
		US-7088242	08/08/2006	Aupperle, Bryan E., et al.	
		US-7088252	08/08/2006	Weekes, David	
		US-7109868	09/19/2006	Yoakum, Jay	
		US-7119669	10/10/2006	Lundsgaard, Soren K., et al.	
		US-7120928	10/10/2006	Sheth, Dinesh et al.	
		US-7139396	11/21/2006	Montgomery, Peter L., et al.	
		US-7146367	12/05/2006	Shutt, Michael J.	
		US-7149189	12/12/2006	Huntington, Stephen G., et al.	
		US-7155238	12/26/2006	Katz, Daniel A.	
		US-7158912	01/02/2007	Vock, Curtis A., et al.	

**EXAMINER**

**DATE CONSIDERED**

Substitute Disclosure Statement Form (PTO-1449)  
\* EXAMINER: Initial if reference considered, whether or not citation is in conformance with MPEP 609. Draw line through citation if not in conformance and not considered. Include copy of this form with next communication to applicant. 1 Applicant's unique citation designation number (optional) 2 Applicant is to place a check mark here if English language Translation is attached

Substitute for form 1449A/PTO  <b>INFORMATION DISCLOSURE STATEMENT BY APPLICANT</b>  (Use as many sheets as necessary)				<i>Complete if Known</i> <b>Application Number</b> 12/419,451 <b>Filing Date</b> April 7, 2009 <b>First Named Inventor</b> Scalisi, Joseph <b>Art Unit</b> 2618 <b>Examiner Name</b> Unknown	
Sheet	5	of	6	Attorney Docket No: LB1-006USC1	

US PATENT DOCUMENTS					
Examiner Initial *	Cite No	Document Number	Publication Date	Name of Patentee or Applicant of Cited Document	Filing Date If Appropriate
		US-7181192	02/20/2007	Panasik, Carl M., et al.	
		US-7200673	04/03/2007	Augart, Steven	
		US-7218242	05/15/2007	Scalisi, Joseph F., et al.	
		US-7246007	07/17/2007	Ferman, Martin A., et al.	
		US-7257836	08/14/2007	Moore, Timothy M.	
		US-7272212	09/18/2007	Eberle, Hannes et al.	
		US-7272662	09/18/2007	Chesnais, Pascal et al.	
		US-7284191	10/16/2007	Grefenstette, Gregory T., et al.	
		US-7299277	11/20/2007	Moran, Mike et al.	
		US-7302634	11/27/2007	Lucovsky, Mark H., et al.	
		US-7313825	12/25/2007	Redlich, Ron M., et al.	
		US-7571628	08/11/2009	D'Anieri, Marissa S.	
		US-7598855	10/06/2009	Scalisi, Joseph F.	
		US-7612663	11/03/2009	Sun, Chun-I	
		US-7626499	12/01/2009	Burneske, Gregory W., et al.	
		US-7728724	06/01/2010	Scalisi, Joseph F., et al.	
		US-7823424	11/02/2010	Shabtay, Yaniv et al.	
		US-7926314	04/19/2011	Tollefson, Dale A.	

FOREIGN PATENT DOCUMENTS					
Examiner Initials*	Cite No	Foreign Patent Document	Publication Date	Name of Patentee or Applicant of cited Document	T <sup>2</sup>
		WO-2007107022	09/27/2007	Krisl, Michal	

OTHER DOCUMENTS -- NON PATENT LITERATURE DOCUMENTS			
Examiner Initials*	Cite No <sup>1</sup>	Include name of the author (in CAPITAL LETTERS), title of the article (when appropriate), title of the item (book, magazine, journal, serial, symposium, catalog, etc.), date, page(s), volume-issue number(s), publisher, city and/or country where published.	T <sup>2</sup>
		HUFF, GREG H., et al., "Directional Reconfigurable Antennas on Laptop Computers: Simulation, Measurement and Evaluation of Candidate Integration Positions", <u>IEEE Transactions on Antennas</u> , Vol 52, No. 12, (12/2004),pgs 3220-3227	
		FREDRICK, JONATHAN D., et al., "Smart Antennas Based on Spatial Multiplexing of Local Elements (SMILE) for Mutual Coupling Reduction", <u>IEEE Transactions on Antennas and Propagation</u> , Vol. 52, No. 1, (1/2004),pgs 106-114	

**EXAMINER**

**DATE CONSIDERED**

Substitute Disclosure Statement Form (PTO-1449)  
\* EXAMINER: Initial if reference considered, whether or not citation is in conformance with MPEP 609. Draw line through citation if not in conformance and not considered. Include copy of this form with next communication to applicant. <sup>1</sup> Applicant's unique citation designation number (optional) <sup>2</sup> Applicant is to place a check mark here if English language Translation is attached

Substitute for form 1449A/PTO  <b>INFORMATION DISCLOSURE STATEMENT BY APPLICANT</b>  (Use as many sheets as necessary)				<i>Complete if Known</i> <b>Application Number</b> 12/419,451 <b>Filing Date</b> April 7, 2009 <b>First Named Inventor</b> Scalisi, Joseph <b>Art Unit</b> 2618 <b>Examiner Name</b> Unknown	
Sheet	6	of	6	Attorney Docket No: LB1-006USC1	

OTHER DOCUMENTS -- NON PATENT LITERATURE DOCUMENTS			
Examiner Initials*	Cite No <sup>1</sup>	Include name of the author (in CAPITAL LETTERS), title of the article (when appropriate), title of the item (book, magazine, journal, serial, symposium, catalog, etc.), date, page(s), volume-issue number(s), publisher, city and/or country where published.	T <sup>2</sup>
		"Electric Vehicle (EV) Charging Information", <u>Pasadena Water &amp; Power Website, www.cityofpasadena.net,</u>	
		"Mobile Transmit Diversity", <u>Magnolia Broadband Internet Article, 14 pages</u>	
		HANSEN, MICHAEL "Overmolding: A Multifaceted Medical Device Technology", <u>Medical Device &amp; Diagnostic Industry, (1/2006),5 pages</u>	
		"Material Property Data for Various Thermoplastic Elastomers", <u>MATLAB, (5/29/2007),7 pages</u>	
		MANNION, PATRICK "Antenna Diversity Doubles CDMA Net Capacity", <u>EE Times, (5/12/2003),3 pages</u>	
		BURK, STEVE "Overmolding of Embedded Electronics", <u>Connector Specifier, Retrieved from the Internet at http://cs.pennet.com on May 20, 2007,(4/2001),4 pages</u>	
		SCHUSTER, MIKE et al., "Increasing the Frequency Response of the ADXL Series Accelerometers", <u>Analog Devices Application Note AN-377, (2/2006),1 page</u>	
		"Small and Thin +_5g Accelerometer", <u>Analog Devices - ADXL320, (2004),16 pages</u>	
		MATSAKIS, DEMETRIOS "The Timing Group Delay (TGD) Correction and GPS Timing Basis", <u>Proceedings of the 63rd Annual Meeting of The Institute of Navigation, Cambridge, MA, (April 2007),6 pages</u>	
		"GPS Compass Solutions-Application vs. Accuracy", <u>CEACT Information Systems, (9/13/06),10 pages</u>	
		"ET301 GPS-UAV Development Platform", <u>(7/12/06),11 pages</u>	
		LEMAIRE, CHRISTOPHE "Surface Micromachined Sensors for Vehicle Navigation Systems", <u>Analog Devices, Inc., Retrieved from the Internet from http://www.analog.com/en/content/0,2886,764%255F800%255F8077%255F0,00.html on December 25, 2007.,(12/2007),4 pages</u>	
		LI, XIAOJING et al., "The Complementary Characteristics of GPS and Accelerometer in Monitoring Structural Deformation", <u>ION 2005 Meeting, (2005),9 pages</u>	
		LI, XIAOJING et al., "Full-Scale Structural Monitoring Using an Integrated GPS and Accelerometer System", <u>University of New South Wales, (2/14/2006),15 pages</u>	

**EXAMINER**

**DATE CONSIDERED**

Substitute Disclosure Statement Form (PTO-1449)  
 \* EXAMINER: Initial if reference considered, whether or not citation is in conformance with MPEP 609. Draw line through citation if not in conformance and not considered. Include copy of this form with next communication to applicant. <sup>1</sup> Applicant's unique citation designation number (optional) <sup>2</sup> Applicant is to place a check mark here if English language Translation is attached

(19) World Intellectual Property Organization  
International Bureau



(43) International Publication Date  
27 September 2007 (27.09.2007)

PCT

(10) International Publication Number  
WO 2007/107022 A1

(51) International Patent Classification:

B65G 17/08 (2006.01) B65G 43/00 (2006.01)  
B65G 17/40 (2006.01) B29C 45/14 (2006.01)

(81) Designated States (unless otherwise indicated, for every kind of national protection available): AE, AG, AL, AM, AT, AU, AZ, BA, BB, BG, BR, BW, BY, BZ, CA, CH, CN, CO, CR, CU, CZ, DE, DK, DM, DZ, EC, EE, EG, ES, FI, GB, GD, GE, GH, GM, GT, HN, HR, HU, ID, IL, IN, IS, JP, KE, KG, KM, KN, KP, KR, KZ, LA, LC, LK, LR, LS, LT, LU, LY, MA, MD, MG, MK, MN, MW, MX, MY, MZ, NA, NG, NI, NO, NZ, OM, PG, PH, PL, PT, RO, RS, RU, SC, SD, SE, SG, SK, SL, SM, SV, SY, TJ, TM, TN, TR, TT, TZ, UA, UG, US, UZ, VC, VN, ZA, ZM, ZW.

(21) International Application Number:

PCT/CH2007/000140

(22) International Filing Date: 15 March 2007 (15.03.2007)

(25) Filing Language: English

(26) Publication Language: English

(30) Priority Data:

11/385,153 21 March 2006 (21.03.2006) US

(71) Applicant (for all designated States except US): HAB-ASIT AG [CH/CH]; Römerstrasse 1, CH-4153 Reinach (CH).

(72) Inventor; and

(75) Inventor/Applicant (for US only): KRISL, Michal [CH/CH]; J.J. Balmer-Str. 10, CH-4053 Basel (CH).

(74) Agent: BOHEST INTELLECTUAL PROPERTY; A. Braun Braun Héritier Eschmann AG, Holbeinstrasse 36-38, CH-4051 Basel (CH).

(84) Designated States (unless otherwise indicated, for every kind of regional protection available): ARIPO (BW, GH, GM, KE, LS, MW, MZ, NA, SD, SL, SZ, TZ, UG, ZM, ZW), Eurasian (AM, AZ, BY, KG, KZ, MD, RU, TJ, TM), European (AT, BE, BG, CH, CY, CZ, DE, DK, EE, ES, FI, FR, GB, GR, HU, IE, IS, IT, LT, LU, LV, MC, MT, NL, PL, PT, RO, SE, SI, SK, TR), OAPI (BF, BJ, CF, CG, CI, CM, GA, GN, GQ, GW, ML, MR, NE, SN, TD, TG).

Published:

— with international search report

For two-letter codes and other abbreviations, refer to the "Guidance Notes on Codes and Abbreviations" appearing at the beginning of each regular issue of the PCT Gazette.

(54) Title: MODULAR CONVEYOR BELT WITH RFID

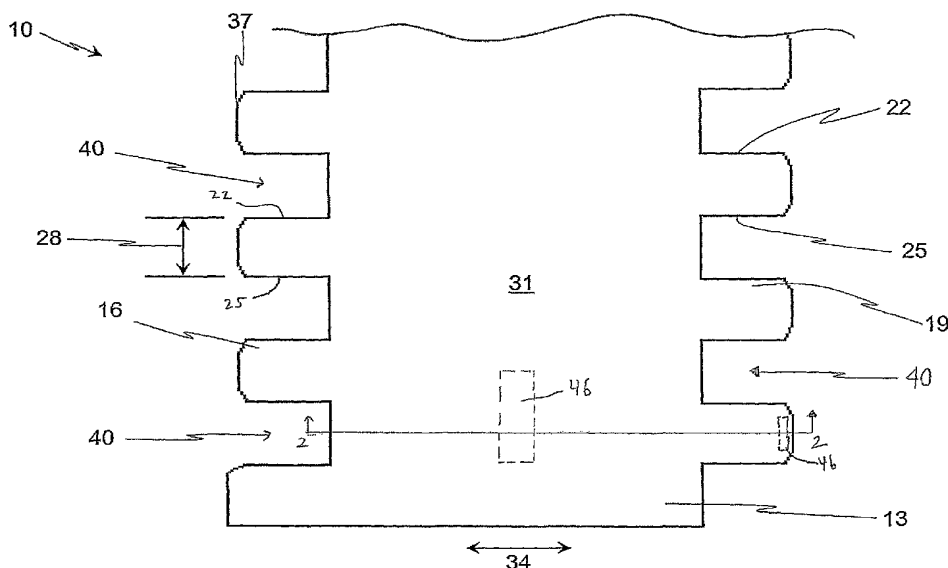

(57) Abstract: A belt module (10) has an intermediate section (31), a first plurality of link ends (16) extending from the intermediate section (31) in a direction of belt travel (34), and a second plurality of link ends (19) extending from the intermediate section (31) in a direction opposite to the first link ends (16). The first and second plurality of link ends (16, 19) have transverse pivot rod openings defined therein. The second plurality of link ends (19) is offset from the first plurality of link ends (16) such that adjacent belt modules (10) can be intercalated and connected by a pivot rod disposed through the transverse openings. The belt module (10) includes at least one RFID transponder (46) disposed in at least one of the plurality of link ends (16, 19), the intermediate section (31), the pivot rod, or an attachment for use with the belt module (16).

WO 2007/107022 A1



MODULAR CONVEYOR BELT WITH RFID

**FIELD OF THE INVENTION**

[0001] This invention relates to conveyor belts and, more particularly, to modular conveyor belts having at least one radio frequency identification device.

**BACKGROUND OF THE INVENTION**

[0002] Conveyor belts, particularly modular belts, are widely used to transport goods in production lines, distribution centers and the like. In such premises, it is often necessary and desirable to provide each individual conveyed article with specific information which is needed to correctly pack, label and ship the article to an end user.

[0003] To facilitate automatic and efficient information transmission at various positions throughout a conveying system, radio frequency identification devices (RFIDs) may be tagged to the goods, thus providing an ability to identify and track the goods by an external electronic reading device.

[0004] One disadvantage of this method is a required tagging of each good being conveyed, the RFID tag being attached directly to or very near the good. Another disadvantage associated with tagging each good is the requirement to either remove each RFID tag so it may be reused or leave the RFID tag attached to the good and lose the tag altogether. If the goods being conveyed are high volume items, the need to attach and later remove or lose the RFID tag may have high labor and/or resource requirements.

[0005] Another circumstance where RFID tags may be utilized is in a tracking or monitoring of information relating to the conveyor belt itself. Such information may be utilized to correctly identify each conveyor system, track characteristics or properties of each conveyor system and control cleaning cycles for or maintenance information relating to the conveyor system. Until the present, such information has been maintained on disparate systems, such as logbooks, offline computer systems and the like.

#### **SUMMARY OF THE INVENTION**

[0006] In order to eliminate the above shortcomings, a new system for integrated identification on conveyor belts is proposed. RFID tags may be attached to or implanted within the belt module or pivot rod, thus serving to identify a conveyed item on a conveyor belt without a need to attach the RFID tag to the conveyed item itself. Additionally, when the conveyed item is offloaded from the conveyor belt, information contained in or associated with the RFID tag and/or to the conveyed item may be erased or reset such that the RFID may be capable of being reused. Additionally, the RFID tag may be used for identification of the conveyor belt itself, providing various information such as, but not limited to, belt type, product line and lifetime maintenance cycles.

[0007] In one embodiment of the invention, RFID tags may be coupled to a belt module by preparing small cavities in the belt module or pivot rod. The RFID tag may then be inserted and fixed in the cavity.

[0008] In an alternative embodiment of the invention, RFID tags may be directly molded into the belt module in

such a way that the RFID tags may be completely covered by the module body and protected against fluid and mechanical contact. This embodiment may be suitable to the fabrication of belt modules with integral RFID tags as many belt modules are injection molded. By utilizing this technique, one or more RFID tags may be positioned anywhere within the belt module, such as, but not limited to, below the belt, in a link pin, within link ends, near the edges of the module or under the conveying surface. Another advantage of molding the RFID tag integral with the belt module is that the RFID tag may not be easily lost, damaged or tampered with.

**[0009]** Conveyor belt modules may be assembled to meet any requirement, purpose or cost. Typically, belt modules containing RFID tags may be limited to a number necessary to provide maximum information at a minimum of cost. In one embodiment, belt modules containing RFID tags may be introduced at various positions throughout the conveyor belt to denote information such as, but not limited to, item types, temperature, humidity, pressure, tension, item location or belt measurement. In another embodiment, belt modules having RFID tags may comprise every or nearly every belt module of the conveyor system. This configuration may provide similar information as listed above with finer resolution.

**[0010]** The present invention meets the above-described need by providing a belt module, a modular belt system and a method for providing a component for a modular conveyor belt according to independent claims 1, 15 and 20. Preferred embodiments are defined in the dependent claims.

[0011] In particular, the present invention meets the above-described need by providing a belt module with a base portion having a first end, a second end, and an intermediate section extending in a transverse direction from the first end to the second end. The module includes a first plurality of link ends extending from the intermediate section in a direction of belt travel substantially perpendicular to the transverse direction. Each of the first plurality of link ends has first openings that are aligned in the transverse direction. The module includes a second plurality of link ends extending from the intermediate section in a direction opposite to the first link ends. The second plurality of link ends each have second openings aligned in the transverse direction. The module has at least one RFID tag embedded within or attached to the module.

#### **BRIEF DESCRIPTION OF THE DRAWINGS**

[0012] The invention is illustrated in the drawings in which like reference characters designate the same or similar parts throughout the figures of which:

[0013] FIG. 1 is a top plan view of a section of a belt module with RFID devices;

[0014] FIG. 2 is a side cross-sectional view taken along line 2-2 of FIG. 1;

[0015] FIG. 3 is a side view of a pivot rod with at least one RFID device implanted in various locations throughout the pivot rod;

[0016] FIGS. 4A to 4C show a diagrammatic section through an injection molding apparatus suitable for manufacturing a module for a modular conveyor belt according to the present invention;

[0017] FIG. 5 is a top plan view of a flush grid belt module;

[0018] FIG. 6 is a bottom plan view of the module shown in FIG. 5;

[0019] FIG. 7A is a side elevation view showing a snap-on hold down tab in an exploded view;

[0020] FIG. 7B is a side elevation view showing the snap-on hold down tab installed in the module;

[0021] FIG. 8 is a perspective view of a module with snap-on side guards having RFID tags; and,

[0022] FIG. 9 is a perspective view of a module with flights containing RFID tags.

#### **DETAILED DESCRIPTION OF THE INVENTION**

[0023] Referring to FIGS. 1-3 generally and initially to FIGS. 1 and 2, the belt module 10 of the present invention includes a top surface 13. The module 10 has a first plurality of link ends 16 and a second plurality of link ends 19 disposed opposite from the first link ends 16. The first plurality of link ends 16 have opposed side walls 22, 25 that provide a transverse thickness 28 connected to an intermediate section 31 which has a top surface 13 that may be substantially rectangular in plan view. The transverse thickness 28 extends in a direction of belt travel 34 from the intermediate section 31 to a first distal portion 37. The second plurality of link ends 19 have similar geometry except they extend opposite to the first plurality of link ends 16 in the direction of belt travel indicated by arrow 34. As will be evident to those of ordinary skill in the art based on this

disclosure, the belt module 10 may be driven in either direction along arrow 34.

**[0024]** The link ends 16 and 19 are offset in a direction transverse to the direction of belt travel 34. Accordingly, adjacent modules 10 can be positioned such that the link ends 16 fit in the spaces 40 disposed between link ends 19, and link ends 19 fit in the spaces 40 disposed between link ends 16. The link ends 16, 19 have transverse openings 41 and 43 (FIG. 2) that extend through the transverse thickness 28 between and to the opposed side walls 22, 25. As will be evident to those of ordinary skill in the art, modules 10 can be positioned such that link ends 16 and 19 are intercalated with the link ends 16 and 19 of an adjacent module 10. The side-by-side and intercalated modules 10 can then be connected by pivot rods to provide an endless belt capable of articulating about a sprocket to form a conveying system.

**[0025]** Module 10 may be formed out of plastic or other materials suitable for many applications including conveying of food products. The material may be lightweight, non-corrosive, and easily cleaned. The module 10 may be thermoformed from a plastic resin raw material as known to those of ordinary skill in the art.

**[0026]** As shown in Figs. 1 and 2, the RFID tags 46 may be disposed on the module 10 in many locations including, but not limited to, the link ends 16, 19; the intermediate section 31; or the like.

**[0027]** In another embodiment of the invention shown in Fig. 3, RFID tags 46 may be integrated into a head 52 or a shaft 55 of a pivot rod 58. The integration can be

performed by insertion into a machined or pre-molded cavity or by a molding process. Because the pivot rods are very versatile and can be used to assemble various types of modular belts for different applications, it is possible to produce a series of such rods equipped with RFID's and to keep the rods in stock to be used for assembly of a customized belt where needed. The RFID may be integrated in any location of the rod, but preferably near one end or both ends of the rod. Rods with RFID's can then be installed in each link or in every second, third, etc. link or in any greater distance. If there is a defect, the pivot rod can be easily and inexpensively replaced.

**[0028]** The RFID tags 46 may be integrated into the module 10 in a variety of ways. Returning to FIG. 2, in one embodiment of the present invention, a recess 49 may be formed in the module 10 by drilling or machining such that the recess 49 is capable of receiving an RFID tag 46. The RFID tag 46 may be secured in the recess 49 by filling the recess 49 with a cross-linked or hot melt adhesive 50.

**[0029]** In an alternative embodiment of the invention, RFID tags 46 may be directly molded into the module 10 in such a way that the RFID tags 46 may be completely covered by the module 10 and protected against fluid and mechanical contact. This embodiment may be suitable to the fabrication of belt modules with integral RFID tags 46 as many belt modules 10 are injection molded. RFID tags suitable for injection molding may be obtained from UPM Rafsec of Tampere, Finland and other sources. By utilizing this technique, one or more RFID tags 46 may be positioned anywhere within the module 10, such as, but not limited to, below the module 10, in a pivot rod 58,

within link ends 16, 19, near the edges of the module or under the conveying surface. Another advantage of molding the RFID tag 46 integral with the module 10 is that the RFID tag 46 may not be easily lost, damaged or tampered with.

**[0030]** Figs. 4A to 4C show a molding apparatus 110 including a mold 111 for making a module for a modular conveyor belt according to the present invention. The mold 111 for producing the modules 10 includes first and second mating mold halves 111A, 111B forming a mold cavity 116 for receiving a plastic melt from an injection unit 118. The mating mold halves 111A, 111B are mounted on a stationary platen 120 and a moving platen 122, respectively. The stationary platen 120, moving platen 122 and injection unit 118 are supported by a common base 124. The mold 111 includes a sprue channel 126 through the first mold half 111A which is in fluid flow communication with a nozzle 128 on the injection unit 118 when material is injected into the mold cavity 116. The nozzle 128 is equipped with a shut-off valve (not shown) of the type that is well known in the art.

**[0031]** The injection unit 118 has a barrel 130 which includes a feed screw 132 of a configuration that is typical for injection molding. The feed screw is controlled to reciprocate in the barrel 130 to plasticize and inject plastic into the mold 111. The injection unit 118 is equipped with means, such as a hydraulic cylinder (not shown) to move the unit 118 linearly toward and away from the mold 111. More specifically, the injection unit 118 is moved against the mold 111 for injection, then is retracted away from the mold 111 and stationary platen 120.



[0032] A cycle of operation for the production of a module made by a molding method according to the present invention will now be described with respect to Figs. 4A to 4C. The injection unit 118 is retracted to a rearward position (Fig. 4A), that provides clearance between the stationary platen 120 and the nozzle 128. The injection unit 118 plasticizes a sufficient quantity of the material 140 by rotating and retracting the feed screw 132 in a conventional manner so a full shot of melt is prepared.

[0033] An RFID tag is placed inside the dedicated cavity 116 of the mold 111. The RFID tag is kept in position by a mechanical holder or by a vacuum device as will be evident to those of ordinary skill in the art based on this disclosure.

[0034] The injection unit 118 moves forward to a position where the nozzle 128 communicates with the sprue channel 126 of the mold 111. As shown in Fig. 4C, the injection unit 118 then injects the polymeric material into the mold 111 by advancing the feed screw 132 in a manner typical of the injection molding process. The injected plastics surround the RFID tag while filling the cavity 116. If present, the mechanical holder is withdrawn before the full freezing of the plastic. After cooling, the two mold halves open and the piece, with the RFID tag embedded, can be removed. As will be evident to those of ordinary skill in the art based on this disclosure, mold 116 may be shaped to form a module 10 or other shape such as a pivot rod 58.

[0035] Turning to FIGS. 5 and 6, one example of the present invention is shown in connection with a flush grid belt module 200. In FIG. 5, the upper conveying

surface 203 is shown. Vertical openings 206 are disposed on the module 200 and may extend from the intermediate section 209 toward the distal end 212 of the link ends 215. The link ends 215 are separated by spaces 218 that receive link ends 221 on adjacent modules. Each link end 215 has a transverse pivot rod opening 224 capable of aligning with transverse pivot rod openings 225 on intercalated link ends 221. Insertion of the pivot rod (not shown) connects adjacent modules 200 to form an endless belt capable of articulating about a sprocket. A cavity 230 may be formed at any suitable location on the module 200. In the example shown, the cavity 230 is located near the edge of module 200. The cavity 230 may be produced in many ways such as by drilling, milling, pre-molding, or the like. An RFID tag 233 is inserted into the cavity 230 and held in position by mechanical means such as a friction fit, engagement with protuberances inside the cavity 230, or the like. Other means for securing the RFID tag 233 such as cross-linked or hot melt adhesives, or the like, may also be suitable.

**[0036]** Another embodiment of the invention is shown in FIG. 7A. A module 300 has link ends 303 with spaces 304 disposed therebetween for receiving link ends from an adjacent module. The module 300 includes a snap-on hold down tab 306. The hold down tab 306 engages with an opening in the module 300 located near the edge 309. The tab 306 has a protruding portion 312 that forms a shoulder 315. The tab 306 can be pushed in the direction of arrow 318 until it snaps into place in the opening in the end of the module 300. An RFID tag 316 is disposed on the tab 306. As described above in connection with other embodiments, the RFID tag 316 may be integrated into the tab 306 in a variety of ways. A recess may be

formed by drilling, milling, pre-molding or the like. The RFID tag 316 may be secured in the recess by adhesives or the like or by mechanical means. Also, the RFID tag 316 may be integrally molded as described above.

**[0037]** As shown in FIG. 7B, after it is attached to the module 300, the hold down tab 306 has a projection 325 that extends substantially parallel to the conveying surface 328. The projection 325 engages with a guide (not shown) that fits into the space 329 between the bottom surface 330 of the module 300 and the projection 325.

**[0038]** In Fig. 8, a module 400 is shown with snap-on side guards 403 having RFID tags 406 disposed thereon. The side guards 403 fit into openings 409 located near the edge 412 of the module 400. The RFID tag 406 may be integrated into the side guard 403 by means of a recess or by being molded integrally as described above.

**[0039]** Turning to Fig. 9, a module 500 is shown with flights 503 that extend upward from the conveying surface 506. Flights 503 may be formed integrally with the module 500 during the injection molding process. Alternatively, the flights may be formed from a separate component that is attached to the module. The flights may be formed separately from similar materials to the module such as a hard plastic or the flights may be formed from softer, resilient materials. The separate flights may be attached to the modules in various ways as will be evident to those of ordinary skill in the art based on this disclosure.

**[0040]** The flights 503 may be provided with RFID tags 509. As discussed previously, the RFID tags 509 may be

integrated into the flights 503 by means of recesses formed in the flights or by co-molding the RFID tags 509 into the modules 500 as an integral part of the flights 503.

**[0041]** While the invention has been described in connection with certain embodiments, it is not intended to limit the scope of the invention to the particular forms set forth, but, on the contrary, it is intended to cover such alternatives, modifications, and equivalents as may be included within the scope of the invention as defined by the appended claims.

CLAIMS

1. Belt module (10; 200; 300; 400; 500), comprising:  
a body having an intermediate section (31; 209), the  
5 body having a first plurality of link ends (16; 215; 303)  
extending from the intermediate section (31; 209) in a  
direction of belt travel (34), the first plurality of  
link ends (16; 215; 303) each having first transverse  
pivot rod openings (41; 224) defined therein, the body  
10 having a second plurality of link ends (19; 221)  
extending from the intermediate section (31; 209) in a  
direction opposite to the first link ends (16; 215; 303),  
the second plurality of link ends (19; 221) each having  
second transverse pivot rod openings (43; 225) defined  
15 therein, the second plurality of link ends (19; 221)  
being offset from the first plurality of link ends (16;  
215; 303) such that adjacent belt modules (10; 200; 300;  
400; 500) can be intercalated; and  
at least one RFID transponder (46; 233; 316; 406;  
20 509) disposed on the module (10; 200; 300; 400; 500).
2. Belt module (10; 200; 300; 400; 500) according to  
claim 1, wherein the RFID transponder (46; 233; 316; 406;  
509) is capable of receiving a signal.
3. Belt module (10; 200; 300; 400; 500) according to  
25 claim 1 or 2, wherein the RFID transponder (46; 233; 316;  
406; 509) is capable of transmitting a signal.
4. Belt module (10; 200; 300; 400; 500) according to  
one of claims 1 to 3, wherein the RFID transponder (46;  
233; 316; 406; 509) is disposed inside a bore (49; 230)  
30 formed in the body.

5. Belt module (10; 200; 300; 400; 500) according to one of claims 1 to 3, wherein the RFID transponder (46; 233; 316; 406; 509) is molded integrally into the body.
6. Belt module (500) according to one of claims 1 to 5,  
5 comprising a flight (503) extending from the intermediate section.
7. Belt module (500) according to claim 6, wherein the RFID transponder (509) is disposed on the flight (503).
8. Belt module (300; 400) according to one of claims 1  
10 to 5, wherein the body has at least one opening (409) for receiving an attachment (306; 403).
9. Belt module (300; 400) according to claim 8, wherein the RFID transponder (316; 406) is disposed on the attachment (306; 403).
- 15 10. Belt module (400) according to claim 8 or 9, wherein the attachment comprises a side guard (403).
11. Belt module (300) according to claim 8 or 9, wherein the attachment comprises a hold down tab (306).
12. Belt module (10; 200) according to one of claims 1  
20 to 11, wherein the RFID transponder (46; 233) or at least one of the RFID transponders (46; 233) is disposed on the intermediate section (31; 209).
13. Belt module (10; 200) according to claim 12, wherein the RFID transponder (46; 233) is disposed inside a bore  
25 (49; 230) formed in the intermediate section (31; 209).
14. Belt module (10; 200) according to claim 12, wherein the RFID transponder (46; 233) is molded integrally into the intermediate section (31; 209).

15. Modular belt system, including:

a plurality of belt modules (10; 200; 300; 400; 500) having an intermediate section (31; 209) and having a plurality of first link ends (16; 215; 303) extending  
5 outwardly from the intermediate section (31; 209) in a direction of belt travel (34) and having a plurality of second link ends (19; 221) extending outwardly from the intermediate section (31; 209) in the opposite direction, the first and second link ends (16, 19; 215, 221; 303)  
10 having transverse pivot rod openings (41, 43; 224, 225) defined therein; and,

a pivot rod (58) extending transverse to the direction of belt travel (34) through the openings (41; 224) in the first link ends (16; 215; 303) of one of the  
15 plurality of belt modules (10; 200; 300; 400; 500) and extending through the openings (43; 225) in the second link ends (19; 221) of an adjacent belt module (10; 200; 300; 400; 500) such that the first and second link ends (16, 19; 215, 221; 303) of the adjacent belt modules (10;  
20 200; 300; 400; 500) are intercalated into adjacent hinged rows, the pivot rod (58) having at least one RFID transponder (46) therein.

16. Modular belt system according to claim 15, wherein the RFID transponder (46) is capable of receiving a  
25 signal.

17. Modular belt system according to claim 15 or 16, wherein the RFID transponder (46) is capable of transmitting a signal.

18. Modular belt system according to one of claims 15 to  
30 17, wherein the RFID transponder (46) is disposed inside a bore formed in the pivot rod (58).

19. Modular belt system according to one of claims 15 to 17, wherein the RFID transponder (46) is molded integrally into the pivot rod (58).

20. Method for providing a component (10; 200; 500; 58; 306; 403) for a modular conveyor belt, comprising:  
5 providing a molding apparatus (110) having an injection unit (118) with a barrel (130) housing a feed screw (132);  
providing a mold (111) with a cavity (116)  
10 configured to the shape of the component (10; 200; 500; 58; 306; 403) being produced;  
positioning at least one RFID transponder (46; 233; 316; 406; 509) in the cavity (116);  
connecting the barrel (130) with the mold (111) and  
15 actuating the feed screw (132) so that polymeric material (140) is injected into the mold (111) around the RFID transponder (46; 233; 316; 406; 509); and,  
removing the component (10; 200; 500; 58; 306; 403) from the mold (111), the component (10; 200; 500; 58; 306; 403) being formed such that the polymeric material  
20 (140) surrounds the RFID transponder (46; 233; 316; 406; 509).

21. Method according to claim 20, wherein the component is a module (10; 200; 500) comprising a first plurality  
25 of link ends (16; 215), a second plurality of link ends (19; 221) and an intermediate section (31; 209) integrally formed with and adjoining the first and second plurality of link ends (16, 19; 215, 221).

22. Method according to claim 20, wherein the component  
30 is a pivot rod (58).



23. Method according to claim 20, wherein the component is an attachment (306; 403).
24. Method according to claim 23, wherein the attachment comprises a side guard (403).
- 5 25. Method according to claim 23, wherein the attachment comprises a hold down tab (306).

Fig. 1

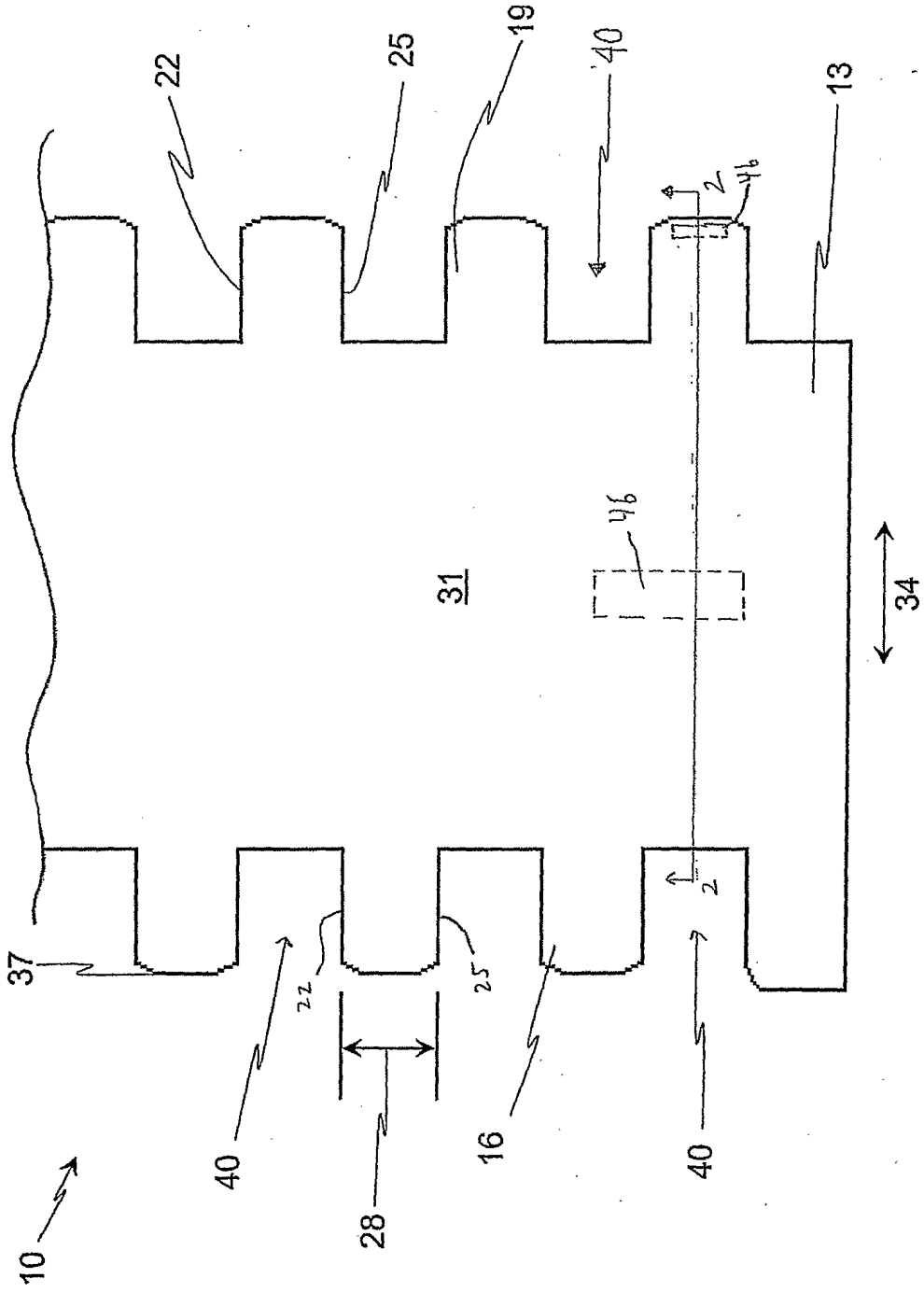
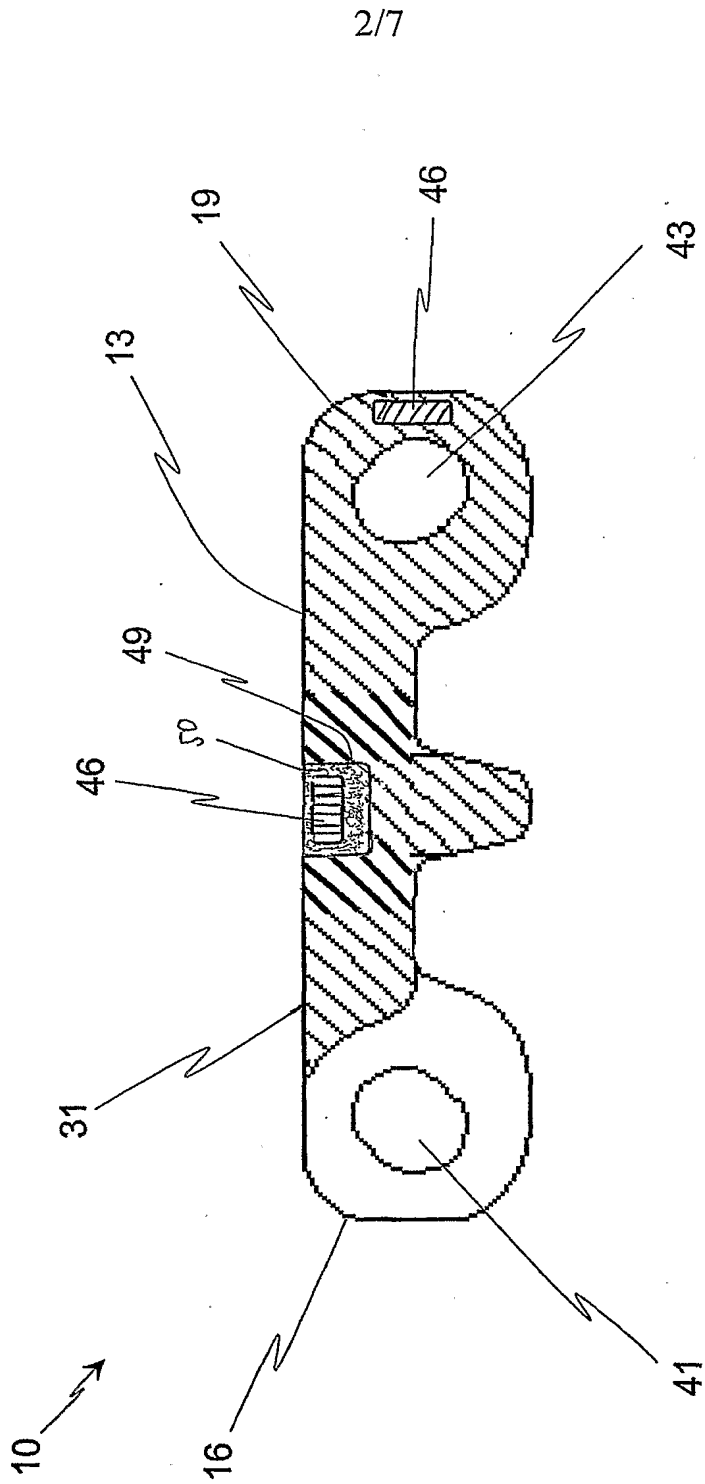
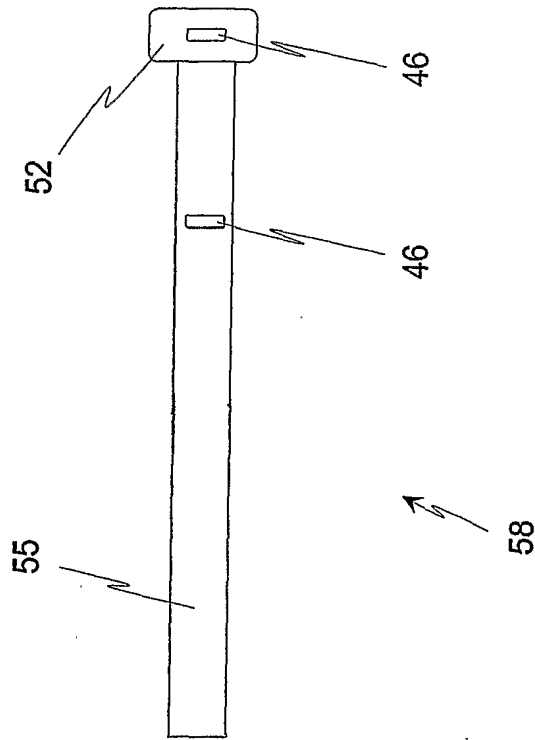

Fig. 2



3/7

Fig. 3



110/

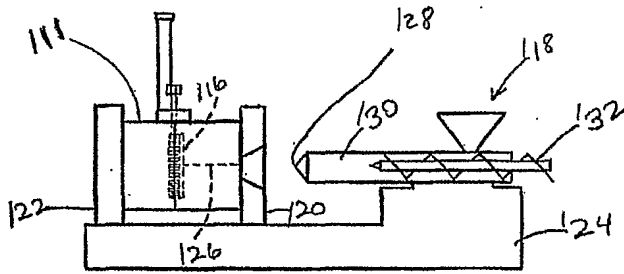

FIG. 4A

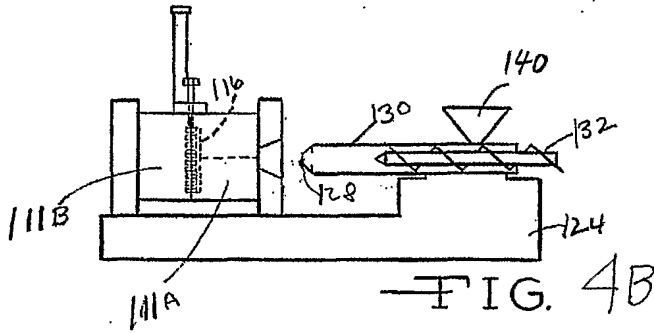

FIG. 4B

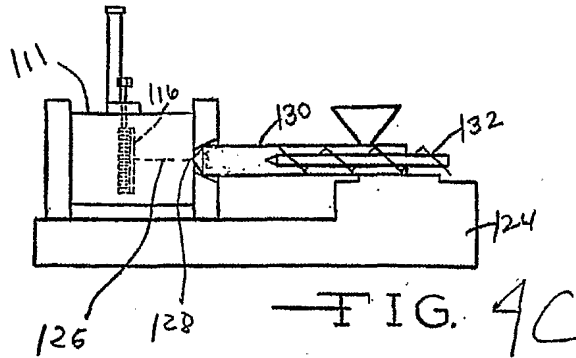

FIG. 4C

5/7

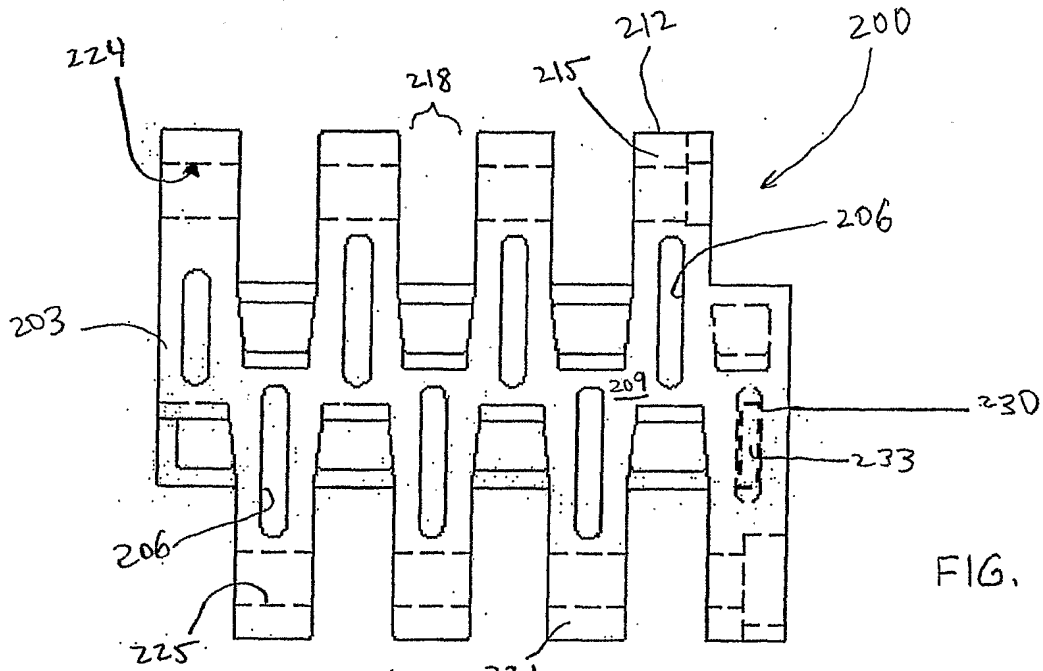

FIG. 5

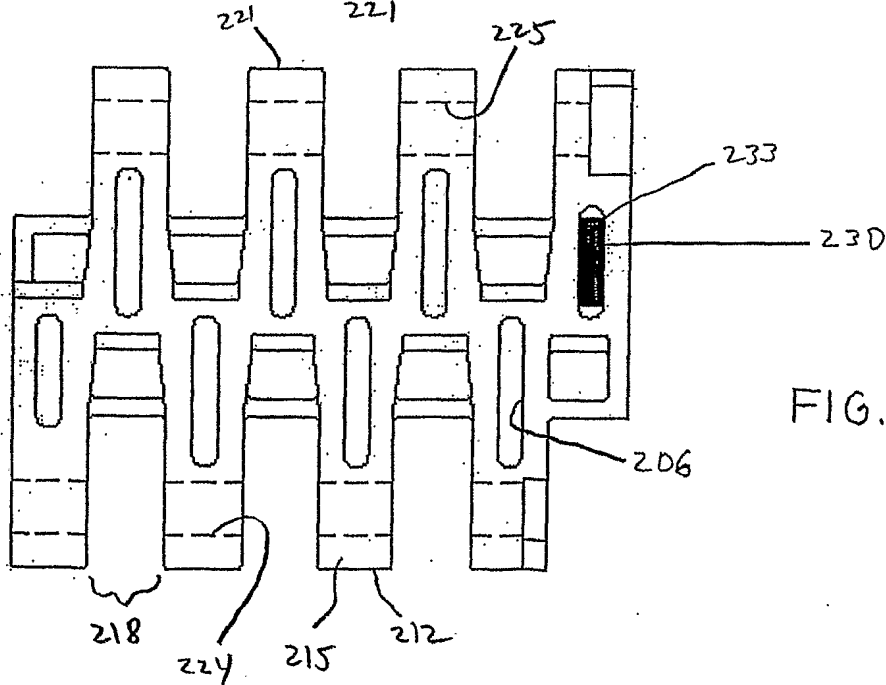

FIG. 6

6/7

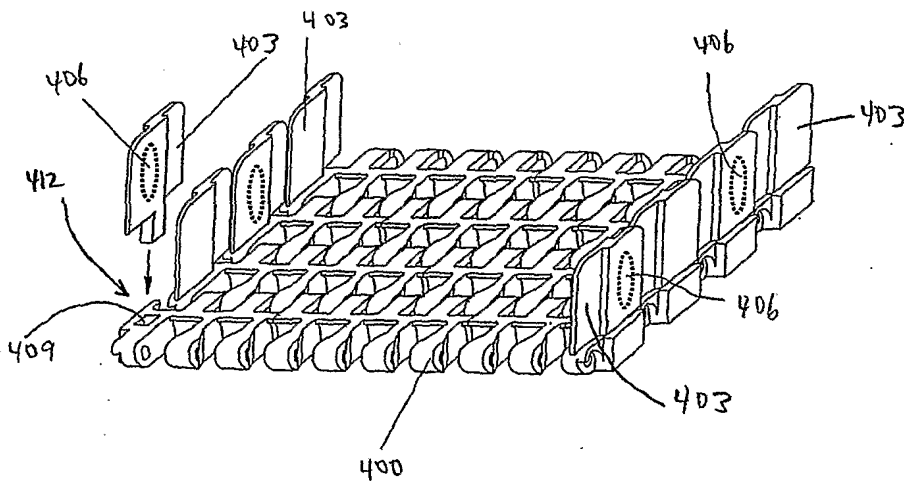
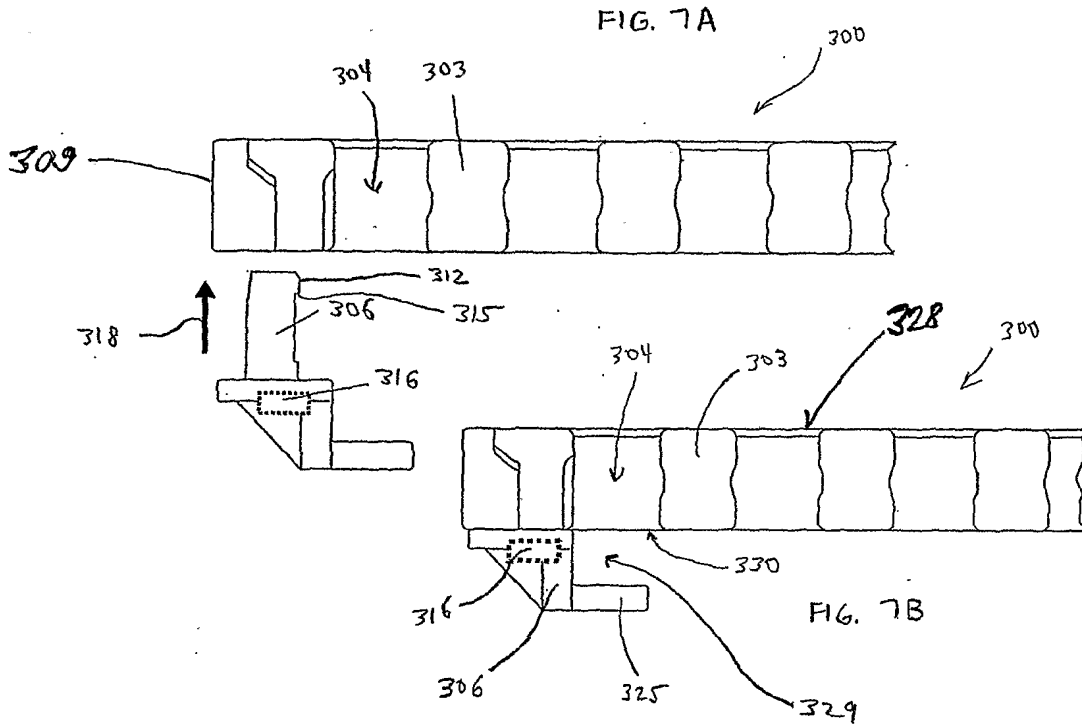

FIG. 8

7/7

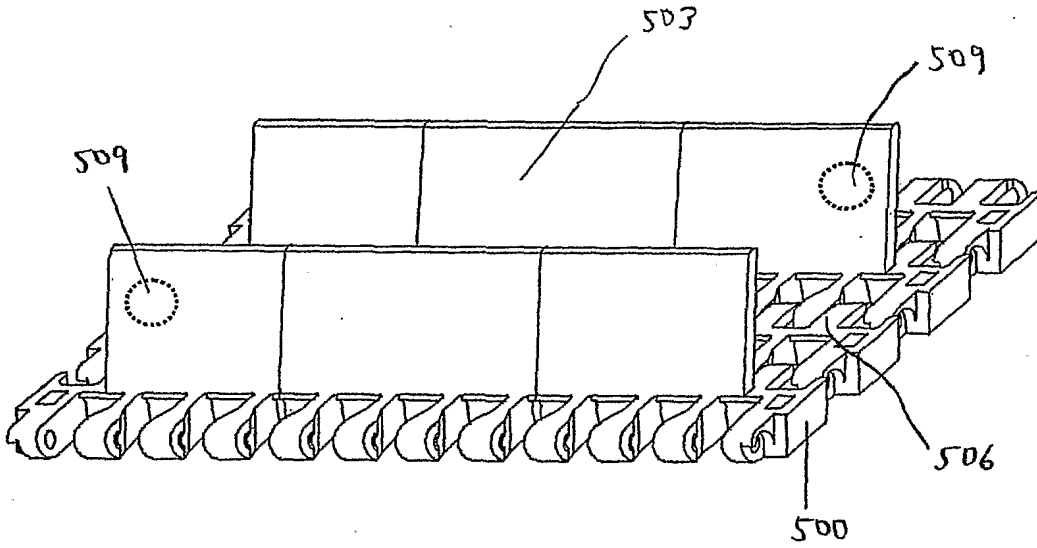

FIG. 9



INTERNATIONAL SEARCH REPORT

International application No  
PCT/CH2007/000140

A. CLASSIFICATION OF SUBJECT MATTER  
INV. B65G17/08 B65G17/40 B65G43/00 B29C45/14

According to International Patent Classification (IPC) or to both national classification and IPC

B. FIELDS SEARCHED

Minimum documentation searched (classification system followed by classification symbols)  
B65G B29C

Documentation searched other than minimum documentation to the extent that such documents are included in the fields searched

Electronic data base consulted during the international search (name of data base and, where practical, search terms used)

EPO-Internal, WPI Data

C. DOCUMENTS CONSIDERED TO BE RELEVANT

Category*	Citation of document, with indication, where appropriate, of the relevant passages	Relevant to claim No.
Y	EP 0 175 483 A1 (LAITRAM CORP [US]) 26 March 1986 (1986-03-26) page 8, line 1 - page 19, line 23 figures 1-24B -----	1-25
Y	DE 202 11 954 U1 (AUMUND FOERDERERBAU GMBH & CO [DE]) 16 January 2003 (2003-01-16)  page 3, line 10 - page 7, line 17 figures 1-3 -----	1-4, 6-13, 15-18
Y	US 2005/053684 A1 (PITSCHENEDER WALTHER [AT] ET AL) 10 March 2005 (2005-03-10) page 1, paragraph 3 - page 2, paragraph 27 figures 1-4 -----	5,14, 19-25
A	US 6 264 577 B1 (HUTCHINS THOMAS GOODSSELL [US]) 24 July 2001 (2001-07-24) the whole document -----	1

Further documents are listed in the continuation of Box C.

See patent family annex.

\* Special categories of cited documents :

- \*A\* document defining the general state of the art which is not considered to be of particular relevance
- \*E\* earlier document but published on or after the international filing date
- \*L\* document which may throw doubts on priority claim(s) or which is cited to establish the publication date of another citation or other special reason (as specified)
- \*O\* document referring to an oral disclosure, use, exhibition or other means
- \*P\* document published prior to the international filing date but later than the priority date claimed

- \*T\* later document published after the international filing date or priority date and not in conflict with the application but cited to understand the principle or theory underlying the invention
- \*X\* document of particular relevance; the claimed invention cannot be considered novel or cannot be considered to involve an inventive step when the document is taken alone
- \*Y\* document of particular relevance; the claimed invention cannot be considered to involve an inventive step when the document is combined with one or more other such documents, such combination being obvious to a person skilled in the art.
- \*Z\* document member of the same patent family

Date of the actual completion of the international search

14 June 2007

Date of mailing of the international search report

25/06/2007

Name and mailing address of the ISA/

European Patent Office, P.B. 5818 Patentlaan 2  
NL - 2280 HV Rijswijk  
Tel. (+31-70) 340-2040, Tx. 31 651 epo nl,  
Fax: (+31-70) 340-3016

Authorized officer

PAPATHEOFRASTOU, M

**INTERNATIONAL SEARCH REPORT**

Information on patent family members

International application No  
PCT/CH2007/000140

Patent document cited in search report		Publication date	Patent family member(s)	Publication date
EP 0175483	A1	26-03-1986	DE 3571020 D1 JP 61145007 A	20-07-1989 02-07-1986
DE 20211954	U1	16-01-2003	NONE	
US 2005053684	A1	10-03-2005	AT 7304 U1 DE 102004043274 A1	25-01-2005 23-06-2005
US 6264577	B1	24-07-2001	NONE	

## Electronic Acknowledgement Receipt

<b>EFS ID:</b>	10211973
<b>Application Number:</b>	12419451
<b>International Application Number:</b>	
<b>Confirmation Number:</b>	1643
<b>Title of Invention:</b>	APPARATUS AND METHOD FOR ADJUSTING REFRESH RATE OF LOCATION COORDINATES OF A TRACKING DEVICE
<b>First Named Inventor/Applicant Name:</b>	Joseph F. Scalisi
<b>Customer Number:</b>	93892
<b>Filer:</b>	Christopher W. Lattin/Melissa Nelson
<b>Filer Authorized By:</b>	Christopher W. Lattin
<b>Attorney Docket Number:</b>	LBTECH.012CP1
<b>Receipt Date:</b>	01-JUN-2011
<b>Filing Date:</b>	07-APR-2009
<b>Time Stamp:</b>	19:14:45
<b>Application Type:</b>	Utility under 35 USC 111(a)

### Payment information:

Submitted with Payment	no
------------------------	----

### File Listing:

Document Number	Document Description	File Name	File Size(Bytes)/ Message Digest	Multi Part /.zip	Pages (if appl.)
1		LB1006USC1IDSasFiled.pdf	201802 <small>52dc326e81c05b24689e53dd323baf776501ead5</small>	yes	8

Multipart Description/PDF files in .zip description					
Document Description			Start	End	
Transmittal Letter			1	2	
Information Disclosure Statement (IDS) Filed (SB/08)			3	8	
<b>Warnings:</b>					
<b>Information:</b>					
2	Foreign Reference	07107022.pdf	941683	no	27
			c9add804ab6196570e9aa691fb534071c337fab4		
<b>Warnings:</b>					
<b>Information:</b>					
3	NPL Documents	HUFF.pdf	666644	no	7
			88d4c291fba7e7eed8002465f71bab87301c14a9		
<b>Warnings:</b>					
<b>Information:</b>					
4	NPL Documents	FREDRICK.pdf	881131	no	10
			f1b066cbc28065091d3f4c537a64373bc5b7f89a		
<b>Warnings:</b>					
<b>Information:</b>					
5	NPL Documents	Pasadena.pdf	227676	no	1
			1429b28944aa0b264f7ed162b69e9981feb4f36		
<b>Warnings:</b>					
<b>Information:</b>					
6	NPL Documents	Magnolia.pdf	827491	no	14
			e2cf9a71a10a5c03f30ce6ed75e457c42645142c		
<b>Warnings:</b>					
<b>Information:</b>					
7	NPL Documents	Hansen.pdf	379048	no	5
			b4bed6405951f00b8089dcad67615552e342aabe		
<b>Warnings:</b>					
<b>Information:</b>					
8	NPL Documents	MATLAB.pdf	202744	no	7
			1af1ad0008818a1538984554756963f950e590fc		
<b>Warnings:</b>					
<b>Information:</b>					

9	NPL Documents	Mannion.pdf	430868	no	3
			c2abcc147be0b7e73e28817a4b587b89615572c6		
<b>Warnings:</b>					
<b>Information:</b>					
10	NPL Documents	Burk.pdf	302069	no	4
			2a3cc5c5715c7fbedd65158da0bb65ede1d6d863		
<b>Warnings:</b>					
<b>Information:</b>					
11	NPL Documents	Shuster.pdf	55196	no	1
			a9894c200fc49328badd10737b0c39d9b41bc403		
<b>Warnings:</b>					
<b>Information:</b>					
12	NPL Documents	AnalogSmallThin.pdf	468535	no	16
			980bca1dc07e9b769ccd4cacaee53d4e5db070d5		
<b>Warnings:</b>					
<b>Information:</b>					
13	NPL Documents	Matsakis.pdf	467893	no	6
			79c826a9f3ca06c17c534afcbef6aac34eb26bb0		
<b>Warnings:</b>					
<b>Information:</b>					
14	NPL Documents	CEACT.pdf	1939643	no	10
			6992fcd9cbfb66b26eb3b66b7669f4d65e2ce30		
<b>Warnings:</b>					
<b>Information:</b>					
15	NPL Documents	DevelopmentPlatform.pdf	598365	no	11
			61103a955bb57e95ade096e2d31ebf4b210920f2		
<b>Warnings:</b>					
<b>Information:</b>					
16	NPL Documents	Lemaire.pdf	258328	no	4
			cd72b29d566147ebb13a4c263032141d52e31025		
<b>Warnings:</b>					
<b>Information:</b>					
17	NPL Documents	Li.pdf	715036	no	9
			9d32be4a2e07fdceddad44d4e35cc8955a084ab		
<b>Warnings:</b>					
<b>Information:</b>					

18	NPL Documents	LiFullScale.pdf	1073213	no	15
			616c42827a88ecbc0ee8114d35a899bc9b9662b7		

**Warnings:**

**Information:**

<b>Total Files Size (in bytes):</b>	10637365
-------------------------------------	----------

**This Acknowledgement Receipt evidences receipt on the noted date by the USPTO of the indicated documents, characterized by the applicant, and including page counts, where applicable. It serves as evidence of receipt similar to a Post Card, as described in MPEP 503.**

**New Applications Under 35 U.S.C. 111**

**If a new application is being filed and the application includes the necessary components for a filing date (see 37 CFR 1.53(b)-(d) and MPEP 506), a Filing Receipt (37 CFR 1.54) will be issued in due course and the date shown on this Acknowledgement Receipt will establish the filing date of the application.**

**National Stage of an International Application under 35 U.S.C. 371**

**If a timely submission to enter the national stage of an international application is compliant with the conditions of 35 U.S.C. 371 and other applicable requirements a Form PCT/DO/EO/903 indicating acceptance of the application as a national stage submission under 35 U.S.C. 371 will be issued in addition to the Filing Receipt, in due course.**

**New International Application Filed with the USPTO as a Receiving Office**

**If a new international application is being filed and the international application includes the necessary components for an international filing date (see PCT Article 11 and MPEP 1810), a Notification of the International Application Number and of the International Filing Date (Form PCT/RO/105) will be issued in due course, subject to prescriptions concerning national security, and the date shown on this Acknowledgement Receipt will establish the international filing date of the application.**

**IN THE UNITED STATES PATENT AND TRADEMARK OFFICE**

Applicant:	Joseph F. Scalisi et al.	Examiner:	Unknown
Serial No.:	12/419,451	Group Art Unit:	2618
Filed:	April 7, 2009	Docket:	LB1-006USC1
Title:	APPARATUS AND METHOD FOR ADJUSTING REFRESH RATE OF LOCATION COORDINATES OF A TRACKING DEVICE		

---

**SUPPLEMENTAL INFORMATION DISCLOSURE STATEMENT**

Commissioner for Patents  
P.O. Box 1450  
Alexandria, VA 22313-1450

In compliance with the duty imposed by 37 C.F.R. § 1.56, and in accordance with 37 C.F.R. §§ 1.97 *et. seq.*, the referenced materials are brought to the attention of the Examiner for consideration in connection with the above-identified patent application. Applicant respectfully requests that this Supplemental Information Disclosure Statement be entered and the documents listed on the attached Form 1449 be considered by the Examiner and made of record. Pursuant to the provisions of MPEP 609, Applicant requests that a copy of the 1449 form, initialed as being considered by the Examiner, be returned to the Applicant with the next official communication.

Pursuant to 37 C.F.R. §1.97(b), it is believed that no fee or statement is required with the Supplemental Information Disclosure Statement.

Pursuant to 37 C.F.R. 1.98(a)(2), Applicant believes that copies of cited U.S. Patents and Published Applications, and Non-Published Applications identifiable by USPTO Serial Number, are no longer required to be provided to the Office. Notification of this change to this effect was provided in the United States Patent and Trademark Office OG Notices dated October 12, 2004 and October 19, 2004. Thus, Applicant has not included copies of any US Patents or US Patent Applications identifiable by serial number that may be cited with this submission. Should the Office require copies to be provided, Applicant respectfully requests that notice of such requirement be directed to Applicant's below-signed representative. Applicant acknowledges the requirement to submit copies of foreign patent documents and non-patent literature in accordance with 37 C.F.R. 1.98(a)(2).

**SUPPLEMENTAL INFORMATION DISCLOSURE STATEMENT**

Serial No :12/419,451

Filing Date: April 7, 2009

Title: APPARATUS AND METHOD FOR ADJUSTING REFRESH RATE OF LOCATION COORDINATES OF A TRACKING DEVICE

---

**Page 2**

Dkt: LB1-006USC1

Respectfully submitted,

Joseph F. Scalisi et al.

By their Representatives,

Date 5/25/2011

By /Christopher Lattin/  
Christopher Lattin  
Reg. No. 56064



Substitute for form 1449A/PTO  <b>INFORMATION DISCLOSURE STATEMENT BY APPLICANT</b>  (Use as many sheets as necessary)		<table border="1" style="width: 100%; border-collapse: collapse;"> <tr> <td colspan="2" style="text-align: right;"><i>Complete if Known</i></td> </tr> <tr> <td style="width: 50%;"><b>Application Number</b></td> <td>12/419,451</td> </tr> <tr> <td><b>Filing Date</b></td> <td>April 7, 2009</td> </tr> <tr> <td><b>First Named Inventor</b></td> <td>Scalisi, Joseph</td> </tr> <tr> <td><b>Art Unit</b></td> <td>2618</td> </tr> <tr> <td><b>Examiner Name</b></td> <td>Unknown</td> </tr> </table>		<i>Complete if Known</i>		<b>Application Number</b>	12/419,451	<b>Filing Date</b>	April 7, 2009	<b>First Named Inventor</b>	Scalisi, Joseph	<b>Art Unit</b>	2618	<b>Examiner Name</b>	Unknown
<i>Complete if Known</i>															
<b>Application Number</b>	12/419,451														
<b>Filing Date</b>	April 7, 2009														
<b>First Named Inventor</b>	Scalisi, Joseph														
<b>Art Unit</b>	2618														
<b>Examiner Name</b>	Unknown														
Sheet	1	of	1	Attorney Docket No: LB1-006USC1											

US PATENT DOCUMENTS					
Examiner Initial *	Cite No	Document Number	Publication Date	Name of Patentee or Applicant of Cited Document	Filing Date If Appropriate
		US-20030177094	09/18/2003	Needham, Bradford H., et al.	
		US-20030235307	12/25/2003	Miyamoto, Kazuhiro	
		US-20050044356	02/24/2005	Srivastava, Sunil et al.	
		US-20060205416	09/14/2006	Kayzar, Brett A., et al.	
		US-20070287473	12/13/2007	Dupray, Dennis J.	
		US-20080028063	01/31/2008	Holmes, John S., et al.	
		US-20080088437	04/17/2008	Aninye, Steve et al.	
		US-20080171559	07/17/2008	Frank, Scott et al.	
		US-20080228654	09/18/2008	Edge, Stephen W.	
		US-20090098857	04/16/2009	De Atley, Dallas	
		US-4218582	08/19/1980	Hellman, Martin E., et al.	
		US-6654883	11/25/2003	Tatebayashi, Makoto	
		US-7268700	09/11/2007	Hoffberg, Steven M.	
		US-7501952	03/10/2009	Forster, Ian J.	
		US-7501984	03/10/2009	Forster, Ian J., et al.	
		US-7995994	08/09/2011	Khetawat, Amit et al.	

FOREIGN PATENT DOCUMENTS					
Examiner Initials*	Cite No	Foreign Patent Document	Publication Date	Name of Patentee or Applicant of cited Document	T <sup>2</sup>

OTHER DOCUMENTS -- NON PATENT LITERATURE DOCUMENTS			
Examiner Initials*	Cite No <sup>1</sup>	Include name of the author (in CAPITAL LETTERS), title of the article (when appropriate), title of the item (book, magazine, journal, serial, symposium, catalog, etc.), date, page(s), volume-issue number(s), publisher, city and/or country where published.	T <sup>2</sup>

**EXAMINER**

**DATE CONSIDERED**

Substitute Disclosure Statement Form (PTO-1449)  
\* EXAMINER: Initial if reference considered, whether or not citation is in conformance with MPEP 609. Draw line through citation if not in conformance and not considered. Include copy of this form with next communication to applicant. <sup>1</sup> Applicant's unique citation designation number (optional) <sup>2</sup> Applicant is to place a check mark here if English language Translation is attached

## Electronic Acknowledgement Receipt

<b>EFS ID:</b>	10972956
<b>Application Number:</b>	12419451
<b>International Application Number:</b>	
<b>Confirmation Number:</b>	1643
<b>Title of Invention:</b>	APPARATUS AND METHOD FOR ADJUSTING REFRESH RATE OF LOCATION COORDINATES OF A TRACKING DEVICE
<b>First Named Inventor/Applicant Name:</b>	Joseph F. Scalisi
<b>Customer Number:</b>	93892
<b>Filer:</b>	Christopher W. Lattin/Melissa Nelson
<b>Filer Authorized By:</b>	Christopher W. Lattin
<b>Attorney Docket Number:</b>	LBTECH.012CP1
<b>Receipt Date:</b>	18-SEP-2011
<b>Filing Date:</b>	07-APR-2009
<b>Time Stamp:</b>	20:26:13
<b>Application Type:</b>	Utility under 35 USC 111(a)

### Payment information:

Submitted with Payment	no
------------------------	----

### File Listing:

Document Number	Document Description	File Name	File Size(Bytes)/ Message Digest	Multi Part /.zip	Pages (if appl.)
1		LB1006USC1IDSasFiled.pdf	153308 <small>6e82b9f34781d11bafa1ddec6d8b64271480e6cf2</small>	yes	3

<b>Multipart Description/PDF files in .zip description</b>			
<b>Document Description</b>		<b>Start</b>	<b>End</b>
Transmittal Letter		1	2
Information Disclosure Statement (IDS) Form (SB08)		3	3

**Warnings:**

**Information:**

<b>Total Files Size (in bytes):</b>	153308
-------------------------------------	--------

**This Acknowledgement Receipt evidences receipt on the noted date by the USPTO of the indicated documents, characterized by the applicant, and including page counts, where applicable. It serves as evidence of receipt similar to a Post Card, as described in MPEP 503.**

**New Applications Under 35 U.S.C. 111**

**If a new application is being filed and the application includes the necessary components for a filing date (see 37 CFR 1.53(b)-(d) and MPEP 506), a Filing Receipt (37 CFR 1.54) will be issued in due course and the date shown on this Acknowledgement Receipt will establish the filing date of the application.**

**National Stage of an International Application under 35 U.S.C. 371**

**If a timely submission to enter the national stage of an international application is compliant with the conditions of 35 U.S.C. 371 and other applicable requirements a Form PCT/DO/EO/903 indicating acceptance of the application as a national stage submission under 35 U.S.C. 371 will be issued in addition to the Filing Receipt, in due course.**

**New International Application Filed with the USPTO as a Receiving Office**

**If a new international application is being filed and the international application includes the necessary components for an international filing date (see PCT Article 11 and MPEP 1810), a Notification of the International Application Number and of the International Filing Date (Form PCT/RO/105) will be issued in due course, subject to prescriptions concerning national security, and the date shown on this Acknowledgement Receipt will establish the international filing date of the application.**

**IN THE UNITED STATES PATENT AND TRADEMARK OFFICE**

Applicant:	Joseph F. Scalisi et al.	Examiner:	Unknown
Serial No.:	12/419,451	Group Art Unit:	2618
Filed:	April 7, 2009	Docket:	LB1-006USC1
Title:	APPARATUS AND METHOD FOR ADJUSTING REFRESH RATE OF LOCATION COORDINATES OF A TRACKING DEVICE		

---

**SUPPLEMENTAL INFORMATION DISCLOSURE STATEMENT**

Commissioner for Patents  
P.O. Box 1450  
Alexandria, VA 22313-1450

In compliance with the duty imposed by 37 C.F.R. § 1.56, and in accordance with 37 C.F.R. §§ 1.97 *et. seq.*, the referenced materials are brought to the attention of the Examiner for consideration in connection with the above-identified patent application. Applicant respectfully requests that this Supplemental Information Disclosure Statement be entered and the documents listed on the attached Form 1449 be considered by the Examiner and made of record. Pursuant to the provisions of MPEP 609, Applicant requests that a copy of the 1449 form, initialed as being considered by the Examiner, be returned to the Applicant with the next official communication.

Pursuant to 37 C.F.R. §1.97(b), it is believed that no fee or statement is required with the Supplemental Information Disclosure Statement.

Pursuant to 37 C.F.R. 1.98(a)(2), Applicant believes that copies of cited U.S. Patents and Published Applications, and Non-Published Applications identifiable by USPTO Serial Number, are no longer required to be provided to the Office. Notification of this change to this effect was provided in the United States Patent and Trademark Office OG Notices dated October 12, 2004 and October 19, 2004. Thus, Applicant has not included copies of any US Patents or US Patent Applications identifiable by serial number that may be cited with this submission. Should the Office require copies to be provided, Applicant respectfully requests that notice of such requirement be directed to Applicant's below-signed representative. Applicant acknowledges the requirement to submit copies of foreign patent documents and non-patent literature in accordance with 37 C.F.R. 1.98(a)(2).

SUPPLEMENTAL INFORMATION DISCLOSURE STATEMENT

Serial No :12/419,451

Filing Date: April 7, 2009

Title: APPARATUS AND METHOD FOR ADJUSTING REFRESH RATE OF LOCATION COORDINATES OF A TRACKING DEVICE

---

Page 2

Dkt: LB1-006USC1

Respectfully submitted,

Joseph F. Scalisi et al.

By their Representatives,

Date 9/18/2011

By /Christopher Lattin/

Christopher Lattin

Reg. No. 56064

Substitute for form 1449A/PTO  <b>INFORMATION DISCLOSURE STATEMENT BY APPLICANT</b>  (Use as many sheets as necessary)	<table border="1" style="width: 100%; border-collapse: collapse;"> <tr> <td colspan="2" style="text-align: right;"><i>Complete if Known</i></td> </tr> <tr> <td style="width: 60%;"><b>Application Number</b></td> <td>12/419,451</td> </tr> <tr> <td><b>Filing Date</b></td> <td>April 7, 2009</td> </tr> <tr> <td><b>First Named Inventor</b></td> <td>Scalisi, Joseph</td> </tr> <tr> <td><b>Art Unit</b></td> <td>2618</td> </tr> <tr> <td><b>Examiner Name</b></td> <td>Unknown</td> </tr> </table>	<i>Complete if Known</i>		<b>Application Number</b>	12/419,451	<b>Filing Date</b>	April 7, 2009	<b>First Named Inventor</b>	Scalisi, Joseph	<b>Art Unit</b>	2618	<b>Examiner Name</b>	Unknown
<i>Complete if Known</i>													
<b>Application Number</b>	12/419,451												
<b>Filing Date</b>	April 7, 2009												
<b>First Named Inventor</b>	Scalisi, Joseph												
<b>Art Unit</b>	2618												
<b>Examiner Name</b>	Unknown												
Sheet 1 of 1	Attorney Docket No: LB1-006USC1												

US PATENT DOCUMENTS					
Examiner Initial *	Cite No	Document Number	Publication Date	Name of Patentee or Applicant of Cited Document	Filing Date If Appropriate
		US-20080108370	05/08/2008	Aninye, Steve	
		US-20090177385	07/09/2009	Mike, Matas et al.	
		US-5555286	09/10/1996	Tendler, Robert K.	
		US-6243039	06/05/2001	Elliot, Bruce D.	
		US-6278370	08/21/2001	Underwood, Lowell	
		US-6300875	10/09/2001	Schafer, Robert W.	
		US-6327533	12/04/2001	Chou, Yue-Hong	
		US-7099921	08/29/2006	Engstrom, Eric et al.	

FOREIGN PATENT DOCUMENTS					
Examiner Initials*	Cite No	Foreign Patent Document	Publication Date	Name of Patentee or Applicant of cited Document	T <sup>2</sup>

OTHER DOCUMENTS -- NON PATENT LITERATURE DOCUMENTS			
Examiner Initials*	Cite No <sup>1</sup>	Include name of the author (in CAPITAL LETTERS), title of the article (when appropriate), title of the item (book, magazine, journal, serial, symposium, catalog, etc.), date, page(s), volume-issue number(s), publisher, city and/or country where published.	T <sup>2</sup>

**EXAMINER**

**DATE CONSIDERED**

Substitute Disclosure Statement Form (PTO-1449)  
 \* EXAMINER: Initial if reference considered, whether or not citation is in conformance with MPEP 609. Draw line through citation if not in conformance and not considered. Include copy of this form with next communication to applicant. <sup>1</sup> Applicant's unique citation designation number (optional) <sup>2</sup> Applicant is to place a check mark here if English language Translation is attached

## Electronic Acknowledgement Receipt

<b>EFS ID:</b>	12218204
<b>Application Number:</b>	12419451
<b>International Application Number:</b>	
<b>Confirmation Number:</b>	1643
<b>Title of Invention:</b>	APPARATUS AND METHOD FOR ADJUSTING REFRESH RATE OF LOCATION COORDINATES OF A TRACKING DEVICE
<b>First Named Inventor/Applicant Name:</b>	Joseph F. Scalisi
<b>Customer Number:</b>	93892
<b>Filer:</b>	Christopher W. Lattin/Melissa Nelson
<b>Filer Authorized By:</b>	Christopher W. Lattin
<b>Attorney Docket Number:</b>	LB1-006USC1
<b>Receipt Date:</b>	02-MAR-2012
<b>Filing Date:</b>	07-APR-2009
<b>Time Stamp:</b>	22:52:37
<b>Application Type:</b>	Utility under 35 USC 111(a)

### Payment information:

Submitted with Payment	no
------------------------	----

### File Listing:

Document Number	Document Description	File Name	File Size(Bytes)/ Message Digest	Multi Part /.zip	Pages (if appl.)
1		LB1006USC1IDSasFiled.pdf	151920 <small>97530a99b7a1fcf7d914e01cef965c6c0f99d39</small>	yes	3

<b>Multipart Description/PDF files in .zip description</b>			
<b>Document Description</b>		<b>Start</b>	<b>End</b>
Transmittal Letter		1	2
Information Disclosure Statement (IDS) Form (SB08)		3	3

**Warnings:**

**Information:**

<b>Total Files Size (in bytes):</b>	151920
-------------------------------------	--------

**This Acknowledgement Receipt evidences receipt on the noted date by the USPTO of the indicated documents, characterized by the applicant, and including page counts, where applicable. It serves as evidence of receipt similar to a Post Card, as described in MPEP 503.**

**New Applications Under 35 U.S.C. 111**

**If a new application is being filed and the application includes the necessary components for a filing date (see 37 CFR 1.53(b)-(d) and MPEP 506), a Filing Receipt (37 CFR 1.54) will be issued in due course and the date shown on this Acknowledgement Receipt will establish the filing date of the application.**

**National Stage of an International Application under 35 U.S.C. 371**

**If a timely submission to enter the national stage of an international application is compliant with the conditions of 35 U.S.C. 371 and other applicable requirements a Form PCT/DO/EO/903 indicating acceptance of the application as a national stage submission under 35 U.S.C. 371 will be issued in addition to the Filing Receipt, in due course.**

**New International Application Filed with the USPTO as a Receiving Office**

**If a new international application is being filed and the international application includes the necessary components for an international filing date (see PCT Article 11 and MPEP 1810), a Notification of the International Application Number and of the International Filing Date (Form PCT/RO/105) will be issued in due course, subject to prescriptions concerning national security, and the date shown on this Acknowledgement Receipt will establish the international filing date of the application.**



**IN THE UNITED STATES PATENT AND TRADEMARK OFFICE**

Applicant:	Joseph F. Scalisi et al.	Examiner:	Unknown
Serial No.:	12/419,451	Group Art Unit:	2618
Filed:	April 7, 2009	Docket:	LB1-006USC1
Title:	APPARATUS AND METHOD FOR ADJUSTING REFRESH RATE OF LOCATION COORDINATES OF A TRACKING DEVICE		

---

**SUPPLEMENTAL INFORMATION DISCLOSURE STATEMENT**

Commissioner for Patents  
P.O. Box 1450  
Alexandria, VA 22313-1450

In compliance with the duty imposed by 37 C.F.R. § 1.56, and in accordance with 37 C.F.R. §§ 1.97 *et. seq.*, the referenced materials are brought to the attention of the Examiner for consideration in connection with the above-identified patent application. Applicant respectfully requests that this Supplemental Information Disclosure Statement be entered and the documents listed on the attached Form 1449 be considered by the Examiner and made of record. Pursuant to the provisions of MPEP 609, Applicant requests that a copy of the 1449 form, initialed as being considered by the Examiner, be returned to the Applicant with the next official communication.

Pursuant to 37 C.F.R. §1.97(b), it is believed that no fee or statement is required with the Supplemental Information Disclosure Statement.

Pursuant to 37 C.F.R. 1.98(a)(2), Applicant believes that copies of cited U.S. Patents and Published Applications, and Non-Published Applications identifiable by USPTO Serial Number, are no longer required to be provided to the Office. Notification of this change to this effect was provided in the United States Patent and Trademark Office OG Notices dated October 12, 2004 and October 19, 2004. Thus, Applicant has not included copies of any US Patents or US Patent Applications identifiable by serial number that may be cited with this submission. Should the Office require copies to be provided, Applicant respectfully requests that notice of such requirement be directed to Applicant's below-signed representative. Applicant acknowledges the requirement to submit copies of foreign patent documents and non-patent literature in accordance with 37 C.F.R. 1.98(a)(2).

SUPPLEMENTAL INFORMATION DISCLOSURE STATEMENT

Serial No :12/419,451

Filing Date: April 7, 2009

Title: APPARATUS AND METHOD FOR ADJUSTING REFRESH RATE OF LOCATION COORDINATES OF A TRACKING DEVICE

---

Page 2

Dkt: LB1-006USC1

Respectfully submitted,

Joseph F. Scalisi et al.

By their Representatives,

Date 3/2/2012

By / Christopher Lattin/

Christopher Lattin

Reg. No. 56064

PLUS Search Results for S/N 12419451, Searched Thu May 31 08:37:57 EDT 2012

The Patent Linguistics Utility System (PLUS) is a USPTO automated search system for U.S. Patents from 1971 to the present PLUS is a query-by-example search system which produces a list of patents that are most closely related linguistically to the application searched. This search was prepared by the staff of the Scientific and Technical Information Center, SIRA.

6252544 99	20060129308 83
6429812 99	
6720876 99	
20090174603 99	
20090189807 99	
20090315767 99	
20120119905 99	
20120122480 99	
6225945 83	
6225945 83	
5398034 83	
5938148 83	
4457006 83	
5467274 83	
5731757 83	
5902351 83	
6239721 83	
6275185 83	
6442476 83	
6581000 83	
6910657 83	
7027919 83	
7106189 83	
7292223 83	
7317987 83	
7321305 83	
7328671 83	
7376507 83	
7489249 83	
7541974 83	
7619561 83	
7626499 83	
7646336 83	
7845560 83	
7848881 83	
7940211 83	
7966126 83	
7978128 83	
7940211 83	
7966126 83	
7978128 83	
8102256 83	
20020087264 83	
20040093159 83	
20050001814 83	
20050033515 83	
20050077424 83	
20050107954 83	
20050242947 83	



UNITED STATES PATENT AND TRADEMARK OFFICE

UNITED STATES DEPARTMENT OF COMMERCE
United States Patent and Trademark Office
Address: COMMISSIONER FOR PATENTS
P.O. Box 1450
Alexandria, Virginia 22313-1450
www.uspto.gov

Table with columns: APPLICATION NO., FILING DATE, FIRST NAMED INVENTOR, ATTORNEY DOCKET NO., CONFIRMATION NO. Includes details for application 12/419,451 filed 04/07/2009 by Joseph F. Scalisi, attorney LB1-006USC1, confirmation 1643. Also includes examiner NGUYEN, PHUNG, art unit 2612, and notification date 06/08/2012 via ELECTRONIC mode.

Please find below and/or attached an Office communication concerning this application or proceeding.

The time period for reply, if any, is set in the attached communication.

Notice of the Office communication was sent electronically on above-indicated "Notification Date" to the following e-mail address(es):

info@timberlinepatents.com
melissa@timberlinepatents.com
mark\_farrell@comcast.net

<b>Office Action Summary</b>	<b>Application No.</b> 12/419,451	<b>Applicant(s)</b> SCALISI ET AL.	
	<b>Examiner</b> PHUNG NGUYEN	<b>Art Unit</b> 2612	

-- The MAILING DATE of this communication appears on the cover sheet with the correspondence address --

**Period for Reply**

A SHORTENED STATUTORY PERIOD FOR REPLY IS SET TO EXPIRE 3 MONTH(S) OR THIRTY (30) DAYS, WHICHEVER IS LONGER, FROM THE MAILING DATE OF THIS COMMUNICATION.

- Extensions of time may be available under the provisions of 37 CFR 1.136(a). In no event, however, may a reply be timely filed after SIX (6) MONTHS from the mailing date of this communication.
- If NO period for reply is specified above, the maximum statutory period will apply and will expire SIX (6) MONTHS from the mailing date of this communication.
- Failure to reply within the set or extended period for reply will, by statute, cause the application to become ABANDONED (35 U.S.C. § 133). Any reply received by the Office later than three months after the mailing date of this communication, even if timely filed, may reduce any earned patent term adjustment. See 37 CFR 1.704(b).

**Status**

- 1)  Responsive to communication(s) filed on 07 April 2009.
- 2a)  This action is **FINAL**.
- 2b)  This action is non-final.
- 3)  An election was made by the applicant in response to a restriction requirement set forth during the interview on \_\_\_\_\_; the restriction requirement and election have been incorporated into this action.
- 4)  Since this application is in condition for allowance except for formal matters, prosecution as to the merits is closed in accordance with the practice under *Ex parte Quayle*, 1935 C.D. 11, 453 O.G. 213.

**Disposition of Claims**

- 5)  Claim(s) 1-21 is/are pending in the application.
  - 5a) Of the above claim(s) \_\_\_\_\_ is/are withdrawn from consideration.
- 6)  Claim(s) 1-7 and 18-21 is/are allowed.
- 7)  Claim(s) 8,10,13,15 and 16 is/are rejected.
- 8)  Claim(s) 9,11,12,14 and 17 is/are objected to.
- 9)  Claim(s) \_\_\_\_\_ are subject to restriction and/or election requirement.

**Application Papers**

- 10)  The specification is objected to by the Examiner.
- 11)  The drawing(s) filed on \_\_\_\_\_ is/are: a)  accepted or b)  objected to by the Examiner.  
 Applicant may not request that any objection to the drawing(s) be held in abeyance. See 37 CFR 1.85(a).  
 Replacement drawing sheet(s) including the correction is required if the drawing(s) is objected to. See 37 CFR 1.121(d).
- 12)  The oath or declaration is objected to by the Examiner. Note the attached Office Action or form PTO-152.

**Priority under 35 U.S.C. § 119**

- 13)  Acknowledgment is made of a claim for foreign priority under 35 U.S.C. § 119(a)-(d) or (f).
  - a)  All    b)  Some \*    c)  None of:
    - 1.  Certified copies of the priority documents have been received.
    - 2.  Certified copies of the priority documents have been received in Application No. \_\_\_\_\_.
    - 3.  Copies of the certified copies of the priority documents have been received in this National Stage application from the International Bureau (PCT Rule 17.2(a)).

\* See the attached detailed Office action for a list of the certified copies not received.

**Attachment(s)**

- 1)  Notice of References Cited (PTO-892)
- 2)  Notice of Draftperson's Patent Drawing Review (PTO-948)
- 3)  Information Disclosure Statement(s) (PTO/SB/08)  
 Paper No(s)/Mail Date \_\_\_\_\_.
- 4)  Interview Summary (PTO-413)  
 Paper No(s)/Mail Date \_\_\_\_\_.
- 5)  Notice of Informal Patent Application
- 6)  Other: \_\_\_\_\_.

## DETAILED ACTION

### *Specification*

1. Applicant is requested to update the status of U.S. Patent Application No. 11/969,905, filed on January 6, 2008 indicated in the instant application.

### *Claim Rejections - 35 USC § 102*

2. The following is a quotation of the appropriate paragraphs of 35 U.S.C. 102 that form the basis for the rejections under this section made in this Office action:

A person shall be entitled to a patent unless –

(e) the invention was described in (1) an application for patent, published under section 122(b), by another filed in the United States before the invention by the applicant for patent or (2) a patent granted on an application for patent by another filed in the United States before the invention by the applicant for patent, except that an international application filed under the treaty defined in section 351(a) shall have the effects for purposes of this subsection of an application filed in the United States only if the international application designated the United States and was published under Article 21(2) of such treaty in the English language.

3. Claims 8, 10, 13, 15, and 16 are rejected under 35 U.S.C. 102(e) as being anticipated by Huang et al. (US 7,826,968).

**Regarding claim 8:** Huang et al. disclose method, device and vehicle utilizing the same comprising a battery power monitor; a charging unit; and an electrical power resource management component to adjust cycle timing of at least one of a request rate of location coordinate packets to a target host and a listen rate of the location coordinate packets responsive to an estimated charge level of the charging unit (col. 5, lines 5-14).

**Regarding claim 10:** Huang et al. disclose a charge control management of the portable electronic tracking device that estimates charge capability and adjust cycling of the at least one

Art Unit: 2612

of a request rate of location coordinate packets to a host target and a listen rate of the location coordinate packets to maximize charge capability (col. 5, lines 7-9).

**Regarding claim 13:** Huang et al. disclose wherein the listen rate of the location coordinates comprises a global positioning system (GPS) system refresh rate of the location coordinates (col. 5, lines 5-7).

**Regarding claims 15 and 16:** Huang et al. disclose wherein the power charging monitor measures a power level of the power charging unit and substantially automatically adjusts power usage responsive to available power of the power charging unit to maximize power unit life and wherein the power charging monitor measures a power level of the power charging unit and adjusts a power level applied to the location tracking circuitry responsive to the signal level (col. 5, lines 9-14).

*Allowable Subject Matter*

4. Claims 1-7 and 18-21 are allowed.

5. Claims 9, 11, 12, 14, and 17 are objected to as being dependent upon a rejected base claim, but would be allowable if rewritten in independent form including all of the limitations of the base claim and any intervening claims.

The following is an examiner's statement of reasons for allowance:

Regarding claim 1, patentability resides in "the updated set of network communication signaling protocols having a value that is responsive to a user input request; wherein the local battery power adjustment mechanism activates or deactivates at least one portion of the transceiver circuitry or the processor to conserve the battery charge level in response to the value", in combination with the other limitations of the claim.

Art Unit: 2612

Regarding claim 9, patentability resides in “wherein to electrical power resource management component comprises a substantially real-time user viewable display icon that indicates the estimate charge level and provides an on-line user adjustable cursor display that adjusts at least one of the request rate of the location coordinate packets to the target host and the listen rate of the location coordinate packets and gives substantially automatic updated estimated charge level of the charging unit”.

Regarding claim 11, patentability resides in “a cycle management apparatus to set up a timing schedule to maximize effectiveness of the request rate and listen rate responsive to measured velocity of the portable electronic tracking device”.

Regarding claim 14, patentability resides in “wherein the request rate and the listen rate are set remotely by a user using a mobile phone or wireless communication device”.

Regarding claim 17, patentability resides in “wherein the power level comprises a multitude of threshold value determined by a user or system administrator to intermittently activate or deactivate the location tracking circuitry to conserve power of the power charging unit in response to the estimated charge level of the power unit”.

Regarding claim 18, patentability resides in “readjusting the initial timing schedule for communication of signaling parameters in accordance with a local request by a remote user using an Internet accessible icon that displays user viewable tradeoffs between the estimated charge unit life and charge unit update rate”, in combination with the other limitations of the claim.



Art Unit: 2612

***Conclusion***

6. Any inquiry concerning this communication or earlier communications from the examiner should be directed to Phung T Nguyen whose telephone number is 571-272-2968. The examiner can normally be reached on 8:00am-4:30pm Mon thru. Friday.

If attempts to reach the examiner by telephone are unsuccessful, the examiner's supervisor, Daniel J. Wu can be reached on 571-272-2964. The fax numbers for the organization where this application or proceeding is assigned is 571-273-8300.

/Phung T Nguyen/

Primary Examiner, Art Unit 2612

Date: June 3, 2012

<b>Notice of References Cited</b>	Application/Control No. 12/419,451	Applicant(s)/Patent Under Reexamination SCALISI ET AL.	
	Examiner PHUNG NGUYEN	Art Unit 2612	Page 1 of 1

**U.S. PATENT DOCUMENTS**

*	Document Number Country Code-Number-Kind Code	Date MM-YYYY	Name	Classification
*	A US-7,826,968	11-2010	Huang et al.	701/469
*	B US-7,123,189	10-2006	Lalik et al.	342/357.31
*	C US-6,975,941	12-2005	Lau et al.	701/491
	D US-			
	E US-			
	F US-			
	G US-			
	H US-			
	I US-			
	J US-			
	K US-			
	L US-			
	M US-			

**FOREIGN PATENT DOCUMENTS**

*	Document Number Country Code-Number-Kind Code	Date MM-YYYY	Country	Name	Classification
	N				
	O				
	P				
	Q				
	R				
	S				
	T				

**NON-PATENT DOCUMENTS**

*	Document Number Country Code-Number-Kind Code	Date MM-YYYY	Country	Name	Classification
	Include as applicable: Author, Title Date, Publisher, Edition or Volume, Pertinent Pages)				
	U				
	V				
	W				
	X				

\*A copy of this reference is not being furnished with this Office action. (See MPEP § 707.05(a).)  
Dates in MM-YYYY format are publication dates. Classifications may be US or foreign.



Substitute for form 1449A/PTO  <b>INFORMATION DISCLOSURE STATEMENT BY APPLICANT</b>  (Use as many sheets as necessary)		<i>Complete if Known</i>	
		<b>Application Number</b>	12/419,451
		<b>Filing Date</b>	April 7, 2009
		<b>First Named Inventor</b>	Scalisi, Joseph
		<b>Art Unit</b>	2618
		<b>Examiner Name</b>	Unknown
Sheet	1	of	1
Attorney Docket No: LB1-006USC1			

US PATENT DOCUMENTS					
Examiner Initial *	Cite No	Document Number	Publication Date	Name of Patentee or Applicant of Cited Document	Filing Date If Appropriate
		US-20030177094	09/18/2003	Needham, Bradford H., et al.	
		US-20030235307	12/25/2003	Miyamoto, Kazuhiro	
		US-20050044356	02/24/2005	Srivastava, Sunil et al.	
		US-20060205416	09/14/2006	Kayzar, Brett A., et al.	
		US-20070287473	12/13/2007	Dupray, Dennis J.	
		US-20080028063	01/31/2008	Holmes, John S., et al.	
		US-20080088437	04/17/2008	Aninye, Steve et al.	
		US-20080171559	07/17/2008	Frank, Scott et al.	
		US-20080228654	09/18/2008	Edge, Stephen W.	
		US-20090098857	04/16/2009	De Atley, Dallas	
		US-4218582	08/19/1980	Hellman, Martin E., et al.	
		US-6654883	11/25/2003	Tatebayashi, Makoto	
		US-7268700	09/11/2007	Hoffberg, Steven M.	
		US-7501952	03/10/2009	Forster, Ian J.	
		US-7501984	03/10/2009	Forster, Ian J., et al.	
		US-7995994	08/09/2011	Khetawat, Amit et al.	

FOREIGN PATENT DOCUMENTS					
Examiner Initials*	Cite No	Foreign Patent Document	Publication Date	Name of Patentee or Applicant of cited Document	T <sup>2</sup>

OTHER DOCUMENTS -- NON PATENT LITERATURE DOCUMENTS			
Examiner Initials*	Cite No <sup>1</sup>	Include name of the author (in CAPITAL LETTERS), title of the article (when appropriate), title of the item (book, magazine, journal, serial, symposium, catalog, etc.), date, page(s), volume-issue number(s), publisher, city and/or country where published.	T <sup>2</sup>

EXAMINER /Phung Nguyen/ DATE CONSIDERED 06/03/2012

Substitute Disclosure Statement Form (PTO-1449)  
 \* EXAMINER: Initial if reference considered, whether or not citation is in conformance with MPEP 609. Draw line through citation if not in conformance and not considered. Include copy of this form with next communication to applicant. <sup>1</sup> Applicant's unique citation designation number (optional) <sup>2</sup> Applicant is to place a check mark here if English language Translation is attached



UNITED STATES PATENT AND TRADEMARK OFFICE

UNITED STATES DEPARTMENT OF COMMERCE  
 United States Patent and Trademark Office  
 Address: COMMISSIONER FOR PATENTS  
 P.O. Box 1450  
 Alexandria, Virginia 22313-1450  
 www.uspto.gov

BIB DATA SHEET

CONFIRMATION NO. 1643

<b>SERIAL NUMBER</b> 12/419,451	<b>FILING or 371(c) DATE</b> 04/07/2009 <b>RULE</b>	<b>CLASS</b> 340	<b>GROUP ART UNIT</b> 2612	<b>ATTORNEY DOCKET NO.</b> LB1-006USC1	
<b>APPLICANTS</b> Joseph F. Scalisi, Yorba Linda, CA; Roger B. Anderson, Arcadia, CA; <b>** CONTINUING DATA *****</b> This application is a CIP of 11/969,905 01/06/2008 PAT 8,102,256 and is a CIP of 11/753,979 05/25/2007 and is a CIP of 11/933,024 10/31/2007 and is a CIP of 11/784,400 04/05/2007 ABN and is a CIP of 11/935,901 11/06/2007 <b>** FOREIGN APPLICATIONS *****</b> <b>** IF REQUIRED, FOREIGN FILING LICENSE GRANTED ** ** SMALL ENTITY **</b> 04/16/2009					
Foreign Priority claimed <input type="checkbox"/> Yes <input checked="" type="checkbox"/> No 35 USC 119(a-d) conditions met <input type="checkbox"/> Yes <input checked="" type="checkbox"/> No Verified and Acknowledged <u>/PHUNG NGUYEN/</u> Examiner's Signature	<input type="checkbox"/> Met after Allowance Initials	<b>STATE OR COUNTRY</b> CA	<b>SHEETS DRAWINGS</b> 7	<b>TOTAL CLAIMS</b> 21	<b>INDEPENDENT CLAIMS</b> 3
<b>ADDRESS</b> Timberline Patent Law Group 108 N. Washington St. Suite 417 Spokane, WA 99201 UNITED STATES					
<b>TITLE</b> APPARATUS AND METHOD FOR ADJUSTING REFRESH RATE OF LOCATION COORDINATES OF A TRACKING DEVICE					
<b>FILING FEE RECEIVED</b> 488	FEES: Authority has been given in Paper No. _____ to charge/credit DEPOSIT ACCOUNT No. _____ for following:		<input type="checkbox"/> All Fees <input type="checkbox"/> 1.16 Fees (Filing) <input type="checkbox"/> 1.17 Fees (Processing Ext. of time) <input type="checkbox"/> 1.18 Fees (Issue) <input type="checkbox"/> Other _____ <input type="checkbox"/> Credit		

<b>Search Notes</b>  	<b>Application/Control No.</b>  12419451	<b>Applicant(s)/Patent Under Reexamination</b>  SCALISI ET AL.
	<b>Examiner</b>  PHUNG NGUYEN	<b>Art Unit</b>  2612

SEARCHED			
Class	Subclass	Date	Examiner
340	539.13,539.21,686.1,636.1,636.2,636.19	06/03/12	PTN
320	108	06/03/12	PTN

SEARCH NOTES		
Search Notes	Date	Examiner

INTERFERENCE SEARCH			
Class	Subclass	Date	Examiner

--	--

Under the Paperwork Reduction Act of 1995, no persons are required to respond to a collection of information unless it contains a valid OMB control number.

Substitute for form 1449/PTO  <b>INFORMATION DISCLOSURE STATEMENT BY APPLICANT</b>  <i>(Use as many sheets as necessary)</i>		<b>Complete if Known</b>	
		Application Number	12/419,451
		Filing Date	04-07-2009
		First Named Inventor	Joseph F. Scalisi
		Art Unit	
		Examiner Name	
Sheet 1	of 1	Attorney Docket Number	LBTECH.012CP1

NON PATENT LITERATURE DOCUMENTS			
Examiner Initials*	Cite No. <sup>1</sup>	Include name of the author (in CAPITAL LETTERS), title of the article (when appropriate), title of the item (book, magazine, journal, serial, symposium, catalog, etc.), date, page(s), volume-issue number(s), publisher, city and/or country where published.	T <sup>2</sup>
	R1	Analog Devices Application Note AN-377 "Increase the Frequency Response of the ADXL Series Accelerometers" by Mike Shutster, et al.	
	R2	Analog Devices Small and Thin ± 5 g Accelerometer ADXL320	
	R3	Timing Group Delay (TGD) Correction and GPS Timing Biases by Demetrios Matsakis	
	R4	GPS Compass Solutions Geac Information Systems	
	R5	ET301 GPS-UAV Development Platform	
	R6	Surface Micromachined Sensor for Vehicle Navigation Systems by Christophe Lemaire and Bob Sulouff, Analog Devices, Inc. Micromachined Products Division	
	R7	Complementary Characteristics of GPS and Accelerometer in Monitoring Structural Deformation by Xiaoqing Li, et al.	
	R8	Full Scale structural monitoring using and integrated GPS and accelerometer system by Xiaoqing Li, et al.	

Examiner Signature	/Phung Nguyen/	Date Considered	06/03/2012
--------------------	----------------	-----------------	------------

\*EXAMINER: Initial if reference considered, whether or not citation is in conformance with MPEP 609. Draw line through citation if not in conformance and not considered. Include copy of this form with next communication to applicant.

<sup>1</sup> Applicant's unique citation designation number (optional). <sup>2</sup> Applicant is to place a check mark here if English language Translation is attached.

This collection of information is required by 37 CFR 1.98. The information is required to obtain or retain a benefit by the public which is to file (and by the USPTO to process) an application. Confidentiality is governed by 35 U.S.C. 122 and 37 CFR 1.14. This collection is estimated to take 2 hours to complete, including gathering, preparing, and submitting the completed application form to the USPTO. Time will vary depending upon the individual case. Any comments on the amount of time you require to complete this form and/or suggestions for reducing this burden, should be sent to the Chief Information Officer, U.S. Patent and Trademark Office, P.O. Box 1450, Alexandria, VA 22313-1450. DO NOT SEND FEES OR COMPLETED FORMS TO THIS ADDRESS. SEND TO: Commissioner for Patents, P.O. Box 1450, Alexandria, VA 22313-1450.

If you need assistance in completing the form, call 1-800-PTO-9199 (1-800-786-9199) and select option 2.

ALL REFERENCES CONSIDERED EXCEPT WHERE INDICATED THROUGH. /P.N./

Substitute for form 1449A/PTO  <b>INFORMATION DISCLOSURE STATEMENT BY APPLICANT</b>  (Use as many sheets as necessary)		<i>Complete if Known</i>	
		<b>Application Number</b>	12/419,451
		<b>Filing Date</b>	April 7, 2009
		<b>First Named Inventor</b>	Scalisi, Joseph
		<b>Art Unit</b>	2618
		<b>Examiner Name</b>	Unknown
Sheet	1	of	6
Attorney Docket No: LB1-006USC1			

US PATENT DOCUMENTS					
Examiner Initial *	Cite No	Document Number	Publication Date	Name of Patentee or Applicant of Cited Document	Filing Date If Appropriate
		US-20010030667	10/18/2001	Kelts, Brett R.	
		US-20010048364	12/06/2001	Kalthoff, Robert M., et al.	
		US-20020041328	04/11/2002	LeCompte, Malcolm et al.	
		US-20020067256	06/06/2002	Kail IV, Karl A.	
		US-20020077130	06/20/2002	Owensby, Craig A.	
		US-20020180602	12/05/2002	Yoakum, Jay	
		US-20020186135	12/12/2002	Wagner, Colleen	
		US-20020196123	12/26/2002	Diehl, Joseph R., et al.	
		US-20030043200	03/06/2003	Faieta, Baldo et al.	
		US-20030131073	07/10/2003	Lucovsky, Mark H., et al.	
		US-20030208518	11/06/2003	Gura, Nils et al.	
		US-20030210262	11/13/2003	Gahm, Thomas et al.	
		US-20030212729	11/13/2003	Eberle, Hans et al.	
		US-20040010689	01/15/2004	Vanstone, Scott A., et al.	
		US-20040165726	08/26/2004	Yamamichi, Masato et al.	
		US-20040166879	08/26/2004	Meadows, Vernon et al.	
		US-20040172403	09/02/2004	Steele, Rhea L., et al.	
		US-20040212493	10/28/2004	Stilp, Louis A.	
		US-20050012620	01/20/2005	Yoakum, Jay	
		US-20050071736	03/31/2006	Schneider, Tina F., et al.	
		US-20050099303	05/12/2005	Suckerman, Andrew M.	
		US-20050159883	07/21/2005	Humphries, Laymon S., et al.	
		US-20050181870	08/18/2005	Nguyen, Binh T., et al.	
		US-20050188403	08/25/2005	Kotzin, Michael D.	
		US-20050210260	09/22/2005	Venkatesan, Ramarathnam et al.	
		US-20050246647	11/03/2005	Beam, Tyler K., et al.	
		US-20050248459	11/10/2005	Bonalle, David S., et al.	
		US-20060009152	01/12/2006	Millard, Thomas A., et al.	
		US-20060206246	09/14/2006	Walker, Richard C.	
		US-20060211405	09/21/2006	Scalisi, Joseph F., et al.	
		US-20060232429	10/19/2006	Jain, Amit et al.	
		US-20060253590	11/09/2006	Nagy, David et al.	
		US-20060290497	12/28/2006	Sugata, T.	
		US-20070028088	02/01/2007	Bayrak, Coskun et al.	
		US-20070033531	02/08/2007	Marsh, Christopher	

EXAMINER

/Phung Nguyen/

DATE CONSIDERED

06/03/2012

Substitute Disclosure Statement Form (PTO-1449)  
 \* EXAMINER: Initial if reference considered, whether or not citation is in conformance with MPEP 609. Draw line through citation if not in conformance and not considered. Include copy of this form with next communication to applicant. 1 Applicant's unique citation designation number (optional) 2 Applicant is to place a check mark here if English language Translation is attached

ALL REFERENCES CONSIDERED EXCEPT WHERE INDICATED THROUGH. /P.N./



Substitute for form 1449A/PTO  <b>INFORMATION DISCLOSURE STATEMENT BY APPLICANT</b>  (Use as many sheets as necessary)		<table border="1" style="width: 100%; border-collapse: collapse;"> <tr> <td colspan="2" style="text-align: right;"><i>Complete if Known</i></td> </tr> <tr> <td style="width: 50%;"><b>Application Number</b></td> <td>12/419,451</td> </tr> <tr> <td><b>Filing Date</b></td> <td>April 7, 2009</td> </tr> <tr> <td><b>First Named Inventor</b></td> <td>Scalisi, Joseph</td> </tr> <tr> <td><b>Art Unit</b></td> <td>2618</td> </tr> <tr> <td><b>Examiner Name</b></td> <td>Unknown</td> </tr> </table>		<i>Complete if Known</i>		<b>Application Number</b>	12/419,451	<b>Filing Date</b>	April 7, 2009	<b>First Named Inventor</b>	Scalisi, Joseph	<b>Art Unit</b>	2618	<b>Examiner Name</b>	Unknown
<i>Complete if Known</i>															
<b>Application Number</b>	12/419,451														
<b>Filing Date</b>	April 7, 2009														
<b>First Named Inventor</b>	Scalisi, Joseph														
<b>Art Unit</b>	2618														
<b>Examiner Name</b>	Unknown														
Sheet	2	of	6	Attorney Docket No: LB1-006USC1											

US PATENT DOCUMENTS					
Examiner Initial *	Cite No	Document Number	Publication Date	Name of Patentee or Applicant of Cited Document	Filing Date If Appropriate
		US-20070053513	03/08/2007	Hoffberg, Steven M.	
		US-20070054530	03/08/2007	Bauer, Michael et al.	
		US-20070061303	03/15/2007	Ramer, Jorey et al.	
		US-20070073719	03/29/2007	Ramer, Jorey et al.	
		US-20070083819	04/12/2007	Shoemaker, Garth B.	
		US-20070159322	07/12/2007	Campbell, Garratt	
		US-20070229350	10/04/2007	Scalisi, Joseph F., et al.	
		US-20070255620	11/01/2007	Tumminaro, John et al.	
		US-20070288427	12/13/2007	Ramer, Jorey et al.	
		US-20080010585	01/10/2008	Schneider, Tina F.	
		US-20080059504	03/06/2008	Barbetta, Jackie et al.	
		US-20080059889	03/06/2008	Parker, Cheryl et al.	
		US-20080090550	04/17/2008	Scalisi, Joseph F., et al.	
		US-20080109762	05/08/2008	Hundal, Gurpal S., et al.	
		US-20080129491	06/05/2008	Ruperto, Netzer A., et al.	
		US-20080172173	07/17/2008	Chang, Eric et al.	
		US-20080252254	10/16/2008	Osada, Takeshi	
		US-20080252459	10/16/2008	Butler, Timothy P., et al.	
		US-20090098903	04/16/2009	Donaldson, Jesse E., et al.	
		US-20090103722	04/23/2009	Anderson, Roger B., et al.	
		US-20090111393	04/30/2009	Scalisi, Joseph F., et al.	
		US-20090117921	05/07/2009	Beydler, Michael L., et al.	
		US-20090119119	05/07/2009	Scalisi, Joseph F., et al.	
		US-20090174603	07/09/2009	Scalisi, Joseph F., et al.	
		US-20090201127	08/13/2009	Stobbe, Anatoli et al.	
		US-20090315706	12/24/2009	Scalisi, Joseph F., et al.	
		US-20090315767	12/24/2009	Scalisi, Joseph F., et al.	
		US-3924102	12/02/1975	Hanekom, Nicolaas W.	
		US-4379334	04/05/1983	Feagins, Jr., Thomas J., et al.	
		US-4807453	02/28/1989	Bernier, Denis et al.	
		US-4850007	07/18/1989	Marino, Patrick J., et al.	
		US-4885920	12/12/1989	Larson, Donna J.	
		US-5079541	01/07/1992	Moody, Thomas O.	
		US-5127042	06/30/1992	Gillig, Steven F., et al.	
		US-5353331	10/04/1994	Emery, Mark J., et al.	

EXAMINER

/Phung Nguyen/

DATE CONSIDERED

06/03/2012

Substitute Disclosure Statement Form (PTO-1449)  
 \* EXAMINER: Initial if reference considered, whether or not citation is in conformance with MPEP 609. Draw line through citation if not in conformance and not considered. Include copy of this form with next communication to applicant. 1 Applicant's unique citation designation number (optional) 2 Applicant is to place a check mark here if English language Translation is attached

ALL REFERENCES CONSIDERED EXCEPT WHERE INDICATED THROUGH. /P.N./

Substitute for form 1449A/PTO  <b>INFORMATION DISCLOSURE STATEMENT BY APPLICANT</b>  (Use as many sheets as necessary)				<i>Complete if Known</i> <b>Application Number</b> 12/419,451 <b>Filing Date</b> April 7, 2009 <b>First Named Inventor</b> Scalisi, Joseph <b>Art Unit</b> 2618 <b>Examiner Name</b> Unknown	
Sheet	3	of	6	Attorney Docket No: LB1-006USC1	

US PATENT DOCUMENTS					
Examiner Initial *	Cite No	Document Number	Publication Date	Name of Patentee or Applicant of Cited Document	Filing Date If Appropriate
		US-5361612	11/08/1994	Voiculescu, Danut et al.	
		US-5386468	01/31/1995	Akiyama, Ryota et al.	
		US-5417092	05/23/1995	Iu, Chien-Chzh	
		US-5432542	07/11/1995	Thibadeau, Robert et al.	
		US-5490402	02/13/1996	Shieh, Jin-Ren	
		US-5541976	07/30/1996	Ghisler, Walter	
		US-5563579	10/08/1996	Carter, Ronald L.	
		US-5565909	10/15/1996	Thibadeau, Robert et al.	
		US-5768920	06/23/1998	DeBevoise, Bruce D.	
		US-5785181	07/28/1998	Quartarao, Jr., Peter J.	
		US-5876765	03/02/1999	Hinterlechner, Gerhard et al.	
		US-5967841	10/19/1999	Bianca, Giuseppe et al.	
		US-5973599	11/26/1999	Nicholson, Mark et al.	
		US-6088453	07/11/2000	Shimbo, Atsushi	
		US-6141356	10/31/2000	Gorman, Michael G.	
		US-6236365	05/22/2001	LeBlanc, Frederick W., et al.	
		US-6330817	12/18/2001	Frolov, George	
		US-6388612	05/14/2002	Neher, Timothy J.	
		US-6414629	07/02/2002	Curcio, Joseph A.	
		US-6441741	08/27/2002	Yoakum, Jay	
		US-6445921	09/03/2002	Bell, John R.	
		US-6453037	09/17/2002	Welter, Jr., William G.	
		US-6498797	12/24/2002	Anerousis, Nikolaos et al.	
		US-6546253	04/08/2003	Chow, Albert et al.	
		US-6611755	08/26/2003	Coffee, John R., et al.	
		US-6633835	10/14/2003	Moran, Mike et al.	
		US-6674368	01/06/2004	Hawkins, Dale K., et al.	
		US-6708028	03/16/2004	Byrne, John D.	
		US-6716101	04/06/2004	Meadows, Vernon	
		US-6731212	05/04/2004	Hirose, Yuuki et al.	
		US-6732090	05/04/2004	Shanahan, James G., et al.	
		US-6735630	05/11/2004	Gelvin, David C., et al.	
		US-6747561	06/08/2004	Reeves, William F., et al.	
		US-6754470	06/22/2004	Hendrickson, Keith et al.	
		US-6768942	07/27/2004	Chojnacki, Robert	

EXAMINER

/Phung Nguyen/

DATE CONSIDERED

06/03/2012

Substitute Disclosure Statement Form (PTO-1449)  
 \* EXAMINER: Initial if reference considered, whether or not citation is in conformance with MPEP 609. Draw line through citation if not in conformance and not considered. Include copy of this form with next communication to applicant. 1 Applicant's unique citation designation number (optional) 2 Applicant is to place a check mark here if English language Translation is attached

ALL REFERENCES CONSIDERED EXCEPT WHERE INDICATED THROUGH. /P.N./

Substitute for form 1449A/PTO  <b>INFORMATION DISCLOSURE STATEMENT BY APPLICANT</b>  (Use as many sheets as necessary)		<i>Complete if Known</i>	
		<b>Application Number</b>	12/419,451
		<b>Filing Date</b>	April 7, 2009
		<b>First Named Inventor</b>	Scalisi, Joseph
		<b>Art Unit</b>	2618
		<b>Examiner Name</b>	Unknown
	4	of	6
Attorney Docket No: LB1-006USC1			

US PATENT DOCUMENTS					
Examiner Initial *	Cite No	Document Number	Publication Date	Name of Patentee or Applicant of Cited Document	Filing Date If Appropriate
		US-6778089	08/17/2004	Yoakum, Jay	
		US-6812824	11/02/2004	Goldinger, James et al.	
		US-6819247	11/16/2004	Birnbach, Jeffrey M., et al.	
		US-6833787	12/21/2004	Levi, Andrew E.	
		US-6850252	02/01/2005	Hoffberg, Steven M.	
		US-6859533	02/22/2005	Wang, Xin et al.	
		US-6879244	04/12/2005	Scalisi, Joseph F.	
		US-6882897	04/19/2005	Fernandez, Dennis S.	
		US-6928280	08/09/2005	Xanthos, James et al.	
		US-6937726	08/30/2005	Wang, Xin	
		US-6952181	10/04/2005	Karr, Charles L., et al.	
		US-6975941	12/13/2005	Lau, Chung	
		US-6978021	12/20/2005	Chojnacki, Robert	
		US-6988026	01/17/2006	Breed, David S.	
		US-6992584	01/31/2006	Dooley, Saul R., et al.	
		US-6998985	02/14/2006	Reisman et al.	
		US-6998995	02/14/2006	Nakajima, Yutaka	
		US-7020701	03/28/2007	Gelvin, David C., et al.	
		US-7038590	05/02/2006	Hoffman, Mark et al.	
		US-7049957	05/23/2006	Watson, Mitchell L.	
		US-7064711	06/20/2006	Strickland, Stuart et al.	
		US-7065244	06/20/2006	Akimov, Vassili A.	
		US-7065348	06/20/2006	Aoki, Hidehiko et al.	
		US-7065370	06/20/2006	Ogaki, Tadao et al.	
		US-7079650	07/18/2006	Knudsen, Erik	
		US-7088242	08/08/2006	Aupperle, Bryan E., et al.	
		US-7088252	08/08/2006	Weekes, David	
		US-7109868	09/19/2006	Yoakum, Jay	
		US-7119669	10/10/2006	Lundsgaard, Soren K., et al.	
		US-7120928	10/10/2006	Sheth, Dinesh et al.	
		US-7139396	11/21/2006	Montgomery, Peter L., et al.	
		US-7146367	12/05/2006	Shutt, Michael J.	
		US-7149189	12/12/2006	Huntington, Stephen G., et al.	
		US-7155238	12/26/2006	Katz, Daniel A.	
		US-7158912	01/02/2007	Vock, Curtis A., et al.	

EXAMINER

/Phung Nguyen/

DATE CONSIDERED

06/03/2012

Substitute Disclosure Statement Form (PTO-1449)  
\* EXAMINER: Initial if reference considered, whether or not citation is in conformance with MPEP 609. Draw line through citation if not in conformance and not considered. Include copy of this form with next communication to applicant. 1 Applicant's unique citation designation number (optional) 2 Applicant is to place a check mark here if English language Translation is attached

ALL REFERENCES CONSIDERED EXCEPT WHERE INDICATED THROUGH. /P.N./

Substitute for form 1449A/PTO  <b>INFORMATION DISCLOSURE STATEMENT BY APPLICANT</b>  (Use as many sheets as necessary)				<i>Complete if Known</i> <b>Application Number</b> 12/419,451 <b>Filing Date</b> April 7, 2009 <b>First Named Inventor</b> Scalisi, Joseph <b>Art Unit</b> 2618 <b>Examiner Name</b> Unknown	
Sheet	5	of	6	Attorney Docket No: LB1-006USC1	

US PATENT DOCUMENTS					
Examiner Initial *	Cite No	Document Number	Publication Date	Name of Patentee or Applicant of Cited Document	Filing Date If Appropriate
		US-7181192	02/20/2007	Panasik, Carl M., et al.	
		US-7200673	04/03/2007	Augart, Steven	
		US-7218242	05/15/2007	Scalisi, Joseph F., et al.	
		US-7246007	07/17/2007	Ferman, Martin A., et al.	
		US-7257836	08/14/2007	Moore, Timothy M.	
		US-7272212	09/18/2007	Eberle, Hannes et al.	
		US-7272662	09/18/2007	Chesnais, Pascal et al.	
		US-7284191	10/16/2007	Grefenstette, Gregory T., et al.	
		US-7299277	11/20/2007	Moran, Mike et al.	
		US-7302634	11/27/2007	Lucovsky, Mark H., et al.	
		US-7313825	12/25/2007	Redlich, Ron M., et al.	
		US-7571628	08/11/2009	D'Anieri, Marissa S.	
		US-7598855	10/06/2009	Scalisi, Joseph F.	
		US-7612663	11/03/2009	Sun, Chun-I	
		US-7626499	12/01/2009	Burneske, Gregory W., et al.	
		US-7728724	06/01/2010	Scalisi, Joseph F., et al.	
		US-7823424	11/02/2010	Shabtay, Yaniv et al.	
		US-7926314	04/19/2011	Tollefson, Dale A.	

FOREIGN PATENT DOCUMENTS					
Examiner Initials*	Cite No	Foreign Patent Document	Publication Date	Name of Patentee or Applicant of cited Document	T <sup>2</sup>
		WO-2007107022	09/27/2007	Krisl, Michal	

OTHER DOCUMENTS -- NON PATENT LITERATURE DOCUMENTS			
Examiner Initials*	Cite No <sup>1</sup>	Include name of the author (in CAPITAL LETTERS), title of the article (when appropriate), title of the item (book, magazine, journal, serial, symposium, catalog, etc.), date, page(s), volume-issue number(s), publisher, city and/or country where published.	T <sup>2</sup>
		HUFF, GREG H., et al., "Directional Reconfigurable Antennas on Laptop Computers: Simulation, Measurement and Evaluation of Candidate Integration Positions", <u>IEEE Transactions on Antennas</u> , Vol 52, No. 12, (12/2004),pgs 3220-3227	
		FREDRICK, JONATHAN D., et al., "Smart Antennas Based on Spatial Multiplexing of Local Elements (SMILE) for Mutual Coupling Reduction", <u>IEEE Transactions on Antennas and Propagation</u> , Vol. 52, No. 1, (1/2004),pgs 106-114	

EXAMINER

/Phung Nguyen/

DATE CONSIDERED

06/03/2012

Substitute Disclosure Statement Form (PTO-1449)  
\* EXAMINER: Initial if reference considered, whether or not citation is in conformance with MPEP 609. Draw line through citation if not in conformance and not considered. Include copy of this form with next communication to applicant. 1 Applicant's unique citation designation number (optional) 2 Applicant is to place a check mark here if English language Translation is attached

ALL REFERENCES CONSIDERED EXCEPT WHERE INDICATED THROUGH. /P.N./

Substitute for form 1449A/PTO  <b>INFORMATION DISCLOSURE STATEMENT BY APPLICANT</b>  (Use as many sheets as necessary)		<i>Complete if Known</i>	
		<b>Application Number</b>	12/419,451
		<b>Filing Date</b>	April 7, 2009
		<b>First Named Inventor</b>	Scalisi, Joseph
		<b>Art Unit</b>	2618
		<b>Examiner Name</b>	Unknown
	6	of	6
Attorney Docket No: LB1-006USC1			

OTHER DOCUMENTS -- NON PATENT LITERATURE DOCUMENTS			
Examiner Initials*	Cite No <sup>1</sup>	Include name of the author (in CAPITAL LETTERS), title of the article (when appropriate), title of the item (book, magazine, journal, serial, symposium, catalog, etc.), date, page(s), volume-issue number(s), publisher, city and/or country where published.	T <sup>2</sup>
		"Electric Vehicle (EV) Charging Information" Pasadena Water & Power Website, <a href="http://www.cityofpasadena.net">www.cityofpasadena.net</a> ,	
		<del>"Mobile Transmit Diversity", Magnolia Broadband Internet Article, 14 pages</del>	
		HANSEN, MICHAEL "Overmolding: A Multifaceted Medical Device Technology", Medical Device & Diagnostic Industry, (1/2006),5 pages	
		"Material Property Data for Various Thermoplastic Elastomers", <u>MATLAB</u> , (5/29/2007),7 pages	
		MANNION, PATRICK "Antenna Diversity Doubles CDMA Net Capacity", <u>EE Times</u> , (5/12/2003),3 pages	
		BURK, STEVE "Overmolding of Embedded Electronics", <u>Connector Specifier</u> , Retrieved from the Internet at <a href="http://cs.pennet.com">http://cs.pennet.com</a> on May 20, 2007,(4/2001),4 pages	
		SCHUSTER, MIKE et al., "Increasing the Frequency Response of the ADXL Series Accelerometers", <u>Analog Devices Application Note AN-377</u> , (2/2006),1 page	
		"Small and Thin +_5g Accelerometer", <u>Analog Devices - ADXL320</u> , (2004),16 pages	
		MATSAKIS, DEMETRIOS "The Timing Group Delay (TGD) Correction and GPS Timing Basis", <u>Proceedings of the 63rd Annual Meeting of The Institute of Navigation, Cambridge, MA</u> , (April 2007),6 pages	
		"GPS Compass Solutions-Application vs. Accuracy", <u>CEACT Information Systems</u> , (9/13/06),10 pages	
		"ET301 GPS-UAV Development Platform", (7/12/06),11 pages	
		LEMAIRE, CHRISTOPHE "Surface Micromachined Sensors for Vehicle Navigation Systems", <u>Analog Devices, Inc.</u> , Retrieved from the Internet from <a href="http://www.analog.com/en/content/0,2886,764%255F800%255F8077%255F0,00.html">http://www.analog.com/en/content/0,2886,764%255F800%255F8077%255F0,00.html</a> on December 25, 2007.,(12/2007),4 pages	
		LI, XIAOJING et al., "The Complementary Characteristics of GPS and Accelerometer in Monitoring Structural Deformation", <u>ION 2005 Meeting</u> , (2005),9 pages	
		LI, XIAOJING et al., "Full-Scale Structural Monitoring Using an Integrated GPS and Accelerometer System", <u>University of New South Wales</u> , (2/14/2006),15 pages	

EXAMINER

/Phung Nguyen/

DATE CONSIDERED

06/03/2012

Substitute Disclosure Statement Form (PTO-1449)  
\* EXAMINER: Initial if reference considered, whether or not citation is in conformance with MPEP 609. Draw line through citation if not in conformance and not considered. Include copy of this form with next communication to applicant. 1 Applicant's unique citation designation number (optional) 2 Applicant is to place a check mark here if English language Translation is attached

ALL REFERENCES CONSIDERED EXCEPT WHERE INDICATED THROUGH. /P.N./

Substitute for form 1449A/PTO  <b>INFORMATION DISCLOSURE STATEMENT BY APPLICANT</b>  (Use as many sheets as necessary)	<table border="1" style="width: 100%; border-collapse: collapse;"> <tr> <td colspan="2" style="text-align: right;"><i>Complete if Known</i></td> </tr> <tr> <td style="width: 60%;"><b>Application Number</b></td> <td>12/419,451</td> </tr> <tr> <td><b>Filing Date</b></td> <td>April 7, 2009</td> </tr> <tr> <td><b>First Named Inventor</b></td> <td>Scalisi, Joseph</td> </tr> <tr> <td><b>Art Unit</b></td> <td>2618</td> </tr> <tr> <td><b>Examiner Name</b></td> <td>Unknown</td> </tr> </table>	<i>Complete if Known</i>		<b>Application Number</b>	12/419,451	<b>Filing Date</b>	April 7, 2009	<b>First Named Inventor</b>	Scalisi, Joseph	<b>Art Unit</b>	2618	<b>Examiner Name</b>	Unknown
<i>Complete if Known</i>													
<b>Application Number</b>	12/419,451												
<b>Filing Date</b>	April 7, 2009												
<b>First Named Inventor</b>	Scalisi, Joseph												
<b>Art Unit</b>	2618												
<b>Examiner Name</b>	Unknown												
Sheet 1 of 1	Attorney Docket No: LB1-006USC1												

US PATENT DOCUMENTS					
Examiner Initial *	Cite No	Document Number	Publication Date	Name of Patentee or Applicant of Cited Document	Filing Date If Appropriate
		US-20080108370	05/08/2008	Aninye, Steve	
		US-20090177385	07/09/2009	Mike, Matas et al.	
		US-5555286	09/10/1996	Tendler, Robert K.	
		US-6243039	06/05/2001	Elliot, Bruce D.	
		US-6278370	08/21/2001	Underwood, Lowell	
		US-6300875	10/09/2001	Schafer, Robert W.	
		US-6327533	12/04/2001	Chou, Yue-Hong	
		US-7099921	08/29/2006	Engstrom, Eric et al.	

FOREIGN PATENT DOCUMENTS					
Examiner Initials*	Cite No	Foreign Patent Document	Publication Date	Name of Patentee or Applicant of cited Document	T <sup>2</sup>

OTHER DOCUMENTS -- NON PATENT LITERATURE DOCUMENTS			
Examiner Initials*	Cite No <sup>1</sup>	Include name of the author (in CAPITAL LETTERS), title of the article (when appropriate), title of the item (book, magazine, journal, serial, symposium, catalog, etc.), date, page(s), volume-issue number(s), publisher, city and/or country where published.	T <sup>2</sup>

**EXAMINER**

/Phung Nguyen/

**DATE CONSIDERED**

06/03/2012

Substitute Disclosure Statement Form (PTO-1449)  
 \* EXAMINER: Initial if reference considered, whether or not citation is in conformance with MPEP 609. Draw line through citation if not in conformance and not considered. Include copy of this form with next communication to applicant. <sup>1</sup> Applicant's unique citation designation number (optional) <sup>2</sup> Applicant is to place a check mark here if English language Translation is attached

ALL REFERENCES CONSIDERED EXCEPT WHERE INDICATED OTHERWISE THROUGH. /P.N./

<b>Index of Claims</b>  	<b>Application/Control No.</b>  12419451	<b>Applicant(s)/Patent Under Reexamination</b>  SCALISI ET AL.
	<b>Examiner</b>  PHUNG NGUYEN	<b>Art Unit</b>  2612

✓	<b>Rejected</b>
=	<b>Allowed</b>

-	<b>Cancelled</b>
÷	<b>Restricted</b>

N	<b>Non-Elected</b>
I	<b>Interference</b>

A	<b>Appeal</b>
O	<b>Objected</b>

Claims renumbered in the same order as presented by applicant
  CPA
  T.D.
  R.1.47

CLAIM		DATE							
Final	Original	06/03/2012							
	1	=							
	2	=							
	3	=							
	4	=							
	5	=							
	6	=							
	7	=							
	8	✓							
	9	O							
	10	✓							
	11	O							
	12	O							
	13	✓							
	14	O							
	15	✓							
	16	✓							
	17	O							
	18	=							
	19	=							
	20	=							
	21	=							

**IN THE UNITED STATES PATENT AND TRADEMARK OFFICE**

Application Serial No.....12/419,451  
Filing Date.....April 7, 2009  
Confirmation No.....1643  
Inventorship.....Joseph F. Scalisi  
Group Art Unit.....2612  
Examiner .....Phung Nguyen  
Attorney Docket No. .... LB1-006USC1  
Title: APPARATUS AND METHOD FOR ADJUSTING REFRESH RATE OF LOCATION  
COORDINATES OF A TRACKING DEVICE

**RESPONSE TO OFFICE ACTION OF JUNE 8, 2011**

To: COMMISSIONER FOR PATENTS  
P.O. Box 1450  
Alexandria, VA 22313-1450

From: Patrick D. S. Reed (P: 509.220.7358)  
**Customer No. 93892**  
Timberline Patent Law Group  
108 N. Washington Street, Suite 417  
Spokane, WA 99201

This communication is being filed in response to the Office Action of June 8, 2011, for which a three-month extension of the period for filing a response is set to expire on September 8, 2012. Favorable consideration is respectfully requested.

**Amendments to the Specification** begin on page 2 of this document.

**A Claims listing with claim amendments** begins on page 3 of this document.

**Remarks** begin on page 10 of this document.



## AMENDMENTS TO THE SPECIFICATION

Please amend the paragraph, beginning on page 1, line 5 of the original specification with the following paragraph.

### *Priority and Related Applications*

This application is a continuation-in-part of and claims priority to U.S. Patent number 8,102,256, originally filed as U.S. patent application number 11/969,905 entitled "Apparatus and Method for Determining Location and Tracking Coordinates of a Tracking Device" that was filed on January 6, 2008[.,,]; and incorporates by reference in their entirety and claims priority to: U.S. patent application Serial No. 11/753,979 filed on May 25, 2007, entitled "Apparatus and Method for Providing Location Information on Individuals and Objects Using Tracking Devices"; U.S. patent application Serial No. 11/933,024 filed on October 31, 2007, entitled "Apparatus and Method for Manufacturing an Electronic Package"; US patent application Serial No. 11/784,400 filed on April 5, 2007, entitled "Communication System and Method Including Dual Mode Capability"; US patent application Serial No. 11/784,318 filed on April 5, 2007, entitled "Communication System and Method Including Communication Billing Options"; and U.S. Patent number 8,244,468, originally filed as US patent application Serial No. 11/935,901 filed on November 6, 2007, entitled "System and Method for Creating and Managing a Personalized Web Interface for Monitoring Location Information on Individuals and Objects Using Tracking Devices."

## **IN THE CLAIMS**

### **Claims pending**

- At time of the Action: Claims 1 – 21
- After this Response: Claims 1 – 15 and 18 – 21

**Canceled claims:** Claims 16-17

**Amended claims:** Claims 1-12, 15, 18 and 20

### **Claims Listing:**

This listing of the claims will replace all prior versions and listings of claim in the present application.

1. (Currently Amended) A portable electronic tracking device to monitor location coordinates of one or more individuals and objects using a satellite navigation system, the portable electronic tracking device comprising:

a battery having a battery charge level;

transceiver circuitry;

processor circuitry;

a battery power monitor to measure in real-time the battery charge level and to make a prediction of an estimated remaining battery charge level in response to the battery charge level;

local battery power adjustment mechanism to generate in substantially real-time an updated set of network communication signaling protocols associated with at least one of a request rate of location coordinate packets to be communicated to a target host and a listen rate of the location coordinate packets from a satellite navigation system, the updated set of network communication signaling protocols having a value that is responsive to a user input request;

wherein the local battery power adjustment mechanism activates or deactivates at least one portion of the transceiver circuitry or the processor circuitry to conserve the battery charge level in response to the value.

2. (Currently Amended) The device of claim 1, wherein the local battery power adjustment mechanism comprises an adjustable screen icon to graphically display in substantially real-time a trade-off relationship between the remaining battery charge level and an update rate of the location coordinate packets that is in response to the updated set of network communication signaling protocols.

3. (Currently Amended) The device of claim 1, wherein the local battery power adjustment mechanism comprises a timing adjustment mechanism that adjusts the at least one of the request rate of the location coordinate packets to the target host and the listen rate of the location coordinates from a satellite navigation system in accordance with a current position of the tracking device.

4. (Currently Amended) The device of claim 1, wherein the local battery power adjustment mechanism comprises a user adjustable electronic display that indicates a current level of battery power and allows a user a capability to adjust power level thereof.

5. (Currently Amended) The device of claim 4, wherein the local battery power adjustment mechanism comprises an automatic sleep mode to set at least one of the request rate of the location coordinate packets to the target host and the listen rate of the location coordinates from the satellite navigation system to a minimal level until

the battery power monitor measures a sustainable battery charge level to process the at least one portion of an receive signal.

6. (Currently Amended) The device of claim 4, wherein the local battery power adjustment mechanism comprises a charge control management of the portable electronic tracking device that estimates charge capability and adjusts cycling of the at least one of a request rate of location coordinate packets to a target host and a listen rate of the location coordinate packets from the satellite navigation system to maximize charge capability.

7. (Currently Amended) The device of claim 1, wherein the local battery power adjustment mechanism comprises a cycle management apparatus to set up a timing schedule to maximize effectiveness of the request rate and the ~~response~~ listen rate in response to a substantially real-time measured velocity of the portable electronic tracking device.

8. (Currently Amended) A local charging management device to manage electrical resource capability for an electronic tracking device that is tracked by at least one other tracking device comprising:

a battery power level monitor;

a charging unit; and

an electrical power resource management component to adjust cycle timing of at least one of a request rate of location coordinate packets to a target host and a listen rate of the location coordinate packets responsive to an estimated charge level of the charging unit.

wherein the battery power level monitor measures a power level of the charging unit and adjusts a power level applied to location tracking circuitry responsive to one or more signal levels, the power level comprising a multitude of threshold values determined by a user or system administrator to intermittently activate or deactivate the location tracking circuitry to conserve power of the charging unit in response to the estimated charge level of the charging unit.

9. (Currently Amended) The apparatus of claim 8, wherein [[to]] the electrical power resource management component comprises a substantially real-time user viewable display icon that indicates the estimated charge level and provides an on-line user adjustable cursor display that adjusts at least one of the request rate of the location coordinate packets to the target host and the listen rate of the location coordinate packets and gives substantially automatic updated estimated charge level of the charging unit.

10. (Currently Amended) The apparatus of claim 8, wherein the local charging management device comprises a charge control management of the portable electronic tracking device that estimates charge capability and adjusts cycling of the at least one of a request rate of location coordinate packets to a host target and a listen rate of the location coordinate packets to maximize charge capability.

11. (Currently Amended) The apparatus of claim 8, wherein the local charging management device comprises a cycle management apparatus to set up a timing schedule to maximize effectiveness of the request rate and listen rate responsive to measured velocity of the portable electronic tracking device.

12. (Currently Amended) The apparatus of claim 11, wherein the local charging management device electrically couples to a mobile phone to remote control the local apparatus to setup <sup>[[up]]</sup> a timing schedule from a multitude of wireless communication networks to communicate information between the electronic tracking device and the mobile phone.

13. (Original) The apparatus of claim 8, wherein the listen rate of the location coordinates comprises a global positioning system (GPS) system refresh rate of the location coordinates.

14. (Original) The apparatus of claim 8, wherein the request rate and the listen rate are set remotely by a user using a mobile phone or wireless communication device.

15. (Currently Amended) The apparatus of claim 8, wherein the battery power charging level monitor measures a power level of the ~~power~~ charging unit and substantially automatically adjusts power usage responsive to available power of the ~~power~~ charging unit to maximize power unit life.

16 - 17. (Canceled)

18. (Currently Amended) A method to control power usage comprising:  
measuring charging unit power level of a tracking device communicated by a location coordinate tracking system;

adjusting charging unit power level of the tracking device in response to a substantially-real life estimate of ~~[[the]]~~ a unit power level of a charge unit of the tracking device;

creating an initial timing schedule for communication of signaling parameters associated with a target host request rate communicated with location coordinate information and listen rate of the location coordinate information, the initial time schedule being at least partially automatically and responsive to an estimated power level of the charge unit; and

readjusting the initial timing schedule for communication of signaling parameters in accordance with a local request by a remote user using an Internet accessible icon that displays user viewable tradeoffs between ~~[[the]]~~ an estimated charge unit life and a charge unit update rate.

19. (Original) The method of claim 18, wherein creating an initial timing schedule for communication of signaling parameters comprises creating a management schedule for setting a rate at which messages are exchanged between the tracking device and a target host.

20. (Currently Amended) The method of claim 18, wherein creating an initial timing schedule for communication of signaling parameters comprises creating a management schedule for setting a rate at which messages are exchanged between ~~[[the]]~~ a navigational satellite system and the tracking device to a local device to maximize effectiveness of the request rate and the listen rate to the location coordinate information in response to a measured velocity of the ~~portable electronic~~ tracking device.

21. (Original) The method of claim 18, wherein readjusting the timing schedule for communication of signaling parameters in accordance with a local request by a remote user comprise electrically coupling the tracking device to a mobile phone to remote control cycling the location coordinates to setup up a timing schedule between a multitude of wireless communication networks to communicate information between the electronic tracking device and the mobile phone.



## **REMARKS**

Reconsideration and allowance of all pending claims in view of the foregoing amendments and the following remarks are respectfully requested.

### **Specification Objections**

The specification is herein amended to correct informalities, specifically to conform the specification to the current status of U.S. Patent Applications indicated in the instant application. These revisions introduce no new matter.

### **Rejections under 35 U.S.C. §102(e)**

**Claims 8, 10, 13, 15, and 16** stand rejected under 35 U.S.C. §102(e) as being anticipated by Huang et al., (U.S. Patent Application No. 7,826,968; hereafter “Huang”). The Applicants respectfully traverse this rejection.

Nevertheless, without commenting on the propriety of the rejection and in the interest of expediting allowance of the application, the Applicants herein amend claims 8, 10 and 15 for clarification. Claim 16 is canceled herein.

**Independent claim 8**, as presently amended, recites (amendments underlined):

wherein the battery power level monitor measures a power level of the charging unit and adjusts a power level applied to location tracking circuitry responsive to one or more signal levels, the power level comprising a multitude of threshold values determined by a user or system administrator to intermittently activate or deactivate the location tracking circuitry to conserve power of the charging unit in response to the estimated charge level of the charging unit.

Applicants respectfully submit that Huang fails to disclose at least these elements of claim 8, which were previously recited in canceled claims 16 and 17.

Applicants herein amend independent claim 8 to recite features previously recited in allowable dependent claim 17, including “the power level comprising a multitude of threshold values determined by a user or system administrator to intermittently activate or deactivate the location tracking circuitry to conserve power of the charging unit in response to the estimated charge level of the charging unit,” and in intervening claim 16. Applicants herein cancel claims 16 and 17 without prejudice.

Applicants respectfully submit that independent claim 8 is in allowable form and request the Examiner to withdraw the rejection of the claim.

**Dependent claims 10, 13 and 15** are dependent from independent claim 8. Dependent claims 10, 13, and 15 are allowable by virtue of this dependency, as well as for additional features that each claim recites.

Allowable Subject Matter

A. Claims 1-7 and 18-21 are allowed by the Office. Applicants herein amend claims 1-7 and 18 to correct typographical errors, promote consistency in the language of the claims, and the like. No substantive amendments have been made to claims 1-7 and 18-21.

B. Claims 9, 11, 12, 14 and 17 are objected to as being dependent upon a rejected base claim, but would be allowable if rewritten in independent form including all of the limitations of the base claim and any intervening claim (Office Action, page 3).

Applicants thank the Examiner for the allowable indication of these claims and appreciate the Examiner's assistance in advancing prosecution of the application.

Applicants herein amend independent claim 8 to recite features formerly recited in allowable dependent claim 17 and to recite features formerly recited in the intervening claim 16. The amendments to independent claim 8 are purely of form (i.e., dependent form to independent form), and are not to overcome prior art or any other objections. Accordingly, dependent claims 16 and 17 are herein cancelled without prejudice.

Applicants respectfully submit that independent claim 8 is in allowable form. Therefore, Applicants submit that claims 9, 11, 12, and 14 are in condition for allowance.

Conclusion

All objections and rejections having been addressed, it is respectfully submitted that the present application is now in condition for allowance, and early and forthright issuance of a Notice to that effect is earnestly solicited.

If any issues remain that would prevent allowance of this application, Applicants request that the Examiner contact the undersigned representative before issuing a subsequent Action.

Respectfully Submitted,

Dated: September 10, 2012

By: /Patrick D. S. Reed/  
Patrick D. S. Reed  
Reg. No. 61,227

## Electronic Acknowledgement Receipt

<b>EFS ID:</b>	13705927
<b>Application Number:</b>	12419451
<b>International Application Number:</b>	
<b>Confirmation Number:</b>	1643
<b>Title of Invention:</b>	APPARATUS AND METHOD FOR ADJUSTING REFRESH RATE OF LOCATION COORDINATES OF A TRACKING DEVICE
<b>First Named Inventor/Applicant Name:</b>	Joseph F. Scalisi
<b>Customer Number:</b>	93892
<b>Filer:</b>	Christopher W. Lattin/Melissa Nelson
<b>Filer Authorized By:</b>	Christopher W. Lattin
<b>Attorney Docket Number:</b>	LB1-006USC1
<b>Receipt Date:</b>	10-SEP-2012
<b>Filing Date:</b>	07-APR-2009
<b>Time Stamp:</b>	23:19:28
<b>Application Type:</b>	Utility under 35 USC 111(a)

### Payment information:

Submitted with Payment	no
------------------------	----

### File Listing:

Document Number	Document Description	File Name	File Size(Bytes)/ Message Digest	Multi Part /.zip	Pages (if appl.)
1		LB1006USResponsetoOA20120823.pdf	133554 <small>13236df92780e62c630ccb70709482be1f0fd667</small>	yes	12

<b>Multipart Description/PDF files in .zip description</b>			
<b>Document Description</b>		<b>Start</b>	<b>End</b>
Amendment/Req. Reconsideration-After Non-Final Reject		1	1
Specification		2	2
Claims		3	9
Applicant Arguments/Remarks Made in an Amendment		10	12

**Warnings:**

**Information:**

<b>Total Files Size (in bytes):</b>	133554
-------------------------------------	--------

**This Acknowledgement Receipt evidences receipt on the noted date by the USPTO of the indicated documents, characterized by the applicant, and including page counts, where applicable. It serves as evidence of receipt similar to a Post Card, as described in MPEP 503.**

**New Applications Under 35 U.S.C. 111**

**If a new application is being filed and the application includes the necessary components for a filing date (see 37 CFR 1.53(b)-(d) and MPEP 506), a Filing Receipt (37 CFR 1.54) will be issued in due course and the date shown on this Acknowledgement Receipt will establish the filing date of the application.**

**National Stage of an International Application under 35 U.S.C. 371**

**If a timely submission to enter the national stage of an international application is compliant with the conditions of 35 U.S.C. 371 and other applicable requirements a Form PCT/DO/EO/903 indicating acceptance of the application as a national stage submission under 35 U.S.C. 371 will be issued in addition to the Filing Receipt, in due course.**

**New International Application Filed with the USPTO as a Receiving Office**

**If a new international application is being filed and the international application includes the necessary components for an international filing date (see PCT Article 11 and MPEP 1810), a Notification of the International Application Number and of the International Filing Date (Form PCT/RO/105) will be issued in due course, subject to prescriptions concerning national security, and the date shown on this Acknowledgement Receipt will establish the international filing date of the application.**

Under the Paperwork Reduction Act of 1995, no persons are required to respond to a collection of information unless it displays a valid OMB control number.

<b>PATENT APPLICATION FEE DETERMINATION RECORD</b> Substitute for Form PTO-875	Application or Docket Number <b>12/419,451</b>	Filing Date <b>04/07/2009</b>	<input type="checkbox"/> To be Mailed
---	---	----------------------------------	---------------------------------------

APPLICATION AS FILED – PART I			OTHER THAN SMALL ENTITY			
	(Column 1)	(Column 2)	SMALL ENTITY <input checked="" type="checkbox"/>	OR		
FOR	NUMBER FILED	NUMBER EXTRA	RATE (\$)	FEE (\$)	RATE (\$)	FEE (\$)
<input type="checkbox"/> BASIC FEE <small>(37 CFR 1.16(a), (b), or (c))</small>	N/A	N/A	N/A		N/A	
<input type="checkbox"/> SEARCH FEE <small>(37 CFR 1.16(k), (j), or (m))</small>	N/A	N/A	N/A		N/A	
<input type="checkbox"/> EXAMINATION FEE <small>(37 CFR 1.16(o), (p), or (q))</small>	N/A	N/A	N/A		N/A	
TOTAL CLAIMS <small>(37 CFR 1.16(j))</small>	minus 20 =	*	X \$ =	OR	X \$ =	
INDEPENDENT CLAIMS <small>(37 CFR 1.16(h))</small>	minus 3 =	*	X \$ =		X \$ =	
<input type="checkbox"/> APPLICATION SIZE FEE <small>(37 CFR 1.16(s))</small>	If the specification and drawings exceed 100 sheets of paper, the application size fee due is \$250 (\$125 for small entity) for each additional 50 sheets or fraction thereof. See 35 U.S.C. 41(a)(1)(G) and 37 CFR 1.16(s).					
<input type="checkbox"/> MULTIPLE DEPENDENT CLAIM PRESENT <small>(37 CFR 1.16(j))</small>						
* If the difference in column 1 is less than zero, enter "0" in column 2.			TOTAL		TOTAL	

APPLICATION AS AMENDED – PART II					OTHER THAN SMALL ENTITY			
	(Column 1)	(Column 2)	(Column 3)					
AMENDMENT	<b>09/10/2012</b>	CLAIMS REMAINING AFTER AMENDMENT	HIGHEST NUMBER PREVIOUSLY PAID FOR	PRESENT EXTRA	RATE (\$)	ADDITIONAL FEE (\$)	RATE (\$)	ADDITIONAL FEE (\$)
	Total <small>(37 CFR 1.16(i))</small>	* 19	Minus ** 20	= 0	X \$30 =	0	OR	X \$ =
	Independent <small>(37 CFR 1.16(h))</small>	* 3	Minus ***3	= 0	X \$125 =	0	OR	X \$ =
	<input type="checkbox"/> Application Size Fee <small>(37 CFR 1.16(s))</small>						OR	
	<input type="checkbox"/> FIRST PRESENTATION OF MULTIPLE DEPENDENT CLAIM <small>(37 CFR 1.16(j))</small>						OR	
					TOTAL ADD'L FEE	<b>0</b>	OR	TOTAL ADD'L FEE

	(Column 1)	(Column 2)	(Column 3)					
AMENDMENT		CLAIMS REMAINING AFTER AMENDMENT	HIGHEST NUMBER PREVIOUSLY PAID FOR	PRESENT EXTRA	RATE (\$)	ADDITIONAL FEE (\$)	RATE (\$)	ADDITIONAL FEE (\$)
	Total <small>(37 CFR 1.16(i))</small>	*	Minus **	=	X \$ =		OR	X \$ =
	Independent <small>(37 CFR 1.16(h))</small>	*	Minus ***	=	X \$ =		OR	X \$ =
	<input type="checkbox"/> Application Size Fee <small>(37 CFR 1.16(s))</small>						OR	
	<input type="checkbox"/> FIRST PRESENTATION OF MULTIPLE DEPENDENT CLAIM <small>(37 CFR 1.16(j))</small>						OR	
					TOTAL ADD'L FEE		OR	TOTAL ADD'L FEE

\* If the entry in column 1 is less than the entry in column 2, write "0" in column 3.  
 \*\* If the "Highest Number Previously Paid For" IN THIS SPACE is less than 20, enter "20".  
 \*\*\* If the "Highest Number Previously Paid For" IN THIS SPACE is less than 3, enter "3".  
 The "Highest Number Previously Paid For" (Total or Independent) is the highest number found in the appropriate box in column 1.

Legal Instrument Examiner:  
/NICOLE LOVE-HENSLEY/

This collection of information is required by 37 CFR 1.16. The information is required to obtain or retain a benefit by the public which is to file (and by the USPTO to process) an application. Confidentiality is governed by 35 U.S.C. 122 and 37 CFR 1.14. This collection is estimated to take 12 minutes to complete, including gathering, preparing, and submitting the completed application form to the USPTO. Time will vary depending upon the individual case. Any comments on the amount of time you require to complete this form and/or suggestions for reducing this burden, should be sent to the Chief Information Officer, U.S. Patent and Trademark Office, U.S. Department of Commerce, P.O. Box 1450, Alexandria, VA 22313-1450. DO NOT SEND FEES OR COMPLETED FORMS TO THIS ADDRESS. **SEND TO: Commissioner for Patents, P.O. Box 1450, Alexandria, VA 22313-1450.**

If you need assistance in completing the form, call 1-800-PTO-9199 and select option 2.



NOTICE OF ALLOWANCE AND FEE(S) DUE

93892 7590 09/20/2012
Timberline Patent Law Group
108 N. Washington St.
Suite 417
Spokane, WA 99201

EXAMINER
NGUYEN, PHUNG
ART UNIT PAPER NUMBER
2612

DATE MAILED: 09/20/2012

Table with 5 columns: APPLICATION NO., FILING DATE, FIRST NAMED INVENTOR, ATTORNEY DOCKET NO., CONFIRMATION NO.

12/419,451 04/07/2009 Joseph F. Scalisi LB1-006USC1 1643
TITLE OF INVENTION: APPARATUS AND METHOD FOR ADJUSTING REFRESH RATE OF LOCATION COORDINATES OF A TRACKING DEVICE

Table with 7 columns: APPLN. TYPE, SMALL ENTITY, ISSUE FEE DUE, PUBLICATION FEE DUE, PREV. PAID ISSUE FEE, TOTAL FEE(S) DUE, DATE DUE

THE APPLICATION IDENTIFIED ABOVE HAS BEEN EXAMINED AND IS ALLOWED FOR ISSUANCE AS A PATENT. PROSECUTION ON THE MERITS IS CLOSED. THIS NOTICE OF ALLOWANCE IS NOT A GRANT OF PATENT RIGHTS. THIS APPLICATION IS SUBJECT TO WITHDRAWAL FROM ISSUE AT THE INITIATIVE OF THE OFFICE OR UPON PETITION BY THE APPLICANT. SEE 37 CFR 1.313 AND MPEP 1308.

THE ISSUE FEE AND PUBLICATION FEE (IF REQUIRED) MUST BE PAID WITHIN THREE MONTHS FROM THE MAILING DATE OF THIS NOTICE OR THIS APPLICATION SHALL BE REGARDED AS ABANDONED. THIS STATUTORY PERIOD CANNOT BE EXTENDED. SEE 35 U.S.C. 151. THE ISSUE FEE DUE INDICATED ABOVE DOES NOT REFLECT A CREDIT FOR ANY PREVIOUSLY PAID ISSUE FEE IN THIS APPLICATION. IF AN ISSUE FEE HAS PREVIOUSLY BEEN PAID IN THIS APPLICATION (AS SHOWN ABOVE), THE RETURN OF PART B OF THIS FORM WILL BE CONSIDERED A REQUEST TO REAPPLY THE PREVIOUSLY PAID ISSUE FEE TOWARD THE ISSUE FEE NOW DUE.

HOW TO REPLY TO THIS NOTICE:

I. Review the SMALL ENTITY status shown above.

If the SMALL ENTITY is shown as YES, verify your current SMALL ENTITY status:

- A. If the status is the same, pay the TOTAL FEE(S) DUE shown above.
B. If the status above is to be removed, check box 5b on Part B - Fee(s) Transmittal and pay the PUBLICATION FEE (if required) and twice the amount of the ISSUE FEE shown above, or

If the SMALL ENTITY is shown as NO:

- A. Pay TOTAL FEE(S) DUE shown above, or
B. If applicant claimed SMALL ENTITY status before, or is now claiming SMALL ENTITY status, check box 5a on Part B - Fee(s) Transmittal and pay the PUBLICATION FEE (if required) and 1/2 the ISSUE FEE shown above.

II. PART B - FEE(S) TRANSMITTAL, or its equivalent, must be completed and returned to the United States Patent and Trademark Office (USPTO) with your ISSUE FEE and PUBLICATION FEE (if required). If you are charging the fee(s) to your deposit account, section "4b" of Part B - Fee(s) Transmittal should be completed and an extra copy of the form should be submitted. If an equivalent of Part B is filed, a request to reapply a previously paid issue fee must be clearly made, and delays in processing may occur due to the difficulty in recognizing the paper as an equivalent of Part B.

III. All communications regarding this application must give the application number. Please direct all communications prior to issuance to Mail Stop ISSUE FEE unless advised to the contrary.

IMPORTANT REMINDER: Utility patents issuing on applications filed on or after Dec. 12, 1980 may require payment of maintenance fees. It is patentee's responsibility to ensure timely payment of maintenance fees when due.

**PART B - FEE(S) TRANSMITTAL**

**Complete and send this form, together with applicable fee(s), to: Mail Mail Stop ISSUE FEE  
 Commissioner for Patents  
 P.O. Box 1450  
 Alexandria, Virginia 22313-1450  
 or Fax (571)-273-2885**

**INSTRUCTIONS:** This form should be used for transmitting the ISSUE FEE and PUBLICATION FEE (if required). Blocks 1 through 5 should be completed where appropriate. All further correspondence including the Patent, advance orders and notification of maintenance fees will be mailed to the current correspondence address as indicated unless corrected below or directed otherwise in Block 1, by (a) specifying a new correspondence address; and/or (b) indicating a separate "FEE ADDRESS" for maintenance fee notifications.

CURRENT CORRESPONDENCE ADDRESS (Note: Use Block 1 for any change of address)

Note: A certificate of mailing can only be used for domestic mailings of the Fee(s) Transmittal. This certificate cannot be used for any other accompanying papers. Each additional paper, such as an assignment or formal drawing, must have its own certificate of mailing or transmission.

93892                      7590                      09/20/2012  
**Timberline Patent Law Group**  
 108 N. Washington St.  
 Suite 417  
 Spokane, WA 99201

**Certificate of Mailing or Transmission**

I hereby certify that this Fee(s) Transmittal is being deposited with the United States Postal Service with sufficient postage for first class mail in an envelope addressed to the Mail Stop ISSUE FEE address above, or being facsimile transmitted to the USPTO (571) 273-2885, on the date indicated below.

(Depositor's name)
(Signature)
(Date)

APPLICATION NO.	FILING DATE	FIRST NAMED INVENTOR	ATTORNEY DOCKET NO.	CONFIRMATION NO.
-----------------	-------------	----------------------	---------------------	------------------

12/419,451                      04/07/2009                      Joseph F. Scalisi                      LBI-006USC1                      1643

TITLE OF INVENTION: APPARATUS AND METHOD FOR ADJUSTING REFRESH RATE OF LOCATION COORDINATES OF A TRACKING DEVICE

APPLN. TYPE	SMALL ENTITY	ISSUE FEE DUE	PUBLICATION FEE DUE	PREV. PAID ISSUE FEE	TOTAL FEE(S) DUE	DATE DUE
-------------	--------------	---------------	---------------------	----------------------	------------------	----------

nonprovisional                      YES                      \$870                      \$300                      \$0                      \$1170                      12/20/2012

EXAMINER	ART UNIT	CLASS-SUBCLASS
----------	----------	----------------

NGUYEN, PHUNG                      2612                      340-539130

1. Change of correspondence address or indication of "Fee Address" (37 CFR 1.363). <input type="checkbox"/> Change of correspondence address (or Change of Correspondence Address form PTO/SB/122) attached. <input type="checkbox"/> "Fee Address" indication (or "Fee Address" Indication form PTO/SB/47; Rev 03-02 or more recent) attached. <b>Use of a Customer Number is required.</b>	2. For printing on the patent front page, list (1) the names of up to 3 registered patent attorneys or agents OR, alternatively, 1 _____ (2) the name of a single firm (having as a member a registered attorney or agent) and the names of up to 2 registered patent attorneys or agents. If no name is listed, no name will be printed. 2 _____ 3 _____
--	--

3. ASSIGNEE NAME AND RESIDENCE DATA TO BE PRINTED ON THE PATENT (print or type)

PLEASE NOTE: Unless an assignee is identified below, no assignee data will appear on the patent. If an assignee is identified below, the document has been filed for recordation as set forth in 37 CFR 3.11. Completion of this form is NOT a substitute for filing an assignment.

(A) NAME OF ASSIGNEE \_\_\_\_\_ (B) RESIDENCE: (CITY and STATE OR COUNTRY) \_\_\_\_\_

Please check the appropriate assignee category or categories (will not be printed on the patent) :     Individual     Corporation or other private group entity     Government

4a. The following fee(s) are submitted: <input type="checkbox"/> Issue Fee <input type="checkbox"/> Publication Fee (No small entity discount permitted) <input type="checkbox"/> Advance Order - # of Copies _____	4b. Payment of Fee(s); ( <b>Please first reapply any previously paid issue fee shown above</b> ) <input type="checkbox"/> A check is enclosed. <input type="checkbox"/> Payment by credit card. Form PTO-2038 is attached. <input type="checkbox"/> The Director is hereby authorized to charge the required fee(s), any deficiency, or credit any overpayment, to Deposit Account Number _____ (enclose an extra copy of this form).
--	--

5. **Change in Entity Status** (from status indicated above)

a. Applicant claims SMALL ENTITY status. See 37 CFR 1.27.       b. Applicant is no longer claiming SMALL ENTITY status. See 37 CFR 1.27(g)(2).

NOTE: The Issue Fee and Publication Fee (if required) will not be accepted from anyone other than the applicant; a registered attorney or agent; or the assignee or other party in interest as shown by the records of the United States Patent and Trademark Office.

Authorized Signature \_\_\_\_\_ Date \_\_\_\_\_  
 Typed or printed name \_\_\_\_\_ Registration No. \_\_\_\_\_

This collection of information is required by 37 CFR 1.311. The information is required to obtain or retain a benefit by the public which is to file (and by the USPTO to process) an application. Confidentiality is governed by 35 U.S.C. 122 and 37 CFR 1.14. This collection is estimated to take 12 minutes to complete, including gathering, preparing, and submitting the completed application form to the USPTO. Time will vary depending upon the individual case. Any comments on the amount of time you require to complete this form and/or suggestions for reducing this burden, should be sent to the Chief Information Officer, U.S. Patent and Trademark Office, U.S. Department of Commerce, P.O. Box 1450, Alexandria, Virginia 22313-1450. DO NOT SEND FEES OR COMPLETED FORMS TO THIS ADDRESS. SEND TO: Commissioner for Patents, P.O. Box 1450, Alexandria, Virginia 22313-1450.

Under the Paperwork Reduction Act of 1995, no persons are required to respond to a collection of information unless it displays a valid OMB control number.





UNITED STATES PATENT AND TRADEMARK OFFICE

UNITED STATES DEPARTMENT OF COMMERCE
United States Patent and Trademark Office
Address: COMMISSIONER FOR PATENTS
P.O. Box 1450
Alexandria, Virginia 22313-1450
www.uspto.gov

Table with 5 columns: APPLICATION NO., FILING DATE, FIRST NAMED INVENTOR, ATTORNEY DOCKET NO., CONFIRMATION NO.
12/419,451 04/07/2009 Joseph F. Scalisi LB1-006USC1 1643

93892 7590 09/20/2012
Timberline Patent Law Group
108 N. Washington St.
Suite 417
Spokane, WA 99201

EXAMINER

NGUYEN, PHUNG

ART UNIT PAPER NUMBER

2612

DATE MAILED: 09/20/2012

Determination of Patent Term Adjustment under 35 U.S.C. 154 (b)

(application filed on or after May 29, 2000)

The Patent Term Adjustment to date is 730 day(s). If the issue fee is paid on the date that is three months after the mailing date of this notice and the patent issues on the Tuesday before the date that is 28 weeks (six and a half months) after the mailing date of this notice, the Patent Term Adjustment will be 730 day(s).

If a Continued Prosecution Application (CPA) was filed in the above-identified application, the filing date that determines Patent Term Adjustment is the filing date of the most recent CPA.

Applicant will be able to obtain more detailed information by accessing the Patent Application Information Retrieval (PAIR) WEB site (http://pair.uspto.gov).

Any questions regarding the Patent Term Extension or Adjustment determination should be directed to the Office of Patent Legal Administration at (571)-272-7702. Questions relating to issue and publication fee payments should be directed to the Customer Service Center of the Office of Patent Publication at 1-(888)-786-0101 or (571)-272-4200.

## Privacy Act Statement

**The Privacy Act of 1974 (P.L. 93-579)** requires that you be given certain information in connection with your submission of the attached form related to a patent application or patent. Accordingly, pursuant to the requirements of the Act, please be advised that: (1) the general authority for the collection of this information is 35 U.S.C. 2(b)(2); (2) furnishing of the information solicited is voluntary; and (3) the principal purpose for which the information is used by the U.S. Patent and Trademark Office is to process and/or examine your submission related to a patent application or patent. If you do not furnish the requested information, the U.S. Patent and Trademark Office may not be able to process and/or examine your submission, which may result in termination of proceedings or abandonment of the application or expiration of the patent.

The information provided by you in this form will be subject to the following routine uses:

1. The information on this form will be treated confidentially to the extent allowed under the Freedom of Information Act (5 U.S.C. 552) and the Privacy Act (5 U.S.C. 552a). Records from this system of records may be disclosed to the Department of Justice to determine whether disclosure of these records is required by the Freedom of Information Act.
2. A record from this system of records may be disclosed, as a routine use, in the course of presenting evidence to a court, magistrate, or administrative tribunal, including disclosures to opposing counsel in the course of settlement negotiations.
3. A record in this system of records may be disclosed, as a routine use, to a Member of Congress submitting a request involving an individual, to whom the record pertains, when the individual has requested assistance from the Member with respect to the subject matter of the record.
4. A record in this system of records may be disclosed, as a routine use, to a contractor of the Agency having need for the information in order to perform a contract. Recipients of information shall be required to comply with the requirements of the Privacy Act of 1974, as amended, pursuant to 5 U.S.C. 552a(m).
5. A record related to an International Application filed under the Patent Cooperation Treaty in this system of records may be disclosed, as a routine use, to the International Bureau of the World Intellectual Property Organization, pursuant to the Patent Cooperation Treaty.
6. A record in this system of records may be disclosed, as a routine use, to another federal agency for purposes of National Security review (35 U.S.C. 181) and for review pursuant to the Atomic Energy Act (42 U.S.C. 218(c)).
7. A record from this system of records may be disclosed, as a routine use, to the Administrator, General Services, or his/her designee, during an inspection of records conducted by GSA as part of that agency's responsibility to recommend improvements in records management practices and programs, under authority of 44 U.S.C. 2904 and 2906. Such disclosure shall be made in accordance with the GSA regulations governing inspection of records for this purpose, and any other relevant (i.e., GSA or Commerce) directive. Such disclosure shall not be used to make determinations about individuals.
8. A record from this system of records may be disclosed, as a routine use, to the public after either publication of the application pursuant to 35 U.S.C. 122(b) or issuance of a patent pursuant to 35 U.S.C. 151. Further, a record may be disclosed, subject to the limitations of 37 CFR 1.14, as a routine use, to the public if the record was filed in an application which became abandoned or in which the proceedings were terminated and which application is referenced by either a published application, an application open to public inspection or an issued patent.
9. A record from this system of records may be disclosed, as a routine use, to a Federal, State, or local law enforcement agency, if the USPTO becomes aware of a violation or potential violation of law or regulation.

**Notice of Allowability**

**Application No.**

12/419,451

**Examiner**

PHUNG NGUYEN

**Applicant(s)**

SCALISI ET AL.

**Art Unit**

2612

**-- The MAILING DATE of this communication appears on the cover sheet with the correspondence address--**

All claims being allowable, PROSECUTION ON THE MERITS IS (OR REMAINS) CLOSED in this application. If not included herewith (or previously mailed), a Notice of Allowance (PTOL-85) or other appropriate communication will be mailed in due course. **THIS NOTICE OF ALLOWABILITY IS NOT A GRANT OF PATENT RIGHTS.** This application is subject to withdrawal from issue at the initiative of the Office or upon petition by the applicant. See 37 CFR 1.313 and MPEP 1308.

- 1.  This communication is responsive to 09/10/12.
- 2.  An election was made by the applicant in response to a restriction requirement set forth during the interview on \_\_\_\_; the restriction requirement and election have been incorporated into this action.
- 3.  The allowed claim(s) is/are 1-15,18-21 (renumbered as 1-19).
- 4.  Acknowledgment is made of a claim for foreign priority under 35 U.S.C. § 119(a)-(d) or (f).
  - a)  All    b)  Some\*    c)  None    of the:
    - 1.  Certified copies of the priority documents have been received.
    - 2.  Certified copies of the priority documents have been received in Application No. \_\_\_\_ .
    - 3.  Copies of the certified copies of the priority documents have been received in this national stage application from the International Bureau (PCT Rule 17.2(a)).

\* Certified copies not received: \_\_\_\_.

Applicant has THREE MONTHS FROM THE "MAILING DATE" of this communication to file a reply complying with the requirements noted below. Failure to timely comply will result in ABANDONMENT of this application.

**THIS THREE-MONTH PERIOD IS NOT EXTENDABLE.**

- 5.  A SUBSTITUTE OATH OR DECLARATION must be submitted. Note the attached EXAMINER'S AMENDMENT or NOTICE OF INFORMAL PATENT APPLICATION (PTO-152) which gives reason(s) why the oath or declaration is deficient.
  - 6.  CORRECTED DRAWINGS ( as "replacement sheets") must be submitted.
    - (a)  including changes required by the Notice of Draftsperson's Patent Drawing Review ( PTO-948) attached
      - 1)  hereto or 2)  to Paper No./Mail Date \_\_\_\_.
    - (b)  including changes required by the attached Examiner's Amendment / Comment or in the Office action of Paper No./Mail Date \_\_\_\_.
- Identifying indicia such as the application number (see 37 CFR 1.84(c)) should be written on the drawings in the front (not the back) of each sheet. Replacement sheet(s) should be labeled as such in the header according to 37 CFR 1.121(d).**
- 7.  DEPOSIT OF and/or INFORMATION about the deposit of BIOLOGICAL MATERIAL must be submitted. Note the attached Examiner's comment regarding REQUIREMENT FOR THE DEPOSIT OF BIOLOGICAL MATERIAL.

**Attachment(s)**

- 1.  Notice of References Cited (PTO-892)
- 2.  Notice of Draftsperson's Patent Drawing Review (PTO-948)
- 3.  Information Disclosure Statements (PTO/SB/08), Paper No./Mail Date \_\_\_\_
- 4.  Examiner's Comment Regarding Requirement for Deposit of Biological Material
- 5.  Notice of Informal Patent Application
- 6.  Interview Summary (PTO-413), Paper No./Mail Date \_\_\_\_ .
- 7.  Examiner's Amendment/Comment
- 8.  Examiner's Statement of Reasons for Allowance
- 9.  Other \_\_\_\_.

/PHUNG NGUYEN/  
Primary Examiner, Art Unit 2612





**UNITED STATES PATENT AND TRADEMARK OFFICE**

UNITED STATES DEPARTMENT OF COMMERCE  
**United States Patent and Trademark Office**  
 Address: COMMISSIONER FOR PATENTS  
 P.O. Box 1450  
 Alexandria, Virginia 22313-1450  
 www.uspto.gov

**BIB DATA SHEET**
**CONFIRMATION NO. 1643**

SERIAL NUMBER	FILING or 371(c) DATE	CLASS	GROUP ART UNIT	ATTORNEY DOCKET NO.		
12/419,451	04/07/2009	340	2612	LB1-006USC1		
<b>APPLICANTS</b> Joseph F. Scalisi, Yorba Linda, CA; Roger B. Anderson, Arcadia, CA;						
<b>** CONTINUING DATA *****</b> This application is a CIP of 11/969,905 01/06/2008 PAT 8,102,256 PTN and is a CIP of 11/753,979 05/25/2007 and is a CIP of 11/933,024 10/31/2007 and is a CIP of 11/784,400 04/05/2007 ABN and is a CIP of 11/935,901 11/06/2007 PAT 8,244,468 PTN						
<b>** FOREIGN APPLICATIONS *****</b>						
<b>** IF REQUIRED, FOREIGN FILING LICENSE GRANTED ** ** SMALL ENTITY **</b> 04/16/2009						
Foreign Priority claimed	<input type="checkbox"/> Yes <input checked="" type="checkbox"/> No	<input type="checkbox"/> Met after Allowance	<b>STATE OR COUNTRY</b>	<b>SHEETS DRAWINGS</b>	<b>TOTAL CLAIMS</b>	<b>INDEPENDENT CLAIMS</b>
35 USC 119(a-d) conditions met	<input type="checkbox"/> Yes <input checked="" type="checkbox"/> No	Initials	CA	7	21	3
Verified and Acknowledged	/PHUNG NGUYEN/ Examiner's Signature					
<b>ADDRESS</b> Timberline Patent Law Group 108 N. Washington St. Suite 417 Spokane, WA 99201 UNITED STATES						
<b>TITLE</b> APPARATUS AND METHOD FOR ADJUSTING REFRESH RATE OF LOCATION COORDINATES OF A TRACKING DEVICE						
<b>FILING FEE RECEIVED</b> 488	FEES: Authority has been given in Paper No. _____ to charge/credit DEPOSIT ACCOUNT No. _____ for following:			<input type="checkbox"/> All Fees		
				<input type="checkbox"/> 1.16 Fees (Filing)		
				<input type="checkbox"/> 1.17 Fees (Processing Ext. of time)		
				<input type="checkbox"/> 1.18 Fees (Issue)		
				<input type="checkbox"/> Other _____		
			<input type="checkbox"/> Credit			

<b>Search Notes</b>  	<b>Application/Control No.</b>  12419451	<b>Applicant(s)/Patent Under Reexamination</b>  SCALISI ET AL.
	<b>Examiner</b>  PHUNG NGUYEN	<b>Art Unit</b>  2612

SEARCHED			
Class	Subclass	Date	Examiner
340	539.13,539.21,686.1,636.1,636.2,636.19	06/03/12	PTN
320	108	06/03/12	PTN

SEARCH NOTES		
Search Notes	Date	Examiner

INTERFERENCE SEARCH			
Class	Subclass	Date	Examiner
320	108	09/14/12	PTN

--	--

<b>INFORMATION DISCLOSURE STATEMENT BY APPLICANT</b> ( Not for submission under 37 CFR 1.99)	Application Number		12419451
	Filing Date		2009-04-07
	First Named Inventor	Joseph F. Scalisi	
	Art Unit		2612
	Examiner Name	Phung NGUYEN	
	Attorney Docket Number		LB1-006USC1

U.S.PATENTS						Remove
Examiner Initial*	Cite No	Patent Number	Kind Code <sup>1</sup>	Issue Date	Name of Patentee or Applicant of cited Document	Pages,Columns,Lines where Relevant Passages or Relevant Figures Appear
	1	6078575	A	2000-06-20	Dommety Gopal et al.	Entire Document
	2	6396403	B1	2002-05-28	Haner	Entire Document
	3	6774797		2004-08-01	Freathy et al.	Entire Document
	4	6998985	B2	2006-02-14	Reisman et al.	Entire Document
	5	7019644	B2	2006-03-28	Barrie	Entire Document
	6	7742774	B2	2010-06-22	Oh Seung et al.	Entire Document
	7	7823073	B2	2010-10-26	Holmes et al.	Entire Document
	8	7831264	B2	2010-11-09	Miegel	Entire Document

**INFORMATION DISCLOSURE  
STATEMENT BY APPLICANT**  
( Not for submission under 37 CFR 1.99)

Application Number	12419451
Filing Date	2009-04-07
First Named Inventor	Joseph F. Scalisi
Art Unit	2612
Examiner Name	Phung NGUYEN
Attorney Docket Number	LB1-006USC1

9	7995994	B2	2011-08-09	Khetawat et al.	Entire Document
10	8010601	B2	2011-08-30	Jennings et al.	Entire Document

If you wish to add additional U.S. Patent citation information please click the Add button. **Add**

**U.S.PATENT APPLICATION PUBLICATIONS** Remove

Examiner Initial*	Cite No	Publication Number	Kind Code <sup>1</sup>	Publication Date	Name of Patentee or Applicant of cited Document	Pages, Columns, Lines where Relevant Passages or Relevant Figures Appear
	1	20030004776	A	2003-01-02	Perrella et al.	Entire Document
	2	20060176149	A	2006-08-10	Douglas	Entire Document
	3	20060223518	A	2006-10-05	Haney	Entire Document
	4	20070200695	A	2007-08-30	Almstrand et al.	Entire Document
	5	20070240212	A	2007-10-11	Matalytski	Entire Document
	6	20080021741	A	2008-01-24	Holla et al.	Entire Document
	7	20090177385	A	2009-07-09	Matas et al.	Entire Document



<b>INFORMATION DISCLOSURE STATEMENT BY APPLICANT</b> ( Not for submission under 37 CFR 1.99)	Application Number	12419451
	Filing Date	2009-04-07
	First Named Inventor	Joseph F. Scalisi
	Art Unit	2612
	Examiner Name	Phung NGUYEN
	Attorney Docket Number	LB1-006USC1

8	20100216487	A	2010-08-26	Yamaguchi	Entire Document
---	-------------	---	------------	-----------	-----------------

If you wish to add additional U.S. Published Application citation information please click the Add button. **Add**

<b>FOREIGN PATENT DOCUMENTS</b>								Remove
Examiner Initial*	Cite No	Foreign Document Number <sup>3</sup>	Country Code <sup>2</sup> i	Kind Code <sup>4</sup>	Publication Date	Name of Patentee or Applicant of cited Document	Pages, Columns, Lines where Relevant Passages or Relevant Figures Appear	T <sup>5</sup>
	1							<input type="checkbox"/>

If you wish to add additional Foreign Patent Document citation information please click the Add button **Add**

<b>NON-PATENT LITERATURE DOCUMENTS</b>			Remove
Examiner Initials*	Cite No	Include name of the author (in CAPITAL LETTERS), title of the article (when appropriate), title of the item (book, magazine, journal, serial, symposium, catalog, etc), date, pages(s), volume-issue number(s), publisher, city and/or country where published.	T <sup>5</sup>
	1		<input type="checkbox"/>

If you wish to add additional non-patent literature document citation information please click the Add button **Add**

<b>EXAMINER SIGNATURE</b>	
Examiner Signature	Date Considered

\*EXAMINER: Initial if reference considered, whether or not citation is in conformance with MPEP 609. Draw line through a citation if not in conformance and not considered. Include copy of this form with next communication to applicant.

<sup>1</sup> See Kind Codes of USPTO Patent Documents at [www.USPTO.GOV](http://www.USPTO.GOV) or MPEP 901.04. <sup>2</sup> Enter office that issued the document, by the two-letter code (WIPO Standard ST.3). <sup>3</sup> For Japanese patent documents, the indication of the year of the reign of the Emperor must precede the serial number of the patent document. <sup>4</sup> Kind of document by the appropriate symbols as indicated on the document under WIPO Standard ST.16 if possible. <sup>5</sup> Applicant is to place a check mark here if English language translation is attached.

**INFORMATION DISCLOSURE  
STATEMENT BY APPLICANT**  
( Not for submission under 37 CFR 1.99)

Application Number	12419451
Filing Date	2009-04-07
First Named Inventor	Joseph F. Scalisi
Art Unit	2612
Examiner Name	Phung NGUYEN
Attorney Docket Number	LB1-006USC1

**CERTIFICATION STATEMENT**

Please see 37 CFR 1.97 and 1.98 to make the appropriate selection(s):

That each item of information contained in the information disclosure statement was first cited in any communication from a foreign patent office in a counterpart foreign application not more than three months prior to the filing of the information disclosure statement. See 37 CFR 1.97(e)(1).

**OR**

That no item of information contained in the information disclosure statement was cited in a communication from a foreign patent office in a counterpart foreign application, and, to the knowledge of the person signing the certification after making reasonable inquiry, no item of information contained in the information disclosure statement was known to any individual designated in 37 CFR 1.56(c) more than three months prior to the filing of the information disclosure statement. See 37 CFR 1.97(e)(2).

See attached certification statement.

Fee set forth in 37 CFR 1.17 (p) has been submitted herewith.

None

**SIGNATURE**

A signature of the applicant or representative is required in accordance with CFR 1.33, 10.18. Please see CFR 1.4(d) for the form of the signature.

Signature	/Mark Farrell/	Date (YYYY-MM-DD)	2012-12-20
Name/Print	Mark Farrell	Registration Number	45988

This collection of information is required by 37 CFR 1.97 and 1.98. The information is required to obtain or retain a benefit by the public which is to file (and by the USPTO to process) an application. Confidentiality is governed by 35 U.S.C. 122 and 37 CFR 1.14. This collection is estimated to take 1 hour to complete, including gathering, preparing and submitting the completed application form to the USPTO. Time will vary depending upon the individual case. Any comments on the amount of time you require to complete this form and/or suggestions for reducing this burden, should be sent to the Chief Information Officer, U.S. Patent and Trademark Office, U.S. Department of Commerce, P.O. Box 1450, Alexandria, VA 22313-1450. **DO NOT SEND FEES OR COMPLETED FORMS TO THIS ADDRESS. SEND TO: Commissioner for Patents, P.O. Box 1450, Alexandria, VA 22313-1450.**

## Privacy Act Statement

The Privacy Act of 1974 (P.L. 93-579) requires that you be given certain information in connection with your submission of the attached form related to a patent application or patent. Accordingly, pursuant to the requirements of the Act, please be advised that: (1) the general authority for the collection of this information is 35 U.S.C. 2(b)(2); (2) furnishing of the information solicited is voluntary; and (3) the principal purpose for which the information is used by the U.S. Patent and Trademark Office is to process and/or examine your submission related to a patent application or patent. If you do not furnish the requested information, the U.S. Patent and Trademark Office may not be able to process and/or examine your submission, which may result in termination of proceedings or abandonment of the application or expiration of the patent.

The information provided by you in this form will be subject to the following routine uses:

1. The information on this form will be treated confidentially to the extent allowed under the Freedom of Information Act (5 U.S.C. 552) and the Privacy Act (5 U.S.C. 552a). Records from this system of records may be disclosed to the Department of Justice to determine whether the Freedom of Information Act requires disclosure of these records.
2. A record from this system of records may be disclosed, as a routine use, in the course of presenting evidence to a court, magistrate, or administrative tribunal, including disclosures to opposing counsel in the course of settlement negotiations.
3. A record in this system of records may be disclosed, as a routine use, to a Member of Congress submitting a request involving an individual, to whom the record pertains, when the individual has requested assistance from the Member with respect to the subject matter of the record.
4. A record in this system of records may be disclosed, as a routine use, to a contractor of the Agency having need for the information in order to perform a contract. Recipients of information shall be required to comply with the requirements of the Privacy Act of 1974, as amended, pursuant to 5 U.S.C. 552a(m).
5. A record related to an International Application filed under the Patent Cooperation Treaty in this system of records may be disclosed, as a routine use, to the International Bureau of the World Intellectual Property Organization, pursuant to the Patent Cooperation Treaty.
6. A record in this system of records may be disclosed, as a routine use, to another federal agency for purposes of National Security review (35 U.S.C. 181) and for review pursuant to the Atomic Energy Act (42 U.S.C. 218(c)).
7. A record from this system of records may be disclosed, as a routine use, to the Administrator, General Services, or his/her designee, during an inspection of records conducted by GSA as part of that agency's responsibility to recommend improvements in records management practices and programs, under authority of 44 U.S.C. 2904 and 2906. Such disclosure shall be made in accordance with the GSA regulations governing inspection of records for this purpose, and any other relevant (i.e., GSA or Commerce) directive. Such disclosure shall not be used to make determinations about individuals.
8. A record from this system of records may be disclosed, as a routine use, to the public after either publication of the application pursuant to 35 U.S.C. 122(b) or issuance of a patent pursuant to 35 U.S.C. 151. Further, a record may be disclosed, subject to the limitations of 37 CFR 1.14, as a routine use, to the public if the record was filed in an application which became abandoned or in which the proceedings were terminated and which application is referenced by either a published application, an application open to public inspections or an issued patent.
9. A record from this system of records may be disclosed, as a routine use, to a Federal, State, or local law enforcement agency, if the USPTO becomes aware of a violation or potential violation of law or regulation.

## Electronic Patent Application Fee Transmittal

<b>Application Number:</b>	12419451
<b>Filing Date:</b>	07-Apr-2009
<b>Title of Invention:</b>	APPARATUS AND METHOD FOR ADJUSTING REFRESH RATE OF LOCATION COORDINATES OF A TRACKING DEVICE
<b>First Named Inventor/Applicant Name:</b>	Joseph F. Scalisi
<b>Filer:</b>	Mark Farrell/Melissa Nelson
<b>Attorney Docket Number:</b>	LB1-006USC1

Filed as Large Entity

### Utility under 35 USC 111(a) Filing Fees

Description	Fee Code	Quantity	Amount	Sub-Total in USD(\$)
<b>Basic Filing:</b>				
<b>Pages:</b>				
<b>Claims:</b>				
<b>Miscellaneous-Filing:</b>				
<b>Petition:</b>				
<b>Patent-Appeals-and-Interference:</b>				
<b>Post-Allowance-and-Post-Issuance:</b>				
<b>Extension-of-Time:</b>				

Description	Fee Code	Quantity	Amount	Sub-Total in USD(\$)
<b>Miscellaneous:</b>				
Submission- Information Disclosure Stmt	1806	1	180	180
<b>Total in USD (\$)</b>				<b>180</b>

## Electronic Acknowledgement Receipt

<b>EFS ID:</b>	14535916
<b>Application Number:</b>	12419451
<b>International Application Number:</b>	
<b>Confirmation Number:</b>	1643
<b>Title of Invention:</b>	APPARATUS AND METHOD FOR ADJUSTING REFRESH RATE OF LOCATION COORDINATES OF A TRACKING DEVICE
<b>First Named Inventor/Applicant Name:</b>	Joseph F. Scalisi
<b>Customer Number:</b>	93892
<b>Filer:</b>	Mark Farrell/Melissa Nelson
<b>Filer Authorized By:</b>	Mark Farrell
<b>Attorney Docket Number:</b>	LB1-006USC1
<b>Receipt Date:</b>	20-DEC-2012
<b>Filing Date:</b>	07-APR-2009
<b>Time Stamp:</b>	21:23:02
<b>Application Type:</b>	Utility under 35 USC 111(a)

### Payment information:

Submitted with Payment	yes
Payment Type	Credit Card
Payment was successfully received in RAM	\$180
RAM confirmation Number	9947
Deposit Account	
Authorized User	

### File Listing:

Document Number	Document Description	File Name	File Size(Bytes)/ Message Digits	Multi Part If appl.	Pages If appl.)

1	Information Disclosure Statement (IDS) Form (SB08)	LB1006USC1IDS.pdf	612610	no	5
			1a04799b09aefff7cb540dfc3952b9f0163b59c		
<b>Warnings:</b>					
<b>Information:</b>					
2	Fee Worksheet (SB06)	fee-info.pdf	30625	no	2
			8f871fd1b0db83607b22dbe71a856c5f92e870cb1		
<b>Warnings:</b>					
<b>Information:</b>					
<b>Total Files Size (in bytes):</b>			643235		

**This Acknowledgement Receipt evidences receipt on the noted date by the USPTO of the indicated documents, characterized by the applicant, and including page counts, where applicable. It serves as evidence of receipt similar to a Post Card, as described in MPEP 503.**

**New Applications Under 35 U.S.C. 111**

**If a new application is being filed and the application includes the necessary components for a filing date (see 37 CFR 1.53(b)-(d) and MPEP 506), a Filing Receipt (37 CFR 1.54) will be issued in due course and the date shown on this Acknowledgement Receipt will establish the filing date of the application.**

**National Stage of an International Application under 35 U.S.C. 371**

**If a timely submission to enter the national stage of an international application is compliant with the conditions of 35 U.S.C. 371 and other applicable requirements a Form PCT/DO/EO/903 indicating acceptance of the application as a national stage submission under 35 U.S.C. 371 will be issued in addition to the Filing Receipt, in due course.**

**New International Application Filed with the USPTO as a Receiving Office**

**If a new international application is being filed and the international application includes the necessary components for an international filing date (see PCT Article 11 and MPEP 1810), a Notification of the International Application Number and of the International Filing Date (Form PCT/RO/105) will be issued in due course, subject to prescriptions concerning national security, and the date shown on this Acknowledgement Receipt will establish the international filing date of the application.**

PART B - FEE(S) TRANSMITTAL

Complete and send this form, together with applicable fee(s), to: **Mail** Mail Stop ISSUE FEE  
 Commissioner for Patents  
 P.O. Box 1450  
 Alexandria, Virginia 22313-1450  
 or **Fax** (571)-273-2855

INSTRUCTIONS: This form should be used for transmitting the ISSUE FEE and PUBLICATION FEE (if required). Blocks 1 through 5 should be completed where appropriate. All further correspondence including the Patent, advance orders and notification of maintenance fees will be mailed to the current correspondence address as indicated unless corrected below or directed otherwise in Block 1, by (a) specifying a new correspondence address; and/or (b) indicating a separate "FEE ADDRESS" for maintenance fee notifications.

CURRENT CORRESPONDENCE ADDRESS (Note: Use Block 1 for any change of address)

Note: A certificate of mailing can only be used for domestic mailings of the Fee(s) Transmittal. This certificate cannot be used for any other accompanying papers. Each additional paper, such as an assignment or formal drawing, must have its own certificate of mailing or transmission.

73802 7390 09/20/2012  
 Timberline Patent Law Group  
 108 N. Washington St.  
 Suite 417  
 Spokane, WA 99201

Certificate of Mailing or Transmission  
 I hereby certify that this Fee(s) Transmittal is being deposited with the United States Postal Service with sufficient postage for first class mail in an envelope addressed to the Mail Stop ISSUE FEE address above, or being facsimile transmitted to the USPTO (571) 273-2855, on the date indicated below.

Filed via EPS Web	(Depositor's name)
	(Signature)
	(Date)

APPLICATION NO.	FILING DATE	FIRST NAMED INVENTOR	ATTORNEY DOCKET NO.	CONFIRMATION NO.
12/19,451	04/07/2009	Joseph F. Scallisi	LB1-006USC1	1643

TITLE OF INVENTION: APPARATUS AND METHOD FOR ADJUSTING REFRESH RATE OF LOCATION COORDINATES OF A TRACKING DEVICE

APPLN. TYPE	SMALL ENTITY	ISSUE FEE DUE	PUBLICATION FEE DUE	PREV. PAID ISSUE FEE	TOTAL FEE(S) DUE	DATE DUE
nonprovisional	YES	\$870	\$300	\$0	\$1170	12/20/2012

EXAMINER	ART. UND.	CLASS. SUBCLASS
NGUYEN, PHUNG	2612	340-539130

1. Change of correspondence address or indication of "Fee Address" (37 CFR 1.363).  
 Change of correspondence address (or Change of Correspondence Address form PTO/SB/122) attached.  
 "Fee Address" indication (or "Fee Address" Indication form PTO/SB/47; Rev. 03-02 or more recent) attached. Use of a Customer Number is required.

2. For printing on the patent front page, list **TIMBERLINE Patent Law Group PLLC**  
 (1) the names of up to 3 registered patent attorneys or agents OR, alternatively,  
 (2) the name of a single firm (having as a member a registered attorney or agent) and the names of up to 2 registered patent attorneys or agents. If no name is listed, no name will be printed.

1 Mark Farrell 45,988  
 2  
 3

3. ASSIGNEE NAME AND RESIDENCE DATA TO BE PRINTED ON THE PATENT (print or type)  
 PLEASE NOTE: Unless an assignee is identified below, no assignee data will appear on the patent. If an assignee is identified below, the document has been filed for recordation as set forth in 37 CFR 3.11. Completion of this form is NOT a substitute for filing an assignment.

(A) NAME OF ASSIGNEE: Location Based Technologies Inc.  
 (B) RESIDENCE: (CITY and STATE OR COUNTRY): Irvine, CA

Please check the appropriate assignee category or categories (will not be printed on the patent):  Individual  Corporation or other private group entity  Government

4a. The following fee(s) are submitted:  
 Issue Fee  
 Publication Fee (No small entity discount permitted)  
 Advance Order - # of Copies \_\_\_\_\_

4b. Payment of Fee(s): (Please first reapply any previously paid issue fee shown above)  
 A check is enclosed  
 Payment by credit card. Form PTO-2008 is attached.  
 The Director is hereby authorized to charge the required fee(s), any deficiency, or credit any overpayment, to Deposit Account Number \_\_\_\_\_ (enclose an extra copy of this form).

5. Change in Entity Status (from status indicated above)  
 a. Applicant claims SMALL ENTITY status. See 37 CFR 1.27.  b. Applicant is no longer claiming SMALL ENTITY status. See 37 CFR 1.27(g)(2)

NOTE: The Issue Fee and Publication Fee (if required) will not be accepted from anyone other than the applicant, a registered attorney or agent, or the assignee or other party in interest as shown by the records of the United States Patent and Trademark Office.

Authorized Signature: Mark Farrell Date: 12-19-2012  
 Typed or printed name: Mark Farrell Registration No.: 45988

This collection of information is required by 37 CFR 1.311. The information is required to obtain or retain a benefit by the public, which is to file (and by the USPTO to process) an application. Confidentiality is governed by 35 U.S.C. 122 and 37 CFR 1.14. This collection is estimated to take 12 minutes to complete, including gathering, preparing, and submitting the completed application form to the USPTO. Time will vary depending upon the individual case. Any comments on the amount of time you require to complete this form and/or suggestions for reducing this burden, should be sent to the Chief Information Officer, U.S. Patent and Trademark Office, U.S. Department of Commerce, P.O. Box 1450, Alexandria, Virginia 22313-1450. DO NOT SEND FEES OR COMPLETED FORMS TO THIS ADDRESS. SEND TO: Commissioner for Patents, P.O. Box 1450, Alexandria, Virginia 22313-1450.

Under the Paperwork Reduction Act of 1995, no person is required to respond to a collection of information unless it displays a valid OMB control number.



## Electronic Patent Application Fee Transmittal

<b>Application Number:</b>	12419451
<b>Filing Date:</b>	07-Apr-2009
<b>Title of Invention:</b>	APPARATUS AND METHOD FOR ADJUSTING REFRESH RATE OF LOCATION COORDINATES OF A TRACKING DEVICE
<b>First Named Inventor/Applicant Name:</b>	Joseph F. Scalisi
<b>Filer:</b>	Mark Farrell/Melissa Nelson
<b>Attorney Docket Number:</b>	LB1-006USC1

Filed as Small Entity

### Utility under 35 USC 111(a) Filing Fees

Description	Fee Code	Quantity	Amount	Sub-Total in USD(\$)
<b>Basic Filing:</b>				
<b>Pages:</b>				
<b>Claims:</b>				
<b>Miscellaneous-Filing:</b>				
<b>Petition:</b>				
<b>Patent-Appeals-and-Interference:</b>				
<b>Post-Allowance-and-Post-Issuance:</b>				
Utility Appl issue fee	2501	1	885	885
Publ. Fee- early, voluntary, or normal	1504	1	300	300

IPR2020-01189

Description	Fee Code	Quantity	Amount	Sub-Total in USD(\$)
<b>Extension-of-Time:</b>				
<b>Miscellaneous:</b>				
<b>Total in USD (\$)</b>				<b>1185</b>

## Electronic Acknowledgement Receipt

<b>EFS ID:</b>	14535933
<b>Application Number:</b>	12419451
<b>International Application Number:</b>	
<b>Confirmation Number:</b>	1643
<b>Title of Invention:</b>	APPARATUS AND METHOD FOR ADJUSTING REFRESH RATE OF LOCATION COORDINATES OF A TRACKING DEVICE
<b>First Named Inventor/Applicant Name:</b>	Joseph F. Scalisi
<b>Customer Number:</b>	93892
<b>Filer:</b>	Mark Farrell/Melissa Nelson
<b>Filer Authorized By:</b>	Mark Farrell
<b>Attorney Docket Number:</b>	LB1-006USC1
<b>Receipt Date:</b>	20-DEC-2012
<b>Filing Date:</b>	07-APR-2009
<b>Time Stamp:</b>	21:27:54
<b>Application Type:</b>	Utility under 35 USC 111(a)

### Payment information:

Submitted with Payment	yes
Payment Type	Credit Card
Payment was successfully received in RAM	\$1185
RAM confirmation Number	9970
Deposit Account	
Authorized User	

### File Listing:

Document Number	Document Description	File Name	File Size(Bytes)/ Message Digits	Multi Part If appl.	Pages If appl.)

1	Issue Fee Payment (PTO-85B)	LB1006USC1IssueFeeTransmittal.pdf	1348092 cd39dd5e5e7522c61cf6bd30ebb92ba1929fb945	no	1
<b>Warnings:</b>					
<b>Information:</b>					
2	Fee Worksheet (SB06)	fee-info.pdf	32077 2e2f82713f62f9f511da34e0f221bba692315a7e	no	2
<b>Warnings:</b>					
<b>Information:</b>					
<b>Total Files Size (in bytes):</b>				1380169	

**This Acknowledgement Receipt evidences receipt on the noted date by the USPTO of the indicated documents, characterized by the applicant, and including page counts, where applicable. It serves as evidence of receipt similar to a Post Card, as described in MPEP 503.**

**New Applications Under 35 U.S.C. 111**

**If a new application is being filed and the application includes the necessary components for a filing date (see 37 CFR 1.53(b)-(d) and MPEP 506), a Filing Receipt (37 CFR 1.54) will be issued in due course and the date shown on this Acknowledgement Receipt will establish the filing date of the application.**

**National Stage of an International Application under 35 U.S.C. 371**

**If a timely submission to enter the national stage of an international application is compliant with the conditions of 35 U.S.C. 371 and other applicable requirements a Form PCT/DO/EO/903 indicating acceptance of the application as a national stage submission under 35 U.S.C. 371 will be issued in addition to the Filing Receipt, in due course.**

**New International Application Filed with the USPTO as a Receiving Office**

**If a new international application is being filed and the international application includes the necessary components for an international filing date (see PCT Article 11 and MPEP 1810), a Notification of the International Application Number and of the International Filing Date (Form PCT/RO/105) will be issued in due course, subject to prescriptions concerning national security, and the date shown on this Acknowledgement Receipt will establish the international filing date of the application.**

<b>INFORMATION DISCLOSURE STATEMENT BY APPLICANT</b> ( Not for submission under 37 CFR 1.99)	Application Number		12419451
	Filing Date		2009-04-07
	First Named Inventor	Joseph F. Scalisi	
	Art Unit		2612
	Examiner Name	Phung NGUYEN	
	Attorney Docket Number		LB1-006USC1

U.S.PATENTS						Remove
Examiner Initial*	Cite No	Patent Number	Kind Code <sup>1</sup>	Issue Date	Name of Patentee or Applicant of cited Document	Pages,Columns,Lines where Relevant Passages or Relevant Figures Appear
	1	6078575	A	2000-06-20	Dommety Gopal et al.	Entire Document
	2	6396403	B1	2002-05-28	Haner	Entire Document
	3	6774797		2004-08-01	Freathy et al.	Entire Document
	4	6998985	B2	2006-02-14	Reisman et al.	Entire Document
	5	7019644	B2	2006-03-28	Barrie	Entire Document
	6	7742774	B2	2010-06-22	Oh Seung et al.	Entire Document
	7	7823073	B2	2010-10-26	Holmes et al.	Entire Document
	8	7831264	B2	2010-11-09	Miegel	Entire Document

**INFORMATION DISCLOSURE  
STATEMENT BY APPLICANT**  
( Not for submission under 37 CFR 1.99)

Application Number	12419451
Filing Date	2009-04-07
First Named Inventor	Joseph F. Scalisi
Art Unit	2612
Examiner Name	Phung NGUYEN
Attorney Docket Number	LB1-006USC1

9	7995994	B2	2011-08-09	Khetawat et al.	Entire Document
10	8010601	B2	2011-08-30	Jennings et al.	Entire Document

If you wish to add additional U.S. Patent citation information please click the Add button.

**Add**

**U.S.PATENT APPLICATION PUBLICATIONS**

**Remove**

Examiner Initial*	Cite No	Publication Number	Kind Code <sup>1</sup>	Publication Date	Name of Patentee or Applicant of cited Document	Pages, Columns, Lines where Relevant Passages or Relevant Figures Appear
	1	20030004776	A	2003-01-02	Perrella et al.	Entire Document
	2	20060176149	A	2006-08-10	Douglas	Entire Document
	3	20060223518	A	2006-10-05	Haney	Entire Document
	4	20070200695	A	2007-08-30	Almstrand et al.	Entire Document
	5	20070240212	A	2007-10-11	Matalytski	Entire Document
	6	20080021741	A	2008-01-24	Holla et al.	Entire Document
	7	20090177385	A	2009-07-09	Matas et al.	Entire Document

**INFORMATION DISCLOSURE  
STATEMENT BY APPLICANT**  
( Not for submission under 37 CFR 1.99)

Application Number	12419451
Filing Date	2009-04-07
First Named Inventor	Joseph F. Scalisi
Art Unit	2612
Examiner Name	Phung NGUYEN
Attorney Docket Number	LB1-006USC1

8	20100216487	A	2010-08-26	Yamaguchi	Entire Document
---	-------------	---	------------	-----------	-----------------

If you wish to add additional U.S. Published Application citation information please click the Add button. **Add**

**FOREIGN PATENT DOCUMENTS**

**Remove**

Examiner Initial*	Cite No	Foreign Document Number <sup>3</sup>	Country Code <sup>2</sup>	Kind Code <sup>4</sup>	Publication Date	Name of Patentee or Applicant of cited Document	Pages, Columns, Lines where Relevant Passages or Relevant Figures Appear	T <sup>5</sup>
	1							<input type="checkbox"/>

If you wish to add additional Foreign Patent Document citation information please click the Add button **Add**

**NON-PATENT LITERATURE DOCUMENTS**

**Remove**

Examiner Initials*	Cite No	Include name of the author (in CAPITAL LETTERS), title of the article (when appropriate), title of the item (book, magazine, journal, serial, symposium, catalog, etc), date, pages(s), volume-issue number(s), publisher, city and/or country where published.	T <sup>5</sup>
	1		<input type="checkbox"/>

If you wish to add additional non-patent literature document citation information please click the Add button **Add**

**EXAMINER SIGNATURE**

Examiner Signature	/Phung Nguyen/	Date Considered	12/29/2012
--------------------	----------------	-----------------	------------

\*EXAMINER: Initial if reference considered, whether or not citation is in conformance with MPEP 609. Draw line through a citation if not in conformance and not considered. Include copy of this form with next communication to applicant.

<sup>1</sup> See Kind Codes of USPTO Patent Documents at [www.USPTO.GOV](http://www.USPTO.GOV) or MPEP 901.04. <sup>2</sup> Enter office that issued the document, by the two-letter code (WIPO Standard ST.3). <sup>3</sup> For Japanese patent documents, the indication of the year of the reign of the Emperor must precede the serial number of the patent document. <sup>4</sup> Kind of document by the appropriate symbols as indicated on the document under WIPO Standard ST.16 if possible. <sup>5</sup> Applicant is to place a check mark here if English language translation is attached.

<b>INFORMATION DISCLOSURE STATEMENT BY APPLICANT</b> ( Not for submission under 37 CFR 1.99)	Application Number	12419451
	Filing Date	2009-04-07
	First Named Inventor	Joseph F. Scalisi
	Art Unit	2612
	Examiner Name	Phung NGUYEN
	Attorney Docket Number	LB1-006USC1

**CERTIFICATION STATEMENT**

Please see 37 CFR 1.97 and 1.98 to make the appropriate selection(s):

That each item of information contained in the information disclosure statement was first cited in any communication from a foreign patent office in a counterpart foreign application not more than three months prior to the filing of the information disclosure statement. See 37 CFR 1.97(e)(1).

**OR**

That no item of information contained in the information disclosure statement was cited in a communication from a foreign patent office in a counterpart foreign application, and, to the knowledge of the person signing the certification after making reasonable inquiry, no item of information contained in the information disclosure statement was known to any individual designated in 37 CFR 1.56(c) more than three months prior to the filing of the information disclosure statement. See 37 CFR 1.97(e)(2).

- See attached certification statement.
- Fee set forth in 37 CFR 1.17 (p) has been submitted herewith.
- None

**SIGNATURE**

A signature of the applicant or representative is required in accordance with CFR 1.33, 10.18. Please see CFR 1.4(d) for the form of the signature.

Signature	/Mark Farrell/	Date (YYYY-MM-DD)	2012-12-20
Name/Print	Mark Farrell	Registration Number	45988

This collection of information is required by 37 CFR 1.97 and 1.98. The information is required to obtain or retain a benefit by the public which is to file (and by the USPTO to process) an application. Confidentiality is governed by 35 U.S.C. 122 and 37 CFR 1.14. This collection is estimated to take 1 hour to complete, including gathering, preparing and submitting the completed application form to the USPTO. Time will vary depending upon the individual case. Any comments on the amount of time you require to complete this form and/or suggestions for reducing this burden, should be sent to the Chief Information Officer, U.S. Patent and Trademark Office, U.S. Department of Commerce, P.O. Box 1450, Alexandria, VA 22313-1450. **DO NOT SEND FEES OR COMPLETED FORMS TO THIS ADDRESS. SEND TO: Commissioner for Patents, P.O. Box 1450, Alexandria, VA 22313-1450.**



## Privacy Act Statement

The Privacy Act of 1974 (P.L. 93-579) requires that you be given certain information in connection with your submission of the attached form related to a patent application or patent. Accordingly, pursuant to the requirements of the Act, please be advised that: (1) the general authority for the collection of this information is 35 U.S.C. 2(b)(2); (2) furnishing of the information solicited is voluntary; and (3) the principal purpose for which the information is used by the U.S. Patent and Trademark Office is to process and/or examine your submission related to a patent application or patent. If you do not furnish the requested information, the U.S. Patent and Trademark Office may not be able to process and/or examine your submission, which may result in termination of proceedings or abandonment of the application or expiration of the patent.

The information provided by you in this form will be subject to the following routine uses:

1. The information on this form will be treated confidentially to the extent allowed under the Freedom of Information Act (5 U.S.C. 552) and the Privacy Act (5 U.S.C. 552a). Records from this system of records may be disclosed to the Department of Justice to determine whether the Freedom of Information Act requires disclosure of these records.
2. A record from this system of records may be disclosed, as a routine use, in the course of presenting evidence to a court, magistrate, or administrative tribunal, including disclosures to opposing counsel in the course of settlement negotiations.
3. A record in this system of records may be disclosed, as a routine use, to a Member of Congress submitting a request involving an individual, to whom the record pertains, when the individual has requested assistance from the Member with respect to the subject matter of the record.
4. A record in this system of records may be disclosed, as a routine use, to a contractor of the Agency having need for the information in order to perform a contract. Recipients of information shall be required to comply with the requirements of the Privacy Act of 1974, as amended, pursuant to 5 U.S.C. 552a(m).
5. A record related to an International Application filed under the Patent Cooperation Treaty in this system of records may be disclosed, as a routine use, to the International Bureau of the World Intellectual Property Organization, pursuant to the Patent Cooperation Treaty.
6. A record in this system of records may be disclosed, as a routine use, to another federal agency for purposes of National Security review (35 U.S.C. 181) and for review pursuant to the Atomic Energy Act (42 U.S.C. 218(c)).
7. A record from this system of records may be disclosed, as a routine use, to the Administrator, General Services, or his/her designee, during an inspection of records conducted by GSA as part of that agency's responsibility to recommend improvements in records management practices and programs, under authority of 44 U.S.C. 2904 and 2906. Such disclosure shall be made in accordance with the GSA regulations governing inspection of records for this purpose, and any other relevant (i.e., GSA or Commerce) directive. Such disclosure shall not be used to make determinations about individuals.
8. A record from this system of records may be disclosed, as a routine use, to the public after either publication of the application pursuant to 35 U.S.C. 122(b) or issuance of a patent pursuant to 35 U.S.C. 151. Further, a record may be disclosed, subject to the limitations of 37 CFR 1.14, as a routine use, to the public if the record was filed in an application which became abandoned or in which the proceedings were terminated and which application is referenced by either a published application, an application open to public inspections or an issued patent.
9. A record from this system of records may be disclosed, as a routine use, to a Federal, State, or local law enforcement agency, if the USPTO becomes aware of a violation or potential violation of law or regulation.



UNITED STATES PATENT AND TRADEMARK OFFICE

UNITED STATES DEPARTMENT OF COMMERCE
United States Patent and Trademark Office
Address: COMMISSIONER FOR PATENTS
P.O. Box 1450
Alexandria, Virginia 22313-1450
www.uspto.gov

Table with columns: APPLICATION NO., FILING DATE, FIRST NAMED INVENTOR, ATTORNEY DOCKET NO., CONFIRMATION NO.
Row 1: 12/419,451, 04/07/2009, Joseph F. Scalisi, LB1-006USC1, 1643
Row 2: 93892, 7590, 01/04/2013, EXAMINER NGUYEN, PHUNG
Row 3: ART UNIT 2681, PAPER NUMBER
Row 4: NOTIFICATION DATE 01/04/2013, DELIVERY MODE ELECTRONIC

Please find below and/or attached an Office communication concerning this application or proceeding.

The time period for reply, if any, is set in the attached communication.

Notice of the Office communication was sent electronically on above-indicated "Notification Date" to the following e-mail address(es):

info@timberlinepatents.com
melissa@timberlinepatents.com
mark\_farrell@comcast.net

**Supplemental  
Notice of Allowability**

**Application No.**

12/419,451

**Examiner**

PHUNG NGUYEN

**Applicant(s)**

SCALISI ET AL.

**Art Unit**

2681

**-- The MAILING DATE of this communication appears on the cover sheet with the correspondence address--**

All claims being allowable, PROSECUTION ON THE MERITS IS (OR REMAINS) CLOSED in this application. If not included herewith (or previously mailed), a Notice of Allowance (PTOL-85) or other appropriate communication will be mailed in due course. **THIS NOTICE OF ALLOWABILITY IS NOT A GRANT OF PATENT RIGHTS.** This application is subject to withdrawal from issue at the initiative of the Office or upon petition by the applicant. See 37 CFR 1.313 and MPEP 1308.

1.  This communication is responsive to 09/10/12.
2.  An election was made by the applicant in response to a restriction requirement set forth during the interview on \_\_\_\_; the restriction requirement and election have been incorporated into this action.
3.  The allowed claim(s) is/are 1-15,18-21 (renumbered as 1-19).
4.  Acknowledgment is made of a claim for foreign priority under 35 U.S.C. § 119(a)-(d) or (f).
  - a)  All    b)  Some\*    c)  None    of the:
    1.  Certified copies of the priority documents have been received.
    2.  Certified copies of the priority documents have been received in Application No. \_\_\_\_ .
    3.  Copies of the certified copies of the priority documents have been received in this national stage application from the International Bureau (PCT Rule 17.2(a)).

\* Certified copies not received: \_\_\_\_.

Applicant has **THREE MONTHS FROM THE "MAILING DATE"** of this communication to file a reply complying with the requirements noted below. Failure to timely comply will result in ABANDONMENT of this application.

**THIS THREE-MONTH PERIOD IS NOT EXTENDABLE.**

5.  A SUBSTITUTE OATH OR DECLARATION must be submitted. Note the attached EXAMINER'S AMENDMENT or NOTICE OF INFORMAL PATENT APPLICATION (PTO-152) which gives reason(s) why the oath or declaration is deficient.
6.  CORRECTED DRAWINGS ( as "replacement sheets") must be submitted.
  - (a)  including changes required by the Notice of Draftsperson's Patent Drawing Review ( PTO-948) attached
    - 1)  hereto or 2)  to Paper No./Mail Date \_\_\_\_.
  - (b)  including changes required by the attached Examiner's Amendment / Comment or in the Office action of Paper No./Mail Date \_\_\_\_.

**Identifying indicia such as the application number (see 37 CFR 1.84(c)) should be written on the drawings in the front (not the back) of each sheet. Replacement sheet(s) should be labeled as such in the header according to 37 CFR 1.121(d).**
7.  DEPOSIT OF and/or INFORMATION about the deposit of BIOLOGICAL MATERIAL must be submitted. Note the attached Examiner's comment regarding REQUIREMENT FOR THE DEPOSIT OF BIOLOGICAL MATERIAL.

**Attachment(s)**

- |   |  |
|---|--|
| 1. <input type="checkbox"/> Notice of References Cited (PTO-892)  | 5. <input type="checkbox"/> Notice of Informal Patent Application                      |
| 2. <input type="checkbox"/> Notice of Draftsperson's Patent Drawing Review (PTO-948)                              | 6. <input type="checkbox"/> Interview Summary (PTO-413),<br>Paper No./Mail Date ____ . |
| 3. <input checked="" type="checkbox"/> Information Disclosure Statements (PTO/SB/08),<br>Paper No./Mail Date ____ | 7. <input type="checkbox"/> Examiner's Amendment/Comment                               |
| 4. <input type="checkbox"/> Examiner's Comment Regarding Requirement for Deposit<br>of Biological Material        | 8. <input type="checkbox"/> Examiner's Statement of Reasons for Allowance              |
|   | 9. <input type="checkbox"/> Other ____.  |

/PHUNG NGUYEN/  
Primary Examiner, Art Unit 2681



UNITED STATES PATENT AND TRADEMARK OFFICE

UNITED STATES DEPARTMENT OF COMMERCE  
United States Patent and Trademark Office  
Address: COMMISSIONER FOR PATENTS  
P.O. Box 1450  
Alexandria, Virginia 22313-1450  
www.uspto.gov

APPLICATION NO.	FILING DATE	FIRST NAMED INVENTOR	ATTORNEY DOCKET NO.	CONFIRMATION NO.
12/419,451	04/07/2009	Joseph F. Scalisi	LB1-006USC1	1643
93892	7590	06/06/2013	EXAMINER	
Timberline Patent Law Group PLLC			NGUYEN, PHUNG	
9116 E SPRAGUE AVE			ART UNIT	PAPER NUMBER
# 384			2681	
Spokane, WA 99206-3601			NOTIFICATION DATE	DELIVERY MODE
			06/06/2013	ELECTRONIC

**Please find below and/or attached an Office communication concerning this application or proceeding.**

The time period for reply, if any, is set in the attached communication.

Notice of the Office communication was sent electronically on above-indicated "Notification Date" to the following e-mail address(es):

info@timberlinepatents.com  
melissa@timberlinepatents.com



UNITED STATES PATENT AND TRADEMARK OFFICE

Commissioner for Patents  
United States Patent and Trademark Office  
P.O. Box 1450  
Alexandria, VA 22313-1450  
www.uspto.gov

Application No. : 12419451  
Applicant : Scalisi  
Filing Date : 04/07/2009  
Date Mailed : 06/06/2013

## NOTICE TO FILE CORRECTED APPLICATION PAPERS

### *Notice of Allowance Mailed*

This application has been accorded an Allowance Date and is being prepared for issuance. The application, however, is incomplete for the reasons below.

**Applicant is given 1 month from the mail date of this Notice, or the time remaining from the Notice of Allowance and Fee(s) Due, whichever is longer, within which to respond.**

The application is not in compliance with 37 CFR 1.78, as indicated in the attachment. The consequences of failure to respond within the above-identified time period are set forth in the attachment.

Even if the Office has recognized a benefit claim and has entered it into the Office's database and included it on applicant's filing receipt, the benefit claim is not a proper benefit claim unless the reference in compliance with 37 CFR 1.78 is included, depending upon the application's filing date and as indicated in the attachment, in an application data sheet or in the first sentence(s) of the specification and all other requirements are met.

**This period for reply is NOT extendable under 37 CFR 1.136(a).**

See attachment.

*A copy of this notice **MUST** be returned with the reply. Please address response to "Mail Stop Issue Fee, Commissioner for Patents, P.O. Box 1450, Alexandria, VA 22313-1450".*

/Kevin Danemark/  
Publication Branch  
Office of Data Management  
(571) 272-4200

**APPLICATION FILED PRIOR TO SEPTEMBER 16, 2012,  
NOT IN COMPLIANCE WITH 37 CFR 1.78**

- The 37 CFR 1.78(a)(2) reference on the application data sheet or in the first sentence(s) of the specification does not indicate the relationship (continuation, division, continuation-in-part) to the prior U.S. nonprovisional application or international application designating the U.S. See document coded SPEC dated 09/10/2012, listing application number(s) 11/753979, 11/933024, 11/784400, 11/784318, and 11/935901.
- The 37 CFR 1.78(a)(2) reference on the application data sheet or in the first sentence(s) of the specification following the title does not provide the U.S. nonprovisional application number (series code and serial number) or, with respect to an international PCT application designating the U.S., it provides the international application number or international filing date but not both. See document coded dated , in which the following is missing: .
- The 37 CFR 1.78(a)(2) reference on the application data sheet or in the first sentence(s) of the specification following the title shows an incorrect, incomplete, or illegible U.S. nonprovisional application number, international PCT application number, or international PCT filing date. See document coded dated , in which the following error was made: .
- The 37 CFR 1.78(a)(2) reference to the prior U.S. nonprovisional application or international application designating the U.S. is not present on an application data sheet or in the first sentence(s) of the specification following the title, thus removing the validating link under 35 U.S.C. 119(a)-(d) to a prior foreign application or under 35 U.S.C. 119(e) to a prior U.S. provisional application.
- The 37 CFR 1.78(a)(2) reference to the prior U.S. nonprovisional application or international application designating the U.S. is not present on an application data sheet or in the first sentence(s) of the specification following the title.
- The 37 CFR 1.78(a)(5) reference to the prior U.S. provisional application is not present on an application data sheet or in first sentence(s) of the specification following the title.
- The 37 CFR 1.78(a)(5) reference to the prior U.S. provisional application on an application data sheet or in first sentence(s) of the specification following the title does not provide the provisional application number (series code and serial number). See document coded dated , in which the following is missing: .
- The 37 CFR 1.78(a)(5) reference to the prior U.S. provisional application on an application data sheet or in first sentence(s) of the specification following the title shows an incorrect, incomplete, or illegible U.S. provisional application number. See document coded dated , in which the following error was made: .
- Other: .

**HOW TO RESPOND**

A proper response to this notice would include any one of: (1) a supplemental Application Data Sheet (ADS) pursuant to 37 CFR 1.76(c) which provides benefit information that complies with 37 CFR 1.78(a)(2) or 37 CFR 1.78(a)(5); (2) an amendment to the first sentence(s) of the specification which provides benefit information that complies with 37 CFR 1.78(a)(2) or 37 CFR 1.78(a)(5); or (3) a petition filed pursuant to the provisions of 37 CFR 1.78(a)(3) or 37 CFR 1.78(a)(6) if the benefit information from the document identified above by code and date does not accurately reflect the benefits under 35 U.S.C. 119(e), 120, 121 or 365(c) as claimed by applicant (a grantable petition would include either a supplemental ADS or an amendment to the first sentence(s) of the specification as required by 37 CFR 1.78(a)(3)(i) or 37 CFR 1.78(a)(6)(i)). Such amendments to the specification or supplemental ADS submission may be filed after payment of the issue fee if limited to informalities noted herein. See Waiver of 37 CFR 1.312 for Document Required by Office of Patent Publication, 1280 Off. Gaz. Patent Office 918 (March 23, 2004).

**WARNING:** If Applicant fails to timely submit a proper response, the benefit information will be deleted and the patent will be printed without the benefit information present.

Under the Paperwork Reduction Act of 1995, no persons are required to respond to a collection of information unless it contains a valid OMB control number.

<b>Application Data Sheet 37 CFR 1.76</b>		Attorney Docket Number	LB1-006USC1
		Application Number	12/419,451
Title of Invention	APPARATUS AND METHOD FOR ADJUSTING REFRESH RATE OF LOCATION COORDINATES OF A TRACKING DEVICE		
The application data sheet is part of the provisional or nonprovisional application for which it is being submitted. The following form contains the bibliographic data arranged in a format specified by the United States Patent and Trademark Office as outlined in 37 CFR 1.76. This document may be completed electronically and submitted to the Office in electronic format using the Electronic Filing System (EFS) or the document may be printed and included in a paper filed application.			

### Secrecy Order 37 CFR 5.2

<input type="checkbox"/> Portions or all of the application associated with this Application Data Sheet may fall under a Secrecy Order pursuant to 37 CFR 5.2 (Paper filers only. Applications that fall under Secrecy Order may not be filed electronically.)
--

### Inventor Information:

<b>Inventor 1</b>					<input type="button" value="Remove"/>
<b>Legal Name</b>					
<b>Prefix</b>	<b>Given Name</b>	<b>Middle Name</b>	<b>Family Name</b>	<b>Suffix</b>	
	Joseph	F.	Scalisi		
<b>Residence Information (Select One)</b> <input checked="" type="radio"/> US Residency <input type="radio"/> Non US Residency <input type="radio"/> Active US Military Service					
<b>City</b>	Yorba Linda	<b>State/Province</b>	CA	<b>Country of Residence</b> <sup>i</sup>	US

<b>Mailing Address of Inventor:</b>					
<b>Address 1</b>	21520 Yorba Linda Blvd., G357				
<b>Address 2</b>					
<b>City</b>	Yorba Linda	<b>State/Province</b>	CA		
<b>Postal Code</b>	92887	<b>Country</b> <sup>1</sup>	US		

<b>Inventor 2</b>					<input type="button" value="Remove"/>
<b>Legal Name</b>					
<b>Prefix</b>	<b>Given Name</b>	<b>Middle Name</b>	<b>Family Name</b>	<b>Suffix</b>	
	Roger	B.	Anderson		
<b>Residence Information (Select One)</b> <input checked="" type="radio"/> US Residency <input type="radio"/> Non US Residency <input type="radio"/> Active US Military Service					
<b>City</b>	Arcadia	<b>State/Province</b>	CA	<b>Country of Residence</b> <sup>i</sup>	US

<b>Mailing Address of Inventor:</b>					
<b>Address 1</b>	928 Othello St.				
<b>Address 2</b>					
<b>City</b>	Arcadia	<b>State/Province</b>	CA		
<b>Postal Code</b>	91006	<b>Country</b> <sup>1</sup>	US		

All Inventors Must Be Listed - Additional Inventor Information blocks may be generated within this form by selecting the **Add** button.

### Correspondence Information:

Enter either Customer Number or complete the Correspondence Information section below. For further information see 37 CFR 1.33(a).

<b>Application Data Sheet 37 CFR 1.76</b>		Attorney Docket Number	LB1-006USC1
		Application Number	
Title of Invention	APPARATUS AND METHOD FOR ADJUSTING REFRESH RATE OF LOCATION COORDINATES OF A TRACKING DEVICE		

An Address is being provided for the correspondence information of this application.

Customer Number	93892		
Email Address	Mark <mark_farrell@comcast.net>	<input type="button" value="Add Email"/>	<input type="button" value="Remove Email"/>

### Application Information:

Title of the Invention	APPARATUS AND METHOD FOR ADJUSTING REFRESH RATE OF LOCATION COORDINATES OF A TRACKING DEVICE		
Attorney Docket Number	LB1-006USC1	Small Entity Status Claimed	<input checked="" type="checkbox"/>
Application Type	Nonprovisional		
Subject Matter	Utility		
Suggested Class (if any)		Sub Class (if any)	
Suggested Technology Center (if any)			
Total Number of Drawing Sheets (if any)	7	Suggested Figure for Publication (if any)	1

### Publication Information:

Request Early Publication (Fee required at time of Request 37 CFR 1.219)

**Request Not to Publish.** I hereby request that the attached application not be published under 35 U.S.C. 122(b) and certify that the invention disclosed in the attached application **has not and will not** be the subject of an application filed in another country, or under a multilateral international agreement, that requires publication at eighteen months after filing.

### Representative Information:

Representative information should be provided for all practitioners having a power of attorney in the application. Providing this information in the Application Data Sheet does not constitute a power of attorney in the application (see 37 CFR 1.32). Either enter Customer Number or complete the Representative Name section below. If both sections are completed the customer number will be used for the Representative Information during processing.

Please Select One:	<input checked="" type="radio"/> Customer Number	<input type="radio"/> US Patent Practitioner	<input type="radio"/> Limited Recognition (37 CFR 11.9)
Customer Number	93892		

### Domestic Benefit/National Stage Information:

This section allows for the applicant to either claim benefit under 35 U.S.C. 119(e), 120, 121, or 365(c) or indicate National Stage entry from a PCT application. Providing this information in the application data sheet constitutes the specific reference required by 35 U.S.C. 119(e) or 120, and 37 CFR 1.78.

Prior Application Status	Patented		<input type="button" value="Remove"/>		
Application Number	Continuity Type	Prior Application Number	Filing Date (YYYY-MM-DD)	Patent Number	Issue Date (YYYY-MM-DD)
12419451	Continuation in part of	11969905	2008-01-06	8102256	2012-01-24

IPR2020-01189



<b>Application Data Sheet 37 CFR 1.76</b>		Attorney Docket Number	LB1-006USC1		
		Application Number			
Title of Invention	APPARATUS AND METHOD FOR ADJUSTING REFRESH RATE OF LOCATION COORDINATES OF A TRACKING DEVICE				
Prior Application Status	Patented		<input type="button" value="Remove"/>		
Application Number	Continuity Type	Prior Application Number	Filing Date (YYYY-MM-DD)	Patent Number	Issue Date (YYYY-MM-DD)
11969905	Continuation in part of	11935901	2007-11-06	8244468	2012-08-14
Prior Application Status	Pending		<input type="button" value="Remove"/>		
Application Number	Continuity Type	Prior Application Number	Filing Date (YYYY-MM-DD)		
11969905	Continuation in part of	11933024	2007-10-31		
Prior Application Status	Pending		<input type="button" value="Remove"/>		
Application Number	Continuity Type	Prior Application Number	Filing Date (YYYY-MM-DD)		
11969905	Continuation in part of	11753979	2007-05-25		
Prior Application Status	Abandoned		<input type="button" value="Remove"/>		
Application Number	Continuity Type	Prior Application Number	Filing Date (YYYY-MM-DD)		
11969905	Continuation in part of	11784400	2007-04-05		
Prior Application Status	Abandoned		<input type="button" value="Remove"/>		
Application Number	Continuity Type	Prior Application Number	Filing Date (YYYY-MM-DD)		
11969905	Continuation in part of	11784318	2008-04-17		
Additional Domestic Benefit/National Stage Data may be generated within this form by selecting the <b>Add</b> button.					<input type="button" value="Add"/>

### Foreign Priority Information:

This section allows for the applicant to claim benefit of foreign priority and to identify any prior foreign application for which priority is not claimed. Providing this information in the application data sheet constitutes the claim for priority as required by 35 U.S.C. 119(b) and 37 CFR 1.55(a).			
			<input type="button" value="Remove"/>
Application Number	Country <sup>i</sup>	Filing Date (YYYY-MM-DD)	Priority Claimed
			<input type="radio"/> Yes <input checked="" type="radio"/> No
Additional Foreign Priority Data may be generated within this form by selecting the <b>Add</b> button.			<input type="button" value="Add"/>

### Authorization to Permit Access:

<input type="checkbox"/> Authorization to Permit Access to the Instant Application by the Participating Offices
---

Under the Paperwork Reduction Act of 1995, no persons are required to respond to a collection of information unless it contains a valid OMB control number.

<b>Application Data Sheet 37 CFR 1.76</b>	Attorney Docket Number	LB1-006USC1
	Application Number	
Title of Invention	APPARATUS AND METHOD FOR ADJUSTING REFRESH RATE OF LOCATION COORDINATES OF A TRACKING DEVICE	

If checked, the undersigned hereby grants the USPTO authority to provide the European Patent Office (EPO), the Japan Patent Office (JPO), the Korean Intellectual Property Office (KIPO), the World Intellectual Property Office (WIPO), and any other intellectual property offices in which a foreign application claiming priority to the instant patent application is filed access to the instant patent application. See 37 CFR 1.14(c) and (h). This box should not be checked if the applicant does not wish the EPO, JPO, KIPO, WIPO, or other intellectual property office in which a foreign application claiming priority to the instant patent application is filed to have access to the instant patent application.

In accordance with 37 CFR 1.14(h)(3), access will be provided to a copy of the instant patent application with respect to: 1) the instant patent application-as-filed; 2) any foreign application to which the instant patent application claims priority under 35 U.S.C. 119(a)-(d) if a copy of the foreign application that satisfies the certified copy requirement of 37 CFR 1.55 has been filed in the instant patent application; and 3) any U.S. application-as-filed from which benefit is sought in the instant patent application.

In accordance with 37 CFR 1.14(c), access may be provided to information concerning the date of filing this Authorization.

## Applicant Information:

Providing assignment information in this section does not substitute for compliance with any requirement of part 3 of Title 37 of CFR to have an assignment recorded by the Office.			
<b>Applicant 1</b>			
If the applicant is the inventor (or the remaining joint inventor or inventors under 37 CFR 1.45), this section should not be completed. The information to be provided in this section is the name and address of the legal representative who is the applicant under 37 CFR 1.43; or the name and address of the assignee, person to whom the inventor is under an obligation to assign the invention, or person who otherwise shows sufficient proprietary interest in the matter who is the applicant under 37 CFR 1.46. If the applicant is an applicant under 37 CFR 1.46 (assignee, person to whom the inventor is obligated to assign, or person who otherwise shows sufficient proprietary interest) together with one or more joint inventors, then the joint inventor or inventors who are also the applicant should be identified in this section.			
<input type="button" value="Remove"/>			
<input checked="" type="radio"/> Assignee	<input type="radio"/> Legal Representative under 35 U.S.C. 117		
<input type="radio"/> Person to whom the inventor is obligated to assign.	<input type="radio"/> Person who shows sufficient proprietary interest		
If applicant is the legal representative, indicate the authority to file the patent application, the inventor is:			
Name of the Deceased or Legally Incapacitated Inventor : <input type="text"/>			
If the Assignee is an Organization check here. <input checked="" type="checkbox"/>			
Organization Name	Location Based Technologies Inc.		
<b>Mailing Address Information:</b>			
Address 1	49 Discovery, Suite 260		
Address 2			
City	Irvine	State/Province	CA
Country <sup>i</sup>	US	Postal Code	92618
Phone Number		Fax Number	

IPR2020-01189

Apple EX1002 Page 338

Under the Paperwork Reduction Act of 1995, no persons are required to respond to a collection of information unless it contains a valid OMB control number.

<b>Application Data Sheet 37 CFR 1.76</b>	Attorney Docket Number	LB1-006USC1
	Application Number	
Title of Invention	APPARATUS AND METHOD FOR ADJUSTING REFRESH RATE OF LOCATION COORDINATES OF A TRACKING DEVICE	

Email Address	
---------------	--

Additional Applicant Data may be generated within this form by selecting the Add button.

**Signature:**

NOTE: This form must be signed in accordance with 37 CFR 1.33. See 37 CFR 1.4 for signature requirements and certifications					
<b>Signature</b>	/Mark Farrell/			Date (YYYY-MM-DD)	2013-06-17
First Name	Mark	Last Name	Farrell	Registration Number	45988
Additional Signature may be generated within this form by selecting the Add button.					<input type="button" value="Add"/>

This collection of information is required by 37 CFR 1.76. The information is required to obtain or retain a benefit by the public which is to file (and by the USPTO to process) an application. Confidentiality is governed by 35 U.S.C. 122 and 37 CFR 1.14. This collection is estimated to take 23 minutes to complete, including gathering, preparing, and submitting the completed application data sheet form to the USPTO. Time will vary depending upon the individual case. Any comments on the amount of time you require to complete this form and/or suggestions for reducing this burden, should be sent to the Chief Information Officer, U.S. Patent and Trademark Office, U.S. Department of Commerce, P.O. Box 1450, Alexandria, VA 22313-1450. DO NOT SEND FEES OR COMPLETED FORMS TO THIS ADDRESS. **SEND TO: Commissioner for Patents, P.O. Box 1450, Alexandria, VA 22313-1450.**

## Privacy Act Statement

The Privacy Act of 1974 (P.L. 93-579) requires that you be given certain information in connection with your submission of the attached form related to a patent application or patent. Accordingly, pursuant to the requirements of the Act, please be advised that: (1) the general authority for the collection of this information is 35 U.S.C. 2(b)(2); (2) furnishing of the information solicited is voluntary; and (3) the principal purpose for which the information is used by the U.S. Patent and Trademark Office is to process and/or examine your submission related to a patent application or patent. If you do not furnish the requested information, the U.S. Patent and Trademark Office may not be able to process and/or examine your submission, which may result in termination of proceedings or abandonment of the application or expiration of the patent.

The information provided by you in this form will be subject to the following routine uses:

1. The information on this form will be treated confidentially to the extent allowed under the Freedom of Information Act (5 U.S.C. 552) and the Privacy Act (5 U.S.C. 552a). Records from this system of records may be disclosed to the Department of Justice to determine whether the Freedom of Information Act requires disclosure of these records.
2. A record from this system of records may be disclosed, as a routine use, in the course of presenting evidence to a court, magistrate, or administrative tribunal, including disclosures to opposing counsel in the course of settlement negotiations.
3. A record in this system of records may be disclosed, as a routine use, to a Member of Congress submitting a request involving an individual, to whom the record pertains, when the individual has requested assistance from the Member with respect to the subject matter of the record.
4. A record in this system of records may be disclosed, as a routine use, to a contractor of the Agency having need for the information in order to perform a contract. Recipients of information shall be required to comply with the requirements of the Privacy Act of 1974, as amended, pursuant to 5 U.S.C. 552a(m).
5. A record related to an International Application filed under the Patent Cooperation Treaty in this system of records may be disclosed, as a routine use, to the International Bureau of the World Intellectual Property Organization, pursuant to the Patent Cooperation Treaty.
6. A record in this system of records may be disclosed, as a routine use, to another federal agency for purposes of National Security review (35 U.S.C. 181) and for review pursuant to the Atomic Energy Act (42 U.S.C. 218(c)).
7. A record from this system of records may be disclosed, as a routine use, to the Administrator, General Services, or his/her designee, during an inspection of records conducted by GSA as part of that agency's responsibility to recommend improvements in records management practices and programs, under authority of 44 U.S.C. 2904 and 2906. Such disclosure shall be made in accordance with the GSA regulations governing inspection of records for this purpose, and any other relevant (i.e., GSA or Commerce) directive. Such disclosure shall not be used to make determinations about individuals.
8. A record from this system of records may be disclosed, as a routine use, to the public after either publication of the application pursuant to 35 U.S.C. 122(b) or issuance of a patent pursuant to 35 U.S.C. 151. Further, a record may be disclosed, subject to the limitations of 37 CFR 1.14, as a routine use, to the public if the record was filed in an application which became abandoned or in which the proceedings were terminated and which application is referenced by either a published application, an application open to public inspections or an issued patent.
9. A record from this system of records may be disclosed, as a routine use, to a Federal, State, or local law enforcement agency, if the USPTO becomes aware of a violation or potential violation of law or regulation.

## Electronic Acknowledgement Receipt

<b>EFS ID:</b>	16166787
<b>Application Number:</b>	12419451
<b>International Application Number:</b>	
<b>Confirmation Number:</b>	1643
<b>Title of Invention:</b>	APPARATUS AND METHOD FOR ADJUSTING REFRESH RATE OF LOCATION COORDINATES OF A TRACKING DEVICE
<b>First Named Inventor/Applicant Name:</b>	Joseph F. Scalisi
<b>Customer Number:</b>	93892
<b>Filer:</b>	Mark Farrell/Melissa Nelson
<b>Filer Authorized By:</b>	Mark Farrell
<b>Attorney Docket Number:</b>	LB1-006USC1
<b>Receipt Date:</b>	26-JUN-2013
<b>Filing Date:</b>	07-APR-2009
<b>Time Stamp:</b>	22:11:25
<b>Application Type:</b>	Utility under 35 USC 111(a)

### Payment information:

Submitted with Payment	no
------------------------	----

### File Listing:

Document Number	Document Description	File Name	File Size(Bytes)/ Message Digest	Multi Part /.zip	Pages (if appl.)
1	Application Data Sheet	LB1006USC1ADS.pdf	1396537 <small>c3e4800d30a27a1d4dc91ce83e40395674a6bdee</small>	no	6

### Warnings:

### Information:

IPR2020-01189

**This Acknowledgement Receipt evidences receipt on the noted date by the USPTO of the indicated documents, characterized by the applicant, and including page counts, where applicable. It serves as evidence of receipt similar to a Post Card, as described in MPEP 503.**

**New Applications Under 35 U.S.C. 111**

**If a new application is being filed and the application includes the necessary components for a filing date (see 37 CFR 1.53(b)-(d) and MPEP 506), a Filing Receipt (37 CFR 1.54) will be issued in due course and the date shown on this Acknowledgement Receipt will establish the filing date of the application.**

**National Stage of an International Application under 35 U.S.C. 371**

**If a timely submission to enter the national stage of an international application is compliant with the conditions of 35 U.S.C. 371 and other applicable requirements a Form PCT/DO/EO/903 indicating acceptance of the application as a national stage submission under 35 U.S.C. 371 will be issued in addition to the Filing Receipt, in due course.**

**New International Application Filed with the USPTO as a Receiving Office**

**If a new international application is being filed and the international application includes the necessary components for an international filing date (see PCT Article 11 and MPEP 1810), a Notification of the International Application Number and of the International Filing Date (Form PCT/RO/105) will be issued in due course, subject to prescriptions concerning national security, and the date shown on this Acknowledgement Receipt will establish the international filing date of the application.**



UNITED STATES PATENT AND TRADEMARK OFFICE

UNITED STATES DEPARTMENT OF COMMERCE
United States Patent and Trademark Office
Address: COMMISSIONER FOR PATENTS
P.O. Box 1450
Alexandria, Virginia 22313-1450
www.uspto.gov

Table with 7 columns: APPLICATION NUMBER, FILING or 371(c) DATE, GRP ART UNIT, FIL FEE REC'D, ATTY. DOCKET NO, TOT CLAIMS, IND CLAIMS. Row 1: 12/419,451, 04/07/2009, 2681, 788, LB1-006USC1, 21, 3

CONFIRMATION NO. 1643

CORRECTED FILING RECEIPT



93892
Timberline Patent Law Group PLLC
9116 E SPRAGUE AVE
# 384
Spokane, WA 99206-3601

Date Mailed: 06/28/2013

Receipt is acknowledged of this non-provisional patent application. The application will be taken up for examination in due course. Applicant will be notified as to the results of the examination. Any correspondence concerning the application must include the following identification information: the U.S. APPLICATION NUMBER, FILING DATE, NAME OF APPLICANT, and TITLE OF INVENTION. Fees transmitted by check or draft are subject to collection. Please verify the accuracy of the data presented on this receipt. If an error is noted on this Filing Receipt, please submit a written request for a Filing Receipt Correction. Please provide a copy of this Filing Receipt with the changes noted thereon. If you received a "Notice to File Missing Parts" for this application, please submit any corrections to this Filing Receipt with your reply to the Notice. When the USPTO processes the reply to the Notice, the USPTO will generate another Filing Receipt incorporating the requested corrections

Inventor(s)

Joseph F. Scalisi, Yorba Linda, CA;
Roger B. Anderson, Arcadia, CA;

Applicant(s)

Joseph F. Scalisi, Yorba Linda, CA;
Roger B. Anderson, Arcadia, CA;

Power of Attorney: The patent practitioners associated with Customer Number 93892

Domestic Priority data as claimed by applicant

This application is a CIP of 11/969,905 01/06/2008 PAT 8102256
and is a CIP of 11/753,979 05/25/2007
and is a CIP of 11/933,024 10/31/2007
and is a CIP of 11/784,400 04/05/2007 ABN
and is a CIP of 11/935,901 11/06/2007 PAT 8244468
and is a CIP of 11/784,318 04/05/2007 ABN

Foreign Applications for which priority is claimed (You may be eligible to benefit from the Patent Prosecution Highway program at the USPTO. Please see http://www.uspto.gov for more information.) - None.

Foreign application information must be provided in an Application Data Sheet in order to constitute a claim to foreign priority. See 37 CFR 1.55 and 1.76.

If Required, Foreign Filing License Granted: 04/16/2009

The country code and number of your priority application, to be used for filing abroad under the Paris Convention, is US 12/419,451

Projected Publication Date: Not Applicable

**Non-Publication Request:** No

**Early Publication Request:** No

**\*\* SMALL ENTITY \*\***

**Title**

APPARATUS AND METHOD FOR ADJUSTING REFRESH RATE OF LOCATION COORDINATES OF A TRACKING DEVICE

**Preliminary Class**

340

**Statement under 37 CFR 1.55 or 1.78 for AIA (First Inventor to File) Transition Applications:**

### **PROTECTING YOUR INVENTION OUTSIDE THE UNITED STATES**

Since the rights granted by a U.S. patent extend only throughout the territory of the United States and have no effect in a foreign country, an inventor who wishes patent protection in another country must apply for a patent in a specific country or in regional patent offices. Applicants may wish to consider the filing of an international application under the Patent Cooperation Treaty (PCT). An international (PCT) application generally has the same effect as a regular national patent application in each PCT-member country. The PCT process **simplifies** the filing of patent applications on the same invention in member countries, but **does not result** in a grant of "an international patent" and does not eliminate the need of applicants to file additional documents and fees in countries where patent protection is desired.

Almost every country has its own patent law, and a person desiring a patent in a particular country must make an application for patent in that country in accordance with its particular laws. Since the laws of many countries differ in various respects from the patent law of the United States, applicants are advised to seek guidance from specific foreign countries to ensure that patent rights are not lost prematurely.

Applicants also are advised that in the case of inventions made in the United States, the Director of the USPTO must issue a license before applicants can apply for a patent in a foreign country. The filing of a U.S. patent application serves as a request for a foreign filing license. The application's filing receipt contains further information and guidance as to the status of applicant's license for foreign filing.

Applicants may wish to consult the USPTO booklet, "General Information Concerning Patents" (specifically, the section entitled "Treaties and Foreign Patents") for more information on timeframes and deadlines for filing foreign patent applications. The guide is available either by contacting the USPTO Contact Center at 800-786-9199, or it can be viewed on the USPTO website at <http://www.uspto.gov/web/offices/pac/doc/general/index.html>.

For information on preventing theft of your intellectual property (patents, trademarks and copyrights), you may wish to consult the U.S. Government website, <http://www.stopfakes.gov>. Part of a Department of Commerce initiative, this website includes self-help "toolkits" giving innovators guidance on how to protect intellectual property in specific countries such as China, Korea and Mexico. For questions regarding patent enforcement issues, applicants may call the U.S. Government hotline at 1-866-999-HALT (1-866-999-4258).



**LICENSE FOR FOREIGN FILING UNDER**  
**Title 35, United States Code, Section 184**  
**Title 37, Code of Federal Regulations, 5.11 & 5.15**

**GRANTED**

The applicant has been granted a license under 35 U.S.C. 184, if the phrase "IF REQUIRED, FOREIGN FILING LICENSE GRANTED" followed by a date appears on this form. Such licenses are issued in all applications where the conditions for issuance of a license have been met, regardless of whether or not a license may be required as set forth in 37 CFR 5.15. The scope and limitations of this license are set forth in 37 CFR 5.15(a) unless an earlier license has been issued under 37 CFR 5.15(b). The license is subject to revocation upon written notification. The date indicated is the effective date of the license, unless an earlier license of similar scope has been granted under 37 CFR 5.13 or 5.14.

This license is to be retained by the licensee and may be used at any time on or after the effective date thereof unless it is revoked. This license is automatically transferred to any related applications(s) filed under 37 CFR 1.53(d). This license is not retroactive.

The grant of a license does not in any way lessen the responsibility of a licensee for the security of the subject matter as imposed by any Government contract or the provisions of existing laws relating to espionage and the national security or the export of technical data. Licensees should apprise themselves of current regulations especially with respect to certain countries, of other agencies, particularly the Office of Defense Trade Controls, Department of State (with respect to Arms, Munitions and Implements of War (22 CFR 121-128)); the Bureau of Industry and Security, Department of Commerce (15 CFR parts 730-774); the Office of Foreign Assets Control, Department of Treasury (31 CFR Parts 500+) and the Department of Energy.

**NOT GRANTED**

No license under 35 U.S.C. 184 has been granted at this time, if the phrase "IF REQUIRED, FOREIGN FILING LICENSE GRANTED" DOES NOT appear on this form. Applicant may still petition for a license under 37 CFR 5.12, if a license is desired before the expiration of 6 months from the filing date of the application. If 6 months has lapsed from the filing date of this application and the licensee has not received any indication of a secrecy order under 35 U.S.C. 181, the licensee may foreign file the application pursuant to 37 CFR 5.15(b).

---

***SelectUSA***

The United States represents the largest, most dynamic marketplace in the world and is an unparalleled location for business investment, innovation, and commercialization of new technologies. The U.S. offers tremendous resources and advantages for those who invest and manufacture goods here. Through SelectUSA, our nation works to promote and facilitate business investment. SelectUSA provides information assistance to the international investor community; serves as an ombudsman for existing and potential investors; advocates on behalf of U.S. cities, states, and regions competing for global investment; and counsels U.S. economic development organizations on investment attraction best practices. To learn more about why the United States is the best country in the world to develop technology, manufacture products, deliver services, and grow your business, visit <http://www.SelectUSA.gov> or call +1-202-482-6800.

Substitute for form 1449A/PTO  <b>INFORMATION DISCLOSURE STATEMENT BY APPLICANT</b>  (Use as many sheets as necessary)		<i>Complete if Known</i>	
		<b>Application Number</b>	12/419,451
		<b>Filing Date</b>	April 7, 2009
		<b>First Named Inventor</b>	Scalisi, Joseph
		<b>Art Unit</b>	2618
		<b>Examiner Name</b>	Unknown
Sheet	3	of	6
Attorney Docket No: LB1-006USC1			

US PATENT DOCUMENTS					
Examiner Initial *	Cite No	Document Number	Publication Date	Name of Patentee or Applicant of Cited Document	Filing Date If Appropriate
		US-5361612	11/08/1994	Voiculescu, Danut et al.	
		US-5386468	01/31/1995	Akiyama, Ryota et al.	
		US-5417092	05/23/1995	Iu, Chien-Chzh	
		US-5432542	07/11/1995	Thibadeau, Robert et al.	
		US-5490402	02/13/1996	Shieh, Jin-Ren	
		US-5541976	07/30/1996	Ghisler, Walter	
		US-5563579	10/08/1996	Carter, Ronald L.	
		US-5565909	10/15/1996	Thibadeau, Robert et al.	
		US-5768920	06/23/1998	DeBevoise, Bruce D.	
		US-5785181	07/28/1998	Quartarao, Jr., Peter J.	
		US-5876765	03/02/1999	Hinterlechner, Gerhard et al.	
		US-5967841	10/19/1999	Bianca, Giuseppe et al.	
		US-5973599	<del>11/26/1999</del>	Nicholson, Mark et al.	10/1999
		US-6088453	07/11/2000	Shimbo, Atsushi	
		US-6141356	10/31/2000	Gorman, Michael G.	
		US-6236365	05/22/2001	LeBlanc, Frederick W., et al.	
		US-6330817	12/18/2001	Frolov, George	
		US-6388612	05/14/2002	Neher, Timothy J.	
		US-6414629	07/02/2002	Curcio, Joseph A.	
		US-6441741	08/27/2002	Yoakum, Jay	
		US-6445921	09/03/2002	Bell, John R.	
		US-6453037	09/17/2002	Welter, Jr., William G.	
		US-6498797	12/24/2002	Anerousis, Nikolaos et al.	
		US-6546253	04/08/2003	Chow, Albert et al.	
		US-6611755	08/26/2003	Coffee, John R., et al.	
		US-6633835	10/14/2003	Moran, Mike et al.	
		US-6674368	01/06/2004	Hawkins, Dale K., et al.	
		US-6708028	03/16/2004	Byrne, John D.	
		US-6716101	04/06/2004	Meadows, Vernon	
		US-6731212	05/04/2004	Hirose, Yuuki et al.	
		US-6732090	05/04/2004	Shanahan, James G., et al.	
		US-6735630	05/11/2004	Gelvin, David C., et al.	
		US-6747561	06/08/2004	Reeves, William F., et al.	
		US-6754470	06/22/2004	Hendrickson, Keith et al.	
		US-6768942	07/27/2004	Chojnacki, Robert	

Change(s) applied to document, /K.D.D./ 7/2/2013

**EXAMINER** /Phung Nguyen/ **DATE CONSIDERED** 06/03/2012

Substitute Disclosure Statement Form (PTO-1449)  
 \* EXAMINER: Initial if reference considered, whether or not citation is in conformance with MPEP 609. Draw line through citation if not in conformance and not considered. Include copy of this form with next communication to applicant. 1 Applicant's unique citation designation number (optional) 2 Applicant is to place a check mark here if English language Translation is attached

Substitute for form 1449A/PTO			
<b>INFORMATION DISCLOSURE STATEMENT BY APPLICANT</b>  (Use as many sheets as necessary)		<i>Complete if Known</i>	
		Application Number	12/419,451
		Filing Date	April 7, 2009
		First Named Inventor	Scalisi, Joseph
		Art Unit	2618
		Examiner Name	Unknown
Sheet	1	of	6
Attorney Docket No: LB1-006USC1			

US PATENT DOCUMENTS					
Examiner Initial *	Cite No	Document Number	Publication Date	Name of Patentee or Applicant of Cited Document	Filing Date If Appropriate
		US-20010030667	10/18/2001	Kelts, Brett R.	
		US-20010048364	12/06/2001	Kalthoff, Robert M., et al.	
		US-20020041328	04/11/2002	LeCompte, Malcolm et al.	
		US-20020067256	06/06/2002	Kail IV, Karl A.	
		US-20020077130	06/20/2002	Owensby, Craig A.	
		US-20020180602	12/05/2002	Yoakum, Jay	
		US-20020186135	12/12/2002	Wagner, Colleen	
		US-20020196123	12/26/2002	Diehl, Joseph R., et al.	
		US-20030043200	03/06/2003	Faieta, Baldo et al.	
		US-20030131073	07/10/2003	Lucovsky, Mark H., et al.	
		US-20030208518	11/06/2003	Gura, Nils et al.	
		US-20030210262	11/13/2003	Gahm, Thomas et al.	
		US-20030212729	11/13/2003	Eberle, Hans et al.	
		US-20040010689	01/15/2004	Vanstone, Scott A., et al.	
		US-20040165726	08/26/2004	Yamamichi, Masato et al.	
		US-20040166879	08/26/2004	Meadows, Vernon et al.	
		US-20040172403	09/02/2004	Steele, Rhea L., et al.	
		US-20040212493	10/28/2004	Stilp, Louis A.	
		US-20050012620	01/20/2005	Yoakum, Jay	
		US-20050071736	03/31/2006	Schneider, Tina F., et al.	
		US-20050099303	05/12/2005	Suckerman, Andrew M.	
		US-20050159883	07/21/2005	Humphries, Laymon S., et al.	
		US-20050181870	08/18/2005	Nguyen, Binh T., et al.	
		US-20050188403	08/25/2005	Kotzin, Michael D.	
		US-20050210260	09/22/2005	Venkatesan, Ramarathnam et al.	
		US-20050246647	11/03/2005	Beam, Tyler K., et al.	
		US-20050248459	11/10/2005	Bonalle, David S., et al.	
		US-20060009152	01/12/2006	Millard, Thomas A., et al.	
		US-20060206246	09/14/2006	Walker, Richard C.	
		US-20060211405	09/21/2006	Scalisi, Joseph F., et al.	
		US-20060232429	10/19/2006	<del>Jain, Amit et al.</del> Gonzalez	
		US-20060253590	11/09/2006	Nagy, David et al.	
		US-20060290497	12/28/2006	Sugata, T.	
		US-20070028088	02/01/2007	Bayrak, Coskun et al.	
		US-20070033531	02/08/2007	Marsh, Christopher	

Change(s) applied to document, /K.D.D./ 7/2/2013

EXAMINER /Phung Nguyen/ DATE CONSIDERED 06/03/2012

Substitute Disclosure Statement Form (PTO-1449)  
 \* EXAMINER: Initial if reference considered, whether or not citation is in conformance with MPEP 609. Draw line through citation if not in conformance and not considered. Include copy of this form with next communication to applicant. 1 Applicant's unique citation designation number (optional) 2 Applicant is to place a check mark here if English language Translation is attached



APPLICATION NO.	ISSUE DATE	PATENT NO.	ATTORNEY DOCKET NO.	CONFIRMATION NO.
12/419,451	07/30/2013	8497774	LB1-006USC1	1643

93892 7590 07/10/2013  
 Timberline Patent Law Group PLLC  
 9116 E SPRAGUE AVE  
 # 384  
 Spokane, WA 99206-3601

### ISSUE NOTIFICATION

The projected patent number and issue date are specified above.

**Determination of Patent Term Adjustment under 35 U.S.C. 154 (b)**  
 (application filed on or after May 29, 2000)

The Patent Term Adjustment is 992 day(s). Any patent to issue from the above-identified application will include an indication of the adjustment on the front page.

If a Continued Prosecution Application (CPA) was filed in the above-identified application, the filing date that determines Patent Term Adjustment is the filing date of the most recent CPA.

Applicant will be able to obtain more detailed information by accessing the Patent Application Information Retrieval (PAIR) WEB site (<http://pair.uspto.gov>).

Any questions regarding the Patent Term Extension or Adjustment determination should be directed to the Office of Patent Legal Administration at (571)-272-7702. Questions relating to issue and publication fee payments should be directed to the Application Assistance Unit (AAU) of the Office of Data Management (ODM) at (571)-272-4200.

APPLICANT(s) (Please see PAIR WEB site <http://pair.uspto.gov> for additional applicants):

Joseph F. Scalisi, Yorba Linda, CA;  
 Roger B. Anderson, Arcadia, CA;

The United States represents the largest, most dynamic marketplace in the world and is an unparalleled location for business investment, innovation, and commercialization of new technologies. The USA offers tremendous resources and advantages for those who invest and manufacture goods here. Through SelectUSA, our nation works to encourage and facilitate business investment. To learn more about why the USA is the best country in the world to develop technology, manufacture products, and grow your business, visit [SelectUSA.gov](http://SelectUSA.gov).

Under the Paperwork Reduction Act of 1995, no persons are required to respond to a collection of information unless it displays a valid OMB control number

# POWER OF ATTORNEY BY APPLICANT

I hereby revoke all previous powers of attorney given in the application identified in either the attached transmittal letter or the boxes below.

<b>Application Number</b>	<b>Filing Date</b>
12419451	April 7, 2009

(Note: The boxes above may be left blank if information is provided on form PTO/AIA/82A.)

- I hereby appoint the Patent Practitioner(s) associated with the following Customer Number as my/our attorney(s) or agent(s), and to transact all business in the United States Patent and Trademark Office connected therewith for the application referenced in the attached transmittal letter (form PTO/AIA/82A) or identified above: 124179
- OR**
- I hereby appoint Practitioner(s) named in the attached list (form PTO/AIA/82C) as my/our attorney(s) or agent(s), and to transact all business in the United States Patent and Trademark Office connected therewith for the patent application referenced in the attached transmittal letter (form PTO/AIA/82A) or identified above. (Note: Complete form PTO/AIA/82C.)

**Please recognize or change the correspondence address for the application identified in the attached transmittal letter or the boxes above to:**

- The address associated with the above-mentioned Customer Number
- OR**
- The address associated with Customer Number:
- OR**

Firm or Individual Name			
Address			
City	State	Zip	
Country			
Telephone	Email		

I am the Applicant (if the Applicant is a juristic entity, list the Applicant name in the box):

- Inventor or Joint Inventor (title not required below)
- Legal Representative of a Deceased or Legally Incapacitated Inventor (title not required below)
- Assignee or Person to Whom the Inventor is Under an Obligation to Assign (provide signer's title if applicant is a juristic entity)
- Person Who Otherwise Shows Sufficient Proprietary Interest (e.g., a petition under 37 CFR 1.46(b)(2) was granted in the application or is concurrently being filed with this document) (provide signer's title if applicant is a juristic entity)

**SIGNATURE of Applicant for Patent**

The undersigned (whose title is supplied below) is authorized to act on behalf of the applicant (e.g., where the applicant is a juristic entity).

Signature	/David Morse/	Date (Optional)	
Name	David Morse		
Title	CEO of Location Based Technologies, Inc.		

**NOTE:** Signature - This form must be signed by the applicant in accordance with 37 CFR 1.33. See 37 CFR 1.4 for signature requirements and certifications. If more than one applicant, use multiple forms.

Total of 1 forms are submitted.

This collection of information is required by 37 CFR 1.131, 1.32, and 1.33. The information is required to obtain or retain a benefit by the public which is to file (and by the USPTO to process) an application. Confidentiality is governed by 35 U.S.C. 122 and 37 CFR 1.11 and 1.14. This collection is estimated to take 3 minutes to complete, including gathering, preparing, and submitting the completed application form to the USPTO. Time will vary depending upon the individual case. Any comments on the amount of time you require to complete this form and/or suggestions for reducing this burden, should be sent to the Chief Information Officer, U.S. Patent and Trademark Office, U.S. Department of Commerce, P.O. Box 1450, Alexandria, VA 22313-1450. DO NOT SEND FEES OR COMPLETED FORMS TO THIS ADDRESS. SEND TO: Commissioner for Patents, P.O. Box 1450, Alexandria, VA 22313-1450.

*If you need assistance in completing the form, call 1-800-PTO-9199 and select option 1.*

## Electronic Acknowledgement Receipt

<b>EFS ID:</b>	33051903
<b>Application Number:</b>	12419451
<b>International Application Number:</b>	
<b>Confirmation Number:</b>	1643
<b>Title of Invention:</b>	APPARATUS AND METHOD FOR ADJUSTING REFRESH RATE OF LOCATION COORDINATES OF A TRACKING DEVICE
<b>First Named Inventor/Applicant Name:</b>	Joseph F. Scalisi
<b>Customer Number:</b>	93892
<b>Filer:</b>	Wesley E. Schwie
<b>Filer Authorized By:</b>	
<b>Attorney Docket Number:</b>	LB1-006USC1
<b>Receipt Date:</b>	29-JUN-2018
<b>Filing Date:</b>	07-APR-2009
<b>Time Stamp:</b>	14:58:09
<b>Application Type:</b>	Utility under 35 USC 111(a)

### Payment information:

Submitted with Payment	no
------------------------	----

### File Listing:

Document Number	Document Description	File Name	File Size(Bytes)/ Message Digest	Multi Part /.zip	Pages (if appl.)
1	Power of Attorney	PowerofAttorney-David.pdf	126739 <small>0fa2be370cb122dcf798b7719b8e5163dba0b770</small>	no	1

### Warnings:

IPR2020-01189

<b>Information:</b>	
<b>Total Files Size (in bytes):</b>	126739
<p><b>This Acknowledgement Receipt evidences receipt on the noted date by the USPTO of the indicated documents, characterized by the applicant, and including page counts, where applicable. It serves as evidence of receipt similar to a Post Card, as described in MPEP 503.</b></p> <p><b><u>New Applications Under 35 U.S.C. 111</u></b> If a new application is being filed and the application includes the necessary components for a filing date (see 37 CFR 1.53(b)-(d) and MPEP 506), a Filing Receipt (37 CFR 1.54) will be issued in due course and the date shown on this Acknowledgement Receipt will establish the filing date of the application.</p> <p><b><u>National Stage of an International Application under 35 U.S.C. 371</u></b> If a timely submission to enter the national stage of an international application is compliant with the conditions of 35 U.S.C. 371 and other applicable requirements a Form PCT/DO/EO/903 indicating acceptance of the application as a national stage submission under 35 U.S.C. 371 will be issued in addition to the Filing Receipt, in due course.</p> <p><b><u>New International Application Filed with the USPTO as a Receiving Office</u></b> If a new international application is being filed and the international application includes the necessary components for an international filing date (see PCT Article 11 and MPEP 1810), a Notification of the International Application Number and of the International Filing Date (Form PCT/RO/105) will be issued in due course, subject to prescriptions concerning national security, and the date shown on this Acknowledgement Receipt will establish the international filing date of the application.</p>	

**PETITION TO ACCEPT UNINTENTIONALLY DELAYED PAYMENT OF MAINTENANCE FEE IN AN EXPIRED PATENT (37 CFR 1.378(b))**

Patent Number	Issue Date	Application Number	Filing Date	Docket Number (if applicable)
8497774	30-Jul-2013	12419451	07-Apr-2009	

CAUTION: Maintenance fee (and surcharge, if any) payment must correctly identify: (1) the patent number and (2) the application number of the actual U.S. application leading to issuance of that patent to ensure the fee(s) is/are associated with the correct patent. 37 CFR 1.366(c) and (d).

Applicants claims the following fee status:

Small Entity

Micro Entity

Regular Undiscounted

Applicants selects the following :

3 1/2

7 1/2

11 1/2

**PETITION FEE**

The petition fee required by 37 CFR 1.17(m) (Fee Code 1558/2558) must be paid as a condition of accepting unintentionally delayed payment of the maintenance fee.

**MAINTENANCE FEE (37 CFR 1.20(e)-(g))**

The appropriate maintenance fee must be submitted with this petition.

**STATEMENT**

THE UNDERSIGNED CERTIFIES THAT THE DELAY IN PAYMENT OF THE MAINTENANCE FEE TO THIS PATENT WAS UNINTENTIONAL

PETITIONER(S) REQUEST THAT THE DELAYED PAYMENT OF THE MAINTENANCE FEE BE ACCEPTED AND THE PATENT REINSTATED

THIS PORTION MUST BE COMPLETED BY THE SIGNATORY OR SIGNATORIES

37 CFR 1.378(c) states: "Any petition under this section must be signed in compliance with 37 CFR 1.33(b) ."

I certify, in accordance with 37 CFR 1.4(d)(4) that I am

- An attorney or agent registered to practice before the Patent and Trademark Office who has been given power of attorney in this application.
- An attorney or agent registered to practice before the Patent and Trademark Office
- A sole patentee
- A joint patentee; I certify that I am authorized to sign this submission on behalf of all the other patentees as evidenced by the power of attorney in the application
- A joint patentee; all of whom are signing this e-petition
- The assignee of record of the entire interest that qualifies as an authorized party under 37 CFR 1.33(b)



Attorney			
A signature of the applicant or representative is required in accordance with 37 CFR 1.33 and 10.18. Please see 37 CFR 1.4(d) for the form of the signature			
Signature	/Wesley Schwie/		
Name	Wesley Schwie	Registration Number	64950

## Electronic Patent Application Fee Transmittal

<b>Application Number:</b>	12419451
<b>Filing Date:</b>	07-Apr-2009
<b>Title of Invention:</b>	APPARATUS AND METHOD FOR ADJUSTING REFRESH RATE OF LOCATION COORDINATES OF A TRACKING DEVICE
<b>First Named Inventor/Applicant Name:</b>	Joseph F. Scalisi
<b>Filer:</b>	Wesley E. Schwie
<b>Attorney Docket Number:</b>	LB1-006USC1

Filed as Small Entity

### Filing Fees for Utility under 35 USC 111(a)

Description	Fee Code	Quantity	Amount	Sub-Total in USD(\$)
<b>Basic Filing:</b>				
MAINTENANCE FEE DUE AT 3.5 YEARS	2551	1	800	800
PET. DELAY PYMT MAINTAIN PATENT IN FORCE	2558	1	1000	1000

**Pages:**

**Claims:**

**Miscellaneous-Filing:**

**Petition:**

**Patent-Appeals-and-Interference:**

Description	Fee Code	Quantity	Amount	Sub-Total in USD(\$)
<b>Post-Allowance-and-Post-Issuance:</b>				
<b>Extension-of-Time:</b>				
<b>Miscellaneous:</b>				
<b>Total in USD (\$)</b>				<b>1800</b>



UNITED STATES PATENT AND TRADEMARK OFFICE

---

Commissioner for Patents  
United States Patent and Trademark Office  
P.O. Box 1450  
Alexandria, VA 22313-1450  
[www.uspto.gov](http://www.uspto.gov)

In re Patent No. 8497774 :  
Issue Date: July 30,2013 :  
Application No. 12419451 :DECISION GRANTING PETITION  
Filed: April 7,2009 :UNDER 37 CFR 1.378(b)  
Attorney Docket No. LB1-006USC1 :

This is a decision on the electronic petition, filed July 3,2018 ,under 37 CFR 1.378(b) to accept the unintentionally delayed payment of the 3.5 year maintenance fee for the above-identified patent.

The petition is **GRANTED**.

The maintenance fee is accepted, and the above-identified patent reinstated as of July 3,2018 . This decision also constitutes notice that the fee has been accepted. An electronic copy of the petition and this decision has been created as an entry in the Image File Wrapper. Nevertheless, petitioner should print and retain an independent copy.

Telephone inquiries related to this electronic decision should be directed to the Electronic Business Center at 1-866-217-9197.

## Electronic Acknowledgement Receipt

<b>EFS ID:</b>	33081720
<b>Application Number:</b>	12419451
<b>Patent Number:</b>	8497774
<b>Confirmation Number:</b>	1643
<b>Petition Issued Date:</b>	July 3,2018
<b>Title of Invention:</b>	APPARATUS AND METHOD FOR ADJUSTING REFRESH RATE OF LOCATION COORDINATES OF A TRACKING DEVICE
<b>First Named Inventor/Applicant Name:</b>	Joseph F. Scalisi
<b>Customer Number:</b>	93892
<b>Filer:</b>	Wesley E. Schwie
<b>Filer Authorized By:</b>	
<b>Attorney Docket Number:</b>	LB1-006USC1
<b>Receipt Date:</b>	03-JUL-2018
<b>Filing Date:</b>	07-APR-2009
<b>Time Stamp:</b>	14:35:06
<b>Application Type:</b>	Utility under 35 USC 111(a)

### Payment information:

Submitted with Payment	yes
Payment Type	CARD
Payment was successfully received in RAM	\$1800
RAM confirmation Number	070518INTEFSW14373900
Deposit Account	
Authorized User	

The Director of the USPTO is hereby authorized to charge indicated fees and credit any overpayment as follows:

IPR2020-01189

--	--	--	--	--	--

**File Listing:**

Document Number	Document Description	File Name	File Size(Bytes)/ Message Digest	Multi Part /.zip	Pages (if appl.)
1	Petition automatically granted by EFS	petition-request.pdf	32631	no	2
			9f432a178f398522cdd8c2aeb9dd5f4e858e d949		

**Warnings:**

**Information:**

2	Fee Worksheet (SB06)	fee-info.pdf	32294	no	2
			b2bbc181d4b4e0174a1abf97728d8ba526 2d9206		

**Warnings:**

**Information:**

<b>Total Files Size (in bytes):</b>	64925
-------------------------------------	-------

**This Acknowledgement Receipt evidences receipt on the noted date by the USPTO of the indicated documents, characterized by the applicant, and including page counts, where applicable. It serves as evidence of receipt similar to a Post Card, as described in MPEP 503.**

**New Applications Under 35 U.S.C. 111**

**If a new application is being filed and the application includes the necessary components for a filing date (see 37 CFR 1.53(b)-(d) and MPEP 506), a Filing Receipt (37 CFR 1.54) will be issued in due course and the date shown on this Acknowledgement Receipt will establish the filing date of the application.**

**National Stage of an International Application under 35 U.S.C. 371**

**If a timely submission to enter the national stage of an international application is compliant with the conditions of 35 U.S.C. 371 and other applicable requirements a Form PCT/DO/EO/903 indicating acceptance of the application as a national stage submission under 35 U.S.C. 371 will be issued in addition to the Filing Receipt, in due course.**

**New International Application Filed with the USPTO as a Receiving Office**

**If a new international application is being filed and the international application includes the necessary components for an international filing date (see PCT Article 11 and MPEP 1810), a Notification of the International Application Number and of the International Filing Date (Form PCT/RO/105) will be issued in due course, subject to prescriptions concerning national security, and the date shown on this Acknowledgement Receipt will establish the international filing date of the application.**



UNITED STATES PATENT AND TRADEMARK OFFICE

UNITED STATES DEPARTMENT OF COMMERCE  
United States Patent and Trademark Office  
Address: COMMISSIONER FOR PATENTS  
P.O. Box 1450  
Alexandria, Virginia 22313-1450  
www.uspto.gov

APPLICATION NUMBER	FILING OR 371(C) DATE	FIRST NAMED APPLICANT	ATTY. DOCKET NO./TITLE
12/419,451	04/07/2009	Joseph F. Scalisi	LB1-006USC1

**CONFIRMATION NO. 1643**

**POWER OF ATTORNEY NOTICE**



93892  
Timberline Patent Law Group PLLC  
9116 E SPRAGUE AVE  
# 384  
Spokane, WA 99206-3601

Date Mailed: 07/11/2018

**NOTICE REGARDING CHANGE OF POWER OF ATTORNEY**

This is in response to the Power of Attorney filed 06/29/2018.

- The Power of Attorney to you in this application has been revoked by the assignee who has intervened as provided by 37 CFR 3.71. Future correspondence will be mailed to the new address of record(37 CFR 1.33).

Questions about the contents of this notice and the requirements it sets forth should be directed to the Office of Data Management, Application Assistance Unit, at (571) 272-4000 or (571) 272-4200 or 1-888-786-0101.

/tmwilliams/



UNITED STATES PATENT AND TRADEMARK OFFICE

UNITED STATES DEPARTMENT OF COMMERCE  
United States Patent and Trademark Office  
Address: COMMISSIONER FOR PATENTS  
P.O. Box 1450  
Alexandria, Virginia 22313-1450  
www.uspto.gov

APPLICATION NUMBER	FILING OR 371(C) DATE	FIRST NAMED APPLICANT	ATTY. DOCKET NO./TITLE
12/419,451	04/07/2009	Joseph F. Scalisi	LB1-006USC1

**CONFIRMATION NO. 1643**

**POA ACCEPTANCE LETTER**



124179  
Schwie Law, LLC  
445 Minnesota St  
Suite 1500  
St. Paul, MN 55101

Date Mailed: 07/11/2018

**NOTICE OF ACCEPTANCE OF POWER OF ATTORNEY**

This is in response to the Power of Attorney filed 06/29/2018.

The Power of Attorney in this application is accepted. Correspondence in this application will be mailed to the above address as provided by 37 CFR 1.33.

Questions about the contents of this notice and the requirements it sets forth should be directed to the Office of Data Management, Application Assistance Unit, at (571) 272-4000 or (571) 272-4200 or 1-888-786-0101.

/tmwilliams/