

Under the Paperwork Reduction Act of 1995, no persons are required to respond to a collection of information unless it displays a valid OMB control number.

(Also referred to as FORM PTO-1465)

REQUEST FOR EX PARTE REEXAMINATION TRANSMITTAL FORMAddress to:
**Mail Stop Ex Parte Reexam
Commissioner for Patents
P.O. Box 1450
Alexandria, VA 22313-1450**

Attorney Docket No.: 418263007US

Date:

1. This is a request for *ex parte* reexamination pursuant to 37 CFR 1.510 of patent number 6,411,941 issued June 25, 2002. The request is made by:
 patent owner. third party requester.
2. The name and address of the person requesting reexamination is:

Chun M. Ng Perkins Coie LLP P.O. Box 1247 Seattle, WA 98111-1247

3. a. A check in the amount of \$ _____ is enclosed to cover the reexamination fee, 37 CFR 1.20(c)(1);
 b. The Director is hereby authorized to charge the fee as set forth in 37 CFR 1.20(c)(1) to Deposit Account No. 50-0665; or
 c. Payment by EFT Account SEA1PIRM in the amount of \$2,520.00 is hereby authorized.
4. Any refund should be made by check or credit to Deposit Account No. 50-0665 37 CFR 1.26(c). If payment is made by credit card, refund must be to credit card account.
5. A copy of the patent to be reexamined having a double column format on one side of a separate paper is enclosed. 37 CFR 1.510(b)(4)
6. CD-ROM or CD-R in duplicate, Computer Program (Appendix) or large table
 Landscape Table on CD
7. Nucleotide and/or Amino Acid Sequence Submission
If applicable, items a. - c. are required.
 a. Computer Readable Form (CRF)
 b. Specification Sequence Listing on:
 i. CD-ROM (2 copies) or CD-R (2 copies); or
 ii. paper
 c. Statements verifying identity of above copies
8. A copy of any disclaimer, certificate of correction or reexamination certificate issued in the patent is included.
9. Reexamination of claim(s) 1-19 is requested.
10. A copy of every patent or printed publication relied upon is submitted herewith including a listing thereof on Form PTO/SB/08, PTO-1449, or equivalent.
11. An English language translation of all necessary and pertinent non-English language patents and/or printed publications is included.

Under the Paperwork Reduction Act of 1995, no persons are required to respond to a collection of information unless it displays a valid OMB control number.

12. The attached detailed request includes at least the following items:
- a. A statement identifying each substantial new question of patentability based on prior patents and printed publications. 37 CFR 1.510(b)(1)
 - b. An identification of every claim for which reexamination is requested, and a detailed explanation of the pertinency and manner of applying the cited art to every claim for which reexamination is requested. 37 CFR 1.510(b)(2)

13. A proposed amendment is included (only where the patent owner is the requester). 37 CFR 1.510(e)

14. a. It is certified that a copy of this request (if filed by other than the patent owner) has been served in its entirety on the patent owner as provided in 37 CFR 1.33(c). The name and address of the party served and the date of service are:

Robert Kinberg
 Venable LLP
 575 7th Street NW
 Washington, DC 20004

Date of Service: May 28, 2009 ; or

- b. A duplicate copy is enclosed since service on patent owner was not possible.

15. Correspondence Address: Direct all communication about the reexamination to:

The address associated with Customer Number: 45979

OR

Firm or Individual Name

Address

City	State	Zip
Country	Telephone	Email

16. The patent is currently the subject of the following concurrent proceeding(s):
- a. Copending reissue Application No. _____
 - b. Copending reexamination Control No. _____
 - c. Copending Interference No. _____
 - d. Copending litigation styled:
 Ancora Technologies, Inc. v. Toshiba America Information Systems, Inc. et al.,
 No. 2-09-cv-00270-MJP (W.D. Wa.)

WARNING: Information on this form may become public. Credit card information should not be included on this form. Provide credit card information and authorization on PTO-2038.

 Authorized Signature 5/28/09
Date

 Chun M. Ng 36,878
 Typed/Printed Name Registration No.

- For Patent Owner Requester
 For Third Party Requester

1
2
3
4
5
6
7
8
9
10
11
12
13
14
15
16
17
18
19
20
21
22
23
24
25
26
27
28

PROOF OF SERVICE – MAIL

STATE OF WASHINGTON, COUNTY OF KING

I am and was at all times herein mentioned employed in the County of King, State of Washington. I am over the age of 18 years and not a party to the within action or proceeding. My business address is 1201 Third Avenue, Suite 4800, Seattle, Washington 98101-3099.

On May 28, 2009, I served a true copy of the **REQUEST FOR EX PARTE REEXAMINATION OF U.S. PATENT NO. 6,411,941** as filed with the United States Patent Office on the patent owner by mailing said document enclosed in a sealed envelope (for collection and mailing, with postage thereon fully prepaid, on the same date, following ordinary business practices) by Express Mail, addressed as follows:

*Robert Kinberg
Venable LLP
575 7th Street NW
Washington, D.C. 20004*

I declare under penalty of perjury under the laws of the State of Washington and the United States of America that the foregoing is true and correct; that I am employed in the office of a member of the Washington bar at whose direction this service was made; and that this Proof of Service was executed on May 28, 2009, at Seattle, Washington.

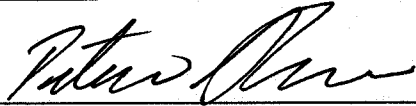

Peter Sher

IN THE UNITED STATES PATENT AND TRADEMARK OFFICE

In re U.S. Patent of:

Mullor et al.

**REQUEST FOR EX PARTE
REEXAMINATION UNDER
35 U.S.C. §302**

U.S. Patent No: 6,411,941

Reexamination Request Control No:

Not Yet Assigned

Filed: October 1, 1998

Issued: June 25, 2002

For: **METHOD OF RESTRICTING
SOFTWARE OPERATION WITHIN
A LICENSE LIMITATION**

Commissioner of Patents
P.O. Box 1450
Alexandria, VA 22313-1450

REQUEST FOR EX PARTE REEXAMINATION

Dear Sir:

Pursuant to 35 U.S.C. §§ 302-307 and 37 C.F.R. § 1.510, requester Microsoft Corporation hereby requests *ex parte* reexamination of claims 1-19 of United States Patent No. 6,411,941 ("the '941 patent"), which issued on June 25, 2002, to Miki Mullor and Julian Valiko. The '941 patent was based on an application filed October 1, 1998 and claims priority to an application filed in Israel on May 21, 1998. A copy of the '941 patent is attached to this request as Exhibit A. The '941 patent is currently the subject of pending litigation including *Ancora Technologies, Inc. v. Toshiba America Information Systems, Inc. et al.*, No. SACV 08-0626-AG (C.D. Cal.).¹ The original complaint for the

¹ The lawsuit was recently transferred to the Western District of Washington, and is now captioned as *Ancora Technologies, Inc. v. Toshiba America Information Systems, Inc. et al.*, No. 2:09-cv-00270-MJP (W.D. Wa.)

suit is attached as Exhibit B. In the pending litigation, the patent owner has proposed an extremely broad claim construction that expands the scope of the patent well beyond the scope that was argued during the original prosecution of the '941 patent. Had the patent owner asserted such scope during the original prosecution, these claims would not have been allowed. Even with the narrower construction that the patent owner originally argued, the '941 patent was anticipated by the references discussed below. Given the current, broad claim construction that patent owner now asserts, the invalidity of the patent's claims is even clearer. An opening Markman brief filed by patent owner (hereinafter "Patent Owner's Markman Brief") is attached to this request as Exhibit C.²

The substantial new questions of patentability raised in this request involve prior art questions that were not considered during prosecution of the application leading to the '941 patent. As detailed below, claims 1-19 of the '941 patent were anticipated under 35 U.S.C. § 102 in view of a patent to Robert Schwartz et al. filed in 1997. Claims 1-19 were also anticipated under § 102 in view of a patent to David Lewis filed in 1994.

During the original prosecution of the '941 patent, patent owner made strong statements distinguishing low-level programs that regularly access the BIOS from operating system level programs such as the claimed system. Amendment for Application No. 09/164,777 filed on February 5, 2002, at 5 (attached as Exhibit D). However, patent owner now asserts that claim 1 of the '941 patent covers any system that verifies a program (i.e. any set of instructions that can be executed by a computer) using information stored in a non-volatile memory area of the BIOS of a computer. Patent Owner's Markman Brief at 14-21. Thus, patent owner's arguments during prosecution are clearly no longer operative. Requestors respectfully assert that this changing story should be considered when evaluating the substantial new question of patentability and in any resulting reexamination.

The prior art references cited in this request raise substantial new questions of patentability that were not considered during prosecution of the application leading to

² 37 C.F.R. § 1.104(c)(3) (2007) ("In rejecting claims the examiner may rely upon admissions by the applicant, or the patent owner in a reexamination proceeding, as to any matter affecting patentability").

the '941 patent and more closely match the claimed limitations than the references previously considered by the PTO in connection with the '941 patent.

The prior art references on which this request is based, all of which pre-date the May 21, 1998 priority date of the '941 patent, are as follows:

- U.S. Patent No. 6,153,835, "System and Method for an Electronic Postage Scale with Variable Function Keys and Window Screens," issued to Schwartz et al. on November 28, 2000, based on an application filed June 7, 1995 and claiming priority to an application filed October 14, 1993 ("Schwartz '835") (attached as Exhibit E);
- U.S. Patent No. 5,734,819, "Method and Apparatus for Validating System Operation," issued to David Otto Lewis on March 31, 1998, based on an application filed October 12, 1994 ("Lewis '819") (attached as Exhibit F);

The remainder of this request is organized as follows. Section I provides an overview of the '941 patent. Section II provides an overview of the prior art cited in this request. Section III summarizes the substantial new questions of patentability introduced by this request. Section IV explains how that art compares to the claims at issue (detailed claim charts appear in Exhibit I). Section V concludes with a request that this request be granted and that the claims at issue be rejected.

I. OVERVIEW OF THE '941 PATENT

The '941 patent is directed to a method for enforcing a license restriction on a software program. '941 Patent at Abstract. The system uses a verification structure in a non-volatile memory area of the BIOS of a computer to verify that the computer is licensed to run the software program. *Id.* at C6:59-67. The specification of the '941 patent does not define "BIOS"; however, the term is well-known in the computer industry. According to the IBM Dictionary of Computing (excerpts attached as Exhibit G), the Basic Input/Output System (BIOS) is "[c]ode that controls basic hardware operations, such as interactions with diskette drives, hard disk drives, and the keyboard. IBM Dictionary 56, 65. As described in the '941 patent's specification, the BIOS may include both a read-only memory (ROM) section and an electrically erasable programmable read-only memory (EEPROM) section. In addition, during prosecution patent owner distinguished the claims over a prior art reference that stored license

information in persistent storage on a hard drive or magnetic disk drive. Amendment for Application No. 09/164,777 filed on February 5, 2002, at 5-7. Thus, "BIOS", as used in the '941 patent, apparently refers to a memory area in a computer that encompasses multiple non-volatile memory components but does not include a hard drive. The purported inventive aspect of the method is that it uses a writeable portion of the BIOS to store a verification structure for the software program. *Id.*

Figure 2 below shows the basic process for executing the method of the '941 patent. As shown in the figure, the process is a simple sequence of *selecting* a software program, *setting up* a verification structure in the BIOS, *verifying* the program using the verification structure, and *acting* on the verification. '941 patent at C6:4-52. During the setup phase, the system creates a verification structure and stores the structure in a non-volatile area of the BIOS. *Id.* at C6:18-28. During the verification phase, the system verifies the license using the stored verification structure. *Id.* at C6:29-39. After the verification phase, the system acts on the program based on the verification. *Id.* at C6:40-52.

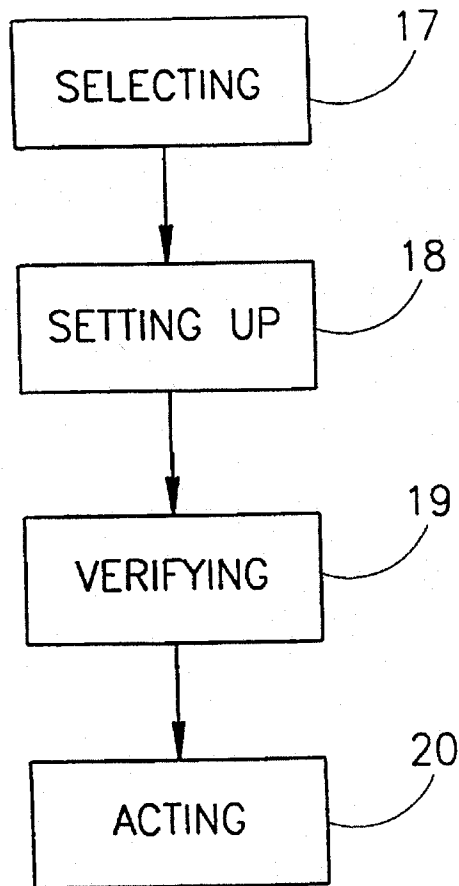

Claim 1 is directed to exactly this process.³ Claim 1 reads as follows:

1. A method of restricting software operation within a license for use with a computer including an erasable, non-volatile memory area of a BIOS of the computer, and a volatile memory area; the method comprising the steps of:

selecting a program residing in the volatile memory,

using an agent to set up a verification structure in the erasable, non-volatile memory of the BIOS, the verification structure accommodating data that includes at least one license record,

³ In the context of reexamination, the "broadest reasonable interpretation" standard provided in MPEP §2111 for claim interpretation during patent examination is used, and the statutory presumption of validity for issued patents does not apply. MPEP §2258(I)(G). The standard applied by a court during litigation may or may not overlap with MPEP §2111. The requester expressly reserves the right to argue a claim construction in the pending litigation that is different from a claim interpretation in this request.

verifying the program using at least the verification structure from the erasable non-volatile memory of the BIOS, and

acting on the program according to the verification.

The method of claim 1 consists first of selecting the program whose license is being verified. According to patent owner, this step simply means "running a program in the volatile memory." Patent Owner's Markman Brief at 16. In the next step, the system creates the verification structure (including a license record) in a non-volatile, erasable memory area of the BIOS. (Although the claim recites that this step is performed by an "agent", the specification provides no information on what the "agent" is. However, according to patent owner's statements, the "agent" is a program that performs a task. *Id.* at 17.) In the next step, the system verifies the program using the verification structure. The final step of the method is acting on the program based on the verification. This may include, for example, running the program if the verification is successful.

Most of this method was well-known in the art well before the filing of the '941 patent in 1998. In fact, the '941 patent itself acknowledges this in the background section, which states that "software based products have been developed to validate authorized software usage by writing a license signature onto the computer's volatile memory (e.g. hard drive)."⁴ See '941 patent at C1:19-21. Thus, based on patent owner's own admitted prior art, the innovation of claim 1 can only be that the license information was stored in a writeable memory area of the BIOS, rather than on a hard drive.

Claim 18, which is the only other independent claim, reads as follows:

18. A method for accessing an application software program using a pseudo-unique key stored in a first non-erasable non-volatile memory area of a computer, the first non-volatile memory area being unable to be programmatically changed, the method, comprising:

⁴ It should be noted that the specification misuses the term "volatile" here. As defined by the IBM Dictionary of Computing, "volatile storage" is "a storage device whose contents are lost when power is cut off. Contrast with nonvolatile storage". IBM Dictionary of Computing at 740. A hard drive is therefore non-volatile storage.

loading the application software program residing in a non-volatile memory area of the computer;

using an agent to perform the following steps:

extracting license information from software program;

encrypting license information using the pseudo-unique key stored in the first non-volatile memory area;

storing the encrypting license information in a second erasable, writable, non-volatile memory area of the BIOS of the computer;

subsequently verifying the application software program based on the encrypted license information stored in the second erasable, writable, non-volatile memory area of the BIOS; and

acting on the application software program based on the verification.

The method operates on a computer system that has a pseudo-unique key⁵ stored in a non-erasable section of memory. According to the specification of the '941 patent, the pseudo-unique key may be a bit string which "uniquely identifies each first nonvolatile memory" or is "of sufficient length such that: there is an acceptably low probability of a successful unauthorized transfer of licensed software between two computers. . . ." '941 patent at C4:10-18. In addition, the key for identifying the computer "may be composed of the pseudo-unique key exclusively, or, if desired, in combination with information, e.g., information relating to the registration of the user. . . ." *Id.* at C4:6-10.

The application being accessed is loaded from the nonvolatile memory. An agent then executes a set of steps. As discussed above, according to patent owner's statements, this simply means that a software program performs the steps. In any event, the agent extracts license information from the program and encrypts the license

⁵ Interestingly, Patent Owner's Markman brief proposes that "pseudo-unique key" be construed to mean "data that is not necessarily unique." Patent Owner's Markman Brief at 10.

information using the key. The encrypted information is then stored in a writeable, non-volatile memory area in the BIOS of the computer.

At a later point, the agent verifies the program based on the encrypted license information. According to the specification, a system may verify a program by again extracting the license information from the program and re-generating the encrypted license information using the pseudo-unique key. The system then compares the generated information to the stored information. If the stored encrypted license information has been copied to a different computer, the re-encrypted data will differ from the stored data because the key is different. The program may then be terminated based on the failure to match.

It is important to note that, despite patent owner's contentions during prosecution, software developers could use well-known techniques to develop software programs that accessed data in the BIOS of a computer. For example, a contemporaneously published textbook describes methods for using the C programming language to access the computer's BIOS data area to determine information about the computer's hardware, such as whether a LPT (line printer) was installed. MUHAMMAD ALI MAZIDI AND JANICE GILLISPIE MAZIDI, THE 80X86 IBM PC AND COMPATIBLE COMPUTERS (VOLS. I & II): ASSEMBLY LANGUAGE, DESIGN, AND INTERFACING 808-816 (2d ed. 1998) ("Mazidi") (attached as Exhibit H).

II. PRIOR ART OVERVIEW

A. The Schwartz '835 Patent

The Schwartz '835 patent (assigned to Ascom Hasler Mailing Systems) disclosed an electronic postage scale system.⁶ Schwartz '835 at Abstract. The postage scale was controlled by application software that could be updated from time to time. Schwartz '835 at C10:15-20. During the update process, the system required a user to enter an authorization code to prove that the software was licensed. Figure 8 of the patent depicted a general structure of the electronic components of the device.

⁶ Schwartz '835 claims priority as a division of an application filed on October 14, 1993 and is therefore prior art to the '941 patent under 35 U.S.C. § 102(e).

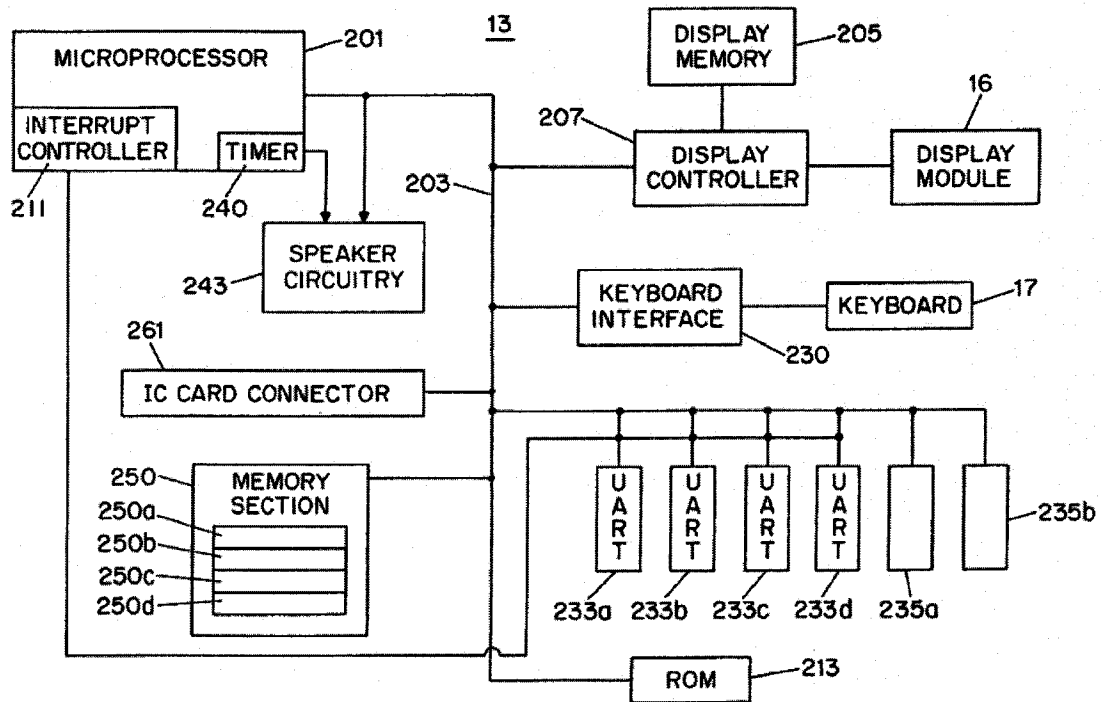

FIG. 8

As shown in the figure, the system included a memory section 250 and a ROM 213. The ROM stored a unique serial number that was pre-assigned to the system. See Schwartz '835 at C7:48-50. The memory section had multiple sections 250a-d, including a flash EEPROM section 250a and an erasable programmable read-only memory (EPROM) 250b. *Id.* at C7:50-54. As shown below in Figure 9, the system's memory space included a BIOS module 309, which was stored partially on the flash EEPROM 250a and partially on the EPROM 250b. Thus, as with the '941 patent, part of the BIOS was stored in a memory component that was difficult to modify (EPROM), while another part was stored in a memory component that was easier to modify (EEPROM).

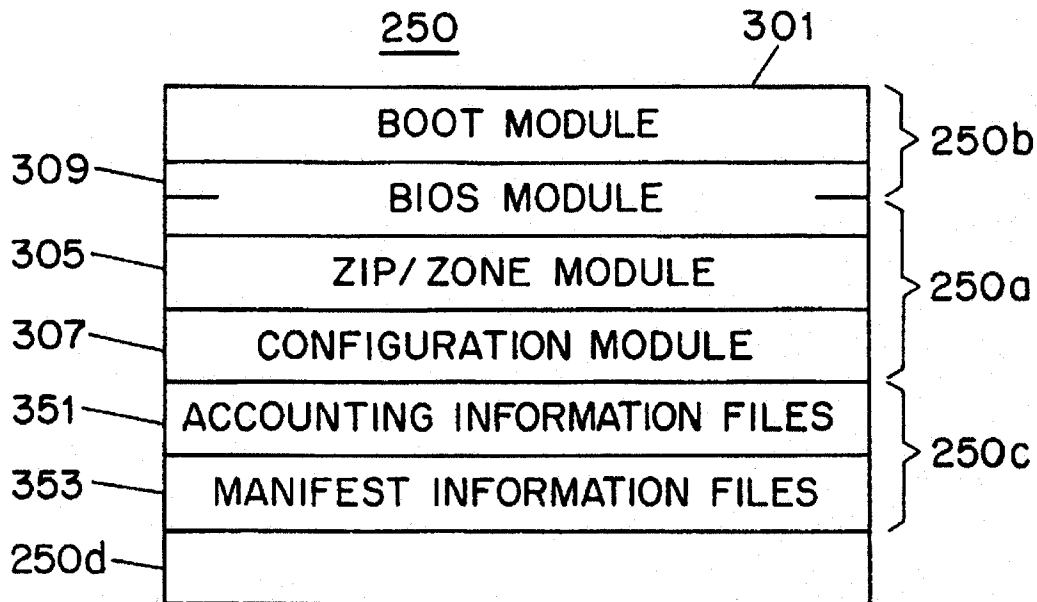

FIG. 9

When new software was installed to the system, a user was required to enter an authorization number. *Id.* at C10:21-25. The authorization number was based on information specific to the particular system, including the serial number and model number of the device and version numbers of various databases. *Id.* at C10:25-37. The system verified the initial authorization by generating an electronic signature based on the same system information. *Id.* at C10:45-49. If the results matched, the system stored the authorization information in a memory buffer. *Id.* at C10:47-54. Subsequently, the system used the stored signature to verify authorization by generating an electronic signature based on the same system information. *Id.* at C11:24-36. The system then compared the generated electronic signature against the electronic signature stored in the memory buffer. *Id.* at C11:36-38. If the values matched, the system began operating (i.e. the software was executed). *Id.* at C11:38-40.

According to Schwartz '835, the disclosed verification method was useful to deter unauthorized copying because "even though the software [could] be copied onto [] similar systems, the latter [systems] would not be operational without proper authorization numbers, which need to be derived in part from their respective serial numbers." *Id.* at C12:30-41.

B. The Lewis '819 Patent

Like Schwartz '835, the Lewis '819 patent (assigned to IBM) also disclosed a method and system for validating aspects of a computer system.⁷ Lewis '819 at Abstract. According to Lewis '819, the invention met a need for a system that used a non-volatile memory to store critical information and was able to monitor the critical information to "detect whether the information has been altered so the system may not be run in its altered state." *Id.* at C2:66 to C3:3. Figure 1 shows a logical diagram of the system disclosed by Lewis '819.

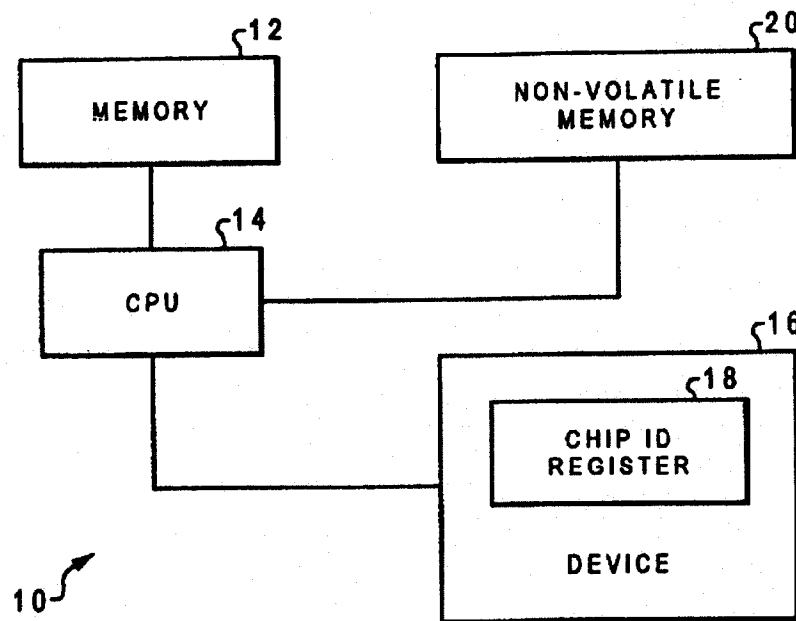

Fig. 1

As shown in Figure 1, the system included a CPU 14 and a memory unit 12 that "contain[ed] instructions and programs that [were] executed in CPU 14." *Id.* at C4:23-27. The system also included a non-volatile memory (NVM) 20 and a system device 16 that contained a chip ID register 18. *Id.* at Fig. 1; at C4:27-41. The chip ID register 18 stored a unique chip identifier. *Id.* at C4:34-35. The system used system information, including device type and the chip ID, to generate a Message Authentication Code (MAC), which was an encrypted message used to verify the system. *Id.* at C2:7-20; at C4:55 to C5:9. The resulting MAC was then stored in the NVM. *Id.* at C5:8-9.

⁷ Lewis '819 issued on March 31, 1998 from an application filed on October 12, 1994 and is therefore prior art to the '941 patent under 35 U.S.C. § 102(a) and § 102(e).

While the system was operating, it used the stored MAC to verify that the system had not been tampered with. *Id.* at C5:27-31. During the verification process, the system read system information from the NVM into memory and generated a new MAC based on the system information. *Id.* at C5:31-35. The system compared the new MAC to the MAC previously stored in the NVM and aborted operation if the values were not equal. *Id.* at C5:35-42. The system could also compare a chip ID value stored in the NVM with the chip ID in the chip ID register 18. *Id.* at C5:42-45. If the values were equal, the system was verified and operation continued. *Id.* at C5:45-46. Otherwise, the system determined that data had been copied from another system and aborted operation. *Id.* at C5:45-50.

III. A SUBSTANTIAL NEW ISSUE OF PATENTABILITY EXISTS

A substantial new issue of patentability exists because new prior art has been cited that meets the detailed language of each of claims 1-19 of the '941 patent. Exhibit I of this request includes claim charts explaining how Schwartz '835 and Lewis '819 each anticipated or made obvious each of the claims. In addition, Section IV below summarizes the reasons for invalidity and elaborating on the relevant claim elements.

As described above, claim 1 of the '941 is directed to a simple process of selecting a program, setting up a verification structure in the BIOS, verifying the program using the verification structure, and acting on the verification. Independent claim 18 is directed to a similar process. The new references create a substantial new question of patentability because they (1) disclose the details of each of these independent claims, and (2) disclose or render obvious each element of the dependent claims.

The chart below summarizes the grounds for invalidity for each of the claims of the '941 patent:

Claim	Grounds for Invalidity
1, 2, 4, 5, 6, 7, 8, 9, 10, 12, 13, 14, 15, 17, 18, 19	<ul style="list-style-type: none"> • Anticipated by Schwartz '835 • Anticipated by Lewis '819
3	<ul style="list-style-type: none"> • Anticipated by Schwartz '835 • Obvious in view of Schwartz '835

	<ul style="list-style-type: none"> • Anticipated by Lewis '819
11	<ul style="list-style-type: none"> • Anticipated by Schwartz '835 • Anticipated by Lewis '819 • Obvious in view of Lewis '819
16	<ul style="list-style-type: none"> • Obvious in view of Schwartz '835 • Anticipated by Lewis '819 • Obvious in view of Lewis '819

A. Schwartz '835 Discloses the Details of the Issued Claims and Raises a Substantial New Question of Patentability

Schwartz '835 was filed in June 1995, well before the earliest priority date of the '941 patent. Schwartz '835 disclosed each of the elements of independent claim 1. In particular, Schwartz '835 disclosed a system and method for restricting software operation within a license for use on a personal computer having an erasable, non-volatile memory area of a BIOS. Schwartz '835 at C12:29-40; at C7:48-59; at C8:13-15. Schwartz '835 disclosed that the method began when the system selected a program residing in memory by running the program. *Id.* at C8:26-31. Schwartz '835 also disclosed that the system set up a verification structure in the non-volatile memory area of the BIOS by encrypting system data and storing the encrypted information in a flash EEPROM. *Id.* at C10:21-54; at C7:48-59. At a later time, the system verified the software using the stored verification structure and acted on the program according to the verification. *Id.* at C11:24-40; at C12:8-14. Schwartz '835 disclosed the elements of claim 18 for similar reasons.

In addition, Schwartz '835 anticipated or made obvious each of dependent claims 2-17 and 19. Thus, Schwartz '835 raises a substantial new question of patentability for each of the claims of the '941 patent.

B. Lewis '819 Discloses the Details of the Issued Claims and Raises a Substantial New Question of Patentability

Lewis '819 was filed in October 1994 and issued in March 1998 and was, therefore, filed and issued before the earliest priority date of the '941 patent. Lewis '819 also disclosed each of the elements of independent claims 1. Specifically, Lewis '819

disclosed a system and method for restricting software operation within a license for use on a personal computer having an erasable, non-volatile memory area of a BIOS. Lewis '819 at Abstract; at C1:8-16; at C3:6-15; at C4:40-54. Lewis '918 also disclosed that the system operated by selecting a program residing in memory. *Id.* at C4:23-31; at C5:10-20; at C5:27-31. The system then set up a verification structure in the non-volatile memory of the BIOS by generating an encrypted Message Authentication Code (MAC) using a unique chip identifier and other system information. *Id.* at C2:7-48; at C4:55 to C5:9. Lewis '819 further disclosed that the system verified the software using the verification structure (the stored encrypted MAC) and acted on the program according to the verification. *Id.* at C5:10-50. Lewis '819 also disclosed the elements of claim 18 for similar reasons.

In addition, Lewis '819 anticipated or made obvious each of dependent claims 2-17 and 19. Thus, Lewis '819 raises a substantial new question of patentability for each of the claims of the '941 patent.

IV. EXPLANATION OF PERTINENCY AND MANNER OF APPLYING THE CITED PRIOR ART

The claim charts in attached Exhibit I show how each of the limitations of claims 1-19 of the '941 patent are found in the disclosures of the prior art references cited in this request. The explanation below summarizes the analysis in those charts. In order to simplify the discussion, independent claims 1 and 18 are discussed before the remaining dependent claims. In addition, related claims have been combined for clarity.

A. Unpatentability of Claim 1

1. Anticipation of Claim 1 by Schwartz '835

Claim 1 was unpatentable because it was anticipated by the disclosure of the Schwartz '835 patent. Schwartz '835 disclosed a hardware and software system that included features well beyond the subject matter of the '941 patent. However, Schwartz '835 specifically discussed and disclosed a verification system that employs a method identical to the method recited in claim 1. This result is to be expected, given the breadth of the patent owner's asserted construction of claim 1 and the common purposes of the '941 patent and the Schwartz '835 reference.

a. **"[R]estricting software operation within a license for use with a computer including an erasable, non-volatile memory area of a BIOS of the computer and a volatile memory area" of Claim 1**

Schwartz '835 disclosed the preamble of claim 1. Schwartz '835 stated that the verification requirement was "desirable in that it help[ed] deter unauthorized copying of software of system 10 onto other similar systems." Schwartz '835 at C12:29-31. In particular, "even though the software can be copied onto the similar systems, the latter would not be operational without a proper authorization number. . . ." *Id.* at C12:31-35. In addition, Schwartz '835 also disclosed various hardware components that meet the requirements of the preamble, including a writeable flash EEPROM used to store part of the BIOS (*Id.* at C7:50-57) and a static random access memory (SRAM) that was used as work space when the system was active. *Id.* at C8:19-20. Accordingly, the system of Schwartz '835 meets the preamble of claim 1.

b. **"[S]electing a program residing in the volatile memory" of Claim 1**

According to patent owner's prior statements, "selecting a program" simply means "running a program in the volatile memory." Patent Owner's Markman Brief at 16. Schwartz '835 disclosed that the computer system executed an application program to perform various tasks on the system. *Id.* at C8:26-31.

c. **"[U]sing an agent to set up a verification structure in the erasable, non-volatile memory of the BIOS . . ." of Claim 1**

Schwartz '835 disclosed an authorization process that was executed when the system software was updated. Schwartz '835 at C10:15-20. To enable the updated software, the system required a user to enter an authorization number. *Id.* at C10:21-25. The system then generated an electronic signature based on data stored on the device, such as the serial number and model number of the device. *Id.* at C10:29-42. The system compared the authorization number to the electronic signature and, if the numbers matched, stored the electronic signature in a memory buffer in the configuration module. *Id.* at C10:49-54; at C11:36-38. As discussed below, the electronic signature functioned as a verification structure that the system could use to confirm that operation is authorized. Figure 9 shows that the configuration module is

stored in the flash EEPROM 250a along with the BIOS module. See, also, *id.* at C7:48-62.

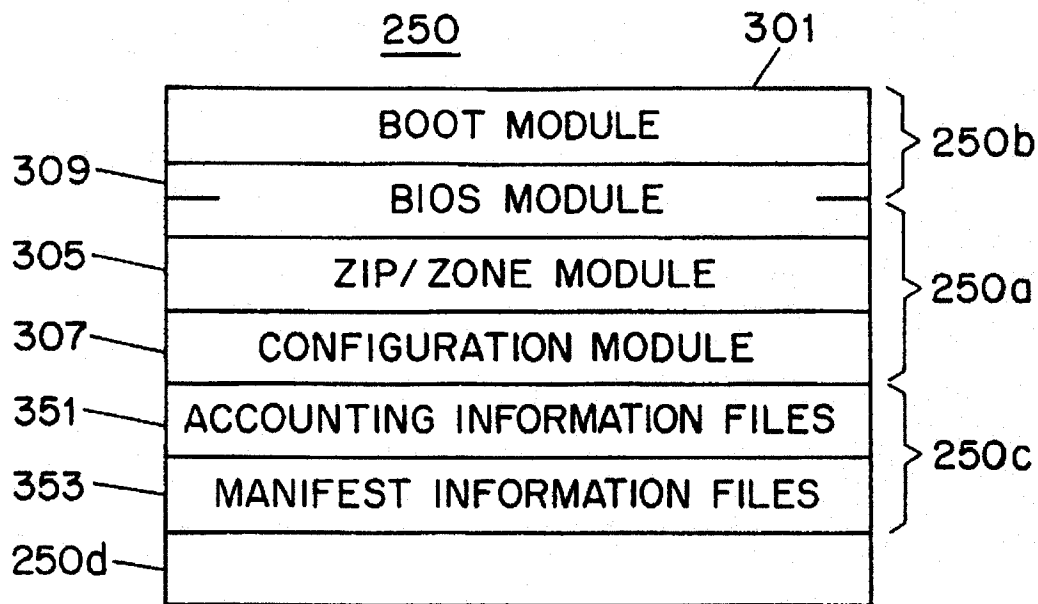

FIG. 9

The '941 patent provides little information for interpreting what an "agent" is in this claim. However, the broadest reasonable interpretation for purposes of this request is patent owner's own proposed interpretation, which defines an agent as "a program to perform a task." Patent Owner's Markman Brief at 17. The agent is disclosed by Schwartz '835, which describes a routine 700 that is used to process and verify an authorization number. Schwartz '835 at C11:58 to C12:14; at Fig. 12. Other routines are inherently disclosed, because Schwartz '835 describes a computer system that uses software to execute the verification process. A software program would be required to execute the process.

- d. **"[V]erifying the program using at least the verification structure from the erasable non-volatile memory of the BIOS" of Claim 1**

During normal operation or when the device was first turned on, the system used the stored verification structure to verify that the software was authorized. *Id.* at C11:24-40. To execute the process, the system generated a new electronic signature based on the same data as it used to generate the original electronic signature (e.g.,

serial number, model number, etc.). *Id.* at C11:24-36. The system then compared the generated electronic signature to the electronic signature stored in the configuration module. *Id.* at C11:36-38. Based on the result of the comparison, the system could become operational or request a new authorization. *Id.* at C11:38-40.

e. **"[A]cting on the program according to the verification" of Claim 1**

As stated above, Schwartz '835 disclosed that the system acted on the program based on the result of the verification. After comparing the generated electronic signature to the stored signature, the system either began operating normally or requested a new authorization number based on the result of the comparison. *Id.* Schwartz '835 therefore disclosed every element of claim 1.

2. **Anticipation of Claim 1 by Lewis '819**

Claim 1 was also unpatentable because it was anticipated by the disclosure of Lewis '819. The stated object of the invention disclosed by Lewis '819 is nearly identical to the goals of both Schwartz '835 and the '941 patent: "to provide a computer system having a non-volatile memory with security information written into the non-volatile memory and a way of detecting when that information has been altered so as to prevent operation of any portion of the computer system once tampering has been detected." Lewis '819 at C3:10-15. As discussed below, Lewis '819 used similar components and steps to achieve this object.

a. **"[R]estricting software operation within a license for use with a computer including an erasable, non-volatile memory area of a BIOS of the computer and a volatile memory area" of Claim 1**

Similar to the '941 patent, Lewis '819 described a system for protecting from unauthorized use to "prevent operation of [a] computer system once tampering has been detected." Lewis '819 at 1:13-15. As shown in Figure 1 below, the system was implemented in a computer with a memory 12 and a non-volatile memory (NVM) 20. The NVM stored authorized system information, such as device type and device serial number, and verification information generated by the system. *Id.* at C4:40-54.

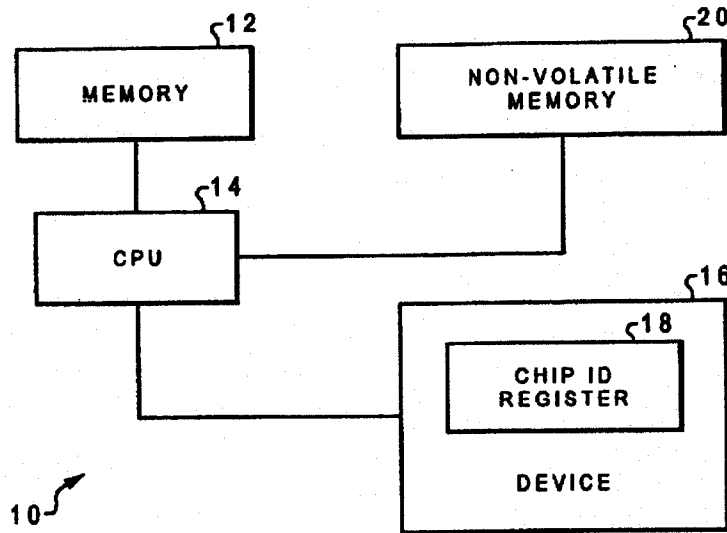

Fig. 1

Although Lewis '819 did not explicitly disclose that the NVM stored the BIOS, this was inherently present in the reference. Lewis '819 discloses that the NVM can be an EEPROM flash type of memory. Lewis '819 at C1:31-37. As discussed above, the '941 patent did not provide a clear definition the term "BIOS", but did state that the BIOS may include multiple non-volatile memory sections (e.g., a ROM section and an EEPROM section). '941 patent at C5:12-16. These sections were separate from the "volatile memory area", such as the internal RAM of a computer. During prosecution, patent owner stated that "all computers must have a BIOS" and that the BIOS was located in storage separate from storage used by the operating system for applications. Amendment for Application No. 09/164,777 filed on February 5, 2002, at 5. In the case of the Lewis '819 patent, the NVM 20 stores system- or hardware-level information (e.g., information related to the device 16), while the memory 12 stores "instructions and programs that are executed in CPU 14." Lewis '819 at C4:25-27; at C4:40-48. Thus, Lewis '819 inherently discloses that the NVM can be an EEPROM storing BIOS for a computer, even though it does not use the exact term.

Alternatively, it would have been obvious to one skilled in the art at the time of the invention to use the NVM EEPROM to store the BIOS of the computer system. As admitted by the patent owner, BIOS stored in an NVM EEPROM flash type of memory was a standard component of computer systems at the time of invention of the '941

patent. Thus, an engineer designing a system according to Lewis '819 would have known that BIOS could be stored in an NVM EEPROM, which could also be used to hold the authorized system information taught by Lewis '819.

b. "[S]electing a program residing in the volatile memory" of Claim 1

Lewis '819 disclosed that the memory unit 12 contained programs that were executed by the CPU, including programs used to control the device 16. Lewis '819 at C4:23-27.

c. "[U]sing an agent to set up a verification structure in the erasable, non-volatile memory of the BIOS . . ." of Claim 1

The system disclosed by Lewis '819 used an encrypted Message Authentication Code (MAC) to detect modifications of the device serial number (i.e., for verification). *Id.* at C2:7-13. The system generated the encrypted MAC using the process disclosed in Figure 3 of the reference.

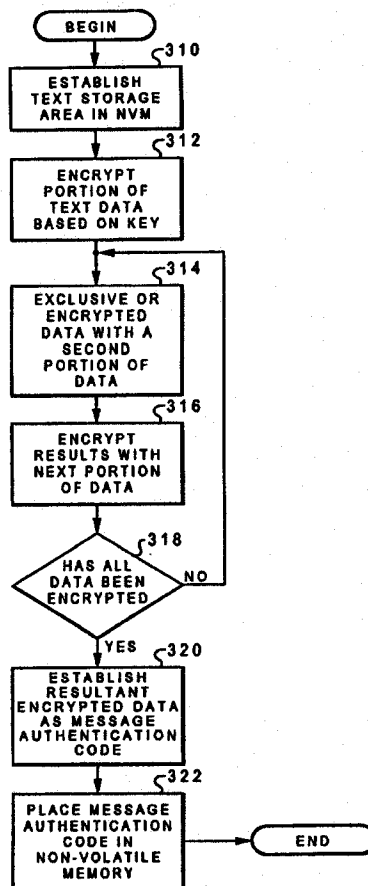

Fig. 3

The system used data stored in the NVM, including the device type, device serial number, and chip ID, to generate the MAC data. *Id.* at C4:48 to C5:7. The resulting encrypted value was then stored in the NVM in step 322 of the process in Figure 3. Although Lewis '819 did not explicitly state that the MAC was generated by an agent, the reference inherently disclosed this for the reasons explained in Section IV(a)(1)(c).

d. "[V]erifying the program using at least the verification structure from the erasable non-volatile memory of the BIOS" of Claim 1

Lewis '819 also disclosed the verification step of claim 1. Figure 4, which is included below, shows the verification process according to Lewis '819. As shown in steps 410 and 412 of the figure, the system generated a MAC using the system data from the NVM. *Id.* at C5:31-35. In block 414, the system compared the generated MAC to the stored MAC and aborted system operation if the values did not compare. *Id.* at C5:35-40. Thus, Lewis '819 disclosed this element of claim 1.

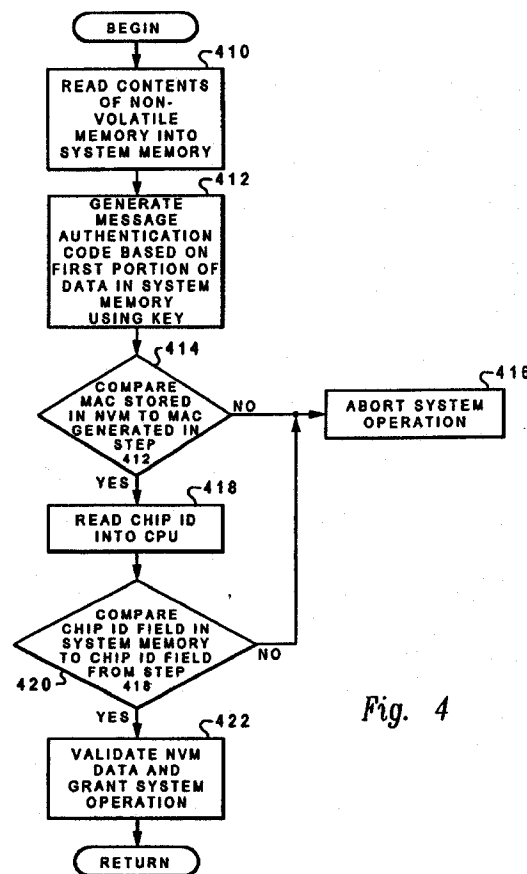

Fig. 4

e. **"[A]cting on the program according to the verification" of Claim 1**

As noted above, in steps 414 and 416 of Figure 4, the system aborts if the two values do not compare. *Id.* at C5:38-40.

B. **Unpatentability of Claim 18**

1. **Anticipation of Claim 18 by Schwartz '835**

Claim 18 is the second independent claim in the '941 patent. It is equally invalid for the same reasons discussed above. The method of claim 18 includes steps in which an agent encrypts the license information and stores the encrypted information in an erasable, writeable, non-volatile memory area of the BIOS. The system then uses the stored information to verify the program and acts on the program based on the verification.

a. **"A method for accessing an application software program using a pseudo-unique key stored in a first non-erasable memory area of a computer" of Claim 18**

This preamble is disclosed by Schwartz '819. As discussed above, Schwartz '819 described (among other things) a system for controlling the application software to limit its use to a single authorized device. Schwartz '835 at Abstract. Schwartz '835 further disclosed that the computer was identified by a unique serial number, which was "permanently" stored in a read-only memory (ROM). Schwartz '835 at C7:48-50.

b. **"[L]oading an application program" of Claim 18**

Schwartz '835 disclosed that the computer system executed an application program to perform various tasks on the system. *Id.* at C8:26-31. Thus, this step was disclosed by Schwartz '835 in numerous places in the reference.

c. **"[E]xtracting license information" of Claim 18**

Schwartz '835 disclosed that the system began the verifying process by reading system and software information, including the serial number of the device and version numbers of several software components. Schwartz '835 at C10:29-38. Thus, Schwartz '835 meets this element of claim 18.

d. "[E]ncrypting license information using the pseudo-unique key" of Claim 18

Claim 18 specifies encrypting "using" the pseudo-unique key. Under the broadest reasonable interpretation used for interpreting claims during prosecution, this element would clearly be met by the Schwartz '835 system, which generated the electronic signature by encrypting system information that included a unique serial number stored in the ROM. *Id.* at C7:48-50; at C10:29-38.

e. "[S]toring the encrypting license information" of Claim 18

This element is disclosed by the reference for the same reasons as the "setting up" step of claim 1. Schwartz '835 states the system stored the encrypted electronic signature in the configuration module, which is stored on the same memory component as the BIOS. *Id.* at C10:49-54 ("If the two signatures match, the authorization number is declared valid; the authorization number will then be stored in a first memory buffer. . . ."); at C11:36-40 ("The electronic signature, thus generated, is compared with the electronic signature stored in configuration module 307.").

f. "[S]ubsequently verifying the application software program based on the encrypted license information" of Claim 18

Schwartz '835 disclosed that the system used the electronic signature to verify that the software was authorized to operate. *Id.* at C11:25-40. In particular, the system read system information, including the serial number and software version numbers, from the memory and generated an electronic signature based on the newly read values. *Id.* at C11:24-36. The system then compared the generated electronic signature with the electronic signature stored in the configuration module. *Id.* at C11:36-38.

g. "[A]cting on the application software program based on the verification" of Claim 18

Schwartz '835 disclosed that the system acted based on the verification by either aborting operation or prompting for a new authorization number. *Id.* at C11:38-40.

2. Anticipation of Claim 18 by Lewis '819

a. "A method for accessing an application software program using a pseudo-unique key stored in a first non-erasable memory area of a computer" of Claim 18

As discussed above, Lewis '819 described a system for protecting from unauthorized use to "prevent operation of [a] computer system once tampering has been detected." Lewis '819 at 1:13-15. As shown in Figure 1, the system included a chip ID register 18, which stored a unique chip identifier. *Id.* at C4:37-39. Lewis '819 also described several methods for implementing the chip ID register so that the register could be made non-changeable. *Id.* at C1:46 to C2:6.

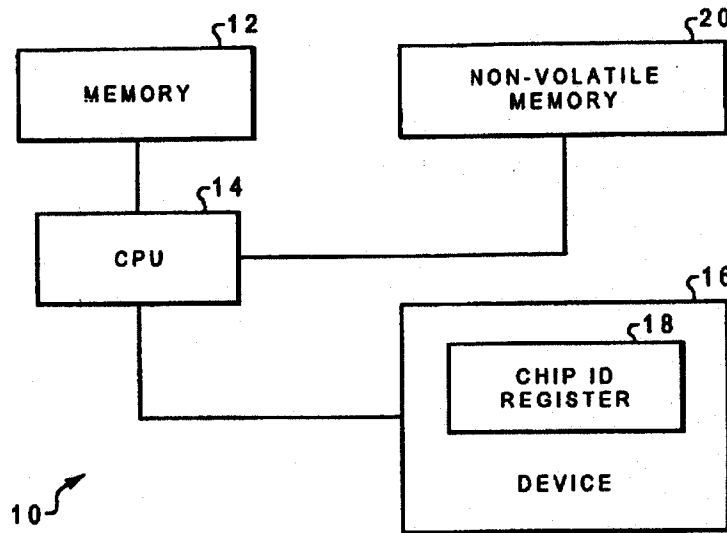

Fig. 1

b. "[L]oading an application program" of Claim 18

This step was disclosed by Lewis '819 in various places. See, e.g., Lewis '819 at C4:23-27 ("Computer system 10 includes a memory unit 12 connected to a central processing unit (CPU) 14. The memory unit 12 contains instructions and programs that are executed in CPU 14.).

c. "[U]sing an agent" of Claim 18

This was disclosed by Lewis '819 for the same reasons as discussed in Section IV(A)(2)(c). In particular, using a software program to execute a set of tasks is

fundamental to the functioning of a general-purpose computer such as the system in Figure 1 of Lewis '819.

d. "[E]xtracting license information" of Claim 18

Lewis '819 disclosed that the system extracted license information from the NVM, including the device type, device serial number, and unique device data. Lewis '819 at C4:41-52. As discussed above for claim 1, Lewis '819 inherently includes that the NVM is the BIOS of the system.

e. "[E]ncrypting license information using the pseudo-unique key" of Claim 18

As discussed above, a broadest reasonable interpretation of this claim element requires that the encrypting step use the pseudo-unique key, but does not require that the key be used as the encryption key. In Lewis '819, the chip ID is used as an input to the process of Figure 3, which generates the MAC using an encryption process. Therefore, Lewis '819 meets this claim element.

f. "[S]toring the encrypting license information" of Claim 18

After the system encrypts the system information to generate the MAC, it stores the data in the NVM. Lewis '819 at Fig. 3; at C5:8-9 ("In step 322, the MAC is placed in NVM 2- at locations 32-39, shown in Fig. 2.").

g. "[S]ubsequently verifying the application software program based on the encrypted license information" of Claim 18

Figure 4 (included below) and its associated text disclosed this element of claim 18. In particular, Lewis '819 disclosed that the system used the MAC to verify that the software had not been modified. *Id.* at C5:10-14 ("The MAC is used to provide a means, or digital signature, for detecting when a serial number or any other critical data written into NVM 20 is altered. Once there is modification or duplication detected, the software program stored in memory 12 can then take steps to prevent software programs from running on the altered device 16."); at C5:27-45.

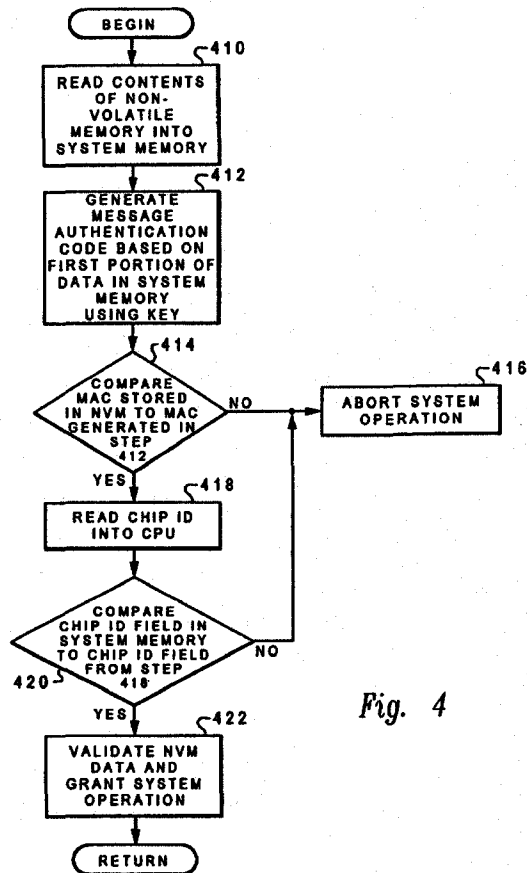

Fig. 4

h. "[A]cting on the application software program based on the verification" of Claim 18

After verifying the MAC and chip ID according to the process of Figure 4, the system either aborted operation (step 416) or granted operation (step 422). *Id.* at C5:38-40; at C5:47-50.

C. Unpatentability of Claims 2, 3, 4, and 5

Claim 2 adds to claim 1 the further step of "establishing a license authorization bureau." However, claim 2 provides no additional information to assist in understanding what a "license authorization bureau" is. Further, the specification of the '941 patent merely defines the bureau as "a telecommunications accessible processor where functions such as formatting, encrypting, and verifying may be performed" ('941 patent at C3:42-44), while also noting that "the bureau, instead of being external entity [sic] may form part of the computer." *Id.* at C6:1-3. Thus, a broadest reasonable interpretation suggests that the bureau should be construed as a component located on the computer or a remote device that may carry out some steps of the process.

Claim 3 depends on claim 2 and adds steps that use the license bureau to accomplish the "setting up" step of claim 1. In particular, claim 3 states:

3. A method according to claim 2, wherein setting up a verification structure further comprising the steps of: establishing, between the computer and the bureau, a two-way data-communications linkage; transferring, from the computer to the bureau, a request-for-license including an identification of the computer and the license-record's contents from the selected program; forming an encrypted license-record at the bureau by encrypting parts of the request-for-license using part of the identification as an encryption key; transferring, from the bureau to the computer, the encrypted license-record; and storing the encrypted license record in the erasable non-volatile memory area of the BIOS.

Thus, claim 3 adds the additional elements of communicating with the bureau to transfer a request for license, form an encrypted license record using part of the identification as an encryption key, and store the encrypted license record.

Claim 4 also depends on claim 2 and adds steps that use the license bureau to accomplish the "verifying" step of claim 1. In particular, claim 4 reads:

4. A method according to claim 2, wherein verifying the program further comprises the steps of: establishing, between the computer and the bureau, a two-way data-communications linkage; transferring, from the computer to the bureau, a request-for-license verification including an identification of the computer, an encrypted license-record for the selected program from the erasable, non-volatile memory area of the BIOS, and the program's license-record; enabling the comparing at the bureau; and transferring, from the bureau to the computer, the result of the comparing.

Thus, claim 4 adds that the system communicates with the bureau to send the license information, carries out the comparing at the bureau, and provides the result to the requesting system.

Claim 5 depends from claim 5 and simply adds that "the identification of the computer includes the unique key."

Given the '941 patent's broad definition of the license bureau, most of the elements of these claims that relate to the license bureau are inherently disclosed by

any computer system that meets the remaining elements. For example, as discussed above, the license bureau could be a component implemented on the same computer system as the software being verified. In this configuration, a computer system executing the claimed process would inherently set up a communication connection with the license bureau and transmit data to or from the bureau. Communication between computer components is an essential aspect of a computer system and is so well-known that most references do not bother to discuss it.

1. Anticipation of Claim 2 by Schwartz '835

Schwartz '835 disclosed that the system included routines that controlled the microprocessor to execute various verification steps, such as receiving a new authorization from the user. See, e.g., Schwartz '835 at C11:58 to C12:14. Thus, Schwartz '835 disclosed that the license bureau was implemented on the main microprocessor. To the extent that this is not explicitly disclosed, it is inherent in a computer system that individual processes can be implemented to run on multiple components in the computer system.

2. Anticipation of Claim 2 by Lewis '819

Lewis '819 disclosed the license bureau for the same reasons as Schwartz '835. Lewis '819 disclosed that the microprocessor was used to execute programs stored in the memory to, among other things, control a device. Lewis '819 at C4:25-31. These programs included the processes described in Figures 3 and 4, which are directed to the setting up and verifying steps of claim 1. Thus, Lewis '819 disclosed that the license bureau was implemented on the microprocessor.

3. Obviousness of Claim 3 in View of Schwartz '835

As discussed above, any reference disclosing a computer system (such as Schwartz '835) would inherently disclose communicating with a license bureau contained in the same system. Schwartz '835 further disclosed that the system read system information from memory to provide input to set up the verification structure. Schwartz '835 at C10:29-38. After retrieving the system information, the system used a first encryption algorithm to generate the electronic signature. Schwartz '835 at C10:29-32. The system then stored the electronic signature in the configuration module as discussed above. Schwartz '835 at C10:43-54.

Schwartz '835 discloses the creation of an electronic or digital signature in which several items stored in the system (e.g., system serial number, system model number, version number of the application software, and an option number that corresponds to enabled and disabled system options) are encrypted and combined to form the signature. *Id.* at C10:22-42. One skilled in the art would have been motivated to use information stored on the device to provide the encryption key. In addition, using existing system information to provide the encryption would be more efficient because it would save storage space. Thus, it would have been obvious to use the serial number of the device to encrypt the electronic signature.

4. Anticipation of Claim 3 by Lewis '819

The communication steps of claim 3 are inherently disclosed by Lewis '819 for the same reasons that they were disclosed by Schwartz '835 – components in a computer system are inherently configured to communicate with each other when they interact to execute a particular process.

The remaining steps are also disclosed by Lewis '819. Lewis '819 disclosed that system transferred identification of the computer (the chip ID and an encryption key) and license data (e.g., the device type and device serial number) in order to calculate the MAC. Lewis '819 at C4:48-54. The system then generated the MAC based on this information, using the stored encryption key to execute the encryption. *Id.* at C2:7-20; at C2:21-25. The resulting value was stored in the NVM. *Id.* at C5:8-9. Thus, Lewis '819 disclosed all of the elements of claim 3. To the extent that Lewis '819 fails to explicitly disclose the elements of claim 3, the claim was obvious for the same reasons discussed immediately above in Section IV(C)(3).

5. Anticipation of Claim 4 by Schwartz '835

As discussed above, Schwartz '835 inherently disclosed establishing a connection with the license bureau and transferring data between the computer and the bureau. Schwartz '835 also disclosed the remaining elements of claim 4. In particular, during the verification process, the system read the identification of the computer (i.e., the serial number), license information (e.g., software version numbers and option configuration information), and the electronic signature from memory. Schwartz '835 at C11:24-40. The system then re-generated the electronic signature from the

identification and license information and compared the stored signature to the generated signature to determine if the system is authorized. Schwartz '835 at C11:36-38 ("The electronic signature, thus generated, is compared with the electronic signature stored in configuration module 307.").

6. Anticipation of Claim 4 by Lewis '819

Lewis '819 inherently disclosed the communication steps of this claim for the same reasons as discussed above. The remaining steps are disclosed by Figure 4 of Lewis '819 (included below), which described the process by which the system verified the MAC information.

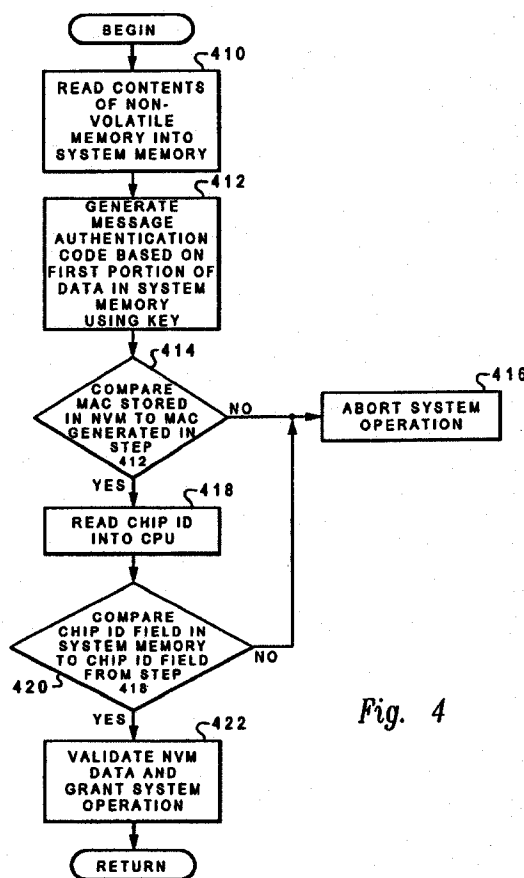

Fig. 4

In step 410, the system read the contents of the NVM, including the device type, device serial number, and MAC data. Lewis '819 at C4:40-54; at C5:31-32. In step 418, the system also read the chip ID. The system then "enable[ed] the comparing" by generating a new MAC from the device data (in step 412) and comparing the generated MAC to the stored MAC (in step 414). The final step of the claim was

inherently executed in Figure 4 when system operation was aborted (step 416) or granted (step 422) based on the comparison.

7. Anticipation of Claim 5 by Schwartz '835

Schwartz '835 disclosed that the computer was identified by a unique serial number, which was used to generate the electronic signature (i.e., setting up the verification structure). Schwartz '835 at C7:48-50; at C10:21-42.

8. Anticipation of Claim 5 by Lewis '819

Lewis '819 disclosed that the system included a chip ID register 18 which stored a unique identifier designated by the manufacturer. Lewis '819 at C4:33-39. The system used the chip ID to generate the MAC. *Id.* at C4:48-52.

D. Unpatentability of Claim 6

Claim 6 depends on claim 1 and adds only that the selected program is "established in the volatile memory of the computer" and that the program contains "contents used to form the license record." Claim 6 states:

6. A method according to claim 1 wherein selecting a program includes the steps of: establishing a licensed-software-program in the volatile memory of the computer wherein said licensed-software-program includes contents used to form the license-record.

1. Anticipation of Claim 6 by Schwartz '835

In general, the first part of this claim is inherently disclosed by any standard computer system, because it is well-known that computer systems execute programs by loading (or "establishing") the programs into volatile memory at runtime. This is supported by the reference, which states that the system uses the memory space provided by the SRAM as a work space. Schwartz '835 at C8:23-25. Schwartz '835 further stated that the electronic signature was generated based on information in the software, including the software's version number. *Id.* at C11:24-40. Thus, this claim is anticipated by Schwartz '835.

2. Anticipation of Claim 6 by Lewis '819

Similarly, Lewis '819 disclosed that the system loaded instructions (i.e., a program) for controlling a system device into the CPU. Lewis '819 at C4:25-31. The system then used information associated with the device to generate the MAC (the

"license record"). In particular, the MAC is generated from "information that the device manufacturer uses as part of the device control." *Id.* at C4:41-43. Thus, although the information is stored separately, it is included as "contents" of the program because it is used to control the device.

E. Unpatentability of Claim 7

Claim 7 depends on claim 6 and states that the step of setting up the verification structure also includes "establishing or certifying the existence of a pseudo-unique key" and "establishing at least one license-record location" in the same memory as the key or in the memory area in the BIOS. Claim 7 states:

7. A method according to claim 6 wherein using an agent to set up the verification structure includes the steps of: establishing or certifying the existence of a pseudo-unique key in a first non-volatile memory area of the computer; and establishing at least one license-record location in the first nonvolatile memory area or in the erasable, non-volatile memory area of the BIOS.

1. Anticipation of Claim 7 by Schwartz '835

Schwartz '835 disclosed that the system generated the electronic signature from, among other data, the "serial number of the system", which was stored in a ROM in the device. Schwartz '835 at C10:29-38. The electronic signature (i.e., the license record) was stored in the configuration module, which was a memory area associated with the BIOS. Schwartz '835 at C10:43-54; at C11:36-38. To the extent that Schwartz '835 did not explicitly disclose "establishing or certifying the existence of a pseudo-unique key", the element was inherently disclosed because the system would have to establish the existence of the key in order to use it in generating the electronic signature.

2. Anticipation of Claim 7 by Lewis '819

The system in Lewis '819 used a unique chip ID stored in the chip ID register 18 to generate the MAC. Lewis '819 at C4:33-39; at C4:41-54. The system stored the generated MAC in the NVM, which is equivalent to storing it in the BIOS for the reasons discussed above in Section IV(A)(2)(a). To the extent that Lewis '819 does not explicitly disclose "establishing or certifying the existence of a pseudo-unique key", the element was inherently disclosed for the reasons discussed above.

F. Unpatentability of Claim 8

Claim 8 also depends from claim 6 and adds the limitations of forming a license record by encrypting selected data and "establishing" the record in a record location.⁸

Claim 8 recites:

8. A method according to claim 6 wherein establishing a license-record includes the steps of: forming a license-record by encrypting of the contents used to form a license-record with other predetermined data contents, using the key; and establishing the encrypted license-record in one of the at least one established license-record locations.

1. Anticipation of Claim 8 by Schwartz '835

The features of claim 8 correspond to the "encrypting" and "storing" steps of claim 18 and were anticipated by Schwartz '835 for the same reasons.

2. Anticipation of Claim 8 by Lewis '819

Claim 8 was also anticipated by Lewis '819 for the same reasons as claim 18, as explained in Section IV(B)(2)(e) and (f).

G. Unpatentability of Claims 9 and 10

Claim 9 depends from claim 7 and is directed to two alternative methods for verifying the license:

1. Encrypting information from the software program and comparing the results to the data stored in the BIOS, or
2. Decrypting the data stored in the BIOS and comparing the results to information from the software program.

Claim 9 is drafted to cover either method independently and so is anticipated by any reference that discloses one of the two methods. Claim 10 depends from claim 9 and adds only that the operation of the software program is restricted in some way if the comparison indicates that the values do not match. The claims state:

9. A method according to claim 7 wherein verifying the program includes the steps of: encrypting the licensed-software-program's license-record contents from the volatile memory area or decrypting the license-record in the

⁸ Claim 8 references several elements that are not introduced in the claim or its parent claims. The discussion of the claim is based on a reasonable interpretation of what these elements refer to.

erasable, non-volatile memory area of the BIOS, using the pseudo-unique key; and comparing the encrypted licenses-software-program's license-record contents with the encrypted license-record in the erasable, non-volatile memory area of the BIOS, or comparing the license-software-program's license-record contents with the decrypted license-record in erasable non-volatile memory area of the BIOS.

10. A method according to claim 9 wherein acting on the program includes the step: restricting the program's operation with predetermined limitations if the comparing yields non-unity or insufficiency.

1. Anticipation of Claims 9 and 10 by Schwartz '835

Schwartz '835 discloses the first of the methods for the same reasons as claim 18. Specifically, during normal operation, the system verified that operation was authorized by reading system data, including the serial number and software version number, from the system memory. Schwartz '835 at C11:24-33. The system then generated an electronic signature from the data using an encryption algorithm. *Id.* at C11:33-36. If the generated electronic signature was identical to the stored signature, the system determined that operation was authorized. *Id.* at C11:36-40. Otherwise, the system restricted operation and prompted the user to provide a new authorization number. *Id.* at C11:39-40. Thus, Schwartz '835 disclosed all of the elements of claims 9 and 10.

2. Anticipation of Claims 9 and 10 by Lewis '819

During the verification process disclosed in Lewis '819, the system generated a MAC based on the license record information. Lewis '819 at Fig. 4, at C5:27-35. The system then verified operation by comparing the generated MAC to the stored MAC. *Id.* at Fig. 4, at C5:35-38 ("In step 414, the system compares the MAC stored in memory 12 from bytes 32-39 of the NVM 20 data with the MAC generated in step 412."). If the comparison did not indicate a match, the system aborted operation. *Id.* at C5:45-50. Thus, Lewis '819 disclosed the elements of claims 9 and 10.

H. Unpatentability of Claim 11

1. Anticipation of Claim 11 by Schwartz '835

Claim 11 depends from claim 1 and adds only that the volatile memory is a RAM (random-access memory). This is disclosed by Schwartz '835. Schwartz '835 at C7:50-57; at C8:21-25.

2. Anticipation of Claim 11 by Lewis '819

Lewis '819 does not explicitly state that the system included a RAM. However, Lewis '819 did disclose that the system included a memory 12 that contained instructions that were loaded into the CPU for execution. Lewis '819 at 25-27. Further, RAM is a standard component for all computer systems, so it would inherently be disclosed by the computer system of Lewis '819. Alternatively, it would have been obvious to include a RAM in the computer system disclosed by Lewis '819.

I. Unpatentability of Claims 12 and 13

1. Anticipation of Claims 12 and 13 by Schwartz '835

Claim 12 depends from claim 1 and adds that "a pseudo-unique key is stored in the non-volatile memory of the BIOS." Similarly, claim 13 adds that "a unique key is stored in a first non-volatile area of the computer." Schwartz '835 disclosed that the device included a read-only memory (ROM) that stored a unique serial number associated with the device. Schwartz '835 at C7:48-50. Therefore, claims 12 and 13 were anticipated by Schwartz '835.

2. Anticipation of Claims 12 and 13 by Lewis '819

Lewis '819 also disclosed these elements. In particular, Lewis '819 disclosed that the computer system 10 included a chip ID register 18 that stored a unique chip ID. Lewis '819 at figure 1; at C4: 33-35. Thus, Lewis '819 disclosed that the chip ID was stored in a nonvolatile memory of the computer. Although Lewis '819 did not explicitly disclose that the chip ID was stored in the BIOS, this is inherent for the reasons discussed above with respect to claim 1.

J. Unpatentability of Claim 14

1. Anticipation of Claim 14 by Schwartz '835

Claim 14 depends from claim 12 and adds that "using the agent to set up the verification record . . . includes encrypting a license record data in the program using at least the unique key." This claim was disclosed by Schwartz '835 for the same reasons discussed in Section IV(B)(1)(d).

2. Anticipation of Claim 14 by Lewis '819

Claim 14 is anticipated by Lewis '819 for the same reasons discussed for claim 18 in Section IV(B)(2)(d).

K. Unpatentability of Claims 15, 17, and 19

Claim 15 depends from claim 14 and adds a set of steps similar to the first method of claim 9. Claim 19 is identical to claim 15 but depends on claim 18. Claim 17 depends from claim 13 and adds only that the verifying step includes encrypting the license record using the unique key. The claims read as follows:

15. The method according to claim 14, wherein the verification comprises:

extracting the license record from the software program;

encrypting the license record using the unique key stored in the first non-volatile memory area of the computer to form second encrypted license information; and

comparing the encrypted license information stored in the erasable, non-volatile memory area of the BIOS of the computer with the second encrypted license information.

17. The method according to claim 13, wherein the step of verifying the program includes encrypting the license record that is accommodated in the program using at least the unique key.

19. The method of claim 18, wherein the verification comprises:

extracting the license information from the software program;

encrypting the license information using the pseudo-unique key stored in the first non-volatile memory area of the computer to form second encrypted license information; and

comparing the encrypted license information stored in the second erasable, writable, non-volatile memory area of the BIOS of the computer with the second encrypted license information.

1. Anticipation of Claims 15, 17, and 19 by Schwartz '835

Schwartz '835 discloses these claims for the same reasons as claim 18. Specifically, during normal operation, the system verified that operation was authorized by reading system data, including the serial number and software version number, from the system memory. Schwartz '835 at C11:24-33. The system then generated an electronic signature from the data using an encryption algorithm. *Id.* at C11:33-36. If the generated electronic signature was identical to the stored signature, the system determined that operation was authorized. *Id.* at C11:36-40. Otherwise, the system restricted operation and prompted the user to provide a new authorization number. *Id.* at C11:39-40. Thus, Schwartz '835 disclosed all of the elements of claims 15, 17, and 19.

2. Anticipation of Claims 15, 17, and 19 by Lewis '819

During the verification process disclosed in Lewis '819, the system first read the information in the NVM, including the chip ID, into the system memory. Lewis '819 at Fig. 4; at C11:24-33. The system applied the encryption method of Figure 3 to generate a MAC using the information. Lewis '819 at Fig. 4, at C5:27-35. The system then verified operation by comparing the generated MAC to the stored MAC. *Id.* at Fig. 4, at C5:35-38 ("In step 414, the system compares the MAC stored in memory 12 from bytes 32-39 of the NVM 20 data with the MAC generated in step 412."). Thus, Lewis '819 disclosed the elements of claims 15, 17, and 19.

L. Unpatentability of Claim 16

1. Obviousness of Claim 16 by Schwartz '835

Claim 16 depends from claim 13 and adds that the verifying step includes "decrypting the license record data . . . using at least the unique key." Schwartz '835 did not explicitly disclose this element. However, in describing the initial authorization

process, Schwartz '835 disclosed that the authorization number was originally generated by encrypting the license data (including the serial number) on the device. Schwartz '835 at C12:17-20. After the user entered the authorization number into the system, it could verify the authorization number by decrypting the number and comparing the result to the license data on the system. *Id.* at C12:20-29. Although this step is only carried out during the initial authorization step, it would have been obvious to one skilled in the art to apply a similar decryption step to the ongoing verification process. Thus, claim 16 would have been obvious in view of the disclosure of Schwartz '835.

2. Anticipation of Claim 16 by Lewis '819

Lewis '819 disclosed the elements of claim 16. In its discussion of encryption techniques, Lewis '819 discusses an encryption technique that uses RSA, where a private key is used to encrypt the text where the unique chip identifier is included. Lewis '819 at C2: 49-52. The software program then uses a public key to decrypt the encrypted data and compares the results of the encryption to information stored in the hardware of the computer system. Lewis '819 at C2: 52-56 ("A public key is then used by the software program to decrypt the encrypted data and a comparison is made by the software program of the unique chip identifier in the hardware with that in the encrypted text."). To the extent that Lewis '819 fails to explicitly disclose claim 16, it would have been obvious to apply these teachings to the process in Figure 4 to produce a system that decrypted the verification structure.

V. CONCLUSION

The prior art documents presented above were not previously considered by the Office. The claims of the '941 patent were not patentable over the prior art documents cited herein. The prior art documents disclose the subject matter of the '941 patent in a manner such that this request raises substantial new questions of patentability for all claims.

In view of the foregoing, it is respectfully submitted that a substantial new question of patentability of claims 1-19 of Patent No. 6,411,941 has been raised by this Request. Accordingly, the Office is requested to grant this Request and to initiate reexamination with special dispatch.

As an aid to the application of the presented prior art to claims of the '941 patent,
claim charts are provided at Exhibit I attached hereto.

Dated: 5/28/09

Respectfully submitted,

By: 

Chun M. Ng
Registration No. 36,878
PERKINS COIE LLP
P.O. Box 1247
Seattle, Washington 98111-1247
(206) 359-8000
(206) 359-7198 (Fax)

LIST OF ATTACHED EXHIBITS

- Exhibit A: Copy of the entire patent for which reexamination is requested, including the front face, drawings, and specification/claims (in double column format) of U.S. Patent No. 6,411,941 entitled, "Method of Restricting Software Operation Within a License Limitation," issued June 25, 2002.
- Exhibit B: Copy of the complaint in *Ancora Technologies, Inc. v. Toshiba America Information Systems, Inc. et al.*, No. SACV 08-0626-AG (C.D. Cal.).
- Exhibit C: Ancora Technologies, Inc's Opening Markman Brief, *Ancora Technologies, Inc. v. Toshiba America Information Systems*, No. SACV08-626-AG (C.D. Cal. Jan. 26, 2009) ("Patent Owner's Markman Brief").
- Exhibit D: Amendment for Application No. 09/164,777, filed February 5, 2002.
- Exhibit E: U.S. Patent No. 6,153,835, "System and Method for an Electronic Postage Scale with Variable Function Keys and Window Screens," issued to Schwartz et al. on November 28, 2000, based on an application filed June 7, 1995 and claiming priority to an application filed October 14, 1993 ("Schwartz '835").
- Exhibit F: U.S. Patent No. 5,734,819, "Method and Apparatus for Validating System Operation," issued to David Otto Lewis on March 31, 1998, based on an application filed October 12, 1994 ("Lewis '819").
- Exhibit G: IBM DICTIONARY OF COMPUTING 56, 65, 739 (George McDaniel ed., 1993) ("IBM Dictionary").
- Exhibit H: MUHAMMAD ALI MAZIDI AND JANICE GILLISPIE MAZIDI, THE 80X86 IBM PC AND COMPATIBLE COMPUTERS (VOLS. I & II): ASSEMBLY LANGUAGE, DESIGN, AND INTERFACING 808-816 (2d ed. 1998) ("Mazidi").
- Exhibit I: Claim Charts Matching Claims 1-19 to the Prior Art.

EXHIBIT A

Mullor et al., USP 6,411,941



US006411941B1

(12) **United States Patent**
Mullor et al.

(10) **Patent No.:** **US 6,411,941 B1**
(45) **Date of Patent:** **Jun. 25, 2002**

(54) **METHOD OF RESTRICTING SOFTWARE OPERATION WITHIN A LICENSE LIMITATION**

(75) Inventors: **Miki Mullor; Julian Valiko**, both of Ramat Hasharon (IL)

(73) Assignee: **Beeble, Inc.**, Newport Beach, CA (US)

(*) Notice: Subject to any disclaimer, the term of this patent is extended or adjusted under 35 U.S.C. 154(b) by 0 days.

(21) Appl. No.: **09/164,777**

(22) Filed: **Oct. 1, 1998**

(30) **Foreign Application Priority Data**

May 21, 1998 (IL) 124571

(51) **Int. Cl.**⁷ **G06F 17/60**

(52) **U.S. Cl.** **705/59; 705/50; 705/51; 705/53; 705/57**

(58) **Field of Search** **705/51, 54, 56, 705/57, 58, 59, 1, 50, 52, 53; 713/187, 189, 200**

(56) **References Cited**

U.S. PATENT DOCUMENTS

- 4,866,769 A 9/1989 Karp
- 4,903,296 A 2/1990 Chandra et al.
- 4,924,378 A 5/1990 Hershey et al.
- 5,386,369 A 1/1995 Christiano
- 5,390,297 A 2/1995 Barber et al.
- 5,479,639 A * 12/1995 Ewertz et al. 395/430
- 5,490,216 A * 2/1996 Richardson, III 380/4
- 5,671,412 A 9/1997 Christiano
- 5,684,951 A * 11/1997 Goodman et al. 395/188.01
- 5,754,763 A 5/1998 Bereiter
- 5,758,068 A 5/1998 Brandt et al.
- 5,758,069 A 5/1998 Olsen
- 5,790,664 A 8/1998 Coley et al.
- 5,826,011 A 10/1998 Chou et al.
- 5,892,900 A * 4/1999 Ginter et al. 395/186
- 5,905,860 A 5/1999 Olsen et al.

- 6,000,030 A * 12/1999 Steinberg et al. 713/200
- 6,006,190 A 12/1999 Baena-Arnaiz et al.
- 6,021,438 A 2/2000 Duvvoori et al.
- 6,023,763 A 2/2000 Grumpstrup et al.
- 6,052,600 A * 4/2000 Fette et al. 455/509
- 6,055,503 A 4/2000 Horstmann
- 6,067,582 A * 5/2000 Smith et al. 710/5
- 6,073,256 A 6/2000 Sesma
- 6,078,909 A 6/2000 Knutson
- 6,128,741 A 10/2000 Goetz et al.
- 6,173,446 B1 1/2001 Khan et al.
- 6,189,146 B1 * 2/2001 Misra et al. 717/11
- 6,192,475 B1 2/2001 Wallace
- 6,198,875 B1 * 3/2001 Edenson et al. 386/94
- 6,226,747 B1 5/2001 Larsson et al.
- 6,233,567 B1 5/2001 Cohen
- 6,243,468 B1 6/2001 Pearce et al.
- 6,272,636 B1 8/2001 Neville et al.
- 6,298,138 B1 10/2001 Gotoh et al.

FOREIGN PATENT DOCUMENTS

JP 408286906 A * 11/1996 G06F/9/06

OTHER PUBLICATIONS

Dornbusch et al., Destop management software: no need to adjust your set., Infoworld, v17, n37, p60.*

* cited by examiner

Primary Examiner—Hyung-Sub Sough

Assistant Examiner—Calvin L Hewitt

(74) *Attorney, Agent, or Firm*—Venable; Robert Kinberg; Jeffri A. Kaminski

(57) **ABSTRACT**

A method of restricting software operation within a license limitation that is applicable for a computer having a first non-volatile memory area, a second non-volatile memory area, and a volatile memory area. The method includes the steps of selecting a program residing in the volatile memory, setting up a verification structure in the non-volatile memories, verifying the program using the structure, and acting on the program according to the verification.

19 Claims, 2 Drawing Sheets

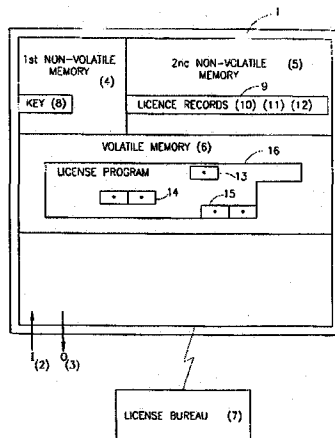

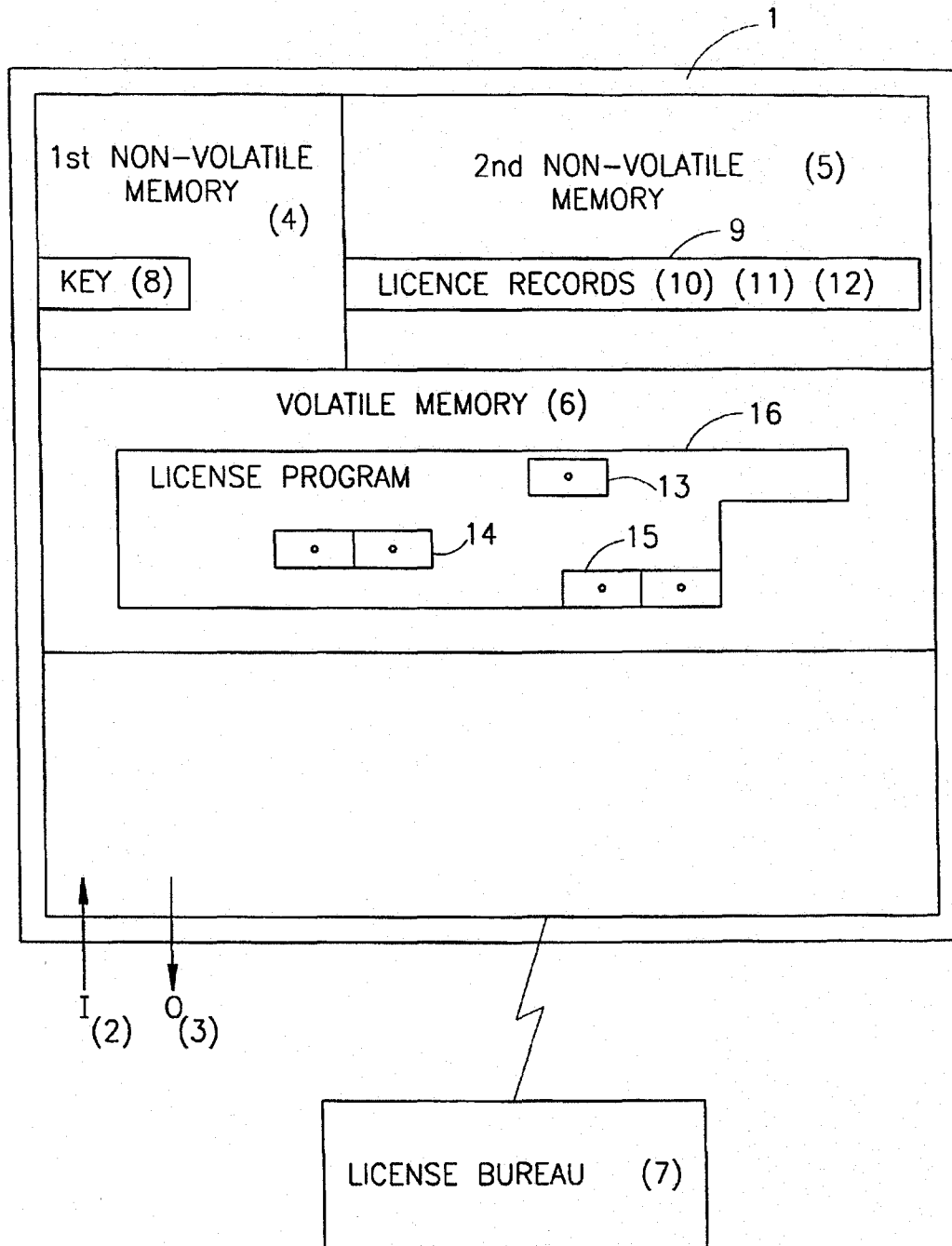

FIG. 1

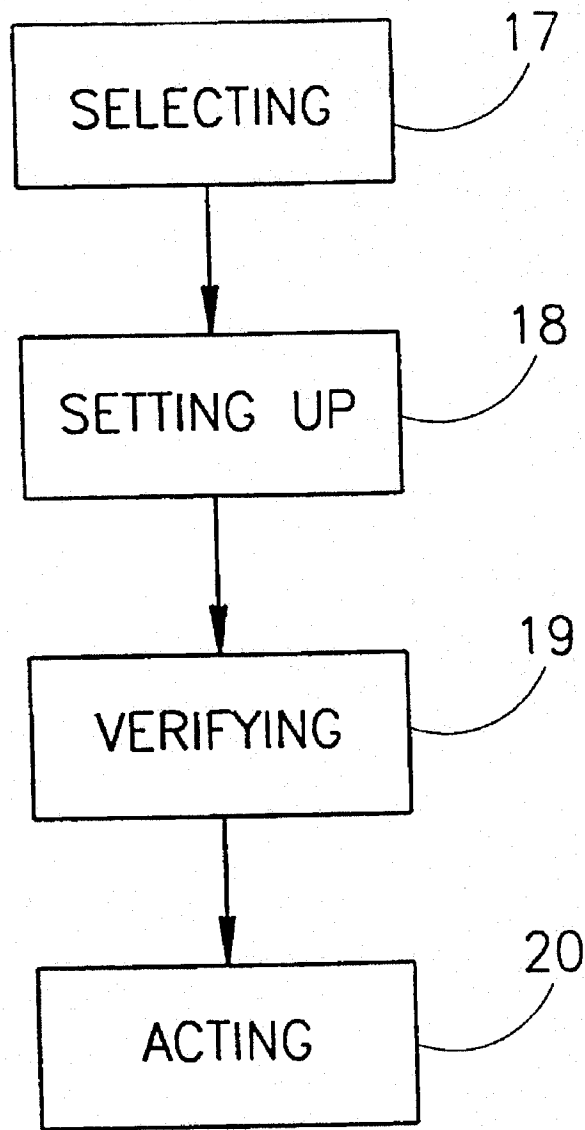

FIG.2

1

METHOD OF RESTRICTING SOFTWARE OPERATION WITHIN A LICENSE LIMITATION

FIELD OF THE INVENTION

This invention relates to a method and system of identifying and restricting an unauthorized software program's operation.

BACKGROUND OF THE INVENTION

Numerous methods have been devised for the identifying and restricting of an unauthorized software program's operation. These methods have been primarily motivated by the grand proliferation of illegally copied software, which is engulfing the marketplace. This illegal copying represents billions of dollars in lost profits to commercial software developers.

Software based products have been developed to validate authorized software usage by writing a license signature onto the computer's volatile memory (e.g. hard disk). These products may be appropriate for restricting honest software users, but they are very vulnerable to attack at the hands of skilled system's programmers (e.g. "hackers"). These license signatures are also subject to the physical instabilities of their volatile memory media.

Hardware based products have also been developed to validate authorized software usage by accessing a dongle that is coupled e.g. to the parallel port of the P.C. These units are expensive, inconvenient, and not particularly suitable for software that may be sold by downloading (e.g. over the internet).

There is accordingly a need in the art to provide for a system and method that substantially reduce or overcome the drawbacks of hitherto known solutions.

SUMMARY OF THE INVENTION

The present invention relates to a method of restricting software operation within a license limitation. This method strongly relies on the use of a key and of a record, which have been written into the non-volatile memory of a computer.

For a better understanding of the underlying concept of the invention, there follows a specific non-limiting example. Thus, consider a conventional computer having a conventional BIOS module in which a key was embedded at the ROM section thereof, during manufacture. The key constitutes, effectively, a unique identification code for the host computer. It is important to note that the key is stored in a non-volatile portion of the BIOS, i.e. it cannot be removed or modified.

Further, according to the invention, each application program that is to be licensed to run on the specified computer, is associated with a license record; that consists of author name, program name and number of licensed users (for network). The license record may be held in either encrypted or explicit form.

Now, there commences an initial license establishment procedure, where a verification structure is set in the BIOS so as to indicate that the specified program is licensed to run on the specified computer. This is implemented by encrypting the license record (or portion thereof) using said key (or portion thereof) exclusively or in conjunction with other identification information) as an encryption key. The resulting encrypted license record is stored in another (second) non-volatile section of the BIOS, e.g. E²PROM (or the

2

ROM). It should be noted that unlike the first non-volatile section, the data in the second non-volatile memory may optionally be erased or modified (using E²PROM manipulation commands), so as to enable to add, modify or remove licenses. The actual format of the license may include a string of terms that correspond to a license registration entry (e.g. lookup table entry or entries) at a license registration bureau (which will be further described as part of the preferred embodiment of the present invention).

Having placed the encrypted license record in the second non-volatile memory (e.g. the E²PROM), the process of verifying a license may be commenced. Thus, when a program is loaded into the memory of the computer, a so called license verifier application, that is a priori running in the computer, accesses the program under question, retrieves therefrom the license record, encrypts the record utilizing the specified unique key (as retrieved from the ROM section of the BIOS) and compares the so encrypted record to the encrypted records that reside in the E²PROM. In the case of match, the program is verified to run on the computer. If on the other hand the sought encrypted data record is not found in the E²PROM database, this means that the program under question is not properly licensed and appropriate application define action is invoked (e.g. informing to the user on the unlicensed status, halting the operation of the program under question etc.)

Those versed in the art will readily appreciate that any attempt to run a program at an unlicensed site will be immediately detected. Consider, for example, that a given application, say Lotus 123, is verified to run on a given computer having a first identification code (k₁) stored in the ROM portion of the BIOS thereof. This obviously requires that the license record (LR) of the application after having been encrypted using k₁ giving rise to (LR)_{k₁} is stored in the E²PROM of the first computer.

Suppose now that a hacker attempts to run the specified application in a second computer having a second identification code (k₂) stored in the ROM portion of the BIOS thereof. All or a portion the database contents (including of course (LR)_{k₁}) that reside in the E²PROM portion in the first computer may be copied in a known per se means to the second computer. It is important to note that the hacker is unable to modify the key in the ROM of the second computer to k₁, since, as recalled, the contents of the ROM is established during manufacture and is practically invariable.

Now, when the application under question is executed in the second computer, the license verifier retrieves said LR from the application and, as explained above, encrypts it using the key as retrieved from the ROM of the second computer, i.e. k₂ giving rise to encrypted license record (LR)_{k₂}. Obviously, the value (LR)_{k₂} does not reside in the E²PROM database section of the second computer (since it was not legitimately licensed) and therefore the specified application is invalidated. It goes without saying that the data copied from the first (legitimate) computer is rendered useless, since comparing (LR)_{k₂} with the copied value (LR)_{k₁} results, of course, in mismatch.

The example above is given for clarity of explanation only and is by no means binding.

In its broadest aspect, the invention provides for a method of restricting software operation within a license limitation including; for a computer having a first non-volatile memory area, a second non-volatile memory area, and a volatile memory area; the steps of: selecting a program residing in the volatile memory, setting up a verification structure in the

non-volatile memories, verifying the program using the structure, and acting on the program according to the verification.

An important advantage in utilizing non-volatile memory such as that residing in the BIOS is that the required level of system programming expertise that is necessary to intercept or modify commands, interacting with the BIOS, is substantially higher than those needed for tampering with data residing in volatile memory such as hard disk. Furthermore, there is a much higher cost to the programmer, if his tampering is unsuccessful, i.e. if data residing in the BIOS (which is necessary for the computer's operability) is inadvertently changed by the hacker. This is too high of a risk for the ordinary software hacker to pay. Note that various recognized means for hindering the professional-like hacker may also be utilized (e.g. anti-debuggers, etc.) in conjunction with the present invention.

In the context of the present invention, a "computer" relates to a digital data processor. These processors are found in personal computers, or on one or more processing cards in multi-processor machines. Today, a processor normally includes a first non-volatile memory, a second non-volatile memory, and data linkage access to a volatile memory. There are also processors having only one non-volatile memory or having more than two non-volatile memories; all of which should be considered logically as relating to having a first and a second non-volatile memory areas. There are also computational environments where the volatile memory is distributed into numerous physical components, using a bus, LAN, etc.; all of which should logically be considered as being a volatile memory area.

According to the preferred embodiment of the present invention, there is further provided a license authentication bureau which can participate in either or both of:

- (i) establishing the license record in the second non-volatile memory; and
- (ii) verifying if the key and license record in the non-volatile memory(s) is compatible with the license record information as extracted from the application under question.

The bureau is a telecommunications accessible processor where functions such as formatting, encrypting, and verifying may be performed. Performing these or other functions at the bureau helps to limit the understanding of potential software hackers; since they can not observe how these functions are constructed. Additional security may also be achieved by forcing users of the bureau to register, collecting costs for connection to the bureau, logging transactions at the bureau, etc.

According to one example of using the bureau, setting up a verification structure further includes the steps of: establishing, between the computer and the bureau, a two-way data-communications linkage; transferring, from the computer to the bureau, a request-for-license including an identification of the computer and the license-record's contents from the selected program; forming an encrypted license-record at the bureau by encrypting parts of the request-for-license using part of the identification as the encryption key; and transferring, from the bureau to the computer, the encrypted license-record.

According to another example of using the bureau, verifying the program further includes the steps of: establishing, between the computer and the bureau, a two-way data-communications linkage; transferring, from the computer to the bureau, a request-for-license-verification including an identification of the computer, the encrypted license-record

for the selected program from the second non-volatile memory, and the licensed-software-program's license-record contents; enabling the comparing at the bureau; and transferring, from the bureau to the computer, the result of the comparing.

The actual key that serves for identifying the computer may be composed of the pseudo-unique key exclusively, or, if desired, in combination with information, e.g. information related to the registration of the user such as e.g. place, telephone number, user name, license number, etc. In the context of the present invention, a "pseudo-unique" key may relate to a bit string which uniquely identifies each first non-volatile memory. Alternately the "pseudo-unique" key may relate to a random bit string (or to an assigned bit string) of sufficient length such that: there is an acceptably low probability of a successful unauthorized transfer of licensed software between two computers, where the first volatile memories of these two computers have the same key.

It should be noted that the license bureau might maintain a registry of keys and of licensed programs that have been registered at the bureau in association with these keys. This registry may be used to help facilitate the formalization of procedures for the transfer of ownership of licensed software from use on one computer to use on another computer.

Constructing the key in the manner specified may hinder the hacker in cracking the proposed encryption scheme of the invention, in particular when the establishment of the license record or the verification thereof is performed in the bureau. Those versed in the art will readily appreciate that the invention is by no means bound by the data, the algorithms, or the manner of operation of the bureau. It should be noted that the tasks of establishing and/or verifying a license record may be shared between the bureau and the computer, done exclusively at the computer, or done exclusively at the bureau. The pseudo-unique key length needs to be long enough to hinder encryption attack schemes. The establishing of the key may be done at any time from the non-volatile memory's manufacture until an attempted use of an established license-record in the non-volatile memory. The key is used for encryption or decryption operations associated with license-records. In principle, the manufacturer of the licensed-software-program may specify the license-record format and therefore different formats may, if desired, be used for respective applications.

According to the preferred embodiment of the present invention, the pseudo-unique key is a unique-identification bit string that is written onto the first non-volatile memory by the manufacturer of the is memory media.

According to one, non-limiting, preferred embodiment of the present invention, the first non-volatile memory area is a ROM section of a BIOS; the second non-volatile memory area is a E²PROM section of a BIOS; and the volatile memory is a RAM e.g. hard disk and/or internal memory of the computer.

The present invention also relates to a non-volatile memory media used as a BIOS of a computer, for restricting software operation within a license limitation, wherein a pseudo-unique key is established.

According to the preferred embodiment of the non-volatile memory media of the present invention, the pseudo-unique key is established in a ROM section of the BIOS.

BRIEF DESCRIPTION OF THE DRAWINGS

In order to understand the invention and to see how it may be carried out in practice, a preferred embodiment will now be described, by way of non-limiting example only, with reference to the accompanying drawings, in which:

FIG. 1 is a schematic diagram of a computer and a license bureau; and

FIG. 2 is a generalized flow chart of the sequence of operations performed according to one embodiment of the invention.

DETAILED DESCRIPTION OF A PREFERRED EMBODIMENT

A schematic diagram of a computer and a license bureau is shown in FIG. 1. Thus, a computer processor (1) is associated with input operations (2) and with output operations (3). This computer (processor) internally contains a first non-volatile memory area (4) (e.g. the ROM section of the BIOS), a second non-volatile memory area (5) (e.g. the E²PROM section of the BIOS), and a volatile memory area (6) (e.g. the internal RAM memory of the computer).

The computer processor is in temporary telecommunications linkage with a license bureau (7).

The first non-volatile memory includes a pseudo-random identification key (8), which exclusively or in combination with other information (e.g. user name), is sufficient to uniquely differentiate this first non-volatile memory from all other first non-volatile memories. As specified before, said key constitutes unique identification of the computer.

The second non-volatile memory includes a license-record-area (9) e.g. which contains at least one encrypted license-record (e.g. three records 10-12). The volatile memory accommodates a license program (16) having license record fields (13-15) appended thereto. By way of example said fields stand for Application names (e.g. Lotus 123), Vendor name (Lotus inc.), and number of licensed copies (1 for stand alone usage, >1 for number of licensed users for a network application).

Those versed in the art will readily appreciate that the license record is not necessarily bound to continuous fields. In fact, the various license content components of the data record may be embedded in various locations in the application. Any component may, if desired, be encrypted.

Each one of the encrypted license records (10-12) is obtained by encrypting the corresponding license record as extracted from program 16, utilizing for encryption the identification key (8).

In a typical, yet not exclusive, sequence of operation, a transaction/request is sent, by the computer to the bureau. This transaction includes the key (8), the encrypted license-records (10-12), contents from the license program used in forming a license record (e.g. fields 13-15), and other items of information as desired.

The bureau forms the proposed license-record from the contents, encrypts (utilizing predetermined encryption algorithm) the so formed license-record using the key (8), and compares the so formed encrypted license-record with the license-record (10-12). The bureau generates an overlay according to the result of the comparison indicating successful comparison, non-critical failure comparison and the critical failure comparison.

The bureau returns the overlay which will direct the computer in subsequent operation. Thus, a success overlay will allow the license program to operate. A non-critical failure overlay will ask for additional user interactions. A critical failure overlay will cause permanent disruption to the computer's BIOS operations. Thus, software operation of the program is methodologically according to a license limitation restriction.

Those versed in the art will readily appreciate that the implementation as described with reference to FIG. 1 is by

no means binding. Thus, by way of non-limiting example, the bureau, instead of being external entity may form part of the computer.

Attention is now directed to FIG. 2, showing a generalized flow chart of the sequence of operations performed according to one embodiment of the invention.

Thus, selecting (17) a program includes the step of: establishing a licensed-software-program in the volatile memory of the computer wherein the licensed-software-program includes contents used to form a license-record. These contents, be they centralize or decentralized, may include terms, identifications, specifications, or limitations related to the manufacturer of a software product, the distributor of a software product, the purchaser of a software product, a licensor, a licensee, items of computer hardware or components thereof, or to other terms and conditions related to the aforesaid.

Setting up (18) the verification structure includes the steps of: establishing or certifying the existence of a pseudo-unique key in the first non-volatile memory area; and establishing at least one license-record location in the first or the second nonvolatile memory area.

Establishing a license-record includes the steps of: forming a license-record by encrypting of the contents used to form a license-record with other predetermined data contents, using the key; and establishing the encrypted license-record in one of the at least one established license-record locations (e.g. 10-12 in FIG. 1).

Verifying (19) the program includes the steps of: encrypting the licensed-software-program's license-record contents from the volatile memory area or decrypting the license-record in the first or the second non-volatile memory area, using the key; and comparing the encrypted licensed-software-program's license-record contents with the encrypted license-record in the first or the second non-volatile memory area, or comparing the licensed-software-program's license-record contents with the decrypted license-record in the first or the second non-volatile memory area.

Acting (20) on the program includes the step of: restricting the program's operation with predetermined limitations if the comparing yields non-unity or insufficiency. In this context "non-unity" relates to being unequal with respect to a specific equation (e.g. $A=B+1$); and "insufficiency" relates to being outside of a relational bound (e.g. $A>B+1$). "Restricting the program's operation with predetermined limitations" may include actions such as erasing the software in volatile memory, warning the license applicant/user, placing a fine on the applicant/user through the billing service charges collected at the license bureau (if applicable), or scrambling sections of the BIOS of the computer (or of functions interacting therewith).

The present invention has been described with a certain degree of particularity but it should be understood that various modifications and alterations may be made without departing from the scope or spirit of the invention as defined by the following claims.

What is claimed is:

1. A method of restricting software operation within a license for use with a computer including an erasable, non-volatile memory area of a BIOS of the computer, and a volatile memory area; the method comprising the steps of: selecting a program residing in the volatile memory, using an agent to set up a verification structure in the erasable, non-volatile memory of the BIOS, the verification structure accommodating data that includes at least one license record,

verifying the program using at least the verification structure from the erasable non-volatile memory of the BIOS, and

acting on the program according to the verification.

2. A method according to claim 1, further comprising the steps of:

establishing a license authentication bureau.

3. A method according to claim 2, wherein setting up a verification structure further comprising the steps of: establishing, between the computer and the bureau, a two-way data-communications linkage; transferring, from the computer to the bureau, a request-for-license including an identification of the computer and the license-record's contents from the selected program; forming an encrypted license-record at the bureau by encrypting parts of the request-for-license using part of the identification as an encryption key; transferring, from the bureau to the computer, the encrypted license-record; and storing the encrypted license record in the erasable non-volatile memory area of the BIOS.

4. A method according to claim 2, wherein verifying the program further comprises the steps of: establishing, between the computer and the bureau, a two-way data-communications linkage; transferring, from the computer to the bureau, a request-for-license verification including an identification of the computer, an encrypted license-record for the selected program from the erasable, non-volatile memory area of the BIOS, and the program's license-record; enabling the comparing at the bureau; and transferring, from the bureau to the computer, the result of the comparing.

5. A method according to claim 3 wherein the identification of the computer includes the unique key.

6. A method according to claim 1 wherein selecting a program includes the steps of: establishing a licensed-software-program in the volatile memory of the computer wherein said licensed-software-program includes contents used to form the license-record.

7. A method according to claim 6 wherein using an agent to set up the verification structure includes the steps of: establishing or certifying the existence of a pseudo-unique key in a first non-volatile memory area of the computer; and establishing at least one license-record location in the first nonvolatile memory area or in the erasable, non-volatile memory area of the BIOS.

8. A method according to claim 6 wherein establishing a license-record includes the steps of: forming a license-record by encrypting of the contents used to form a license-record with other predetermined data contents, using the key; and establishing the encrypted license-record in one of the at least one established license-record locations.

9. A method according to claim 7 wherein verifying the program includes the steps of: encrypting the licensed-software-program's license-record contents from the volatile memory area or decrypting the license-record in the erasable, non-volatile memory area of the BIOS, using the pseudo-unique key; and comparing the encrypted licenses-software-program's license-record contents with the encrypted license-record in the erasable, non-volatile memory area of the BIOS, or comparing the license-software-program's license-record contents with the decrypted license-record in erasable non-volatile memory area of the BIOS.

10. A method according to claim 9 wherein acting on the program includes the step: restricting the program's operation with predetermined limitations if the comparing yields non-unity or insufficiency.

11. A method according to claim 1 wherein the volatile memory is a RAM.

12. The method of claim 1, wherein a pseudo-unique key is stored in the non-volatile memory of the BIOS.

13. The method of claim 1, wherein a unique key is stored in a first non-volatile memory area of the computer.

14. The method according claim 13, wherein the step of using the agent to set up the verification record, including the license record, includes encrypting a license record data in the program using at least the unique key.

15. The method according to claim 14, wherein the verification comprises:

extracting the license record from the software program; encrypting the license record using the unique key stored in the first non-volatile memory area of the computer to form second encrypted license information; and

comparing the encrypted license information stored in the erasable, non-volatile memory area of the BIOS of the computer with the second encrypted license information.

16. The method according to claim 13, wherein the step of verifying the program includes a decrypting the license record data accommodated in the erasable second non-volatile memory area of the BIOS using at least the unique key.

17. The method according to claim 13, wherein the step of verifying the program includes encrypting the license record that is accommodated in the program using at least the unique key.

18. A method for accessing an application software program using a pseudo-unique key stored in a first non-erasable non-volatile memory area of a computer, the first non-volatile memory area being unable to be programmatically changed, the method, comprising:

loading the application software program residing in a non-volatile memory area of the computer;

using an agent to perform the following steps:

extracting license information from software program; encrypting license information using the pseudo-unique key stored in the first non-volatile memory area;

storing the encrypting license information in a second erasable, writable, non-volatile memory area of the BIOS of the computer;

subsequently verifying the application software program based on the encrypted license information stored in the second erasable, writable, non-volatile memory area of the BIOS; and

acting on the application software program based on the verification.

19. The method of claim 18, wherein the verification comprises:

extracting the license information from the software program;

encrypting the license information using the pseudo-unique key stored in the first non-volatile memory area of the computer to form second encrypted license information; and

comparing the encrypted license information stored in the second erasable, writable, non-volatile memory area of the BIOS of the computer with the second encrypted license information.

* * * * *

Electronic Patent Application Fee Transmittal

Application Number:				
Filing Date:				
Title of Invention:	METHOD OF RESTRICTING SOFTWARE OPERATION WITHIN A LICENSE LIMITATION			
First Named Inventor/Applicant Name:	Miki Mullor			
Filer:	Maurice J. Pirio/Peter Sher			
Attorney Docket Number:	418263007US			
Filed as Large Entity				
ex parte reexam Filing Fees				
Description	Fee Code	Quantity	Amount	Sub-Total in USD(\$)
Basic Filing:				
Request for ex parte reexamination	1812	1	2520	2520
Pages:				
Claims:				
Miscellaneous-Filing:				
Petition:				
Patent-Appeals-and-Interference:				
Post-Allowance-and-Post-Issuance:				
Extension-of-Time:				

Description	Fee Code	Quantity	Amount	Sub-Total in USD(\$)
Miscellaneous:				
Total in USD (\$)				2520

Electronic Acknowledgement Receipt

EFS ID:	5416862
Application Number:	90010560
International Application Number:	
Confirmation Number:	1017
Title of Invention:	METHOD OF RESTRICTING SOFTWARE OPERATION WITHIN A LICENSE LIMITATION
First Named Inventor/Applicant Name:	Miki Mullor
Customer Number:	45979
Filer:	Maurice J. Pirio/Peter Sher
Filer Authorized By:	Maurice J. Pirio
Attorney Docket Number:	418263007US
Receipt Date:	28-MAY-2009
Filing Date:	
Time Stamp:	19:35:26
Application Type:	Reexam (Third Party)

Payment information:

Submitted with Payment	yes
Payment Type	Electronic Funds Transfer
Payment was successfully received in RAM	\$2520
RAM confirmation Number	4849
Deposit Account	
Authorized User	

File Listing:

Document Number	Document Description	File Name	File Size(Bytes)/ Message Digest	Multi Part /.zip	Pages (if appl.)
-----------------	----------------------	-----------	-------------------------------------	------------------	------------------

1		MSTransmittal.pdf	2211394	yes	42
			68626e77401bdbd1c4a35598ac0e04177e4f5198		
Multipart Description/PDF files in .zip description					
		Document Description	Start	End	
		Transmittal of New Application	1	2	
		Reexam Certificate of Service	3	3	
		Specification	4	42	
Warnings:					
Information:					
2	Appendix to the Specification	exhibita.pdf	620353	no	8
			29e784b33135d9bc2ddc049b56080791de378bc		
Warnings:					
Information:					
3	Appendix to the Specification	exhibitb.pdf	1162103	no	18
			06c38faf6d286d941062a3358228ea67f135bb36		
Warnings:					
Information:					
4	Appendix to the Specification	exhibitc.pdf	9469885	no	131
			c0dd8c3efc15b4d04c15bf8817ace627390fa1ba		
Warnings:					
Information:					
5	Appendix to the Specification	ExhibitD.pdf	389705	no	10
			adb0053ead62bca1a499d0ca2ee85bb327743569		
Warnings:					
Information:					
6	Appendix to the Specification	exhibite.pdf	2135865	no	32
			f3d32f32713d541e441773de46c0014d0d9a9ce7		
Warnings:					
Information:					
7	Appendix to the Specification	exhibitf.pdf	549768	no	8
			b3fc4f1fa1b0ea5dd723caa9690651f49504c2c6		
Warnings:					
Information:					

8	Appendix to the Specification	exhibitg.pdf	366302	no	7
			1ce0b6e842be84694eff3eda9153d8c3a9fd f5a7		
Warnings:					
Information:					
9	Appendix to the Specification	exhibith.pdf	1017881	no	12
			da2af7749a1265eca9cc0b08c5d92b6258b c40b2		
Warnings:					
Information:					
10	Appendix to the Specification	exhibiti.pdf	2948731	no	41
			8d585d20eb17605eaa13e249dd86eaf149 db9c1		
Warnings:					
Information:					
11	Fee Worksheet (PTO-875)	fee-info.pdf	30098	no	2
			5aec1b186dd9f61f11bb9eb7f08ec4fc2fd830 69f		
Warnings:					
Information:					
Total Files Size (in bytes):			20902085		

This Acknowledgement Receipt evidences receipt on the noted date by the USPTO of the indicated documents, characterized by the applicant, and including page counts, where applicable. It serves as evidence of receipt similar to a Post Card, as described in MPEP 503.

New Applications Under 35 U.S.C. 111

If a new application is being filed and the application includes the necessary components for a filing date (see 37 CFR 1.53(b)-(d) and MPEP 506), a Filing Receipt (37 CFR 1.54) will be issued in due course and the date shown on this Acknowledgement Receipt will establish the filing date of the application.

National Stage of an International Application under 35 U.S.C. 371

If a timely submission to enter the national stage of an international application is compliant with the conditions of 35 U.S.C. 371 and other applicable requirements a Form PCT/DO/EO/903 indicating acceptance of the application as a national stage submission under 35 U.S.C. 371 will be issued in addition to the Filing Receipt, in due course.

New International Application Filed with the USPTO as a Receiving Office

If a new international application is being filed and the international application includes the necessary components for an international filing date (see PCT Article 11 and MPEP 1810), a Notification of the International Application Number and of the International Filing Date (Form PCT/RO/105) will be issued in due course, subject to prescriptions concerning national security, and the date shown on this Acknowledgement Receipt will establish the international filing date of the application.

Application Number 	Application/Control No. 90/010,560	Applicant(s)/Patent Under Reexamination 6411941
	Examiner	Art Unit 3999

Index of Claims 	Application/Control No. 90010560	Applicant(s)/Patent Under Reexamination 6411941
	Examiner	Art Unit 3999

✓	Rejected
=	Allowed

-	Cancelled
÷	Restricted

N	Non-Elected
I	Interference

A	Appeal
O	Objected

Claims renumbered in the same order as presented by applicant
 CPA
 T.D.
 R.1.47

CLAIM		DATE									
Final	Original										
	19										

Issue Classification



Application/Control No.

90010560

Applicant(s)/Patent Under Reexamination

6411941

Examiner

Art Unit

3999

ORIGINAL						INTERNATIONAL CLASSIFICATION											
CLASS			SUBCLASS			CLAIMED					NON-CLAIMED						
705			59														
CROSS REFERENCE(S)																	
CLASS	SUBCLASS (ONE SUBCLASS PER BLOCK)																

Claims renumbered in the same order as presented by applicant CPA T.D. R.1.47

Final	Original	Final	Original	Final	Original	Final	Original	Final	Original	Final	Original	Final	Original	Final	Original

(Assistant Examiner)		(Date)		Total Claims Allowed:	
(Primary Examiner)		(Date)		O.G. Print Claim(s)	O.G. Print Figure

Reexamination 	Application/Control No. 90010560	Applicant(s)/Patent Under Reexamination 6411941
	Certificate Date	Certificate Number

Requester Correspondence Address: **Patent Owner** **Third Party**

PERKINS COIE LLP/MSFT
 P.O. BOX 1247
 SEATTLE, WA 98111-1247

LITIGATION REVIEW <input type="checkbox"/>	(examiner initials)	(date)
Case Name	Director Initials	

COPENDING OFFICE PROCEEDINGS	
TYPE OF PROCEEDING	NUMBER

--	--

Search Notes 	Application/Control No. 90010560	Applicant(s)/Patent Under Reexamination 6411941
	Examiner	Art Unit 3999

SEARCHED			
Class	Subclass	Date	Examiner
705	59		

SEARCH NOTES		
Search Notes	Date	Examiner

INTERFERENCE SEARCH			
Class	Subclass	Date	Examiner

--	--



UNITED STATES PATENT AND TRADEMARK OFFICE

UNITED STATES DEPARTMENT OF COMMERCE
 United States Patent and Trademark Office
 Address: COMMISSIONER FOR PATENTS
 P.O. Box 1450
 Alexandria, Virginia 22313-1450
 www.uspto.gov



Bib Data Sheet

CONFIRMATION NO. 1017

SERIAL NUMBER 90/010,560	FILING OR 371(c) DATE 05/29/2009 RULE	CLASS 705	GROUP ART UNIT 3993	ATTORNEY DOCKET NO. 418263007US
------------------------------------	-----------------------------------------------------------	---------------------	-------------------------------	-------------------------------------------

APPLICANTS
 6411941, Residence Not Provided;
 BEEBLE, INC.(OWNER), NEWPORT BEACH, CA;
 CHUN M. NG(3RD.PTY.REQ.), SEATTLE, WA;
 PERKINS COIE LLP/ MSFT, SEATTLE, WA

**** CONTINUING DATA *******
 This application is a REX of 09/164,777 10/01/1998 PAT 6,411,941

**** FOREIGN APPLICATIONS *******

Foreign Priority claimed <input type="checkbox"/> yes <input type="checkbox"/> no	STATE OR COUNTRY	SHEETS DRAWING	TOTAL CLAIMS 19	INDEPENDENT CLAIMS 2	
35 USC 119 (a-d) conditions met <input type="checkbox"/> yes <input type="checkbox"/> no <input type="checkbox"/> Met after Allowance					
Verified and Acknowledged	Examiner's Signature	Initials			

ADDRESS
 26694

TITLE
 METHOD OF RESTRICTING SOFTWARE OPERATION WITHIN A LICENSE LIMITATION

FILING FEE RECEIVED 2520	FEES: Authority has been given in Paper No. _____ to charge/credit DEPOSIT ACCOUNT No. _____ for following:	<input type="checkbox"/> All Fees
		<input type="checkbox"/> 1.16 Fees (Filing)
		<input type="checkbox"/> 1.17 Fees (Processing Ext. of time)
		<input type="checkbox"/> 1.18 Fees (Issue)
		<input type="checkbox"/> Other _____
		<input type="checkbox"/> Credit

Litigation Search Report CRU 3999

Reexam Control No. 90/010,560

TO: Examiner
Location: CRU
Art Unit: 3992
Date: 06/08/09

From: Shanette Brown
Location: CRU 3999
MDW 07C71
Phone: (571) 272-6632
Shanett.Brown@uspto.gov

Search Notes

Litigation search for US Patent Number: **6,411,941**

Sources:

- 1) I performed a KeyCite Search in Westlaw, which retrieves all history on the patent including any litigation.
- 2) I performed a search on the patent in Lexis CourtLink for any open dockets or closed cases.
- 3) I performed a search in Lexis in the Federal Courts and Administrative Materials databases for any cases found.
- 4) I performed a search in Lexis in the IP Journal and Periodicals database for any articles on the patent.
- 5) I performed a search in Lexis in the news databases for any articles about the patent or any articles about litigation on this patent.



Date of Printing: Jun 08, 2009

KEYCITE

C US PAT 6411941 METHOD OF RESTRICTING SOFTWARE OPERATION WITHIN A LICENSE LIMITATION, Assignee: Beeble, Inc. (Jun 25, 2002)

History

Direct History

=> **1 METHOD OF RESTRICTING SOFTWARE OPERATION WITHIN A LICENSE LIMITATION, US PAT 6411941, 2002 WL 1375346 (U.S. PTO Utility Jun 25, 2002) (NO. 09/164777)**

Patent Family

2 UNAUTHORIZED SOFTWARE OPERATION RESTRICTION METHOD IN COMPUTER, INVOLVES SETTING UP VERIFICATION STRUCTURE INCLUDING LICENSE RECORD DATA IN EEPROM, TO VERIFY PROGRAM STORED IN RAM, Derwent World Patents Legal 2002-536422

Assignments

- 3 Action: ASSIGNMENT OF ASSIGNORS INTEREST (SEE DOCUMENT FOR DETAILS). Number of Pages: 003, (DATE RECORDED: Dec 21, 2004)**
- 4 ACTION: REQUEST FOR CORRECTION TO CORRECT THE ASSIGNOR'S NAME PREVIOUSLY RECORDED AT REEL 012617, FRAME 0830 NUMBER OF PAGES: 004, (DATE RECORDED: May 09, 2002)**
- 5 ACTION: ASSIGNMENT OF ASSIGNORS INTEREST (SEE DOCUMENT FOR DETAILS). NUMBER OF PAGES: 004, (DATE RECORDED: Feb 27, 2002)**
- 6 ACTION: ASSIGNMENT OF ASSIGNORS INTEREST (SEE DOCUMENT FOR DETAILS). NUMBER OF PAGES: 002, (DATE RECORDED: Oct 01, 1998)**

Patent Status Files

.. Patent Suit(See LitAlert Entries),

Docket Summaries

- 8 ANCORA TECHNOLOGIES INC v. TOSHIBA AMERICA INFORMATION SYSTEMS INC ET AL, (W.D.WASH. Feb 27, 2009) (NO. 2:09CV00270), (35 USC 145 PATENT INFRINGEMENT)**
- 9 ANCORA TECHNOLOGIES INC v. TOSHIBA AMERICA INFORMATION SYSTEMS INC ET AL, (C.D.CAL. Jun 06, 2008) (NO. 8:08CV00626), (35 USC 145 PATENT INFRINGEMENT)**

Litigation Alert

10 LitAlert P2009-12-06 (Feb 27, 2009) Action Taken: Complaint

Prior Art (Coverage Begins 1976)

- C** 11 APPARATUS FOR LICENSING SOFTWARE APPLICATIONS, US PAT 6173446 Assignee: Ultimus, Inc., (U.S. PTO Utility 2001)
- C** 12 AUTOMATED SYSTEM FOR MANAGEMENT OF LICENSED SOFTWARE, US PAT 5790664 Assignee: Network Engineering Software, Inc., (U.S. PTO Utility 1998)
- C** 13 COMPACT TRANSPARENT DONGLE DEVICE, US PAT 6128741 Assignee: Rainbow Technologies, Inc., (U.S. PTO Utility 2000)
- C** 14 COMPUTER IMPLEMENTED METHOD AND A COMPUTER SYSTEM FOR ENFORCING SOFTWARE LICENSES, US PAT 6006190 Assignee: Tartaroukos LLC, (U.S. PTO Utility 1999)
- C** 15 COMPUTER SYSTEM WITH A PAGED NON-VOLATILE MEMORY, US PAT 5479639 Assignee: Intel Corporation, (U.S. PTO Utility 1995)
- C** 16 DIGITAL PRODUCT EXECUTION CONTROL, US PAT 6073256 Assignee: Preview Systems, Inc., (U.S. PTO Utility 2000)
- C** 17 DIGITAL PRODUCT EXECUTION CONTROL AND SECURITY, US PAT 6272636 Assignee: Preview Systems, Inc, (U.S. PTO Utility 2001)
- C** 18 ELECTRONIC LICENSING SYSTEM, US PAT 5758069 Assignee: Novell, Inc., (U.S. PTO Utility 1998)
- C** 19 FAULT TOLERANT ELECTRONIC LICENSING SYSTEM, US PAT 5905860 Assignee: Novell, Inc., (U.S. PTO Utility 1999)
- C** 20 HARDWARE ASSIST FOR PROTECTING PC SOFTWARE, US PAT 4866769 Assignee: IBM Corporation, (U.S. PTO Utility 1989)
- C** 21 IMPLEMENTING A SHARED HIGHER LEVEL OF PRIVILEGE ON PERSONAL COMPUTERS FOR COPY PROTECTION OF SOFTWARE, US PAT 4903296 Assignee: International Business Machines, (U.S. PTO Utility 1990)
- C** 22 LICENSE MANAGEMENT SYSTEM FOR SOFTWARE APPLICATIONS, US PAT 5671412 Assignee: Globetrotter Software, Incorporated, (U.S. PTO Utility 1997)
- C** 23 LICENSE MANAGEMENT SYSTEM USING DAEMONS AND ALIASING, US PAT 6021438 Assignee: Wyatt River Software, Inc., (U.S. PTO Utility 2000)
- C** 24 LICENSE MANGAGEMENT SYSTEM AND LICENSE STORAGE KEY, US PAT 4924378 Assignee: Prime Computer, Inc., (U.S. PTO Utility 1990)
- C** 25 LICENSE METERING SYSTEM FOR SOFTWARE APPLICATIONS, US PAT 5386369 Assignee: Globetrotter Software Inc., (U.S. PTO Utility 1995)
- C** 26 METHOD AND APPARATUS FOR LICENSING COMPUTER PROGRAMS USING A DSA SIGNATURE, US PAT 6078909 Assignee: International Business Machines, (U.S. PTO Utility 2000)
- C** 27 METHOD AND APPARATUS FOR SOFTWARE LICENSE MANAGEMENT, US PAT 5758068 Assignee: International Business Machines, (U.S. PTO Utility 1998)

- C** 28 METHOD AND APPARATUS FOR SOFTWARE LICENSING ELECTRONICALLY DISTRIBUTED PROGRAMS, US PAT 6233567 Assignee: Intel Corporation, (U.S. PTO Utility 2001)
- C** 29 METHOD AND SYSTEM FOR USER AUTHORIZATION OVER A MULTI-USER COMPUTER SYSTEM, US PAT 5684951 Assignee: Synopsys, Inc., (U.S. PTO Utility 1997)
- C** 30 METHOD FOR PREVENTING SOFTWARE PIRACY DURING INSTALLATION FROM A READ ONLY STORAGE MEDIUM, US PAT 6226747 Assignee: Microsoft Corporation, (U.S. PTO Utility 2001)
- C** 31 METHOD OF AND APPARATUS FOR PROTECTING AND UPGRADING SOFTWARE USING A REMOVABLE HARDLOCK, US PAT 6023763 Assignee: Fisher Controls International, Inc., (U.S. PTO Utility 2000)
- C** 32 METHOD OF METERING AND PROTECTING COMPUTER SOFTWARE, US PAT 5826011 Assignee: Rainbow Technologies, Inc., (U.S. PTO Utility 1998)
- C** 33 OPTICAL DISK, AN OPTICAL DISK BARCODE FORMING METHOD, AN OPTICAL DISK REPRODUCTION APPARATUS, A MARKING FORMING APPARATUS, A METHOD OF FORMING A LASER MARKING ON AN OPTICAL DISK, AND A METHOD OF MANUFACTURING AN OPTICAL DISK, US PAT 6298138 Assignee: Matsushita Electric Industrial Co., Ltd., (U.S. PTO Utility 2001)
- C** 34 SOFTWARE ANTI-PIRACY SYSTEM THAT ADAPTS TO HARDWARE UPGRADES, US PAT 6243468 Assignee: Microsoft Corporation, (U.S. PTO Utility 2001)
- C** 35 SOFTWARE AUDITING MECHANISM FOR A DISTRIBUTED COMPUTER ENTERPRISE ENVIRONMENT, US PAT 5754763 Assignee: International Business Machines, (U.S. PTO Utility 1998)
- C** 36 SOFTWARE FINGERPRINTING AND BRANDING, US PAT 6000030 Assignee: EMC Corporation, (U.S. PTO Utility 1999)
- C** 37 SOFTWARE PROGRAM SELF-MODIFICATION, US PAT 6055503 Assignee: Preview Systems, (U.S. PTO Utility 2000)
- C** 38 SOFTWARE PROGRAMMABLE RADIO AND METHOD FOR CONFIGURING, US PAT 6052600 Assignee: Motorola, Inc., (U.S. PTO Utility 2000)
- C** 39 SYSTEM AND METHOD FOR CLOAKING SOFTWARE, US PAT 6192475 (U.S. PTO Utility 2001)
- C** 40 SYSTEM AND METHOD FOR SOFTWARE LICENSING, US PAT 6189146 Assignee: Microsoft Corporation, (U.S. PTO Utility 2001)
- P** 41 SYSTEM FOR CONTROLLING THE NUMBER OF CONCURRENT COPIES OF A PROGRAM IN A NETWORK BASED ON THE NUMBER OF AVAILABLE LICENSES, US PAT 5390297 Assignee: Auto-trol Technology Corporation, (U.S. PTO Utility 1995)
- C** 42 SYSTEM FOR INSTALLING INFORMATION RELATED TO A SOFTWARE APPLICATION TO A REMOTE COMPUTER OVER A NETWORK, US PAT 6067582 Assignee: ANGEL Secure Networks, Inc., (U.S. PTO Utility 2000)
- H** 43 SYSTEM FOR SOFTWARE REGISTRATION, US PAT 5490216 Assignee: Uniloc Private Limited, (U.S. PTO Utility 1996)

- H** 44 SYSTEMS AND METHODS FOR SECURE TRANSACTION MANAGEMENT AND ELECTRONIC RIGHTS PROTECTION, US PAT 5892900 Assignee: InterTrust Technologies Corp., (U.S. PTO Utility 1999)
- C** 45 TIRIS BASED BIOS FOR PROTECTION OF COPYRIGHTED" PROGRAM MATER, US PAT 6198875 Assignee: Texas Instruments Incorporated, (U.S. PTO Utility 2001)

US District Court Civil Docket

**U.S. District - Washington Western
(Seattle)**

2:09cv270

**Ancora Technologies Inc v. Toshiba America Information Systems Inc et
A**

This case was retrieved from the court on Wednesday, June 03, 2009

Date Filed: 02/27/2009
Assigned To: Judge Marsha J Pechman
Referred To:
Nature of suit: Patent (830)
Cause: Patent Infringement
Lead Docket: None
Other Central District California - Southern Division, Docket: 08-00626 -AG-MLG
Jurisdiction: Federal Question

Class Code: JURYDEMAND, PROTO, TRANSIN
Closed: No
Statute: 35:145
Jury Demand: Plaintiff
Demand Amount: \$0
NOS Patent
Description: Patent

Litigants

Ancora Technologies Inc
Plaintiff

Attorneys

John S Leroy
[COR.LD.NTC]
Brooks Kushman PC
1000 Town Center
Twenty-Second Floor
Southfield, MI 48075
USA
248-358-4400
Pro Hac Vice
Email: JLEROY@BROOKSKUSHMAN.COM

Marc Lorelli
[COR.LD.NTC]
Brooks Kushman PC
1000 Town Center
Twenty-Second Floor
Southfield, MI 48075
USA
248-358-4400
Pro Hac Vice
Email: MLORELLI@BROOKSKUSHMAN.COM

Mark Cantor
[COR.LD.NTC]
Brooks Kushman PC
1000 Town Center
Twenty-Second Floor
Southfield, MI 48075
USA
248-358-4400
Pro Hac Vice
Email: MCANTOR@BROOKSKUSHMAN.COM

Daniel J Walker
[COR LD NTC]
Susman Godfrey (Wa)
1201 Third Ave
Ste 3800
Seattle , WA 98101
USA
206-373-7385
Email: DWALKER@SUSMANGODFREY.COM

Drew Derrick Hansen
[COR LD NTC]
Susman Godfrey (Wa)
1201 Third Ave
Ste 3800
Seattle , WA 98101
USA
206-516-3880
Email: Dhansen@susmangodfrey.com

Floyd G Short
[COR LD NTC]
Susman Godfrey (Wa)
1201 Third Ave
Ste 3800
Seattle , WA 98101
USA
206-373-7381
Fax: 206-516-3883
Email: Fshort@susmangodfrey.com

Toshiba America Information Systems Inc
Defendant

Chad S Campbell
[COR LD NTC]
Perkins Coie Brown & Bain
2901 N Central Ave
P O Box 400
Phoenix , AZ 85012-0400
USA
602-351-8393
Fax: 602-351-8000
Pro Hac Vice
Email: CSCAMPBELL@PERKINSCOIE.COM

Lauren Sliger
[COR LD NTC]
Perkins Coie (Santa Monica)
1620 26TH St
6TH FL
Santa Monica , CA 90404
USA
310-788-9900
Pro Hac Vice
Email: LSLIGER@PERKINSCOIE.COM

Arthur W Harrigan , Jr
[COR LD NTC]
Danielson Harrigan & Tollefson
999 3RD Ave
Ste 4400
Seattle , WA 98104
USA
206-623-1700
Fax: Fax 623-8717
Email: ARTHURH@DHLT.COM

Christopher T Wion

Dell Inc
Defendant

[COR LD NTC]
Danielson Harrigan Leyh & Tollefson
999 3RD Ave
Ste 4400
Seattle , WA 98104
USA
206-623-1700
Email: CHRISW@DHLT.COM

Chad S Campbell
[COR LD NTC]
Perkins Coie Brown & Bain
2901 N Central Ave
P O Box 400
Phoenix , AZ 85012-0400
USA
602-351-8393
Fax: 602-351-8000
Pro Hac Vice
Email: CSCAMPBELL@PERKINSCOIE.COM

Lauren Sliger
[COR LD NTC]
Perkins Coie (Santa Monica)
1620 26TH St
6TH FL
Santa Monica , CA 90404
USA
310-788-9900
Pro Hac Vice
Email: LSLIGER@PERKINSCOIE.COM

Christopher T Wion
[COR LD NTC]
Danielson Harrigan Leyh & Tollefson
999 3RD Ave
Ste 4400
Seattle , WA 98104
USA
206-623-1700
Email: CHRISW@DHLT.COM

Hewlett-Packard Company
Defendant

Chad S Campbell
[COR LD NTC]
Perkins Coie Brown & Bain
2901 N Central Ave
P O Box 400
Phoenix , AZ 85012-0400
USA
602-351-8393
Fax: 602-351-8000
Pro Hac Vice
Email: CSCAMPBELL@PERKINSCOIE.COM

Lauren Sliger
[COR LD NTC]
Perkins Coie (Santa Monica)
1620 26TH St
6TH FL
Santa Monica , CA 90404
USA
310-788-9900
Pro Hac Vice
Email: LSLIGER@PERKINSCOIE.COM

Christopher T Wion
[COR LD NTC]
Danielson Harrigan Leyh & Tollefson
999 3RD Ave
Ste 4400
Seattle , WA 98104
USA
206-623-1700
Email: CHRISW@DHLT.COM

Miki Mullor Thirdparty
Defendant

Toshiba America Information Systems Inc A California
Corporation
Counter Claimant

Hewlett-Packard Company
Counter Claimant

Dell Inc
Counter Claimant

Ancora Technologies Inc A Delaware Corporation
Counter Defendant

Mark Cantor
[COR LD NTC]
Brooks Kushman PC
1000 Town Center
Twenty-Second Floor
Southfield , MI 48075
USA
248-358-4400
Pro Hac Vice
Email: MCANTOR@BROOKSKUSHMAN.COM

Ancora Technologies Inc
Counter Defendant

Ancora Technologies Inc
Counter Defendant

Microsoft Corporation
Intervenor

Chad S Campbell
[COR LD NTC]
Perkins Coie Brown & Bain
2901 N Central Ave
P O Box 400
Phoenix , AZ 85012-0400
USA
602-351-8393
Fax: 602-351-8000
Pro Hac Vice
Email: CSCAMPBELL@PERKINSCOIE.COM

Lauren Sliger
[COR LD NTC]
Perkins Coie (Santa Monica)
1620 26TH St
6TH FL
Santa Monica , CA 90404
USA
310-788-9900
Pro Hac Vice
Email: LSLIGER@PERKINSCOIE.COM

Arthur W Harrigan , Jr
[COR LD NTC]
Danielson Harrigan & Tollefson

999 3RD Ave
Ste 4400
Seattle , WA 98104
USA
206-623-1700
Fax: Fax 623-8717
Email: ARTHURH@DHLT.COM

Christopher T Wion
[COR LD NTC]
Danielson Harrigan Leyh & Tollefson
999 3RD Ave
Ste 4400
Seattle , WA 98104
USA
206-623-1700
Email: CHRISW@DHLT.COM

Stacy Quan
[COR LD NTC]
Microsoft Corp
One Microsoft Way
Redmond , WA 98052
USA
425-882-8080
Email: STACY.QUAN@MICROSOFT.COM

T Andrew Culbert
[COR LD NTC]
Microsoft Corp
One Microsoft Way
Redmond , WA 98052
USA
425-706-6921
Email: ANDYCU@MICROSOFT.COM

Date	#	Proceeding Text
02/27/2009	1	Case transferred in from District of Southern California, Case Number 08-626; with documents 1-162 to follow.(MKB) (Additional attachment(s) added on 3/3/2009: # 1 Transfer Order to Western District of Washington (Dkt.161)) (MKB). (Entered: 03/03/2009)
02/27/2009	2	California Dockets 1-10: (Attachments: # 1 Complaint (Dkt.1), # 2 Certification and Notice of Interested Parties by Ancora (Dkt.2), # 3 Report on the Filing of An Action Regarding a Patent (Dkt.3), # 4 Stipulation Extending Time to Answer by Toshiba (Dkt.4), # 5 Corporate Disclosure Statement by Toshiba (Dkt.5), # 6 Certification and Notice of Interested Parties by Hewlett-Packard (Dkt.6), # 7 Stipulation Extending Time to Answer by Hewlett-Packard (Dkt.7), # 8 Application of C. Benson appear PHV (Dkt.8), # 9 Application of M. Barrett to appear PHV (Dkt.9), # 10 Proof of Service by Dell (Dkt.10))(MKB) (Entered: 03/03/2009)
02/27/2009	3	California Dockets 11-20: Stipulation Extending Time to Answer as to Dell (Dkt.11) (Attachments: # 1 Order granting M. Barrett PHV (Dkt.12), # 2 Order granting C. Benson PHV (Dkt.13), # 3 Application of M. Cantor PHV (Dkt.14), # 4 Proposed Order (Dkt.14-1), # 5 Application of M. Lorelli PHV (Dkt.15), # 6 Proposed Order (Dkt.15-1), # 7 Order granting M. Cantor PHV (Dkt.16), # 8 Order granting M. Lorelli PHV (Dkt.17), # 9 Stipulation for Extension of Time to Answer by Hewlett-Packard (Dkt.18), # 10 Proposed Order (Dkt.18-1), # 11 Order granting extension (18) (Dkt.19), # 12 Answer to Complaint with Jury Demand and Counterclaim by Dell (Dkt.20))(MKB) (Entered: 03/03/2009)
02/27/2009	4	California Dockets 21-30: Certificate and Notice of Interested Parties by Dell (Dkt.21) (Attachments: # 1 Answer to Complaint and Counterclaims by Hewlett-Packard (Dkt.22), # 2 Order re Early Meeting and Scheduling Conference (Dkt.23), # 3 Notice to Filer of Deficiencies (Dkt.24), # 4 Notice of Manual Filing by Dell (Dkt.25), # 5 Answer to Complaint and Counterclaim by Toshiba (Dkt.26), # 6 Notice of Change of Attorney Information re A. Hall by Toshiba (Dkt.27), # 7 Notice of Change of Attorney re I. Lateef by Toshiba (Dkt.28), # 8 Notice of Change of Attorney Information re S. Jensen by Toshiba (Dkt.29), # 9 Answer and Counterclaims by Hewlett-Packard (Dkt.30))(MKB) (Entered: 03/03/2009)

- 02/27/2009 5 California Dockets 31-40: Answer to Complaint and Counterclaim by Dell (Dkt.31). (Attachments: # 1 Notice of Discrepancy and Order (Dkt.32), # 2 Notice of Change of Attorney Information re M. Mizrahi by Ancora (Dkt.33), # 3 Notice to Filer of Deficiencies (Dkt.34), # 4 Answer to Dell's Counterclaim (Dkt.35), # 5 Answer to Hewlett-Packard's Counterclaim (Dkt.36), # 6 Answer to Toshiba's Counterclaims (Dkt.37), # 7 Application of J. LeRoy PHV (Dkt.38), # 8 Proposed Order (Dkt.38-1), # 9 Notice of Unopposed Motion to Intervene by Microsoft (Dkt.39), # 10 Memorandum In Support of Motion to Intervene (Dkt.40))(MKB) (Entered: 03/03/2009)
- 02/27/2009 6 California Dockets 41-50: Stipulation re Motion to Intervene by Microsoft (Dkt.41) (Attachments: # 1 Application of S. Minder PHV (Dkt.42), # 2 Proposed Order (Dkt.42-1), # 3 Application of C. Campbell PHV (Dkt.43), # 4 Proposed Order (Dkt.43-1), # 5 Certification and Notice of Interested Parties by Microsoft (Dkt.44), # 6 Order granting J. LeRoy appearance for Ancora (Dkt.45), # 7 Order granting C. Campbell appearance for Microsoft (Dkt.46), # 8 Order granting S. Minder appearance for Microsoft (Dkt.47), # 9 Order Returning Case for Reassignment Upon Recusal (Dkt.48), # 10 Order Granting Microsoft's Motion to Intervene (39) (Dkt.49), # 11 Notice of Clerical Error (Dkt.50))(MKB) (Entered: 03/03/2009)
- 02/27/2009 7 California Dockets 51-60: Notice of Appearance by D. Lacy Kusters for Hewlett-Packard (Dkt.51) (Attachments: # 1 Complaint in Intervention for Declaratory Judgment by Microsoft (Dkt.52), # 2 Summons (Dkt.52-1), # 3 Proof of Service by Microsoft (Dkt.53), # 4 Joint Report (Dkt.54), # 5 Answer to Intervenor Complaint by Ancora (Dkt.55), # 6 Stipulation to Continue by Microsoft (Dkt.56), # 7 Proposed Order (Dkt.56-1), # 8 Order granting Stipulation to Continue (56) (Dkt.57), # 9 Scheduling Order (Dkt.58), # 10 Minutes of Scheduling Conference (Dkt. 59), # 11 Notice of Change of Attorney Information re L. Sliger by Hewlett-Packard (Dkt.60))(MKB) (Entered: 03/03/2009)
- 02/27/2009 8 California Dockets 61-70: Notice of Change of Attorney Information re L. Sliger by Hewlett-Packard (Dkt.61). (Attachments: # 1 Notice of Change of Attorney Information re L. Sliger by Hewlett-Packard (Dkt.62), # 2 Notice of Change of Attorney Information re L. Sliger by Hewlett-Packard (Dkt.63), # 3 Answer to Counterclaims by Microsoft (Dkt.64), # 4 Notice and Motion to Withdraw (Dkt. 65), # 5 Exhibit Signature page (Dkt. 65-1), # 6 Proposed Order (Dkt.65-2), # 7 Order Granting Motion to Withdraw (65) (Dkt.66), # 8 Stipulation to Reschedule (Dkt. 67), # 9 Proposed Order (Dkt.67-1), # 10 Stipulation for Protective Order (Dkt.68), # 11 Proposed Order (Dkt.68-1), # 12 Order Granting Stipulation to Reschedule (67) (Dkt.69), # 13 Protective Order (Dkt.70))(MKB) (Entered: 03/03/2009)
- 02/27/2009 9 California Dockets 71-78: Notice of Change of Attorney Information re L. Sliger by Toshiba (Dkt.71). (Attachments: # 1 Notice of Change of Attorney Information re L. Sliger by Toshiba (Dkt.72), # 2 Notice of Change of Attorney Information re L. Sliger by Toshiba (Dkt.73), # 3 Notice of Change of Attorney Information re L. Sliger by Toshiba (Dkt.74), # 4 Notice of Taking Deposition of Miki Mullor by Microsoft (Dkt.75), # 5 Notice of Manual Filing (Dkt.76), # 6 Notice of Motion re Joint Stipulation for Entry of Final Protective Order (Dkt.77), # 7 Proposed Order (Dkt.77-1), # 8 Declaration of Miki Mullor (Dkt.78))(MKB) (Entered: 03/03/2009)
- 02/27/2009 10 California Docket 79: Declaration of David M. LaSpaluto (Dkt.79). (Attachments: # 1 Exhibit 1 (Dkt.79-1), # 2 Exhibit 2-5 (Dkt.79-2), # 3 Exhibit 6-14 (Dkt.79-3), # 4 Exhibit 15-22 (Dkt.79-4), # 5 Exhibit 23-24 (Dkt.79-5), # 6 Exhibit 25-26 (Dkt.79-6), # 7 Exhibit 27 (Dkt.79-7), # 8 Exhibit 28-30 (Dkt.79-8), # 9 Exhibit 31 (Dkt.79-9), # 10 Exhibit 32 (Dkt.79-10), # 11 Exhibit 33 (Dkt.79-11), # 12 Exhibit 34 (Dkt.79-12))(MKB) (Entered: 03/03/2009)
- 02/27/2009 11 California Dockets 80-90 with the exception of dockets 84, 85, 86 which were sealed per Court order: Notice and Motion to Withdraw (Dkt.80). (Attachments: # 1 Order Continuing Hearing (Dkt.81), # 2 Application to File Under Seal (Dkt.82), # 3 Order Granting Application to Seal (Dkt.83), # 4 Joint Stipulation re Application to Seal (82) (Dkt.87), # 5 Proposed Order (Dkt.87-1), # 6 Order Rescheduling Hearing (Dkt.88), # 7 Notice and Motion to Compel Microsoft (Dkt.89), # 8 Proposed Order (Dkt.89-1), # 9 Joint Stipulation to Motion to Compel Microsoft (Dkt.90))(MKB) (Entered: 03/03/2009)
- 02/27/2009 12 California Dockets 91-94: Declaration of Mark Mizrahi In Support of Motion to Compel Microsoft (Dkt.91). (Attachments: # 1 Exhibit 1 (Dkt.91-1), # 2 Exhibit 2 (Dkt.91-2), # 3 Exhibit 3 (Dkt.91-3), # 4 Exhibit 4 (Dkt.91-4), # 5 Exhibit 5 (Dkt.91-5), # 6 Exhibit 6 (Dkt.91-6), # 7 Exhibit 7 (Dkt.91-7), # 8 Declaration of Scott Minder in Opposition to Motion to Compel (Dkt.92), # 9 Supplemental Exhibits to Minder Declaration (Dkt.92-1), # 10 Notice and Motion to Compel Defendants Hewlett-Packard, Dell, Toshiba by Ancora (Dkt.93), # 11 Proposed Order (Dkt.93-1), # 12 Joint Stipulation to Motion to Compel (93) (Dkt.94))(MKB) (Entered: 03/03/2009)
- 02/27/2009 13 California Dockets 95-100: Declaration of Mark Mizrahi In Support of Motion to Compel (93) (Dkt.95). (Attachments: # 1 Exhibit 1 (Dkt.95-1), # 2 Exhibit 2 (Dkt.95-2), # 3 Exhibit 3 (Dkt.95-3), # 4 Exhibit 4 (Dkt.95-4), # 5 Exhibit 5 (Dkt.95-5), # 6 Exhibit 6 (Dkt.95-6), # 7

- Exhibit 7 (Dkt.95-7), # 8 Exhibit 8 (Dkt.95-8), # 9 Exhibit 9 (Dkt.95-9), # 10 Exhibit 10 (Dkt.95-10), # 11 Exhibit 11 (Dkt.95-11), # 12 Exhibit 12 (Dkt.95-12), # 13 Exhibit 13 (Dkt.95-13), # 14 Exhibit 14 (Dkt.95-14), # 15 Declaration of Scott Minder in Opposition to Motion to Compel Hewlett-Packard, Dell, Toshiba by Ancora (Dkt.96), # 16 First Amended Answer to Intervenor Complaint (52) (Dkt.97), # 17 Exhibit A (Dkt.97-1), # 18 Notice and Motion for Leave to File Amended Answers by Microsoft (Dkt.98), # 19 Proposed Order (Dkt.98-1), # 20 Memorandum in Support of Motion to File Amended Answers by Microsoft (Dkt.99), # 21 Exhibit A-D (Dkt.99-1), # 22 Notice and Motion to Withdraw (Dkt.100))(MKB) (Entered: 03/03/2009)
- 02/27/2009 14 California Dockets 101-102: Opening Markman Brief by Ancora (Dkt.101) (Attachments: # 1 Exhibit 1 (Dkt.101-1), # 2 Exhibit 2 (Dkt.101-2), # 3 Exhibit 3 (Dkt.101-3), # 4 Exhibit 4 (Dkt.101-4), # 5 Exhibit 5 (Dkt.101-5), # 6 Exhibit 6 (Dkt.101-6), # 7 Exhibit 7 (Dkt.101-7), # 8 Exhibit 8 (Dkt.101-8), # 9 Exhibit 9 (Dkt.101-9), # 10 Exhibit 10 (Dkt.101-10), # 11 Exhibit 11 (Dkt.101-11), # 12 Exhibit 12 (Dkt.101-12), # 13 Exhibit 13 (Dkt.101-13), # 14 Exhibit 14 (Dkt.101-14), # 15 Opening Claims Construction Brief by Microsoft (Dkt.102))(MKB) (Entered: 03/03/2009)
- 02/27/2009 15 California Docket 103: Declaration of Chad S. Campbell re Markman Brief (102)(Dkt.103) (Attachments: # 1 Exhibit A-B Part 1 (Dkt.103-1), # 2 Exhibit B part 2 (Dkt.103-2), # 3 Exhibit B part 3 (Dkt.103-3), # 4 Exhibit B part 4 (Dkt.103-4), # 5 Exhibit C-D part 5 (Dkt.103-5), # 6 Exhibit E part 6 (Dkt.103-6), # 7 Exhibit E part 7 (Dkt.103-7), # 8 Exhibit F-G part 8 (Dkt.103-8))(MKB) (Entered: 03/03/2009)
- 02/27/2009 16 California Dockets 104-114: Supplement to Motion to Compel Microsoft by Ancora (Dkt.104) (Attachments: # 1 Exhibit A (Dkt.104-1), # 2 Exhibit B (Dkt.104-2), # 3 Exhibit C (Dkt.104-3), # 4 Supplement to Motion to Compel (93) by Ancora (Dkt.105), # 5 Supplement to Stipulation for Protective Order (84) by Ancora (Dkt.106), # 6 Memorandum in Support re Supplemental Memorandum in Support of Joint Stipulation re Motion for Entry of Final Protective Order by Microsoft (Dkt.107), # 7 Declaration of David M. LaSpaluto re (107) by Microsoft (Dkt.108), # 8 Exhibit 1-2 (Dkt.108-1), # 9 Memorandum in Opposition of Supplemental Memorandum in Opposition to Motion to Compel Microsoft by Microsoft (Dkt.109), # 10 Declaration of Scott S. Minder re (109) by Microsoft (Dkt.110), # 11 Exhibit 1 (Dkt.110-1), # 12 Memorandum in Opposition of Supplemental Memorandum in Opposition to Plaintiff's Motion to Compel Defendants by Toshiba (Dkt.111), # 13 Declaration of Scott Minder re (111) by Toshiba (Dkt.112), # 14 Exhibit 1-3 (Dkt.112-1), # 15 Notice of Manual Filing (Dkt.113), # 16 Notice of Motion to Transfer Venue by Microsoft, Toshiba, Dell, Hewlett-Packard (Dkt.114), # 17 Proposed Order (Dkt.114-1))(MKB) (Entered: 03/03/2009)
- 02/27/2009 17 California Dockets 115-124 (Dkts. 125 and 126 were sealed by order of the Court): Declaration of Cam D'Amico in Support of Motion to Transfer Venue (Dkt.115) (Attachments: # 1 Declaration of John Hong In support of Motion to Transfer Venue (Dkt.116), # 2 Declaration of Eric Peacock In Support of Motion to Transfer Venue (Dkt.117), # 3 Declaration of Chad Anson In Support of Motion to Transfer Venue (Dkt.118), # 4 Order Granting Motion to Withdraw for Dell (Dkt.119), # 5 Proof of Service (Dkt.120), # 6 Application to File Papers Under Seal and Shorten Time by Microsoft (Dkt.121), # 7 Order Shortening Time and Granting Application to Seal (Dkt.122), # 8 Ex Parte Application to Continue Hearing on Motion to Transfer Venue by Ancora (Dkt.123), # 9 Exhibit 1 (Dkt.123-1), # 10 Proposed Order (Dkt.123-2), # 11 Opposition to Ancora's Ex Parte Application to Continue Hearing (123) (Dkt.124))(MKB) (Entered: 03/03/2009)
- 02/27/2009 18 California Dockets 127-132: Order re Continue Hearing (Dkt.127) (Attachments: # 1 Application to Clarify Order Dated February 5, 2009 (Dkt.128), # 2 Notice of Lodging (Dkt.130), # 3 Notice of Lodging (Dkt.130), # 4 Proposed Order (Dkt.130-1), # 5 Memorandum In Opposition to Motion to Transfer by Ancora (Dkt.131), # 6 Notice of Manual Filing (Dkt.132))(MKB) (Entered: 03/03/2009)
- 02/27/2009 19 California Docket 133 (with the exception of Exhibits 2,7 & 8 which were sealed by order of the Court and are entered as California Dkt.146):Memorandum in Opposition to Declaration of Counsel re Motion to Transfer (Dkt.133). (Attachments: # 1 Exhibit 1 Dkt.133-1), # 2 Exhibit 3 (Dkt.133-3), # 3 Exhibit 4 (Dkt.133-4), # 4 Exhibit 5 (Dkt.133-5), # 5 Exhibit 6 (Dkt.133-6), # 6 Exhibit 9 (Dkt.133-9), # 7 Exhibit 10 (Dkt.133-10), # 8 Exhibit 11 (Dkt.133-11), # 9 Exhibit 12 (Dkt.133-12), # 10 Exhibit 13 (Dkt.133-13), # 11 Exhibit 14 (Dkt.133-14), # 12 Exhibit 15 (Dkt.133-15), # 13 Exhibit 16 (Dkt.133-16), # 14 Exhibit 17 (Dkt.133-17), # 15 Exhibit 18 (Dkt.133-18), # 16 Exhibit 19 (Dkt.133-19), # 17 Exhibit 20 (Dkt.133-20), # 18 Exhibit 21 (Dkt.133-21), # 19 Exhibit 22 (Dkt.133-22), # 20 Exhibit 23 (Dkt.133-23), # 21 Exhibit 24 (Dkt.133-24))(MKB) (Entered: 03/03/2009)
- 02/27/2009 20 California Dockets 134-145:Order re Application to Clarify Order Dated February 5, 2009 (Dkt.134) (Attachments: # 1 Application to File Confidential Exhibits 2, 7 & 8 (133) (Dkt.135), # 2 Order Granting File Confidential Exhibits 2, 7 & 8 (133) (Dkt.136), # 3 Order on Motion to Compel (89)(93) (Dkt.137), # 4 Notice and Motion to Dismiss Count II of Ancora's

- Counterclaims in it's First Amended Answer by Microsoft (Dkt.138), # 5 Proposed Order (Dkt.138-1), # 6 Memorandum In Support of Motion to Dismiss (138) (Dkt.139), # 7 Notice of Manual Filing (Dkt.140), # 8 Declaration of Supplemental Declaration of Cam D'Amico In Support of Reply re Motion to Transfer Venue (Dkt.141), # 9 Supplement/Sur-Reply by Ancora (Dkt.142), # 10 Supplement /Declaration of Mark B. Mizrahi by Ancora (Dkt.143), # 11 Notice of Manual Filing (Dkt.144), # 12 Notice of Manual Filing (Dkt.145))(MKB) (Entered: 03/03/2009)
- 02/27/2009 21 California Documents 147-162 (with the exception of documents 152, 153, 154, 155 which are under seal. Also, document 146 which are Exhibits 2, 7 and 8 to the Decl. of Counsel in Opposition to Motion to Transfer Venue): Application for Leave to File a Sur-Reply and to File Under Seal Confidential Exhibit 25 to Decl of Mark Mizrahi (Dkt. 147). (Attachments: # 1 Order Granting Application for Leave to File a Sur-Reply and to File Under Seal Confidential Exhibit 25 to Decl of Mark B Mizrahi (Dkt. 148), # 2 Application for Leave to File Papers Under Seal (Dkt. 149), # 3 Order Granting Application for Leave to File Under Seal (Dkt. 150), # 4 Application for Leave to File Papers Under Seal (Dkt. 151), # 5 Application for attorney John Rogers to Appear PHV (Dkt. 156), # 6 Proposed Order on Application for PHC (Dkt. 156-1), # 7 Letter Certificate of Good Standing (Dkt. 156-2), # 8 Order Granting Application To File Under Seal - Microsoft & Defts' 2nd Suppl Decl of Cnsl in Sup of Mtn to Transfer (Dkt. 157), # 9 Opposition to Motion to Dismiss Count II (Dkt. 158), # 10 Minutes of Motion Hearing RE: Intervenor's & Defts' Motion to Transfer Venue & Motion for Leave to File Prop. Amended Answers to Ancora Tech Inc's Complaint & Counterclaim (Dkt. 159), # 11 Order Granting Application for atty John Rogers to Appear Pro Hac Vice (Dkt. 160), # 12 ORDER TRANSFERRING CASE TO WESTERN DISTRICT OF WASHINGTON & Vacating Hearing on Motion to Amend (Dkt. 161), # 13 Minutes of In Chambers Order Vacating Hearing On Motion To Dismiss (Dkt. 162))(PM) (Entered: 03/04/2009)
- 03/04/2009 22 Letter from Clerk's Office to counsel re receipt of case from the Central District of California (Southern Division-Santa Ana)and of Western District of Washington case number and judge assignment. Counsel are also advised of pro hac vice application and ECF registration requirement. (sent electronically to all counsel via Ad hoc feature of ECF)(PM) (Entered: 03/04/2009)
- 03/04/2009 23 ORDER REGARDING INITIAL DISCLOSURES, JOINT STATUS REPORT AND EARLY SETTLEMENT Joint Status Report due by 4/15/2009, FRCP 26f Conference Deadline is 4/1/2009, Initial Disclosure Deadline is 4/8/2009, by Judge Marsha J. Pechman. (RM) Modified on 3/5/2009 - mailed copy of order to all pending cnsl of record(MD). (Entered: 03/04/2009)
- 03/04/2009 24 STANDING ORDER FOR PATENT CASES describing joint claim chart and prehearing statement procedures by Judge Marsha J. Pechman. (RK) Modified on 3/5/2009 -mailed copy of order to all pending counsel of record(MD). (Entered: 03/04/2009)
- 03/05/2009 25 APPLICATION OF ATTORNEY Chad S. Campbell FOR LEAVE TO APPEAR PRO HAC VICE for Defendant Toshiba America Information Systems Inc (Fee Paid) Receipt No. 0981000000001689697. (Harrigan, Arthur) (Entered: 03/05/2009)
- 03/06/2009 26 ORDER re 25 Application for Leave to Appear Pro Hac Vice. The Court ADMITS Attorney Chad S Campbell for Toshiba America Information Systems Inc, Dell Inc and Hewlett-Packard Company, Intervenor Microsoft Corporation by Bruce Rifkin. (No document associated with this docket entry, text only.)(DS) Modified on 3/6/2009 - to add intervenor Microsoft Corporation re: appearance to appear Pro Hac Vice (MD). (Entered: 03/06/2009)
- 03/09/2009 27 NOTICE of Appearance by attorney Christopher T Wion on behalf of Defendants Toshiba America Information Systems Inc, Dell Inc, Hewlett-Packard Company, Intervenor Microsoft Corporation. (Wion, Christopher) (Entered: 03/09/2009)
- 03/11/2009 28 NOTICE of Appearance by attorney Drew Derrick Hansen on behalf of Plaintiff Ancora Technologies Inc. (Hansen, Drew) (Entered: 03/11/2009)
- 03/11/2009 29 NOTICE of Appearance by attorney Floyd G Short on behalf of Plaintiff Ancora Technologies Inc. (Short, Floyd) (Entered: 03/11/2009)
- 03/11/2009 30 NOTICE of Appearance by attorney Daniel J Walker on behalf of Plaintiff Ancora Technologies Inc. (Walker, Daniel) (Entered: 03/11/2009)
- 03/12/2009 31 APPLICATION OF ATTORNEY Mark Cantor FOR LEAVE TO APPEAR PRO HAC VICE for Plaintiff Ancora Technologies Inc (Fee Paid) Receipt No. 0981000000001695827. (Attachments: # 1 ECF registration form)(Hansen, Drew) (Entered: 03/12/2009)
- 03/12/2009 32 APPLICATION OF ATTORNEY Marc Lorelli FOR LEAVE TO APPEAR PRO HAC VICE for Plaintiff Ancora Technologies Inc (Fee Paid) Receipt No. 0981000000001695840. (Attachments: # 1 ECF Registration form)(Hansen, Drew) (Entered: 03/12/2009)
- 03/12/2009 33 APPLICATION OF ATTORNEY John LeRoy FOR LEAVE TO APPEAR PRO HAC VICE for Plaintiff

- Ancora Technologies Inc (Fee Paid) Receipt No. 0981000000001695843. (Attachments: # 1 ECF Registration form)(Hansen, Drew) (Entered: 03/12/2009)
- 03/13/2009 34 ORDER re 31 Application for Leave to Appear Pro Hac Vice. The Court ADMITS Attorney Mark Cantor for Ancora Technologies Inc, by Bruce Rifkin. (No document associated with this docket entry, text only.)(DS) (Entered: 03/13/2009)
- 03/13/2009 35 ORDER re 32 Application for Leave to Appear Pro Hac Vice. The Court ADMITS Attorney Marc Lorelli for Ancora Technologies Inc, by Bruce Rifkin. (No document associated with this docket entry, text only.)(DS) (Entered: 03/13/2009)
- 03/13/2009 36 ORDER re 33 Application for Leave to Appear Pro Hac Vice. The Court ADMITS Attorney John S. LeRoy for Ancora Technologies Inc, by Bruce Rifkin. (No document associated with this docket entry, text only.)(DS) (Entered: 03/13/2009)
- 03/20/2009 37 NOTICE TO THE COURT ; filed by Defendant Toshiba America Information Systems Inc, Counter Claimant Toshiba America Information Systems Inc. (Uribe, Mauricio) (Entered: 03/20/2009)
- 04/10/2009 38 NOTICE of Appearance by attorney Stacy Quan on behalf of Intervenor Microsoft Corporation. (Quan, Stacy) (Entered: 04/10/2009)
- 04/15/2009 39 JOINT STATUS REPORT signed by all parties estimated Trial Days: 10. Filed by Intervenor Microsoft Corporation.(Wion, Christopher) (Entered: 04/15/2009)
- 04/29/2009 40 STIPULATION and (Proposed) Protective Order by parties. (Harrigan, Arthur) (Entered: 04/29/2009)
- 04/29/2009 41 STIPULATION AND PROPOSED ORDER to Facilitate Consolidation of Actions Between the Parties by parties. (Harrigan, Arthur) (Entered: 04/29/2009)
- 05/01/2009 42 NOTICE of Appearance by attorney T. Andrew Culbert on behalf of Intervenor Microsoft Corporation. (Culbert, T.) (Entered: 05/01/2009)
- 05/04/2009 43 APPLICATION OF ATTORNEY Lauren Sliger FOR LEAVE TO APPEAR PRO HAC VICE for Intervenor Microsoft Corporation (Fee Paid) Receipt No. 0981000000001742002. (Attachments: # 1 ECF Registration)(Harrigan, Arthur) (Entered: 05/04/2009)
- 05/05/2009 44 ORDER re 43 Application for Leave to Appear Pro Hac Vice. The Court ADMITS Lauren Sliger for defendants Toshiba America Information Systems Inc, Dell Inc, Hewlett-Packard Company and intervenor, Microsoft Corporation, by Bruce Rifkin. (No document associated with this docket entry, text only.)(DS) (Entered: 05/05/2009)
- 05/05/2009 45 STIPULATION AND PROTECTIVE ORDER by Judge Marsha J. Pechman. (MD) (Entered: 05/05/2009)
- 05/11/2009 46 NOTICE of Hearing: Telephone Conference RE: expert for Markman hearing is scheduled for 5/12/2009 at 03:00 PM before Judge Marsha J. Pechman.(RM) (Entered: 05/11/2009)
- 05/12/2009 47 STIPULATION AND ORDER: Stipulation (Dkt. No. 41) to Facilitate Consolidation of Actions between the Parties is approved and that the parties shall comply with the terms of the Stipulation, by Judge Marsha J. Pechman. (RK) (Entered: 05/12/2009)
- 05/12/2009 50 MINUTE ENTRY for proceedings held before Judge Marsha J. Pechman- Dep Clerk: Rhonda Miller; Pla Counsel: Mark Lorelli, Mark Cantor, Drew Hansen; Def Counsel: Chad Campbell, Arthur Harrigan, Christopher Wion, Stacy Quan; CR: Joe Roth; Telephone Conference held on 5/12/2009. After amended complaint is filed, the parties are directed to file an updated joint status report and include proposed tutorial options for the Court in preparation for the Markman hearing. (RM) (Entered: 05/14/2009)
- 05/13/2009 48 AMENDED COMPLAINT AND THIRD PARTY COMPLAINT against defendant(s) Miki Mullor, Ancora Technologies Inc, Ancora Technologies Inc(a Delaware corporation) with JURY DEMAND, filed by Microsoft Corporation.(Wion, Christopher) (Entered: 05/13/2009)
- 05/14/2009 49 Second MOTION to Amend 48 Amended Complaint, in Intervention against Plaintiff Ancora Technologies and Third Party Complaint Against Miki Mullor by Intervenor Microsoft Corporation. (Attachments: # 1 Appendix A, # 2 Appendix B, # 3 Proposed Order) Noting Date 5/26/2009, (Wion, Christopher) (Entered: 05/14/2009)
- 05/15/2009 51 AMENDED COMPLAINT against defendant(s) Dell Inc, Toshiba America Information Systems Inc, Hewlett-Packard Company, Microsoft Corporation, Toshiba America Information Systems Inc with JURY DEMAND, filed by Ancora Technologies Inc, Ancora Technologies Inc(a Delaware corporation).(Cantor, Mark) (Entered: 05/15/2009)
- 05/20/2009 52 RESPONSE, by Plaintiff Ancora Technologies Inc, to 49 Second MOTION to Amend 48 Amended Complaint, in Intervention against Plaintiff Ancora Technologies and Third Party Complaint Against Miki MullorSecond MOTION to Amend 48 Amended Complaint, in Intervention against

- Plaintiff Ancora Technologies and Third Party Complaint Against Miki Mullor. (Lorelli, Marc)
(Entered: 05/20/2009)
- 05/23/2009 53 APPLICATION OF ATTORNEY Scott S. Minder FOR LEAVE TO APPEAR PRO HAC VICE for Intervenor Microsoft Corporation (Fee Paid) Receipt No. 0981000000001759741. (Attachments: # 1 Supplement ECF Registration)(Harrigan, Arthur) (Entered: 05/23/2009)
- 05/26/2009 54 REPLY, filed by Intervenor Microsoft Corporation, TO RESPONSE to 49 Second MOTION to Amend 48 Amended Complaint, in Intervention against Plaintiff Ancora Technologies and Third Party Complaint Against Miki MullorSecond MOTION to Amend 48 Amended Complaint, in Intervention against Plaintiff Ancora Technologies and Third Party Complaint Against Miki Mullor (Wion, Christopher) (Entered: 05/26/2009)
- 05/27/2009 55 ORDER granting 49 Microsoft's Motion for leave to file second Amended complaint in intervention against plaintiff Ancora Technologies, Inc and third party complaint against Miki Mullor. Counsel is directed to e-file their Amended Complaint, by Judge Marsha J. Pechman. (MD) (Entered: 05/28/2009)
- 05/29/2009 56 Second AMENDED COMPLAINT in Intervention Against Plaintiff Ancora Technologies and Third Party Complaint Against Miki Mullor against defendant(s) Ancora Technologies Inc with JURY DEMAND, filed by Microsoft Corporation.(Wion, Christopher) (Entered: 05/29/2009)
- 06/02/2009 57 MINUTE ORDER directing the parties to file an updated joint status report and include proposed tutorial options for the Court in preparation for the Markman hearing. Joint Status Report due by 6/17/2009. Authorized by Judge Marsha J. Pechman. (RM) (Entered: 06/02/2009)

Copyright © 2009 LexisNexis CourtLink, Inc. All rights reserved.
*** THIS DATA IS FOR INFORMATIONAL PURPOSES ONLY ***

US District Court Civil Docket

**U.S. District - California Central
(Southern Division)**

8:08cv626

**Ancora Technologies Inc v. Toshiba America Information Systems Inc et
A**

This case was retrieved from the court on Monday, June 08, 2009

Date Filed: 06/06/2008
Assigned To: Judge Andrew J Guilford
Referred To: Magistrate Judge Marc L Goldman
Nature of suit: Patent (830)
Cause: Patent Infringement
Lead Docket: None
Other Docket: None
Jurisdiction: Federal Question

Class Code: (MLGx), AO120, CLOSED, DISCOVERY, PROTORD, TRANSFERRED
Closed: Yes
Statute: 35:145
Jury Demand: Both
Demand Amount: \$0
NOS Patent
Description:

Litigants

Ancora Technologies Inc
Plaintiff

Attorneys

John S Leroy
[COR LD NTC]
Brooks Kushman PC
1000 Town Center 22ND Floor
Southfield , MI 48075
USA
248-358-4400
Fax: 248-358-3351
Pro Hac Vice
Email: JLEROY@BROOKSKUSHMAN.COM

Marc Lorelli
[COR LD NTC]
Brooks Kushman
1000 Town Center, 22ND Floor
Southfield , MI 48075
USA
248-358-4400
Email: MLORELLI@BROOKSKUSHMAN.COM

Mark A Cantor
[COR LD NTC]
Brooks & Kushman
1000 Town Center, 22ND FL
Southfield , MI 48075
USA
248-358-4400
Email: McAntor@brookskushman.com

Mark B Mizrahi
[COR LD NTC]
Brooks Kushman PC

Toshiba America Information Systems Inc
Defendant

6701 Center Drive West Suite 610
Los Angeles , CA 90045
USA
310-348-8200
Fax: 310-846-4799
Email: MMIZRAHI@BROOKSKUSHMAN.COM

Chad S Campbell
[COR LD NTC]
Perkins Coie Brown & Bain PA
2901 North Central Avenue Suite 2000
Phoenix , AZ 85012-2788
USA
602-351-8393
Fax: 602-648-7193
Email: CSCAMPBELL@PERKINSCOIE.COM

David Matthew Laspaluto
[COR LD NTC]
Perkins Coie Brown and Bain
2901 North Central Avenue Suite 2000
Phoenix , AZ 85012
USA
602-351-8175
Fax: 602-648-7017
Email: DLASPALUTO@PERKINSCOIE.COM

David S Laspaluto
[COR LD NTC]
Perkins Coie Brown and Bain
2901 North Central Avenue Suite 2000
Phoenix , AZ 85012-2788
USA
602-351-8000
Fax: 602-648-7000
Email: DLASPALUTO@PERKINSCOIE.COM

Irfan A Lateef
[COR LD NTC]
Knobbe Martens Olson and Bear
2040 Main Street
14TH Floor
Irvine , CA 92614
USA
949-760-0404
Fax: 949-760-9502
Email: IRFAN.LATEEF@KMOB.COM

Jon W Gurka
[COR LD NTC]
Knobbe Martens Olson and Bear LLP
2040 Main Street 14TH Floor
Irvine , CA 92614
USA
949-760-0404
Fax: 949-760-9502
Email: JGURKA@KMOB.COM

Lauren C Sliger
[COR LD NTC]
Perkins Coie
1620 26TH Street 6TH FL
Santa Monica , CA 90404
USA
310-788-9900
Fax: 310-788-3399

Email: LSLIGER@PERKINSCOIE.COM

Scott S Minder
[COR LD NTC]
Perkins Coie Brown and Bain PA
2901 North Central Avenue Suite 2000
Phoenix , AZ 85012-2788
USA
602-351-8000
Fax: 602-648-7000
Pro Hac Vice
Email: SMINDER@PERKINSCOIE.COM

Andrew J Hall
[COR LD NTC]
Knobbe Martens Olson and Bear
2040 Main Street, 14TH Floor
Irvine , CA 92614
USA
949-760-0404
Email: LITIGATION@KMOB.COM

Stephen C Jensen
[COR LD NTC]
Knobbe Martens Olson and Bear LLP
2040 Main Street
Fourteenth Street
Irvine , CA 92614
USA
949-760-0404
Email: LITIGATION@KMOB.COM

Dell Inc
Defendant

Brandon C Fernald
[COR LD NTC]
[Term: 01/30/2009]
Fulbright and Jaworski LLP
555 South Flower Street 41ST Floor
Los Angeles , CA 90071
USA
213-892-9200
Email: BFERNALD@FULBRIGHT.COM

Chad S Campbell
[COR LD NTC]
Perkins Coie Brown & Bain PA
2901 North Central Avenue Suite 2000
Phoenix , AZ 85012-2788
USA
602-351-8393
Fax: 602-648-7193
Email: CSCAMPBELL@PERKINSCOIE.COM

Christopher R Benson
[COR LD NTC]
[Term: 01/30/2009]
Fulbright and Jaworski LLP
600 Congress Avenue Suite 2400
Austin , TX 78701
USA
512-474-5201
Fax: 512-536-4598
Pro Hac Vice
Email: CBENSON@FULBRIGHT.COM

David Matthew Laspaluto
[COR LD NTC]

Perkins Coie Brown and Bain
2901 North Central Avenue Suite 2000
Phoenix , AZ 85012
USA
602-351-8175
Fax: 602-648-7017
Email: DLASPALUTO@PERKINSCOIE.COM

David S Laspaluto
[COR LD NTC]
Perkins Coie Brown and Bain
2901 North Central Avenue Suite 2000
Phoenix , AZ 85012-2788
USA
602-351-8000
Fax: 602-648-7000
Email: DLASPALUTO@PERKINSCOIE.COM

Lauren C Sliger
[COR LD NTC]
Perkins Coie
1620 26TH Street 6TH FL
Santa Monica , CA 90404
USA
310-788-9900
Fax: 310-788-3399
Email: LSLIGER@PERKINSCOIE.COM

Michael C Barrett
[COR LD NTC]
[Term: 01/30/2009]
Fulbright and Jaworski LLP
600 Congress Avenue Suite 2400
Austin , TX 78701
USA
512-474-5201
Email: MBARRETT@FULBRIGHT.COM

Scott S Minder
[COR LD NTC]
Perkins Coie Brown and Bain PA
2901 North Central Avenue Suite 2000
Phoenix , AZ 85012-2788
USA
602-351-8000
Fax: 602-648-7000
Pro Hac Vice
Email: SMINDER@PERKINSCOIE.COM

Hewlett-Packard Company
Defendant

Chad S Campbell
[COR LD NTC]
Perkins Coie Brown & Bain PA
2901 North Central Avenue Suite 2000
Phoenix , AZ 85012-2788
USA
602-351-8393
Fax: 602-648-7193
Email: CSCAMPBELL@PERKINSCOIE.COM

Darryl M Woo
[COR LD NTC]
[Term: 12/02/2008]
Fenwick and West LLP
555 California Street 12TH Floor
San Francisco , CA 94111
USA

415-875-2300
Email: DWOO@FENWICK.COM

David Matthew Laspaluto
[COR LD NTC]
Perkins Coie Brown and Bain
2901 North Central Avenue Suite 2000
Phoenix , AZ 85012
USA
602-351-8175
Fax: 602-648-7017
Email: DLASPALUTO@PERKINSCOIE.COM

David S Laspaluto
[COR LD NTC]
Perkins Coie Brown and Bain
2901 North Central Avenue Suite 2000
Phoenix , AZ 85012-2788
USA
602-351-8000
Fax: 602-648-7000
Email: DLASPALUTO@PERKINSCOIE.COM

Lauren C Sliger
[COR LD NTC]
Perkins Coie South Tower
1620 26TH Street 6TH FL
Santa Monica , CA 90404
USA
310-788-9900
Fax: 310-788-3399
Email: LSLIGER@PERKINSCOIE.COM

Scott S Minder
[COR LD NTC]
Perkins Coie Brown and Bain PA
2901 North Central Avenue Suite 2000
Phoenix , AZ 85012-2788
USA
602-351-8000
Fax: 602-648-7000
Pro Hac Vice
Email: SMINDER@PERKINSCOIE.COM

David M Lacy Kusters
[COR LD NTC]
[Term: 12/02/2008]
Fenwick and West LLP
555 California Street 12TH Floor
San Francisco , CA 94104
USA
415-875-2300
Fax: 415-281-1350
Email: DLACYKUSTERS@FENWICK.COM

Heather N Mewes
[COR LD NTC]
[Term: 12/02/2008]
Fenwick & West LLP
555 California Street
San Francisco , CA 94041
USA
415-975-2300
Fax: 415-281-1350
Email: HMEWES@FENWICK.COM

Microsoft Corporation
Intervenor

Chad S Campbell
[COR LD NTC]
Perkins Coie Brown & Bain PA
2901 North Central Avenue Suite 2000
Phoenix , AZ 85012-2788
USA
602-351-8393
Fax: 602-648-7193
Email: CSCAMPBELL@PERKINSCOIE.COM

David Matthew Laspaluto
[COR LD NTC]
Perkins Coie Brown and Bain
2901 North Central Avenue Suite 2000
Phoenix , AZ 85012
USA
602-351-8175
Fax: 602-648-7017
Email: DLASPALUTO@PERKINSCOIE.COM

David S Laspaluto
[COR LD NTC]
Perkins Coie Brown and Bain
2901 North Central Avenue Suite 2000
Phoenix , AZ 85012-2788
USA
602-351-8000
Fax: 602-648-7000
Email: DLASPALUTO@PERKINSCOIE.COM

John W Rogers
[COR LD NTC]
Perkins Coie Brown & Bain PA
2901 North Central Avenue Suite 2000
Phoenix , AZ 85012
USA
602-351-8450
Fax: 602-648-7014
Pro Hac Vice
Email: JWROGERS@PERKINSCOIE.COM

Lauren C Sliger
[COR LD NTC]
Perkins Coie
1620 26TH Street 6TH FL
Santa Monica , CA 90404
USA
310-788-9900
Fax: 310-788-3399
Email: LSLIGER@PERKINSCOIE.COM

Scott S Minder
[COR LD NTC]
Perkins Coie Brown and Bain PA
2901 North Central Avenue Suite 2000
Phoenix , AZ 85012-2788
USA
602-351-8000
Fax: 602-648-7000
Pro Hac Vice
Email: SMINDER@PERKINSCOIE.COM

Toshiba America Information Systems, Inc A California
Corporation
Counter Claimant

Chad S Campbell
[COR LD NTC]
Perkins Coie Brown & Bain PA
2901 North Central Avenue Suite 2000

Phoenix , AZ 85012-2788
USA
602-351-8393
Fax: 602-648-7193
Email: CSCAMPBELL@PERKINSCOIE.COM

David Matthew Laspaluto
[COR LD NTC]
Perkins Coie Brown and Bain
2901 North Central Avenue Suite 2000
Phoenix , AZ 85012
USA
602-351-8175
Fax: 602-648-7017
Email: DLASPALUTO@PERKINSCOIE.COM

Jon W Gurka
[COR LD NTC]
Knobbe Martens Olson and Bear LLP
2040 Main Street 14TH Floor
Irvine , CA 92614
USA
949-760-0404
Fax: 949-760-9502
Email: JGURKA@KMOB.COM

Lauren C Sliger
[COR LD NTC]
Perkins Coie
1620 26TH Street 6TH FL
Santa Monica , CA 90404
USA
310-788-9900
Fax: 310-788-3399
Email: LSLIGER@PERKINSCOIE.COM

Scott S Minder
[COR LD NTC]
Perkins Coie Brown and Bain PA
2901 North Central Avenue Suite 2000
Phoenix , AZ 85012-2788
USA
602-351-8000
Fax: 602-648-7000
Pro Hac Vice
Email: SMINDER@PERKINSCOIE.COM

Ancora Technologies, Inc A Delaware Corporation
Counter Defendant

John S Leroy
[COR LD NTC]
Brooks Kushman PC
1000 Town Center 22ND Floor
Southfield , MI 48075
USA
248-358-4400
Fax: 248-358-3351
Pro Hac Vice
Email: JLEROY@BROOKSKUSHMAN.COM

Marc Lorelli
[COR LD NTC]
Brooks Kushman
1000 Town Center, 22ND Floor
Southfield , MI 48075
USA
248-358-4400
Email: MLORELLI@BROOKSKUSHMAN.COM

Mark A Cantor
[COR LD NTC]
Brooks & Kushman
1000 Town Center, 22ND FL
Southfield , MI 48075
USA
248-358-4400
Email: McAntor@brookskushman.com

Mark B Mizrahi
[COR LD NTC]
Brooks Kushman PC
6701 Center Drive West Suite 610
Los Angeles , CA 90045
USA
310-348-8200
Fax: 310-846-4799
Email: MMIZRAHI@BROOKSKUSHMAN.COM

Hewlett-Packard Company
Counter Claimant

Darryl M Woo
[COR LD NTC]
[Term: 12/02/2008]
Fenwick and West LLP
555 California Street 12TH Floor
San Francisco , CA 94111
USA
415-875-2300
Email: DWOOFENWICK.COM

Lauren C Sliger
[COR LD NTC]
Perkins Coie
1620 26TH Street 6TH FL
Santa Monica , CA 90404
USA
310-788-9900
Fax: 310-788-3399
Email: LSLIGER@PERKINSCOIE.COM

David M Lacy Kusters
[COR LD NTC]
[Term: 12/02/2008]
Fenwick and West LLP
555 California Street 12TH Floor
San Francisco , CA 94104
USA
415-875-2300
Fax: 415-281-1350
Email: DLACYKUSTERS@FENWICK.COM

Heather N Mewes
[COR LD NTC]
[Term: 12/02/2008]
Fenwick & West LLP
555 California Street
San Francisco , CA 94041
USA
415-975-2300
Fax: 415-281-1350
Email: HMEWES@FENWICK.COM

Ancora Technologies Inc
Counter Defendant

John S Leroy
[COR LD NTC]
Brooks Kushman PC

1000 Town Center 22ND Floor
Southfield , MI 48075
USA
248-358-4400
Fax: 248-358-3351
Pro Hac Vice
Email: JLEROY@BROOKSKUSHMAN.COM

Marc Lorelli
[COR LD NTC]
Brooks Kushman
1000 Town Center, 22ND Floor
Southfield , MI 48075
USA
248-358-4400
Email: MLORELLI@BROOKSKUSHMAN.COM

Mark A Cantor
[COR LD NTC]
Brooks & Kushman
1000 Town Center, 22ND FL
Southfield , MI 48075
USA
248-358-4400
Email: McAntor@brookskushman.com

Mark B Mizrahi
[COR LD NTC]
Brooks Kushman PC
6701 Center Drive West Suite 610
Los Angeles , CA 90045
USA
310-348-8200
Fax: 310-846-4799
Email: MMIZRAHI@BROOKSKUSHMAN.COM

Dell Inc
Counter Claimant

Brandon C Fernald
[COR LD NTC]
[Term: 01/30/2009]
Fulbright and Jaworski LLP
555 South Flower Street 41ST Floor
Los Angeles , CA 90071
USA
213-892-9200
Email: BFERNALD@FULBRIGHT.COM

Chad S Campbell
[COR LD NTC]
Perkins Coie Brown & Bain PA
2901 North Central Avenue Suite 2000
Phoenix , AZ 85012-2788
USA
602-351-8393
Fax: 602-648-7193
Email: CSCAMPBELL@PERKINSCOIE.COM

Christopher R Benson
[COR LD NTC]
[Term: 01/30/2009]
Fulbright and Jaworski LLP
600 Congress Avenue Suite 2400
Austin , TX 78701
USA
512-474-5201
Fax: 512-536-4598
Pro Hac Vice

Email: CBENSON@FULBRIGHT.COM

David Matthew Laspaluto
[COR LD NTC]
Perkins Coie Brown and Bain
2901 North Central Avenue Suite 2000
Phoenix , AZ 85012
USA
602-351-8175
Fax: 602-648-7017
Email: DLASPALUTO@PERKINSCOIE.COM

Lauren C Sliger
[COR LD NTC]
Perkins Coie
1620 26TH Street 6TH FL
Santa Monica , CA 90404
USA
310-788-9900
Fax: 310-788-3399
Email: LSLIGER@PERKINSCOIE.COM

Michael C Barrett
[COR LD NTC]
[Term: 01/30/2009]
Fulbright and Jaworski LLP
600 Congress Avenue Suite 2400
Austin , TX 78701
USA
512-474-5201
Email: MBARRETT@FULBRIGHT.COM

Scott S Minder
[COR LD NTC]
Perkins Coie Brown and Bain PA
2901 North Central Avenue Suite 2000
Phoenix , AZ 85012-2788
USA
602-351-8000
Fax: 602-648-7000
Pro Hac Vice
Email: SMINDER@PERKINSCOIE.COM

Ancora Technologies Inc
Counter Defendant

John S Leroy
[COR LD NTC]
Brooks Kushman PC
1000 Town Center 22ND Floor
Southfield , MI 48075
USA
248-358-4400
Fax: 248-358-3351
Pro Hac Vice
Email: JLERROY@BROOKSKUSHMAN.COM

Marc Lorelli
[COR LD NTC]
Brooks Kushman
1000 Town Center, 22ND Floor
Southfield , MI 48075
USA
248-358-4400
Email: MLORELLI@BROOKSKUSHMAN.COM

Mark A Cantor
[COR LD NTC]
Brooks & Kushman

1000 Town Center, 22ND FL
 Southfield , MI 48075
 USA
 248-358-4400
 Email: McAntor@brookskushman.com

Mark B Mizrahi
 [COR LD NTC]
 Brooks Kushman PC
 6701 Center Drive West Suite 610
 Los Angeles , CA 90045
 USA
 310-348-8200
 Fax: 310-846-4799
 Email: MMIZRAHI@BROOKSKUSHMAN.COM

Date	#	Proceeding Text
06/06/2008	1	COMPLAINT against defendants Toshiba America Information Systems Inc, Dell Inc, Hewlett-Packard Company.(Filing fee \$ 350 paid) Jury Demand., filed by plaintiff Ancora Technologies Inc.(twdb) (nca). (Entered: 06/09/2008)
06/06/2008	--	20 DAY Summons Issued re Complaint - (Discovery) 1 as to defendants Toshiba America Information Systems Inc, Dell Inc, Hewlett-Packard Company. (twdb) (Entered: 06/09/2008)
06/06/2008	2	CERTIFICATION AND NOTICE of Interested Parties filed by plaintiff Ancora Technologies Inc, (twdb) (nca). (Entered: 06/09/2008)
06/06/2008	3	REPORT ON THE FILING OF AN ACTION Regarding a Patent or a Trademark (Initial Notification) filed by Ancora Technologies Inc. (twdb) (nca). (Entered: 06/09/2008)
07/07/2008	4	FIRST STIPULATION Extending Time to Answer the complaint as to Toshiba America Information Systems Inc answer now due 8/13/2008, filed by Defendant Toshiba America Information Systems Inc.(Gurka, Jon) (Entered: 07/07/2008)
07/07/2008	5	CORPORATE DISCLOSURE STATEMENT filed by Defendant Toshiba America Information Systems Inc identifying Toshiba Corporation as Corporate Parent. (Gurka, Jon) (Entered: 07/07/2008)
07/08/2008	6	CERTIFICATION AND NOTICE of Interested Parties filed by Defendant Hewlett-Packard Company, identifying None. (Woo, Darryl) (Entered: 07/08/2008)
07/08/2008	7	FIRST STIPULATION Extending Time to Answer the complaint as to Hewlett-Packard Company answer now due 8/7/2008, filed by Defendant Hewlett-Packard Company.(Mewes, Heather) (Entered: 07/08/2008)
07/16/2008	8	APPLICATION OF NON-RESIDENT ATTORNEY Christopher R. Benson for Leave to Appear Pro Hac Vice. FEE PAID. filed by defendant Dell Inc. (db) (Entered: 07/17/2008)
07/16/2008	9	APPLICATION OF NON-RESIDENT ATTORNEY Michael C Barrett for Leave to Appear Pro Hac Vice. FEE PAID, filed by Defendant Dell Inc. Lodged none. (In) (Entered: 07/17/2008)
07/16/2008	10	PROOF OF SERVICE filed by Defendant Dell Inc re APPLICATION OF NON-RESIDENT ATTORNEY Michael C Barrett for Leave to Appear Pro Hac Vice 9 , APPLICATION OF NON-RESIDENT ATTORNEY Christopher R. Benson for Leave to Appear Pro Hac Vice 8 served on 07/16/08. (In) (Entered: 07/17/2008)
07/21/2008	12	ORDER by Judge Andrew J. Guilford Granting Michael C. Barrett to appear on behalf of Defendant Dell Inc. Brandon C. Fernald is designated as local counsel. Fee PAID. (ade) (Entered: 07/23/2008)
07/21/2008	13	ORDER by Judge Andrew J. Guilford Granting Christopher R. Benson to appear on behalf of Defendant Dell Inc. Brandon C. Fernald is designated as local counsel. Fee PAID. (ade) (Entered: 07/23/2008)
07/22/2008	11	FIRST STIPULATION Extending Time to Answer the complaint as to Dell Inc answer now due 8/13/2008, filed by plaintiff Ancora Technologies Inc.(Mizrahi, Mark) (Entered: 07/22/2008)
07/28/2008	14	APPLICATION OF NON-RESIDENT ATTORNEY Mark A. Cantor for Leave to Appear Pro Hac Vice. FEE NOT PAID. filed by Plaintiff Ancora Technologies Inc. (Attachments: # 1 Proposed Order) (Mizrahi, Mark) (Entered: 07/28/2008)
07/28/2008	15	APPLICATION OF NON-RESIDENT ATTORNEY Marc Lorelli for Leave to Appear Pro Hac Vice. FEE NOT PAID. filed by Plaintiff Ancora Technologies Inc. (Attachments: # 1 Proposed Order)

- (Mizrahi, Mark) (Entered: 07/28/2008)
- 08/01/2008 16 ORDER by Judge Andrew J. Guilford Granting APPLICATION OF NON-RESIDENT ATTORNEY Mark A. Cantor for Leave to Appear Pro Hac Vice. FEE PAID 14 by Mark A. Cantor to appear on behalf of Plaintiff Ancora Technologies Inc. Mark B. Mizrahi is designated as local counsel. (db) (Entered: 08/01/2008)
- 08/01/2008 17 ORDER by Judge Andrew J. Guilford Granting APPLICATION OF NON-RESIDENT ATTORNEY Marc Lorelli for Leave to Appear Pro Hac Vice. 15 Marc Lorelli to appear on behalf of Plaintiff Ancora Technologies Inc. Mark B. Mizrahi is designated as local counsel. Fee Paid. (nbo) (Entered: 08/04/2008)
- 08/05/2008 18 Second STIPULATION for Extension of Time to File Answer to August 13, 2008 re Complaint - (Discovery) 1 filed by Defendant Hewlett-Packard Company. (Attachments: # 1 Proposed Order Granting Second Joint Stipulation to Extend Time to Respond to Complaint)(Mewes, Heather) (Entered: 08/05/2008)
- 08/07/2008 19 ORDER by Judge Andrew J. Guilford granting Second Joint Stipulation to Extend Time 18 . Defendant Hewlett-Packard Company shall answer or otherwise respond to Plaintiffs Complaint for Patent Infringement on or before 08/13/08. (db) (Entered: 08/08/2008)
- 08/13/2008 20 ANSWER to Complaint - (Discovery) 1 with JURY DEMAND and COUNTERCLAIMS filed by Defendant Dell Inc.(Barrett, Michael) (Entered: 08/13/2008)
- 08/13/2008 21 Certificate and Notice of Interested Parties filed by Defendant Dell Inc, identifying None. (Barrett, Michael) (Entered: 08/13/2008)
- 08/13/2008 22 ANSWER to Complaint - (Discovery) 1 and Counterclaims filed by Defendant and Counterclaimant Hewlett-Packard Company.(Mewes, Heather) (Entered: 08/13/2008)
- 08/13/2008 23 ORDER RE EARLY MEETING OF PARTIES AND SCHEDULING CONFERENCE by Judge Andrew J. Guilford. Scheduling Conference set for 10/27/08 at 9:00 a.m. (See document for further details) (db) (Entered: 08/14/2008)
- 08/13/2008 26 ANSWER to Complaint - (Discovery) 1 , COUNTERCLAIM against Ancora Technologies Inc filed by Defendant and Counterclaimant Toshiba America Information Systems Inc.(db) (Entered: 08/15/2008)
- 08/14/2008 24 NOTICE TO FILER OF DEFICIENCIES in Electronically Filed Documents. The following error(s) was found: Civil Case Initiating Documents. Complaints (such as third-party complaints, amended complaints, complaints in intervention, counterclaims and cross-claims) and other civil case initiating documents shall be filed in the traditional manner rather than electronically pursuant to General Order 08-02 RE: Answer to Complaint (Discovery) 20 , Answer to Complaint (Discovery) 22 . In response to this notice the court may order (1) an amended or correct document to be filed (2) the document stricken or (3) take other action as the court deems appropriate. (rrp) (Entered: 08/14/2008)
- 08/15/2008 25 NOTICE of Manual Filing filed by Defendant Dell Inc of Defendant Dell Inc.'s Answer and Counterclaims To Plaintiff's Complaint for Patent Infringement. (Fernald, Brandon) (Entered: 08/15/2008)
- 08/15/2008 27 NOTICE of Change of Attorney Information for attorney Andrew J Hall counsel for Defendant Toshiba America Information Systems Inc. Adding Andrew J. Hall as attorney as counsel of record for Toshiba America Information Systems, Inc. for the reason indicated in the G-06 Notice. Filed by defendant Toshiba America Information Systems, Inc. (Hall, Andrew) (Entered: 08/15/2008)
- 08/15/2008 28 NOTICE of Change of Attorney Information for attorney Irfan A Lateef counsel for Defendant Toshiba America Information Systems Inc. Adding Irfan A. Lateef as attorney as counsel of record for Toshiba America Information Systems, Inc. for the reason indicated in the G-06 Notice. Filed by defendant Toshiba America Information Systems, Inc. (Lateef, Irfan) (Entered: 08/15/2008)
- 08/15/2008 29 NOTICE of Change of Attorney Information for attorney Stephen C Jensen counsel for Defendant Toshiba America Information Systems Inc. Adding Stephen C. Jensen as attorney as counsel of record for Toshiba America Information Systems, Inc. for the reason indicated in the G-06 Notice. Filed by defendant Toshiba America Information Systems, Inc. (Jensen, Stephen) (Entered: 08/15/2008)
- 08/15/2008 30 ANSWER AND COUNTERCLAIMS against Ancora Technologies Inc filed by Defendant Hewlett-Packard Company.(smi) (Entered: 08/18/2008)
- 08/15/2008 31 ANSWER to Complaint - (Discovery) 1 , COUNTERCLAIM against Ancora Technologies Inc filed by defendant/counter complainant Dell Inc.(db) (Entered: 08/18/2008)
- 08/18/2008 32 NOTICE OF DISCREPANCY AND Order by Judge Andrew J. Guilford, ORDERING Answer and

- Counterclaims submitted by Defendant Hewlett-Packard Company received on 08/14/08 is not to be filed but instead rejected. Denial based on: Answer filed 08/15/08. (db) (Entered: 08/19/2008)
- 09/02/2008 33 NOTICE of Change of Attorney Information for attorney Mark B Mizrahi counsel for Plaintiff Ancora Technologies Inc. Changing firm name to Brooks Kushman P.C.. Changing email to mmizrahi@brookskushman.com. Filed by plaintiff Ancora Technologies, inc. (Mizrahi, Mark) (Entered: 09/02/2008)
- 09/02/2008 34 NOTICE TO FILER OF DEFICIENCIES in Electronically Filed Documents. The following error(s) was found: account information (new phone and fax numbers) were not updated in the ECF system RE: Notice of Change of Attorney Information (G-06), Notice of Change of Attorney Information (G-06) 33 . In response to this notice the court may order (1) an amended or correct document to be filed (2) the document stricken or (3) take other action as the court deems appropriate. (vh) (Entered: 09/02/2008)
- 09/02/2008 35 ANSWER to Dell, Inc.'s Counterclaim filed by plaintiff-counterdefendant Ancora Technologies Inc.(Mizrahi, Mark) (Entered: 09/02/2008)
- 09/02/2008 36 ANSWER to Hewlett-Packard Company's Counterclaim filed by plaintiff-counterdefendant Ancora Technologies Inc.(Mizrahi, Mark) (Entered: 09/02/2008)
- 09/02/2008 37 ANSWER to Toshiba America Information Systems, Inc.'s Counterclaims filed by plaintiff-counterdefendant Ancora Technologies Inc.(Mizrahi, Mark) (Entered: 09/02/2008)
- 09/08/2008 38 APPLICATION for attorney John S. LeRoy to Appear Pro Hac Vice (PHV Fee of \$185 receipt number 0973000000004231353 paid.) filed by plaintiff Ancora Technologies Inc. (Attachments: # 1 Proposed Order)(Mizrahi, Mark) (Entered: 09/08/2008)
- 09/08/2008 39 NOTICE OF UNOPPOSED MOTION to Intervene filed by Movant Microsoft Corporation. Motion set for hearing on 9/29/2008 at 10:00 AM before Judge Andrew J. Guilford. (db) Modified on 9/11/2008 (rla). Lodged Order. (Entered: 09/09/2008)
- 09/08/2008 40 MEMORANDUM in Support of unopposed MOTION to Intervene 39 filed by Movant Microsoft Corporation. (db) Modified on 10/1/2008 (db). (Entered: 09/09/2008)
- 09/08/2008 41 STIPULATION regarding Motion to Intervene by filed by Movant Microsoft Corporation.(db) (Entered: 09/09/2008)
- 09/08/2008 44 Certification and Notice of Interested Parties filed by Movant Microsoft Corporation. (db) (Entered: 09/10/2008)
- 09/09/2008 42 APPLICATION for attorney Scott S. Minder to Appear Pro Hac Vice (PHV Fee of \$185 receipt number 0973000000004239439 paid.) filed by Intervenor Microsoft Corporation. (Attachments: # 1 Proposed Order Application of Non-Resident Attorney to Appear in a Specific Case)(Sliger, Lauren) (Entered: 09/09/2008)
- 09/09/2008 43 APPLICATION for attorney Chad S. Campbell to Appear Pro Hac Vice (PHV Fee of \$185 receipt number 0973000000004239675 paid.) filed by Intervenor Microsoft Corporation. (Attachments: # 1 Proposed Order Application of Non-Resident Attorney to Appear in a Specific Case)(Sliger, Lauren) (Entered: 09/09/2008)
- 09/09/2008 45 ORDER by Judge Andrew J. Guilford Granting John S. LeRoy to appear on behalf of Plaintiff Ancora Technologies Inc. Mark B. Mizrahi is designated as local counsel. (ade) (Entered: 09/11/2008)
- 09/11/2008 46 ORDER by Judge Andrew J. Guilford Granting APPLICATION for attorney Chad S. Campbell to Appear Pro Hac Vice on behalf of Microsoft Corporation (PHV Fee of \$185 receipt number 0973000000004239675 paid 43 . Lauren Sliger is designated as local counsel. (db) (Entered: 09/12/2008)
- 09/11/2008 47 ORDER by Judge Andrew J. Guilford Granting APPLICATION for attorney Scott S. Minder to Appear Pro Hac Vice on behalf of Microsoft 42 . Lauren Sliger is designated as local counsel. Fee PAID. (db) (Entered: 09/12/2008)
- 09/15/2008 48 ORDER RETURNING CASE FOR REASSIGNMENT UPON RECUSAL by Magistrate Judge Arthur Nakazato. ORDER case returned to the Clerk for random reassignment Discovery pursuant to General Order 05-07 and General Order 07-02. Case randomly reassigned from Magistrate Judge Arthur Nakazato to Magistrate Judge Marc L. Goldman for all further proceedings. The case number will now reflect the initials of the transferee Judge SACV 08-626 AG (MLGx). (jal) (Entered: 09/15/2008)
- 09/22/2008 49 MINUTES OF IN CHAMBERS ORDER by Judge Andrew J. Guilford: GRANTING MICROSOFT CORPORATIONS Motion to Intervene 39 : Accordingly, the Court VACATES the hearing on this matter scheduled for September 29, 2008. After considering Applicant's arguments, the Court GRANTS the Motion. (See document for further details.) (rla) (Entered: 09/22/2008)

- 10/01/2008 50 NOTICE OF CLERICAL ERROR: During initial docketing of Memornadum 40 , incorrect filed date was entered on docket. Docket will be corrected to reflect correct filed date of 09/08/08. (db) (Entered: 10/01/2008)
- 10/02/2008 51 NOTICE of Appearance filed by attorney David M Lacy Kusters on behalf of Counter Claimant Hewlett-Packard Company, Defendant Hewlett-Packard Company (Kusters, David) (Entered: 10/02/2008)
- 10/03/2008 52 MICROSOFT CORPORATION'S COMPLAINT IN INTERVENTION FOR DECLARATORY JUDGMENT AGAINST ANCORA TECHNOLOGIES, INC. Jury trial demanded. (smi) (Additional attachment(s) added on 10/6/2008: # 1 Summons) (smi). (Entered: 10/06/2008)
- 10/03/2008 -- 20 DAY Summons Issued re Intervenor Complaint 52 as to Plaintiff Ancora Technologies Inc. (smi) (Entered: 10/06/2008)
- 10/08/2008 53 PROOF OF SERVICE filed by Intervenor Microsoft Corporation, re Intervenor Complaint 52 , Summons Issued served on 10/06/2008. (Sliger, Lauren) (Entered: 10/08/2008)
- 10/20/2008 54 JOINT REPORT Rule 26(f) Discovery Plan ; estimated length of trial between 5 and 10 days, filed by Intervenor Microsoft Corporation.. (Sliger, Lauren) (Entered: 10/20/2008)
- 10/27/2008 55 ANSWER to Intervenor Complaint 52 filed by counterdefendant Ancora Technologies, Inc., Ancora Technologies Inc.(LeRoy, John) (Entered: 10/27/2008)
- 10/27/2008 58 SCHEDULING ORDER by Judge Andrew J. Guilford, Set/Reset Deadlines/Hearings:(Discovery cut-off 5/30/2009. Final Pretrial Conference set for 1/11/2010 08:30 AM before Judge Andrew J. Guilford. Jury Trial set for 1/26/2010 09:00 AM before Judge Andrew J. Guilford.) (ade) (Entered: 11/06/2008)
- 10/27/2008 59 MINUTES OF Scheduling Conference held before Judge Andrew J. Guilford, Set/Reset Deadlines/Hearings:(Discovery cut-off 5/30/2009. Motions due by 9/4/2009. Final Pretrial Conference set for 1/11/2010 08:30 AM before Judge Andrew J. Guilford. Jury Trial set for 1/26/2010 09:00 AM before Judge Andrew J. Guilford. Markman Hearing set on 2/24/2009 at 09:00 AM before Judge Andrew J. Guilford.)Court Reporter: Bernadette Balajadia. (ade) (Entered: 11/06/2008)
- 11/03/2008 56 STIPULATION to Continue Initial Rule 26(a) Disclosures from 11/03/08 to 11/10/08 filed by Intervenor Microsoft Corporation. (Attachments: # 1 Proposed Order Continuing Initial Rule 26 (a) Disclosures by One Week)(Campbell, Chad) (Entered: 11/03/2008)
- 11/04/2008 57 ORDER by Judge Andrew J. Guilford, APPROVING Stipulation to Continue Initial Rule 26(a) Disclosure by One Week 56 : (Rule 26 Meeting Report due by 11/10/2008.) (rla) (Entered: 11/05/2008)
- 11/11/2008 60 NOTICE of Change of Attorney Information for attorney Lauren C Sliger counsel for Counter Claimant Hewlett-Packard Company, Defendant Hewlett-Packard Company. Adding Chad S. Campbell as attorney as counsel of record for Hewlett-Packard Company for the reason indicated in the G-06 Notice. Filed by Defendant/Counterclaimant Hewlett-Packard Company (Sliger, Lauren) (Entered: 11/11/2008)
- 11/11/2008 61 NOTICE of Change of Attorney Information for attorney Lauren C Sliger counsel for Counter Claimant Hewlett-Packard Company, Defendant Hewlett-Packard Company. Adding David S. LaSpaluto as attorney as counsel of record for Hewlett-Packard Company for the reason indicated in the G-06 Notice. Filed by Defendant/Counterclaimant Hewlett-Packard Company (Sliger, Lauren) (Entered: 11/11/2008)
- 11/11/2008 62 NOTICE of Change of Attorney Information for attorney Lauren C Sliger counsel for Counter Claimant Hewlett-Packard Company, Defendant Hewlett-Packard Company. Adding Scott S. Minder as attorney as counsel of record for Hewlett-Packard Company for the reason indicated in the G-06 Notice. Filed by Defendant/Counterclaimant Hewlett-Packard Company (Sliger, Lauren) (Entered: 11/11/2008)
- 11/11/2008 63 NOTICE of Change of Attorney Information for attorney Lauren C Sliger counsel for Counter Claimant Hewlett-Packard Company, Defendant Hewlett-Packard Company. Adding Lauren Sliger as attorney as counsel of record for Hewlett-Packard Company for the reason indicated in the G-06 Notice. Filed by Defendant/Counterclaimant Hewlett-Packard Company (Sliger, Lauren) (Entered: 11/11/2008)
- 11/19/2008 64 MICROSOFT CORPORATION'S ANSWER TO ANCORA TECHNOLOGIES, INC.'S, COUNTERCLAIMS ANSWER filed by Intervenor Microsoft Corporation.(Campbell, Chad) (Entered: 11/19/2008)
- 11/26/2008 65 NOTICE OF MOTION AND MOTION of Fenwick & West, LLP, Darryl Woo, Heather Mewes, David Lacy Kusters to Withdraw as Attorney of Record for Hewlett-Packard Company filed by Defendant/Counter-Claimant Hewlett-Packard Company. (Attachments: # 1 Exhibit Signature Page, # 2 Proposed Order Granting Motion to Withdraw as Counsel of Record for Hewlett-

- Packard Company)(Mewes, Heather) (Entered: 11/26/2008)
- 12/02/2008 66 ORDER by Judge Andrew J. Guilford GRANTING MOTION of Fenwick & West, LLP, Darryl Woo, Heather Mewes, David Lacy Kusters to Withdraw as Attorney of Record for Hewlett-Packard Company 65 . (nbo) (Entered: 12/03/2008)
- 12/10/2008 67 STIPULATION to Reschedule Dates Associated with Markman Hearing and Pleading Amendments filed by Intervenor Microsoft Corporation. (Attachments: # 1 Proposed Order Granting Stipulation to Modify Dates)(Campbell, Chad) (Entered: 12/10/2008)
- 12/10/2008 68 STIPULATION for Protective Order filed by Intervenor Microsoft Corporation. (Attachments: # 1 Proposed Order Interim Protective Order)(Campbell, Chad) (Entered: 12/10/2008)
- 12/16/2008 69 ORDER GRANTING STIPULATION TO MODIFY DATES ASSOCIATED WITH MARKMAN HEARING AND PLEADING AMENDMENTS by Judge Andrew J. Guilford 67 . Opening Markman Briefs due 01/26/09, Rebuttal Markman Briefs due 02/13/09, Markman Hearing 03/03/09 at 9:00 a.m. (See Order for further details) (db) (Entered: 12/17/2008)
- 12/16/2008 70 PROTECTIVE ORDER by Magistrate Judge Marc L. Goldman (ade) (Entered: 12/17/2008)
- 12/23/2008 71 NOTICE of Change of Attorney Information for attorney Lauren C Sliger counsel for Counter Claimants Toshiba America Information Systems, Inc., Dell Inc, Defendants Toshiba America Information Systems Inc, Dell Inc. Adding Lauren Sliger as attorney as counsel of record for Toshiba America Information Systems, Inc. and Dell, Inc. for the reason indicated in the G-06 Notice. Filed by Defendants Toshiba America Information, Systems, Inc. and Dell, Inc. (Sliger, Lauren) (Entered: 12/23/2008)
- 12/23/2008 72 NOTICE of Change of Attorney Information for attorney Lauren C Sliger counsel for Counter Claimants Toshiba America Information Systems, Inc., Dell Inc, Defendants Toshiba America Information Systems Inc, Dell Inc. Adding Chad S. Campbell as attorney as counsel of record for Toshiba America Information Systems, Inc. and Dell, Inc. for the reason indicated in the G-06 Notice. Filed by Defendants Toshiba America Information, Systems, Inc. and Dell, Inc. (Sliger, Lauren) (Entered: 12/23/2008)
- 12/23/2008 73 NOTICE of Change of Attorney Information for attorney Lauren C Sliger counsel for Counter Claimants Toshiba America Information Systems, Inc., Dell Inc, Defendants Toshiba America Information Systems Inc, Dell Inc. Adding David S. LaSpaluto as attorney as counsel of record for Toshiba America Information, Systems, Inc. and Dell, Inc. for the reason indicated in the G-06 Notice. Filed by Defendants Toshiba America Information, Systems, Inc. and Dell, Inc. (Sliger, Lauren) (Entered: 12/23/2008)
- 12/23/2008 74 NOTICE of Change of Attorney Information for attorney Lauren C Sliger counsel for Counter Claimants Toshiba America Information Systems, Inc., Dell Inc, Defendants Toshiba America Information Systems Inc, Dell Inc. Adding Scott S. Minder as attorney as counsel of record for Toshiba America Information, Systems, Inc. and Dell, Inc. for the reason indicated in the G-06 Notice. Filed by Defendants Toshiba America Information, Systems, Inc. and Dell, Inc. (Sliger, Lauren) (Entered: 12/23/2008)
- 12/23/2008 75 NOTICE of Taking Deposition of Miki Mullor on January 8 and 9, 2009 filed by Intervenor Microsoft Corporation. Subpoena Issued. (Campbell, Chad) (Entered: 12/23/2008)
- 01/05/2009 76 NOTICE of Manual Filing filed by Counter Claimants Toshiba America Information Systems, Inc., Hewlett-Packard Company, Dell Inc, Intervenor Microsoft Corporation, Defendants Toshiba America Information Systems Inc, Dell Inc, Hewlett-Packard Company of Documents to be filed Under Seal. (Sliger, Lauren) (Entered: 01/05/2009)
- 01/05/2009 77 NOTICE Notice of Motion re: Joint Stipulation Pursuant to L.R. 37-2 for Entry of Final Protective Order filed by Defendants and Intervenor Hewlett-Packard Company, Dell Inc, Microsoft Corporation, Toshiba America Information Systems Inc. (Attachments: # 1 Proposed Order re Entry of Final Protective Order)(Sliger, Lauren) (Entered: 01/05/2009)
- 01/05/2009 78 DECLARATION re Notice (Other), Notice (Other) 77 of Motion re: Joint Stipulation Pursuant to L.R. 87-2 for Entry of Final Protective Order filed by Counter Claimants Toshiba America Information Systems, Inc., Hewlett-Packard Company, Dell Inc, Intervenor Microsoft Corporation, Defendants Toshiba America Information Systems Inc, Dell Inc, Hewlett-Packard Company. (Sliger, Lauren) (Entered: 01/05/2009)
- 01/05/2009 79 DECLARATION of David M. LaSpaluto re Notice (Other), Notice (Other) 77 filed by Counter Claimants Toshiba America Information Systems, Inc., Hewlett-Packard Company, Dell Inc, Intervenor Microsoft Corporation, Defendants Toshiba America Information Systems Inc, Dell Inc, Hewlett-Packard Company. (Attachments: # 1 Exhibit 1 to Decl. of Counsel for Microsoft and Hewlett-Packard Company in Support of Joint Stipulation Under Rule 37-2 re Motion for Entry of A Final Protective Order, # 2 Exhibit 2-5 to Decl. of Counsel for Microsoft and Hewlett-Packard Company in Support of Joint Stipulation Under Rule 37-2 re Motion for Entry of A Final

- Protective Order, # 3 Exhibit 6-14 to Decl. of Counsel for Microsoft and Hewlett-Packard Company in Support of Joint Stipulation Under Rule 37-2 re Motion for Entry of A Final Protective Order, # 4 Exhibit 15-22 to Decl. of Counsel for Microsoft and Hewlett-Packard Company in Support of Joint Stipulation Under Rule 37-2 re Motion for Entry of A Final Protective Order, # 5 Exhibit 23-24 to Decl. of Counsel for Microsoft and Hewlett-Packard Company in Support of Joint Stipulation Under Rule 37-2 re Motion for Entry of A Final Protective Order, # 6 Exhibit 25-26 to Decl. of Counsel for Microsoft and Hewlett-Packard Company in Support of Joint Stipulation Under Rule 37-2 re Motion for Entry of A Final Protective Order, # 7 Exhibit 27 to Decl. of Counsel for Microsoft and Hewlett-Packard Company in Support of Joint Stipulation Under Rule 37-2 re Motion for Entry of A Final Protective Order, # 8 Exhibit 28-30 to Decl. of Counsel for Microsoft and Hewlett-Packard Company in Support of Joint Stipulation Under Rule 37-2 re Motion for Entry of A Final Protective Order, # 9 Exhibit 31 to Decl. of Counsel for Microsoft and Hewlett-Packard Company in Support of Joint Stipulation Under Rule 37-2 re Motion for Entry of A Final Protective Order, # 10 Exhibit 32 to Decl. of Counsel for Microsoft and Hewlett-Packard Company in Support of Joint Stipulation Under Rule 37-2 re Motion for Entry of A Final Protective Order, # 11 Exhibit 33 to Decl. of Counsel for Microsoft and Hewlett-Packard Company in Support of Joint Stipulation Under Rule 37-2 re Motion for Entry of A Final Protective Order, # 12 Exhibit 34 to Decl. of Counsel for Microsoft and Hewlett-Packard Company in Support of Joint Stipulation Under Rule 37-2 re Motion for Entry of A Final Protective Order)(Sliger, Lauren) (Entered: 01/05/2009)
- 01/05/2009 82 APPLICATION to File Under Seal 1) Joint Stipulation Under Rule 37-2 re Motion for Entry of Final Protective Order; 2) Declaration of Scott Field; and 3) Declaration of Counsel. Filed by Intervenor Microsoft Corporation. (ade) (Entered: 01/08/2009)
- 01/05/2009 83 ORDER by Judge Andrew J. Guilford, GRANTING APPLICATION to Seal 82 1) Joint Stipulation Under Rule 37-2 re Motion for Entry of Final Protective Order 2) Declaration of Scott Field; 3) Declaration of Counsel (ade) (Entered: 01/08/2009)
- 01/05/2009 84 SEALED DOCUMENT RE: Joint STIPULATION for Motion for Protective Order (ade) (Entered: 01/12/2009)
- 01/05/2009 85 SEALED DOCUMENT RE: DECLARATION of Scott Field in Support of Joint Stipulation(ade) (Entered: 01/12/2009)
- 01/05/2009 86 SEALED DOCUMENT RE: DECLARATION of Counsel In support of Joint Stipulation (Attachments: # 1 1, # 2 2, # 3 3, # 4 4, # 5 5)(ade) (Entered: 01/12/2009)
- 01/06/2009 80 NOTICE OF MOTION AND MOTION of Stephen Jensen, Jon Gurka, Irfan Lateef to Withdraw as Attorney of Record for Toshiba America Information Systems, Inc. filed by Defendant Toshiba America Information Systems Inc. Motion set for hearing on 1/12/2009 at 10:00 AM before Judge Andrew J. Guilford. (Attachments: # 1 Proposed Order [Proposed] Order Granting Motion to Withdraw as Counsel of Record for Toshiba America Systems, Inc.)(Lateef, Irfan) (Entered: 01/06/2009)
- 01/07/2009 81 MINUTES OF IN CHAMBERS ORDER by Judge Andrew J. Guilford: CONTINUING HEARING ON DEFENDANT'S MOTION TO WITHDRAW 80 : The Court CONTINUES the hearing from January 12, 2009 to February 2, 2009 at 10:00 a.m. (rla) (Entered: 01/07/2009)
- 01/15/2009 87 JOINT STIPULATION to APPLICATION to Seal 82 Reschedule February 3, 2009 Hearing and Shorten Time Under LR37-3 filed by Intervenor Microsoft Corporation. (Attachments: # 1 Proposed Order Rescheduling February 3, 2009 Hearing and Shortening Time Under LR37-3) (Campbell, Chad) (Entered: 01/15/2009)
- 01/16/2009 88 ORDER Rescheduling 2/3/09 hearing and shortening time under L.R.37-3 by Magistrate Judge Marc L. Goldman 87 . See Order for further deadlines.(Motion set for hearing on 2/10/2009 at 10:00 AM before Magistrate Judge Marc L. Goldman.) (twdb) (Entered: 01/20/2009)
- 01/21/2009 89 NOTICE OF MOTION AND MOTION to Compel Microsoft Corporation to Produce Documents and to Provide Further Responses to Plaintiff's First Set Of Interrogatories; Request for Monetary Sanctions filed by plaintiff Ancora Technologies Inc. Motion set for hearing on 2/10/2009 at 10:00 AM before Judge Andrew J. Guilford. (Attachments: # 1 Proposed Order)(Mizrahi, Mark) (Entered: 01/21/2009)
- 01/21/2009 90 JOINT STIPULATION to MOTION to Compel Microsoft Corporation to Produce Documents and to Provide Further Responses to Plaintiff's First Set Of Interrogatories; Request for Monetary Sanctions 89 filed by Plaintiff Ancora Technologies Inc. (Mizrahi, Mark) (Entered: 01/21/2009)
- 01/21/2009 91 DECLARATION of Mark Mizrahi In Support Of MOTION to Compel Microsoft Corporation to Produce Documents and to Provide Further Responses to Plaintiff's First Set Of Interrogatories; Request for Monetary Sanctions 89 filed by Plaintiff Ancora Technologies Inc. (Attachments: # 1 Exhibit 1-12/22/08 letter, # 2 Exhibit 2-Court's Minute Order re Scheduling Conference and Order Granting Stipulation to Modify Dates Associated with Markman Hearing and Pleading

- Amendments, # 3 Exhibit 3-12/5/08 letter, # 4 Exhibit 4-Microsoft's Complaint in Intervention for Declaratory Judgment Against Ancora, # 5 Exhibit 5-12/16/08 letter, # 6 Exhibit 6-Excerpts of E.D. Texas local patent rules, # 7 Exhibit 7-Microsoft's Responses to Plaintiff's First Request for Production of Documents)(Mizrahi, Mark) (Entered: 01/21/2009)
- 01/21/2009 92 DECLARATION of Scott Minder In Opposition To MOTION to Compel Microsoft Corporation to Produce Documents and to Provide Further Responses to Plaintiff's First Set Of Interrogatories; Request for Monetary Sanctions 89 filed by Plaintiff Ancora Technologies Inc. (Attachments: # 1 Supplement Exhibits to Minder Declaration (Ex 7-12))(Mizrahi, Mark) (Entered: 01/21/2009)
- 01/21/2009 93 NOTICE OF MOTION AND MOTION to Compel Defendants Hewlett-Packard Company, Dell, Inc., and Toshiba America Information Systems, Inc. to Produce Documents and To Provide Further Responses to Plaintiff's First Set of Interrogatories; Request for Monetary Sanctions filed by plaintiff Ancora Technologies Inc. Motion set for hearing on 2/10/2009 at 10:00 AM before Judge Andrew J. Guilford. (Attachments: # 1 Proposed Order)(Mizrahi, Mark) (Entered: 01/21/2009)
- 01/21/2009 94 JOINT STIPULATION to MOTION to Compel Defendants Hewlett-Packard Company, Dell, Inc., and Toshiba America Information Systems, Inc. to Produce Documents and To Provide Further Responses to Plaintiff's First Set of Interrogatories; Request for Monetary Sanctions 93 filed by Plaintiff Ancora Technologies Inc. (Mizrahi, Mark) (Entered: 01/21/2009)
- 01/21/2009 95 DECLARATION of Mark Mizrahi In Support Of MOTION to Compel Defendants Hewlett-Packard Company, Dell, Inc., and Toshiba America Information Systems, Inc. to Produce Documents and To Provide Further Responses to Plaintiff's First Set of Interrogatories; Request for Monetary Sanctions 93 filed by Plaintiff Ancora Technologies Inc. (Attachments: # 1 Exhibit 1- 12/16/08 letter, # 2 Exhibit 2- 1/7/09 letter, # 3 Exhibit 3- Minute Order re Scheduling Conference and Order Granting Stipulation to Modify Dates Associated with Markman Hearing and Pleading Amendments, # 4 Exhibit 4- 12/10/08 letter, # 5 Exhibit 5- 11/28/08 letter, # 6 Exhibit 6- 12/11/08 letter, # 7 Exhibit 7- HP's Answer and Counterclaims, # 8 Exhibit 8- Dell's Answer and Counterclaims, # 9 Exhibit 9- Toshiba's Answer and Counterclaims, # 10 Exhibit 10- HP's Responses to Plaintiffs First Request for Production of Documents, # 11 Exhibit 11- Dell's Responses to Ancora's First Request for Production of Documents, # 12 Exhibit 12- Toshiba's Responses to Plaintiff's First Request for Production of Documents, # 13 Exhibit 13- 1/12/09 letter, # 14 Exhibit 14- 1/12/09 letter)(Mizrahi, Mark) (Entered: 01/21/2009)
- 01/21/2009 96 DECLARATION of Scott Minder In Opposition To MOTION to Compel Defendants Hewlett-Packard Company, Dell, Inc., and Toshiba America Information Systems, Inc. to Produce Documents and To Provide Further Responses to Plaintiff's First Set of Interrogatories; Request for Monetary Sanctions 93 filed by Plaintiff Ancora Technologies Inc. (Mizrahi, Mark) (Entered: 01/21/2009)
- 01/23/2009 97 FIRST AMENDED ANSWER to Intervenor Complaint 52 AND COUNTERCLAIMS filed by plaintiff Ancora Technologies Inc. (Attachments: # 1 Exhibit A - State of Washington Cmplaint - Microsoft v Miki Mullor and Ancora Technologies)(Cantor, Mark) (Entered: 01/23/2009)
- 01/23/2009 98 NOTICE OF MOTION AND First MOTION for Leave to file Amended Answers by Microsoft, TAIS, HP and Dell filed by Intervenor Microsoft Corporation. Motion set for hearing on 2/23/2009 at 10:00 AM before Judge Andrew J. Guilford. (Attachments: # 1 Proposed Order Granting Motion for Leave to File Amended Answers)(Campbell, Chad) (Entered: 01/23/2009)
- 01/23/2009 99 MEMORANDUM in Support of First MOTION for Leave to file Amended Answers by Microsoft, TAIS, HP and Dell 98 filed by Intervenor Microsoft Corporation. (Attachments: # 1 Exhibit A-D) (Campbell, Chad) (Entered: 01/23/2009)
- 01/26/2009 100 NOTICE OF MOTION AND MOTION of Fulbright & Jaworski and its attorneys, Christopher R. Benson, Michael C. Barrett and Brandon C. Fernald to Withdraw as Attorney filed by Defendant Dell Inc. (Fernald, Brandon) (Entered: 01/26/2009)
- 01/26/2009 101 BRIEF filed by Plaintiff Ancora Technologies, Inc., Ancora Technologies Inc. [OPENING MARKMAN BRIEF] regarding Order, 69 . (Attachments: # 1 Exhibit 1 - USPN 6,411,941, # 2 Exhibit 2 - 2/20/02 Reasons for Allowance, # 3 Exhibit 3 - 2/20/03 e-mail to Microsoft, # 4 Exhibit 4 - 2/11/03 e-mail to Microsoft, # 5 Exhibit 5 - Mullor employment agrmt with Microsoft, # 6 Exhibit 6 - Publication No. US 2006/0288422, # 7 Exhibit 7 - Microsoft Complaint against Mullor, # 8 Exhibit 8 - Letter from Campbell to Cantor, # 9 Exhibit 9 - Notice of Claim Terms, # 10 Exhibit 10 - Letter from Lorelli to Campbell, # 11 Exhibit 11 - Microsoft Computer Dictionary, # 12 Exhibit 12 - 5/21/05 Response to Office Action, # 13 Exhibit 13 - 6/21/01 Office Action, # 14 Exhibit 14 - 1/7/02 Office Action)(LeRoy, John) (Entered: 01/26/2009)
- 01/26/2009 102 Opening Claims Construction Brief of Microsoft and Defendants BRIEF filed by Intervenor and Defendants Microsoft Corporation. regarding Order, 69 . (Campbell, Chad) (Entered: 01/26/2009)
- 01/26/2009 103 DECLARATION of Chad S. Campbell re Brief (non-motion non-appeal) 102 in Support of Opening

- Claims Construction Brief by Microsoft and Defendants filed by Intervenor Microsoft Corporation. (Attachments: # 1 Exhibit A-B, Part I, # 2 Exhibit B, Part II, # 3 Exhibit B, Part III, # 4 Exhibit B, Part IV, # 5 Exhibit C-D, Part V, # 6 Exhibit E, Part VI, # 7 Exhibit E, Part VII, # 8 Exhibit F-G, Part VIII)(Campbell, Chad) (Entered: 01/26/2009)
- 01/27/2009 104 SUPPLEMENT to MOTION to Compel Microsoft Corporation to Produce Documents and to Provide Further Responses to Plaintiff's First Set Of Interrogatories; Request for Monetary Sanctions 89 filed by Plaintiff Ancora Technologies Inc. (Attachments: # 1 Exhibit A - Supplemental Joint Status Report on Microsoft's Compliance With The Final Judgments, # 2 Exhibit B - C.V. of Adisehu Dasari, # 3 Exhibit C - Interrogatory No. 1 to Microsoft)(Mizrahi, Mark) (Entered: 01/27/2009)
- 01/27/2009 105 SUPPLEMENT to MOTION to Compel Defendants Hewlett-Packard Company, Dell, Inc., and Toshiba America Information Systems, Inc. to Produce Documents and To Provide Further Responses to Plaintiff's First Set of Interrogatories; Request for Monetary Sanctions 93 filed by Plaintiff Ancora Technologies Inc. (Mizrahi, Mark) (Entered: 01/27/2009)
- 01/27/2009 106 SUPPLEMENT to Stipulation for Protective Order 84 filed by Counter Defendants Ancora Technologies, Inc., Ancora Technologies Inc, Ancora Technologies Inc, Plaintiff Ancora Technologies Inc. (LeRoy, John) (Entered: 01/27/2009)
- 01/27/2009 107 MEMORANDUM in Support Supplemental Memorandum in Support of the Joint Stipulation Under Rule 37-2 re Motion for Entry of a Final Protective Order filed by Intervenor Microsoft Corporation. (LaSpaluto, David) (Entered: 01/27/2009)
- 01/27/2009 108 DECLARATION of David M. LaSpaluto re Memorandum in Support of Motion 107 Joint Stipulation Under Rule 37-2 re Entry of Final Protective Order filed by Intervenor Microsoft Corporation. (Attachments: # 1 Exhibit 1 and 2)(LaSpaluto, David) (Entered: 01/27/2009)
- 01/27/2009 109 MEMORANDUM in Opposition Supplemental Memorandum in Opposition to Plaintiff's Motion to Compel Microsoft filed by Intervenor Microsoft Corporation. (Campbell, Chad) (Entered: 01/27/2009)
- 01/27/2009 110 DECLARATION of Scott S. Minder re MEMORANDUM in Opposition to Motion 109 of Plaintiff to Compel Microsoft filed by Intervenor Microsoft Corporation. (Attachments: # 1 Exhibit 1) (Campbell, Chad) (Entered: 01/27/2009)
- 01/27/2009 111 MEMORANDUM in Opposition Supplemental Memorandum in Opposition to Plaintiff's Motion to Compel Defendants filed by Defendants Toshiba America Information Systems Inc, Dell Inc, Hewlett-Packard Company. (Campbell, Chad) (Entered: 01/27/2009)
- 01/27/2009 112 DECLARATION of Scott Minder re MEMORANDUM in Opposition to Motion 111 of Plaintiff to Compel Defendants filed by Defendants Toshiba America Information Systems Inc, Dell Inc, Hewlett-Packard Company. (Attachments: # 1 Exhibit 1-3)(Campbell, Chad) (Entered: 01/27/2009)
- 01/29/2009 113 NOTICE of Manual Filing filed by Counter Claimants Toshiba America Information Systems, Inc., Hewlett-Packard Company, Dell Inc, Intervenor Microsoft Corporation, Defendants Toshiba America Information Systems Inc, Dell Inc, Hewlett-Packard Company of Under Seal Documents. (Sliger, Lauren) (Entered: 01/29/2009)
- 01/29/2009 114 NOTICE OF MOTION TO TRANSFER VENUE filed by Intervenor & Defendants Toshiba America Information Systems, Inc., Hewlett-Packard Company, Dell Inc, Microsoft Corporation, Toshiba America Information Systems Inc. (Attachments: # 1 Proposed Order Granting Motion to Transfer Venue)(Sliger, Lauren) (Entered: 01/29/2009)
- 01/29/2009 115 DECLARATION of Cam D'Amico re Notice (Other), Notice (Other) 114 of Motion to Transfer Venue filed by Counter Claimants Toshiba America Information Systems, Inc., Hewlett-Packard Company, Dell Inc, Intervenor Microsoft Corporation, Defendants Toshiba America Information Systems Inc, Dell Inc, Hewlett-Packard Company. (Sliger, Lauren) (Entered: 01/29/2009)
- 01/29/2009 116 DECLARATION of John Hong re Notice (Other), Notice (Other) 114 of Motion to Transfer Venue filed by Counter Claimants Toshiba America Information Systems, Inc., Hewlett-Packard Company, Dell Inc, Intervenor Microsoft Corporation, Defendants Toshiba America Information Systems Inc, Dell Inc, Hewlett-Packard Company. (Sliger, Lauren) (Entered: 01/29/2009)
- 01/29/2009 117 DECLARATION of Eric Peacock re Notice (Other), Notice (Other) 114 of Motion to Transfer Venue filed by Counter Claimants Toshiba America Information Systems, Inc., Hewlett-Packard Company, Dell Inc, Intervenor Microsoft Corporation, Defendants Toshiba America Information Systems Inc, Dell Inc, Hewlett-Packard Company. (Sliger, Lauren) (Entered: 01/29/2009)
- 01/29/2009 118 DECLARATION of Chad Anson re Notice (Other), Notice (Other) 114 of Motion to Transfer Venue filed by Counter Claimants Toshiba America Information Systems, Inc., Hewlett-Packard Company, Dell Inc, Intervenor Microsoft Corporation, Defendants Toshiba America Information Systems Inc, Dell Inc, Hewlett-Packard Company. (Sliger, Lauren) (Entered: 01/29/2009)

- 01/29/2009 120 PROOF OF SERVICE re. Application for Leave to File Papers Under Seal, Proposed Order Shortening Time; Memorandum in Support of Motion to Transfer Venue; Declaration of Counsel in Support of Motion to Transfer Venue filed by Intervenor Microsoft Corporation mail served on 1/29/09. (smi) (Entered: 02/02/2009)
- 01/29/2009 121 APPLICATION FOR LEAVE TO FILE PAPERS UNDER SEAL AND TO SHORTEN TIME FOR LR 7-3 CONFERENCE RE MOTION TO TRANSFER VENUE filed by Intervenor and Defendants Dell Inc, Microsoft Corporation, Toshiba America Information Systems Inc, Hewlett-Packard Company. (smi) (Entered: 02/02/2009)
- 01/29/2009 122 ORDER Shortening Time on L.R. 7-3 AND GRANTING APPLICATION to Seal 121 by Judge Andrew J. Guilford. (ade) (Entered: 02/02/2009)
- 01/29/2009 125 SEALED DOCUMENT - MEMORANDUM IN SUPPORT OF MOTION TO TRANFER VENUE (smi) (Entered: 02/04/2009)
- 01/29/2009 126 SEALED DOCUMENT - DECLARATION OF COUNSEL IN SUPPORT OF MOTION TO TRANFER VENUE (smi) (Entered: 02/04/2009)
- 01/30/2009 119 ORDER GRANTING MOTION TO WITHDRAW AS COUNSEL FOR DELL INC by Judge Andrew J. Guilford. IT IS ORDERED that: Fulbright & Jaworski, LLP and its attorneys Christopher R. Benson, Michael C. Barrett, and Brandon Fernald, shall be removed as counsel of record for Dell Inc. in this action. (smi) (Entered: 01/30/2009)
- 02/04/2009 123 EX PARTE APPLICATION to Continue Hearing on Microsoft's Motion to Transfer Venue from February 23, 2009 to March 3, 2009 filed by Plaintiff Ancora Technologies Inc. (Attachments: # 1 Exhibit 1 - 1/31/09 Email, # 2 Proposed Order)(Mizrahi, Mark) (Entered: 02/04/2009)
- 02/04/2009 124 Opposition to Ancora's Ex Parte Application to Continue the Hearing Date on Motion to Transfer Venue Opposition re: EX PARTE APPLICATION to Continue Hearing on Microsoft's Motion to Transfer Venue from February 23, 2009 to March 3, 2009 123 filed by Intervenor Microsoft Corporation, Defendants Toshiba America Information Systems Inc, Dell Inc, Hewlett-Packard Company. (Campbell, Chad) (Entered: 02/04/2009)
- 02/05/2009 127 MINUTES OF IN CHAMBERS ORDER by Judge Andrew J. Guilford: CONTINUING HEARINGS: The Court DENIES the Application 123 . The Court will not continue the hearing on the Motion. But the Court CONTINUES the Markman hearing, currently set for March 3, 2009, to March 24, 2009 at 9:00 a.m. Plaintiff's rebuttal Markman brief, currently due February 13, 2009, will now be due March 6, 2009. (rla) (Entered: 02/05/2009)
- 02/06/2009 128 Application to Clarify Minutes In-Chambers Order Dated February 5, 2009 re: Minutes of In Chambers Order/Directive - no proceeding held, Terminate Deadlines and Hearings, Set Hearings,,, 127 (Campbell, Chad) (Entered: 02/06/2009)
- 02/06/2009 129 NOTICE OF LODGING filed for Proposed Order Re Application to Clarify Minutes In-Chambers Order Dated February 5, 2009 re Miscellaneous Document 128 (Campbell, Chad) (Entered: 02/06/2009)
- 02/06/2009 130 NOTICE OF LODGING filed for Proposed Order Re Application to Clarify Minutes In-Chambers Order Dated February 5, 2009 re Miscellaneous Document 128 (Attachments: # 1 Proposed Order Re Application to Clarify Minutes In-Chambers Order Dated February 5, 2009)(Campbell, Chad) (Entered: 02/06/2009)
- 02/09/2009 131 MEMORANDUM in Opposition to Defendants' Motion to Transfer Venue (28 U.S.C. 1404(a)) filed by Plaintiff Ancora Technologies Inc. (Lorelli, Marc) (Entered: 02/09/2009)
- 02/09/2009 132 NOTICE of Manual Filing filed by Plaintiff Ancora Technologies Inc of Exhibits 2, 7 and 8 to Declaration of Counsel in Opposition to Microsoft's Motion to Transfer. (Lorelli, Marc) (Entered: 02/09/2009)
- 02/09/2009 133 MEMORANDUM in Opposition DECLARATION of Counsel Regarding Microsoft's Motion to Transfer Venue filed by Plaintiff Ancora Technologies Inc. (Attachments: # 1 Exhibit 1 - USPN 6411941, # 2 Exhibit 2 - FILED UNDER SEAL ('941 notice letters), # 3 Exhibit 3 - Mullor's Microsoft Employee Agreement, # 4 Exhibit 4 - Saavedra Declaration, # 5 Exhibit 5 - Mullor Declaration, # 6 Exhibit 6 - HP's 2nd Supp. Int. Responses, # 7 Exhibit 7 - FILED UNDER SEAL (Excerpts of Mullor's deposition transcript), # 8 Exhibit 8 - FILED UNDER SEAL (Ancora/American Megatrends Agreement), # 9 Exhibit 9 - Press Articles, # 10 Exhibit 10 - Microsoft's Subpoena on Mullor, # 11 Exhibit 11 - Ancor's Supp Resp to Microsoft 1st Ints, # 12 Exhibit 12 - Microsoft website download, # 13 Exhibit 13 - US App Publ 2006/0288422, # 14 Exhibit 14 - Google webpage download, # 15 Exhibit 15 - mydigitalife forum thread, # 16 Exhibit 16 - Google webpage download, # 17 Exhibit 17 - webpage download, # 18 Exhibit 18 - Google webpage download, # 19 Exhibit 19 - Part 1 - Google webpage in Mandarin Chinese, # 20 Exhibit 19 - Part 2, # 21 Exhibit 20 - Google webpage download, # 22 Exhibit 21 - Google webpage download, # 23 Exhibit 22 - California Business Portal - corporation information for

- Microsoft Corporation, # 24 Exhibit 23 - Microsoft Corporation webpages showing addresses) (Lorelli, Marc) (Entered: 02/09/2009)
- 02/10/2009 135 APPLICATION for Leave to File Confidential Exhibits 2, 7, and 8 to the Declaration of Counsel in Opposition to Microsoft's Motion to Transfer Venue Under Seal. Filed by plaintiff Ancora Technologies Inc. Lodged order. (ade) (Entered: 02/12/2009)
- 02/10/2009 136 ORDER by Judge Andrew J. Guilford, GRANTING APPLICATION for Leave to File Confidential Exhibits 2, 7 and 8 to the Declaration of Counsel in Opposition to Microsoft's Motion to Transfer Venue Under Seal. 135 (ade) (Entered: 02/12/2009)
- 02/10/2009 146 SEALED DOCUMENT RE: EXHIBITS 2,7 AND 8 to the Declaration of Counsel in Opposition to Motion to Transfer Venue. (ade) (Entered: 02/19/2009)
- 02/11/2009 134 ORDER by Judge Andrew J. Guilford, re APPLICATION TO CLARIFY MINUTES OF INCHAMBERS ORDER 128 : IT IS HEREBY ORDERED that Microsoft and the Defendants' rebuttal Markman brief will be due on March 6, 2009 rather than February 13. SO ORDERED. (rla) (Entered: 02/11/2009)
- 02/11/2009 137 MINUTES OF IN CHAMBERS ORDER held before Magistrate Judge Marc L. Goldman: Order on Plaintiff's Motion to Compel Documents and Provide Further Responses from Defendants Dell, Hewlett-Packard and Toshiba 93 ; Plaintiff's Motion to Compel Defendant Microsoft to Produce Documents and Provide Further Responses 89 ; and Defendant's Motion for a Final Protective Order: The parties shall submit a final protective order conforming to the agreement of the parties and produce documents in accordance with the agreed upon schedule. Plaintiff's motion to compel more complete answers to the interrogatories is GRANTED. In doing so, the Court adopts the reasoning of the court in Firetrace USA, LLC v. Jesclard, 2009 WL 73671 (D. Ariz.2009). (See document for further details.) (rla) (Entered: 02/12/2009)
- 02/12/2009 138 NOTICE OF MOTION AND MOTION to Dismiss Count II of Ancora Technologies, Inc.'s Counterclaims in its First Amended Answer filed by Intervenor Microsoft Corporation. Motion set for hearing on 3/9/2009 at 10:00 AM before Judge Andrew J. Guilford. (Attachments: # 1 Proposed Order Granting Motion to Dismiss Count II of Ancora Technologies, Inc.'s Counterclaims)(Campbell, Chad) (Entered: 02/12/2009)
- 02/12/2009 139 MEMORANDUM in Support of MOTION to Dismiss Count II of Ancora Technologies, Inc.'s Counterclaims in its First Amended Answer 138 filed by Intervenor Microsoft Corporation. (Campbell, Chad) (Entered: 02/12/2009)
- 02/13/2009 140 NOTICE of Manual Filing filed by Counter Claimants Toshiba America Information Systems, Inc., Hewlett-Packard Company, Dell Inc, Intervenor Microsoft Corporation, Defendants Toshiba America Information Systems Inc, Dell Inc, Hewlett-Packard Company of Under Seal Documents. (Sliger, Lauren) (Entered: 02/13/2009)
- 02/13/2009 141 DECLARATION OF SUPPLEMENTAL DECLARATION OF CAM D'AMICO IN SUPPORT OF REPLY RE MOTION TO TRANSFER VENUE re Memorandum in Support of Motion 125 To Transfer Venue [Sealed Document] filed by Counter Claimants Toshiba America Information Systems, Inc., Hewlett-Packard Company, Dell Inc, Intervenor Microsoft Corporation, Defendants Toshiba America Information Systems Inc, Dell Inc, Hewlett-Packard Company. (Sliger, Lauren) (Entered: 02/13/2009)
- 02/17/2009 142 SUPPLEMENT /SUR-REPLY in Opposition to Microsoft's Motion to Transfer Venue filed by Plaintiff Ancora Technologies Inc. (Mizrahi, Mark) (Entered: 02/17/2009)
- 02/17/2009 143 SUPPLEMENT /Declaration of Mark B. Mizrahi in Support of Sur-Reply in Opposition to Motion to Transfer Venue filed by Plaintiff Ancora Technologies Inc. (Mizrahi, Mark) (Entered: 02/17/2009)
- 02/17/2009 144 NOTICE of Manual Filing re Sur-Reply in Opposition to Motion to Transfer Venue filed by plaintiff Ancora Technologies Inc. (Mizrahi, Mark) (Entered: 02/17/2009)
- 02/18/2009 145 NOTICE of Manual Filing filed by Counter Claimants Toshiba America Information Systems, Inc., Hewlett-Packard Company, Dell Inc, Intervenor Microsoft Corporation, Defendants Toshiba America Information Systems Inc, Dell Inc, Hewlett-Packard Company of Under Seal Documents. (Sliger, Lauren) (Entered: 02/18/2009)
- 02/18/2009 147 APPLICATION for Leave to File a Sur-Reply and to File Under Seal Confidential Exhibit 25 to the Declaration of Mark B. Mizrahi in Support of Ancora Technologies, Inc.'s Sur-Reply in Opposition to Microsoft's Motion to Transfer Venue. Filed by Plaintiff Ancora Technologies Inc. (nbo) (Entered: 02/20/2009)
- 02/18/2009 148 ORDER by Judge Andrew J. Guilford GRANTING APPLICATION for Leave to File a Sur-Reply and to File Under Seal Confidential Exhibit 25 to the Declaration of Mark B. Mizrahi in Support of Ancora Technologies, Inc.'s Sur-Reply in Opposition to Microsoft's Motion to Transfer Venue 147 . (nbo) (Entered: 02/20/2009)

- 02/18/2009 149 APPLICATION for Leave to File Papers Under Seal. Filed by Intervenor Microsoft Corporation and Defendants, Toshiba America Information Systems Inc, Dell Inc, and Hewlett-Packard Company. (nbo) (Entered: 02/20/2009)
- 02/18/2009 150 ORDER by Judge Andrew J. Guilford GRANTING APPLICATION for Leave to File Under Seal 149 . (nbo) (Entered: 02/20/2009)
- 02/18/2009 151 APPLICATION for Leave to File Papers Under Seal (Second Supplemental Declaration of Counsel in Support of Reply in Support of Motion to Transfer Venue) filed by Defendants Toshiba America Information Systems Inc, Dell Inc, Hewlett-Packard Company. (db) (Entered: 02/20/2009)
- 02/18/2009 152 SEALED DOCUMENT RE: SECOND SUPPLEMENTAL DECLARATION of Counsel in Support of Motion to Transfer Venue. (ade) (Entered: 02/20/2009)
- 02/18/2009 153 SEALED DOCUMENT RE: NOTICE of Filing Under Seal Confidential Exhibit 25 (ade) (Entered: 02/20/2009)
- 02/18/2009 154 SEALED DOCUMENT RE: SUPPLEMENTAL DECLARATION of Counsel in Support of Reply re Motion to Transfer Venue (ade) (Entered: 02/20/2009)
- 02/18/2009 155 SEALED DOCUMENT RE: REPLY IN SUPPORT OF MOTION TO TRANSFER VENUE (ade) (Entered: 02/20/2009)
- 02/18/2009 157 ORDER by Judge Andrew J. Guilford GRANTING APPLICATION TO FILE UNDER SEAL 151 . IT IS ORDERED that leave to file under seal Microsoft and Defendants' Second Supplemental Declaration of Counsel In Support of Motion to Transfer Venue is GRANTED. (smi) (Entered: 02/20/2009)
- 02/20/2009 156 APPLICATION for attorney John W. Rogers to Appear Pro Hac Vice (PHV Fee of \$185 receipt number 0973000000004927614 paid.) filed by Defendant and Intervenor Toshiba America Information Systems, Inc., Hewlett-Packard Company, Dell Inc, Microsoft Corporation, Toshiba America Information Systems Inc. (Attachments: # 1 Proposed Order on Application of Non-Resident Attorney to Appear in a Specific Case, # 2 Letter Certificate of Good Standing)(Sliger, Lauren) (Entered: 02/20/2009)
- 02/23/2009 158 OPPOSITION to MOTION to Dismiss Count II of Ancora Technologies, Inc.'s Counterclaims in its First Amended Answer 138 filed by Plaintiff Ancora Technologies Inc. (Mizrahi, Mark) (Entered: 02/23/2009)
- 02/23/2009 159 MINUTES OF Motion Hearing held before Judge Andrew J. Guilford RE: INTERVENOR'S AND DEFENDANTS' MOTION TO TRANSFER VENUE AND MOTION FOR LEAVE TO FILE PROPOSED AMENDED ANSWERS TO ANCORA TECHNOLOGIES, INC'S COMPLAINT AND COUNTERCLAIM. Matter is argued and taken under submission. Court Reporter: Denise Paddock. (smi) (Entered: 02/24/2009)
- 02/25/2009 160 ORDER by Judge Andrew J. Guilford Granting APPLICATION for attorney John W. Rogers to Appear Pro Hac Vice (PHV Fee of \$185 receipt number 0973000000004927614 paid.) 156 John W. Rogers to appear on behalf of Intervenor Microsoft Corporation. Lauren Sliger is designated as local counsel. Fee PAID. (ade) (Entered: 02/26/2009)
- 02/27/2009 161 ORDER by Judge Andrew J. Guilford transferring case to Western District of Washington. GRANTING MICROSOFT'S MOTION TO TRANSFER VENUE : (See document for further details.) (MD JS-6. Case Terminated.) The Court VACATES the hearing on the Motion to Amend. IT IS SO ORDERED. (rla) (Entered: 02/27/2009)
- 02/27/2009 162 MINUTES OF IN CHAMBERS ORDER by Judge Andrew J. Guilford: VACATING HEARING ON MOTION TO DISMISS. (rla) (Entered: 02/27/2009)
- 05/05/2009 163 TRANSCRIPT for proceedings held on 2-10-09 10:00a.m. & 1:01p.m.. Court Reporter/Electronic Court Recorder: Babykin CourtHouse Services, phone number 626-963-0566. Transcript may be viewed at the court public terminal or purchased through the Court Reporter/Electronic Court Recorder before the deadline for Release of Transcript Restriction. After that date it may be obtained through PACER. Notice of Intent to Redact due within 7 days of this date. Redaction Request due 5/26/2009. Redacted Transcript Deadline set for 6/5/2009. Release of Transcript Restriction set for 8/3/2009. (bem) (Entered: 05/05/2009)
- 05/05/2009 164 NOTICE OF FILING TRANSCRIPT filed for proceedings 2-10-09 10:00a.m. & 1:01p.m. (bem) (Entered: 05/05/2009)

LexisNexis® Total Research System

Switch Client | Preferences | Sign Out |  Help

My Lexis™

Search

Research Tasks

Get a Document

Shepard's®

Alerts

Total Litigator

Transactional A

FOCUS™ Terms Search Within 

Advanced...

Source: [Command Searching > Utility, Design and Plant Patents](#) Terms: **patno=6411941** ([Edit Search](#) | [Suggest Terms for My Search](#))

164777 (09) 6411941 June 25, 2002

UNITED STATES PATENT AND TRADEMARK OFFICE GRANTED PATENT

6411941[Get Drawing Sheet 1 of 2](#)[Access PDF of Official Patent *](#)[Order Patent File History / Wrapper from REEDFAX®](#)[Link to Claims Section](#)

June 25, 2002

Method of restricting software operation within a license limitation

REEXAM-LITIGATE:

NOTICE OF LITIGATION

Ancora Technologies Inc v. Toshiba America Information Systems Inc et al, Filed February 27, 2009, D.C. W.D. Washington, Doc. No. 2:09cv270

APPL-NO: 164777 (09)**FILED-DATE:** October 1, 1998**GRANTED-DATE:** June 25, 2002**ASSIGNEE-PRE-ISSUE:** October 1, 1998 - ASSIGNMENT OF ASSIGNORS INTEREST (SEE DOCUMENT FOR DETAILS)., M.Y.P.D. TECHNOLOGIES LTD., C/O KEREN-SCHECHTER LAW FIRM 21 HAR SINAI STREETTEL-AVIV 65816, (1); Reel and Frame Number: 009510/0320
February 27, 2002 - ASSIGNMENT OF ASSIGNORS INTEREST (SEE DOCUMENT FOR DETAILS)., BEEBLE, INC. P.O. BOX 4066NEWPORT BEACH, CALIFORNIA, 92661, Reel and Frame Number: 012617/0830

May 9, 2002 - REQUEST FOR CORRECTION TO CORRECT THE ASSIGNOR'S NAME PREVIOUSLY RECORDED AT REEL 012617, FRAME 0830, BEEBLE, INC. PO BOX 4066NEWPORT BEACH, CALIFORNIA, 92661, Reel and Frame Number: 012882/0558

May 9, 2002 - REQUEST FOR CORRECTION TO CORRECT THE ASSIGNOR S NAME PREVIOUSLY RECORDED AT REEL 012617, FRAME 0830, BEEBLE, INC. PO BOX 4066NEWPORT BEACH, CALIFORNIA, 92661, Reel and Frame Number: 012882/0558

ASSIGNEE-AT-ISSUE: Beeble, Inc., Newport Beach, California, United States (US), United States company or corporation (02)**ASSIGNEE-AFTER-ISSUE:** December 21, 2004 - ASSIGNMENT OF ASSIGNORS INTEREST (SEE DOCUMENT FOR DETAILS)., ANCORA TECHNOLOGIES INC. 3972 BARRANCA PKWY,

SUITE J458IRVINE, CALIFORNIA, 92606, Reel and Frame Number: 015494/0243

CORE TERMS: memory, computer, license, non-volatile, bureau, license-record, software, encrypted, volatile, identification ...

Source: [Command Searching](#) > [Utility, Design and Plant Patents](#) 

Terms: **patno=6411941** ([Edit Search](#) | [Suggest Terms for My Search](#))

View: **Custom**

Segments: Appl-no, Assignee, Assignee-iid, Cert-correction, Lit-reex, Reexam-cert, Reexam-litigate, Reissue, Reissue-comment

Date/Time: Monday, June 8, 2009 - 3:21 PM EDT

[My Lexis™](#) | [Search](#) | [Research Tasks](#) | [Get a Document](#) | [Shepard's®](#) | [Alerts](#) | [Total Litigator](#) | [Transactional Advisor](#) | [Counsel Selector](#)
[History](#) | [Delivery Manager](#) | [Switch Client](#) | [Preferences](#) | [Sign Out](#) | [Help](#)



[About LexisNexis](#) | [Terms & Conditions](#) | [Contact Us](#)
Copyright © 2009 LexisNexis, a division of Reed Elsevier Inc. All rights reserved.

Command Searching > Patent Cases from Federal Courts and Administrative Materials ⓘ

Search

Enter Search Terms

Terms and Connectors Natural Language Easy Search™

6411941 or 6,411,941

[Suggest terms for my search](#)

[Check spelling](#)

Restrict by Document Segment

Select a document segment, enter search terms for the segment, then click Add.

Select a Segment [v] [] Add [↑]

Note: Segment availability differs between sources. Segments may not be applied consistently across sources.

Restrict by Date

No Date Restrictions [v] From [] To [] [Date formats...](#)

Search Connectors

and and w/p in same paragraph
or or w/seg in same segment
w/N within N words w/s in same sentence
pre/N precedes by N words and_not and not

> [More Connectors & Commands...](#)

How Do I...?

- > [Combine sources?](#)
- > [Restrict by date?](#)
- > [Restrict by document segment?](#)
- > [Use wildcards as placeholders for one or more characters?](#)

[View Tutorials](#)



No Documents Found

No documents were found for your search terms

"6411941 or 6,411,941"

Click "Save this search as an Alert" to schedule your search to run in the future.

- OR -

Click "Edit Search" to return to the search form and modify your search.

Suggestions:

- Check for spelling errors .
 - Remove some search terms.
 - Use more common search terms, such as those listed in "Suggested Words and Concepts"
 - Use a less restrictive date range.
-

Save this Search as an Alert

Edit Search



LexisNexis®

[About LexisNexis](#) | [Terms & Conditions](#) | [Contact Us](#)

Copyright © 2009 LexisNexis, a division of Reed Elsevier Inc. All rights reserved.

Command Searching > Patent, Trademark & Copyright Periodicals, Combined ⓘ

Search

Enter Search Terms

Terms and Connectors Natural Language Easy Search™

6411941 or 6,411,941

[Suggest terms for my search](#)

[Check spelling](#)

Restrict by Document Segment

Select a document segment, enter search terms for the segment, then click Add.

Select a Segment [v] [] Add [↑]

Note: Segment availability differs between sources. Segments may not be applied consistently across sources.

Restrict by Date

No Date Restrictions [v] From [] To [] [Date formats...](#)

Search Connectors

and and w/p in same paragraph
or or w/seg in same segment
w/N within N words w/s in same sentence
pre/N precedes by N words and not and not

> [More Connectors & Commands...](#)

How Do I...?

- > [Combine sources?](#)
- > [Restrict by date?](#)
- > [Restrict by document segment?](#)
- > [Use wildcards as placeholders for one or more characters?](#)

[View Tutorials](#)

No Documents Found

No documents were found for your search terms

"6411941 or 6,411,941"

Click "Save this search as an Alert" to schedule your search to run in the future.

- OR -

Click "Edit Search" to return to the search form and modify your search.

Suggestions:

- Check for spelling errors .
 - Remove some search terms.
 - Use more common search terms, such as those listed in "Suggested Words and Concepts"
 - Use a less restrictive date range.
-

Save this Search as an Alert

Edit Search



[About LexisNexis](#) | [Terms & Conditions](#) | [Contact Us](#)

Copyright © 2009 LexisNexis, a division of Reed Elsevier Inc. All rights reserved.

LexisNexis® Total Research System

Switch Client | Preferences | Sign Out | ? Help

My Lexis™ Search Research Tasks Get a Document Shepard's® Alerts Total Litigator Transactional A
by Source | by Topic or Headnote | by Guided Search Form | by Dot Command |

Command Searching > News, All (English, Full Text) ⓘ

Search

Enter Search Terms

Terms and Connectors Natural Language Easy Search™

6411941 or 6,411,941

[Suggest terms for my search](#)

[Check spelling](#)

Restrict by Document Segment

Select a document segment, enter search terms for the segment, then click Add.

Select a Segment [v] [] Add | ↑

Note: Segment availability differs between sources. Segments may not be applied consistently across sources.

Restrict by Date

No Date Restrictions [v] From [] To [] [Date formats...](#)

Search Connectors

and and w/p in same paragraph
or or w/seg in same segment
w/N within N words w/s in same sentence
pre/N precedes by N words and not and not

> [More Connectors & Commands...](#)

How Do I...?

- > [Combine sources?](#)
- > [Restrict by date?](#)
- > [Restrict by document segment?](#)
- > [Use wildcards as placeholders for one or more characters?](#)

[View Tutorials](#)

[My Lexis™](#) | [Search](#) | [Research Tasks](#) | [Get a Document](#) | [Shepard's®](#) | [Alerts](#) | [Total Litigator](#) | [Transactional Advisor](#) | [Counsel Selector](#)

[History](#) | [Delivery Manager](#) | [Switch Client](#) | [Preferences](#) | [Sign Out](#) | [Help](#)

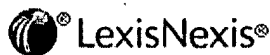

[About LexisNexis](#) | [Terms & Conditions](#) | [Contact Us](#)
Copyright © 2009 LexisNexis, a division of Reed Elsevier Inc. All rights reserved.

LexisNexis® Total Research System

[Switch Client](#) | [Preferences](#) | [Sign Out](#) | [Help](#)

[My Lexis™](#) | [Search](#) | [Research Tasks](#) | [Get a Document](#) | [Shepard's®](#) | [Alerts](#) | [Total Litigator](#) | [Transactional A](#)

FOCUS™ Terms Search Within

[Advanced...](#)

Source: [Command Searching > News, All \(English, Full Text\)](#) ⓘ
Terms: **6411941 or 6,411,941** ([Edit Search](#) | [Suggest Terms for My Search](#))

Select for FOCUS™ or Delivery

- 1. [Gizmodo](#), February 2, 2009 Monday 1:00 PM EST, , 719 words, Former Employee Responds to Microsoft Spying Allegations [Microsoft] ... U.S. Patent No. **6,411,941** relating to software anti- ...
- 2. [THE SEATTLE POST-INTELLIGENCER](#), January 30, 2009 Friday, NEWS; Pg. A1, 421 words, MICROSOFT SUES CEO OF ANCORA FOR SPYING\ DECEPTION CHARGED IN PATENT DISPUTE, P-I STAFF AND NEWS SERVICES ... patent, US Patent **6,411,941**. "This lawsuit is about protecting our ...

Source: [Command Searching > News, All \(English, Full Text\)](#) ⓘ
Terms: **6411941 or 6,411,941** ([Edit Search](#) | [Suggest Terms for My Search](#))
View: [Cite](#)

Date/Time: Monday, June 8, 2009 - 3:27 PM EDT

[My Lexis™](#) | [Search](#) | [Research Tasks](#) | [Get a Document](#) | [Shepard's®](#) | [Alerts](#) | [Total Litigator](#) | [Transactional Advisor](#) | [Counsel Selector](#)
[History](#) | [Delivery Manager](#) | [Switch Client](#) | [Preferences](#) | [Sign Out](#) | [Help](#)



LexisNexis®

[About LexisNexis](#) | [Terms & Conditions](#) | [Contact Us](#)
Copyright © 2009 LexisNexis, a division of Reed Elsevier Inc. All rights reserved.

Patent Assignment Abstract of Title

Total Assignments: 4

Application #: 09164777

Filing Dt: 10/01/1998

Patent #: 6411941

Issue Dt: 06/25/2002

PCT #: NONE

Publication #: NONE

Pub Dt:

Inventors: MIKI MULLOR, JULIAN VALIKO

Title: METHOD OF RESTRICTING SOFTWARE OPERATION WITHIN A LICENSE LIMITATION

Assignment: 1

Reel/Frame: 009510 / 0320 Received: 10/20/1998 Recorded: 10/01/1998 Mailed: 02/05/1999 Pages: 2

Conveyance: ASSIGNMENT OF ASSIGNORS INTEREST (SEE DOCUMENT FOR DETAILS).

Assignors: MULLOR, MIKI

Exec Dt: 08/28/1998

VALIKO, JULIAN

Exec Dt: 08/28/1998

Assignee: M.Y.P.D. TECHNOLOGIES LTD., C/O KEREN-SCHECHTER LAW FIRM

21 HAR SINAI STREET
TEL-AVIV 65816, ISRAEL

Correspondent: VENABLE

ROBERT KINBERG
SUITE 300 EAST
1100 NEW YORK AVENUE, N.W.
WASHINGTON, D.C. 20005-3955

Assignment: 2

Reel/Frame: 012617 / 0830 Received: 03/04/2002 Recorded: 02/27/2002 Mailed: 04/24/2002 Pages: 4

Conveyance: ASSIGNMENT OF ASSIGNORS INTEREST (SEE DOCUMENT FOR DETAILS).

Assignor: M.Y.P.D. TECHNOLOGIES, INC.

Exec Dt: 02/21/2002

Assignee: BEEBLE, INC.

P.O. BOX 4066
NEWPORT BEACH, CALIFORNIA 92661

Correspondent: VENABLE

JEFFRI A. KAMINSKI
P.O. BOX 34385
WASHINGTON, D.C. 20043-9998

Assignment: 3

Reel/Frame: 012882 / 0558 Received: 05/15/2002 Recorded: 05/09/2002 Mailed: 07/15/2002 Pages: 4

Conveyance: REQUEST FOR CORRECTION TO CORRECT THE ASSIGNOR'S NAME PREVIOUSLY RECORDED AT REEL 012617, FRAME 0830

Assignor: M.Y.P.D. TECHNOLOGIES, LTD.

Exec Dt: 02/21/2002

Assignee: BEEBLE, INC.

PO BOX 4066
NEWPORT BEACH, CALIFORNIA 92661

Correspondent: VENABLE

PO BOX 34385
WASHINGTON, D.C. 20043-9998

Assignment: 4

Reel/Frame: 015494 / 0243 Received: 12/21/2004 Recorded: 12/21/2004 Mailed: 12/29/2004 Pages: 3

Conveyance: ASSIGNMENT OF ASSIGNORS INTEREST (SEE DOCUMENT FOR DETAILS).

Assignor: BEEBLE, INC.

Exec Dt: 12/20/2004

Assignee: ANCORA TECHNOLOGIES INC.

3972 BARRANCA PKWY, SUITE J458
IRVINE, CALIFORNIA 92606

Correspondent: ROBERT KINBERG

575 7TH STREET NW
WASHINGTON, DC 20004



UNITED STATES PATENT AND TRADEMARK OFFICE

UNITED STATES DEPARTMENT OF COMMERCE
United States Patent and Trademark Office
Address: COMMISSIONER FOR PATENTS
P.O. Box 1450
Alexandria, Virginia 22313-1450
www.uspto.gov

REEXAM CONTROL NUMBER	FILING OR 371 (c) DATE	PATENT NUMBER
90/010,560	05/29/2009	6411941

**CONFIRMATION NO. 1017
REEXAM ASSIGNMENT NOTICE**

26694
VENABLE LLP
P.O. BOX 34385
WASHINGTON, DC 20043-9998



Date Mailed: 06/09/2009

NOTICE OF ASSIGNMENT OF REEXAMINATION REQUEST

The above-identified request for reexamination has been assigned to Art Unit 3993. All future correspondence to the proceeding should be identified by the control number listed above and directed to the assigned Art Unit.

A copy of this Notice is being sent to the latest attorney or agent of record in the patent file or to all owners of record. (See 37 CFR 1.33(c)). If the addressee is not, or does not represent, the current owner, he or she is required to forward all communications regarding this proceeding to the current owner(s). An attorney or agent receiving this communication who does not represent the current owner(s) may wish to seek to withdraw pursuant to 37 CFR 1.36 in order to avoid receiving future communications. If the address of the current owner(s) is unknown, this communication should be returned within the request to withdraw pursuant to Section 1.36.

cc: Third Party Requester(if any)
PERKINS COIE LLP/ MSFT
P.O. BOX 1247
SEATTLE, WA 98111-1247

/sdstevenson/

Legal Instruments Examiner
Central Reexamination Unit 571-272-7705; FAX No. 571-273-9900



UNITED STATES PATENT AND TRADEMARK OFFICE

UNITED STATES DEPARTMENT OF COMMERCE
United States Patent and Trademark Office
Address: COMMISSIONER FOR PATENTS
P.O. Box 1450
Alexandria, Virginia 22313-1450
www.uspto.gov

REEXAM CONTROL NUMBER	FILING OR 371 (c) DATE	PATENT NUMBER
90/010,560	05/29/2009	6411941

PERKINS COIE LLP/ MSFT
P.O. BOX 1247
SEATTLE, WA 98111-1247

**CONFIRMATION NO. 1017
REEXAMINATION REQUEST
NOTICE**



Date Mailed: 06/09/2009

NOTICE OF REEXAMINATION REQUEST FILING DATE

(Third Party Requester)

Requester is hereby notified that the filing date of the request for reexamination is 05/29/2009, the date that the filing requirements of 37 CFR § 1.510 were received.

A decision on the request for reexamination will be mailed within three months from the filing date of the request for reexamination. (See 37 CFR 1.515(a)).

A copy of the Notice is being sent to the person identified by the requester as the patent owner. Further patent owner correspondence will be the latest attorney or agent of record in the patent file. (See 37 CFR 1.33). Any paper filed should include a reference to the present request for reexamination (by Reexamination Control Number).

cc: Patent Owner
26694
VENABLE LLP
P.O. BOX 34385
WASHINGTON, DC 20043-9998

/sdstevenson/

Legal Instruments Examiner
Central Reexamination Unit 571-272-7705; FAX No. 571-273-9900

Docket No.: 418263007US
(PATENT)

IN THE UNITED STATES PATENT AND TRADEMARK OFFICE

In re Reexamination Application of:
Miki Mullor (Patent No. 6,411,941)

Application No.: 90/010,560

Confirmation No.: 1017

Filed: May 29, 2009

Art Unit: 3992

For: METHOD OF RESTRICTING SOFTWARE
OPERATION WITHIN A LICENSE
LIMITATION

Examiner: M. E. Heneghan

TRANSMITTAL LETTER

Commissioner for Patents
P.O. Box 1450
Alexandria, VA 22313-1450

Madam:

Enclosed are the following items for filing in connection with the above-referenced Reexamination Application:

1. Corrected Exhibit I

The Director is hereby authorized to charge any deficiency in the fees filed, asserted to be filed or which should have been filed herewith (or with any paper

Application No.: 90/010,560

Docket No.: 418263007US

hereafter filed in this application by this firm) to our Deposit Account No. 50-0665, under Order No. 418263007US.

Dated:

6/29/09

Respectfully submitted,

By

Chun M. Ng

Registration No.: 36,878

PERKINS COIE LLP

P.O. Box 1247

Seattle, Washington 98111-1247

(206) 359-8000

Attorney for Applicant

EXHIBIT I

Claim Charts Matching Claims 1-19 to the Prior Art

Exhibit I: Claim Charts for Claims 1-19¹

<p align="center">U.S. Patent No. 6,411,941 Claims 1-19²</p>	<p align="center">Schwartz '835</p>
<p>1. A method of restricting software operation within a license for use with a computer including an erasable, non-volatile memory area of a BIOS of the computer, and a volatile memory area; the method comprising the steps of:</p>	<p>Schwartz '835 disclosed this preamble. [Schwartz '835 at C12:29-40 ("The authorization number verification requirement is desirable in that it helps deter unauthorized copying of software of system 10 onto other similar systems. This stems from the fact that even though the software can be copied onto the similar systems, the latter would not be operational without proper authorization numbers, which need to be derived in part from their respective unique serial numbers. In addition, since system 10 would only become operational with a proper authorization number, which specifies a valid combination of software versions for use in the system, the verification requirement thus ensures that the combination of software in system 10 is compatible."); at C7:48-59 ("In addition, console 13 includes read-only-memory (ROM) 213 permanently storing a unique serial number pre-assigned to system 10. Console 13 also includes memory section 250 comprising flash electrically erasable programmable read-only-memory (EEPROM) 250a having a capacity of 128 Kbytes, EPROM 250b having a capacity of 32 Kbytes, a nonvolatile static random-access-memory (SRAM) 250c having a capacity of 128 Kbytes, and SRAM 250d having a capacity of 128 Kbytes, all of which are of conventional design. Flash EEPROM 250a may illustratively be an AT29C010 memory manufactured and marketed by Atmel Corporation."); at C8:13-15 ("Basic Input/Output System (BIOS) module 309 contains firmware responsible for basic machine operation of system 10."); at C8:21-25 ("The memory space provided by memory 250c is used for storing accounting information files numerically denoted 351 and manifest information files denoted 353. When the system is in operation, the</p>

¹ In the context of reexamination, the "broadest reasonable interpretation" standard provided in MPEP § 2111 for claim interpretation during patent examination is used, and the statutory presumption of validity for issued patents does not apply. MPEP § 2258(I)(G). The standard applied by a court during litigation may or may not overlap with MPEP § 2111. The requester expressly reserves the right to argue a claim construction in the pending litigation that is different from a claim interpretation in this request.

² The text of claims 3, 4, 7, and 9 has been reformatted for clarity.

<p>selecting a program residing in the volatile memory,</p>	<p>memory space provided by memory 250d is utilized as work space.".)] Schwartz '835 disclosed this element. [<i>Id.</i> at C8:26-31 ("In this particular illustrative embodiment, rate schedule data, an operating system and an application program (hereinafter referred to as the "carrier service program") are provided to the user in an IC card. This application program when executed causes system 10 to perform certain tasks in accordance with the invention.".)]</p>
<p>using an agent to set up a verification structure in the erasable, non-volatile memory of the BIOS, the verification structure accommodating data that includes at least one license record,</p>	<p>Schwartz '835 disclosed this element. [<i>Id.</i> at C10:21-42 ("In accordance with still another aspect of the invention, the user of system 10 needs to enter a valid authorization number, which is unique to system 10, in order to enable the new application software, or other new data or system options selected by the user. The authorization number, which is generated outside system 10 and provided to the user, is 64 bits long and consists of a 32-bit electronic signature and another 32-bit encrypted option segment. In order to generate the electronic signature, a combination of (a) the serial number of system 10, (b) the model number of system 10, (c) the version number of the application software, (d) the version number of the rate schedule data, (e) the version number of the zip/zone data, and (f) a 32-bit option number whose bit pattern corresponds to a particular combination of enabled and disabled system options, are first encrypted in accordance with a first encryption algorithm. The signature is then derived from the encrypted version of the combination of numbers (a) through (f). On the other hand, the encrypted option segment is generated by encrypting only the 32-bit option number in (f) in accordance with a second encryption algorithm."); at C10:43-54 ("It suffices to know for now that after the user enters the authorization number, its encrypted option segment is first decrypted to recover the underlying option number. With the recovered option number, and additional numbers, system 10 independently generates an electronic signature. The generated signature is compared with the electronic signature of the authorization number just entered. If the two signatures match, the authorization number is declared valid; the authorization number will then be stored in a first memory buffer and the recovered option number will be stored in a second memory buffer in configuration module 307."); at C7:48-59 ("In addition,</p>

console 13 includes read-only-memory (ROM) 213 permanently storing a unique serial number pre-assigned to system 10. Console 13 also includes memory section 250 comprising flash electrically erasable programmable read-only-memory (EEPROM) 250a having a capacity of 128 Kbytes, EPROM 250b having a capacity of 32 Kbytes, a nonvolatile static random-access-memory (SRAM) 250c having a capacity of 128 Kbytes, and SRAM 250d having a capacity of 128 Kbytes, all of which are of conventional design. Flash EEPROM 250a may illustratively be an AT29C010 memory manufactured and marketed by Atmel Corporation."); at C8:13-15 ("Basic Input/Output System (BIOS) module 309 contains firmware responsible for basic machine operation of system 10."); at Fig. 9:

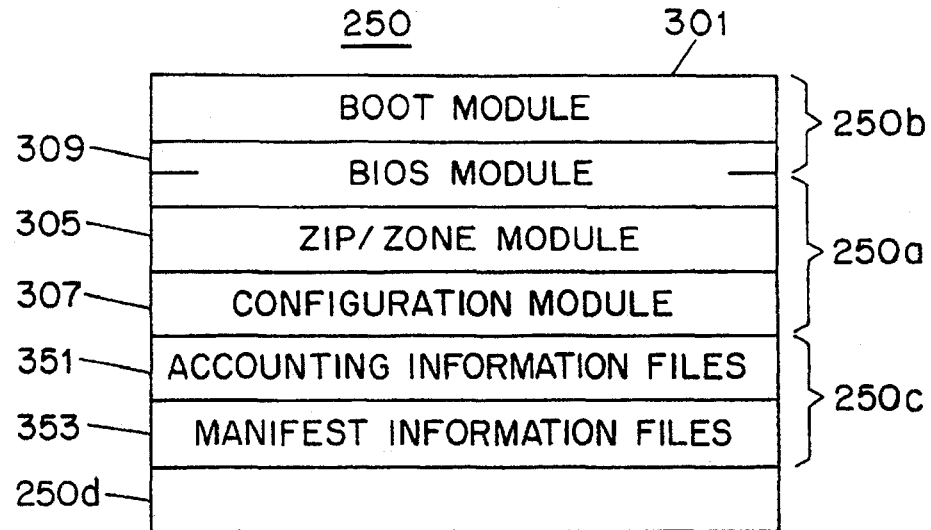

FIG. 9

verifying the program using at least the verification structure from the erasable non-volatile memory of the BIOS, and

]. Schwartz '835 disclosed this element. [*Id.* at C11:24-40 ("In the normal mode of operation or each time when system 10 is powered up, microprocessor 201 reads off (i) the serial number of system 10 from ROM 213, (ii) the model number of system 10 which is stored in BIOS module

	<p>309, (iii) the version number of the application software which is stored in the application module, (iv) the version number of the rate schedule data which is stored in the rate module, (v) the version number of the zip/zone data which is stored in module 305, and (vi) the option number which is stored in configuration module 307. Microprocessor 201 generates an electronic signature based on numbers (i) through (vi) using the aforementioned first encryption algorithm. The electronic signature, thus generated, is compared with the electronic signature stored in configuration module 307. If there is no mismatch, system 10 becomes operational. Otherwise if there is any mismatch, system 10 would prompt for a new authorization number.".)]</p>
<p>acting on the program according to the verification.</p>	<p>Schwartz '835 disclosed this element. [<i>Id.</i> at C11:38-40 ("If there is no mismatch, system 10 becomes operational. Otherwise if there is any mismatch, system 10 would prompt for a new authorization number."); at C12:8-14 ("The authorization number is validated at step 709 if microprocessor 201 finds that the two signatures match. Otherwise, a message such as "Invalid Authorization Number" is displayed at step 711 on screen 9. only when the user's authorization number is validated, does system 10 become operational, as indicated at step 713.".)]</p>
<p>2. A method according to claim 1, further comprising the steps of:</p>	
<p>establishing a license authentication bureau.</p>	<p>Schwartz '835 disclosed this element. [<i>Id.</i> at C11:58 to C12:14 ("System 10 is equipped with routine 700 of FIG. 12 for verifying the number entry. Instructed by routine 700, microprocessor 201 reads from keyboard interface 230 the authorization number just entered, as indicated at step 701. Routine 700 then proceeds to step 703 where microprocessor 201 causes the decryption of the encrypted option segment of the authorization number to recover the underlying option number. Such decryption is accomplished by using a decryption algorithm inverse to the second encryption algorithm. At step 705, microprocessor 201 reads off the above numbers (i) through (v), with number (iv) being the new version number of the rate schedule data. Using the recovered option number, and numbers (i) through (v) just read, microprocessor 201 at step 707 generates an electronic signature using the</p>

	<p>first encryption algorithm. The electronic signature, thus generated, is compared by microprocessor 201 at step 708 with the electronic signature in the authorization number entered by the user. The authorization number is validated at step 709 if microprocessor 201 finds that the two signatures match. Otherwise, a message such as "Invalid Authorization Number" is displayed at step 711 on screen 9. only when the user's authorization number is validated, does system 10 become operational, as indicated at step 713.).]</p> <p>To the extent that the reference does not explicitly disclose this element, the reference inherently disclosed the element.</p>
<p>3. A method according to claim 2, wherein setting up a verification structure further comprising the steps of:</p>	
<p>establishing, between the computer and the bureau, a two-way data-communications linkage;</p>	<p>Schwartz '835 disclosed this element. [<i>Id.</i> at C11:58 to C12:14 ("System 10 is equipped with routine 700 of FIG. 12 for verifying the number entry. Instructed by routine 700, microprocessor 201 reads from keyboard interface 230 the authorization number just entered, as indicated at step 701. Routine 700 then proceeds to step 703 where microprocessor 201 causes the decryption of the encrypted option segment of the authorization number to recover the underlying option number. Such decryption is accomplished by using a decryption algorithm inverse to the second encryption algorithm. At step 705, microprocessor 201 reads off the above numbers (i) through (v), with number (iv) being the new version number of the rate schedule data. Using the recovered option number, and numbers (i) through (v) just read, microprocessor 201 at step 707 generates an electronic signature using the first encryption algorithm. The electronic signature, thus generated, is compared by microprocessor 201 at step 708 with the electronic signature in the authorization number entered by the user. The authorization number is validated at step 709 if microprocessor 201 finds that the two signatures match. Otherwise, a message such as "Invalid Authorization Number" is displayed at step 711 on screen 9. only when the user's authorization number is validated, does system 10 become operational, as indicated at step 713.).]</p>

	To the extent that the reference does not explicitly disclose this element, the reference inherently disclosed the element.
transferring, from the computer to the bureau, a request-for-license including an identification of the computer and the license-record's contents from the selected program;	Schwartz '835 disclosed this element. [<i>Id.</i> at C10:29-38 ("In order to generate the electronic signature, a combination of (a) the serial number of system 10, (b) the model number of system 10, (c) the version number of the application software, (d) the version number of the rate schedule data, (e) the version number of the zip/zone data, and (f) a 32-bit option number whose bit pattern corresponds to a particular combination of enabled and disabled system options, are first encrypted in accordance with a first encryption algorithm.").]
forming an encrypted license-record at the bureau by encrypting parts of the request-for-license using part of the identification as an encryption key;	Schwartz '835 disclosed this element. [<i>Id.</i> at C10:29-42 ("In order to generate the electronic signature, a combination of (a) the serial number of system 10, (b) the model number of system 10, (c) the version number of the application software, (d) the version number of the rate schedule data, (e) the version number of the zip/zone data, and (f) a 32-bit option number whose bit pattern corresponds to a particular combination of enabled and disabled system options, are first encrypted in accordance with a first encryption algorithm. The signature is then derived from the encrypted version of the combination of numbers (a) through (f). On the other hand, the encrypted option segment is generated by encrypting only the 32-bit option number in (f) in accordance with a second encryption algorithm."); at C10:43-47 ("It suffices to know for now that after the user enters the authorization number, its encrypted option segment is first decrypted to recover the underlying option number. With the recovered option number, and additional numbers, system 10 independently generates an electronic signature.").]
transferring, from the bureau to the computer, the encrypted license-record; and	Schwartz '835 disclosed this element. [<i>Id.</i> at C10:43-54 ("It suffices to know for now that after the user enters the authorization number, its encrypted option segment is first decrypted to recover the underlying option number. With the recovered option number, and additional numbers, system 10 independently generates an electronic signature. The generated signature is compared with the electronic signature of the authorization number just entered. If the two signatures match, the authorization number is declared valid; the authorization number will then be stored in a first memory buffer

	and the recovered option number will be stored in a second memory buffer in configuration module 307.".)]
storing the encrypted license record in the erasable non-volatile memory area of the BIOS.	Schwartz '835 disclosed this element. [<i>Id.</i> at C10:43-54 ("It suffices to know for now that after the user enters the authorization number, its encrypted option segment is first decrypted to recover the underlying option number. With the recovered option number, and additional numbers, system 10 independently generates an electronic signature. The generated signature is compared with the electronic signature of the authorization number just entered. If the two signatures match, the authorization number is declared valid; the authorization number will then be stored in a first memory buffer and the recovered option number will be stored in a second memory buffer in configuration module 307."); at C11:67 to C12:8 ("At step 705, microprocessor 201 reads off the above numbers (i) through (v), with number (iv) being the new version number of the rate schedule data. Using the recovered option number, and numbers (i) through (v) just read, microprocessor 201 at step 707 generates an electronic signature using the first encryption algorithm. The electronic signature, thus generated, is compared by microprocessor 201 at step 708 with the electronic signature in the authorization number entered by the user."); at C11:36-40 ("The electronic signature, thus generated, is compared with the electronic signature stored in configuration module 307. If there is no mismatch, system 10 becomes operational. Otherwise if there is any mismatch, system 10 would prompt for a new authorization number.".)]
4. A method according to claim 2, wherein verifying the program further comprises the steps of:	
establishing, between the computer and the bureau, a two-way data-communications linkage;	Schwartz '835 disclosed this element. [<i>Id.</i> at C11:24-33 ("In the normal mode of operation or each time when system 10 is powered up, microprocessor 201 reads off (i) the serial number of system 10 from ROM 213, (ii) the model number of system 10 which is stored in BIOS module 309, (iii) the version number of the application software which is stored in the application module, (iv) the version number of the rate schedule data which is stored in the rate module, (v) the version number of the zip/zone

	<p>data which is stored in module 305, and (vi) the option number which is stored in configuration module 307."); at C11:51-61 ("Upon-subsequent power up of system 10, because of the fact that the rate schedule data has been updated and the rate module now contains the new version number, system 10 prompts the user for an authorization number on screen 9 as discussed before. In response, the user needs to enter on keyboard 17 the necessary authorization number which is derived partly on the new version number. System 10 is equipped with routine 700 of FIG. 12 for verifying the number entry. Instructed by routine 700, microprocessor 201 reads from keyboard interface 230 the authorization number just entered, as indicated at step 701.".)]</p> <p>To the extent that the reference does not explicitly disclose this element, the reference inherently disclosed the element.</p>
<p>transferring, from the computer to the bureau, a request-for-license verification including an identification of the computer, an encrypted license-record for the selected program from the erasable, non-volatile memory area of the BIOS, and the program's license-record;</p>	<p>Schwartz '835 disclosed this element. [<i>Id.</i> at C11:24-40 ("In the normal mode of operation or each time when system 10 is powered up, microprocessor 201 reads off (i) the serial number of system 10 from ROM 213, (ii) the model number of system 10 which is stored in BIOS module 309, (iii) the version number of the application software which is stored in the application module, (iv) the version number of the rate schedule data which is stored in the rate module, (v) the version number of the zip/zone data which is stored in module 305, and (vi) the option number which is stored in configuration module 307. Microprocessor 201 generates an electronic signature based on numbers (i) through (vi) using the aforementioned first encryption algorithm. The electronic signature, thus generated, is compared with the electronic signature stored in configuration module 307. If there is no mismatch, system 10 becomes operational. Otherwise if there is any mismatch, system 10 would prompt for a new authorization number.".)]</p> <p>To the extent that the reference does not explicitly disclose this element, the reference inherently disclosed the element.</p>
<p>enabling the comparing at the bureau; and</p>	<p>Schwartz '835 disclosed this element. [<i>Id.</i> at C11:36-38 ("The electronic</p>

	<p>signature, thus generated, is compared with the electronic signature stored in configuration module 307.".)]</p> <p>To the extent that the reference does not explicitly disclose this element, the reference inherently disclosed the element.</p>
transferring, from the bureau to the computer, the result of the comparing.	<p>Schwartz '835 disclosed this element [Id. at C11:36-40 ("The electronic signature, thus generated, is compared with the electronic signature stored in configuration module 307. If there is no mismatch, system 10 becomes operational. Otherwise if there is any mismatch, system 10 would prompt for a new authorization number.".)]</p> <p>To the extent that the reference does not explicitly disclose this element, the reference inherently disclosed the element.</p>
5. A method according to claim 3 wherein the identification of the computer includes the unique key.	<p>Schwartz '835 disclosed this element. [Id. at C7:48-50 ("In addition, console 13 includes read-only-memory (ROM) 213 permanently storing a unique serial number pre-assigned to system 10."); C10:21-42 ("In accordance with still another aspect of the invention, the user of system 10 needs to enter a valid authorization number, which is unique to system 10, in order to enable the new application software, or other new data or system options selected by the user. The authorization number, which is generated outside system 10 and provided to the user, is 64 bits long and consists of a 32-bit electronic signature and another 32-bit encrypted option segment. In order to generate the electronic signature, a combination of (a) the serial number of system 10, (b) the model number of system 10, (c) the version number of the application software, (d) the version number of the rate schedule data, (e) the version number of the zip/zone data, and (f) a 32-bit option number whose bit pattern corresponds to a particular combination of enabled and disabled system options, are first encrypted in accordance with a first encryption algorithm. The signature is then derived from the encrypted version of the combination of numbers (a) through (f). On the other hand, the encrypted option segment is generated by encrypting only the 32-bit option number in (f) in accordance with a second encryption algorithm.".)]</p>
6. A method according to claim 1 wherein	<p>Schwartz '835 disclosed this element. [Id. at C11:24-40 ("In the normal</p>

<p>selecting a program includes the steps of: establishing a licensed-software-program in the volatile memory of the computer wherein said licensed-software-program includes contents used to form the license-record.</p>	<p>mode of operation or each time when system 10 is powered up, microprocessor 201 reads off (i) the serial number of system 10 from ROM 213, (ii) the model number of system 10 which is stored in BIOS module 309, (iii) the version number of the application software which is stored in the application module, (iv) the version number of the rate schedule data which is stored in the rate module, (v) the version number of the zip/zone data which is stored in module 305, and (vi) the option number which is stored in configuration module 307. Microprocessor 201 generates an electronic signature based on numbers (i) through (vi) using the aforementioned first encryption algorithm. The electronic signature, thus generated, is compared with the electronic signature stored in configuration module 307. If there is no mismatch, system 10 becomes operational. Otherwise if there is any mismatch, system 10 would prompt for a new authorization number.").</p> <p>To the extent that the reference does not explicitly disclose this element, the reference inherently disclosed the element.</p>
<p>7. A method according to claim 6 wherein using an agent to set up the verification structure includes the steps of:</p>	
<p>establishing or certifying the existence of a pseudo-unique key in a first non-volatile memory area of the computer; and</p>	<p>Schwartz '835 disclosed this element. [<i>Id.</i> at C10:29-38 ("In order to generate the electronic signature, a combination of (a) the serial number of system 10, (b) the model number of system 10, (c) the version number of the application software, (d) the version number of the rate schedule data, (e) the version number of the zip/zone data, and (f) a 32-bit option number whose bit pattern corresponds to a particular combination of enabled and disabled system options, are first encrypted in accordance with a first encryption algorithm."].]</p>
<p>establishing at least one license-record location in the first nonvolatile memory area or in the erasable, non-volatile memory area of the BIOS.</p>	<p>Schwartz '835 disclosed this element. [<i>Id.</i> at C10:43-54 ("It suffices to know for now that after the user enters the authorization number, its encrypted option segment is first decrypted to recover the underlying option number. With the recovered option number, and additional numbers, system 10 independently generates an electronic signature. The generated signature</p>

	is compared with the electronic signature of the authorization number just entered. If the two signatures match, the authorization number is declared valid; the authorization number will then be stored in a first memory buffer and the recovered option number will be stored in a second memory buffer in configuration module 307."); at C11:36-38 ("The electronic signature, thus generated, is compared with the electronic signature stored in configuration module 307.".)]
8. A method according to claim 6 wherein establishing a license-record includes the steps of:	
forming a license-record by encrypting of the contents used to form a license-record with other predetermined data contents, using the key; and	Schwartz '835 disclosed this element. [<i>Id.</i> at C10:29-38 ("In order to generate the electronic signature, a combination of (a) the serial number of system 10, (b) the model number of system 10, (c) the version number of the application software, (d) the version number of the rate schedule data, (e) the version number of the zip/zone data, and (f) a 32-bit option number whose bit pattern corresponds to a particular combination of enabled and disabled system options, are first encrypted in accordance with a first encryption algorithm.".)]
establishing the encrypted license-record in one of the at least one established license-record locations.	Schwartz '835 disclosed this element. [<i>Id.</i> at C10:43-54 ("It suffices to know for now that after the user enters the authorization number, its encrypted option segment is first decrypted to recover the underlying option number. With the recovered option number, and additional numbers, system 10 independently generates an electronic signature. The generated signature is compared with the electronic signature of the authorization number just entered. If the two signatures match, the authorization number is declared valid; the authorization number will then be stored in a first memory buffer and the recovered option number will be stored in a second memory buffer in configuration module 307."); at C11:36-38 ("The electronic signature, thus generated, is compared with the electronic signature stored in configuration module 307.".)]
9. A method according to claim 7 wherein verifying the program includes the steps of:	
encrypting the licensed-software-program's license-record contents from the volatile memory	Schwartz '835 disclosed this element. [<i>Id.</i> at C11:24-40 ("In the normal mode of operation or each time when system 10 is powered up,

<p>area or decrypting the license-record in the erasable, non-volatile memory area of the BIOS, using the pseudo-unique key; and</p>	<p>microprocessor 201 reads off (i) the serial number of system 10 from ROM 213, (ii) the model number of system 10 which is stored in BIOS module 309, (iii) the version number of the application software which is stored in the application module, (iv) the version number of the rate schedule data which is stored in the rate module, (v) the version number of the zip/zone data which is stored in module 305, and (vi) the option number which is stored in configuration module 307. Microprocessor 201 generates an electronic signature based on numbers (i) through (vi) using the aforementioned first encryption algorithm. The electronic signature, thus generated, is compared with the electronic signature stored in configuration module 307. If there is no mismatch, system 10 becomes operational. Otherwise if there is any mismatch, system 10 would prompt for a new authorization number.".)]</p>
<p>comparing the encrypted licenses-software-program's license-record contents with the encrypted license-record in the erasable, non-volatile memory area of the BIOS, or comparing the license-software-program's license-record contents with the decrypted license-record in erasable non-volatile memory area of the BIOS.</p>	<p>Schwartz '835 disclosed this element. [<i>Id.</i> at C11:24-40 ("In the normal mode of operation or each time when system 10 is powered up, microprocessor 201 reads off (i) the serial number of system 10 from ROM 213, (ii) the model number of system 10 which is stored in BIOS module 309, (iii) the version number of the application software which is stored in the application module, (iv) the version number of the rate schedule data which is stored in the rate module, (v) the version number of the zip/zone data which is stored in module 305, and (vi) the option number which is stored in configuration module 307. Microprocessor 201 generates an electronic signature based on numbers (i) through (vi) using the aforementioned first encryption algorithm. The electronic signature, thus generated, is compared with the electronic signature stored in configuration module 307. If there is no mismatch, system 10 becomes operational. Otherwise if there is any mismatch, system 10 would prompt for a new authorization number.".)]</p>
<p>10. A method according to claim 9 wherein acting on the program includes the step: restricting the program's operation with predetermined limitations if the comparing yields non-unity or insufficiency.</p>	<p>Schwartz '835 disclosed this element. [<i>Id.</i> at C11:38-40 ("If there is no mismatch, system 10 becomes operational. Otherwise if there is any mismatch, system 10 would prompt for a new authorization number."); at C12:8-14 ("The authorization number is validated at step 709 if microprocessor 201 finds that the two signatures match. Otherwise, a</p>

	message such as "Invalid Authorization Number" is displayed at step 711 on screen 9. only when the user's authorization number is validated, does system 10 become operational, as indicated at step 713.".)]
11. A method according to claim 1 wherein the volatile memory is a RAM.	Schwartz '835 disclosed this element. [<i>Id.</i> at C7:48-59 ("In addition, console 13 includes read-only-memory (ROM) 213 permanently storing a unique serial number pre-assigned to system 10. Console 13 also includes memory section 250 comprising flash electrically erasable programmable read-only-memory (EEPROM) 250a having a capacity of 128 Kbytes, EPROM 250b having a capacity of 32 Kbytes, a nonvolatile static random-access-memory (SRAM) 250c having a capacity of 128 Kbytes, and SRAM 250d having a capacity of 128 Kbytes, all of which are of conventional design. Flash EEPROM 250a may illustratively be an AT29C010 memory manufactured and marketed by Atmel Corporation."); at C8:21-25 ("The memory space provided by memory 250c is used for storing accounting information files numerically denoted 351 and manifest information files denoted 353. When the system is in operation, the memory space provided by memory 250d is utilized as work space.").
12. The method of claim 1, wherein a pseudo-unique key is stored in the non-volatile memory of the BIOS.	Schwartz '835 disclosed this element. [<i>Id.</i> at C7:48-50 ("In addition, console 13 includes read-only-memory (ROM) 213 permanently storing a unique serial number pre-assigned to system 10.".)]
13. The method of claim 1, wherein a unique key is stored in a first non-volatile memory area of the computer.	Schwartz '835 disclosed this element. [<i>Id.</i> at C7:48-50 ("In addition, console 13 includes read-only-memory (ROM) 213 permanently storing a unique serial number pre-assigned to system 10.".)]
14. The method according claim 13, wherein the step of using the agent to set up the verification record, including the license record, includes encrypting a license record data in the program using at least the unique key.	Schwartz '835 disclosed this element. [<i>Id.</i> at C10:29-38 ("In order to generate the electronic signature, a combination of (a) the serial number of system 10, (b) the model number of system 10, (c) the version number of the application software, (d) the version number of the rate schedule data, (e) the version number of the zip/zone data, and (f) a 32-bit option number whose bit pattern corresponds to a particular combination of enabled and disabled system options, are first encrypted in accordance with a first encryption algorithm.".)]
15. The method according to claim 14, wherein the verification comprises:	

<p>extracting the license record from the software program;</p>	<p>Schwartz '835 disclosed this element. [<i>Id.</i> at C11:24-33 ("In the normal mode of operation or each time when system 10 is powered up, microprocessor 201 reads off (i) the serial number of system 10 from ROM 213, (ii) the model number of system 10 which is stored in BIOS module 309, (iii) the version number of the application software which is stored in the application module, (iv) the version number of the rate schedule data which is stored in the rate module, (v) the version number of the zip/zone data which is stored in module 305, and (vi) the option number which is stored in configuration module 307.").]</p>
<p>encrypting the license record using the unique key stored in the first non-volatile memory area of the computer to form second encrypted license information; and</p>	<p>Schwartz '835 disclosed this element. [<i>Id.</i> at C11:33-36 ("Microprocessor 201 generates an electronic signature based on numbers (i) through (vi) using the aforementioned first encryption algorithm.").]</p>
<p>comparing the encrypted license information stored in the erasable, non-volatile memory area of the BIOS of the computer with the second encrypted license information.</p>	<p>Schwartz '835 disclosed this element. [<i>Id.</i> at C11:36-40 ("The electronic signature, thus generated, is compared with the electronic signature stored in configuration module 307. If there is no mismatch, system 10 becomes operational. Otherwise if there is any mismatch, system 10 would prompt for a new authorization number.").]</p>
<p>16. The method according to claim 13, wherein the step of verifying the program includes a decrypting the license record data accommodated in the erasable second non-volatile memory area of the BIOS using at least the unique key.</p>	<p>Schwartz '835 disclosed this element. [<i>Id.</i> at C12:15-29 ("An alternative validation technique involving use of a differently formatted authorization number will now be described. In accordance with this alternative technique, the authorization number is generated by encrypting the above numbers (a) through (f) using a standard encryption algorithm. After the user enters such an authorization number, system 10 decrypts the entered number using a decryption algorithm inverse to the standard encryption algorithm, and recovers the underlying numbers (a) through (f). System 10 then retrieves therewithin the above numbers (i) through (v) in the manner described before, and compares them with the corresponding, recovered numbers (a) through (e). The authorization number is validated if the two sets of numbers match.").]</p> <p>To the extent that Schwartz '835 did not explicitly disclose this element, the element was obvious in view of the disclosure.</p>

<p>17. The method according to claim 13, wherein the step of verifying the program includes encrypting the license record that is accommodated in the program using at least the unique key.</p>	<p>Schwartz '835 disclosed this element. [<i>Id.</i> at C11:24-40 ("In the normal mode of operation or each time when system 10 is powered up, microprocessor 201 reads off (i) the serial number of system 10 from ROM 213, (ii) the model number of system 10 which is stored in BIOS module 309, (iii) the version number of the application software which is stored in the application module, (iv) the version number of the rate schedule data which is stored in the rate module, (v) the version number of the zip/zone data which is stored in module 305, and (vi) the option number which is stored in configuration module 307. Microprocessor 201 generates an electronic signature based on numbers (i) through (vi) using the aforementioned first encryption algorithm. The electronic signature, thus generated, is compared with the electronic signature stored in configuration module 307. If there is no mismatch, system 10 becomes operational. Otherwise if there is any mismatch, system 10 would prompt for a new authorization number."].]</p>
<p>18. A method for accessing an application software program using a pseudo-unique key stored in a first non-erasable non-volatile memory area of a computer, the first non-volatile memory area being unable to be programmatically changed, the method, comprising:</p>	<p>Schwartz '835 disclosed this preamble. [Schwartz '835 at C12:29-40 ("The authorization number verification requirement is desirable in that it helps deter unauthorized copying of software of system 10 onto other similar systems. This stems from the fact that even though the software can be copied onto the similar systems, the latter would not be operational without proper authorization numbers, which need to be derived in part from their respective unique serial numbers. In addition, since system 10 would only become operational with a proper authorization number, which specifies a valid combination of software versions for use in the system, the verification requirement thus ensures that the combination of software in system 10 is compatible."); at C7:48-50 ("In addition, console 13 includes read-only-memory (ROM) 213 permanently storing a unique serial number pre-assigned to system 10."); at C10:21-42 ("In accordance with still another aspect of the invention, the user of system 10 needs to enter a valid authorization number, which is unique to system 10, in order to enable the new application software, or other new data or system options selected by the user. The authorization number, which is generated outside system 10 and provided to the user, is 64 bits long and consists of a 32-bit electronic</p>

	signature and another 32-bit encrypted option segment. In order to generate the electronic signature, a combination of (a) the serial number of system 10, (b) the model number of system 10, (c) the version number of the application software, (d) the version number of the rate schedule data, (e) the version number of the zip/zone data, and (f) a 32-bit option number whose bit pattern corresponds to a particular combination of enabled and disabled system options, are first encrypted in accordance with a first encryption algorithm. The signature is then derived from the encrypted version of the combination of numbers (a) through (f). On the other hand, the encrypted option segment is generated by encrypting only the 32-bit option number in (f) in accordance with a second encryption algorithm.".)]
loading the application software program residing in a non-volatile memory area of the computer;	Schwartz '835 disclosed this element. [<i>Id.</i> at C8:26-31 ("In this particular illustrative embodiment, rate schedule data, an operating system and an application program (hereinafter referred to as the "carrier service program") are provided to the user in an IC card. This application program when executed causes system 10 to perform certain tasks in accordance with the invention."); at C12:59 to C13:3 ("It should also be noted that in the event that system 10 becomes inoperational and requires maintenance, in order to start a new system, the user only needs to physically transfer, from system 10 to the new system, ROM 213 and memory 250a. As mentioned before, ROM 213 contains a unique serial number; and memory 250 contains, among other things, user programmed information in configuration module 307 and zip/zone data in zip/zone module 305. Other data including the rate schedule data and the application code are loaded onto the new system through IC cards. As soon as the user enters a proper authorization number, the new system is ready for operation.".)]
using an agent to perform the following steps:	Schwartz '835 disclosed this element. [<i>Id.</i> at C11:41 to C12:14 ("To this end, the new data or new application code for updating system 10 contains therewithin its own new version number. Thus, in the previous example where the user is provided with IC card 401 to update the rate schedule data, EPROM 403 contains not only the new data and the header information, but also a new version number within the new data. This new data including the new version number is downloaded from card 401 to the rate module on

	<p>power up of system 10 in a manner described before. After the data transfer is complete, system 10 is then turned off and the card is removed. Upon-subsequent power up of system 10, because of the fact that the rate schedule data has been updated and the rate module now contains the new version number, system 10 prompts the user for an authorization number on screen 9 as discussed before. In response, the user needs to enter on keyboard 17 the necessary authorization number which is derived partly on the new version number. System 10 is equipped with routine 700 of FIG. 12 for verifying the number entry. Instructed by routine 700, microprocessor 201 reads from keyboard interface 230 the authorization number just entered, as indicated at step 701. Routine 700 then proceeds to step 703 where microprocessor 201 causes the decryption of the encrypted option segment of the authorization number to recover the underlying option number. Such decryption is accomplished by using a decryption algorithm inverse to the second encryption algorithm. At step 705, microprocessor 201 reads off the above numbers (i) through (v), with number (iv) being the new version number of the rate schedule data. Using the recovered option number, and numbers (i) through (v) just read, microprocessor 201 at step 707 generates an electronic signature using the first encryption algorithm. The electronic signature, thus generated, is compared by microprocessor 201 at step 708 with the electronic signature in the authorization number entered by the user. The authorization number is validated at step 709 if microprocessor 201 finds that the two signatures match. Otherwise, a message such as "Invalid Authorization Number" is displayed at step 711 on screen 9. only when the user's authorization number is validated, does system 10 become operational, as indicated at step 713.".]</p> <p>To the extent that the reference does not explicitly disclose this element, the reference inherently disclosed the element.</p>
<p>extracting license information from software program;</p>	<p>Schwartz '835 disclosed this element. [<i>Id.</i> at C10:21-42 ("In accordance wish still another aspect of the invention, the user of system 10 needs to enter a valid authorization number, which is unique to system 10, in order to enable the new application software, or other new data or system options</p>

	<p>selected by the user. The authorization number, which is generated outside system 10 and provided to the user, is 64 bits long and consists of a 32-bit electronic signature and another 32-bit encrypted option segment. In order to generate the electronic signature, a combination of (a) the serial number of system 10, (b) the model number of system 10, (c) the version number of the application software, (d) the version number of the rate schedule data, (e) the version number of the zip/zone data, and (f) a 32-bit option number whose bit pattern corresponds to a particular combination of enabled and disabled system options, are first encrypted in accordance with a first encryption algorithm. The signature is then derived from the encrypted version of the combination of numbers (a) through (f). On the other hand, the encrypted option segment is generated by encrypting only the 32-bit option number in (f) in accordance with a second encryption algorithm.".]</p>
<p>encrypting license information using the pseudo-unique key stored in the first non-volatile memory area;</p>	<p>Schwartz '835 disclosed this element. [<i>Id.</i> at C10:29-38 ("In order to generate the electronic signature, a combination of (a) the serial number of system 10, (b) the model number of system 10, (c) the version number of the application software, (d) the version number of the rate schedule data, (e) the version number of the zip/zone data, and (f) a 32-bit option number whose bit pattern corresponds to a particular combination of enabled and disabled system options, are first encrypted in accordance with a first encryption algorithm.".)]</p>
<p>storing the encrypting license information in a second erasable, writable, non-volatile memory area of the BIOS of the computer;</p>	<p>Schwartz '835 disclosed this element. [<i>Id.</i> at C10:43-54 ("It suffices to know for now that after the user enters the authorization number, its encrypted option segment is first decrypted to recover the underlying option number. With the recovered option number, and additional numbers, system 10 independently generates an electronic signature. The generated signature is compared with the electronic signature of the authorization number just entered. If the two signatures match, the authorization number is declared valid; the authorization number will then be stored in a first memory buffer and the recovered option number will be stored in a second memory buffer in configuration module 307."); at C11:36-40 ("The electronic signature, thus generated, is compared with the electronic signature stored in configuration module 307. If there is no mismatch, system 10 becomes operational.</p>

Otherwise if there is any mismatch, system 10 would prompt for a new authorization number."); at Fig. 9:

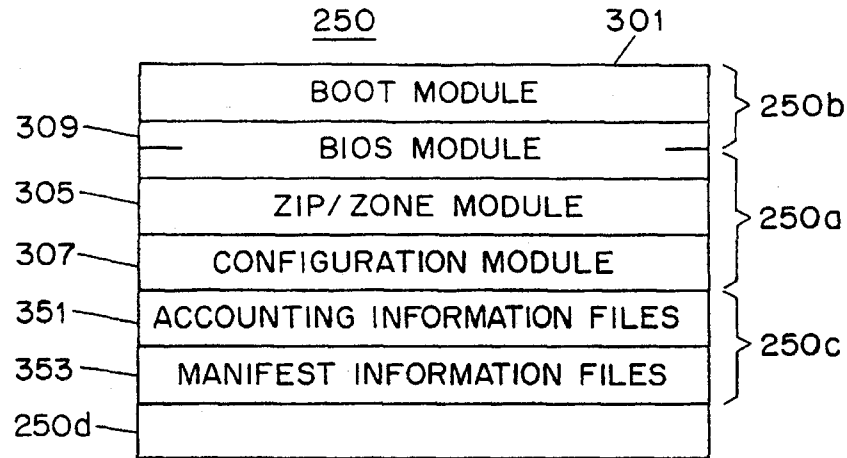

FIG. 9

subsequently verifying the application software program based on the encrypted license information stored in the second erasable, writable, non-volatile memory area of the BIOS; and

Schwartz '835 disclosed this element. [*Id.* at C11:24-40 ("In the normal mode of operation or each time when system 10 is powered up, microprocessor 201 reads off (i) the serial number of system 10 from ROM 213, (ii) the model number of system 10 which is stored in BIOS module 309, (iii) the version number of the application software which is stored in the application module, (iv) the version number of the rate schedule data which is stored in the rate module, (v) the version number of the zip/zone data which is stored in module 305, and (vi) the option number which is stored in configuration module 307. Microprocessor 201 generates an electronic signature based on numbers (i) through (vi) using the aforementioned first encryption algorithm. The electronic signature, thus generated, is compared with the electronic signature stored in configuration module 307. If there is no mismatch, system 10 becomes operational. Otherwise if there is any mismatch, system 10 would prompt for a new authorization number.".)]

<p>acting on the application software program based on the verification.</p>	<p>Schwartz '835 disclosed this element. [<i>Id.</i> at C11:38-40 ("If there is no mismatch, system 10 becomes operational. Otherwise if there is any mismatch, system 10 would prompt for a new authorization number."); at C12:8-14 ("The authorization number is validated at step 709 if microprocessor 201 finds that the two signatures match. Otherwise, a message such as "Invalid Authorization Number" is displayed at step 711 on screen 9. only when the user's authorization number is validated, does system 10 become operational, as indicated at step 713.").]</p>
<p>19. The method of claim 18, wherein the verification comprises:</p>	
<p>extracting the license information from the software program;</p>	<p>Schwartz '835 disclosed this element. [<i>Id.</i> at C11:24-40 ("In the normal mode of operation or each time when system 10 is powered up, microprocessor 201 reads off (i) the serial number of system 10 from ROM 213, (ii) the model number of system 10 which is stored in BIOS module 309, (iii) the version number of the application software which is stored in the application module, (iv) the version number of the rate schedule data which is stored in the rate module, (v) the version number of the zip/zone data which is stored in module 305, and (vi) the option number which is stored in configuration module 307. Microprocessor 201 generates an electronic signature based on numbers (i) through (vi) using the aforementioned first encryption algorithm. The electronic signature, thus generated, is compared with the electronic signature stored in configuration module 307. If there is no mismatch, system 10 becomes operational. Otherwise if there is any mismatch, system 10 would prompt for a new authorization number.").]</p>
<p>encrypting the license information using the pseudo-unique key stored in the first non-volatile memory area of the computer to form second encrypted license information; and</p>	<p>Schwartz '835 disclosed this element. [<i>Id.</i> at C11:24-40 ("In the normal mode of operation or each time when system 10 is powered up, microprocessor 201 reads off (i) the serial number of system 10 from ROM 213, (ii) the model number of system 10 which is stored in BIOS module 309, (iii) the version number of the application software which is stored in the application module, (iv) the version number of the rate schedule data which is stored in the rate module, (v) the version number of the zip/zone data which is stored in module 305, and (vi) the option number which is</p>

	<p>stored in configuration module 307. Microprocessor 201 generates an electronic signature based on numbers (i) through (vi) using the aforementioned first encryption algorithm. The electronic signature, thus generated, is compared with the electronic signature stored in configuration module 307. If there is no mismatch, system 10 becomes operational. Otherwise if there is any mismatch, system 10 would prompt for a new authorization number.".)]</p>
<p>comparing the encrypted license information stored in the second erasable, writable, non-volatile memory area of the BIOS of the computer with the second encrypted license information.</p>	<p>Schwartz '835 disclosed this element. [<i>Id.</i> at C11:36-40 ("The electronic signature, thus generated, is compared with the electronic signature stored in configuration module 307. If there is no mismatch, system 10 becomes operational. Otherwise if there is any mismatch, system 10 would prompt for a new authorization number.".)]</p>

<p align="center">U.S. Patent No. 6,411,941 Claims 1-19</p>	<p align="center">Lewis '819</p>
<p>1. A method of restricting software operation within a license for use with a computer including an erasable, non-volatile memory area of a BIOS of the computer, and a volatile memory area; the method comprising the steps of:</p>	<p>Lewis '819 disclosed this preamble. [Lewis '819 at Abstract ("A method and apparatus for providing system operation validation is disclosed. The method and apparatus for validation operates within a computer system comprising a central processing unit coupled to a programmable memory, and to a system device. The programmable memory may store programs and instructions executable on the CPU and a non-volatile memory is also provided for access by the CPU."); at C1:8-16 ("The present invention relates, generally, to a computer system having a non-volatile memory and, more specifically, to electronic security information being stored in the non-volatile memory. More specifically, the present invention relates to a computer system having a non-volatile memory with security information written into the non-volatile memory and a way of detecting when that information has been altered so as to prevent operation of the computer system once tampering has been detected."); at C3:6-15 ("It is therefore one object of the present invention to provide a computer system having a non-volatile memory:</p>

	<p>It is another object of the present invention to provide electronic security information stored in the non-volatile memory.</p> <p>It is yet another object of the present invention to provide a computer system having a non-volatile memory with security information written into the non-volatile memory and a way of detecting when that information has been altered so as to prevent operation of any portion of the computer system once tampering has been detected."); at C4:40-54 ("A non-volatile memory device (NVM) 20 is further connected to CPU 14. NVM 20 contains various information that the device manufacturer uses as part of the device 16 control, such as DEVICE TYPE, DEVICE SERIAL NUMBER, and any other UNIQUE DEVICE DATA. To be able to detect any alteration in the NVM 20, a CHIP ID is included so that any software programs in memory 12 can compare the chip ID in device 16 with the chip ID written in NVM 20. Additionally, an encryption code, for example, a Message Authentication Code (MAC) is written in NVM 20 where the DEVICE TYPE, DEVICE SERIAL NUMBER, CHIP ID and UNIQUE DEVICE DATA are used as the text input to the MAC generation method. Further, an encryption key is further provided to which the software programs in memory 12 also have access.".)]</p> <p>To the extent that the reference does not explicitly disclose this element, the reference inherently disclosed the element.</p>
<p>selecting a program residing in the volatile memory,</p>	<p>Lewis '819 disclosed this element. [<i>Id.</i> at C4:23-31 ("Computer system 10 includes a memory unit 12 connected to a central processing unit (CPU) 14. The memory unit 12 contains instructions and programs that are executed in CPU 14. These instructions are used to control a device 16, which may be an electro-mechanical device such as, for example, a DASD device, with an electronic device controller, tape reader or diskette reader, or an electronic device such as, for example, a cache controller."); at C5:10-20 ("The MAC is used to provide a means, or digital signature, for detecting when a serial number or any other critical data written into NVM 20 is altered. Once there</p>

	<p>is modification or duplication detected, the software program stored in memory 12 can then take steps to prevent software programs from running on the altered device 16. To provide modification detection of NVM 20, the system uses several ID items. First, a unique chip identifier that is different from any other chip, which is non-alterable, is used as a standard by which the software determines the identity of the device and whether alterations have occurred. Second, the software programs are given the ability to read this chip identifier."; at C5:27-31 ("While system 10 is operating, system code is retrieved from memory 12 into CPU 14 for execution. Prior to using device 16, the system code performs a chip identification and NVM content alteration detection test, which is illustrated in the flowchart of FIG. 4.".)]</p>
<p>using an agent to set up a verification structure in the erasable, non-volatile memory of the BIOS, the verification structure accommodating data that includes at least one license record,</p>	<p>Lewis '819 disclosed this element. [<i>Id.</i> at Fig. 3; at C2:7-20 ("There are several encryption techniques that can be used that can provide the manufacturer the capability to detect any duplication or modification of the non-volatile memory data such as a serial number. One example of the encryption technique is the Message Authentication Code (MAC), which uses the Data Encryption Standard encryption algorithm. The MAC routine is passed a string of text data and an encryption key and returns an 8 byte MAC. Since the DES encryption encrypts 8 bytes at a time and the result of the previous 8 byte encryption is used with the next 8 bytes of encryption, the last 8 bytes of the encryption are dependent on all of the previous text data so any change in any of the previous data will be detected in the last 8 bytes of the encryption (the MAC)."); at C2:21-48 ("At the time the device is manufactured, the manufacturer will select an 8 byte encryption key that must be kept secret. The unique chip Identifier is included in the text portion of the data to be encrypted along with any other data the manufacturer wants to prevent being modified. A MAC is then generated and written along with the data in the non-volatile memory along with the data. The operating system software program then reads the non-volatile memory and the unique chip identifier from the hardware. If the unique chip identifier found in the text portion of the non-volatile memory does not compare with the one in the hardware, then the text has been altered (probably copied from another machine) and the software program can reject the device as being an invalid</p>

	<p>device. If the unique chip identifier in the non-volatile memory does match the one in the chip, then the software program verifies that the MAC is correct by generating a new MAC for the text of the non-volatile memory using the same key that was used to generate the MAC in manufacturing and then compares the MAC generated with the MAC in the non-volatile memory. If the MACs compare then the software program is assured that none of the text data that is covered by the MAC has been altered. Since only the manufacturer and the checking software knows the key to create the MAC AND the unique chip identifier is part of the text that created the MAC, it is not possible to alter the text or MAC unless the encryption key is known. Obviously the key must be kept secret and protected by the software and the manufacturer."); at C4:55 to C5:9 ("FIG. 3 is a block diagram of a flowchart depicting the method used to generate the MAC shown in FIG. 2. In step 310, a text storage area is established in NVM 20, to which the MAC is checked, consisting of 0-31 of the NVM address base. In this example, the text has a length of 32 bytes. In step 312, a 64 bit key is used to encrypt the first eight (8) bytes of the text data using a data encryption scheme (DES) method, which is well known to those skilled in the art, to yield eight (8) bytes of encrypted data. Next, in step 314, these eight (8) bytes of encrypted data are exclusively ORed with the next eight (8) bytes of the text data. The results are then encrypted in step 316, using the DES method and the same key. The results are eight (8) bytes of encrypted data that include the current eight (8) bytes of the text, plus all the previous eight (8) byte blocks of text. The system continues to encrypt the remaining text using steps 314 and 316. In step 318, the system determines whether all the text has been encrypted and if so, in step 320, a resultant eight (8) bytes is used as the MAC, which is used to detect any change in any of the text that was used as input to generate the MAC. In step 322, the MAC is placed in NVM 20 at locations 32-39, shown in FIG. 2.".)]</p>
<p>verifying the program using at least the verification structure from the erasable non-volatile memory of the BIOS, and</p>	<p>Lewis '819 disclosed this element. [Id. at Fig. 4; at C5:10-26 ("The MAC is used to provide a means, or digital signature, for detecting when a serial number or any other critical data written into NVM 20 is altered. Once there is modification or duplication detected, the software program stored in</p>

	<p>memory 12 can then take steps to prevent software programs from running on the altered device 16. To provide modification detection of NVM 20, the system uses several ID items. First, a unique chip identifier that is different from any other chip, which is non-alterable, is used as a standard by which the software determines the identity of the device and whether alterations have occurred. Second, the software programs are given the ability to read this chip identifier. Third, the non-volatile memory is included to hold the text covered by the encryption algorithm. The non-volatile memory is that non-volatile memory used to store data that the manufacturer wants to prevent from being altered (such as warranty data) using an encryption technique in which the unique chip identifier is used as part of the encryption algorithm or the chip identifier."); at C5:27-50 ("While system 10 is operating, system code is retrieved from memory 12 into CPU 14 for execution. Prior to using device 16, the system code performs a chip identification and NVM content alteration detection test, which is illustrated in the flowchart of FIG. 4. In step 410, the system reads the contents of NVM 20 into memory 12. Next, in step 412, the system generates a Message Authentication Code of the first 32 bytes of the NVM data that was stored in memory 12, using the same key that the manufacturer used to create the MAC stored in bytes 32-39 in NVM 20. In step 414, the system compares the MAC stored in memory 12 from bytes 32-39 of the NVM 20 data with the MAC generated in step 412. If the MACs do not compare, then the NVM 20 data is not valid and the device 16 cannot be used and the system aborts in step 416. If the MACs do compare, the system, in step 418, reads the chip ID from the chip ID register 18 into CPU 14. Next, in step 420, the system compares the chip ID field from bytes 16-23 of the NVM data stored in memory 12 with the chip ID field read from chip ID register 18 read in step 418. If the fields compare, then the NVM data is valid and system operation is granted in step 422; otherwise the NVM data has been copied from another system (because the MAC was good, it had to have been copied from another system) and the device cannot be used and the system aborts in step 416.".)]</p>
<p>acting on the program according to the</p>	<p>Lewis '819 disclosed this element. [<i>Id.</i> at C5:45-50 ("If the fields compare,</p>

verification.	then the NVM data is valid and system operation is granted in step 422; otherwise the NVM data has been copied from another system (because the MAC was good, it had to have been copied from another system) and the device cannot be used and the system aborts in step 416.".]
2. A method according to claim 1, further comprising the steps of:	
establishing a license authentication bureau.	Lewis '819 disclosed this element. [<i>Id.</i> at C3:16-21 ("The foregoing objects are achieved as is now described. According to the present invention, a method and apparatus for providing system operation validation is disclosed. The method and apparatus for validation operates within a computer system comprising a central processing unit coupled to a programmable memory, and to a system device."); at C5:56-63 ("1. In a computer system comprising a central processing unit (CPU) coupled to a programmable memory, which may store programs and instructions executable on said CPU, a system device, coupled to said CPU, and a non-volatile memory, coupled to said CPU, a system operation validator comprising: a chip identifier located in a chip identifier register within said system device;
3. A method according to claim 2, wherein setting up a verification structure further comprising the steps of:	
establishing, between the computer and the bureau, a two-way data-communications linkage;	Lewis '819 disclosed this element. [<i>Id.</i> at C4:55-59 ("FIG. 3 is a block diagram of a flowchart depicting the method used to generate the MAC shown in FIG. 2. In step 310, a text storage area is established in NVM 20, to which the MAC is checked, consisting of 0-31 of the NVM address base."); at C5:8-9 ("In step 322, the MAC is placed in NVM 20 at locations 32-39, shown in FIG. 2.".)] To the extent that the reference does not explicitly disclose this element, the reference inherently disclosed the element.
transferring, from the computer to the bureau, a request-for-license including an identification of	Lewis '819 disclosed this element. [<i>Id.</i> at C3:27-32 ("Selected information stored within the non-volatile memory is used, along with the chip identifier,

<p>the computer and the license-record's contents from the selected program;</p>	<p>to generate a first encryption code associated with the system device. An encryption key is used to generate a second encryption code associated with the computer system."); at C4:40-54 ("A non-volatile memory device (NVM) 20 is further connected to CPU 14. NVM 20 contains various information that the device manufacturer uses as part of the device 16 control, such as DEVICE TYPE, DEVICE SERIAL NUMBER, and any other UNIQUE DEVICE DATA. To be able to detect any alteration in the NVM 20, a CHIP ID is included so that any software programs in memory 12 can compare the chip ID in device 16 with the chip ID written in NVM 20. Additionally, an encryption code, for example, a Message Authentication Code (MAC) is written in NVM 20 where the DEVICE TYPE, DEVICE SERIAL NUMBER, CHIP ID and UNIQUE DEVICE DATA are used as the text input to the MAC generation method. Further, an encryption key is further provided to which the software programs in memory 12 also have access."); at C4:55-59 ("FIG. 3 is a block diagram of a flowchart depicting the method used to generate the MAC shown in FIG. 2. In step 310, a text storage area is established in NVM 20, to which the MAC is checked, consisting of 0-31 of the NVM address base."); at C2:7-20 ("There are several encryption techniques that can be used that can provide the manufacturer the capability to detect any duplication or modification of the non-volatile memory data such as a serial number. One example of the encryption technique is the Message Authentication Code (MAC), which uses the Data Encryption Standard encryption algorithm. The MAC routine is passed a string of text data and an encryption key and returns an 8 byte MAC. Since the DES encryption encrypts 8 bytes at a time and the result of the previous 8 byte encryption is used with the next 8 bytes of encryption, the last 8 bytes of the encryption are dependent on all of the previous text data so any change in any of the previous data will be detected in the last 8 bytes of the encryption (the MAC).").]</p>
<p>forming an encrypted license-record at the bureau by encrypting parts of the request-for-license using part of the identification as an encryption key;</p>	<p>Lewis '819 disclosed this element. [<i>Id.</i> at C2:7-20 ("There are several encryption techniques that can be used that can provide the manufacturer the capability to detect any duplication or modification of the non-volatile memory data such as a serial number. One example of the encryption</p>

	<p>technique is the Message Authentication Code (MAC), which uses the Data Encryption Standard encryption algorithm. The MAC routine is passed a string of text data and an encryption key and returns an 8 byte MAC. Since the DES encryption encrypts 8 bytes at a time and the result of the previous 8 byte encryption is used with the next 8 bytes of encryption, the last 8 bytes of the encryption are dependent on all of the previous text data so any change in any of the previous data will be detected in the last 8 bytes of the encryption (the MAC)."; at C2:21-25 ("At the time the device is manufactured, the manufacturer will select an 8 byte encryption key that must be kept secret. The unique chip Identifier is included in the text portion of the data to be encrypted along with any other data the manufacturer wants to prevent being modified."); at C4:48-54 ("Additionally, an encryption code, for example, a Message Authentication Code (MAC) is written in NVM 20 where the DEVICE TYPE, DEVICE SERIAL NUMBER, CHIP ID and UNIQUE DEVICE DATA are used as the text input to the MAC generation method. Further, an encryption key is further provided to which the software programs in memory 12 also have access.".)]</p>
<p>transferring, from the bureau to the computer, the encrypted license-record; and</p>	<p>Lewis '819 disclosed this element. [<i>Id.</i> at Fig. 3; at C5:3-7 ("In step 318, the system determines whether all the text has been encrypted and if so, in step 320, a resultant eight (8) bytes is used as the MAC, which is used to detect any change in any of the text that was used as input to generate the MAC.".)]</p>
<p>storing the encrypted license record in the erasable non-volatile memory area of the BIOS.</p>	<p>Lewis '819 disclosed this element. [<i>Id.</i> at Fig. 3; at C5:8-9 ("In step 322, the MAC is placed in NVM 20 at locations 32-39, shown in FIG. 2.".)]</p>
<p>4. A method according to claim 2, wherein verifying the program further comprises the steps of:</p>	
<p>establishing, between the computer and the bureau, a two-way data-communications linkage;</p>	<p>Lewis '819 disclosed this element. [<i>Id.</i> at C5:27-32 ("While system 10 is operating, system code is retrieved from memory 12 into CPU 14 for execution. Prior to using device 16, the system code performs a chip identification and NVM content alteration detection test, which is illustrated in the flowchart of FIG. 4. In step 410, the system reads the contents of NVM 20 into memory 12.".)]</p>

	To the extent that the reference does not explicitly disclose this element, the reference inherently disclosed the element.
transferring, from the computer to the bureau, a request-for-license verification including an identification of the computer, an encrypted license-record for the selected program from the erasable, non-volatile memory area of the BIOS, and the program's license-record;	Lewis '819 disclosed this element. [Id. at C3:27-36 ("Selected information stored within the non-volatile memory is used, along with the chip identifier, to generate a first encryption code associated with the system device. An encryption key is used to generate a second encryption code associated with the computer system. The first and second encryption codes are matched to provide a first level system operation validation. A second chip identifier is generated, which identifier is associated with the computer system. Both chip identifiers are compared to provide a second level system operation validation."); at C5:27-49 ("While system 10 is operating, system code is retrieved from memory 12 into CPU 14 for execution. Prior to using device 16, the system code performs a chip identification and NVM content alteration detection test, which is illustrated in the flowchart of FIG. 4. In step 410, the system reads the contents of NVM 20 into memory 12. Next, in step 412, the system generates a Message Authentication Code of the first 32 bytes of the NVM data that was stored in memory 12, using the same key that the manufacturer used to create the MAC stored in bytes 32-39 in NVM 20. In step 414, the system compares the MAC stored in memory 12 from bytes 32-39 of the NVM 20 data with the MAC generated in step 412. If the MACs do not compare, then the NVM 20 data is not valid and the device 16 cannot be used and the system aborts in step 416. If the MACs do compare, the system, in step 418, reads the chip ID from the chip ID register 18 into CPU 14. Next, in step 420, the system compares the chip ID field from bytes 16-23 of the NVM data stored in memory 12 with the chip ID field read from chip ID register 18 read in step 418. If the fields compare, then the NVM data is valid and system operation is granted in step 422; otherwise the NVM data has been copied from another system (because the MAC was good, it had to have been copied from another system) and the device cannot be used and the system aborts in step 416."].]
enabling the comparing at the bureau; and	Lewis '819 disclosed this element. [Id. at C5:27-49 ("While system 10 is operating, system code is retrieved from memory 12 into CPU 14 for

	<p>execution. Prior to using device 16, the system code performs a chip identification and NVM content alteration detection test, which is illustrated in the flowchart of FIG. 4. In step 410, the system reads the contents of NVM 20 into memory 12. Next, in step 412, the system generates a Message Authentication Code of the first 32 bytes of the NVM data that was stored in memory 12, using the same key that the manufacturer used to create the MAC stored in bytes 32-39 in NVM 20. In step 414, the system compares the MAC stored in memory 12 from bytes 32-39 of the NVM 20 data with the MAC generated in step 412. If the MACs do not compare, then the NVM 20 data is not valid and the device 16 cannot be used and the system aborts in step 416. If the MACs do compare, the system, in step 418, reads the chip ID from the chip ID register 18 into CPU 14. Next, in step 420, the system compares the chip ID field from bytes 16-23 of the NVM data stored in memory 12 with the chip ID field read from chip ID register 18 read in step 418. If the fields compare, then the NVM data is valid and system operation is granted in step 422; otherwise the NVM data has been copied from another system (because the MAC was good, it had to have been copied from another system) and the device cannot be used and the system aborts in step 416.".]</p>
<p>transferring, from the bureau to the computer, the result of the comparing.</p>	<p>Lewis '819 disclosed this element. [<i>Id.</i> at C5:45-49 ("If the fields compare, then the NVM data is valid and system operation is granted in step 422; otherwise the NVM data has been copied from another system (because the MAC was good, it had to have been copied from another system) and the device cannot be used and the system aborts in step 416.").]</p> <p>To the extent that the reference does not explicitly disclose this element, the reference inherently disclosed the element.</p>
<p>5. A method according to claim 3 wherein the identification of the computer includes the unique key.</p>	<p>Lewis '819 disclosed this element. [<i>Id.</i> at C4:33-39 ("Device 16 further includes a chip ID register 18, which includes a unique chip identifier within the chip ID register 18. The chip identifier is read by an instruction executed in CPU 14. The unique chip identifier is built as part of the chip identifier register 18 so that each chip in a manufactured set has a different unique chip identifier.").]</p>

<p>6. A method according to claim 1 wherein selecting a program includes the steps of: establishing a licensed-software-program in the volatile memory of the computer wherein said licensed-software-program includes contents used to form the license-record.</p>	<p>Lewis '819 disclosed this element. [<i>Id.</i> at C4:40-54 ("A non-volatile memory device (NVM) 20 is further connected to CPU 14. NVM 20 contains various information that the device manufacturer uses as part of the device 16 control, such as DEVICE TYPE, DEVICE SERIAL NUMBER, and any other UNIQUE DEVICE DATA. To be able to detect any alteration in the NVM 20, a CHIP ID is included so that any software programs in memory 12 can compare the chip ID in device 16 with the chip ID written in NVM 20. Additionally, an encryption code, for example, a Message Authentication Code (MAC) is written in NVM 20 where the DEVICE TYPE, DEVICE SERIAL NUMBER, CHIP ID and UNIQUE DEVICE DATA are used as the text input to the MAC generation method. Further, an encryption key is further provided to which the software programs in memory 12 also have access."); at C5:27-32 ("While system 10 is operating, system code is retrieved from memory 12 into CPU 14 for execution. Prior to using device 16, the system code performs a chip identification and NVM content alteration detection test, which is illustrated in the flowchart of FIG. 4. In step 410, the system reads the contents of NVM 20 into memory 12.").]</p>
<p>7. A method according to claim 6 wherein using an agent to set up the verification structure includes the steps of:</p>	
<p>establishing or certifying the existence of a pseudo-unique key in a first non-volatile memory area of the computer; and</p>	<p>Lewis '819 disclosed this element. [<i>Id.</i> at C4:33-39 "Device 16 further includes a chip ID register 18, which includes a unique chip identifier within the chip ID register 18. The chip identifier is read by an instruction executed in CPU 14. The unique chip identifier is built as part of the chip identifier register 18 so that each chip in a manufactured set has a different unique chip identifier."); at C4:41-54 ("NVM 20 contains various information that the device manufacturer uses as part of the device 16 control, such as DEVICE TYPE, DEVICE SERIAL NUMBER, and any other UNIQUE DEVICE DATA. To be able to detect any alteration in the NVM 20, a CHIP ID is included so that any software programs in memory 12 can compare the chip ID in device 16 with the chip ID written in NVM 20. Additionally, an encryption code, for example, a Message Authentication Code (MAC) is</p>

	written in NVM 20 where the DEVICE TYPE, DEVICE SERIAL NUMBER, CHIP ID and UNIQUE DEVICE DATA are used as the text input to the MAC generation method. Further, an encryption key is further provided to which the software programs in memory 12 also have access.".)]
establishing at least one license-record location in the first nonvolatile memory area or in the erasable, non-volatile memory area of the BIOS.	Lewis '819 disclosed this element. [Id. at Fig. 3; at C4:56-63 ("In step 310, a text storage area is established in NVM 20, to which the MAC is checked, consisting of 0-31 of the NVM address base. In this example, the text has a length of 32 bytes. In step 312, a 64 bit key is used to encrypt the first eight (8) bytes of the text data using a data encryption scheme (DES) method, which is well known to those skilled in the art, to yield eight (8) bytes of encrypted data.".)]
8. A method according to claim 6 wherein establishing a license-record includes the steps of:	
forming a license-record by encrypting of the contents used to form a license-record with other predetermined data contents, using the key; and	Lewis '819 disclosed this element. [Id. at Fig. 3; at C4:48-54 ("Additionally, an encryption code, for example, a Message Authentication Code (MAC) is written in NVM 20 where the DEVICE TYPE, DEVICE SERIAL NUMBER, CHIP ID and UNIQUE DEVICE DATA are used as the text input to the MAC generation method. Further, an encryption key is further provided to which the software programs in memory 12 also have access."); at C4:55 to C5:7 ("FIG. 3 is a block diagram of a flowchart depicting the method used to generate the MAC shown in FIG. 2. In step 310, a text storage area is established in NVM 20, to which the MAC is checked, consisting of 0-31 of the NVM address base. In this example, the text has a length of 32 bytes. In step 312, a 64 bit key is used to encrypt the first eight (8) bytes of the text data using a data encryption scheme (DES) method, which is well known to those skilled in the art, to yield eight (8) bytes of encrypted data. Next, in step 314, these eight (8) bytes of encrypted data are exclusively ORed with the next eight (8) bytes of the text data. The results are then encrypted in step 316, using the DES method and the same key. The results are eight (8) bytes of encrypted data that include the current eight (8) bytes of the text, plus all the previous eight (8) byte blocks of text. The system continues to encrypt the remaining text using steps 314 and 316. In step 318, the system determines whether all the text has been encrypted

	and if so, in step 320, a resultant eight (8) bytes is used as the MAC, which is used to detect any change in any of the text that was used as input to generate the MAC.".)]
establishing the encrypted license-record in one of the at least one established license-record locations.	Lewis '819 disclosed this element. [<i>Id.</i> at C5:8-9 ("In step 322, the MAC is placed in NVM 20 at locations 32-39, shown in FIG. 2.".)]
9. A method according to claim 7 wherein verifying the program includes the steps of:	
encrypting the licensed-software-program's license-record contents from the volatile memory area or decrypting the license-record in the erasable, non-volatile memory area of the BIOS, using the pseudo-unique key; and	Lewis '819 disclosed this element. [<i>Id.</i> at C4:40-54 ("A non-volatile memory device (NVM) 20 is further connected to CPU 14. NVM 20 contains various information that the device manufacturer uses as part of the device 16 control, such as DEVICE TYPE, DEVICE SERIAL NUMBER, and any other UNIQUE DEVICE DATA. To be able to detect any alteration in the NVM 20, a CHIP ID is included so that any software programs in memory 12 can compare the chip ID in device 16 with the chip ID written in NVM 20. Additionally, an encryption code, for example, a Message Authentication Code (MAC) is written in NVM 20 where the DEVICE TYPE, DEVICE SERIAL NUMBER, CHIP ID and UNIQUE DEVICE DATA are used as the text input to the MAC generation method. Further, an encryption key is further provided to which the software programs in memory 12 also have access."); at Fig. 4; at C5:27-35 ("While system 10 is operating, system code is retrieved from memory 12 into CPU 14 for execution. Prior to using device 16, the system code performs a chip identification and NVM content alteration detection test, which is illustrated in the flowchart of FIG. 4. In step 410, the system reads the contents of NVM 20 into memory 12. Next, in step 412, the system generates a Message Authentication Code of the first 32 bytes of the NVM data that was stored in memory 12, using the same key that the manufacturer used to create the MAC stored in bytes 32-39 in NVM 20.".)]
comparing the encrypted licenses-software-program's license-record contents with the encrypted license-record in the erasable, non-volatile memory area of the BIOS,	Lewis '819 disclosed this element. [<i>Id.</i> at C5:35-38 ("In step 414, the system compares the MAC stored in memory 12 from bytes 32-39 of the NVM 20 data with the MAC generated in step 412.".)]

<p>or comparing the license-software-program's license-record contents with the decrypted license-record in erasable non-volatile memory area of the BIOS.</p>	
<p>10. A method according to claim 9 wherein acting on the program includes the step: restricting the program's operation with predetermined limitations if the comparing yields non-unity or insufficiency.</p>	<p>Lewis '819 disclosed this element. [<i>Id.</i> at C5:45-50 ("If the fields compare, then the NVM data is valid and system operation is granted in step 422; otherwise the NVM data has been copied from another system (because the MAC was good, it had to have been copied from another system) and the device cannot be used and the system aborts in step 416.").]</p>
<p>11. A method according to claim 1 wherein the volatile memory is a RAM.</p>	<p>To the extent that the reference does not explicitly disclose this element, the reference inherently disclosed the element.</p>
<p>12. The method of claim 1, wherein a pseudo-unique key is stored in the non-volatile memory of the BIOS.</p>	<p>Lewis '819 disclosed this element. [<i>Id.</i> at C4:33-39 ("Device 16 further includes a chip ID register 18, which includes a unique chip identifier within the chip ID register 18. The chip identifier is read by an instruction executed in CPU 14. The unique chip identifier is built as part of the chip identifier register 18 so that each chip in a manufactured set has a different unique chip identifier.").]</p> <p>To the extent that the reference does not explicitly disclose this element, the reference inherently disclosed the element.</p>
<p>13. The method of claim 1, wherein a unique key is stored in a first non-volatile memory area of the computer.</p>	<p>Lewis '819 disclosed this element. [<i>Id.</i> at C4:33-39 ("Device 16 further includes a chip ID register 18, which includes a unique chip identifier within the chip ID register 18. The chip identifier is read by an instruction executed in CPU 14. The unique chip identifier is built as part of the chip identifier register 18 so that each chip in a manufactured set has a different unique chip identifier.").]</p>
<p>14. The method according claim 13, wherein the step of using the agent to set up the verification record, including the license record, includes encrypting a license record data in the program using at least the unique key.</p>	<p>Lewis '819 disclosed this element. [<i>Id.</i> at C4:48-54 ("Additionally, an encryption code, for example, a Message Authentication Code (MAC) is written in NVM 20 where the DEVICE TYPE, DEVICE SERIAL NUMBER, CHIP ID and UNIQUE DEVICE DATA are used as the text input to the MAC generation method. Further, an encryption key is further provided to which the software programs in memory 12 also have access."); at C4:55 to C5:7</p>

<p>15. The method according to claim 14, wherein the verification comprises:</p>	
<p>extracting the license record from the software program;</p>	<p>Lewis '819 disclosed this element. [<i>Id.</i> at C3:27-32 ("Selected information stored within the non-volatile memory is used, along with the chip identifier, to generate a first encryption code associated with the system device. An encryption key is used to generate a second encryption code associated with the computer system."); at C5:27-32 ("While system 10 is operating, system code is retrieved from memory 12 into CPU 14 for execution. Prior to using device 16, the system code performs a chip identification and NVM content alteration detection test, which is illustrated in the flowchart of FIG. 4. In step 410, the system reads the contents of NVM 20 into memory 12.").]</p>
<p>encrypting the license record using the unique key stored in the first non-volatile memory area of the computer to form second encrypted license information; and</p>	<p>Lewis '819 disclosed this element. [<i>Id.</i> at C3:27-32 ("Selected information stored within the non-volatile memory is used, along with the chip identifier, to generate a first encryption code associated with the system device. An encryption key is used to generate a second encryption code associated with the computer system."); at C5:32-35 ("Next, in step 412, the system generates a Message Authentication Code of the first 32 bytes of the NVM data that was stored in memory 12, using the same key that the manufacturer used to create the MAC stored in bytes 32-39 in NVM 20.").]</p>
<p>comparing the encrypted license information stored in the erasable, non-volatile memory area of the BIOS of the computer with the second encrypted license information.</p>	<p>Lewis '819 disclosed this element. [<i>Id.</i> at C3:32-33 ("The first and second encryption codes are matched to provide a first level system operation validation."); at C5:35-40 ("In step 414, the system compares the MAC stored in memory 12 from bytes 32-39 of the NVM 20 data with the MAC generated in step 412. If the MACs do not compare, then the NVM 20 data is not valid and the device 16 cannot be used and the system aborts in step 416.").]</p>
<p>16. The method according to claim 13, wherein the step of verifying the program includes a decrypting the license record data accommodated in the erasable second non-volatile memory area of the BIOS using at least the unique key.</p>	<p>Lewis '819 disclosed this element. [<i>Id.</i> at C2:49-65 ("Another encryption technique that can be used is RSA where the manufacturer uses a private key to encrypt the text where the unique chip identifier is again included in the text where modification detection is required. A public key is then used by the software program to decrypt the encrypted data and a comparison is made by the software program of the unique chip identifier in the hardware with that in the encrypted text. If there is a match then the text is valid,</p>

	<p>otherwise the text has been copied from another machine or has been otherwise altered. The advantage of the RSA is that two different keys are used for encryption and decryption and if the public key is known, the private key can not be determined whereas DES uses the same key for encryption and decryption so the software program must hide the key very well. This invention does not rely on any specific encryption technique only on the fact that the manufacturer can control access to the encryption key."].]</p>
<p>17. The method according to claim 13, wherein the step of verifying the program includes encrypting the license record that is accommodated in the program using at least the unique key.</p>	<p>Lewis '819 disclosed this element. [<i>Id.</i> at C3:27-32 ("Selected information stored within the non-volatile memory is used, along with the chip identifier, to generate a first encryption code associated with the system device. An encryption key is used to generate a second encryption code associated with the computer system."); at C5:27-35 ("While system 10 is operating, system code is retrieved from memory 12 into CPU 14 for execution. Prior to using device 16, the system code performs a chip identification and NVM content alteration detection test, which is illustrated in the flowchart of FIG. 4. In step 410, the system reads the contents of NVM 20 into memory 12. Next, in step 412, the system generates a Message Authentication Code of the first 32 bytes of the NVM data that was stored in memory 12, using the same key that the manufacturer used to create the MAC stored in bytes 32-39 in NVM 20.").]</p>
<p>18. A method for accessing an application software program using a pseudo-unique key stored in a first non-erasable non-volatile memory area of a computer, the first non-volatile memory area being unable to be programmatically changed, the method, comprising:</p>	<p>Lewis '819 disclosed this preamble. [Lewis '819 at Abstract ("A method and apparatus for providing system operation validation is disclosed. The method and apparatus for validation operates within a computer system comprising a central processing unit coupled to a programmable memory, and to a system device. The programmable memory may store programs and instructions executable on the CPU and a non-volatile memory is also provided for access by the CPU."); at C1:8-16 ("The present invention relates, generally, to a computer system having a non-volatile memory and, more specifically, to electronic security information being stored in the non-volatile memory. More specifically, the present invention relates to a computer system having a non-volatile memory with security information written into the non-volatile memory and a way of detecting when that information has been altered so as to prevent operation of the computer</p>

	<p>system once tampering has been detected."); at C3:6-15 ("It is therefore one object of the present invention to provide a computer system having a non-volatile memory.</p> <p>It is another object of the present invention to provide electronic security information stored in the non-volatile memory.</p> <p>It is yet another object of the present invention to provide a computer system having a non-volatile memory with security information written into the non-volatile memory and a way of detecting when that information has been altered so as to prevent operation of any portion of the computer system once tampering has been detected."); at C4:33-39 ("Device 16 further includes a chip ID register 18, which includes a unique chip identifier within the chip ID register 18. The chip identifier is read by an instruction executed in CPU 14. The unique chip identifier is built as part of the chip identifier register 18 so that each chip in a manufactured set has a different unique chip identifier."); at C4:40-54 ("A non-volatile memory device (NVM) 20 is further connected to CPU 14. NVM 20 contains various information that the device manufacturer uses as part of the device 16 control, such as DEVICE TYPE, DEVICE SERIAL NUMBER, and any other UNIQUE DEVICE DATA. To be able to detect any alteration in the NVM 20, a CHIP ID is included so that any software programs in memory 12 can compare the chip ID in device 16 with the chip ID written in NVM 20. Additionally, an encryption code, for example, a Message Authentication Code (MAC) is written in NVM 20 where the DEVICE TYPE, DEVICE SERIAL NUMBER, CHIP ID and UNIQUE DEVICE DATA are used as the text input to the MAC generation method. Further, an encryption key is further provided to which the software programs in memory 12 also have access.".)]</p>
loading the application software program residing in a non-volatile memory area of the computer;	Lewis '819 disclosed this element. [Id. at C5:27-28 ("While system 10 is operating, system code is retrieved from memory 12 into CPU 14 for execution.".)]
using an agent to perform the following steps:	Lewis '819 disclosed this element. [Id. at C5:28-31 ("Prior to using device 16, the system code performs a chip identification and NVM content

<p>extracting license information from software program;</p>	<p>alteration detection test, which is illustrated in the flowchart of FIG. 4.".)]</p> <p>Lewis '819 disclosed this element. [<i>Id.</i> at C4:41-52 ("NVM 20 contains various information that the device manufacturer uses as part of the device 16 control, such as DEVICE TYPE, DEVICE SERIAL NUMBER, and any other UNIQUE DEVICE DATA. To be able to detect any alteration in the NVM 20, a CHIP ID is included so that any software programs in memory 12 can compare the chip ID in device 16 with the chip ID written in NVM 20. Additionally, an encryption code, for example, a Message Authentication Code (MAC) is written in NVM 20 where the DEVICE TYPE, DEVICE SERIAL NUMBER, CHIP ID and UNIQUE DEVICE DATA are used as the text input to the MAC generation method."); at C4:55-56 ("FIG. 3 is a block diagram of a flowchart depicting the method used to generate the MAC shown in FIG. 2.".)]</p>
<p>encrypting license information using the pseudo-unique key stored in the first non-volatile memory area;</p>	<p>Lewis '819 disclosed this element. [<i>Id.</i> at C4:41-54 ("NVM 20 contains various information that the device manufacturer uses as part of the device 16 control, such as DEVICE TYPE, DEVICE SERIAL NUMBER, and any other UNIQUE DEVICE DATA. To be able to detect any alteration in the NVM 20, a CHIP ID is included so that any software programs in memory 12 can compare the chip ID in device 16 with the chip ID written in NVM 20. Additionally, an encryption code, for example, a Message Authentication Code (MAC) is written in NVM 20 where the DEVICE TYPE, DEVICE SERIAL NUMBER, CHIP ID and UNIQUE DEVICE DATA are used as the text input to the MAC generation method. Further, an encryption key is further provided to which the software programs in memory 12 also have access."); at C4:55 to C5:7 ("FIG. 3 is a block diagram of a flowchart depicting the method used to generate the MAC shown in FIG. 2. In step 310, a text storage area is established in NVM 20, to which the MAC is checked, consisting of 0-31 of the NVM address base. In this example, the text has a length of 32 bytes. In step 312, a 64 bit key is used to encrypt the first eight (8) bytes of the text data using a data encryption scheme (DES) method, which is well known to those skilled in the art, to yield eight (8) bytes of encrypted data. Next, in step 314, these eight (8) bytes of encrypted data are exclusively ORed with the next eight (8) bytes of the text data. The</p>

	<p>results are then encrypted in step 316, using the DES method and the same key. The results are eight (8) bytes of encrypted data that include the current eight (8) bytes of the text, plus all the previous eight (8) byte blocks of text. The system continues to encrypt the remaining text using steps 314 and 316. In step 318, the system determines whether all the text has been encrypted and if so, in step 320, a resultant eight (8) bytes is used as the MAC, which is used to detect any change in any of the text that was used as input to generate the MAC.".)]</p>
<p>storing the encrypting license information in a second erasable, writable, non-volatile memory area of the BIOS of the computer;</p>	<p>Lewis '819 disclosed this element. [<i>Id.</i> at C4:48-54 ("Additionally, an encryption code, for example, a Message Authentication Code (MAC) is written in NVM 20 where the DEVICE TYPE, DEVICE SERIAL NUMBER, CHIP ID and UNIQUE DEVICE DATA are used as the text input to the MAC generation method. Further, an encryption key is further provided to which the software programs in memory 12 also have access."); at C5:7-9 ("In step 322, the MAC is placed in NVM 20 at locations 32-39, shown in FIG. 2.".)]</p>
<p>subsequently verifying the application software program based on the encrypted license information stored in the second erasable, writable, non-volatile memory area of the BIOS; and</p>	<p>Lewis '819 disclosed this element. [<i>Id.</i> at C5:10-14 ("The MAC is used to provide a means, or digital signature, 10 for detecting when a serial number or any other critical data written into NVM 20 is altered. Once there is modification or duplication detected, the software program stored in memory 12 can then take steps to prevent software programs from running on the altered device 16."); at C5:27-45 ("While system 10 is operating, system code is retrieved from memory 12 into CPU 14 for execution. Prior to using device 16, the system code performs a chip identification and NVM content alteration detection test, which is illustrated in the flowchart of FIG. 4. In step 410, the system reads the contents of NVM 20 into memory 12. Next, in step 412, the system generates a Message Authentication Code of the first 32 bytes of the NVM data that was stored in memory 12, using the same key that the manufacturer used to create the MAC stored in bytes 32-39 in NVM 20. In step 414, the system compares the MAC stored in memory 12 from bytes 32-39 of the NVM 20 data with the MAC generated in step 412. If the MACs do not compare, then the NVM 20 data is not valid and the device 16 cannot be used and the system aborts in step 416. If the MACs do compare,</p>

	the system, in step 418, reads the chip ID from the chip ID register 18 into CPU 14. Next, in step 420, the system compares the chip ID field from bytes 16-23 of the NVM data stored in memory 12 with the chip ID field read from chip ID register 18 read in step 418.".]
acting on the application software program based on the verification.	Lewis '819 disclosed this element. [<i>Id.</i> at C5:45-49 ("If the fields compare, then the NVM data is valid and system operation is granted in step 422; otherwise the NVM data has been copied from another system (because the MAC was good, it had to have been copied from another system) and the device cannot be used and the system aborts in step 416.").]
19. The method of claim 18, wherein the verification comprises:	
extracting the license information from the software program;	Lewis '819 disclosed this element. [<i>Id.</i> at C5:27-31 ("Prior to using device 16, the system code performs a chip identification and NVM content alteration detection test, which is illustrated in the flowchart of FIG. 4. ")
encrypting the license information using the pseudo-unique key stored in the first non-volatile memory area of the computer to form second encrypted license information; and	Lewis '819 disclosed this element. [<i>Id.</i> at C3:27-32 ("Selected information stored within the non-volatile memory is used, along with the chip identifier, to generate a first encryption code associated with the system device. An encryption key is used to generate a second encryption code associated with the computer system."); at C5:32-35 ("Next, in step 412, the system generates a Message Authentication Code of the first 32 bytes of the NVM data that was stored in memory 12, using the same key that the manufacturer used to create the MAC stored in bytes 32-39 in NVM 20.").]
comparing the encrypted license information stored in the second erasable, writable, non-volatile memory area of the BIOS of the computer with the second encrypted license information.	Lewis '819 disclosed this element. [<i>Id.</i> at C3:32-33 ("The first and second encryption codes are matched to provide a first level system operation validation."); at C5:35-40 ("In step 414, the system compares the MAC stored in memory 12 from bytes 32-39 of the NVM 20 data with the MAC generated in step 412. If the MACs do not compare, then the NVM 20 data is not valid and the device 16 cannot be used and the system aborts in step 416.").]

Electronic Acknowledgement Receipt

EFS ID:	5609625
Application Number:	90010560
International Application Number:	
Confirmation Number:	1017
Title of Invention:	METHOD OF RESTRICTING SOFTWARE OPERATION WITHIN A LICENSE LIMITATION
First Named Inventor/Applicant Name:	6411941
Customer Number:	26694
Filer:	Maurice J. Pirio/Peter Sher
Filer Authorized By:	Maurice J. Pirio
Attorney Docket Number:	418263007US
Receipt Date:	29-JUN-2009
Filing Date:	29-MAY-2009
Time Stamp:	19:05:31
Application Type:	Reexam (Third Party)

Payment information:

Submitted with Payment	no
------------------------	----

File Listing:

Document Number	Document Description	File Name	File Size(Bytes)/ Message Digest	Multi Part /.zip	Pages (if appl.)
1		exhibit.pdf	2743195 <small>7c64280d6fbb711a625345cc5598a27057d dc56a</small>	yes	44

Multipart Description/PDF files in .zip description			
Document Description		Start	End
Transmittal Letter		1	2
Reexam Certificate of Service		3	3
Appendix to the Specification		4	44

Warnings:

Information:

Total Files Size (in bytes):	2743195
-------------------------------------	---------

This Acknowledgement Receipt evidences receipt on the noted date by the USPTO of the indicated documents, characterized by the applicant, and including page counts, where applicable. It serves as evidence of receipt similar to a Post Card, as described in MPEP 503.

New Applications Under 35 U.S.C. 111

If a new application is being filed and the application includes the necessary components for a filing date (see 37 CFR 1.53(b)-(d) and MPEP 506), a Filing Receipt (37 CFR 1.54) will be issued in due course and the date shown on this Acknowledgement Receipt will establish the filing date of the application.

National Stage of an International Application under 35 U.S.C. 371

If a timely submission to enter the national stage of an international application is compliant with the conditions of 35 U.S.C. 371 and other applicable requirements a Form PCT/DO/EO/903 indicating acceptance of the application as a national stage submission under 35 U.S.C. 371 will be issued in addition to the Filing Receipt, in due course.

New International Application Filed with the USPTO as a Receiving Office

If a new international application is being filed and the international application includes the necessary components for an international filing date (see PCT Article 11 and MPEP 1810), a Notification of the International Application Number and of the International Filing Date (Form PCT/RO/105) will be issued in due course, subject to prescriptions concerning national security, and the date shown on this Acknowledgement Receipt will establish the international filing date of the application.



UNITED STATES PATENT AND TRADEMARK OFFICE

UNITED STATES DEPARTMENT OF COMMERCE
United States Patent and Trademark Office
Address: COMMISSIONER FOR PATENTS
P.O. Box 1450
Alexandria, Virginia 22313-1450
www.uspto.gov

APPLICATION NO.	FILING DATE	FIRST NAMED INVENTOR	ATTORNEY DOCKET NO.	CONFIRMATION NO.
90/010,560	05/29/2009	6411941	418263007US	1017
26694	7590	08/03/2009	EXAMINER	
VENABLE LLP P.O. BOX 34385 WASHINGTON, DC 20043-9998			ART UNIT	PAPER NUMBER

DATE MAILED: 08/03/2009

Please find below and/or attached an Office communication concerning this application or proceeding.



DO NOT USE IN PALM PRINTER

(THIRD PARTY REQUESTER'S CORRESPONDENCE ADDRESS)

PERKINS COIE/MSFT
P.O. BOX 1247
SEATTLE, WA 98111-1247

EX PARTE REEXAMINATION COMMUNICATION TRANSMITTAL FORM

REEXAMINATION CONTROL NO. 90/010,560.

PATENT NO. 6411941.

ART UNIT 3992.

Enclosed is a copy of the latest communication from the United States Patent and Trademark Office in the above identified *ex parte* reexamination proceeding (37 CFR 1.550(f)).

Where this copy is supplied after the reply by requester, 37 CFR 1.535, or the time for filing a reply has passed, no submission on behalf of the *ex parte* reexamination requester will be acknowledged or considered (37 CFR 1.550(g)).

Order Granting / Denying Request For Ex Parte Reexamination	Control No. 90/010,560	Patent Under Reexamination 6411941	
	Examiner MATTHEW HENEGHAN	Art Unit 3992	

--The MAILING DATE of this communication appears on the cover sheet with the correspondence address--

The request for *ex parte* reexamination filed 29 May 2009 has been considered and a determination has been made. An identification of the claims, the references relied upon, and the rationale supporting the determination are attached.

Attachments: a) PTO-892, b) PTO/SB/08, c) Other: _____

1. The request for *ex parte* reexamination is GRANTED.

RESPONSE TIMES ARE SET AS FOLLOWS:

For Patent Owner's Statement (Optional): TWO MONTHS from the mailing date of this communication (37 CFR 1.530 (b)). **EXTENSIONS OF TIME ARE GOVERNED BY 37 CFR 1.550(c).**

For Requester's Reply (optional): TWO MONTHS from the **date of service** of any timely filed Patent Owner's Statement (37 CFR 1.535). **NO EXTENSION OF THIS TIME PERIOD IS PERMITTED.** If Patent Owner does not file a timely statement under 37 CFR 1.530(b), then no reply by requester is permitted.

2. The request for *ex parte* reexamination is DENIED.

This decision is not appealable (35 U.S.C. 303(c)). Requester may seek review by petition to the Commissioner under 37 CFR 1.181 within ONE MONTH from the mailing date of this communication (37 CFR 1.515(c)). **EXTENSION OF TIME TO FILE SUCH A PETITION UNDER 37 CFR 1.181 ARE AVAILABLE ONLY BY PETITION TO SUSPEND OR WAIVE THE REGULATIONS UNDER 37 CFR 1.183.**

In due course, a refund under 37 CFR 1.26 (c) will be made to requester:

- a) by Treasury check or,
- b) by credit to Deposit Account No. _____, or
- c) by credit to a credit card account, unless otherwise notified (35 U.S.C. 303(c)).

--	--	--

cc:Requester (if third party requester)

DECISION GRANTING *EX PARTE* EXAMINATION

Reexamination

An Ex Parte Reexamination has been requested by a third party on 28 May 2009 for claims 1-19 of U.S. Patent No. 6,411,941 (hereinafter "the '941 patent"), granted on 25 June 2002.

A substantial new question of patentability affecting claims 1-19 of United States Patent Number 6,411,941 is raised by the request for *ex parte* reexamination.

The patent owner is reminded of the continuing responsibility under 37 CFR 1.565(a) to apprise the Office of any litigation activity, or other prior or concurrent proceeding, involving Patent No. 6,411,941 throughout the course of this reexamination proceeding. The third party requester is also reminded of the ability to similarly apprise the Office of any such activity or proceeding throughout the course of this reexamination proceeding. See MPEP §§ 2207, 2282 and 2286.

Extensions of time under 37 CFR 1.136(a) will not be permitted in these proceedings because the provisions of 37 CFR 1.136 apply only to "an applicant" and not to parties in a reexamination proceeding. Additionally, 35 U.S.C. 305 requires that *ex parte* reexamination proceedings "will be conducted with special dispatch" (37

Art Unit: 3992

CFR 1.550(a)). Extensions of time in *ex parte* reexamination proceedings are provided for in 37 CFR 1.550(c).

References Submitted by Requester

U.S. Patent No. 5,734,819 to Lewis (hereinafter "Lewis")

U.S. Patent No. 6,153,835 to Schwartz et al. (hereinafter "Schwartz")

Neither of the references cited above were discussed by the Office in a previous examination or reexamination proceeding.

Several other references have been submitted by the Requester; however, these references are not being relied upon to establish a Substantial New Question of Patentability. These references are not being made part of the record at this time.

Prosecution History

The '941 patent was originally filed as Application No. 09/164,777 on 1 October 1998, having claims 1-15. Foreign priority was claimed to Israel Patent Application No. 124571, filed 21 May 1998, for which a certified copy in English was concurrently filed.

Art Unit: 3992

The Office mailed a non-final office action on 18 October 2000, rejecting claims 1-15. Claims 1-4 and 11-13 were rejected under 35 U.S.C. 102(e) over U.S. Patent No. 5,892,900 to Ginter et al. (hereinafter Ginter). Claims 5, 7, and 8 were rejected under 35 U.S.C. 103(a) over Ginter in view of U.S. Patent No. 5,684,951 to Goldman et al. (hereinafter Goldman). Claim 9 was rejected under 35 U.S.C. 103(a) over Ginter in view of Goldman further in view of U.S. Patent No. 5,490,216 to Richardson, III (hereinafter Richardson), although the explanation of the rejection to that claim did not rely upon Richardson at all. Claims 14 and 15 were not discussed. It is noted that the explanation of this rejections also suggested that claims 6 and 10 should also have been rejected over Ginter.

A second non-final rejection was mailed on 20 December 2000 that clarified the previous office action, stating that claims 1-4, 6, and 10-13 were rejected under 35 U.S.C. 102(e) over Ginter and claims 5, 7-9, 14, and 15 were rejected under 35 U.S.C. 103(a) over Ginter in view of Goldman.

The Applicant responded on 21 May 2001, amending claim 1, cancelling claims 14 and 15, and adding claims 16-20.

The Office mailed a final rejection on 22 June 2001, rejecting claims 1-13 and 16-20. Claims 1-13 and 16-19 were rejected under 35 U.S.C. 112, first paragraph, for incorporating new matter. Claim 20 was rejected under 35 U.S.C 112, second paragraph for being incomplete. Claims 1-4, 6, and 10-13 were rejected under 35

Art Unit: 3992

U.S.C. 102(e) over Ginter. Claims 5, 7-9, and 16-20 were rejected under 35 U.S.C. 103 over Ginver in view of Goldman.

The Applicant filed an amendment on 14 November 2001 with a Request for Continued Examination (RCE), amending claims 1, 3-7, 9-12, and 16-20 and adding claims 21-23.

The Office then mailed a non-final rejection on 15 January 2002, rejecting all of the claims. Claims 11, 12, 15, 16 were rejected under 35 U.S.C. 112, first paragraph for lacking enablement. Claims 20 and 21 were rejected under 35 U.S.C. 112, second paragraph for being indefinite. The office action stated that claims 1-23 were rejected under 35 U.S.C. 103(a) over U.S. Patent No. 6,189,146 to Misra et al. (hereinafter Misra) in view of Goldman further in view of U.S. Patent No. 5,479,639 to Ewertz et al. (hereinafter Ewertz). It is noted that only claims 1-13 and 16-23 should have been rejected in this action, as claims 14 and 15 had been previously cancelled.

The Applicant responded by filing an amendment on 5 February 2002, amending claims 16 and 20 and cancelling claims 11 and 12, leaving claims 1-10, 13, and 16-23 to be examined.

A Notice of Allowance was mailed by the Office on 28 March 2002, including an Examiner's Amendment amending claims 1 and 20. Regarding claims 1-10, 13, and 16-19, the Examiner noted that,

"...the key distinction between the present invention and the closest prior art, is that the Misra et al., and Ginter et al. systems and the Ewertz et al. system run at the operating system level and

Art Unit: 3992

BIOS level, respectively. More specifically, the closest prior art systems, singly or collectively, do not teach licensed programs running at the OS level interacting with a program verification structure stored in the BIOS to verify the program using the verification structure and having a user act on the program according to the verification. Further, it is well known to those of ordinary skill of the art that a computer BIOS is not setup to manage a software license verification structure. The present invention overcomes this difficulty by using an agent to set up a verification structure in the erasable, non-volatile memory of the BIOS. “

Regarding claims 20-23, the Examiner noted that,

“... a key distinction between the present invention and the closest prior art, is that the Misra et al., and Ginter et al. systems and the Ewertz et al. system run at the operating system level and BIOS level, respectively. More specifically, the closest prior art systems, singly or collectively, do not teach extracting licensing information from a software program, encrypting the information and storing it in the BIOS. Further, it is well known to those of ordinary skill of the art that a computer BIOS is not setup to store license information. The present invention overcomes this difficulty by utilizing an agent to verify the application software program using the license information stored in the erasable, writable, non-volatile memory of the BIOS.”

The claims were renumbered as claims 1-19.

None of the claims of the '941 patent have been subject to a final holding of invalidity by a court.

Claims of the '941 Patent

The following are the 2 independent claims of the '941 patent:

Claim 1: A method of restricting software operation within a license for use with a computer including an erasable, non-volatile memory area of a BIOS of the computer, and a volatile memory area; the method comprising the steps of:

selecting a program residing in the volatile memory,

using an agent to set up a verification structure in the erasable, non-volatile memory of

the BIOS, the verification structure accommodating data that includes at least one license record,

verifying the program using at least the verification structure from the erasable non-volatile memory of the BIOS, and

acting on the program according to the verification.

Claim 18: A method for accessing an application software program using a pseudo-unique key stored in a first non-erasable non-volatile memory area of a computer, the first non-volatile memory area being unable to be programmatically changed, the method, comprising:

loading the application software program residing in a non-volatile memory area of the computer;

using an agent to perform the following steps:

Art Unit: 3992

extracting license information from software program;

encrypting license information using the pseudo-unique key stored in the first non-volatile memory area;

storing the encrypting license information in a second erasable, writable, non-volatile memory area of the BIOS of the computer;

subsequently verifying the application software program based on the encrypted license information stored in the second erasable, writable, non-volatile memory area of the BIOS; and

acting on the application software program based on the verification.

Claim Construction

During reexamination, claims are given the broadest reasonable interpretation consistent with the specification and limitations in the specification are not read into the claims (In re Yamamoto, 740 F.2d 1569, 222 USPQ 934 (Fed. Cir. 1984)).

“BIOS”

The Microsoft Computer Dictionary, 5th Edition, 2002 defines BIOS as “the set of essential software routines that test hardware at startup, starts the operating system,

Art Unit: 3992

and supports the transfer of data among hardware devices.” This definition is consistent with the specification of the ‘941 patent. Since a BIOS is therefore defined by the functional descriptive material contained within it, one skilled in the art would consider any non-functional descriptive material, such as tables, to be part of the BIOS only if it is made and used by the functions of the BIOS itself. This does not preclude such material being also used or modified by programs located outside of the BIOS, such as applications running in an operating system. The fact that a program or table resides in non-volatile memory does not necessarily mean that it is part of the BIOS. It is therefore the case that a reasonable examiner would only consider a table to be in BIOS if it were, at a minimum, created by a function residing in the BIOS.

Substantial New Questions of Patentability (SNQ)

Lewis

Lewis discloses the loading into system memory (volatile) of a program, for which an encryption code (a MAC) is constructed using a driver for an external device in non-volatile RAM. It is common in the art to implement such drivers in the BIOS area. The driver is used to write the MAC, which is derived using the computer's chip ID, to a table in non-volatile RAM, in order to use it later to verify that the program is on the computer on which it was installed. The correlating of specific instantiations of programs to specific computers constitutes a de facto license for that computer to use the program. Since the art cited during prosecution did not show such information being stored in and

Art Unit: 3992

used from the memory of the BIOS, it is agreed that a reasonable examiner would have found this reference important in determining the patentability of claims 1-19.

Schwartz

Schwartz discloses a postage scale that may receive new programs and store licensing information in related to these programs in non-volatile memory. See figure 9. The programs that provide this functionality, however, do not reside in BIOS; rather, they are instantiated as applications running on the operating system. It is therefore the case that the table created cannot be considered to be in BIOS either. Schwartz is therefore merely cumulative to the art cited by the Examiner during prosecution, insofar as it teaches to the claim limitations. It is NOT agreed that a reasonable examiner would have found this reference important in determining the patentability of claims 1-19.

Art Unit: 3992

Conclusion

All correspondence relating to this *ex parte* reexamination proceeding should be directed:

By Mail to: Mail Stop *Ex Parte* Reexam
Central Reexamination Unit
Commissioner for Patents
United States Patent & Trademark Office
P.O. Box 1450
Alexandria, VA 22313-1450

By FAX to: (571) 273-9900
Central Reexamination Unit

By hand: Customer Service Window
Randolph Building
401 Dulany Street
Alexandria, VA 22314

Registered users of EFS-Web may alternatively submit such correspondence via the electronic filing system EFS-Web, at <https://portal.uspto.gov/authenticate/authenticateuserlocalepf.html>. EFS-Web offers the benefit of quick submission to the particular area of the Office that needs to act on the correspondence. Also, EFS-Web submissions are "soft scanned" (i.e., electronically uploaded) directly into the official file for the reexamination proceeding, which offers parties the opportunity to review the content of their submissions after the "soft scanning" process is complete.

Any inquiry concerning this communication should be directed to Examiner Matthew Heneghan at telephone number (571)272-3834.

/Matthew Heneghan/

Primary Examiner, USPTO AU 3992

Conferees:



Notice of References Cited	Application/Control No. 90/010,560	Applicant(s)/Patent Under Reexamination 6411941	
	Examiner MATTHEW HENEGHAN	Art Unit 3992	Page 1 of 1

U.S. PATENT DOCUMENTS

*	Document Number Country Code-Number-Kind Code	Date MM-YYYY	Name	Classification
*	A US-5,734,819	03-1998	Lewis, David Otto	726/29
*	B US-6,153,835	11-2000	Schwartz et al.	177/25.13
	C US-			
	D US-			
	E US-			
	F US-			
	G US-			
	H US-			
	I US-			
	J US-			
	K US-			
	L US-			
	M US-			

FOREIGN PATENT DOCUMENTS

*	Document Number Country Code-Number-Kind Code	Date MM-YYYY	Country	Name	Classification
	N				
	O				
	P				
	Q				
	R				
	S				
	T				

NON-PATENT DOCUMENTS

*	Include as applicable: Author, Title Date, Publisher, Edition or Volume, Pertinent Pages)	
U	Microsoft Computer Dictionary, 5 th Edition, 2002, p. 60	
V		
W		
X		

*A copy of this reference is not being furnished with this Office action. (See MPEP § 707.05(a).)
Dates in MM-YYYY format are publication dates. Classifications may be US or foreign.

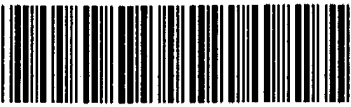
Reexamination 	Application/Control No. 90/010,560	Applicant(s)/Patent Under Reexamination 6411941
	Certificate Date	Certificate Number

Requester Correspondence Address: <input type="checkbox"/> Patent Owner <input checked="" type="checkbox"/> Third Party
PERKINS COIE/MSFT P.O. BOX 1247 SEATTLE, WA 98111-1247

LITIGATION REVIEW <input checked="" type="checkbox"/>	/MH/ <small>(examiner initials)</small>	7/22/09 <small>(date)</small>
Case Name		Director Initials
U.S. District - Washington Western, 2:09cv270, Ancora Technologies Inc v. Toshiba America Information Systems Inc et A (OPEN)		<i>Eu - heard to on</i> ↓
U.S. District - California Central, 8:08cv626, Ancora Technologies Inc v. Toshiba America Information Systems Inc et A (CLOSED)		

COPENDING OFFICE PROCEEDINGS	
TYPE OF PROCEEDING	NUMBER
1. None.	
2.	
3.	
4.	



UNITED STATES PATENT AND TRADEMARK OFFICE

UNITED STATES DEPARTMENT OF COMMERCE
 United States Patent and Trademark Office
 Address: COMMISSIONER FOR PATENTS
 P.O. Box 1450
 Alexandria, Virginia 22313-1450
 www.uspto.gov



Bib Data Sheet

CONFIRMATION NO. 1017

SERIAL NUMBER 90/010,560	FILING OR 371(c) DATE 05/29/2009 RULE	CLASS 705	GROUP ART UNIT 3993	ATTORNEY DOCKET NO. 418263007US
------------------------------------	-----------------------------------------------------------	---------------------	-------------------------------	-------------------------------------------

APPLICANTS
 6411941, Residence Not Provided;
 BEEBLE, INC. (OWNER), NEWPORT BEACH, CA;
 CHUN M. NG (3RD.PTY.REQ.), SEATTLE, WA;
 PERKINS COIE LLP/ MSFT, SEATTLE, WA

**** CONTINUING DATA *******
 This application is a REX of 09/164,777 10/01/1998 PAT 6,411,941

**** FOREIGN APPLICATIONS *******

Foreign Priority claimed <input checked="" type="checkbox"/> yes <input type="checkbox"/> no	STATE OR COUNTRY	SHEETS DRAWING	TOTAL CLAIMS 19	INDEPENDENT CLAIMS 2
35 USC 119 (a-d) conditions met <input checked="" type="checkbox"/> yes <input type="checkbox"/> no <input type="checkbox"/> Met after Allowance				
Verified and Acknowledged	<i>[Signature]</i> Examiner's Signature	<i>[Initials]</i> Initials		

ADDRESS
 26694

TITLE
 METHOD OF RESTRICTING SOFTWARE OPERATION WITHIN A LICENSE LIMITATION

FILING FEE RECEIVED 2520	FEES: Authority has been given in Paper No. _____ to charge/credit DEPOSIT ACCOUNT No. _____ for following:	<input type="checkbox"/> All Fees <input type="checkbox"/> 1.16 Fees (Filing) <input type="checkbox"/> 1.17 Fees (Processing Ext. of time) <input type="checkbox"/> 1.18 Fees (Issue) <input type="checkbox"/> Other _____ <input type="checkbox"/> Credit
------------------------------------	-------------------------------------------------------------------------------------------------------------------	---------------------------------------------------------------------------------------------------------------------------------------------------------------------------------------------------------------------------------------------------------------------------------

Search Notes 	Application/Control No. 90010560	Applicant(s)/Patent Under Reexamination 6411941
	Examiner .Matthew Heneghan	Art Unit 3992

SEARCHED			
Class	Subclass	Date	Examiner

SEARCH NOTES		
Search Notes	Date	Examiner
Litigation Search	6/8/09	MH
Review of Prosecution History	7/22/09	MH

INTERFERENCE SEARCH			
Class	Subclass	Date	Examiner

--	--

Under the Paperwork Reduction Act of 1995, no persons are required to respond to a collection of information unless it displays a valid OMB control number.

POWER OF ATTORNEY TO PROSECUTE APPLICATIONS BEFORE THE USPTO

I hereby revoke all previous powers of attorney given in the application identified in the attached statement under 37 CFR 3.73(b).

I hereby appoint:

Practitioners associated with the Customer Number: 22045

OR

Practitioner(s) named below (if more than ten patent practitioners are to be named, then a customer number must be used):

Name	Registration Number	Name	Registration Number

as attorney(s) or agent(s) to represent the undersigned before the United States Patent and Trademark Office (USPTO) in connection with any and all patent applications assigned only to the undersigned according to the USPTO assignment records or assignment documents attached to this form in accordance with 37 CFR 3.73(b).

Please change the correspondence address for the application identified in the attached statement under 37 CFR 3.73(b) to:

The address associated with Customer Number: 22045

OR

<input type="checkbox"/> Firm or Individual Name			
Address			
City	State	Zip	
Country			
Telephone	Email		

Assignee Name and Address:

Ancora Technologies Inc.
 14014 Moorpark, #215
 Sherman Oaks, CA 91423

A copy of this form, together with a statement under 37 CFR 3.73(b) (Form PTO/SB/96 or equivalent) is required to be filed in each application in which this form is used. The statement under 37 CFR 3.73(b) may be completed by one of the practitioners appointed in this form if the appointed practitioner is authorized to act on behalf of the assignee, and must identify the application in which this Power of Attorney is to be filed.

SIGNATURE of Assignee of Record

The individual whose signature and title is supplied below is authorized to act on behalf of the assignee

Signature		Date	08- 21 -2009
Name	Miki Mullor	Telephone	(951) 4-Mullor
Title	Chairman		

This collection of information is required by 37 CFR 1.31, 1.32 and 1.33. The information is required to obtain or retain a benefit by the public which is to file (and by the USPTO to process) an application. Confidentiality is governed by 35 U.S.C. 122 and 37 CFR 1.11 and 1.14. This collection is estimated to take 3 minutes to complete, including gathering, preparing, and submitting the completed application form to the USPTO. Time will vary depending upon the individual case. Any comments on the amount of time you require to complete this form and/or suggestions for reducing this burden, should be sent to the Chief Information Officer, U.S. Patent and Trademark Office, U.S. Department of Commerce, P.O. Box 1450, Alexandria, VA 22313-1450. DO NOT SEND FEES OR COMPLETED FORMS TO THIS ADDRESS. **SEND TO: Commissioner for Patents, P.O. Box 1450, Alexandria, VA 22313-1450.**

If you need assistance in completing the form, call 1-800-PTO-9199 and select option 2.

IN THE UNITED STATES PATENT AND TRADEMARK OFFICE

In re application of:

Group Art Unit: 3992

Miki Mullor et al.

Examiner: Matthew Heneghan

Serial No.: 90/010,560

Filed: 05/29/09

For: Method of Restricting Software Operation Within a Licensee
Limitation

Attorney Docket No.: ANCC 0104 R

STATEMENT UNDER 37 C.F.R. § 3.73(b)
ESTABLISHING RIGHT OF ASSIGNEE TO TAKE ACTION

Commissioner for Patents
U.S. Patent & Trademark Office
P.O. Box 1450
Alexandria, VA 22313-1450

Sir:

Ancora Technologies Inc., a Delaware corporation having its principal offices at 14014 Moorpark, #215, Sherman Oaks, California 91423, is the assignee of the entire right, title and interest in the above-identified application, U.S. Reexamination Serial No. 90/010,560, by virtue of an assignment from the Assignor thereof dated December 20, 2004. The assignment was recorded in the U.S. Patent and Trademark Office on December 21, 2004, at Reel 015494, Frames 0243.

The undersigned (whose title is supplied below) is empowered to act on behalf of Ancora Technologies Inc.

Ancora Technologies Inc.

Date: August 21, 2009



Signature

Printed Name: Miki Mullor
Title: Chairman

Electronic Acknowledgement Receipt

EFS ID:	5946534
Application Number:	90010560
International Application Number:	
Confirmation Number:	1017
Title of Invention:	METHOD OF RESTRICTING SOFTWARE OPERATION WITHIN A LICENSE LIMITATION
First Named Inventor/Applicant Name:	6411941
Customer Number:	26694
Filer:	John E. Nemazi/Carolyn Bielaniec
Filer Authorized By:	John E. Nemazi
Attorney Docket Number:	418263007US
Receipt Date:	25-AUG-2009
Filing Date:	29-MAY-2009
Time Stamp:	13:06:18
Application Type:	Reexam (Patent Owner)

Payment information:

Submitted with Payment	no
------------------------	----

File Listing:

Document Number	Document Description	File Name	File Size(Bytes)/ Message Digest	Multi Part /.zip	Pages (if appl.)
1	Power of Attorney	Power_of_Attorney.pdf	70109 <small>7de4dc89507865eff6c45e2658c1781925e6c98d</small>	no	1

Warnings:

Information:

2	Assignee showing of ownership per 37 CFR 3.73(b).	Statement_under_37CFR373b.pdf	30679 26aebf5b6a5c7fc3327b525d1d5b9964ca240be4	no	1
---	---------------------------------------------------	-------------------------------	---------------------------------------------------	----	---

Warnings:

Information:

Total Files Size (in bytes):	100788
-------------------------------------	--------

This Acknowledgement Receipt evidences receipt on the noted date by the USPTO of the indicated documents, characterized by the applicant, and including page counts, where applicable. It serves as evidence of receipt similar to a Post Card, as described in MPEP 503.

New Applications Under 35 U.S.C. 111

If a new application is being filed and the application includes the necessary components for a filing date (see 37 CFR 1.53(b)-(d) and MPEP 506), a Filing Receipt (37 CFR 1.54) will be issued in due course and the date shown on this Acknowledgement Receipt will establish the filing date of the application.

National Stage of an International Application under 35 U.S.C. 371

If a timely submission to enter the national stage of an international application is compliant with the conditions of 35 U.S.C. 371 and other applicable requirements a Form PCT/DO/EO/903 indicating acceptance of the application as a national stage submission under 35 U.S.C. 371 will be issued in addition to the Filing Receipt, in due course.

New International Application Filed with the USPTO as a Receiving Office

If a new international application is being filed and the international application includes the necessary components for an international filing date (see PCT Article 11 and MPEP 1810), a Notification of the International Application Number and of the International Filing Date (Form PCT/RO/105) will be issued in due course, subject to prescriptions concerning national security, and the date shown on this Acknowledgement Receipt will establish the international filing date of the application.



UNITED STATES PATENT AND TRADEMARK OFFICE

UNITED STATES DEPARTMENT OF COMMERCE
United States Patent and Trademark Office
Address: COMMISSIONER FOR PATENTS
P.O. Box 1450
Alexandria, Virginia 22313-1450
www.uspto.gov

APPLICATION NUMBER	FILING OR 371(C) DATE	FIRST NAMED APPLICANT	ATTY. DOCKET NO./TITLE
90/010,560	05/29/2009	6411941	418263007US

CONFIRMATION NO. 1017

POA ACCEPTANCE LETTER



22045
BROOKS KUSHMAN P.C.
1000 TOWN CENTER
TWENTY-SECOND FLOOR
SOUTHFIELD, MI 48075

Date Mailed: 08/26/2009

NOTICE OF ACCEPTANCE OF POWER OF ATTORNEY

This is in response to the Power of Attorney filed 08/25/2009.

The Power of Attorney in this application is accepted. Correspondence in this application will be mailed to the above address as provided by 37 CFR 1.33.

/sdstevenson/

Office of Data Management, Application Assistance Unit (571) 272-4000, or (571) 272-4200, or 1-888-786-0101



UNITED STATES PATENT AND TRADEMARK OFFICE

UNITED STATES DEPARTMENT OF COMMERCE
United States Patent and Trademark Office
Address: COMMISSIONER FOR PATENTS
P.O. Box 1450
Alexandria, Virginia 22313-1450
www.uspto.gov

APPLICATION NUMBER	FILING OR 371(C) DATE	FIRST NAMED APPLICANT	ATTY. DOCKET NO./TITLE
90/010,560	05/29/2009	6411941	418263007US

CONFIRMATION NO. 1017

POWER OF ATTORNEY NOTICE

26694
VENABLE LLP
P.O. BOX 34385
WASHINGTON, DC 20043-9998



Date Mailed: 08/26/2009

NOTICE REGARDING CHANGE OF POWER OF ATTORNEY

This is in response to the Power of Attorney filed 08/25/2009.

- The Power of Attorney to you in this application has been revoked by the assignee who has intervened as provided by 37 CFR 3.71. Future correspondence will be mailed to the new address of record(37 CFR 1.33).

/sdstevenson/

Office of Data Management, Application Assistance Unit (571) 272-4000, or (571) 272-4200, or 1-888-786-0101



UNITED STATES PATENT AND TRADEMARK OFFICE

UNITED STATES DEPARTMENT OF COMMERCE
 United States Patent and Trademark Office
 Address: COMMISSIONER FOR PATENTS
 P.O. Box 1450
 Alexandria, Virginia 22313-1450
 www.uspto.gov



Bib Data Sheet

CONFIRMATION NO. 1017

SERIAL NUMBER 90/010,560	FILING OR 371(c) DATE 05/29/2009 RULE	CLASS 705	GROUP ART UNIT 3992	ATTORNEY DOCKET NO. 418263007US
------------------------------------	-----------------------------------------------------------	---------------------	-------------------------------	-------------------------------------------

APPLICANTS
 6411941, Residence Not Provided;
 BEEBLE, INC.(OWNER), NEWPORT BEACH, CA;
 CHUN M. NG(3RD.PTY.REQ.), SEATTLE, WA;
 PERKINS COIE LLP/ MSFT, SEATTLE, WA

**** CONTINUING DATA *******
 This application is a REX of 09/164,777 10/01/1998 PAT 6,411,941

**** FOREIGN APPLICATIONS *******

Foreign Priority claimed <input type="checkbox"/> yes <input type="checkbox"/> no	STATE OR COUNTRY	SHEETS DRAWING	TOTAL CLAIMS 19	INDEPENDENT CLAIMS 2
35 USC 119 (a-d) conditions met <input type="checkbox"/> yes <input type="checkbox"/> no <input type="checkbox"/> Met after Allowance				
Verified and Acknowledged	Examiner's Signature	Initials		

ADDRESS
 22045

TITLE
 METHOD OF RESTRICTING SOFTWARE OPERATION WITHIN A LICENSE LIMITATION

FILING FEE RECEIVED 2520	FEES: Authority has been given in Paper No. _____ to charge/credit DEPOSIT ACCOUNT No. _____ for following:	<input type="checkbox"/> All Fees
		<input type="checkbox"/> 1.16 Fees (Filing)
		<input type="checkbox"/> 1.17 Fees (Processing Ext. of time)
		<input type="checkbox"/> 1.18 Fees (Issue)
		<input type="checkbox"/> Other _____
		<input type="checkbox"/> Credit

Litigation Search Report CRU 3999

Reexam Control No. 90/010,560

TO: Matthew Heneghan
Location: CRU
Art Unit : 3992
Date: 02/12/10

From: James R. Matthews
Location: CRU 3999
MDW 7C71
Phone: (571) 272-4233

Case Serial Number: 90/010,560

JamesR.Matthews@uspto.gov

Search Notes

Litigation was found involving U.S. Patent No.6,411,941.

Sources:

2:09CV270 – CLOSED

8:08CV626 - CLOSED

- 1) I performed a KeyCite Search in Westlaw, which retrieves all history on the patent including any litigation.
- 2) I performed a search on the patent in Lexis CourtLink for any open dockets or closed cases.
- 3) I performed a search in Lexis in the Federal Courts and Administrative Materials databases for any cases found.
- 4) I performed a search in Lexis in the IP Journal and Periodicals database for any articles on the patent.
- 5) I performed a search in Lexis in the news databases for any articles about the patent or any articles about litigation on this patent.

KEYCITE

C US PAT 6411941 METHOD OF RESTRICTING SOFTWARE OPERATION WITHIN A LICENSE LIMITATION, Assignee: Beeble, Inc. (Jun 25, 2002)

History**Direct History**

=> **1 METHOD OF RESTRICTING SOFTWARE OPERATION WITHIN A LICENSE LIMITATION, US PAT 6411941, 2002 WL 1375346 (U.S. PTO Utility Jun 25, 2002) (NO. 09/164777)**

Patent Family

2 UNAUTHORIZED SOFTWARE OPERATION RESTRICTION METHOD IN COMPUTER, INVOLVES SETTING UP VERIFICATION STRUCTURE INCLUDING LICENSE RECORD DATA IN EEPROM, TO VERIFY PROGRAM STORED IN RAM, Derwent World Patents Legal 2002-536422

Assignments

- 3 Action: ASSIGNMENT OF ASSIGNORS INTEREST (SEE DOCUMENT FOR DETAILS). Number of Pages: 003, (DATE RECORDED: Dec 21, 2004)**
- 4 ACTION: REQUEST FOR CORRECTION TO CORRECT THE ASSIGNOR'S NAME PREVIOUSLY RECORDED AT REEL 012617, FRAME 0830 NUMBER OF PAGES: 004, (DATE RECORDED: May 09, 2002)**
- 5 ACTION: ASSIGNMENT OF ASSIGNORS INTEREST (SEE DOCUMENT FOR DETAILS). NUMBER OF PAGES: 004, (DATE RECORDED: Feb 27, 2002)**
- 6 ACTION: ASSIGNMENT OF ASSIGNORS INTEREST (SEE DOCUMENT FOR DETAILS). NUMBER OF PAGES: 002, (DATE RECORDED: Oct 01, 1998)**

Patent Status Files

- .. Request for Re-Examination, (OG DATE: Aug 18, 2009)
- .. Patent Suit(See LitAlert Entries),

Docket Summaries

- 9 ANCORA TECHNOLOGIES INC v. TOSHIBA AMERICA INFORMATION SYSTEMS INC ET AL, (W.D.WASH. Feb 27, 2009) (NO. 2:09CV00270), (35 USC 145 PATENT INFRINGEMENT)**
- 10 ANCORA TECHNOLOGIES INC v. TOSHIBA AMERICA INFORMATION SYSTEMS INC ET AL, (C.D.CAL. Jun 06, 2008) (NO. 8:08CV00626), (35 USC 145 PATENT INFRINGEMENT)**

MENT)

Litigation Alert

11 Derwent LitAlert P2009-12-06 (Feb 27, 2009) Action Taken: Complaint

Prior Art (Coverage Begins 1976)

- C** 12 APPARATUS FOR LICENSING SOFTWARE APPLICATIONS, US PAT 6173446 Assignee: Ultimus, Inc., (U.S. PTO Utility 2001)
- C** 13 AUTOMATED SYSTEM FOR MANAGEMENT OF LICENSED SOFTWARE, US PAT 5790664 Assignee: Network Engineering Software, Inc., (U.S. PTO Utility 1998)
- C** 14 COMPACT TRANSPARENT DONGLE DEVICE, US PAT 6128741 Assignee: Rainbow Technologies, Inc., (U.S. PTO Utility 2000)
- C** 15 COMPUTER IMPLEMENTED METHOD AND A COMPUTER SYSTEM FOR ENFORCING SOFTWARE LICENSES, US PAT 6006190 Assignee: Tartaroukos LLC, (U.S. PTO Utility 1999)
- C** 16 COMPUTER SYSTEM WITH A PAGED NON-VOLATILE MEMORY, US PAT 5479639 Assignee: Intel Corporation, (U.S. PTO Utility 1995)
- C** 17 DIGITAL PRODUCT EXECUTION CONTROL, US PAT 6073256 Assignee: Preview Systems, Inc., (U.S. PTO Utility 2000)
- C** 18 DIGITAL PRODUCT EXECUTION CONTROL AND SECURITY, US PAT 6272636 Assignee: Preview Systems, Inc, (U.S. PTO Utility 2001)
- C** 19 ELECTRONIC LICENSING SYSTEM, US PAT 5758069 Assignee: Novell, Inc., (U.S. PTO Utility 1998)
- C** 20 FAULT TOLERANT ELECTRONIC LICENSING SYSTEM, US PAT 5905860 Assignee: Novell, Inc., (U.S. PTO Utility 1999)
- C** 21 HARDWARE ASSIST FOR PROTECTING PC SOFTWARE, US PAT 4866769 Assignee: IBM Corporation, (U.S. PTO Utility 1989)
- C** 22 IMPLEMENTING A SHARED HIGHER LEVEL OF PRIVILEGE ON PERSONAL COMPUTERS FOR COPY PROTECTION OF SOFTWARE, US PAT 4903296 Assignee: International Business Machines, (U.S. PTO Utility 1990)
- C** 23 LICENSE MANAGEMENT SYSTEM FOR SOFTWARE APPLICATIONS, US PAT 5671412 Assignee: Globetrotter Software, Incorporated, (U.S. PTO Utility 1997)
- C** 24 LICENSE MANAGEMENT SYSTEM USING DAEMONS AND ALIASING, US PAT 6021438 Assignee: Wyatt River Software, Inc., (U.S. PTO Utility 2000)
- C** 25 LICENSE MANGAGEMENT SYSTEM AND LICENSE STORAGE KEY, US PAT 4924378 Assignee: Prime Computer, Inc., (U.S. PTO Utility 1990)
- C** 26 LICENSE METERING SYSTEM FOR SOFTWARE APPLICATIONS, US PAT 5386369 Assignee: Globetrotter Software Inc., (U.S. PTO Utility 1995)
- C** 27 METHOD AND APPARATUS FOR LICENSING COMPUTER PROGRAMS USING A DSA SIGNATURE, US PAT 6078909 Assignee: International Business Machines, (U.S. PTO Utility 2000)

- C 28 METHOD AND APPARATUS FOR SOFTWARE LICENSE MANAGEMENT, US PAT 5758068 Assignee: International Business Machines, (U.S. PTO Utility 1998)
- C 29 METHOD AND APPARATUS FOR SOFTWARE LICENSING ELECTRONICALLY DISTRIBUTED PROGRAMS, US PAT 6233567 Assignee: Intel Corporation, (U.S. PTO Utility 2001)
- C 30 METHOD AND SYSTEM FOR USER AUTHORIZATION OVER A MULTI-USER COMPUTER SYSTEM, US PAT 5684951 Assignee: Synopsys, Inc., (U.S. PTO Utility 1997)
- C 31 METHOD FOR PREVENTING SOFTWARE PIRACY DURING INSTALLATION FROM A READ ONLY STORAGE MEDIUM, US PAT 6226747 Assignee: Microsoft Corporation, (U.S. PTO Utility 2001)
- C 32 METHOD OF AND APPARATUS FOR PROTECTING AND UPGRADING SOFTWARE USING A REMOVABLE HARDLOCK, US PAT 6023763 Assignee: Fisher Controls International, Inc., (U.S. PTO Utility 2000)
- C 33 METHOD OF METERING AND PROTECTING COMPUTER SOFTWARE, US PAT 5826011 Assignee: Rainbow Technologies, Inc., (U.S. PTO Utility 1998)
- C 34 OPTICAL DISK, AN OPTICAL DISK BARCODE FORMING METHOD, AN OPTICAL DISK REPRODUCTION APPARATUS, A MARKING FORMING APPARATUS, A METHOD OF FORMING A LASER MARKING ON AN OPTICAL DISK, AND A METHOD OF MANUFACTURING AN OPTICAL DISK, US PAT 6298138 Assignee: Matsushita Electric Industrial Co., Ltd., (U.S. PTO Utility 2001)
- C 35 SOFTWARE ANTI-PIRACY SYSTEM THAT ADAPTS TO HARDWARE UPGRADES, US PAT 6243468 Assignee: Microsoft Corporation, (U.S. PTO Utility 2001)
- C 36 SOFTWARE AUDITING MECHANISM FOR A DISTRIBUTED COMPUTER ENTERPRISE ENVIRONMENT, US PAT 5754763 Assignee: International Business Machines, (U.S. PTO Utility 1998)
- C 37 SOFTWARE FINGERPRINTING AND BRANDING, US PAT 6000030 Assignee: EMC Corporation, (U.S. PTO Utility 1999)
- C 38 SOFTWARE PROGRAM SELF-MODIFICATION, US PAT 6055503 Assignee: Preview Systems, (U.S. PTO Utility 2000)
- C 39 SOFTWARE PROGRAMMABLE RADIO AND METHOD FOR CONFIGURING, US PAT 6052600 Assignee: Motorola, Inc., (U.S. PTO Utility 2000)
- C 40 SYSTEM AND METHOD FOR CLOAKING SOFTWARE, US PAT 6192475 (U.S. PTO Utility 2001)
- C 41 SYSTEM AND METHOD FOR SOFTWARE LICENSING, US PAT 6189146 Assignee: Microsoft Corporation, (U.S. PTO Utility 2001)
- ▷ 42 SYSTEM FOR CONTROLLING THE NUMBER OF CONCURRENT COPIES OF A PROGRAM IN A NETWORK BASED ON THE NUMBER OF AVAILABLE LICENSES, US PAT 5390297 Assignee: Auto-trol Technology Corporation, (U.S. PTO Utility 1995)
- C 43 SYSTEM FOR INSTALLING INFORMATION RELATED TO A SOFTWARE APPLICATION TO A REMOTE COMPUTER OVER A NETWORK, US PAT 6067582 Assignee: ANGEL Secure Networks, Inc., (U.S. PTO Utility 2000)

- P** 44 SYSTEM FOR SOFTWARE REGISTRATION, US PAT 5490216 Assignee: Uniloc Private Limited, (U.S. PTO Utility 1996)
- H** 45 SYSTEMS AND METHODS FOR SECURE TRANSACTION MANAGEMENT AND ELECTRONIC RIGHTS PROTECTION, US PAT 5892900 Assignee: InterTrust Technologies Corp., (U.S. PTO Utility 1999)
- C** 46 TIRIS BASED BIOS FOR PROTECTION OF COPYRIGHTED™ PROGRAM MATER, US PAT 6198875 Assignee: Texas Instruments Incorporated, (U.S. PTO Utility 2001)

© 2010 Thomson Reuters. All rights reserved.

US District Court Civil Docket

**U.S. District - Washington Western
(Seattle)**

2:09cv270

**Ancora Technologies Inc v. Toshiba America Information Systems Inc et
A**

This case was retrieved from the court on Wednesday, February 10, 2010

Date Filed: **02/27/2009**
Assigned To: **Judge Marsha J Pechman**
Referred To:
Nature of
 suit: **Patent (830)**
Cause: **Patent Infringement**
Lead Docket: **None**
 Other **Central District California - Southern**
Docket: **Division, 08-00626 -AG-MLG**
Jurisdiction: **Federal Question**

Class Code: **CLOSED, JURYDEMAND,
PROTO, TRANSIN**
Closed: **Yes**
Statute: **35:145**
Jury Demand: **Both**
Demand
Amount: **\$0**
NOS
Description: **Patent**

Litigants

Ancora Technologies Inc
Plaintiff

Attorneys

John S Leroy
[COR LD NTC]
Brooks Kushman PC
1000 Town Center
Twenty-Second Floor
Southfield , MI 48075
USA
248-358-4400
Pro Hac Vice
Email: JLEROY@BROOKSKUSHMAN.COM

Marc Lorelli
[COR LD NTC]
Brooks Kushman PC
1000 Town Center
Twenty-Second Floor
Southfield , MI 48075
USA
248-358-4400
Pro Hac Vice
Email: MLORELLI@BROOKSKUSHMAN.COM

Mark Cantor
[COR LD NTC]
Brooks Kushman PC
1000 Town Center
Twenty-Second Floor
Southfield , MI 48075
USA
248-358-4400
Pro Hac Vice
Email: MCANTOR@BROOKSKUSHMAN.COM

Daniel J Walker
[COR LD NTC]
Susman Godfrey (Wa)
1201 Third Ave
Ste 3800
Seattle , WA 98101
USA
206-373-7385
Email: DWALKER@SUSMANGODFREY.COM

Drew Derrick Hansen
[COR LD NTC]
Susman Godfrey (Wa)
1201 Third Ave
Ste 3800
Seattle , WA 98101
USA
206-516-3880
Email: Dhansen@susmangodfrey.com

Floyd G Short
[COR LD NTC]
Susman Godfrey (Wa)
1201 Third Ave
Ste 3800
Seattle , WA 98101
USA
206-373-7381
Fax: 206-516-3883
Email: Fshort@susmangodfrey.com

Toshiba America Information Systems Inc
Defendant

Chad S Campbell
[COR LD NTC]
Perkins Coie Brown & Bain
2901 N Central Ave
P O Box 400
Phoenix , AZ 85012-0400
USA
602-351-8393
Fax: 602-351-8000
Pro Hac Vice
Email: CSCAMPBELL@PERKINSCOIE.COM

Lauren Sliger
[COR LD NTC]
Perkins Coie (Santa Monica)
1620 26TH St
6TH FL
Santa Monica , CA 90404
USA
310-788-9900
Pro Hac Vice
Email: LSLIGER@PERKINSCOIE.COM

Scott S Minder
[COR LD NTC]
Perkins Coie Brown & Bain PA
2901 North Central Avenue
Ste 2000
Phoenix , AZ 85012
USA
602-351-8290
Pro Hac Vice
Email: SMINDER@PERKINSCOIE.COM

Arthur W Harrigan , Jr

[COR LD NTC]
Danielson Harrigan & Tollefson
999 3RD Ave
Ste 4400
Seattle , WA 98104
USA
206-623-1700
Fax: Fax 623-8717
Email: ARTHURH@DHLT.COM

Christopher T Wion
[COR LD NTC]
Danielson Harrigan Leyh & Tollefson
999 3RD Ave
Ste 4400
Seattle , WA 98104
USA
206-623-1700
Email: CHRISW@DHLT.COM

Dell Inc
Defendant

Chad S Campbell
[COR LD NTC]
Perkins Coie Brown & Bain
2901 N Central Ave
P O Box 400
Phoenix , AZ 85012-0400
USA
602-351-8393
Fax: 602-351-8000
Pro Hac Vice
Email: CSCAMPBELL@PERKINSCOIE.COM

Lauren Sliger
[COR LD NTC]
Perkins Cole (Santa Monica)
1620 26TH St
6TH FL
Santa Monica , CA 90404
USA
310-788-9900
Pro Hac Vice
Email: LSLIGER@PERKINSCOIE.COM

Scott S Minder
[COR LD NTC]
Perkins Coie Brown & Bain PA
2901 North Central Avenue
Ste 2000
Phoenix , AZ 85012
USA
602-351-8290
Pro Hac Vice
Email: SMINDER@PERKINSCOIE.COM

Christopher T Wion
[COR LD NTC]
Danielson Harrigan Leyh & Tollefson
999 3RD Ave
Ste 4400
Seattle , WA 98104
USA
206-623-1700
Email: CHRISW@DHLT.COM

Hewlett-Packard Company

Chad S Campbell

Defendant

[COR LD NTC]
Perkins Coie Brown & Bain
2901 N Central Ave
P O Box 400
Phoenix , AZ 85012-0400
USA
602-351-8393
Fax: 602-351-8000
Pro Hac Vice
Email: CSCAMPBELL@PERKINSCOIE.COM

Lauren Sliger
[COR LD NTC]
Perkins Coie (Santa Monica)
1620 26TH St
6TH FL
Santa Monica , CA 90404
USA
310-788-9900
Pro Hac Vice
Email: LSLIGER@PERKINSCOIE.COM

Scott S Minder
[COR LD NTC]
Perkins Coie Brown & Bain PA
2901 North Central Avenue
Ste 2000
Phoenix , AZ 85012
USA
602-351-8290
Pro Hac Vice
Email: SMINDER@PERKINSCOIE.COM

Christopher T Wion
[COR LD NTC]
Danielson Harrigan Leyh & Tollefson
999 3RD Ave
Ste 4400
Seattle , WA 98104
USA
206-623-1700
Email: CHRISW@DHLT.COM

Miki Mullor Thirdparty
Defendant

Toshiba America Information Systems Inc A California
Corporation
Counter Claimant

Hewlett-Packard Company
Counter Claimant

Dell Inc
Counter Claimant

Ancora Technologies Inc A Delaware Corporation
Counter Defendant

Marc Lorelli
[COR LD NTC]
Brooks Kushman PC
1000 Town Center
Twenty-Second Floor
Southfield , MI 48075
USA
248-358-4400
Pro Hac Vice
Email: MLORELLI@BROOKSKUSHMAN.COM

Mark Cantor
[COR LD NTC]
Brooks Kushman PC
1000 Town Center
Twenty-Second Floor
Southfield , MI 48075
USA
248-358-4400
Pro Hac Vice
Email: MCANTOR@BROOKSKUSHMAN.COM

Ancora Technologies Inc
Counter Defendant

Marc Lorelli
[COR LD NTC]
Brooks Kushman PC
1000 Town Center
Twenty-Second Floor
Southfield , MI 48075
USA
248-358-4400
Pro Hac Vice
Email: MLORELLI@BROOKSKUSHMAN.COM

Ancora Technologies Inc
Counter Defendant

Marc Lorelli
[COR LD NTC]
Brooks Kushman PC
1000 Town Center
Twenty-Second Floor
Southfield , MI 48075
USA
248-358-4400
Pro Hac Vice
Email: MLORELLI@BROOKSKUSHMAN.COM

Microsoft Corporation
Intervenor

Chad S Campbell
[COR LD NTC]
Perkins Coie Brown & Bain
2901 N Central Ave
P O Box 400
Phoenix , AZ 85012-0400
USA
602-351-8393
Fax: 602-351-8000
Pro Hac Vice
Email: CSCAMPBELL@PERKINSCOIE.COM

Lauren Sliger
[COR LD NTC]
Perkins Coie (Santa Monica)
1620 26TH St
6TH FL
Santa Monica , CA 90404
USA
310-788-9900
Pro Hac Vice
Email: LSLIGER@PERKINSCOIE.COM

Scott S Minder
[COR LD NTC]
Perkins Coie Brown & Bain PA
2901 North Central Avenue
Ste 2000
Phoenix , AZ 85012
USA

602-351-8290
Pro Hac Vice
Email: SMINDER@PERKINSCOIE.COM

Arthur W Harrigan , Jr
[COR LD NTC]
Danielson Harrigan & Tollefson
999 3RD Ave
Ste 4400
Seattle , WA 98104
USA
206-623-1700
Fax: Fax 623-8717
Email: ARTHURH@DHLT.COM

Christopher T Wion
[COR LD NTC]
Danielson Harrigan Leyh & Tollefson
999 3RD Ave
Ste 4400
Seattle , WA 98104
USA
206-623-1700
Email: CHRISW@DHLT.COM

Stacy Quan
[COR LD NTC]
Microsoft Corp
One Microsoft Way
Redmond , WA 98052
USA
425-882-8080
Email: STACY.QUAN@MICROSOFT.COM

T Andrew Culbert
[COR LD NTC]
Microsoft Corp
One Microsoft Way
Redmond , WA 98052
USA
425-706-6921
Email: ANDYCU@MICROSOFT.COM

Toshiba America Information Systems Inc
Counter Claimant

Chad S Campbell
[COR LD NTC]
Perkins Coie Brown & Bain
2901 N Central Ave
P O Box 400
Phoenix , AZ 85012-0400
USA
602-351-8393
Fax: 602-351-8000
Pro Hac Vice
Email: CSCAMPBELL@PERKINSCOIE.COM

Lauren Sliger
[COR LD NTC]
Perkins Coie (Santa Monica)
1620 26TH St
6TH FL
Santa Monica , CA 90404
USA
310-788-9900
Pro Hac Vice
Email: LSLIGER@PERKINSCOIE.COM

Arthur W Harrigan , Jr
[COR LD NTC]
Danielson Harrigan & Tollefson
999 3RD Ave
Ste 4400
Seattle , WA 98104
USA
206-623-1700
Fax: Fax 623-8717
Email: ARTHURH@DHLT.COM

Christopher T Wion
[COR LD NTC]
Danielson Harrigan Leyh & Tollefson
999 3RD Ave
Ste 4400
Seattle , WA 98104
USA
206-623-1700
Email: CHRISW@DHLT.COM

Ancora Technologies Inc A Delaware Corporation
Counter Defendant

Marc Lorelli
[COR LD NTC]
Brooks Kushman PC
1000 Town Center
Twenty-Second Floor
Southfield , MI 48075
USA
248-358-4400
Pro Hac Vice
Email: MLORELLI@BROOKSKUSHMAN.COM

Mark Cantor
[COR LD NTC]
Brooks Kushman PC
1000 Town Center
Twenty-Second Floor
Southfield , MI 48075
USA
248-358-4400
Pro Hac Vice
Email: MCANTOR@BROOKSKUSHMAN.COM

Dell Inc
Counter Claimant

Chad S Campbell
[COR LD NTC]
Perkins Coie Brown & Bain
2901 N Central Ave
P O Box 400
Phoenix , AZ 85012-0400
USA
602-351-8393
Fax: 602-351-8000
Pro Hac Vice
Email: CSCAMPBELL@PERKINSCOIE.COM

Lauren Sliger
[COR LD NTC]
Perkins Coie (Santa Monica)
1620 26TH St
6TH FL
Santa Monica , CA 90404
USA
310-788-9900
Pro Hac Vice
Email: LSLIGER@PERKINSCOIE.COM

Ancora Technologies Inc A Delaware Corporation
Counter Defendant

Christopher T Wion
[COR LD NTC]
Danielson Harrigan Leyh & Tollefson
999 3RD Ave
Ste 4400
Seattle , WA 98104
USA
206-623-1700
Email: CHRISW@DHLT.COM

Marc Lorelli
[COR LD NTC]
Brooks Kushman PC
1000 Town Center
Twenty-Second Floor
Southfield , MI 48075
USA
248-358-4400
Pro Hac Vice
Email: MLORELLI@BROOKSKUSHMAN.COM

Mark Cantor
[COR LD NTC]
Brooks Kushman PC
1000 Town Center
Twenty-Second Floor
Southfield , MI 48075
USA
248-358-4400
Pro Hac Vice
Email: MCANTOR@BROOKSKUSHMAN.COM

Hewlett-Packard Company
Counter Claimant

Chad S Campbell
[COR LD NTC]
Perkins Coie Brown & Bain
2901 N Central Ave
P O Box 400
Phoenix , AZ 85012-0400
USA
602-351-8393
Fax: 602-351-8000
Pro Hac Vice
Email: CSCAMPBELL@PERKINSCOIE.COM

Lauren Sliger
[COR LD NTC]
Perkins Coie (Santa Monica)
1620 26TH St
6TH FL
Santa Monica , CA 90404
USA
310-788-9900
Pro Hac Vice
Email: LSLIGER@PERKINSCOIE.COM

Christopher T Wion
[COR LD NTC]
Danielson Harrigan Leyh & Tollefson
999 3RD Ave
Ste 4400
Seattle , WA 98104
USA
206-623-1700
Email: CHRISW@DHLT.COM

Ancora Technologies Inc A Delaware Corporation
Counter Defendant

Marc Lorelli
[COR LD NTC]
Brooks Kushman PC
1000 Town Center
Twenty-Second Floor
Southfield , MI 48075
USA
248-358-4400
Pro Hac Vice
Email: MLORELLI@BROOKSKUSHMAN.COM

Mark Cantor
[COR LD NTC]
Brooks Kushman PC
1000 Town Center
Twenty-Second Floor
Southfield , MI 48075
USA
248-358-4400
Pro Hac Vice
Email: MCANTOR@BROOKSKUSHMAN.COM

Microsoft Corporation
Counter Claimant

Chad S Campbell
[COR LD NTC]
Perkins Coie Brown & Bain
2901 N Central Ave
P O Box 400
Phoenix , AZ 85012-0400
USA
602-351-8393
Fax: 602-351-8000
Pro Hac Vice
Email: CSCAMPBELL@PERKINSCOIE.COM

Lauren Sliger
[COR LD NTC]
Perkins Coie (Santa Monica)
1620 26TH St
6TH FL
Santa Monica , CA 90404
USA
310-788-9900
Pro Hac Vice
Email: LSLIGER@PERKINSCOIE.COM

Arthur W Harrigan , Jr
[COR LD NTC]
Danielson Harrigan & Tollefson
999 3RD Ave
Ste 4400
Seattle , WA 98104
USA
206-623-1700
Fax: Fax 623-8717
Email: ARTHURH@DHLT.COM

Christopher T Wion
[COR LD NTC]
Danielson Harrigan Leyh & Tollefson
999 3RD Ave
Ste 4400
Seattle , WA 98104
USA
206-623-1700

Email: CHRISW@DHLT.COM

Stacy Quan
[COR LD NTC]
Microsoft Corp
One Microsoft Way
Redmond , WA 98052
USA
425-882-8080
Email: STACY.QUAN@MICROSOFT.COM

T Andrew Culbert
[COR LD NTC]
Microsoft Corp
One Microsoft Way
Redmond , WA 98052
USA
425-706-6921
Email: ANDYCU@MICROSOFT.COM

Ancora Technologies Inc A Delaware Corporation
Counter Defendant

Marc Lorelli
[COR LD NTC]
Brooks Kushman PC
1000 Town Center
Twenty-Second Floor
Southfield , MI 48075
USA
248-358-4400
Pro Hac Vice
Email: MLORELLI@BROOKSKUSHMAN.COM

Mark Cantor
[COR LD NTC]
Brooks Kushman PC
1000 Town Center
Twenty-Second Floor
Southfield , MI 48075
USA
248-358-4400
Pro Hac Vice
Email: MCANTOR@BROOKSKUSHMAN.COM

Date	#	Proceeding Text
02/27/2009	1	Case transferred in from District of Southern California, Case Number 08-626; with documents 1-162 to follow.(MKB) (Additional attachment(s) added on 3/3/2009: # 1 Transfer Order to Western District of Washington (Dkt.161)) (MKB). (Entered: 03/03/2009)
02/27/2009	2	California Dockets 1-10: (Attachments: # 1 Complaint (Dkt.1), # 2 Certification and Notice of Interested Parties by Ancora (Dkt.2), # 3 Report on the Filing of An Action Regarding a Patent (Dkt.3), # 4 Stipulation Extending Time to Answer by Toshiba (Dkt.4), # 5 Corporate Disclosure Statement by Toshiba (Dkt.5), # 6 Certification and Notice of Interested Parties by Hewlett-Packard (Dkt.6), # 7 Stipulation Extending Time to Answer by Hewlett-Packard (Dkt.7), # 8 Application of C. Benson appear PHV (Dkt.8), # 9 Application of M. Barrett to appear PHV (Dkt.9), # 10 Proof of Service by Dell (Dkt.10))(MKB) (Entered: 03/03/2009)
02/27/2009	3	California Dockets 11-20: Stipulation Extending Time to Answer as to Dell (Dkt.11) (Attachments: # 1 Order granting M. Barrett PHV (Dkt.12), # 2 Order granting C. Benson PHV (Dkt.13), # 3 Application of M. Cantor PHV (Dkt.14), # 4 Proposed Order (Dkt.14-1), # 5 Application of M. Lorelli PHV (Dkt.15), # 6 Proposed Order (Dkt15-1), # 7 Order granting M. Cantor PHV (Dkt.16), # 8 Order granting M. Lorelli PHV (Dkt.17), # 9 Stipulation for Extension of Time to Answer by Hewlett-Packard (Dkt.18), # 10 Proposed Order (Dkt.18-1), # 11 Order granting extension (18) (Dkt.19), # 12 Answer to Complaint with Jury Demand and Counterclaim by Dell (Dkt.20))(MKB) (Entered: 03/03/2009)
02/27/2009	4	California Dockets 21-30: Certificate and Notice of Interested Parties by Dell (Dkt.21) (Attachments: # 1 Answer to Complaint and Counterclaims by Hewlett-Packard (Dkt.22), # 2

- Order re Early Meeting and Scheduling Conference (Dkt.23), # 3 Notice to Filer of Deficiencies (Dkt.24), # 4 Notice of Manual Filing by Dell (Dkt.25), # 5 Answer to Complaint and Counterclaim by Toshiba (Dkt.26), # 6 Notice of Change of Attorney Information re A. Hall by Toshiba (Dkt.27), # 7 Notice of Change of Attorney re I. Lateef by Toshiba (Dkt.28), # 8 Notice of Change of Attorney Information re S. Jensen by Toshiba (Dkt.29), # 9 Answer and Counterclaims by Hewlett-Packard (Dkt.30))(MKB) (Entered: 03/03/2009)
- 02/27/2009 5 California Dockets 31-40: Answer to Complaint and Counterclaim by Dell (Dkt.31). (Attachments: # 1 Notice of Discrepancy and Order (Dkt.32), # 2 Notice of Change of Attorney Information re M. Mizrahi by Ancora (Dkt.33), # 3 Notice to Filer of Deficiencies (Dkt.34), # 4 Answer to Dell's Counterclaim (Dkt.35), # 5 Answer to Hewlett-Packard's Counterclaim (Dkt.36), # 6 Answer to Toshiba's Counterclaims (Dkt.37), # 7 Application of J. LeRoy PHV (Dkt.38), # 8 Proposed Order (Dkt.38-1), # 9 Notice of Unopposed Motion to Intervene by Microsoft (Dkt.39), # 10 Memorandum In Support of Motion to Intervene (Dkt.40))(MKB) (Entered: 03/03/2009)
- 02/27/2009 6 California Dockets 41-50: Stipulation re Motion to Intervene by Microsoft (Dkt.41) (Attachments: # 1 Application of S. Minder PHV (Dkt.42), # 2 Proposed Order (Dkt.42-1), # 3 Application of C. Campbell PHV (Dkt.43), # 4 Proposed Order (Dkt.43-1), # 5 Certification and Notice of Interested Parties by Microsoft (Dkt.44), # 6 Order granting J. LeRoy appearance for Ancora (Dkt.45), # 7 Order granting C. Campbell appearance for Microsoft (Dkt.46), # 8 Order granting S. Minder appearance for Microsoft (Dkt.47), # 9 Order Returning Case for Reassignment Upon Recusal (Dkt.48), # 10 Order Granting Microsoft's Motion to Intervene (39) (Dkt.49), # 11 Notice of Clerical Error (Dkt.50))(MKB) (Entered: 03/03/2009)
- 02/27/2009 7 California Dockets 51-60: Notice of Appearance by D. Lacy Kusters for Hewlett-Packard (Dkt.51) (Attachments: # 1 Complaint in Intervention for Declaratory Judgment by Microsoft (Dkt.52), # 2 Summons (Dkt.52-1), # 3 Proof of Service by Microsoft (Dkt.53), # 4 Joint Report (Dkt.54), # 5 Answer to Intervenor Complaint by Ancora (Dkt.55), # 6 Stipulation to Continue by Microsoft (Dkt.56), # 7 Proposed Order (Dkt.56-1), # 8 Order granting Stipulation to Continue (56) (Dkt.57), # 9 Scheduling Order (Dkt.58), # 10 Minutes of Scheduling Conference (Dkt. 59), # 11 Notice of Change of Attorney Information re L. Sliger by Hewlett-Packard (Dkt.60))(MKB) (Entered: 03/03/2009)
- 02/27/2009 8 California Dockets 61-70: Notice of Change of Attorney Information re L. Sliger by Hewlett-Packard (Dkt.61). (Attachments: # 1 Notice of Change of Attorney Information re L. Sliger by Hewlett-Packard (Dkt.62), # 2 Notice of Change of Attorney Information re L. Sliger by Hewlett-Packard (Dkt.63), # 3 Answer to Counterclaims by Microsoft (Dkt.64), # 4 Notice and Motion to Withdraw (Dkt. 65), # 5 Exhibit Signature page (Dkt. 65-1), # 6 Proposed Order (Dkt.65-2), # 7 Order Granting Motion to Withdraw (65) (Dkt.66), # 8 Stipulation to Reschedule (Dkt. 67), # 9 Proposed Order (Dkt.67-1), # 10 Stipulation for Protective Order (Dkt.68), # 11 Proposed Order (Dkt.68-1), # 12 Order Granting Stipulation to Reschedule (67) (Dkt.69), # 13 Protective Order (Dkt.70))(MKB) (Entered: 03/03/2009)
- 02/27/2009 9 California Dockets 71-78: Notice of Change of Attorney Information re L. Sliger by Toshiba (Dkt.71). (Attachments: # 1 Notice of Change of Attorney Information re L. Sliger by Toshiba (Dkt.72), # 2 Notice of Change of Attorney Information re L. Sliger by Toshiba (Dkt.73), # 3 Notice of Change of Attorney Information re L. Sliger by Toshiba (Dkt.74), # 4 Notice of Taking Deposition of Miki Mullor by Microsoft (Dkt.75), # 5 Notice of Manual Filing (Dkt.76), # 6 Notice of Motion re Joint Stipulation for Entry of Final Protective Order (Dkt.77), # 7 Proposed Order (Dkt.77-1), # 8 Declaration of Miki Mullor (Dkt.78))(MKB) (Entered: 03/03/2009)
- 02/27/2009 10 California Docket 79: Declaration of David M. LaSpaluto (Dkt.79). (Attachments: # 1 Exhibit 1 (Dkt.79-1), # 2 Exhibit 2-5 (Dkt.79-2), # 3 Exhibit 6-14 (Dkt.79-3), # 4 Exhibit 15-22 (Dkt.79-4), # 5 Exhibit 23-24 (Dkt.79-5), # 6 Exhibit 25-26 (Dkt.79-6), # 7 Exhibit 27 (Dkt.79-7), # 8 Exhibit 28-30 (Dkt.79-8), # 9 Exhibit 31 (Dkt.79-9), # 10 Exhibit 32 (Dkt.79-10), # 11 Exhibit 33 (Dkt.79-11), # 12 Exhibit 34 (Dkt.79-12))(MKB) (Entered: 03/03/2009)
- 02/27/2009 11 California Dockets 80-90 with the exception of dockets 84, 85, 86 which were sealed per Court order: Notice and Motion to Withdraw (Dkt.80). (Attachments: # 1 Order Continuing Hearing (Dkt.81), # 2 Application to File Under Seal (Dkt.82), # 3 Order Granting Application to Seal (Dkt.83), # 4 Joint Stipulation re Application to Seal (82) (Dkt.87), # 5 Proposed Order (Dkt.87-1), # 6 Order Rescheduling Hearing (Dkt.88), # 7 Notice and Motion to Compel Microsoft (Dkt.89), # 8 Proposed Order (Dkt.89-1), # 9 Joint Stipulation to Motion to Compel Microsoft (Dkt.90))(MKB) (Entered: 03/03/2009)
- 02/27/2009 12 California Dockets 91-94: Declaration of Mark Mizrahi In Support of Motion to Compel Microsoft (Dkt.91). (Attachments: # 1 Exhibit 1 (Dkt.91-1), # 2 Exhibit 2 (Dkt.91-2), # 3 Exhibit 3 (Dkt.91-3), # 4 Exhibit 4 (Dkt.91-4), # 5 Exhibit 5 (Dkt.91-5), # 6 Exhibit 6 (Dkt.91-6), # 7 Exhibit 7 (Dkt.91-7), # 8 Declaration of Scott Minder in Opposition to Motion to Compel (Dkt.92), # 9 Supplemental Exhibits to Minder Declaration (Dkt.92-1), # 10 Notice and Motion

to Compel Defendants Hewlett-Packard, Dell, Toshiba by Ancora (Dkt.93), # 11 Proposed Order (Dkt.93-1), # 12 Joint Stipulation to Motion to Compel (93) (Dkt.94))(MKB) (Entered: 03/03/2009)

- 02/27/2009 13 California Dockets 95-100: Declaration of Mark Mizrahi in Support of Motion to Compel (93) (Dkt.95). (Attachments: # 1 Exhibit 1 (Dkt.95-1), # 2 Exhibit 2 (Dkt.95-2), # 3 Exhibit 3 (Dkt.95-3), # 4 Exhibit 4 (Dkt.95-4), # 5 Exhibit 5 (Dkt.95-5), # 6 Exhibit 6 (Dkt.95-6), # 7 Exhibit 7 (Dkt.95-7), # 8 Exhibit 8 (Dkt.95-8), # 9 Exhibit 9 (Dkt.95-9), # 10 Exhibit 10 (Dkt.95-10), # 11 Exhibit 11 (Dkt.95-11), # 12 Exhibit 12 (Dkt.95-12), # 13 Exhibit 13 Dkt.95-13), # 14 Exhibit 14 (Dkt.95-14), # 15 Declaration of Scott Minder in Opposition to Motion to Compel Hewlett-Packard, Dell, Toshiba by Ancora (Dkt.96), # 16 First Amended Answer to Intervenor Complaint (52) (Dkt.97), # 17 Exhibit A (Dkt.97-1), # 18 Notice and Motion for Leave to File Amended Answers by Microsoft (Dkt.98), # 19 Proposed Order (Dkt.98-1), # 20 Memorandum in Support of Motion to File Amended Answers by Microsoft (Dkt.99), # 21 Exhibit A-D (Dkt.99-1), # 22 Notice and Motion to Withdraw (Dkt.100))(MKB) (Entered: 03/03/2009)
- 02/27/2009 14 California Dockets 101-102: Opening Markman Brief by Ancora (Dkt.101) (Attachments: # 1 Exhibit 1 (Dkt.101-1), # 2 Exhibit 2 (Dkt.101-2), # 3 Exhibit 3 (Dkt.101-3), # 4 Exhibit 4 (Dkt.101-4), # 5 Exhibit 5 (Dkt.101-5), # 6 Exhibit 6 (Dkt..101-6), # 7 Exhibit 7 (Dkt.101-7), # 8 Exhibit 8 (Dkt.101-8), # 9 Exhibit 9 (Dkt.101-9), # 10 Exhibit 10 (Dkt.101-10), # 11 Exhibit 11 (Dkt.101-11), # 12 Exhibit 12 (Dkt.101-12), # 13 Exhibit 13 (Dkt.101-13), # 14 Exhibit 14 (Dkt.101-14), # 15 Opening Claims Construction Brief by Microsoft (Dkt.102))(MKB) (Entered: 03/03/2009)
- 02/27/2009 15 California Docket 103: Declaration of Chad S. Campbell re Markman Brief (102)(Dkt.103) (Attachments: # 1 Exhibit A-B Part 1 (Dkt.103-1), # 2 Exhibit B part 2 (Dkt.103-2), # 3 Exhibit B part 3 (Dkt.103-3), # 4 Exhibit B part 4 (Dkt.103-4), # 5 Exhibit C-D part 5 (Dkt.103-5), # 6 Exhibit E part 6 (Dkt.103-6), # 7 Exhibit E part 7 (Dkt.103-7), # 8 Exhibit F-G part 8 (Dkt.103-8))(MKB) (Entered: 03/03/2009)
- 02/27/2009 16 California Dockets 104-114: Supplement to Motion to Compel Microsoft by Ancora (Dkt.104) (Attachments: # 1 Exhibit A (Dkt.104-1), # 2 Exhibit B (Dkt.104-2), # 3 Exhibit C (Dkt.104-3), # 4 Supplement to Motion to Compel (93) by Ancora (Dkt.105), # 5 Supplement to Stipulation for Protective Order (84) by Ancora (Dkt.106), # 6 Memorandum in Support re Supplemental Memorandum in Support of Joint Stipulation re Motion for Entry of Final Protective Order by Microsoft (Dkt.107), # 7 Declaration of David M. LaSpaluto re (107) by Microsoft (Dkt.108), # 8 Exhibit 1-2 (Dkt.108-1), # 9 Memorandum in Opposition of Supplemental Memorandum in Opposition to Motion to Compel Microsoft by Microsoft (Dkt.109), # 10 Declaration of Scott S. Minder re (109) by Microsoft (Dkt.110), # 11 Exhibit 1 (Dkt.110-1), # 12 Memorandum in Opposition of Supplemental Memorandum in Opposition to Plaintiff's Motion to Compel Defendants by Toshiba (Dkt.111), # 13 Declaration of Scott Minder re (111) by Toshiba (Dkt.112), # 14 Exhibit 1-3 (Dkt112-1), # 15 Notice of Manual Filing (Dkt.113), # 16 Notice of Motion to Transfer Venue by Microsoft, Toshiba, Dell, Hewlett-Packard (Dkt.114), # 17 Proposed Order (Dkt.114-1))(MKB) (Entered: 03/03/2009)
- 02/27/2009 17 California Dockets 115-124 (Dkts. 125 and 126 were sealed by order of the Court): Declaration of Cam D'Amico in Support of Motion to Transfer Venue (Dkt.115) (Attachments: # 1 Declaration of John Hong In support of Motion to Transfer Venue (Dkt.116), # 2 Declaration of Eric Peacock In Support of Motion to Transfer Venue (Dkt.117), # 3 Declaration of Chad Anson In Support of Motion to Transfer Venue (Dkt.118), # 4 Order Granting Motion to Withdraw for Dell (Dkt.119), # 5 Proof of Service (Dkt.120), # 6 Application to File Papers Under Seal and Shorten Time by Microsoft (Dkt.121), # 7 Order Shortening Time and Granting Application to Seal (Dkt.122), # 8 Ex Parte Application to Continue Hearing on Motion to Transfer Venue by Ancora (Dkt.123), # 9 Exhibit 1 (Dkt.123-1), # 10 Proposed Order (Dkt.123-2), # 11 Opposition to Ancora's Ex Parte Application to Continue Hearing (123) (Dkt.124))(MKB) (Entered: 03/03/2009)
- 02/27/2009 18 California Dockets 127-132: Order re Continue Hearing (Dkt.127) (Attachments: # 1 Application to Clarify Order Dated February 5, 2009 (Dkt.128), # 2 Notice of Lodging (Dkt.130), # 3 Notice of Lodging (Dkt.130), # 4 Proposed Order (Dkt.130-1), # 5 Memorandum In Opposition to Motion to Transfer by Ancora (Dkt.131), # 6 Notice of Manual Filing (Dkt.132))(MKB) (Entered: 03/03/2009)
- 02/27/2009 19 California Docket 133 (with the exception of Exhibits 2,7 & 8 which were sealed by order of the Court and are entered as California Dkt.146):Memorandum in Opposition to Declaration of Counsel re Motion to Transfer (Dkt.133). (Attachments: # 1 Exhibit 1 Dkt.133-1), # 2 Exhibit 3 (Dkt.133-3), # 3 Exhibit 4 (Dkt.133-4), # 4 Exhibit 5 (Dkt.133-5), # 5 Exhibit 6 (Dkt.133-6), # 6 Exhibit 9 (Dkt.133-9), # 7 Exhibit 10 (Dkt.133-10), # 8 Exhibit 11 (Dkt.133-11), # 9 Exhibit 12 (Dkt133-12), # 10 Exhibit 13 (Dkt.133-13), # 11 Exhibit 14 (Dkt.133-14), # 12 Exhibit 15 (Dkt.133-15), # 13 Exhibit 16 (Dkt.133-16), # 14 Exhibit 17 (Dkt.133-17), # 15 Exhibit 18 (Dkt.133-18), # 16 Exhibit 19 (Dkt.133-19), # 17 Exhibit 20 (Dkt.133-20), # 18 Exhibit 21

(Dkt.133-21), # 19 Exhibit 22 (Dkt.133-22), # 20 Exhibit 23 (Dkt.133-23), # 21 Exhibit 24 (Dkt.133-24))(MKB) (Entered: 03/03/2009)

02/27/2009 20 California Dockets 134-145:Order re Application to Clarify Order Dated February 5, 2009 (Dkt.134) (Attachments: # 1 Application to File Confidential Exhibits 2, 7 & 8 (133) (Dkt.135), # 2 Order Granting File Confidential Exhibits 2, 7 & 8 (133) (Dkt.136), # 3 Order on Motion to Compel (89)(93) (Dkt.137), # 4 Notice and Motion to Dismiss Count II of Ancora's Counterclaims in it's First Amended Answer by Microsoft (Dkt.138), # 5 Proposed Order (Dkt.138-1), # 6 Memorandum In Support of Motion to Dismiss (138) (Dkt.139), # 7 Notice of Manual Filing (Dkt.140), # 8 Declaration of Supplemental Declaration of Cam D'Amico In Support of Reply re Motion to Transfer Venue (Dkt.141), # 9 Supplement/Sur-Reply by Ancora (Dkt.142), # 10 Supplement /Declaration of Mark B. Mizrahi by Ancora (Dkt.143), # 11 Notice of Manual Filing (Dkt.144), # 12 Notice of Manual Filing (Dkt.145))(MKB) (Entered: 03/03/2009)

02/27/2009 21 California Documents 147-162 (with the exception of documents 152, 153, 154, 155 which are under seal. Also, document 146 which are Exhibits 2, 7 and 8 to the Decl. of Counsel in Opposition to Motion to Transfer Venue): Application for Leave to File a Sur-Reply and to File Under Seal Confidential Exhibit 25 to Decl of Mark Mizrahi (Dkt. 147). (Attachments: # 1 Order Granting Application for Leave to File a Sur-Reply and to File Under Seal Confidential Exhibit 25 to Decl of Mark B Mizrahi (Dkt. 148), # 2 Application for Leave to File Papers Under Seal (Dkt. 149), # 3 Order Granting Application for Leave to File Under Seal (Dkt. 150), # 4 Application for Leave to File Papers Under Seal (Dkt. 151), # 5 Application for attorney John Rogers to Appear PHV (Dkt. 156), # 6 Proposed Order on Application for PHC (Dkt. 156-1), # 7 Letter Certificate of Good Standing (Dkt. 156-2), # 8 Order Granting Application To File Under Seal - Microsoft & Defts' 2nd Suppl Decl of Cnsl in Sup of Mtn to Transfer (Dkt. 157), # 9 Opposition to Motion to Dismiss Count II (Dkt. 158), # 10 Minutes of Motion Hearing RE: Intervenor's & Defts' Motion to Transfer Venue & Motion for Leave to File Prop. Amended Answers to Ancora Tech Inc's Complaint & Counterclaim (Dkt. 159), # 11 Order Granting Application for atty John Rogers to Appear Pro Hac Vice (Dkt. 160), # 12 ORDER TRANSFERRING CASE TO WESTERN DISTRICT OF WASHINGTON & Vacating Hearing on Motion to Amend (Dkt. 161), # 13 Minutes of In Chambers Order Vacating Hearing On Motion To Dismiss (Dkt. 162))(PM) (Entered: 03/04/2009)

03/04/2009 22 Letter from Clerk's Office to counsel re receipt of case from the Central District of California (Southern Division-Santa Ana)and of Western District of Washington case number and judge assignment. Counsel are also advised of pro hac vice application and ECF registration requirement. (sent electronically to all counsel via Ad hoc feature of ECF)(PM) (Entered: 03/04/2009)

03/04/2009 23 ORDER REGARDING INITIAL DISCLOSURES, JOINT STATUS REPORT AND EARLY SETTLEMENT Joint Status Report due by 4/15/2009, FRCP 26f Conference Deadline is 4/1/2009, Initial Disclosure Deadline is 4/8/2009, by Judge Marsha J. Pechman. (RM) Modified on 3/5/2009 - mailed copy of order to all pending cnsl of record(MD). (Entered: 03/04/2009)

03/04/2009 24 STANDING ORDER FOR PATENT CASES describing joint claim chart and prehearing statement procedures by Judge Marsha J. Pechman. (RK) Modified on 3/5/2009 -mailed copy of order to all pending counsel of record(MD). (Entered: 03/04/2009)

03/05/2009 25 APPLICATION OF ATTORNEY Chad S. Campbell FOR LEAVE TO APPEAR PRO HAC VICE for Defendant Toshiba America Information Systems Inc (Fee Paid) Receipt No. 0981000000001689697. (Harrigan, Arthur) (Entered: 03/05/2009)

03/06/2009 26 ORDER re 25 Application for Leave to Appear Pro Hac Vice. The Court ADMITS Attorney Chad S Campbell for Toshiba America Information Systems Inc, Dell Inc and Hewlett-Packard Company, Intervenor Microsoft Corporation by Bruce Rifkin. (No document associated with this docket entry, text only.)(DS) Modified on 3/6/2009 - to add intervenor Microsoft Corporation re: appearance to appear Pro Hac Vice (MD). (Entered: 03/06/2009)

03/09/2009 27 NOTICE of Appearance by attorney Christopher T Wion on behalf of Defendants Toshiba America Information Systems Inc, Dell Inc, Hewlett-Packard Company, Intervenor Microsoft Corporation. (Wion, Christopher) (Entered: 03/09/2009)

03/11/2009 28 NOTICE of Appearance by attorney Drew Derrick Hansen on behalf of Plaintiff Ancora Technologies Inc. (Hansen, Drew) (Entered: 03/11/2009)

03/11/2009 29 NOTICE of Appearance by attorney Floyd G Short on behalf of Plaintiff Ancora Technologies Inc. (Short, Floyd) (Entered: 03/11/2009)

03/11/2009 30 NOTICE of Appearance by attorney Daniel J Walker on behalf of Plaintiff Ancora Technologies Inc. (Walker, Daniel) (Entered: 03/11/2009)

03/12/2009 31 APPLICATION OF ATTORNEY Mark Cantor FOR LEAVE TO APPEAR PRO HAC VICE for Plaintiff

Ancora Technologies Inc (Fee Paid) Receipt No. 0981000000001695827. (Attachments: # 1 ECF registration form)(Hansen, Drew) (Entered: 03/12/2009)

03/12/2009 32 APPLICATION OF ATTORNEY Marc Lorelli FOR LEAVE TO APPEAR PRO HAC VICE for Plaintiff Ancora Technologies Inc (Fee Paid) Receipt No. 0981000000001695840. (Attachments: # 1 ECF Registration form)(Hansen, Drew) (Entered: 03/12/2009)

03/12/2009 33 APPLICATION OF ATTORNEY John LeRoy FOR LEAVE TO APPEAR PRO HAC VICE for Plaintiff Ancora Technologies Inc (Fee Paid) Receipt No. 0981000000001695843. (Attachments: # 1 ECF Registration form)(Hansen, Drew) (Entered: 03/12/2009)

03/13/2009 34 ORDER re 31 Application for Leave to Appear Pro Hac Vice. The Court ADMITS Attorney Mark Cantor for Ancora Technologies Inc, by Bruce Rifkin. (No document associated with this docket entry, text only.)(DS) (Entered: 03/13/2009)

03/13/2009 35 ORDER re 32 Application for Leave to Appear Pro Hac Vice. The Court ADMITS Attorney Marc Lorelli for Ancora Technologies Inc, by Bruce Rifkin. (No document associated with this docket entry, text only.)(DS) (Entered: 03/13/2009)

03/13/2009 36 ORDER re 33 Application for Leave to Appear Pro Hac Vice. The Court ADMITS Attorney John S. LeRoy for Ancora Technologies Inc, by Bruce Rifkin. (No document associated with this docket entry, text only.)(DS) (Entered: 03/13/2009)

03/20/2009 37 NOTICE TO THE COURT ; filed by Defendant Toshiba America Information Systems Inc, Counter Claimant Toshiba America Information Systems Inc. (Uribe, Mauricio) (Entered: 03/20/2009)

04/10/2009 38 NOTICE of Appearance by attorney Stacy Quan on behalf of Intervenor Microsoft Corporation. (Quan, Stacy) (Entered: 04/10/2009)

04/15/2009 39 JOINT STATUS REPORT signed by all parties estimated Trial Days: 10. Filed by Intervenor Microsoft Corporation.(Wion, Christopher) (Entered: 04/15/2009)

04/29/2009 40 STIPULATION and (Proposed) Protective Order by parties. (Harrigan, Arthur) (Entered: 04/29/2009)

04/29/2009 41 STIPULATION AND PROPOSED ORDER to Facilitate Consolidation of Actions Between the Parties by parties. (Harrigan, Arthur) (Entered: 04/29/2009)

05/01/2009 42 NOTICE of Appearance by attorney T. Andrew Culbert on behalf of Intervenor Microsoft Corporation. (Culbert, T.) (Entered: 05/01/2009)

05/04/2009 43 APPLICATION OF ATTORNEY Lauren Sliger FOR LEAVE TO APPEAR PRO HAC VICE for Intervenor Microsoft Corporation (Fee Paid) Receipt No. 0981000000001742002. (Attachments: # 1 ECF Registration)(Harrigan, Arthur) (Entered: 05/04/2009)

05/05/2009 44 ORDER re 43 Application for Leave to Appear Pro Hac Vice. The Court ADMITS Lauren Sliger for defendants Toshiba America Information Systems Inc, Dell Inc, Hewlett-Packard Company and intervenor, Microsoft Corporation, by Bruce Rifkin. (No document associated with this docket entry, text only.)(DS) (Entered: 05/05/2009)

05/05/2009 45 STIPULATION AND PROTECTIVE ORDER by Judge Marsha J. Pechman. (MD) (Entered: 05/05/2009)

05/11/2009 46 NOTICE of Hearing: Telephone Conference RE: expert for Markman hearing is scheduled for 5/12/2009 at 03:00 PM before Judge Marsha J. Pechman.(RM) (Entered: 05/11/2009)

05/12/2009 47 STIPULATION AND ORDER: Stipulation (Dkt. No. 41) to Facilitate Consolidation of Actions between the Parties is approved and that the parties shall comply with the terms of the Stipulation, by Judge Marsha J. Pechman. (RK) (Entered: 05/12/2009)

05/12/2009 50 MINUTE ENTRY for proceedings held before Judge Marsha J. Pechman- Dep Clerk: Rhonda Miller; Pla Counsel: Mark Lorelli, Mark Cantor, Drew Hansen; Def Counsel: Chad Campbell, Arthur Harrigan, Christopher Wion, Stacy Quan; CR: Joe Roth; Telephone Conference held on 5/12/2009. After amended complaint is filed, the parties are directed to file an updated joint status report and include proposed tutorial options for the Court in preparation for the Markman hearing. (RM) (Entered: 05/14/2009)

05/13/2009 48 AMENDED COMPLAINT AND THIRD PARTY COMPLAINT against defendant(s) Miki Mullor, Ancora Technologies Inc, Ancora Technologies Inc(a Delaware corporation) with JURY DEMAND, filed by Microsoft Corporation.(Wion, Christopher) (Entered: 05/13/2009)

05/14/2009 49 Second MOTION to Amend 48 Amended Complaint, in Intervention against Plaintiff Ancora Technologies and Third Party Complaint Against Miki Mullor by Intervenor Microsoft Corporation. (Attachments: # 1 Appendix A, # 2 Appendix B, # 3 Proposed Order) Noting Date 5/26/2009, (Wion, Christopher) (Entered: 05/14/2009)

05/15/2009 51 AMENDED COMPLAINT against defendant(s) Dell Inc, Toshiba America Information Systems Inc,

Hewlett-Packard Company, Microsoft Corporation, Toshiba America Information Systems Inc with JURY DEMAND, filed by Ancora Technologies Inc, Ancora Technologies Inc(a Delaware corporation).(Cantor, Mark) (Entered: 05/15/2009)

05/20/2009 52 RESPONSE, by Plaintiff Ancora Technologies Inc, to 49 Second MOTION to Amend 48 Amended Complaint, in Intervention against Plaintiff Ancora Technologies and Third Party Complaint Against Miki MullorSecond MOTION to Amend 48 Amended Complaint, in Intervention against Plaintiff Ancora Technologies and Third Party Complaint Against Miki Mullor. (Lorelli, Marc) (Entered: 05/20/2009)

05/23/2009 53 APPLICATION OF ATTORNEY Scott S. Minder FOR LEAVE TO APPEAR PRO HAC VICE for Intervenor Microsoft Corporation (Fee Paid) Receipt No. 0981000000001759741. (Attachments: # 1 Supplement ECF Registration)(Harrigan, Arthur) (Entered: 05/23/2009)

05/26/2009 54 REPLY, filed by Intervenor Microsoft Corporation, TO RESPONSE to 49 Second MOTION to Amend 48 Amended Complaint, in Intervention against Plaintiff Ancora Technologies and Third Party Complaint Against Miki MullorSecond MOTION to Amend 48 Amended Complaint, in Intervention against Plaintiff Ancora Technologies and Third Party Complaint Against Miki Mullor (Wion, Christopher) (Entered: 05/26/2009)

05/27/2009 55 ORDER granting 49 Microsoft's Motion for leave to file second Amended complaint in intervention against plaintiff Ancora Technologies, Inc and third party complaint against Miki Mullor. Counsel is directed to e-file their Amended Complaint, by Judge Marsha J. Pechman. (MD) (Entered: 05/28/2009)

05/29/2009 56 Second AMENDED COMPLAINT in Intervention Against Plaintiff Ancora Technologies and Third Party Complaint Against Miki Mullor against defendant(s) Ancora Technologies Inc with JURY DEMAND, filed by Microsoft Corporation.(Wion, Christopher) (Entered: 05/29/2009)

06/02/2009 57 MINUTE ORDER directing the parties to file an updated joint status report and include proposed tutorial options for the Court in preparation for the Markman hearing. Joint Status Report due by 6/17/2009. Authorized by Judge Marsha J. Pechman. (RM) (Entered: 06/02/2009)

06/04/2009 58 ANSWER to 51 Amended Complaint, with JURY DEMAND, COUNTERCLAIM against plaintiff Ancora Technologies Inc(a Delaware corporation) by Toshiba America Information Systems Inc. (Wion, Christopher) (Entered: 06/04/2009)

06/04/2009 59 ANSWER to 51 Amended Complaint, with JURY DEMAND, COUNTERCLAIM against plaintiff Ancora Technologies Inc(a Delaware corporation) by Dell Inc.(Wion, Christopher) (Entered: 06/04/2009)

06/04/2009 60 ANSWER to 51 Amended Complaint, with JURY DEMAND, COUNTERCLAIM against plaintiff Ancora Technologies Inc(a Delaware corporation) by Hewlett-Packard Company.(Wion, Christopher) (Entered: 06/04/2009)

06/04/2009 61 ANSWER to 51 Amended Complaint, with JURY DEMAND, COUNTERCLAIM against plaintiff Ancora Technologies Inc(a Delaware corporation) by Microsoft Corporation.(Wion, Christopher) (Entered: 06/04/2009)

06/05/2009 62 ORDER re 53 Application for Leave to Appear Pro Hac Vice. The Court ADMITS Attorney Scott S Minder for Toshiba America Information Systems Inc, Dell Inc, Hewlett-Packard Company and Microsoft Corporation, by Bruce Rifkin. (No document associated with this docket entry, text only.)(DS) (Entered: 06/05/2009)

06/15/2009 63 MOTION to Dismiss Counts I-V of Microsoft's Second Amended Complaint by Plaintiff Ancora Technologies Inc. Oral Argument Requested. (Attachments: # 1 Exhibit 1, # 2 Exhibit 2, # 3 Exhibit 3, # 4 Exhibit 4, # 5 Exhibit 5, # 6 Proposed Order Granting Motion to Dismiss) Noting Date 7/10/2009, (Hansen, Drew) (Entered: 06/15/2009)

06/17/2009 64 JOINT STATUS REPORT signed by all parties estimated Trial Days: 5 - 10.. (Wion, Christopher) (Entered: 06/17/2009)

06/22/2009 65 ANSWER to 60 Answer to Amended Complaint, Counterclaim by Ancora Technologies Inc, Ancora Technologies Inc(a Delaware corporation).(Lorelli, Marc) (Entered: 06/22/2009)

06/22/2009 66 ANSWER to 59 Answer to Amended Complaint, Counterclaim by Ancora Technologies Inc, Ancora Technologies Inc(a Delaware corporation).(Lorelli, Marc) (Entered: 06/22/2009)

06/22/2009 67 ANSWER to 58 Answer to Amended Complaint, Counterclaim by Ancora Technologies Inc, Ancora Technologies Inc(a Delaware corporation).(Lorelli, Marc) (Entered: 06/22/2009)

06/26/2009 68 NOTICE of Hearing: Telephone Conference regarding joint status report set for 6/29/2009 at 02:00 PM before Judge Marsha J. Pechman.(RM) (Entered: 06/26/2009)

06/29/2009 69 MINUTE ENTRY for proceedings held before Judge Marsha J. Pechman- Dep Clerk: Rhonda Miller; Pla Counsel: Mark Cantor, John LeRoy; Def Counsel: Chad Campbell, Arthur Harrigan;

CR: Joe Roth; Telephone Conference regarding Joint Status Report held on 6/29/2009. Court to issue scheduling order. (RM) (Entered: 06/30/2009)

06/30/2009 70 ORDER SETTING BRIEFING DEADLINES AND STAYING DISCOVERY ON THE PATENT CLAIMS. The Court STAYS all discovery related to the patent claims until September 1, 2009. The court sets the following deadlines: Sept 17, 2009 - Microsoft's motion for sanctions; Oct 5, 2009 - Response to Motion for sanctions; Oct 9, 2009 - Reply on Motion for sanctions, by Judge Marsha J. Pechman. (MD) (Entered: 07/01/2009)

07/06/2009 71 MOTION to Seal Microsoft's Response to Ancora Technology's Motion to Dismiss Counts I - V of Microsoft's Second Amended Complaint in Intervention by Intervenor Microsoft Corporation. Noting Date 7/24/2009, (Wion, Christopher) (Entered: 07/06/2009)

07/06/2009 72 SEALED DOCUMENT Intervenor Microsoft Corporation's Response to Ancora's Motion to Dismiss Counts I-V of Microsoft's Second Amended Complaint in Intervention by Intervenor Microsoft Corporation re 71 MOTION to Seal Microsoft's Response to Ancora Technology's Motion to Dismiss Counts I - V of Microsoft's Second Amended Complaint in Intervention. (Attachments: # 1 Proposed Order)(Wion, Christopher) (Entered: 07/06/2009)

07/06/2009 73 RESPONSE, by Intervenor Microsoft Corporation, to 63 MOTION to Dismiss Counts I-V of Microsoft's Second Amended Complaint. (Attachments: # 1 Proposed Order)(Wion, Christopher) (Entered: 07/06/2009)

07/10/2009 74 REPLY, filed by Counter Defendants Ancora Technologies Inc, Ancora Technologies Inc, Ancora Technologies Inc, Ancora Technologies Inc, Ancora Technologies Inc, Ancora Technologies Inc, Plaintiff Ancora Technologies Inc, TO RESPONSE to 63 MOTION to Dismiss Counts I-V of Microsoft's Second Amended Complaint (Lorelli, Marc) (Entered: 07/10/2009)

08/03/2009 75 ORDER granting 71 Microsoft's Motion to Seal. Microsoft is directed to file a redacted version of its response within 10 days of this Minute Order, by Judge Marsha J. Pechman.(MD) (Entered: 08/04/2009)

09/16/2009 76 STIPULATION AND PROPOSED ORDER JOINT REPORT RE BRIEFING ON MICROSOFTS MOTION FOR SANCTIONS by parties re 70 Order,. (Wion, Christopher) (Entered: 09/16/2009)

09/16/2009 77 MINUTE ORDER re: 76 Stipulation seeking relief from Microsoft's September 17, 2009 deadline filed by Ancora Technologies Inc. If the parties fail to execute a written settlement agreement by October 16, 2009, Microsoft must file its motion no later than October 23, 2009, by Judge Marsha J. Pechman. (MD) (Entered: 09/17/2009)

09/17/2009 78 NOTICE that the following is RE-NOTED: 63 MOTION to Dismiss Counts I-V of Microsoft's Second Amended Complaint. Filed by Plaintiff Ancora Technologies Inc. Noting Date 10/16/2009, (Hansen, Drew) (Entered: 09/17/2009)

10/09/2009 79 NOTICE OF FILING OF OFFICIAL TRANSCRIPT of Telephone Conference held on 6/29/2009 before Judge Marsha J. Pechman. Parties have ten (10) calendar days to file with the court a Notice of Intent to Request Redaction of this transcript. If no such Notice is filed, the transcript may be made remotely electronically available to the public without redaction after 90 calendar days. Transcript may be viewed at the court public terminal or purchased through the Court Reporter/Transcriber before the deadline for Release of Transcript Restriction. After that date it may be obtained through PACER. Information regarding the policy can be found on the court's website at www.wawd.uscourts.gov. To purchase a copy of the transcript contact court reporter Joe Roth by telephone at 206-370-8508. . Release of Transcript Restriction set for 1/7/2010, (LMK) (Entered: 10/09/2009)

10/21/2009 80 MINUTE ORDER RE-NOTING 63 MOTION to Dismiss Counts I-V of Microsoft's Second Amended Complaint ; RE-Noting Date 11/6/2009. If the parties fail to execute a written settlement agreement by 11/6/09, Microsoft must file its motion no later than 11/13/09, by Judge Marsha J. Pechman. (MD) (Entered: 10/21/2009)

11/04/2009 81 STIPULATION AND PROPOSED ORDER re Modification to Protective Order by parties re 45 Protective Order. (Lorelli, Marc) (Entered: 11/04/2009)

11/05/2009 82 STIPULATION AND ORDER re 81 Stipulation re: modification to the Protectove prder filed by Ancora Technologies Inc, re: 45 Protective Order by Judge Marsha J. Pechman. (MD) (Entered: 11/05/2009)

11/12/2009 83 STIPULATION AND PROPOSED ORDER OF DISMISSAL by parties. (Wion, Christopher) (Entered: 11/12/2009)

11/16/2009 84 STIPULATION AND ORDER - IT IS HEREBY ORDERED that the parties Stipulation of Dismissal is approved and all pending claims and counterclaims asserted in this action are DISMISSED, WITH PREJUDICE. Each party shall bear its own costs, expenses and attorneys fees. Re: 83 Stipulation filed by Microsoft Corporation. Motions terminated: 63 MOTION to Dismiss Counts I-

V of Microsoft's Second Amended Complaint filed by Ancora Technologies Inc, by Judge Marsha J. Pechman. (MD) (Entered: 11/17/2009)

Copyright © 2010 LexisNexis CourtLink, Inc. All rights reserved.
*** THIS DATA IS FOR INFORMATIONAL PURPOSES ONLY ***

US District Court Civil Docket

U.S. District - California Central
(Southern Division)

8:08cv626

Ancora Technologies Inc v. Toshiba America Information Systems Inc et A

This case was retrieved from the court on Friday, February 12, 2010

Date Filed: 06/06/2008	Class Code: CLOSED
Assigned To: Judge Andrew J Guilford	Closed: Yes
Referred To: Magistrate Judge Marc L Goldman	Statute: 35:145
Nature of suit: Patent (830)	Jury Demand: Both
Cause: Patent Infringement	Demand Amount: \$0
Lead Docket: None	NOS Description: Patent
Other Docket: None	
Jurisdiction: Federal Question	

Litigants

Ancora Technologies Inc
Plaintiff

Attorneys

John S Leroy
[COR LD NTC]
Brooks Kushman PC
1000 Town Center 22ND Floor
Southfield , MI 48075
USA
248-358-4400
Fax: 248-358-3351
Pro Hac Vice
Email: JLERROY@BROOKSKUSHMAN.COM

Marc Lorelli
[COR LD NTC]
Brooks Kushman PC
1000 Town Center 22ND Floor
Southfield , MI 48075
USA
248-358-4400
Fax: 248-358-3351
Pro Hac Vice
Email: MLORELLI@BROOKSKUSHMAN.COM

Mark A Cantor
[COR LD NTC]
Brooks Kushman PC
1000 Town Center 22ND Floor
Southfield , MI 48075
USA
248-358-4400
Fax: 248-358-3351
Pro Hac Vice
Email: MCANTOR@BROOKSKUSHMAN.COM

Mark B Mizrahi
[COR LD NTC]

Toshiba America Information Systems Inc
Defendant

Brooks Kushman PC
6701 Center Drive West Suite 610
Los Angeles , CA 90045
USA
310-348-8200
Fax: 310-846-4799
Email: MMIZRAHI@BROOKSKUSHMAN.COM

Chad S Campbell
[COR LD NTC]
Perkins Coie Brown & Bain PA
2901 North Central Avenue Suite 2000
Phoenix , AZ 85012-2788
USA
602-351-8393
Fax: 602-648-7193
Email: CSCAMPBELL@PERKINSCOIE.COM

David Matthew Laspaluto
[COR LD NTC]
Perkins Coie Brown and Bain
2901 North Central Avenue Suite 2000
Phoenix , AZ 85012
USA
602-351-8175
Fax: 602-648-7017
Email: DLASPALUTO@PERKINSCOIE.COM

David S Laspaluto
[COR LD NTC]
Perkins Coie Brown and Bain
2901 North Central Avenue Suite 2000
Phoenix , AZ 85012-2788
USA
602-351-8000
Fax: 602-648-7000
Email: DLASPALUTO@PERKINSCOIE.COM

Irfan A Lateef
[COR LD NTC]
Knobbe Martens Olson and Bear
2040 Main Street
14TH Floor
Irvine , CA 92614
USA
949-760-0404
Fax: 949-760-9502
Email: IRFAN.LATEEF@KMOB.COM

Jon W Gurka
[COR LD NTC]
Knobbe Martens Olson and Bear LLP
2040 Main Street 14TH Floor
Irvine , CA 92614
USA
949-760-0404
Fax: 949-760-9502
Email: JGURKA@KMOB.COM

Lauren C Sliger
[COR LD NTC]
Perkins Coie
1620 26TH Street 6TH FL
Santa Monica , CA 90404
USA
310-788-9900

Fax: 310-788-3399
Email: LSLIGER@PERKINSCOIE.COM

Scott S Minder
[COR LD NTC]
Perkins Coie Brown and Bain PA
2901 North Central Avenue Suite 2000
Phoenix , AZ 85012-2788
USA
602-351-8000
Fax: 602-648-7000
Pro Hac Vice
Email: SMINDER@PERKINSCOIE.COM

Andrew J Hall
[COR LD NTC]
Knobbe Martens Olson and Bear
2040 Main Street, 14TH Floor
Irvine , CA 92614
USA
949-760-0404
Email: LITIGATION@KMOB.COM

Stephen C Jensen
[COR LD NTC]
Knobbe Martens Olson and Bear LLP
2040 Main Street
Fourteenth Street
Irvine , CA 92614
USA
949-760-0404
Email: LITIGATION@KMOB.COM

Dell Inc
Defendant

Brandon C Fernald
[COR LD NTC]
[Term: 01/30/2009]
Fulbright and Jaworski LLP
555 South Flower Street 41ST Floor
Los Angeles , CA 90071
USA
213-892-9200
Email: BFERNALD@FULBRIGHT.COM

Chad S Campbell
[COR LD NTC]
Perkins Coie Brown & Bain PA
2901 North Central Avenue Suite 2000
Phoenix , AZ 85012-2788
USA
602-351-8393
Fax: 602-648-7193
Email: CSCAMPBELL@PERKINSCOIE.COM

Christopher R Benson
[COR LD NTC]
[Term: 01/30/2009]
Fulbright and Jaworski LLP
600 Congress Avenue Suite 2400
Austin , TX 78701
USA
512-474-5201
Fax: 512-536-4598
Pro Hac Vice
Email: CBENSON@FULBRIGHT.COM

David Matthew Laspaluto

[COR LD NTC]
Perkins Coie Brown and Bain
2901 North Central Avenue Suite 2000
Phoenix , AZ 85012
USA
602-351-8175
Fax: 602-648-7017
Email: DLASPALUTO@PERKINSCOIE.COM

David S Laspaluto
[COR LD NTC]
Perkins Coie Brown and Bain
2901 North Central Avenue Suite 2000
Phoenix , AZ 85012-2788
USA
602-351-8000
Fax: 602-648-7000
Email: DLASPALUTO@PERKINSCOIE.COM

Lauren C Sliger
[COR LD NTC]
Perkins Coie
1620 26TH Street 6TH FL
Santa Monica , CA 90404
USA
310-788-9900
Fax: 310-788-3399
Email: LSLIGER@PERKINSCOIE.COM

Michael C Barrett
[COR LD NTC]
[Term: 01/30/2009]
Fulbright and Jaworski LLP
600 Congress Avenue Suite 2400
Austin , TX 78701
USA
512-474-5201
Email: MBARRETT@FULBRIGHT.COM

Scott S Minder
[COR LD NTC]
Perkins Coie Brown and Bain PA
2901 North Central Avenue Suite 2000
Phoenix , AZ 85012-2788
USA
602-351-8000
Fax: 602-648-7000
Pro Hac Vice
Email: SMINDER@PERKINSCOIE.COM

Hewlett-Packard Company
Defendant

Chad S Campbell
[COR LD NTC]
Perkins Coie Brown & Bain PA
2901 North Central Avenue Suite 2000
Phoenix , AZ 85012-2788
USA
602-351-8393
Fax: 602-648-7193
Email: CSCAMPBELL@PERKINSCOIE.COM

Darryl M Woo
[COR LD NTC]
[Term: 12/02/2008]
Fenwick and West LLP
555 California Street 12TH Floor
San Francisco , CA 94111

USA
415-875-2300
Email: DWO@FENWICK.COM

David Matthew Laspaluto
[COR LD NTC]
Perkins Coie Brown and Bain
2901 North Central Avenue Suite 2000
Phoenix , AZ 85012
USA
602-351-8175
Fax: 602-648-7017
Email: DLASPALUTO@PERKINSCOIE.COM

David S Laspaluto
[COR LD NTC]
Perkins Coie Brown and Bain
2901 North Central Avenue Suite 2000
Phoenix , AZ 85012-2788
USA
602-351-8000
Fax: 602-648-7000
Email: DLASPALUTO@PERKINSCOIE.COM

Lauren C Sliger
[COR LD NTC]
Perkins Coie South Tower
1620 26TH Street 6TH FL
Santa Monica , CA 90404
USA
310-788-9900
Fax: 310-788-3399
Email: LSLIGER@PERKINSCOIE.COM

Scott S Minder
[COR LD NTC]
Perkins Coie Brown and Bain PA
2901 North Central Avenue Suite 2000
Phoenix , AZ 85012-2788
USA
602-351-8000
Fax: 602-648-7000
Pro Hac Vice
Email: SMINDER@PERKINSCOIE.COM

David M Lacy Kusters
[COR LD NTC]
[Term: 12/02/2008]
Fenwick and West LLP
555 California Street 12TH Floor
San Francisco , CA 94104
USA
415-875-2300
Fax: 415-281-1350
Email: DLACYKUSTERS@FENWICK.COM

Heather N Mewes
[COR LD NTC]
[Term: 12/02/2008]
Fenwick & West LLP
555 California Street
San Francisco , CA 94041
USA
415-975-2300
Fax: 415-281-1350
Email: HMEWES@FENWICK.COM

Microsoft Corporation
Intervenor

Chad S Campbell
[COR LD NTC]
Perkins Coie Brown & Bain PA
2901 North Central Avenue Suite 2000
Phoenix , AZ 85012-2788
USA
602-351-8393
Fax: 602-648-7193
Email: CSCAMPBELL@PERKINSCOIE.COM

David Matthew Laspaluto
[COR LD NTC]
Perkins Coie Brown and Bain
2901 North Central Avenue Suite 2000
Phoenix , AZ 85012
USA
602-351-8175
Fax: 602-648-7017
Email: DLASPALUTO@PERKINSCOIE.COM

David S Laspaluto
[COR LD NTC]
Perkins Coie Brown and Bain
2901 North Central Avenue Suite 2000
Phoenix , AZ 85012-2788
USA
602-351-8000
Fax: 602-648-7000
Email: DLASPALUTO@PERKINSCOIE.COM

John W Rogers
[COR LD NTC]
Perkins Coie Brown & Bain PA
2901 North Central Avenue Suite 2000
Phoenix , AZ 85012
USA
602-351-8450
Fax: 602-648-7014
Pro Hac Vice
Email: JWROGERS@PERKINSCOIE.COM

Lauren C Sliger
[COR LD NTC]
Perkins Coie
1620 26TH Street 6TH FL
Santa Monica , CA 90404
USA
310-788-9900
Fax: 310-788-3399
Email: LSLIGER@PERKINSCOIE.COM

Scott S Minder
[COR LD NTC]
Perkins Coie Brown and Bain PA
2901 North Central Avenue Suite 2000
Phoenix , AZ 85012-2788
USA
602-351-8000
Fax: 602-648-7000
Pro Hac Vice
Email: SMINDER@PERKINSCOIE.COM

Toshiba America Information Systems, Inc A California
Corporation
Counter Claimant

Chad S Campbell
[COR LD NTC]
Perkins Coie Brown & Bain PA
2901 North Central Avenue Suite 2000

Phoenix , AZ 85012-2788
USA
602-351-8393
Fax: 602-648-7193
Email: CSCAMPBELL@PERKINSCOIE.COM

David Matthew Laspaluto
[COR LD NTC]
Perkins Coie Brown and Bain
2901 North Central Avenue Suite 2000
Phoenix , AZ 85012
USA
602-351-8175
Fax: 602-648-7017
Email: DLASPALUTO@PERKINSCOIE.COM

Jon W Gurka
[COR LD NTC]
Knobbe Martens Olson and Bear LLP
2040 Main Street 14TH Floor
Irvine , CA 92614
USA
949-760-0404
Fax: 949-760-9502
Email: JGURKA@KMOB.COM

Lauren C Sliger
[COR LD NTC]
Perkins Coie
1620 26TH Street 6TH FL
Santa Monica , CA 90404
USA
310-788-9900
Fax: 310-788-3399
Email: LSLIGER@PERKINSCOIE.COM

Scott S Minder
[COR LD NTC]
Perkins Coie Brown and Bain PA
2901 North Central Avenue Suite 2000
Phoenix , AZ 85012-2788
USA
602-351-8000
Fax: 602-648-7000
Pro Hac Vice
Email: SMINDER@PERKINSCOIE.COM

Ancora Technologies, Inc A Delaware Corporation
Counter Defendant

John S Leroy
[COR LD NTC]
Brooks Kushman PC
1000 Town Center 22ND Floor
Southfield , MI 48075
USA
248-358-4400
Fax: 248-358-3351
Pro Hac Vice
Email: JLEROY@BROOKSKUSHMAN.COM

Marc Lorelli
[COR LD NTC]
Brooks Kushman PC
1000 Town Center 22ND Floor
Southfield , MI 48075
USA
248-358-4400
Fax: 248-358-3351

Pro Hac Vice
Email: MLORELLI@BROOKSKUSHMAN.COM

Mark A Cantor
[COR LD NTC]
Brooks Kushman PC
1000 Town Center 22ND Floor
Southfield , MI 48075
USA
248-358-4400
Fax: 248-358-3351
Pro Hac Vice
Email: MCANTOR@BROOKSKUSHMAN.COM

Mark B Mizrahi
[COR LD NTC]
Brooks Kushman PC
6701 Center Drive West Suite 610
Los Angeles , CA 90045
USA
310-348-8200
Fax: 310-846-4799
Email: MMIZRAHI@BROOKSKUSHMAN.COM

Hewlett-Packard Company
Counter Claimant

Darryl M Woo
[COR LD NTC]
[Term: 12/02/2008]
Fenwick and West LLP
555 California Street 12TH Floor
San Francisco , CA 94111
USA
415-875-2300
Email: DWOOW@FENWICK.COM

Lauren C Sliger
[COR LD NTC]
Perkins Coie
1620 26TH Street 6TH FL
Santa Monica , CA 90404
USA
310-788-9900
Fax: 310-788-3399
Email: LSLIGER@PERKINSCOIE.COM

David M Lacy Kusters
[COR LD NTC]
[Term: 12/02/2008]
Fenwick and West LLP
555 California Street 12TH Floor
San Francisco , CA 94104
USA
415-875-2300
Fax: 415-281-1350
Email: DLACYKUSTERS@FENWICK.COM

Heather N Mewes
[COR LD NTC]
[Term: 12/02/2008]
Fenwick & West LLP
555 California Street
San Francisco , CA 94041
USA
415-975-2300
Fax: 415-281-1350
Email: HMEWES@FENWICK.COM

Ancora Technologies Inc
Counter Defendant

John S Leroy
[COR LD NTC]
Brooks Kushman PC
1000 Town Center 22ND Floor
Southfield , MI 48075
USA
248-358-4400
Fax: 248-358-3351
Pro Hac Vice
Email: JLERoy@BROOKSKUSHMAN.COM

Marc Lorelli
[COR LD NTC]
Brooks Kushman PC
1000 Town Center 22ND Floor
Southfield , MI 48075
USA
248-358-4400
Fax: 248-358-3351
Pro Hac Vice
Email: MLORELLI@BROOKSKUSHMAN.COM

Mark A Cantor
[COR LD NTC]
Brooks Kushman PC
1000 Town Center 22ND Floor
Southfield , MI 48075
USA
248-358-4400
Fax: 248-358-3351
Pro Hac Vice
Email: MCANTOR@BROOKSKUSHMAN.COM

Mark B Mizrahi
[COR LD NTC]
Brooks Kushman PC
6701 Center Drive West Suite 610
Los Angeles , CA 90045
USA
310-348-8200
Fax: 310-846-4799
Email: MMIZRAHI@BROOKSKUSHMAN.COM

Dell Inc
Counter Claimant

Brandon C Fernald
[COR LD NTC]
[Term: 01/30/2009]
Fulbright and Jaworski LLP
555 South Flower Street 41ST Floor
Los Angeles , CA 90071
USA
213-892-9200
Email: BFERNALD@FULBRIGHT.COM

Chad S Campbell
[COR LD NTC]
Perkins Coie Brown & Bain PA
2901 North Central Avenue Suite 2000
Phoenix , AZ 85012-2788
USA
602-351-8393
Fax: 602-648-7193
Email: CSCAMPBELL@PERKINSCOIE.COM

Christopher R Benson
[COR LD NTC]
[Term: 01/30/2009]

Fulbright and Jaworski LLP
600 Congress Avenue Suite 2400
Austin , TX. 78701
USA
512-474-5201
Fax: 512-536-4598
Pro Hac Vice
Email: CBENSON@FULBRIGHT.COM

David Matthew Laspaluto
[COR LD NTC]
Perkins Coie Brown and Bain
2901 North Central Avenue Suite 2000
Phoenix , AZ 85012
USA
602-351-8175
Fax: 602-648-7017
Email: DLASPALUTO@PERKINSCOIE.COM

Lauren C Sliger
[COR LD NTC]
Perkins Coie
1620 26TH Street 6TH FL
Santa Monica , CA 90404
USA
310-788-9900
Fax: 310-788-3399
Email: LSLIGER@PERKINSCOIE.COM

Michael C Barrett
[COR LD NTC]
[Term: 01/30/2009]
Fulbright and Jaworski LLP
600 Congress Avenue Suite 2400
Austin , TX 78701
USA
512-474-5201
Email: MBARRETT@FULBRIGHT.COM

Scott S Minder
[COR LD NTC]
Perkins Coie Brown and Bain PA
2901 North Central Avenue Suite 2000
Phoenix , AZ 85012-2788
USA
602-351-8000
Fax: 602-648-7000
Pro Hac Vice
Email: SMINDER@PERKINSCOIE.COM

Ancora Technologies Inc
Counter Defendant

John S Leroy
[COR LD NTC]
Brooks Kushman PC
1000 Town Center 22ND Floor
Southfield , MI 48075
USA
248-358-4400
Fax: 248-358-3351
Pro Hac Vice
Email: JLEROY@BROOKSKUSHMAN.COM

Marc Lorelli
[COR LD NTC]
Brooks Kushman PC
1000 Town Center 22ND Floor
Southfield , MI 48075

USA
248-358-4400
Fax: 248-358-3351
Pro Hac Vice
Email: MLORELLI@BROOKSKUSHMAN.COM

Mark A Cantor
[COR LD NTC]
Brooks Kushman PC
1000 Town Center 22ND Floor
Southfield , MI 48075
USA
248-358-4400
Fax: 248-358-3351
Pro Hac Vice
Email: MCANTOR@BROOKSKUSHMAN.COM

Mark B Mizrahi
[COR LD NTC]
Brooks Kushman PC
6701 Center Drive West Suite 610
Los Angeles , CA 90045
USA
310-348-8200
Fax: 310-846-4799
Email: MMIZRAHI@BROOKSKUSHMAN.COM

Date	#	Proceeding Text
06/06/2008	1	COMPLAINT against defendants Toshiba America Information Systems Inc, Dell Inc, Hewlett-Packard Company.(Filing fee \$ 350 paid) Jury Demand., filed by plaintiff Ancora Technologies Inc.(twdb) (nca). (Entered: 06/09/2008)
06/06/2008	--	20 DAY Summons Issued re Complaint - (Discovery) 1 as to defendants Toshiba America Information Systems Inc, Dell Inc, Hewlett-Packard Company. (twdb) (Entered: 06/09/2008)
06/06/2008	2	CERTIFICATION AND NOTICE of Interested Parties filed by plaintiff Ancora Technologies Inc, (twdb) (nca). (Entered: 06/09/2008)
06/06/2008	3	REPORT ON THE FILING OF AN ACTION Regarding a Patent or a Trademark (Initial Notification) filed by Ancora Technologies Inc. (twdb) (nca). (Entered: 06/09/2008)
07/07/2008	4	FIRST STIPULATION Extending Time to Answer the complaint as to Toshiba America Information Systems Inc answer now due 8/13/2008, filed by Defendant Toshiba America Information Systems Inc.(Gurka, Jon) (Entered: 07/07/2008)
07/07/2008	5	CORPORATE DISCLOSURE STATEMENT filed by Defendant Toshiba America Information Systems Inc identifying Toshiba Corporation as Corporate Parent. (Gurka, Jon) (Entered: 07/07/2008)
07/08/2008	6	CERTIFICATION AND NOTICE of Interested Parties filed by Defendant Hewlett-Packard Company, identifying None. (Woo, Darryl) (Entered: 07/08/2008)
07/08/2008	7	FIRST STIPULATION Extending Time to Answer the complaint as to Hewlett-Packard Company answer now due 8/7/2008, filed by Defendant Hewlett-Packard Company.(Mewes, Heather) (Entered: 07/08/2008)
07/16/2008	8	APPLICATION OF NON-RESIDENT ATTORNEY Christopher R. Benson for Leave to Appear Pro Hac Vice. FEE PAID. filed by defendant Dell Inc. (db) (Entered: 07/17/2008)
07/16/2008	9	APPLICATION OF NON-RESIDENT ATTORNEY Michael C Barrett for Leave to Appear Pro Hac Vice. FEE PAID, filed by Defendant Dell Inc. Lodged none. (In) (Entered: 07/17/2008)
07/16/2008	10	PROOF OF SERVICE filed by Defendant Dell Inc re APPLICATION OF NON-RESIDENT ATTORNEY Michael C Barrett for Leave to Appear Pro Hac Vice 9 , APPLICATION OF NON-RESIDENT ATTORNEY Christopher R. Benson for Leave to Appear Pro Hac Vice 8 served on 07/16/08. (In) (Entered: 07/17/2008)
07/21/2008	12	ORDER by Judge Andrew J. Guilford Granting Michael C. Barrett to appear on behalf of Defendant Dell Inc. Brandon C. Fernald is designated as local counsel. Fee PAID. (ade) (Entered: 07/23/2008)
07/21/2008	13	ORDER by Judge Andrew J. Guilford Granting Christopher R. Benson to appear on behalf of

Defendant Dell Inc. Brandon C. Fernald is designated as local counsel. Fee PAID. (ade)
(Entered: 07/23/2008)

07/22/2008 11 FIRST STIPULATION Extending Time to Answer the complaint as to Dell Inc answer now due 8/13/2008, filed by plaintiff Ancora Technologies Inc.(Mizrahi, Mark) (Entered: 07/22/2008)

07/28/2008 14 APPLICATION OF NON-RESIDENT ATTORNEY Mark A. Cantor for Leave to Appear Pro Hac Vice. FEE NOT PAID. filed by Plaintiff Ancora Technologies Inc. (Attachments: # 1 Proposed Order) (Mizrahi, Mark) (Entered: 07/28/2008)

07/28/2008 15 APPLICATION OF NON-RESIDENT ATTORNEY Marc Lorelli for Leave to Appear Pro Hac Vice. FEE NOT PAID. filed by Plaintiff Ancora Technologies Inc. (Attachments: # 1 Proposed Order) (Mizrahi, Mark) (Entered: 07/28/2008)

08/01/2008 16 ORDER by Judge Andrew J. Guilford Granting APPLICATION OF NON-RESIDENT ATTORNEY Mark A. Cantor for Leave to Appear Pro Hac Vice. FEE PAID 14 by Mark A. Cantor to appear on behalf of Plaintiff Ancora Technologies Inc. Mark B. Mizrahi is designated as local counsel. (db) (Entered: 08/01/2008)

08/01/2008 17 ORDER by Judge Andrew J. Guilford Granting APPLICATION OF NON-RESIDENT ATTORNEY Marc Lorelli for Leave to Appear Pro Hac Vice. 15 Marc Lorelli to appear on behalf of Plaintiff Ancora Technologies Inc. Mark B. Mizrahi is designated as local counsel. Fee Paid. (nbo) (Entered: 08/04/2008)

08/05/2008 18 Second STIPULATION for Extension of Time to File Answer to August 13, 2008 re Complaint - (Discovery) 1 filed by Defendant Hewlett-Packard Company. (Attachments: # 1 Proposed Order Granting Second Joint Stipulation to Extend Time to Respond to Complaint)(Mewes, Heather) (Entered: 08/05/2008)

08/07/2008 19 ORDER by Judge Andrew J. Guilford granting Second Joint Stipulation to Extend Time 18 . Defendant Hewlett-Packard Company shall answer or otherwise respond to Plaintiffs Complaint for Patent Infringement on or before 08/13/08. (db) (Entered: 08/08/2008)

08/13/2008 20 ANSWER to Complaint - (Discovery) 1 with JURY DEMAND and COUNTERCLAIMS filed by Defendant Dell Inc.(Barrett, Michael) (Entered: 08/13/2008)

08/13/2008 21 Certificate and Notice of Interested Parties filed by Defendant Dell Inc, identifying None. (Barrett, Michael) (Entered: 08/13/2008)

08/13/2008 22 ANSWER to Complaint - (Discovery) 1 and Counterclaims filed by Defendant and Counterclaimant Hewlett-Packard Company.(Mewes, Heather) (Entered: 08/13/2008)

08/13/2008 23 ORDER RE EARLY MEETING OF PARTIES AND SCHEDULING CONFERENCE by Judge Andrew J. Guilford. Scheduling Conference set for 10/27/08 at 9:00 a.m. (See document for further details) (db) (Entered: 08/14/2008)

08/13/2008 26 ANSWER to Complaint - (Discovery) 1 , COUNTERCLAIM against Ancora Technologies Inc filed by Defendant and Counterclaimant Toshiba America Information Systems Inc.(db) (Entered: 08/15/2008)

08/14/2008 24 NOTICE TO FILER OF DEFICIENCIES in Electronically Filed Documents. The following error(s) was found: Civil Case Initiating Documents. Complaints (such as third-party complaints, amended complaints, complaints in intervention, counterclaims and cross-claims) and other civil case initiating documents shall be filed in the traditional manner rather than electronically pursuant to General Order 08-02 RE: Answer to Complaint (Discovery) 20 , Answer to Complaint (Discovery) 22 . In response to this notice the court may order (1) an amended or correct document to be filed (2) the document stricken or (3) take other action as the court deems appropriate. (rrp) (Entered: 08/14/2008)

08/15/2008 25 NOTICE of Manual Filing filed by Defendant Dell Inc of Defendant Dell Inc.'s Answer and Counterclaims To Plaintiff's Complaint for Patent Infringement. (Fernald, Brandon) (Entered: 08/15/2008)

08/15/2008 27 NOTICE of Change of Attorney Information for attorney Andrew J Hall counsel for Defendant Toshiba America Information Systems Inc. Adding Andrew J. Hall as attorney as counsel of record for Toshiba America Information Systems, Inc. for the reason indicated in the G-06 Notice. Filed by defendant Toshiba America Information Systems, Inc. (Hall, Andrew) (Entered: 08/15/2008)

08/15/2008 28 NOTICE of Change of Attorney Information for attorney Irfan A Lateef counsel for Defendant Toshiba America Information Systems Inc. Adding Irfan A. Lateef as attorney as counsel of record for Toshiba America Information Systems, Inc. for the reason indicated in the G-06 Notice. Filed by defendant Toshiba America Information Systems, Inc. (Lateef, Irfan) (Entered: 08/15/2008)

08/15/2008 29 NOTICE of Change of Attorney Information for attorney Stephen C Jensen counsel for Defendant

Toshiba America Information Systems Inc. Adding Stephen C. Jensen as attorney as counsel of record for Toshiba America Information Systems, Inc. for the reason indicated in the G-06 Notice. Filed by defendant Toshiba America Information Systems, Inc. (Jensen, Stephen) (Entered: 08/15/2008)

- 08/15/2008 30 ANSWER AND COUNTERCLAIMS against Ancora Technologies Inc filed by Defendant Hewlett-Packard Company.(smi) (Entered: 08/18/2008)
- 08/15/2008 31 ANSWER to Complaint - (Discovery) 1 , COUNTERCLAIM against Ancora Technologies Inc filed by defendant/counter complainant Dell Inc.(db) (Entered: 08/18/2008)
- 08/18/2008 32 NOTICE OF DISCREPANCY AND Order by Judge Andrew J. Guilford, ORDERING Answer and Counterclaims submitted by Defendant Hewlett-Packard Company received on 08/14/08 is not to be filed but instead rejected. Denial based on: Answer filed 08/15/08. (db) (Entered: 08/19/2008)
- 09/02/2008 33 NOTICE of Change of Attorney Information for attorney Mark B Mizrahi counsel for Plaintiff Ancora Technologies Inc. Changing firm name to Brooks Kushman P.C.. Changing email to mmizrahi@brookskushman.com. Filed by plaintiff Ancora Technologies, inc. (Mizrahi, Mark) (Entered: 09/02/2008)
- 09/02/2008 34 NOTICE TO FILER OF DEFICIENCIES in Electronically Filed Documents. The following error(s) was found: account information (new phone and fax numbers) were not updated in the ECF system RE: Notice of Change of Attorney Information (G-06), Notice of Change of Attorney Information (G-06) 33 . In response to this notice the court may order (1) an amended or correct document to be filed (2) the document stricken or (3) take other action as the court deems appropriate. (vh) (Entered: 09/02/2008)
- 09/02/2008 35 ANSWER to Dell, Inc.'s Counterclaim filed by plaintiff-counterdefendant Ancora Technologies Inc.(Mizrahi, Mark) (Entered: 09/02/2008)
- 09/02/2008 36 ANSWER to Hewlett-Packard Company's Counterclaim filed by plaintiff-counterdefendant Ancora Technologies Inc.(Mizrahi, Mark) (Entered: 09/02/2008)
- 09/02/2008 37 ANSWER to Toshiba America Information Systems, Inc.'s Counterclaims filed by plaintiff-counterdefendant Ancora Technologies Inc.(Mizrahi, Mark) (Entered: 09/02/2008)
- 09/08/2008 38 APPLICATION for attorney John S. LeRoy to Appear Pro Hac Vice (PHV Fee of \$185 receipt number 0973000000004231353 paid.) filed by plaintiff Ancora Technologies Inc. (Attachments: # 1 Proposed Order)(Mizrahi, Mark) (Entered: 09/08/2008)
- 09/08/2008 39 NOTICE OF UNOPPOSED MOTION to Intervene filed by Movant Microsoft Corporation. Motion set for hearing on 9/29/2008 at 10:00 AM before Judge Andrew J. Guilford. (db) Modified on 9/11/2008 (rla). Lodged Order. (Entered: 09/09/2008)
- 09/08/2008 40 MEMORANDUM in Support of unopposed MOTION to Intervene 39 filed by Movant Microsoft Corporation. (db) Modified on 10/1/2008 (db). (Entered: 09/09/2008)
- 09/08/2008 41 STIPULATION regarding Motion to Intervene by filed by Movant Microsoft Corporation.(db) (Entered: 09/09/2008)
- 09/08/2008 44 Certification and Notice of Interested Parties filed by Movant Microsoft Corporation. (db) (Entered: 09/10/2008)
- 09/09/2008 42 APPLICATION for attorney Scott S. Minder to Appear Pro Hac Vice (PHV Fee of \$185 receipt number 0973000000004239439 paid.) filed by Intervenor Microsoft Corporation. (Attachments: # 1 Proposed Order Application of Non-Resident Attorney to Appear in a Specific Case)(Sliger, Lauren) (Entered: 09/09/2008)
- 09/09/2008 43 APPLICATION for attorney Chad S. Campbell to Appear Pro Hac Vice (PHV Fee of \$185 receipt number 0973000000004239675 paid.) filed by Intervenor Microsoft Corporation. (Attachments: # 1 Proposed Order Application of Non-Resident Attorney to Appear in a Specific Case)(Sliger, Lauren) (Entered: 09/09/2008)
- 09/09/2008 45 ORDER by Judge Andrew J. Guilford Granting John S. LeRoy to appear on behalf of Plaintiff Ancora Technologies Inc. Mark B. Mizrahi is designated as local counsel. (ade) (Entered: 09/11/2008)
- 09/11/2008 46 ORDER by Judge Andrew J. Guilford Granting APPLICATION for attorney Chad S. Campbell to Appear Pro Hac Vice on behalf of Microsoft Corporation (PHV Fee of \$185 receipt number 0973000000004239675 paid 43 . Lauren Sliger is designated as local counsel. (db) (Entered: 09/12/2008)
- 09/11/2008 47 ORDER by Judge Andrew J. Guilford Granting APPLICATION for attorney Scott S. Minder to Appear Pro Hac Vice on behalf of Microsoft 42 . Lauren Sliger is designated as local counsel. Fee PAID. (db) (Entered: 09/12/2008)

09/15/2008 48 ORDER RETURNING CASE FOR REASSIGNMENT UPON RECUSAL by Magistrate Judge Arthur Nakazato. ORDER case returned to the Clerk for random reassignment Discovery pursuant to General Order 05-07 and General Order 07-02. Case randomly reassigned from Magistrate Judge Arthur Nakazato to Magistrate Judge Marc L. Goldman for all further proceedings. The case number will now reflect the initials of the transferee Judge SACV 08-626 AG (MLGx). (jal) (Entered: 09/15/2008)

09/22/2008 49 MINUTES OF IN CHAMBERS ORDER by Judge Andrew J. Guilford: GRANTING MICROSOFT CORPORATIONS Motion to Intervene 39 : Accordingly, the Court VACATES the hearing on this matter scheduled for September 29, 2008. After considering Applicant's arguments, the Court GRANTS the Motion. (See document for further details.) (rla) (Entered: 09/22/2008)

10/01/2008 50 NOTICE OF CLERICAL ERROR: During initial docketing of Memornadum 40 , incorrect filed date was entered on docket. Docket will be corrected to reflect correct filed date of 09/08/08. (db) (Entered: 10/01/2008)

10/02/2008 51 NOTICE of Appearance filed by attorney David M Lacy Kusters on behalf of Counter Claimant Hewlett-Packard Company, Defendant Hewlett-Packard Company (Kusters, David) (Entered: 10/02/2008)

10/03/2008 52 MICROSOFT CORPORATION'S COMPLAINT IN INTERVENTION FOR DECLARATORY JUDGMENT AGAINST ANCORA TECHNOLOGIES, INC. Jury trial demanded. (smi) (Additional attachment(s) added on 10/6/2008: # 1 Summons) (smi). (Entered: 10/06/2008)

10/03/2008 -- 20 DAY Summons Issued re Intervenor Complaint 52 as to Plaintiff Ancora Technologies Inc. (smi) (Entered: 10/06/2008)

10/08/2008 53 PROOF OF SERVICE filed by Intervenor Microsoft Corporation, re Intervenor Complaint 52 , Summons Issued served on 10/06/2008. (Sliger, Lauren) (Entered: 10/08/2008)

10/20/2008 54 JOINT REPORT Rule 26(f) Discovery Plan ; estimated length of trial between 5 and 10 days, filed by Intervenor Microsoft Corporation.. (Sliger, Lauren) (Entered: 10/20/2008)

10/27/2008 55 ANSWER to Intervenor Complaint 52 filed by counterdefendant Ancora Technologies, Inc., Ancora Technologies Inc.(LeRoy, John) (Entered: 10/27/2008)

10/27/2008 58 SCHEDULING ORDER by Judge Andrew J. Guilford, Set/Reset Deadlines/Hearings:(Discovery cut-off 5/30/2009. Final Pretrial Conference set for 1/11/2010 08:30 AM before Judge Andrew J. Guilford. Jury Trial set for 1/26/2010 09:00 AM before Judge Andrew J. Guilford.) (ade) (Entered: 11/06/2008)

10/27/2008 59 MINUTES OF Scheduling Conference held before Judge Andrew J. Guilford, Set/Reset Deadlines/Hearings:(Discovery cut-off 5/30/2009. Motions due by 9/4/2009. Final Pretrial Conference set for 1/11/2010 08:30 AM before Judge Andrew J. Guilford. Jury Trial set for 1/26/2010 09:00 AM before Judge Andrew J. Guilford. Markman Hearing set on 2/24/2009 at 09:00 AM before Judge Andrew J. Guilford.)Court Reporter: Bernadette Balajadia. (ade) (Entered: 11/06/2008)

11/03/2008 56 STIPULATION to Continue Initial Rule 26(a) Disclosures from 11/03/08 to 11/10/08 filed by Intervenor Microsoft Corporation. (Attachments: # 1 Proposed Order Continuing Initial Rule 26 (a) Disclosures by One Week)(Campbell, Chad) (Entered: 11/03/2008)

11/04/2008 57 ORDER by Judge Andrew J. Guilford, APPROVING Stipulation to Continue Initial Rule 26(a) Disclosure by One Week 56 : (Rule 26 Meeting Report due by 11/10/2008.) (rla) (Entered: 11/05/2008)

11/11/2008 60 NOTICE of Change of Attorney Information for attorney Lauren C Sliger counsel for Counter Claimant Hewlett-Packard Company, Defendant Hewlett-Packard Company. Adding Chad S. Campbell as attorney as counsel of record for Hewlett-Packard Company for the reason indicated in the G-06 Notice. Filed by Defendant/Counterclaimant Hewlett-Packard Company (Sliger, Lauren) (Entered: 11/11/2008)

11/11/2008 61 NOTICE of Change of Attorney Information for attorney Lauren C Sliger counsel for Counter Claimant Hewlett-Packard Company, Defendant Hewlett-Packard Company. Adding David S. LaSpaluto as attorney as counsel of record for Hewlett-Packard Company for the reason indicated in the G-06 Notice. Filed by Defendant/Counterclaimant Hewlett-Packard Company (Sliger, Lauren) (Entered: 11/11/2008)

11/11/2008 62 NOTICE of Change of Attorney Information for attorney Lauren C Sliger counsel for Counter Claimant Hewlett-Packard Company, Defendant Hewlett-Packard Company. Adding Scott S. Minder as attorney as counsel of record for Hewlett-Packard Company for the reason indicated in the G-06 Notice. Filed by Defendant/Counterclaimant Hewlett-Packard Company (Sliger, Lauren) (Entered: 11/11/2008)

11/11/2008 63 NOTICE of Change of Attorney Information for attorney Lauren C Sliger counsel for Counter

Claimant Hewlett-Packard Company, Defendant Hewlett-Packard Company. Adding Lauren Sliger as attorney as counsel of record for Hewlett-Packard Company for the reason indicated in the G-06 Notice. Filed by Defendant/Counterclaimant Hewlett-Packard Company (Sliger, Lauren) (Entered: 11/11/2008)

11/19/2008 64 MICROSOFT CORPORATION'S ANSWER TO ANCORA TECHNOLOGIES, INC.'S, COUNTERCLAIMS ANSWER filed by Intervenor Microsoft Corporation.(Campbell, Chad) (Entered: 11/19/2008)

11/26/2008 65 NOTICE OF MOTION AND MOTION of Fenwick & West, LLP, Darryl Woo, Heather Mewes, David Lacy Kusters to Withdraw as Attorney of Record for Hewlett-Packard Company filed by Defendant/Counter-Claimant Hewlett-Packard Company. (Attachments: # 1 Exhibit Signature Page, # 2 Proposed Order Granting Motion to Withdraw as Counsel of Record for Hewlett-Packard Company)(Mewes, Heather) (Entered: 11/26/2008)

12/02/2008 66 ORDER by Judge Andrew J. Guilford GRANTING MOTION of Fenwick & West, LLP, Darryl Woo, Heather Mewes, David Lacy Kusters to Withdraw as Attorney of Record for Hewlett-Packard Company 65 . (nbo) (Entered: 12/03/2008)

12/10/2008 67 STIPULATION to Reschedule Dates Associated with Markman Hearing and Pleading Amendments filed by Intervenor Microsoft Corporation. (Attachments: # 1 Proposed Order Granting Stipulation to Modify Dates)(Campbell, Chad) (Entered: 12/10/2008)

12/10/2008 68 STIPULATION for Protective Order filed by Intervenor Microsoft Corporation. (Attachments: # 1 Proposed Order Interim Protective Order)(Campbell, Chad) (Entered: 12/10/2008)

12/16/2008 69 ORDER GRANTING STIPULATION TO MODIFY DATES ASSOCIATED WITH MARKMAN HEARING AND PLEADING AMENDMENTS by Judge Andrew J. Guilford 67 . Opening Markman Briefs due 01/26/09, Rebuttal Markman Briefs due 02/13/09, Markman Hearing 03/03/09 at 9:00 a.m. (See Order for further details) (db) (Entered: 12/17/2008)

12/16/2008 70 PROTECTIVE ORDER by Magistrate Judge Marc L. Goldman (ade) (Entered: 12/17/2008)

12/23/2008 71 NOTICE of Change of Attorney Information for attorney Lauren C Sliger counsel for Counter Claimants Toshiba America Information Systems, Inc., Dell Inc, Defendants Toshiba America Information Systems Inc, Dell Inc. Adding Lauren Sliger as attorney as counsel of record for Toshiba America Information Systems, Inc. and Dell, Inc. for the reason indicated in the G-06 Notice. Filed by Defendants Toshiba America Information, Systems, Inc. and Dell, Inc. (Sliger, Lauren) (Entered: 12/23/2008)

12/23/2008 72 NOTICE of Change of Attorney Information for attorney Lauren C Sliger counsel for Counter Claimants Toshiba America Information Systems, Inc., Dell Inc, Defendants Toshiba America Information Systems Inc, Dell Inc. Adding Chad S. Campbell as attorney as counsel of record for Toshiba America Information Systems, Inc. and Dell, Inc. for the reason indicated in the G-06 Notice. Filed by Defendants Toshiba America Information, Systems, Inc. and Dell, Inc. (Sliger, Lauren) (Entered: 12/23/2008)

12/23/2008 73 NOTICE of Change of Attorney Information for attorney Lauren C Sliger counsel for Counter Claimants Toshiba America Information Systems, Inc., Dell Inc, Defendants Toshiba America Information Systems Inc, Dell Inc. Adding David S. LaSpaluto as attorney as counsel of record for Toshiba America Information, Systems, Inc. and Dell, Inc. for the reason indicated in the G-06 Notice. Filed by Defendants Toshiba America Information, Systems, Inc. and Dell, Inc. (Sliger, Lauren) (Entered: 12/23/2008)

12/23/2008 74 NOTICE of Change of Attorney Information for attorney Lauren C Sliger counsel for Counter Claimants Toshiba America Information Systems, Inc., Dell Inc, Defendants Toshiba America Information Systems Inc, Dell Inc. Adding Scott S. Minder as attorney as counsel of record for Toshiba America Information, Systems, Inc. and Dell, Inc. for the reason indicated in the G-06 Notice. Filed by Defendants Toshiba America Information, Systems, Inc. and Dell, Inc. (Sliger, Lauren) (Entered: 12/23/2008)

12/23/2008 75 NOTICE of Taking Deposition of Miki Mullor on January 8 and 9, 2009 filed by Intervenor Microsoft Corporation. Subpoena Issued. (Campbell, Chad) (Entered: 12/23/2008)

01/05/2009 76 NOTICE of Manual Filing filed by Counter Claimants Toshiba America Information Systems, Inc., Hewlett-Packard Company, Dell Inc, Intervenor Microsoft Corporation, Defendants Toshiba America Information Systems Inc, Dell Inc, Hewlett-Packard Company of Documents to be filed Under Seal. (Sliger, Lauren) (Entered: 01/05/2009)

01/05/2009 77 NOTICE Notice of Motion re: Joint Stipulation Pursuant to L.R. 37-2 for Entry of Final Protective Order filed by Defendants and Intervenor Hewlett-Packard Company, Dell Inc, Microsoft Corporation, Toshiba America Information Systems Inc. (Attachments: # 1 Proposed Order re Entry of Final Protective Order)(Sliger, Lauren) (Entered: 01/05/2009)

01/05/2009 78 DECLARATION re Notice (Other), Notice (Other) 77 of Motion re: Joint Stipulation Pursuant to L.R. 87-2 for Entry of Final Protective Order filed by Counter Claimants Toshiba America

Information Systems, Inc., Hewlett-Packard Company, Dell Inc, Intervenor Microsoft Corporation, Defendants Toshiba America Information Systems Inc, Dell Inc, Hewlett-Packard Company. (Sliger, Lauren) (Entered: 01/05/2009)

- 01/05/2009 79 DECLARATION of David M. LaSpaluto re Notice (Other), Notice (Other) 77 filed by Counter Claimants Toshiba America Information Systems, Inc., Hewlett-Packard Company, Dell Inc, Intervenor Microsoft Corporation, Defendants Toshiba America Information Systems Inc, Dell Inc, Hewlett-Packard Company. (Attachments: # 1 Exhibit 1 to Decl. of Counsel for Microsoft and Hewlett-Packard Company in Support of Joint Stipulation Under Rule 37-2 re Motion for Entry of A Final Protective Order, # 2 Exhibit 2-5 to Decl. of Counsel for Microsoft and Hewlett-Packard Company in Support of Joint Stipulation Under Rule 37-2 re Motion for Entry of A Final Protective Order, # 3 Exhibit 6-14 to Decl. of Counsel for Microsoft and Hewlett-Packard Company in Support of Joint Stipulation Under Rule 37-2 re Motion for Entry of A Final Protective Order, # 4 Exhibit 15-22 to Decl. of Counsel for Microsoft and Hewlett-Packard Company in Support of Joint Stipulation Under Rule 37-2 re Motion for Entry of A Final Protective Order, # 5 Exhibit 23-24 to Decl. of Counsel for Microsoft and Hewlett-Packard Company in Support of Joint Stipulation Under Rule 37-2 re Motion for Entry of A Final Protective Order, # 6 Exhibit 25-26 to Decl. of Counsel for Microsoft and Hewlett-Packard Company in Support of Joint Stipulation Under Rule 37-2 re Motion for Entry of A Final Protective Order, # 7 Exhibit 27 to Decl. of Counsel for Microsoft and Hewlett-Packard Company in Support of Joint Stipulation Under Rule 37-2 re Motion for Entry of A Final Protective Order, # 8 Exhibit 28-30 to Decl. of Counsel for Microsoft and Hewlett-Packard Company in Support of Joint Stipulation Under Rule 37-2 re Motion for Entry of A Final Protective Order, # 9 Exhibit 31 to Decl. of Counsel for Microsoft and Hewlett-Packard Company in Support of Joint Stipulation Under Rule 37-2 re Motion for Entry of A Final Protective Order, # 10 Exhibit 32 to Decl. of Counsel for Microsoft and Hewlett-Packard Company in Support of Joint Stipulation Under Rule 37-2 re Motion for Entry of A Final Protective Order, # 11 Exhibit 33 to Decl. of Counsel for Microsoft and Hewlett-Packard Company in Support of Joint Stipulation Under Rule 37-2 re Motion for Entry of A Final Protective Order, # 12 Exhibit 34 to Decl. of Counsel for Microsoft and Hewlett-Packard Company in Support of Joint Stipulation Under Rule 37-2 re Motion for Entry of A Final Protective Order)(Sliger, Lauren) (Entered: 01/05/2009)
- 01/05/2009 82 APPLICATION to File Under Seal 1) Joint Stipulation Under Rule 37-2 re Motion for Entry of Final Protective Order; 2) Declaration of Scott Field; and 3) Declaration of Counsel. Filed by Intervenor Microsoft Corporation. (ade) (Entered: 01/08/2009)
- 01/05/2009 83 ORDER by Judge Andrew J. Guilford, GRANTING APPLICATION to Seal 82 1) Joint Stipulation Under Rule 37-2 re Motion for Entry of Final Protective Order 2) Declaration of Scott Field; 3) Declaration of Counsel (ade) (Entered: 01/08/2009)
- 01/05/2009 84 SEALED DOCUMENT RE: Joint STIPULATION for Motion for Protective Order (ade) (Entered: 01/12/2009)
- 01/05/2009 85 SEALED DOCUMENT RE: DECLARATION of Scott Field in Support of Joint Stipulation(ade) (Entered: 01/12/2009)
- 01/05/2009 86 SEALED DOCUMENT RE: DECLARATION of Counsel In support of Joint Stipulation (Attachments: # 1 1, # 2 2, # 3 3, # 4 4, # 5 5)(ade) (Entered: 01/12/2009)
- 01/06/2009 80 NOTICE OF MOTION AND MOTION of Stephen Jensen, Jon Gurka, Irfan Lateef to Withdraw as Attorney of Record for Toshiba America Information Systems, Inc. filed by Defendant Toshiba America Information Systems Inc. Motion set for hearing on 1/12/2009 at 10:00 AM before Judge Andrew J. Guilford. (Attachments: # 1 Proposed Order [Proposed] Order Granting Motion to Withdraw as Counsel of Record for Toshiba America Systems, Inc.)(Lateef, Irfan) (Entered: 01/06/2009)
- 01/07/2009 81 MINUTES OF IN CHAMBERS ORDER by Judge Andrew J. Guilford: CONTINUING HEARING ON DEFENDANT'S MOTION TO WITHDRAW 80 : The Court CONTINUES the hearing from January 12, 2009 to February 2, 2009 at 10:00 a.m. (rla) (Entered: 01/07/2009)
- 01/15/2009 87 JOINT STIPULATION to APPLICATION to Seal 82 Reschedule February 3, 2009 Hearing and Shorten Time Under LR37-3 filed by Intervenor Microsoft Corporation. (Attachments: # 1 Proposed Order Rescheduling February 3, 2009 Hearing and Shortening Time Under LR37-3) (Campbell, Chad) (Entered: 01/15/2009)
- 01/16/2009 88 ORDER Rescheduling 2/3/09 hearing and shortening time under L.R.37-3 by Magistrate Judge Marc L. Goldman 87 . See Order for further deadlines.(Motion set for hearing on 2/10/2009 at 10:00 AM before Magistrate Judge Marc L. Goldman.) (twdb) (Entered: 01/20/2009)
- 01/21/2009 89 NOTICE OF MOTION AND MOTION to Compel Microsoft Corporation to Produce Documents and to Provide Further Responses to Plaintiff's First Set Of Interrogatories; Request for Monetary Sanctions filed by plaintiff Ancora Technologies Inc. Motion set for hearing on 2/10/2009 at 10:00 AM before Judge Andrew J. Guilford. (Attachments: # 1 Proposed Order)(Mizrahi, Mark)

(Entered: 01/21/2009)

- 01/21/2009 90 JOINT STIPULATION to MOTION to Compel Microsoft Corporation to Produce Documents and to Provide Further Responses to Plaintiff's First Set Of Interrogatories; Request for Monetary Sanctions 89 filed by Plaintiff Ancora Technologies Inc. (Mizrahi, Mark) (Entered: 01/21/2009)
- 01/21/2009 91 DECLARATION of Mark Mizrahi In Support Of MOTION to Compel Microsoft Corporation to Produce Documents and to Provide Further Responses to Plaintiff's First Set Of Interrogatories; Request for Monetary Sanctions 89 filed by Plaintiff Ancora Technologies Inc. (Attachments: # 1 Exhibit 1-12/22/08 letter, # 2 Exhibit 2-Court's Minute Order re Scheduling Conference and Order Granting Stipulation to Modify Dates Associated with Markman Hearing and Pleading Amendments, # 3 Exhibit 3-12/5/08 letter, # 4 Exhibit 4-Microsoft's Complaint in Intervention for Declaratory Judgment Against Ancora, # 5 Exhibit 5-12/16/08 letter, # 6 Exhibit 6-Excerpts of E.D. Texas local patent rules, # 7 Exhibit 7-Microsoft's Responses to Plaintiff's First Request for Production of Documents)(Mizrahi, Mark) (Entered: 01/21/2009)
- 01/21/2009 92 DECLARATION of Scott Minder In Opposition To MOTION to Compel Microsoft Corporation to Produce Documents and to Provide Further Responses to Plaintiff's First Set Of Interrogatories; Request for Monetary Sanctions 89 filed by Plaintiff Ancora Technologies Inc. (Attachments: # 1 Supplement Exhibits to Minder Declaration (Ex 7-12))(Mizrahi, Mark) (Entered: 01/21/2009)
- 01/21/2009 93 NOTICE OF MOTION AND MOTION to Compel Defendants Hewlett-Packard Company, Dell, Inc., and Toshiba America Information Systems, Inc. to Produce Documents and To Provide Further Responses to Plaintiff's First Set of Interrogatories; Request for Monetary Sanctions filed by plaintiff Ancora Technologies Inc. Motion set for hearing on 2/10/2009 at 10:00 AM before Judge Andrew J. Guilford. (Attachments: # 1 Proposed Order)(Mizrahi, Mark) (Entered: 01/21/2009)
- 01/21/2009 94 JOINT STIPULATION to MOTION to Compel Defendants Hewlett-Packard Company, Dell, Inc., and Toshiba America Information Systems, Inc. to Produce Documents and To Provide Further Responses to Plaintiff's First Set of Interrogatories; Request for Monetary Sanctions 93 filed by Plaintiff Ancora Technologies Inc. (Mizrahi, Mark) (Entered: 01/21/2009)
- 01/21/2009 95 DECLARATION of Mark Mizrahi In Support Of MOTION to Compel Defendants Hewlett-Packard Company, Dell, Inc., and Toshiba America Information Systems, Inc. to Produce Documents and To Provide Further Responses to Plaintiff's First Set of Interrogatories; Request for Monetary Sanctions 93 filed by Plaintiff Ancora Technologies Inc. (Attachments: # 1 Exhibit 1- 12/16/08 letter, # 2 Exhibit 2- 1/7/09 letter, # 3 Exhibit 3- Minute Order re Scheduling Conference and Order Granting Stipulation to Modify Dates Associated with Markman Hearing and Pleading Amendments, # 4 Exhibit 4- 12/10/08 letter, # 5 Exhibit 5- 11/28/08 letter, # 6 Exhibit 6- 12/11/08 letter, # 7 Exhibit 7- HP's Answer and Counterclaims, # 8 Exhibit 8- Dell's Answer and Counterclaims, # 9 Exhibit 9- Toshiba's Answer and Counterclaims, # 10 Exhibit 10- HP's Responses to Plaintiff's First Request for Production of Documents, # 11 Exhibit 11- Dell's Responses to Ancora's First Request for Production of Documents, # 12 Exhibit 12- Toshiba's Responses to Plaintiff's First Request for Production of Documents, # 13 Exhibit 13- 1/12/09 letter, # 14 Exhibit 14- 1/12/09 letter)(Mizrahi, Mark) (Entered: 01/21/2009)
- 01/21/2009 96 DECLARATION of Scott Minder In Opposition To MOTION to Compel Defendants Hewlett-Packard Company, Dell, Inc., and Toshiba America Information Systems, Inc. to Produce Documents and To Provide Further Responses to Plaintiff's First Set of Interrogatories; Request for Monetary Sanctions 93 filed by Plaintiff Ancora Technologies Inc. (Mizrahi, Mark) (Entered: 01/21/2009)
- 01/23/2009 97 FIRST AMENDED ANSWER to Intervenor Complaint 52 AND COUNTERCLAIMS filed by plaintiff Ancora Technologies Inc. (Attachments: # 1 Exhibit A - State of Washington Complaint - Microsoft v Miki Mullor and Ancora Technologies)(Cantor, Mark) (Entered: 01/23/2009)
- 01/23/2009 98 NOTICE OF MOTION AND First MOTION for Leave to file Amended Answers by Microsoft, TAIS, HP and Dell filed by Intervenor Microsoft Corporation. Motion set for hearing on 2/23/2009 at 10:00 AM before Judge Andrew J. Guilford. (Attachments: # 1 Proposed Order Granting Motion for Leave to File Amended Answers)(Campbell, Chad) (Entered: 01/23/2009)
- 01/23/2009 99 MEMORANDUM in Support of First MOTION for Leave to file Amended Answers by Microsoft, TAIS, HP and Dell 98 filed by Intervenor Microsoft Corporation. (Attachments: # 1 Exhibit A-D) (Campbell, Chad) (Entered: 01/23/2009)
- 01/26/2009 100 NOTICE OF MOTION AND MOTION of Fulbright & Jaworski and its attorneys, Christopher R. Benson, Michael C. Barrett and Brandon C. Fernald to Withdraw as Attorney filed by Defendant Dell Inc. (Fernald, Brandon) (Entered: 01/26/2009)
- 01/26/2009 101 BRIEF filed by Plaintiff Ancora Technologies, Inc., Ancora Technologies Inc. [OPENING MARKMAN BRIEF] regarding Order, 69 . (Attachments: # 1 Exhibit 1 - USPN 6,411,941, # 2 Exhibit 2 - 2/20/02 Reasons for Allowance, # 3 Exhibit 3 - 2/20/03 e-mail to Microsoft, # 4 Exhibit 4 - 2/11/03 e-mail to Microsoft, # 5 Exhibit 5 - Mullor employment agrmt with Microsoft,

6 Exhibit 6 - Publication No. US 2006/0288422, # 7 Exhibit 7 - Microsoft Complaint against Mullor, # 8 Exhibit 8 - Letter from Campbell to Cantor, # 9 Exhibit 9 - Notice of Claim Terms, # 10 Exhibit 10 - Letter from Lorelli to Campbell, # 11 Exhibit 11 - Microsoft Computer Dictionary, # 12 Exhibit 12 - 5/21/05 Response to Office Action, # 13 Exhibit 13 - 6/21/01 Office Action, # 14 Exhibit 14 - 1/7/02 Office Action)(LeRoy, John) (Entered: 01/26/2009)

- 01/26/2009 102 Opening Claims Construction Brief of Microsoft and Defendants BRIEF filed by Intervenor and Defendants Microsoft Corporation. regarding Order, 69 . (Campbell, Chad) (Entered: 01/26/2009)
- 01/26/2009 103 DECLARATION of Chad S. Campbell re Brief (non-motion non-appeal) 102 in Support of Opening Claims Construction Brief by Microsoft and Defendants filed by Intervenor Microsoft Corporation. (Attachments: # 1 Exhibit A-B, Part I, # 2 Exhibit B, Part II, # 3 Exhibit B, Part III, # 4 Exhibit B, Part IV, # 5 Exhibit C-D, Part V, # 6 Exhibit E, Part VI, # 7 Exhibit E, Part VII, # 8 Exhibit F-G, Part VIII)(Campbell, Chad) (Entered: 01/26/2009)
- 01/27/2009 104 SUPPLEMENT to MOTION to Compel Microsoft Corporation to Produce Documents and to Provide Further Responses to Plaintiff's First Set Of Interrogatories; Request for Monetary Sanctions 89 filed by Plaintiff Ancora Technologies Inc. (Attachments: # 1 Exhibit A - Supplemental Joint Status Report on Microsoft's Compliance With The Final Judgments, # 2 Exhibit B - C.V. of Adisehu Dasari, # 3 Exhibit C - Interrogatory No. 1 to Microsoft)(Mizrahi, Mark) (Entered: 01/27/2009)
- 01/27/2009 105 SUPPLEMENT to MOTION to Compel Defendants Hewlett-Packard Company, Dell, Inc., and Toshiba America Information Systems, Inc. to Produce Documents and To Provide Further Responses to Plaintiff's First Set of Interrogatories; Request for Monetary Sanctions 93 filed by Plaintiff Ancora Technologies Inc. (Mizrahi, Mark) (Entered: 01/27/2009)
- 01/27/2009 106 SUPPLEMENT to Stipulation for Protective Order 84 filed by Counter Defendants Ancora Technologies, Inc., Ancora Technologies Inc, Ancora Technologies Inc, Plaintiff Ancora Technologies Inc. (LeRoy, John) (Entered: 01/27/2009)
- 01/27/2009 107 MEMORANDUM in Support Supplemental Memorandum in Support of the Joint Stipulation Under Rule 37-2 re Motion for Entry of a Final Protective Order filed by Intervenor Microsoft Corporation. (LaSpaluto, David) (Entered: 01/27/2009)
- 01/27/2009 108 DECLARATION of David M. LaSpaluto re Memorandum in Support of Motion 107 Joint Stipulation Under Rule 37-2 re Entry of Final Protective Order filed by Intervenor Microsoft Corporation. (Attachments: # 1 Exhibit 1 and 2)(LaSpaluto, David) (Entered: 01/27/2009)
- 01/27/2009 109 MEMORANDUM in Opposition Supplemental Memorandum in Opposition to Plaintiff's Motion to Compel Microsoft filed by Intervenor Microsoft Corporation. (Campbell, Chad) (Entered: 01/27/2009)
- 01/27/2009 110 DECLARATION of Scott S. Minder re MEMORANDUM in Opposition to Motion 109 of Plaintiff to Compel Microsoft filed by Intervenor Microsoft Corporation. (Attachments: # 1 Exhibit 1) (Campbell, Chad) (Entered: 01/27/2009)
- 01/27/2009 111 MEMORANDUM in Opposition Supplemental Memorandum in Opposition to Plaintiff's Motion to Compel Defendants filed by Defendants Toshiba America Information Systems Inc, Dell Inc, Hewlett-Packard Company. (Campbell, Chad) (Entered: 01/27/2009)
- 01/27/2009 112 DECLARATION of Scott Minder re MEMORANDUM in Opposition to Motion 111 of Plaintiff to Compel Defendants filed by Defendants Toshiba America Information Systems Inc, Dell Inc, Hewlett-Packard Company. (Attachments: # 1 Exhibit 1-3)(Campbell, Chad) (Entered: 01/27/2009)
- 01/29/2009 113 NOTICE of Manual Filing filed by Counter Claimants Toshiba America Information Systems, Inc., Hewlett-Packard Company, Dell Inc, Intervenor Microsoft Corporation, Defendants Toshiba America Information Systems Inc, Dell Inc, Hewlett-Packard Company of Under Seal Dcouments. (Sliger, Lauren) (Entered: 01/29/2009)
- 01/29/2009 114 NOTICE OF MOTION TO TRANSFER VENUE filed by Intervenor & Defendants Toshiba America Information Systems, Inc., Hewlett-Packard Company, Dell Inc, Microsoft Corporation, Toshiba America Information Systems Inc. (Attachments: # 1 Proposed Order Granting Motion to Transfer Venue)(Sliger, Lauren) (Entered: 01/29/2009)
- 01/29/2009 115 DECLARATION of Cam D'Amico re Notice (Other), Notice (Other) 114 of Motion to Transfer Venue filed by Counter Claimants Toshiba America Information Systems, Inc., Hewlett-Packard Company, Dell Inc, Intervenor Microsoft Corporation, Defendants Toshiba America Information Systems Inc, Dell Inc, Hewlett-Packard Company. (Sliger, Lauren) (Entered: 01/29/2009)
- 01/29/2009 116 DECLARATION of John Hong re Notice (Other), Notice (Other) 114 of Motion to Transfer Venue filed by Counter Claimants Toshiba America Information Systems, Inc., Hewlett-Packard Company, Dell Inc, Intervenor Microsoft Corporation, Defendants Toshiba America Information

Systems Inc, Dell Inc, Hewlett-Packard Company. (Sliger, Lauren) (Entered: 01/29/2009)

01/29/2009 117 DECLARATION of Eric Peacock re Notice (Other), Notice (Other) 114 of Motion to Transfer Venue filed by Counter Claimants Toshiba America Information Systems, Inc., Hewlett-Packard Company, Dell Inc, Intervenor Microsoft Corporation, Defendants Toshiba America Information Systems Inc, Dell Inc, Hewlett-Packard Company. (Sliger, Lauren) (Entered: 01/29/2009)

01/29/2009 118 DECLARATION of Chad Anson re Notice (Other), Notice (Other) 114 of Motion to Transfer Venue filed by Counter Claimants Toshiba America Information Systems, Inc., Hewlett-Packard Company, Dell Inc, Intervenor Microsoft Corporation, Defendants Toshiba America Information Systems Inc, Dell Inc, Hewlett-Packard Company. (Sliger, Lauren) (Entered: 01/29/2009)

01/29/2009 120 PROOF OF SERVICE re. Application for Leave to File Papers Under Seal, Proposed Order Shortening Time; Memorandum in Support of Motion to Transfer Venue; Declaration of Counsel in Support of Motion to Transfer Venue filed by Intervenor Microsoft Corporation mail served on 1/29/09. (smi) (Entered: 02/02/2009)

01/29/2009 121 APPLICATION FOR LEAVE TO FILE PAPERS UNDER SEAL AND TO SHORTEN TIME FOR LR 7-3 CONFERENCE RE MOTION TO TRANSFER VENUE filed by Intervenor and Defendants Dell Inc, Microsoft Corporation, Toshiba America Information Systems Inc, Hewlett-Packard Company. (smi) (Entered: 02/02/2009)

01/29/2009 122 ORDER Shortening Time on L.R. 7-3 AND GRANTING APPLICATION to Seal 121 by Judge Andrew J. Guilford. (ade) (Entered: 02/02/2009)

01/29/2009 125 SEALED DOCUMENT - MEMORANDUM IN SUPPORT OF MOTION TO TRANSFER VENUE (smi) (Entered: 02/04/2009)

01/29/2009 126 SEALED DOCUMENT - DECLARATION OF COUNSEL IN SUPPORT OF MOTION TO TRANSFER VENUE (smi) (Entered: 02/04/2009)

01/30/2009 119 ORDER GRANTING MOTION TO WITHDRAW AS COUNSEL FOR DELL INC by Judge Andrew J. Guilford. IT IS ORDERED that: Fulbright & Jaworski, LLP and its attorneys Christopher R. Benson, Michael C. Barrett, and Brandon Fernald, shall be removed as counsel of record for Dell Inc. in this action. (smi) (Entered: 01/30/2009)

02/04/2009 123 EX PARTE APPLICATION to Continue Hearing on Microsoft's Motion to Transfer Venue from February 23, 2009 to March 3, 2009 filed by Plaintiff Ancora Technologies Inc. (Attachments: # 1 Exhibit 1 - 1/31/09 Email, # 2 Proposed Order)(Mizrahi, Mark) (Entered: 02/04/2009)

02/04/2009 124 Opposition to Ancora's Ex Parte Application to Continue the Hearing Date on Motion to Transfer Venue Opposition re: EX PARTE APPLICATION to Continue Hearing on Microsoft's Motion to Transfer Venue from February 23, 2009 to March 3, 2009 123 filed by Intervenor Microsoft Corporation, Defendants Toshiba America Information Systems Inc, Dell Inc, Hewlett-Packard Company. (Campbell, Chad) (Entered: 02/04/2009)

02/05/2009 127 MINUTES OF IN CHAMBERS ORDER by Judge Andrew J. Guilford: CONTINUING HEARINGS: The Court DENIES the Application 123 . The Court will not continue the hearing on the Motion. But the Court CONTINUES the Markman hearing, currently set for March 3, 2009, to March 24, 2009 at 9:00 a.m. Plaintiff's rebuttal Markman brief, currently due February 13, 2009, will now be due March 6, 2009. (ria) (Entered: 02/05/2009)

02/06/2009 128 Application to Clarify Minutes In-Chambers Order Dated February 5, 2009 re: Minutes of In Chambers Order/Directive - no proceeding held, Terminate Deadlines and Hearings, Set Hearings,,, 127 (Campbell, Chad) (Entered: 02/06/2009)

02/06/2009 129 NOTICE OF LODGING filed for Proposed Order Re Application to Clarify Minutes In-Chambers Order Dated February 5, 2009 re Miscellaneous Document 128 (Campbell, Chad) (Entered: 02/06/2009)

02/06/2009 130 NOTICE OF LODGING filed for Proposed Order Re Application to Clarify Minutes In-Chambers Order Dated February 5, 2009 re Miscellaneous Document 128 (Attachments: # 1 Proposed Order Re Application to Clarify Minutes In-Chambers Order Dated February 5, 2009)(Campbell, Chad) (Entered: 02/06/2009)

02/09/2009 131 MEMORANDUM in Opposition to Defendants' Motion to Transfer Venue (28 U.S.C. 1404(a)) filed by Plaintiff Ancora Technologies Inc. (Lorelli, Marc) (Entered: 02/09/2009)

02/09/2009 132 NOTICE of Manual Filing filed by Plaintiff Ancora Technologies Inc of Exhibits 2, 7 and 8 to Declaration of Counsel in Opposition to Microsoft's Motion to Transfer. (Lorelli, Marc) (Entered: 02/09/2009)

02/09/2009 133 MEMORANDUM in Opposition DECLARATION of Counsel Regarding Microsoft's Motion to Transfer Venue filed by Plaintiff Ancora Technologies Inc. (Attachments: # 1 Exhibit 1 - USPN 6411941, # 2 Exhibit 2 - FILED UNDER SEAL ('941 notice letters), # 3 Exhibit 3 - Mullor's Microsoft Employee Agreement, # 4 Exhibit 4 - Saavedra Declaration, # 5 Exhibit 5 - Mullor Declaration,

6 Exhibit 6 - HP's 2nd Supp. Int. Responses, # 7 Exhibit 7 - FILED UNDER SEAL (Excerpts of Mullor's deposition transcript), # 8 Exhibit 8 - FILED UNDER SEAL (Ancora/American Megatrends Agreement), # 9 Exhibit 9 - Press Articles, # 10 Exhibit 10 - Microsoft's Subpoena on Mullor, # 11 Exhibit 11 - Ancor's Supp Resp to Microsoft 1st Ints, # 12 Exhibit 12 - Microsoft website download, # 13 Exhibit 13 - US App Publ 2006/0288422, # 14 Exhibit 14 - Google webpage download, # 15 Exhibit 15 - mydigitallife forum thread, # 16 Exhibit 16 - Google webpage download, # 17 Exhibit 17 - webpage download, # 18 Exhibit 18 - Google webpage download, # 19 Exhibit 19 - Part 1 - Google webpage in Mandarin Chinese, # 20 Exhibit 19 - Part 2, # 21 Exhibit 20 - Google webpage download, # 22 Exhibit 21 - Google webpage download, # 23 Exhibit 22 - California Business Portal - corporation information for Microsoft Corporation, # 24 Exhibit 23 - Microsoft Corporation webpages showing addresses) (Lorelli, Marc) (Entered: 02/09/2009)

- 02/10/2009 135 APPLICATION for Leave to File Confidential Exhibits 2, 7, and 8 to the Declaration of Counsel in Opposition to Microsoft's Motion to Transfer Venue Under Seal. Filed by plaintiff Ancora Technologies Inc. Lodged order. (ade) (Entered: 02/12/2009)
- 02/10/2009 136 ORDER by Judge Andrew J. Guilford, GRANTING APPLICATION for Leave to File Confidential Exhibits 2, 7 and 8 to the Declaration of Counsel in Opposition to Microsoft's Motion to Transfer Venue Under Seal. 135 (ade) (Entered: 02/12/2009)
- 02/10/2009 146 SEALED DOCUMENT RE: EXHIBITS 2,7 AND 8 to the Declaration of Counsel in Opposition to Motion to Transfer Venue. (ade) (Entered: 02/19/2009)
- 02/11/2009 134 ORDER by Judge Andrew J. Guilford, re APPLICATION TO CLARIFY MINUTES OF INCHAMBERS ORDER 128 : IT IS HEREBY ORDERED that Microsoft and the Defendants' rebuttal Markman brief will be due on March 6, 2009 rather than February 13. SO ORDERED. (rla) (Entered: 02/11/2009)
- 02/11/2009 137 MINUTES OF IN CHAMBERS ORDER held before Magistrate Judge Marc L. Goldman: Order on Plaintiff's Motion to Compel Documents and Provide Further Responses from Defendants Dell, Hewlett-Packard and Toshiba 93 ; Plaintiff's Motion to Compel Defendant Microsoft to Produce Documents and Provide Further Responses 89 ; and Defendant's Motion for a Final Protective Order: The parties shall submit a final protective order conforming to the agreement of the parties and produce documents in accordance with the agreed upon schedule. Plaintiffs motion to compel more complete answers to the interrogatories is GRANTED. In doingso, the Court adopts the reasoning of the court in Firetrace USA, LLC v. Jesclard, 2009 WL 73671 (D. Ariz.2009). (See document for further details.) (rla) (Entered: 02/12/2009)
- 02/12/2009 138 NOTICE OF MOTION AND MOTION to Dismiss Count II of Ancora Technologies, Inc.'s Counterclaims in its First Amended Answer filed by Intervenor Microsoft Corporation. Motion set for hearing on 3/9/2009 at 10:00 AM before Judge Andrew J. Guilford. (Attachments: # 1 Proposed Order Granting Motion to Dismiss Count II of Ancora Technologies, Inc.'s Counterclaims)(Campbell, Chad) (Entered: 02/12/2009)
- 02/12/2009 139 MEMORANDUM in Support of MOTION to Dismiss Count II of Ancora Technologies, Inc.'s Counterclaims in its First Amended Answer 138 filed by Intervenor Microsoft Corporation. (Campbell, Chad) (Entered: 02/12/2009)
- 02/13/2009 140 NOTICE of Manual Filing filed by Counter Claimants Toshiba America Information Systems, Inc., Hewlett-Packard Company, Dell Inc, Intervenor Microsoft Corporation, Defendants Toshiba America Information Systems Inc, Dell Inc, Hewlett-Packard Company of Under Seal Documents. (Sliger, Lauren) (Entered: 02/13/2009)
- 02/13/2009 141 DECLARATION of SUPPLEMENTAL DECLARATION OF CAM D'AMICO IN SUPPORT OF REPLY RE MOTION TO TRANSFER VENUE re Memorandum in Support of Motion 125 To Transfer Venue [Sealed Document] filed by Counter Claimants Toshiba America Information Systems, Inc., Hewlett-Packard Company, Dell Inc, Intervenor Microsoft Corporation, Defendants Toshiba America Information Systems Inc, Dell Inc, Hewlett-Packard Company. (Sliger, Lauren) (Entered: 02/13/2009)
- 02/17/2009 142 SUPPLEMENT /SUR-REPLY in Opposition to Microsoft's Motion to Transfer Venue filed by Plaintiff Ancora Technologies Inc. (Mizrahi, Mark) (Entered: 02/17/2009)
- 02/17/2009 143 SUPPLEMENT /Declaration of Mark B. Mizrahi in Support of Sur-Reply in Opposition to Motion to Transfer Venue filed by Plaintiff Ancora Technologies Inc. (Mizrahi, Mark) (Entered: 02/17/2009)
- 02/17/2009 144 NOTICE of Manual Filing re Sur-Reply in Opposition to Motion to Transfer Venue filed by plaintiff Ancora Technologies Inc. (Mizrahi, Mark) (Entered: 02/17/2009)
- 02/18/2009 145 NOTICE of Manual Filing filed by Counter Claimants Toshiba America Information Systems, Inc., Hewlett-Packard Company, Dell Inc, Intervenor Microsoft Corporation, Defendants Toshiba America Information Systems Inc, Dell Inc, Hewlett-Packard Company of Under Seal Documents. (Sliger, Lauren) (Entered: 02/18/2009)

02/18/2009 147 APPLICATION for Leave to File a Sur-Reply and to File Under Seal Confidential Exhibit 25 to the Declaration of Mark B. Mizrahi in Support of Ancora Technologies, Inc.'s Sur-Reply in Opposition to Microsoft's Motion to Transfer Venue. Filed by Plaintiff Ancora Technologies Inc. (nbo) (Entered: 02/20/2009)

02/18/2009 148 ORDER by Judge Andrew J. Guilford GRANTING APPLICATION for Leave to File a Sur-Reply and to File Under Seal Confidential Exhibit 25 to the Declaration of Mark B. Mizrahi in Support of Ancora Technologies, Inc.'s Sur-Reply in Opposition to Microsoft's Motion to Transfer Venue 147 . (nbo) (Entered: 02/20/2009)

02/18/2009 149 APPLICATION for Leave to File Papers Under Seal. Filed by Intervenor Microsoft Corporation and Defendants, Toshiba America Information Systems Inc, Dell Inc, and Hewlett-Packard Company. (nbo) (Entered: 02/20/2009)

02/18/2009 150 ORDER by Judge Andrew J. Guilford GRANTING APPLICATION for Leave to File Under Seal 149 . (nbo) (Entered: 02/20/2009)

02/18/2009 151 APPLICATION for Leave to File Papers Under Seal (Second Supplemental Declaration of Counsel in Support of Reply in Support of Motion to Transfer Venue) filed by Defendants Toshiba America Information Systems Inc, Dell Inc, Hewlett-Packard Company. (db) (Entered: 02/20/2009)

02/18/2009 152 SEALED DOCUMENT RE: SECOND SUPPLEMENTAL DECLARATION of Counsel in Support of Motion to Transfer Venue. (ade) (Entered: 02/20/2009)

02/18/2009 153 SEALED DOCUMENT RE: NOTICE of Filing Under Seal Confidential Exhibit 25 (ade) (Entered: 02/20/2009)

02/18/2009 154 SEALED DOCUMENT RE: SUPPLEMENTAL DECLARATION of Counsel in Support of Reply re Motion to Transfer Venue (ade) (Entered: 02/20/2009)

02/18/2009 155 SEALED DOCUMENT RE: REPLY IN SUPPORT OF MOTION TO TRANSFER VENUE (ade) (Entered: 02/20/2009)

02/18/2009 157 ORDER by Judge Andrew J. Guilford GRANTING APPLICATION TO FILE UNDER SEAL 151 . IT IS ORDERED that leave to file under seal Microsoft and Defendants' Second Supplemental Declaration of Counsel In Support of Motion to Transfer Venue is GRANTED. (smi) (Entered: 02/20/2009)

02/20/2009 156 APPLICATION for attorney John W. Rogers to Appear Pro Hac Vice (PHV Fee of \$185 receipt number 0973000000004927614 paid.) filed by Defendant and Intervenor Toshiba America Information Systems, Inc., Hewlett-Packard Company, Dell Inc, Microsoft Corporation, Toshiba America Information Systems Inc. (Attachments: # 1 Proposed Order on Application of Non-Resident Attorney to Appear in a Specific Case, # 2 Letter Certificate of Good Standing)(Sliger, Lauren) (Entered: 02/20/2009)

02/23/2009 158 OPPOSITION to MOTION to Dismiss Count II of Ancora Technologies, Inc.'s Counterclaims in its First Amended Answer 138 filed by Plaintiff Ancora Technologies Inc. (Mizrahi, Mark) (Entered: 02/23/2009)

02/23/2009 159 MINUTES OF Motion Hearing held before Judge Andrew J. Guilford RE: INTERVENOR'S AND DEFENDANTS' MOTION TO TRANSFER VENUE AND MOTION FOR LEAVE TO FILE PROPOSED AMENDED ANSWERS TO ANCORA TECHNOLOGIES, INC'S COMPLAINT AND COUNTERCLAIM. Matter is argued and taken under submission. Court Reporter: Denise Paddock. (smi) (Entered: 02/24/2009)

02/25/2009 160 ORDER by Judge Andrew J. Guilford Granting APPLICATION for attorney John W. Rogers to Appear Pro Hac Vice (PHV Fee of \$185 receipt number 0973000000004927614 paid.) 156 John W. Rogers to appear on behalf of Intervenor Microsoft Corporation. Lauren Sliger is designated as local counsel. Fee PAID. (ade) (Entered: 02/26/2009)

02/27/2009 161 ORDER by Judge Andrew J. Guilford transferring case to Western District of Washington. GRANTING MICROSOFT'S MOTION TO TRANSFER VENUE : (See document for further details.) (MD JS-6. Case Terminated.) The Court VACATES the hearing on the Motion to Amend. IT IS SO ORDERED. (ria) (Entered: 02/27/2009)

02/27/2009 162 MINUTES OF IN CHAMBERS ORDER by Judge Andrew J. Guilford: VACATING HEARING ON MOTION TO DISMISS. (ria) (Entered: 02/27/2009)

05/05/2009 163 TRANSCRIPT for proceedings held on 2-10-09 10:00a.m. & 1:01p.m.. Court Reporter/Electronic Court Recorder: Babykin CourtHouse Services, phone number 626-963-0566. Transcript may be viewed at the court public terminal or purchased through the Court Reporter/Electronic Court Recorder before the deadline for Release of Transcript Restriction. After that date it may be obtained through PACER. Notice of Intent to Redact due within 7 days of this date. Redaction Request due 5/26/2009. Redacted Transcript Deadline set for 6/5/2009. Release of Transcript

Restriction set for 8/3/2009. (bem) (Entered: 05/05/2009)

05/05/2009 164 NOTICE OF FILING TRANSCRIPT filed for proceedings 2-10-09 10:00a.m. & 1:01p.m. (bem)
(Entered: 05/05/2009)

Copyright © 2010 LexisNexis CourtLink, Inc. All rights reserved.
*** THIS DATA IS FOR INFORMATIONAL PURPOSES ONLY ***

FOCUS™ Terms Search Within Using
Semantic Concepts [What's this?](#) [Advanced...](#)

Source: [Command Searching > Utility, Design and Plant Patents](#)

Terms: **patno=6411941** ([Edit Search](#) | [Suggest Terms for My Search](#))

164777 (09) 6411941 June 25, 2002

UNITED STATES PATENT AND TRADEMARK OFFICE GRANTED PATENT

6411941

[Get Drawing Sheet 1 of 2](#)

[Access PDF of Official Patent *](#)

[Order Patent File History / Wrapper from REEDFAX®](#)

[Link to Claims Section](#)

June 25, 2002

Method of restricting , , software operation within a , , license limitation,

REEXAM-LITIGATE:

NOTICE OF LITIGATION

Ancora Technologies Inc v. Toshiba America Information Systems Inc et al, Filed February 27, 2009, D.C. W.D. Washington, Doc. No. 2:09cv270

INVENTOR: Mullor, Miki - Ramat Hasharon, Israel (IL)Valiko, Julian - Ramat Hasharon, Israel (IL)

APPL-NO: 164777 (09)

FILED-DATE: October 1, 1998

GRANTED-DATE: June 25, 2002

PRIORITY: May 21, 1998 - 124571, Israel (IL)

ASSIGNEE-PRE-ISSUE: October 1, 1998 - ASSIGNMENT OF ASSIGNORS INTEREST (SEE DOCUMENT FOR DETAILS)., M.Y.P.D. TECHNOLOGIES LTD., C/O KEREN-SCHECHTER LAW FIRM 21 HAR SINAI STREETTEL-AVIV 65816, (1), Reel and Frame Number: 009510/0320
February 27, 2002 - ASSIGNMENT OF ASSIGNORS INTEREST (SEE DOCUMENT FOR DETAILS)., BEEBLE, INC. P.O. BOX 4066NEWPORT BEACH, CALIFORNIA, 92661, Reel and Frame Number: 012617/0830

May 9, 2002 - REQUEST FOR CORRECTION TO CORRECT THE ASSIGNOR'S NAME PREVIOUSLY RECORDED AT REEL 012617, FRAME 0830, BEEBLE, INC. PO BOX 4066NEWPORT BEACH, CALIFORNIA, 92661, Reel and Frame Number: 012882/0558

May 9, 2002 - REQUEST FOR CORRECTION TO CORRECT THE ASSIGNOR S NAME PREVIOUSLY RECORDED AT REEL 012617, FRAME 0830, BEEBLE, INC. PO BOX 4066NEWPORT BEACH, CALIFORNIA, 92661, Reel and Frame Number: 012882/0558

ASSIGNEE-AT-ISSUE: Beeble, Inc., Newport Beach, California, United States (US), United States company or corporation (02)

ASSIGNEE-AFTER-ISSUE: December 21, 2004 - ASSIGNMENT OF ASSIGNORS INTEREST (SEE DOCUMENT FOR DETAILS)., ANCORA TECHNOLOGIES INC. 3972 BARRANCA PKWY, SUITE J458IRVINE, CALIFORNIA, 92606, Reel and Frame Number: 015494/0243

LEGAL-REP: VenableKinberg, Robert; Kaminski, Jeffri A.

PUB-TYPE: June 25, 2002 - Utility Patent having no previously published pre-grant publication (B1)

PUB-COUNTRY: United States (US)

US-MAIN-CL: 705#59

US-ADDL-CL: 705#50, 705#51, 705#53, 705#57

CL: 705

IPC-MAIN-CL: [7] G06F 017#60

PRIM-EXMR: Sough, Hyung-Sub

ASST-EXMR: Hewitt, Calvin L

REF-CITED:

4866769, September, 1989, Karp, United States (US)
4903296, February, 1990, Chandra et al., United States (US)
4924378, May, 1990, Hershey et al., United States (US)
5386369, January, 1995, Christiano, United States (US)
5390297, February, 1995, Barber et al., United States (US)
5479639, December, 1995, Ewertz et al., United States (US), 395#430
5490216, February, 1996, Richadson, III, United States (US), 380#4
5671412, September, 1997, Christiano, United States (US)
5684951, November, 1997, Goodman et al., United States (US), 395#188.01
5754763, May, 1998, Bereiter, United States (US)
5758068, May, 1998, Brandt et al., United States (US)
5758069, May, 1998, Olsen, United States (US)
5790664, August, 1998, Coley et al., United States (US)
5826011, October, 1998, Chou et al., United States (US)
5892900, April, 1999, Ginter et al., United States (US), 395#186
5905860, May, 1999, Olsen et al., United States (US)
6000030, December, 1999, Steinberg et al., United States (US), 713#200
6006190, December, 1999, Baena-Arnaiz et al., United States (US)
6021438, February, 2000, Duvvoorri et al., United States (US)
6023763, February, 2000, Grumpstrup et al., United States (US)
6052600, April, 2000, Fette et al., United States (US), 455#509
6055503, April, 2000, Horstmann, United States (US)
6067582, May, 2000, Smith et al., United States (US), 710#5
6073256, June, 2000, Sesma, United States (US)
6078909, June, 2000, Knutson, United States (US)
6128741, October, 2000, Goetz et al., United States (US)
6173446, January, 2001, Khan et al., United States (US)
6189146, February, 2001, Misra et al., United States (US), 717#11
6192475, February, 2001, Wallance, United States (US)

6198875, March, 2001, Edenson et al., United States (US), 386#94
6226747, May, 2001, Larsson et al., United States (US)
6233567, May, 2001, Cohen, United States (US)
6243468, June, 2001, Pearce et al., United States (US)
6272636, August, 2001, Neville et al., United States (US)
6298138, October, 2001, Gotoh et al., United States (US)
408286906, November, 1996, G06F 906, Japan (JP), G06#F.906

NON-PATENT LITERATURE: Dornbusch et al., Destop management software: no need to adjust your set., Infoworld, v17, n37, p60.

CORE TERMS: memory, computer, license, non-volatile, bureau, license-record, software, encrypted, volatile, identification, user, restricting, licensed, pseudo-unique, verification, verifying, processor, hacker, licensed-software-program's, encryption, encrypting, comparing, residing, overlay, stored, string, transferring, appreciate, utilizing, linkage

ENGLISH-ABST:

A method of restricting software operation within a license limitation that is applicable for a computer having a first non-volatile memory area, a second non-volatile memory area, and a volatile memory area. The method includes the steps of selecting a program residing in the volatile memory, setting up a verification structure in the non-volatile memories, verifying the program using the structure, and acting on the program according to the verification.

NO-OF-CLAIMS: 19

EXMPL-CLAIM: 18

NO-OF-FIGURES: 2

NO-DRWNG-PP: 2

SUMMARY:

FIELD OF THE INVENTION

This invention relates to a method and system of identifying and restricting an unauthorized software program's operation.

BACKGROUND OF THE INVENTION

Numerous methods have been devised for the identifying and restricting of an unauthorized software program's operation. These methods have been primarily motivated by the grand proliferation of illegally copied software, which is engulfing the marketplace. This illegal copying represents billions of dollars in lost profits to commercial software developers.

Software based products have been developed to validate authorized software usage by writing a license signature onto the computer's volatile memory (e.g. hard disk). These products may be appropriate for restricting honest software users, but they are very vulnerable to attack at the hands of skilled system's programmers (e.g. "hackers"). These license signatures are also subject to the physical instabilities of their volatile memory media.

Hardware based products have also been developed to validate authorized software usage by

accessing a dongle that is coupled e.g. to the parallel port of the P.C. These units are expensive, inconvenient, and not particularly suitable for software that may be sold by downloading (e.g. over the internet).

There is accordingly a need in the art to provide for a system and method that substantially reduce or overcome the drawbacks of hitherto known solutions.

SUMMARY OF THE INVENTION

The present invention relates to a method of restricting software operation within a license limitation. This method strongly relies on the use of a key and of a record, which have been written into the non-volatile memory of a computer.

For a better understanding of the underlying concept of the invention, there follows a specific non-limiting example. Thus, consider a conventional computer having a conventional BIOS module in which a key was embedded at the ROM section thereof, during manufacture. The key constitutes, effectively, a unique identification code for the host computer. It is important to note that the key is stored in a non-volatile portion of the BIOS, i.e. it cannot be removed or modified.

Further, according to the invention, each application program that is to be licensed to run on the specified computer, is associated with a license record; that consists of author name, program name and number of licensed users (for network). The license record may be held in either encrypted or explicit form.

Now, there commences an initial license establishment procedure, where a verification structure is set in the BIOS so as to indicate that the specified program is licensed to run on the specified computer. This is implemented by encrypting the license record (or portion thereof) using said key (or portion thereof) exclusively or in conjunction with other identification information) as an encryption key. The resulting encrypted license record is stored in another (second) non-volatile section of the BIOS, e.g. E2PROM (or the ROM). It should be noted that unlike the first non-volatile section, the data in the second non-volatile memory may optionally be erased or modified (using E2PROM manipulation commands), so as to enable to add, modify or remove licenses. The actual format of the license may include a string of terms that correspond to a license registration entry (e.g. lookup table entry or entries) at a license registration bureau (which will be further described as part of the preferred embodiment of the present invention).

Having placed the encrypted license record in the second non-volatile memory (e.g. the E2PROM), the process of verifying a license may be commenced. Thus, when a program is loaded into the memory of the computer, a so called license verifier application, that is a priori running in the computer, accesses the program under question, retrieves therefrom the license record, encrypts the record utilizing the specified unique key (as retrieved from the ROM section of the BIOS) and compares the so encrypted record to the encrypted records that reside in the E2PROM. In the case of match, the program is verified to run on the computer. If on the other hand the sought encrypted data record is not found in the E2PROM database, this means that the program under question is not properly licensed and appropriate application define action is invoked (e.g. informing to the user on the unlicensed status, halting the operation of the program under question etc.)

Those versed in the art will readily appreciate that any attempt to run a program at an unlicensed site will be immediately detected. Consider, for example, that a given application, say Lotus 123, is verified to run on a given computer having a first identification code (k1) stored in the ROM portion of the BIOS thereof. This obviously requires that the license record (LR) of the application after having been encrypted using k1 giving rise to (LR)k1 is stored in

the E2PROM of the first computer.

Suppose now that a hacker attempts to run the specified application in a second computer having a second identification code (k2) stored in the ROM portion of the BIOS thereof. All or a portion the database contents (including of course (LR)k1) that reside in the E2PROM portion in the first computer may be copied in a known per se means to the second computer. It is important to note that the hacker is unable to modify the key in the ROM of the second computer to K1, since, as recalled, the contents of the ROM is established during manufacture and is practically invariable.

Now, when the application under question is executed in the second computer, the license verifier retrieves said LR from the application and, as explained above, encrypts it using the key as retrieved from the ROM of the second computer, i.e k2 giving rise to encrypted license record (LR)k2. Obviously, the value (LR)k2 does not reside in the E2PROM database section of the second computer (since it was not legitimately licensed) and therefore the specified application is invalidated. It goes without saying that the data copied from the first (legitimate) computer is rendered useless, since comparing (LR)k2 with the copied value (LR)k1 results, of course, in mismatch.

The example above is given for clarity of explanation only and is by no means binding.

In its broadest aspect, the invention provides for a method of restricting software operation within a license limitation including; for a computer having a first non-volatile memory area, a second non-volatile memory area, and a volatile memory area; the steps of: selecting a program residing in the volatile memory, setting up a verification structure in the non-volatile memories, verifying the program using the structure, and acting on the program according to the verification.

An important advantage in utilizing non-volatile memory such as that residing in the BIOS is that the required level of system programming expertise that is necessary to intercept or modify commands, interacting with the BIOS, is substantially higher than those needed for tampering with data residing in volatile memory such as hard disk. Furthermore, there is a much higher cost to the programmer, if his tampering is unsuccessful, i.e. if data residing in the BIOS (which is necessary for the computer's operability) is inadvertently changed by the hacker. This is too high of a risk for the ordinary software hacker to pay. Note that various recognized means for hindering the professional-like hacker may also be utilized (e.g. anti-debuggers, etc.) in conjunction with the present invention.

In the context of the present invention, a "computer" relates to a digital data processor. These processors are found in personal computers, or on one or more processing cards in multi-processor machines. Today, a processor normally includes a first non-volatile memory, a second non-volatile memory, and data linkage access to a volatile memory. There are also processors having only one non-volatile memory or having more than two non-volatile memories; all of which should be considered logically as relating to having a first and a second non-volatile memory areas. There are also computational environments where the volatile memory is distributed into numerous physical components, using a bus, LAN, etc.; all of which should logically be considered as being a volatile memory area.

According to the preferred embodiment of the present invention, there is further provided a license authentication bureau which can participate in either or both of:

- (i) establishing the license record in the second non-volatile memory; and
- (ii) verifying if the key and license record in the non-volatile memory(s) is compatible with the license record information as extracted from the application under question.

The bureau is a telecommunications accessible processor where functions such as formatting, encrypting, and verifying may be performed. Performing these or other functions at the bureau helps to limit the understanding of potential software hackers; since they can not observe how these functions are constructed. Additional security may also be achieved by forcing users of the bureau to register, collecting costs for connection to the bureau, logging transactions at the bureau, etc.

According to one example of using the bureau, setting up a verification structure further includes the steps of: establishing, between the computer and the bureau, a two-way data-communications linkage; transferring, from the computer to the bureau, a request-for-license including an identification of the computer and the license-record's contents from the selected program; forming an encrypted license-record at the bureau by encrypting parts of the request-for-license using part of the identification as the encryption key; and transferring, from the bureau to the computer, the encrypted license-record.

According to another example of using the bureau, verifying the program further includes the steps of: establishing, between the computer and the bureau, a two-way data-communications linkage; transferring, from the computer to the bureau, a request-for-license-verification including an identification of the computer, the encrypted license-record for the selected program from the second non-volatile memory, and the licensed-software-program's license-record contents; enabling the comparing at the bureau; and transferring, from the bureau to the computer, the result of the comparing.

The actual key that serves for identifying the computer may be composed of the pseudo-unique key exclusively, or, if desired, in combination with information, e.g. information related to the registration of the user such as e.g. place, telephone number, user name, license number, etc. In the context of the present invention, a "pseudo-unique" key may relate to a bit string which uniquely identifies each first non-volatile memory. Alternately the "pseudo-unique" key may relate to a random bit string (or to an assigned bit string) of sufficient length such that: there is an acceptably low probability of a successful unauthorized transfer of licensed software between two computers, where the first volatile memories of these two computers have the same key.

It should be noted that the license bureau might maintain a registry of keys and of licensed programs that have been registered at the bureau in association with these keys. This registry may be used to help facilitate the formalization of procedures for the transfer of ownership of licensed software from use on one computer to use on another computer.

Constructing the key in the manner specified may hinder the hacker in cracking the proposed encryption scheme of the invention, in particular when the establishment of the license record or the verification thereof is performed in the bureau. Those versed in the art will readily appreciate that the invention is by no means bound by the data, the algorithms, or the manner of operation of the bureau. It should be noted that the tasks of establishing and/or verifying a license record may be shared between the bureau and the computer, done exclusively at the computer, or done exclusively at the bureau. The pseudo-unique key length needs to be long enough to hinder encryption attack schemes. The establishing of the key may be done at any time from the non-volatile memory's manufacture until an attempted use of an established license-record in the non-volatile memory. The key is used for encryption or decryption operations associated with license-records. In principle, the manufacturer of the licensed-software-program may specify the license-record format and therefore different formats may, if desired, be used for respective applications.

According to the preferred embodiment of the present invention, the pseudo-unique key is a unique-identification bit string that is written onto the first non-volatile memory by the manufacturer of the is memory media.

According to one, non-limiting, preferred embodiment of the present invention, the first non-volatile memory area is a ROM section of a BIOS; the second non-volatile memory area is a E2PROM section of a BIOS; and the volatile memory is a RAM e.g. hard disk and/or internal memory of the computer.

The present invention also relates to a non-volatile memory media used as a BIOS of a computer, for restricting software operation within a license limitation, wherein a pseudo-unique key is established.

According to the preferred embodiment of the non-volatile memory media of the present invention, the pseudo-unique key is established in a ROM section of the BIOS.

DRWDESC:

BRIEF DESCRIPTION OF THE DRAWINGS

In order to understand the invention and to see how it may be carried out in practice, a preferred embodiment will now be described, by way of non-limiting example only, with reference to the accompanying drawings, in which:

FIG. 1 is a schematic diagram of a computer and a license bureau; and

FIG. 2 is a generalized flow chart of the sequence of operations performed according to one embodiment of the invention.

DETDESC:

DETAILED DESCRIPTION OF A PREFERRED EMBODIMENT

A schematic diagram of a computer and a license bureau is shown in FIG. 1. Thus, a computer processor (1) is associated with input operations (2) and with output operations (3). This computer (processor) internally contains a first non-volatile memory area (4) (e.g. the ROM section of the BIOS), a second non-volatile memory area (5) (e.g. the E2PROM section of the BIOS), and a volatile memory area (6) (e.g. the internal RAM memory of the computer).

The computer processor is in temporary telecommunications linkage with a license bureau (7).

The first non-volatile memory includes a pseudo-random identification key (8), which exclusively or in combination with other information (e.g. user name), is sufficient to uniquely differentiate this first non-volatile memory from all other first non-volatile memories. As specified before, said key constitutes unique identification of the computer.

The second non-volatile memory includes a license-record-area (9) e.g. which contains at least one encrypted license-record (e.g. three records 10-12). The volatile memory accommodates a license program (16) having license record fields (13-15) appended thereto. By way of example said fields stand for Application names (e.g. Lotus 123), Vendor name (Lotus inc.), and number of licensed copies (1 for stand alone usage, >1 for number of licensed users for a network application).

Those versed in the art will readily appreciate that the license record is not necessarily bound

to continuous fields. In fact, the various license content components of the data record may be embedded in various locations in the application. Any component may, if desired, be encrypted.

Each one of the encrypted license records (10-12) is obtained by encrypting the corresponding license record as extracted from program 16, utilizing for encryption the identification key (8).

In a typical, yet not exclusive, sequence of operation, a transaction/request is sent, by the computer to the bureau. This transaction includes the key (8), the encrypted license-records (10-12), contents from the license program used in forming a license record (e.g. fields 13-15), and other items of information as desired.

The bureau forms the proposed license-record from the contents, encrypts (utilizing predetermined encryption algorithm) the so formed license-record using the key (8), and compares the so formed encrypted license-record with the license-record (10-12). The bureau generates an overlay according to the result of the comparison indicating successful comparison, non-critical failure comparison and the critical failure comparison.

The bureau returns the overlay which will direct the computer in subsequent operation. Thus, a success overlay will allow the license program to operate. A non-critical failure overlay will ask for additional user interactions. A critical failure overlay will cause permanent disruption to the computer's BIOS operations. Thus, software operation of the program is methodologically according to a license limitation restriction.

Those versed in the art will readily appreciate that the implementation as described with reference to FIG. 1 is by no means binding. Thus, by way of non-limiting example, the bureau, instead of being external entity may form part of the computer.

Attention is now directed to FIG. 2, showing a generalized flow chart of the sequence of operations performed according to one embodiment of the invention.

Thus, selecting (17) a program includes the step of: establishing a licensed-software-program in the volatile memory of the computer wherein the licensed-software-program includes contents used to form a license-record. These contents, be they centralized or decentralized, may include terms, identifications, specifications, or limitations related to the manufacturer of a software product, the distributor of a software product, the purchaser of a software product, a licensor, a licensee, items of computer hardware or components thereof, or to other terms and conditions related to the aforesaid.

Setting up (18) the verification structure includes the steps of: establishing or certifying the existence of a pseudo-unique key in the first non-volatile memory area; and establishing at least one license-record location in the first or the second nonvolatile memory area.

Establishing a license-record includes the steps of: forming a license-record by encrypting of the contents used to form a license-record with other predetermined data contents, using the key; and establishing the encrypted license-record in one of the at least one established license-record locations (e.g. 10-12 in FIG. 1).

Verifying (19) the program includes the steps of: encrypting the licensed-software-program's license-record contents from the volatile memory area or decrypting the license-record in the first or the second non-volatile memory area, using the key; and comparing the encrypted licensed-software-program's license-record contents with the encrypted license-record in the first or the second non-volatile memory area, or comparing the licensed-software-program's license-record contents with the decrypted license-record in the first or the second non-volatile memory area.

Acting (20) on the program includes the step of: restricting the program's operation with predetermined limitations if the comparing yields non-unity or insufficiency. In this context "non-unity" relates to being unequal with respect to a specific equation (e.g. $A[\text{equals}]B[\text{plus}]1$); and "insufficiency" relates to being outside of a relational bound (e.g. $A > B[\text{plus}]1$). "Restricting the program's operation with predetermined limitations" may include actions such as erasing the software in volatile memory, warning the license applicant/user, placing a fine on the applicant/user through the billing service charges collected at the license bureau (if applicable), or scrambling sections of the BIOS of the computer (or of functions interacting therewith).

The present invention has been described with a certain degree of particularity but it should be understood that various modifications and alterations may be made without departing from the scope or spirit of the invention as defined by the following claims.

ENGLISH-CLAIMS:

[Return to Top of Patent](#)

What is claimed is:

1. A method of restricting software operation within a license for use with a computer including an erasable, non-volatile memory area of a BIOS of the computer, and a volatile memory area; the method comprising the steps of:

selecting a program residing in the volatile memory,

using an agent to set up a verification structure in the erasable, non-volatile memory of the BIOS, the verification structure accommodating data that includes at least one license record,

verifying the program using at least the verification structure from the erasable non-volatile memory of the BIOS, and

acting on the program according to the verification.

2. A method according to claim 1, further comprising the steps of:

establishing a license authentication bureau.

3. A method according to claim 2, wherein setting up a verification structure further comprising the steps of: establishing, between the computer and the bureau, a two-way data-communications linkage; transferring, from the computer to the bureau, a request-for-license including an identification of the computer and the license-record's contents from the selected program; forming an encrypted license-record at the bureau by encrypting parts of the request-for-license using part of the identification as an encryption key; transferring, from the bureau to the computer, the encrypted license-record; and storing the encrypted license record in the erasable non-volatile memory area of the BIOS.

4. A method according to claim 2, wherein verifying the program further comprises the steps of: establishing, between the computer and the bureau, a two-way data-communications linkage; transferring, from the computer to the bureau, a request-for-license verification including an identification of the computer, an encrypted license-record for the selected program from the erasable, non-volatile memory area of the BIOS, and the program's license-record; enabling the comparing at the bureau; and transferring, from the bureau to the computer, the result of the comparing.

5. A method according to claim 3 wherein the identification of the computer includes the unique key.
6. A method according to claim 1 wherein selecting a program includes the steps of: establishing a licensed-software-program in the volatile memory of the computer wherein said licensed-software-program includes contents used to form the license-record.
7. A method according to claim 6 wherein using an agent to set up the verification structure includes the steps of: establishing or certifying the existence of a pseudo-unique key in a first non-volatile memory area of the computer; and establishing at least one license-record location in the first nonvolatile memory area or in the erasable, non-volatile memory area of the BIOS.
8. A method according to claim 6 wherein establishing a license-record includes the steps of: forming a license-record by encrypting of the contents used to form a license-record with other predetermined data contents, using the key; and establishing the encrypted license-record in one of the at least one established license-record locations.
9. A method according to claim 7 wherein verifying the program includes the steps of: encrypting the licensed-software-program's license-record contents from the volatile memory area or decrypting the license-record in the erasable, non-volatile memory area of the BIOS, using the pseudo-unique key; and comparing the encrypted licenses-software-program's license-record contents with the encrypted license-record in the erasable, non-volatile memory area of the BIOS, or comparing the license-software-program's license-record contents with the decrypted license-record in erasable non-volatile memory area of the BIOS.
10. A method according to claim 9 wherein acting on the program includes the step: restricting the program's operation with predetermined limitations if the comparing yields non-unity or insufficiency.
11. A method according to claim 1 wherein the volatile memory is a RAM.
12. The method of claim 1, wherein a pseudo-unique key is stored in the non-volatile memory of the BIOS.
13. The method of claim 1, wherein a unique key is stored in a first non-volatile memory area of the computer.
14. The method according claim 13, wherein the step of using the agent to set up the verification record, including the license record, includes encrypting a license record data in the program using at least the unique key.
15. The method according to claim 14, wherein the verification comprises:
 - extracting the license record from the software program;
 - encrypting the license record using the unique key stored in the first non-volatile memory area of the computer to form second encrypted license information; and
 - comparing the encrypted license information stored in the erasable, non-volatile memory area of the BIOS of the computer with the second encrypted license information.
16. The method according to claim 13, wherein the step of verifying the program includes a decrypting the license record data accommodated in the erasable second non-volatile memory area of the BIOS using at least the unique key.

17. The method according to claim 13, wherein the step of verifying the program includes encrypting the license record that is accommodated in the program using at least the unique key.

18. A method for accessing an application software program using a pseudo-unique key stored in a first non-erasable non-volatile memory area of a computer, the first non-volatile memory area being unable to be programmatically changed, the method, comprising:

loading the application software program residing in a non-volatile memory area of the computer;

using an agent to perform the following steps:

extracting license information from software program;

encrypting license information using the pseudo-unique key stored in the first non-volatile memory area;

storing the encrypting license information in a second erasable, writable, non-volatile memory area of the BIOS of the computer;

subsequently verifying the application software program based on the encrypted license information stored in the second erasable, writable, non-volatile memory area of the BIOS; and

acting on the application software program based on the verification.

19. The method of claim 18, wherein the verification comprises:

extracting the license information from the software program;

encrypting the license information using the pseudo-unique key stored in the first non-volatile memory area of the computer to form second encrypted license information; and

comparing the encrypted license information stored in the second erasable, writable, non-volatile memory area of the BIOS of the computer with the second encrypted license information.

LOAD-DATE: March 11, 2009

Source: [Command Searching](#) > [Utility, Design and Plant Patents](#) 

Terms: **patno=6411941** ([Edit Search](#) | [Suggest Terms for My Search](#))

View: Full

Date/Time: Friday, February 12, 2010 - 3:12 PM EST

[My Lexis™](#) | [Search](#) | [Research Tasks](#) | [Get a Document](#) | [Shepard's®](#) | [Alerts](#) | [Total Litigator](#) | [Transactional Advisor](#) | [Counsel Selector](#)
[History](#) | [Delivery Manager](#) | [Switch Client](#) | [Preferences](#) | [Sign Out](#) | [Help](#)



LexisNexis®

[About LexisNexis](#) | [Terms & Conditions](#) | [Contact Us](#)

Copyright © 2010 LexisNexis, a division of Reed Elsevier Inc. All rights reserved.

Command Searching > Patent Cases from Federal Courts and Administrative Materials

Search

Select Search Type and Enter Search Terms

Terms & Connectors	6411941 or 6,411,941
Natural Language	
Easy Search™	

Suggest terms for my search

Check spelling

Restrict by Document Segment

Select a document segment, enter search terms for the segment, then click Add.

Select a Segment Add ↑

Note: Segment availability differs between sources. Segments may not be applied consistently across sources.

Restrict by Date

No Date Restrictions From To Date formats...

Search Connectors

- and and w/p in same paragraph
- or or w/seg in same segment
- w/N within N words w/s in same sentence
- pre/N precedes by N words and not and not

> More Connectors & Commands...

How Do I...?

- > Combine sources?
- > Restrict by date?
- > Restrict by document segment?
- > Use wildcards as placeholders for one or more characters?

View Tutorials



No Documents Found

No documents were found for your search terms

"6411941 or 6,411,941"

Click "Save this search as an Alert" to schedule your search to run in the future.

- OR -

Click "Edit Search" to return to the search form and modify your search.

Suggestions:

- Check for spelling errors .
 - Remove some search terms.
 - Use more common search terms, such as those listed in "Suggested Words and Concepts"
 - Use a less restrictive date range.
-

Save this Search as an Alert

Edit Search



LexisNexis®

[About LexisNexis](#) | [Terms & Conditions](#) | [Contact Us](#)

Copyright © 2010 LexisNexis, a division of Reed Elsevier Inc. All rights reserved.

Command Searching > Patent, Trademark & Copyright Periodicals, Combined

Search

Select Search Type and Enter Search Terms

Terms & Connectors	6411941 or 6,411,941
Natural Language	
Easy Search™	

[Suggest terms for my search](#)

[Check spelling](#)

Restrict by Document Segment

Select a document segment, enter search terms for the segment, then click Add.

Select a Segment Add

Note: Segment availability differs between sources. Segments may not be applied consistently across sources.

Restrict by Date

No Date Restrictions From To Date formats...

Search Connectors

- and and w/p in same paragraph
- or or w/seg in same segment
- w/N within N words w/s in same sentence
- pre/N precedes by N words and not and not
- > [More Connectors & Commands...](#)

How Do I...?

- > [Combine sources?](#)
- > [Restrict by date?](#)
- > [Restrict by document segment?](#)
- > [Use wildcards as placeholders for one or more characters?](#)
- [View Tutorials](#)



No Documents Found

No documents were found for your search terms

"6411941 or 6,411,941"

Click "Save this search as an Alert" to schedule your search to run in the future.

- OR -

Click "Edit Search" to return to the search form and modify your search.

Suggestions:

- Check for spelling errors .
 - Remove some search terms.
 - Use more common search terms, such as those listed in "Suggested Words and Concepts"
 - Use a less restrictive date range.
-

Save this Search as an Alert

Edit Search



LexisNexis®

[About LexisNexis](#) | [Terms & Conditions](#) | [Contact Us](#)

Copyright © 2010 LexisNexis, a division of Reed Elsevier Inc. All rights reserved.

Command Searching > News, All (English, Full Text)

Search

Select Search Type and Enter Search Terms

Terms & Connectors	6411941 or 6,411,941
Natural Language	
Easy Search™	

[Suggest terms for my search](#)

[Check spelling](#)

Restrict by Document Segment

Select a document segment, enter search terms for the segment, then click Add.

Select a Segment Add

Note: Segment availability differs between sources. Segments may not be applied consistently across sources.

Restrict by Date

No Date Restrictions From To Date formats...

Search Connectors

- and and w/p in same paragraph
- or or w/seg in same segment
- w/N within N words w/s in same sentence
- pre/N precedes by N words and not and not

> [More Connectors & Commands...](#)

How Do I...?

- > [Combine sources?](#)
- > [Restrict by date?](#)
- > [Restrict by document segment?](#)
- > [Use wildcards as placeholders for one or more characters?](#)

[View Tutorials](#)

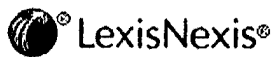

FOCUS™ Terms Search Within
Advanced...Source: [Command Searching > News, All \(English, Full Text\)](#) 
Terms: **6411941** or **6,411,941** ([Edit Search](#) | [Suggest Terms for My Search](#)) Select for FOCUS™ or Delivery

Former Employee Responds to Microsoft Spying Allegations [Microsoft] Gizmodo February 2, 2009 Monday 1:00 PM EST

Copyright 2009 Newstex LLC
All Rights Reserved
Newstex Web Blogs
Copyright 2009 Gizmodo
Gizmodo

February 2, 2009 Monday 1:00 PM EST

LENGTH: 719 words

HEADLINE: Former Employee Responds to [Microsoft](#) Spying Allegations [[Microsoft](#)]

BODY:

Feb. 2, 2009 ([Gawker Media](#) delivered by Newstex) -- Miki Mullor, former [Microsoft](#) (NASDAQ:MSFT) employee and CEO of Ancora Technologies Inc, has responded to allegations that he spied on the software giant in order to uncover evidence that the company stole his anti-piracy technology. Mullor's statement: In response to numerous requests for comments regarding a lawsuit filed against me in Washington, I would like to make the following comments. I am the inventor of U.S. Patent No. **6,411,941** relating to software anti-piracy technology, and [Ancora](#) is my company.

I applied for my patent in 1998. In 2002, the patent issued from the United States Patent and Trademark Office. In 2003, I approached [Microsoft](#) and had several discussions with a [Microsoft](#) lawyer and employees of Microsofts Anti Piracy group about my invention and the benefits [Microsoft](#) could realize by using it. [Microsoft](#) declined and said they had no interest in my invention. After 3 years of working at a start up without salary and benefits, and with a first child about to be born, it was time for me to move on and look for a job to support my family. We ceased business operations at Ancora in 2005, and [Microsoft](#) was the first company to extend me an employment offer. I accepted. In early 2006, I moved my family to Seattle from Los Angeles, bought a house and focused on my new career at [Microsoft](#). I enjoyed my job very much, and [Microsoft](#) commended my work and even promoted me. When I joined [Microsoft](#), I notified them in writing of Ancora and my patent in both my resume and in my employment agreement. In its complaint against me, [Microsoft](#) withheld the portions of these key documents that show this. At the same time I was employed at [Microsoft](#), but unknown to me, [Microsoft](#) was developing what is now known as OEM Activation. OEM Activation is installed on computers made by [HP](#) (NYSE:HPQ), Dell, Toshiba and others (called OEMs) to prevent piracy of Microsofts Windows Vista software installed on those computers. This work was being done in a different department at [Microsoft](#). OEM Activation is a blatant copy of my invention. In fact,

the same Microsoft ↘ person that I explained my invention to back in 2003 was involved in the development of OEM Activation. In June 2008, my company Ancora filed a patent infringement lawsuit against HP, Dell and Toshiba in the federal court in Los Angeles. Microsoft ↘ fired me for trying to protect my own invention "- an invention I told them about before they ever hired me. Microsoft ↘ was added to the Los Angeles case shortly after I was fired. Recently, Microsoft ↘ filed a retaliation suit against me personally in Seattle. Microsoft ↘ accuses me of lying, deceit, fraud and misappropriation. These are shameful, dishonest attacks on my character by Microsoft ↘ " the company that stole my idea in the first place. Their attacks are untrue, and they hurt me and my family. Microsoft ↘ basically admits stealing my idea in the complaint they filed because they are asking for a license to my patent. Microsoft ↘ would only need a license to my patent if they were infringing it in the first place. My patent case in Los Angeles has been going on for several months now with substantial progress. Clearly, Microsoft ↘ and the PC OEMs realized that they have no defense on the merits of the patent case. They are now looking for ways to avoid being held liable for their actions " they stole the technology, theyre infringing our patent, and the use of our invention by Microsoft ↘ and the OEMs has generated millions of dollars in profits that would have otherwise been lost to piracy. Microsofts complaint against me in Washington is a shameful and a desperate attempt to put pressure on me and my family from continuing to pursue our legal rights in the federal court in Los Angeles. We will not stop until the truth comes out. We are ready to take the stand for all other inventors and entrepreneurs and tell Microsoft ↘: øno more. As mentioned in the initial article, Microsoft ↘ does admit to using Ancora technology"claiming that it was their right to do so because Mullor did not disclose ownership of the patent when he was hired. Whether or not Muller did, in fact, submit this disclosure and/or spy on the company will be up to the courts to decide. Newstex ID: GAWK-0002-31404621

NOTES: The views expressed on blogs distributed by Newstex and its re-distributors ("Blogs on Demand®") are solely the author's and not necessarily the views of Newstex or its re-distributors. Posts from such authors are provided "AS IS", with no warranties, and confer no rights. The material and information provided in Blogs on Demand® are for general information only and should not, in any respect, be relied on as professional advice. No content on such Blogs on Demand® is "read and approved" before it is posted. Accordingly, neither Newstex nor its re-distributors make any claims, promises or guarantees about the accuracy, completeness, or adequacy of the information contained therein or linked to from such blogs, nor take responsibility for any aspect of such blog content. All content on Blogs on Demand® shall be construed as author-based content and commentary. Accordingly, no warranties or other guarantees will be offered as to the quality of the opinions, commentary or anything else offered on such Blogs on Demand®. Reader's comments reflect their individual opinion and their publication within Blogs on Demand® shall not infer or connote an endorsement by Newstex or its re-distributors of such reader's comments or views. Newstex and its re-distributors expressly reserve the right to delete posts and comments at its and their sole discretion.

LOAD-DATE: February 2, 2009

Source: [Command Searching > News, All \(English, Full Text\)](#) 

Terms: **6411941** or **6,411,941** ([Edit Search](#) | [Suggest Terms for My Search](#))

View: Full

Date/Time: Friday, February 12, 2010 - 3:17 PM EST

[My Lexis™](#) | [Search](#) | [Research Tasks](#) | [Get a Document](#) | [Shepard's®](#) | [Alerts](#) | [Total Litigator](#) | [Transactional Advisor](#) | [Counsel Selector](#)



Advanced...

Source: [Command Searching](#) > [News, All \(English, Full Text\)](#) ⓘTerms: **6411941** or **6,411,941** ([Edit Search](#) | [Suggest Terms for My Search](#)) Select for FOCUS™ or Delivery

*MICROSOFT SUES CEO OF ANCORA FOR SPYING\ DECEPTION CHARGED IN PATENT DISPUTE
THE SEATTLE POST-INTELLIGENCER January 30, 2009 Friday*

Copyright 2009 Seattle Post-Intelligencer
THE SEATTLE POST-INTELLIGENCER

January 30, 2009 Friday

SECTION: NEWS; Pg. A1

LENGTH: 421 words

HEADLINE: MICROSOFT ↘SUES CEO OF ANCORA FOR SPYING\ DECEPTION CHARGED IN PATENT DISPUTE

BYLINE: P-I STAFF AND NEWS SERVICES

BODY:

Microsoft Corp. ↘is suing a former employee, claiming that he applied for a job at the company under false pretenses and then used his role at Microsoft ↘to gain access to confidential data related to patent litigation he is now waging.

Miki Mullor was hired by Microsoft ↘in November 2005, after stating in his job application he was a former employee at Ancora Technologies, a Sammamish software development company that he said had gone out of business.

But, according to Microsoft, ↘Ancora had not gone out of business and Mullor was still chief executive.

While at Microsoft, ↘Mullor downloaded confidential documents to his company-issued laptop, according to the complaint, which was filed Jan. 22 in King County Superior Court.

Those documents, Microsoft ↘said, were related to the subject matter of a patent complaint Ancora later filed in June 2008 against Dell Inc., ↘Hewlett-Packard Co. ↘and Toshiba America Information Systems Inc., stating that their use of certain Microsoft ↘technology violated an Ancora patent. Microsoft ↘is now also a party in that case.

"The documents downloaded by Mullor relate directly to the subject matter of Ancora's Patent Action," Microsoft ↘said in the complaint. "These documents had no bearing on Mullor's work at Microsoft ↘at the time."

Microsoft fired Mullor in September 2008.

On Ancora's Web site, Mullor is listed as chairman and founder. His biography notes that he previously worked at Microsoft.

The Web site also highlights the patent litigation:

"To secure each copy of (Windows), without burdening the honest user, (PC makers) use a technology known as System Locked Pre-Installation (SLP) to protect Windows against piracy.

"SLP is Ancora's technology and is covered by our pioneer patent, US Patent **6,411,941**.

"This lawsuit is about protecting our patent rights from being infringed by HP, Dell and Toshiba. This is not David vs. Goliath. This is David vs. three Goliaths."

In an interview, Mark Cantor, an attorney for Mullor in that case, described the Microsoft complaint as "simply a retaliatory lawsuit by Microsoft to get the patent case transferred to Seattle."

The patent case is scheduled for trial in a Los Angeles federal court on Jan. 26, 2010.

Microsoft is seeking a court order barring Mullor from any involvement in the patent claim, including assisting Ancora with prosecuting the suit or providing trade-secret information he improperly acquired.

Mullor, reached at his home in Sammamish, referred all calls to Cantor, who said a lawyer hasn't been retained in the Seattle case.

LOAD-DATE: January 31, 2009

Source: [Command Searching](#) > **News, All (English, Full Text)** 

Terms: **6411941 or 6,411,941** ([Edit Search](#) | [Suggest Terms for My Search](#))

View: Full

Date/Time: Friday, February 12, 2010 - 3:17 PM EST

[My Lexis™](#) | [Search](#) | [Research Tasks](#) | [Get a Document](#) | [Shepard's®](#) | [Alerts](#) | [Total Litigator](#) | [Transactional Advisor](#) | [Counsel Selector](#)
[History](#) | [Delivery Manager](#) | [Switch Client](#) | [Preferences](#) | [Sign Out](#) | [Help](#)



LexisNexis®

[About LexisNexis](#) | [Terms & Conditions](#) | [Contact Us](#)

Copyright © 2010 LexisNexis, a division of Reed Elsevier Inc. All rights reserved.



UNITED STATES PATENT AND TRADEMARK OFFICE

UNITED STATES DEPARTMENT OF COMMERCE
United States Patent and Trademark Office
Address: COMMISSIONER FOR PATENTS
P.O. Box 1450
Alexandria, Virginia 22313-1450
www.uspto.gov

APPLICATION NO.	FILING DATE	FIRST NAMED INVENTOR	ATTORNEY DOCKET NO.	CONFIRMATION NO.
90/010,560	05/29/2009	6411941	ANCC0104R	1017

22045 7590 03/09/2010

BROOKS KUSHMAN P.C.
1000 TOWN CENTER
TWENTY-SECOND FLOOR
SOUTHFIELD, MI 48075

EXAMINER

ART UNIT PAPER NUMBER

DATE MAILED: 03/09/2010

Please find below and/or attached an Office communication concerning this application or proceeding.



DO NOT USE IN PALM PRINTER

(THIRD PARTY REQUESTER'S CORRESPONDENCE ADDRESS)

PERKINS COIE LLP/MSFT
P.O. BOX 1247
SEATTLE, WA 98111-1247

EX PARTE REEXAMINATION COMMUNICATION TRANSMITTAL FORM

REEXAMINATION CONTROL NO. 90/010,560.

PATENT NO. 6411941.

ART UNIT 3992.

Enclosed is a copy of the latest communication from the United States Patent and Trademark Office in the above identified *ex parte* reexamination proceeding (37 CFR 1.550(f)).

Where this copy is supplied after the reply by requester, 37 CFR 1.535, or the time for filing a reply has passed, no submission on behalf of the *ex parte* reexamination requester will be acknowledged or considered (37 CFR 1.550(g)).

**Notice of Intent to Issue
Ex Parte Reexamination Certificate**

Control No. 90/010,560	Patent Under Reexamination 6411941	
Examiner MATTHEW HENEGHAN	Art Unit 3992	

-- The MAILING DATE of this communication appears on the cover sheet with the correspondence address --

1. Prosecution on the merits is (or remains) closed in this *ex parte* reexamination proceeding. This proceeding is subject to reopening at the initiative of the Office or upon petition. Cf. 37 CFR 1.313(a). A Certificate will be issued in view of
 - (a) Patent owner's communication(s) filed: _____.
 - (b) Patent owner's late response filed: _____.
 - (c) Patent owner's failure to file an appropriate response to the Office action mailed: _____.
 - (d) Patent owner's failure to timely file an Appeal Brief (37 CFR 41.31).
 - (e) Other: See Continuation Sheet.

Status of *Ex Parte* Reexamination:

 - (f) Change in the Specification: Yes No
 - (g) Change in the Drawing(s): Yes No
 - (h) Status of the Claim(s):
 - (1) Patent claim(s) confirmed: 1-19.
 - (2) Patent claim(s) amended (including dependent on amended claim(s)): _____
 - (3) Patent claim(s) cancelled: _____.
 - (4) Newly presented claim(s) patentable: _____.
 - (5) Newly presented cancelled claims: _____.
2. Note the attached statement of reasons for patentability and/or confirmation. Any comments considered necessary by patent owner regarding reasons for patentability and/or confirmation must be submitted promptly to avoid processing delays. Such submission(s) should be labeled: "Comments On Statement of Reasons for Patentability and/or Confirmation."
3. Note attached NOTICE OF REFERENCES CITED (PTO-892).
4. Note attached LIST OF REFERENCES CITED (PTO/SB/08).
5. The drawing correction request filed on _____ is: approved disapproved.
6. Acknowledgment is made of the priority claim under 35 U.S.C. § 119(a)-(d) or (f).
 - a) All b) Some* c) None of the certified copies have
 - been received.
 - not been received.
 - been filed in Application No. 09/164,777.
 - been filed in reexamination Control No. _____.
 - been received by the International Bureau in PCT Application No. _____.

* Certified copies not received: _____.
7. Note attached Examiner's Amendment.
8. Note attached Interview Summary (PTO-474).
9. Other: _____.

cc: Requester (if third party requester)
U.S. Patent and Trademark Office
PTOL-469 (Rev.08-06)

Notice of Intent to Issue Ex Parte Reexamination Certificate

Part of Paper No 20100222

Continuation of 1(e) Other: The Patent Owner did not file a statement under 37 CFR 1.530 in response to the Order Granting Ex Parte Reexamination mailed 3 August 2009.

DETAILED ACTION

Reexamination

An Ex Parte Reexamination has been granted for claims 1-19 of U.S. Patent No. 6,411,941 (hereinafter "the '941 patent"). See Order, mailed 3 August 2009.

The patent owner is reminded of the continuing responsibility under 37 CFR 1.565(a) to apprise the Office of any litigation activity, or other prior or concurrent proceeding, involving Patent No. 6,411,941 throughout the course of this reexamination proceeding. The third party requester is also reminded of the ability to similarly apprise the Office of any such activity or proceeding throughout the course of this reexamination proceeding. See MPEP §§ 2207, 2282 and 2286.

Claims 1-19 have been examined.

References Submitted by Requester

The following reference has been cited as establishing a substantial new question of patentability. See Order, mailed 3 August 2009.

U.S. Patent No. 5,734,819 to Lewis (hereinafter Lewis)

Allowable Subject Matter

Claims 1-19 are confirmed.

The following is a statement of reasons for the indication of allowable subject matter:

Claim 1 recites: A method of restricting software operation within a license for use with a computer including an erasable, non-volatile memory area of a BIOS of the computer, and a volatile memory area; the method comprising the steps of:

selecting a program residing in the volatile memory,

using an agent to set up a verification structure in the erasable, non-volatile memory of the BIOS, the verification structure accommodating data that includes at least one license record,

verifying the program using at least the verification structure from the erasable non-volatile memory of the BIOS, and

acting on the program according to the verification.

Claim 18 recites: A method for accessing an application software program using a pseudo-unique key stored in a first non-erasable non-volatile memory area of a computer, the first non-volatile memory area being unable to be programmatically changed, the method, comprising:

Art Unit: 3992

loading the application software program residing in a non-volatile memory area of the computer;

using an agent to perform the following steps:

extracting license information from software program;

encrypting license information using the pseudo-unique key stored in the first non-volatile memory area;

storing the encrypting license information in a second erasable, writable, non-volatile memory area of the BIOS of the computer;

subsequently verifying the application software program based on the encrypted license information stored in the second erasable, writable, non-volatile memory area of the BIOS; and

acting on the application software program based on the verification.

Lewis discloses an invention that stores license information in non-volatile memory (which is the BIOS, since it is being setup and used by the system program) related to a system device, such as a DASD device, tape reader or diskette reader, or a cache controller, for which a program having instructions to control that device (a device driver) is instantiated in volatile memory (see Lewis, column 4, lines 25-31). Although the program is clearly associated with the device, the verification structure that is set up in non-volatile memory by Lewis is derived from a combination of non-functional descriptive material and information on the device itself, rather from the substance of the device driver, and is only being used to verify the device itself (or the information for

Art Unit: 3992

the device written to non-volatile memory) and not the program that drives the device.

Lewis' invention is not being used to verify the program (as per claim 1) or for verifying the application software program (as per claim 18), but rather just the device that the program is being used to access (see Lewis, column 5, lines 27-49). Lewis therefore does not anticipate or render obvious claims 1 or 18 and no art has been supplied that overcomes these deficiencies in Lewis.

Claims 2-17 and 19 are confirmed based upon their dependence upon allowable claims.

Art Unit: 3992

Conclusion

All correspondence relating to this *ex parte* reexamination proceeding should be directed:

By Mail to: Mail Stop *Ex Parte* Reexam
Central Reexamination Unit
Commissioner for Patents
United States Patent & Trademark Office
P.O. Box 1450
Alexandria, VA 22313-1450

By FAX to: (571) 273-9900
Central Reexamination Unit

By hand: Customer Service Window
Randolph Building
401 Dulany Street
Alexandria, VA 22314

Registered users of EFS-Web may alternatively submit such correspondence via the electronic filing system EFS-Web, at <https://portal.uspto.gov/authenticate/authenticateuserlocalepf.html>. EFS-Web offers the benefit of quick submission to the particular area of the Office that needs to act on the correspondence. Also, EFS-Web submissions are "soft scanned" (i.e., electronically uploaded) directly into the official file for the reexamination proceeding, which offers parties the opportunity to review the content of their submissions after the "soft scanning" process is complete.

Any inquiry concerning this communication should be directed to Examiner Matthew Heneghan at telephone number (571)272-3834.

/Matthew Heneghan/

Primary Examiner, USPTO AU 3992

Conferees:

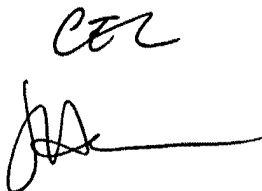

**JESSICA HARRISON
SUPERVISORY PATENT EXAMINER**

Issue Classification 	Application/Control No. 90010560	Applicant(s)/Patent Under Reexamination 6411941
	Examiner	Art Unit 3999

ORIGINAL					INTERNATIONAL CLASSIFICATION														
CLASS		SUBCLASS			CLAIMED					NON-CLAIMED									
705		59			G	O	6	F	21/22 (2006.01.01)										
CROSS REFERENCE(S)																			
CLASS	SUBCLASS (ONE SUBCLASS PER BLOCK)																		
705	50	51	53	57															

<input checked="" type="checkbox"/> Claims renumbered in the same order as presented by applicant <input type="checkbox"/> CPA <input type="checkbox"/> T.D. <input type="checkbox"/> R.1.47															
Final	Original	Final	Original	Final	Original	Final	Original	Final	Original	Final	Original	Final	Original	Final	Original

(Assistant Examiner) _____ (Date) _____ /MATTHEW HENEGHAN/ USPTO AU 3992 (Primary Examiner) _____ (Date) _____		Total Claims Allowed: 19	
		O.G. Print Claim(s)	O.G. Print Figure
		1	1

Reexamination 	Application/Control No. 90/010,560	Applicant(s)/Patent Under Reexamination 6411941
	Certificate Date	Certificate Number C1

Requester Correspondence Address: <input type="checkbox"/> Patent Owner <input checked="" type="checkbox"/> Third Party
PERKINS COIE LLP/MSFT P.O. BOX 1247 SEATTLE, WA 98111-1247

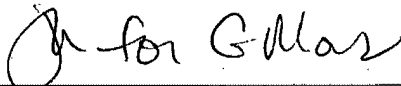
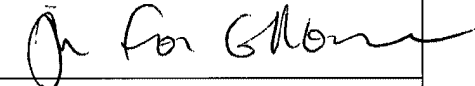
LITIGATION REVIEW <input checked="" type="checkbox"/>	/MH/ <small>(examiner initials)</small>	2/22/10 <small>(date)</small>
Case Name	Director Initials	
U.S. District-Washington Western, 2:09cv270, Ancora Technologies Inc v. Toshiba America Information Systems Inc et A (CLOSED)		
U.S District -California Central, 8:08cv626, Ancora Technologies Inc v. Toshiba America Infomration Systems Inc et A (CLOSED)		

COPENDING OFFICE PROCEEDINGS	
TYPE OF PROCEEDING	NUMBER
1. None.	
2.	
3.	
4.	

Search Notes 	Application/Control No. 90010560	Applicant(s)/Patent Under Reexamination 6411941
	Examiner .Matthew Heneghan	Art Unit 3992

SEARCHED			
Class	Subclass	Date	Examiner

SEARCH NOTES		
Search Notes	Date	Examiner
Litigation Search	6/8/09	MH
Review of Prosecution History	7/22/09	MH
Updated Litigation Search	2/12/10	MH
Review for NIRC	2/24/10	MH

INTERFERENCE SEARCH			
Class	Subclass	Date	Examiner

--	--



UNITED STATES PATENT AND TRADEMARK OFFICE

UNITED STATES DEPARTMENT OF COMMERCE
 United States Patent and Trademark Office
 Address: COMMISSIONER FOR PATENTS
 P.O. Box 1450
 Alexandria, Virginia 22313-1450
 www.uspto.gov



Bib Data Sheet

CONFIRMATION NO. 1017

SERIAL NUMBER 90/010,560	FILING OR 371(c) DATE 05/29/2009 RULE	CLASS 705	GROUP ART UNIT 3992	ATTORNEY DOCKET NO. 418263007US
------------------------------------	-----------------------------------------------------------	---------------------	-------------------------------	-------------------------------------------

APPLICANTS
 6411941, Residence Not Provided;
 BEEBLE, INC.(OWNER), NEWPORT BEACH, CA;
 CHUN M. NG(3RD.PTY.REQ.), SEATTLE, WA;
 PERKINS COIE LLP/ MSFT, SEATTLE, WA

**** CONTINUING DATA *******
 This application is a REX of 09/164,777 10/01/1998 PAT 6,411,941 ✓

**** FOREIGN APPLICATIONS *******

Foreign Priority claimed <input checked="" type="checkbox"/> yes <input type="checkbox"/> no	STATE OR COUNTRY	SHEETS DRAWING	TOTAL CLAIMS 19	INDEPENDENT CLAIMS 2
35 USC 119 (a-d) conditions met <input checked="" type="checkbox"/> yes <input type="checkbox"/> no <input type="checkbox"/> Met after				
Verified and Acknowledged	Allowance 2/26/10	Examiner's Signature	Initials	

ADDRESS
 22045

TITLE
 METHOD OF RESTRICTING SOFTWARE OPERATION WITHIN A LICENSE LIMITATION

FILING FEE RECEIVED 2520	FEES: Authority has been given in Paper No. _____ to charge/credit DEPOSIT ACCOUNT No. _____ for following:	<input type="checkbox"/> All Fees <input type="checkbox"/> 1.16 Fees (Filing) <input type="checkbox"/> 1.17 Fees (Processing Ext. of time) <input type="checkbox"/> 1.18 Fees (Issue) <input type="checkbox"/> Other _____ <input type="checkbox"/> Credit
------------------------------------	-------------------------------------------------------------------------------------------------------------------	---------------------------------------------------------------------------------------------------------------------------------------------------------------------------------------------------------------------------------------------------------------------------------



US006411941C1

(12) **EX PARTE REEXAMINATION CERTIFICATE (7545th)**
United States Patent

Mullor et al.

(10) **Number:** **US 6,411,941 C1**

(45) **Certificate Issued:** **Jun. 1, 2010**

(54) **METHOD OF RESTRICTING SOFTWARE OPERATION WITHIN A LICENSE LIMITATION**

(75) Inventors: **Miki Mullor**, Ramat Hasharon (IL);
Julian Valiko, Ramat Hasharon (IL)

(73) Assignee: **Ancora Technologies Inc.**, Irvine, CA (US)

Reexamination Request:

No. 90/010,560, May 29, 2009

Reexamination Certificate for:

Patent No.: **6,411,941**
Issued: **Jun. 25, 2002**
Appl. No.: **09/164,777**
Filed: **Oct. 1, 1998**

(30) **Foreign Application Priority Data**

May 21, 1998 (IL) 124571

(51) **Int. Cl.**
G06F 21/22 (2006.01)

(52) **U.S. Cl.** **705/59; 705/50; 705/51;**
705/53; 705/57

(58) **Field of Classification Search** 705/59
See application file for complete search history.

(56) **References Cited**

U.S. PATENT DOCUMENTS

5,734,819 A * 3/1998 Lewis 726/29
6,153,835 A * 11/2000 Schwartz et al. 177/25.13

OTHER PUBLICATIONS

Microsoft Computer Dictionary, 5th Edition, 2002, p. 60.*

* cited by examiner

Primary Examiner—Matthew Heneghan

(57) **ABSTRACT**

A method of restricting software operation within a license limitation that is applicable for a computer having a first non-volatile memory area, a second non-volatile memory area, and a volatile memory area. The method includes the steps of selecting a program residing in the volatile memory, setting up a verification structure in the non-volatile memories, verifying the program using the structure, and acting on the program according to the verification.

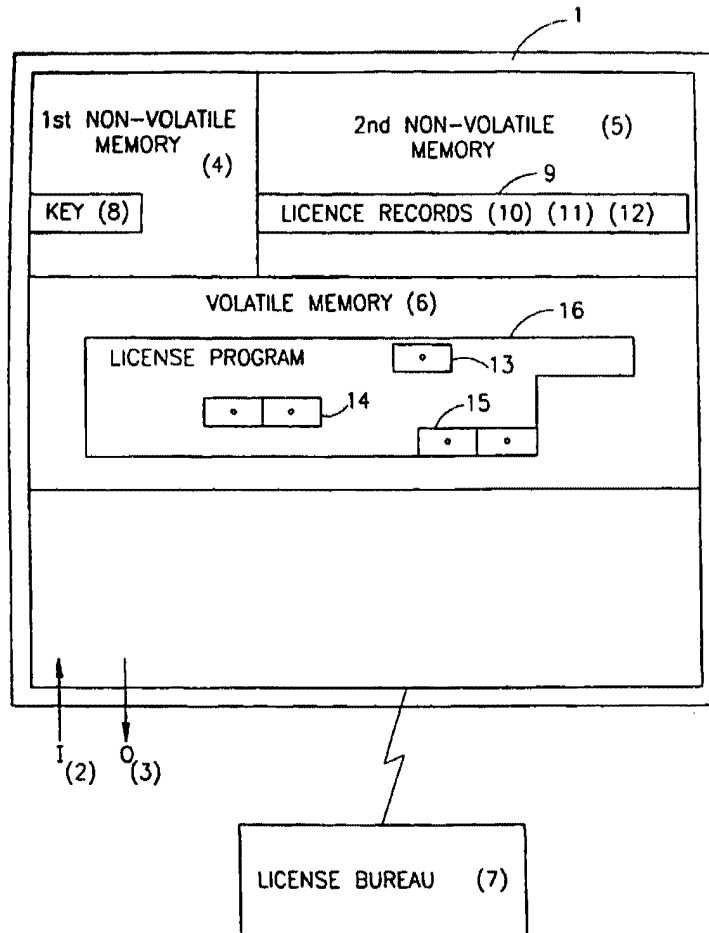

1
EX PARTE
REEXAMINATION CERTIFICATE
ISSUED UNDER 35 U.S.C. 307

NO AMENDMENTS HAVE BEEN MADE TO
THE PATENT

2
AS A RESULT OF REEXAMINATION, IT HAS BEEN
DETERMINED THAT:

5 The patentability of claims 1-19 is confirmed.

* * * * *