

**United States Patent** [19]

[11] **Patent Number:** **5,648,031**

**Sturtevant et al.**

[45] **Date of Patent:** **Jul. 15, 1997**

- [54] **METHOD OF FORMING ANTISLIP SURFACES ON THERMOFORMED PRODUCTS**
- [75] Inventors: **Thomas M. Sturtevant**, South China; **Edward E. Cullivan**, Palermo, both of Me.
- [73] Assignee: **Custom Plastics Molding, Inc.**, Benton, Me.

4,693,507	9/1987	Dresen et al. .	
4,721,641	1/1988	Bailey .....	428/88
4,745,139	5/1988	Haas et al. .	
4,760,103	7/1988	Kraft et al. .	
5,053,253	10/1991	Haenggi et al. .	
5,094,902	3/1992	Haenggi et al. .	
5,110,657	5/1992	Ainslie .	
5,194,194	3/1993	Kato et al. ....	264/510
5,263,761	11/1993	Hathaway et al. ....	296/39.2

**FOREIGN PATENT DOCUMENTS**

850791	10/1960	United Kingdom .....	264/134
--------	---------	----------------------	---------

**OTHER PUBLICATIONS**

Printing inks, Materials Handbook, 12th ed., Brady et al. ed. pp. 406-407 1986.

Hans Deamer, Printing, Modern Plastics Encyclopedia 1988, pp. 356-357 Oct. 1987.

*Primary Examiner*—Catherine Timm  
*Attorney, Agent, or Firm*—W. G. Fasse; W. F. Fasse

- [21] Appl. No.: **282,219**
- [22] Filed: **Jul. 28, 1994**
- [51] **Int. Cl.**<sup>6</sup> ..... **B29C 51/02; B29C 51/10**
- [52] **U.S. Cl.** ..... **264/80; 264/134; 264/510; 264/512; 264/309; 264/DIG. 72; 296/39.2**
- [58] **Field of Search** ..... 264/510, 511, 264/512, 134, 309, DIG. 72, 131, 132, 80; 427/256, 261, 264, 270, 272, 276, 421, 422, 426; 296/39.2

[56] **References Cited**

**U.S. PATENT DOCUMENTS**

73,919	1/1868	Newton .	
1,411,912	4/1922	Fisher .	
1,657,687	1/1928	Schuler .	
2,120,406	6/1938	Hansen .....	264/309
2,576,290	11/1951	Fisher, Jr. ....	427/421
2,793,136	5/1957	Root .	
3,124,807	3/1964	Frenkel et al. ....	264/545
3,148,103	9/1964	Gallagher .....	264/132
3,450,563	6/1969	Krueger .	
3,573,155	3/1971	Mitchell .	
3,598,677	8/1971	Bergmeister et al. .	
3,629,051	12/1971	Mitchell .	
3,629,380	12/1971	Edwards .....	264/132
3,878,147	4/1975	Craven .	
4,109,041	8/1978	Tellman .	
4,196,259	4/1980	Augustin et al. .	
4,329,312	5/1982	Ganz .....	264/309
4,420,513	12/1983	Coke et al. .	
4,488,918	12/1984	Jofs .....	156/79
4,592,583	6/1986	Dresen et al. .	
4,614,686	9/1986	Coke et al. .	
4,692,370	9/1987	Reckziegel et al. ....	427/286

[57] **ABSTRACT**

A process for selectively forming an antislip surface on a product thermoformed from a plastic sheet is applied to truck bed liners, for example. The surface of the plastic sheet of HDPE or other thermoplastic material is cleaned and masked, to prepare a good molecular bonding surface on selected surface areas. A sprayable or liquid polymer selected to achieve desired characteristics of hardness and toughness without brittleness, such as a thermosetting elastomeric polymer, is formed into droplets, which are sprayed or otherwise applied onto the selected surface area. The droplets form a stippled pattern of primarily separate bumps across the selected surface area to be treated, occupying substantially less than 50% of the exposed area. After partial hardening of the bumps, the plastic sheet is thermoformed at thermoforming temperatures to produce the thermoformed product. Thermoforming tightly bonds the bumps or droplets to the thermoplastic sheet material, hardens the droplets forming macroscopic asperities, increases or enhances the three dimensional surface relief, and explodes some droplets with entrapped air to increase surface roughness.

**55 Claims, 4 Drawing Sheets**

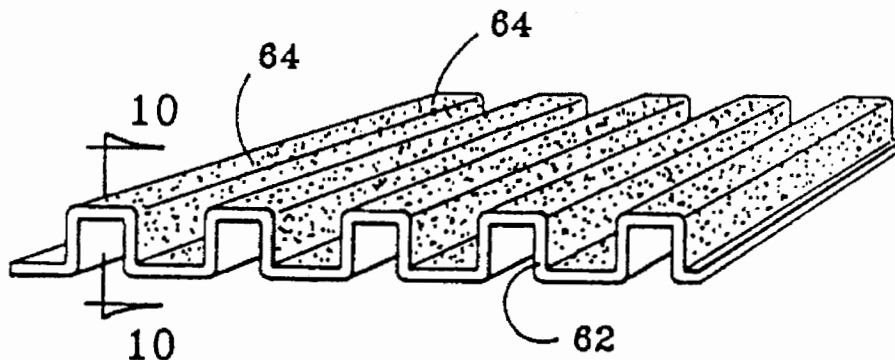

FIG. 1

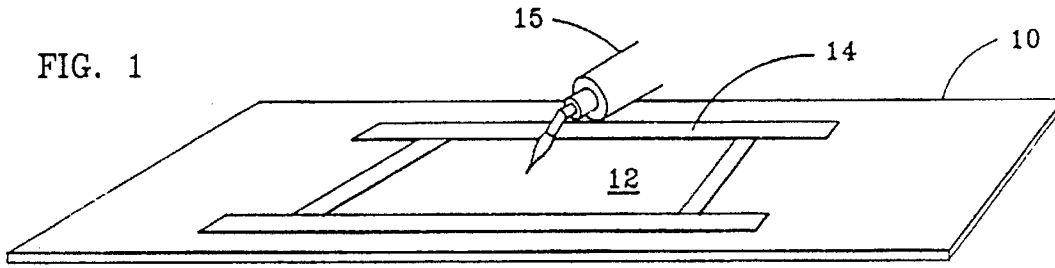

FIG. 2

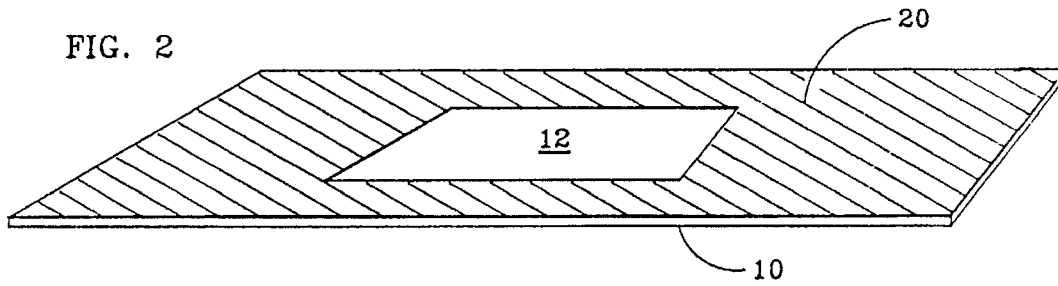
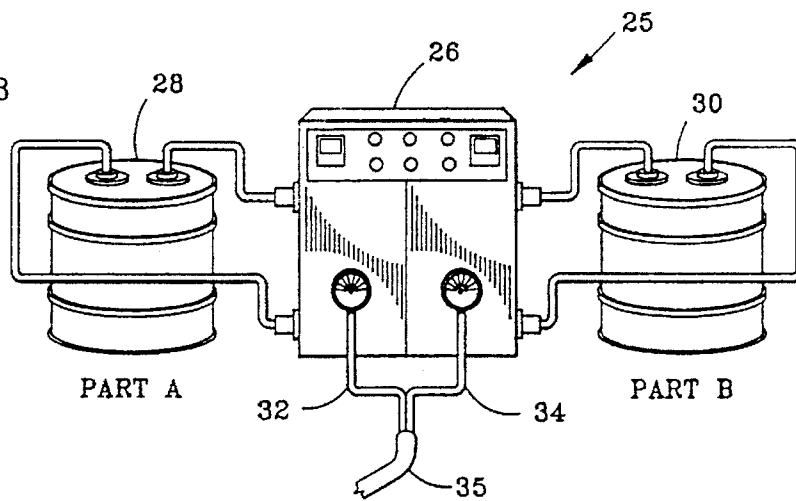
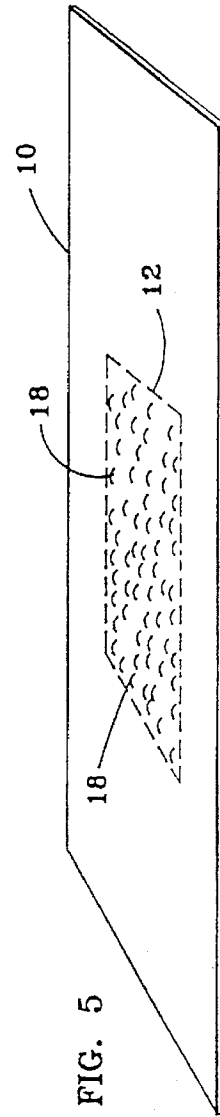
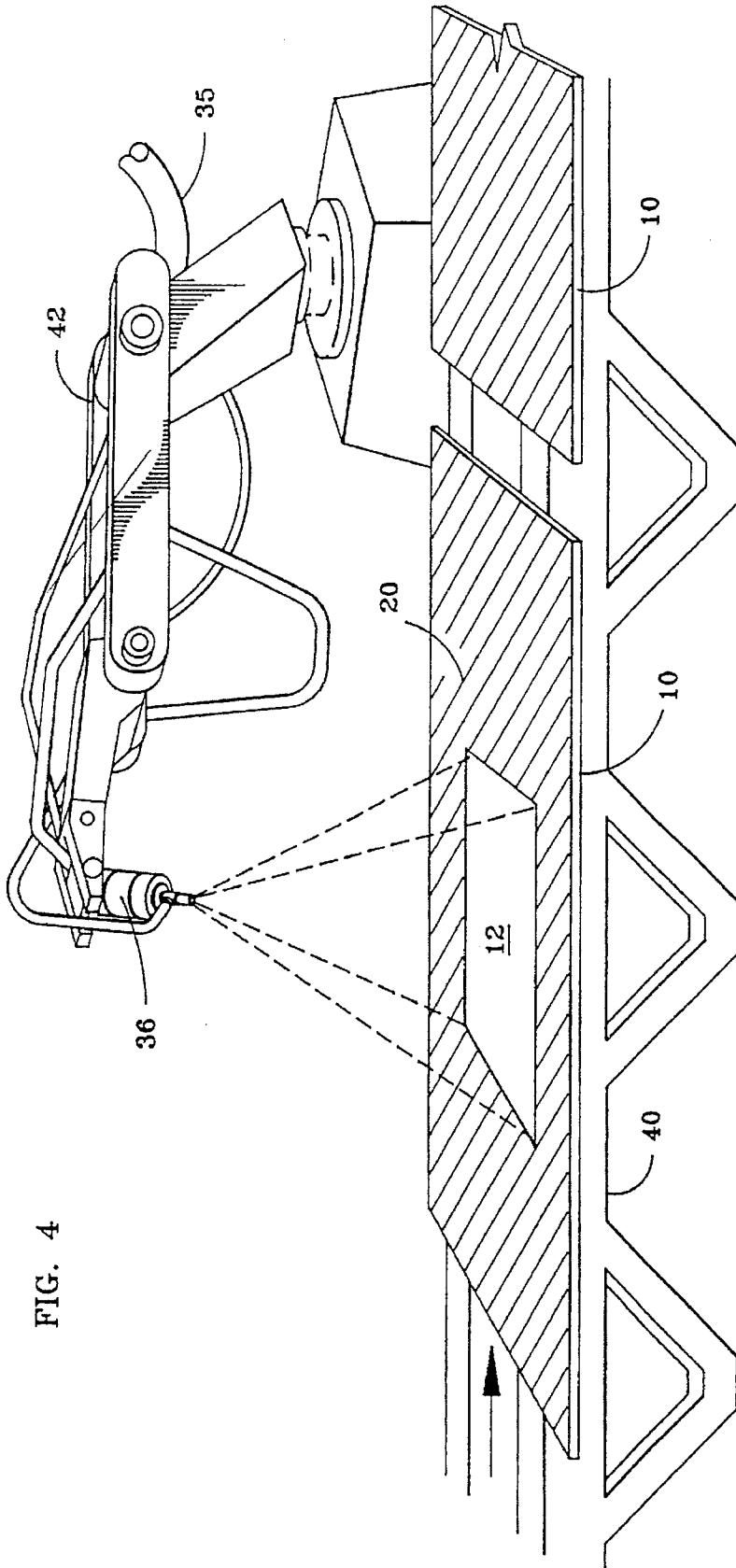

FIG. 3





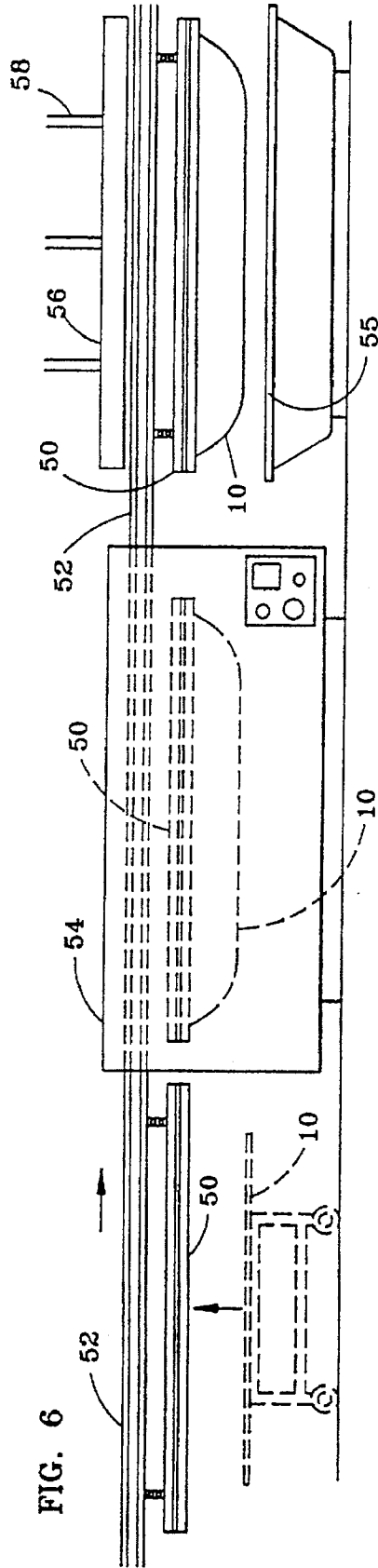

FIG. 6

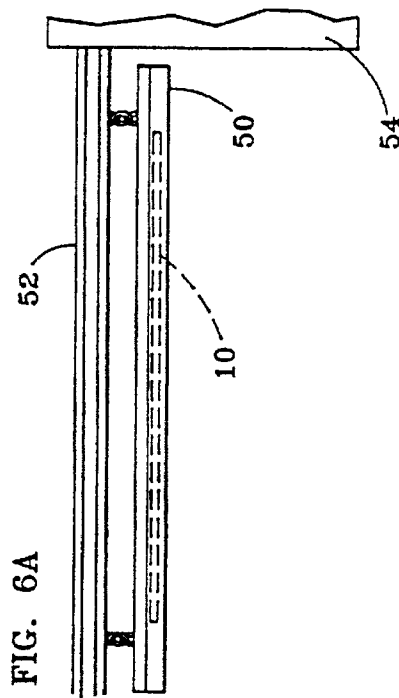

FIG. 6A

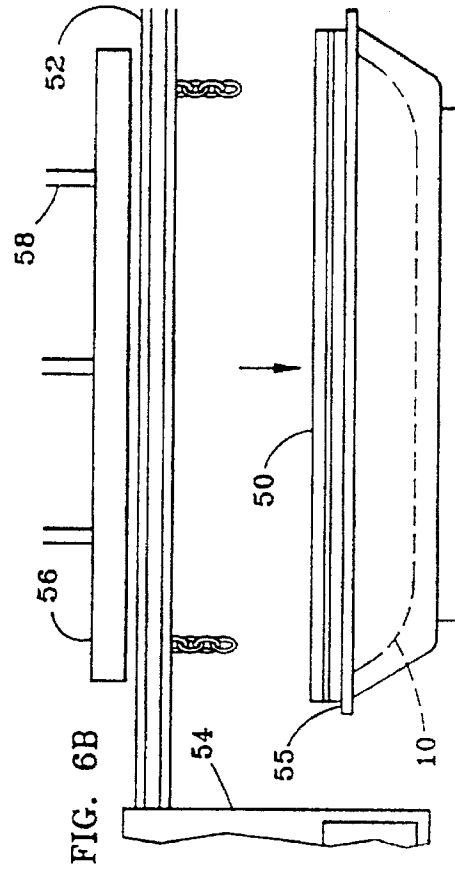

FIG. 6B

FIG. 7

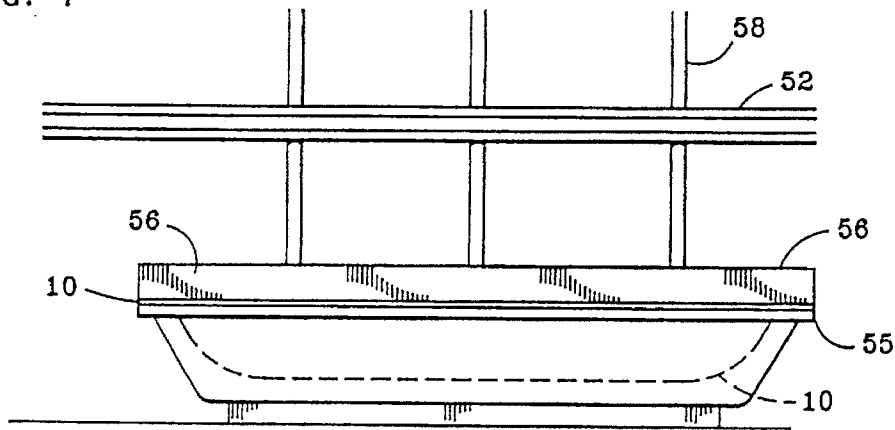

FIG. 8

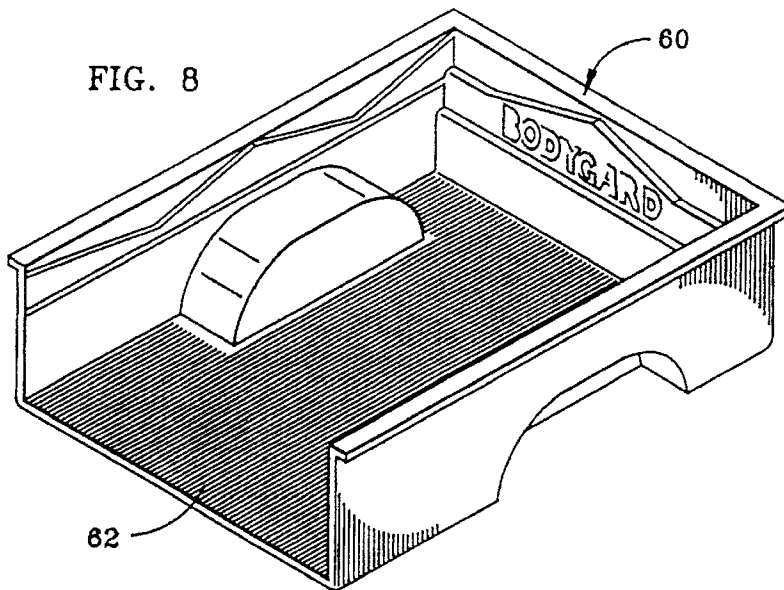

FIG. 9

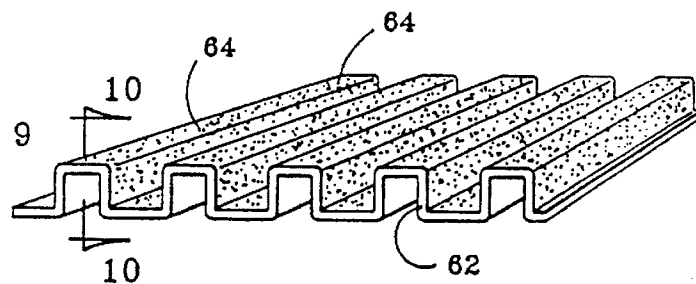
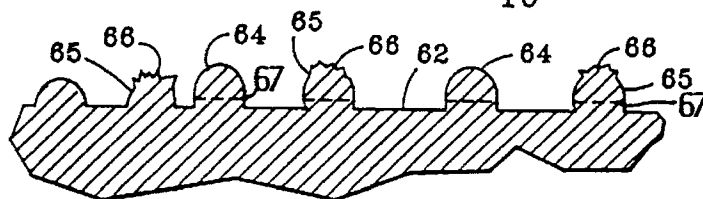

FIG. 10



# Explore Litigation Insights

Docket Alarm provides insights to develop a more informed litigation strategy and the peace of mind of knowing you're on top of things.

## Real-Time Litigation Alerts



Keep your litigation team up-to-date with **real-time alerts** and advanced team management tools built for the enterprise, all while greatly reducing PACER spend.

Our comprehensive service means we can handle Federal, State, and Administrative courts across the country.

## Advanced Docket Research



With over 230 million records, Docket Alarm's cloud-native docket research platform finds what other services can't. Coverage includes Federal, State, plus PTAB, TTAB, ITC and NLRB decisions, all in one place.

Identify arguments that have been successful in the past with full text, pinpoint searching. Link to case law cited within any court document via Fastcase.

## Analytics At Your Fingertips



Learn what happened the last time a particular judge, opposing counsel or company faced cases similar to yours.

Advanced out-of-the-box PTAB and TTAB analytics are always at your fingertips.

## API

Docket Alarm offers a powerful API (application programming interface) to developers that want to integrate case filings into their apps.

## LAW FIRMS

Build custom dashboards for your attorneys and clients with live data direct from the court.

Automate many repetitive legal tasks like conflict checks, document management, and marketing.

## FINANCIAL INSTITUTIONS

Litigation and bankruptcy checks for companies and debtors.

## E-DISCOVERY AND LEGAL VENDORS

Sync your system to PACER to automate legal marketing.