

IN THE UNITED STATES PATENT AND TRADEMARK OFFICE

Inventor: David F. MACNEIL et al.
 Title: DESIGNING AND MANUFACTURING VEHICLE FLOOR TRAYS
 Filed: Herewith

UTILITY PATENT APPLICATION TRANSMITTAL

New nonprovisional application under 37 CFR 1.53(b), Electronic Filing

- 1. Specification, including claims and abstract [Total Pages 42]
- 2. Drawing(s) [Total Pages 12]
- 3. Declaration of Inventor(s) [Total Pages 3]
 - a. Newly executed
 - b. Copy from a prior application (37 CFR 1.63(d))
 (for continuation/divisional with Box 15 completed)
 [Note Box 4 below]
 - i. DELETION OF INVENTOR(S)
 Signed statement attached deleting inventor(s) named in the prior application
 (see 37 CFR 1.63(d)(2) and 1.33(b)).
- 4. Incorporation By Reference (*useable if Box 3b is checked*). The entire disclosure of the prior application, from which a copy of the oath or declaration is supplied under Box 3b, is considered as being part of the disclosure of the accompanying application and is hereby incorporated by reference therein.
- 5. Application Data Sheet
- 6. CD-ROM or CD-R in duplicate, large table or Computer Program (Appendix)

DOCUMENTS ACCOMPANYING APPLICATION PARTS

- 8. Assignment Papers (cover sheet and documents, submitted for recordation via EPAS)
- 9. 37 CFR 3.73(b) Statement and Power of Attorney Power of Attorney
 (when there is an assignee)
- 10. English Translation Document (*if applicable*)

- 11. Information Disclosure Statement (IDS)/PTO/SB/08A,B Copy of those listed references which are not US patents or US patent application publications
- 12. Preliminary Amendment
- 13. Certified Copy of Priority Document(s) *(if foreign priority is claimed)*
- 14. Other:
- 15. If a CONTINUING APPLICATION, check the appropriate box and supply the requisite information.
 Continuation Division Continuation-in-part (CIP) ...of prior application No.: 11/463,203

Examiner: Alexander P. TAOUSAKIS Art Unit: 3726

16. Correspondence Address: **CUSTOMER NUMBER 64770**

NAME: Jefferson Perkins
 ADDRESS: MOMKUS MCCLUSKEY, LLC
 1001 Warrenville Road, Suite 500
 CITY: Lisle STATE: Illinois ZIP CODE: 60532-4306
 COUNTRY: USA TELEPHONE: (630) 434 0414 FAX: (630) 434 0444

17. SIGNATURE OF ATTORNEY FOR APPLICANT:

NAME: Jefferson Perkins
 SIGNATURE: /Jefferson Perkins/
 REGISTRATION: 31,407
 DATE: September 10, 2010

IN THE UNITED STATES PATENT AND TRADEMARK OFFICE

Inventor: David F. MACNEIL et al.
 Title: DESIGNING AND MANUFACTURING VEHICLE FLOOR TRAYS
 Filed: Herewith

UTILITY PATENT APPLICATION TRANSMITTAL

New nonprovisional application under 37 CFR 1.53(b), Electronic Filing

- 1. Specification, including claims and abstract [Total Pages]
- 2. Drawing(s) [Total Pages]
- 3. Declaration of Inventor(s) [Total Pages]
 - a. Newly executed
 - b. Copy from a prior application (37 CFR 1.63(d))
 (for continuation/divisional with Box 15 completed)
 [Note Box 4 below]
 - i. DELETION OF INVENTOR(S)
 Signed statement attached deleting inventor(s) named in the prior application
 (see 37 CFR 1.63(d)(2) and 1.33(b)).
- 4. Incorporation By Reference (useable if Box 3b is checked). The entire disclosure of the prior application, from which a copy of the oath or declaration is supplied under Box 3b, is considered as being part of the disclosure of the accompanying application and is hereby incorporated by reference therein.
- 5. Application Data Sheet
- 6. CD-ROM or CD-R in duplicate, large table or Computer Program (Appendix)

DOCUMENTS ACCOMPANYING APPLICATION PARTS

- 8. Assignment Papers (cover sheet and documents, submitted for recordation via EPAS)
- 9. 37 CFR 3.73(b) Statement and Power of Attorney Power of Attorney
 (when there is an assignee)
- 10. English Translation Document (if applicable)

- 11. Information Disclosure Statement (IDS)/PTO/SB/08A,B Copy of those listed references which are not US patents or US patent application publications
- 12. Preliminary Amendment
- 13. Certified Copy of Priority Document(s) *(if foreign priority is claimed)*
- 14. Other:
- 15. If a CONTINUING APPLICATION, check the appropriate box and supply the requisite information.
 Continuation Division Continuation-in-part (CIP) ...of prior application No.: 11/463,203

Examiner: Alexander P. TAOUSAKIS Art Unit: 3726

16. Correspondence Address: **CUSTOMER NUMBER 64770**

NAME: Jefferson Perkins
 ADDRESS: MOMKUS MCCLUSKEY, LLC
 1001 Warrenville Road, Suite 500
 CITY: Lisle STATE: Illinois ZIP CODE: 60532-4306
 COUNTRY: USA TELEPHONE: (630) 434 0414 FAX: (630) 434 0444

17. SIGNATURE OF ATTORNEY FOR APPLICANT:

NAME: Jefferson Perkins
 SIGNATURE: /Jefferson Perkins/
 REGISTRATION: 31,407
 DATE: September 10, 2010

APPLICATION FOR UNITED STATES PATENT

**INVENTOR: DAVID F. MACNEIL
 SCOTT A. VARGO**

**TITLE: DESIGNING AND MANUFACTURING VEHICLE
 FLOOR TRAYS**

MOMKUS MCCLUSKEY, LLC
1001 Warrenville Road, Suite 500
Lisle, IL 60532
Attorneys
Telephone: (630) 434-0400
Facsimile: (630) 434-0444
www.momlaw.com

DESIGNING AND MANUFACTURING VEHICLE FLOOR TRAYS

RELATED APPLICATIONS

[0001] This application is a continuation of copending United States Nonprovisional Application No. 11/463,203 filed on August 8, 2006, which is in turn a division of United States Nonprovisional Application No. 10/976,441 filed on October 29, 2004, now United States Patent No. 7,316,847. The disclosures and drawings of those applications are fully incorporated by reference herein.

BACKGROUND OF THE INVENTION

[0002] Motor vehicles are almost always operated in the out of doors and are frequently parked there. It is therefore very common for their occupants to have wet or muddy feet – if the occupants have not just finished an outdoor activity, at least they have had to walk across a possibly wet, snowy or muddy surface to access their vehicles. For decades, therefore, vehicle owners have been attempting to protect the enclosed interiors of their vehicles (cars, trucks, SUVs) from what they themselves track into them. The conventional solution to this has been to provide a vehicle floor mat which may be periodically removed by the owner and cleaned.

[0003] Human beings have a tendency to move their feet around, and foot motion is an absolute requirement in operating most vehicles. This has caused a problem, in that the occupants of a vehicle have a tendency to push around the floor mats with their feet. The floor mats end up not being centered on the area protected, or pushed up so as to occlude the gas, brake or clutch pedals, or bunched up or folded over – all undesirable conditions. One objective of floor mat manufacturers has therefore been to provide a floor mat that will stay put and which will not adversely affect vehicle operation.

[0004] The foot wells of cars, trucks and SUVs vary in size in shape from one model of vehicle to the next. Floor mat manufacturers have noticed that floor mats which at least approximately conform to the shape of the bottom surface of the foot well stay in place better and offer more protection. It is also common for such floor mats, where provided for front seat foot wells, to have portions which are meant to lie against the firewalls or front surfaces of the foot wells. Even as so extended it is not too hard to provide a floor mat of flexible material that will approximately conform to these two surfaces, as the designer only has to mark a two-dimensional periphery of the mat in providing one which will fit reasonably well.

[0005] More recently, vehicle floor trays have come onto the market. Most front-seat vehicle foot wells are actually three-dimensional concave shapes, typically with complex curved surfaces. Floor trays have sidewalls that offer enhanced protection to the surfaces surrounding the vehicle floor, as might be needed against wearers with very muddy or snowy shoes. Conventional vehicle floor trays try to fit into these three-dimensional cavities, but so far their fit to the surfaces that they are supposed to protect has been less than optimum. A conventional vehicle floor tray is typically molded of a single-ply rubber or plastic material, exhibits enough stiffness to retain a three-dimensional shape, but is also at least somewhat flexible. Fitting such a tray to the complex three-dimensional surface of a vehicle foot well has proven to be difficult, and the products currently in the marketplace have limited consumer acceptance because of their loose fit inside the foot well. There is often, and in many places, a considerable space between the exterior wall of these conventional trays and the interior surface of the foot well. This causes the wall to noticeably deform when the occupant's foot contacts it. Vehicle owners have a tendency to dislike floor trays which rattle, deform, shift and flop about. A need therefore persists for a floor tray that will have a more exact fit to the vehicle foot well for which it is

provided, that stays in place once it is installed, and that provides a more solid and certain feel to the occupants' feet.

[0006] Some vehicle floor mats that are now on the market have fluid reservoirs built into them. Particularly in cold or wet climates, dirty water has a tendency to be shed onto the floor mat, where it persists until it evaporates. If there is enough of it, it will leak off of the floor mat and stain the carpeting of the foot well that the mat was meant to protect. These reservoirs typically are recessed areas in the mats that provide the mats with an enhanced ability to retain snow-melt and the like, until the water evaporates or can be disposed of by the vehicle owner or user. One advanced design places treads in the middle of the reservoir, such that the feet of the occupant are held above any fluid that the reservoir collects. But including such a reservoir within a floor tray that otherwise has an acceptable fit to the surface of a vehicle foot well has not yet been done, since there are problems in incorporating a three-dimensional liquid-holding vessel into a product that ideally conforms, on its lower surface, to the surface of the foot well. Further, a reservoir which collects drip water from a large surface, such as a vehicle floor tray, will exhibit more problems in keeping the collected fluid from sloshing about in a moving vehicle.

[0007] Conventional vehicle floor mats and trays are molded from a single rubber or plastic material. The selection of this material is controlled by its cost, its resistance to shear forces, its tensile strength, its abrasion resistance, its ability to conform to the surface of the vehicle foot well, its sound-deadening properties and how slippery or nonslippery it is relative to the occupants' feet, with nonslipperiness (having a relatively high coefficient of friction) being advantageous. Often the designer must make tradeoffs among these different design constraints in specifying the material from which the tray or mat is to be made.

SUMMARY OF THE INVENTION

[0008] According to one aspect of the invention, there is provided a vehicle floor cover, mat or tray which is removably installable by a consumer and which is formed of at least three layers that are bonded together, preferably by coextrusion. The three layers include a central layer whose composition is distinct from a bottom layer and a top layer. Preferably, all three layers are formed of thermoplastic polymer materials. In another aspect of the invention, the top layer exhibits a kinetic coefficient of friction with respect to a sample meant to emulate a typical shoe outsole (neoprene rubber, Shore A Durometer 60) of at least about 0.82.

[0009] Preferably, a major portion of the central layer is a polyolefin. More preferably, the polyolefin is either a polypropylene or a polyethylene. Most preferably, the polyolefin is high molecular weight polyethylene (HMPE) as herein defined. In an alternative embodiment, the central layer can be a styrene-acrylonitrile copolymer (SAN) or an acrylonitrile-butadiene-styrene (ABS) polymer blend.

[0010] Preferably, a major portion of the top layer is a thermoplastic elastomer, such as one of the proprietary compositions sold under the trademarks SANTOPRENE®, GEOLAST® and VYRAM®. VYRAM® is particularly preferred. In another embodiment, a major portion of the top layer can be an ABS polymer blend. Where ABS is used in both the top and central layers, it is preferred that the amount of the polybutadiene phase in the top layer be greater than the amount of this phase in the central layer.

[0011] It is further preferred that a major portion of the bottom layer likewise be a thermoplastic elastomer, and conveniently it can be, but does not have to be, of the same composition as the major portion of the top layer.

[0012] Preferably one or more of the layers is actually a polymer blend, in which a minor portion is preselected for its coextrusion compatibility with the adjacent layer(s). Thus, a minor portion of the top and bottom layers can consist of a polyolefin, while a minor portion of the central layer can consist of a thermoplastic elastomer. In each case, it is preferred that the minor portion be no more than about one part in four by weight of each layer, or a weight ratio of 1:3. Where all three layers are preselected to be ABS blends, the amount of polybutadiene preferably is decreased in the central layer relative to the top and bottom layers.

[0013] While the preferred embodiment of the vehicle floor cover consists of three integral layers, any one of the recited layers can in fact be made up of two or more sublayers, such that the total number of sublayers in the resultant mat or tray can exceed three.

[0014] In another embodiment, the thermoplastic elastomer constituent of the top, central and/or bottom layers described above can be replaced with a natural or synthetic rubber, including styrene butadiene rubber, butadiene rubber, acrylonitrile butadiene rubber (NBR) or ethylene propylene rubber (EPDM).

[0015] According to a related aspect of the invention, a vehicle floor cover is provided that has three layers bonded together, preferably by coextrusion. Major portions of the top and bottom layer consist of thermoplastic elastomer(s). The top and bottom layers have compositions distinct from the central layer, which can be chosen for its relatively low expense. It is preferred that a major portion of the central layer be a polyolefin and that major portions of the top and bottom layers be one or more thermoplastic elastomers. The polyolefin may be selected from the group consisting of polypropylene and polyethylene, and preferably is a high molecular weight polyethylene (HMPE). The thermoplastic elastomer can, for example, be SANTOPRENE®,

GEOLAST® or VYRAM®, with VYRAM® being particularly preferred. It is also preferred that each of the layers be a polymer blend, with a minor portion of each layer being chosen for its coextrusion compatibility with adjacent layers. For example, the top and bottom layers can consist of a 3:1 weight ratio of VYRAM®/HMPE, and the central layer of a 3:1 weight ratio of HMPE/VYRAM®.

[0016] In an embodiment alternative to the one above, the top and bottom layers can consist of ABS polymer blends and the central layer can consist of SAN or an ABS in which the polybutadiene phase is present in a smaller concentration than in the top and bottom layers.

[0017] In yet another embodiment, the thermoplastic elastomer recited in this aspect of the invention may be replaced with a natural or synthetic rubber, such as styrene butadiene rubber (SBR), butadiene rubber, acrylonitrile butadiene rubber (NBR) or ethylene propylene rubber (EPDM).

[0018] In a further aspect of the invention, a vehicle floor tray or mat according to the invention is made of three layers, wherein a top layer and a bottom layer have composition(s) distinct from the central layer, and wherein at least one of the shear strength per cross-sectional area, tensile strength per cross-sectional area and stiffness per cross-sectional area is greater than any one of the layers from which the tray or mat is composed. It has been found that a triextruded vehicle mat or floor tray according to the invention exhibits a tensile strength at yield, a tensile stress at break, a tensile modulus, a shear strength and a flexural modulus (stiffness) which are superior to either a polyolefin-dominated single extrusion or a thermoplastic elastomer-dominated single extrusion. The triextrusion tray demonstrates these enhanced physical properties while at the same time affording an enhanced coefficient of friction to the feet of the occupant and improved

tactile properties. By presenting such a surface to the shoe of the driver or passenger, the footing of the driver or passenger will be more sure and comfortable.

[0019] In a further aspect of the invention, a vehicle foot well tray is provided as a part of a system that has the vehicle foot well as its other main component. The tray has a greatly enhanced conformance to the surface of the vehicle foot well for which it is provided. At least two upstanding walls of the tray, both extending from the tray floor to a top margin, conform to respective surfaces of the vehicle foot well such that at least within that one-third of the area of the outer surface of these upstanding walls of the tray which is adjacent the top margin, 90% of that top third area departs by no more than about one-eighth of an inch from the foot well surfaces to which they mate. These upstanding tray surfaces may be opposed surfaces or adjacent surfaces, and preferably are both. In a preferred embodiment, the tray departs from a door sill surface of the vehicle foot well, and/or a sill curve of the vehicle foot well, by about 0.025 inches. The upstanding sidewalls of the floor tray conform to the foot well surfaces which they cover, even where such foot well surfaces present both concave and convex surface elements.

[0020] In a still further aspect of the invention, a top margin of a vehicle floor tray is substantially coplanar on at least two upstanding sidewalls thereof. Preferably, the top margin of the tray is substantially coplanar through three or even four continuous upstanding sidewalls. This eases the design of the floor tray, increases hoop strength and assures that all upstanding surfaces of the vehicle foot well will receive adequate protection from muddy footwear. In a particularly preferred embodiment, the plane of the top margin is forwardly and upwardly tilted relative to a horizontal floor. This provides enhanced protection to the vehicle foot well

precisely in the place where muddy footwear are likely to be, near the accelerator, brake and clutch pedals or the firewall. In a preferred embodiment, the tray is at least five inches deep at its deepest part.

[0021] In a further aspect of the invention, the above mentioned tight tolerances are made possible by a novel vehicle floor tray manufacturing method. In a first step according to the invention, points on a surface of the vehicle foot well are digitally measured with a coordinate measuring machine (CMM). These points are stored in a computer memory. A foot well surface is generated which includes these points, preferably by connecting linear groups of the points together by using B-splines, and lofting between the B-splines to create areal portions of the foot well surface. Using this typically complex three-dimensional, predominately concave surface, which may have several concavely and convexly curved portions, a corresponding substantially convex outer floor tray surface is built up such that in many regions, the distance between the outer surface of the tray and the surface of the foot well is no more than about one eighth of an inch, insuring a snug fit.

[0022] In one embodiment of the invention, a reservoir is incorporated into the tray floor as a collection and evaporation area for drip water from the feet and legs of the occupant. Combination baffles/treads are provided in the reservoir to impede lateral movement of the collected fluid. Longitudinal and transverse portions of these baffles are joined together. Channels are cut into another portion of the central area of the tray to direct fluid to the reservoir, such that the bottom of the channels is beneath a general tray floor surface but above the bottom of the reservoir. In a preferred driver's side embodiment, the channels are omitted from a

portion of the floor tray upper surface to leave a blank space where the driver's heel will rest when operating the gas and brake pedals.

BRIEF DESCRIPTION OF THE DRAWINGS

[0023] Further aspects of the invention and their advantages can be discerned in the following detailed description, in which like characters denote like parts and in which:

[0024] FIGURE 1 is an isometric view of one embodiment of a vehicle floor tray according to the invention;

[0025] FIGURE 2 is a top view of the floor tray illustrated in FIGURE 1;

[0026] FIGURE 3 is an isometric and transverse sectional view of the floor tray seen in FIGURES 1 and 2, the section taken substantially along line 3 -3 of FIGURE 2;

[0027] FIGURE 4 is an isometric and longitudinal sectional view of the floor tray shown in FIGURES 1 and 2, the section taken substantially along line 4 - 4 of FIGURE 2;

[0028] FIGURE 5 is a side view of the tray illustrated in FIGURE 1, taken from the outer side;

[0029] FIGURE 6 is a highly magnified sectional view of a vehicle floor tray, showing triextruded layers;

[0030] FIGURE 7 is a schematic block diagram showing steps in a design and manufacturing process according to the invention; and

[0031] FIGURE 8 is an isometric and schematic view of a digitally acquired vehicle foot well floor surface from which the illustrated floor tray was made;

[0032] FIGURE 9 is a partly transverse sectional, partly isometric view of both the floor tray illustrated in FIGURE 2 and the vehicle foot well surface illustrated in FIGURE 8, taken substantially along line 9 – 9 of FIGURE 2 and substantially along line 9 - 9 of FIGURE 8;

[0033] FIGURE 10 is a partly transverse sectional, partly isometric view of both the floor tray illustrated in FIGURE 2 and the vehicle foot well surface illustrated in FIGURE 8, taken substantially along line 10 – 10 of FIGURE 2 and substantially along line 10 – 10 of FIGURE 8;

[0034] FIGURE 11 is a detail of a firewall region of FIGURE 10;

[0035] FIGURE 12 is a detail of a seat pedestal region of FIGURE 10;

[0036] FIGURE 13 is a partly longitudinal sectional, partly isometric view of both the floor tray illustrated in FIGURE 2 and the vehicle foot well surface illustrated in FIGURE 8, taken substantially along line 13 – 13 of FIGURE 2 and substantially along line 13 – 13 of FIGURE 8; and

[0037] FIGURE 14 is a detail of a kick plate region of FIGURE 13.

DETAILED DESCRIPTION

[0038] An isometric view of one commercial embodiment is shown in FIGURE 1. The illustrated vehicle floor tray indicated generally at 100 is preferably molded from a blank, in sheet form, of water-impervious thermoplastic polymer material having a uniform thickness, although the present invention could be fabricated from another process such as injection molding. The floor tray 100 is preferably formed of a triextruded thermoplastic material such that the properties of a central or core layer can be different than the properties of the external or

jacket layers, and such that the triextrusion is tougher and stiffer per unit thickness than any of the layers from which it is made, as will be described in more detail below.

[0039] The vehicle floor tray or cover 100 is meant to protect both the floor and at least the lower sides of a vehicle foot well, and thus takes on a much more three-dimensional shape than is typical of prior art floor mats. The floor tray 100 includes a floor or central panel 102, which in the illustrated embodiment includes a plurality of fore-to-aft or longitudinal parallel straight channels 104 that are disposed in a forward region 106 of the floor panel 102. Preferably these channels are about an eighth of an inch deep so that they will correctly channel runoff, and can be about one-quarter of an inch wide. In FIGURE 1, forward is a direction to the upper left, while rearward is the direction to the lower right, and the terms are used in conformance with the orientation of the vehicle in which the tray is designed to be placed. As used herein, “longitudinal” means for-and-aft or along the axis of vehicle travel, while “transverse” means at a ninety degree angle to such an axis, or side-to-side.

[0040] A rearward or back region 108 of the floor panel 102 is largely occupied by a reservoir 110, whose bottom is made up by a substantially planar general surface 112. General surface 112 is situated to be below a general surface 114 of the forward region 106. Preferably, the general bottom reservoir surface 112 is also below the bottommost points of the respective channels 104, as by about one-eighth of an inch, so that fluid in the channels 104 will empty into the reservoir 110.

[0041] The channels 104 are designed to channel liquid runoff from the user’s feet or footwear to the reservoir 110. In many vehicles, the portion of the vehicle floor (not shown in this Figure; see FIGURES 8 - 11) which underlies the forward region 106 slopes from front to rear, and thus

the tray 100, by simply conforming to the contour of the underlying vehicle floor portion, will channel fluid to the reservoir. For those vehicle designs in which the underlying vehicle floor is not pitched in this manner, the tray 100 can advantageously be designed to create this fluid flow, as by making the material thicker in portion 106 than in portion 108, or by giving the bottoms of channels 104 a front-to-rear slope.

[0042] The channels 104 occupy most of the forward region 106, although in this and other commercial embodiments a space 116 on the forward right hand side has been left open to receive the foot of the driver that operates the accelerator and brake pedals. In the illustrated embodiment, this space or clear area 116 is delimited by a 180 degree arc of a circle of about four inch radius (shown in dashed line). The clear area 116 is provided so that the relatively deep channels 104 do not catch the heel of the driver's shoe. In other embodiments, the clear area 116 can take other shapes or positions, so long as the heels of almost all drivers, while operating the brake and accelerator pedals of the vehicle for which the particular tray is designed, will rest within its confines.

[0043] The reservoir 110 has interspersed within it a plurality of tread surfaces or baffles 118, which have two purposes. The first purpose is to elevate the shoe or foot of the occupant above any fluid which may have collected in the reservoir 110. The second purpose is to prevent this accumulated fluid from sloshing around. To this end, most of the tread surfaces/baffles 118 have both fore-to-aft or longitudinal portions 120 and side-to-side or transverse portions 122. This prevents large fluid movement in a forward or rearward direction, as would otherwise happen during acceleration or braking of the vehicle, and also large fluid movement side-to-side, as when the vehicle is turning. Preferably, each or at least most of the fore-to-aft portions 120 are

joined to respective side-to-side portions. This further compartmentalizes and restricts the movement of collected fluid. Fluid in one portion of the reservoir 110 may make its way only slowly and through a complicated path to another distant portion of the reservoir 110, through channels 124 around the ends of the treads or baffles 118. The reservoir design thus creates a large surface area which promotes evaporation of the fluid, while at the same time restricts fluid movement prior to such evaporation.

[0044] Disposed around the central or floor panel 102 are a series of upstanding side panels, which will vary in number and configuration from one vehicle model to the next. In the illustrated embodiment these upstanding panels include a back panel 130 that is disposed adjacent the bottom of a vehicle front seat, or a vehicle pedestal for receiving same; an inner side panel 132 that closely fits a transmission tunnel or “hump” in this vehicle; a forward panel 134 that closely conforms to a vehicle firewall; and an outer side panel 136. In most embodiments, the outer side panel or kick plate panel 136 will only extend from its transition with panel 134 to a corner 138, at which point there begins a door sill curve 208 which transitions into a door sill panel 140. Unlike the other panels, the sill panel 140 is not generally upstanding but instead conforms to the sill of a vehicle door and lies in a substantially horizontal plane. In this way occupant ingress and egress is not occluded. In many embodiments, including the illustrated embodiment, the sill panel 140 is at an elevation below that of the general surface 114 of the floor forward region 106 and even below the general surface (bottom) 112 of the reservoir 110. Very large amounts of fluid (in excess of the reservoir capacity) may therefore flow right out of the vehicle without having the opportunity to damage the vehicle interior. It should be noted that in these FIGURES, the lines dividing the panels are conceptual only and do not appear in the

final part. As will be described in further detail below, the tray 100 preferably is integrally molded as a one-piece construction.

[0045] In one important aspect of the invention, the tray 100 is closely fitted to the vehicle foot well in which it is designed to be placed. Panels 130, 132, 134, 136 and 140 are all formed so as to as closely conform to the vehicle surfaces against which they are positioned, to an extent not found in prior art vehicle floor trays. In a preferred embodiment, at least throughout the top one-third of the areas of these panels that is adjacent a vehicle tray top margin 150, at least ninety percent of the points on the outer surface of the peripheral or side panels 130-136 are no more than about one-eighth of an inch from the corresponding points on the surfaces that they are formed to mate with. This close conformance occurs even where the underlying vehicular surface is complexly curved or angled. Certain portions of the vehicle foot well surface, such as kick plate transition plate 214, can have both convexly and concavely curved elements. The preferred tolerance of door sill curve 208 and sill plate 140 is even tighter, about 0.025 in.

[0046] The close conformance of the tray side panels to respective surfaces of the vehicle foot well produces a protective tray which will not be horizontally displaced under lateral forces created by the occupant's feet, or by the motion of the vehicle. Opposing pairs of the peripheral panels "nest" or "cage" the tray 100, preventing its lateral movement. Thus, outer side panel or kick plate panel 136, which closely conforms to a vehicle side wall at that position, has as its counterpart a portion 142 of the inner side panel 132. Any tendency of the tray 100 to shift leftward is stopped by panel 136; any tendency of the tray 100 to shift rightward is stopped by panel portion 142. In a similar manner, the upstanding rearward and forward panels 130 and 134 cooperate to "cage" any forward or rearward motion of the tray 100 within the vehicle foot well.

[0047] The close conformance of the outer or lower surfaces of panels 130-136, 218, 140 to their respective mating surfaces of the vehicle foot well also increases the frictional force which will oppose any lateral movement. The result of this close conformance is to provide a floor tray which will not undesirably shift position, and which will provide a steady and sure rest to the feet of the occupants.

[0048] In most commercial embodiments of the vehicle floor tray 100, the side panels 130 – 136, 140 will not be formed to abruptly extend from the bottom panel 102, but rather will be joined to the bottom or central panel 102 through transitions. These transitions may be sloped or curved and will have a varying degree of gradualness. According to the invention, the transitions between the outer and bottom surfaces of the tray 100 conform wherever possible to underlying surfaces of the vehicle foot adjacent these transitions.

[0049] In FIGURE 2, for example, there is seen a large transition or subpanel 200 which extends from forward portion 106. A further subpanel 202 joins transitional subpanel 202 to the forward sidewall 134. Inner or transmission tunnel sidewall 132 is joined to the pan 102 through a curved transitional fillet 204. The rear upstanding panel 130 is joined to the rear portion of bottom panel 102 through a small transition 206. A transition or sill curve 208 between the outer sidewall 136 and the sill panel 140 takes the form of a gradual curved surface.

[0050] The present invention also employs (typically) curved transitions between adjacent side panels. For example, a curved transition 210 joins the back panel 130 to the inner side panel 132. A curved transition 212 joins the transmission tunnel or inner side panel 132 to the front or firewall panel 134. A transition 214, which in this embodiment takes the shape of an S-curve and conforms to a portion of vehicle wheel well, joins the front panel 134 to the outer side panel

136. The close conformance (preferably to a tolerance of about 1/8 in.) wherever possible to the transitions of the vehicle foot well surface by the outer surface of the tray 100 enhances a close fit.

[0051] In the illustrated embodiment, the tray according to the invention has been made by placing a sheet of substantially uniformly thick triextruded thermoplastic material into a mold and heating the mold. When this process is used, discrete layers having different characteristics can persist into the final product, as will be described in more detail below. On the other hand, as using this manufacturing process it is difficult to provide the channels and reservoir structure according to one aspect of the invention while closely conforming the bottom surface 300 (FIGURES 3 and 4) to a mating surface of the vehicle foot well. In this central area, and according to the preferred manufacturing process, a departure away from 1/8 in. tolerance must be made in order to obtain the above-described benefits of fluid flow and retention. But because the side panels 130 – 136, 140 and their associated transitions continue to closely conform to most of the remaining vehicle foot well surfaces, the tray 100 continues to be locked in one place.

[0052] FIGURES 10 – 14 superimpose a floor tray 100 on a surface 802 of a vehicle foot well for which the tray is designed according to the invention. In the part-isometric, part-longitudinal sectional view seen in FIGURE 10, It can be seen that on the section taken there is a quite tight conformance of the lower surface 300 of the tray 100 to the modeled surface 802 of the vehicle foot well. As best seen in FIGURE 11, the outer surface of the firewall sidewall 134 stays within one-eighth of an inch of the firewall surface 826 for at least three-quarters of the length of surface 826 as measured from the top margin 150 of the tray. In areas 1000, 1002 and 1004

(FIGURE 10), the modeled surface 802 of the vehicle foot well is actually above or to the interior to the tray 100. This negative interference is tolerable and in some instances is even desirable because the surface 802 is that of a vehicle carpet, which can or even should be depressed upon the installation of the tray 100 into the vehicle foot well. Such a tight fit is particularly desirable, for example, in the region of the tray around the accelerator pedal.

[0053] FIGURE 12 is a detail of FIGURE 10 in the area of the seat pedestal and a portion of the reservoir 110. Once again, there is a very tight conformance of the outer surface of the back panel 130 to the modeled seat pedestal surface 828 throughout most of its length on this section, well within 1/8 inch.

[0054] FIGURE 13 shows a side-to-side or transverse section taken in a relatively forward location, so as to cut through the kick plate tray and foot well surfaces 136, 830 on one side and the tray and foot well transmission tunnel surfaces 132, 810 on the other. As can be seen, tolerance to within 1/8 of an inch is maintained at least for the upper one-third of the surface area of these mating surfaces. Areas 1000, 1002 (partially represented in FIGURE 13) and 1006 are areas of negative standoff or interference in which the modeled surface 802 of the vehicle foot well is positioned interiorly of the vehicle tray 100. As above explained, this mismatch is permissible if held to 1/8 inch or less, and is even desirable in some points, because the surface 802 is an image of vehicle carpeting rather than a hard surface.

[0055] In FIGURE 14, there is seen at 1400 an intentional increase of radius of the transition between kick plate panel 136 and bottom wall 102. This is done because, for the model shown, the foot well kick plate surface 830 is both vertical and is relatively deep. Therefore, sidewall 136 needs to have a draft of at least two degrees (and more preferably five degrees) relative to

the surface 830 to insure that the wall of the tray 100 will remain acceptably thick enough at the junction of walls 136, 102. The increase of the radius 1400 accomplishes this. Nonetheless, even on this section the outer surface of the kick plate 136 stays within one-eighth of an inch of the kick plate surface 830 for at least one-third of the length, as measured from margin 150.

[0056] More generally, at least ninety percent of that top one-third of the surface area of each sidewall 130 – 136 that is adjacent the top margin 150 stays within 1/8 in. of the vehicle foot well surfaces with which they are designed to mate. Alternatively, ninety percent of the top one-half of the outer surface area of all upstanding sidewalls is within this 1/8 inch tolerance of respective foot well surfaces. In even a further alternative measurement of tolerance, it is preferred that at least fifty percent of the outer area of the upstanding sidewalls 130 – 136 be within 1/8 inch of the vehicle foot wells to which they correspond, regardless of position relative to the top margin 150.

[0057] As best seen in FIGURES 1, 5 and 10, a top margin 150 of the tray 100, which terminates all of the upstanding sidewalls 130, 132, 134, 136 and 138, substantially lies in a single plane which is tilted forwardly upwardly relative to the horizontal plane. The continuous nature of the top margin 150 means that the produced tray 100 has a higher hoop strength, and better protects the vehicle carpeting from dirt or mud on the sides of the occupant's feet. The occupant's feet tend to occupy positions on the forward region 106, but the position of the top margin 150 around this region is high, being at least five inches removed from the floor of the tray at its greatest separation.

COMPOSITION

[0058] According to one aspect of the invention, it is preferred that the tray or cover 100 not be of uniform composition throughout, but rather be a laminate having at least three layers which are bonded together. A preferred composition of the tray 100 is shown in the highly magnified sectional detail shown in FIGURE 6. In this illustrated embodiment, the tray 100 consists of a top layer 600, a central or core layer 602, and a bottom layer 604. All three layers 600 – 604 preferably consist of one or more water-impervious thermoplastic polymers, but layers 600 and 604 have properties which are at least different from core layer 602 and may even have properties which are different from each other. The trilayer cover is shown to be a three-dimensional floor tray in the drawings, but can also be a more two-dimensional floor mat of more limited coverage. Top layer 600 is made from a material selected for its tactile properties, its relatively high static and dynamic coefficients of friction with respect to typical footwear, and its resistance to chemical attack from road salt and other substances into which it may come into contact. Top layer 600 preferably includes a major portion of a thermoplastic elastomer such as VYRAM®, SANTOPRENE® or GEOLAST®, which are proprietary compositions available from Advanced Elastomer Systems. VYRAM® is preferred, particularly Grade 101-75 (indicating a Shore A hardness of 75). An upper surface 606 of the top layer 600 may be textured by a “haircell” pattern or the like so as to provide a pleasing tactile feel and visual appearance, as may a lower surface of the bottom layer 604.

[0059] It is preferred that top layer 600 be a polymer blend, in which instance a minor portion of the composition of the top layer 600 is selected for its coextrusion compatibility with core layer 602. A polyolefin polymer is preferred, such as polypropylene or more preferably polyethylene, even more particularly a high molecular weight polyethylene (HMPE). As used herein, HMPE is

a commodity product, available from many sources, and distinguished in the industry from low density polyethylene (LDPE) and high density polyethylene (HDPE) by its approximate properties:

Characteristic	LDPE	HDPE	HMPE
Specific Gravity, ASTM D-792	0.918	0.96	0.95
Tensile Modulus, ASTM D-638, psi	22,500	95,000	125,000
Tensile Strength @ Yield, ASTM D-638, psi	1,800	4,500	3,600 – 3,700
Flexural Modulus, ASTM D-790, psi		225,000	165,000 – 175,000
Hardness, ASTM D-2240, Shore D	45	66	68

[0060] In the above table, the testing methods by which the properties are determined are given for the purpose of reproducibility.

[0061] Particularly where the thermoplastic elastomer and the polyolefin are respectively selected as VYRAM® and HMPE, the proportion by weight of the thermoplastic elastomer to polyolefin material in layer 600 is preferably selected to be about 3:1. It has been discovered that some polyolefin material needs to be present in layer 600 for coextrusion compatibility with central layer 602, in the instance where a major portion of the layer 602 is also a polyolefin.

[0062] In an alternative embodiment, the thermoplastic elastomer component of the top layer 600 may be replaced with an elastomer such as natural rubber, acryl-nitrile butadiene rubber (NBR), styrene butadiene rubber (SBR), or ethylene propylene diene rubber (EPDM).

[0063] In a further alternative embodiment, layer 600 can be an acrylonitrile butadiene styrene (ABS) blend. ABS is a material in which submicroscopic particles of polybutadiene are dispersed in a phase of styrene acrylonitrile (SAN) copolymer. For layer 600, the percentage

by weight of polybutadiene, which lends elastomeric properties to the material, should be chosen as relatively high.

[0064] The core or central layer 602 preferably is composed of a thermoplastic polymer material that is selected for its toughness, stiffness and inexpensiveness rather than its tactile or frictional properties. Preferably a major portion of it is a polyolefin such as polypropylene or polyethylene. More preferably, a major portion of the layer 602 is composed of HMPE as that material has been defined above.

[0065] It is preferred that the central layer 602 be a blend, and in that instance a minor portion of layer 602 is composed of a material selected for its coextrusion compatibility with top layer 600 (and bottom layer 604 described below). In the illustrated embodiment, this minor portion is a thermoplastic elastomer such as SANTOPRENE®, GEOLAST® or VYRAM®. VYRAM® Grade 101-75 is particularly preferred. For layer 602, and particularly where the polyolefin and the thermoplastic elastomer are respectively selected as HMPE and VYRAM®, the proportion by weight of polyolefin to thermoplastic elastomer is preferred to be about 3:1. More generally, the percentages of the minor portions in layers 600 and 602 (and layer 604) are selected as being the minimum necessary for good coextrusion compatibility.

[0066] In an alternative embodiment, where layer 600 has been chosen as a polybutadiene-rich layer of ABS, layer 602 is chosen as a grade of ABS having less of a percentage by weight of polybutadiene in it, or none at all (effectively, styrene acrylonitrile copolymer or SAN).

[0067] Bottom layer 604 has a lower surface 300 which will be adjacent the vehicle foot well top surface. Typically, this surface is carpeted. The bottom layer 604 is a thermoplastic polymer

material selected for its wear characteristics, as well as its sound-deadening qualities and a yieldability that allows the layer 604 to better grip “hard points” in the vehicle foot well surface as well as conform to foot well surface irregularities. Preferably, a major portion of the layer 604 is composed of a thermoplastic elastomer, such as SANTOPRENE®, GEOLAST® or, preferably, VYRAM®. VYRAM® Grade 101-75 is particularly preferred.

[0068] It is preferred that the bottom layer 604 be a polymer blend. In this instance, a minor portion of the bottom layer 604 is selected for its coextrusion compatibility with the core layer 602. Where core layer 602 is mostly made of a polyolefin material, it is preferred that a polyolefin be used as the minor portion of the bottom layer 604. This polyolefin can be, for example, polypropylene or polyethylene, and preferably is HMPE. The amount of the minor portion is selected to be that minimum amount that assures good coextrusion compatibility. Where the polyolefin and the thermoplastic elastomer are respectively chosen to be HMPE and VYRAM®, it has been found that the thermoplastic elastomer: polyolefin ratio by weight in the layer 604 should be about 3:1.

[0069] In an alternative embodiment, the thermoplastic elastomer component of layer 604 may be replaced with a rubber, such as natural rubber, NBR, SBR or EPDM.

[0070] In another alternative embodiment, where the central layer 602 has been selected as ABS or SAN, layer 604 can be selected as a grade of ABS which has a higher percentage by weight of polybutadiene in it than in central layer 602.

[0071] Bottom jacketing layer 604 conveniently can have the same composition as top jacketing layer 600, but the two jacketing layers do not have to be similar. What is important that, where

the tray 100 is to be formed as a triextrusion (as is preferred), layers 600, 602 and 604 be sufficiently compatible that they can be triextruded as a single sheet.

[0072] It is preferred that most of the thickness of the tray 100 be made up by the core layer 602, which is used as the principal structural component of the tray 100. The core layer 602 has at least minimally acceptable tensile strength, shear strength and high flexural modulus, while at the same time being significantly less expensive than the thermoplastic elastomer-dominated jacketing layers. The jacketing layers 600 and 604 are selected to present good wear surfaces and to have a good resistance to chemical attack from substances such as road salt. Top layer 600 is selected to exhibit a relatively high coefficient of friction with respect to typical occupant footwear. The composition of bottom layer 604 is selected for its sound-deadening and yieldability qualities.

[0073] The total thickness of tray 100 is the sum of dimensions a , b and c . In the illustrated embodiment, jacketing layer thicknesses a and c are each about 12.5% of the total thickness, while core layer thickness b is about 75%. In one embodiment, the total thickness of the tray 100 (or, more precisely, of the blank sheet used to mold the tray 100) is approximately 0.120 inch. Of this, core layer 602 is about 0.09 inch, while jacketing layers 600 and 604 are each about 0.0150 inch. In an alternative embodiment, the layer 600 can be made to be appreciably thicker than layer 604, as top surface 606 is a wear surface for the shoes of the occupant and will see more abrasive dirt and more wear than surface 300 in typical applications. In another alternative embodiment, the thickness of layer 604 may be increased, allowing it to even better conform to the vehicle foot well surface with which it is designed to mate and to increase sound-deadening.

[0074] A preferred embodiment of the present invention combines the high coefficient of friction, tactile qualities, sound-deadening and yieldability obtainable with a thermoplastic elastomer with the modest cost of a polyolefin. To demonstrate the technical advantages of a triextrusion tray over monoextruded prior art structures, tests measuring tensile strength, shear strength, flexural modulus and coefficient of friction were performed on (1) a triextrusion sheet material made and used according to the invention, (2) a monoextruded sheet of 75 wt. pct. VYRAM®/ 25 wt. pct. HMPE, and (3) a monoextruded sheet of wt. pct. VYRAM® / 75 wt. pct. HMPE. The particular tests and their results are described below.

[0075] The first two tests performed concern static and dynamic coefficients of friction.

Example 1

[0076] These tests determined static and kinetic coefficients of friction of a sheet of triextrusion material with respect to an object meant to emulate an typical occupant shoe outsole. This “shoe” was composed of Shore A Durometer 60 neoprene rubber, formed as a “sled” measuring 2.5 in. x 2.5 in. x 0.238 in. The “shoes” were drawn across an upper, textured surface of a .120 in. triextrusion sheet formed according to a preferred embodiment of the invention measuring 4 in. x 12 in. according to the procedure set forth in ASTM D 1894-01. The triextrusion sheet had, as its top layer, a blend of 75 wt. pct. VYRAM® Grade 101-75/25 wt. pct. HMPE. The core layer was 75 wt. pct. HMPE/25 wt. pct. VYRAM® Grade 101-75. The bottom layer was a blend of 25 wt. pct. HMPE/75 wt. pct. VYRAM® Grade 101-75. The bottom and top layers each comprised about 12.5% of the sheet thickness while the middle core layer comprised about 75% of the sheet thickness. Results are tabulated as follows.

Test	Static	Sled	Static	Kinetic	Sled	Kinetic
------	--------	------	--------	---------	------	---------

Number	Load (g)	Weight (g)	Coefficient of Friction	Load (g)	Weight (g)	Coefficient of Friction
1	166	199.9	0.830	189	199.9	0.945
2	155	199.9	0.775	166	199.9	0.830
3	171	200.0	0.855	179	200.0	0.895
4	145	199.9	0.725	160	199.9	0.800
5	150	199.9	0.750	163	199.9	0.815
Average			0.787			0.857
Std. Dev.			0.054			0.061

Example 2

[0077] Five neoprene rubber “sleds” fabricated as above were drawn across a 4 in. x 12 in. sheet of a single-extrusion 75 wt. pct. HMPE/25 wt. pct. VYRAM® Grade 101-75, according to ASTM D 1894-01. Results are tabulated below.

Test Number	Static Load (g)	Sled Weight (g)	Static Coefficient of Friction	Kinetic Load (g)	Sled Weight (g)	Kinetic Coefficient of Friction
1	157	200.1	0.785	162	200.1	0.810
2	151	200.0	0.755	148	200.0	0.740
3	163	200.1	0.815	170	200.0	0.850
4	146	200.1	0.730	148	200.1	0.740
5	154	200.1	0.770	155	200.1	0.775
Average			0.771			0.783
Std. Dev.			0.032			0.047

[0078] The above tests show that with respect to a typical shoe sole composition, a material consisting mostly of a thermoplastic elastomer like VYRAM® exhibits a higher coefficient of friction than a material consisting mostly of a high molecular weight polyolefin.

Example 3

[0079] These tests compared the tensile strength of a sheet of triextruded material as above described with a sheet of single-extruded blend of material consisting of 75 wt. pct. VYRAM®, Grade 101-75, and 25 wt. pct. HMPE, and further with a sheet of a single-extruded blend of

material of 75 wt. pct. HMPE and 25 wt. pct. VYRAM® Grade 101-75. The tested single-extruded VYRAM®-dominated sheet was approximately .070 in. thick, while the HMPE-dominated sheet was approximately .137 in. thick. The triextrusion sheet was about .120 in. thick. The triextrusion sheet, the single-extruded VYRAM®-dominated sheet and the single-extruded HMPE-dominated sheet were die-cut into samples having an average width of 0.250". The test performed was according to the ASTM D 638-03 testing standard. A cross-head speed of 20 in. / min. was used. The extensiometer was set at 1000% based on 1.0" gauge length. Samples were conditioned at 40 hours at 23 Celsius and 50% relative humidity prior to testing at these conditions. Test results are tabulated below.

	Test Number	Tensile Strength at Yield (psi)	Elongation at Yield (%)	Tensile Stress at Break (psi)	Elongation at Break (%)	Tensile Modulus (Youngs) (psi)
Tri-Extrusion	1	1680	24	1530	730	30800
	2	1710	21	1610	710	30100
	3	1700	21	1620	730	32200
	4	1740	19	1660	770	32700
	5	1690	17	1630	700	24400
	Average	1700	20	1610	730	30000
	Std.Dev.	23	3	48	27	3320
75%Vyram/ 25%HMPE	1	1040	53	1400	620	15900
	2	1010	45	1430	630	17100
	3	1050	98	1390	640	17100
	4	1010	62	1430	620	16700
	5	1030	88	1420	610	17100
	Average	1030	69	1410	620	16800
	Std.Dev.	18	23	18	11	522
75%HMPE/ 25%Vyram	1	919	63	1130	630	30200
	2	914	61	1110	630	34100
	3	925	69	1120	650	29500
	4	910	67	1110	650	21500
	5	912	68	1140	700	24000
	Average	916	66	1120	650	27900
	Std.Dev.	6	3	13	29	5060

[0080] The above data demonstrate that a triextrusion material according to the invention exhibits markedly greater tensile strength than a thermoplastic elastomer-dominated single-extrusion material. Also of interest is that the three-layer laminate exhibited a higher strength at yield and stress at break than the HMPE-dominated material, while showing a comparable tensile Young's modulus.

Example 4

[0081] Tests were performed on the above three materials for shear strength according to Test Standard ASTM D732-02. In these tests, a 1.00 in. dia. punch was applied to a 2.0 inch square of material until shear was achieved. The crosshead moved at 0.05 in/min. The test samples were preconditioned for at least 40 hours at 23 Celsius and 50% relative humidity, which were the conditions under which the tests were performed. Test results are tabulated below.

Sample Name	Test Number	Thickness (in.)	Shear Force (lbf)	Shear Strength (psi)
Tri-Extrusion	1	0.119	747	2000
	2	0.122	783	2040
	3	0.119	747	2000
	4	0.121	757	1990
	5	0.117	734	2000
	Average		754	2010
	Std. Dev.		18	19
75% VYRAM/ 25% HMPE	1	0.072	423	1870
	2	0.070	416	1890
	3	0.073	489	2130
	4	0.072	481	2130
	5	0.073	455	1980
	Average		453	2000
	Std. Dev.		33	126
75% HMPE/ 25% VYRAM	1	0.135	680	1600
	2	0.137	688	1600
	3	0.134	687	1630

	4	0.136	724	1690
	5	0.137	687	1600
	Average		693	1620
	Std. Dev.		18	39

[0082] The above test data show that, as normalized for the different thicknesses tested, the triextrusion material is similar in shear strength to the 75%VYRAM/ 25% HMPE single-extrusion blend, and superior in shear strength to the 75%HMPE/25%VYRAM® single-extrusion blend.

Example 5

[0083] Tests were performed to determine the flexural properties of samples of a tri-extrusion material of the above-described formulation, a 75 wt. pct. Vyram/25 wt. pct. HMPE material, and a 75 wt. pct. HMPE/25wt. pct. VYRAM material (in all tests. the thermoplastic elastomer used was VYRAM® Grade 101-75). The tests were performed according to the ASTM D790-03 test method, Method I, Procedure A. For the tri-extrusion the dimensions of the samples averaged 0.490” x 0.0119” x 5.00”, the span length was 1.904 in., and the cross-head speed was 0.051 in./min. For the 75%Vyram/25%HMPE material, the dimensions of the samples averaged 0.484” x 0.072” x 5.00”, the span length was 1.152 in., and the cross-head speed was 0.031 in./min. For the 75%HMPE/25%Vyram material, the dimensions of the samples averaged 0.50” x 0.138” x 5.00”, the span length was 2.208 in., and the cross-head speed was 0.059 in/min. In all tests, the span-to-depth ratio was 16 +/- 1:1, the radius of the supports was 0.197 in., and the radius of the loading nose was 0.197 in. The tests were performed at 23 Celsius and 50% relative humidity and the samples conditioned for 40 hours at this temperature and humidity before the tests were performed. Results are tabulated below.

Sample Name	Test Number	Flexural Stress At 5% Deflection (psi)	Flexural Modulus (tangent*)(psi)
Triextrusion	1	294	33400
	2	317	36000
	3	304	33500
	4	318	35700
	5	305	33200
	Average	308	34400
	Std. Dev.		
75%Vyram/ 25%HMPE	1	234	15400
	2	238	16400
	3	230	14500
	4	225	14300
	5	228	14300
	Average	231	15000
	Std. Dev.	5	915
75%HMPE/ 25%Vyram	1	508	13000
	2	505	13800
	3	496	13100
	4	497	12900
	5	518	13800
	Average	505	13300
	Std. Dev.	9	444

[0084] The asterisk in the table indicates that the reported values were arrived at by computer generated curve fit. These data show that the triextrusion is significantly stiffer than either monoextruded sheet. Overall, the triextrusion demonstrates superior properties in terms of tensile strength, shear strength and stiffness per unit cross-sectional area in comparison with that of any of the layers of materials from which the laminate is made, demonstrating that a triextruded tray or mat will be tougher and stiffer than one made of either monoextruded blend by itself.

PROCESS

[0085] FIGUREs 7 and 8 provide an overview of a process for making the vehicle floor trays or covers according to the invention. The vehicle floor trays and covers are custom-fabricated for discrete vehicle models. At step 700, points on the vehicle foot well for which the floor tray is to be manufactured are digitally measured and captured. Preferably this step uses a coordinate measuring machine (CMM) which records each of a large plurality of points on the surface of the vehicle foot well to which the floor tray is to be fitted. The inventor has found that a FARO® Arm has been efficacious in obtaining these data using a contact method. It has been found that laying out points in linear groups, as by marking the locations to be measured on tape prior to measurement, is efficacious in capturing enough data points to later recreate the surface of which they are a part.

[0086] The data thus collected are stored in a file. The points of surface data are spaced from each other as a function of the complexity of the surface on which they reside. Few points of data are needed to establish large surface planes. More points of data are used in defining curved surfaces, with the density of data points varying according to the sharpness of the curve. In FIGURE 8, representative ones of these points are shown by small “x”s at 800, on a surface 802 that is reconstituted using the technique described immediately below. A typical data file will contain about a thousand points, spread over an imaged foot well surface area of about ten square feet.

[0087] The CMM data file is imported into a CAD program, which is used by a designer to reconstitute a vehicle foot well surface from the captured points. First, at step 701 different

“lines” of these points are connected together by B-splines 804. The splines 804, which the CAD program can automatically generate, are used to estimate all of the points on the line other than the captured data points of that line. The splines 804 are separated apart from each other as a function of the topographical complexity of the portion of the surface that they cover. For large flat areas, such as sill plate 806, the splines 804 may be separated far apart, as a plane between the splines is a good estimate of the surface in that area. For complex or tightly curved areas, such as sill curve 832 or kick plate transitional area 833, the splines 804 are tightly packed together because the surface segments have to be small in order to reproduce those curved surfaces of the foot well with acceptable accuracy.

[0088] Once the splines 804 have been assembled, the designer lofts an area between each pair of parallel splines 804 in order to create different areal segments 808. The “lofting” process proceeds along each of the major surfaces of the part, piecewise, until that surface is entirely recreated. For example, a transmission tunnel sidewall surface 810 is recreated by lofting an area 812 between a spline 814 to an adjacent spline 816 along the same surface. The designer then lofts the next area 818 from spline 816 to spline 820. Next, an area 822 from spline 820 to spline 824 is added, and so forth down the rest of the transmission tunnel surface 810 until that entire component of the vehicle foot well surface has been created. In similar fashion, the other major surfaces are added: a combination firewall/floor area segment 826, a pedestal sidewall 828, a kick plate segment 830, a sill plate curve 832 and the sill plate 806.

[0089] The resultant reconstructed vehicle foot well surface 802 is used, at steps 703 – 707, 709, 711, to construct a vehicle floor tray that fits the surface 802 to an enhanced degree of precision. At step 703, the designer chooses top and bottom sketch planes, which intersect the surface 802

at the top and bottom elevations of the tray to be designed. A top sketch plane intersects surface 802 at a locus high up on the sidewalls 810, 828, 830, 832 and 834. This locus is seen in FIGURE 1 as a top margin 150 of the upstanding sidewalls 130, 132, 134, 136 and the transitions between them. In the preferred embodiment, the top sketch plane is tilted and inclines upward in a forward direction. This produces a tray which is deeper near the firewall than it is near the seat, preferably producing a tray that is at least five inches deep at its deepest part. This protects the foot well carpet from the possibly muddy sides of an occupant's shoes or boots. A bottom sketch plane is defined to be coplanar with the bottom surface tray sill plate 140, spaced from the vehicle foot well sill plate 806 by a tight tolerance, such as 0.025". This bottom sketch plane does not intersect the remainder of the structure but is instead projected upward onto the vehicle foot well surface to create a locus that approximates the marginal outline of the floor/firewall segment 826.

[0090] At step 704, sidewalls are drawn in to span the top and bottom sketch planes. These prototypical sidewalls are created by first drawing a plurality of straight lines, each drawn from a point on the upper sketch plane locus to a point on the lower sketch plane locus. Since the upper sketch plane is more extensive and has a different shape from the lower sketch plane, the lateral margins of the upper and lower sketch planes are not congruent, and the straight lines drawn from the upper sketch plane may be canted at various angles to each other. In general, these lines will slope inwardly from the top sketch plane to the bottom sketch plane. The areas in between these lines can be lofted to create polygonal surfaces of a completed tray solid.

[0091] The resultant solid has a planar top surface, nearly planar bottom surface and sidewalls which make abrupt corners with them. The actual transitions between the vehicle foot well

sidewall surfaces and the floor are almost always curved, to a greater or lesser extent depending on the area in question and on the vehicle model. Therefore, at step 705, curves are fitted to the reconstructed vehicle foot well surface and these curves are substituted in for the previous abrupt angular shapes. The largest of these curves occurs across the firewall 834, to conform to that sloping and typically curved surface rather than to a horizontal extension of the bottom sketch plane. Curves are also used to modify the transitions between the floor 102 and the transmission tunnel surface 132, the kick plate 136, and the seat pedestal sidewall 130.

[0092] The above techniques aim to approximate, as closely as possible, the shape of the upstanding sidewalls 810, 828, 830 and 834, to a zero standoff from the foot well surface. In some instances, the outer surface of the tray 100 may actually extend slightly beyond the imaged side walls of the vehicle foot well (see portions 1000 – 1006 in FIGURES 10 – 14), creating a negative standoff. This is permissible to some degree because the surface to which the tray is being shaped is carpeted and the pile may be intentionally depressed at certain points.

[0093] The door sill 806 and the sill curve 832 typically are hard surfaces that must comply to close manufacturer tolerances. A vehicle door is designed to mate with these surfaces. Because of this it is important to match these surfaces carefully, and preferably this is done in this process to a preselected standoff of 0.025 inch.

[0094] At step 704, and for certain vehicle models, certain radii of the transitional surfaces are increased, in an intentional departure from the foot well surface. This is done, for example, where the curved transition is one from a deep vertical surface to the floor, as might occur between a vertical kick plate and firewall surface segments 836, 838. See transition 1400 in FIGURE 14. This is done to make sure that the preferred vacuum molding process, which uses a

female tool, does not create a thin place in the molded part at the deep corners. Where the sidewall surfaces are sloped inward by more than five degrees, such radiusing is unnecessary.

[0095] At step 707, which can be before, during or after steps 704 and 705, the tray solid is additionally modified to take into account irregularities in the reconstructed foot well surface. For example, the vehicle carpeting might have had rolls or wrinkles in it that should not be reproduced in a tray meant to fit the vehicle. This steps also smoothes out those surface irregularities which are artifacts of the surface acquisition and reconstruction steps 700 – 702.

[0096] Once a basic shape for the vehicle floor tray has been formed, it is modified at 709 in order to create the reservoir 110 and channels 104 (See Figures 1 – 4). This modification is necessary because, as has been explained, while there is a close conformance or mating between most of the exterior or lower surfaces of the floor tray on the one hand to the upper or interior surfaces of the vehicle foot well surfaces on the other, there must be a departure from this close conformance in order to create the profile needed by the reservoir and channels. In a preferred embodiment, a predetermined file containing the outer surface of the reservoir and channel surface is integrated into the floor of the tray solid. The importation of this design into the floor of the tray solid will cause a departure from the imaged vehicle surface floor of as much as $\frac{1}{4}$ inch in the areas around the reservoir periphery. This departure decreases as a function of distance from the imported pattern. The produced vehicle floor tray will nonetheless fit tightly to the vehicle foot well, because (1) the floor carpeting will be depressed to a greater extent under the reservoir than in peripheral areas (see, e.g., region 1004 in FIGURE 10), and (2) the upstanding sidewalls continue to closely conform to the corresponding surfaces of the vehicle foot well.

[0097] At step 711, the tray solid developed at steps 703 – 707, 709 is “shelled”. This means that the solid is carved out to leave a thin layer that is a uniform thickness (preferably about .120 - .125 in.) from the outer surface.

[0098] The result is a tray data file 708 that is a complete representation of both the upper and lower surfaces of the floor tray, to a precision sufficient to create only a 1/8 in. departure or less from a large portion of the respective surfaces of the vehicle foot well. This data file, typically as translated into a .stl format that approximates surfaces with a large plurality of small triangles, is used at 710 to command a stereolithographic apparatus (SLA). The SLA creates a solid plastic image or model of the design by selectively curing liquid photopolymer using a laser. The SLA is used to determine fit to an actual vehicle foot well and to make any necessary adjustments.

[0099] As modified with experience gained from fitting the SLA, at 712 the vehicle tray data file is used to make a commercial mold for producing the vehicle floor trays or covers. Triextruded sheets or blanks 714 are placed in the mold and heated to produce the vehicle floor trays at 716.

[00100] Three-dimensional vehicle floor trays for many different vehicle models can be quickly and accurately manufactured using this method. The method can also be modified to produce double trays, in which a single tray is provided which covers both driver and passenger vehicle foot wells as well as the intervening transmission tunnel. The technique can be used to create other vehicle floor covers as well, such as the liners used in the cargo areas of minivans and SUVs.

[00101] In summary, a novel vehicle floor tray has been shown and described which fits, within tight tolerances, to the vehicle foot well for which it is created. The floor tray according to the

invention includes a reservoir and channel system for retaining runoff in a way that will not slosh around in the foot well. By using a triextruded sheet blank, the tray combines the desirable coefficient of friction and yieldability characteristics of a thermoplastic elastomer, the lower cost of a polyolefin and a toughness that exceeds either material taken alone.

[00102] While an illustrated embodiment of the present invention has been described and illustrated in the appended drawings, the present invention is not limited thereto but only by the scope and spirit of the appended claims.

WE CLAIM:

1. A process for manufacturing a vehicle floor tray, comprising the steps of:
 - digitally measuring the three-dimensional position of a plurality of points on a substantially carpeted surface of a vehicle foot well for which the vehicle floor tray is to be provided;
 - storing said points in a memory;
 - using the stored points to construct a model of the vehicle foot well surface;
 - using the model of the vehicle foot well surface to construct a three-dimensional representation of a vehicle floor tray;
 - using the stored three-dimensional representation to construct a mold for the vehicle floor tray; and
 - manufacturing the vehicle floor tray by molding polymer material in the mold.

2. The process of Claim 1, wherein said step of digitally measuring the three-dimensional position of the points on the surface of the vehicle foot well comprises using a coordinate measurement machine (CMM).

3. The process of Claim 1, wherein the step of using the model of the vehicle foot well surface to construct a three-dimensional representation of a vehicle floor tray comprises the substeps of
 - using the model of the vehicle foot well surface to construct a lower surface of the vehicle floor tray representation; and

shelling the lower surface of the vehicle floor tray representation to create an upper surface of the vehicle floor tray representation which is displaced by a uniform thickness away from the lower surface of the vehicle floor tray representation.

4. The process of Claim 1, wherein the step of using the stored three-dimensional representation to construct a mold for the vehicle floor tray comprises the substeps of using a file derived from the stored three-dimensional representation to command a stereolithographic apparatus (SLA); responsive to the last said substep of using, selectively curing liquid photopolymer in the SLA with a laser; and responsive to the substep of curing, forming a plastic model of the vehicle floor tray.

5. The process of Claim 1, and further comprising the step of modifying the drawn sidewalls of the three-dimensional representation of the vehicle floor tray to conform at least the upper two-thirds of the area of the outer surface of the sidewalls nearest to the top margin to respective surfaces of the vehicle foot well model, such that through those areas the sidewalls of the vehicle floor tray do not depart from the corresponding surfaces of the vehicle foot well by more than one-eighth of an inch.

6. A process for manufacturing a vehicle floor tray, comprising the steps of:

digitally measuring the three-dimensional position of a plurality of points on a surface of a vehicle foot well for which the vehicle floor tray is to be provided;

storing said points in a memory;

using the stored points to construct a model of the vehicle foot well surface, said step of using the stored points including the steps of

connecting together groups of the stored points with B-splines;

lofting between the B-splines to create areal segments of the surface of the vehicle foot well model;

using the model of the vehicle foot well surface to construct a three-dimensional image of a vehicle floor tray; and

manufacturing the vehicle floor tray by molding polymer material in the mold.

7. A process for manufacturing a vehicle floor tray, comprising the steps of:

digitally measuring the three-dimensional position of a plurality of points on a surface of a vehicle foot well for which the vehicle floor tray is to be provided;

storing said points in a memory;

using the stored points to construct a model of the vehicle foot well surface;

using the model of the vehicle foot well surface to construct a three-dimensional image of a vehicle floor tray, said step of using the model including the substeps of

establishing a top sketch plane to intersect the vehicle foot well model and to establish a top margin of the vehicle floor tray;

establishing a bottom sketch plane to be at the lowest elevation of the vehicle floor tray image to be created;

drawing sidewalls between the top sketch plane and the bottom sketch plane to approximate corresponding sidewalls of the vehicle foot well tray; and
using the stored three-dimensional image to construct a mold for the vehicle floor tray.

8. The process of Claim 7, and further comprising the step of:
tilting the top sketch plane so that it is at an angle to a floor of the vehicle foot well model, such that the produced vehicle floor tray is deeper in a direction toward the vehicle firewall than it is toward a seat of the occupant.

DESIGNING AND MANUFACTURING A VEHICLE FLOOR TRAY

ABSTRACT OF THE DISCLOSURE

A vehicle floor tray is molded from a multiple extrusion polymer sheet such that it has high shear and tensile strength, an acceptable degree of stiffness and a high coefficient of friction on its upper surface. The floor tray design is digitally fitted to a foot well of a particular vehicle such that large areas of at least two upstanding walls of the tray depart from respective surfaces of the foot well by no more than an eighth of an inch.

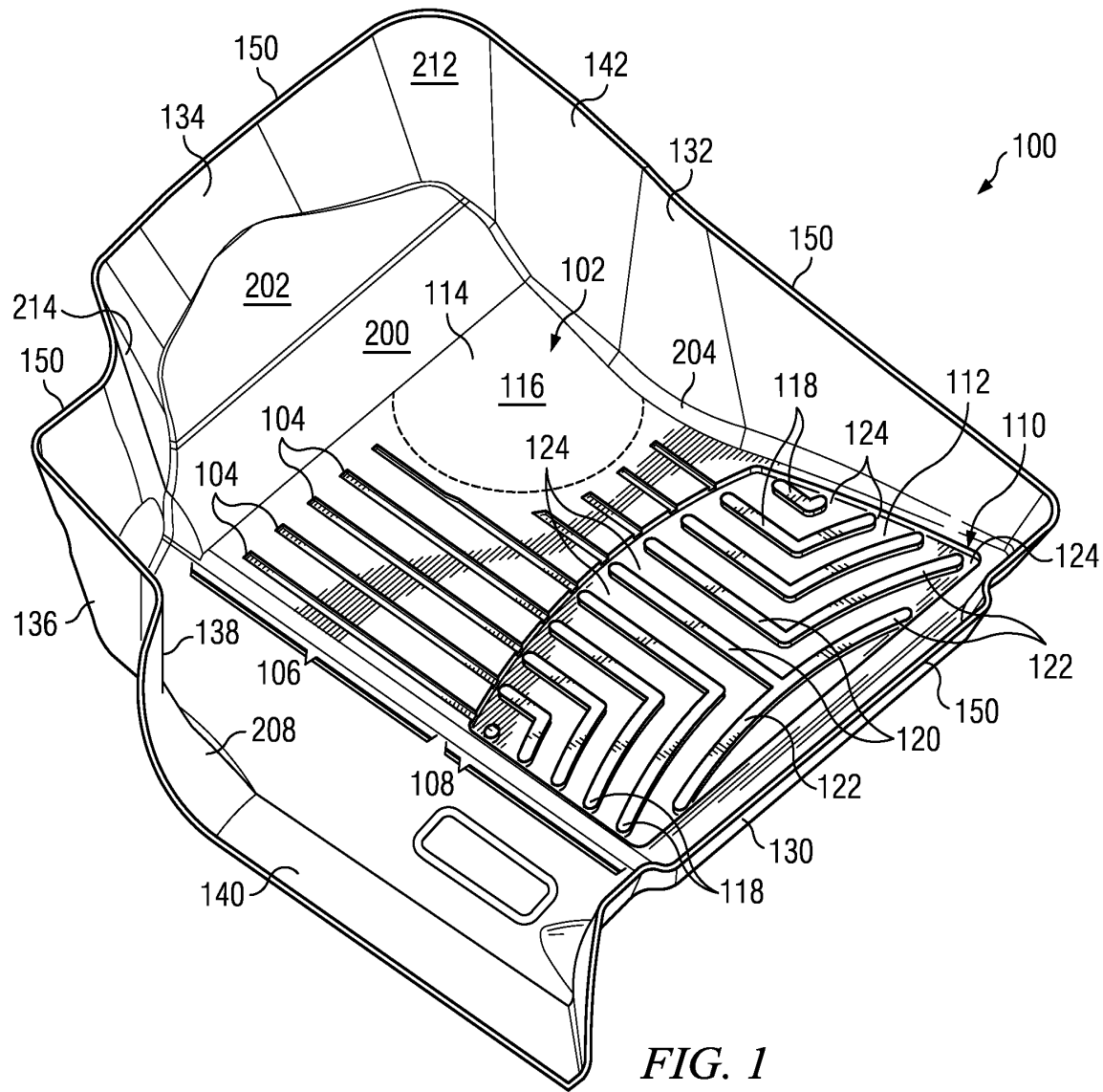
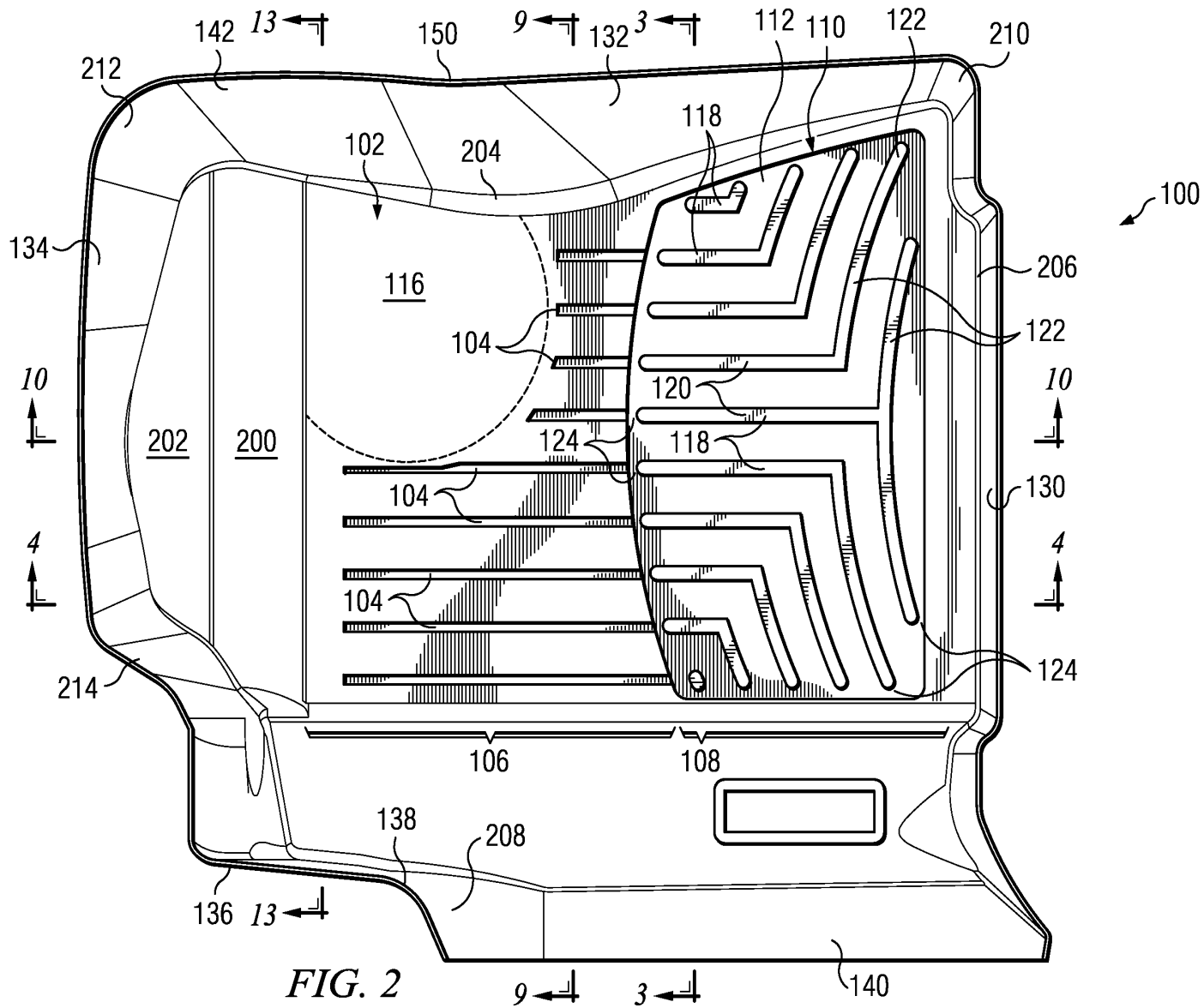

FIG. 1



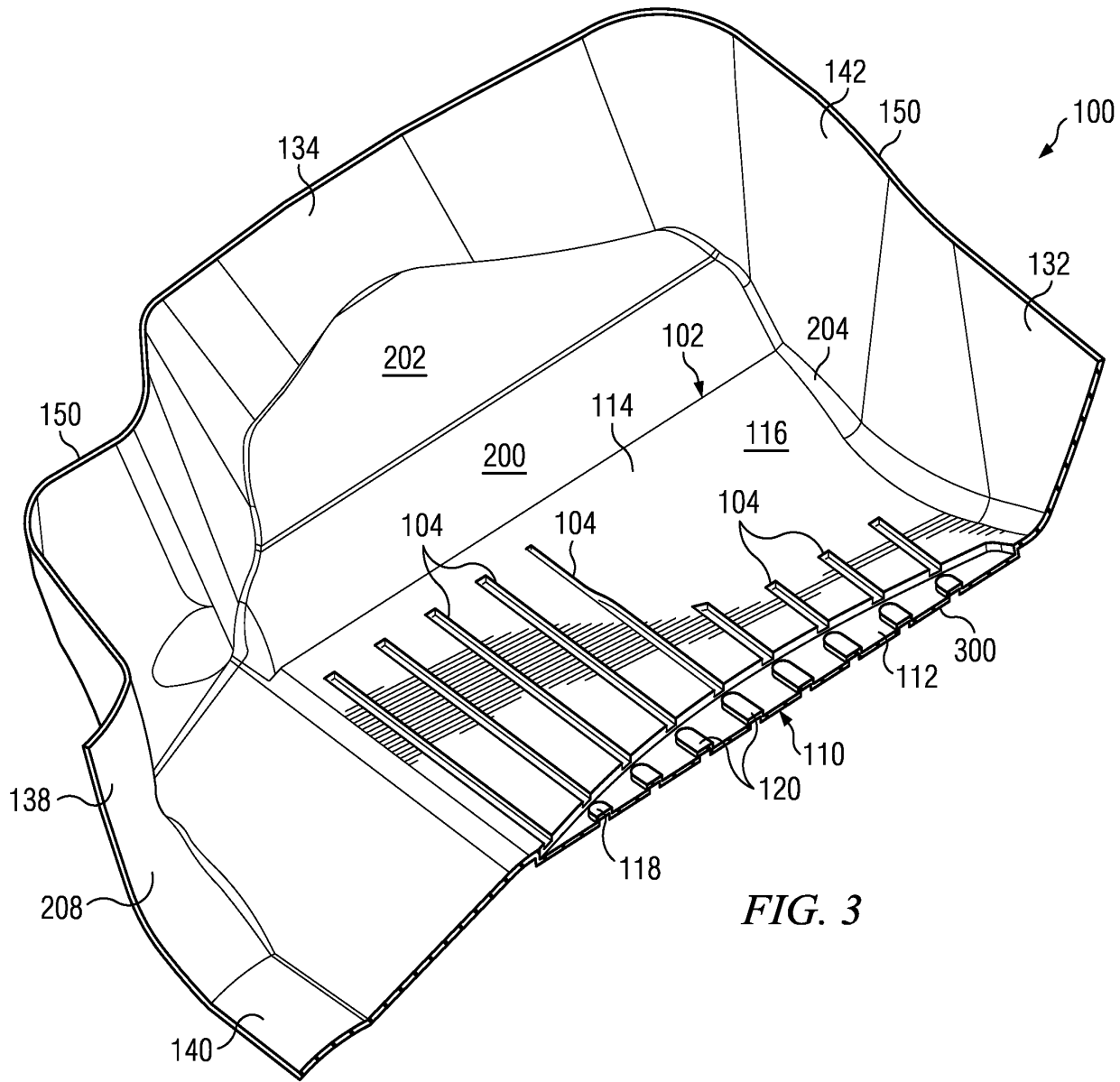

FIG. 3

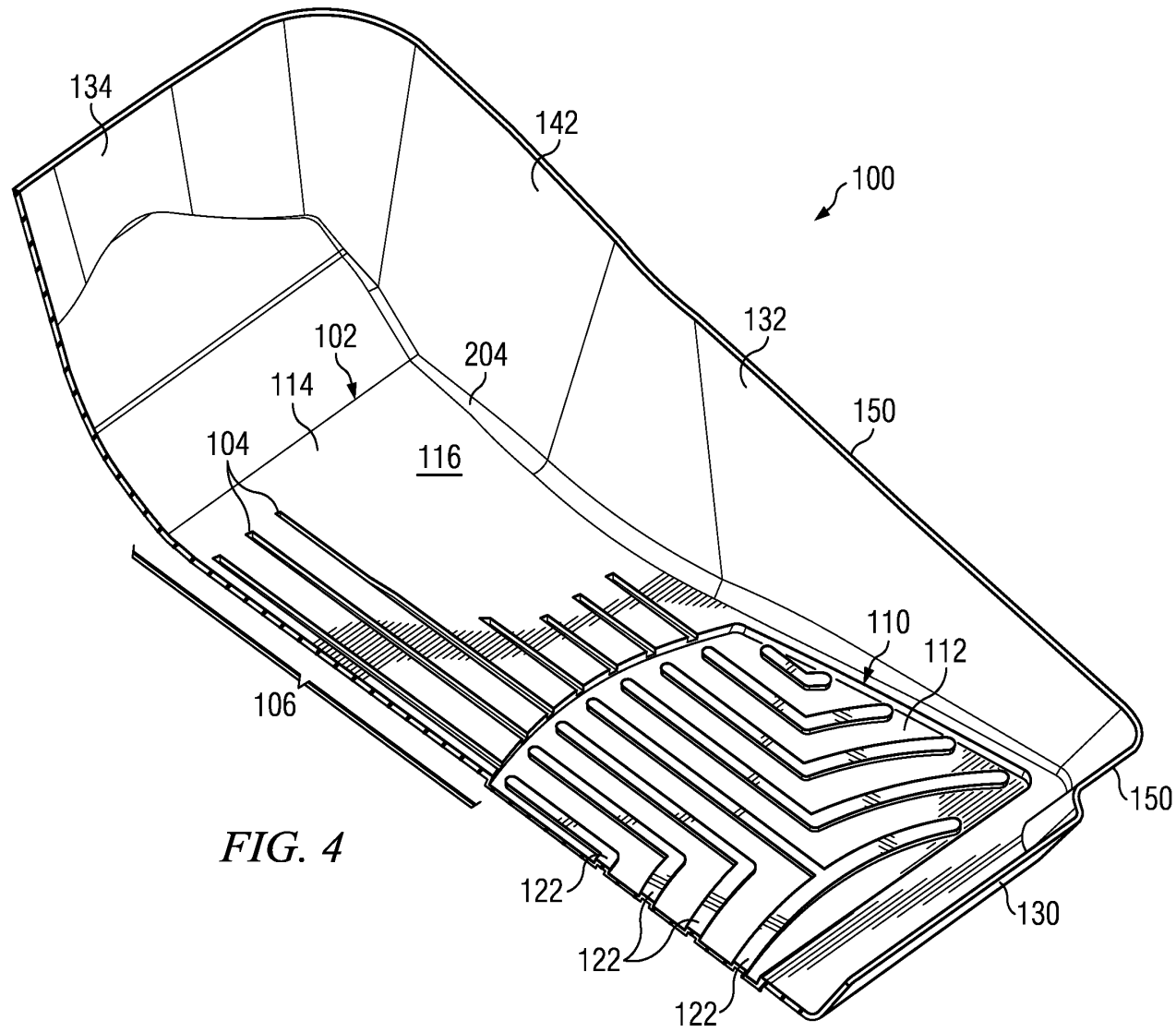

FIG. 4

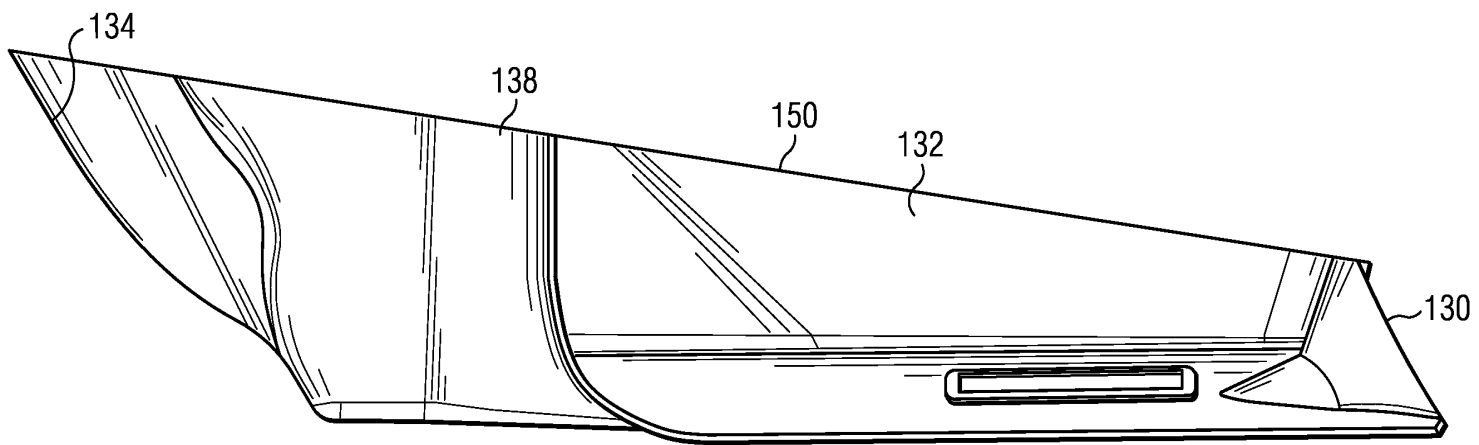
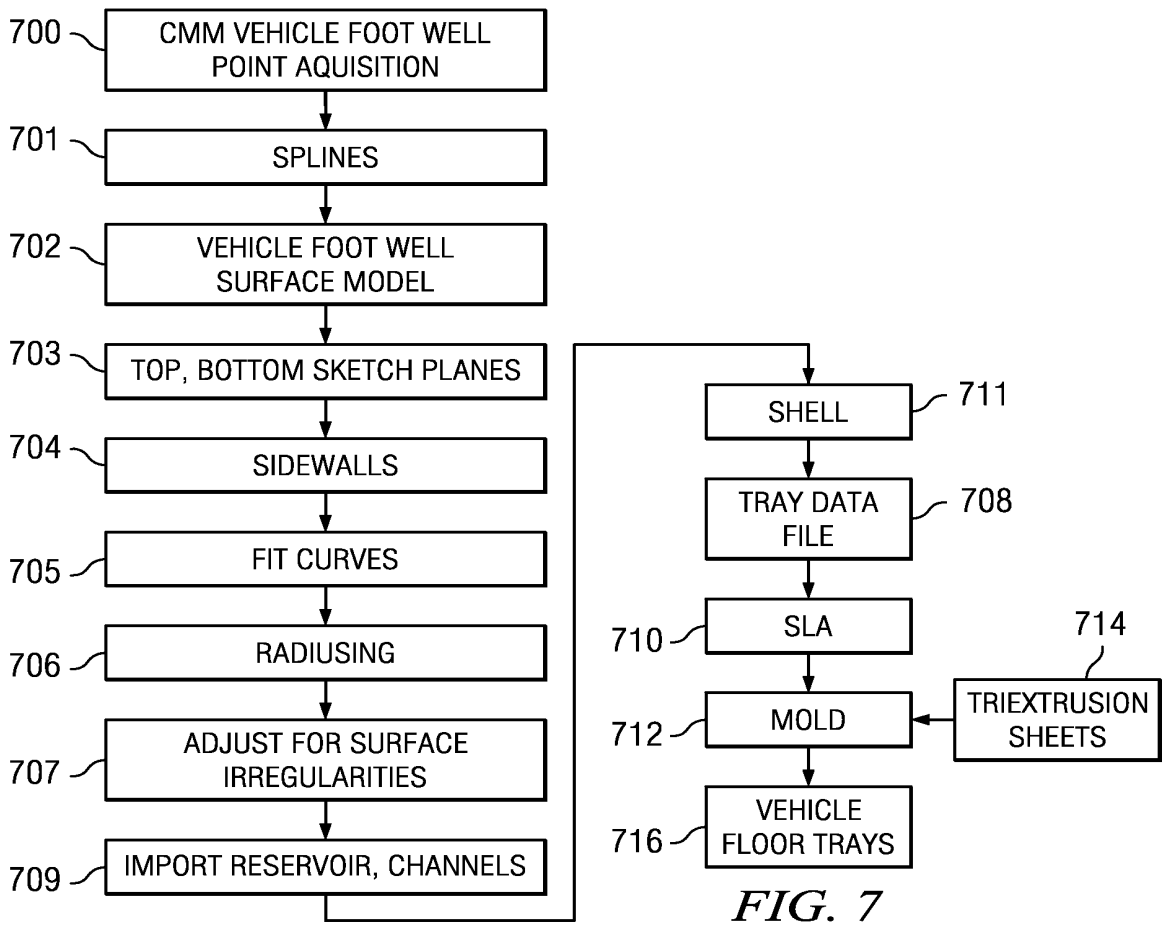
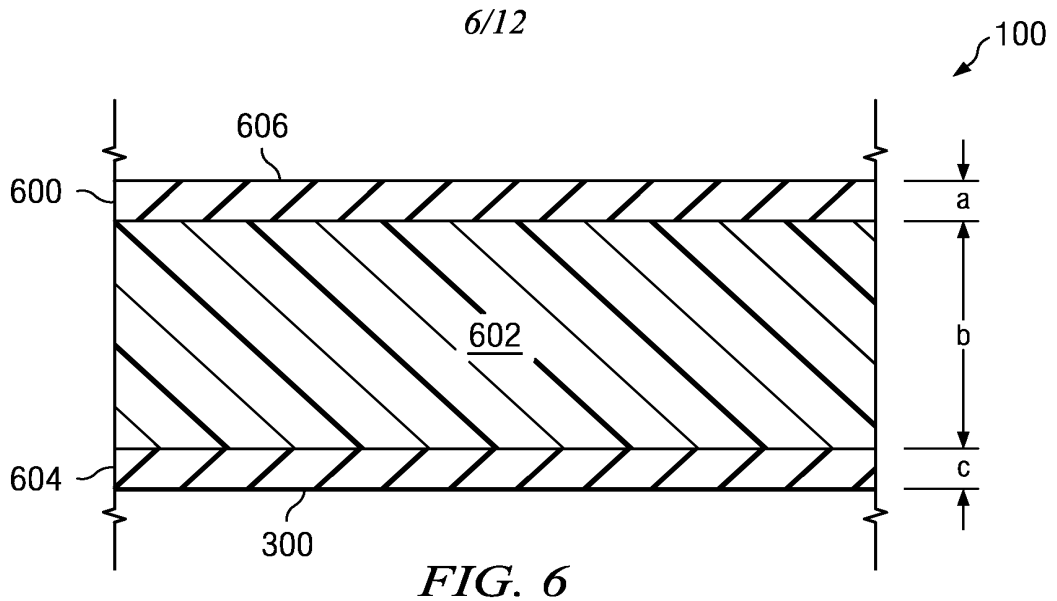

FIG. 5



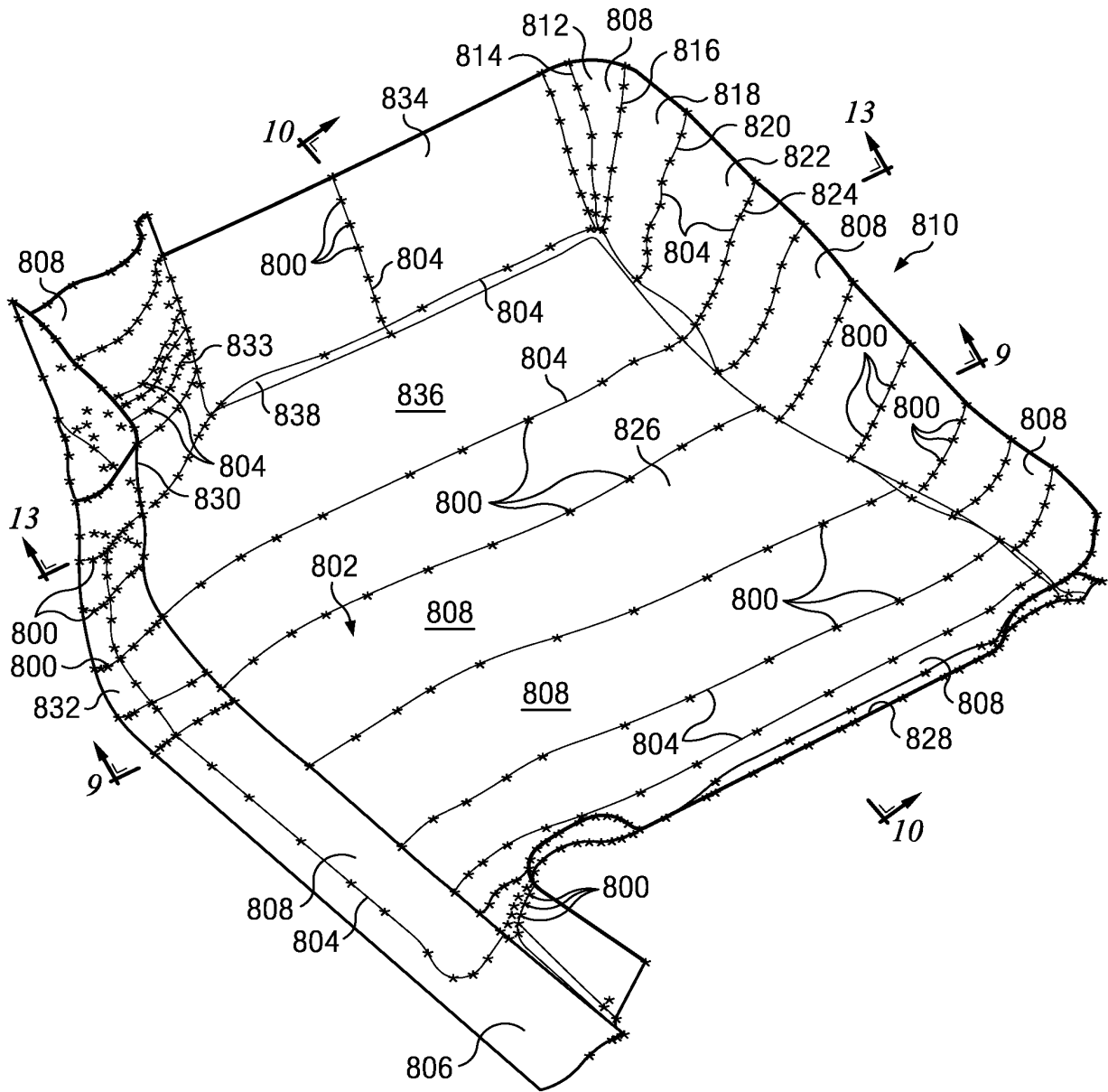

FIG. 8

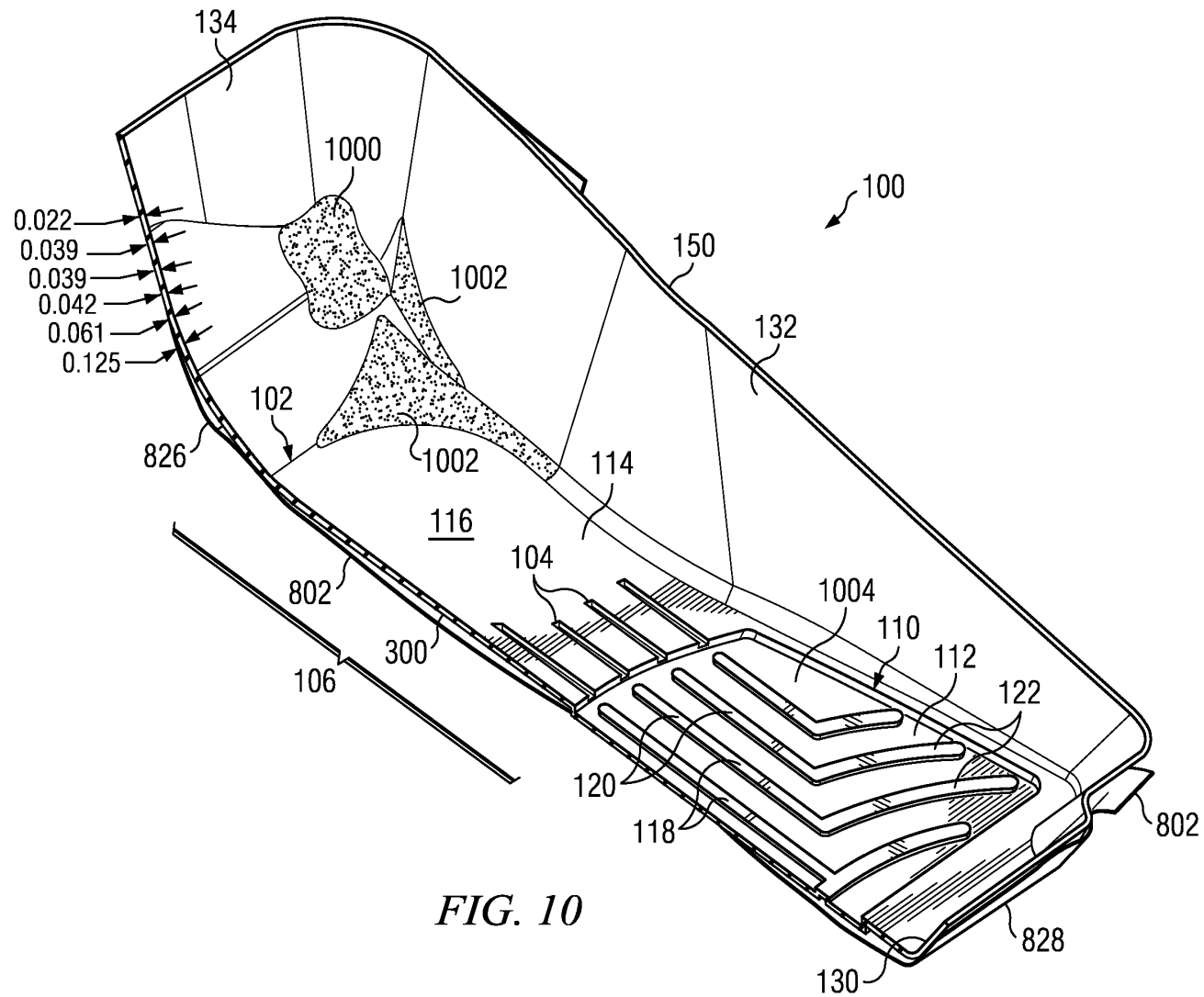

FIG. 10

10/12

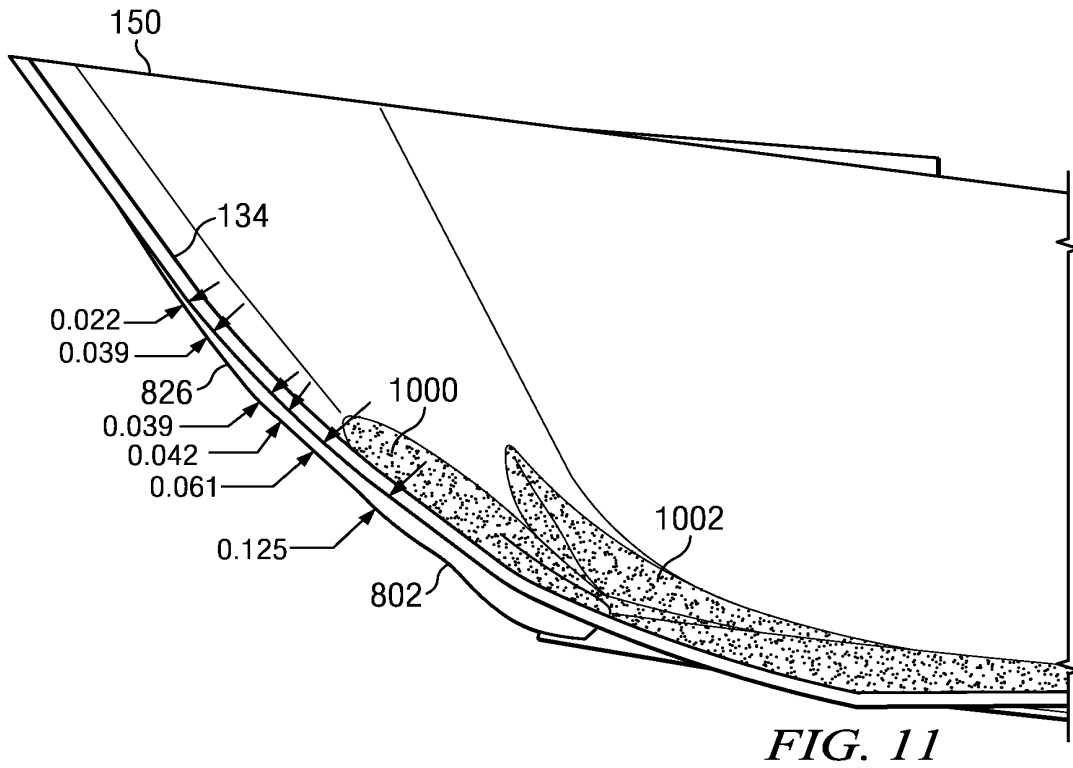

FIG. 11

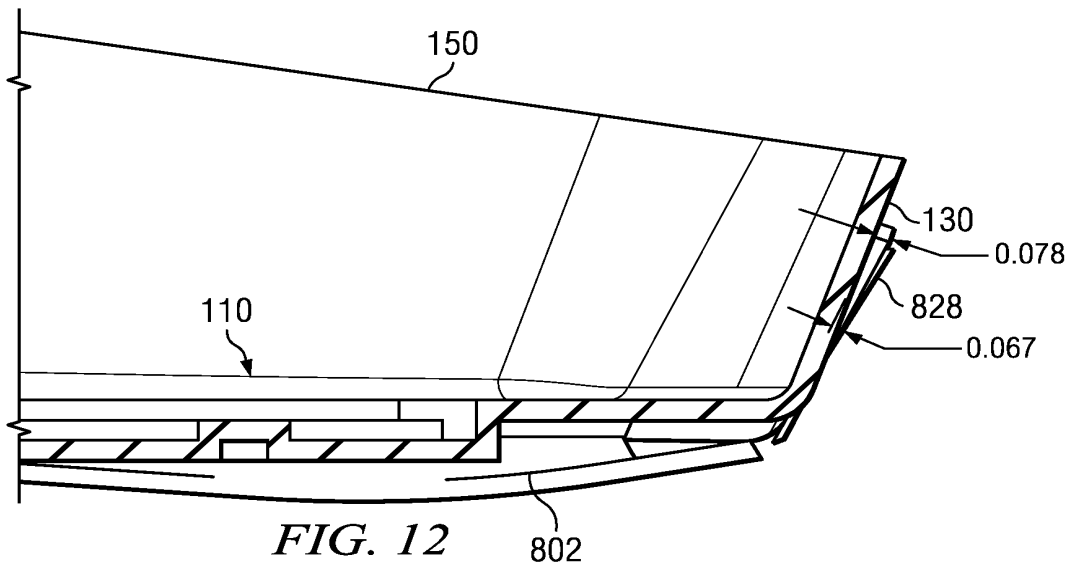
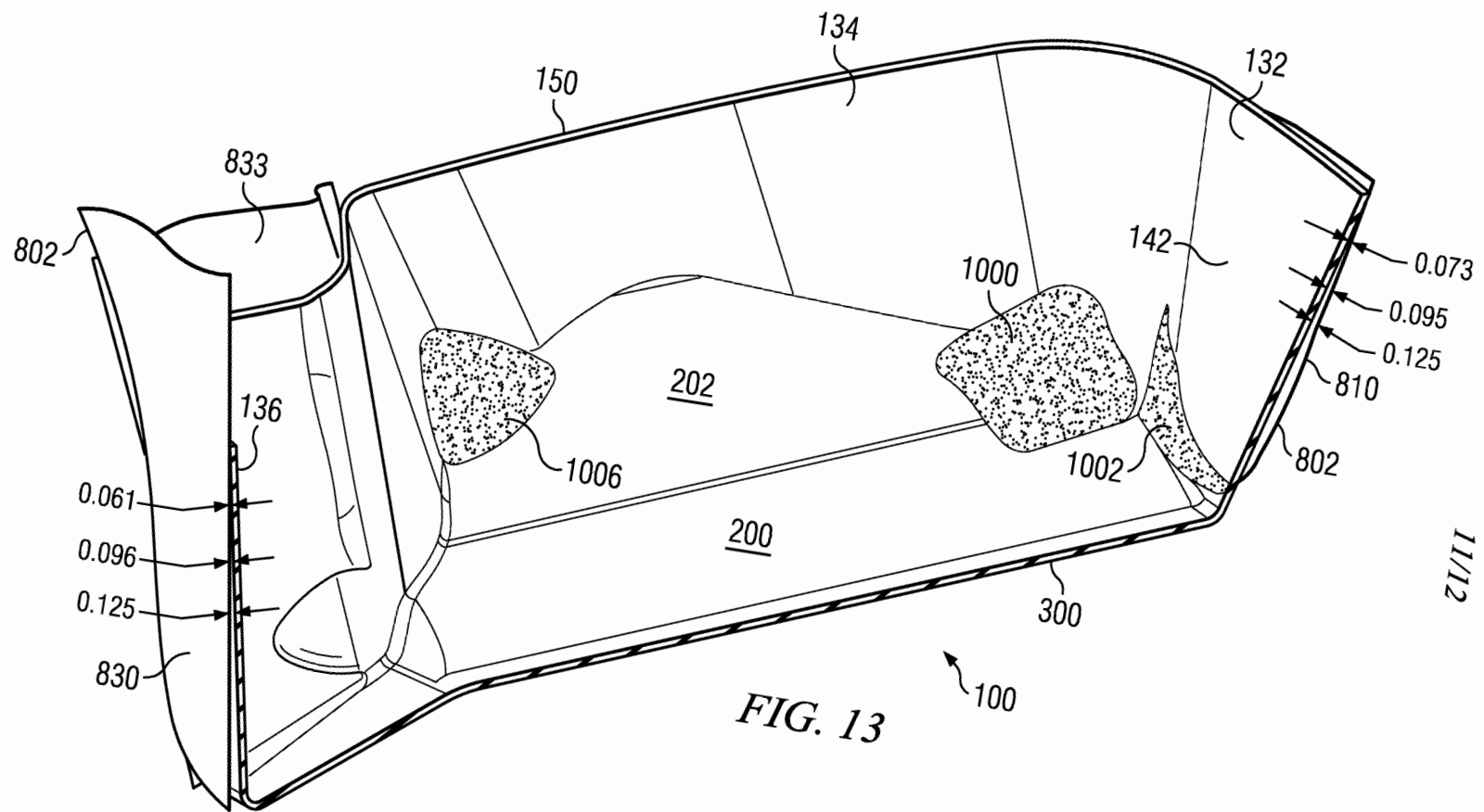

FIG. 12



11/12

31700.000254

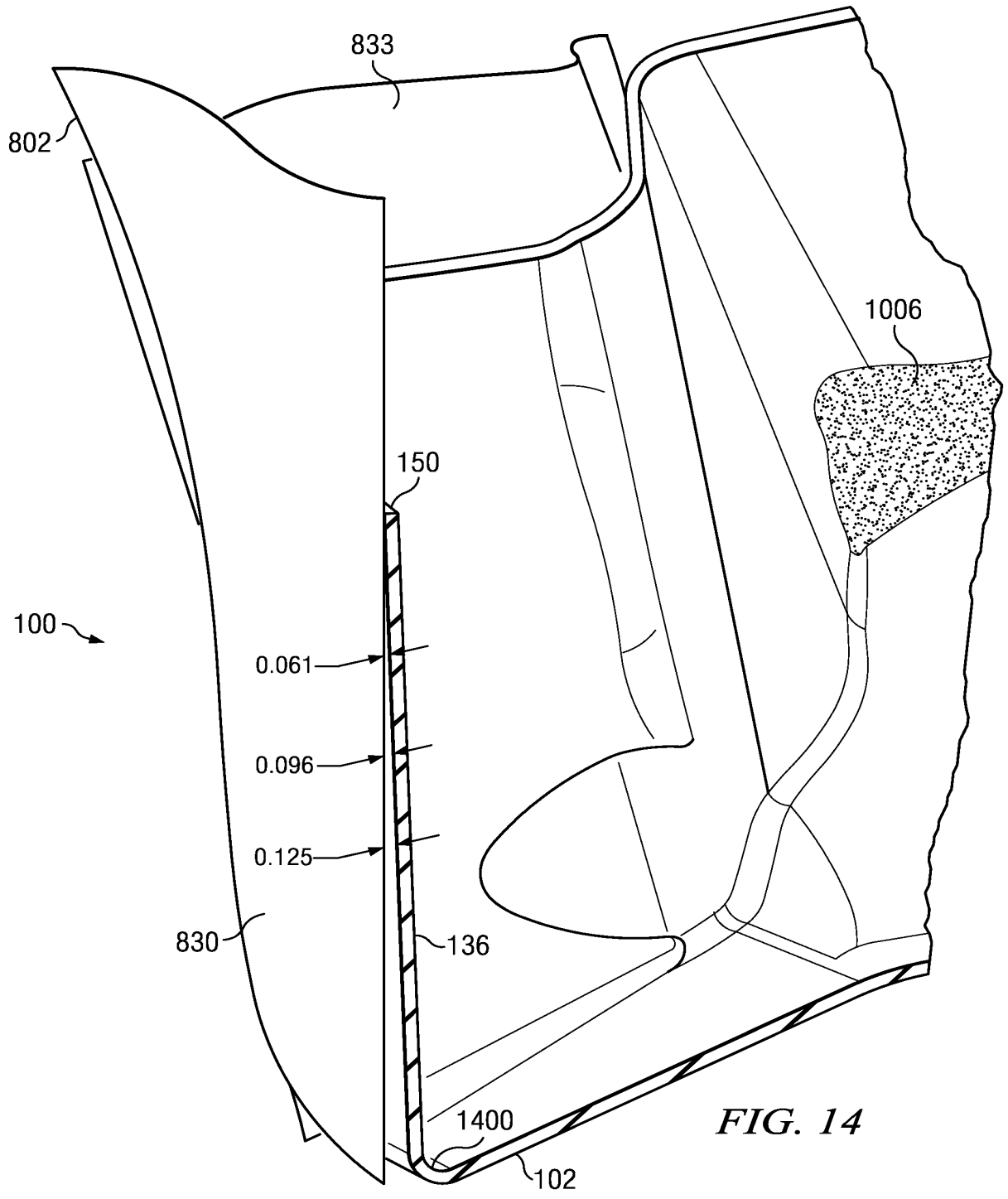

FIG. 14

INVENTORS' DECLARATION

As a below named inventor, I declare that:

My citizenship is as stated below next to my name; that I believe I am the original, first and joint inventor of the subject matter which is claimed and for which a patent is sought on the invention or design entitled DESIGNING AND MANUFACTURING VEHICLE FLOOR TRAYS, the specification of which is filed herewith; that I have reviewed and understand the contents of the above-identified application, including the claims, as amended by any amendment referred to above; and that I acknowledge the duty to disclose to the U.S. Patent and Trademark Office all information known to me to be material to patentability as defined in 37 C.F.R. §1.56, including for continuation-in-part applications, material information which became available between the filing date of the prior application and the national or PCT international filing date of the continuation-in-part application.

Direct all telephone calls to Jefferson Perkins at Telephone No. (630) 434-0414.

Address all correspondence to:

Momkus McCluskey, LLC
1001 Warrenville Road, Suite 500
Lisle, Illinois 60532-4306
email: jperkins@momlaw.com

Customer No. 064770

I hereby acknowledge that the attorneys of the foregoing firm represent the assignee of the above-identified invention and do not represent me.

I declare that all statements made herein of my own knowledge are true and that all statements made on information and belief are believed to be true; and further that these statements were made with the knowledge that willful false statements and the like so made are punishable by fine or imprisonment, or both (18 U.S.C. 1001) and may jeopardize the validity of the application or any patent issuing thereon.

United States Application Number: **Not yet assigned**

Full Name of First Joint Inventor: **David F. MacNeil**

Signature of Inventor: _____

~~DAVID F. MACNEIL~~

Date of Signature: _____

9/10/10

Citizenship: _____

US

Full Name of Second Joint Inventor: **Scott A. Vargo**

Signature of Inventor: _____

Date of Signature: _____

Citizenship: _____

US

I declare that all statements made herein of my own knowledge are true and that all statements made on information and belief are believed to be true; and further that these statements were made with the knowledge that willful false statements and the like so made are punishable by fine or imprisonment, or both (18 U.S.C. 1001) and may jeopardize the validity of the application or any patent issuing thereon.

United States Application Number:	Not yet assigned
Full Name of First Joint Inventor:	David F. MacNeil
Signature of Inventor:	_____
Date of Signature:	_____
Citizenship:	US
Full Name of Second Joint Inventor:	Scott A. Vargo
Signature of Inventor:	_____ /Scott A. Vargo/
Date of Signature:	_____ September 10, 2010
Citizenship:	US

Under the Paperwork Reduction Act of 1995, no persons are required to respond to a collection of information unless it contains a valid OMB control number.

Application Data Sheet 37 CFR 1.76	Attorney Docket Number	31700.000254
	Application Number	
Title of Invention	DESIGNING AND MANUFACTURING VEHICLE FLOOR TRAYS	
The application data sheet is part of the provisional or nonprovisional application for which it is being submitted. The following form contains the bibliographic data arranged in a format specified by the United States Patent and Trademark Office as outlined in 37 CFR 1.76. This document may be completed electronically and submitted to the Office in electronic format using the Electronic Filing System (EFS) or the document may be printed and included in a paper filed application.		

Secrecy Order 37 CFR 5.2

Portions or all of the application associated with this Application Data Sheet may fall under a Secrecy Order pursuant to 37 CFR 5.2 (Paper filers only. Applications that fall under Secrecy Order may not be filed electronically.)

Applicant Information:

Applicant 1						<input type="button" value="Remove"/>
Applicant Authority <input checked="" type="radio"/> Inventor		<input type="radio"/> Legal Representative under 35 U.S.C. 117		<input type="radio"/> Party of Interest under 35 U.S.C. 118		
Prefix	Given Name	Middle Name	Family Name	Suffix		
	David	F.	MACNEIL			
Residence Information (Select One) <input checked="" type="radio"/> US Residency <input type="radio"/> Non US Residency <input type="radio"/> Active US Military Service						
City	Hinsdale	State/Province	IL	Country of Residenceⁱ	US	
Citizenship under 37 CFR 1.41(b)ⁱ		US				
Mailing Address of Applicant:						
Address 1	1 MacNeil Court					
Address 2						
City	Bolingbrook	State/Province	IL			
Postal Code	60440	Countryⁱ	US			
Applicant 2						<input type="button" value="Remove"/>
Applicant Authority <input checked="" type="radio"/> Inventor		<input type="radio"/> Legal Representative under 35 U.S.C. 117		<input type="radio"/> Party of Interest under 35 U.S.C. 118		
Prefix	Given Name	Middle Name	Family Name	Suffix		
	Scott	A.	VARGO			
Residence Information (Select One) <input checked="" type="radio"/> US Residency <input type="radio"/> Non US Residency <input type="radio"/> Active US Military Service						
City	Lombard	State/Province	IL	Country of Residenceⁱ	US	
Citizenship under 37 CFR 1.41(b)ⁱ		US				
Mailing Address of Applicant:						
Address 1	1 MacNeil Court					
Address 2						
City	Bolingbrook	State/Province	IL			
Postal Code	60440	Countryⁱ	US			
All Inventors Must Be Listed - Additional Inventor Information blocks may be generated within this form by selecting the Add button.						<input type="button" value="Add"/>

Correspondence Information:

Enter either Customer Number or complete the Correspondence Information section below. For further information see 37 CFR 1.33(a).

An Address is being provided for the correspondence Information of this application.

Under the Paperwork Reduction Act of 1995, no persons are required to respond to a collection of information unless it contains a valid OMB control number.

Application Data Sheet 37 CFR 1.76		Attorney Docket Number	31700.000254	
		Application Number		
Title of Invention	DESIGNING AND MANUFACTURING VEHICLE FLOOR TRAYS			
Customer Number	64770			
Email Address	jperkins@momlaw.com	<input type="button" value="Add Email"/>	<input type="button" value="Remove Email"/>	

Application Information:

Title of the Invention	DESIGNING AND MANUFACTURING VEHICLE FLOOR TRAYS			
Attorney Docket Number	31700.000254	Small Entity Status Claimed	<input checked="" type="checkbox"/>	
Application Type	Nonprovisional			
Subject Matter	Utility			
Suggested Class (if any)		Sub Class (if any)		
Suggested Technology Center (if any)				
Total Number of Drawing Sheets (if any)	12	Suggested Figure for Publication (if any)	7	

Publication Information:

<input type="checkbox"/>	Request Early Publication (Fee required at time of Request 37 CFR 1.219)
<input type="checkbox"/>	Request Not to Publish. I hereby request that the attached application not be published under 35 U.S.C. 122(b) and certify that the invention disclosed in the attached application has not and will not be the subject of an application filed in another country, or under a multilateral international agreement, that requires publication at eighteen months after filing.

Representative Information:

Representative information should be provided for all practitioners having a power of attorney in the application. Providing this information in the Application Data Sheet does not constitute a power of attorney in the application (see 37 CFR 1.32). Enter either Customer Number or complete the Representative Name section below. If both sections are completed the Customer Number will be used for the Representative Information during processing.			
Please Select One:	<input checked="" type="radio"/> Customer Number	<input type="radio"/> US Patent Practitioner	<input type="radio"/> Limited Recognition (37 CFR 11.9)
Customer Number	64770		

Domestic Benefit/National Stage Information:

This section allows for the applicant to either claim benefit under 35 U.S.C. 119(e), 120, 121, or 365(c) or indicate National Stage entry from a PCT application. Providing this information in the application data sheet constitutes the specific reference required by 35 U.S.C. 119(e) or 120, and 37 CFR 1.78(a)(2) or CFR 1.78(a)(4), and need not otherwise be made part of the specification.			
Prior Application Status	Pending	<input type="button" value="Remove"/>	
Application Number	Continuity Type	Prior Application Number	Filing Date (YYYY-MM-DD)
	Continuation of	11463203	2006-08-08
Prior Application Status	Patented	<input type="button" value="Remove"/>	

Under the Paperwork Reduction Act of 1995, no persons are required to respond to a collection of information unless it contains a valid OMB control number.

Application Data Sheet 37 CFR 1.76		Attorney Docket Number	31700.000254		
		Application Number			
Title of Invention	DESIGNING AND MANUFACTURING VEHICLE FLOOR TRAYS				
Application Number	Continuity Type	Prior Application Number	Filing Date (YYYY-MM-DD)	Patent Number	Issue Date (YYYY-MM-DD)
11463203	Division of	10976441	2004-10-29	7316847	2008-01-08
Additional Domestic Benefit/National Stage Data may be generated within this form by selecting the Add button.					<input type="button" value="Add"/>

Foreign Priority Information:

This section allows for the applicant to claim benefit of foreign priority and to identify any prior foreign application for which priority is not claimed. Providing this information in the application data sheet constitutes the claim for priority as required by 35 U.S.C. 119(b) and 37 CFR 1.55(a).

<input type="button" value="Remove"/>			
Application Number	Country ⁱ	Parent Filing Date (YYYY-MM-DD)	Priority Claimed
			<input type="radio"/> Yes <input checked="" type="radio"/> No
Additional Foreign Priority Data may be generated within this form by selecting the Add button.			<input type="button" value="Add"/>

Assignee Information:

Providing this information in the application data sheet does not substitute for compliance with any requirement of part 3 of Title 37 of the CFR to have an assignment recorded in the Office.

<input type="button" value="Remove"/>			
Assignee 1			
If the Assignee is an Organization check here. <input checked="" type="checkbox"/>			
Organization Name	MacNeil IP LLC		
Mailing Address Information:			
Address 1	1 MacNeil Court		
Address 2			
City	Bolingbrook	State/Province	IL
Country ⁱ	US	Postal Code	60440
Phone Number		Fax Number	
Email Address			
Additional Assignee Data may be generated within this form by selecting the Add button.			<input type="button" value="Add"/>

Signature:

A signature of the applicant or representative is required in accordance with 37 CFR 1.33 and 10.18. Please see 37 CFR 1.4(d) for the form of the signature.

Signature	/Jefferson Perkins/		Date (YYYY-MM-DD)	2010-09-10
First Name	Jefferson	Last Name	Perkins	Registration Number
				31407

Under the Paperwork Reduction Act of 1995, no persons are required to respond to a collection of information unless it contains a valid OMB control number.

Application Data Sheet 37 CFR 1.76		Attorney Docket Number	31700.000254
		Application Number	
Title of Invention	DESIGNING AND MANUFACTURING VEHICLE FLOOR TRAYS		

This collection of information is required by 37 CFR 1.76. The information is required to obtain or retain a benefit by the public which is to file (and by the USPTO to process) an application. Confidentiality is governed by 35 U.S.C. 122 and 37 CFR 1.14. This collection is estimated to take 23 minutes to complete, including gathering, preparing, and submitting the completed application data sheet form to the USPTO. Time will vary depending upon the individual case. Any comments on the amount of time you require to complete this form and/or suggestions for reducing this burden, should be sent to the Chief Information Officer, U.S. Patent and Trademark Office, U.S. Department of Commerce, P.O. Box 1450, Alexandria, VA 22313-1450. DO NOT SEND FEES OR COMPLETED FORMS TO THIS ADDRESS. **SEND TO: Commissioner for Patents, P.O. Box 1450, Alexandria, VA 22313-1450.**

Privacy Act Statement

The Privacy Act of 1974 (P.L. 93-579) requires that you be given certain information in connection with your submission of the attached form related to a patent application or patent. Accordingly, pursuant to the requirements of the Act, please be advised that: (1) the general authority for the collection of this information is 35 U.S.C. 2(b)(2); (2) furnishing of the information solicited is voluntary; and (3) the principal purpose for which the information is used by the U.S. Patent and Trademark Office is to process and/or examine your submission related to a patent application or patent. If you do not furnish the requested information, the U.S. Patent and Trademark Office may not be able to process and/or examine your submission, which may result in termination of proceedings or abandonment of the application or expiration of the patent.

The information provided by you in this form will be subject to the following routine uses:

1. The information on this form will be treated confidentially to the extent allowed under the Freedom of Information Act (5 U.S.C. 552) and the Privacy Act (5 U.S.C. 552a). Records from this system of records may be disclosed to the Department of Justice to determine whether the Freedom of Information Act requires disclosure of these records.
2. A record from this system of records may be disclosed, as a routine use, in the course of presenting evidence to a court, magistrate, or administrative tribunal, including disclosures to opposing counsel in the course of settlement negotiations.
3. A record in this system of records may be disclosed, as a routine use, to a Member of Congress submitting a request involving an individual, to whom the record pertains, when the individual has requested assistance from the Member with respect to the subject matter of the record.
4. A record in this system of records may be disclosed, as a routine use, to a contractor of the Agency having need for the information in order to perform a contract. Recipients of information shall be required to comply with the requirements of the Privacy Act of 1974, as amended, pursuant to 5 U.S.C. 552a(m).
5. A record related to an International Application filed under the Patent Cooperation Treaty in this system of records may be disclosed, as a routine use, to the International Bureau of the World Intellectual Property Organization, pursuant to the Patent Cooperation Treaty.
6. A record in this system of records may be disclosed, as a routine use, to another federal agency for purposes of National Security review (35 U.S.C. 181) and for review pursuant to the Atomic Energy Act (42 U.S.C. 218(c)).
7. A record from this system of records may be disclosed, as a routine use, to the Administrator, General Services, or his/her designee, during an inspection of records conducted by GSA as part of that agency's responsibility to recommend improvements in records management practices and programs, under authority of 44 U.S.C. 2904 and 2906. Such disclosure shall be made in accordance with the GSA regulations governing inspection of records for this purpose, and any other relevant (i.e., GSA or Commerce) directive. Such disclosure shall not be used to make determinations about individuals.
8. A record from this system of records may be disclosed, as a routine use, to the public after either publication of the application pursuant to 35 U.S.C. 122(b) or issuance of a patent pursuant to 35 U.S.C. 151. Further, a record may be disclosed, subject to the limitations of 37 CFR 1.14, as a routine use, to the public if the record was filed in an application which became abandoned or in which the proceedings were terminated and which application is referenced by either a published application, an application open to public inspections or an issued patent.
9. A record from this system of records may be disclosed, as a routine use, to a Federal, State, or local law enforcement agency, if the USPTO becomes aware of a violation or potential violation of law or regulation.

IN THE UNITED STATES PATENT AND TRADEMARK OFFICE

Applicant: David F. MACNEIL
Application No.: Not yet assigned
Filed: Herewith
Art Unit: Not yet assigned
Examiner: Not yet assigned
Confirmation No.: Not yet assigned

CERTIFICATE OF TRANSMISSION BY
ELECTRONIC FILING
I hereby certify that this correspondence is
being transmitted via the USPTO electronic
filing system in accordance with 37 CFR
§1.6(a)(4) on September 10, 2010.

/Patricia Romanelli/
Patricia Romanelli

Title: DESIGNING AND MANUFACTURING VEHICLE FLOOR TRAYS

Mail Stop Amendment
Commissioner for Patents
P.O. Box 1450
Alexandria, VA 22313-1450

INFORMATION DISCLOSURE STATEMENT UNDER 37 C.F.R. §1.97(B)

Dear Sir:

Pursuant to 37 C.F.R. §§ 1.56 and 1.97(b), Applicant brings to the attention of the Examiner the documents listed on the attached form PTO/SB/08a. This Information Disclosure Statement is being filed prior to receipt of the first Office Action on the merits. Applicant encloses copies of those listed documents other than those which are US patents, US published patent applications, or which have been made of record in an application upon which Applicant relies for a priority date under 35 USC § 120. 37 CFR § 1.97(d).

Applicant respectfully requests that the Examiner consider the listed documents, and evidence that consideration of relevant portions thereof by making appropriate notations on the attached forms.

It is believed that these references either taken alone or in combination do not disclose or suggest the invention claimed by the Applicant. However, it is the Applicant's desire to have these references available in the record for both the Examiner and the public to see. The Applicant specifically reserves all rights of privilege and confidence with respect to this matter and submission of this document is not to be construed as a waiver of those rights. Moreover, submission of this document should not be considered an admission that the references cited herein are proper prior art to the aforementioned application.

This submission does not represent that a search has been made or that no better art exists and does not constitute an admission that each or all of the listed documents are material or constitute "prior art." If it should be determined that any of the listed documents do not constitute "prior art" under United States law, Applicant reserves the right to present to the Office the relevant facts and law regarding the appropriate status of such documents.

Applicant further reserves the right to take appropriate action to establish the patentability of the disclosed invention over the listed documents, should one or more of the documents be applied against the claims of the present application.

No fee is thought to be due in connection with this Information Disclosure Statement Under 37 C.F.R. §1.97(b). However, the Commissioner is hereby authorized to charge any deficiency to Deposit Account No. 503982 of Momkus McCluskey, LLC.

Respectfully submitted,

/Jefferson Perkins/

Jefferson Perkins

Registration No. 31,407

CUSTOMER NO. 64770

MOMKUS McCLUSKEY, LLC
1001 Warrenville Road, Suite 500
Lisle, Illinois 60532-4306
Telephone: (630) 434-0414
Fax: (630) 434-0444
Email: jperkins@momlaw.com

INFORMATION DISCLOSURE STATEMENT BY APPLICANT (Not for submission under 37 CFR 1.99)	Application Number		
	Filing Date		
	First Named Inventor	David F. MACNEIL	
	Art Unit		
	Examiner Name		
	Attorney Docket Number	31700.000254	

U.S. PATENTS						Remove
Examiner Initial*	Cite No	Patent Number	Kind Code ¹	Issue Date	Name of Patentee or Applicant of cited Document	Pages, Columns, Lines where Relevant Passages or Relevant Figures Appear
	1	4280729	A	1981-07-28	Morawski	
	2	4406492	A	1983-09-27	Cackowski	
	3	4591532	A	1986-05-27	Tanaka	
	4	6027782	A	2000-02-22	Sherman	
	5	6793872	B1	2004-09-21	Buss	
	6	6953545	B1	2005-10-11	Tyler	
	7	D377780		1997-02-04	MacNeil	
	8	5776583	A1	1998-07-07	Peyton	

**INFORMATION DISCLOSURE
STATEMENT BY APPLICANT**
(Not for submission under 37 CFR 1.99)

Application Number		
Filing Date		
First Named Inventor	David F. MACNEIL	
Art Unit		
Examiner Name		
Attorney Docket Number	31700.000254	

	9	6155629	A	2000-12-05	Sherman	
	10	6732030	B2	2004-05-04	Jones	
	11	6058618	A	2000-05-09	Hemmelgarn et al.	
	12	5208995	A	1993-05-11	McKendrick	
	13	7401837	B2	2008-07-22	MacNeil	
	14	7444748	B2	2008-11-04	MacNeil	
	15	6007319	A	1999-12-28	Jacobson	
	16	5019993	A	1991-05-28	Montalcini et al.	
	17	7215430	B2	2007-05-08	Kacyra et al.	
	18	2188342	A	1940-01-30	England	
	19	5856828	A	1999-01-05	Letcher, Jr.	

**INFORMATION DISCLOSURE
STATEMENT BY APPLICANT**
(Not for submission under 37 CFR 1.99)

Application Number		
Filing Date		
First Named Inventor	David F. MACNEIL	
Art Unit		
Examiner Name		
Attorney Docket Number	31700.000254	

	20	6817649	B1	2004-11-16	Stanesic	
--	----	---------	----	------------	----------	--

If you wish to add additional U.S. Patent citation information please click the Add button.

U.S.PATENT APPLICATION PUBLICATIONS

Examiner Initial*	Cite No	Publication Number	Kind Code ¹	Publication Date	Name of Patentee or Applicant of cited Document	Pages,Columns,Lines where Relevant Passages or Relevant Figures Appear
	1	20060091695	A1	2006-05-04	MacNeil	
	2	20040048036	A1	2004-03-11	Nakasuji et al.	
	3	20060288578	A1	2006-12-28	MacNeil	

If you wish to add additional U.S. Published Application citation information please click the Add button.

FOREIGN PATENT DOCUMENTS

Examiner Initial*	Cite No	Foreign Document Number ³	Country Code ² j	Kind Code ⁴	Publication Date	Name of Patentee or Applicant of cited Document	Pages,Columns,Lines where Relevant Passages or Relevant Figures Appear	T ⁵
	1	0 968 875	EP	B1	2000-01-05	T.P. Chomarat	Abstract, Claims (partial translation only)	<input type="checkbox"/>
	2	1 198 466	CA	A	1985-12-24	Du Pont et al.	Abstract (partial translation only)	<input type="checkbox"/>
	3	1 101 016	CA	A	1981-05-12	Morawski		<input type="checkbox"/>

If you wish to add additional Foreign Patent Document citation information please click the Add button.

NON-PATENT LITERATURE DOCUMENTS

**INFORMATION DISCLOSURE
STATEMENT BY APPLICANT**
(Not for submission under 37 CFR 1.99)

Application Number		
Filing Date		
First Named Inventor	David F. MACNEIL	
Art Unit		
Examiner Name		
Attorney Docket Number	31700.000254	

Examiner Initials*	Cite No	Include name of the author (in CAPITAL LETTERS), title of the article (when appropriate), title of the item (book, magazine, journal, serial, symposium, catalog, etc), date, pages(s), volume-issue number(s), publisher, city and/or country where published.	T ⁵
	1	Husky Liner for 1999 Ford Super Duty, downloaded from http://www.huskyliners.com/superduty.html on January 3, 2005	<input type="checkbox"/>
	2	Autoform Trunk Liner, English web page, downloaded from http://www.autoform.se/eng/products_trunk_liners.htm on October 20, 2004	<input type="checkbox"/>
	3	"Installation Instructions For Your F-150/F-250 Ford Truck Front Floor Liners", Winfield Consumer Products, February 1, 2001, downloaded from http://www.huskyliners.com on January 3, 2005	<input type="checkbox"/>
	4	Husky Deep Tray Floor Liner, downloaded from http://www.truckstuffusa.com/cusfitdeepr.html on January 3, 2005	<input type="checkbox"/>
	5	Web pages featuring products from 3D Carpet Liners, Weatherboots, Nifty Products, Inc. and Husky, downloaded from http://www.premiermotoring.net on August 11, 2004	<input type="checkbox"/>
	6	WeatherTech Floor Mat and Cargo Liner Product Sheets, MacNeil Automotive Products Limited, Downers Grove, IL, Nov. 1994, 4 pp.	<input type="checkbox"/>
	7	Faro Laser ScanArm, downloaded from http://www.faro.com/Products/ScanArm.asp on September 23, 2004	<input type="checkbox"/>
	8	Faro ScanArm Product Techsheet, downloaded from http://www.faro.com/Products/Product_Techsheets.asp?techsheet_id=106 on October 11, 2004	<input type="checkbox"/>
	9	"CMM Produces Bikes With Custom-Look", downloaded from http://manufacturingcenter.com/man/articles/0604/0604CMM.asp on October 11, 2004	<input type="checkbox"/>
	10	"Stereolithography (SLA) for Rapid Precision Prototypes", p.1, downloaded from http://www.boedeker.com/sla.htm on October 12, 2004	<input type="checkbox"/>

INFORMATION DISCLOSURE STATEMENT BY APPLICANT (Not for submission under 37 CFR 1.99)	Application Number		
	Filing Date		
	First Named Inventor	David F. MACNEIL	
	Art Unit		
	Examiner Name		
	Attorney Docket Number		31700.000254

	11	"About Coordinate Measuring Machines (CMM)", downloaded from http://cmm.globalspec.com on October 11, 2004	<input type="checkbox"/>
	12	"Bagagerumsmattor", downloaded from http://www.autoform.se/sv/produkter_bagagerumsmattor.htm on October 20, 2004	<input type="checkbox"/>
	13	CANADIAN INTELLECTUAL PROPERTY OFFICE, Requisition by the Examiner dated December 17, 2009 on Canadian Patent Application No. 2,672,116.	<input type="checkbox"/>
	14	BRITISH PATENT OFFICE, Search Report on GB Patent Appln. No. GB 0522091.8, 14 Feb 2006	<input type="checkbox"/>
	15	BRITISH PATENT OFFICE, Search Report on GB Patent Appln. No. GB 0522091.8, Claims 47 - 66, 77 and 78, 23 June 2006	<input type="checkbox"/>
	16	BRITISH PATENT OFFICE, Search Report on Patent Appln. No. GB 0522091.8, Claims 67 - 70, 26 June 2006	<input type="checkbox"/>
	17	BRITISH PATENT OFFICE, Search Report on Patent Appln. No. GB 0522091.8, Claims 71 -73, 27 June 2006	<input type="checkbox"/>
	18	BRITISH PATENT OFFICE, Search Report on Patent Appln. No. GB 0522091.8, Claims 79 - 84 and 101 - 105, 23 June 2006	<input type="checkbox"/>
	19	BRITISH PATENT OFFICE, Search Report on Patent Appln. No. GB 522091.8, claims 85 - 100, 27 June 2006	<input type="checkbox"/>

If you wish to add additional non-patent literature document citation information please click the Add button

EXAMINER SIGNATURE

Examiner Signature	Date Considered
--------------------	-----------------

*EXAMINER: Initial if reference considered, whether or not citation is in conformance with MPEP 609. Draw line through a citation if not in conformance and not considered. Include copy of this form with next communication to applicant.

**INFORMATION DISCLOSURE
STATEMENT BY APPLICANT**
(Not for submission under 37 CFR 1.99)

Application Number	
Filing Date	
First Named Inventor	David F. MACNEIL
Art Unit	
Examiner Name	
Attorney Docket Number	31700.000254

¹ See Kind Codes of USPTO Patent Documents at www.USPTO.GOV or MPEP 901.04. ² Enter office that issued the document, by the two-letter code (WIPO Standard ST.3). ³ For Japanese patent documents, the indication of the year of the reign of the Emperor must precede the serial number of the patent document. ⁴ Kind of document by the appropriate symbols as indicated on the document under WIPO Standard ST.16 if possible. ⁵ Applicant is to place a check mark here if English language translation is attached.

**INFORMATION DISCLOSURE
STATEMENT BY APPLICANT**
(Not for submission under 37 CFR 1.99)

Application Number		
Filing Date		
First Named Inventor	David F. MACNEIL	
Art Unit		
Examiner Name		
Attorney Docket Number	31700.000254	

CERTIFICATION STATEMENT

Please see 37 CFR 1.97 and 1.98 to make the appropriate selection(s):

That each item of information contained in the information disclosure statement was first cited in any communication from a foreign patent office in a counterpart foreign application not more than three months prior to the filing of the information disclosure statement. See 37 CFR 1.97(e)(1).

OR

That no item of information contained in the information disclosure statement was cited in a communication from a foreign patent office in a counterpart foreign application, and, to the knowledge of the person signing the certification after making reasonable inquiry, no item of information contained in the information disclosure statement was known to any individual designated in 37 CFR 1.56(c) more than three months prior to the filing of the information disclosure statement. See 37 CFR 1.97(e)(2).

- See attached certification statement.
- Fee set forth in 37 CFR 1.17 (p) has been submitted herewith.
- None

SIGNATURE

A signature of the applicant or representative is required in accordance with CFR 1.33, 10.18. Please see CFR 1.4(d) for the form of the signature.

Signature	/Jefferson Perkins/	Date (YYYY-MM-DD)	2010-09-10
Name/Print	Jefferson Perkins	Registration Number	31407

This collection of information is required by 37 CFR 1.97 and 1.98. The information is required to obtain or retain a benefit by the public which is to file (and by the USPTO to process) an application. Confidentiality is governed by 35 U.S.C. 122 and 37 CFR 1.14. This collection is estimated to take 1 hour to complete, including gathering, preparing and submitting the completed application form to the USPTO. Time will vary depending upon the individual case. Any comments on the amount of time you require to complete this form and/or suggestions for reducing this burden, should be sent to the Chief Information Officer, U.S. Patent and Trademark Office, U.S. Department of Commerce, P.O. Box 1450, Alexandria, VA 22313-1450. **DO NOT SEND FEES OR COMPLETED FORMS TO THIS ADDRESS. SEND TO: Commissioner for Patents, P.O. Box 1450, Alexandria, VA 22313-1450.**

Privacy Act Statement

The Privacy Act of 1974 (P.L. 93-579) requires that you be given certain information in connection with your submission of the attached form related to a patent application or patent. Accordingly, pursuant to the requirements of the Act, please be advised that: (1) the general authority for the collection of this information is 35 U.S.C. 2(b)(2); (2) furnishing of the information solicited is voluntary; and (3) the principal purpose for which the information is used by the U.S. Patent and Trademark Office is to process and/or examine your submission related to a patent application or patent. If you do not furnish the requested information, the U.S. Patent and Trademark Office may not be able to process and/or examine your submission, which may result in termination of proceedings or abandonment of the application or expiration of the patent.

The information provided by you in this form will be subject to the following routine uses:

1. The information on this form will be treated confidentially to the extent allowed under the Freedom of Information Act (5 U.S.C. 552) and the Privacy Act (5 U.S.C. 552a). Records from this system of records may be disclosed to the Department of Justice to determine whether the Freedom of Information Act requires disclosure of these records.
2. A record from this system of records may be disclosed, as a routine use, in the course of presenting evidence to a court, magistrate, or administrative tribunal, including disclosures to opposing counsel in the course of settlement negotiations.
3. A record in this system of records may be disclosed, as a routine use, to a Member of Congress submitting a request involving an individual, to whom the record pertains, when the individual has requested assistance from the Member with respect to the subject matter of the record.
4. A record in this system of records may be disclosed, as a routine use, to a contractor of the Agency having need for the information in order to perform a contract. Recipients of information shall be required to comply with the requirements of the Privacy Act of 1974, as amended, pursuant to 5 U.S.C. 552a(m).
5. A record related to an International Application filed under the Patent Cooperation Treaty in this system of records may be disclosed, as a routine use, to the International Bureau of the World Intellectual Property Organization, pursuant to the Patent Cooperation Treaty.
6. A record in this system of records may be disclosed, as a routine use, to another federal agency for purposes of National Security review (35 U.S.C. 181) and for review pursuant to the Atomic Energy Act (42 U.S.C. 218(c)).
7. A record from this system of records may be disclosed, as a routine use, to the Administrator, General Services, or his/her designee, during an inspection of records conducted by GSA as part of that agency's responsibility to recommend improvements in records management practices and programs, under authority of 44 U.S.C. 2904 and 2906. Such disclosure shall be made in accordance with the GSA regulations governing inspection of records for this purpose, and any other relevant (i.e., GSA or Commerce) directive. Such disclosure shall not be used to make determinations about individuals.
8. A record from this system of records may be disclosed, as a routine use, to the public after either publication of the application pursuant to 35 U.S.C. 122(b) or issuance of a patent pursuant to 35 U.S.C. 151. Further, a record may be disclosed, subject to the limitations of 37 CFR 1.14, as a routine use, to the public if the record was filed in an application which became abandoned or in which the proceedings were terminated and which application is referenced by either a published application, an application open to public inspections or an issued patent.
9. A record from this system of records may be disclosed, as a routine use, to a Federal, State, or local law enforcement agency, if the USPTO becomes aware of a violation or potential violation of law or regulation.

Electronic Patent Application Fee Transmittal

Application Number:				
Filing Date:				
Title of Invention:	DESIGNING AND MANUFACTURING VEHICLE FLOOR TRAYS			
First Named Inventor/Applicant Name:	David F. MACNEIL			
Filer:	Jefferson Perkins/Patricia Romanelli			
Attorney Docket Number:	31700.000254			
Filed as Small Entity				
Utility under 35 USC 111(a) Filing Fees				
Description	Fee Code	Quantity	Amount	Sub-Total in USD(\$)
Basic Filing:				
Utility filing Fee (Electronic filing)	4011	1	82	82
Utility Search Fee	2111	1	270	270
Utility Examination Fee	2311	1	110	110
Pages:				
Claims:				
Miscellaneous-Filing:				
Petition:				
Patent-Appeals-and-Interference:				

Description	Fee Code	Quantity	Amount	Sub-Total in USD(\$)
Post-Allowance-and-Post-Issuance:				
Extension-of-Time:				
Miscellaneous:				
Total in USD (\$)				462

Electronic Acknowledgement Receipt

EFS ID:	8398363
Application Number:	12879899
International Application Number:	
Confirmation Number:	7976
Title of Invention:	DESIGNING AND MANUFACTURING VEHICLE FLOOR TRAYS
First Named Inventor/Applicant Name:	David F. MACNEIL
Customer Number:	64770
Filer:	Jefferson Perkins/Patricia Romanelli
Filer Authorized By:	Jefferson Perkins
Attorney Docket Number:	31700.000254
Receipt Date:	10-SEP-2010
Filing Date:	
Time Stamp:	18:27:57
Application Type:	Utility under 35 USC 111(a)

Payment information:

Submitted with Payment	yes
Payment Type	Deposit Account
Payment was successfully received in RAM	\$462
RAM confirmation Number	5350
Deposit Account	503982
Authorized User	
The Director of the USPTO is hereby authorized to charge indicated fees and credit any overpayment as follows: Charge any Additional Fees required under 37 C.F.R. Section 1.21 (Miscellaneous fees and charges)	

File Listing:					
Document Number	Document Description	File Name	File Size(Bytes)/ Message Digest	Multi Part /.zip	Pages (if appl.)
1	Transmittal of New Application	Transmittal.pdf	105395 8dc76490a6d495b22b401392004ba912459341e2	no	2
Warnings:					
Information:					
2		Specification.pdf	203017 2b8fbd161426087477bd39214feac0b66ec8b9a	yes	42
	Multipart Description/PDF files in .zip description				
	Document Description		Start	End	
	Specification		1	37	
	Claims		38	41	
	Abstract		42	42	
Warnings:					
Information:					
3	Drawings-only black and white line drawings	Drawings.pdf	556715 ec06ef7c0417e60cfd35757f0ab7a917542bdb91	no	12
Warnings:					
Information:					
4	Oath or Declaration filed	Declaration.pdf	191191 0ff2a1421b009c4dfed2f58234d8dbfe79705d41	no	3
Warnings:					
Information:					
5	Application Data Sheet	ADS.pdf	967258 e1e85e0167548b177051316b21b63397eada0e44	no	5
Warnings:					
Information:					
6	Transmittal Letter	IDSTransmittal.pdf	91900 6eace5c39e5c5cc958afefb012acc99b8d9c29fb	no	3
Warnings:					
Information:					
7	Information Disclosure Statement (IDS) Filed (SB/08)	IDS.pdf	614220 0f816c24f17e7f9a24fc2e698927ef4ada5c9875	no	8

Warnings:					
Information:					
8	Fee Worksheet (PTO-875)	fee-info.pdf	33058	no	2
			c9dcca5122800407708988d18ab1cd2d8f7769e		
Warnings:					
Information:					
			Total Files Size (in bytes):	2762754	
<p>This Acknowledgement Receipt evidences receipt on the noted date by the USPTO of the indicated documents, characterized by the applicant, and including page counts, where applicable. It serves as evidence of receipt similar to a Post Card, as described in MPEP 503.</p> <p><u>New Applications Under 35 U.S.C. 111</u> If a new application is being filed and the application includes the necessary components for a filing date (see 37 CFR 1.53(b)-(d) and MPEP 506), a Filing Receipt (37 CFR 1.54) will be issued in due course and the date shown on this Acknowledgement Receipt will establish the filing date of the application.</p> <p><u>National Stage of an International Application under 35 U.S.C. 371</u> If a timely submission to enter the national stage of an international application is compliant with the conditions of 35 U.S.C. 371 and other applicable requirements a Form PCT/DO/EO/903 indicating acceptance of the application as a national stage submission under 35 U.S.C. 371 will be issued in addition to the Filing Receipt, in due course.</p> <p><u>New International Application Filed with the USPTO as a Receiving Office</u> If a new international application is being filed and the international application includes the necessary components for an international filing date (see PCT Article 11 and MPEP 1810), a Notification of the International Application Number and of the International Filing Date (Form PCT/RO/105) will be issued in due course, subject to prescriptions concerning national security, and the date shown on this Acknowledgement Receipt will establish the international filing date of the application.</p>					

IN THE UNITED STATES PATENT & TRADEMARK OFFICE

In re the application of: David F. MACNEIL et al.
Application Number: 12/879,899
Filed: September 10, 2010
For: DESIGNING AND MANUFACTURING VEHICLE FLOOR TRAYS
Confirmation No.: 7976

CERTIFICATE UNDER 37 C.F.R. §3.73(b)
AND POWER OF ATTORNEY

I, David F. MacNeil, am the Manager of MacNeil IP LLC, an Illinois limited liability company (“Assignee”). The Assignee is the owner of the entire right, title and interest in the above-identified patent application (“the Patent Application”) by virtue of an assignment from the inventors of the Patent Application.

As evidence of this assignment, the Assignee points to the assignment recorded at Reel 024971 Frame 0346.

As Manager of Assignee the undersigned is empowered to sign this document on behalf of the Assignee and has full power to grant and revoke powers of attorney.

Assignee hereby appoints the Practitioners associated with Customer Number 64770 as its attorneys to prosecute this Patent Application and to transact all business in the U.S. Patent and Trademark Office connected with the Patent Application and with any resulting patent, said attorneys being of the firm of Momkus McCluskey, LLC, with full power of substitution and revocation, to prosecute this application and represent the undersigned before all competent International Authorities.

Please direct all correspondence to:

Momkus McCluskey, LLC
1001 Warrenville Road, Suite 500
Lisle, Illinois 60532-4306
Fax: (630) 434-0444
email: jperkins@momlaw.com

CUSTOMER NUMBER 64770

Please direct all telephone calls to:

Jefferson Perkins
(630) 434-0414

I hereby declare that all statements made herein of my own knowledge are true, and that all statements made on information and belief are believed to be true; and further, that these statements are made with the knowledge that willful false statements, and the like so made, are punishable by fine or imprisonment, or both, under Section 1001, Title 18 of the United States Code, and that such willful false statements may jeopardize the validity of the application or any patent issuing thereon.

MACNEIL IP LLC

Signature: 

Name: David F. MacNeil

Its: Manager

Date: 9/14/10

Electronic Acknowledgement Receipt

EFS ID:	8453707
Application Number:	12879899
International Application Number:	
Confirmation Number:	7976
Title of Invention:	DESIGNING AND MANUFACTURING VEHICLE FLOOR TRAYS
First Named Inventor/Applicant Name:	David F. MACNEIL
Customer Number:	64770
Filer:	Jefferson Perkins/Patricia Romanelli
Filer Authorized By:	Jefferson Perkins
Attorney Docket Number:	31700.000254
Receipt Date:	20-SEP-2010
Filing Date:	10-SEP-2010
Time Stamp:	15:28:52
Application Type:	Utility under 35 USC 111(a)

Payment information:

Submitted with Payment	no
------------------------	----

File Listing:

Document Number	Document Description	File Name	File Size(Bytes)/ Message Digest	Multi Part /.zip	Pages (if appl.)
1	Power of Attorney	POA.pdf	376063 <small>a4a4e16a101eafe9bf52563445999fe672db8217</small>	no	2

Warnings:

Information:

This Acknowledgement Receipt evidences receipt on the noted date by the USPTO of the indicated documents, characterized by the applicant, and including page counts, where applicable. It serves as evidence of receipt similar to a Post Card, as described in MPEP 503.

New Applications Under 35 U.S.C. 111

If a new application is being filed and the application includes the necessary components for a filing date (see 37 CFR 1.53(b)-(d) and MPEP 506), a Filing Receipt (37 CFR 1.54) will be issued in due course and the date shown on this Acknowledgement Receipt will establish the filing date of the application.

National Stage of an International Application under 35 U.S.C. 371

If a timely submission to enter the national stage of an international application is compliant with the conditions of 35 U.S.C. 371 and other applicable requirements a Form PCT/DO/EO/903 indicating acceptance of the application as a national stage submission under 35 U.S.C. 371 will be issued in addition to the Filing Receipt, in due course.

New International Application Filed with the USPTO as a Receiving Office

If a new international application is being filed and the international application includes the necessary components for an international filing date (see PCT Article 11 and MPEP 1810), a Notification of the International Application Number and of the International Filing Date (Form PCT/RO/105) will be issued in due course, subject to prescriptions concerning national security, and the date shown on this Acknowledgement Receipt will establish the international filing date of the application.



UNITED STATES PATENT AND TRADEMARK OFFICE

UNITED STATES DEPARTMENT OF COMMERCE
United States Patent and Trademark Office
Address: COMMISSIONER FOR PATENTS
P.O. Box 1450
Alexandria, Virginia 22313-1450
www.uspto.gov

APPLICATION NUMBER	FILING OR 371(C) DATE	FIRST NAMED APPLICANT	ATTY. DOCKET NO./TITLE
12/879,899	09/10/2010	David F. MacNeil	31700.000254

CONFIRMATION NO. 7976

64770
Momkus McCluskey, LLC
1001 Warrentville Road, Suite 500
Lisle, IL 60532

POA ACCEPTANCE LETTER



Date Mailed: 10/04/2010

NOTICE OF ACCEPTANCE OF POWER OF ATTORNEY

This is in response to the Power of Attorney filed 09/20/2010.

The Power of Attorney in this application is accepted. Correspondence in this application will be mailed to the above address as provided by 37 CFR 1.33.

/tlulu/

Office of Data Management, Application Assistance Unit (571) 272-4000, or (571) 272-4200, or 1-888-786-0101



UNITED STATES PATENT AND TRADEMARK OFFICE

UNITED STATES DEPARTMENT OF COMMERCE
United States Patent and Trademark Office
Address: COMMISSIONER FOR PATENTS
P.O. Box 1450
Alexandria, Virginia 22313-1450
www.uspto.gov

Table with 7 columns: APPLICATION NUMBER, FILING or 371(c) DATE, GRP ART UNIT, FIL FEE REC'D, ATTY.DOCKET.NO, TOT CLAIMS, IND CLAIMS. Values: 12/879,899, 09/10/2010, 3612, 462, 31700.000254, 8, 3

CONFIRMATION NO. 7976

64770
Momkus McCluskey, LLC
1001 Warrenville Road, Suite 500
Lisle, IL 60532

FILING RECEIPT



Date Mailed: 10/04/2010

Receipt is acknowledged of this non-provisional patent application. The application will be taken up for examination in due course. Applicant will be notified as to the results of the examination. Any correspondence concerning the application must include the following identification information: the U.S. APPLICATION NUMBER, FILING DATE, NAME OF APPLICANT, and TITLE OF INVENTION. Fees transmitted by check or draft are subject to collection. Please verify the accuracy of the data presented on this receipt. If an error is noted on this Filing Receipt, please submit a written request for a Filing Receipt Correction. Please provide a copy of this Filing Receipt with the changes noted thereon. If you received a "Notice to File Missing Parts" for this application, please submit any corrections to this Filing Receipt with your reply to the Notice. When the USPTO processes the reply to the Notice, the USPTO will generate another Filing Receipt incorporating the requested corrections

Applicant(s)

David F. MacNeil, Hinsdale, IL;
Scott A. Vergo, Lombard, IL;

Assignment For Published Patent Application

MacNeil IP LLC, Bolingbrook, IL

Power of Attorney: The patent practitioners associated with Customer Number 64770

Domestic Priority data as claimed by applicant

This application is a CON of 11/463,203 08/08/2006
which is a DIV of 10/976,441 10/29/2004 PAT 7,316,847

Foreign Applications

If Required, Foreign Filing License Granted: 09/20/2010

The country code and number of your priority application, to be used for filing abroad under the Paris Convention, is US 12/879,899

Projected Publication Date: 01/13/2011

Non-Publication Request: No

Early Publication Request: No

** SMALL ENTITY **

Title

DESIGNING AND MANUFACTURING VEHICLE FLOOR TRAYS

Preliminary Class

296

PROTECTING YOUR INVENTION OUTSIDE THE UNITED STATES

Since the rights granted by a U.S. patent extend only throughout the territory of the United States and have no effect in a foreign country, an inventor who wishes patent protection in another country must apply for a patent in a specific country or in regional patent offices. Applicants may wish to consider the filing of an international application under the Patent Cooperation Treaty (PCT). An international (PCT) application generally has the same effect as a regular national patent application in each PCT-member country. The PCT process **simplifies** the filing of patent applications on the same invention in member countries, but **does not result** in a grant of "an international patent" and does not eliminate the need of applicants to file additional documents and fees in countries where patent protection is desired.

Almost every country has its own patent law, and a person desiring a patent in a particular country must make an application for patent in that country in accordance with its particular laws. Since the laws of many countries differ in various respects from the patent law of the United States, applicants are advised to seek guidance from specific foreign countries to ensure that patent rights are not lost prematurely.

Applicants also are advised that in the case of inventions made in the United States, the Director of the USPTO must issue a license before applicants can apply for a patent in a foreign country. The filing of a U.S. patent application serves as a request for a foreign filing license. The application's filing receipt contains further information and guidance as to the status of applicant's license for foreign filing.

Applicants may wish to consult the USPTO booklet, "General Information Concerning Patents" (specifically, the section entitled "Treaties and Foreign Patents") for more information on timeframes and deadlines for filing foreign patent applications. The guide is available either by contacting the USPTO Contact Center at 800-786-9199, or it can be viewed on the USPTO website at <http://www.uspto.gov/web/offices/pac/doc/general/index.html>.

For information on preventing theft of your intellectual property (patents, trademarks and copyrights), you may wish to consult the U.S. Government website, <http://www.stopfakes.gov>. Part of a Department of Commerce initiative, this website includes self-help "toolkits" giving innovators guidance on how to protect intellectual property in specific countries such as China, Korea and Mexico. For questions regarding patent enforcement issues, applicants may call the U.S. Government hotline at 1-866-999-HALT (1-866-999-4158).

LICENSE FOR FOREIGN FILING UNDER

Title 35, United States Code, Section 184

Title 37, Code of Federal Regulations, 5.11 & 5.15

GRANTED

The applicant has been granted a license under 35 U.S.C. 184, if the phrase "IF REQUIRED, FOREIGN FILING LICENSE GRANTED" followed by a date appears on this form. Such licenses are issued in all applications where the conditions for issuance of a license have been met, regardless of whether or not a license may be required as

set forth in 37 CFR 5.15. The scope and limitations of this license are set forth in 37 CFR 5.15(a) unless an earlier license has been issued under 37 CFR 5.15(b). The license is subject to revocation upon written notification. The date indicated is the effective date of the license, unless an earlier license of similar scope has been granted under 37 CFR 5.13 or 5.14.

This license is to be retained by the licensee and may be used at any time on or after the effective date thereof unless it is revoked. This license is automatically transferred to any related applications(s) filed under 37 CFR 1.53(d). This license is not retroactive.

The grant of a license does not in any way lessen the responsibility of a licensee for the security of the subject matter as imposed by any Government contract or the provisions of existing laws relating to espionage and the national security or the export of technical data. Licensees should apprise themselves of current regulations especially with respect to certain countries, of other agencies, particularly the Office of Defense Trade Controls, Department of State (with respect to Arms, Munitions and Implements of War (22 CFR 121-128)); the Bureau of Industry and Security, Department of Commerce (15 CFR parts 730-774); the Office of Foreign Assets Control, Department of Treasury (31 CFR Parts 500+) and the Department of Energy.

NOT GRANTED

No license under 35 U.S.C. 184 has been granted at this time, if the phrase "IF REQUIRED, FOREIGN FILING LICENSE GRANTED" DOES NOT appear on this form. Applicant may still petition for a license under 37 CFR 5.12, if a license is desired before the expiration of 6 months from the filing date of the application. If 6 months has lapsed from the filing date of this application and the licensee has not received any indication of a secrecy order under 35 U.S.C. 181, the licensee may foreign file the application pursuant to 37 CFR 5.15(b).

IN THE UNITED STATES PATENT & TRADEMARK OFFICE

In re the application of: David F. MACNEIL et al.
Application Number: 12/879,899
Filing Date: September 10, 2010
Art Unit: 3726
Examiner: not assigned
Confirmation Number: 7976

CERTIFICATE OF TRANSMISSION BY
ELECTRONIC FILING
I hereby certify that this correspondence is
being transmitted via the USPTO electronic
filing system in accordance with 37 CFR
§1.6(a)(4) on December 1, 2010.

/Patricia Romanelli/
Patricia Romanelli

For: DESIGNING AND MANUFACTURING VEHICLE FLOOR TRAYS

Commissioner for Patents
P.O. Box 1450
Alexandria, VA 22313-1450

PRELIMINARY AMENDMENT

Dear Sir:

Applicants amend the claims as follows.

IN THE CLAIMS

Please amend the claims according to the following Claim Listing. In particular, Applicants have canceled Claims 1-3 and 6, have added new Claims 9-39 and have amended Claims 4 and 5.

CLAIM LISTING

1. (Canceled).

2. (Canceled).

3. (Canceled).

4. (Currently Amended) The process of Claim [[1]]Z, wherein the step of using the stored three-dimensional ~~representation~~ electronic image to construct a mold for the vehicle floor tray comprises the substeps of

using a file derived from the stored three-dimensional ~~representation~~ electronic image to command a sterelithographic apparatus (SLA);

responsive to the last said substep of using, selectively curing liquid photopolymer in the SLA with a laser; and

responsive to the substep of curing, forming a plastic model of the vehicle floor tray.

5. (Currently Amended) The process of Claim [[1]]Z, and further comprising the step of modifying the drawn sidewalls of the three-dimensional ~~representation~~ electronic image of the vehicle floor tray to conform at least the upper ~~two-thirds~~ one-third of the area of the outer surface of the sidewalls nearest to the top margin to respective surfaces of the vehicle foot well model, such that ~~through~~ ninety percent of those areas the sidewalls of the vehicle floor tray do

not depart from the corresponding surfaces of the vehicle foot well by more than one-eighth of an inch.

6. (Canceled).

7. (Currently amended) A process for ~~manufacturing~~ thermoforming a vehicle floor tray from a sheet of thermoplastic material, comprising the steps of:

digitally measuring the three-dimensional position of a plurality of points on a substantially carpeted surface of a vehicle foot well for which the vehicle floor tray is to be provided;

storing said points in a memory;

~~using~~ including the stored points in an electronic ~~to construct~~ a model of the vehicle foot well surface;

using the model of the vehicle foot well surface to construct a three-dimensional electronic image of a vehicle floor tray, said step of using the model including the substeps of

establishing a top sketch plane to intersect the vehicle foot well surface model and to establish a top margin of the vehicle floor tray;

establishing a bottom sketch plane to be at the lowest elevation of the vehicle floor tray image to be created;

drawing sidewalls between the top sketch plane and the bottom sketch plane to approximate corresponding sidewalls of the vehicle foot well tray; and

using the stored three-dimensional electronic image to construct a mold for the vehicle floor tray.

8. (Original) The process of Claim 7, and further comprising the step of:

tilting the top sketch plane so that it is at an angle to a floor of the vehicle foot well model, such that the produced vehicle floor tray is deeper in a direction toward the vehicle firewall than it is toward a seat of the occupant.

9. (New) The process of Claim 7, wherein the mold is a female mold.

10. (New) The process of Claim 7, wherein the step of using the foot well surface model comprises the substeps of

using the foot well surface model to construct a lower surface of the three dimensional electronic image of the vehicle floor tray; and

shelling a lower surface of the three dimensional electronic image to create an upper surface which is displaced by a uniform thickness away from the lower surface of the three dimensional electronic image of the vehicle floor tray.

11. (New) The process of Claim 7, wherein said step of using the stored three-dimensional electronic image of the vehicle floor tray to construct a mold for the floor tray includes the substeps of

converting the electronic image of the floor tray into a file readable by
stereolithographic apparatus;
commanding the stereolithographic apparatus with the file to create a physical
SLA model of the floor tray;
test-fitting the physical SLA model of the floor model into the vehicle foot well;
and
adjusting the electronic image of the floor tray to optimize the fit of the floor tray
as molded to the vehicle foot well.

12. (New) A vehicle floor tray thermoformed from a sheet of thermoplastic polymeric
material, comprising:

a floor substantially conforming to a floor of a vehicle foot well, the floor having
at least one longitudinally disposed lateral side and at least one transversely disposed lateral side;

a first panel integrally formed with the floor of the floor tray, upwardly extending
from the transversely disposed lateral side of the floor of the floor tray, and closely conforming
to a first foot well wall, the first panel of the tray joined to the floor of the tray by a curved
transition;

a second panel wall integrally formed with the floor and the first wall, upwardly
extending from the longitudinally disposed lateral side of the floor, and closely conforming to a
second foot well wall, the second panel of tray joined to the floor of the tray and to the first panel
of the tray by curved transitions;

the floor of the tray having an upper surface consisting of a forward region and a

rearward region, a reservoir disposed in the rearward region, a general upper surface of the reservoir being lower than a general upper surface of the forward region;

a plurality of upstanding, hollow, elongate baffles disposed in the reservoir, each of the baffles having at least two ends remote from each other, the baffles adapted to elevate the shoe or foot of the occupant above fluid collected in the reservoir and impeding lateral movement, induced by vehicle acceleration, of fluid collected in the reservoir, any portion of the general upper surface of the reservoir connected to a remote portion of the general upper surface of the reservoir by a path formed around ends of the baffles.

13. (New) The floor tray of Claim 12, wherein the baffles include longitudinally oriented portions and transversely oriented portions.

14. (New) The floor tray of Claim 12, further comprising a third panel joined to the floor of the tray and one of the first and second panels by curved transitions and upwardly extending from a third lateral side of the floor of the tray.

15. (New) The floor tray of Claim 14, further comprising a fourth panel of the tray joined to the floor and at least one of the second and third panels by curved transitions, the fourth panel upwardly extending from a fourth lateral side of the floor of the tray.

16. (New) The floor tray of Claim 12, wherein the top margin of at least one of the first and second panels is at least five inches higher than the floor of the tray at its greatest vertical separation therefrom.

17. (New) The floor tray of Claim 12, wherein the first and second panels have top margins which are substantially coplanar with each other.

18. (New) A system including a vehicle and a removable tray for a foot well of the vehicle, comprising:

a vehicle foot well having a surface including a floor, an upstanding generally transverse first wall extending upward from the floor, an upstanding generally longitudinal second wall extending from the floor and substantially formed at an angle to the first wall, the foot well being generally arranged in a longitudinal or fore and aft direction substantially parallel to a direction of travel of the vehicle, at least a portion of the vehicle foot well surface being compressible carpeting;

a vehicle foot well surface model stored as a digital, machine-readable record, the model being a reconstruction of the vehicle foot well surface;

a tray data file electronically derived from the vehicle foot well surface model, the tray data file modified from the vehicle foot well surface model to include a reservoir to be formed in a floor of the floor tray, the tray data file used to make a mold for a vehicle floor tray;

and

a vehicle floor tray thermoformed from a sheet of thermoplastic polymeric material using the mold and for fitting into the vehicle foot well, the tray having a floor with a forward region and a rearward region disposed rearward of the forward region, the reservoir formed in the rearward region;

a plurality of side panels of the tray including an upstanding generally transversely oriented first panel of the tray joined to the floor by a curved transition and closely conforming to said first wall of the vehicle foot well, an upstanding generally longitudinally oriented second panel of the tray joined to the floor and to the first panel by curved transitions and closely conforming to said second wall of the vehicle foot well, the side panels of the tray having an upper margin and an outer surface, at least ninety percent of the one-third of the outer surface of the side panels of the tray adjacent the upper margin being within one-eighth inch of the vehicle foot well walls to which they respectively conform.

19. (New) The system of Claim 18, wherein a height of the top margin of at least one of the first and second panels of the tray measured vertically from the floor of the tray is at least five inches at its highest part.

20. (New) The system of Claim 18, wherein the outside surface of the second panel of the tray faces a transmission tunnel of the vehicle.

21. (New) The system of Claim 18, wherein an outside surface of the second panel of the tray faces a kick plate of the vehicle foot well.

22. (New) The system of Claim 18, wherein an outside surface of the first panel of the tray faces a firewall of the vehicle foot well.

23. (New) The system of Claim 18, wherein an outside surface of the first panel of the tray faces a seat pedestal of the vehicle foot well or a surface of a vehicle seat.

24. (New) The system of Claim 18, wherein the vehicle foot well surface model replicates the vehicle foot well surface as it exists in a substantially uncompressed condition, the vehicle foot well surface being selectively compressed by the tray once the tray is installed in the vehicle.

25. (New) The system of Claim 18, wherein, when the floor tray is superimposed on the vehicle foot well surface model, portions of the bottom surface of the floor tray are in negative standoff with the vehicle foot well surface model.

26. (New) The system of Claim 25, wherein said portions of the vehicle floor tray in negative standoff include a region of the first panel of the vehicle floor tray which covers a corresponding region of the first wall of the vehicle foot well near an accelerator pedal of the vehicle.

27. (New) A system including a vehicle and a removable tray for a foot well of the vehicle, comprising:

a vehicle foot well having a substantially carpeted upper surface including a floor, an upstanding generally transverse first wall extending upward from the floor, an upstanding generally longitudinal second wall extending from the floor and substantially formed at an angle to the first wall, and an upstanding generally longitudinal third wall extending from the floor and substantially formed at an angle to the first wall; and

a consumer-installable and removable tray thermoformed from a sheet of thermoplastic material for fitting to the upper surface of the vehicle foot well, a floor of the tray approximately conforming to the floor of the foot well, an upstanding generally transversely oriented first panel of the tray joined to the floor of the tray by a curved transition and closely conforming to said first wall of the vehicle foot well, an upstanding generally longitudinally oriented second panel of the tray joined to the floor of the tray and to the first panel of the tray by respective curved transitions, the second panel of the tray closely conforming to said second wall of the vehicle foot well, and an upstanding generally longitudinal third panel of the tray joined to the floor of the tray and to the first panel of the tray by respective curved transitions, the third panel of the tray closely conforming to said third wall of the vehicle foot well;

the first, second, and third panels of the tray having a top margin and an outer surface facing a respective wall of the vehicle foot well, for each said upstanding panel of the tray, at least ninety percent of at least that one-third of an area of the outer surface of the tray panel which is adjacent the top margin of the tray panel being no more than one-eighth of an inch from the surface of a respective wall of the vehicle foot well.

28. (New) The system of Claim 27, wherein the vehicle foot well has a fourth generally transversely oriented wall extending from the floor of the vehicle foot well, substantially formed at an angle to the second wall, and having a surface, and wherein the tray further includes a fourth generally transversely oriented panel extending from the floor of the tray, the fourth panel of the tray having a top margin and an outer surface facing the fourth wall of the vehicle foot well, the fourth panel joined to the floor of the tray, the second panel and the third panel by respective curved transitions, at least ninety percent of that one-third of an area of the outer surface which is adjacent the top margin of first the tray panel being no more than one-eighth of an inch from the surface of the fourth wall of the vehicle foot well.

29. (New) The system of Claim 27, wherein a depth of said first panel of the tray as vertically measured from the top margin to the floor is at least five inches at its deepest part.

30. (New) The system of Claim 27, wherein the outside surface of the first panel of the tray faces a firewall of the vehicle foot well.

31. (New) The system of Claim 27, wherein the outside surface of the second panel of the tray faces a transmission tunnel of the vehicle foot well.

32. (New) The system of Claim 27, wherein at least one of the vehicle foot well walls includes a curved surface, an outside surface of a respective upstanding panel of the tray being a

conforming curved surface, each of said curved surfaces containing both concave and convex curves.

33. (New) The system of Claim 27, wherein the vehicle foot well upper surface includes a substantially horizontally disposed uncarpeted door sill plate surface, the vehicle tray including a mating sill plate panel, a lower surface of the vehicle tray sill plate panel being no more than about 0.025 inch from the door sill plate surface.

34. (New) The system of Claim 27, wherein the vehicle foot well upper surface includes an uncarpeted door sill curve surface which curves forwardly from a substantially horizontal position to a substantially upstanding position, the vehicle tray including a mating sill curve panel, an outer surface of the sill curve panel of the tray being no more than about 0.025 inch from the door sill curve surface.

35. (New) The system of Claim 27, wherein the floor of the tray has a forward region with an upper surface and a rearward region disposed rearwardly of the forward region, a reservoir disposed in the forward region, a general upper surface of the reservoir being downwardly displaced from the upper surface of the forward region.

36. (New) The system of Claim 35, wherein the tray further includes a plurality of elongate, hollow baffles upstanding from the general upper surface of the reservoir.

37. (New) A system including a vehicle and a tray for removable installation by a consumer into a foot well of the vehicle, comprising:

a substantially carpeted vehicle foot well upper surface including a floor, at least first, second, and third upstanding walls extending from the floor; and

a tray thermoformed from a sheet of thermoplastic material, the tray adapted for removable installation into the vehicle foot well by a consumer, a floor of the tray approximately conforming to the floor of the foot well, an upstanding first panel of the tray joined to the floor of the tray by a curved transition, the first panel of the tray having a first outer surface facing the first wall of the vehicle foot well, an upstanding second panel of the tray joined to the floor of the tray and to the first panel of the tray by respective curved transitions and having a second outer surface facing the second wall of the vehicle foot well, an upstanding third panel of the tray joined to the floor of the tray and to the first panel of the tray by respective curved transitions, the third panel of the tray having a third outer surface facing the third wall of the vehicle foot well, at least fifty percent of the area of the first, second, and third outer surfaces being no more than one-eighth of an inch from the closest surface of the vehicle foot well.

38. (New) The system of Claim 37, wherein the floor of the tray consists of a forward region with an upper surface and a rearward region disposed rearwardly of the forward region, a reservoir disposed in the rearward region, a general upper surface of the reservoir being downwardly displaced from the upper surface of the forward region.

39. (New) The system of Claim 38, wherein the tray further includes a plurality of elongate, hollow baffles upstanding from the general upper surface of the reservoir.

REMARKS

Applicants electronically submit herewith an excess claims fee of \$610.00. No other fee is believed to be due with the filing of this Preliminary Amendment. However, the Commissioner is hereby authorized to charge any deficiency or credit any overpayment to Deposit Account No. 503982 of Momkus McCluskey, LLC.

Respectfully submitted,

/Jefferson Perkins/

Registration No. 31,407

CUSTOMER NO. 64770

MOMKUS McCLUSKEY, LLC
1001 Warrenville Rd., Suite 500
Lisle, Illinois 60532
Telephone: (630) 434-0414
Fax: (630) 434-0444
Email: jperkins@momlaw.com

Electronic Patent Application Fee Transmittal

Application Number:	12879899			
Filing Date:	10-Sep-2010			
Title of Invention:	DESIGNING AND MANUFACTURING VEHICLE FLOOR TRAYS			
First Named Inventor/Applicant Name:	David F. MacNeil			
Filer:	Jefferson Perkins/Patricia Romanelli			
Attorney Docket Number:	31700.000254			
Filed as Small Entity				
Utility under 35 USC 111(a) Filing Fees				
Description	Fee Code	Quantity	Amount	Sub-Total in USD(\$)
Basic Filing:				
Pages:				
Claims:				
Claims in excess of 20	2202	15	26	390
Independent claims in excess of 3	2201	2	110	220
Miscellaneous-Filing:				
Petition:				
Patent-Appeals-and-Interference:				
Post-Allowance-and-Post-Issuance:				

Description	Fee Code	Quantity	Amount	Sub-Total in USD(\$)
Extension-of-Time:				
Miscellaneous:				
Total in USD (\$)				610

Electronic Acknowledgement Receipt

EFS ID:	8941858
Application Number:	12879899
International Application Number:	
Confirmation Number:	7976
Title of Invention:	DESIGNING AND MANUFACTURING VEHICLE FLOOR TRAYS
First Named Inventor/Applicant Name:	David F. MacNeil
Customer Number:	64770
Filer:	Jefferson Perkins/Patricia Romanelli
Filer Authorized By:	Jefferson Perkins
Attorney Docket Number:	31700.000254
Receipt Date:	01-DEC-2010
Filing Date:	10-SEP-2010
Time Stamp:	12:57:35
Application Type:	Utility under 35 USC 111(a)

Payment information:

Submitted with Payment	yes
Payment Type	Deposit Account
Payment was successfully received in RAM	\$610
RAM confirmation Number	11069
Deposit Account	503982
Authorized User	
The Director of the USPTO is hereby authorized to charge indicated fees and credit any overpayment as follows: Charge any Additional Fees required under 37 C.F.R. Section 1.21 (Miscellaneous fees and charges)	

File Listing:					
Document Number	Document Description	File Name	File Size(Bytes)/ Message Digest	Multi Part /.zip	Pages (if appl.)
1		PreliminaryAmendment.pdf	129304 1f2749d5398e314f1ba4084b60fb2295155c299e	yes	15
Multipart Description/PDF files in .zip description					
	Document Description		Start	End	
	Preliminary Amendment		1	1	
	Claims		2	14	
	Applicant Arguments/Remarks Made in an Amendment		15	15	
Warnings:					
Information:					
2	Fee Worksheet (PTO-875)	fee-info.pdf	31809 1184886caa41af48ab69ccc33effb681edde18aa	no	2
Warnings:					
Information:					
Total Files Size (in bytes):			161113		
<p>This Acknowledgement Receipt evidences receipt on the noted date by the USPTO of the indicated documents, characterized by the applicant, and including page counts, where applicable. It serves as evidence of receipt similar to a Post Card, as described in MPEP 503.</p> <p><u>New Applications Under 35 U.S.C. 111</u> If a new application is being filed and the application includes the necessary components for a filing date (see 37 CFR 1.53(b)-(d) and MPEP 506), a Filing Receipt (37 CFR 1.54) will be issued in due course and the date shown on this Acknowledgement Receipt will establish the filing date of the application.</p> <p><u>National Stage of an International Application under 35 U.S.C. 371</u> If a timely submission to enter the national stage of an international application is compliant with the conditions of 35 U.S.C. 371 and other applicable requirements a Form PCT/DO/EO/903 indicating acceptance of the application as a national stage submission under 35 U.S.C. 371 will be issued in addition to the Filing Receipt, in due course.</p> <p><u>New International Application Filed with the USPTO as a Receiving Office</u> If a new international application is being filed and the international application includes the necessary components for an international filing date (see PCT Article 11 and MPEP 1810), a Notification of the International Application Number and of the International Filing Date (Form PCT/RO/105) will be issued in due course, subject to prescriptions concerning national security, and the date shown on this Acknowledgement Receipt will establish the international filing date of the application.</p>					

Under the Paperwork Reduction Act of 1995, no persons are required to respond to a collection of information unless it displays a valid OMB control number.

PATENT APPLICATION FEE DETERMINATION RECORD Substitute for Form PTO-875	Application or Docket Number 12/879,899	Filing Date 09/10/2010	<input type="checkbox"/> To be Mailed
---	---	----------------------------------	---------------------------------------

APPLICATION AS FILED – PART I			OTHER THAN SMALL ENTITY			
(Column 1)	(Column 2)	SMALL ENTITY <input checked="" type="checkbox"/>	OR	SMALL ENTITY		
FOR	NUMBER FILED	NUMBER EXTRA	RATE (\$)	FEE (\$)	RATE (\$)	FEE (\$)
<input checked="" type="checkbox"/> BASIC FEE <small>(37 CFR 1.16(a), (b), or (c))</small>	N/A	N/A	N/A	82	N/A	
<input checked="" type="checkbox"/> SEARCH FEE <small>(37 CFR 1.16(k), (l), or (m))</small>	N/A	N/A	N/A	270	N/A	
<input checked="" type="checkbox"/> EXAMINATION FEE <small>(37 CFR 1.16(o), (p), or (q))</small>	N/A	N/A	N/A	110	N/A	
TOTAL CLAIMS <small>(37 CFR 1.16(i))</small>	8 minus 20 =	* 0	X \$26 =	0	OR	X \$ =
INDEPENDENT CLAIMS <small>(37 CFR 1.16(h))</small>	3 minus 3 =	* 0	X \$110 =	0	OR	X \$ =
<input type="checkbox"/> APPLICATION SIZE FEE <small>(37 CFR 1.16(s))</small>	If the specification and drawings exceed 100 sheets of paper, the application size fee due is \$250 (\$125 for small entity) for each additional 50 sheets or fraction thereof. See 35 U.S.C. 41(a)(1)(G) and 37 CFR 1.16(s).					
<input type="checkbox"/> MULTIPLE DEPENDENT CLAIM PRESENT <small>(37 CFR 1.16(j))</small>						
* If the difference in column 1 is less than zero, enter "0" in column 2.			TOTAL	462	TOTAL	

APPLICATION AS AMENDED – PART II					OTHER THAN SMALL ENTITY					
	(Column 1)	(Column 2)	(Column 3)		SMALL ENTITY	OR	SMALL ENTITY			
AMENDMENT	12/01/2010	CLAIMS REMAINING AFTER AMENDMENT	HIGHEST NUMBER PREVIOUSLY PAID FOR	PRESENT EXTRA	RATE (\$)	ADDITIONAL FEE (\$)	RATE (\$)	ADDITIONAL FEE (\$)		
	Total <small>(37 CFR 1.16(i))</small>	* 35	Minus	** 20	=	15	OR	X \$ =		
	Independent <small>(37 CFR 1.16(h))</small>	* 5	Minus	*** 3	=	2	OR	X \$ =		
	<input type="checkbox"/> Application Size Fee <small>(37 CFR 1.16(s))</small>									
	<input type="checkbox"/> FIRST PRESENTATION OF MULTIPLE DEPENDENT CLAIM <small>(37 CFR 1.16(j))</small>									
					TOTAL ADD'L FEE	610	OR	TOTAL ADD'L FEE		

	(Column 1)	(Column 2)	(Column 3)		SMALL ENTITY	OR	SMALL ENTITY			
AMENDMENT	CLAIMS REMAINING AFTER AMENDMENT	HIGHEST NUMBER PREVIOUSLY PAID FOR	PRESENT EXTRA	RATE (\$)	ADDITIONAL FEE (\$)	RATE (\$)	ADDITIONAL FEE (\$)			
	Total <small>(37 CFR 1.16(i))</small>	*	Minus	**	=	OR	X \$ =			
	Independent <small>(37 CFR 1.16(h))</small>	*	Minus	***	=	OR	X \$ =			
	<input type="checkbox"/> Application Size Fee <small>(37 CFR 1.16(s))</small>									
	<input type="checkbox"/> FIRST PRESENTATION OF MULTIPLE DEPENDENT CLAIM <small>(37 CFR 1.16(j))</small>									
					TOTAL ADD'L FEE	OR	TOTAL ADD'L FEE			

* If the entry in column 1 is less than the entry in column 2, write "0" in column 3.
 ** If the "Highest Number Previously Paid For" IN THIS SPACE is less than 20, enter "20".
 *** If the "Highest Number Previously Paid For" IN THIS SPACE is less than 3, enter "3".
 The "Highest Number Previously Paid For" (Total or Independent) is the highest number found in the appropriate box in column 1.

Legal Instrument Examiner:
 /JULIET MCMILLAN/

This collection of information is required by 37 CFR 1.16. The information is required to obtain or retain a benefit by the public which is to file (and by the USPTO to process) an application. Confidentiality is governed by 35 U.S.C. 122 and 37 CFR 1.14. This collection is estimated to take 12 minutes to complete, including gathering, preparing, and submitting the completed application form to the USPTO. Time will vary depending upon the individual case. Any comments on the amount of time you require to complete this form and/or suggestions for reducing this burden, should be sent to the Chief Information Officer, U.S. Patent and Trademark Office, U.S. Department of Commerce, P.O. Box 1450, Alexandria, VA 22313-1450. DO NOT SEND FEES OR COMPLETED FORMS TO THIS ADDRESS. **SEND TO: Commissioner for Patents, P.O. Box 1450, Alexandria, VA 22313-1450.**
 If you need assistance in completing the form, call 1-800-PTO-9199 and select option 2.



UNITED STATES PATENT AND TRADEMARK OFFICE

UNITED STATES DEPARTMENT OF COMMERCE
United States Patent and Trademark Office
Address: COMMISSIONER FOR PATENTS
P.O. Box 1450
Alexandria, Virginia 22313-1450
www.uspto.gov

Table with 4 columns: APPLICATION NUMBER (12/879,899), FILING OR 371(C) DATE (09/10/2010), FIRST NAMED APPLICANT (David F. MacNeil), ATTY. DOCKET NO./TITLE (31700.000254)

CONFIRMATION NO. 7976

64770
Momkus McCluskey, LLC
1001 Warrentville Road, Suite 500
Lisle, IL 60532

PUBLICATION NOTICE



Title:DESIGNING AND MANUFACTURING VEHICLE FLOOR TRAYS
Publication No.US-2011-0009994-A1
Publication Date:01/13/2011

NOTICE OF PUBLICATION OF APPLICATION

The above-identified application will be electronically published as a patent application publication pursuant to 37 CFR 1.211, et seq. The patent application publication number and publication date are set forth above.

The publication may be accessed through the USPTO's publically available Searchable Databases via the Internet at www.uspto.gov. The direct link to access the publication is currently http://www.uspto.gov/patft/.

The publication process established by the Office does not provide for mailing a copy of the publication to applicant. A copy of the publication may be obtained from the Office upon payment of the appropriate fee set forth in 37 CFR 1.19(a)(1). Orders for copies of patent application publications are handled by the USPTO's Office of Public Records. The Office of Public Records can be reached by telephone at (703) 308-9726 or (800) 972-6382, by facsimile at (703) 305-8759, by mail addressed to the United States Patent and Trademark Office, Office of Public Records, Alexandria, VA 22313-1450 or via the Internet.

In addition, information on the status of the application, including the mailing date of Office actions and the dates of receipt of correspondence filed in the Office, may also be accessed via the Internet through the Patent Electronic Business Center at www.uspto.gov using the public side of the Patent Application Information and Retrieval (PAIR) system. The direct link to access this status information is currently http://pair.uspto.gov/. Prior to publication, such status information is confidential and may only be obtained by applicant using the private side of PAIR.

Further assistance in electronically accessing the publication, or about PAIR, is available by calling the Patent Electronic Business Center at 1-866-217-9197.

Office of Data Management, Application Assistance Unit (571) 272-4000, or (571) 272-4200, or 1-888-786-0101



UNITED STATES PATENT AND TRADEMARK OFFICE

UNITED STATES DEPARTMENT OF COMMERCE
United States Patent and Trademark Office
Address: COMMISSIONER FOR PATENTS
P.O. Box 1450
Alexandria, Virginia 22313-1450
www.uspto.gov

APPLICATION NO.	FILING DATE	FIRST NAMED INVENTOR	ATTORNEY DOCKET NO.	CONFIRMATION NO.
-----------------	-------------	----------------------	---------------------	------------------

12/879,899	09/10/2010	David F. MacNeil	31700.000254	7976
------------	------------	------------------	--------------	------

64770 7590 12/16/2011
 Momkus McCluskey, LLC
 1001 Warrenville Road, Suite 500
 Lisle, IL 60532

EXAMINER

TAOUSAKIS, ALEXANDER P

ART UNIT	PAPER NUMBER
----------	--------------

3726

NOTIFICATION DATE	DELIVERY MODE
-------------------	---------------

12/16/2011	ELECTRONIC
------------	------------

Please find below and/or attached an Office communication concerning this application or proceeding.

The time period for reply, if any, is set in the attached communication.

Notice of the Office communication was sent electronically on above-indicated "Notification Date" to the following e-mail address(es):

jperkins@momlaw.com
 promanelli@momlaw.com
 sbehnken@momlaw.com

Office Action Summary	Application No. 12/879,899	Applicant(s) MACNEIL ET AL.	
	Examiner ALEXANDER P. TAOUSAKIS	Art Unit 3726	

-- The MAILING DATE of this communication appears on the cover sheet with the correspondence address --

Period for Reply

A SHORTENED STATUTORY PERIOD FOR REPLY IS SET TO EXPIRE 1 MONTH(S) OR THIRTY (30) DAYS, WHICHEVER IS LONGER, FROM THE MAILING DATE OF THIS COMMUNICATION.

- Extensions of time may be available under the provisions of 37 CFR 1.136(a). In no event, however, may a reply be timely filed after SIX (6) MONTHS from the mailing date of this communication.
- If NO period for reply is specified above, the maximum statutory period will apply and will expire SIX (6) MONTHS from the mailing date of this communication.
- Failure to reply within the set or extended period for reply will, by statute, cause the application to become ABANDONED (35 U.S.C. § 133). Any reply received by the Office later than three months after the mailing date of this communication, even if timely filed, may reduce any earned patent term adjustment. See 37 CFR 1.704(b).

Status

- 1) Responsive to communication(s) filed on 10 September 2010.
- 2a) This action is **FINAL**. 2b) This action is non-final.
- 3) An election was made by the applicant in response to a restriction requirement set forth during the interview on _____; the restriction requirement and election have been incorporated into this action.
- 4) Since this application is in condition for allowance except for formal matters, prosecution as to the merits is closed in accordance with the practice under *Ex parte Quayle*, 1935 C.D. 11, 453 O.G. 213.

Disposition of Claims

- 5) Claim(s) 1-39 is/are pending in the application.
- 5a) Of the above claim(s) _____ is/are withdrawn from consideration.
- 6) Claim(s) _____ is/are allowed.
- 7) Claim(s) _____ is/are rejected.
- 8) Claim(s) _____ is/are objected to.
- 9) Claim(s) 1-39 are subject to restriction and/or election requirement.

Application Papers

- 10) The specification is objected to by the Examiner.
- 11) The drawing(s) filed on _____ is/are: a) accepted or b) objected to by the Examiner.
Applicant may not request that any objection to the drawing(s) be held in abeyance. See 37 CFR 1.85(a).
Replacement drawing sheet(s) including the correction is required if the drawing(s) is objected to. See 37 CFR 1.121(d).
- 12) The oath or declaration is objected to by the Examiner. Note the attached Office Action or form PTO-152.

Priority under 35 U.S.C. § 119

- 13) Acknowledgment is made of a claim for foreign priority under 35 U.S.C. § 119(a)-(d) or (f).
- a) All b) Some * c) None of:
1. Certified copies of the priority documents have been received.
2. Certified copies of the priority documents have been received in Application No. _____.
3. Copies of the certified copies of the priority documents have been received in this National Stage application from the International Bureau (PCT Rule 17.2(a)).

* See the attached detailed Office action for a list of the certified copies not received.

Attachment(s)

- | | |
|--|---|
| 1) <input type="checkbox"/> Notice of References Cited (PTO-892) | 4) <input type="checkbox"/> Interview Summary (PTO-413) |
| 2) <input type="checkbox"/> Notice of Draftsperson's Patent Drawing Review (PTO-948) | Paper No(s)/Mail Date. _____ |
| 3) <input type="checkbox"/> Information Disclosure Statement(s) (PTO/SB/08) | 5) <input type="checkbox"/> Notice of Informal Patent Application |
| Paper No(s)/Mail Date _____ | 6) <input type="checkbox"/> Other: _____ |

DETAILED ACTION

Election/Restrictions

Restriction to one of the following inventions is required under 35 U.S.C. 121:

- I. Claims 4-5 and 7-11, drawn to a process, classified in class 29, subclass 897.2.
- II. Claims 12-17, drawn to a floor tray, classified in class 296, subclass 193.07.
- III. Claims 18-39, drawn to a system, classified in class 700, subclass 98.

The inventions are distinct, each from the other because of the following reasons:

Inventions I and II are related as process of making and product made. The inventions are distinct if either or both of the following can be shown: (1) that the process as claimed can be used to make another and materially different product or (2) that the product as claimed can be made by another and materially different process (MPEP § 806.05(f)). In the instant case the product as claimed can be made by another and materially different process, such as one where the tray dimensions are predetermined by creating a physical model.

Inventions I and II are related as process and apparatus for its practice. The inventions are distinct if it can be shown that either: (1) the process as claimed can be practiced by another and materially different apparatus or by hand, or (2) the apparatus as claimed can be used to practice another and materially different process. (MPEP § 806.05(e)). In this case the apparatus as claimed can be used to practice another and

materially different process, such as one where the dimensions are hand measured, which are inputting into a medium and converted to a digital model.

Inventions II and III are related as apparatus and product made. The inventions in this relationship are distinct if either or both of the following can be shown: (1) that the apparatus as claimed is not an obvious apparatus for making the product and the apparatus can be used for making a materially different product or (2) that the product as claimed can be made by another and materially different apparatus (MPEP § 806.05(g)). In this case the product as claimed can be made by another and materially different apparatus, such as one which utilizes a physical model instead of a digital model.

Restriction for examination purposes as indicated is proper because all these inventions listed in this action are independent or distinct for the reasons given above and there would be a serious search and/or examination burden if restriction were not required because at least the following reason(s) apply:

The groups have separate status in the art due to their different classification.

Applicant is advised that the reply to this requirement to be complete must include (i) an election of a invention to be examined even though the requirement may be traversed (37 CFR 1.143) and (ii) identification of the claims encompassing the elected invention.

The election of an invention may be made with or without traverse. To reserve a right to petition, the election must be made with traverse. If the reply does not distinctly and specifically point out supposed errors in the restriction requirement, the election

shall be treated as an election without traverse. Traversal must be presented at the time of election in order to be considered timely. Failure to timely traverse the requirement will result in the loss of right to petition under 37 CFR 1.144. If claims are added after the election, applicant must indicate which of these claims are readable upon the elected invention.

Should applicant traverse on the ground that the inventions are not patentably distinct, applicant should submit evidence or identify such evidence now of record showing the inventions to be obvious variants or clearly admit on the record that this is the case. In either instance, if the examiner finds one of the inventions unpatentable over the prior art, the evidence or admission may be used in a rejection under 35 U.S.C. 103(a) of the other invention.

Applicant is reminded that upon the cancellation of claims to a non-elected invention, the inventorship must be amended in compliance with 37 CFR 1.48(b) if one or more of the currently named inventors is no longer an inventor of at least one claim remaining in the application. Any amendment of inventorship must be accompanied by a request under 37 CFR 1.48(b) and by the fee required under 37 CFR 1.17(i).

The examiner has required restriction between product and process claims. Where applicant elects claims directed to the product, and the product claims are subsequently found allowable, withdrawn process claims that depend from or otherwise require all the limitations of the allowable product claim will be considered for rejoinder. All claims directed to a nonelected process invention must require all the limitations of an allowable product claim for that process invention to be rejoined.

In the event of rejoinder, the requirement for restriction between the product claims and the rejoined process claims will be withdrawn, and the rejoined process claims will be fully examined for patentability in accordance with 37 CFR 1.104. Thus, to be allowable, the rejoined claims must meet all criteria for patentability including the requirements of 35 U.S.C. 101, 102, 103 and 112. Until all claims to the elected product are found allowable, an otherwise proper restriction requirement between product claims and process claims may be maintained. Withdrawn process claims that are not commensurate in scope with an allowable product claim will not be rejoined. See MPEP § 821.04(b). Additionally, in order to retain the right to rejoinder in accordance with the above policy, applicant is advised that the process claims should be amended during prosecution to require the limitations of the product claims. **Failure to do so may result in a loss of the right to rejoinder.** Further, note that the prohibition against double patenting rejections of 35 U.S.C. 121 does not apply where the restriction requirement is withdrawn by the examiner before the patent issues. See MPEP § 804.01.

Any inquiry concerning this communication or earlier communications from the examiner should be directed to ALEXANDER P. TAOUSAKIS whose telephone number is (571)272-3497. The examiner can normally be reached on M-F 8:00-4:30.

If attempts to reach the examiner by telephone are unsuccessful, the examiner's supervisor, David Bryant can be reached on (571) 272-4526. The fax phone number for the organization where this application or proceeding is assigned is 571-273-8300.

Information regarding the status of an application may be obtained from the Patent Application Information Retrieval (PAIR) system. Status information for published applications may be obtained from either Private PAIR or Public PAIR. Status information for unpublished applications is available through Private PAIR only. For more information about the PAIR system, see <http://pair-direct.uspto.gov>. Should you have questions on access to the Private PAIR system, contact the Electronic Business Center (EBC) at 866-217-9197 (toll-free). If you would like assistance from a USPTO Customer Service Representative or access to the automated information system, call 800-786-9199 (IN USA OR CANADA) or 571-272-1000.

ALEXANDER P TAOUSAKIS
Primary Examiner
Art Unit 3726

/ALEXANDER P TAOUSAKIS/
Primary Examiner, Art Unit 3726

<i>Index of Claims</i> 	Application/Control No. 12879899	Applicant(s)/Patent Under Reexamination MACNEIL ET AL.
	Examiner ALEXANDER P TAOUSAKIS	Art Unit 3726

✓	Rejected
=	Allowed

-	Cancelled
÷	Restricted

N	Non-Elected
I	Interference

A	Appeal
O	Objected

Claims renumbered in the same order as presented by applicant
 CPA
 T.D.
 R.1.47

CLAIM		DATE									
Final	Original	12/13/2011									
	1	÷									
	2	÷									
	3	÷									
	4	÷									
	5	÷									
	6	÷									
	7	÷									
	8	÷									
	9	÷									
	10	÷									
	11	÷									
	12	÷									
	13	÷									
	14	÷									
	15	÷									
	16	÷									
	17	÷									
	18	÷									
	19	÷									
	20	÷									
	21	÷									
	22	÷									
	23	÷									
	24	÷									
	25	÷									
	26	÷									
	27	÷									
	28	÷									
	29	÷									
	30	÷									
	31	÷									
	32	÷									
	33	÷									
	34	÷									
	35	÷									
	36	÷									

<i>Index of Claims</i> 	Application/Control No. 12879899	Applicant(s)/Patent Under Reexamination MACNEIL ET AL.
	Examiner ALEXANDER P TAOUSAKIS	Art Unit 3726

✓	Rejected
=	Allowed

-	Cancelled
÷	Restricted

N	Non-Elected
I	Interference

A	Appeal
O	Objected

<input type="checkbox"/> Claims renumbered in the same order as presented by applicant		<input type="checkbox"/> CPA	<input type="checkbox"/> T.D.	<input type="checkbox"/> R.1.47					
CLAIM		DATE							
Final	Original	12/13/2011							
	37	÷							
	38	÷							
	39	÷							

IN THE UNITED STATES PATENT & TRADEMARK OFFICE

In re the application of: David F. MACNEIL et al.
Application Number: 12/879,899
Filing Date: September 10, 2010
Art Unit: 3726
Examiner: Alexander TAOUSAKIS
Confirmation Number: 7976

CERTIFICATE OF TRANSMISSION BY ELECTRONIC FILING
I hereby certify that this correspondence is being transmitted via the USPTO electronic filing system in accordance with 37 CFR §1.6(a)(4) on the date below:
_____ 15 February 2012 Date
/Patricia Romanelli/ Patricia Romanelli

For: DESIGNING AND MANUFACTURING VEHICLE FLOOR TRAYS

Commissioner for Patents
P.O. Box 1450
Alexandria, VA 22313-1450

REPLY TO RESTRICTION/ELECTION REQUIREMENT

Dear Sir:

This communication is responsive to the Examiner's Action mailed December 16, 2011.

IN THE CLAIMS

Please amend the claims as set forth in the claim set below.

CLAIM SET

1-11. (Canceled).

12. (Previously presented) A vehicle floor tray thermoformed from a sheet of thermoplastic polymeric material, comprising:

a floor substantially conforming to a floor of a vehicle foot well, the floor having at least one longitudinally disposed lateral side and at least one transversely disposed lateral side;

a first panel integrally formed with the floor of the floor tray, upwardly extending from the transversely disposed lateral side of the floor of the floor tray, and closely conforming to a first foot well wall, the first panel of the tray joined to the floor of the tray by a curved transition;

a second panel wall integrally formed with the floor and the first wall, upwardly extending from the longitudinally disposed lateral side of the floor, and closely conforming to a second foot well wall, the second panel of tray joined to the floor of the tray and to the first panel of the tray by curved transitions;

the floor of the tray having an upper surface consisting of a forward region and a rearward region, a reservoir disposed in the rearward region, a general upper surface of the reservoir being lower than a general upper surface of the forward region;

a plurality of upstanding, hollow, elongate baffles disposed in the reservoir, each of the baffles having at least two ends remote from each other, the baffles adapted to elevate the shoe or foot of the occupant above fluid collected in the reservoir and impeding lateral movement, induced by vehicle acceleration, of fluid collected in the reservoir, any portion of the

general upper surface of the reservoir connected to a remote portion of the general upper surface of the reservoir by a path formed around ends of the baffles.

13. (Previously presented) The floor tray of Claim 12, wherein the baffles include longitudinally oriented portions and transversely oriented portions.

14. (Previously presented) The floor tray of Claim 12, further comprising a third panel joined to the floor of the tray and one of the first and second panels by curved transitions and upwardly extending from a third lateral side of the floor of the tray.

15. (Previously presented) The floor tray of Claim 14, further comprising a fourth panel of the tray joined to the floor and at least one of the second and third panels by curved transitions, the fourth panel upwardly extending from a fourth lateral side of the floor of the tray.

16. (Previously presented) The floor tray of Claim 12, wherein the top margin of at least one of the first and second panels is at least five inches higher than the floor of the tray at its greatest vertical separation therefrom.

17. (Previously presented) The floor tray of Claim 12, wherein the first and second panels have top margins which are substantially coplanar with each other.

18 - 39. (Canceled).

REMARKS

In the action, the Examiner found there to be three patentably distinct inventions in the application: Group I - Claims 4, 5, and 7-11, drawn to a process; Group II - Claims 12-17, drawn to a floor tray; and Group III - 18-39, drawn to a system. The Examiner required Applicants to elect a single invention for prosecution on the merits in this application.

In response, Applicants elect Group II, Claims 12-17, drawn to a floor tray, for prosecution in this application. Applicants now await a first action on the merits of the elected claims.

The requisite fee for a one-month extension of time is being submitted herewith. The Commissioner is hereby authorized to charge any deficiency to Deposit Account No. 503982 of Momkus McCluskey, LLC.

Respectfully submitted,

/Steven Behnken/
Steven Behnken
Registration No. 62,451

CUSTOMER NO. 64770

MOMKUS McCLUSKEY, LLC
1001 Warrenville Rd., Suite 500
Lisle, Illinois 60532
Telephone: (630) 434-0400 Ext. 123
Fax: (630) 434-0444
Email: sbehnken@momlaw.com

Electronic Patent Application Fee Transmittal

Application Number:	12879899			
Filing Date:	10-Sep-2010			
Title of Invention:	DESIGNING AND MANUFACTURING VEHICLE FLOOR TRAYS			
First Named Inventor/Applicant Name:	David F. MacNeil			
Filer:	Steven P. Behnken/Patricia Romanelli			
Attorney Docket Number:	31700.000254			
Filed as Small Entity				
Utility under 35 USC 111(a) Filing Fees				
Description	Fee Code	Quantity	Amount	Sub-Total in USD(\$)
Basic Filing:				
Pages:				
Claims:				
Miscellaneous-Filing:				
Petition:				
Patent-Appeals-and-Interference:				
Post-Allowance-and-Post-Issuance:				
Extension-of-Time:				
Extension - 1 month with \$0 paid	2251	1	75	75

Description	Fee Code	Quantity	Amount	Sub-Total in USD(\$)
Miscellaneous:				
Total in USD (\$)				75

Electronic Acknowledgement Receipt

EFS ID:	12080125
Application Number:	12879899
International Application Number:	
Confirmation Number:	7976
Title of Invention:	DESIGNING AND MANUFACTURING VEHICLE FLOOR TRAYS
First Named Inventor/Applicant Name:	David F. MacNeil
Customer Number:	64770
Filer:	Steven P. Behnken/Patricia Romanelli
Filer Authorized By:	Steven P. Behnken
Attorney Docket Number:	31700.000254
Receipt Date:	15-FEB-2012
Filing Date:	10-SEP-2010
Time Stamp:	11:23:47
Application Type:	Utility under 35 USC 111(a)

Payment information:

Submitted with Payment	yes
Payment Type	Deposit Account
Payment was successfully received in RAM	\$75
RAM confirmation Number	9625
Deposit Account	503982
Authorized User	
The Director of the USPTO is hereby authorized to charge indicated fees and credit any overpayment as follows: Charge any Additional Fees required under 37 C.F.R. Section 1.21 (Miscellaneous fees and charges)	

File Listing:					
Document Number	Document Description	File Name	File Size(Bytes)/ Message Digest	Multi Part /.zip	Pages (if appl.)
1		RplyToREReq.pdf	126023 d7794a729ac9244b246e2c3782255c300c8fcfc	yes	4
Multipart Description/PDF files in .zip description					
	Document Description		Start	End	
	Response to Election / Restriction Filed		1	1	
	Claims		2	3	
	Applicant Arguments/Remarks Made in an Amendment		4	4	
Warnings:					
Information:					
2	Fee Worksheet (SB06)	fee-info.pdf	30361 b1e3225052cf08d3d8fc688a8538caaf8f32b98c	no	2
Warnings:					
Information:					
Total Files Size (in bytes):			156384		
<p>This Acknowledgement Receipt evidences receipt on the noted date by the USPTO of the indicated documents, characterized by the applicant, and including page counts, where applicable. It serves as evidence of receipt similar to a Post Card, as described in MPEP 503.</p> <p><u>New Applications Under 35 U.S.C. 111</u> If a new application is being filed and the application includes the necessary components for a filing date (see 37 CFR 1.53(b)-(d) and MPEP 506), a Filing Receipt (37 CFR 1.54) will be issued in due course and the date shown on this Acknowledgement Receipt will establish the filing date of the application.</p> <p><u>National Stage of an International Application under 35 U.S.C. 371</u> If a timely submission to enter the national stage of an international application is compliant with the conditions of 35 U.S.C. 371 and other applicable requirements a Form PCT/DO/EO/903 indicating acceptance of the application as a national stage submission under 35 U.S.C. 371 will be issued in addition to the Filing Receipt, in due course.</p> <p><u>New International Application Filed with the USPTO as a Receiving Office</u> If a new international application is being filed and the international application includes the necessary components for an international filing date (see PCT Article 11 and MPEP 1810), a Notification of the International Application Number and of the International Filing Date (Form PCT/RO/105) will be issued in due course, subject to prescriptions concerning national security, and the date shown on this Acknowledgement Receipt will establish the international filing date of the application.</p>					

Under the Paperwork Reduction Act of 1995, no persons are required to respond to a collection of information unless it displays a valid OMB control number.

PATENT APPLICATION FEE DETERMINATION RECORD Substitute for Form PTO-875	Application or Docket Number 12/879,899	Filing Date 09/10/2010	<input type="checkbox"/> To be Mailed
---	---	----------------------------------	---------------------------------------

APPLICATION AS FILED – PART I			OTHER THAN SMALL ENTITY			
	(Column 1)	(Column 2)	SMALL ENTITY <input checked="" type="checkbox"/>	OR		
FOR	NUMBER FILED	NUMBER EXTRA	RATE (\$)	FEE (\$)	RATE (\$)	FEE (\$)
<input type="checkbox"/> BASIC FEE <small>(37 CFR 1.16(a), (b), or (c))</small>	N/A	N/A	N/A		N/A	
<input type="checkbox"/> SEARCH FEE <small>(37 CFR 1.16(k), (l), or (m))</small>	N/A	N/A	N/A		N/A	
<input type="checkbox"/> EXAMINATION FEE <small>(37 CFR 1.16(o), (p), or (q))</small>	N/A	N/A	N/A		N/A	
TOTAL CLAIMS <small>(37 CFR 1.16(i))</small>	minus 20 = *		X \$ =		X \$ =	
INDEPENDENT CLAIMS <small>(37 CFR 1.16(h))</small>	minus 3 = *		X \$ =		X \$ =	
<input type="checkbox"/> APPLICATION SIZE FEE <small>(37 CFR 1.16(s))</small>	If the specification and drawings exceed 100 sheets of paper, the application size fee due is \$250 (\$125 for small entity) for each additional 50 sheets or fraction thereof. See 35 U.S.C. 41(a)(1)(G) and 37 CFR 1.16(s).					
<input type="checkbox"/> MULTIPLE DEPENDENT CLAIM PRESENT <small>(37 CFR 1.16(j))</small>						
* If the difference in column 1 is less than zero, enter "0" in column 2.			TOTAL		TOTAL	

APPLICATION AS AMENDED – PART II					OTHER THAN SMALL ENTITY					
	(Column 1)	(Column 2)	(Column 3)		SMALL ENTITY	OR				
AMENDMENT	02/15/2012	CLAIMS REMAINING AFTER AMENDMENT	HIGHEST NUMBER PREVIOUSLY PAID FOR	PRESENT EXTRA	RATE (\$)	ADDITIONAL FEE (\$)		RATE (\$)	ADDITIONAL FEE (\$)	
	Total (37 CFR 1.16(i))	* 6	Minus	** 35	=	0	OR	X \$ =		
	Independent (37 CFR 1.16(h))	* 1	Minus	***5	=	0	OR	X \$ =		
	<input type="checkbox"/> Application Size Fee (37 CFR 1.16(s))							OR		
	<input type="checkbox"/> FIRST PRESENTATION OF MULTIPLE DEPENDENT CLAIM (37 CFR 1.16(j))							OR		
					TOTAL ADD'L FEE	0	OR	TOTAL ADD'L FEE		

	(Column 1)	(Column 2)	(Column 3)		SMALL ENTITY	OR				
AMENDMENT		CLAIMS REMAINING AFTER AMENDMENT	HIGHEST NUMBER PREVIOUSLY PAID FOR	PRESENT EXTRA	RATE (\$)	ADDITIONAL FEE (\$)		RATE (\$)	ADDITIONAL FEE (\$)	
	Total (37 CFR 1.16(i))	*	Minus	**	=		OR	X \$ =		
	Independent (37 CFR 1.16(h))	*	Minus	***	=		OR	X \$ =		
	<input type="checkbox"/> Application Size Fee (37 CFR 1.16(s))							OR		
	<input type="checkbox"/> FIRST PRESENTATION OF MULTIPLE DEPENDENT CLAIM (37 CFR 1.16(j))							OR		
					TOTAL ADD'L FEE		OR	TOTAL ADD'L FEE		

* If the entry in column 1 is less than the entry in column 2, write "0" in column 3.
 ** If the "Highest Number Previously Paid For" IN THIS SPACE is less than 20, enter "20".
 *** If the "Highest Number Previously Paid For" IN THIS SPACE is less than 3, enter "3".
 The "Highest Number Previously Paid For" (Total or Independent) is the highest number found in the appropriate box in column 1.

Legal Instrument Examiner:
/CATHERINE SMITH/

This collection of information is required by 37 CFR 1.16. The information is required to obtain or retain a benefit by the public which is to file (and by the USPTO to process) an application. Confidentiality is governed by 35 U.S.C. 122 and 37 CFR 1.14. This collection is estimated to take 12 minutes to complete, including gathering, preparing, and submitting the completed application form to the USPTO. Time will vary depending upon the individual case. Any comments on the amount of time you require to complete this form and/or suggestions for reducing this burden, should be sent to the Chief Information Officer, U.S. Patent and Trademark Office, U.S. Department of Commerce, P.O. Box 1450, Alexandria, VA 22313-1450. DO NOT SEND FEES OR COMPLETED FORMS TO THIS ADDRESS. **SEND TO: Commissioner for Patents, P.O. Box 1450, Alexandria, VA 22313-1450.**
 If you need assistance in completing the form, call 1-800-PTO-9199 and select option 2.

INFORMATION DISCLOSURE STATEMENT BY APPLICANT (Not for submission under 37 CFR 1.99)	Application Number	12879899
	Filing Date	2010-09-10
	First Named Inventor	David F. MACNEIL
	Art Unit	3726
	Examiner Name	Alexander Taousakis
	Attorney Docket Number	31700.000254

U.S. PATENTS						Remove
Examiner Initial*	Cite No	Patent Number	Kind Code ¹	Issue Date	Name of Patentee or Applicant of cited Document	Pages, Columns, Lines where Relevant Passages or Relevant Figures Appear
	1	5919540	A	1999-07-06	Bailey	
	2	5482759	A	1996-01-09	Primeau	
	3	4721641	A	1988-01-26	Bailey	
	4	5254384	A	1993-10-19	Gordon	
	5	4420180	A	1983-12-13	Dupont et al.	
	6	6261667	B1	2001-07-17	Yang	
	7	4828898		1989-05-09	Bailey	
	8	6534146	B1	2003-03-18	Mentz	

**INFORMATION DISCLOSURE
STATEMENT BY APPLICANT**
(Not for submission under 37 CFR 1.99)

Application Number		12879899
Filing Date		2010-09-10
First Named Inventor	David F. MACNEIL	
Art Unit	3726	
Examiner Name	Alexander Taousakis	
Attorney Docket Number	31700.000254	

	9	D242136		1976-11-02	Matlock	
	10	3401975		1968-09-17	Oger	
	11	5474829	A	1995-12-12	Woosley	
	12	3288187	A	1966-11-29	Wheaton	
	13	6022503	A	2000-02-08	Hudkins et al.	
	14	6794013	B1	2004-09-21	Iacovelli et al.	
	15	6605333	B2	2003-08-12	Ferreira et al.	
	16	5891546	A	1999-04-06	Sherman	
	17	5725926	A	1998-03-10	Wang	
	18	4420180	A	1983-12-13	Dupont et al.	
	19	3605166	A	1971-09-20	Chen	

**INFORMATION DISCLOSURE
STATEMENT BY APPLICANT**
(Not for submission under 37 CFR 1.99)

Application Number		12879899
Filing Date		2010-09-10
First Named Inventor	David F. MACNEIL	
Art Unit	3726	
Examiner Name	Alexander Taousakis	
Attorney Docket Number	31700.000254	

	20	3488081	A	1970-01-06	Nolen	
	21	3390912	A	1967-07-02	Stata	
	22	4579764	A	1986-04-01	Peoples, Jr. et al.	
	23	2709105	A	1955-05-24	Kramer	
	24	3450429	A	1969-06-17	Stata	
	25	D422256	S	2000-04-04	Lu	
	26	D408342	S	1999-04-20	Yang	
	27	D393238	S	1998-04-07	Kraines	
	28	4382986	A	1983-05-10	Reuben	
	29	D313789		1991-01-15	Thundercloud	
	30	D372011	S	1996-07-23	Tyler	

**INFORMATION DISCLOSURE
STATEMENT BY APPLICANT**
(Not for submission under 37 CFR 1.99)

Application Number		12879899
Filing Date		2010-09-10
First Named Inventor	David F. MACNEIL	
Art Unit	3726	
Examiner Name	Alexander Taousakis	
Attorney Docket Number	31700.000254	

	31	D454323	S	2002-03-12	Lu	
	32	D432478		2000-10-24	Lu	
	33	D425005	S	2000-05-16	Rizvi	
	34	D420965	S	2000-02-22	Iacovelli et al.	
	35	D358571	S	1995-05-23	Thundercloud	
	36	D278525	S	1985-04-23	Morawski	
	37	5830560	A	1998-11-03	Koa	
	38	4211447		1980-07-08	Divincenzo	
	39	3087752		1963-04-30	Winchester	
	40	7607713	B2	2009-10-27	MacNeil	
	41	7316847	B2	2008-01-08	MacNeil	

**INFORMATION DISCLOSURE
STATEMENT BY APPLICANT**
(Not for submission under 37 CFR 1.99)

Application Number	12879899
Filing Date	2010-09-10
First Named Inventor	David F. MACNEIL
Art Unit	3726
Examiner Name	Alexander Taousakis
Attorney Docket Number	31700.000254

If you wish to add additional U.S. Patent citation information please click the Add button. **Add**

U.S.PATENT APPLICATION PUBLICATIONS						Remove
Examiner Initial*	Cite No	Publication Number	Kind Code ¹	Publication Date	Name of Patentee or Applicant of cited Document	Pages, Columns, Lines where Relevant Passages or Relevant Figures Appear
	1	20030143358	A1	2003-07-31	Needles	
	2	20060091694	A1	2006-05-04	MacNeil	
	3	20010020316	A1	2001-09-13	Ferreira et al.	
	4	20040224130	A1	2004-11-11	Melucci et al.	
	5	20050191459	A1	2005-09-01	Ferreira et al.	
	6	20080061580	A1	2008-03-13	MacNeil	
	7	20090092795	A1	2009-04-09	MacNeil	
	8	20090230717	A1	2009-09-17	MacNeil	

If you wish to add additional U.S. Published Application citation information please click the Add button. **Add**

FOREIGN PATENT DOCUMENTS						Remove
---------------------------------	--	--	--	--	--	--------

INFORMATION DISCLOSURE STATEMENT BY APPLICANT (Not for submission under 37 CFR 1.99)	Application Number		12879899	
	Filing Date		2010-09-10	
	First Named Inventor	David F. MACNEIL		
	Art Unit	3726		
	Examiner Name	Alexander Taousakis		
	Attorney Docket Number	31700.000254		

Examiner Initial*	Cite No	Foreign Document Number ³	Country Code ² j	Kind Code ⁴	Publication Date	Name of Patentee or Applicant of cited Document	Pages, Columns, Lines where Relevant Passages or Relevant Figures Appear	T ⁵
	1	11268570	JP		1999-10-05	Suzuki		<input checked="" type="checkbox"/>
	2	1302459	CA		1992-06-02	Bailey		<input type="checkbox"/>
	3	1863477	DE	U	1962-12-06	Krapf et al.	English translation unavailable	<input type="checkbox"/>
	4	8434890	DE	U1	1985-02-28	Wurstl	English translation unavailable	<input type="checkbox"/>
	5	406227305	JP	A	1994-08-16	Abe		<input checked="" type="checkbox"/>
	6	1292028	CA		1991-11-12	Altus		<input type="checkbox"/>
	7	2431099	CA		2004-01-11	Whitaker		<input type="checkbox"/>
	8	8332976	JP	A	1996-12-17	Takao		<input checked="" type="checkbox"/>
If you wish to add additional Foreign Patent Document citation information please click the Add button								Add
NON-PATENT LITERATURE DOCUMENTS								Remove
Examiner Initials*	Cite No	Include name of the author (in CAPITAL LETTERS), title of the article (when appropriate), title of the item (book, magazine, journal, serial, symposium, catalog, etc), date, pages(s), volume-issue number(s), publisher, city and/or country where published.						T ⁵

**INFORMATION DISCLOSURE
STATEMENT BY APPLICANT**
(Not for submission under 37 CFR 1.99)

Application Number		12879899
Filing Date		2010-09-10
First Named Inventor	David F. MACNEIL	
Art Unit	3726	
Examiner Name	Alexander Taousakis	
Attorney Docket Number	31700.000254	

1	Photographs of a Highland Floor Guard with unknown date of manufacture, obtained by Applicant in 2010, and believed to be on sale and in public use prior to October 29, 2003.	<input type="checkbox"/>
2	American Specialty Equipment Corp., "Big Book" catalog for "Performance Parts, Truck Accessories, And Sport Compact Equipment," 2000, page 366.	<input type="checkbox"/>
3	Add-On 2002-2003 Automotive Accessory Catalog, 2002, pages 192 and 447.	<input type="checkbox"/>
4	Floor Mat Comparison Chart, Stylinconcepts.com, June 2, 2002.	<input type="checkbox"/>
5	Advertisement for Highland's Black Armor Floor Guard, Stylin Concepts "Custom Truck Accessories" catalog, 2003, pp. 1, 2 and 109.	<input type="checkbox"/>
6	Image from advertisement for Black Armor Floor Guard, Stylinconcepts.com; April 3, 2002, recovered from http://web.archive.org/20020403230231/stylinconcepts.com/Images/BlackArmorWLogo.jpg .	<input type="checkbox"/>
7	List of "front custom auto floor mats", etrailer.com (as downloaded by web.archive.org), June 4, 2004.	<input type="checkbox"/>
8	Description and illustration of "Front Custom Auto floor Mats"; etrailer.com (as downloaded by web.archive.org), June 4, 2004.	<input type="checkbox"/>
9	Advertisement for Highland floor guards, Counterman Info Pages, prior to Nov. 2002, page 27.	<input type="checkbox"/>
10	Highland Catalog and Jobber sheet; prior to 2004.	<input type="checkbox"/>
11	Highland Application Guide, 2004.	<input type="checkbox"/>

**INFORMATION DISCLOSURE
STATEMENT BY APPLICANT**
(Not for submission under 37 CFR 1.99)

Application Number		12879899
Filing Date		2010-09-10
First Named Inventor	David F. MACNEIL	
Art Unit	3726	
Examiner Name	Alexander Taousakis	
Attorney Docket Number	31700.000254	

12	Volvo Accessories brochure, 1990, pages 1 and 23.	<input type="checkbox"/>
13	Volvo 760 GLE Accessories Brochure, 1983, pages 1-3.	<input type="checkbox"/>
14	Volvo Accessories brochure, 1981, pages 1, 27.	<input type="checkbox"/>
15	Volvo Accessories brochure, 1983, page 1, 11, 16.	<input type="checkbox"/>
16	Photographs of Volvo floor mat with unknown manufacture date, obtained by Applicant in 2010, and believed to be on sale and in public use prior to October 29, 2003.	<input type="checkbox"/>
17	Photographs of a Husky Liner floor tray with unknown manufacture date, obtained by Applicant in 2010, and believed to be on sale and in public use prior to October 29, 2003.	<input type="checkbox"/>
18	Husky Liners Product Catalog, 2001, pages 1-2.	<input type="checkbox"/>
19	Husky Liners Product Catalog, 2002, selected pages.	<input type="checkbox"/>
20	Husky Liners Product Catalog, 2003 ½ , SEMA Show Edition, selected pages.	<input type="checkbox"/>
21	Photographs of Winfield's Husky Liner Model 3780 for 2000-2001 BMW X-5 possessed by Applicant, believed to be on sale and in public use prior to October 29, 2003.	<input type="checkbox"/>
22	1998 Lund Product Catalog, p. 24, Lund SportMat Molded Floor Trays.	<input type="checkbox"/>

INFORMATION DISCLOSURE STATEMENT BY APPLICANT (Not for submission under 37 CFR 1.99)	Application Number		12879899
	Filing Date		2010-09-10
	First Named Inventor	David F. MACNEIL	
	Art Unit	3726	
	Examiner Name	Alexander Taousakis	
	Attorney Docket Number	31700.000254	

	23	Web advertisement for Fox Weatherboots, foxweatherboots.com (as downloaded by web.archive.org), March 3, 2000.	<input type="checkbox"/>
	24	Nifty Products Catalog, 2003-2004, selected pages.	<input type="checkbox"/>
	25	Advertisement of unknown publication date for Husky Liner 3D Molded Carpeted Front Floor Liners, obtained by Applicant in 2010, and believed to be on sale and in public use prior to October 29, 2003.	<input type="checkbox"/>
	26	Photographs of Husky Liner 3D Floor Liners manufactured August 2010, in possession of Applicant, and believed to be on sale and in public use prior to October 29, 2003.	<input type="checkbox"/>
	27	Geomagic Press Release, "Geomagic, Inc. Wins Second Computer Graphics World Innovation Award," December 10, 1998.	<input type="checkbox"/>
	28	Geomagic Press Release, "Geomagic to Introduce Unique Solution for 3D Content Creation at SIGGRAPH '99," August 3, 1999.	<input type="checkbox"/>
	29	Geomagic Press Release, "Geomagic Announces Geomagic Studio 2.0," January 14, 2000.	<input type="checkbox"/>
	30	Geomagic Press Release, "Geomagic, QTE Offer RevQuick, Automatic Surface Generation for Mastercam," September 25, 2000.	<input type="checkbox"/>
	31	Advertisement, "Third Party Options (Romer, A CimCore Company)," 2000.	<input type="checkbox"/>
	32	SON, SEOKBAE; PARK, HYUNPUNG; and LEE, KWAN; "Automated laser scanning system for reverse engineering and inspection," Int. J. Machine Tools & Manufacture, 42, 889-897 (2002).	<input type="checkbox"/>
	33	"Competition Rising in Portable CMMs," Quality Magazine, May 5, 2003.	<input type="checkbox"/>

**INFORMATION DISCLOSURE
STATEMENT BY APPLICANT**
(Not for submission under 37 CFR 1.99)

Application Number		12879899
Filing Date		2010-09-10
First Named Inventor	David F. MACNEIL	
Art Unit	3726	
Examiner Name	Alexander Taousakis	
Attorney Docket Number	31700.000254	

34	Press Release by Brown and Sharpe, "Portable K Series Optical CMMs," 9/1/2002.	<input type="checkbox"/>
35	"CAM2 software," as downloaded from http://web.archive.org/web/20040215065613/www.faro.com/Products on 11/4/2010.	<input type="checkbox"/>
36	"Laser Scanner edges out CMM in the race to market," Machine Design.com, February 5, 2004.	<input type="checkbox"/>
37	"Highres Delivers Complete Reverse Engineering Software Suite for SolidWorks 2001Plus," Reverse Engineering.com, April 25, 2002.	<input type="checkbox"/>
38	"HighRes Provides 3D Reverse Engineering Software to Higher Education Learning Institutions", ReverseEngineering.com, May 21, 2002.	<input type="checkbox"/>
39	"HighRes Reverse Engineering Software now Ships with Every Romer 3000i and Stinger II Portable CMM in North America," ReverseEngineering.com, October 14, 2002.	<input type="checkbox"/>
40	Press Release, "FARO Debuts Affordable "Advantage" Line of Measurement Products," September 4, 2003.	<input type="checkbox"/>
41	CANADIAN INTELLECTUAL PROPERTY OFFICE, Requisition by the Examiner in connection with Canadian Patent Application No. 2,672,423 dated December 14, 2010.	<input type="checkbox"/>
42	JAPANESE PATENT OFFICE, Rejection issued in connection with Japanese Patent Application No. 2005-317635 dispatched on January 5, 2011.	<input checked="" type="checkbox"/>
43	CANADIAN INTELLECTUAL PROPERTY OFFICE, Requisition by the Examiner issued in connection with Canadian Patent Application No. 2,672,095, January 14, 2011.	<input type="checkbox"/>
44	Photographs of Ford Windstar floor mat with unknown manufacture date, obtained by Applicant in 2010, and believed to be on sale and in public use prior to October 29, 2003.	<input type="checkbox"/>

INFORMATION DISCLOSURE STATEMENT BY APPLICANT (Not for submission under 37 CFR 1.99)	Application Number	12879899
	Filing Date	2010-09-10
	First Named Inventor	David F. MACNEIL
	Art Unit	3726
	Examiner Name	Alexander Taousakis
	Attorney Docket Number	31700.000254

If you wish to add additional non-patent literature document citation information please click the Add button **Add**

EXAMINER SIGNATURE

Examiner Signature		Date Considered	
--------------------	--	-----------------	--

*EXAMINER: Initial if reference considered, whether or not citation is in conformance with MPEP 609. Draw line through a citation if not in conformance and not considered. Include copy of this form with next communication to applicant.

¹ See Kind Codes of USPTO Patent Documents at www.USPTO.GOV or MPEP 901.04. ² Enter office that issued the document, by the two-letter code (WIPO Standard ST.3). ³ For Japanese patent documents, the indication of the year of the reign of the Emperor must precede the serial number of the patent document. ⁴ Kind of document by the appropriate symbols as indicated on the document under WIPO Standard ST.16 if possible. ⁵ Applicant is to place a check mark here if English language translation is attached.

**INFORMATION DISCLOSURE
STATEMENT BY APPLICANT**
(Not for submission under 37 CFR 1.99)

Application Number		12879899	
Filing Date		2010-09-10	
First Named Inventor	David F. MACNEIL		
Art Unit	3726		
Examiner Name	Alexander Taousakis		
Attorney Docket Number	31700.000254		

CERTIFICATION STATEMENT

Please see 37 CFR 1.97 and 1.98 to make the appropriate selection(s):

That each item of information contained in the information disclosure statement was first cited in any communication from a foreign patent office in a counterpart foreign application not more than three months prior to the filing of the information disclosure statement. See 37 CFR 1.97(e)(1).

OR

That no item of information contained in the information disclosure statement was cited in a communication from a foreign patent office in a counterpart foreign application, and, to the knowledge of the person signing the certification after making reasonable inquiry, no item of information contained in the information disclosure statement was known to any individual designated in 37 CFR 1.56(c) more than three months prior to the filing of the information disclosure statement. See 37 CFR 1.97(e)(2).

See attached certification statement.

Fee set forth in 37 CFR 1.17 (p) has been submitted herewith.

None

SIGNATURE

A signature of the applicant or representative is required in accordance with CFR 1.33, 10.18. Please see CFR 1.4(d) for the form of the signature.

Signature	/Jefferson Perkins/	Date (YYYY-MM-DD)	2012-02-17
Name/Print	Jefferson Perkins	Registration Number	31,407

This collection of information is required by 37 CFR 1.97 and 1.98. The information is required to obtain or retain a benefit by the public which is to file (and by the USPTO to process) an application. Confidentiality is governed by 35 U.S.C. 122 and 37 CFR 1.14. This collection is estimated to take 1 hour to complete, including gathering, preparing and submitting the completed application form to the USPTO. Time will vary depending upon the individual case. Any comments on the amount of time you require to complete this form and/or suggestions for reducing this burden, should be sent to the Chief Information Officer, U.S. Patent and Trademark Office, U.S. Department of Commerce, P.O. Box 1450, Alexandria, VA 22313-1450. **DO NOT SEND FEES OR COMPLETED FORMS TO THIS ADDRESS. SEND TO: Commissioner for Patents, P.O. Box 1450, Alexandria, VA 22313-1450.**

Privacy Act Statement

The Privacy Act of 1974 (P.L. 93-579) requires that you be given certain information in connection with your submission of the attached form related to a patent application or patent. Accordingly, pursuant to the requirements of the Act, please be advised that: (1) the general authority for the collection of this information is 35 U.S.C. 2(b)(2); (2) furnishing of the information solicited is voluntary; and (3) the principal purpose for which the information is used by the U.S. Patent and Trademark Office is to process and/or examine your submission related to a patent application or patent. If you do not furnish the requested information, the U.S. Patent and Trademark Office may not be able to process and/or examine your submission, which may result in termination of proceedings or abandonment of the application or expiration of the patent.

The information provided by you in this form will be subject to the following routine uses:

1. The information on this form will be treated confidentially to the extent allowed under the Freedom of Information Act (5 U.S.C. 552) and the Privacy Act (5 U.S.C. 552a). Records from this system of records may be disclosed to the Department of Justice to determine whether the Freedom of Information Act requires disclosure of these records.
2. A record from this system of records may be disclosed, as a routine use, in the course of presenting evidence to a court, magistrate, or administrative tribunal, including disclosures to opposing counsel in the course of settlement negotiations.
3. A record in this system of records may be disclosed, as a routine use, to a Member of Congress submitting a request involving an individual, to whom the record pertains, when the individual has requested assistance from the Member with respect to the subject matter of the record.
4. A record in this system of records may be disclosed, as a routine use, to a contractor of the Agency having need for the information in order to perform a contract. Recipients of information shall be required to comply with the requirements of the Privacy Act of 1974, as amended, pursuant to 5 U.S.C. 552a(m).
5. A record related to an International Application filed under the Patent Cooperation Treaty in this system of records may be disclosed, as a routine use, to the International Bureau of the World Intellectual Property Organization, pursuant to the Patent Cooperation Treaty.
6. A record in this system of records may be disclosed, as a routine use, to another federal agency for purposes of National Security review (35 U.S.C. 181) and for review pursuant to the Atomic Energy Act (42 U.S.C. 218(c)).
7. A record from this system of records may be disclosed, as a routine use, to the Administrator, General Services, or his/her designee, during an inspection of records conducted by GSA as part of that agency's responsibility to recommend improvements in records management practices and programs, under authority of 44 U.S.C. 2904 and 2906. Such disclosure shall be made in accordance with the GSA regulations governing inspection of records for this purpose, and any other relevant (i.e., GSA or Commerce) directive. Such disclosure shall not be used to make determinations about individuals.
8. A record from this system of records may be disclosed, as a routine use, to the public after either publication of the application pursuant to 35 U.S.C. 122(b) or issuance of a patent pursuant to 35 U.S.C. 151. Further, a record may be disclosed, subject to the limitations of 37 CFR 1.14, as a routine use, to the public if the record was filed in an application which became abandoned or in which the proceedings were terminated and which application is referenced by either a published application, an application open to public inspections or an issued patent.
9. A record from this system of records may be disclosed, as a routine use, to a Federal, State, or local law enforcement agency, if the USPTO becomes aware of a violation or potential violation of law or regulation.

Electronic Acknowledgement Receipt

EFS ID:	12102425
Application Number:	12879899
International Application Number:	
Confirmation Number:	7976
Title of Invention:	DESIGNING AND MANUFACTURING VEHICLE FLOOR TRAYS
First Named Inventor/Applicant Name:	David F. MacNeil
Customer Number:	64770
Filer:	Jefferson Perkins/Patricia Romanelli
Filer Authorized By:	Jefferson Perkins
Attorney Docket Number:	31700.000254
Receipt Date:	17-FEB-2012
Filing Date:	10-SEP-2010
Time Stamp:	13:17:00
Application Type:	Utility under 35 USC 111(a)

Payment information:

Submitted with Payment	no
------------------------	----

File Listing:

Document Number	Document Description	File Name	File Size(Bytes)/ Message Digest	Multi Part /.zip	Pages (if appl.)
1	Transmittal Letter	IDS_Transmittal.pdf	110209 e71a2bb6f89c0f64695c039a1d1f3cd734ef814e	no	6

Warnings:

Information:

2	Information Disclosure Statement (IDS) Form (SB08)	IDS2Custom.pdf	615935 ec44baf5c2c8ea887bd752e6367f79302e81 fbd5	no	13
Warnings:					
Information:					
3	Foreign Reference	ForDoc1_JP_H11-268570.pdf	3245143 822ad4431dafd9495b92466b044bdd0e5 dd6c07	no	20
Warnings:					
Information:					
4	Foreign Reference	ForDoc2_CA1302459.pdf	25963252 fb8044b49932ac7d19b42f63a0395d077b70 26113	no	36
Warnings:					
Information:					
5	Foreign Reference	ForDoc3_DE1863477.pdf	2962134 fbb6dfbc10b6308fa0c08de4c2d62b7d33f8 c98f	no	9
Warnings:					
Information:					
6	Foreign Reference	ForDoc4_DE8434890.pdf	19663788 b1e66a2137781022bc20d5996417dc60d1 89a285	no	20
Warnings:					
Information:					
7	Foreign Reference	ForDoc6_CA1292028.pdf	2555064 bd7fc411e024069ce334e9527f9a37bddc4 da733	no	25
Warnings:					
Information:					
8	Foreign Reference	ForDoc7_CA2431099.pdf	5004810 d4f7d8ebf574fcb37180773b68ee25fb77de aeb9	no	21
Warnings:					
Information:					
9	Non Patent Literature	NPL1Highland.pdf	9385092 180e3ca6785a4763b87e7c50f8f79c9b6363 0ef3	no	7
Warnings:					
Information:					
10	Non Patent Literature	NPL2AmSpecEquipBigBook.pdf	5039785 d6b4b2a079895738637c40cd4b0759fd6d dfd455	no	2
Warnings:					
Information:					

11	Non Patent Literature	NPL3AddOnCatalog.pdf	5802545 552710d7b5384747fa17e9b23a5ae89ba0a638ed	no	3
Warnings:					
Information:					
12	Non Patent Literature	NPL4StylinconceptsFloorMatChart.pdf	1779083 1c74510710876593b24dcb569b461f6d2783ad56	no	2
Warnings:					
Information:					
13	Non Patent Literature	NPL5AdHighlandBlackArmor.pdf	6735732 ea4df128e901aa79a95777e5ef25572c52b86324	no	3
Warnings:					
Information:					
14	Non Patent Literature	NPL6StylinconceptsImageBlackArmor.pdf	115075 6ebf8cfacda3e0b064bbd5b8ab5646f341e3001c	no	1
Warnings:					
Information:					
15	Non Patent Literature	NPL7etrailerListCustomMats.pdf	2886031 7d8b15b464fe1a1655c9297b5c19039f6828cf08	no	48
Warnings:					
Information:					
16	Non Patent Literature	NPL8etrailerFrontCustomFloorMats.pdf	1392759 14e1e3b56231a16f07d0777b5ba4a33baaece236	no	2
Warnings:					
Information:					
17	Non Patent Literature	NPL9CountermanInfoAdHighland.pdf	2267042 8821b0679c0b9e0280db7b594a4a7fbd7d6ad4f	no	1
Warnings:					
Information:					
18	Non Patent Literature	NPL10HighlandCatalogAndJobberSheet.pdf	4626636 776ec2b690de8416fc77072a7e736b64b10208eb	no	2
Warnings:					
Information:					
19	Non Patent Literature	NPL11HighlandApplicationGuide.pdf	495786 41790cd8a1ea122a8ad60600f37db208df0d0167	no	2
Warnings:					
Information:					

20	Non Patent Literature	NPL12VolvoAccessoriesBrochure.pdf	3452696 1667584002b2f9804503a87b7a2eedcacdb765e3	no	2
Warnings:					
Information:					
21	Non Patent Literature	NPL13Volvo760GLEAccessBrochure.pdf	4211288 0fcd1a37f4e56615218ea6ab5dd4f047bfed125c	no	3
Warnings:					
Information:					
22	Non Patent Literature	NPL14VolvoAccessBroch1981.pdf	3817347 1af1879e9b685274e1db3827ac88437124793af2	no	3
Warnings:					
Information:					
23	Non Patent Literature	NPL15VolvoAccessBroch1983.pdf	3005524 e2e574efcd4d7d7041a99432a9db6d1818a02b91	no	3
Warnings:					
Information:					
24	Non Patent Literature	NPL16VolvoFloorMatPhotos.pdf	14994856 e74cd332ade5161d0da57fbc86b9800720230c59	no	7
Warnings:					
Information:					
25	Non Patent Literature	NPL17HuskyLinerFloorTrayPhotos.pdf	7094743 0a15c479b66e66ef9cae75fcbdd4d04287ebc04d3	no	4
Warnings:					
Information:					
26	Non Patent Literature	NPL18HuskyLinerProdCatalog2001.pdf	3940512 160efe513291b41991f9351dd53717df05e7b802	no	2
Warnings:					
Information:					
27	Non Patent Literature	NPL19HuskyLinerProdCatalog2002.pdf	6142025 c0a1118641776ebaf8c0da3b6b0da28d97367a7d	no	3
Warnings:					
Information:					
28	Non Patent Literature	NPL20HuskyLinerProdCatalogSEMAEdition.pdf	6023871 ab75e25d33c72cfaa9dc53e3ce0708829ee9353	no	3
Warnings:					
Information:					

29	Non Patent Literature	NPL21HuskyLinerModel3780.pdf	8239421 8af109c0573666756108dab0336c85908ed9b949	no	7
Warnings:					
Information:					
30	Non Patent Literature	NPL22LundCatalog.pdf	1479522 c89b0e9353dfdf1da974206179f924d589709b8b6	no	1
Warnings:					
Information:					
31	Non Patent Literature	NPL23AdWeatherBoots.pdf	166422 63889115b61154883f251df9481809fc56ce97dd	no	2
Warnings:					
Information:					
32	Non Patent Literature	NPL24NiftyProductsCatalog.pdf	4791246 d2aa198d054ca4776c9d084dd4386cb52fa35493	no	2
Warnings:					
Information:					
33	Non Patent Literature	NPL25AdHuskyLiner3dMoldedCarpetedFlrLiner.pdf	2182951 7d1711971d890b35d1da9fb5087d9ca4b9f9de2a	no	1
Warnings:					
Information:					
34	Non Patent Literature	NPL26HuskyLiner3dFloorLinerPhotos.pdf	16943054 86ceb344e9ff25dd24df84090b342f8a1e5834d5	no	6
Warnings:					
Information:					
35	Non Patent Literature	NPL27GeomagicPressReleaseDecember1998.pdf	128803 dffcb57b9a73e8043a69dc21e1ddb5593cd0b03e0	no	1
Warnings:					
Information:					
36	Non Patent Literature	NPL28GeomagicPressReleaseAugust1999.pdf	114951 68872f2b087267d944bdf9ef387834725d007b3f	no	1
Warnings:					
Information:					
37	Non Patent Literature	NPL29GeomagicPressReleaseJanuary2000.pdf	146103 33d2c594deda302e914239bb22f85b9ccb3481cb	no	1
Warnings:					
Information:					

38	Non Patent Literature	NPL30GeomagicPressReleaseSeptember2000.pdf	96279 d33099c771d3a12557b91894da969f7c7c3f3eeaa	no	1
Warnings:					
Information:					
39	Non Patent Literature	NPL31AdThirdPartyOptions.pdf	2373424 a369f38bca31091d60c3b3900cef10929edecc866	no	3
Warnings:					
Information:					
40	Non Patent Literature	NPL32AutomatedLaserScanningSystem.pdf	4321627 1f85d4db160cfab76f681f32b1d07345bdaf6c4	no	9
Warnings:					
Information:					
41	Non Patent Literature	NPL33CompetitionRisingInPortableCMMs.pdf	1225902 ff0d1767a49a3d249ee843b3423a72053faebccf	no	3
Warnings:					
Information:					
42	Non Patent Literature	NPL34PressReleaseByBrownAndSharpe.pdf	314049 564795e329e15a60bd44582fd6235ffe8f1a10e5	no	2
Warnings:					
Information:					
43	Non Patent Literature	NPL35CAM2software.pdf	1616950 ef33db35db2154ed307ec25c31078b1cc2b3141	no	3
Warnings:					
Information:					
44	Non Patent Literature	NPL36LaserScannerEdgesOutCMM.pdf	1725577 c34aeda1b81b3332b36be11c2854f4c9389ae9f	no	2
Warnings:					
Information:					
45	Non Patent Literature	NPL37ReverseEngineeringApril2002.pdf	391735 f2ff6d7097dfebaa6ced31097f942fa94f380d0	no	2
Warnings:					
Information:					
46	Non Patent Literature	NPL38ReverseEngineeringMay2002.pdf	473876 63872ae33d280f90ffc980bf04b9587aa5510dd	no	2
Warnings:					
Information:					

47	Non Patent Literature	NPL39ReverseEngineeringOctober2002.pdf	311069 7256b3de881b63e2f150732d7a9f2d12838c15298	no	2
Warnings:					
Information:					
48	Non Patent Literature	NPL40PressReleaseFAROSeptember2003.pdf	305507 3a6d39629217a507a873ae5d34768615beb15278	no	1
Warnings:					
Information:					
49	Non Patent Literature	NPL41CIPORequisition.pdf	245979 b0d91f3426b55236b0b0ef60e42b69d03f028d44	no	2
Warnings:					
Information:					
50	Non Patent Literature	NPL42JPRejectionApp2005317635.pdf	471725 04366e3981f9e57480f642e1341c129bc2d293ce	no	4
Warnings:					
Information:					
51	Non Patent Literature	NPL43OACA2672095.pdf	189554 279fd81c193ec98c73bafae2717436313488338f	no	2
Warnings:					
Information:					
52	Non Patent Literature	NPL44Windstarphotos.pdf	21688464 320dcc5cae45af21c66312196ca6cedb3a9600a8	no	16
Warnings:					
Information:					
53	Foreign Reference	ForDoc5_JP_406227305_.pdf	581430 b42a2e0ec565711ee093feb888cb1e281f4df661	no	5
Warnings:					
Information:					
54	Foreign Reference	ForDoc8_JP8332976_.pdf	698563 6028e2cda63f0da9ea00665901f3b3562c34001d	no	7
Warnings:					
Information:					
Total Files Size (in bytes):				224552946	

This Acknowledgement Receipt evidences receipt on the noted date by the USPTO of the indicated documents, characterized by the applicant, and including page counts, where applicable. It serves as evidence of receipt similar to a Post Card, as described in MPEP 503.

New Applications Under 35 U.S.C. 111

If a new application is being filed and the application includes the necessary components for a filing date (see 37 CFR 1.53(b)-(d) and MPEP 506), a Filing Receipt (37 CFR 1.54) will be issued in due course and the date shown on this Acknowledgement Receipt will establish the filing date of the application.

National Stage of an International Application under 35 U.S.C. 371

If a timely submission to enter the national stage of an international application is compliant with the conditions of 35 U.S.C. 371 and other applicable requirements a Form PCT/DO/EO/903 indicating acceptance of the application as a national stage submission under 35 U.S.C. 371 will be issued in addition to the Filing Receipt, in due course.

New International Application Filed with the USPTO as a Receiving Office

If a new international application is being filed and the international application includes the necessary components for an international filing date (see PCT Article 11 and MPEP 1810), a Notification of the International Application Number and of the International Filing Date (Form PCT/RO/105) will be issued in due course, subject to prescriptions concerning national security, and the date shown on this Acknowledgement Receipt will establish the international filing date of the application.

IN THE UNITED STATES PATENT AND TRADEMARK OFFICE

Applicant: David F. MACNEIL
Application No.: 12/879,899
Filed: Sept. 10, 2010
Art Unit: 3726
Examiner: Alexander TAOUSAKIS
Confirmation No.: 7976

CERTIFICATE OF TRANSMISSION BY
ELECTRONIC FILING
I hereby certify that this correspondence is
being transmitted via the USPTO electronic
filing system in accordance with 37 CFR
§1.6(a)(4) on February 17, 2012.

/Patricia Romanelli/
Patricia Romanelli

Title: DESIGNING AND MANUFACTURING VEHICLE FLOOR TRAYS

Mail Stop Amendment
Commissioner for Patents
P.O. Box 1450
Alexandria, VA 22313-1450

INFORMATION DISCLOSURE STATEMENT UNDER 37 C.F.R. §1.97(B)

Dear Sir:

Pursuant to 37 C.F.R. §§ 1.56 and 1.97(b), Applicants bring to the attention of the Examiner the documents listed on the attached form PTO/SB/08a. This Information Disclosure Statement is being filed prior to receipt of the first Office Action on the merits. Applicants enclose copies of those listed documents other than those which are U.S. patents, U.S. published patent applications, or which have been made of record in an application upon which Applicant relies for a priority date under 35 USC § 120. 37 CFR § 1.97(d). Applicant provides a description of several of the references below.

Specifically, Applicants would like to draw the Examiner's attention to Non-Patent Literature Document 1, which is a series of photographs of a product called the Highland Floor Guard. The precise date of first public use or sale of the pictured Floor Guard is unknown, but Applicants believe that this product was on sale and in public use prior to October 29, 2003. A nonskid surface covers the floor, and a similar surface is provided for the wall meant to cover the firewall of the vehicle foot well.

It is believed that this part was made by thermoforming, it has a height of approximately five inches above the floor, and it is substantially uniform in thickness because the bottom surface continues to substantially conform to, or "follows", the contours of the upper surface.

Non-Patent Literature Document 16 is a collection of photographs showing various views of a pair of Volvo mats, part number 1129300-8. The precise date of first sale or public use of the pictured mats is unknown, but it is believed that they were placed in public use before October 29, 2003. See Non-Patent Literature Documents 12-15. The mat is rigid. The mat has a circumferential lip around three sides of the floor which is about one inch high. A fourth side of the floor is bounded by a firewall flap which stands up about six to seven inches vertically from the mat floor.

About the rear fifty percent of the floor is occupied by a nonskid surface formed by a two-dimensional array of small cells, each of which is a rounded rectangle, and each of which is sealed from its neighbors by its sidewalls. The bottom of each of the cells is lower than the portion of the floor surface forward of the cell array.

The Volvo mat is formed by injection molding. Its bottom surface does not follow or conform to the contours of its top surface, and the thickness between the top and bottom surfaces

varies substantially across the floor due to the presence of the nonskid surface molded only into its top surface.

Non-Patent Literature Document 17 is a collection of photographs showing various views of a HuskyLiner floor tray made by Winfield Consumer Products, Inc.. The precise date of first public use or sale of the pictured floor tray is unknown; Applicants believe that a floor tray identified with the HUSKYLINER mark and sharing some of the characteristics of the pictured product was in public use and on sale prior to October 29, 2003. The prior art HuskyLiner had a nonskid, “diamondplate” surface which occupied most of the upper surface of the floor and walls of this part, and had a height of approximately five inches.

Applicant believes that the prior art Husky Liner was formed by thermoforming a sheet of plastic that was substantially uniformly thick. A population of “nibs” were formed to stand up from one surface of the sheet of plastic. This surface later forms the bottom surface of the tray. The nibs are each about 0.14 inches in diameter and are regularly distributed across the bottom surface at one inch centers. The amount of the surface occupied by the nibs is less than two percent (<2%) of the total surface area of the sheet. Therefore, the beginning sheet is substantially uniformly thick, because it is capable of being molded into a vehicle floor tray by a thermoforming process.

The sheet is softened and sucked onto a male or convex tool, which molded the upper surface of the tray. The bottom surface of the sheet/tray is presented upwardly during this process, and the bottom surface continues to conform to, or follow, the contours of the upper surface. Thus, the part is also substantially uniformly thick when finished.

Applicants regard the male thermoforming process used to form the HuskyLiner to be equivalent to the female thermoforming process used by Applicants’ employer, since it produces

parts whose variance in thickness (due to thinning along any deeper walls or features as the softened plastic conforms to the tool surface) will be similar.

Non-Patent Literature Document 21 is a collection of photographs of a floor tray provided for a 2000 BMW X-5. The precise date of public sale or use of the pictured part is unknown, but Applicants believe that this part was placed in public use before October 29, 2003. The X-5 tray has a floor with a nonskid surface. The contours of the bottom of the part generally conform to, or follow, the contours of its upper surface, and Applicants believe that this part was created by thermoforming. This part has a height of approximately six and one half inches from the floor.

Non-Patent Literature Document 26 is a collection of photographs of a “Husky 3D Molded Carpeted Liner.” A part similar to the pictured part was believed to be placed in public use prior to October 29, 2003. This part was compression-molded from a composite blank, the bottom layer of which was a polymer foam and the top layer of which was flocking. The part had a dished floor with a raised margin. The layers are stitched together around the edges.

Non-Patent Literature Document 44 is a collection of photographs of a Ford Windstar floor tray. A part similar to the pictured part was believed to be placed in public use prior to October 29, 2003. The part has a floor with a nonskid surface, and the contours of the bottom of the part generally conform to, or follow, the contours of its upper surface. Applicants believe that this part was created by thermoforming and that this part has a height of approximately five inches from the floor.

Applicant respectfully requests that the Examiner consider the listed documents and indicate that consideration by making appropriate notations on the attached forms. It is believed that these references either taken alone or in combination do not disclose or suggest the invention

claimed by the Applicant. However, it is the Applicant's desire to have these references available in the record for both the Examiner and the public to see. The Applicant specifically reserves all rights of privilege and confidence with respect to this matter and submission of this document is not to be construed as a waiver of those rights. Moreover, submission of this document should not be considered an admission that the references cited herein are proper prior art to the aforementioned application.

This submission does not represent that a search has been made or that no better art exists and does not constitute an admission that each or all of the listed documents are material or constitute "prior art." If it should be determined that any of the listed documents do not constitute "prior art" under United States law, Applicant reserves the right to present to the Office the relevant facts and law regarding the appropriate status of such documents.

Applicant further reserves the right to take appropriate action to establish the patentability of the disclosed invention over the listed documents, should one or more of the documents be applied against the claims of the present application.

No fee is thought to be due in connection with this Information Disclosure Statement Under 37 C.F.R. §1.97(b). However, the Commissioner is hereby authorized to charge any deficiency to Deposit Account No. 503982 of Momkus McCluskey, LLC.

Respectfully submitted,

/Jefferson Perkins/

Jefferson Perkins

Registration No. 31,407

CUSTOMER NO. 64770

MOMKUS McCLUSKEY, LLC
1001 Warrenville Road, Suite 500
Lisle, Illinois 60532-4306
Telephone: (630) 434-0414
Fax: (630) 434-0444
Email: jperkins@momlaw.com

INFORMATION DISCLOSURE STATEMENT BY APPLICANT (Not for submission under 37 CFR 1.99)	Application Number	12879899
	Filing Date	2010-09-10
	First Named Inventor	David F. MACNEIL
	Art Unit	3726
	Examiner Name	Alexander Taousakis
	Attorney Docket Number	31700.000254

U.S.PATENTS	Remove
--------------------	--------

Examiner Initial*	Cite No	Patent Number	Kind Code ¹	Issue Date	Name of Patentee or Applicant of cited Document	Pages,Columns,Lines where Relevant Passages or Relevant Figures Appear
	1					

If you wish to add additional U.S. Patent citation information please click the Add button. Add

U.S.PATENT APPLICATION PUBLICATIONS	Remove
--	--------

Examiner Initial*	Cite No	Publication Number	Kind Code ¹	Publication Date	Name of Patentee or Applicant of cited Document	Pages,Columns,Lines where Relevant Passages or Relevant Figures Appear
	1					

If you wish to add additional U.S. Published Application citation information please click the Add button. Add

FOREIGN PATENT DOCUMENTS	Remove
---------------------------------	--------

Examiner Initial*	Cite No	Foreign Document Number ³	Country Code ² j	Kind Code ⁴	Publication Date	Name of Patentee or Applicant of cited Document	Pages,Columns,Lines where Relevant Passages or Relevant Figures Appear	T ⁵
	1	200052835	JP		2000-02-22	Shengzhou Enterp. Co. Ltd.		<input type="checkbox"/>
	2	H8-85377	JP		1996-04-02	Muratsubaki Masaaki		<input type="checkbox"/>
	3	H3-47245	JP		1991-05-01		English translation unavailable	<input type="checkbox"/>

INFORMATION DISCLOSURE STATEMENT BY APPLICANT (Not for submission under 37 CFR 1.99)	Application Number	12879899
	Filing Date	2010-09-10
	First Named Inventor	David F. MACNEIL
	Art Unit	3726
	Examiner Name	Alexander Taousakis
	Attorney Docket Number	31700.000254

4	2002356124	JP		2002-12-10	Japan Vilene Co. Ltd	<input type="checkbox"/>
---	------------	----	--	------------	----------------------	--------------------------

If you wish to add additional Foreign Patent Document citation information please click the Add button **Add**

NON-PATENT LITERATURE DOCUMENTS

Remove

Examiner Initials*	Cite No	Include name of the author (in CAPITAL LETTERS), title of the article (when appropriate), title of the item (book, magazine, journal, serial, symposium, catalog, etc), date, pages(s), volume-issue number(s), publisher, city and/or country where published.	T ⁵
	1	STRICTLY Catalog for Explorer/Mountaineer/Expedition/Navigator. MacNeil Automotive Products Limited, Downers Grove, IL, 1999, pp. 1- 2 and 4 - 7.	<input type="checkbox"/>
	2	CANADIAN INTELLECTUAL PROPERTY OFFICE, Requisition by Examiner issued on Canadian Application No. 2,524,795 on April 23, 2008.	<input type="checkbox"/>
	3	U.S. PATENT AND TRADEMARK OFFICE, Office Action issued on U.S. Application No. 11/463,215 on November 27, 2007.	<input type="checkbox"/>
	4	U.S. PATENT AND TRADEMARK OFFICE, Office Action issued on U.S. Application No. 11/463,215 on June 6, 2007.	<input type="checkbox"/>
	5	BRITISH PATENT OFFICE, Search Report issued on GB Application No. 0625354.6 dated November 6,2007.	<input type="checkbox"/>
	6	U.S. PATENT AND TRADEMARK OFFICE, Office Action issued on U.S. Application No. 11/463,203 on August 13, 2009.	<input type="checkbox"/>
	7	U.S. PATENT AND TRADEMARK OFFICE, Office Action issued on U.S. Application No. 11/934,320 on June 10, 2009.	<input type="checkbox"/>
	8	U.S. PATENT AND TRADEMARK OFFICE, Office Action issued on U.S. Application No. 12/332,757 on June 11,2009.	<input type="checkbox"/>

INFORMATION DISCLOSURE STATEMENT BY APPLICANT (Not for submission under 37 CFR 1.99)	Application Number		12879899
	Filing Date		2010-09-10
	First Named Inventor	David F. MACNEIL	
	Art Unit	3726	
	Examiner Name	Alexander Taousakis	
	Attorney Docket Number	31700.000254	

9	BRITISH PATENT OFFICE, Search Report on GB Appln. No. 0625354.6 dated March 3, 2008.	<input type="checkbox"/>
10	JAPANESE PATENT OFFICE, Notice issued on JP Application No. 2005-317635, dated January 5, 2011.	<input type="checkbox"/>
11	CANADIAN INTELLECTUAL PROPERTY OFFICE, Requisition on CA 2,672,423, dated on Dec. 14, 2010.	<input type="checkbox"/>
12	CANADIAN INTELLECTUAL PROPERTY OFFICE, Requisition on CA 2,672,095, dated on Jan. 14, 2011.	<input type="checkbox"/>
13	GERMAN PATENT AND TRADEMARK OFFICE, Official Action on DE 10 2005 063 533.4-21, dated September 1, 2011.	<input type="checkbox"/>
14	CANADIAN INTELLECTUAL PROPERTY OFFICE, Requisition on CA 2,672,097, dated on Dec. 19, 2011.	<input type="checkbox"/>

If you wish to add additional non-patent literature document citation information please click the Add button **Add**

EXAMINER SIGNATURE

Examiner Signature		Date Considered	
--------------------	--	-----------------	--

***EXAMINER:** Initial if reference considered, whether or not citation is in conformance with MPEP 609. Draw line through a citation if not in conformance and not considered. Include copy of this form with next communication to applicant.

¹ See Kind Codes of USPTO Patent Documents at www.USPTO.GOV or MPEP 901.04. ² Enter office that issued the document, by the two-letter code (WIPO Standard ST.3). ³ For Japanese patent documents, the indication of the year of the reign of the Emperor must precede the serial number of the patent document. ⁴ Kind of document by the appropriate symbols as indicated on the document under WIPO Standard ST.16 if possible. ⁵ Applicant is to place a check mark here if English language translation is attached.

INFORMATION DISCLOSURE STATEMENT BY APPLICANT (Not for submission under 37 CFR 1.99)	Application Number	12879899
	Filing Date	2010-09-10
	First Named Inventor	David F. MACNEIL
	Art Unit	3726
	Examiner Name	Alexander Taousakis
	Attorney Docket Number	31700.000254

CERTIFICATION STATEMENT

Please see 37 CFR 1.97 and 1.98 to make the appropriate selection(s):

That each item of information contained in the information disclosure statement was first cited in any communication from a foreign patent office in a counterpart foreign application not more than three months prior to the filing of the information disclosure statement. See 37 CFR 1.97(e)(1).

OR

That no item of information contained in the information disclosure statement was cited in a communication from a foreign patent office in a counterpart foreign application, and, to the knowledge of the person signing the certification after making reasonable inquiry, no item of information contained in the information disclosure statement was known to any individual designated in 37 CFR 1.56(c) more than three months prior to the filing of the information disclosure statement. See 37 CFR 1.97(e)(2).

- See attached certification statement.
- Fee set forth in 37 CFR 1.17 (p) has been submitted herewith.
- None

SIGNATURE

A signature of the applicant or representative is required in accordance with CFR 1.33, 10.18. Please see CFR 1.4(d) for the form of the signature.

Signature	/Jefferson Perkins/	Date (YYYY-MM-DD)	2012-02-17
Name/Print	Jefferson Perkins	Registration Number	31,407

This collection of information is required by 37 CFR 1.97 and 1.98. The information is required to obtain or retain a benefit by the public which is to file (and by the USPTO to process) an application. Confidentiality is governed by 35 U.S.C. 122 and 37 CFR 1.14. This collection is estimated to take 1 hour to complete, including gathering, preparing and submitting the completed application form to the USPTO. Time will vary depending upon the individual case. Any comments on the amount of time you require to complete this form and/or suggestions for reducing this burden, should be sent to the Chief Information Officer, U.S. Patent and Trademark Office, U.S. Department of Commerce, P.O. Box 1450, Alexandria, VA 22313-1450. **DO NOT SEND FEES OR COMPLETED FORMS TO THIS ADDRESS. SEND TO: Commissioner for Patents, P.O. Box 1450, Alexandria, VA 22313-1450.**

Privacy Act Statement

The Privacy Act of 1974 (P.L. 93-579) requires that you be given certain information in connection with your submission of the attached form related to a patent application or patent. Accordingly, pursuant to the requirements of the Act, please be advised that: (1) the general authority for the collection of this information is 35 U.S.C. 2(b)(2); (2) furnishing of the information solicited is voluntary; and (3) the principal purpose for which the information is used by the U.S. Patent and Trademark Office is to process and/or examine your submission related to a patent application or patent. If you do not furnish the requested information, the U.S. Patent and Trademark Office may not be able to process and/or examine your submission, which may result in termination of proceedings or abandonment of the application or expiration of the patent.

The information provided by you in this form will be subject to the following routine uses:

1. The information on this form will be treated confidentially to the extent allowed under the Freedom of Information Act (5 U.S.C. 552) and the Privacy Act (5 U.S.C. 552a). Records from this system of records may be disclosed to the Department of Justice to determine whether the Freedom of Information Act requires disclosure of these records.
2. A record from this system of records may be disclosed, as a routine use, in the course of presenting evidence to a court, magistrate, or administrative tribunal, including disclosures to opposing counsel in the course of settlement negotiations.
3. A record in this system of records may be disclosed, as a routine use, to a Member of Congress submitting a request involving an individual, to whom the record pertains, when the individual has requested assistance from the Member with respect to the subject matter of the record.
4. A record in this system of records may be disclosed, as a routine use, to a contractor of the Agency having need for the information in order to perform a contract. Recipients of information shall be required to comply with the requirements of the Privacy Act of 1974, as amended, pursuant to 5 U.S.C. 552a(m).
5. A record related to an International Application filed under the Patent Cooperation Treaty in this system of records may be disclosed, as a routine use, to the International Bureau of the World Intellectual Property Organization, pursuant to the Patent Cooperation Treaty.
6. A record in this system of records may be disclosed, as a routine use, to another federal agency for purposes of National Security review (35 U.S.C. 181) and for review pursuant to the Atomic Energy Act (42 U.S.C. 218(c)).
7. A record from this system of records may be disclosed, as a routine use, to the Administrator, General Services, or his/her designee, during an inspection of records conducted by GSA as part of that agency's responsibility to recommend improvements in records management practices and programs, under authority of 44 U.S.C. 2904 and 2906. Such disclosure shall be made in accordance with the GSA regulations governing inspection of records for this purpose, and any other relevant (i.e., GSA or Commerce) directive. Such disclosure shall not be used to make determinations about individuals.
8. A record from this system of records may be disclosed, as a routine use, to the public after either publication of the application pursuant to 35 U.S.C. 122(b) or issuance of a patent pursuant to 35 U.S.C. 151. Further, a record may be disclosed, subject to the limitations of 37 CFR 1.14, as a routine use, to the public if the record was filed in an application which became abandoned or in which the proceedings were terminated and which application is referenced by either a published application, an application open to public inspections or an issued patent.
9. A record from this system of records may be disclosed, as a routine use, to a Federal, State, or local law enforcement agency, if the USPTO becomes aware of a violation or potential violation of law or regulation.

Electronic Acknowledgement Receipt

EFS ID:	12102774
Application Number:	12879899
International Application Number:	
Confirmation Number:	7976
Title of Invention:	DESIGNING AND MANUFACTURING VEHICLE FLOOR TRAYS
First Named Inventor/Applicant Name:	David F. MacNeil
Customer Number:	64770
Filer:	Jefferson Perkins/Patricia Romanelli
Filer Authorized By:	Jefferson Perkins
Attorney Docket Number:	31700.000254
Receipt Date:	17-FEB-2012
Filing Date:	10-SEP-2010
Time Stamp:	13:39:09
Application Type:	Utility under 35 USC 111(a)

Payment information:

Submitted with Payment	no
------------------------	----

File Listing:

Document Number	Document Description	File Name	File Size(Bytes)/ Message Digest	Multi Part /.zip	Pages (if appl.)
1	Information Disclosure Statement (IDS) Form (SB08)	IDS3.pdf	612633 <small>ef7aee0bde8ba87e79c66106d202242dfc8f3b40</small>	no	5

Warnings:

Information:

A U.S. Patent Number Citation or a U.S. Publication Number Citation is required in the Information Disclosure Statement (IDS) form for autoloading of data into USPTO systems. You may remove the form to add the required data in order to correct the Informational Message if you are citing U.S. References. If you chose not to include U.S. References, the image of the form will be processed and be made available within the Image File Wrapper (IFW) system. However, no data will be extracted from this form. Any additional data such as Foreign Patent Documents or Non Patent Literature will be manually reviewed and keyed into USPTO systems.

2	Foreign Reference	ForDoc1_JP200052835.pdf	1036953	no	12
			3bcb87cc7b61e0a82a3c24a2f5152bccf62ffa		
Warnings:					
Information:					
3	Foreign Reference	ForDoc2_JP_H8-85377.pdf	1038373	no	12
			73707a685d7f251edfb6976b59e23afaae857068		
Warnings:					
Information:					
4	Foreign Reference	ForDoc3_JP_H3-47245.pdf	1182287	no	10
			f39d27ef02eedfaa4f5ae7c567745446922e9c0		
Warnings:					
Information:					
5	Foreign Reference	ForDoc4_JP_2002356124.pdf	1218079	no	14
			f587dae3b134a4d4fa37931c5e26b2c1565d6dff		
Warnings:					
Information:					
6	Non Patent Literature	NPL1-StrictlyCatalog1.pdf	21283037	no	6
			ce0993b537d339341d258a7f609c193e506232aa		
Warnings:					
Information:					
7	Non Patent Literature	NPL2-CIPO.pdf	2605800	no	3
			1c7df8844ab2a30c2e39c2465dea147f34d7468e		
Warnings:					
Information:					
8	Non Patent Literature	NPL3-US_OA11-27-2007.pdf	4347810	no	7
			aac7442d94f9f28e8194ea0242626e37b6056a5		
Warnings:					
Information:					
9	Non Patent Literature	NPL4-US_OA06-06-2007.pdf	17169134	no	19
			98522feb78565675b4076617dbe92b85718a06e0		
Warnings:					
Information:					

10	Non Patent Literature	NPL5-GBSrchRpt11-06-2007.pdf	1037961 f16de6507b997fb0c769447fa6c5f18355b30811	no	3
Warnings:					
Information:					
11	Non Patent Literature	NPL6-US_OA8-13-2009.pdf	8452224 9cc79640ff0f5c4d8ffca04e91ea4c68fde5cea	no	11
Warnings:					
Information:					
12	Non Patent Literature	NPL7-US_OA06-10-2009.pdf	1507817 c50bb875dcfd0a2097b57467a4b6524c18f33420	no	13
Warnings:					
Information:					
13	Non Patent Literature	NPL8-US_OA06-11-2009.pdf	2130111 19927f9734adaa79a0f406e890acb820e68f849f	no	18
Warnings:					
Information:					
14	Non Patent Literature	NPL9-GBSrchRpt03-03-2008.pdf	89846 1b3efefd2e1b275a1db1d940056ddb29b7fd0fe7	no	1
Warnings:					
Information:					
15	Non Patent Literature	NPL10-JP_Notice01_05_2011.pdf	223668 0ea72e4b8ed78380b95109bbeedf4b7698381d3c	no	4
Warnings:					
Information:					
16	Non Patent Literature	NPL11-CA_Req12-14-2010.pdf	2343203 bb7a1ffb074f0d0a63ba43f20cbe59650055901	no	2
Warnings:					
Information:					
17	Non Patent Literature	NPL12-CA_Req1-14-2011.pdf	1845874 438920040d26d83b56d03a18539b610cba6bf0fe	no	2
Warnings:					
Information:					
18	Non Patent Literature	NPL13-DE_OA9-1-2011.pdf	390134 25b31f99a85cb5247713130b6e3ca7802cf3f42a	no	5
Warnings:					
Information:					

19	Non Patent Literature	NPL14-CA_Req12-19-2011.pdf	115871 18616961c0290bf39379c3611d71928ced4 9137c	no	2
----	-----------------------	----------------------------	--	----	---

Warnings:

Information:

Total Files Size (in bytes):	68630815
-------------------------------------	----------

This Acknowledgement Receipt evidences receipt on the noted date by the USPTO of the indicated documents, characterized by the applicant, and including page counts, where applicable. It serves as evidence of receipt similar to a Post Card, as described in MPEP 503.

New Applications Under 35 U.S.C. 111

If a new application is being filed and the application includes the necessary components for a filing date (see 37 CFR 1.53(b)-(d) and MPEP 506), a Filing Receipt (37 CFR 1.54) will be issued in due course and the date shown on this Acknowledgement Receipt will establish the filing date of the application.

National Stage of an International Application under 35 U.S.C. 371

If a timely submission to enter the national stage of an international application is compliant with the conditions of 35 U.S.C. 371 and other applicable requirements a Form PCT/DO/EO/903 indicating acceptance of the application as a national stage submission under 35 U.S.C. 371 will be issued in addition to the Filing Receipt, in due course.

New International Application Filed with the USPTO as a Receiving Office

If a new international application is being filed and the international application includes the necessary components for an international filing date (see PCT Article 11 and MPEP 1810), a Notification of the International Application Number and of the International Filing Date (Form PCT/RO/105) will be issued in due course, subject to prescriptions concerning national security, and the date shown on this Acknowledgement Receipt will establish the international filing date of the application.



UNITED STATES PATENT AND TRADEMARK OFFICE

UNITED STATES DEPARTMENT OF COMMERCE
United States Patent and Trademark Office
Address: COMMISSIONER FOR PATENTS
P.O. Box 1450
Alexandria, Virginia 22313-1450
www.uspto.gov

APPLICATION NO.	FILING DATE	FIRST NAMED INVENTOR	ATTORNEY DOCKET NO.	CONFIRMATION NO.
12/879,899	09/10/2010	David F. MacNeil	31700.000254	7976
64770	7590	05/03/2012	EXAMINER	
Momkus McCluskey, LLC 1001 Warrenville Road, Suite 500 Lisle, IL 60532			ROMAIN, PINEL E	
			ART UNIT	PAPER NUMBER
			3612	
			NOTIFICATION DATE	DELIVERY MODE
			05/03/2012	ELECTRONIC

Please find below and/or attached an Office communication concerning this application or proceeding.

The time period for reply, if any, is set in the attached communication.

Notice of the Office communication was sent electronically on above-indicated "Notification Date" to the following e-mail address(es):

jperkins@momlaw.com
promanelli@momlaw.com
sbehnken@momlaw.com

Office Action Summary	Application No. 12/879,899	Applicant(s) MACNEIL ET AL.	
	Examiner PINEL ROMAIN	Art Unit 3612	

-- The MAILING DATE of this communication appears on the cover sheet with the correspondence address --

Period for Reply

A SHORTENED STATUTORY PERIOD FOR REPLY IS SET TO EXPIRE 3 MONTH(S) OR THIRTY (30) DAYS, WHICHEVER IS LONGER, FROM THE MAILING DATE OF THIS COMMUNICATION.

- Extensions of time may be available under the provisions of 37 CFR 1.136(a). In no event, however, may a reply be timely filed after SIX (6) MONTHS from the mailing date of this communication.
- If NO period for reply is specified above, the maximum statutory period will apply and will expire SIX (6) MONTHS from the mailing date of this communication.
- Failure to reply within the set or extended period for reply will, by statute, cause the application to become ABANDONED (35 U.S.C. § 133). Any reply received by the Office later than three months after the mailing date of this communication, even if timely filed, may reduce any earned patent term adjustment. See 37 CFR 1.704(b).

Status

- 1) Responsive to communication(s) filed on ____.
- 2a) This action is **FINAL**. 2b) This action is non-final.
- 3) An election was made by the applicant in response to a restriction requirement set forth during the interview on ____; the restriction requirement and election have been incorporated into this action.
- 4) Since this application is in condition for allowance except for formal matters, prosecution as to the merits is closed in accordance with the practice under *Ex parte Quayle*, 1935 C.D. 11, 453 O.G. 213.

Disposition of Claims

- 5) Claim(s) 12-17 is/are pending in the application.
5a) Of the above claim(s) ____ is/are withdrawn from consideration.
- 6) Claim(s) ____ is/are allowed.
- 7) Claim(s) 12-17 is/are rejected.
- 8) Claim(s) ____ is/are objected to.
- 9) Claim(s) ____ are subject to restriction and/or election requirement.

Application Papers

- 10) The specification is objected to by the Examiner.
- 11) The drawing(s) filed on ____ is/are: a) accepted or b) objected to by the Examiner.
Applicant may not request that any objection to the drawing(s) be held in abeyance. See 37 CFR 1.85(a).
Replacement drawing sheet(s) including the correction is required if the drawing(s) is objected to. See 37 CFR 1.121(d).
- 12) The oath or declaration is objected to by the Examiner. Note the attached Office Action or form PTO-152.

Priority under 35 U.S.C. § 119

- 13) Acknowledgment is made of a claim for foreign priority under 35 U.S.C. § 119(a)-(d) or (f).
a) All b) Some * c) None of:
1. Certified copies of the priority documents have been received.
2. Certified copies of the priority documents have been received in Application No. ____.
3. Copies of the certified copies of the priority documents have been received in this National Stage application from the International Bureau (PCT Rule 17.2(a)).

* See the attached detailed Office action for a list of the certified copies not received.

Attachment(s)

- | | |
|--|--|
| 1) <input type="checkbox"/> Notice of References Cited (PTO-892) | 4) <input type="checkbox"/> Interview Summary (PTO-413)
Paper No(s)/Mail Date. ____ . |
| 2) <input type="checkbox"/> Notice of Draftsperson's Patent Drawing Review (PTO-948) | 5) <input type="checkbox"/> Notice of Informal Patent Application |
| 3) <input checked="" type="checkbox"/> Information Disclosure Statement(s) (PTO/SB/08)
Paper No(s)/Mail Date <u>02/17/2012;09/10/2010</u> ; | 6) <input type="checkbox"/> Other: ____. |

DETAILED ACTION

Claim Rejections - 35 USC § 112

The following is a quotation of the second paragraph of 35 U.S.C. 112:

The specification shall conclude with one or more claims particularly pointing out and distinctly claiming the subject matter which the applicant regards as his invention.

1. Claims 12- 17 are rejected under 35 U.S.C. 112, second paragraph, as being indefinite for failing to particularly point out and distinctly claim the subject matter which applicant regards as the invention.

a. Claim 12 recites the limitation “the first wall” in line 9. There is insufficient antecedent basis for this limitation in the claim.

b. Regarding claim 13, the following terms are directional elements which are not clearly defined with a vehicle reference point;

“Lateral side”;

“A fourth lateral side”

“A first panel” and “the first wall” are not clearly defined,

“ A second panel”, and “curved transition” are also unclear

Regarding Claim 14, recite “a third panel”, “a fourth panel” are also unclear.

Claim Rejections - 35 USC § 103

The following is a quotation of 35 U.S.C. 103(a) which forms the basis for all obviousness rejections set forth in this Office action:

Art Unit: 3612

(a) A patent may not be obtained though the invention is not identically disclosed or described as set forth in section 102 of this title, if the differences between the subject matter sought to be patented and the prior art are such that the subject matter as a whole would have been obvious at the time the invention was made to a person having ordinary skill in the art to which said subject matter pertains. Patentability shall not be negated by the manner in which the invention was made.

2. Claims 12-17 are rejected under 35 U.S.C. 103(a) as being unpatentable over Sherman (6,027,782) in view of Suzuki (H10-96742) cited by applicant.

a. Regarding Claim 12, Sherman discloses a vehicle floor tray (10) a sheet of thermoplastic polymeric material, comprising:

- a floor (11) substantially conforming to a floor of a vehicle foot well, the floor having at least one longitudinally (44) disposed lateral side (45) and at least one transversely disposed lateral side;
- a first panel (12) integrally formed with the floor of the floor tray, upwardly extending from the transversely disposed lateral side of the floor of the floor tray, and closely conforming to a first foot well wall (near 22), the first panel of the tray joined to the floor of the tray by a curved transition (near 16);
- a second panel wall (12) integrally formed with the floor and the first wall, upwardly extending from the longitudinally disposed lateral side of the floor, and closely conforming to a second foot well wall, the second panel of tray joined to the floor of the tray and to the first panel of the tray by curved transitions;

The floor of the tray having an upper surface consisting of a forward region (15) and a rearward region (near 13).

Sherman fails to disclose

The vehicle floor tray is thermoformed

a reservoir disposed in the rearward region,
a general upper surface of the reservoir being lower than
a general upper surface of the forward region;
a plurality of upstanding, hollow, elongate baffles disposed in the reservoir, each
of the baffles having at least two ends remote from each other,
the baffles adapted to elevate the shoe or foot of the occupant above fluid
collected in the reservoir and impeding lateral movement, induced by vehicle
acceleration, of fluid collected in the reservoir, any portion of the
general upper surface of the reservoir connected to a remote portion of the
general upper surface of the reservoir by a path formed around ends of the
baffles

Thermoformed is molding process not given patentable weight in an
apparatus claim. However, Sherman is capable of the of being thermoformed in
order in order to reduce molding cost.

However, Suzuki teaches a reservoir (4) disposed in the rearward region,
a general upper surface of the reservoir being lower than a general upper surface
of the forward region; a plurality of upstanding, hollow, elongate baffles disposed
in the reservoir, each of the baffles having at least two ends remote from each
other, the baffles adapted to elevate the shoe or foot of the occupant above fluid
collected in the reservoir and impeding lateral movement, induced by vehicle
acceleration, of fluid collected in the reservoir, any portion of the general upper

surface of the reservoir connected to a remote portion of the general upper surface of the reservoir by a path formed around ends of the baffles

It would have been obvious to one of ordinary skill in the art at the time of the invention was made motivated to modify the apparatus as disclose by Sherman to include a reservoir (4) as taught by Suzuki in order to provide a drain area to remove water from the user's foot and out of the vehicle

b. Regarding Claim 13, Sherman as modified discloses wherein the baffles include longitudinally (18) oriented portions and *transverse*ly oriented portions.

c. Regarding Claim 14, Sherman as modified disclose a third panel joined to the floor of the tray and one of the first and second panels by curved transitions (17) and upwardly extending from a third lateral side of the floor of the tray.

d. Regarding Claim 15, Sherman as modified discloses the floor tray of Claim 14, further comprising a fourth panel(near 23) of the tray joined to the floor and at least one of the second and third panels by curved transitions, the fourth panel upwardly extending from a fourth lateral side of the floor of the tray.

e. Regarding Claim 16, Sherman as modified failed to disclose wherein the top margin of at least one of the first and second panels is at least five inches higher than the floor of the tray at its greatest vertical separation therefrom. However, it would have

Art Unit: 3612

been obvious to one having ordinary skill in the art at the time the invention was made to be at least five inches higher than the floor of the tray, since it has been held that discovering an optimum value of a result effective variable involves only routine skill in the art. *In re Boesch*, 617 F.2d 272, 205 USPQ 215 (CCPA 1980).

f. Regarding Claim 17, Sherman as modified discloses wherein the first and second panels have top margins which are substantially coplanar with each other (fig.4).

Conclusion

Any inquiry concerning this communication or earlier communications from the examiner should be directed to PINEL ROMAIN whose telephone number is (571)270-7013. The examiner can normally be reached on Monday -Thursday From 7:30 am to 5:00 pm.

If attempts to reach the examiner by telephone are unsuccessful, the examiner's supervisor, Glenn Dayoan can be reached on 571-272-6659. The fax phone number for the organization where this application or proceeding is assigned is 571-273-8300.

Information regarding the status of an application may be obtained from the Patent Application Information Retrieval (PAIR) system. Status information for published applications may be obtained from either Private PAIR or Public PAIR. Status information for unpublished applications is available through Private PAIR only. For more information about the PAIR system, see <http://pair-direct.uspto.gov>. Should you have questions on access to the Private PAIR system, contact the Electronic Business Center (EBC) at 866-217-9197 (toll-free). If you would like assistance from a USPTO Customer Service Representative or access to the automated information system, call 800-786-9199 (IN USA OR CANADA) or 571-272-1000.

/PINEL E ROMAIN/
Examiner, Art Unit 3612

/D GLENN DAYOAN/
Supervisory Patent Examiner, Art Unit 3612

Receipt date: 02/17/2012

Doc code: IDS

Doc description: Information Disclosure Statement (IDS) Filed

PTO/SB/08a (01-10)

Approved for use through 07/31/2012. OMB 0651-0031

U.S. Patent and Trademark Office; U.S. DEPARTMENT OF COMMERCE

Under the Paperwork Reduction Act of 1995, no persons are required to respond to a collection of information unless it contains a valid OMB control number.

INFORMATION DISCLOSURE STATEMENT BY APPLICANT (Not for submission under 37 CFR 1.99)	Application Number	12879899
	Filing Date	2010-09-10
	First Named Inventor	David F. MACNEIL
	Art Unit	3726
	Examiner Name	Alexander Taousakis
	Attorney Docket Number	31700.000254

U.S. PATENTS Remove

Examiner Initial*	Cite No	Patent Number	Kind Code ¹	Issue Date	Name of Patentee or Applicant of cited Document	Pages, Columns, Lines where Relevant Passages or Relevant Figures Appear
	1					

If you wish to add additional U.S. Patent citation information please click the Add button. Add

U.S. PATENT APPLICATION PUBLICATIONS Remove

Examiner Initial*	Cite No	Publication Number	Kind Code ¹	Publication Date	Name of Patentee or Applicant of cited Document	Pages, Columns, Lines where Relevant Passages or Relevant Figures Appear
	1					

If you wish to add additional U.S. Published Application citation information please click the Add button. Add

FOREIGN PATENT DOCUMENTS Remove

Examiner Initial*	Cite No	Foreign Document Number ³	Country Code ² j	Kind Code ⁴	Publication Date	Name of Patentee or Applicant of cited Document	Pages, Columns, Lines where Relevant Passages or Relevant Figures Appear	T ⁵
	1	200052835	JP		2000-02-22	Shengzhou Enterp. Co. Ltd.		<input type="checkbox"/>
	2	H8-85377	JP		1996-04-02	Muratsubaki Masaaki		<input type="checkbox"/>
	3	H3-47245	JP		1991-05-01		English translation unavailable	<input type="checkbox"/>

Receipt date: 02/17/2012 INFORMATION DISCLOSURE STATEMENT BY APPLICANT (Not for submission under 37 CFR 1.99)	Application Number		12879899	
	Filing Date		2010-09-10	
	First Named Inventor	David F. MACNEIL		
	Art Unit	3726		
	Examiner Name	Alexander Taousakis		
	Attorney Docket Number	31700.000254		

4	2002356124	JP		2002-12-10	Japan Vilene Co. Ltd	<input type="checkbox"/>
---	------------	----	--	------------	----------------------	--------------------------

If you wish to add additional Foreign Patent Document citation information please click the Add button **Add**

NON-PATENT LITERATURE DOCUMENTS **Remove**

Examiner Initials*	Cite No	Include name of the author (in CAPITAL LETTERS), title of the article (when appropriate), title of the item (book, magazine, journal, serial, symposium, catalog, etc), date, pages(s), volume-issue number(s), publisher, city and/or country where published.	T ⁵
	1	STRICTLY Catalog for Explorer/Mountaineer/Expedition/Navigator. MacNeil Automotive Products Limited, Downers Grove, IL, 1999, pp. 1- 2 and 4 - 7.	<input type="checkbox"/>
	2	CANADIAN INTELLECTUAL PROPERTY OFFICE, Requisition by Examiner issued on Canadian Application No. 2,524,795 on April 23, 2008.	<input type="checkbox"/>
	3	U.S. PATENT AND TRADEMARK OFFICE, Office Action issued on U.S. Application No. 11/463,215 on November 27, 2007.	<input type="checkbox"/>
	4	U.S. PATENT AND TRADEMARK OFFICE, Office Action issued on U.S. Application No. 11/463,215 on June 6, 2007.	<input type="checkbox"/>
	5	BRITISH PATENT OFFICE, Search Report issued on GB Application No. 0625354.6 dated November 6,2007.	<input type="checkbox"/>
	6	U.S. PATENT AND TRADEMARK OFFICE, Office Action issued on U.S. Application No. 11/463,203 on August 13, 2009.	<input type="checkbox"/>
	7	U.S. PATENT AND TRADEMARK OFFICE, Office Action issued on U.S. Application No. 11/934,320 on June 10, 2009.	<input type="checkbox"/>
	8	U.S. PATENT AND TRADEMARK OFFICE, Office Action issued on U.S. Application No. 12/332,757 on June 11,2009.	<input type="checkbox"/>

INFORMATION DISCLOSURE STATEMENT BY APPLICANT (Not for submission under 37 CFR 1.99)	Application Number		12879899
	Filing Date		2010-09-10
	First Named Inventor	David F. MACNEIL	
	Art Unit	3726	
	Examiner Name	Alexander Taousakis	
	Attorney Docket Number	31700.000254	

9	BRITISH PATENT OFFICE, Search Report on GB Appln. No. 0625354.6 dated March 3, 2008.	<input type="checkbox"/>
10	JAPANESE PATENT OFFICE, Notice issued on JP Application No. 2005-317635, dated January 5, 2011.	<input type="checkbox"/>
11	CANADIAN INTELLECTUAL PROPERTY OFFICE, Requisition on CA 2,672,423, dated on Dec. 14, 2010.	<input type="checkbox"/>
12	CANADIAN INTELLECTUAL PROPERTY OFFICE, Requisition on CA 2,672,095, dated on Jan. 14, 2011.	<input type="checkbox"/>
13	GERMAN PATENT AND TRADEMARK OFFICE, Official Action on DE 10 2005 063 533.4-21, dated September 1, 2011.	<input type="checkbox"/>
14	CANADIAN INTELLECTUAL PROPERTY OFFICE, Requisition on CA 2,672,097, dated on Dec. 19, 2011.	<input type="checkbox"/>

If you wish to add additional non-patent literature document citation information please click the Add button **Add**

EXAMINER SIGNATURE

Examiner Signature	/Pinel Romain/ (03/01/2012)	Date Considered	03/01/2012
--------------------	-----------------------------	-----------------	------------

***EXAMINER:** Initial if reference considered, whether or not citation is in conformance with MPEP 609. Draw line through a citation if not in conformance and not considered. Include copy of this form with next communication to applicant.

¹ See Kind Codes of USPTO Patent Documents at www.USPTO.GOV or MPEP 901.04. ² Enter office that issued the document, by the two-letter code (WIPO Standard ST.3). ³ For Japanese patent documents, the indication of the year of the reign of the Emperor must precede the serial number of the patent document. ⁴ Kind of document by the appropriate symbols as indicated on the document under WIPO Standard ST.16 if possible. ⁵ Applicant is to place a check mark here if English language translation is attached.

INFORMATION DISCLOSURE STATEMENT BY APPLICANT (Not for submission under 37 CFR 1.99)	Application Number		12879899
	Filing Date		2010-09-10
	First Named Inventor	David F. MACNEIL	
	Art Unit	3726	
	Examiner Name	Alexander Taousakis	
	Attorney Docket Number	31700.000254	

CERTIFICATION STATEMENT

Please see 37 CFR 1.97 and 1.98 to make the appropriate selection(s):

That each item of information contained in the information disclosure statement was first cited in any communication from a foreign patent office in a counterpart foreign application not more than three months prior to the filing of the information disclosure statement. See 37 CFR 1.97(e)(1).

OR

That no item of information contained in the information disclosure statement was cited in a communication from a foreign patent office in a counterpart foreign application, and, to the knowledge of the person signing the certification after making reasonable inquiry, no item of information contained in the information disclosure statement was known to any individual designated in 37 CFR 1.56(c) more than three months prior to the filing of the information disclosure statement. See 37 CFR 1.97(e)(2).

- See attached certification statement.
- Fee set forth in 37 CFR 1.17 (p) has been submitted herewith.
- None

SIGNATURE

A signature of the applicant or representative is required in accordance with CFR 1.33, 10.18. Please see CFR 1.4(d) for the form of the signature.

Signature	/Jefferson Perkins/	Date (YYYY-MM-DD)	2012-02-17
Name/Print	Jefferson Perkins	Registration Number	31,407

This collection of information is required by 37 CFR 1.97 and 1.98. The information is required to obtain or retain a benefit by the public which is to file (and by the USPTO to process) an application. Confidentiality is governed by 35 U.S.C. 122 and 37 CFR 1.14. This collection is estimated to take 1 hour to complete, including gathering, preparing and submitting the completed application form to the USPTO. Time will vary depending upon the individual case. Any comments on the amount of time you require to complete this form and/or suggestions for reducing this burden, should be sent to the Chief Information Officer, U.S. Patent and Trademark Office, U.S. Department of Commerce, P.O. Box 1450, Alexandria, VA 22313-1450. **DO NOT SEND FEES OR COMPLETED FORMS TO THIS ADDRESS. SEND TO: Commissioner for Patents, P.O. Box 1450, Alexandria, VA 22313-1450.**

Receipt date: 02/17/2012

Privacy Act Statement

The Privacy Act of 1974 (P.L. 93-579) requires that you be given certain information in connection with your submission of the attached form related to a patent application or patent. Accordingly, pursuant to the requirements of the Act, please be advised that: (1) the general authority for the collection of this information is 35 U.S.C. 2(b)(2); (2) furnishing of the information solicited is voluntary; and (3) the principal purpose for which the information is used by the U.S. Patent and Trademark Office is to process and/or examine your submission related to a patent application or patent. If you do not furnish the requested information, the U.S. Patent and Trademark Office may not be able to process and/or examine your submission, which may result in termination of proceedings or abandonment of the application or expiration of the patent.

The information provided by you in this form will be subject to the following routine uses:

1. The information on this form will be treated confidentially to the extent allowed under the Freedom of Information Act (5 U.S.C. 552) and the Privacy Act (5 U.S.C. 552a). Records from this system of records may be disclosed to the Department of Justice to determine whether the Freedom of Information Act requires disclosure of these records.
2. A record from this system of records may be disclosed, as a routine use, in the course of presenting evidence to a court, magistrate, or administrative tribunal, including disclosures to opposing counsel in the course of settlement negotiations.
3. A record in this system of records may be disclosed, as a routine use, to a Member of Congress submitting a request involving an individual, to whom the record pertains, when the individual has requested assistance from the Member with respect to the subject matter of the record.
4. A record in this system of records may be disclosed, as a routine use, to a contractor of the Agency having need for the information in order to perform a contract. Recipients of information shall be required to comply with the requirements of the Privacy Act of 1974, as amended, pursuant to 5 U.S.C. 552a(m).
5. A record related to an International Application filed under the Patent Cooperation Treaty in this system of records may be disclosed, as a routine use, to the International Bureau of the World Intellectual Property Organization, pursuant to the Patent Cooperation Treaty.
6. A record in this system of records may be disclosed, as a routine use, to another federal agency for purposes of National Security review (35 U.S.C. 181) and for review pursuant to the Atomic Energy Act (42 U.S.C. 218(c)).
7. A record from this system of records may be disclosed, as a routine use, to the Administrator, General Services, or his/her designee, during an inspection of records conducted by GSA as part of that agency's responsibility to recommend improvements in records management practices and programs, under authority of 44 U.S.C. 2904 and 2906. Such disclosure shall be made in accordance with the GSA regulations governing inspection of records for this purpose, and any other relevant (i.e., GSA or Commerce) directive. Such disclosure shall not be used to make determinations about individuals.
8. A record from this system of records may be disclosed, as a routine use, to the public after either publication of the application pursuant to 35 U.S.C. 122(b) or issuance of a patent pursuant to 35 U.S.C. 151. Further, a record may be disclosed, subject to the limitations of 37 CFR 1.14, as a routine use, to the public if the record was filed in an application which became abandoned or in which the proceedings were terminated and which application is referenced by either a published application, an application open to public inspections or an issued patent.
9. A record from this system of records may be disclosed, as a routine use, to a Federal, State, or local law enforcement agency, if the USPTO becomes aware of a violation or potential violation of law or regulation.

ALL REFERENCES CONSIDERED EXCEPT WHERE LINED THROUGH. /P.R./



UNITED STATES PATENT AND TRADEMARK OFFICE

UNITED STATES DEPARTMENT OF COMMERCE
 United States Patent and Trademark Office
 Address: COMMISSIONER FOR PATENTS
 P.O. Box 1450
 Alexandria, Virginia 22313-1450
 www.uspto.gov

BIB DATA SHEET

CONFIRMATION NO. 7976

SERIAL NUMBER 12/879,899	FILING or 371(c) DATE 09/10/2010 RULE	CLASS 296	GROUP ART UNIT 3612	ATTORNEY DOCKET NO. 31700.000254	
APPLICANTS David F. MacNeil, Hinsdale, IL; Scott A. Vergo, Lombard, IL; ** CONTINUING DATA ***** This application is a CON of 11/463,203 08/08/2006 ABN which is a DIV of 10/976,441 10/29/2004 PAT 7,316,847 ** FOREIGN APPLICATIONS ***** ** IF REQUIRED, FOREIGN FILING LICENSE GRANTED *** SMALL ENTITY ** 09/20/2010					
Foreign Priority claimed <input type="checkbox"/> Yes <input checked="" type="checkbox"/> No 35 USC 119(a-d) conditions met <input type="checkbox"/> Yes <input checked="" type="checkbox"/> No Verified and Acknowledged <u>/PINEL E ROMAIN/</u> Examiner's Signature	<input type="checkbox"/> Met after Allowance PER Initials	STATE OR COUNTRY IL	SHEETS DRAWINGS 12	TOTAL CLAIMS 8	INDEPENDENT CLAIMS 3
ADDRESS Momkus McCluskey, LLC 1001 Warrenville Road, Suite 500 Lisle, IL 60532 UNITED STATES					
TITLE DESIGNING AND MANUFACTURING VEHICLE FLOOR TRAYS					
FILING FEE RECEIVED 1072	FEES: Authority has been given in Paper No. _____ to charge/credit DEPOSIT ACCOUNT No. _____ for following:		<input type="checkbox"/> All Fees <input type="checkbox"/> 1.16 Fees (Filing) <input type="checkbox"/> 1.17 Fees (Processing Ext. of time) <input type="checkbox"/> 1.18 Fees (Issue) <input type="checkbox"/> Other _____ <input type="checkbox"/> Credit		

Search Notes	Application/Control No.	Applicant(s)/Patent Under Reexamination
	Examiner	Art Unit

SEARCHED			
Class	Subclass	Date	Examiner

SEARCH NOTES		
Search Notes	Date	Examiner

INTERFERENCE SEARCH			
Class	Subclass	Date	Examiner

--	--

<i>Index of Claims</i> 	Application/Control No. 12879899	Applicant(s)/Patent Under Reexamination MACNEIL ET AL.
	Examiner ALEXANDER P TAOUSAKIS	Art Unit 3726

✓	Rejected	-	Cancelled	N	Non-Elected	A	Appeal
=	Allowed	÷	Restricted	I	Interference	O	Objected

Claims renumbered in the same order as presented by applicant
 CPA
 T.D.
 R.1.47

CLAIM		DATE									
Final	Original	04/20/2012									
	1	-									
	2	-									
	3	-									
	4	-									
	5	-									
	6	-									
	7	-									
	8	-									
	9	-									
	10	-									
	11	-									
	12	✓									
	13	✓									
	14	✓									
	15	✓									
	16	✓									
	17	✓									
	18	-									
	19	-									
	20	-									
	21	-									
	22	-									
	23	-									
	24	-									
	25	-									
	26	-									
	27	-									
	28	-									
	29	-									
	30	-									
	31	-									
	32	-									
	33	-									
	34	-									
	35	-									
	36	-									

<i>Index of Claims</i> 	Application/Control No. 12879899	Applicant(s)/Patent Under Reexamination MACNEIL ET AL.
	Examiner ALEXANDER P TAOUSAKIS	Art Unit 3726

✓	Rejected
=	Allowed

-	Cancelled
÷	Restricted

N	Non-Elected
I	Interference

A	Appeal
O	Objected

<input type="checkbox"/> Claims renumbered in the same order as presented by applicant		<input type="checkbox"/> CPA	<input type="checkbox"/> T.D.	<input type="checkbox"/> R.1.47					
CLAIM		DATE							
Final	Original	04/20/2012							
	37	-							
	38	-							
	39	-							

EAST Search History

EAST Search History (Prior Art)

Ref #	Hits	Search Query	DBs	Default Operator	Plurals	Time Stamp
S1	2	"US 20110009994"	US-PGPUB; USPAT; USOCR; DERWENT	AND	ON	2012/02/26; 12:36
S2	579	"700/98".CCLS.	USPAT	AND	ON	2012/02/26; 12:36
S3	2	"US 20090115225"	US-PGPUB; USPAT; USOCR; DERWENT	AND	ON	2012/02/26; 12:41
S4	443	296/97.23	US-PGPUB; USPAT; USOCR; DERWENT	AND	ON	2012/02/26; 13:46
S5	3784	428/138	US-PGPUB; USPAT; USOCR; DERWENT	AND	ON	2012/02/26; 14:51
S6	341	(296/97.23).CCLS.	US-PGPUB; USPAT; USOCR; FPRS; EPO; JPO; DERWENT; IBM_TDB	OR	OFF	2012/02/26; 14:51
S7	3766	S5 not S6	US-PGPUB; USPAT; USOCR; FPRS; EPO; JPO; DERWENT; IBM_TDB	AND	ON	2012/02/26; 14:59
S8	15	("4280729" "4406492" "4591532" "5776583" "6027782" "6953545").PN.	US-PGPUB; USPAT; USOCR; FPRS; EPO; JPO; DERWENT; IBM_TDB	AND	ON	2012/02/26; 14:59
S9	104	("1776510" "2623242" "2701890" "2810672" "2897963" "2915427" "3050329" "3082032" "3149875" "3206785" "3312498" "3387315" "3390912" "3488081" "3555601" "3605166" "3856610" "4211447" "4280729" "4382986" "4405682" "4420180" "4428999" "4444825" "4480011" "4520057" "4529639" "4579764" "4721641" "4828898" "5034258" "5171619" "5362544"	US-PGPUB; USPAT; USOCR	AND	ON	2012/04/19; 16:15

EAST Search History

"5474829" "5554333" "5891546" "6020044" "D171301").PN. OR ("4280729" "4406492" "4591532" "5776583" "6027782" "6953545").URPN.				
---	--	--	--	--

EAST Search History (Interference)

<This search history is empty>

4/ 20/ 2012 9:15:50 AM

C:\ Users\ promain\ Documents\ EAST\ Workspaces\ 12879899 _ floor _ mat .wsp

Doc code: IDS

Doc description: Information Disclosure Statement (IDS) Filed

12879899 - GALL: 3612

Approved for use through 07/31/2012. OMB 0651-0031

U.S. Patent and Trademark Office; U.S. DEPARTMENT OF COMMERCE

Under the Paperwork Reduction Act of 1995, no persons are required to respond to a collection of information unless it contains a valid OMB control number.

INFORMATION DISCLOSURE STATEMENT BY APPLICANT (Not for submission under 37 CFR 1.99)	Application Number	12879899
	Filing Date	2010-09-10
	First Named Inventor	David F. MACNEIL
	Art Unit	3726
	Examiner Name	Alexander Taousakis
	Attorney Docket Number	31700.000254

U.S. PATENTS						Remove
Examiner Initial*	Cite No	Patent Number	Kind Code ¹	Issue Date	Name of Patentee or Applicant of cited Document	Pages, Columns, Lines where Relevant Passages or Relevant Figures Appear
	1	5919540	A	1999-07-06	Bailey	
	2	5482759	A	1996-01-09	Primeau	
	3	4721641	A	1988-01-26	Bailey	
	4	5254384	A	1993-10-19	Gordon	
	5	4420180	A	1983-12-13	Dupont et al.	
	6	6261667	B1	2001-07-17	Yang	
	7	4828898		1989-05-09	Bailey	
	8	6534146	B1	2003-03-18	Mentz	

INFORMATION DISCLOSURE STATEMENT BY APPLICANT (Not for submission under 37 CFR 1.99)	Application Number	12879899	12879899 - GAU: 3612
	Filing Date	2010-09-10	
	First Named Inventor	David F. MACNEIL	
	Art Unit	3726	
	Examiner Name	Alexander Taousakis	
	Attorney Docket Number	31700.000254	

	9	D242136		1976-11-02	Matlock	
	10	3401975		1968-09-17	Oger	
	11	5474829	A	1995-12-12	Woosley	
	12	3288187	A	1966-11-29	Wheaton	
	13	6022503	A	2000-02-08	Hudkins et al.	
	14	6794013	B1	2004-09-21	Iacovelli et al.	
	15	6605333	B2	2003-08-12	Ferreira et al.	
	16	5891546	A	1999-04-06	Sherman	
	17	5725926	A	1998-03-10	Wang	
	18	4420180	A	1983-12-13	Dupont et al.	
	19	3605166	A	1971-09-20	Chen	

**INFORMATION DISCLOSURE
STATEMENT BY APPLICANT**
(Not for submission under 37 CFR 1.99)

Application Number	12879899	12879899 - GAU: 3612
Filing Date	2010-09-10	
First Named Inventor	David F. MACNEIL	
Art Unit	3726	
Examiner Name	Alexander Taousakis	
Attorney Docket Number	31700.000254	

	20	3488081	A	1970-01-06	Nolen	
	21	3390912	A	1967-07-02	Stata	
	22	4579764	A	1986-04-01	Peoples, Jr. et al.	
	23	2709105	A	1955-05-24	Kramer	
	24	3450429	A	1969-06-17	Stata	
	25	D422256	S	2000-04-04	Lu	
	26	D408342	S	1999-04-20	Yang	
	27	D393238	S	1998-04-07	Kraines	
	28	4382986	A	1983-05-10	Reuben	
	29	D313789		1991-01-15	Thundercloud	
	30	D372011	S	1996-07-23	Tyler	

**INFORMATION DISCLOSURE
STATEMENT BY APPLICANT**
(Not for submission under 37 CFR 1.99)

Application Number	12879899	12879899 - GAU: 3612
Filing Date	2010-09-10	
First Named Inventor	David F. MACNEIL	
Art Unit	3726	
Examiner Name	Alexander Taousakis	
Attorney Docket Number	31700.000254	

31	D454323	S	2002-03-12	Lu	
32	D432478		2000-10-24	Lu	
33	D425005	S	2000-05-16	Rizvi	
34	D420965	S	2000-02-22	Iacovelli et al.	
35	D358571	S	1995-05-23	Thundercloud	
36	D278525	S	1985-04-23	Morawski	
37	5830560	A	1998-11-03	Koa	
38	4211447		1980-07-08	Divincenzo	
39	3087752		1963-04-30	Winchester	
40	7607713	B2	2009-10-27	MacNeil	
41	7316847	B2	2008-01-08	MacNeil	

INFORMATION DISCLOSURE STATEMENT BY APPLICANT (Not for submission under 37 CFR 1.99)	Application Number	12879899	12879899 - GAU: 3612
	Filing Date	2010-09-10	
	First Named Inventor	David F. MACNEIL	
	Art Unit	3726	
	Examiner Name	Alexander Taousakis	
	Attorney Docket Number	31700.000254	

If you wish to add additional U.S. Patent citation information please click the Add button. Add

U.S.PATENT APPLICATION PUBLICATIONS						Remove
Examiner Initial*	Cite No	Publication Number	Kind Code ¹	Publication Date	Name of Patentee or Applicant of cited Document	Pages, Columns, Lines where Relevant Passages or Relevant Figures Appear
	1	20030143358	A1	2003-07-31	Needles	
	2	20060091694	A1	2006-05-04	MacNeil	
	3	20010020316	A1	2001-09-13	Ferreira et al.	
	4	20040224130	A1	2004-11-11	Melucci et al.	
	5	20050191459	A1	2005-09-01	Ferreira et al.	
	6	20080061580	A1	2008-03-13	MacNeil	
	7	20090092795	A1	2009-04-09	MacNeil	
	8	20090230717	A1	2009-09-17	MacNeil	

If you wish to add additional U.S. Published Application citation information please click the Add button. Add

FOREIGN PATENT DOCUMENTS						Remove
--------------------------	--	--	--	--	--	--------

INFORMATION DISCLOSURE STATEMENT BY APPLICANT (Not for submission under 37 CFR 1.99)	Application Number	12879899	12879899 - GAU: 3612
	Filing Date	2010-09-10	
	First Named Inventor	David F. MACNEIL	
	Art Unit	3726	
	Examiner Name	Alexander Taousakis	
	Attorney Docket Number	31700.000254	

Examiner Initial*	Cite No	Foreign Document Number ³	Country Code ² j	Kind Code ⁴	Publication Date	Name of Patentee or Applicant of cited Document	Pages, Columns, Lines where Relevant Passages or Relevant Figures Appear	T ⁵
	1	11268570	JP		1999-10-05	Suzuki		<input checked="" type="checkbox"/>
	2	1302459	CA		1992-06-02	Bailey		<input type="checkbox"/>
	3	1863477	DE	U	1962-12-06	Krapf et al.	English translation unavailable	<input type="checkbox"/>
	4	8434890	DE	U1	1985-02-28	Wurstl	English translation unavailable	<input type="checkbox"/>
	5	406227305	JP	A	1994-08-16	Abe		<input checked="" type="checkbox"/>
	6	1292028	CA		1991-11-12	Altus		<input type="checkbox"/>
	7	2431099	CA		2004-01-11	Whitaker		<input type="checkbox"/>
	8	8332976	JP	A	1996-12-17	Takao		<input checked="" type="checkbox"/>

If you wish to add additional Foreign Patent Document citation information please click the Add button **Add**

NON-PATENT LITERATURE DOCUMENTS **Remove**

Examiner Initials*	Cite No	Include name of the author (in CAPITAL LETTERS), title of the article (when appropriate), title of the item (book, magazine, journal, serial, symposium, catalog, etc), date, pages(s), volume-issue number(s), publisher, city and/or country where published.	T ⁵

**INFORMATION DISCLOSURE
STATEMENT BY APPLICANT**
(Not for submission under 37 CFR 1.99)

Application Number	12879899	12879899 - GAU: 3612
Filing Date	2010-09-10	
First Named Inventor	David F. MACNEIL	
Art Unit	3726	
Examiner Name	Alexander Taousakis	
Attorney Docket Number	31700.000254	

1	Photographs of a Highland Floor Guard with unknown date of manufacture, obtained by Applicant in 2010, and believed to be on sale and in public use prior to October 29, 2003.	<input type="checkbox"/>
2	American Specialty Equipment Corp., "Big Book" catalog for "Performance Parts, Truck Accessories, And Sport Compact Equipment," 2000, page 366.	<input type="checkbox"/>
3	Add-On 2002-2003 Automotive Accessory Catalog, 2002, pages 192 and 447.	<input type="checkbox"/>
4	Floor Mat Comparison Chart, Stylinconcepts.com, June 2, 2002.	<input type="checkbox"/>
5	Advertisement for Highland's Black Armor Floor Guard, Stylin Concepts "Custom Truck Accessories" catalog, 2003, pp. 1, 2 and 109.	<input type="checkbox"/>
6	Image from advertisement for Black Armor Floor Guard, Stylinconcepts.com; April 3, 2002, recovered from http://web.archive.org/20020403230231/stylinconcepts.com/Images/BlackArmorWLogo.jpg .	<input type="checkbox"/>
7	List of "front custom auto floor mats", etrailer.com (as downloaded by web.archive.org), June 4, 2004.	<input type="checkbox"/>
8	Description and illustration of "Front Custom Auto floor Mats"; etrailer.com (as downloaded by web.archive.org), June 4, 2004.	<input type="checkbox"/>
9	Advertisement for Highland floor guards, Counterman Info Pages, prior to Nov. 2002, page 27.	<input type="checkbox"/>
10	Highland Catalog and Jobber sheet; prior to 2004.	<input type="checkbox"/>
11	Highland Application Guide, 2004.	<input type="checkbox"/>

**INFORMATION DISCLOSURE
STATEMENT BY APPLICANT**
(Not for submission under 37 CFR 1.99)

Application Number	12879899	12879899 - GAU: 3612
Filing Date	2010-09-10	
First Named Inventor	David F. MACNEIL	
Art Unit	3726	
Examiner Name	Alexander Taousakis	
Attorney Docket Number	31700.000254	

12	Volvo Accessories brochure, 1990, pages 1 and 23.	<input type="checkbox"/>
13	Volvo 760 GLE Accessories Brochure, 1983, pages 1-3.	<input type="checkbox"/>
14	Volvo Accessories brochure, 1981, pages 1, 27.	<input type="checkbox"/>
15	Volvo Accessories brochure, 1983, page 1, 11, 16.	<input type="checkbox"/>
16	Photographs of Volvo floor mat with unknown manufacture date, obtained by Applicant in 2010, and believed to be on sale and in public use prior to October 29, 2003.	<input type="checkbox"/>
17	Photographs of a Husky Liner floor tray with unknown manufacture date, obtained by Applicant in 2010, and believed to be on sale and in public use prior to October 29, 2003.	<input type="checkbox"/>
18	Husky Liners Product Catalog, 2001, pages 1-2.	<input type="checkbox"/>
19	Husky Liners Product Catalog, 2002, selected pages.	<input type="checkbox"/>
20	Husky Liners Product Catalog, 2003 ½ , SEMA Show Edition, selected pages.	<input type="checkbox"/>
21	Photographs of Winfield's Husky Liner Model 3780 for 2000-2001 BMW X-5 possessed by Applicant, believed to be on sale and in public use prior to October 29, 2003.	<input type="checkbox"/>
22	1998 Lund Product Catalog, p. 24, Lund SportMat Molded Floor Trays.	<input type="checkbox"/>

INFORMATION DISCLOSURE STATEMENT BY APPLICANT (Not for submission under 37 CFR 1.99)	Application Number		12879899	12879899 - GAU: 3612
	Filing Date		2010-09-10	
	First Named Inventor	David F. MACNEIL		
	Art Unit	3726		
	Examiner Name	Alexander Taousakis		
	Attorney Docket Number	31700.000254		

	23	Web advertisement for Fox Weatherboots, foxweatherboots.com (as downloaded by web.archive.org), March 3, 2000.	<input type="checkbox"/>
	24	Nifty Products Catalog, 2003-2004, selected pages.	<input type="checkbox"/>
	25	Advertisement of unknown publication date for Husky Liner 3D Molded Carpeted Front Floor Liners, obtained by Applicant in 2010, and believed to be on sale and in public use prior to October 29, 2003.	<input type="checkbox"/>
	26	Photographs of Husky Liner 3D Floor Liners manufactured August 2010, in possession of Applicant, and believed to be on sale and in public use prior to October 29, 2003.	<input type="checkbox"/>
	27	Geomagic Press Release, "Geomagic, Inc. Wins Second Computer Graphics World Innovation Award," December 10, 1998.	<input type="checkbox"/>
	28	Geomagic Press Release, "Geomagic to Introduce Unique Solution for 3D Content Creation at SIGGRAPH '99," August 3, 1999.	<input type="checkbox"/>
	29	Geomagic Press Release, "Geomagic Announces Geomagic Studio 2.0," January 14, 2000.	<input type="checkbox"/>
	30	Geomagic Press Release, "Geomagic, QTE Offer RevQuick, Automatic Surface Generation for Mastercam," September 25, 2000.	<input type="checkbox"/>
	31	Advertisement, "Third Party Options (Romer, A CimCore Company)," 2000.	<input type="checkbox"/>
	32	SON, SEOKBAE; PARK, HYUNPUNG; and LEE, KWAN; "Automated laser scanning system for reverse engineering and inspection," Int. J. Machine Tools & Manufacture, 42, 889-897 (2002).	<input type="checkbox"/>
	33	"Competition Rising in Portable CMMs," Quality Magazine, May 5, 2003.	<input type="checkbox"/>

**INFORMATION DISCLOSURE
STATEMENT BY APPLICANT**
(Not for submission under 37 CFR 1.99)

Application Number	12879899	12879899 - GAU: 3612
Filing Date	2010-09-10	
First Named Inventor	David F. MACNEIL	
Art Unit	3726	
Examiner Name	Alexander Taousakis	
Attorney Docket Number	31700.000254	

34	Press Release by Brown and Sharpe, "Portable K Series Optical CMMs," 9/1/2002.	<input type="checkbox"/>
35	"CAM2 software," as downloaded from http://web.archive.org/web/20040215065613/www.faro.com/Products on 11/4/2010.	<input type="checkbox"/>
36	"Laser Scanner edges out CMM in the race to market," Machine Design.com, February 5, 2004.	<input type="checkbox"/>
37	"Highres Delivers Complete Reverse Engineering Software Suite for SolidWorks 2001Plus," Reverse Engineering.com, April 25, 2002.	<input type="checkbox"/>
38	"HighRes Provides 3D Reverse Engineering Software to Higher Education Learning Institutions", ReverseEngineering.com, May 21, 2002.	<input type="checkbox"/>
39	"HighRes Reverse Engineering Software now Ships with Every Romer 3000i and Stinger II Portable CMM in North America," ReverseEngineering.com, October 14, 2002.	<input type="checkbox"/>
40	Press Release, "FARO Debuts Affordable "Advantage" Line of Measurement Products," September 4, 2003.	<input type="checkbox"/>
41	CANADIAN INTELLECTUAL PROPERTY OFFICE, Requisition by the Examiner in connection with Canadian Patent Application No. 2,672,423 dated December 14, 2010.	<input type="checkbox"/>
42	JAPANESE PATENT OFFICE, Rejection issued in connection with Japanese Patent Application No. 2005-317635 dispatched on January 5, 2011.	<input checked="" type="checkbox"/>
43	CANADIAN INTELLECTUAL PROPERTY OFFICE, Requisition by the Examiner issued in connection with Canadian Patent Application No. 2,672,095, January 14, 2011.	<input type="checkbox"/>
44	Photographs of Ford Windstar floor mat with unknown manufacture date, obtained by Applicant in 2010, and believed to be on sale and in public use prior to October 29, 2003.	<input type="checkbox"/>

INFORMATION DISCLOSURE STATEMENT BY APPLICANT (Not for submission under 37 CFR 1.99)	Application Number	12879899	12879899 - GAU: 3612
	Filing Date	2010-09-10	
	First Named Inventor	David F. MACNEIL	
	Art Unit	3726	
	Examiner Name	Alexander Taousakis	
	Attorney Docket Number	31700.000254	

If you wish to add additional non-patent literature document citation information please click the Add button **Add**

EXAMINER SIGNATURE

Examiner Signature	/Pinel Romain/ (04/17/2012)	Date Considered	
--------------------	-----------------------------	-----------------	--

*EXAMINER: Initial if reference considered, whether or not citation is in conformance with MPEP 609. Draw line through a citation if not in conformance and not considered. Include copy of this form with next communication to applicant.

¹ See Kind Codes of USPTO Patent Documents at www.USPTO.GOV or MPEP 901.04. ² Enter office that issued the document, by the two-letter code (WIPO Standard ST.3). ³ For Japanese patent documents, the indication of the year of the reign of the Emperor must precede the serial number of the patent document. ⁴ Kind of document by the appropriate symbols as indicated on the document under WIPO Standard ST.16 if possible. ⁵ Applicant is to place a check mark here if English language translation is attached.

INFORMATION DISCLOSURE STATEMENT BY APPLICANT (Not for submission under 37 CFR 1.99)	Application Number	12879899	12879899 - GAU: 3612
	Filing Date	2010-09-10	
	First Named Inventor	David F. MACNEIL	
	Art Unit	3726	
	Examiner Name	Alexander Taousakis	
	Attorney Docket Number	31700.000254	

CERTIFICATION STATEMENT

Please see 37 CFR 1.97 and 1.98 to make the appropriate selection(s):

That each item of information contained in the information disclosure statement was first cited in any communication from a foreign patent office in a counterpart foreign application not more than three months prior to the filing of the information disclosure statement. See 37 CFR 1.97(e)(1).

OR

That no item of information contained in the information disclosure statement was cited in a communication from a foreign patent office in a counterpart foreign application, and, to the knowledge of the person signing the certification after making reasonable inquiry, no item of information contained in the information disclosure statement was known to any individual designated in 37 CFR 1.56(c) more than three months prior to the filing of the information disclosure statement. See 37 CFR 1.97(e)(2).

See attached certification statement.

Fee set forth in 37 CFR 1.17 (p) has been submitted herewith.

None

SIGNATURE

A signature of the applicant or representative is required in accordance with CFR 1.33, 10.18. Please see CFR 1.4(d) for the form of the signature.

Signature	/Jefferson Perkins/	Date (YYYY-MM-DD)	2012-02-17
Name/Print	Jefferson Perkins	Registration Number	31,407

This collection of information is required by 37 CFR 1.97 and 1.98. The information is required to obtain or retain a benefit by the public which is to file (and by the USPTO to process) an application. Confidentiality is governed by 35 U.S.C. 122 and 37 CFR 1.14. This collection is estimated to take 1 hour to complete, including gathering, preparing and submitting the completed application form to the USPTO. Time will vary depending upon the individual case. Any comments on the amount of time you require to complete this form and/or suggestions for reducing this burden, should be sent to the Chief Information Officer, U.S. Patent and Trademark Office, U.S. Department of Commerce, P.O. Box 1450, Alexandria, VA 22313-1450. **DO NOT SEND FEES OR COMPLETED FORMS TO THIS ADDRESS. SEND TO: Commissioner for Patents, P.O. Box 1450, Alexandria, VA 22313-1450.**

Privacy Act Statement

The Privacy Act of 1974 (P.L. 93-579) requires that you be given certain information in connection with your submission of the attached form related to a patent application or patent. Accordingly, pursuant to the requirements of the Act, please be advised that: (1) the general authority for the collection of this information is 35 U.S.C. 2(b)(2); (2) furnishing of the information solicited is voluntary; and (3) the principal purpose for which the information is used by the U.S. Patent and Trademark Office is to process and/or examine your submission related to a patent application or patent. If you do not furnish the requested information, the U.S. Patent and Trademark Office may not be able to process and/or examine your submission, which may result in termination of proceedings or abandonment of the application or expiration of the patent.

The information provided by you in this form will be subject to the following routine uses:

1. The information on this form will be treated confidentially to the extent allowed under the Freedom of Information Act (5 U.S.C. 552) and the Privacy Act (5 U.S.C. 552a). Records from this system of records may be disclosed to the Department of Justice to determine whether the Freedom of Information Act requires disclosure of these records.
2. A record from this system of records may be disclosed, as a routine use, in the course of presenting evidence to a court, magistrate, or administrative tribunal, including disclosures to opposing counsel in the course of settlement negotiations.
3. A record in this system of records may be disclosed, as a routine use, to a Member of Congress submitting a request involving an individual, to whom the record pertains, when the individual has requested assistance from the Member with respect to the subject matter of the record.
4. A record in this system of records may be disclosed, as a routine use, to a contractor of the Agency having need for the information in order to perform a contract. Recipients of information shall be required to comply with the requirements of the Privacy Act of 1974, as amended, pursuant to 5 U.S.C. 552a(m).
5. A record related to an International Application filed under the Patent Cooperation Treaty in this system of records may be disclosed, as a routine use, to the International Bureau of the World Intellectual Property Organization, pursuant to the Patent Cooperation Treaty.
6. A record in this system of records may be disclosed, as a routine use, to another federal agency for purposes of National Security review (35 U.S.C. 181) and for review pursuant to the Atomic Energy Act (42 U.S.C. 218(c)).
7. A record from this system of records may be disclosed, as a routine use, to the Administrator, General Services, or his/her designee, during an inspection of records conducted by GSA as part of that agency's responsibility to recommend improvements in records management practices and programs, under authority of 44 U.S.C. 2904 and 2906. Such disclosure shall be made in accordance with the GSA regulations governing inspection of records for this purpose, and any other relevant (i.e., GSA or Commerce) directive. Such disclosure shall not be used to make determinations about individuals.
8. A record from this system of records may be disclosed, as a routine use, to the public after either publication of the application pursuant to 35 U.S.C. 122(b) or issuance of a patent pursuant to 35 U.S.C. 151. Further, a record may be disclosed, subject to the limitations of 37 CFR 1.14, as a routine use, to the public if the record was filed in an application which became abandoned or in which the proceedings were terminated and which application is referenced by either a published application, an application open to public inspections or an issued patent.
9. A record from this system of records may be disclosed, as a routine use, to a Federal, State, or local law enforcement agency, if the USPTO becomes aware of a violation or potential violation of law or regulation.

ALL REFERENCES CONSIDERED EXCEPT WHERE LINED THROUGH. /P.R./

Doc code: IDS

Doc description: Information Disclosure Statement (IDS) Filed

12879899 - GALL: 3612

Approved for use through 07/31/2012. OMB 0651-0031

U.S. Patent and Trademark Office; U.S. DEPARTMENT OF COMMERCE

Under the Paperwork Reduction Act of 1995, no persons are required to respond to a collection of information unless it contains a valid OMB control number.

INFORMATION DISCLOSURE STATEMENT BY APPLICANT (Not for submission under 37 CFR 1.99)	Application Number		
	Filing Date		
	First Named Inventor	David F. MACNEIL	
	Art Unit		
	Examiner Name		
	Attorney Docket Number	31700.000254	

U.S. PATENTS						Remove
Examiner Initial*	Cite No	Patent Number	Kind Code ¹	Issue Date	Name of Patentee or Applicant of cited Document	Pages, Columns, Lines where Relevant Passages or Relevant Figures Appear
	1	4280729	A	1981-07-28	Morawski	
	2	4406492	A	1983-09-27	Cackowski	
	3	4591532	A	1986-05-27	Tanaka	
	4	6027782	A	2000-02-22	Sherman	
	5	6793872	B1	2004-09-21	Buss	
	6	6953545	B1	2005-10-11	Tyler	
	7	D377780		1997-02-04	MacNeil	
	8	5776583	A1	1998-07-07	Peyton	

**INFORMATION DISCLOSURE
STATEMENT BY APPLICANT**
(Not for submission under 37 CFR 1.99)

Application Number		12879899 - GAU: 3612
Filing Date		
First Named Inventor	David F. MACNEIL	
Art Unit		
Examiner Name		
Attorney Docket Number	31700.000254	

9	6155629	A	2000-12-05	Sherman	
10	6732030	B2	2004-05-04	Jones	
11	6058618	A	2000-05-09	Hemmelgarn et al.	
12	5208995	A	1993-05-11	McKendrick	
13	7401837	B2	2008-07-22	MacNeil	
14	7444748	B2	2008-11-04	MacNeil	
15	6007319	A	1999-12-28	Jacobson	
16	5019993	A	1991-05-28	Montalcini et al.	
17	7215430	B2	2007-05-08	Kacyra et al.	
18	2188342	A	1940-01-30	England	
19	5856828	A	1999-01-05	Letcher, Jr.	

INFORMATION DISCLOSURE STATEMENT BY APPLICANT (Not for submission under 37 CFR 1.99)	Application Number		12879899 - GAU: 3612	
	Filing Date			
	First Named Inventor	David F. MACNEIL		
	Art Unit			
	Examiner Name			
	Attorney Docket Number		31700.000254	

	20	6817649	B1	2004-11-16	Stanesic	
--	----	---------	----	------------	----------	--

If you wish to add additional U.S. Patent citation information please click the Add button.

U.S.PATENT APPLICATION PUBLICATIONS

Examiner Initial*	Cite No	Publication Number	Kind Code ¹	Publication Date	Name of Patentee or Applicant of cited Document	Pages,Columns,Lines where Relevant Passages or Relevant Figures Appear
	1	20060091695	A1	2006-05-04	MacNeil	
	2	20040048036	A1	2004-03-11	Nakasuji et al.	
	3	20060288578	A1	2006-12-28	MacNeil	

If you wish to add additional U.S. Published Application citation information please click the Add button.

FOREIGN PATENT DOCUMENTS

Examiner Initial*	Cite No	Foreign Document Number ³	Country Code ² j	Kind Code ⁴	Publication Date	Name of Patentee or Applicant of cited Document	Pages,Columns,Lines where Relevant Passages or Relevant Figures Appear	T ⁵
	1	0 968 875	EP	B1	2000-01-05	T.P. Chomarat	Abstract, Claims (partial translation only)	<input type="checkbox"/>
	2	1 198 466	CA	A	1985-12-24	Du Pont et al.	Abstract (partial translation only)	<input type="checkbox"/>
	3	1 101 016	CA	A	1981-05-12	Morawski		<input type="checkbox"/>

If you wish to add additional Foreign Patent Document citation information please click the Add button.

NON-PATENT LITERATURE DOCUMENTS

INFORMATION DISCLOSURE STATEMENT BY APPLICANT (Not for submission under 37 CFR 1.99)	Application Number		12879899 - GAU: 3612
	Filing Date		
	First Named Inventor	David F. MACNEIL	
	Art Unit		
	Examiner Name		
	Attorney Docket Number		31700.000254

Examiner Initials*	Cite No	Include name of the author (in CAPITAL LETTERS), title of the article (when appropriate), title of the item (book, magazine, journal, serial, symposium, catalog, etc), date, pages(s), volume-issue number(s), publisher, city and/or country where published.	T ⁵
	1	Husky Liner for 1999 Ford Super Duty, downloaded from http://www.huskyliners.com/superduty.html on January 3, 2005	<input type="checkbox"/>
	2	Autoform Trunk Liner, English web page, downloaded from http://www.autoform.se/eng/products_trunk_liners.htm on October 20, 2004	<input type="checkbox"/>
	3	"Installation Instructions For Your F-150/F-250 Ford Truck Front Floor Liners", Winfield Consumer Products, February 1, 2001, downloaded from http://www.huskyliners.com on January 3, 2005	<input type="checkbox"/>
	4	Husky Deep Tray Floor Liner, downloaded from http://www.truckstuffusa.com/cusfitdeeptr.html on January 3, 2005	<input type="checkbox"/>
	5	Web pages featuring products from 3D Carpet Liners, Weatherboots, Nifty Products, Inc. and Husky, downloaded from http://www.premiermotoring.net on August 11, 2004	<input type="checkbox"/>
	6	WeatherTech Floor Mat and Cargo Liner Product Sheets, MacNeil Automotive Products Limited, Downers Grove, IL, Nov. 1994, 4 pp.	<input type="checkbox"/>
	7	Faro Laser ScanArm, downloaded from http://www.faro.com/Products/ScanArm.asp on September 23, 2004	<input type="checkbox"/>
	8	Faro ScanArm Product Techsheet, downloaded from http://www.faro.com/Products/Product_Techsheets.asp?techsheet_id=106 on October 11, 2004	<input type="checkbox"/>
	9	"CMM Produces Bikes With Custom-Look", downloaded from http://manufacturingcenter.com/man/articles/0604/0604CMM.asp on October 11, 2004	<input type="checkbox"/>
	10	"Stereolithography (SLA) for Rapid Precision Prototypes", p.1, downloaded from http://www.boedeker.com/sla.htm on October 12, 2004	<input type="checkbox"/>

INFORMATION DISCLOSURE STATEMENT BY APPLICANT (Not for submission under 37 CFR 1.99)	Application Number		12879899 - GAU: 3612
	Filing Date		
	First Named Inventor	David F. MACNEIL	
	Art Unit		
	Examiner Name		
	Attorney Docket Number		31700.000254

11	"About Coordinate Measuring Machines (CMM)", downloaded from http://cmm.globalspec.com on October 11, 2004	<input type="checkbox"/>
12	"Bagagerumsmattor", downloaded from http://www.autoform.se/sv/produkter_bagagerumsmattor.htm on October 20, 2004	<input type="checkbox"/>
13	CANADIAN INTELLECTUAL PROPERTY OFFICE, Requisition by the Examiner dated December 17, 2009 on Canadian Patent Application No. 2,672,116.	<input type="checkbox"/>
14	BRITISH PATENT OFFICE, Search Report on GB Patent Appln. No. GB 0522091.8, 14 Feb 2006	<input type="checkbox"/>
15	BRITISH PATENT OFFICE, Search Report on GB Patent Appln. No. GB 0522091.8, Claims 47 - 66, 77 and 78, 23 June 2006	<input type="checkbox"/>
16	BRITISH PATENT OFFICE, Search Report on Patent Appln. No. GB 0522091.8, Claims 67 - 70, 26 June 2006	<input type="checkbox"/>
17	BRITISH PATENT OFFICE, Search Report on Patent Appln. No. GB 0522091.8, Claims 71 -73, 27 June 2006	<input type="checkbox"/>
18	BRITISH PATENT OFFICE, Search Report on Patent Appln. No. GB 0522091.8, Claims 79 - 84 and 101 - 105, 23 June 2006	<input type="checkbox"/>
19	BRITISH PATENT OFFICE, Search Report on Patent Appln. No. GB 522091.8, claims 85 - 100, 27 June 2006	<input type="checkbox"/>

If you wish to add additional non-patent literature document citation information please click the Add button

EXAMINER SIGNATURE

Examiner Signature	/Pinel Romain/ (04/21/2012)	Date Considered	
--------------------	-----------------------------	-----------------	--

*EXAMINER: Initial if reference considered, whether or not citation is in conformance with MPEP 609. Draw line through a citation if not in conformance and not considered. Include copy of this form with next communication to applicant.

INFORMATION DISCLOSURE STATEMENT BY APPLICANT (Not for submission under 37 CFR 1.99)	Application Number	12879899 - GAU: 3612
	Filing Date	
	First Named Inventor	David F. MACNEIL
	Art Unit	
	Examiner Name	
	Attorney Docket Number	31700.000254

¹ See Kind Codes of USPTO Patent Documents at www.USPTO.GOV or MPEP 901.04. ² Enter office that issued the document, by the two-letter code (WIPO Standard ST.3). ³ For Japanese patent documents, the indication of the year of the reign of the Emperor must precede the serial number of the patent document. ⁴ Kind of document by the appropriate symbols as indicated on the document under WIPO Standard ST.16 if possible. ⁵ Applicant is to place a check mark here if English language translation is attached.

IN THE UNITED STATES PATENT & TRADEMARK OFFICE

In re the application of: David F. MACNEIL et al.
Application Number: 12/879,899
Filing Date: September 10, 2010
Art Unit: 3612
Examiner: Pinel E. ROMAIN
Confirmation Number: 7976

CERTIFICATE OF TRANSMISSION BY
ELECTRONIC FILING
I hereby certify that this correspondence is
being transmitted via the USPTO electronic
filing system in accordance with 37 CFR
§1.6(a)(4) on June 13, 2012.
/Patricia Romanelli/
Patricia Romanelli

For: DESIGNING AND MANUFACTURING VEHICLE FLOOR TRAYS

Commissioner for Patents
P.O. Box 1450
Alexandria, VA 22313-1450

REPLY TO OFFICE ACTION

Dear Sir:

This communication is responsive to the Examiner's Action mailed May 3, 2012.

IN THE CLAIMS

Please amend the claims as set forth in the claim listing below. In particular, Applicant amends Claims 12, 14, 15, and 16.

CLAIM LISTING

1-11. (Canceled).

12. (Amended) A vehicle floor tray thermoformed from a sheet of thermoplastic polymeric material of substantially uniform thickness, comprising:

a ~~floor~~ central panel substantially conforming to a floor of a vehicle foot well, the ~~floor~~ central panel of the floor tray having at least one longitudinally disposed lateral side and at least one transversely disposed lateral side;

a first panel integrally formed with the ~~floor~~ central panel of the floor tray, upwardly extending from the transversely disposed lateral side of the ~~floor~~ central panel of the floor tray, and closely conforming to a first foot well wall, the first panel of the floor tray joined to the ~~floor~~ central panel of the floor tray by a curved transition;

a second panel ~~wall~~ integrally formed with the ~~floor~~ central panel of the floor tray and the first panel wall, upwardly extending from the longitudinally disposed lateral side of the central panel of the floor tray ~~floor~~, and closely conforming to a second foot well wall, the second panel of the floor tray joined to the ~~floor~~ central panel of the floor tray and to the first panel of the floor tray by curved transitions;

~~a reservoir disposed in the~~ floor central panel of the floor tray; ~~having an upper surface consisting of a forward region and a rearward region, a reservoir disposed in the rearward region, a general upper surface of the reservoir being lower than a general upper surface of the forward region;~~

a plurality of upstanding, hollow, elongate baffles disposed in the reservoir, each

of the baffles having at least two ends remote from each other, the central panel, the first panel, the second panel, the reservoir and the baffles each having a thickness from a point on the upper surface to a closest point on the bottom surface thereof, said thicknesses, as a result of the tray being thermoformed from the sheet of thermoplastic polymeric material of substantially uniform thickness, being substantially uniform throughout the tray;

the baffles each having a width more than two times the thickness of the last said substantially uniform thickness, and adapted to elevate the shoe or foot of the occupant above fluid collected in the reservoir and impeding lateral movement, induced by vehicle acceleration, of fluid collected in the reservoir, any portion of the ~~general upper surface of the~~ reservoir connected to a remote portion of the ~~general upper surface of the~~ reservoir by a path formed around ends of the baffles.

13. (Previously presented) The floor tray of Claim 12, wherein the baffles include longitudinally oriented portions and transversely oriented portions.

14. (Amended) The floor tray of Claim 12, further comprising a third panel integrally formed with ~~joined to~~ the ~~floor~~ central panel of the floor tray and joined to at least one of the first and second panels by curved transitions ~~and~~ , the third panel upwardly extending from a third lateral side of the ~~floor~~ central panel of the floor tray.

15. (Amended) The floor tray of Claim 14, further comprising a fourth panel ~~of the tray~~ integrally formed with ~~joined to~~ the ~~floor~~ central panel of the floor tray and joined to at least one

of the second and third panels by curved transitions, the fourth panel upwardly extending from a fourth lateral side of the ~~floor~~ central panel of the floor tray.

16. (Amended) The floor tray of Claim 12, wherein the top margin of at least one of the first and second panels is at least five inches higher than the ~~floor~~ central panel of the floor tray at its greatest vertical separation therefrom.

17. (Previously presented) The floor tray of Claim 12, wherein the first and second panels have top margins which are substantially coplanar with each other.

18 - 39. (Canceled).

REMARKS

Applicant's phone call with the Examiner on June 13, 2012 confirmed that the latest Office Action is a non-final action and the summary page was marked "final" incorrectly.

In the latest Office Action, the Examiner rejected claims 12- 17 under 35 U.S.C. 112 as being indefinite. Specifically, the Examiner found that the limitation "the first wall" in Claim 12 had insufficient antecedent basis. Furthermore, the Examiner found that additional directional terms were not clearly defined. With respect to the identified directional terms, it appears there has been some confusion as to which claims are currently before the Examiner. Pursuant to the agreement reached during Applicant's phone call with the Examiner on May 7, 2012, the terms were clarified to the extent that Applicant could identify and locate the defects. To better distinguish the tray from the foot well, Applicant has employed the word "panel" for tray structure and "wall" for vehicle foot well structure. If further clarification is necessary, please contact the undersigned.

The Examiner rejected Claims 12 - 17 under 35 U.S.C. 103(a) as being obvious over U.S. Patent No. 6, 027,782 to Sherman ("Sherman") in view of Japanese Patent No. H10-96742 to Suzuki ("Suzuki").

Applicant has amended independent Claim 12 to recite a reservoir disposed in the central panel of the floor tray. Claim 12 has also been amended to reflect that the mat is made with a sheet of thermoplastic polymeric material of substantially uniform thickness. Support for this amendment is found in Paragraph [0051] of the Specification.

Thermoforming, while providing a rapid manufacturing technique and minimizing material cost, imposes significant obstacles in designing features into the completed, molded product. Among these are that all features such as treads or baffles necessarily must be hollow,

as they are all made by softening a sheet of substantially uniform thickness until the sheet conforms on one side to a mold. After molding, the thickness of the material is substantially the same as the starting, unsoftened sheet, with variations caused by step coverage.

For example, in order to form a tread or baffle in a thermoformed tray, it is not enough to simply raise the top surface of the tray; one must also raise the bottom surface to the same extent. The top surface of the tray as molded is a mathematical projection of the bottom surface, and the top surface is always separated from the closest point on the bottom surface by a thickness of material that stays fairly constant. The upstanding feature, as seen from the top side, necessarily is not the same width (in a horizontal direction) as is the corresponding feature on the bottom; in the illustrated embodiment, in which a female mold is used, the feature in the bottom surface is always narrower than the corresponding feature in the top surface by about two thicknesses of the thermoplastic material used to mold the part. Accordingly, Claim 12 has been amended to recite a central panel, a first panel, a second panel, a reservoir, and baffles each having a thickness from a point on the upper surface to a closest point on the bottom surface that is substantially uniform throughout the tray. Additional support for this amendment is found in Figures 3 and 4.

Each tread or baffle is hollow and has an elongate shape, the length of each baffle being several times greater than its width. In the illustrated embodiment with a female mold, the formation of the baffles necessarily requires that the mold have a three-sided contoured shape corresponding to the sides and top of the bottom surface of the baffles. Because the mold contours that form the baffles each have a width, the corresponding baffles as molded have a width that is at least this width plus two times the thickness of the thermoformed thermoplastic

polymeric material. For the width to be equal to two times the thickness of the thermoplastic material, the mold would need to be a two dimensional blade-like projection and the resulting formation would not be hollow. Accordingly, Applicant has amended Claim 12 to recite that each baffle must have a width greater than two times the thickness of the tray as measured from a point on the upper surface of the tray to a closest point on the bottom surface. Support for this amendment is found in Figures 3 and 4.

Applicant has amended dependent claims 14, 15, and 16 to conform terminology and disclose that the third and fourth panels are integrally formed with the central panel of the floor tray and joined to at least one of the other panels by curved transitions.

Applicant respectfully disagrees that the claimed invention is made obvious by Sherman in view of Suzuki. Sherman discloses an aftermarket molded vehicle floor mat made from a multi-layered material which has a tufted carpet top layer, a moldable thermoplastic mid-layer and a non-slip substrate bottom layer. *See* Sherman at Col. 2, Lines 13 – 15. The carpet layer includes a backing and pile yarns secured to the backing. *See* Sherman Col. 3, Lines 57 – 60. The pile yarns can be made of natural or synthetic materials. *See* Sherman Col. 3, Lines 62 – 3. Due to the textured surface created by the pile yarns of the tufted layer, the surface of the Sherman mat is uneven and varied. Accordingly Sherman does not disclose a floor tray thermoformed from a sheet of thermoplastic polymeric material of substantially uniform thickness as Claim 12 requires.

The Sherman mat does not disclose or suggest a reservoir as required by independent Claim 12. Claim 12 recites a reservoir disposed in the central panel of the tray. In contrast, the floor of the Sherman mat is featureless, and covered with tufted carpeting, except for the heel

pad 39 which is secured to the top surface of the carpet. *See* Fig. 1. Furthermore, Claim 12 recites hollow elongate baffles disposed in the reservoir. Since Sherman does not disclose a reservoir, *a fortiori* it does not disclose baffles within it as required by independent Claim 12 and dependent Claim 13.

Applicant respectfully disagrees that the claimed invention is made obvious in view of Suzuki. Suzuki discloses a vehicle floor mat which has "anti-slip protrusions." *See* Suzuki Translation at 5. The anti-slip protrusions in the Suzuki mat are solid. *See* Fig. 3. The Suzuki mat has upright walls (12, 3, 11, 4) surrounding a mat floor with a discharge port 10 for discharging water and debris to the outside when the mat is being washed. *See* Suzuki Translation at 2 and 5; *See also* Figs. 1, 2, and 6. The Suzuki mat is made to fit a box-like compartment and is formed as a single piece from plastic, FRP or hard rubber. *See* Suzuki Translation at 7.

As related above, Claim 12 requires that the floor tray be thermoformed with the resulting product having a substantially uniform thickness. However, the Suzuki mat does not have a uniform thickness. The Suzuki mat has upstanding treads 2 that are solid and depending gripping elements (see Figure 6) that are likewise. Each one of these features occasions a substantial increase in the mat thickness. The Suzuki structure also shows a plate 13 (Figures 7, 6, 5 and 8) that is either molded into the mat or is inserted into a deep cavity for it.

From these design elements, it is apparent that the Suzuki mat is injection-molded rather than thermoformed, as it is impossible to make these shapes in a thermoforming process. Thermoforming also imposes constraints on the size and spacing of such features which do not exist in injection molding.

It would not have been obvious to simply borrow a shape seen in an injection-molded

mat and attempt to incorporate it into a thermoformed product. In Suzuki, the designer simply selected the bottom of the mat or tray to be flat. This is not possible in a thermoformed product having baffles molded into it. In addition, the Suzuki anti-slip protrusions are solid. *See* Fig. 3. Thermoforming does not allow for substantial differences in the thicknesses of features. Nor is it possible to thermoform a tray from a flat blank that has an inserted plate like plate 13 shown in Suzuki's Figure 7. Accordingly, Suzuki does not meet or suggest the limitation of Claim 12 that the floor tray be thermoformed. Furthermore, Suzuki does not meet the limitation of Claim 12 that the central panel, the first panel, the reservoir and baffles disposed in the reservoir be substantially uniformly thick. Nor does Suzuki disclose or suggest hollow baffles with a width greater than twice the thickness of the polymeric material, or how to make baffles in a thermoformed product (by making them hollow, and by imposing limits on their dimensions such that thermoforming can create the feature desired). Suzuki doesn't need to care about minimum feature width as his part is injection-molded, and could not have contemplated this critical limitation in the design of a thermoformed tray.

In addition, dependent Claims 14 and 15 disclose third and fourth panels which are integrally formed with the central panel of the floor tray and are joined to at least one of the first and second panels by curved transitions (third panel) or second and third panels (fourth panel). In contrast, Sherman's double-walled edges teach away from substantial conformance. The Sherman structure borders a featureless floor or central panel with walls which, in two out of four instances, are formed as double walls. *See, e.g.*, Figure 1. Sherman discloses that the floor mat edges adjacent to the door 12 and adjacent to the seat pedestal 13 have double walled edges. *See* Sherman Col. 3, lines 16 – 19; *See also* Figs. 5 and 6. The double walled edges do not

substantially conform to the closest foot well wall as required by both dependent Claims 14 and 15.

Claims 13, 16, and 17, dependent on allowable independent Claim 12, are patentable at least for being dependent on an allowable claim.

In summary, Applicant has demonstrated why the claims as amended patentably define over Sherman in view of Suzuki, and the rest of the art made of record. Applicant therefore respectfully requests the Examiner to issue a Notice of Allowance on the claims as amended.

No fee is thought to be due with the submission of this Reply, which is being submitted within the shortened statutory period set by the Examiner in his last Office Action. However the Commissioner is hereby authorized to charge any deficiency to Deposit Account No. 503982 of Momkus McCluskey, LLC.

Respectfully submitted,

/Karen Blouin/

Karen Blouin

Registration No. 57,098

CUSTOMER NO. 64770

MOMKUS McCLUSKEY, LLC
1001 Warrenville Rd., Suite 500
Lisle, Illinois 60532
Telephone: (630) 434-0400 Ext. 142
Fax: (630) 434-0444
Email: kblouin@momlaw.com

Electronic Acknowledgement Receipt

EFS ID:	13001497
Application Number:	12879899
International Application Number:	
Confirmation Number:	7976
Title of Invention:	DESIGNING AND MANUFACTURING VEHICLE FLOOR TRAYS
First Named Inventor/Applicant Name:	David F. MacNeil
Customer Number:	64770
Filer:	Karen L. Blouin/Patricia Romanelli
Filer Authorized By:	Karen L. Blouin
Attorney Docket Number:	31700.000254
Receipt Date:	13-JUN-2012
Filing Date:	10-SEP-2010
Time Stamp:	12:44:06
Application Type:	Utility under 35 USC 111(a)

Payment information:

Submitted with Payment	no
------------------------	----

File Listing:

Document Number	Document Description	File Name	File Size(Bytes)/ Message Digest	Multi Part /.zip	Pages (if appl.)
1		ROA.pdf	145390 <small>e90b081d9d36963d4d097e615d7210139e547f7a</small>	yes	10

Multipart Description/PDF files in .zip description		
Document Description	Start	End
Amendment/Req. Reconsideration-After Non-Final Reject	1	1
Claims	2	4
Applicant Arguments/Remarks Made in an Amendment	5	10

Warnings:

Information:

Total Files Size (in bytes):	145390
-------------------------------------	--------

This Acknowledgement Receipt evidences receipt on the noted date by the USPTO of the indicated documents, characterized by the applicant, and including page counts, where applicable. It serves as evidence of receipt similar to a Post Card, as described in MPEP 503.

New Applications Under 35 U.S.C. 111

If a new application is being filed and the application includes the necessary components for a filing date (see 37 CFR 1.53(b)-(d) and MPEP 506), a Filing Receipt (37 CFR 1.54) will be issued in due course and the date shown on this Acknowledgement Receipt will establish the filing date of the application.

National Stage of an International Application under 35 U.S.C. 371

If a timely submission to enter the national stage of an international application is compliant with the conditions of 35 U.S.C. 371 and other applicable requirements a Form PCT/DO/EO/903 indicating acceptance of the application as a national stage submission under 35 U.S.C. 371 will be issued in addition to the Filing Receipt, in due course.

New International Application Filed with the USPTO as a Receiving Office

If a new international application is being filed and the international application includes the necessary components for an international filing date (see PCT Article 11 and MPEP 1810), a Notification of the International Application Number and of the International Filing Date (Form PCT/RO/105) will be issued in due course, subject to prescriptions concerning national security, and the date shown on this Acknowledgement Receipt will establish the international filing date of the application.

Under the Paperwork Reduction Act of 1995, no persons are required to respond to a collection of information unless it displays a valid OMB control number.

PATENT APPLICATION FEE DETERMINATION RECORD Substitute for Form PTO-875	Application or Docket Number 12/879,899	Filing Date 09/10/2010	<input type="checkbox"/> To be Mailed
---	---	----------------------------------	---------------------------------------

APPLICATION AS FILED – PART I			OTHER THAN SMALL ENTITY			
(Column 1)	(Column 2)		SMALL ENTITY <input checked="" type="checkbox"/>	OR		
FOR	NUMBER FILED	NUMBER EXTRA	RATE (\$)	FEE (\$)	RATE (\$)	FEE (\$)
<input type="checkbox"/> BASIC FEE <small>(37 CFR 1.16(a), (b), or (c))</small>	N/A	N/A	N/A		N/A	
<input type="checkbox"/> SEARCH FEE <small>(37 CFR 1.16(k), (l), or (m))</small>	N/A	N/A	N/A		N/A	
<input type="checkbox"/> EXAMINATION FEE <small>(37 CFR 1.16(o), (p), or (q))</small>	N/A	N/A	N/A		N/A	
TOTAL CLAIMS <small>(37 CFR 1.16(i))</small>	minus 20 = *		X \$ =		X \$ =	
INDEPENDENT CLAIMS <small>(37 CFR 1.16(h))</small>	minus 3 = *		X \$ =		X \$ =	
<input type="checkbox"/> APPLICATION SIZE FEE <small>(37 CFR 1.16(s))</small>	If the specification and drawings exceed 100 sheets of paper, the application size fee due is \$250 (\$125 for small entity) for each additional 50 sheets or fraction thereof. See 35 U.S.C. 41(a)(1)(G) and 37 CFR 1.16(s).					
<input type="checkbox"/> MULTIPLE DEPENDENT CLAIM PRESENT <small>(37 CFR 1.16(j))</small>						
* If the difference in column 1 is less than zero, enter "0" in column 2.			TOTAL		TOTAL	

APPLICATION AS AMENDED – PART II					OTHER THAN SMALL ENTITY			
	(Column 1)	(Column 2)	(Column 3)		SMALL ENTITY	OR		
AMENDMENT	06/13/2012	CLAIMS REMAINING AFTER AMENDMENT	HIGHEST NUMBER PREVIOUSLY PAID FOR	PRESENT EXTRA	RATE (\$)	ADDITIONAL FEE (\$)	RATE (\$)	ADDITIONAL FEE (\$)
	Total (37 CFR 1.16(i))	* 6	Minus	** 35	=	0	X \$ =	X \$ =
	Independent (37 CFR 1.16(h))	* 1	Minus	***5	=	0	X \$ =	X \$ =
	<input type="checkbox"/> Application Size Fee (37 CFR 1.16(s))							
	<input type="checkbox"/> FIRST PRESENTATION OF MULTIPLE DEPENDENT CLAIM (37 CFR 1.16(j))							
					TOTAL ADD'L FEE	0	OR	TOTAL ADD'L FEE

	(Column 1)	(Column 2)	(Column 3)		SMALL ENTITY	OR	
AMENDMENT	CLAIMS REMAINING AFTER AMENDMENT	HIGHEST NUMBER PREVIOUSLY PAID FOR	PRESENT EXTRA	RATE (\$)	ADDITIONAL FEE (\$)	RATE (\$)	ADDITIONAL FEE (\$)
	Total (37 CFR 1.16(i))	*	Minus	**	=	X \$ =	X \$ =
	Independent (37 CFR 1.16(h))	*	Minus	***	=	X \$ =	X \$ =
	<input type="checkbox"/> Application Size Fee (37 CFR 1.16(s))						
	<input type="checkbox"/> FIRST PRESENTATION OF MULTIPLE DEPENDENT CLAIM (37 CFR 1.16(j))						
					TOTAL ADD'L FEE		TOTAL ADD'L FEE

* If the entry in column 1 is less than the entry in column 2, write "0" in column 3.
 ** If the "Highest Number Previously Paid For" IN THIS SPACE is less than 20, enter "20".
 *** If the "Highest Number Previously Paid For" IN THIS SPACE is less than 3, enter "3".
 The "Highest Number Previously Paid For" (Total or Independent) is the highest number found in the appropriate box in column 1.

Legal Instrument Examiner:
 /DIANA BATES/

This collection of information is required by 37 CFR 1.16. The information is required to obtain or retain a benefit by the public which is to file (and by the USPTO to process) an application. Confidentiality is governed by 35 U.S.C. 122 and 37 CFR 1.14. This collection is estimated to take 12 minutes to complete, including gathering, preparing, and submitting the completed application form to the USPTO. Time will vary depending upon the individual case. Any comments on the amount of time you require to complete this form and/or suggestions for reducing this burden, should be sent to the Chief Information Officer, U.S. Patent and Trademark Office, U.S. Department of Commerce, P.O. Box 1450, Alexandria, VA 22313-1450. DO NOT SEND FEES OR COMPLETED FORMS TO THIS ADDRESS. **SEND TO: Commissioner for Patents, P.O. Box 1450, Alexandria, VA 22313-1450.**
 If you need assistance in completing the form, call 1-800-PTO-9199 and select option 2.

INFORMATION DISCLOSURE STATEMENT BY APPLICANT (Not for submission under 37 CFR 1.99)	Application Number		12879899	
	Filing Date		2010-09-10	
	First Named Inventor	David F. MACNEIL		
	Art Unit	3612		
	Examiner Name	Pinel E. ROMAIN		
	Attorney Docket Number	31700.000254		

U.S. PATENTS	Remove
---------------------	--------

Examiner Initial*	Cite No	Patent Number	Kind Code ¹	Issue Date	Name of Patentee or Applicant of cited Document	Pages, Columns, Lines where Relevant Passages or Relevant Figures Appear
	1	6431629	B1	2002-08-13	Emery	
	2	4693507	A	1987-09-15	Dresen et al.	

If you wish to add additional U.S. Patent citation information please click the Add button. Add

U.S. PATENT APPLICATION PUBLICATIONS	Remove
---	--------

Examiner Initial*	Cite No	Publication Number	Kind Code ¹	Publication Date	Name of Patentee or Applicant of cited Document	Pages, Columns, Lines where Relevant Passages or Relevant Figures Appear
	1					

If you wish to add additional U.S. Published Application citation information please click the Add button. Add

FOREIGN PATENT DOCUMENTS	Remove
---------------------------------	--------

Examiner Initial*	Cite No	Foreign Document Number ³	Country Code ² j	Kind Code ⁴	Publication Date	Name of Patentee or Applicant of cited Document	Pages, Columns, Lines where Relevant Passages or Relevant Figures Appear	T ⁵
	1							<input type="checkbox"/>

If you wish to add additional Foreign Patent Document citation information please click the Add button. Add

NON-PATENT LITERATURE DOCUMENTS	Remove
--	--------

INFORMATION DISCLOSURE STATEMENT BY APPLICANT (Not for submission under 37 CFR 1.99)	Application Number		12879899
	Filing Date		2010-09-10
	First Named Inventor	David F. MACNEIL	
	Art Unit	3612	
	Examiner Name	Pinel E. ROMAIN	
	Attorney Docket Number	31700.000254	

Examiner Initials*	Cite No	Include name of the author (in CAPITAL LETTERS), title of the article (when appropriate), title of the item (book, magazine, journal, serial, symposium, catalog, etc), date, pages(s), volume-issue number(s), publisher, city and/or country where published.	T ⁵
	1		<input type="checkbox"/>

If you wish to add additional non-patent literature document citation information please click the Add button **Add**

EXAMINER SIGNATURE

Examiner Signature		Date Considered	
--------------------	--	-----------------	--

*EXAMINER: Initial if reference considered, whether or not citation is in conformance with MPEP 609. Draw line through a citation if not in conformance and not considered. Include copy of this form with next communication to applicant.

¹ See Kind Codes of USPTO Patent Documents at www.USPTO.GOV or MPEP 901.04. ² Enter office that issued the document, by the two-letter code (WIPO Standard ST.3). ³ For Japanese patent documents, the indication of the year of the reign of the Emperor must precede the serial number of the patent document. ⁴ Kind of document by the appropriate symbols as indicated on the document under WIPO Standard ST.16 if possible. ⁵ Applicant is to place a check mark here if English language translation is attached.

INFORMATION DISCLOSURE STATEMENT BY APPLICANT (Not for submission under 37 CFR 1.99)	Application Number		12879899
	Filing Date		2010-09-10
	First Named Inventor	David F. MACNEIL	
	Art Unit		3612
	Examiner Name	Pinel E. ROMAIN	
	Attorney Docket Number		31700.000254

CERTIFICATION STATEMENT

Please see 37 CFR 1.97 and 1.98 to make the appropriate selection(s):

That each item of information contained in the information disclosure statement was first cited in any communication from a foreign patent office in a counterpart foreign application not more than three months prior to the filing of the information disclosure statement. See 37 CFR 1.97(e)(1).

OR

That no item of information contained in the information disclosure statement was cited in a communication from a foreign patent office in a counterpart foreign application, and, to the knowledge of the person signing the certification after making reasonable inquiry, no item of information contained in the information disclosure statement was known to any individual designated in 37 CFR 1.56(c) more than three months prior to the filing of the information disclosure statement. See 37 CFR 1.97(e)(2).

See attached certification statement.

Fee set forth in 37 CFR 1.17 (p) has been submitted herewith.

None

SIGNATURE

A signature of the applicant or representative is required in accordance with CFR 1.33, 10.18. Please see CFR 1.4(d) for the form of the signature.

Signature	/Jefferson Perkins/	Date (YYYY-MM-DD)	2012-07-25
Name/Print	Jefferson Perkins	Registration Number	31407

This collection of information is required by 37 CFR 1.97 and 1.98. The information is required to obtain or retain a benefit by the public which is to file (and by the USPTO to process) an application. Confidentiality is governed by 35 U.S.C. 122 and 37 CFR 1.14. This collection is estimated to take 1 hour to complete, including gathering, preparing and submitting the completed application form to the USPTO. Time will vary depending upon the individual case. Any comments on the amount of time you require to complete this form and/or suggestions for reducing this burden, should be sent to the Chief Information Officer, U.S. Patent and Trademark Office, U.S. Department of Commerce, P.O. Box 1450, Alexandria, VA 22313-1450. **DO NOT SEND FEES OR COMPLETED FORMS TO THIS ADDRESS. SEND TO: Commissioner for Patents, P.O. Box 1450, Alexandria, VA 22313-1450.**

Privacy Act Statement

The Privacy Act of 1974 (P.L. 93-579) requires that you be given certain information in connection with your submission of the attached form related to a patent application or patent. Accordingly, pursuant to the requirements of the Act, please be advised that: (1) the general authority for the collection of this information is 35 U.S.C. 2(b)(2); (2) furnishing of the information solicited is voluntary; and (3) the principal purpose for which the information is used by the U.S. Patent and Trademark Office is to process and/or examine your submission related to a patent application or patent. If you do not furnish the requested information, the U.S. Patent and Trademark Office may not be able to process and/or examine your submission, which may result in termination of proceedings or abandonment of the application or expiration of the patent.

The information provided by you in this form will be subject to the following routine uses:

1. The information on this form will be treated confidentially to the extent allowed under the Freedom of Information Act (5 U.S.C. 552) and the Privacy Act (5 U.S.C. 552a). Records from this system of records may be disclosed to the Department of Justice to determine whether the Freedom of Information Act requires disclosure of these records.
2. A record from this system of records may be disclosed, as a routine use, in the course of presenting evidence to a court, magistrate, or administrative tribunal, including disclosures to opposing counsel in the course of settlement negotiations.
3. A record in this system of records may be disclosed, as a routine use, to a Member of Congress submitting a request involving an individual, to whom the record pertains, when the individual has requested assistance from the Member with respect to the subject matter of the record.
4. A record in this system of records may be disclosed, as a routine use, to a contractor of the Agency having need for the information in order to perform a contract. Recipients of information shall be required to comply with the requirements of the Privacy Act of 1974, as amended, pursuant to 5 U.S.C. 552a(m).
5. A record related to an International Application filed under the Patent Cooperation Treaty in this system of records may be disclosed, as a routine use, to the International Bureau of the World Intellectual Property Organization, pursuant to the Patent Cooperation Treaty.
6. A record in this system of records may be disclosed, as a routine use, to another federal agency for purposes of National Security review (35 U.S.C. 181) and for review pursuant to the Atomic Energy Act (42 U.S.C. 218(c)).
7. A record from this system of records may be disclosed, as a routine use, to the Administrator, General Services, or his/her designee, during an inspection of records conducted by GSA as part of that agency's responsibility to recommend improvements in records management practices and programs, under authority of 44 U.S.C. 2904 and 2906. Such disclosure shall be made in accordance with the GSA regulations governing inspection of records for this purpose, and any other relevant (i.e., GSA or Commerce) directive. Such disclosure shall not be used to make determinations about individuals.
8. A record from this system of records may be disclosed, as a routine use, to the public after either publication of the application pursuant to 35 U.S.C. 122(b) or issuance of a patent pursuant to 35 U.S.C. 151. Further, a record may be disclosed, subject to the limitations of 37 CFR 1.14, as a routine use, to the public if the record was filed in an application which became abandoned or in which the proceedings were terminated and which application is referenced by either a published application, an application open to public inspections or an issued patent.
9. A record from this system of records may be disclosed, as a routine use, to a Federal, State, or local law enforcement agency, if the USPTO becomes aware of a violation or potential violation of law or regulation.

Electronic Patent Application Fee Transmittal

Application Number:	12879899
Filing Date:	10-Sep-2010
Title of Invention:	DESIGNING AND MANUFACTURING VEHICLE FLOOR TRAYS
First Named Inventor/Applicant Name:	David F. MacNeil
Filer:	Jefferson Perkins/Patricia Romanelli
Attorney Docket Number:	31700.000254

Filed as Small Entity

Utility under 35 USC 111(a) Filing Fees

Description	Fee Code	Quantity	Amount	Sub-Total in USD(\$)
Basic Filing:				
Pages:				
Claims:				
Miscellaneous-Filing:				
Petition:				
Patent-Appeals-and-Interference:				
Post-Allowance-and-Post-Issuance:				
Extension-of-Time:				

Description	Fee Code	Quantity	Amount	Sub-Total in USD(\$)
Miscellaneous:				
Submission- Information Disclosure Stmt	1806	1	180	180
Total in USD (\$)				180

Electronic Acknowledgement Receipt

EFS ID:	13334491
Application Number:	12879899
International Application Number:	
Confirmation Number:	7976
Title of Invention:	DESIGNING AND MANUFACTURING VEHICLE FLOOR TRAYS
First Named Inventor/Applicant Name:	David F. MacNeil
Customer Number:	64770
Filer:	Jefferson Perkins/Patricia Romanelli
Filer Authorized By:	Jefferson Perkins
Attorney Docket Number:	31700.000254
Receipt Date:	25-JUL-2012
Filing Date:	10-SEP-2010
Time Stamp:	12:44:56
Application Type:	Utility under 35 USC 111(a)

Payment information:

Submitted with Payment	yes
Payment Type	Deposit Account
Payment was successfully received in RAM	\$180
RAM confirmation Number	10251
Deposit Account	503982
Authorized User	
The Director of the USPTO is hereby authorized to charge indicated fees and credit any overpayment as follows: Charge any Additional Fees required under 37 C.F.R. Section 1.21 (Miscellaneous fees and charges)	

File Listing:					
Document Number	Document Description	File Name	File Size(Bytes)/ Message Digest	Multi Part /.zip	Pages (if appl.)
1	Information Disclosure Statement (IDS) Form (SB08)	IDS.pdf	612048 ba47444a238c273572cae5e11a000bf6ba90323c	no	4
Warnings:					
Information:					
2	Fee Worksheet (SB06)	fee-info.pdf	30455 998872c89ef7da2e8e5b3302ca55ff50dbbe8d21	no	2
Warnings:					
Information:					
Total Files Size (in bytes):			642503		
<p>This Acknowledgement Receipt evidences receipt on the noted date by the USPTO of the indicated documents, characterized by the applicant, and including page counts, where applicable. It serves as evidence of receipt similar to a Post Card, as described in MPEP 503.</p> <p><u>New Applications Under 35 U.S.C. 111</u> If a new application is being filed and the application includes the necessary components for a filing date (see 37 CFR 1.53(b)-(d) and MPEP 506), a Filing Receipt (37 CFR 1.54) will be issued in due course and the date shown on this Acknowledgement Receipt will establish the filing date of the application.</p> <p><u>National Stage of an International Application under 35 U.S.C. 371</u> If a timely submission to enter the national stage of an international application is compliant with the conditions of 35 U.S.C. 371 and other applicable requirements a Form PCT/DO/EO/903 indicating acceptance of the application as a national stage submission under 35 U.S.C. 371 will be issued in addition to the Filing Receipt, in due course.</p> <p><u>New International Application Filed with the USPTO as a Receiving Office</u> If a new international application is being filed and the international application includes the necessary components for an international filing date (see PCT Article 11 and MPEP 1810), a Notification of the International Application Number and of the International Filing Date (Form PCT/RO/105) will be issued in due course, subject to prescriptions concerning national security, and the date shown on this Acknowledgement Receipt will establish the international filing date of the application.</p>					

IN THE UNITED STATES PATENT & TRADEMARK OFFICE

In re the application of: David F. MACNEIL et al.
Application Number: 12/879,899
Filing Date: September 10, 2010
Art Unit: 3612
Examiner: Pinel E. ROMAIN
Confirmation Number: 7976

CERTIFICATE OF TRANSMISSION BY
ELECTRONIC FILING
I hereby certify that this correspondence is
being transmitted via the USPTO electronic
filing system in accordance with 37 CFR
§1.6(a)(4) on July 26, 2012.
/Patricia Romanelli/
Patricia Romanelli

For: DESIGNING AND MANUFACTURING VEHICLE FLOOR TRAYS

Commissioner for Patents
P.O. Box 1450
Alexandria, VA 22313-1450

AMENDMENT

Dear Sir:

This communication is responsive to the phone interview with Examiner conducted on July 24, 2012.

IN THE TITLE

Please amend the Title of the Invention as follows:

~~DESIGNING AND MANUFACTURING VEHICLE FLOOR TRAYS TRAY~~

IN THE CLAIMS

Please amend the claims as set forth in the claim listing below. In particular, Applicant

Reply to Examiner's Office Action

Attorney Docket No. 31700.000254

amends Claims 12 and 16 and cancels Claim 13.

CLAIM LISTING

1-11. (Canceled)

12. (Currently Amended) A vehicle floor tray thermoformed from a sheet of thermoplastic polymeric material of substantially uniform thickness, comprising:

a central panel substantially conforming to a floor of a vehicle foot well, the central panel of the floor tray having at least one longitudinally disposed lateral side and at least one transversely disposed lateral side;

a first panel integrally formed with the central panel of the floor tray, upwardly extending from the transversely disposed lateral side of the central panel of the floor tray, and closely conforming to a first foot well wall, the first panel of the floor tray joined to the central panel of the floor tray by a curved transition;

a second panel integrally formed with the central panel of the floor tray and the first panel, upwardly extending from the longitudinally disposed lateral side of the central panel of the floor tray, and closely conforming to a second foot well wall, the second panel of the floor tray joined to the central panel of the floor tray and to the first panel of the floor tray by curved transitions;

a reservoir disposed in the central panel of the floor tray;

a plurality of upstanding, hollow, elongate baffles disposed in the reservoir, each of the baffles having at least two ends remote from each other, the central panel, the first panel, the second panel, the reservoir and the baffles each having a thickness from a point on the upper surface to a closest point on the bottom surface thereof, said thicknesses, as a result of the tray

being thermoformed from the sheet of thermoplastic polymeric material of substantially uniform thickness, being substantially uniform throughout the tray;

the baffles each having a width more than two times the thickness of the last said substantially uniform thickness, the baffles ~~and~~ adapted to elevate the shoe or foot of the occupant above fluid collected in the reservoir ~~and impeding lateral movement, induced by vehicle acceleration, of fluid collected in the reservoir, ones of the baffles each including at least one longitudinally oriented portion which impedes transverse movement, induced by vehicle acceleration, of fluid collected in the reservoir, and at least one transversely oriented portion joined to the at least one longitudinal portion and disposed to impede the longitudinal movement, induced by vehicle acceleration, of fluid collected in the reservoir,~~ any portion of the reservoir connected to a remote portion of the reservoir by a path formed around ends of the baffles.

13. (Canceled)

14. (Previously presented) The floor tray of Claim 12, further comprising a third panel integrally formed with the central panel of the floor tray and joined to at least one of the first and second panels by curved transitions, the third panel upwardly extending from a third lateral side of the central panel of the floor tray.

15. (Previously presented) The floor tray of Claim 14, further comprising a fourth panel integrally formed with the central panel of the floor tray and joined to at least one of the second and third panels by curved transitions, the fourth panel upwardly extending from a fourth lateral side of the central panel of the floor tray.

16. (Currently amended) The floor tray of Claim 12, wherein ~~the top margin of~~ at least one of the first and second panels has a top margin, the top margin being ~~is~~ at least five inches higher than the central panel of the floor tray at its greatest vertical separation therefrom.

17. (Previously presented) The floor tray of Claim 12, wherein the first and second panels have top margins which are substantially coplanar with each other.

18 - 39. (Canceled)

REMARKS

Applicants thank the Examiner for the telephone interview that was conducted on July 24, 2012. Applicants' counsel and the Examiner discussed the Sherman (US 6,027,782) and Suzuki (JP H10 - 96742) references at that interview. In a subsequent telephone call, the Examiner brought to the attention of Applicant's counsel U.S. Patent No. 3,390,912 to Stata ("Stata") for its disclosure of hollow treads. Stata discloses an injection-molded motor vehicle floor mat. It was agreed that adding the limitations of Claim 13 to Claim 12 would define over Stata and the other art made of record.

Accordingly, Applicants present herewith an amendment to Claim 12, to which the limitations of Claim 13 substantially have been added. Claim 12 now recites that ones of the hollow baffles each have a longitudinally oriented portion and a transversely oriented position joined to the longitudinally oriented portion. The longitudinally oriented portion impedes transverse movement of fluid collected in the reservoir, where the movement is induced by vehicle acceleration (such as turning). The transversely oriented portion impedes the longitudinal movement of fluid collected in the reservoir, where the movement is induced by vehicle acceleration (such as forward acceleration or braking). Support for this amendment can be found in paragraph [0043] of the Specification.

In addition, the Examiner noted that in Claim 16, antecedent basis was missing for "the top margin" in Claim 16. Applicants have amended Claim 16 to correct this.

Applicants have also amended the Title, for the Examiner's consideration, to accurately reflect the subject matter which is claimed.

All rejections and objections of the Examiner having been overcome, Applicants respectfully request the Examiner to issue a Notice of Allowance on the claims as amended.

Reply to Examiner's Office Action

Attorney Docket No. 31700.000254

No fee is thought to be due with the submission of this Amendment. However the Commissioner is hereby authorized to charge any deficiency to Deposit Account No. 503982 of Momkus McCluskey, LLC.

Respectfully submitted,

/Jefferson Perkins/
Jefferson Perkins
Registration No. 31,407

CUSTOMER NO. 64770

MOMKUS McCLUSKEY, LLC
1001 Warrenville Rd., Suite 500
Lisle, Illinois 60532
Telephone: (630) 434-0414
Fax: (630) 434-0444
Email: jperkins@momlaw.com

Electronic Acknowledgement Receipt

EFS ID:	13343624
Application Number:	12879899
International Application Number:	
Confirmation Number:	7976
Title of Invention:	DESIGNING AND MANUFACTURING VEHICLE FLOOR TRAYS
First Named Inventor/Applicant Name:	David F. MacNeil
Customer Number:	64770
Filer:	Jefferson Perkins/Patricia Romanelli
Filer Authorized By:	Jefferson Perkins
Attorney Docket Number:	31700.000254
Receipt Date:	26-JUL-2012
Filing Date:	10-SEP-2010
Time Stamp:	10:23:45
Application Type:	Utility under 35 USC 111(a)

Payment information:

Submitted with Payment	no
------------------------	----

File Listing:

Document Number	Document Description	File Name	File Size(Bytes)/ Message Digest	Multi Part /.zip	Pages (if appl.)
1		Amendment.pdf	130823 <small>b6f9eeda3c8f8a4d28d891e81e109ca2495f1b5</small>	yes	7

Multipart Description/PDF files in .zip description			
Document Description		Start	End
Amendment/Req. Reconsideration-After Non-Final Reject		1	2
Claims		3	5
Applicant Arguments/Remarks Made in an Amendment		6	7

Warnings:

Information:

Total Files Size (in bytes):	130823
-------------------------------------	--------

This Acknowledgement Receipt evidences receipt on the noted date by the USPTO of the indicated documents, characterized by the applicant, and including page counts, where applicable. It serves as evidence of receipt similar to a Post Card, as described in MPEP 503.

New Applications Under 35 U.S.C. 111

If a new application is being filed and the application includes the necessary components for a filing date (see 37 CFR 1.53(b)-(d) and MPEP 506), a Filing Receipt (37 CFR 1.54) will be issued in due course and the date shown on this Acknowledgement Receipt will establish the filing date of the application.

National Stage of an International Application under 35 U.S.C. 371

If a timely submission to enter the national stage of an international application is compliant with the conditions of 35 U.S.C. 371 and other applicable requirements a Form PCT/DO/EO/903 indicating acceptance of the application as a national stage submission under 35 U.S.C. 371 will be issued in addition to the Filing Receipt, in due course.

New International Application Filed with the USPTO as a Receiving Office

If a new international application is being filed and the international application includes the necessary components for an international filing date (see PCT Article 11 and MPEP 1810), a Notification of the International Application Number and of the International Filing Date (Form PCT/RO/105) will be issued in due course, subject to prescriptions concerning national security, and the date shown on this Acknowledgement Receipt will establish the international filing date of the application.

Under the Paperwork Reduction Act of 1995, no persons are required to respond to a collection of information unless it displays a valid OMB control number.

PATENT APPLICATION FEE DETERMINATION RECORD Substitute for Form PTO-875	Application or Docket Number 12/879,899	Filing Date 09/10/2010	<input type="checkbox"/> To be Mailed
---	---	----------------------------------	---------------------------------------

APPLICATION AS FILED – PART I			OTHER THAN SMALL ENTITY				
	(Column 1)	(Column 2)	SMALL ENTITY <input checked="" type="checkbox"/>	OR			
FOR	NUMBER FILED	NUMBER EXTRA	RATE (\$)	FEE (\$)	OR	RATE (\$)	FEE (\$)
<input type="checkbox"/> BASIC FEE <small>(37 CFR 1.16(a), (b), or (c))</small>	N/A	N/A	N/A			N/A	
<input type="checkbox"/> SEARCH FEE <small>(37 CFR 1.16(k), (l), or (m))</small>	N/A	N/A	N/A			N/A	
<input type="checkbox"/> EXAMINATION FEE <small>(37 CFR 1.16(o), (p), or (q))</small>	N/A	N/A	N/A			N/A	
TOTAL CLAIMS <small>(37 CFR 1.16(i))</small>	minus 20 =	*	X \$ =		OR	X \$ =	
INDEPENDENT CLAIMS <small>(37 CFR 1.16(h))</small>	minus 3 =	*	X \$ =			X \$ =	
<input type="checkbox"/> APPLICATION SIZE FEE <small>(37 CFR 1.16(s))</small>	If the specification and drawings exceed 100 sheets of paper, the application size fee due is \$250 (\$125 for small entity) for each additional 50 sheets or fraction thereof. See 35 U.S.C. 41(a)(1)(G) and 37 CFR 1.16(s).						
<input type="checkbox"/> MULTIPLE DEPENDENT CLAIM PRESENT <small>(37 CFR 1.16(j))</small>							
* If the difference in column 1 is less than zero, enter "0" in column 2.			TOTAL			TOTAL	

APPLICATION AS AMENDED – PART II					OTHER THAN SMALL ENTITY					
	(Column 1)	(Column 2)	(Column 3)		SMALL ENTITY	OR				
AMENDMENT	07/26/2012	CLAIMS REMAINING AFTER AMENDMENT	HIGHEST NUMBER PREVIOUSLY PAID FOR	PRESENT EXTRA	RATE (\$)	ADDITIONAL FEE (\$)		RATE (\$)	ADDITIONAL FEE (\$)	
	Total (37 CFR 1.16(i))	* 5	Minus	** 35	=	0	OR	X \$ =		
	Independent (37 CFR 1.16(h))	* 1	Minus	***5	=	0	OR	X \$ =		
	<input type="checkbox"/> Application Size Fee (37 CFR 1.16(s))									
	<input type="checkbox"/> FIRST PRESENTATION OF MULTIPLE DEPENDENT CLAIM (37 CFR 1.16(j))									
					TOTAL ADD'L FEE	0	OR	TOTAL ADD'L FEE		

	(Column 1)	(Column 2)	(Column 3)		SMALL ENTITY	OR			
AMENDMENT	CLAIMS REMAINING AFTER AMENDMENT	HIGHEST NUMBER PREVIOUSLY PAID FOR	PRESENT EXTRA	RATE (\$)	ADDITIONAL FEE (\$)		RATE (\$)	ADDITIONAL FEE (\$)	
	Total (37 CFR 1.16(i))	*	Minus	**	=	OR	X \$ =		
	Independent (37 CFR 1.16(h))	*	Minus	***	=	OR	X \$ =		
	<input type="checkbox"/> Application Size Fee (37 CFR 1.16(s))								
	<input type="checkbox"/> FIRST PRESENTATION OF MULTIPLE DEPENDENT CLAIM (37 CFR 1.16(j))								
					TOTAL ADD'L FEE		OR	TOTAL ADD'L FEE	

* If the entry in column 1 is less than the entry in column 2, write "0" in column 3.
 ** If the "Highest Number Previously Paid For" IN THIS SPACE is less than 20, enter "20".
 *** If the "Highest Number Previously Paid For" IN THIS SPACE is less than 3, enter "3".
 The "Highest Number Previously Paid For" (Total or Independent) is the highest number found in the appropriate box in column 1.

Legal Instrument Examiner:
/TARA WITCHER/

This collection of information is required by 37 CFR 1.16. The information is required to obtain or retain a benefit by the public which is to file (and by the USPTO to process) an application. Confidentiality is governed by 35 U.S.C. 122 and 37 CFR 1.14. This collection is estimated to take 12 minutes to complete, including gathering, preparing, and submitting the completed application form to the USPTO. Time will vary depending upon the individual case. Any comments on the amount of time you require to complete this form and/or suggestions for reducing this burden, should be sent to the Chief Information Officer, U.S. Patent and Trademark Office, U.S. Department of Commerce, P.O. Box 1450, Alexandria, VA 22313-1450. DO NOT SEND FEES OR COMPLETED FORMS TO THIS ADDRESS. **SEND TO: Commissioner for Patents, P.O. Box 1450, Alexandria, VA 22313-1450.**
 If you need assistance in completing the form, call 1-800-PTO-9199 and select option 2.

Applicant-Initiated Interview Summary	Application No. 12/879,899	Applicant(s) MACNEIL ET AL.	
	Examiner PINEL ROMAIN	Art Unit 3612	

All participants (applicant, applicant's representative, PTO personnel):

- (1) PINEL ROMAIN. (3) _____.
(2) Karen Blouin. (4) Jeff Perkins.

Date of Interview: 24 June 2012.

Type: Telephonic Video Conference
 Personal [copy given to: applicant applicant's representative]

Exhibit shown or demonstration conducted: Yes No.
If Yes, brief description: _____.

Issues Discussed 101 112 102 103 Others
(For each of the checked box(es) above, please describe below the issue and detailed description of the discussion)

Claim(s) discussed: 12 and 16.

Identification of prior art discussed: Sherman (6,027,782); Suzuki (H10-96742); Strata(3,390,912).

Substance of Interview

(For each issue discussed, provide a detailed description and indicate if agreement was reached. Some topics may include: identification or clarification of a reference or a portion thereof, claim interpretation, proposed amendments, arguments of any applied references etc...)

Discussed claim 12, with respect to the prior art and uniform thickness, hollow structure of the baffle and the antecedent basis was missing for "the top margin" in claim 16. Also discussed the hollow structure disclose by Strata. Examiner suggested adding the limitations of claim 13 into claim 12 to overcome the Strata prior art.

Applicant recordation instructions: The formal written reply to the last Office action must include the substance of the interview. (See MPEP section 713.04). If a reply to the last Office action has already been filed, applicant is given a non-extendable period of the longer of one month or thirty days from this interview date, or the mailing date of this interview summary form, whichever is later, to file a statement of the substance of the interview

Examiner recordation instructions: Examiners must summarize the substance of any interview of record. A complete and proper recordation of the substance of an interview should include the items listed in MPEP 713.04 for complete and proper recordation including the identification of the general thrust of each argument or issue discussed, a general indication of any other pertinent matters discussed regarding patentability and the general results or outcome of the interview, to include an indication as to whether or not agreement was reached on the issues raised.

Attachment

/PINEL E ROMAIN/
Examiner, Art Unit 3612

Summary of Record of Interview Requirements

Manual of Patent Examining Procedure (MPEP), Section 713.04, Substance of Interview Must be Made of Record

A complete written statement as to the substance of any face-to-face, video conference, or telephone interview with regard to an application must be made of record in the application whether or not an agreement with the examiner was reached at the interview.

Title 37 Code of Federal Regulations (CFR) § 1.133 Interviews

Paragraph (b)

In every instance where reconsideration is requested in view of an interview with an examiner, a complete written statement of the reasons presented at the interview as warranting favorable action must be filed by the applicant. An interview does not remove the necessity for reply to Office action as specified in §§ 1.111, 1.135. (35 U.S.C. 132)

37 CFR §1.2 Business to be transacted in writing.

All business with the Patent or Trademark Office should be transacted in writing. The personal attendance of applicants or their attorneys or agents at the Patent and Trademark Office is unnecessary. The action of the Patent and Trademark Office will be based exclusively on the written record in the Office. No attention will be paid to any alleged oral promise, stipulation, or understanding in relation to which there is disagreement or doubt.

The action of the Patent and Trademark Office cannot be based exclusively on the written record in the Office if that record is itself incomplete through the failure to record the substance of interviews.

It is the responsibility of the applicant or the attorney or agent to make the substance of an interview of record in the application file, unless the examiner indicates he or she will do so. It is the examiner's responsibility to see that such a record is made and to correct material inaccuracies which bear directly on the question of patentability.

Examiners must complete an Interview Summary Form for each interview held where a matter of substance has been discussed during the interview by checking the appropriate boxes and filling in the blanks. Discussions regarding only procedural matters, directed solely to restriction requirements for which interview recordation is otherwise provided for in Section 812.01 of the Manual of Patent Examining Procedure, or pointing out typographical errors or unreadable script in Office actions or the like, are excluded from the interview recordation procedures below. Where the substance of an interview is completely recorded in an Examiners Amendment, no separate Interview Summary Record is required.

The Interview Summary Form shall be given an appropriate Paper No., placed in the right hand portion of the file, and listed on the "Contents" section of the file wrapper. In a personal interview, a duplicate of the Form is given to the applicant (or attorney or agent) at the conclusion of the interview. In the case of a telephone or video-conference interview, the copy is mailed to the applicant's correspondence address either with or prior to the next official communication. If additional correspondence from the examiner is not likely before an allowance or if other circumstances dictate, the Form should be mailed promptly after the interview rather than with the next official communication.

The Form provides for recordation of the following information:

- Application Number (Series Code and Serial Number)
- Name of applicant
- Name of examiner
- Date of interview
- Type of interview (telephonic, video-conference, or personal)
- Name of participant(s) (applicant, attorney or agent, examiner, other PTO personnel, etc.)
- An indication whether or not an exhibit was shown or a demonstration conducted
- An identification of the specific prior art discussed
- An indication whether an agreement was reached and if so, a description of the general nature of the agreement (may be by attachment of a copy of amendments or claims agreed as being allowable). Note: Agreement as to allowability is tentative and does not restrict further action by the examiner to the contrary.
- The signature of the examiner who conducted the interview (if Form is not an attachment to a signed Office action)

It is desirable that the examiner orally remind the applicant of his or her obligation to record the substance of the interview of each case. It should be noted, however, that the Interview Summary Form will not normally be considered a complete and proper recordation of the interview unless it includes, or is supplemented by the applicant or the examiner to include, all of the applicable items required below concerning the substance of the interview.

A complete and proper recordation of the substance of any interview should include at least the following applicable items:

- 1) A brief description of the nature of any exhibit shown or any demonstration conducted,
- 2) an identification of the claims discussed,
- 3) an identification of the specific prior art discussed,
- 4) an identification of the principal proposed amendments of a substantive nature discussed, unless these are already described on the Interview Summary Form completed by the Examiner,
- 5) a brief identification of the general thrust of the principal arguments presented to the examiner,
(The identification of arguments need not be lengthy or elaborate. A verbatim or highly detailed description of the arguments is not required. The identification of the arguments is sufficient if the general nature or thrust of the principal arguments made to the examiner can be understood in the context of the application file. Of course, the applicant may desire to emphasize and fully describe those arguments which he or she feels were or might be persuasive to the examiner.)
- 6) a general indication of any other pertinent matters discussed, and
- 7) if appropriate, the general results or outcome of the interview unless already described in the Interview Summary Form completed by the examiner.

Examiners are expected to carefully review the applicant's record of the substance of an interview. If the record is not complete and accurate, the examiner will give the applicant an extendable one month time period to correct the record.

Examiner to Check for Accuracy

If the claims are allowable for other reasons of record, the examiner should send a letter setting forth the examiner's version of the statement attributed to him or her. If the record is complete and accurate, the examiner should place the indication, "Interview Record OK" on the paper recording the substance of the interview along with the date and the examiner's initials.



UNITED STATES PATENT AND TRADEMARK OFFICE

UNITED STATES DEPARTMENT OF COMMERCE
United States Patent and Trademark Office
Address: COMMISSIONER FOR PATENTS
P.O. Box 1450
Alexandria, Virginia 22313-1450
www.uspto.gov

NOTICE OF ALLOWANCE AND FEE(S) DUE

64770 7590 08/03/2012
Momkus McCluskey, LLC
1001 Warrenville Road, Suite 500
Lisle, IL 60532

EXAMINER
ROMAIN, PINEL E

ART UNIT PAPER NUMBER

3612

DATE MAILED: 08/03/2012

Table with 5 columns: APPLICATION NO., FILING DATE, FIRST NAMED INVENTOR, ATTORNEY DOCKET NO., CONFIRMATION NO.

TITLE OF INVENTION: DESIGNING AND MANUFACTURING VEHICLE FLOOR TRAYS

Table with 7 columns: APPLN. TYPE, SMALL ENTITY, ISSUE FEE DUE, PUBLICATION FEE DUE, PREV. PAID ISSUE FEE, TOTAL FEE(S) DUE, DATE DUE

THE APPLICATION IDENTIFIED ABOVE HAS BEEN EXAMINED AND IS ALLOWED FOR ISSUANCE AS A PATENT. PROSECUTION ON THE MERITS IS CLOSED. THIS NOTICE OF ALLOWANCE IS NOT A GRANT OF PATENT RIGHTS. THIS APPLICATION IS SUBJECT TO WITHDRAWAL FROM ISSUE AT THE INITIATIVE OF THE OFFICE OR UPON PETITION BY THE APPLICANT. SEE 37 CFR 1.313 AND MPEP 1308.

THE ISSUE FEE AND PUBLICATION FEE (IF REQUIRED) MUST BE PAID WITHIN THREE MONTHS FROM THE MAILING DATE OF THIS NOTICE OR THIS APPLICATION SHALL BE REGARDED AS ABANDONED. THIS STATUTORY PERIOD CANNOT BE EXTENDED. SEE 35 U.S.C. 151. THE ISSUE FEE DUE INDICATED ABOVE DOES NOT REFLECT A CREDIT FOR ANY PREVIOUSLY PAID ISSUE FEE IN THIS APPLICATION. IF AN ISSUE FEE HAS PREVIOUSLY BEEN PAID IN THIS APPLICATION (AS SHOWN ABOVE), THE RETURN OF PART B OF THIS FORM WILL BE CONSIDERED A REQUEST TO REAPPLY THE PREVIOUSLY PAID ISSUE FEE TOWARD THE ISSUE FEE NOW DUE.

HOW TO REPLY TO THIS NOTICE:

I. Review the SMALL ENTITY status shown above.

If the SMALL ENTITY is shown as YES, verify your current SMALL ENTITY status:

A. If the status is the same, pay the TOTAL FEE(S) DUE shown above.

B. If the status above is to be removed, check box 5b on Part B - Fee(s) Transmittal and pay the PUBLICATION FEE (if required) and twice the amount of the ISSUE FEE shown above, or

If the SMALL ENTITY is shown as NO:

A. Pay TOTAL FEE(S) DUE shown above, or

B. If applicant claimed SMALL ENTITY status before, or is now claiming SMALL ENTITY status, check box 5a on Part B - Fee(s) Transmittal and pay the PUBLICATION FEE (if required) and 1/2 the ISSUE FEE shown above.

II. PART B - FEE(S) TRANSMITTAL, or its equivalent, must be completed and returned to the United States Patent and Trademark Office (USPTO) with your ISSUE FEE and PUBLICATION FEE (if required). If you are charging the fee(s) to your deposit account, section "4b" of Part B - Fee(s) Transmittal should be completed and an extra copy of the form should be submitted. If an equivalent of Part B is filed, a request to reapply a previously paid issue fee must be clearly made, and delays in processing may occur due to the difficulty in recognizing the paper as an equivalent of Part B.

III. All communications regarding this application must give the application number. Please direct all communications prior to issuance to Mail Stop ISSUE FEE unless advised to the contrary.

IMPORTANT REMINDER: Utility patents issuing on applications filed on or after Dec. 12, 1980 may require payment of maintenance fees. It is patentee's responsibility to ensure timely payment of maintenance fees when due.

PART B - FEE(S) TRANSMITTAL

**Complete and send this form, together with applicable fee(s), to: Mail Mail Stop ISSUE FEE
 Commissioner for Patents
 P.O. Box 1450
 Alexandria, Virginia 22313-1450
 or Fax (571)-273-2885**

INSTRUCTIONS: This form should be used for transmitting the ISSUE FEE and PUBLICATION FEE (if required). Blocks 1 through 5 should be completed where appropriate. All further correspondence including the Patent, advance orders and notification of maintenance fees will be mailed to the current correspondence address as indicated unless corrected below or directed otherwise in Block 1, by (a) specifying a new correspondence address; and/or (b) indicating a separate "FEE ADDRESS" for maintenance fee notifications.

CURRENT CORRESPONDENCE ADDRESS (Note: Use Block 1 for any change of address)

Note: A certificate of mailing can only be used for domestic mailings of the Fee(s) Transmittal. This certificate cannot be used for any other accompanying papers. Each additional paper, such as an assignment or formal drawing, must have its own certificate of mailing or transmission.

64770 7590 08/03/2012
Momkus McCluskey, LLC
 1001 Warrenville Road, Suite 500
 Lisle, IL 60532

Certificate of Mailing or Transmission

I hereby certify that this Fee(s) Transmittal is being deposited with the United States Postal Service with sufficient postage for first class mail in an envelope addressed to the Mail Stop ISSUE FEE address above, or being facsimile transmitted to the USPTO (571) 273-2885, on the date indicated below.

(Depositor's name)
(Signature)
(Date)

APPLICATION NO.	FILING DATE	FIRST NAMED INVENTOR	ATTORNEY DOCKET NO.	CONFIRMATION NO.
12/879,899	09/10/2010	David F. MacNeil	31700.000254	7976

TITLE OF INVENTION: DESIGNING AND MANUFACTURING VEHICLE FLOOR TRAYS

APPLN. TYPE	SMALL ENTITY	ISSUE FEE DUE	PUBLICATION FEE DUE	PREV. PAID ISSUE FEE	TOTAL FEE(S) DUE	DATE DUE
nonprovisional	YES	\$870	\$300	\$0	\$1170	11/05/2012

EXAMINER	ART UNIT	CLASS-SUBCLASS
ROMAIN, PINEL E	3612	296-075000

<p>1. Change of correspondence address or indication of "Fee Address" (37 CFR 1.363).</p> <p><input type="checkbox"/> Change of correspondence address (or Change of Correspondence Address form PTO/SB/122) attached.</p> <p><input type="checkbox"/> "Fee Address" indication (or "Fee Address" Indication form PTO/SB/47; Rev 03-02 or more recent) attached. Use of a Customer Number is required.</p>	<p>2. For printing on the patent front page, list</p> <p>(1) the names of up to 3 registered patent attorneys or agents OR, alternatively, _____ 1</p> <p>(2) the name of a single firm (having as a member a registered attorney or agent) and the names of up to 2 registered patent attorneys or agents. If no name is listed, no name will be printed. _____ 2</p> <p>_____ 3</p>
---	---

3. ASSIGNEE NAME AND RESIDENCE DATA TO BE PRINTED ON THE PATENT (print or type)

PLEASE NOTE: Unless an assignee is identified below, no assignee data will appear on the patent. If an assignee is identified below, the document has been filed for recordation as set forth in 37 CFR 3.11. Completion of this form is NOT a substitute for filing an assignment.

(A) NAME OF ASSIGNEE _____ (B) RESIDENCE: (CITY and STATE OR COUNTRY) _____

Please check the appropriate assignee category or categories (will not be printed on the patent) : Individual Corporation or other private group entity Government

<p>4a. The following fee(s) are submitted:</p> <p><input type="checkbox"/> Issue Fee</p> <p><input type="checkbox"/> Publication Fee (No small entity discount permitted)</p> <p><input type="checkbox"/> Advance Order - # of Copies _____</p>	<p>4b. Payment of Fee(s): (Please first reapply any previously paid issue fee shown above)</p> <p><input type="checkbox"/> A check is enclosed.</p> <p><input type="checkbox"/> Payment by credit card. Form PTO-2038 is attached.</p> <p><input type="checkbox"/> The Director is hereby authorized to charge the required fee(s), any deficiency, or credit any overpayment, to Deposit Account Number _____ (enclose an extra copy of this form).</p>
---	--

5. Change in Entity Status (from status indicated above)

a. Applicant claims SMALL ENTITY status. See 37 CFR 1.27. b. Applicant is no longer claiming SMALL ENTITY status. See 37 CFR 1.27(g)(2).

NOTE: The Issue Fee and Publication Fee (if required) will not be accepted from anyone other than the applicant; a registered attorney or agent; or the assignee or other party in interest as shown by the records of the United States Patent and Trademark Office.

Authorized Signature _____ Date _____

Typed or printed name _____ Registration No. _____

This collection of information is required by 37 CFR 1.311. The information is required to obtain or retain a benefit by the public which is to file (and by the USPTO to process) an application. Confidentiality is governed by 35 U.S.C. 122 and 37 CFR 1.14. This collection is estimated to take 12 minutes to complete, including gathering, preparing, and submitting the completed application form to the USPTO. Time will vary depending upon the individual case. Any comments on the amount of time you require to complete this form and/or suggestions for reducing this burden, should be sent to the Chief Information Officer, U.S. Patent and Trademark Office, U.S. Department of Commerce, P.O. Box 1450, Alexandria, Virginia 22313-1450. DO NOT SEND FEES OR COMPLETED FORMS TO THIS ADDRESS. SEND TO: Commissioner for Patents, P.O. Box 1450, Alexandria, Virginia 22313-1450.

Under the Paperwork Reduction Act of 1995, no persons are required to respond to a collection of information unless it displays a valid OMB control number.



UNITED STATES PATENT AND TRADEMARK OFFICE

UNITED STATES DEPARTMENT OF COMMERCE
United States Patent and Trademark Office
Address: COMMISSIONER FOR PATENTS
P.O. Box 1450
Alexandria, Virginia 22313-1450
www.uspto.gov

Table with 5 columns: APPLICATION NO., FILING DATE, FIRST NAMED INVENTOR, ATTORNEY DOCKET NO., CONFIRMATION NO.
12/879,899 09/10/2010 David F. MacNeil 31700.000254 7976

64770 7590 08/03/2012
Momkus McCluskey, LLC
1001 Warrenville Road, Suite 500
Lisle, IL 60532

Table with 1 column: EXAMINER

ROMAIN, PINEL E

Table with 2 columns: ART UNIT, PAPER NUMBER

3612

DATE MAILED: 08/03/2012

Determination of Patent Term Adjustment under 35 U.S.C. 154 (b)
(application filed on or after May 29, 2000)

The Patent Term Adjustment to date is 0 day(s). If the issue fee is paid on the date that is three months after the mailing date of this notice and the patent issues on the Tuesday before the date that is 28 weeks (six and a half months) after the mailing date of this notice, the Patent Term Adjustment will be 0 day(s).

If a Continued Prosecution Application (CPA) was filed in the above-identified application, the filing date that determines Patent Term Adjustment is the filing date of the most recent CPA.

Applicant will be able to obtain more detailed information by accessing the Patent Application Information Retrieval (PAIR) WEB site (http://pair.uspto.gov).

Any questions regarding the Patent Term Extension or Adjustment determination should be directed to the Office of Patent Legal Administration at (571)-272-7702. Questions relating to issue and publication fee payments should be directed to the Customer Service Center of the Office of Patent Publication at 1-(888)-786-0101 or (571)-272-4200.

Privacy Act Statement

The Privacy Act of 1974 (P.L. 93-579) requires that you be given certain information in connection with your submission of the attached form related to a patent application or patent. Accordingly, pursuant to the requirements of the Act, please be advised that: (1) the general authority for the collection of this information is 35 U.S.C. 2(b)(2); (2) furnishing of the information solicited is voluntary; and (3) the principal purpose for which the information is used by the U.S. Patent and Trademark Office is to process and/or examine your submission related to a patent application or patent. If you do not furnish the requested information, the U.S. Patent and Trademark Office may not be able to process and/or examine your submission, which may result in termination of proceedings or abandonment of the application or expiration of the patent.

The information provided by you in this form will be subject to the following routine uses:

1. The information on this form will be treated confidentially to the extent allowed under the Freedom of Information Act (5 U.S.C. 552) and the Privacy Act (5 U.S.C. 552a). Records from this system of records may be disclosed to the Department of Justice to determine whether disclosure of these records is required by the Freedom of Information Act.
2. A record from this system of records may be disclosed, as a routine use, in the course of presenting evidence to a court, magistrate, or administrative tribunal, including disclosures to opposing counsel in the course of settlement negotiations.
3. A record in this system of records may be disclosed, as a routine use, to a Member of Congress submitting a request involving an individual, to whom the record pertains, when the individual has requested assistance from the Member with respect to the subject matter of the record.
4. A record in this system of records may be disclosed, as a routine use, to a contractor of the Agency having need for the information in order to perform a contract. Recipients of information shall be required to comply with the requirements of the Privacy Act of 1974, as amended, pursuant to 5 U.S.C. 552a(m).
5. A record related to an International Application filed under the Patent Cooperation Treaty in this system of records may be disclosed, as a routine use, to the International Bureau of the World Intellectual Property Organization, pursuant to the Patent Cooperation Treaty.
6. A record in this system of records may be disclosed, as a routine use, to another federal agency for purposes of National Security review (35 U.S.C. 181) and for review pursuant to the Atomic Energy Act (42 U.S.C. 218(c)).
7. A record from this system of records may be disclosed, as a routine use, to the Administrator, General Services, or his/her designee, during an inspection of records conducted by GSA as part of that agency's responsibility to recommend improvements in records management practices and programs, under authority of 44 U.S.C. 2904 and 2906. Such disclosure shall be made in accordance with the GSA regulations governing inspection of records for this purpose, and any other relevant (i.e., GSA or Commerce) directive. Such disclosure shall not be used to make determinations about individuals.
8. A record from this system of records may be disclosed, as a routine use, to the public after either publication of the application pursuant to 35 U.S.C. 122(b) or issuance of a patent pursuant to 35 U.S.C. 151. Further, a record may be disclosed, subject to the limitations of 37 CFR 1.14, as a routine use, to the public if the record was filed in an application which became abandoned or in which the proceedings were terminated and which application is referenced by either a published application, an application open to public inspection or an issued patent.
9. A record from this system of records may be disclosed, as a routine use, to a Federal, State, or local law enforcement agency, if the USPTO becomes aware of a violation or potential violation of law or regulation.

Notice of Allowability	Application No.	Applicant(s)	
	12/879,899	MACNEIL ET AL.	
	Examiner	Art Unit	
	PINEL ROMAIN	3612	

-- The MAILING DATE of this communication appears on the cover sheet with the correspondence address--

All claims being allowable, PROSECUTION ON THE MERITS IS (OR REMAINS) CLOSED in this application. If not included herewith (or previously mailed), a Notice of Allowance (PTOL-85) or other appropriate communication will be mailed in due course. **THIS NOTICE OF ALLOWABILITY IS NOT A GRANT OF PATENT RIGHTS.** This application is subject to withdrawal from issue at the initiative of the Office or upon petition by the applicant. See 37 CFR 1.313 and MPEP 1308.

1. This communication is responsive to June 13 2012.
2. An election was made by the applicant in response to a restriction requirement set forth during the interview on ____; the restriction requirement and election have been incorporated into this action.
3. The allowed claim(s) is/are 12,14-17.
4. Acknowledgment is made of a claim for foreign priority under 35 U.S.C. § 119(a)-(d) or (f).
 - a) All b) Some* c) None of the:
 1. Certified copies of the priority documents have been received.
 2. Certified copies of the priority documents have been received in Application No. ____ .
 3. Copies of the certified copies of the priority documents have been received in this national stage application from the International Bureau (PCT Rule 17.2(a)).

* Certified copies not received: ____.

Applicant has THREE MONTHS FROM THE "MAILING DATE" of this communication to file a reply complying with the requirements noted below. Failure to timely comply will result in ABANDONMENT of this application.

THIS THREE-MONTH PERIOD IS NOT EXTENDABLE.

5. A SUBSTITUTE OATH OR DECLARATION must be submitted. Note the attached EXAMINER'S AMENDMENT or NOTICE OF INFORMAL PATENT APPLICATION (PTO-152) which gives reason(s) why the oath or declaration is deficient.
6. CORRECTED DRAWINGS (as "replacement sheets") must be submitted.
 - (a) including changes required by the Notice of Draftsperson's Patent Drawing Review (PTO-948) attached
 - 1) hereto or 2) to Paper No./Mail Date ____.
 - (b) including changes required by the attached Examiner's Amendment / Comment or in the Office action of Paper No./Mail Date ____.

Identifying indicia such as the application number (see 37 CFR 1.84(c)) should be written on the drawings in the front (not the back) of each sheet. Replacement sheet(s) should be labeled as such in the header according to 37 CFR 1.121(d).
7. DEPOSIT OF and/or INFORMATION about the deposit of BIOLOGICAL MATERIAL must be submitted. Note the attached Examiner's comment regarding REQUIREMENT FOR THE DEPOSIT OF BIOLOGICAL MATERIAL.

Attachment(s)

- | | |
|---|---|
| 1. <input checked="" type="checkbox"/> Notice of References Cited (PTO-892) | 5. <input type="checkbox"/> Notice of Informal Patent Application |
| 2. <input type="checkbox"/> Notice of Draftsperson's Patent Drawing Review (PTO-948) | 6. <input checked="" type="checkbox"/> Interview Summary (PTO-413),
Paper No./Mail Date <u>7/24/12</u> . |
| 3. <input checked="" type="checkbox"/> Information Disclosure Statements (PTO/SB/08),
Paper No./Mail Date <u>7/25/2012</u> | 7. <input checked="" type="checkbox"/> Examiner's Amendment/Comment |
| 4. <input type="checkbox"/> Examiner's Comment Regarding Requirement for Deposit
of Biological Material | 8. <input type="checkbox"/> Examiner's Statement of Reasons for Allowance |
| | 9. <input type="checkbox"/> Other ____. |

/PINEL E ROMAIN/
Examiner, Art Unit 3612

EXAMINER'S AMENDMENT

An examiner's amendment to the record appears below. Should the changes and/or additions be unacceptable to applicant, an amendment may be filed as provided by 37 CFR 1.312. To ensure consideration of such an amendment, it MUST be submitted no later than the payment of the issue fee.

Changes Specification in Paragraph 0043:

Replace "thread surfaces or baffles"; to -- thread surfaces or upstanding, hollow elongate baffles--;

Regarding claim 12, replace "ones of the baffles" to -- the baffles--.

Conclusion

Any inquiry concerning this communication or earlier communications from the examiner should be directed to PINEL ROMAIN whose telephone number is (571)270-7013. The examiner can normally be reached on Monday -Thursday From 7:30 am to 5:00 pm.

If attempts to reach the examiner by telephone are unsuccessful, the examiner's supervisor, Glenn Dayoan can be reached on 571-272-6659. The fax phone number for the organization where this application or proceeding is assigned is 571-273-8300.

Information regarding the status of an application may be obtained from the Patent Application Information Retrieval (PAIR) system. Status information for published applications may be obtained from either Private PAIR or Public PAIR. Status information for unpublished applications is available through Private PAIR only. For more information about the PAIR system, see <http://pair-direct.uspto.gov>. Should you have questions on access to the Private PAIR system, contact the Electronic Business Center (EBC) at 866-217-9197 (toll-free). If you would like assistance from a USPTO Customer Service Representative or access to the automated information system, call 800-786-9199 (IN USA OR CANADA) or 571-272-1000.

/PINEL E ROMAIN/
Examiner, Art Unit 3612

/D GLENN DAYOAN/
Supervisory Patent Examiner, Art Unit 3612

Notice of References Cited	Application/Control No. 12/879,899	Applicant(s)/Patent Under Reexamination MACNEIL ET AL.	
	Examiner PINEL ROMAIN	Art Unit 3612	Page 1 of 1

U.S. PATENT DOCUMENTS

*	Document Number Country Code-Number-Kind Code	Date MM-YYYY	Name	Classification
*	A US-3,450,429	06-1969	STATA STANLEY S	296/97.23
*	B US-3,390,912	07-1968	STATA STANLEY S	296/97.23
*	C US-6,261,667	07-2001	Yang, Ming-Shun	428/172
	D US-			
	E US-			
	F US-			
	G US-			
	H US-			
	I US-			
	J US-			
	K US-			
	L US-			
	M US-			

FOREIGN PATENT DOCUMENTS

*	Document Number Country Code-Number-Kind Code	Date MM-YYYY	Country	Name	Classification
	N				
	O				
	P				
	Q				
	R				
	S				
	T				

NON-PATENT DOCUMENTS

*	Include as applicable: Author, Title Date, Publisher, Edition or Volume, Pertinent Pages)
U	
V	
W	
X	

*A copy of this reference is not being furnished with this Office action. (See MPEP § 707.05(a).)
Dates in MM-YYYY format are publication dates. Classifications may be US or foreign.

Issue Classification 	Application/Control No. 12879899	Applicant(s)/Patent Under Reexamination MACNEIL ET AL.
	Examiner PINEL ROMAIN	Art Unit 3612

ORIGINAL						INTERNATIONAL CLASSIFICATION														
CLASS			SUBCLASS			CLAIMED					NON-CLAIMED									
296			75			B	6	0	N	3 / 06 (2006.01.01)										
CROSS REFERENCE(S)																				
CLASS	SUBCLASS (ONE SUBCLASS PER BLOCK)																			
296	97.23																			

<input checked="" type="checkbox"/> Claims renumbered in the same order as presented by applicant <input type="checkbox"/> CPA <input type="checkbox"/> T.D. <input type="checkbox"/> R.1.47															
Final	Original	Final	Original	Final	Original	Final	Original	Final	Original	Final	Original	Final	Original	Final	Original

/PINEL ROMAIN/ Examiner. Art Unit 3612 (Assistant Examiner)	7/24/2012 (Date)	Total Claims Allowed: 6	
/GLENN DAYOAN/ Supervisory Patent Examiner. Art Unit 3612 (Primary Examiner)	07/30/2012 (Date)	O.G. Print Claim(s) 12	O.G. Print Figure 1

INFORMATION DISCLOSURE STATEMENT BY APPLICANT (Not for submission under 37 CFR 1.99)	Application Number		12879899	
	Filing Date		2010-09-10	
	First Named Inventor	David F. MACNEIL		
	Art Unit	3612		
	Examiner Name	Pinel E. ROMAIN		
	Attorney Docket Number	31700.000254		

U.S. PATENTS	Remove
---------------------	--------

Examiner Initial*	Cite No	Patent Number	Kind Code ¹	Issue Date	Name of Patentee or Applicant of cited Document	Pages, Columns, Lines where Relevant Passages or Relevant Figures Appear
	1	6431629	B1	2002-08-13	Emery	
	2	4693507	A	1987-09-15	Dresen et al.	

If you wish to add additional U.S. Patent citation information please click the Add button. Add

U.S. PATENT APPLICATION PUBLICATIONS	Remove
---	--------

Examiner Initial*	Cite No	Publication Number	Kind Code ¹	Publication Date	Name of Patentee or Applicant of cited Document	Pages, Columns, Lines where Relevant Passages or Relevant Figures Appear
	1					

If you wish to add additional U.S. Published Application citation information please click the Add button. Add

FOREIGN PATENT DOCUMENTS	Remove
---------------------------------	--------

Examiner Initial*	Cite No	Foreign Document Number ³	Country Code ² j	Kind Code ⁴	Publication Date	Name of Patentee or Applicant of cited Document	Pages, Columns, Lines where Relevant Passages or Relevant Figures Appear	T ⁵
	1							<input type="checkbox"/>

If you wish to add additional Foreign Patent Document citation information please click the Add button. Add

NON-PATENT LITERATURE DOCUMENTS	Remove
--	--------

INFORMATION DISCLOSURE STATEMENT BY APPLICANT (Not for submission under 37 CFR 1.99)	Application Number		12879899
	Filing Date		2010-09-10
	First Named Inventor	David F. MACNEIL	
	Art Unit	3612	
	Examiner Name	Pinel E. ROMAIN	
	Attorney Docket Number	31700.000254	

Examiner Initials*	Cite No	Include name of the author (in CAPITAL LETTERS), title of the article (when appropriate), title of the item (book, magazine, journal, serial, symposium, catalog, etc), date, pages(s), volume-issue number(s), publisher, city and/or country where published.	T ⁵
	1		<input type="checkbox"/>

If you wish to add additional non-patent literature document citation information please click the Add button **Add**

EXAMINER SIGNATURE

Examiner Signature	/Pinel Romain/ (07/26/2012)	Date Considered	
--------------------	-----------------------------	-----------------	--

*EXAMINER: Initial if reference considered, whether or not citation is in conformance with MPEP 609. Draw line through a citation if not in conformance and not considered. Include copy of this form with next communication to applicant.

¹ See Kind Codes of USPTO Patent Documents at www.USPTO.GOV or MPEP 901.04. ² Enter office that issued the document, by the two-letter code (WIPO Standard ST.3). ³ For Japanese patent documents, the indication of the year of the reign of the Emperor must precede the serial number of the patent document. ⁴ Kind of document by the appropriate symbols as indicated on the document under WIPO Standard ST.16 if possible. ⁵ Applicant is to place a check mark here if English language translation is attached.

**INFORMATION DISCLOSURE
STATEMENT BY APPLICANT**
(Not for submission under 37 CFR 1.99)

Application Number	12879899
Filing Date	2010-09-10
First Named Inventor	David F. MACNEIL
Art Unit	3612
Examiner Name	Pinel E. ROMAIN
Attorney Docket Number	31700.000254

CERTIFICATION STATEMENT

Please see 37 CFR 1.97 and 1.98 to make the appropriate selection(s):

That each item of information contained in the information disclosure statement was first cited in any communication from a foreign patent office in a counterpart foreign application not more than three months prior to the filing of the information disclosure statement. See 37 CFR 1.97(e)(1).

OR

That no item of information contained in the information disclosure statement was cited in a communication from a foreign patent office in a counterpart foreign application, and, to the knowledge of the person signing the certification after making reasonable inquiry, no item of information contained in the information disclosure statement was known to any individual designated in 37 CFR 1.56(c) more than three months prior to the filing of the information disclosure statement. See 37 CFR 1.97(e)(2).

See attached certification statement.

Fee set forth in 37 CFR 1.17 (p) has been submitted herewith.

None

SIGNATURE

A signature of the applicant or representative is required in accordance with CFR 1.33, 10.18. Please see CFR 1.4(d) for the form of the signature.

Signature	/Jefferson Perkins/	Date (YYYY-MM-DD)	2012-07-25
Name/Print	Jefferson Perkins	Registration Number	31407

This collection of information is required by 37 CFR 1.97 and 1.98. The information is required to obtain or retain a benefit by the public which is to file (and by the USPTO to process) an application. Confidentiality is governed by 35 U.S.C. 122 and 37 CFR 1.14. This collection is estimated to take 1 hour to complete, including gathering, preparing and submitting the completed application form to the USPTO. Time will vary depending upon the individual case. Any comments on the amount of time you require to complete this form and/or suggestions for reducing this burden, should be sent to the Chief Information Officer, U.S. Patent and Trademark Office, U.S. Department of Commerce, P.O. Box 1450, Alexandria, VA 22313-1450. DO NOT SEND FEES OR COMPLETED FORMS TO THIS ADDRESS. **SEND TO: Commissioner for Patents, P.O. Box 1450, Alexandria, VA 22313-1450.**

Privacy Act Statement

The Privacy Act of 1974 (P.L. 93-579) requires that you be given certain information in connection with your submission of the attached form related to a patent application or patent. Accordingly, pursuant to the requirements of the Act, please be advised that: (1) the general authority for the collection of this information is 35 U.S.C. 2(b)(2); (2) furnishing of the information solicited is voluntary; and (3) the principal purpose for which the information is used by the U.S. Patent and Trademark Office is to process and/or examine your submission related to a patent application or patent. If you do not furnish the requested information, the U.S. Patent and Trademark Office may not be able to process and/or examine your submission, which may result in termination of proceedings or abandonment of the application or expiration of the patent.

The information provided by you in this form will be subject to the following routine uses:

1. The information on this form will be treated confidentially to the extent allowed under the Freedom of Information Act (5 U.S.C. 552) and the Privacy Act (5 U.S.C. 552a). Records from this system of records may be disclosed to the Department of Justice to determine whether the Freedom of Information Act requires disclosure of these records.
2. A record from this system of records may be disclosed, as a routine use, in the course of presenting evidence to a court, magistrate, or administrative tribunal, including disclosures to opposing counsel in the course of settlement negotiations.
3. A record in this system of records may be disclosed, as a routine use, to a Member of Congress submitting a request involving an individual, to whom the record pertains, when the individual has requested assistance from the Member with respect to the subject matter of the record.
4. A record in this system of records may be disclosed, as a routine use, to a contractor of the Agency having need for the information in order to perform a contract. Recipients of information shall be required to comply with the requirements of the Privacy Act of 1974, as amended, pursuant to 5 U.S.C. 552a(m).
5. A record related to an International Application filed under the Patent Cooperation Treaty in this system of records may be disclosed, as a routine use, to the International Bureau of the World Intellectual Property Organization, pursuant to the Patent Cooperation Treaty.
6. A record in this system of records may be disclosed, as a routine use, to another federal agency for purposes of National Security review (35 U.S.C. 181) and for review pursuant to the Atomic Energy Act (42 U.S.C. 218(c)).
7. A record from this system of records may be disclosed, as a routine use, to the Administrator, General Services, or his/her designee, during an inspection of records conducted by GSA as part of that agency's responsibility to recommend improvements in records management practices and programs, under authority of 44 U.S.C. 2904 and 2906. Such disclosure shall be made in accordance with the GSA regulations governing inspection of records for this purpose, and any other relevant (i.e., GSA or Commerce) directive. Such disclosure shall not be used to make determinations about individuals.
8. A record from this system of records may be disclosed, as a routine use, to the public after either publication of the application pursuant to 35 U.S.C. 122(b) or issuance of a patent pursuant to 35 U.S.C. 151. Further, a record may be disclosed, subject to the limitations of 37 CFR 1.14, as a routine use, to the public if the record was filed in an application which became abandoned or in which the proceedings were terminated and which application is referenced by either a published application, an application open to public inspections or an issued patent.
9. A record from this system of records may be disclosed, as a routine use, to a Federal, State, or local law enforcement agency, if the USPTO becomes aware of a violation or potential violation of law or regulation.

ALL REFERENCES CONSIDERED EXCEPT WHERE LINED THROUGH. /P.R./

Search Notes 	Application/Control No. 12879899	Applicant(s)/Patent Under Reexamination MACNEIL ET AL.
	Examiner PINEL ROMAIN	Art Unit 3612

SEARCHED			
Class	Subclass	Date	Examiner
296	97.23,75	7/24/2012	PER
428	81	7/24/2012	PER
15	215	7/24/2012	PER

SEARCH NOTES		
Search Notes	Date	Examiner
See East search report for search history	7/24/2012	PER

INTERFERENCE SEARCH			
Class	Subclass	Date	Examiner
296	97.23	7/24/2012	PER
15	215	7/24/2012	PER
	B60n3/06	7/24/2012	PER

--	--

EAST Search History

EAST Search History (Prior Art)

Ref #	Hits	Search Query	DBs	Default Operator	Plurals	Time Stamp
L1	7828	(B62d25/20).IPCR.	DERWENT	OR	OFF	2012/07/24 15:25
L2	1140	(B60n3/06).IPCR.	DERWENT	OR	OFF	2012/07/24 15:29
L4	349	(296/97.23).CCLS.	US-PGPUB; USPAT; USOCR; FPRS; EPO; JPO; DERWENT; IBM_TDB	OR	OFF	2012/07/24 15:35
L5	187	L4 L1	USPAT	OR	OFF	2012/07/24 15:35
S1	2	"US 20110009994"	US-PGPUB; USPAT; USOCR; DERWENT	AND	ON	2012/02/26 12:36
S2	579	"700/98".CCLS.	USPAT	AND	ON	2012/02/26 12:36
S3	2	"US 20090115225"	US-PGPUB; USPAT; USOCR; DERWENT	AND	ON	2012/02/26 12:41
S5	3784	428/138	US-PGPUB; USPAT; USOCR; DERWENT	AND	ON	2012/02/26 14:51
S6	341	(296/97.23).CCLS.	US-PGPUB; USPAT; USOCR; FPRS; EPO; JPO; DERWENT; IBM_TDB	OR	OFF	2012/02/26 14:51
S7	3766	S5 not S6	US-PGPUB; USPAT; USOCR; FPRS; EPO; JPO; DERWENT; IBM_TDB	AND	ON	2012/02/26 14:59
S8	15	("4280729" "4406492" "4591532" "5776583" "6027782" "6953545").PN.	US-PGPUB; USPAT; USOCR; FPRS; EPO; JPO; DERWENT; IBM_TDB	AND	ON	2012/02/26 14:59
S9	104	("1776510" "2623242" "2701890"	US-PGPUB;	AND	ON	2012/04/19;

EAST Search History

		"2810672" "2897963" "2915427" "3050329" "3082032" "3149875" "3206785" "3312498" "3387315" "3390912" "3488081" "3555601" "3605166" "3856610" "4211447" "4280729" "4382986" "4405682" "4420180" "4428999" "4444825" "4480011" "4520057" "4529639" "4579764" "4721641" "4828898" "5034258" "5171619" "5362544" "5474829" "5554333" "5891546" "6020044" "D171301").PN. OR ("4280729" "4406492" "4591532" "5776583" "6027782" "6953545").URFN.	USPAT; USOCR			16:15
S10	464	296/97.23	US-PGPUB; USPAT; USOCR; DERWENT	AND	ON	2012/07/24 11:53
S16	601	(428/81).CCLS.	USPAT; USOCR	OR	OFF	2012/07/24 12:47
S17	8809	(B62d25/20).IPCR.	US-PGPUB; USPAT; DERWENT	OR	OFF	2012/07/24 13:01
S18	7828	(B62d25/20).IPCR.	DERWENT	OR	OFF	2012/07/24 13:01
S21	349	(296/97.23).CCLS.	US-PGPUB; USPAT; USOCR; FPRS; EPO; JPO; DERWENT; IBM_TDB	OR	OFF	2012/07/24 13:07
S30	506	(296/75).CCLS.	US-PGPUB; USPAT; USOCR; FPRS; EPO; JPO; DERWENT; IBM_TDB	OR	OFF	2012/07/24 13:13
S31	448	S21 S30	USPAT	OR	OFF	2012/07/24 13:19
S32	16	S21 S30	US-PGPUB; USPAT; USOCR; FPRS; EPO; JPO; DERWENT; IBM_TDB	AND	OFF	2012/07/24 13:19
S34	654033	428/81 hollow thread	USPAT	OR	OFF	2012/07/24 13:30
S35	2	428/81 (hollow thread)	USPAT	AND	OFF	2012/07/24 13:30
S36	590	(15/215).CCLS.	USPAT; USOCR	OR	OFF	2012/07/24 13:35
S37	65	("20010020316" "20040224130" "20050191459" "20060091695" "20070110950" "2188342" "2709105" "3087752" "3288187" "3390912" "3401975" "3450429" "3488081"	US-PGPUB; USPAT; USOCR	OR	OFF	2012/07/24 13:36

EAST Search History

		"3605166" "4211447" "4280729"				
		"4382986" "4406492" "4420180"				
		"4579764" "4693507" "4721641"				
		"4828898" "5254384" "5482759"				
		"5725926" "5776583" "5830560"				
		"5891546" "5919540" "6027782"				
		"6155629" "6261667" "6431629"				
		"6534146" "6605333" "6793872"				
		"6794013" "6953545" "7401837"				
		"D242136" "D278525" "D313789"				
		"D358571" "D372011" "D377780"				
		"D393238" "D408342" "D420965"				
		"D422256" "D425005" "D432478"				
		"D454323" "D525576").PN. OR ("7686371").URPN.				
S38	15	("3450429").URPN.	USPAT	OR	OFF	2012/07/24: 14:09

7/ 24/ 2012 3:36:53 PM

C:\ Users\ promain\ Documents\ EAST\ Workspaces\ 12879899_floor_mat.wsp

PART B - FEE(S) TRANSMITTAL

Complete and send this form, together with applicable fee(s), to: Mail **Mail Stop ISSUE FEE
Commissioner for Patents
P.O. Box 1450
Alexandria, Virginia 22313-1450**
or Fax **(571)-273-2885**

INSTRUCTIONS: This form should be used for transmitting the ISSUE FEE and PUBLICATION FEE (if required). Blocks 1 through 5 should be completed where appropriate. All further correspondence including the Patent, advance orders and notification of maintenance fees will be mailed to the current correspondence address as indicated unless corrected below or directed otherwise in Block 1, by (a) specifying a new correspondence address; and/or (b) indicating a separate "FEE ADDRESS" for maintenance fee notifications.

CURRENT CORRESPONDENCE ADDRESS (Note: Use Block 1 for any change of address)

64770 7590 08/03/2012
Momkus McCluskey, LLC
1001 Warrenville Road, Suite 500
Lisle, IL 60532

Note: A certificate of mailing can only be used for domestic mailings of the Fee(s) Transmittal. This certificate cannot be used for any other accompanying papers. Each additional paper, such as an assignment or formal drawing, must have its own certificate of mailing or transmission.

Certificate of Mailing or Transmission

I hereby certify that this correspondence is being transmitted via the USPTO electronic filing system in accordance with 37 CFR §1.6(a)(4) on August 8, 2012.

Patricia Romanelli	(Depositor's name)
/Patricia Romanelli/	(Signature)
August 8, 2012	(Date)

APPLICATION NO.	FILING DATE	FIRST NAMED INVENTOR	ATTORNEY DOCKET NO.	CONFIRMATION NO.
12/879,899	09/10/2010	David F. MacNeil	31700.000254	7976

TITLE OF INVENTION: DESIGNING AND MANUFACTURING VEHICLE FLOOR TRAYS

APPLN. TYPE	SMALL ENTITY	ISSUE FEE DUE	PUBLICATION FEE DUE	PREV. PAID ISSUE FEE	TOTAL FEE(S) DUE	DATE DUE
nonprovisional	YES	\$870	\$300	\$0	\$1170	11/05/2012

EXAMINER	ART UNIT	CLASS-SUBCLASS
ROMAIN, PINEL E	3612	296-075000

1. Change of correspondence address or indication of "Fee Address" (37 CFR 1.363).
 Change of correspondence address (or Change of Correspondence Address form PTO/SB/122) attached.
 "Fee Address" indication (or "Fee Address" Indication form PTO/SB/47; Rev 03-02 or more recent) attached. Use of a Customer Number is required.

2. For printing on the patent front page, list
 (1) the names of up to 3 registered patent attorneys or agents OR, alternatively,
 (2) the name of a single firm (having as a member a registered attorney or agent) and the names of up to 2 registered patent attorneys or agents. If no name is listed, no name will be printed.
 1 Momkus McCluskey, LLC
 2 Jefferson Perkins
 3

3. ASSIGNEE NAME AND RESIDENCE DATA TO BE PRINTED ON THE PATENT (print or type)

PLEASE NOTE: Unless an assignee is identified below, no assignee data will appear on the patent. If an assignee is identified below, the document has been filed for recordation as set forth in 37 CFR 3.11. Completion of this form is NOT a substitute for filing an assignment.

(A) NAME OF ASSIGNEE MacNeil IP LLC (B) RESIDENCE: (CITY and STATE OR COUNTRY) Bolingbrook, Illinois

Please check the appropriate assignee category or categories (will not be printed on the patent): Individual Corporation or other private group entity Government

4a. The following fee(s) are submitted:

- Issue Fee
- Publication Fee (No small entity discount permitted)
- Advance Order - # of Copies

4b. Payment of Fee(s): (Please first reapply any previously paid issue fee shown above)

- A check is enclosed.
- Payment by credit card. Form PTO-2038 is attached.
- The Director is hereby authorized to charge the required fee(s), any deficiency, or credit any overpayment, to Deposit Account Number 503282 (enclose an extra copy of this form).

5. Change in Entity Status (from status indicated above)

- a. Applicant claims SMALL ENTITY status. See 37 CFR 1.27.
- b. Applicant is no longer claiming SMALL ENTITY status. See 37 CFR 1.27(g)(2).

NOTE: The Issue Fee and Publication Fee (if required) will not be accepted from anyone other than the applicant; a registered attorney or agent; or the assignee or other party in interest as shown by the records of the United States Patent and Trademark Office.

Authorized Signature /Jefferson Perkins/ Date August 8, 2012
 Typed or printed name Jefferson Perkins Registration No. 31,407

This collection of information is required by 37 CFR 1.311. The information is required to obtain or retain a benefit by the public which is to file (and by the USPTO to process) an application. Confidentiality is governed by 35 U.S.C. 122 and 37 CFR 1.14. This collection is estimated to take 12 minutes to complete, including gathering, preparing, and submitting the completed application form to the USPTO. Time will vary depending upon the individual case. Any comments on the amount of time you require to complete this form and/or suggestions for reducing this burden, should be sent to the Chief Information Officer, U.S. Patent and Trademark Office, U.S. Department of Commerce, P.O. Box 1450, Alexandria, Virginia 22313-1450. DO NOT SEND FEES OR COMPLETED FORMS TO THIS ADDRESS. SEND TO: Commissioner for Patents, P.O. Box 1450, Alexandria, Virginia 22313-1450.

Under the Paperwork Reduction Act of 1995, no persons are required to respond to a collection of information unless it displays a valid OMB control number.

Electronic Patent Application Fee Transmittal

Application Number:	12879899			
Filing Date:	10-Sep-2010			
Title of Invention:	DESIGNING AND MANUFACTURING VEHICLE FLOOR TRAYS			
First Named Inventor/Applicant Name:	David F. MacNeil			
Filer:	Jefferson Perkins/Patricia Romanelli			
Attorney Docket Number:	31700.000254			
Filed as Small Entity				
Utility under 35 USC 111(a) Filing Fees				
Description	Fee Code	Quantity	Amount	Sub-Total in USD(\$)
Basic Filing:				
Pages:				
Claims:				
Miscellaneous-Filing:				
Petition:				
Patent-Appeals-and-Interference:				
Post-Allowance-and-Post-Issuance:				
Utility Appl issue fee	2501	1	870	870
Publ. Fee- early, voluntary, or normal	1504	1	300	300

Description	Fee Code	Quantity	Amount	Sub-Total in USD(\$)
Extension-of-Time:				
Miscellaneous:				
Total in USD (\$)				1170

Electronic Acknowledgement Receipt

EFS ID:	13449997
Application Number:	12879899
International Application Number:	
Confirmation Number:	7976
Title of Invention:	DESIGNING AND MANUFACTURING VEHICLE FLOOR TRAYS
First Named Inventor/Applicant Name:	David F. MacNeil
Customer Number:	64770
Filer:	Jefferson Perkins/Patricia Romanelli
Filer Authorized By:	Jefferson Perkins
Attorney Docket Number:	31700.000254
Receipt Date:	08-AUG-2012
Filing Date:	10-SEP-2010
Time Stamp:	16:40:29
Application Type:	Utility under 35 USC 111(a)

Payment information:

Submitted with Payment	yes
Payment Type	Deposit Account
Payment was successfully received in RAM	\$1170
RAM confirmation Number	3361
Deposit Account	503982
Authorized User	

The Director of the USPTO is hereby authorized to charge indicated fees and credit any overpayment as follows:

Charge any Additional Fees required under 37 C.F.R. Section 1.21 (Miscellaneous fees and charges)

File Listing:					
Document Number	Document Description	File Name	File Size(Bytes)/ Message Digest	Multi Part /.zip	Pages (if appl.)
1	Issue Fee Payment (PTO-85B)	IssueFeeTransmittal.pdf	1792992 f04ab08e9aac88aa734385325f2fb0ed69b7fda	no	1
Warnings:					
Information:					
2	Fee Worksheet (SB06)	fee-info.pdf	31734 0580bf39e3b018bad4da1b4f8a24d4e71ba18d9	no	2
Warnings:					
Information:					
Total Files Size (in bytes):			1824726		
<p>This Acknowledgement Receipt evidences receipt on the noted date by the USPTO of the indicated documents, characterized by the applicant, and including page counts, where applicable. It serves as evidence of receipt similar to a Post Card, as described in MPEP 503.</p> <p><u>New Applications Under 35 U.S.C. 111</u> If a new application is being filed and the application includes the necessary components for a filing date (see 37 CFR 1.53(b)-(d) and MPEP 506), a Filing Receipt (37 CFR 1.54) will be issued in due course and the date shown on this Acknowledgement Receipt will establish the filing date of the application.</p> <p><u>National Stage of an International Application under 35 U.S.C. 371</u> If a timely submission to enter the national stage of an international application is compliant with the conditions of 35 U.S.C. 371 and other applicable requirements a Form PCT/DO/EO/903 indicating acceptance of the application as a national stage submission under 35 U.S.C. 371 will be issued in addition to the Filing Receipt, in due course.</p> <p><u>New International Application Filed with the USPTO as a Receiving Office</u> If a new international application is being filed and the international application includes the necessary components for an international filing date (see PCT Article 11 and MPEP 1810), a Notification of the International Application Number and of the International Filing Date (Form PCT/RO/105) will be issued in due course, subject to prescriptions concerning national security, and the date shown on this Acknowledgement Receipt will establish the international filing date of the application.</p>					

EXAMINER'S AMENDMENT

An examiner's amendment to the record appears below. Should the changes and/or additions be unacceptable to applicant, an amendment may be filed as provided by 37 CFR 1.312. To ensure consideration of such an amendment, it MUST be submitted no later than the payment of the issue fee.

Changes Specification in Paragraph 0043: line 1

Replace "^{tread}~~thread~~ surfaces or baffles"; to -- ^{tread}~~thread~~ surfaces or upstanding, hollow elongate baffles--;

Regarding claim 12, replace "ones of the baffles" to -- the baffles--.

Conclusion

Any inquiry concerning this communication or earlier communications from the examiner should be directed to PINEL ROMAIN whose telephone number is (571)270-7013. The examiner can normally be reached on Monday -Thursday From 7:30 am to 5:00 pm.

If attempts to reach the examiner by telephone are unsuccessful, the examiner's supervisor, Glenn Dayoan can be reached on 571-272-6659. The fax phone number for the organization where this application or proceeding is assigned is 571-273-8300.

Change(s) applied
to document,
/D.H.P./
8/10/2012



UNITED STATES PATENT AND TRADEMARK OFFICE

UNITED STATES DEPARTMENT OF COMMERCE
United States Patent and Trademark Office
Address: COMMISSIONER FOR PATENTS
P.O. Box 1450
Alexandria, Virginia 22313-1450
www.uspto.gov

APPLICATION NO.	ISSUE DATE	PATENT NO.	ATTORNEY DOCKET NO.	CONFIRMATION NO.
12/879,899	09/18/2012	8267459	31700.000254	7976

64770 7590 08/29/2012
Momkus McCluskey, LLC
1001 Warrenville Road, Suite 500
Lisle, IL 60532

ISSUE NOTIFICATION

The projected patent number and issue date are specified above.

Determination of Patent Term Adjustment under 35 U.S.C. 154 (b)
(application filed on or after May 29, 2000)

The Patent Term Adjustment is 0 day(s). Any patent to issue from the above-identified application will include an indication of the adjustment on the front page.

If a Continued Prosecution Application (CPA) was filed in the above-identified application, the filing date that determines Patent Term Adjustment is the filing date of the most recent CPA.

Applicant will be able to obtain more detailed information by accessing the Patent Application Information Retrieval (PAIR) WEB site (<http://pair.uspto.gov>).

Any questions regarding the Patent Term Extension or Adjustment determination should be directed to the Office of Patent Legal Administration at (571)-272-7702. Questions relating to issue and publication fee payments should be directed to the Application Assistance Unit (AAU) of the Office of Data Management (ODM) at (571)-272-4200.

APPLICANT(s) (Please see PAIR WEB site <http://pair.uspto.gov> for additional applicants):

David F. MacNeil, Hinsdale, IL;
Scott A. Vergo, Lombard, IL;

The United States represents the largest, most dynamic marketplace in the world and is an unparalleled location for business investment, innovation, and commercialization of new technologies. The USA offers tremendous resources and advantages for those who invest and manufacture goods here. Through SelectUSA, our nation works to encourage and facilitate business investment. To learn more about why the USA is the best country in the world to develop technology, manufacture products, and grow your business, visit SelectUSA.gov.

IN THE UNITED STATES PATENT & TRADEMARK OFFICE

In re the application of: MacNeil IP LLC
Application Number: 12/879,899
Filed: September 10, 2010
Patent Number: 8,267,459 B2
Issue Date: September 18, 2012
Confirmation Number: 7976

CERTIFICATE OF TRANSMISSION
BY ELECTRONIC FILING

I hereby certify that this correspondence is being transmitted via the U.S. Patent and Trademark Office (USPTO) electronic filing system (EFS-Web) to the USPTO on August 11, 2014.

/Patricia Romanelli/
Patricia Romanelli

For: DESIGNING AND MANUFACTURING VEHICLE FLOOR TRAYS

Commissioner for Patents
P.O. Box 1450
Alexandria, VA 22313-1450

**NOTIFICATION OF LOSS OF ENTITLEMENT TO
SMALL ENTITY STATUS UNDER 37 CFR § 1.27(g)(2)**

Dear Sir:

This communication serves as notification of a loss of entitlement to small entity status of the owner of the above identified application under 37 CFR § 1.27(g)(2).

No fee is thought to be due in connection with this submission. Nonetheless, the Commissioner is hereby authorized to charge any deficiency relating to this submission to Deposit Account No. 506166 of Perkins IP Law Group LLC.

Respectfully submitted,

/Jefferson Perkins/
Jefferson Perkins
Registration No. 31,407

CUSTOMER NO. 115904

PERKINS IP LAW GROUP LLC
4200 Commerce Court, Suite 310
Lisle, Illinois 60532
Telephone: (630) 505-1305
Fax: (630) 505-1312
Email: jperkins@perkinsip.com

IN THE UNITED STATES PATENT & TRADEMARK OFFICE

In re the patent of: MacNeil IP LLC
Patent No.: 8,267,459 B2
Issue Date: September 18, 2012
Title: DESIGNING AND MANUFACTURING VEHICLE FLOOR TRAYS

Commissioner for Patents
P.O. Box 1450
Alexandria, VA 22313-1450

**REVOCAION OF POWER OF ATTORNEY, APPOINTMENT OF NEW ATTORNEYS
AND CERTIFICATE UNDER 37 C.F.R. §3.73(c)**

I, David F. MacNeil, am the Manager of MacNeil IP LLC, a limited liability company duly organized and existing under the laws of the State of Illinois (“Owner”). The Owner is the assignee and owner of the entire right, title and interest in the above-identified patent (“Patent”) by virtue of an assignment from the inventors of this Patent, U.S. Patent No. 8,267,459 B2 issued September 18, 2012. As evidence of this assignment, the Owner points to the Assignment recorded at Reel 024971, Frame 0346.

As the Manager of Owner the undersigned is authorized to act on behalf of Owner and has full power to grant and revoke powers of attorney.

Owner hereby revokes all previously granted powers of attorney.

Owner hereby appoints Practitioners associated with Customer Number 115904 as its attorneys to prosecute this Patent Application and to transact all business in the U.S. Patent and Trademark Office connected with the Patent Application and with any resulting patent, said attorneys being of the firm of Perkins IP Law Group LLC, with full power of substitution and

revocation, to prosecute this application and represent the undersigned before all competent International Authorities.

Please direct all correspondence to:

**Perkins IP Law Group LLC
4200 Commerce Court, Suite 310
Lisle, IL 60532**

CUSTOMER NUMBER 115904

Please direct all telephone calls to:

Jefferson Perkins
(630) 505-1305

I hereby declare that all statements made herein of my own knowledge are true, and that all statements made on information and belief are believed to be true; and further, that these statements are made with the knowledge that willful false statements, and the like so made, are punishable by fine or imprisonment, or both, under Section 1001, Title 18 of the United States Code, and that such willful false statements may jeopardize the validity of the application or any patent issuing thereon.

MACNEIL IP LLC

Signature:	<u>/David F. MacNeil/</u>
Name:	David F. MacNeil
Its:	Manager
Date:	<u>08-06-2014</u>

Electronic Acknowledgement Receipt

EFS ID:	19832973
Application Number:	12879899
International Application Number:	
Confirmation Number:	7976
Title of Invention:	DESIGNING AND MANUFACTURING VEHICLE FLOOR TRAYS
First Named Inventor/Applicant Name:	David F. MacNeil
Customer Number:	64770
Filer:	Jefferson Perkins/Patricia Romanelli
Filer Authorized By:	Jefferson Perkins
Attorney Docket Number:	31700.000254
Receipt Date:	11-AUG-2014
Filing Date:	10-SEP-2010
Time Stamp:	16:49:53
Application Type:	Utility under 35 USC 111(a)

Payment information:

Submitted with Payment	no
------------------------	----

File Listing:

Document Number	Document Description	File Name	File Size(Bytes)/ Message Digest	Multi Part /.zip	Pages (if appl.)
1	Notification of loss of entitlement to small entity status	NotOfLossOfSmEntStatus.pdf	122050 <small>9095958f65d01dd9c7c2e96a091a47c9bba2f1c1</small>	no	2

Warnings:

Information:

2	Power of Attorney	RevAndPOA0254.pdf	78090	no	2
			4311181d97c93bdc433b67bce79bfcf1945eb7c6		

Warnings:

Information:

Total Files Size (in bytes):	200140
-------------------------------------	--------

This Acknowledgement Receipt evidences receipt on the noted date by the USPTO of the indicated documents, characterized by the applicant, and including page counts, where applicable. It serves as evidence of receipt similar to a Post Card, as described in MPEP 503.

New Applications Under 35 U.S.C. 111

If a new application is being filed and the application includes the necessary components for a filing date (see 37 CFR 1.53(b)-(d) and MPEP 506), a Filing Receipt (37 CFR 1.54) will be issued in due course and the date shown on this Acknowledgement Receipt will establish the filing date of the application.

National Stage of an International Application under 35 U.S.C. 371

If a timely submission to enter the national stage of an international application is compliant with the conditions of 35 U.S.C. 371 and other applicable requirements a Form PCT/DO/EO/903 indicating acceptance of the application as a national stage submission under 35 U.S.C. 371 will be issued in addition to the Filing Receipt, in due course.

New International Application Filed with the USPTO as a Receiving Office

If a new international application is being filed and the international application includes the necessary components for an international filing date (see PCT Article 11 and MPEP 1810), a Notification of the International Application Number and of the International Filing Date (Form PCT/RO/105) will be issued in due course, subject to prescriptions concerning national security, and the date shown on this Acknowledgement Receipt will establish the international filing date of the application.



UNITED STATES PATENT AND TRADEMARK OFFICE

UNITED STATES DEPARTMENT OF COMMERCE
United States Patent and Trademark Office
Address: COMMISSIONER FOR PATENTS
P.O. Box 1450
Alexandria, Virginia 22313-1450
www.uspto.gov

APPLICATION NUMBER	FILING OR 371(C) DATE	FIRST NAMED APPLICANT	ATTY. DOCKET NO./TITLE
12/879,899	09/10/2010	David F. MacNeil	31700.0254

CONFIRMATION NO. 7976

POA ACCEPTANCE LETTER

115904
Perkins IP Law Group LLC
4200 Commerce Court
Suite 310
Lisle, IL 60532



Date Mailed: 09/17/2014

NOTICE OF ACCEPTANCE OF POWER OF ATTORNEY

This is in response to the Power of Attorney filed 08/11/2014.

The Power of Attorney in this application is accepted. Correspondence in this application will be mailed to the above address as provided by 37 CFR 1.33.

/sleutchit/

Office of Data Management, Application Assistance Unit (571) 272-4000, or (571) 272-4200, or 1-888-786-0101



UNITED STATES PATENT AND TRADEMARK OFFICE

UNITED STATES DEPARTMENT OF COMMERCE
United States Patent and Trademark Office
Address: COMMISSIONER FOR PATENTS
P.O. Box 1450
Alexandria, Virginia 22313-1450
www.uspto.gov

APPLICATION NUMBER	FILING OR 371(C) DATE	FIRST NAMED APPLICANT	ATTY. DOCKET NO./TITLE
12/879,899	09/10/2010	David F. MacNeil	31700.000254

CONFIRMATION NO. 7976

POWER OF ATTORNEY NOTICE

64770
Perkins IP Law Group LLC
4200 Commerce Court, Suite 310
Lisle, IL 60532



Date Mailed: 09/17/2014

NOTICE REGARDING CHANGE OF POWER OF ATTORNEY

This is in response to the Power of Attorney filed 08/11/2014.

- The Power of Attorney to you in this application has been revoked by the assignee who has intervened as provided by 37 CFR 3.71. Future correspondence will be mailed to the new address of record(37 CFR 1.33).

/sleutchit/

Office of Data Management, Application Assistance Unit (571) 272-4000, or (571) 272-4200, or 1-888-786-0101