

## ABSTRACT OF THE DISCLOSURE

Keyboards, keypads and other data entry devices can suffer from a keying ambiguity problem. In a small keyboard, for example, a user's finger is likely to overlap from a desired key to onto adjacent ones. An iterative method of removing keying ambiguity from a keyboard comprising an array of capacitive keys involves measuring a signal strength associated with each key in the array, comparing the measured signal strengths to find a maximum, determining that the key having the maximum signal strength is the unique user-selected key, and maintaining that selection until either the initially selected key's signal strength drops below some threshold level or a second key's signal strength exceeds the first key's signal strength.

**[0001]** This application is a continuation-in-part of the inventor's US 11/160,885, filed on July 14, 2005, which is a continuation of the inventor's US Patent 6,993,607, filed on July 11, 2003, which claimed the priority of his US provisional application 60/395,368, filed July 12, 2002. Moreover, this application claims the priority of the inventor's provisional application 60/597,851, filed December 21, 2005.

## BACKGROUND INFORMATION

**[0002]** The invention relates to method and apparatus for controlling an array of non-bistable keys, such as capacitive position sensors, and, more specifically for preventing accidental false inputs from keys adjacent to a selected key in a capacitive keyboard.

**[0003]** Arrays of capacitive proximity sensors are often used in keyboards, keypads and other touch-input apparatus. Two characteristics of capacitive sensors that lead to their use instead of conventional metallic switches are: 1) Capacitive sensors can be made in small sizes, which is desirable if a small, tightly packed keyboard is required; and 2) Capacitive sensors are particularly easy to environmentally seal, which is desirable if the keyboard is to be used in a wet environment or where there is a concern that contaminants may be spilled on the keyboard.

**[0004]** Conventional capacitive sensors, when tightly packed, or when used in the presence of conductive liquid films, suffer a keying ambiguity problem. In a small keyboard, for example, a user's finger is likely to overlap from a desired key to onto adjacent ones. This is especially problematic if the user has large fingers or if he or she presses on the keyboard surface hard enough to deform his or her finger. The same sort of effect is found when a conducting film is spilled on a keyboard, in

which case the user's finger is sensed as though it were the size of the puddle. Problems of this sort are particularly acute in cash register keyboards used in food service establishments where beverage and food sauce spills are a frequent occurrence.

**[0005]** In his US Patent 5,730,165, the inventor teaches a capacitive field sensor employing a single coupling plate and a method of detecting a change in capacitance of the coupling plate,  $C_x$ , to ground. The apparatus taught in US 5,730,165 comprises pulse circuitry for charging the coupling plate and for subsequently transferring the charge from the plate into a charge detector, which may be a sampling capacitor,  $C_s$ . The transferring operation is carried out by means of a transfer switch electrically connected between the coupling plate and the charge detector. The disclosure of US 5,730,165 is herein incorporated by reference.

**[0006]** In his US patent 6,466,036 the inventor teaches pulse circuitry for measuring capacitance to ground, the circuitry comprising a plurality of electrical switching elements, each of which has one side electrically connected to either a power supply voltage or to a circuit ground point. This circuit arrangement, which may be used with a keyboard as well as for many other applications, is more compatible with available integrated circuit design and manufacturing practices than is prior art pulse circuitry, which commonly had one side of at least one switching element floating. These improved arrangements thereby provide superior performance at a lower manufacturing cost. The disclosure of US patent 6,466,036 is herein incorporated by reference.

SUMMARY OF THE INVENTION

**[0007]** One aspect of the invention is that it may provide an iterative method of removing keying ambiguity by measuring a detected signal strength associated with each key in an array, comparing the measured signal strengths to find a maximum, determining that the key having the maximum signal strength is the unique user-selected first key, and maintaining that selection until either the first key's signal strength drops below some threshold level or a second key's signal strength exceeds the first key's signal strength. When any key is selected its signal strength value may be enhanced relative to all the other keys so as to deselect all other keys. In this aspect, the array under consideration may be a keyboard, or any convenient subset thereof.

**[0008]** A particular preferred embodiment of the invention is an array of capacitive keys in which each key has a respective detection integrator counter (DI) associated with it. Each DI is a clocked counter that counts up by one incremental value on each capacitive acquisition cycle during which a signal strength from the associated key is above some nominal threshold value, and that counts down toward zero if the signal strength is less than the nominal value. A controller receives a respective input from each DI and determines that one of the keys is selected, e.g., wins, when the detection integration (DI) count associated with that key meets a respectively selected terminal count value, TC. The incremental magnitude used for counting down can be the same as that for counting up, e.g., 1, or it can be different, e.g., 2, to preferentially accelerate the count-down 'losing' process over the winning process, in order to facilitate better suppression of noise. The rate of counting down any of the DI counters can also be the complete value, i.e., the DI can be cleared in one cycle. In this embodiment, when two or more keys have signal strengths above their nominal thresholds, the key with the lesser signal strength will have its associated DI decremented or cleared each cycle



while this condition exists. If any two or more keys have equal and maximal signal strengths, such keys' DI's will continue to increment until the first to reach its TC 'wins' and is set as the unique user-selected key.

**[0009]** In another aspect of the invention, the DI of a key selected at a first instant may be decremented or cleared and that key deselected even if the signal strength of that key is above the threshold value and its DI equals its associated TC value, if second key becomes selected at a later instant by virtue of its signal strength being greater than the signal strength of the first key while also being above its own threshold value and having its associated DI equal its associated TC. If there are multiple keys with signal strengths above their associated threshold values, their associated DIs will count up and down in competition, until one key's DI finally equals its TC and wins over all others including over the previously selected key.

**[0010]** In the above discussions, it should be understood that the principle of having one signal greater than another has been somewhat simplified for explanatory purposes. In order to avoid indecisiveness and eliminate oscillation between two or more keys having more or less the same signal strengths, the winning key may preferably be given a slight advantage in subsequent repetitions of the decision process. This may be done, for example, by requiring a non-selected key's signal to exceed the currently selected key's signal by a small amount. This can be done by subtracting a small amount off the signals of non-selected keys, or by adding a small amount onto the selected key's signal.

**[0011]** An advantage of this method over those disclosed in my US Patent 6,993,607 is that the method disclosed herein permits the smooth rollover of key selection as a finger slides from one key to the next, while

still reducing key ambiguity. In the aforementioned patent, the first key to win remains selected even if the maximal signal strength has shifted to a new key, provided that the first key has enough signal strength left to retain its state, i.e., by having its signal strength in excess of its associated threshold value. Therefore the instant invention may be referred to as 'non-locking' key ambiguity reduction.

**[0012]** In yet another aspect of the invention, if the signal strengths of two keys that are approaching a detection threshold value and that are both in a defined keyboard neighborhood both exceed the threshold value and their signal strengths are equal to each other (or are within a selected tolerance value) at the same time, an algorithm executed by a controller may be used to declare one of the two keys to be active and the other to be inactive. It will be recognized that a wide variety of algorithms are possible and include, but are not limited to, a random, or pseudo-random selection of the active key, or a declaration of activity based on which key was scanned first.

**[0013]** The principle also applies in the minimal case where the DI's terminal count (TC) is chosen to be equal to one. This is functionally the same as though there were no DI, but rather just a simple signal comparison function with an inhibiting logic gate following it. Here, the inputs to the inhibiting gate also includes the logical comparisons of the signal strengths among the keys in a neighborhood in order to skew subsequent comparisons to favor the already selected key over competing keys having respective output signals above respective threshold values.

**[0014]** Those skilled in the keyboard arts will understand that the above-mentioned neighborhoods can be defined in a wide variety of

ways. In some cases, a neighborhood of a given key may consist of all the keys immediately adjacent the given key, or may comprise all the keys having no more than one key between them and the given key. In other cases, the neighborhood may comprise all the keys in a matrix array -- e.g., in a keyboard for use in a numerical data entry application in which only one key is to be active at a time so that the sequence of input digits is uniquely determined. In other cases, such as in a typing or computer-input keyboard, the neighborhood of a key may comprise all other keys in the keyboard except for special purpose keys, such as a capitalization shift key, a control key, and the like. Moreover, some embodiments of the invention provide a keyboard that is configurable by a user who programs a controller to selectively consider or ignore various keys in an array. In some cases there might be two neighborhoods, each acting independently of the other for key ambiguity resolution purposes.

**[0015]** Although it is believed that the foregoing rather broad summary description may be of use to one who is skilled in the art and who wishes to learn how to practice the invention, it will be recognized that the foregoing recital is not intended to list all of the features and advantages. Those skilled in the art will appreciate that they may readily use both the underlying ideas and the specific embodiments disclosed in the following Detailed Description as a basis for designing other arrangements for carrying out the same purposes of the present invention and that such equivalent constructions are within the spirit and scope of the invention in its broadest form. Moreover, it may be noted that different embodiments of the invention may provide various combinations of the recited features and advantages of the invention, and that less than all of the recited features and advantages may be provided by some embodiments.

## DESCRIPTION OF THE DRAWING

**[0016]** Figures 1a to 1c show an array of tightly spaced capacitive buttons.

**[0017]** Figure 2 shows a 2-D touch surface such as a capacitive mouse surface or a capacitive touch screen, with buttons around it.

**[0018]** Figure 3 shows a 2-D touch surface such as a capacitive mouse surface or a capacitive touch screen, with a guard ring disposed around it to suppress activation of the touch screen area when a finger strays just outside the 2-D mouse or screen area.

**[0019]** Figure 4 is a schematic block diagram of a preferred apparatus of the invention.

**[0020]** Figure 5a is a flow chart showing logical operations carried out in a preferred method of the invention when Key 1 is initially active.

**[0021]** Figure 5b is a flow chart showing logical operations carried out in a preferred method of the invention when Key 1 is initially inactive.

## DETAILED DESCRIPTION

**[0022]** In studying this Detailed Description, the reader may be aided by noting definitions of certain words and phrases used throughout this patent document. Wherever those definitions are provided, those of ordinary skill in the art should understand that in many, if not most instances, such definitions apply to both preceding and following uses of such defined words and phrases. At the outset of this Description, one

may note that the terms "include" and "comprise," as well as derivatives thereof, mean inclusion without limitation; the term "or," is inclusive, meaning and/or. The word 'key' as generally used in this Disclosure and as specifically used in the Claims attached hereto refers to a touchable portion of a mechanical to electrical transducing device that is non-bistable in nature. This term specifically excludes conventional mechanical switches in which two or more electrical conductors are moved into or away from contact with each other to make or break an electrical connection. The terms 'keyboard', 'key pad' and the like all refer to arrays of keys for data input without limitation as to the size or configuration of the array. A 'key' can also be a dimensional sensing surface such as an XY touch screen or a 'trackpad', or a sensing zone not intended for normal human data entry such as an object or body part sensor. 'Touch' can mean either human or mechanical contact or proximity to a key. 'User' can mean either a human or a mechanical object. A 'finger' can be, inter alia, a human finger, a mechanical finger or a stylus.

**[0023]** Capacitive sensors, unlike bistable electromechanical switches which are either open or closed, provide a signal that varies with the degree of touch or extent or coupling between a user's finger and a sensing element of a keyboard. Other non-bistable touch sensors, such as an array of piezoelectric sensors in which the output from a given sensor increases with increasing activation force, share many of the properties of capacitive keys. Thus, much of the subsequent disclosure should be understood as being relevant to non-capacitive keys that also provide an output signal responsive to a degree of coupling between the key and a user's finger, stylus, or other key-activating or pointing implement that is proximate the key.

**[0024]** Turning now to Fig. 1A, one finds an array of 'N' tightly spaced capacitive keys in a key panel 11 which would benefit from the invention. When using such small key panels it is inevitable that a finger will encompass much more than the intended key. A finger touching a principle desired key electrode 1 could easily create a 'fingerprint' outline 3, as shown in dashed lines, where the fingerprint has a centroid location A. This fingerprint also encompasses keys other than the intended key. The amount of intersecting surface area between the dashed line and each key area is a reasonable representation of the amount of signal level change each intersected key will receive due to the touch, although even non-touched keys will also see an increase in signal due to mere finger proximity and to fringe-field effects within the touch panel.

**[0025]** In this case, the desire is to select the one and only one key which is intended by the user while suppressing outputs from adjacent keys intersected by the fingerprint. In this 'non-locking' key suppression invention, if the finger slides to a new key location 4, shown dotted with its centroid at location B, where the movement is shown by the arrow from A to B, this movement will not cause the first key 1 to remain solely active even though it has sufficient signal to still retain its state, i.e., its signal still lies above its threshold level despite being reduced by the movement to a new key. Instead, the invention provides that the newly intended key 2, having a larger signal level due to a higher degree of fingerprint intersection than key 1, becomes the solely active key by switching off the active state of key 1.

**[0026]** Figures 1b and 1c further detail the change in signals on the keys of Fig. 1a by virtue of the relative electrode surface intersections with the fingerprint first at location A (Fig. 1b) and then at location B (Fig 1c). The signal strengths are shown in the bar plots in the lower portions

of the respective figures. It is desired that in order for a key to 'win' the status of user-selected key, its signal change must exceed a threshold value, and its signal has to be the largest. In Fig. 1b, key 1 wins. In Fig. 1c, key 2 wins.

**[0027]** If the key selection method operates solely by picking a maximum signal strength, the keyboard may be subject to an undesirable rapid switching back and forth between two keys having nearly-identical signal strengths (e.g., fingerprint areas). This sort of 'chatter' is preferably prevented by biasing or skewing the key selection method to favor an already selected key. That is, the switchover process is made slightly more difficult than would occur with straight equivalence. This bias may be provided in many ways in subsequent key selection decisions. These ways may be equivalent to adding an incremental value to the signal associated with the selected key; multiplying the signal strength of the selected key by a value greater than one in subsequent selections; subtracting a respective incremental value from the signal strengths associated with each of the non-selected keys; or multiplying the signal strength of each of the non-selected keys by a respective value less than one.

**[0028]** Fig. 2 shows a configuration of a capacitive mouse or capacitive touch screen area 6 with surrounding buttons 7. The principles of operation described in conjunction with Fig. 1a-c apply similarly to Fig. 2, in that the area 6 can be treated as a single key with a single signal strength for purposes of key suppression. Fig. 2 applies when the keys 7 are very close to pointing surface 6 and fingerprints 3 and 4 can overlap both the capacitive screen and one or more capacitive buttons. Moreover, it should be recognized that although the drawing depicts a two-dimensional touch surface, the same considerations apply to a one-

dimensional touch surface of the sort commonly referred to as a slider, scroll-wheel, or the like.

**[0029]** Fig 3. shows a configuration of a capacitive touch input area 6 with a surrounding 'key' 8. The principles of operation described in conjunction with Fig. 1 apply similarly to Fig. 3, in that the area 6 can be treated as a single key with a single signal strength for purposes of key suppression, while the outer 'key' 8 acts to detect errant touch which falls partially on both 6 and 8. The area 6 can comprise any suitable input arrangement such as a capacitive mouse surface, a capacitive touch screen or a keypad comprising discrete keys.

**[0030]** In this example, the guard electrode 8 is not necessarily intended as an actual control key. A finger sliding from 3 to 4 would still potentially leave the active screen 6, but in fact the touch would not be legal since its areal centroid at 'B' lies principally outside the input area. 'Key' 8 detects this out-of-position fingerprint and appropriate logic causes the screen 6 to fall out of detection or to be ignored by further processing. It may be noted that some uses of the guard ring structure do not involve having a finger touching the keypad. For example, one could arrange a guard ring around a capacitive cell phone keypad and use the guard ring output to suppress readings from all the keys in the keypad while the user was talking on the cell phone and holding the keypad of the phone against his or her head.

**[0031]** The guard electrode 'key' 8 in the latter case can also be a discrete solid electrode shape, for example a rectangle, disk, arc, or stripe or other shape, placed in some other location reasonably proximate input area 6. This guard electrode would be activated by placing the product against the user's head or other body part (for



example placing the product in a clothing pocket with the keypad side towards the user's body) in order to suppress further output from the keypad under such adverse conditions. A suitable position for such a 'key' might be near the earpiece of a cell phone, some distance away from the keypad or touchscreen.

**[0032]** The guard electrode 'key' 8 can also be either a ring as shown in Fig. 3, or a discrete solid electrode shape, such as a rectangle, disk, arc, or stripe or other shape, placed in some other location reasonably proximate the input area 6 so as to be activated by a mechanical closure. This could provide a cover which, when closed, would cause the guard key 8 to induce the suppression of input area 6.

**[0033]** In order to make the determination of an out-of-position fingerprint for use with the apparatus shown in Fig. 3, the same sorts of biasing arrangements can be used to prevent chatter as discussed supra. However, relationships described above with respect to Fig. 2 presume the gain of the sensing channels with respect to finger surface area to be comparable, so that equivalent fingerprint surface areas on different keys produce comparable signal changes. This is not always the case in any of the instances described with respect to Figs. 1a-c, 2 or 3. The electrode sizes of different keys may not be equal, and for various reasons (such as stray loading capacitance variations, etc.) the electrical gains among the various keys can differ. In these instances the incremental values added might be negative. Alternatively, signals from competing keys could be scaled into a state of equivalence by using scaling constants that are experimentally determined to accord with a particular configuration. In any event, one can scale and/or offset the signals into equivalence for comparison purposes and thereby create the desired suppression effect without chatter.

**[0034]** Turning now to Fig. 4, one finds a schematic representation of apparatus of the invention 10, comprising an array of N capacitive proximity sensors 12 labeled “Key 1”, . . . , “Key N”. Each of the sensors 12 has an output to a respective counter logic 14 that supplies data to and is controlled by suitable control logic 16. Those skilled in the electronic arts will appreciate that although the counters 14 and control logic 16 are depicted with discrete blocks in the schematic diagram, these features could be provided either by separate physical circuit elements, or could all be provided by a single microcontroller, as depicted by the dashed phantom line 18 in Fig. 4. Moreover, although the array of keys 12 is depicted as being a simple linear array, it will be appreciated by one who reads the complete disclosure contained herein that many other sorts of arrays can be used and will encompass, without being limited to, arrays used as computer keyboards, keypads of the sort commonly used in telephony and automated banking, cash register data input keyboards, etc., as well as various other configurations discussed in conjunction with Fig. 3.

**[0035]** The addition of counters 14, or of the logical function equivalent thereof, when used in the accordance with the teachings of this disclosure, can remove or resolve ambiguities by methods involving comparison of signal strengths from various keys 12. This process involves examining the differences over one or more sequential signal samples.

**[0036]** Turning now to Figs. 5a and 5b, one finds flow charts depicting a preferred method of the invention for operating the apparatus 10 so as to suppress extraneous key signals or to otherwise resolve keying ambiguities. This method may be carried out by a microprocessor 18

operating under control of a program stored in a, preferably, non-volatile memory, or may be carried out by means of discrete circuit elements connected to provide hardwired logic. Although the flowcharts of Figs. 5a and 5b depict operation in terms of a single sensor key 1 (variously labeled “Key 1” or “K1”) with associated signal level S1 and associated Detection Integrator DI 1, it will be understood that this simplification is solely in the interest of clarity of presentation and that an algorithm controlling an actual keyboard could carry out substantially the depicted method for each of the N keys in a parallel fashion.

**[0037]** The depicted method relies on iterated comparisons of sensor outputs, and selects a single sensor output to become active or ‘on’ based on that sensor both having an output in excess of a detection threshold for some selected number of counter cycles (which may be one) and thereafter having the highest output of all the sensors in the array that have also exceeded the detection threshold for the selected number of cycles of the counters. It will be recognized that one could choose to clock all the counters in parallel in order to achieve this, or that one could scan through the counters and operate them one at a time in rapid succession so as to provide the selected number of counter cycles for each sensor within a sufficiently short time period that a user could not perceive a delay in operation of the keyboard.

**[0038]** A signal S1, acquired from sensor key K1 (Step 24), is compared with a selected signal threshold value (Step 26). If S1 is less than the threshold value, the value, DI1, in the DI associated with K1 is decremented by a selected amount (Z) or otherwise reduced (Step 28) if it is greater than zero. If the value S1 is at or above its detection threshold, it is then compared against all other signals S<sub>j</sub> in Step 29. If it has the strongest change in signal due to touch, subject to a possible non-

dithering bias value 'k' if another key is active (Step 30) then counter DI1 can increment (Step 31). If the condition of Step 30 is not met, DI1 is decremented or otherwise reduced (Step 28). Only if the counter DI1 equals terminal count value TC (Step 32) does the key become active or ON in Step 33. When it does so the control logic forces all other active keys to become inactive and resets their respective DI counters. In keyboards comprising a large number of keys, only one of which should be active at a time, this OFF status will, of course, be the predominant result of an analysis of the output of any given key. The action of incrementing or decrementing of counter values as described supra can be numerically reversed to achieve the same effect and should be considered to be logically equivalent to the above explanation.

**[0039]** Note that in Fig. 5a, in order for a key to gain dominance over an already active key, it must exceed the active key's last measured signal level by a small added amount 'k', as shown in Step 30 to prevent selection dithering. Although the value k is depicted as an additive constant, it can also be determined as a percentage of the signal level of the active key, or by any of a number of other methods. The incremental value 'k' can also be zero, i.e., nothing is added or subtracted, although this would tend to make the decision process unstable should there be any small amount of signal noise which would introduce dithering between two competing keys. Finally the key K1 can gain dominance in Step 33 if the TC is reached, and when it does so it forces all other active keys to become inactive and resets their DI counters.

**[0040]** Turning off a key can be forced via a different key winning in its Step 33, as shown in Fig. 5a, or it can be carried out according to the method depicted in Fig. 5b. Whether a key remains on, in the absence of any other keys with larger signals (Fig. 5a), is determined by whether the

key's signal change remains above a hysteresis level. In Step 35, the determination is made if the signal is below the hysteresis point, and if so the DI is reduced in value by some known amount 'Z' (Step 36). If the DI count falls to zero, the key is made inactive (Step 38). On the other hand, if the signal change remains above the threshold level, the DI counter is increased again to its limit TC (step 40). If the signal falls between the threshold and the hysteresis level, the DI counter remains unchanged.

**[0041]** It should be noted that the case where  $TC=1$  also works with the flow of Figures 5a and 5b.

**[0042]** There are, of course, many possible variations and extensions of the procedure sketched out in Fig. 4 and Figs 5a,b. For example, one may consider a rare case in which a user brings his or her finger up to a keyboard so that the point of touch is exactly between two keys. In this case, one could modify the depicted process to either select just one of those keys (e.g., by means of a known pseudo-random number selection algorithm, or by sample sequence order) or by suppressing the output of both keys until the user move his or her finger enough that one of the two keys had a higher output than the other.

**[0043]** Although the present invention has been described with respect to several preferred embodiments, many modifications and alterations can be made without departing from the invention. Accordingly, it is intended that all such modifications and alterations be considered as within the spirit and scope of the invention as defined in the attached claims.

What is claimed is:

1) An apparatus for supplying a unique key output from an operating key board comprising a plurality of keys when a user is proximate two or more keys thereof, the apparatus comprising:

a respective sensor uniquely associated with each of the two or more keys, each of the sensors connected to supply a respective output signal representative of the user's coupling thereto to a controller;

the controller operable to iteratively compare all of the two or more output signals supplied thereto to respective threshold values and to each other, to initially select as the key for supplying the unique key output that one of the two or more keys having a maximum value of all the signal outputs that exceed their respective thresholds, and, on subsequent iterations, to bias the iterated comparison in favor of the previously selected key.

2) The apparatus of Claim 1 wherein each key comprises a respective capacitive proximity sensor.

3) The apparatus of Claim 1 wherein one of the keys of the plurality thereof comprises a guard ring disposed around at least one other of the keys in the plurality thereof.

4) The apparatus of Claim 1 wherein the controller is operable to bias the iterated comparison by increasing respective differences between the value associated with the previously selected key and the respective value associated with each of the other of the two or more keys.

5) The apparatus of Claim 1 wherein each of the sensors has a counter respectively associated therewith and wherein the controller is operable to bias the iterated comparison by changing a value stored in at least one of the counters.

6) The apparatus of Claim 1 wherein the controller comprises a microcontroller operable under control of a stored program.

7) A method of providing a unique output representative of a key uniquely selected by a user from a plurality of keys in which each key is operable to provide a respective detected signal having a respective signal strength responsive to a presence of at least a portion of the user, the method comprising the sequentially executed steps of:

(a) measuring the respective detected signal strength associated with each key in the plurality thereof;

(b) comparing each of the measured signal strengths with a respective selected threshold value to form a subset of keys having associated signals greater than the respective threshold values;

(c) determining that no key has been selected if the subset is empty, and otherwise determining that the key that is in the subset and that is associated with a maximum signal strength is the current uniquely selected key;

(d) subsequent to determining a uniquely selected key, modifying step (c) to bias subsequent determinations in favor of the uniquely selected key and then repeating steps (a), (b) and the modified step (c).

8) The method of Claim 7 wherein the step of measuring the respective detected signal strength associated with each key comprises measuring a respective signal representative of a respective capacitive coupling of the user to the respective key.

9) The method of Claim 7 wherein the plurality of keys comprises a keyboard array and the portion of the user comprises a finger.

10) The method of Claim 7 wherein one of the keys in the plurality thereof is operable as a two dimensional touch surface.

11) The method of Claim 7 wherein one of the keys in the plurality thereof is a guard ring disposed about at least one other of the keys.

12) The method of Claim 7 wherein step d) comprises increasing the signal strength associated with the uniquely selected key.

13) The method of Claim 7 wherein step d) comprises decreasing the signal strength associated with each of the keys other than the uniquely selected key.

14) The method of Claim 7 wherein each of the keys has associated therewith a respective counter containing a value that is altered if the respective measured signal value exceeds the respective threshold, wherein the step of determining a maximum signal strength comprises comparing respective values stored in respective counters and wherein the modification to the determining step (c) comprises changing a value stored in at least one of the counters.

15) The method of Claim 7 wherein steps (b), (c), and (d) are carried out by a microcontroller.

16) A method of providing a unique output representative of a key selected by a user from a plurality of keys operable to provide respective detected signals having respective signal strengths responsive to a presence of at least a portion of the user, the method comprising the steps of:



(a) measuring, at a first instant, the respective detected signal strength associated with each key in the plurality thereof, and retaining for further consideration at the first instant respective retained values representative of only those signal strengths exceeding respective threshold values;

(b) selecting, as the initial user-selected key, that key having the maximum of all the values retained at the first instant;

(c) measuring, at a second instant, later than the first instant, the respective detected signal strength associated with each key in the plurality thereof, and retaining for further consideration at the second instant respective retained values representative only of those signal strengths exceeding respective threshold values;

(d) comparing, in a fashion biased in favor of the initial user-selected key, the values retained for further consideration at the second instant to select the user-selected key at the second instant.

17) The method of Claim 16 wherein the step of measuring the respective detected signal strength associated with each key comprises measuring a respective signal representative of a respective capacitive coupling of the user to the respective key.

18) The method of Claim 16 wherein the plurality of keys comprises a keyboard array and the portion of the user comprises a finger.

19) The method of Claim 16 wherein one of the keys in the plurality thereof is operable as a two dimensional touch surface.

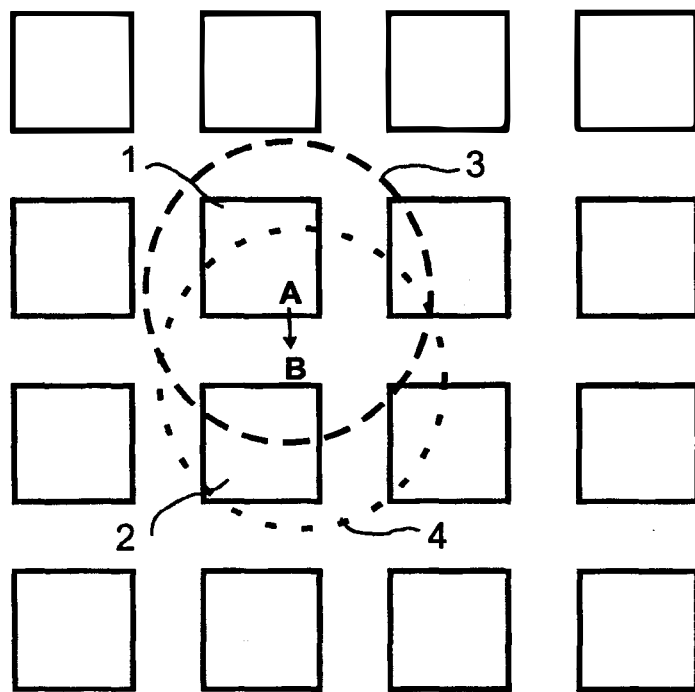
20) The method of Claim 16 wherein one of the keys in the plurality thereof is a guard ring disposed about at least one other of the keys.

21) The method of Claim 16 wherein the comparison in step (d) is biased in favor of the initially selected key by increasing the signal strength value associated with the initially user-selected key.

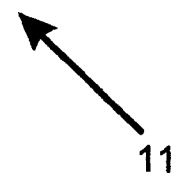
22) The method of Claim 16 wherein the comparison in step (d) is biased in favor of the initially selected key by decreasing respective signal strength values associated with all keys other than the initially user-selected key.

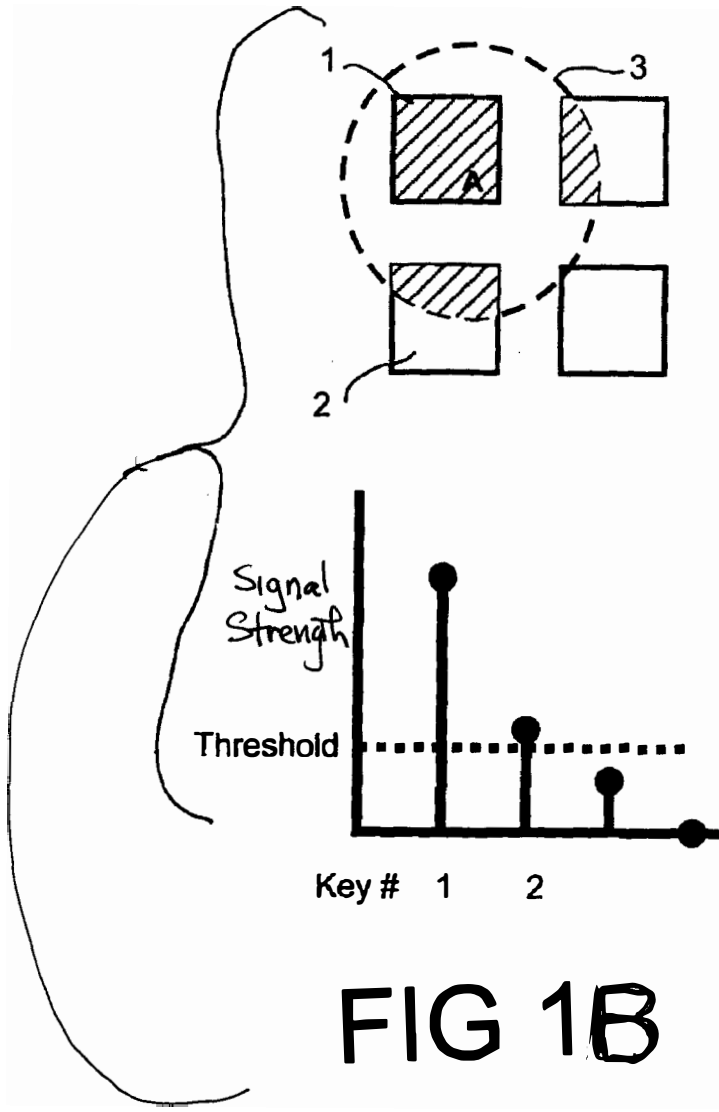
23) The method of Claim 16 wherein each key has a counter respectively associated therewith, and wherein the steps of retaining, comparing, and altering are carried out by means of logical and arithmetic operations conducted on the respective counters.

24) The method of Claim 16, wherein the selecting, comparing and retaining steps are carried out by a microcontroller.

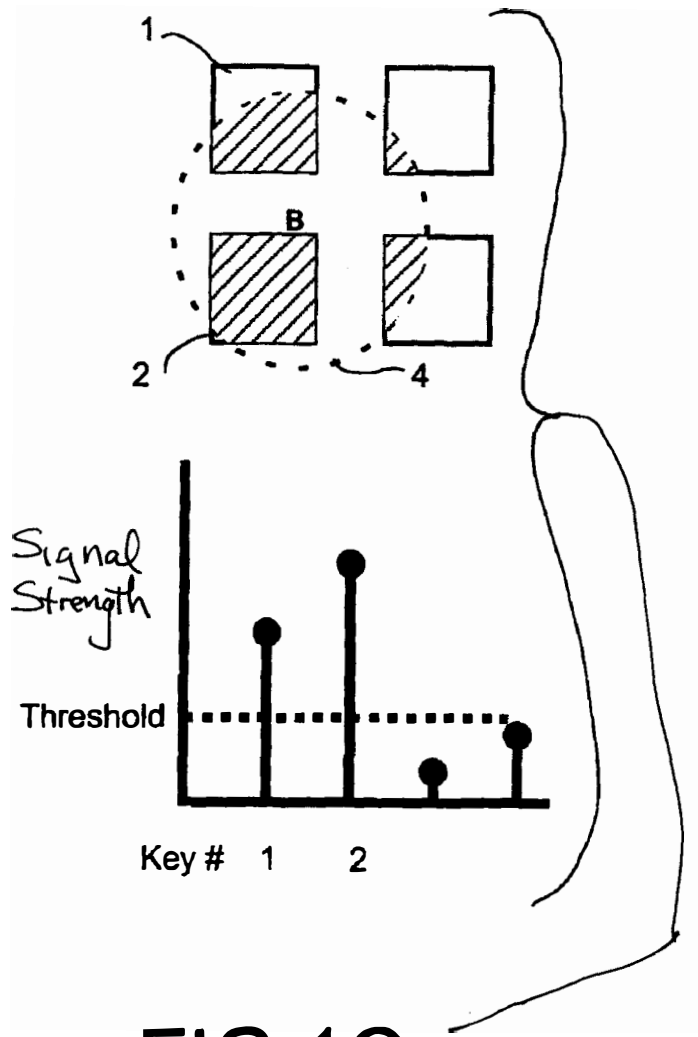


**FIG 1A**





**FIG 1B**



**FIG 1C**

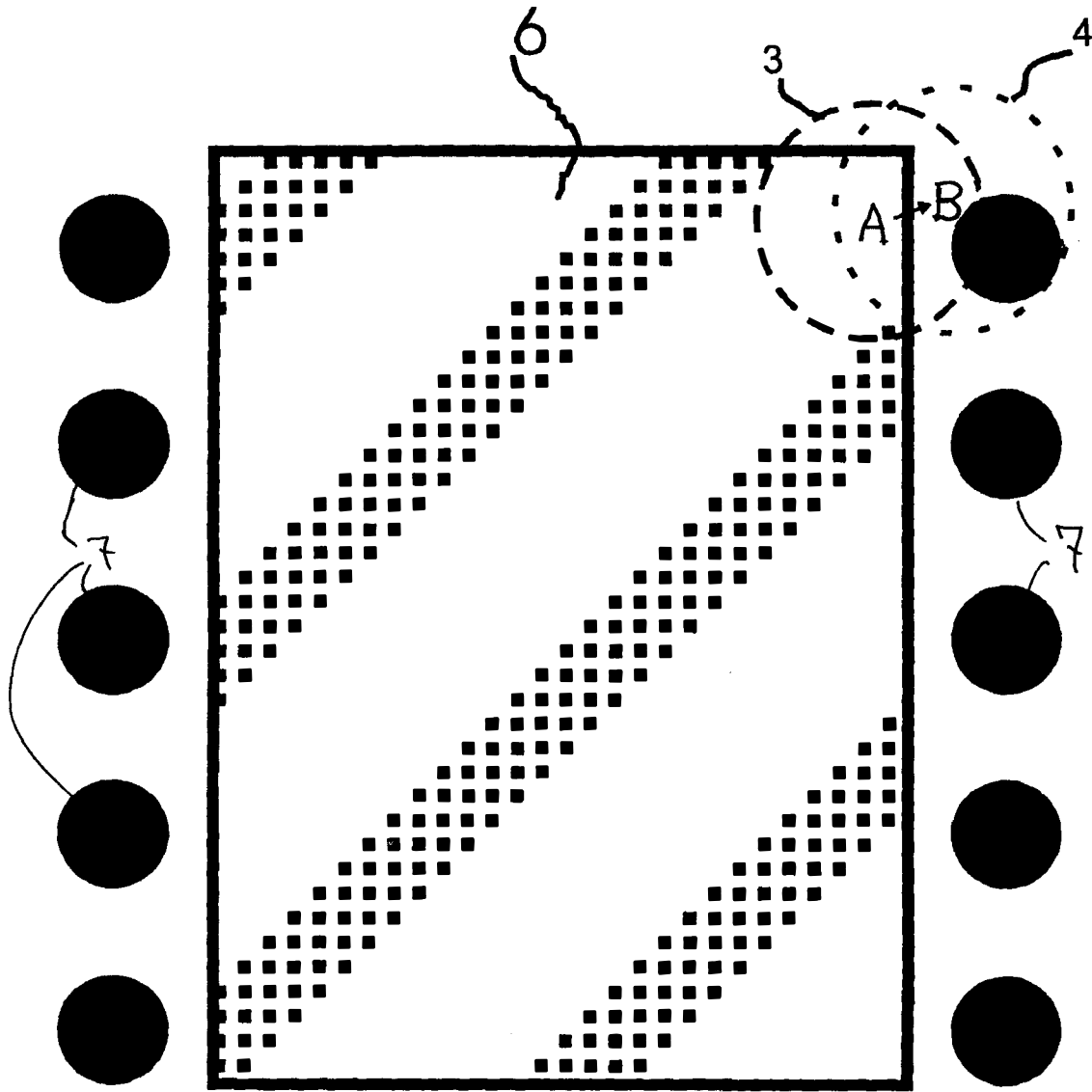


FIG 2

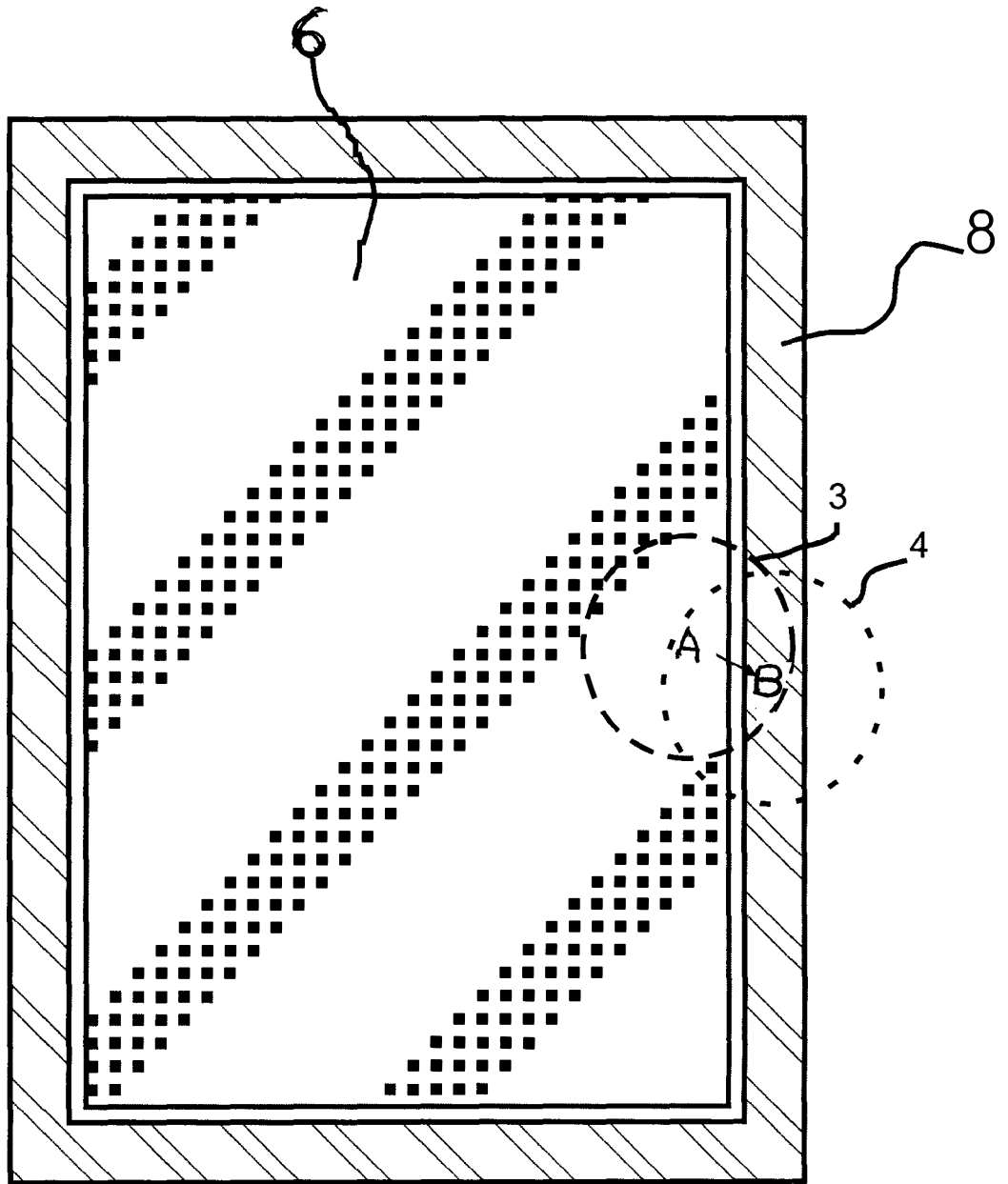


FIG 3

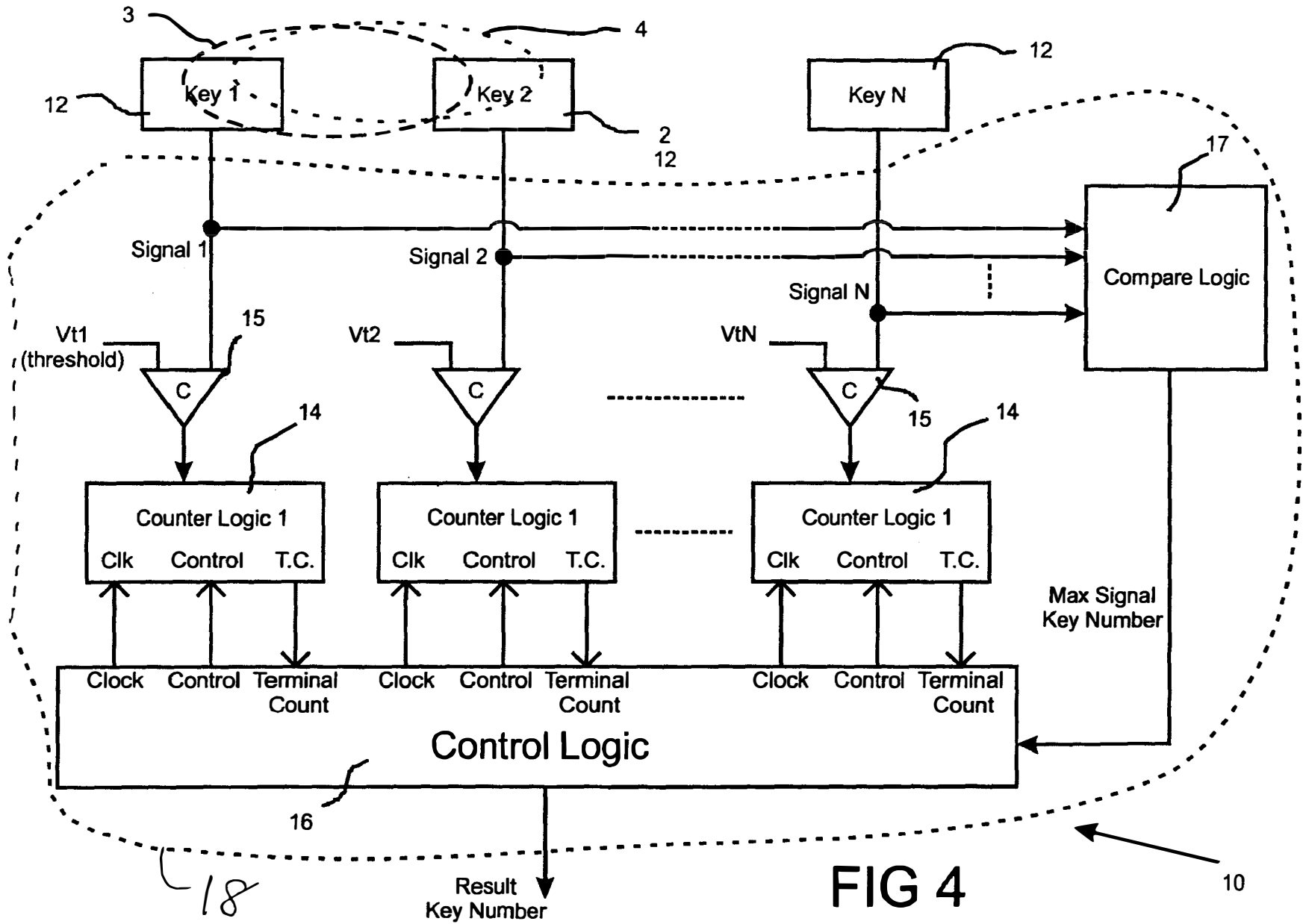


FIG 4

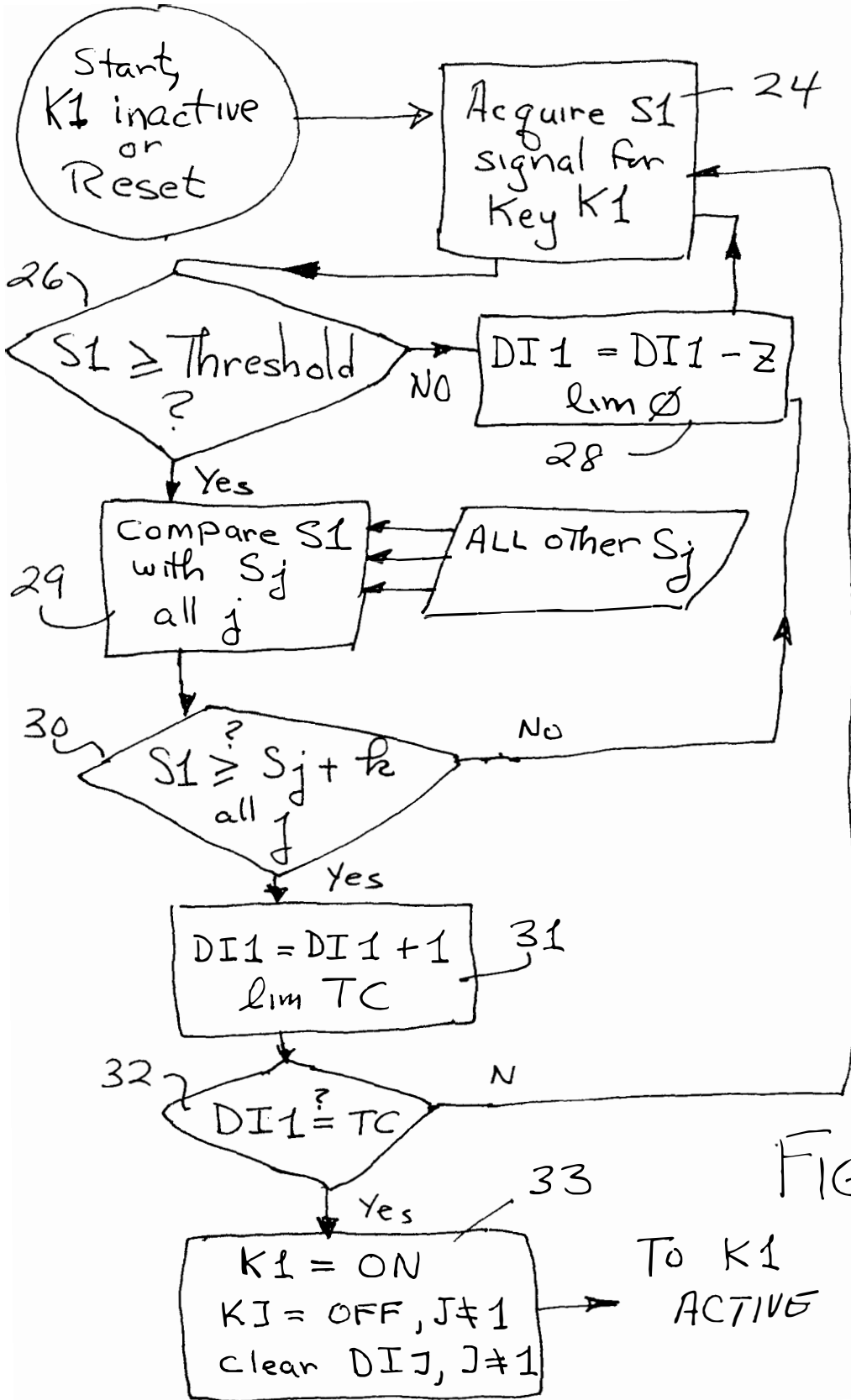


FIG. 5A



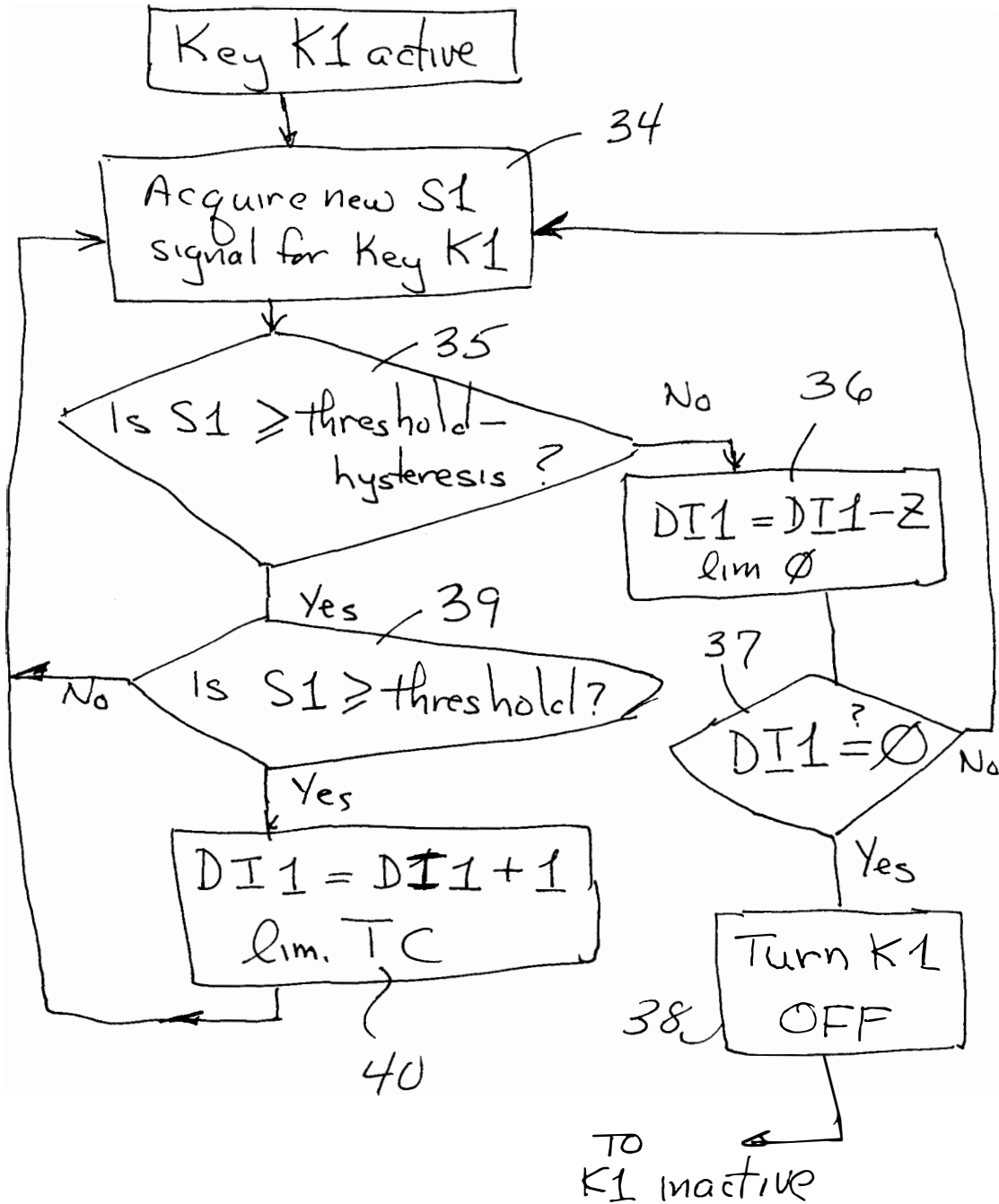


FIG. 5B

Under the Paperwork Reduction Act of 1995, no persons are required to respond to a collection of information unless it contains a valid OMB control number.

<b>Application Data Sheet 37 CFR 1.76</b>		Attorney Docket Number	PKX
		Application Number	
Title of Invention	Capacitive Keyboard with Non-Locking Reduced Keying Ambiguity		
The application data sheet is part of the provisional or nonprovisional application for which it is being submitted. The following form contains the bibliographic data arranged in a format specified by the United States Patent and Trademark Office as outlined in 37 CFR 1.76. This document may be completed electronically and submitted to the Office in electronic format using the Electronic Filing System (EFS) or the document may be printed and included in a paper filed application.			

**Secrecy Order 37 CFR 5.2**

- Portions or all of the application associated with this Application Data Sheet may fall under a Secrecy Order pursuant to 37 CFR 5.2 (Paper filers only. Applications that fall under Secrecy Order may not be filed electronically.)

**Applicant Information:**

<b>Applicant 1</b>					<b>Remove</b>
<b>Applicant Authority</b>		<input checked="" type="radio"/> Inventor		<input type="radio"/> Legal Representative under 35 U.S.C. 117	<input type="radio"/> Party of Interest under 35 U.S.C. 118
<b>Prefix</b>	<b>Given Name</b>	<b>Middle Name</b>	<b>Family Name</b>		<b>Suffix</b>
	Harald		Philipp		
<b>Residence Information (Select One)</b> <input type="radio"/> US Residency <input checked="" type="radio"/> Non US Residency <input type="radio"/> Active US Military Service					
<b>City</b>	Hamble	<b>Country Of Residence<sup>i</sup></b>	GB		
<b>Citizenship under 37 CFR 1.41(b)<sup>i</sup></b>		US			
<b>Mailing Address of Applicant:</b>					
<b>Address 1</b>	7 Cirrus Gardens				
<b>Address 2</b>					
<b>City</b>	Hamble, Hampshire		<b>State/Province</b>		
<b>Postal Code</b>	SO31 4RH	<b>Country<sup>i</sup></b>	GB		
All Inventors Must Be Listed - Additional Inventor Information blocks may be generated within this form by selecting the <b>Add</b> button.					<b>Add</b>

**Correspondence Information:**

Enter either Customer Number or complete the Correspondence Information section below. For further information see 37 CFR 1.33(a).			
<input type="checkbox"/> An Address is being provided for the correspondence information of this application.			
<b>Customer Number</b>	20191		
<b>Email Address</b>	dak@patent-faq.com	<b>Add Email</b>	<b>Remove Email</b>

**Application Information:**

<b>Title of the Invention</b>	Capacitive Keyboard with Non-Locking Reduced Keying Ambiguity		
<b>Attorney Docket Number</b>	PKX	<b>Small Entity Status Claimed</b>	<input checked="" type="checkbox"/>
<b>Application Type</b>	Nonprovisional		
<b>Subject Matter</b>	Utility		
<b>Suggested Class (if any)</b>	345	<b>Sub Class (if any)</b>	168
<b>Suggested Technology Center (if any)</b>			
<b>Total Number of Drawing Sheets (if any)</b>	7	<b>Suggested Figure for Publication (if any)</b>	5A

Samsung EX1002 Page 30

<b>Application Data Sheet 37 CFR 1.76</b>	Attorney Docket Number	PKX
	Application Number	
Title of Invention	Capacitive Keyboard with Non-Locking Reduced Keying Ambiguity	

<b>Publication Information:</b>	
<input type="checkbox"/>	Request Early Publication (Fee required at time of Request 37 CFR 1.219)
<input type="checkbox"/>	Request Not to Publish. I hereby request that the attached application not be published under 35 U.S.C. 122(b) and certify that the invention disclosed in the attached application has not been and will not be the subject of an application filed in another country, or under a multilateral agreement, that requires publication at eighteen months after filing.

### Representative Information:

Representative information should be provided for all practitioners having a power of attorney in the application. Providing this information in the Application Data Sheet does not constitute a power of attorney in the application (see 37 CFR 1.32). Enter either Customer Number or complete the Representative Name section below. If both sections are completed the Customer Number will be used for the Representative Information during processing.			
Please Select One:	<input checked="" type="radio"/> Customer Number	<input type="radio"/> US Patent Practitioner	<input type="radio"/> US Representative (37 CFR 11.9)
Customer Number	20191		

### Domestic Priority Information:

This section allows for the applicant to claim benefit under 35 U.S.C. 119(e), 120, 121, or 365(c). Providing this information in the application data sheet constitutes the specific reference required by 35 U.S.C. 119(e) or 120, and 37 CFR 1.78(a)(2) or CFR 1.78(a)(4), and need not otherwise be made part of the specification.					
Prior Application Status	Pending		<input type="button" value="Remove"/>		
Application Number	Continuity Type	Prior Application Number	Filing Date (YYYY-MM-DD)		
	non provisional of	60/597851	2005-12-21		
Prior Application Status	Pending		<input type="button" value="Remove"/>		
Application Number	Continuity Type	Prior Application Number	Filing Date (YYYY-MM-DD)		
	Continuation in part of	11/160885	2005-07-14		
Prior Application Status	Patented		<input type="button" value="Remove"/>		
Application Number	Continuity Type	Prior Application Number	Filing Date (YYYY-MM-DD)	Patent Number	Issue Date (YYYY-MM-DD)
11/160885	Continuation of	10/617602	2003-07-11	6993607	2006-01-31
Prior Application Status	Expired		<input type="button" value="Remove"/>		
Application Number	Continuity Type	Prior Application Number	Filing Date (YYYY-MM-DD)		
10/617602	non provisional of	60/395368	2002-07-12		
Additional Domestic Priority Data may be generated within this form by selecting the <b>Add</b> button.					<input type="button" value="Add"/>

### Foreign Priority Information:

This section allows for the applicant to claim benefit of foreign priority and to identify any prior foreign application for which priority is not claimed. Providing this information in the application data sheet constitutes the claim for priority as required by 35 U.S.C. 119(b) and 37 CFR 1.55(a).
---

Under the Paperwork Reduction Act of 1995, no persons are required to respond to a collection of information unless it contains a valid OMB control number.

<b>Application Data Sheet 37 CFR 1.76</b>	Attorney Docket Number	PKX
	Application Number	
Title of Invention	Capacitive Keyboard with Non-Locking Reduced Keying Ambiguity	

			<input type="button" value="Remove"/>
Application Number	Country <sup>i</sup>	Parent Filing Date (YYYY-MM-DD)	Priority Claimed
			<input checked="" type="radio"/> Yes <input type="radio"/> No
Additional Foreign Priority Data may be generated within this form by selecting the Add button.			<input type="button" value="Add"/>

**Assignee Information:**

Providing this information in the application data sheet does not substitute for compliance with any requirement of part 3 of Title 37 of the CFR to have an assignment recorded in the Office.				
<b>Assignee 1</b>				<input type="button" value="Remove"/>
If the Assignee is an Organization check here. <input type="checkbox"/>				
Prefix	Given Name	Middle Name	Family Name	Suffix
<b>Mailing Address Information:</b>				
Address 1				
Address 2				
City		State/Province		
Country <sup>i</sup>	Postal Code			
Phone Number		Fax Number		
Email Address				
Additional Assignee Data may be generated within this form by selecting the Add button.				<input type="button" value="Add"/>

**Signature:**

A signature of the applicant or representative is required in accordance with 37 CFR 1.33 and 10.18. Please see 37 CFR 1.4(d) for the form of the signature.				
<b>Signature</b>	/David A Kiewit/		Date (YYYY-MM-DD)	2006-04-12
First Name	David	Last Name	Kiewit	Registration Number
				34640

This collection of information is required by 37 CFR 1.76. The information is required to obtain or retain a benefit by the public which is to file (and by the USPTO to process) an application. Confidentiality is governed by 35 U.S.C. 122 and 37 CFR 1.14. This collection is estimated to take 23 minutes to complete, including gathering, preparing, and submitting the completed application data sheet form to the USPTO. Time will vary depending upon the individual case. Any comments on the amount of time you require to complete this form and/or suggestions for reducing this burden, should be sent to the Chief Information Officer, U.S. Patent and Trademark Office, U.S. Department of Commerce, P.O. Box 1450, Alexandria, VA 22313-1450. DO NOT SEND FEES OR COMPLETED FORMS TO THIS ADDRESS. **SEND TO: Commissioner for Patents, P.O. Box 1450, Alexandria, VA 22313-1450.**

# Privacy Act Statement

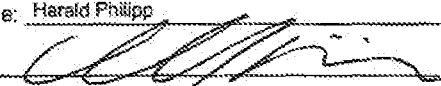
The Privacy Act of 1974 (P.L. 93-579) requires that you be given certain information in connection with your submission of the attached form related to a patent application or patent. Accordingly, pursuant to the requirements of the Act, please be advised that: (1) the general authority for the collection of this information is 35 U.S.C. 2(b)(2); (2) furnishing of the information solicited is voluntary; and (3) the principal purpose for which the information is used by the U.S. Patent and Trademark Office is to process and/or examine your submission related to a patent application or patent. If you do not furnish the requested information, the U.S. Patent and Trademark Office may not be able to process and/or examine your submission, which may result in termination of proceedings or abandonment of the application or expiration of the patent.

The information provided by you in this form will be subject to the following routine uses:

1. The information on this form will be treated confidentially to the extent allowed under the Freedom of Information Act (5 U.S.C. 552) and the Privacy Act (5 U.S.C. 552a). Records from this system of records may be disclosed to the Department of Justice to determine whether the Freedom of Information Act requires disclosure of these records.
2. A record from this system of records may be disclosed, as a routine use, in the course of presenting evidence to a court, magistrate, or administrative tribunal, including disclosures to opposing counsel in the course of settlement negotiations.
3. A record in this system of records may be disclosed, as a routine use, to a Member of Congress submitting a request involving an individual, to whom the record pertains, when the individual has requested assistance from the Member with respect to the subject matter of the record.
4. A record in this system of records may be disclosed, as a routine use, to a contractor of the Agency having need for the information in order to perform a contract. Recipients of information shall be required to comply with the requirements of the Privacy Act of 1974, as amended, pursuant to 5 U.S.C. 552a(m).
5. A record related to an International Application filed under the Patent Cooperation Treaty in this system of records may be disclosed, as a routine use, to the International Bureau of the World Intellectual Property Organization, pursuant to the Patent Cooperation Treaty.
6. A record in this system of records may be disclosed, as a routine use, to another federal agency for purposes of National Security review (35 U.S.C. 181) and for review pursuant to the Atomic Energy Act (42 U.S.C. 218(c)).
7. A record from this system of records may be disclosed, as a routine use, to the Administrator, General Services, or his/her designee, during an inspection of records conducted by GSA as part of that agency's responsibility to recommend improvements in records management practices and programs, under authority of 44 U.S.C. 2904 and 2906. Such disclosure shall be made in accordance with the GSA regulations governing inspection of records for this purpose, and any other relevant (i.e., GSA or Commerce) directive. Such disclosure shall not be used to make determinations about individuals.
8. A record from this system of records may be disclosed, as a routine use, to the public after either publication of the application pursuant to 35 U.S.C. 122(b) or issuance of a patent pursuant to 35 U.S.C. 151. Further, a record may be disclosed, subject to the limitations of 37 CFR 1.14, as a routine use, to the public if the record was filed in an application which became abandoned or in which the proceedings were terminated and which application is referenced by either a published application, an application open to public inspections or an issued patent.
9. A record from this system of records may be disclosed, as a routine use, to a Federal, State, or local law enforcement agency, if the USPTO becomes aware of a violation or potential violation of law or regulation.

Under the Paperwork Reduction Act of 1995, no persons are required to respond to a collection of information unless it displays a valid OMB control number.

**DECLARATION (37 CFR 1.63) FOR UTILITY OR DESIGN APPLICATION USING AN  
APPLICATION DATA SHEET (37 CFR 1.76)**

Title of Invention	Capacitive Keyboard with Non-Locking Reduced Keying Ambiguity
As the below named inventor(s), I/we declare that:	
This declaration is directed to:	
<input checked="" type="checkbox"/> The attached application, or <input type="checkbox"/> Application No. _____ filed on _____ <input type="checkbox"/> As amended on _____ (if applicable);	
I/we believe that I/we am/are the original and first inventor(s) of the subject matter which is claimed and for which a patent is sought;	
I/we have reviewed and understand the contents of the above-identified application, including the claims, as amended by any amendment specifically referred to above;	
I/we acknowledge the duty to disclose to the United States Patent and Trademark Office all information known to me/us to be material to patentability as defined in 37 CFR 1.56, including for continuation-in-part applications, material information which became available between the filing date of the prior application and the national or PCT International filing date of the continuation-in-part application.	
<b>WARNING:</b>	
Petitioner/applicant is cautioned to avoid submitting personal information in documents filed in a patent application that may contribute to identity theft. Personal information such as social security numbers, bank account numbers, or credit card numbers (other than a check or credit card authorization form PTO-2038 submitted for payment purposes) is never required by the USPTO to support a petition or an application. If this type of personal information is included in documents submitted to the USPTO, petitioners/applicants should consider redacting such personal information from the documents before submitting them to the USPTO. Petitioner/applicant is advised that the record of a patent application is available to the public after publication of the application (unless a non-publication request in compliance with 37 CFR 1.213(a) is made in the application) or issuance of a patent. Furthermore, the record from an abandoned application may also be available to the public if the application is referenced in a published application or an issued patent (see 37 CFR 1.14). Checks and credit card authorization forms PTO-2038 submitted for payment purposes are not retained in the application file and therefore are not publicly available.	
All statements made herein of my/own knowledge are true, all statements made herein on information and belief are believed to be true, and further that these statements were made with the knowledge that willful false statements and the like are punishable by fine or imprisonment, or both, under 18 U.S.C. 1001, and may jeopardize the validity of the application or any patent issuing thereon.	
FULL NAME OF INVENTOR(S)	
Inventor one: Harald Philipp	
Signature: 	Citizen of: US
Inventor two: _____	
Signature: _____	Citizen of: _____
<input type="checkbox"/> Additional inventors or a legal representative are being named on _____ additional form(s) attached hereto.	

This collection of information is required by 35 U.S.C. 115 and 37 CFR 1.63. The information is required to obtain or retain a benefit by the public which is to file (and by the USPTO to process) an application. Confidentiality is governed by 35 U.S.C. 122 and 37 CFR 1.11 and 1.14. This collection is estimated to take 1 minute to complete, including gathering, preparing, and submitting the completed application form to the USPTO. Time will vary depending upon the individual case. Any comments on the amount of time you require to complete this form and/or suggestions for reducing this burden, should be sent to the Chief Information Officer, U.S. Patent and Trademark Office, U.S. Department of Commerce, P.O. Box 1450, Alexandria, VA 22313-1450. DO NOT SEND FEES OR COMPLETED FORMS TO THIS ADDRESS. SEND TO: Commissioner for Patents, P.O. Box 1450, Alexandria, VA 22313-1450.

If you need assistance in completing the form, call 1-800-PTO-9199 and select option 2.

Under the Paperwork Reduction Act of 1995, no persons are required to respond to a collection of information unless it displays a valid OMB control number.

**POWER OF ATTORNEY  
and  
CORRESPONDENCE ADDRESS  
INDICATION FORM**

Application Number	
Filing Date	
First Named Inventor	Philipp
Title	Capacitive Keyboard with Non-Lockin
Art Unit	
Examiner Name	
Attorney Docket Number	PKX

I hereby revoke all previous powers of attorney given in the above-identified application.

I hereby appoint:

 Practitioners associated with the Customer Number:

20191

OR

 Practitioner(s) named below:

Name	Registration Number

as my/our attorney(s) or agent(s) to prosecute the application identified above, and to transact all business in the United States Patent and Trademark Offices connected therewith.

Please recognize or change the correspondence address for the above-identified application to:

 The address associated with the above-mentioned Customer Number:

OR

 The address associated with Customer Number: Firm or Individual Name

Address

City

State

Zip

Country


Telephone

Email

I am the:

 Applicant/Inventor. Assignee of record of the entire interest. See 37 CFR 3.71.  
Statement under 37 CFR 3.73(b) is enclosed. (Form PTO/SB/95)

SIGNATURE of Applicant or Assignee of Record

Signature		Date	
Name	Harald Philipp	Telephone	412-391-7367
Title and Company			

NOTE: Signatures of all the inventors or assignees of record of the entire interest or their representative(s) are required. Submit multiple forms if more than one signature is required, see below.

 Total of \_\_\_\_\_ forms are submitted.

This collection of information is required by 37 CFR 1.31, 1.32 and 1.33. The information is required to obtain or retain a benefit by the public which is to file (and by the USPTO to process) an application. Confidentiality is governed by 35 U.S.C. 122 and 37 CFR 1.11 and 1.14. This collection is estimated to take 3 minutes to complete, including gathering, preparing, and submitting the completed application form to the USPTO. Time will vary depending upon the individual case. Any comments on the amount of time you require to complete this form and/or suggestions for reducing this burden, should be sent to the Chief Information Officer, U.S. Patent and Trademark Office, U.S. Department of Commerce, P.O. Box 1450, Alexandria, VA 22313-1450. DO NOT SEND FEES OR COMPLETED FORMS TO THIS ADDRESS. SEND TO: Commissioner for Patents, P.O. Box 1450, Alexandria, VA 22313-1450.

If you need assistance in completing the form, call 1-800-PTO-9199 and select option 2.

<b>INFORMATION DISCLOSURE STATEMENT BY APPLICANT</b> ( Not for submission under 37 CFR 1.99)	Application Number		
	Filing Date		2006-04-12
	First Named Inventor	Philipp	
	Art Unit		
	Examiner Name		
	Attorney Docket Number		PKX

U.S.PATENTS							Remove	
Examiner Initial*	Cite No	Patent Number	Kind Code <sup>1</sup>	Issue Date	Name of Patentee or Applicant of cited Document	Pages,Columns,Lines where Relevant Passages or Relevant Figures Appear		
	1	4145748		1979-03-20	Eichelberger et al.			
	2	4954823		1990-09-04	Binstead			
If you wish to add additional U.S. Patent citation information please click the Add button.							Add	
U.S.PATENT APPLICATION PUBLICATIONS							Remove	
Examiner Initial*	Cite No	Publication Number	Kind Code <sup>1</sup>	Publication Date	Name of Patentee or Applicant of cited Document	Pages,Columns,Lines where Relevant Passages or Relevant Figures Appear		
	1							
If you wish to add additional U.S. Published Application citation information please click the Add button.							Add	
FOREIGN PATENT DOCUMENTS							Remove	
Examiner Initial*	Cite No	Foreign Document Number <sup>3</sup>	Country Code <sup>2</sup> i	Kind Code <sup>4</sup>	Publication Date	Name of Patentee or Applicant of cited Document	Pages,Columns,Lines where Relevant Passages or Relevant Figures Appear	T <sup>5</sup>
	1							<input type="checkbox"/>
If you wish to add additional Foreign Patent Document citation information please click the Add button							Add	
NON-PATENT LITERATURE DOCUMENTS							Remove	



**INFORMATION DISCLOSURE  
STATEMENT BY APPLICANT**  
( Not for submission under 37 CFR 1.99)

Application Number		
Filing Date		2006-04-12
First Named Inventor	Philipp	
Art Unit		
Examiner Name		
Attorney Docket Number	PKX	

Examiner Initials*	Cite No	Include name of the author (in CAPITAL LETTERS), title of the article (when appropriate), title of the item (book, magazine, journal, serial, symposium, catalog, etc), date, pages(s), volume-issue number(s), publisher, city and/or country where published.	T <sup>5</sup>
	1		<input type="checkbox"/>

If you wish to add additional non-patent literature document citation information please click the Add button

**EXAMINER SIGNATURE**

Examiner Signature		Date Considered	
--------------------	--	-----------------	--

\*EXAMINER: Initial if reference considered, whether or not citation is in conformance with MPEP 609. Draw line through a citation if not in conformance and not considered. Include copy of this form with next communication to applicant.

<sup>1</sup> See Kind Codes of USPTO Patent Documents at [www.USPTO.GOV](http://www.USPTO.GOV) or MPEP 901.04. <sup>2</sup> Enter office that issued the document, by the two-letter code (WIPO Standard ST.3). <sup>3</sup> For Japanese patent documents, the indication of the year of the reign of the Emperor must precede the serial number of the patent document. <sup>4</sup> Kind of document by the appropriate symbols as indicated on the document under WIPO Standard ST.16 if possible. <sup>5</sup> Applicant is to place a check mark here if English language translation is attached.

**INFORMATION DISCLOSURE  
STATEMENT BY APPLICANT**  
( Not for submission under 37 CFR 1.99)

Application Number		
Filing Date		2006-04-12
First Named Inventor	Philipp	
Art Unit		
Examiner Name		
Attorney Docket Number	PKX	

**CERTIFICATION STATEMENT**

Please see 37 CFR 1.97 and 1.98 to make the appropriate selection(s):

That each item of information contained in the information disclosure statement was first cited in any communication from a foreign patent office in a counterpart foreign application not more than three months prior to the filing of the information disclosure statement. See 37 CFR 1.97(e)(1).

**OR**

That no item of information contained in the information disclosure statement was cited in a communication from a foreign patent office in a counterpart foreign application, and, to the knowledge of the person signing the certification after making reasonable inquiry, no item of information contained in the information disclosure statement was known to any individual designated in 37 CFR 1.56(c) more than three months prior to the filing of the information disclosure statement. See 37 CFR 1.97(e)(2).

- See attached certification statement.
- Fee set forth in 37 CFR 1.17 (p) has been submitted herewith.
- None

**SIGNATURE**

A signature of the applicant or representative is required in accordance with CFR 1.33, 10.18. Please see CFR 1.4(d) for the form of the signature.

Signature	/David A Kiewit/	Date (YYYY-MM-DD)	2006-04-12
Name/Print	David Kiewit	Registration Number	34640

This collection of information is required by 37 CFR 1.97 and 1.98. The information is required to obtain or retain a benefit by the public which is to file (and by the USPTO to process) an application. Confidentiality is governed by 35 U.S.C. 122 and 37 CFR 1.14. This collection is estimated to take 1 hour to complete, including gathering, preparing and submitting the completed application form to the USPTO. Time will vary depending upon the individual case. Any comments on the amount of time you require to complete this form and/or suggestions for reducing this burden, should be sent to the Chief Information Officer, U.S. Patent and Trademark Office, U.S. Department of Commerce, P.O. Box 1450, Alexandria, VA 22313-1450. **DO NOT SEND FEES OR COMPLETED FORMS TO THIS ADDRESS. SEND TO: Commissioner for Patents, P.O. Box 1450, Alexandria, VA 22313-1450.**

## Privacy Act Statement

The Privacy Act of 1974 (P.L. 93-579) requires that you be given certain information in connection with your submission of the attached form related to a patent application or patent. Accordingly, pursuant to the requirements of the Act, please be advised that: (1) the general authority for the collection of this information is 35 U.S.C. 2(b)(2); (2) furnishing of the information solicited is voluntary; and (3) the principal purpose for which the information is used by the U.S. Patent and Trademark Office is to process and/or examine your submission related to a patent application or patent. If you do not furnish the requested information, the U.S. Patent and Trademark Office may not be able to process and/or examine your submission, which may result in termination of proceedings or abandonment of the application or expiration of the patent.

The information provided by you in this form will be subject to the following routine uses:

1. The information on this form will be treated confidentially to the extent allowed under the Freedom of Information Act (5 U.S.C. 552) and the Privacy Act (5 U.S.C. 552a). Records from this system of records may be disclosed to the Department of Justice to determine whether the Freedom of Information Act requires disclosure of these records.
2. A record from this system of records may be disclosed, as a routine use, in the course of presenting evidence to a court, magistrate, or administrative tribunal, including disclosures to opposing counsel in the course of settlement negotiations.
3. A record in this system of records may be disclosed, as a routine use, to a Member of Congress submitting a request involving an individual, to whom the record pertains, when the individual has requested assistance from the Member with respect to the subject matter of the record.
4. A record in this system of records may be disclosed, as a routine use, to a contractor of the Agency having need for the information in order to perform a contract. Recipients of information shall be required to comply with the requirements of the Privacy Act of 1974, as amended, pursuant to 5 U.S.C. 552a(m).
5. A record related to an International Application filed under the Patent Cooperation Treaty in this system of records may be disclosed, as a routine use, to the International Bureau of the World Intellectual Property Organization, pursuant to the Patent Cooperation Treaty.
6. A record in this system of records may be disclosed, as a routine use, to another federal agency for purposes of National Security review (35 U.S.C. 181) and for review pursuant to the Atomic Energy Act (42 U.S.C. 218(c)).
7. A record from this system of records may be disclosed, as a routine use, to the Administrator, General Services, or his/her designee, during an inspection of records conducted by GSA as part of that agency's responsibility to recommend improvements in records management practices and programs, under authority of 44 U.S.C. 2904 and 2906. Such disclosure shall be made in accordance with the GSA regulations governing inspection of records for this purpose, and any other relevant (i.e., GSA or Commerce) directive. Such disclosure shall not be used to make determinations about individuals.
8. A record from this system of records may be disclosed, as a routine use, to the public after either publication of the application pursuant to 35 U.S.C. 122(b) or issuance of a patent pursuant to 35 U.S.C. 151. Further, a record may be disclosed, subject to the limitations of 37 CFR 1.14, as a routine use, to the public if the record was filed in an application which became abandoned or in which the proceedings were terminated and which application is referenced by either a published application, an application open to public inspections or an issued patent.
9. A record from this system of records may be disclosed, as a routine use, to a Federal, State, or local law enforcement agency, if the USPTO becomes aware of a violation or potential violation of law or regulation.

## Electronic Patent Application Fee Transmittal

<b>Application Number:</b>				
<b>Filing Date:</b>				
<b>Title of Invention:</b>	Capacitive Keyboard with Non-Locking Reduced Keying Ambiguity			
<b>First Named Inventor:</b>	Harald Philipp			
<b>Filer:</b>	David A. Kiewit			
<b>Attorney Docket Number:</b>	PKX			
Filed as Small Entity				
<b>Utility Filing Fees</b>				
<b>Description</b>	<b>Fee Code</b>	<b>Quantity</b>	<b>Amount</b>	<b>Sub-Total in USD(\$)</b>
<b>Basic Filing:</b>				
Utility filing Fee (Electronic filing)	4011	1	75	75
Utility Search Fee	2111	1	250	250
Utility Examination Fee	2311	1	100	100
<b>Pages:</b>				
<b>Claims:</b>				
Claims in excess of 20	2202	4	25	100
<b>Miscellaneous-Filing:</b>				
<b>Petition:</b>				

Description	Fee Code	Quantity	Amount	Sub-Total in USD(\$)
<b>Patent-Appeals-and-Interference:</b>				
Post-Allowance-and-Post-Issuance:				
<b>Extension-of-Time:</b>				
<b>Miscellaneous:</b>				
<b>Total in USD (\$)</b>				<b>525</b>

## Electronic Acknowledgement Receipt

<b>EFS ID:</b>	1021525
<b>Application Number:</b>	11279402
<b>Confirmation Number:</b>	8070
<b>Title of Invention:</b>	Capacitive Keyboard with Non-Locking Reduced Keying Ambiguity
<b>First Named Inventor:</b>	Harald Philipp
<b>Customer Number:</b>	20191
<b>Filer:</b>	David A. Kiewit
<b>Filer Authorized By:</b>	
<b>Attorney Docket Number:</b>	PKX
<b>Receipt Date:</b>	12-APR-2006
<b>Filing Date:</b>	
<b>Time Stamp:</b>	09:37:13
<b>Application Type:</b>	Utility
<b>International Application Number:</b>	

### Payment information:

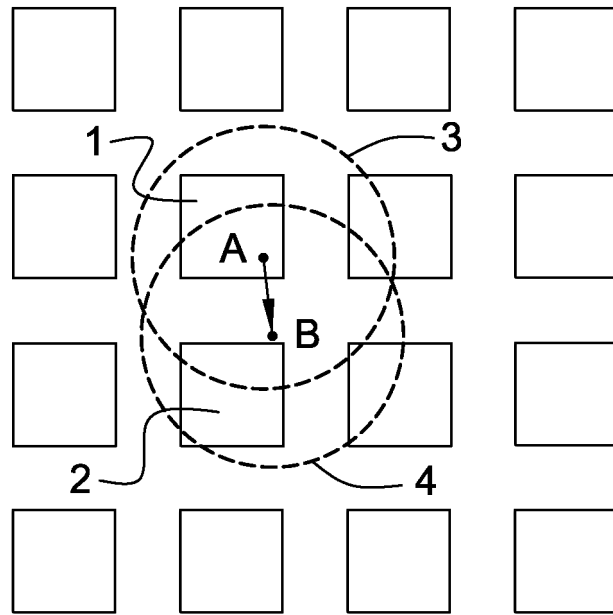
Submitted with Payment	yes
Payment was successfully received in RAM	\$ 525.0
RAM confirmation Number	258
Deposit Account	501012
The Director of the USPTO is hereby authorized to charge indicated fees and credit any overpayment as follows: Charge any Additional Fees required under 37 C.F.R. Section 1.16 and 1.17	

Document Number	Document Description	File Name	File Size(Bytes)	Multi Part	Pages
1	Abstract	pkxabstr.pdf	13636	no	1
<b>Warnings:</b>					
<b>Information:</b>					
2	Specification	pkxspec.pdf	87094	no	16
<b>Warnings:</b>					
<b>Information:</b>					
3	Claims	pkxclaims.pdf	27082	no	5
<b>Warnings:</b>					
<b>Information:</b>					
4	Drawings	pkxdwg.pdf	111819	no	7
<b>Warnings:</b>					
<b>Information:</b>					
5	Application Data Sheet	pkxADS.pdf	2100816	no	4
<b>Warnings:</b>					
<b>Information:</b>					
6	Oath or Declaration filed	pkxdecl.pdf	562488	no	1
<b>Warnings:</b>					
<b>Information:</b>					
7	Power of Attorney (may include Associate POA)	pkxpoa.pdf	440560	no	1
<b>Warnings:</b>					
<b>Information:</b>					
8	Information Disclosure Statement (IDS) Filed	pkxIDS.pdf	781628	no	4
<b>Warnings:</b>					
<b>Information:</b>					
9	Fee Worksheet (PTO-875)	fee-info.pdf	8452	no	2
<b>Warnings:</b>					

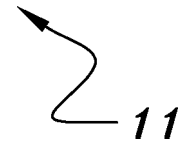
<b>Information:</b>	
<b>Total Files Size (in bytes):</b>	4133575
<p><b>This Acknowledgement Receipt evidences receipt on the noted date by the USPTO of the indicated documents, characterized by the applicant, and including page counts, where applicable. It serves as evidence of receipt similar to a Post Card, as described in MPEP 503.</b></p> <p><b><u>New Applications Under 35 U.S.C. 111</u></b> If a new application is being filed and the application includes the necessary components for a filing date (see 37 CFR 1.53(b)-(d) and MPEP 506), a Filing Receipt (37 CFR 1.54) will be issued in due course and the date shown on this Acknowledgement Receipt will establish the filing date of the application.</p> <p><b><u>National Stage of an International Application under 35 U.S.C. 371</u></b> If a timely submission to enter the national stage of an international application is compliant with the conditions of 35 U.S.C. 371 and other applicable requirements a Form PCT/DO/EO/903 indicating acceptance of the application as a national stage submission under 35 U.S.C. 371 will be issued in addition to the Filing Receipt, in due course.</p>	

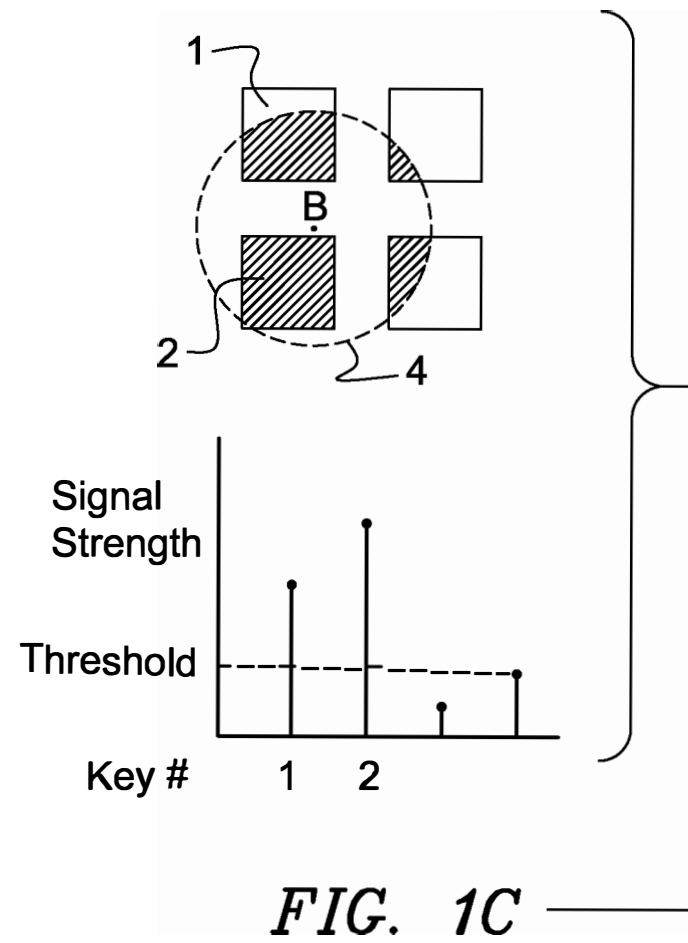
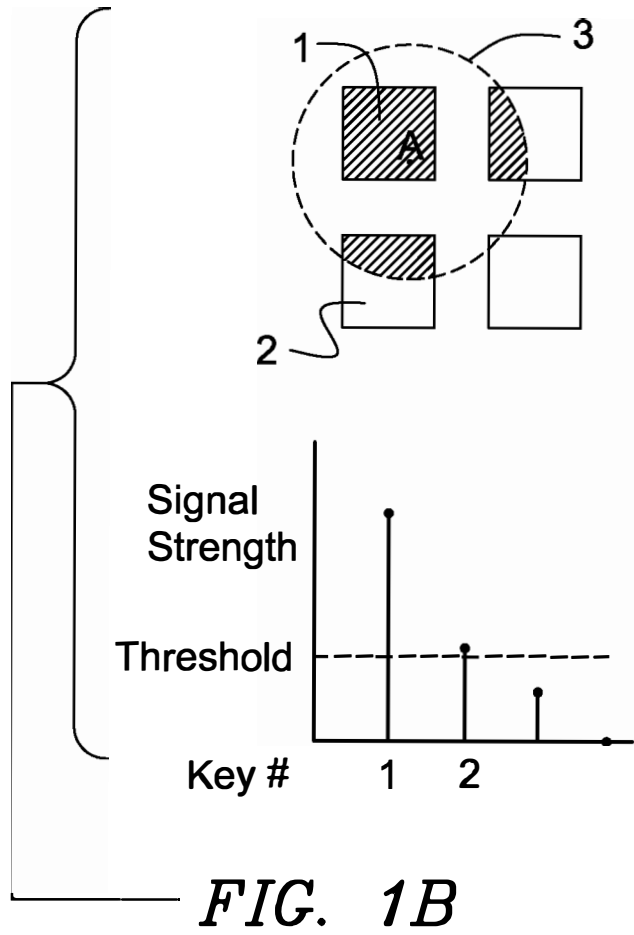


*Replacement Sheet 1/7*



***FIG. 1A***





Replacement Sheet 2/7

Replacement Sheet 3/7

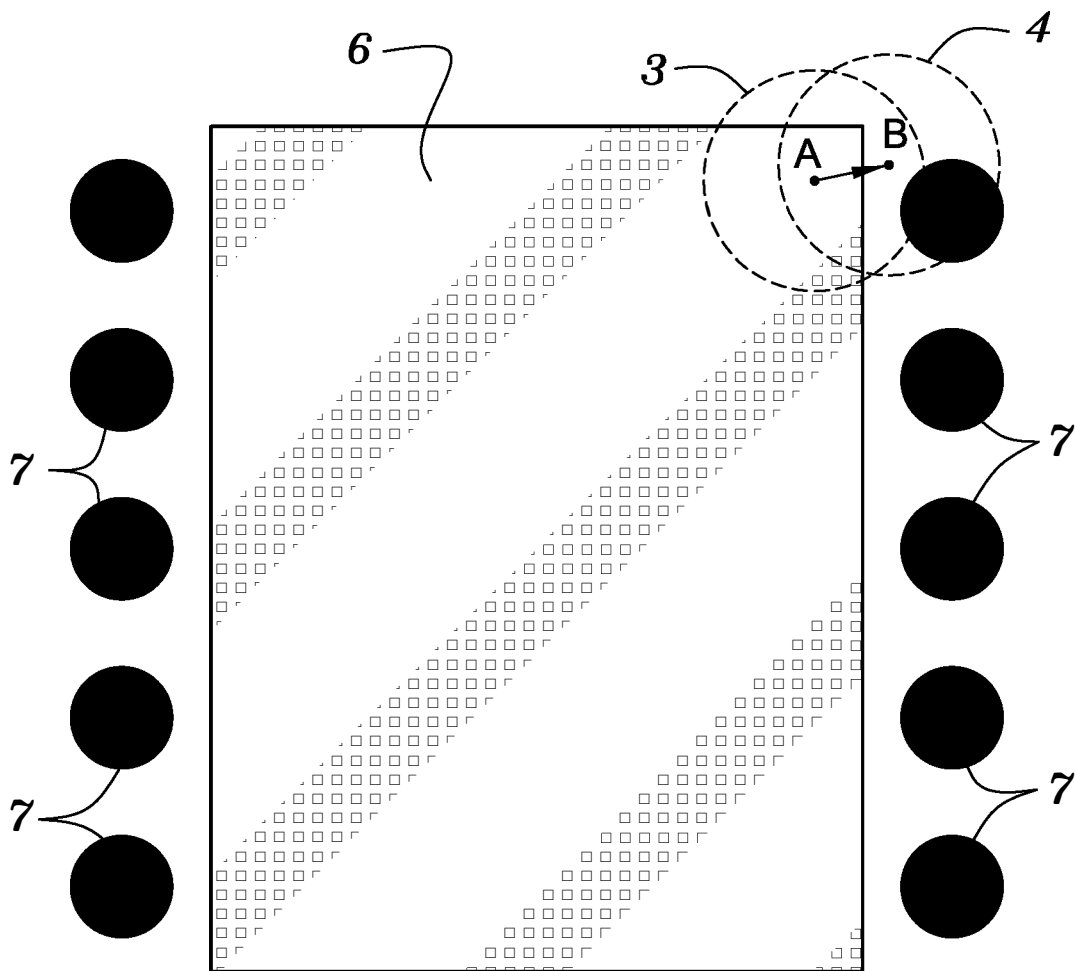


FIG. 2

Replacement Sheet 4/7

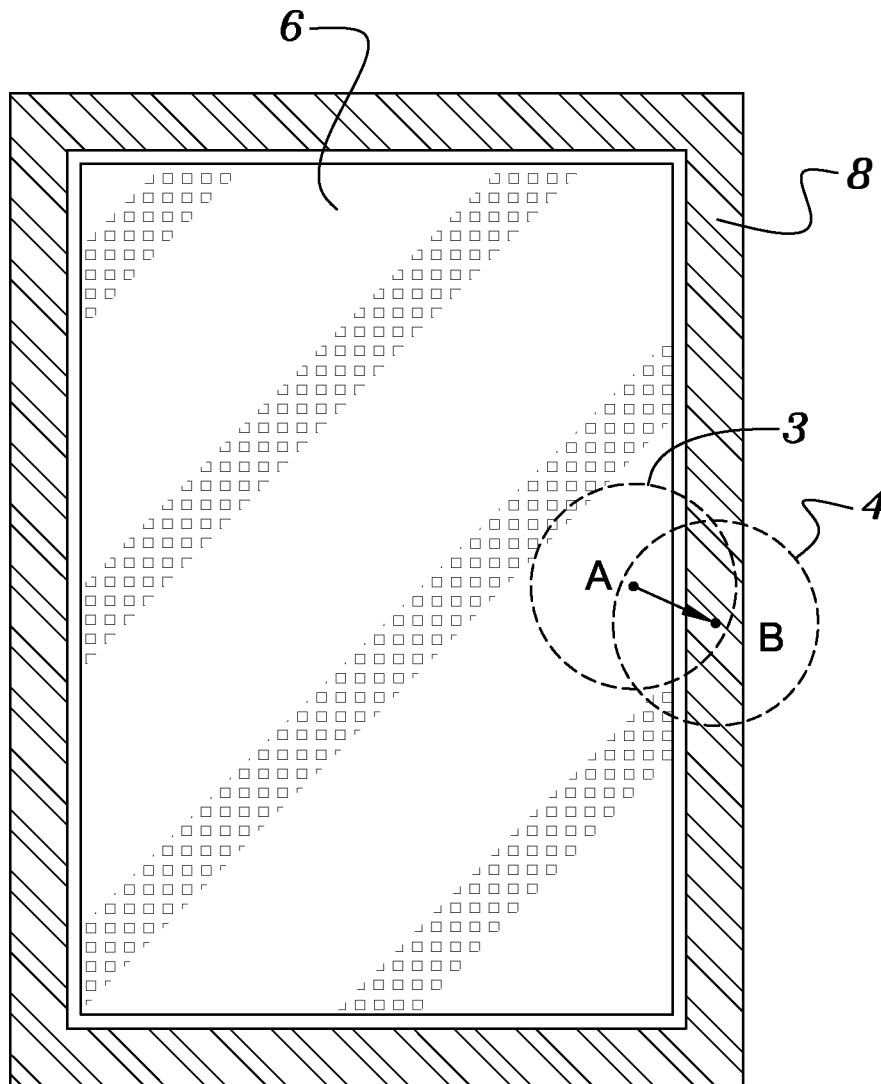
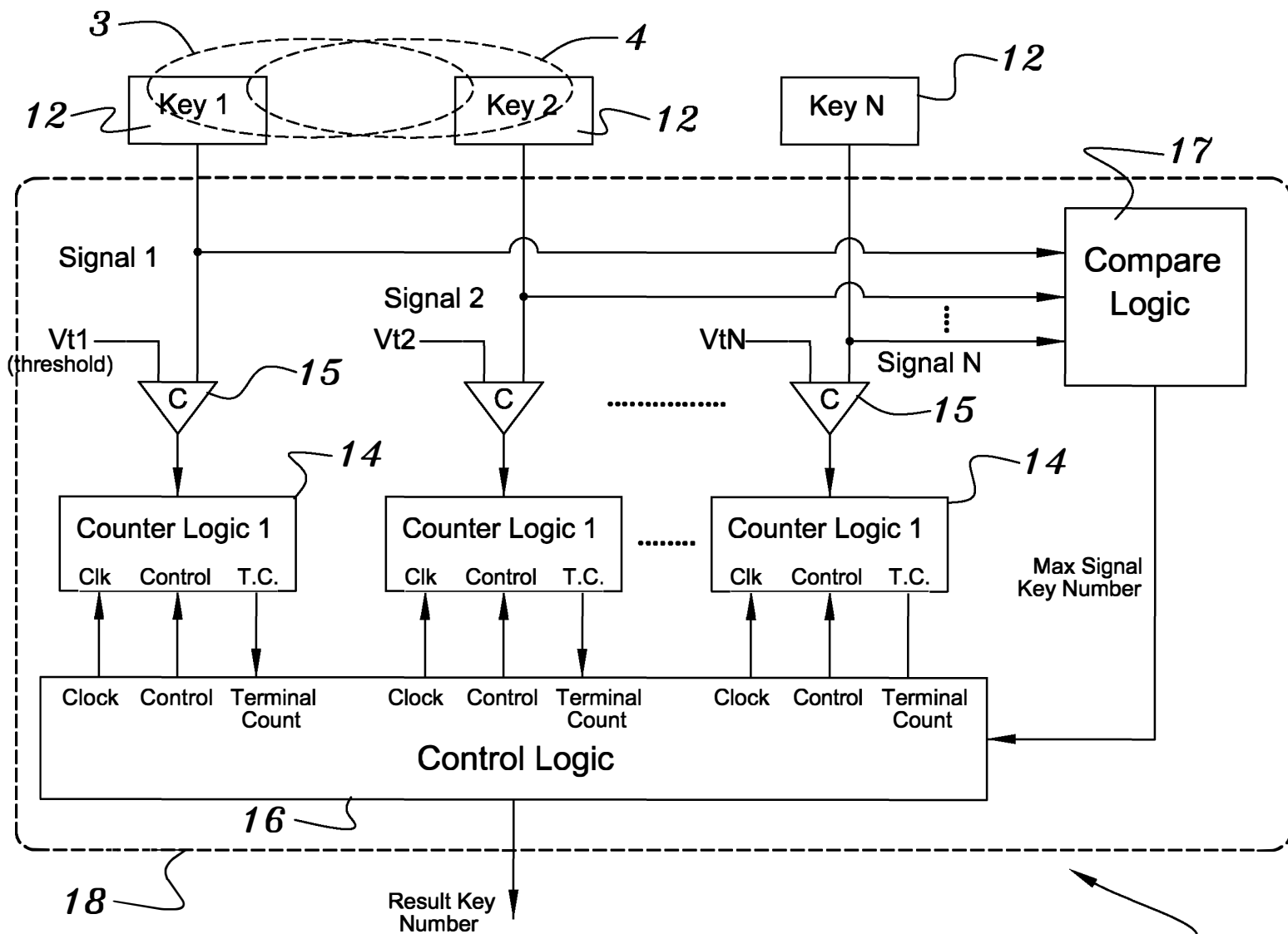


FIG. 3



Replacement Sheet 5/7

FIG. 4

Replacement Sheet 6/7

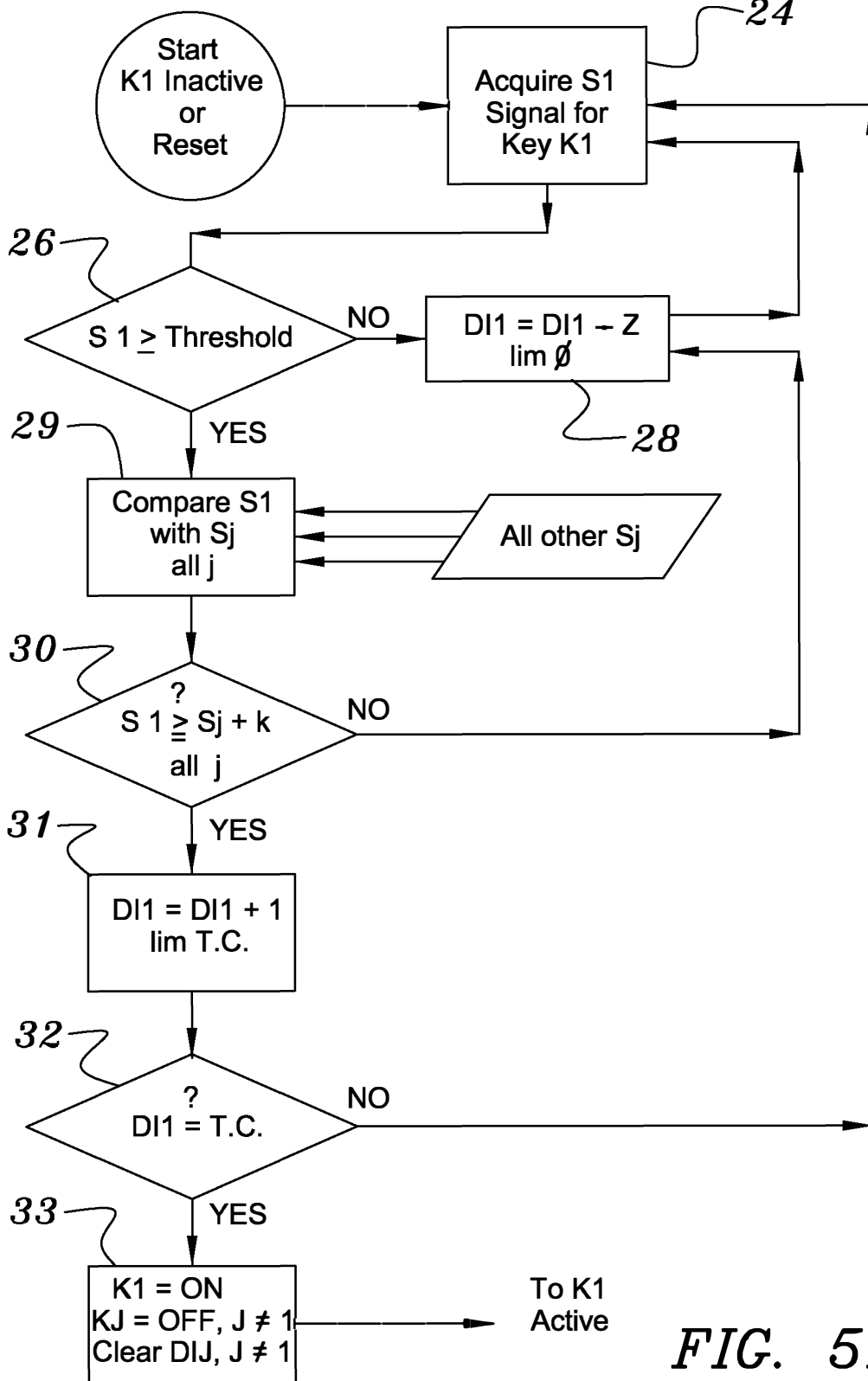


FIG. 5A

Replacement Sheet 7/7

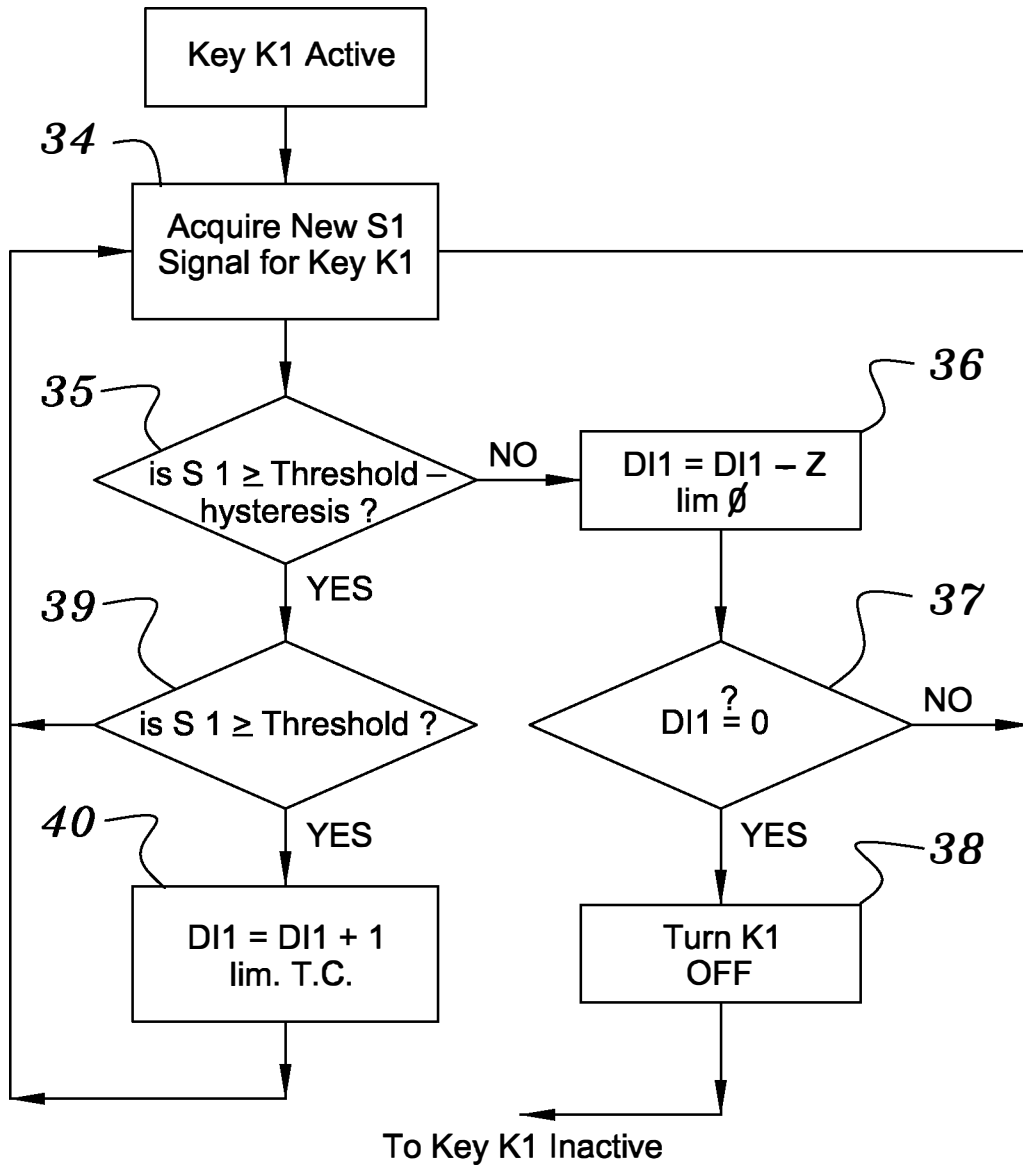


FIG. 5B

## Electronic Acknowledgement Receipt

<b>EFS ID:</b>	1034729
<b>Application Number:</b>	11279402
<b>Confirmation Number:</b>	8070
<b>Title of Invention:</b>	Capacitive Keyboard with Non-Locking Reduced Keying Ambiguity
<b>First Named Inventor:</b>	Harald Philipp
<b>Customer Number:</b>	20191
<b>Filer:</b>	David A. Kiewit
<b>Filer Authorized By:</b>	
<b>Attorney Docket Number:</b>	PKX
<b>Receipt Date:</b>	01-MAY-2006
<b>Filing Date:</b>	
<b>Time Stamp:</b>	09:48:12
<b>Application Type:</b>	Utility
<b>International Application Number:</b>	

### Payment information:

Submitted with Payment	no
------------------------	----

### File Listing:

Document Number	Document Description	File Name	File Size(Bytes)	Multi Part	Pages
1	Drawings	pkxFML811.pdf	295362	no	7



<b>Warnings:</b>	
<b>Information:</b>	
<b>Total Files Size (in bytes):</b>	295362
<p><b>This Acknowledgement Receipt evidences receipt on the noted date by the USPTO of the indicated documents, characterized by the applicant, and including page counts, where applicable. It serves as evidence of receipt similar to a Post Card, as described in MPEP 503.</b></p> <p><b><u>New Applications Under 35 U.S.C. 111</u></b> If a new application is being filed and the application includes the necessary components for a filing date (see 37 CFR 1.53(b)-(d) and MPEP 506), a Filing Receipt (37 CFR 1.54) will be issued in due course and the date shown on this Acknowledgement Receipt will establish the filing date of the application.</p> <p><b><u>National Stage of an International Application under 35 U.S.C. 371</u></b> If a timely submission to enter the national stage of an international application is compliant with the conditions of 35 U.S.C. 371 and other applicable requirements a Form PCT/DO/EO/903 indicating acceptance of the application as a national stage submission under 35 U.S.C. 371 will be issued in addition to the Filing Receipt, in due course.</p>	



*Ifw*

PTO/SB/21 (09-06)  
 Approved for use through 03/31/2007. OMB 0651-0031  
 U.S. Patent and Trademark Office; U.S. DEPARTMENT OF COMMERCE

Under the Paperwork Reduction Act of 1995, no persons are required to respond to a collection of information unless it displays a valid OMB control number.

<b>TRANSMITTAL FORM</b>	Application Number	11/279,402
	Filing Date	2006-04-12
	First Named Inventor	Philipp
	Art Unit	2635
	Examiner Name	
(to be used for all correspondence after initial filing)		
Total Number of Pages in This Submission	Attorney Docket Number	PKX

ENCLOSURES (Check all that apply)		
<input type="checkbox"/> Fee Transmittal Form	<input type="checkbox"/> Drawing(s)	<input type="checkbox"/> After Allowance Communication to TC
<input type="checkbox"/> Fee Attached	<input type="checkbox"/> Licensing-related Papers	<input type="checkbox"/> Appeal Communication to Board of Appeals and Interferences
<input type="checkbox"/> Amendment/Reply	<input type="checkbox"/> Petition	<input type="checkbox"/> Appeal Communication to TC (Appeal Notice, Brief, Reply Brief)
<input type="checkbox"/> After Final	<input type="checkbox"/> Petition to Convert to a Provisional Application	<input type="checkbox"/> Proprietary Information
<input type="checkbox"/> Affidavits/declaration(s)	<input type="checkbox"/> Power of Attorney, Revocation	<input type="checkbox"/> Status Letter
<input type="checkbox"/> Extension of Time Request	<input type="checkbox"/> Change of Correspondence Address	<input type="checkbox"/> Other Enclosure(s) (please identify below):
<input type="checkbox"/> Express Abandonment Request	<input type="checkbox"/> Terminal Disclaimer	
<input checked="" type="checkbox"/> Information Disclosure Statement	<input type="checkbox"/> Request for Refund	
<input type="checkbox"/> Certified Copy of Priority Document(s)	<input type="checkbox"/> CD, Number of CD(s) _____	
<input type="checkbox"/> Reply to Missing Parts/ Incomplete Application	<input type="checkbox"/> Landscape Table on CD	
<input type="checkbox"/> Reply to Missing Parts under 37 CFR 1.52 or 1.53	<b>Remarks</b>	
	Information Disclosure Statement is filed before mailing of a first Office Action	

SIGNATURE OF APPLICANT, ATTORNEY, OR AGENT			
Firm Name	David Kiewit		
Signature			
Printed name	David Kiewit		
Date	2006-10-04	Reg. No.	34640

CERTIFICATE OF TRANSMISSION/MAILING			
I hereby certify that this correspondence is being facsimile transmitted to the USPTO or deposited with the United States Postal Service with sufficient postage as first class mail in an envelope addressed to: Commissioner for Patents, P.O. Box 1450, Alexandria, VA 22313-1450 on the date shown below:			
Signature			
Typed or printed name	David Kiewit	Date	2006-10-04

This collection of information is required by 37 CFR 1.5. The information is required to obtain or retain a benefit by the public which is to file (and by the USPTO to process) an application. Confidentiality is governed by 35 U.S.C. 122 and 37 CFR 1.11 and 1.14. This collection is estimated to 2 hours to complete, including gathering, preparing, and submitting the completed application form to the USPTO. Time will vary depending upon the individual case. Any comments on the amount of time you require to complete this form and/or suggestions for reducing this burden, should be sent to the Chief Information Officer, U.S. Patent and Trademark Office, U.S. Department of Commerce, P.O. Box 1450, Alexandria, VA 22313-1450. DO NOT SEND FEES OR COMPLETED FORMS TO THIS ADDRESS. SEND TO: Commissioner for Patents, P.O. Box 1450, Alexandria, VA 22313-1450.

If you need assistance in completing the form, call 1-800-PTO-9199 and select option 2.



Under the Paperwork Reduction Act of 1995, no persons are required to respond to a collection of information unless it contains a valid OMB control number.

Substitute for form 1449/PTO  <b>INFORMATION DISCLOSURE STATEMENT BY APPLICANT</b>  (Use as many sheets as necessary)		<b>Complete if Known</b>	
		Application Number	11/279,402
		Filing Date	2006-04-12
		First Named Inventor	Philipp
		Art Unit	2635
		Examiner Name	
Sheet 2 of 2	Attorney Docket Number	PKX	

NON PATENT LITERATURE DOCUMENTS			
Examiner Initials*	Cite No. <sup>1</sup>	Include name of the author (in CAPITAL LETTERS), title of the article (when appropriate), title of the item (book, magazine, journal, serial, symposium, catalog, etc.), date, page(s), volume-issue number(s), publisher, city and/or country where published.	T <sup>2</sup>
		ISA from PCT/GB/002275, an application substantially the same as the captioned case.	
		Written Opinion of ISA (EPO) in PCT/GB/00275	

Examiner Signature		Date Considered	
--------------------	--	-----------------	--

\*EXAMINER: Initial if reference considered, whether or not citation is in conformance with MPEP 609. Draw line through citation if not in conformance and not considered. Include copy of this form with next communication to applicant.  
<sup>1</sup> Applicant's unique citation designation number (optional). <sup>2</sup> Applicant is to place a check mark here if English language Translation is attached.  
 This collection of information is required by 37 CFR 1.98. The information is required to obtain or retain a benefit by the public which is to file (and by the USPTO to process) an application. Confidentiality is governed by 35 U.S.C. 122 and 37 CFR 1.14. This collection is estimated to take 2 hours to complete, including gathering, preparing, and submitting the completed application form to the USPTO. Time will vary depending upon the individual case. Any comments on the amount of time you require to complete this form and/or suggestions for reducing this burden, should be sent to the Chief Information Officer, U.S. Patent and Trademark Office, P.O. Box 1450, Alexandria, VA 22313-1450. DO NOT SEND FEES OR COMPLETED FORMS TO THIS ADDRESS. SEND TO: Commissioner for Patents, P.O. Box 1450, Alexandria, VA 22313-1450.

If you need assistance in completing the form, call 1-800-PTO-9199 (1-800-786-9199) and select option 2.

In Re PATENT APPLICATION of

**Applicant:** Philipp  
**Filing Date:** 04/12/2006

**Docket:** PKX  
**Application Number:** 11279402

**Identification Of Applications And Patents Having At Least One Inventor In Common**  
(37 CRF §1.78 (f) (1) (i) - (ii))

The captioned application has a filing date that is the same as or within two months of the filing date of:

Application serial number	Filing date	Inventor in common
11/422799	06/07/2006	Philipp

The identification of the other pending or patented nonprovisional application(s) required by paragraph (f)(1)(i) of this section is submitted within:

  (A) Four months from the actual filing date in a nonprovisional application filed under 35 U.S.C. 111(a);

  (B) Four months from the date on which the national stage commenced under 35 U.S.C. 371(b) or (f) in a nonprovisional application entering the national stage from an international application under 35 U.S.C. 371;

  (C) Two months from the mailing date of the initial filing receipt in such other nonprovisional application for which identification is required by paragraph (f)(1)(i) of this section; or

  X (D) A time period ending on February 1, 2008.

Respectfully submitted on September 20, 2007

/David A Kiewit/  
David A Kiewit  
Reg. 34640

## Electronic Acknowledgement Receipt

<b>EFS ID:</b>	2223185
<b>Application Number:</b>	11279402
<b>International Application Number:</b>	
<b>Confirmation Number:</b>	8070
<b>Title of Invention:</b>	Capacitive Keyboard with Non-Locking Reduced Keying Ambiguity
<b>First Named Inventor/Applicant Name:</b>	Harald Philipp
<b>Customer Number:</b>	20191
<b>Filer:</b>	David A. Kiewit
<b>Filer Authorized By:</b>	
<b>Attorney Docket Number:</b>	PKX
<b>Receipt Date:</b>	20-SEP-2007
<b>Filing Date:</b>	12-APR-2006
<b>Time Stamp:</b>	19:07:12
<b>Application Type:</b>	Utility under 35 USC 111(a)

### Payment information:

Submitted with Payment	no
------------------------	----

### File Listing:

Document Number	Document Description	File Name	File Size(Bytes) /Message Digest	Multi Part /.zip	Pages (if appl.)
1	Miscellaneous Incoming Letter	pkx2mo.pdf	28301 <small>7a9bba912d0d6b52b30b1bc12bd72e4529522465</small>	no	1

**Warnings:**

<b>Information:</b>	
<b>Total Files Size (in bytes):</b>	28301
<p>This Acknowledgement Receipt evidences receipt on the noted date by the USPTO of the indicated documents, characterized by the applicant, and including page counts, where applicable. It serves as evidence of receipt similar to a Post Card, as described in MPEP 503.</p> <p><b><u>New Applications Under 35 U.S.C. 111</u></b>  If a new application is being filed and the application includes the necessary components for a filing date (see 37 CFR 1.53(b)-(d) and MPEP 506), a Filing Receipt (37 CFR 1.54) will be issued in due course and the date shown on this Acknowledgement Receipt will establish the filing date of the application.</p> <p><b><u>National Stage of an International Application under 35 U.S.C. 371</u></b>  If a timely submission to enter the national stage of an international application is compliant with the conditions of 35 U.S.C. 371 and other applicable requirements a Form PCT/DO/EO/903 indicating acceptance of the application as a national stage submission under 35 U.S.C. 371 will be issued in addition to the Filing Receipt, in due course.</p> <p><b><u>New International Application Filed with the USPTO as a Receiving Office</u></b>  If a new international application is being filed and the international application includes the necessary components for an international filing date (see PCT Article 11 and MPEP 1810), a Notification of the International Application Number and of the International Filing Date (Form PCT/RO/105) will be issued in due course, subject to prescriptions concerning national security, and the date shown on this Acknowledgement Receipt will establish the international filing date of the application.</p>	

RECEIVED  
CENTRAL FAX CENTER

APR 30 2009

IN THE UNITED STATES PATENT AND TRADEMARK OFFICEREVOCATION AND POWER OF ATTORNEY  
CERTIFICATE UNDER 37 CFR § 3.73(b)&  
CHANGE OF CORRESPONDENCE ADDRESSCommissioner for Patents  
P.O. Box 1450  
Alexandria, VA 22313-1450

In accordance with 37 C.F.R. Section 1.36, M.P.E.P. Section 402.05 and 402.07, please revoke any existing Powers of Attorney, if any, for the below listed applications, and appoint the following attorneys and/or patent agents to prosecute these applications and to transact all business in the Patent and Trademark Office in connection therewith:

Customer Number: 76287

<u>Appl. Serial</u> <u>No.:</u> <u>&amp;</u> <u>Docket No.</u>	<u>Filing Date</u>	<u>Applicant</u>	<u>Reel/Frames</u>	<u>Recordation</u> <u>Date</u>
10/916,744 3050.004US1	Aug 12, 2004	Philipp	021791/0040	11/05/2008
10/916,759 3050.005US1	Aug 12, 2004	Philipp	021791/0040	11/05/2008
11/422,799 3050.008US1	June 7, 2005	Philipp	021791/0040	11/05/2008
11/333,489 3050.009US1	Jan 17, 2006	Philipp	021791/0040	11/05/2008
11/536,583 3050.012US1	Sep 28, 2006	Philipp	021791/0040	11/05/2008
11/163,944 3050.014US1	Nov 4, 2005	Philipp	021791/0040	11/05/2008
11/532,560 3050.016US1	Sept. 18, 2006	Philipp et al	021787/0321	11/05/2008
12/061,483 3050.017US1	Apr 2, 2008	Philipp et al	021834/0001	11/14/2008

- 1 -



<u>Appl. Serial No.:</u> & <u>Docket No.</u>	<u>Filing Date</u>	<u>Applicant</u>	<u>Reel/Frames</u>	<u>Recordation Date</u>
11/734,813 3050.020US1	Apr 13, 2007	Philipp	021791/0040	11/05/2008
* 11/279,402 3050.022US1	Apr 12, 2006	Philipp	021791/0040	11/05/2008
11/750,430 3050.023US1	May 18, 2007	Philipp	021791/0040	11/05/2008
11/765,393 3050.024US1	Jun 19, 2007	Philipp	021791/0040	11/05/2008
11/743,349 3050.026US1	May 2, 2007	Philipp	021791/0040	11/05/2008
11/868,563 3050.028US1	Oct 8, 2007	Philipp	021791/0040	11/05/2008
11/868,566 3050.029US1	Oct 8, 2007	Philipp	021791/0040	11/05/2008
12/179,769 3050.030US1	Jul 25, 2008	Philipp et al	021758/0843	10/29/2008
11/750,588 3050.031US1	May 18, 2007	Hristov	021834/0870	11/14/2008

**CERTIFICATE UNDER 37 CFR § 3.73(b)**

Atmel Corporation hereby certifies that it is the assignee of the entire right, title and interest in the patent applications identified above by virtue of:

assignments from the inventor(s) of the patent applications identified above; and  
assignment from ORG Limited to Atmel Corporation filed on even-date herewith  
(attached). To the best of my knowledge and belief, titles are in Atmel Corporation, the assignee.


Pursuant to 37 C.F.R. § 3.73(b) I hereby declare that I am empowered to sign this certificate on behalf of Atmel Corporation, the assignee.

I hereby declare that all statements made herein of my own knowledge are true, and that all statements made on information and belief are believed to be true.

Please direct all correspondence in this case to:

Schwegman, Lundberg & Woessner, P.A.  
Customer No. 76287

Date 4/29/09

By   
Name: Patrick Reutens  
Title: Chief Legal Officer

RECEIVED  
CENTRAL FAX CENTER

APR 30 2009

SCHWEGMAN ■ LUNDBERG ■ WOESSNER  
 PATENT, TRADEMARK & COPYRIGHT ATTORNEYS  
 P.O. Box 2938  
 Minneapolis, MN 55402  
 Telephone (612) 373-6900 Facsimile (612) 339-3061

April 30, 2009

TO: Commissioner for Patents  
 Attn: Daniel Wu  
 Patent Examining Corps  
 Facsimile Center  
 P.O. Box 1450  
 Alexandria, VA 22313-1450

FROM: Bradley A. ForrestOUR REF: 3050.022US1FAX NUMBER (571) 273-8300

\* Please deliver to Examiner Daniel Wu in Art Unit 2612. \*

Document(s) Transmitted: Revocation and Power of Attorney & Change of Correspondence  
 Address with as-filed Assignment Recordation Sheet with appendix ( 8 pgs.).

Total pages of this transmission, including cover letter: 9 pgs.

If you do NOT receive all of the pages described above, please telephone us at 612-373-6900 or fax us  
 at 612-339-3061.

In re. Patent Application of: Harald PhilippExaminer: Daniel WuSerial No.: 11/279,402Group Art Unit: 2612Filed: April 12, 2006Docket No.: 3050.022US1Title: Capacitive Keyboard with Non-Locking Reduced Keying AmbiguityBy: Bradley A. ForrestName: Bradley A. ForrestReg. No.: 30,837

I hereby certify that this paper is being transmitted by facsimile to the U.S. Patent and Trademark Office  
 on the date shown below.

Michele Quaranto  
 Michele Quaranto

4-30-09  
 Date of Transmission



UNITED STATES PATENT AND TRADEMARK OFFICE

UNITED STATES DEPARTMENT OF COMMERCE  
United States Patent and Trademark Office  
Address: COMMISSIONER FOR PATENTS  
P.O. Box 1450  
Alexandria, Virginia 22313-1450  
www.uspto.gov

APPLICATION NUMBER	FILING OR 371(C) DATE	FIRST NAMED APPLICANT	ATTY. DOCKET NO./TITLE
11/279,402	04/12/2006	Harald Philipp	PKX

76287  
SCHWEGMAN, LUNDBERG & WOESSNER / ATMEL  
P.O. BOX 2938  
MINNEAPOLIS, MN 55402

**CONFIRMATION NO. 8070**  
**POA ACCEPTANCE LETTER**



Date Mailed: 05/15/2009

**NOTICE OF ACCEPTANCE OF POWER OF ATTORNEY**

This is in response to the Power of Attorney filed 04/30/2009.

The Power of Attorney in this application is accepted. Correspondence in this application will be mailed to the above address as provided by 37 CFR 1.33.

/mtekle michael/

Office of Data Management, Application Assistance Unit (571) 272-4000, or (571) 272-4200, or 1-888-786-0101



UNITED STATES PATENT AND TRADEMARK OFFICE

UNITED STATES DEPARTMENT OF COMMERCE  
United States Patent and Trademark Office  
Address: COMMISSIONER FOR PATENTS  
P.O. Box 1450  
Alexandria, Virginia 22313-1450  
www.uspto.gov

APPLICATION NUMBER	FILING OR 371(C) DATE	FIRST NAMED APPLICANT	ATTY. DOCKET NO./TITLE
11/279,402	04/12/2006	Harald Philipp	PKX

**CONFIRMATION NO. 8070**

**POWER OF ATTORNEY NOTICE**

20191  
DAVID KIEWIT  
5901 THIRD ST SOUTH  
ST PETERSBURG, FL 33705



Date Mailed: 05/15/2009

**NOTICE REGARDING CHANGE OF POWER OF ATTORNEY**

This is in response to the Power of Attorney filed 04/30/2009.

- The Power of Attorney to you in this application has been revoked by the assignee who has intervened as provided by 37 CFR 3.71. Future correspondence will be mailed to the new address of record(37 CFR 1.33).

/mtekle michael/

Office of Data Management, Application Assistance Unit (571) 272-4000, or (571) 272-4200, or 1-888-786-0101



NOTICE OF ALLOWANCE AND FEE(S) DUE

76287 7500 06/17/2009

SCHWEGMAN, LUNDBERG & WOESSNER / ATMEL
P.O. BOX 2938
MINNEAPOLIS, MN 55402

EXAMINER
WONG, ALBERT KANG
ART UNIT PAPER NUMBER

2612
DATE MAILED: 06/17/2009

Table with 5 columns: APPLICATION NO., FILING DATE, FIRST NAMED INVENTOR, ATTORNEY DOCKET NO., CONFIRMATION NO.

11/279,402 04/12/2006 Harald Philipp 3050.022US1 8070

TITLE OF INVENTION: CAPACITIVE KEYBOARD WITH NON-LOCKING REDUCED KEYING AMBIGUITY

Table with 7 columns: APPLN. TYPE, SMALL ENTITY, ISSUE FEE DUE, PUBLICATION FEE DUE, PREV. PAID ISSUE FEE, TOTAL FEE(S) DUE, DATE DUE

nonprovisional YES \$755 \$300 \$0 \$1055 09/17/2009

THE APPLICATION IDENTIFIED ABOVE HAS BEEN EXAMINED AND IS ALLOWED FOR ISSUANCE AS A PATENT. PROSECUTION ON THE MERITS IS CLOSED. THIS NOTICE OF ALLOWANCE IS NOT A GRANT OF PATENT RIGHTS. THIS APPLICATION IS SUBJECT TO WITHDRAWAL FROM ISSUE AT THE INITIATIVE OF THE OFFICE OR UPON PETITION BY THE APPLICANT. SEE 37 CFR 1.313 AND MPEP 1308.

THE ISSUE FEE AND PUBLICATION FEE (IF REQUIRED) MUST BE PAID WITHIN THREE MONTHS FROM THE MAILING DATE OF THIS NOTICE OR THIS APPLICATION SHALL BE REGARDED AS ABANDONED. THIS STATUTORY PERIOD CANNOT BE EXTENDED. SEE 35 U.S.C. 151. THE ISSUE FEE DUE INDICATED ABOVE DOES NOT REFLECT A CREDIT FOR ANY PREVIOUSLY PAID ISSUE FEE IN THIS APPLICATION. IF AN ISSUE FEE HAS PREVIOUSLY BEEN PAID IN THIS APPLICATION (AS SHOWN ABOVE), THE RETURN OF PART B OF THIS FORM WILL BE CONSIDERED A REQUEST TO REAPPLY THE PREVIOUSLY PAID ISSUE FEE TOWARD THE ISSUE FEE NOW DUE.

HOW TO REPLY TO THIS NOTICE:

I. Review the SMALL ENTITY status shown above.

If the SMALL ENTITY is shown as YES, verify your current SMALL ENTITY status:

A. If the status is the same, pay the TOTAL FEE(S) DUE shown above.

B. If the status above is to be removed, check box 5b on Part B - Fee(s) Transmittal and pay the PUBLICATION FEE (if required) and twice the amount of the ISSUE FEE shown above, or

If the SMALL ENTITY is shown as NO:

A. Pay TOTAL FEE(S) DUE shown above, or

B. If applicant claimed SMALL ENTITY status before, or is now claiming SMALL ENTITY status, check box 5a on Part B - Fee(s) Transmittal and pay the PUBLICATION FEE (if required) and 1/2 the ISSUE FEE shown above.

II. PART B - FEE(S) TRANSMITTAL, or its equivalent, must be completed and returned to the United States Patent and Trademark Office (USPTO) with your ISSUE FEE and PUBLICATION FEE (if required). If you are charging the fee(s) to your deposit account, section "4b" of Part B - Fee(s) Transmittal should be completed and an extra copy of the form should be submitted. If an equivalent of Part B is filed, a request to reapply a previously paid issue fee must be clearly made, and delays in processing may occur due to the difficulty in recognizing the paper as an equivalent of Part B.

III. All communications regarding this application must give the application number. Please direct all communications prior to issuance to Mail Stop ISSUE FEE unless advised to the contrary.

IMPORTANT REMINDER: Utility patents issuing on applications filed on or after Dec. 12, 1980 may require payment of maintenance fees. It is patentee's responsibility to ensure timely payment of maintenance fees when due.

**PART B - FEE(S) TRANSMITTAL**

**Complete and send this form, together with applicable fee(s), to: Mail Mail Stop ISSUE FEE  
 Commissioner for Patents  
 P.O. Box 1450  
 Alexandria, Virginia 22313-1450  
 or Fax (571)-273-2885**

**INSTRUCTIONS:** This form should be used for transmitting the ISSUE FEE and PUBLICATION FEE (if required). Blocks 1 through 5 should be completed where appropriate. All further correspondence including the Patent, advance orders and notification of maintenance fees will be mailed to the current correspondence address as indicated unless corrected below or directed otherwise in Block 1, by (a) specifying a new correspondence address; and/or (b) indicating a separate "FEE ADDRESS" for maintenance fee notifications.

CURRENT CORRESPONDENCE ADDRESS (Note: Use Block 1 for any change of address)

76287 7500 06/17/2009

**SCHWEGMAN, LUNDBERG & WOESSNER / ATMEL**  
 P.O. BOX 2938  
 MINNEAPOLIS, MN 55402

Note: A certificate of mailing can only be used for domestic mailings of the Fee(s) Transmittal. This certificate cannot be used for any other accompanying papers. Each additional paper, such as an assignment or formal drawing, must have its own certificate of mailing or transmission.

**Certificate of Mailing or Transmission**

I hereby certify that this Fee(s) Transmittal is being deposited with the United States Postal Service with sufficient postage for first class mail in an envelope addressed to the Mail Stop ISSUE FEE address above, or being facsimile transmitted to the USPTO (571) 273-2885, on the date indicated below.

(Depositor's name)
(Signature)
(Date)

APPLICATION NO.	FILING DATE	FIRST NAMED INVENTOR	ATTORNEY DOCKET NO.	CONFIRMATION NO.
11/279,402	04/12/2006	Harald Philipp	3050.022US1	8070

TITLE OF INVENTION: CAPACITIVE KEYBOARD WITH NON-LOCKING REDUCED KEYING AMBIGUITY

APPLN. TYPE	SMALL ENTITY	ISSUE FEE DUE	PUBLICATION FEE DUE	PREV. PAID ISSUE FEE	TOTAL FEE(S) DUE	DATE DUE
nonprovisional	YES	\$755	\$300	\$0	\$1055	09/17/2009

EXAMINER	ART UNIT	CLASS-SUBCLASS
WONG, ALBERT KANG	2612	341-033000

<p>1. Change of correspondence address or indication of "Fee Address" (37 CFR 1.363).</p> <p><input type="checkbox"/> Change of correspondence address (or Change of Correspondence Address form PTO/SB/122) attached.</p> <p><input type="checkbox"/> "Fee Address" indication (or "Fee Address" Indication form PTO/SB/47; Rev 03-02 or more recent) attached. <b>Use of a Customer Number is required.</b></p>	<p>2. For printing on the patent front page, list</p> <p>(1) the names of up to 3 registered patent attorneys or agents OR, alternatively, 1 _____</p> <p>(2) the name of a single firm (having as a member a registered attorney or agent) and the names of up to 2 registered patent attorneys or agents. If no name is listed, no name will be printed. 2 _____</p> <p>3 _____</p>
---	---

3. ASSIGNEE NAME AND RESIDENCE DATA TO BE PRINTED ON THE PATENT (print or type)

PLEASE NOTE: Unless an assignee is identified below, no assignee data will appear on the patent. If an assignee is identified below, the document has been filed for recordation as set forth in 37 CFR 3.11. Completion of this form is NOT a substitute for filing an assignment.

(A) NAME OF ASSIGNEE \_\_\_\_\_ (B) RESIDENCE: (CITY AND STATE OR COUNTRY) \_\_\_\_\_

Please check the appropriate assignee category or categories (will not be printed on the patent) :  Individual  Corporation or other private group entity  Government

<p>4a. The following fee(s) are submitted:</p> <p><input type="checkbox"/> Issue Fee</p> <p><input type="checkbox"/> Publication Fee (No small entity discount permitted)</p> <p><input type="checkbox"/> Advance Order - # of Copies _____</p>	<p>4b. Payment of Fee(s); (Please first reapply any previously paid issue fee shown above)</p> <p><input type="checkbox"/> A check is enclosed.</p> <p><input type="checkbox"/> Payment by credit card. Form PTO-2038 is attached.</p> <p><input type="checkbox"/> The Director is hereby authorized to charge the required fee(s), any deficiency, or credit any overpayment, to Deposit Account Number _____ (enclose an extra copy of this form).</p>
---	--

5. Change in Entity Status (from status indicated above)

a. Applicant claims SMALL ENTITY status. See 37 CFR 1.27.  b. Applicant is no longer claiming SMALL ENTITY status. See 37 CFR 1.27(g)(2).

NOTE: The Issue Fee and Publication Fee (if required) will not be accepted from anyone other than the applicant; a registered attorney or agent; or the assignee or other party in interest as shown by the records of the United States Patent and Trademark Office.

Authorized Signature \_\_\_\_\_ Date \_\_\_\_\_

Typed or printed name \_\_\_\_\_ Registration No. \_\_\_\_\_

This collection of information is required by 37 CFR 1.311. The information is required to obtain or retain a benefit by the public which is to file (and by the USPTO to process) an application. Confidentiality is governed by 35 U.S.C. 122 and 37 CFR 1.14. This collection is estimated to take 12 minutes to complete, including gathering, preparing, and submitting the completed application form to the USPTO. Time will vary depending upon the individual case. Any comments on the amount of time you require to complete this form and/or suggestions for reducing this burden, should be sent to the Chief Information Officer, U.S. Patent and Trademark Office, U.S. Department of Commerce, P.O. Box 1450, Alexandria, Virginia 22313-1450. DO NOT SEND FEES OR COMPLETED FORMS TO THIS ADDRESS. SEND TO: Commissioner for Patents, P.O. Box 1450, Alexandria, Virginia 22313-1450.

Under the Paperwork Reduction Act of 1995, no persons are required to respond to a collection of information unless it displays a valid OMB control number.



UNITED STATES PATENT AND TRADEMARK OFFICE

UNITED STATES DEPARTMENT OF COMMERCE
United States Patent and Trademark Office
Address: COMMISSIONER FOR PATENTS
P. O. Box 1450
Alexandria, Virginia 22313-1450
www.uspto.gov

Table with 5 columns: APPLICATION NO., FILING DATE, FIRST NAMED INVENTOR, ATTORNEY DOCKET NO., CONFIRMATION NO.
11/279,402 04/12/2006 Harald Philipp 3050.022US1 8070

76287 7500 06/17/2009

SCHWEGMAN, LUNDBERG & WOESSNER / ATMEL
P.O. BOX 2938
MINNEAPOLIS, MN 55402

EXAMINER

WONG, ALBERT KANG

ART UNIT PAPER NUMBER

2612

DATE MAILED: 06/17/2009

Determination of Patent Term Adjustment under 35 U.S.C. 154 (b)

(application filed on or after May 29, 2000)

The Patent Term Adjustment to date is 736 day(s). If the issue fee is paid on the date that is three months after the mailing date of this notice and the patent issues on the Tuesday before the date that is 28 weeks (six and a half months) after the mailing date of this notice, the Patent Term Adjustment will be 736 day(s).

If a Continued Prosecution Application (CPA) was filed in the above-identified application, the filing date that determines Patent Term Adjustment is the filing date of the most recent CPA.

Applicant will be able to obtain more detailed information by accessing the Patent Application Information Retrieval (PAIR) WEB site (http://pair.uspto.gov).

Any questions regarding the Patent Term Extension or Adjustment determination should be directed to the Office of Patent Legal Administration at (571)-272-7702. Questions relating to issue and publication fee payments should be directed to the Customer Service Center of the Office of Patent Publication at 1-(888)-786-0101 or (571)-272-4200.



**Notice of Allowability**

**Application No.**

11/279,402

**Examiner**

ALBERT K. WONG

**Applicant(s)**

PHILIPP, HARALD

**Art Unit**

2612

**-- The MAILING DATE of this communication appears on the cover sheet with the correspondence address--**

All claims being allowable, PROSECUTION ON THE MERITS IS (OR REMAINS) CLOSED in this application. If not included herewith (or previously mailed), a Notice of Allowance (PTOL-85) or other appropriate communication will be mailed in due course. **THIS NOTICE OF ALLOWABILITY IS NOT A GRANT OF PATENT RIGHTS.** This application is subject to withdrawal from issue at the initiative of the Office or upon petition by the applicant. See 37 CFR 1.313 and MPEP 1308.

- 1.  This communication is responsive to the application filed 4/12/06.
- 2.  The allowed claim(s) is/are 1-24.
- 3.  Acknowledgment is made of a claim for foreign priority under 35 U.S.C. § 119(a)-(d) or (f).
  - a)  All b)  Some\* c)  None of the:
    - 1.  Certified copies of the priority documents have been received.
    - 2.  Certified copies of the priority documents have been received in Application No. \_\_\_\_\_.
    - 3.  Copies of the certified copies of the priority documents have been received in this national stage application from the International Bureau (PCT Rule 17.2(a)).

\* Certified copies not received: \_\_\_\_\_.

Applicant has THREE MONTHS FROM THE "MAILING DATE" of this communication to file a reply complying with the requirements noted below. Failure to timely comply will result in ABANDONMENT of this application.

**THIS THREE-MONTH PERIOD IS NOT EXTENDABLE.**

- 4.  A SUBSTITUTE OATH OR DECLARATION must be submitted. Note the attached EXAMINER'S AMENDMENT or NOTICE OF INFORMAL PATENT APPLICATION (PTO-152) which gives reason(s) why the oath or declaration is deficient.
  - 5.  CORRECTED DRAWINGS ( as "replacement sheets") must be submitted.
    - (a)  including changes required by the Notice of Draftsperson's Patent Drawing Review ( PTO-948) attached
      - 1)  hereto or 2)  to Paper No./Mail Date \_\_\_\_\_.
    - (b)  including changes required by the attached Examiner's Amendment / Comment or in the Office action of Paper No./Mail Date \_\_\_\_\_.
- Identifying indicia such as the application number (see 37 CFR 1.84(c)) should be written on the drawings in the front (not the back) of each sheet. Replacement sheet(s) should be labeled as such in the header according to 37 CFR 1.121(d).**
- 6.  DEPOSIT OF and/or INFORMATION about the deposit of BIOLOGICAL MATERIAL must be submitted. Note the attached Examiner's comment regarding REQUIREMENT FOR THE DEPOSIT OF BIOLOGICAL MATERIAL.

**Attachment(s)**

- 1.  Notice of References Cited (PTO-892)
- 2.  Notice of Draftsperson's Patent Drawing Review (PTO-948)
- 3.  Information Disclosure Statements (PTO/SB/08), Paper No./Mail Date \_\_\_\_\_
- 4.  Examiner's Comment Regarding Requirement for Deposit of Biological Material
- 5.  Notice of Informal Patent Application
- 6.  Interview Summary (PTO-413), Paper No./Mail Date \_\_\_\_\_.
- 7.  Examiner's Amendment/Comment
- 8.  Examiner's Statement of Reasons for Allowance
- 9.  Other \_\_\_\_\_.

Art Unit: 2612

1. This Office action is in response to the application filed April 12, 2006. Claims 1-24 are pending. This application is a continuation-in-part of 11/160,885, filed July 14, 2005 (now Patent 7,256,714) which is a continuation of 10/617,602 (now Patent 6,993,607) filed July 11, 2003.

#### **EXAMINER'S AMENDMENT**

2. An examiner's amendment to the record appears below. Should the changes and/or additions be unacceptable to applicant, an amendment may be filed as provided by 37 CFR 1.312. To ensure consideration of such an amendment, it **MUST** be submitted no later than the payment of the issue fee.

The application has been amended as follows:

In paragraph [0001], line 2; insert after 2005: "now USP 7,256,714"

In paragraph [0001], line 3; insert after inventor's: "application 10/617,602, now"

3. Claims 1-24 are allowed.

4. The following is an examiner's statement of reasons for allowance: The claims recite an apparatus and method for determining input on a keyboard by measuring sensor values associated with keys wherein the controller biases the determination based on the previously selected or determined key. Such a combination is not taught, suggested or made obvious by the prior art of record.

Any comments considered necessary by applicant must be submitted no later than the payment of the issue fee and, to avoid processing delays, should preferably accompany the issue

Art Unit: 2612

fee. Such submissions should be clearly labeled "Comments on Statement of Reasons for Allowance."

5. Any inquiry concerning this communication or earlier communications from the examiner should be directed to ALBERT K. WONG whose telephone number is (571)272-3057. The examiner can normally be reached on M-Th.

If attempts to reach the examiner by telephone are unsuccessful, the examiner's supervisor, Brian A. Zimmerman can be reached on 571-272-3059. The fax phone number for the organization where this application or proceeding is assigned is 571-273-8300.

Information regarding the status of an application may be obtained from the Patent Application Information Retrieval (PAIR) system. Status information for published applications may be obtained from either Private PAIR or Public PAIR. Status information for unpublished applications is available through Private PAIR only. For more information about the PAIR system, see <http://pair-direct.uspto.gov>. Should you have questions on access to the Private PAIR system, contact the Electronic Business Center (EBC) at 866-217-9197 (toll-free). If you would like assistance from a USPTO Customer Service Representative or access to the automated information system, call 800-786-9199 (IN USA OR CANADA) or 571-272-1000.

/Albert K Wong/  
Primary Examiner, Art Unit 2612

June 7, 2009

<b>Notice of References Cited</b>	Application/Control No. 11/279,402	Applicant(s)/Patent Under Reexamination PHILIPP, HARALD	
	Examiner ALBERT K. WONG	Art Unit 2612	Page 1 of 1

**U.S. PATENT DOCUMENTS**

*	Document Number Country Code-Number-Kind Code	Date MM-YYYY	Name	Classification
*	A US-4,651,133	03-1987	Ganesan et al.	341/26
*	B US-5,469,364	11-1995	Hughey et al.	702/65
*	C US-5,189,417	02-1993	Caldwell et al.	341/26
	D US-			
	E US-			
	F US-			
	G US-			
	H US-			
	I US-			
	J US-			
	K US-			
	L US-			
	M US-			

**FOREIGN PATENT DOCUMENTS**

*	Document Number Country Code-Number-Kind Code	Date MM-YYYY	Country	Name	Classification
	N				
	O				
	P				
	Q				
	R				
	S				
	T				

**NON-PATENT DOCUMENTS**

*	Document Number Country Code-Number-Kind Code	Date MM-YYYY	Country	Name	Classification
	U				
	V				
	W				
	X				

\*A copy of this reference is not being furnished with this Office action. (See MPEP § 707.05(a).)  
Dates in MM-YYYY format are publication dates. Classifications may be US or foreign.



*Ifw*

Approved for use through 03/31/2007. OMB 0651-0031  
U.S. Patent and Trademark Office; U.S. DEPARTMENT OF COMMERCE

Under the Paperwork Reduction Act of 1995, no persons are required to respond to a collection of information unless it displays a valid OMB control number.

<b>TRANSMITTAL FORM</b>	Application Number	11/279,402	
	Filing Date	2006-04-12	
	First Named Inventor	Philipp	
	Art Unit	2635	
	Examiner Name		
(to be used for all correspondence after initial filing)		Attorney Docket Number	PKX
Total Number of Pages in This Submission			

ENCLOSURES (Check all that apply)		
<input type="checkbox"/> Fee Transmittal Form <input type="checkbox"/> Fee Attached <input type="checkbox"/> Amendment/Reply <input type="checkbox"/> After Final <input type="checkbox"/> Affidavits/declaration(s) <input type="checkbox"/> Extension of Time Request <input type="checkbox"/> Express Abandonment Request <input checked="" type="checkbox"/> Information Disclosure Statement <input type="checkbox"/> Certified Copy of Priority Document(s) <input type="checkbox"/> Reply to Missing Parts/ Incomplete Application <input type="checkbox"/> Reply to Missing Parts under 37 CFR 1.52 or 1.53	<input type="checkbox"/> Drawing(s) <input type="checkbox"/> Licensing-related Papers <input type="checkbox"/> Petition <input type="checkbox"/> Petition to Convert to a Provisional Application <input type="checkbox"/> Power of Attorney, Revocation <input type="checkbox"/> Change of Correspondence Address <input type="checkbox"/> Terminal Disclaimer <input type="checkbox"/> Request for Refund <input type="checkbox"/> CD, Number of CD(s) _____ <input type="checkbox"/> Landscape Table on CD	<input type="checkbox"/> After Allowance Communication to TC <input type="checkbox"/> Appeal Communication to Board of Appeals and Interferences <input type="checkbox"/> Appeal Communication to TC (Appeal Notice, Brief, Reply Brief) <input type="checkbox"/> Proprietary Information <input type="checkbox"/> Status Letter <input type="checkbox"/> Other Enclosure(s) (please identify below):
Remarks Information Disclosure Statement is filed before mailing of a first Office Action		

SIGNATURE OF APPLICANT, ATTORNEY, OR AGENT			
Firm Name	David Kiewit		
Signature			
Printed name	David Kiewit		
Date	2006-10-04	Reg. No.	34640

CERTIFICATE OF TRANSMISSION/MAILING			
I hereby certify that this correspondence is being facsimile transmitted to the USPTO or deposited with the United States Postal Service with sufficient postage as first class mail in an envelope addressed to: Commissioner for Patents, P.O. Box 1450, Alexandria, VA 22313-1450 on the date shown below:			
Signature			
Typed or printed name	David Kiewit	Date	2006-10-04

This collection of information is required by 37 CFR 1.5. The information is required to obtain or retain a benefit by the public which is to file (and by the USPTO to process) an application. Confidentiality is governed by 35 U.S.C. 122 and 37 CFR 1.11 and 1.14. This collection is estimated to 2 hours to complete, including gathering, preparing, and submitting the completed application form to the USPTO. Time will vary depending upon the individual case. Any comments on the amount of time you require to complete this form and/or suggestions for reducing this burden, should be sent to the Chief Information Officer, U.S. Patent and Trademark Office, U.S. Department of Commerce, P.O. Box 1450, Alexandria, VA 22313-1450. DO NOT SEND FEES OR COMPLETED FORMS TO THIS ADDRESS. SEND TO: Commissioner for Patents, P.O. Box 1450, Alexandria, VA 22313-1450.

If you need assistance in completing the form, call 1-800-PTO-9199 and select option 2.



Under the Paperwork Reduction Act of 1995, no persons are required to respond to a collection of information unless it contains a valid OMB control number.


Substitute for form 1449/PTO  <b>INFORMATION DISCLOSURE STATEMENT BY APPLICANT</b>  (Use as many sheets as necessary)		<b>Complete if Known</b>	
		Application Number	11/279,402
		Filing Date	2006-04-12
		First Named Inventor	Philipp
		Art Unit	2635
		Examiner Name	
Sheet	2	of	2
		Attorney Docket Number	PKX

NON PATENT LITERATURE DOCUMENTS			
Examiner Initials*	Cite No. <sup>1</sup>	Include name of the author (in CAPITAL LETTERS), title of the article (when appropriate), title of the item (book, magazine, journal, serial, symposium, catalog, etc.), date, page(s), volume-issue number(s), publisher, city and/or country where published.	T <sup>2</sup>
		ISA from PCT/GB/002275, an application substantially the same as the captioned case.	
		Written Opinion of ISA (EPO) in PCT/GB/00275	

Examiner Signature	/Albert Wong/	Date Considered	06/07/2009
--------------------	---------------	-----------------	------------

\*EXAMINER: Initial if reference considered, whether or not citation is in conformance with MPEP 609. Draw line through citation if not in conformance and not considered. Include copy of this form with next communication to applicant.  
<sup>1</sup> Applicant's unique citation designation number (optional). <sup>2</sup> Applicant is to place a check mark here if English language Translation is attached.  
 This collection of information is required by 37 CFR 1.98. The information is required to obtain or retain a benefit by the public which is to file (and by the USPTO to process) an application. Confidentiality is governed by 35 U.S.C. 122 and 37 CFR 1.14. This collection is estimated to take 2 hours to complete, including gathering, preparing, and submitting the completed application form to the USPTO. Time will vary depending upon the individual case. Any comments on the amount of time you require to complete this form and/or suggestions for reducing this burden, should be sent to the Chief Information Officer, U.S. Patent and Trademark Office, P.O. Box 1450, Alexandria, VA 22313-1450. DO NOT SEND FEES OR COMPLETED FORMS TO THIS ADDRESS. SEND TO: Commissioner for Patents, P.O. Box 1450, Alexandria, VA 22313-1450.

If you need assistance in completing the form, call 1-800-PTO-9199 (1-800-786-9199) and select option 2.

<b>Search Notes</b>  	<b>Application/Control No.</b>  11279402	<b>Applicant(s)/Patent Under Reexamination</b>  PHILIPP, HARALD
	<b>Examiner</b>  ALBERT K WONG	<b>Art Unit</b>  2612


SEARCHED			
Class	Subclass	Date	Examiner
341	20, 22, 26, 33	6/7/09	
400	479.1		
345	173		
200	600		
178	18.01		
702	65, 64		

SEARCH NOTES		
Search Notes	Date	Examiner
EAST		
search terms:capacitive, keyboard, scan, predict, bias, keys, selection, previous	6/7/09	AKW

INTERFERENCE SEARCH			
Class	Subclass	Date	Examiner
all searched classes		6/7/09	AKW

--	--



<b>Issue Classification</b> 	<b>Application/Control No.</b> 11279402	<b>Applicant(s)/Patent Under Reexamination</b> PHILIPP, HARALD
	<b>Examiner</b> ALBERT K WONG	<b>Art Unit</b> 2612

ORIGINAL				INTERNATIONAL CLASSIFICATION													
CLASS		SUBCLASS		CLAIMED						NON-CLAIMED							
341		33		H	0	3	M	11 / 00 (2006.01.01)									
<b>CROSS REFERENCE(S)</b>																	
CLASS	SUBCLASS (ONE SUBCLASS PER BLOCK)																
341	26																
345	173																
400	479.1																
200	600																

<input checked="" type="checkbox"/> Claims renumbered in the same order as presented by applicant <input type="checkbox"/> CPA <input type="checkbox"/> T.D. <input type="checkbox"/> R.1.47															
Final	Original	Final	Original	Final	Original	Final	Original	Final	Original	Final	Original	Final	Original	Final	Original

NONE		<b>Total Claims Allowed:</b>	
(Assistant Examiner)		24	
/ALBERT K WONG/ Primary Examiner.Art Unit 2612		O.G. Print Claim(s)	
(Primary Examiner)		1	
(Date)		O.G. Print Figure	
6/7/09		1A	
(Date)			

<b>INFORMATION DISCLOSURE STATEMENT BY APPLICANT</b> ( Not for submission under 37 CFR 1.99)	Application Number		
	Filing Date		2006-04-12
	First Named Inventor	Philipp	
	Art Unit		
	Examiner Name		
	Attorney Docket Number		PKX

U.S.PATENTS							Remove	
Examiner Initial*	Cite No	Patent Number	Kind Code <sup>1</sup>	Issue Date	Name of Patentee or Applicant of cited Document	Pages,Columns,Lines where Relevant Passages or Relevant Figures Appear		
/A.W./	1	4145748		1979-03-20	Eichelberger et al.			
/A.W./	2	4954823		1990-09-04	Binstead			
If you wish to add additional U.S. Patent citation information please click the Add button.							Add	
U.S.PATENT APPLICATION PUBLICATIONS							Remove	
Examiner Initial*	Cite No	Publication Number	Kind Code <sup>1</sup>	Publication Date	Name of Patentee or Applicant of cited Document	Pages,Columns,Lines where Relevant Passages or Relevant Figures Appear		
	1							
If you wish to add additional U.S. Published Application citation information please click the Add button.							Add	
FOREIGN PATENT DOCUMENTS							Remove	
Examiner Initial*	Cite No	Foreign Document Number <sup>3</sup>	Country Code <sup>2</sup> i	Kind Code <sup>4</sup>	Publication Date	Name of Patentee or Applicant of cited Document	Pages,Columns,Lines where Relevant Passages or Relevant Figures Appear	T <sup>5</sup>
	1							<input type="checkbox"/>
If you wish to add additional Foreign Patent Document citation information please click the Add button							Add	
NON-PATENT LITERATURE DOCUMENTS							Remove	

**INFORMATION DISCLOSURE  
STATEMENT BY APPLICANT**  
( Not for submission under 37 CFR 1.99)

Application Number		
Filing Date		2006-04-12
First Named Inventor	Philipp	
Art Unit		
Examiner Name		
Attorney Docket Number	PKX	

Examiner Initials*	Cite No	Include name of the author (in CAPITAL LETTERS), title of the article (when appropriate), title of the item (book, magazine, journal, serial, symposium, catalog, etc), date, pages(s), volume-issue number(s), publisher, city and/or country where published.	T <sup>5</sup>
	1		<input type="checkbox"/>

If you wish to add additional non-patent literature document citation information please click the Add button

**EXAMINER SIGNATURE**

Examiner Signature	/Albert Wong/	Date Considered	06/07/2009
--------------------	---------------	-----------------	------------

\*EXAMINER: Initial if reference considered, whether or not citation is in conformance with MPEP 609. Draw line through a citation if not in conformance and not considered. Include copy of this form with next communication to applicant.

<sup>1</sup> See Kind Codes of USPTO Patent Documents at [www.USPTO.GOV](http://www.USPTO.GOV) or MPEP 901.04. <sup>2</sup> Enter office that issued the document, by the two-letter code (WIPO Standard ST.3). <sup>3</sup> For Japanese patent documents, the indication of the year of the reign of the Emperor must precede the serial number of the patent document. <sup>4</sup> Kind of document by the appropriate symbols as indicated on the document under WIPO Standard ST.16 if possible. <sup>5</sup> Applicant is to place a check mark here if English language translation is attached.

**INFORMATION DISCLOSURE  
STATEMENT BY APPLICANT**  
( Not for submission under 37 CFR 1.99)

Application Number			
Filing Date		2006-04-12	
First Named Inventor	Philipp		
Art Unit			
Examiner Name			
Attorney Docket Number		PKX	

**CERTIFICATION STATEMENT**

Please see 37 CFR 1.97 and 1.98 to make the appropriate selection(s):

That each item of information contained in the information disclosure statement was first cited in any communication from a foreign patent office in a counterpart foreign application not more than three months prior to the filing of the information disclosure statement. See 37 CFR 1.97(e)(1).

**OR**

That no item of information contained in the information disclosure statement was cited in a communication from a foreign patent office in a counterpart foreign application, and, to the knowledge of the person signing the certification after making reasonable inquiry, no item of information contained in the information disclosure statement was known to any individual designated in 37 CFR 1.56(c) more than three months prior to the filing of the information disclosure statement. See 37 CFR 1.97(e)(2).

See attached certification statement.

Fee set forth in 37 CFR 1.17 (p) has been submitted herewith.

None

**SIGNATURE**

A signature of the applicant or representative is required in accordance with CFR 1.33, 10.18. Please see CFR 1.4(d) for the form of the signature.

Signature	/David A Kiewit/	Date (YYYY-MM-DD)	2006-04-12
Name/Print	David Kiewit	Registration Number	34640

This collection of information is required by 37 CFR 1.97 and 1.98. The information is required to obtain or retain a benefit by the public which is to file (and by the USPTO to process) an application. Confidentiality is governed by 35 U.S.C. 122 and 37 CFR 1.14. This collection is estimated to take 1 hour to complete, including gathering, preparing and submitting the completed application form to the USPTO. Time will vary depending upon the individual case. Any comments on the amount of time you require to complete this form and/or suggestions for reducing this burden, should be sent to the Chief Information Officer, U.S. Patent and Trademark Office, U.S. Department of Commerce, P.O. Box 1450, Alexandria, VA 22313-1450. **DO NOT SEND FEES OR COMPLETED FORMS TO THIS ADDRESS. SEND TO: Commissioner for Patents, P.O. Box 1450, Alexandria, VA 22313-1450.**

## Privacy Act Statement

The Privacy Act of 1974 (P.L. 93-579) requires that you be given certain information in connection with your submission of the attached form related to a patent application or patent. Accordingly, pursuant to the requirements of the Act, please be advised that: (1) the general authority for the collection of this information is 35 U.S.C. 2(b)(2); (2) furnishing of the information solicited is voluntary; and (3) the principal purpose for which the information is used by the U.S. Patent and Trademark Office is to process and/or examine your submission related to a patent application or patent. If you do not furnish the requested information, the U.S. Patent and Trademark Office may not be able to process and/or examine your submission, which may result in termination of proceedings or abandonment of the application or expiration of the patent.

The information provided by you in this form will be subject to the following routine uses:

1. The information on this form will be treated confidentially to the extent allowed under the Freedom of Information Act (5 U.S.C. 552) and the Privacy Act (5 U.S.C. 552a). Records from this system of records may be disclosed to the Department of Justice to determine whether the Freedom of Information Act requires disclosure of these records.
2. A record from this system of records may be disclosed, as a routine use, in the course of presenting evidence to a court, magistrate, or administrative tribunal, including disclosures to opposing counsel in the course of settlement negotiations.
3. A record in this system of records may be disclosed, as a routine use, to a Member of Congress submitting a request involving an individual, to whom the record pertains, when the individual has requested assistance from the Member with respect to the subject matter of the record.
4. A record in this system of records may be disclosed, as a routine use, to a contractor of the Agency having need for the information in order to perform a contract. Recipients of information shall be required to comply with the requirements of the Privacy Act of 1974, as amended, pursuant to 5 U.S.C. 552a(m).
5. A record related to an International Application filed under the Patent Cooperation Treaty in this system of records may be disclosed, as a routine use, to the International Bureau of the World Intellectual Property Organization, pursuant to the Patent Cooperation Treaty.
6. A record in this system of records may be disclosed, as a routine use, to another federal agency for purposes of National Security review (35 U.S.C. 181) and for review pursuant to the Atomic Energy Act (42 U.S.C. 218(c)).
7. A record from this system of records may be disclosed, as a routine use, to the Administrator, General Services, or his/her designee, during an inspection of records conducted by GSA as part of that agency's responsibility to recommend improvements in records management practices and programs, under authority of 44 U.S.C. 2904 and 2906. Such disclosure shall be made in accordance with the GSA regulations governing inspection of records for this purpose, and any other relevant (i.e., GSA or Commerce) directive. Such disclosure shall not be used to make determinations about individuals.
8. A record from this system of records may be disclosed, as a routine use, to the public after either publication of the application pursuant to 35 U.S.C. 122(b) or issuance of a patent pursuant to 35 U.S.C. 151. Further, a record may be disclosed, subject to the limitations of 37 CFR 1.14, as a routine use, to the public if the record was filed in an application which became abandoned or in which the proceedings were terminated and which application is referenced by either a published application, an application open to public inspections or an issued patent.
9. A record from this system of records may be disclosed, as a routine use, to a Federal, State, or local law enforcement agency, if the USPTO becomes aware of a violation or potential violation of law or regulation.



UNITED STATES PATENT AND TRADEMARK OFFICE

UNITED STATES DEPARTMENT OF COMMERCE  
 United States Patent and Trademark Office  
 Address: COMMISSIONER FOR PATENTS  
 P.O. Box 1450  
 Alexandria, Virginia 22313-1450  
 www.uspto.gov

BIB DATA SHEET

CONFIRMATION NO. 8070

<b>SERIAL NUMBER</b> 11/279,402	<b>FILING or 371(c) DATE</b> 04/12/2006 <b>RULE</b>	<b>CLASS</b> 341	<b>GROUP ART UNIT</b> 2612	<b>ATTORNEY DOCKET NO.</b> 3050.022US1	
<b>APPLICANTS</b> Harald Philipp, Hamble,;					
<b>** CONTINUING DATA *****</b> This appln claims benefit of 60/597,851 12/21/2005 and is a CIP of 11/160,885 07/14/2005 PAT 7,256,714 and is a CON of 10/617,602 07/11/2003 PAT 6,993,607 which claims benefit of 60/395,368 07/12/2002					
<b>** FOREIGN APPLICATIONS *****</b>					
<b>** IF REQUIRED, FOREIGN FILING LICENSE GRANTED ** ** SMALL ENTITY **</b> 05/23/2006					
Foreign Priority claimed <input type="checkbox"/> Yes <input checked="" type="checkbox"/> No 35 USC 119(a-d) conditions met <input type="checkbox"/> Yes <input checked="" type="checkbox"/> No Verified and /ALBERT KANG WONG/ Acknowledged Examiner's Signature	<input type="checkbox"/> Met after Allowance Initials	<b>STATE OR COUNTRY</b>	<b>SHEETS DRAWINGS</b> 7	<b>TOTAL CLAIMS</b> 24	<b>INDEPENDENT CLAIMS</b> 3
<b>ADDRESS</b> SCHWEGMAN, LUNDBERG & WOESSNER / ATMEL P.O. BOX 2938 MINNEAPOLIS, MN 55402 UNITED STATES					
<b>TITLE</b> Capacitive Keyboard with Non-Locking Reduced Keying Ambiguity					
<b>FILING FEE RECEIVED</b> 525	FEES: Authority has been given in Paper No. _____ to charge/credit DEPOSIT ACCOUNT No. _____ for following:		<input type="checkbox"/> All Fees <input type="checkbox"/> 1.16 Fees (Filing) <input type="checkbox"/> 1.17 Fees (Processing Ext. of time) <input type="checkbox"/> 1.18 Fees (Issue) <input type="checkbox"/> Other _____ <input type="checkbox"/> Credit		



UNITED STATES PATENT AND TRADEMARK OFFICE

UNITED STATES DEPARTMENT OF COMMERCE  
 United States Patent and Trademark Office  
 Address: COMMISSIONER FOR PATENTS  
 P.O. Box 1450  
 Alexandria, Virginia 22313-1450  
 www.uspto.gov



Bib Data Sheet

CONFIRMATION NO. 8070

<b>SERIAL NUMBER</b> 11/279,402	<b>FILING OR 371(c) DATE</b> 04/12/2006 <b>RULE</b>	<b>CLASS</b> 341	<b>GROUP ART UNIT</b> 2612	<b>ATTORNEY DOCKET NO.</b> 3050.022US1
------------------------------------	---	---------------------	-------------------------------	---

**APPLICANTS**

Harald Philipp, Hamble, UNITED KINGDOM;

**\*\* CONTINUING DATA \*\*\*\*\***

This appln claims benefit of 60/597,851 12/21/2005  
 and is a CIP of 11/160,885 07/14/2005 PAT 7,256,714  
 which is a CON of 10/617,602 07/11/2003 PAT 6,993,607  
 which claims benefit of 60/395,368 07/12/2002

*See 7/7/09*

**\*\* FOREIGN APPLICATIONS \*\*\*\*\***

**IF REQUIRED, FOREIGN FILING LICENSE GRANTED\*\* SMALL ENTITY\*\***

\*\* 05/23/2006

Foreign Priority claimed <input type="checkbox"/> yes <input checked="" type="checkbox"/> no	<b>STATE OR COUNTRY</b> UNITED KINGDOM	<b>SHEETS DRAWING</b> 7	<b>TOTAL CLAIMS</b> 24	<b>INDEPENDENT CLAIMS</b> 3	
35 USC 119 (a-d) conditions met <input type="checkbox"/> yes <input checked="" type="checkbox"/> no <input type="checkbox"/> Met after Allowance					
Verified and Acknowledged	Examiner's Signature	Initials			

**ADDRESS**

76287

**TITLE**

CAPACITIVE KEYBOARD WITH NON-LOCKING REDUCED KEYING AMBIGUITY

<b>FILING FEE RECEIVED</b> 525	FEES: Authority has been given in Paper No. _____ to charge/credit DEPOSIT ACCOUNT No. _____ for following:	<input type="checkbox"/> All Fees
		<input type="checkbox"/> 1.16 Fees ( Filing )
		<input type="checkbox"/> 1.17 Fees ( Processing Ext. of time )
		<input type="checkbox"/> 1.18 Fees ( Issue )
		<input type="checkbox"/> Other _____
		<input type="checkbox"/> Credit

<p style="text-align: center;"><b>REQUEST FOR CONTINUED EXAMINATION (RCE) TRANSMITTAL</b></p> <p>Subsection (b) of 35 U.S.C. § 132, effective on May 29, 2000, provides for continued examination of an utility or plant application filed on or after June 8, 1995. See The American Inventors Protection Act of 1999 (AIPA).</p>	<i>Application Number</i>	11/279,402
	<i>Filing Date</i>	April 12, 2006
	<i>First Named Inventor</i>	Harald Philipp
	<i>Confirmation Number</i>	8070
	<i>Group Art Unit</i>	2612
	<i>Examiner Name</i>	Daniel Wu
	<i>Attorney Docket Number</i>	3050.022US1
	<i>Customer No.</i>	76287

This is a Request for Continued Examination (RCE) under 37 C.F.R § 1.114 of the above-identified application entitled Capacitive Keyboard with Non-Locking Reduced Keying Ambiguity

1. Submission required under 37 C.F.R. § 1.114:

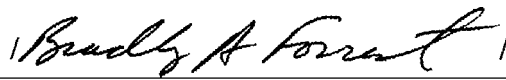
Information Disclosure Statement (2 pages), Form 1449 (1 page), and copies of cited documents (5).

2. Fees

Authorization to charge deposit account 19-0743 in the amount of \$810.00 to pay the RCE filing fee required under 37 C.F.R. § 1.17(e).

**The Commissioner is hereby authorized to charge any additional fees or credit overpayment to Deposit Account No. 19-0743.**

SCHWEGMAN, LUNDBERG & WOESSNER, P.A.

By:   
Bradley A. Forrest  
Reg. No. 30,837

CERTIFICATE UNDER 37 C.F.R 1.8: The undersigned hereby certifies that this correspondence is being filed using the USPTO's electronic filing system EFS-Web, and is addressed to: Mail Stop RCE, Commissioner for Patents, P.O. Box 1450, Alexandria, VA 22313-1450 on this 17th day of September, 2009.

Nicole Jack  
Name

/Nicole Jack/  
Signature



S/N 11/279,402

PATENT

IN THE UNITED STATES PATENT AND TRADEMARK OFFICE

Applicant:	Harald Philipp	Examiner:	Daniel Wu
Serial No.:	11/279,402	Group Art Unit:	2612
Filed:	April 12, 2006	Docket:	3050.022US1
Customer No.:	76287	Confirmation No.:	8070
Title:	Capacitive Keyboard with Non-Locking Reduced Keying Ambiguity		

---

INFORMATION DISCLOSURE STATEMENT

Mail Stop RCE  
Commissioner for Patents  
P.O. Box 1450  
Alexandria, VA 22313-1450

In compliance with the duty imposed by 37 C.F.R. § 1.56, and in accordance with 37 C.F.R. §§ 1.97 *et. seq.*, the enclosed materials are brought to the attention of the Examiner for consideration in connection with the above-identified patent application. Applicant respectfully requests that this Information Disclosure Statement be entered and the documents listed on the attached PTO 1449 Form be considered by the Examiner and made of record. Pursuant to the provisions of MPEP 609, Applicant requests that a copy of the PTO 1449 Form, initialed as being considered by the Examiner, be returned to the Applicant with the next official communication.

Pursuant to 37 C.F.R. § 1.97(b), it is believed that no fee or statement is required with the Information Disclosure Statement. However, if an Office Action on the merits has been mailed, the Commissioner is hereby authorized to charge the required fees to Deposit Account No. 19-0743 in order to have this Information Disclosure Statement considered.

Pursuant to 37 C.F.R. § 1.98(a)(2), copies of cited U.S. Patents and Published Applications, and Non-Published Applications identifiable by USPTO Serial Number, are no longer required to be provided to the Office. Applicant acknowledges the requirement to submit copies of foreign patent documents and non-patent literature in accordance with 37 C.F.R § 1.98(a)(2).

INFORMATION DISCLOSURE STATEMENT

Serial Number:11/279,402

Filing Date: April 12, 2006

Title: Capacitive Keyboard with Non-Locking Reduced Keying Ambiguity

Page 2

Dkt: 3050.022US1

The Examiner is invited to contact the Applicant's Representative at the telephone number indicated if there are any questions regarding this communication.

Respectfully submitted,

SCHWEGMAN, LUNDBERG & WOESSNER, P.A.

P.O. Box 2938

Minneapolis, MN 55402

(612) 373-6972

Date 17 September 2009 By *Bradley A Forrest*  
Bradley A. Forrest  
Reg. No. 30,837

CERTIFICATE UNDER 37 CFR 1.8: The undersigned hereby certifies that this correspondence is being filed using the USPTO's electronic filing system EFS-Web, and is addressed to: Mail Stop RCE, Commissioner for Patents, P.O. Box 1450, Alexandria, VA 22313-1450 on this 17th day of September, 2009.

Nicole Jack  
Name

/Nicole Jack/  
Signature

Under the Paperwork Reduction Act of 1995, no persons are required to respond to a collection of information unless it contains a valid OMB control number.

Substitute for form 1449A/PTO  <b>INFORMATION DISCLOSURE STATEMENT BY APPLICANT</b>  (Use as many sheets as necessary)	<i>Complete if Known</i>	
	<b>Application Number</b>	11/279,402
	<b>Filing Date</b>	April 12, 2006
	<b>First Named Inventor</b>	Harald Philipp
	<b>Group Art Unit</b>	2612
	<b>Examiner Name</b>	Daniel Wu
Sheet 1 of 1	Attorney Docket No: 3050.022US1	

US PATENT DOCUMENTS				
Examiner Initial *	USP Document Number	Publication Date	Name of Patentee or Applicant of cited Document	Filing Date If Appropriate
	US-4,305,135	12/08/1981	Dahl, Jerome P., et al.	07/30/1979
	US-4,420,744	12/13/1983	Jesson, Joseph E.	02/12/1981
	US-4,616,213	10/07/1986	Danish, Sherif	01/14/1983
	US-4,617,554	10/14/1986	Krause, Charles A., et al.	08/26/1983
	US-5,469,159	11/21/1995	Fukazawa, Makoto	06/09/1992
	US-5,508,700	04/16/1996	Taylor, Thomas M., et al.	03/17/1994
	US-5,583,498	12/10/1996	Sukigara, Akihiko	11/08/1994
	US-5,585,733	12/17/1996	Paglione, Robert W.	06/07/1995
	US-5,730,165	03/24/1998	Philipp, Harald	12/26/1995
	US-5,844,506	12/01/1998	Binstead, Ronald Peter	10/03/1996
	US-6,137,427	10/24/2000	Binstead, Ronald P	10/27/1998
	US-6,452,514	09/17/2002	Philipp, Harald	01/26/2000
	US-6,466,036	10/15/2002	Philipp, Harald	09/07/1999
	US-6,943,705	09/13/2005	Bolender, Robert James, et al.	09/19/2002
	US-7,091,886	08/15/2006	DePue, Todd L., et al.	06/09/2004
	US-7,158,054	01/02/2007	Pihlaja, Pekka	09/21/2004

FOREIGN PATENT DOCUMENTS				
Examiner Initials*	Foreign Document No	Publication Date	Name of Patentee or Applicant of cited Document	T <sup>1</sup>
	EP-0609021A2	08/03/1994	Boie, Robert Albert, et al.	
	EP-0689122A1	12/27/1995	Katsumi, Murai, et al.	

OTHER DOCUMENTS – NON PATENT LITERATURE DOCUMENTS		
Examiner Initials*	Include name of the author (in CAPITAL LETTERS), title of the article (when appropriate), title of the item (book, magazine, journal, serial, symposium, catalog, etc.), date, page(s), volume-issue number(s), publisher, city and/or country where published.	T <sup>1</sup>
	"Application Serial No. 10/617,602, Amendment filed January 27, 2005", 6 pages	
	"Application Serial No. 10/617,602, Notice of Allowance mailed 4/27/05", 9 pages	
	"Application Serial No. 11/160,885, Notice of Allowance mailed June 8, 2007", 8 pages	

EXAMINER

DATE CONSIDERED

\* EXAMINER: Initial if reference considered, whether or not citation is in conformance with MPEP 609. Draw line through citation if not in conformance and not considered. Include copy of this form with next communication to applicant. 1 Applicant is to place a check mark here if English language Translation is attached



⑫

**EUROPEAN PATENT APPLICATION**

⑳ Application number : **94300416.8**

⑤① Int. Cl.<sup>5</sup> : **G06K 11/16**

㉒ Date of filing : **19.01.94**

③⑩ Priority : **29.01.93 US 11040**

④③ Date of publication of application :  
**03.08.94 Bulletin 94/31**

⑧④ Designated Contracting States :  
**FR GB**

⑦① Applicant : **AT & T Corp.**  
**32 Avenue of the Americas**  
**New York, NY 10013-2412 (US)**

⑦② Inventor : **Boie, Robert Albert**  
**200 Linden Avenue**  
**Westfield, New Jersey 07090 (US)**  
Inventor : **Ruedisueli, Laurence W.**  
**33 Dell Lane**  
**Berkeley Heights, New Jersey 07922 (US)**  
Inventor : **Wagner, Eric Richard**  
**400 Rahway Avenue**  
**South Plainfield, New Jersey 07080 (US)**

⑦④ Representative : **Johnston, Kenneth Graham et al**  
**AT&T (UK) Ltd.**  
**5 Mornington Road**  
**Woodford Green Essex, IG8 OTU (GB)**

⑤④ **Capacitive position sensor.**

⑤⑦ A computer input device for use as a computer mouse or keyboard comprises a thin, insulating surface covering an array of electrodes. Such electrodes are arranged in a grid pattern and can be connected in columns and rows. Each column and row is connected to circuitry for measuring the capacitance seen by each column and row. The position of an object, such as a finger or handheld stylus, with respect to the array is determined from the centroid of such capacitance values, which is calculated in a microcontroller. For applications in which the input device is used as a mouse, the microcontroller forwards position change information to the computer. For applications in which the input device is used as a keyboard, the microcomputer identifies a key from the position of the touching object and forwards such key identity to the computer.

**Field of the Invention**

This invention relates to sensors for capacitively sensing the position or movement of an object, such as a finger, on a surface.

5

**Background of the Invention**

Numerous devices are known for sensing the position of objects on surfaces, many of which relate to computer input tablets. For example, U. S. Patent No. 5,113,041 to Greg E. Blonder et al. discloses a computer input tablet for use with a stylus in which the position of the stylus can be determined from signals transmitted to the stylus from a grid of signal lines embedded in the tablet, and U. S. Patent No 4,806,709 to Blair Evans discloses a touch-screen having a resistive layer with a number of point electrodes spaced thereon such that the position of a finger touching the screen can be determined from the relative values of the currents drawn from the point electrodes. The first such device requires means for the stylus itself to transmit information, such as a direct electrical connection. The second such device, and other kinds of tablets that sense the pressure of a finger or stylus, do not require such information-transmitting means.

10

15

Computer input tablets can be used for input of textual or graphical information. Various systems are known in the art which process handwritten text as if it were entered on a keyboard. Graphical information can also be captured by means of such tablets.

20

Other input devices such as computer "mice," joysticks and trackballs can be used with computers to control the position of a cursor on a display screen, such as a video terminal, for input of graphical information and for interactive programs such as computer games and programs using "windows" for display of information. Movement of a mouse in a particular direction on a surface causes a corresponding movement of the cursor or other object on the screen. Similarly, movement of a joystick or trackball in a particular direction causes such movement.

25

Input devices such as mice, joysticks and trackballs can be cumbersome because of their size and shape and, particularly with mice, the room needed for use. These drawbacks are more apparent with respect to portable computers, such as the so-called "notebook" computers. It is desirable, therefore, to furnish such control capabilities in an input device that can be incorporated in a small space, but without sacrificing ease of use. It is also desirable to be able to use such a device for multiple functions, for example, a particular area of a computer keyboard that can also be used as a mouse without losing its functionality as a keyboard. Further, it is desirable that such an input device be capable of operation by a finger or handheld stylus that does not require an electrical connection or other means for transmitting information.

30

35

**Summary of the Invention**

The capacitive sensor of the invention comprises a thin, insulating surface covering a plurality of electrodes. The position of an object, such as a finger or hand-held stylus, with respect to the electrodes, is determined from the centroid of capacitance values measured at the electrodes. The electrodes can be arranged in one or two dimensions. In a two-dimensional array, the capacitance for each electrode can be measured separately or the electrodes can be divided into separate elements connected in columns and rows and the capacitances measured for each column and row. The x and y coordinates of the centroid are calculated in a microcontroller from the measured capacitances. For applications in which the sensor is used to emulate a mouse or trackball, the microcontroller forwards position change information to utilizing means. For applications in which the sensor is used to emulate a keyboard, the microcontroller identifies a key from the position of the touching object and forwards such key identification to utilizing means.

40

45

These and other aspects of the invention will become apparent from the attached drawings and detailed description.

50

**Brief Description of the Drawing**

FIG. 1 is a graphic diagram showing the relationship between the position of a user's finger and capacitances at electrodes in a two-dimensional sensor constructed in accordance with the invention.

FIG. 2 is a more detailed representation of interdigitated electrode components at the intersections of rows and columns in a two-dimensional sensor.

55

FIG. 3 is an alternate arrangement for electrodes in the array.

FIG. 4 is an overall block diagram of a two-dimensional capacitive position sensor in accordance with the invention.

FIG. 5 is a diagram of an integrating amplifier and bootstrap circuit associated with the electrodes.

FIG. 6 is a flow chart showing operation of the capacitive position sensor of the invention as a computer mouse or trackball.

FIG. 7 is a diagram showing use of the capacitive position sensor of the invention as a keyboard.

5 FIG. 8 is a flow chart showing operation of the capacitive position sensor of the invention as a keyboard.

### Detailed Description

10 The invention will be described in terms of an exemplary two-dimensional embodiment adapted to emulate a computer mouse or keyboard for use with a personal computer. However, it will be clear to those skilled in the art that the principles of the invention can be utilized in other applications in which it is convenient to sense position of an object capacitively in one or more dimensions.

15 The operational principle of the capacitive position sensor of the invention is shown in FIG. 1. Electrode array 100 is a square or rectangular array of electrodes 101 arranged in a grid pattern of rows and columns, as in an array of tiles. A 4 x 4 array is shown, which we have found adequate for emulating a computer mouse by finger strokes on the array. However, the invention can be used with arrays of other sizes, if desired. The electrodes are covered with a thin layer of insulating material (not shown). Finger 102 is shown positioned with respect to array 100. Electrode array 100 can be one-dimensional for applications in which position in only one dimension is to be sensed.

20 Histogram 110 shows the capacitances for electrodes 101 in array 100 with respect to finger 102. Such capacitances are a two-dimensional sampling of the distribution of capacitance between array 100 and finger 102. The centroid (center of gravity or first moment) 111 of such distribution will correspond to the position of finger 102, or some other object touching array 100, if suitable sampling criteria are met; that is, by choosing electrodes of sufficiently small size when compared to the extent of the distribution. Such criteria are discussed  
25 in the Blonder et al. patent referred to above.

The x and y coordinates of the centroid can be determined by directly measuring the capacitance at each electrode 101 and calculating such x and y coordinates from such measured capacitances. Thus, for the 4 x 4 array 100, sixteen capacitance measurements would be needed. The number of measurements can be reduced, however, by taking advantage of the fact that the one-dimensional centroids of the projections of the distribution onto the x and y axes also correspond to the finger position. Such projections can be formed by  
30 subdividing each electrode 101 into two elements, as shown in FIG. 2.

FIG. 2 shows four such subdivided electrodes in more detail at an intersection of two rows and two columns in array 100. As can be seen from FIG. 2, a horizontal element 201 and a vertical element 202 are situated at each intersection of a row and column. Horizontal elements 201 are interconnected by leads 203 and vertical elements 202 are interconnected by leads 204. Elements 201 and 202 can be interdigitated as shown. It is advantageous for the conducting areas of elements 201 and 202 to cover the surface of array 100 as completely as possible. For finger strokes, we have used interdigitated elements 201 and 202 that are approximately 0.37" square. Smaller electrodes 101 or elements 201 and 202 be desirable for use with a hand-held stylus having a smaller cross-section than a finger.  
35

40 As will be clear to those skilled in the art, elements 201 and 202 can be fabricated in one plane of a multi-layer printed circuit board together with one set of interconnections, for example, the horizontal row connections 203. The vertical row connections 204 can then be fabricated in another plane of the circuit board with appropriate via connections between the planes.

45 Other electrode array configurations can be used, if desired. For example, FIG. 3 shows horizontal strip electrodes 203' overlapping vertical strip electrodes 204'. Electrodes 203' and 204' are separated by a thin insulating layer (not shown) and covered by another thin insulating layer (not shown). In such a configuration, areas of electrodes 204' must be left unmasked by electrodes 203' so that electrodes 204' can still "see" the capacitance of an object touching the surface in which such electrodes are embedded. A similar configuration of electrodes is shown in the Blonder et al. patent. However, the structure of FIG. 2 is preferred because the interdigitated elements 201 and 202 do not overlap and the capacitance values measured can be higher for a given area of array 100, thus providing greater noise immunity.  
50

FIG. 4 is an overall block diagram of a capacitive sensor 400 in accordance with the invention. Electrode array 100 comprises rows and columns of electrodes, for example, rows and columns of connected horizontal and vertical elements as shown in FIG. 2. Referring again to FIG. 4, each row and column of electrodes from array 100 is connected to an integrating amplifier and bootstrap circuit 401, which is shown in more detail in  
55 FIG. 5 and will be described below. Each of the outputs from circuits 401 can be selected by multiplexer 402 under control of microcontroller 406. The selected output is then forwarded to summing circuit 403, where such output is combined with a signal from trimmer resistor 409. Synchronous detector and filter 404 convert the

output from summing circuit 403 to a signal related to the capacitance of the row or column selected by multiplexer 402. RF oscillator 408 provides an RF signal, for example, 100 kilohertz, to circuits 401, synchronous detector and filter 404 via inverter 410, and guard plane 411. Guard plane 411 is a substantially continuous plane parallel to array 100 and associated connections, and serves to isolate array 100 from extraneous signals. The operation of synchronous detector and filter 404 is well known in the art, for example, see page 889 of "The Art of Electronics," Second Edition, by Horowitz and Hill, Cambridge University Press (1989).

Apparatus similar to that shown in FIG. 4 can also be used for applications in which it is desired to measure separate capacitance values for each electrode in array 100 instead of the collective capacitances of subdivided electrode elements connected in rows and columns. To measure such capacitances separately, a circuit 401 is provided for each electrode in array 100 and multiplexer 402 is enlarged to accommodate the outputs from all circuits 401.

The output of synchronous detector and filter 404 is converted to digital form by analog-to-digital converter 405 and forwarded to microcontroller 406. Thus, microcontroller 406 can obtain a digital value representing the capacitance seen by any row or column of electrode elements (or electrode if measured separately) selected by multiplexer 402. Buttons 407, which can be auxiliary pushbuttons or switches situated near array 400, are also connected to microcontroller 406. Buttons 407 can be used, for example, for the same purposes as the buttons on a computer mouse. Microcontroller 407 sends data to utilizing means, such as a personal computer (not shown) over lead 420. A particular device that can be used for A/D converter 405 and microcontroller 406 is the 87C552 circuit made by Intel Corporation, which includes both an A/D converter and a microprocessor.

FIG. 5 is a circuit diagram of each integrating amplifier and bootstrap circuit 401. The RF signal from RF oscillator 408 drives the base of transistor Q1 and the bootstrap circuit comprised of resistor 501 and capacitor 502. Current source 503 provides a constant DC bias current through transistor Q1. An electrode in array 100 is connected to the emitter of transistor Q1. The RF current to an electrode is determined by the capacitance seen by the electrode; thus, an increase in capacitance caused by the proximity of an object, such as a finger, causes an increase in such current. Such an increase is reflected as a change in the RF current flowing from the collector of transistor Q1. The collector of transistor Q1 is connected to the input node of integrating amplifier 505 via coupling capacitor 506. For a change in capacitance,  $\Delta C$ , at the electrode, the change in the amplitude of the output signal from amplifier 505 will be approximately  $A(\Delta C/C_T)$ , where A is the amplitude of the RF signal from oscillator 408 and  $C_T$  is the value of integrating capacitor 507. Resistor 508 provides a bias current for amplifier 505 and resistor 504 provides bias current for transistor Q1.

The effects of electrode-to-electrode capacitances, wiring capacitances and other extraneous capacitances are minimized by driving all electrodes and guard plane 411 in unison from RF oscillator 408. The bootstrap circuit serves to minimize any signal due to the finite impedance of the biasing circuit of transistor Q1. The base-to-collector capacitance of transistors Q1 and other stray capacitances in the circuit can be compensated for by adjusting trim resistor 109 shown in FIG. 1.

In using the position sensor of the invention as a computer mouse or trackball to control a cursor, movement of the mouse or trackball is emulated by touching array 100 with finger 102, or some other object, and stroking finger 102 over array 100 to move the cursor. Changes in position of the finger with respect to array 100 are reflected in corresponding changes in position of the cursor. Thus, for such an application, microcontroller 406 sends data over lead 420 relating to changes in position. FIG. 6 is a flow chart of the operation of microcontroller 406 in such an application.

Referring to FIG. 6, microcomputer 406 reads the initial capacitance values for all the elements in array 100 and stores such values (step 601). Such initial values should reflect the state of array 100 without a finger or other object being nearby, accordingly, it may be desirable to repeat step 601 a number of times and then to select the minimum capacitance values read as the initial values, thereby compensating for the effect of any objects moving close to array 100 during the initialization step. After initialization, all capacitance values are periodically read and the initial values subtracted to yield a remainder value for each element (step 602). If one or more of the remainders exceeds a preset threshold (step 603), indicating that an object is close to or touching array 100, then the x and y coordinates of the centroid of capacitance for such object can be calculated from such remainders (step 604). For applications in which the electrodes of array 100 are connected in rows and columns, as shown in FIG. 2 and FIG. 3, such calculation can be performed as follows:

$$x = \frac{\sum_{n_x=1}^{u_x} n_x V(n_x)}{\sum_{n_x=1}^{u_x} V(n_x)} \quad (1)$$

$$y = \frac{\sum_{n_y=1}^{u_y} n_y V(n_y)}{\sum_{n_y=1}^{u_y} V(n_y)} \quad (2)$$

where:

$u_x$  is the number of columns,  $V(n_x)$  is the value measured for column  $n_x$ ,  $u_y$  is the number of rows and  $V(n_y)$  is the value measured for row  $n_y$ . To avoid spurious operation, it may be desirable to require that two or more measurements exceed the preset threshold. The threshold can be set to some percentage of the range of A/D converter 405, for example 10-15% of such range.

For applications in which the capacitance values for the electrode 101 in array 100 are measured separately, the  $x$  and  $y$  values of the centroid can also be calculated using equations (1) and (2) by adding all the capacitances measured for a row or column to obtain the value of  $V$  for such row or column. Such addition has the same effect as if the electrodes were connected together in a row or column.

When set, the "T" flag indicates that remainders were above the threshold during the previous iteration through step 603. Such flag is set during step 606 and cleared during step 607. Thus, after the first iteration through step 603, indicating a new stroke of finger 102 on array 100, the "T" flag is set and the  $x$  and  $y$  values just calculated are stored. During each subsequent iteration during such stroke, the changes in  $x$  and  $y$  ( $dx$  and  $dy$ ) are calculated (step 608) as follows:

$$dx = x_c - x_p \quad (3)$$

$$dy = y_c - y_p \quad (4)$$

where  $x_c$  and  $y_c$  are the values just calculated in step 605 and  $x_p$  and  $y_p$  are the values calculated and stored (step 610) during the previous iteration.

It may be desirable to remove jitter from the least-significant bit in the values of  $dx$  and  $dy$  calculated (step 609). This can be accomplished by incrementing negative values by 1 and decrementing positive values by 1, leaving zero values without change.

The values calculated for  $x$  and  $y$  are stored (step 610) for use in calculating  $dx$  and  $dy$  during the next iteration. Then, if other inputs, such as buttons 407, are connected to microcontroller 406, the state of such inputs is read (step 611). Finally, if  $x$  and  $y$  have changed ( $dx \neq 0$  or  $dy \neq 0$ ) or the state of buttons 407 has changed (step 612), data relating to such changes is sent over line 420 to the computer or other utilizing means to which sensor 400 is connected (step 613). Such data typically includes  $dx$ ,  $dy$  and the current state of the buttons, which corresponds to that sent to a computer by a conventional computer mouse or trackball. Finally the states of such other inputs are stored (step 614) for use during the next iteration.

Typically the cycle time through the above-described steps will be about 20 milliseconds, depending on the time constant of the filter in circuit 404. After each change of multiplexer 402, microcontroller 406 is programmed to wait approximately 2 milliseconds for the output of circuit 404 to settle.

It will be clear that the absolute values of  $x$  and  $y$  can be included in the data sent over line 420 to utilizing means, if desired. For example, capacitive input sensor 400 can be adapted for use as a general purpose input pad for entering handwritten information. For such an application, it may be desirable to increase the number of electrodes to improve definition, but even a 4x4 matrix for use with finger input can produce useful input data because of the interpolating effect of the centroid-finding calculations performed in step 604.

Instead of using buttons 407 for additional input when array sensor 100 is used as a computer mouse, it may be desirable to sense different finger pressures. For example, to perform a "click and drag" operation, a typical use of a computer mouse, a heavier finger pressure can be used on array 100 than when an ordinary cursor movement is desired. Clearly finger pressures can be sensed by electromechanical or other means,



but differences in the capacitances sensed by sensor 400 can also be used for this purpose.

The magnitudes of the capacitance values sensed by array 100 are somewhat related to finger pressure because of the compressibility of the fingertip when contacting array 100. Higher finger pressure will cause higher capacitance values to be sensed. This effect can be enhanced by replacing the insulating layer (not shown) on array 100 with a compressible insulating layer. Different finger pressures can be set by defining one or more additional thresholds for use in step 603. An ordinary touch would cause the remainders to exceed only the first threshold; a heavier touch would cause at least one remainder to exceed a higher threshold, which could then be used to indicate a different button state.

FIG. 7 is a diagram showing how an array 100 can be used as a keyboard in accordance with the invention. Again, array 100 is shown as a 4 x 4 matrix of electrodes, but with a keyboard pattern overlay superimposed on the matrix. Such a keyboard pattern can be printed on the insulating layer covering the electrodes. Note that the individual "keys" in the keyboard do not necessarily correspond to the underlying electrodes. The x and y coordinates are shown for reference purposes. Since the values obtained for x and y in a 4 x 4 matrix using equations (1) and (2) will range from 1 to 4, this range is shown on the coordinates.

The identity of a key touched is determined from the x and y values computed for the centroid of capacitance resulting from the touch. For example, using the x and y coordinates shown in FIG. 7, a "5" can be defined as a touch with  $[1.7 \leq x \leq 2.3, 2.3 \leq y \leq 2.7]$ ; a "0" can be defined as a touch with  $[1 \leq x \leq 2.3, 1 \leq y \leq 1.3]$ ; and a "+" can be defined as a touch with  $[3.7 \leq x \leq 4, 2.4 \leq y \leq 3.5]$ . These ranges are chosen to leave guard bands between adjacent keys.

FIG. 8 is a flow chart showing operation of microcontroller 406 when the capacitive position sensor of the invention is used as a keyboard. Steps 801, 802, 803 and 805 are similar to steps 601, 602, 603 and 604, respectively, in FIG. 6. In step 806, the identity of the key touched is determined from the values of x and y calculated in step 806. In step 807, the identity of the key touched is sent to utilizing means. The "T" flag is set in step 808, cleared in step 809 and tested in step 804. Such flag assures that the key identity is sent to utilizing means only once.

It should be clear that the various ways described above of using the capacitive position sensor of the invention can be combined. For example, a combination mouse-keyboard can be implemented in which one portion of array 100 is used as a mouse responsive to finger strokes and a second portion is used as a keyboard responsive to finger touches. Alternatively, array 100 can be adapted to operate in different modes: the first mode as a mouse, the second as a keyboard. Switching between modes can be accomplished, for example, with one of buttons 407, or with extra pressure in a specified region of array 100. Thus, where space is at a premium, such as in a portable computer, the capacitive position sensor of the invention can be used as part of the keyboard and also as a mouse.

The invention has been shown and described with reference to particular embodiments. However, it will be understood by those skilled in the art that various changes may be made therein without departing from the spirit and scope of the invention.

## Claims

1. A sensor (100) for capacitively sensing the position of an object on a surface, which includes an array of electrodes (101) on said surface, an insulating layer covering said electrodes and means (401, 402, 403, 404, 405, 408, 409, 410) for measuring a capacitance value for each said electrode;

### CHARACTERIZED BY

- means (406) operative when at least one of said capacitance values exceeds a first preset threshold for determining the position of said object by calculating the centroid of capacitance for said array from said measured capacitance values and
- means (406) for sending said position to utilizing means.

2. The sensor of claim 1

### CHARACTERIZED IN THAT

- said array is a two-dimensional array and said electrodes are arranged in rows and columns.

3. The sensor of claim 1

### CHARACTERIZED IN THAT

- said calculating means periodically calculates changes in said position and said sending means periodically sends said changes to said utilizing means.

4. The sensor of claim 2  
FURTHER CHARACTERIZED IN THAT  
said sensor is adapted for use as a keyboard wherein said means for calculating further comprises:  
a stored range of coordinates (in 406) for each key in said keyboard;  
5 means for determining a key identity from said calculated position and said stored range and said  
sending means sends said key identity to said utilizing means.
5. The sensor of claim 1  
FURTHER CHARACTERIZED BY  
10 means operative when at least one of said capacitance values exceeds at least a second preset  
threshold for indicating to said utilizing means the thresholds exceeded.
6. The sensor of claim 2  
FURTHER CHARACTERIZED BY  
15 at each intersection of a row and a column, a first electrode element is connected to other electrode  
elements in said row, thereby forming the electrode for said row, and a second electrode element is con-  
nected to other electrode elements in said column, thereby forming the electrode for said column.
7. The sensor of claim 6  
FURTHER CHARACTERIZED BY  
20 said first and second electrode elements at each intersection are interdigitated.
8. The sensor of claim 1  
FURTHER CHARACTERIZED IN THAT  
25 said measuring means further comprises:  
means (408) for supplying an RF signal in unison to each said electrode,  
means (401) for sensing RF current signals for each said electrode, and  
means (403, 404, 409, 410) for converting said RF current signals into signals representative of  
the capacitances seen by each said electrode.
9. The sensor of claim 8  
FURTHER CHARACTERIZED BY  
30 a guard plane (411) substantially parallel to said electrodes, and said means for supplying further  
comprises:  
35 means for supplying said RF signal to said guard plane in unison with the RF signals supplied to  
said electrodes.
10. The sensor of any of claims 1-9  
CHARACTERIZED IN THAT  
40 said sensor is adapted for use as a touch-sensitive input device for a computer.

45

50

55

FIG. 1

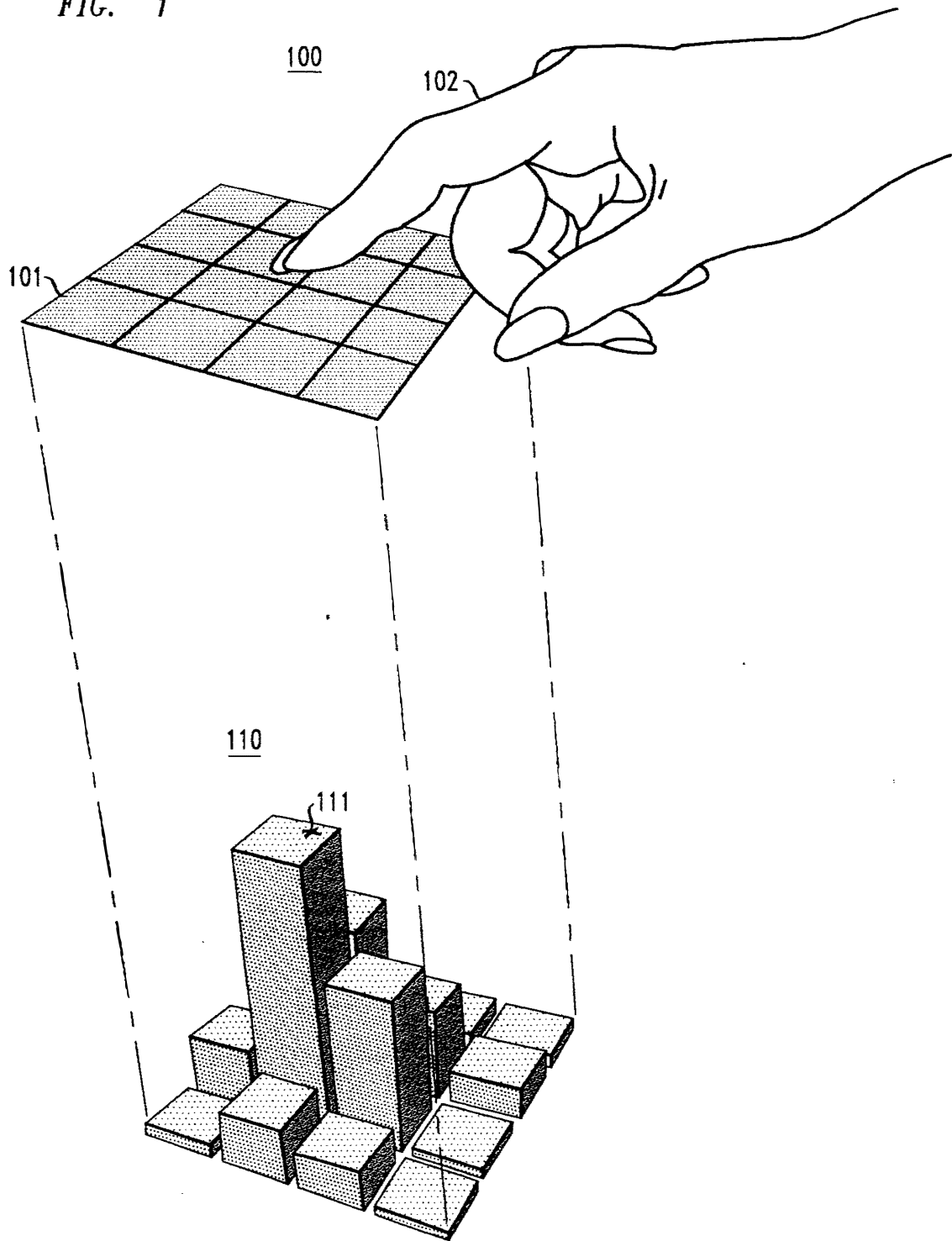


FIG. 2

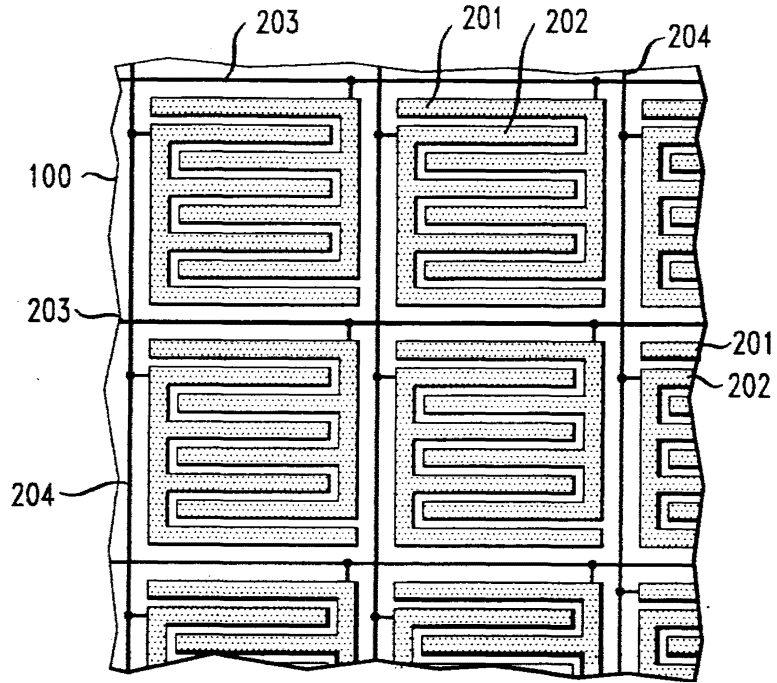


FIG. 3

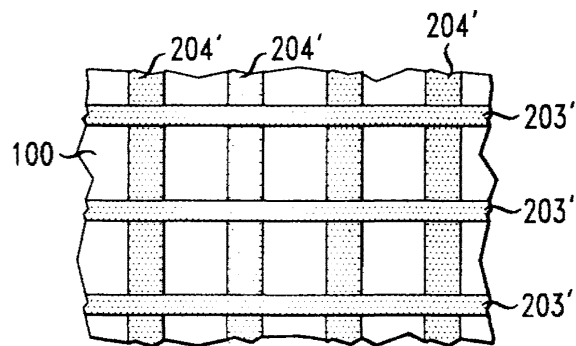


FIG. 4

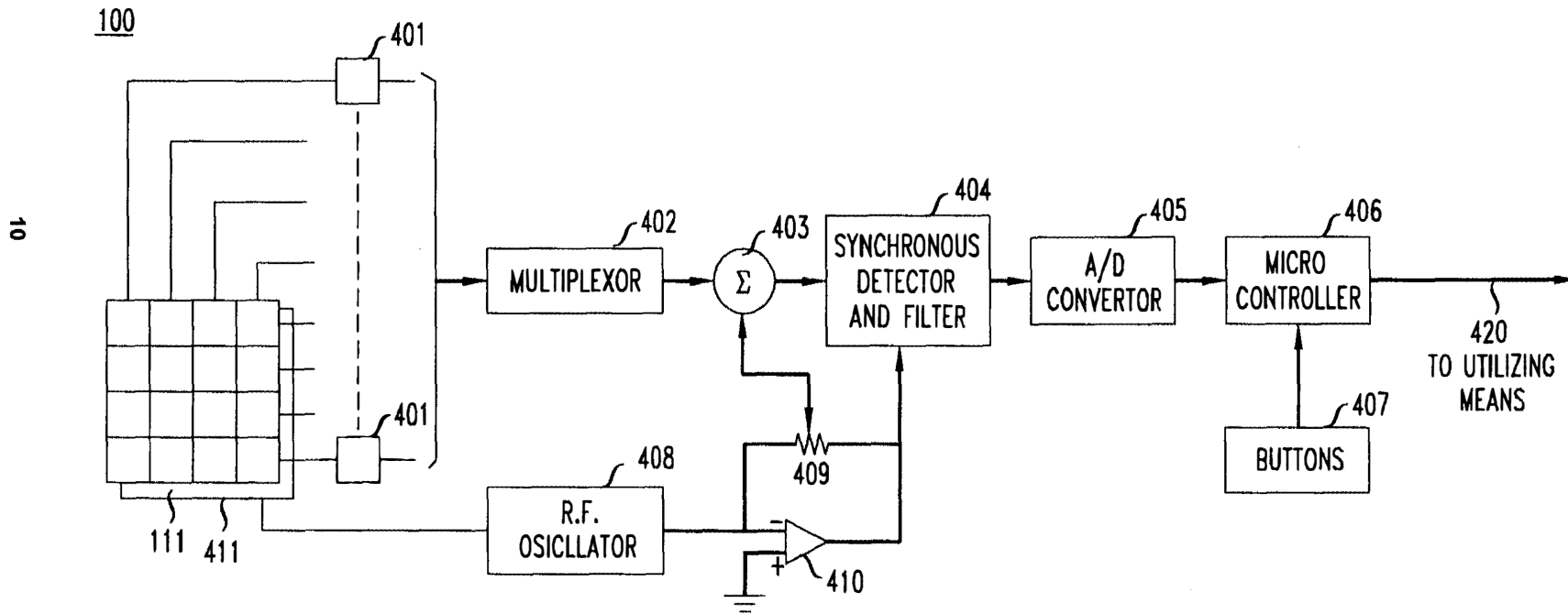


FIG. 5

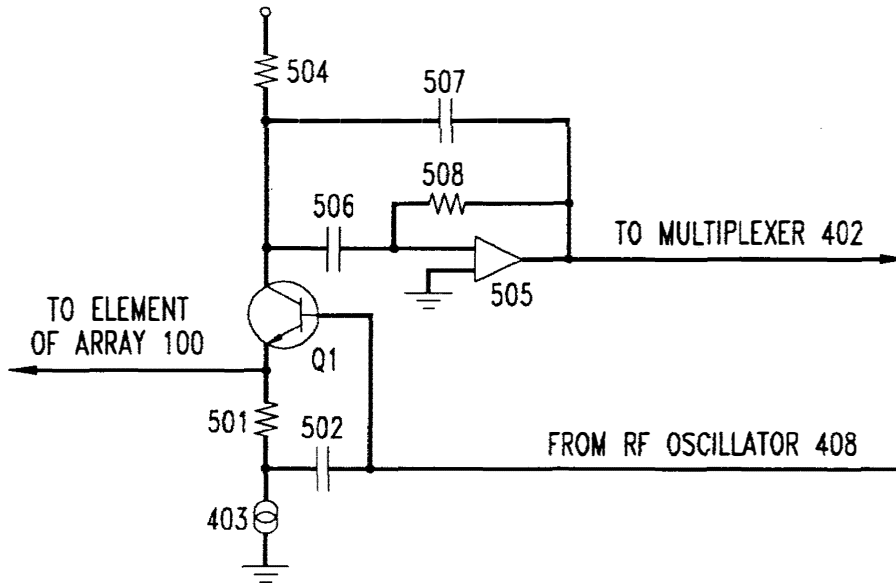


FIG. 7

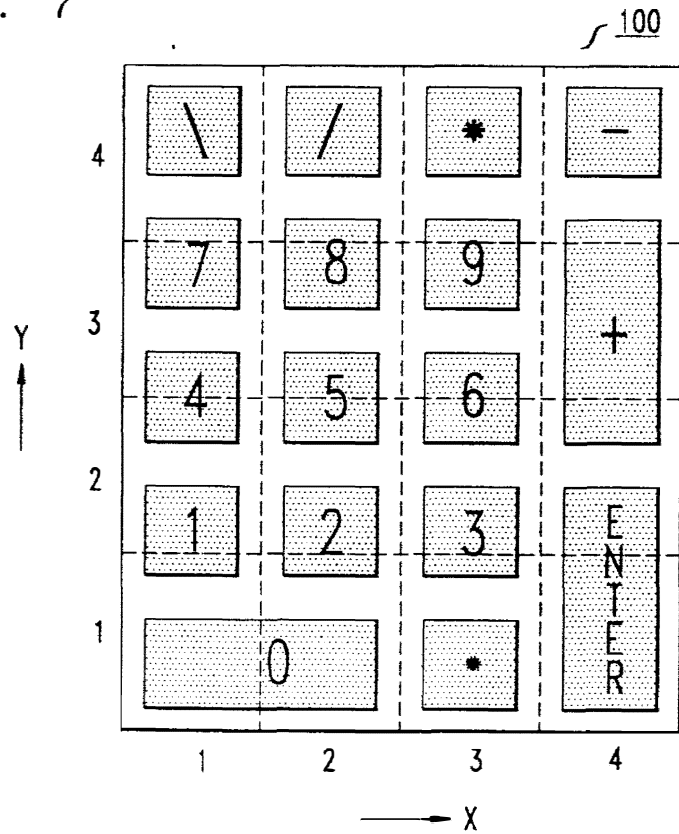


FIG. 6

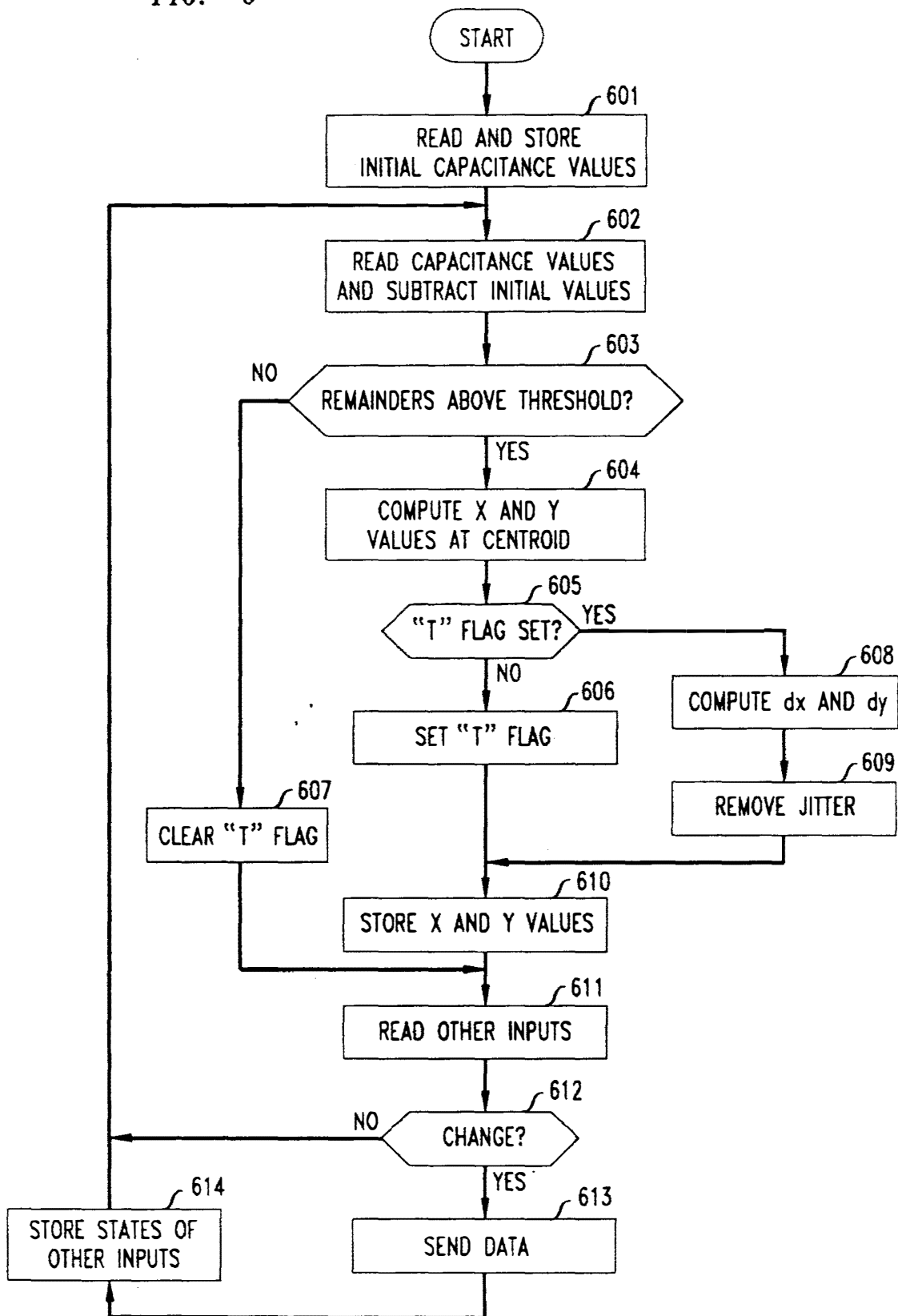
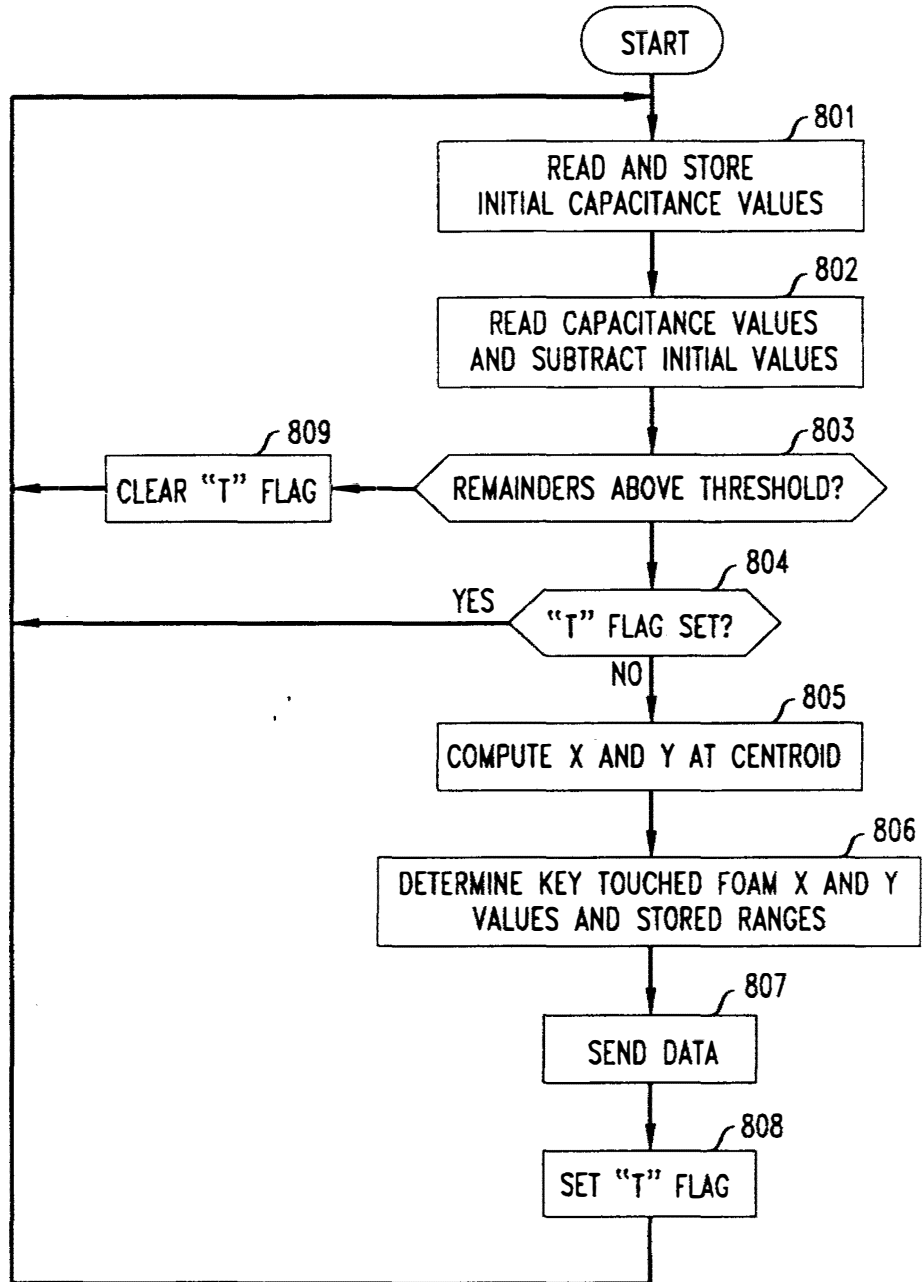


FIG. 8







Europäisches Patentamt  
European Patent Office  
Office européen des brevets



Publication number:

**0 689 122 A1**

12

**EUROPEAN PATENT APPLICATION  
published in accordance with Art.  
158(3) EPC**

21 Application number: **95906501.2**

51 Int. Cl.<sup>6</sup>: **G06F 3/02**

22 Date of filing: **20.01.95**

86 International application number:  
**PCT/JP95/00062**

87 International publication number:  
**WO 95/20187 (27.07.95 95/32)**

30 Priority: **24.01.94 JP 5974/94**

43 Date of publication of application:  
**27.12.95 Bulletin 95/52**

84 Designated Contracting States:  
**DE FR GB**

71 Applicant: **MATSUSHITA ELECTRIC  
INDUSTRIAL CO., LTD.  
1006, Ohaza Kadoma  
Kadoma-shi,  
Osaka 571 (JP)**

72 Inventor: **MURAI, Katsumi  
Nishi 2-919,  
6 Banchi, Sotojimachou  
Moriguchishi,  
Osaka 570 (JP)  
Inventor: **HASHIMOTO, Kenji****

**Shoushin-Ryo,  
24-2, Fujinokidai 3-chome  
Nara-shi,  
Nara 630 (JP)  
Inventor: **SAWAI, Tsurugi  
5-13, Katayamatyou 3-chome,  
Nagataku  
Koube-shi,  
Hyougo 653 (JP)  
Inventor: **HORIOKA, Atsushi  
1-18-808, Oomiyatyou 3-chome  
Nara-shi,  
Nara 630 (JP)******

74 Representative: **Grünecker, Kinkeldey,  
Stockmair & Schwanhäusser  
Anwaltssozietät  
Maximilianstrasse 58  
D-80538 München (DE)**

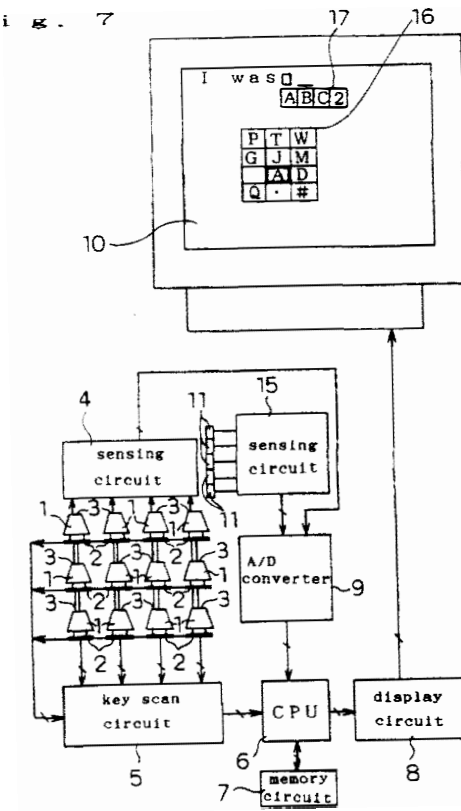
54 **DATA INPUT PROCESSOR**

57 A data input processor which facilitates data entry. As shown in the figure, a keyboard (16) with keys (1) is displayed on a screen (10). When a finger touches or comes very close to one of the keys, the image of the key is reversed on the screen (10). Accordingly, an operator can confirm which key

he or she is going to depress on the screen, and thus the operator can strike the object key (1) and input data in a word processor with confidence. Therefore, an input error can be reduced and the input operation can be made easily.

**EP 0 689 122 A1**

Fig. 7



## TECHNICAL FIELD

The present invention relates to an input processing system for characters and pattern information, or more in particular to an information input processing system capable of being input even with a single hand and a coordinate input system.

## BACKGROUND ART

In recent years, the extended use of personal computers has made many documents electronic data. In spite of this, every person cannot operate the keyboard. Especially, there are not so many people who can enter data at high speed with blind touch. One of the reason for this is that the key arrangement on the current keyboard has no special meaning and lacks the logical connection and therefore difficult to remember. Also, the recent trend is toward a directly-operated interface such as a mouse. In extreme cases, information can be entered or accessed without using the keyboard. Nevertheless, the latter method using the mouse or the like has its advantages and disadvantages. The pen input system which is widely proposed, on the other hand, poses the problem of entry speed and has yet to form a mainstream.

It is therefore necessary to review the keyboard system. First, the number of keys on the keyboard which is too many is required to be reduced by any means. For this purpose, it is necessary to express a code by a combination of a plurality of keys and to assign a plurality of codes to each key. When a plurality of codes are assigned to each key, however, each key becomes difficult to remember. Novice users learn the keys while searching for characters on keytops. A complicated system, however, poses an obstacle to such a process and makes difficult early transfer to blind touch. Further, users operating the keyboard on the job try to learn the key layout earnestly, while the home or entertainment users are less motivated to learn the key layout.

On the other hand, the keyboard is an optimum means for character entry. The mouse is not suited to pattern input to which the tablet is most suitable. For entering information in simplistic fashion, the button system with keys is an optimum means. Further, the tablet, which cannot easily transmit reaction directly to the operator by physical depression like the keyboard, requires a separate mechanism such as a switch.

In view of this, there is a demand for an input device easily operable by the novice users, which gives the feeling of a mechanical operation like the keyboard as a pointing device such as a tablet without considerable increase in hardware scale. A pointing device requires a positional selection.

Even when a mechanism is provided for positional selection by depressing a tablet, the particular position selected is not identified when a plurality of fingers are placed on the tablet. A superior operability is desired as when selection is made by applying a force with fingers placed at the actually-selected positions (keys) on the keyboard.

Accordingly, an object of the present invention is to provide an information input processing system, in which in view of the above-mentioned problems of the conventional systems, the keys on the keyboard or the positional information are proposed to the user before normal key operation thereby to assist in blind touch and reduce the error in key operation, or to permit the operation with a single hand, thus making it possible to enter input data comfortably in all scenes.

Another object of the invention is to provide an information input system, in which taking advantage of the fact that the touch degree of fingers applied to the tablet is proportional to the finger pressure, the finger position is detected from the touch information for detecting the finger coordinate position, and at the same time the change in finger touch degree with a force applied beyond a predetermined setting is detected by the same sensor, whereby both positional information and selection information are input.

## DISCLOSURE OF THE INVENTION

The present invention is such information input apparatus comprising:

- a plurality of switch circuits;
- an array of keys for opening and closing the switch circuits through transmission of forces;
- a plurality of sensors for detecting direct contact or proximity of a finger to all or a part of the keys;
- a signal processing means for receiving and processing data outputs from the sensors and switch circuits;
- a first display means for displaying as a corresponding information code the direct contact or proximity of the finger to the specific key detected by the sensors; and
- a second display means for displaying, in a manner different from that of the first display means, a corresponding specific information code when the switch circuit is closed by pressing the specific key.

As described above, according to the invention, when the user attempts to enter input data in the keyboard, the key intended can be displayed and transmitted in the surround of the character string being entered using the peripheral visual sense without directly viewing the key tops by simply watching the display screen. The display itself is

guide means different from the information input. The psychological fear that a given key, once depressed, may be impossible to restore is removed and the character about to be struck at the time of normal key entry is fed back in display beforehand to prevent an erroneous key entry. Also, according to the invention, the keys can be clicked by four fingers including the forefinger, the middle finger, the third finger and the little finger, and by making the thumb approach a plurality of thumb proximity sensors under the respective keys. one of the sensors can be designated. The movement of the thumb under the remaining four fingers is physiologically natural in a range where no unreasonable force is exerted on muscles. In addition, no fatigue occurs since the thumb position is entered with a proximity sensor requiring no force and the other keys are struck at the same time as the thumb sensor in a reasonable range including the 10-keys.

According to the invention, a proximity sensor is provided on the tablet surface, and when the operator depresses the tablet surface, it is assumed that the change in proximity or touch area due to the finger distortion is detected and a specific position is detected. Also, the position is assumed to be pointed when a finger touches lightly. In this configuration, when the operator moves the finger on the tablet, the cursor is moved and selection accomplished by depressing with the finger in the same position. For detection of the coordinate which is the center of the finger touch position, for example, the touch position on the tablet is detected, and whether a setting is exceeded by the area is checked during the process of finding the center point. Also, if a plurality of sensors are prepared for detecting a plurality of finger positions, it is possible to check which finger is pressurized. In this way, an operation similar to keyboard input can be accomplished with a minimum increase in hardware.

And the present invention is a coordinate data input apparatus comprising:

stripes of resistors mounted on a tablet;

a current applying means for applying to the striped resistors a current including alternate current components;

an insulator layer for insulating the striped resistors; and

a current measuring means for measuring a current running across the striped resistors, in which

a coordinate data along a major axis of the striped resistors is given by measuring with the current measuring means a change in the current caused by that the alternate current components of the applied current by-passes a part of the striped resistor and flows through an earth capacitance of

an object which moves towards the insulator layer, and

a coordinate data along a minor axis of the striped resistors is given by measuring a change in the current applied to a specific one of the striped resistors or a difference of the current between two adjacent striped resistors.

Thus coordinate data along a major axis of the striped resistors is obtained as well as the coordinate data along a minor axis .

#### BRIEF DESCRIPTION OF THE DRAWINGS

Fig.1 is a diagram showing the function blocks of an information input processing system according to an embodiment of the present invention, Fig.2 shows the process sequence for a microcomputer of the information input processing system according to an embodiment of the invention, Fig.3 shows a word-processing display screen of an information input processing system according to an embodiment of the invention, Fig.4 is a full view of an information input processing system according to an embodiment of the invention, Fig.5 is a full view of an information input processing system according to an embodiment of the invention, Fig.6 is a full view of an information input processing system according to an embodiment of the invention, Fig.7 is a diagram showing the function blocks of an information input processing system according to an embodiment of the invention, Fig.8 shows a word-processing display screen of an information input processing system according to an embodiment of the invention, Fig.9 shows a word-processing display screen of an information input processing system according to an embodiment of the invention, Fig.10 shows the process sequence for a microcomputer of an information input processing system according to an embodiment of the invention, Fig.11 shows the process sequence for a microcomputer of an information input processing system according to an embodiment of the invention, Fig.12 shows a word-processing display screen of an information input processing system according to an embodiment of the invention, Fig.13 is a diagram showing the function blocks of an information input processing system according to an embodiment of the invention, Fig.14 shows a word-processing display screen of an information input processing system according to an embodiment of the invention, Fig.15 shows a word-processing display screen of an information input processing system according to an embodiment of the invention, Fig.16 shows a part of the keyboard of an information input processing system according to an embodiment of the invention, Fig.17 is a diagram showing the function blocks of an information input processing system according to an em-

bodiment of the invention, Fig.18 shows a word-processing display screen of an information input processing system described in Claim according to the invention, Fig.19 is a full view of an information input processing system according to an embodiment of the invention, Fig.20 is a full view of an information input processing system according to an embodiment of the invention, Fig.21 is a full view of an information input processing system according to an embodiment of the invention, Fig.22 is a full view of an information input processing system according to an embodiment of the invention, Fig.23 is a diagram showing the function blocks of an information input processing system according to an embodiment of the invention, Fig.24 is a full view of an information input processing system according to an embodiment of the invention, Fig.25 shows the process sequence for a microcomputer of an information processing system according to an embodiment of the invention, Fig.26 is a full view of an information input processing system according to an embodiment of the invention, Fig.27 shows the process sequence for a microcomputer of an information input processing system according to an embodiment of the invention, Fig.28 is a full view of an information input processing system according to an embodiment of the invention, Fig.29 shows the process sequence for a microcomputer of an information input processing system according to an embodiment of the invention, Fig.30 shows a word-processing display screen of an information input processing system as described in Claim of the invention, Fig.31 is a full view of an information input processing system according to an embodiment of the invention, Fig.32 is a full view of an information input processing system according to an embodiment of the invention, Fig.33 is a full view of an information input processing system according to an embodiment of the invention, Fig.34 is a full view of an information input processing system according to an embodiment of the invention, Fig.35 is a full view of an information input processing system according to an embodiment of the invention, Fig.36 is a diagram showing the relation between the fingers and information symbols according to an embodiment of the invention, Fig.37 is a diagram showing the display screen according to a 36th embodiment of the invention, Fig.38 is a diagram showing the display screen according to the 36th embodiment of the invention, Fig.39 is a diagram showing the display screen according to the 36th embodiment of the invention, Fig.40 is a plane view and a side view of a cover according to an embodiment of the invention, Fig.41 is a side view of a cover and a housing according to the same embodiment of the invention, Fig.42 is a front view of the cover in bent form according to an

embodiment of the invention, Fig.43 is a plane view of the cover, the keyboard and the housing according to an embodiment of the invention, Fig.44 is a side view of the cover and the housing according to an embodiment of the invention, Fig.45 is a plane view of the cover, the keyboard and the housing according to an embodiment of the invention, Fig.46 is a front view and a sectional view of the cover according to an embodiment of the invention, Fig.47 is a plane view of a cover and a head band according to an embodiment of the invention, Fig.48 is a plane view of the cover and the head band according to an embodiment of the invention, Fig.49 is a side view of the cover and the head band according to an embodiment of the invention, Fig.50 is a diagram showing the function blocks of an information input processing system according to an embodiment of the invention, Fig.51 is a flowchart showing the process sequence for a microcomputer of an information input processing system according to an embodiment of the invention, Fig.52 shows an example method for determining the coordinate of the finger center for an information input processing system according to an embodiment of the invention, Fig.53 is a diagram showing the function blocks of an information input processing system according to an embodiment of the invention, Fig.54 is a flowchart showing the process sequence for a microcomputer of an information input processing system according to an embodiment of the invention, Fig.55 is a full view of the housing of an information input processing system according to an embodiment of the invention, Fig.56 is a sectional view of a sensor of an information input processing system according to an embodiment of the invention, Fig.57 is a diagram for explaining the principle of a mechanism of an information input processing system according to an embodiment of the invention, Fig.58 is a diagram for explaining the mechanism of an information input processing system according to an embodiment of the invention, Fig.59 is an external appearance of the housing of an information input processing system according to an embodiment of the invention, Fig.60 is a flowchart showing the process sequence for a microcomputer of an information input processing system according to an embodiment of the invention, Fig.61 is a diagram showing the function blocks of an information input processing system according to an embodiment of the invention, Fig.62 is a diagram showing the function blocks of an information input processing system according to an embodiment of the invention, Fig.63 is a diagram for explaining the operation of an information input processing system according to an embodiment of the invention, Fig.64a is a sectional view of the sensor of an information input process-

ing system according to an embodiment of the invention, Fig.64b is a sectional view of the sensor in another condition, Fig.65 is a diagram for explaining the mechanism of a light transmitter-receiver of an information input processing system according to the invention, Fig.66 is a diagram showing the function blocks of an information input processing system according to an embodiment of the invention, Fig.67 is a diagram showing the function blocks of an information input processing system according to an embodiment of the invention, Fig.68 is a flowchart showing the process sequence for a microcomputer of an information input processing system as described in Claim of the invention, Fig.69 is a diagram for explaining the mechanism of the light transmitter-receiver of an information input processing system according to the invention, Fig.70 is a diagram showing a full view of a single-hand-operated keyboard as an example of an information input processing system according to the invention, Fig.71 is a diagram showing a full view of a single-hand-operated keyboard and a thumb light sensor, Fig.72 is a diagram illustrating the hysteresis relation to be held between the on/off state of a switch and the distance between the thumb and the sensor, Figs.73a and 73b show a configuration example of a pointing device for detecting the operation of a tabular movable object, Fig.74 is a diagram showing the configuration of another embodiment of the pointing device capable of operation in relative positions by a pressure-sensing rubber, Fig.75a is a diagram showing the configuration of a detection circuit for a pressure-sensing rubber ball, Fig.75b is a diagram for explaining the operation thereof, Fig.76 is a diagram showing the configuration of an embodiment of a pad, Fig.77 is a diagram illustrating the distinction between the pen tip and the finger tip and the priority order of selection utilizing the touch area of the pad according to an embodiment of the invention, Fig.78 is a flowchart showing a method of detection in Fig.77, Fig.79 is a diagram illustrating the operation of pad selection according to an embodiment, Fig.80 is a flowchart showing a method of detection in Fig.79, Fig.81 is a diagram showing the case in which the same resistor of the pad is shared by two fingers or more, Fig.82 is a flowchart showing a method of detection in Fig.81, Fig.83 is a block diagram showing another embodiment of the coordinate input means according to the invention, Fig.84 is a diagram showing an embodiment of the method for detecting the touch position of the operator's finger or the like with a tablet 1101, Fig.85 is a diagram showing the chronological change of current  $I_{ai}$ , Fig.86 is a diagram showing an equivalent circuit according to the same embodiment, Fig.87 is a diagram showing the chronological change of current  $I_{ai}$ , Fig.88 is a

flowchart showing a method of detection according to the same embodiment, Fig.89 is a side view of a tablet, Fig.90 is a diagram for explaining a pre-determined amount  $p$ , Fig.91 is a configuration diagram for explaining a method of detecting the touch position of the operator's finger or the like according to another embodiment, Fig.92 is a diagram showing an equivalent circuit of the same embodiment, Fig.93 is a diagram showing the chronological change of current  $I_{bij}$ , Figs.94 and 95 are flowcharts showing specific operations of the same embodiment, Fig.96 is a block diagram of the coordinate input means according to another embodiment of the invention, and Fig.97 is a diagram showing an information input processing system having not only the keyboard function but also the tablet function capable of coordinate input.

#### BEST MODE FOR CARRYING OUT THE INVENTION

Embodiments of the invention will be described in detail below with reference to the drawings.

Fig.1 is a function block diagram showing an information input processing system according to an embodiment of the invention. In Fig.1, numeral 1 designates a keytop, numeral 2 a key switch, numeral 3 an electrode, numeral 4 a sensing circuit for amplifying the potential induced to the electrode, numeral 5 a key scan circuit, numeral 6 a microcomputer, numeral 7 a memory circuit, numeral 8 a display circuit, numeral 9 an A/D converter, and numeral 10 a display. Now, assuming that a finger touches or approaches a specific keytop, an inductive potential is generated in a corresponding electrode 3. Though described in simplified form in the drawing, the potential of the keytops (12 keytops in the case of the shown drawing) is amplified by the sensing circuit 4, and after being time-division-multiplexed, is applied to the A/D converter 9. By comparing the outputs thus applied with each other, the microcomputer can specify the key that has been touched or most closely approached by the finger. These operations can be carried out by the normal microcomputer process (such as the word processing) and time-division processing. Fig.2 shows a part of the process sequence for a microcomputer, that is, a part of the word processing operation in Japanese. This process representing an interrupt handling decides and displays (display step 1) at regular time intervals whether the finger has touched or approached a keytop, and when the keytop 1 is struck by the finger, turns on a switch 2, thereby deciding whether an actual key entry is made from the keyboard (display step 2). Thus the process performs two display steps. The display step 2 is similar to the character input display in the conventional word-

processing operation. In the display step 1, the character being entered by the operator is displayed at the tail end of an established sentence (In Japanese, the process called "establishing" is required for converting kana to kanji characters) prior to actual character input (display step 2). The operator watches the established sentence with his central viewfield and the character in the display step 1 with the peripheral viewfield. Fig.3 shows a display screen for word processing in Japanese, in which the character

" 1 "

in touch with the user's finger is displayed in reverse with a different color at the tail end of the sentence being entered. This display itself provides a guide different from the information input and disappears when the finger is detached. The immediately preceding section displays an unestablished character

" ㄗ "

This example represents the input in Japanese, in which case a converter is displayed specifically for conversion into kanji character (the last character but one), while this display is not required in other languages such as English.

Fig.4 is a top plane view and a side view showing the outline of an information input processing system according to another embodiment of the invention. In Fig.4, numeral 1 designates keytops, numeral 10 a display, numeral 11 a photosensor, numeral 12 a hinge and numeral 13 a thumb insertion hole formed under the keytop. Though not visible in this diagram, three more photosensors 11 are mounted in the thumb insertion hole 13. The operator places the palm of his right hand in the right recess 10' of the display 10 and moves his thumb in the insertion hole 13, thereby selecting by approaching the thumb to one of the five photosensors 11 arranged in arcuate form. Each keytop corresponds to five characters. The five photosensors detect the position of the thumb. The thumb is recognized to exist at the position of the photosensor 11 with highest output, thereby selecting one of the five characters.

Now, another embodiment is shown in Fig.5. In Fig.5a, numeral 1 designates a keytop, numeral 13 a thumb insertion hole under the keytop, and numeral 11 a photosensor. The operator inserts his thumb into the thumb insertion hole 13 sideways, and strikes the keytop 1 with the remaining four fingers. Fig.5b is a perspective view as viewed from the direction of arrow A in Fig.5a. Of the six

photosensors 11, three are arranged on the bottom of the insertion hole 13, and the remaining three on the deep side surface of the insertion hole 13.

Now, another embodiment will be described with reference to Fig.6. In Fig.6, numeral 14 designates a protrusion and numeral 11 a photosensor. The operator touches the protrusion 14 and thus can recognize the position of the photosensor 11 each time he moves this thumb.

Another embodiment will be explained with reference to Fig.7. In Fig.7, numeral 15 designates a sensing circuit for sensing the approach of a finger, numeral 16 a screen area corresponding to the physical position of the keytop 1 displayed on the display, and numeral 17 a screen area for displaying the information symbols assigned to a given keytop 1 in a lateral series. The approach of the finger to the electrode 3 on the keytop 1 is transmitted from the sensing circuit 15 through an A/D converter 9 to a CPU 6. Numeral 11 designates a photosensor for detecting the approach of the thumb. The operator enters a character by combining the thumb position with the type of the keytop. When a specific one of the electrodes 3 is touched or approached by the finger, the portion of the keytop layout screen area 16 corresponding to the specific key is brightly displayed. In the drawing under consideration, the portion "A" is touched by the finger and brightly displayed. This indicates that the finger is placed on the keytop on the third row from top and the second column from left of the central keytop in Fig.5. In similar fashion, it indicates which character is intended for selection, "A", "B", "C" or "2". Also, the characters "A", "B", "C" and "2" are displayed in the screen area 17, at the top of which a bar-shaped bright marker moves in correspondence with the thumb position so that the character to be selected is displayed brightly. In this case, the marker is indicated above "B", and therefore a corresponding switch 2 is closed and the actual character "B" is input when the operator strongly strikes the keytop touched or approached by his finger under the same condition. Further, the software of the word processor is executed and the input characters (I was) are displayed on the display 10 with the cursor arranged at the next place to "was" indicating that a character is being input. The coordinate information of the cursor is retrieved by the computer 6 at regular intervals of time, and the cursor is sequentially moved in accordance with the character input in such a manner as to position the screen areas 16 and 17 right under and around the character input cursor for the screen.

Another embodiment is shown in Fig.8. In Fig.8, numeral 10 designates a display screen, numeral 16' a screen corresponding to the physical layout of the keytops displayed on the display, and

numeral 17' a display screen corresponding to the physical position of the thumb. In this diagram, four assigned characters are displayed at the places corresponding to the physical positions of the keytops, which are combined with the thumb position respectively to select one of the four characters at the time of striking the . Further, the display section 17' indicates in a different color that the thumb is at the third sensor position from left. At the same time, in order to indicate that the forefinger approaches the second row (ghi4) on the left column, the middle finger approaches the top (tuv8) on the middle column and the third finger approaches the third row (def3) on the right column on each keytop, a bright frame is displayed at each display position. Furthermore, the places of characters "I", "V" and "F" are brightly displayed in enlarged reverse display in combination with the thumb sensors thereby to present the characters selected.

Now, another embodiment is shown in Fig.9. In Fig.9, numeral 10 shows a display screen, numeral 16" a screen corresponding to the physical layout of the keytops displayed on the display, and numeral 17" a display screen corresponding to the physical position of the thumb. In this diagram, the four characters assigned to the keytops are staggered in the form of footprints, and as in Fig.8, are combined with the thumb position respectively thereby to select one of the four characters at the time of striking the key. In this way, the staggered display can display the data in horizontal direction in a shorter form.

Another embodiment will be explained with reference to Fig.10

Fig.10 shows a part of the process sequence for a microcomputer executing the word-processing software. The circuit of Fig.1 assumes that a plurality of fingers approach a plurality of keytops. This process is initiated by a timer interrupt by the microcomputer 6. In the case where each keyboard has received a sensing input higher than a specified value, i.e., in face of a finger approach, the output value of the sensing circuit which is larger than the other outputs applied to the A/D converter 9 is listed up as the one having a larger degree of proximity. Also, the chronological variation of the degree of proximity to the adjacent keytops and the direction of movement are determined, and the weighting calculation is made based on the physical position or comparison is made with the signal output under steady condition, after which a key intended to be struck is identified and displayed. The weighted data represents such data that the finger placed at the home position key, for example, is not much expected to move and the finger structure is such that any attempt to move the middle finger tends to move the forefinger or an

attempt to move the third finger tends to move the little finger. The events related to such a phenomenon are also stored in memory as weighted data in advance, which are appropriately modified by learning. The changing degree of proximity (degree of touch) of a plurality of approaching electrodes and the degree of proximity of a finger to the electrodes being approached from a far and high point are determined, whereby a character of the key expected to be reached is displayed as a candidate under the cursor in the screen. This display permits the operator to visually determine the character of the key to be struck (intended character) a considerable time before touching the particular keytop. The character displayed naturally is not input in the word-processing software until the corresponding key is actually struck.

Now, another embodiment will be explained with reference to Figs.11, 12a and 12b. Fig.11 shows a part of the process sequence for a microcomputer in the process of execution of the word-processing software, assuming that a plurality of fingers approach a plurality of keytops in the circuit shown in Fig.1. This process is assumed to be initiated by the timer interrupt of the microcomputer 6 so that a plurality of fingers touch or approach a plurality of keytops. This process is basically similar to the process of Fig.10 and is adapted to display not only a single character decided to be most intended for striking, but in the case where a plurality of keytops are approached by the finger, to display also surrounding keytops. The information relating to the proximate arrangement of keys is stored in the memory 7 in advance, and when the characters around a key determined to be most intended is displayed on the screen. Fig.12a shows a screen for executing the word-processing software, which displays the approach of the fingers to the characters keys "A", "S", "Z" and "X" on the ASCII-type keyboard. More specifically, in the case under consideration, the finger is located at the boundary of these keytops. These characters are displayed in such a fashion that when the operator jogs his finger a little, the whole of these characters is also oscillated. Also, as a method of display in oscillated fashion, the physical relative positions are not displayed in a bit-mapped manner oscillating the display, but marks are attached to indicate the relative positions always in the case where the finger is out of position as shown in Fig.12b for displaying a character. More specifically, a longitudinal line is drawn to the left of "S" and a lateral line under "S" for display to inform the operator that the finger is at a position near to "A" and "X", thereby urging the operator to move this finger to the position where the marks disappear. In similar fashion, a color may be used instead of a mark to indicate a



displacement.

Now, another embodiment will be described with reference to Figs.13 and 14. Fig.13 is a function block diagram, and Fig.14 a display screen in the process of executing the word-processing software. The circuit of Fig.13 is substantially identical to that of Fig.1, the only difference being that a switch 18 and a keytop 19 are added. This key is assigned for execution of a specific function, and when this key is pressed during execution of the word-processing software, the screen transfers from the word-processing screen to the icon screen shown in Fig.14. Each icon is displayed in positions corresponding to the physical positions in the horizontal and vertical directions of the keys. In the process, assuming that any finger touches or approaches the key, the brightness of a specific icon changes as shown in Fig.14, thereby indicating that a corresponding process is expected to be executed. If the key is pressed under this condition, the actual process is accessed and executed.

Now, another embodiment will be explained with reference to Fig.15. Fig.15 shows a display screen, which displays a descriptive statement of the icon changed in color in Fig.14. The explanation of function of an icon corresponding to the physical position of each keytop touched is thus displayed at the lower part of the screen.

Now, another embodiment will be explained with reference to Fig.16. In Fig.16 showing a side view of a part of the keyboard, numeral 1 designates a keytop, numeral 2 a switch and numeral 3' nine small electrodes arranged in three rows and three columns on each keytop. The output of each electrode is connected to sensing circuits 4 in Fig.1 respectively. When the upper part of the keytop is approached by a finger, a detailed positional information can be obtained and displayed. In other words, a given keytop 1 providing a mechanical switch has nine electrical switches in combination thereon and thereby is able to handle a greater amount of positional information.

Now, another embodiment will be explained in Figs.17, 18a and 18b. Fig.17 is a diagram showing the function blocks, and Figs.18a and 18b are display screens. In the circuit of Fig.17, numeral 20 designates a keytop, numeral 21 a HELP function switch, and numeral 22 an electrode of a proximity sensor. This circuit, which is substantially the same as the one shown in Fig.1, has added thereto the switch 21 for contributing the HELP function described above. This switch 21 is a display change-over switch. When this switch 21 is not approached or touched by a finger, as shown in Fig.18a, the position of the fingers approaching each keytop is displayed by a combination of bit maps of small points (hatched portions in the model keyboard display having three columns and four rows). Also,

the thumb position is indicated by a solid black square mark ■ among all the marks arranged in lateral direction. When the finger approaches a proximity sensor 22, on the other hand, characters corresponding to the keytops respectively are displayed in large form as shown in Fig.18b (similar to Fig.8). More specifically, when he is not sure what is the character on the keytop, the operator makes his finger approach the proximity sensor 22 and a target keytop, and thus can know a corresponding character. In addition, the related descriptive statement is displayed when the keytop 20 is pressed further and the switch 21 is turned on. In this way, the HELP level is divided into two stages. This keytop 20 is mounted at the upper left part of the keyboard housing (for right-handed persons). This keytop 20 is located at a position difficult to reach by a single hand, and therefore it is always necessary to press it by the opposite hand (the left hand in the case under consideration). This layout induces the operator to blind touch at early time.

Now, another embodiment is explained with reference to Fig.19. In Fig.19, numeral 23 designates a housing for right-handed persons, and numeral 24 is a depression. This depression has a plurality of keytops mounted thereon. Another set of keytops is arranged in such positions as to surround the depression 24. Numeral 25 designates a palm rest with the upper left side thereof raised and the right side thereof recessed in the figure. Numeral 11 designates one of photosensors, numeral 13 a thumb insertion hole, and numeral 26 an electric wire for communication to the host computer and supplying power. The operator places the recess of the palm of his right hand on the raised portion of the palm rest 25 and touches keytops on the depression 24 by his forefinger, middle finger and third finger respectively, with the thumb inserted in the thumb insertion hole 13. An acceleration sensor 27 is mounted in the lower part of the housing in the palm rest 25 for realizing the mouse function. In other words, the operator can input either by way of the keyboard or pointing.

Now, another embodiment will be described with reference to Fig.20. In Fig.20, numeral 28 designates an accommodable tongue, on which a photosensor 11 is arranged for detecting the touch or approach of the thumb. The thumb thus can be detected by the photosensor 11 as well as by photosensors 11' mounted in the thumb insertion hole 13. These photosensors 11, 11' are arranged in arcuate form following the movement of the thumb. Numeral 27 designates an acceleration sensor mounted in the housing 23. When the housing 23 is moved, the acceleration sensor 27 detects the acceleration, and the result of detection is transmitted to an external CPU, thus functioning as a mouse. The operator places his right hand on the

palm rest 25, and moves his thumb in arcuate form along the insertion hole 13 or the tongue 18. As a result, the positional information of the thumb is obtained by the photosensors 11, 11'.

Now, another embodiment will be explained with reference to Fig.21. In Fig.21, numeral 29 designates a plurality of holes arranged along the periphery of the housing, in each of which a photosensor 11" is arranged. In the case where the little finger of the operator approaches a hole 29, it is detected and as in the case of the thumb, the information symbol corresponding to the keytop 1 can be modified. More specifically, according to this embodiment, these photosensors 11" are made to correspond to the normal keyboard shift or control keys. On the display screen, the position where the little finger is sensed is indicated by a mark corresponding to the position of the hole.

Now, another embodiment will be explained with reference to Figs.22 and 23. Fig.22 is a plane view, and Fig.23 is a diagram showing the function blocks. In these diagrams, numeral 25 designates a palm rest, numeral 29 first holes, numeral 30 second holes, and numeral 31 a display cursor. Numeral 16"" designates a display area corresponding to the physical position of keytops. CCD imaging devices 33 are built in the palm rest 25, so that an object on the keytops 1 can be imaged through a lens 32. The second holes 30 are located at a position higher than the first holes 29, and therefore cannot be reached by the little finger with the palm placed on the palm rest 25. The operator therefore has no choice but to use his third finger to insert any of his fingers at all into any of the second holes 30, and only the forefinger and the middle finger can touch the keytops 1. Numeral 34 designates an image processing circuit for processing signals from the CCD imaging devices 33. When the third finger is inserted in a hole 30, the image processing circuit 34 is energized so that the coordinate position of the finger on the keytops 1 is determined by trigonometrical survey (range finger method). If two fingers touch or approach the keytops 1, the coordinates of two points are determined. Assuming that the the two points represent the head and the tail end of a portion of a sentence to be deleted, for example, the CPU 6 retrieves these points as the range designating information while at the same time display the information in reverse display on the display 10. Alternatively, if the two points are to represent a figure, on the other hand, the type of the figure such as the circle is selected by the thumb position, the circle center by the forefinger, and the radius of the circle by the middle finger. In this way, a circle can be specified. As another alternative, in the case where the designation of a single point is sufficient for the above-mentioned purpose, the middle finger is in-

serted in a hole 30 with the thumb approached to the thumb sensor for specifying the figure.

Now, another embodiment is described with reference to Fig.24. In Fig.24, numeral 35 designates a depression inclined with respect to the housing 23. Keytops 1 are arranged on the depression. The depth of the depression is deeper rightward and downward with the keytops are mounted inclined positions. This construction with this side and the right side of the depression formed deeper naturally fits the shape of the hand and contributes to reduce the fatigue of the operator.

Another embodiment is explained with reference to Figs.25 and 23.

Fig.25 is a flowchart for controlling the position of a display pointer of the display 10 by summing the absolute coordinate position (fine positional coordinate) (finger positions on the keytops) and the relative coordinate position (coarse positional coordinate)(relative position of the housing) determined in the circuit shown in the block diagram of Fig.23. More specifically, the operator designates a position designation mode to the CPU by pressing a predetermined switch on the housing 23 and thus enters the interrupt process shown in Fig.25. The CPU 6 receives the absolute coordinate position of the finger on the keytop 1 determined from the CCD imaging device 33 and the image processing circuit 34 and the relative position coordinate of the housing 23 from the acceleration sensor 27, and applies the sum thereof providing coordinate information to the host computer, which information is displayed as mouse pointer information on the display 10. The display includes a rectangular display area corresponding to the whole of the keytops as the relative position information due to only the acceleration sensor. For this reason, in the case where the operator places his finger on a keytop and moves the housing 23, the particular rectangle is moved together with the mouse pointer therein. Further movement of the finger without moving the housing 23 results in only the mouse pointer being displayed moving in the rectangle while the rectangle remains stationary. The operator moves the housing for coarse coordinate designation and the finger in the depression for fine coordinate designation. According to this embodiment, the relative coordinate is detected by the use of an acceleration sensor. Instead, optical means may be used for the same purpose. In such a method, the movement of an image obtained by imaging the desk top surface may be processed in an image processing circuit to determine the image movement. If the operator lifts the housing, the image may be enlarged or blurs, in which case the coordinate is not calculated. In other words, the system can be handled with a sense similar to a mechanical mouse.

Now, another embodiment will be explained with reference to Figs.26 and 27. In Fig.26 showing a full view, numeral 36 designates a switch. Fig.27 showing a flowchart, on the other hand, represents a part of the process for character input during the execution of the word-processing software. When the operator presses a correction switch with a palm while entering a character (the switch 36 located to the left in the raised portion of the palm rest according to the embodiment), the process is started. The CPU, deciding that a word (or a partial character string of a word) already entered is erroneous, refers to a character dictionary for words near to the word in entry and at the same time searches grammar and collocation dictionaries or the like for predicting and listing up candidate words. A total of 12 candidate words (or partial character strings of a word) including 4 in rows and 3 in columns of keyboard are displayed. Each key corresponds to a word on display, so that the word associated with a key approached by the finger is highlighted. In the case where the operator has found a word to be corrected and entered, the particular word can be corrected and entered by the operator pressing (striking) the corresponding key further. Suppose a candidate cannot be found, this process is terminated by pressing the correction switch 36 again. Also, in the case where the entire word on display is not correct but only a part of the word, the particular part is input by specifying a word or a partial character string of the candidate words on display by touching or approaching the corresponding key with the finger, while at the same time touching or approaching the thumb proximity sensors with a sliding thumb. A part of the specified candidate word or partial character string is selected by color reversal or other methods. Upon selection of a desired portion, the corresponding key is struck thereby to input only the desired character string in the candidate. In this way, a correct character string is input. Though not described in the flowchart to avoid complication, candidate words following the partial character string entered at this time point is further displayed on the screen. Subsequently, the operator continues to input words or partial character strings in similar fashion.

Now, another embodiment will be explained with reference to Figs.28, 29 and 30. Fig.28 shows a full view, in which numeral 37 designates a candidate word selection switch. Fig.29 is a flowchart representing a part of the process for character input during the execution of the word-processing software. When the operator enters characters as in the normal case of character input, the process is started. The CPU receives the same characters and refers to a character dictionary making up words and at the same time searches

grammar and collocation dictionaries, so that each whole word is complemented and predicted thus presenting candidate words. A total of 12 words (or partial character strings of a word) including four in rows and three in columns of keys are thus displayed as candidate words. The operator presses a candidate word selection switch (the switch 37 arranged to the left of the recess of the palm rest according to the embodiment under consideration) to transfer to the candidate word selection mode. Since each key corresponds to a word on display, the candidate word corresponding to a specific key touched or approached by the finger is highlighted. In the case where the operator has found a word to be entered, the required word can be input by pressing the corresponding key.

In the case where only a part of the word on display coincides with the desired word, on the other hand, in order to input the particular part, a word or a partial character string is specified out of the candidates on display by touching or approaching a corresponding key with the finger, while at the same time making the thumb touch or approach by sliding over the thumb proximity sensors. The candidate word or the part of the partial character string thus specified is selected by color reversal or the like method. Upon selection of the desired part in this way, the corresponding key is struck thereby to enter only the desired character string among the candidates. By doing so, a correct partial character string is input. At this time point, candidate words having the partial character string entered are displayed further on the screen, and the operator continues to input a word or a partial character string. A candidate screen on display for the input process described above is shown in Fig.30. The character "v" is a character string being entered, under which 12 candidate words beginning with "v" are arranged and displayed in correspondence with the keys. The operator, when desiring the "victor", can easily enter the character string "victor" by pressing the right key on the third row from top. The process of normal character input of course is continued if the operator fails to press the candidate input switch 37.

Now, another embodiment will be explained with reference to Fig.31.

According to this embodiment, a plurality of sensors 11 for detecting the touch or approach of the thumb are provided at the upper left part on the operator's side of the housing 23. The sensors 11 are preferably positioned about 1 cm nearer to the root from the finger tip taking different lengths of the thumb of the like into consideration. Sensors 29' and 30' similar to those in the holes on the top side of Fig.26 are arranged in shallow depressions on the right side of the housing.

Now, another embodiment will be described with reference to Fig.32.

According to this embodiment, a rectangular switch 40 is arranged at the upper left part on this side of the housing 23, which switch is adapted to turn on by being pressed. The switch 40 is equipped with the function of a return key or the like, for example. A plurality of sensors 11 for detecting the touch or approach of the thumb are provided on the switch 40. Numeral 41 designates protrusions for notifying the thumb position by the feel of touch.

Now, another embodiment will be explained with reference to Fig.33.

According to this embodiment, a rectangular switch 40 is provided at the upper left side on this side of the housing 23, which switch is turned on by being pressed. This switch 40 is equipped with the function of a return key or the like, for example. A plurality of sensors 11 for detecting the touch or approach of the thumb are arranged on the switch 40. Each sensor 11 includes two child sensors a and b for detecting the thumb position. More specifically, there are arranged five sensors in each lateral direction and two sensors in each longitudinal direction of the thumb. This is in order to permit the sensors 11 to securely detect the presence of the thumb with variations of the hand position with respect to the housing 23 or against various lengths of the thumb. In view of the fact that the difference in length or relative position of the thumb occurs in the longitudinal direction of the thumb, two sensors are provided in longitudinal direction. As a result, the same thumb position is detected regardless of which one of the upper or lower child sensor 11a or 11b is touched. Numeral 41 designates protrusions for informing the operator of the thumb position by the feel of touch.

Now, another embodiment will be described with reference to Fig.34.

According to this embodiment, the number of thumb sensors 11 is smaller than the number of types of thumb position designation. As shown in Fig.34, there are provided four thumb sensors 11. Specifically, vowel "a" groups are designated when the finger is detached from all the sensors, vowel "i" groups are designated by use of the lowest sensor, vowel "u" groups by use of the second lowest sensor, vowel "e" groups by use of the third lowest sensor, and vowel "o" groups by the use of the top sensor. Though not illustrated, a single CCD or the like provides a sufficient thumb sensors by measuring the thumb position by an image input unit like CCD. In this way, the number of types of the thumb position designation is not necessarily coincident with the number of thumb sensors.

Now, another embodiment will be explained with reference to Fig.35.

According to this embodiment, the number of thumb position sensors is reduced while a little finger sensor provides a supporting function. More specifically, there are only two thumb position sensors. The operation mode is switched between three states, i.e., when the thumb is detached, when the thumb approaches the lower sensor or when the thumb approaches the upper sensor. Further, the little finger sensor enters the shift mode for entering sonants or the like when touching the lowest key 42 (to the right of the alphanumeric keys) and/or the key 43 (to the lower right ENTER key) in the second stage from the bottom. Various related combinations are shown in Fig.36.

These screens are displayed in the same way as if three cards are turned over by the thumb. More specifically, the thumb is detached with the little finger not approaching the sensors 42 and 43 in Fig.37. Therefore, the "a", "ka" and "sa" groups can be entered, so that 3 x 5 characters corresponding to the keyboard layout are displayed at the uppermost part, and the characters touched or approached on the keys are displayed in distinction. In Fig.38, on the other hand, the thumb approaches the lower sensor with the little finger not approaching the sensors 42, 43, and therefore entry of the "ta", "na" and "ha" groups is made possible, and 3 x 5 characters corresponding to the keyboard layout are displayed at the top. Characters approaching or touching the sensors are displayed in distinction. Also, in Fig.39, the thumb is detached, with the little finger approaching the sensors 42 and 43. As a result, the "a", "ga" and "za" groups can be entered, so that 3 x 5 characters corresponding to the keyboard layout are displayed at the top, with the characters approaching or touching the keyboard being displayed in distinction.

A supermicrocomputer may of course be built in the back of the keyboard described above.

A cover according to an embodiment of the invention will be explained with reference to Figs.40 to 45. Fig.40 includes a plane view (40a) and a side view (40b) of a cover 50 mounted on the above-mentioned keyboard housing 23 in closed state. Fig.41, on the other hand, is a diagram showing the cover 50 removed from the housing 23. More specifically, the cover 50 is generally channel-shaped, and can be closed in such a way as to cover the housing 23. At the same time, the cover 50 can be freely demountable while remaining electrically connected with a cord (replaceable with a connector). The cover 50 is adapted to be bent inward at the central portion thereof. Numeral 51 designates a bent portion. Numeral 52 represents the side of the cover. The side 52 is cut

off at a point thereof corresponding to the bent portion 51. Numeral 53 shows the cut portion. Consequently, as shown in Fig.41, when the cover 50 is bent inward, the respective sides portions 52 are partially overlaid one on another.

Further, the forward end (the upper right side in Fig.41) 54 of the cover 50 has mounted thereon a display unit 55 of liquid crystal type or the like in an openable fashion. When the display unit opens, the display unit 55 is suspended from the cover body. Various symbols or the like can be displayed on the inner side (the left side in Fig.41) 55a of the display unit 55. Fig.42 is a diagram showing the display unit 55 of Fig.41 as viewed from the direction of arrow W. Characters "BBC" are displayed on the display unit 55. These characters not visible directly in the rear view of Fig.42 (and therefore are indicated by dotted line). A concave magnification mirror (having a paraboloidal surface) 57 is mounted on the lower side (in Fig.41) 56 split by the bent portion 51 on the back side of the cover 50. As a consequence, with the cover 50 open, the screen displayed on the display unit 55 is projected in enlarged form on the concave magnification mirror 57. The angle of the respective members is designed to ensure such a magnification. The operator thus can view an enlarged image of "BBC" by the concave magnification mirror 57 as shown in Fig.42. Fig.43 shows the state in which the cover 50 is open from the housing 23.

In closing the cover 50, the display unit 55 is rotated inward into closed state, the bent portion is extended and covered on the housing 23. In the process, the display unit 55, etc. positioned inside are accommodated in the recesses of the keyboard surface.

Also, Fig.44 shows the state in which the cover 50 is rotatable by a hinge 58. Fig.45, on the other hand, shows the cover 50 connected by a connector 59 to the housing 23.

Now, another embodiment of the invention will be described with reference to Figs.46 to 49.

The upper part of Fig.46 shows a cover 50 and the lower part the same cover 50 cut away along a one-dot chain and viewed from above. As obvious from this sectional view, (cylindrical) expansions 52a are formed at the end on this side of the upper side surface 52 of the cover 50 (See Fig.41). Fig.48, on the other hand, shows the cover 50 and a head band 60 separated from each other. Also, Figs.47 and 49 are diagrams showing the state in which the cover 50 is mounted on the head band 60 through the expansions 52a. Fig.47 is a plane view and Fig.49 a side view.

In Figs.47 to 49, a tabular holder 61 is protruded from each of the right and left sides on the front of the head band 60. A cylindrical recess 61a into which the expansion 52 is to be inserted is

formed at the forward end of each of the tabular holders 61. As a result, the cover 50 can be easily attached to the head band 60 by inserting the cylindrical expansions 52a of the cover 50 into the cylindrical recesses 61a of the tabular holder 61 from above as shown in Fig.49. Under this condition, the operator can set the display unit 52 at an easily visible position regardless of the orientation of the housing 23.

The tabular holder 61 of the head band 60 has two plates, one of which can be slidably inserted into the other. The distance between the cylindrical recess 61a at the forward end of the head band 60 and the eyes of the operator can thus be adjusted. Numeral 62 designates a surface fastener.

Also, in the aforementioned embodiment, it is of course possible to take off the cover and taking advantage of the connector on the housing 23 side, display data on a screen display unit of a common personal computer.

According to this invention, any object such as a ballpoint pen used for touching, approaching or pressing is of course equivalent to a finger.

As obvious from the foregoing description, according to the invention, there are obtained the following advantages:

- (1) Key input or position input is possible by a single hand.
- (2) A feedback operation is effected in which a particular key is searched for without performing any operation of striking the key. The user therefore is free of any psychological burden.
- (3) Even with a small number of keys, they can be assigned to a plurality of symbols easily.
- (4) A compact cover with a display unit is provided.

As described above, according to the invention, the difficulty of operation of an information processing input system is considerably improved.

Now, another embodiment of the invention will be described in detail with reference to the drawings.

Fig.50 is a block diagram showing the functions of an information input processing system according to an embodiment of the invention. In Fig.50, numeral 101 designates electrodes formed on the tablet surface, numeral 102 an analog selector, numeral 103 an A/D converter, numeral 104 a one-chip microcomputer, numeral 106 a speaker and numeral 105 a personal computer acting as a host. Also, Fig.51 is a flowchart showing the processes for a microcomputer 104. Fig.52 shows the principle of a method for determining the central coordinate from the potential of each electrode sensor.

Now, in the case where a finger touches a plurality of specific electrodes 101, an inductive potential is generated in each corresponding elec-

trode as a sensor. Although described in a fewer number for simplification in the drawing, a greater number of electrodes are actually used. The potential of each electrode is multiplexed in time division by an analog selector 102 and applied to the A/D converter 103 (step S1). The outputs thus retrieved are compared with each other, whereby the degree of finger touch can be checked for each electrode as a contact area ratio by the microcomputer. The finger is larger than the electrode, and therefore it follows that the electrodes are sampled spatially over the tablet surface. The coordinate of the finger center can be calculated in the same way as when determining the apex of a mountain (step S2). Assume that the sum of the outputs of the electrode sensors is proportional to the contact area. The act of strongly pressing the finger increases the contact area. When a given threshold value A is exceeded (step S3), the speaker 106 is sounded in order to inform the operator that the coordinate position where the finger is placed has been selected (step S4). Selection information having an equivalent meaning to the button click of the mouse, for example, is sent to the personal computer making up a host together with the central coordinate of the finger (step S5). If the finger pressure is less than the threshold A (step S3), on the other hand, only the coordinate position is sent (step S6).

Now, another embodiment will be described with reference to Figs.53 and 54. In Fig.53, numeral 107 designates a switch, and numeral 108 an LED. A tablet selection switch is added to the circuit of Fig.50 and the LED is used in place of the speaker. Also, the nine electrodes on the left side of the electrode set 101 are assigned to the keys 101a, and the nine electrodes on the right side of the electrode set 101 to the keys 101b. Fig.54 is a flowchart, in which if the tablet selection switch is on, as in Fig.51, the central coordinate of the finger or the selection information is sent (steps S1 to S7). If the tablet selection switch is off, on the other hand, the keyboard is assumed to have been selected, so that in the case where the sum of sensor potentials is more than A, a key is decided to which the central coordinate of the finger is to assigned, and the codes of the selection key and the key in touch with the finger are sent to the host personal computer (step S3, steps S8 to S11). Also, if the total sum is less than A, only the code of the key in touch with the finger is sent (step S12).

Now, another embodiment will be described with reference to Figs.55 and 56. In Fig.55, numeral 109 designates phototransistors, and numeral 110 an infrared ray LED. The phototransistors 109 receive the light from the infrared ray LED 110 and detects the position of the thumb. Fig.56 shows a

housing packaged with the circuit of Fig.55. The position of the thumb is detected by an optical proximity sensor configured of the infrared ray LED 110 and the phototransistor 109 including the phototransistor 109 and the infrared ray LED 110 and mounted on the left side of the housing. This finger position is combined with the finger position on the tablet surface to selectively input a combination of key information .

Now, another embodiment will be explained with reference to Fig.57. In Fig.57, numeral 111 designates a plastic film. Each of the plastic films 111 is formed in a cup-shaped protrusion and bonded to the lower part of a keytop 101' having the electrode shown in Fig.50. When a force is applied to each keytop, the key presents a feeling of click. In this example, the click feeling is transmitted to the operator, and at the same time the pressure of the finger is influenced by the click and detected in the form of ups and downs. More specifically, the setting of touch degree assumes the same value as the critical value of finger pressure causing the click. Although this example uses a sensor with electrodes directly exposed, it is actually desirable to use a sensor of such a type that the capacitance variation against the ground due to the proximity of a finger without exposing any electrode is desirable. In such a case, a shield plate is further provided under each film 111 for a further increased capacitance against the ground as any electrode causing the click approaches the shield plate. This type of structure makes it possible to detect a signal of the setting of touch degree more easily by the secondary effect due to the film deformation.

Now, another embodiment will be explained with reference to Fig.58. In Fig.58, numeral 112 designates a slide mechanism for transmitting the force to a tablet selection switch 107. Also, numeral 113 designates a partition plate arranged at the boundary with the keys in such a manner that each of the four corners thereof coincides with the protrusion of the plastic film. The partition plate 113 also has four notches at the ends thereof acting in combination with the stopper of the slide mechanism 112. Further, the protrusion of the plastic film is also arranged under the portion of the tablet corresponding to each key. Numeral 114 designates a spring, and numeral 115 a spring support. When the slide mechanism 112 is pushed, the stoppers at the notches of the partition plate 113 move so that the partition plate 113 cannot be pressed any more. At the same time, the slide mechanism 112 presses the switch 107.

Now, another embodiment will be described with reference to Fig.59. In Fig.59, numeral 116 designates a slider mechanism. An optical proximity sensor comprising an infrared ray LED 110 and

a phototransistor 109 mounted on the slider 116 is adapted to slide vertically along the side portion of the housing. Individual personal differences of the thumb are adjusted by this slide mechanism.

Now, another embodiment will be explained with reference to Fig.60. Fig.60 is a flowchart, in which in the case where the optical proximity sensors each configured of the phototransistor 109 and the infrared ray LED 110 approach the thumb (step S8), the sensor most approached by the finger is detected (steps S9 to S15). When the thumb goes away (step S8), the value once selected is held (steps S16 and S17).

Now, another embodiment will be explained with reference to Fig.61. In Fig.61, four proximity sensors 109' are included each comprising a phototransistor 109 and an infrared ray LED 110. Of the four proximity sensors 109', one is arranged extensively in lateral direction thereby to detect the movement of the forward end of the thumb, i.e., the vertical movement of the finger (in parallel to the paper). This sensor can give a shift of a key for discriminating the lower-case and upper-case letters of English, for example.

Now, another embodiment will be explained with reference to Figs.62 and 63. Fig.62 is a plane view, and Fig.63 a flowchart representing the operation. In Fig.62, numeral 117 designates a matrix electrode formed on the tablet. Each intersections of the matrix are insulated. In Fig.62, the outputs of the matrix electrode are multiplexed by an analog selector 102'. The center of the finger position is calculated along the directions i and j of the matrix, after which calculations are made to rotate the coordinate by 45 degree (steps S1 to S3) thereby to correct along X and Y directions. This is by reason of the fact that when fingers are placed on the tablet, they are unavoidably overlaid one on another in horizontal direction and therefore it is difficult to detect the touch of a plurality of fingers by matrix. The probability of fingers being overlaid one on another can be considerably reduced by the above-mentioned processing in diagonal direction.

Now, another embodiment will be explained with reference to Figs.64a and 64b. In Fig.64a, numeral 118 designates a proximity sensor film with capacitance-detecting electrodes wire-printed on the back side thereof, numeral 119 a plastic sheet corresponding to the keytops, and numeral 120 a partition plate having a hole at the portion thereof corresponding to the keytops and also a stopper at the lower part of each hole. A protrusion of the plastic film 111 is arranged at the lower part of each plastic sheet 119. Normally, each plastic film 111 is pressed down. When the plastic films 111 are pushed up as shown in Fig.63b, however, the plastic sheet 111 corresponding to each keytop

119 raises the sensor film.

Now, another embodiment will be described with reference to Figs.65 and 66. In Fig.65, numeral 121 designates a light transmitter-receiver unit, numeral 122 a support system rotatable in both vertically and horizontally, numeral 123 a lateral drive coil, numeral 124 a lateral rotating magnet, numeral 125 a vertical drive coil, numeral 126 a vertical rotating magnet, numeral 127 a hair-type spring, and numeral 128 a support member making up a part of the housing. In Fig.66, on the other hand, numeral 129 designates a photodiode, numeral 130 an amplifier, numeral 131 a filter circuit, numeral 132 a sync detection circuit, numeral 133 demodulator circuit, numeral 134 an infrared ray LED, numeral 135 a modulator circuit, numeral 136 a coil drive circuit, numeral 137 a D/A converter, numeral 138 an integration circuit and numeral 139 an A/D converter. The light transmitter-receiver unit 121 has built therein a photodiode 129 and an LED 134 for performing optical communications with a personal computer making up an external host computer. The light transmitter-receiver unit 121 is mounted on a support system of a rotating mechanism 122 like a gyro top, and therefore the D/A converter is finely vibrated (wobbled) by being supplied with data in such a manner as to maximize the light quantity of external infrared rays focused on the phototransistor 129. The signal level is detected by the integration circuit 138 which integrates signal data of very high frequencies and retrieves a signal level, which is converted into a digital value by the A/D converter 139 and applied to the microcomputer. The setting of the D/A converter providing a maximum signal data represents the directional data of the external light. Also, the data from the tablet 1 are multiplexed by an analog selector, and through the A/D converter 103, are applied to the microcomputer. The pointing information as absolute position information is thus supplied. Also, the directional data of the external light is synthesized as relative information, and through the modulation circuit 135 and the LED 134, applied to an external light-receiving element. In similar fashion, a signal from an external source is applied through the sync circuit 132 and the demodulation circuit 133 to the microcomputer 104. Normally, in infrared ray communications, a great number of LEDs are used to prevent signals from being interrupted by emitting light in many directions. By directing a light transmitter-receiver unit toward the direction of transmission and receiving as in the above-mentioned case, however, power consumption can be reduced while at the same time producing pointing information.

Now, another embodiment will be explained with reference to Fig.67. In Fig.67, numeral 140 designates a switch arranged at the lower part of



the housing. This switch 140 is adapted to turn on when the housing is placed on the desk. As in the case where the mouse is raised in the air when it is liable to be displaced out of the mouse pad, the switch information is used for stopping the cursor on the screen or, when used as an air-borne mouse but not on the desk as a remote controller for TV, for detection of the reverse operation of the light transmitter-receiver unit as compared when it is operated on the desk.

Now, another embodiment is described with reference to Fig.68. This drawing is a flowchart for explaining the operation. When a light signal is received from an external source, a light transmitter-receiver unit begins to track the external light. In the process, such mutual communication attributes, that is, information on whether a television or a computer is used for communication or what is the memory capacity provided are exchanged (steps S1, S2, S3). This operation is maintained only as long as the optical communication is established, and is automatically reset by an interrupt from another device or an automatic power off when information exchange ceases for a predetermined length of time (steps S1, S5). Exchange of key information is also possible with a pointer on the desk or an air-borne mouse.

Now, another embodiment will be explained with reference to Fig.69. In Fig.69, numeral 141 designates a focus drive coil on which a light transmitter-receiver unit is mounted, and numeral 142 a focus moving magnet. This drive coil causes the phototransistor of the light-receiving unit to move back and forth thereby to detect the distance to an external light source.

As obvious from the foregoing embodiments, in an information input processing system according to the invention, the key input or position input is possible by a single hand. Also, the position input and the key striking operation can be realized with the same sensor.

The following is a description of another embodiment related to the embodiments described above with reference to Figs.56 or 61, and other drawings.

More specifically, Fig.70 is a diagram showing a full view of a single-hand-operated keyboard shown as an example of an information input processing system according to the invention.

A housing 151 of the single-hand-operated keyboard is laterally symmetric. A thumb light sensor 152, which is replaceable and so constructed as to have an electrical contact connectable on both right and left sides, can be operated by either right or left hand.

Also, Fig.71 is a diagram showing a full view of a single-hand-operated keyboard and a thumb light sensor. A housing 201 of the single-hand-operated

keyboard has a slidable thumb sensor 202. Any person therefore can operate the keyboard smoothly by slide adjustment in accordance with his finger length. Each sensor 203 of the thumb light sensor 202 may be equipped with a focusing lens 204 for an improved sensitivity.

Fig.72 is an illustration of providing hysteresis between the on/off operations of the switch and the distance between the thumb and the sensor. When hysteresis is represented by 301, the distance by which the thumb departs away and turns off the switch is shorter than the distance by which the thumb approaches and turns on the switch, and therefore, the switch can be changed over rapidly. In the case where hysteresis is given by 302, the distance by which the thumb departs away and turns off the switch is longer than the distance by which the thumb approaches and turns on the switch, so that once the switch is turned on, therefore, the switch-on state can be held stably. In accordance with the user propensities, the hysteresis 301 or 302 can be selected.

Now, a pointing device will be described as an embodiment of the coordinate input system according to the invention.

Figs.73a and 73b show an example configuration of the pointing device for detecting the operation of a tabular movable object.

An opening 402 inside the case of a tabular movable object 401 has a circular structure, so that the force in X and Y directions can be detected even when the pen or the finger comes into contact with the opening. In similar fashion, a rectangular opening can attain a similar effect by performing a high-friction machining on the inner wall thereof. Pressure-sensing rubber balls 403 may be arranged inside the opening 402 and scratched by the finger or pen, or the tabular movable object is pressed down, whereby the direction and the distance covered can be indicated by the pressure-sensing rubber balls 403 and an electrical circuit for detecting the change thereof.

Fig.74 shows the configuration of another embodiment of a pointing device capable of operation in relative positions by means of pressure-sensing rubbers.

This embodiment includes a resistor-type touch panel 501 and pressure-sensing rubber balls 502 and dead-zone spacers 503 around the panel 501. The absolute-positional operation is performed by use of the touch panel, and the movement of the touch panel with respect to the pressure-sensing rubber balls is detected to perform the relative-positional operation.

Now, with reference to Fig.75a, the configuration of a detection circuit with pressure-sensing rubber balls used in Figs.73a, 73b and 74 will be explained.



In Fig.75a, the voltage changed under the pressure of four pressure-sensing rubber balls 171 is sampled by an A/D converter 172 and the amount and direction of change are detected by calculations at an MPU 173.

Fig.75b is a diagram for explaining the operation described with reference to Figs.73a, 73b and 74. The operation on a surface (say, 183) maintaining a coordinate system always fixed with respect to a tablet surface 181 and a screen surface 182 is assumed to be an absolute-positional operation. In contrast, the operation on a surface 183 whose movement causes a change in the coordinate system of the tablet surface 181 and the screen surface 182 is assumed to be a relative-positional operation. As a result, the coordinate information can be input much more readily than in the prior art.

Fig.76 is a diagram showing the configuration of a pad according to an embodiment. In Fig.76, a pad 601 is composed of a resistor 602 coated with an inorganic coating material containing a substance of high dielectric constant (such as titanium oxide powder) 603 or mixed by fusion in a film-like material.

Fig.77 is a diagram showing an embodiment of the invention in which the priority order of selection is determined using the contact area of the pad and the distinction between the pen tip and the finger tip. A method of detection for this particular case is shown as a flowchart in Fig.78.

Upon detection of the on-state of a switch 703 (S1001), the position having the largest area is selected in priority among the sizes of the areas 702 in touch with the finger tips on the pad 701, thereby making it possible to give a plurality of functions to the switch according to the position. More specifically, even when the same switch 703 is turned on, the positional information may be different. Whether the same finger or pen is touched is decided from whether the difference between the detection positions of adjacent resistors is not more than a threshold level  $\alpha$ , and it is thus decided whether a single or a plurality of fingers or pens are touched (S1003 to S1007). In the case where the contact area of only less than a threshold value  $\beta$  can be detected, it is possible to decide that a pen-like object but not a finger tip is touched (S1008, S1009). In the case where a contact area more than  $\beta$  is detected, on the other hand, it is decided that a finger tip is in touch (S1010). This configuration permits a decision on whether a touch is by the pen or by the finger.

Fig.79 is a diagram showing an embodiment for selection operation of the pad. A method of detection for this case is shown as a flowchart in Fig.80.

This embodiment relates to a pad 801, a contactable pad area 802, the ground 803 and a protruded metal plate 804. When the whole pad is pressed, the approach of a resistor to the ground is detected, and thus start of the selection operation is detected (S1101 to S1103), with the result that the feeling of click that the switch of the protruded metal plate 804 is turned on is fed back to the operator.

Fig.81 is a diagram showing an embodiment in which the same resistor of a pad is shared by two or more fingers. This is the case in which a resistor 904 is shared by two fingers at points 902 and 903 on the pad 901. A method of detection for this case is shown as a flowchart in Fig.82. With this configuration, even when two or more fingers share the same resistor of the pad, the contact area and the central position of each finger can be defined (S1206).

Now, a coordinate input system according to another embodiment of the invention will be explained with reference to Fig.83 and other drawings.

In these drawings, numeral 1101 designates a tablet to be touched by the fingers of the operator or the like (details described later). Numeral 1102 designates a mechanical switch arranged on the lower side of the tablet 1101, which is adapted to turn on when the operator applies pressure on the tablet 1101. Numeral 1103 designates a current detection circuit, and numeral 1104 an analog switch for switching the resistors on the tablet 1101 in accordance with a command from the MPU 1106. Numeral 1004 designates an A/D converter for converting the analog voltage detected by the tablet 1101 into a digital value. Numeral 1106 designates an MPU for receiving and processing a value obtained from the A/D converter 1004 while at the same time controlling the tablet 1101 (the method of control will be described later). Information from the mechanical switch 1102 is also received. Numeral 1107 designates a host CPU providing the computer body for performing such operations as moving the cursor in accordance with the input from the operator, and numeral 1108 a display for outputting the result of the processing operation in the host CPU 1107 as visual information.

Fig.84 is a diagram showing a method of detecting the contact position of the finger of the operator or the like using the tablet 1101 according to an embodiment.

Numeral 1101 designates a tablet, numeral 1104 an analog switch, numeral 1105 an A/D converter, numeral 1106 an MPU, numeral 1111 the operator's finger, numeral 1112 a terminal, numeral 1113 an operational amplifier, numeral 1114 a sample-and-hold circuit and numeral 1115 a current

detecting resistor.

Band resistors  $x_1$ – $x_n$  (each having the resistance  $R$ ) are arranged along  $x$  (horizontal) axis on the tablet 1101. An end of each band (striped) resistor is connected to the ground, and the other end to the analog switch 1104. This analog change-over switch is for selecting only one of the band (striped) resistors in compliance with a command from the MPU 1106.

The ends of each band resistor on the tablet 1101 has an unused portion unable to be approached by the finger. This is by reason of the fact that it is necessary to avoid a measurement error which might be caused by a reduced time constant due to the band resistor and the capacitance of the contacted portion of the finger when a part of a band resistor near any of the ends thereof is touched by the finger.

First, explanation will be made about a method for detecting the finger position along  $y$  (vertical) axis when the operator's finger 1111 touches the resistor  $x_n$  through an insulating material as shown.

The analog switch 1104 selects the band resistor  $x_1$ , a potential  $E$  is applied to a terminal 1112, and thus a current  $I_a$  is detected in the resistor. Then, the analog switch 1104 is switched to the band resistors  $x_2, x_3, \dots, x_n$  in that order, so that the currents  $I_{a2}, I_{a3}, \dots, I_{an}$  are sequentially detected by the voltage across the current detection resistor 1115 sequentially. When the band resistor  $x_i$  is selected, the current is expressed as

$$I_{ai} = E/R \quad (1)$$

The chronological change of this current is shown in Fig.85. Actually, a minute transient phenomenon can be observed due to a stray capacitance and is not shown in Fig.85.

The resistor is touched by the operator's finger 1111, and therefore the path from the finger to the ground through the human body makes up a sort of capacitor (with a capacitance of  $C$ ). A related equivalent circuit is shown in Fig.86. Let the distance from the analog switch 1104 to the point of contact by the operator's finger 1111 be  $y_{1i}$  (upper side in Fig.84), the resistance therebetween be  $R_{1i}$ , the distance from the point of contact by the operator's finger 1111 to the ground be  $y_{2i}$  (lower side in Fig.84), and the resistance therebetween be  $R_{2i}$ . Then, the following relation is held.

$$R = R_{1i} + R_{2i} \quad (2)$$

$$y_{1i} : y_{2i} = R_{1i} : R_{2i} \quad (3)$$

Also, the current  $I_{ai}$  is given as

$$I_{ai} = E(SCR_{2i} + 1) / [R_{1i}(SCR_{2i} + 1) + R_{2i}] \quad (4)$$

The related chronological change is shown in Fig.87.

Equation 4 shows that the current of  $I_{ai} = E/R_{1i}$  can be detected at the time of touching the finger ( $S = \infty$ ). Since  $E$  is known,  $R_{1i}$  is determined, followed by determining  $R_{2i}$  from Equation 2. The finger position along  $y$  axis is determined from Equation 3.

The flat portion of the current  $I_{ai}$  actually observed corresponds to the portion of a sufficiently high frequency in transient response. More specifically, the exact position of  $y$  is where the capacitance in the contact area between the finger and a band resistor exceeds a certain value (the position where the time constant is met, i.e., where the length of the striped contact area of the band resistor from the upstream side exceeds a predetermined amount  $p$ ), and does not represent the center of the finger contact section. This fact is shown further in Fig.90. For this reason,  $y$  undergoes a change when the finger is pressed strongly. Also, since the time constant is changed depending on the finger position along  $y$  axis, the predetermined value  $p$  itself becomes a function of  $y$ . As a consequence, in order to determine the actual center position of the finger, the position of the finger outline located upstream of the striped contact area is determined by calculations, after which it is necessary to calculate the center or perform the correcting operation using the  $x$ -axis data assuming that the finger contact area is circular. The current  $I_{ai}$  is detected in such a fashion that an operational amplifier 1113 is actuated by the voltage across a current detecting resistor 1115 in which the current  $I_{ai}$  flows, and the peak value ( $I_{ai} = E/R_{1i}$  in Fig.87) is held by a sample-and-hold circuit 1114. The data thus sampled is applied through the A/D converter 1105 to the MPU 1106.

For the position detection along  $x$  axis, the band resistors  $x_i$  are scanned and the one having a transient response more than the stray capacitance is selected. Of all the resistors  $x_i$  touched by the finger, those resistors are selected for which a current  $I_{ai} = E/R_{1i}$  more than a setting can be detected (which is hereinafter referred to as the "ON-resistor" for simplification). In order to secure a high detection accuracy, normally, band resistors are arranged with sufficiently small intervals as compared with the touch width of the finger. Therefore, there is not a single ON-resistor but there exist adjacent ON-resistors. The adjacent ON-resistors undergo a change in accordance with the finger pressure or the relative position of the finger along  $x$  axis.

The average of these  $x$  coordinate values or, by assuming a finger shape, the center position thereof is determined as an  $x$ -axis position where the finger is touched.

Also, when the tablet surface for designating a place is strongly pressed to depress the mechanical switch 1202 or when the cursor is held at a certain position with the finger detached, the contact area of the finger changes. In the process, the center position of the finger calculated is liable to be displaced, and therefore the immediately preceding value is held.

In the case where a plurality of points are touched by a plurality of fingers at the same time, an OFF-resistor being sandwiched by ON-resistors may be detected. With regard to each ON-resistor, therefore, the average value thereof or the center position is estimated, whereby a plurality of points can be simultaneously input and detected. A method of detection used for this purpose is shown as a flowchart in Fig.88.

In this way, the touch position of the operator's finger 1111 on the tablet 1101 can be detected. Further, it is possible to detect the position where pressure is applied on the tablet 1101. Fig.89 is a side view of the tablet 1101. In Fig.89, numeral 1202 designates a mechanical switch, and other component parts similar to those in the aforementioned embodiments are designated by the same reference numerals respectively as in other drawings.

In this embodiment, the mechanical switch 1202 is installed on the lower side of the tablet 1101 and turns on under the pressure applied thereto by the operator's finger 1111. In the process, the operator's finger 1111 is naturally in contact with the tablet surface, and therefore the contact position is detected as a position under pressure. Suppose the mechanical switch 1202 turns on, it is decided that the tablet 1101 is pressured, while if the mechanical switch 1202 is off, a simple touch is decided.

By use of this mechanism, instead of the conventional operation for entering a coordinate (by moving the mouse) and pressing a button on a pointing device such as the mouse, an equivalent operation can be performed by moving the finger on the tablet while in touch with it to enter a coordinate, and directly pressuring a tablet with the same finger.

Now, explanation will be made about another embodiment of a method for detecting the contact position of the operator's finger or the like with reference to Fig.91 and other drawings.

The main difference between the embodiment under consideration and the embodiment described above with reference to Fig.84 lies in the following.

Specifically, the above-mentioned embodiment uses an analog switch 1004 having 16 terminals corresponding to band resistors  $x_1 \sim x_{16}$ . According to this embodiment, in contrast, the band resistors  $x_1 \sim x_{16}$  are divided into four groups (sets), and an

analog switch is arranged on the upstream and downstream sides of these band resistors. In this way, a switch of a simpler structure can be used with a fewer number of terminals of the analog switch while maintaining the appropriate resolution. More specifically, as shown in Fig.91, the number of terminals of each analog switch is four.

In Fig.91, numeral 1101 designates a tablet, numeral 1121 an operator's finger, numeral 1122 a first analog switch, numeral 1123 a second analog switch, numeral 1124 a terminal, numeral 1125 a first current detecting resistor, numeral 1126 a first operational amplifier, numeral 1127 a first sample-and-hold circuit, numeral 1131 an A/D converter, numeral 1132 an MPU, numeral 1128 a second current detecting resistor, numeral 1129 a second operational amplifier, and numeral 1130 a second sample-and-hold circuit.

Band resistors  $x_1 \sim x_m$  on the tablet 1101 are divided into sets of  $n$  to make up  $m$  sets of band resistors (Fig.91 shows the case in which  $m = 4$  and  $n = 4$ ). The upstream end of each resistor set is connected to the first analog switch 1122, and the contents of each set are switched by the second analog switch 1123 on the downstream side thereby to check the distribution corresponding to the capacitance of finger touch. This distribution ratio is checked by reading the value of the rise portion of a response waveform after the lapse of a predetermined length of time.

The aforementioned configuration leads to the basic operation described below.

More specifically, first, the current  $I_a$  is measured, whereby which set of band resistors is touched by the finger is roughly checked, and once a set touched by the finger is detected, the current  $I_b$  is measured for each band resistor included in the particular set. In this way, a resolution similar to that of the embodiment described above can be obtained.

The operation is explained below more specifically.

First, explanation will be made about a method of detecting the average finger position along  $y$  (vertical) axis for a particular set of band resistors touched by the operator's finger 1121 by detecting the particular set through an insulating material as shown in the drawing.

The connection of the first analog switch 1122 to terminals a, b, c, d is expressed by  $i$  ( $= 1$  to  $m$ ), and the connection of the second analog switch 1123 to terminals e, f, g, h is given as  $j$  ( $= 1$  to  $n$ ). The first analog switch 1122 is connected to the terminal a ( $i = 1$ ), the band resistors  $x_1 \sim x_4$  are selected, a voltage  $E$  is applied to the terminal 1124, a current is supplied to the band resistor set, and the upstream current  $I_{a1}$  is checked to see whether it exceeds a threshold value.

In the case where the current  $I_{ai}$  exceeds a threshold level, the connection of the first analog switch 1122 to a terminal remains in state i, while the second analog switch 1123 is sequentially switched to perform an operation similar to the one described above. In the process, the current  $I_{ai}$  is detected by detecting the voltage across the first current detecting resistor 1125, and the current  $I_{bij}$  by detecting the voltage across the second current detecting resistor 1128. In this case, if the only requirement is to specify a resistor set touched by the finger 1121, it is sufficient to detect only the upstream current  $I_{ai}$  and check the variation thereof.

As a result, it is decided which resistor set is touched by the finger. The average position of the finger along y axis can be determined by the current  $I_{ai}$  in a manner similar to the one described above. This average position, however, is affected by the circumventing current or the like not found in the aforementioned embodiments, and therefore is less accurate than the position along y axis determined in the above-mentioned embodiments.

The current  $I_{bij}$  on downstream side, on the other hand, is given by Equation 5 as follows:

$$I_{bij} = E / (R_{1ij}R_{2ij}SC + R_{1ij} + R_{2ij}) \quad (5)$$

A related equivalent circuit is shown in Fig.92, and the chronological change of the current  $I_{bij}$  in Fig.93. Though not shown, according to still another embodiment, the resistance value dropping from the terminals e, f, g, h to the ground is dynamically changed to determine a more accurate distribution ratio. The contents of the above-mentioned embodiment are shown in the flowcharts of Figs.94 and 95.

With the embodiment explained with reference to Fig.91, a resistor 1140 for preventing flow-in is arranged at an end (on the second operational amplifier 1129 side in the drawing) of the second analog switch 1123. This is in order to prevent the current from flowing into the resistors during operation.

More preferably, a diode is added between the downstream terminal of each band resistor (specifically, each of the band resistors  $x_5 \sim x_{16}$ ) and the intersection between each band resistor and each terminal e, f, g, h of the second analog switch 1123 in such a manner that the current flows in the forward direction from the band resistor to each terminal of the second analog switch 1123.

As a result, the unrequired current can be prevented from flowing into the resistors, thereby leading to the advantage of reducing the resistor 1140 for preventing current in-flow to a small value.

Now, a coordinate input system according to another embodiment of the invention will be ex-

plained with reference to Fig.96.

In Fig.96, characters e, f, g, h correspond to characters e, f, g, h in Fig.91 respectively, each being associated with one of the four band resistors included in each group. According to the embodiment shown in Fig.91,  $I_b$  is selected by a switch circuit. In the present embodiment, by contrast, the differences e-f, f-g, g-h, i.e., the current ratio of each adjacent band resistors are directly observed by three operational amplifiers 2121 to 2123 thereby to determine the current distribution in each group. Each difference is sample-held as a voltage by the sample-and-hold circuits 2124 to 2126, and sent to a microprocessor 2128. As a result, an advantage similar to that of the above-mentioned embodiment is obtained.

An example application of the aforementioned embodiment is shown in Fig.97. Fig.97 shows an information input processing system in which band resistors  $x_1 \sim x_{16}$  are provided on the input panel section of the single-hand-operated keyboard 201 shown in Fig.71, so that the keyboard function doubles as the function of a tablet capable of coordinate input as described above, thereby further facilitating information entry as described above than in the prior art.

## INDUSTRIAL APPLICABILITY

As described above, an information input processing system, a cover and a coordinate input system according to the present invention, as compared with the prior art, can be input with information or various types of data more easily. In the case where characters or pattern information are input, therefore, a single-hand entry is possible, thereby greatly contributing to the utility as an input processing system for various types of data.

## Claims

1. An information input apparatus comprising:
  - a plurality of switch circuits;
  - an array of keys for opening and closing the switch circuits through transmission of forces;
  - a plurality of sensors for detecting direct touch or proximity of a finger to all or a part of the keys;
  - a signal processing means for receiving and processing data outputs from the sensors and switch circuits;
  - a first display means for displaying as a corresponding information code the direct touch or proximity of the finger to the specific key detected by the sensors; and
  - a second display means for displaying, in a manner different from that of the first display

means, a corresponding specific information code when the switch circuit is closed by pressing the specific key.

- 2. An information input apparatus comprising:
  - a plurality of switch circuits;
  - an array of keys for opening and closing the switch circuits through transmission of forces;
  - a plurality of thumb proximity sensors for detecting direct touch or proximity of an object; and
  - a signal processing means for receiving and processing data outputs from the thumb proximity sensors and switch circuits;
    - said thumb proximity sensors being located in an upper, equal, or lower position to a face of the keys , wherein
      - specifying one of the thumb proximity sensors by a detection of direct touch or proximity action of the thumb and specifying one of the keys by pressing of other finger or fingers than the thumb are executed and ,
    - a plurality of information codes are made corresponding to combinations of both the specifying and entry is executed.
- 3. An information input apparatus according to claim 2, wherein
  - at least some of the thumb proximity sensors are mounted within an insertion hole of a lower part of a face of the array of the keys , the hole of which is provided for inserting the thumb from side face into the lower part of the array of the keys .
- 4. An information input apparatus according to claim 2, wherein
  - each of the thumb proximity sensors has on surface a corresponding projection or recess of a tangible shape.
- 5. An information input apparatus comprising:
  - a plurality of switch circuits;
  - an array of keys for opening and closing the switch circuits through transmission of forces;
  - a plurality of sensors for detecting direct touch or proximity of a finger to the key, each sensor being mounted on surface of all or a part of the keys or on separately of the keys;
    - a signal processing means for receiving and processing data outputs from the sensors and switch circuits;
    - a first display means for informing about a part or all of the direct touch or proximity of the finger detected by the sensors . with correspondence to a physical positions of the

- sensors;
  - a second display means for displaying, in a manner different from that of the first display means, when the switch circuit is closed by pressing the specific key , a corresponding specific information code ; and
  - a means for moving an indication produced by the first display means and an indication displayed by the second display means to a proximity of a position of a cursor which indicates a data entry on a screen.
- 6. An information input apparatus comprising:
  - a plurality of switch circuits;
  - an array of keys for opening and closing the switch circuits through transmission of forces;
  - a plurality of finger sensors for detecting direct touch or proximity of a finger to all or a part of the keys;
  - a plurality of thumb proximity sensors for detecting direct touch or proximity of an object;
  - a signal processing means for receiving and processing data outputs from the finger sensors, thumb proximity sensors, and switch circuits;
    - a first display means for informing about a part or all of the direct touch or proximity of the finger detected by the finger sensors , with correspondence to a physical positions of the sensors ;
    - a second display means for displaying, in a manner different from that of the first display means, when the switch circuit is closed by pressing the specific key , a corresponding specific information code ; and wherein
      - on a display screen for a plurality of information codes corresponding to the each keys , the first display means displays with a desired display manner information codes corresponding to one or more specific keys of direct touch or proximity, and further by specifying one of the thumb proximity sensors a part of the displayed information codes are selectively specified with a different display manner.
  - 7. An information input apparatus according to claim 6, wherein
    - the plurality of the information codes corresponding to the each keys are displayed separately in a form of a footprint-like sequence on the screen.
  - 8. An information input apparatus comprising:
    - a plurality of switch circuits;
    - an array of keys for opening and closing