



(19) **United States**

(12) **Patent Application Publication** (10) **Pub. No.: US 2002/0101172 A1**

**Bu**

(43) **Pub. Date:**

**Aug. 1, 2002**

(54) **OLED ACTIVE DRIVING SYSTEM WITH CURRENT FEEDBACK**

(57) **ABSTRACT**

(76) Inventor: **Lin-kai Bu, Tainan (TW)**

The invention provides an organic light emitting diode active driving system with current feedback, thereby a driving current for organic light emitting diode is not affected by variation of characteristic parameters of thin film transistor under an active driving mode. The active driving system in accordance with the invention includes a transistor and a current comparator for driving an organic light emitting diode. The transistor has two current carrying electrodes respectively connected to a cathode of the organic light emitting diode and ground, and a gate controlled by a data signal. The current comparator has two input terminals respectively receive a reference current with predetermined value and a driving current flowing through the organic light emitting diode. The current comparator compares the reference current and the driving current, and then outputs a voltage to the gate of the transistor in response to the comparison result so as to make the value of the driving current equal to that of the reference current. Therefore, the active driving system for organic light emitting diode array or flat panel display in accordance with the invention can achieve a desirable light emission uniformity.

Correspondence Address:  
**MARTINE & PENILLA, LLP**  
**710 LAKEWAY DRIVE**  
**SUITE 170**  
**SUNNYVALE, CA 94085 (US)**

(21) Appl. No.: **09/823,180**

(22) Filed: **Mar. 29, 2001**

(30) **Foreign Application Priority Data**

Jan. 2, 2001 (TW)..... 090100073

**Publication Classification**

(51) **Int. Cl.<sup>7</sup>** ..... **G09G 3/10**

(52) **U.S. Cl.** ..... **315/169.3**

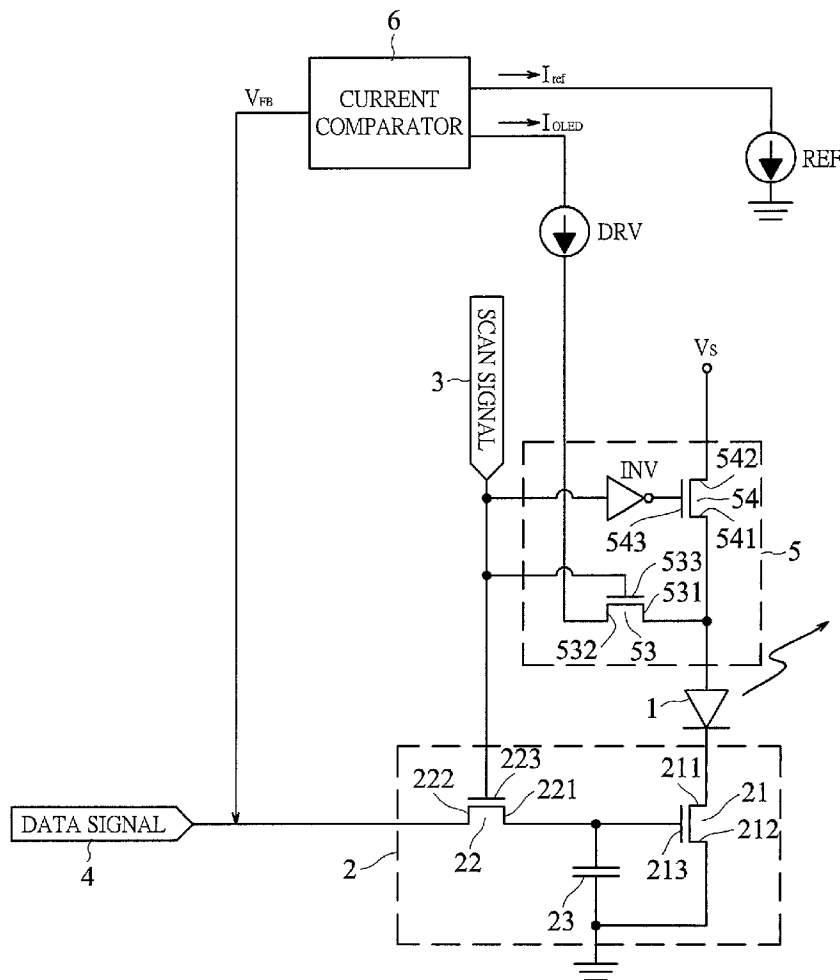

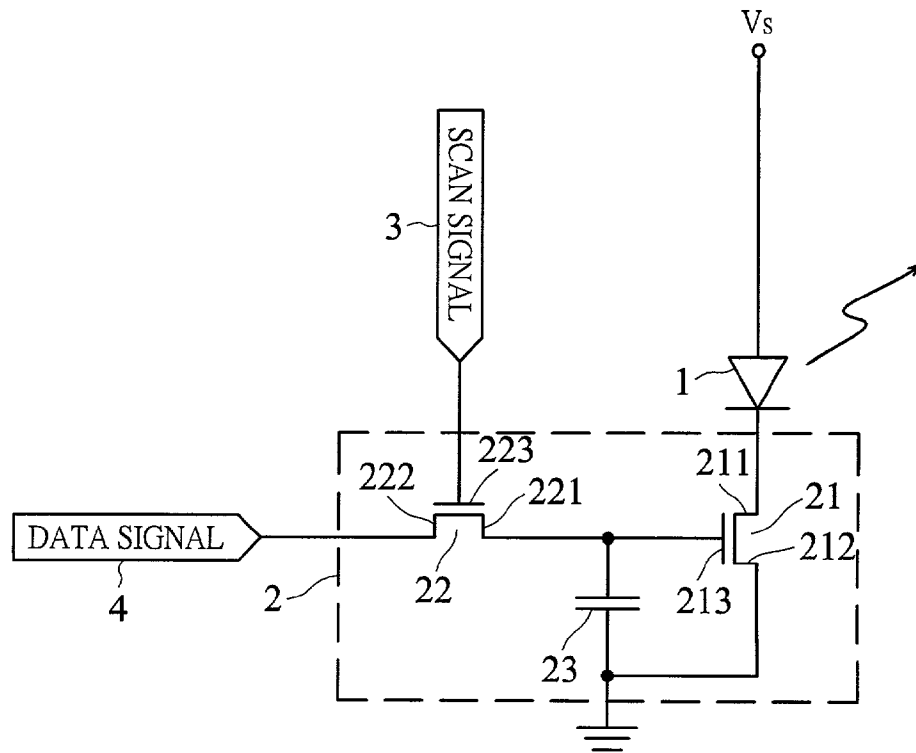

Fig. 1  
(PRIOR ART)

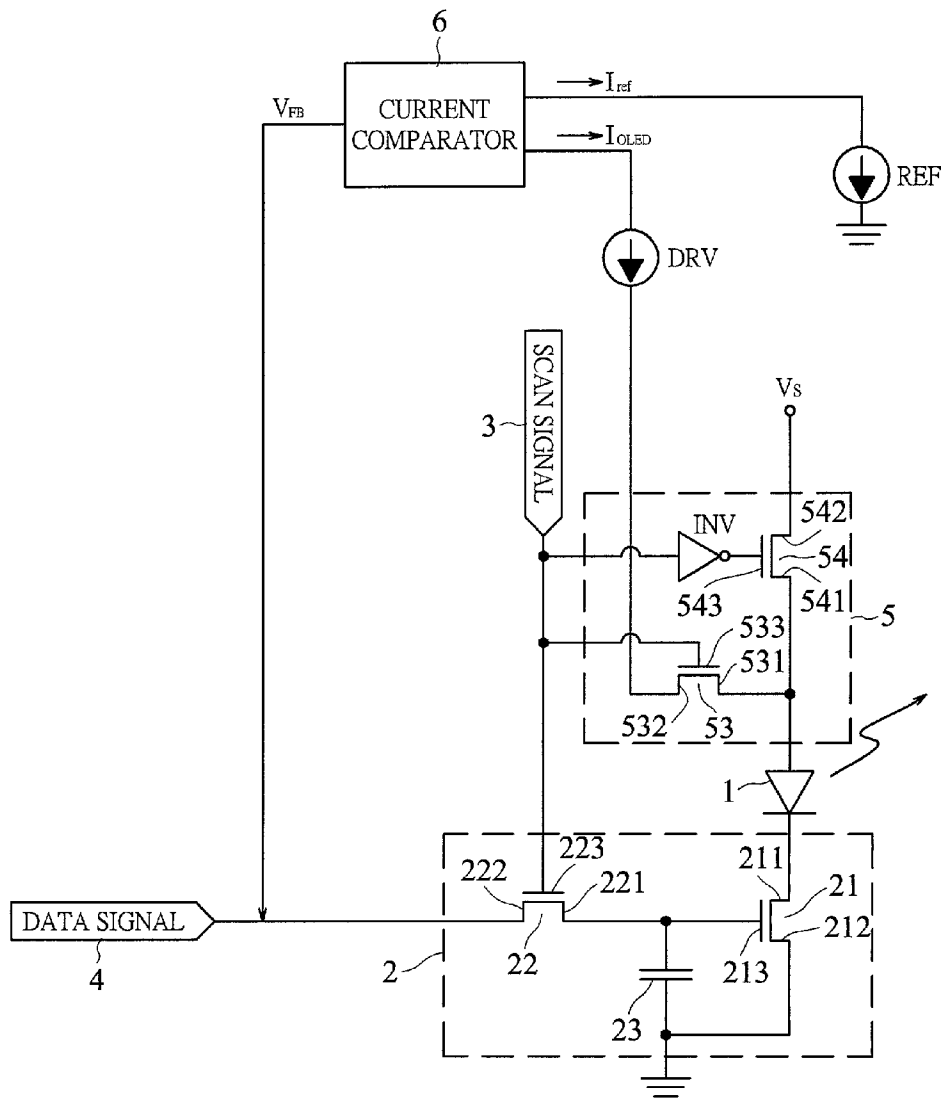

Fig. 2

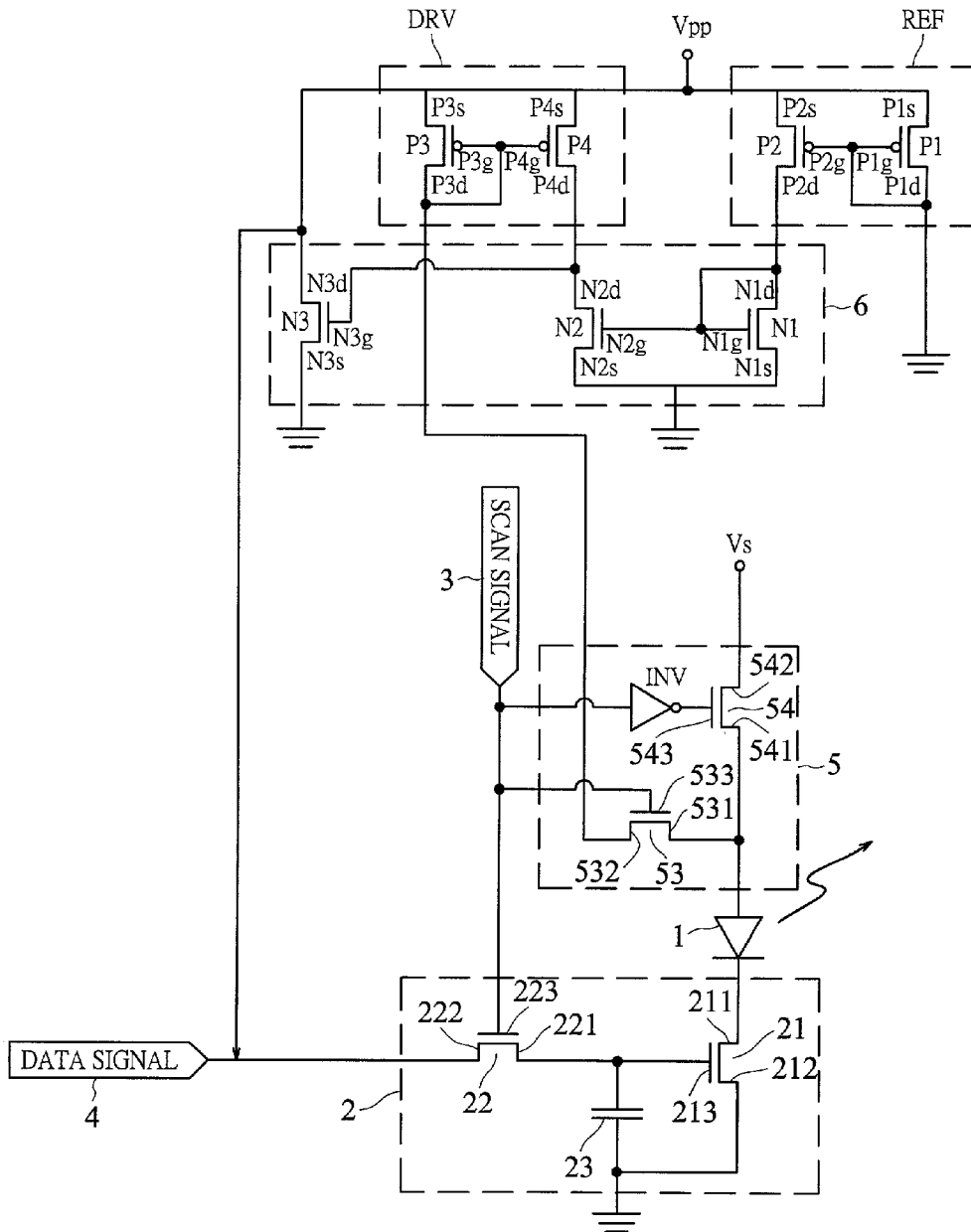

Fig. 3

## OLED ACTIVE DRIVING SYSTEM WITH CURRENT FEEDBACK

### BACKGROUND OF THE INVENTION

[0001] 1. Field of the Invention

[0002] The invention relates to an active driving circuit system for organic light emitting diode (OLED) and, more particularly, to an OLED active driving system for improving light emission uniformity of an array or flat panel display (FPD) made up of OLEDs by current feedback.

[0003] 2. Description of the Related Art

[0004] Recently, since OLED arrays can generate relatively high luminance of light and have relatively low production and operation costs, they are becoming more and more popular as FPDs. Besides, OLEDs can be fabricated in a variety of sizes from very small (less than a tenth millimeter in diameter) to relatively large (greater than an inch) so that OLED arrays can be fabricated in a variety of sizes. Also, OLED arrays can generate most colors of light with relative ease and provide a very wide viewing angle.

[0005] All OLEDs work on the same general principles described as follows. Firstly, one or more layers of organic material are sandwiched between two electrodes. A current is then applied to the OLEDs, causing negatively charged electrons to move into the organic material from the cathode. Positive charges typically referred to as holes move in from the anode. Then, the positive and negative charges meet, combine, and produce photons in the center layers (i.e., the organic material). The color of the photons depends on the electronic properties of the organic material in which the photons are generated.

[0006] As disclosed in U.S. Pat. No. 5,748,160, two-dimensional OLED arrays typically contain rows and columns of OLEDs. **FIG. 1** shows one of the OLEDs, which is designated by reference numeral **1**. Referring to **FIG. 1**, the OLED **1** is connected to a circuit block **2**. The circuit block **2** includes a first transistor **21** having a current carrying electrode **211** connected to a cathode of the OLED **1** and a current carrying electrode **212** connected to ground. The circuit block **2** further includes a second transistor **22** having a current carrying electrode **221** connected to a gate electrode **213** of the first transistor **21**. Another current carrying electrode **222** of the second transistor **22** serves as a data signal input terminal **4**, and a gate electrode **223** of the second transistor **22** serves as a scan signal input terminal **3**. Besides, a capacitor **23** is connected between the gate electrode **213** and ground as a storage element so as to maintain the OLED **1** in an ON mode for a specific period of time, and control the flowing of some fixed current, wherein the current value is determined by the gate-source voltage  $V_{gs}$  of the first transistor **21**.

[0007] The OLED **1** is addressed by supplying a scan signal to the gate electrode **223** of the second transistor **22**, and supplying a data signal to the current carrying electrode **222**. Specifically, the scan signal activates the second transistor **22** so that the data signal is input to the gate electrode **213** of the first transistor **21** through the current carrying electrodes **222** and **221**. Thereby, the gate electrode **213** is activated. At this time, a current path is completed between the cathode of OLED **1** and ground. Since a supply voltage

$V_s$  is connected to the anode of OLED **1**, the current flows through the OLED **1**, which thus emits light.

[0008] OLEDs are typically current driven devices (i.e., emit due to current flowing through them), as opposed to voltage driven devices such as liquid crystal displays (LCDs). Therefore, in an array or FPD made up of OLEDs, it must be assured that each of the OLEDs is driven by the same current under the same supply voltage in order to achieve superior light emission uniformity. However, since the first transistors **21** of the OLEDs do not have the same characteristic parameters, different driving currents can be generated under the same supply voltage. Therefore, the conventional array or FPD made up of OLEDs cannot achieve desirable light emission uniformity.

### SUMMARY OF THE INVENTION

[0009] In view of the above-mentioned requirement for light emission uniformity of OLED array or FPD, the invention provides an OLED active driving system with current feedback. With the OLED active driving system, a driving current for OLED is not affected by variation of characteristic parameters of thin film transistor under an active driving mode, so that the OLED array or FPD can achieve desirable light emission uniformity.

[0010] In one embodiment in accordance with the invention, a cathode of an OLED is connected to a current carrying electrode of a first transistor. A current carrying electrode of a second transistor is connected to a gate electrode of the first transistor. Another current carrying electrode of the second transistor serves as a data signal input terminal, and the gate electrode serves as a scan signal input terminal. A capacitor is connected between a gate electrode of the first transistor and ground as a storage element. Two current carrying electrodes of a third transistor are respectively connected to an anode of the OLED and a comparison terminal of a current comparator. A gate electrode of the third transistor is connected to the scan signal input terminal. Two current carrying electrodes of a fourth transistor are respectively connected to the anode of the OLED and a supply voltage. The gate electrode of the fourth transistor serves to receive a reverse signal of the scan signal.

[0011] In order to make the driving current input from the third transistor into the OLED not affected by variation of characteristic parameters of a thin film transistor under active driving mode, another comparison terminal of the current comparator is connected to a reference current source for receiving a reference current with predetermined value. The current comparator compares the driving current and the reference current, and then outputs a voltage to the gate electrode of first transistor in response to the comparison result. The gate electrode of the first transistor controls the value of driving current, and therefore the driving current is maintained at the value of reference current due to the feedback effect of the voltage.

### BRIEF DESCRIPTION OF DRAWINGS

[0012] **FIG. 1** is a circuit diagram showing one unit of a conventional organic light emitting diode array;

[0013] **FIG. 2** is a circuit diagram showing one unit of an organic light emitting diode array, with the use of an active driving system with current feedback, in accordance with the invention; and

# Explore Litigation Insights

Docket Alarm provides insights to develop a more informed litigation strategy and the peace of mind of knowing you're on top of things.

## Real-Time Litigation Alerts



Keep your litigation team up-to-date with **real-time alerts** and advanced team management tools built for the enterprise, all while greatly reducing PACER spend.

Our comprehensive service means we can handle Federal, State, and Administrative courts across the country.

## Advanced Docket Research



With over 230 million records, Docket Alarm's cloud-native docket research platform finds what other services can't. Coverage includes Federal, State, plus PTAB, TTAB, ITC and NLRB decisions, all in one place.

Identify arguments that have been successful in the past with full text, pinpoint searching. Link to case law cited within any court document via Fastcase.

## Analytics At Your Fingertips



Learn what happened the last time a particular judge, opposing counsel or company faced cases similar to yours.

Advanced out-of-the-box PTAB and TTAB analytics are always at your fingertips.

## API

Docket Alarm offers a powerful API (application programming interface) to developers that want to integrate case filings into their apps.

## LAW FIRMS

Build custom dashboards for your attorneys and clients with live data direct from the court.

Automate many repetitive legal tasks like conflict checks, document management, and marketing.

## FINANCIAL INSTITUTIONS

Litigation and bankruptcy checks for companies and debtors.

## E-DISCOVERY AND LEGAL VENDORS

Sync your system to PACER to automate legal marketing.