

UNITED STATES PATENT AND TRADEMARK OFFICE

---

BEFORE THE PATENT TRIAL AND APPEAL BOARD

---

CIXI CITY LIYUAN AUTO PARTS CO. LTD., TYGER AUTO, INC.,  
AND HONG KONG CAR START INDUSTRIAL CO. LTD.,  
Petitioner,

v.

LAURMARK ENTERPRISES, INC.,  
Patent Owner.

---

IPR2020-01030  
Patent 8,061,758 B2

---

Before PATRICK R. SCANLON, JOHN P. PINKERTON, and  
MICHAEL L. WOODS, *Administrative Patent Judges*.

PINKERTON, *Administrative Patent Judge*.

DECISION  
Denying Institution of *Inter Partes* Review  
35 U.S.C. § 314

## INTRODUCTION

Cixi City Liyuan Auto Parts Co. Ltd., Tyger Auto, Inc., and Hong Kong Car Start Industrial Co. Ltd. (collectively, “Petitioner”) filed a petition for *inter partes* review of claims 2, 3, and 4 of U.S. Patent No. 8,061,758 B2 (Ex. 1001, “the ’758 patent”). Paper 1 (“Pet.”). Laurmark Enterprises, Inc., d/b/a BAK Industries (“Patent Owner”) filed Mandatory Notices of Patent Owner (Paper 5, “PO Notices”) and a Preliminary Response (Paper 7, “Prelim. Resp.”), contending that the Petition should be denied as to all challenged claims. Prelim. Resp. 1.

Institution of an *inter partes* review is authorized by statute when “the information presented in the petition . . . and any response . . . shows that there is a reasonable likelihood that the petitioner would prevail with respect to at least 1 of the claims challenged in the petition.” 35 U.S.C. § 314(a) (2018); *see* 37 C.F.R. § 42.108. Upon consideration of the Petition, and the associated evidence, as well as the arguments in the Preliminary Response, for the reasons discussed below, we do not institute an *inter partes* review of any challenged claim.

### *A. Related Matters*

The parties identify the following matters in which the ’758 Patent is at issue, and that would affect, or be affected by, a decision in this proceeding: *Certain Pick-Up Truck Folding Bed Cover Systems and Components Thereof*, ITC Investigation No. 337-TA-1188; and *Extang Corp. et al. v. Tyger Auto Inc.*, No. 5:18-cv-02074 (C.D. Cal.) (stayed pending the ITC investigation). Pet. 99; PO Notices 2.



Figure 2 of the '758 patent is a plan view of the cover and pick-up truck box shown in Figure 1. *Id.* at 2:7–8. As shown in Figure 2, cover 100 includes four panels 102 connected by hinge joints 104A, 104B, 104C, and 104D that allow panels 102 to fold onto each other, from the tail gate at the back to the front cab wall, to open cover 100. *Id.* at 3:38–43. Hinge joints 104A and 104D may have the same design. *Id.* at 3:43–45. Hinge joints 104B and 104C are different, however, in that they include spacer bar 110 and 112, respectively, each of which is dimensioned to allow the panels to fold flat onto each other without stressing the hinge joints. *Id.* at 3:45–50.

Figure 8 of the '758 patent is also reproduced below.

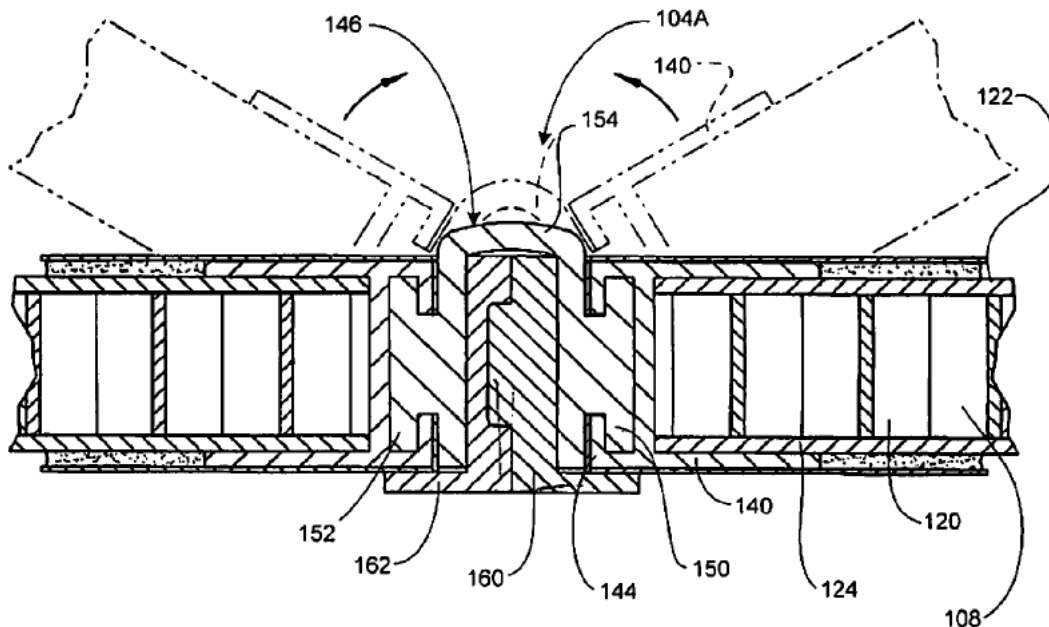

**FIG. 8**

Figure 8 is a section view taken along line 8–8 of Figure 2. *Id.* at 2:18. Hinge joints 104 that connect adjacent panels 102 include hinge strip 146, typically made of rubber or other resilient or flexible material. *Id.* at 4:40–44. Hinge strip 146 has first and second fittings or attachment features 150 and 152, formed as T-sections. *Id.* at 4:44–47. As shown in Figure 8, lateral frame 140 is provided with a metal extrusion having a slot between arms 144, with the slot dimensioned to slide over and interlock with fittings 152 and 154 on hinge strip 146. *Id.* at 4:52–56. Fittings 150 and 152 are spaced apart by a flat or web section 154 of hinge strip 146. *Id.* at 4:56–58. As also shown in Figure 8, first and second hinge joint backing bars 160 and 162 may be used to stiffen and strengthen hinge joints 104. *Id.* at 4:64–66.

### *C. Illustrative Claim*

Among the challenged claims, claim 2 is independent. Claim 2 is illustrative of the subject matter of the challenged claims and provides as follows (with paragraph notations added consistent with those used by Petitioner):

- 2.0 A cover for a pick-up truck cargo box, comprising:
  - (2.1) a first panel, a second panel, and a third panel, with each panel having a core material between the top and bottom plates;
  - (2.2) a first lateral member attached to the front lateral edge of the first panel;
  - (2.3) a first spacer bar, with the first lateral frame member including a first interlocking element interlocked with a back lateral edge of the first spacer bar and with first panel pivotally attached to the first spacer bar;
  - (2.4) a second lateral member attached to a back lateral edge of the second panel, with the second lateral member

# Explore Litigation Insights

Docket Alarm provides insights to develop a more informed litigation strategy and the peace of mind of knowing you're on top of things.

## Real-Time Litigation Alerts



Keep your litigation team up-to-date with **real-time alerts** and advanced team management tools built for the enterprise, all while greatly reducing PACER spend.

Our comprehensive service means we can handle Federal, State, and Administrative courts across the country.

## Advanced Docket Research



With over 230 million records, Docket Alarm's cloud-native docket research platform finds what other services can't. Coverage includes Federal, State, plus PTAB, TTAB, ITC and NLRB decisions, all in one place.

Identify arguments that have been successful in the past with full text, pinpoint searching. Link to case law cited within any court document via Fastcase.

## Analytics At Your Fingertips



Learn what happened the last time a particular judge, opposing counsel or company faced cases similar to yours.

Advanced out-of-the-box PTAB and TTAB analytics are always at your fingertips.

## API

Docket Alarm offers a powerful API (application programming interface) to developers that want to integrate case filings into their apps.

## LAW FIRMS

Build custom dashboards for your attorneys and clients with live data direct from the court.

Automate many repetitive legal tasks like conflict checks, document management, and marketing.

## FINANCIAL INSTITUTIONS

Litigation and bankruptcy checks for companies and debtors.

## E-DISCOVERY AND LEGAL VENDORS

Sync your system to PACER to automate legal marketing.