



US007562128B1

(12) **United States Patent**
Caris et al.

(10) **Patent No.:** **US 7,562,128 B1**
(45) **Date of Patent:** **Jul. 14, 2009**

(54) **STB CONNECTS REMOTE TO WEB SITE FOR CUSTOMIZED CODE DOWNLOADS**

(75) Inventors: **Franciscus Cornelis Caris**, San Jose, CA (US); **Frederik Ekkel**, Cupertino, CA (US); **Thomas James Dubil**, Morgan Hill, CA (US)

(73) Assignee: **Philips Koninklijke Philips Electronics N.V.**, Eindhoven (NL)

(*) Notice: Subject to any disclaimer, the term of this patent is extended or adjusted under 35 U.S.C. 154(b) by 903 days.

(21) Appl. No.: **09/653,784**

(22) Filed: **Sep. 1, 2000**

Related U.S. Application Data

(63) Continuation-in-part of application No. 09/519,546, filed on Mar. 6, 2000, now abandoned.

(51) **Int. Cl.**
G06F 15/177 (2006.01)
G06F 12/00 (2006.01)

(52) **U.S. Cl.** **709/220**; 709/221

(58) **Field of Classification Search** 709/220, 709/221, 203, 217-218, 226-229, 250; 700/1; 706/95; 455/304; 348/164, 172, 14.05, 734; 340/825; 345/720, 40, 11; 379/74; 398/106; 369/24-25

See application file for complete search history.

(56) **References Cited**

U.S. PATENT DOCUMENTS

| | | | | |
|-----------|-----|---------|------------------|------------|
| 4,450,520 | A * | 5/1984 | Hollaar et al. | 710/65 |
| 5,228,077 | A * | 7/1993 | Darbee | 379/102.01 |
| 5,410,326 | A * | 4/1995 | Goldstein | 348/734 |
| 5,414,756 | A * | 5/1995 | Levine | 379/67 |
| 5,544,161 | A * | 8/1996 | Bigham et al. | 370/397 |
| 5,583,864 | A * | 12/1996 | Lightfoot et al. | 370/396 |
| 5,583,920 | A * | 12/1996 | Wheeler, Jr. | 379/88.01 |
| 5,608,447 | A * | 3/1997 | Farry et al. | 725/116 |

| | | | | |
|-----------|-----|--------|-----------------------|---------|
| 5,629,868 | A | 5/1997 | Tessier et al. | |
| 5,671,404 | A * | 9/1997 | Lizee et al. | 707/5 |
| 5,761,606 | A * | 6/1998 | Wolzien | 725/110 |
| 5,790,753 | A * | 8/1998 | Krishnamoorthy et al. | 79/203 |
| 5,794,210 | A * | 8/1998 | Goldhaber et al. | 705/14 |

(Continued)

FOREIGN PATENT DOCUMENTS

EP 0862304 A2 9/1998

(Continued)

OTHER PUBLICATIONS

NetSupport Manager 5 offers affordable remote control, Hammond, Eric., InfoWorld v21n46, p. 52, 64, Nov. 15, 1999, ISSN 0199-6649.*

(Continued)

Primary Examiner—Zarni Maung

(57) **ABSTRACT**

A set top box (STB) is marketed together with a programmable remote. The remote has a dedicated button to connect the STB to a specific server on the Internet. The consumer can notify the server of his/her other CE equipment, which he/she desires to be controllable through the same remote as the one that came with the STB. The server downloads to the STB data representative of the relevant control codes. The STB is provided with means to program the remote with these codes. In return the server has obtained detailed and accurate information about this consumer's equipment. A reliable customer base can thus be built for streamlining Help Desk operations.

20 Claims, 2 Drawing Sheets

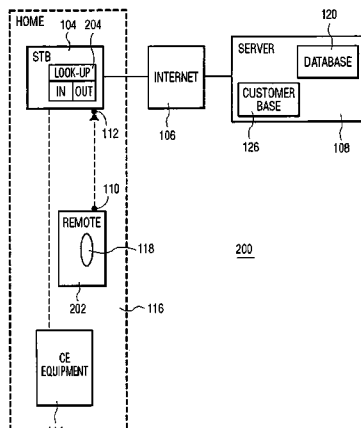

U.S. PATENT DOCUMENTS

| | | | | |
|--------------|------|---------|------------------|------------|
| 5,819,294 | A | 10/1998 | Chambers | |
| 5,915,026 | A | 6/1999 | Mankovitz | |
| 5,933,811 | A * | 8/1999 | Angles et al. | 705/14 |
| 6,008,735 | A * | 12/1999 | Chiloyan et al. | 340/825.22 |
| 6,075,527 | A * | 6/2000 | Ichihashi et al. | 715/721 |
| 6,104,334 | A * | 8/2000 | Allport | 341/175 |
| 6,249,809 | B1 * | 6/2001 | Bro | 709/217 |
| 6,314,572 | B1 * | 11/2001 | LaRocca et al. | 725/60 |
| 6,477,573 | B1 * | 11/2002 | Lea | 709/224 |
| 6,490,726 | B2 * | 12/2002 | Harrison et al. | 725/110 |
| 6,493,688 | B1 * | 12/2002 | Bakker et al. | 706/20 |
| 6,563,430 | B1 * | 5/2003 | Kemink et al. | 340/825.49 |
| 6,578,142 | B1 * | 6/2003 | Anderson et al. | 713/2 |
| 2002/0080154 | A1 * | 6/2002 | Matthews et al. | 345/700 |

FOREIGN PATENT DOCUMENTS

| | | |
|----|------------|---------|
| WO | 9950807 | 10/1999 |
| WO | 0017738 A1 | 3/2000 |
| WO | 0017789 A1 | 3/2000 |

| | | |
|----|------------|--------|
| WO | 0028436 A1 | 5/2000 |
| WO | 0039772 | 7/2000 |

OTHER PUBLICATIONS

- Take Control, Freed, Les PC Magazine, Mar. 9, 2000, p. 64, ISSN 0888-8507.*
- A universal information appliance, Eustice, K.F., et al., IBM Journal, vol. 38, No. 4, 199, ISBN 0018-8670/99, p. 575-601.*
- A Middleware Component Supporting Flexible User Interaction for Networked Home Appliances, Nakajima, T., pp. 68-74.*
- Consumer Electronics, Technology 1997, Analysis & Forecast, IEEE Spectrum, Jan. 1997, ISBN 0018-9235/97, p. 43-48.*
- On Newstands Now, Issue 2.08, Aug. 1994, Fetish, Jacobs, D., p. 1.*
- Product Review-The Lexison 500T System Controller, Long, D., Apr. 1996, p. 1-3.*
- A Set-top for Internet Browsing: The UTVSurfer system, Loiue, Wai Ming, vol. 38/01 of Masters Abstracts, ISBN 0-612-40941-4, 1998, p. 1-99.*
- Design and Implementation of Internet-TV, Tomari, Y., et al., IEEE ISBN 0098-3063/97, 1997, p.. 953-960.*

* cited by examiner

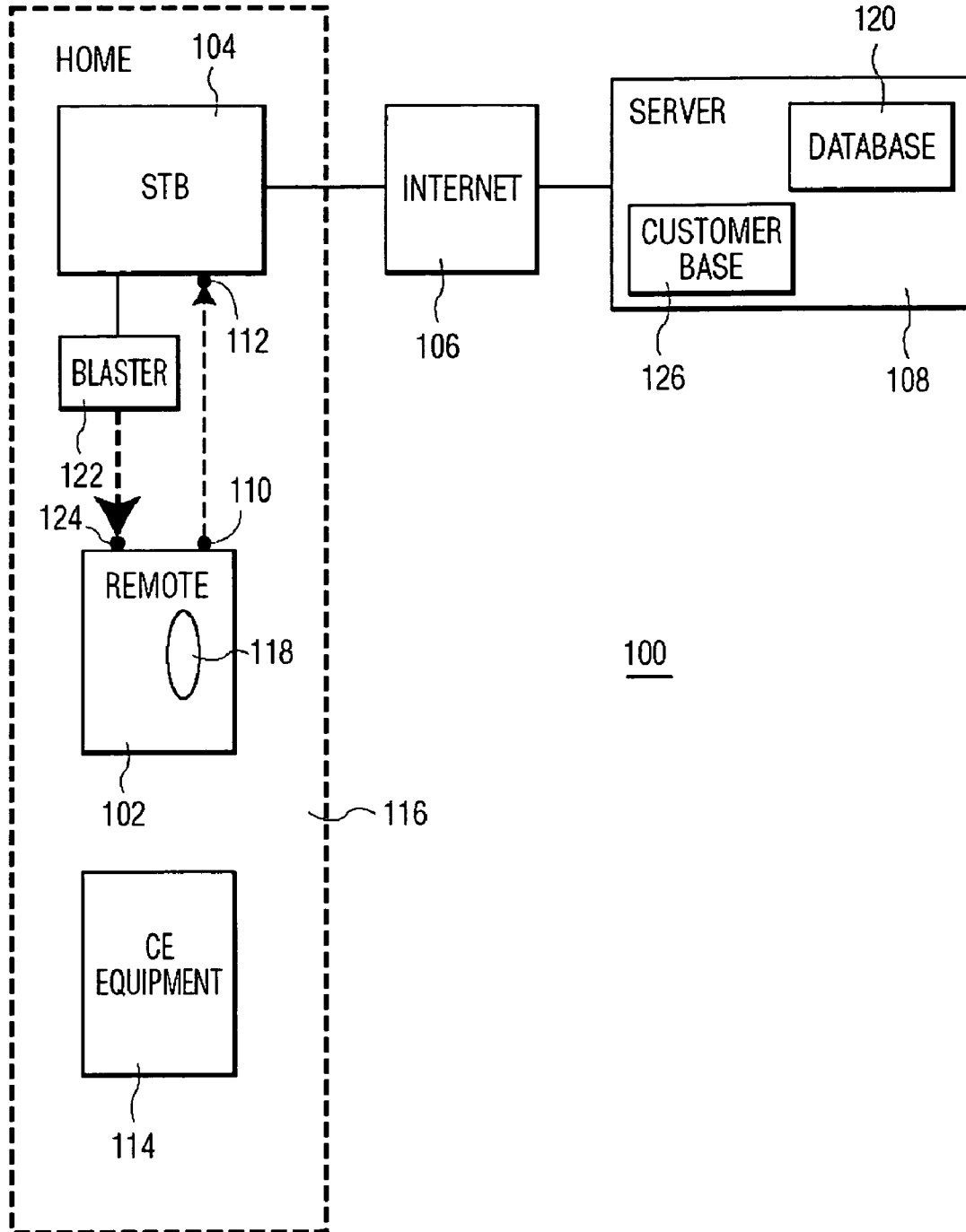

FIG. 1

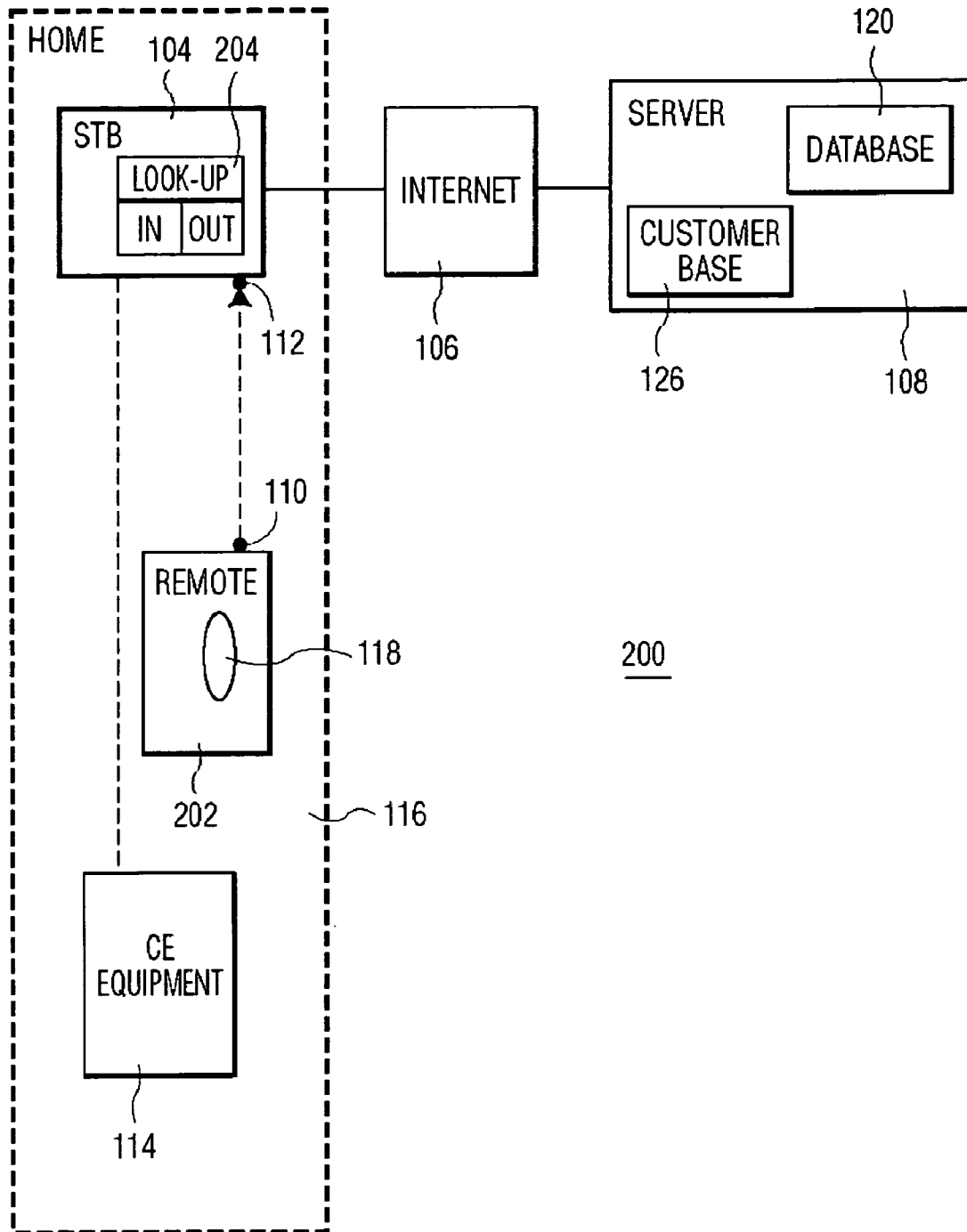

FIG. 2

1

STB CONNECTS REMOTE TO WEB SITE FOR CUSTOMIZED CODE DOWNLOADS

This application is a continuation-in-part of U.S. patent application No. 09/519,546, filed Mar. 6, 2000 now abandoned. 5

FIELD OF THE INVENTION

The invention relates to a business model and network architecture supporting the interests of network operators, manufacturers of IP-connected electronic equipment and end-users of the equipment. 10

BACKGROUND ART

Philips Electronics provides the SmartConnect (SM) service to end-users of CE equipment, especially equipment that is Internet-connected. An implementation of the SmartConnect (SM) service uses a special button on a remote control device that enables the user to directly connect, e.g., via a set top box (STB), to a dedicated SmartConnect (SM) web site. The site provides Philips Electronics with direct contact to the individual end-user, enables warranty registration, alerts the user to additional accessory sales, and provides specific content, advice, services, etc., all supported by the individual user's profile. 20

Aspects of the SmartConnect (SM) service are discussed in published International Application WO0017789, corresponding to U.S. Ser. No. 09/160,490, herein incorporated by reference, and in published International Application WO028436, corresponding to U.S. Ser. No. 09/189,535, herein incorporated by reference. 25

The SmartConnect (SM) service enables, e.g., customizing a technical functionality of network—(e.g., Internet)-enabled equipment of an end-user and supplying customized content information. A profile of the end-user and information about a technical feature for use with the equipment are stored at a server system. Based on the user-profile it is determined whether or not the user should be notified about the availability of this feature. If it has been decided that there is a match between the user profile as stored and the information about this feature, the end-user gets notified via the network of the option to obtain the feature for being added to his/her equipment. In case the feature relates to new software, it can be downloaded via the network for preferably automatic installation in the equipment. In case the feature comprises a hardware component, it can be shipped to the end-user upon acceptance of the offer. A helpdesk is preferably provided through the network to help the end-user install the feature. 30

SmartConnect (SM) is based on the insight that network-enabled equipment is becoming a flexible repository into which the end-user can place new and exciting features over time, dependent on the user's needs or desires, context of use, advancement of technology, etc. Not all end-users are always interested in all possible features for creating enhanced functionality of the equipment. Accordingly, a user-profile is established, either when the user registers his equipment with the notification service, or dynamically as a consequence of the user's interaction with the server system, or through a combination thereof. The profile is used to select technical features that are likely of interest to the user. In this manner, the user is kept abreast of the latest trends of interest to him/her. This approach implicitly supports virtual recycling 35

2

nical software or hardware features as needed thus assists in slowing down the trend that products become obsolete fairly quickly, but without barring the manufacturer or aftermarket sales organizations from continuing doing business.

SUMMARY OF THE INVENTION

The inventors believe that the above SmartConnect (SM) concept can be made an attractive feature to Network Operators, especially where STB's are concerned, since the Network Operators assume full control and responsibility of the equipment with respect to the end-users. To this end, the inventors propose to market a programmable, remote control device together with IP-connected consumer electronics (CE) equipment, e.g., a set-top box. This remote has a SmartConnect (SM) button for connection via the set-top box to the SmartConnect (SM) service site on the Web. The SmartConnect (SM) server has a database of control codes for most of the commercially available equipment that can be controlled via a remote. The server can also contain information regarding the remote's user-interface (UI's) to the equipment, e.g., button names, graphical user interface panels for a touch screen remote, and other features that support user-interaction with the remote. The user provides to the server information about further equipment he/she has available and would like to be controllable through a single remote. The database is queried based on the user's input. When the proper code sets and accompanying UI data have been found, the codes and UI data are downloaded to the user's STB. Preferably, the server or STB enables the user to configure the code and data, e.g., for causing a single action at the remote to execute multiple activities of the user's appliances. This configuration can be formed prior to the transfer of the code and UI data to the remote. The STB enables programming its remote with the downloaded codes and/or UI data, e.g., through an IR or RF transmitter/blaster or a serial cable connecting the STB to a serial port of the remote for unidirectional communication with the STB, or through any other suitable means and procedures. 40

As an alternative to a dedicate hard button on the remote, the user can also access the server via selection in a menu displayed on a display monitor, e.g., the display monitor of TV set or another apparatus driven by the STB, or the LCD touch screen of a universal programmable remote such as the PRONTO™ of Philips Electronics. 45

As to the server containing data regarding the remote's UI, this relates to, e.g., the specific location of each of the remote's hard buttons or softkeys, or their names, so as to be able to associate a specific code with a button. When the remote has an LCD touch screen, such as the PRONTO™ of Philips Electronics, the UI data can also relate to, e.g., one or more panels of softkeys, and/or to the desired distribution of the softkeys among the panels. Preferably, the softkeys are clustered in a semantically logical manner so as to enhance user-friendliness of the remote in operational use. 50

Preferably, the consumer is allowed to affect or manipulate the data prior to the data being programmed into the remote control device. This can be achieved, e.g., through a menu displayed via the STB, wherein the consumer is requested to specify whether or not he/she desires certain operations with respect to the data. The menu can be displayed on, e.g., the TV's monitor or a display of a touch screen based handheld. The server is capable of making suggestions regarding these operations because of this consumer's profile. For example, the menu offers the option to program a single action on the 55

Explore Litigation Insights

Docket Alarm provides insights to develop a more informed litigation strategy and the peace of mind of knowing you're on top of things.

Real-Time Litigation Alerts



Keep your litigation team up-to-date with **real-time alerts** and advanced team management tools built for the enterprise, all while greatly reducing PACER spend.

Our comprehensive service means we can handle Federal, State, and Administrative courts across the country.

Advanced Docket Research



With over 230 million records, Docket Alarm's cloud-native docket research platform finds what other services can't. Coverage includes Federal, State, plus PTAB, TTAB, ITC and NLRB decisions, all in one place.

Identify arguments that have been successful in the past with full text, pinpoint searching. Link to case law cited within any court document via Fastcase.

Analytics At Your Fingertips



Learn what happened the last time a particular judge, opposing counsel or company faced cases similar to yours.

Advanced out-of-the-box PTAB and TTAB analytics are always at your fingertips.

API

Docket Alarm offers a powerful API (application programming interface) to developers that want to integrate case filings into their apps.

LAW FIRMS

Build custom dashboards for your attorneys and clients with live data direct from the court.

Automate many repetitive legal tasks like conflict checks, document management, and marketing.

FINANCIAL INSTITUTIONS

Litigation and bankruptcy checks for companies and debtors.

E-DISCOVERY AND LEGAL VENDORS

Sync your system to PACER to automate legal marketing.