

I, Nigel David CROSSAN MA (Oxon), MSc,
translator to RWS Group Ltd, of Europa House, Chiltern Park, Chiltern Hill, Chalfont St Peter,
Buckinghamshire, United Kingdom, hereby declare that I am conversant with the English and
German languages and am a competent translator thereof. I declare further that to the best of
my knowledge and belief the following is a true and correct translation of the accompanying
document in the German language.

Signed this 12th day of May 2021

A handwritten signature in black ink that reads "Nigel D. Crossan". The signature is written in a cursive style with a long, sweeping underline.

N. D. CROSSAN

For and on behalf of RWS Group Ltd



EUROPEAN PATENT APPLICATION

(21) Application number: **92111076.3**

(51) Int. Cl.⁵: **F16H 61/02**

(22) Date of filing: **30.06.92**

(43) Date of publication of application:
05.01.94 Bulletin 94/01

(71) Applicant: **SIEMENS AKTIENGESELLSCHAFT
Wittelsbacherplatz 2
D-80333 Munich(DE)**

(84) Designated Contracting States:
**AT BE CH DE DK ES FR GB GR IT LI LU MC
NL PT SE**

(72) Inventor: **Graf, Friedrich, Dipl.-Ing.
Amselweg 5
W-8400 Regensburg(DE)
Inventor: Probst, Gregor, Dipl.-Ing.
Dreisesselstrasse 15
W-8300 Landshut(DE)
Inventor: Weil, Hans-Georg, Dipl.-Ing.
Wangenerstrasse 64
W-8130 Starnberg(DE)**

(54) Transmission control.

(57) By means of the control (6) for a motor vehicle transmission, the gears are automatically shifted as a function of at least the position of the accelerator and the speed of the vehicle with reference to stored characteristic shift diagrams (SKF1...SKFn). The load state of the motor vehicle and the driving style of the driver are also taken into account. By means of a fuzzy logic controller (23) with a rule base, various signals (DK, n_{ab}) which report the operating states of the motor vehicle are evaluated and the following control signals are produced as a response to this: an adjustment signal (load) which characterizes the vehicle load state and an adjustment signal (driver) which characterizes the driving style, which signals bring about a switch-over of the characteristic shift diagram; and also an inhibit signal (shift), which prevents shifts which would result in a dynamically unfavourable driving state.

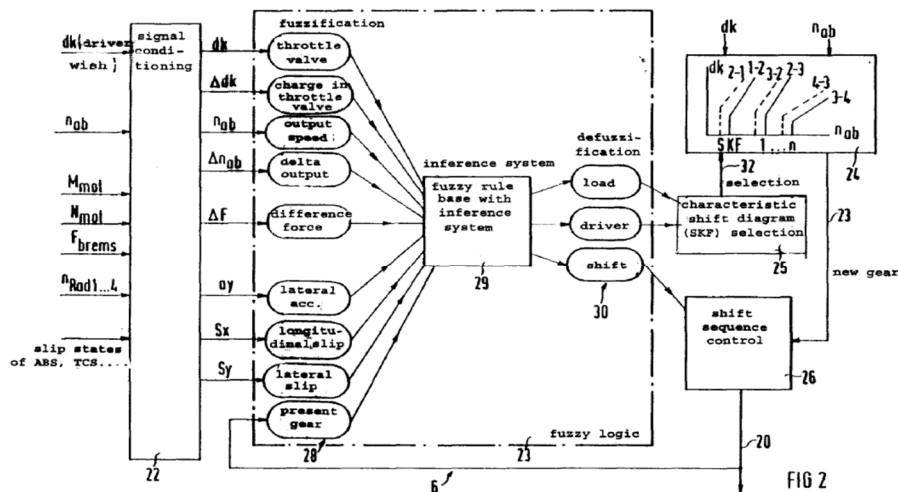

The invention relates to a control for a motor vehicle transmission (transmission control) according to the preamble of Claim 1.

In a known transmission control of this kind (DE-
5 C 33 41 652), the gears are automatically shifted as a function of the position of the accelerator and the speed of the vehicle or engine speed with reference to stored characteristic shift diagrams. Here, the load state of the vehicle, i.e. the load of the vehicle and the gradient of
10 the roadway, and the individual driving style of the driver are also taken into account. The taking into account of the respective driving situation takes place by means of characteristic diagram adaptation, i.e. by selecting a characteristic diagram which is suitable for the
15 respective driving situation, the gear shifts then being controlled according to the said characteristic diagram. In order to take into account the various variables which influence the handling characteristics of the motor vehicle, a considerable outlay with known methods of open-
20 loop and closed-loop control technology is made.

In other known automatic transmission controls (US-A 4 841 815; EP-A 0 375 155; A. Takahashi, A method of predicting driving environment, IFSA '91, Brussels, p. 203 - 206) the selection of the respective gear to be
25 shifted is made by means of controllers which operate according to the methods of fuzzy logic. With this logic, expert knowledge which has been acquired from experience is described in the form of a so-called rules base and thus used for the open-loop or closed-loop processes. The
30 controls of the fuzzy logic are however subject to certain uncertainties, they have not gained complete theoretical acceptance. Under certain circumstances, malfunctions can therefore occur which, given the very high safety

requirements which apply in automobile technology, are not tolerable under certain circumstances.

The invention is based on the object of providing a transmission control which takes into account the various variables influencing driving dynamics without a large degree of outlay and yet is operationally reliable without restriction.

This object is achieved by means of a transmission control according to Patent Claim 1.

The advantages of the transmission control according to the invention lie in particular in the fact that many influencing variables can be taken into account easily with the fuzzy logic and yet, thanks to the use of characteristic diagrams, it is always ensured that no unacceptable gear shifts are carried out.

Exemplary embodiments of the invention are explained below with reference to the drawing, in which:

- Figure 1 shows the essential components of a motor vehicle with a transmission control according to the invention, in a schematic view,
- Figure 2 shows the transmission control of the motor vehicle according to Figure 1 as a block diagram,
- Figure 3 shows a fuzzy controller in a continuous control circuit,
- Figure 4 shows a throttle valve angle entered over the travel or the route of the motor vehicle (continuous line: fuzzy transmission control; broken line: conventional transmission control)
- Figure 5 shows the brake light signal over the travel,
- Figure 6 shows the speed of the motor vehicle over the travel,
- Figure 7 shows the lateral acceleration of the motor vehicle over the travel,

Figure 8 shows the gears shifted by the transmission control according to Figure 2, over the travel,
Figure 9 shows the gears shifted by a transmission control without fuzzy controller, over the
5 travel,
Figure 10 shows a schematic view of the route travelled through by a motor vehicle according to Figure 1 with fuzzy logic,
Figure 11 shows a corresponding route travelled through
10 by a motor vehicle with a transmission control not according to the invention,
Figure 12 shows a driver detection signal of the transmission control according to Figure 2, over the travel,
15 Figure 13 shows a load-detection signal of the transmission control according to Figure 2, over the travel,
Figure 14 shows characteristic shift diagram numbers of the transmission control according to Figure 2,
20 over the travel,
Figure 15 shows a shift-up inhibit signal of the transmission control according to Figure 2, over the travel, and
Figure 16 shows a shift-down inhibit signal of the
25 transmission control according to Figure 2, entered over the travel.

A (schematically illustrated) motor vehicle 1 (Figure 1) has an engine 2 which is controlled by an engine control 3. The engine output shaft 4 is connected via a
30 (not separately illustrated here) torque converter with a transmission 5 which is controlled by an electronic transmission control 6 according to the invention. The transmission output shaft 8 is connected to the driven

Explore Litigation Insights

Docket Alarm provides insights to develop a more informed litigation strategy and the peace of mind of knowing you're on top of things.

Real-Time Litigation Alerts



Keep your litigation team up-to-date with **real-time alerts** and advanced team management tools built for the enterprise, all while greatly reducing PACER spend.

Our comprehensive service means we can handle Federal, State, and Administrative courts across the country.

Advanced Docket Research



With over 230 million records, Docket Alarm's cloud-native docket research platform finds what other services can't. Coverage includes Federal, State, plus PTAB, TTAB, ITC and NLRB decisions, all in one place.

Identify arguments that have been successful in the past with full text, pinpoint searching. Link to case law cited within any court document via Fastcase.

Analytics At Your Fingertips



Learn what happened the last time a particular judge, opposing counsel or company faced cases similar to yours.

Advanced out-of-the-box PTAB and TTAB analytics are always at your fingertips.

API

Docket Alarm offers a powerful API (application programming interface) to developers that want to integrate case filings into their apps.

LAW FIRMS

Build custom dashboards for your attorneys and clients with live data direct from the court.

Automate many repetitive legal tasks like conflict checks, document management, and marketing.

FINANCIAL INSTITUTIONS

Litigation and bankruptcy checks for companies and debtors.

E-DISCOVERY AND LEGAL VENDORS

Sync your system to PACER to automate legal marketing.