



US005530225A

United States Patent [19] Hajaligol

[11] **Patent Number:** 5,530,225
[45] **Date of Patent:** Jun. 25, 1996

[54] **INTERDIGITATED CYLINDRICAL HEATER FOR USE IN AN ELECTRICAL SMOKING ARTICLE**

[75] **Inventor:** Mohammad R. Hajaligol, Richmond, Va.

[73] **Assignee:** Philip Morris Incorporated, New York, N.Y.

[21] **Appl. No.:** 333,470

[22] **Filed:** Nov. 2, 1994

Related U.S. Application Data

[63] Continuation-in-part of Ser. No. 224,848, Apr. 8, 1994, which is a continuation-in-part of Ser. No. 118,665, Sep. 10, 1993, Pat. No. 5,388,594, which is a continuation-in-part of Ser. No. 943,504, Sep. 11, 1992, which is a continuation-in-part of Ser. No. 666,926, Mar. 11, 1991, abandoned, which is a continuation of Ser. No. 12,799, Feb. 2, 1993.

[51] **Int. Cl.⁶** H05B 3/58; A24F 1/22

[52] **U.S. Cl.** 219/535; 219/553; 131/194

[58] **Field of Search** 219/535, 542, 219/552-553; 131/194, 197; 128/202.21, 203.27; 338/310, 312, 320; 392/386

[56] References Cited

U.S. PATENT DOCUMENTS

2,971,039	2/1961	Western	219/553
4,503,319	3/1985	Moritoki	219/553
4,732,168	3/1988	Resce	131/194
4,788,077	11/1988	Kang	.	
5,060,671	10/1991	Counts et al.	131/329
5,095,921	3/1992	Losee et al.	131/194
5,157,242	10/1992	Hetherington	219/553
5,224,498	7/1993	Deevi et al.	131/194
5,235,157	8/1993	Blackburn	219/268
5,249,586	10/1993	Morgan	128/203.27
5,274,214	12/1993	Blackburn	219/268
5,285,050	2/1994	Blackburn	219/268
5,322,075	6/1994	Deevi et al.	.	
5,353,813	10/1994	Deevi	219/553
5,388,594	2/1995	Counts	128/203.27

OTHER PUBLICATIONS

Amin "Arc Spray Coatings Using Inert Gases," TWI Bulletin 6, pp. 129-132, Nov./Dec. 1992.
 Blunt et al, "High Velocity Spraying for Electronic Substrates," TWI Connect—World Centre for Materials Joining Technology, No. 40, Dec. 1992.
 Filmer et al, "Plasma Spray Deposition of Alumina-Based Ceramic," Ceramic Bulletin, vol. 69, No. 12, pp. 1955-1958, 1990.
 Herman, "Coatings and Coating Practices," Advanced Materials & Processes, pp. 59-60, 84-85, Jan. 1990.
 Herman, "Plasma-Sprayed Coatings," Scientific American, pp. 112-116, 1988.
 Herman, "Plasma Spray Deposition Processes," MRS Bulletin, pp. 60-67, 1988.
 Sampath et al, "Microstructure and Properties of Plasma-Spray Consolidated/Two-Phase Nickel Aluminides," vol. 25, pp. 1425-1430, 1991.

(List continued on next page.)

Primary Examiner—Teresa J. Walberg
Assistant Examiner—Sam Paik
Attorney, Agent, or Firm—Kevin B. Osborne; James E. Schardt; Charles E. B. Glenn

[57] ABSTRACT

A heater having a generally cylindrical or tubular configuration comprised of a selected plurality of thermally conductive heater blades and adjacent heat sink and aerosol barrier blades interposed between the heater blades to form an interdigitated structure. A respective gap is defined between a heater blade and an adjacent heat sink blade to prevent heat loss during an electrical pulse which heats the heater blade. During the subsequent cooling period and puff interval, the adjacent heat sink blades prevent heat from propagating to other parts of the aerosol generating tube, i.e., the cigarette. In addition to the thermal function, the barrier blades also block the escape of moisture generated by the aerosol generating medium, thereby limiting the propagation of condensation. The respective gaps between the interdigitated blades are defined to be wide enough to prevent heat losses during pulsing from a heater blade to adjacent blades yet small enough to prevent escape of significant amounts of vapor.

49 Claims, 12 Drawing Sheets

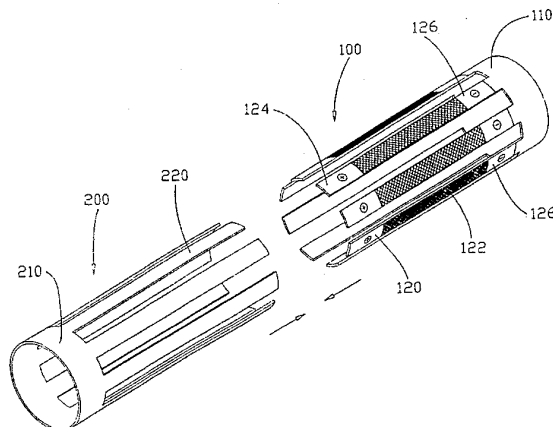

RAI Strategic Holdings, Inc.
 Exhibit 2010
 Philip Morris Products, S.A. v. RAI Strategic Holdings, Inc.
 IPR2020-00919

OTHER PUBLICATIONS

- Sampath et al, "Structure and Properties of Vacuum Plasma Sprayed Hard Coatings," *Memories et Etudes Scientifiques Revue de Metallurgie*, pp. 289-294, Mai 1991.
- Srivatsan et al, "Review Use of Spray Techniques to Synthesize Particulate-Reinforced Metal-Matrix Composites," *Journal of Materials Science* 27, pp. 5965-5981, 1992.
- Street et al, "Trends In Laser Cutting of Advanced Materials," *TWI Bulletin* 5, pp. 108-111, Sep./Oct. 1992.
- Tiwari et al, Spray Forming of MoSi_2 and MoSi_2 -Based Composites, *Mat. Res. Soc. Symp. Proc.*, vol. 213, Materials Research Society, pp. 807-813, 1991.
- Tiwari et al, "Thermal Spray Forming of Particulate Composites," Dept. of Mat. Sci. & Engineering, State University of New York, Stony Brook, NY 11794-2275 and Flame Spray Industries, Inc., 152 Haven Ave., Port Washington, NY 11050.
- Tiwari et al, "Incorporating of Reinforcements in Spray Formed MMCs", Department of Materials Science and Engineering, State University of New York, Stony Brook, NY 11794-2275.
- Travis, "Making Materials That Are Good to the Last Drop," *Research News*, vol. 258, p. 1307, Nov. 1992.
- Wang et al, "Activation Energy for Crystal Growth Using Isothermal and Continuous Heating Processes", *Journal of Materials Science*, Chapman and Hall, vol. 25, pp. 2339-2343, 1990.
- Wang et al, "Thermomechanical Properties of Plasma-Sprayed Oxides in the $\text{MgO-Al}_2\text{O}_3\text{-SiO}_2$ system," *Surface and Coatings Technology*, vol. 42, pp. 203-216, 1990.
- Wu et al, "Heat Transfer to a Particle in a Thermal Plasma," *Trans IChemE*, vol. 69, Part A, pp. 21-24, Jan. 1991.
- Zaat, "A Quarter of a Century of Plasma Spraying," *Ann Rev. Mater. Sci.* by Annual Reviews, Inc., pp. 13:9-42, 1983.
- Zatorski et al, "Wear of Plasma-Sprayed Alumina-Titania Coatings," *High Performance Ceramic Films and Coatings* by Elsevier Science Publishers B. V., pp., 591-601, 1991.
- Fen et al., "Cyclic Oxidation of Haynes 230 alloy," Chapman & Hall, pp. 1514-1520 (1992).
- Reinshagen and Sikka, "Thermal Spraying of Selected Aluminides," *Proceedings of the Fourth National Thermal Spray Conference*, Pittsburgh, PA, USA, pp. 307-313, (4-10 May 1991).
- Kutner, "Thermal Spray by Design," Reprint from *Advanced Materials & Processes* incorporating *Metal Progress*, Oct. (1988).
- "Characterizing THERMAL SPRAY COATINGS," article based on presentations made at the fourth National Thermal Spray Conference, 4-10 May (1991) and which appeared in "Advanced Materials and Processes," May 1992, pp. 23-27.
- Howes, Jr., "Computerized Plasma Control for Applying Medical-Quality Coatings," *Industrial Heating*, pp. 22-25, Aug., 1993.

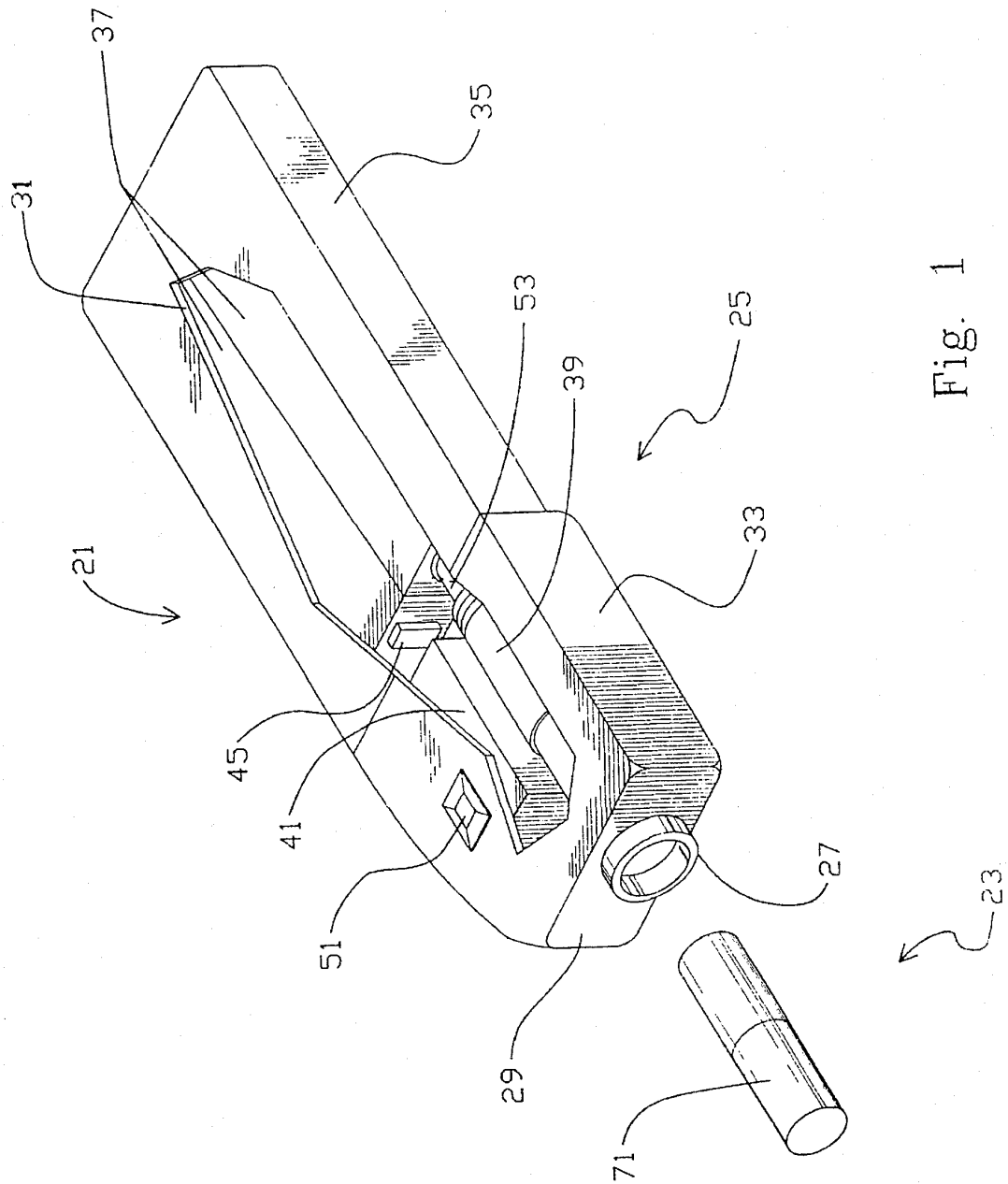

Fig. 1

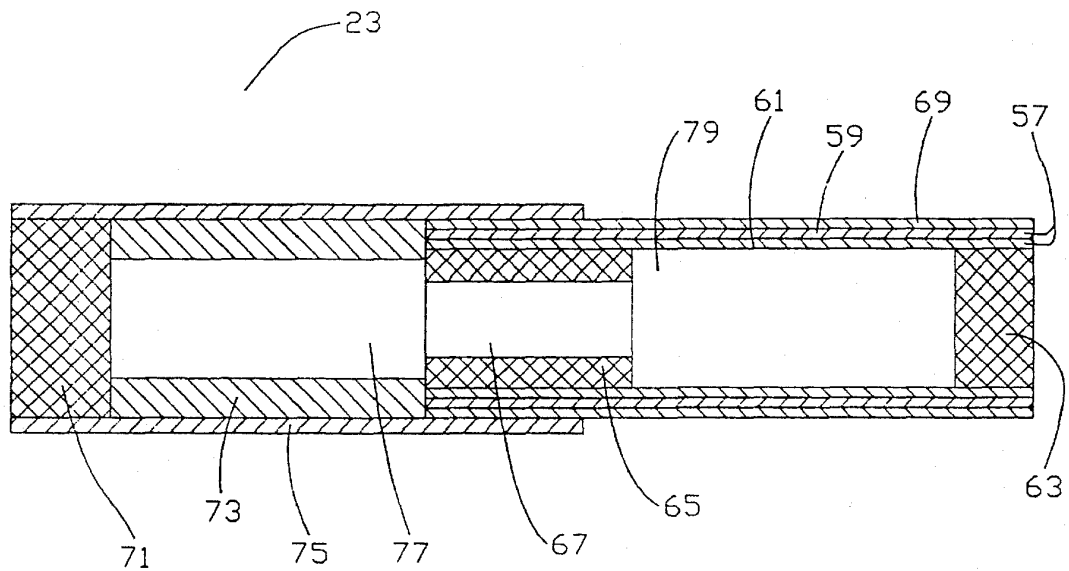

Fig. 2

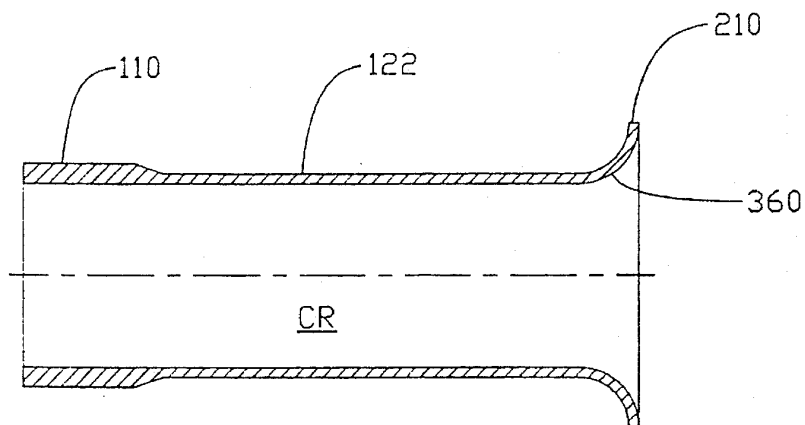

Fig. 6

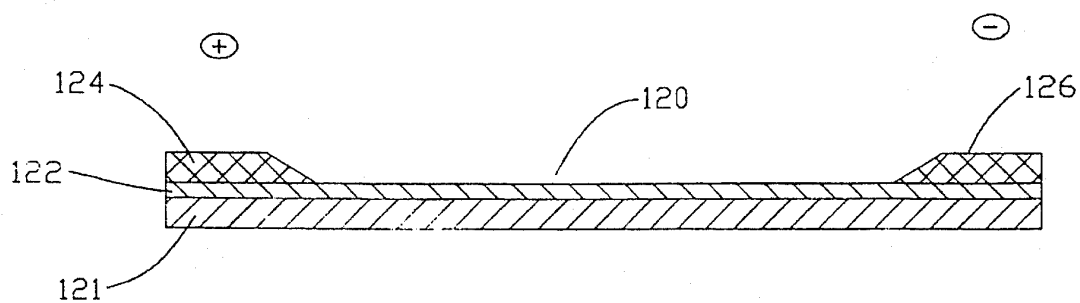

Fig. 3

Explore Litigation Insights

Docket Alarm provides insights to develop a more informed litigation strategy and the peace of mind of knowing you're on top of things.

Real-Time Litigation Alerts



Keep your litigation team up-to-date with **real-time alerts** and advanced team management tools built for the enterprise, all while greatly reducing PACER spend.

Our comprehensive service means we can handle Federal, State, and Administrative courts across the country.

Advanced Docket Research



With over 230 million records, Docket Alarm's cloud-native docket research platform finds what other services can't. Coverage includes Federal, State, plus PTAB, TTAB, ITC and NLRB decisions, all in one place.

Identify arguments that have been successful in the past with full text, pinpoint searching. Link to case law cited within any court document via Fastcase.

Analytics At Your Fingertips



Learn what happened the last time a particular judge, opposing counsel or company faced cases similar to yours.

Advanced out-of-the-box PTAB and TTAB analytics are always at your fingertips.

API

Docket Alarm offers a powerful API (application programming interface) to developers that want to integrate case filings into their apps.

LAW FIRMS

Build custom dashboards for your attorneys and clients with live data direct from the court.

Automate many repetitive legal tasks like conflict checks, document management, and marketing.

FINANCIAL INSTITUTIONS

Litigation and bankruptcy checks for companies and debtors.

E-DISCOVERY AND LEGAL VENDORS

Sync your system to PACER to automate legal marketing.