



US005665262A

United States Patent [19]
Hajaligol et al.

[11] **Patent Number:** **5,665,262**
[45] **Date of Patent:** **Sep. 9, 1997**

[54] **TUBULAR HEATER FOR USE IN AN ELECTRICAL SMOKING ARTICLE**
[75] **Inventors:** **Mohammad R. Hajaligol**, Richmond; **Grier S. Fleischhauer**, Midlothian, both of Va.; **Seetharama C. Deevi**, Oak Ridge, Tenn.; **Charles T. Higgins**, Richmond; **Patrick H. Hayes**, Chester, both of Va.; **Herbert Herman**, Port Jefferson; **Robert V. Gansert**, Lake Grove, both of N.Y.; **Alfred L. Collins**, Powhatan, Va.; **Billy J. Keen, Jr.**, Chesterfield, Va.; **Bernard C. Laroy**, Richmond, Va.; **A. Clifton Lilly, Jr.**, Chesterfield, Va.

[73] **Assignee:** **Philip Morris Incorporated**, New York, N.Y.

[21] **Appl. No.:** **370,125**

[22] **Filed:** **Jan. 9, 1995**

Related U.S. Application Data

[63] Continuation of Ser. No. 224,848, Apr. 8, 1994, abandoned, which is a continuation-in-part of Ser. No. 118,665, Sep. 10, 1993, Pat. No. 5,388,594, which is a continuation-in-part of Ser. No. 943,504, Sep. 11, 1992, Pat. No. 5,502,214, which is a continuation-in-part of Ser. No. 666,926, Mar. 11, 1991, abandoned.

[51] **Int. Cl.⁶** **H05B 3/10; A24F 1/22**

[52] **U.S. Cl.** **219/553; 219/543; 131/194**

[58] **Field of Search** 219/538, 539, 219/542, 543, 553; 338/283; 392/386; 501/102-105; 131/194, 195

[56] **References Cited**

U.S. PATENT DOCUMENTS

1,771,366 7/1930 Wyss et al. .
1,968,509 7/1934 Tiffany .
2,057,353 10/1936 Whittemore .
2,104,266 1/1938 McCormick .
2,442,004 5/1948 Hayward-Butt .

(List continued on next page.)

FOREIGN PATENT DOCUMENTS

1202378 3/1986 Canada .
87/104459 2/1988 China .
0 438 862 7/1982 European Pat. Off. .
0 295 122 12/1988 European Pat. Off. .
0 358 002 3/1990 European Pat. Off. .
0 358 114 3/1990 European Pat. Off. .
0 430 566 6/1991 European Pat. Off. .

(List continued on next page.)

OTHER PUBLICATIONS

Amin, "Arc Spray Coatings Using Inert Gases," TWI Bulletin 6, pp. 129-132, Nov./Dec. 1992.

(List continued on next page.)

Primary Examiner—Teresa J. Walberg

Assistant Examiner—Sam Paik

Attorney, Agent, or Firm—James T. Moore; James E. Schardt; Charles E. B. Glenn

[57] **ABSTRACT**

A cylindrical tube is provided of a mechanically strong and flexible electrical conductor such as a metal and has a plurality of separated regions. An electrically insulating layer such as a ceramic is applied on the outer surface except for one exposed portion. Electrically resistive heaters are then applied to the insulated regions and are electrically connected at one end to the underlying electrical conducting region. The electrical conductor is connected to the negative terminal of a power source. The other end of all the heaters are adapted to be connected to the positive terminal of the source. Accordingly, an electrically resistive heating circuit is formed wherein the tube serves as a common for all of the heating elements. The tubular heater can comprise an exposed end hub with a plurality of blades extending therefrom. Each blade can have an individual heater deposited thereon. Alternatively, every other blade can have a heater deposited thereon. The blades having no heater function as barriers to minimize outward escape of generated vapors. These barrier blades also function as heat sinks for the heaters on adjacent blades.

79 Claims, 15 Drawing Sheets

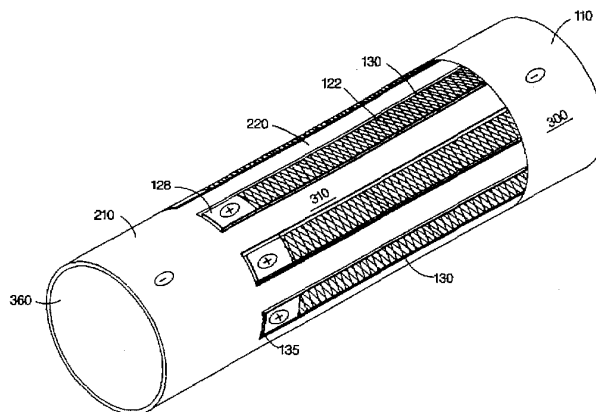

RAI Strategic Holdings, Inc.
Exhibit 2009
Philip Morris Products, S.A. v. RAI Strategic Holdings, Inc.
IPR2020-00919

U.S. PATENT DOCUMENTS

2,971,039 2/1961 Westeren .
 2,974,669 3/1961 Ellis .
 3,200,819 8/1965 Gilbert .
 3,255,760 6/1966 Selke .
 3,363,633 1/1968 Weber .
 3,402,723 9/1968 Hu .
 3,482,580 12/1969 Hollabaugh .
 3,608,560 9/1971 Briskin et al. .
 3,738,374 6/1973 Bennett .
 3,744,496 7/1973 McCarty et al. .
 3,804,100 4/1974 Fariello .
 3,889,690 6/1975 Guarnieri .
 4,016,061 4/1977 Wasa et al. .
 4,068,672 1/1978 Guerra .
 4,077,784 3/1978 Vayrynen .
 4,131,119 12/1978 Blasutti .
 4,141,369 12/1979 Burruss .
 4,164,230 8/1979 Pearman .
 4,193,411 3/1980 Faris et al. .
 4,215,708 8/1980 Bron .
 4,219,032 8/1980 Tabatnik et al. .
 4,246,913 1/1981 Ogden et al. .
 4,256,945 3/1981 Carter et al. .
 4,259,970 4/1981 Green, Jr. .
 4,303,083 12/1981 Burruss, Jr. .
 4,319,591 3/1982 Keith et al. .
 4,393,884 7/1983 Jacobs .
 4,431,903 2/1984 Riccio .
 4,436,100 3/1984 Green, Jr. .
 4,463,247 7/1984 Lawrence et al. .
 4,503,319 3/1985 Moritoki et al. .
 4,505,282 3/1985 Cogbill et al. .
 4,507,394 3/1985 Mase et al. 501/103
 4,562,337 12/1985 Lawrence .
 4,570,646 2/1986 Herron .
 4,580,583 4/1986 Green, Jr. .
 4,621,649 11/1986 Osterrath .
 4,623,401 11/1986 Derbyshire et al. .
 4,637,407 1/1987 Bonanno et al. .
 4,659,680 4/1987 Guile 501/103
 4,659,912 4/1987 Derbyshire .
 4,732,168 3/1988 Resee et al. .
 4,735,217 4/1988 Gerth et al. .
 4,771,796 9/1988 Myer .
 4,776,353 10/1988 Lilja et al. .
 4,788,077 11/1988 Kang .
 4,837,421 6/1989 Luthy .
 4,846,199 7/1989 Rose .
 4,848,376 7/1989 Lilja et al. .
 4,874,924 10/1989 Yamamoto et al. .
 4,877,989 10/1989 Drews .
 4,891,343 1/1990 Quadair 501/103
 4,922,901 5/1990 Brooks et al. .
 4,945,931 8/1990 Goti .
 4,947,874 8/1990 Brooks et al. .
 4,947,875 8/1990 Brooks et al. .
 4,966,171 10/1990 Serrano et al. .
 4,981,522 1/1991 Nichols et al. .
 4,991,606 2/1991 Serrano et al. .
 5,040,552 8/1991 Nystrom et al. .
 5,060,671 10/1991 Counts et al. 131/329
 5,076,296 12/1991 Schleich et al. .
 5,093,894 3/1992 Deevi et al. .
 5,095,921 3/1992 Losee et al. 131/194
 5,144,962 9/1992 Counts et al. .
 5,157,242 10/1992 Hetherington et al. .
 5,159,940 11/1992 Hayward et al. .
 5,224,498 7/1993 Deevi et al. 131/194
 5,235,157 8/1993 Blackburn 219/268
 5,249,586 10/1993 Morgan et al. .

5,274,214 12/1993 Blackburn 219/268
 5,285,050 2/1994 Blackburn 219/268
 5,322,075 6/1994 Deevi et al. .
 5,353,813 10/1994 Deevi et al. .
 5,369,723 11/1994 Counts et al. .
 5,388,594 2/1995 Counts et al. .

FOREIGN PATENT DOCUMENTS

0 503 767 A1 9/1992 European Pat. Off. .
 36 40 917 8/1988 Germany .
 37 35 704 5/1989 Germany .
 61-68061 4/1986 Japan .
 64-17386 1/1989 Japan .
 2 132 539 7/1984 United Kingdom .
 2 148 079 5/1985 United Kingdom .
 2 148 676 5/1985 United Kingdom .
 86/02528 5/1986 WIPO .
 WO 94/06314 3/1994 WIPO .

OTHER PUBLICATIONS

Blunt et al, "High Velocity Spraying for Electronic Substrates," TWI Connect—World Centre for Materials Joining Technology, No. 40, Dec. 1992.
 Filmer et al, "Plasma Spray Deposition of Alumina-Based Ceramic," Ceramic Bulletin, vol. 69, No. 12, pp. 1955-1958, 1990.
 Herman, "Coatings and Coating Practices," Advanced Materials & Processes, pp. 59-60, 84-85, Jan. 1990.
 Herman, "Plasma-Sprayed Coatings," Scientific American, pp. 112-116, 1988.
 Herman, "Plasma Spray Deposition Processes," MRS Bulletin, pp. 60-67, 1988.
 Sampath et al, "Microstructure and Properties of Plasma-Spray Consolidated/Two-Phase Nickel Aluminides," vol. 25, pp. 1425-1430, 1991.
 Sampath et al, "Structure and Properties of Vacuum Plasma Sprayed Hard Coatings," Memories et Etudes Scientifiques Revue de Metallurgie, pp. 289-294, Mai 1991.
 Srivatsan et al, "Review Use of Spray Techniques to Synthesize Particulate-Reinforced Metal-Matrix Composites," Journal of Materials Science 27, pp. 5965-5981, 1992.
 Street et al, "Trends In Laser Cutting of Advanced Materials," TWI Bulletin 5, pp. 108-111, Sep/Oct. 1992.
 Tiwari et al, Spray Forming of MoSi₂ and MoSi₂-Based Composites, Mat. Res. Soc. Symp. Proc., vol. 213, Materials Research Society, pp. 807-813, 1991.
 Tiwari et al, "Thermal Spray Forming of Particulate Composites," Dept. of Mat. Sci. & Engineering, State University of New York, Stony Brook, NY 11794-2275 and Flame Spray Industries, Inc., 152 Haven Avenue, Port Washington, NY 11050.
 Tiwari et al, "Incorporating of Reinforcements in Spray Formed MMCs", Department of Materials Science and Engineering, State University of New York, Stony Brook, NY 11794-2275.
 Travis, "Making Materials That Are Good to the Last Drop," Research News, vol. 258, p. 1307, Nov. 1992.
 Wang et al, "Activation Energy for Crystal Growth Using Isothermal and Continuous Heating Processes", Journal of Materials Science, Chapman and Hall, vol. 25, pp. 2339-2343, 1990.
 Wang et al, "Thermomechanical Properties of Plasma-Sprayed Oxides in the MgO-Al₂O₃-SiO₂ system," Surface and Coatings Technology, vol. 42, pp. 203-216, 1990.
 Wu et al, "Heat Transfer to a Particle in a Thermal Plasma," Trans IChemE, vol. 69, Part A, pp. 21-24, Jan. 1991.

Zaat, "A Quarter of a Century of Plasma Spraying," *Ann. Rev. Mater. Sci.* by Annual Reviews, Inc., pp. 13:9-42, 1983.

Zatorski et al, "Wear of Plasma-Sprayed Alumina-Titania Coatings," *High Performance Ceramic Films and Coatings* by Elsevier Science Publishers B.V., pp., 591-601, 1991.

Fen et al., "Cyclic oxidation of Haynes 230 alloy," *Chapman & Hall*, pp. 1514-1520 (1992).

Reinshagen and Sikka, "Thermal Spraying of Selected Aluminides," *Proceedings of the Fourth National Thermal Spray Conference*, Pittsburgh, PA USA, pp. 307-313 (4-10 May 1991).

Kutner, "Thermal spray by design," Reprint from *Advanced Materials & Processes Incorporating Metal Progress*, Oct. (1988).

"Characterizing Thermal Spray Coatings," Article based on presentations made at the Fourth National Thermal Spray Conference, 4-10 May (1991) and appearing in *Advanced Materials and Processes*, May 1992, pp. 23-27.

Howes, Jr., "Computerized Plasma Control for Applying Medical-Quality Coatings," *Industrial Heating*, pp. 22-25, Aug., 1993.

V. Sikka, "Processing of Intermetallic Aluminides", *Intermetallic Metallurgy and Processing Intermetallic Compounds*, ed. Stoloff et al., Van Nostrand Reinhold, N.Y., 1994.

Excerpt from "NASA Tech Briefs," Jul./Aug. 1988, p. 31.

"PCT Thermistors," *Keystone Carbon Company product literature*.

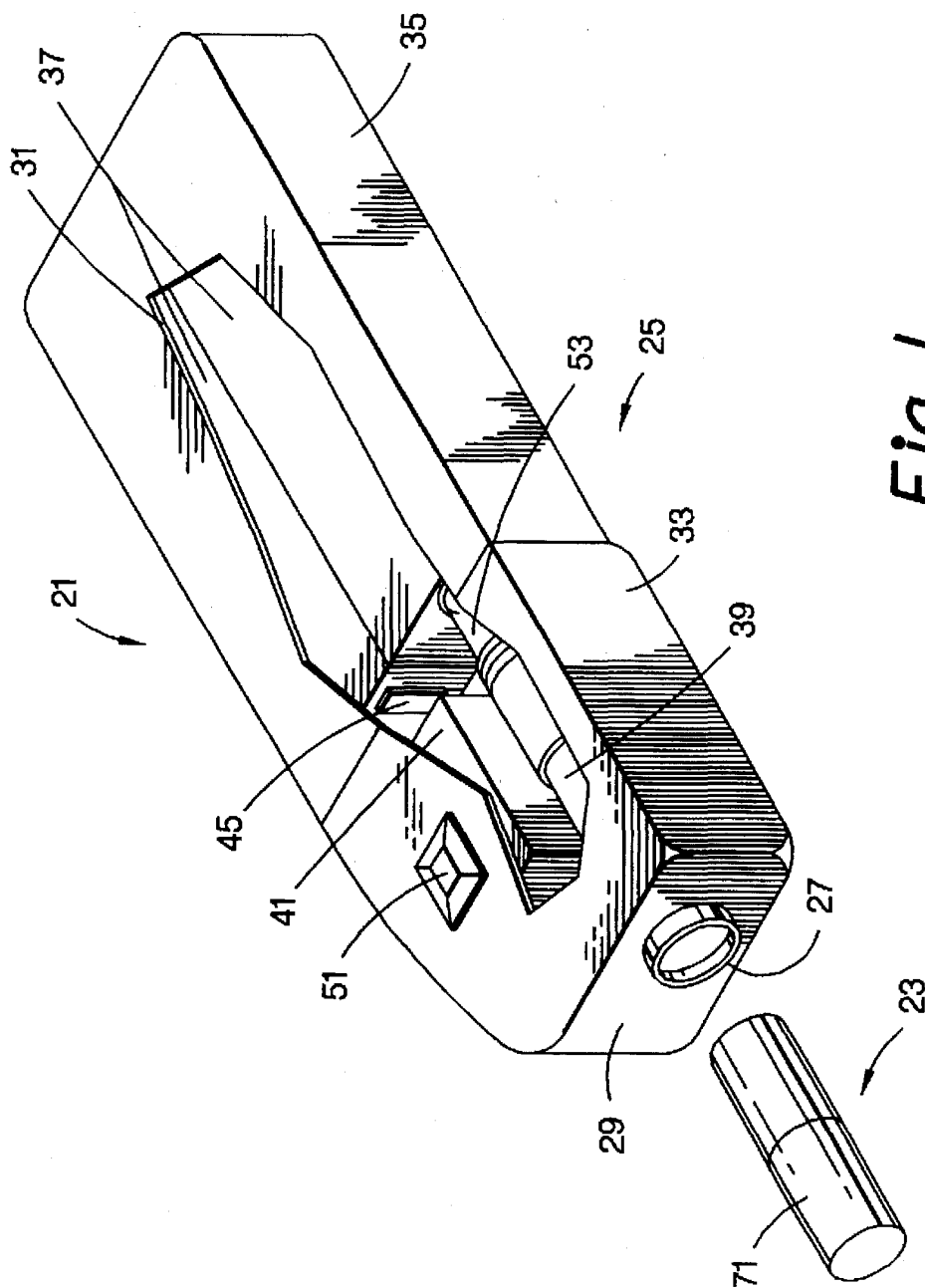

Fig. 1

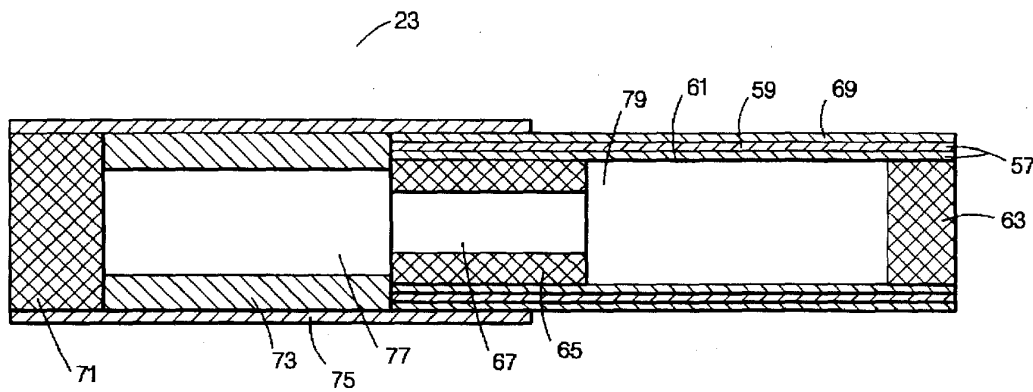

Fig. 2

Explore Litigation Insights

Docket Alarm provides insights to develop a more informed litigation strategy and the peace of mind of knowing you're on top of things.

Real-Time Litigation Alerts



Keep your litigation team up-to-date with **real-time alerts** and advanced team management tools built for the enterprise, all while greatly reducing PACER spend.

Our comprehensive service means we can handle Federal, State, and Administrative courts across the country.

Advanced Docket Research



With over 230 million records, Docket Alarm's cloud-native docket research platform finds what other services can't. Coverage includes Federal, State, plus PTAB, TTAB, ITC and NLRB decisions, all in one place.

Identify arguments that have been successful in the past with full text, pinpoint searching. Link to case law cited within any court document via Fastcase.

Analytics At Your Fingertips



Learn what happened the last time a particular judge, opposing counsel or company faced cases similar to yours.

Advanced out-of-the-box PTAB and TTAB analytics are always at your fingertips.

API

Docket Alarm offers a powerful API (application programming interface) to developers that want to integrate case filings into their apps.

LAW FIRMS

Build custom dashboards for your attorneys and clients with live data direct from the court.

Automate many repetitive legal tasks like conflict checks, document management, and marketing.

FINANCIAL INSTITUTIONS

Litigation and bankruptcy checks for companies and debtors.

E-DISCOVERY AND LEGAL VENDORS

Sync your system to PACER to automate legal marketing.