



(12) **United States Patent**
Shabtay et al.

(10) **Patent No.:** **US 10,225,479 B2**
(45) **Date of Patent:** **Mar. 5, 2019**

(54) **DUAL APERTURE ZOOM DIGITAL CAMERA**

(56) **References Cited**

(71) Applicant: **Corephotonics Ltd.**, Tel Aviv (IL)

U.S. PATENT DOCUMENTS
2,354,503 A 7/1944 Cox
2,378,170 A 6/1945 Aklin
(Continued)

(72) Inventors: **Gal Shabtay**, Tel Aviv (IL); **Ephraim Goldenberg**, Ashdod (IL); **Oded Gigushinski**, Herzlia (IL); **Noy Cohen**, Tel Aviv (IL)

FOREIGN PATENT DOCUMENTS

(73) Assignee: **Corephotonics Ltd.**, Tel Aviv (IL)

CN 101276415 A 10/2008
CN 102739949 A 10/2012
(Continued)

(*) Notice: Subject to any disclaimer, the term of this patent is extended or adjusted under 35 U.S.C. 154(b) by 0 days.

OTHER PUBLICATIONS

(21) Appl. No.: **16/048,242**

Statistical Modeling and Performance Characterization of a Real-Time Dual Camera Surveillance System, Greienhagen et al., Publisher: IEEE, 2000, 8 pages.

(22) Filed: **Jul. 28, 2018**

(Continued)

(65) **Prior Publication Data**

Primary Examiner — Cynthia Segura
(74) *Attorney, Agent, or Firm* — Nathan and Associates; Menachem Nathan

US 2018/0359423 A1 Dec. 13, 2018

Related U.S. Application Data

(63) Continuation of application No. 15/865,869, filed on Jan. 9, 2018, which is a continuation of application (Continued)

(51) **Int. Cl.**
H04N 5/232 (2006.01)
H04N 5/225 (2006.01)
(Continued)

(57) **ABSTRACT**

A dual-aperture zoom digital camera operable in both still and video modes. The camera includes Wide and Tele imaging sections with respective lens/sensor combinations and image signal processors and a camera controller operatively coupled to the Wide and Tele imaging sections. The Wide and Tele imaging sections provide respective image data. The controller is configured to combine in still mode at least some of the Wide and Tele image data to provide a fused output image from a particular point of view, and to provide without fusion continuous zoom video mode output images, each output image having a given output resolution, wherein the video mode output images are provided with a smooth transition when switching between a lower zoom factor (ZF) value and a higher ZF value or vice versa, and wherein at the lower ZF the output resolution is determined by the Wide sensor while at the higher ZF value the output resolution is determined by the Tele sensor.

(52) **U.S. Cl.**
CPC **H04N 5/23296** (2013.01); **G02B 13/009** (2013.01); **G02B 13/0015** (2013.01);
(Continued)

(58) **Field of Classification Search**
CPC G02B 13/0015; G02B 27/0075
See application file for complete search history.

40 Claims, 8 Drawing Sheets

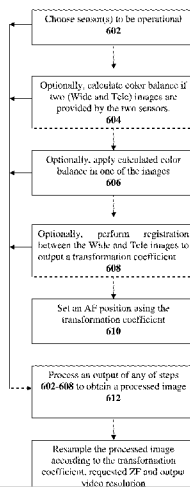

Related U.S. Application Data

No. 15/424,853, filed on Feb. 5, 2017, now Pat. No. 10,015,408, which is a continuation of application No. 14/880,251, filed on Oct. 11, 2015, now Pat. No. 9,661,233, which is a continuation of application No. 14/365,711, filed as application No. PCT/IB2014/062180 on Jun. 12, 2014, now Pat. No. 9,185,291.

(60) Provisional application No. 61/834,486, filed on Jun. 13, 2013.

(51) **Int. Cl.**
G02B 13/00 (2006.01)
G02B 27/00 (2006.01)

(52) **U.S. Cl.**
 CPC **G02B 27/0075** (2013.01); **H04N 5/225** (2013.01); **H04N 5/2258** (2013.01); **H04N 5/2259** (2013.01); **H04N 5/23212** (2013.01); **H04N 5/23232** (2013.01); **H04N 5/23245** (2013.01)

(56) **References Cited**

U.S. PATENT DOCUMENTS

2,441,093 A 5/1948 Aklin
 3,388,956 A 6/1968 Eggert et al.
 3,524,700 A 8/1970 Eggert et al.
 3,864,027 A 2/1975 Harada
 3,942,876 A 3/1976 Betensky
 4,134,645 A 1/1979 Sugiyama et al.
 4,199,785 A 4/1980 McCullough et al.
 4,338,001 A 7/1982 Matsui
 4,465,345 A 8/1984 Yazawa
 5,000,551 A 3/1991 Shibayama
 5,005,083 A 4/1991 Grage et al.
 5,032,917 A 7/1991 Aschwanden
 5,051,830 A 9/1991 von Hoessle
 5,248,971 A 9/1993 Mandl
 5,287,093 A 2/1994 Amano et al.
 5,436,660 A 7/1995 Sakamoto
 5,444,478 A 8/1995 Lelong et al.
 5,459,520 A 10/1995 Sasaki
 5,657,402 A 8/1997 Bender et al.
 5,682,198 A 10/1997 Katayama et al.
 5,768,443 A 6/1998 Michael et al.
 5,926,190 A 7/1999 Turkowski et al.
 5,940,641 A 8/1999 McIntyre et al.
 5,982,951 A 11/1999 Katayama et al.
 6,101,334 A 8/2000 Fantone
 6,128,416 A 10/2000 Oura
 6,148,120 A 11/2000 Sussman
 6,208,765 B1 3/2001 Bergen
 6,268,611 B1 7/2001 Pettersson et al.
 6,549,215 B2 4/2003 Jouppi
 6,611,289 B1 8/2003 Yu et al.
 6,643,416 B1 11/2003 Daniels et al.
 6,650,368 B1 11/2003 Doron
 6,654,180 B2 11/2003 Ori
 6,680,748 B1 1/2004 Monti
 6,714,665 B1 3/2004 Hanna et al.
 6,724,421 B1 4/2004 Glatt
 6,738,073 B2 5/2004 Park et al.
 6,741,250 B1 5/2004 Furlan et al.
 6,750,903 B1 6/2004 Miyatake et al.
 6,778,207 B1 8/2004 Lee et al.
 7,002,583 B2 2/2006 Rabb, III
 7,015,954 B1 3/2006 Foote et al.
 7,038,716 B2 5/2006 Klein et al.
 7,187,504 B2 3/2007 Horiuchi
 7,199,348 B2 4/2007 Olsen et al.
 7,206,136 B2 4/2007 Labaziewicz et al.
 7,248,294 B2 7/2007 Slatter

7,339,621 B2 3/2008 Fortier
 7,346,217 B1 3/2008 Gold, Jr.
 7,365,793 B2 4/2008 Cheatle et al.
 7,411,610 B2 8/2008 Doyle
 7,424,218 B2 9/2008 Baudisch et al.
 7,509,041 B2 3/2009 Hosono
 7,515,351 B2 4/2009 Chen et al.
 7,533,819 B2 5/2009 Barkan et al.
 7,564,635 B1 7/2009 Tang
 7,619,683 B2 11/2009 Davis
 7,643,225 B1 1/2010 Tsai
 7,660,049 B2 2/2010 Tang
 7,684,128 B2 3/2010 Tang
 7,688,523 B2 3/2010 Sano
 7,692,877 B2 4/2010 Tang et al.
 7,697,220 B2 4/2010 Iyama
 7,738,016 B2 6/2010 Toyofuku
 7,738,186 B2 6/2010 Chen et al.
 7,773,121 B1 8/2010 Huntsberger et al.
 7,777,972 B1 8/2010 Chen et al.
 7,813,057 B2 10/2010 Lin
 7,821,724 B2 10/2010 Tang et al.
 7,826,149 B2 11/2010 Tang et al.
 7,826,151 B2 11/2010 Tsai
 7,869,142 B2 1/2011 Chen et al.
 7,880,776 B2 2/2011 LeGall et al.
 7,898,747 B2 3/2011 Tang
 7,916,401 B2 3/2011 Chen et al.
 7,918,398 B2 4/2011 Li et al.
 7,957,075 B2 6/2011 Tang
 7,957,076 B2 6/2011 Tang
 7,957,079 B2 6/2011 Tang
 7,961,406 B2 6/2011 Tang et al.
 7,964,835 B2 6/2011 Olsen et al.
 7,978,239 B2 7/2011 Deeever et al.
 8,000,031 B1 8/2011 Tsai
 8,004,777 B2 8/2011 Yoshihito Souma
 8,077,400 B2 12/2011 Tang
 8,115,825 B2 2/2012 Culbert et al.
 8,149,327 B2 4/2012 Lin et al.
 8,149,523 B2 4/2012 Ozaki
 8,154,610 B2 4/2012 Jo et al.
 8,218,253 B2 7/2012 Tang
 8,228,622 B2 7/2012 Tang
 8,233,224 B2 7/2012 Chen
 8,238,695 B1 8/2012 Davey et al.
 8,253,843 B2 8/2012 Lin
 8,274,552 B2 9/2012 Dahi et al.
 8,279,537 B2 10/2012 Sato
 8,363,337 B2 1/2013 Tang et al.
 8,390,729 B2 3/2013 Long et al.
 8,391,697 B2 3/2013 Cho et al.
 8,395,851 B2 3/2013 Tang et al.
 8,400,555 B1 3/2013 Georgiev et al.
 8,400,717 B2 3/2013 Chen et al.
 8,439,265 B2 5/2013 Ferren et al.
 8,446,484 B2 5/2013 Muukki et al.
 8,451,549 B2 5/2013 Yamanaka et al.
 8,483,452 B2 7/2013 Ueda et al.
 8,503,107 B2 8/2013 Chen et al.
 8,508,649 B2* 8/2013 Reshidko G02B 13/0045
 8,514,491 B2 8/2013 Duparrie 348/345
 8,514,502 B2 8/2013 Chen
 8,547,389 B2 10/2013 Hoppe et al.
 8,553,106 B2 10/2013 Scarff
 8,587,691 B2 11/2013 Takane
 8,619,148 B1 12/2013 Watts et al.
 8,780,465 B2 7/2014 Chae
 8,803,990 B2 8/2014 Smith
 8,810,923 B2 8/2014 Shinohara
 8,854,745 B1 10/2014 Chen
 8,896,655 B2 11/2014 Mauchly et al.
 8,958,164 B2 2/2015 Kwon et al.
 8,976,255 B2 3/2015 Matsuoto et al.
 9,019,387 B2 4/2015 Nakano
 9,025,073 B2 5/2015 Attar et al.

(56)	References Cited		2008/0030592	A1 *	2/2008	Border	H04N 5/232 348/218.1
	U.S. PATENT DOCUMENTS		2008/0030611	A1	2/2008	Jenkins	
			2008/0084484	A1	4/2008	Ochi et al.	
	9,137,447 B2	9/2015	2008/0117316	A1	5/2008	Orimoto	
	9,185,291 B1	11/2015	2008/0218611	A1	9/2008	Parulski et al.	
	9,215,377 B2	12/2015	2008/0218612	A1	9/2008	Border et al.	
	9,215,385 B2	12/2015	2008/0218613	A1 *	9/2008	Janson	G03B 15/00 348/262
	9,229,194 B2	1/2016					
	9,235,036 B2	1/2016	2008/0219654	A1 *	9/2008	Border	H04N 5/23212 396/89
	9,270,875 B2	2/2016					
	9,279,957 B2	3/2016	2008/0304161	A1	12/2008	Souma	
	9,286,680 B1	3/2016	2009/0086074	A1	4/2009	Li et al.	
	9,344,626 B2	5/2016	2009/0122195	A1	5/2009	Van Baar et al.	
	9,360,671 B1	6/2016	2009/0122406	A1	5/2009	Rouvinen et al.	
	9,369,621 B2	6/2016	2009/0122423	A1	5/2009	Park et al.	
	9,402,032 B2 *	7/2016	2009/0128644	A1	5/2009	Camp et al.	
	9,413,930 B2	8/2016	2009/0219547	A1	9/2009	Kauhainen et al.	
	9,413,984 B2	8/2016	2009/0252484	A1	10/2009	Hasuda et al.	
	9,420,180 B2	8/2016	2009/0295949	A1	12/2009	Ojala	
	9,438,792 B2	9/2016	2010/0013906	A1	1/2010	Border et al.	
	9,485,432 B1	11/2016	2010/0020221	A1	1/2010	Tupman et al.	
	9,488,802 B2	11/2016	2010/0060746	A9	3/2010	Olsen et al.	
	9,568,712 B2	2/2017	2010/0103194	A1	4/2010	Chen et al.	
	9,578,257 B2	2/2017	2010/0238327	A1	9/2010	Griffith et al.	
	9,618,748 B2	4/2017	2010/0283842	A1	11/2010	Guissin et al.	
	9,678,310 B2	6/2017	2011/0001838	A1	1/2011	Lee	
	9,681,057 B2	6/2017	2011/0064327	A1 *	3/2011	Dagher	G06T 5/004 382/263
	9,723,220 B2	8/2017					
	9,736,365 B2	8/2017	2011/0080487	A1	4/2011	Venkataraman et al.	
	9,736,391 B2	8/2017	2011/0115965	A1	5/2011	Engelhardt et al.	
	9,762,812 B2 *	9/2017	2011/0128288	A1	6/2011	Petrou et al.	
	9,768,310 B2	9/2017	2011/0164172	A1	7/2011	Shintani et al.	
	9,800,798 B2	10/2017	2011/0229054	A1	9/2011	Weston et al.	
	9,817,213 B2	11/2017	2011/0234853	A1	9/2011	Hayashi et al.	
	9,851,803 B2	12/2017	2011/0234881	A1	9/2011	Wakabayashi et al.	
	9,894,287 B2	2/2018	2011/0242286	A1	10/2011	Pace et al.	
	9,900,522 B2	2/2018	2011/0242355	A1	10/2011	Goma et al.	
	9,927,600 B2	3/2018	2012/0026366	A1 *	2/2012	Golan	H04N 5/232 348/240.2
	2002/0005902 A1	1/2002					
	2002/0063711 A1	5/2002	2012/0062780	A1	3/2012	Morihisa	
	2002/0075258 A1	6/2002	2012/0069235	A1	3/2012	Imai	
	2002/0122113 A1	9/2002	2012/0075489	A1	3/2012	Nishihara	
	2003/0030729 A1	2/2003	2012/0092777	A1	4/2012	Tochigi et al.	
	2003/0093805 A1	5/2003	2012/0105579	A1	5/2012	Jeon et al.	
	2003/0160886 A1	8/2003	2012/0105708	A1	5/2012	Hagiwara	
	2003/0202113 A1	10/2003	2012/0154929	A1	6/2012	Tsai et al.	
	2004/0008773 A1	1/2004	2012/0196648	A1	8/2012	Havens et al.	
	2004/0017386 A1	1/2004	2012/0229663	A1	9/2012	Nelson et al.	
	2004/0027367 A1	2/2004	2012/0249815	A1	10/2012	Bohn et al.	
	2004/0061788 A1	4/2004	2012/0287315	A1	11/2012	Huang et al.	
	2004/0240052 A1	12/2004	2012/0320467	A1	12/2012	Baik et al.	
	2005/0013509 A1	1/2005	2013/0002928	A1	1/2013	Imai	
	2005/0046740 A1	3/2005	2013/0093842	A1	4/2013	Yahata	
	2005/0141103 A1	6/2005	2013/0135445	A1	5/2013	Dahi et al.	
	2005/0157184 A1	7/2005	2013/0182150	A1	7/2013	Asakura	
	2005/0168840 A1	8/2005	2013/0201360	A1	8/2013	Song	
	2005/0200718 A1	9/2005	2013/0202273	A1	8/2013	Ouedraogo et al.	
	2006/0054782 A1	3/2006	2013/0208178	A1	8/2013	Park	
	2006/0056056 A1	3/2006	2013/0235224	A1	9/2013	Park et al.	
	2006/0125937 A1	6/2006	2013/0250150	A1	9/2013	Malone et al.	
	2006/0170793 A1	8/2006	2013/0258044	A1	10/2013	Betts-LaCroix	
	2006/0175549 A1	8/2006	2013/0286488	A1	10/2013	Chae	
	2006/0187310 A1	8/2006	2013/0321668	A1	12/2013	Kamath	
	2006/0187322 A1	8/2006	2014/0022436	A1	1/2014	Kim et al.	
	2006/0187338 A1	8/2006	2014/0049615	A1	2/2014	Uwagawa	
	2007/0024737 A1	2/2007	2014/0118584	A1	5/2014	Lee et al.	
	2007/0146503 A1 *	6/2007	2014/0192238	A1	7/2014	Attar et al.	
			2014/0192253	A1	7/2014	Laroia	
			2014/0204480	A1	7/2014	Jo et al.	
			2014/0285907	A1	9/2014	Tang et al.	
	2007/0177025 A1	8/2007	2014/0293453	A1	10/2014	Ogino et al.	
	2007/0188653 A1	8/2007	2014/0313316	A1	10/2014	Olsson et al.	
	2007/0189386 A1	8/2007	2014/0362242	A1	12/2014	Takizawa	
	2007/0229983 A1	10/2007	2014/0362274	A1	12/2014	Christie et al.	
	2007/0257184 A1	11/2007	2015/0002683	A1	1/2015	Hu et al.	
	2007/0285550 A1	12/2007	2015/0042870	A1	2/2015	Chan et al.	
	2008/0017557 A1	1/2008					

(56)

References Cited

U.S. PATENT DOCUMENTS

2015/0154776 A1 6/2015 Zhang et al.
 2015/0162048 A1 6/2015 Hirata et al.
 2015/0195458 A1 7/2015 Nakayama et al.
 2015/0215516 A1 7/2015 Dolgin
 2015/0237280 A1 8/2015 Choi et al.
 2015/0242994 A1 8/2015 Shen
 2015/0253647 A1 9/2015 Mercado
 2015/0271471 A1 9/2015 Hsieh et al.
 2015/0316744 A1 11/2015 Chen
 2015/0334309 A1 11/2015 Peng et al.
 2016/0044250 A1 2/2016 Shabtay et al.
 2016/0070088 A1 3/2016 Koguchi
 2016/0085089 A1 3/2016 Mercado
 2016/0154202 A1 6/2016 Wippermann et al.
 2016/0154204 A1 6/2016 Lim et al.
 2016/0187631 A1 6/2016 Choi et al.
 2016/0191819 A1* 6/2016 Sakai H04N 5/23245
 348/333.12
 2016/0202453 A1* 7/2016 Iwasawa G02B 13/18
 359/684
 2016/0212358 A1 7/2016 Shikata
 2016/0301840 A1 10/2016 Du et al.
 2016/0313537 A1 10/2016 Mercado
 2016/0353012 A1 12/2016 Kao et al.
 2017/0019616 A1 1/2017 Zhu et al.
 2017/0054911 A1* 2/2017 Lee H04N 5/23293
 2017/0102522 A1 4/2017 Jo
 2017/0115471 A1 4/2017 Shinohara
 2017/0214846 A1 7/2017 Du et al.
 2017/0214866 A1 7/2017 Zhu et al.
 2017/0289458 A1 10/2017 Song et al.
 2018/0096487 A1* 4/2018 Nash H04N 5/217
 2018/0120674 A1 5/2018 Avivi et al.
 2018/0150973 A1 5/2018 Tang et al.
 2018/0152640 A1* 5/2018 Shabtay H04N 5/2258
 2018/0224630 A1 8/2018 Lee et al.
 2018/0241922 A1 8/2018 Baldwin et al.
 2018/0295292 A1 10/2018 Lee et al.
 2018/0359423 A1* 12/2018 Shabtay H04N 5/2258

FOREIGN PATENT DOCUMENTS

CN 103024272 A 4/2013
 CN 104297906 A 1/2015
 EP 1536633 A1 6/2005
 EP 2523450 A1 11/2012
 JP S54157620 A 12/1979
 JP S59121015 A 7/1984
 JP 04211230 A 8/1992
 JP H07318864 A 12/1995
 JP 08271976 A 10/1996
 JP 2003298920 A 10/2003
 JP 2004133054 A 4/2004
 JP 2005099265 A 4/2005
 JP 2006238325 A 9/2006
 JP 2007228006 A 9/2007
 JP 2007306282 A 11/2007

JP 2008076485 A 4/2008
 JP 2012203234 A 10/2012
 JP 2013106289 A 5/2013
 KR 20100008936 A 1/2010
 KR 20140014787 A 2/2014
 KR 20140023552 A 2/2014
 KR 101477178 B1 12/2014
 WO 2013058111 A1 4/2013
 WO 2013063097 A1 5/2013

OTHER PUBLICATIONS

A 3MPixel Multi-Aperture Image Sensor with 0.7µm Pixels in 0.11µm CMOS, Fife et al., Stanford University, 2008, 3 pages.
 Dual camera intelligent sensor for high definition 360 degrees surveillance, Scotti et al., Publisher: IET, May 9, 2000, 8 pages.
 Dual-sensor foveated imaging system, Hua et al., Publisher: Optical Society of America, Jan. 14, 2008, 11 pages.
 Defocus Video Matting, McGuire et al., Publisher: ACM SIG-GRAPH, Jul. 31, 2005, 11 pages.
 Compact multi-aperture imaging with high angular resolution, Santacana et al., Publisher: Optical Society of America, 2015, 10 pages.
 Multi-Aperture Photography, Green et al., Publisher: Mitsubishi Electric Research Laboratories, Inc., Jul. 2007, 10 pages.
 Multispectral Bilateral Video Fusion, Bennett et al., Publisher: IEEE, May 2007, 10 pages.
 Super-resolution imaging using a camera array, Santacana et al., Publisher: Optical Society of America, 2014, 6 pages.
 Optical Splitting Trees for High-Precision Monocular Imaging, McGuire et al., Publisher: IEEE, 2007, 11 pages.
 High Performance Imaging Using Large Camera Arrays, Wilburn et al., Publisher: Association for Computing Machinery, Inc., 2005, 12 pages.
 Real-time Edge-Aware Image Processing with the Bilateral Grid, Chen et al., Publisher: ACM SIGGRAPH, 9 pages.
 Superimposed multi-resolution imaging, Caries et al., Publisher: Optical Society of America, 2017, 13 pages.
 Viewfinder Alignment, Adams et al., Publisher: EUROGRAPHICS, 2008, 10 pages.
 Dual-Camera System for Multi-Level Activity Recognition, Bodor et al., Publisher: IEEE, Oct. 2014, 6 pages.
 Engineered to the task: Why camera-phone cameras are different, Giles Humpston, Publisher: Solid State Technology, Jun. 2009, 3 pages.
 A compact and cost effective design for cell phone zoom lens, Chang et al., Sep. 2007, 8 pages.
 Consumer Electronic Optics: How small a lens can be? The case of panomorph lenses, Thibault et al., Sep. 2014, 7 pages.
 Optical design of camera optics for mobile phones, Steinich et al., 2012, pp. 51-58 (8 pages).
 The Optics of Miniature Digital Camera Modules, Bareau et al., 2006, 11 pages.
 Modeling and measuring liquid crystal tunable lenses, Peter P. Clark, 2014, 7 pages.
 Mobile Platform Optical Design, Peter P. Clark, 2014, 7 pages.

* cited by examiner

100

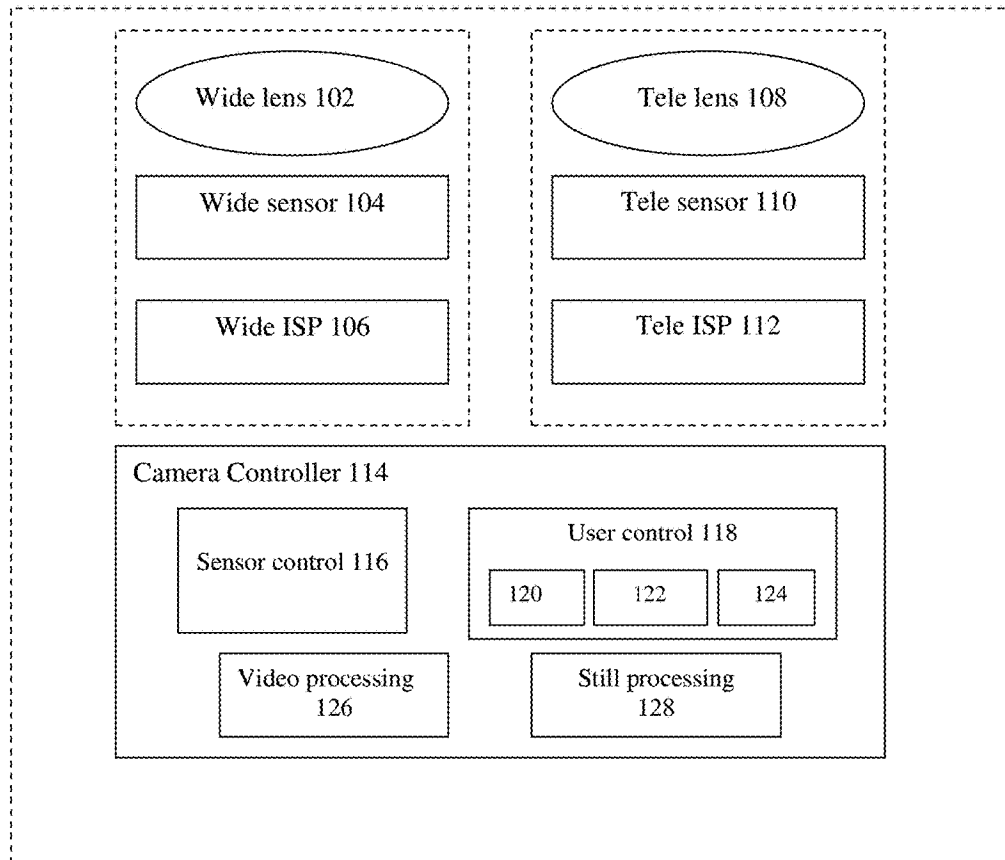

FIG. 1A

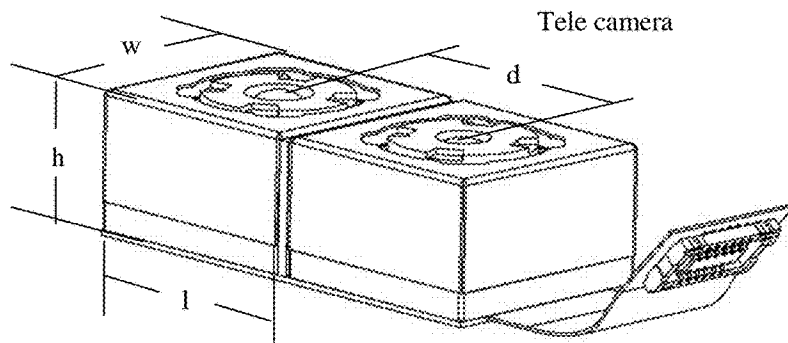

FIG. 1B

Explore Litigation Insights

Docket Alarm provides insights to develop a more informed litigation strategy and the peace of mind of knowing you're on top of things.

Real-Time Litigation Alerts



Keep your litigation team up-to-date with **real-time alerts** and advanced team management tools built for the enterprise, all while greatly reducing PACER spend.

Our comprehensive service means we can handle Federal, State, and Administrative courts across the country.

Advanced Docket Research



With over 230 million records, Docket Alarm's cloud-native docket research platform finds what other services can't. Coverage includes Federal, State, plus PTAB, TTAB, ITC and NLRB decisions, all in one place.

Identify arguments that have been successful in the past with full text, pinpoint searching. Link to case law cited within any court document via Fastcase.

Analytics At Your Fingertips



Learn what happened the last time a particular judge, opposing counsel or company faced cases similar to yours.

Advanced out-of-the-box PTAB and TTAB analytics are always at your fingertips.

API

Docket Alarm offers a powerful API (application programming interface) to developers that want to integrate case filings into their apps.

LAW FIRMS

Build custom dashboards for your attorneys and clients with live data direct from the court.

Automate many repetitive legal tasks like conflict checks, document management, and marketing.

FINANCIAL INSTITUTIONS

Litigation and bankruptcy checks for companies and debtors.

E-DISCOVERY AND LEGAL VENDORS

Sync your system to PACER to automate legal marketing.