



UNITED STATES PATENT AND TRADEMARK OFFICE

UNITED STATES DEPARTMENT OF COMMERCE
United States Patent and Trademark Office
Address: COMMISSIONER FOR PATENTS
P. O. Box 1450
Alexandria, Virginia 22313-1450
www.uspto.gov

APPLICATION NO.	ISSUE DATE	PATENT NO.	ATTORNEY DOCKET NO.	CONFIRMATION NO.
16/048,242	03/05/2019	10225479	COREPH-0079 US CON3	4814

92342 7590 02/13/2019
Nathan & Associates Patent Agents Ltd
P.O.Box 10178
Tel Aviv, 6110101
ISRAEL

ISSUE NOTIFICATION

The projected patent number and issue date are specified above.

Determination of Patent Term Adjustment under 35 U.S.C. 154 (b) (application filed on or after May 29, 2000)

The Patent Term Adjustment is 0 day(s). Any patent to issue from the above-identified application will include an indication of the adjustment on the front page.

If a Continued Prosecution Application (CPA) was filed in the above-identified application, the filing date that determines Patent Term Adjustment is the filing date of the most recent CPA.

Applicant will be able to obtain more detailed information by accessing the Patent Application Information Retrieval (PAIR) WEB site (<http://pair.uspto.gov>).

Any questions regarding the Patent Term Extension or Adjustment determination should be directed to the Office of Patent Legal Administration at (571)-272-7702. Questions relating to issue and publication fee payments should be directed to the Application Assistance Unit (AAU) of the Office of Data Management (ODM) at (571)-272-4200.

APPLICANT(s) (Please see PAIR WEB site <http://pair.uspto.gov> for additional applicants):

Gal Shabtay, Tel Aviv, ISRAEL;
Corephotonics Ltd., Tel Aviv, ISRAEL;
Ephraim Goldenberg, Ashdod, ISRAEL;
Oded Gigushinski, Herzlia, ISRAEL;
Noy Cohen, Tel Aviv, ;

The United States represents the largest, most dynamic marketplace in the world and is an unparalleled location for business investment, innovation, and commercialization of new technologies. The USA offers tremendous resources and advantages for those who invest and manufacture goods here. Through SelectUSA, our nation works to encourage and facilitate business investment. To learn more about why the USA is the best country in the world to develop technology, manufacture products, and grow your business, visit SelectUSA.gov.

Doc code: IDS

PTO/SB/08a (01-10)

Doc description: Information Disclosure Statement (IDS) Filed

Approved for use through 07/31/2012. OMB 0651-0031

U.S. Patent and Trademark Office; U.S. DEPARTMENT OF COMMERCE

Under the Paperwork Reduction Act of 1995, no persons are required to respond to a collection of information unless it contains a valid OMB control number.

INFORMATION DISCLOSURE STATEMENT BY APPLICANT (Not for submission under 37 CFR 1.99)	Application Number	16048242
	Filing Date	2018-07-28
	First Named Inventor	Gal Shabtay
	Art Unit	
	Examiner Name	
	Attorney Docket Number	COREPH-0079 US CON3

U.S. PATENTS

Remove

Examiner Initial*	Cite No	Patent Number	Kind Code ¹	Issue Date	Name of Patentee or Applicant of cited Document	Pages, Columns, Lines where Relevant Passages or Relevant Figures Appear
	1	9286680	B1	2016-03-15	Jiang et al.	
	2	9736391	B2	2017-08-15	Du et al.	
	3	9894287	B2	2018-02-13	Qian et al.	
	4	6750903	B1	2004-06-15	Miyatake et al.	
	5	5032917	A	1991-07-16	Felix Aschwarden	
	6	5287093	A	1994-02-15	Amano et al.	
	7	5287093	A	02-1994 1995-02-28	John T. Hall Amano et al.	
Change(s) applied to document, /C.M./ 1/22/2019	8	5444478	A	1995-08-22	Lelong et al.	



UNITED STATES PATENT AND TRADEMARK OFFICE

UNITED STATES DEPARTMENT OF COMMERCE
United States Patent and Trademark Office
Address: COMMISSIONER FOR PATENTS
P.O. Box 1450
Alexandria, Virginia 22313-1450
www.uspto.gov

APPLICATION NO.	FILING DATE	FIRST NAMED INVENTOR	ATTORNEY DOCKET NO.	CONFIRMATION NO.
16/048,242	07/28/2018	Gal Shabtay	COREPH-0079 US CON3	4814
92342	7590	02/04/2019	EXAMINER	
Nathan & Associates Patent Agents Ltd P.O.Box 10178 Tel Aviv, 6110101 ISRAEL			SEGURA, CYNTHIA	
			ART UNIT	PAPER NUMBER
			2697	
			NOTIFICATION DATE	DELIVERY MODE
			02/04/2019	ELECTRONIC

Please find below and/or attached an Office communication concerning this application or proceeding.

The time period for reply, if any, is set in the attached communication.

Notice of the Office communication was sent electronically on above-indicated "Notification Date" to the following e-mail address(es):

amirr@natpatent.com
dorong@natpatent.com
info@natpatent.com



UNITED STATES DEPARTMENT OF COMMERCE
U.S. Patent and Trademark Office
 Address: COMMISSIONER FOR PATENTS
 P.O. Box 1450
 Alexandria, Virginia 22313-1450

APPLICATION NO./ CONTROL NO.	FILING DATE	FIRST NAMED INVENTOR/ PATENT IN REEXAMINATION	ATTORNEY DOCKET NO.
16/048,242	07/28/2018	Shabtay et al.	COREPH-0079 US CO

Nathan & Associates Patent Agents Ltd P.O.Box 10178 Tel Aviv, 6110101	EXAMINER	
	CYNTHIA SEGURA	
	ART UNIT	PAPER
	2697	20190130

DATE MAILED: _____

Please find below and/or attached an Office communication concerning this application or proceeding.

Commissioner for Patents

The IDS filed on 9/20/2018 (content of 25 pages) listed an improper patent number. The Citation Number 89 in page 9 included the following number: 98896655. This number has been updated with US Patent No. 8,896, 655. Accordingly, the IDS has been corrected and re-initialed.

/CYNTHIA SEGURA/
 Primary Examiner, Art Unit 2697

Doc code: IDS

Doc description: Information Disclosure Statement (IDS) Filed

PTO/SB/08a (01-10)

Approved for use through 07/31/2012. OMB 0651-0031

U.S. Patent and Trademark Office; U.S. DEPARTMENT OF COMMERCE

Under the Paperwork Reduction Act of 1995, no persons are required to respond to a collection of information unless it contains a valid OMB control number.

INFORMATION DISCLOSURE STATEMENT BY APPLICANT (Not for submission under 37 CFR 1.99)	Application Number	16048242
	Filing Date	2018-07-28
	First Named Inventor	Gal Shabtay
	Art Unit	
	Examiner Name	
	Attorney Docket Number	COREPH-0079 US CON3

U.S. PATENTS						Remove
Examiner Initial*	Cite No	Patent Number	Kind Code ¹	Issue Date	Name of Patentee or Applicant of cited Document	Pages, Columns, Lines where Relevant Passages or Relevant Figures Appear
	1	9286680	B1	2016-03-15	Jiang et al.	
	2	9736391	B2	2017-08-15	Du et al.	
	3	9894287	B2	2018-02-13	Qian et al.	
	4	6750903	B1	2004-06-15	Miyatake et al.	
	5	5032917	A	1991-07-16	Felix Aschwanden	
	6	5287093	A	1994-02-15	Amano et al.	
	7	5287093	A	1995-02-28	John T. Hall	
	8	5444478	A	1995-08-22	Lelong et al.	

INFORMATION DISCLOSURE STATEMENT BY APPLICANT (Not for submission under 37 CFR 1.99)	Application Number		16048242		
	Filing Date		2018-07-28		
	First Named Inventor	Gal Shabtay			
	Art Unit				
	Examiner Name				
	Attorney Docket Number		COREPH-0079 US CON3		

9	5657402	A	1997-08-12	Bender et al.
10	5682198	A	1997-10-28	Katayama et al.
11	5926190	A	1999-07-20	Turkowski et al.
12	6128416	A	2000-10-03	Koutatsu Oura
13	6148120	A	2000-11-14	Michael Sussman
14	6208765	B1	2001-03-27	James Russell Bergen
15	7002583	B2	2006-02-21	Maurice F. Rabb, III
16	7346217	B1	2008-03-18	V. Edward Gold, Jr.
17	7424218	B2	2008-09-09	Baudisch et al.
18	7533819	B2	2009-05-19	Barkan et al.
19	7619683	B2	2009-11-17	Raymond A. Davis

INFORMATION DISCLOSURE STATEMENT BY APPLICANT (Not for submission under 37 CFR 1.99)	Application Number		16048242		
	Filing Date		2018-07-28		
	First Named Inventor	Gal Shabtay			
	Art Unit				
	Examiner Name				
	Attorney Docket Number		COREPH-0079 US CON3		

20	6268611	B1	2001-07-31	Pettersson et al.
21	6714665	B1	2004-03-30	Hanna et al.
22	5005083	A	1991-04-02	Grage et al.
23	5940641	A	1999-08-17	McIntyre et al.
24	6741250	B1	2004-05-25	Furlan et al.
25	7365793	B2	2008-04-29	Cheatle et al.
26	9413930	B2	2016-08-09	Joergen Geerds
27	4199785	A	1980-04-22	McCullough et al.
28	8400555	B1	2013-03-19	Georgiev et al.
29	8553106	B2	2013-10-08	Lawrence Scarff
30	9800798	B2	2017-10-24	Ravirala et al.

INFORMATION DISCLOSURE STATEMENT BY APPLICANT (Not for submission under 37 CFR 1.99)	Application Number		16048242		
	Filing Date		2018-07-28		
	First Named Inventor	Gal Shabtay			
	Art Unit				
	Examiner Name				
	Attorney Docket Number		COREPH-0079 US CON3		

31	5768443	A	1998-06-16	Michael et al.
32	6101334	A	2000-08-08	Stephen D. Fantone
33	6611289	B1	2003-08-26	Yu et al.
34	7015954	B1	2006-03-21	Foote et al.
35	7256944	B2	2007-08-14	Labaziewicz et al.
36	8587691	B2	2013-11-19	Yasuo Takane
37	8274552	B2	2012-09-25	Dahi et al.
38	8390729	B2	2013-03-05	Long et al.
39	8803990	B2	2014-08-12	Scott Smith
40	9270875	B2	2016-02-23	Brisedoux et al.
41	9485432	B1	2016-11-01	Medasani et al.

INFORMATION DISCLOSURE STATEMENT BY APPLICANT (Not for submission under 37 CFR 1.99)	Application Number		16048242		
	Filing Date		2018-07-28		
	First Named Inventor	Gal Shabtay			
	Art Unit				
	Examiner Name				
	Attorney Docket Number		COREPH-0079 US CON3		

42	5436660	A	1995-07-25	Yukio Sakamoto
43	6549215	B2	2003-04-15	Norman P. Jouppi
44	7411610	B2	2008-08-12	Michael Doyle
45	8439265	B2	2013-05-14	Ferren et al.
46	5248971	A	1993-09-28	William J. Mandl
47	5459520	A	1995-10-17	Tadao Sasaki
48	7038716	B2	2006-05-02	Klein et al.
49	7339621	B2	2008-03-04	Justin Fortier
50	9215385	B2	2015-12-15	Xiaodong Luo
51	7305180	B2	2007-12-04	Labaziewicz et al.
52	7978239	B2	2011-07-12	Deever et al.

INFORMATION DISCLOSURE STATEMENT BY APPLICANT (Not for submission under 37 CFR 1.99)	Application Number		16048242		
	Filing Date		2018-07-28		
	First Named Inventor	Gal Shabtay			
	Art Unit				
	Examiner Name				
	Attorney Docket Number		COREPH-0079 US CON3		

53	7199348	B2	2007-04-03	Olsen et al.
54	8115825	B2	2012-02-14	Culbert et al.
55	7964835	B2	2011-06-21	Olsen et al.
56	8154610	B2	2012-04-10	Jo et al.
57	8619148	B2	2013-12-31	Watts et al.
58	5051830	A	1991-09-24	Wolfgang von Hoessle
59	5982951	A	1999-11-09	Katayama et al.
60	6738073	B2	2004-05-18	Park et al.
61	9025073	B2	2015-05-05	Aitar et al.
62	9025077	B2	2015-05-05	Aitar et al.
63	9413984	B2	2016-08-09	Aitar et al.

INFORMATION DISCLOSURE STATEMENT BY APPLICANT (Not for submission under 37 CFR 1.99)	Application Number		16048242		
	Filing Date		2018-07-28		
	First Named Inventor	Gal Shabtay			
	Art Unit				
	Examiner Name				
	Attorney Docket Number		COREPH-0079 US CON3		

64	9578257	B2	2017-02-21	Attar et al.
65	9681057	B2	2017-06-13	Attar et al.
66	7206136	B2	2007-04-17	Labaziewicz et al.
67	7509041	B2	2009-03-24	Eiji Hosono
68	8976255	B2	2015-03-10	Matsuoto et al.
69	9041835	B2	2015-05-26	Yoshiaki Honda
70	9723220	B2	2017-08-01	Kazuhiko Sugie
71	8483452	B2	2013-07-09	Jeda et al.
72	9137447	B2	2015-09-15	Koji Shibuno
73	7880776	B2	2011-02-01	LeGall et al.
74	9618748	B2	2017-04-11	Munger et al.

INFORMATION DISCLOSURE STATEMENT BY APPLICANT (Not for submission under 37 CFR 1.99)	Application Number		16048242		
	Filing Date		2018-07-28		
	First Named Inventor	Gal Shabtay			
	Art Unit				
	Examiner Name				
	Attorney Docket Number		COREPH-0079 US CON3		

75	9019387	B2	2015-04-28	Akira Nakano
76	8446484	B2	2013-05-21	Muukki et al.
77	8238695	B1	2012-08-07	Davey et al.
78	6680748	B1	2004-01-20	John Mario Monti
79	9344626	B2	2016-05-17	Silverstein et al.
80	9420180	B2	2016-08-16	Chongting Jin
81	8391697	B2	2013-03-05	Cho et al.
82	9438792	B2	2016-09-06	Nakada et al.
83	9215377	B2	2015-12-15	Sokeila et al.
84	9360671	B1	2016-06-07	Changyin Zhou
85	9736365	B2	2017-08-15	Rajiv Laroia

INFORMATION DISCLOSURE STATEMENT BY APPLICANT (Not for submission under 37 CFR 1.99)	Application Number		16048242		
	Filing Date		2018-07-28		
	First Named Inventor	Gal Shabtay			
	Art Unit				
	Examiner Name				
	Attorney Docket Number		COREPH-0079 US CON3		

	86	9851803	B2	2017-12-26	Fisher et al.
	87	6778207	B1	2004-08-17	Lee et al
	88	8514491	B2	2013-08-20	Jacques Duparre
/C.S/	89	98896655 8896655	B2	2014-11-25	Mauchly et al.
	90	9369621	B2	2016-06-14	Malone et al.
	91	9900522	B2	2018-02-20	Yuesheng Lu
	92	8547389	B2	2013-10-01	Hoppe et al.
	93	7738016	B2	2010-06-15	Toshiyuki Toyofuku
	94	7918398	B2	2011-04-05	Li et al.
	95	7248294	B2	2007-07-24	David Neil Slatter
	96	6724421	B1	2004-04-20	Terry Laurence Glatt

INFORMATION DISCLOSURE STATEMENT BY APPLICANT (Not for submission under 37 CFR 1.99)	Application Number	16048242
	Filing Date	2018-07-28
	First Named Inventor	Gal Shabtay
	Art Unit	
	Examiner Name	
	Attorney Docket Number	COREPH-0079 US CON3

97	8149327	B2	2012-04-03	Lin et al.
98	6643416	B1	2003-11-04	Daniels et al.
99	6650368	B1	2003-11-18	Amir Doron

If you wish to add additional U.S. Patent citation information please click the Add button.

U.S.PATENT APPLICATION PUBLICATIONS

Examiner Initial*	Cite No	Publication Number	Kind Code ¹	Publication Date	Name of Patentee or Applicant of cited Document	Pages, Columns, Lines where Relevant Passages or Relevant Figures Appear
	1	20090295949	A1	2009-12-03	Kai Markus Ojala	
	2	20110080487	A1	2011-04-07	Venkataraman et al.	
	3	20170289458	A1	2017-10-05	Song et al.	
	4	20130250150	A1	2013-09-26	Malone et al.	
	5	20140118584	A1	2014-05-01	Lee et al.	
	6	20160301840	A1	2016-10-13	Du et al.	

INFORMATION DISCLOSURE STATEMENT BY APPLICANT (Not for submission under 37 CFR 1.99)	Application Number		16048242		
	Filing Date		2018-07-28		
	First Named Inventor	Gal Shabtay			
	Art Unit				
	Examiner Name				
	Attorney Docket Number		COREPH-0079 US CON3		

7	20170019616	A1	2017-01-19	Zhu et al.
8	20170214846	A1	2017-07-27	Du et al.
9	20180150973	A1	2018-05-31	Tang et al.
10	20020005902	A1	2002-01-17	Henry Yuen
11	20100103194	A1	2010-04-29	Chen et al.
12	20130135445	A1	2013-05-30	Dahi et al.
13	20150154776	A1	2015-06-04	Zhang et al.
14	20170214866	A1	2017-07-27	Zhu et al.
15	20120287315	A1	2012-11-15	Huang et al.
16	20150271471	A1	2015-09-24	Hsieh et al.
17	20150334309	A1	2015-11-19	Peng et al.

INFORMATION DISCLOSURE STATEMENT BY APPLICANT (Not for submission under 37 CFR 1.99)	Application Number		16048242		
	Filing Date		2018-07-28		
	First Named Inventor	Gal Shabtay			
	Art Unit				
	Examiner Name				
	Attorney Docket Number		COREPH-0079 US CON3		

18	20160353012	A1	2016-12-01	Kao et al.
19	20020122113	A1	2002-09-05	Jonathan Foote
20	20030093805	A1	2003-05-15	J.M. Gin
21	20040027367	A1	2004-02-12	Maurizio Pilu
22	20050013509	A1	2005-01-20	Ramin Samadani
23	20070188653	A1	2007-08-16	Pollock et al.
24	20080017557	A1	2008-01-24	Calvin J. Witdouch
25	20100013906	A1	2010-01-21	Border et al,
26	20080030592	A1	2008-02-07	Border et al,
27	20090122195	A1	2009-05-14	Van Baar et al.
28	20050046740	A1	2005-03-03	Raymond Davis

INFORMATION DISCLOSURE STATEMENT BY APPLICANT (Not for submission under 37 CFR 1.99)	Application Number		16048242		
	Filing Date		2018-07-28		
	First Named Inventor	Gal Shabtay			
	Art Unit				
	Examiner Name				
	Attorney Docket Number		COREPH-0079 US CON3		

	29	20060054782	A1	2006-03-16	Olsen et al.
	30	20060056056	A1	2006-03-16	Ahiska et al.
	31	20070257184	A1	2007-11-08	Olsen et al.
	32	20070285550	A1	2007-12-13	Jae-Gon Son
	33	20080030611	A1	2008-02-07	Michael V. Jenkins
	34	20090086074	A1	2009-04-02	Li et al.
	35	20100060746	A9	2010-03-11	Olsen et al.
	36	20130235224	A1	2013-09-12	Park et al.
	37	20040008773	A1	2004-01-15	Osamu Itokawa
	38	20040017386	A1	2004-01-29	Liu et al.
	39	20040240052	A1	2004-12-02	Minefuji et al.

INFORMATION DISCLOSURE STATEMENT BY APPLICANT (Not for submission under 37 CFR 1.99)	Application Number		16048242		
	Filing Date		2018-07-28		
	First Named Inventor	Gal Shabtay			
	Art Unit				
	Examiner Name				
	Attorney Docket Number		COREPH-0079 US CON3		

40	20030202113	A1	2003-10-30	Sumito Yoshikawa
41	20060187310	A1	2006-08-24	Janson et al.
42	20060187322	A1	2006-08-24	Janson et al.
43	20060187338	A1	2006-08-24	May et al.
44	20070024737	A1	2007-02-01	Nakamura et al.
45	20080025634	A1	2008-01-31	Border et al.
46	20080218611	A1	2008-09-11	Parulski et al.
47	20080218612	A1	2008-09-11	Border et al.
48	20080218613	A1	2008-09-11	Janson et al.
49	20080219654	A1	2008-09-11	Border et al.
50	20110242286	A1	2011-10-06	Pace et al.

INFORMATION DISCLOSURE STATEMENT BY APPLICANT (Not for submission under 37 CFR 1.99)	Application Number		16048242		
	Filing Date		2018-07-28		
	First Named Inventor	Gal Shabtay			
	Art Unit				
	Examiner Name				
	Attorney Docket Number		COREPH-0079 US CON3		

51	20080117316	A1	2008-05-22	Masaaki Orimoto
52	20160212358	A1	2016-07-21	Yasuhito Shikata
53	20030160886	A1	2003-08-28	Misawa et al.
54	20070177025	A1	2007-08-02	Kopet et al.
55	20070189386	A1	2007-08-16	Imagawa et al.
56	20080024614	A1	2008-01-31	Li et al.
57	20110242355	A1	2011-10-06	Goma et al.
58	20120196648	A1	2012-08-02	Havens et al.
59	20130258044	A1	2013-10-03	Betts-LaCroix
60	20140192253	A1	2014-07-10	Rajiv Laroia
61	20150092066	A1	2015-04-02	Geiss et al.

INFORMATION DISCLOSURE STATEMENT BY APPLICANT (Not for submission under 37 CFR 1.99)	Application Number		16048242		
	Filing Date		2018-07-28		
	First Named Inventor	Gal Shabtay			
	Art Unit				
	Examiner Name				
	Attorney Docket Number		COREPH-0079 US CON3		

62	20060175549	A1	2006-08-10	Miller et al.
63	20120075489	A1	2012-03-29	H. Keith Nishihara
64	20130182150	A1	2013-07-18	Ayako Asakura
65	20140192238	A1	2014-07-10	Attar et al.
66	20090295949	A1	2009-12-03	Kai Markus Ojala
67	20100238327	A1	2010-09-23	Griffith et al.
68	20120229663	A1	2012-09-13	Nelson et al.
69	20130201360	A1	2013-08-08	Yong-Bae Song
70	20150242994	A1	2015-08-27	Ji Shen
71	20050157184	A1	2005-07-21	Nakanishi et al.
72	20050200718	A1	2005-09-15	Chang-Hee Lee

INFORMATION DISCLOSURE STATEMENT BY APPLICANT (Not for submission under 37 CFR 1.99)	Application Number		16048242		
	Filing Date		2018-07-28		
	First Named Inventor	Gal Shabtay			
	Art Unit				
	Examiner Name				
	Attorney Docket Number		COREPH-0079 US CON3		

73	20040061788	A1	2004-04-01	John Bateman
74	20150215516	A1	2015-07-30	Benjamin P. Dolgin
75	20140313316	A1	2014-10-23	Olsson et al.
76	20110229054	A1	2011-09-22	Weston et al.
77	20020063711	A1	2016-06-14	Park et al.
78	20090128644	A1	2009-05-21	Camp et al.
79	20130321668	A1	2013-12-05	Ajith Kamath
80	20130202273	A1	2013-08-08	Ouedraogo et al.
81	20120069235	A1	2012-03-22	Francisco Imai
82	20130002928	A1	2013-01-03	Francisco Imai
83	20120105579	A1	2012-05-03	Jeon et al.

INFORMATION DISCLOSURE STATEMENT BY APPLICANT (Not for submission under 37 CFR 1.99)	Application Number		16048242		
	Filing Date		2018-07-28		
	First Named Inventor	Gal Shabtay			
	Art Unit				
	Examiner Name				
	Attorney Docket Number		COREPH-0079 US CON3		

84	20030030729	A1	2003-02-13	Prentice et al.
85	20110064327	A1	2011-03-17	Dagher et al.
86	20110128288	A1	2011-06-02	Petrou et al.
87	20120026366	A1	2012-02-02	Golan et al.
88	20130093842	A1	2013-04-18	Kazuhiro Yahata
89	20150237280	A1	2015-08-20	Choi et al.
90	20060125937	A1	2006-06-15	LeGall et al.
91	20060170793	A1	2006-08-03	Pasqualette et al.
92	20080084484	A1	2008-04-10	Ochi et al.
93	20110234853	A1	2011-09-29	Hayashi et al.
94	20160154202	A1	2016-06-02	Wippermann et al.

INFORMATION DISCLOSURE STATEMENT BY APPLICANT (Not for submission under 37 CFR 1.99)	Application Number		16048242	
	Filing Date		2018-07-28	
	First Named Inventor	Gal Shabtay		
	Art Unit			
	Examiner Name			
	Attorney Docket Number		COREPH-0079 US CON3	

95	20120249815	A1	2012-10-04	Bohn et al.
96	20160044250	A1	2016-02-11	Shabtay et al.
97	20150195458	A1	2015-07-09	Nakayama et al.
98	20140362242	A1	2014-12-11	Teruyuki Takizawa
99	20090122406	A1	2009-05-14	Rouvinen et al.
100	20090252484	A1	2009-10-08	Hasuda et al.
101	20090219547	A1	2009-09-03	Kauhanen et al.
102	20140049615	A1	2014-02-20	Satoshi Uwagawa
103	20110164172	A1	2011-07-07	Shintani et al.

If you wish to add additional U.S. Published Application citation information please click the Add button.

FOREIGN PATENT DOCUMENTS

Examiner Initial*	Cite No	Foreign Document Number ³	Country Code ²	Kind Code ⁴	Publication Date	Name of Patentee or Applicant of cited Document	Pages, Columns, Lines where Relevant Passages or Relevant Figures Appear	T ⁵
-------------------	---------	--------------------------------------	---------------------------	------------------------	------------------	---	--	----------------

INFORMATION DISCLOSURE STATEMENT BY APPLICANT (Not for submission under 37 CFR 1.99)	Application Number		16048242	
	Filing Date		2018-07-28	
	First Named Inventor	Gal Shabtay		
	Art Unit			
	Examiner Name			
	Attorney Docket Number		COREPH-0079 US CON3	

1	102739949	CN	A	2012-10-17	Zhang Kerun		
2	103024272	CN	A	2013-04-03	Gao Xiaowen		
3	2523450	EP	A1	2012-11-14	Huang et al.		
4	101276415	CN	A	2008-10-01	Wu et al.		
5	2007306282	JP	A	2007-11-22	Yasuaki Kayanuma		
6	2003298920	JP	A	2003-10-17	Misawa et al.		
7	2006238325	JP	A	2006-09-07	Kagiyada et al.		
8	2013106289	JP	A	2013-05-30	Konno et al.		
9	2005099265	JP	A	2005-04-14	Ito et al.		
10	101477178	KR	B1	2014-12-29	Sun et al.		
11	20100008936	KR	A	2010-01-27	Sun et al.		

INFORMATION DISCLOSURE STATEMENT BY APPLICANT (Not for submission under 37 CFR 1.99)	Application Number		16048242	
	Filing Date		2018-07-28	
	First Named Inventor	Gal Shabtay		
	Art Unit			
	Examiner Name			
	Attorney Docket Number		COREPH-0079 US CON3	

12	08271976	JP	A	1996-10-18	Tamamura Hideo		
13	04211230	JP	A	1992-08-03	Jeda Satoshi		
14	20140014787	KR	A	2014-02-06	Young-Ho Kim		
15	2007228006	JP	A	2007-09-06	Ichigo		
16	H07318864	JP	A	1995-12-08	Kawamura et al.		

If you wish to add additional Foreign Patent Document citation information please click the Add button

Add

NON-PATENT LITERATURE DOCUMENTS

Remove

Examiner Initials*	Cite No	Include name of the author (in CAPITAL LETTERS), title of the article (when appropriate), title of the item (book, magazine, journal, serial, symposium, catalog, etc), date, pages(s), volume-issue number(s), publisher, city and/or country where published.	T ⁵
	1	Statistical Modeling and Performance Characterization of a Real-Time Dual Camera Surveillance System, Greenhagen et al., Publisher: IEEE, 2000, 8 pages	
	2	A 3MPixel Multi-Aperture Image Sensor with 0.7µm Pixels in 0.11µm CMOS, Fife et al., Stanford University, 2008, 3 pages	
	3	Dual camera intelligent sensor for high definition 360 degrees surveillance, Scotti et al., Publisher: IET, 05/09/2000, 8 pages	
	4	Dual-sensor foveated imaging system, Hua et al., Publisher: Optical Society of America, 01/14/2008, 11 pages	

INFORMATION DISCLOSURE STATEMENT BY APPLICANT (Not for submission under 37 CFR 1.99)	Application Number	16048242
	Filing Date	2018-07-28
	First Named Inventor	Gal Shabtay
	Art Unit	
	Examiner Name	
	Attorney Docket Number	COREPH-0079 US CON3

5	Defocus Video Matting, McGuire et al., Publisher: ACM SIGGRAPH, 07/31/2005, 11 pages
6	Compact multi-aperture imaging with high angular resolution, Santacana et al., Publisher: Optical Society of America, 2015, 10 pages
7	Multi-Aperture Photography, Green et al., Publisher: Mitsubishi Electric Research Laboratories, Inc., July 2007, 10 pages
8	Multispectral Bilateral Video Fusion, Bennett et al., Publisher: IEEE, May 2007, 10 pages
9	Super-resolution imaging using a camera array, Santacana et al., Publisher: Optical Society of America, 2014, 6 pages
10	Optical Splitting Trees for High-Precision Monocular Imaging, McGuire et al., Publisher: IEEE, 2007, 11 pages
11	High Performance Imaging Using Large Camera Arrays, Wilburn et al., Publisher: Association for Computing Machinery, Inc., 2005, 12 pages
12	Real-time Edge-Aware Image Processing with the Bilateral Grid, Chen et al., Publisher: ACM SIGGRAPH, 9 pages
13	Superimposed multi-resolution imaging, Carles et al., Publisher: Optical Society of America, 2017, 13 pages
14	Viewfinder Alignment, Adams et al., Publisher: EUROGRAPHICS, 2008, 10 pages
15	Dual-Camera System for Multi-Level Activity Recognition, Bodor et al., Publisher: IEEE, October 2014, 6 pages

INFORMATION DISCLOSURE STATEMENT BY APPLICANT (Not for submission under 37 CFR 1.99)	Application Number	16048242 16/048,242 - GAU: 2697
	Filing Date	2018-07-28
	First Named Inventor	Gal Shabtay
	Art Unit	
	Examiner Name	
	Attorney Docket Number	COREPH-0079 US CON3

16	Engineered to the task: Why camera-phone cameras are different, Giles Humpston, Publisher: Solid State Technology, June 2009, 3 pages
----	---

If you wish to add additional non-patent literature document citation information please click the Add button

EXAMINER SIGNATURE

Examiner Signature	/CYNTHIA SEGURA/	Date Considered	01/30/2019
--------------------	------------------	-----------------	------------

*EXAMINER: Initial if reference considered, whether or not citation is in conformance with MPEP 609. Draw line through a citation if not in conformance and not considered. Include copy of this form with next communication to applicant.

¹ See Kind Codes of USPTO Patent Documents at www.USPTO.GOV or MPEP 901.04. ² Enter office that issued the document, by the two-letter code (WIPO Standard ST.3). ³ For Japanese patent documents, the indication of the year of the reign of the Emperor must precede the serial number of the patent document. ⁴ Kind of document by the appropriate symbols as indicated on the document under WIPO Standard ST.16 if possible. ⁵ Applicant is to place a check mark here if English language translation is attached.

ALL REFERENCES CONSIDERED EXCEPT WHERE LINED THROUGH. /C.S/

INFORMATION DISCLOSURE STATEMENT BY APPLICANT (Not for submission under 37 CFR 1.99)	Application Number	16048242
	Filing Date	2018-07-28
	First Named Inventor	Gal Shabtay
	Art Unit	
	Examiner Name	
	Attorney Docket Number	COREPH-0079 US CON3

CERTIFICATION STATEMENT

Please see 37 CFR 1.97 and 1.98 to make the appropriate selection(s):

That each item of information contained in the information disclosure statement was first cited in any communication from a foreign patent office in a counterpart foreign application not more than three months prior to the filing of the information disclosure statement. See 37 CFR 1.97(e)(1).

OR

That no item of information contained in the information disclosure statement was cited in a communication from a foreign patent office in a counterpart foreign application, and, to the knowledge of the person signing the certification after making reasonable inquiry, no item of information contained in the information disclosure statement was known to any individual designated in 37 CFR 1.56(c) more than three months prior to the filing of the information disclosure statement. See 37 CFR 1.97(e)(2).

See attached certification statement.

The fee set forth in 37 CFR 1.17 (p) has been submitted herewith.

A certification statement is not submitted herewith.

SIGNATURE

A signature of the applicant or representative is required in accordance with CFR 1.33, 10.18. Please see CFR 1.4(d) for the form of the signature.

Signature	/Menachem Nathan/	Date (YYYY-MM-DD)	2018-09-20
Name/Print	Menachem Nathan	Registration Number	65392

This collection of information is required by 37 CFR 1.97 and 1.98. The information is required to obtain or retain a benefit by the public which is to file (and by the USPTO to process) an application. Confidentiality is governed by 35 U.S.C. 122 and 37 CFR 1.14. This collection is estimated to take 1 hour to complete, including gathering, preparing and submitting the completed application form to the USPTO. Time will vary depending upon the individual case. Any comments on the amount of time you require to complete this form and/or suggestions for reducing this burden, should be sent to the Chief Information Officer, U.S. Patent and Trademark Office, U.S. Department of Commerce, P.O. Box 1450, Alexandria, VA 22313-1450. **DO NOT SEND FEES OR COMPLETED FORMS TO THIS ADDRESS. SEND TO: Commissioner for Patents, P.O. Box 1450, Alexandria, VA 22313-1450.**

Privacy Act Statement

The Privacy Act of 1974 (P.L. 93-579) requires that you be given certain information in connection with your submission of the attached form related to a patent application or patent. Accordingly, pursuant to the requirements of the Act, please be advised that: (1) the general authority for the collection of this information is 35 U.S.C. 2(b)(2); (2) furnishing of the information solicited is voluntary; and (3) the principal purpose for which the information is used by the U.S. Patent and Trademark Office is to process and/or examine your submission related to a patent application or patent. If you do not furnish the requested information, the U.S. Patent and Trademark Office may not be able to process and/or examine your submission, which may result in termination of proceedings or abandonment of the application or expiration of the patent.

The information provided by you in this form will be subject to the following routine uses:

1. The information on this form will be treated confidentially to the extent allowed under the Freedom of Information Act (5 U.S.C. 552) and the Privacy Act (5 U.S.C. 552a). Records from this system of records may be disclosed to the Department of Justice to determine whether the Freedom of Information Act requires disclosure of these records.
2. A record from this system of records may be disclosed, as a routine use, in the course of presenting evidence to a court, magistrate, or administrative tribunal, including disclosures to opposing counsel in the course of settlement negotiations.
3. A record in this system of records may be disclosed, as a routine use, to a Member of Congress submitting a request involving an individual, to whom the record pertains, when the individual has requested assistance from the Member with respect to the subject matter of the record.
4. A record in this system of records may be disclosed, as a routine use, to a contractor of the Agency having need for the information in order to perform a contract. Recipients of information shall be required to comply with the requirements of the Privacy Act of 1974, as amended, pursuant to 5 U.S.C. 552a(m).
5. A record related to an International Application filed under the Patent Cooperation Treaty in this system of records may be disclosed, as a routine use, to the International Bureau of the World Intellectual Property Organization, pursuant to the Patent Cooperation Treaty.
6. A record in this system of records may be disclosed, as a routine use, to another federal agency for purposes of National Security review (35 U.S.C. 181) and for review pursuant to the Atomic Energy Act (42 U.S.C. 218(c)).
7. A record from this system of records may be disclosed, as a routine use, to the Administrator, General Services, or his/her designee, during an inspection of records conducted by GSA as part of that agency's responsibility to recommend improvements in records management practices and programs, under authority of 44 U.S.C. 2904 and 2906. Such disclosure shall be made in accordance with the GSA regulations governing inspection of records for this purpose, and any other relevant (i.e., GSA or Commerce) directive. Such disclosure shall not be used to make determinations about individuals.
8. A record from this system of records may be disclosed, as a routine use, to the public after either publication of the application pursuant to 35 U.S.C. 122(b) or issuance of a patent pursuant to 35 U.S.C. 151. Further, a record may be disclosed, subject to the limitations of 37 CFR 1.14, as a routine use, to the public if the record was filed in an application which became abandoned or in which the proceedings were terminated and which application is referenced by either a published application, an application open to public inspections or an issued patent.
9. A record from this system of records may be disclosed, as a routine use, to a Federal, State, or local law enforcement agency, if the USPTO becomes aware of a violation or potential violation of law or regulation.



UNITED STATES PATENT AND TRADEMARK OFFICE

UNITED STATES DEPARTMENT OF COMMERCE
United States Patent and Trademark Office
Address: COMMISSIONER FOR PATENTS
P.O. Box 1450
Alexandria, Virginia 22313-1450
www.uspto.gov

APPLICATION NO.	FILING DATE	FIRST NAMED INVENTOR	ATTORNEY DOCKET NO.	CONFIRMATION NO.
16/048,242	07/28/2018	Gal Shabtay	COREPH-0079 US CON3	4814
92342	7590	01/22/2019	EXAMINER	
Nathan & Associates Patent Agents Ltd P.O.Box 10178 Tel Aviv, 6110101 ISRAEL			SEGURA, CYNTHIA	
			ART UNIT	PAPER NUMBER
			2662	
			NOTIFICATION DATE	DELIVERY MODE
			01/22/2019	ELECTRONIC

Please find below and/or attached an Office communication concerning this application or proceeding.

The time period for reply, if any, is set in the attached communication.

Notice of the Office communication was sent electronically on above-indicated "Notification Date" to the following e-mail address(es):

amirr@natpatent.com
dorong@natpatent.com
info@natpatent.com

Corrected Notice of Allowability	Application No. 16/048,242	Applicant(s) Shabtay et al.	
	Examiner CYNTHIA SEGURA	Art Unit 2662	AIA Status Yes

-- The MAILING DATE of this communication appears on the cover sheet with the correspondence address--

All claims being allowable, PROSECUTION ON THE MERITS IS (OR REMAINS) CLOSED in this application. If not included herewith (or previously mailed), a Notice of Allowance (PTOL-85) or other appropriate communication will be mailed in due course. **THIS NOTICE OF ALLOWABILITY IS NOT A GRANT OF PATENT RIGHTS.** This application is subject to withdrawal from issue at the initiative of the Office or upon petition by the applicant. See 37 CFR 1.313 and MPEP 1308.

1. This communication is responsive to IDS filed on 1/5/2019.
 A declaration(s)/affidavit(s) under **37 CFR 1.130(b)** was/were filed on _____.
2. An election was made by the applicant in response to a restriction requirement set forth during the interview on _____; the restriction requirement and election have been incorporated into this action.
3. The allowed claim(s) is/are 1-40 . As a result of the allowed claim(s), you may be eligible to benefit from the **Patent Prosecution Highway** program at a participating intellectual property office for the corresponding application. For more information, please see http://www.uspto.gov/patents/init_events/pph/index.jsp or send an inquiry to PPHfeedback@uspto.gov.
4. Acknowledgment is made of a claim for foreign priority under 35 U.S.C. § 119(a)-(d) or (f).

Certified copies:

- a) All b) Some *c) None of the:
1. Certified copies of the priority documents have been received.
 2. Certified copies of the priority documents have been received in Application No. _____.
 3. Copies of the certified copies of the priority documents have been received in this national stage application from the International Bureau (PCT Rule 17.2(a)).

* Certified copies not received: _____.

Applicant has THREE MONTHS FROM THE "MAILING DATE" of this communication to file a reply complying with the requirements noted below. Failure to timely comply will result in ABANDONMENT of this application.

THIS THREE-MONTH PERIOD IS NOT EXTENDABLE.

5. CORRECTED DRAWINGS (as "replacement sheets") must be submitted.
 including changes required by the attached Examiner's Amendment / Comment or in the Office action of Paper No./Mail Date _____.
Identifying indicia such as the application number (see 37 CFR 1.84(c)) should be written on the drawings in the front (not the back) of each sheet. Replacement sheet(s) should be labeled as such in the header according to 37 CFR 1.121(d).
6. DEPOSIT OF and/or INFORMATION about the deposit of BIOLOGICAL MATERIAL must be submitted. Note the attached Examiner's comment regarding REQUIREMENT FOR THE DEPOSIT OF BIOLOGICAL MATERIAL.

Attachment(s)

- | | |
|---|---|
| 1. <input type="checkbox"/> Notice of References Cited (PTO-892) | 5. <input type="checkbox"/> Examiner's Amendment/Comment |
| 2. <input checked="" type="checkbox"/> Information Disclosure Statements (PTO/SB/08),
Paper No./Mail Date _____. | 6. <input type="checkbox"/> Examiner's Statement of Reasons for Allowance |
| 3. <input type="checkbox"/> Examiner's Comment Regarding Requirement for Deposit
of Biological Material _____. | 7. <input type="checkbox"/> Other _____. |
| 4. <input type="checkbox"/> Interview Summary (PTO-413),
Paper No./Mail Date _____. | |

/CYNTHIA SEGURA/
Primary Examiner, Art Unit 2662

INFORMATION DISCLOSURE STATEMENT BY APPLICANT (Not for submission under 37 CFR 1.99)	Application Number	16048242 16/048,242 - GAU: 2662
	Filing Date	2018-07-28
	First Named Inventor	Gal Shabtay
	Art Unit	
	Examiner Name	
	Attorney Docket Number	COREPH-0079 US CON3

U.S.PATENTS Remove						
Examiner Initial*	Cite No	Patent Number	Kind Code ¹	Issue Date	Name of Patentee or Applicant of cited Document	Pages,Columns,Lines where Relevant Passages or Relevant Figures Appear
	1	8149523	B2	2012-04-03	Yuichi Ozaki	
	2	9279957	B2	2016-03-08	Kanda et al.	
	3	9488802	B2	2016-11-08	Chen et al.	
	4	9185291	B1	2015-11-10	Shabtay at el.	
	5	8958164	B2	2015-02-17	Kwon et al.	
If you wish to add additional U.S. Patent citation information please click the Add button.						Add
U.S.PATENT APPLICATION PUBLICATIONS Remove						
Examiner Initial*	Cite No	Publication Number	Kind Code ¹	Publication Date	Name of Patentee or Applicant of cited Document	Pages,Columns,Lines where Relevant Passages or Relevant Figures Appear
	1	20170115471	A1	2017-04-27	Yoshikazu Shinohara	

ALL REFERENCES CONSIDERED EXCEPT WHERE LINED THROUGH. /C.S/

INFORMATION DISCLOSURE STATEMENT BY APPLICANT (Not for submission under 37 CFR 1.99)	Application Number	16048242 16/048,242 - GAU: 2662
	Filing Date	2018-07-28
	First Named Inventor	Gal Shabtay
	Art Unit	
	Examiner Name	
	Attorney Docket Number	COREPH-0079 US CON3

2	20140362274	A1	2014-12-11	Christie et al.
3	20110001838	A1	2011-01-06	Sung Hwan Lee

If you wish to add additional U.S. Published Application citation information please click the Add button.

FOREIGN PATENT DOCUMENTS

Examiner Initial*	Cite No	Foreign Document Number ³	Country Code ² i	Kind Code ⁴	Publication Date	Name of Patentee or Applicant of cited Document	Pages, Columns, Lines where Relevant Passages or Relevant Figures Appear	T ⁵
	1							

If you wish to add additional Foreign Patent Document citation information please click the Add button.

NON-PATENT LITERATURE DOCUMENTS

Examiner Initials*	Cite No	Include name of the author (in CAPITAL LETTERS), title of the article (when appropriate), title of the item (book, magazine, journal, serial, symposium, catalog, etc), date, pages(s), volume-issue number(s), publisher, city and/or country where published.	T ⁵
	1		

If you wish to add additional non-patent literature document citation information please click the Add button.

EXAMINER SIGNATURE

Examiner Signature	/CYNTHIA SEGURA/	Date Considered	01/16/2019
--------------------	------------------	-----------------	------------

*EXAMINER: Initial if reference considered, whether or not citation is in conformance with MPEP 609. Draw line through a citation if not in conformance and not considered. Include copy of this form with next communication to applicant.

¹ See Kind Codes of USPTO Patent Documents at www.USPTO.GOV or MPEP 901.04. ² Enter office that issued the document, by the two-letter code (WIPO Standard ST.3). ³ For Japanese patent documents, the indication of the year of the reign of the Emperor must precede the serial number of the patent document. ⁴ Kind of document by the appropriate symbols as indicated on the document under WIPO Standard ST.16 if possible. ⁵ Applicant is to place a check mark here if English language translation is attached.

ALL REFERENCES CONSIDERED EXCEPT WHERE LINED THROUGH. /C.S/

INFORMATION DISCLOSURE STATEMENT BY APPLICANT (Not for submission under 37 CFR 1.99)	Application Number	16048242	16/048,242 - GAU: 2662
	Filing Date	2018-07-28	
	First Named Inventor	Gal Shabtay	
	Art Unit		
	Examiner Name		
	Attorney Docket Number	COREPH-0079 US CON3	

CERTIFICATION STATEMENT

Please see 37 CFR 1.97 and 1.98 to make the appropriate selection(s):

That each item of information contained in the information disclosure statement was first cited in any communication from a foreign patent office in a counterpart foreign application not more than three months prior to the filing of the information disclosure statement. See 37 CFR 1.97(e)(1).

OR

That no item of information contained in the information disclosure statement was cited in a communication from a foreign patent office in a counterpart foreign application, and, to the knowledge of the person signing the certification after making reasonable inquiry, no item of information contained in the information disclosure statement was known to any individual designated in 37 CFR 1.56(c) more than three months prior to the filing of the information disclosure statement. See 37 CFR 1.97(e)(2).

See attached certification statement.

The fee set forth in 37 CFR 1.17 (p) has been submitted herewith.

A certification statement is not submitted herewith.

SIGNATURE

A signature of the applicant or representative is required in accordance with CFR 1.33, 10.18. Please see CFR 1.4(d) for the form of the signature.

Signature	/Menachem Nathan/	Date (YYYY-MM-DD)	2019-01-05
Name/Print	MENACHEM NATHAN	Registration Number	65392

This collection of information is required by 37 CFR 1.97 and 1.98. The information is required to obtain or retain a benefit by the public which is to file (and by the USPTO to process) an application. Confidentiality is governed by 35 U.S.C. 122 and 37 CFR 1.14. This collection is estimated to take 1 hour to complete, including gathering, preparing and submitting the completed application form to the USPTO. Time will vary depending upon the individual case. Any comments on the amount of time you require to complete this form and/or suggestions for reducing this burden, should be sent to the Chief Information Officer, U.S. Patent and Trademark Office, U.S. Department of Commerce, P.O. Box 1450, Alexandria, VA 22313-1450. **DO NOT SEND FEES OR COMPLETED FORMS TO THIS ADDRESS. SEND TO: Commissioner for Patents, P.O. Box 1450, Alexandria, VA 22313-1450.**

Privacy Act Statement

The Privacy Act of 1974 (P.L. 93-579) requires that you be given certain information in connection with your submission of the attached form related to a patent application or patent. Accordingly, pursuant to the requirements of the Act, please be advised that: (1) the general authority for the collection of this information is 35 U.S.C. 2(b)(2); (2) furnishing of the information solicited is voluntary; and (3) the principal purpose for which the information is used by the U.S. Patent and Trademark Office is to process and/or examine your submission related to a patent application or patent. If you do not furnish the requested information, the U.S. Patent and Trademark Office may not be able to process and/or examine your submission, which may result in termination of proceedings or abandonment of the application or expiration of the patent.

The information provided by you in this form will be subject to the following routine uses:

1. The information on this form will be treated confidentially to the extent allowed under the Freedom of Information Act (5 U.S.C. 552) and the Privacy Act (5 U.S.C. 552a). Records from this system of records may be disclosed to the Department of Justice to determine whether the Freedom of Information Act requires disclosure of these records.
2. A record from this system of records may be disclosed, as a routine use, in the course of presenting evidence to a court, magistrate, or administrative tribunal, including disclosures to opposing counsel in the course of settlement negotiations.
3. A record in this system of records may be disclosed, as a routine use, to a Member of Congress submitting a request involving an individual, to whom the record pertains, when the individual has requested assistance from the Member with respect to the subject matter of the record.
4. A record in this system of records may be disclosed, as a routine use, to a contractor of the Agency having need for the information in order to perform a contract. Recipients of information shall be required to comply with the requirements of the Privacy Act of 1974, as amended, pursuant to 5 U.S.C. 552a(m).
5. A record related to an International Application filed under the Patent Cooperation Treaty in this system of records may be disclosed, as a routine use, to the International Bureau of the World Intellectual Property Organization, pursuant to the Patent Cooperation Treaty.
6. A record in this system of records may be disclosed, as a routine use, to another federal agency for purposes of National Security review (35 U.S.C. 181) and for review pursuant to the Atomic Energy Act (42 U.S.C. 218(c)).
7. A record from this system of records may be disclosed, as a routine use, to the Administrator, General Services, or his/her designee, during an inspection of records conducted by GSA as part of that agency's responsibility to recommend improvements in records management practices and programs, under authority of 44 U.S.C. 2904 and 2906. Such disclosure shall be made in accordance with the GSA regulations governing inspection of records for this purpose, and any other relevant (i.e., GSA or Commerce) directive. Such disclosure shall not be used to make determinations about individuals.
8. A record from this system of records may be disclosed, as a routine use, to the public after either publication of the application pursuant to 35 U.S.C. 122(b) or issuance of a patent pursuant to 35 U.S.C. 151. Further, a record may be disclosed, subject to the limitations of 37 CFR 1.14, as a routine use, to the public if the record was filed in an application which became abandoned or in which the proceedings were terminated and which application is referenced by either a published application, an application open to public inspections or an issued patent.
9. A record from this system of records may be disclosed, as a routine use, to a Federal, State, or local law enforcement agency, if the USPTO becomes aware of a violation or potential violation of law or regulation.

Doc code: IDS

Doc description: Information Disclosure Statement (IDS) Filed

PTO/SB/08a (02-18)

Approved for use through 11/30/2020. OMB 0651-0031

U.S. Patent and Trademark Office; U.S. DEPARTMENT OF COMMERCE

Under the Paperwork Reduction Act of 1995, no persons are required to respond to a collection of information unless it contains a valid OMB control number.

INFORMATION DISCLOSURE STATEMENT BY APPLICANT (Not for submission under 37 CFR 1.99)	Application Number	16048242
	Filing Date	2018-07-28
	First Named Inventor	Gal Shabtay
	Art Unit	
	Examiner Name	
	Attorney Docket Number	COREPH-0079 US CON3

U.S.PATENTS							Remove
Examiner Initial*	Cite No	Patent Number	Kind Code ¹	Issue Date	Name of Patentee or Applicant of cited Document	Pages,Columns,Lines where Relevant Passages or Relevant Figures Appear	
	1	9185291	B1	2015-11-10	Shabtay et al.		
	2	7773121	B1	2010-08-10	Huntsberger et al.		
	3	9927600	B2	2018-03-27	Goldenberg et al.		
	4	9768310	B2	2017-09-19	Ahn et al.		

If you wish to add additional U.S. Patent citation information please click the Add button. Add

U.S.PATENT APPLICATION PUBLICATIONS							Remove
Examiner Initial*	Cite No	Publication Number	Kind Code ¹	Publication Date	Name of Patentee or Applicant of cited Document	Pages,Columns,Lines where Relevant Passages or Relevant Figures Appear	
	1	20120062780	A1	2012-03-15	Tajjiro MORIHISA		
	2	20150162048	A1	2015-06-11	Hirata et al.		

ALL REFERENCES CONSIDERED EXCEPT WHERE LINED THROUGH. /c.s/

INFORMATION DISCLOSURE STATEMENT BY APPLICANT (Not for submission under 37 CFR 1.99)	Application Number		16048242		
	Filing Date		2018-07-28		
	First Named Inventor	Gal Shabtay			
	Art Unit				
	Examiner Name				
	Attorney Docket Number		COREPH-0079 US CON3		

3	20180241922	A1	2018-08-23	Baldwin et al.
4	20180295292	A1	2018-10-11	Lee et al.
5	20110234881	A1	2011-09-29	Wakabayashi et al.
6	20100020221	A1	2010-01-28	Tupman et al.
7	20150002683	A1	2015-01-01	Hu et al.
8	20150042870	A1	2015-02-12	Chan et al.
9	20120320467	A1	2012-12-20	Baik et al.
10	20020075258	A1	2002-06-20	Park et al.
11	20100283842	A1	2010-11-11	Guissin et al.
12	20160070088	A1	2016-03-10	Mutsumi KOGUCHI
13	20180120674	A1	2018-05-03	Avivi et al.

INFORMATION DISCLOSURE STATEMENT BY APPLICANT (Not for submission under 37 CFR 1.99)	Application Number		16048242		
	Filing Date		2018-07-28		
	First Named Inventor	Gal Shabtay			
	Art Unit				
	Examiner Name				
	Attorney Docket Number		COREPH-0079 US CON3		

	14	20150316744	A1	2015-11-05	Hsing-Hung Chen	
	15	20160154204	A1	2016-06-02	Lim et al.	

If you wish to add additional U.S. Published Application citation information please click the Add button.

FOREIGN PATENT DOCUMENTS

Examiner Initial*	Cite No	Foreign Document Number ³	Country Code ² i	Kind Code ⁴	Publication Date	Name of Patentee or Applicant of cited Document	Pages, Columns, Lines where Relevant Passages or Relevant Figures Appear	T ⁵
	1	1536633	EP	A1	2005-06-01	Sony Corp		
	2	2008076485	JP	A	2008-04-03	Mitani et al.		
	3	2004133054	JP	A	2004-04-30	Futami et al.		

If you wish to add additional Foreign Patent Document citation information please click the Add button.

NON-PATENT LITERATURE DOCUMENTS

Examiner Initials*	Cite No	Include name of the author (in CAPITAL LETTERS), title of the article (when appropriate), title of the item (book, magazine, journal, serial, symposium, catalog, etc), date, pages(s), volume-issue number(s), publisher, city and/or country where published.	T ⁵
	1		

If you wish to add additional non-patent literature document citation information please click the Add button.

EXAMINER SIGNATURE

Examiner Signature	/CYNTHIA SEGURA/	Date Considered	01/16/2019
--------------------	------------------	-----------------	------------

*EXAMINER: Initial if reference considered, whether or not citation is in conformance with MPEP 609. Draw line through a citation if not in conformance and not considered. Include copy of this form with next communication to applicant.

INFORMATION DISCLOSURE STATEMENT BY APPLICANT (Not for submission under 37 CFR 1.99)	Application Number	16048242
	Filing Date	2018-07-28
	First Named Inventor	Gal Shabtay
	Art Unit	
	Examiner Name	
	Attorney Docket Number	COREPH-0079 US CON3

¹ See Kind Codes of USPTO Patent Documents at www.USPTO.GOV or MPEP 901.04. ² Enter office that issued the document, by the two-letter code (WIPO Standard ST.3). ³ For Japanese patent documents, the indication of the year of the reign of the Emperor must precede the serial number of the patent document. ⁴ Kind of document by the appropriate symbols as indicated on the document under WIPO Standard ST.16 if possible. ⁵ Applicant is to place a check mark here if English language translation is attached.

INFORMATION DISCLOSURE STATEMENT BY APPLICANT (Not for submission under 37 CFR 1.99)	Application Number	16048242
	Filing Date	2018-07-28
	First Named Inventor	Gal Shabtay
	Art Unit	
	Examiner Name	
	Attorney Docket Number	COREPH-0079 US CON3

CERTIFICATION STATEMENT

Please see 37 CFR 1.97 and 1.98 to make the appropriate selection(s):

That each item of information contained in the information disclosure statement was first cited in any communication from a foreign patent office in a counterpart foreign application not more than three months prior to the filing of the information disclosure statement. See 37 CFR 1.97(e)(1).

OR

That no item of information contained in the information disclosure statement was cited in a communication from a foreign patent office in a counterpart foreign application, and, to the knowledge of the person signing the certification after making reasonable inquiry, no item of information contained in the information disclosure statement was known to any individual designated in 37 CFR 1.56(c) more than three months prior to the filing of the information disclosure statement. See 37 CFR 1.97(e)(2).



See attached certification statement.

The fee set forth in 37 CFR 1.17 (p) has been submitted herewith.

A certification statement is not submitted herewith.

SIGNATURE

A signature of the applicant or representative is required in accordance with CFR 1.33, 10.18. Please see CFR 1.4(d) for the form of the signature.

Signature	/Menachem Nathan/	Date (YYYY-MM-DD)	2019-01-05
Name/Print	MENACHEM NATHAN	Registration Number	65392

This collection of information is required by 37 CFR 1.97 and 1.98. The information is required to obtain or retain a benefit by the public which is to file (and by the USPTO to process) an application. Confidentiality is governed by 35 U.S.C. 122 and 37 CFR 1.14. This collection is estimated to take 1 hour to complete, including gathering, preparing and submitting the completed application form to the USPTO. Time will vary depending upon the individual case. Any comments on the amount of time you require to complete this form and/or suggestions for reducing this burden, should be sent to the Chief Information Officer, U.S. Patent and Trademark Office, U.S. Department of Commerce, P.O. Box 1450, Alexandria, VA 22313-1450. **DO NOT SEND FEES OR COMPLETED FORMS TO THIS ADDRESS. SEND TO: Commissioner for Patents, P.O. Box 1450, Alexandria, VA 22313-1450.**

Privacy Act Statement

The Privacy Act of 1974 (P.L. 93-579) requires that you be given certain information in connection with your submission of the attached form related to a patent application or patent. Accordingly, pursuant to the requirements of the Act, please be advised that: (1) the general authority for the collection of this information is 35 U.S.C. 2(b)(2); (2) furnishing of the information solicited is voluntary; and (3) the principal purpose for which the information is used by the U.S. Patent and Trademark Office is to process and/or examine your submission related to a patent application or patent. If you do not furnish the requested information, the U.S. Patent and Trademark Office may not be able to process and/or examine your submission, which may result in termination of proceedings or abandonment of the application or expiration of the patent.

The information provided by you in this form will be subject to the following routine uses:

1. The information on this form will be treated confidentially to the extent allowed under the Freedom of Information Act (5 U.S.C. 552) and the Privacy Act (5 U.S.C. 552a). Records from this system of records may be disclosed to the Department of Justice to determine whether the Freedom of Information Act requires disclosure of these records.
2. A record from this system of records may be disclosed, as a routine use, in the course of presenting evidence to a court, magistrate, or administrative tribunal, including disclosures to opposing counsel in the course of settlement negotiations.
3. A record in this system of records may be disclosed, as a routine use, to a Member of Congress submitting a request involving an individual, to whom the record pertains, when the individual has requested assistance from the Member with respect to the subject matter of the record.
4. A record in this system of records may be disclosed, as a routine use, to a contractor of the Agency having need for the information in order to perform a contract. Recipients of information shall be required to comply with the requirements of the Privacy Act of 1974, as amended, pursuant to 5 U.S.C. 552a(m).
5. A record related to an International Application filed under the Patent Cooperation Treaty in this system of records may be disclosed, as a routine use, to the International Bureau of the World Intellectual Property Organization, pursuant to the Patent Cooperation Treaty.
6. A record in this system of records may be disclosed, as a routine use, to another federal agency for purposes of National Security review (35 U.S.C. 181) and for review pursuant to the Atomic Energy Act (42 U.S.C. 218(c)).
7. A record from this system of records may be disclosed, as a routine use, to the Administrator, General Services, or his/her designee, during an inspection of records conducted by GSA as part of that agency's responsibility to recommend improvements in records management practices and programs, under authority of 44 U.S.C. 2904 and 2906. Such disclosure shall be made in accordance with the GSA regulations governing inspection of records for this purpose, and any other relevant (i.e., GSA or Commerce) directive. Such disclosure shall not be used to make determinations about individuals.
8. A record from this system of records may be disclosed, as a routine use, to the public after either publication of the application pursuant to 35 U.S.C. 122(b) or issuance of a patent pursuant to 35 U.S.C. 151. Further, a record may be disclosed, subject to the limitations of 37 CFR 1.14, as a routine use, to the public if the record was filed in an application which became abandoned or in which the proceedings were terminated and which application is referenced by either a published application, an application open to public inspections or an issued patent.
9. A record from this system of records may be disclosed, as a routine use, to a Federal, State, or local law enforcement agency, if the USPTO becomes aware of a violation or potential violation of law or regulation.

EAST Search History

EAST Search History (Prior Art)

Ref #	Hits	Search Query	DBs	Default Operator	Plurals	Time Stamp
L1	1	16/048242.app.	US-PGPUB; USPAT; FPRS; EPO; JPO; IBM_TDB	OR	ON	2019/01/16 17:56
L2	30	("20020075258" "20100020221" "20100283842" "20110234881" "20120062780" "20120320467" "20150002683" "20150042870" "20150162048" "20150316744" "20160070088" "20160154204" "20180120674" "20180241922" "20180295292" "7773121" "9185291" "9768310" "9927600").PN.	US-PGPUB; USPAT; FPRS; EPO; JPO; IBM_TDB	OR	ON	2019/01/16 18:04
L3	19	("20020075258" "20100020221" "20100283842" "20110234881" "20120062780" "20120320467" "20150002683" "20150042870" "20150162048" "20150316744" "20160070088" "20160154204" "20180120674" "20180241922" "20180295292" "7773121" "9185291" "9768310" "9927600").PN.	US-PGPUB; USPAT	OR	ON	2019/01/16 18:04
L4	5	("8149523" "8279957" "8488802" "8185291" "8958164").PN.	US-PGPUB; USPAT	OR	ON	2019/01/16 18:05
L5	1	("20170115471").PN.	US-PGPUB; USPAT	OR	ON	2019/01/16 18:05
L6	2	("20140362274" "20110001838").PN.	US-PGPUB; USPAT	OR	ON	2019/01/16 18:07
L7	39	"1536633" "2008076485" "2004133054"	US-PGPUB; USPAT; FPRS; EPO; JPO; IBM_TDB	OR	ON	2019/01/16 18:08
L8	4	"1536633" "2008076485" "2004133054"	EPO; JPO	OR	ON	2019/01/16 18:08

1/ 16/ 2019 6:29:31 PM

C:\Users\ccalderon\Documents\EAST\Workspaces\16048242_IDS.wsp

UNITED STATES PATENT AND TRADEMARK OFFICE
COMMISSIONER FOR PATENTS
P.O.BOX 1450
ALEXANDRIA VA 22313-1451

PRESORTED
FIRST-CLASS MAIL
U.S. POSTAGE PAID
POSTEDIGITAL
NNNNN

Nathan & Associates Patent Agents Ltd
P.O.Box 10178
Tel Aviv, 6110101
ISRAEL



**Courtesy Reminder for
Application Serial No: 16/048,242**

Attorney Docket No: COREPH-0079 US CON3
Customer Number: 92342
Date of Electronic Notification: 01/09/2019

This is a courtesy reminder that new correspondence is available for this application. If you have not done so already, please review the correspondence. The official date of notification of the outgoing correspondence will be indicated on the form PTOL-90 accompanying the correspondence.

An email notification regarding the correspondence was sent to the following email address(es) associated with your customer number:

amirr@natpatent.com
dorong@natpatent.com
info@natpatent.com

To view your correspondence online or update your email addresses, please visit us anytime at <https://sportal.uspto.gov/secure/myportal/privatepair>. If you have any questions, please email the Electronic Business Center (EBC) at EBC@uspto.gov or call 1-866-217-9197.



UNITED STATES PATENT AND TRADEMARK OFFICE

UNITED STATES DEPARTMENT OF COMMERCE
United States Patent and Trademark Office
Address: COMMISSIONER FOR PATENTS
P.O. Box 1450
Alexandria, Virginia 22313-1450
www.uspto.gov

NOTICE OF ALLOWANCE AND FEE(S) DUE

92342 7590 01/09/2019
Nathan & Associates Patent Agents Ltd
P.O.Box 10178
Tel Aviv, 6110101
ISRAEL

EXAMINER

SEGURA, CYNTHIA

ART UNIT PAPER NUMBER

2662

DATE MAILED: 01/09/2019

Table with 5 columns: APPLICATION NO., FILING DATE, FIRST NAMED INVENTOR, ATTORNEY DOCKET NO., CONFIRMATION NO.
16/048,242 07/28/2018 Gal Shabtay COREPH-0079 US CON3 4814

TITLE OF INVENTION: DUAL APERTURE ZOOM DIGITAL CAMERA

Table with 7 columns: APPLN. TYPE, ENTITY STATUS, ISSUE FEE DUE, PUBLICATION FEE DUE, PREV. PAID ISSUE FEE, TOTAL FEE(S) DUE, DATE DUE
nonprovisional SMALL \$500 \$0.00 \$0.00 \$500 04/09/2019

THE APPLICATION IDENTIFIED ABOVE HAS BEEN EXAMINED AND IS ALLOWED FOR ISSUANCE AS A PATENT. PROSECUTION ON THE MERITS IS CLOSED. THIS NOTICE OF ALLOWANCE IS NOT A GRANT OF PATENT RIGHTS. THIS APPLICATION IS SUBJECT TO WITHDRAWAL FROM ISSUE AT THE INITIATIVE OF THE OFFICE OR UPON PETITION BY THE APPLICANT. SEE 37 CFR 1.313 AND MPEP 1308.

THE ISSUE FEE AND PUBLICATION FEE (IF REQUIRED) MUST BE PAID WITHIN THREE MONTHS FROM THE MAILING DATE OF THIS NOTICE OR THIS APPLICATION SHALL BE REGARDED AS ABANDONED. THIS STATUTORY PERIOD CANNOT BE EXTENDED. SEE 35 U.S.C. 151. THE ISSUE FEE DUE INDICATED ABOVE DOES NOT REFLECT A CREDIT FOR ANY PREVIOUSLY PAID ISSUE FEE IN THIS APPLICATION. IF AN ISSUE FEE HAS PREVIOUSLY BEEN PAID IN THIS APPLICATION (AS SHOWN ABOVE), THE RETURN OF PART B OF THIS FORM WILL BE CONSIDERED A REQUEST TO REAPPLY THE PREVIOUSLY PAID ISSUE FEE TOWARD THE ISSUE FEE NOW DUE.

HOW TO REPLY TO THIS NOTICE:

I. Review the ENTITY STATUS shown above. If the ENTITY STATUS is shown as SMALL or MICRO, verify whether entitlement to that entity status still applies.

If the ENTITY STATUS is the same as shown above, pay the TOTAL FEE(S) DUE shown above.

If the ENTITY STATUS is changed from that shown above, on PART B - FEE(S) TRANSMITTAL, complete section number 5 titled "Change in Entity Status (from status indicated above)".

For purposes of this notice, small entity fees are 1/2 the amount of undiscounted fees, and micro entity fees are 1/2 the amount of small entity fees.

II. PART B - FEE(S) TRANSMITTAL, or its equivalent, must be completed and returned to the United States Patent and Trademark Office (USPTO) with your ISSUE FEE and PUBLICATION FEE (if required). If you are charging the fee(s) to your deposit account, section "4b" of Part B - Fee(s) Transmittal should be completed and an extra copy of the form should be submitted. If an equivalent of Part B is filed, a request to reapply a previously paid issue fee must be clearly made, and delays in processing may occur due to the difficulty in recognizing the paper as an equivalent of Part B.

III. All communications regarding this application must give the application number. Please direct all communications prior to issuance to Mail Stop ISSUE FEE unless advised to the contrary.

IMPORTANT REMINDER: Maintenance fees are due in utility patents issuing on applications filed on or after Dec. 12, 1980. It is patentee's responsibility to ensure timely payment of maintenance fees when due. More information is available at www.uspto.gov/PatentMaintenanceFees.

PART B - FEE(S) TRANSMITTAL

Complete and send this form, together with applicable fee(s), by mail or fax, or via EFS-Web.

By mail, send to: Mail Stop ISSUE FEE
 Commissioner for Patents
 P.O. Box 1450
 Alexandria, Virginia 22313-1450

By fax, send to: (571)-273-2885

INSTRUCTIONS: This form should be used for transmitting the ISSUE FEE and PUBLICATION FEE (if required). Blocks 1 through 5 should be completed where appropriate. All further correspondence including the Patent, advance orders and notification of maintenance fees will be mailed to the current correspondence address as indicated unless corrected below or directed otherwise in Block 1, by (a) specifying a new correspondence address; and/or (b) indicating a separate "FEE ADDRESS" for maintenance fee notifications.

CURRENT CORRESPONDENCE ADDRESS (Note: Use Block 1 for any change of address)

92342 7590 01/09/2019
 Nathan & Associates Patent Agents Ltd
 P.O.Box 10178
 Tel Aviv, 6110101
 ISRAEL

Note: A certificate of mailing can only be used for domestic mailings of the Fee(s) Transmittal. This certificate cannot be used for any other accompanying papers. Each additional paper, such as an assignment or formal drawing, must have its own certificate of mailing or transmission.

Certificate of Mailing or Transmission

I hereby certify that this Fee(s) Transmittal is being deposited with the United States Postal Service with sufficient postage for first class mail in an envelope addressed to the Mail Stop ISSUE FEE address above, or being transmitted to the USPTO via EFS-Web or by facsimile to (571) 273-2885, on the date below.

_____ (Typed or printed name)
_____ (Signature)
_____ (Date)

APPLICATION NO.	FILING DATE	FIRST NAMED INVENTOR	ATTORNEY DOCKET NO.	CONFIRMATION NO.
16/048,242	07/28/2018	Gal Shabtay	COREPH-0079 US CON3	4814

TITLE OF INVENTION: DUAL APERTURE ZOOM DIGITAL CAMERA

APPLN. TYPE	ENTITY STATUS	ISSUE FEE DUE	PUBLICATION FEE DUE	PREV. PAID ISSUE FEE	TOTAL FEE(S) DUE	DATE DUE
nonprovisional	SMALL	\$500	\$0.00	\$0.00	\$500	04/09/2019

EXAMINER	ART UNIT	CLASS-SUBCLASS
SEGURA, CYNTHIA	2662	348-240990

<p>1. Change of correspondence address or indication of "Fee Address" (37 CFR 1.363).</p> <p><input type="checkbox"/> Change of correspondence address (or Change of Correspondence Address form PTO/SB/122) attached.</p> <p><input type="checkbox"/> "Fee Address" indication (or "Fee Address" Indication form PTO/SB/47; Rev 03-09 or more recent) attached. Use of a Customer Number is required.</p>	<p>2. For printing on the patent front page, list</p> <p>(1) The names of up to 3 registered patent attorneys or agents OR, alternatively, _____ 1</p> <p>(2) The name of a single firm (having as a member a registered attorney or agent) and the names of up to 2 registered patent attorneys or agents. If no name is listed, no name will be printed. _____ 2</p> <p>_____ 3</p>
---	---

3. ASSIGNEE NAME AND RESIDENCE DATA TO BE PRINTED ON THE PATENT (print or type)

PLEASE NOTE: Unless an assignee is identified below, no assignee data will appear on the patent. If an assignee is identified below, the document must have been previously recorded, or filed for recordation, as set forth in 37 CFR 3.11 and 37 CFR 3.81(a). Completion of this form is NOT a substitute for filing an assignment.

(A) NAME OF ASSIGNEE _____ (B) RESIDENCE: (CITY and STATE OR COUNTRY) _____

Please check the appropriate assignee category or categories (will not be printed on the patent): Individual Corporation or other private group entity Government

4a. Fees submitted: Issue Fee Publication Fee (if required) Advance Order - # of Copies _____

4b. Method of Payment: (Please first reapply any previously paid fee shown above)

Electronic Payment via EFS-Web Enclosed check Non-electronic payment by credit card (Attach form PTO-2038)

The Director is hereby authorized to charge the required fee(s), any deficiency, or credit any overpayment to Deposit Account No. _____

5. Change in Entity Status (from status indicated above)

Applicant certifying micro entity status. See 37 CFR 1.29

Applicant asserting small entity status. See 37 CFR 1.27

Applicant changing to regular undiscounted fee status.

NOTE: Absent a valid certification of Micro Entity Status (see forms PTO/SB/15A and 15B), issue fee payment in the micro entity amount will not be accepted at the risk of application abandonment.

NOTE: If the application was previously under micro entity status, checking this box will be taken to be a notification of loss of entitlement to micro entity status.

NOTE: Checking this box will be taken to be a notification of loss of entitlement to small or micro entity status, as applicable.

NOTE: This form must be signed in accordance with 37 CFR 1.31 and 1.33. See 37 CFR 1.4 for signature requirements and certifications.

Authorized Signature _____ Date _____

Typed or printed name _____ Registration No. _____



UNITED STATES PATENT AND TRADEMARK OFFICE

UNITED STATES DEPARTMENT OF COMMERCE
United States Patent and Trademark Office
Address: COMMISSIONER FOR PATENTS
P.O. Box 1450
Alexandria, Virginia 22313-1450
www.uspto.gov

Table with 5 columns: APPLICATION NO., FILING DATE, FIRST NAMED INVENTOR, ATTORNEY DOCKET NO., CONFIRMATION NO. Includes application details for Gal Shabtay and Nathan & Associates Patent Agents Ltd.

Determination of Patent Term Adjustment under 35 U.S.C. 154 (b)
(Applications filed on or after May 29, 2000)

The Office has discontinued providing a Patent Term Adjustment (PTA) calculation with the Notice of Allowance.

Section 1(h)(2) of the AIA Technical Corrections Act amended 35 U.S.C. 154(b)(3)(B)(i) to eliminate the requirement that the Office provide a patent term adjustment determination with the notice of allowance.

Any questions regarding the Patent Term Extension or Adjustment determination should be directed to the Office of Patent Legal Administration at (571)-272-7702.

OMB Clearance and PRA Burden Statement for PTOL-85 Part B

The Paperwork Reduction Act (PRA) of 1995 requires Federal agencies to obtain Office of Management and Budget approval before requesting most types of information from the public. When OMB approves an agency request to collect information from the public, OMB (i) provides a valid OMB Control Number and expiration date for the agency to display on the instrument that will be used to collect the information and (ii) requires the agency to inform the public about the OMB Control Number's legal significance in accordance with 5 CFR 1320.5(b).

The information collected by PTOL-85 Part B is required by 37 CFR 1.311. The information is required to obtain or retain a benefit by the public which is to file (and by the USPTO to process) an application. Confidentiality is governed by 35 U.S.C. 122 and 37 CFR 1.14. This collection is estimated to take 30 minutes to complete, including gathering, preparing, and submitting the completed application form to the USPTO. Time will vary depending upon the individual case. Any comments on the amount of time you require to complete this form and/or suggestions for reducing this burden, should be sent to the Chief Information Officer, U.S. Patent and Trademark Office, U.S. Department of Commerce, P.O. Box 1450, Alexandria, Virginia 22313-1450. DO NOT SEND FEES OR COMPLETED FORMS TO THIS ADDRESS. SEND TO: Commissioner for Patents, P.O. Box 1450, Alexandria, Virginia 22313-1450. Under the Paperwork Reduction Act of 1995, no persons are required to respond to a collection of information unless it displays a valid OMB control number.

Privacy Act Statement

The Privacy Act of 1974 (P.L. 93-579) requires that you be given certain information in connection with your submission of the attached form related to a patent application or patent. Accordingly, pursuant to the requirements of the Act, please be advised that: (1) the general authority for the collection of this information is 35 U.S.C. 2(b)(2); (2) furnishing of the information solicited is voluntary; and (3) the principal purpose for which the information is used by the U.S. Patent and Trademark Office is to process and/or examine your submission related to a patent application or patent. If you do not furnish the requested information, the U.S. Patent and Trademark Office may not be able to process and/or examine your submission, which may result in termination of proceedings or abandonment of the application or expiration of the patent.

The information provided by you in this form will be subject to the following routine uses:

1. The information on this form will be treated confidentially to the extent allowed under the Freedom of Information Act (5 U.S.C. 552) and the Privacy Act (5 U.S.C. 552a). Records from this system of records may be disclosed to the Department of Justice to determine whether disclosure of these records is required by the Freedom of Information Act.
2. A record from this system of records may be disclosed, as a routine use, in the course of presenting evidence to a court, magistrate, or administrative tribunal, including disclosures to opposing counsel in the course of settlement negotiations.
3. A record in this system of records may be disclosed, as a routine use, to a Member of Congress submitting a request involving an individual, to whom the record pertains, when the individual has requested assistance from the Member with respect to the subject matter of the record.
4. A record in this system of records may be disclosed, as a routine use, to a contractor of the Agency having need for the information in order to perform a contract. Recipients of information shall be required to comply with the requirements of the Privacy Act of 1974, as amended, pursuant to 5 U.S.C. 552a(m).
5. A record related to an International Application filed under the Patent Cooperation Treaty in this system of records may be disclosed, as a routine use, to the International Bureau of the World Intellectual Property Organization, pursuant to the Patent Cooperation Treaty.
6. A record in this system of records may be disclosed, as a routine use, to another federal agency for purposes of National Security review (35 U.S.C. 181) and for review pursuant to the Atomic Energy Act (42 U.S.C. 218(c)).
7. A record from this system of records may be disclosed, as a routine use, to the Administrator, General Services, or his/her designee, during an inspection of records conducted by GSA as part of that agency's responsibility to recommend improvements in records management practices and programs, under authority of 44 U.S.C. 2904 and 2906. Such disclosure shall be made in accordance with the GSA regulations governing inspection of records for this purpose, and any other relevant (i.e., GSA or Commerce) directive. Such disclosure shall not be used to make determinations about individuals.
8. A record from this system of records may be disclosed, as a routine use, to the public after either publication of the application pursuant to 35 U.S.C. 122(b) or issuance of a patent pursuant to 35 U.S.C. 151. Further, a record may be disclosed, subject to the limitations of 37 CFR 1.14, as a routine use, to the public if the record was filed in an application which became abandoned or in which the proceedings were terminated and which application is referenced by either a published application, an application open to public inspection or an issued patent.
9. A record from this system of records may be disclosed, as a routine use, to a Federal, State, or local law enforcement agency, if the USPTO becomes aware of a violation or potential violation of law or regulation.

Notice of Allowability	Application No. 16/048,242	Applicant(s) Shabtay et al.	
	Examiner CYNTHIA SEGURA	Art Unit 2662	AIA Status Yes

-- The MAILING DATE of this communication appears on the cover sheet with the correspondence address--

All claims being allowable, PROSECUTION ON THE MERITS IS (OR REMAINS) CLOSED in this application. If not included herewith (or previously mailed), a Notice of Allowance (PTOL-85) or other appropriate communication will be mailed in due course. **THIS NOTICE OF ALLOWABILITY IS NOT A GRANT OF PATENT RIGHTS.** This application is subject to withdrawal from issue at the initiative of the Office or upon petition by the applicant. See 37 CFR 1.313 and MPEP 1308.

- 1. This communication is responsive to 7/28/2018.
 A declaration(s)/affidavit(s) under **37 CFR 1.130(b)** was/were filed on _____.
- 2. An election was made by the applicant in response to a restriction requirement set forth during the interview on _____; the restriction requirement and election have been incorporated into this action.
- 3. The allowed claim(s) is/are 1-40 . As a result of the allowed claim(s), you may be eligible to benefit from the **Patent Prosecution Highway** program at a participating intellectual property office for the corresponding application. For more information, please see http://www.uspto.gov/patents/init_events/pph/index.jsp or send an inquiry to PPHfeedback@uspto.gov.
- 4. Acknowledgment is made of a claim for foreign priority under 35 U.S.C. § 119(a)-(d) or (f).

Certified copies:

- a) All b) Some *c) None of the:
 - 1. Certified copies of the priority documents have been received.
 - 2. Certified copies of the priority documents have been received in Application No. _____.
 - 3. Copies of the certified copies of the priority documents have been received in this national stage application from the International Bureau (PCT Rule 17.2(a)).

* Certified copies not received: _____.

Applicant has THREE MONTHS FROM THE "MAILING DATE" of this communication to file a reply complying with the requirements noted below. Failure to timely comply will result in ABANDONMENT of this application.

THIS THREE-MONTH PERIOD IS NOT EXTENDABLE.

- 5. CORRECTED DRAWINGS (as "replacement sheets") must be submitted.
 including changes required by the attached Examiner's Amendment / Comment or in the Office action of Paper No./Mail Date _____.
Identifying indicia such as the application number (see 37 CFR 1.84(c)) should be written on the drawings in the front (not the back) of each sheet. Replacement sheet(s) should be labeled as such in the header according to 37 CFR 1.121(d).
- 6. DEPOSIT OF and/or INFORMATION about the deposit of BIOLOGICAL MATERIAL must be submitted. Note the attached Examiner's comment regarding REQUIREMENT FOR THE DEPOSIT OF BIOLOGICAL MATERIAL.

Attachment(s)

- 1. Notice of References Cited (PTO-892)
- 2. Information Disclosure Statements (PTO/SB/08),
Paper No./Mail Date _____.
- 3. Examiner's Comment Regarding Requirement for Deposit
of Biological Material _____.
- 4. Interview Summary (PTO-413),
Paper No./Mail Date _____.
- 5. Examiner's Amendment/Comment
- 6. Examiner's Statement of Reasons for Allowance
- 7. Other _____.

/CYNTHIA SEGURA/
Primary Examiner, Art Unit 2662

DETAILED ACTION

Notice of Pre-AIA or AIA Status

1. The present application, filed on or after March 16, 2013, is being examined under the first inventor to file provisions of the AIA.

Information Disclosure Statement

2. The information disclosure statements (IDS) submitted 09/20/2018 are in compliance with the provisions of 37 CFR 1.97 and were considered by the examiner.

Allowable Subject Matter

3. **Claims 1-40** are allowed.

4. The following is an examiner's statement of reasons for allowance:

5. **Claim 1**, the prior art does not teach or fairly suggest "...the Tele lens has a respective effective focal length EFL_T and total track length TTL_T fulfilling the condition $EFL_T/TTL_T > 1$; ... a camera controller operatively coupled to the first and second AF mechanisms and to the Wide and Tele image sensors and configured to control the AF mechanisms and to process the Wide and Tele images to create a fused image, wherein areas in the Tele image that are not focused are not combined with the Wide image to create the fused image and wherein the camera controller is further operative to output the fused image with a point of view (POV) of the Wide camera by mapping Tele image pixels to matching pixels within the Wide image..." **and used in combination with all of the other limitations of claim 1.**

6. **Claims 2-18** depend on allowable claim 1. Therefore, the dependent claims are also held allowable.

7. **Claim 19**, the prior art does not teach or fairly suggest "...the Tele lens has a respective effective focal length EFL_T and total track length TTL_T fulfilling the condition $EFL_T/TTL_T > 1$;... the Wide and Tele lenses have different F numbers $F\#_{Wide}$ and $F\#_{Tele}$, wherein the Wide and Tele image sensors have pixels with respective pixel sizes $Pixel\ size_{Wide}$ and $Pixel\ size_{Tele}$ wherein $Pixel\ size_{Wide}$ is not equal to $Pixel\ size_{Tele}$, and wherein the Tele camera has a Tele camera depth of field (DOF_T) shallower than a DOF of the Wide camera (DOF_W); and e) a camera controller operatively coupled to the first and second AF mechanisms and to the Wide and Tele image sensors and configured to control the AF mechanisms, to process the Wide and Tele images to find translations between matching points in the images to calculate depth information and to create a fused image suited for portrait photos, the fused image having a DOF shallower than DOF_T and having a blurred background..." **and used in combination with all of the other limitations of claim 19.**

8. **Claims 20-22** depend on allowable claim 19. Therefore, the dependent claims are also held allowable.

9. **Claim 23**, the prior art does not teach or fairly suggest "...the Tele lens has a respective effective focal length EFL_T and total track length TTL_T fulfilling the condition $EFL_T/TTL_T > 1$; b) acquiring a Wide image with the Wide sensor and a Tele image with

the Tele sensor; c) processing the Wide and Tele images to create a fused image, wherein areas in the Tele image that are not focused are not combined with the Wide image to create the fused image; and d) outputting the fused image with a point of view (POV) of the Wide camera by mapping Tele image pixels to matching pixels within the Wide image...” **and used in combination with all of the other limitations of claim 23.**

10. **Claims 24-40** depend on allowable claim 23. Therefore, the dependent claims are also held allowable.

11. Any comments considered necessary by applicant must be submitted no later than the payment of the issue fee and, to avoid processing delays, should preferably accompany the issue fee. Such submissions should be clearly labeled “Comments on Statement of Reasons for Allowance.”

Citation of Pertinent Art

12. The prior art made of record and not relied upon is considered pertinent to applicant’s disclosure.

Border (US-PGPUB 2008/0030592) discloses the control processor and timing generator 40 also receives signals from automatic focus and automatic exposure detectors 46. The image compositor 202 generates a composite image 208 using image data from both the wide image 204 and the telephoto image 206.

Golan (US-PGPUB 2012/0026366) discloses a camera system 600 including a color image sensor 612 having wide FOV 642 and a monochrome image sensor 610 having narrow FOV 640. Fusion module 760 merges the Y information, obtained from monochrome image sensor 610, and the color (Cr, Cb) information.

Shiraki (US-PGPUB 2007/0146503) discloses when the switching lever 94 is situated at "Z," the second image-capturing system 30 is commanded to solely capture an image. When the switching lever 94 is situated at "W," the first image-capturing system 20 is commanded to solely capture an image. When the switching lever 94 is situated at "C," the first and second image-capturing systems 20, 30 are commanded to simultaneously capture an image.

Sakai (US-PGPUB 2016/0191819) discloses since this combined image S has a central portion that is kept in focus but the peripheral is blurred, as the image is made large, an image is obtained that appears to have been taken while optically zooming from the wide-angle side to the telephoto side during exposure. The original image P may also be a still image, and images Z1-Zn may be sequentially clipped from continuously captured images.

Belote (US Patent 9,762,812) discloses the imager optics being further configured to focus the second electromagnetic radiation onto the imaging sensor, and the imaging sensor being further configured to produce combined image frames from the first electromagnetic radiation and the second electromagnetic radiation together, the combined image frames including imagery from both the narrow and wide fields-of-views.

Conclusion

13. Any inquiry concerning this communication or earlier communications from the examiner should be directed to CYNTHIA SEGURA whose telephone number is (571)270-3580. The examiner can normally be reached on Monday - Friday; 9:00am to 6:00pm.

Examiner interviews are available via telephone, in-person, and video conferencing using a USPTO supplied web-based collaboration tool. To schedule an interview, applicant is encouraged to use the USPTO Automated Interview Request (AIR) at <http://www.uspto.gov/interviewpractice>.

If attempts to reach the examiner by telephone are unsuccessful, the examiner's supervisor, Roberto Velez can be reached on (571)272-8597. The fax phone number for the organization where this application or proceeding is assigned is 571-273-8300.

Information regarding the status of an application may be obtained from the Patent Application Information Retrieval (PAIR) system. Status information for published applications may be obtained from either Private PAIR or Public PAIR. Status information for unpublished applications is available through Private PAIR only. For more information about the PAIR system, see <http://pair-direct.uspto.gov>. Should you have questions on access to the Private PAIR system, contact the Electronic Business Center (EBC) at 866-217-9197 (toll-free). If you would like assistance from a USPTO Customer Service Representative or access to the automated information system, call 800-786-9199 (IN USA OR CANADA) or 571-272-1000.

/CYNTHIA SEGURA/
Primary Examiner, Art Unit 2662
12/21/2018

Notice of References Cited	Application/Control No. 16/048,242	Applicant(s)/Patent Under Reexamination Shabtay et al.	
	Examiner CYNTHIA SEGURA	Art Unit 2662	Page 1 of 2

U.S. PATENT DOCUMENTS

*		Document Number Country Code-Number-Kind Code	Date MM-YYYY	Name	CPC Classification	US Classification
*	A	US-9402032-B2	07-2016	Dror; Michael	G02B9/60	1/1
*	B	US-8508649-B2	08-2013	Reshidko; Pavel	G02B13/0045	348/345
*	C	US-20180152640-A1	05-2018	Shabtay; Gal	H04N5/2258	1/1
*	D	US-20180359423-A1	12-2018	Shabtay; Gal	H04N5/2258	1/1
*	E	US-20180096487-A1	04-2018	Nash; James Wilson	H04N5/217	1/1
*	F	US-20170054911-A1	02-2017	LEE; Tae-hee	H04N5/23293	1/1
*	G	US-20160202453-A1	07-2016	IWASAWA; Yoshito	G02B13/18	359/684
*	H	US-20160191819-A1	06-2016	SAKAI; Koji	H04N5/23245	348/333.12
*	I	US-20080030592-A1	02-2008	Border; John N.	H04N5/232	348/218.1
*	J	US-9762812-B2	09-2017	Belote; Brent	G02B5/005	1/1
*	K	US-20120026366-A1	02-2012	Golan; Chen	H04N5/232	348/240.2
*	L	US-20110064327-A1	03-2011	Dagher; Joseph C.	G06T5/004	382/263
*	M	US-20080219654-A1	09-2008	Border; John N.	H04N5/23212	396/89

FOREIGN PATENT DOCUMENTS

*		Document Number Country Code-Number-Kind Code	Date MM-YYYY	Country	Name	CPC Classification
	N					
	O					
	P					
	Q					
	R					
	S					
	T					

NON-PATENT DOCUMENTS

*		Include as applicable: Author, Title Date, Publisher, Edition or Volume, Pertinent Pages)
	U	
	V	
	W	
	X	

*A copy of this reference is not being furnished with this Office action. (See MPEP § 707.05(a).)
Dates in MM-YYYY format are publication dates. Classifications may be US or foreign.

Notice of References Cited	Application/Control No. 16/048,242	Applicant(s)/Patent Under Reexamination Shabtay et al.	
	Examiner CYNTHIA SEGURA	Art Unit 2662	Page 2 of 2

U.S. PATENT DOCUMENTS

*	Document Number Country Code-Number-Kind Code	Date MM-YYYY	Name	CPC Classification	US Classification
*	A US-20080218613-A1	09-2008	Janson; Wilbert F.	G03B15/00	348/262
*	B US-20070146503-A1	06-2007	Shiraki; Hidenori	H04N3/1593	348/231.3
C					
D					
E					
F					
G					
H					
I					
J					
K					
L					
M					

FOREIGN PATENT DOCUMENTS

*	Document Number Country Code-Number-Kind Code	Date MM-YYYY	Country	Name	CPC Classification
N					
O					
P					
Q					
R					
S					
T					

NON-PATENT DOCUMENTS

*	Include as applicable: Author, Title Date, Publisher, Edition or Volume, Pertinent Pages)
U	
V	
W	
X	

*A copy of this reference is not being furnished with this Office action. (See MPEP § 707.05(a).)
Dates in MM-YYYY format are publication dates. Classifications may be US or foreign.

Issue Classification 	Application/Control No. 16/048,242	Applicant(s)/Patent Under Reexamination Shabtay et al.
	Examiner CYNTHIA SEGURA	Art Unit 2662

CPC						
Symbol				Type	Version	
H04N		5	23296	F	2013-01-01	
H04N		5	225	I	2013-01-01	
H04N		5	23212	I	2013-01-01	
H04N		5	2259	I	2013-01-01	
H04N		5	2258	I	2013-01-01	
H04N		5	23232	I	2013-01-01	
H04N		5	23245	I	2013-01-01	
G02B		13	009	I	2013-01-01	
G02B		13	0015	I	2013-01-01	
G02B		27	0075	I	2013-01-01	

CPC Combination Sets				
Symbol	Type	Set	Ranking	Version

NONE	Total Claims Allowed:	
(Assistant Examiner)	(Date)	40
/CYNTHIA SEGURA/ Primary Examiner, Art Unit 2662	21 December 2018	O.G. Print Claim(s)
(Primary Examiner)	(Date)	1
		O.G. Print Figure
		6

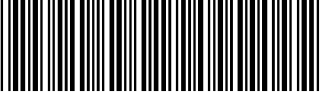
Issue Classification 	Application/Control No. 16/048,242	Applicant(s)/Patent Under Reexamination Shabtay et al.
	Examiner CYNTHIA SEGURA	Art Unit 2662

INTERNATIONAL CLASSIFICATION			
CLAIMED			
H04N		5	232
H04N		5	225
G02B		13	00
G02B		27	00

NON-CLAIMED			

US ORIGINAL CLASSIFICATION	
CLASS	SUBCLASS

CROSS REFERENCES(S)						
CLASS	SUBCLASS (ONE SUBCLASS PER BLOCK)					

NONE			Total Claims Allowed:	
(Assistant Examiner)	(Date)	40		
/CYNTHIA SEGURA/ Primary Examiner, Art Unit 2662	21 December 2018	O.G. Print Claim(s)	O.G. Print Figure	
(Primary Examiner)	(Date)	1	6	

Issue Classification 	Application/Control No. 16/048,242	Applicant(s)/Patent Under Reexamination Shabtay et al.
	Examiner CYNTHIA SEGURA	Art Unit 2662

Claims renumbered in the same order as presented by applicant
 CPA
 T.D.
 R.1.47

CLAIMS															
Final	Original	Final	Original	Final	Original	Final	Original	Final	Original	Final	Original	Final	Original	Final	Original
1	1	13	10	19	19	28	28	40	37						
2	2	14	11	20	20	32	29	29	38						
3	3	15	12	21	21	33	30	30	39						
4	4	16	13	22	22	34	31	31	40						
5	5	17	14	23	23	35	32								
6	6	18	15	24	24	36	33								
10	7	7	16	25	25	37	34								
11	8	8	17	26	26	38	35								
12	9	9	18	27	27	39	36								

NONE	Total Claims Allowed:	
(Assistant Examiner)	(Date)	40
/CYNTHIA SEGURA/ Primary Examiner, Art Unit 2662	21 December 2018	O.G. Print Claim(s)
(Primary Examiner)	(Date)	1
		O.G. Print Figure
		6

<i>Search Notes</i> 	Application/Control No. 16/048,242	Applicant(s)/Patent Under Reexamination Shabtay et al.
	Examiner CYNTHIA SEGURA	Art Unit 2662

CPC - Searched*		
Symbol	Date	Examiner
G02B13/0015	12/20/2018	CS
G02B27/0075	12/20/2018	CS

CPC Combination Sets - Searched*		
Symbol	Date	Examiner

US Classification - Searched*			
Class	Subclass	Date	Examiner

* See search history printout included with this form or the SEARCH NOTES box below to determine the scope of the search.

Search Notes		
Search Notes	Date	Examiner
Inventor search	12/20/2018	CS
Refs. checked: applsn 14365711, 14880251, 15424853	12/20/2018	CS
East search: H04N5/23296; G02B13/0015; G02B27/0075; G02B13/009; H04N5/23245; H04N5/2258; H04N5/23232; H04N5/2259; H04N5/225; H04N5/23212 plus key words	12/20/2018	CS
East text search	12/20/2018	CS
East text search	12/21/2018	CS

Interference Search			
US Class/CPC Symbol	US Subclass/CPC Group	Date	Examiner
All	US-PGPUB text search	12/20/2018	CS
All	US-PGPUB text search	12/21/2018	CS

/CYNTHIA SEGURA/ Primary Examiner, Art Unit 2662	
---	--

<i>Search Notes</i> 	Application/Control No. 16/048,242	Applicant(s)/Patent Under Reexamination Shabtay et al.
	Examiner CYNTHIA SEGURA	Art Unit 2662

/CYNTHIA SEGURA/ Primary Examiner, Art Unit 2662	
---	--

<i>Index of Claims</i> 	Application/Control No. 16/048,242	Applicant(s)/Patent Under Reexamination Shabtay et al.
	Examiner CYNTHIA SEGURA	Art Unit 2662

✓	Rejected	-	Cancelled	N	Non-Elected	A	Appeal
=	Allowed	÷	Restricted	I	Interference	O	Objected

CLAIMS									
<input type="checkbox"/> Claims renumbered in the same order as presented by applicant <input type="checkbox"/> CPA <input type="checkbox"/> T.D. <input type="checkbox"/> R.1.47									
CLAIM			DATE						
Final	Original	12/21/2018							
1	1	=							
2	2	=							
3	3	=							
4	4	=							
5	5	=							
6	6	=							
10	7	=							
11	8	=							
12	9	=							
13	10	=							
14	11	=							
15	12	=							
16	13	=							
17	14	=							
18	15	=							
7	16	=							
8	17	=							
9	18	=							
19	19	=							
20	20	=							
21	21	=							
22	22	=							
23	23	=							
24	24	=							
25	25	=							
26	26	=							
27	27	=							
28	28	=							
32	29	=							
33	30	=							
34	31	=							
35	32	=							
36	33	=							
37	34	=							
38	35	=							
39	36	=							
40	37	=							
29	38	=							
30	39	=							
31	40	=							

Doc code: IDS

Doc description: Information Disclosure Statement (IDS) Filed

PTO/SB/08a (01-10)

Approved for use through 07/31/2012. OMB 0651-0031

U.S. Patent and Trademark Office; U.S. DEPARTMENT OF COMMERCE

Under the Paperwork Reduction Act of 1995, no persons are required to respond to a collection of information unless it contains a valid OMB control number.

INFORMATION DISCLOSURE STATEMENT BY APPLICANT (Not for submission under 37 CFR 1.99)	Application Number	16048242
	Filing Date	2018-07-28
	First Named Inventor	Gal Shabtay
	Art Unit	
	Examiner Name	
	Attorney Docket Number	COREPH-0079 US CON3

U.S. PATENTS Remove						
Examiner Initial*	Cite No	Patent Number	Kind Code ¹	Issue Date	Name of Patentee or Applicant of cited Document	Pages, Columns, Lines where Relevant Passages or Relevant Figures Appear
	1	9286680	B1	2016-03-15	Jiang et al.	
	2	9736391	B2	2017-08-15	Du et al.	
	3	9894287	B2	2018-02-13	Qian et al.	
	4	6750903	B1	2004-06-15	Miyatake et al.	
	5	5032917	A	1991-07-16	Felix Aschwanden	
	6	5287093	A	1994-02-15	Amano et al.	
	7	5287093	A	1995-02-28	John T. Hall	
	8	5444478	A	1995-08-22	Lelong et al.	

INFORMATION DISCLOSURE STATEMENT BY APPLICANT (Not for submission under 37 CFR 1.99)	Application Number		16048242		
	Filing Date		2018-07-28		
	First Named Inventor	Gal Shabtay			
	Art Unit				
	Examiner Name				
	Attorney Docket Number		COREPH-0079 US CON3		

9	5657402	A	1997-08-12	Bender et al.
10	5682198	A	1997-10-28	Katayama et al.
11	5926190	A	1999-07-20	Turkowski et al.
12	6128416	A	2000-10-03	Koutatsu Oura
13	6148120	A	2000-11-14	Michael Sussman
14	6208765	B1	2001-03-27	James Russell Bergen
15	7002583	B2	2006-02-21	Maurice F. Rabb, III
16	7346217	B1	2008-03-18	V. Edward Gold, Jr.
17	7424218	B2	2008-09-09	Baudisch et al.
18	7533819	B2	2009-05-19	Barkan et al.
19	7619683	B2	2009-11-17	Raymond A. Davis

INFORMATION DISCLOSURE STATEMENT BY APPLICANT (Not for submission under 37 CFR 1.99)	Application Number		16048242		
	Filing Date		2018-07-28		
	First Named Inventor	Gal Shabtay			
	Art Unit				
	Examiner Name				
	Attorney Docket Number		COREPH-0079 US CON3		

20	6268611	B1	2001-07-31	Pettersson et al.
21	6714665	B1	2004-03-30	Hanna et al.
22	5005083	A	1991-04-02	Grage et al.
23	5940641	A	1999-08-17	McIntyre et al.
24	6741250	B1	2004-05-25	Furlan et al.
25	7365793	B2	2008-04-29	Cheatle et al.
26	9413930	B2	2016-08-09	Joergen Geerds
27	4199785	A	1980-04-22	McCullough et al.
28	8400555	B1	2013-03-19	Georgiev et al.
29	8553106	B2	2013-10-08	Lawrence Scarff
30	9800798	B2	2017-10-24	Ravirala et al.

INFORMATION DISCLOSURE STATEMENT BY APPLICANT (Not for submission under 37 CFR 1.99)	Application Number		16048242 16/048,242 - GAU: 2662		
	Filing Date		2018-07-28		
	First Named Inventor	Gal Shabtay			
	Art Unit				
	Examiner Name				
	Attorney Docket Number		COREPH-0079 US CON3		

31	5768443	A	1998-06-16	Michael et al.
32	6101334	A	2000-08-08	Stephen D. Fantone
33	6611289	B1	2003-08-26	Yu et al.
34	7015954	B1	2006-03-21	Foote et al.
35	7256944	B2	2007-08-14	Labaziewicz et al.
36	8587691	B2	2013-11-19	Yasuo Takane
37	8274552	B2	2012-09-25	Dahi et al.
38	8390729	B2	2013-03-05	Long et al.
39	8803990	B2	2014-08-12	Scott Smith
40	9270875	B2	2016-02-23	Brisedoux et al.
41	9485432	B1	2016-11-01	Medasani et al.

INFORMATION DISCLOSURE STATEMENT BY APPLICANT (Not for submission under 37 CFR 1.99)	Application Number		16048242 16/048,242 - GAU: 2662		
	Filing Date		2018-07-28		
	First Named Inventor	Gal Shabtay			
	Art Unit				
	Examiner Name				
	Attorney Docket Number		COREPH-0079 US CON3		

42	5436660	A	1995-07-25	Yukio Sakamoto
43	6549215	B2	2003-04-15	Norman P. Jouppi
44	7411610	B2	2008-08-12	Michael Doyle
45	8439265	B2	2013-05-14	Ferren et al.
46	5248971	A	1993-09-28	William J. Mandl
47	5459520	A	1995-10-17	Tadao Sasaki
48	7038716	B2	2006-05-02	Klein et al.
49	7339621	B2	2008-03-04	Justin Fortier
50	9215385	B2	2015-12-15	Xiaodong Luo
51	7305180	B2	2007-12-04	Labaziewicz et al.
52	7978239	B2	2011-07-12	Deever et al.

INFORMATION DISCLOSURE STATEMENT BY APPLICANT (Not for submission under 37 CFR 1.99)	Application Number	16048242 16/048,242 - GAU: 2662
	Filing Date	2018-07-28
	First Named Inventor	Gal Shabtay
	Art Unit	
	Examiner Name	
	Attorney Docket Number	COREPH-0079 US CON3

53	7199348	B2	2007-04-03	Olsen et al.
54	8115825	B2	2012-02-14	Culbert et al.
55	7964835	B2	2011-06-21	Olsen et al.
56	8154610	B2	2012-04-10	Jo et al.
57	8619148	B2	2013-12-31	Watts et al.
58	5051830	A	1991-09-24	Wolfgang von Hoessle
59	5982951	A	1999-11-09	Katayama et al.
60	6738073	B2	2004-05-18	Park et al.
61	9025073	B2	2015-05-05	Aitar et al.
62	9025077	B2	2015-05-05	Aitar et al.
63	9413984	B2	2016-08-09	Aitar et al.

INFORMATION DISCLOSURE STATEMENT BY APPLICANT (Not for submission under 37 CFR 1.99)	Application Number		16048242 16/048,242 - GAU: 2662		
	Filing Date		2018-07-28		
	First Named Inventor	Gal Shabtay			
	Art Unit				
	Examiner Name				
	Attorney Docket Number		COREPH-0079 US CON3		

64	9578257	B2	2017-02-21	Attar et al.
65	9681057	B2	2017-06-13	Attar et al.
66	7206136	B2	2007-04-17	Labaziewicz et al.
67	7509041	B2	2009-03-24	Eiji Hosono
68	8976255	B2	2015-03-10	Matsuoto et al.
69	9041835	B2	2015-05-26	Yoshiaki Honda
70	9723220	B2	2017-08-01	Kazuhiko Sugie
71	8483452	B2	2013-07-09	Jeda et al.
72	9137447	B2	2015-09-15	Koji Shibuno
73	7880776	B2	2011-02-01	LeGall et al.
74	9618748	B2	2017-04-11	Munger et al.

INFORMATION DISCLOSURE STATEMENT BY APPLICANT (Not for submission under 37 CFR 1.99)	Application Number		16048242		
	Filing Date		2018-07-28		
	First Named Inventor	Gal Shabtay			
	Art Unit				
	Examiner Name				
	Attorney Docket Number		COREPH-0079 US CON3		

75	9019387	B2	2015-04-28	Akira Nakano
76	8446484	B2	2013-05-21	Muukki et al.
77	8238695	B1	2012-08-07	Davey et al.
78	6680748	B1	2004-01-20	John Mario Monti
79	9344626	B2	2016-05-17	Silverstein et al.
80	9420180	B2	2016-08-16	Chongting Jin
81	8391697	B2	2013-03-05	Cho et al.
82	9438792	B2	2016-09-06	Nakada et al.
83	9215377	B2	2015-12-15	Sokeila et al.
84	9360671	B1	2016-06-07	Changyin Zhou
85	9736365	B2	2017-08-15	Rajiv Laroia

INFORMATION DISCLOSURE STATEMENT BY APPLICANT (Not for submission under 37 CFR 1.99)	Application Number		16048242 16/048,242 - GAU: 2662		
	Filing Date		2018-07-28		
	First Named Inventor	Gal Shabtay			
	Art Unit				
	Examiner Name				
	Attorney Docket Number		COREPH-0079 US CON3		

86	9851803	B2	2017-12-26	Fisher et al.
87	6778207	B1	2004-08-17	Lee et al
88	8514491	B2	2013-08-20	Jacques Duparre
89	98896655	B2	2014-11-25	Mauchly et al.
90	9369621	B2	2016-06-14	Malone et al.
91	9900522	B2	2018-02-20	Yuesheng Lu
92	8547389	B2	2013-10-01	Hoppe et al.
93	7738016	B2	2010-06-15	Toshiyuki Toyofuku
94	7918398	B2	2011-04-05	Li et al.
95	7248294	B2	2007-07-24	David Neil Slatter
96	6724421	B1	2004-04-20	Terry Laurence Glatt

**INFORMATION DISCLOSURE
STATEMENT BY APPLICANT**
(Not for submission under 37 CFR 1.99)

Application Number	16048242	16/048,242 - GAU: 2662
Filing Date	2018-07-28	
First Named Inventor	Gal Shabtay	
Art Unit		
Examiner Name		
Attorney Docket Number	COREPH-0079 US CON3	

97	8149327	B2	2012-04-03	Lin et al.
98	6643416	B1	2003-11-04	Daniels et al.
99	6650368	B1	2003-11-18	Amir Doron

If you wish to add additional U.S. Patent citation information please click the Add button.

Add

U.S.PATENT APPLICATION PUBLICATIONS

Remove

Examiner Initial*	Cite No	Publication Number	Kind Code ¹	Publication Date	Name of Patentee or Applicant of cited Document	Pages, Columns, Lines where Relevant Passages or Relevant Figures Appear
	1	20090295949	A1	2009-12-03	Kai Markus Ojala	
	2	20110080487	A1	2011-04-07	Venkataraman et al.	
	3	20170289458	A1	2017-10-05	Song et al.	
	4	20130250150	A1	2013-09-26	Malone et al.	
	5	20140118584	A1	2014-05-01	Lee et al.	
	6	20160301840	A1	2016-10-13	Du et al.	

INFORMATION DISCLOSURE STATEMENT BY APPLICANT (Not for submission under 37 CFR 1.99)	Application Number		16048242 16/048,242 -- GAU: 2662		
	Filing Date		2018-07-28		
	First Named Inventor	Gal Shabtay			
	Art Unit				
	Examiner Name				
	Attorney Docket Number		COREPH-0079 US CON3		

7	20170019616	A1	2017-01-19	Zhu et al.
8	20170214846	A1	2017-07-27	Du et al.
9	20180150973	A1	2018-05-31	Tang et al.
10	20020005902	A1	2002-01-17	Henry Yuen
11	20100103194	A1	2010-04-29	Chen et al.
12	20130135445	A1	2013-05-30	Dahi et al.
13	20150154776	A1	2015-06-04	Zhang et al.
14	20170214866	A1	2017-07-27	Zhu et al.
15	20120287315	A1	2012-11-15	Huang et al.
16	20150271471	A1	2015-09-24	Hsieh et al.
17	20150334309	A1	2015-11-19	Peng et al.

INFORMATION DISCLOSURE STATEMENT BY APPLICANT (Not for submission under 37 CFR 1.99)	Application Number	16048242 16/048,242 - GAU: 2662
	Filing Date	2018-07-28
	First Named Inventor	Gal Shabtay
	Art Unit	
	Examiner Name	
	Attorney Docket Number	COREPH-0079 US CON3

18	20160353012	A1	2016-12-01	Kao et al.
19	20020122113	A1	2002-09-05	Jonathan Foote
20	20030093805	A1	2003-05-15	J.M. Gin
21	20040027367	A1	2004-02-12	Maurizio Pilu
22	20050013509	A1	2005-01-20	Ramin Samadani
23	20070188653	A1	2007-08-16	Pollock et al.
24	20080017557	A1	2008-01-24	Calvin J. Witdouck
25	20100013906	A1	2010-01-21	Border et al,
26	20080030592	A1	2008-02-07	Border et al,
27	20090122195	A1	2009-05-14	Van Baar et al.
28	20050046740	A1	2005-03-03	Raymond Davis

INFORMATION DISCLOSURE STATEMENT BY APPLICANT (Not for submission under 37 CFR 1.99)	Application Number		16048242 16/048,242 - GAU: 2662		
	Filing Date		2018-07-28		
	First Named Inventor	Gal Shabtay			
	Art Unit				
	Examiner Name				
	Attorney Docket Number		COREPH-0079 US CON3		

29	20060054782	A1	2006-03-16	Olsen et al.
30	20060056056	A1	2006-03-16	Ahiska et al.
31	20070257184	A1	2007-11-08	Olsen et al.
32	20070285550	A1	2007-12-13	Jae-Gon Son
33	20080030611	A1	2008-02-07	Michael V. Jenkins
34	20090086074	A1	2009-04-02	Li et al.
35	20100060746	A9	2010-03-11	Olsen et al.
36	20130235224	A1	2013-09-12	Park et al.
37	20040008773	A1	2004-01-15	Osamu Itokawa
38	20040017386	A1	2004-01-29	Liu et al.
39	20040240052	A1	2004-12-02	Minefuji et al.

INFORMATION DISCLOSURE STATEMENT BY APPLICANT (Not for submission under 37 CFR 1.99)	Application Number		16048242 16/048,242 - GAU: 2662		
	Filing Date		2018-07-28		
	First Named Inventor	Gal Shabtay			
	Art Unit				
	Examiner Name				
	Attorney Docket Number		COREPH-0079 US CON3		

40	20030202113	A1	2003-10-30	Sumito Yoshikawa
41	20060187310	A1	2006-08-24	Janson et al.
42	20060187322	A1	2006-08-24	Janson et al.
43	20060187338	A1	2006-08-24	May et al.
44	20070024737	A1	2007-02-01	Nakamura et al.
45	20080025634	A1	2008-01-31	Border et al.
46	20080218611	A1	2008-09-11	Parulski et al.
47	20080218612	A1	2008-09-11	Border et al.
48	20080218613	A1	2008-09-11	Janson et al.
49	20080219654	A1	2008-09-11	Border et al.
50	20110242286	A1	2011-10-06	Pace et al.

INFORMATION DISCLOSURE STATEMENT BY APPLICANT (Not for submission under 37 CFR 1.99)	Application Number		16048242	16/048,242 - GAU: 2662	
	Filing Date		2018-07-28		
	First Named Inventor	Gal Shabtay			
	Art Unit				
	Examiner Name				
	Attorney Docket Number		COREPH-0079 US CON3		

51	20080117316	A1	2008-05-22	Masaaki Orimoto
52	20160212358	A1	2016-07-21	Yasuhito Shikata
53	20030160886	A1	2003-08-28	Misawa et al.
54	20070177025	A1	2007-08-02	Kopet et al.
55	20070189386	A1	2007-08-16	Imagawa et al.
56	20080024614	A1	2008-01-31	Li et al.
57	20110242355	A1	2011-10-06	Goma et al.
58	20120196648	A1	2012-08-02	Havens et al.
59	20130258044	A1	2013-10-03	Betts-LaCroix
60	20140192253	A1	2014-07-10	Rajiv Laroia
61	20150092066	A1	2015-04-02	Geiss et al.

INFORMATION DISCLOSURE STATEMENT BY APPLICANT (Not for submission under 37 CFR 1.99)	Application Number	16048242 16/048,242 - GAU: 2662
	Filing Date	2018-07-28
	First Named Inventor	Gal Shabtay
	Art Unit	
	Examiner Name	
	Attorney Docket Number	COREPH-0079 US CON3

62	20060175549	A1	2006-08-10	Miller et al.
63	20120075489	A1	2012-03-29	H. Keith Nishihara
64	20130182150	A1	2013-07-18	Ayako Asakura
65	20140192238	A1	2014-07-10	Attar et al.
66	20090295949	A1	2009-12-03	Kai Markus Ojala
67	20100238327	A1	2010-09-23	Griffith et al.
68	20120229663	A1	2012-09-13	Nelson et al.
69	20130201360	A1	2013-08-08	Yong-Bae Song
70	20150242994	A1	2015-08-27	Ji Shen
71	20050157184	A1	2005-07-21	Nakanishi et al.
72	20050200718	A1	2005-09-15	Chang-Hee Lee

INFORMATION DISCLOSURE STATEMENT BY APPLICANT (Not for submission under 37 CFR 1.99)	Application Number	16048242 16/048,242 - GAU: 2662
	Filing Date	2018-07-28
	First Named Inventor	Gal Shabtay
	Art Unit	
	Examiner Name	
	Attorney Docket Number	COREPH-0079 US CON3

73	20040061788	A1	2004-04-01	John Bateman
74	20150215516	A1	2015-07-30	Benjamin P. Dolgin
75	20140313316	A1	2014-10-23	Olsson et al.
76	20110229054	A1	2011-09-22	Weston et al.
77	20020063711	A1	2016-06-14	Park et al.
78	20090128644	A1	2009-05-21	Camp et al.
79	20130321668	A1	2013-12-05	Ajith Kamath
80	20130202273	A1	2013-08-08	Ouedraogo et al.
81	20120069235	A1	2012-03-22	Francisco Imai
82	20130002928	A1	2013-01-03	Francisco Imai
83	20120105579	A1	2012-05-03	Jeon et al.

INFORMATION DISCLOSURE STATEMENT BY APPLICANT (Not for submission under 37 CFR 1.99)	Application Number		16048242 16/048,242 - GAU: 2662		
	Filing Date		2018-07-28		
	First Named Inventor	Gal Shabtay			
	Art Unit				
	Examiner Name				
	Attorney Docket Number		COREPH-0079 US CON3		

84	20030030729	A1	2003-02-13	Prentice et al.
85	20110064327	A1	2011-03-17	Dagher et al.
86	20110128288	A1	2011-06-02	Petrou et al.
87	20120026366	A1	2012-02-02	Golan et al.
88	20130093842	A1	2013-04-18	Kazuhiro Yahata
89	20150237280	A1	2015-08-20	Choi et al.
90	20060125937	A1	2006-06-15	LeGall et al.
91	20060170793	A1	2006-08-03	Pasqualette et al.
92	20080084484	A1	2008-04-10	Ochi et al.
93	20110234853	A1	2011-09-29	Hayashi et al.
94	20160154202	A1	2016-06-02	Wippermann et al.

**INFORMATION DISCLOSURE
STATEMENT BY APPLICANT**
(Not for submission under 37 CFR 1.99)

Application Number	16048242	16/048,242 - GAU: 2662
Filing Date	2018-07-28	
First Named Inventor	Gal Shabtay	
Art Unit		
Examiner Name		
Attorney Docket Number	COREPH-0079 US CON3	

95	20120249815	A1	2012-10-04	Bohn et al.
96	20160044250	A1	2016-02-11	Shabtay et al.
97	20150195458	A1	2015-07-09	Nakayama et al.
98	20140362242	A1	2014-12-11	Teruyuki Takizawa
99	20090122406	A1	2009-05-14	Rouvinen et al.
100	20090252484	A1	2009-10-08	Hasuda et al.
101	20090219547	A1	2009-09-03	Kauhanen et al.
102	20140049615	A1	2014-02-20	Satoshi Uwagawa
103	20110164172	A1	2011-07-07	Shintani et al.

If you wish to add additional U.S. Published Application citation information please click the Add button.

FOREIGN PATENT DOCUMENTS

Examiner Initial*	Cite No	Foreign Document Number ³	Country Code ^{2j}	Kind Code ⁴	Publication Date	Name of Patentee or Applicant of cited Document	Pages, Columns, Lines where Relevant Passages or Relevant Figures Appear	T ⁵
-------------------	---------	--------------------------------------	----------------------------	------------------------	------------------	---	--	----------------

INFORMATION DISCLOSURE STATEMENT BY APPLICANT (Not for submission under 37 CFR 1.99)	Application Number		16048242 16/048,242 - GAU: 2662	
	Filing Date		2018-07-28	
	First Named Inventor	Gal Shabtay		
	Art Unit			
	Examiner Name			
	Attorney Docket Number		COREPH-0079 US CON3	

1	102739949	CN	A	2012-10-17	Zhang Kerun		
2	103024272	CN	A	2013-04-03	Gao Xiaowen		
3	2523450	EP	A1	2012-11-14	Huang et al.		
4	101276415	CN	A	2008-10-01	Wu et al.		
5	2007306282	JP	A	2007-11-22	Yasuaki Kayanuma		
6	2003298920	JP	A	2003-10-17	Misawa et al.		
7	2006238325	JP	A	2006-09-07	Kagiwada et al.		
8	2013106289	JP	A	2013-05-30	Konno et al.		
9	2005099265	JP	A	2005-04-14	Ito et al.		
10	101477178	KR	B1	2014-12-29	Sun et al.		
11	20100008936	KR	A	2010-01-27	Sun et al.		

INFORMATION DISCLOSURE STATEMENT BY APPLICANT (Not for submission under 37 CFR 1.99)	Application Number	16048242	16/048,242 - GAU: 2662
	Filing Date	2018-07-28	
	First Named Inventor	Gal Shabtay	
	Art Unit		
	Examiner Name		
	Attorney Docket Number	COREPH-0079 US CON3	

12	08271976	JP	A	1996-10-18	Tamamura Hideo
13	04211230	JP	A	1992-08-03	Jeda Satoshi
14	20140014787	KR	A	2014-02-06	Young-Ho Kim
15	2007228006	JP	A	2007-09-06	Ichigo
16	H07318864	JP	A	1995-12-08	Kawamura et al.

If you wish to add additional Foreign Patent Document citation information please click the Add button

NON-PATENT LITERATURE DOCUMENTS

Examiner Initials*	Cite No	Include name of the author (in CAPITAL LETTERS), title of the article (when appropriate), title of the item (book, magazine, journal, serial, symposium, catalog, etc), date, pages(s), volume-issue number(s), publisher, city and/or country where published.	T5
	1	Statistical Modeling and Performance Characterization of a Real-Time Dual Camera Surveillance System, Greenhagen et al., Publisher: IEEE, 2000, 8 pages	
	2	A 3MPixel Multi-Aperture Image Sensor with 0.7µm Pixels in 0.11µm CMOS, Fife et al., Stanford University, 2008, 3 pages	
	3	Dual camera intelligent sensor for high definition 360 degrees surveillance, Scotti et al., Publisher: IET, 05/09/2000, 8 pages	
	4	Dual-sensor foveated imaging system, Hua et al., Publisher: Optical Society of America, 01/14/2008, 11 pages	

INFORMATION DISCLOSURE STATEMENT BY APPLICANT (Not for submission under 37 CFR 1.99)	Application Number	16048242 16/048,242 - GAU: 2662
	Filing Date	2018-07-28
	First Named Inventor	Gal Shabtay
	Art Unit	
	Examiner Name	
	Attorney Docket Number	COREPH-0079 US CON3

5	Defocus Video Matting, McGuire et al., Publisher: ACM SIGGRAPH, 07/31/2005, 11 pages
6	Compact multi-aperture imaging with high angular resolution, Santacana et al., Publisher: Optical Society of America, 2015, 10 pages
7	Multi-Aperture Photography, Green et al., Publisher: Mitsubishi Electric Research Laboratories, Inc., July 2007, 10 pages
8	Multispectral Bilateral Video Fusion, Bennett et al., Publisher: IEEE, May 2007, 10 pages
9	Super-resolution imaging using a camera array, Santacana et al., Publisher: Optical Society of America, 2014, 6 pages
10	Optical Splitting Trees for High-Precision Monocular Imaging, McGuire et al., Publisher: IEEE, 2007, 11 pages
11	High Performance Imaging Using Large Camera Arrays, Wilburn et al., Publisher: Association for Computing Machinery, Inc., 2005, 12 pages
12	Real-time Edge-Aware Image Processing with the Bilateral Grid, Chen et al., Publisher: ACM SIGGRAPH, 9 pages
13	Superimposed multi-resolution imaging, Carles et al., Publisher: Optical Society of America, 2017, 13 pages
14	Viewfinder Alignment, Adams et al., Publisher: EUROGRAPHICS, 2008, 10 pages
15	Dual-Camera System for Multi-Level Activity Recognition, Bodor et al., Publisher: IEEE, October 2014, 6 pages

INFORMATION DISCLOSURE STATEMENT BY APPLICANT (Not for submission under 37 CFR 1.99)	Application Number	16048242 16/048,242 - GAU: 2662
	Filing Date	2018-07-28
	First Named Inventor	Gal Shabtay
	Art Unit	
	Examiner Name	
	Attorney Docket Number	COREPH-0079 US CON3

16	Engineered to the task: Why camera-phone cameras are different, Giles Humpston, Publisher: Solid State Technology, June 2009, 3 pages
----	---

If you wish to add additional non-patent literature document citation information please click the Add button

EXAMINER SIGNATURE

Examiner Signature	/CYNTHIA SEGURA/	Date Considered	12/21/2018
--------------------	------------------	-----------------	------------

*EXAMINER: Initial if reference considered, whether or not citation is in conformance with MPEP 609. Draw line through a citation if not in conformance and not considered. Include copy of this form with next communication to applicant.

¹ See Kind Codes of USPTO Patent Documents at www.USPTO.GOV or MPEP 901.04. ² Enter office that issued the document, by the two-letter code (WIPO Standard ST.3). ³ For Japanese patent documents, the indication of the year of the reign of the Emperor must precede the serial number of the patent document. ⁴ Kind of document by the appropriate symbols as indicated on the document under WIPO Standard ST.16 if possible. ⁵ Applicant is to place a check mark here if English language translation is attached.

INFORMATION DISCLOSURE STATEMENT BY APPLICANT (Not for submission under 37 CFR 1.99)	Application Number	16048242 16/048,242 - GAU: 2662
	Filing Date	2018-07-28
	First Named Inventor	Gal Shabtay
	Art Unit	
	Examiner Name	
	Attorney Docket Number	COREPH-0079 US CON3

CERTIFICATION STATEMENT

Please see 37 CFR 1.97 and 1.98 to make the appropriate selection(s):

That each item of information contained in the information disclosure statement was first cited in any communication from a foreign patent office in a counterpart foreign application not more than three months prior to the filing of the information disclosure statement. See 37 CFR 1.97(e)(1).

OR

That no item of information contained in the information disclosure statement was cited in a communication from a foreign patent office in a counterpart foreign application, and, to the knowledge of the person signing the certification after making reasonable inquiry, no item of information contained in the information disclosure statement was known to any individual designated in 37 CFR 1.56(c) more than three months prior to the filing of the information disclosure statement. See 37 CFR 1.97(e)(2).

See attached certification statement.

The fee set forth in 37 CFR 1.17 (p) has been submitted herewith.

A certification statement is not submitted herewith.

SIGNATURE

A signature of the applicant or representative is required in accordance with CFR 1.33, 10.18. Please see CFR 1.4(d) for the form of the signature.

Signature	/Menachem Nathan/	Date (YYYY-MM-DD)	2018-09-20
Name/Print	Menachem Nathan	Registration Number	65392

This collection of information is required by 37 CFR 1.97 and 1.98. The information is required to obtain or retain a benefit by the public which is to file (and by the USPTO to process) an application. Confidentiality is governed by 35 U.S.C. 122 and 37 CFR 1.14. This collection is estimated to take 1 hour to complete, including gathering, preparing and submitting the completed application form to the USPTO. Time will vary depending upon the individual case. Any comments on the amount of time you require to complete this form and/or suggestions for reducing this burden, should be sent to the Chief Information Officer, U.S. Patent and Trademark Office, U.S. Department of Commerce, P.O. Box 1450, Alexandria, VA 22313-1450. **DO NOT SEND FEES OR COMPLETED FORMS TO THIS ADDRESS. SEND TO: Commissioner for Patents, P.O. Box 1450, Alexandria, VA 22313-1450.**

Privacy Act Statement

The Privacy Act of 1974 (P.L. 93-579) requires that you be given certain information in connection with your submission of the attached form related to a patent application or patent. Accordingly, pursuant to the requirements of the Act, please be advised that: (1) the general authority for the collection of this information is 35 U.S.C. 2(b)(2); (2) furnishing of the information solicited is voluntary; and (3) the principal purpose for which the information is used by the U.S. Patent and Trademark Office is to process and/or examine your submission related to a patent application or patent. If you do not furnish the requested information, the U.S. Patent and Trademark Office may not be able to process and/or examine your submission, which may result in termination of proceedings or abandonment of the application or expiration of the patent.

The information provided by you in this form will be subject to the following routine uses:

1. The information on this form will be treated confidentially to the extent allowed under the Freedom of Information Act (5 U.S.C. 552) and the Privacy Act (5 U.S.C. 552a). Records from this system of records may be disclosed to the Department of Justice to determine whether the Freedom of Information Act requires disclosure of these records.
2. A record from this system of records may be disclosed, as a routine use, in the course of presenting evidence to a court, magistrate, or administrative tribunal, including disclosures to opposing counsel in the course of settlement negotiations.
3. A record in this system of records may be disclosed, as a routine use, to a Member of Congress submitting a request involving an individual, to whom the record pertains, when the individual has requested assistance from the Member with respect to the subject matter of the record.
4. A record in this system of records may be disclosed, as a routine use, to a contractor of the Agency having need for the information in order to perform a contract. Recipients of information shall be required to comply with the requirements of the Privacy Act of 1974, as amended, pursuant to 5 U.S.C. 552a(m).
5. A record related to an International Application filed under the Patent Cooperation Treaty in this system of records may be disclosed, as a routine use, to the International Bureau of the World Intellectual Property Organization, pursuant to the Patent Cooperation Treaty.
6. A record in this system of records may be disclosed, as a routine use, to another federal agency for purposes of National Security review (35 U.S.C. 181) and for review pursuant to the Atomic Energy Act (42 U.S.C. 218(c)).
7. A record from this system of records may be disclosed, as a routine use, to the Administrator, General Services, or his/her designee, during an inspection of records conducted by GSA as part of that agency's responsibility to recommend improvements in records management practices and programs, under authority of 44 U.S.C. 2904 and 2906. Such disclosure shall be made in accordance with the GSA regulations governing inspection of records for this purpose, and any other relevant (i.e., GSA or Commerce) directive. Such disclosure shall not be used to make determinations about individuals.
8. A record from this system of records may be disclosed, as a routine use, to the public after either publication of the application pursuant to 35 U.S.C. 122(b) or issuance of a patent pursuant to 35 U.S.C. 151. Further, a record may be disclosed, subject to the limitations of 37 CFR 1.14, as a routine use, to the public if the record was filed in an application which became abandoned or in which the proceedings were terminated and which application is referenced by either a published application, an application open to public inspections or an issued patent.
9. A record from this system of records may be disclosed, as a routine use, to a Federal, State, or local law enforcement agency, if the USPTO becomes aware of a violation or potential violation of law or regulation.



UNITED STATES PATENT AND TRADEMARK OFFICE

UNITED STATES DEPARTMENT OF COMMERCE
 United States Patent and Trademark Office
 Address: COMMISSIONER FOR PATENTS
 P.O. Box 1450
 Alexandria, Virginia 22313-1450
 www.uspto.gov

BIB DATA SHEET

CONFIRMATION NO. 4814

SERIAL NUMBER 16/048,242	FILING or 371(c) DATE 07/28/2018 RULE	CLASS 348	GROUP ART UNIT 2662	ATTORNEY DOCKET NO. COREPH-0079 US CON3		
APPLICANTS Corephotonics Ltd., Tel Aviv, ISRAEL; INVENTORS Gal Shabtay, Tel Aviv, ISRAEL; Ephraim Goldenberg, Ashdod, ISRAEL; Oded Gigushinski, Herzlia, ISRAEL; Noy Cohen, Tel Aviv; ** CONTINUING DATA ***** This application is a CON of 15/865,869 01/09/2018 which is a CON of 15/424,853 02/05/2017 PAT 10015408 which is a CON of 14/880,251 10/11/2015 PAT 9661233 which is a CON of 14/365,711 06/16/2014 PAT 9185291 which is a 371 of PCT/IB2014/062180 06/12/2014 which claims benefit of 61/834,486 06/13/2013 ** FOREIGN APPLICATIONS ***** ** IF REQUIRED, FOREIGN FILING LICENSE GRANTED ** * SMALL ENTITY ** 08/29/2018						
Foreign Priority claimed <input type="checkbox"/> Yes <input checked="" type="checkbox"/> No	35 USC 119(a-d) conditions met <input type="checkbox"/> Yes <input checked="" type="checkbox"/> No	<input type="checkbox"/> Met after Allowance Initials	STATE OR COUNTRY ISRAEL	SHEETS DRAWINGS 8	TOTAL CLAIMS 40	INDEPENDENT CLAIMS 3
ADDRESS Nathan & Associates Patent Agents Ltd P.O.Box 10178 Tel Aviv, 6110101 ISRAEL						
TITLE DUAL APERTURE ZOOM DIGITAL CAMERA						
FILING FEE RECEIVED 1865	FEES: Authority has been given in Paper No. _____ to charge/credit DEPOSIT ACCOUNT No. _____ for following:		<input type="checkbox"/> All Fees <input type="checkbox"/> 1.16 Fees (Filing) <input type="checkbox"/> 1.17 Fees (Processing Ext. of time) <input type="checkbox"/> 1.18 Fees (Issue) <input type="checkbox"/> Other _____ <input type="checkbox"/> Credit			

INFORMATION DISCLOSURE STATEMENT BY APPLICANT (Not for submission under 37 CFR 1.99)	Application Number	16048242 16/048,242 -- GAU: 2662
	Filing Date	2018-07-28
	First Named Inventor	Gal Shabtay
	Art Unit	
	Examiner Name	
	Attorney Docket Number	COREPH-0079 US CON3

U.S.PATENTS						Remove
Examiner Initial*	Cite No	Patent Number	Kind Code ¹	Issue Date	Name of Patentee or Applicant of cited Document	Pages, Columns, Lines where Relevant Passages or Relevant Figures Appear
	1	9235036	B2	2016-01-12	Kato et al.	
	2	4134645	A	1979-01-16	Sugiyama et al.	
	3	7697220	B2	2010-04-13	Noriyuki Iyama	
	4	8279537	B2	2012-10-02	Setsu Sato	
	5	9438792	B2	2016-09-06	Nakada et al.	
	6	7777972	B1	2010-08-17	Chen et al.	
	7	8233224	B2	2012-07-31	Chun-Shan Chen	
	8	8854745	B1	2014-10-07	Wei-Yu Chen	

INFORMATION DISCLOSURE STATEMENT BY APPLICANT (Not for submission under 37 CFR 1.99)	Application Number		16048242 16/048,242 - GAU: 2662		
	Filing Date		2018-07-28		
	First Named Inventor	Gal Shabtay			
	Art Unit				
	Examiner Name				
	Attorney Docket Number		COREPH-0079 US CON3		

9	8004777	B2	2011-08-23	Yoshihito Souma
10	8780465	B2	2014-07-15	Kyu Min Chae
11	9817213	B2	2017-11-14	Romeo I. Mercado
12	7515351	B2	2009-04-07	Chen et al.
13	7564635	B1	2009-07-21	Hsiang-Chi Tang
14	7643225	B1	2010-01-05	Tsung-Han Tsai
15	7660049	B2	2010-02-09	Hsiang Chi TANG
16	7684128	B2	2010-03-23	Hsiang-Chi Tang
17	7692877	B2	2010-04-06	Tang et al.
18	7738186	B2	2010-06-15	Chen et al.
19	8363337	B2	2013-01-29	Tang et al.

INFORMATION DISCLOSURE STATEMENT BY APPLICANT (Not for submission under 37 CFR 1.99)	Application Number		16048242 16/048,242 - GAU: 2662		
	Filing Date		2018-07-28		
	First Named Inventor	Gal Shabtay			
	Art Unit				
	Examiner Name				
	Attorney Docket Number		COREPH-0079 US CON3		

20	7813057	B2	2010-10-12	Ming Ching Lin
21	7821724	B2	2010-10-26	Tang et al.
22	7826149	B2	2010-11-02	Tang et al.
23	7826151	B2	2010-11-02	Tsung-Han Tsai
24	7869142	B2	2011-01-11	Chen et al.
25	7898747	B2	2011-03-01	Hsiang Chi Tang
26	7916401	B2	2011-03-29	Chen et al.
27	7957076	B2	2011-06-07	Hsiang Chi Tang
28	7957075	B2	2011-06-07	Hsiang Chi Tang
29	7957079	B2	2011-06-07	Hsiang Chi Tang
30	7961406	B1	2011-06-14	Tang et al.

INFORMATION DISCLOSURE STATEMENT BY APPLICANT (Not for submission under 37 CFR 1.99)	Application Number	16048242 16/048,242 - GAU: 2662
	Filing Date	2018-07-28
	First Named Inventor	Gal Shabtay
	Art Unit	
	Examiner Name	
	Attorney Docket Number	COREPH-0079 US CON3

31	8000031	B2	2011-08-16	Tsung Han Tsai
32	8077400	B2	2011-12-13	Hsiang Chi Tang
33	8514502	B2	2013-08-20	Chun-Shan Chen
34	8395851	B2	2013-03-12	Tang et al.
35	8218253	B2	2012-07-10	Hsiang Chi Tang
36	8228622	B2	2012-07-24	Hsiang Chi Tang
37	8253843	B2	2012-08-28	Ming-Ching Lin
38	8400717	B2	2013-03-19	Chen et al.
39	8503107	B2	2013-08-06	Chen et al.
40	3388956	A	1968-06-18	Eggert et al.
41	3524700	A	1970-08-18	Eggert et al.

INFORMATION DISCLOSURE STATEMENT BY APPLICANT (Not for submission under 37 CFR 1.99)	Application Number		16048242 16/048,242 - GAU: 2662		
	Filing Date		2018-07-28		
	First Named Inventor	Gal Shabtay			
	Art Unit				
	Examiner Name				
	Attorney Docket Number		COREPH-0079 US CON3		

42	3864027	A	1975-02-04	Kenichi Harada
43	3942876	A	1976-03-09	Ellis I. Betensky
44	5000551	A	1991-03-19	Atsushi Shibayama
45	6654180	B2	2003-11-25	Tetsuya Ori
46	7187504	B2	2007-03-06	Akihisa Horiuchi
47	8451549	B2	2013-05-28	Yamanaka et al.
48	2378170	A	1945-06-12	George H Aklin
49	2441093	A	1948-05-04	George H Aklin
50	2354503	A	1944-07-25	Cox Arthur
51	7688523	B2	2010-03-30	Eigo Sano
52	4338001	A	1982-07-06	Sei Matsui

INFORMATION DISCLOSURE STATEMENT BY APPLICANT (Not for submission under 37 CFR 1.99)	Application Number	16048242 16/048,242 - GAU: 2662
	Filing Date	2018-07-28
	First Named Inventor	Gal Shabtay
	Art Unit	
	Examiner Name	
	Attorney Docket Number	COREPH-0079 US CON3

53	4465345	A	1984-08-14	Junichi Yazawa
54	9229194	B2	2016-01-05	Yoneyama et al.
55	8810923	B2	2014-08-19	Yoshikazu Shinohara
56	9678310	B2	2017-06-13	Iwasaki et al.
57	7918398	B2	2011-04-05	Li et al.
58	9568712	B2	2017-02-14	Dror et al.

If you wish to add additional U.S. Patent citation information please click the Add button.

U.S.PATENT APPLICATION PUBLICATIONS

Examiner Initial*	Cite No	Publication Number	Kind Code ¹	Publication Date	Name of Patentee or Applicant of cited Document	Pages, Columns, Lines where Relevant Passages or Relevant Figures Appear
	1	20140022436	A1	2014-01-23	Kim et al.	
	2	20140204480	A1	2014-07-24	Jo et al.	
	3	20050141103	A1	2005-06-30	Kiichiro Nishina	

ALL REFERENCES CONSIDERED EXCEPT WHERE LINED THROUGH. /c.s/

INFORMATION DISCLOSURE STATEMENT BY APPLICANT (Not for submission under 37 CFR 1.99)	Application Number	16048242	16/048,242 - GAU: 2662
	Filing Date	2018-07-28	
	First Named Inventor	Gal Shabtay	
	Art Unit		
	Examiner Name		
	Attorney Docket Number	COREPH-0079 US CON3	

4	20050168840	A1	2005-08-04	Kobayashi et al.
5	20070229983	A1	2007-10-04	Masakazu Saori
6	20090122423	A1	2009-05-14	Park et al.
7	20120154929	A1	2012-06-21	Tsai et al.
8	20130208178	A1	2013-08-15	Young-woo Park
9	20080304161	A1	2008-12-11	Yoshihito Souma
10	20160187631	A1	2016-06-30	Choi et al.
11	20180224630	A1	2018-08-09	Lee et al.
12	20110115965	A1	2011-05-19	Engelhardt et al.
13	20130286488	A1	2013-10-31	Kyu Min Chae
14	20170102522	A1	2017-04-13	Yong Joo Jo

INFORMATION DISCLOSURE STATEMENT BY APPLICANT (Not for submission under 37 CFR 1.99)	Application Number	16048242 16/048,242 - GAU: 2662
	Filing Date	2018-07-28
	First Named Inventor	Gal Shabtay
	Art Unit	
	Examiner Name	
	Attorney Docket Number	COREPH-0079 US CON3

15	20140285907	A1	2014-09-25	Tang et al.
16	20120092777	A1	2012-04-19	Tochigi et al.
17	20120105708	A1	2012-05-03	Yasuaki Hagiwara
18	20150116569	A1	2015-04-30	Romeo I. Mercado
19	20150253647	A1	2015-09-10	Romeo I. Mercado
20	20160085089	A1	2016-03-24	Romeo I. Mercado
21	20160313537	A1	2016-10-27	Romeo I. Mercado
22	20140293453	A1	2014-10-02	Ogino et al.

If you wish to add additional U.S. Published Application citation information please click the Add button.

FOREIGN PATENT DOCUMENTS

Examiner Initial*	Cite No	Foreign Document Number ³	Country Code ² i	Kind Code ⁴	Publication Date	Name of Patentee or Applicant of cited Document	Pages, Columns, Lines where Relevant Passages or Relevant Figures Appear	T ⁵
	1	2007306282	JP	A	2007-11-22	Yasuaki Kayanuma		

**INFORMATION DISCLOSURE
STATEMENT BY APPLICANT**
(Not for submission under 37 CFR 1.99)

Application Number	16048242 16/048,242 -- GAU: 2662	
Filing Date	2018-07-28	
First Named Inventor	Gal Shabtay	
Art Unit		
Examiner Name		
Attorney Docket Number	COREPH-0079 US CON3	

2	2013106289	JP	A	2013-05-30	Konno et al.
3	20140023552	KR	A	2014-02-27	Kim Bum Geun
4	S59121015	JP	A	1984-07-12	Yasushi Matsui
5	2012203234	JP	A	2012-10-22	Matsuzaka et al.
6	2013058111	WO	A1	2013-04-25	Hiroaki Tanaka
7	S54157620	JP	A	1979-12-12	Toshiko Shimokura
8	2013063097	WO	A1	2013-05-02	Cahall et al.
9	104297906	CN	A	2015-01-21	Bo et al.

If you wish to add additional Foreign Patent Document citation information please click the Add button

NON-PATENT LITERATURE DOCUMENTS

Examiner Initials*	Cite No	Include name of the author (in CAPITAL LETTERS), title of the article (when appropriate), title of the item (book, magazine, journal, serial, symposium, catalog, etc), date, pages(s), volume-issue number(s), publisher, city and/or country where published.	T5
--------------------	---------	---	----

	1	A compact and cost effective design for cell phone zoom lens, Chang et al., September 2007, 8 pages	
--	---	---	--

ALL REFERENCES CONSIDERED EXCEPT WHERE LINED THROUGH. /C.S/

INFORMATION DISCLOSURE STATEMENT BY APPLICANT (Not for submission under 37 CFR 1.99)	Application Number		16048242 16/048,242 - GAU: 2662
	Filing Date		2018-07-28
	First Named Inventor	Gal Shabtay	
	Art Unit		
	Examiner Name		
	Attorney Docket Number		COREPH-0079 US CON3

2	Consumer Electronic Optics: How small a lens can be? The case of panomorph lenses, Thibault et al., September 2014, 7 pages
3	Optical design of camera optics for mobile phones, Steinich et al., 2012, Pages 51-58 (8 pages)
4	The Optics of Miniature Digital Camera Modules, Bareau et al., 2006, 11 pages
5	Modeling and measuring liquid crystal tunable lenses, Peter P. Clark, 2014, 7 pages
6	Mobile Platform Optical Design, Peter P. Clark, 2014, 7 pages

If you wish to add additional non-patent literature document citation information please click the Add button

EXAMINER SIGNATURE

Examiner Signature	/CYNTHIA SEGURA/	Date Considered	12/21/2018
--------------------	------------------	-----------------	------------

*EXAMINER: Initial if reference considered, whether or not citation is in conformance with MPEP 609. Draw line through a citation if not in conformance and not considered. Include copy of this form with next communication to applicant.

¹ See Kind Codes of USPTO Patent Documents at www.USPTO.GOV or MPEP 901.04. ² Enter office that issued the document, by the two-letter code (WIPO Standard ST.3). ³ For Japanese patent documents, the indication of the year of the reign of the Emperor must precede the serial number of the patent document. ⁴ Kind of document by the appropriate symbols as indicated on the document under WIPO Standard ST.16 if possible. ⁵ Applicant is to place a check mark here if English language translation is attached.

ALL REFERENCES CONSIDERED EXCEPT WHERE LINED THROUGH. /C.S./

INFORMATION DISCLOSURE STATEMENT BY APPLICANT (Not for submission under 37 CFR 1.99)	Application Number	16048242 16/048,242 - GAU: 2662
	Filing Date	2018-07-28
	First Named Inventor	Gal Shabtay
	Art Unit	
	Examiner Name	
	Attorney Docket Number	COREPH-0079 US CON3

CERTIFICATION STATEMENT

Please see 37 CFR 1.97 and 1.98 to make the appropriate selection(s):

That each item of information contained in the information disclosure statement was first cited in any communication from a foreign patent office in a counterpart foreign application not more than three months prior to the filing of the information disclosure statement. See 37 CFR 1.97(e)(1).

OR

That no item of information contained in the information disclosure statement was cited in a communication from a foreign patent office in a counterpart foreign application, and, to the knowledge of the person signing the certification after making reasonable inquiry, no item of information contained in the information disclosure statement was known to any individual designated in 37 CFR 1.56(c) more than three months prior to the filing of the information disclosure statement. See 37 CFR 1.97(e)(2).

See attached certification statement.

The fee set forth in 37 CFR 1.17 (p) has been submitted herewith.

A certification statement is not submitted herewith.

SIGNATURE

A signature of the applicant or representative is required in accordance with CFR 1.33, 10.18. Please see CFR 1.4(d) for the form of the signature.

Signature	/Menachem Nathan/	Date (YYYY-MM-DD)	2018-09-20
Name/Print	Menachem Nathan	Registration Number	65392

This collection of information is required by 37 CFR 1.97 and 1.98. The information is required to obtain or retain a benefit by the public which is to file (and by the USPTO to process) an application. Confidentiality is governed by 35 U.S.C. 122 and 37 CFR 1.14. This collection is estimated to take 1 hour to complete, including gathering, preparing and submitting the completed application form to the USPTO. Time will vary depending upon the individual case. Any comments on the amount of time you require to complete this form and/or suggestions for reducing this burden, should be sent to the Chief Information Officer, U.S. Patent and Trademark Office, U.S. Department of Commerce, P.O. Box 1450, Alexandria, VA 22313-1450. **DO NOT SEND FEES OR COMPLETED FORMS TO THIS ADDRESS. SEND TO: Commissioner for Patents, P.O. Box 1450, Alexandria, VA 22313-1450.**

Privacy Act Statement

The Privacy Act of 1974 (P.L. 93-579) requires that you be given certain information in connection with your submission of the attached form related to a patent application or patent. Accordingly, pursuant to the requirements of the Act, please be advised that: (1) the general authority for the collection of this information is 35 U.S.C. 2(b)(2); (2) furnishing of the information solicited is voluntary; and (3) the principal purpose for which the information is used by the U.S. Patent and Trademark Office is to process and/or examine your submission related to a patent application or patent. If you do not furnish the requested information, the U.S. Patent and Trademark Office may not be able to process and/or examine your submission, which may result in termination of proceedings or abandonment of the application or expiration of the patent.

The information provided by you in this form will be subject to the following routine uses:

1. The information on this form will be treated confidentially to the extent allowed under the Freedom of Information Act (5 U.S.C. 552) and the Privacy Act (5 U.S.C. 552a). Records from this system of records may be disclosed to the Department of Justice to determine whether the Freedom of Information Act requires disclosure of these records.
2. A record from this system of records may be disclosed, as a routine use, in the course of presenting evidence to a court, magistrate, or administrative tribunal, including disclosures to opposing counsel in the course of settlement negotiations.
3. A record in this system of records may be disclosed, as a routine use, to a Member of Congress submitting a request involving an individual, to whom the record pertains, when the individual has requested assistance from the Member with respect to the subject matter of the record.
4. A record in this system of records may be disclosed, as a routine use, to a contractor of the Agency having need for the information in order to perform a contract. Recipients of information shall be required to comply with the requirements of the Privacy Act of 1974, as amended, pursuant to 5 U.S.C. 552a(m).
5. A record related to an International Application filed under the Patent Cooperation Treaty in this system of records may be disclosed, as a routine use, to the International Bureau of the World Intellectual Property Organization, pursuant to the Patent Cooperation Treaty.
6. A record in this system of records may be disclosed, as a routine use, to another federal agency for purposes of National Security review (35 U.S.C. 181) and for review pursuant to the Atomic Energy Act (42 U.S.C. 218(c)).
7. A record from this system of records may be disclosed, as a routine use, to the Administrator, General Services, or his/her designee, during an inspection of records conducted by GSA as part of that agency's responsibility to recommend improvements in records management practices and programs, under authority of 44 U.S.C. 2904 and 2906. Such disclosure shall be made in accordance with the GSA regulations governing inspection of records for this purpose, and any other relevant (i.e., GSA or Commerce) directive. Such disclosure shall not be used to make determinations about individuals.
8. A record from this system of records may be disclosed, as a routine use, to the public after either publication of the application pursuant to 35 U.S.C. 122(b) or issuance of a patent pursuant to 35 U.S.C. 151. Further, a record may be disclosed, subject to the limitations of 37 CFR 1.14, as a routine use, to the public if the record was filed in an application which became abandoned or in which the proceedings were terminated and which application is referenced by either a published application, an application open to public inspections or an issued patent.
9. A record from this system of records may be disclosed, as a routine use, to a Federal, State, or local law enforcement agency, if the USPTO becomes aware of a violation or potential violation of law or regulation.

EAST Search History

EAST Search History (Prior Art)

Ref #	Hits	Search Query	DBs	Default Operator	Plurals	Time Stamp
S1	1	16/048242.app.	US-PGPUB; USPAT; FPRS; EPO; JPO; IBM_TDB	OR	ON	2018/12/20 15:18
S2	358	Shabtay-Gal.in. Goldenberg-Ephraim.in. Gigushinski-Oded.in. Cohen-Noy.in.	US-PGPUB; USPAT; FPRS; EPO; JPO; IBM_TDB	OR	ON	2018/12/20 15:25
S3	6	S2 and ("TTL" near4 "1").clm.	US-PGPUB; USPAT; FPRS; EPO; JPO; IBM_TDB	OR	ON	2018/12/20 15:26
S4	1	14/365711.app.	US-PGPUB; USPAT; FPRS; EPO; JPO; IBM_TDB	OR	ON	2018/12/20 15:30
S5	2	14/880251.app.	US-PGPUB; USPAT; FPRS; EPO; JPO; IBM_TDB	OR	ON	2018/12/20 15:35
S6	2	15/424853.app.	US-PGPUB; USPAT; FPRS; EPO; JPO; IBM_TDB	OR	ON	2018/12/20 15:36
S7	1	15/865869.app.	US-PGPUB; USPAT; FPRS; EPO; JPO; IBM_TDB	OR	ON	2018/12/20 15:40
S8	1	16/048242.app.	US-	OR	ON	2018/12/20

			PGPUB; USPAT; FPRS; EPO; JPO; IBM_TDB			15:41
S9	9	(US-20160050374-\$ or US-20170150061-\$ or US-20180152640-\$ or US-20180359423-\$).did. or (US-9402032-\$ or US-8508649-\$ or US-9185291-\$ or US-9661233-\$ or US-10015408-\$).did.	US-PGPUB; USPAT	OR	ON	2018/12/20 15:52
S10	7	S9 and (no\$2 near2 focused)	US-PGPUB; USPAT; FPRS; EPO; JPO; IBM_TDB	OR	ON	2018/12/20 15:52
S11	69503	(H04N5/23296 or G02B13/0015 or G02B27/0075 or G02B13/009 or H04N5/23245 or H04N5/2258 or H04N5/23232 or H04N5/2259 or H04N5/225 or H04N5/23212).cpc.	US-PGPUB; USPAT; FPRS; EPO; JPO; IBM_TDB	OR	ON	2018/12/20 16:11
S12	50	S11 and (wide\$4 with (tele telephoto) with (AF autofocus\$4 auto-focus\$4 focus\$4) with (composite fused combined combining merg\$4 add\$4 mix\$4 fusing))	US-PGPUB; USPAT; FPRS; EPO; JPO; IBM_TDB	OR	ON	2018/12/20 16:13
S13	10407	H04N5/23296.cpc.	US-PGPUB; USPAT; FPRS; EPO; JPO; IBM_TDB	OR	ON	2018/12/20 16:39
S14	18	S11 and ((expand\$4 bigger wide\$4) with (smaller narrow\$4 tele telephoto) with (FOV POV view)) same ((AF autofocus\$4 auto-focus\$4 focus\$4) with (composite fused combined combining merg\$4 add\$4 mix\$4 fusing))	US-PGPUB; USPAT; FPRS; EPO; JPO; IBM_TDB	OR	ON	2018/12/20 16:41
S15	41	("20030227556" "20060275025" "20070109399" "20070146503" "20080030592" "20080218613" "20080219654" "20090273688" "20100277619" "20110064327" "20120026366" "20150029601" "20150085174" "20150244942" "5172235" "5436660" "6977676" "7305180" "7388182" "7561191" "7676146" "7724300" "7843499" "8149327" "8439265" "8542287" "8553106" "8660420" "8731390" "8860849").PN. OR ("9185291").URPN.	US-PGPUB; USPAT; USOCR	OR	ON	2018/12/20 16:44
S16	25	("20020044691" "20070025713" "20080030592" "20080218613"	US-PGPUB;	OR	ON	2018/12/20 16:45

		"20100277619" "20110018970" "20110064327" "20120026366" "20120063736" "20130223834" "20130259335" "20140098195" "20140192210" "20150029601" "20150085174" "7305180" "7561191" "7676146" "8149327" "8439265" "8542287" "8553106" "8660420" "8731390" "9185291").PN. OR ("9661233").URPN.	USPAT; USOCR			
S17	25	("20060187312" "20070229697" "20080030592" "20080187310" "20080218613" "20090002839" "20100277269" "20110080487" "20110129210" "20120074227" "20120206458" "20120314296" "20130182335" "20130215289" "20130335833" "20140009585" "20150009395" "20150161798" "20150198784" "20170102513" "20170249053" "20170276911" "9405099" "9576369" "9633442").PN. OR ("10015408").URPN.	US- PGPUB; USPAT; USOCR	OR	ON	2018/12/20 16:46
S18	66	((expand\$4 bigger wide\$4) with (smaller narrow\$4 tele telephoto) with (FOV POV view)) same ((AF autofocus\$4 auto-focus\$4 focus\$4) with (composite fused combined combining merg\$4 add\$4 mix\$4 fusing))	US- PGPUB; USPAT; FPRS; EPO; JPO; IBM_TDB	OR	ON	2018/12/20 16:46
S19	4149	((expand\$4 bigger wide\$4) with (smaller narrow\$4 tele telephoto) with (FOV POV view lens\$4 optic\$4) with (less\$4 greater higher lower exceed\$4 ratio rate condition equation) with ("1" "2"))	US- PGPUB; USPAT; FPRS; EPO; JPO; IBM_TDB	OR	ON	2018/12/20 16:49
S20	449	S11 and S19	US- PGPUB; USPAT; FPRS; EPO; JPO; IBM_TDB	OR	ON	2018/12/20 16:51
S21	1636	G02B13/0015.cpc.	US- PGPUB; USPAT; FPRS; EPO; JPO; IBM_TDB	OR	ON	2018/12/20 17:01
S22	2675	G02B27/0075.cpc.	US- PGPUB; USPAT; FPRS; EPO; JPO; IBM_TDB	OR	ON	2018/12/20 17:16
S26	72	((expand\$4 bigger wide\$4) with (smaller narrow\$4 tele telephoto) with (FOV POV view)) same ((AF autofocus\$4 auto-focus\$4 focus\$4) with (composite fused combined	US- PGPUB; USPAT; FPRS;	OR	ON	2018/12/21 08:25

	combining merg\$4 add\$4 mix\$4 fusing synthesiz\$4))	EPO; JPO; IBM_TDB		
--	---	-------------------------	--	--

EAST Search History (Interference)

Ref #	Hits	Search Query	DBs	Default Operator	Plurals	Time Stamp
S23	63	(wide\$4 with (tele telephoto) with (AF autofocus\$4 auto-focus\$4 focus\$4) with (composite fused combined combining merg\$4 add\$4 mix\$4 fusing)).clm.	US-PGPUB	OR	ON	2018/12/20 16:15
S24	61	S23 and ((focus focal track) near3 (length distance amount separat\$4)).clm.	US-PGPUB	OR	ON	2018/12/20 16:15
S25	14	((((expand\$4 bigger wide\$4) with (smaller narrow\$4 tele telephoto) with (FOV POV view)) same ((AF autofocus\$4 auto-focus\$4 focus\$4) with (composite fused combined combining merg\$4 add\$4 mix\$4 fusing))))).clm.	US-PGPUB	OR	ON	2018/12/20 16:47
S27	18	((((expand\$4 bigger wide\$4) with (smaller narrow\$4 tele telephoto) with (FOV POV view)).clm. and ((AF autofocus\$4 auto-focus\$4 focus\$4) with (composite fused combined combining merg\$4 add\$4 mix\$4 fusing synthesiz\$4)).clm.)	US-PGPUB	OR	ON	2018/12/21 12:37

12/ 21/ 2018 1:06:58 PM

C:\Users\ccalderon\Documents\EAST\Workspaces\16048242_b.wsp

PART B - FEE(S) TRANSMITTAL

Complete and send this form, together with applicable fee(s), by mail or fax, or via EFS-Web.

By mail, send to: Mail Stop ISSUE FEE
 Commissioner for Patents
 P.O. Box 1450
 Alexandria, Virginia 22313-1450

By fax, send to: (571)-273-2885

INSTRUCTIONS: This form should be used for transmitting the ISSUE FEE and PUBLICATION FEE (if required). Blocks 1 through 5 should be completed where appropriate. All further correspondence including the Patent, advance orders and notification of maintenance fees will be mailed to the current correspondence address as indicated unless corrected below or directed otherwise in Block 1, by (a) specifying a new correspondence address; and/or (b) indicating a separate "FEE ADDRESS" for maintenance fee notifications.

CURRENT CORRESPONDENCE ADDRESS (Note: Use Block 1 for any change of address)

92342 7590 01/09/2019
 Nathan & Associates Patent Agents Ltd
 P.O.Box 10178
 Tel Aviv, 6110101
 ISRAEL

Note: A certificate of mailing can only be used for domestic mailings of the Fee(s) Transmittal. This certificate cannot be used for any other accompanying papers. Each additional paper, such as an assignment or formal drawing, must have its own certificate of mailing or transmission.

Certificate of Mailing or Transmission

I hereby certify that this Fee(s) Transmittal is being deposited with the United States Postal Service with sufficient postage for first class mail in an envelope addressed to the Mail Stop ISSUE FEE address above, or being transmitted to the USPTO via EFS-Web or by facsimile to (571) 273-2885, on the date below.

(Typed or printed name)
(Signature)
(Date)

APPLICATION NO.	FILING DATE	FIRST NAMED INVENTOR	ATTORNEY DOCKET NO.	CONFIRMATION NO.
16/048,242	07/28/2018	Gal Shabtay	COREPH-0079 US CON3	4814

TITLE OF INVENTION: DUAL APERTURE ZOOM DIGITAL CAMERA

APPLN. TYPE	ENTITY STATUS	ISSUE FEE DUE	PUBLICATION FEE DUE	PREV. PAID ISSUE FEE	TOTAL FEE(S) DUE	DATE DUE
nonprovisional	SMALL	\$500	\$0.00	\$0.00	\$500	04/09/2019

EXAMINER	ART UNIT	CLASS-SUBCLASS
SEGURA, CYNTHIA	2662	348-240990

1. Change of correspondence address or indication of "Fee Address" (37 CFR 1.363).

- Change of correspondence address (or Change of Correspondence Address form PTO/SB/122) attached.
- "Fee Address" indication (or "Fee Address" Indication form PTO/SB/47; Rev 03-09 or more recent) attached. **Use of a Customer Number is required.**

2. For printing on the patent front page, list

- (1) The names of up to 3 registered patent attorneys or agents OR, alternatively,
- (2) The name of a single firm (having as a member a registered attorney or agent) and the names of up to 2 registered patent attorneys or agents. If no name is listed, no name will be printed.

- 1 Nathan and Associates
- 2 Menachem Nathan
- 3 _____

3. ASSIGNEE NAME AND RESIDENCE DATA TO BE PRINTED ON THE PATENT (print or type)

PLEASE NOTE: Unless an assignee is identified below, no assignee data will appear on the patent. If an assignee is identified below, the document must have been previously recorded, or filed for recordation, as set forth in 37 CFR 3.11 and 37 CFR 3.81(a). Completion of this form is NOT a substitute for filing an assignment.

(A) NAME OF ASSIGNEE

(B) RESIDENCE: (CITY and STATE OR COUNTRY)

Corephotonics Ltd.

Tel Aviv, Israel

Please check the appropriate assignee category or categories (will not be printed on the patent): Individual Corporation or other private group entity Government

4a. Fees submitted: Issue Fee Publication Fee (if required) Advance Order - # of Copies _____

4b. Method of Payment: (Please first reapply any previously paid fee shown above)

- Electronic Payment via EFS-Web Enclosed check Non-electronic payment by credit card (Attach form PTO-2038)

The Director is hereby authorized to charge the required fee(s), any deficiency, or credit any overpayment to Deposit Account No. _____

5. Change in Entity Status (from status indicated above)

- Applicant certifying micro entity status. See 37 CFR 1.29
- Applicant asserting small entity status. See 37 CFR 1.27
- Applicant changing to regular undiscounted fee status.

NOTE: Absent a valid certification of Micro Entity Status (see forms PTO/SB/15A and 15B), issue fee payment in the micro entity amount will not be accepted at the risk of application abandonment.
 NOTE: If the application was previously under micro entity status, checking this box will be taken to be a notification of loss of entitlement to micro entity status.
 NOTE: Checking this box will be taken to be a notification of loss of entitlement to small or micro entity status, as applicable.

NOTE: This form must be signed in accordance with 37 CFR 1.31 and 1.33. See 37 CFR 1.4 for signature requirements and certifications.

Authorized Signature /Menachem Nathan/

Date 2019/01/09

Typed or printed name Menachem Nathan

Registration No. 65392

Electronic Patent Application Fee Transmittal

Application Number:	16048242			
Filing Date:	28-Jul-2018			
Title of Invention:	DUAL APERTURE ZOOM DIGITAL CAMERA			
First Named Inventor/Applicant Name:	Gal Shabtay			
Filer:	Menachem Nathan			
Attorney Docket Number:	COREPH-0079 US CON3			
Filed as Small Entity				
Filing Fees for Utility under 35 USC 111(a)				
Description	Fee Code	Quantity	Amount	Sub-Total in USD(\$)
Basic Filing:				
Pages:				
Claims:				
Miscellaneous-Filing:				
Petition:				
Patent-Appeals-and-Interference:				
Post-Allowance-and-Post-Issuance:				
UTILITY APPL ISSUE FEE	2501	1	500	500

Description	Fee Code	Quantity	Amount	Sub-Total in USD(\$)
Extension-of-Time:				
Miscellaneous:				
Total in USD (\$)				500

Electronic Acknowledgement Receipt

EFS ID:	34808984
Application Number:	16048242
International Application Number:	
Confirmation Number:	4814
Title of Invention:	DUAL APERTURE ZOOM DIGITAL CAMERA
First Named Inventor/Applicant Name:	Gal Shabtay
Customer Number:	92342
Filer:	Menachem Nathan
Filer Authorized By:	
Attorney Docket Number:	COREPH-0079 US CON3
Receipt Date:	09-JAN-2019
Filing Date:	28-JUL-2018
Time Stamp:	16:38:42
Application Type:	Utility under 35 USC 111(a)

Payment information:

Submitted with Payment	yes
Payment Type	CARD
Payment was successfully received in RAM	\$500
RAM confirmation Number	011019INTEFSW16395900
Deposit Account	
Authorized User	

The Director of the USPTO is hereby authorized to charge indicated fees and credit any overpayment as follows:

--	--	--	--	--	--

File Listing:

Document Number	Document Description	File Name	File Size(Bytes)/ Message Digest	Multi Part /.zip	Pages (if appl.)
1	Issue Fee Payment (PTO-85B)	Issue_fee.pdf	541973	no	1
			9e8d6c5b93f24d5d320a019ec9cc1c25dbc32283		

Warnings:

Information:

2	Fee Worksheet (SB06)	fee-info.pdf	30106	no	2
			a8d0260b972560f5a9b5ed382f501577d80f464		

Warnings:

Information:

Total Files Size (in bytes):	572079
-------------------------------------	--------

This Acknowledgement Receipt evidences receipt on the noted date by the USPTO of the indicated documents, characterized by the applicant, and including page counts, where applicable. It serves as evidence of receipt similar to a Post Card, as described in MPEP 503.

New Applications Under 35 U.S.C. 111

If a new application is being filed and the application includes the necessary components for a filing date (see 37 CFR 1.53(b)-(d) and MPEP 506), a Filing Receipt (37 CFR 1.54) will be issued in due course and the date shown on this Acknowledgement Receipt will establish the filing date of the application.

National Stage of an International Application under 35 U.S.C. 371

If a timely submission to enter the national stage of an international application is compliant with the conditions of 35 U.S.C. 371 and other applicable requirements a Form PCT/DO/EO/903 indicating acceptance of the application as a national stage submission under 35 U.S.C. 371 will be issued in addition to the Filing Receipt, in due course.

New International Application Filed with the USPTO as a Receiving Office

If a new international application is being filed and the international application includes the necessary components for an international filing date (see PCT Article 11 and MPEP 1810), a Notification of the International Application Number and of the International Filing Date (Form PCT/RO/105) will be issued in due course, subject to prescriptions concerning national security, and the date shown on this Acknowledgement Receipt will establish the international filing date of the application.

INFORMATION DISCLOSURE STATEMENT BY APPLICANT (Not for submission under 37 CFR 1.99)	Application Number	16048242
	Filing Date	2018-07-28
	First Named Inventor	Gal Shabtay
	Art Unit	
	Examiner Name	
	Attorney Docket Number	COREPH-0079 US CON3

U.S.PATENTS							Remove
Examiner Initial*	Cite No	Patent Number	Kind Code ¹	Issue Date	Name of Patentee or Applicant of cited Document	Pages,Columns,Lines where Relevant Passages or Relevant Figures Appear	
	1	9185291	B1	2015-11-10	Shabtay et al.		
	2	7773121	B1	2010-08-10	Huntsberger et al.		
	3	9927600	B2	2018-03-27	Goldenberg et al.		
	4	9768310	B2	2017-09-19	Ahn et al.		

If you wish to add additional U.S. Patent citation information please click the Add button. [Add](#)

U.S.PATENT APPLICATION PUBLICATIONS							Remove
Examiner Initial*	Cite No	Publication Number	Kind Code ¹	Publication Date	Name of Patentee or Applicant of cited Document	Pages,Columns,Lines where Relevant Passages or Relevant Figures Appear	
	1	20120062780	A1	2012-03-15	Taijiro MORIHISA		
	2	20150162048	A1	2015-06-11	Hirata et al.		

INFORMATION DISCLOSURE STATEMENT BY APPLICANT (Not for submission under 37 CFR 1.99)	Application Number		16048242	
	Filing Date		2018-07-28	
	First Named Inventor	Gal Shabtay		
	Art Unit			
	Examiner Name			
	Attorney Docket Number		COREPH-0079 US CON3	

3	20180241922	A1	2018-08-23	Baldwin et al.
4	20180295292	A1	2018-10-11	Lee et al.
5	20110234881	A1	2011-09-29	Wakabayashi et al.
6	20100020221	A1	2010-01-28	Tupman et al.
7	20150002683	A1	2015-01-01	Hu et al.
8	20150042870	A1	2015-02-12	Chan et al.
9	20120320467	A1	2012-12-20	Baik et al.
10	20020075258	A1	2002-06-20	Park et al.
11	20100283842	A1	2010-11-11	Guissin et al.
12	20160070088	A1	2016-03-10	Mutsumi KOGUCHI
13	20180120674	A1	2018-05-03	Avivi et al.

INFORMATION DISCLOSURE STATEMENT BY APPLICANT (Not for submission under 37 CFR 1.99)	Application Number		16048242		
	Filing Date		2018-07-28		
	First Named Inventor	Gal Shabtay			
	Art Unit				
	Examiner Name				
	Attorney Docket Number		COREPH-0079 US CON3		

	14	20150316744	A1	2015-11-05	Hsing-Hung Chen
	15	20160154204	A1	2016-06-02	Lim et al.

If you wish to add additional U.S. Published Application citation information please click the Add button.

FOREIGN PATENT DOCUMENTS

Examiner Initial*	Cite No	Foreign Document Number ³	Country Code ² i	Kind Code ⁴	Publication Date	Name of Patentee or Applicant of cited Document	Pages, Columns, Lines where Relevant Passages or Relevant Figures Appear	T ⁵
	1	1536633	EP	A1	2005-06-01	Sony Corp		
	2	2008076485	JP	A	2008-04-03	Mitani et al.		
	3	2004133054	JP	A	2004-04-30	Futami et al.		

If you wish to add additional Foreign Patent Document citation information please click the Add button.

NON-PATENT LITERATURE DOCUMENTS

Examiner Initials*	Cite No	Include name of the author (in CAPITAL LETTERS), title of the article (when appropriate), title of the item (book, magazine, journal, serial, symposium, catalog, etc), date, pages(s), volume-issue number(s), publisher, city and/or country where published.	T ⁵
	1		

If you wish to add additional non-patent literature document citation information please click the Add button.

EXAMINER SIGNATURE

Examiner Signature		Date Considered	
--------------------	--	-----------------	--

*EXAMINER: Initial if reference considered, whether or not citation is in conformance with MPEP 609. Draw line through a citation if not in conformance and not considered. Include copy of this form with next communication to applicant.

INFORMATION DISCLOSURE STATEMENT BY APPLICANT (Not for submission under 37 CFR 1.99)	Application Number	16048242
	Filing Date	2018-07-28
	First Named Inventor	Gal Shabtay
	Art Unit	
	Examiner Name	
	Attorney Docket Number	COREPH-0079 US CON3

¹ See Kind Codes of USPTO Patent Documents at www.USPTO.GOV or MPEP 901.04. ² Enter office that issued the document, by the two-letter code (WIPO Standard ST.3). ³ For Japanese patent documents, the indication of the year of the reign of the Emperor must precede the serial number of the patent document. ⁴ Kind of document by the appropriate symbols as indicated on the document under WIPO Standard ST.16 if possible. ⁵ Applicant is to place a check mark here if English language translation is attached.

INFORMATION DISCLOSURE STATEMENT BY APPLICANT (Not for submission under 37 CFR 1.99)	Application Number	16048242
	Filing Date	2018-07-28
	First Named Inventor	Gal Shabtay
	Art Unit	
	Examiner Name	
	Attorney Docket Number	COREPH-0079 US CON3

CERTIFICATION STATEMENT

Please see 37 CFR 1.97 and 1.98 to make the appropriate selection(s):

That each item of information contained in the information disclosure statement was first cited in any communication from a foreign patent office in a counterpart foreign application not more than three months prior to the filing of the information disclosure statement. See 37 CFR 1.97(e)(1).

OR

That no item of information contained in the information disclosure statement was cited in a communication from a foreign patent office in a counterpart foreign application, and, to the knowledge of the person signing the certification after making reasonable inquiry, no item of information contained in the information disclosure statement was known to any individual designated in 37 CFR 1.56(c) more than three months prior to the filing of the information disclosure statement. See 37 CFR 1.97(e)(2).

See attached certification statement.

The fee set forth in 37 CFR 1.17 (p) has been submitted herewith.

A certification statement is not submitted herewith.

SIGNATURE

A signature of the applicant or representative is required in accordance with CFR 1.33, 10.18. Please see CFR 1.4(d) for the form of the signature.

Signature	/Menachem Nathan/	Date (YYYY-MM-DD)	2019-01-05
Name/Print	MENACHEM NATHAN	Registration Number	65392

This collection of information is required by 37 CFR 1.97 and 1.98. The information is required to obtain or retain a benefit by the public which is to file (and by the USPTO to process) an application. Confidentiality is governed by 35 U.S.C. 122 and 37 CFR 1.14. This collection is estimated to take 1 hour to complete, including gathering, preparing and submitting the completed application form to the USPTO. Time will vary depending upon the individual case. Any comments on the amount of time you require to complete this form and/or suggestions for reducing this burden, should be sent to the Chief Information Officer, U.S. Patent and Trademark Office, U.S. Department of Commerce, P.O. Box 1450, Alexandria, VA 22313-1450. **DO NOT SEND FEES OR COMPLETED FORMS TO THIS ADDRESS. SEND TO: Commissioner for Patents, P.O. Box 1450, Alexandria, VA 22313-1450.**

Privacy Act Statement

The Privacy Act of 1974 (P.L. 93-579) requires that you be given certain information in connection with your submission of the attached form related to a patent application or patent. Accordingly, pursuant to the requirements of the Act, please be advised that: (1) the general authority for the collection of this information is 35 U.S.C. 2(b)(2); (2) furnishing of the information solicited is voluntary; and (3) the principal purpose for which the information is used by the U.S. Patent and Trademark Office is to process and/or examine your submission related to a patent application or patent. If you do not furnish the requested information, the U.S. Patent and Trademark Office may not be able to process and/or examine your submission, which may result in termination of proceedings or abandonment of the application or expiration of the patent.

The information provided by you in this form will be subject to the following routine uses:

1. The information on this form will be treated confidentially to the extent allowed under the Freedom of Information Act (5 U.S.C. 552) and the Privacy Act (5 U.S.C. 552a). Records from this system of records may be disclosed to the Department of Justice to determine whether the Freedom of Information Act requires disclosure of these records.
2. A record from this system of records may be disclosed, as a routine use, in the course of presenting evidence to a court, magistrate, or administrative tribunal, including disclosures to opposing counsel in the course of settlement negotiations.
3. A record in this system of records may be disclosed, as a routine use, to a Member of Congress submitting a request involving an individual, to whom the record pertains, when the individual has requested assistance from the Member with respect to the subject matter of the record.
4. A record in this system of records may be disclosed, as a routine use, to a contractor of the Agency having need for the information in order to perform a contract. Recipients of information shall be required to comply with the requirements of the Privacy Act of 1974, as amended, pursuant to 5 U.S.C. 552a(m).
5. A record related to an International Application filed under the Patent Cooperation Treaty in this system of records may be disclosed, as a routine use, to the International Bureau of the World Intellectual Property Organization, pursuant to the Patent Cooperation Treaty.
6. A record in this system of records may be disclosed, as a routine use, to another federal agency for purposes of National Security review (35 U.S.C. 181) and for review pursuant to the Atomic Energy Act (42 U.S.C. 218(c)).
7. A record from this system of records may be disclosed, as a routine use, to the Administrator, General Services, or his/her designee, during an inspection of records conducted by GSA as part of that agency's responsibility to recommend improvements in records management practices and programs, under authority of 44 U.S.C. 2904 and 2906. Such disclosure shall be made in accordance with the GSA regulations governing inspection of records for this purpose, and any other relevant (i.e., GSA or Commerce) directive. Such disclosure shall not be used to make determinations about individuals.
8. A record from this system of records may be disclosed, as a routine use, to the public after either publication of the application pursuant to 35 U.S.C. 122(b) or issuance of a patent pursuant to 35 U.S.C. 151. Further, a record may be disclosed, subject to the limitations of 37 CFR 1.14, as a routine use, to the public if the record was filed in an application which became abandoned or in which the proceedings were terminated and which application is referenced by either a published application, an application open to public inspections or an issued patent.
9. A record from this system of records may be disclosed, as a routine use, to a Federal, State, or local law enforcement agency, if the USPTO becomes aware of a violation or potential violation of law or regulation.

Under the Paperwork Reduction Act of 1995 no persons are required to respond to a collection of information unless it displays a valid OMB control number

UTILITY PATENT APPLICATION TRANSMITTAL <i>(Only for new nonprovisional applications under 37 CFR 1.53(b))</i>	Attorney Docket No.	COREPH-0079 US CON3
	First Named Inventor	Gal Shabtay
	Title	DUAL APERTURE ZOOM DIGITAL CAMERA
	Express Mail Label No.	

APPLICATION ELEMENTS <i>See MPEP chapter 600 concerning utility patent application contents.</i>	ADDRESS TO: Commissioner for Patents P.O. Box 1450 Alexandria, VA 22313-1450
--	--

1. <input type="checkbox"/> Fee Transmittal Form (PTO/SB/17 or equivalent) 2. <input type="checkbox"/> Applicant asserts small entity status. See 37 CFR 1.27 3. <input type="checkbox"/> Applicant certifies micro entity status. See 37 CFR 1.29. Applicant must attach form PTO/SB/15A or B or equivalent. 4. <input type="checkbox"/> Specification [Total Pages _____] Both the claims and abstract must start on a new page. (See MPEP § 608.01(a) for information on the preferred arrangement) 5. <input type="checkbox"/> Drawing(s) (35 U.S.C. 113) [Total Sheets _____] 6. <input type="checkbox"/> Inventor's Oath or Declaration [Total Pages _____] (including substitute statements under 37 CFR 1.64 and assignments serving as an oath or declaration under 37 CFR 1.63(e)) a. <input type="checkbox"/> Newly executed (original or copy) b. <input type="checkbox"/> A copy from a prior application (37 CFR 1.63(d)) 7. <input type="checkbox"/> Application Data Sheet * See note below. See 37 CFR 1.76 (PTO/AIA/14 or equivalent) 8. CD-ROM or CD-R in duplicate, large table, or Computer Program (Appendix) <input type="checkbox"/> Landscape Table on CD 9. Nucleotide and/or Amino Acid Sequence Submission (if applicable, items a. – c. are required) a. <input type="checkbox"/> Computer Readable Form (CRF) b. <input type="checkbox"/> Specification Sequence Listing on: i. <input type="checkbox"/> CD-ROM or CD-R (2 copies); or ii. <input type="checkbox"/> Paper c. <input type="checkbox"/> Statements verifying identity of above copies	ACCOMPANYING APPLICATION PAPERS 10. <input type="checkbox"/> Assignment Papers (cover sheet & document(s)) Name of Assignee _____ 11. <input type="checkbox"/> 37 CFR 3.73(c) Statement <input type="checkbox"/> Power of Attorney (when there is an assignee) 12. <input type="checkbox"/> English Translation Document (if applicable) 13. <input checked="" type="checkbox"/> Information Disclosure Statement (PTO/SB/08 or PTO-1449) <input checked="" type="checkbox"/> Copies of citations attached 14. <input type="checkbox"/> Preliminary Amendment 15. <input type="checkbox"/> Return Receipt Postcard (MPEP § 503) (Should be specifically itemized) 16. <input type="checkbox"/> Certified Copy of Priority Document(s) (if foreign priority is claimed) 17. <input type="checkbox"/> Nonpublication Request Under 35 U.S.C. 122(b)(2)(B)(i). Applicant must attach form PTO/SB/35 or equivalent. 18. <input checked="" type="checkbox"/> Other: Remarks - This is an IDS. Citation or identification of any reference in this IDS shall not be construed as an admission that such reference is available as prior art. _____ _____
--	--

***Note:** (1) Benefit claims under 37 CFR 1.78 and foreign priority claims under 1.55 **must** be included in an Application Data Sheet (ADS).
 (2) For applications filed under 35 U.S.C. 111, the application must contain an ADS specifying the applicant if the applicant is an assignee, person to whom the inventor is under an obligation to assign, or person who otherwise shows sufficient proprietary interest in the matter. See 37 CFR 1.46(b).

19. CORRESPONDENCE ADDRESS					
<input checked="" type="checkbox"/> The address associated with Customer Number: 92342 _____ OR <input type="checkbox"/> Correspondence address below					
Name					
Address					
City	State	Zip Code			
Country	Telephone	Email			

Signature	/Menachem Nathan/	Date	01-05-2019
Name (Print/Type)	MENACHEM NATHAN	Registration No. (Attorney/Agent)	65,392

This collection of information is required by 37 CFR 1.53(b). The information is required to obtain or retain a benefit by the public which is to file (and by the USPTO to process) an application. Confidentiality is governed by 35 U.S.C. 122 and 37 CFR 1.11 and 1.14. This collection is estimated to take 12 minutes to complete, including gathering, preparing, and submitting the completed application form to the USPTO. Time will vary depending upon the individual case. Any comments on the amount of time you require to complete this form and/or suggestions for reducing this burden, should be sent to the Chief Information Officer, U.S. Patent and Trademark Office, U.S. Department of Commerce, P.O. Box 1450, Alexandria, VA 22313-1450. DO NOT SEND FEES OR COMPLETED FORMS TO THIS ADDRESS. **SEND TO: Commissioner for Patents, P.O. Box 1450, Alexandria, VA 22313-1450.**

If you need assistance in completing the form, call 1-800-PTO-9199 and select option 2.

Privacy Act Statement

The **Privacy Act of 1974 (P.L. 93-579)** requires that you be given certain information in connection with your submission of the attached form related to a patent application or patent. Accordingly, pursuant to the requirements of the Act, please be advised that: (1) the general authority for the collection of this information is 35 U.S.C. 2(b)(2); (2) furnishing of the information solicited is voluntary; and (3) the principal purpose for which the information is used by the U.S. Patent and Trademark Office is to process and/or examine your submission related to a patent application or patent. If you do not furnish the requested information, the U.S. Patent and Trademark Office may not be able to process and/or examine your submission, which may result in termination of proceedings or abandonment of the application or expiration of the patent.

The information provided by you in this form will be subject to the following routine uses:

1. The information on this form will be treated confidentially to the extent allowed under the Freedom of Information Act (5 U.S.C. 552) and the Privacy Act (5 U.S.C. 552a). Records from this system of records may be disclosed to the Department of Justice to determine whether disclosure of these records is required by the Freedom of Information Act.
2. A record from this system of records may be disclosed, as a routine use, in the course of presenting evidence to a court, magistrate, or administrative tribunal, including disclosures to opposing counsel in the course of settlement negotiations.
3. A record in this system of records may be disclosed, as a routine use, to a Member of Congress submitting a request involving an individual, to whom the record pertains, when the individual has requested assistance from the Member with respect to the subject matter of the record.
4. A record in this system of records may be disclosed, as a routine use, to a contractor of the Agency having need for the information in order to perform a contract. Recipients of information shall be required to comply with the requirements of the Privacy Act of 1974, as amended, pursuant to 5 U.S.C. 552a(m).
5. A record related to an International Application filed under the Patent Cooperation Treaty in this system of records may be disclosed, as a routine use, to the International Bureau of the World Intellectual Property Organization, pursuant to the Patent Cooperation Treaty.
6. A record in this system of records may be disclosed, as a routine use, to another federal agency for purposes of National Security review (35 U.S.C. 181) and for review pursuant to the Atomic Energy Act (42 U.S.C. 218(c)).
7. A record from this system of records may be disclosed, as a routine use, to the Administrator, General Services, or his/her designee, during an inspection of records conducted by GSA as part of that agency's responsibility to recommend improvements in records management practices and programs, under authority of 44 U.S.C. 2904 and 2906. Such disclosure shall be made in accordance with the GSA regulations governing inspection of records for this purpose, and any other relevant (*i.e.*, GSA or Commerce) directive. Such disclosure shall not be used to make determinations about individuals.
8. A record from this system of records may be disclosed, as a routine use, to the public after either publication of the application pursuant to 35 U.S.C. 122(b) or issuance of a patent pursuant to 35 U.S.C. 151. Further, a record may be disclosed, subject to the limitations of 37 CFR 1.14, as a routine use, to the public if the record was filed in an application which became abandoned or in which the proceedings were terminated and which application is referenced by either a published application, an application open to public inspection or an issued patent.
9. A record from this system of records may be disclosed, as a routine use, to a Federal, State, or local law enforcement agency, if the USPTO becomes aware of a violation or potential violation of law or regulation.

INFORMATION DISCLOSURE STATEMENT BY APPLICANT (Not for submission under 37 CFR 1.99)	Application Number	16048242
	Filing Date	2018-07-28
	First Named Inventor	Gal Shabtay
	Art Unit	
	Examiner Name	
	Attorney Docket Number	COREPH-0079 US CON3

U.S.PATENTS							Remove
Examiner Initial*	Cite No	Patent Number	Kind Code ¹	Issue Date	Name of Patentee or Applicant of cited Document	Pages,Columns,Lines where Relevant Passages or Relevant Figures Appear	
	1	8149523	B2	2012-04-03	Yuichi Ozaki		
	2	9279957	B2	2016-03-08	Kanda et al.		
	3	9488802	B2	2016-11-08	Chen et al.		
	4	9185291	B1	2015-11-10	Shabtay at el.		
	5	8958164	B2	2015-02-17	Kwon et al.		
If you wish to add additional U.S. Patent citation information please click the Add button.							Add
U.S.PATENT APPLICATION PUBLICATIONS							Remove
Examiner Initial*	Cite No	Publication Number	Kind Code ¹	Publication Date	Name of Patentee or Applicant of cited Document	Pages,Columns,Lines where Relevant Passages or Relevant Figures Appear	
	1	20170115471	A1	2017-04-27	Yoshikazu Shinohara		

INFORMATION DISCLOSURE STATEMENT BY APPLICANT (Not for submission under 37 CFR 1.99)	Application Number		16048242		
	Filing Date		2018-07-28		
	First Named Inventor	Gal Shabtay			
	Art Unit				
	Examiner Name				
	Attorney Docket Number		COREPH-0079 US CON3		

2	20140362274	A1	2014-12-11	Christie et al.
3	20110001838	A1	2011-01-06	Sung Hwan Lee

If you wish to add additional U.S. Published Application citation information please click the Add button.

FOREIGN PATENT DOCUMENTS

Examiner Initial*	Cite No	Foreign Document Number ³	Country Code ² i	Kind Code ⁴	Publication Date	Name of Patentee or Applicant of cited Document	Pages, Columns, Lines where Relevant Passages or Relevant Figures Appear	T ⁵
	1							

If you wish to add additional Foreign Patent Document citation information please click the Add button.

NON-PATENT LITERATURE DOCUMENTS

Examiner Initials*	Cite No	Include name of the author (in CAPITAL LETTERS), title of the article (when appropriate), title of the item (book, magazine, journal, serial, symposium, catalog, etc), date, pages(s), volume-issue number(s), publisher, city and/or country where published.	T ⁵
	1		

If you wish to add additional non-patent literature document citation information please click the Add button.

EXAMINER SIGNATURE

Examiner Signature		Date Considered	
--------------------	--	-----------------	--

*EXAMINER: Initial if reference considered, whether or not citation is in conformance with MPEP 609. Draw line through a citation if not in conformance and not considered. Include copy of this form with next communication to applicant.

¹ See Kind Codes of USPTO Patent Documents at www.USPTO.GOV or MPEP 901.04. ² Enter office that issued the document, by the two-letter code (WIPO Standard ST.3). ³ For Japanese patent documents, the indication of the year of the reign of the Emperor must precede the serial number of the patent document. ⁴ Kind of document by the appropriate symbols as indicated on the document under WIPO Standard ST.16 if possible. ⁵ Applicant is to place a check mark here if English language translation is attached.

INFORMATION DISCLOSURE STATEMENT BY APPLICANT (Not for submission under 37 CFR 1.99)	Application Number	16048242
	Filing Date	2018-07-28
	First Named Inventor	Gal Shabtay
	Art Unit	
	Examiner Name	
	Attorney Docket Number	COREPH-0079 US CON3

CERTIFICATION STATEMENT

Please see 37 CFR 1.97 and 1.98 to make the appropriate selection(s):

That each item of information contained in the information disclosure statement was first cited in any communication from a foreign patent office in a counterpart foreign application not more than three months prior to the filing of the information disclosure statement. See 37 CFR 1.97(e)(1).

OR

That no item of information contained in the information disclosure statement was cited in a communication from a foreign patent office in a counterpart foreign application, and, to the knowledge of the person signing the certification after making reasonable inquiry, no item of information contained in the information disclosure statement was known to any individual designated in 37 CFR 1.56(c) more than three months prior to the filing of the information disclosure statement. See 37 CFR 1.97(e)(2).

See attached certification statement.

The fee set forth in 37 CFR 1.17 (p) has been submitted herewith.

A certification statement is not submitted herewith.

SIGNATURE

A signature of the applicant or representative is required in accordance with CFR 1.33, 10.18. Please see CFR 1.4(d) for the form of the signature.

Signature	/Menachem Nathan/	Date (YYYY-MM-DD)	2019-01-05
Name/Print	MENACHEM NATHAN	Registration Number	65392

This collection of information is required by 37 CFR 1.97 and 1.98. The information is required to obtain or retain a benefit by the public which is to file (and by the USPTO to process) an application. Confidentiality is governed by 35 U.S.C. 122 and 37 CFR 1.14. This collection is estimated to take 1 hour to complete, including gathering, preparing and submitting the completed application form to the USPTO. Time will vary depending upon the individual case. Any comments on the amount of time you require to complete this form and/or suggestions for reducing this burden, should be sent to the Chief Information Officer, U.S. Patent and Trademark Office, U.S. Department of Commerce, P.O. Box 1450, Alexandria, VA 22313-1450. **DO NOT SEND FEES OR COMPLETED FORMS TO THIS ADDRESS. SEND TO: Commissioner for Patents, P.O. Box 1450, Alexandria, VA 22313-1450.**

Privacy Act Statement

The Privacy Act of 1974 (P.L. 93-579) requires that you be given certain information in connection with your submission of the attached form related to a patent application or patent. Accordingly, pursuant to the requirements of the Act, please be advised that: (1) the general authority for the collection of this information is 35 U.S.C. 2(b)(2); (2) furnishing of the information solicited is voluntary; and (3) the principal purpose for which the information is used by the U.S. Patent and Trademark Office is to process and/or examine your submission related to a patent application or patent. If you do not furnish the requested information, the U.S. Patent and Trademark Office may not be able to process and/or examine your submission, which may result in termination of proceedings or abandonment of the application or expiration of the patent.

The information provided by you in this form will be subject to the following routine uses:

1. The information on this form will be treated confidentially to the extent allowed under the Freedom of Information Act (5 U.S.C. 552) and the Privacy Act (5 U.S.C. 552a). Records from this system of records may be disclosed to the Department of Justice to determine whether the Freedom of Information Act requires disclosure of these records.
2. A record from this system of records may be disclosed, as a routine use, in the course of presenting evidence to a court, magistrate, or administrative tribunal, including disclosures to opposing counsel in the course of settlement negotiations.
3. A record in this system of records may be disclosed, as a routine use, to a Member of Congress submitting a request involving an individual, to whom the record pertains, when the individual has requested assistance from the Member with respect to the subject matter of the record.
4. A record in this system of records may be disclosed, as a routine use, to a contractor of the Agency having need for the information in order to perform a contract. Recipients of information shall be required to comply with the requirements of the Privacy Act of 1974, as amended, pursuant to 5 U.S.C. 552a(m).
5. A record related to an International Application filed under the Patent Cooperation Treaty in this system of records may be disclosed, as a routine use, to the International Bureau of the World Intellectual Property Organization, pursuant to the Patent Cooperation Treaty.
6. A record in this system of records may be disclosed, as a routine use, to another federal agency for purposes of National Security review (35 U.S.C. 181) and for review pursuant to the Atomic Energy Act (42 U.S.C. 218(c)).
7. A record from this system of records may be disclosed, as a routine use, to the Administrator, General Services, or his/her designee, during an inspection of records conducted by GSA as part of that agency's responsibility to recommend improvements in records management practices and programs, under authority of 44 U.S.C. 2904 and 2906. Such disclosure shall be made in accordance with the GSA regulations governing inspection of records for this purpose, and any other relevant (i.e., GSA or Commerce) directive. Such disclosure shall not be used to make determinations about individuals.
8. A record from this system of records may be disclosed, as a routine use, to the public after either publication of the application pursuant to 35 U.S.C. 122(b) or issuance of a patent pursuant to 35 U.S.C. 151. Further, a record may be disclosed, subject to the limitations of 37 CFR 1.14, as a routine use, to the public if the record was filed in an application which became abandoned or in which the proceedings were terminated and which application is referenced by either a published application, an application open to public inspections or an issued patent.
9. A record from this system of records may be disclosed, as a routine use, to a Federal, State, or local law enforcement agency, if the USPTO becomes aware of a violation or potential violation of law or regulation.

Electronic Acknowledgement Receipt

EFS ID:	34771131
Application Number:	16048242
International Application Number:	
Confirmation Number:	4814
Title of Invention:	DUAL APERTURE ZOOM DIGITAL CAMERA
First Named Inventor/Applicant Name:	Gal Shabtay
Customer Number:	92342
Filer:	Menachem Nathan
Filer Authorized By:	
Attorney Docket Number:	COREPH-0079 US CON3
Receipt Date:	05-JAN-2019
Filing Date:	28-JUL-2018
Time Stamp:	07:58:58
Application Type:	Utility under 35 USC 111(a)

Payment information:

Submitted with Payment	no
------------------------	----

File Listing:

Document Number	Document Description	File Name	File Size(Bytes)/ Message Digest	Multi Part /.zip	Pages (if appl.)
1	Information Disclosure Statement (IDS) Form (SB08)	System_IDS2.pdf	1035233 <small>94deb1d4995386e45babbd01b0c8c9094b2a0829</small>	no	6

Warnings:

Information:					
2	Transmittal Letter	System_IDS2_TF.pdf	277390 8ac0644f1fc843e44dc9dbeae5433d448925b092	no	2
Warnings:					
Information:					
3	Information Disclosure Statement (IDS) Form (SB08)	Lens_IDS2.pdf	1034608 e2fa1f073077cd5ec08ed4f2597baf471764df98	no	4
Warnings:					
Information:					
4	Foreign Reference	System_FR2.pdf	227921 d1680c578dcd39a42a78adf55de77d1781c344a0	no	3
Warnings:					
The page size in the PDF is too large. The pages should be 8.5 x 11 or A4. If this PDF is submitted, the pages will be resized upon entry into the Image File Wrapper and may affect subsequent processing					
Information:					
Total Files Size (in bytes):			2575152		
<p>This Acknowledgement Receipt evidences receipt on the noted date by the USPTO of the indicated documents, characterized by the applicant, and including page counts, where applicable. It serves as evidence of receipt similar to a Post Card, as described in MPEP 503.</p> <p><u>New Applications Under 35 U.S.C. 111</u> If a new application is being filed and the application includes the necessary components for a filing date (see 37 CFR 1.53(b)-(d) and MPEP 506), a Filing Receipt (37 CFR 1.54) will be issued in due course and the date shown on this Acknowledgement Receipt will establish the filing date of the application.</p> <p><u>National Stage of an International Application under 35 U.S.C. 371</u> If a timely submission to enter the national stage of an international application is compliant with the conditions of 35 U.S.C. 371 and other applicable requirements a Form PCT/DO/EO/903 indicating acceptance of the application as a national stage submission under 35 U.S.C. 371 will be issued in addition to the Filing Receipt, in due course.</p> <p><u>New International Application Filed with the USPTO as a Receiving Office</u> If a new international application is being filed and the international application includes the necessary components for an international filing date (see PCT Article 11 and MPEP 1810), a Notification of the International Application Number and of the International Filing Date (Form PCT/RO/105) will be issued in due course, subject to prescriptions concerning national security, and the date shown on this Acknowledgement Receipt will establish the international filing date of the application.</p>					

Abstract

The motion of a moving subject is captured at a short time interval up to a wide area by tracking and photographing the moving subject. A wide angle area is photographed by a first camera, an area narrower than the wide angle area is photographed by a second camera, the presence or absence of the motion in an image is detected by a motion detecting section by comparing the first image with the second image in terms of the difference of luminance levels. The correlation of the positions of the first image and the second image is recorded by a memory, and the photographing direction of the second camera is controlled by a controller by using the correlation information when the presence of the motion is detected by the motion detecting section.

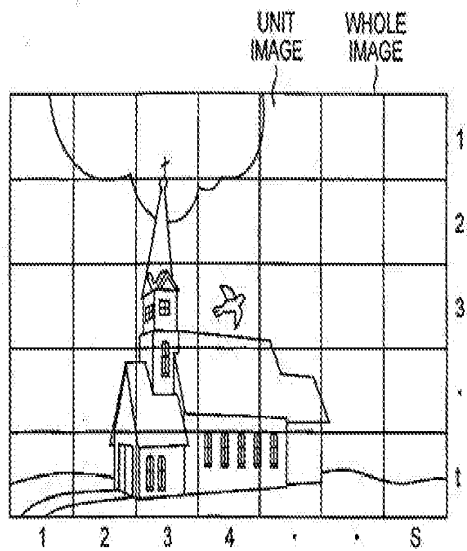

FIG. 1

EP1536633A1
 EP Application

Download PDF Find Prior Art Similar

Other languages: German, French

Inventor: Hiroshi Sony Corporation Hibi, Yuichi Sony Corporation Koike, Hideo Sony Corporation Miyamaki, Hirofumi Sony Corporation Sugiuchi, Masaharu Sony Corporation Suzuki, Satoshi Sony Corporation Tabuchi, Asako Sony Corporation Tamura

Current Assignee: Sony Corp

Original Assignee: Sony Corp

Priority date: 2003-11-27

Family: EP (1) KR (1) CN (1)

Date	App/Pub Number	Status
2004-11-25	EP20040028026	Withdrawn
2005-06-01	EP1536633A1	Application

EUROPEAN PATENT OFFICE

Patent Abstracts of Japan

PUBLICATION NUMBER : 2008076485
PUBLICATION DATE : 03-04-08

APPLICATION DATE : 19-09-06
APPLICATION NUMBER : 2006252495

APPLICANT : KONICA MINOLTA OPTO INC;

INVENTOR : MITANI YOSHIJI;

INT.CL. : G02B 7/04 (2006.01), G02B 7/08
(2006.01)

TITLE : LENS BARREL AND IMAGING
APPARATUS

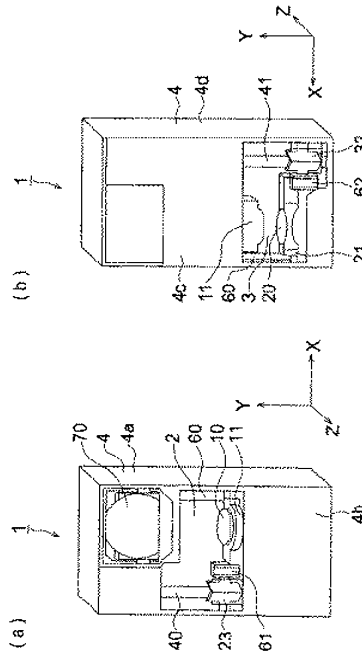

ABSTRACT : PROBLEM TO BE SOLVED: To provide a lens barrel that is small and rigid and can easily be incorporated and to provide a small imaging apparatus.

SOLUTION: The box-shaped lens barrel includes: an imaging optical system having two lens groups held in lens frames; and two drive shafts for supporting the respective lens frames so that they are movable relative to each other in the direction of an optical axis. In the lens barrel, openings are made in opposite walls of the lens barrel, which are orthogonal to a plane including the two drive shafts so as to be displaced from each other in the direction of the optical axis.

COPYRIGHT: (C)2008,JPO&INPIT

EUROPEAN PATENT OFFICE

Patent Abstracts of Japan

PUBLICATION NUMBER : 2004133054
PUBLICATION DATE : 30-04-04

APPLICATION DATE : 08-10-02
APPLICATION NUMBER : 2002295258

APPLICANT : OLYMPUS CORP;

INVENTOR : FUTAMI AKIRA;

INT.CL. : G02B 7/02 G02B 7/04 G02B 7/08
G03B 9/14 G03B 9/26 H04N 5/225

TITLE : LENS BARREL

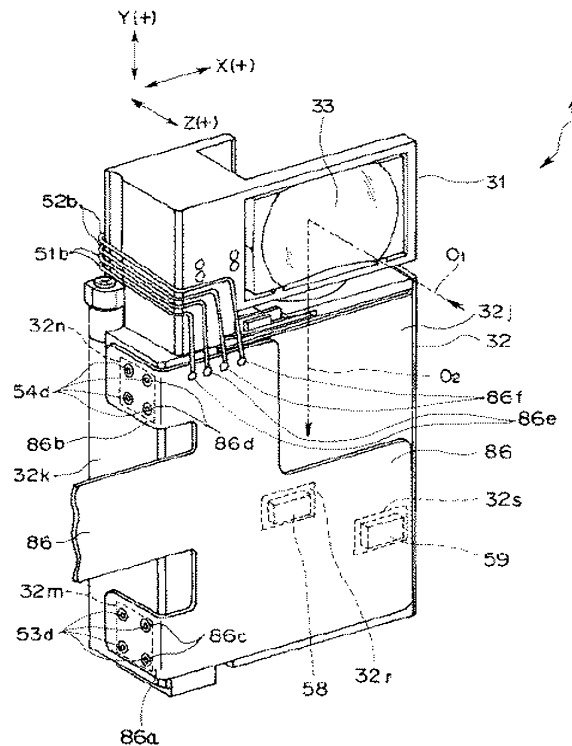

ABSTRACT : PROBLEM TO BE SOLVED: To provide a lens barrel made reliable, and made small in size and thin in thickness.

SOLUTION: The lens barrel 10 has a 1st group frame 31 and a fixed frame 32, and incorporates a prism to refract subject luminous flux from an incident optical axis to an optical axis being in a perpendicular direction in the 1st group frame. A lens group capable of moving forward and backward, a shutter unit and a CCD or the like are arranged in the frame 32, and a solenoid for driving a shutter is arranged on the left side of the frame 31 and a step motor for driving a lens group is arranged on the left side wall part 32k of the frame 32. PRs 58 and 59 for detecting the position of a lens group are positioned on a front side wall part 32j and mounted on an FPC for connection 86, and the motor terminals 53d and 54d of the step motor are inserted through the insertion holes 32m and 32n of the wall part 32k to the outside and connected to the FPC 86. By arranging the solenoid and the step motor on the left side of the frame member, the lens barrel is thinned.

COPYRIGHT: (C)2004,JPO



UNITED STATES PATENT AND TRADEMARK OFFICE

UNITED STATES DEPARTMENT OF COMMERCE
United States Patent and Trademark Office
Address: COMMISSIONER FOR PATENTS
P.O. Box 1450
Alexandria, Virginia 22313-1450
www.uspto.gov

APPLICATION NUMBER	FILING OR 371(C) DATE	FIRST NAMED APPLICANT	ATTY. DOCKET NO./TITLE
16/048,242	07/28/2018	Gal Shabtay	COREPH-0079 US CON3

CONFIRMATION NO. 4814

92342
Nathan & Associates Patent Agents Ltd
P.O.Box 10178
Tel Aviv, 6110101
ISRAEL

PUBLICATION NOTICE



Title:DUAL APERTURE ZOOM DIGITAL CAMERA

Publication No.US-2018-0359423-A1

Publication Date:12/13/2018

NOTICE OF PUBLICATION OF APPLICATION

The above-identified application will be electronically published as a patent application publication pursuant to 37 CFR 1.211, et seq. The patent application publication number and publication date are set forth above.

The publication may be accessed through the USPTO's publically available Searchable Databases via the Internet at www.uspto.gov. The direct link to access the publication is currently <http://www.uspto.gov/patft/>.

The publication process established by the Office does not provide for mailing a copy of the publication to applicant. A copy of the publication may be obtained from the Office upon payment of the appropriate fee set forth in 37 CFR 1.19(a)(1). Orders for copies of patent application publications are handled by the USPTO's Public Records Division. The Public Records Division can be reached by telephone at (571) 272-3150 or (800) 972-6382, by facsimile at (571) 273-3250, by mail addressed to the United States Patent and Trademark Office, Public Records Division, Alexandria, VA 22313-1450 or via the Internet.

In addition, information on the status of the application, including the mailing date of Office actions and the dates of receipt of correspondence filed in the Office, may also be accessed via the Internet through the Patent Electronic Business Center at www.uspto.gov using the public side of the Patent Application Information and Retrieval (PAIR) system. The direct link to access this status information is currently <https://portal.uspto.gov/pair/PublicPair>. Prior to publication, such status information is confidential and may only be obtained by applicant using the private side of PAIR.

Further assistance in electronically accessing the publication, or about PAIR, is available by calling the Patent Electronic Business Center at 1-866-217-9197.

Office of Data Management, Application Assistance Unit (571) 272-4000, or (571) 272-4200, or 1-888-786-0101

INFORMATION DISCLOSURE STATEMENT BY APPLICANT (Not for submission under 37 CFR 1.99)	Application Number	16048242
	Filing Date	2018-07-28
	First Named Inventor	Gal Shabtay
	Art Unit	
	Examiner Name	
	Attorney Docket Number	COREPH-0079 US CON3

U.S.PATENTS							Remove
Examiner Initial*	Cite No	Patent Number	Kind Code ¹	Issue Date	Name of Patentee or Applicant of cited Document	Pages, Columns, Lines where Relevant Passages or Relevant Figures Appear	
	1	9235036	B2	2016-01-12	Kato et al.		
	2	4134645	A	1979-01-16	Sugiyama et al.		
	3	7697220	B2	2010-04-13	Noriyuki Iyama		
	4	8279537	B2	2012-10-02	Setsu Sato		
	5	9438792	B2	2016-09-06	Nakada et al.		
	6	7777972	B1	2010-08-17	Chen et al.		
	7	8233224	B2	2012-07-31	Chun-Shan Chen		
	8	8854745	B1	2014-10-07	Wei-Yu Chen		

INFORMATION DISCLOSURE STATEMENT BY APPLICANT (Not for submission under 37 CFR 1.99)	Application Number		16048242
	Filing Date		2018-07-28
	First Named Inventor	Gal Shabtay	
	Art Unit		
	Examiner Name		
	Attorney Docket Number		COREPH-0079 US CON3

9	8004777	B2	2011-08-23	Yoshihito Souma
10	8780465	B2	2014-07-15	Kyu Min Chae
11	9817213	B2	2017-11-14	Romeo I. Mercado
12	7515351	B2	2009-04-07	Chen et al.
13	7564635	B1	2009-07-21	Hsiang-Chi Tang
14	7643225	B1	2010-01-05	Tsung-Han Tsai
15	7660049	B2	2010-02-09	Hsiang Chi TANG
16	7684128	B2	2010-03-23	Hsiang-Chi Tang
17	7692877	B2	2010-04-06	Tang et al.
18	7738186	B2	2010-06-15	Chen et al.
19	8363337	B2	2013-01-29	Tang et al.

INFORMATION DISCLOSURE STATEMENT BY APPLICANT (Not for submission under 37 CFR 1.99)	Application Number		16048242		
	Filing Date		2018-07-28		
	First Named Inventor	Gal Shabtay			
	Art Unit				
	Examiner Name				
	Attorney Docket Number		COREPH-0079 US CON3		

20	7813057	B2	2010-10-12	Ming Ching Lin
21	7821724	B2	2010-10-26	Tang et al.
22	7826149	B2	2010-11-02	Tang et al.
23	7826151	B2	2010-11-02	Tsung-Han Tsai
24	7869142	B2	2011-01-11	Chen et al.
25	7898747	B2	2011-03-01	Hsiang Chi Tang
26	7916401	B2	2011-03-29	Chen et al.
27	7957076	B2	2011-06-07	Hsiang Chi Tang
28	7957075	B2	2011-06-07	Hsiang Chi Tang
29	7957079	B2	2011-06-07	Hsiang Chi Tang
30	7961406	B1	2011-06-14	Tang et al.

INFORMATION DISCLOSURE STATEMENT BY APPLICANT (Not for submission under 37 CFR 1.99)	Application Number	16048242
	Filing Date	2018-07-28
	First Named Inventor	Gal Shabtay
	Art Unit	
	Examiner Name	
	Attorney Docket Number	COREPH-0079 US CON3

31	8000031	B2	2011-08-16	Tsung Han Tsai
32	8077400	B2	2011-12-13	Hsiang Chi Tang
33	8514502	B2	2013-08-20	Chun-Shan Chen
34	8395851	B2	2013-03-12	Tang et al.
35	8218253	B2	2012-07-10	Hsiang Chi Tang
36	8228622	B2	2012-07-24	Hsiang Chi Tang
37	8253843	B2	2012-08-28	Ming-Ching Lin
38	8400717	B2	2013-03-19	Chen et al.
39	8503107	B2	2013-08-06	Chen et al.
40	3388956	A	1968-06-18	Eggert et al.
41	3524700	A	1970-08-18	Eggert et al.

INFORMATION DISCLOSURE STATEMENT BY APPLICANT (Not for submission under 37 CFR 1.99)	Application Number		16048242	
	Filing Date		2018-07-28	
	First Named Inventor	Gal Shabtay		
	Art Unit			
	Examiner Name			
	Attorney Docket Number		COREPH-0079 US CON3	

42	3864027	A	1975-02-04	Kenichi Harada
43	3942876	A	1976-03-09	Ellis I. Betensky
44	5000551	A	1991-03-19	Atsushi Shibayama
45	6654180	B2	2003-11-25	Tetsuya Ori
46	7187504	B2	2007-03-06	Akihisa Horiuchi
47	8451549	B2	2013-05-28	Yamanaka et al.
48	2378170	A	1945-06-12	George H Aklin
49	2441093	A	1948-05-04	George H Aklin
50	2354503	A	1944-07-25	Cox Arthur
51	7688523	B2	2010-03-30	Eigo Sano
52	4338001	A	1982-07-06	Sei Matsui

INFORMATION DISCLOSURE STATEMENT BY APPLICANT (Not for submission under 37 CFR 1.99)	Application Number	16048242
	Filing Date	2018-07-28
	First Named Inventor	Gal Shabtay
	Art Unit	
	Examiner Name	
	Attorney Docket Number	COREPH-0079 US CON3

53	4465345	A	1984-08-14	Junichi Yazawa
54	9229194	B2	2016-01-05	Yoneyama et al.
55	8810923	B2	2014-08-19	Yoshikazu Shinohara
56	9678310	B2	2017-06-13	Iwasaki et al.
57	7918398	B2	2011-04-05	Li et al.
58	9568712	B2	2017-02-14	Dror et al.

If you wish to add additional U.S. Patent citation information please click the Add button.

Add

U.S.PATENT APPLICATION PUBLICATIONS

Remove

Examiner Initial*	Cite No	Publication Number	Kind Code ¹	Publication Date	Name of Patentee or Applicant of cited Document	Pages, Columns, Lines where Relevant Passages or Relevant Figures Appear
	1	20140022436	A1	2014-01-23	Kim et al.	
	2	20140204480	A1	2014-07-24	Jo et al.	
	3	20050141103	A1	2005-06-30	Kiichiro Nishina	

INFORMATION DISCLOSURE STATEMENT BY APPLICANT (Not for submission under 37 CFR 1.99)	Application Number		16048242		
	Filing Date		2018-07-28		
	First Named Inventor	Gal Shabtay			
	Art Unit				
	Examiner Name				
	Attorney Docket Number		COREPH-0079 US CON3		

4	20050168840	A1	2005-08-04	Kobayashi et al.
5	20070229983	A1	2007-10-04	Masakazu Saori
6	20090122423	A1	2009-05-14	Park et al.
7	20120154929	A1	2012-06-21	Tsai et al.
8	20130208178	A1	2013-08-15	Young-woo Park
9	20080304161	A1	2008-12-11	Yoshihito Souma
10	20160187631	A1	2016-06-30	Choi et al.
11	20180224630	A1	2018-08-09	Lee et al.
12	20110115965	A1	2011-05-19	Engelhardt et al.
13	20130286488	A1	2013-10-31	Kyu Min Chae
14	20170102522	A1	2017-04-13	Yong Joo Jo

INFORMATION DISCLOSURE STATEMENT BY APPLICANT (Not for submission under 37 CFR 1.99)	Application Number		16048242		
	Filing Date		2018-07-28		
	First Named Inventor	Gal Shabtay			
	Art Unit				
	Examiner Name				
	Attorney Docket Number		COREPH-0079 US CON3		

	15	20140285907	A1	2014-09-25	Tang et al.
	16	20120092777	A1	2012-04-19	Tochigi et al.
	17	20120105708	A1	2012-05-03	Yasuaki Hagiwara
	18	20150116569	A1	2015-04-30	Romeo I. Mercado
	19	20150253647	A1	2015-09-10	Romeo I. Mercado
	20	20160085089	A1	2016-03-24	Romeo I. Mercado
	21	20160313537	A1	2016-10-27	Romeo I. Mercado
	22	20140293453	A1	2014-10-02	Ogino et al.

If you wish to add additional U.S. Published Application citation information please click the Add button.

FOREIGN PATENT DOCUMENTS

Examiner Initial*	Cite No	Foreign Document Number ³	Country Code ² i	Kind Code ⁴	Publication Date	Name of Patentee or Applicant of cited Document	Pages, Columns, Lines where Relevant Passages or Relevant Figures Appear	T ⁵
	1	2007306282	JP	A	2007-11-22	Yasuaki Kayanuma		

INFORMATION DISCLOSURE STATEMENT BY APPLICANT (Not for submission under 37 CFR 1.99)	Application Number		16048242	
	Filing Date		2018-07-28	
	First Named Inventor	Gal Shabtay		
	Art Unit			
	Examiner Name			
	Attorney Docket Number		COREPH-0079 US CON3	

2	2013106289	JP	A	2013-05-30	Konno et al.		
3	20140023552	KR	A	2014-02-27	Kim Bum Geun		
4	S59121015	JP	A	1984-07-12	Yasushi Matsui		
5	2012203234	JP	A	2012-10-22	Matsuzaka et al.		
6	2013058111	WO	A1	2013-04-25	Hiroaki Tanaka		
7	S54157620	JP	A	1979-12-12	Toshiko Shimokura		
8	2013063097	WO	A1	2013-05-02	Cahall et al.		
9	104297906	CN	A	2015-01-21	Bo et al.		

If you wish to add additional Foreign Patent Document citation information please click the Add button

NON-PATENT LITERATURE DOCUMENTS

Examiner Initials*	Cite No	Include name of the author (in CAPITAL LETTERS), title of the article (when appropriate), title of the item (book, magazine, journal, serial, symposium, catalog, etc), date, pages(s), volume-issue number(s), publisher, city and/or country where published.	T5
	1	A compact and cost effective design for cell phone zoom lens, Chang et al., September 2007, 8 pages	

INFORMATION DISCLOSURE STATEMENT BY APPLICANT (Not for submission under 37 CFR 1.99)	Application Number		16048242
	Filing Date		2018-07-28
	First Named Inventor	Gal Shabtay	
	Art Unit		
	Examiner Name		
	Attorney Docket Number		COREPH-0079 US CON3

2	Consumer Electronic Optics: How small a lens can be? The case of panomorph lenses, Thibault et al., September 2014, 7 pages
3	Optical design of camera optics for mobile phones, Steinich et al., 2012, Pages 51-58 (8 pages)
4	The Optics of Miniature Digital Camera Modules, Bareau et al., 2006, 11 pages
5	Modeling and measuring liquid crystal tunable lenses, Peter P. Clark, 2014, 7 pages
6	Mobile Platform Optical Design, Peter P. Clark, 2014, 7 pages

If you wish to add additional non-patent literature document citation information please click the Add button

EXAMINER SIGNATURE

Examiner Signature		Date Considered	
--------------------	--	-----------------	--

*EXAMINER: Initial if reference considered, whether or not citation is in conformance with MPEP 609. Draw line through a citation if not in conformance and not considered. Include copy of this form with next communication to applicant.

¹ See Kind Codes of USPTO Patent Documents at www.USPTO.GOV or MPEP 901.04. ² Enter office that issued the document, by the two-letter code (WIPO Standard ST.3). ³ For Japanese patent documents, the indication of the year of the reign of the Emperor must precede the serial number of the patent document. ⁴ Kind of document by the appropriate symbols as indicated on the document under WIPO Standard ST.16 if possible. ⁵ Applicant is to place a check mark here if English language translation is attached.

INFORMATION DISCLOSURE STATEMENT BY APPLICANT (Not for submission under 37 CFR 1.99)	Application Number	16048242
	Filing Date	2018-07-28
	First Named Inventor	Gal Shabtay
	Art Unit	
	Examiner Name	
	Attorney Docket Number	COREPH-0079 US CON3

CERTIFICATION STATEMENT

Please see 37 CFR 1.97 and 1.98 to make the appropriate selection(s):

That each item of information contained in the information disclosure statement was first cited in any communication from a foreign patent office in a counterpart foreign application not more than three months prior to the filing of the information disclosure statement. See 37 CFR 1.97(e)(1).

OR

That no item of information contained in the information disclosure statement was cited in a communication from a foreign patent office in a counterpart foreign application, and, to the knowledge of the person signing the certification after making reasonable inquiry, no item of information contained in the information disclosure statement was known to any individual designated in 37 CFR 1.56(c) more than three months prior to the filing of the information disclosure statement. See 37 CFR 1.97(e)(2).

See attached certification statement.

The fee set forth in 37 CFR 1.17 (p) has been submitted herewith.

A certification statement is not submitted herewith.

SIGNATURE

A signature of the applicant or representative is required in accordance with CFR 1.33, 10.18. Please see CFR 1.4(d) for the form of the signature.

Signature	/Menachem Nathan/	Date (YYYY-MM-DD)	2018-09-20
Name/Print	Menachem Nathan	Registration Number	65392

This collection of information is required by 37 CFR 1.97 and 1.98. The information is required to obtain or retain a benefit by the public which is to file (and by the USPTO to process) an application. Confidentiality is governed by 35 U.S.C. 122 and 37 CFR 1.14. This collection is estimated to take 1 hour to complete, including gathering, preparing and submitting the completed application form to the USPTO. Time will vary depending upon the individual case. Any comments on the amount of time you require to complete this form and/or suggestions for reducing this burden, should be sent to the Chief Information Officer, U.S. Patent and Trademark Office, U.S. Department of Commerce, P.O. Box 1450, Alexandria, VA 22313-1450. **DO NOT SEND FEES OR COMPLETED FORMS TO THIS ADDRESS. SEND TO: Commissioner for Patents, P.O. Box 1450, Alexandria, VA 22313-1450.**

Privacy Act Statement

The Privacy Act of 1974 (P.L. 93-579) requires that you be given certain information in connection with your submission of the attached form related to a patent application or patent. Accordingly, pursuant to the requirements of the Act, please be advised that: (1) the general authority for the collection of this information is 35 U.S.C. 2(b)(2); (2) furnishing of the information solicited is voluntary; and (3) the principal purpose for which the information is used by the U.S. Patent and Trademark Office is to process and/or examine your submission related to a patent application or patent. If you do not furnish the requested information, the U.S. Patent and Trademark Office may not be able to process and/or examine your submission, which may result in termination of proceedings or abandonment of the application or expiration of the patent.

The information provided by you in this form will be subject to the following routine uses:

1. The information on this form will be treated confidentially to the extent allowed under the Freedom of Information Act (5 U.S.C. 552) and the Privacy Act (5 U.S.C. 552a). Records from this system of records may be disclosed to the Department of Justice to determine whether the Freedom of Information Act requires disclosure of these records.
2. A record from this system of records may be disclosed, as a routine use, in the course of presenting evidence to a court, magistrate, or administrative tribunal, including disclosures to opposing counsel in the course of settlement negotiations.
3. A record in this system of records may be disclosed, as a routine use, to a Member of Congress submitting a request involving an individual, to whom the record pertains, when the individual has requested assistance from the Member with respect to the subject matter of the record.
4. A record in this system of records may be disclosed, as a routine use, to a contractor of the Agency having need for the information in order to perform a contract. Recipients of information shall be required to comply with the requirements of the Privacy Act of 1974, as amended, pursuant to 5 U.S.C. 552a(m).
5. A record related to an International Application filed under the Patent Cooperation Treaty in this system of records may be disclosed, as a routine use, to the International Bureau of the World Intellectual Property Organization, pursuant to the Patent Cooperation Treaty.
6. A record in this system of records may be disclosed, as a routine use, to another federal agency for purposes of National Security review (35 U.S.C. 181) and for review pursuant to the Atomic Energy Act (42 U.S.C. 218(c)).
7. A record from this system of records may be disclosed, as a routine use, to the Administrator, General Services, or his/her designee, during an inspection of records conducted by GSA as part of that agency's responsibility to recommend improvements in records management practices and programs, under authority of 44 U.S.C. 2904 and 2906. Such disclosure shall be made in accordance with the GSA regulations governing inspection of records for this purpose, and any other relevant (i.e., GSA or Commerce) directive. Such disclosure shall not be used to make determinations about individuals.
8. A record from this system of records may be disclosed, as a routine use, to the public after either publication of the application pursuant to 35 U.S.C. 122(b) or issuance of a patent pursuant to 35 U.S.C. 151. Further, a record may be disclosed, subject to the limitations of 37 CFR 1.14, as a routine use, to the public if the record was filed in an application which became abandoned or in which the proceedings were terminated and which application is referenced by either a published application, an application open to public inspections or an issued patent.
9. A record from this system of records may be disclosed, as a routine use, to a Federal, State, or local law enforcement agency, if the USPTO becomes aware of a violation or potential violation of law or regulation.

INFORMATION DISCLOSURE STATEMENT BY APPLICANT (Not for submission under 37 CFR 1.99)	Application Number	16048242
	Filing Date	2018-07-28
	First Named Inventor	Gal Shabtay
	Art Unit	
	Examiner Name	
	Attorney Docket Number	COREPH-0079 US CON3

U.S.PATENTS Remove						
Examiner Initial*	Cite No	Patent Number	Kind Code ¹	Issue Date	Name of Patentee or Applicant of cited Document	Pages, Columns, Lines where Relevant Passages or Relevant Figures Appear
	1	9286680	B1	2016-03-15	Jiang et al.	
	2	9736391	B2	2017-08-15	Du et al.	
	3	9894287	B2	2018-02-13	Qian et al.	
	4	6750903	B1	2004-06-15	Miyatake et al.	
	5	5032917	A	1991-07-16	Felix Aschwanden	
	6	5287093	A	1994-02-15	Amano et al.	
	7	5287093	A	1995-02-28	John T. Hall	
	8	5444478	A	1995-08-22	Lelong et al.	

INFORMATION DISCLOSURE STATEMENT BY APPLICANT (Not for submission under 37 CFR 1.99)	Application Number		16048242	
	Filing Date		2018-07-28	
	First Named Inventor	Gal Shabtay		
	Art Unit			
	Examiner Name			
	Attorney Docket Number		COREPH-0079 US CON3	

9	5657402	A	1997-08-12	Bender et al.
10	5682198	A	1997-10-28	Katayama et al.
11	5926190	A	1999-07-20	Turkowski et al.
12	6128416	A	2000-10-03	Koutatsu Oura
13	6148120	A	2000-11-14	Michael Sussman
14	6208765	B1	2001-03-27	James Russell Bergen
15	7002583	B2	2006-02-21	Maurice F. Rabb, III
16	7346217	B1	2008-03-18	V. Edward Gold, Jr.
17	7424218	B2	2008-09-09	Baudisch et al.
18	7533819	B2	2009-05-19	Barkan et al.
19	7619683	B2	2009-11-17	Raymond A. Davis

INFORMATION DISCLOSURE STATEMENT BY APPLICANT (Not for submission under 37 CFR 1.99)	Application Number		16048242		
	Filing Date		2018-07-28		
	First Named Inventor	Gal Shabtay			
	Art Unit				
	Examiner Name				
	Attorney Docket Number		COREPH-0079 US CON3		

20	6268611	B1	2001-07-31	Pettersson et al.
21	6714665	B1	2004-03-30	Hanna et al.
22	5005083	A	1991-04-02	Grage et al.
23	5940641	A	1999-08-17	McIntyre et al.
24	6741250	B1	2004-05-25	Furlan et al.
25	7365793	B2	2008-04-29	Cheatle et al.
26	9413930	B2	2016-08-09	Joergen Geerds
27	4199785	A	1980-04-22	McCullough et al.
28	8400555	B1	2013-03-19	Georgiev et al.
29	8553106	B2	2013-10-08	Lawrence Scarff
30	9800798	B2	2017-10-24	Ravirala et al.

INFORMATION DISCLOSURE STATEMENT BY APPLICANT (Not for submission under 37 CFR 1.99)	Application Number	16048242
	Filing Date	2018-07-28
	First Named Inventor	Gal Shabtay
	Art Unit	
	Examiner Name	
	Attorney Docket Number	COREPH-0079 US CON3

31	5768443	A	1998-06-16	Michael et al.
32	6101334	A	2000-08-08	Stephen D. Fantone
33	6611289	B1	2003-08-26	Yu et al.
34	7015954	B1	2006-03-21	Foote et al.
35	7256944	B2	2007-08-14	Labaziewicz et al.
36	8587691	B2	2013-11-19	Yasuo Takane
37	8274552	B2	2012-09-25	Dahi et al.
38	8390729	B2	2013-03-05	Long et al.
39	8803990	B2	2014-08-12	Scott Smith
40	9270875	B2	2016-02-23	Brisedoux et al.
41	9485432	B1	2016-11-01	Medasani et al.

INFORMATION DISCLOSURE STATEMENT BY APPLICANT (Not for submission under 37 CFR 1.99)	Application Number		16048242		
	Filing Date		2018-07-28		
	First Named Inventor	Gal Shabtay			
	Art Unit				
	Examiner Name				
	Attorney Docket Number		COREPH-0079 US CON3		

42	5436660	A	1995-07-25	Yukio Sakamoto
43	6549215	B2	2003-04-15	Norman P. Jouppi
44	7411610	B2	2008-08-12	Michael Doyle
45	8439265	B2	2013-05-14	Ferren et al.
46	5248971	A	1993-09-28	William J. Mandl
47	5459520	A	1995-10-17	Tadao Sasaki
48	7038716	B2	2006-05-02	Klein et al.
49	7339621	B2	2008-03-04	Justin Fortier
50	9215385	B2	2015-12-15	Xiaodong Luo
51	7305180	B2	2007-12-04	Labaziewicz et al.
52	7978239	B2	2011-07-12	Deever et al.

INFORMATION DISCLOSURE STATEMENT BY APPLICANT (Not for submission under 37 CFR 1.99)	Application Number		16048242		
	Filing Date		2018-07-28		
	First Named Inventor	Gal Shabtay			
	Art Unit				
	Examiner Name				
	Attorney Docket Number		COREPH-0079 US CON3		

53	7199348	B2	2007-04-03	Olsen et al.
54	8115825	B2	2012-02-14	Culbert et al.
55	7964835	B2	2011-06-21	Olsen et al.
56	8154610	B2	2012-04-10	Jo et al.
57	8619148	B2	2013-12-31	Watts et al.
58	5051830	A	1991-09-24	Wolfgang von Hoessle
59	5982951	A	1999-11-09	Katayama et al.
60	6738073	B2	2004-05-18	Park et al.
61	9025073	B2	2015-05-05	Attar et al.
62	9025077	B2	2015-05-05	Attar et al.
63	9413984	B2	2016-08-09	Attar et al.

INFORMATION DISCLOSURE STATEMENT BY APPLICANT (Not for submission under 37 CFR 1.99)	Application Number		16048242	
	Filing Date		2018-07-28	
	First Named Inventor	Gal Shabtay		
	Art Unit			
	Examiner Name			
	Attorney Docket Number		COREPH-0079 US CON3	

64	9578257	B2	2017-02-21	Attar et al.
65	9681057	B2	2017-06-13	Attar et al.
66	7206136	B2	2007-04-17	Labaziewicz et al.
67	7509041	B2	2009-03-24	Eiji Hosono
68	8976255	B2	2015-03-10	Matsuoto et al.
69	9041835	B2	2015-05-26	Yoshiaki Honda
70	9723220	B2	2017-08-01	Kazuhiko Sugie
71	8483452	B2	2013-07-09	Jeda et al.
72	9137447	B2	2015-09-15	Koji Shibuno
73	7880776	B2	2011-02-01	LeGall et al.
74	9618748	B2	2017-04-11	Munger et al.

INFORMATION DISCLOSURE STATEMENT BY APPLICANT (Not for submission under 37 CFR 1.99)	Application Number		16048242	
	Filing Date		2018-07-28	
	First Named Inventor	Gal Shabtay		
	Art Unit			
	Examiner Name			
	Attorney Docket Number		COREPH-0079 US CON3	

75	9019387	B2	2015-04-28	Akira Nakano
76	8446484	B2	2013-05-21	Muukki et al.
77	8238695	B1	2012-08-07	Davey et al.
78	6680748	B1	2004-01-20	John Mario Monti
79	9344626	B2	2016-05-17	Silverstein et al.
80	9420180	B2	2016-08-16	Chongting Jin
81	8391697	B2	2013-03-05	Cho et al.
82	9438792	B2	2016-09-06	Nakada et al.
83	9215377	B2	2015-12-15	Sokeila et al.
84	9360671	B1	2016-06-07	Changyin Zhou
85	9736365	B2	2017-08-15	Rajiv Laroia

INFORMATION DISCLOSURE STATEMENT BY APPLICANT (Not for submission under 37 CFR 1.99)	Application Number		16048242	
	Filing Date		2018-07-28	
	First Named Inventor	Gal Shabtay		
	Art Unit			
	Examiner Name			
	Attorney Docket Number		COREPH-0079 US CON3	

86	9851803	B2	2017-12-26	Fisher et al.
87	6778207	B1	2004-08-17	Lee et al
88	8514491	B2	2013-08-20	Jacques Duparre
89	98896655	B2	2014-11-25	Mauchly et al.
90	9369621	B2	2016-06-14	Malone et al.
91	9900522	B2	2018-02-20	Yuesheng Lu
92	8547389	B2	2013-10-01	Hoppe et al.
93	7738016	B2	2010-06-15	Toshiyuki Toyofuku
94	7918398	B2	2011-04-05	Li et al.
95	7248294	B2	2007-07-24	David Neil Slatter
96	6724421	B1	2004-04-20	Terry Laurence Glatt

INFORMATION DISCLOSURE STATEMENT BY APPLICANT (Not for submission under 37 CFR 1.99)	Application Number	16048242
	Filing Date	2018-07-28
	First Named Inventor	Gal Shabtay
	Art Unit	
	Examiner Name	
	Attorney Docket Number	COREPH-0079 US CON3

97	8149327	B2	2012-04-03	Lin et al.
98	6643416	B1	2003-11-04	Daniels et al.
99	6650368	B1	2003-11-18	Amir Doron

If you wish to add additional U.S. Patent citation information please click the Add button.

U.S.PATENT APPLICATION PUBLICATIONS

Examiner Initial*	Cite No	Publication Number	Kind Code ¹	Publication Date	Name of Patentee or Applicant of cited Document	Pages, Columns, Lines where Relevant Passages or Relevant Figures Appear
	1	20090295949	A1	2009-12-03	Kai Markus Ojala	
	2	20110080487	A1	2011-04-07	Venkataraman et al.	
	3	20170289458	A1	2017-10-05	Song et al.	
	4	20130250150	A1	2013-09-26	Malone et al.	
	5	20140118584	A1	2014-05-01	Lee et al.	
	6	20160301840	A1	2016-10-13	Du et al.	

INFORMATION DISCLOSURE STATEMENT BY APPLICANT (Not for submission under 37 CFR 1.99)	Application Number		16048242		
	Filing Date		2018-07-28		
	First Named Inventor	Gal Shabtay			
	Art Unit				
	Examiner Name				
	Attorney Docket Number		COREPH-0079 US CON3		

7	20170019616	A1	2017-01-19	Zhu et al.
8	20170214846	A1	2017-07-27	Du et al.
9	20180150973	A1	2018-05-31	Tang et al.
10	20020005902	A1	2002-01-17	Henry Yuen
11	20100103194	A1	2010-04-29	Chen et al.
12	20130135445	A1	2013-05-30	Dahi et al.
13	20150154776	A1	2015-06-04	Zhang et al.
14	20170214866	A1	2017-07-27	Zhu et al.
15	20120287315	A1	2012-11-15	Huang et al.
16	20150271471	A1	2015-09-24	Hsieh et al.
17	20150334309	A1	2015-11-19	Peng et al.

INFORMATION DISCLOSURE STATEMENT BY APPLICANT (Not for submission under 37 CFR 1.99)	Application Number		16048242	
	Filing Date		2018-07-28	
	First Named Inventor	Gal Shabtay		
	Art Unit			
	Examiner Name			
	Attorney Docket Number		COREPH-0079 US CON3	

18	20160353012	A1	2016-12-01	Kao et al.
19	20020122113	A1	2002-09-05	Jonathan Foote
20	20030093805	A1	2003-05-15	J.M. Gin
21	20040027367	A1	2004-02-12	Maurizio Pilu
22	20050013509	A1	2005-01-20	Ramin Samadani
23	20070188653	A1	2007-08-16	Pollock et al.
24	20080017557	A1	2008-01-24	Calvin J. Witdouch
25	20100013906	A1	2010-01-21	Border et al,
26	20080030592	A1	2008-02-07	Border et al,
27	20090122195	A1	2009-05-14	Van Baar et al.
28	20050046740	A1	2005-03-03	Raymond Davis

INFORMATION DISCLOSURE STATEMENT BY APPLICANT (Not for submission under 37 CFR 1.99)	Application Number		16048242
	Filing Date		2018-07-28
	First Named Inventor	Gal Shabtay	
	Art Unit		
	Examiner Name		
	Attorney Docket Number		COREPH-0079 US CON3

29	20060054782	A1	2006-03-16	Olsen et al.
30	20060056056	A1	2006-03-16	Ahiska et al.
31	20070257184	A1	2007-11-08	Olsen et al.
32	20070285550	A1	2007-12-13	Jae-Gon Son
33	20080030611	A1	2008-02-07	Michael V. Jenkins
34	20090086074	A1	2009-04-02	Li et al.
35	20100060746	A9	2010-03-11	Olsen et al.
36	20130235224	A1	2013-09-12	Park et al.
37	20040008773	A1	2004-01-15	Osamu Itokawa
38	20040017386	A1	2004-01-29	Liu et al.
39	20040240052	A1	2004-12-02	Minefuji et al.

INFORMATION DISCLOSURE STATEMENT BY APPLICANT (Not for submission under 37 CFR 1.99)	Application Number		16048242
	Filing Date		2018-07-28
	First Named Inventor	Gal Shabtay	
	Art Unit		
	Examiner Name		
	Attorney Docket Number		COREPH-0079 US CON3

40	20030202113	A1	2003-10-30	Sumito Yoshikawa
41	20060187310	A1	2006-08-24	Janson et al.
42	20060187322	A1	2006-08-24	Janson et al.
43	20060187338	A1	2006-08-24	May et al.
44	20070024737	A1	2007-02-01	Nakamura et al.
45	20080025634	A1	2008-01-31	Border et al.
46	20080218611	A1	2008-09-11	Parulski et al.
47	20080218612	A1	2008-09-11	Border et al.
48	20080218613	A1	2008-09-11	Janson et al.
49	20080219654	A1	2008-09-11	Border et al.
50	20110242286	A1	2011-10-06	Pace et al.

INFORMATION DISCLOSURE STATEMENT BY APPLICANT (Not for submission under 37 CFR 1.99)	Application Number		16048242		
	Filing Date		2018-07-28		
	First Named Inventor	Gal Shabtay			
	Art Unit				
	Examiner Name				
	Attorney Docket Number		COREPH-0079 US CON3		

51	20080117316	A1	2008-05-22	Masaaki Orimoto
52	20160212358	A1	2016-07-21	Yasuhito Shikata
53	20030160886	A1	2003-08-28	Misawa et al.
54	20070177025	A1	2007-08-02	Kopet et al.
55	20070189386	A1	2007-08-16	Imagawa et al.
56	20080024614	A1	2008-01-31	Li et al.
57	20110242355	A1	2011-10-06	Goma et al.
58	20120196648	A1	2012-08-02	Havens et al.
59	20130258044	A1	2013-10-03	Betts-LaCroix
60	20140192253	A1	2014-07-10	Rajiv Laroia
61	20150092066	A1	2015-04-02	Geiss et al.

INFORMATION DISCLOSURE STATEMENT BY APPLICANT (Not for submission under 37 CFR 1.99)	Application Number		16048242
	Filing Date		2018-07-28
	First Named Inventor	Gal Shabtay	
	Art Unit		
	Examiner Name		
	Attorney Docket Number		COREPH-0079 US CON3

62	20060175549	A1	2006-08-10	Miller et al.
63	20120075489	A1	2012-03-29	H. Keith Nishihara
64	20130182150	A1	2013-07-18	Ayako Asakura
65	20140192238	A1	2014-07-10	Attar et al.
66	20090295949	A1	2009-12-03	Kai Markus Ojala
67	20100238327	A1	2010-09-23	Griffith et al.
68	20120229663	A1	2012-09-13	Nelson et al.
69	20130201360	A1	2013-08-08	Yong-Bae Song
70	20150242994	A1	2015-08-27	Ji Shen
71	20050157184	A1	2005-07-21	Nakanishi et al.
72	20050200718	A1	2005-09-15	Chang-Hee Lee

INFORMATION DISCLOSURE STATEMENT BY APPLICANT (Not for submission under 37 CFR 1.99)	Application Number		16048242		
	Filing Date		2018-07-28		
	First Named Inventor	Gal Shabtay			
	Art Unit				
	Examiner Name				
	Attorney Docket Number		COREPH-0079 US CON3		

73	20040061788	A1	2004-04-01	John Bateman
74	20150215516	A1	2015-07-30	Benjamin P. Dolgin
75	20140313316	A1	2014-10-23	Olsson et al.
76	20110229054	A1	2011-09-22	Weston et al.
77	20020063711	A1	2016-06-14	Park et al.
78	20090128644	A1	2009-05-21	Camp et al.
79	20130321668	A1	2013-12-05	Ajith Kamath
80	20130202273	A1	2013-08-08	Ouedraogo et al.
81	20120069235	A1	2012-03-22	Francisco Imai
82	20130002928	A1	2013-01-03	Francisco Imai
83	20120105579	A1	2012-05-03	Jeon et al.

INFORMATION DISCLOSURE STATEMENT BY APPLICANT (Not for submission under 37 CFR 1.99)	Application Number		16048242	
	Filing Date		2018-07-28	
	First Named Inventor	Gal Shabtay		
	Art Unit			
	Examiner Name			
	Attorney Docket Number		COREPH-0079 US CON3	

84	20030030729	A1	2003-02-13	Prentice et al.
85	20110064327	A1	2011-03-17	Dagher et al.
86	20110128288	A1	2011-06-02	Petrou et al.
87	20120026366	A1	2012-02-02	Golan et al.
88	20130093842	A1	2013-04-18	Kazuhiro Yahata
89	20150237280	A1	2015-08-20	Choi et al.
90	20060125937	A1	2006-06-15	LeGall et al.
91	20060170793	A1	2006-08-03	Pasquarette et al.
92	20080084484	A1	2008-04-10	Ochi et al.
93	20110234853	A1	2011-09-29	Hayashi et al.
94	20160154202	A1	2016-06-02	Wippermann et al.

INFORMATION DISCLOSURE STATEMENT BY APPLICANT (Not for submission under 37 CFR 1.99)	Application Number	16048242
	Filing Date	2018-07-28
	First Named Inventor	Gal Shabtay
	Art Unit	
	Examiner Name	
	Attorney Docket Number	COREPH-0079 US CON3

95	20120249815	A1	2012-10-04	Bohn et al.
96	20160044250	A1	2016-02-11	Shabtay et al.
97	20150195458	A1	2015-07-09	Nakayama et al.
98	20140362242	A1	2014-12-11	Teruyuki Takizawa
99	20090122406	A1	2009-05-14	Rouvinen et al.
100	20090252484	A1	2009-10-08	Hasuda et al.
101	20090219547	A1	2009-09-03	Kauhanen et al.
102	20140049615	A1	2014-02-20	Satoshi Uwagawa
103	20110164172	A1	2011-07-07	Shintani et al.

If you wish to add additional U.S. Published Application citation information please click the Add button.

FOREIGN PATENT DOCUMENTS

Examiner Initial*	Cite No	Foreign Document Number ³	Country Code ²	Kind Code ⁴	Publication Date	Name of Patentee or Applicant of cited Document	Pages, Columns, Lines where Relevant Passages or Relevant Figures Appear	T ⁵
-------------------	---------	--------------------------------------	---------------------------	------------------------	------------------	---	--	----------------

INFORMATION DISCLOSURE STATEMENT BY APPLICANT (Not for submission under 37 CFR 1.99)	Application Number		16048242		
	Filing Date		2018-07-28		
	First Named Inventor	Gal Shabtay			
	Art Unit				
	Examiner Name				
	Attorney Docket Number		COREPH-0079 US CON3		

1	102739949	CN	A	2012-10-17	Zhang Kerun		
2	103024272	CN	A	2013-04-03	Gao Xiaowen		
3	2523450	EP	A1	2012-11-14	Huang et al.		
4	101276415	CN	A	2008-10-01	Wu et al.		
5	2007306282	JP	A	2007-11-22	Yasuaki Kayanuma		
6	2003298920	JP	A	2003-10-17	Misawa et al.		
7	2006238325	JP	A	2006-09-07	Kagiwada et al.		
8	2013106289	JP	A	2013-05-30	Konno et al.		
9	2005099265	JP	A	2005-04-14	Ito et al.		
10	101477178	KR	B1	2014-12-29	Sun et al.		
11	20100008936	KR	A	2010-01-27	Sun et al.		

INFORMATION DISCLOSURE STATEMENT BY APPLICANT (Not for submission under 37 CFR 1.99)	Application Number		16048242	
	Filing Date		2018-07-28	
	First Named Inventor	Gal Shabtay		
	Art Unit			
	Examiner Name			
	Attorney Docket Number		COREPH-0079 US CON3	

12	08271976	JP	A	1996-10-18	Tamamura Hideo		
13	04211230	JP	A	1992-08-03	Jeda Satoshi		
14	20140014787	KR	A	2014-02-06	Young-Ho Kim		
15	2007228006	JP	A	2007-09-06	Ichigo		
16	H07318864	JP	A	1995-12-08	Kawamura et al.		

If you wish to add additional Foreign Patent Document citation information please click the Add button

NON-PATENT LITERATURE DOCUMENTS

Examiner Initials*	Cite No	Include name of the author (in CAPITAL LETTERS), title of the article (when appropriate), title of the item (book, magazine, journal, serial, symposium, catalog, etc), date, pages(s), volume-issue number(s), publisher, city and/or country where published.	T5
	1	Statistical Modeling and Performance Characterization of a Real-Time Dual Camera Surveillance System, Greienhagen et al., Publisher: IEEE, 2000, 8 pages	
	2	A 3MPixel Multi-Aperture Image Sensor with 0.7µm Pixels in 0.11µm CMOS, Fife et al., Stanford University, 2008, 3 pages	
	3	Dual camera intelligent sensor for high definition 360 degrees surveillance, Scotti et al., Publisher: IET, 05/09/2000, 8 pages	
	4	Dual-sensor foveated imaging system, Hua et al., Publisher: Optical Society of America, 01/14/2008, 11 pages	

INFORMATION DISCLOSURE STATEMENT BY APPLICANT (Not for submission under 37 CFR 1.99)	Application Number		16048242
	Filing Date		2018-07-28
	First Named Inventor	Gal Shabtay	
	Art Unit		
	Examiner Name		
	Attorney Docket Number		COREPH-0079 US CON3

5	Defocus Video Matting, McGuire et al., Publisher: ACM SIGGRAPH, 07/31/2005, 11 pages
6	Compact multi-aperture imaging with high angular resolution, Santacana et al., Publisher: Optical Society of America, 2015, 10 pages
7	Multi-Aperture Photography, Green et al., Publisher: Mitsubishi Electric Research Laboratories, Inc., July 2007, 10 pages
8	Multispectral Bilateral Video Fusion, Bennett et al., Publisher: IEEE, May 2007, 10 pages
9	Super-resolution imaging using a camera array, Santacana et al., Publisher: Optical Society of America, 2014, 6 pages
10	Optical Splitting Trees for High-Precision Monocular Imaging, McGuire et al., Publisher: IEEE, 2007, 11 pages
11	High Performance Imaging Using Large Camera Arrays, Wilburn et al., Publisher: Association for Computing Machinery, Inc., 2005, 12 pages
12	Real-time Edge-Aware Image Processing with the Bilateral Grid, Chen et al., Publisher: ACM SIGGRAPH, 9 pages
13	Superimposed multi-resolution imaging, Carles et al., Publisher: Optical Society of America, 2017, 13 pages
14	Viewfinder Alignment, Adams et al., Publisher: EUROGRAPHICS, 2008, 10 pages
15	Dual-Camera System for Multi-Level Activity Recognition, Bodor et al., Publisher: IEEE, October 2014, 6 pages

INFORMATION DISCLOSURE STATEMENT BY APPLICANT (Not for submission under 37 CFR 1.99)	Application Number	16048242
	Filing Date	2018-07-28
	First Named Inventor	Gal Shabtay
	Art Unit	
	Examiner Name	
	Attorney Docket Number	COREPH-0079 US CON3

16	Engineered to the task: Why camera-phone cameras are different, Giles Humpston, Publisher: Solid State Technology, June 2009, 3 pages
----	---

If you wish to add additional non-patent literature document citation information please click the Add button

EXAMINER SIGNATURE

Examiner Signature		Date Considered	
--------------------	--	-----------------	--

*EXAMINER: Initial if reference considered, whether or not citation is in conformance with MPEP 609. Draw line through a citation if not in conformance and not considered. Include copy of this form with next communication to applicant.

¹ See Kind Codes of USPTO Patent Documents at www.USPTO.GOV or MPEP 901.04. ² Enter office that issued the document, by the two-letter code (WIPO Standard ST.3). ³ For Japanese patent documents, the indication of the year of the reign of the Emperor must precede the serial number of the patent document. ⁴ Kind of document by the appropriate symbols as indicated on the document under WIPO Standard ST.16 if possible. ⁵ Applicant is to place a check mark here if English language translation is attached.

INFORMATION DISCLOSURE STATEMENT BY APPLICANT (Not for submission under 37 CFR 1.99)	Application Number	16048242
	Filing Date	2018-07-28
	First Named Inventor	Gal Shabtay
	Art Unit	
	Examiner Name	
	Attorney Docket Number	COREPH-0079 US CON3

CERTIFICATION STATEMENT

Please see 37 CFR 1.97 and 1.98 to make the appropriate selection(s):

That each item of information contained in the information disclosure statement was first cited in any communication from a foreign patent office in a counterpart foreign application not more than three months prior to the filing of the information disclosure statement. See 37 CFR 1.97(e)(1).

OR

That no item of information contained in the information disclosure statement was cited in a communication from a foreign patent office in a counterpart foreign application, and, to the knowledge of the person signing the certification after making reasonable inquiry, no item of information contained in the information disclosure statement was known to any individual designated in 37 CFR 1.56(c) more than three months prior to the filing of the information disclosure statement. See 37 CFR 1.97(e)(2).

See attached certification statement.

The fee set forth in 37 CFR 1.17 (p) has been submitted herewith.

A certification statement is not submitted herewith.

SIGNATURE

A signature of the applicant or representative is required in accordance with CFR 1.33, 10.18. Please see CFR 1.4(d) for the form of the signature.

Signature	/Menachem Nathan/	Date (YYYY-MM-DD)	2018-09-20
Name/Print	Menachem Nathan	Registration Number	65392

This collection of information is required by 37 CFR 1.97 and 1.98. The information is required to obtain or retain a benefit by the public which is to file (and by the USPTO to process) an application. Confidentiality is governed by 35 U.S.C. 122 and 37 CFR 1.14. This collection is estimated to take 1 hour to complete, including gathering, preparing and submitting the completed application form to the USPTO. Time will vary depending upon the individual case. Any comments on the amount of time you require to complete this form and/or suggestions for reducing this burden, should be sent to the Chief Information Officer, U.S. Patent and Trademark Office, U.S. Department of Commerce, P.O. Box 1450, Alexandria, VA 22313-1450. **DO NOT SEND FEES OR COMPLETED FORMS TO THIS ADDRESS. SEND TO: Commissioner for Patents, P.O. Box 1450, Alexandria, VA 22313-1450.**

Privacy Act Statement

The Privacy Act of 1974 (P.L. 93-579) requires that you be given certain information in connection with your submission of the attached form related to a patent application or patent. Accordingly, pursuant to the requirements of the Act, please be advised that: (1) the general authority for the collection of this information is 35 U.S.C. 2(b)(2); (2) furnishing of the information solicited is voluntary; and (3) the principal purpose for which the information is used by the U.S. Patent and Trademark Office is to process and/or examine your submission related to a patent application or patent. If you do not furnish the requested information, the U.S. Patent and Trademark Office may not be able to process and/or examine your submission, which may result in termination of proceedings or abandonment of the application or expiration of the patent.

The information provided by you in this form will be subject to the following routine uses:

1. The information on this form will be treated confidentially to the extent allowed under the Freedom of Information Act (5 U.S.C. 552) and the Privacy Act (5 U.S.C. 552a). Records from this system of records may be disclosed to the Department of Justice to determine whether the Freedom of Information Act requires disclosure of these records.
2. A record from this system of records may be disclosed, as a routine use, in the course of presenting evidence to a court, magistrate, or administrative tribunal, including disclosures to opposing counsel in the course of settlement negotiations.
3. A record in this system of records may be disclosed, as a routine use, to a Member of Congress submitting a request involving an individual, to whom the record pertains, when the individual has requested assistance from the Member with respect to the subject matter of the record.
4. A record in this system of records may be disclosed, as a routine use, to a contractor of the Agency having need for the information in order to perform a contract. Recipients of information shall be required to comply with the requirements of the Privacy Act of 1974, as amended, pursuant to 5 U.S.C. 552a(m).
5. A record related to an International Application filed under the Patent Cooperation Treaty in this system of records may be disclosed, as a routine use, to the International Bureau of the World Intellectual Property Organization, pursuant to the Patent Cooperation Treaty.
6. A record in this system of records may be disclosed, as a routine use, to another federal agency for purposes of National Security review (35 U.S.C. 181) and for review pursuant to the Atomic Energy Act (42 U.S.C. 218(c)).
7. A record from this system of records may be disclosed, as a routine use, to the Administrator, General Services, or his/her designee, during an inspection of records conducted by GSA as part of that agency's responsibility to recommend improvements in records management practices and programs, under authority of 44 U.S.C. 2904 and 2906. Such disclosure shall be made in accordance with the GSA regulations governing inspection of records for this purpose, and any other relevant (i.e., GSA or Commerce) directive. Such disclosure shall not be used to make determinations about individuals.
8. A record from this system of records may be disclosed, as a routine use, to the public after either publication of the application pursuant to 35 U.S.C. 122(b) or issuance of a patent pursuant to 35 U.S.C. 151. Further, a record may be disclosed, subject to the limitations of 37 CFR 1.14, as a routine use, to the public if the record was filed in an application which became abandoned or in which the proceedings were terminated and which application is referenced by either a published application, an application open to public inspections or an issued patent.
9. A record from this system of records may be disclosed, as a routine use, to a Federal, State, or local law enforcement agency, if the USPTO becomes aware of a violation or potential violation of law or regulation.

Under the Paperwork Reduction Act of 1995 no persons are required to respond to a collection of information unless it displays a valid OMB control number

UTILITY PATENT APPLICATION TRANSMITTAL <i>(Only for new nonprovisional applications under 37 CFR 1.53(b))</i>	Attorney Docket No.	COREPH-0079 US CON3
	First Named Inventor	Gal Shabtay
	Title	DUAL APERTURE ZOOM DIGITAL CAMERA
	Express Mail Label No.	

APPLICATION ELEMENTS <i>See MPEP chapter 600 concerning utility patent application contents.</i>	Commissioner for Patents P.O. Box 1450 Alexandria, VA 22313-1450
--	---

<p>1. <input type="checkbox"/> Fee Transmittal Form (PTO/SB/17 or equivalent)</p> <p>2. <input type="checkbox"/> Applicant asserts small entity status. See 37 CFR 1.27</p> <p>3. <input type="checkbox"/> Applicant certifies micro entity status. See 37 CFR 1.29. Applicant must attach form PTO/SB/15A or B or equivalent.</p> <p>4. <input type="checkbox"/> Specification [Total Pages _____] Both the claims and abstract must start on a new page. (See MPEP § 608.01(a) for information on the preferred arrangement)</p> <p>5. <input type="checkbox"/> Drawing(s) (35 U.S.C. 113) [Total Sheets _____]</p> <p>6. <input type="checkbox"/> Inventor's Oath or Declaration [Total Pages _____] (including substitute statements under 37 CFR 1.64 and assignments serving as an oath or declaration under 37 CFR 1.63(e))</p> <p>a. <input type="checkbox"/> Newly executed (original or copy)</p> <p>b. <input type="checkbox"/> A copy from a prior application (37 CFR 1.63(d))</p> <p>7. <input type="checkbox"/> Application Data Sheet * See note below. See 37 CFR 1.76 (PTO/AIA/14 or equivalent)</p> <p>8. CD-ROM or CD-R in duplicate, large table, or Computer Program (Appendix)</p> <p><input type="checkbox"/> Landscape Table on CD</p> <p>9. Nucleotide and/or Amino Acid Sequence Submission (if applicable, items a. – c. are required)</p> <p>a. <input type="checkbox"/> Computer Readable Form (CRF)</p> <p>b. <input type="checkbox"/> Specification Sequence Listing on:</p> <p>i. <input type="checkbox"/> CD-ROM or CD-R (2 copies); or</p> <p>ii. <input type="checkbox"/> Paper</p> <p>c. <input type="checkbox"/> Statements verifying identity of above copies</p>	<p style="text-align: center;">ACCOMPANYING APPLICATION PAPERS</p> <p>10. <input type="checkbox"/> Assignment Papers (cover sheet & document(s)) Name of Assignee _____</p> <p>11. <input type="checkbox"/> 37 CFR 3.73(c) Statement <input type="checkbox"/> Power of Attorney (when there is an assignee)</p> <p>12. <input type="checkbox"/> English Translation Document (if applicable)</p> <p>13. <input checked="" type="checkbox"/> Information Disclosure Statement (PTO/SB/08 or PTO-1449) <input checked="" type="checkbox"/> Copies of citations attached</p> <p>14. <input type="checkbox"/> Preliminary Amendment</p> <p>15. <input type="checkbox"/> Return Receipt Postcard (MPEP § 503) (Should be specifically itemized)</p> <p>16. <input type="checkbox"/> Certified Copy of Priority Document(s) (if foreign priority is claimed)</p> <p>17. <input type="checkbox"/> Nonpublication Request Under 35 U.S.C. 122(b)(2)(B)(i). Applicant must attach form PTO/SB/35 or equivalent.</p> <p>18. <input checked="" type="checkbox"/> Other: Remarks - This is an IDS. Citation or identification of any reference in this IDS shall not be construed as an admission that such reference is available as prior art. _____ _____</p>
---	---

*Note: (1) Benefit claims under 37 CFR 1.78 and foreign priority claims under 1.55 must be included in an Application Data Sheet (ADS).
 (2) For applications filed under 35 U.S.C. 111, the application must contain an ADS specifying the applicant if the applicant is an assignee, person to whom the inventor is under an obligation to assign, or person who otherwise shows sufficient proprietary interest in the matter. See 37 CFR 1.46(b).

19. CORRESPONDENCE ADDRESS

The address associated with Customer Number: 92342 OR Correspondence address below

Name			
Address			
City	State	Zip Code	
Country	Telephone	Email	

Signature	/Menachem Nathan/	Date	09-20-2018
Name (Print/Type)	MENACHEM NATHAN	Registration No. (Attorney/Agent)	65,392

This collection of information is required by 37 CFR 1.53(b). The information is required to obtain or retain a benefit by the public which is to file (and by the USPTO to process) an application. Confidentiality is governed by 35 U.S.C. 122 and 37 CFR 1.11 and 1.14. This collection is estimated to take 12 minutes to complete, including gathering, preparing, and submitting the completed application form to the USPTO. Time will vary depending upon the individual case. Any comments on the amount of time you require to complete this form and/or suggestions for reducing this burden, should be sent to the Chief Information Officer, U.S. Patent and Trademark Office, U.S. Department of Commerce, P.O. Box 1450, Alexandria, VA 22313-1450. DO NOT SEND FEES OR COMPLETED FORMS TO THIS ADDRESS. SEND TO: Commissioner for Patents, P.O. Box 1450, Alexandria, VA 22313-1450.

If you need assistance in completing the form, call 1-800-PTO-9199 and select option 2.

Privacy Act Statement

The **Privacy Act of 1974 (P.L. 93-579)** requires that you be given certain information in connection with your submission of the attached form related to a patent application or patent. Accordingly, pursuant to the requirements of the Act, please be advised that: (1) the general authority for the collection of this information is 35 U.S.C. 2(b)(2); (2) furnishing of the information solicited is voluntary; and (3) the principal purpose for which the information is used by the U.S. Patent and Trademark Office is to process and/or examine your submission related to a patent application or patent. If you do not furnish the requested information, the U.S. Patent and Trademark Office may not be able to process and/or examine your submission, which may result in termination of proceedings or abandonment of the application or expiration of the patent.

The information provided by you in this form will be subject to the following routine uses:

1. The information on this form will be treated confidentially to the extent allowed under the Freedom of Information Act (5 U.S.C. 552) and the Privacy Act (5 U.S.C. 552a). Records from this system of records may be disclosed to the Department of Justice to determine whether disclosure of these records is required by the Freedom of Information Act.
2. A record from this system of records may be disclosed, as a routine use, in the course of presenting evidence to a court, magistrate, or administrative tribunal, including disclosures to opposing counsel in the course of settlement negotiations.
3. A record in this system of records may be disclosed, as a routine use, to a Member of Congress submitting a request involving an individual, to whom the record pertains, when the individual has requested assistance from the Member with respect to the subject matter of the record.
4. A record in this system of records may be disclosed, as a routine use, to a contractor of the Agency having need for the information in order to perform a contract. Recipients of information shall be required to comply with the requirements of the Privacy Act of 1974, as amended, pursuant to 5 U.S.C. 552a(m).
5. A record related to an International Application filed under the Patent Cooperation Treaty in this system of records may be disclosed, as a routine use, to the International Bureau of the World Intellectual Property Organization, pursuant to the Patent Cooperation Treaty.
6. A record in this system of records may be disclosed, as a routine use, to another federal agency for purposes of National Security review (35 U.S.C. 181) and for review pursuant to the Atomic Energy Act (42 U.S.C. 218(c)).
7. A record from this system of records may be disclosed, as a routine use, to the Administrator, General Services, or his/her designee, during an inspection of records conducted by GSA as part of that agency's responsibility to recommend improvements in records management practices and programs, under authority of 44 U.S.C. 2904 and 2906. Such disclosure shall be made in accordance with the GSA regulations governing inspection of records for this purpose, and any other relevant (*i.e.*, GSA or Commerce) directive. Such disclosure shall not be used to make determinations about individuals.
8. A record from this system of records may be disclosed, as a routine use, to the public after either publication of the application pursuant to 35 U.S.C. 122(b) or issuance of a patent pursuant to 35 U.S.C. 151. Further, a record may be disclosed, subject to the limitations of 37 CFR 1.14, as a routine use, to the public if the record was filed in an application which became abandoned or in which the proceedings were terminated and which application is referenced by either a published application, an application open to public inspection or an issued patent.
9. A record from this system of records may be disclosed, as a routine use, to a Federal, State, or local law enforcement agency, if the USPTO becomes aware of a violation or potential violation of law or regulation.

Abstract

PROBLEM TO BE SOLVED: To provide a thin camera module that can selectively obtain images of different magnifications, and is suitable to portable equipment.

SOLUTION: The camera module comprises a plurality of lens units 21, 22 having different focal lengths, image sensor chips 25a and 25b which process imaging signals based upon light made incident through the lens units, and a selecting means of selecting the light made incident through the plurality of lens units and imaging signals based upon the light. This selecting means is operative to select light made incident through one of the plurality of lens units or an imaging signal based upon the light.

COPYRIGHT (C) 2008, JPO & INPIT

JP2007306282A

JP Application



Download PDF



Find Prior Art



Similar

Other languages: Japanese

Inventor: Yasuaki Koyama, Aizhao

Original Assignee: Citizen Electronics Co Ltd, Citizen Electronics Co., Ltd.

Priority date: 2006-05-11

Family: JP (1)

Date	App/Pub Number	Status
2006-05-11	JP2006132321A	Pending
2007-11-22	JP2007306282A	Application

Imaging apparatus

Abstract

PROBLEM TO BE SOLVED: To provide high image quality with high resolution for an entire wide variable power region. **SOLUTION:** An imaging apparatus includes first and second imaging optical systems LN1 and LN2 with single focus, which look the same direction. A focal length of the second imaging optical system LN2 is longer than that of the first imaging optical system LN1. Zooming is performed from a wide angle end to an intermediate focal length state with an electronic zoom by segmentation of an image obtained in the first imaging optical system LN1, and zooming is performed from the intermediate focal length state to a telescopic end with an electronic zoom by segmentation of an image obtained in the second imaging optical system. Thus, zooming from the wide angle end to the telescopic end is performed as a whole. Both the first and second imaging optical systems LN1 and LN2 consist of four or more lenses of first lenses of positive power and second lenses of negative power in order from an object side, the lenses nearest to the image side are negative lenses; composite focal lengths of the first lenses and the second lenses are positive and they satisfy a conditional expression $1.0 < f_{w1}/f_{m1} < 1.5$.

Images (23)

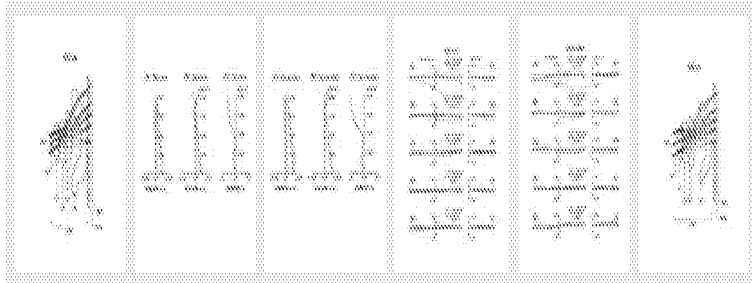

JP2013106289A
 JP Application

[Download PDF](#) [Find Prior Art](#) [Similar](#)

Other languages: Japanese

Inventor: Kenji Kanno, 賢治 金野, Keiji Matsuzaka, 慶二 松坂, Keiko Yamada, 基子 山田

Original Assignee: Konica Minolta Advanced Layers Inc., コニカ ミノルタアドバンスレイヤー株式会社

Priority date: 2011-11-16

Family: JP (1)

Date	App./Pub Number	Status
2011-11-16	JP2011250322A	Active
2013-05-30	JP2013106289A	Application
2015-07-01	JP5741395B2	Grant

Optical system

Abstract

An optical system according to an embodiment comprises: a first lens, a second lens, a third lens, a fourth lens, and a fifth lens arranged from the top of an object in order and satisfies an equation 1, $(\text{Sag } 2/\text{Sag } 1) < 2$, and an equation 2, $(H5/\text{Sag } 5) > 1$. In equation 1, Sag 1 is the Sag value of the surface of the first lens in an object side, and Sag 2 is the Sag value of the surface of the first lens in an image side. In equation 2, H5 is the height of an inflection point on the surface of the fifth lens in the image side, and Sag 5 is the Sag value of the inflection point on the surface of the fifth lens in the image side.

Images (1)

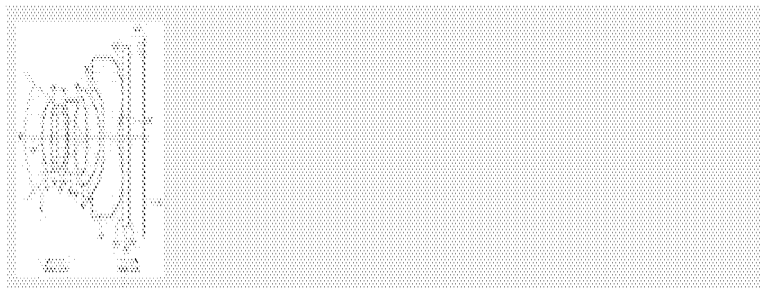

KR20140023552A

KR Application

[Download PDF](#) [Find Prior Art](#) [Similar](#)

Other languages: Korean

Inventor: Kim Duro Geun

Original Assignee: LG Innotek Co., Ltd.

Priority date : 2012-08-16

Family: KR (1)

Date	App/Pub Number	Status
2012-08-16	KR20120089538A	
2014-02-27	KR20140023552A	Application

Info: Cited by (1), Legal events, Similar documents, Priority and Related Applications

External links: Espacenet, Global Dossier, Discuss

Photographic lens subjected to short distance correction

Abstract

PURPOSETo correct satisfactorily various aberrations even in case of photographing of a short distance, and to make a tilted lens durable enough even in a state that a diaphragm is opened by setting a prescribed air space by a reference image magnification state between a positive lens component of an object side and a lens group of an image side, reducing the space at the time of focusing to a short distance object, and also magnifying the space behind a negative lens component. **CONSTITUTION**As for a deformed Gauss type lens of an F1.4 class, the image surface moves in the positive direction as an image magnification is raised, therefore, the image surface is corrected to the negative direction by magnifying an air space d_6 behind a negative meniscus lens L3, and also an asymmetrical property of a comatic aberration is corrected. In this case, the lenses L2, L3 can be moved to the front side as one body in a state that the lenses L1, L4-L7 remain fixed by setting a correcting amount of an air space d_2 between a positive lens L1 and a positive meniscus lens L2, and a correcting amount of the space d_6 to the same amount, and also the correcting amount can be decided independently to the lenses L2, L3, respectively. Accordingly, in a fast photographic lens of an area extending from a standard to a telephoto, various aberrations are corrected satisfactorily even in case of a short distance photographing, and an excellent image-forming performance can be maintained at all times.

JPS59121015A
Patent Application

Find Prior Art Similar

Inventor: Yasushi Matsui
Original Assignee: Nippon Kogaku Kk. <Nikon>
Priority date: 1982-12-28

Family: JP (1)

Date	App/Pub Number	Status
1982-12-28	JP22753782A	Expired - Lifetime
1984-07-12	JPS59121015A	Application
1993-08-09	JPH0532428Z	Grant

Info: Patent citations (2), Cited by (2), Similar documents, Priority and Related Applications

External links: Espacenet, Global Dossier, Databases

Imaging optical system, imaging apparatus and digital instrument

Abstract

PROBLEM TO BE SOLVED: To provide an imaging optical system composed of five lenses able to correct various aberrations more satisfactorily while achieving a smaller size, and an imaging apparatus and a digital instrument that have the optical system. **SOLUTION:** An imaging optical system 1 includes, in order from an object side, first to fifth lenses 11 to 15. The first lens 11 is convex on the object side and has positive refractive power, a second lens 12 has negative refractive power, and the fifth lens 15 has negative refractive power and has an aspherical shape that is concave on an image side and has a vertical contact at a position other than the position of an intersection with the center axis. If the focal distance of the entire system is f , the focal distance of the fifth lens 15 is f_5 , an amount of sag on an object side surface on the principal ray at the maximum field angle is z_5 , the thickness of a core is t_5 , the length of the optical path of an e line on the principal ray at the maximum field angle is p_5e , the length of the optical path of a c line on the principal ray on the axis is p_5c , the maximum image height is Y , and the entire optical length is TL , the imaging optical system satisfies $0.2 < f_5/f < 0.5$, $1 < (z_5/t_5) < 4$, $2.5 < p_5e/p_5c < 5$ and $0.63 < Y/TL < 0.9$.

Images (14)

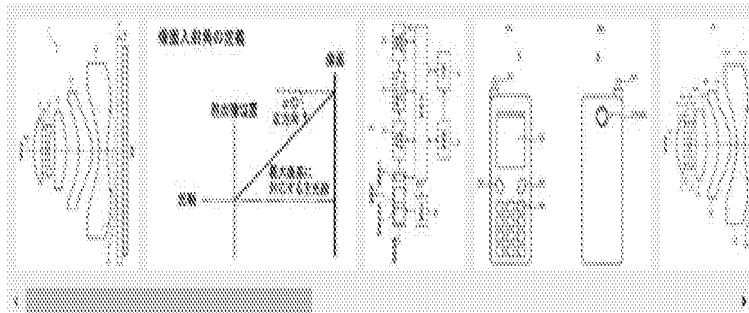

JP2012203234A

JP Application



Download PDF



Find Prior Art



Similar

Other languages: Japanese

Inventor: Keiji Matsuzaka, Keiko Yamada 松崎 健二, 山田 慶子

Original Assignee: Konica Minolta Advanced Layers Inc., コニカミノルタアドバンスドレイヤー株式会社

Priority date: 2011-03-25

Family: JP (1)

Date	App/Publ Number	Status
2011-03-25	JP2011068208A	Pending
2012-10-22	JP2012203234A	Application

Info: Patent citations (7), Cited by (4), Legal events, Similar documents, Priority and Related Applications

External links: Espacenet, Global Dossier, Discuss

Image-capturing lens

Abstract

An image-capturing lens comprises in order from the object side a positive first lens, a stop, a positive second lens, a negative third lens, a positive fourth lens, and a negative fifth lens, satisfies the conditional expression of $0 < f1/f2 < 1.26$ (where $f1$ is the focal length of the first lens and $f2$ is the focal length of the second lens), and forms an image of an object on the image-capturing surface of an image-capturing element.

Images (15)

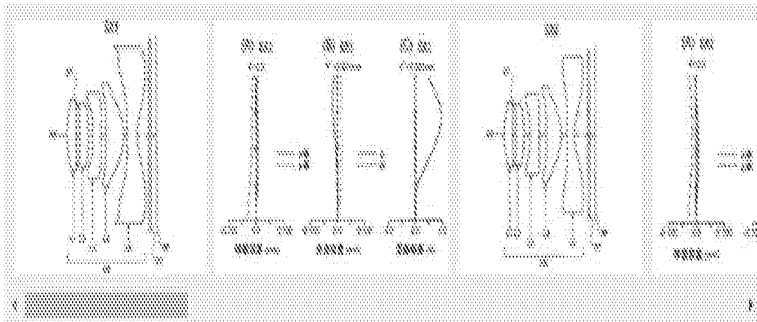

WO/2013/058111A1

WO Application



Find Prior Art



Similar

Other languages: French, Japanese

Inventor: 田中 玄晴

Original Assignee: コニカミノルタアドバンスドレイヤー株式会社

Priority date : 2011-10-20

Family: JP (1) WO (1)

Date	App/Pub Number	Status
2012-10-03	PCT/JP2012/075631	
2013-04-25	WO2013058111A1	Application

Info: Patent citations (14), Cited by (4), Legal events, Similar documents, Priority and Related Applications

External links: Espacenet, Global Dossier, PatentScope, Discuss

Photographic telephoto lens

Abstract

PURPOSE: To achieve the balance of aberration correction and prevent the degradation in the positive coma aberration and distortion aberration produced from the refracting power of the front group by making the combined thickness of the 5-group type through combination of positive and negative single lenses smaller under the specified conditions.

CONSTITUTION: The front group disposed with a biconvex single lens L_1 whose convex face of a larger curvature is opposed to the object side as the 1st group subsequently from the object side, a plane-concave or negative meniscus single lens L_2 whose object side is a concave lens as the 2nd group and a positive meniscus single lens L_3 whose convex face of a larger curvature is faced to the object side as well as the rear group disposed with a negative meniscus single lens L_4 whose convex face is faced to the image side as the 4th group and a positive single lens L_5 on the image side as the 5th group are disposed on the optical axis by leaving a specified distance. The formulas (1) thru (7) are satisfied in respective specifications. (f is focal length, d is axial air spacing, r is radius of curvature and v is Abbe number).

COPYRIGHT (C) 1979, JFO & Japio

JPS54157620A
JP Application

Find Prior Art Σ Similar

Inventor: Toshiro Shimokura

Original Assignee: Konanroku Photo Ind Co Ltd

Priority date: 1978-06-01

Family: JP (1)

Date	App/Pub Number	Status
1978-06-01	JP6491078A	Expired
1979-12-12	JPS54157620A	Application
1981-12-21	JPS56537258Z	Grant

Info: Patent citations (4), Cited by (3), Similar documents, Priority and Related Applications

External links: Espacenet, Global Dossier, Discuss



(43) International Publication Date
2 May 2013 (02.05.2013)

- (51) **International Patent Classification:**
G02B 13/00 (2006.01) *H04N 5/232* (2006.01)
- (21) **International Application Number:**
PCT/US20 12/06 1668
- (22) **International Filing Date:**
24 October 2012 (24.10.2012)
- (25) **Filing Language:** English
- (26) **Publication Language:** English
- (30) **Priority Data:**
61/550,789 24 October 2011 (24.10.2011) US
- (71) **Applicant (for all designated States except US): DIGITALOPTICS CORPORATION MEMS [US/US];**
400 E. Live Oak Avenue, Arcadia, California 91006 (US).
- (72) **Inventors; and**
- (71) **Applicants (for US only): CAHALL, Scott [US/US];**
9815 David Taylor Drive, Charlotte, North Carolina 28262 (US). **SCHMIDT, Jack [US/US];** 9815 David Taylor Drive, Charlotte, North Carolina 28262 (US).
- (74) **Agents: JOSHI, Vinay et al; TUROCY & WATSON, LLP,** 127 Public Square, 57th FL, Key Tower, Cleveland, Ohio 44114 (US).
- (81) **Designated States (unless otherwise indicated, for every kind of national protection available):** AE, AG, AL, AM, AO, AT, AU, AZ, BA, BB, BG, BH, BN, BR, BW, BY, BZ, CA, CH, CL, CN, CO, CR, CU, CZ, DE, DK, DM,

DO, DZ, EC, EE, EG, ES, FI, GB, GD, GE, GH, GM, GT, HN, HR, HU, ID, IL, IN, IS, JP, KE, KG, KM, KN, KP, KR, KZ, LA, LC, LK, LR, LS, LT, LU, LY, MA, MD, ME, MG, MK, MN, MW, MX, MY, MZ, NA, NG, NI, NO, NZ, OM, PA, PE, PG, PH, PL, PT, QA, RO, RS, RU, RW, SC, SD, SE, SG, SK, SL, SM, ST, SV, SY, TH, TJ, TM, TN, TR, TT, TZ, UA, UG, US, UZ, VC, VN, ZA, ZM, ZW.

(84) **Designated States (unless otherwise indicated, for every kind of regional protection available):** ARIPO (BW, GH, GM, KE, LR, LS, MW, MZ, NA, RW, SD, SL, SZ, TZ, UG, ZM, ZW), Eurasian (AM, AZ, BY, KG, KZ, RU, TJ, TM), European (AL, AT, BE, BG, CH, CY, CZ, DE, DK, EE, ES, FI, FR, GB, GR, HR, HU, IE, IS, IT, LT, LU, LV, MC, MK, MT, NL, NO, PL, PT, RO, RS, SE, SI, SK, SM, TR), OAPI (BF, BJ, CF, CG, CI, CM, GA, GN, GQ, GW, ML, MR, NE, SN, TD, TG).

Declarations under Rule 4.17:

— as to applicant's entitlement to apply for and be granted a patent (Rule 4.17(H))

Published:

— with international search report (Art. 21(3))
— before the expiration of the time limit for amending the claims and to be republished in the event of receipt of amendments (Rule 48.2(h))

(54) **Title:** OPTICAL OBJECTIVE HAVING FIVE LENSES WITH FRONT FOCUSING

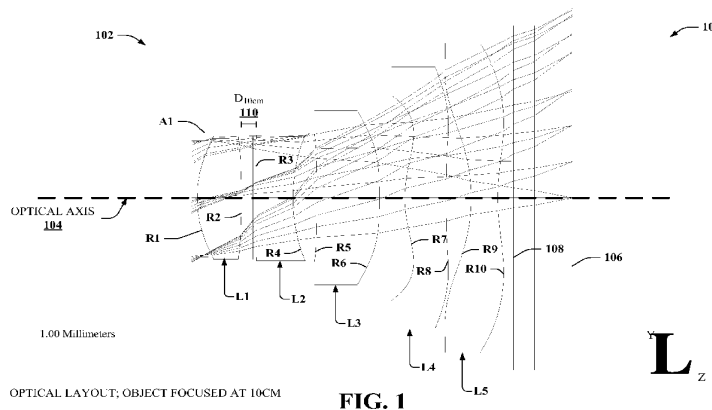

(57) **Abstract:** Optical system comprising five lenses, a front pupil and achieving focus for objects from close to infinity by adjusting, via a MEMS actuator, the position of a subset of lenses located on the object-side of the optical system. The most object-side, biconvex, lens provides a substantial amount of the system's optical power for achieving focus from an object as close as 10 cm away from the aperture stop.

WO 2013/063097 A1

OPTICAL OBJECTIVE HAVING FIVE LENSES WITH FRONT FOCUSING

CROSS-REFERENCE TO RELATED APPLICATIONS

[0001] This application claims the benefit of U. S. Provisional Patent Application Serial No. 61/550,789 entitled "OPTICAL SYSTEM WITH MICROELECTROMECHANICAL SYSTEM IMAGE FOCUS ACTUATOR" filed October 24, 2011. The entirety of the above-noted application is incorporated by reference herein.

TECHNICAL FIELD

[0002] The following relates generally to imaging optics, and more particularly to a compact optical lens system with micro electromechanical system (MEMS) actuator for focusing the optical lens system.

BACKGROUND

[0003] Applications for optics and optical devices have become numerous in conjunction with advances in optical fabrication technology. One interesting advancement in optical technology is fabrication of micro lenses, and other optical components on a millimeter or micrometer scale, or less. Compared with traditional optical elements typically on the scale of centimeters or larger, micro optics have made optical systems compatible with smaller devices than traditional telescopes, microscopes, cameras, and so on.

[0004] One mechanism facilitating the fabrication of micro optics is wafer-level optics. Wafer-level optics is a fabrication technology that enables design and manufacture of optical components using techniques similar to semiconductor manufacturing. The technology is generally scalable with different size scales (e.g., millimeter, micrometer, etc.). Moreover, wafer-level optics can produce single-element as well as multi-element optical structures, yielding precision aligned stacks of lens elements. The end result of wafer-level optics provide cost effective, miniaturized optical components that enable reduced form factor for optical systems. These optical systems can be employed in a wide range of small or miniature devices, including camera modules for mobile phones, surveillance equipment, miniature video cameras,

and the like.

[0005] Although wafer-level optics is one relatively recent technology for fabricating small optical components, some traditional fabrication techniques have been adapted to small-scale optical fabrication as well. For instance, plastic fabrication techniques including injection molding, and others can be employed for manufacturing small-scale optical components. Further, glass fabrication techniques have been adapted for miniaturized optical components, providing high quality optical surfaces for small-scale devices.

[0006] In addition to optical elements, the miniaturization of digital imaging sensors has also facilitated the continuing miniaturization of image capture and recording devices. Improvements in image sensors have provided high resolution image detectors utilizing micro-scale pixilation, and at high signal to noise ratio and increasingly lower cost. In conjunction with micro optics, such as wafer-level optical components, small, relatively inexpensive digital capture and recording devices can match or exceed the capabilities of relatively expensive, yet very high quality camera systems utilizing traditional optics of just a decade ago. Although quality is very high for modern micro optical devices, one persistent limitation has been zoom capability for miniature optical systems. One solution has been the introduction of digital zoom, which sacrifices optical resolution to enlarge an image. For high resolution sensors, this often provides a suitable alternative to traditional optical zoom capability. However, optical zoom provides advantages that digital zoom cannot achieve.

[0007] For example, the inventors of the disclosed subject matter suggest it would be desirable to have a miniature optical system with optical auto-focus capability. Such an optical system that achieves close focus would be additionally desirable.

SUMMARY

[0008] The following presents a simplified summary of one or more aspects in order to provide a basic understanding of such aspects. This summary is not an extensive overview of all contemplated aspects, and is intended to neither identify key or critical elements of all aspects nor delineate the scope of any or all aspects. Its sole purpose is to present some concepts of one or more aspects in a simplified form as a prelude to the more detailed description that is presented later.

[0009] Particular aspects of the subject disclosure provide a miniaturized optical system. In some aspects, the miniaturized optical system can comprise an injection

molded optical system. In further aspects, the miniaturized optical system can be an auto-focus optical system comprising five optical components. In still other aspects, the miniaturized optical system can be an auto-focus optical system employing a micro electromechanical system (MEMS) actuator to achieve focusing of the optical system.

[0010] In one or more other aspects of the subject disclosure, provided is an optical system that employs a MEMS actuator to achieve close focus. In one such aspect, the close focus can comprise a substantially 10cm object distance. Further, according to other aspects, the optical system can be configured to achieve close focus and infinity focus by adjusting position of a subset of optical components of the optical system. In particular aspects, the subset of optical components can comprise a single optical component of the optical system. In at least one such aspect, the single optical component can be a lens closest along an optical axis of the optical system to an object being imaged by the optical system (referred to as an object-side lens). In such aspect(s), the MEMS actuator can be configured to displace the object-side lens of the optical system a first distance configured to focus an object at infinity onto an image sensor associated with the optical system, and to displace the object-side lens a second distance configured to focus a close object (*e.g.*, an object substantially 10cm from the object-side lens) onto the image sensor.

[0011] According to one or more additional aspects, an auto-focus optical system disclosed herein can be configured to include an aperture stop. In a particular aspect, the auto-focus optical system can comprise injection molded plastic lenses, whereas in other aspects, the auto-focus optical system can comprise wafer-level optical lenses, glass lenses, or a suitable combination thereof. In another aspect, the aperture stop can be positioned on an object side of the object-side lens of the optical system. In one alternative aspect, a MEMS actuator can be configured to move a subset of optical components of the optical system to focus an object, while maintaining the aperture stop in a fixed position along an optical axis of the optical system. In another alternative aspect, the MEMS actuator can instead be configured to move both the subset of optical components and the aperture stop relative to the optical axis, to focus the object.

[0012] According to still other aspects, disclosed is an auto-focus optical system comprising a plurality of optical components. The plurality of optical components can, in some such aspects, comprise an object-side lens providing a substantial amount of optical power to the optical system. In at least one such aspect, the object-side lens can comprise substantially half or greater than half of the combined focal length of the

optical system. In another aspect, the object-side lens can comprise substantially three-quarters or more of the combined focal length of the optical system. In a particular aspect, a MEMS actuator is connected to the object-side lens, and is configured to displace the object-side lens a first distance configured to focus an object at infinity, and a second distance configured to focus an object close to the optical system. According to one specific embodiment, a ratio of the focal length of the object-side lens and of a combined focal length of the optical system can be a function of a difference in magnitude of the first distance and the second distance along an optical axis of the optical system.

[0013] According to additional aspects, the subject disclosure provides a micro-optical system comprising five optical lenses. In one such aspect, an objective lens of the five optical lenses can be configured to supply all positive refractive power of the five optical lenses. In this aspect, the remaining four lenses have a combined net negative refractive power. In at least one particular aspect, the remaining four lenses can have respective negative refractive powers, with a combined net negative refractive power. According to an alternative or additional aspect, a third lens of the five optical lenses can have a convex object side surface and a concave image side surface. As yet another alternative or additional aspect, a spacing between a fourth of the five optical lenses and a fifth of the five optical lenses can be a largest spacing between lenses of the optical system. In another aspect, the micro-optical system can be an auto-focus system in which a subset of the five optical lenses are movable along an optical axis to refine a focus of the optical system. In one specific aspect, the subset of the five optical lenses can comprise the objective lens, and the subset being movable by a MEMS actuator.

[0014] In further aspects of the subject disclosure, provided is a micro-optical system comprising five optical lenses. The five optical lenses can be arranged into a plurality of lens groups, each lens group comprising respective subsets of the five optical lenses. Each group comprises inter-lens distances equal to or less than a distance(s) between the plurality of optical groups. In a further aspect, each lens within at least one of the plurality of lens groups comprises at least one optical surface having both a concave portion and a convex portion. In a particular aspect, an effective focal length of the micro-optical system varies in response to a change in position along an optical axis of a first lens of the five optical lenses, and in an alternative or additional aspect, a back focal length of the micro-optical system remains substantially the same in response to the change in position along the optical axis of the first lens.

[0015] To the accomplishment of the foregoing and related ends, the one or more aspects comprise the features hereinafter fully described and particularly pointed out in the claims. The following description and the annexed drawings set forth in detail certain illustrative aspects of the one or more aspects. These aspects are indicative, however, of but a few of the various ways in which the principles of various aspects can be employed and the described aspects are intended to include all such aspects and their equivalents.

BRIEF DESCRIPTION OF THE DRAWINGS

[0016] Figure 1 illustrates a diagram of an example optical imaging system configured to focus a relatively close object, according to various aspects of the subject disclosure.

[0017] Figure 2 illustrates a diagram of a sample optical imaging system configured to focus an object substantially at infinity, according to other disclosed aspects.

[0018] Figure 3 depicts a diagram of an example optical imaging system comprising a plurality of injection molded optical components.

[0019] Figure 4 illustrates a diagram of example field curvature and distortion graphs for a sample optical imaging system focusing a relatively close object.

[0020] Figure 5 illustrates a diagram of example field curvature and distortion graphs for the sample optical imaging system of Figure 4, focusing an object substantially at infinity.

[0021] Figure 6 depicts a diagram of a sample lateral color graph for an example optical imaging system focusing a relatively close object, according to further aspects.

[0022] Figure 7 illustrates a diagram of a sample lateral color graph for the example optical imaging system of Figure 6 focusing an object substantially at infinity, according other aspects.

[0023] Figure 8 depicts a diagram of transverse ray fan plots for a disclosed optical imaging system with an object focused at 10cm.

[0024] Figure 9 illustrates a diagram of transverse ray fan plots for the disclosed optical imaging system of Figure 8, with an object focused substantially at infinity.

[0001] Figure 10 illustrates a cross-section of a sample optical system for focusing an image of an object at 10cm according to aspects of the subject disclosure.

[0002] Figure 11 illustrates a cross-section of a sample optical system for focusing an image of an object at infinity according to aspects of the subject disclosure.

[0003] Figure 12 illustrates an example graph of field curvature and distortion for an object at 10cm according to aspects of the subject disclosure.

[0004] Figure 13 illustrates an example graph of field curvature and distortion for an object at infinity in other aspects of the subject disclosure.

[0005] Figure 14 illustrates an example graph of primary lateral color for an object at 10cm according to an aspect(s).

[0006] Figure 15 illustrates an example graph of primary lateral color for an object at infinity according to one or more other aspects.

[0007] Figure 16 illustrates an example transverse ray fan plot for various image heights for an object at 10cm according to still other aspects.

[0025] Figure 17 illustrates an example transverse ray fan plot for various image heights for an object at infinity according to at least one other aspect.

[0026] Figure 18 depicts a transverse ray fan plot for a range of field angles for an example micro-optical system according to additional disclosed aspects.

[0027] Figure 19 illustrates a sample diagram of the micro-optical system of Figure 18 including lenses and optical surfaces.

[0028] Figure 20 depicts an example graph of field curvature and distortion for an object focused by the micro-optical system of Figure 18.

[0029] Figure 21 illustrates a sample graph of longitudinal aberration for a pupil radius of 0.90 millimeters in an aspect.

[0030] Figure 22 depicts an example graph of lateral color for a disclosed micro-optical system according to further aspects.

[0031] Figure 23 illustrates a transverse ray fan plot for a range of field angles for a micro-optical system focused in the near-field according to disclosed aspects.

[0032] Figure 24 depicts a sample diagram of the micro-optical system of Figure 23 including lenses and optical surfaces.

[0033] Figure 25 illustrates an example diagram of field curvature and distortion for a near-field object focused by the micro-optical system of Figure 23.

[0034] Figure 26 depicts a sample diagram of longitudinal aberration for pupil radius of 0.90 millimeters for a disclosed micro-optical system, in an aspect.

[0035] Figure 27 illustrates an example diagram of lateral color for a disclosed micro-optical system according to still other disclosed aspects.

[0036] Figures 28A, 28B, 28C and 28D illustrate diagrams of an example micro-optical system focused at infinity according to further aspects, and related optical performance graphs.

[0037] Figures 29A, 29B, 29C and 29D depict the micro-optical system of Figure 28 focused in the near-field and related optical performance graphs.

DETAILED DESCRIPTION

[0038] Various aspects are now described with reference to the drawings, wherein like reference numerals are used to refer to like elements throughout. In the following description, for purposes of explanation, numerous specific details are set forth in order to provide a thorough understanding of one or more aspects. It will be evident, however, that such aspect(s) can be practiced without these specific details. In other instances, well-known structures and devices are shown in block diagram form in order to facilitate describing one or more aspects.

[0039] In addition, it should be apparent that the teaching herein can be embodied in a wide variety of forms and that the specific structures or functions disclosed herein are merely representative. Based on the teachings herein one skilled in the art should appreciate that the disclosed aspects can be implemented independently of other aspects, and that two or more of these aspects can be combined in various ways. For example, an apparatus can be implemented and/or a method practiced using any number of the aspects set forth herein. In addition, an apparatus can be implemented and/or a method practiced using other structure and/or functionality in addition to or other than one or more of the aspects set forth herein. As an example, many of the apparatuses and lens systems disclosed herein are described in the context of providing high resolution optical imaging *via* compact fixed position optical lens arrangements. One skilled in the art should appreciate that similar techniques could apply to other optical lens architectures. For example, the lens arrangements used herein may be used in mechanical focus or auto-focus systems whereby the optical arrangement is automatically or manually displaced relative to the image plane.

[0040] In at least one aspect of the subject disclosure, an optical imaging system is provided. The optical imaging system can comprise a first group of lenses and a second group of lenses. The optical imaging system can be focused by repositioning the first group of lenses relative to the second group of lenses along an optical axis of the optical imaging system. In at least one aspect of the subject disclosure, the second

group of lenses includes an image sensor for the optical imaging system. In particular aspects of the subject disclosure, the first group of lenses can comprise a single lens. For instance, the single lens can include an object-side lens, which is an optical element closest to an object side of the optical imaging system.

[0041] Referring now to the drawings, Figure 1 depicts a block diagram of an example optical system 100 according to aspects of the subject disclosure. System 100 comprises an arrangement of optical elements 102 positioned transverse to an optical axis 104. As utilized herein, an optical element refers to a single piece of refractive or reflective material at least partially transparent to electromagnetic radiation at least partially within the visible spectrum (*e.g.*, including wavelengths approximately 400 to 700 nanometers [nm]). Examples of suitable material include ground and polished glass, molded glass or glass formed from a replication molding process, wafer-level optics (WLO), injection-molded plastic, etched micro optics formed on an optical substrate, or the like. Additionally, an optical element will have at least one refractive or reflective surface. One example of an optical element utilized herein is an optical lens. An optical lens is an optical element comprising two opposing refractive surfaces, and an edge between the opposing surfaces that defines an outer diameter (for a circular lens) or perimeter of the lens, and an edge thickness of the lens. A typical arrangement of optical lenses includes a series of lenses 102 at least generally transverse to an axis (optical axis 104). It should be appreciated, however, that other possible arrangements can exist consistent with the subject disclosure. A "lens component" is defined herein as (A) a single lens element spaced so far from any adjacent lens element that the spacing cannot be neglected in computing the image forming properties of the respective lens elements, or (B) two or more lens elements that have adjacent lens surfaces either in full overall contact or so close together that any spacing between the adjacent lens surfaces are so small that the spacing(s) can be neglected in computing image forming properties of the two or more lens elements. Thus, some lens elements can also be lens components, and the terms "lens element" and "lens component" are not mutually exclusive terms. In addition, it should be appreciated that the term "optical component" is utilized herein to refer to a superset of items having significant properties related to imaging optical systems, and includes optical elements such as lens elements and lens components, as well as various optical stops including but not limited to aperture stops, but can also include various other items such as a thin film, a bandpass filter, a lowpass or highpass filter, a polarizing filter, a mirror, *etc.*

[0042] Light entering the left side, or object side, of optical elements 102 can interact sequentially with respective elements (102) and exit the right side, or image side, of the elements 102, toward an optical sensor 106. It should be appreciated that not all light interacting with the left side of the optical elements 102 will be transmitted to the sensor 106; some light can be reflected off of respective elements (102), some light can be scattered away from the optical axis 104 and absorbed (*e.g.*, by an optical stop - not depicted), and so forth. However, in general, the optical elements 102 will receive light from an object on one side of the elements (*e.g.*, the left side) and form a real image of the object on an opposite side of the elements (*e.g.*, on the right side). The real image will be formed along the optical axis 104 a certain distance from the optical elements 102, called an image distance (ID). Notably, the ID depends primarily on a corresponding object distance (OD - distance between the object and the optical elements 102 along the optical axis 104) and a refractive power, or optical power, of the combined optical elements 102.

[0043] Sensor 106 can be a digital device comprising a multi-dimensional array (*e.g.*, a two dimensional array) of electro-optical sensors, or pixels. Examples of such a device can include a charge-coupled device (CCD) array, or a complementary metal-oxide semiconductor (CMOS) array, or some other suitable array of optical sensors. Each electro-optical sensor, or pixel, of such array is configured to output an electric signal when irradiated with light. Furthermore, an amount of electric current for the electric signal is directly related to energy density of light irradiating the pixel. Accordingly, by collecting output current levels from each pixel of the array, sensor 106 can digitally reproduce a two dimensional radiant energy pattern of light irradiating the sensor 106. Additionally, where the pixel surface or sensor plane of sensor 106 is placed at the above-mentioned ID, the two dimensional radiant energy pattern that is produced is that of a real optical image generated by optical elements 102. Accordingly, sensor 106 can be utilized to digitally reproduce that image. Resolution of a digital image generated by sensor 106 depends on a number of pixels within an active array of sensor 106. In addition, optical system 100 can comprise a cover plate 108 between the optical elements 102 and image sensor 106, as depicted by Figure 1.

[0044] As depicted by optical system 100, optical elements 102 can comprise five optical lenses, including lens L1, lens L2, lens L3, lens L4 and lens L5, from the object-side of optical elements 102 to an image-side of optical elements 102. As depicted, lens L1 is a biconvex lens having positive optical power, having convex

object-side and convex image-side surfaces, R1 and R2, respectively. Additionally, lens LI can have a relatively strong positive optical power, relative to lenses L2, L3, L4 and L5. In at least one aspect, lens LI can have a relatively strong positive optical power relative to a combination of lenses L2, L3, L4 and L5. In a particular aspect, lens LI can provide at least about half or more of the combined focal length of optical elements 102. In an alternative aspect, lens LI can provide substantially about three-quarters or more of the combined focal length of optical elements 102. In related aspects, the optical power of the object-side lens ($L1_{power}$) can be about 1.25x the combined optical power of optical elements 102 (*e.g.*, $L1_{power} \leq 1.25 * (L1_{power} + L2_{power} + L3_{power} + L4_{power} + L5_{power})$). In a particular aspect, an aperture stop A1 can be positioned at or in front of an object-side of lens LI. Aperture stop A1 is described in more detail below.

[0045] Lens L2 can have an overall negative optical power. Further, lens L2, in one aspect, can have a mildly concave object-side surface R3. In an alternative aspect, object-side surface R3 can be flat, with no optical power. As yet another alternative aspect, object-side surface R3 can be mildly convex. An image-side surface R4 of lens L2 can have concave curvature. Moreover, lens L2 can be configured to provide chromatic aberration correction for optical system 100. In at least one aspect, lens L2 can provide a majority of chromatic aberration correction for optical system 100.

[0046] Lens L3 comprises an object-side surface R5 and an image-side surface R6. Object-side surface R5 can be mildly concave, in particular aspects. Moreover, image-side surface R6 can be convex. In a particular aspect, lens L3 can have a positive optical power.

[0047] Lens L4 comprises an object-side surface R7 and an image-side surface R8. Object-side surface R7 can have convex curvature near optical axis 104. Moreover, in at least one aspect of the subject disclosure, object-side surface R7 can transition to concave further from optical axis 104. Moreover, image-side surface R8 can be substantially flat with little or no optical power near optical axis 104, and transition to convex curvature away from optical axis 104. In an alternative aspect, image-side surface R8 can be convex near optical axis 104 having significant optical power for low to mid field angles, as well as convex away from optical axis 104. In a particular aspect, lens L4 can have positive power for low field angles (*e.g.*, field angles between zero and about 12 to 15 degrees). In another aspect, lens L4 can have small positive, small negative, or substantially zero optical power for medium field angles

(*e.g.*, field angles between about 12 to 15 degrees and about 22 to 25 degrees). In yet another aspect, lens L4 can have small positive, small negative, or substantially zero optical power for for high field angles (*e.g.*, field angles between about 22 to 25 degrees and about 33 or more degrees, up to a maximum accepted field angle of optical system 100).

[0048] Lens L5 comprises an object-side surface R9 and an image-side surface R10. Object-side surface R9 can have concave curvature for low and medium field angles. In at least one aspect, object-side surface R9 can transition to mildly concave or no curvature for high field angles. Image-side surface R10 can be concave near optical axis 104. Moreover, image-side surface R10 can transition from concave to convex for medium and high field angles, as depicted.

[0049] As depicted, optical elements 102 can have respective spaces (*e.g.*, air spacing) between respective lenses L1, L2, L3, L4 and L5. In at least one disclosed embodiment, a first on-axis distance between lens L1 and L2 can be substantially small compared with a third on-axis distance between lens L3 and lens L4. In another embodiment, the first on-axis distance can be substantially small compared to a second on-axis distance between lens L2 and L3, and a fourth on-axis distance between lens L4 and L5, in addition to the third on-axis distance. In at least one embodiment, the second, third and fourth on-axis distances can be substantially similar in magnitude, at least in comparison with the first on-axis distance. In other embodiments, these relations between the first, second, third and fourth on-axis distances need not exist. For instance, other relationships between the first, second, third and fourth on-axis distances may exist instead.

[0050] In at least one aspect of the subject disclosure, a MEMS actuator can be connected at least to lens L1. The MEMS actuator can be configured to reposition lens L1 along optical axis 104 to focus objects at different object distances. As one example, the MEMS actuator can change the first distance between lens L1 and lens L2 to focus objects at differing object distances. In at least one aspect, the MEMS actuator can position lens L1 a distance $D_{io_{cm}}$ 110 from lens L2 to focus onto sensor 106 an image of an object that is substantially 10 centimeters (cm) from a position of aperture stop A1 on optical axis 104.

[0051] According to further aspects, aperture stop A1 can be fixed relative to optical axis 104. In another aspect, aperture stop A1 can be fixed relative to a position of lens L1. In the latter aspect, aperture stop A1 can be moved by a MEMS actuator in

conjunction with lens LI when focusing an image of an object. According to still other aspects, the MEMS actuator can be configured to move lens LI, either alone or in conjunction with aperture stop A1, a total distance along optical axis 104. The total distance can, in a particular aspect, at one end thereof focus an image of an object at infinity, and at an opposite end thereof, focus an image of an object substantially at 10cm from aperture stop A1. As utilized herein, an object at infinity includes an object distance that satisfies the paraxial approximation known in the art of optical imaging science. The paraxial approximation, broadly stated, refers to an object at such a distance that an angle - subtending a first optical ray that is parallel with optical axis 104 and a second optical ray that originates at a point on the object farthest from the optical axis and passes through optical axis 104 at aperture stop A1 - is substantially zero degrees. In yet another aspect, lens LI can have a focal length that is at least in part a function of a magnitude of the total distance. In still other aspects, a ratio of the focal length of lens LI and a combined focal length of optical elements 102 can at least in part be a function of the magnitude of the total distance.

[0052] Because the pixel array of sensor 106 generates an electronic reproduction of a real image, data generated by sensor 106 (and other sensors disclosed herein) in the form of electric signals can be saved to memory, projected to a display for viewing (*e.g.*, digital display screen), edited in software, and so on. Thus, at least one application of optical system 100 is in conjunction with a digital camera or video camera comprising a digital display. Furthermore, optical system 100 and other optical systems included in the subject disclosure can be implemented in conjunction with a camera module of an electronic device. Such an electronic device can include a wide array of consumer, commercial or industrial devices. Examples include consumer electronics, including a cell phone, smart phone, laptop computer, net-book, PDA, computer monitor, television, flat-screen television, and so forth, surveillance or monitoring equipment, including commercial equipment (*e.g.*, ATM cameras, bank teller window cameras, convenience store cameras, warehouse cameras and so on), personal surveillance equipment (*e.g.*, pen camera, eyeglass camera, button camera, *etc.*), or industrial surveillance equipment (*e.g.*, airfield cameras, freight yard cameras, rail yard camera, and so on). For instance in consumer electronics, because optical system 100 can comprise optical components having physical dimensions on the order of a few millimeters or less, and because at least some of optical elements 102 can have a fixed position, system 100 and other disclosed systems are well suited for various

types of mini or micro camera modules. It is to be appreciated, however, that the disclosed systems are not limited to this particular application; rather, other applications known to those of skill in the art or made known by way of the context provided herein, are included within the scope of the subject disclosure.

[0053] Figure 2 illustrates a diagram of an example optical imaging system 200 according to additional aspects of the subject disclosure. Optical imaging system 200 can comprise a set of optical elements 202 arranged transverse to an optical axis 204. Furthermore, optical elements 202 can be configured to focus an image onto an image plane 206 of an object located substantially at infinity from an aperture stop A1 of optical imaging system 200. In at least one aspect, optical elements 202 can be substantially similar to optical elements 102 of Figure 1, *supra*, except for the first distance between lens L1 and lens L2. Particularly, this first distance in optical imaging system 200 can be a distance INFINITY 210 configured to focus the object located substantially at infinity, discussed above. Furthermore, as described at Figure 1, *supra*, aperture stop A1 can, in one aspect, be fixed in position relative to optical axis 204. In an alternative aspect, aperture stop A1 can be fixed in position relative to lens L1, and move along optical axis 204 with lens L2.

[0054] It should be appreciated that surfaces R1 through R10 of lenses L1 through L5 of optical elements 102 and 202 (as well as other optical surfaces described throughout the subject disclosure) can be of varying shapes. In one aspect, one or more of the surfaces can be spherical surfaces. In other aspects, one or more of the surfaces can be conic surfaces. In yet other aspects, one or more of the surfaces can be aspheric surfaces, according to a suitable aspheric equation, such as the even aspheric equation:

$$(1) \ z = \left[\frac{CY^2}{1 + (1 - (1 + K)^2 Y^2)^{1/2}} \right] + \sum_i (A_i * r^i),$$

where *z* is the sag height (in mm) of a line drawn from a point on the aspheric lens surface at a radial distance, *Y* from the optical axis to the tangential plane of the aspheric surface vertex, *C* is the curvature of the aspheric lens surface on the optical axis, *Y* is the radial distance (in mm) from the optical axis, *K* is the conic constant, and *A_i* is the *i*th aspheric coefficient, with the summation over even number *i*. However, these aspects are not to be construed as limiting the scope of the subject disclosure. Rather, various surfaces can be odd aspheric, or of an aspheric equation comprising even and odd coefficients.

[0055] Further to the above, it should be appreciated that lenses of optical

elements 102 and 202 (and optical lenses of various other optical systems provided throughout the subject disclosure) can be made of various suitable types of transparent material, and formed according to various suitable processes for generating an optical quality surface. In one aspect, lenses LI through L5 can be ground and polished glass, where the glass is selected to have an index of refraction resulting in a desired effective focal length for the combined lenses LI through L5. In another aspect, the lenses can be an optical-quality injected molded plastic (or plastic of optical quality formed by another suitable method), wherein the plastic has an index of refraction suitable to provide the desired effective focal length. In at least one other aspect, the lenses LI through L5 can be etched from a transparent glass, crystalline or other suitable structure (*e.g.*, silicon dioxide - SiO₂ wafer) with a lithographic etching process similar to that used to etch semiconductor chips (*e.g.*, solid state memory chip, data processing chip). In a particular aspect, optical elements 102 and optical elements 202 can be described according to the optical prescription of Tables 1 - 9, below.

Parameter Description	Value
Effective Focal Length (in air at system temperature and pressure)	4.131396
Effective Focal Length (in image space)	4.131396
Back Focal Length	0.349633
Total Track Length (TTL)	5.49089
Image Space F/#	2.293412
Paraxial Working F/#	2.44
Working F/#	2.857105
Image Space NA	0.1752143
Object Space NA	0.008991
Stop Radius	0.90071
Paraxial Image Height	2.956
Paraxial Magnification	-0.04388
Entrance Pupil Diameter	1.801419
Entrance Pupil Position	0.18
Exit Pupil Diameter	1.236574
Exit Pupil Position	-3.03634
Maximum Radial Field	2.956

Lens Units	Millimeters (mm)
Angular Magnification	1.183246

Table 1: General Optical Properties

<u>Field #</u>	<u>X-Value</u>	<u>Y-Value</u>	<u>Weight</u>
1	0	0	1
2	0	0.571	1
3	0	1.142	1
4	0	1.714	1
5	0	2.285	1
6	0	2.57	1
7	0	2.856	0.2
8	0	2.956	0.2

Table 2: Field Type v. Real Image Height (in mm)

<u>Field / #</u>	<u>VDX</u>	<u>VDY</u>	<u>VCX</u>	<u>VCY</u>	<u>VAN</u>
1	0	0	0	0	0
2	0	0	0	0	0
3	0	0	0	0	0
4	0	0	0	0	0
5	0	-0.04364	0.000234	0.043642	0
6	0	-0.081	0.001432	0.081006	0
7	0	-0.1227	0.004184	0.122713	0
8	0	-0.13916	0.006035	0.139171	0

Table 3: Vignetting Factors for Fields of Table 2

<u>Wavelength #</u>	<u>Value (in μm)</u>	<u>Weight</u>
1	0.47	91
2	0.51	503
3	0.555	1000
4	0.61	503
5	0.65	107

Table 4: Wavelengths Used for Raytracing

Surface	Type	Radius	Thickness	Material	Diameter	Conic	Notes
Object 1	Standard	Infinity	100		132.31 88	0	
	Standard	Infinity	0.1 8		2.036472	0	
Stop	Standard	Infinity	-0. 1		1.85939	0	
3	EvenAsph	1.974507	0.637634	APEL551 4ML	1.9071 53	0	
4	EvenAsph	-13.5665	0.166808		1.93921 2	0	
5	Standard	Infinity	0.049504		1.93921 2	0	not vignetting
6	EvenAsph	68.79989	0.528506	OKP4HT	1.951 274	0	
7	EvenAsph	2.992822	0.247886		1.977445	0	
8	Standard	Infinity	0.09498		2	0	Vignetting at 1.000
9	EvenAsph	143.3822	0.902332	APEL551 4ML	2.122436	0	
10	EvenAsph	-24.6284	0.367969		2.741 479	0	
11	EvenAsph	1.9791 7	0.596974	APEL551 4ML	3.225637	0	
12	EvenAsph	91.68886	0.360983		4.1271 83	0	
13	EvenAsph	-3.10061	0.38221 5	APEL551 4ML	4.395569	0	
14	EvenAsph	3.49791 4	0.2251		4.876466	0	
15	EvenAsph	Infinity	0.3	N-BK7	5.271 775	0	
16	Standard	Infinity	0.55		5.427336	0	
Image	Standard				0	0	

Table 5: Surface Data Summary

Surface	Parameter Description	Value
R1	Even Asphere	
	Coefficient on r 2	0
	Coefficient on r 4	-0.01328
	Coefficient on r 6	0.020358
	Coefficient on r 8	-0.03418
	Coefficient on r 10	0.012665
	Coefficient on r 12	0
	Coefficient on r 14	0
	Coefficient on r 16	0
R2	Even Asphere	
	Coefficient on r 2	0
	Coefficient on r 4	-0.0043
	Coefficient on r 6	0.001395
	Coefficient on r 8	-0.02717
	Coefficient on r 10	0.022646
	Coefficient on r 12	0
Coefficient on r 14	0	

	Coefficient on r 16	0
R3	Even Asphere	
	Coefficient on r 2	0
	Coefficient on r 4	-0.01683
	Coefficient on r 6	0.019474
	Coefficient on r 8	-0.03875
	Coefficient on r 10	0.034171
	Coefficient on r 12	0
	Coefficient on r 14	0
	Coefficient on r 16	0
R4	Even Asphere	
	Coefficient on r 2	0
	Coefficient on r 4	-0.01678
	Coefficient on r 6	0.057631
	Coefficient on r 8	-0.06199
	Coefficient on r 10	0.029185
	Coefficient on r 12	0
	Coefficient on r 14	0
	Coefficient on r 16	0
R5	Even Asphere	
	Coefficient on r 2	0
	Coefficient on r 4	-0.07378
	Coefficient on r 6	0.078871
	Coefficient on r 8	-0.04834
	Coefficient on r 10	0.007991
	Coefficient on r 12	0
	Coefficient on r 14	0
	Coefficient on r 16	0
R6	Even Asphere	
	Coefficient on r 2	0
	Coefficient on r 4	-0.20739
	Coefficient on r 6	0.12271
	Coefficient on r 8	-0.04163
	Coefficient on r 10	0.006751
	Coefficient on r 12	0

	Coefficient on r 14	0
	Coefficient on r 16	0
R7	Even Asphere	
	Coefficient on r 2	0
	Coefficient on r 4	-0.15706
	Coefficient on r 6	0.019487
	Coefficient on r 8	-0.00924
	Coefficient on r 10	0.001005
	Coefficient on r 12	0
	Coefficient on r 14	0
	Coefficient on r 16	0
R8	Even Asphere	
	Coefficient on r 2	0
	Coefficient on r 4	0.054595
	Coefficient on r 6	-0.04501
	Coefficient on r 8	0.010689
	Coefficient on r 10	-0.00087
	Coefficient on r 12	0
	Coefficient on r 14	0
	Coefficient on r 16	0
R9	Even Asphere	
	Coefficient on r 2	0
	Coefficient on r 4	-0.01701
	Coefficient on r 6	0.02087
	Coefficient on r 8	-0.00363
	Coefficient on r 10	0.000212
	Coefficient on r 12	0
	Coefficient on r 14	0
	Coefficient on r 16	0
R10	Even Asphere	
	Coefficient on r 2	0
	Coefficient on r 4	-0.07822
	Coefficient on r 6	0.013989
	Coefficient on r 8	-0.00152
	Coefficient on r 10	6.37E-05

	Coefficient on r 12	0
	Coefficient on r 14	0
	Coefficient on r 16	0

Table 6: Surface Aspheric Coefficients

<u>Surface</u>	<u>Edge</u>
Object	100
1	0.18
Stop	0.13436
3	0.361345
4	0.208736
5	0.052866
6	0.700429
7	0.0726
8	0.054707
9	0.625532
10	0.494114
11	0.625166
12	0.144313
13	0.505743
14	0.480978
15	0.3
16	0.55
Image	0

Table 7: Edge Thickness Data

Temperature (Temp) in degrees Celsius and pressure (Press) in atmospheres								
Surface	Material	Temp	Press	<u>0.47</u>	<u>0.51</u>	<u>0.555</u>	<u>0.61</u>	<u>0.65</u>
0		20	1	1	1	1	1	
1		20	1	1	1	1	1	
2		20	1	1	1	1	1	
3	APEL55 14ML	20	1	1.552896	1.549574	1.546504	1.543579	1.541977
4		20	1	1	1	1	1	
5		20	1	1	1	1	1	
6	OKP4HT	20	1	1.65642	1.646281	1.637383	1.62927	1.625419
7		20	1	1	1	1	1	
8		20	1	1	1	1	1	
9	APEL55 14ML	20	1	1.552896	1.549574	1.546504	1.543579	1.541977
10		20	1	1	1	1	1	
11	APEL55 14ML	20	1	1.552896	1.549574	1.546504	1.543579	1.541977
12		20	1	1	1	1	1	
13	APEL55	20	1	1.552896	1.549574	1.546504	1.543579	1.541977

	14ML							
14		20	1	1	1	1	1	
15	N-BK7	20	1	1.523605	1.520769	1.51 8274	1.51 5909	1.51 452
16		20	1	1	1	1	1	
17		20	1	1	1	1	1	

Table 8: Index of Refraction Data

		Wavelengths (μm):					
		0.47		0.51		0.555	
Number	Field (mm)	Tan	Sag	Tan	Sag	Tan	Sag
1	0	2.4569	2.4569	2.4571	2.4571	2.4591	2.4591
2	0.571	2.5045	2.4888	2.5043	2.4886	2.506	2.4902
3	1.142	2.5363	2.5666	2.5363	2.5654	2.538	2.5662
4	1.714	2.6412	2.6707	2.644	2.6687	2.6478	2.6688
5	2.285	3.1763	2.8179	3.1806	2.8155	3.1856	2.8152
6	2.57	3.6191	2.9098	3.6212	2.9074	3.6236	2.907
7	2.856	4.1799	3.0168	4.1688	3.0144	4.1575	3.014
8	2.956	4.4668	3.0594	4.4391	3.0571	4.4113	3.0567

Table 9: F/Number Data

		Wavelengths (μm)			
		0.61		0.65	
Number	Field (mm)	Tan	Sag	Tan	Sag
1	0	2.4624	2.4624	2.4666	2.4666
2	0.571	2.509	2.4932	2.5132	2.4973
3	1.142	2.5408	2.5684	2.5444	2.5721
4	1.714	2.6522	2.6703	2.656	2.6736
5	2.285	3.1911	2.8164	3.1952	2.8194
6	2.57	3.6263	2.908	3.6281	2.911
7	2.856	4.1459	3.0151	4.1376	3.018
8	2.956	4.3835	3.0578	4.3641	3.0606

Table 9A: F/Number Data (Continued)

[0056] Table 1 provides general optical information for an embodiment of optical imaging systems 100 and 200. Table 2 provides image heights in the y axis, measured at the image sensor 106 or image sensor 206, for eight different optical fields, and provides weights for the respective fields. Table 3 includes vignetting data for the eight fields indicated in Table 2. Table 4 depicts wavelengths of respective rays traced

in optical imaging systems 100 and 200, depicted at Figures 1 and 2. Table 5 provides a summary of general optical surface characteristics for the lenses of optical elements 102 and optical elements 202, including surface type, radius of curvature, thickness, material (from standard glass and plastic catalogues), diameter, conic constant, and notes regarding vignetting. Table 6 describes even aspheric coefficients for the surfaces of Table 5, whereas Table 7 provides edge thickness information for those surfaces. Table 8 provides index of refraction data for multiple wavelengths for the optical fields identified at Table 2. Tables 9 and 9A provide F/# data for those same wavelengths and optical fields.

[0057] Figure 3 illustrates a diagram of an example injection molded plastic optical system 300 (also referred to as system 300) according to further aspects of the subject disclosure. System 300 can be formed from multiple injection molded plastic components. In one embodiment, two or more of lenses L1, L2, L3, L4 and L5 can be formed from a single mold. In other embodiments, respective lenses can be formed from separate molds and assembled, as depicted, after molding. In other aspects, formation of lenses L1, L2, L3, L4 and L5 can result from another optical fabrication technique, such as wafer-level optic fabrication. In at least one disclosed aspect, system 300 can be substantially similar to optical imaging system 100. In another aspect, system 300 can be substantially similar to optical imaging system 200. According to yet other aspects, system 300 can comprise MEMS hardware configured to displace lens L1 along optical axis 302 to achieve focusing at an image plane 304 of system 300. In a particular embodiment, system 300 can comprise lens surfaces R1 and R2 of lens L1, surfaces R3 and R4 of lens L2, surfaces R5 and R6 of lens L3, surfaces R7 and R8 of lens L4, and surfaces R9 and R10 of lens L5, that are substantially similar to surfaces R1 - R10 described at Figure 1, *supra*.

[0058] Figure 4 illustrates a diagram of field curvature and F-Tan(Theta) Distortion (referred to hereinafter as distortion) for an optical imaging system as described herein. Particularly, Figure 4 illustrates field curvature and distortion for an object distance of 10cm, which can correspond with optical imaging system 100 of Figure 1, *supra*. The field curvature and distortion graphs utilize five wavelengths, having wavelengths of 0.470, 0.510, 0.555, 0.610 and 0.650 μm , respectively, and have a maximum field angle of 33.391 degrees. The left-hand graph depicts field curvature in millimeters along a y-axis at an image plane of an optical imaging system. Field curvature data is depicted for Sagittal rays (delineated as 'S' on Figure 4) and Tangential

rays (delineated as 'T' on Figure 4). As is clear from the graph, field curvature is minimal for sagittal rays over most of the image plane, and field curvature is within a few microns for tangential rays for most of the image plane, and several microns at the outer edge of the image plane (high y values).

[0059] The distortion graph on the right hand side also includes curves for the above five wavelengths. The distortion data is normalized to 0% at the optical axis. Throughout the image plane, distortion is less than about 1.5%, and less than one percent for low field angles.

[0060] Figure 5 depicts a diagram of field curvature and distortion for an optical imaging system focusing an object at infinity. Thus, the graphs of Figure 5 can correspond with optical imaging system 200 of Figure 2, *supra*. The field curvature and distortion graphs of Figure 5 employ graphs for the same wavelengths as for Figure 4, for a maximum field angle of 34.897 degrees. Field curvature includes lines for sagittal rays (S) for the indicated wavelengths, as well as transverse rays (T) for those same wavelengths. As depicted, field curvature for an object in focus at 10cm is within about +/- 50 microns.

[0061] Distortion at infinity varies a bit more than for the 10cm graph of Figure 4. Distortion is again normalized to 0% on the optical axis. The distortion ranges from about a half percent at medium field angles to about negative one and a half percent at the edge of the image plane. Total distortion for all field angles is about two percent.

[0062] Figure 6 illustrates a graph of primary lateral color for an optical imaging system as described herein. Particularly, the primary lateral color graph of Figure 6 is for an object in focus at 10cm object distance, and therefore can correspond with optical imaging system 100 of Figure 1, *supra*. The maximum field for the primary lateral color graph is 2.9560 mm, and ranges in wavelengths between 0.4700 and 0.6500 $\mu\eta$. As depicted, lateral color variation is well within a half a micron for small field angles, varies to just over negative one microns for medium field angles, and becomes as large as about negative one and a half microns for higher field angles. Overall distortion remains below two microns for the image plane.

[0063] Figure 7 illustrates a graph of primary lateral color for an object in focus at infinity. Accordingly, Figure 7 can correspond with optical imaging system 200 of Figure 2, *supra*. Similar to Figure 6, the maximum field is 2.9560 mm for wavelengths between 0.4700 and 0.6500 $\mu\eta$. For low and medium field angles, primary lateral color remains at or below about one half a micron. Only at larger field angles does the

primary lateral color exceed half a micron, reaching a peak at just over about two microns at an edge of the image plane.

[0064] Figure 8 illustrates several transverse ray fan plots at an image plane of an optical imaging system described herein. Particularly, the transverse ray fan plots of Figure 8 correspond with an object in focus at 10cm object distance, and therefore can correspond with optical imaging system 100 of Figure 1, *supra*. The transverse ray fan plots depict transverse ray error (e_y) along a vertical axis, and pupil diameter (P_y) along the horizontal axis, for various image heights. Flatter plots indicate optimal performance and minimal error, whereas greater deviations along the vertical axis indicate greater transverse ray error. As is depicted by Figure 8, transverse ray error is minimal for near the optical axis (small image height), and generally increases with image height. The scale ranges from positive 25 microns to negative 25 microns along the x and y axis, respectively. The transverse ray fan plots include wavelengths between 0.470 and 0.650 wavelengths.

[0065] Figure 9 depicts several transverse ray fan plots for an object in focus at infinity, and therefore can correspond with optical imaging system 200 of Figure 2, *supra*. Similar to Figure 8, the plots exhibit minimal error near the optical axis, and generally low error for small pupil diameters at all field angles. At higher field angles and particularly higher pupil diameters, the transverse ray error increases. Generally, transverse ray error for the object at infinity is less than for the object at 10cm.

[0066] Referring now to the drawings, Figure 10 depicts a cross sectional view of an optical system 1000 for an object at 10cm comprising an arrangement of optical elements 1002 positioned in a like manner relative to an optical axis 1004. Light entering the left side, or object side, of optical elements 1002 can interact sequentially with respective elements 1002 and exit the right side, or image side, of the elements 1002, toward an image sensor 1006. The real image will be formed along the optical axis 1004 a certain distance from the optical elements 1002, called an image distance (ID). Notably, the ID depends primarily on a corresponding object distance (OD - distance between the object and the optical elements 1002 along the optical axis 1004) and a refractive power, or optical power, of the combined optical elements 102.

[0067] Sensor 1006 can be a digital device comprising a multi-dimensional array (*e.g.*, a two dimensional array) of electro-optical sensors, or pixels, which can include a CCD array, or a CMOS array, *etc.* Resolution of a digital image generated by sensor 1006 depends on a number of pixels within the sensor plane array 1008, which in

turn is dependent on pixel area and total array area. Thus, for example, for relatively square pixels approximately 1.4 microns per side (1.96 square microns), a 0.4 cm square sensor array can comprise as many as 8.1 megapixels (Mp). Said differently, such a sensor would have resolution of about 8Mp. Because the pixel array generates an electronic reproduction of a real image, data generated by sensor 1006 in the form of electric signals can be saved to memory, projected to a display for viewing (*e.g.*, digital display screen), edited in software, and so on.

[0068] It should be appreciated that the optical imaging arrangement 1000 depicted in Figure 10 (and other optical imaging systems disclosed herein) is not intended to be drawn to scale. For instance, lens thicknesses, positions and heights are not necessarily depicted in proper proportion with actual sizes. Rather, arrangement 1002 is intended to provide a visual context of an imaging system to aid conceptual understanding of other aspects disclosed herein.

[0069] Optical system 1000 comprises a first lens L1, a second lens L2, a third lens L3, a fourth lens L4, and a fifth lens L5 centered upon an optical axis 104. The lenses are numbered starting from the object side to the image side. Thus, lens L1 is closest to the object, and lens L5 is closest to the image. Aperture A1 can be embedded into lens L1, or can be fixed to L1 physically. Accordingly, in this embodiment, aperture A1 does not move relative to lens L1. In certain aspects of the disclosure, the aperture A1 can have a 50 μ m depth.

[0070] Lenses L1 through L5 each have two opposed refracting surfaces. A radius of curvature for the respective surfaces is denoted by the letter "R" followed by a surface number, starting with the object side surface of lens L1. Thus, the surfaces in order from object side to image side are object side surface R1 and image side surface R2 of lens L1, object side surface R3 and image side surface R4 of lens L2, object side surface R5 and image side surface R6 of lens L3, object side surface R7 and image side surface R8 of lens L4, and object side surface R9 and image side surface R10 of lens L5. The respective surface identifiers (R1, R2, R3, ..., R10) are also utilized to represent the radius of curvature for the respective surfaces. Additionally, refractive index n_j denotes the refractive index of the lens medium associated with the j^{th} surface, and v_{di} is the Abbe number of the lens medium associated with the j^{th} surface.

[0071] Lens L1 can have a large positive refractive power, with both optical surfaces, R1 and R2, being convex. As utilized herein, the terms large or small refractive power (whether positive or negative) are intended to be relative to other

lenses of a particular optical system. Thus, for instance, referring to lens LI as having large positive refractive power implies that lens LI has greater than average positive refractive power as compared with other positive power lenses of optical system 1000. Conversely, a lens having small positive refractive power for optical system 1000 will have less than the average positive refractive power.

[0072] In an embodiment, LI can be moveable relative to lenses L2-L5 and the sensor plane 1008. Movement can be achieved using MEMS or other appropriate actuators. In this embodiment, L2-L5 remain fixed relative to the image sensor plane 1008 and image sensor 1006. In some aspects of the disclosure, the range of movement of LI is around $100\mu\text{m}$. The movement of LI allows optical system 1000 to maintain focus on objects at various distances. In Figure 10, the optical system 1000 is focused on an object at a distance of 10cm from the optical system. In Figure 2, the optical system 1100 is focused on an object at optical infinity.

[0073] In certain embodiments, there is an inverse relationship between the refractive power of LI and the range of motion required to focus on objects at various distances. An LI with a higher power requires a shorter range of movement to focus on objects at various distances and vice versa. According to some aspects of the disclosure, the axial gap, or distance between lenses LI and L2 at the optical axis is around $125\mu\text{m}$, with a gap of about $170\mu\text{m}$ at the clear aperture.

[0074] L2 can have a meniscus shape (having smaller thickness near the optical axis than away from the optical axis), with optical surface R3 being convex, and optical surface R4 being concave. In some aspects of the disclosure, lens L2 provides most of the chromatic correction for optical system 1000 and has negative refractive power. Lens L3 can be biconvex near the optical axis 1004 as optical surface R5 is convex near the optical axis 1004 and concave away from the optical axis 1004 and image side optical surface R6 is convex. According to some aspects of the disclosure, lens L3 can have a positive refractive power. In certain embodiments, L2 can be mounted on to L3, such that L2 is fixed to L3, and L2 does not touch an optical barrel that arranges lenses LI - L5 of optical system 1000 along optical axis 1004.

[0075] Lens L4 has a concave object side optical surface R7, and a convex shaped image side optical surface R8. Lens L5 can be meniscus shaped with a convex optical surface R9 near optical axis 1004 and optical surface R10 that is concave near the optical axis 104.

[0076] It should be appreciated that surfaces R1-R10 (as well as other optical surfaces described throughout the subject disclosure, including optical surfaces for system 200 can be of varying shapes. In one aspect, one or more of the surfaces can be spherical surfaces. In other aspects, one or more of the surfaces can be conic surfaces. In yet other aspects, one or more of the surfaces can be aspheric surfaces, according to a suitable aspheric equation, such as the even aspheric equation:

$$\text{[0077]} \quad (1) \quad z = \left[\frac{CY^2}{1 + (1 - (1 + K)C^2Y^2)^{1/2}} \right] + \sum_i (A_i * Y^i), \text{ where } z \text{ is the sag}$$

height (in mm) of a line drawn from a point on the aspheric lens surface at a radial distance, Y from the optical axis to the tangential plane of the aspheric surface vertex, C is the curvature of the aspheric lens surface on the optical axis, Y is the radial distance (in mm) from the optical axis, K is the conic constant, and A_i is the i^{th} aspheric coefficient, with the summation over even number i . However, these aspects are not to be construed as limiting the scope of the subject disclosure. Rather, various surfaces can be odd aspheric, or of an aspheric equation comprising even and odd coefficients.

[0078] Further to the above, it should be appreciated that lenses L1-L5 of optical system 1000 (and the optical lenses of optical system 1100) can be made of various suitable types of transparent material, formed according to various suitable processes for generating an optical quality surface. In one aspect, the lenses L1-L5 can be ground and polished glass, where the glass is selected to have an index of refraction resulting in a desired effective focal length for the combined lenses L1-L5. In another aspect, the lenses can be an optical-quality injected molded plastic (or plastic of optical quality formed by another suitable method), wherein the plastic has an index of refraction suitable to provide the desired effective focal length. In at least one other aspect, the lenses L1-L5 can be etched from a transparent glass, crystalline or other suitable structure (e.g., silicon dioxide - SiO_2 wafer) with a lithographic etching process similar to that used to etch semiconductor chips (e.g., solid state memory chip, data processing chip).

[0079] According to various aspects, the lenses L1, L2, L3, L4 and L5 can be made of plastic (e.g., APL5014, OKP4HT, or ZE-330R or another suitable plastic having similar refractive index and Abbe number, or a suitable combination thereof). In one specific aspect, lenses L1, L3, and L5 are made of one plastic (e.g., APL5014) while lenses L2 and L4 are made of different plastics (e.g., OKP4HT and ZE-330R

respectively). It should be appreciated, however, that in other aspects the lenses can be of other materials having similar Abbe numbers or refractive indices instead.

[0080] Turning now to Figure 11, a cross-section of a sample optical system focused at infinity according to aspects of the subject disclosure is shown. The optical system 1100 of Figure 11 is similar to optical system 100, although optical system 1100 is focused on an object at infinity as opposed to at 10 cm. A difference between optical system 1100 and optical system 1000 is that LI is positioned at a different distance from the sensor 1106 relative to lenses L2-L5.

[0081] According to one specific aspect of the subject disclosure, a prescription for the respective lenses LI, L2, L3, L4 and L5 is provided in Tables 10-13, below. Table 10 lists general lens data for the respective lenses, and Table 11 lists surface data including radius of curvature (R) (in mm) near the optical axis, distance between surfaces, diameter of the respective lenses, and material of the respective lenses. Furthermore, Table 12 provides aspheric constants A_i for $i = 2, 4, 6, 8, 10, 12, 14, 16$ of equation (1), *supra*, for aspheric surfaces of Table 11, where the index "i" is denoted by "r" *{e.g., as generated in the optical design software program ZEMAX, available from ZEMAX Development Corporation}*. Table 13 provides refractive index n_i of the i^{th} lens for a set of wavelengths. Table 14 provides a range of fields versus image height, Table 15 provides vignetting information for optical systems 1000 and 1100, Table 16 provides wavelength and weights used for the raytracing of Figures 10 and 11, Table 17 provides surface data for optical systems 1000 and 1100, including radius, thickness, material, diameter, and conic constant. Additionally, Table 18 provides edge thickness information for optical systems 1000 and 1100.

Surfaces (including apertures)	15
Stops	1
System Aperture	Float by stop size = 0.886727
Apodization	Uniform Factor = 0.00000E+000
Temperature (C)	2.00000E+001
Pressure (ATM)	1.00000E+000
Effective Focal Length	4.28412 (in air at system temp & pressure)
Effective Focal Length	4.28412 (in image space)

Back Focal Length	0.5015793
TTL	5.299934
Image Space F/#	2.415692
Paraxial Working F/#	2.415692
Working F/#	2.40149
Image Space NA	0.202684
Object Space NA	8.867272e-011
Stop Radius	0.8867272
Paraxial Image Height	2.856
Paraxial Magnification	0
Entrance Pupil Diameter	1.773454
Entrance Pupil Position	0
Field Type	Real Image height in mm
Maximum Radial Field	2.856
Primary Wavelength	0.555 μm
Lens Units	mm
Angular Magnification	1.39828

Table 10: General Properties for Optical Systems 1000 and 1100

(Optical Properties defined in Optical Design Software Zemax)

Surface	Type	Radius (mm)	Thickness (mm)	Medium	Diameter (mm)
OBJ	Standard	Infinity	Infinity		0
A1	Standard	Infinity	0.05		1.773454
R1	Even_Asph	2.031962	0.545	APL5014	1.774436
R2	Even_Asph	-17.60993	0.1242087		1.867362
R3	Even_Asph	4.178319	0.3	OKP4-HT	1.941112
R4	Even_Asph	1.60308	0.3519566		2.054041
R5	Even_Asph	5.790688	0.6445624	APL5014	2.132792
R6	Even_Asph	-2.417954	0.2002186		2.449247
R7	Even_Asph	-0.9919052	0.3658935	ZE-330R	2.5699
R8	Even_Asph	-1.223582	0.5116968		2.686087
R9	Even_Asph	12.46394	1.123586	APL5014	2.987795
R10	Even_Asph	2.132428	0.3415114		4.646312
14	Standard	Infinity	0.3	D263T	6

15	Standard	Infinity	0.4913		6
IMA	Standard	Infinity			6.4

Table 11: Surface Data for Lens Elements for Optical System 1000 and 1100

Surface	Conic	Note
OBJ	0	
A1	0	stop1
R1	-1	L1-1
R2	-1	L1-2
R3	-1	L2-1
R4	-1	L2-2
R5	-1	L3-1
R6	-1	L3-2
R7	-1	L4-1
R8	-1	L4-2
R9	-1	L5-1
R10	-1	L5-2
14	0	Ir cut-off (D263T)
15	0	
IMA		

Table 11: Continued

Surface	R1	
	Coeff on r2	0
	Coeff on r4	0.021400101
	Coeff on r6	-0.0044229854
	Coeff on r8	-0.00018162551
	Coeff on r10	0
	Coeff on r12	0
	Coeff on r14	0
	Coeff on r16	0
Surface	R2	
	Coeff on r2	0
	Coeff on r4	0.0013366226
	Coeff on r6	0.0044675095

	Coeff on r8	-0.0065254167
	Coeff on r10	0
	Coeff on r12	0
	Coeff on r14	0
	Coeff on r16	0
Surface	R3	
	Coeff on r2	0
	Coeff on r4	-0.15575931
	Coeff on r6	0.11775238
	Coeff on r8	-0.040496241
	Coeff on r10	0
	Coeff on r12	0
	Coeff on r14	0
	Coeff on r16	0
Surface	R4	
	Coeff on r2	0
	Coeff on r4	-0.17899613
	Coeff on r6	0.13165259
	Coeff on r8	-0.041877243
	Coeff on r10	0
	Coeff on r12	0
	Coeff on r14	0
	Coeff on r16	0
Surface	R5	
	Coeff on r2	0
	Coeff on r4	-0.034806957
	Coeff on r6	-0.055196853
	Coeff on r8	-0.0076170308
	Coeff on r10	0
	Coeff on r12	0
	Coeff on r14	0
	Coeff on r16	0
Surface	R6	
	Coeff on r2	0
	Coeff on r4	0.020581236
	Coeff on r6	-0.0065040866
	Coeff on r8	-0.018006387
	Coeff on r10	0
	Coeff on r12	0
	Coeff on r14	0
	Coeff on r16	0
Surface	R7	

	Coeff on r2	0
	Coeff on r4	0.17752822
	Coeff on r6	0.0025820117
	Coeff on r8	0.0073104429
	Coeff on r10	-0.0065708267
	Coeff on r12	0
	Coeff on r14	0
	Coeff on r16	0
Surface	R8	
	Coeff on r2	0
	Coeff on r4	0.03288338
	Coeff on r6	0.076502466
	Coeff on r8	-0.06842281
	Coeff on r10	0.038984099
	Coeff on r12	-0.0076836467
	Coeff on r14	0
	Coeff on r16	0
Surface	R9	
	Coeff on r2	0
	Coeff on r4	-0.1830718
	Coeff on r6	0.075510932
	Coeff on r8	-0.034603365
	Coeff on r10	0.0066539539
	Coeff on r12	-0.00029016159
	Coeff on r14	0
	Coeff on r16	0
Surface	R10	
	Coeff on r2	0
	Coeff on r4	-0.15124446
	Coeff on r6	0.071176496
	Coeff on r8	-0.029255744
	Coeff on r10	0.0080879291
	Coeff on r12	-0.0014220241
	Coeff on r14	0.00014276636
	Coeff on r16	-6.2275295e-006

Table 12: Aspheric Coefficients for Optical System 1000 and 1100

Surface	Medium	Temp	Pressure	Index (for given wavelength in μm)				
				<u>0.47</u>	<u>0.41</u>	<u>0.555</u>	<u>0.61</u>	<u>0.65</u>
L1	APL5014	20	1	1.5518	1.5483	1.5452	1.5424	1.5408

L2	OKP4-HT	20	1	1.6564	1.6458	1.6369	1.6291	1.6248
L3	APL5014	20	1	1.5518	1.5483	1.5452	1.5424	1.5408
L4	ZE-330R	20	1	1.5172	1.5139	1.5111	1.5084	1.5069
L5	APL5014	20	1	1.5518	1.5483	1.5452	1.5424	1.5408

Table 13: Index of Refraction for Optical Systems 1000 and 1100

Field #	X-Value	Y-Value	Weight
1	0	0	1
2	0	0.571	1
3	0	1.142	1
4	0	1.714	1
5	0	2.285	1
6	0	2.57	1
7	0	2.856	1

Table 14: Field Type v. Real Image Height (in mm)

Field / #	VDX	VDY	VCX	VCY	VAN
1	0	0	0	0	0
2	0	-0.00376	0.00001	0.003764	0
3	0	-0.00751	0.00003	0.007509	0
4	0	-0.01125	0.000093	0.011253	0
5	0	-0.01512	0.00015	0.015117	0
6	0	-0.01707	0.000226	0.017069	0
7	0	-0.019	0.000251	0.018997	0
1	0	0	0	0	0

Table 15: Vignetting Factors for Fields of Table 2

Wavelength #	Value (in μm)	Weight
1	0.47	91
2	0.51	503
3	0.555	1000
4	0.61	503
5	0.65	107

Table 16: Wavelengths Used for Raytracing

Surface	Type	Radius	Thickness	Material	Diameter	Conic	Notes
---------	------	--------	-----------	----------	----------	-------	-------

Object	Standard	Infinity	Infinity		0	0	
Stop	Standard	Infinity	0.05		1.773454	0	
2	Standard	Infinity	-0.204		1.773454	0	
3	EvenAsph	2.031 962	0.545	APL501 4	1.774436	-1	L1
4	EvenAsph	-17.6099	0.124209		1.867362	-1	
5	EvenAsph	4.17831 9	0.3	OKP4HT	1.941 112	-1	L2
6	EvenAsph	1.60308	0.351 957		2.054041	-1	
7	EvenAsph	5.790688	0.644562	APL501 4	2.132792	-1	L3
8	EvenAsph	-2.41 795	0.20021 9		2.449247	-1	
9	EvenAsph	-0.991 9 1	0.365894	ZE-330R	2.5699	-1	L4
10	EvenAsph	-1.22358	0.51 1697		2.686087	-1	
11	EvenAsph	12.46394	1.123586	APL501 4	2.987795	-1	L5
12	EvenAsph	2.132428	0.341 5 11		4.64631 2	-1	
13	Standard	Infinity	0.3	D263T	6	0	IRCF
14	Standard	Infinity	0.491 3	N-BK7	6	0	
Image	Standard	Infinity	6.4		0	0	

Table 17: Surface Data Summary

<u>Surface</u>	<u>Edge</u>
Stop	0.05
2	0.000726
3	0.315728
4	0.189805
5	0.491449
6	0.078721
7	0.308446
8	0.214072
9	0.303193
10	0.428579
11	1.31122
12	0.662695
13	0.3
14	0.4913
Image	0

Table 18: Edge Thickness Data

[0082] Figure 12 illustrates a graph of field curvature and distortion for optical configuration 1002. Further, the field curvature and distortion values are displayed for several wavelengths ranging from 0.470μm to 0.650μm. Field curvature is within about 10 microns for these wavelengths for low field angles, and is less than 100 microns even at the perimeter of the image plane. Further, distortion is well within the range of two and negative two percent. As would be clear to one of skill in the art, aberrations are well compensated for by the subject optical arrangement 1002.

[0083] Figure 13 illustrates a graph of field curvature and distortion for optical configuration 1102. Further, the field curvature and distortion values are displayed for

several wavelengths ranging from $0.470\mu\text{m}$ to $0.650\mu\text{m}$. Field curvature is well within the range of ± 100 microns, and distortion is well within the range of two and negative two percent. As would be clear to one of skill in the art, aberrations are well compensated for by the subject optical arrangement 1102.

[0084] Figure 14 depicts a graph of lateral color for optical arrangement 1002. A maximum field for the graph is 2.8560mm . Additionally, the lateral color curve is over a range of wavelengths from $0.470\mu\text{m}$ to $0.650\mu\text{m}$. The primary lateral color for an object in focus at 10cm is about $-3.5\mu\text{m}$ as depicted by the graph.

[0085] Figure 15 depicts a graph of lateral color for optical arrangement 1102 for an object in focus at infinity. A maximum field for the graph is 2.8560mm . Additionally, the lateral color curve is over a range of wavelengths from $0.470\mu\text{m}$ to $0.650\mu\text{m}$. The primary lateral color for the object in focus at infinity is about $+0.8$ microns.

[0086] Figure 16 and Figure 17 depict transverse ray fan plots for optical arrangements 1002 and 1102 respectively. The transverse ray fan plots depict transverse aberration (e_y and e_x) along the y and x axis for pupil diameters P_y and P_x . The transverse ray fan plots are made at image heights 0.000mm (1600 and 1700), 0.5710mm (1602 and 1702), 1.1420mm (1604 and 1704), 1.7140mm (1606 and 1706), 2.2850mm (1608 and 1708), 2.5700mm (1610 and 1710), and 2.8560mm (1612 and 1712). The plots are generally within acceptable ranges for optical imaging and accordingly, the optical arrangements 1002 and 1102 have good imaging quality.

[0087] Figure 18 illustrates a diagram of an example ray plot diagram for an optical system 1800 according to alternative aspects of the subject disclosure. System 1800 comprises an arrangement of optical elements 1802. Optical rays are depicted intersecting optical elements 1802 within a field of view of optical system 1800. On-axis rays are focused onto the optical axis at an image plane or focal plane associated with optical elements 1802, and rays originating at larger field angles are depicted as converging at farther distances from the optical axis at the image plane.

[0088] A left-most side of optical elements 1802 is an object side of optical system 1800, and a right-most side of optical elements 1802 is an image side of optical system 1800. A real image of the object is formed at the image plane of optical elements 1802 when optical elements 1802 are properly in focus. In at least one aspect of the subject disclosure, optical system 1800 can comprise a variable focus optical system, in which a subset of optical elements 1802 can be moved along the optical axis

to bring an image of an object into focus at the image plane. In particular aspects, a set of positions of the subset of optical elements 1802 can correspond with a set of object distances having respective images in focus at the image plane. In other words, when the subset of optical elements 1802 is positioned at one of the set of positions, an object at a corresponding one of the set of object distances will be in focus at the image plane. A position of optical elements 1802 as depicted by Figure 18 and Figure 19, *infra*, illustrate an example arrangement in which optical elements of system 1800 are in a position to focus an object located at infinity onto the image plane. A position of optical elements 1802 as depicted by Figures 23 and 24, *infra*, illustrate an example arrangement in which the optical elements are in a position to focus a near-field object onto the image plane.

[0089] Figure 19 depicts a diagram of an example optical system 1900 comprising optical elements and optical surfaces according to additional aspects of the subject disclosure. Optical system 1900 can be substantially similar to optical system 1800. As indicated, optical system 1900 is configured to focus an image of an object located in the far-field (*e.g.*, at infinity).

[0090] Optical system 1900 can comprise a set of optical elements 1902 centered along an optical axis 1904. Optical elements 1902 can be configured to focus an image that can be captured by a sensor 1908. Sensor 1908 can comprise a multi-dimensional array of optical-sensitive pixels located at an image plane of sensor 1908. The optical-sensitive pixels can output electrical signals in response to electro-magnetic energy (*e.g.*, light) focused by optical elements 1902 upon sensor 1908. Moreover, the electrical signals can have characteristics related to optical characteristics of the electro-magnetic energy. These electrical signals can be utilized to re-produce the image focused by optical elements 1902 and captured by sensor 1908, as described herein or known in the art. Optical system 1900 can also comprise a cover plate 1906 for sensor 1908. Cover plate can protect the optical-sensitive pixels of sensor 1908 from dust or other particles that might otherwise absorb or scatter electro-magnetic energy focused by optical elements 1902, thereby distorting the image.

[0091] Optical elements 1902 can comprise five optical lenses, including lens LI, lens L2, lens L3, lens L4 and lens L5 (referred to collectively as lenses LI - L5). The optical lenses are numbered from left - the object side of optical system 1900 - to right - the image side of optical system 1900. The left-most lens, LI, is therefore also

referred to herein as the object-side lens. Alternatively, lens LI can be referred to as an objective lens of optical system 1900.

[0092] As depicted, lens LI is a bi-convex lens having positive optical power, and having a convex object-side surface R1 and convex image-side surface R2. Furthermore, lens LI can have a strong optical power relative to lenses L2, L3, L4 and L5 of optical elements 1902. In particular aspects, lens LI can have greater positive optical power than either of lenses L2, L3, L4 or L5. In a further aspect, LI can have greater positive optical power than any subset of lenses L2, L3, L4 and L5. In at least one alternative or additional aspect, lens LI can have greater positive optical power than the combination of lenses L2, L3, L4 and L5. As depicted, an aperture stop A1 can be located about the object side surface R1 of lens LI.

[0093] Lens 2 can be a lens having a negative optical power. Lens L2 can have an object-side surface R3 and an image-side surface R4. Surface R3 can be mildly convex, in some aspects of the subject disclosure. In other aspects, surface R3 can be substantially flat with no significant optical power. In still other aspects of the subject disclosure, surface R3 can have a complex curvature that is convex for a subset of pupil radii (*e.g.*, a range of distances from optical axis 1904) of surface R3, and concave for a different subset of pupil radii of surface R3. As an example, surface R3 can have a concave curvature from the optical axis 1904 to a first pupil radius, and can have a convex curvature from the first pupil radius to a second pupil radius, where the second pupil radius is larger than the first pupil radius. An image side surface R4 can have a concave curvature, providing the majority of negative optical power of lens L2.

[0094] Lens L3 can be a meniscus lens having a convex curvature toward the object side of lens L3. As depicted, lens L3 comprises an object side surface R5 and image side surface R6. Object side surface R5 can have convex curvature. In particular aspects, convexity of object side surface R5 can be stronger near optical axis 1904 than near a perimeter of lens L3. Said differently, a radius of curvature of object side surface R5 can increase with increasing pupil radius of object side surface R5, and in at least one aspect become infinite near the perimeter of lens L3. Image side surface R6 can have concave curvature. In at least one aspect, a radius of curvature of image side surface R6 can increase with increasing pupil radius of lens L3. In an alternative or additional aspect, image side surface R6 can be convex near the perimeter of lens L3.

[0095] Lens L4 comprises an object side surface R7 and an image side surface R8. Lens L4 can be a meniscus lens toward the image side of optical elements 1902.

Additionally, lens L4 can have mild positive optical power. In one alternative or additional aspect, positive power of lens L4 can be greater near optical axis 1904 as compared with a periphery of lens L4, whereas in other aspects the positive power can be substantially constant over the surface of image side surface R8.

[0096] Lens L5 comprises an object side surface R9 and image side surface R10. Object side surface R9 can have concave curvature for low and medium field angles, and reduced curvature at higher field angles. Image side surface R10 can be concave near optical axis 1904. Further, image side surface R10 can transition from concave to convex for medium and high field angles.

[0097] Optical elements 1902 can have respective spaces (air gaps) between respective lenses L1, L2, L3, L4 and L5. In a particular aspect, an on-axis air distance between lens L4 and lens L5 can be a largest of a set of air distances among lenses L1 - L5. In an alternative or additional aspect, an air distance between lens L3 and lens L4 can be a second largest of the set of air distances among lenses L1 - L5.

[0098] In a further aspect of the subject disclosure, an actuator can be connected to a subset of optical elements 1902. In one example, the actuator can be a MEMS actuator, whereas in other aspects the actuator can be another type of actuator known in the art. The actuator can be configured to reposition the subset of optical lenses along optical axis 1904. Repositioning the subset of optical lenses can cause images of objects at different object distances to come into focus at sensor 1908 of optical system 1900. In particular aspects, optical lenses 1902 can be configured to focus an image of an object located in the far field (*e.g.*, infinity, ...) onto sensor 1908. According to further aspects, the subset of optical elements 1902 can be repositioned to focus an object in the near field at sensor 1908. In a specific aspect, the subset of optical elements can include lens L1, and lens L1 can be positioned as depicted by Figure 19 by the MEMS actuator to bring an object located at infinity into focus at sensor 1908, and can be positioned as depicted by Figure 23 by the MEMS actuator to bring an object at an object distance of substantially 12.8 centimeters (cm) into focus at sensor 1908.

[0099] In a further aspect, aperture stop A1 can be fixed relative to optical axis 1904. In another aspect, aperture stop A1 can be fixed relative to a position of lens L1. In the latter aspect, aperture stop A1 can be moved by a MEMS actuator in conjunction with lens L1 when focusing an image of an object onto sensor 1908. According to still other aspects, the MEMS actuator can be configured to move lens L1, either alone or in conjunction with aperture stop A1, a total distance along optical axis 1904. The total

distance can, at one end thereof, focus an image of an object at infinity on sensor 1908, and at another end thereof, focus an image of an object at an object distance of substantially 12.8cm at sensor 1908.

[00100] Lenses LI - L5 can be of various suitable types of suitable optically transparent material, and formed according to a suitable method(s) for generating an optical quality surface. In one aspect, lenses LI - L5 can be ground or polished glass, where the glass is selected to have an index of refraction resulting in a desired effective focal length for the combined lenses LI - L5. In another aspect, the lenses can be an optical-quality injection molded plastic (or plastic of optical quality formed by another suitable fabrication method), wherein the plastic has an index of refraction suitable to provide the desired focal length. In another aspect(s), the lenses LI - L5 can be etched from a transparent glass, crystalline or other suitable structure with a lithographic etching process similar to that used to etch semiconductor chips. In a specific aspect(s), lenses LI - L5 can be of differing glasses, plastics or suitable optical-transparent medium, by one or more of the above or similar suitable fabrication techniques (note that cover 1908 is a fictional material). In a further aspect, optical elements 1902 can have be described according to the optical prescription of Tables 19 - 27A.

<u>Parameter Description</u>	<u>Value</u>
Effective Focal Length (in air at system temperature and pressure)	4.803702
Effective Focal Length (in image space)	4.803702
Back Focal Length	0.1097044
Total Track Length (TTL)	5.588093
Image Space F/#	2.668723
Paraxial Working F/#	2.668742
Working F/#	2.647852
Image Space NA	0.1841501
Object Space NA	9e-007
Stop Radius	0.9
Paraxial Image Height	3.492
Paraxial Magnification	-4.803736e-006
Entrance Pupil Diameter	1.8
Entrance Pupil Position	0.05

Exit Pupil Diameter	1.214476
Exit Pupil Position	-3.231397
Maximum Radial Field	3.492
Lens Units	Millimeters (mm)
Angular Magnification	1.482119

Table 1: General Optical Properties (Object in Focus at Infinity)

Field #	X-Value	Y-Value	Weight
1	0	0	1
2	0	0.339	1
3	0	0.678	1
4	0	1.018	1
5	0	1.357	1
6	0	1.696	1
7	0	2.035	1
8	0	2.375	1
9	0	2.714	1
10	0	3.053	1
11	0	3.392	1
12	0	3.492	1

Table 20: Field Type v. Real Image Height (in mm)

Field / #	VDX	VDY	VCX	VCY	VAN
1	0	0	0	0	0
2	0	0	0	0	0
3	0	0	0	0	0
4	0	0	0	0	0
5	0	0	0	0	0
6	0	0	0	0	0
7	0	-0.005032	0.000003	0.005032	0
8	0	-0.018773	0.000041	0.018775	0
9	0	-0.031175	0.000230	0.031178	0
10	0	-0.062274	0.000739	0.062281	0
11	0	-0.154303	0.005254	0.154319	0
12	0	-0.218933	0.013148	0.218954	0

Table 21: Vignetting Factors for Fields of Table 20

Wavelength #	Value (in μm)	Weight
1	0.4358	0.15
2	0.4861	0.45
3	0.5461	1.00

4	0.5876	0.80
5	0.6563	0.10

Table 22: Wavelengths Used for Raytracing

Surface	Type	Radius	Thickness	Material	Diameter	Conic	Notes
Object	Standard	Infinity	1000000		1471328	0	
1	Standard	Infinity	0.05		2.054093	0	Stop1
Stop	Standard	Infinity	-0.176644		1.8	0	A1
3	EvenAsph	2.024203	0.721	ZEONF52R	1.872	-1	R1
4	EvenAsph	-11.83444	0		1.89	0	R2
5	Standard	Infinity	0.1656548		2.013514	0	Stop 2
6	EvenAsph	-250	0.32	EP5000	1.91	0	R3
7	EvenAsph	2.745619	0.3434152		2.093864	0	R4
8	Standard	Infinity	0.0030239		2.284004	0	Stop 3
9	EvenAsph	2.970147	0.3494011	EP5000	2.456709	0	R5
10	EvenAsph	3.958667	0.1844251		2.735497	0	R6
11	Standard	Infinity	0.3353069		2.904996	0	Stop 4
12	EvenAsph	-4.538803	0.5144013	ZEONF52R	3.007844	0	R7
13	EvenAsph	-1.564577	0.2719004		3.349097	-1	R8
14	Standard	Infinity	0.421506		5.022903	0	Stop 5
15	EvenAsph	-3.333743	0.908	ZEONF52R	5.142131	0	R9
16	EvenAsph	3.980869	0.6500583		6.098372	0	R10
17	Standard	Infinity	0.3		6.850686	0	CG 1908
18	Standard	Infinity	0.1		7.016723	0	
Image	Standard	Infinity			7.009976	0	

Table 23: Surface Data Summary

Surface	Parameter Description	Value
R1	Even Asphere	
	Coefficient on r 2	0
	Coefficient on r 4	0.0072492627
	Coefficient on r 6	-0.0011425636
	Coefficient on r 8	-0.026147557
	Coefficient on r 10	0.02892707
	Coefficient on r 12	-0.015728565
	Coefficient on r 14	0
	Coefficient on r 16	0

R2	Even Asphere	
	Coefficient on r 2	0
	Coefficient on r 4	-0.018496708
	Coefficient on r 6	0.041017657
	Coefficient on r 8	-0.14989043
	Coefficient on r 10	0.18705355
	Coefficient on r 12	-0.081043198
	Coefficient on r 14	0
	Coefficient on r 16	0
R3	Even Asphere	
	Coefficient on r 2	0
	Coefficient on r 4	-0.04452888
	Coefficient on r 6	0.1590456
	Coefficient on r 8	-0.32756888
	Coefficient on r 10	0.38155806
	Coefficient on r 12	-0.15580658
	Coefficient on r 14	0
	Coefficient on r 16	0
R4	Even Asphere	
	Coefficient on r 2	0
	Coefficient on r 4	-0.067461498
	Coefficient on r 6	0.16544449
	Coefficient on r 8	-0.23156178
	Coefficient on r 10	0.20660588
	Coefficient on r 12	-0.067541427
	Coefficient on r 14	0
	Coefficient on r 16	0
R5	Even Asphere	
	Coefficient on r 2	0
	Coefficient on r 4	-0.10351059
	Coefficient on r 6	0.083284677
	Coefficient on r 8	-0.073446626
	Coefficient on r 10	0.031355945
	Coefficient on r 12	-0.005953706
	Coefficient on r 14	0

	Coefficient on r 16	0
R6	Even Asphere	
	Coefficient on r 2	0
	Coefficient on r 4	-0.080839736
	Coefficient on r 6	0.05806703
	Coefficient on r 8	-0.042396061
	Coefficient on r 10	0.013117216
	Coefficient on r 12	-0.001392345
	Coefficient on r 14	0
	Coefficient on r 16	0
R7	Even Asphere	
	Coefficient on r 2	0
	Coefficient on r 4	-0.061283862
	Coefficient on r 6	0.056005953
	Coefficient on r 8	-0.023784572
	Coefficient on r 10	0.004382924
	Coefficient on r 12	0
	Coefficient on r 14	0
	Coefficient on r 16	0
R8	Even Asphere	
	Coefficient on r 2	0
	Coefficient on r 4	0.005176523
	Coefficient on r 6	0.02067126
	Coefficient on r 8	0.001625502
	Coefficient on r 10	-0.001134584
	Coefficient on r 12	0
	Coefficient on r 14	0
	Coefficient on r 16	0
R9	Even Asphere	
	Coefficient on r 2	0
	Coefficient on r 4	0.019100544
	Coefficient on r 6	-0.000208483
	Coefficient on r 8	5.84E-05
	Coefficient on r 10	-3.36E-06
	Coefficient on r 12	0

	Coefficient on r 14	0
	Coefficient on r 16	0
RIO	Even Asphere	
	Coefficient on r 2	0
	Coefficient on r 4	-0.038366245
	Coefficient on r 6	0.004903112
	Coefficient on r 8	-0.000509017
	Coefficient on r 10	1.88E-05
	Coefficient on r 12	1.99E-07
	Coefficient on r 14	0
	Coefficient on r 16	0

Table 24: Surface Aspheric Coefficients

<u>Surface</u>	<u>Edge</u>
Object	1000000
1	0.05
Stop	0.036971
3	0.45386
4	0.053525
5	0.17191
6	0.53351
7	0.123651
8	0.113652
9	0.301427
10	0.121772
11	0.050401
12	0.30346
13	0.767748
14	0.053483
15	0.953242
16	0.972839
17	0.3
18	0.1
Image	0

Table 25: Edge Thickness Data

Temperature (Temp) in degrees Celsius and pressure (Press) in atmospheres								
<u>Surface</u>	<u>Material</u>	<u>Temp</u>	<u>Press</u>	0.4358	0.4861	0.5461	0.5876	0.6563
0		20	1	1	1	1	1	1
1		20	1	1	1	1	1	1
2		20	1	1	1	1	1	1
3	ZEONF5	20	1	1.5467026	1.54130926	1.53688	1.53462	1.531786

	2R							
4		20	1	1	1	1	1	1
5		20	1	1	1	1	1	1
6	EP5000	20	1	1.671 40227	1.6545931 2	1.641 7 1 7	1.635484	1.628005
7		20	1	1	1	1	1	1
8		20	1	1	1	1	1	1
9	EP5000	20	1	1.671 40227	1.6545931 2	1.641 7 1 7	1.635484	1.628005
10		20	1	1	1	1	1	1
11		20	1	1	1	1	1	1
12	ZEONF5 2R	20	1	1.5467026	1.541 30926	1.53688	1.53462	1.53 1786
13		20	1	1	1	1	1	1
14		20	1	1	1	1	1	1
15	ZEON F52R	20	1	1.5467026	1.541 309 26	1.53688	1.53462	1.53 1786
16		20	1	1	1	1	1	1
17	MODE L	20	1	1.5267041 6	1.522378 72	1.51 871 9	1.51 6798	1.51 4329
18		20	1	1	1	1	1	1
19		20	1	1	1	1	1	1

Table 26: Index of Refraction Data

		Wavelengths (μm):					
		0.4358		0.4861		0.5461	
Number	Field (mm)	Tan	Sag	Tan	Sag	Tan	Sag
1	0	2.6405	2.6405	2.6425	2.6425	2.6479	2.6479
2	0.339	2.6528	2.6499	2.6546	2.6517	2.6597	2.6568
3	0.678	2.681	2.6772	2.6823	2.6783	2.6871	2.683
4	1.018	2.7091	2.7201	2.7106	2.7201	2.7153	2.7239
5	1.357	2.7373	2.7739	2.7401	2.7726	2.7455	2.7753
6	1.696	2.8006	2.8361	2.8059	2.8335	2.8128	2.8352
7	2.035	2.9489	2.9083	2.9563	2.9045	2.9645	2.9052
8	2.375	3.1818	2.9917	3.1891	2.9868	3.196	2.9866
9	2.714	3.5028	3.0817	3.5075	3.076	3.5109	3.075
10	3.053	4.1133	3.1794	4.1121	3.1732	4.109	3.1717
11	3.392	5.1478	3.3011	5.1473	3.2949	5.1404	3.2931
12	3.492	5.7808	3.3568	5.7754	3.3511	5.7637	3.3495

Table 27: F/Number Data

		Wavelengths (μm)			
		0.5876		0.6563	
Number	Field (mm)	Tan	Sag	Tan	Sag
1	0	2.6519	2.6519	2.6583	2.6583
2	0.339	2.6637	2.6608	2.67	2.6671
3	0.678	2.6909	2.6867	2.697	2.6927
4	1.018	2.719	2.7272	2.7249	2.7327

5	1.357	2.7494	2.7781	2.7555	2.7831
6	1.696	2.8173	2.8375	2.824	2.8417
7	2.035	2.9694	2.907	2.9763	2.9106
8	2.375	3.2	2.9879	3.2054	2.9909
9	2.714	3.5125	3.0759	3.5143	3.0782
10	3.053	4.1067	3.1722	4.1033	3.1741
11	3.392	5.1347	3.2934	5.1255	3.295
12	3.492	5.7553	3.3499	5.7426	3.3515

Table 27A: F/Number Data (Continued)

[00101] Table 19 provides general optical information for an embodiment of optical systems 1800, 1900 of Figures 18 and 19, respectively. Table 20 provides image heights in the y axis, measured at the image sensor 1906 for a set of optical fields, and respective weights for the respective fields. Table 21 includes vignetting data for the set of optical fields of Table 20. Table 22 depicts wavelengths of respective rays traced in optical imaging system 1800, depicted at Figure 18. Table 23 provides a summary of general optical surface characteristics for lenses of optical elements 1902, including surface type, radius of curvature, thickness, material (from standard glass and plastic catalogues; not that a fictitious material is used for cover glass 1908), diameter, conic constant and applicable notes. Table 24 describes aspheric coefficients for the surfaces of Table 23, whereas Table 25 provides edge thickness information for those surfaces. Table 26 provides index of refraction data for multiple wavelengths for the optical fields identified at Table 20. Tables 27 and 27A provide F/# data for those same wavelengths and optical fields.

[00102] Figure 20 depicts a diagram of field curvature and distortion for the optical systems 1800, 1900 of Figures 18 and 19, *supra*. Particularly, the field curvature and distortion depicted in Figure 20 correspond with the optical elements 1902 configured to focus an image of an object at infinity onto sensor 1906. The field curvature and distortion graphs utilize five wavelengths, including 0.436, 0.486, 0.546, 0.588 and 0.656 $\mu\eta$ respectively. Moreover, the rays are traced with a maximum field of 35.543 degrees. The left-hand graph depicts field curvature in millimeters along a y axis at an image plane of an optical imaging system. Field curvature curves are depicted for Sagittal rays (delineated by an 'S') and Tangential rays (delineated by a 'T'). The range of field curvature over the utilized wavelengths is within a few microns for sagittal and tangential rays. The distortion graphs on the right-hand side of Figure 20 also includes curves for the above five wavelengths. The distortion data is

normalized to 0% at the optical axis. Throughout the image plane, distortion is less than about -1%, and for mid to low field angles below about + / - one half a percent.

[00103] Figure 21 illustrates a diagram of longitudinal aberration for a set of wavelengths. Longitudinal aberration of Figure 21 relates to optical elements 1902, configured to image an object located at infinity onto sensor 1906. The listed wavelengths include 0.436, 0.486, 0.546, 0.588 and 0.656 μm . The graph charts longitudinal aberration in millimeters for increasing field angles, for a pupil radius of 0.9mm. At low field angles the longitudinal aberration is generally positive and less than about 0.02 millimeters. At high field angles, the longitudinal aberration is more negative and generally less than about 0.03 millimeters. The longitudinal aberration graph of Figure 21 indicates optical elements 1902 provide reasonably good aberration correction for the identified wavelengths.

[00104] Figure 22 depicts a graph of lateral color for optical elements 1902 of Figure 19, *supra*. Accordingly, the graph of lateral color relates to optical elements 1902 configured to focus an image of an object located at infinity onto sensor 1906. The maximum field for the lateral color graph is 3.3920 millimeters, and wavelengths for the lateral color graph range from 0.4358 through 0.6563 μm . In addition, data is referenced to 0.546100 μm . For most field angles the lateral color is within about + / - 0.5 microns. At high field angles, lower wavelengths exhibit lateral color about -1 micron or greater, and higher wavelengths exhibit lateral color about 1 micron.

[00105] Figure 23 illustrates a diagram of an example optical system 2300 according to still other aspects of the subject disclosure. Optical system 2300 can comprise a set of optical elements 2302, as depicted. In at least one aspect of the subject disclosure, optical elements 2302 can comprise a set of lenses substantially similar to optical elements 1802 and 1902 of Figures 18 and 19, *supra*, but having a different focus position. Specifically, a subset of optical elements 2302 can be positioned in a manner suitable to focus an image of a near-field object at an image plane of optical elements 2302. As depicted, the near-field object position for optical elements 2302 is 12.8cm. By repositioning the subset of optical elements 2302 between the position depicted by Figure 23 and that of optical elements 1902 of Figure 19, optical system 2300 can focus different object distances between the near-field object and an object at infinity.

[00106] Optical system 2300 illustrates a set of ray fans representing light incident upon optical elements 2302 at discrete field angles. A field angle of zero is

depicted by rays of light that converge at an optical axis of optical system 2300 at an image plane of optical elements 2302. Light converging at points on the image plane at increasing distances from the optical axis represent rays of light encountering optical elements 2302 at correspondingly larger field angles.

[00107] Figure 24 depicts a diagram of an example optical system 2400 according to still other aspects of the subject disclosure. Optical system 2400 delineates optical lenses and associated optical surfaces of optical system 2300 of Figure 23. Further, in at least one aspect, the optical lenses and associated optical surfaces of optical system 2300 can be substantially similar to the optical lenses and optical surfaces of optical systems 1800 and 1900 of Figures 18 and 19, *supra*. Optical system 2400 can differ from optical systems 1800 and 1900 in that optical elements 2402 can be configured to focus an image of an object located at substantially 12.8cm at a sensor 2408. Other aspects of optical system 2400 and optical elements 2402, including optical surfaces R1 and R2 of lens L1, R3 and R4 of lens L2, R5 and R6 of lens L3, R7 and R8 of lens L4, and R9 and R10 of lens L5. Further, sensor 2408 and cover glass 2406 can be substantially similar to sensor 1906 and cover glass 1908 of optical system 1900.

[00108] According to a particular aspect of the subject disclosure, optical elements 2402 comprise an object lens, lens L1, which is connected to an actuator (*e.g.*, MEMS actuator, ...) to facilitate auto-focusing for optical system 2400. In the arrangement of optical elements 2402 depicted by Figure 24, and in particular an air distance $distance_{near}$ between lens L1 and lens L2, optical elements 2402 are configured to focus a real image of an object at an object distance of 12.8cm onto sensor 2408. By moving lens L1 into a position depicted by optical elements 1902 of Figure 19, where the air distance between lens L1 and lens L2 is a $distance^{\wedge}$, optical system 2400 can be configured to focus an image of an object at infinity, instead. In at least one alternative or additional aspect of the subject disclosure, lens L1 can be repositioned to change the air distance between $distance_{near}$ and $distance^{\wedge}$, thereby focusing an image of an object located at points between 12.8cm and infinity at sensor 2408. Optical elements 2402 can have image characteristics as described by the optical characteristics of Tables 28 - 31A.

<u>Parameter Description</u>	<u>Value</u>
------------------------------	--------------

Effective Focal Length (in air at system temperature and pressure)	4.673877
Effective Focal Length (in image space)	4.673877
Back Focal Length	-0.05732965
Total Track Length (TTL)	5.668093
Image Space F/#	2.596598
Paraxial Working F/#	2.7471 79
Working F/#	2.738746
Image Space NA	0.1 790633
Object Space NA	0.007028331
Stop Radius	0.9
Paraxial Image Height	3.492
Paraxial Magnification	-0.03861 7 11
Entrance Pupil Diameter	1.8
Entrance Pupil Position	0.05
Exit Pupil Diameter	1.198642
Exit Pupil Position	-3.269722
Maximum Radial Field	3.492
Lens Units	Millimeters (mm)
Angular Magnification	1.501698

Table 28: General Optical Properties (Object in Focus at ~12.8cm)

Field / #	<u>VDX</u>	<u>VDY</u>	<u>VCX</u>	<u>VCY</u>	<u>VAN</u>
1	0	0	0	0	0
2	0	0	0	0	0
3	0	0	0	0	0
4	0	0	0	0	0
5	0	0	0	0	0
6	0	0	0	0	0
7	0	-0.00588	0.000003	0.005875	0
8	0	-0.02139	0.000058	0.021397	0
9	0	-0.0355	0.00023	0.035498	0
10	0	-0.06623	0.000798	0.066238	0
11	0	-0.16868	0.006487	0.1687	0
12	0	-0.24396	0.016135	0.243989	0

Table 29: Vignetting Factors for Fields of Table 20

Surface	Type	Radius	Thickness	Material	Diameter	Conic	Notes
Object	Standard	Infinity	128		179.1413	0	
1	Standard	Infinity	0.05		2.060591	0	Stop1
Stop	Standard	Infinity	-0.176644		1.8	0	A 1
3	EvenAsph	2.024203	0.721	ZEONF52R	1.872	-1	R 1
4	EvenAsph	-11.8344	0.08		1.89	0	R2
5	Standard	Infinity	0.1656548		2.015092	0	Stop 2
6	EvenAsph	-250	0.32	EP5000	1.91	0	R3
7	EvenAsph	2.745619	0.3434152		2.093864	0	R4
8	Standard	Infinity	0.00302399		2.284414	0	Stop 3
9	EvenAsph	2.970147	0.3494011	EP5000	2.456709	0	R5
10	EvenAsph	3.958667	0.1844251		2.735497	0	R6
11	Standard	Infinity	0.3353069		2.905287	0	Stop 4
12	EvenAsph	-4.5388	0.5144013	ZEONF52R	3.007844	0	R7
13	EvenAsph	-1.56458	0.2719004		3.349097	-1	R8
14	Standard	Infinity	0.421506		5.039133	0	Stop 5
15	EvenAsph	-3.33374	0.908	ZEONF52R	5.142131	0	R9
16	EvenAsph	3.980869	0.6500583		6.098372	0	R 10
17	Standard	Infinity	0.3		6.852322	0	CG 1908
18	Standard	Infinity	0.1		7.029509	0	
Image	Standard	Infinity			7.027898	0	

Table 30: Surface Data Summary

		Wavelengths (μm):					
		0.4358		0.4861		0.5461	
Number	Field (mm)	Tan	Sag	Tan	Sag	Tan	Sag
1	0	2.7277	2.7277	2.7317	2.7317	2.7387	2.7387
2	0.339	2.7368	2.7372	2.7406	2.741	2.7475	2.7479
3	0.678	2.7568	2.7652	2.7602	2.7683	2.7668	2.7746
4	1.018	2.7759	2.8091	2.7796	2.8111	2.7862	2.8166
5	1.357	2.8003	2.8645	2.8054	2.8651	2.8128	2.8695
6	1.696	2.8707	2.929	2.8781	2.9282	2.8869	2.9315
7	2.035	3.0426	3.0048	3.0514	3.0027	3.0608	3.0049
8	2.375	3.3173	3.0938	3.3236	3.0904	3.33	3.0916
9	2.714	3.7043	3.1909	3.7032	3.1866	3.7021	3.1868
10	3.053	4.4104	3.2987	4.3944	3.2936	4.3798	3.2932
11	3.392	5.6482	3.4392	5.6174	3.4339	5.587	3.4329
12	3.492	6.4939	3.5062	6.4341	3.5014	6.3828	3.5006

Table 31: F/Number Data

		Wavelengths (μm)			
		0.5876		0.6563	
Number	Field (mm)	Tan	Sag	Tan	Sag

1	0	2.7437	2.7437	2.7514	2.7514
2	0.339	2.7524	2.7528	2.7599	2.7603
3	0.678	2.7716	2.7793	2.7789	2.7865
4	1.018	2.7909	2.8208	2.7981	2.8276
5	1.357	2.8177	2.8733	2.8251	2.8794
6	1.696	2.8924	2.9347	2.9003	2.9401
7	2.035	3.0664	3.0075	3.0742	3.0122
8	2.375	3.3337	3.0937	3.339	3.0977
9	2.714	3.7016	3.1884	3.701	3.1917
10	3.053	4.372	3.2943	4.3618	3.2971
11	3.392	5.5698	3.4337	5.5469	3.436
12	3.492	6.3558	3.5014	6.3211	3.5037

Table 31A: F/Number Data (Continued)

[00109] Tables 28 - 31A comprise optical characteristics and image characteristics of optical system 2400 that differ from the configuration of optical system 1900. Table 28 provides general optical information for the embodiment of optical system 2400. Table 29 includes vignetting data for the set of optical fields of Table 20. Table 30 provides a summary of general optical characteristics for lenses of optical elements 2402, including surface type, radius of curvature, thickness, material (from standard glass and plastic catalogues, including a fictitious material for cover glass 2408), diameter, conic constant and applicable notes. Tables 31 and 31A provide F/# data for identified wavelengths and optical fields.

[00110] Figure 25 illustrates a diagram of field curvature and distortion for the optical system 2400 of Figure 24, *supra*. Wavelengths employed for the field curvature and distortion graphs include 0.436, 0.486, 0.546, 0.588 and 0.656 μm . Rays traced to generate these graphs have units in field angle with a maximum field of 34.188 degrees. The field curvature for both tangential and sagittal rays are generally positive and less than about 0.05 mm for all field angles. Distortion is less than about 1% for mid to low field angles, and increases to about 1.6% at high field angles.

[00111] Figure 26 illustrates a diagram of longitudinal aberration for optical system 2400. The longitudinal aberration graph is provided for five wavelengths, including 0.436, 0.486, 0.546, 0.588 and 0.656 μm . The graph charts longitudinal aberration in millimeters for increasing field angles, and with pupil radius of 0.9mm. At low field angles the longitudinal aberration is generally positive and less than about 0.04 millimeters. At higher field angles, the longitudinal aberration ranges positive to negative for different field angles, and is generally between positive 0.03 millimeters and about negative 0.035 millimeters.

[00112] Figure 27 depicts a graph of lateral color for optical elements 2402 of Figure 24, *supra*. The graph of lateral color relates to optical elements 2402 configured to focus an image of an object located at about 12.8cm onto sensor 2406. The maximum field for the lateral color graph is 3.3920 millimeters, and wavelengths employed for the graph range from 0.4358 through 0.6563 μm . In addition, data is referenced to 0.546100 μm . For all field angles the lateral color is less than about +3 microns and greater than about -1 microns. At low and mid field angles, the lateral color ranges between about +1 micron and about -0.25 microns.

[00113] Figures 28A - 28D illustrate an example optical system according to one or more additional aspects of the subject disclosure. The optical system is depicted at Figure 28A on the upper left in a configuration to focus an image of an object at infinity onto a sensor of the optical system. Figures 29A - 29D illustrate the example optical system in a configuration to focus an image of a near-field object onto the sensor of the optical system. The latter configuration can be achieved, for instance, by decreasing an air distance between the first left-most lens closest to the object side of the optical system, closer to the second lens on the object side of the optical system.

[00114] Generally, the optical system comprises five lenses, from an object side to image side, including lens LI (also referred to as an objective lens), lens L2, lens L3, lens L4 and lens L5 (referred to collectively as lenses LI - L5). Moreover, the optical system of Figures 28A - 28D can comprise two or more lens groups, defined at least in part on an on-axis inter-lens air distance between respective lenses of the two or more lens groups. As an example, the five lenses of the optical system can be arranged into two lens groups, a first of the lens groups comprising a first lens, second lens and third lens from the object side of the optical system, and where the second of the lens groups comprising a fourth lens and fifth lens from the object side of the optical system. The lens groups can be constrained to have on-axis air distances between lenses that is smaller than an on-axis air distance between the first and the second lens groups.

[00115] Figures 28B - 28D illustrate image characteristics for the optical system of Figure 28A configured to focus an image of an object at infinity on a sensor of the optical system (far field focus configuration). Figures 29B - 29D illustrate image characteristics for the optical system of Figure 29A configured to focus a near-field object on the sensor (near field focus configuration). Figure 28B depicts a graph of field curvature and distortion for the far field focus configuration, with a maximum field greater than about 32 degrees for wavelengths between about 0.47 and about 0.65

microns. Figure 28C illustrates a graph of longitudinal aberration for the far field configuration at the above wavelengths, and for a pupil radius of about 0.991mm, and Figure 28D depicts a graph of lateral color for this configuration having a maximum field of about 2.956 millimeters having data referenced to wavelength of about 0.555 microns.

[00116] Figure 29B illustrates field curvature and distortion for the near field configuration of the optical system, depicted at Figure 29A. The field curvature and distortion has a maximum field of about 34.51 degrees for wavelengths between about 0.470 and about 0.650 microns. Figure 29C depicts longitudinal aberration for the near field configuration with pupil radius of about 0.991 millimeters and wavelengths of about 0.470, 0.510, 0.555, 0.610 and 0.650 microns. Figure 29D illustrates a graph of lateral color for the near field configuration, with a maximum field of about 2.9560 millimeters and with data referenced to wavelength of 0.555 microns. The optical system of Figures 28A and 29A are described by the optical and image characteristics provided by Tables 32 - 40A, below.

<u>Parameter Description</u>	<u>Value</u>
Effective Focal Length (in air at system temperature and pressure)	4.309199
Effective Focal Length (in image space)	4.309199
Back Focal Length	0.528864
Total Track Length (TTL)	5.348668
Image Space F/#	2.44563
Paraxial Working F/#	2.44563
Working F/#	2.468005
Image Space NA	0.200303
Object Space NA	8.81E-11
Stop Radius	0.881
Paraxial Image Height	2.956
Paraxial Magnification	0
Entrance Pupil Diameter	1.762
Entrance Pupil Position	0
Exit Pupil Diameter	1.257817
Exit Pupil Position	-3.09729

Maximum Radial Field	2.956
Lens Units	Millimeters (mm)
Angular Magnification	1.400838

Table 32: General Optical Properties (Object in Focus at Infinity)

Field #	X-Value	Y-Value	Weight
1	0	0	1
2	0	0.571	1
3	0	1.142	1
4	0	1.714	1
5	0	2.285	1
6	0	2.57	1
7	0	2.856	0.2
8	0	2.956	0.2

Table 33: Field Type v. Real Image Height (in mm)

Field / #	VDX	VDY	VCX	VCY	VAN
1	0	0	0	0	0
2	0	0.003903	0.00001	0.003903	0
3	0	0.007781	0.000035	0.007783	0
4	0	0.01172	0.000106	0.011721	0
5	0	-0.00257	0.000337	0.034007	0
6	0	-0.04564	0.001626	0.08102	0
7	0	-0.09687	0.005447	0.136263	0
8	0	-0.14243	0.009529	0.183383	0

Table 34: Vignetting Factors for Fields of Table 20

Wavelength #	Value (in μm)	Weight
1	0.47	91
2	0.51	503
3	0.555	1000
4	0.61	503
5	0.65	107

Table 35: Wavelengths Used for Raytracing

Surface	Type	Radius	Thickness	Material	Diameter	Conic	Notes
Object	Standard	Infinity	Infinity		0	0	
Stop	Standard	Infinity	-0.05		1.762	0	Stop
2	Standard	Infinity	-0.05		1.762	0	Vig
3	EvenAsph	1.9541 12	0.658876	APEL551 4ML	1.8681 1	0	L 1
4	EvenAsph	-16.4984	0.12381 2		1.900083	0	
5	EvenAsph	28.78283	0.537232	EP5000-F	1.936491	0	L2
6	EvenAsph	2.751 3	0.242475		2.0091 9	0	
7	Standard	Infinity	0.05		2.05	0	
8	Standard	Infinity	0.08601 6		2.05	0	
9	EvenAsph	-34.5053	0.862679	APEL551 4ML	2.120461	0	L3
10	EvenAsph	-6.1921 6	0.424308		2.71 6502	0	
11	EvenAsph	2.722564	0.5091 04	APEL551 4ML	3.355454	0	L4
12	EvenAsph	-4.26721	-0.19		4.009626	0	
13	Standard	Infinity	0.05		4.16	0	
14	Standard	Infinity	0.389066		4.16	0	
15	EvenAsph	-2.51 369	0.4261 0 1	APEL551 4ML	4.449728	0	L5
16	EvenAsph	2.608397	0.329		4.87851 7	0	
17	Standard	Infinity	0.3	N-BK7	5.233205	0	CG 1908
18	Standard	Infinity	0.55		5.402932	0	
Image	Standard	Infinity			5.91 7565	0	

Table 36: Surface Data Summary

Surface	Parameter Description	Value
R1	Even Asphere	
	Coefficient on r 2	0
	Coefficient on r 4	-0.00386
	Coefficient on r 6	0.009055
	Coefficient on r 8	-0.01604
	Coefficient on r 10	0.006453
	Coefficient on r 12	0
	Coefficient on r 14	0
	Coefficient on r 16	0
R2	Even Asphere	
	Coefficient on r 2	0
	Coefficient on r 4	0.014879
	Coefficient on r 6	-0.02489
	Coefficient on r 8	0.011334
	Coefficient on r 10	0.003758
	Coefficient on r 12	0
	Coefficient on r 14	0
	Coefficient on r 16	0

R3	Even Asphere	
	Coefficient on r 2	0
	Coefficient on r 4	0.001774
	Coefficient on r 6	-0.03857
	Coefficient on r 8	0.035738
	Coefficient on r 10	-0.00277
	Coefficient on r 12	0
	Coefficient on r 14	0
	Coefficient on r 16	0
R4	Even Asphere	
	Coefficient on r 2	0
	Coefficient on r 4	-0.00027
	Coefficient on r 6	0.001123
	Coefficient on r 8	0.000761
	Coefficient on r 10	0.006183
	Coefficient on r 12	0
	Coefficient on r 14	0
	Coefficient on r 16	0
R5	Even Asphere	
	Coefficient on r 2	0
	Coefficient on r 4	-0.04891
	Coefficient on r 6	0.029453
	Coefficient on r 8	-0.01911
	Coefficient on r 10	0.004124
	Coefficient on r 12	0
	Coefficient on r 14	0
	Coefficient on r 16	0
R6	Even Asphere	
	Coefficient on r 2	0
	Coefficient on r 4	-0.13503
	Coefficient on r 6	0.048368
	Coefficient on r 8	0.001742
	Coefficient on r 10	-0.00582
	Coefficient on r 12	0.00078
	Coefficient on r 14	5.79E-05

	Coefficient on r 16	0.000106
R7	Even Asphere	
	Coefficient on r 2	0
	Coefficient on r 4	-0.1187
	Coefficient on r 6	0.031933
	Coefficient on r 8	-0.0214
	Coefficient on r 10	0.008804
	Coefficient on r 12	-0.0012
	Coefficient on r 14	-0.00074
	Coefficient on r 16	0.00021 6
R8	Even Asphere	
	Coefficient on r 2	0
	Coefficient on r 4	0.070788
	Coefficient on r 6	-0.01663
	Coefficient on r 8	-0.00017
	Coefficient on r 10	-0.00047
	Coefficient on r 12	0.000282
	Coefficient on r 14	-1.50E-05
	Coefficient on r 16	-2.54E-06
R9	Even Asphere	
	Coefficient on r 2	0
	Coefficient on r 4	0.019234
	Coefficient on r 6	0.011958
	Coefficient on r 8	-0.00178
	Coefficient on r 10	1.79E-05
	Coefficient on r 12	5.79E-06
	Coefficient on r 14	9.92E-07
	Coefficient on r 16	4.90E-08
R10	Even Asphere	
	Coefficient on r 2	0
	Coefficient on r 4	-0.10214
	Coefficient on r 6	0.027793
	Coefficient on r 8	-0.0071
	Coefficient on r 10	0.000868
	Coefficient on r 12	1.66E-05

	Coefficient on r 14	-1.31 E-05
	Coefficient on r 16	7.35E-07

Table 37: Surface Aspheric Coefficients

<u>Surface</u>	<u>Edge</u>
Stop	-0.05
2	0.184732
3	0.400359
4	0.15927
5	0.723662
6	0.044372
7	0.05
8	0.026648
9	0.560283
10	0.571295
11	0.51101
12	0.022871
13	0.05
14	0.126282
15	0.613075
16	0.40481
17	0.3
18	0.55
Image	0

Table 38: Edge Thickness Data

Temperature (Temp) in degrees Celsius and pressure (Press) in atmospheres								
<u>Surface</u>	<u>Material</u>	<u>Temp</u>	<u>Press</u>	0.4358	0.4861	0.5461	0.5876	0.6563
0		20	1	1	1	1	1	1
1		20	1	1	1	1	1	1
2		20	1	1	1	1	1	1
3	APEL55 14ML	20	1	1.552896	1.549574	1.546504	1.543579	1.541977
4		20	1	1	1	1	1	1
5	EP5000- F	20	1	1.657924	1.647547	1.638966	1.631351	1.627143
6		20	1	1	1	1	1	1
7		20	1	1	1	1	1	1
8		20	1	1	1	1	1	1
9	APEL55 14ML	20	1	1.552896	1.549574	1.546504	1.543579	1.541977
10		20	1	1	1	1	1	1
11	APEL55 14ML	20	1	1.552896	1.549574	1.546504	1.543579	1.541977
12		20	1	1	1	1	1	1
13		20	1	1	1	1	1	1
14		20	1	1	1	1	1	1

15	APEL 551 4 ML	20	1	1.552896	1.549574	1.546504	1.543579	1.541 977
16		20	1	1	1	1	1	1
17	N-BK7	20	1	1.523605	1.520769	1.51 8274	1.51 5909	1.51 452
18		20	1	1	1	1	1	1
19		20	1	1	1	1	1	1

Table 39: Index of Refraction Data

		Wavelengths (μm):					
		0.4358		0.4861		0.5461	
Number	Field (mm)	Tan	Sag	Tan	Sag	Tan	Sag
1	0	2.4671	2.4671	2.4655	2.4655	2.468	2.468
2	0.571	2.5183	2.4954	2.516	2.4934	2.5179	2.4954
3	1.142	2.5939	2.5672	2.5915	2.564	2.5931	2.5651
4	1.714	2.7124	2.6738	2.7134	2.6698	2.717	2.6702
5	2.285	3.1321	2.8097	3.1364	2.8053	3.1424	2.8052
6	2.57	3.6079	2.8988	3.613	2.8941	3.6195	2.8939
7	2.856	3.8132	3.003	3.8209	2.9987	3.8222	2.9987
8	2.956	4.0285	3.0378	4.0284	3.0345	4.0233	3.0351

Table 40: F/Number Data

		Wavelengths (μm)			
		0.5876		0.6563	
Number	Field (mm)	Tan	Sag	Tan	Sag
1	0	2.4725	2.4725	2.4748	2.4748
2	0.571	2.522	2.4996	2.524	2.5017
3	1.142	2.5966	2.5685	2.5984	2.5702
4	1.714	2.7219	2.6729	2.7244	2.6742
5	2.285	3.1492	2.8075	3.1529	2.8085
6	2.57	3.6267	2.896	3.6307	2.8969
7	2.856	3.8203	3.0009	3.8197	3.0019
8	2.956	4.0151	3.0376	4.0105	3.0389

Table 40A: F/Number Data (Continued)

[00117] Tables 32 - 40A provides optical and image characteristics for the optical system of Figure 28A, having a far field focus configuration. Table 32 provides general optical information for this optical system. Table 33 provides image heights in the y axis, measured at an image sensor of the optical system, for a set of optical fields and

respective weights for the respective optical fields. Table 34 includes vignetting data for the set of optical fields of Table 33. Table 35 depicts wavelengths of respective rays traced in the optical imaging system of Figure 28. Table 36 provides a summary of general optical surface characteristics for lenses of this optical system, including surface type, radius of curvature, thickness, material (from standard glass and plastic catalogues), diameter, conic constant and applicable notes. Table 37 describes aspheric coefficients for the surfaces of Table 35, whereas Table 38 provides edge thickness information for those surfaces. Table 39 provides index of refraction data for multiple wavelengths and listed optical fields. Tables 40 and 40A provide F/# data for those same wavelengths and optical fields.

[00118] As utilized herein, the word "exemplary" is intended to mean serving as an example, instance, or illustration. Any aspect or design described herein as "exemplary" is not necessarily to be construed as preferred or advantageous over other aspects or designs. Rather, use of the word exemplary is intended to present concepts in a concrete fashion. As used in this application, the term "or" is intended to mean an inclusive "or" rather than an exclusive "or". That is, unless specified otherwise, or clear from context, "X employs A or B" is intended to mean any of the natural inclusive permutations. That is, if X employs A; X employs B; or X employs both A and B, then "X employs A or B" is satisfied under any of the foregoing instances. In addition, the articles "a" and "an" as used in this application and the appended claims should generally be construed to mean "one or more" unless specified otherwise or clear from context to be directed to a singular form.

[00119] Furthermore, various portions of electronic systems associated with disclosed optical systems described herein may include or consist of artificial intelligence or knowledge or rule based components, sub-components, processes, means, methodologies, or mechanisms (*e.g.*, support vector machines, neural networks, expert systems, Bayesian belief networks, fuzzy logic, data fusion engines, classifiers. .). Such components, *inter alia*, and in addition to that already described herein, can automate certain mechanisms or processes performed thereby to make portions of the systems and methods more adaptive as well as efficient and intelligent. For instance, such components can automate optimization of image quality of an optical system, as described above (*e.g.*, see electronic device 500 of Figure 5, *supra*).

[00120] What has been described above includes examples of aspects of the claimed subject matter. It is, of course, not possible to describe every conceivable

combination of components or methodologies for purposes of describing the claimed subject matter, but one of ordinary skill in the art can recognize that many further combinations and permutations of the disclosed subject matter are possible.

Accordingly, the disclosed subject matter is intended to embrace all such alterations, modifications and variations that fall within the spirit and scope of the appended claims. Furthermore, to the extent that the terms "includes," "has" or "having" are used in either the detailed description or the claims, such terms are intended to be inclusive in a manner similar to the term "comprising" as "comprising" is interpreted when employed as a transitional word in a claim.

CLAIMS

What is Claimed is:

1. An optical imaging system arranged along an optical axis, comprising:
 - a set of optical lenses including a first lens group and a second lens group, wherein the second lens group is fixed in position along the optical axis;
 - a micro electromechanical system (MEMS) actuator mechanically connected to the first lens group and configured to adjust a position of the first lens group along the optical axis, wherein a first adjusted position is configured to focus an image of an object positioned far from the optical imaging system onto an image plane associated with the optical imaging system, and wherein a second adjusted position is configured to focus an image of an object positioned near to the optical imaging system onto the image plane;wherein:
 - the set of optical lenses comprising five lenses;
 - the MEMS actuator is configured to adjust a position of the first lens group along the optical axis up to between 50 and 150 micrometers;
 - the first optical lens group comprising a biconvex object-side lens; and
 - a ratio of the focal length of the biconvex object-side lens to a combined focal length of the five lenses is greater than one half.
2. The optical imaging system of claim 1, further comprising an aperture stop positioned at an object-side of the biconvex object-side lens.
3. The optical imaging system of claim 2, wherein the aperture stop is fixed in position along the optical axis.
4. The optical imaging system of claim 2, wherein the aperture stop is fixed in position relative to the first lens group.

5. The optical imaging system of claim 4, wherein the MEMS actuator is configured to reposition the first lens group and the aperture stop along the optical axis and maintain the fixed position between the aperture stop and the first lens group at least at the first adjusted position and at the second adjusted position.
6. The optical imaging system of claim 1, the second lens group comprising four lens elements, including a second lens, a third lens, a fourth lens and a fifth lens.
7. The optical imaging system of claim 6, the second lens having a concave image-side surface and a flat or a weak convex curvature on an object-side surface.
8. The optical imaging system of claim 7, the second lens having a negative optical power, and formed of an OKP4HT plastic.
9. The optical imaging system of claim 6, the third lens having a concave object-side surface and a convex image-side surface, a positive optical power, and formed of an APEL5514ML glass.
10. The optical imaging system of claim 6, the fourth lens having an object-side surface that is convex near the optical axis and transitions to concave away from the optical axis, and an image-side surface having convex curvature.
11. The optical imaging system of claim 10, the fourth lens having positive optical power near the optical axis, and having small negative optical power, small positive optical power, or no optical power away from the optical axis, and the fourth lens is formed of an APEL55 14ML plastic.
12. The optical imaging system of claim 6, the fifth lens having an object-side surface that is concave near the optical axis and that transitions to convex away from the optical axis, and an image-side surface that is concave near the optical axis and transitions to convex away from the optical axis.

13. The optical imaging system of claim 12, the fifth lens having large negative optical power near the optical axis, and positive optical power away from the optical axis, and the fifth lens is formed of an APEL5514ML plastic.
14. The optical imaging system of claim 1, the biconvex object-side lens is formed of an APEL55 14ML plastic.
15. The optical imaging system of claim 1, wherein an optical power of the biconvex object-side lens is at least in part a function of a distance along the optical axis between the first adjusted position and the second adjusted position.
16. The optical imaging system of claim 1, wherein the ratio of the focal length of the biconvex object-side lens to a combined focal length of the five lenses is about three quarters.
17. The optical imaging system of claim 1, wherein the ratio of the optical power of the biconvex object-side lens to a combined optical power of the five lenses is at least in part a function of a distance along the optical axis between the first adjusted position and the second adjusted position.
18. The optical imaging system of claim 1, wherein the object positioned far from the optical system is positioned substantially at infinity, and wherein the object positioned near to the optical system is positioned at substantially 10cm from an aperture stop of the optical imaging system.

19. An optical system comprising:
a plurality of optical elements arranged along a common optical axis for forming a real image of an object, said optical elements including:
a first lens having a positive refractive power, with both surfaces, one facing an object side and another facing an image side, having convex shape;
a second lens having negative refractive power and a meniscus shape, with the surface facing the object side having a convex shape and the surface facing the image side having a concave shape;
a third lens having positive refractive power, and a biconvex shape near the optical axis, and the surface facing the object side is concave away from the optical axis;
a fourth lens, with the surface facing the object side having a concave shape, and the surface facing the image side having a convex shape; and
a fifth lens having a meniscus shape with the surface facing the object side having a convex shape and the surface facing the image side having a concave shape near the optical axis and a convex shape away from the optical axis; and
an actuator configured to move the first lens along the optical axis.
20. The optical system of claim 19, wherein the motor is a microelectromechanical system.
21. The optical system of claim 19, wherein the second lens performs a majority of chromatic correction for the optical system.
22. The optical system of claim 19, further comprising an aperture that is embedded into the first lens and moves with the first lens, wherein the aperture having a depth of $50\mu\text{m}$.
23. The optical system of claim 19, wherein the F-number of the optical system is approximately 2.4.
24. The optical system of claim 19, wherein one or more of the lenses are made of plastic.

25. The optical system of claim 19, wherein the surfaces of the lenses are aspheric.
26. The optical system of claim 19, wherein the refractive index of the lenses is within a range of about 1.5 to about 1.66.
27. The optical system of claim 19, wherein the range of movement for the first lens is between about 0μm and about 100μm.
28. The optical system of claim 19, wherein an amount of movement to focus an image of an object is inversely proportional to the positive refractive power of the first lens.
29. The optical system of claim 19, wherein the primary lateral color range for the optical system focused on an object at infinity is equal to or less than approximately 1μm.
30. The optical system of claim 19, wherein the primary lateral color range for the optical system focused on an object at 10cm is equal to or less than approximately 4μm.

31. An optical imaging system arranged along an optical axis, comprising:
a set of optical lenses including a first lens group and a second lens group,
wherein the second lens group is fixed in position along the optical axis and comprises a majority of the optical lenses of the set of optical lenses; and
an actuator mechanically connected to the first lens group and configured to adjust a position of the first lens group along the optical axis, wherein a first adjusted position is configured to focus an image of an object positioned far from the optical imaging system onto an image plane associated with the optical imaging system, and wherein a second adjusted position is configured to focus an image of an object positioned near to the optical imaging system onto the image plane;
wherein:
the set of optical lenses comprising five lenses;
the actuator is configured to adjust a position of the first lens group along the optical axis up to between 50 and 150 micrometers;
the second optical lens group comprising a third lens of the set of optical lenses that is third in sequence from an object side of the set of optical lenses, the third lens having a meniscus shape that is convex toward the object side of the set of optical lenses.
32. The optical imaging system of claim 31, wherein the actuator comprises a micro electromechanical system (MEMS) actuator.
33. The optical imaging system of claim 31, the first optical lens group comprising a biconvex objective lens that provides a majority of the positive optical power of the set of optical lenses.
34. The optical imaging system of claim 33, wherein the biconvex objective lens has greater positive refractive power than a combined refractive power of the set of optical lenses.
35. The optical imaging system of claim 31, wherein an effective focal length of the set of optical lenses is between about 4.5 and about 5.0 millimeters.

36. The optical imaging system of claim 31, wherein a ratio of total track length to effective focal length of the optical system is between about 1.1 and about 1.2.
37. The optical imaging system of claim 31, wherein the first lens group comprises a single lens of the set of optical lenses.
38. The optical imaging system of claim 37, wherein the single lens is an objective lens of the optical system.
39. The optical imaging system of claim 37, wherein the second adjusted position focuses an image of an object at an object distance of about 12.8 centimeters onto the image plane.
40. The optical imaging system of claim 31, wherein an air distance between a third lens and a fourth lens of the set of optical lenses, numbered from an object side of the set of optical lenses, is a largest of air distances between respective ones of the set of optical lenses.
41. The optical imaging system of claim 31, wherein an air distance between a fourth lens and a fifth lens of the set of optical lenses, numbered from an object side of the set of optical lenses, is a largest of air distances between respective ones of the set of optical lenses.
42. The optical imaging system of claim 31, further comprising an aperture stop about an object side surface of a first lens of the set of optical lenses, numbered from an object side of the set of optical lenses.
43. The optical imaging system of claim 42, further comprising a stop between a second and third lens of the set of optical lenses, numbered from an object side of the set of optical lenses.
44. The optical imaging system of claim 43, further comprising a second stop between the third lens and a fourth lens of the set of optical lenses.

45. The optical imaging system of claim 44, further comprising a third stop between the fourth lens and a fifth lens of the set of optical lenses.

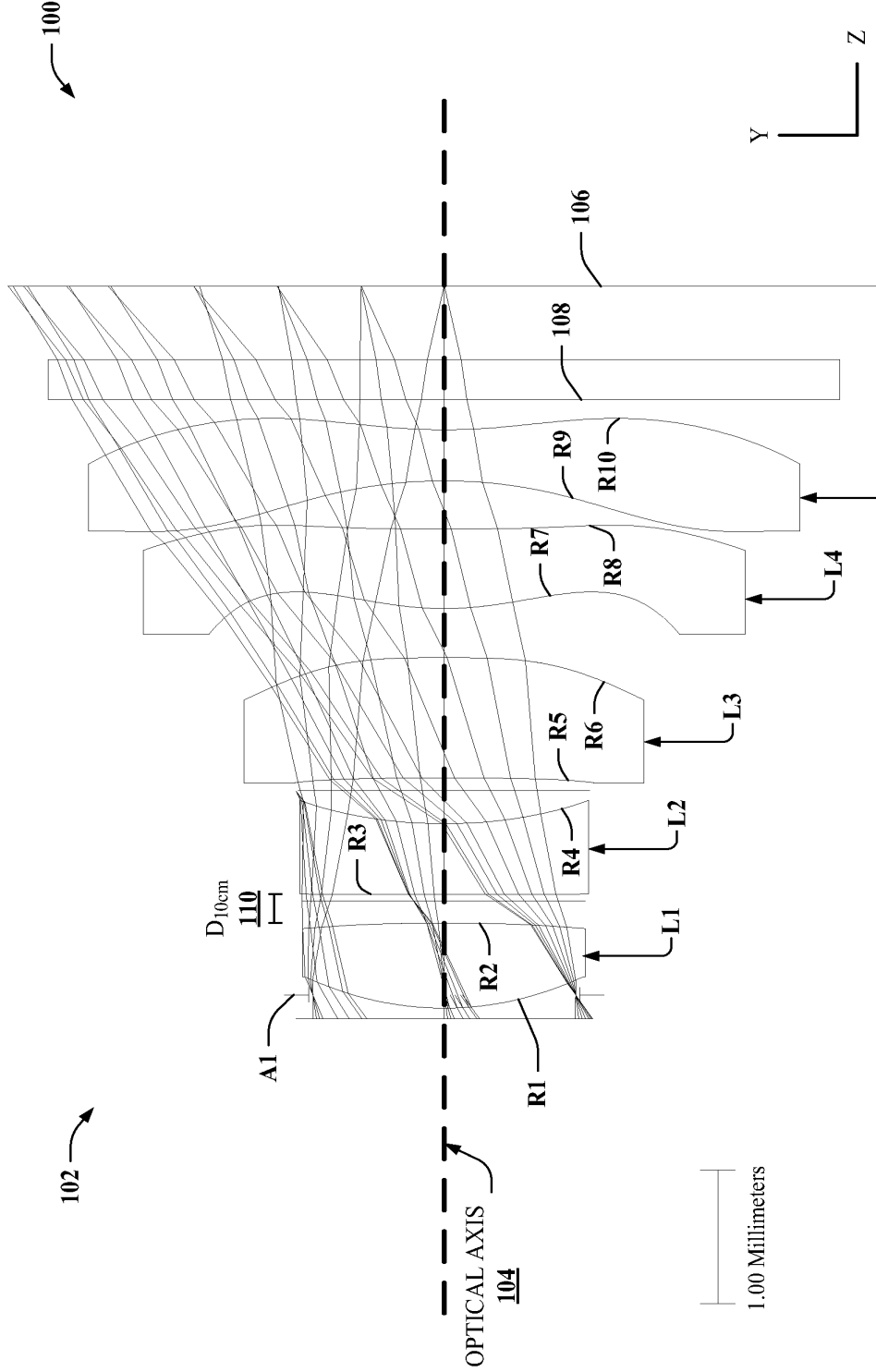
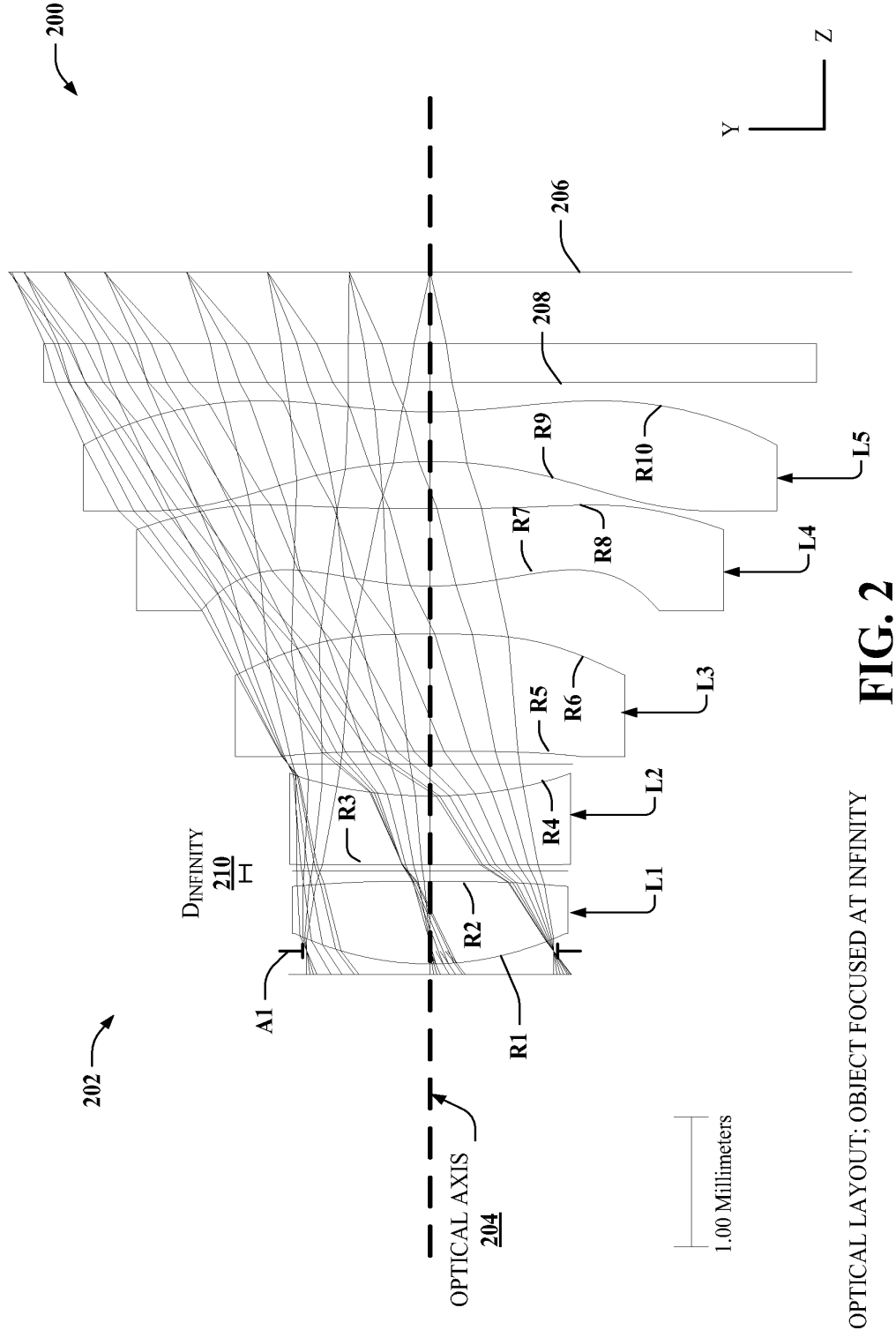

FIG. 1

OPTICAL LAYOUT; OBJECT FOCUSED AT 10CM



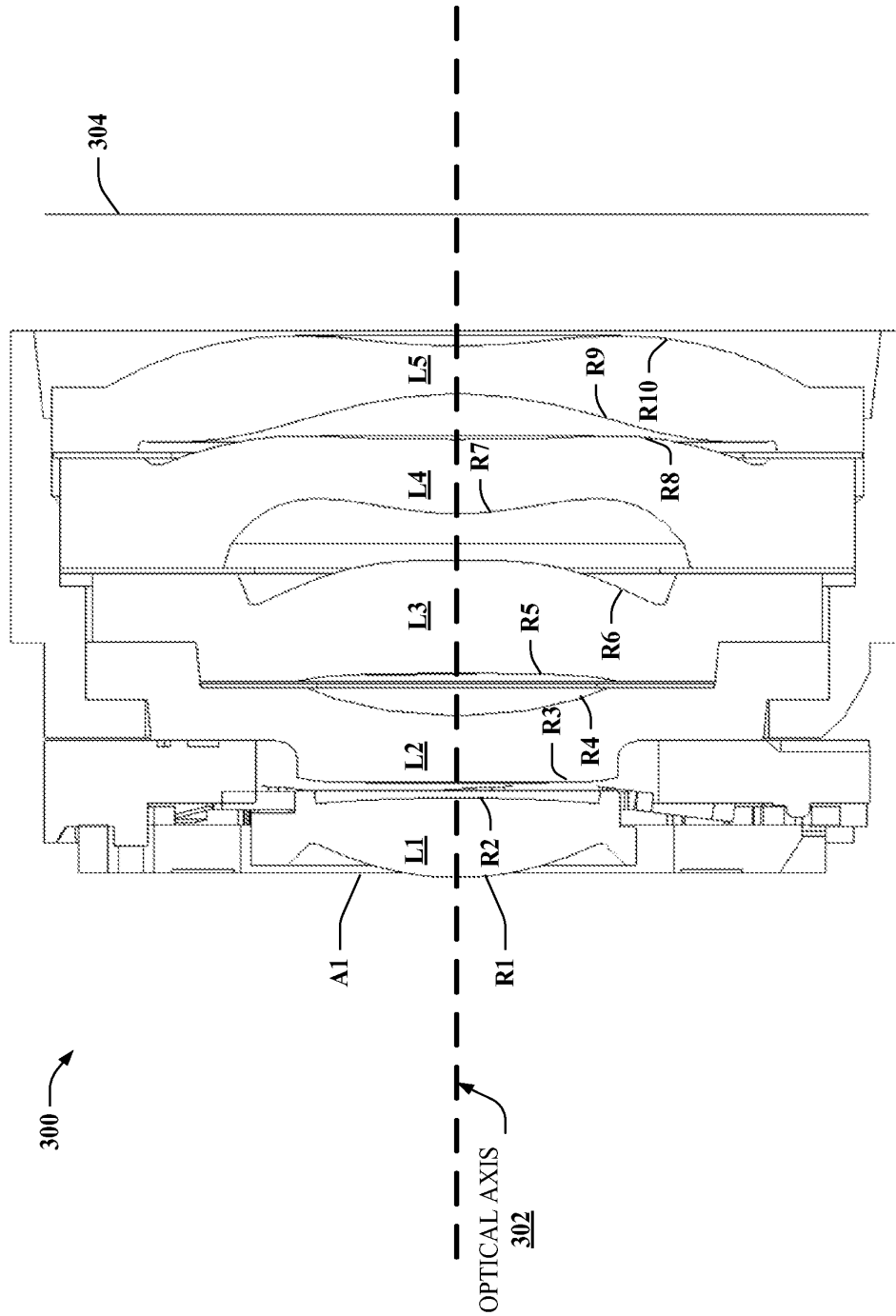

FIG. 3

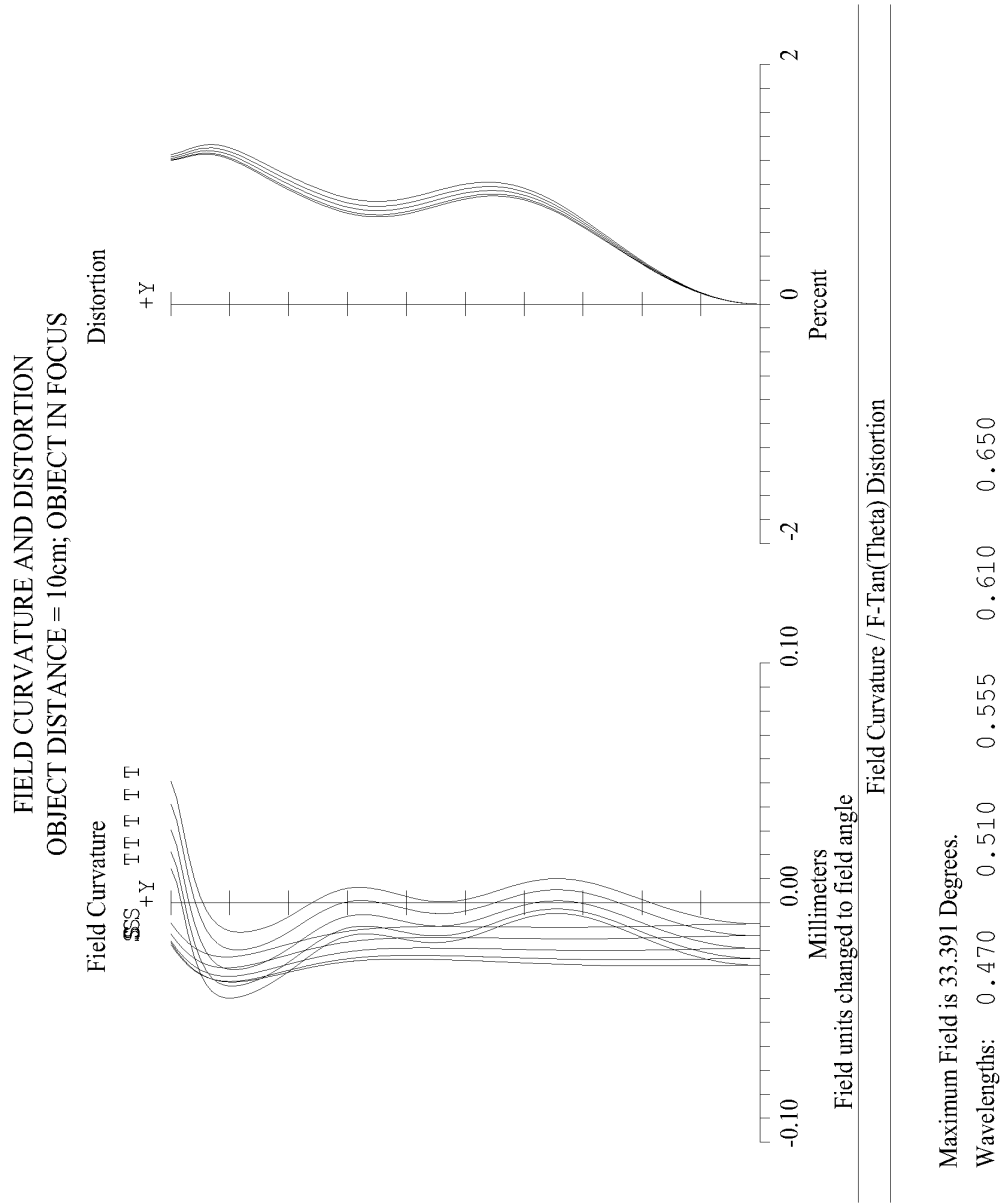

FIG. 4

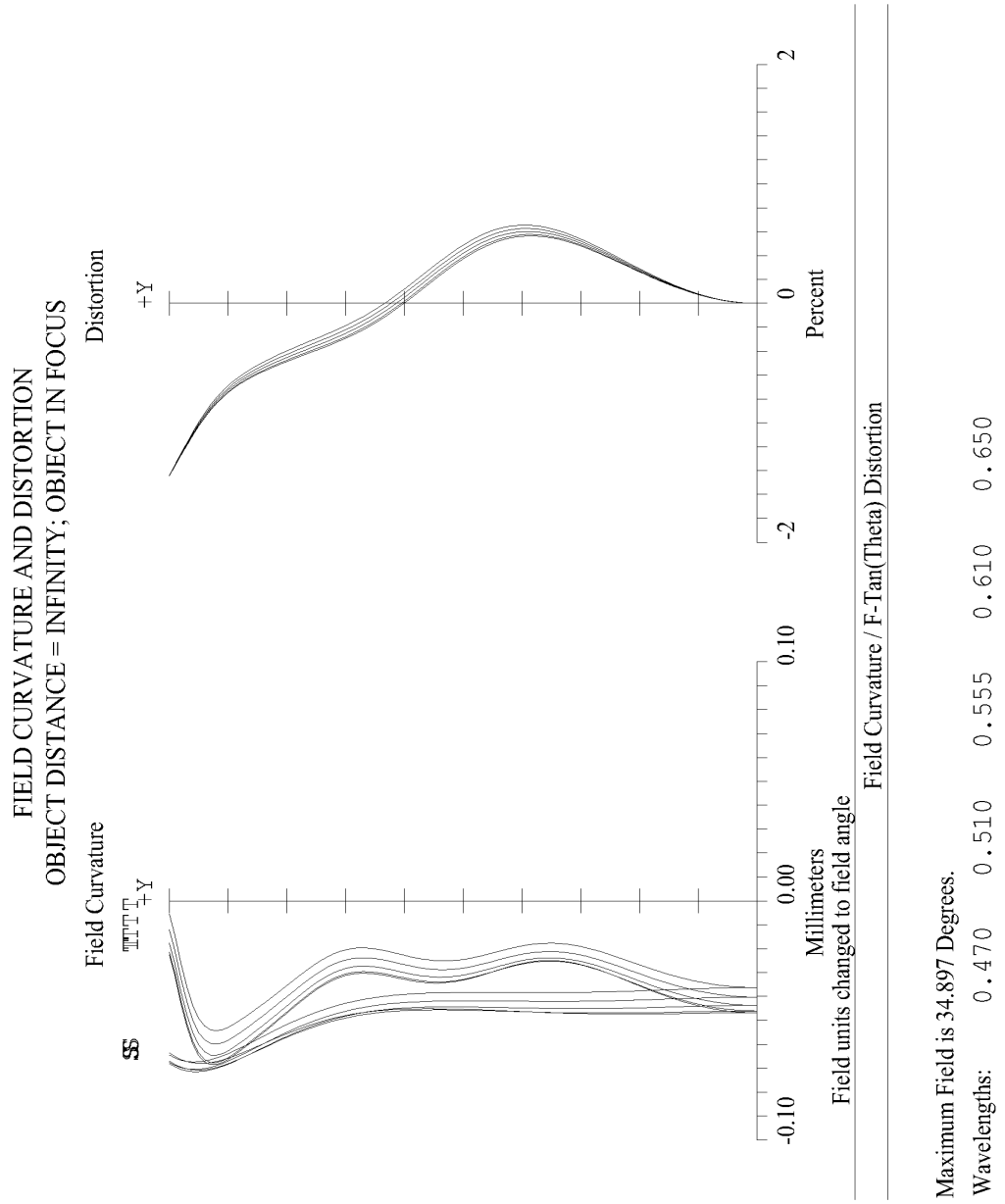

FIG. 5

6/29

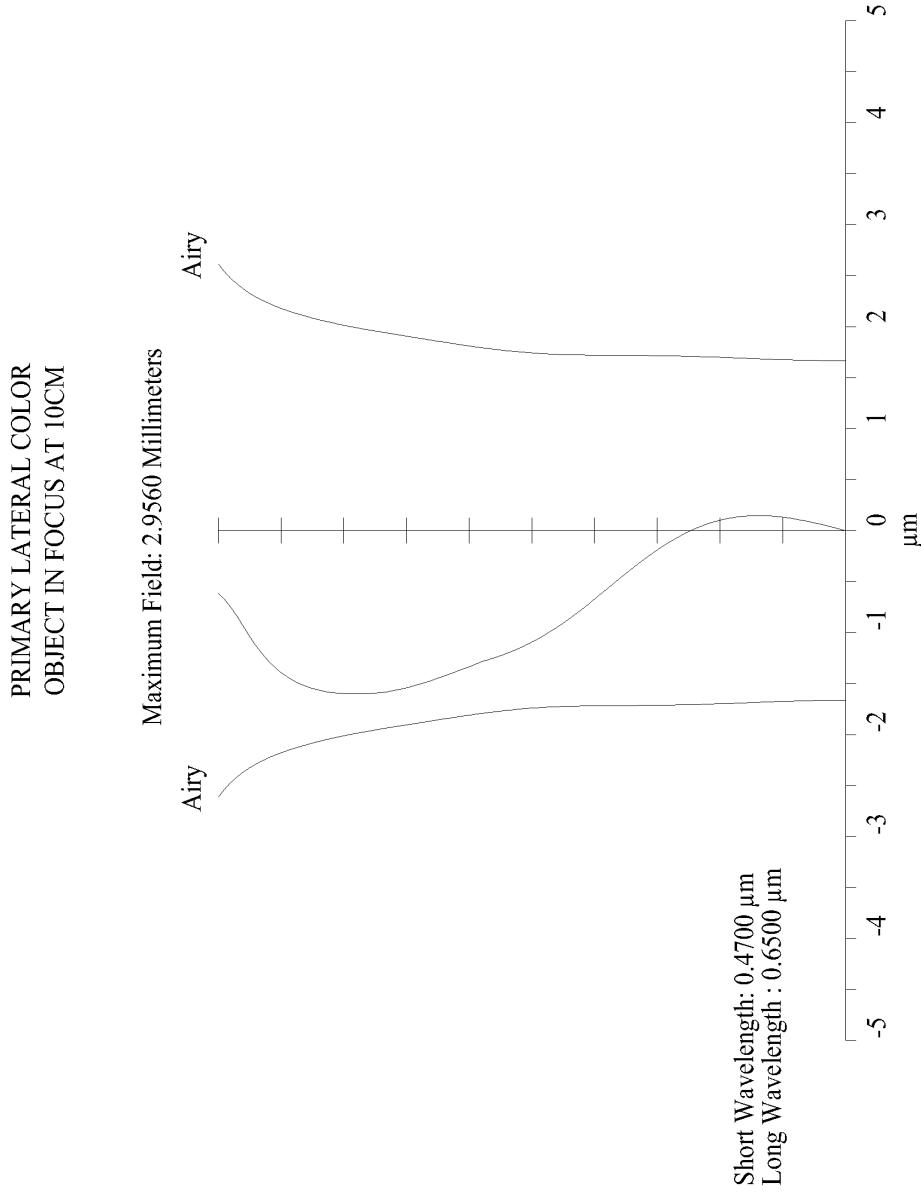

FIG. 6

7/29

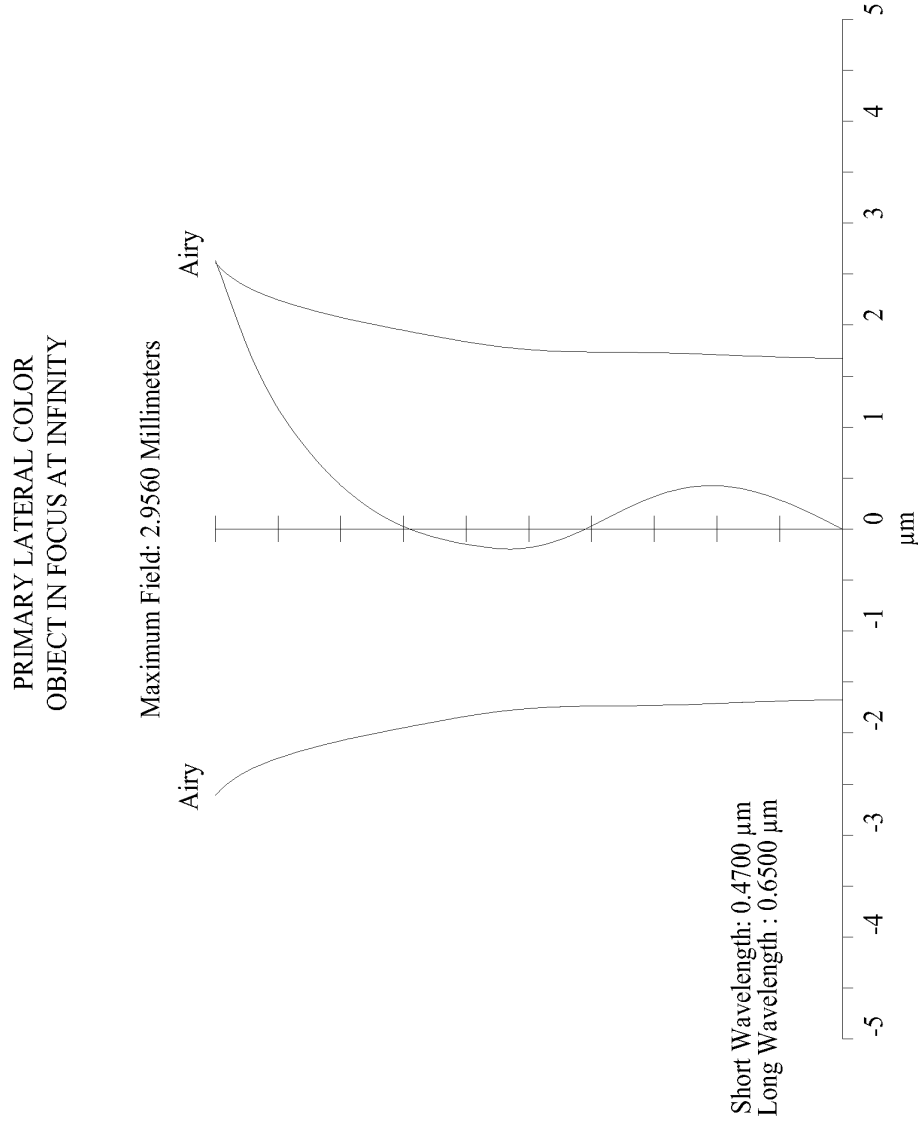

FIG. 7

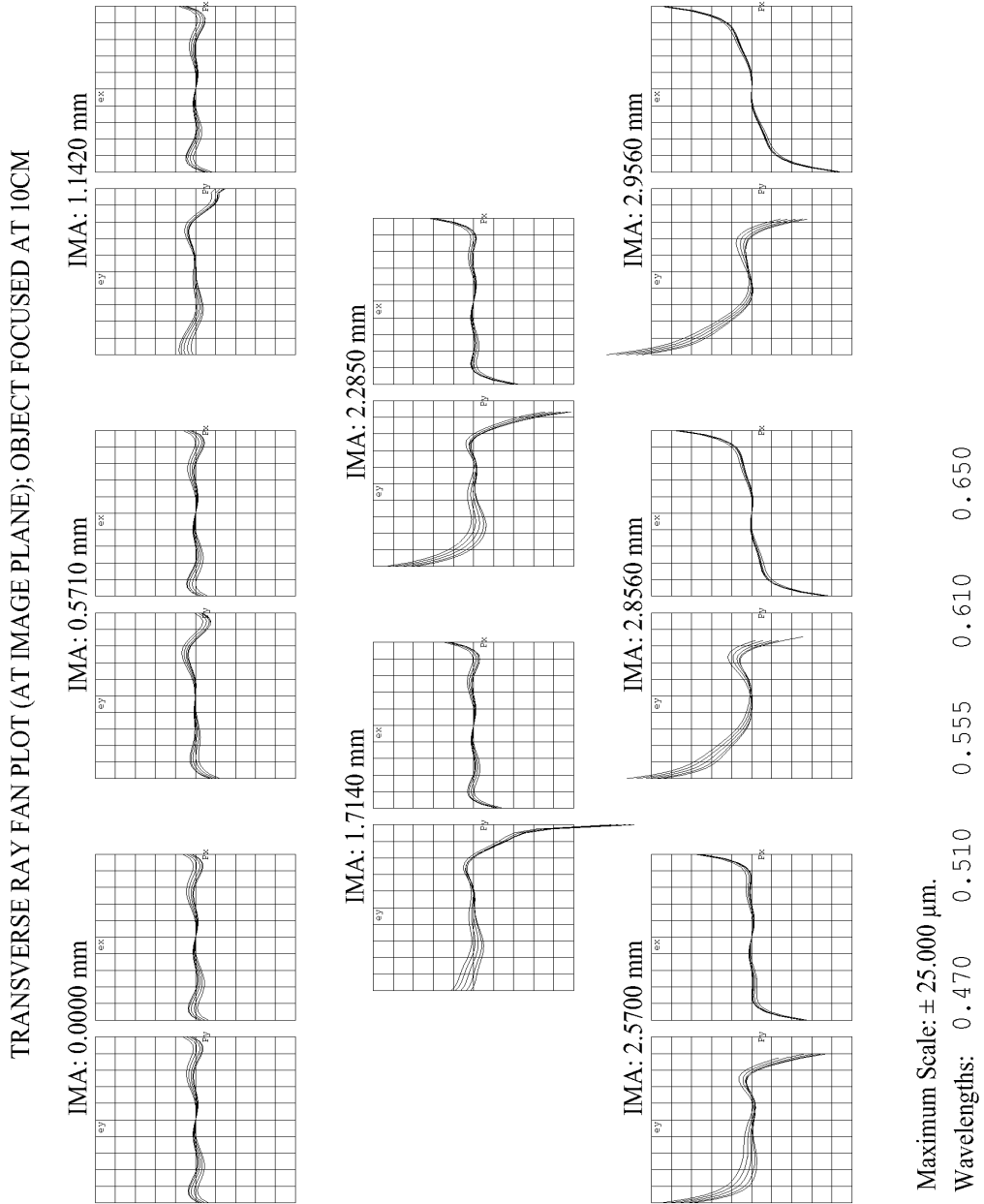
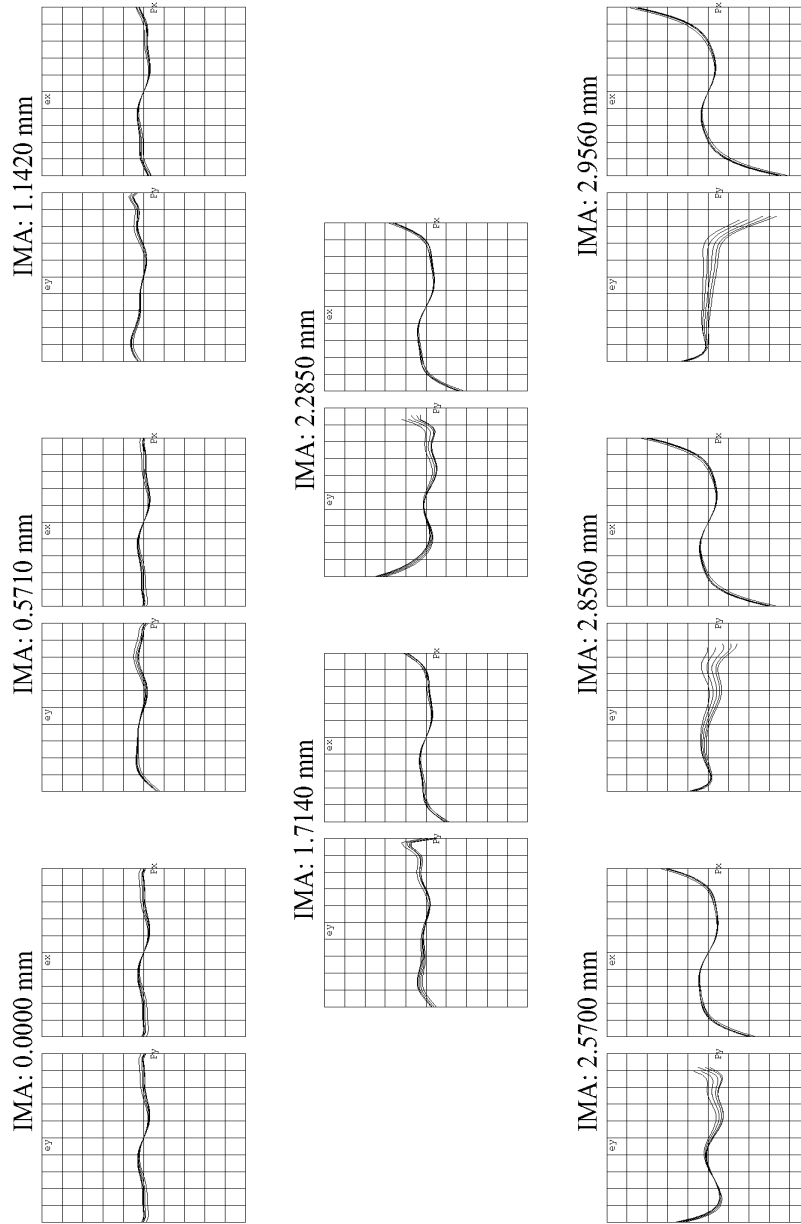

FIG. 8

9/29

TRANSVERSE RAY FAN PLOT (AT IMAGE PLANE); OBJECT FOCUSED AT INFINITY



Maximum Scale: $\pm 25.000 \mu\text{m}$.

Wavelengths: 0.470 0.510 0.555 0.610 0.650

FIG. 9

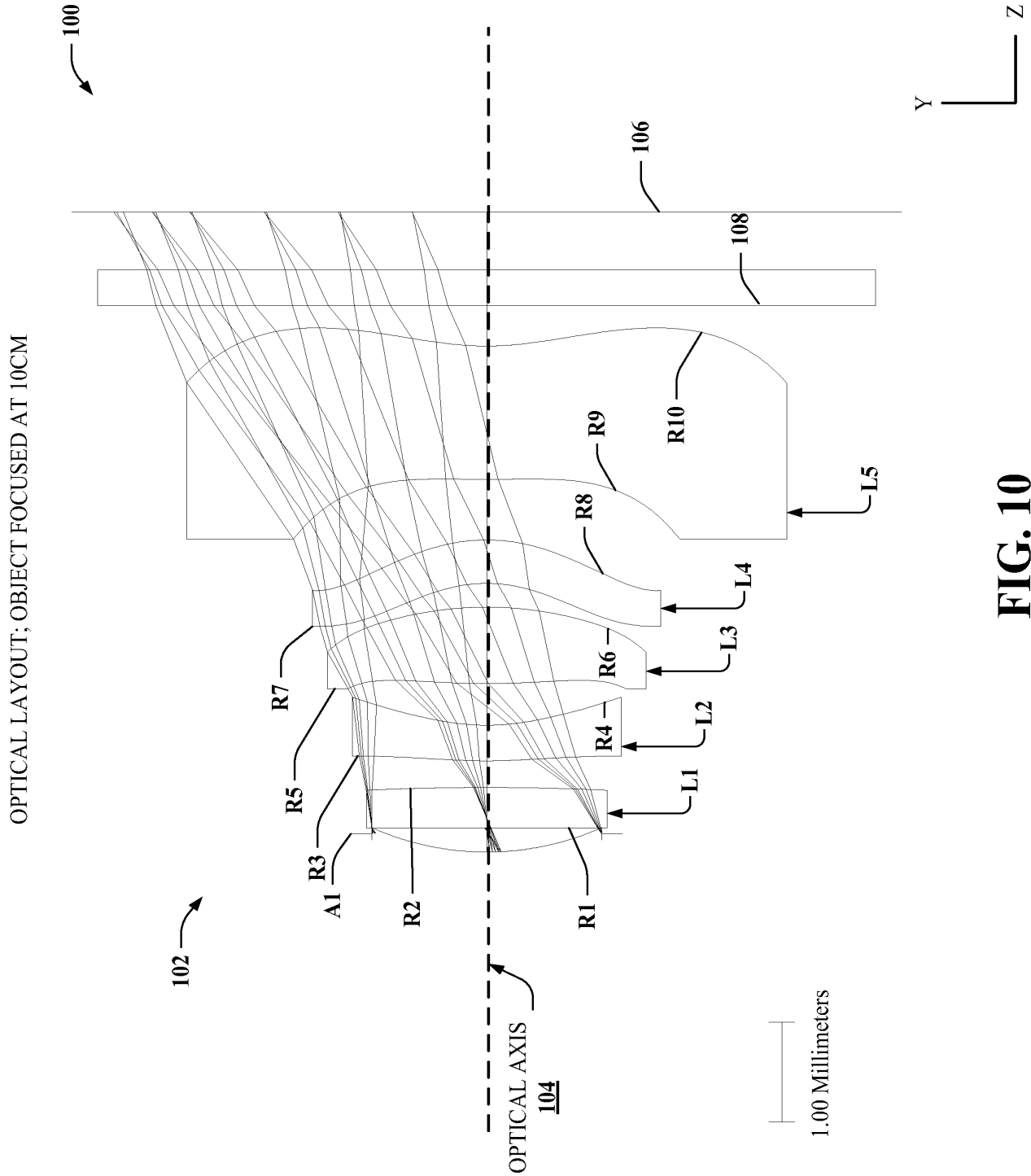

FIG. 10

OPTICAL LAYOUT; OBJECT FOCUSED AT INFINITY

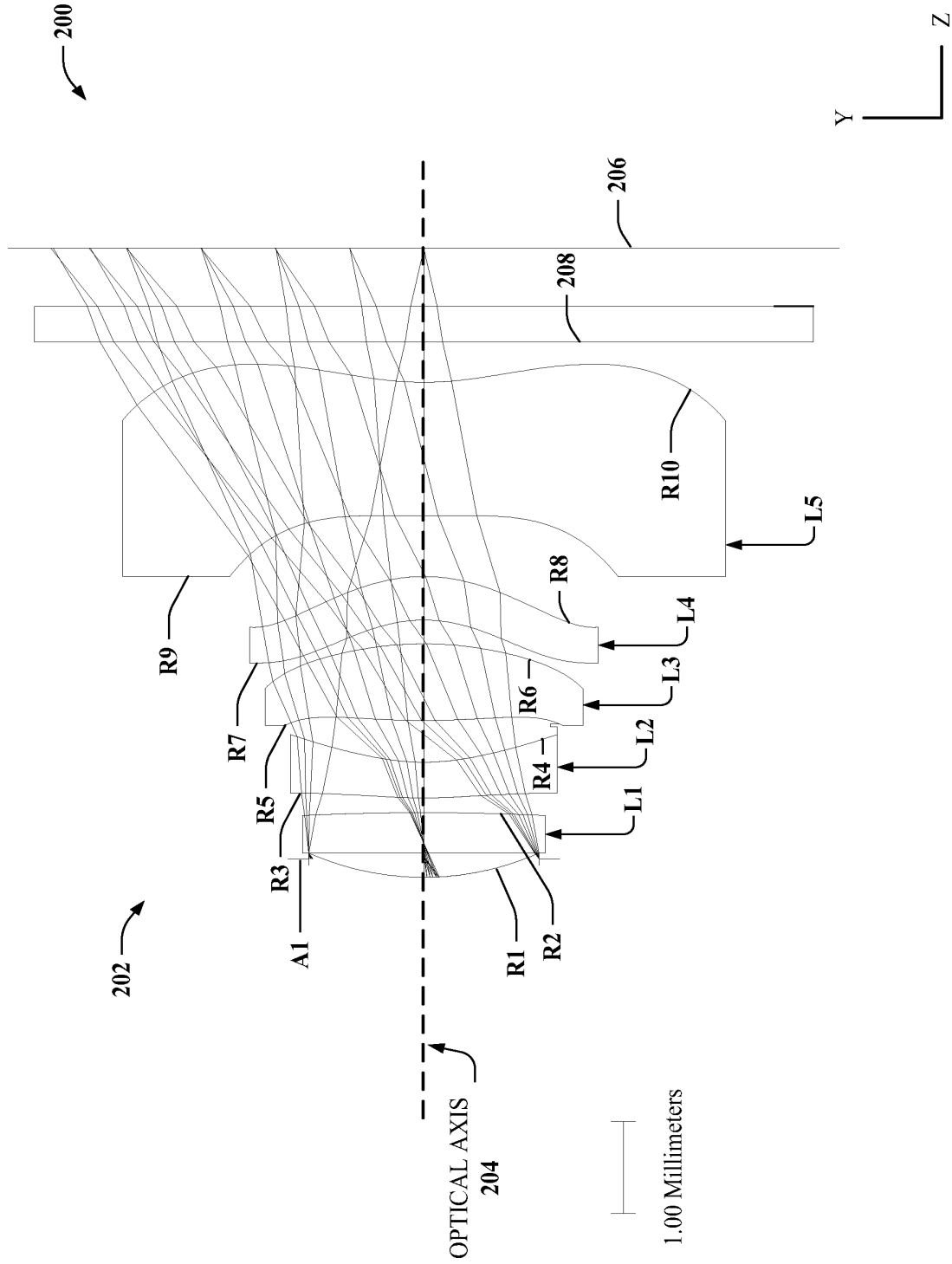

FIG. 11

FIELD CURVATURE: 10cm - Infinity

300 →

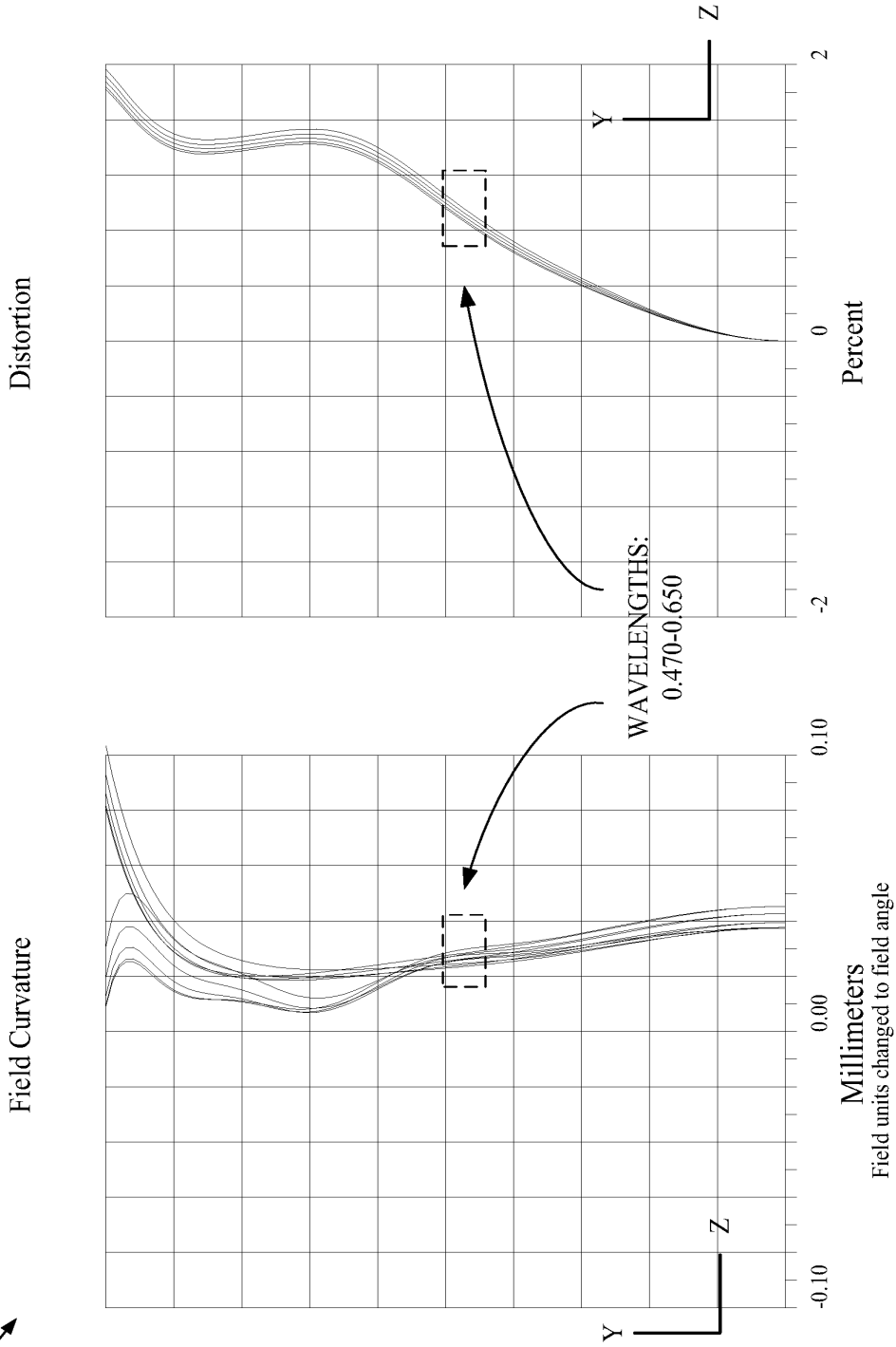

FIG. 12

FIELD CURVATURE: Distortion -
Infinity

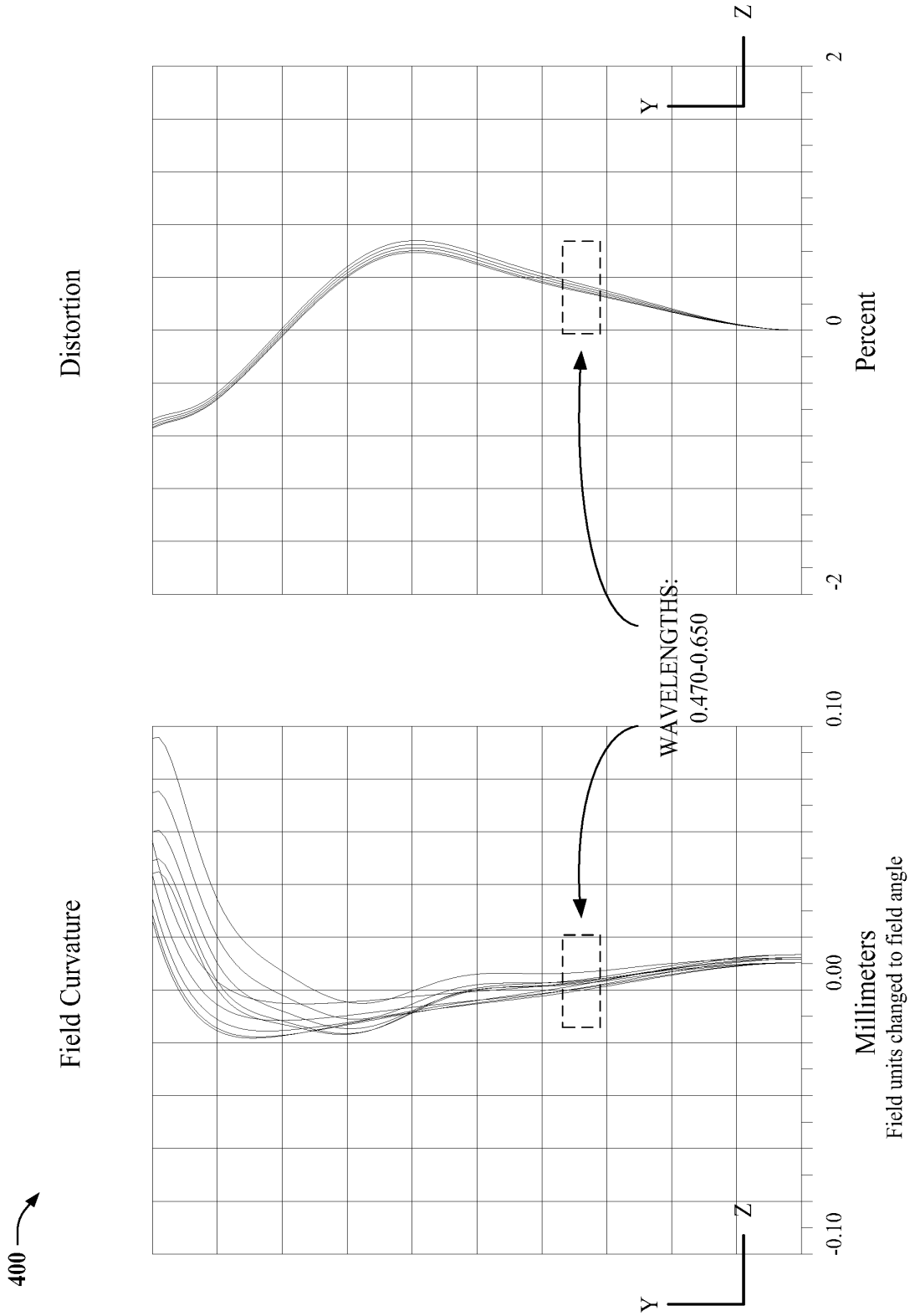

FIG. 13

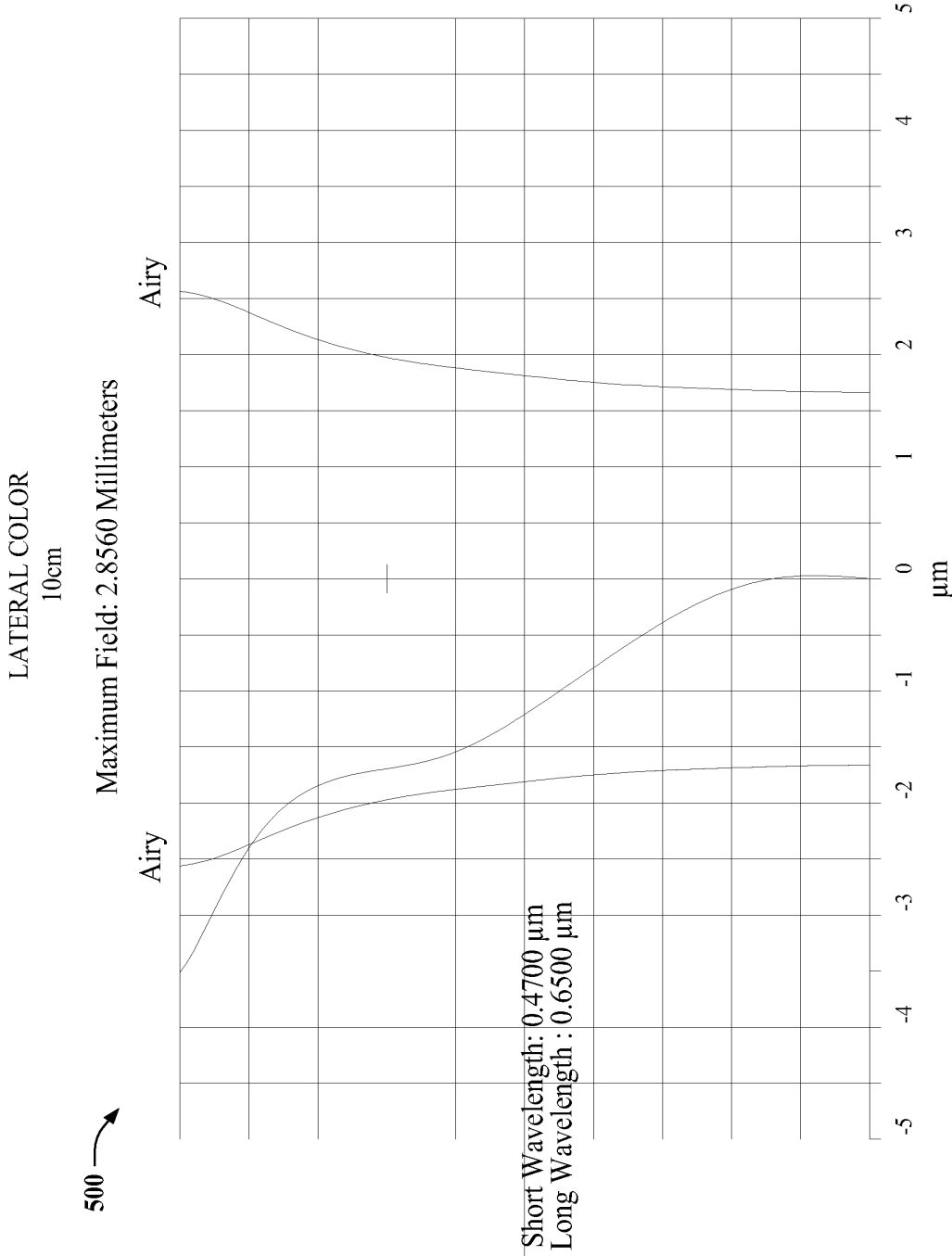

FIG. 14

LATERAL COLOR
INFINITY

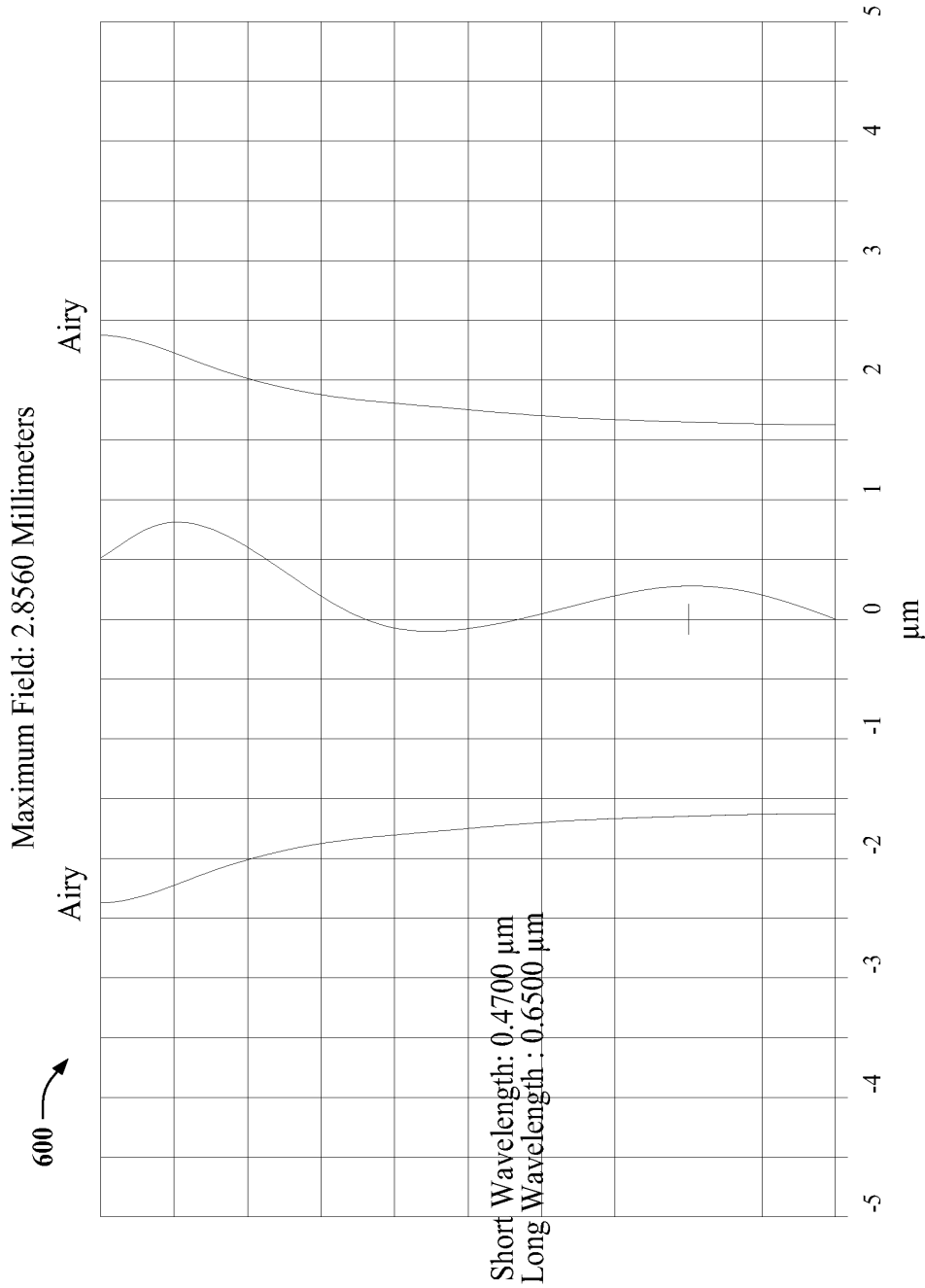

FIG. 15

TRANSVERSE RAY FAN PLOT 10cm

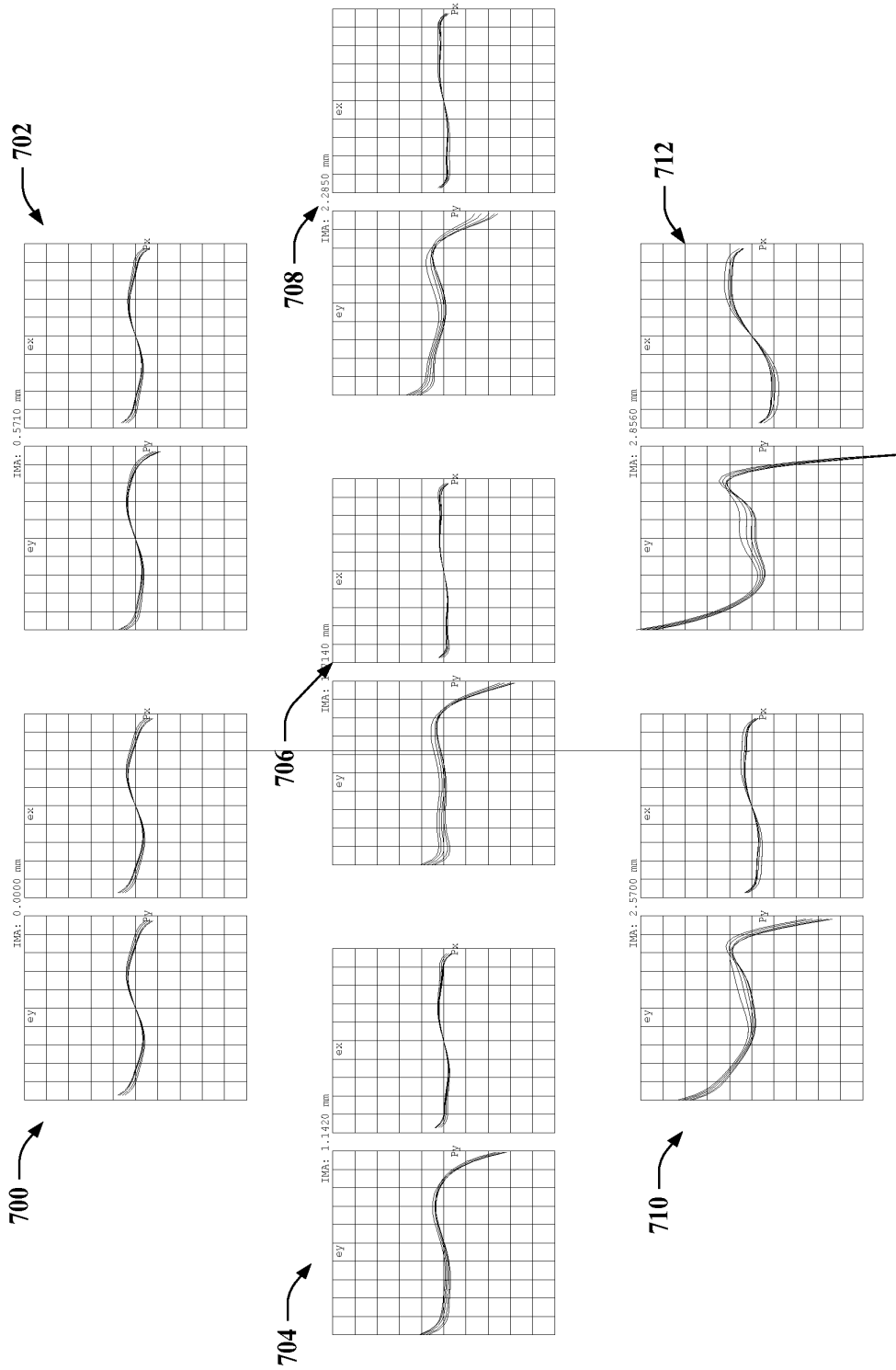

FIG. 16

TRANSVERSE RAY FAN PLOT: INFINITY

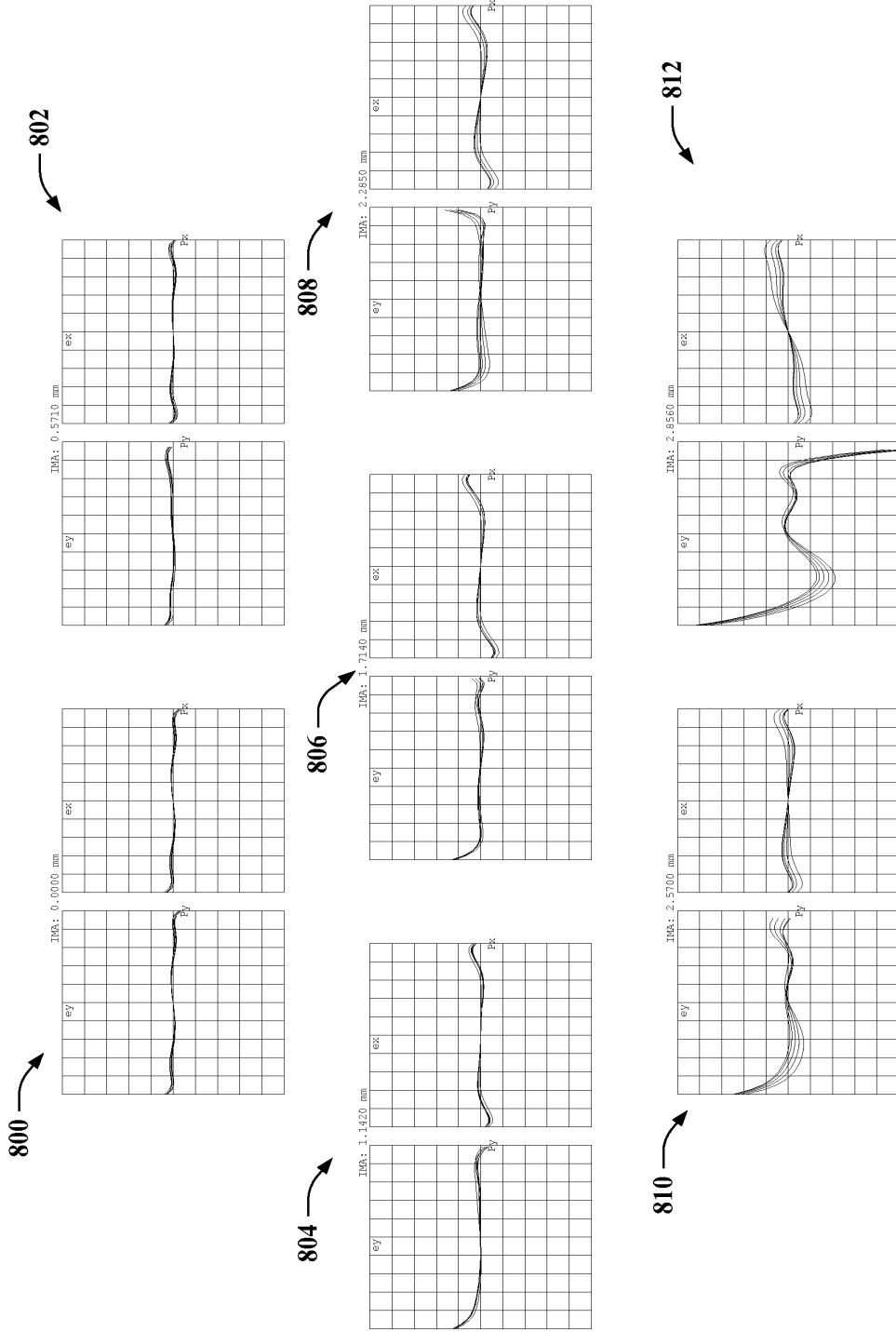

FIG. 17

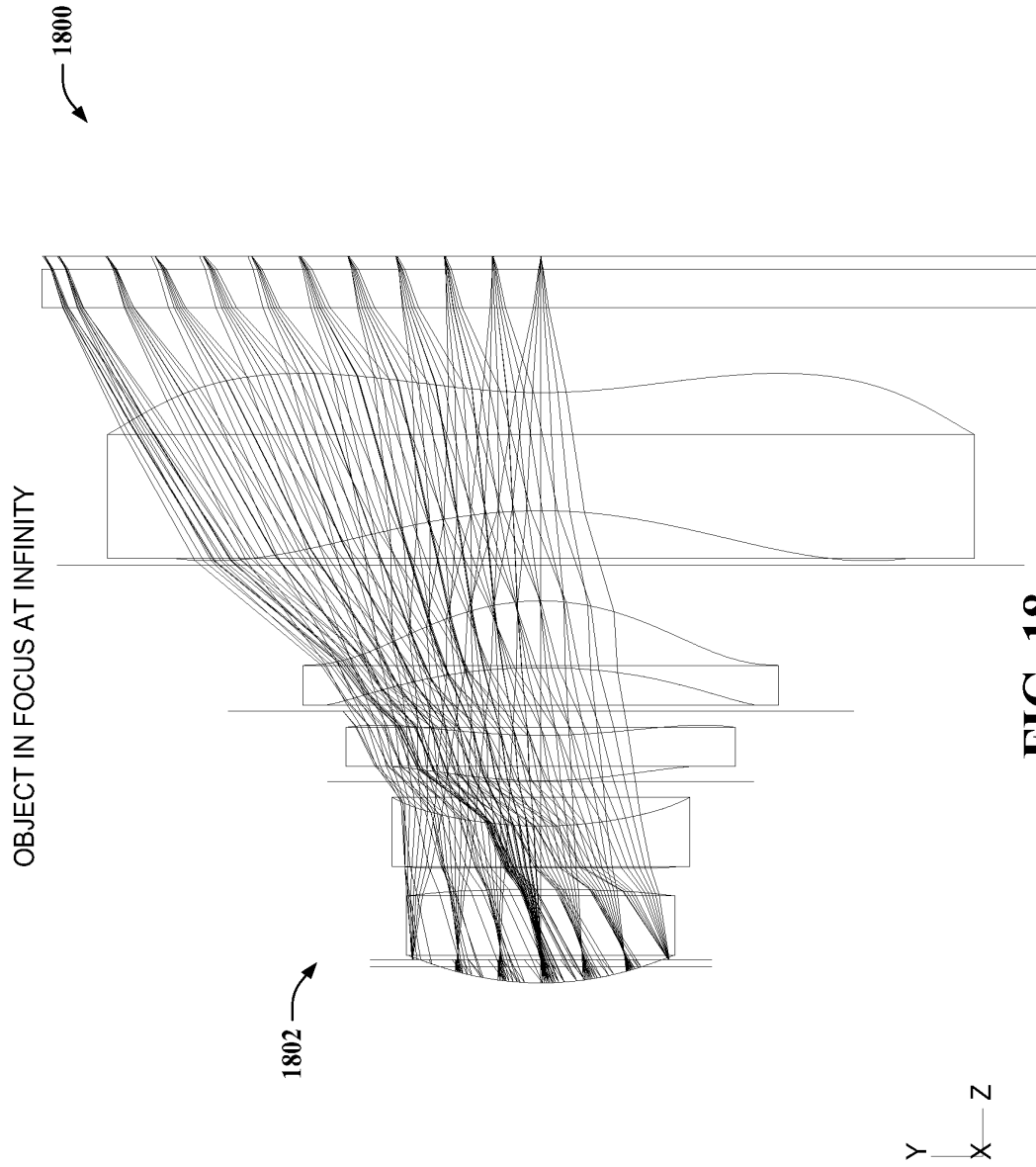

FIG. 18

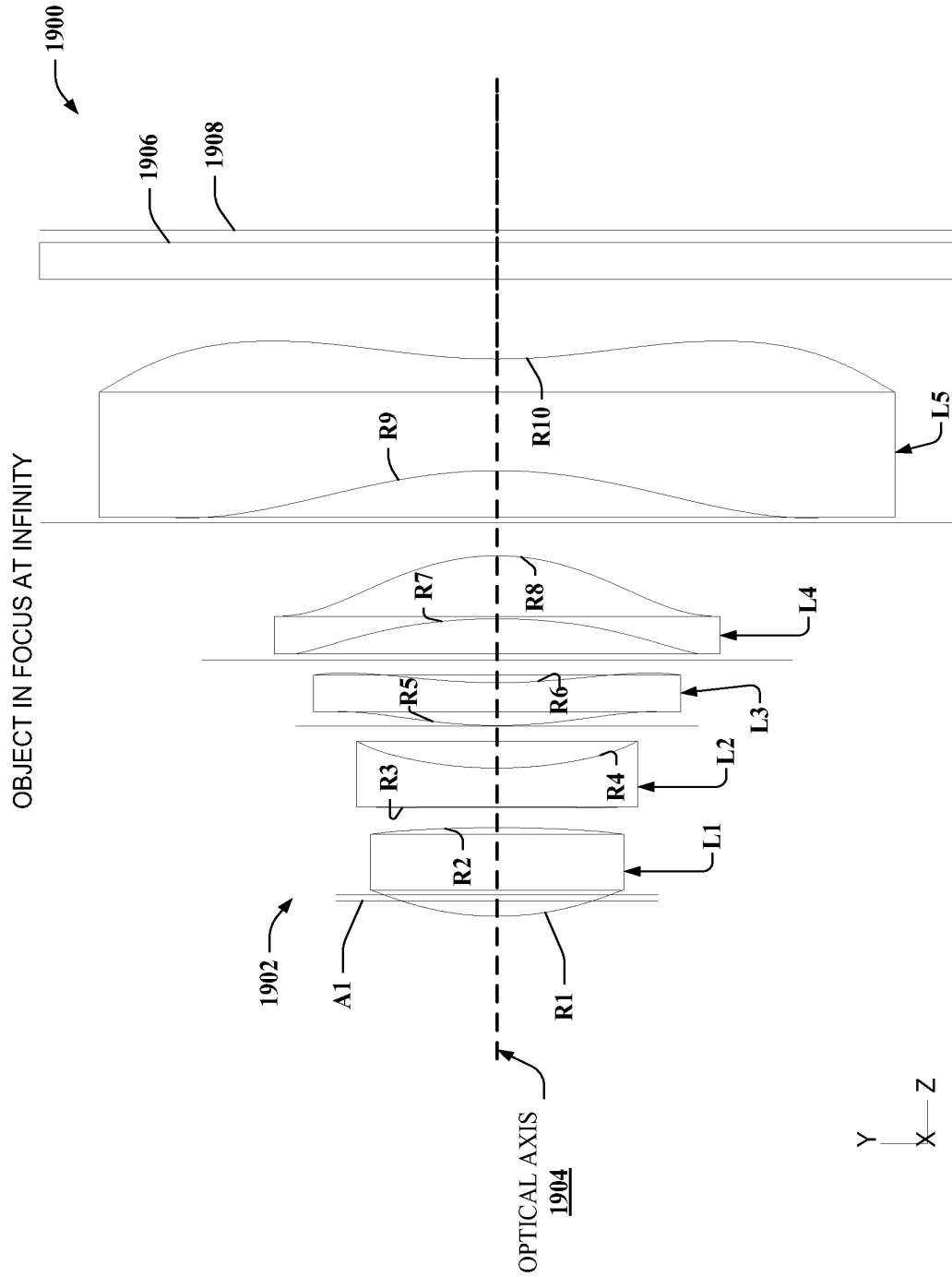

FIG. 19

OBJECT IN FOCUS AT INFINITY

Maximum Field is 35.543 Degrees.

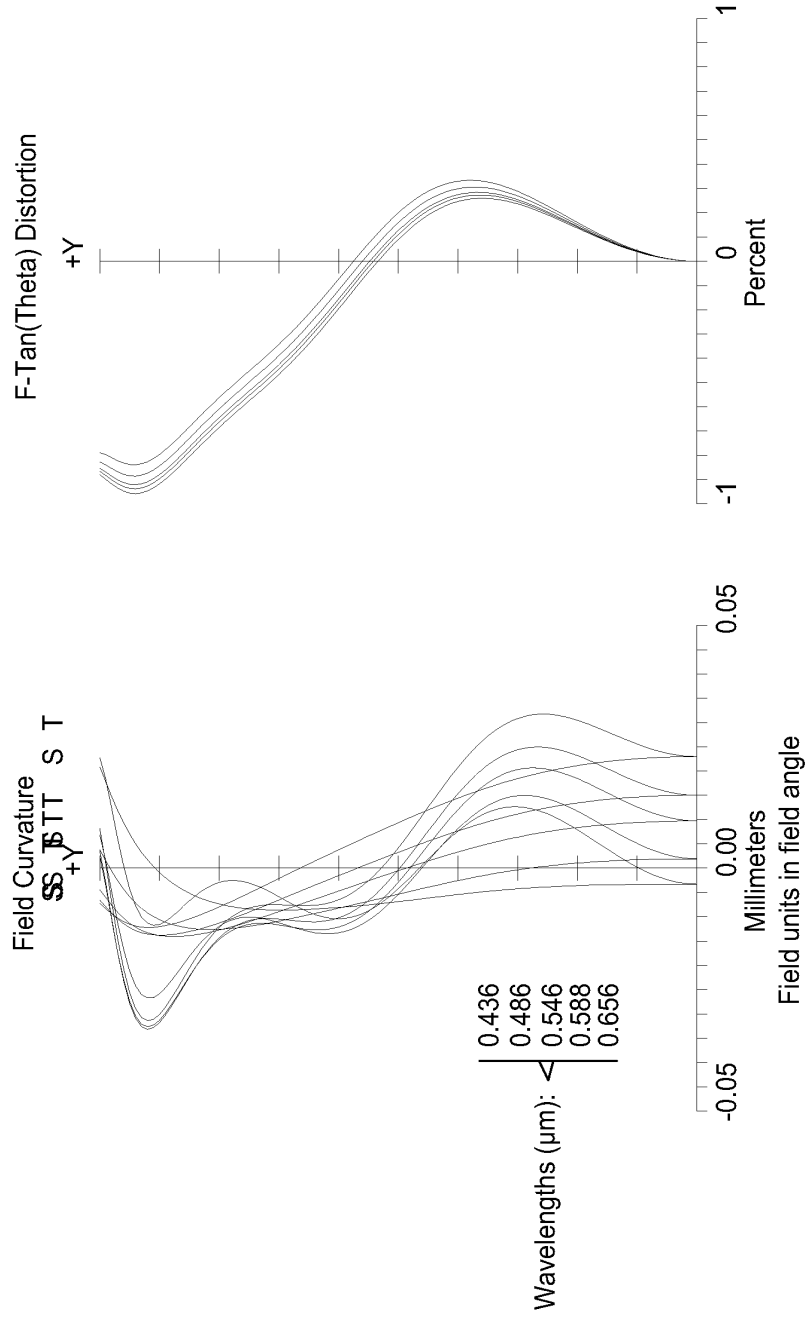

FIG. 20

OBJECT IN FOCUS AT INFINITY

Longitudinal Aberration

Pupil Radius: 0.9000 Millimeters

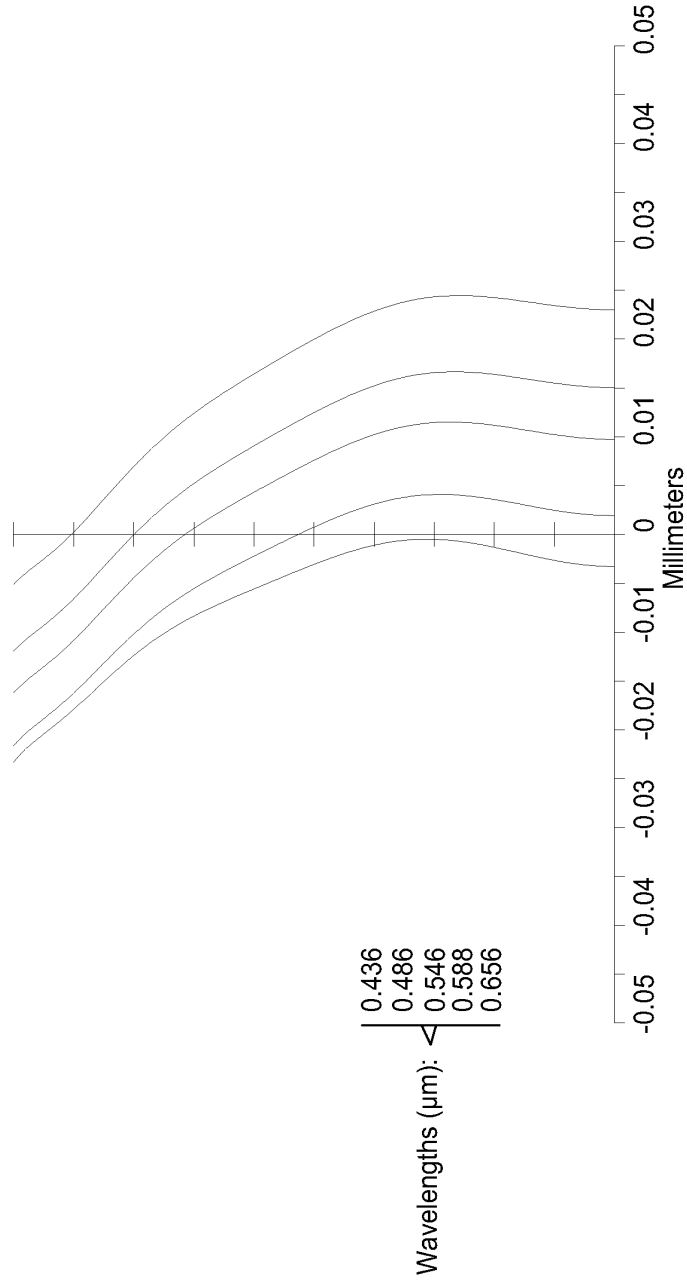

FIG. 21

OBJECT IN FOCUS AT INFINITY
Lateral Color

Maximum Field: 3.3920 Millimeters

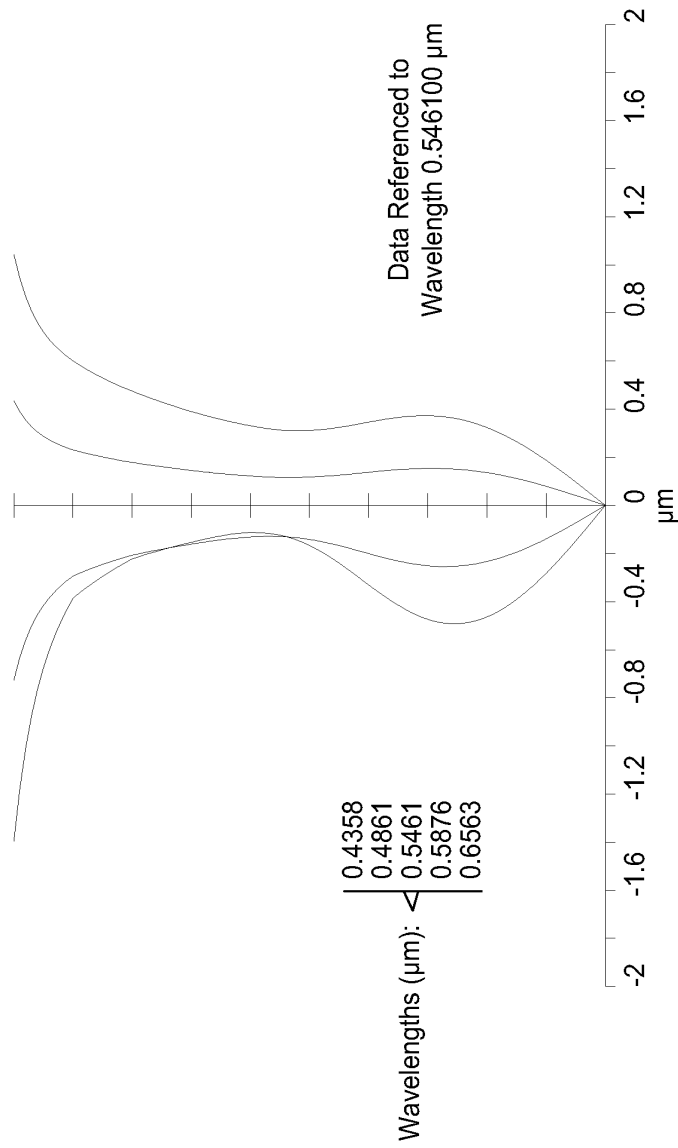

FIG. 22

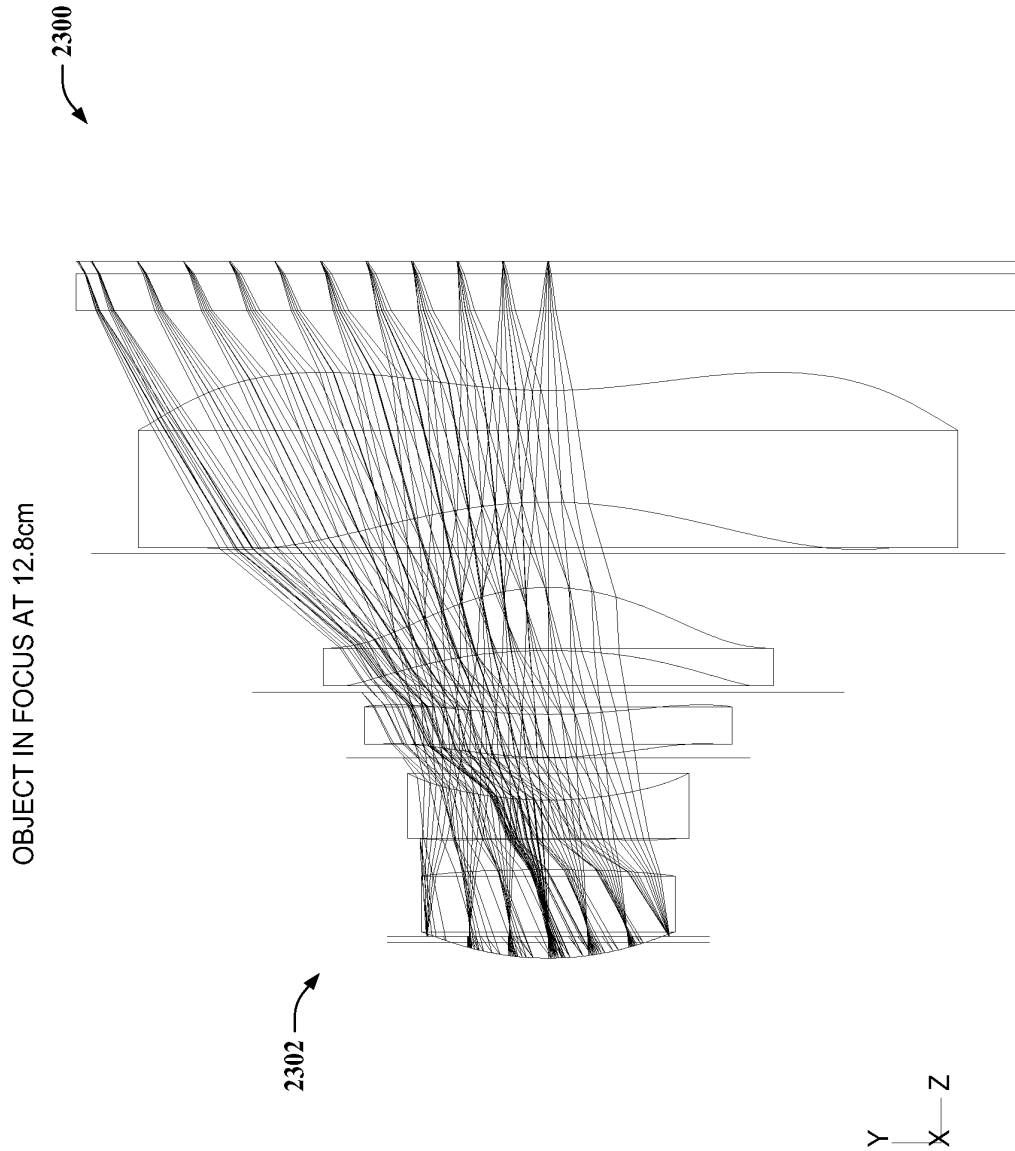

FIG. 23

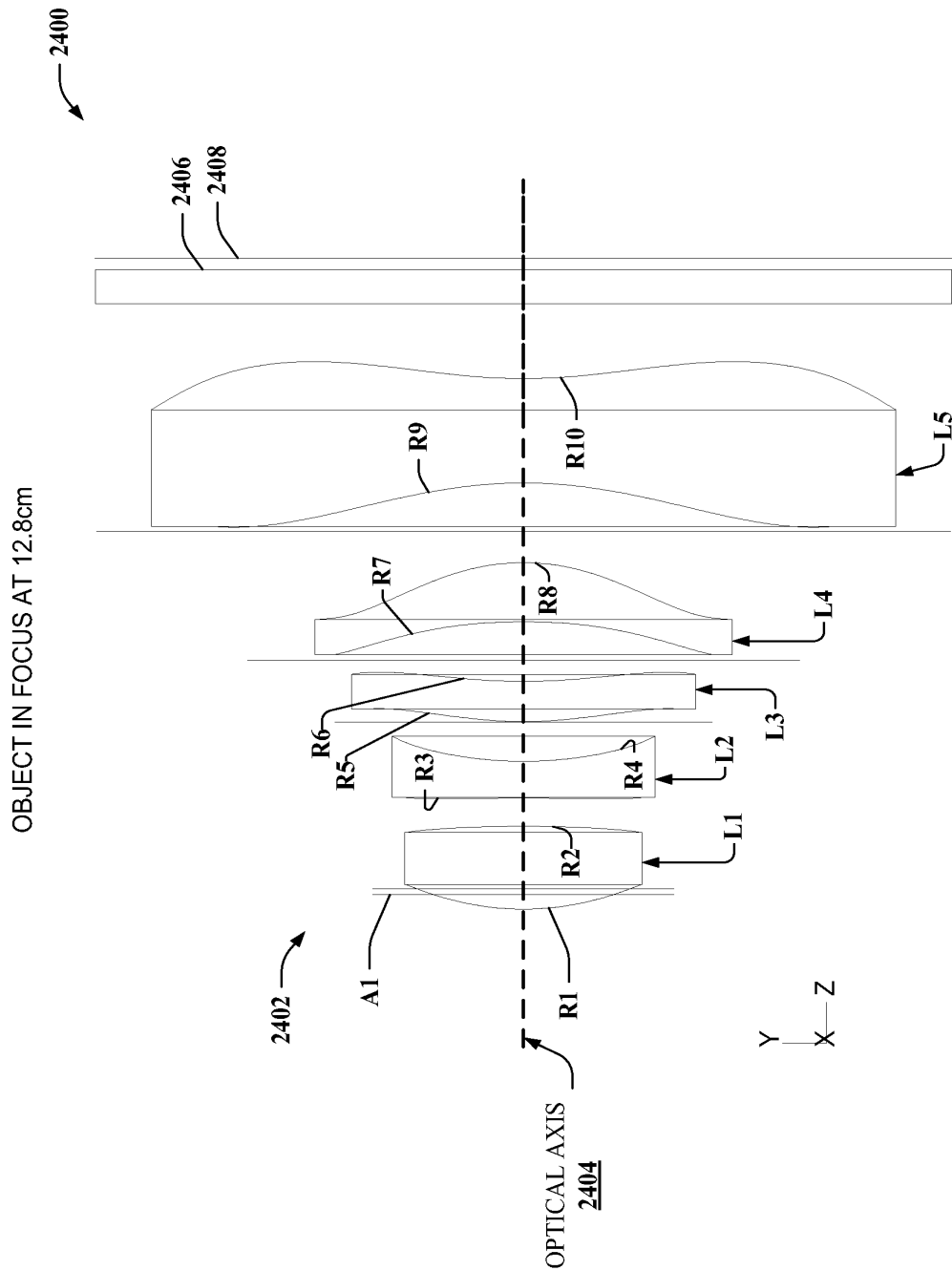

FIG. 24

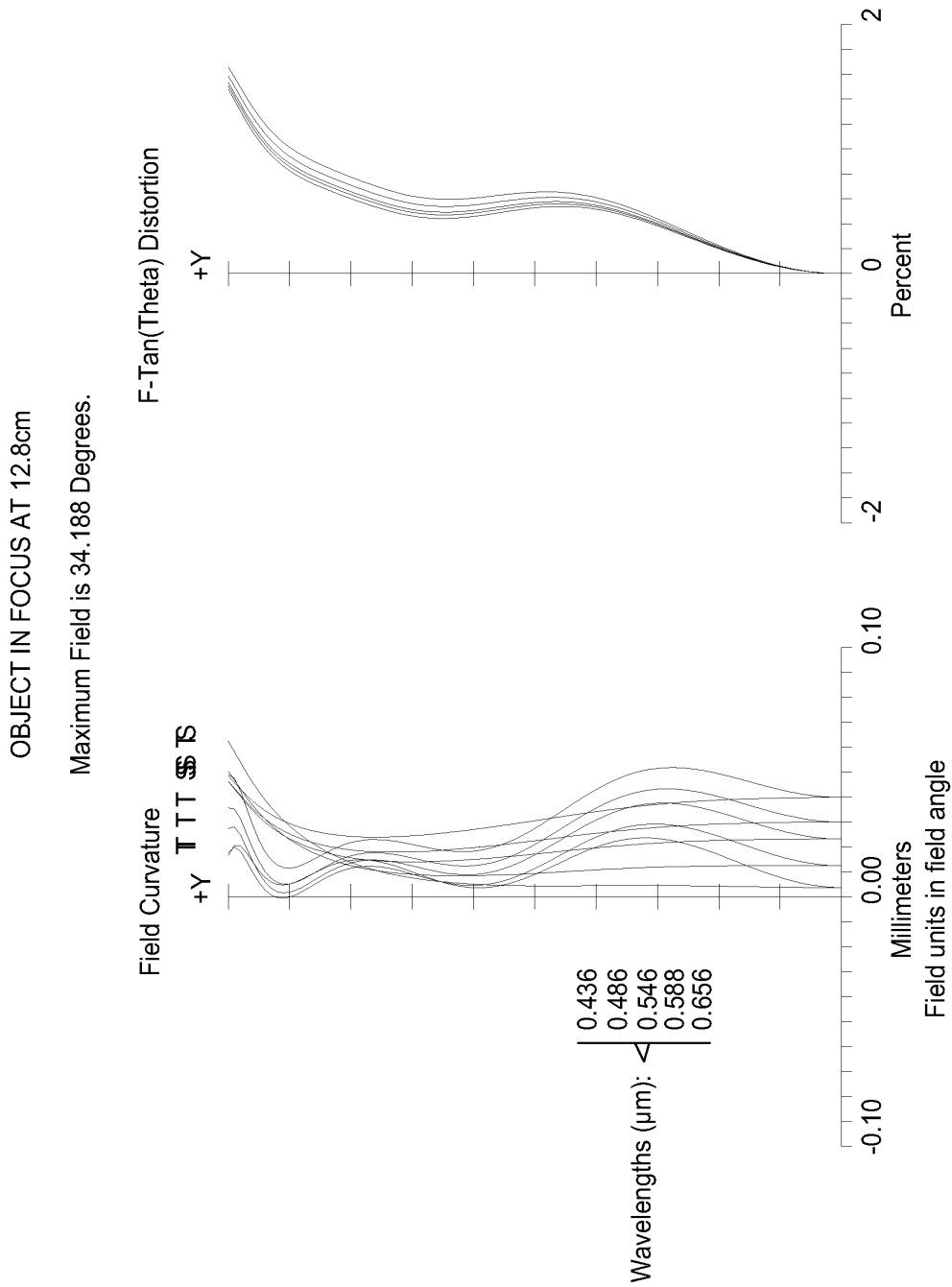

FIG. 25

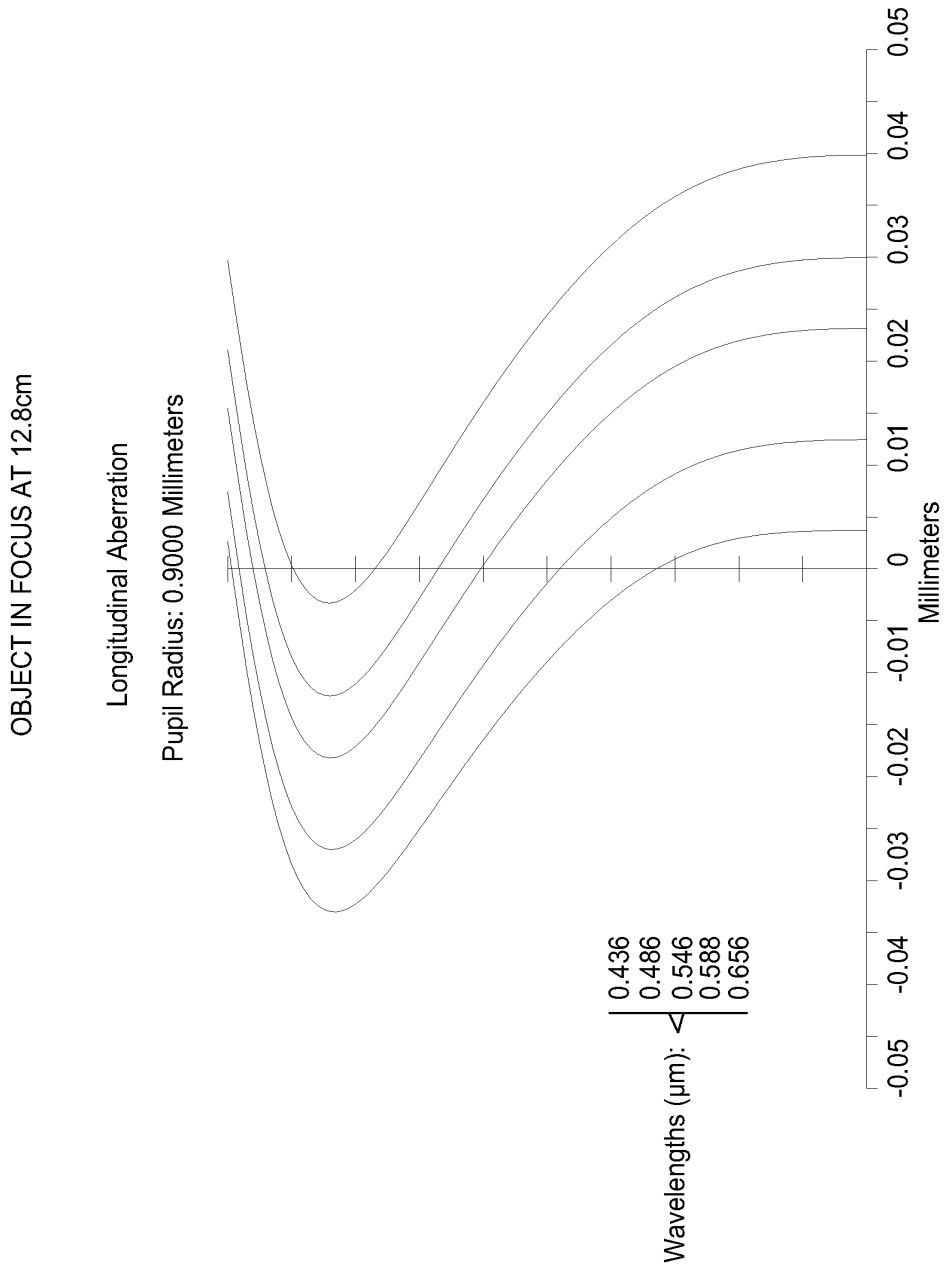

FIG. 26

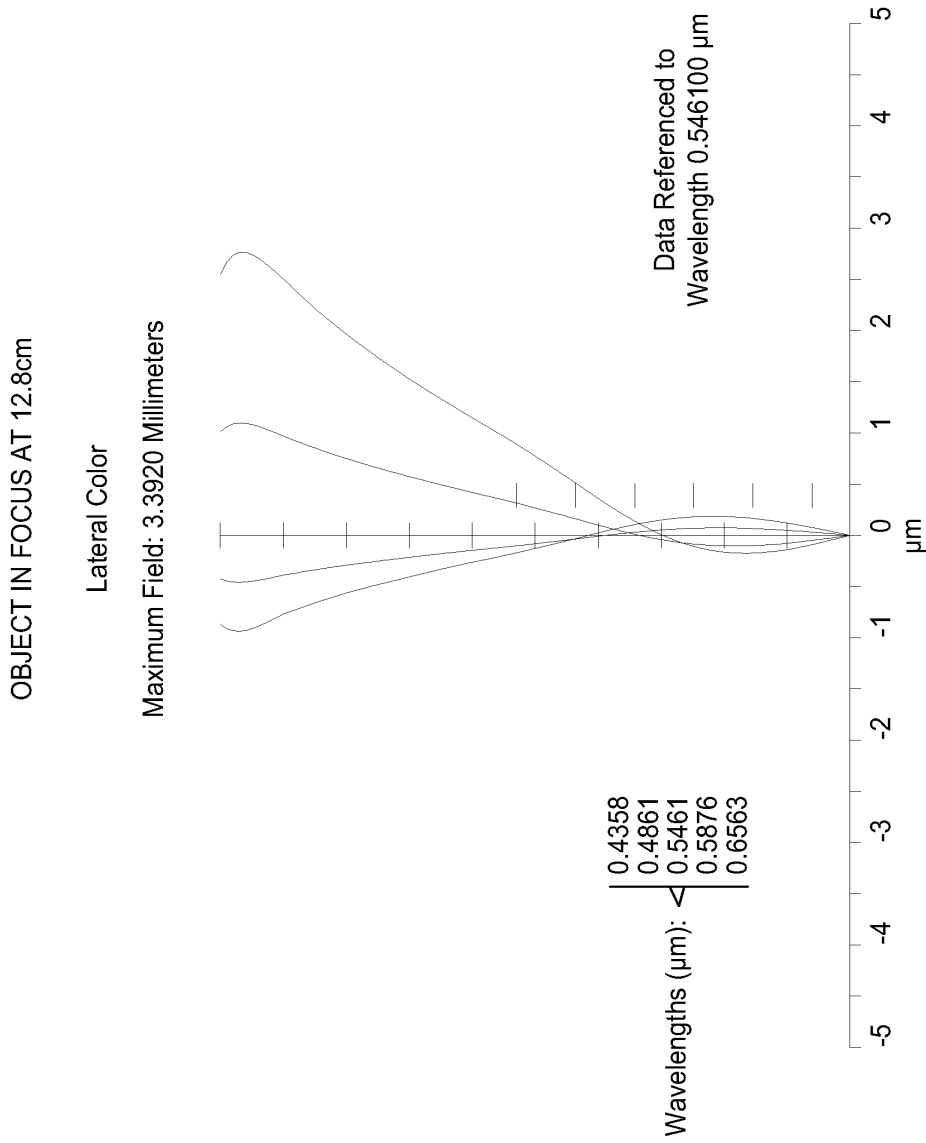
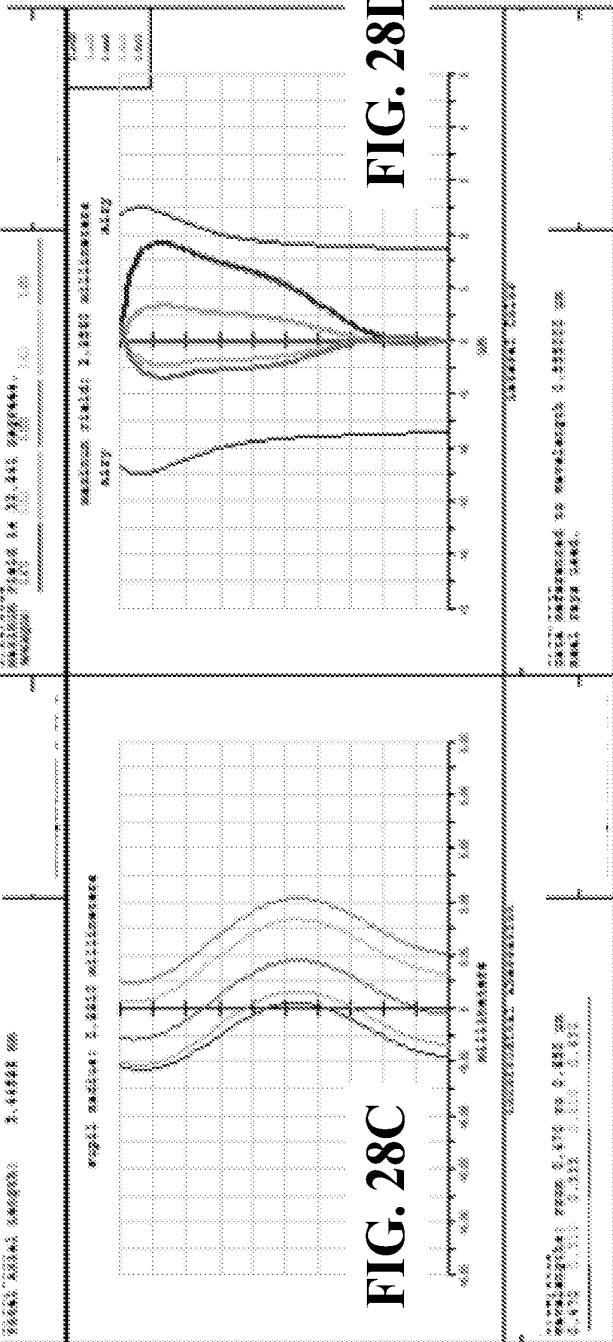
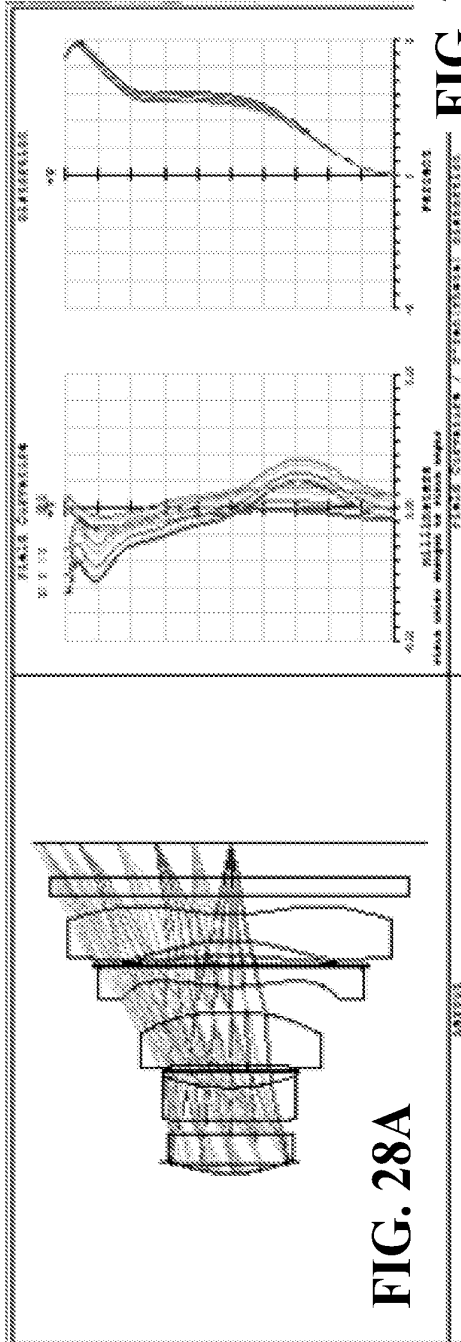
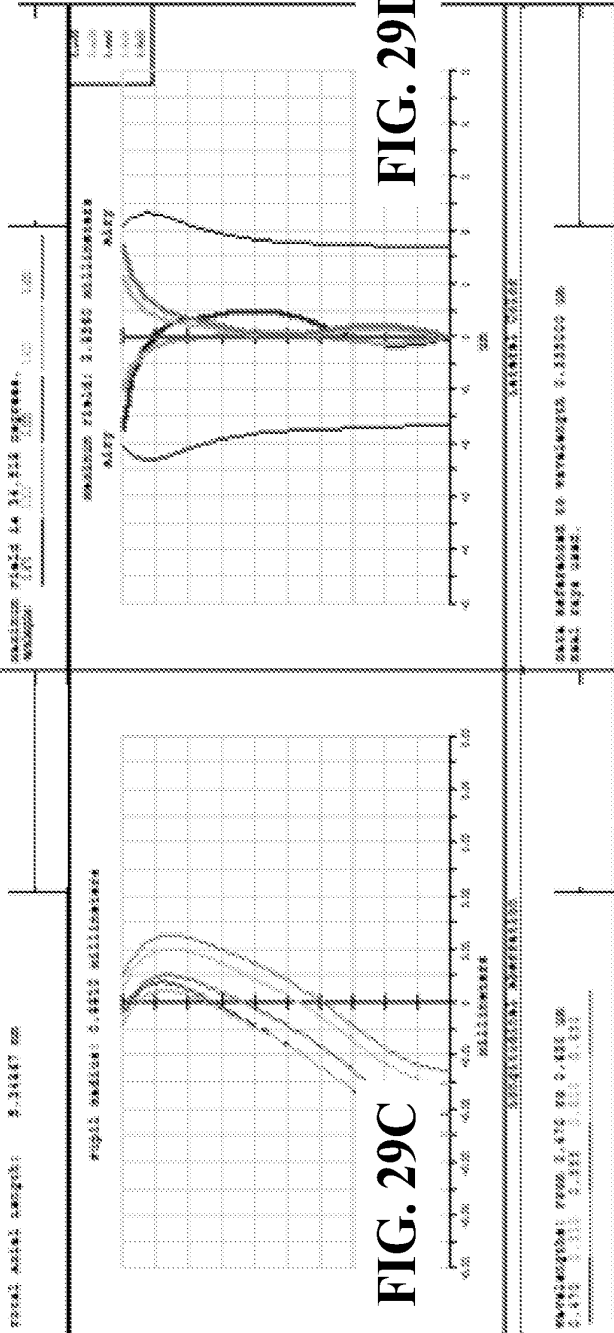
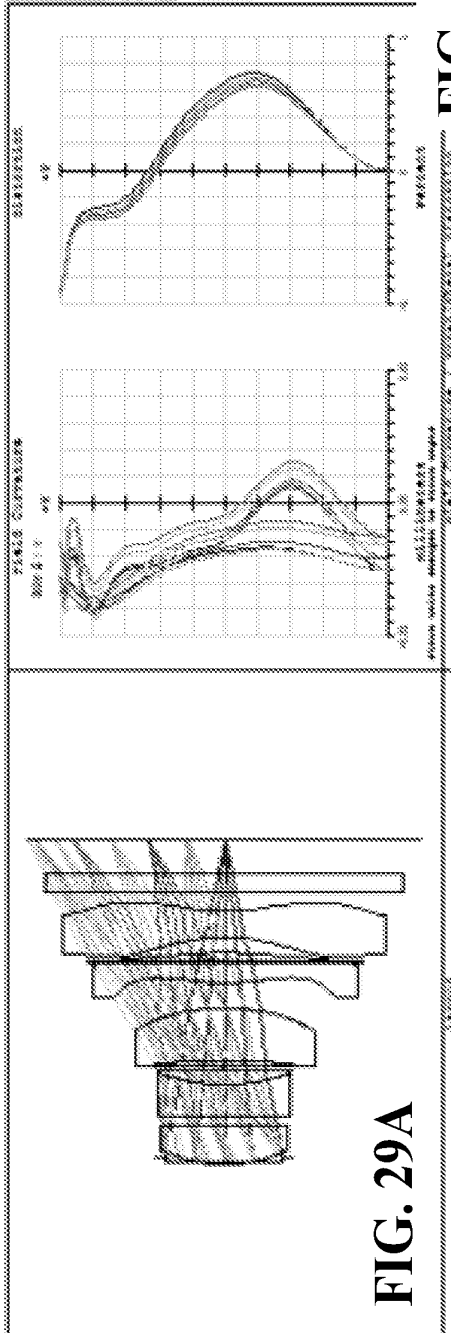

FIG. 27





INTERNATIONAL SEARCH REPORT

International application No
PCT/US2012/061668

A. CLASSIFICATION OF SUBJECT MATTER INV. G02B13/00 H04N5/232 ADD..		
According to International Patent Classification (IPC) or to both national classification and IPC		
B. FIELDS SEARCHED Minimum documentation searched (classification system followed by classification symbols) G02B H04N		
Documentation searched other than minimum documentation to the extent that such documents are included in the fields searched		
Electronic data base consulted during the international search (name of data base and, where practicable, search terms used) EPO-Internal		
C. DOCUMENTS CONSIDERED TO BE RELEVANT		
Category*	Citation of document, with indication, where appropriate, of the relevant passages	Relevant to claim No.
X	JP 2010 224521 A (KONICA MINOLTA OPTO INC) 7 October 2010 (2010-10-07)	1,14-18
Y	abstract; figure 5 -----	6-13
Y	US 5 598 299 A (HAYAKAWA) 28 January 1997 (1997-01-28) figure 1 -----	6-13
A	JP 2011 209554 A (Y. SHINOHARA) 20 October 2011 (2011-10-20) figures 4,11; tables 7,19 -----	19-30
X	JP 7 181389 A (MINOLTA CO LTD) 21 July 1995 (1995-07-21) abstract; figure 1 paragraph [0023] ; table 1 -----	31-35, 40-42
<input type="checkbox"/> Further documents are listed in the continuation of Box C.		
<input checked="" type="checkbox"/> See patent family annex.		
* Special categories of cited documents :		
"A" document defining the general state of the art which is not considered to be of particular relevance "E" earlier application or patent but published on or after the international filing date "L" document which may throw doubts on priority claim(s) on which is cited to establish the publication date of another citation or other special reason (as specified) "O" document referring to an oral disclosure, use, exhibition or other means "P" document published prior to the international filing date but later than the priority date claimed		"T" later document published after the international filing date or priority date and not in conflict with the application but cited to understand the principle or theory underlying the invention "X" document of particular relevance; the claimed invention cannot be considered novel or cannot be considered to involve an inventive step when the document is taken alone "Y" document of particular relevance; the claimed invention cannot be considered to involve an inventive step when the document is combined with one or more other such documents, such combination being obvious to a person skilled in the art "&" document member of the same patent family
Date of the actual completion of the international search 14 March 2013		Date of mailing of the international search report 21/03/2013
Name and mailing address of the ISA/ European Patent Office, P.B. 5818 Patentlaan 2 NL - 2280 HV Rijswijk Tel. (+31-70) 340-2040. Fax: (+31-70) 340-3016		Authorized officer Michel , Alain

4

INTERNATIONAL SEARCH REPORT

International application No.
PCT/US2012/061668

Box No. II Observations where certain claims were found unsearchable (Continuation of item 2 of first sheet)

This international search report has not been established in respect of certain claims under Article 17(2)(a) for the following reasons:

- 1. Claims Nos.:
because they relate to subject matter not required to be searched by this Authority, namely:

- 2. Claims Nos.:
because they relate to parts of the international application that do not comply with the prescribed requirements to such an extent that no meaningful international search can be carried out, specifically:

- 3. Claims Nos.:
because they are dependent claims and are not drafted in accordance with the second and third sentences of Rule 6.4(a).

Box No. III Observations where unity of invention is lacking (Continuation of item 3 of first sheet)

This International Searching Authority found multiple inventions in this international application, as follows:

see additional sheet

- 1. As all required additional search fees were timely paid by the applicant, this international search report covers all searchable claims.

- 2. As all searchable claims could be searched without effort justifying an additional fees, this Authority did not invite payment of additional fees.

- 3. As only some of the required additional search fees were timely paid by the applicant, this international search report covers only those claims for which fees were paid, specifically claims Nos. :

- 4. No required additional search fees were timely paid by the applicant. Consequently, this international search report is restricted to the invention first mentioned in the claims; it is covered by claims Nos. :

Remark on Protest

- The additional search fees were accompanied by the applicant's protest and, where applicable, the payment of a protest fee.
- The additional search fees were accompanied by the applicant's protest but the applicable protest fee was not paid within the time limit specified in the invitation.
- No protest accompanied the payment of additional search fees.

FURTHER INFORMATION CONTINUED FROM PCT/ISA/ 210

This International Searching Authority found multiple (groups of) inventions in this international application, as follows:

1. claims : 1-18

Claim 1 relates to an imaging system having two lens groups , five lenses and front-focusing carried out by a MEMS actuator. Claims 2-18 depend on claim 1.

The underlying problem to be solved is how to enable a small lens displacement during focusing.

The special feature is the first lens group comprising a biconvex object-side lens, the focal length of which being greater than half of the focal length of the whole imaging system.

2. claims : 19-30

Independent claim 19 relates to an optical system having five lenses , focusing being carried out by moving the first lens. Claims 20-30 depend on claim 19.

The underlying problem to be solved is how to reduce field curvature and distortion.

The special feature is the lens constitution of the optical system, the first and the fourth lenses being biconvex, the second and the fifth lenses being menisci and the third lens being concave-convex.

3. claims : 31-45

Independent claim 31 relates to an imaging system having two lens groups , the first lens group for focusing and consisting of two lenses and the second lens group having three lenses . Claims 32-45 depend on claim 31.

The underlying problem to be solved is how to reduce primary lateral colour.

The special feature is the second lens group comprising a fore-front lens being a meniscus that has a convex surface towards the object side.

INTERNATIONAL SEARCH REPORT

Information on patent family members

International application No
PCT/US2012/061668

Patent document cited in search report	Publication date	Patent family member(s)	Publication date
JP 2010224521	A 07-10-2010	CN 101819315 A JP 2010224521 A JP 2011138175 A US 2010220229 AI	01-09-2010 07-10-2010 14-07-2011 02-09-2010
US 5598299	A 28-01 -1997	JP 3141681 B2 JP 7294853 A US 5598299 A	05-03 -2001 10-11 -1995 28-01 -1997
JP 2011209554	A 20-10 -2011	NONE	
JP 7181389	A 21-07 -1995	NONE	

Form PCT/ISA/210 (patent family annex) (April 2005)

Optical lens

Abstract

The invention relates to an optical lens which sequentially comprises a front lens group with positive focal power, a diaphragm element and a rear lens group with positive focal power from the object space to the image space. The front lens group sequentially comprises a first lens and a second lens from the object space to the image space. The first lens is a biconcave lens with negative focal power. The second lens is a biconvex lens with positive focal power. The rear lens group sequentially comprises a third lens, a fourth lens and a fifth lens from the object space to the image space. A gluing lens is formed by the third lens and the fourth lens. The fifth lens is an aspheric surface lens with positive focal power, and two concave faces of the fifth lens are in the same direction crescent shape. According to the optical lens, high pixels, small deformation and large apertures can be achieved under the condition that the requirements for low cost and miniaturization are met, a perfect image can still be kept within the temperature range of -40 DEG C to 85 DEG C, and the optical lens is particularly suitable for monitors and vehicle-mounted camera systems which work in the day and at night or under a poor illumination condition.

CN104297906A

Pat. Application



Download PDF



Find Prior Art



Similar

Other languages: Chinese

Inventor: Yao Bin, Xie Qiansan, Yan Wenwei

Original Assignee: Ningbo Hanyu Vehicle Optical Technology Co., Ltd.

Priority date : 2014-10-20

Family: CN (3)

Date	App/Pub Number	Status
2014-10-20	CN 201410559069	
2015-01-21	CN104297906A	Application
2015	CN 201520613120	
2015	CN 201510679740	

Control method for multi-lens camera and multi-lens device

Abstract

Disclosed is an improved device provided with a multi-lens and multi-sensor camera module. The device has a new mechanism for adjusting multiple lenses and angles of sensors. The new device makes each lens integrated with perspective of the sensors by using a new principle so that images composited by a multi-lens module have high quality and satisfactory properties such as high resolution, high depth of field, high color saturation, high signal-to-noise ratio, high dynamic range, high sensitivity and the like.

CN102739949A

CN Application

 Download PDF  Find Prior Art  Similar

Other languages: Chinese

Inventor: Zhang Kerun

Original Assignee: Zhang Kerun

Priority date: 2011-04-01

Family: CN (1)



Date	App/Pub Number	Status
2011-04-01	CN 201110082063	
2012-10-17	CN102739949A	Application

Double camera control device, method and system of mobile terminal and mobile terminal

Abstract

The invention is suitable for camera control technology and provides a double camera control device of a mobile terminal. The mobile terminal comprises a first camera, a second camera, a power supply unit and a control chip, the power supply unit respectively supplies power for the first camera and the second camera in single mode, and the control chip is respectively communicated with the first camera and the second camera in single mode. The double camera control device of the mobile terminal enables two cameras to be power-supplied and communicated individually and avoids mutual interference of control of the two cameras. In use, users can select opening of singular camera and can also open two cameras simultaneously to preview and shoot at the same time, after shooting, pictures of the double camera can be combined, and accordingly shooting experience of the users is well improved.

CN103024272A
Patent Application

 Download PDF  Find Prior Art  Similar

Other languages: Chinese

Inventor: [Gao Xiaowen](#)

Original Assignee: Guangdong Opal Mobile Communication Co., Ltd.

Priority date: 2012-12-14

Family: CN (1)

Date	App./Pub Number	Status
2012-12-14	CN 201210545949	
2013-04-03	CN103024272A	Application



(11) **EP 2 523 450 A1**

(12) **EUROPEAN PATENT APPLICATION**

(43) Date of publication:
14.11.2012 Bulletin 2012/46

(51) Int Cl.:
H04N 5/225 (2006.01)

(21) Application number: 11165407.5

(22) Date of filing: 10.05.2011

(84) Designated Contracting States:
AL AT BE BG CH CY CZ DE DK EE ES FI FR GB
GR HR HU IE IS IT LI LT LU LV MC MK MT NL NO
PL PT RO RS SE SI SK SM TR
Designated Extension States:
BA ME

• **Chang, Wen-Chi**
Taoyuan City
Taoyuan County 330 (TW)

(71) Applicant: **HTC Corporation**
Taoyuan County 330 (TW)

(74) Representative: **2K Patentanwälte Blasberg
Kewitz & Reichel
Partnerschaft
Corneliusstraße 18
60325 Frankfurt a. M. (DE)**

(72) Inventors:
• **Huang, Chun-Hsiang**
Taoyuan City
Taoyuan County 330 (TW)

(54) **Handheld electronic device with dual image capturing method and computer program product**

(57) A handheld electrical device includes a first lens module with a first image capturing boundary, a second lens module with a second image capturing boundary, an input unit and a control unit. The first image capturing boundary is different from the second image capturing

boundary. The input unit receives a user input for capturing images. When the input unit receives the user input, the control unit controls the first lens module and the second lens module to respectively capture a first image and a second image at the same time.

100

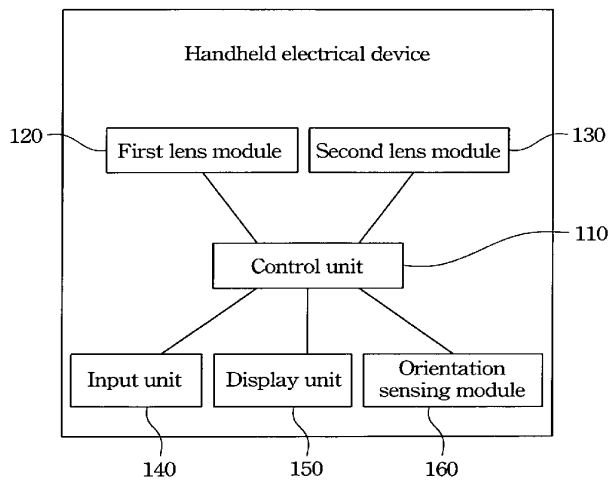

Fig. 2

EP 2 523 450 A1

Description**BACKGROUND**

Technical Field

[0001] The present invention relates to an electrical device, an image capturing method and a computer program product for loading into thereof. More particularly, the present invention relates to a handheld electrical device, a dual image capturing method and a computer program product for loading into thereof.

Description of Related Art

[0002] As 3C (Computer, Communications and Consumer) technology develops, there are more and more people utilizing handheld electrical devices in their daily life. Most common handheld electrical devices are personal digital assistants (PDA), mobile phones, smart phones etc. Since mobile electrical devices are designed much smaller and easy to carry, more and more people use handheld electrical device and more functions are developed for different users.

[0003] Nowadays, most handheld electrical devices are equipped with cameras. Wherein, images captured and output by such cameras are landscape images (or called landscape images). If users want images output vertically (as portrait images), the images must be reduced or cut since the width/length ratio of the portrait image and that of the landscape image are different. However, users may not be satisfied with the portrait images after reduce or cut. In particular, when the images captured are video, distortion of the portrait images (videos) thereof may be more obviously since the image may be further trans-coded, which may disturbs users.

SUMMARY

[0004] According to one embodiment of this invention, a handheld electrical device is provided. When a user wants to utilize the handheld electrical device to capture images, the handheld electrical device controls different lens modules, image capturing boundaries of which are different, to capture images with the different image capturing boundaries at the same time. The handheld electrical device includes a first lens module with a first image capturing boundary, a second lens module with a second image capturing boundary, an input unit and a control unit. The first lens module and the second lens module are disposed on the handheld electrical device respectively. Wherein, the first image capturing boundary and the second image capturing boundary are different. The input unit is configured to receive a user input for capturing images. When the input unit receives the user input, the control unit controls the first lens module and the second lens module to respectively capture a first image and a second image at the same time.

[0005] According to another embodiment of this invention, a dual image capturing method is provided. In the dual image capturing method, when a user wants to utilize a handheld electrical device to capture images, the handheld electrical device controls different lens modules, image capturing boundaries of which are different, to capture images with the different image capturing boundaries at the same time. The dual image capturing method is suitable for a handheld electrical device. The handheld electrical device includes a first lens module with a first image capturing boundary and a second lens module with a second image capturing boundary. Wherein, the first image capturing boundary and the second image capturing boundary are different. The dual image capturing method can be implemented as a computer program product, which includes at least one program instruction. The at least one program instruction of the computer program product is used for being loaded into the handheld electrical device. After the at least one program instruction of the computer program product is loaded into the handheld electrical device, the handheld electrical device executes the steps of the dual image capturing method. The dual image capturing method includes the following steps: a user input for capturing images is received. When the user input is received, a first image and a second image are captured at the same time by the first lens module and the second lens module respectively.

[0006] Above all, the handheld electrical device can capture images in different image capturing boundaries at the same time without moving the handheld electrical device. Hence, when capturing images occurring in a flash, images in different image capturing boundaries can be captured to avoid missing any of the boundaries. Besides, if the images captured by the handheld electrical device are videos, the user can switch between portrait images and landscape images without too much image distortion.

[0007] These and other features, aspects, and advantages of the present invention will become better understood with reference to the following description and appended claims. It is to be understood that both the foregoing general description and the following detailed description are by examples, and are intended to provide further explanation of the invention as claimed.

BRIEF DESCRIPTION OF THE DRAWINGS

[0008] The invention can be more fully understood by reading the following detailed description of the embodiments, with reference made to the accompanying drawings as follows:

Fig. 1 is a rear-view diagram of a handheld electrical device according to one embodiment of this invention;

Fig. 2 is a block diagram of the handheld electrical device in Fig. 1;

Fig. 3 illustrates a front-view diagram of the handheld electrical device in Fig. 1 in a portrait orientation; Fig. 4 illustrates a front-view diagram of the handheld electrical device in Fig. 1 in a landscape orientation; Fig. 5 illustrates an embodiment of the indication line displayed on the handheld electrical device 100 in Fig. 1; Fig. 6 illustrates another embodiment of the indication line displayed on the handheld electrical device 100 in Fig. 1; Fig. 7 illustrates an embodiment of the miniature displayed on the handheld electrical device 100 in Fig. 1; Fig. 8 illustrates another embodiment of the miniature displayed on the handheld electrical device 100 in Fig. 1; and Fig. 9 is a flow diagram of a dual image capturing method according to one embodiment of this invention.

DETAILED DESCRIPTION

[0009] Reference will now be made in detail to the present embodiments of the invention, examples of which are illustrated in the accompanying drawings. Wherever possible, the same reference numbers are used in the drawings and the description to refer to the same or like parts.

[0010] Fig. 1 is a rear-view diagram of a handheld electrical device according to one embodiment of this invention. Fig. 2 is a block diagram of the handheld electrical device in Fig. 1. When a user wants to utilize the handheld electrical device to capture images, the handheld electrical device controls different lens modules, image capturing boundaries of which are different, to capture images with the different image capturing boundaries at the same time.

[0011] The handheld electrical device 100 includes a control unit 110, a first lens module 120, a second lens module 130, and an input unit 140. The first lens module 120 and the second lens module 130 are disposed on the handheld electrical device 100 respectively. The first lens module 120, the second lens module 130, and the input unit 140 are electrically connected to the control unit 110. The input unit 140 may be at least one button, a keyboard, a graphical user interface (GUI) or other types of input units.

[0012] The first lens module 120 can capture scenes with a first image capturing boundary. The second lens module 130 can capture scenes with a second image capturing boundary. Wherein, the first image capturing boundary and the second image capturing boundary are different. The input unit 140 is configured to receive a user input for capturing images. When the input unit 140 receives the user input, the control unit 110 controls the first lens module 120 and the second lens module 130 to respectively capture a first image and a second image at the same time. Wherein, the first image and the second

image may include pictures, videos or other types of image. Therefore, the handheld electrical device 100 can capture images in different image capturing boundaries at the same time without moving the handheld electrical device 100. Hence, when capturing images occurring in a flash, images in different image capturing boundaries can be captured to avoid missing any of the boundaries.

[0013] In one embodiment of this invention, the first image captured by the first lens module 120 is a portrait image (captured in a portrait mode), and the second image captured by the second lens module 130 is a landscape image (captured in a landscape mode). Hence, the disposed orientation of the first lens module 120 is substantially vertical to that of the second lens module 130. Therefore, the first image (portrait image) captured by the first lens module 120 may be substantially vertical to the second image (landscape image) captured by the second lens module 130. In other words, a portrait image and a landscape image can be captured at the same time without moving the handheld electrical device 100. In addition, when the user selects a video mode of a traditional handheld electrical device, the user can only take a landscape video. If the user wants to view the landscape video on a portrait screen, the user has to wait a long time for image trans-coding. In other words, during the trans-coding, the original coded landscape video must be decoded before encoding to a portrait video. Since the image trans-coding takes a long time, the user can't view the landscape images immediately. Besides, since the landscape images are coded twice, the landscape images may be distorted, which may lead to worse image quality. If the present invention is applied, the user can switch between portrait images and landscape images without too much image distortion.

[0014] Besides, the handheld electrical device 100 can display image captured by different lens modules with different image capturing boundaries corresponding to the orientation (such as portrait orientation or landscape orientation) of the handheld electrical device 100. Hence, the handheld electrical device 100 may further include a display unit 150 and an orientation sensing module 160. The orientation sensing module 160 is configured to sense an orientation of the handheld electrical device. Wherein, the orientation sensing module 160 may be a g sensor or any other element which can sense the orientation of the handheld electrical device 100. Hence, when the handheld electrical device 100 is in a photograph mode, the handheld electrical device 100 can control the display unit 150 to display images captured by different lens modules with different image capturing boundaries corresponding to the orientation of the handheld electrical device 100. Wherein, when the orientation sensing module 160 senses that the handheld electrical device 100 is in a first orientation, the control unit 110 controls the display unit 150 to display a scene captured by the first lens module 120 with the first image capturing boundary; when the orientation sensing module 160 senses that the handheld electrical device 100 is in a

second orientation, the control unit 110 controls the display unit 150 to display another scene captured by the second lens module 130 with the second image capturing boundary. Wherein, the first orientation and the second orientation are different. Hence, when the handheld electrical device 100 is in the photograph mode, the handheld electrical device 100 can control its display unit 150 to display scenes captured by different lens modules with different image capturing boundaries in real time corresponding to the orientation of the handheld electrical device 100. In other words, when the handheld electrical device 100 is in the photograph mode, the user can change the orientation of the handheld electrical device 100 to control the handheld electrical device 100 to display scenes captured with different image capturing boundaries.

[0015] Fig. 3 illustrates a front-view diagram of the handheld electrical device in Fig. 1 in a portrait orientation. Fig. 4 illustrates a front-view diagram of the handheld electrical device in Fig. 1 in a landscape orientation. In one embodiment of this invention, the first orientation of the handheld electrical device 100 may be a portrait orientation, and the second orientation of the handheld electrical device 100 may be a landscape orientation. Hence, when the orientation sensing module 160 senses that the handheld electrical device 100 is in the portrait orientation, the control unit 110 controls the display unit 150 to display the portrait image captured by the first lens module 120 with the first image capturing boundary (as shown in Fig. 3). When the orientation sensing module 160 senses that the handheld electrical device 100 is in the landscape orientation, the control unit 110 controls the display unit 150 to display the landscape image captured by the second lens module 130 with the second image capturing boundary (as shown in Fig. 4). In other embodiments, the first orientation and the second orientation are not limited to the portrait orientation and the landscape orientation in this disclosure. Therefore, when the handheld electrical device 100 is in the photograph mode, the user can put the handheld electrical device 100 in the portrait or landscape orientation to display the portrait or landscape image correspondingly for user's convenience. Besides, the portrait image being displayed horizontally or the landscape image being displayed vertically on the display unit 150, which may waste the display area of the display unit 150, can be avoided.

[0016] When the handheld electrical device 100 displays images captured by one of the lens modules, at least one indication line to indicate the boundary of the other lens module can be displayed on the displayed images. Hence, when the handheld electrical device 100 is in the photograph mode and the orientation sensing module 160 senses that the handheld electrical device 100 is in the first orientation, the control unit 110 controls the display unit 150 to display a scene captured by the first lens module 120 with the first image capturing boundary, and to further display one or more first indication lines on the displayed scenes. Wherein the one or more

first indication lines indicate the position that the second image capturing boundary captured by the second lens module 130 corresponds to the first image capturing boundary. In one embodiment of this invention, the first indication line may be a fixed position on the displayed first image capturing boundary. In another embodiment of this invention, the position of the first indication line can be obtained by comparing the scenes captured with the first image capturing boundary with that with the second image capturing boundary. However, the corresponding position of the first indication line can be obtained utilizing other methods, which should not be limited in this disclosure.

[0017] Besides, when the handheld electrical device 100 is in the photograph mode and the orientation sensing module 160 senses that the orientation of the handheld electrical device 100 is in the second orientation, the control unit 110 controls the display unit 150 to display a scene captured by the second lens module 130 with the second image capturing boundary, and to further display one or more second indication lines on the displayed scenes to indicate the first image capturing boundary captured by the first lens module 120. Therefore, when the handheld electrical device 100 displays images captured by one of the lens modules, at least one indication line to indicate the boundary of the other lens module can be displayed on the displayed images, which can help users understand the boundary captured by the other lens module.

[0018] Fig. 5 illustrates an embodiment of the indication line displayed on the handheld electrical device 100 in Fig. 1. Fig. 6 illustrates another embodiment of the indication line displayed on the handheld electrical device 100 in Fig. 1. For example, the first orientation of the handheld electrical device 100 may be a portrait orientation, and the second orientation of the handheld electrical device 100 may be a landscape orientation. Hence, when the handheld electrical device 100 is in the photograph mode and the orientation sensing module 160 senses that the handheld electrical device 100 is in the portrait orientation, the control unit 110 controls the display unit 150 to display the portrait image 201 captured by the first lens module 120 with the first image capturing boundary, and to further display a first indication line 201a (as shown in Fig. 5) on the displayed first image 201. Wherein the first indication line 201a indicate the position that the second image capturing boundary captured by the second lens module 130 corresponds to the first image capturing boundary. Besides, when the orientation sensing module 160 senses that the handheld electrical device 100 is in the landscape orientation, the control unit 110 controls the display unit 150 to display the landscape image 202 captured by the second lens module 130 with the second image capturing boundary, and to further display one second indication line 202a on the displayed scenes (as shown in Fig. 6) to indicate the first image capturing boundary captured by the first lens module 120. Therefore, when photographing portrait images,

the corresponding landscape images can be indicated; when photographing landscape images, the corresponding portrait images can be indicated, which can assist users during photographing. In other embodiments, more indication lines can be further displayed, which should not be limited in this disclosure.

[0019] When the handheld electrical device 100 displays images captured by one of the lens modules, a miniature captured by the other lens module can be further displayed. Hence, when the handheld electrical device 100 is in the photograph mode and the orientation sensing module 160 senses that the handheld electrical device is in the first orientation, the control unit 110 controls the display unit 150 to further display a first miniature captured with the second image capturing boundary. When the handheld electrical device 100 is in the photograph mode and the orientation sensing module senses that the handheld electrical device 100 is in the second orientation, the control unit 110 controls the display unit 150 to further display a second miniature captured with the first image capturing boundary. Therefore, when the handheld electrical device 100 displays images captured by one of the lens modules, users can reach the miniature captured by the other lens module with the other image capturing boundary.

[0020] Fig. 7 illustrates an embodiment of the miniature displayed on the handheld electrical device 100 in Fig. 1. Fig. 8 illustrates another embodiment of the miniature displayed on the handheld electrical device 100 in Fig. 1. For example, the first orientation of the handheld electrical device 100 may be a portrait orientation, and the second orientation of the handheld electrical device 100 may be a landscape orientation. Hence, when the handheld electrical device 100 is in the photograph mode and the orientation sensing module 160 senses that the handheld electrical device is in the portrait orientation, the control unit 110 controls the display unit 150 to display the portrait image 301 captured by the first lens module 120 with the first image capturing boundary, and to further display a first miniature 301a of the landscape image captured with the second image capturing boundary (as shown in Fig. 7). When the handheld electrical device 100 is in the photograph mode and the orientation sensing module 160 senses that the handheld electrical device is in the landscape orientation, the control unit 110 controls the display unit 150 to display the landscape image 302 captured by the first lens module 130 with the second image capturing boundary, and to further display a second miniature 302a of the portrait image captured with the first image capturing boundary (as shown in Fig. 8).

[0021] When the handheld electrical device 100 is in a browsing mode, the handheld electrical device 100 can display images corresponding to its orientation. Hence, when the handheld electrical device 100 is in a browsing mode and the orientation sensing module 160 senses that the handheld electrical device 100 is in the first orientation, the control unit 110 controls the display unit 150

to display the first image. When the handheld electrical device 100 is in the browsing mode and the orientation sensing module 160 senses that the handheld electrical device 100 is in the second orientation, the control unit 110 controls the display unit 150 to display the second image. Hence, when the handheld electrical device 100 is in the browsing mode, the handheld electrical device 100 can control its display unit 150 to display images captured with different image capturing boundaries corresponding to the orientation of the handheld electrical device 100. In other words, when the handheld electrical device 100 is in the browsing mode, the user can change the orientation of the handheld electrical device 100 to control the handheld electrical device 100 to display images captured with different image capturing boundaries for browsing, which is convenient to users for operation.

[0022] In addition, the handheld electrical device 100 can set the first image capturing boundary and the second image capturing boundary according to the interesting characteristics set by the user. Hence, the control unit 110 can receive an interesting characteristic through the input unit 140. The control unit 110 determines the first image capturing boundary and the second image capturing boundary automatically according to the interesting characteristic. Then, the first lens module 120 can capture the first image with the interesting characteristic according to the first image capturing boundary; the second lens module 130 can capture the second image with the interesting characteristic according to the second image capturing boundary. Wherein, the interesting characteristic may be a human facial feature, smiling feature etc.. Therefore, the interesting characteristic, which interests user, can always captured in the image.

[0023] Fig. 9 is a flow diagram of a dual image capturing method according to one embodiment of this invention. In the dual image capturing method, when a user wants to utilize a handheld electrical device to capture images, the handheld electrical device controls different lens modules, image capturing boundaries of which are different, to capture images with the different image capturing boundaries at the same time. The dual image capturing method is suitable for a handheld electrical device. The handheld electrical device includes a first lens module with a first image capturing boundary and a second lens module with a second image capturing boundary. Wherein, the first image capturing boundary and the second image capturing boundary are different. The dual image capturing method can be implemented as a computer program product, which includes at least one program instruction. The at least one program instruction of the computer program product is used for being loaded into the handheld electrical device. After the at least one program instruction of the computer program product is loaded into the handheld electrical device, the handheld electrical device executes the steps of the dual image capturing method. The computer program product can be stored in a handheld-electrical-device readable storage medium. Any suitable storage medium may be used

including nonvolatile memory such as read only memory (ROM), programmable read only memory (PROM), erasable programmable read only memory (EPROM), and electrically erasable programmable read only memory (EEPROM) devices; volatile memory such as SRAM, DRAM, and DDR-RAM; optical storage devices such as CD-ROMs and DVD-ROMs; and magnetic storage devices such as hard disk drives and floppy disk drives.

[0024] The dual image capturing method 400 includes the following steps:

[0025] In step 410, a user input for capturing images is received.

[0026] In step 420, when the user input is received (step 410), a first image and a second image are captured at the same time by the first lens module and the second lens module respectively. Wherein, the first image is the one captured by the first lens module with the first image capturing boundary, and the second image is the one captured by the second lens module with the second image capturing boundary. The first image and the second image may include pictures, videos or other types of image. Therefore, the handheld electrical device can capture images with different image capturing boundaries at the same time without moving the handheld electrical device.

[0027] In one embodiment of step 420, the first image, which is captured by the first lens module with the first image capturing boundary, may be a portrait image (captured in a portrait mode), and the second image, which is captured by the second lens module with the second image capturing boundary, may be a landscape image (captured in a landscape mode). Therefore, a portrait image and a landscape image can be captured at the same time without moving the handheld electrical device. In addition, when the user selects a video mode of a traditional handheld electrical device, the user can only take a landscape video. If the user wants to view the landscape video on a portrait screen, the user has to wait a long time for image trans-coding. In other words, during the trans-coding, the original coded landscape video must be decoded before encoding to a portrait video. Since the image trans-coding takes a long time, the user can't view the landscape images immediately. Besides, since the landscape images are coded twice, the landscape images may be distorted, which may lead to worse image quality. If the present invention is applied, the user can switch between portrait images and landscape images without too much image distortion.

[0028] Besides, the handheld electrical device can display image captured by different lens modules with different image capturing boundaries corresponding to the orientation (such as portrait orientation or landscape orientation) of the handheld electrical device. Hence, in step 430, an orientation of the handheld electrical device may be sensed. Wherein, the orientation of the handheld electrical device may be sensed (step 430) utilizing a g sensor or any other element which can do orientation sensing.

[0029] In step 440, when the handheld electrical device

is in a first orientation and the handheld electrical device is in a photograph mode, the handheld electrical device displays a scene captured by the first lens module with the first image capturing boundary.

[0030] In step 450, when the handheld electrical device is in a second orientation and the handheld electrical device is in a photograph mode, the handheld electrical device displays another scene captured by the second lens module with the second image capturing boundary.

Wherein, the first orientation and the second orientation are different. Hence, when the handheld electrical device is in the photograph mode, the handheld electrical device can display scenes captured by different lens modules with different image capturing boundaries in real time corresponding to the orientation of the handheld electrical device. Besides, the first orientation of the handheld electrical device may be a portrait orientation, the second orientation of the handheld electrical device may be a landscape orientation, the first image corresponding to the first orientation (portrait orientation) is a portrait image, and the second image corresponding to the second orientation (landscape orientation) is a landscape image. Therefore, when the handheld electrical device is in the photograph mode, the user can put the handheld electrical device in the portrait or landscape orientation correspondingly for user's convenience. Besides, the portrait image being displayed horizontally or the landscape image being displayed vertically on the display unit of the handheld electrical device, which may waste the display area of the handheld electrical device, can be avoided.

[0031] When the handheld electrical device displays images captured by one of the lens modules, at least one indication line to indicate the boundary of the other lens module can be displayed on the displayed images. Hence, when the handheld electrical device is in the photograph mode and the handheld electrical device is in the first orientation, the handheld electrical device can further display one or more first indication lines on the displayed scenes on the displayed images in step 440.

Wherein the one or more first indication lines indicate the position that the second image capturing boundary captured by the second lens module corresponds to the first image capturing boundary. Besides, when the handheld electrical device is in the photograph mode and the handheld electrical device is in the second orientation, the handheld electrical device further displays one or more second indication lines on the displayed images in step 450. Wherein the one or more second indication lines indicate the position that the first image capturing boundary captured by the first lens module corresponds to the second image capturing boundary. Therefore, when the handheld electrical device displays images captured by one of the lens modules, at least one indication line to indicate the corresponding boundary of the other lens module can be displayed on the displayed images, which can help users understand the boundary captured by the other lens module.

[0032] When the handheld electrical device displays

images captured by one of the lens modules, a miniature captured by the other lens module can be further displayed. Hence, when the handheld electrical device is in the photograph mode and the handheld electrical device is in the first orientation, the handheld electrical device may further display a first miniature captured with the second image capturing boundary on the images displayed in step 440. When the handheld electrical device is in the photograph mode and the handheld electrical device is in the second orientation, the handheld electrical device may further display a second miniature captured with the first image capturing boundary on the images displayed in step 450. Therefore, when the handheld electrical device displays images captured by one of the lens modules, users can reach the miniature captured by the other lens module in the other image capturing boundary.

[0033] When the handheld electrical device is in a browsing mode, the handheld electrical device can display images corresponding to its orientation. Hence, when the handheld electrical device is in the first orientation and the handheld electrical device is in the browsing mode, the handheld electrical device displays the first image captured by the first lens module. Besides, when the handheld electrical device is in the second orientation and the handheld electrical device is in the browsing mode, the handheld electrical device displays the second image captured by the second lens module. Hence, when the handheld electrical device is in the browsing mode, the handheld electrical device can display images captured with different image capturing boundaries corresponding to the orientation of the handheld electrical device.

[0034] In addition, the handheld electrical device can set the first image capturing boundary and the second image capturing boundary, which are taken as the factor to execute step 420, according to the interesting characteristics set by the user. Hence, the dual image capturing method 400 may further includes the following steps: an interesting characteristic is received. The first image capturing boundary and the second image capturing boundary are determined automatically according to the interesting characteristic, such that the image with the interesting characteristic can be captured. Wherein, the interesting characteristic may be a human facial feature, smiling feature etc.. Hence, in step 420, the first image and the second image are captured at the same time by the first lens module and the second lens module according to the first image capturing boundary and the second image capturing boundary respectively. Therefore, the interesting characteristic, which interests user, can always captured in the image.

[0035] Above all, the handheld electrical device can capture images with different image capturing boundaries at the same time without moving the handheld electrical device. Hence, when capturing images occurring in a flash, images in different image capturing boundaries can be captured to avoid missing any of the boundaries.

Besides, if the images captured by the handheld electrical device are videos, the user can switch between portrait images and landscape images without too much image distortion.

[0036] Although the present invention has been described in considerable detail with reference to certain embodiments thereof, other embodiments are possible. Therefore, the spirit and scope of the appended claims should not be limited to the description of the embodiments contained herein. It will be apparent to those skilled in the art that various modifications and variations can be made to the structure of the present invention without departing from the scope or spirit of the invention. In view of the foregoing, it is intended that the present invention cover modifications and variations of this invention provided they fall within the scope of the following claims.

Claims

1. A handheld electrical device comprising:

a first lens module with a first image capturing boundary, disposed on the handheld electrical device ;

a second lens module with a second image capturing boundary, disposed on the handheld electrical device, wherewith the first image capturing boundary and the second image capturing boundary are different;

an input unit, configured to receive a user input for capturing images; and

a control unit, configured to control the first lens module and the second lens module to respectively capture a first image and a second image at the same time when the input unit receives the user input.

2. The handheld electrical device of claim 1, wherein the first image is a portrait image, the second image is a landscape image, and the disposed orientation of the first lens module is substantially vertical to that of the second lens module.

3. The handheld electrical device of claim 1 further comprising:

a display unit;

an orientation sensing module, configured to sense an orientation of the handheld electrical device; and

wherein when the handheld electrical device is in a photograph mode:

when the orientation sensing module senses that the handheld electrical device is in a first orientation, the control unit controls the display unit to display a scene captured

by the first lens module with the first image capturing boundary; and
 when the orientation sensing module senses that the handheld electrical device is in a second orientation, the control unit controls the display unit to display another scene captured by the second lens module with the second image capturing boundary.

- 4. The handheld electrical device of claim 3, wherein:

when the handheld electrical device is in the photograph mode and the orientation sensing module senses that the handheld electrical device is in the first orientation, the control unit controls the display unit to further display one or more first indication lines to indicate the second image capturing boundary; and
 when the handheld electrical device is in the photograph mode and the orientation sensing module senses that the handheld electrical device is in the second orientation, the control unit controls the display unit to further display one or more second indication lines to indicate the first image capturing boundary.

- 5. The handheld electrical device of claim 3, wherein:

when the handheld electrical device is in the photograph mode and the orientation sensing module senses that the handheld electrical device is in the first orientation, the control unit controls the display unit to further display a first miniature captured by the second lens module with the second image capturing boundary; and
 when the handheld electrical device is in the photograph mode and the orientation sensing module senses that the handheld electrical device is in the second orientation, the control unit controls the display unit to further display a second miniature captured by the first lens module with the first image capturing boundary.

- 6. The handheld electrical device of claim 1 further comprising:

when the handheld electrical device is in a browsing mode and a orientation sensing module of the handheld electrical device senses that the handheld electrical device is in a first orientation, the control unit controls a display unit of the handheld electrical device to display the first image; and
 when the handheld electrical device is in the browsing mode and the orientation sensing module senses that the handheld electrical device is in a second orientation, the control unit controls the display unit to display the second

image.

- 7. The handheld electrical device of claim 1, wherein the first image and the second image include pictures and/or videos.

- 8. A dual image capturing method for a handheld electrical device, wherein the handheld electrical device comprises a first lens module with a first image capturing boundary and a second lens module with a second image capturing boundary, wherewith the first image capturing boundary is different from the second image capturing boundary, the method comprises:

receiving a user input for capturing images; and capturing a first image and a second image at the same time by the first lens module and the second lens module respectively when the user input is received.

- 9. The method of claim 8, wherein the first image is a portrait image, and the second image is a landscape image.

- 10. The method of claim 8 further comprising:

sensing an orientation of the handheld electrical device; and
 when the handheld electrical device is in a photograph mode:

when handheld electrical device is in a first orientation, making the handheld electrical device display a scene captured by the first lens module with the first image capturing boundary; and
 when the handheld electrical device is in a second orientation, making the handheld electrical device display another scene captured by the second lens module with the second image capturing boundary.

- 11. The method of claim 10 further comprising:

when the handheld electrical device is in the photograph mode and the handheld electrical device is in the first orientation, further displaying one or more first indication lines to indicate the second image capturing boundary; and
 when the handheld electrical device is in the photograph mode and the handheld electrical device is in the second orientation, further displaying one or more second indication lines to indicate the first image capturing boundary.

- 12. The method of claim 10 further comprising:

when the handheld electrical device is in the photograph mode and the handheld electrical device is in the first orientation, further displaying a first miniature captured by the second lens module with the second image capturing boundary; and

5

when the handheld electrical device is in the photograph mode and the handheld electrical device is in the second orientation, further displaying a second miniature captured by the first lens module with the first image capturing boundary.

10

- 13. The method of claim 8 further comprising:

15

when the handheld electrical device is in a browsing mode and the handheld electrical device is in a first orientation, displaying the first image; and

when the handheld electrical device is in the browsing mode and the handheld electrical device is in a second orientation, displaying the second image.

20

- 14. The method of claim 8, wherein the first image and the second image include pictures and/or videos.

25

- 15. A computer program product comprising at least one program instruction for being loaded into a handheld electrical device, wherein the handheld electrical device comprises a first lens module with a first image capturing boundary and a second lens module with a second image capturing boundary, wherewith the first image capturing boundary is different from the second image capturing boundary, wherein the at least one program instruction executes at least following steps after loading into the handheld electrical device:

30

35

receiving a user input for capturing images; and capturing a first image and a second image at the same time by the first lens module and the second lens module respectively when the user input is received.

40

45

50

55

100

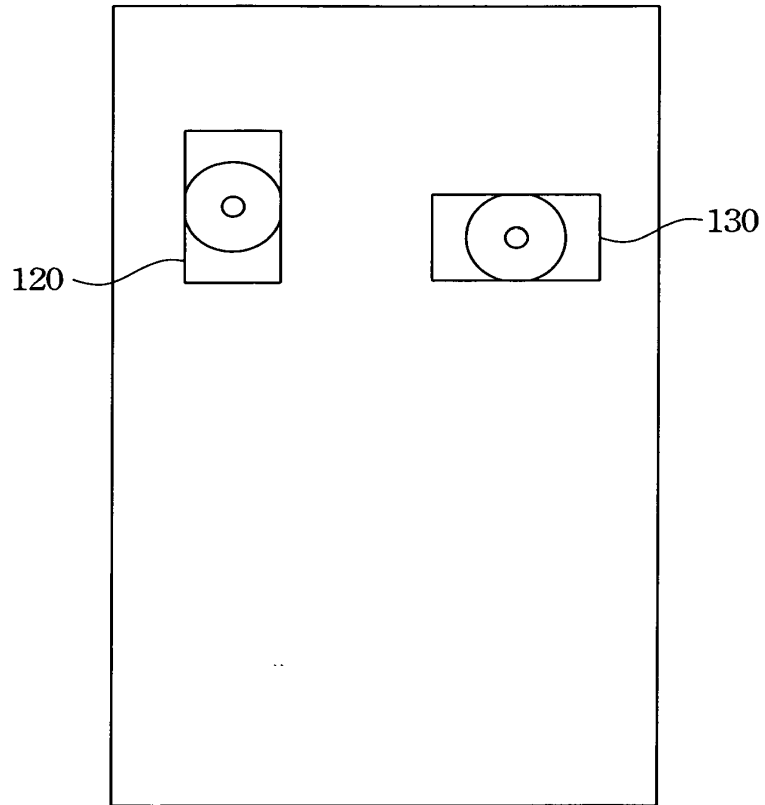

Fig. 1

100

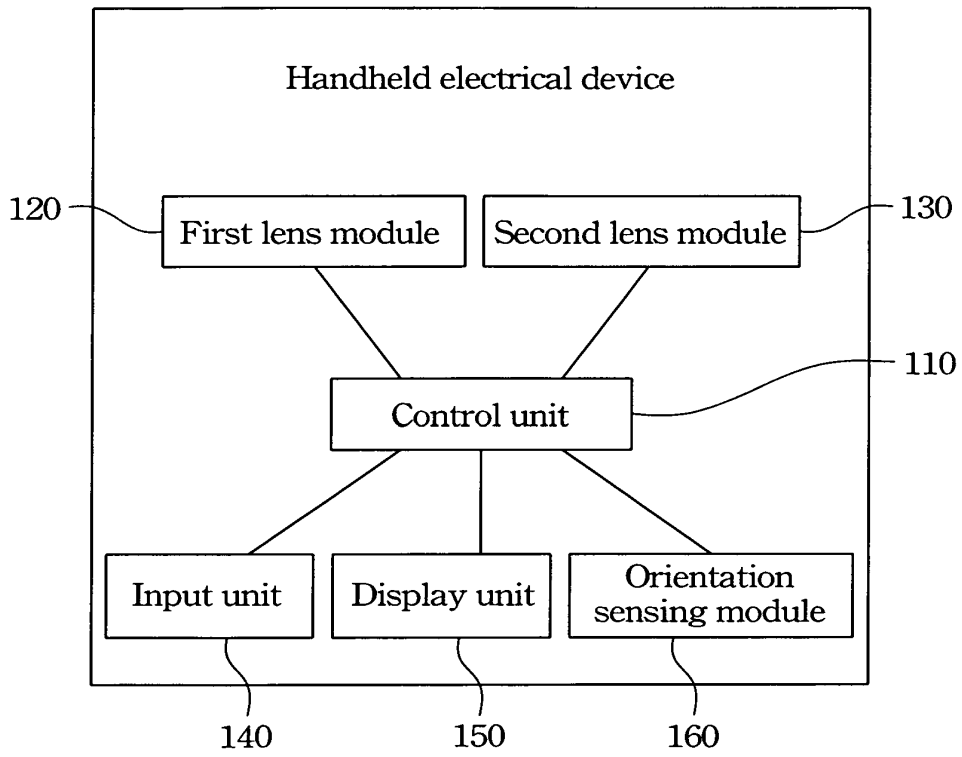

Fig. 2

100

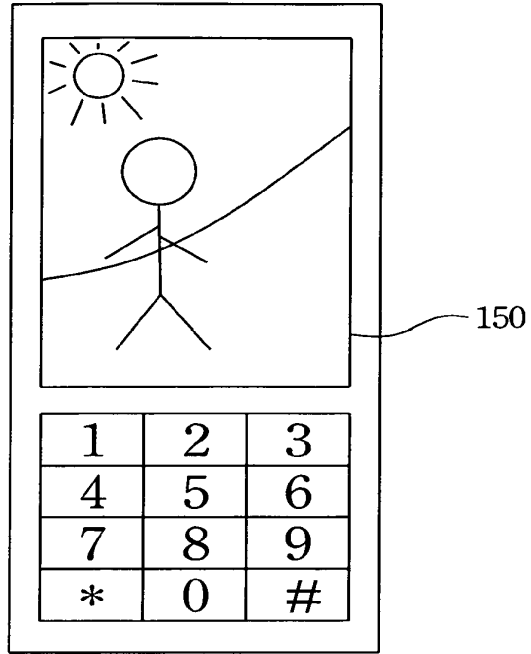

Fig. 3

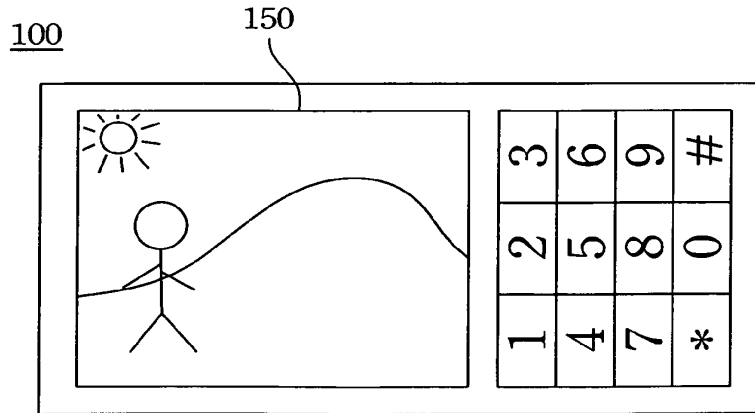

Fig. 4

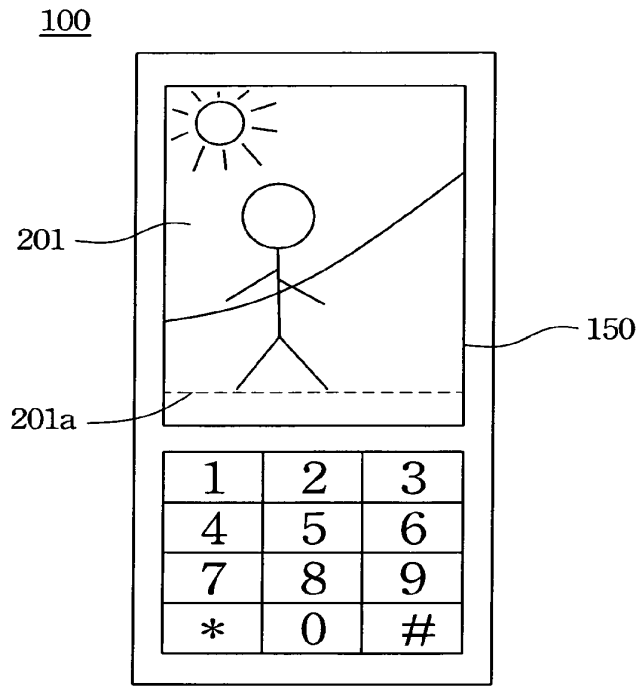

Fig. 5

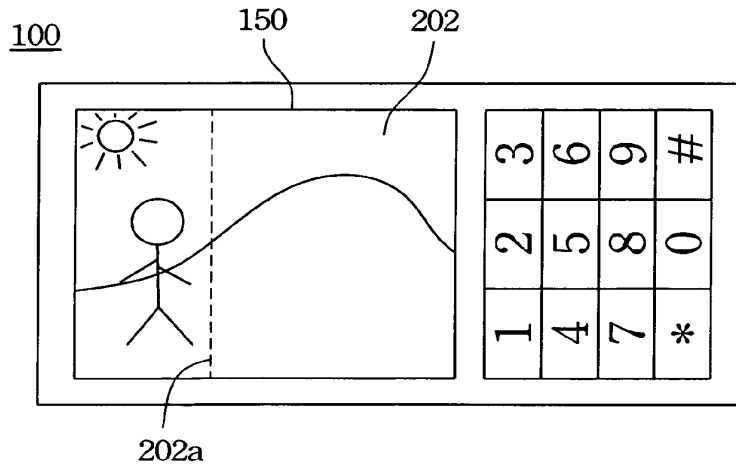

Fig. 6

100

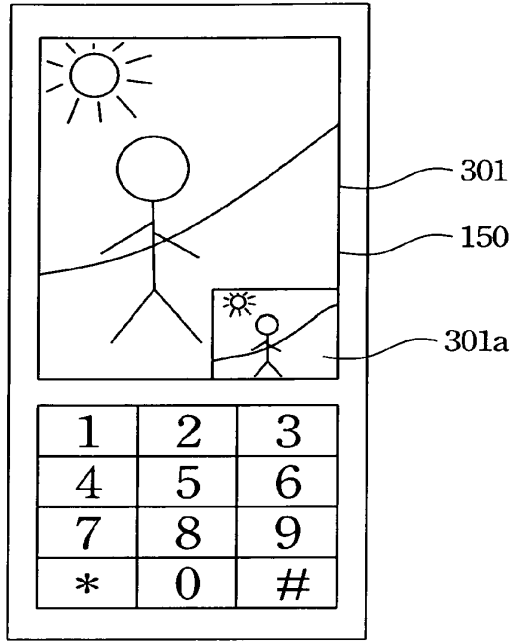

Fig. 7

100

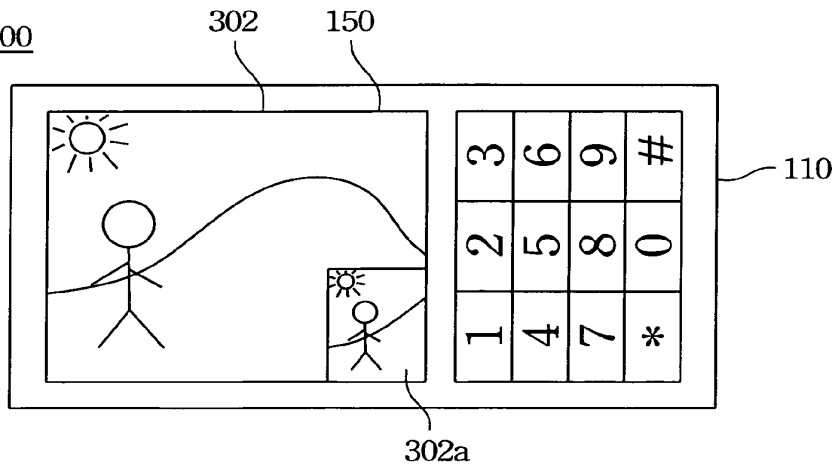

Fig. 8

400

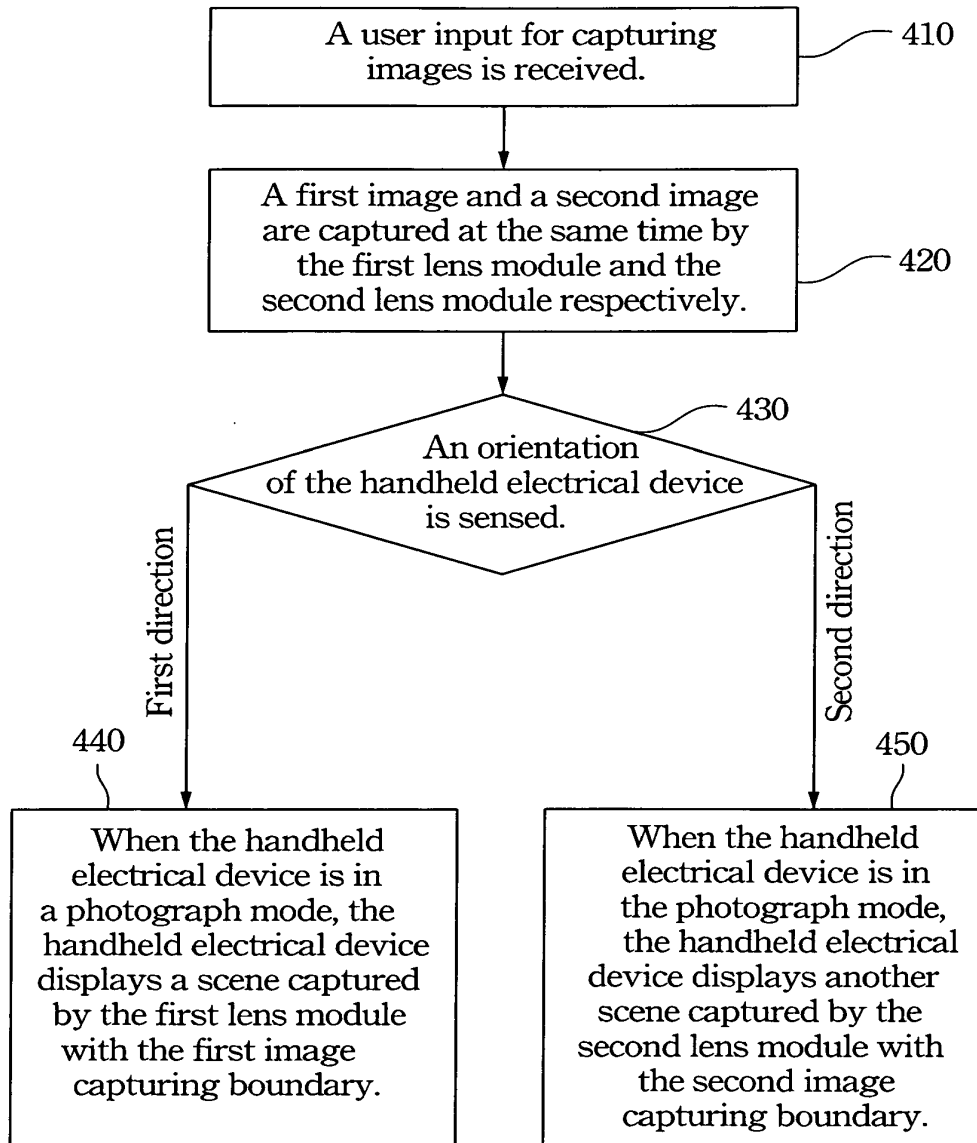

Fig. 9



EUROPEAN SEARCH REPORT

Application Number
EP 11 16 5407

DOCUMENTS CONSIDERED TO BE RELEVANT			
Category	Citation of document with indication, where appropriate, of relevant passages	Relevant to claim	CLASSIFICATION OF THE APPLICATION (IPC)
X	US 2007/285550 A1 (SON JAE-GON [KR]) 13 December 2007 (2007-12-13)	1,7,8, 14,15	INV. H04N5/225
Y	* abstract; claims 1-5; figures 1,2 *	3-6, 10-13	
Y	----- US 2011/045812 A1 (KIM HO-SOO [KR] ET AL) 24 February 2011 (2011-02-24) * abstract; claims 11,21; figures 26-31 * * paragraphs [0007], [0011], [0148] - paragraph [0165] *	3-6, 10-13	
X	----- EP 1 763 243 A2 (LG ELECTRONICS INC [KR]) 14 March 2007 (2007-03-14)	1,7,8, 14,15	
Y	* abstract; figures 3,11, 14 * * paragraph [0037] - paragraph [0043] *	3-6, 10-13	
X	----- EP 1 560 421 A1 (MATSUSHITA ELECTRIC IND CO LTD [JP] PANASONIC CORP [JP]) 3 August 2005 (2005-08-03)	1,7,8, 14,15	
Y	* abstract; figures 2-4 *	3-6, 10-13	TECHNICAL FIELDS SEARCHED (IPC)
X	----- WO 01/31893 A1 (NOKIA MOBILE PHONES LTD [FI]; HAERMAE ESA [FI]) 3 May 2001 (2001-05-03)	1,7,8, 14,15	H04N H04M G06F
Y	* abstract; figure 2 *	3-6, 10-13	
X	----- EP 1 566 974 A1 (SANYO ELECTRIC CO [JP]) 24 August 2005 (2005-08-24)	1,7,8, 14,15	
Y	* abstract; figures 1a-b *	3-6, 10-13	
A	----- US 2010/238327 A1 (GRIFFITH JOHN D [US] ET AL) 23 September 2010 (2010-09-23) * the whole document *	1-15	
The present search report has been drawn up for all claims			
Place of search Munich		Date of completion of the search 8 August 2011	Examiner Katruff, Martin
CATEGORY OF CITED DOCUMENTS X : particularly relevant if taken alone Y : particularly relevant if combined with another document of the same category A : technological background O : non-written disclosure P : intermediate document T : theory or principle underlying the invention E : earlier patent document, but published on, or after the filing date D : document cited in the application L : document cited for other reasons & : member of the same patent family, corresponding document			

3
EPO FORM 1503 (03/02) (P/04/001)

**ANNEX TO THE EUROPEAN SEARCH REPORT
ON EUROPEAN PATENT APPLICATION NO.**

EP 11 16 5407

This annex lists the patent family members relating to the patent documents cited in the above-mentioned European search report. The members are as contained in the European Patent Office EDP file on The European Patent Office is in no way liable for these particulars which are merely given for the purpose of information.

08-08-2011

Patent document cited in search report	Publication date	Patent family member(s)	Publication date
US 2007285550 A1	13-12-2007	CN 101090442 A	19-12-2007
US 2011045812 A1	24-02-2011	KR 20110020082 A	02-03-2011
EP 1763243 A2	14-03-2007	JP 2007082223 A US 2007057866 A1	29-03-2007 15-03-2007
EP 1560421 A1	03-08-2005	AU 2003301611 A1 CN 1708979 A WO 2004039065 A1 JP 3948387 B2 JP 2004147046 A KR 20050062633 A US 2006044396 A1	13-05-2004 14-12-2005 06-05-2004 25-07-2007 20-05-2004 23-06-2005 02-03-2006
WO 0131893 A1	03-05-2001	AU 1148001 A EP 1232633 A1 FI 992309 A	08-05-2001 21-08-2002 27-04-2001
EP 1566974 A1	24-08-2005	CN 1685741 A WO 2004030374 A1 JP 3989348 B2 JP 2004120611 A KR 20050059187 A US 2006170785 A1	19-10-2005 08-04-2004 10-10-2007 15-04-2004 17-06-2005 03-08-2006
US 2010238327 A1	23-09-2010	WO 2010108119 A2	23-09-2010

EPO FORM P0459

For more details about this annex : see Official Journal of the European Patent Office, No. 12/82

Apparatus and method for realizing multi-resolutions image acquisition with multi-focusing video camera

Abstract

A device and a method for using a multi-focusing camera to realize collection of multi-resolution images are disclosed, comprising five focusing cameras having restraining relationship with others, wherein four of them are located at the same horizontal plane and on four top points of the same square, and the four cameras have the identical focus which is set as f_1 ; the rest 1 camera is located in the direction of the four cameras, axes line of the camera is perpendicular to the surfaces of four cameras and passes a central point O of the square, and the distance from the fifth camera to the rest four cameras is d , the focus of the camera is set as f_2 , and initial setting is performed to the parameters and locations of the five focusing cameras with the location relationship satisfying the following restraint: $f_2 = f_1 + d$. The invention achieves the function of lossless zooming film of the multi-focusing camera with adjustable details of scenes and images, and with flexible and controllable structure, the invention can rapidly collect the multi-resolution images in the large visual scene.

CN101276415A
CN Application

[Download PDF](#) [Find Prior Art](#) [Similar](#)

Other languages: Chinese

Inventor: Wei Wu, Zhong Zhou, Zhang Shupin, Xu Zhao, Zhao Yuping

Original Assignee: Beijing Aerospace University

Priority date : 2008-03-03

Family: CN (1)

Date	App./Pub Number	Status
2008-03-03	CN 200810101241	
2008-10-01	CN101276415A	Application

Abstract

PROBLEM TO BE SOLVED: To provide a thin camera module that can selectively obtain images of different magnifications, and is suitable to portable equipment.

SOLUTION: The camera module comprises a plurality of lens units 21, 22 having different focal lengths, image sensor chips 25a and 25b which process imaging signals based upon light made incident through the lens units, and a selecting means of selecting the light made incident through the plurality of lens units and imaging signals based upon the light. This selecting means is operative to select light made incident through one of the plurality of lens units or an imaging signal based upon the light.

COPYRIGHT (C) 2008, JPO & INPIT

JP2007306282A

JP Application



Download PDF



Find Prior Art



Similar

Other languages: Japanese

Inventor: Yasuaki Koyama, Aizhao

Original Assignee: Citizen Electronics Co Ltd, Citizen Electronics Co., Ltd.

Priority date: 2006-05-11

Family: JP (1)

Date	App/Pub Number	Status
2006-05-11	JP2006132321A	Pending
2007-11-22	JP2007306282A	Application

Digital camera

Abstract

PROBLEM TO BE SOLVED: To provide a digital camera provided with a plurality of photographing optical systems and imaging elements for realizing high magnification zooming without interruption and upsizing.

SOLUTION: The digital camera has two kinds of modes comprising: a high image quality mode for processing an image obtained by composing high quality image information with a small field angle and possible for optical zooming obtained by a combination of a first CCD 30 with a small size and high pixel density, a first imaging lens 12 with a short focal length, a second CCD 32 with a large size and low pixel density, and a second imaging lens 14 with a long focal length and slightly lower quality image information with a large field angle by an image interpolation means; and a high magnification mode for processing an image obtained by composing high quality image information with a minimum field angle obtained by a combination of the first CCD 30 and the second imaging lens 14, and the second CCD 32 and the first imaging lens 12 and low quality image information with a large field angle by the image interpolation means 38. Each mode can be selected by selecting an optical path from each lens to each CCD to change the combination of the lenses and the CCDs.

COPYRIGHT. (C)2004, JPO



Other languages: Japanese

Inventor: Mitohumi Misawa, Michitaka Nakazawa, 苑史 三沢 通隆 中沢

Original Assignee: Fuji Photo Film Co Ltd, 富士写真フイルム株式会社

Priority date: 2002-03-29

Family: JP (1)

Date	App/Pub Number	Status
2002-03-29	JP2002096977A	Pending
2003-10-17	JP2003298920A	Application

Info: Cited by (23), Similar documents, Priority and Related Applications

External links: Espacenet, Global Dossier, Discuss

Camera system

Abstract

<P>PROBLEM TO BE SOLVED: To provide a camera system which makes a display image legible when a control of PTZ or the like is performed while an image of a Tele camera is seen by a display device, and which makes a display image legible in a recorded image in a camera system with a Tele/Wide camera. <P>SOLUTION: A camera system has a Tele camera means which enables a high-powered zoom by which a narrow range is photographed with a subject centered, a Wide camera means which enables a wide angle shot by which a wide range is photographed including an adjacent area of a subject. The camera system is provided with a means for performing a PTZ (pan, tilt and zoom) control to a Tele camera, a means for communicating between the Tele camera and a Wide camera, a means for cutting an image complying with the PTZ control of the Tele camera from a Wide image, a means for magnifying the image cut from the Wide image to a Tele image, and a means for switching the Tele image with the Wide image to be transmitted. An image while the Tele camera is moving is substituted for an image by the Wide camera. <P>COPYRIGHT: (C)2006, JPO&NCIP

JP2006238325A
JP Application

[Download PDF](#) [Find Prior Art](#) [Similar](#)

Other languages: Japanese

Inventor: Keisuke Kagiwada, 菅谷 健和臣

Original Assignee: Canon Inc. 株式会社 / 株式会社

Priority date : 2005-02-28

Family: JP (3)

Date	App/Pub Number	Status
2005-02-28	JP2005053349A	Withdrawn
2006-09-07	JP2006238325A	Application

Info: Cited by (6), Legal events, Similar documents, Priority and Related Applications

External links: Espacenet, Global Dossier, Datasica

Imaging apparatus

Abstract

PROBLEM TO BE SOLVED: To provide high image quality with high resolution for an entire wide variable power region. **SOLUTION:** An imaging apparatus includes first and second imaging optical systems LN1 and LN2 with single focus, which look the same direction. A focal length of the second imaging optical system LN2 is longer than that of the first imaging optical system LN1. Zooming is performed from a wide angle end to an intermediate focal length state with an electronic zoom by segmentation of an image obtained in the first imaging optical system LN1, and zooming is performed from the intermediate focal length state to a telescopic end with an electronic zoom by segmentation of an image obtained in the second imaging optical system. Thus, zooming from the wide angle end to the telescopic end is performed as a whole. Both the first and second imaging optical systems LN1 and LN2 consist of four or more lenses of first lenses of positive power and second lenses of negative power in order from an object side, the lenses nearest to the image side are negative lenses, composite focal lengths of the first lenses and the second lenses are positive and they satisfy a conditional expression $1.0 < f_{w1}/f_{m1} < 1.5$.

Images (23)

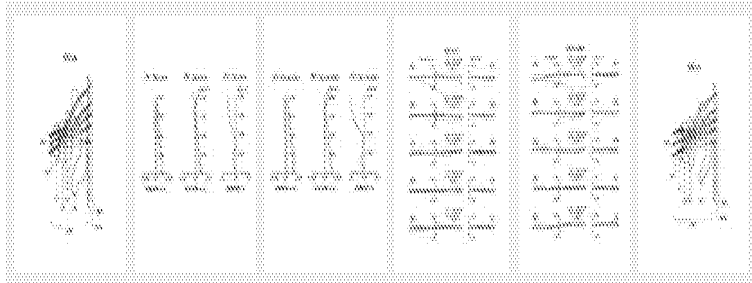

JP2013106289A
 JP Application

[Download PDF](#) [Find Prior Art](#) [Similar](#)

Other languages: Japanese

Inventor: Kenji Kanno, 賢治 金野, Keiji Matsuzaka, 賢二 松坂, Keiko Yamada, 基子 山田

Original Assignee: Konica Minolta Advanced Layers Inc., コニカ ミノルタアドバンスレイヤー株式会社

Priority date: 2011-11-16

Family: JP (1)

Date	App./Pub Number	Status
2011-11-16	JP2011250322A	Active
2013-05-30	JP2013106289A	Application
2015-07-01	JP5741395B2	Grant

Imaging apparatus, imaging method, and range finding method

Abstract

<P>PROBLEM TO BE SOLVED: To provide an imaging apparatus which realizes high precision range finding by utilizing a plurality of imaging systems having different photographic viewing angles and an imaging method and a range finding method, and to provide an imaging apparatus which realizes compensation of parallax caused among the plurality of imaging systems, with simple configuration, and an imaging method. <P>SOLUTION: Imaging signals from imaging systems 10A, 10B, and 10C are corrected so that photographed images by the respective imaging systems 10A, 10B, and 10C photographed at mutually different photographic viewing angles can be images photographed in the mutually same photographing conditions with respect to viewing angles, and correlation operations among photographic images by the imaging systems 10A, 10B, and 10C are performed on the basis of the respective corrected imaging signals, and a distance to an object is calculated on the basis of correlation values. Parallax correction is performed on the basis of information of the calculated distance. <P>COPYRIGHT: (C)2005,JPC&NCIP!

Images (18)

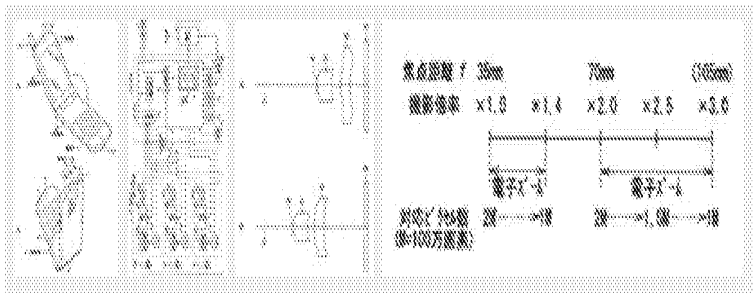

JP2005099265A
 JM Application
 Download PDF Find Prior Art Similar

Other languages: Japanese

Inventor: Yoshihiro Ito, Kenichi Sato, Hideo Yoshida, 伊藤 浩史, 佐藤 健一, 吉野 秀夫

Original Assignee: Fujifilm Photo Film Co Ltd, Fujifilm Corp, フジフイルム株式会社, 富士写真フイルム株式会社

Priority date: 2003-09-24

Family: JP (1)

Date	App/Pub Number	Status
2003-09-24	JP2003331404A	Pending
2005-04-14	JP2005099265A	Application

Photographing method using a mobile terminal having a dual camera and this

Abstract

translated from Korean

The present invention relates to, and more particularly a portable terminal and a recording method using the same, recognizing the face of the photographer to take a picture and having a dual camera on the mobile terminal having a photographing function.

The present invention dual-in camera, a mobile terminal having a second camera portion, wherein the first the photographer of the image input via the camera part is a first camera unit, of the subject image is photographed person's image is input to be input recognizing the photographed to the subject to be imaged is characterized in that a control unit for controlling the second camera unit. Because the recorded picture by recognizing the image of the photographer by using a dual-camera provided in the mobile terminal can acquire the right image to prevent camera shake, there is an advantage that the photographer can take an image of an object at the moment of intended.

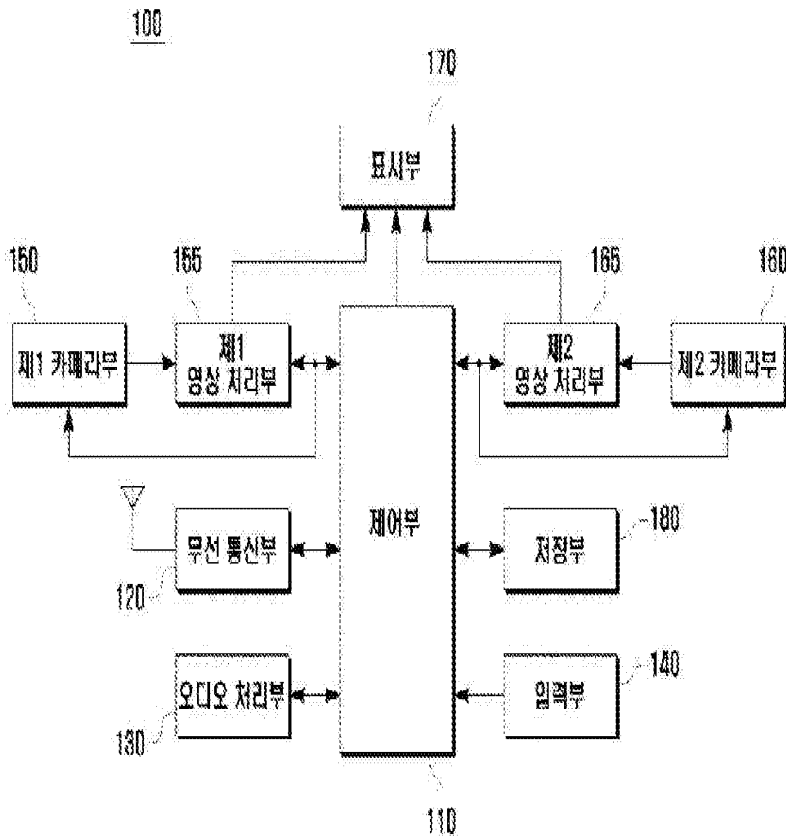

KR101477178B1
 Korean

Download PDF Find Prior Art Similar

Other languages: Korean

Inventor: friendship, Lee Byung-sun

Original Assignee: Samsung Electronics Co., Ltd.

Priority date: 2008-07-17

Family: KR (1)

Date	App/Pub Number	Status
2008-07-17	KR20080069570A	
2010-01-27	KR20100008936A	Application
2014-12-29	KR101477178B1	Grant

Portable terminal having dual camera and photographing method using the same

Abstract

PURPOSE: A portable terminal with a dual camera and a photographing method using the same are provided to exactly and stably photograph at the time when a photographer intends regardless of the shake due to hand. **CONSTITUTION:** A first camera part(150) collects a first image. A second camera part(160) collects a second image. A controller(110) recognizes the first image inputted through the first camera part. The controller checks whether the recognized first image belongs to a preset reference image or not. According to the confirmation result, the controller controls the camera operation of the second camera part.

Images (4)

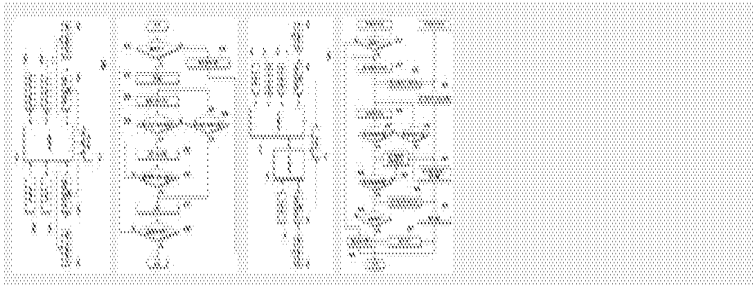

KR20100008936A
KIP Application

[Download PDF](#) [Find Prior Art](#) [Similar](#)

Other languages: Korean

Inventor: Friendship, Lee Byung-sun

Original Assignee: Samsung Electronics Co., Ltd.

Priority date : 2008-07-17

Family: KR (1)

Date	App/Pub Number	Status
2008-07-17	KR20080068570A	
2010-01-27	KR20100008936A	Application
2014-12-29	KR101477178B1	Grant

EUROPEAN PATENT OFFICE

Patent Abstracts of Japan

PUBLICATION NUMBER : 08271976
PUBLICATION DATE : 18-10-96

APPLICATION DATE : 29-03-95
APPLICATION NUMBER : 07094242

APPLICANT : CANON INC;

INVENTOR : TAMAMURA HIDEO;

INT.CL. : G03B 19/06 G03B 17/20 G03B 17/48
H04N 5/335

TITLE : CAMERA

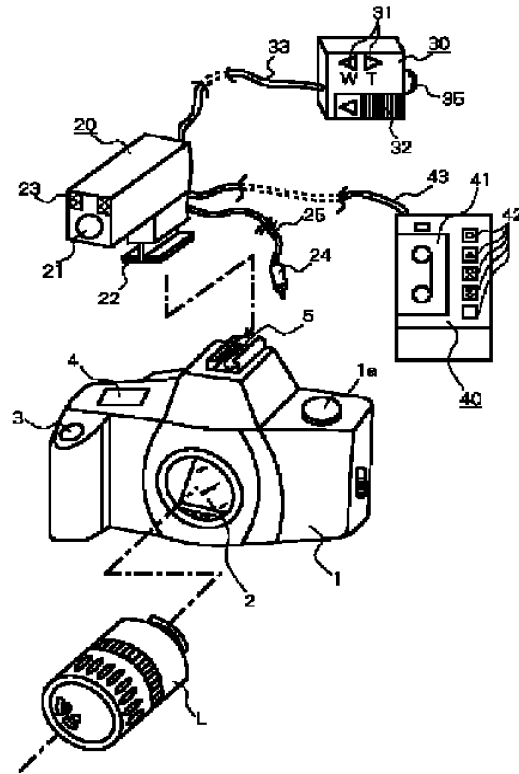

ABSTRACT : PURPOSE: To enhance operability and quick photographing property by improving a finder function, in a camera provided with both video and still camera functions.

CONSTITUTION: The camera is constituted of a video camera part consisting of each of a video photographing camera unit 20, an operation unit 30 for changing a zoom ratio, driven by motor and a video deck part 40 recording video on a magnetic tape and a still camera part for exposing a silver salt photographic film, to record a still picture. The video taken by the video camera part is displayed as a picture on an LCD in a camera main body 1 and a half mirror is disposed in mid-way of an optical path, so that when the picture is optically led to a part of a visual field in an optical finder, the picture of the video is placed in the still picture as a window. Further, a light shielding plate can be overlapped with or retreated from the rear surface of the half mirror, in accordance with the operation of a photographer.

COPYRIGHT: (C)1996,JPO

EUROPEAN PATENT OFFICE

Patent Abstracts of Japan

PUBLICATION NUMBER : 04211230
PUBLICATION DATE : 03-08-92

APPLICATION DATE : 19-10-90
APPLICATION NUMBER : 02282755

APPLICANT : FUJI PHOTO FILM CO LTD;

INVENTOR : UEDA SATOSHI;

INT.CL. : G03B 5/00 G01P 9/00

TITLE : COMPENSATOR FOR CAMERA
SHAKE BY HAND

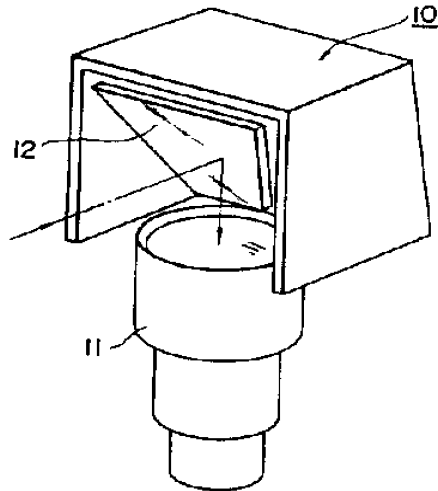

ABSTRACT : PURPOSE: To realize the downsizing and cost reduction of a device by arranging a mirror to compensate camera shake caused by hand in front of a photographing lens, making possible design of the photographing lens without taking the mirror into consideration, and simplifying a mirror support mechanism.

CONSTITUTION: A compensator 10 to compensate camera shake caused by hand is arranged in front of a photographing lens 11, and generally, introduces a subject image to the photographing lens 11 by folding down the image by 90 degrees by means of a mirror 12. The mirror 12 is tiltable supported in all directions, and when a camera is put in tilting motion due to camera shake and the like, the mirror 12 is put in tilting motion by a half of the camera shake angle in the opposite direction to the camera shake direction, and thereby, image oscillation caused by camera shake and the like can be compensated.

COPYRIGHT: (C)1992,JPO&Japio

Camera module

Abstract

The present invention relates to a camera module. According to an embodiment of the present invention, the camera module includes a reflector reflecting the optical image of an object; a lens; an actuator adjusting the focus of the optical image of the object; and an image sensor changing the optical image of the object to an electrical signal. [Reference numerals] (AA) Optical image

Images (5)

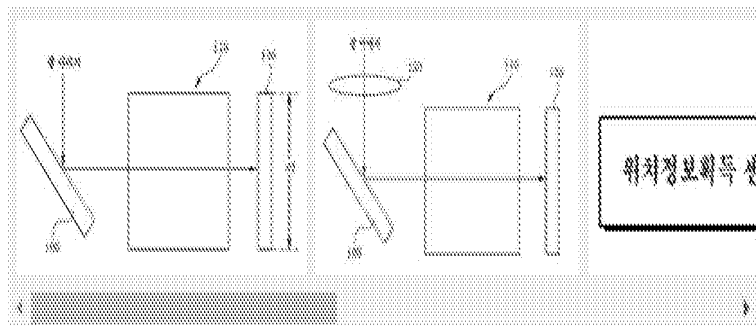

KR20140014787A

LG Application

Download PDF

Find Prior Art

Smiler

Other languages: Korean

Inventor: Kim, Yeong-Ho

Original Assignee: LG Innotek Co., Ltd.

Priority date : 2012-07-26

Family: KR (1)

Date	App./Pub Number	Status
2012-07-26	KR20120081773A	
2014-02-06	KR20140014787A	Application

Digital camera

Abstract

<P>PROBLEM TO BE SOLVED: To provide a digital camera of a bent optical system for realizing pan/tilt photographing. <P>SOLUTION: A mirror 210 for bending incident light onto an imaging element is supported turnably around the X revolving axis and the Z revolving axis. A second actuator 321 is driven in response to a pan operation by a user to revolve the mirror 210 around the Z revolving axis. A first actuator 311 is driven in response to a tilt operation by the user to revolve the mirror 210 around the X revolving axis. Thus, the pan/tilt at moving picture photographing is achieved by the revolving of the mirror 210 in response to the user operation. That is, since the pan/tilt photographing can be executed in a state that a camera main body is at a standstill, a camera shake and an image shake caused by movement of the camera main body can be prevented. <P>COPYRIGHT: (C)2007 JPO&INPIT

Images (12)

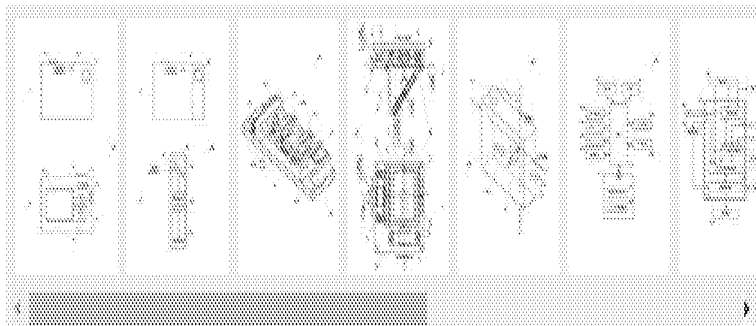

JP2007228006A
JP Application

Download PDF Find Prior Art Similar

Other languages: Japanese

Inventor: Kazunori Kita, Ichigo

Original Assignee: Casio Comput Co Ltd, Casio Computer Co, Ltd.

Priority date : 2006-02-21

Family: JP (1)

Date	App/Pub Number	Status
2006-02-21	JP2006043435A	Expired - Fee Related
2007-09-06	JP2007228006A	Application
2011-02-02	JP45228292	Grant

Optical axis correcting mechanism

Abstract

PURPOSE: To prevent the generation of erroneous detection on the respective positions by correcting hand shake in the vertical direction by so-called an ABS system and in the horizontal direction by so-called a gimbal system.

CONSTITUTION: When hand shake in the vertical direction is generated, angle data detected by a hand shake amount arithmetic circuit 38V is compared with the position data of a correcting convex lens 5 obtained by a position sensor 18 in a position control circuit 39V for the correcting lens, the amount of angle to be corrected is detected, the correction data are outputted to a lens driving means 7, the correcting convex lens 5 is moved in the vertical direction and the optical axis is corrected. When hand shake in the horizontal direction is generated, the angle data are compared with the position data of a lens barrel 14 obtained by an angle position sensor 34, the amount of angle to be corrected is detected, the correction data are outputted to a barrel driving means 22, the lens barrel 14 is rotated in the horizontal direction and the optical axis is corrected.

COPYRIGHT (C) 1995, JPO

JPH07318854A

Application

Find Prior Art

Σ Status

Other languages: Japanese

Inventor: Hiroshi Kawamura, Eiji Oshima, Kazuhiro Tanaka, Eiji Oshima, Yoshikawa, Wada and Tanaka

Original Assignee: Sony Corp, Sony Corporation

Priority date: 1994-05-20

Family: JP (1)

<u>Date</u>	<u>App/Pub Number</u>	<u>Status</u>
1994-05-20	JP12984994A	Expired - Fee Related
1995-12-08	JPH07318854A	Application
2002-12-09	JP235578782	Grant

Electronic Acknowledgement Receipt

EFS ID:	33782936
Application Number:	16048242
International Application Number:	
Confirmation Number:	4814
Title of Invention:	DUAL APERTURE ZOOM DIGITAL CAMERA
First Named Inventor/Applicant Name:	Gal Shabtay
Customer Number:	92342
Filer:	Menachem Nathan
Filer Authorized By:	
Attorney Docket Number:	COREPH-0079 US CON3
Receipt Date:	20-SEP-2018
Filing Date:	28-JUL-2018
Time Stamp:	16:19:49
Application Type:	Utility under 35 USC 111(a)

Payment information:

Submitted with Payment	no
------------------------	----

File Listing:

Document Number	Document Description	File Name	File Size(Bytes)/ Message Digest	Multi Part /.zip	Pages (if appl.)
1	Information Disclosure Statement (IDS) Form (SB08)	IDS_Lens.pdf	615167 <small>08918cf4936d1796001d8337f8aa5e559cdc4898</small>	no	12

Warnings:

Information:					
2	Information Disclosure Statement (IDS) Form (SB08)	IDS_System.pdf	619212	no	25
			aa9bf323b28b1a73702e9814fe0cdd234882a3f2		
Warnings:					
Information:					
3	Transmittal Letter	IDS_TF.pdf	277379	no	2
			bfae9503ada0bfd319a8184210268f6837664e53		
Warnings:					
Information:					
4	Foreign Reference	Lens_FR.pdf	2602347	no	110
			a3ba49b7753b9e70b0353fc6e285bb9106fab23c		
Warnings:					
The page size in the PDF is too large. The pages should be 8.5 x 11 or A4. If this PDF is submitted, the pages will be resized upon entry into the Image File Wrapper and may affect subsequent processing					
Information:					
5	Foreign Reference	System_FR.pdf	1993077	no	32
			7bf396163d3e460d9c5a11fffa1fef3a10be0638		
Warnings:					
The page size in the PDF is too large. The pages should be 8.5 x 11 or A4. If this PDF is submitted, the pages will be resized upon entry into the Image File Wrapper and may affect subsequent processing					
Information:					
6	Non Patent Literature	Lens_Papers.pdf	4681685	no	48
			c8a8ad8853971fe9772d8b90d079b6f7005a1b30		
Warnings:					
Information:					
7	Non Patent Literature	System_Papers_1.pdf	12596180	no	71
			abfbf59e56bac7d1bec70fa137ebece9bcaba6c1		
Warnings:					
Information:					

8	Non Patent Literature	System_Papers_2.pdf	18602061	no	30
			fc9eaa87e72407066fb661359284558849ee5fb2		
Warnings:					
Information:					
9	Non Patent Literature	System_Papers_3.pdf	22596931	no	41
			f70328c454d821bcf4223a3b9a870213248de69e		
Warnings:					
Information:					
Total Files Size (in bytes):			64584039		
<p>This Acknowledgement Receipt evidences receipt on the noted date by the USPTO of the indicated documents, characterized by the applicant, and including page counts, where applicable. It serves as evidence of receipt similar to a Post Card, as described in MPEP 503.</p> <p><u>New Applications Under 35 U.S.C. 111</u> If a new application is being filed and the application includes the necessary components for a filing date (see 37 CFR 1.53(b)-(d) and MPEP 506), a Filing Receipt (37 CFR 1.54) will be issued in due course and the date shown on this Acknowledgement Receipt will establish the filing date of the application.</p> <p><u>National Stage of an International Application under 35 U.S.C. 371</u> If a timely submission to enter the national stage of an international application is compliant with the conditions of 35 U.S.C. 371 and other applicable requirements a Form PCT/DO/EO/903 indicating acceptance of the application as a national stage submission under 35 U.S.C. 371 will be issued in addition to the Filing Receipt, in due course.</p> <p><u>New International Application Filed with the USPTO as a Receiving Office</u> If a new international application is being filed and the international application includes the necessary components for an international filing date (see PCT Article 11 and MPEP 1810), a Notification of the International Application Number and of the International Filing Date (Form PCT/RO/105) will be issued in due course, subject to prescriptions concerning national security, and the date shown on this Acknowledgement Receipt will establish the international filing date of the application.</p>					



UNITED STATES PATENT AND TRADEMARK OFFICE

UNITED STATES DEPARTMENT OF COMMERCE
United States Patent and Trademark Office
Address: COMMISSIONER FOR PATENTS
P.O. Box 1450
Alexandria, Virginia 22313-1450
www.uspto.gov

Table with 7 columns: APPLICATION NUMBER, FILING or 371(c) DATE, GRP ART UNIT, FIL FEE REC'D, ATTY. DOCKET NO, TOT CLAIMS, IND CLAIMS. Row 1: 16/048,242, 07/28/2018, 2661, 1865, COREPH-0079 US CON3, 40, 3

CONFIRMATION NO. 4814

UPDATED FILING RECEIPT



92342
Nathan & Associates Patent Agents Ltd
P.O.Box 10178
Tel Aviv, 6110101
ISRAEL

Date Mailed: 09/07/2018

Receipt is acknowledged of this non-provisional patent application. The application will be taken up for examination in due course. Applicant will be notified as to the results of the examination. Any correspondence concerning the application must include the following identification information: the U.S. APPLICATION NUMBER, FILING DATE, NAME OF APPLICANT, and TITLE OF INVENTION. Fees transmitted by check or draft are subject to collection. Please verify the accuracy of the data presented on this receipt. If an error is noted on this Filing Receipt, please submit a written request for a Filing Receipt Correction. Please provide a copy of this Filing Receipt with the changes noted thereon. If you received a "Notice to File Missing Parts" for this application, please submit any corrections to this Filing Receipt with your reply to the Notice. When the USPTO processes the reply to the Notice, the USPTO will generate another Filing Receipt incorporating the requested corrections

Inventor(s)

Gal Shabtay, Tel Aviv, ISRAEL;
Ephraim Goldenberg, Ashdod, ISRAEL;
Oded Gigushinski, Herzlia, ISRAEL;
Noy Cohen, Tel Aviv;

Applicant(s)

Corephotonics Ltd., Tel Aviv, ISRAEL;

Power of Attorney: The patent practitioners associated with Customer Number 92342

Domestic Priority data as claimed by applicant

This application is a CON of 15/865,869 01/09/2018
which is a CON of 15/424,853 02/05/2017 PAT 10015408
which is a CON of 14/880,251 10/11/2015 PAT 9661233
which is a CON of 14/365,711 06/16/2014 PAT 9185291
which is a 371 of PCT/IB2014/062180 06/12/2014
which claims benefit of 61/834,486 06/13/2013

Foreign Applications for which priority is claimed (You may be eligible to benefit from the Patent Prosecution Highway program at the USPTO. Please see http://www.uspto.gov for more information.) - None.

Foreign application information must be provided in an Application Data Sheet in order to constitute a claim to foreign priority. See 37 CFR 1.55 and 1.76.

Permission to Access Application via Priority Document Exchange: Yes

Permission to Access Search Results: Yes

Applicant may provide or rescind an authorization for access using Form PTO/SB/39 or Form PTO/SB/69 as appropriate.

If Required, Foreign Filing License Granted: 08/29/2018

The country code and number of your priority application, to be used for filing abroad under the Paris Convention, is **US 16/048,242**

Projected Publication Date: 12/13/2018

Non-Publication Request: No

Early Publication Request: No

**** SMALL ENTITY ****

Title

DUAL APERTURE ZOOM DIGITAL CAMERA

Preliminary Class

348

Statement under 37 CFR 1.55 or 1.78 for AIA (First Inventor to File) Transition Applications: No

PROTECTING YOUR INVENTION OUTSIDE THE UNITED STATES

Since the rights granted by a U.S. patent extend only throughout the territory of the United States and have no effect in a foreign country, an inventor who wishes patent protection in another country must apply for a patent in a specific country or in regional patent offices. Applicants may wish to consider the filing of an international application under the Patent Cooperation Treaty (PCT). An international (PCT) application generally has the same effect as a regular national patent application in each PCT-member country. The PCT process **simplifies** the filing of patent applications on the same invention in member countries, but **does not result** in a grant of "an international patent" and does not eliminate the need of applicants to file additional documents and fees in countries where patent protection is desired.

Almost every country has its own patent law, and a person desiring a patent in a particular country must make an application for patent in that country in accordance with its particular laws. Since the laws of many countries differ in various respects from the patent law of the United States, applicants are advised to seek guidance from specific foreign countries to ensure that patent rights are not lost prematurely.

Applicants also are advised that in the case of inventions made in the United States, the Director of the USPTO must issue a license before applicants can apply for a patent in a foreign country. The filing of a U.S. patent application serves as a request for a foreign filing license. The application's filing receipt contains further information and guidance as to the status of applicant's license for foreign filing.

Applicants may wish to consult the USPTO booklet, "General Information Concerning Patents" (specifically, the section entitled "Treaties and Foreign Patents") for more information on timeframes and deadlines for filing foreign patent applications. The guide is available either by contacting the USPTO Contact Center at 800-786-9199, or it can be viewed on the USPTO website at <http://www.uspto.gov/web/offices/pac/doc/general/index.html>.

For information on preventing theft of your intellectual property (patents, trademarks and copyrights), you may wish to consult the U.S. Government website, <http://www.stopfakes.gov>. Part of a Department of Commerce initiative, this website includes self-help "toolkits" giving innovators guidance on how to protect intellectual property in specific

page 2 of 4

countries such as China, Korea and Mexico. For questions regarding patent enforcement issues, applicants may call the U.S. Government hotline at 1-866-999-HALT (1-866-999-4258).

LICENSE FOR FOREIGN FILING UNDER
Title 35, United States Code, Section 184
Title 37, Code of Federal Regulations, 5.11 & 5.15

GRANTED

The applicant has been granted a license under 35 U.S.C. 184, if the phrase "IF REQUIRED, FOREIGN FILING LICENSE GRANTED" followed by a date appears on this form. Such licenses are issued in all applications where the conditions for issuance of a license have been met, regardless of whether or not a license may be required as set forth in 37 CFR 5.15. The scope and limitations of this license are set forth in 37 CFR 5.15(a) unless an earlier license has been issued under 37 CFR 5.15(b). The license is subject to revocation upon written notification. The date indicated is the effective date of the license, unless an earlier license of similar scope has been granted under 37 CFR 5.13 or 5.14.

This license is to be retained by the licensee and may be used at any time on or after the effective date thereof unless it is revoked. This license is automatically transferred to any related applications(s) filed under 37 CFR 1.53(d). This license is not retroactive.

The grant of a license does not in any way lessen the responsibility of a licensee for the security of the subject matter as imposed by any Government contract or the provisions of existing laws relating to espionage and the national security or the export of technical data. Licensees should apprise themselves of current regulations especially with respect to certain countries, of other agencies, particularly the Office of Defense Trade Controls, Department of State (with respect to Arms, Munitions and Implements of War (22 CFR 121-128)); the Bureau of Industry and Security, Department of Commerce (15 CFR parts 730-774); the Office of Foreign Assets Control, Department of Treasury (31 CFR Parts 500+) and the Department of Energy.

NOT GRANTED

No license under 35 U.S.C. 184 has been granted at this time, if the phrase "IF REQUIRED, FOREIGN FILING LICENSE GRANTED" DOES NOT appear on this form. Applicant may still petition for a license under 37 CFR 5.12, if a license is desired before the expiration of 6 months from the filing date of the application. If 6 months has lapsed from the filing date of this application and the licensee has not received any indication of a secrecy order under 35 U.S.C. 181, the licensee may foreign file the application pursuant to 37 CFR 5.15(b).

SelectUSA

The United States represents the largest, most dynamic marketplace in the world and is an unparalleled location for business investment, innovation, and commercialization of new technologies. The U.S. offers tremendous resources and advantages for those who invest and manufacture goods here. Through SelectUSA, our nation works to promote and facilitate business investment. SelectUSA provides information assistance to the international investor community; serves as an ombudsman for existing and potential investors; advocates on behalf of U.S. cities, states, and regions competing for global investment; and counsels U.S. economic development organizations on investment attraction best practices. To learn more about why the United States is the best country in the world to develop

technology, manufacture products, deliver services, and grow your business, visit <http://www.SelectUSA.gov> or call +1-202-482-6800.

PATENT APPLICATION FEE DETERMINATION RECORD Substitute for Form PTO-875	Application or Docket Number 16/048,242
---	--

APPLICATION AS FILED - PART I			SMALL ENTITY		OR	OTHER THAN SMALL ENTITY	
	(Column 1)	(Column 2)					
FOR	NUMBER FILED	NUMBER EXTRA	RATE(\$)	FEE(\$)		RATE(\$)	FEE(\$)
BASIC FEE <small>(37 CFR 1.16(a), (b), or (c))</small>	N/A	N/A	N/A	75		N/A	
SEARCH FEE <small>(37 CFR 1.16(k), (l), or (m))</small>	N/A	N/A	N/A	330		N/A	
EXAMINATION FEE <small>(37 CFR 1.16(o), (p), or (q))</small>	N/A	N/A	N/A	380		N/A	
TOTAL CLAIMS <small>(37 CFR 1.16(i))</small>	40	minus 20 = *	x 50 =	1000	OR		
INDEPENDENT CLAIMS <small>(37 CFR 1.16(h))</small>	3	minus 3 = *	x 230 =	0.00			
APPLICATION SIZE FEE <small>(37 CFR 1.16(s))</small>	If the specification and drawings exceed 100 sheets of paper, the application size fee due is \$310 (\$155 for small entity) for each additional 50 sheets or fraction thereof. See 35 U.S.C. 41(a)(1)(G) and 37 CFR 1.16(s).			0.00			
MULTIPLE DEPENDENT CLAIM PRESENT <small>(37 CFR 1.16(j))</small>				0.00			
* If the difference in column 1 is less than zero, enter "0" in column 2.			TOTAL	1785		TOTAL	

APPLICATION AS AMENDED - PART II					SMALL ENTITY		OR	OTHER THAN SMALL ENTITY		
	(Column 1)	(Column 2)	(Column 3)							
AMENDMENT A		CLAIMS REMAINING AFTER AMENDMENT	HIGHEST NUMBER PREVIOUSLY PAID FOR	PRESENT EXTRA	RATE(\$)	ADDITIONAL FEE(\$)		RATE(\$)	ADDITIONAL FEE(\$)	
	Total <small>(37 CFR 1.16(i))</small>	*	Minus	**	x	=	OR	x	=	
	Independent <small>(37 CFR 1.16(h))</small>	*	Minus	***	x	=	OR	x	=	
	Application Size Fee <small>(37 CFR 1.16(s))</small>							OR		
	FIRST PRESENTATION OF MULTIPLE DEPENDENT CLAIM <small>(37 CFR 1.16(j))</small>							OR		
TOTAL ADD'L FEE							OR	TOTAL ADD'L FEE		
AMENDMENT B		CLAIMS REMAINING AFTER AMENDMENT	HIGHEST NUMBER PREVIOUSLY PAID FOR	PRESENT EXTRA	RATE(\$)	ADDITIONAL FEE(\$)		RATE(\$)	ADDITIONAL FEE(\$)	
	Total <small>(37 CFR 1.16(i))</small>	*	Minus	**	x	=	OR	x	=	
	Independent <small>(37 CFR 1.16(h))</small>	*	Minus	***	x	=	OR	x	=	
	Application Size Fee <small>(37 CFR 1.16(s))</small>							OR		
	FIRST PRESENTATION OF MULTIPLE DEPENDENT CLAIM <small>(37 CFR 1.16(j))</small>							OR		
TOTAL ADD'L FEE							OR	TOTAL ADD'L FEE		
<p>* If the entry in column 1 is less than the entry in column 2, write "0" in column 3.</p> <p>** If the "Highest Number Previously Paid For" IN THIS SPACE is less than 20, enter "20".</p> <p>*** If the "Highest Number Previously Paid For" IN THIS SPACE is less than 3, enter "3".</p> <p>The "Highest Number Previously Paid For" (Total or Independent) is the highest found in the appropriate box in column 1.</p>										



UNITED STATES PATENT AND TRADEMARK OFFICE

UNITED STATES DEPARTMENT OF COMMERCE
United States Patent and Trademark Office
Address: COMMISSIONER FOR PATENTS
P.O. Box 1450
Alexandria, Virginia 22313-1450
www.uspto.gov

Table with 7 columns: APPLICATION NUMBER, FILING or 371(c) DATE, GRP ART UNIT, FIL FEE REC'D, ATTY.DOCKET.NO, TOT CLAIMS, IND CLAIMS. Row 1: 16/048,242, 07/28/2018, 2676, 1785, COREPH-0079 US CON3, 40, 3

CONFIRMATION NO. 4814

FILING RECEIPT

92342
Nathan & Associates Patent Agents Ltd
P.O.Box 10178
Tel Aviv, 6110101
ISRAEL



Date Mailed: 08/30/2018

Receipt is acknowledged of this non-provisional patent application. The application will be taken up for examination in due course. Applicant will be notified as to the results of the examination. Any correspondence concerning the application must include the following identification information: the U.S. APPLICATION NUMBER, FILING DATE, NAME OF APPLICANT, and TITLE OF INVENTION. Fees transmitted by check or draft are subject to collection. Please verify the accuracy of the data presented on this receipt. If an error is noted on this Filing Receipt, please submit a written request for a Filing Receipt Correction. Please provide a copy of this Filing Receipt with the changes noted thereon. If you received a "Notice to File Missing Parts" for this application, please submit any corrections to this Filing Receipt with your reply to the Notice. When the USPTO processes the reply to the Notice, the USPTO will generate another Filing Receipt incorporating the requested corrections

Inventor(s)

Gal Shabtay, Tel Aviv, ISRAEL;
Ephraim Goldenberg, Ashdod, ISRAEL;
Oded Gigushinski, Herzlia, ISRAEL;
Noy Cohen, Tel Aviv;

Applicant(s)

Corephotonics Ltd., Tel Aviv, ISRAEL;

Power of Attorney: The patent practitioners associated with Customer Number 92342

Domestic Priority data as claimed by applicant

This application is a CON of 15/865,869 01/09/2018
which is a CON of 15/424,853 02/05/2017 PAT 10015408
which is a CON of 14/880,251 10/11/2015 PAT 9661233
which is a CON of 14/365,711 06/16/2014 PAT 9185291
which is a 371 of PCT/IB2014/062180 06/12/2014
which claims benefit of 61/834,486 06/13/2013

Foreign Applications for which priority is claimed (You may be eligible to benefit from the Patent Prosecution Highway program at the USPTO. Please see http://www.uspto.gov for more information.) - None.

Foreign application information must be provided in an Application Data Sheet in order to constitute a claim to foreign priority. See 37 CFR 1.55 and 1.76.

Permission to Access Application via Priority Document Exchange: Yes

Permission to Access Search Results: Yes

Applicant may provide or rescind an authorization for access using Form PTO/SB/39 or Form PTO/SB/69 as appropriate.

If Required, Foreign Filing License Granted: 08/29/2018

The country code and number of your priority application, to be used for filing abroad under the Paris Convention, is **US 16/048,242**

Projected Publication Date: 12/06/2018

Non-Publication Request: No

Early Publication Request: No

**** SMALL ENTITY ****

Title

DUAL APERTURE ZOOM DIGITAL CAMERA

Preliminary Class

358

Statement under 37 CFR 1.55 or 1.78 for AIA (First Inventor to File) Transition Applications: No

PROTECTING YOUR INVENTION OUTSIDE THE UNITED STATES

Since the rights granted by a U.S. patent extend only throughout the territory of the United States and have no effect in a foreign country, an inventor who wishes patent protection in another country must apply for a patent in a specific country or in regional patent offices. Applicants may wish to consider the filing of an international application under the Patent Cooperation Treaty (PCT). An international (PCT) application generally has the same effect as a regular national patent application in each PCT-member country. The PCT process **simplifies** the filing of patent applications on the same invention in member countries, but **does not result** in a grant of "an international patent" and does not eliminate the need of applicants to file additional documents and fees in countries where patent protection is desired.

Almost every country has its own patent law, and a person desiring a patent in a particular country must make an application for patent in that country in accordance with its particular laws. Since the laws of many countries differ in various respects from the patent law of the United States, applicants are advised to seek guidance from specific foreign countries to ensure that patent rights are not lost prematurely.

Applicants also are advised that in the case of inventions made in the United States, the Director of the USPTO must issue a license before applicants can apply for a patent in a foreign country. The filing of a U.S. patent application serves as a request for a foreign filing license. The application's filing receipt contains further information and guidance as to the status of applicant's license for foreign filing.

Applicants may wish to consult the USPTO booklet, "General Information Concerning Patents" (specifically, the section entitled "Treaties and Foreign Patents") for more information on timeframes and deadlines for filing foreign patent applications. The guide is available either by contacting the USPTO Contact Center at 800-786-9199, or it can be viewed on the USPTO website at <http://www.uspto.gov/web/offices/pac/doc/general/index.html>.

For information on preventing theft of your intellectual property (patents, trademarks and copyrights), you may wish to consult the U.S. Government website, <http://www.stopfakes.gov>. Part of a Department of Commerce initiative, this website includes self-help "toolkits" giving innovators guidance on how to protect intellectual property in specific

page 2 of 4

countries such as China, Korea and Mexico. For questions regarding patent enforcement issues, applicants may call the U.S. Government hotline at 1-866-999-HALT (1-866-999-4258).

LICENSE FOR FOREIGN FILING UNDER
Title 35, United States Code, Section 184
Title 37, Code of Federal Regulations, 5.11 & 5.15

GRANTED

The applicant has been granted a license under 35 U.S.C. 184, if the phrase "IF REQUIRED, FOREIGN FILING LICENSE GRANTED" followed by a date appears on this form. Such licenses are issued in all applications where the conditions for issuance of a license have been met, regardless of whether or not a license may be required as set forth in 37 CFR 5.15. The scope and limitations of this license are set forth in 37 CFR 5.15(a) unless an earlier license has been issued under 37 CFR 5.15(b). The license is subject to revocation upon written notification. The date indicated is the effective date of the license, unless an earlier license of similar scope has been granted under 37 CFR 5.13 or 5.14.

This license is to be retained by the licensee and may be used at any time on or after the effective date thereof unless it is revoked. This license is automatically transferred to any related applications(s) filed under 37 CFR 1.53(d). This license is not retroactive.

The grant of a license does not in any way lessen the responsibility of a licensee for the security of the subject matter as imposed by any Government contract or the provisions of existing laws relating to espionage and the national security or the export of technical data. Licensees should apprise themselves of current regulations especially with respect to certain countries, of other agencies, particularly the Office of Defense Trade Controls, Department of State (with respect to Arms, Munitions and Implements of War (22 CFR 121-128)); the Bureau of Industry and Security, Department of Commerce (15 CFR parts 730-774); the Office of Foreign Assets Control, Department of Treasury (31 CFR Parts 500+) and the Department of Energy.

NOT GRANTED

No license under 35 U.S.C. 184 has been granted at this time, if the phrase "IF REQUIRED, FOREIGN FILING LICENSE GRANTED" DOES NOT appear on this form. Applicant may still petition for a license under 37 CFR 5.12, if a license is desired before the expiration of 6 months from the filing date of the application. If 6 months has lapsed from the filing date of this application and the licensee has not received any indication of a secrecy order under 35 U.S.C. 181, the licensee may foreign file the application pursuant to 37 CFR 5.15(b).

SelectUSA

The United States represents the largest, most dynamic marketplace in the world and is an unparalleled location for business investment, innovation, and commercialization of new technologies. The U.S. offers tremendous resources and advantages for those who invest and manufacture goods here. Through SelectUSA, our nation works to promote and facilitate business investment. SelectUSA provides information assistance to the international investor community; serves as an ombudsman for existing and potential investors; advocates on behalf of U.S. cities, states, and regions competing for global investment; and counsels U.S. economic development organizations on investment attraction best practices. To learn more about why the United States is the best country in the world to develop

technology, manufacture products, deliver services, and grow your business, visit <http://www.SelectUSA.gov> or call +1-202-482-6800.

IN THE UNITED STATES PATENT AND TRADEMARK OFFICE

In re Applicant: § Confirmation No: 4814
Gal Shabtay §
Serial No.:16/048,242 §
Title: DUAL APERTURE ZOOM
DIGITAL CAMERA
Filed: 07/28/2018 §
§ Attorney Docket: Coreph-0079 US CON3

Mail Stop Missing Parts
Commissioner for Patents
P.O. Box 1450
Alexandria, VA 22313-1450

APPLICANT RESPONSE TO PRE-EXAM FORMALITIES NOTICE

This is in response to the Formalities Letter dated 08/30/2018 (attached), which response is made timely and for which a fee of \$80 is paid herewith.

Respectfully submitted,

/Menachem Nathan/
Menachem Nathan
Agent for Applicant
Reg. No.65392

September 4, 2018
Tel: 516-442-9736

Electronic Patent Application Fee Transmittal

Application Number:	16048242			
Filing Date:	28-Jul-2018			
Title of Invention:	DUAL APERTURE ZOOM DIGITAL CAMERA			
First Named Inventor/Applicant Name:	Gal Shabtay			
Filer:	Menachem Nathan			
Attorney Docket Number:	COREPH-0079 US CON3			
Filed as Small Entity				
Filing Fees for Utility under 35 USC 111(a)				
Description	Fee Code	Quantity	Amount	Sub-Total in USD(\$)
Basic Filing:				
Pages:				
Claims:				
Miscellaneous-Filing:				
LATE FILING FEE FOR OATH OR DECLARATION	2051	1	80	80
Petition:				
Patent-Appeals-and-Interference:				
Post-Allowance-and-Post-Issuance:				

Description	Fee Code	Quantity	Amount	Sub-Total in USD(\$)
Extension-of-Time:				
Miscellaneous:				
Total in USD (\$)				80

Electronic Acknowledgement Receipt

EFS ID:	33620574
Application Number:	16048242
International Application Number:	
Confirmation Number:	4814
Title of Invention:	DUAL APERTURE ZOOM DIGITAL CAMERA
First Named Inventor/Applicant Name:	Gal Shabtay
Customer Number:	92342
Filer:	Menachem Nathan
Filer Authorized By:	
Attorney Docket Number:	COREPH-0079 US CON3
Receipt Date:	04-SEP-2018
Filing Date:	28-JUL-2018
Time Stamp:	16:28:21
Application Type:	Utility under 35 USC 111(a)

Payment information:

Submitted with Payment	yes
Payment Type	CARD
Payment was successfully received in RAM	\$80
RAM confirmation Number	090518INTEFSW16290300
Deposit Account	
Authorized User	

The Director of the USPTO is hereby authorized to charge indicated fees and credit any overpayment as follows:

--	--	--	--	--	--

File Listing:

Document Number	Document Description	File Name	File Size(Bytes)/ Message Digest	Multi Part /.zip	Pages (if appl.)
1	Oath or Declaration filed	Supplemental_declaration.pdf	206127	no	2
			c0a45a0d782c11172614fcccc40a4b77427e da5a		

Warnings:

Information:

2	Transmittal Letter	Response_Missing_Parts.pdf	68148	no	1
			11fcf33ed9a568ae437f5844dcb374ca9559 0c07		

Warnings:

Information:

3	Fee Worksheet (SB06)	fee-info.pdf	30208	no	2
			c7c07b0d6ca1fce9c1f2fd8a347bc24b7e9d 168a		

Warnings:

Information:

Total Files Size (in bytes):	304483
-------------------------------------	--------

This Acknowledgement Receipt evidences receipt on the noted date by the USPTO of the indicated documents, characterized by the applicant, and including page counts, where applicable. It serves as evidence of receipt similar to a Post Card, as described in MPEP 503.

New Applications Under 35 U.S.C. 111

If a new application is being filed and the application includes the necessary components for a filing date (see 37 CFR 1.53(b)-(d) and MPEP 506), a Filing Receipt (37 CFR 1.54) will be issued in due course and the date shown on this Acknowledgement Receipt will establish the filing date of the application.

National Stage of an International Application under 35 U.S.C. 371

If a timely submission to enter the national stage of an international application is compliant with the conditions of 35 U.S.C. 371 and other applicable requirements a Form PCT/DO/EO/903 indicating acceptance of the application as a national stage submission under 35 U.S.C. 371 will be issued in addition to the Filing Receipt, in due course.

New International Application Filed with the USPTO as a Receiving Office

If a new international application is being filed and the international application includes the necessary components for an international filing date (see PCT Article 11 and MPEP 1810), a Notification of the International Application Number and of the International Filing Date (Form PCT/RO/105) will be issued in due course, subject to prescriptions concerning national security, and the date shown on this Acknowledgement Receipt will establish the international filing date of the application.

SUPPLEMENTAL SHEET FOR DECLARATION**ADDITIONAL INVENTOR(S)**

Supplemental Sheet (for PTO/AIA/08,09)

Page 1 of 1

Legal Name of Additional Joint Inventor, if any:			
(E.g., Given Name (first and middle (if any)) and Family Name or Surname)			
Oded Gigushinski			
Inventor's /Oded Gigushinski/ Signature			Date (Optional)
Residence: City Herzlia	State	Country IL	
23 Achi Dakar St.			
Mailing Address			
City Herzlia	State	Zip 4670223	Country IL
Legal Name of Additional Joint Inventor, if any:			
(E.g., Given Name (first and middle (if any)) and Family Name or Surname)			
Inventor's Signature			Date (Optional)
Residence: City	State	Country	
Mailing Address			
City	State	Zip	Country
Legal Name of Additional Joint Inventor, if any:			
(E.g., Given Name (first and middle (if any)) and Family Name or Surname)			
Inventor's Signature			Date (Optional)
Residence: City	State	Country	
Mailing Address			
City	State	Zip	Country

This collection of information is required by 35 U.S.C. 115 and 37 CFR 1.63. The information is required to obtain or retain a benefit by the public which is to file (and by the USPTO to process) an application. Confidentiality is governed by 35 U.S.C. 122 and 37 CFR 1.11 and 1.14. This collection is estimated to take 21 minutes to complete, including gathering, preparing, and submitting the completed application form to the USPTO. Time will vary depending upon the individual case. Any comments on the amount of time you require to complete this form and/or suggestions for reducing this burden, should be sent to the Chief Information Officer, U.S. Patent and Trademark Office, U.S. Department of Commerce, P.O. Box 1450, Alexandria, VA 22313-1450. DO NOT SEND FEES OR COMPLETED FORMS TO THIS ADDRESS. **SEND TO: Commissioner for Patents, P.O. Box 1450, Alexandria, VA 22313-1450.**

If you need assistance in completing the form, call 1-800-PTO-9199 (1-800-786-9199) and select option 2.

Privacy Act Statement

The **Privacy Act of 1974 (P.L. 93-579)** requires that you be given certain information in connection with your submission of the attached form related to a patent application or patent. Accordingly, pursuant to the requirements of the Act, please be advised that: (1) the general authority for the collection of this information is 35 U.S.C. 2(b)(2); (2) furnishing of the information solicited is voluntary; and (3) the principal purpose for which the information is used by the U.S. Patent and Trademark Office is to process and/or examine your submission related to a patent application or patent. If you do not furnish the requested information, the U.S. Patent and Trademark Office may not be able to process and/or examine your submission, which may result in termination of proceedings or abandonment of the application or expiration of the patent.

The information provided by you in this form will be subject to the following routine uses:

1. The information on this form will be treated confidentially to the extent allowed under the Freedom of Information Act (5 U.S.C. 552) and the Privacy Act (5 U.S.C. 552a). Records from this system of records may be disclosed to the Department of Justice to determine whether disclosure of these records is required by the Freedom of Information Act.
2. A record from this system of records may be disclosed, as a routine use, in the course of presenting evidence to a court, magistrate, or administrative tribunal, including disclosures to opposing counsel in the course of settlement negotiations.
3. A record in this system of records may be disclosed, as a routine use, to a Member of Congress submitting a request involving an individual, to whom the record pertains, when the individual has requested assistance from the Member with respect to the subject matter of the record.
4. A record in this system of records may be disclosed, as a routine use, to a contractor of the Agency having need for the information in order to perform a contract. Recipients of information shall be required to comply with the requirements of the Privacy Act of 1974, as amended, pursuant to 5 U.S.C. 552a(m).
5. A record related to an International Application filed under the Patent Cooperation Treaty in this system of records may be disclosed, as a routine use, to the International Bureau of the World Intellectual Property Organization, pursuant to the Patent Cooperation Treaty.
6. A record in this system of records may be disclosed, as a routine use, to another federal agency for purposes of National Security review (35 U.S.C. 181) and for review pursuant to the Atomic Energy Act (42 U.S.C. 218(c)).
7. A record from this system of records may be disclosed, as a routine use, to the Administrator, General Services, or his/her designee, during an inspection of records conducted by GSA as part of that agency's responsibility to recommend improvements in records management practices and programs, under authority of 44 U.S.C. 2904 and 2906. Such disclosure shall be made in accordance with the GSA regulations governing inspection of records for this purpose, and any other relevant (*i.e.*, GSA or Commerce) directive. Such disclosure shall not be used to make determinations about individuals.
8. A record from this system of records may be disclosed, as a routine use, to the public after either publication of the application pursuant to 35 U.S.C. 122(b) or issuance of a patent pursuant to 35 U.S.C. 151. Further, a record may be disclosed, subject to the limitations of 37 CFR 1.14, as a routine use, to the public if the record was filed in an application which became abandoned or in which the proceedings were terminated and which application is referenced by either a published application, an application open to public inspection or an issued patent.
9. A record from this system of records may be disclosed, as a routine use, to a Federal, State, or local law enforcement agency, if the USPTO becomes aware of a violation or potential violation of law or regulation.



UNITED STATES PATENT AND TRADEMARK OFFICE

UNITED STATES DEPARTMENT OF COMMERCE
United States Patent and Trademark Office
Address: COMMISSIONER FOR PATENTS
P.O. Box 1450
Alexandria, Virginia 22313-1450
www.uspto.gov

Table with 4 columns: APPLICATION NUMBER (16/048,242), FILING OR 371(C) DATE (07/28/2018), FIRST NAMED APPLICANT (Gal Shabtay), ATTY. DOCKET NO./TITLE (COREPH-0079 US CON3)

CONFIRMATION NO. 4814

FORMALITIES LETTER

92342
Nathan & Associates Patent Agents Ltd
P.O.Box 10178
Tel Aviv, 6110101
ISRAEL



Date Mailed: 08/30/2018

NOTICE TO FILE MISSING PARTS OF NONPROVISIONAL APPLICATION

FILED UNDER 37 CFR 1.53(b)

Filing Date Granted

Items Required To Avoid Abandonment:

An application number and filing date have been accorded to this application. The item(s) indicated below, however, are missing.

Applicant is given TWO MONTHS from the date of this Notice within which to file all required items below to avoid abandonment. Extensions of time may be obtained by filing a petition accompanied by the extension fee under the provisions of 37 CFR 1.136(a).

- Surcharge as set forth in 37 CFR 1.16(f) must be submitted.
The surcharge is due for any one of:
• late submission of the basic filing fee, search fee, or examination fee,
• late submission of inventor's oath or declaration,
• filing an application that does not contain at least one claim on filing, or
• submission of an application filed by reference to a previously filed application.

SUMMARY OF FEES DUE:

The fee(s) required within TWO MONTHS from the date of this Notice to avoid abandonment is/are itemized below. Small entity discount is in effect. If applicant is qualified for micro entity status, an acceptable Certification of Micro Entity Status must be submitted to establish micro entity status. (See 37 CFR 1.29 and forms PTO/SB/15A and 15B.)

- \$ 80 surcharge.
• \$(0) previous unapplied payment amount.
• \$ 80 TOTAL FEE BALANCE DUE.

Items Required To Avoid Processing Delays:

Applicant is notified that the above-identified application contains the deficiencies noted below. No period for reply is set forth in this notice for correction of these deficiencies. However, if a deficiency relates to the inventor's oath or declaration, the applicant must file an oath or declaration in compliance with 37 CFR 1.63, or a substitute statement in compliance with 37 CFR 1.64, executed by or with respect to each actual inventor no later than the expiration of the time period set in the "Notice of Allowability" to avoid abandonment. See 37 CFR 1.53(f).

- A properly executed inventor's oath or declaration has not been received for the following inventor(s):

Oded Gigushinski

Replies must be received in the USPTO within the set time period or must include a proper Certificate of Mailing or Transmission under 37 CFR 1.8 with a mailing or transmission date within the set time period. For more information and a suggested format, see Form PTO/SB/92 and MPEP 512.

Replies should be mailed to:

Mail Stop Missing Parts
Commissioner for Patents
P.O. Box 1450
Alexandria VA 22313-1450

Registered users of EFS-Web may alternatively submit their reply to this notice via EFS-Web, including a copy of this Notice and selecting the document description "Applicant response to Pre-Exam Formalities Notice".
<https://portal.uspto.gov/authenticate/AuthenticateUserLocalEPF.html>

For more information about EFS-Web please call the USPTO Electronic Business Center at 1-866-217-9197 or visit our website at <http://www.uspto.gov/ebc>.

If you are not using EFS-Web to submit your reply, you must include a copy of this notice.

Questions about the contents of this notice and the requirements it sets forth should be directed to the Office of Data Management, Application Assistance Unit, at (571) 272-4000 or (571) 272-4200 or 1-888-786-0101.

/kgebremichael/



UNITED STATES PATENT AND TRADEMARK OFFICE

UNITED STATES DEPARTMENT OF COMMERCE
United States Patent and Trademark Office
Address: COMMISSIONER FOR PATENTS
P.O. Box 1450
Alexandria, Virginia 22313-1450
www.uspto.gov

Table with 7 columns: APPLICATION NUMBER, FILING or 371(c) DATE, GRP ART UNIT, FIL FEE REC'D, ATTY. DOCKET NO, TOT CLAIMS, IND CLAIMS. Row 1: 16/048,242, 07/28/2018, 2676, 1785, COREPH-0079 US CON3, 40, 3

CONFIRMATION NO. 4814

FILING RECEIPT

92342
Nathan & Associates Patent Agents Ltd
P.O.Box 10178
Tel Aviv, 6110101
ISRAEL



Date Mailed: 08/30/2018

Receipt is acknowledged of this non-provisional patent application. The application will be taken up for examination in due course. Applicant will be notified as to the results of the examination. Any correspondence concerning the application must include the following identification information: the U.S. APPLICATION NUMBER, FILING DATE, NAME OF APPLICANT, and TITLE OF INVENTION. Fees transmitted by check or draft are subject to collection. Please verify the accuracy of the data presented on this receipt. If an error is noted on this Filing Receipt, please submit a written request for a Filing Receipt Correction. Please provide a copy of this Filing Receipt with the changes noted thereon. If you received a "Notice to File Missing Parts" for this application, please submit any corrections to this Filing Receipt with your reply to the Notice. When the USPTO processes the reply to the Notice, the USPTO will generate another Filing Receipt incorporating the requested corrections

Inventor(s)

Gal Shabtay, Tel Aviv, ISRAEL;
Ephraim Goldenberg, Ashdod, ISRAEL;
Oded Gigushinski, Herzlia, ISRAEL;
Noy Cohen, Tel Aviv;

Applicant(s)

Corephotonics Ltd., Tel Aviv, ISRAEL;

Power of Attorney: The patent practitioners associated with Customer Number 92342

Domestic Priority data as claimed by applicant

This application is a CON of 15/865,869 01/09/2018
which is a CON of 15/424,853 02/05/2017 PAT 10015408
which is a CON of 14/880,251 10/11/2015 PAT 9661233
which is a CON of 14/365,711 06/16/2014 PAT 9185291
which is a 371 of PCT/IB2014/062180 06/12/2014
which claims benefit of 61/834,486 06/13/2013

Foreign Applications for which priority is claimed (You may be eligible to benefit from the Patent Prosecution Highway program at the USPTO. Please see http://www.uspto.gov for more information.) - None. Foreign application information must be provided in an Application Data Sheet in order to constitute a claim to foreign priority. See 37 CFR 1.55 and 1.76.

Permission to Access Application via Priority Document Exchange: Yes

Permission to Access Search Results: Yes

Applicant may provide or rescind an authorization for access using Form PTO/SB/39 or Form PTO/SB/69 as appropriate.

If Required, Foreign Filing License Granted: 08/29/2018

The country code and number of your priority application, to be used for filing abroad under the Paris Convention, is **US 16/048,242**

Projected Publication Date: 12/06/2018

Non-Publication Request: No

Early Publication Request: No

**** SMALL ENTITY ****

Title

DUAL APERTURE ZOOM DIGITAL CAMERA

Preliminary Class

358

Statement under 37 CFR 1.55 or 1.78 for AIA (First Inventor to File) Transition Applications: No

PROTECTING YOUR INVENTION OUTSIDE THE UNITED STATES

Since the rights granted by a U.S. patent extend only throughout the territory of the United States and have no effect in a foreign country, an inventor who wishes patent protection in another country must apply for a patent in a specific country or in regional patent offices. Applicants may wish to consider the filing of an international application under the Patent Cooperation Treaty (PCT). An international (PCT) application generally has the same effect as a regular national patent application in each PCT-member country. The PCT process **simplifies** the filing of patent applications on the same invention in member countries, but **does not result** in a grant of "an international patent" and does not eliminate the need of applicants to file additional documents and fees in countries where patent protection is desired.

Almost every country has its own patent law, and a person desiring a patent in a particular country must make an application for patent in that country in accordance with its particular laws. Since the laws of many countries differ in various respects from the patent law of the United States, applicants are advised to seek guidance from specific foreign countries to ensure that patent rights are not lost prematurely.

Applicants also are advised that in the case of inventions made in the United States, the Director of the USPTO must issue a license before applicants can apply for a patent in a foreign country. The filing of a U.S. patent application serves as a request for a foreign filing license. The application's filing receipt contains further information and guidance as to the status of applicant's license for foreign filing.

Applicants may wish to consult the USPTO booklet, "General Information Concerning Patents" (specifically, the section entitled "Treaties and Foreign Patents") for more information on timeframes and deadlines for filing foreign patent applications. The guide is available either by contacting the USPTO Contact Center at 800-786-9199, or it can be viewed on the USPTO website at <http://www.uspto.gov/web/offices/pac/doc/general/index.html>.

For information on preventing theft of your intellectual property (patents, trademarks and copyrights), you may wish to consult the U.S. Government website, <http://www.stopfakes.gov>. Part of a Department of Commerce initiative, this website includes self-help "toolkits" giving innovators guidance on how to protect intellectual property in specific

page 2 of 4

countries such as China, Korea and Mexico. For questions regarding patent enforcement issues, applicants may call the U.S. Government hotline at 1-866-999-HALT (1-866-999-4258).

LICENSE FOR FOREIGN FILING UNDER
Title 35, United States Code, Section 184
Title 37, Code of Federal Regulations, 5.11 & 5.15

GRANTED

The applicant has been granted a license under 35 U.S.C. 184, if the phrase "IF REQUIRED, FOREIGN FILING LICENSE GRANTED" followed by a date appears on this form. Such licenses are issued in all applications where the conditions for issuance of a license have been met, regardless of whether or not a license may be required as set forth in 37 CFR 5.15. The scope and limitations of this license are set forth in 37 CFR 5.15(a) unless an earlier license has been issued under 37 CFR 5.15(b). The license is subject to revocation upon written notification. The date indicated is the effective date of the license, unless an earlier license of similar scope has been granted under 37 CFR 5.13 or 5.14.

This license is to be retained by the licensee and may be used at any time on or after the effective date thereof unless it is revoked. This license is automatically transferred to any related applications(s) filed under 37 CFR 1.53(d). This license is not retroactive.

The grant of a license does not in any way lessen the responsibility of a licensee for the security of the subject matter as imposed by any Government contract or the provisions of existing laws relating to espionage and the national security or the export of technical data. Licensees should apprise themselves of current regulations especially with respect to certain countries, of other agencies, particularly the Office of Defense Trade Controls, Department of State (with respect to Arms, Munitions and Implements of War (22 CFR 121-128)); the Bureau of Industry and Security, Department of Commerce (15 CFR parts 730-774); the Office of Foreign Assets Control, Department of Treasury (31 CFR Parts 500+) and the Department of Energy.

NOT GRANTED

No license under 35 U.S.C. 184 has been granted at this time, if the phrase "IF REQUIRED, FOREIGN FILING LICENSE GRANTED" DOES NOT appear on this form. Applicant may still petition for a license under 37 CFR 5.12, if a license is desired before the expiration of 6 months from the filing date of the application. If 6 months has lapsed from the filing date of this application and the licensee has not received any indication of a secrecy order under 35 U.S.C. 181, the licensee may foreign file the application pursuant to 37 CFR 5.15(b).

SelectUSA

The United States represents the largest, most dynamic marketplace in the world and is an unparalleled location for business investment, innovation, and commercialization of new technologies. The U.S. offers tremendous resources and advantages for those who invest and manufacture goods here. Through SelectUSA, our nation works to promote and facilitate business investment. SelectUSA provides information assistance to the international investor community; serves as an ombudsman for existing and potential investors; advocates on behalf of U.S. cities, states, and regions competing for global investment; and counsels U.S. economic development organizations on investment attraction best practices. To learn more about why the United States is the best country in the world to develop

technology, manufacture products, deliver services, and grow your business, visit <http://www.SelectUSA.gov> or call +1-202-482-6800.

DUAL APERTURE ZOOM DIGITAL CAMERA

CROSS REFERENCE TO RELATED APPLICATIONS

5 This application is a Continuation application of US patent application No. 15/865,869, filed January 9, 2018, which was a Continuation application of US patent application No. 15/424,853 filed February 5, 2017, which was a Continuation application of US patent application No. 14/880,251 filed October 11, 2015 (issued as US patent 9661233), which was a Continuation application of US patent application No. 14/365,711 filed June 16,
10 2014 (issued as US patent 9185291), which was a 371 application from international patent application PCT/IB2014/062180 filed June 12, 2014, and is related to and claims priority from US Provisional Patent Application No. 61/834,486 having the same title and filed June 13, 2013, which is incorporated herein by reference in its entirety.

15 FIELD

Embodiments disclosed herein relate in general to digital cameras and in particular to thin zoom digital cameras with both still image and video capabilities

20 BACKGROUND

Digital camera modules are currently being incorporated into a variety of host devices. Such host devices include cellular telephones, personal data assistants (PDAs), computers, and so forth. Consumer demand for digital camera modules in host devices continues to grow.

25 Host device manufacturers prefer digital camera modules to be small, so that they can be incorporated into the host device without increasing its overall size. Further, there is an increasing demand for such cameras to have higher-performance characteristics. One such characteristic possessed by many higher-performance cameras (e.g., standalone digital still cameras) is the ability to vary the focal length of the camera to increase and decrease the
30 magnification of the image. This ability, typically accomplished with a zoom lens, is known as optical zooming. "Zoom" is commonly understood as a capability to provide different magnifications of the same scene and/or object by changing the focal length of an optical system, with a higher level of zoom associated with greater magnification and a lower level of zoom associated with lower magnification. Optical zooming is typically accomplished by

mechanically moving lens elements relative to each other. Such zoom lenses are typically more expensive, larger and less reliable than fixed focal length lenses. An alternative approach for approximating the zoom effect is achieved with what is known as digital zooming. With digital zooming, instead of varying the focal length of the lens, a processor in the camera crops the image and interpolates between the pixels of the captured image to create a magnified but lower-resolution image.

Attempts to use multi-aperture imaging systems to approximate the effect of a zoom lens are known. A multi-aperture imaging system (implemented for example in a digital camera) includes a plurality of optical sub-systems (also referred to as "sub-cameras"). Each sub-camera includes one or more lenses and/or other optical elements which define an aperture such that received electro-magnetic radiation is imaged by the optical sub-system and a resulting image is directed towards a two-dimensional (2D) pixelated image sensor region. The image sensor (or simply "sensor") region is configured to receive the image and to generate a set of image data based on the image. The digital camera may be aligned to receive electromagnetic radiation associated with scenery having a given set of one or more objects. The set of image data may be represented as digital image data, as well known in the art. Hereinafter in this description, "image" "image data" and "digital image data" may be used interchangeably. Also, "object" and "scene" may be used interchangeably.

Multi-aperture imaging systems and associated methods are described for example in US Patent Publications No. 2008/0030592, 2010/0277619 and 2011/0064327. In US 2008/0030592, two sensors are operated simultaneously to capture an image imaged through an associated lens. A sensor and its associated lens form a lens/sensor combination. The two lenses have different focal lengths. Thus, even though each lens/sensor combination is aligned to look in the same direction, each captures an image of the same subject but with two different fields of view (FOVs). One sensor is commonly called "Wide" and the other "Tele". Each sensor provides a separate image, referred to respectively as "Wide" (or "W") and "Tele" (or "T") images. A W-image reflects a wider FOV and has lower resolution than the T-image. The images are then stitched (fused) together to form a composite ("fused") image. In the composite image, the central portion is formed by the relatively higher-resolution image taken by the lens/sensor combination with the longer focal length, and the peripheral portion is formed by a peripheral portion of the relatively lower-resolution image taken by the lens/sensor combination with the shorter focal length. The user selects a desired amount of zoom and the composite image is used to interpolate values from the chosen amount of zoom to provide a respective zoom image. The solution offered by US 2008/0030592 requires, in

video mode, very large processing resources in addition to high frame rate requirements and high power consumption (since both cameras are fully operational).

US 2010/0277619 teaches a camera with two lens/sensor combinations, the two lenses having different focal lengths, so that the image from one of the combinations has a FOV approximately 2-3 times greater than the image from the other combination. As a user of the camera requests a given amount of zoom, the zoomed image is provided from the lens/sensor combination having a FOV that is next larger than the requested FOV. Thus, if the requested FOV is less than the smaller FOV combination, the zoomed image is created from the image captured by that combination, using cropping and interpolation if necessary. Similarly, if the requested FOV is greater than the smaller FOV combination, the zoomed image is created from the image captured by the other combination, using cropping and interpolation if necessary. The solution offered by US 2010/0277619 leads to parallax artifacts when moving to the Tele camera in video mode.

In both US 2008/0030592 and US 2010/0277619, different focal length systems cause Tele and Wide matching FOVs to be exposed at different times using CMOS sensors. This degrades the overall image quality. Different optical F numbers ("F#") cause image intensity differences. Working with such a dual sensor system requires double bandwidth support, i.e. additional wires from the sensors to the following HW component. Neither US 2008/0030592 nor US 2010/0277619 deal with registration errors. Neither US2008/000592 nor US 2010/0277619 refer to partial fusion, i.e. fusion of less than all the pixels of both Wide and Tele images in still mode.

US 2011/0064327 discloses multi-aperture imaging systems and methods for image data fusion that include providing first and second sets of image data corresponding to an imaged first and second scene respectively. The scenes overlap at least partially in an overlap region, defining a first collection of overlap image data as part of the first set of image data, and a second collection of overlap image data as part of the second set of image data. The second collection of overlap image data is represented as a plurality of image data sub-cameras such that each of the sub-cameras is based on at least one characteristic of the second collection, and each sub-camera spans the overlap region. A fused set of image data is produced by an image processor, by modifying the first collection of overlap image data based on at least a selected one of, but less than all of, the image data sub-cameras. The systems and methods disclosed in this application deal solely with fused still images.

None of the known art references provide a thin (e.g. fitting in a cell-phone) dual-aperture zoom digital camera with fixed focal length lenses, the camera configured to operate

in both still mode and video mode to provide still and video images, wherein the camera configuration uses partial or full fusion to provide a fused image in still mode and does not use any fusion to provide a continuous, smooth zoom in video mode.

Therefore there is a need for, and it would be advantageous to have thin digital cameras with optical zoom operating in both video and still mode that do not suffer from commonly encountered problems and disadvantages, some of which are listed above.

SUMMARY

Embodiments disclosed herein teach the use of dual-aperture (also referred to as dual-lens or two-sensor) optical zoom digital cameras. The cameras include two sub-cameras, a Wide sub-camera and a Tele sub-camera, each sub-camera including a fixed focal length lens, an image sensor and an image signal processor (ISP). The Tele sub-camera is the higher zoom sub-camera and the Wide sub-camera is the lower zoom sub-camera. In some embodiments, the lenses are thin lenses with short optical paths of less than about 9mm. In some embodiments, the thickness/effective focal length (EFL) ratio of the Tele lens is smaller than about 1. The image sensor may include two separate 2D pixelated sensors or a single pixelated sensor divided into at least two areas. The digital camera can be operated in both still and video modes. In still mode, zoom is achieved "with fusion" (full or partial), by fusing W and T images, with the resulting fused image including always information from both W and T images. Partial fusion may be achieved by not using fusion in image areas where the Tele image is not focused. This advantageously reduces computational requirements (e.g. time).

In video mode, optical zoom is achieved "without fusion", by switching between the W and T images to shorten computational time requirements, thus enabling high video rate. To avoid discontinuities in video mode, the switching includes applying additional processing blocks, which include image scaling and shifting.

In order to reach optical zoom capabilities, a different magnification image of the same scene is captured (grabbed) by each camera sub-camera, resulting in FOV overlap between the two sub-cameras. Processing is applied on the two images to fuse and output one fused image in still mode. The fused image is processed according to a user zoom factor request. As part of the fusion procedure, up-sampling may be applied on one or both of the grabbed images to scale it to the image grabbed by the Tele sub-camera or to a scale defined by the user. The fusion or up-sampling may be applied to only some of the pixels of a sensor.

Down-sampling can be performed as well if the output resolution is smaller than the sensor resolution.

5 The cameras and associated methods disclosed herein address and correct many of the problems and disadvantages of known dual-aperture optical zoom digital cameras. They provide an overall zoom solution that refers to all aspects: optics, algorithmic processing and system hardware (HW). The proposed solution distinguishes between video and still mode in the processing flow and specifies the optical requirements and HW requirements. In addition, it provides an innovative optical design that enables a low TTL/EFL ratio using a specific lens curvature order.

10 Due to the large focal length, objects that are in front or behind the plane of focus appear very blurry, and a nice foreground-to-background contrast is achieved. However, it is difficult to create such a blur using a compact camera with a relatively short focal length and small aperture size, such as a cell-phone camera. In some embodiments, a dual-aperture zoom system disclosed herein can be used to capture a shallow DOF photo (shallow compared with
15 a DOF of a Wide camera alone), by taking advantage of the longer focal length of the Tele lens. The reduced DOF effect provided by the longer Tele focal length can be further enhanced in the final image by fusing data from an image captured simultaneously with the Wide lens. Depending on the distance to the object, with the Tele lens focused on a subject of the photo, the Wide lens can be focused to a closer distance than the subject so that objects
20 behind the subject appear very blurry. Once the two images are captured, information from the out-of-focus blurred background in the Wide image is fused with the original Tele image background information, providing a blurrier background and even shallower DOF.

In an embodiment there is provided a zoom digital camera comprising a Wide imaging section that includes a fixed focal length Wide lens with a Wide FOV, a Wide sensor and a
25 Wide image signal processor (ISP), the Wide imaging section operative to provide Wide image data of an object or scene; a Tele imaging section that includes a fixed focal length Tele lens with a Tele FOV that is narrower than the Wide FOV, a Tele sensor and a Tele ISP, the Tele imaging section operative to provide Tele image data of the object or scene; and a camera controller operatively coupled to the Wide and Tele imaging sections, the camera
30 controller configured to combine in still mode at least some of the Wide and Tele image data to provide a fused output image of the object or scene from a particular point of view (POV), and to provide without fusion continuous zoom video mode output images of the object or scene, a camera controller operatively coupled to the Wide and Tele imaging sections, the camera controller configured to combine in still mode at least some of the Wide and Tele

image data to provide a fused output image of the object or scene from a particular point of view and to provide without fusion continuous zoom video mode output images of the object or scene, each output image having a respective output resolution, wherein the video output images are provided with a smooth transition when switching between a lower zoom factor (ZF) value and a higher ZF value or vice versa, wherein at the lower ZF value the output resolution is determined by the Wide sensor, and wherein at the higher ZF value the output resolution is determined by the Tele sensor.

In an embodiment, the camera controller configuration to provide video output images with a smooth transition when switching between a lower ZF value and a higher ZF value or vice versa includes a configuration that uses at high ZF secondary information from the Wide camera and uses at low ZF secondary information from the Tele camera. As used herein, "secondary information" refers to white balance gain, exposure time, analog gain and color correction matrix.

In a dual-aperture camera image plane, as seen by each sub-camera (and respective image sensor), a given object will be shifted and have different perspective (shape). This is referred to as point-of-view (POV). The system output image can have the shape and position of either sub-camera image or the shape or position of a combination thereof. If the output image retains the Wide image shape then it has the Wide perspective POV. If it retains the Wide camera position then it has the Wide position POV. The same applies for Tele images position and perspective. As used in this description, the perspective POV may be of the Wide or Tele sub-cameras, while the position POV may shift continuously between the Wide and Tele sub-cameras. In fused images, it is possible to register Tele image pixels to a matching pixel set within the Wide image pixels, in which case the output image will retain the Wide POV ("Wide fusion"). Alternatively, it is possible to register Wide image pixels to a matching pixel set within the Tele image pixels, in which case the output image will retain the Tele POV ("Tele fusion"). It is also possible to perform the registration after either sub-camera image is shifted, in which case the output image will retain the respective Wide or Tele perspective POV.

In an embodiment there is provided a method for obtaining zoom images of an object or scene in both still and video modes using a digital camera, the method comprising the steps of providing in the digital camera a Wide imaging section having a Wide lens with a Wide FOV, a Wide sensor and a Wide image signal processor (ISP), a Tele imaging section having a Tele lens with a Tele FOV that is narrower than the Wide FOV, a Tele sensor and a Tele ISP, and a camera controller operatively coupled to the Wide and Tele imaging sections; and

configuring the camera controller to combine in still mode at least some of the Wide and Tele image data to provide a fused output image of the object or scene from a particular point of view, and to provide without fusion continuous zoom video mode output images of the object or scene, each output image having a respective output resolution, wherein the video mode
5 output images are provided with a smooth transition when switching between a lower ZF value and a higher ZF value or vice versa, and wherein at the lower ZF value the output resolution is determined by the Wide sensor while at the higher ZF value the output resolution is determined by the Tele sensor.

10 BRIEF DESCRIPTION OF THE DRAWINGS

Non-limiting examples of embodiments disclosed herein are described below with reference to figures attached hereto that are listed following this paragraph. The drawings and descriptions are meant to illuminate and clarify embodiments disclosed herein, and should not
15 be considered limiting in any way.

FIG. 1A shows schematically a block diagram illustrating a dual-aperture zoom imaging system disclosed herein;

FIG. 1B is a schematic mechanical diagram of the dual-aperture zoom imaging system of FIG. 1A:

20 FIG. 2 shows an example of Wide sensor, Tele sensor and their respective FOVs;

FIG. 3 shows a schematically embodiment of CMOS sensor image grabbing vs. time;

FIG. 4 shows schematically a sensor time configuration which enables sharing one sensor interface using dual sensor zoom system;

FIG. 5 shows an embodiment of a method disclosed herein for acquiring a zoom
25 image in capture mode;

FIG. 6 shows an embodiment of a method disclosed herein for acquiring a zoom image in video/preview mode;

FIG. 7 shows a graph illustrating an effective resolution zoom factor;

FIG. 8 shows one embodiment of a lens block in a thin camera disclosed herein;

30 FIG. 9 shows another embodiment of a lens block in a thin camera disclosed herein.

DETAILED DESCRIPTION

FIG. 1A shows schematically a block diagram illustrating an embodiment of a dual-

aperture zoom imaging system (also referred to simply as “digital camera” or “camera”) disclosed herein and numbered **100**. Camera **100** comprises a Wide imaging section (“sub-camera”) that includes a Wide lens block **102**, a Wide image sensor **104** and a Wide image processor **106**. Camera **100** further comprises a Tele imaging section (“sub-camera”) that includes a Tele lens block **108**, a Tele image sensor **110** and a Tele image processor **112**. The image sensors may be physically separate or may be part of a single larger image sensor. The Wide sensor pixel size can be equal to or different from the Tele sensor pixel size. Camera **100** further comprises a camera fusion processing core (also referred to as “controller”) **114** that includes a sensor control module **116**, a user control module **118**, a video processing module **126** and a capture processing module **128**, all operationally coupled to sensor control block **110**. User control module **118** comprises an operational mode function **120**, a region of interest (ROI) function **122** and a zoom factor (ZF) function **124**.

Sensor control module **116** is connected to the two sub-cameras and to the user control module **118** and used to choose, according to the zoom factor, which of the sensors is operational and to control the exposure mechanism and the sensor readout. Mode choice function **120** is used for choosing capture/video modes. ROI function **122** is used to choose a region of interest. As used herein, “ROI” is a user defined as a sub-region of the image that may be exemplarily 4% or less of the image area. The ROI is the region on which both sub-cameras are focused on. . Zoom factor function **124** is used to choose a zoom factor. Video processing module **126** is connected to mode choice function **120** and used for video processing. Still processing module **128** is connected to the mode choice function **120** and used for high image quality still mode images. The video processing module is applied when the user desires to shoot in video mode. The capture processing module is applied when the user wishes to shoot still pictures.

FIG. 1B is a schematic mechanical diagram of the dual-aperture zoom imaging system of FIG. 1A. Exemplary dimensions: Wide lens TTL = 4.2mm and EFL = 3.5mm; Tele lens TTL = 6mm and EFL = 7 mm; both Wide and Tele sensors 1/3 inch. External dimensions of Wide and Tele cameras: width (w) and length (l) = 8.5 mm and height (h) = 6.8 mm. Distance “d” between camera centers = 10mm.

Following is a detailed description and examples of different methods of use of camera **100**.

Design for continuous and smooth zoom in video mode

In an embodiment, in order to reach high quality continuous and smooth optical zooming in video camera mode while reaching real optical zoom using fixed focal length sub-cameras, the system is designed according to the following rules (Equations 1-3):

$$\tan(\text{FOV}_{\text{Wide}})/\tan(\text{FOV}_{\text{Tele}}) = \text{PL}_{\text{Wide}}/\text{PL}_{\text{video}} \quad (1)$$

where \tan refers to "tangent", while FOV_{Wide} and FOV_{Tele} refer respectively to the Wide and Tele lens fields of view (in degrees). As used herein, the FOV is measured from the center axis to the corner of the sensor (i.e. half the angle of the normal definition). PL_{Wide} and PL_{video} refer respectively to the "in-line" (i.e. in a line) number of Wide sensor pixels and in-line number of output video format pixels. The ratio $\text{PL}_{\text{Wide}}/\text{PL}_{\text{video}}$ is called an "oversampling ratio". For example, in order to get full and continuous optical zoom experience with a 12Mp sensor (sensor dimensions 4000x3000) and a required 1080p (dimension 1920x1080) video format, the FOV ratio should be $4000/1920=2.083$. Moreover, if the Wide lens FOV is given as $\text{FOV}_{\text{Wide}} = 37.5^\circ$, the required Tele lens FOV is 20.2° . The zoom switching point is set according to the ratio between sensor pixels in-line and the number of pixels in-line in the video format and defined as:

$$Z_{\text{switch}} = \text{PL}_{\text{Wide}}/\text{PL}_{\text{video}} \quad (2)$$

Maximum optical zoom is reached according to the following formula:

$$Z_{\text{max}} = \tan(\text{FOV}_{\text{Wide}})/\tan(\text{FOV}_{\text{Tele}}) * \text{PL}_{\text{Tele}}/\text{PL}_{\text{video}} \quad (3)$$

For example: for the configuration defined above and assuming $\text{PL}_{\text{Tele}}=4000$ and $\text{PL}_{\text{video}}=1920$, $Z_{\text{max}}=4.35$.

In an embodiment, the sensor control module has a setting that depends on the Wide and Tele FOVs and on a sensor oversampling ratio, the setting used in the configuration of each sensor. For example, when using a 4000x3000 sensor and when outputting a 1920x1080 image, the oversampling ratio is $4000/1920=2.0833$.

In an embodiment, the Wide and Tele FOVs and the oversampling ratio satisfy the condition

$$0.8 * \text{PL}_{\text{Wide}}/\text{PL}_{\text{video}} < \tan(\text{FOV}_{\text{Wide}})/\tan(\text{FOV}_{\text{Tele}}) < 1.2 * \text{PL}_{\text{Wide}}/\text{PL}_{\text{video}} \quad (4)$$

Still mode operation/function

In still camera mode, the obtained image is fused from information obtained by both sub-cameras at all zoom levels, see FIG. 2, which shows a Wide sensor **202** and a Tele sensor **204** and their respective FOVs. Exemplarily, as shown, the Tele sensor FOV is half the Wide sensor FOV. The still camera mode processing includes two stages: (1) setting HW settings and configuration, where a first objective is to control the sensors in such a way that matching FOVs in both images (Tele and Wide) are scanned at the same time. A second objective is to control the relative exposures according to the lens properties. A third objective is to minimize the required bandwidth from both sensors for the ISPs; and (2) image processing that fuses the Wide and the Tele images to achieve optical zoom, improves SNR and provides wide dynamic range.

FIG. 3 shows image line numbers vs. time for an image section captured by CMOS sensors. A fused image is obtained by line (row) scans of each image. To prevent matching FOVs in both sensors to be scanned at different times, a particular configuration is applied by the camera controller on both image sensors while keeping the same frame rate. The difference in FOV between the sensors determines the relationship between the rolling shutter time and the vertical blanking time for each sensor. In the particular configuration, the scanning is synchronized such that the same points of the object in each view are obtained simultaneously.

Specifically with reference to FIG. 3 and according to an embodiment of a method disclosed herein, the configuration to synchronize the scanning includes: setting the Tele sensor vertical blanking time VB_{Tele} to equal the Wide sensor vertical blanking time VB_{Wide} plus half the Wide sensor rolling shutter time RST_{Wide} ; setting the Tele and Wide sensor exposure times ET_{Tele} and ET_{Wide} to be equal or different; setting the Tele sensor rolling shutter time RST_{Tele} to be $0.5 * RST_{Wide}$; and setting the frame rates of the two sensors to be equal. This procedure results in identical image pixels in the Tele and Wide sensor images being exposed at the same time

In another embodiment, the camera controller synchronizes the Wide and Tele sensors so that for both sensors the rolling shutter starts at the same time.

The exposure times applied to the two sensors could be different, for example in order to reach same image intensity using different F# and different pixel size for the Tele and Wide systems. In this case, the relative exposure time may be configured according to the formula below:

$$ET_{Tele} = ET_{Wide} \cdot (F\#_{Tele}/F\#_{Wide})^2 \cdot (\text{Pixel size}_{Wide}/\text{Pixel size}_{Tele})^2 \quad (5)$$

Other exposure time ratios may be applied to achieve wide dynamic range and improved
 5 SNR. Fusing two images with different intensities will result in wide dynamic range image.

In more detail with reference to FIG. 3, in the first stage, after the user chooses a
 required zoom factor ZF, the sensor control module configures each sensor as follows:

1) Cropping index Wide sensor:

$$Y_{Wide \text{ start}} = 1/2 \cdot PC_{Wide} (1 - 1/ZF)$$

$$10 \quad Y_{Wide \text{ end}} = 1/2 \cdot PC_{Wide} (1 + 1/ZF)$$

where PC is the number of pixels in a column, and Y is the row number

2) Cropping index Tele sensor:

If $ZF > \tan(\text{FOV}_{Wide})/\tan(\text{FOV}_{Tele})$, then

$$Y_{Tele \text{ start}} = 1/2 \cdot PC_{Tele} (1 - (1/ZF) \cdot \tan(\text{FOV}_{Tele})/\tan(\text{FOV}_{Wide}))$$

$$15 \quad Y_{Tele \text{ end}} = 1/2 \cdot PC_{Tele} (1 + (1/ZF) \cdot \tan(\text{FOV}_{Tele})/\tan(\text{FOV}_{Wide}))$$

If $ZF < \tan(\text{FOV}_{Wide})/\tan(\text{FOV}_{Tele})$, then

$$Y_{Tele \text{ start}} = 0$$

$$Y_{Tele \text{ end}} = PC_{Tele}$$

20 This will result in an exposure start time of the Tele sensor with a delay of (in numbers of lines, relative to the Wide sensor start time):

$$(1 - ZF / (\tan(\text{FOV}_{Wide})/\tan(\text{FOV}_{Tele}))) \cdot 1 / (2 \cdot \text{FPS}) \quad (6)$$

25 where FPS is the sensor's frame per second configuration. In cases where $ZF > \tan(\text{FOV}_{Wide})/\tan(\text{FOV}_{Tele})$, no delay will be introduced between Tele and Wide exposure starting point. For example, for a case where $\tan(\text{FOV}_{Wide})/\tan(\text{FOV}_{Tele}) = 2$ and $ZF = 1$, the Tele image first pixel is exposed $1/4 \cdot (1/\text{FPS})$ second after the Wide image first pixel was exposed.

30 After applying the cropping according to the required zoom factor, the sensor rolling shutter time and the vertical blank should be configured in order to satisfy the equation to keep the same frame rate:

$$VB_{Wide} + RST_{Wide} = VB_{Tele} + RST_{Tele} \quad (7)$$

FIG. 3 exemplifies Eq. (7). One way to satisfy Eq. (7) is to increase the RST_{Wide} . Controlling the RST_{Wide} may be done by changing the horizontal blanking (HB) of the Wide sensor. This will cause a delay between the data coming out from each row of the Wide sensor.

Generally, working with a dual-sensor system requires multiplying the bandwidth to the following block, for example the ISP. For example, using 12Mp working at 30fps, 10bit per pixel requires working at 3.6Gbit/sec. In this example, supporting this bandwidth requires 4 lanes from each sensor to the respective following ISP in the processing chain. Therefore, working with two sensors requires double bandwidth (7.2Gbit/sec) and 8 lanes connected to the respective following blocks. The bandwidth can be reduced by configuring and synchronizing the two sensors. Consequently, the number of lanes can be half that of a conventional configuration (3.6Gbit/sec).

FIG. 4 shows schematically a sensor time configuration that enables sharing one sensor interface using a dual-sensor zoom system, while fulfilling the conditions in the description of FIG. 3 above. For simplicity, assuming the Tele sensor image is magnified by a factor of 2 compared with the Wide sensor image, the Wide sensor horizontal blanking time HB_{Wide} is set to twice the Wide sensor line readout time. This causes a delay between output Wide lines. This delay time matches exactly the time needed to output two lines from the Tele sensor. After outputting two lines from the Tele sensor, the Tele sensor horizontal blanking time HB_{Tele} is set to be one Wide line readout time, so, while the Wide sensor outputs a row from the sensor, no data is being output from the Tele sensor. For this example, every 3rd line in the Tele sensor is delayed by an additional HB_{Tele} . In this delay time, one line from the Wide sensor is output from the dual-sensor system. After the sensor configuration stage, the data is sent in parallel or by using multiplexing into the processing section.

FIG. 5 shows an embodiment of a method disclosed herein for acquiring a zoom image in still mode. In ISP step **502**, the data of each sensor is transferred to the respective ISP component, which performs on the data various processes such as denoising, demosaicing, sharpening, scaling, etc, as known in the art. After the processing in step **502**, all following actions are performed in capture processing core **128**: in rectification step **504**, both Wide and Tele images are aligned to be on the epipolar line; in registration step **506**, mapping between the Wide and the Tele aligned images is performed to produce a registration map; in resampling step **508**, the Tele image is resampled according to the registration map, resulting in a re-sampled Tele image; in decision step **510**, the re-sampled Tele image and the Wide

image are processed to detect errors in the registration and to provide a decision output. In more detail, in step **510**, the re-sampled Tele image data is compared with the Wide image data and if the comparison detects significant dissimilarities, an error is indicated. In this case, the Wide pixel values are chosen to be used in the output image. Then, in fusion step **512**, the decision output, re-sampled Tele image and the Wide image are fused into a single zoom image.

To reduce processing time and power, steps **506, 508, 510, 512** could be bypassed by not fusing the images in non-focused areas. In this case, all steps specified above should be applied on focused areas only. Since the Tele optical system will introduce shallower depth of field than the Wide optical system, defocused areas will suffer from lower contrast in the Tele system.

Zoom-in and Zoom-out in still camera mode

We define the following: $TFOV = \tan(\text{camera FOV}/2)$. “Low ZF” refers to all ZF that comply with $ZF < \text{Wide TFOV}/\text{Tele TFOV}$. “High ZF” refers to all ZF that comply with $ZF > \text{Wide TFOV}/\text{Tele TFOV}$. “ZFT” refers to a ZF that complies with $ZF = \text{Wide TFOV}/\text{Tele TFOV}$. In one embodiment, zoom-in and zoom-out in still mode is performed as follows:

Zoom-in: at low ZF up to slightly above ZFT, the output image is a digitally zoomed, Wide fusion output. For the up-transfer ZF, the Tele image is shifted and corrected by global registration (GR) to achieve smooth transition. Then, the output is transformed to a Tele fusion output. For higher (than the up-transfer) ZF, the output is the Tele fusion output digitally zoomed.

Zoom-out: at high ZF down to slightly below ZFT, the output image is a digitally zoomed, Tele fusion output. For the down-transfer ZF, the Wide image is shifted and corrected by GR to achieve smooth transition. Then, the output is transformed to a Wide fusion output. For lower (than the down-transfer) ZF, the output is basically the down-transfer ZF output digitally zoomed but with gradually smaller Wide shift correction, until for $ZF=1$ the output is the unchanged Wide camera output.

In another embodiment, zoom-in and zoom-out in still mode is performed as follows:

Zoom-in: at low ZF up to slightly above ZFT, the output image is a digitally zoomed, Wide fusion output. For the up-transfer ZF and above, the output image is the Tele fusion output.

Zoom-out: at high ZF down to slightly below ZFT, the output image is a digitally

zoomed, Tele fusion output. For the down-transfer ZF and below, the output image is the Wide fusion output.

Video mode operation/function

5

Smooth transition

When a dual-aperture camera switches the camera output between sub-cameras or points of view, a user will normally see a "jump" (discontinuous) image change. However, a change in the zoom factor for the same camera and POV is viewed as a continuous change. A "smooth transition" is a transition between cameras or POVs that minimizes the jump effect. This may include matching the position, scale, brightness and color of the output image before and after the transition. However, an entire image position matching between the sub-camera outputs is in many cases impossible, because parallax causes the position shift to be dependent on the object distance. Therefore, in a smooth transition as disclosed herein, the position matching is achieved only in the ROI region while scale brightness and color are matched for the entire output image area.

Zoom-in and Zoom-out in video mode

20

In video mode, sensor oversampling is used to enable continuous and smooth zoom experience. Processing is applied to eliminate the changes in the image during crossover from one sub-camera to the other. Zoom from 1 to Z_{switch} is performed using the Wide sensor only. From Z_{switch} and on, it is performed mainly by the Tele sensor. To prevent "jumps" (roughness in the image), switching to the Tele image is done using a zoom factor which is a bit higher ($Z_{\text{switch}} + \Delta\text{Zoom}$) than Z_{switch} . ΔZoom is determined according to the system's properties and is different for cases where zoom-in is applied and cases where zoom-out is applied ($\Delta\text{Zoom}_{\text{in}} \neq \Delta\text{Zoom}_{\text{out}}$). This is done to prevent residual jumps artifacts to be visible at a certain zoom factor. The switching between sensors, for an increasing zoom and for decreasing zoom, is done on a different zoom factor.

The zoom video mode operation includes two stages: (1) sensor control and configuration, and (2) image processing. In the range from 1 to Z_{switch} , only the Wide sensor is operational, hence, power can be supplied only to this sensor. Similar conditions hold for a Wide AF mechanism. From $Z_{\text{switch}} + \Delta\text{Zoom}$ to Z_{max} only the Tele sensor is operational, hence,

power is supplied only to this sensor. Similarly, only the Tele sensor is operational and power is supplied only to it for a Tele AF mechanism. Another option is that the Tele sensor is operational and the Wide sensor is working in low frame rate. From Z_{switch} to $Z_{\text{switch}}+\Delta\text{Zoom}$, both sensors are operational.

5 Zoom-in: at low ZF up to slightly above ZFT, the output image is the digitally zoomed, unchanged Wide camera output. For the up-transfer ZF, the output is a transformed Tele sub-camera output, where the transformation is performed by a global registration (GR) algorithm to achieve smooth transition. For higher (than the up-transfer), the output is the transfer ZF output digitally zoomed.

10 Zoom-out: at high ZF down to slightly below ZFT, the output image is the digitally zoomed transformed Tele camera output. For the down-transfer ZF, the output is a shifted Wide camera output, where the Wide shift correction is performed by the GR algorithm to achieve smooth transition, i.e. with no jump in the ROI region. For lower (than the down-transfer) ZF, the output is basically the down-transfer ZF output digitally zoomed but with
15 gradually smaller Wide shift correction, until for ZF=1 the output is the unchanged Wide camera output.

FIG. 6 shows an embodiment of a method disclosed herein for acquiring a zoom image in video/preview mode for 3 different zoom factor (ZF) ranges: (a) ZF range = 1 : Z_{switch} ; (b) ZF range = Z_{switch} : $Z_{\text{switch}} + \Delta\text{Zoom}_{\text{in}}$; and (c) Zoom factor range = $Z_{\text{switch}} + \Delta\text{Zoom}_{\text{in}}$: Z_{max} . The description is with reference to a graph of effective resolution vs. zoom value (FIG. 7). In step **602**, sensor control module **116** chooses (directs) the sensor (Wide, Tele or both) to be operational. Specifically, if the ZF range = 1: Z_{switch} , module **116** directs the Wide sensor to be operational and the Tele sensor to be non-operational. If the ZF range is Z_{switch} : $Z_{\text{switch}} + \Delta\text{Zoom}_{\text{in}}$, module **116** directs both sensors to be operational and the zoom
20 image is generated from the Wide sensor. If the ZF range is $Z_{\text{switch}} + \Delta\text{Zoom}_{\text{in}}$: Z_{max} , module **116** directs the Wide sensor to be non-operational and the Tele sensor to be operational. After the sensor choice in step **602**, all following actions are performed in video processing core **126**. Optionally, in step **604**, color balance is calculated if two images are provided by the two sensors. Optionally yet, in step **606**, the calculated color balance is applied in one of the
25 images (depending on the zoom factor). Further optionally, in step **608**, registration is performed between the Wide and Tele images to output a transformation coefficient. The transformation coefficient can be used to set an AF position in step **610**. In step **612**, an output of any of steps **602-608** is applied on one of the images (depending on the zoom factor) for image signal processing that may include denoising, demosaicing, sharpening, scaling, etc. In
30

step **614**, the processed image is resampled according to the transformation coefficient, the requested ZF (obtained from zoom function **124**) and the output video resolution (for example 1080p). To avoid a transition point to be executed at the same ZF, ΔZoom can change while zooming in and while zooming out. This will result in hysteresis in the sensor switching point.

5 In more detail, for ZF range 1 : Z_{switch} , for $ZF < Z_{\text{switch}}$, the Wide image data is transferred to the ISP in step **612** and resampled in step **614**. For ZF range = $Z_{\text{switch}} : Z_{\text{switch}} + \Delta\text{Zoom}_{\text{in}}$, both sensors are operational and the zoom image is generated from the Wide sensor. The color balance is calculated for both images according to a given ROI. In addition, for a given ROI, registration is performed between the Wide and Tele images to output a
10 transformation coefficient. The transformation coefficient is used to set an AF position. The transformation coefficient includes the translation between matching points in the two images. This translation can be measured in a number of pixels. Different translations will result in a different number of pixel movements between matching points in the images. This movement can be translated into depth and the depth can be translated into an AF position. This enables
15 to set the AF position by only analyzing two images (Wide & Tele). The result is fast focusing.

Both color balance ratios and transformation coefficient are used in the ISP step. In parallel, the Wide image is processed to provide a processed image, followed by resampling. For ZF range = $Z_{\text{switch}} + \Delta\text{Zoom}_{\text{in}} : Z_{\text{max}}$ and for Zoom factor $> Z_{\text{switch}} + \Delta\text{Zoom}_{\text{in}}$, the color
20 balance calculated previously is now applied on the Tele image. The Tele image data is transferred to the ISP in step **612** and resampled in step **614**. To eliminate crossover artifacts and to enable smooth transition to the Tele image, the processed Tele image is resampled according to the transformation coefficient, the requested ZF (obtained from zoom function
124) and the output video resolution (for example 1080p).

25 FIG. 7 shows the effective resolution as a function of the zoom factor for a zoom-in case and for a zoom-out case $\Delta\text{Zoom}_{\text{up}}$ is set when we zoom in, and $\Delta\text{Zoom}_{\text{down}}$ is set when we zoom out. Setting $\Delta\text{Zoom}_{\text{up}}$ to be different from $\Delta\text{Zoom}_{\text{down}}$ will result in transition between the sensors to be performed at different zoom factor (“hysteresis”) when zoom-in is used and when zoom-out is used. This hysteresis phenomenon in the video mode results in
30 smooth continuous zoom experience.

Optical Design

Additional optical design considerations were taken into account to enable reaching

optical zoom resolution using small total track length (TTL). These considerations refer to the Tele lens. In an embodiment, the camera is “thin” (see also FIG. 1B) in the sense that it has an optical path of less than 9mm and a thickness/focal length (FP) ratio smaller than about 0.85. Exemplarily, as shown in FIG. 8, such a thin camera has a lens block that includes
5 (along an optical axis starting from an object) five lenses: a first lens element **802** with positive power and two lenses **804** and **806** and with negative power, a fourth lens **808** with positive power and a fifth lens **810** with negative power. In the embodiment of FIG. 8, the EFL is 7 mm, the TTL is 4.7 mm, $f = 6.12$ and $FOV = 20^\circ$. Thus the Tele lens TTL/EFL ratio is smaller than 0.9. In other embodiments, the Tele lens TTL/EFL ratio may be smaller than 1.

10 In another embodiment of a lens block in a thin camera, shown in FIG. 9, the camera has a lens block that includes (along an optical axis starting from an object) a first lens element **902** with positive power a second lens element **904** with negative power, a third lens element with positive power **906** and a fourth lens element with negative power **908**, and a fifth lens element **910** with positive or negative power. In this embodiment, $f = 7.14$, $F\# =$
15 3.5 , $TTL = 5.8\text{mm}$ and $FOV = 22.7^\circ$.

In conclusion, dual aperture optical zoom digital cameras and associated methods disclosed herein reduce the amount of processing resources, lower frame rate requirements, reduce power consumption, remove parallax artifacts and provide continuous focus (or provide loss of focus) when changing from Wide to Tele in video mode. They provide a
20 dramatic reduction of the disparity range and avoid false registration in capture mode. They reduce image intensity differences and enable work with a single sensor bandwidth instead of two, as in known cameras.

All patent applications mentioned in this specification are herein incorporated in their entirety by reference into the specification, to the same extent as if each individual patent
25 application was specifically and individually indicated to be incorporated herein by reference. In addition, citation or identification of any reference in this application shall not be construed as an admission that such reference is available as prior art to the present disclosure.

While this disclosure has been described in terms of certain embodiments and generally associated methods, alterations and permutations of the embodiments and methods
30 will be apparent to those skilled in the art. The disclosure is to be understood as not limited by the specific embodiments described herein, but only by the scope of the appended claims.

WHAT IS CLAIMED IS:

1. A dual-aperture digital camera for imaging an object or scene, comprising:
 - a) a Wide camera comprising a Wide lens and a Wide image sensor, the Wide camera having a respective field of view FOV_W and being operative to provide a Wide image of the object or scene;
 - b) a Tele camera comprising a Tele lens and a Tele image sensor, the Tele camera having a respective field of view FOV_T narrower than FOV_W and being operative to provide a Tele image of the object or scene, wherein the Tele lens has a respective effective focal length EFL_T and total track length TTL_T fulfilling the condition $EFL_T/TTL_T > 1$;
 - c) a first autofocus (AF) mechanism coupled mechanically to, and used to perform an AF action on the Wide lens;
 - d) a second AF mechanism coupled mechanically to, and used to perform an AF action on the Tele lens; and
 - e) a camera controller operatively coupled to the first and second AF mechanisms and to the Wide and Tele image sensors and configured to control the AF mechanisms and to process the Wide and Tele images to create a fused image, wherein areas in the Tele image that are not focused are not combined with the Wide image to create the fused image and wherein the camera controller is further operative to output the fused image with a point of view (POV) of the Wide camera by mapping Tele image pixels to matching pixels within the Wide image.
2. The dual-aperture digital camera of claim 1, wherein the camera controller is further configured to perform rectification of the Wide and Tele images by aligning these images to be on an approximately epipolar line to obtain rectified Wide and Tele images.
3. The dual-aperture digital camera of claim 2, wherein the camera controller is further configured to perform mapping between the rectified Wide and Tele images to produce a registration map.
4. The dual-aperture digital camera of claim 3, wherein the camera controller is further configured to perform resampling of the Tele image according to the registration map to provide a re-sampled Tele image.

5. The dual-aperture digital camera of claim 4, wherein the camera controller is further configured to process the re-sampled Tele image and the Wide image to detect an error in the registration and to provide a decision output.
6. The dual-aperture digital camera of claim 5, wherein, if an error is detected, the camera controller is further configured to choose Wide pixel values to be used in the output image for pixels that caused the error.
7. The dual-aperture digital camera of claim 1, wherein the Wide and Tele image sensors have pixels with identical pixel counts.
8. The dual-aperture digital camera of claim 7, wherein the pixel count is 12 MP.
9. The dual-aperture digital camera of claim 1, wherein the Wide and Tele image sensors have pixels with respective pixel sizes Pixel size_{Wide} and Pixel size_{Tele} and wherein Pixel size_{Wide} is equal to Pixel size_{Tele}.
10. The dual-aperture digital camera of claim 1, wherein the Wide and Tele image sensors have pixels with respective pixel sizes Pixel size_{Wide} and Pixel size_{Tele} and wherein Pixel size_{Wide} is not equal to Pixel size_{Tele}.
11. The dual-aperture digital camera of claim 1, wherein the Wide and Tele lenses have different F numbers F#_{Wide} and F#_{Tele}.
12. The dual-aperture digital camera of claim 11, wherein the camera controller is further configured to synchronize scanning of the Wide and Tele image sensors such that matching FOVs in the Wide and Tele images are scanned at the same time.
13. The dual-aperture digital camera of claim 11, wherein the camera controller is further configured to synchronize the Wide and Tele image sensors to start exposure at the same time.
14. The dual-aperture digital camera of claim 1, wherein the Wide and Tele lenses have respective F numbers F#_{Wide} and F#_{Tele} and wherein the camera controller is further configured to set respective Wide and Tele image sensor exposure times ET_{Wide} and ET_{Tele} to fulfill the condition $ET_{Tele} = ET_{Wide} \times (F\#_{Tele}/F\#_{Wide})^2 \times (Pixel\ size_{Wide}/Pixel\ size_{Tele})^2$.

15. The dual-aperture digital camera of claim 1, wherein the Wide and Tele lenses have respective F numbers $F\#_{Wide}$ and $F\#_{Tele}$ and wherein the camera controller is further configured to set respective Wide and Tele image sensor exposure times ET_{Wide} and ET_{Tele} to be equal.

16. The dual-aperture digital camera of claim 6, wherein the Wide and Tele image sensors have pixels with identical pixel counts and with respective pixel sizes $Pixel\ size_{Wide}$ and $Pixel\ size_{Tele}$ wherein $Pixel\ size_{Wide}$ is equal to $Pixel\ size_{Tele}$, wherein the Wide and Tele lenses have different F numbers $F\#_{Wide}$ and $F\#_{Tele}$, and wherein the camera controller is further configured to synchronize the Wide and Tele image sensors to start exposure at the same time.

17. The dual-aperture digital camera of claim 6, wherein the Wide and Tele image sensors have pixels with identical pixel counts and with respective pixel sizes $Pixel\ size_{Wide}$ and $Pixel\ size_{Tele}$ wherein $Pixel\ size_{Wide}$ is not equal to $Pixel\ size_{Tele}$, wherein the Wide and Tele lenses have different F numbers $F\#_{Wide}$ and $F\#_{Tele}$, and wherein the camera controller is further configured to synchronize the Wide and Tele image sensors to start exposure at the same time.

18. The dual-aperture digital camera of claim 6, wherein the Wide and Tele image sensors have pixels with respective pixel sizes $Pixel\ size_{Wide}$ and $Pixel\ size_{Tele}$ and wherein $Pixel\ size_{Wide}$ is not equal to $Pixel\ size_{Tele}$, wherein the Wide and Tele lenses have different F numbers $F\#_{Wide}$ and $F\#_{Tele}$, and wherein the camera controller is further configured to synchronize the Wide and Tele image sensors to start exposure at the same time.

19. A dual-aperture digital camera for imaging an object or scene, comprising:

a) a Wide camera comprising a Wide lens and a Wide image sensor, the Wide camera having a respective field of view FOV_W and being operative to provide a Wide image of the object or scene;

b) a Tele camera comprising a Tele lens and a Tele image sensor, the Tele camera having a respective field of view FOV_T narrower than FOV_W and being operative to provide a Tele image of the object or scene, wherein the Tele lens has a respective effective focal length EFL_T and total track length TTL_T fulfilling the condition $EFL_T/TTL_T > 1$;

c) a first autofocus (AF) mechanism coupled mechanically to, and used to perform an AF action on the Wide lens;

d) a second AF mechanism coupled mechanically to, and used to perform an AF action on the Tele lens, wherein the Wide and Tele lenses have different F numbers $F\#_{\text{Wide}}$ and $F\#_{\text{Tele}}$, wherein the Wide and Tele image sensors have pixels with respective pixel sizes $\text{Pixel size}_{\text{Wide}}$ and $\text{Pixel size}_{\text{Tele}}$ wherein $\text{Pixel size}_{\text{Wide}}$ is not equal to $\text{Pixel size}_{\text{Tele}}$, and wherein the Tele camera has a Tele camera depth of field (DOF_T) shallower than a DOF of the Wide camera (DOF_W); and

e) a camera controller operatively coupled to the first and second AF mechanisms and to the Wide and Tele image sensors and configured to control the AF mechanisms, to process the Wide and Tele images to find translations between matching points in the images to calculate depth information and to create a fused image suited for portrait photos, the fused image having a DOF shallower than DOF_T and having a blurred background.

20. The dual-aperture digital camera of claim 19, wherein the Tele lens includes five lens elements along an optical axis from an object side to an image side, starting from the object side with a first lens element with positive power, a second lens element with negative power, a fourth lens element with negative power and a fifth lens element, wherein the largest distance between consecutive lens elements along the optical axis is a distance between the fourth lens element and the fifth lens element.

21. The dual-aperture digital camera of claim 20, wherein the fused image having a DOF shallower than DOF_T is output as a portrait photo similar to a portrait photo taken with a digital single-lens reflex (DSLR) camera.

22. The dual-aperture digital camera of claim 21, wherein the DSLR has a focal length between 50-80 mm.

23. A method comprising:

a) providing a dual-camera comprising a Wide camera and a Tele camera, the Wide and Tele cameras having respective Wide and Tele lenses, Wide and Tele image sensors and Wide and Tele fields of view FOV_W and FOV_T , wherein FOV_T is narrower than FOV_W , wherein the Tele lens has a respective effective focal length EFL_T and total track length TTL_T fulfilling the condition $\text{EFL}_T/\text{TTL}_T > 1$;

b) acquiring a Wide image with the Wide sensor and a Tele image with the Tele sensor;

- c) processing the Wide and Tele images to create a fused image, wherein areas in the Tele image that are not focused are not combined with the Wide image to create the fused image; and
 - d) outputting the fused image with a point of view (POV) of the Wide camera by mapping Tele image pixels to matching pixels within the Wide image.
24. The method of claim 23, further comprising rectifying the Wide and Tele images by aligning these images to be on an approximately epipolar line to obtain rectified Wide and Tele images.
25. The method of claim 24, further comprising mapping between the rectified Wide and Tele images to produce a registration map.
26. The method of claim 25, further comprising resampling the Tele image according to the registration map to provide a re-sampled Tele image.
27. The method of claim 26, further comprising processing the re-sampled Tele image and the Wide image to detect an error in the registration and to provide a decision output.
28. The method of claim 27, wherein if an error is detected, further comprising choosing Wide pixel values to be used in the output image for those pixels that caused the error.
29. The method of claim 23, wherein the Wide and Tele image sensors have pixels with identical pixel counts.
30. The method of claim 29, wherein the pixel count is 12 MP.
31. The method of claim 23, wherein the Wide and Tele image sensors have pixels with respective pixel sizes $\text{Pixel size}_{\text{Wide}}$ and $\text{Pixel size}_{\text{Tele}}$ and wherein $\text{Pixel size}_{\text{Wide}}$ is equal to $\text{Pixel size}_{\text{Tele}}$.
32. The method of claim 23, wherein the Wide and Tele image sensors have pixels with respective pixel sizes $\text{Pixel size}_{\text{Wide}}$ and $\text{Pixel size}_{\text{Tele}}$ and wherein $\text{Pixel size}_{\text{Wide}}$ is not equal to $\text{Pixel size}_{\text{Tele}}$.

33. The method of claim 23, wherein the Wide and Tele lenses have different F numbers $F\#_{Wide}$ and $F\#_{Tele}$.
34. The method of claim 33, further comprising synchronizing scanning of the Wide and Tele image sensors such that matching FOVs in the Wide and Tele images are scanned at the same time.
35. The method of claim 33, further comprising synchronizing the Wide and Tele image sensors to start exposure at the same time.
36. The method of claim 23, wherein the Wide and Tele lenses have respective F numbers $F\#_{Wide}$ and $F\#_{Tele}$, the method further comprising setting respective Wide and Tele image sensor exposure times ET_{Wide} and ET_{Tele} to fulfill the condition $ET_{Tele} = ET_{Wide} \times (F\#_{Tele}/F\#_{Wide})^2 \times (\text{Pixel size}_{Wide}/\text{Pixel size}_{Tele})^2$.
37. The method of claim 23, wherein the Wide and Tele lenses have respective F numbers $F\#_{Wide}$ and $F\#_{Tele}$, the method further comprising setting respective Wide and Tele image sensor exposure times ET_{Wide} and ET_{Tele} to be equal.
38. The method of claim 28, wherein the Wide and Tele image sensors have pixels with identical pixel counts and with respective pixel sizes Pixel size_{Wide} and Pixel size_{Tele} wherein Pixel size_{Wide} is equal to Pixel size_{Tele} and wherein the Wide and Tele lenses have different F numbers $F\#_{Wide}$ and $F\#_{Tele}$, the method further comprising synchronizing the Wide and Tele image sensors to start exposure at the same time.
39. The method of claim 28, wherein the Wide and Tele image sensors have pixels with identical pixel counts and with respective pixel sizes Pixel size_{Wide} and Pixel size_{Tele} wherein Pixel size_{Wide} is not equal to Pixel size_{Tele} and wherein the Wide and Tele lenses have different F numbers $F\#_{Wide}$ and $F\#_{Tele}$, the method further comprising synchronizing the Wide and Tele image sensors to start exposure at the same time.
40. The method of claim 28, wherein the Wide and Tele image sensors have pixels with respective pixel sizes Pixel size_{Wide} and Pixel size_{Tele} wherein Pixel size_{Wide} is not equal to Pixel size_{Tele} and wherein the Wide and Tele lenses have different F numbers $F\#_{Wide}$ and $F\#_{Tele}$.

Tele, the method further comprising synchronizing the Wide and Tele image sensors to start exposure at the same time.

ABSTRACT

A dual-aperture zoom digital camera operable in both still and video modes. The camera includes Wide and Tele imaging sections with respective lens/sensor combinations and image signal processors and a camera controller operatively coupled to the Wide and Tele imaging sections. The Wide and Tele imaging sections provide respective image data. The controller is configured to combine in still mode at least some of the Wide and Tele image data to provide a fused output image from a particular point of view, and to provide without fusion continuous zoom video mode output images, each output image having a given output resolution, wherein the video mode output images are provided with a smooth transition when switching between a lower zoom factor (ZF) value and a higher ZF value or vice versa, and wherein at the lower ZF the output resolution is determined by the Wide sensor while at the higher ZF value the output resolution is determined by the Tele sensor.

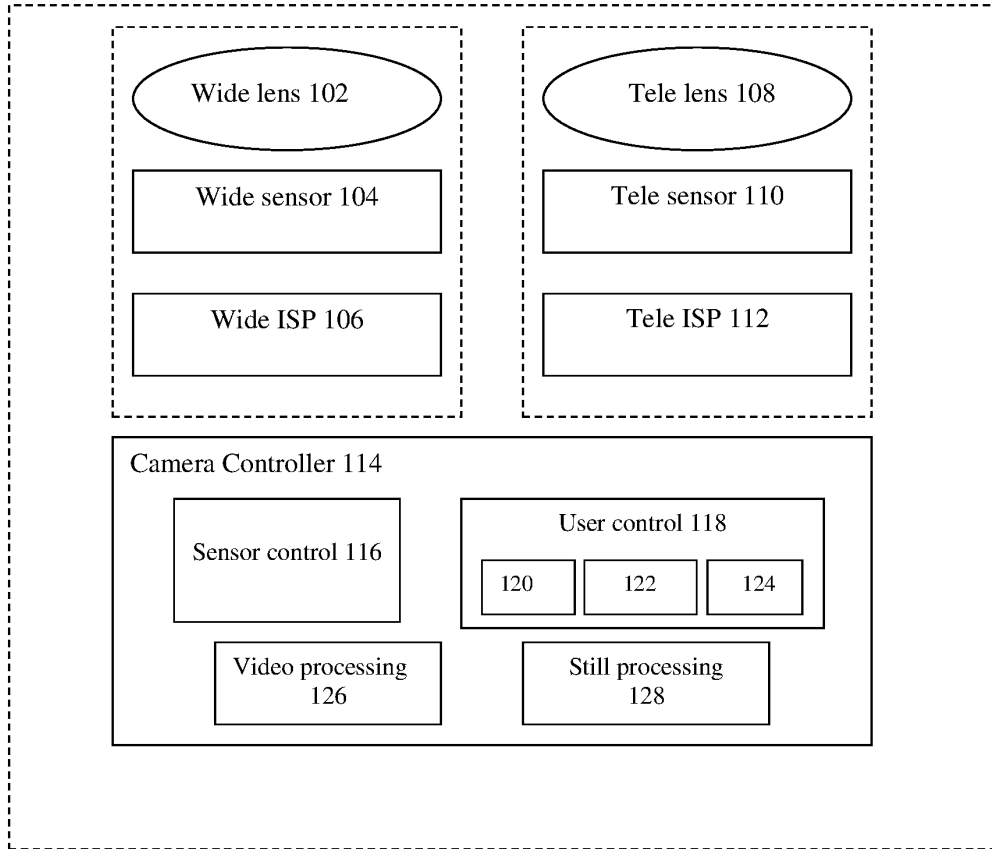

FIG. 1A

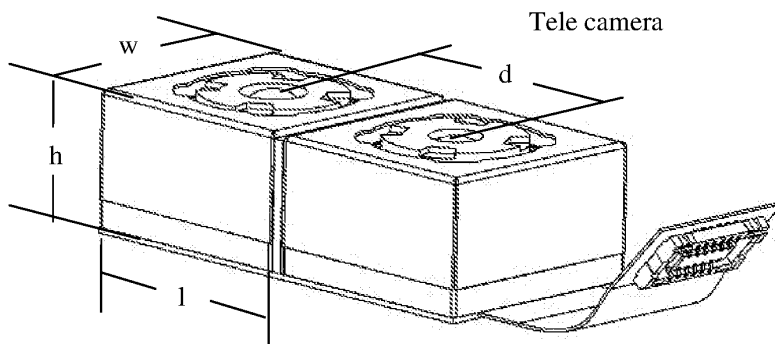

FIG. 1B

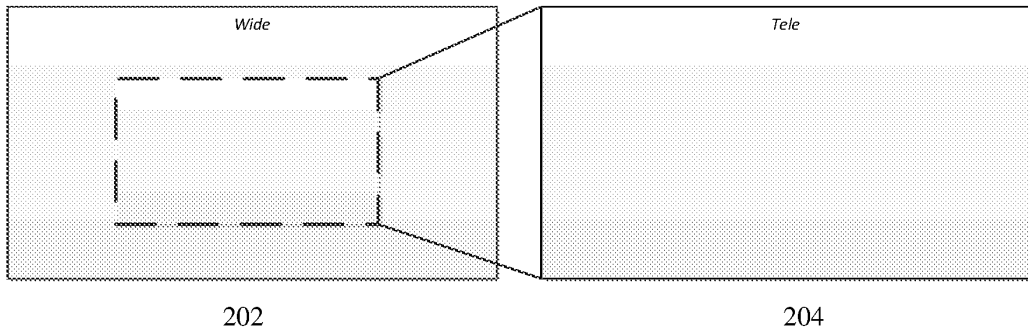

FIG. 2

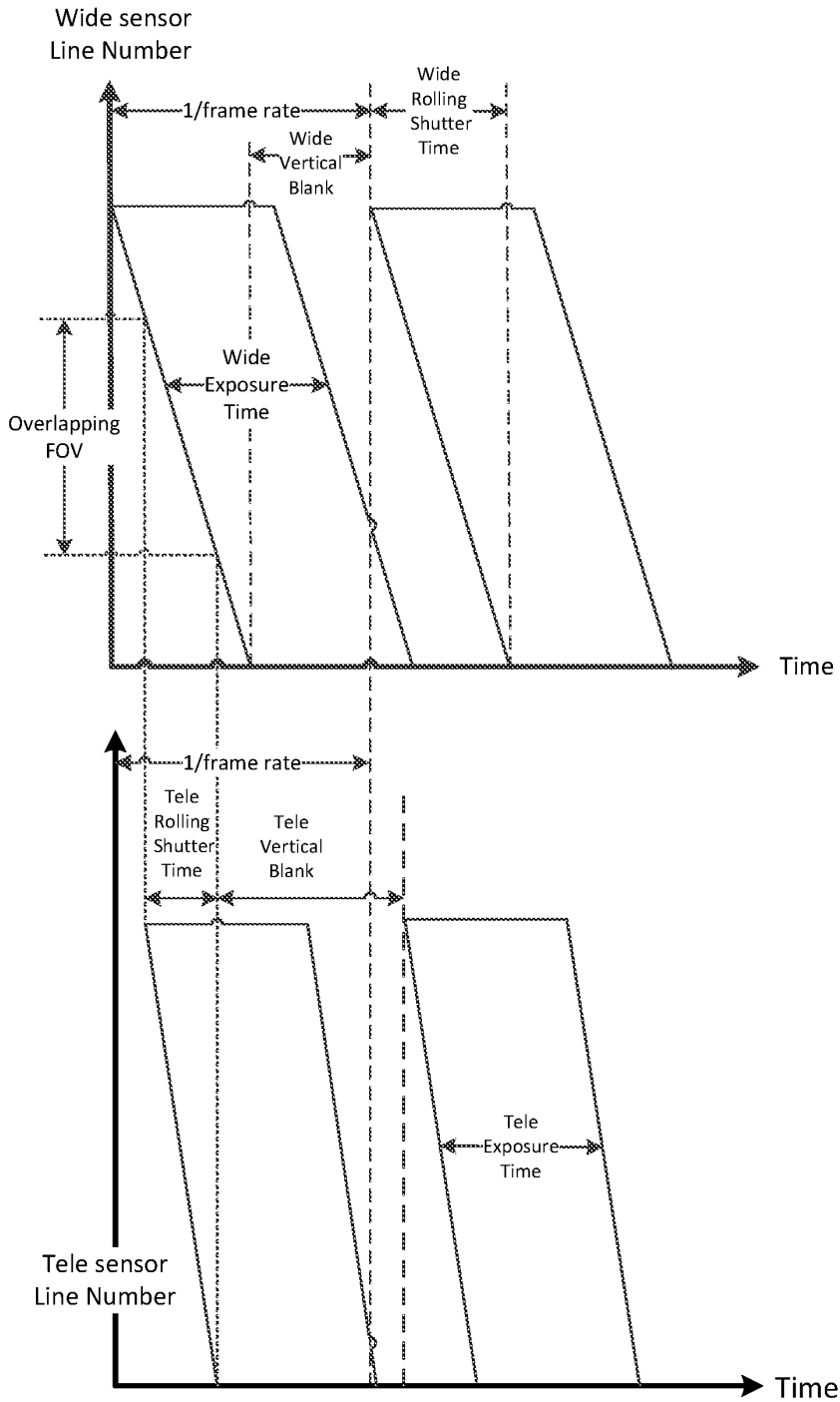

FIG. 3

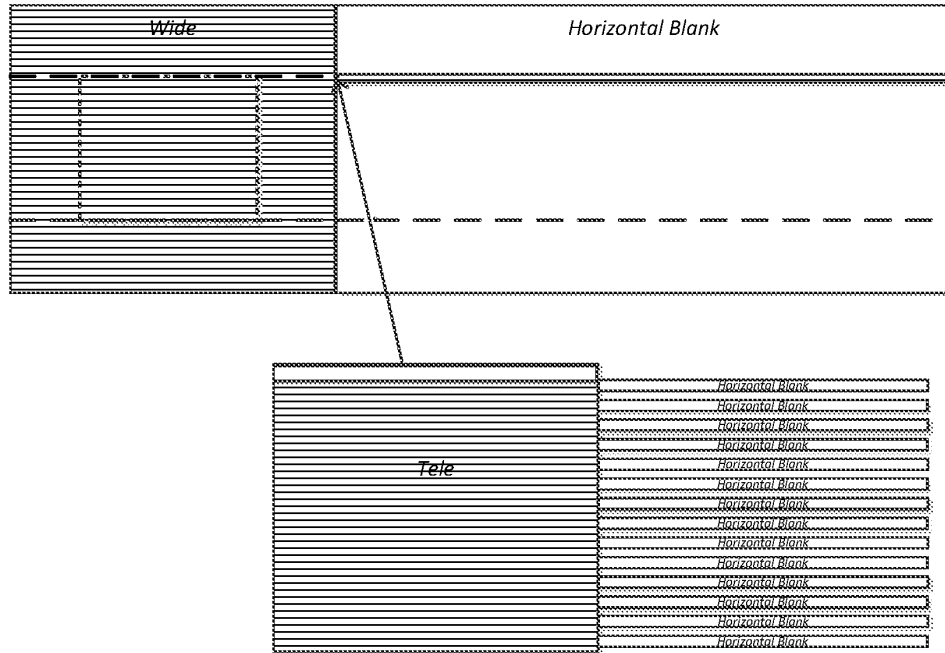

FIG. 4

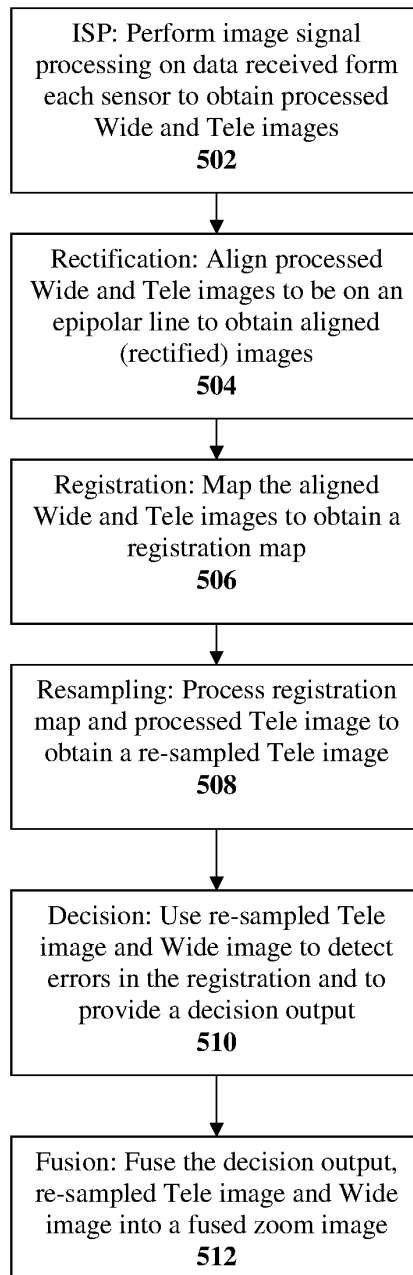

FIG. 5

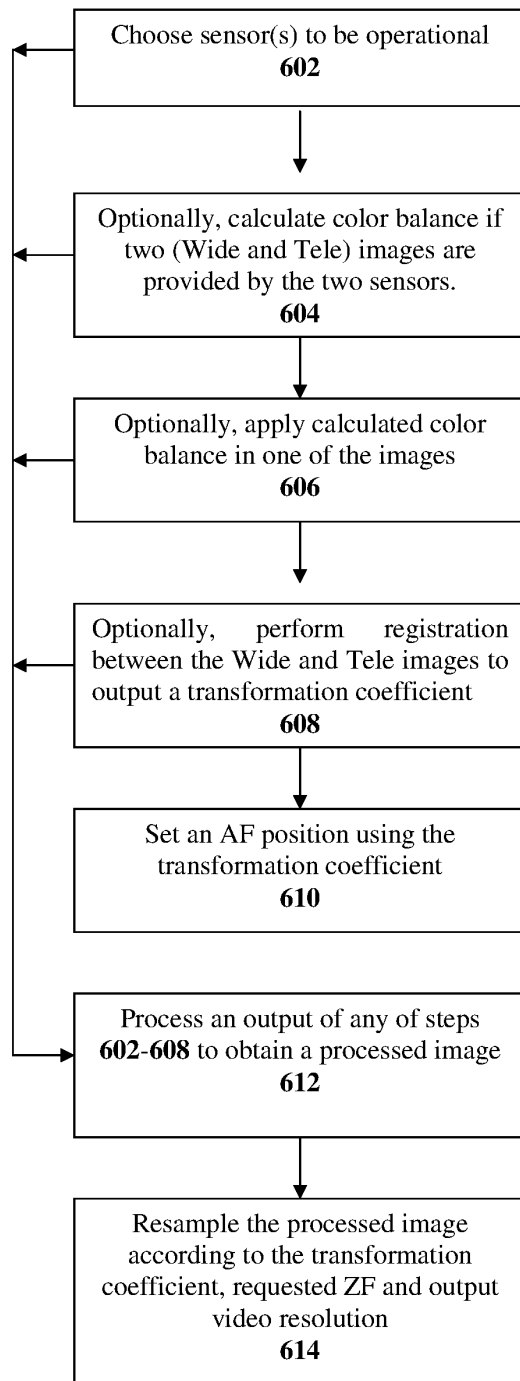

FIG. 6

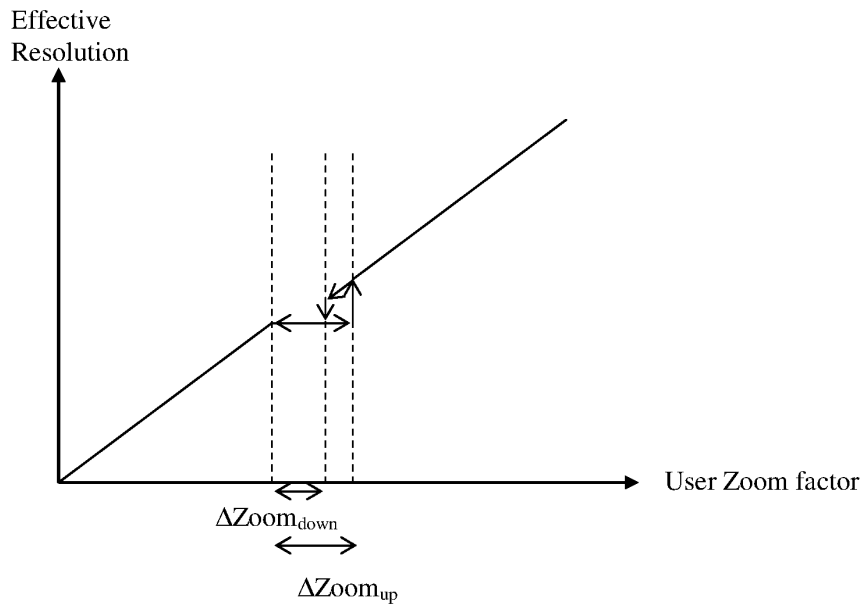

FIG. 7

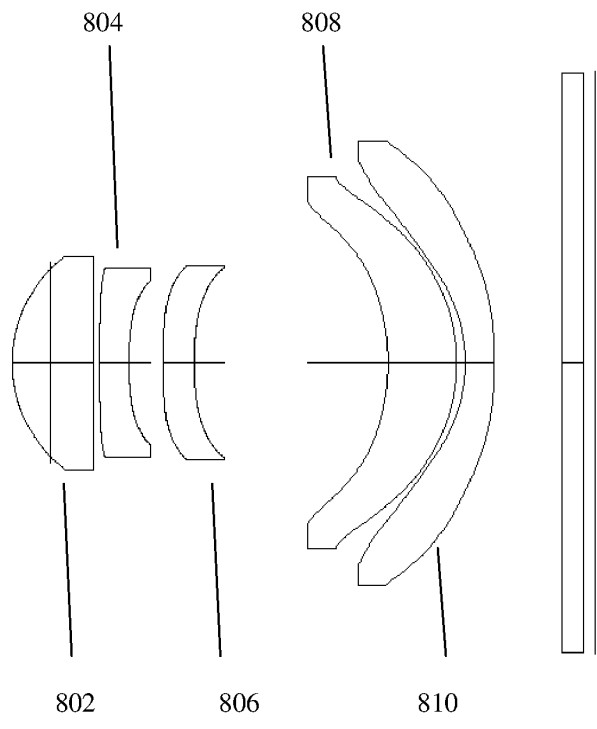

FIG. 8

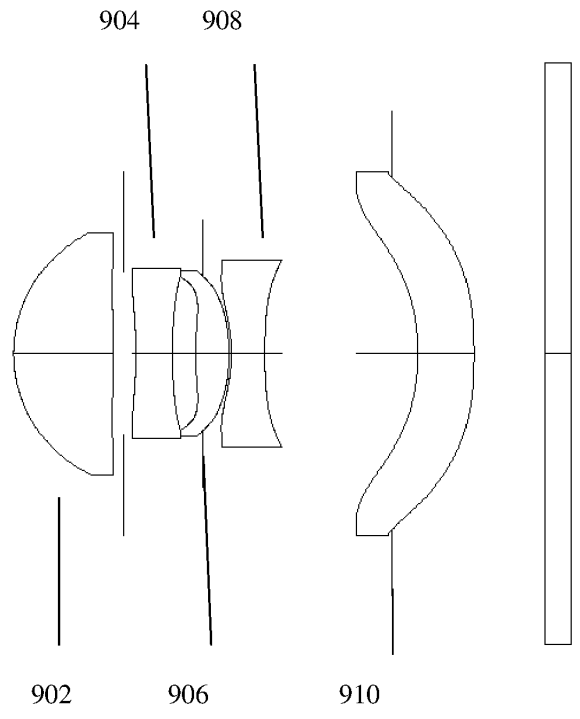

FIG. 9

Under the Paperwork Reduction Act of 1995, no persons are required to respond to a collection of information unless it contains a valid OMB control number.

Application Data Sheet 37 CFR 1.76		Attorney Docket Number	COREPH-0079 US CON3
		Application Number	
Title of Invention	DUAL APERTURE ZOOM DIGITAL CAMERA		
The application data sheet is part of the provisional or nonprovisional application for which it is being submitted. The following form contains the bibliographic data arranged in a format specified by the United States Patent and Trademark Office as outlined in 37 CFR 1.76. This document may be completed electronically and submitted to the Office in electronic format using the Electronic Filing System (EFS) or the document may be printed and included in a paper filed application.			

Secrecy Order 37 CFR 5.2:

Portions or all of the application associated with this Application Data Sheet may fall under a Secrecy Order pursuant to 37 CFR 5.2 (Paper filers only. Applications that fall under Secrecy Order may not be filed electronically.)

Inventor Information:

Inventor 1					<input type="button" value="Remove"/>
Legal Name					
Prefix	Given Name	Middle Name	Family Name	Suffix	
	Gal		Shabtay		
Residence Information (Select One) US Residency <input type="radio"/> Non US Residency Active US Military Service					
City	Tel Aviv	Country of Residenceⁱ	L		
Mailing Address of Inventor:					
Address 1	4 Shmuel Shnitzer St.				
Address 2					
City	Tel Aviv	State/Province			
Postal Code	6958313	Countryⁱ	IL		
Inventor 2					<input type="button" value="Remove"/>
Legal Name					
Prefix	Given Name	Middle Name	Family Name	Suffix	
	Ephraim		Goldenberg		
Residence Information (Select One) US Residency <input checked="" type="radio"/> Non US Residency Active US Military Service					
City	Ashdod	Country of Residenceⁱ	L		
Mailing Address of Inventor:					
Address 1	32 Tel Chai St.				
Address 2					
City	Ashdod	State/Province			
Postal Code	7751025	Countryⁱ	IL		
Inventor 3					<input type="button" value="Remove"/>
Legal Name					

Under the Paperwork Reduction Act of 1995, no persons are required to respond to a collection of information unless it contains a valid OMB control number.

Application Data Sheet 37 CFR 1.76		Attorney Docket Number	COREPH-0079 US CON3
		Application Number	
Title of Invention	DUAL APERTURE ZOOM DIGITAL CAMERA		

Prefix	Given Name	Middle Name	Family Name	Suffix
	Oded		Gigushinski	
Residence Information (Select One) US Residency <input checked="" type="radio"/> Non US Residency Active US Military Service				

City	Herzlia	Country of Residence ⁱ	L
------	---------	-----------------------------------	---

Mailing Address of Inventor:

Address 1	23 Ahi Dakar St.		
Address 2			
City	Herzlia	State/Province	
Postal Code	4670223	Country ⁱ	IL

Inventor	4	<input type="button" value="Remove"/>
Legal Name		

Prefix	Given Name	Middle Name	Family Name	Suffix
	Noy		Cohen	
Residence Information (Select One) US Residency <input checked="" type="radio"/> Non US Residency Active US Military Service				

City	Tel Aviv	Country of Residence ⁱ	
------	----------	-----------------------------------	--

Mailing Address of Inventor:

Address 1	30 Shlomo Ben Yossef St.		
Address 2			
City	Tel Aviv	State/Province	
Postal Code	6912529	Country ⁱ	IL

All Inventors Must Be Listed - Additional Inventor Information blocks may be generated within this form by selecting the button.

Correspondence Information:

Enter either Customer Number or complete the Correspondence Information section below.
For further information see 37 CFR 1.33(a).

An Address is being provided for the correspondence information of this application.

Customer Number	92342		
Email Address		<input type="button" value="Add Email"/>	<input type="button" value="Remove Email"/>

Application Data Sheet 37 CFR 1.76		Attorney Docket Number	COREPH-0079 US CON3
		Application Number	
Title of Invention	DUAL APERTURE ZOOM DIGITAL CAMERA		

Application Information:

Title of the Invention	DUAL APERTURE ZOOM DIGITAL CAMERA		
Attorney Docket Number	COREPH-0079 US CON3	Small Entity Status Claimed	<input type="checkbox"/>
Application Type	Nonprovisional		
Subject Matter	Utility		
Total Number of Drawing Sheets (if any)	8	Suggested Figure for Publication (if any)	1A

Filing By Reference:

Only complete this section when filing an application by reference under 35 U.S.C. 111(c) and 37 CFR 1.57(a). Do not complete this section if application papers including a specification and any drawings are being filed. Any domestic benefit or foreign priority information must be provided in the appropriate section(s) below (i.e., "Domestic Benefit/National Stage Information" and "Foreign Priority Information").

For the purposes of a filing date under 37 CFR 1.53(b), the description and any drawings of the present application are replaced by this reference to the previously filed application, subject to conditions and requirements of 37 CFR 1.57(a).

Application number of the previously filed application	Filing date (YYYY-MM-DD)	Intellectual Property Authority or Country

Publication Information:

Request Early Publication (Fee required at time of Request 37 CFR 1.219)

Request Not to Publish. I hereby request that the attached application not be published under 35 U.S.C. 122(b) and certify that the invention disclosed in the attached application **has not and will not** be the subject of an application filed in another country, or under a multilateral international agreement, that requires publication at eighteen months after filing.

Representative Information:

Representative information should be provided for all practitioners having a power of attorney in the application. Providing this information in the Application Data Sheet does not constitute a power of attorney in the application (see 37 CFR 1.32). Either enter Customer Number or complete the Representative Name section below. If both sections are completed the customer number will be used for the Representative Information during processing.

Please Select One:	<input checked="" type="radio"/> Customer Number	<input type="radio"/> US Patent Practitioner	<input type="radio"/> Limited Recognition (37 CFR 11.9)
Customer Number	92342		

Under the Paperwork Reduction Act of 1995, no persons are required to respond to a collection of information unless it contains a valid OMB control number.

Application Data Sheet 37 CFR 1.76		Attorney Docket Number	COREPH-0079 US CON3
		Application Number	
Title of Invention	DUAL APERTURE ZOOM DIGITAL CAMERA		

Domestic Benefit/National Stage Information:

This section allows for the applicant to either claim benefit under 35 U.S.C. 119(e), 120, 121, 365(c), or 386(c) or indicate National Stage entry from a PCT application. Providing benefit claim information in the Application Data Sheet constitutes the specific reference required by 35 U.S.C. 119(e) or 120, and 37 CFR 1.78.

When referring to the current application, please leave the "Application Number" field blank.

Prior Application Status	Pending		Remove		
Application Number	Continuity Type	Prior Application Number	Filing or 371(c) Date (YYYY-MM-DD)		
	Continuation of	15865869	2018-01-09		
Prior Application Status	Pending		Remove		
Application Number	Continuity Type	Prior Application Number	Filing or 371(c) Date (YYYY-MM-DD)		
15865869	Continuation of	15424853	2017-02-05		
Prior Application Status	Patented		Remove		
Application Number	Continuity Type	Prior Application Number	Filing Date (YYYY-MM-DD)	Patent Number	Issue Date (YYYY-MM-DD)
15424853	Continuation of	14880251	2015-10-11	9661233	2017-05-23
Prior Application Status	Patented		Remove		
Application Number	Continuity Type	Prior Application Number	Filing Date (YYYY-MM-DD)	Patent Number	Issue Date (YYYY-MM-DD)
14880251	Continuation of	14365711	2014-06-16	9185291	2015-11-10
Prior Application Status	Expired		Remove		
Application Number	Continuity Type	Prior Application Number	Filing or 371(c) Date (YYYY-MM-DD)		
14365711	a 371 of international	PCT/IB2014/062180	2014-06-12		
Prior Application Status	Expired		Remove		
Application Number	Continuity Type	Prior Application Number	Filing or 371(c) Date (YYYY-MM-DD)		
PCT/IB2014/062180	Claims benefit of provisional	61834486	2013-06-13		
Additional Domestic Benefit/National Stage Data may be generated within this form by selecting the Add button.					Add

Foreign Priority Information:

Under the Paperwork Reduction Act of 1995, no persons are required to respond to a collection of information unless it contains a valid OMB control number.

Application Data Sheet 37 CFR 1.76		Attorney Docket Number	COREPH-0079 US CON3
		Application Number	
Title of Invention	DUAL APERTURE ZOOM DIGITAL CAMERA		

This section allows for the applicant to claim priority to a foreign application. Providing this information in the application data sheet constitutes the claim for priority as required by 35 U.S.C. 119(b) and 37 CFR 1.55. When priority is claimed to a foreign application that is eligible for retrieval under the priority document exchange program (PDX)ⁱ the information will be used by the Office to automatically attempt retrieval pursuant to 37 CFR 1.55(i)(1) and (2). Under the PDX program, applicant bears the ultimate responsibility for ensuring that a copy of the foreign application is received by the Office from the participating foreign intellectual property office, or a certified copy of the foreign priority application is filed, within the time period specified in 37 CFR 1.55(g)(1).

Application Number	Country ⁱ	Filing Date (YYYY-MM-DD)	Access Code ⁱ (if applicable)	Remove

Additional Foreign Priority Data may be generated within this form by selecting the **Add** button.

Statement under 37 CFR 1.55 or 1.78 for AIA (First Inventor to File) Transition Applications

- This application (1) claims priority to or the benefit of an application filed before March 16, 2013 and (2) also contains, or contained at any time, a claim to a claimed invention that has an effective filing date on or after March 16, 2013.
- NOTE: By providing this statement under 37 CFR 1.55 or 1.78, this application, with a filing date on or after March 16, 2013, will be examined under the first inventor to file provisions of the AIA.

Application Data Sheet 37 CFR 1.76		Attorney Docket Number	COREPH-0079 US CON3
		Application Number	
Title of Invention	DUAL APERTURE ZOOM DIGITAL CAMERA		

Authorization or Opt-Out of Authorization to Permit Access:

When this Application Data Sheet is properly signed and filed with the application, applicant has provided written authority to permit a participating foreign intellectual property (IP) office access to the instant application-as-filed (see paragraph A in subsection 1 below) and the European Patent Office (EPO) access to any search results from the instant application (see paragraph B in subsection 1 below).

Should applicant choose not to provide an authorization identified in subsection 1 below, applicant **must opt-out** of the authorization by checking the corresponding box A or B or both in subsection 2 below.

NOTE: This section of the Application Data Sheet is **ONLY** reviewed and processed with the **INITIAL** filing of an application. After the initial filing of an application, an Application Data Sheet cannot be used to provide or rescind authorization for access by a foreign IP office(s). Instead, Form PTO/SB/39 or PTO/SB/69 must be used as appropriate.

1. Authorization to Permit Access by a Foreign Intellectual Property Office(s)

A. Priority Document Exchange (PDX) - Unless box A in subsection 2 (opt-out of authorization) is checked, the undersigned hereby **grants the USPTO authority** to provide the European Patent Office (EPO), the Japan Patent Office (JPO), the Korean Intellectual Property Office (KIPO), the State Intellectual Property Office of the People's Republic of China (SIPO), the World Intellectual Property Organization (WIPO), and any other foreign intellectual property office participating with the USPTO in a bilateral or multilateral priority document exchange agreement in which a foreign application claiming priority to the instant patent application is filed, access to: (1) the instant patent application-as-filed and its related bibliographic data, (2) any foreign or domestic application to which priority or benefit is claimed by the instant application and its related bibliographic data, and (3) the date of filing of this Authorization. See 37 CFR 1.14(h)(1).

B. Search Results from U.S. Application to EPO - Unless box B in subsection 2 (opt-out of authorization) is checked, the undersigned hereby **grants the USPTO authority** to provide the EPO access to the bibliographic data and search results from the instant patent application when a European patent application claiming priority to the instant patent application is filed. See 37 CFR 1.14(h)(2).

The applicant is reminded that the EPO's Rule 141(1) EPC (European Patent Convention) requires applicants to submit a copy of search results from the instant application without delay in a European patent application that claims priority to the instant application.

2. Opt-Out of Authorizations to Permit Access by a Foreign Intellectual Property Office(s)

A. Applicant **DOES NOT** authorize the USPTO to permit a participating foreign IP office access to the instant application-as-filed. If this box is checked, the USPTO will not be providing a participating foreign IP office with any documents and information identified in subsection 1A above.

B. Applicant **DOES NOT** authorize the USPTO to transmit to the EPO any search results from the instant patent application. If this box is checked, the USPTO will not be providing the EPO with search results from the instant application.

NOTE: Once the application has published or is otherwise publicly available, the USPTO may provide access to the application in accordance with 37 CFR 1.14.

Under the Paperwork Reduction Act of 1995, no persons are required to respond to a collection of information unless it contains a valid OMB control number.

Application Data Sheet 37 CFR 1.76		Attorney Docket Number	COREPH-0079 US CON3
		Application Number	
Title of Invention	DUAL APERTURE ZOOM DIGITAL CAMERA		

Applicant Information:

Providing assignment information in this section does not substitute for compliance with any requirement of part 3 of Title 37 of CFR to have an assignment recorded by the Office.			
Applicant	1	<input type="button" value="Remove"/>	
If the applicant is the inventor (or the remaining joint inventor or inventors under 37 CFR 1.45), this section should not be completed. The information to be provided in this section is the name and address of the legal representative who is the applicant under 37 CFR 1.43; or the name and address of the assignee, person to whom the inventor is under an obligation to assign the invention, or person who otherwise shows sufficient proprietary interest in the matter who is the applicant under 37 CFR 1.46. If the applicant is an applicant under 37 CFR 1.46 (assignee, person to whom the inventor is obligated to assign, or person who otherwise shows sufficient proprietary interest) together with one or more joint inventors, then the joint inventor or inventors who are also the applicant should be identified in this section.			
<input type="button" value="Clear"/>			
<input checked="" type="radio"/> Assignee	Legal Representative under 35 U.S.C. 117	Joint Inventor	
Person to whom the inventor is obligated to assign.		Person who shows sufficient proprietary interest	
If applicant is the legal representative, indicate the authority to file the patent application, the inventor is:			
▼			
Name of the Deceased or Legally Incapacitated Inventor: <input type="text"/>			
If the Applicant is an Organization check here. <input checked="" type="checkbox"/>			
Organization Name	Corephotonics Ltd.		
Mailing Address Information For Applicant:			
Address 1	25 Habarzel St.		
Address 2	Ramat Hachayal		
City	Tel Aviv	State/Province	
Country	IL	Postal Code	6971035
Phone Number		Fax Number	
Email Address			
Additional Applicant Data may be generated within this form by selecting the Add button. <input type="button" value="Add"/>			

Assignee Information including Non-Applicant Assignee Information:

Providing assignment information in this section does not substitute for compliance with any requirement of part 3 of Title 37 of CFR to have an assignment recorded by the Office.

Under the Paperwork Reduction Act of 1995, no persons are required to respond to a collection of information unless it contains a valid OMB control number.

Application Data Sheet 37 CFR 1.76		Attorney Docket Number	COREPH-0079 US CON3
		Application Number	
Title of Invention	DUAL APERTURE ZOOM DIGITAL CAMERA		

Assignee 1				
Complete this section if assignee information, including non-applicant assignee information, is desired to be included on the patent application publication. An assignee-applicant identified in the "Applicant Information" section will appear on the patent application publication as an applicant. For an assignee-applicant, complete this section only if identification as an assignee is also desired on the patent application publication.				
				<input type="button" value="Remove"/>
If the Assignee or Non-Applicant Assignee is an Organization check here. <input type="checkbox"/>				
Prefix	Given Name	Middle Name	Family Name	Suffix
Mailing Address Information For Assignee including Non-Applicant Assignee:				
Address 1				
Address 2				
City		State/Province		
Country i		Postal Code		
Phone Number		Fax Number		
Email Address				
Additional Assignee or Non-Applicant Assignee Data may be generated within this form by selecting the Add button.				<input type="button" value="Add"/>

Signature:

NOTE: This Application Data Sheet must be signed in accordance with 37 CFR 1.33(b). **However, if this Application Data Sheet is submitted with the INITIAL filing of the application and either box A or B is not checked in subsection 2 of the "Authorization or Opt-Out of Authorization to Permit Access" section, then this form must also be signed in accordance with 37 CFR 1.14(c).**

This Application Data Sheet **must** be signed by a patent practitioner if one or more of the applicants is a **juristic entity** (e.g., corporation or association). If the applicant is two or more joint inventors, this form must be signed by a patent practitioner, **all** joint inventors who are the applicant, or one or more joint inventor-applicants who have been given power of attorney (e.g., see USPTO Form PTO/AIA/81) on behalf of **all** joint inventor-applicants.

See 37 CFR 1.4(d) for the manner of making signatures and certifications.

Signature	/Menachem Nathan/		Date (YYYY-MM-DD)	2018-07-28
First Name	MENACHEM	Last Name	NATHAN	Registration Number
				65392
Additional Signature may be generated within this form by selecting the Add button.				<input type="button" value="Add"/>

Under the Paperwork Reduction Act of 1995, no persons are required to respond to a collection of information unless it contains a valid OMB control number.

Application Data Sheet 37 CFR 1.76		Attorney Docket Number	COREPH-0079 US CON3
		Application Number	
Title of Invention	DUAL APERTURE ZOOM DIGITAL CAMERA		

This collection of information is required by 37 CFR 1.76. The information is required to obtain or retain a benefit by the public which is to file (and by the USPTO to process) an application. Confidentiality is governed by 35 U.S.C. 122 and 37 CFR 1.14. This collection is estimated to take 23 minutes to complete, including gathering, preparing, and submitting the completed application data sheet form to the USPTO. Time will vary depending upon the individual case. Any comments on the amount of time you require to complete this form and/or suggestions for reducing this burden, should be sent to the Chief Information Officer, U.S. Patent and Trademark Office, U.S. Department of Commerce, P.O. Box 1450, Alexandria, VA 22313-1450. DO NOT SEND FEES OR COMPLETED FORMS TO THIS ADDRESS. **SEND TO: Commissioner for Patents, P.O. Box 1450, Alexandria, VA 22313-1450.**

Privacy Act Statement

The Privacy Act of 1974 (P.L. 93-579) requires that you be given certain information in connection with your submission of the attached form related to a patent application or patent. Accordingly, pursuant to the requirements of the Act, please be advised that: (1) the general authority for the collection of this information is 35 U.S.C. 2(b)(2); (2) furnishing of the information solicited is voluntary; and (3) the principal purpose for which the information is used by the U.S. Patent and Trademark Office is to process and/or examine your submission related to a patent application or patent. If you do not furnish the requested information, the U.S. Patent and Trademark Office may not be able to process and/or examine your submission, which may result in termination of proceedings or abandonment of the application or expiration of the patent.

The information provided by you in this form will be subject to the following routine uses:

1. The information on this form will be treated confidentially to the extent allowed under the Freedom of Information Act (5 U.S.C. 552) and the Privacy Act (5 U.S.C. 552a). Records from this system of records may be disclosed to the Department of Justice to determine whether the Freedom of Information Act requires disclosure of these records.
2. A record from this system of records may be disclosed, as a routine use, in the course of presenting evidence to a court, magistrate, or administrative tribunal, including disclosures to opposing counsel in the course of settlement negotiations.
3. A record in this system of records may be disclosed, as a routine use, to a Member of Congress submitting a request involving an individual, to whom the record pertains, when the individual has requested assistance from the Member with respect to the subject matter of the record.
4. A record in this system of records may be disclosed, as a routine use, to a contractor of the Agency having need for the information in order to perform a contract. Recipients of information shall be required to comply with the requirements of the Privacy Act of 1974, as amended, pursuant to 5 U.S.C. 552a(m).
5. A record related to an International Application filed under the Patent Cooperation Treaty in this system of records may be disclosed, as a routine use, to the International Bureau of the World Intellectual Property Organization, pursuant to the Patent Cooperation Treaty.
6. A record in this system of records may be disclosed, as a routine use, to another federal agency for purposes of National Security review (35 U.S.C. 181) and for review pursuant to the Atomic Energy Act (42 U.S.C. 218(c)).
7. A record from this system of records may be disclosed, as a routine use, to the Administrator, General Services, or his/her designee, during an inspection of records conducted by GSA as part of that agency's responsibility to recommend improvements in records management practices and programs, under authority of 44 U.S.C. 2904 and 2906. Such disclosure shall be made in accordance with the GSA regulations governing inspection of records for this purpose, and any other relevant (i.e., GSA or Commerce) directive. Such disclosure shall not be used to make determinations about individuals.
8. A record from this system of records may be disclosed, as a routine use, to the public after either publication of the application pursuant to 35 U.S.C. 122(b) or issuance of a patent pursuant to 35 U.S.C. 151. Further, a record may be disclosed, subject to the limitations of 37 CFR 1.14, as a routine use, to the public if the record was filed in an application which became abandoned or in which the proceedings were terminated and which application is referenced by either a published application, an application open to public inspections or an issued patent.
9. A record from this system of records may be disclosed, as a routine use, to a Federal, State, or local law enforcement agency, if the USPTO becomes aware of a violation or potential violation of law or regulation.

Under the Paperwork Reduction Act of 1995, no persons are required to respond to a collection of information unless it contains a valid OMB control number.

<p>DECLARATION FOR UTILITY OR DESIGN PATENT APPLICATION (37 CFR 1.63)</p> <p><input checked="" type="checkbox"/> Declaration Submitted With Initial Filing OR <input type="checkbox"/> Declaration Submitted After Initial Filing (surcharge (37 CFR 1.16(f)) required)</p>	Attorney Docket Number	COREPH-0079 US CON3
	First Named Inventor	Gal Shabtay
	<i>COMPLETE IF KNOWN</i>	
	Application Number	
	Filing Date	
	Art Unit	
	Examiner Name	

DUAL APERTURE ZOOM DIGITAL CAMERA

(Title of the Invention)

As a below named inventor, I hereby declare that:

This declaration is directed to:

The attached application,

OR

United States Application Number or PCT International application number _____

filed on _____.

The above-identified application was made or authorized to be made by me.

I believe I am the original inventor or an original joint inventor of a claimed invention in the application.

I hereby acknowledge that any willful false statement made in this declaration is punishable under 18 U.S.C. 1001 by fine or imprisonment of not more than five (5) years, or both.

Direct all correspondence to:	<input checked="" type="checkbox"/>	The address associated with Customer Number:	92342	OR	<input type="checkbox"/>	Correspondence address below
Name						
Address						
City			State		Zip	
Country		Telephone		Email		

[Page 1 of 2]

This collection of information is required by 35 U.S.C. 115 and 37 CFR 1.63. The information is required to obtain or retain a benefit by the public which is to file (and by the USPTO to process) an application. Confidentiality is governed by 35 U.S.C. 122 and 37 CFR 1.11 and 1.14. This collection is estimated to take 21 minutes to complete, including gathering, preparing, and submitting the completed application form to the USPTO. Time will vary depending upon the individual case. Any comments on the amount of time you require to complete this form and/or suggestions for reducing this burden, should be sent to the Chief Information Officer, U.S. Patent and Trademark Office, U.S. Department of Commerce, P.O. Box 1450, Alexandria, VA 22313-1450. DO NOT SEND FEES OR COMPLETED FORMS TO THIS ADDRESS. **SEND TO: Commissioner for Patents, P.O. Box 1450, Alexandria, VA 22313-1450.**

If you need assistance in completing the form, call 1-800-PTO-9199 and select option 2.

Under the Paperwork Reduction Act of 1995, no persons are required to respond to a collection of information unless it contains a valid OMB control number.

DECLARATION — Utility or Design Patent Application**WARNING:**

Petitioner/applicant is cautioned to avoid submitting personal information in documents filed in a patent application that may contribute to identity theft. Personal information such as social security numbers, bank account numbers, or credit card numbers (other than a check or credit card authorization form PTO-2038 submitted for payment purposes) is never required by the USPTO to support a petition or an application. If this type of personal information is included in documents submitted to the USPTO, petitioners/applicants should consider redacting such personal information from the documents before submitting them to the USPTO. Petitioner/applicant is advised that the record of a patent application is available to the public after publication of the application (unless a non-publication request in compliance with 37 CFR 1.213(a) is made in the application) or issuance of a patent. Furthermore, the record from an abandoned application may also be available to the public if the application is referenced in a published application or an issued patent (see 37 CFR 1.14). Checks and credit card authorization forms PTO-2038 submitted for payment purposes are not retained in the application file and therefore are not publicly available. Petitioner/applicant is advised that documents which form the record of a patent application (such as the PTO/SB/01) are placed into the Privacy Act system of records DEPARTMENT OF COMMERCE, COMMERCE-PAT-7, System name: *Patent Application Files*. Documents not retained in an application file (such as the PTO-2038) are placed into the Privacy Act system of COMMERCE/PAT-TM-10, System name: *Deposit Accounts and Electronic Funds Transfer Profiles*.

LEGAL NAME OF SOLE OR FIRST INVENTOR:

(E.g., Given Name (first and middle if any) and Family Name or Surname)

Gal Shabtay

Inventor's Signature

/Gal Shabtay/

Date (Optional)

Residence: City

Tel Aviv

State

Country

IL

Mailing Address

4 Shmuel Shnitzer St.

City

Tel Aviv

State

Zip

6958313

Country

IL

Additional inventors are being named on the 1 Supplemental sheet(s) PTO/AIA/10 attached hereto

Privacy Act Statement

The Privacy Act of 1974 (P.L. 93-579) requires that you be given certain information in connection with your submission of the attached form related to a patent application or patent. Accordingly, pursuant to the requirements of the Act, please be advised that: (1) the general authority for the collection of this information is 35 U.S.C. 2(b)(2); (2) furnishing of the information solicited is voluntary; and (3) the principal purpose for which the information is used by the U.S. Patent and Trademark Office is to process and/or examine your submission related to a patent application or patent. If you do not furnish the requested information, the U.S. Patent and Trademark Office may not be able to process and/or examine your submission, which may result in termination of proceedings or abandonment of the application or expiration of the patent.

The information provided by you in this form will be subject to the following routine uses:

1. The information on this form will be treated confidentially to the extent allowed under the Freedom of Information Act (5 U.S.C. 552) and the Privacy Act (5 U.S.C. 552a). Records from this system of records may be disclosed to the Department of Justice to determine whether disclosure of these records is required by the Freedom of Information Act.
2. A record from this system of records may be disclosed, as a routine use, in the course of presenting evidence to a court, magistrate, or administrative tribunal, including disclosures to opposing counsel in the course of settlement negotiations.
3. A record in this system of records may be disclosed, as a routine use, to a Member of Congress submitting a request involving an individual, to whom the record pertains, when the individual has requested assistance from the Member with respect to the subject matter of the record.
4. A record in this system of records may be disclosed, as a routine use, to a contractor of the Agency having need for the information in order to perform a contract. Recipients of information shall be required to comply with the requirements of the Privacy Act of 1974, as amended, pursuant to 5 U.S.C. 552a(m).
5. A record related to an International Application filed under the Patent Cooperation Treaty in this system of records may be disclosed, as a routine use, to the International Bureau of the World Intellectual Property Organization, pursuant to the Patent Cooperation Treaty.
6. A record in this system of records may be disclosed, as a routine use, to another federal agency for purposes of National Security review (35 U.S.C. 181) and for review pursuant to the Atomic Energy Act (42 U.S.C. 218(c)).
7. A record from this system of records may be disclosed, as a routine use, to the Administrator, General Services, or his/her designee, during an inspection of records conducted by GSA as part of that agency's responsibility to recommend improvements in records management practices and programs, under authority of 44 U.S.C. 2904 and 2906. Such disclosure shall be made in accordance with the GSA regulations governing inspection of records for this purpose, and any other relevant (i.e., GSA or Commerce) directive. Such disclosure shall not be used to make determinations about individuals.
8. A record from this system of records may be disclosed, as a routine use, to the public after either publication of the application pursuant to 35 U.S.C. 122(b) or issuance of a patent pursuant to 35 U.S.C. 151. Further, a record may be disclosed, subject to the limitations of 37 CFR 1.14, as a routine use, to the public if the record was filed in an application which became abandoned or in which the proceedings were terminated and which application is referenced by either a published application, an application open to public inspection or an issued patent.
9. A record from this system of records may be disclosed, as a routine use, to a Federal, State, or local law enforcement agency, if the USPTO becomes aware of a violation or potential violation of law or regulation.

SUPPLEMENTAL SHEET FOR DECLARATION**ADDITIONAL INVENTOR(S)**

Supplemental Sheet (for PTO/AIA/08,09)

Page 1 of 1**Legal Name of Additional Joint Inventor, if any:**

(E.g., Given Name (first and middle (if any)) and Family Name or Surname)

Ephraim Goldenberg

Inventor's /Ephraim Goldenberg/
Signature

Date (Optional)

Residence: City Ashdod

State

Country IL

32 Tel Chai. St.

Mailing Address

City Ashdod

State

Zip 7751025

Country IL

Legal Name of Additional Joint Inventor, if any:

(E.g., Given Name (first and middle (if any)) and Family Name or Surname)

Oded Gigushinsky

Inventor's /Oded Gigushinsky/
Signature

Date (Optional)

Residence: City Herzlia

State

Country IL

23 Achi Dakar St.

Mailing Address

City Herzlia

State

Zip 4670223

Country IL

Legal Name of Additional Joint Inventor, if any:

(E.g., Given Name (first and middle (if any)) and Family Name or Surname)

Noy Cohen

Inventor's /Noy Cohen/
Signature

Date (Optional)

Residence: City Tel Aviv

State

Country IL

30 Shlomo Ben Yossef St.

Mailing Address

City Tel Aviv

State

Zip 6912529

Country IL

This collection of information is required by 35 U.S.C. 115 and 37 CFR 1.63. The information is required to obtain or retain a benefit by the public which is to file (and by the USPTO to process) an application. Confidentiality is governed by 35 U.S.C. 122 and 37 CFR 1.11 and 1.14. This collection is estimated to take 21 minutes to complete, including gathering, preparing, and submitting the completed application form to the USPTO. Time will vary depending upon the individual case. Any comments on the amount of time you require to complete this form and/or suggestions for reducing this burden, should be sent to the Chief Information Officer, U.S. Patent and Trademark Office, U.S. Department of Commerce, P.O. Box 1450, Alexandria, VA 22313-1450. DO NOT SEND FEES OR COMPLETED FORMS TO THIS ADDRESS. **SEND TO: Commissioner for Patents, P.O. Box 1450, Alexandria, VA 22313-1450.**

If you need assistance in completing the form, call 1-800-PTO-9199 (1-800-786-9199) and select option 2.

Privacy Act Statement

The **Privacy Act of 1974 (P.L. 93-579)** requires that you be given certain information in connection with your submission of the attached form related to a patent application or patent. Accordingly, pursuant to the requirements of the Act, please be advised that: (1) the general authority for the collection of this information is 35 U.S.C. 2(b)(2); (2) furnishing of the information solicited is voluntary; and (3) the principal purpose for which the information is used by the U.S. Patent and Trademark Office is to process and/or examine your submission related to a patent application or patent. If you do not furnish the requested information, the U.S. Patent and Trademark Office may not be able to process and/or examine your submission, which may result in termination of proceedings or abandonment of the application or expiration of the patent.

The information provided by you in this form will be subject to the following routine uses:

1. The information on this form will be treated confidentially to the extent allowed under the Freedom of Information Act (5 U.S.C. 552) and the Privacy Act (5 U.S.C. 552a). Records from this system of records may be disclosed to the Department of Justice to determine whether disclosure of these records is required by the Freedom of Information Act.
2. A record from this system of records may be disclosed, as a routine use, in the course of presenting evidence to a court, magistrate, or administrative tribunal, including disclosures to opposing counsel in the course of settlement negotiations.
3. A record in this system of records may be disclosed, as a routine use, to a Member of Congress submitting a request involving an individual, to whom the record pertains, when the individual has requested assistance from the Member with respect to the subject matter of the record.
4. A record in this system of records may be disclosed, as a routine use, to a contractor of the Agency having need for the information in order to perform a contract. Recipients of information shall be required to comply with the requirements of the Privacy Act of 1974, as amended, pursuant to 5 U.S.C. 552a(m).
5. A record related to an International Application filed under the Patent Cooperation Treaty in this system of records may be disclosed, as a routine use, to the International Bureau of the World Intellectual Property Organization, pursuant to the Patent Cooperation Treaty.
6. A record in this system of records may be disclosed, as a routine use, to another federal agency for purposes of National Security review (35 U.S.C. 181) and for review pursuant to the Atomic Energy Act (42 U.S.C. 218(c)).
7. A record from this system of records may be disclosed, as a routine use, to the Administrator, General Services, or his/her designee, during an inspection of records conducted by GSA as part of that agency's responsibility to recommend improvements in records management practices and programs, under authority of 44 U.S.C. 2904 and 2906. Such disclosure shall be made in accordance with the GSA regulations governing inspection of records for this purpose, and any other relevant (*i.e.*, GSA or Commerce) directive. Such disclosure shall not be used to make determinations about individuals.
8. A record from this system of records may be disclosed, as a routine use, to the public after either publication of the application pursuant to 35 U.S.C. 122(b) or issuance of a patent pursuant to 35 U.S.C. 151. Further, a record may be disclosed, subject to the limitations of 37 CFR 1.14, as a routine use, to the public if the record was filed in an application which became abandoned or in which the proceedings were terminated and which application is referenced by either a published application, an application open to public inspection or an issued patent.
9. A record from this system of records may be disclosed, as a routine use, to a Federal, State, or local law enforcement agency, if the USPTO becomes aware of a violation or potential violation of law or regulation.

Electronic Patent Application Fee Transmittal

Application Number:				
Filing Date:				
Title of Invention:	DUAL APERTURE ZOOM DIGITAL CAMERA			
First Named Inventor/Applicant Name:	Gal Shabtay			
Filer:	Menachem Nathan			
Attorney Docket Number:	COREPH-0079 US CON3			
Filed as Small Entity				
Filing Fees for Utility under 35 USC 111(a)				
Description	Fee Code	Quantity	Amount	Sub-Total in USD(\$)
Basic Filing:				
UTILITY FILING FEE (ELECTRONIC FILING)	4011	1	75	75
UTILITY SEARCH FEE	2111	1	330	330
UTILITY EXAMINATION FEE	2311	1	380	380
Pages:				
Claims:				
CLAIMS IN EXCESS OF 20	2202	20	50	1000
Miscellaneous-Filing:				
Petition:				

Description	Fee Code	Quantity	Amount	Sub-Total in USD(\$)
Patent-Appeals-and-Interference:				
Post-Allowance-and-Post-Issuance:				
Extension-of-Time:				
Miscellaneous:				
			Total in USD (\$)	1785

Electronic Acknowledgement Receipt

EFS ID:	33310672
Application Number:	16048242
International Application Number:	
Confirmation Number:	4814
Title of Invention:	DUAL APERTURE ZOOM DIGITAL CAMERA
First Named Inventor/Applicant Name:	Gal Shabtay
Customer Number:	92342
Filer:	Menachem Nathan
Filer Authorized By:	
Attorney Docket Number:	COREPH-0079 US CON3
Receipt Date:	28-JUL-2018
Filing Date:	
Time Stamp:	15:35:45
Application Type:	Utility under 35 USC 111(a)

Payment information:

Submitted with Payment	yes
Payment Type	CARD
Payment was successfully received in RAM	\$1785
RAM confirmation Number	073018INTEFSW15385000
Deposit Account	
Authorized User	

The Director of the USPTO is hereby authorized to charge indicated fees and credit any overpayment as follows:

File Listing:					
Document Number	Document Description	File Name	File Size(Bytes)/ Message Digest	Multi Part /.zip	Pages (if appl.)
1	Specification	filing.pdf	411011	no	33
			a3579333ef6afae446b8a88cace428a7ba80d59		
Warnings:					
Information:					
2	Application Data Sheet	ADS.pdf	1256732	no	10
			11b146d29e6d896f22df137b0511446dfb a25d3		
Warnings:					
Information:					
3	Oath or Declaration filed	Declaration.pdf	103060	no	3
			c2ed47e5e50c6caac3d3b7b92b322f149a72abd4		
Warnings:					
Information:					
4	Oath or Declaration filed	Supplemental_declaration.pdf	207159	no	2
			25f039b47e93cac63047a4be9d6456c63043838a		
Warnings:					
Information:					
5	Fee Worksheet (SB06)	fee-info.pdf	36388	no	2
			7ad2a161b96241f4e658d3136cd6db6beb95ccf2		
Warnings:					
Information:					
Total Files Size (in bytes):			2014350		

This Acknowledgement Receipt evidences receipt on the noted date by the USPTO of the indicated documents, characterized by the applicant, and including page counts, where applicable. It serves as evidence of receipt similar to a Post Card, as described in MPEP 503.

New Applications Under 35 U.S.C. 111

If a new application is being filed and the application includes the necessary components for a filing date (see 37 CFR 1.53(b)-(d) and MPEP 506), a Filing Receipt (37 CFR 1.54) will be issued in due course and the date shown on this Acknowledgement Receipt will establish the filing date of the application.

National Stage of an International Application under 35 U.S.C. 371

If a timely submission to enter the national stage of an international application is compliant with the conditions of 35 U.S.C. 371 and other applicable requirements a Form PCT/DO/EO/903 indicating acceptance of the application as a national stage submission under 35 U.S.C. 371 will be issued in addition to the Filing Receipt, in due course.

New International Application Filed with the USPTO as a Receiving Office

If a new international application is being filed and the international application includes the necessary components for an international filing date (see PCT Article 11 and MPEP 1810), a Notification of the International Application Number and of the International Filing Date (Form PCT/RO/105) will be issued in due course, subject to prescriptions concerning national security, and the date shown on this Acknowledgement Receipt will establish the international filing date of the application.

Under the Paperwork Reduction Act of 1995, no person is required to respond to a collection of information unless it displays a valid OMB control number

POWER OF ATTORNEY TO PROSECUTE APPLICATIONS BEFORE THE USPTO

I hereby revoke all previous powers of attorney given in the application identified in the attached statement under 37 CFR 3.73(c).

I hereby appoint:

Practitioners associated with Customer Number: 92342

OR

Practitioner(s) named below (if more than ten patent practitioners are to be named, then a customer number must be used):

Name	Registration Number

Name	Registration Number

As attorney(s) or agent(s) to represent the undersigned before the United States Patent and Trademark Office (USPTO) in connection with any and all patent applications assigned only to the undersigned according to the USPTO assignment records or assignment documents attached to this form in accordance with 37 CFR 3.73(c).

Please change the correspondence address for the application identified in the attached statement under 37 CFR 3.73(c) to:

The address associated with Customer Number:

OR

Firm or individual name

Address

City State Zip

Country

Telephone Email

Assignee name and address: Corephotonics Ltd.
 25 Habarzel St.
 Ramat HaChayal, Tel-Aviv, 6971035
 Israel

A copy of this form, together with a statement under 37 CFR 3.73(c) (Form PTO/AIA/96 or equivalent) is required to be filed in each application in which this form is used. The statement under 37 CFR 3.73(c) may be completed by one of the practitioners appointed in this form, and must identify the application in which this Power of Attorney is to be filed.

SIGNATURE of Assignee of Record

The individual whose signature and title is supplied below is authorized to act on behalf of the assignee.

Signature/GAL SHABTAY/	Date 2018-07-28
Name GAL SHABTAY	Telephone
Title VP-R&D	

This collection of information is required by 37 CFR 1.31, 1.32, and 1.33. The information is required to obtain or retain a benefit by the public, which is to update (and by the USPTO to process) the file of a patent or reexamination proceeding. Confidentiality is governed by 35 U.S.C. 122 and 37 CFR 1.11 and 1.14. This collection is estimated to take 18 minutes to complete, including gathering, preparing, and submitting the completed application form to the USPTO. Time will vary depending upon the individual case. Any comments on the amount of time you require to complete this form and/or suggestions for reducing this burden, should be sent to the Chief Information Officer, U.S. Patent and Trademark Office, U.S. Department of Commerce, P.O. Box 1450, Alexandria, VA 22313-1450. DO NOT SEND FEES OR COMPLETED FORMS TO THIS ADDRESS. SEND TO: Commissioner for Patents, P.O. Box 1450, Alexandria, VA 22313-1450.

If you need assistance in completing the form, call 1-800-PTO-9199 and select option 2.

Privacy Act Statement

The **Privacy Act of 1974 (P.L. 93-579)** requires that you be given certain information in connection with your submission of the attached form related to a patent application or patent. Accordingly, pursuant to the requirements of the Act, please be advised that: (1) the general authority for the collection of this information is 35 U.S.C. 2(b)(2); (2) furnishing of the information solicited is voluntary; and (3) the principal purpose for which the information is used by the U.S. Patent and Trademark Office is to process and/or examine your submission related to a patent application or patent. If you do not furnish the requested information, the U.S. Patent and Trademark Office may not be able to process and/or examine your submission, which may result in termination of proceedings or abandonment of the application or expiration of the patent.

The information provided by you in this form will be subject to the following routine uses:

1. The information on this form will be treated confidentially to the extent allowed under the Freedom of Information Act (5 U.S.C. 552) and the Privacy Act (5 U.S.C. 552a). Records from this system of records may be disclosed to the Department of Justice to determine whether disclosure of these records is required by the Freedom of Information Act.
2. A record from this system of records may be disclosed, as a routine use, in the course of presenting evidence to a court, magistrate, or administrative tribunal, including disclosures to opposing counsel in the course of settlement negotiations.
3. A record in this system of records may be disclosed, as a routine use, to a Member of Congress submitting a request involving an individual, to whom the record pertains, when the individual has requested assistance from the Member with respect to the subject matter of the record.
4. A record in this system of records may be disclosed, as a routine use, to a contractor of the Agency having need for the information in order to perform a contract. Recipients of information shall be required to comply with the requirements of the Privacy Act of 1974, as amended, pursuant to 5 U.S.C. 552a(m).
5. A record related to an International Application filed under the Patent Cooperation Treaty in this system of records may be disclosed, as a routine use, to the International Bureau of the World Intellectual Property Organization, pursuant to the Patent Cooperation Treaty.
6. A record in this system of records may be disclosed, as a routine use, to another federal agency for purposes of National Security review (35 U.S.C. 181) and for review pursuant to the Atomic Energy Act (42 U.S.C. 218(c)).
7. A record from this system of records may be disclosed, as a routine use, to the Administrator, General Services, or his/her designee, during an inspection of records conducted by GSA as part of that agency's responsibility to recommend improvements in records management practices and programs, under authority of 44 U.S.C. 2904 and 2906. Such disclosure shall be made in accordance with the GSA regulations governing inspection of records for this purpose, and any other relevant (*i.e.*, GSA or Commerce) directive. Such disclosure shall not be used to make determinations about individuals.
8. A record from this system of records may be disclosed, as a routine use, to the public after either publication of the application pursuant to 35 U.S.C. 122(b) or issuance of a patent pursuant to 35 U.S.C. 151. Further, a record may be disclosed, subject to the limitations of 37 CFR 1.14, as a routine use, to the public if the record was filed in an application which became abandoned or in which the proceedings were terminated and which application is referenced by either a published application, an application open to public inspection or an issued patent.
9. A record from this system of records may be disclosed, as a routine use, to a Federal, State, or local law enforcement agency, if the USPTO becomes aware of a violation or potential violation of law or regulation.

Electronic Acknowledgement Receipt

EFS ID:	33310681
Application Number:	16048242
International Application Number:	
Confirmation Number:	4814
Title of Invention:	DUAL APERTURE ZOOM DIGITAL CAMERA
First Named Inventor/Applicant Name:	Gal Shabtay
Customer Number:	92342
Filer:	Menachem Nathan
Filer Authorized By:	
Attorney Docket Number:	COREPH-0079 US CON3
Receipt Date:	28-JUL-2018
Filing Date:	
Time Stamp:	15:43:07
Application Type:	Utility under 35 USC 111(a)

Payment information:

Submitted with Payment	no
------------------------	----

File Listing:

Document Number	Document Description	File Name	File Size(Bytes)/ Message Digest	Multi Part /.zip	Pages (if appl.)
1	Assignee showing of ownership per 37 CFR 3.73	Assignment.pdf	19490 <small>e14eb12f24e6d49bd610fd4c8aeea0563fa1e91</small>	no	1

Warnings:

Information:					
2	Assignee showing of ownership per 37 CFR 3.73	STATEMENT.pdf	117357	no	3
			beac8b031435f8796574b5757608c2a04190c7b7		
Warnings:					
Information:					
3	Power of Attorney	POA.pdf	451982	no	2
			347b245d4092b3388e8066b3bdef474dc6e66e26		
Warnings:					
Information:					
			Total Files Size (in bytes):	588829	
<p>This Acknowledgement Receipt evidences receipt on the noted date by the USPTO of the indicated documents, characterized by the applicant, and including page counts, where applicable. It serves as evidence of receipt similar to a Post Card, as described in MPEP 503.</p> <p><u>New Applications Under 35 U.S.C. 111</u> If a new application is being filed and the application includes the necessary components for a filing date (see 37 CFR 1.53(b)-(d) and MPEP 506), a Filing Receipt (37 CFR 1.54) will be issued in due course and the date shown on this Acknowledgement Receipt will establish the filing date of the application.</p> <p><u>National Stage of an International Application under 35 U.S.C. 371</u> If a timely submission to enter the national stage of an international application is compliant with the conditions of 35 U.S.C. 371 and other applicable requirements a Form PCT/DO/EO/903 indicating acceptance of the application as a national stage submission under 35 U.S.C. 371 will be issued in addition to the Filing Receipt, in due course.</p> <p><u>New International Application Filed with the USPTO as a Receiving Office</u> If a new international application is being filed and the international application includes the necessary components for an international filing date (see PCT Article 11 and MPEP 1810), a Notification of the International Application Number and of the International Filing Date (Form PCT/RO/105) will be issued in due course, subject to prescriptions concerning national security, and the date shown on this Acknowledgement Receipt will establish the international filing date of the application.</p>					

STATEMENT UNDER 37 CFR 3.73(c)Applicant/Patent Owner: Corephotonics Ltd.Application No./Patent No.: 16/048,242 Filed/Issue Date: 2018-07-28Titled: DUAL APERTURE ZOOM DIGITAL CAMERACorephotonics Ltd. _____, a COMPANY

(Name of Assignee)

(Type of Assignee, e.g., corporation, partnership, university, government agency, etc.)

states that, for the patent application/patent identified above, it is (choose **one** of options 1, 2, 3 or 4 below):

1. The assignee of the entire right, title, and interest.
2. An assignee of less than the entire right, title, and interest (check applicable box):
- The extent (by percentage) of its ownership interest is _____%. Additional Statement(s) by the owners holding the balance of the interest must be submitted to account for 100% of the ownership interest.
- There are unspecified percentages of ownership. The other parties, including inventors, who together own the entire right, title and interest are:

Additional Statement(s) by the owner(s) holding the balance of the interest must be submitted to account for the entire right, title, and interest.

3. The assignee of an undivided interest in the entirety (a complete assignment from one of the joint inventors was made). The other parties, including inventors, who together own the entire right, title, and interest are:

Additional Statement(s) by the owner(s) holding the balance of the interest must be submitted to account for the entire right, title, and interest.

4. The recipient, via a court proceeding or the like (e.g., bankruptcy, probate), of an undivided interest in the entirety (a complete transfer of ownership interest was made). The certified document(s) showing the transfer is attached.

The interest identified in option 1, 2 or 3 above (not option 4) is evidenced by either (choose **one** of options A or B below):

- A. An assignment from the inventor(s) of the patent application/patent identified above. The assignment was recorded in the United States Patent and Trademark Office at Reel _____, Frame _____, or for which a copy thereof is attached.

- B. A chain of title from the inventor(s), of the patent application/patent identified above, to the current assignee as follows:

1. From: _____ To: _____

The document was recorded in the United States Patent and Trademark Office at

Reel _____, Frame _____, or for which a copy thereof is attached.

2. From: _____ To: _____

The document was recorded in the United States Patent and Trademark Office at

Reel _____, Frame _____, or for which a copy thereof is attached.

[Page 1 of 2]

This collection of information is required by 37 CFR 3.73(b). The information is required to obtain or retain a benefit by the public which is to file (and by the USPTO to process) an application. Confidentiality is governed by 35 U.S.C. 122 and 37 CFR 1.11 and 1.14. This collection is estimated to take 12 minutes to complete, including gathering, preparing, and submitting the completed application form to the USPTO. Time will vary depending upon the individual case. Any comments on the amount of time you require to complete this form and/or suggestions for reducing this burden, should be sent to the Chief Information Officer, U.S. Patent and Trademark Office, U.S. Department of Commerce, P.O. Box 1450, Alexandria, VA 22313-1450. DO NOT SEND FEES OR COMPLETED FORMS TO THIS ADDRESS. **SEND TO: Commissioner for Patents, P.O. Box 1450, Alexandria, VA 22313-1450.**

If you need assistance in completing the form, call 1-800-PTO-9199 and select option 2.

STATEMENT UNDER 37 CFR 3.73(c)

3. From: _____ To: _____

The document was recorded in the United States Patent and Trademark Office at
Reel _____, Frame _____, or for which a copy thereof is attached.

4. From: _____ To: _____

The document was recorded in the United States Patent and Trademark Office at
Reel _____, Frame _____, or for which a copy thereof is attached.

5. From: _____ To: _____

The document was recorded in the United States Patent and Trademark Office at
Reel _____, Frame _____, or for which a copy thereof is attached.

6. From: _____ To: _____

The document was recorded in the United States Patent and Trademark Office at
Reel _____, Frame _____, or for which a copy thereof is attached.

Additional documents in the chain of title are listed on a supplemental sheet(s).

As required by 37 CFR 3.73(c)(1)(i), the documentary evidence of the chain of title from the original owner to the assignee was, or concurrently is being, submitted for recordation pursuant to 37 CFR 3.11.

[NOTE: A separate copy (i.e., a true copy of the original assignment document(s)) must be submitted to Assignment Division in accordance with 37 CFR Part 3, to record the assignment in the records of the USPTO. See MPEP 302.08]

The undersigned (whose title is supplied below) is authorized to act on behalf of the assignee.

/GAL SHABTAY/ _____

2018-07-28 _____

Signature

Date

GAL SHABTAY _____

VP-R&D _____

Printed or Typed Name

Title or Registration Number

Privacy Act Statement

The **Privacy Act of 1974 (P.L. 93-579)** requires that you be given certain information in connection with your submission of the attached form related to a patent application or patent. Accordingly, pursuant to the requirements of the Act, please be advised that: (1) the general authority for the collection of this information is 35 U.S.C. 2(b)(2); (2) furnishing of the information solicited is voluntary; and (3) the principal purpose for which the information is used by the U.S. Patent and Trademark Office is to process and/or examine your submission related to a patent application or patent. If you do not furnish the requested information, the U.S. Patent and Trademark Office may not be able to process and/or examine your submission, which may result in termination of proceedings or abandonment of the application or expiration of the patent.

The information provided by you in this form will be subject to the following routine uses:

1. The information on this form will be treated confidentially to the extent allowed under the Freedom of Information Act (5 U.S.C. 552) and the Privacy Act (5 U.S.C. 552a). Records from this system of records may be disclosed to the Department of Justice to determine whether disclosure of these records is required by the Freedom of Information Act.
2. A record from this system of records may be disclosed, as a routine use, in the course of presenting evidence to a court, magistrate, or administrative tribunal, including disclosures to opposing counsel in the course of settlement negotiations.
3. A record in this system of records may be disclosed, as a routine use, to a Member of Congress submitting a request involving an individual, to whom the record pertains, when the individual has requested assistance from the Member with respect to the subject matter of the record.
4. A record in this system of records may be disclosed, as a routine use, to a contractor of the Agency having need for the information in order to perform a contract. Recipients of information shall be required to comply with the requirements of the Privacy Act of 1974, as amended, pursuant to 5 U.S.C. 552a(m).
5. A record related to an International Application filed under the Patent Cooperation Treaty in this system of records may be disclosed, as a routine use, to the International Bureau of the World Intellectual Property Organization, pursuant to the Patent Cooperation Treaty.
6. A record in this system of records may be disclosed, as a routine use, to another federal agency for purposes of National Security review (35 U.S.C. 181) and for review pursuant to the Atomic Energy Act (42 U.S.C. 218(c)).
7. A record from this system of records may be disclosed, as a routine use, to the Administrator, General Services, or his/her designee, during an inspection of records conducted by GSA as part of that agency's responsibility to recommend improvements in records management practices and programs, under authority of 44 U.S.C. 2904 and 2906. Such disclosure shall be made in accordance with the GSA regulations governing inspection of records for this purpose, and any other relevant (*i.e.*, GSA or Commerce) directive. Such disclosure shall not be used to make determinations about individuals.
8. A record from this system of records may be disclosed, as a routine use, to the public after either publication of the application pursuant to 35 U.S.C. 122(b) or issuance of a patent pursuant to 35 U.S.C. 151. Further, a record may be disclosed, subject to the limitations of 37 CFR 1.14, as a routine use, to the public if the record was filed in an application which became abandoned or in which the proceedings were terminated and which application is referenced by either a published application, an application open to public inspection or an issued patent.
9. A record from this system of records may be disclosed, as a routine use, to a Federal, State, or local law enforcement agency, if the USPTO becomes aware of a violation or potential violation of law or regulation.

SCORE Placeholder Sheet for IFW Content

Application Number: 16048242

Document Date: 07/28/2018

The presence of this form in the IFW record indicates that the following document type was received in electronic format on the date identified above. This content is stored in the SCORE database.

Since this was an electronic submission, there is no physical artifact folder, no artifact folder is recorded in PALM, and no paper documents or physical media exist. The TIFF images in the IFW record were created from the original documents that are stored in SCORE.

- Drawing

At the time of document entry (noted above):

- USPTO employees may access SCORE content via eDAN using the Supplemental Content tab, or via the SCORE web page.
- External customers may access SCORE content via PAIR using the Supplemental Content tab.

Form Revision Date: August 26, 2013