



US008989517B2

(12) **United States Patent**
Morgan-Mar et al.

(10) **Patent No.:** **US 8,989,517 B2**
(45) **Date of Patent:** **Mar. 24, 2015**

(54) **BOKEH AMPLIFICATION**

(71) Applicant: **Canon Kabushiki Kaisha**, Tokyo (JP)

(72) Inventors: **David Peter Morgan-Mar**,
Wollstonecraft (AU); **Kieran Gerard**
Larkin, Putney (AU); **Matthew**
Raphael Arnison, Umina Beach (AU)

(73) Assignee: **Canon Kabushiki Kaisha**, Tokyo (JP)

(*) Notice: Subject to any disclaimer, the term of this patent is extended or adjusted under 35 U.S.C. 154(b) by 0 days.

(21) Appl. No.: **14/079,481**

(22) Filed: **Nov. 13, 2013**

(65) **Prior Publication Data**

US 2014/0152886 A1 Jun. 5, 2014

(30) **Foreign Application Priority Data**

Dec. 3, 2012 (AU) 2012258467

(51) **Int. Cl.**

G06K 9/36 (2006.01)
G06K 9/40 (2006.01)
H04N 5/225 (2006.01)
H04N 5/228 (2006.01)
H04N 5/262 (2006.01)
H04N 5/232 (2006.01)

(52) **U.S. Cl.**

CPC **H04N 5/23212** (2013.01)
USPC **382/280**; 348/207.1; 348/222.1;
348/239; 382/255; 382/276

(58) **Field of Classification Search**

USPC 348/207.1–207.11, 208.99–208.16,
348/222.1, 239, 241, 345–357, 362–368
See application file for complete search history.

(56) **References Cited**

U.S. PATENT DOCUMENTS

7,065,256 B2 6/2006 Alon et al.
8,422,827 B2 * 4/2013 Ishii et al. 382/299
8,498,483 B2 * 7/2013 Noguchi et al. 382/181
8,624,986 B2 * 1/2014 Li 348/208.13
8,704,909 B2 * 4/2014 Kanaris et al. 348/222.1
8,737,756 B2 * 5/2014 Daneshpanah et al. 382/255

(Continued)

FOREIGN PATENT DOCUMENTS

WO 2008/149363 A2 12/2008

OTHER PUBLICATIONS

Bae, Soonmin, and Durand, Frédo. "Defocus Magnification." Computer Graphics Forum: Proceedings of Eurographics 2007, Prague, Sep. 3-7, 2007. Ed. Cohen-Or, D and Slavik, P. Oxford, UK: Blackwell Publishing, 2007. 26.3:571-579.

(Continued)

Primary Examiner — Michael Osinski

(74) Attorney, Agent, or Firm — Canon U.S.A., Inc. IP Division

(57) **ABSTRACT**

A method of modifying the blur in at least a part of an image of a scene captures at least two images of the scene with different camera parameters to produce a different amount of blur in each image. A corresponding patch in each of the captured images is selected each having an initial amount of blur is used to calculate a set of frequency domain pixel values from a function of transforms of the patches. Each of the pixel values in the set are raised to a predetermined power, forming an amplified set of frequency domain pixel values. The amplified set of frequency domain pixel values is combined with the pixels of the patch in one of the captured images to produce an output image patch with blur modified relative to the initial amount of blur in the image patch.

15 Claims, 13 Drawing Sheets

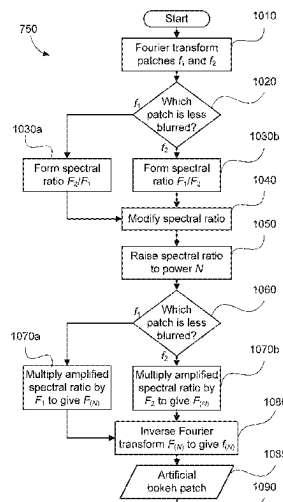
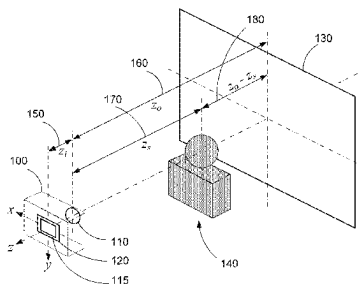

(56)

References Cited

U.S. PATENT DOCUMENTS

2001/0008418 A1* 7/2001 Yamanaka et al. 348/222
2002/0145671 A1* 10/2002 Alon et al. 348/241
2003/0002746 A1* 1/2003 Kusaka 382/255
2007/0036427 A1* 2/2007 Nakamura et al. 382/154
2008/0013861 A1* 1/2008 Li et al. 382/286
2008/0175508 A1* 7/2008 Bando et al. 382/255
2009/0115860 A1* 5/2009 Nakashima et al. 348/208.99
2009/0141163 A1 6/2009 Attar et al.
2009/0297056 A1* 12/2009 Lelescu et al. 382/261
2011/0033132 A1* 2/2011 Ishii et al. 382/275

2011/0090352 A1* 4/2011 Wang et al. 348/208.6
2011/0205382 A1* 8/2011 Kanaris et al. 348/222.1
2012/0206630 A1* 8/2012 Nguyen et al. 348/241
2013/0063566 A1* 3/2013 Morgan-Mar et al. 348/46
2013/0266210 A1* 10/2013 Morgan-Mar et al. 382/154

OTHER PUBLICATIONS

Kubota, Akira, and Aizawa, Kiyoharu. "Reconstructing Arbitrarily Focused Images From Two Differently Focused Images Using Linear Filters." IEEE Transactions on Image Processing 14.11 (2005): 1848-1859.

* cited by examiner

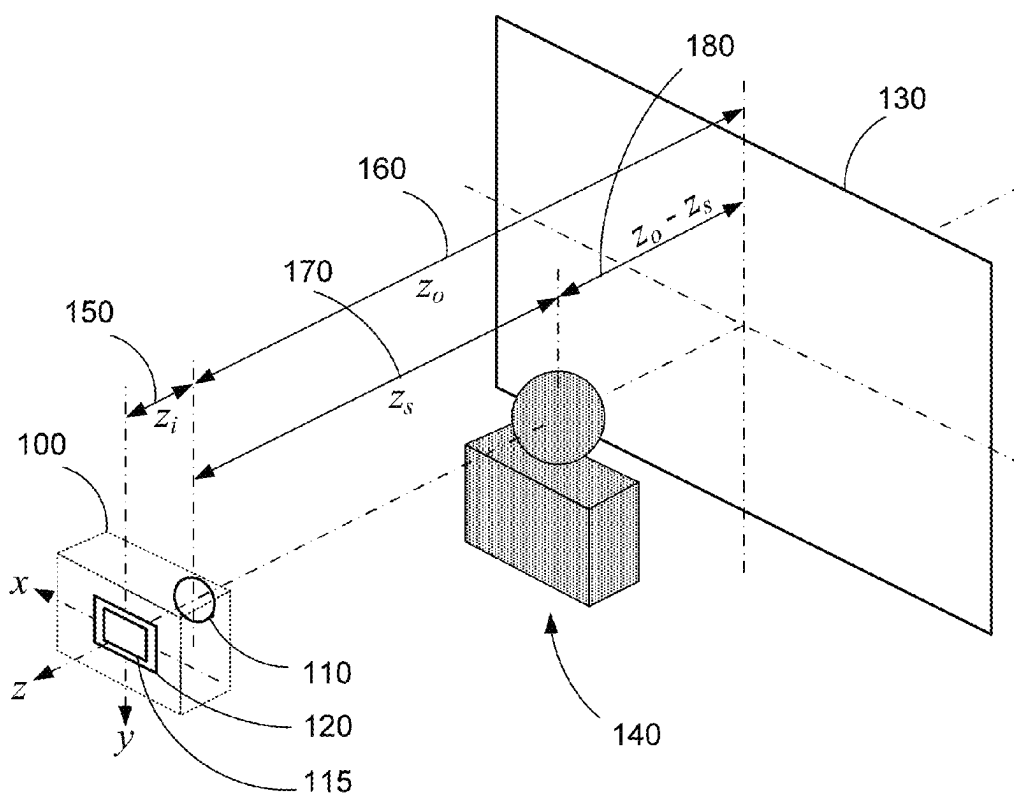

Fig. 1

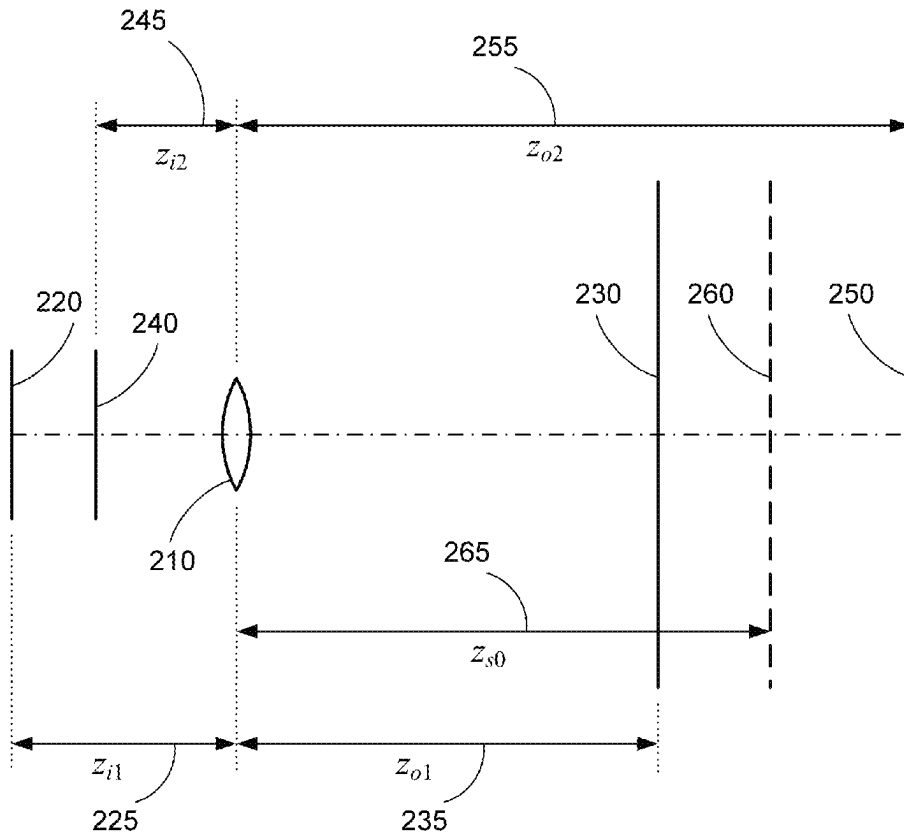

Fig. 2

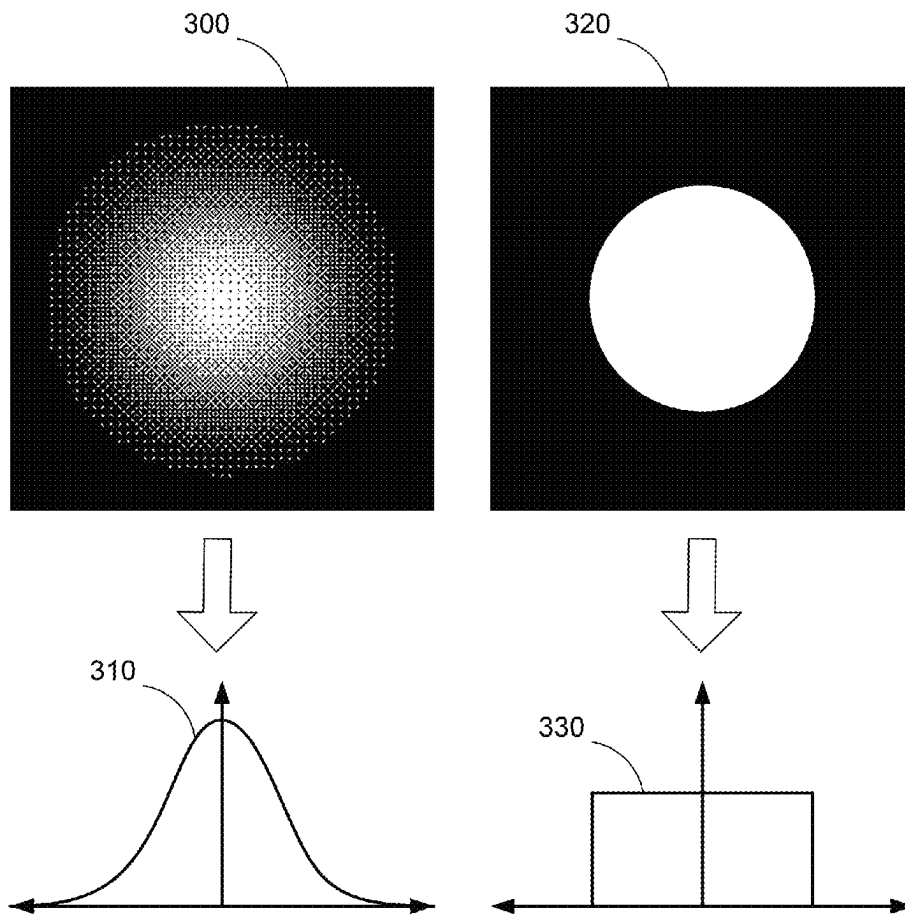

Fig. 3A

Fig. 3B

Explore Litigation Insights

Docket Alarm provides insights to develop a more informed litigation strategy and the peace of mind of knowing you're on top of things.

Real-Time Litigation Alerts



Keep your litigation team up-to-date with **real-time alerts** and advanced team management tools built for the enterprise, all while greatly reducing PACER spend.

Our comprehensive service means we can handle Federal, State, and Administrative courts across the country.

Advanced Docket Research



With over 230 million records, Docket Alarm's cloud-native docket research platform finds what other services can't. Coverage includes Federal, State, plus PTAB, TTAB, ITC and NLRB decisions, all in one place.

Identify arguments that have been successful in the past with full text, pinpoint searching. Link to case law cited within any court document via Fastcase.

Analytics At Your Fingertips



Learn what happened the last time a particular judge, opposing counsel or company faced cases similar to yours.

Advanced out-of-the-box PTAB and TTAB analytics are always at your fingertips.

API

Docket Alarm offers a powerful API (application programming interface) to developers that want to integrate case filings into their apps.

LAW FIRMS

Build custom dashboards for your attorneys and clients with live data direct from the court.

Automate many repetitive legal tasks like conflict checks, document management, and marketing.

FINANCIAL INSTITUTIONS

Litigation and bankruptcy checks for companies and debtors.

E-DISCOVERY AND LEGAL VENDORS

Sync your system to PACER to automate legal marketing.