



US007206136B2

(12) **United States Patent**  
**Labaziewicz et al.**

(10) **Patent No.:** **US 7,206,136 B2**  
(45) **Date of Patent:** **Apr. 17, 2007**

(54) **DIGITAL CAMERA USING MULTIPLE LENSES AND IMAGE SENSORS TO PROVIDE AN EXTENDED ZOOM RANGE**

(75) Inventors: **Peter Labaziewicz**, Tokyo (JP); **Wilbert F. Janson, Jr.**, Shortsville, NY (US); **Kenneth A. Parulski**, Rochester, NY (US)

(73) Assignee: **Eastman Kodak Company**, Rochester, NY (US)

(\* ) Notice: Subject to any disclaimer, the term of this patent is extended or adjusted under 35 U.S.C. 154(b) by 0 days.

4,097,882 A	6/1978	Engelsmann .....	396/73
4,199,785 A	4/1980	McCullough et al. ....	348/704
4,989,078 A *	1/1991	Paxton .....	348/47
5,051,830 A	9/1991	von Hoessle .....	348/335
5,164,831 A	11/1992	Kuchta et al. ....	348/231.7
5,668,597 A	9/1997	Parulski et al. ....	348/350
5,929,903 A	7/1999	Keisow .....	348/97
6,288,742 B1 *	9/2001	Ansari et al. ....	348/211.14
6,611,289 B1 *	8/2003	Yu et al. ....	348/265
6,804,460 B1	10/2004	Oshima et al. ....	396/74
2002/0163582 A1	11/2002	Gruber et al. ....	348/218.1
2003/0020814 A1	1/2003	Ono .....	348/220.1
2003/0160886 A1	8/2003	Misawa et al. ....	348/347
2003/0202113 A1	10/2003	Yoshikawa .....	348/272

(21) Appl. No.: **11/062,174**

(22) Filed: **Feb. 18, 2005**

(65) **Prior Publication Data**

US 2006/0187312 A1 Aug. 24, 2006

(51) **Int. Cl.**

**G02B 15/14** (2006.01)

**G03B 41/00** (2006.01)

**H04N 5/225** (2006.01)

(52) **U.S. Cl.** ..... **359/676; 396/322; 348/207.99**

(58) **Field of Classification Search** ..... **359/676-692, 359/72, 85, 60, 322, 435, 436; 348/240.99, 348/240.1, 239, 240.3, 262-264, 207.99, 348/34, 369, 360, 361, 344; 396/72, 85, 396/60, 322, 435, 436**

See application file for complete search history.

(56) **References Cited**

**U.S. PATENT DOCUMENTS**

3,497,614 A 2/1970 Petrocelli et al. .... 348/704

\* cited by examiner

*Primary Examiner*—Scott J. Sugarman

*Assistant Examiner*—M. Hasan

(74) *Attorney, Agent, or Firm*—Pamela R. Crocker

(57) **ABSTRACT**

A digital camera includes a first image sensor, a first wide angle lens for forming a first image of a scene on the first image sensor; a second image sensor, a zoom lens for forming a second image of the same scene on the second image sensor, a control element for selecting either a first sensor output from the first image sensor or a second sensor output from the second image sensor, and a processing section for producing the output image from the selected sensor output. In one variation of this embodiment, the first lens is also a zoom lens, where the maximum focal length of the first lens is less than or equal to the minimum focal length of the second zoom lens.

**55 Claims, 22 Drawing Sheets**

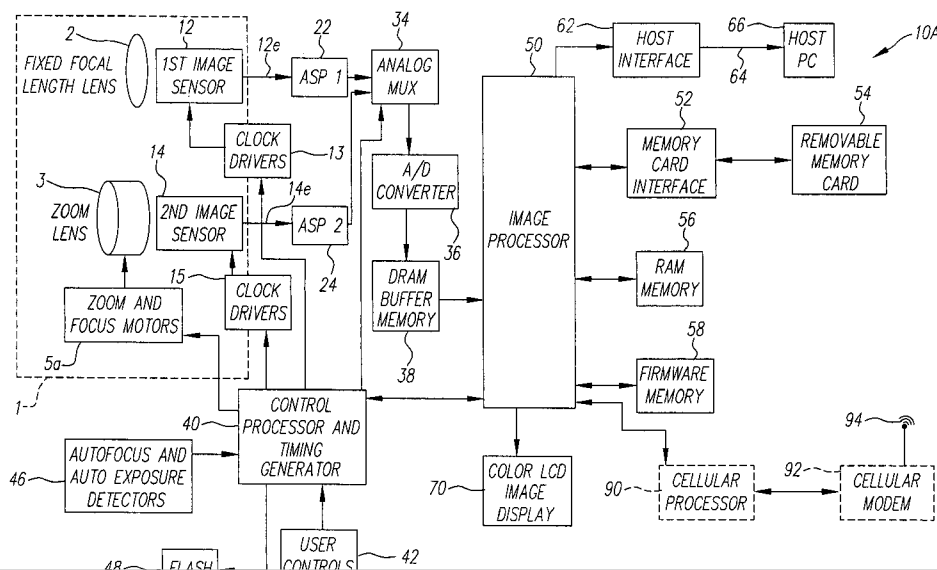

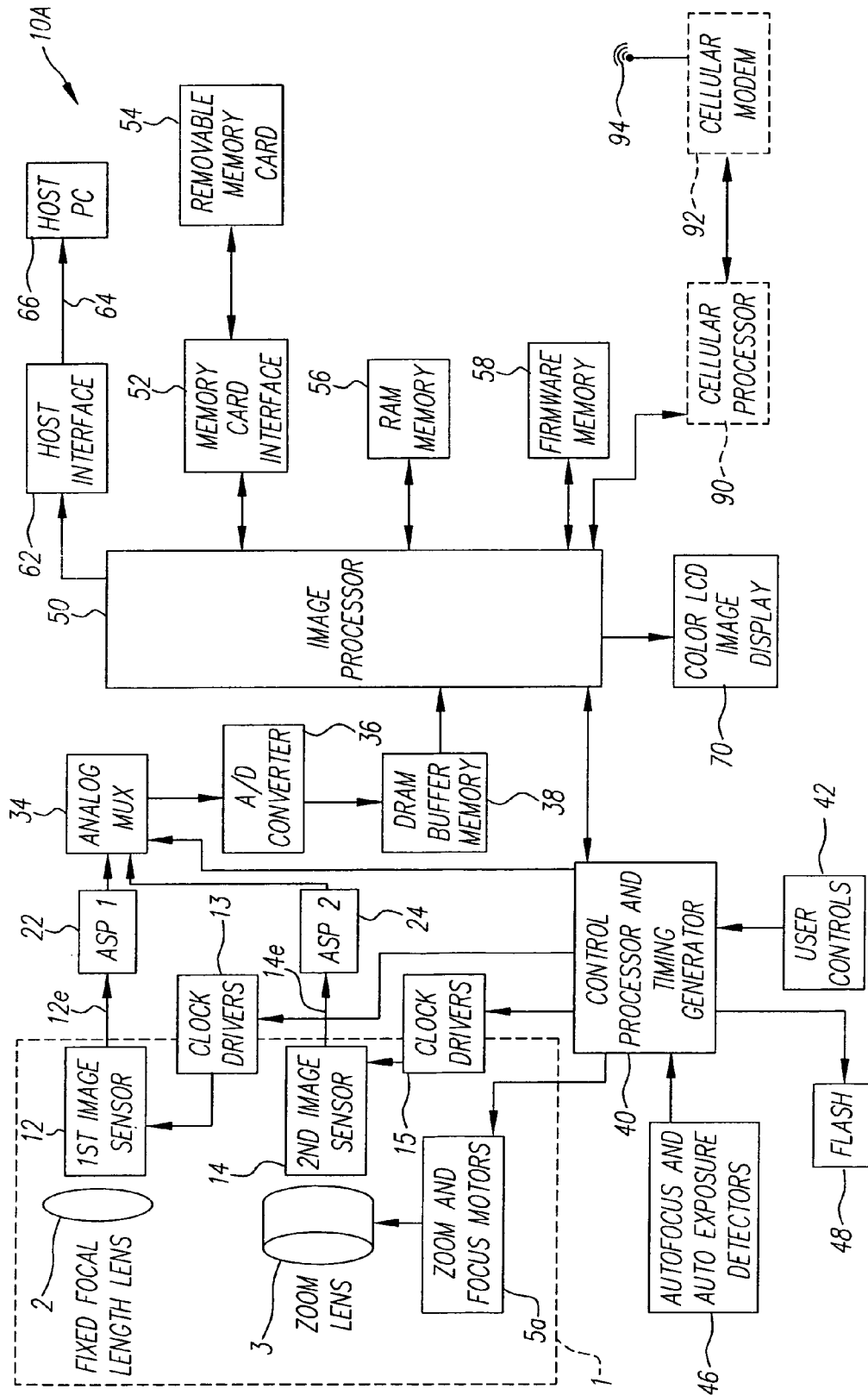

FIG. 1

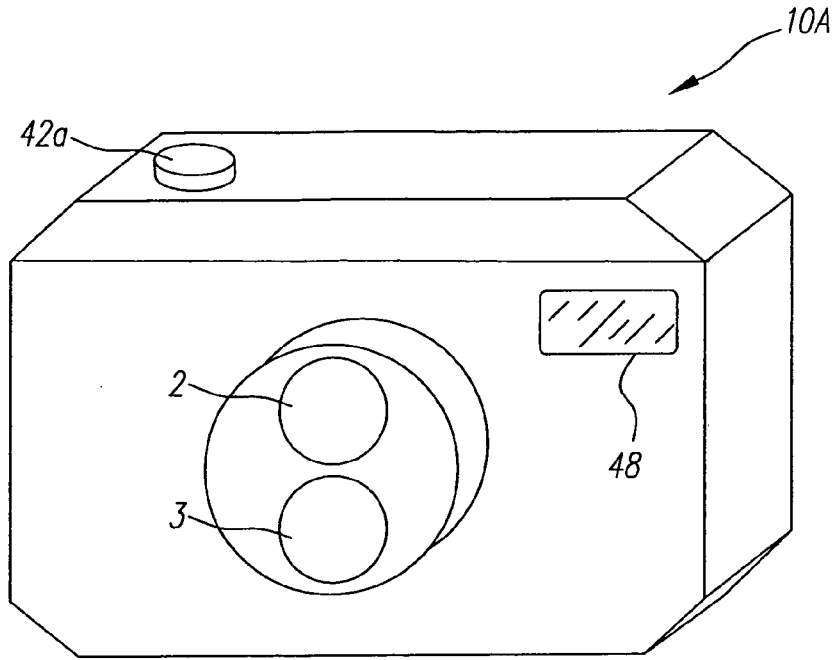

FIG. 2A

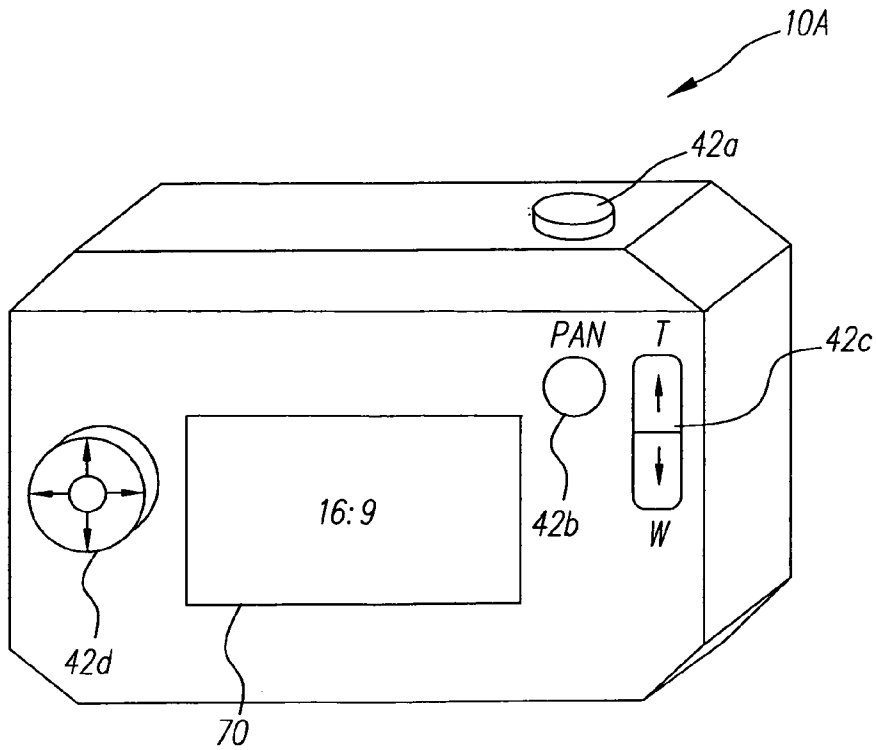

FIG. 2B

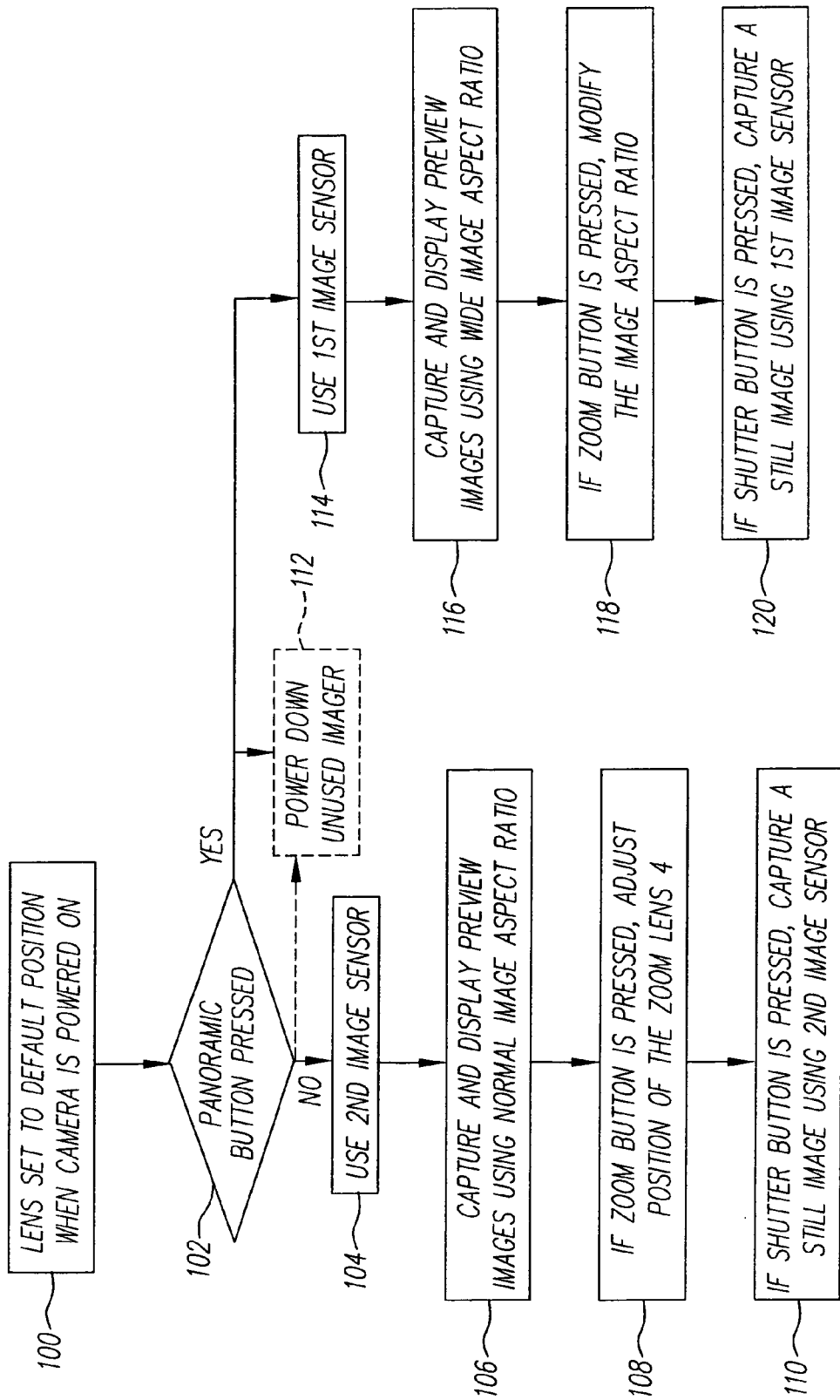

FIG. 3

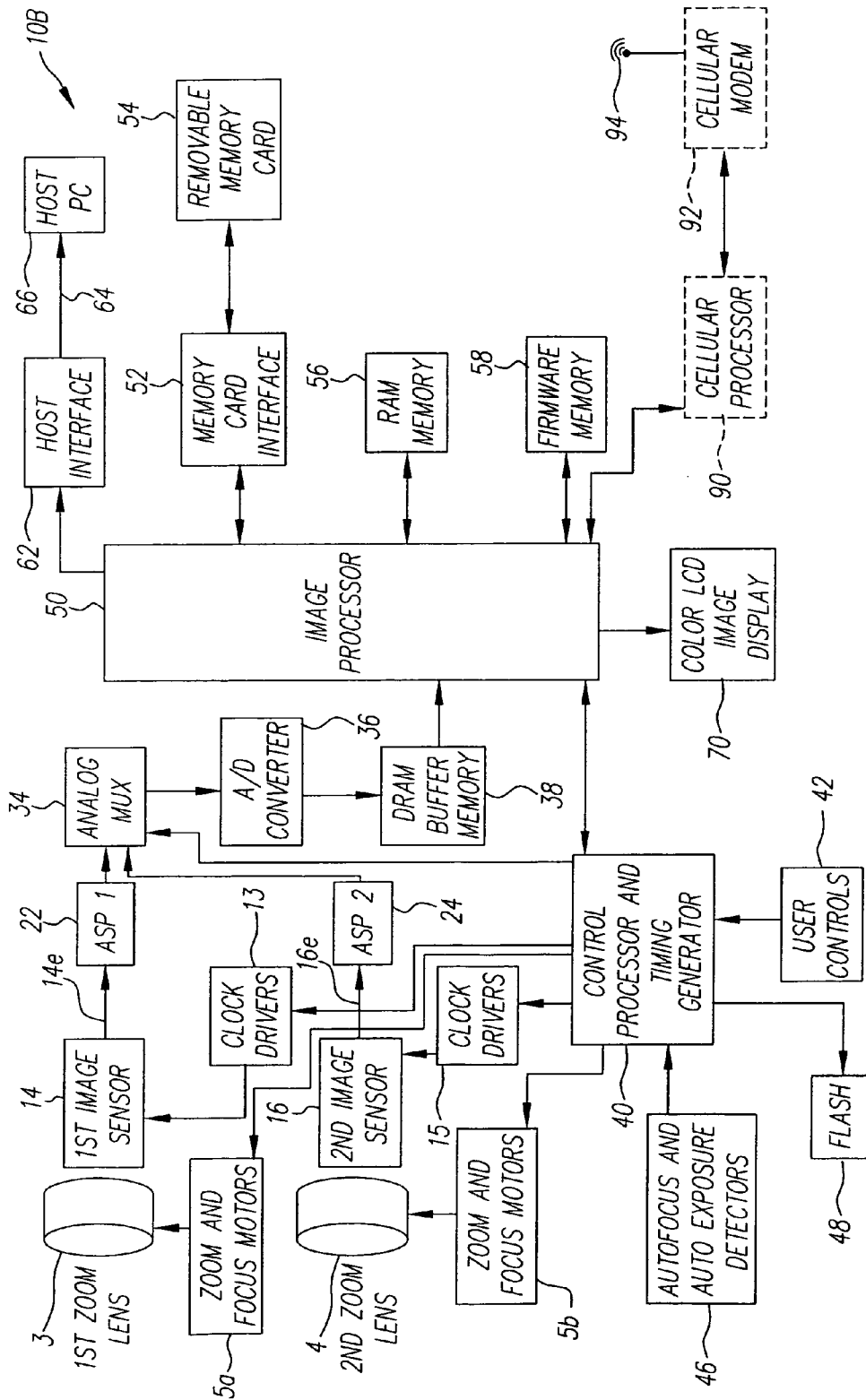

FIG. 4

# Explore Litigation Insights

Docket Alarm provides insights to develop a more informed litigation strategy and the peace of mind of knowing you're on top of things.

## Real-Time Litigation Alerts



Keep your litigation team up-to-date with **real-time alerts** and advanced team management tools built for the enterprise, all while greatly reducing PACER spend.

Our comprehensive service means we can handle Federal, State, and Administrative courts across the country.

## Advanced Docket Research



With over 230 million records, Docket Alarm's cloud-native docket research platform finds what other services can't. Coverage includes Federal, State, plus PTAB, TTAB, ITC and NLRB decisions, all in one place.

Identify arguments that have been successful in the past with full text, pinpoint searching. Link to case law cited within any court document via Fastcase.

## Analytics At Your Fingertips



Learn what happened the last time a particular judge, opposing counsel or company faced cases similar to yours.

Advanced out-of-the-box PTAB and TTAB analytics are always at your fingertips.

## API

Docket Alarm offers a powerful API (application programming interface) to developers that want to integrate case filings into their apps.

## LAW FIRMS

Build custom dashboards for your attorneys and clients with live data direct from the court.

Automate many repetitive legal tasks like conflict checks, document management, and marketing.

## FINANCIAL INSTITUTIONS

Litigation and bankruptcy checks for companies and debtors.

## E-DISCOVERY AND LEGAL VENDORS

Sync your system to PACER to automate legal marketing.