



US010225479B2

(12) **United States Patent**
Shabtay et al.

(10) **Patent No.:** **US 10,225,479 B2**

(45) **Date of Patent:** **Mar. 5, 2019**

(54) **DUAL APERTURE ZOOM DIGITAL CAMERA**

(56) **References Cited**

U.S. PATENT DOCUMENTS

(71) Applicant: **Corephotonics Ltd.**, Tel Aviv (IL)

2,354,503 A 7/1944 Cox
2,378,170 A 6/1945 Aklin
(Continued)

(72) Inventors: **Gal Shabtay**, Tel Aviv (IL); **Ephraim Goldenberg**, Ashdod (IL); **Oded Gigushinski**, Herzlia (IL); **Noy Cohen**, Tel Aviv (IL)

FOREIGN PATENT DOCUMENTS

(73) Assignee: **Corephotonics Ltd.**, Tel Aviv (IL)

CN 101276415 A 10/2008
CN 102739949 A 10/2012
(Continued)

(*) Notice: Subject to any disclaimer, the term of this patent is extended or adjusted under 35 U.S.C. 154(b) by 0 days.

OTHER PUBLICATIONS

(21) Appl. No.: **16/048,242**

Statistical Modeling and Performance Characterization of a Real-Time Dual Camera Surveillance System, Greienhagen et al., Publisher: IEEE, 2000, 8 pages.

(22) Filed: **Jul. 28, 2018**

(Continued)

(65) **Prior Publication Data**

Primary Examiner — Cynthia Segura
(74) *Attorney, Agent, or Firm* — Nathan and Associates; Menachem Nathan

US 2018/0359423 A1 Dec. 13, 2018

Related U.S. Application Data

(63) Continuation of application No. 15/865,869, filed on Jan. 9, 2018, which is a continuation of application (Continued)

(51) **Int. Cl.**
H04N 5/232 (2006.01)
H04N 5/225 (2006.01)
(Continued)

(52) **U.S. Cl.**
CPC **H04N 5/23296** (2013.01); **G02B 13/009** (2013.01); **G02B 13/0015** (2013.01);
(Continued)

(58) **Field of Classification Search**
CPC G02B 13/0015; G02B 27/0075
See application file for complete search history.

(57) **ABSTRACT**

A dual-aperture zoom digital camera operable in both still and video modes. The camera includes Wide and Tele imaging sections with respective lens/sensor combinations and image signal processors and a camera controller operatively coupled to the Wide and Tele imaging sections. The Wide and Tele imaging sections provide respective image data. The controller is configured to combine in still mode at least some of the Wide and Tele image data to provide a fused output image from a particular point of view, and to provide without fusion continuous zoom video mode output images, each output image having a given output resolution, wherein the video mode output images are provided with a smooth transition when switching between a lower zoom factor (ZF) value and a higher ZF value or vice versa, and wherein at the lower ZF the output resolution is determined by the Wide sensor while at the higher ZF value the output resolution is determined by the Tele sensor.

40 Claims, 8 Drawing Sheets

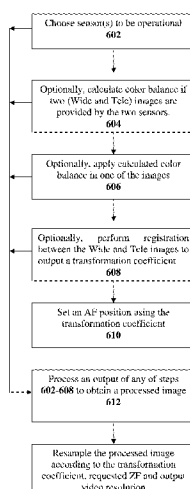

Related U.S. Application Data

No. 15/424,853, filed on Feb. 5, 2017, now Pat. No. 10,015,408, which is a continuation of application No. 14/880,251, filed on Oct. 11, 2015, now Pat. No. 9,661,233, which is a continuation of application No. 14/365,711, filed as application No. PCT/IB2014/062180 on Jun. 12, 2014, now Pat. No. 9,185,291.

- (60) Provisional application No. 61/834,486, filed on Jun. 13, 2013.
- (51) **Int. Cl.**
G02B 13/00 (2006.01)
G02B 27/00 (2006.01)
- (52) **U.S. Cl.**
CPC **G02B 27/0075** (2013.01); **H04N 5/225** (2013.01); **H04N 5/2258** (2013.01); **H04N 5/2259** (2013.01); **H04N 5/23212** (2013.01); **H04N 5/23232** (2013.01); **H04N 5/23245** (2013.01)

(56) **References Cited**

U.S. PATENT DOCUMENTS

2,441,093	A	5/1948	Aklin
3,388,956	A	6/1968	Eggert et al.
3,524,700	A	8/1970	Eggert et al.
3,864,027	A	2/1975	Harada
3,942,876	A	3/1976	Betensky
4,134,645	A	1/1979	Sugiyama et al.
4,199,785	A	4/1980	McCullough et al.
4,338,001	A	7/1982	Matsui
4,465,345	A	8/1984	Yazawa
5,000,551	A	3/1991	Shibayama
5,005,083	A	4/1991	Grage et al.
5,032,917	A	7/1991	Aschwanden
5,051,830	A	9/1991	von Hoessle
5,248,971	A	9/1993	Mandl
5,287,093	A	2/1994	Amano et al.
5,436,660	A	7/1995	Sakamoto
5,444,478	A	8/1995	Lelong et al.
5,459,520	A	10/1995	Sasaki
5,657,402	A	8/1997	Bender et al.
5,682,198	A	10/1997	Katayama et al.
5,768,443	A	6/1998	Michael et al.
5,926,190	A	7/1999	Turkowski et al.
5,940,641	A	8/1999	McIntyre et al.
5,982,951	A	11/1999	Katayama et al.
6,101,334	A	8/2000	Fantone
6,128,416	A	10/2000	Oura
6,148,120	A	11/2000	Sussman
6,208,765	B1	3/2001	Bergen
6,268,611	B1	7/2001	Pettersson et al.
6,549,215	B2	4/2003	Jouppi
6,611,289	B1	8/2003	Yu et al.
6,643,416	B1	11/2003	Daniels et al.
6,650,368	B1	11/2003	Doron
6,654,180	B2	11/2003	Ori
6,680,748	B1	1/2004	Monti
6,714,665	B1	3/2004	Hanna et al.
6,724,421	B1	4/2004	Glatt
6,738,073	B2	5/2004	Park et al.
6,741,250	B1	5/2004	Furlan et al.
6,750,903	B1	6/2004	Miyatake et al.
6,778,207	B1	8/2004	Lee et al.
7,002,583	B2	2/2006	Rabb, III
7,015,954	B1	3/2006	Footo et al.
7,038,716	B2	5/2006	Klein et al.
7,187,504	B2	3/2007	Horiuchi
7,199,348	B2	4/2007	Olsen et al.
7,206,136	B2	4/2007	Labaziewicz et al.
7,248,294	B2	7/2007	Slatter

7,339,621	B2	3/2008	Fortier
7,346,217	B1	3/2008	Gold, Jr.
7,365,793	B2	4/2008	Cheatle et al.
7,411,610	B2	8/2008	Doyle
7,424,218	B2	9/2008	Baudisch et al.
7,509,041	B2	3/2009	Hosono
7,515,351	B2	4/2009	Chen et al.
7,533,819	B2	5/2009	Barkan et al.
7,564,635	B1	7/2009	Tang
7,619,683	B2	11/2009	Davis
7,643,225	B1	1/2010	Tsai
7,660,049	B2	2/2010	Tang
7,684,128	B2	3/2010	Tang
7,688,523	B2	3/2010	Sano
7,692,877	B2	4/2010	Tang et al.
7,697,220	B2	4/2010	Iyama
7,738,016	B2	6/2010	Toyofuku
7,738,186	B2	6/2010	Chen et al.
7,773,121	B1	8/2010	Huntsberger et al.
7,777,972	B1	8/2010	Chen et al.
7,813,057	B2	10/2010	Lin
7,821,724	B2	10/2010	Tang et al.
7,826,149	B2	11/2010	Tang et al.
7,826,151	B2	11/2010	Tsai
7,869,142	B2	1/2011	Chen et al.
7,880,776	B2	2/2011	LeGall et al.
7,898,747	B2	3/2011	Tang
7,916,401	B2	3/2011	Chen et al.
7,918,398	B2	4/2011	Li et al.
7,957,075	B2	6/2011	Tang
7,957,076	B2	6/2011	Tang
7,957,079	B2	6/2011	Tang
7,961,406	B2	6/2011	Tang et al.
7,964,835	B2	6/2011	Olsen et al.
7,978,239	B2	7/2011	Deever et al.
8,000,031	B1	8/2011	Tsai
8,004,777	B2	8/2011	Yoshihito Souma
8,077,400	B2	12/2011	Tang
8,115,825	B2	2/2012	Culbert et al.
8,149,327	B2	4/2012	Lin et al.
8,149,523	B2	4/2012	Ozaki
8,154,610	B2	4/2012	Jo et al.
8,218,253	B2	7/2012	Tang
8,228,622	B2	7/2012	Tang
8,233,224	B2	7/2012	Chen
8,238,695	B1	8/2012	Davey et al.
8,253,843	B2	8/2012	Lin
8,274,552	B2	9/2012	Dahi et al.
8,279,537	B2	10/2012	Sato
8,363,337	B2	1/2013	Tang et al.
8,390,729	B2	3/2013	Long et al.
8,391,697	B2	3/2013	Cho et al.
8,395,851	B2	3/2013	Tang et al.
8,400,555	B1	3/2013	Georgiev et al.
8,400,717	B2	3/2013	Chen et al.
8,439,265	B2	5/2013	Ferren et al.
8,446,484	B2	5/2013	Muukki et al.
8,451,549	B2	5/2013	Yamanaka et al.
8,483,452	B2	7/2013	Ueda et al.
8,503,107	B2	8/2013	Chen et al.
8,508,649	B2*	8/2013	Reshidko G02B 13/0045 348/345
8,514,491	B2	8/2013	Duparrie
8,514,502	B2	8/2013	Chen
8,547,389	B2	10/2013	Hoppe et al.
8,553,106	B2	10/2013	Scarff
8,587,691	B2	11/2013	Takane
8,619,148	B1	12/2013	Watts et al.
8,780,465	B2	7/2014	Chae
8,803,990	B2	8/2014	Smith
8,810,923	B2	8/2014	Shinohara
8,854,745	B1	10/2014	Chen
8,896,655	B2	11/2014	Mauchly et al.
8,958,164	B2	2/2015	Kwon et al.
8,976,255	B2	3/2015	Matsuoto et al.
9,019,387	B2	4/2015	Nakano
9,025,073	B2	5/2015	Attar et al.

(56)	References Cited		2008/0030592	A1 *	2/2008	Border	H04N 5/232 348/218.1
	U.S. PATENT DOCUMENTS		2008/0030611	A1	2/2008	Jenkins	
			2008/0084484	A1	4/2008	Ochi et al.	
	9,137,447 B2	9/2015	2008/0117316	A1	5/2008	Orimoto	
	9,185,291 B1	11/2015	2008/0218611	A1	9/2008	Parulski et al.	
	9,215,377 B2	12/2015	2008/0218612	A1	9/2008	Border et al.	
	9,215,385 B2	12/2015	2008/0218613	A1 *	9/2008	Janson	G03B 15/00 348/262
	9,229,194 B2	1/2016				Border	H04N 5/23212 396/89
	9,235,036 B2	1/2016	2008/0219654	A1 *	9/2008	Border	
	9,270,875 B2	2/2016				Souma	
	9,279,957 B2	3/2016	2008/0304161	A1	12/2008	Li et al.	
	9,286,680 B1	3/2016	2009/0086074	A1	4/2009	Van Baar et al.	
	9,344,626 B2	5/2016	2009/0122195	A1	5/2009	Rouvinen et al.	
	9,360,671 B1	6/2016	2009/0122406	A1	5/2009	Park et al.	
	9,369,621 B2	6/2016	2009/0122423	A1	5/2009	Camp et al.	
	9,402,032 B2 *	7/2016	2009/0128644	A1	5/2009	Kauhainen et al.	
	9,413,930 B2	8/2016	2009/0219547	A1	9/2009	Hasuda et al.	
	9,413,984 B2	8/2016	2009/0252484	A1	10/2009	Ojala	
	9,420,180 B2	8/2016	2009/0295949	A1	12/2009	Border et al.	
	9,438,792 B2	9/2016	2010/0013906	A1	1/2010	Tupman et al.	
	9,485,432 B1	11/2016	2010/0020221	A1	1/2010	Olsen et al.	
	9,488,802 B2	11/2016	2010/0060746	A9	3/2010	Chen et al.	
	9,568,712 B2	2/2017	2010/0103194	A1	4/2010	Griffith et al.	
	9,578,257 B2	2/2017	2010/0238327	A1	9/2010	Guissin et al.	
	9,618,748 B2	4/2017	2010/0283842	A1	11/2010	Lee	
	9,678,310 B2	6/2017	2011/0001838	A1	1/2011	Dagher	G06T 5/004 382/263
	9,681,057 B2	6/2017	2011/0064327	A1 *	3/2011	Venkataraman et al.	
	9,723,220 B2	8/2017				Engelhardt et al.	
	9,736,365 B2	8/2017	2011/0080487	A1	4/2011	Petrou et al.	
	9,736,391 B2	8/2017	2011/0115965	A1	5/2011	Shintani et al.	
	9,762,812 B2 *	9/2017	2011/0128288	A1	6/2011	Weston et al.	
	9,768,310 B2	9/2017	2011/0164172	A1	7/2011	Hayashi et al.	
	9,800,798 B2	10/2017	2011/0164172	A1	7/2011	Wakabayashi et al.	
	9,817,213 B2	11/2017	2011/0229054	A1	9/2011	Pace et al.	
	9,851,803 B2	12/2017	2011/0234853	A1	9/2011	Goma et al.	
	9,894,287 B2	2/2018	2011/0234881	A1	9/2011	Golan	H04N 5/232 348/240.2
	9,900,522 B2	2/2018	2011/0242286	A1	10/2011		
	9,927,600 B2	3/2018	2011/0242355	A1	10/2011		
	2002/0005902 A1	1/2002	2012/0026366	A1 *	2/2012		
	2002/0063711 A1	5/2002				Morihisa	
	2002/0075258 A1	6/2002	2012/0062780	A1	3/2012	Imai	
	2002/0122113 A1	9/2002	2012/0069235	A1	3/2012	Nishihara	
	2003/0030729 A1	2/2003	2012/0075489	A1	3/2012	Tochigi et al.	
	2003/0093805 A1	5/2003	2012/0092777	A1	4/2012	Jeon et al.	
	2003/0160886 A1	8/2003	2012/0105579	A1	5/2012	Hagiwara	
	2003/0202113 A1	10/2003	2012/0105708	A1	5/2012	Tsai et al.	
	2004/0008773 A1	1/2004	2012/0154929	A1	6/2012	Havens et al.	
	2004/0017386 A1	1/2004	2012/0196648	A1	8/2012	Nelson et al.	
	2004/0027367 A1	2/2004	2012/0229663	A1	9/2012	Bohn et al.	
	2004/0061788 A1	4/2004	2012/0249815	A1	10/2012	Huang et al.	
	2004/0240052 A1	12/2004	2012/0287315	A1	11/2012	Baik et al.	
	2005/0013509 A1	1/2005	2012/0320467	A1	12/2012	Imai	
	2005/0046740 A1	3/2005	2013/0002928	A1	1/2013	Yahata	
	2005/0141103 A1	6/2005	2013/0093842	A1	4/2013	Dahi et al.	
	2005/0157184 A1	7/2005	2013/0135445	A1	5/2013	Asakura	
	2005/0168840 A1	8/2005	2013/0182150	A1	7/2013	Song	
	2005/0200718 A1	9/2005	2013/0201360	A1	8/2013	Ouedraogo et al.	
	2006/0054782 A1	3/2006	2013/0202273	A1	8/2013	Park	
	2006/0056056 A1	3/2006	2013/0208178	A1	8/2013	Park et al.	
	2006/0125937 A1	6/2006	2013/0235224	A1	9/2013	Malone et al.	
	2006/0170793 A1	8/2006	2013/0250150	A1	9/2013	Betts-LaCroix	
	2006/0175549 A1	8/2006	2013/0258044	A1	10/2013	Chae	
	2006/0187310 A1	8/2006	2013/0286488	A1	10/2013	Kamath	
	2006/0187322 A1	8/2006	2013/0321668	A1	12/2013	Kim et al.	
	2006/0187338 A1	8/2006	2014/0022436	A1	1/2014	Uwagawa	
	2007/0024737 A1	2/2007	2014/0049615	A1	2/2014	Lee et al.	
	2007/0146503 A1 *	6/2007	2014/0118584	A1	5/2014	Attar et al.	
			2014/0192238	A1	7/2014	Laroia	
			2014/0192253	A1	7/2014	Jo et al.	
			2014/0204480	A1	7/2014	Tang et al.	
			2014/0285907	A1	9/2014	Ogino et al.	
			2014/0293453	A1	10/2014	Olsson et al.	
			2014/0313316	A1	10/2014	Takizawa	
			2014/0362242	A1	12/2014	Christie et al.	
			2014/0362274	A1	12/2014	Hu et al.	
			2015/0002683	A1	1/2015	Chan et al.	
			2015/0042870	A1	2/2015		

(56)

References Cited

U.S. PATENT DOCUMENTS

2015/0154776 A1 6/2015 Zhang et al.
 2015/0162048 A1 6/2015 Hirata et al.
 2015/0195458 A1 7/2015 Nakayama et al.
 2015/0215516 A1 7/2015 Dolgin
 2015/0237280 A1 8/2015 Choi et al.
 2015/0242994 A1 8/2015 Shen
 2015/0253647 A1 9/2015 Mercado
 2015/0271471 A1 9/2015 Hsieh et al.
 2015/0316744 A1 11/2015 Chen
 2015/0334309 A1 11/2015 Peng et al.
 2016/0044250 A1 2/2016 Shabtay et al.
 2016/0070088 A1 3/2016 Koguchi
 2016/0085089 A1 3/2016 Mercado
 2016/0154202 A1 6/2016 Wippermann et al.
 2016/0154204 A1 6/2016 Lim et al.
 2016/0187631 A1 6/2016 Choi et al.
 2016/0191819 A1* 6/2016 Sakai H04N 5/23245
 348/333.12
 2016/0202453 A1* 7/2016 Iwasawa G02B 13/18
 359/684
 2016/0212358 A1 7/2016 Shikata
 2016/0301840 A1 10/2016 Du et al.
 2016/0313537 A1 10/2016 Mercado
 2016/0353012 A1 12/2016 Kao et al.
 2017/0019616 A1 1/2017 Zhu et al.
 2017/0054911 A1* 2/2017 Lee H04N 5/23293
 2017/0102522 A1 4/2017 Jo
 2017/0115471 A1 4/2017 Shinohara
 2017/0214846 A1 7/2017 Du et al.
 2017/0214866 A1 7/2017 Zhu et al.
 2017/0289458 A1 10/2017 Song et al.
 2018/0096487 A1* 4/2018 Nash H04N 5/217
 2018/0120674 A1 5/2018 Avivi et al.
 2018/0150973 A1 5/2018 Tang et al.
 2018/0152640 A1* 5/2018 Shabtay H04N 5/2258
 2018/0224630 A1 8/2018 Lee et al.
 2018/0241922 A1 8/2018 Baldwin et al.
 2018/0295292 A1 10/2018 Lee et al.
 2018/0359423 A1* 12/2018 Shabtay H04N 5/2258

FOREIGN PATENT DOCUMENTS

CN 103024272 A 4/2013
 CN 104297906 A 1/2015
 EP 1536633 A1 6/2005
 EP 2523450 A1 11/2012
 JP S54157620 A 12/1979
 JP S59121015 A 7/1984
 JP 04211230 A 8/1992
 JP H07318864 A 12/1995
 JP 08271976 A 10/1996
 JP 2003298920 A 10/2003
 JP 2004133054 A 4/2004
 JP 2005099265 A 4/2005
 JP 2006238325 A 9/2006
 JP 2007228006 A 9/2007
 JP 2007306282 A 11/2007

JP 2008076485 A 4/2008
 JP 2012203234 A 10/2012
 JP 2013106289 A 5/2013
 KR 20100008936 A 1/2010
 KR 20140014787 A 2/2014
 KR 20140023552 A 2/2014
 KR 101477178 B1 12/2014
 WO 2013058111 A1 4/2013
 WO 2013063097 A1 5/2013

OTHER PUBLICATIONS

A 3MPixel Multi-Aperture Image Sensor with 0.7µm Pixels in 0.11µm CMOS, Fife et al., Stanford University, 2008, 3 pages.
 Dual camera intelligent sensor for high definition 360 degrees surveillance, Scotti et al., Publisher: IET, May 9, 2000, 8 pages.
 Dual-sensor foveated imaging system, Hua et al., Publisher: Optical Society of America, Jan. 14, 2008, 11 pages.
 Defocus Video Matting, McGuire et al., Publisher: ACM SIG-GRAPH, Jul. 31, 2005, 11 pages.
 Compact multi-aperture imaging with high angular resolution, Santacana et al., Publisher: Optical Society of America, 2015, 10 pages.
 Multi-Aperture Photography, Green et al., Publisher: Mitsubishi Electric Research Laboratories, Inc., Jul. 2007, 10 pages.
 Multispectral Bilateral Video Fusion, Bennett et al., Publisher: IEEE, May 2007, 10 pages.
 Super-resolution imaging using a camera array, Santacana et al., Publisher: Optical Society of America, 2014, 6 pages.
 Optical Splitting Trees for High-Precision Monocular Imaging, McGuire et al., Publisher: IEEE, 2007, 11 pages.
 High Performance Imaging Using Large Camera Arrays, Wilburn et al., Publisher: Association for Computing Machinery, Inc., 2005, 12 pages.
 Real-time Edge-Aware Image Processing with the Bilateral Grid, Chen et al., Publisher: ACM SIGGRAPH, 9 pages.
 Superimposed multi-resolution imaging, Caries et al., Publisher: Optical Society of America, 2017, 13 pages.
 Viewfinder Alignment, Adams et al., Publisher: EUROGRAPHICS, 2008, 10 pages.
 Dual-Camera System for Multi-Level Activity Recognition, Bodor et al., Publisher: IEEE, Oct. 2014, 6 pages.
 Engineered to the task: Why camera-phone cameras are different, Giles Humpston, Publisher: Solid State Technology, Jun. 2009, 3 pages.
 A compact and cost effective design for cell phone zoom lens, Chang et al., Sep. 2007, 8 pages.
 Consumer Electronic Optics: How small a lens can be? The case of panomorph lenses, Thibault et al., Sep. 2014, 7 pages.
 Optical design of camera optics for mobile phones, Steinich et al., 2012, pp. 51-58 (8 pages).
 The Optics of Miniature Digital Camera Modules, Bareau et al., 2006, 11 pages.
 Modeling and measuring liquid crystal tunable lenses, Peter P. Clark, 2014, 7 pages.
 Mobile Platform Optical Design, Peter P. Clark, 2014, 7 pages.

* cited by examiner

100

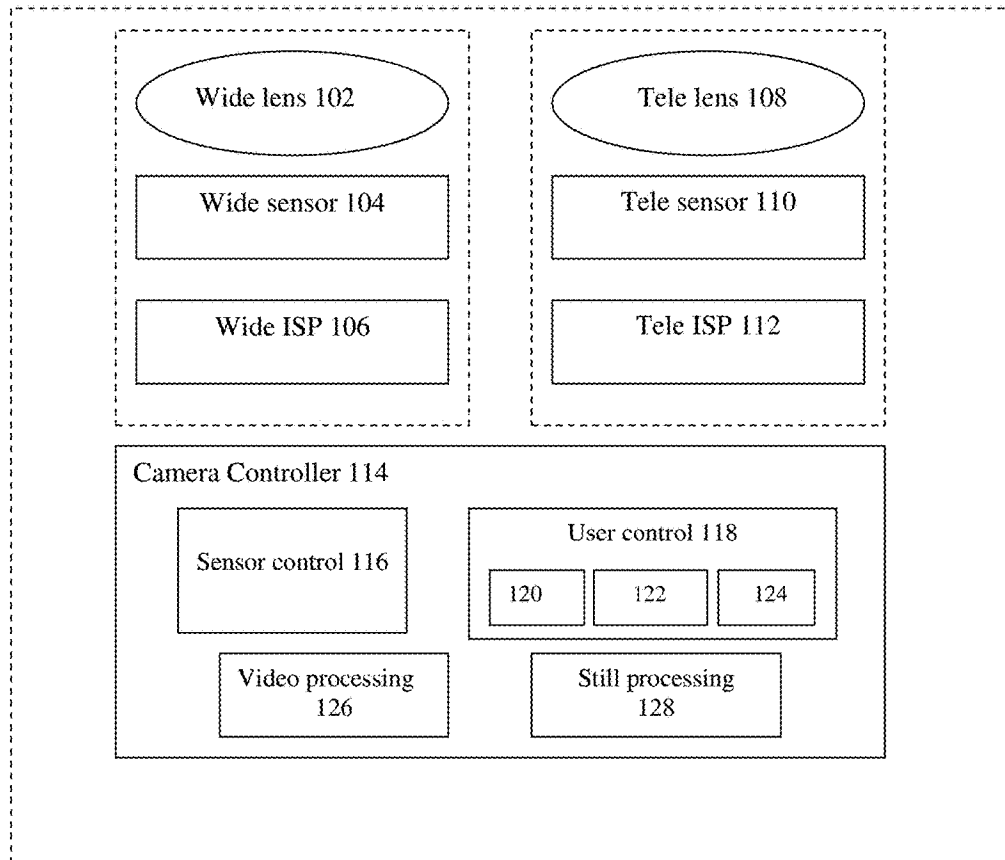

FIG. 1A

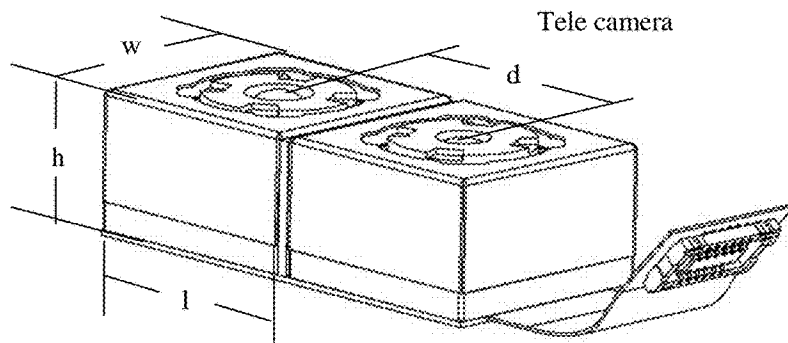

FIG. 1B

Explore Litigation Insights

Docket Alarm provides insights to develop a more informed litigation strategy and the peace of mind of knowing you're on top of things.

Real-Time Litigation Alerts



Keep your litigation team up-to-date with **real-time alerts** and advanced team management tools built for the enterprise, all while greatly reducing PACER spend.

Our comprehensive service means we can handle Federal, State, and Administrative courts across the country.

Advanced Docket Research



With over 230 million records, Docket Alarm's cloud-native docket research platform finds what other services can't. Coverage includes Federal, State, plus PTAB, TTAB, ITC and NLRB decisions, all in one place.

Identify arguments that have been successful in the past with full text, pinpoint searching. Link to case law cited within any court document via Fastcase.

Analytics At Your Fingertips



Learn what happened the last time a particular judge, opposing counsel or company faced cases similar to yours.

Advanced out-of-the-box PTAB and TTAB analytics are always at your fingertips.

API

Docket Alarm offers a powerful API (application programming interface) to developers that want to integrate case filings into their apps.

LAW FIRMS

Build custom dashboards for your attorneys and clients with live data direct from the court.

Automate many repetitive legal tasks like conflict checks, document management, and marketing.

FINANCIAL INSTITUTIONS

Litigation and bankruptcy checks for companies and debtors.

E-DISCOVERY AND LEGAL VENDORS

Sync your system to PACER to automate legal marketing.