

UNITED STATES PATENT AND TRADEMARK OFFICE

BEFORE THE PATENT TRIAL AND APPEAL BOARD

APPLE INC.,
Petitioner,

v.

COREPHOTONICS, LTD.,
Patent Owner.

Case No. IPR2020-00878
U.S. Patent No. 10,330,897

DECLARATION OF TOM D. MILSTER, Ph.D.
PURSUANT TO 37 C.F.R. § 1.68

TABLE OF CONTENTS

I.	BACKGROUND	1
II.	SUMMARY OF OPINIONS	1
III.	EDUCATIONAL AND EMPLOYMENT BACKGROUND.....	4
IV.	LEVEL OF ORDINARY SKILL IN THE ART (POSITA)	9
V.	RELEVANT LEGAL STANDARDS FOR OBVIOUSNESS ..	13
VI.	OVERVIEW OF THE '897 PATENT.....	16
VII.	CLAIM CONSTRUCTION.....	22
VIII.	PRIOR ART REFERENCES	23
	A. Ogino.....	23
	B. Bareau	28
	C. Kingslake	31
	D. Chen	32
	E. Iwasaki	35
	F. Beich	35
IX.	OBVIOUSNESS	36
	A. Ground 2 – Obviousness of Claims 2, 5, 6, 18, and 21–23 over Ogino in view of Bareau	36
	B. Ground 3 – Obviousness of Claims 3, 8, 19, and 24 over Ogino in view of Bareau and Kingslake	61

C.	Ground 4 – Obviousness of Claims 16 and 30 over Chen in view of Iwasaki and Beich	68
X.	DECLARATION.....	72
XI.	APPENDIX	73
A.	Ogino Example 5 modified for f-number 2.8	73
B.	Modified Chen Example 1	76

I. BACKGROUND

1. I have been retained as a technical expert by Patent Owner Corephotonics Ltd. (“Patent Owner” or “Corephotonics”) in this proceeding. Corephotonics has asked me to provide my expert opinions concerning certain technical aspects of imaging system design as they relate to the Petitioner Apple Inc.’s petition for inter partes review of U.S. Patent 10,330,897 (“’897 patent”) in Case No. IPR2020-00878 and the accompanying Declaration of Jose Sasián.

2. The statements in this declaration summarize my opinions on these matters based on my forty years of study and research of imaging systems, my education, knowledge, skills, and my review and analysis of the materials referenced herein.

3. My work in this matter is being billed at the rate of \$625 per hour. I am also being reimbursed for reasonable and customary expenses associated with my work and testimony in this investigation. My compensation is not contingent on the outcome of this matter or the substance of my testimony

II. SUMMARY OF OPINIONS

4. In the preparation of this declaration, I have reviewed:

- The ’897 patent (Ex. 1001)

- The file history of the '897 patent (Ex. 1002)
- Apple's petition for *inter partes* review (Paper 2)
- The Board's institution decision (Paper 7)
- The expert declaration of Jose Sasián (Ex. 1003)
- Prof. Sasián's curriculum vitae (Ex. 1004)
- U.S. Patent No. 9,128,267 ("Ogino") (Ex. 1005)
- W. Smith, *Modern Lens Design* (1992) (Ex. 1006)
- W. Beich and N. Turner, "Polymer Optics: A manufacturer's perspective on the factors that contribute to successful programs" (Ex. 1007)
- U.S. Patent No. 7,777,972 ("Chen '972") (Ex. 1008)
- U.S. Patent No. 9,678,310 ("Iwasaki") (Ex. 1009)
- M. Born and E. Wolf, *Principles of Optics* (1980) (Ex. 1010)
- The file history of the Ogino patent (Ex. 1011)
- J. Bateau and P. Clark, "The Optics of Miniature Digital Camera Modules" (Ex. 1012)
- R. Kingslake, *Optics in Photography* (1992) (Ex. 1013)
- U.S. Patent No. 7,859,588 ("Parulski") (Ex. 1014)
- English translation of Japanese patent application JP2013106289A ("Konno") (Ex. 1015)
- B. Walker, *Optical Engineering Fundamentals* (1995) (Ex. 1016)

- R. Fischer, et al., *Optical Ssystem Design* (2008) (Ex. 1017)
- A. Symmons and M. Schaub, *Field Guide to Molded Optics* (2016) (Exs. 1018 and 2006)
- *Handbook of Optics*, 2nd ed., vol. 2 (1995) (Exs.1019 and 2008)
- U.S. Patent No. 10,324,273 (“Chen”) (Ex. 1020)
- U.S. Patent No. 9,857,568 (Ex. 1021)
- U.S. Patent No. 9,568,712 (Ex. 1022)
- Deposition transcript of Prof. Duncan Moore (Ex. 1023)
- U.S. Patent No. 7,321,475 (“Wang”) (Ex. 1024)
- G. Hollows and S. Singer, “Matching Lenses and Sensors” (Ex. 1025)
- The file history of U.S. Patent No. 9,678,310 (Ex. 1026)
- Deposition transcript of Prof. Sasián, January 22, 2021 (Ex. 2003)
- J. Sasián, *Introduction to Lens Design* (2019) (Ex. 2004)
- P. Clark, “Mobile platform optical design” (Ex. 2005)
- G. Beall, “By Design: Part design 106 – Corner radiuses,” *Plastics Today* (Ex. 2007)
- Declaration of J. Sasián in IPR2019-00030 (Ex. 2009)

5. In forming the opinions set forth herein, I have considered:

a. The documents listed above;

- b. My education, knowledge, skills, and experience in the design and development of imaging systems; and
- c. The level of skill of a person having ordinary skill in the art (POSITA) at the time of the effective filing dates of the '897 patent.

6. As I explain in further detail below, it is my professional and expert opinion that Apple and Dr. Sasián have failed to demonstrate that claims 2, 3, 5, 6, 8, 16, 18, 19, 21–24, 30 of the '897 patent were obvious, under any of the grounds that Apple has raised. I express no opinion concerning Apple's contention that claims 1, 4, 9–15, 17, 20, and 25–29 are anticipated by the Ogino patent.

III. EDUCATIONAL AND EMPLOYMENT BACKGROUND

7. I received a Bachelor of Science degree in Electrical Engineering from the University of Missouri in 1981 and a Doctorate in Optical Sciences from the University of Arizona in 1987. I worked for IBM as a staff optical engineer from 1986 to 1989, and I worked during the summer of 1989 for Lawrence Livermore National Laboratories. I joined the faculty at the University of Arizona's Wyant College of Optical Sciences in 1989.

8. For forty years, I have been working, teaching, or researching in the field of optical devices. I worked for IBM for three years on the subject of

optical storage developing miniature optical systems, and I have been teaching and researching at the University of Arizona for over thirty-one years.

9. I have written over one hundred peer-reviewed papers in the field of optics. A number of these papers relate specifically to miniature optical devices and systems. My technical research has earned several recognitions and awards. For example, my 1995 paper entitled “Linear behavior of a near-field optical scanning system” was selected as a landmark paper in near-field optics.¹ My 1997 paper entitled “Objective lens design for multiple-layer optical data storage” was selected as one of the 300 most influential papers in lens design.² A recent paper entitled “Multiple-order diffractive engineered surface lenses” has been on the Applied Optics ‘Top Downloads’ list for the last three consecutive months.³

10. I am a named inventor on fifteen US patents concerning various advanced optical systems, like data detectors and systems for optical data storage that include miniature optics (US 4,823,220, US 6,111,839, US 6,577,584,

¹ Kann, J. L., Milster, T. D., Froehlich, F. F., Ziolkowski, R. W., & Judkins, J. B. (1995). Linear behavior of a near-field optical scanning system. *JOSA A*, 12(8), 1677-1682.

² Milster, T. D., Upton, R. S., & Luo, H. (1999). Objective lens design for multiple-layer optical data storage. *Optical Engineering*, 38, 295-301.

³ Milster, T. D., Kim, Y. S., Wang, Z., & Purvin, K. (2020). Multiple-order diffractive engineered surface lenses. *Applied optics*, 59(26), 7900-7906.

US 6,577,584, US 7,796,487, US 7,974,170, US 8,003,187), miniature lens designs for fiber communications (US 6,498,875), vacuum ultraviolet systems (US 7,916,291, US 8,472,111, US 9,081,193), miniature-optic blood sensors (9,072,473), near-field sensors (US 8,737,178), and holography (US 9,116,303, US 10,866,406).

11. I have contributed chapters to eleven books about optics, including one chapter entitled “Miniature and Micro Optics,” which has been published in the last three editions of the Handbook of Optics. This chapter discusses the design and use of miniature optical elements, including molded elements, that are similar to those found in cell phone cameras. Material for this chapter was derived from a popular short course I taught for a professional society over a period of about 10 years, and it drew on the experience I received working for IBM and my first several years working as faculty at the University of Arizona.

12. One significant accomplishment I have achieved through my research is breaking the “diffraction barrier” by applying the techniques of near-field scanning optical microscopy (NSOM),⁴ developing specialized near-

⁴ Kann, J. L., Milster, T. D., Froehlich, F. F., Ziolkowski, R. W., & Judkins, J. B. (1995). Linear behavior of a near-field optical scanning system. *JOSA A*, 12(8), 1677-1682; Froehlich, F. F., & Milster, T. D. (1995). Detection of

field probes,⁵ and applying the solid immersion lens (SIL) in various ways.⁶ This work led me to develop new, more efficient miniature optical probes and high-performance miniature optical systems.⁷ In these projects, my students and I applied a mixture of theory, optical design and fabrication techniques to produce real examples of the miniature and micro-optical lenses that we envisioned. One of my recent conference presentations entitled “Practical measurement of cell-phone camera focal length,” specifically addresses the properties of modern cell-phone camera lenses.⁸

probe dither motion in near-field scanning optical microscopy. *Applied optics*, 34(31), 7273-7279.

- ⁵ Hirota, K., Milster, T. D., Zhang, Y., & Erwin, J. K. (2000). Design of a near-field probe for optical recording using a 3-dimensional finite difference time domain method. *Japanese Journal of Applied Physics*, 39(2S), 973.
- ⁶ Shimura, K., Milster, T. D., Jo, J. S., & Hirota, K. (2000). Pupil plane filtering for optical pickup heads with effective numerical aperture of 1.1 and 2.0. *Japanese Journal of Applied Physics*, 39(2S), 897; Zhang, J., Kim, Y., Kim, Y., Valencia, R., Milster, T. D., & Dozer, D. (2009). High resolution semiconductor inspection by using solid immersion lenses. *Japanese Journal of Applied Physics*, 48(3S1), 03A043.
- ⁷ Zhang, Y., Milster, T. D., Kim, J. S., & Park, S. K. (2004). Advanced lens design for bit-wise volumetric optical data storage. *Japanese journal of applied physics*, 43(7S), 4929.
- ⁸ Milster, T. D., & Kuhn, W. P. (2020, August). Practical measurement of cell-phone camera lens focal length. In *Optical System Alignment, Tolerancing, and Verification XIII* (Vol. 11488, p. 1148807). International Society for Optics and Photonics.

13. One of my current projects is directly related to molding optical elements. A recent paper entitled “Precision glass molding of diffractive optical elements with high surface quality” specifically addresses issues for molding small glass structures.⁹ My students, staff and I developed a complete process for molding glass structures with micrometer-size structures and extremely high quality. Although not mentioned in the publication, we also worked on molding plastic lens structures. This experience relates directly to the fabrication of miniature optical components, like those under review for this case.

14. I am a Fellow member of the Optical Society of America and the SPIE – International Society for Optics and Photonics. I am also a Senior Member of the National Association of Inventors.

15. In addition to my research, I have served as a technical expert in both district courts and ITC patent litigation in the United States of America. In the last ten years, I have testified in the following matters: *American Medical Systems, Inc.* and *Laserscope v. Laser Peripherals, LLC*, Civil Action No.

⁹ Zhang, Y., Liang, R., Spires, O. J., Yin, S., Yi, A., & Milster, T. D. (2020). Precision glass molding of diffractive optical elements with high surface quality. *Optics Letters*, 45(23), 6438-6441.

08-CV-4798, United States District Court for the District of Minnesota; *American Medical Systems, Inc. and Laserscope v. Biolitec, Inc., Biolitec AG, Biolitec SIA, Ceramoptec Industries, Inc., Ceramoptec GmbH and Andaoptec, LTD*, Civil Action No. 3:08-CV-30061-MAP, United States District Court for the District of Massachusetts, as well in an arbitration matter between Corephotonics Ltd. and Ningbo Sunny Opotech Co., Ltd., Case No. HKIAC/A19025.

16. A copy of my CV further describing my experience is attached as exhibit 2002.

IV. LEVEL OF ORDINARY SKILL IN THE ART (POSITA)

17. I understand that in evaluating the validity of the '897 patent claims, the content of a patent or printed publication prior art should be interpreted the way a person of ordinary skill in the art would have interpreted the prior art as of the effective filing date of the challenged patent claims.

18. I understand that factors that may be considered in determining the level of ordinary skill in the art at the time of the effective filing date of the challenged patents include: (1) the educational level of the inventor; (2) type of problems encountered in the art; (3) prior art solutions to those problems; (4)

rapidity with which innovations are made; (5) sophistication of the technology; and (6) educational level of active workers in the field.

19. In his declaration, Dr. Sasián offers his opinion that a person having ordinary skill in the art (“POSITA”):

would include someone who had, at the priority date of the ’897 Patent, (i) a Bachelor’s degree in Physics, Optical Sciences, or equivalent training, as well as (ii) approximately three years of experience in designing multi-lens optical systems. Such a person would have had experience in analyzing, tolerancing, adjusting, and optimizing multi-lens systems for manufacturing, and would have been familiar with the specifications of lens systems and their fabrication. In addition, a POSITA would have known how to use lens design software such as Code V, Oslo, or Zemax, and would have taken a lens design course or had equivalent training.

(Ex. 1003, Sasián Decl., ¶¶ 19–20.) I have applied the same definition of a POSITA in this declaration.

20. As noted above, the level of ordinary skill is assessed as of the effective filing date. I understand that this effective filing data may be different for different claims within a patent. I understand that the ’897 patent claims priority by a series of continuations to an application that was filed on January 30, 2017 and issued as U.S. Patent No. 9,857,568. (Ex. 1001, ’897 patent at 1:5–

10.) I understand that this means that the material disclosed in the specification of the '897 patent was also contained in the January 30, 2017 patent application that led to the '568 patent.

21. I understand that the '897 patent also claims priority by a series of continuations and continuations-in-part to a provisional patent application that was filed on July 4, 2013. (Ex. 1001, '897 patent at 1:5–12.) I understand that this means that portions of the '897 patent specification were disclosed in the July 4, 2013 provisional patent application, while other portions may have been added in the January 30, 2017 application leading to the '568 patent.

22. I understand that a claim of the '897 patent is entitled to July 4, 2013 effective filing date if there is a written description in that provisional application that demonstrates that the inventors had possession of the invention recited in the claim at the time the July 4, 2013 application was filed. I understand that if there is not sufficient written description to demonstrate possession of the invention recited in the claim, then that claim is entitled to the January 30, 2017 effective filing date.

23. In his declaration, Dr. Sasián appears to assume that the relevant effective filing date for assessing the level of skill in the art is July 4, 2013. (Ex. 1003, Sasián Decl., ¶¶ 18–21.) The only claims that Dr. Sasián contends have

a January 30, 2017 priority date are claims 16 and 30. (Ex. 1003, Sasián Decl., ¶ 33.)¹⁰ For these reasons, I understand that Apple and Dr. Sasián do not dispute that the challenged claims other than claims 16 and 30 have an effective filing date of July 4, 2013. For the purposes of evaluating the level of skill in the art, I have considered the level of skill in the art as of January 30, 2017 for claims 16 and 30, and as of July 4, 2013 for the other challenged claims. Unless I specifically note otherwise, I do not believe that any of my opinions would change if I had assumed a July 4, 2013 date for claims 16 and 30 or a January 30, 2017 for any of the other claims.

24. I would have met the requirements of a POSITA on July 4, 2013 as well as on January 30, 2017. Some of my past students would also have qualified as POSITAs on these dates. Thus I am qualified to opine on the issues in this IPR.

¹⁰ At the end of this paragraph, Dr. Sasián refers to “the priority date of claims 7 and 12” rather than 16 and 30, but I understand this to be a typographical error. Claim 7 is not challenged in the IPR, and none of the discussion of the paragraph applies to claim 7 or 12.

V. RELEVANT LEGAL STANDARDS FOR OBVIOUSNESS

25. I have been informed of the legal standards for establishing patent invalidity in *inter partes* review proceedings before the Patent Trial and Appeal Board.

26. I understand that the petitioner must prove invalidity of a patent claim by a preponderance of the evidence, that is, the evidence must be sufficient to show that a fact or legal conclusion is more likely than not.

27. I understand that a claim may be anticipated if (1) the claimed invention was patented, described in a printed publication, or in public use, on sale, or otherwise available to the public before the effective filing date of the claimed invention; or (2) the claimed invention was described in a patent or published application, in which the patent or application names another inventor and was effectively filed before the effective filing date of the claimed invention.

28. I understand that, once the claims of a patent have been properly construed, the next step in determining anticipation of a patent claim requires a comparison of the properly construed claim language to the prior art on a limitation-by-limitation basis.

29. I understand that even if a patent claim is not anticipated, it may still be invalid if the differences between the claimed subject matter and the prior art

are such that the subject matter as a whole would have been obvious at the time the invention was made to a person of ordinary skill in the pertinent art.

30. I also understand that a patent may be rendered obvious based on an alleged prior art reference or a combination of such references plus what a person of ordinary skill in the art would understand based on his or her knowledge and the references. It is also my understanding that in assessing the obviousness of claimed subject matter one should evaluate obviousness over the prior art from the perspective of one of ordinary skill in the art at the time the invention was made (and not from the perspective of either a layman or a genius in that art).

31. I understand that a patent claim composed of several elements is not proved obvious merely by demonstrating that each of its elements was known in the prior art. There must be a reason for combining the elements in the manner claimed. That is, there must be a showing that a person of ordinary skill in the art at the time of the invention would have thought of either combining two or more references or modifying a reference to achieve the claimed invention.

32. I understand that an obviousness determination includes the consideration of the following factors: (1) the scope and content of the prior art, (2) the

differences between the prior art and the claims at issue, (3) the level of ordinary skill in the art, and (4) objective evidence of nonobviousness.

33. I understand that the burden is on the petitioner to explain how specific references could be combined, which combinations of elements in specific references would yield a predictable result, and how any specific combination would operate or read on the claims. I further understand that the petitioner cannot rely on conclusory statements but must instead provide a reasoned explanation supported by evidence. I also understand that obviousness does not exist where the prior art discourages or teaches away from the claimed invention. I also understand that even if a reference does not teach away, its statements regarding preferences are relevant to a finding whether a person skilled in the art would be motivated to combine that reference with another reference.

34. I understand that it is impermissible to use hindsight to arrive at the claimed invention. My understanding is that the inventor's own path never leads to a conclusion of obviousness. I also understand that, when assessing whether there was a motivation to combine references to teach a claim element, defining the problem in terms of its solution reveals improper hindsight.

35. I understand that, in this proceeding, prior art to the '897 patent includes patents and printed publications in the relevant art that predate the effective filing date of the '897 patent's challenged claims, which I understand to be January 30, 2017 for claims 16 and 30 and July 4, 2013 for the other challenged claims, as discussed above.

VI. OVERVIEW OF THE '897 PATENT

36. The '897 patent is concerned with designs for a “miniature telephoto lens assembly” of a kind suitable for use in mobile phones and other portable electronic products. (Ex. 1001, '897 patent at 1:26–30.) The example designs shown in the '897 patent utilize five plastic lens elements, each having a complex aspheric shape:

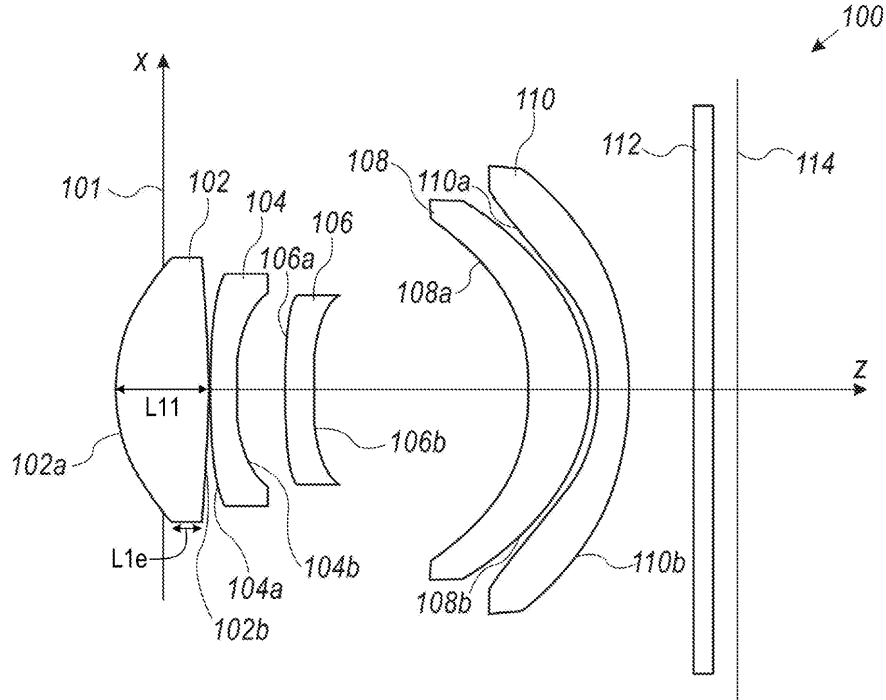

FIG. 1A

37. The use of these multiple lens elements with aspheric shapes makes possible a lens that produces a high-quality image, by minimizing chromatic aberrations and other optical aberrations that would blur or distort the image. (Ex. 1001, '897 patent at 2:22–34, 2:51–57.)

38. These multi-lens systems with aspheric lens surfaces have a vast range of possible designs. For example, the design in figure 1A from the '897 patent requires several dozen numerical parameters to define the shapes, locations, and properties of its lens elements:

TABLE 1

#	Comment	Radius R [mm]	Distances [mm]	Nd/Vd	Diameter [mm]
1	Stop	Infinite	-0.466		2.4
2	L11	1.5800	0.894	1.5345/57.095	2.5
3	L12	-11.2003	0.020		2.4
4	L21	33.8670	0.246	1.63549/23.91	2.2
5	L22	3.2281	0.449		1.9
6	L31	-12.2843	0.290	1.5345/57.095	1.9
7	L32	7.7138	2.020		1.8
8	L41	-2.3755	0.597	1.63549/23.91	3.3
9	L42	-1.8801	0.068		3.6
10	L51	-1.8100	0.293	1.5345/57.095	3.9
11	L52	-5.2768	0.617		4.3
12	Window	Infinite	0.210	1.5168/64.17	3.0
13		Infinite	0.200		3.0

TABLE 2

#	Conic coefficient k	α_2	α_3	α_4	α_5	α_6
2	-0.4668	7.9218E-03	2.3146E-02	-3.3436E-02	2.3650E-02	-9.2437E-03
3	-9.8525	2.0102E-02	2.0647E-04	7.4394E-03	-1.7529E-02	4.5206E-03
4	10.7569	-1.9248E-03	8.6003E-02	1.1676E-02	-4.0607E-02	1.3545E-02
5	1.4395	5.1029E-03	2.4578E-01	-1.7734E-01	2.9848E-01	-1.3320E-01
6	0.0000	2.1629E-01	4.0134E-02	1.3615E-02	2.5914E-03	-1.2292E-02
7	-9.8953	2.3297E-01	8.2917E-02	-1.2725E-01	1.5691E-01	-5.9624E-02
8	0.9938	-1.3522E-02	-7.0395E-03	1.4569E-02	-1.5336E-02	4.3707E-03
9	-6.8097	-1.0654E-01	1.2933E-02	2.9548E-04	-1.8317E-03	5.0111E-04
10	-7.3161	-1.8636E-01	8.3105E-02	-1.8632E-02	2.4012E-03	-1.2816E-04
11	0.0000	-1.1927E-01	7.0245E-02	-2.0735E-02	2.6418E-03	-1.1576E-04

(Ex. 1001, '897 patent, col. 4.)

39. The '897 patent provides examples of lens designs and their corresponding numerical parameters, and it also teaches and claims sets of conditions and relationships among the parameters that help to make a lens system with high performance characteristics. The resulting lens designs are thin and

compact, appropriate for use in mobile devices, and they offer a large focal length (and thus a large degree of image magnification) for their physical size. (Ex. 1001, '897 patent at 2:6–21.)

40. The lens designs in the '897 patent are also manufacturable, meaning that they have shapes that can be successfully and repeatably manufactured using the techniques of plastic injection molding that are commonly used for mobile device camera lenses. The '897 patent designs avoid features such as overly narrow lens edges that make a lens difficult or impossible to manufacture. (Ex. 1001, '897 patent at 2:35–50.)

41. One of the parameters of a lens design that is discussed in the '897 patent and claimed in certain claims is the “f-number” or “F#.” The f-number is a property of a lens that relates to how bright the image formed by the lens is. A lens that forms brighter images is sometimes referred to as a “faster” lens, because for a given image sensor (or a given type of film) and focal length, the minimum amount of time required to capture an image varies inversely with the brightness of the image. For a single thin lens, the f number is equal to the focal length of the lens divided by the diameter of the lens:

$$f - number = \frac{f}{diameter}$$

(Walker, Ex. 1016 at 59.)

42. The diameter of the lens determines how much total light is collected per unit time by the lens from a given scene. Under certain approximations, doubling the diameter increases the amount of light collected by a factor of four. The focal length determines the image size on the sensor and thus determines the size of the distribution area of the collected light. Doubling the focal length increases the area illuminated in the image by a factor of four and reduces the intensity of the light in any given part of the image by a factor of four. So, if both the diameter and focal length are doubled, then the effects approximately cancel out, and the brightness of the image at the sensor is left unchanged, although the image is larger. In other words, it is the ratio of the focal length and the diameter that most strongly effects the image brightness.

43. Because the diameter is in the denominator, a smaller f-number corresponds to a brighter image for a fixed focal length. In more complicated lens systems with multiple lens elements, such as those at issue in this IPR, the amount of light collected no longer depends on the diameter of a single lens (or of a single lens surface), and the effective focal length (EFL) is a function of the lens elements and their spacings. One definition of f number for such

systems instead uses the diameter of the “entrance pupil” (EPD), meaning that the formula is changed to:

$$f\text{-number} = \frac{EFL}{\text{diameter}} = \frac{EFL}{EPD}$$

(Ex. 1003, Sasián Decl. at 58–39.)

44. The concept of the “entrance pupil” is illustrated in the following drawing from Figure 4-2 of Walker:

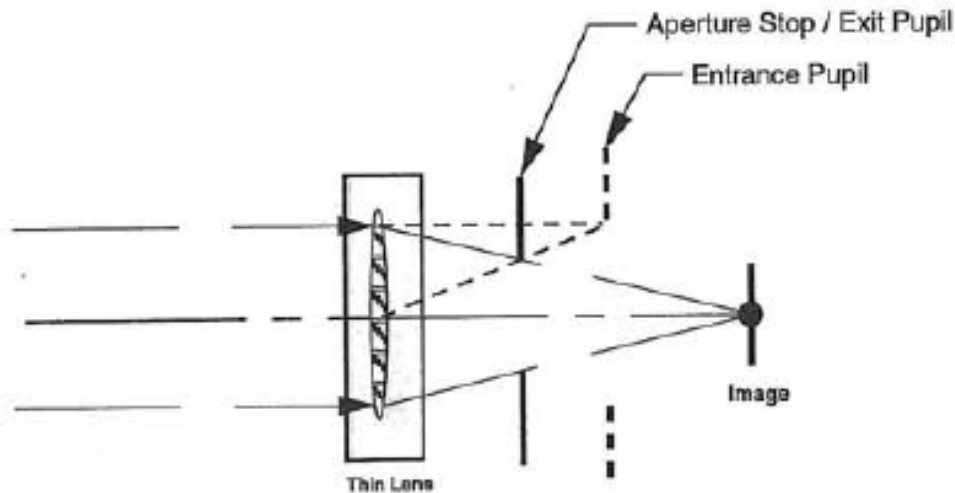

(Ex. 1016, Walker, p. 61.)

45. As shown here, the entrance pupil reflects the size of the bundle of rays parallel to the optical axis of the lens that can enter the lens, travel through the aperture stop, and reach the image plane. Explained another way, the entrance

pupil “is the image of the aperture stop as seen when looking from the object side of the lens.” (Ex. 1016, Walker, p. 60.)

VII. CLAIM CONSTRUCTION

46. Dr. Sasián’s declaration states (Ex. 1003, Sasián Decl., ¶¶ 38–39) that he applies two claim constructions for terms that the Board has previously construed in IPRs concerning U.S. Patent No. 9,402,032 and 9,568,712, patents to which the ’897 patent claims priority:

Effective Focal Length (EFL): “the focal length of a lens assembly.”

Total Track Length (TTL): “the length of the optical axis spacing between the object-side surface of the first lens element and one of: an electronic sensor, a film sensor, and an image plane corresponding to either the electronic sensor or a film sensor.”

IPR2018-01140, Paper 37 at 10–18.

47. I understand that the Board also adopted these same constructions in IPR2019-00030 concerning the ’568 patent, which as I discussed above contains the same specification as the ’897 patent. IPR2019-00030, Paper 32 at 8, 14–15.

48. I have applied these constructions for the terms “Effective Focal Length” (EFL) and “Total Track Length” (TTL) in the ’897 patent claims. For all other terms, I have interpreted them based upon their plain and ordinary

meaning, as they would have been understood by a POSITA, as of the effective filing date, in the context of the '897 patent.

VIII. PRIOR ART REFERENCES

A. Ogino

49. Ogino issued on September 8, 2015 as U.S. Patent No. 9, 128,267. (Ex. 2015.) Apple contends that Ogino has an effective filing date of March 29, 2013, based upon the filing date of the corresponding Japanese patent application. (Petition at 9.)

50. As described in Ogino's abstract, its invention is a system of five lenses with a particular set of shapes:

An imaging lens substantially consists of, in order from an object side, five lenses of a first lens that has a positive refractive power and has a meniscus shape which is convex toward the object side, a second lens that has a biconcave shape, a third lens that has a meniscus shape which is convex toward the object side, a fourth lens that has a meniscus shape which is convex toward the image side; and a fifth lens that has a negative refractive power and has at least one inflection point on an image side surface. Further, the following conditional expression (1) is satisfied.

$$1.4 < f/f_1 < 4 \quad (1)$$

(Ex. 1005, Ogino, Abstract.)

51. This same set of shapes and conditions is described as the “imaging lens of the present invention” in Ogino’s “Summary of the Invention” section. (Ex. 1005, Ogino at 2:1–16.)

52. Ogino describes six examples of this basic system, each of which has this same pattern of shapes:

As in the first embodiment, the imaging lenses according to the second to sixth embodiments of the present invention substantially consist of, in order from the object side, five lenses of: the first lens L1 that has a positive refractive power and has a meniscus shape which is convex toward the object side; the second lens L2 that has a biconcave shape; the third lens L3 that has a meniscus shape which is convex toward the object side; the fourth lens L4 that has a meniscus shape which is convex toward the image side; and the fifth lens L5 that has a negative refractive power and has at least one inflection point on an image side surface.

(Ex. 1005, Ogino at 13:5–16.)

53. Ogino explains the reasons for using each of these shapes, for example in lines 7:28–8:42. For example:

As shown in the embodiments, by making the first lens L1, which is a lens closest to the object, have a positive refractive power and have a meniscus shape which is convex toward the object side in the vicinity of the optical axis, the position of the rear side principal point of the first lens L1 can be set to be close to the object, and thus it is possible to appropriately reduce the total length.

(Ex. 1005, Ogino at 7:31–37.)

54. Apple's grounds utilizing Ogino are all based on Ogino's "Example 5" or modifications to that example. (Ex. 1003, Sasián Decl., ¶¶ 46, 51, 61.) The lens elements of Example 5 are shown in Ogino, Figure 5:

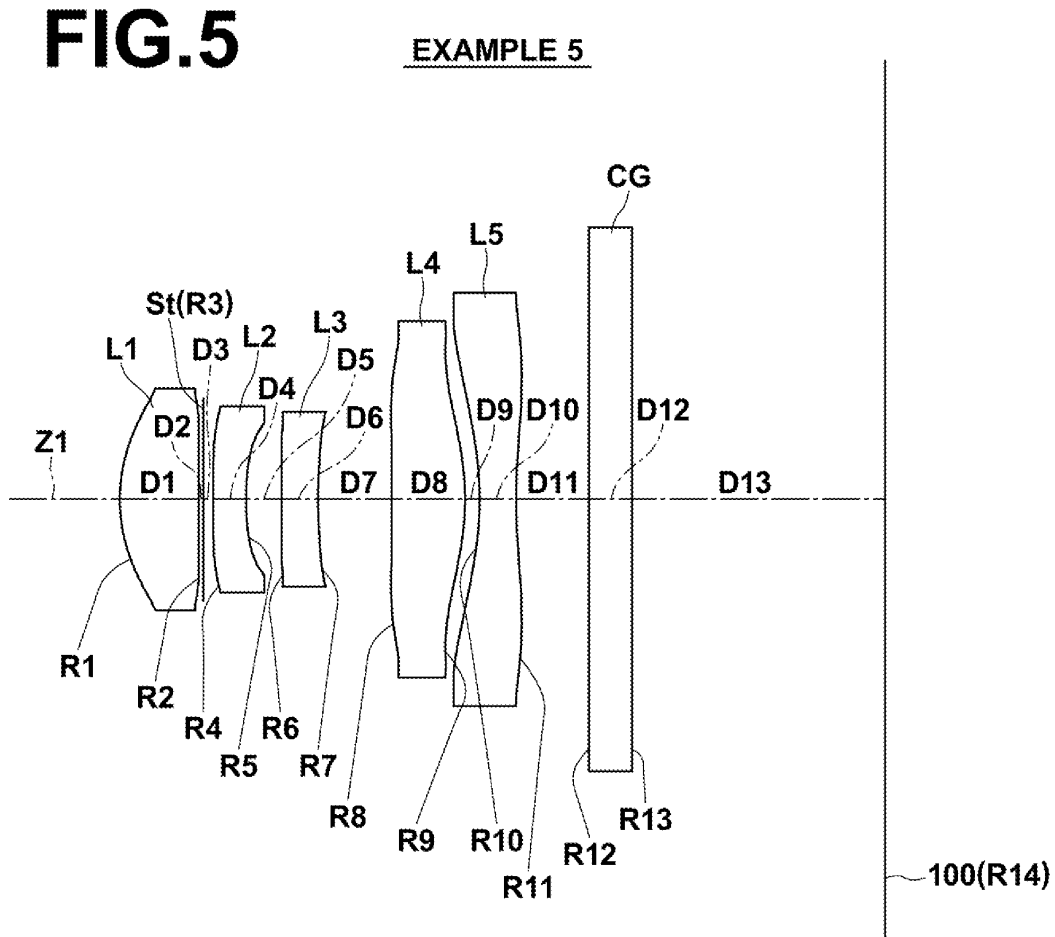

(Ex. 1005, Ogino, Figure 5.)

55. Figure 12 of Ogino provides certain optical characteristics of Example 5, including its f-number of 3.94 and half-angle of view $\omega=25.9^\circ$:

FIG.12

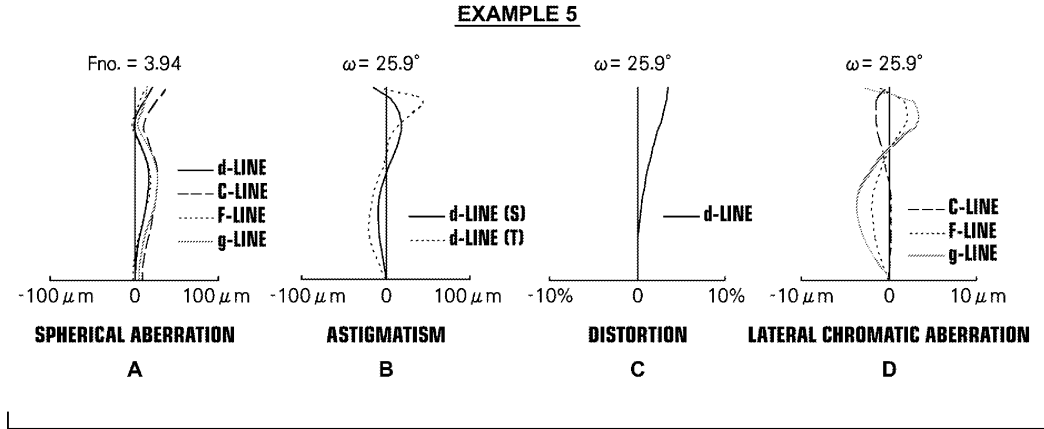

56. The lens prescription for Example 5 is given in Ogino Tables 9 and 10:

TABLE 9

EXAMPLE 5				
f = 5.956, Bf = 2.438, TL = 5.171				
Si	Ri	Di	ndj	vdj
*1	1.12444	0.546	1.54488	54.87
*2	252.97534	0.030		
3	∞	0.069		
(APERTURE STOP)				
*4	-18.78836	0.227	1.63351	23.63
*5	2.25616	0.243		
*6	506.45581	0.253	1.63351	23.63
*7	4.36560	0.506		
*8	-99.83715	0.506	1.63351	23.63
*9	-1.70702	0.100		
*10	-2.17464	0.253	1.54488	54.87
*11	3.61429	0.500		
12	∞	0.300	1.51633	64.14
13	∞	1.740		
14	∞			

*ASPHERIC SURFACE

TABLE 10

EXAMPLE 5 - ASPHERIC SURFACE DATA				
SURFACE NUMBER	KA	A4	A6	A8
1	6.9377302E-01	-8.6315370E-03	-2.9322827E-03	-2.8236519E-01
2	1.0000090E+00	1.0299728E-02	-3.3338883E-02	-3.5854402E-01
3	9.8073731E+00	4.1860316E-01	2.4161475E-01	-7.6083670E-01
4	3.1182039E+00	4.6995645E-01	1.5149631E+00	-2.7101440E+00
5	6.1881621E-01	-1.9777356E-01	1.5104859E+00	-1.5044509E+00
6	9.9999979E-01	-1.3815608E-01	8.2457564E-01	-4.9516542E-01
7	3.2258104E-01	-7.2840681E-02	1.5663313E-01	9.8367802E-02
8	-2.6292010E+00	1.1379689E-01	-1.7291781E-02	2.9845655E-02
9	-1.4000002E+01	-4.4092972E-02	9.9278653E-02	-7.7922450E-02
10	1.3000586E-01	-1.8315230E-01	1.3758774E-01	-9.0542240E-02
	A10	A12	A14	A16
1	3.6582042E-01	-4.2487703E-01	-2.2631039E-01	-2.0344291E-02
2	-2.1599412E-01	-4.4977846E-01	2.5600140E+00	-1.9687116E+00
3	-7.7068397E-01	2.7743135E-01	2.0383002E+00	7.4259109E-01
4	1.3698992E+01	-3.8132984E+01	5.1107685E+01	-2.7851932E+01
5	1.4799995E+00	1.8815842E+01	-1.1654772E+02	1.7961509E+02
6	2.3119410E+00	-1.5309306E+01	2.6135941E+01	-1.0762516E+01
7	-2.7569022E-01	1.7783105E-01	-4.9261478E-02	3.9419268E-03
8	1.7970251E-04	-2.1611961E-02	4.0098433E-03	1.4790761E-03
9	2.0967820E-02	4.6775947E-03	-9.1757326E-04	-4.2752923E-04
10	4.2054637E-02	-1.3115957E-02	2.7031329E-03	-1.9876871E-04

(Ex. 1005, Ogino, column 21.)

B. Bateau

57. Bateau is an article by Jane Bateau and Peter P. Clark, titled “The Optics of Miniature Digital Camera Modules.” (Ex. 1012.) Dr. Sasián states that this was presented at an International Optical Design Conference in June 2006 and that it was published in SPIE Proceedings Vol. 6342 “a few months after the conference.” (Ex. 1003, Sasián Decl., ¶ 47.)

58. Apple does not rely on any detailed lens design from Bateau or any teachings of how a lens designer would create a detailed lens design. Rather, Apple and Dr. Sasián rely on Bateau listing an f-number of 2.8 in its “typical

lens specifications for a ¼" sensor format.” (Ex. 1003, Sasián Decl., ¶¶ 51–53; Ex. 1012, Bateau at 3–4.)

59. Other parts of Bateau illustrate an important point relevant to this IPR: the fact that you can simulate a lens design in lens design software such as Zemax does not mean that you can build that design. As Bateau explains:

Layout drawings can be very misleading. Many times we find ourselves surprised when the mechanical layout of a lens barrel that looked reasonable on paper turns out to be very difficult or impossible to fabricate. Tabs on a barrel that appear substantial in a drawing, are found to be too flimsy to function on the actual part, sharp edges on molded stops don't fill completely because the features are too small.

(Ex. 1012, Bateau at 1.)

60. Bateau explains aspects of the shape and size of lens elements, be they made out of plastic or glass, that are particularly problematic when producing miniature lenses like those at issue in this IPR:

Scaling down such a lens will result in a system that is unmanufacturable. If the design includes molded plastic optics, a scaled down system will result in element edge thicknesses shrinking to the point where the flow of plastic is affected. For glass elements, the edge thicknesses will become too thin to be fabricated without chipping.

(Ex. 1012, Bateau at 1.)

61. Bateau explains that the issue of “geometric tolerances, including both in the size and shape of individual lens elements and their alignment within

the overall system, “proves to be the greatest challenge of producing these lenses.” (Ex. 1012, Bateau at 3.)

62. Bateau explains that there are limits to achievable shapes in miniature lens. For molded lenses, these limits arise from the properties of the lens material, both in liquid form and in solid form, and from the techniques used to make the mold inserts that the lens parts are formed in. According to Bateau:

Plastic injection molded optics have minimum edge thicknesses, minimum center thicknesses and range of acceptability for their center to edge thickness ratio that must be met in order that they can be molded. Additionally, the maximum slope that can be diamond-turned in mold inserts and measured in either the lens or the mold is around 45 degrees.

(Ex. 1012, Bateau at 8.)

63. As Bateau explains, similar limitations apply to glass lens elements: “Traditional glass lenses have similar types of requirements but with different values.” (Ex. 1012, Bateau at 8.) In molded glass lenses, “surfaces with inflections can only be used under very limited circumstances and flanges can only be formed in a restricted range of shapes, no sharp corners or abrupt changes in slope are allowed.” (Ex. 1012, Bateau at 8.)

64. I am very familiar with these issues of manufacturability, which I have encountered frequently in my academic work.

C. Kingslake

65. Kingslake is a text by Rudolf Kingslake titled “Optics in Photography.” (Ex. 1013.) The copyright page contains a copyright date of 1992. (Ex. 1013 at 2.) Apple cites to only a single page from this textbook, page 104. (Ex. 1013 at 3.)

66. This page contains the beginning of Kingslake’s chapter 6, titled “The Brightness of Images.” (Ex. 1013.) The only portions of Kingslake that Apple or Dr. Sasián actually quotes are from the first paragraph of this chapter:

The relation between the aperture of a lens and brightness of the image produced by it on the photographic emulsion is often misunderstood, yet it is of the greatest importance to the photographer who wishes to make the best use of the equipment. The tremendous efforts of lens designers and manufacturers that have been devoted to the production of lenses of extremely high relative aperture are an indication of the need that exists for brighter images and “faster” lenses.

(Ex. 1013, p. 104.)

67. This paragraph refers to “brighter” and “faster” lenses, which as explained above correspond to lenses with smaller f-numbers. Brighter or faster lenses have advantages, in that they are able to capture an image of a given scene with a shorter exposure (which may be desirable for fast-moving scenes) or to capture a lower-light scene with the same exposure duration.

68. However, simply because a property is desirable, does not make it easy to achieve. As Kingslake says, creating lenses with small f-number has required “tremendous efforts of lens designers and manufacturers.” It requires more than simply deciding to have larger diameters of lenses and apertures.

D. Chen

69. The Chen patent issued as U.S. Patent No. 10,324,273 on June 18, 2019 and claims priority to a Chinese patent application filed August 29, 2016. (Ex. 1020, Chen.) It describes “an optical imaging lens set of five lens elements for use in mobile phones, in cameras, in tablet personal computers, or in personal digital assistants.” (Ex. 1020, Chen at 1:17–19.)

70. Apple’s and Dr. Sasián’s obviousness arguments based on Chen are based on a modification of Chen’s Example 1, which is shown in Chen Figure 6:

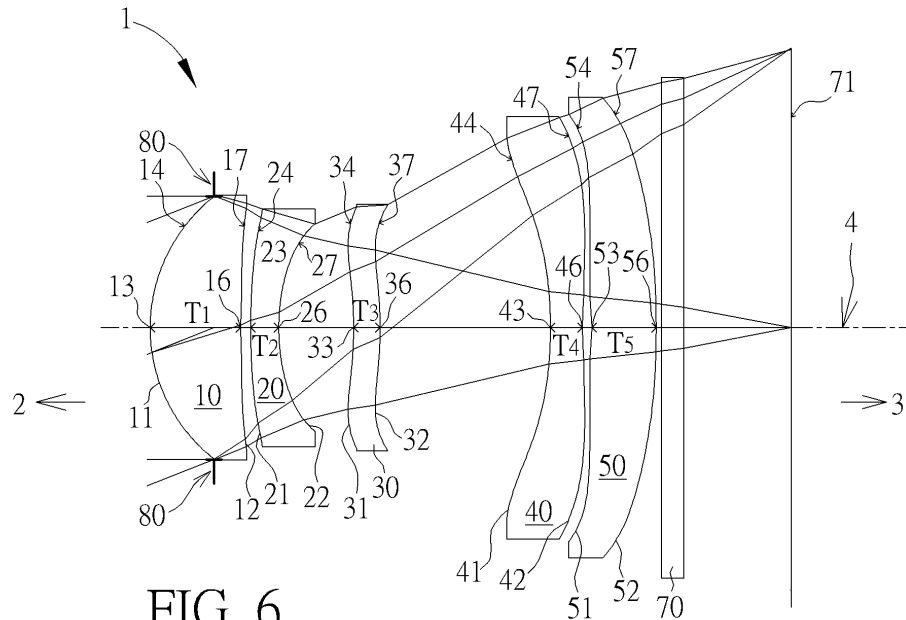

FIG. 6

(Ex. 1020, Chen, Figures 6 and 24, 2:62–63, 8:42–10:12.)

71. According to Chen, this lens system has an effective focal length of 6.582 mm (Ex. 1020, Chen, Figure 42) and a TTL of 6.0187 mm (Ex. 1020, Chen at 10:9.) According to Chen, “[g]enerally speaking,” each of the five lens elements in this system may be made of “transparent plastic material.” (Ex. 1020, Chen at 7:11–22.)

72. Chen also illustrates an important point concerning lens ray trace diagrams produced using lens design software, such as Chen’s figure 6. The lens design software is concerned with the optically clear aperture of the lens element that light passes through and that bend that light to form an image. The

ray trace diagrams generated by software such as Zemax show those parts of the lens elements. But a physical lens element (as opposed to one simulated in software) extends beyond the shape drawn by the lens design software at the maximum diameter of where the light passes through the lens. This is illustrated by Chen Figure 1, which shows “extension parts” E that are part of the lens outside of the light bending portion:

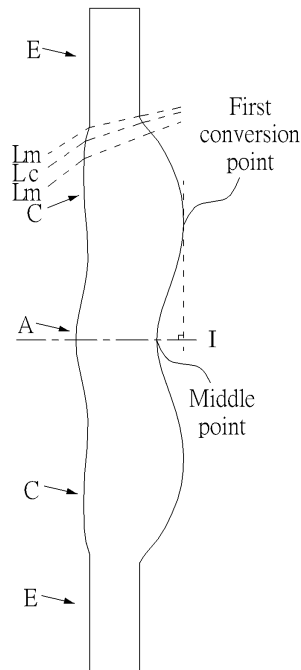

FIG. 1

(Ex. 1020, Figure 1.)

73. The extension parts in this lens element appear to serve as flanges for mounting the lens element, like those described in Bateau. (Ex. 1012, Bateau at 8.)

E. Iwasaki

74. The Iwasaki patent issued as U.S. Patent No. 9,678,310 on June 13, 2017, and it claims priority to a Japanese patent application filed March 25, 2013. (Ex. 1009.) It describes an “imaging lens . . . constituted essentially by four or more lenses.” (Ex. 1009, Iwasaki, Abstract.)

75. The only aspect of Iwasaki that Apple and Dr. Sasián rely on is the 0.145 mm cover glass used in Iwasaki’s examples 1 and 2. (Ex. 1003, Sasián Decl., ¶¶ 72–74; Ex. 1009, Iwasaki, Tables 1 and 3.)

F. Beich

76. Beich is a paper titled “Polymer Optics: A manufacturer’s perspective on the factors that contribute to successful programs,” which lists William S. Beich and Nicholas Turner as its authors. (Ex. 1007, Beich at 1.) According to a statement on its first page, it was published in the Proceedings of SPIE in 2010. (Ex. 1007, Beich at 1.)

77. Beich discusses various considerations and rules of thumb that relate to the manufacturability of lenses using injection molding methods. According

to Dr. Sasián “a POSITA looking to implement optical element specifications using injection molding methods would look to Beich for guidance on limitations and parameters that affect lens manufacturability.” (Ex. 1003, Sasián Decl., ¶ 78.)

78. Beich explains that the “unique nature of injection molding demands a very disciplined approach during the component design and development phase.” (Ex. 1007, Beich at 2.) The paper describes aspects of the injection molding process, such as the “runner system” of channels that convey molten plastic into the mold insert through the sides of the lens. (Ex. 1007, Beich at 6.) Beich explains that “[o]ptics with extremely thick centers and thin edges are very challenging to mold,” and it provides a set of “rules of thumb,” including that the center thickness to edge thickness ratio for a lens element should be less than “3:1” and that the lens diameter tolerance is ± 0.020 mm. (Ex. 1007, Beich at 7.)

IX. OBVIOUSNESS

A. Ground 2 – Obviousness of Claims 2, 5, 6, 18, and 21–23 over Ogino in view of Bateau

79. According to Dr. Sasián, Ogino Example 5 satisfies each of the elements of claims 1 and 17 of the '897 patent. Dependent claims 2, 5, 6, 18, and 21–23 each add the requirement that f-number be less than 2.9, or in the case

of claim 23 that the f-number equal 2.8. But, Ogino Example 5 has an f-number of 3.94. Ogino Figure 12.

80. Dr. Sasián shows how Ogino Example 5 *could* be modified using the Zemax software, to reduce the f-number while leaving all the other characteristics of Example 5 that Apple relies on to satisfy claims 1 and 17 unchanged. However, the fact that Dr. Sasián, a highly skilled and well-regarded lens designer with decades of experience who literally “wrote the book” on the subject could modify Ogino Example 5 in this way in 2020, with the claims of the ’897 patent in front of him, does not demonstrate that a lens designer of merely ordinary skill *would* have thought to follow this approach in 2013.

81. Bateau suggests that a lens with f-number of 2.8 was desirable for use in a miniature digital camera in 2013. But Bateau also shows that lenses with f-number 2.8 were already commercially available years earlier, in 2006. Ogino itself describes other lenses with f-numbers of 2.45, 2.46, 2.47, 2.64, 3.04. (Ex. 1005, Figures 8–11, 13.) If a POSITA looking at Ogino felt that an f-number of 3.94 was not suitable for their particular application and wanted an f-number of 2.8 instead, that person would naturally look to one of Ogino’s other designs, with f-number closer to 2.8, or to one of the hundreds of other miniature lens designs available in the patent literature or in the market. Dr.

Sasián provides no explanation for why a POSITA would pick Ogino Example 5, the Ogino lens that is farthest from this desired f-number and modify it dramatically as Dr. Sasián proposes.

82. Further, the result of Dr. Sasián’s modification to Ogino Example 5 does not satisfy all of the “typical lens specifications” from Bareau. Bareau’s table of specifications lists a field of view “FOV” of 60 degrees, but Bareau suggests that larger angles such as 66 degrees are also “typical.” (Ex. 1012, Bareau at 3.) The unmodified Ogino Example 5 has a half-angle field of view $\omega=25.9^\circ$, or a full field of view of approximately 52° . Dr. Sasián’s modifications reduced the field of view to “+/- 20° ,” i.e., to a full field of view of 40° . (Ex. 1003, Sasián Decl. at 104 and figures on 105 and 106.) Dr. Sasián does not explain why a POSITA seeking to modify Ogino Example 5 based upon the specification in Bareau would modify it to satisfy one of Bareau’s specifications but to move further away from Bareau’s other specifications.

83. Dr. Sasián does point to a patent by Parulski (Ex. 1014) as an example of a cell phone with both wide and narrow angle lenses, but Parulski does not specify any f-number for its narrow angle lenses. Nothing cited by Dr. Sasián suggests that an f-number of 2.8 was desirable in the context of a narrower-

angle lens, and nothing suggests that a POSITA would have been motivated to modify Ogino example 5 to reduce both the f-number and the field of view.

84. Even if there were some evidence that a POSITA would have considered the result of the modifications that Dr. Sasián performs to Ogino Example 5 to be desirable, he does not show that a POSITA would have actually followed the approach that he describes. In modifying Ogino Example 5, Dr. Sasián kept the number of lens elements, the powers of the lens elements, their thicknesses, and their spacings unchanged, except for a small change to the thickness of the first lens element. (Ex. 1003, Sasián Decl. at 104.) He made the small change in thickness of the first lens element, from 0.546 mm (Ex. 1005, Ogino Table 9) to 0.600 mm (Ex. 1003, Sasián Decl. at 107) by hand. (Ex. 2003, Sasián Depo. at 24:14–25:10.) By keeping these parameters (nearly) unchanged, Dr. Sasián ensured that the values of EFL, TTL, lens powers, and lens gaps needed to satisfy other claim elements remained unchanged.

85. In other words, in modifying Ogino Example 5, Dr. Sasián changed the one parameter by hand that needed to be changed to satisfy the claims, the f-number, while forcing the other parameters to stay (nearly) the same, so that the other parameters of the claims did not change.

86. This approach is a natural approach if the goal is to modify Ogino to satisfy the '897 patent claims, but it is not the approach that a POSITA would actually follow. A lens design such as Ogino Example 5 is defined by more than 100 numerical parameters, shown in tables 9 and 10 of Ogino. There are a vast number of ways that various combinations of these parameters could be varied. Further, entire lens elements can be added or removed, substantially increasing the space of available designs. The section of Dr. Sasián's lens design textbook that discusses using lens design software describes 20 "well-known techniques for modifying and improving a lens" for purposes such as to decrease the f-number. (Ex. 2004, Sasián at 133–134.) Following these "well-known" techniques might very well have led a POSITA to change Ogino Example 5 in a direction very different from what Dr. Sasián proposes, in a way that did not satisfy any of the claims of the '897 patent.

87. But more fundamentally, a POSITA looking at Ogino and seeking to meet the specifications of Bateau would have seen that there were already lens designs in Ogino that nearly did so, such as Example 6, with its f-number of 2.64 and field of view of $2 \times 29.8^\circ = 59.6^\circ$. (Ex. 1005, Ogino, Figure 13.) They would not have been motivated to instead look to modifying Example 5, just

to obtain a lens that was *further* from Bateau's specifications than Example 6.

88. In addition, a POSITA would have recognized that the lens design that Dr. Sasián created was not manufacturable. That is, the lens has a shape that lens design software such as Zemax will happily perform ray trace calculations on, but that is extremely difficult to construct in a useful physical lens.

89. I understand that Dr. Sasián has previously offered the opinion that a POSITA would know that the lenses described in Ogino would most likely be made of injection-molded plastic. Specifically, Dr. Sasián noted that:

While Ogino does not specifically indicate that its lens elements can be plastic, a POSITA would recognize that the index of refraction and Abbe number of the lens elements specified in Example 6 of Ogino are within the range of values of plastic materials used for cell phone lenses.

Further lens elements of the sizes and asphericities described in Ogino would preferably be made of plastic via injection molding processes. See Ex.1019, p.34.14 (pdf p.80). A POSITA would also recognize that when designing lens elements for crafting via injection molding, a number of manufacturing realities apply that all promote maximizing the thickness of the lens element at the edge.

(Ex. 2009, IPR2019-00030 Sasián Decl. at 69.)

90. While this earlier statement of Dr. Sasián relates to Ogino Example 6, it applies similarly to Ogino Example 5. For example, the indices of refraction

and Abbe numbers for the materials used in Example 5 are the same as those in Example 6 (Ex. 1005, Ogino, Tables 9, 11), indicating that the same plastic materials were used in both examples.

91. A POSITA would understand that a lens intended for use in a compact camera for a mobile device like Ogino (Ex. 1005, Ogino at 1:7–15) would be made using injection molded plastic. For example, Bateau states that in miniature digital camera modules: “The *majority of these lenses are all-plastic* although some incorporate one glass element (usually the front element) for the advantages of high-index refraction and color correction.” (Ogino Example 5 does not follow the minority approach of a different non-plastic material for the first lens, as the first and fifth lens both use the same material, Ex. 1005, Ogino, Table 9.) Likewise, Clark (one of the authors of the Bateau article) writing about mobile device camera lenses in 2014 wrote: “Conventional lens designs are multi-element injection molded plastic lenses assembled in a plastic barrel, as they were in 2006.” (Ex. 2005, Clark at 3.)

92. To the extent that glass were used in a lens design such as Ogino’s, it would also be molded, as molding is the practical approach to making aspheric lenses, such as those in Ogino:

One of the primary advantages of molded optics has always been the use of aspheric surfaces. Aspheric surfaces are simply

surfaces that are not spherical. Historically, *most optical surfaces have been spherical (or flat) due to ease of fabrication and testing with the exception of molded optics*. Aspheric surfaces have long been the standard in molded optics, regardless of process, again due to ease of manufacture. The mold manufacturing process is well suited to aspheric manufacturing, and only having to cut a small number of molds to make a large quantity of optics made an increase in tooling cost trivial when amortized over a molding run.

(Ex. 2006, Symmons at 6.)

93. I have written a chapter in the Handbook of Optics which contains a section on molded glass and plastic optics. (Ex. 2008, Handbook of Optics, Section 7.5.) As I explain there:

Molded lenses become especially attractive when one is designing an application that requires aspheric surfaces. Conventional techniques for polishing and grinding lenses tend to be time-expensive and do not yield good piece-to-piece uniformity. Direct molding, on the other hand, eliminates the need for any grinding or polishing.

(Ex. 2008, Handbook of Optics, at 7.5–7.6.)

94. The modified lenses discussed by Dr. Sasián have the same indices of refraction and Abbe number as in Ogino's example 5, indicating that these modified lenses would use the same (likely plastic) materials as Ogino. (Ex. 1003, Sasián Decl. at 107, 111; Ex. 1005, Ogino, Table 9.)

95. The main manufacturability problems with Dr. Sasián's f-number 2.8 modification of Ogino concerns the edges of the first lens element:

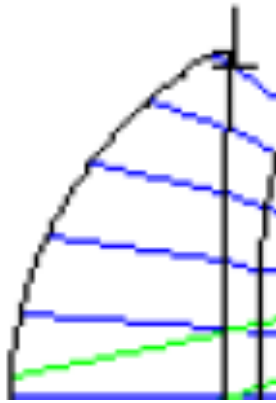

(Ex. 1003, Sasián Decl. at 107.)

96. The left surface of this of this excerpt is the object side surface of the first lens. The blue rays of this drawing are the rays of the bundle that defines the entrance pupil. As the following drawing illustrates, the light forming these blue rays enters as a bundle of parallel rays from the left before being bent by the lens front surface:

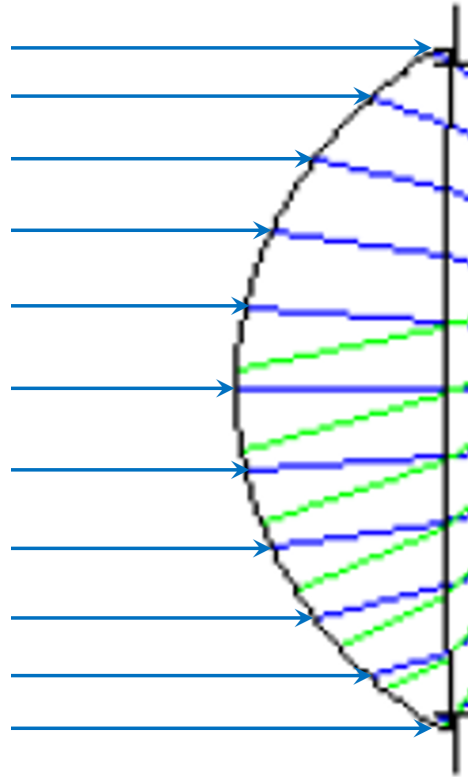

97. The entrance pupil diameter (part of the formula for f-number) is the diameter of this bundle of rays, which in turn is nearly the full diameter of the object-side lens surface in this drawing. In other words, this lens element needs to be at least the diameter shown here in order to achieve the f-number = 2.8 that Dr. Sasián sought to obtain. Put another way, the clear aperture of the first surface needs to be at least as large as shown in this drawing to achieve the f-number Dr. Sasián sought.

98. The resulting shape has a very narrow edge and a large slope at that edge. According to my calculations, the edge thickness is only 0.0394 mm (or 39.4 microns), and the slope is 58.86°:

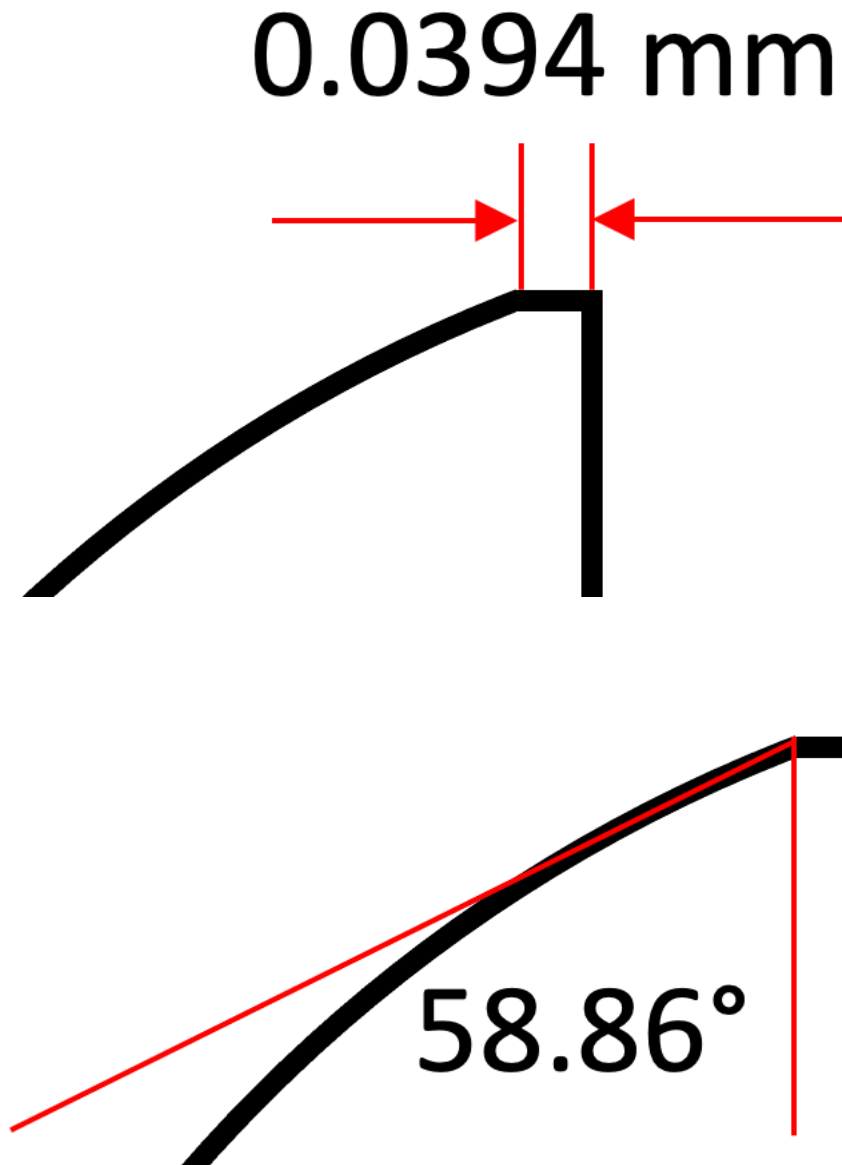

See Appendix Section XI.A.

99. This edge thickness of $39.4\ \mu\text{m}$ (microns) is roughly half the width of a typical human hair, commonly taken to be $75\ \mu\text{m}$.¹¹ This is not the edge of a realistic, practical lens. To see why, it is useful to see an actual commercial lens, as in the following X-ray CT image that I had taken as part of my work outside of this IPR¹²:

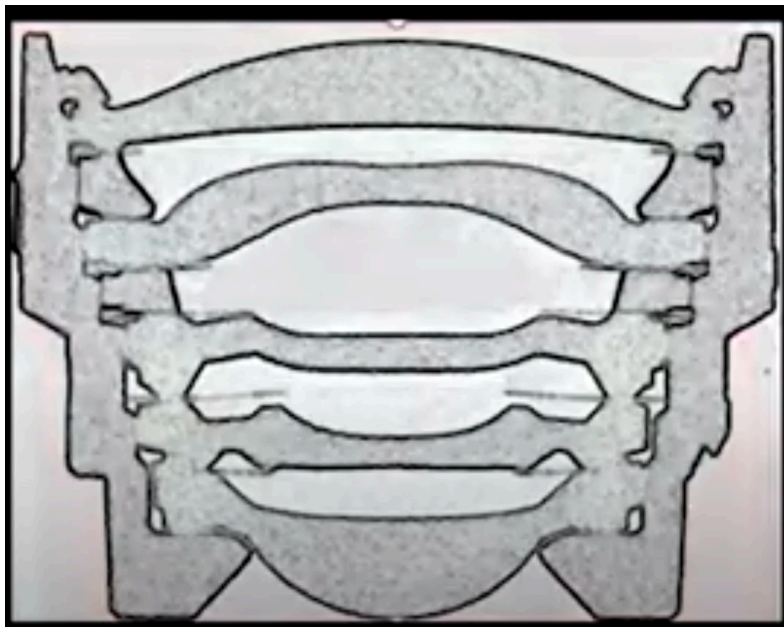

100. This lens has five plastic elements (gray), with air gaps (white) between them. The bottom of this picture is the object side, and the top is the image side. The portion of the lens that light actually passes through is (very) roughly shown in the red shading below:

¹¹ https://en.wikipedia.org/wiki/Hair%27s_breadth

¹² A YouTube video of this work is available at <https://www.youtube.com/watch?v=E8nE8aBSiJQ>.

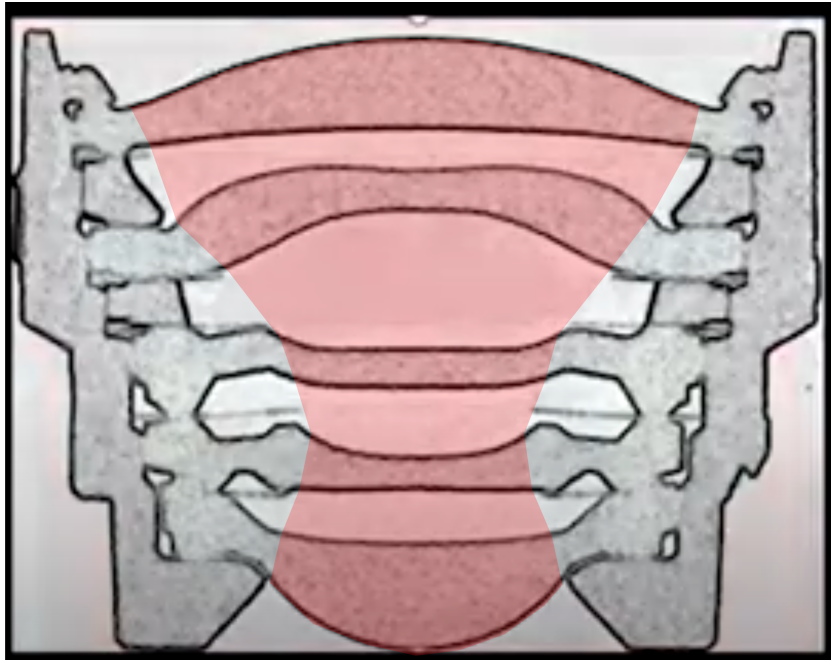

101. The thin black structures protruding from left and right are baffles. There are two important things to note concerning the lens elements in this design. First, each element has a thick mounting flange at its edge, to mount it physically to the roughly cone-shaped lens barrel. Second, the smoothly curved surfaces in the center of each lens element extend beyond the “clear aperture” where light actually passes through the lens. Parts of the curved surfaces are in the shadow of the baffles. In other words, the curved portions of the lens elements are “oversized” relative to their clear apertures.

102. Zemax’s ray traces are only concerned with the parts of the lens elements that bend light, i.e., with their clear apertures. The oversized portions and the mounting portions of the lenses are not included in the Zemax designs

from Dr. Sasián. But a POSITA would understand they need to be there in the actual lens.

103. Oversizing is necessary because a lens cannot be made with perfectly sharp corners and edges. In molded lenses, one reason for this is surface tension of the lens material. If one attempted to inject plastic or glass into a mold with sharp corners such as shown in the Zemax drawing, the liquid would not fill the corners, but would rather form a rounded surface, which would bend light differently than the ideal shape in Zemax:

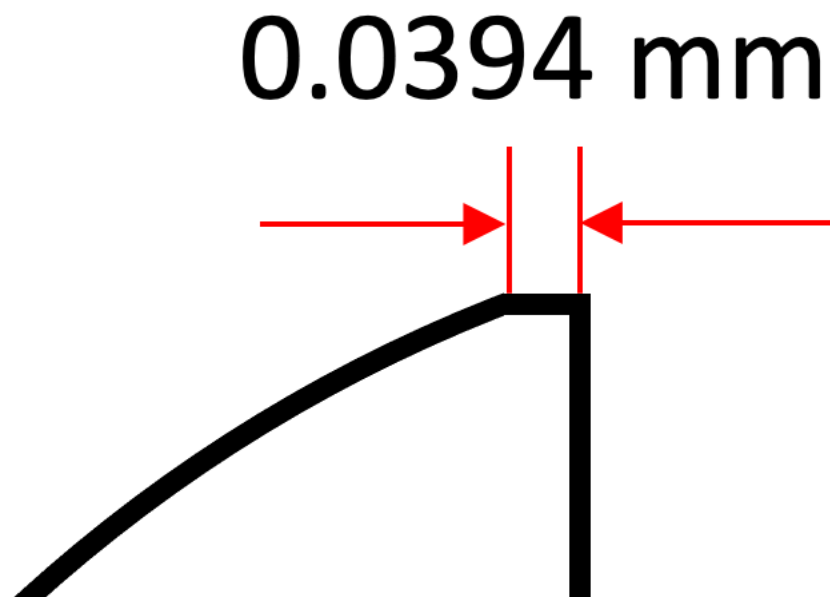

104. In addition, there are limits to the ability to make molds with such sharp corners in the first place, as the diamond-tipped tools typically used to make them have a finite width and are not infinitely sharp.

105. As explained in the Field Guide to Molded Optics, actual molded lenses have rounded corners:

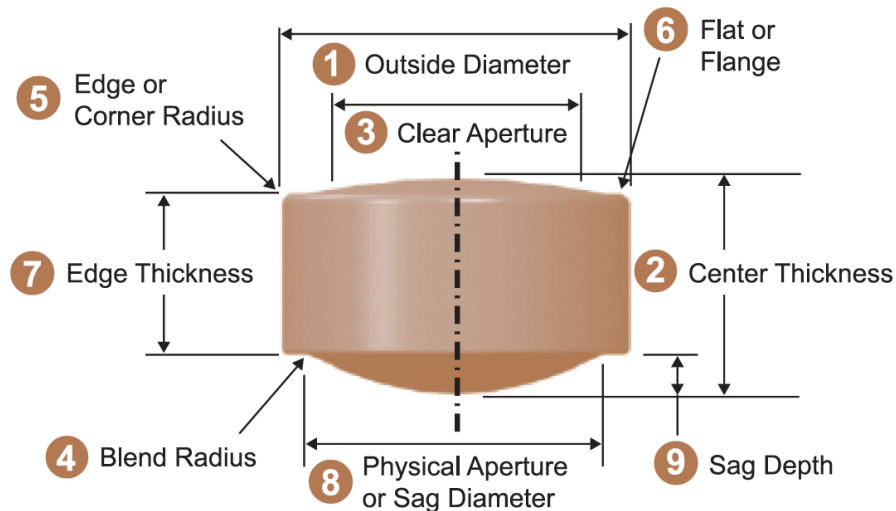

⑤ Edge radius or corner radius (R_c)

The radius on the outside diameter due to volumetric molding.

(Ex. 2006, Symmons, pp. 87–88.)

106. Even if the surface tension and other limitations of injection molding were not a factor, practical lenses will have rounded or chamfered corners rather than sharp 90° corners, regardless of the technology used to make them.

As Dr. Sasián notes in his textbook, “[i]t is imperative that a bevel, or protective chamfer, is specified to avoid the lens edge easily chipping.” (Ex. 2004, Sasián at 112.)

107. A sharp corner is mechanically much weaker than a rounded or chamfered corner. For example, a *Plastics Today* article by Glenn Beall explains that a corner with a 0.02-inch radius of curvature can withstand 8 times the impact load of a corner with a 0.01-inch radius of curvature. (Ex. 2007, Beall.) Making extremely sharp corners without chipping the lens is difficult regardless of the manufacturing technique used.

108. A practical lens design would use an edge shape that permitted oversizing and rounded corners. The importance of oversizing is explained in the *Handbook of Optics* (which as explained above contains a chapter by me):

Surface-tension effects may play a significant role in the accuracy to which a precision optical surface may be molded. Particularly in areas of the part where the ratio of surface area / volume is locally high (corners, edges), surface tension may create nonuniform shrinkage which propagates inward into the clear aperture, resulting in an edge rollback condition similar to that which is familiar to glass opticians. . . . ***These phenomena provide motivation to oversize optical elements, if possible, to a dimension considerably beyond the clear apertures.*** A buffer region, or an integrally molded flange provides the additional benefit of harmlessly absorbing optical inhomogeneities which typically form near the injection gate.

(Ex. 1019, *Handbook of Optics*, Vol. 2 at 34.16.)

109. The Field Guide suggests oversizing of around 4-10% for molded plastics:

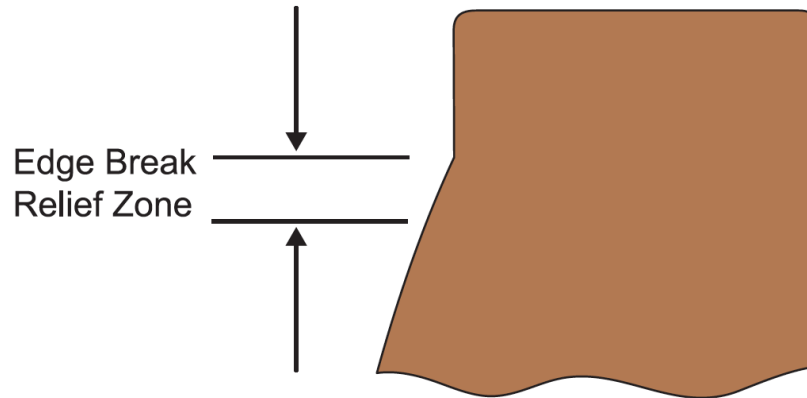

Because of the impact of edge break, molders will require the CA size to be smaller than the full optical surface that is molded. The amount of edge relief will depend on the part size, but one millimeter or more in the radial direction is desired for parts of approximately 10 to 25 mm in diameter.

This much relief is often impractical for smaller parts, where it would be a substantial portion of their diameter. In this case, the edge break relief zone will need to scale down with the part size.

(Ex. 2006, Symmons at 103.)

110. Dr. Sasián’s textbook indicates that even greater degrees of oversizing, 10-20%, are common for traditional polished glass lenses: “A common surface polishing problem is to have the very edge of the surface turned down.

To overcome this figuring problem, there is a tendency to specify a lens diameter larger, say 10–20% larger, than the clear aperture.” (Ex. 2004, Sasián at 111.)

111. The problem with Dr. Sasián’s first modified lens is that the first lens shape leaves no room to oversize or to have rounded or chamfered corners. Given the 0.0394 mm edge thickness and 58.86° slope, the diameter could be increased by less than 0.030 mm before the edge thickness reached zero, i.e., less than 3%. And that assumes that an edge thickness of zero were possible, which it is not.

112. These problems are further compounded by the finite precision of manufacturing techniques. For example, the Beich paper cited by Dr. Sasián provides “rules of thumb” for part tolerances of “ ± 0.020 mm” for center thickness and diameter, “ < 0.020 mm” for the “S1 to S2 Displacement,” i.e., the displacement between the halves of the mold forming the front and back surfaces of the lens, and “ < 0.010 mm” for “wedge,” i.e., the difference in edge thickness from one side of the lens to the other. (Ex. 1007, Beich at 7.) Tolerances for glass molding are similar. (Ex. 2006, Symmons at 95.) As the Field Guide notes, “high repeatability from component to component” is an

advantage of molded lenses over other techniques, so other techniques have tolerance issues as well. (Ex. 2006, Symmons at 2.)

113. The presence of center thickness variation and “wedge” in the molded parts makes the tiny edge thickness more problematic. A Zemax edge thickness of 0.039 mm becomes a thickness ranging from perhaps 0.015 mm to 0.065 mm in practice.

114. Manufacturing tolerances add up. For example, the semi-diameter of the first lens object side in the f-number 2.8 modification of Ogino is 1.0175 mm, while the aperture stop has a semi-diameter of 0.9751 mm, for a difference of only 0.0424 mm. If the lens diameter has a variation of ± 0.020 mm, the lens has a position offset of 0.020 mm, and the aperture stop (likely made by molding or punching) has similar tolerances, these four variances add under the root sum square rule to yield an error that goes as the square root of the number of errors. (Ex. 2004, Sasián at 116–117.) Even if the first lens is slightly oversized, these additive errors can easily lead to a situation where there is an open gap between the first lens and the aperture, allowing light to leak through and adding a diffuse haze to the image, something that is highly undesirable.

115. The less-than-hair's-width edge of the first lens causes at least two further problems. First, as explained in Symmons, the injected liquid comes into the mold via runners from the side. After the part is formed, these now-solid runners must be removed: "It is then cut from the runner/gate system in a process known as degating. The degating process is not perfect and results in residual material being left on the edge of the part. This remaining plastic is called gate vestige." (Ex. 2006, Symmons at 100.) This means that the edge has to be thick enough to provide room for the liquid to flow into the mold and also needs to have space outside the clear aperture to accommodate the imperfect cut of the gate vestige:

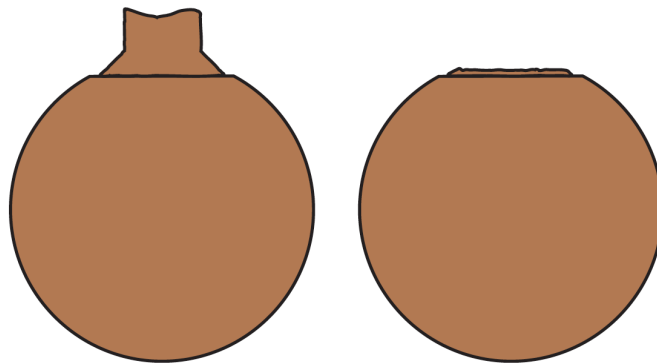

(Ex. 2006, Symmons at 100.)

116. Bateau recognizes this problem when it refers to "element edge thicknesses shrinking to the point where the flow of plastic is affected." (Ex. 1012, Bateau at 1.) The tiny edge thickness of Dr. Sasián's modified lens simply

does not have enough room to allow for proper flow of the liquid or to accommodate runners and degating.

117. It also poses a major problem for mounting the lens element. Any extension or flange of this lens must have at least a portion that is as thin as the edge thickness of the clear aperture, i.e., 0.0394 mm. Such thin flanges will be difficult to form and regardless of how they are made will be vulnerable to chipping and cracking. Indeed, the Field Guide refers to an injection molded plastic lens with a minimum thickness of “on the order of a few hundred microns” as “extremely small.” (Ex. 2006, Symmons 102.) Dr. Sasián proposes a minimum thickness of a few tens of microns, roughly a factor of ten thinner than what the Field Guide considers “extremely small.”

118. These many issues with thin lens edges lead to a rule of thumb in the Beich paper, which Dr. Sasián himself cites as something that a POSITA would be motivated to follow: the “Center Thickness to Edge Thickness Ratio” should be less than 3:1. (Ex. 1007, Beich at 7; Ex. 1003, Sasián Decl., ¶ 78.) Dr. Sasián’s textbook gives a similar rule of thumb, saying “the ratio of lens central thickness to edge thickness should be larger than 3.2.” (Ex. 2004, Sasián at 194.) My chapter in the Handbook of Optics likewise says to use “a center/edge thickness ration less than 3.” (Ex. 2008, Handbook of Optics at

7.11.) By contrast, Dr. Sasián's design has a ratio of 0.6 mm / 0.039375 mm = 15.238, far outside the range of what a POSITA would consider manufacturable.

119. While that rule of thumb applies to plastic lenses, a POSITA would recognize that the tiny edge thickness is similarly problematic for glass lenses. For example, the Field Guide states that "Very small edge thicknesses (<0.4 mm) should be avoided, as these lenses become very difficult to handle and can chip easily." This chipping issue is not unique to molded glasses, but will also apply to glass lenses formed other ways. Bateau recognizes this as a general problem for glass lenses when it warns that "[f]or glass elements, the edge thicknesses will become too thin to be fabricated without chipping." (Ex. 1012, Bateau at 1.) A POSITA would recognize that the edge of Dr. Sasián's lens (0.0394 mm) is too small by a factor of ten for a glass lens.

120. Also problematic for molded glass is the steep slope of the modified lens, 58.86°. As the Field Guide states:

The slope of a lens surface should be kept less than 55 deg for PGM. High slopes create difficulty in mold manufacture and testing. Very steep surfaces can be difficult to manufacture and difficult to measure. Precision diamond grinding is limited to just under 55 deg, but the maximum angle varies based on final geometry and manufacturer. Many surface profilometers cannot measure surfaces this steep and begin to lose accuracy at high angles.

(Ex. 2006, Symmons at 94.)

121. While this discussion appears in the section on glass molding, each of these problems applies equally to molding plastic and indeed to almost any manufacturing technique. For example, Bateau states that for plastic molding, “the maximum slope that can be diamond-turned in mold inserts and measured in either the lens or the mold is around 45 degrees.” (Ex. 1012, Bateau at 8.) A POSITA would recognize that the 58.86° slope in Dr. Sasián’s modified lens is not practical.

122. As this section shows, the first lens in Dr. Sasián’s f-number 2.8 modification of Ogino requires unrealistic manufacturing tolerances, poses practical difficulties in manufacturing, will be vulnerable to chipping and cracking, and will suffer from significant optical defects. A POSITA who had read my chapter or Dr. Sasián’s book would recognize that it violates manufacturing rules of thumb.

123. Both the ’897 patent and Ogino depict lenses of the type of the POSITA would actually consider manufacturable, with curved surfaces that are oversized beyond the clear apertures and with relatively thick edges that facilitate accurate manufacture and mounting:

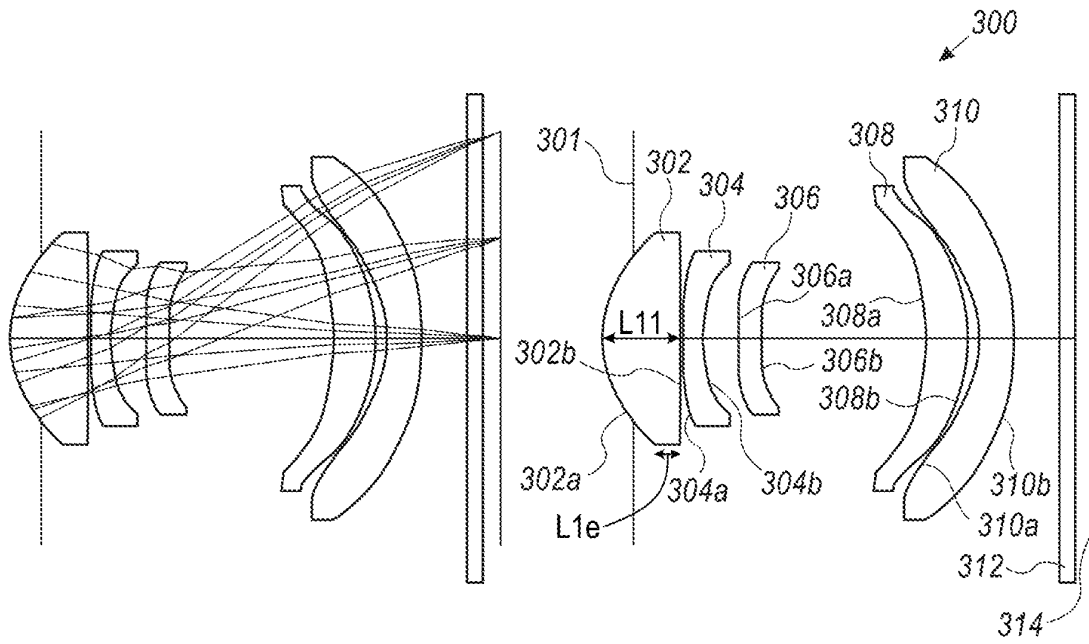
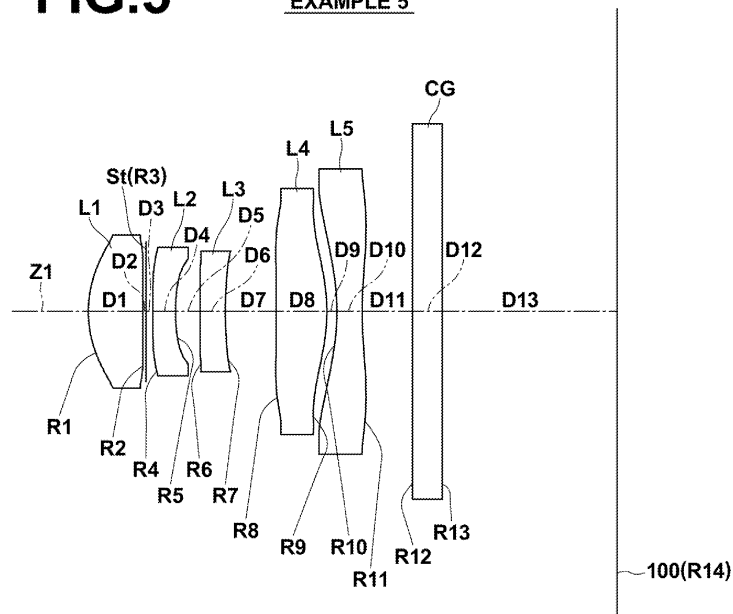

FIG. 3A

(Ex. 1001, '897 patent, Figure 3A.)

FIG.5

EXAMPLE 5



(Ex. 1005, Ogino, Figure 5.)

124. As noted above, the POSITA would not be motivated to reduce the f-number of Ogino Example 5 in the first place, because Ogino has multiple other lens designs that would be more suitable. But, if a POSITA did attempt to modify Example 5, and the best that they could achieve was this unmanufacturable design, unsuitable for use in mobile devices of the type addressed by Ogino and Bateau, the POSITA would wisely have abandoned the effort.

B. Ground 3 – Obviousness of Claims 3, 8, 19, and 24 over Ogino in view of Bateau and Kingslake

125. Apple and Dr. Sasián propose a further modification to Ogino Example 5 to satisfy the limitations of claims 3, 8, 19, and 24. These claims add two limitations that are not satisfied by the first modification to Ogino: an image-side surface diameter between 2.3 mm and 2.5 mm for the first lens element (claims 3 and 19) and a convex image-side surface (claims 8 and 24).

126. The image-side surface diameter of the first lens element in the first modification of Ogino is $2 \times 0.98943 = 1.97886$ mm, outside the range required by claims 3 and 19. This image-side surface is also concave, as shown by the positive value of the radius of curvature (252.97534) in Dr. Sasián’s lens prescription. (Ex. 1003, Sasián Decl. at 107.) The fact that the first lens element has a concave image-side surface is a feature of every example in Ogino and is described by Ogino as a defining feature of its invention.

127. Ogino explains that its invention uses a first lens that “has a positive refractive power and has a meniscus shape which is convex toward the object side.” (Ex. 1005, Ogino, Abstract, 13:5:10.) Ogino explains its reason for including this feature:

by making the first lens L1, which is a lens closest to the object, have a positive refractive power and have a meniscus shape

which is convex toward the object side in the vicinity of the optical axis, the position of the rear side principal point of the first lens L1 can be set to be close to the object, and ***thus it is possible to appropriately reduce the total length***

(Ex. 1005, Ogino at 7:31–37.)

128. A “meniscus” shape is one that is convex on one side and concave on the other, meaning that a meniscus lens that is convex toward the object side necessarily is concave toward the image side. Dr. Sasián explains how the meniscus lens convex toward the object side in each of Ogino’s examples has a concave image-side surface in his analysis of claim 6. (Ex. 1003, Sasián Decl. at 63–66.)

129. So, in order to satisfy these limitations of claims 3, 8, 19, and 24, Dr. Sasián had to substantially change the shape of the first lens element, making it much larger, and changing the image side from concave to convex, among other changes:

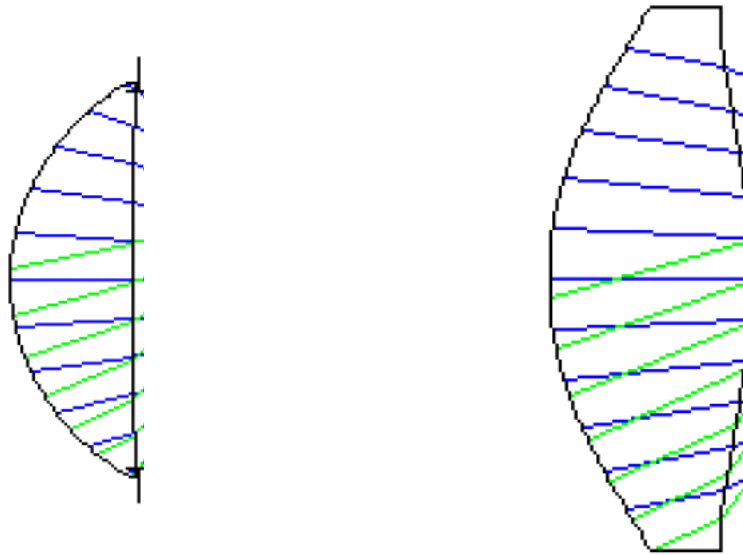

(Ex. 1003, Sasián Decl. at 104 and 108.) Indeed, every single parameter of this lens element was changed except for the lens material. (Ex. 2003, Sasián Depo. at 48:15–24.)

130. If the goal is to increase the image-side surface diameter to be greater than 2.3 mm, that can be done in Zemax (or similar software) by increasing the entrance pupil diameter, as increasing the size of the bundle of rays entering the first lens element more-or-less mechanically requires that the first lens element, including its image-side surface, become larger:

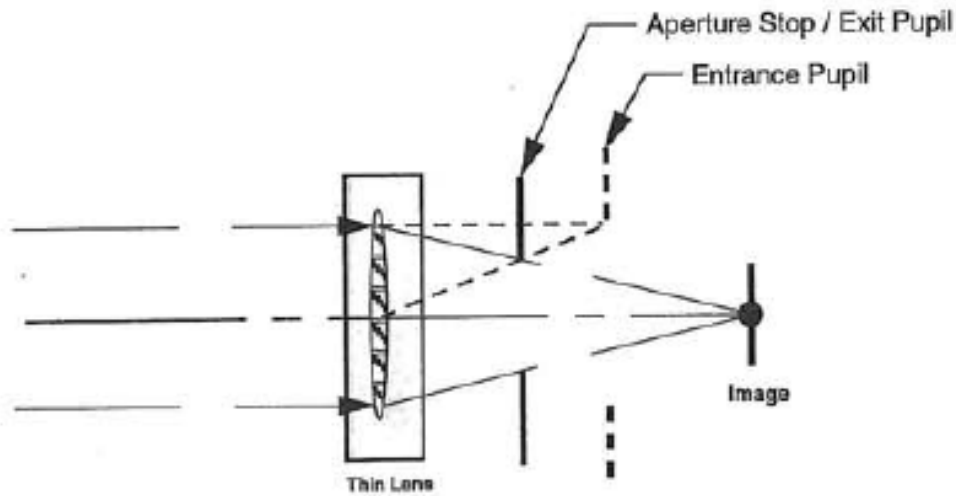

(Ex. 1016, Walker, p. 61.)

131. Likewise, if the goal is to make the image-side surface convex, that can be done by hand. But the fact that these changes are possible does not explain *why* a POSITA would make these specific changes, out of all the many parameters of the design they could change.

132. Dr. Sasián's declaration and testimony are very unclear on what process he used, let alone why he used that process. The result of his changes has an image-side surface diameter of $2 \times 1.17086 \approx 2.34$ mm and a convex image-side surface. (Ex. 1003, Sasián Decl. at 108.) The stated reason for the modifications was to further reduce f-number below 2.8. (Ex. 1003, Sasián Decl., ¶¶ 61–64.) Dr. Sasián cites general statements suggesting lower f-numbers are desirable, but the only specific f-numbers that he points to that are less than

2.8 are the f-numbers in example 1–3 and 6 of Ogino. (Ex. 1003, Sasián Decl., ¶ 62.)

133. As I explained above, if the goal of a POSITA aware of Ogino was to use a lens with small f-number such as 2.45, the natural and obvious thing to do would be to use one of Ogino’s small f-number examples, not to take the example with the largest f-number and modify it beyond recognition. However, even if the small f-number examples in Ogino did suggest to a POSITA that they should reduce the f-number of Example 5, they would not suggest reducing it to be even lower than 2.45.

134. According to Dr. Sasián’s declaration, the second modification of Ogino has an f-number of 2.12. (Ex. 1003, Sasián Decl. at 108.) This value is consistent with his values of $EFL = 5.49$ and $EPD = 2.59$, because $5.49 / 2.59 = 2.12$. This suggests that these numbers actually came from some calculation in Zemax or elsewhere and are not simply a typographical error.

135. I understand that during his deposition, Dr. Sasián testified that the values on page 108 of his declaration should actually be $EPD = 2.239$ and $f\text{-number} = 2.45$, based on a file that he found on a backup drive during a break in the deposition. (Ex. 2003, Sasián Depo. at 58:23–59:16.) It is difficult to

evaluate that testimony, as I understand that Apple has not made a copy of that backup file available to Corephotonics or to me to analyze.

136. It is similarly unclear how Dr. Sasián obtained a design with a convex image-side of the first lens. The blank box to the right of the radius of curvature for this image-side surface indicates that this value was fixed (and thus that that surface was fixed to be convex) during the run of Zemax that produced the screen capture:

Surf	Type	Comment	Radius	
OBJ	Standard		Infinity	
1	Even Asph..		1.606950699	
2	Even Asph..		-2.94377806	
STO	Standard		Infinity	
4	Even Asph..		-18.7883600	

(Ex. 1003, Sasián Decl. at 111; Ex. 2003, Sasián Depo. at 49:20–50:16.)

137. So, in this particular Zemax optimization, the output had a convex image-side of the first lens because that property had been fixed in place. Dr. Sasián testified that this value had “most likely” been produced by a Zemax optimizer in an earlier stage of his work. (Ex. 2003, Sasián Depo. at

49:20–50:1.) But he could not remember any of the details of how he had generated those values, answering a series of questions about this with “probably,” “perhaps,” “I don’t remember exactly the sequence,” “it appears,” “I don’t recall,” etc. (Ex. 2003, Sasián Depo. at 50:18–53:9.) Nothing in his declaration explains these details, either.

138. At most, the declaration shows that Dr. Sasián, a highly experienced lens designer with a copy of the ’897 patent claims in front of him, was able to create a lens system that completely replaced the first lens of Ogino Example 5 with a very different lens that satisfied claims 3, 8, 19, 24. In the process he ignored Ogino’s own teachings about the importance of the meniscus-shaped first lens to reduce the total length.

139. However, Dr. Sasián does not explain why *he* did it or how he did it in 2020, let alone why a *POSITA* would have been motivated to make these changes years earlier. For example, he does not cite to any example of a system with a bi-convex lens that would have motivated the POSITA to try this approach, and he doesn’t explain any benefits that flow from this change. Indeed, the only reason he gives for changing the radii of curvature of the first lens at all (let alone flipping one from a concave positive radius to a convex

negative radius) is a vague statement that he did it “due to the location of the aperture.” (Ex. 1003, Sasián Decl. at 108.)

140. Dr. Sasián’s declaration shows that a highly-skilled designer could have designed a lens that met claims 3, 8, 19, and 24 if given that specific task. He provides no explanation for why a POSITA would have made the specific changes he made the first lens of Example 5, or why that POSITA would have even started with Ogino’s f-number 3.94 lens if her goal were to have a lens with an f-number that matched Ogino’s other examples.

C. Ground 4 – Obviousness of Claims 16 and 30 over Chen in view of Iwasaki and Beich

141. A POSITA would not have been motivated to make the combination proposed by Dr. Sasián for ground 4, for many of the same reasons as I explained in my discussion of ground 2. The combination of Chen, Iwasaki, and Beich uses a first lens taken from Chen’s first example. (Ex. 1003, Sasián Decl., ¶ 74, p. 115; Ex. 1020, Chen, Figure 24.) However, Chen does not specify the diameter or the edge thickness of this lens.

142. Dr. Sasián suggests that a POSITA would choose a semi-diameter for this first lens (or at least for its object-side surface) of 1.2375 mm, barely 0.004 mm larger than the semi-diameter of the stop, 1.2333 mm. (Ex. 1003,

Sasián Decl. at 115.) He finds that this lens would have a center-to-edge thickness ratio of 2.92, just under the value of 3 required by claims 16 and 30.

143. This diameter is essentially the smallest that it could be without disrupting other characteristics of Chen that Dr. Sasián relies upon, such as its f-number. The entrance pupil diameter equals the width of the bunch of parallel blue rays entering the lens from the left, shown in Dr. Sasián's ray trace:

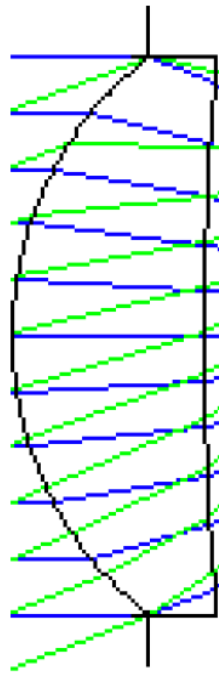

(Ex. 1003, Sasián Decl. at 112.)

144. As this shows, the bundle, and thus the entrance pupil, extends all the way across the left surface of the lens. Apple has not proposed making the

lens smaller, but if it had, the lens cannot be made smaller without reducing the entrance pupil diameter and increasing the f-number.

145. Likewise, Apple has not proposed making the lens larger. But, if it had, the largest that the lens semi-diameter could be without increasing the center-to-edge thickness ratio above 3 would be less than 1.249 mm, approximately 0.012 mm larger (less than 1% larger) than Dr. Sasián proposes. See Appendix Section XI.B.

146. As I explained above, the manufacturing tolerances of lens fabrication do not permit a design such as this. According to Dr. Sasián, a POSITA would have made this lens using injection molded plastic and would have been motivated to choose this lens diameter based on the Beich paper. The Beich paper also says that the tolerance for the diameter of the lens is “ ± 0.020 mm,” and that the displacement between the front surface of the lens and the back surface is “ < 0.020 mm.”

147. As noted above, the semi-diameter of the first lens is only 0.004 mm larger than the stop. If the lens is too small by 0.020 mm in diameter (0.010 mm in semi-diameter), this will make the semi-diameter of the first lens *smaller* than the semi-diameter of the stop by 6 μm . This is even without taking into account other sources of variation in the diameter of the stop and

the alignment of the components. A first lens smaller than the stop will mean that light will leak and scatter around the lens and cause a haze in the image that is highly undesirable. For this reason alone, a POSITA would make the first lens from Chen larger in diameter than Dr. Sasián proposes, something that Dr. Sasián does not consider.

148. But even if Dr. Sasián had proposed increasing the size of the lens to be as large as possible while keeping the thickness ratio under 3, the largest possible semidiameter (under 1.249 mm) would be less than 0.016 mm larger than the stop. A POSITA would recognize that this is unacceptable, given the multiple sources of manufacturing variation of the order of 0.010 mm in semidiameter and adding under the root sum square rule. (Ex. 2004, Sasián at 116–117.)

149. The lens is unacceptable even without taking into account the need to oversize “considerably beyond the clear apertures” (Ex. 1019, Handbook of Optics, Vol. 2 at 34.16.) or by around 4–10% (Ex. 2006, Symmons at 103), or the need for room for rounded corners, discussed in connection with ground 2.

150. Oversizing the 1.2374 mm semi-diameter surface by even 1% (far less than is required in practice) would make it 1.2499 mm in semi-diameter and

would make the center-to-edge thickness ratio greater than 3. See Appendix Section XI.B.

151. For these reasons, a POSITA would recognize that the combination of Chen, Iwasaki, and Beich proposed by Dr. Sasián would not be a practical lens, based on the very manufacturing rules of thumb in Beich, among other reasons. Even if a POSITA was motivated to make a lens with center-to-edge thickness ratio less than 3, that POSITA would not have been motivated to make the Chen Example 1 lens with that ratio, as proposed by Dr. Sasián.

X. DECLARATION

152. I declare that all statements made herein of my own knowledge are true, that all statements made on information and belief are believed to be true, and that these statements were made with knowledge that willful false statements so made are punishable by fine or imprisonment, or both, under section 1001 of Title 18 of the United States Code.

Executed on February 12, 2021



Tom D. Milster, Ph.D.

XI. APPENDIX

153. This appendix describes analysis that I performed of certain of Dr. Sas-
 ián’s modified lens designs using version Zemax OpticStudio 19.4 SP2 Ver-
 sion July 31, 2019 and other software tools.

A. Ogino Example 5 modified for f-number 2.8

154. In order to determine the edge thickness of the first lens element in this
 modification to Ogino, I entered the lens prescription from Dr. Sasián’s Ap-
 pendix into Zemax:

	Surface Type	Comment	Radius	Thickness	Material	Clear Semi-Dia	Mech Semi-Dia	Conic
0	OBJECT Standard ▾		Infinity	Infinity		Infinity	Infinity	0.0000000000
1	Even Asphere ▾		1.12444000...	0.60000000...	1.54,54.9 M	1.01749572...	1.01749572...	-0.0232105800
2	Even Asphere ▾		252.975340...	0.03000000...		0.98943052...	1.01749572...	9.0000000000E-06
3	STOP Standard ▾		Infinity	0.06900000...		0.97614059...	0.97614059...	0.0000000000
4	Even Asphere ▾		-18.788360...	0.22700000...	1.63,23.6 M	0.90041398...	0.90041398...	8.8073731000
5	(aper) Even Asphere ▾		2.25616000...	0.24300000...		0.70000000... U	0.90041398...	2.1182039000
6	Even Asphere ▾		506.455810...	0.25300000...	1.63,23.6 M	0.72452476...	0.75453459...	-0.3811837300
7	Even Asphere ▾		4.36560000...	0.50600000...		0.75453459...	0.75453459...	-2.1000000000E-...
8	(aper) Even Asphere ▾		-99.837150...	0.50600000...	1.63,23.6 M	0.90000000... U	0.90000000...	-0.6774189600
9	(aper) Even Asphere ▾		-1.7070200...	0.10000000...		0.90000000... U	0.90000000...	-3.6292010000
10	(aper) Even Asphere ▾		-2.1746400...	0.25300000...	1.54,54.9 M	0.87000000... U	1.20000000...	-15.0000200000
11	(aper) Even Asphere ▾		3.61429000...	0.50000000...		1.20000000... U	1.20000000...	-0.8699941400
12	(aper) Standard ▾		Infinity	0.30000000...	1.52,64.1 M	2.00000000... U	2.00000000...	0.0000000000
13	(aper) Standard ▾		Infinity	1.46449601... M		2.00000000... U	2.00000000...	0.0000000000
14	IMAGE Standard ▾		Infinity	-		2.25000000... U	2.25000000...	0.0000000000

4th Order Term	6th Order Term
-0.0103234500	-0.0389033400
0.0153195140	4.9453000000E-03
0.3921074730	-0.2861707000
0.5855676230	0.1128867410
-0.0534166900	0.4441811130
-0.1591027500	0.3418778920
-0.0317227500	-0.0497843000
0.2786585180	-0.3763254800
0.0625068120	-0.3023847100
-0.2030606000	0.0542779040

155. I obtained a ray trace consistent with Dr. Sasián's:

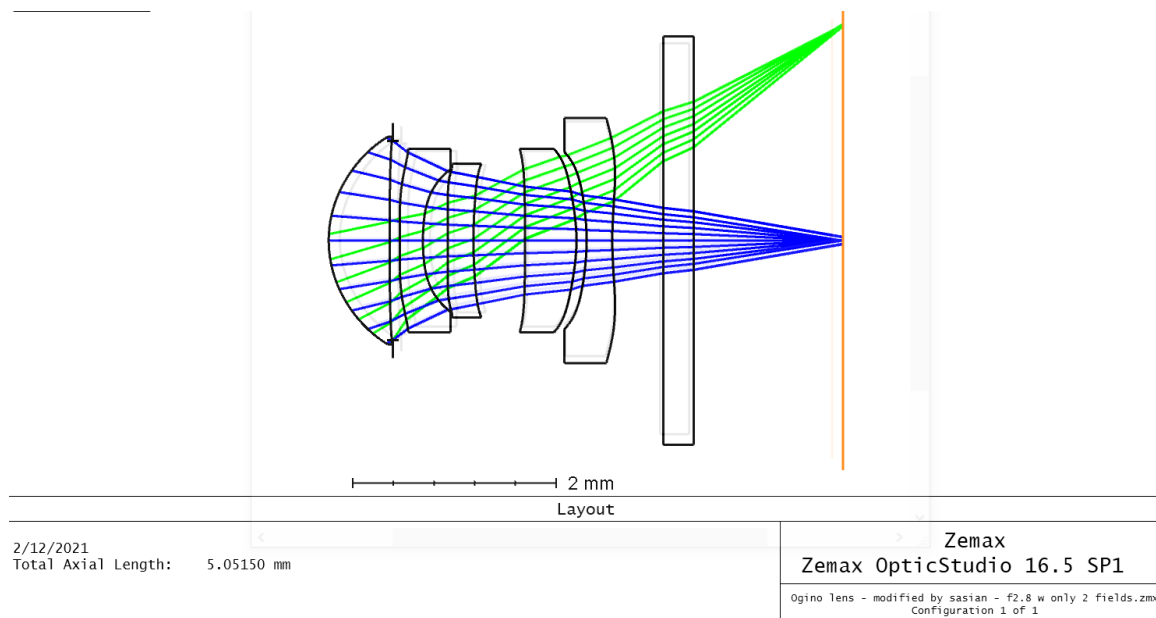

156. Using the same features of Zemax as Dr. Sasián used to determine the edge thickness of a different lens (Ex. 1003, Sasián Decl. at 116), I calculated the edge thickness of this first lens element (surface 1 in this table) to be 0.0394 mm:

EDGE THICKNESS DATA:

Surf	Edge
1	0.039375
2	0.008743
ST0	0.152534
4	0.415597
5	0.013072
6	0.288015
7	0.377455
8	0.335243
9	0.102475
10	0.413544
11	0.559065
12	0.300000
13	1.464496
IMA	0.000000

157. I also calculated the slope of the object-side surface of the first lens at the near the edge of the lens (radius 1.017 mm from optical axis) using the Matlab software. As shown in the following screen capture, I calculated the slope to be 58.86 degrees:

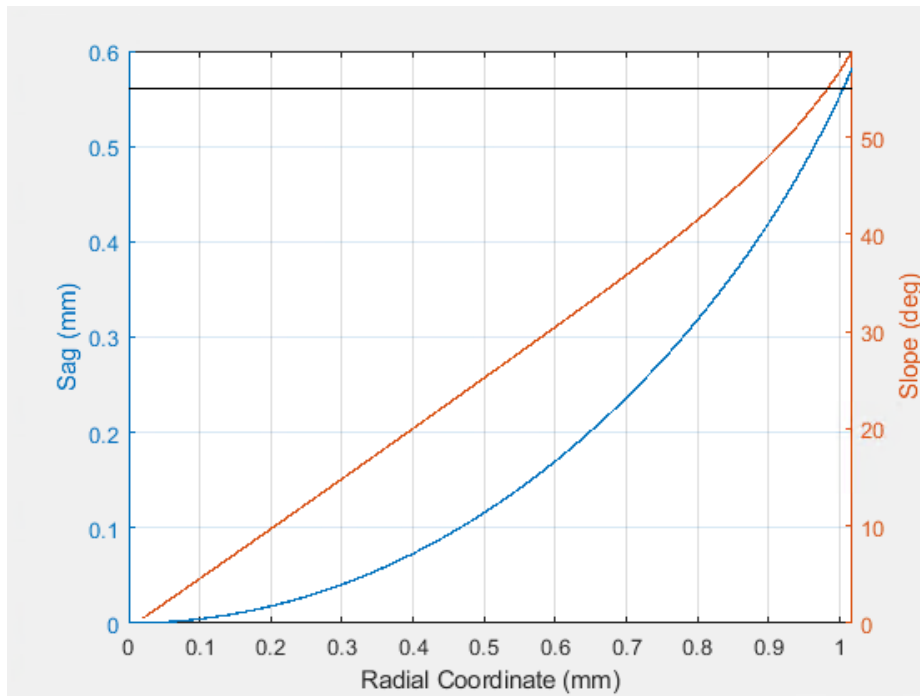

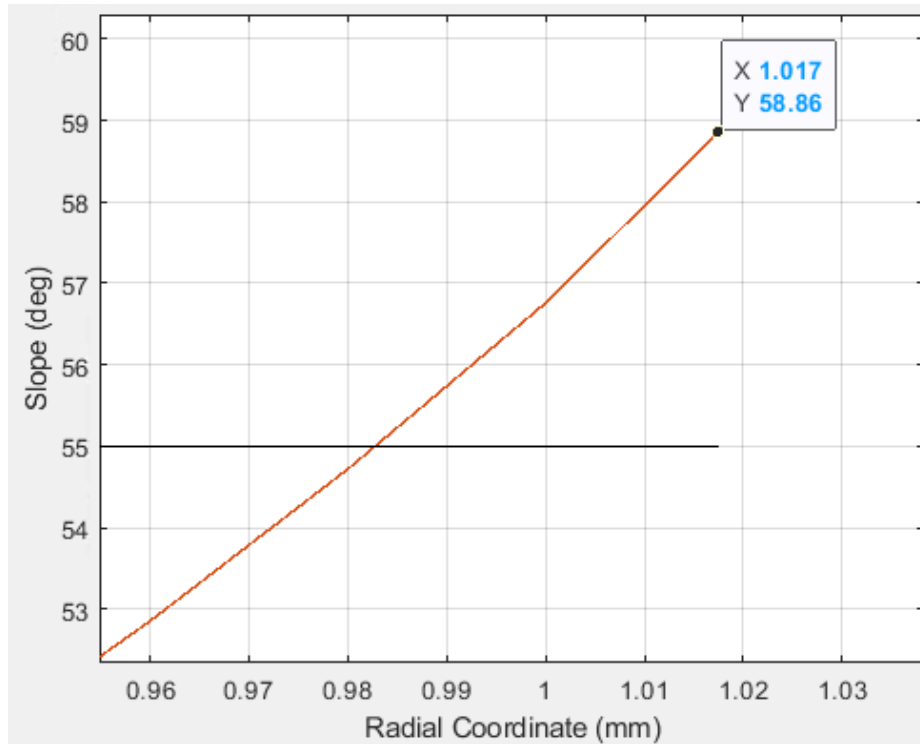

B. Modified Chen Example 1

158. I also determined how much the semi-diameter of the first lens of Chen could be increased (oversized) before the center-to-edge thickness ratio exceeded 3.

159. I entered the lens prescription from Dr. Sasián's Appendix into Zemax:

	Surface Type	Comment	Radius	Thickness	Material	Coating	Clear Semi-Dia	Mech Semi-Dia	Conic
0	OBJECT	Standard ▾	Infinity	Infinity			Infinity	Infinity	0.0000000000
1		Standard ▾	Infinity	0.60200000...			1.47270807...	1.47270807...	0.0000000000
2	STOP	Standard ▾	Infinity	-0.60200000...			1.23332572...	1.23332572...	0.0000000000
3		Even Asphere ▾	1.56500000...	0.85500000...	1.54,56.0 M		1.23752254...	1.23752254...	0.0000000000
4		Even Asphere ▾	34.4640000...	0.08800000...			1.16228726...	1.23752254...	0.0000000000
5		Even Asphere ▾	6.07900000...	0.26400000...	1.64,22.4 M		1.11069106...	1.11069106...	0.0000000000
6		Even Asphere ▾	1.95500000...	0.70400000...			0.97129262...	1.11069106...	0.0000000000
7		Even Asphere ▾	-3.4120000...	0.24900000...	1.54,56.0 M		1.13204884...	1.15059251...	0.0000000000
8		Even Asphere ▾	-3.3300000...	1.59800000...			1.15059251...	1.15059251...	0.0000000000
9		Even Asphere ▾	-4.2830000...	0.31000000...	1.54,56.0 M		1.77040329...	1.96812158...	0.0000000000
10		Even Asphere ▾	16.3270000...	0.06400000...			1.96812158...	1.96812158...	0.0000000000
11		Even Asphere ▾	-61.049000...	0.61900000...	1.64,22.4 M		1.99558556...	2.14712815...	0.0000000000
12		Even Asphere ▾	-8.6800000...	0.05000000...			2.14712815...	2.14712815...	0.0000000000
13		Standard ▾	Infinity	0.14500000...	1.52,64.2 M		2.29436157...	2.31988725...	0.0000000000
14		Standard ▾	Infinity	1.03892862... M			2.31988725...	2.31988725...	0.0000000000
15	IMAGE	Standard ▾	Infinity	-			2.62171118...	2.62171118...	0.0000000000

160. I obtained a ray trace consistent with Dr. Sasián's:

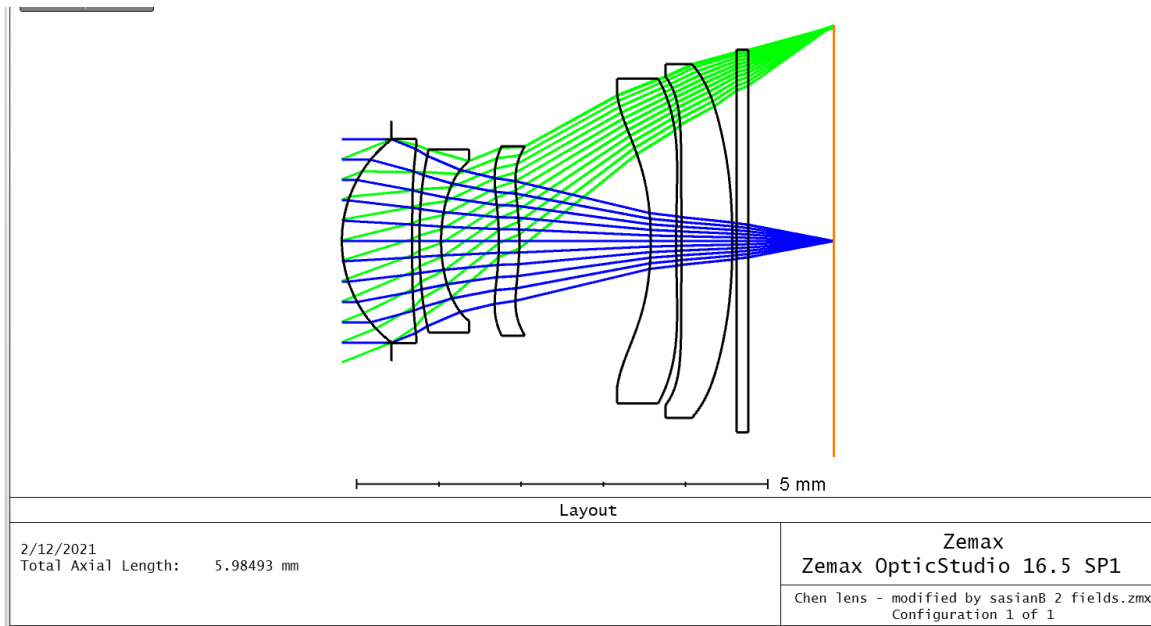

161. I then modified the semi-diameter of the object-side surface of the first lens to be greater than Dr. Sasián's value of 1.2375 mm. I found that increasing the semi-diameter to be 1.249 mm or greater resulted in an edge thickness

of less than 0.285 mm and in a center-to-edge thickness ratio of less than $0.855 \text{ mm} / 0.285 \text{ mm} = 3$.

162. This can be seen in the following ray trace and tables, which show the semi-diameters of the surfaces of the first lens (surfaces 3 and 4) increased to 1.249 mm. The edge thickness is 0.284927 mm (surface 3), i.e., less than 0.285 mm. As the surfaces of this lens grow closer as you go away from the optical axis, increasing the semi-diameter beyond 1.249 mm will further reduce the edge thickness and increase the center-to-edge thickness ratio.

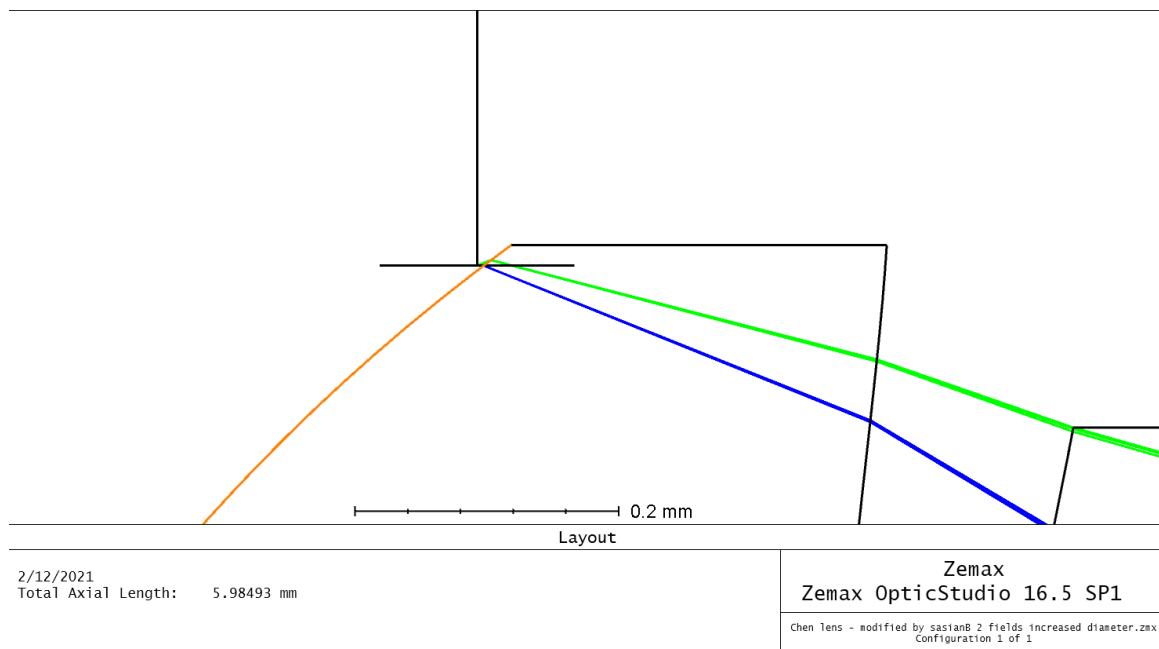

	Surface Type	Material	Coating	Clear Semi-Dia	Mech Semi-Dia	Conic
0	OBJECT Standard ▾			Infinity	Infinity	0.0000000000
1	Standard ▾			1.47270807...	1.47270807...	0.0000000000
2	STOP Standard ▾			1.23332572...	1.23332572...	0.0000000000
3	(aper) Even Asphere ▾	1.54,56.0 M		1.24900000... U	1.24900000...	0.0000000000
4	(aper) Even Asphere ▾			1.24900000... U	1.24900000...	0.0000000000
5	Even Asphere ▾	1.64,22.4 M		1.11069106...	1.11069106...	0.0000000000
6	Even Asphere ▾			0.97129262...	1.11069106...	0.0000000000
7	Even Asphere ▾	1.54,56.0 M		1.13204884...	1.15059251...	0.0000000000
8	Even Asphere ▾			1.15059251...	1.15059251...	0.0000000000
9	Even Asphere ▾	1.54,56.0 M		1.77040329...	1.96812158...	0.0000000000
10	Even Asphere ▾			1.96812158...	1.96812158...	0.0000000000
11	Even Asphere ▾	1.64,22.4 M		1.99558556...	2.14712815...	0.0000000000
12	Even Asphere ▾			2.14712815...	2.14712815...	0.0000000000
13	Standard ▾	1.52,64.2 M		2.29436157...	2.31988725...	0.0000000000
14	Standard ▾			2.31988725...	2.31988725...	0.0000000000
15	IMAGE Standard ▾			2.62171118...	2.62171118...	0.0000000000

EDGE THICKNESS DATA:

Surf	Edge
1	0.602000
STO	0.026069
3	0.284927
4	0.141605
5	0.493827
6	0.388063
7	0.290968
8	1.122661
9	0.498403
10	0.088429
11	0.323001
12	0.541046
13	0.145000
14	1.038929
IMA	0.000000