



US006157705A

United States Patent [19]

[11] Patent Number: **6,157,705**

Perrone

[45] Date of Patent: **Dec. 5, 2000**

[54] **VOICE CONTROL OF A SERVER**

[57] **ABSTRACT**

[75] Inventor: **Jeffrey Perrone**, San Francisco, Calif.
 [73] Assignee: **E*Trade Group, Inc.**, Palo Alto, Calif.
 [21] Appl. No.: **08/985,565**
 [22] Filed: **Dec. 5, 1997**
 [51] **Int. Cl.⁷** **H04M 1/64**
 [52] **U.S. Cl.** **379/88.01; 704/2.84**
 [58] **Field of Search** 379/88.01, 88.02,
 379/88.04, 88.17, 88.13; 705/36, 37, 39,
 44

A method for controlling a server using voice is disclosed. In one embodiment, a client such as a Web browser is coupled over a data communication channel to a server. A telephone at the client side is connected to an interactive voice response (IVR) system that has a speech recognizer at the server side, over a separate, parallel voice communication channel. The IVR system has a control connection to the server. A table of associations between resource identifiers and network addresses is stored in association with the IVR system. A user at the client side establishes a data connection between the client and the server, and a voice connection between the telephone and the IVR system. Control software on the IVR system synchronizes an IVR session to a server session. The control software receives a spoken utterance over the voice communication channel, interprets the utterance to recognize a resource identifier in the utterance, and associates the resource identifier with a network address of a server resource. The IVR system commands the server to deliver the server resource identified by that network address to the client. Thus, the server delivers server resources in response to voice commands at the client side. In an alternate embodiment, the voice communication channel is integrated with the data communication channel. The invention also encompasses an apparatus, computer system, computer program product, and computer data signal configured to carry out the foregoing steps.

[56] **References Cited**

U.S. PATENT DOCUMENTS

5,799,063	8/1998	Krane	379/88.17
5,802,526	9/1998	Fawcett et al.	379/88.17
5,884,262	3/1999	Wise et al.	379/88.01
5,915,001	6/1999	Uppaluru	379/88.17

Primary Examiner—Scott L. Weaver
Attorney, Agent, or Firm—Hickman Palermo Truong & Becker LLP; Christopher J. Palermo; Edward A. Becker

27 Claims, 12 Drawing Sheets

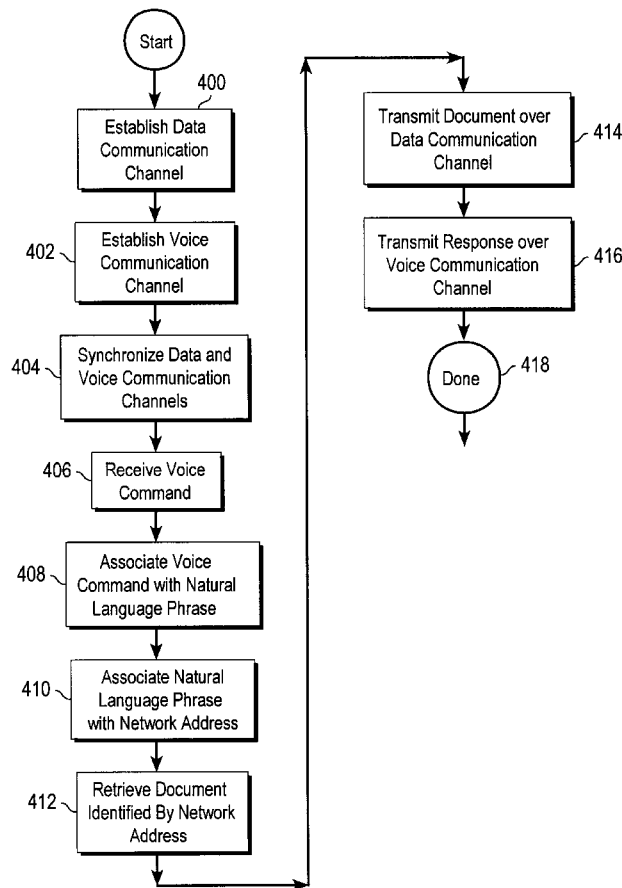

Parus Exhibit 2010

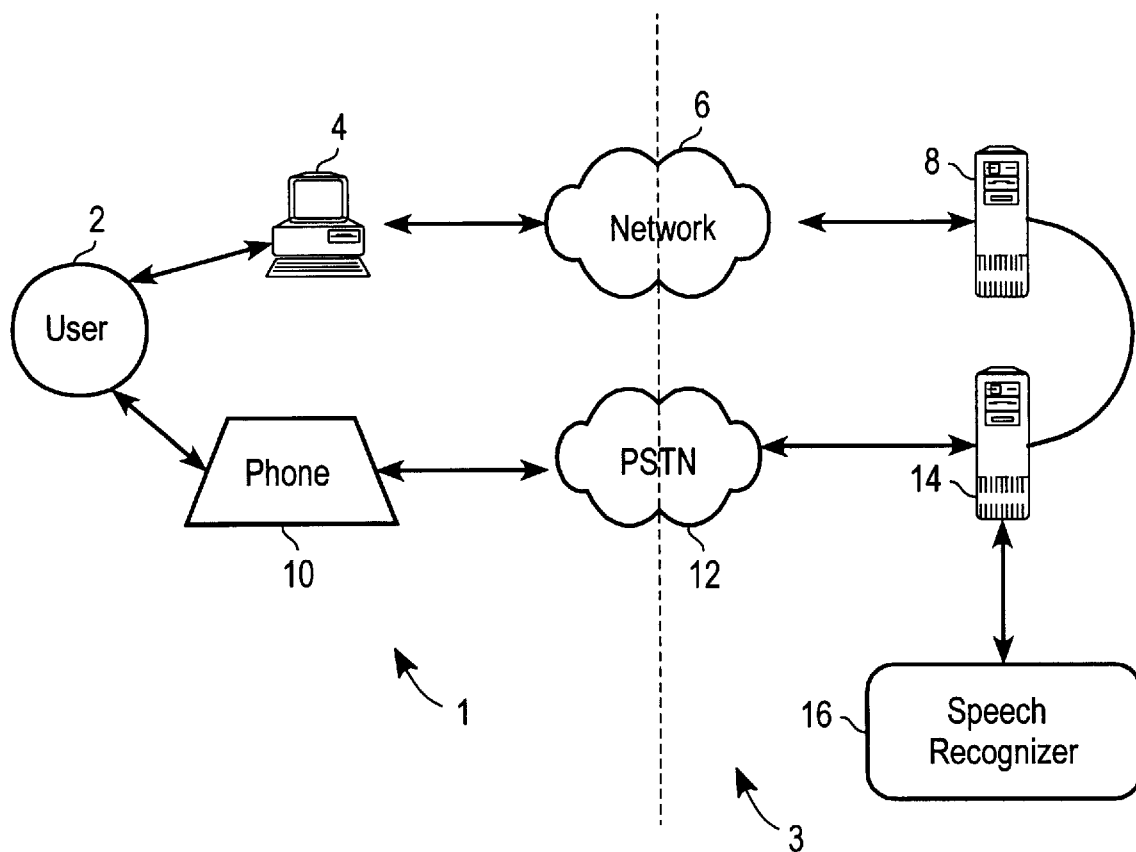

Fig. 1A

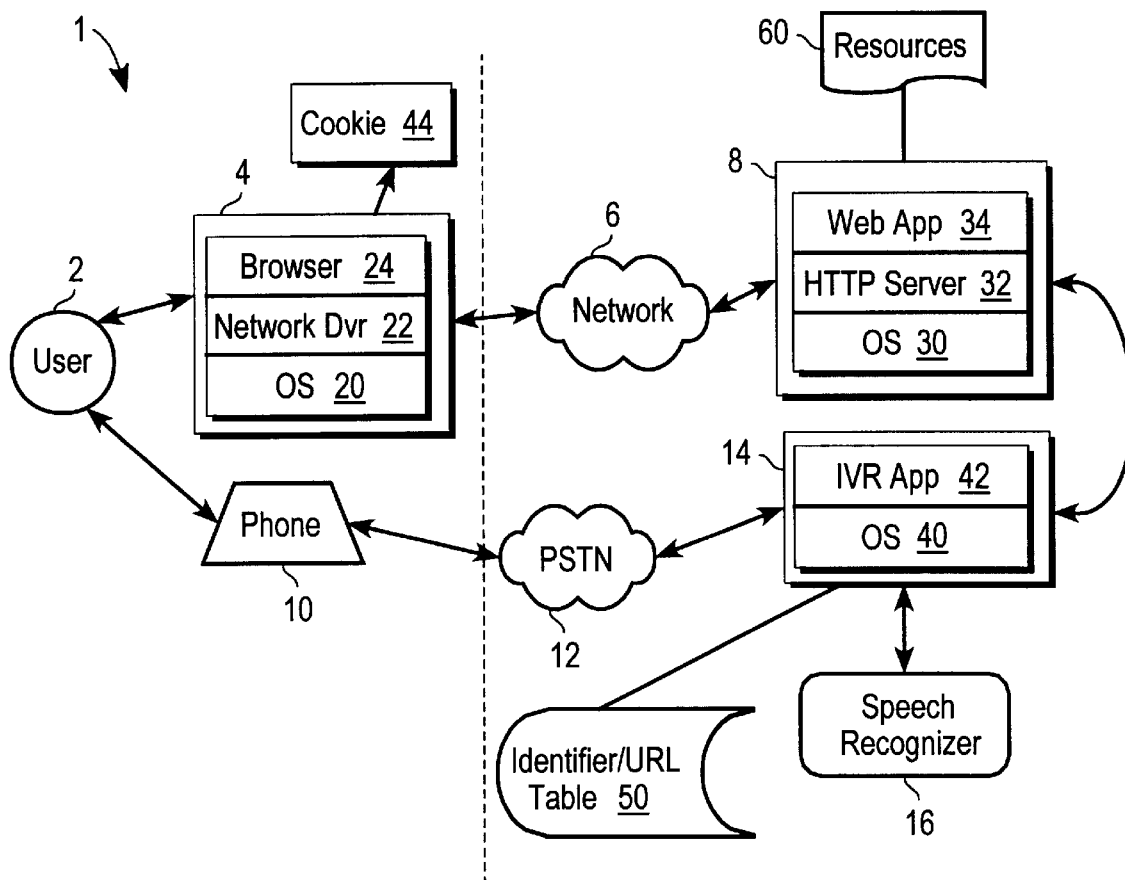

Fig. 1B

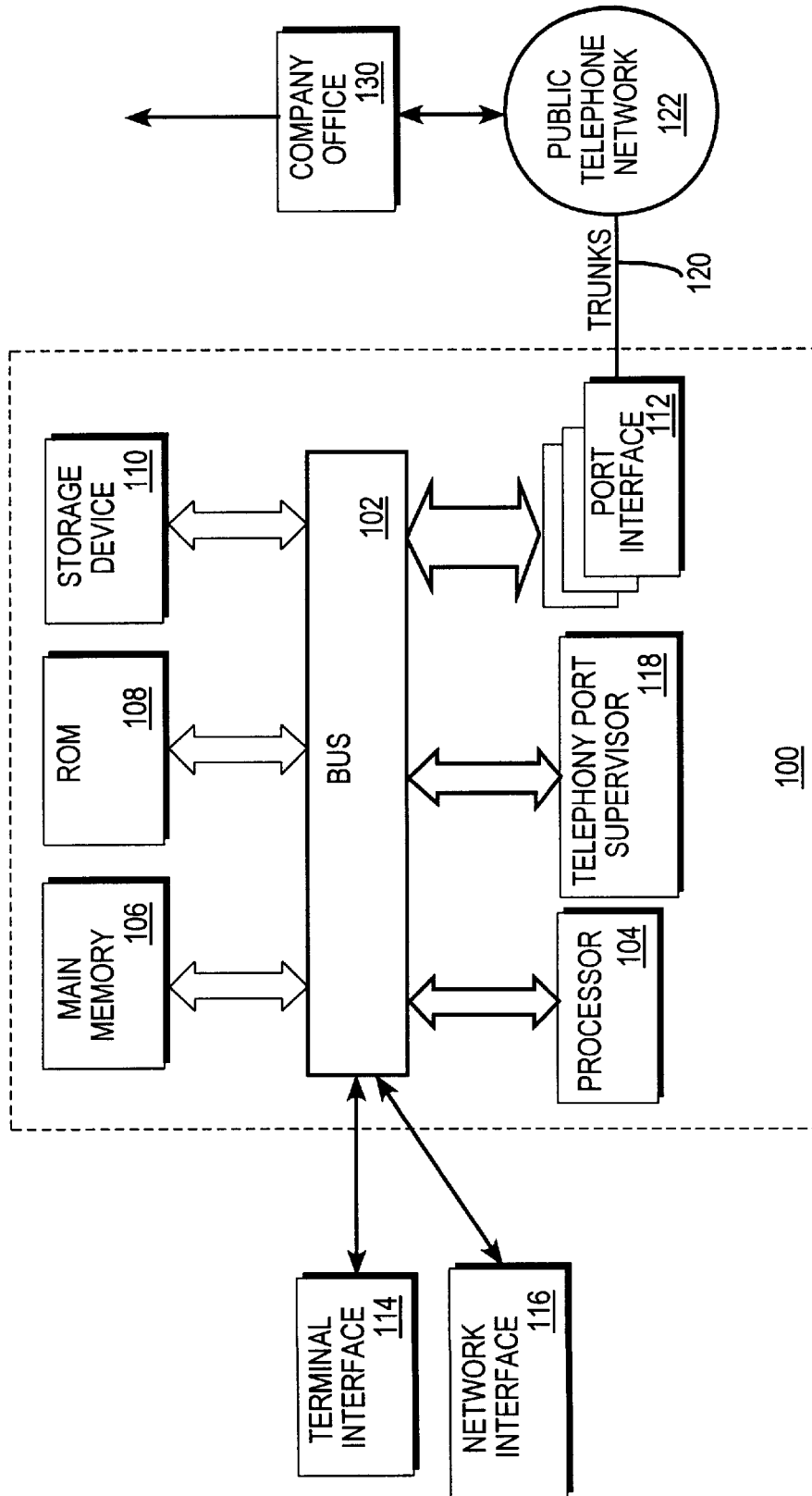

Fig. 16

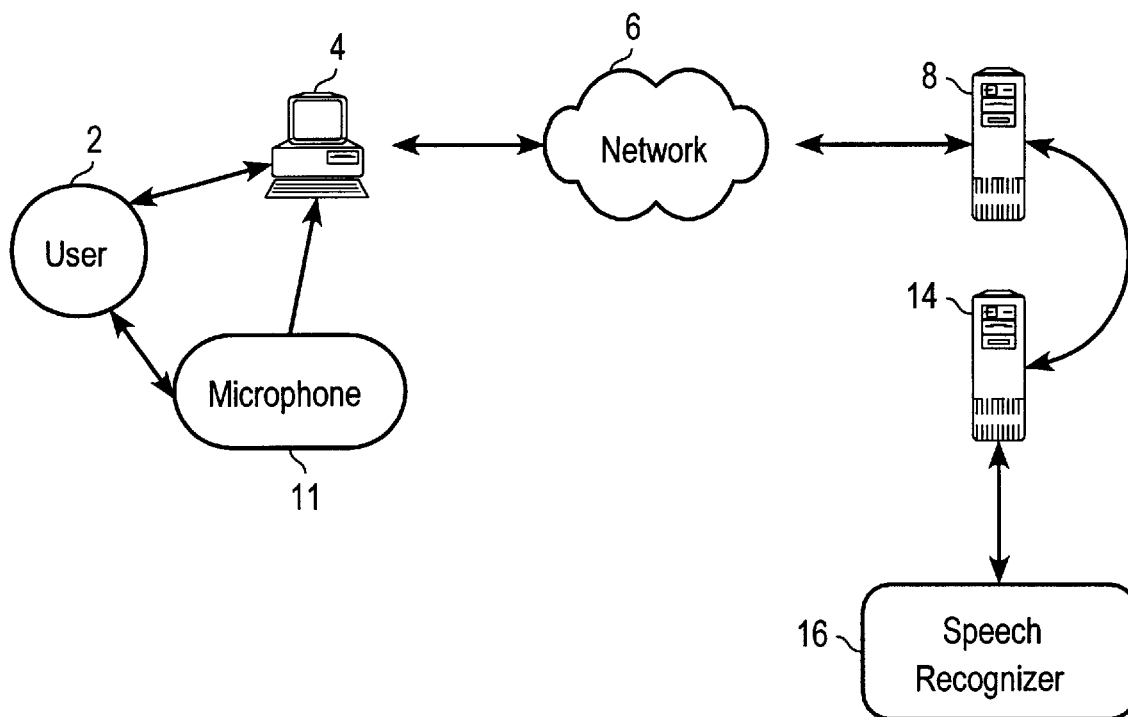

Fig. 2A

Explore Litigation Insights

Docket Alarm provides insights to develop a more informed litigation strategy and the peace of mind of knowing you're on top of things.

Real-Time Litigation Alerts



Keep your litigation team up-to-date with **real-time alerts** and advanced team management tools built for the enterprise, all while greatly reducing PACER spend.

Our comprehensive service means we can handle Federal, State, and Administrative courts across the country.

Advanced Docket Research



With over 230 million records, Docket Alarm's cloud-native docket research platform finds what other services can't. Coverage includes Federal, State, plus PTAB, TTAB, ITC and NLRB decisions, all in one place.

Identify arguments that have been successful in the past with full text, pinpoint searching. Link to case law cited within any court document via Fastcase.

Analytics At Your Fingertips



Learn what happened the last time a particular judge, opposing counsel or company faced cases similar to yours.

Advanced out-of-the-box PTAB and TTAB analytics are always at your fingertips.

API

Docket Alarm offers a powerful API (application programming interface) to developers that want to integrate case filings into their apps.

LAW FIRMS

Build custom dashboards for your attorneys and clients with live data direct from the court.

Automate many repetitive legal tasks like conflict checks, document management, and marketing.

FINANCIAL INSTITUTIONS

Litigation and bankruptcy checks for companies and debtors.

E-DISCOVERY AND LEGAL VENDORS

Sync your system to PACER to automate legal marketing.