

INTERNATIONAL SEARCH REPORT

International Application No. PCT/US91/03469

| | | |
|---------------------------------------------------------------------------------------------------------------------------------------------------------------------------------------------------------------------------------------------------------------------------------------------------------------------------------------------------------------------------------------------------------------------------------------------------------------------------------------------------------------------------------------------------------------------------------------------------------------------------------------------------------------------------------------------------------------------------------------------------------------------------------------------------------------------------------------------------------------------------------------------------------------------------------------------------------------------------------------------------------------------------------------------------------------------------------------------------------------------------------------------------------------------------------------------------------------------------------------------------------------------------------------------------------------------|------------------------------------------------------------------------------------------------------------------------------------------------------------------------------|--------------------------|
| I. CLASSIFICATION OF SUBJECT MATTER (If several classification symbols apply, indicate all) * | | |
| According to International Patent Classification (IPC) or to both National Classification and IPC | | |
| US 379/67 IPC(5) H04M 3/50 | | |
| II. FIELDS SEARCHED | | |
| Minimum Documentation Searched ? | | |
| Classification System | Classification Symbols | |
| U.S. | 379/67, 84, 88, 89, 97, 201, 204, 205, 207, 210, 211, 212, 213, 214 | |
| Documentation Searched other than Minimum Documentation to the Extent that such Documents are Included in the Fields Searched * | | |
| III. DOCUMENTS CONSIDERED TO BE RELEVANT * | | |
| Category * | Citation of Document, ** with indication, where appropriate, of the relevant passages ** | Relevant to Claim No. ** |
| X, P | US, a, ,4959,855 (DAUDELIN) 25 SEPTEMBER 1990 See column 2 lines 60-68, column 3 lines 1-19, column 4 lines 22-65, column 5 lines 38-47, column 8 lines 54-57 | 1-7 |
| <p>* Special categories of cited documents: **</p> <p>"A" document defining the general state of the art which is not considered to be of particular relevance</p> <p>"E" earlier document but published on or after the international filing date</p> <p>"L" document which may throw doubts on priority claim(s) or which is cited to establish the publication date of another citation or other special reason (as specified)</p> <p>"O" document referring to an oral disclosure, use, exhibition or other means</p> <p>"P" document published prior to the international filing date but later than the priority date claimed</p> <p>"T" later document published after the international filing date or priority date and not in conflict with the application but cited to understand the principle or theory underlying the invention</p> <p>"X" document of particular relevance; the claimed invention cannot be considered novel or cannot be considered to involve an inventive step</p> <p>"Y" document of particular relevance; the claimed invention cannot be considered to involve an inventive step when the document is combined with one or more other such documents, such combination being obvious to a person skilled in the art.</p> <p>"A" document member of the same patent family</p> | | |
| IV. CERTIFICATION | | |
| Date of the Actual Completion of the International Search | Date of Mailing of this International Search Report | |
| 26 JUNE 1991 | 01 AUG 1991 | |
| International Searching Authority | Signature of Authorized Officer | |
| ISA/US |  HUYEN D. LE | |

Form PCT/ISA/210 (second sheet) (Rev. 11-87)



INTERNATIONAL APPLICATION PUBLISHED UNDER THE PATENT COOPERATION TREATY (PCT)

| | | |
|--------------------------------------------------------------------------------------------------------------------------------------------------------------------------------------------------------------------------------------------------------------------------------------------------------------------------------------------------------------------------------------------------------------------------------------------------------------------------------------------------------------------------------------------------------------------------------------------------------------------------|------------------------------------------------------------------------------------------------------------------------------------------------------------------------------------------------------------------------------------------------------------------------------------------------------------------------------------------------------------------------------------------------------------------------------------------------------------------------------------------------------------------------------------------------------------------------------------------------------------------------------------------------------------------------------------------|----------------------------------------------------------------------------------------------------------------------------------|
| <p>(51) International Patent Classification⁵ : H04M 11/00, 1/64, 1/56, 1/66, 3/42</p> | A1 | <p>(11) International Publication Number: WO 91/07838 (43) International Publication Date: 30 May 1991 (30.05.91)</p> |
| <p>(21) International Application Number: PCT/US90/06729 (22) International Filing Date: 16 November 1990 (16.11.90)</p> <p>(30) Priority data: 439,601 21 November 1989 (21.11.89) US 480,242 15 February 1990 (15.02.90) US</p> <p>(71) Applicant: FULLER RESEARCH AND DEVELOPMENT COMPANY [US/US]; 325-118th Avenue S.E., Suite 300, Bellevue, WA 98005 (US).</p> <p>(72) Inventors: FULLER, Robert, M. ; 2225 179th Avenue N.E., Redmond, WA 98052 (US). EPLER, Frederick, A. ; 16125 255th S.E., Issaquah, WA 98027 (US). MANOWSKI, Maxwell, E. ; 1204 LaFromboise Street, Enumclaw, WA 98022 (US).</p> | <p>(74) Agents: BERG, Richard, P. et al.; Ladas & Parry, 3600 Wilshire Boulevard, Suite 1520, Los Angeles, CA 90010 (US).</p> <p>(81) Designated States: AT (European patent), AU, BE (European patent), CA, CH (European patent), DE (European patent), DK (European patent), ES (European patent), FR (European patent), GB (European patent), GR (European patent), IT (European patent), JP, KR, LU (European patent), NL (European patent), SE (European patent).</p> <p>Published <i>With international search report. Before the expiration of the time limit for amending the claims and to be republished in the event of the receipt of amendments.</i></p> | |

(54) Title: REMOTE ACCESS TELEPHONE CONTROL SYSTEM

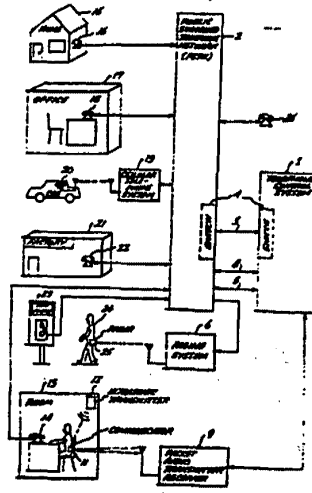

(57) Abstract

A telephone control system (1) which enhances the accessibility of system subscribers by providing a variety of call-handling modes, and various ways of programming by which those subscribers can tailor the system. In operation, subscribers are each assigned a telephone number (ACCESS NUMBER) which can be dialed from any location via the Public Switched Telephone Network (PSTN) (2). The control system determines which subscriber a call is intended for, and by referring to a data base determines the method of call handling which has been preselected by that subscriber (e.g. switching a call to another telephone number). The switching function (4) may be located in the control system itself, or located in the PSTN but under the control of the control system. Hence, the ACCESS NUMBER may be used as the sole telephone number for a subscriber. Callers need not know the subscribers specific whereabouts nor the subscriber's various location-specific telephone numbers such as home, office, car phone, and so forth.

FOR THE PURPOSES OF INFORMATION ONLY

Codes used to identify States party to the PCT on the front pages of pamphlets publishing international applications under the PCT.

| | | | | | |
|----|--------------------------|----|---------------------------------------|----|--------------------------|
| AT | Austria | FI | Finland | ML | Mali |
| AU | Australia | FR | France | MN | Mongolia |
| BB | Barbados | GA | Gabon | MR | Mauritania |
| BE | Belgium | GB | United Kingdom | MW | Malawi |
| BF | Burkina Faso | GN | Guinea | NL | Netherlands |
| BG | Bulgaria | GR | Greece | NO | Norway |
| BJ | Benin | HU | Hungary | PL | Poland |
| BR | Brazil | IT | Italy | RO | Romania |
| CA | Canada | JP | Japan | SD | Sudan |
| CF | Central African Republic | KP | Democratic People's Republic of Korea | SE | Sweden |
| CG | Congo | KR | Republic of Korea | SN | Senegal |
| CH | Switzerland | LI | Liechtenstein | SU | Soviet Union |
| CI | Côte d'Ivoire | LK | Sri Lanka | TD | Chad |
| CM | Cameroon | LU | Luxembourg | TG | Togo |
| DE | Germany | MC | Monaco | US | United States of America |
| DK | Denmark | MG | Madagascar | | |
| ES | Spain | | | | |

REMOTE ACCESS TELEPHONE CONTROL SYSTEM**TECHNICAL FIELD**

5 The present invention pertains to the telephone equipment art and, more particularly, to a telephone control system which allows subscribers to remotely control a plurality of call handling utilities to predeterminedly direct incoming calls.

INCORPORATION BY REFERENCE

10 The subject matter disclosed and claimed in U.S. Application Patent No. 4,893,335, issued January 9, 1990, entitled "Remote Access Telephone Control System", invented by the same inventors and assigned to the applicant of the instant application, is hereby incorporated by reference.

BACKGROUND OF THE INVENTION

15 Despite the availability of numerous telephone central exchange provided functions, such as "call-forwarding", "three-way calling", "call-waiting" and "speed-dialing", as well as the advent and availability of paging and mobile telephone systems, the completion of a call to a system subscriber can often be a complicated, time consuming and tedious task. Unless the telephone subscriber is located at the
20 telephone which receives calls to his assigned phone number, completion of a call from a calling party, despite the aforementioned services, generally involves the calling party leaving a message and awaiting a call back by the subscriber. Even if the subscriber is accessible via mobile telephone or a paging system, human intervention is commonly required to look up and dial specific mobile telephone or
25 paging numbers to attempt to contact the subscriber. Thus, additional delays and costs are incurred.

In addition, even if the subscriber is on a paging system, the successful direction of a message to the subscriber requires that the subscriber manually inform the system of his whereabouts.

30 Finally, existing telephone control systems offer very limited control to either the subscriber or the calling party with respect to the processing of calls.

SUMMARY OF THE INVENTION

In summary, the present invention is directed to a control system which is connected to a telephone exchange and wherein each user of the system is assigned a unique telephone number with the control system routing calls to the user via a user controlled number. The control system comprises an input/output device which is adapted for connection to the telephone exchange trunks or lines to input and output telephone calls. A switching control means controllably connects a call on one line to a different line. Provided memory controllably stores and recalls electronic signals. An electronic processing means is provided for accessing the memory, switching control means and input/output device to direct the flow of input and output calls. The electronic processing means includes means for: a) identifying a call to the system from a caller directed to a specific user, b) recalling from the memory a forwarding number for the user, c) implementing a call to the forwarding number, d) switching the caller's call to the forwarding number, e) identifying a call to the system from a specific user, f) changing the specific user's memory stored forwarding number responsive to a command from the specific user, g) processing calls to the system directed to a specific user in a selected one of a plurality of modes and, h) changing a users call processing mode responsive to a command from the user.

In accordance with one feature of the invention, the control system may forward incoming calls for a subscriber to a telephone number that has been preselected by the subscriber. The call may be directly forwarded, or may be preceded by a brief announcement informing the caller that the call is being forwarded.

In accordance with another feature of the invention, the control system may first screen incoming calls before causing them to be forwarded. The call may be screened by any of several methods, including a 'priority-screen' which allows the caller to determine whether or not the call should be forwarded to the subscriber, a 'VIP code-screen' which will only forward calls if the caller enters a preselected code, and a 'voice-screen' which records the caller's name and business, places the

caller on hold while contacting the subscriber, plays the recorded message, and allows the subscriber to determine if he wishes to be connected to the caller. With any of these screening methods, should the call not ultimately be forwarded to the subscriber, then the call may be delivered to a 'message center', where a message may be left for later pickup by the subscriber.

5 In accordance with another feature of the invention, the control system may cause the subscriber's pager to be activated in conjunction with forwarding of a call. In this way, the subscriber is given notice that the call is being forwarded to the pre-selected telephone number.

10 In accordance with another feature of the invention, the control system may, prior to forwarding a call, provide a courtesy message to the caller such as "...when the call is answered, please ask for your party by name..", or alternately inform the caller "...when the call is answered, please ask for extension number 1234."

15 In accordance with another feature of the invention, the control system may send all calls to a 'message center' where all messages may be left for later pickup by the subscriber. In this way the call is handled without disturbing the subscriber.

20 In accordance with another feature of the invention, the control system may handle calls via a 'branch-routing' mode. In this mode, callers may choose from a directory of options. As an example, the caller may be told: "You have reached ABC Real Estate. Please touch 1 to speak to Mr. Smith, 2 to speak to Mr. Jones, or hold the line to speak to the receptionist." Depending on the programming of the system, each of these selections may cause the call to be forwarded to a specific telephone number, or to another access number. No command may cause the system to follow a predetermined default method for disposing of the call.

25 In accordance with another feature of the invention, the control system may handle calls via a 'meet-me' mode. In this mode, the caller is placed on hold after being told that the user is being paged to a phone. The control system then pages the user. The user then may call the access system, and enter a code to be connected to the caller. In addition, the caller may be given the opportunity to touch 9 to leave a message if he does not wish to wait. If the caller chooses to leave a message, then

30

when the subscriber calls in, he will be informed that the caller did not wait and instead left a message. If the caller hangs up without leaving a message, then the subscriber will be so informed.

5 In accordance with another feature of the invention, the call-handling modes and other features of the control system may be programmed by the subscriber by accessing a command mode by dialing the access number from a touch-tone phone, entering a Personal Identification Number (PIN) code, and then following a series of menu items to select the desired feature, call-handling mode, or forwarding number. This process is further simplified by providing the subscriber with 'mode memories' 10 which contain the most often used call handling modes, and 'number memories' which contain often used telephone numbers such as home phone, office phone, car phone, and so on.

15 In accordance with another feature of the invention, the subscriber may invoke a 'feature timer' which will cause a new call handling mode to take effect at the expiration of a selected time interval.

In accordance with another feature of the invention, the subscriber may invoke a 'weekly schedule' which will cause the current call-handling mode to be automatically selected from a pre-programmed list of call-handling modes, based upon the time-of-day and day-of-week.

20 In accordance with another feature of the invention, the subscriber may cause his calls to be forwarded to him at his current location, without the subscriber needing to enter the telephone number of the current location. Instead, the telephone number of the location is automatically received by the control system as an Automatic Number Identification (ANI) via ANI-capable facilities from the Public 25 Switched Telephone Network (PSTN). The subscriber need only call the control system, enter his PIN code, and select a forwarding mode.

30 In accordance with another feature of the invention, the subscriber may program the operation of the control system by picking up a preregistered phone such as his office or home telephone and touching a 2 or 3 digit speed-dial code. In combination with the ANI capability described above this makes programming very

simple. By way of example, if a subscriber is at home, he may pick up the phone and dial 10#. This causes the telephone company central office to memory dial an 800 number with an NNX that points to ANI-capable trunks connected to the control system. The control system recognizes the ANI as belonging to the home phone of one of its subscribers. The control system then causes all calls to that subscriber to be priority-screen forwarded to the home. If the subscriber had dialed 11#, an 800 number with the same NNX but different last four digits would be dialed, which would cause the control system to select voice-screened forwarding to the home, and so forth.

10 In accordance with another feature of the invention, the subscriber may elect to make an 'outside call' while in the control system command mode, by touching 9 and dialing the desired telephone number.

15 The control system is further enhanced by the addition of a communicator feature. This feature allows a subscriber to move from place to place and have his calls follow him without the need for him to call into the control system. The communicator is a portable device carried on the subscriber's person. The device contains an RF transmitter, an RF receiver, an ultrasonic receiver, a keypad, a 'beeper', and control circuitry. The communicator receives ultrasonic messages from small wall mounted ultrasonic transmitters. These transmitters contain the phone number, and optionally the extension number, of the nearest telephone or a mode appropriate for the location such as do not disturb in a hospital operating room. The communicator also receives radio frequency messages from the control system indicating, or paging, an incoming call for the user. The communicator device can send various radio frequency messages back to the control system, including a message containing the phone number received from the ultrasonic transmitter, a message acknowledging receipt of the page, and messages in response to keypad selections by the subscriber indicating a desire to select a new mode of call handling.

25
30 A feature of the present invention provides a telephone control system which allows subscribers to access the system, even remotely, and implement any of a number of utilities for the handling of subscriber directed calls.

Another feature of the invention provides a telephone control system wherein each subscriber is assigned one telephone number and calls to the system on that number are automatically directed to the subscriber regardless of his location.

5 Another feature of the invention provides the above described telephone control system wherein the system interfaces with callers and subscribers via courtesy messages which minimize or eliminate the need for users to recall complicated control commands.

10 Another feature of the invention provides the above described control system wherein subscribers are provided with portable pager-like communicators which include RF transmitters for transmission directly to the paging system.

Another feature of the present invention provides the above described control system wherein the communicator devices automatically respond to remote locator transmitters to transmit back to the control system the phone number of a telephone proximate the user.

15

BRIEF DESCRIPTION OF THE DRAWINGS

Figure 1 is a block diagram illustrating the various modes of operation and interfacing equipment for the preferred embodiment of the telephone control system;

20 Figure 2 is a block diagram illustrating the principle components of the telephone control system;

Figure 3 is a block diagram of the Communicator;

Figure 4 is a block diagram of the Ultrasonic Transmitter;

Figure 5 is a block diagram of the Call Processing facility;

25 Figure 6 is a flowchart illustrating operation of the E & M Control Circuit;

Figure 7 is a diagram illustrating the Subscriber Master Record;

Figure 8 is a diagram illustrating the Mode Memory;

Figure 9 is a flowchart of the Main Task for the Call Processing facility;

30 Figure 10 is flowchart of the Code Processing Facility-Network Message Task;

Figure 11 is a flowchart of the Code Processing Facility-Call Termination

Task;

Figure 12 is a flowchart of the Call Processing Facility-Call Handler Task;

Figure 13 is a flowchart of the Call Processing Facility-Dynamic Mode Assignment;

5 Figure 14 is a flowchart of the Call Processing Facility-Direct Forwarding Function;

Figure 15 is a flowchart of the Call Processing Facility-Announced Forwarding Function;

10 Figure 16 is a flowchart of the Call Processing Facility-Priority/Urgent Screen Function;

Figure 17 is a flowchart of the Call Processing Facility-VIP Code Screen Function;

Figure 18 is a flowchart of the Call Processing Facility-Branch Routing Function;

15 Figure 19 is a flowchart of the Call Processing Facility-Caller Message Center Function;

Figure 20 is a flowchart of the Call Processing Facility-Voice-Screen Function;

20 Figure 21 is a flowchart of the Call Processing Facility-Meet Me Caller Function;

Figure 22 is a flowchart of the Call Processing Facility-'Send Page' Subroutine;

Figure 23 is a flowchart of the Call Processing Facility-Command Mode Function;

25 Figure 24 is a flowchart of the Call Processing Facility-Command Message Center Function;

Figure 25 is a flowchart of the Call Processing Facility-Command Forwarding Number Function;

30 Figure 26 is a flowchart of the Call Processing Facility-Command Feature Timer Function;

Figure 27 is a flowchart of the Call Processing Facility-Command Memory Function;

Figure 28 is a flowchart of the Call Processing Facility-Command Outside Call Function;

5 Figure 29 is a flowchart of the Call Processing Facility-Command Help Function;

Figure 30 is a flowchart of the Call Processing Facility-Command Meet Me Function;

10 Figure 31 is a flowchart of the Call Processing Facility-Command Branch Route Function;

Figure 32 is a flowchart of the Call Processing Facility-Command Advanced Features Function;

Figure 33 is a block diagram illustrating the principle components of the Meet Me Facility;

15 Figure 34 is a flowchart of the Meet Me Facility Main Task;

Figure 35 is a block diagram illustrating the principle components of the Subscriber Access Facility;

Figure 36 is a flowchart illustrating operation of the E & M Control Circuit for the Subscriber Access Facility;

20 Figure 37 is a flowchart of the Subscriber Access Facility Main Task;

Figure 38 is a block diagram illustrating the principle components of the Communicator Access Facility;

Figure 39 is a flowchart of the Communicator Access Facility Main Task;

25 Figure 40 is a flowchart of the Communicator Main Task;

Figure 41 is a block diagram illustrating the principle components of the Pager Dialing Facility;

Figure 42 is a flowchart of the Pager Dialing Facility Main Task;

30 Figure 43 is a block diagram illustrating the principle components of the Client Services Facility; and;

Figure 44 is a flowchart of the Client Services Facility Main Task.

OVERVIEW OF THE INVENTION

5 FIG. 1 illustrates in block diagram form, the manner in which the Telephone Control System may be used to enhance the accessibility of it's subscribers. As is shown, the Telephone Control System 1 connects with the PSTN 2 via facilities 3. The Telephone Control System 1 may control switch 4, causing it to connect incoming and outgoing trunks.

As is shown, alternate preferred embodiments exist with respect to switch 4.

10 In the first preferred embodiment, the switch 4 is actually part of the PSTN 1. In this embodiment, the facilities 3 must be capable of transmitting switch control signals from the Telephone Control System 1 to the switch 4. An example of this type of facility is a CENTREX line, which allows the transmission of switch control signals in the form of 'hookswitch flashes' and touch tones to initiate call-conferencing and call-transfer. A recently available variation of the CENTREX facility is a CENTREX DID trunk, which not only has the 'hookflash' capability, but also provides the called number in the form of Direct-Inward-Dialing digits. This is the form of facility 3 which is referred to in the detailed description of the preferred embodiment. Another variation of the CENTREX facility provides the called number via a separate data-link known as Simplified Message Desk Interface (SMDI).

15 U.S. Patent 4,893,335, which issued January 9, 1990, incorporated by reference herein, describes in detail a system for controlling the PSTN switch.

20 In an alternate preferred embodiment, the switch 4 is part of the Telephone Control System 1. In this embodiment, the facilities 3 need only include standard DID trunks for the incoming calls, and standard outgoing trunks. The access control system 1 controls switch 4 directly, causing it to connect paths between various incoming and outgoing trunks as required.

25 Again referring to FIG. 1, the Telephone Control System 1 also connects to the PSTN 2 via standard tip-ring phone lines 5, for purposes of communicating with Paging System 6. The Paging System may be any of the commonly known paging

30

systems such as those comprised of transmitters such as Motorola's PACE or Quintron model QT250B and paging terminals such as Glenayre model GL3000XL or BBL System 3, which send encoded messages via radio frequency to cause a unique pager, or beeper, worn by a paging system subscriber, to sound an alert, produce a message in a display, activate a light, vibrate, or produce any of a variety of other alerting mechanisms. Typically, these paging systems will cause a pager to be alerted in response to another individual dialing a phone number which corresponds to that individual's pager. This phone number is routed via the PSTN 2 to a paging terminal via facilities 7, which in turn determines, typically via DID digits, who the call is intended for, and then sends a radio frequency message to alert that individual's pager. To cause a subscriber's pager to be activated, the Telephone Control System 1 then need only come off hook on one of the lines 5, and dial the phone number that corresponds to the subscriber's pager. Although not described in this preferred embodiment, it is anticipated that the Telephone Control System 1 could also interface to a paging system directly via a dedicated data link:

An additional facility 5 connects the Telephone Control System 1 to the PSTN 2. This facility is a trunk which provides the Automatic Number Identification (ANI) of the calling party. An example of such a trunk is the Feature Group D (FGD) trunk which is commonly used by interexchange carriers. The interexchange carriers use the ANI information to properly bill the calling party. The Telephone Control System 1 uses this ANI information in a new and different manner. As will be described in further detail herein, subscribers of the Telephone Control System 1 may program the Telephone Control System 1 by calling it through trunking facilities 5. The access control system 1 automatically acquires the ANI, or phone number of the calling party. This allows the access control system 1 to program the forwarding number for the subscriber without the subscriber needing to manually enter it. Although not described in the preferred embodiment, it is anticipated that other types of facilities which provide ANI information may also be used for this purpose. An example of another type of facility which provides ANI is a CENTREX line with an SMDI data link, which is now available from several types of central offices. The

SMDI data link is capable of passing both the called party number and the calling party number (ANI).

Still referring to FIG. 1, The Telephone Control System 1 is also connected to a Packet Radio Transmitter/Receiver 9 via data-link 10. The Packet Radio Transmitter/Receiver 9 may consist of any of the commonly known radio transceivers such as YAESU FT-470 and ICOM IC-u 4AT, equipped with a packet radio interface such as HEATHKIT HK-21. As will be described in further detail herein, the Packet Radio Transmitter/Receiver 9 is used by the Telephone Control System 1 to interface with the portable Communicator device 11, carried by an Telephone Control System subscriber. The Communicator 11 may both send and receive DATA messages via radio frequency. The Communicator 11 may also receive ultrasonic messages from fixed ultrasonic transmitter 12, shown located in room 13. Ultrasonic transmitter 12 continuously transmits the phone number, and, if appropriate, the extension, of the phone 14 located in the same room or a signal indicating an appropriate call control mode for a given situation such as do not disturb in a hospital operating room. It should be noted that, although the preferred embodiment disclosed herein describes transmitter 12 as ultrasonic, it is anticipated that an infrared transmitter may also be used. The ultrasonic transmitter has the advantage that it will pass signals through a layer of clothes, which would be important for example if the subscriber were carrying the Communicator 11 in a shirt pocket.

To aide in the discussion of the illustrative examples which follow, FIG. 1 also shows a subscriber's home 15, with a home phone 16; a subscriber's office 17, with an office phone 18; a cellular telephone system 19, which interfaces to a subscriber's car-phone 20; a factory 21, with a factory phone 22; a pay telephone 23; a subscriber 24 with pager 25; and a caller's telephone 26.

The illustrative examples which follow are intended only to clarify some of the concepts, features, and objects of the invention, and do not define the scope of the invention.

30 Methods of Call-Handling

Following are several illustrative examples of the various call-handling modes of the Telephone Control System 1.

Direct Forwarding

5 For the sake of this example, assume that a caller at phone 26 wishes to speak to a subscriber to the access control system 1, and further assume that the subscriber is at home 15, and that he has preprogrammed the system to 'direct forward' his calls to him at his home phone 16. The caller dials the access number for the subscriber, and the PSTN delivers the call to the Telephone Control System 1 via facilities 3.
10 The facilities 3 provide the access control system 1 with the called party information (DID) digits. The Telephone Control System then refers to its internal database to determine how to handle the call. The access control system determines that calls for this subscriber are to be handled via 'direct forwarding' mode, and that the call is to be forwarded to the subscriber's home. The access control system then dials the subscriber's home on an outgoing facility 3, and instructs the switch 4 to connect the incoming facility to the outgoing facility to complete the call. The PSTN 2 then
15 delivers the call to home phone 16, causing it to ring, and the subscriber may pick up the phone and connect to the caller. Note that this mode of call-handling is referred to as 'direct forwarding' because the call is forwarded without any announcement or prompting from the Telephone Control System 1.
20

Announced Forwarding

Assume again that a caller at phone 26 wishes to speak to a subscriber to the Telephone Control System 1. Also assume that the subscriber is at home 15, and that
25 this time he has preprogrammed the system to 'Announce-forward' his calls to him at his home phone 16. Again, the caller dials the access number for the subscriber, and the PSTN delivers the call to the Telephone Control System 1 via facilities 3. Upon receiving the DID digits for this subscriber, the Telephone Control System 1 determines that calls for this subscriber are to be handled via 'announced forwarding' mode, and that the call is to be forwarded to the subscriber's home. The access
30

control system then plays a brief greeting to the caller: "Hello, you have reached the
ACCESSLINE for Mr. Jones. We're Connecting your call." The Telephone
Control System then dials the phone number for phone 16 on an outgoing facility 3,
and instructs the switch 4 to connect the incoming facility to the outgoing facility to
5 complete the call. The PSTN 2 then delivers the call to home phone 16, causing it
to ring, and the subscriber may pick up the phone and connect to the caller.

Forwarding with Page

10 Assume again that a caller at phone 26 wishes to speak to a subscriber to the
Telephone Control System 1. Also assume again that the subscriber is at home 15,
and that this time he has preprogrammed the system to 'Forward with page' his calls
to him at his home phone 16. Again, the caller dials the access number for the
subscriber, and the PSTN delivers the call to the Telephone Control System 1 via
15 facilities 3.

Upon receiving the DID digits for this subscriber, the access control system
1 determines that calls for this subscriber are to be handled via 'forward with page'
mode, and that the call is to be forwarded to the subscriber's home. The access
control system then plays a brief greeting to the caller: "Hello, you have reached the
20 **ACCESSLINE** for Mr. Jones. We are sending a page to inform your party of
the call. Please stay on the line." The Telephone Control System 1 then dials the
phone number for the pager corresponding to this subscriber and informs the caller
"We have sent a page to alert your party and will connect you momentarily." The
access control system then dials the phone number for phone 16 on an outgoing
25 facility 3, and instructs the switch 4 to connect the incoming facility to the outgoing
facility to complete the call. The PSTN 2 then delivers the call to home phone 16,
causing it to ring, and the subscriber may pick up the phone and connect to the caller.
The subscriber, having been alerted to the incoming call by his pager, was ready to
receive it.

Message Center

In some cases the subscriber may not be able to take calls and may wish that his callers simply leave a message. In these cases, the subscriber may program the access control system 1 to connect calls to the subscriber's preselected 'message center'. The Telephone Control System 1 may connect calls to either an 'internal message center' or an 'external message center'. The 'external message center' is simply a phone number that the Telephone Control System 1 will forward calls to if in this mode. This may be the phone number for an answering service, a receptionist, a voice mail system, or any other appropriate location as desired by the subscriber. If the subscriber elects to use the 'internal message center', then an example of a typical call may be as follows.

Assume that a caller at phone 26 wishes to speak to a subscriber to the Telephone Control System 1. Also assume that the subscriber does not wish to be disturbed and that he has preprogrammed the system to 'internal message center' mode. The caller dials the access number for the subscriber, and the PSTN delivers the call to the Telephone Control System 1 via facilities 3. Upon receiving the DID digits for this subscriber, the Telephone Control System 1 determines that calls for this subscriber are to be handled via 'internal message center' mode. The Telephone Control System then plays a brief greeting to the caller: "Hello, you have reached the ****ACCESSLINE**** for Mr. Jones. Your party is not readily available at the moment, however we will connect you to your party's message center where you may leave a detailed message.....Please leave your message at the tone." The Telephone Control System 1 then records the callers message and saves it for later playback by the subscriber. In addition, should the subscriber have so elected, the access control system 1 may dial the phone number corresponding to the subscriber's pager, to alert the subscriber to the message.

Priority-Call Screening

Assume again that a caller at phone 26 wishes to speak to a subscriber to the

Telephone Control System 1. This time assume that the subscriber is at his office 17, and that he has preprogrammed the system to send his calls to him at his office via 'priority call-screening', with a message asking the caller to ask for extension 123, which in this example is the extension number of the phone 18 on his desk. Again, the caller at phone 26 dials the access number for the subscriber, and the PSTN 2 delivers the call to the access control system 1 via facilities 3. Upon receiving the DID digits for this subscriber, the Telephone Control System 1 determines that calls for this subscriber are to be handled via 'priority call-screening' mode, and that the call is to be forwarded to the subscriber's office. The access control system 1 then plays a brief greeting to the caller: "Hello, you have reached the ****ACCESSLINE**** for Mr. Jones. Your party is not readily available at the moment. If this call is urgent then please touch 0 now and we will attempt to connect you to your party. Otherwise, please hold the line and we will connect you to your party's message center where you may leave a detailed message." If the caller does not touch 0, then the call is delivered to the 'message center' as described above. If the caller does touch 0, then the Telephone Control System 1 may inform the caller: "Please standby while we connect your call. When the call is answered please ask for extension number 123." The access control system then dials the preprogrammed lead phone number for the subscriber's office 17 on an outgoing facility 3, and instructs the switch 4 to connect the incoming facility to the outgoing facility to complete the call. The PSTN 2 then delivers the call to the receptionist at office 17, causing it to ring. When the receptionist answers, the caller will ask for extension 123, as he was instructed by access control system 1, and the receptionist may connect the call to the subscriber's desk phone 18.

25 VIP Code Screening

Assume again that a caller at phone 26 wishes to speak to a subscriber to the Telephone Control System 1. This time assume that the subscriber is in his car, and that he has preprogrammed the system to send his calls to him at his car-phone 20 via 'VIP code-screening'. In this mode, only those callers who have been told a special

VIP code will be able to reach the subscriber. All other callers will be sent to the message center. Again, the caller at phone 26 dials the access number for the subscriber, and the PSTN 2 delivers the call to the Telephone Control System 1 via facilities 3.

5 Upon receiving the DID digits for this subscriber, the access control system 1 determines that calls for this subscriber are to be handled via 'VIP code-screening' mode, and that the call is to be forwarded to the subscriber's car phone 20. The Telephone Control System 1 then plays a brief greeting to the caller: "Hello, you have reached the ****ACCESSLINE**** for Mr. Jones. Your party is not readily
10 available at the moment. Please enter your VIP code now, or hold the line and we will connect you to your party's message center where you may leave a detailed message." If the caller does not enter the correct VIP code, then the call is delivered to the 'message center' as described above. If the caller does enter the VIP
15 code, then the Telephone Control System 1 may inform the caller: "Please standby while we connect your call." The Telephone Control System then dials the telephone number for car-phone 20 on an outgoing facility 3, and instructs the switch 4 to connect the incoming facility to the outgoing facility to complete the call. The PSTN 2 then delivers the call to the cellular telephone system 19, which in turn delivers the call to the car-phone 20.

20

Voice-Screening

Assume again that a caller at phone 26 wishes to speak to a subscriber of the Telephone Control System 1. This time assume that the subscriber, Mr. Jones, is visiting his client's factory 21, and that he has preprogrammed the system to send his
25 calls to him at this location via 'voice-screening'. Again, the caller at phone 26 dials the access number for the subscriber, and the PSTN 2 delivers the call to the access control system 1 via facilities 3. Upon receiving the DID digits for this subscriber, the Telephone Control System 1 determines that calls for this subscriber are to be handled via 'voice-screening' mode, and that the call is to be forwarded to his client's
30 factory 21. The access control system 1 then plays a brief greeting to the caller:

"Hello, you have reached the ****ACCESSLINE**** for Mr. Jones. Please state your name and the purpose of your call at the tone. After the tone, please stay on the line while we attempt to locate your party and connect your call." The access control system 1 then records the caller's name and business, and then responds: "Thank you, please standby." The access control system then dials the telephone number for factory 21 on an outgoing facility 3, leaving the incoming call on hold. The PSTN 2 then delivers the outgoing call to the lead telephone number of factory 21, which is answered by the factory's receptionist. The Telephone Control System tells the receptionist "We have a call holding for Mr. Jones. Please locate the party." The receptionist pages Mr. Jones via the factory's speaker system, informing him of the call. Mr. Jones then answers the call at phone 22, and enters his Personal Identification Number (PIN) code. The access control system 1 then plays back the callers name and business. The Telephone Control System 1 then asks Mr. Jones: "Please touch 1 to connect the call, 2 to send the caller away, or 3 to send the caller to your message center." In this example, Mr. Jones wishes to speak to the caller, so he touches 1. The Telephone Control System 1 instructs the switch 4 to connect the incoming facility to the outgoing facility to complete the call.

Branch-Routing

Assume again that a caller at phone 26 wishes to speak to a subscriber of the Telephone Control System 1. This time assume that the subscriber is not a person, but a business; the ABC Factory Company 21, and that the Telephone Control System 1 has been preprogrammed to handle their calls via 'branch-routing' mode. Again, the caller at phone 26 dials the access number for the subscriber, and the PSTN 2 delivers the call to the Telephone Control System 1 via facilities 3. Upon receiving the DID digits for this subscriber, the Telephone Control System 1 determines that calls for this subscriber are to be handled via 'branch-routing' mode. The Telephone Control System 1 then refers to it's memory and plays a pre-recorded 'branch-routing' greeting to the caller: "Hello, you have reached the ABC Factory Company. Please touch 1 to speak to the manufacturing manager, 2 to speak to

accounts receivable, 3 to speak to accounts payable, 4 to speak to purchasing, or hold the line to speak to the receptionist." Should the caller need help, he will hold the line for a moment, and the Telephone Control System 1 responds: "Please standby." The Telephone Control System then dials the telephone number for the factory's
5 reception phone 22 on an outgoing facility 3, and instructs the switch 4 to connect the incoming facility to the outgoing facility to complete the call.

Meet-Me

Assume again that a caller at phone 26 wishes to speak to a subscriber to the Telephone Control System 1. This time assume that the subscriber, Mr. Jones, is
10 away from the office today, and that he has preprogrammed the system to handle his calls via 'meet-me' mode. Again, the caller at phone 26 dials the access number for the subscriber, and the PSTN 2 delivers the call to the Telephone Control System 1 via facilities 3. Upon receiving the DID digits for this subscriber, the Telephone Control System 1 determines that calls for this subscriber are to be handled via
15 'meet-me' mode. The Telephone Control System 1 then responds by producing audible ringback to the caller, while dialing the phone number for the pager corresponding to this subscriber on facilities 5. The Telephone Control System 1 then plays a brief message to the caller: "Hello, you have reached the ****ACCESSLINE**** for Mr. Jones. We are paging your party to a phone, please standby. If you are
20 unable to wait you may touch 9 to leave a message. Otherwise please hold the line." The Telephone Control System 1 then places the caller on hold and waits for the subscriber to call in. Meanwhile the subscriber 24 has received the page via his pager 25, and is proceeding to pay phone 23 to answer the call. The subscriber dials his own access number and the PSTN 2 delivers the call to the Telephone Control
25 System 1 via facilities 3. The subscriber then enters his own PIN code and is informed "You have a caller holding for you on your meet-me service. Please touch 4 to be connected to the caller." It is also anticipated that if the caller had hung up or left a message in the meantime, that the subscriber would be so informed. Assuming that the caller is still holding, and that the subscriber touches 4, the access

control system 1 instructs the switch 4 to connect the incoming facility to the outgoing facility to complete the call.

Methods of Programming

5 Although various methods of 'remotely programmable call forwarding' have been attempted in the prior art, these have proven to have limited widespread appeal due to the complicated and inflexible methods by which the users were required to program the systems. By contrast, the access control system employs a variety of different methods to allow the subscriber to easily and effectively program the
10 operation of the Telephone Control System. Following are several illustrative examples of the various methods a subscriber may employ to program the Telephone Control System 1.

Command Mode

15 To use the Command Mode method of programming, the subscriber simply dials his own access number from any telephone, and enters his PIN code. The PSTN 2 delivers the call to the Telephone Control System 1 via facilities 3. The Telephone Control System 1 then informs the caller of the current feature which is selected, and then provides the subscriber with a simple menu of options by which
20 he can choose a new feature. For example, in response to the entry of the PIN code, the subscriber may be prompted: "Hello Mr. Jones. Your calls are currently being VIP code screened to your office. Touch 1 to check messages, 2 to change your forwarding number, 3 to select a memory, 8 for advanced features, 9 to make a call, or touch 0 for help." The subscriber may then make his desired selection. Please
25 note that although the preferred embodiment herein discusses the use of touch tone as the signalling method by which the subscriber controls the Command Mode of the access control system, the inventors anticipate that other signalling methods may also be employed, including, but not limited to, rotary dial pulse detection and voice recognition.

30 Another feature of the Telephone Control System Command Mode allows the

subscriber to program 'mode memories' which contain the most often used call handling methods for that subscriber. For example, a subscriber may program memory 10 to be announced forwarding to his office, memory 20 to be voice screened forwarding to his home, memory 30 to be message center mode, and so forth.

Weekly Schedule

Subscribers who have some routine to their weekly activities may soon grow weary of constantly calling the Telephone Control System and selecting the same call handling methods at the same time, day after day. For this reason, the weekly schedule feature provides a very real benefit to the subscriber. As an example, let us assume that a subscriber, Mr. Jones, starts work at 8:00 AM every morning, and leaves for home at 5:00 PM in the evening. Let us further assume that he takes an hour for lunch from 12:00 to 1:00PM each day. The weekly schedule for this subscriber might be pre-programmed into the Telephone Control System's database to be:

| DAY | TIME | MODE | MEMORY | FEATURE |
|---------|-----------|------|--------|---------------------------------|
| Mon-Fri | 7:30am | 30 | | Message Center |
| Mon-Fri | 8:00am | 10 | | Announced forwarding to office |
| Mon-Fri | 12:00noon | 30 | | Message center |
| Mon-Fri | 1:00pm | 10 | | Announced forwarding to office |
| Mon-Fri | 5:00pm | 20 | | Voice screen forwarding to home |

As calls are received by the Telephone Control System for this subscriber, the Telephone Control System 1 refers to this database and determines the correct call handling method for the day of week and time of day, and delivers the call accordingly.

Another feature of the weekly schedule allows the subscriber to override the weekly schedule should his schedule deviate from the preprogrammed sequence. In

this way the subscriber can move freely about his routine activities, and only he needs to program the access control system should his schedule change from the normal.

Feature Timer

5 To illustrate the use of the Feature Timer capability of the Telephone Control System, assume that a subscriber is visiting a client's office for a one hour appointment, and wishes to have his calls forwarded to him at this location during that time. He may use the Command Mode as described above to select announced forwarding mode and change the forwarding number to be the telephone number of
10 his client's phone. When he leaves he intends to change the call handling mode back to his message center. However, if the subscriber forgets to call the Telephone Control System as he is leaving the client's office, then the client may still continue to receive calls intended for the subscriber. To overcome this problem, the subscriber may have instead used the Feature Timer function when he first called the
15 access control system when he got to the client's office. In this example, the subscriber could have called the access control system, and used Command Mode to select announced forwarding to his client's office. However, instead of hanging up at that point, he could have activated the Feature Timer, programming it to maintain the current mode for one hour and then automatically change the call handling mode
20 to message center mode. In this way, the subscriber would not have to remember to call the Telephone Control System as he leaves the client's office, and the client would not be bothered with the subscriber's calls after he left.

Programming a Forwarding Number Using ANI

25 One difficulty in prior art implementations of remotely programmable call forwarding devices, is that it takes quite a few digits for the user to call the system, enter an access code, and then enter the forwarding number. One means by which the invention described herein overcomes this difficulty is by employing special trunks which provide the called party number, also referred to as ANI. To see how this
30 improves the ease of programming, consider the following example. Assume that the

subscriber is visiting factory 21, and that this is a location that he does not visit regularly, and therefore does not have it's telephone number preprogrammed into the Telephone Control System 1. Further assume, as was discussed earlier, that the access control system 1 is connected to the PSTN with Feature Group D trunks 8
5 which provide ANI, and which can be reached by dialing an 800 number. To cause his calls to get to him at the factory 21, the subscriber in this example would pick up telephone 22 and dial the 800 number which corresponds to the Feature Group D trunk. The PSTN 2 would deliver the call to the Telephone Control System 1 and the Telephone Control System 1 would receive the ANI information digits containing
10 the telephone number of telephone 22. The subscriber then need only enter his PIN code and the call handling feature memory he wishes to use, which might be memory 40, announced forwarding. The subscriber could then hang up and the Telephone Control System 1 would program the database to send all calls for that subscriber to telephone 22 via announced forwarding. As should be obvious, the sequence of digits
15 entered by the subscriber was shorter than if he had to actually enter the phone number. It should also be pointed out that another advantage of this method of programming is that the same sequence of digits is used to program the system each time. In other words, if the subscriber went to another location and wanted his calls to be sent to him via announced forwarding, he could pick up a phone and dial the exact same sequence of digits as was described above. This makes the programming
20 of the Telephone Control System less demanding on the subscriber since he only has to memorize one sequence to accomplish this function. It is also anticipated by the inventors that a subscriber to this service may employ a 'pocket dialer' preprogrammed with this fixed digit sequence, thereby even further simplifying the ease of programming.
25

Programming the Telephone Control System using Speed Calling and ANI

A well known service offered by many telephone companies is 'Speed Calling'. This service allows users to preprogram often used telephone numbers into

memories which can be recalled by dialing a one, two, or three digit code. To see how subscribers can use this service to improve the ease of programming the Telephone Control System, consider the following example. Assume that an Telephone Control System subscriber, who lives at home 15, has preprogrammed the access control system with his home phone number 16. Let us further assume, as
5 was discussed earlier, that the Telephone Control System 1 is connected to the PSTN 2 with Feature Group D trunks 8 which provide ANI, and which can be reached by dialing an 800 number, and assume further that an entire 800-NNX has been dedicated to this trunk group, in this example 800-999-XXXX. By this invention, the
10 last four digits of the 800 number will be used to signify the mode memory which is being selected. In this example, also assume that the subscriber has preprogrammed his telco speed dialing feature so that the sequence 2# causes the telephone number 1-800-999-0010 to be dialed, and that the sequence 3# causes the telephone number 1-800-999-0011 to be dialed. In this example, when the subscriber picks up
15 telephone 16 and dials 2#, the speed dialing feature will cause the number 1-800-999-0010 to be dialed. The PSTN 2 will deliver the call to the access control system 1 via Feature Group D trunks 8. The access control system 1 will receive the ANI digits, and referring to it's database recognize the call as originating at the home telephone of one of it's subscribers. It then will invoke the preprogrammed mode
20 memory 10 for that subscriber, which in this example might be voice-screened forwarding to his home phone. As a further example, if the subscriber had dialed 3#, the Telephone Control System 1 would have invoked memory 11 for that subscriber.

Communicator

25 As described earlier, the Communicator is a portable device carried on the subscriber's person. This example demonstrates some of the ways by which the Communicator can simplify the call handling and programming operations for the Telephone Control System subscriber. Still referring to FIG. 1, assume that the subscriber is carrying a communicator 11 on his belt, and that he has just entered
30 room 13. Also assume that he has selected the 'automatic phone number' mode of

operation for the Communicator 11. When he enters the room, the Communicator 11 detects a signal from the fixed ultrasonic transmitter 12 located near the ceiling. This signal is decoded by the Communicator 11 and is determined to contain a phone number, which in this example happens to correspond to the phone instrument 14 located in the same room 13. Upon receipt of the ultrasonic signal, the Communicator 11 transmits a brief packet message via radio frequency. This message contains the subscriber's access number and the phone number just received form the ultrasonic transmitter 12. This radio frequency message is detected by packet radio transceiver 9 and passed on to the access control system 1 via data link 10. The Telephone Control System 1 then changes the forwarding number for this subscriber to be the new number.

Assume now that a caller at phone 26 wishes to speak to this subscriber. The caller dials the access number for the subscriber, and the PSTN delivers the call to the access control system 1 via facilities 3. Upon receiving the DID digits for this subscriber, the Telephone Control System 1 determines that calls for this subscriber are to be handled via 'direct forwarding' mode, and that the call is to be forwarded to the subscriber at telephone 14. The access control system 1 then sends a page message to the packet radio transceiver 9 via data-link 10. The packet radio transceiver 9 in turn transmits a radio frequency packet message to Communicator 11, causing the beeper in the Communicator 11 to alert the subscriber to the incoming call. The Communicator 11 may also then send an acknowledgment message back via radio frequency to the packet radio transceiver 9. Meanwhile, the Telephone Control System 1 has begun to dial the phone number for phone 14 on an outgoing facility 3, and instructs the switch 4 to connect the incoming facility to the outgoing facility to complete the call. The PSTN 2 then delivers the call to phone 14, causing it to ring, and the subscriber may pick up the phone and connect to the caller. Continuing the illustrative example, assume that the subscriber completes the call and leaves the room 13. Communicator 11 detects the loss of signal from ultrasonic transmitter 12, and realizes therefore that the subscriber has left the room and is no longer able to receive calls at this location. The Communicator 11 then transmits a

brief packet message via radio frequency. This message contains the subscriber's access number and a special message indicating that no phone number is available and that a default mode memory is to be used for call handling. This radio frequency message is detected by packet radio transceiver 9 and passed on to the Telephone Control System 1 via data link 10. The Telephone Control System 1 then changes the method of call handling for this subscriber to the default mode, which may typically be message center mode. It should be obvious now that if the subscriber were to reenter room 13, or to enter another room with a similar ultrasonic transmitter, that a similar sequence of events would occur causing the calls for this subscriber to be routed to the appropriate room. In this way, without any specific action or effort on the part of the subscriber, his calls will follow him from location to location and be handled automatically and properly.

Another feature of the Communicator allows the subscriber to enter a 'manual phone number' mode whereby the Communicator will ignore the messages received from the ultrasonic transmitters, maintaining the last used mode or forwarding number.

Another feature of the Communicator allows the subscriber to select a new method of call-handling by touching keys on the Communicator's keypad. This will cause the Communicator 11 to transmit a 'new mode memory request' packet message via radio frequency to the packet radio transceiver, which in turn will send the message to Telephone Control System 1 via data-link 10, causing the Telephone Control System 1 to change the call handling method for that subscriber.

DETAILED DESCRIPTION

FIG. 2 is a block diagram of the telephone control system 1. The preferred embodiment of the telephone control system 1 consists of a variety of subsystems, or facilities. A Call Processing Facility (CPF) 100 is shown connected to trunks 3. A Pager Dialing Facility (PDF) 105 is shown connected to telephone lines 5. A Subscriber Access Facility (SAF) 110 is shown connected to trunks 8. A Meet-Me Facility (MMF) 115 is shown connected to lines 120. A Communicator Access

Facility (CAF) 125 is shown connected to datalink 10. A Client Services Facility (CSF) 130 is also shown. Each of these facilities is connected to high speed data network 150.

A block diagram of the Communicator 11 is shown in FIG. 3. The operation
5 of the Communicator 11 is controlled by microprocessor 200, which in the preferred embodiment is a single chip microprocessor containing it's own Read-Only-Memory (ROM) and Random-Access-Memory (RAM). A keypad 205, and display 210 are shown connected to microprocessor 10. A transmit data output port 215 is provided by the microprocessor 200. This transmit data is passed to packet data encoder 220
10 which formats the data into packets before sending the packets to antenna 230 via radio frequency transmitter 225. Radio frequency receiver 235 receives data packets from antenna 230 and passes them to packet data decoder 240, which removes the packet format and passes the raw received data to the receive data input port 245 on microprocessor 200. Output port 250 may be used to apply a tone signal to beeper driver 255 which supplies sufficient current to drive beeper 260 to produce an alerting
15 sound. A transducer 265, capable of receiving signals in the ultrasonic frequency range, passes these signals to a 40 KiloHertz filter and amplifier 270. The resulting signal is applied to detector 275 which removes the 40 KiloHertz component from the signal and passes the resulting serial data to input port 280 of microprocessor 200.
20 Also shown is a crystal oscillator 285 which controls the timing of all operations of the microprocessor 200. Power for the Communicator 11 is supplied by battery 290. Improvements that currently exist in the ART may be made to the ultrasonic transmitter and detector to enhance its ability to communicate the ultrasonic data in the presence of multi-path echoes. These improvements include, but are not limited to: frequency shift keying; the transmission of synchronized data and the use of a clock recovery logic to extract the clock timing over a long integration period resulting in a clock move resistant to echoes; the use of error detecting and correcting codes; and the use of sampling and voting techniques to determine the correct bit value after multiple samples during a bit period, the bit period being determined by
25 the clock recovery logic above. In addition, multiple transmitters may be used as a
30

method of obtaining increased coverage and area transmission diversity.

A block diagram of the Ultrasonic Transmitter 12 is illustrated in FIG. 4. Oscillator 300 provides a 40 KiloHertz signal to one input of AND gate 305. The output of crystal oscillator 310 is applied to divider 311 which produces a 75 Hertz
5 signal to the clock input of 6-bit counter 315. The 6 outputs of counter 315 are applied to the address inputs of Read-Only-Memory 320. Memory 320 is pre-programmed with data representing the phone number of the nearest telephone. This data may contain the area code plus seven digits and the extension number if appropriate. With each digit represented by 4 bits, 14 digits and 8 bits of checksum
10 may be transmitted. Only the least significant bits in ROM 320 need be programmed, as the LSB output 325 is used to apply this data to a second input of AND gate 305. As can be seen, the serial data at 325 will continuously output the phone number at a rate of 75 bits per second. AND gate 305 combines the serial data 325 and the 40 KiloHertz signal from oscillator 300 producing a resultant signal which is applied to
15 transducer driver 330. The output of driver 330 is then applied to transducer 335. As should be obvious, the transducer will be generating a 40 KiloHertz signal while the serial data output 325 is high, and will be generating no signal while the serial data output 325 is low. The data is therefore modulated on the 40 KiloHertz carrier at a rate of 75 baud. The 64 bits from the ROM 320 are thus transmitted in a period
20 of 0.853 seconds. This is adequate for the transmission of a phone number and extension. Although this baud rate is relatively low, it has the advantage of reducing the effect of multipath (reflections of the ultrasonic signal arriving at the receiver at different times and phases), and thus improves the reliability of transmission as compared with higher baud rates.

25 A block diagram of the Call Processing Facility (CPF) 100 is shown in FIG. 5.

Referring to FIG. 5, CPF trunk interface 400 interfaces the CPF 100 with trunk 3. As was discussed earlier, the preferred embodiment of the telephone control system 1 employs a CENTREX DID trunk. In this embodiment trunk 3 is provided
30 via a 4-wire E&M trunk provisioned with TYPE I signalling, which is well known

in the art. This type of trunk provides a 2-wire balanced transmit audio connection, shown terminated by line termination 405. This type of trunk also provides a 2-wire balanced receive audio connection, shown terminated by line termination 410. The E-Lead of trunk 3 is shown connected to the current limiting and over voltage protection at reference 415. In a similar fashion, the M-Lead of trunk 3 is shown connected to the current limiting and over voltage protection at reference 420. 2-to-4 wire convertor 425 takes the separate balanced transmit and receive signals from line terminators 405 and 410 and combines them into one single-ended signal at reference 430, which is applied to call processor 435. The E-Lead signal from limiter/protector 415 is passed to current detector 440. As is shown, current detector 440 provides a path for the E-Lead signal through to the negative battery reference of -48 volts at 445. Current Detector 440 also provides an "E-Lead Detect" logic signal indicating the presence of current via the E-lead. This signal is applied to E&M lead control circuit 450. The M-Lead signal for limiter/protector 420 is passed to M-Lead relay 455. This relay is controlled by a "M-Lead Control" signal from control circuit 450. By activating or deactivating relay 455, control circuit 450 is able to take the M-Lead on-hook or off-hook, as the M-Lead will be connected either to -48 volts or to ground. The control circuit 450 outputs an "Incoming Call" signal 470 to buffer 460, and outputs a "Loop Status" signal 475 to call processor 435. The control circuit 450 has as additional inputs a "DID Received" signal 480 from latch 465, and an "On/Off-Hook Control" signal 485 from call processor 435. The output of buffer 460, and the input of latch 465 is applied to CPF internal data bus 490.

Still referring to FIG. 5, the CPF internal data bus 490 connects CPF trunk interface 400, call processor 435, precision busy/ring detector 437, Central Processing Unit (CPU) 495, Random Access Memory (RAM) 500, Disk memory 505, and data network interface 510. Call processor 435 performs the functions of voice record and playback, dual-tone-multi-frequency (DTMF) detection and generation, and call control. The functions of call processor 435 are well known in the art and many products, such as the Model D41B manufactured by Dialogic

Corporation, exist commercially which can accomplish these functions. A voice recognition module 436 is shown connected to call processor 435. Voice recognition module 436 allows call processor 435 to detect, on a speaker-independent basis, a simple set of spoken commands from callers. The simple set consists of 16 words including the digits '0' through '9'. This capability, in combination with the DTMF detection capability of the call processor 435, allows caller to either speak their commands, or enter them from a DTMF phone. A commercially available product which performs this voice recognition function is the Model VR/10 manufactured by Dialogic Corporation.

A precision busy/ring detector 437 is shown connected to the audio signal 430 from CPF trunk interface 400. This detector may be used to perform a rapid detection of precise busy and precise ringing signals, even in the presence of voice. Unlike the busy and ring detection functions of Call Processor 435 which require a cadence match as well as a frequency match, precision busy/ring detector 437 does not require a cadence match and is therefore capable of rapidly detecting precise busy and ringing signals even if a party is conferenced in and speaking on the line. This capability is useful in providing the 'busy/no-answer option' as will be described later. The functions of precise busy/ring detector 437 are well known in the art, and may be typically implemented as follows. The incoming audio signal is applied to the inputs of several identical circuits, each with center frequencies set to detect a different component of the expected busy or ringing signal. Each of these circuits contains a low Q bandpass filter. This filter prevents out-of-band signals such as voice from interfering with the detection function. The output of the bandpass filter is fed to a zero crossing detector. The output of the zero crossing detector is then fed to a high Q bandpass filter again set at the frequency to be detected. The output of the bandpass filter is then sent to a level detector which provides a positive indication if the incoming signal is above a preset amplitude. The output of the busy/ring detector 437 may be read by CPU 495 via the CPF internal data bus 490. CPU 495 controls all functions of CPF 100. The software program which the CPU 100 uses is loaded into RAM 500, from disk memory 505. The disk 505 also is used to store

a variety of other data including the subscriber database for the telephone control system 1. A data network interface 510 is used to connect the CPF 100 to the other subsystems of the telephone control system 1. Data network interface 510 passes data messages between the CPU 495 and these other subsystems. The functions of data network interface 510 are well known in the art, and many products, such as the Model COM4i from Digiboard Corporation, exist commercially which can accomplish these functions. Although only one trunk interface 400, one trunk 3, and one call processor 435 are shown in FIG. 5, it should be readily evident to one skilled in the art that additional trunk interfaces and call processors may be added to support additional trunks.

A flowchart of the operation of E&M control circuit 450 is shown in FIG. 6. At reference 600, the control circuit 450 idles waiting for an indication from current detector 440 that the E-Lead has gone off-hook. When the E-Lead does go off-hook, as shown at reference 605, an "Incoming Call" signal is sent to CPU 495 via buffer 460. The control circuit 450 then idles at 610, waiting for an off-hook signal from call processor 435, signifying that the CPU 495 is ready to accept the call. When the off-hook signal is received, the "Loop Status" 475 is set active as shown at reference 615. The M-Lead is then winked by taking M-Lead relay 455 momentarily off-hook, as shown at reference 620. The control circuit 450 then idles again at 625, waiting for the receipt of the "DID Received" signal 480 from CPU 495 via latch 465. Call processor 435 detects the incoming DID digits on its audio line 430 and decodes the digits passing the digit sequence on to CPU 495. This DID digit sequence represents the 'called number' or ACCESS NUMBER of a subscriber to the telephone control system 1. When the CPU 495 receives the DID digits from call processor 435, the CPU 495 sets the "DID Received" signal 480 active, and the control circuit 450 takes the M-Lead off-hook as shown at reference 630. At this point a call has been established, and the control circuit 450 must now wait until either CPU 495 terminates the call, as signified by on/off-hook control signal 485 going on-hook, or by the calling party terminating the call as signified by the E-Lead detect from current detector 440 going on-hook. These functions are accomplished by control circuit 450

as illustrated at references 635 through 670. At 635 a check is made to determine if on/off-hook control signal 485 is on-hook. If it is still off-hook then a check is made at 640 to determine if the E-lead detect signal is on-hook. If it is on-hook, then the calling party has hung up, and the control circuit 450 sets the "Loop Status" 475 inactive at 645, signalling the call processor 435 that the call is terminated. The call processor 435 may in turn signal CPU 495 that the call is terminated. Control circuit 450 then waits as shown at reference 650 for the "DID Received" signal 480 to become inactive, signifying that the CPU 495 is completed with the call and is ready to accept a new call. When the "DID Received" signal 480 goes inactive, control passes to step 675 where the M-Lead is placed on hook. Control then returns to step 600 where the control circuit 450 restarts its sequence at reference 600. Returning again to reference 635, if the On/off-hook control signal 485 were found to be on-hook, then a 1.5 second timer is started as shown at reference 655. This timer is used to distinguish between a 'hookflash' signal, which is typically less than 1.5 seconds, and an on hook command which should be at least 1.5 seconds. At 660, the control circuit 450 causes the M-Lead relay 455 to place the M-Lead on-hook. At 665 a check is made to determine if the 1.5 second timer has expired. If it has expired, then the signal was a true on-hook command, and control passes to reference 645 for the termination of the call. If at 665 it is determined that the 1.5 second timer has not expired, then a check is made at 670 to determine if the on/off-hook control 485 is still on-hook. If it is still on-hook then the timer is tested again at 665. If the on/off-hook control 485 is off-hook again, then the command was a flash, and control returns to reference 630, where the M-Lead is taken off-hook once more.

A diagram of the Subscriber Master Record, reference 700, is illustrated in FIG 7. The subscriber master record contains information regarding a given subscriber's chosen method of call handling. This information is used by the Telephone Control System 1 to determine how to process the call. One unique subscriber master record exists for each subscriber to the Telephone Control System 1. All subscriber master records are stored in disk 505 and, upon initialization of the Telephone Control System 1, are copied to a common database in RAM memory 500

by CPU 495. This facilitates fast retrieval of this information, which is necessary for the real-time processing of calls to the access control system 1.

5 Still referring to FIG. 7, the subscriber master record 700 contains as its first element an access (DID) number, shown at reference 701. As described earlier, this access number 701 is the unique phone number which is used to reach a given subscriber via the Public Switched Telephone Network 2. A PIN code, which is used by the subscriber to identify himself to the Telephone Control System 1, is shown at 702. At 703, a call handling mode is shown. The call handling mode defines the basic method of call handling which has been chosen by the subscriber. Possible call
10 handling modes include direct forwarding, announced forwarding, message center, voice screen forwarding, urgent screen forwarding, VIP code screen forwarding, and branch-routing. At 704, a standard greeting type is shown. The standard greeting type, 704, defines the courtesy greeting announcement which the subscriber has selected for the Telephone Control System 1 to use when first answering a call. At
15 705, an options field is shown. This options field is used to contain several miscellaneous option flags which may be used to modify the operation of the basic call handling mode. Options 705 include 'page option' which causes a page to be sent when a call is forwarded, an 'emergency/urgent' option which modifies the operation of the priority or urgent screen forwarding mode, a 'busy/no-answer' option which causes calls to be sent to the message center if a busy or no-answer condition
20 is detected, and a voice screen hold off option which modifies the operation of the voice screen forwarding mode. A transfer message type is shown at reference 706. The transfer message type, 706, defines the courtesy announcement which the subscriber has selected for the access control system 1 to use as a call is being
25 transferred. A transfer number is shown at 707. This is the number which the access control system 1 will use when forwarding, or transferring calls for this subscriber. At 708 an extension number is shown which may be used by the Telephone Control System 1 to announce to a caller the extension number of the phone at which the subscriber is located. The subscriber's message center number is shown stored at
30 709. The subscriber's pager number is shown stored at 710. The subscriber's office

number is shown stored at 711. The subscriber's home number is shown stored at 712. The subscriber's mobile phone number is shown stored at 713. At 714 a VIP screen code is shown. The VIP screen code is a code which may be used by a caller to cause his call to be forwarded to the subscriber, when the subscriber has selected
5 VIP code screened forwarding mode. The number of the current feature memory which is being used is shown stored at 715. At 716 a pager message display number is shown. This is the number which the subscriber wishes to appear in the display of his pager when the access control system 1 has taken a message from a caller. At 717 a pager forwarding display number is shown. This is the number which the
10 subscriber wishes to appear in the display of his pager when the Telephone Control System 1 is in the process of forwarding a call to the subscriber. At 718 a communicator dynamic mode display number is shown. This is the number which the subscriber wishes to appear in the display of his communicator 11 when the Telephone Control System 1 has a call holding, and requires that the subscriber select
15 a method of call handling to dispose of the call. The time and date that the last caller abandoned a meet-me call by hanging up without leaving a message is shown stored at 719. The time and date that the last caller abandoned a meet-me call by leaving a message is shown stored at 720. A count of the number of calls which have been transferred to an external message center by the Telephone Control System 1 is
20 shown stored at 721. Shown generally at 722 are the branch routing numbers 0 through 9. These fields contain the phone numbers to which a call should be transferred if a caller touches one of the digits 0 to 9 when the access control system 1 is processing a call using branch-routing mode. The branch-routing default transfer number is shown stored at 723. This is the number to which the call is transferred
25 should a caller not enter one of the digits 0 to 9. Shown stored at 724 is the feature timer duration. This value determines when the feature timer expires. Shown stored at 725 is the feature timer termination mode. This field contains the mode memory which the subscriber wishes to use upon expiration of the feature timer. The fields necessary to implement the weekly schedule function are shown generally at reference
30 726. In the preferred embodiment the weekly schedule may contain up to 32 events

(steps). For each step, the subscriber master record 700 stores a time and date, and a mode memory number to be used at that time and date. The current step number (1 to 32) is shown stored at 727. A flag which indicates to Telephone Control System 1 that the weekly schedule is on, is shown stored at 728. A flag which informs the Telephone Control System 1 as to whether the subscriber is allowed to make multiple outside calls is shown stored at 729. A flag indicating that the subscriber has selected to use his communicator 11 in the 'dynamic mode assignment' mode is shown stored at 730. A count of the number of calls made to this ACCESS NUMBER is shown stored at 731.

10 A diagram of a Mode Memory, reference 800, is illustrated in FIG 8. As described previously, the mode memories are used by subscribers of the Telephone Control System 1 to store their commonly used call handling modes and options. As with the subscriber master records 700, the mode memories 800 are stored in disk 505 and, upon initialization of the Telephone Control System 1, are copied to a
15 common database in RAM memory 500 by CPU 495. Each mode memory is unique to an individual subscriber, and is identified by storing the subscriber's ACCESS NUMBER as part of the mode memory, as shown at reference 801. In the preferred embodiment, the subscriber may have up to 90 mode memories. Each mode memory is identified by a unique mode memory number, 10 through 99. This mode memory
20 number is shown stored as part of the mode memory 800 at reference 802. Shown generally at reference 803, are the various fields which the subscriber has selected to store in the mode memory 800. As can be seen, these are a subset of the fields which are stored in the subscriber master record 700. To invoke a mode memory, the Telephone Control System 1 need only copy the fields from the mode memory
25 800 to the corresponding fields in the subscriber master record 700. The access control system 1 also copies the mode memory number 802 to the current feature memory field 715 of the subscriber master record 700.

A flowchart of the Main Task for the Call Processing Facility (CPF) 100 is shown in FIG. 9. This flowchart represents the instructions, or steps, followed by
30 CPU 495, as it controls functions of CPF 100. The starting point for the CPF -

MAIN TASK is shown at reference 900. At step 901 the CPU 495 performs initialization processes. These processes are well known in the art and include such activities as using a boot PROM to load the operational program from disk, checking for memory errors, performing hardware diagnostics, etc. The subscriber master records 700 are read from disk 505 and copied to a database in memory 500, as shown at step 902. In a similar manner, the mode memories 800 are read from disk and copied to a database in memory, as shown at step 903. At step 904, the multitasking processes are established. The multitasking allows the software to perform more than one process simultaneously. Multitasking techniques are well known in the art. As an example, UNIX is a widely used multitasking operating system. Other well known techniques allow a pseudo-multitasking function to be accomplished on a non-UNIX based operating system by constructing a 'round-robin' scheduler, by which a main process allocates 'time slices' to each of a number of sub-processes. At step 905 a process for the Network Message Task is initialized, and at step 906 control is passed to the CPF - Network Message Task. At step 907 a process for the Call Handler Task for the first trunk 3 is initialized, and at step 908 control is passed to the CPF - Call Handler Task. In a similar fashion, at step 909 a process for the Call Handler Task for the last trunk 3 is initialized, and at step 910 control is passed to the CPF - Call Handler Task. At step 911 a process for the Call Termination Task is initialized, and at step 912 control is passed to the CPF - Call Termination Task.

A flowchart of the CPF - Network Message Task is illustrated in FIG. 10. The function of this task is to receive and process messages received by Data Network Interface 510 from other facilities of the access control system 1. The CPF - Network Message Task is entered at step 1000. At step 1001 a determination is made as to whether a "request master record" message has been received. If this message has been received, then at step 1002 the subscriber master record 700 which corresponds the DID number, ANI number, or PIN code provided in the message is searched for in the database of memory 500. Upon finding this subscriber master record, at step 1003 a message containing a copy of this subscriber master record is

sent back to the requesting facility via data network interface 510. Control then returns to step 1000. Should it be determined at step 1001, that no "request master record" message has been received, then at step 1004 a check is made to determine if an "update master record" message has been received. If such a message has been received, then at step 1005 a master record for a subscriber is recovered from the message and copied to the subscriber's master record 700, at which point control returns to step 1000. If an "update master record" message is not detected at step 1004, then at step 1006 a check is made to determine if a "clear dynamic mode assignment flag" message has been received. If such a message has been received, and the message identifies a specific subscriber DID number, then the dynamic mode assignment flag 730 in the subscriber master record 700 for this subscriber is cleared at step 1007, and control returns to step 1000. If a "clear dynamic mode assignment flag" message is not detected at step 1006, then at step 1008 a check is made to determine if a "set dynamic mode assignment flag" message has been received. If such a message has been received, and the message identifies a specific subscriber DID number, then the dynamic mode assignment flag 730 in the subscriber master record 700 for this subscriber is set at step 1009, and control passes to step 1000. If a "set dynamic mode assignment flag" message is not detected at step 1008, then at step 1010 a check is made to determine if "change to new mode memory" message has been received. If such a message has not been received, then control passes to step 1014. If such a message has been received, and the message identifies a specific subscriber DID number, then at step 1011 a check is made to determine if the message was sent by the Communicator Access Facility (CAF) 125. If the message was not from the CAF 125, then control passes to step 1013. If the message was from the CAF 125, then at step 1012 an indication is sent to the CPF - Dynamic Mode Assignment routine (shown in FIG. 13), that this message was received, and control passes to step 1013. At step 1013, the mode memory number and the subscriber's DID number are removed from the message, and the corresponding mode memory 800 is copied to the corresponding subscriber's subscriber master record 700. Control then returns to step 1000. If at step 1010 it is determined that a

'change to new mode memory message' is not received, then control passes to step 1014, where a determination is made as to whether a 'mode memory inquiry' message is received, and if this is the case then control passes to step 1015 where the mode memory 800 identified in the message for the subscriber identified in the message is retrieved from the database of memory 500 and a message is constructed and sent back to the requesting facility via data network interface 510. Control then returns to step 1001. If at step 1014 it is determined that a 'mode memory inquiry message is not received, then control passes to step 1016, where a determination is made as to whether a 'mode memory update' message is received, and if this is the case, then control passes to step 1017 where the new mode memory contents are retrieved from the message, and the mode memory is copied to the appropriate mode memory 800 in the database of memory 500. Control then returns to step 1001. If at step 1016, it is determined that a 'mode memory update' message is not received, then control passes to step 1018 where a determination is made as to whether a 'create new subscriber' message is received, and if this is the case then control passes to step 1019 where the DID number is retrieved from the message, a subscriber master record 700 is created for this DID number 701, and a set of mode memories 800 are created for this DID number 701. Control then returns to step 1001. If at step 1018 it is determined that a 'create master record' message is not received, then control returns to step 1001.

A flowchart of the CPF - Call Termination Task is illustrated in FIG. 11. The purpose of this task is to monitor the loop status signal 475 for each trunk interface 400, and to terminate any call in progress should the loop status become inactive. In this way the system detects if the calling party has hung up. The CPF - Call Termination Task is entered at step 1100. At step 1101 a trunk pointer is set to a value of 1. At step 1102 the loop status signal 475 for the trunk pointed to by the trunk pointer is read via call processor 435. At step 1103, a determination is made as to whether the loop status signal 475 is active. If the signal is active, then control passes to step 1106. If the signal is not active, then the caller must have hung up, and at step 1104 the trunk is placed on hook by call processor 435 via on/off hook

control signal 485. Then at step 1108 a determination is made as to whether this trunk was processing the "CPF-Meet Me Caller" function, and if this is the case then control passes to step 1109 where the current time and date is stored in the "last meet-me abandon" field 719 of the subscriber master record 700. Control then passes to step 1105. Control also passes to step 1105 if at step 1108 it is determined that the trunk was not processing the "CPF-Meet Me Caller" function. At step 1105 the CPU 495 signals the multitasking process 907 controlling the call handler task for this trunk to return to its entry point 908, thereby terminating any activity on that trunk. Control then passes to step 1106, where a check is made to determine if the trunk pointer is pointing to the last trunk. If the trunk pointer is pointing to the last trunk, then control returns to step 1101. If the trunk pointer is not pointing to the last trunk, then at step 1107 the trunk pointer is incremented and control returns to step 1102.

A flowchart of the CPF - Call Handler Task is illustrated in FIG. 12. The function of this task is to respond to an incoming call on a trunk 3, receive the DID digits identifying the subscriber's ACCESS NUMBER being dialed, determine the method of call handling as specified in the database of memory 500 by subscriber master record 700 which corresponds to that ACCESS NUMBER, and then cause the call to be processed accordingly. The CPF - Call Handler Task is entered at step 1200, a connection point labelled "CPF IDLE" is passed at reference 1201, and at step 1202 the DID received signal 480 is cleared, allowing trunk interface 400 to receive a new call. Control then remains at step 1203 until an incoming call signal 470 is received from the trunk interface 400, at which point control passes to step 1204 causing the call processor to issue an off hook signal via its on/off hook control line 485. Then at step 1205, incoming DID digits are decoded and accepted by the DTMF detector of call processor 435. Then at step 1206, after the DID digits have been received, the DID received signal 480 is set, causing E & M control circuit 450 to force the M-Lead active, thereby seizing the trunk. Control then passes through a connection point labelled "CPF VIRTUAL TRANSFER" at reference 1207. At step 1208 the subscriber master record 700 which corresponds to the received DID

number is retrieved from the database of memory 500. At step 1209 the call count 731 is incremented in the subscriber master record 700. At step 1210 a check is made to determine if the feature timer is active. This is accomplished by checking the feature timer duration 724. The feature timer is active if the feature timer duration 724 is non zero. If the feature timer is not active, then control passes to step 1213. If the feature is active, then another check is made at step 1211 to determine if the feature timer has expired since the last call. This is determined by comparing the feature timer duration 724 with the current time and date maintained by CPU 495. The feature timer has expired if the feature timer duration 724 does not extend beyond the current time and date. If the feature timer has not expired, then control passes to step 1213. If the feature timer has expired, then at step 1212 the mode memory 800 specified by the feature timer termination mode 725 is copied to the subscriber master record 800, and the feature timer duration 724 is cleared to zero. Control then passes to step 1213. A determination is made at step 1213 as to whether the weekly schedule is active by checking the status of the weekly schedule active flag 728. If the weekly schedule is not active, then control passes to step 1217. If the weekly schedule is active, then a determination is made a step 1214 as to whether the current step of the weekly schedule is correct. This is accomplished by finding the current step of weekly schedule 726 as pointed to by the weekly schedule current step 727, and comparing the time and date of the next step with the current time and date. If the current time and date fall between the current step and the next step, then the current step is correct. If, by this process, it is determined that the current step is correct, then control passes to step 1217. Otherwise, at step 1215, the weekly schedule current step 727 is incremented to point to the next step. Then at step 1216, the mode memory number corresponding to the new step of the weekly schedule 726 is found, the corresponding mode memory 800 is copied to the subscriber master record 700, and then control passes to step 1217. At step 1217 the status of the dynamic mode assignment flag 730 is checked, and if it is found to be active, control is passed at step 1218 to the CPF - Dynamic Mode Assignment. Otherwise, control passes through a connector labelled " CPF MODE" at reference 1219, and then

passes to step 1220. At step 1220 a determination is made as to whether the current call handling mode 703 is set for 'direct forwarding', and if so control is passed via step 1221 to the CPF - Direct Forwarding. Otherwise a determination is made at step 1222 as to whether the current call handling mode 703 is set for 'announced forwarding' and if not control passes to step 1230. If the call handling mode 703 is set for 'announced forwarding', then at step 1223 a further check is made to determine if the transfer number 707 is set for meet-me, and if not control passes to step 1230. If the transfer number 707 is set for meet-me, then at step 1224 one audible ring is played to the caller by call processor 435. Then at step 1225, the 'pager display digits' are set to be equal to the DID number, prior to the "send page" subroutine being called at step 1226. Upon receiving a page with his own DID number in the display, the subscriber may recognize this as a meet-me call. Then a 4 second delay is initiated at step 1227, another ring is generated at step 1228, and another 4 second delay is initiated at step 1229, before passing control to step 1230. As can be seen, the effect of steps 1224 to 1229 is to simulate the typical ringing cadence expected by a caller, and in addition allow some time for the page sent at step 1225 to reach the subscriber's pager. Because the caller must wait for the subscriber to get to a phone when the subscriber is using meet-me, the sequence of steps 1224 to 1229 has the effect of reducing the delay perceived by the caller. At step 1230, an audible ring is generated towards the caller by call processor 435. Then at step 1231 a determination is made as to whether the caller has entered the PIN code 702. If the PIN code has been entered, then the caller must be the subscriber, and therefore control passes to the CPF - Command Mode via step 1233. If the PIN code has not been entered, then the control passes to step 1270 where a determination is made as to whether the 'message center access code' has been entered by the caller. In the preferred embodiment the 'message center access code' consists of the digits "*9" and is the same for all subscribers. This code may be used by callers who simply wish to leave a message and do not need to speak with the subscriber. If the 'message center access code' has been entered by the caller, then control passes to the "CPF - Caller Message Center" function as shown at step 1271.

If the 'message center access code' has not been entered, then control passes to connector label "CPF GREETING" as shown at reference 1232.

5 Still referring to FIG. 12, control passes through the connector labelled "CPF GREETING" at reference 1233 to step 1234, where a determination is made as to whether the call handling mode 703 is set for 'branch-routing', and if so control passes through a connector labelled "CPF PIN" at reference 1235. Otherwise, at step 1236 the standard greeting type 704 is retrieved from the subscriber master record 700. If the standard greeting type is 'stock' as determined at step 1237, then control passes to step 1238 where a stock generic greeting is played to the caller: "Hello, you have reached your party's telephone control system." Control then passes through a connector labelled "CPF PIN" at reference 1239. If the standard greeting type is not determined to be 'stock' at step 1237, then a further check is made at step 1240 to determine if the standard greeting type is 'drop-in', and if not the control is passed to step 1245. If the standard greeting type is 'drop-in' then at step 1241 the subscriber's prerecorded drop-in name is retrieved from disk 505. Then at step 1242 the call processor 435 plays the greeting: "Hello, you have reach the telephone control system for....", and then at step 1243 completes the greeting by playing back the pre-recorded name of the subscriber retrieved form disk in step 1241. Control then passes through a connector labelled "CPF PIN" at 1244. As was described earlier, if the standard greeting type was found not to be 'drop-in' at step 1240 then control passed to step 1245. At step 1245, a check is made to determine if the standard greeting type is 'personalized', and if not control passes to step 1238, described earlier. Otherwise, control passes to step 1246 where the subscriber's pre-recorded personalized greeting is retrieved from disk 505, and is then played back to the caller at step 1247 by call processor 435. Control then passes through connector labelled "CPF PIN" at reference 1248 and a check is made at step 1249 to determine if the caller has entered a PIN code. If the PIN code has been entered, then the caller must be the subscriber, and therefore control passes to the CPF - Command Mode via step 1250. If the PIN code has not been entered, then the control passes to step 1272 where a determination is made as to whether the 'message center access

code' has been entered by the caller. As was described earlier, in the preferred embodiment the 'message center access code' consists of the digits "*9" and is the same for all subscribers. This code may be used by callers who simply wish to leave a message and do not need to speak with the subscriber. If the 'message center access code' has been entered by the caller, then control passes to the "CPF - Caller Message Center" function as shown at step 1273. If the 'message center access code' has not been entered, then control passes to step 1251, where the call handling mode 703 is retrieved from the subscriber master record 700. Then at step 1252 a check is made to determine if the call handling mode 703 is set for 'announced forwarding', and if so a further check is made at step 1253 to determine if the transfer number 707 is set for meet-me. If the transfer number is not set for meet-me then control passes to CPF - Announced Forwarding via step 1254. If the transfer number is set for meet-me, then control passes to CPF - Meet-Me Caller via step 1255. If at step 1252 it was determined that the call handling mode was not set for 'announced forwarding', then control passes to step 1256. At step 1256 a check is made to determine if the call handling mode 703 is set for 'urgent screen forwarding', and if so control passes to CPF - Urgent Screen via step 1257. Otherwise, at step 1258 a check is made to determine if the call handling mode 703 is set for 'VIP code screen forwarding', and if so control passes to CPF - VIP Code Screen via step 1259. Otherwise, at step 1260 a check is made to determine if the call handling mode 703 is set for 'voice screen forwarding', and if so control passes to CPF - Voice Screen via step 1261. Otherwise, at step 1262 a check is made to determine if the call handling mode 703 is set for 'branch-routing', and if so control passes to CPF - Branch-Routing via step 1263. Otherwise control passes to CPF - Message Center via step 1264.

A flowchart of the CPF - Dynamic Mode Assignment is illustrated in FIG. 13. The purpose of this function is to process calls for a subscriber who is using a Communicator 11, and who has selected the dynamic mode assignment mode of operation. The dynamic mode assignment mode of operation allows a subscriber to chose dynamically, with each incoming call, the call handling mode to be used for

the call. The subscriber is alerted via his Communicator 11 that an incoming call is present, and the subscriber may then transmit a 'new mode memory' message from his Communicator 11 thereby informing the Telephone Control System 1 as to how the call should be handled. The CPF - Dynamic Mode Assignment function is entered at step 1300, and at step 1301 the 'pager display digits' are set equal to the communicator dynamic mode display number 718. At step 1302, the 'send page' subroutine is called, causing a page to be sent to the subscriber's Communicator 11. At step 1303, a ring count is set to a value of 4. At step 1304 an audible ring is played to the caller by call processor 435, and at step 1313 a determination is made as to whether the caller has entered the PIN code 702. If the PIN code has been entered, then the caller must be the subscriber, and therefore control passes to the CPF - Command Mode via step 1314. If the PIN code has not been entered, then the control passes to step 1315 where a determination is made as to whether the 'message center access code' has been entered by the caller. As was described earlier, in the preferred embodiment the 'message center access code' consists of the digits "*9" and is the same for all subscribers. This code may be used by callers who simply wish to leave a message and do not need to speak with the subscriber. If the 'message center access code' has been entered by the caller, then control passes to the "CPF - Caller Message Center" function as shown at step 1316. If the 'message center access code' has not been entered, then at step 1305 a 4 second delay is initiated, thus creating a typical ring cadence. At step 1306 a check is made to determine if the Network Message Task (Fig. 10) has received a 'new mode memory' message from the Communicator 11 belonging to this subscriber. If such a message has been received, then the control passes to connector labelled "CPF MODE" as indicated at reference 1307. If message was not received, then the ring count is decremented at step 1308, and at step 1309 a check is made to determine if the ring count is 0. If the ring count is not '0', then control returns to step 1304 and the ring cycle is repeated. If the ring count is 0, indicating four rings cycles have been generated without the subscriber responding, then control passes to step 1310, labelled "CPF SORRY" by the connector at reference 1311, and the caller is informed, via call

processor 435: "I'm sorry, your party is not available at the moment. We will connect you to your party's message center where you may leave a detailed message." Control then passes to CPF - Caller Message Center via step 1312.

A flowchart of the CPF - Direct Forwarding function is illustrated in FIG. 14. The purpose of this function is to process calls for a subscriber who has selected the 'direct forwarding' call handling mode. In this mode, calls are transferred without any announcement. Low amplitude 'confidence tones' are generated just prior to the transfer so that the subscriber may have an opportunity to enter his PIN Code. The CPF - Direct Forwarding function is entered at step 1400, and 'confidence tones' are generated at step 1401 by call processor 435. The 'confidence tones' are a prerecorded sequence of tones which are designed to sound similar to the interoffice multifrequency signalling tones that callers are familiar with. In this way the caller has no clear indication that the call is being answered and transferred, and yet at the same time the subscriber is given an indication as to when he may enter his PIN Code. At step 1402, a determination is made as to whether the subscriber has entered his PIN code. If the PIN code has been entered, then control passes to CPF - Command Mode via step 1403. Otherwise control passes to step 1416 where a determination is made as to whether the 'message center access code' has been entered by the caller. As was described earlier, in the preferred embodiment the 'message center access code' consists of the digits "*9" and is the same for all subscribers. This code may be used by callers who simply wish to leave a message and do not need to speak with the subscriber. If the 'message center access code' has been entered by the caller, then control passes to the "CPF - Caller Message Center" function as shown at step 1417. If the 'message center access code' has not been entered, then control passes to a connector labelled "CPF DIAL TRANSFER" at reference 1404 to step 1405, where a check is made to determine if the transfer number 707 contains a reference to a reserved phone number (a tag) or a reference to a mode memory. Tags may be used as follows:

30 TAG DIGIT RESERVED PHONE NUMBER

45

| | | |
|---|---|-----------------------------|
| | 1 | message center number 709 |
| | 2 | pager number 710 |
| | 3 | office number 711 |
| | 4 | home number 712 |
| 5 | 5 | mobile phone number 713 |
| | 6 | meet-me tag |
| | 7 | 'externally entered' number |

As will be described in more detail later in this discussion, if a mode memory
10 800 has a transfer number 707 that is an 'externally entered' number tag, then when
that mode memory is invoked, the transfer number is not changed from the previous
value. Also, if a mode memory which contains a transfer number 707 that is an
'externally entered' number tag can be invoked remotely by the subscriber via a
Feature Group D trunk, causing the ANI number received by the trunk to be used as
15 the transfer number 707. The reference to the mode memory may be in the form of
the two digit mode memory number 10 - 99. Therefore, at step 1405, if the transfer
number 707 contains the digits 1 through 6, or the digits 10 through 99, then control
will pass to step 1406. Otherwise, control will pass to step 1409. At step 1406 a
determination is made as to whether the transfer number 707 contains the meet-me
20 tag (ie. digit 6). If the meet-me tag is found, then control passes to the CPF -
Meet-Me Caller Function via step 1407. If the meet-me tag is not found at step
1406, then control passes to step 1408, where the tag or mode memory is expanded
to a real phone number which can be dialed. If the transfer number 707 contains a
tag, then the corresponding reserved phone number per the table above is used as the
25 expanded number to be dialed. If the transfer number 707 contained a mode memory
number, then the transfer number 707 from the corresponding mode memory 800 is
used as the expanded number to be dialed. Control then passes to step 1409, where
a determination is made as to whether the transfer number to be dialed can be found
as the ACCESS NUMBER 801 in any of the subscriber master records 700. If so,
30 then it is not necessary to do a physical transfer, and the call can be continued on the

same trunk by passing control through the connector labelled "CPF VIRTUAL TRANSFER" at reference 1410. Otherwise, at step 1411 a flash is generated by call processor 435 by producing a 700 millisecond on hook signal on the on/off hook control line 485. This flash places the calling party on hold and causes a second dial tone to be returned on trunk 3 by the serving central office of the PSTN 2. At step 5 1412 a brief pause is introduced to allow time for the dial tone to appear on the trunk, and then at step 1413 the transfer number is dialed via the DTMF generator of call processor 435. Then at step 1418 the 'busy/no-answer' option flag of options 705 of subscriber master record 700 is checked. The function of this option is to 10 handle calls which are being sent to a subscriber even if the subscriber's line is busy or does not answer. If this option is active then at step 1419 a flash is generated by call processor 435 causing the calling party to be taken off hold and connected to the call being placed to the transfer number. The calling party will thus be able to hear the progress of the call and will therefore hear the subscriber answer if the subscriber 15 does indeed answer. At step 1420 a determination is made as to whether the call was local or long distance. If the transfer number was longer than 7 digits, or if the 7 digit number contained a prefix which is long distance in this area, then the call was long distance and a 40 second timer is started at step 1422. If the transfer number was less than or equal to 7 digits, then the call was local and a 25 second timer is 20 started at step 1421. Then at step 1423 a determination is made as to whether precision busy/ring detector 437 is detecting busy signal, and if not control passes to step 1424. If a busy signal is detected at step 1423, indicating that the subscriber's line is busy, then control passes to step 1429 where a flash is generated by call processor 435 causing the call attempt to be dropped but leaving the calling party 25 connected to the telephone control system 1. Control then passes to a connector labelled "CPF - Sorry" as shown at step 1430, which causes the caller to be sent to the subscriber's message center function. If at step 1423 a busy signal was not detected, then control passes to step 1424 where a determination is made as to whether the timer has expired. If the timer has expired, indicating that neither busy or ringing where detected, then control passes to 1414. If at step 1424 it is 30

determined that the timer has not expired, then control passes to step 1425 where a determination is made as to whether precision busy/ring detector 437 is detecting a first ringing signal, and if not control returns to step 1423. If the first ringing signal is detected at step 1426, then control passes to step 1426, where a determination is made as to whether this is the fourth ring signal, and if so, indicating that the subscriber is not answering the call, then control passes to step 1429 causing the caller to be ultimately routed to the subscriber's message center function as was described earlier. If at step 1426 it is determined that this is not the fourth ring, then control passes to step 1427 where control idles until an end-of-ring is detected by precision busy/ring detector 437. Control then passes to step 1428 where a 6 second 'inter-ring timer' is started. Control then passes to step 1431 where a determination is made as to whether precision busy/ring detector 437 is detecting ringing signal and if so control returns to step 1426. If however at step 1431 it is determined that ringing signal is not being detected, then control passes to step 1432 where the 'inter-ring timer' is checked. If the 'inter-ring timer' has not expired then control returns to step 1431. If the 'inter-ring timer' has expired, indicating the subscriber has answered the call, then control passes to step 1414. At step 1414 an on hook signal is generated on the on/off hook control line 485, causing the call to be transferred to the dialed number, and freeing up the trunk 3 to handle another incoming call. Control then passes to the connector labelled "CPF IDLE" at reference 1415.

A flowchart of the CPF - Announced Forwarding function is illustrated in FIG. 15. The purpose of this function is to process calls for a subscriber who has selected the 'announced forwarding' call handling mode. In this mode, callers are greeted with a brief courtesy announcement prior to being transferred. In addition, if a 'page option' has been selected, then a page is sent to the subscriber's pager prior to transferring the call. The CPF - Announced Forwarding function is entered at step 1500 and at step 1501, a determination is made as to whether the page flag of options 705 is set, and if it is not set, then control passes to the connector labelled "CPF AF2" at reference 1502. If the page flag is set, the control passes to step 1503

where the display digits are set equal to the pager forwarding display number 717. At step 1504 the 'send page' subroutine is called causing a page to be sent to the subscriber's pager. Then at step 1505, the call processor 435 plays to the caller the message: "We are sending a page to inform your party of your call. Please stay on the line." At step 1506 a delay is initiated to allow the pager sufficient time to receive the page. Then at step 1507, another message is played to the subscriber: "We have sent a page to your party and we will connect your call momentarily. Please stay on the line." At step 1508 an additional delay is initiated to allow the subscriber the opportunity to get to a phone. Control then passes to the connector labelled "CPF AF2" at reference 1509. The connector labelled "CPF AF2" at reference 1510 passes control to step 1511, where the transfer message type 706 is retrieved from subscriber master record 700. Then at step 1512, a check is made as to whether the transfer message type is '0'. If the transfer message type is '0', indicating no transfer message is to be played, then control passes to the connector labelled "CPF DIAL TRANSFER" at reference 1520. If the transfer message type is not '0', then control passes to step 1513 where a check is made to determine if the transfer message type is '1'. If the transfer message type is '1', then at step 1514 the call processor 435 plays to the caller the message: "We're connecting your call", and then control passes to the connector labelled "CPF DIAL TRANSFER" at reference 1520. If the transfer message type is not '1', then control passes to step 1515 where a check is made to determine if the transfer message type is '2'. If the transfer message type is '2', then at step 1516 the call processor 435 plays to the caller the message: "We're connecting your call. When the call is answered, please ask for your party by name", and then control passes to the connector labelled "CPF DIAL TRANSFER" at reference 1520. If the transfer message type is not '2', then control passes to step 1517 where a check is made to determine if the transfer message type is '3'. If the transfer message type is '3', then at step 1518 the call processor 435 plays to the caller the message: "We're connecting your call. When the call is answered, please ask for extension number...." Then at step 1519, the extension number 708 is retrieved from the subscriber master record 700 and is voiced to the

caller by call processor 435. Control then passes to the connector labelled "CPF DIAL TRANSFER" at reference 1520.

A flowchart of the CPF - Urgent Screen function is illustrated in FIG. 16. The purpose of this function is to process calls for a subscriber who has selected the "priority screen" or 'urgent screen' call handling mode. The CPF - Priority/Urgent Screen function is entered at step 1600, and control passes to step 1601, where call processor 435 plays to the caller the message: "Your party is not readily available at the moment. If this call is..." Control then passes to step 1602 where the urgent/emergency flag of the options 705 is checked. If the flag is set for 'urgent', then the call processor 435 plays to the caller "...urgent...", and if the flag is set for emergency then call processor 435 plays to the caller "...an emergency..." Control then passes to step 1603 where the call processor completes the sentence by playing the message "...then touch 0 now and we will attempt to connect your call. Otherwise, we will connect you to your party's message center where you may leave a detailed message." Then at step 1604, a 5 second timer is started. At step 1605 a determination is made as to whether the caller has touched 0. If the caller has touched 0, then control passes to the CPF - Announced Forwarding function via step 1606. If the caller has not touched 0, then at step 1607 a determination is made as to whether the 5 second timer has expired. If the 5 second timer has not expired then control returns to step 1605. If the 5 second timer has expired, then at step 1608 the caller is informed: "Please standby". Control then passes to the CPF - Caller Message Center function via step 1609.

A flowchart of the CPF - VIP Code Screen function is illustrated in FIG. 17. The purpose of this function is to process calls for a subscriber who has selected the 'VIP code screen' call handling mode. The CPF - VIP Code Screen function is entered at step 1700 and control is passed to step 1701 where the call processor 435 plays to the caller the message: "Your party is not readily available at the moment. Please enter your code now, or we will connect you to your party's message center where you may leave a detailed message." Control then passes to step 1702 where a 5 second timer is started. At step 1703 a determination is made as to whether the

caller has entered the VIP screen code 714 as stored in the subscriber master record 700. If the caller has entered the correct VIP screen code, then control passes to the CPF - Announced Forwarding function via step 1704. If the caller has not entered the VIP screen code 714, then at step 1705 a determination is made as to whether the
5 5 second timer has expired. If the 5 second timer has not expired then control returns to step 1703. If the 5 second timer has expired, then at step 1706 the caller is informed: "Please standby". Control then passes to the CPF - Caller Message Center function via step 1707.

A flowchart of the CPF - Branch Routing function is illustrated in FIG. 18.
10 The purpose of this function is to process calls for a subscriber who has selected the 'branch-routing' call handling mode. The CPF - Branch Routing function is entered at step 1800, and control passes to step 1801 where the prerecorded branch-routing greeting is retrieved from disk 505. Then at step 1802, the playback to the caller of the branch-routing greeting is begun by call processor 435. At step 1803 a
15 determination is made as to whether the caller has entered a digit. If the caller has not entered a digit then at step 1804 a determination is made as to whether the call processor 435 has completed the playback of the branch-routing greeting, and if an additional 5 second shave expired. If this is the case then control passes to step 1805. If this is not the case, then control returns to step 1803. If at step 1803 it is
20 determined that the caller has entered a digit, then control passes to step 1806 where a determination is made as to whether there exists a branch-routing number 722 in the subscriber master record 700 which corresponds to the digit entered by the caller. For example, if the subscriber entered digit 4, then a determination is made as to whether the subscriber master record holds a phone number entry in the branch
25 routing number4 position at 722. If an entry is found in such a manner, then control passes to step 1807. Otherwise, control passes to step 1805 where a the branch routing default number 723 is retrieved for the subscriber master record 700, and is set up to be used as the transfer number for this call. Control then passes to the connector labelled "CPF DIAL TRANSFER" at reference 1808. Should the caller
30 have entered a digit which corresponded to a branch routing number 722, then at step

1807 the corresponding branch routing number 722 is retrieved from the subscriber master record 700, and is setup to be used as the transfer number for this call. Control then passes to the connector labelled "CPF DIAL TRANSFER" at reference 1808.

5 A flowchart of the CPF - Caller Message Center function is illustrated in FIG. 19. The purpose of this function is to process calls for a subscriber who has selected the 'message center' call handling mode. The CPF - Caller Message Center function is entered at step 1900 and control passes to step 1901 where a determination is made as to whether an external message center has been selected. This
10 determination is made by examining the message center number 709 in the subscriber master record 700. If the message center number 709 contains a phone number, then external has been selected. If the message center number 709 does not contain a phone number, then internal message center has been selected. The subscriber may choose an external voice mail system, an answering service, his secretary, or any
15 other appropriate phone number for the external message center number 709. If, at step 1901, it is determined that the subscriber has selected the internal message center, then control passes to step 1902, where the caller is prompted: "Please leave your message at the tone ...BEEP." Then at step 1903 the callers message is recorded by call processor 435 and stored on disk 505. At step 1904 a determination is made as to whether the caller has completed leaving the message. This is
20 accomplished by call processor 435 determining if there has been at least 3 seconds of silence on the line since the last sound. If the caller has not completed leaving a message then the recording continues at step 1903. If the caller has completed leaving a message, then control passes to step 1905, where the caller is prompted:
25 "Thank you for calling. Good-bye." Then at step 1906 the trunk is placed on hook by call processor 435 via on/off hook control signal 485. Control then passes to step 1907, where a decision is made as to whether a message was actually left. A message is determined to be left if at least 3 seconds of non-silence has been recorded, as determined by call processor 435. If a message was not left, then
30 control passes to connector labelled "CPF IDLE" at reference 1908. If a message

was left by the caller, then control passes to step 1909, where the 'display digits' are set equal to the pager message center display number. The 'send page' subroutine is then called at step 1910, and control passes to a connector labelled "CPF IDLE" at reference 1911. Returning now to step 1901, if a determination is made, in the manner described above, that an external message center is selected, then control passes to step 1912 where the party is informed by call processor 435: "Please standby," then control passes to step 193 where a flash is generated by call processor 435 by producing a 700 millisecond on hook signal on the on/off hook control line 485. This flash places the calling party on hold and causes a second dial tone to be returned on trunk 3 by the serving central office of the PSTN 2. At step 1914 a brief pause is introduced to allow time for the dial tone to appear on the trunk, and then at step 1915 the message center number 709 is dialed via the DTMF generator of call processor 435. The message center number may contain special dialing characters, including characters for pausing, waiting for tones, and waiting for answer. Thus a sequence of dialing characters may be constructed to allow the Telephone Control System 1 to transfer calls to a voice mail system requiring the entry of a subscriber ID. For example, an external message center dialing sequence for a typical voice mail system may be: 7 digit phone number of voice mail system + Wait for answer + 4 digit voice mail subscriber ID. Continuing now, at step 1916 an on hook signal is generated on the on/off hook control line 485, causing the call to be transferred to the dialed number, and freeing up the trunk 3 to handle another incoming call. Control then passes to step 1917 where the 'external message center count' 721 in the subscriber master record 700 is incremented. Control then passes to steps 1909 and 1910 where a page is generated as described above, before returning control to the connector labelled "CPF IDLE" at reference 1911.

A flowchart of the CPF - Voice Screen function is illustrated in FIG. 20. The purpose of this function is to process calls for a subscriber who has selected the 'voice screen' call handling mode. The CPF - Voice Screen function is entered at step 2000 and control passes to step 2001 where the caller is prompted by call processor 435: "Please state your name and business at the tone. After the tone

please stay on the line while we attempt to locate your party and connect your call....BEEP." Control then passes to step 2090 where a determination is made as to whether the caller has entered the 'VIP screen code' 714, and if so control passes to the "CPF - Announced Forwarding" function as shown at step 2091. In this way,

5 a caller who knows the 'VIP screen code' is able to be forwarded directly to the subscriber without being voice-screened. If, however, at step 2090 it is determined that the caller has not entered the 'VIP screen code' 714 then control passes to step 2002 where the caller's message is recorded by call processor 435 and stored temporarily on disk 505. At step 2003, the call processor 435 determines that the

10 caller has completed stating his name and business, by detecting the sound of the voice followed by approximately 3 seconds of silence, at which point the call processor 435 prompts the caller: "Thank you, please standby." A flash is generated at step 2004, causing the caller to be placed on hold by the switch 4, and at step 2005 a pause is initiated to allow time for the switch 4 to provide a dial tone, at which

15 point the transfer number 707 is dialed by the DTMF generator of call processor 435. At step 2006, an 'answer timer' is started. At step 2007 a determination is made by call processor 435 as to whether the call has been answered. If the call has not been answered, then at step 2008 a decision is made as to whether a time-out or non-answer signal such as a busy, reorder, or operator intercept has been detected by

20 call processor 435. If so, then control proceeds through a connector labelled "CPF VSCRN FLASH" at reference 2009, to step 2010. Otherwise control returns to step 2207. At step 2010, a flash is generated, causing switch 4 to temporarily conference the caller through to the non-answer signal, and at step 2011 a 2 second pause is invoked. Then at step 2012 another flash is generated causing switch 4 to drop the

25 conference and restore a simple 2-way connection between the caller and the trunk 3. Control then passes to a connector labelled "CPF SORRY" at reference 2013, resulting in the caller being connected to the subscriber's message center as described earlier in FIG. 13. Returning the discussion now to step 2007, if a determination is made that the call is answered, then control passes to step 2014 where the 'voice

30 screen PIN code hold-off flag' of options 705 of the master record 700 is checked.

If this flag has been set, it means that the subscriber wishes to require that a PIN code be entered by the answering party before the called party's message is played. This is very useful if the subscriber is having his calls voice-screen forwarded to his office, for example, where the receptionist may answer the call. In this case the

5 receptionist would connect the call to the subscriber and the subscriber would enter his PIN code to hear the calling party's message before determining whether he wishes to be connected to the calling party. If this flag is set, then control passes to step 2015, where call processor 435 prompts the answering party: "We are trying to reach...". Then at step 2016, the subscriber's prerecorded 'drop-in' name is retrieved

10 from disk 505 and played back to the answering party. At step 2017, the answering party is informed: "Please locate the party or enter your PIN code." Then at step 2018, a 5 second delay is introduced, and at step 2019, a determination is made as to whether the answering party has entered the PIN code 702. If the PIN code is entered, then control passes to step 2021. Otherwise, control passes to step 2020,

15 where a determination is made as to whether the sequence of steps 2015 through 2020 has been repeated ten times. If not, then control returns to step 2015, and the sequence is repeated again. However, if this is the tenth repeat, then control passes to the connector labelled "CPF VSCRN FLASH" at reference 2009, and the calling party is sent to the subscriber's message center as described earlier. If, at step 2014,

20 it is determined that the 'voice screen PIN code hold-off flag' is not set, or if it is set and the PIN code has been entered as determined at step 2019, then control passes to step 2021, where the answering party is informed by call processor 435: "We have a call holding for...", and then to step 2022 where the subscriber's 'drop-in' name is retrieved from disk and played. Then at step 2023, which is identified by the

25 connector labelled "CPF VSCRN LISTEN" at reference 2024, the caller's message which was originally recorded at step 2002 is retrieved from disk 505 and played by call processor 435 to the subscriber. Then at step 2025, which is identified by the connector labelled "CPF VSCRN MENU" at reference 2026, the subscriber is prompted: "Please touch 1 to connect the call, 2 to send the caller to your message

30 center, 3 to politely send the caller away, 4 to listen to the caller's message again.

5 to place the caller on hold for 1 minute, 6 to transfer the call elsewhere, or 7 to ask the caller not to call again." Control then passes through a connector labelled "CPF VSCRN LOOP" at reference 2027. At reference 2028, the connector labelled "CPF VSCRN LOOP" passes control to step 2029 where a 10 second timer is started. Then

5 at step 2030, a determination is made as to whether a digit has been entered by the subscriber, and if so control passes to step 2033. Otherwise, control passes to step 2031 where the 10 second timer is checked, and if it has not expired control returns to step 2030. If the timer has expired, then control is passes to the connector labelled "CPF VSCRN FLASH" at reference 2032, and the caller is connected to the message

10 center as described earlier. If a digit has been entered by the subscriber, then at step 2033, the digit is checked and if it is not '1', control is passes to step 2043. If the digit is '1', then control passes to step 2034, where a flash is generated causing the calling party and the subscriber to be conferenced by switch 4. Then at step 2035 a determination is made as to whether dial tone is present on the line. If so this would

15 indicate that the conference failed, most likely because the calling party had hung up. If this is the case, then control passes to step 2039. Otherwise, if dial tone is not detected, then at step 2036, both the calling party and the subscriber hear call processor 435 play the prompt: "Go ahead please.", and at step 2037, the trunk 3 is placed on hook causing the switch 4 to transfer the call allowing the calling party and

20 the subscriber to continue their conversation, while at the same time freeing up trunk 3 to handle another incoming call by passing control back to the CPF - Call Handler Task via the connector labelled "CPF IDLE" at reference 2038. If the caller had hung up as determined by the detection of dial tone at step 2035, then at step 2039 another flash is generated to cause switch 4 to take the subscriber off of hold. Then

25 at step 2040, the subscriber is informed: "I'm sorry, your party has hung up", and at step 2041 trunk 3 is placed on hook and control is returned to the CPF - Call Handler Task via the connector labelled "CPF IDLE" at reference 2042. If, as described earlier, at step 2033 it is determined that the digit is not '1', then control is passes to step 2043 where it is determined whether the digit is a '2', and if so

30 control is passes to the connector labelled "CPF VSCRN FLASH" at reference 2044

causing the calling party to be connected to the message center as was described earlier. If the digit is not '2', then control passes to step 2045, where it is determined if the digit is a '3', and if not control passes to step 2052. If the digit is a '3', then control passes to step 2046, where a flash is generated causing switch 4

5 to temporarily conference the calling party and the subscriber. Then, after a 2 second pause at step 2047, another flash is generated at step 2048 causing switch 4 to terminate the conference by dropping the subscriber, leaving just the calling party connected to trunk 3. Then at step 2049, the calling party is informed by call processor 435: "I'm sorry, your party is unable to take your call at this time. Thank

10 you for calling. Good-bye." Then at step 2050, the trunk 3 is placed on hook thereby disconnecting the calling party and control is returned to the CPF - Call Handler Task via the connector labelled "CPF IDLE" at reference 2051. If, as described earlier, at step 2045 it is determined that the digit is not '3', then control is passes to step 2052 where it is determined whether the digit is a '4', and if so

15 control is passes to the connector labelled "CPF VSCRN LISTEN" at reference 2053, allowing the subscriber to again hear the calling party's message as described earlier. If at step 2052 it is determined that the digit is not a '4', then control passes to step 2054 where the digit is checked to determine if it is a '5', and if it is not control passes to a connector labelled "CPF VSCRN DIGIT" at reference 2060. If the digit

20 is a '5', then control passes to step 2055 where a one minute timer in started. Then at step 2056 a determination is made whether any further digits have been entered by the subscriber, and if not control passes to step 2058 where the one minute timer is checked. If the timer is found to have expired, then control passes to a connector labelled "CPF VSCRN MENU" at reference 2059, causing the menu of step 2025 to

25 be replayed to the subscriber. If the timer is found to have not expired, then control returns to step 2056 where a determination is again made as to whether any digits have been entered by the subscriber, and if so control passes to a connector labelled "CPF VSCRN LOOP" at reference 2057, thereby allowing the digit to be processed. The connector labelled "CPF VSCRN DIGIT6" at reference 2061 causes control to

30 be passed to step 2062 where a determination is made as to whether the digit pressed

by the subscriber is a 6, and if not control passes to step 2075. If the digit is a '6', then control passes to step 2063 where the subscriber is prompted by call processor 435: "Please enter the telephone number you wish to have this call transferred to." Then at step 2064, the control idles, waiting for a telephone number to be entered by the subscriber. If a phone number is entered, then control passes to step 2065, where the subscriber is prompted: "Number accepted. Please hang up now." Then at step 2066 a flash is generated causing switch 4 to temporarily conference the calling party and the subscriber. Then, after a 2 second pause at step 2067, another flash is generated at step 2068 causing switch 4 to terminate the conference by dropping the subscriber, leaving just the calling party connected to trunk 3. Then at step 2069 the calling party is prompted by call processor 435: " Please standby." Then at step 2070 a flash is generated causing switch 4 to place the calling party on hold and providing a dial tone to the trunk 3. Then, after a pause for dial tone at step 2071, the phone number detected in step 2064 is dialed at step 2072, and at step 2073 trunk 3 is placed on hook causing switch 4 to transfer the calling party to the phone number dialed, and control is returned to the CPF - Call Handler Task via the connector labelled "CPF IDLE" at reference 2074. If, as described earlier, at step 2062 it is determined that the digit entered by the subscriber is not a '6', then control passes to step 2075. At step 2075, a determination is made as to whether the digit is a '7', and if not then control passes to a connector labelled "CPF VSCRN LOOP" at reference 2076 thereby allowing the subscriber to enter another digit. If the digit entered is a '7', as determined at step 2075, then control passes to step 2077 where a flash is generated causing switch 4 to temporarily conference the calling party and the subscriber. Then, after a 2 second pause at step 2078, another flash is generated at step 2079 causing switch 4 to terminate the conference by dropping the subscriber, leaving just the calling party connected to trunk 3. Then at step 2080 the calling party is prompted by call processor 435: "Your party is not interested in your call. Please remove this party from your list and do not call again. Good-bye." Then at step 2081 trunk 3 is placed on hook causing switch 4 to disconnect the calling party, and control is returned to the CPF - Call Handler Task via the connector labelled

"CPF IDLE" at reference 2082.

A flowchart of the CPF - Meet Me Caller function is illustrated in FIG. 21. The purpose of this function is to process calls for a subscriber who has chosen to have his calls handled by the meet-me function. In the preferred embodiment these calls are handled by conferencing the caller on a trunk 3 of the CPF 100 with a line 5 120 on the Meet-Me Facility (MMF) 115. Then when the subscriber calls in to be connected, he is also conference from a trunk 3 of the CPF 100 with a line 120 on the MMF 115. The CPF may then hang up on both the caller's trunk 3 and then subscriber's trunk 3, thereby transferring the caller and subscriber to the MMF lines 10 120. The lines 120 are provisioned with the CENTREX features of 'call transfer' and 'barge-in', so that the caller and subscriber may then be connected as follows: The line 120 which is connected to the caller dials the CENTREX barge-in command (*77) followed by the CENTREX 'intercom code' for the line 120 which is connected to the subscriber. The caller and the subscriber are thus connected, and the line 120 15 which connects to the subscriber may then go on hook, transferring the subscriber to the caller's line 120. The conversation may then take place and only one line of line 120 is used. To fully understand the explanation of the CPF - Meet Me Caller function which follows, it is necessary to also review the explanations which are associated with FIG. 30 (CPF - Command Meet Me), FIG. 33 (MMF block 20 diagram), and FIG. 34 (Meet Me Facility Main Task). Referring now to FIG. 21, the CPF - Meet Me Caller function is entered at step 2100 and control passes to step 2101 where the calling party is informed by call processor 435: "We are paging your party to a phone. Please stay on the line." Then at step 2102 a flash is generated causing switch 4 to place the calling party on hold and generate a dial tone on trunk 25 3. Then at step 2103 the call processor 435 dials the phone number which is associated with one of the lines 120 which are connected to the Meet-Me Facility (MMF) 115, and at step 2104 a 15 second timer is initiated. Then at step 2105, a determination is made as to whether DTMF '*' tone has been detected by call processor 435, indicating that the MMF 115 has answered. If the '*' tone is not 30 detected, then control passes to step 2106 where the 15 second timer is checked, and

if found to have not expired then control returns to step 2105. If the 15 second timer is found to have expired, then control passes to step 2107, where a flash is generated causing switch 4 to temporarily conference the calling party to the number dialed above. Then after a 2 second pause at step 2108, another flash is generated at step 5 2019, causing switch 4 to drop the dialed number from the conference, leaving just the calling party connected to trunk 3. Then at step 2110, a check is made to determine if dial tone is present on trunk 3. If dial tone is found to be present, indicating that the sequence of steps 2107 through 2109 had failed to restore the calling party possibly because the conference thought to be created at step 2107 was not allowed by switch 4, then another flash is generated at step 2111, which is 10 identified by a connector labelled "CPF MM FLASH" at reference 2134. This flash causes switch 4 to reconnect the calling party to trunk 3, and then control passes via a connector labelled "CPF MM MSSG" at reference 2112 to step 2113. If dial tone is not detected at step 2110, then control passes directly to step 2113. At step 2113, 15 the current time and date is stored in the 'last meet-me message left' field 720 of the subscriber master record 700, and then control passes to the connector labelled "CPF SORRY" at reference 2114, causing the caller to be connected to the message center as was described earlier. If at step 2105, the '*' tone is detected, indicating that the MMF 115 has answered, then control passes to step 2115 where call processor 435 20 dials the digit '00' signifying that this is a caller, not a subscriber. Then at step 2116, the call processor 435 dials the subscriber's DID number 701, to identify to the MMF who the calling party is waiting for. Then at step 2117, a flash is generated, causing switch 4 to conference the calling party through to this line 120 of the MMF 115, and at step 2118 a 2 second timer is initiated. Then at step 2119, a 25 determination is made as to whether another '*' tone is detected by call processor 435, indicating the conference was successful. If the '*' tone is not detected, this implies that the conference was not successful, most likely because the calling party has hung up. In this case the 2 second timer is checked at step 2120, and if it is found not to have expired control returns to step 2119. If the 2 second timer has 30 expired, then control passes via a connector labelled "CPF MM ABANDON" at

reference 2121 to step 2122 where the current time and date are stored in the 'last meet-me abandon' field 719 of the subscriber master record. Then control passes to step 2123 where the trunk 3 is placed on hook and control is returned to the CPF - Call Handler Task via the connector labelled "CPF IDLE" at reference 2124. If at

5 step 2119 the '*' tone is detected, then control passes to step 2125 where a repeat count is set to a value of 3. Then at step 2126, the calling party is informed by call processor 435: "We have sent a page to alert your party of the call. Your party is currently proceeding to a phone and we will connect you momentarily. If you are

10 unable to wait, you may touch 9 at any time to leave a detailed message which we will relay to your party as soon as they pick up the line." Then at step 2127, the call processor 435 plays a 'music on-hold' selection of duration 40 seconds. Then at step 2128 a determination is made as to whether the subscriber has called in, by checking the CPF - Call Handler Tasks controlling the other trunks 3 connected to the CPF

15 100. If the subscriber is found, and if he has entered his PIN code 702 and touched 4 indicating he wishes to be connected to the caller, then step 2128 will return a positive indication causing control to pass to the connector labelled "CPF MM SUBCALL" at reference 2129. If a negative indication is returned at step 2128, then control passes to step 2130 where a determination is made as to whether the caller has entered '9'. If the caller does enter '9', then control passes to step 2111, causing the

20 caller to be connected to the message center as describer earlier. If the caller has not entered '9', then control passes to step 2131, where a determination is made as to whether the 40 second music-on-hold selection is complete. If it is not complete, then control returns to step 2128. If the selection is complete, then control passes to step 2132 where the repeat count is decremented. Then at step 2133 a determination is

25 made as to whether the value of the repeat count is now zero. If the value is zero, then control passes to step 2111, causing the caller to be connected to the message center as describer earlier. If the value of the repeat count is not yet zero, then control returns to step 2127, where the sequence of steps 2127 through 2133 is repeated once more. The connector labelled "CPF MM SUBCALL" at reference

30 2135 causes control to be passed to step 2136 where the DTMF fourth column tone

digit 'd' is dialed by call processor 435 to inform the MMF 115 that the subscriber has arrived. Then at step 2137, the call processor 435 prompts the calling party: "Your party has picked up the line. One moment and we will connect you." Then at step 2138, a 20 second timer is initiated, and at step 2139 the call processor 435
5 begins to play audible ringing, with a cadence of 2 seconds on, 4 seconds off, to the caller. Then at step 2140, the 20 second timer is checked, and if it is found to have expired, indicating that the subscriber did not connect to the MMF 115, then control passes to the connector labelled "CPF MM FLASH" at reference 2141, causing the caller to be connected to the message center as was described earlier. If the 20
10 second timer has not expired, then control passes to step 2142 where a determination is made as to whether the subscriber has connected to the MMF 115, as determined by checking with the CPF - Call Handler Task that was found to be controlling the trunk 3 connected to the subscriber. If the subscriber has not connected to the MMF
15 115, then control returns to step 2140. If the subscriber has connected to the MMF 115, then the trunk 3 is placed on hook causing switch 4 to transfer the calling party to the line 120 of the MMF 115, and control is returned to the CPF - Call Handler Task via the connector labelled "CPF IDLE" at reference 2144.

A flowchart of the CPF - Send Page Subroutine is illustrated in FIG. 22. The purpose of this subroutine is to send page messages via the high speed data network
20 150 from the CPF 100 to either the PDF 105, or the CAF 125. These messages contain the pager number and any digits which are to be transmitted to the display of the pager. The CPF - Send Page Subroutine is entered at step 2200 and control passes to step 2201 where the pager number 710 for this subscriber is retrieved from the subscriber master record 700. Then at step 2202, a message is constructed
25 consisting of the pager number 710, and the display digits which were identified as this subroutine was called. Then at step 2203 a determination is made as to whether the pager number 710 represents a communicator. In the preferred embodiment, each communicator 11 is identified by a pager number 710 which starts with the digits '000'. If the pager number 710 is found to be that of a communicator 11, then
30 control passes to step 2204, and the data network interface 510 is instructed to send

the message via network 150 to the Communicator Access Facility (CAF) 125, and then control is returned from this subroutine to the calling program, as represented at step 2206. If the pager number 710 is not found to be that of a communicator 11, then control passes to step 2205, where the data network interface 510 is instructed
5 to send the message via network 150 to the Pager Dialing Facility (PDF) 105, and then control is returned from this subroutine to the calling program, as represented at step 2206.

A flowchart of the CPF - Command Mode function is illustrated in FIG. 23. The CPF - Command Mode function is entered at step 2300 and control passes to step
10 2301 where the subscriber's pre-recorded 'drop-in' name is retrieved from disk 505. Then at step 2302, the call processor 435 prompts the subscriber: "Hello..", and then plays the back the 'drop-in' name. Then at step 2303, a determination is made as to whether a meet-me call is currently holding for this subscriber. This is determined by checking the CPF - Call Handler Tasks which control the other trunks 3 connected
15 to CPF 100. If a meet-me call is found to be holding for this subscriber, then at step 2304, the subscriber is prompted: "A call is holding on your meet-me service. Touch 4 to be connected to the caller." Control then passes to step 2317. If a meet-me call is not holding for this subscriber, then control passes to step 2305 where a determination is made as to whether a meet-me caller was recently holding, but hung
20 up without leaving a message. If the time and date stored in the 'last meet me abandon' field 719 of the subscriber master record 700 is not more than 20 minutes older than the current date and time, then it is determined that a meet-me caller recently abandoned a call, and control passes to step 2306 where the subscriber is prompted: "A call was recently holding on your meet-me service, however the caller
25 chose not to wait and hung up without leaving a message." Control then passes to step 2307 where the 'last meet-me abandon' field 719 of the subscriber master record 700 is cleared. Control then passes to step 2308. Control also passes to step 2308 if, at step 2305, it is determined that a meet-me caller did not recently abandon a call. At step 2308, a determination is made as to whether a meet-me caller is currently
30 leaving a message for the subscriber. This is determined by checking the CPF - Call

Handler Tasks which control the other trunks 3 connected to CPF 100. If it is determined that a meet-me caller is currently leaving a message for this subscriber, then control passes to step 2309, where the subscriber is prompted: "A call was recently holding on your meet-me service, however the caller chose not to wait and is currently leaving you a message. When the message is complete we will connect you to your message center, or you may touch * now to skip this." Control then passes to step 2310 where 'music-on-hold' is played to the subscriber by call processor 435. Control then passes to step 2311 where a determination is made as to whether the meet-me caller has finished leaving the message. If the message is complete, then control passes to the CPF - Command Message Center function as shown at reference 2313. If the caller is still leaving the message, then control passes to step 2312 where a determination is made as to whether the subscriber has entered the '**' digit. If the '**' digit is not entered, then control returns to step 2311. If the '**' digit is entered, then control passes to step 2317. If at step 2308, a determination is made that a meet-me caller is not currently leaving a message for this subscriber, then control passes to step 2314, where a determination is made as to whether a meet-me caller recently left a message for this subscriber. If the time and date stored in the 'last meet me message left' field 720 of the subscriber master record 700 is not more than 20 minutes older than the current date and time, then it is determined that a meet-me caller recently left a message, and control passes to step 2315 where the subscriber is prompted: "A call was recently holding on your meet-me service, however the caller chose not to wait and instead left you a message." Control then passes to step 2316 where the 'last meet-me message left' field 720 of the subscriber master record 700 is cleared. Control then passes to step 2317. Control also passes to step 2317 if, at step 2314, it is determined that a meet-me caller did not recently leave a message. At step 2317, a determination is made as to whether the subscriber has selected an external message center. As described earlier, this determination is made by examining the message center number 709 in the subscriber master record 700. If the message center number 709 contains a phone number, then external has been selected. If the message center number 709 does not contain a phone number,

then internal message center has been selected. If, at step 2317, it is determined that the subscriber has selected an external message center, then control passes to step 2318, where the caller is prompted: "We have transferred...". Control then passes to step 2319 where the 'external message center transfer count' 721 is retrieved from the subscriber master record 700, and is voiced to the subscriber by call processor 435. Control then passes to step 2320, where the prompt is completed by playing: "...since you last checked messages." Control then passes to the connector labelled "CPF MODE DESCR" at reference 2323. If, at step 2317, it is determined that the subscriber had selected the internal message center, then control passes to step 2321 where the number of messages currently stored for this subscriber on disk 505 is determined. At step 2322 then, the call processor 435 prompts the subscriber: "You have X messages.", where X is the number determined above. Control then passes to the connector labelled "CPF MODE DESCR" at reference 2323. The connector labelled "CPF MODE DESCR" at reference 2324, causes control to be passed to step 2325, where a description is played of the current call handling mode. This description includes the current mode memory number 715, the current call handling mode 703, and the current transfer number 707, if appropriate. For example, the subscriber may hear: "Your calls are currently being handled by mode memory 10, urgent-screened forwarding to 555-1111." If the transfer number 707 is the tag for the subscriber's home, office, pager, mobile-phone, or message center, then this would be voiced in words, ie: "..to your home." After playing a description of the current call handling mode, then control passes to step 2326, where a determination is made as to whether the feature timer is currently active. As was described earlier, this determination is made by checking the feature timer duration 724. If the feature timer is found to be active, then it's status is voiced to the subscriber at step 2327. For example, the subscriber may be prompted: "The feature timer is currently active and will cause mode memory 10 to be invoked at 5:30 today." Control then passes to step 2328. Control also passes to step 2308 if the feature timer was found to be inactive at step 2326. At step 2328, a determination is made as to whether the weekly schedule is active. This determination is made by checking the weekly

schedule active flag 728 of the subscriber master record 700. If the weekly schedule is found to be active, then the status of the weekly schedule is voiced to the subscriber at step 2329. For example, the subscriber may be prompted: "The weekly schedule is on, and the next step will cause memory 20 to be invoked at 7:30 PM on Tuesday." Control then passes via connector labelled "CPF MAIN DIRECTORY" at reference 2330 to step 2331. Control also passes via connector 2330 to step 2331 if the weekly schedule is found to be inactive at step 2328. At step 2331 the call processor 435 prompts the subscriber: "Main Directory. Enter 1 to check messages, 2 to change your forwarding number, 3 to select a memory, 9 to make a call, or 0 for help." Control then passes to a loop consisting of steps 2332 through 2339. At each of these steps a determination is made as to whether a particular digit has been entered by the subscriber. If the result is positive on any of these steps, then control is passed to another function. If the digit '1' is found at step 2332, then control passes to the CPF - Command Message Center function, as shown at reference 2340. If the digit '2' is found at step 2333, then control passes to the CPF - Command Forwarding Number function, as shown at reference 2341. If the digit '3' is found at step 2334, then control passes to the CPF - Command Memory function, as shown at reference 2342. If the digit '9' is found at step 2335, then control passes to the CPF - Command Outside Call function, as shown at reference 2343. If the digit '0' is found at step 2336, then control passes to the CPF - Command Help function, as shown at reference 2344. If the digit '4' is found at step 2337, then control passes to the CPF - Command Meet Me function, as shown at reference 2345. If the digit '5' is found at step 2338, then control passes to the CPF - Command Branch Route function, as shown at reference 2346. If the digit '8' is found at step 2339, then control passes to the CPF - Command Advanced features function, as shown at reference 2347.

A flowchart of the CPF - Command Message Center function is illustrated in FIG. 24. The CPF - Command Message Center function is entered at step 2400 and control passes to step 2401 where a determination is made as to whether the subscriber has selected an external message center. As described earlier, this

determination is made by examining the message center number 709 in the subscriber master record 700. If the message center number 709 contains a phone number, then external has been selected. If the message center number 709 does not contain a phone number, then internal message center has been selected. If, at step 2401, it is determined that the subscriber has selected an external message center, then control passes to step 2402, where the caller is prompted: "Please standby." Control then passes to step 2403 where a flash is generated causing switch 4 to place the subscriber on hold and apply a dial tone to trunk 3. Then, after pausing for dial tone at step 2404, the message center number 709 is dialed by call processor 435 at step 2405. Then at step 2406, the trunk 3 is placed on hook, causing switch 4 to transfer the subscriber to the message center number. Then at step 2407, the 'external message center transfer count' 721 of the subscriber master record 700 is cleared. Control is then returned to the CPF - Call Handler Task via the connector labelled "CPF IDLE" at reference 2408. If, at step 2401, it is determined that the subscriber has selected internal message center, then control passes to step 2409, where a determination is made as to whether the subscriber has any messages stored on disk 505. If there are no messages stored for this subscriber, then control passes to step 2410, where the subscriber is informed: "You have no messages." Then at step 2411, the subscriber is prompted: "Enter 8 to return to the main directory." Control then passes to step 2412, where a determination is made as to whether the digit '8' has been entered, and if it has not been entered, then control returns to step 2410. If the digit '8' has been entered, then control passes to the connector labelled "CPF MAIN DIRECTORY" at reference 2413, allowing the subscriber to make additional selections from the main directory of the command mode. If at step 2409, the determination is made that the subscriber does have messages stored on disk 505, then control passes to step 2414, where one of the stored messages is played back to the subscriber, and the subscriber is given the opportunity to save or delete the message by entering the digits '1' or '2' respectively. Control then passes to step 2415, where a determination is made as to whether the digit '9' has been entered. If the digit '9' is entered, then control passes to the CPF - Command Outside Call function as shown at reference 2416, where the

subscriber is given the opportunity to make a call, perhaps returning a call to the person who left the message. If the digit '9' was not entered, then control passes to step 2417, where a determination is made as to whether any more messages are stored on the disk 505. If more messages exist, then control is returned to step 2414. If
5 no more messages exist, then control passes to step 2418, where the subscriber is prompted: "You have no more messages. Enter 8 to return to the main directory." Control then passes to step 2419, where a determination is made as to whether the digit '8' has been entered, and if it has not been entered, then control returns to step 2418. If the digit '8' has been entered, then control passes to the connector labelled
10 "CPF MAIN DIRECTORY" at reference 2413, allowing the subscriber to make additional selections from the main directory of the command mode.

A flowchart of the CPF - Command Forwarding Number function is illustrated in FIG. 25. The CPF - Command Forwarding Number function is entered at step 2500 and control passes to step 2501 where a determination is made as to whether the
15 current call handling mode 703 for this subscriber is 'message center' or branch routing'. Since it is not logical to change a forwarding number in a mode that does not require a forwarding number, if it is determined that either of these modes are active, then control will pass to step 2502, where the subscriber will be prompted: "Invalid command." Control then passes to the connector labelled "CPF MAIN
20 DIRECTORY" at reference 2503, allowing the subscriber to make additional selections from the main directory of the command mode. If, at step 2501, it is determined that the current call handling mode 703 is not 'message center' or 'branch routing', then control passes to step 2504, where a determination is made as to whether the transfer number 707 is set equal to the 'meet-me tag'. If so, then control
25 passes to step 2505, where the subscriber is prompted: "Your calls are currently being forwarded to you via your meet me service." Control then passes to step 2508. If, at step 2504, it is determined that the forwarding number is not equal to the 'meet-me tag' then control passes to step 2506, where the subscriber is prompted: "Your calls are currently being forwarded to..." Control then passes to step 2507,
30 where the transfer number 707 is retrieved from the subscriber master record 700,

and voiced to the subscriber. Control then passes to step 2508, where the subscriber is prompted: "Please enter your new forwarding number, or enter * to skip this, or enter 6 to use your meet-me service." Control then passes to step 2509, where a determination is made as to whether the subscriber has entered a valid phone number, or a tag for home, office, or mobile phone. If so, then control passes to step 2510, where the phone number is stored as the new transfer number 707 in the subscriber master record 700, and the subscriber is prompted: "Accepted, your calls are currently being forwarded to..." , and the transfer number 707 is voiced. Control then passes to the CPF - Command Feature Timer function as shown at reference 2511. If it is determined at step 2509 that the subscriber has not entered a phone number, then control passes to step 2512, where a determination is made as to whether the subscriber has entered the digit '6', and if so control passes to step 2513 where the 'meet-me tag' is stored as the transfer number 707 in the subscriber master record 700, and the subscriber is prompted: "Accepted, your calls are currently being forwarded to you via your meet-me service." Control then passes to the CPF - Command Feature Timer function as shown at reference 2511. If it is determined at step 2512 that the digit '6' has not been entered, then control passes to step 2514, where a determination is made as to whether the digit '*' has been entered, and if not control returns to step 2509. If the digit '*' has been entered, then the transfer number 707 remains unchanged, and control passes to the CPF - Command Feature Timer function as shown at reference 2511.

A flowchart of the CPF - Command Feature Timer function is illustrated in FIG. 26. The CPF - Command Feature Timer function is entered at step 2600 and control passes to step 2601 where the subscriber is prompted: "Please enter the length of time you would like your current feature to be in effect, or enter * to skip the feature timer." Control then passes to step 2602, where a determination is made as to whether the digit '*' has been entered by the subscriber. If the digit '*' has been entered, then control passes to step 2603, where the subscriber is prompted: "Accepted, your feature will be in effect until further notice." Control then passes to the connector labelled "CPF MAIN DIRECTORY" at reference 2613, allowing the

subscriber to make additional selections from the main directory of the command mode. If at step 2602, it is determined that the digit '*' has not been entered, then control passes to step 2604 where a determination is made as to whether a valid duration has been entered. This duration must be in the form of hours first followed
5 by minutes. For example, to enter 1 hour and 20 minutes, the subscriber must enter '1 2 0'. If a valid duration is not found to be entered at step 2604 then control returns to step 2602. If a valid duration is entered, then control passes to step 2605, where the duration is stored as the 'feature timer duration' 724 of the subscriber master record 700, and the subscriber is prompted: "Accepted,..." and the duration
10 time is voiced. Control then passes to step 2606 where the subscriber is prompted: "Please enter the memory number you wish to invoke upon termination of the feature timer, or enter * to use the previous mode, or touch 9 to use the schedule." Control then passes to step 2607, where a determination is made as to whether the subscriber has entered the digit '*', and if so then at step 2608 the previous mode memory is
15 saved in temporary mode memory 0, mode memory 0 is stored as the feature timer termination mode 725 of the subscriber master record, and the subscriber is prompted: "Accepted, your feature will be in effect until (time) at which time the previous mode will be invoked.", where the value of (time) corresponds to the current time plus the feature timer duration 724. Control then passes to the connector
20 labelled "CPF MAIN DIRECTORY" at reference 2613, allowing the subscriber to make additional selections from the main directory of the command mode. If at step 2607 it is determined that the digit '*' has not been entered, then control passes to step 2609, where a determination is made as to whether the digit '9' is entered, and if so control passes to step 2610 where the weekly schedule is saved in temporary
25 mode memory 0, mode memory 0 is stored as the feature timer termination mode 725 of the subscriber master record, and the subscriber is prompted: "Accepted, your feature will be in effect until (time) at which time the weekly schedule will be invoked.", where the value of (time) corresponds to the current time plus the feature timer duration 724. Control passes to the connector labelled "CPF MAIN
30 DIRECTORY" at reference 2613, allowing the subscriber to make additional

5 selections from the main directory of the command mode. If at step 2609 it is determined that the digit '9' has not been entered, then control passes to step 2611, where a determination is made as to whether a valid mode memory 10 through 99 is entered, and if so control passes to step 2612 where the mode memory is stored as the feature timer termination mode 725 of the subscriber master record, and the subscriber is prompted: "Accepted, your feature will be in effect until (time) at which time mode memory XX will be invoked.", where the value of (time) corresponds to the current time plus the feature timer duration 724. Control passes to the connector labelled "CPF MAIN DIRECTORY" at reference 2613, allowing the subscriber to make additional selections from the main directory of the command mode.

10 A flowchart of the CPF - Command Memory function is illustrated in FIG. 27. The CPF - Command Memory function is entered at step 2700 and control passes to step 2701 where the subscriber is prompted: "Your calls are currently being handled via mode memory XX.", where XX is the current mode memory number 715 of the subscriber master record. Control then passes to step 2702, where a description of the mode is voiced to the subscriber. This description includes the current call handling mode 703, and the current transfer number 707, if appropriate. For example, the subscriber may hear: "Your calls are currently being urgent-screened forwarded to 555-1111." If the transfer number 707 is the tag for the subscriber's home, office, pager, mobile-phone, or message center, then this would be voiced in words, ie: "...to your home." Control then passes to step 2703 where the subscriber is prompted: "Please enter a new mode memory number or enter * to skip this." Control then passes to step 2704 where a determination is made as to whether the digit '**' has been entered. If the digit '**' is entered, then control passes to the CPF - Command Feature Timer function as shown at reference 2722. If at step 2704, it is determined that the '**' digit has not been entered, then control passes to step 2705, where a determination is made as to whether a valid 2 digit mode memory number has been entered, and if such a mode memory number has not been entered, then control returns to step 2703. If a valid mode memory number is entered, then control passes to step 2706, where the mode memory number is stored

as the current mode memory number 715 of the subscriber master record 700, the corresponding mode memory 800 is copied to the subscriber master record, the subscriber is prompted: "Accepted, you have selected mode memory XX, which causes your calls to be...", and then control passes to step 2707. At step 2707, the prompt is completed by playing a brief description of the selected mode memory. The description includes the call handling mode 703, and the transfer number 707 if appropriate. For example, at step 2707 the remainder of the prompt may be: "...handled by your message center." At step 2708 a determination is made as to whether the selected mode memory requires an 'externally entered number'. This is determined by checking the transfer number field 707 of the selected mode memory, to determine if it contains an 'externally entered number' tag. If this is the case, then the subscriber must enter a transfer number after selecting this memory. If the externally entered number is not required, then control passes to the CPF - Command Feature Timer function as shown at reference 2722. If it is determined at step 2708 that an externally entered number is required, then control passes to step 2710, where the subscriber is prompted: "Please enter your new forwarding number or enter * to skip this and use....". Control then passes to step 2711 where the previous transfer number is voiced to the subscriber. Control then proceeds to step 2712 where the subscriber is further prompted with: "..or enter 6 to use your meet-me service." Control then passes to step 2713 where a determination is made as to whether the digit '*' has been entered. If the digit '*' has been entered then control passes to step 2716. Otherwise, control passes to step 2714 where a determination is made as to whether a phone number or tag has been entered by the subscriber. If not, then control returns to step 2710. If a phone number or tag has been entered, then control passes to step 2715 where the phone number is stored as the transfer number 707 of the subscriber master record 700, the subscriber is prompted: "Accepted...", and the phone number or tag is voiced. Control then passes to step 2716, where a determination is made as to whether the memory has an extension number in the extension number field 708 of the subscriber master record 700. If an extension number does not exist in this field, then control passes to the CPF - Command

Feature Timer function as shown at reference 2722. If at step 2716 it is determined that an extension number does exist, then control passes to step 2717 where the subscriber is given an opportunity to modify the extension number. At step 2717 the subscriber is prompted: "Please enter your new extension number or enter * to skip this and use". Control then passes to step 2718 where the phrase is completed by voicing the current extension number 708. Control then passes to step 2719 where a determination is made as to whether a new extension number has been entered, and if so, then control passes to step 2720 where the extension number is stored in the extension number field 708, the subscriber is prompted: "Accepted,..", the new extension number is voiced, and control passes to the CPF - Command Feature Timer function as shown at reference 2722. If at step 2719 it is determined that an extension number has not been entered then control passes to step 2721, where a determination is made as to whether the digit "*" is entered, and if the "*" digit is not entered then control returns to step 2717. If at step 2721 it is determined that the "*" digit is entered then control passes to the CPF - Command Feature Timer function as shown at reference 2722.

A flowchart of the CPF - Command Outside Call function is illustrated in FIG. 28. The CPF - Command Outside Call function is entered at step 2800 and control passes to step 2801 where the call processor 435 plays a 'stutter dial tone' to the subscriber. Control then passes to step 2802 where a determination is made as to whether the subscriber has entered the '#' digit. If the '#' digit has been entered, then control passes to the connector labelled "CPF MAIN DIRECTORY" at reference 2803, allowing the subscriber to make additional selections from the main directory of the command mode. If at step 2802 it is determined that the subscriber has not entered the '#' digit, then control passes to step 2804 where a determination is made as to whether the subscriber has entered a phone number that he wishes to be connected to. If a phone number has not been entered, then control returns to step 2802. If at step 2804 it is determined that a phone number has been entered, then control passes to step 2805, where a flash is generated, causing switch 4 to place the subscriber on hold, and applying a dial tone to the trunk 3. Then, after a pause for

dial tone at step 2806, the call processor 435 dials the phone number at step 2807, which had been entered by the subscriber. Control then passes to step 2808, where the 'multiple outside calls allowed' flag 729 of the subscriber master record 700 is checked. If this flag is not active, then control passes to step 2809 where the trunk
5 3 is placed on hook, causing switch 4 to transfer the subscriber to the dialed number, and control is returned to the CPF - Call Handler Task via the connector labelled "CPF IDLE" at reference 2810. If at step 2808 it is determined that the 'multiple outside calls allowed' flag 729 is set, then control passes to step 2811, where a flash is generated which causes the subscriber to be conferenced to the dialed number while
10 maintaining trunk 3 in the connection. In this way the subscriber may make additional calls, or later return to the main directory without hanging up and calling back. After the flash is generated at step 2811, control passes to step 2812 where a loop is entered waiting for the subscriber to enter the digit sequence '##'. When trying to detect DTMF digits while conversation may be present, as is the case in this
15 situation, requiring the two digits in sequence reduces the likelihood of falsing on voice. If the subscriber enters '##', then control passes to step 2813 where a flash is generated causing switch 4 to disconnect the third party from the conference, leaving only the subscriber connected to trunk 3. Control then returns to step 2801, where the subscriber may make another call, or enter '#' to return to the main
20 directory.

A flowchart of the CPF - Command Help function is illustrated in FIG. 29. The purpose of this function is to provide help to the subscriber who is using the Command Mode features of the Telephone Control System. This is accomplished by allowing the subscriber to enter the digit '0' for help from any of the command mode
25 functions. Once the digit '0' is entered, the subscriber is provided with an explanation of the function which was being accessed at that moment. The subscriber may also touch another digit '0' to reach a live client services representative. The CPF - Command Help function is entered at step 2900 and control passes to step 2901 where the step number of the function from which the CPF - Command Help was requested is saved for later use. Then at step 2902, the subscriber is prompted:
30

"You have selected the help function. You may enter 0 to be connected to a client services operator, 8 to return to the main directory, or # to return to the point where you were when you entered the help function." Control then passes to step 2903, where a context sensitive help prompt is played, based on the step number saved in
5 by step 2901. For example, if the saved step number indicated that the help function was accessed while in the CPF - Command Forwarding Number function, then the call processor 435 would play the prestored help prompt associated with that function: "When you selected the help function you were in the process of changing your forwarding number." Control then passes to step 2904 where a determination is made
10 as to whether the digit '0' has been entered, and if so, control then passes to step 2905 where a flash is generated, causing switch 4 to place the subscriber on hold, and applying a dial tone to the trunk 3. Then, after a pause for dial tone at step 2906, the call processor 435 dials the phone number at block 2907, which is associated with a client services representative. Control then passes to step 2908 where the trunk 3
15 is placed on hook, causing switch 4 to transfer the subscriber to the dialed number, and control is returned to the CPF - Call Handler Task via the connector labelled "CPF IDLE" at reference 2909. If at step 2904 it is determined that the digit '0' is not entered, then control passes to step 2910 where a determination is made as to whether the digit '8' has been entered, and if so, control passes to the connector
20 labelled "CPF MAIN DIRECTORY" at reference 2911, allowing the subscriber to make additional selections from the main directory of the command mode. If at step 2910 it is determined that the digit '8' is not entered, then control passes to step 2912 where a determination is made as to whether the digit '#' is entered, and if not control returns to step 2902. If the digit '#' is entered, then the step number that was
25 saved at step 2901 is retrieved and the control returns to that step.

A flowchart of the CPF - Command Meet Me function is illustrated in FIG. 30. The purpose of this function is to process the call for a subscriber who has called in, entered his PIN code 702, and wishes to be connected to a meet-me caller who is holding for him. The CPF - Command Meet Me function is entered at step 3000
30 and control passes to step 3001 where a flash is generated, causing switch 4 to place

the subscriber on hold and apply a dial tone to the trunk 3. Then, after pausing for dial tone at step 3002, the call processor 435 dials the phone number of the lines 120 which are connected to the Meet Me Facility (MMF) 115 at step 3003. Control then passes to step 3004 where a 15 second timer is started, and then to step 3005 where

5 the 15 second timer is checked. If the 15 second timer has not expired, then control passes to step 3006 where a determination is made as to whether a '*' digit is detected, indicating that the MMF 115 has answered the call. If the '*' digit is not detected then control returns to step 3005. If at step 3006, the '*' digit is detected, then control passes to step 3007 where the call processor 435 dials '01' indicating this

10 call is from a subscriber, and then dials the subscriber's DID number 701, thereby fully identifying the call to the MMF 115. Control then passes to step 3008 where a flash is generated causing switch 4 to take the subscriber off of hold and create a conference between the subscriber, trunk 3, and the line 120 of the MMF 115. Control then passes to step 3009 where a 4 second pause is initiated to allow the

15 MMF 115 time to connect the caller into the call. Control then passes to step 3010 where the subscriber and caller are prompted by call processor 435: "Go ahead please." Control then passes to step 3011 where the trunk 3 is placed on hook, causing the switch 4 to transfer the subscriber to the line 120 of the MMF 115. Control is then returned to the CPF - Call Handler Task via the connector labelled

20 "CPF IDLE" at reference 3012. If at step 3005 it is determined that the 15 second timer had expired, indicating that the MMF 115 had not answered the call, then control passes to step 3013 where a flash is generated causing switch 4 to create a temporary conference between the subscriber and the dialed number, and then after a 2 second pause at step 3014 another flash is generated at step 3015 causing switch

25 4 to drop the dialed number from the conference and leave just the subscriber connected to the trunk 3. Control then passes to step 3016 where the subscriber is prompted: "I'm sorry, we are unable to connect your call at this time." Control then passes to the connector labelled "CPF MAIN DIRECTORY" at reference 3017, allowing the subscriber to make additional selections from the main directory of the

30 command mode.

A flowchart of the CPF - Command Branch Route function is illustrated in FIG. 31. The CPF - Command Branch Route function is entered at step 3100 and control passes to step 3101 where a determination is made as to whether the current call handling mode 703 is 'branch-routing', and if it is not control is passes to step 5 3102 where the subscriber is prompted: "Invalid command.", and control passes to the connector labelled "CPF MAIN DIRECTORY" at reference 3103, allowing the subscriber to make additional selections from the main directory of the command mode. If at step 3101 it is determined that the call handling mode 703 is 'branch routing' then control passes to step 3104 where the subscriber is prompted: "Enter 10 1 to record a new branch routing greeting, 2 to change branch routing numbers, 3 to change the branch routing default number, or '#' to return to the main directory." Control then passes to step 3105 where a determination is made as to whether the digit '1' is entered, and if so, control passes to step 3106 where the subscriber is prompted: "Your branch routing greeting is...". Then at step 3107, the branch routing greeting for this subscriber is retrieved from disk 505 and played back to the subscriber. Control then passes to step 3108 where the subscriber is prompted: 15 "Please record your new branch routing greeting at the tone, or enter * to skip this and use the existing branch routing greeting...BEEP." Then at step 3109, the new greeting is recorded and control passes to step 3110 where a determination is made as to whether the greeting is done, and if it is control passes to step 3111 where the new branch routing greeting is saved to disk 505 and then control returns to step 20 3104. If at step 3110 it is determined that the greeting is not done, then control passes to step 3112 where a determination is made as to whether the digit '*' is entered, and if not control returns to step 3109. If at step 3112 it is determined that the digit '*' is entered, then control passes to step 3113 where the old branch routing greeting on disk 505 is left unchanged, and control then passes to step 3104. If at 25 step 3105 it is determined that the digit '1' is not pressed, then control passes to step 3114 where a determination is made as to whether the digit '2' is entered, and if it is entered then control passes to step 3115 where the subscriber is prompted: "Please 30 enter the branch routing directory digit 1 to 9 for the phone number your wish to

change, or touch * to skip this." Control then passes to step 3116 where a determination is made as to whether the digit '*' is entered, and if it is entered control returns to step 3104. If at step 3116 it is determined that the digit '*' is not entered, then control passes to step 3117 where a determination is made as to whether one of the digits '1' to '9' are entered, and if one of those digits is entered control then passes to step 3118. Otherwise control returns to step 3116. At step 3118 the subscriber is prompted: "The branch routing transfer number for digit X is....". Control then passes to step 3119 where the branch routing number 722 that corresponds to the digit entered in step 3117 is retrieved from the subscriber master record 700 and voiced to the subscriber. Then at step 3120 the subscriber is prompted: "Please enter the new branch routing transfer number or touch * to skip this without making a change." Control then passes to step 3121 where a determination is made as to whether the digit '*' is entered, and if it is entered control returns to step 3104. If at step 3121 it is determined that the digit '*' is not entered, then control passes to step 3122 where a determination is made as to whether a phone number has been entered, and if a phone number has not been entered, control returns to step 3121. If at step 3122 a phone number is entered, then control passes to step 3123 where the subscriber is prompted: "Accepted." Then at step 3124 the new phone number is voiced to the subscriber. Control then passes to step 3125 where the new phone number is saved as the branch routing number 722 which corresponds to the digit entered in step 3117. Control then returns to step 3104. If at step 3114 it is determined that the digit '2' is not entered, then control passes to step 3126 where a determination is made as to whether the digit '3' is entered, and if it is entered, then control passes to step 3127 where the subscriber is prompted: "The branch routing default transfer number is ...". Control then passes to step 3128 where the branch routing default number 723 is retrieved from the subscriber master record 700 and voiced to the subscriber. Then at step 3129 the subscriber is prompted: "Please enter the new branch routing default transfer number, or touch * to skip this without making a change." Control then passes to step 3130 where a determination is made as to whether the digit '*' is entered, and if the digit '*' is

entered control returns to step 3104. If at step 3130 it is determined that the digit '*' is not entered, then control passes to step 3131 where a determination is made as to whether a phone number has been entered, and if a phone number has not been entered control returns to step 3130. If it is determined at step 3131 that a phone number has been entered, then control passes to step 3132 where the subscriber is prompted: "Accepted." Control then passes to step 3133 where the new phone number is voiced to the subscriber. Control then passes to step 3134 where the new phone number is saved as the branch routing default number 723 in the subscriber master record. Control then returns to step 3104. If at step 3126 it is determined that the digit '3' is not entered, then control passes to step 3135 where a determination is made as to whether the digit '#' is entered, and if it is not entered control then returns to step 3104. If at step 3135 it is determined that the digit '#' is entered then control passes to the connector labelled "CPF MAIN DIRECTORY" at reference 3136, allowing the subscriber to make additional selections from the main directory of the command mode.

A flowchart of the CPF - Command Advanced Features function is illustrated in FIG. 32. The purpose of this function is provide the subscriber with the opportunity to modify those features of the Telephone Control System 1 which do not need to be modified on a regular basis. These features include allowing the subscriber to program mode memories, allowing the subscriber to record his 'drop-in' name, or his personalized greeting, allowing the subscriber to program his reserved numbers, and allowing the subscriber to activate or deactivate the weekly schedule. The CPF - Command Advanced Features function is entered at step 3200 and control passes to step 3201 where the subscriber is prompted: "Advanced Features Directory. Enter 1 to program mode memories, 2 to record greetings, 3 to program reserved numbers, 4 to activate the weekly schedule, 5 to deactivate the weekly schedule, or # to return to the Main Directory." Control then passes to step 3202 where a determination is made as to whether the digit '1' is entered. If the digit '1' is entered, then control passes to step 3203 where the subscriber is allowed to specify a mode memory number 802 of value '10 to '99'. If the mode memory number 802

specified already exists the call processor voices the status of that memory. The subscriber is then given an opportunity to modify the parameters 803 contained in the mode memory. When the subscriber is finished modifying the contents, the changes are saved in mode memory 800. Control then returns to step 3201. If at step 3202
5 it is determined that the digit '1' is not entered, then control passes to step 3204 where a determination is made as to whether the digit 2 is entered. If the digit '2' is entered, then control passes to step 3205 where the subscriber is allowed to listen to and re-record the 'drop-in' name and the 'personalized greeting'. If the subscriber does re-record either of these, then the changed name or greeting is saved on disk
10 505. Control then returns to step 3201. If at step 3204 it is determined that the digit '2' is not entered, then control passes to step 3206 where a determination is made as to whether the digit '3' is entered. If the digit '3' is entered, then control passes to step 3207 where the subscriber is allowed to modify the 'message center number' 709, the 'pager number' 710, the 'office number' 711, the 'home number' 712, or
15 the 'mobile phone number' 713. If the subscriber changes any of these numbers then the new number is saved in the corresponding field of the subscriber master record 700. Control then returns to step 3201. If at step 3206 it is determined that the digit '3' is not entered, then control passes to step 3208 where a determination is made as to whether the digit '4' is entered. If the digit '4' is entered, then control passes to
20 step 3209 where the subscriber is allowed to activate the weekly schedule. If the subscriber chooses to activate the weekly schedule, then the 'weekly schedule active' flag 728 of the subscriber master record 700 is set. Control then returns to step 3201. If at step 3208 it is determined that the digit '4' is not entered, then control passes to step 3210 where a determination is made as to whether the digit '5' is
25 entered. If the digit '5' is entered, then control passes to step 3211 where the subscriber is allowed to deactivate the weekly schedule. If the subscriber chooses to deactivate the weekly schedule, then the 'weekly schedule active' flag 728 of the subscriber master record 700 is cleared. Control then returns to step 3201. If at step 3210 it is determined that the digit '5' is not entered, then control passes to step 3212
30 where a determination is made as to whether the digit '#' is entered. If the digit '#'

is not entered, then control returns to step 3201. If at step 3212 it is determined that the digit '#' is entered then control passes to the connector labelled "CPF MAIN DIRECTORY" at reference 3213, allowing the subscriber to make additional selections from the main directory of the command mode.

5 A block diagram of the Meet-Me Facility (MMF) 115 is illustrated in FIG. 33. As was discussed earlier, the MMF 115 interfaces to tip-ring lines 120. These lines are provisioned by switch 4 with the CENTREX feature of 'call transfer', which allows a caller to be transferred to another number by flashing, dialing the number, and then going on hook. These lines are also provisioned by switch 4 with the
10 CENTREX feature of 'barge-in', which allows a party on one of the lines 120 to barge into a conversation in progress on another of the lines 120. This is accomplished by flashing, dialing a barge-in code (*77), and then dialing the intercom code associated with the line 120 of the conversation to be barged-in on. As was mentioned earlier, to fully understand the operation of the meet-me feature it is
15 necessary to also review the explanations which are associated with FIG. 21 (CPF - Meet Me Caller), FIG. 30 (CPF - Command Meet Me), and FIG. 34 (Meet Me Facility Main Task). Referring now to FIG. 33, the lines 120 are shown connected to call processors 3300, which contain a tip-ring interface and DTMF generators and detectors. The functions of call processor 330 are well known in the art, and many
20 products, such as the Model D41B manufactured by Dialogic Corporation, exist commercially which can accomplish these functions. The MMF 115 also contains a CPU 3301 which contains among other things a microprocessor, a boot ROM, a RAM, and a disk. The MMF 115 also contains a data network interface module 3302 which connects to the high speed data network 150. The functions of data network
25 interface 150 are well known in the art, and many products, such as the Model COM4i from Digiboard Corporation, exist commercially which can accomplish these functions. The call processors 3300, the CPU 3301, and the data network interface 3302 are all shown connected to an internal data bus 3303. The CPU 3301 initializes itself at power-up using the boot ROM and then loads a control program into memory
30 which it then executes. The control program allows for the control of simultaneous

activities on the lines 120.

A flowchart of the Meet Me Facility Main Task is illustrated in FIG. 34. The Meet Me Facility Main Task is the part of the MMF 115 control program which controls the activities on one of the lines 120. The Meet Me Facility Main Task is entered at step 3400 and control passes to step 3401 where a determination is made as to whether the call processor 3300 has detected a ring signal on the line 120, and if a ring signal is not detected, then control remains at step 3401. If a ring signal is detected, then control passes to step 3402, where the line 120 is taken off hook by call processor 3300, thereby answering the incoming call. At step 3403, a 1 second pause is initiated to allow for the line 120 to settle, and then at step 3404 the call processor 3300 dials the DTMF digit '*' as an answer indication to the CPF 100 which is calling. Then at step 3405 a 5 second timer is started, and control then passes to step 3406 where the 5 second timer is checked. If the 5 second timer has expired, then control passes to step 3407 where the line 120 is placed on-hook by call processor 3300, and then control returns to step 3401. If at step 3406 it is determined that the 5 second timer has not expired, then control passes to step 3408 where a determination is made as to whether the DTMF digit sequence '00' is detected by call processor 3300, indicating the call is a meet-me caller from CPF 100. If the digit sequence '00' is not detected, then control passes to step 3409 where a determination is made as to whether the DTMF digit sequence '01' is detected, indicating the call is a meet-me subscriber from CPF 100. If the digit sequence '01' is not detected, then control returns to step 3406 where the 5 second timer is again checked. If at step 3408 it is determined that the digit sequence '00' is detected, then control passes via a connector labelled "MMF CALLER" at reference 3410 to step 3411, where a determination is made as to whether a DTMF digit sequence representing the Access Number 701 of the subscriber being called is detected by call processor 3300. If a valid phone number is not detected, then control remains at step 3411. If a valid phone number is detected, then control passes to step 3412 where a 2 second pause is initiated. Then at step 3413, the call processor 3300 dials the DTMF digit '*' to inform the CPF 100 that the connection has been successful so far.

Control then passes to step 3414 where a determination is made as to whether the DTMF digit 'd' is detected, indicating that the subscriber has called into the CPF 100, and the CPF 100 is about to conference him to the MMF 115. If the digit 'd' is not detected then control remains at step 3414. If the digit 'd' is detected, then control passes to step 3415 where a flash is generated on lines 120 causing the CENTREX system serving lines 120 to place the calling party (in this case the CPF 100) on hold, and a dial tone to be applied to line 120. Control then passes to step 3416 where a determination is made as to whether the subscriber has yet been connected to one of the other of lines 120 on the MMF 115. If the subscriber has not yet been connected, then control remains at step 3416. If it is determined that the subscriber has connected to one of the other of lines 120, then control passes to step 3417, where the CENTREX 'barge-in code' (*77) is dialed by the DTMF generator of call processor 3300. Then at step 3418, the call processor 3300 dials the intercom code for the line 120 which is currently connected to the subscriber. Control then passes to step 3419 where a 2 second pause is generated, and then to step 3420 where a flash is generated. This causes the line 120 which is connected to the subscriber to be connected via the CENTREX system to the line 120 which is connected to the caller. Control then passes to step 3421 where control remains while the subscriber and caller converse, until a loop interruption signal is detected on line 120 indicating at least one of the two parties has disconnected. Control then passes to step 3422 where the line 120 is placed on hook, and control returns to step 3401. If at step 3409 it is determined that the digit sequence '01' is detected, then control passes via a connector labelled "MMF SUBSCRIBER" at reference 3423 to step 3424, where a determination is made as to whether a DTMF digit sequence representing the Access Number 701 of the subscriber is detected by call processor 3300. If a valid phone number is not detected, then control remains at step 3424. If a valid phone number is detected, then control passes to step 3425 where an indication is made available that a subscriber is connected to the MMF 115 on this line 120. Control then passes to step 3426 where a 3 second pause is initiated, allowing time for the line 120 connected to the subscriber to perform the barge-in sequence. Control then

passes to step 3427 where the line 120 is placed on hook causing the CENTREX system to call transfer the subscriber to the line 120 which has just barged-in. Control then returns to step 3401.

5 A block diagram of the Subscriber Access Facility (SAF) 110 is illustrated in FIG. 35. The SAF 110 provides a means by which subscribers can access the Telephone Control System 1 via trunks which provide automatic number identification (ANI). SAF trunk interface 3500 interfaces the SAF 110 with trunks 8. The trunk interface 3500 is the same trunk interface as was described earlier at reference 400 used in the CPF 100, however the E & M Lead Control Circuit operates under a
10 slightly different set of instructions, as will be described below in the explanation which accompanies FIG. 36. Still referring to FIG. 35, as was discussed earlier, the preferred embodiment of the TELEPHONE CONTROL SYSTEM 1 employs a Feature Group D (FGD) facility for trunks 8. This is provided via a 4-wire E&M trunk provisioned with TYPE I signaling, which is well known in the art. These type
15 of trunks provide a 2-wire balanced transmit audio connection, a 2-wire balanced receive audio connection, an E-Lead, and an M-Lead. Although only one trunk interface 3500, one trunk 8, and one call processor 3504 are shown in FIG. 35, it should be readily evident to one skilled in the art that additional trunk interfaces and call processors may be added to support additional trunks. The trunk interface 3500
20 provides a two-way audio path shown at reference 3501, a loop status output shown at reference 3502, and a on/off hook control input shown at reference 3503. These lines are shown connected to call processor 3504 which performs the functions of voice storage and playback, DTMF generation and detection, and call control. Devices which perform the functions of call processor 3504 are well known in the art
25 and many products, such as the Model D41B manufactured by Dialogic Corporation, exist commercially which can accomplish these functions. Also shown is a multi frequency detector module 3505 which is shown connected to the call processor 3504. A commercially available multi-frequency module capable of performing this function is the Model MF/40 manufactured by Dialogic Corporation. A data network interface
30 3507 is used to connect the SAF 110 to the other subsystems of the Telephone

Control System 1. Data network interface 3507 passes data messages between the SAF 110 and these other subsystems. The functions of data network interface 3507 are well known in the art, and many products, such as the Model COM4i from Digiboard Corporation, exist commercially which can accomplish these functions.

5 CPU 3506, which contains a microprocessor, a boot ROM, a RAM, and a disk, controls all functions of the SAF 110. The trunk interface 3500, the CPU 3506, the call processor 3504, and the data network interface 3507 are all shown connected to an internal data bus 3508. The CPU 3506 initializes itself at power-up using the boot ROM and then loads a control program into memory which it then executes. The

10 control program allows for the control of simultaneous activities on the trunks 8. An explanation of the control program for the SAF 110 accompanies FIG. 37.

A flowchart of the operation of E&M control circuit for the trunk interface 3500 of the SAF 115 is shown in FIG. 36. As the construction of the trunk interface 3500 of FIG. 35 is identical to that of the trunk interface 400 of FIG. 5, the

15 explanation which follows will refer to the reference numbers of FIG 5 when discussing the internal components of the trunk interface 3500. Referring now to FIG. 36, the E&M Lead Control Circuit Operation for the SAF Trunk Interface function is entered at step 3600 and control passes to step 3601 where the control circuit 450 idles waiting for an indication from current detector 440 that the E-Lead

20 has gone off-hook. When the E-Lead does go off-hook, control passes to step 3602 where an "Incoming Call" signal is sent to CPU 3506 via buffer 460. Control then passes to step 3603 where a determination is made as to whether an off-hook signal is received from call processor 3504 signifying that the CPU 3506 is ready to accept the call. If the off hook signal is detected, then control passes to step 3604 where the

25 'loop status' 3502 is set active. Control then passes to step 3605 where the M-Lead is winked by taking the M-Lead relay 455 momentarily off-hook. Control then passes to step 3606 where a determination is made as to whether a 'DID received' signal 480 is detected. If the signal is not detected then control remains at step 3606. If the signal is received, indicating that the multifrequency detector 3505 has detected the

30 'ANI' and 'called number' digits from the FGD trunk 8, then control passes to step

3607 where the M-lead relay is once more winked momentarily off hook to acknowledge receipt of the multifrequency data. A 300 millisecond pause is then initiated at step 3608, prior to taking the M-Lead off hook at 3609 to 'answer' the trunk. At this point audio is established by the switch which is providing the FGD service, and the calling party is connected to the SAF 110. Control then passes to a loop consisting of steps 3610 and 3611. This loop persists until either at step 3610 the on/off hook signal 3503 is taken on hook by the call processor 3504, or at 3611 the E-Lead is determined to be on-hook. In either case the call is ended, and control passes to step 3612 where the 'loop status' signal 3502 is set inactive. Then at step 3613 a determination is made as to whether the 'DID received' signal 480 still remains active indicating the CPU 3506 is not yet ready to receive a new call. If this signal is still active, then control remains at step 3613. If it is determined at step 3613 that the 'DID received' signal 480 is now inactive, then control passes to step 3614 where the M-Lead is placed on hook, terminating the call, and control passes to step 3601.

A flowchart of the Subscriber Access Facility Main Task is illustrated in FIG. 37. This program is loaded into memory and executed by SAF CPU 3506. The Subscriber Access Facility Main Task is entered at step 3700 and control passes to step 3701 where a 'clear DID received' signal is sent to the trunk interface 3500. Control then passes to step 3702 where the 'incoming call' signal of the trunk interface 3500 is checked. If this signal is not active then control remains at step 3702. If this signal is active, then control passes to step 3703, where the output of the multifrequency detector 3505 is checked via call processor 3504. The incoming multifrequency digit sequence 'KP' + '00' + ANI + 'ST' is decoded where 'KP' is the start digit, 'ST' is the stop digit, and the ANI is the phone number of the phone from which the subscriber is calling. Control then passes to step 3704 where, in a similar manner, the incoming multifrequency digit sequence 'KP' + 800 + NXX + XXXX + 'ST' is decoded. Again the 'KP' is the start digit, the 'ST' is the stop digit, and the sequence 800 NXX XXXX is the phone number dialed by the subscriber to reach the trunk 8, the NXX being the prefix which identifies trunk

group 8 to the PSTN 2. This phone number represents the programming function which the subscriber wishes to accomplish. Control then passes to step 3705 where a 'set DID received' signal is sent to the trunk interface 3500, indicating that the multifrequency data has been received. Control then passes to step 3706 where a

5 determination is made as to whether the dialed number was of the form 800 - NXX - 00ab, and if the dialed number was not of this form then control passes to a connector labelled "SAF EXT" at reference 3707. If at step 3706 it is determined that the dialed number is of the form 800 - NXX - 00ab, then control passes to step

10 3710 where a 'request master record' message is constructed using the ANI received in step 3703, and the message is sent via data network interface 3507 to the CPF 100. Control then passes to step 3711 where a determination is made as to whether a response has been received to the 'request master record' message, and if such a response is not received control remains at step 3711. If the response message is received by network interface 3507, then control passes to step 3712 where a

15 determination is made as to whether a valid subscriber master record 700 is included in the returned message. If a valid subscriber master record is not included, then control passes to the connector labelled "SAF REORDER" shown at reference 3713. If at step 3712 a valid subscriber master record 700 is found, then control passes to step 3714 where the DID number 701 is removed from the subscriber master record

20 700. Control then passes to step 3715 where a 'mode memory inquiry' message is constructed using the DID number 701 and the digits 'ab' as detected in step 3706, and the message is sent via data network interface 3507 to the CPF 100. Control then passes to step 3716 where a determination is made as to whether a response has been received to the 'mode memory inquiry' message, and if such a response is not

25 received control remains at step 3716. If the response message is received by network interface 3507, then control passes to step 3717 where a determination is made as to whether a valid mode memory 800 is included in the returned message. If a valid mode memory 800 is not included, then control passes to the connector labelled "SAF REORDER" shown at reference 3718. If at step 3717 a valid mode

30 memory 800 is found, then control passes to step 3720, which is identified by a

connector labelled "SAF UPDATE" at reference 3719. At step 3720 a 'change to new mode memory' message is constructed, again using DID number 701 and the digits 'ab' as detected in step 3706, and the message is sent via data network interface 3507 to the CPF 100. Control then passes to step 3721 where the subscriber is prompted by call processor 3504: "Accepted, you have selected mode memory... 'ab'", where 'ab' are the digits detected in step 3706. Control then passes to step 3722 where the call processor 3504 causes trunk 8 to be placed on-hook, and then control returns to step 3701. If at step 3706 it is determined that the dialed number was not of the form '800 - NXX - 00ab', then control passes to a connector labelled "SAF EXT" as shown at reference 3707. A connector labelled "SAF EXT" is shown at reference 3724, which causes control to be passed to step 3725 where a determination is made as to whether the dialed number was of the form 800 - NXX - cdef, where the digits 'cd' do not equal '00'. If the dialed number is not of this form, then control passes to a connector labelled "SAF REORDER" shown at reference 3745. If at step 3725 it is determined that the dialed number is of this form, then control passes to step 3726 where call processor 3504 prompts the subscriber by playing a 'bong tone'. Control then passes to step 3727 where a determination is made as to whether the subscriber has entered a PIN code, and if the PIN code is not entered control remains at step 3727. If a PIN code is entered, then control passes to step 3728 where a 'request master record' message is constructed using then PIN code entered in step 3727 and the digits 'cdef' detected in step 3706. This message is then sent via data network interface 3507 to the CPF 100. Control then passes to step 3729 where a determination is made as to whether a response has been received to the 'request master record' message, and if such a response is not received control remains at step 3729. If the response message is received by network interface 3507, then control passes to step 3750 where a determination is made as to whether a valid subscriber master record 700 is included in the returned message. If a valid subscriber master record is not included, then control passes to the connector labelled "SAF REORDER" shown at reference 3751. If at step 3750 a valid subscriber master record 700 is found, then this indicates that CPF 100 found

a subscriber master record 700 which had a DID number 701 which had the same last four digits as the digits 'cdef' detected in step 3706, and also had the same PIN code 702 as that detected in step 3727. Control passes to step 3730 where the subscriber is prompted: "Please enter your new mode memory number." Control then passes

5 to step 3731 where a determination is made as to whether the subscriber has entered a memory number '10 to '99', and if such a number has not been entered, then control remains at step 3731. If a mode memory number is entered, then control passes to step 3732 where a 'mode memory inquiry' message is constructed using the DID number 701 and the and the memory number as detected in step 3731, and the

10 message is sent via data network interface 3507 to the CPF 100. Control then passes to step 3733 where a determination is made as to whether a response has been received to the 'mode memory inquiry' message, and if such a response is not received control remains at step 3733. If the response message is received by network interface 3507, then control passes to step 3734 where a determination is

15 made as to whether a valid mode memory 800 is included in the returned message. If a valid mode memory 800 is not included, then control passes to the connector labelled "SAF REORDER" shown at reference 3745. If at step 3734 a valid mode memory 800 is found, then control passes to step 3735, where a determination is made as to whether the mode memory which was received in the message requires

20 an 'externally entered' memory. This is determined by inspecting the transfer number field of the mode memory 800. If it has an 'externally entered number' tag, then the mode memory does require an 'externally entered number'. If at step 3735 it is determined that an 'externally entered number' is not required, then control passes to a connector labelled "SAF UPDATE" at reference 3736, which as described

25 earlier causes the mode memory requested to be invoked. If at step 3735 it is determined that an 'externally entered number' is required, then control passes to step 3737 where the subscriber master record 700 as acquired at step 3750 is retrieved from memory. Control then passes to step 3738 where the mode memory 800 that was acquired in step 3734 is copied field-by-field to the subscriber master record.

30 Control then passes to step 3740, where the ANI number acquired in step 3703 is

copied to the transfer number field 707 of the subscriber master record 700. Control then passes to step 3741 where an 'update master record' message is constructed using this master record, and the message is sent via data network interface 3507 to CPF 100. Control then passes to step 3742 where the subscriber is prompted:

5 "Accepted, you have selected mode memory..xx", where the digits 'xx' are the digits entered by the subscriber at step 3731. Control then passes to step 3743 where the trunk 8 is placed on hook, and then control returns to the Subscriber Access Facility Main Task entry point as shown at reference 3748. If at step 3734, it is determined that the mode memory received in the message was not valid, then control passes to

10 a connector labelled "SAF REORDER" at reference 3745, which causes control to pass to step 3746 where the call processor 3504 plays a 'reorder signal' to the subscriber, indicating that the call is being terminated. Control then passes to step 3747 where the trunk 8 is placed on hook. Control then returns to the Subscriber Access Facility Main Task entry point as shown at reference 3748.

15 A block diagram of the Communicator Access Facility (CAF) 125 is illustrated in FIG. 38. As shown, the CAF 125 contains a serial port interface module 3800 which connects to the serial datalink 10, and a data network interface 3801 which connects to the high speed data network 150. The functions of data network interface 3801 are well known in the art, and many products, such as the Model COM4i from

20 Digiboard Corporation, exist commercially which can accomplish these functions. The operation of the CAF 125 is controlled by CPU module 3802, which consists of a microprocessor, a boot ROM, RAM, and disk. The boot ROM is used to initialize the CPU and load the control program into memory from disk. Operation of the CAF 125 is then controlled by the control program. The control program is

25 described in the explanation which accompanies FIG. 39. Still referring to FIG. 38, the serial port 3800, data network interface 3801, and the CPU module 3802 are all shown connected to internal bus 3803.

A flowchart of the Communicator Access Facility Main Task is illustrated in FIG. 39. This program is loaded into memory and executed by CPU 3802 of the

30 CAF 125. The Communicator Access Facility Main Task is entered at step 3900 and

control passes to step 3901 where a determination is made as to whether a 'page message' is received via data network interface 3801, and if a 'page message' is received then control passes to step 3902 where the page message is sent via serial port 3800 and datalink 10 to packet radio transceiver 9. Control then passes to step

5 3903 where an 'acknowledge timer' is started, and the 'page message' just sent is saved and associated with this 'acknowledge timer'. Control then passes to step 3904. Control also passes to step 3904 if a 'page message' is not received as determined at step 3901. At step 3904, a determination is made as to whether a

10 'phone number' message has been received from a communicator 11 via the serial port interface 3800. If such a message has been received, then control passes to step 3905 where the subscriber's DID number 701 is retrieved from the message, and a 'request master record' message is created and sent to the CPF 100 via data network interface 3801. When the response is received from the CPF 100 via the data network interface 3801, the subscriber master record is retrieved from the response

15 message. Control then passes to step 3906 where the transfer number field 707 of the subscriber master record 700 is updated per the phone number received from the communicator 11 at step 3904. Control then passes to step 3907 where an 'update master record' message is then constructed and sent back to the CPF 100 via data network interface 3801. Control then passes to step 3908, where an 'acknowledge

20 message' is sent back to the communicator 11 via serial port 3800. Control then passes to step 3909. Control also passes to step 3909 if a 'phone number' message is not detected at step 3904. At step 3909 a determination is made as to whether a 'new mode memory' message is received from a communicator 11 via serial port

25 3800. If this message type has been received then control passes to step 3910 where a 'change to new mode memory' message is constructed and sent to CPF 100 via data network interface 3801, and then control passes to step 3908 where an 'acknowledge' message is sent back to the communicator 11 as described earlier. If at step 3909 a 'new mode memory request' message is not detected, then control passes to step 3911 where a determination is made as to whether a 'set dynamic mode assignment mode'

30 message is received from a communicator 11 via serial port 3800. If this message

type is received, then control passes to step 3912, where a 'set dynamic mode assignment flag' message is constructed and sent to CPF 100 via data network interface 3801. Control then passes to step 3908 where an 'acknowledge' message is sent back to the communicator 11 as described earlier. If at step 3911 a 'set dynamic mode assignment mode' message is not detected, then control passes to step 3913 where a determination is made as to whether a 'disable dynamic mode assignment mode' message is received from a communicator 11 via serial port 3800. If this message type is received, then control passes to step 3914, where a 'clear dynamic mode assignment flag' message is constructed and sent to CPF 100 via data network interface 3801. Control then passes to step 3908 where an 'acknowledge' message is sent back to the communicator 11 as described earlier. If at step 3913 a 'disable dynamic mode assignment mode' message is not detected, then control passes to step 3915 where a determination is made as to whether the 'acknowledge timer' has just expired. If the 'acknowledge timer' has just expired, as determined at step 3915, then control passes to step 3916 where the message which was associated with this 'acknowledge timer' is again sent to the communicator 11 via serial port interface 3800, and control then passes to step 3903. If at step 3915 it is determined that an 'acknowledge timer' has not just expired, then control passes to step 3917 where a determination is made as to whether an 'acknowledge' message is received from a communicator via serial port interface 3800, and if an 'acknowledge' message is not received, then control returns to step 3901. If an 'acknowledge' message is received, as determined at step 3917, then the 'acknowledge' timer which is associated with the last message sent to the communicator 11 identified in the 'acknowledge' message is cleared. Control then returns to step 3901.

A flowchart of the Communicator Main Task is illustrated in FIG. 40. This task is executed by microprocessor 200, and controls all operations of the communicator 11. The Communicator Main Task is entered at step 4000 and control passes to step 4001 where a determination is made as to whether a 'page' message is detected at the receive data input 245. If a 'page' message is detected, and the message contains the pager number which corresponds to this communicator, then

control passes to step 4002, where a signal is sent via output port 250 causing the beeper 260 to generate an alerting sound. Control then passes to step 4003 where a display number is retrieved from the decoded 'page' message, and is output to the display 210. Control then passes to step 4004 where a brief 'acknowledge' message is sent via transmit data port 215 to packet data encoder 220 and then to rf transmitter 225. All RF transmissions from communicator 11 are sent as brief packet 'bursts', thus maintaining a longer life for battery 290. Control then returns to step 4001. If at step 4001 it is determined that a 'page' message is not received, then control passes to step 4005 where a determination is made as to whether a 'manual phone number flag' is set, and if the flag is not set control passes to step 4006 where a determination is made as to whether a data message is received from the ultrasonic transmitter 12 via the serial data input 280, and if such a message is received then control passes to step 4007. At step 4007 a determination is made as to whether a 'auto phone number flag' is set and if the flag is not set control passes to step 4009 where the 'auto phone number flag' is set. Control then passes to step 4010 where the phone number which was embedded in the message received at step 4006 is stored in the memory of microprocessor 200. Control then passes to step 4011 where a 'phone number' message is constructed using the phone number of step 4006, and the subscriber DID number 701, as prestored in the RAM of microprocessor 200. This message is then sent to transmit data port 215. Control then passes to step 4012 where an 'acknowledge timer' is started. Control then passes to step 4013 where a '20 second ultrasonic data timer' is started. Control then returns to step 4001. If at step 4007 it is determined that the 'auto phone number flag' is set, then control passes to step 4008, where a determination is made as to whether the phone number received embedded in the message at step 4006 is the same as the phone number currently in memory as stored at step 4010. If the phone numbers match then control passes to step 4013. If at step 4008 it is determined that the phone numbers are different, indicating that the subscriber has moved to a different room, then control passes to step 4009. If at step 4005 it is determined that the 'manual phone number flag' is set, or if at step 4006 it is determined that a data message is not being received via

input port 280, then control passes to step 4014 where a determination is made as to whether the '20 second ultrasonic data timer' has just expired, and if it has, indicating that the subscriber is no longer near an ultrasonic transmitter 12, then control passes to step 4015. At step 4015 the 'auto phone number flag' is cleared and control passes to step 4016 where the a 'new mode memory request' message is constructed using the stored subscriber DID number 701, and the stored 'default mode memory'. Control then passes to step 4017 where an 'acknowledge timer' is started, and then control returns to step 4001. If at step 4014 it is determined that the '20 second ultrasonic data timer' has not just expired, then control passes to step 4018 where a determination is made as to whether the 'acknowledge timer' has just expired, and if it has just expired control passes to step 4019 where the message is re-sent via transmit data port 215. Then at step 4020, an 'acknowledge timer' is started, and then control returns to step 4001. If at step 4018 it is determined that the 'acknowledge timer' has not expired, then control passes to step 4021 where a determination is made as to whether an 'acknowledge' message with a pager number that corresponds to this communicator 11 is received via the receive data input 245, and if such a message is received then control passes to step 4022 where the 'acknowledge timer' is cleared. Control the returns to step 4001. If at step 4021 it is determined that an 'acknowledge' message is not received, then control passes to step 4023 where a determination is made as to whether the subscriber is entering data via the keypad 205, and if the subscriber is not entering data, then control returns to step 4001. If the subscriber is entering data via the keypad, as determined at step 4023, then control passes to step 4024 where a determination is made as to whether the subscriber wishes to program the Telephone Control System 1 to operate under control of a new mode memory. If this is the case, then control passes to step 4025 where a 'new mode memory request message' is constructed and sent to transmit data port 215, and then control passes to step 4033 where an 'acknowledge timer' is started, and then control returns to step 4001. If at step 4024 it is determined that the subscriber is not selecting a new mode memory, then control passes to step 4026 where a determination is made as to whether the subscriber is selecting the dynamic

mode assignment feature, and if this is the case, then control passes to step 4027 where a 'set dynamic mode assignment mode' message is constructed and sent to transmit data port 215, and then control passes to step 4033. If at step 4026 it is determined that the subscriber is not selecting the dynamic mode assignment feature, then control passes to step 4028 where a determination is made as to whether the subscriber is disabling the dynamic mode assignment feature, and if this is the case, then control passes to step 4029 where a 'disable dynamic mode assignment mode' message is constructed and sent to transmit data port 215, and then control passes to step 4033. If at step 4028 it is determined that the subscriber is not disabling the dynamic mode assignment mode, then control passes to step 4030 where a determination is made as to whether the subscriber is entering a phone number, and if a phone number is being entered then control passes to step 4031 where the 'manual phone number flag' is set. Control then passes to step 4032 where a 'phone number' message is constructed using the phone number entered by the subscriber at step 4030, and this message is transmitted via transmit data port 215. Control then passes to step 4033. If at step 4030 it is determined that the subscriber is not entering a phone number, then control passes to step 4034 where a determination is made as to whether the subscriber is selecting the auto-phone number mode, and if this is the case, then control passes to step 4035 where the 'manual phone number flag' is cleared, and control then passes to step 4015. If at step 4034 it is determined that the subscriber is not selecting the auto-phone number mode, then control passes to step 4036, where a determination is made as to whether the subscriber is entering new program data such as the stored DID number, the stored pager number, and the stored default mode memory. If the subscriber is attempting to modify any of these parameters, then control passes to step 4037 where the new data is stored in the RAM of microprocessor 200. Otherwise, control returns to step 4001. As can be understood from the explanation above, one of the primary functions of the Communicator 11 and the Communicator Access Facility 125 is to take the phone number identifying the location of the subscriber, as transmitted by ultrasonic transmitter 12, and cause that number to be used by the Telephone Control System

1 as the forwarding number for the subscriber. It should also be understood that in a similar fashion the ultrasonic transmitter 12 may transmit a 'mode memory number' which, if sent to the Telephone Control System 1 via the Communicator 11 and the Communicator Access Facility 125, would allow that mode memory to be used by the Telephone Control System 1 to specify the call handling mode for the subscriber. In this case, the Communicator 11 receives a data message from an ultrasonic transmitter 12 and determines that the message contains a mode memory. The Communicator 11 then transmits a 'new mode memory request' message, which includes the subscriber's DID number 701, via its RF transmitter 225. This message is received by packet radio transceiver 9 and sent to the CAF 125 via data line 10. The CAF 125 then sends a "change to new mode memory" message to CPF 100 via data network interface 3801. CPF 100 then copies the mode memory referred to in the message to this subscriber's "subscriber master record" 700. To further illustrate this process, consider the example of a hospital operating room where an ultrasonic transmitter 12 is transmitting a message containing a mode memory number which corresponds to the "message center" call handling mode. If a doctor, carrying a Communicator 11 enters the operating room, then the Telephone Control System is automatically programmed to send his calls to the "message center."

A block diagram of the Pager Dialing Facility (PDF) 105 is illustrated in FIG. 41. Standard tip-ring line 5 is shown connected to call processor 4100, which contains a tip-ring interface, DTMF generators, call progress detectors. The functions of call processor 4100 are well known in the art, and many products, such as the Model D41B manufactured by Dialogic Corporation, exist commercially which can accomplish these functions. The PDF 105 also contains a CPU 4101 which contains a microprocessor, a boot ROM, a RAM, and a disk. The PDF 105 also contains a data network interface module 4103 which connects to the high speed data network 150. The functions of data network interface 4103 are well known in the art, and many products, such as the Model COM4i from Digiboard Corporation, exist commercially which can accomplish these functions. The call processor 4100, the CPU 4101, and the data network interface 4103 are all shown connected to an

internal data bus 4102. The CPU 4101 initializes itself at power-up using the boot ROM and then loads a control program into memory which it then executes.

A flowchart of the Pager Dialing Facility Main Task is illustrated in FIG. 42. This program is loaded into memory and executed by CPU 4101 of the PDF 105.

5 The Pager Dialing Facility Main Task is entered at step 4200 and control passes to step 4201 where a determination is made as to whether a 'page' message is received from CPF 100 via data network interface 4201, and if the message is not received then control remains at step 4201. If a 'page' message is received, then the 'pager number' and the 'display digits' are retrieved from the message, and control passes

10 to step 4202 where an 'attempt count' is set to a value of 1. Control then passes to step 4203, where line 5 is taken off hook, and then control passes to step 4204 where call processor 4100 dials the 'pager number'. Control then passes to step 4205 where a determination is made as to whether the call has not been answered due to a time-out or a non-answer signal such as operator intercept, busy, or reorder. If such

15 a signal or time-out condition is not detected then control passes to step 4206 where a determination is made as to whether the call has been answered by the paging terminal, and if the call has not been answered, control returns to step 4205. If at step 4206 it is determined that the call is answered, then control passes to step 4207 where a 1 second pause is initiated, and then control passes to step 4208 where the

20 'display digits' are dialed by call processor 4100. Control then passes to step 4209 where the pager termination digit '#' is dialed, and then control passes to step 4210 where the line 5 is placed on hook. Control then passes to step 4211 where a 2 second delay is initiated before returning control to step 4201. If at step 4205 it is determined that a time-out or non-answer signal is detected, then control passes to

25 step 4212 where the 'attempt count' is incremented. Control then passes to step 4213 where the 'attempt count' is checked and if it is found to be not equal to ten then control passes to step 4214 where the line 5 is placed on hook and then after a 2 second pause a step 4215, control returns to step 4203 to make another attempt at dialing this number. If at step 4213 it is found that the 'attempt count' is now equal

30 to 10, then this page is abandoned by returning control to step 4201.

A block diagram of the Client Services Facility (CSF) 130 is illustrated in FIG. 43. The Client Services Facility (CSF) 130 is used by the service bureau which provides the Telephone Control System service to its subscribers. The CSF 130 allows a client services representative to gain access to the database contained in the CPF 100, and thus be able to review and modify the subscriber master records 700 and mode memories 800 of the subscribers. The CSF 130 contains a CPU 4300 which contains a microprocessor, a boot ROM, a RAM, and a disk. The CSF 130 also contains a data network interface module 4301 which connects to the high speed data network 150. The functions of data network interface 4301 are well known in the art, and many products, such as the Model COM4i from Digiboard Corporation, exist commercially which can accomplish these functions. Also shown is a display monitor 4302, and a keyboard 4303. The CPU 4300 initializes itself at power-up using the boot ROM and then loads a control program into memory which it then executes.

A flowchart of the Client Services Facility Main Program is illustrated in FIG. 44. This program is loaded into memory and executed by CPU 4300 of the CSF 130. The Client Services Facility Main Program is entered at step 4400 and control passes to step 4401 where a determination is made as to whether the client services representative has entered the DID number for a particular subscriber and has requested a subscriber master record 700, and if this is the case then control passes to step 4402 where a 'request master record' message is sent via data network interface 4301 to CPF 100. Control then passes to step 4403 where the subscriber master record 700 is removed from the response message from the CPF 100, and is displayed on monitor 4302. Then at step 4404, the client services representative is allowed to review and modify the contents of the subscriber master record 700 using monitor 4302 and keyboard 4303. Then at step 4405 a determination is made as to whether the client services representative is completed with this operation, and if not, then control returns to step 4404. When the operation is complete, then control passes to step 4406 where an 'update master record' message is constructed and sent to CPF 100 via data network interface 4301. Control then returns to step 4401. If

at step 4401 it is determined that the client services representative is not requesting a subscriber master record 700, then control passes to step 4407 where a determination is made as to whether the client services representative has entered the DID number for a particular subscriber and has requested a subscriber mode memory 800, and if this is the case then control passes to step 4408 where a 'mode memory inquiry' message is sent via data network interface 4301 to CPF 100. Control then passes to step 4409 where the mode memory 800 is removed from the response message from the CPF 100, and is displayed on monitor 4302. Then at step 4410, the client services representative is allowed to review and modify the contents of the mode memory 800 using monitor 4302 and keyboard 4303. Then at step 4411 a determination is made as to whether the client services representative is completed with this operation, and if not, then control returns to step 4410. When the operation is complete, then control passes to step 4412 where an 'update mode memory' message is constructed and sent to CPF 100 via data network interface 4301. Control then returns to step 4401. If at step 4407 it is determined that the client services representative is not requesting a new mode memory, the control passes to step 4413 where a determination is made as to whether the client services representative has entered a DID number and wishes to activate a new subscriber for this number. If this is the case then control passes to step 4414 where a 'create a new subscriber message' is generated with this DID number and the message is sent to CPF 100 via data network interface 4301. Control then returns to step 4401. If at step 4413 it is determined that the client services representative does not wish to create a new subscriber, then control returns to step 4401.

While a preferred embodiment of the invention has been described in detail, it should be apparent that many modifications and variations thereto are possible, all of which fall within the true spirit and scope of the invention. For example, while the preferred embodiment of the control system provides voice synthesized type courtesy messages, any appropriate tones, beeps, etc. would serve as a courtesy message and such is the use of that term throughout the claims appended hereto. In addition, the term "line" as used herein and in the claims appended hereto includes both lines and

trunks. In addition, whereas the preferred embodiment of the invention uses the term "line" to describe the interconnecting medium between the control system and the central exchange, it should be understood throughout the specification and claims that "line" refers to tip and ring pairs, trunks or any other form of connecting circuits.

Claims:

1. A control system adapted for connection to a telephone exchange for receiving and processing calls from a caller to a user, the control system comprising:
5 input/output means adapted for connection to telephone exchange lines to input and output telephone calls; switching control means for controllably connecting a call on one line to a different line; memory means for controllably storing and recalling electronic signals; and electronic processing means for accessing said memory means, switching control means and input/output means to direct the flow of input and output
10 calls, said electronic processing means including means for:

- a) processing calls to the system directed to a specific user in a selected one of at least two distinct modes, one such mode being call forwarding in which case the processing means proceeds with items b) through d),
- b) recalling from said memory means a forwarding number for said user,
- 15 c) implementing a call to said forwarding number,
- d) switching the caller's call to said forwarding number,
- e) identifying a call to said system from a specific user,
- f) changing said specific user's memory means stored forwarding number responsive to a command from said specific user, and
- 20 g) changing a users call processing mode responsive a command from said user.

2. The control system of claim 1 wherein the electronic processing means further comprises means for recalling from said memory means a courtesy message indicating that a call transfer is being effectuated and transmitting said message to
25 said caller.

3. The control system of claim 1 including a message center mode wherein the electronic processing means further comprises means for: storing as a user mode control signal a message center mode signal that represents the user not being available and, upon recalling said message center mode signal in processing an

incoming call, recalling from said memory means a courtesy message indicating that the user is not available and that the caller can leave a message, transmitting said courtesy message to said caller, recording a message sent by the caller and allowing the specific user to call the system and access such message.

5 4. The control system of claim 1 including a priority call screening mode wherein the electronic processing means further comprises means for: storing as a user mode control signal a priority screening mode signal that represents the user not being available except for a priority call and, upon recalling said priority screening mode signal in processing an incoming call, recalling from said memory means a
10 message indicating that the user is not available unless the call is a priority call in which event the caller should transmit a specific command from his calling station, transmitting said message to said caller and, responsive to said caller transmitting said specific command, proceeding with steps b) - d) to forward said call.

15 5. The control system of claim 4 wherein the electronic processing means further comprises means for: responding to said caller not transmitting said specific command to process said caller's call in accordance with a predetermined default processing mode.

20 6. The control system of claim 4 wherein the electronic processing means further comprises means for: responding to said caller not transmitting said specific command by recalling from said memory means a courtesy message indicating that the caller can leave a message, transmitting said message to said caller, recording a message sent by the caller, and allowing the specific user to call the system and access such message.

25 7. The control system of claim 1 including a VIP screening mode wherein the electronic processing means further comprises means for: storing as a user mode control signal a VIP screening mode signal that represents the user not being available except for callers having a VIP code and, upon recalling said VIP screening mode signal in processing an incoming call, recalling from said memory means a
30 message indicating that the user is not available unless the caller has said VIP code in which event the caller should transmit said VIP code from his calling station,

transmitting said message to said caller and, responsive to said caller transmitting said VIP code, proceeding with steps b) - d) to forward said call.

5 8. The control system of claim 7 wherein the electronic processing means further comprises means for: responding to said caller not entering said VIP code to process said caller's call in accordance with a predetermined default processing mode.

9. The control system of claim 7 wherein the electronic processing means further comprises means for: responding to said caller not entering said VIP code by recalling from said memory means a courtesy message indicating that the caller can leave a message, transmitting said message to said caller, recording a message sent
10 by the caller, and allowing the specific user to call the system and access such message.

10. The control system of claim 1 including a branch routing mode wherein the electronic control means further comprises means for: responding to an incoming call to a specific user to recall from said memory means a courtesy message
15 indicating to the caller that his call could be branched to any of a plurality of options responsive to the caller transmitting an appropriate command corresponding to the desired branch, transmitting said courtesy message to said caller and, responsive to the caller transmitting said command, proceeding with steps b) -d) to forward said call.

20 11. The control system of claim 1 including a voice-screening mode wherein the electronic control system comprises means for: storing as a user mode control signal a voice-screen mode signal and, upon recalling said voice-screening mode signal in processing an incoming call, recalling from said memory means a message
25 requesting that the caller transmit specific identification information, transmitting said message to said caller, recording the caller's response to said message, implementing a call to the user's forwarding number, transmitting the caller's response, and responding to a command response from the user to appropriately dispose of the caller's call.

12. The control system of claim 11 wherein the electronic control system

further comprises means for: upon completing said call to said user's forwarding number, recalling a courtesy message from said memory means indicating that the user is being called by a caller, interleaving with said courtesy message the caller's recorded identification information, said courtesy message further including the user's option to transmit a first control command signal to connect the user to the caller or an alternate control command signal to recall a second courtesy message from said memory means and send such message to said caller, transmitting said courtesy message to said user, and responding to the user transmitting a control command to appropriately dispose of the caller's call.

13. The control system of claim 11 wherein the electronic processing means further comprises means for: responding to a second control command from said user to recall a terminating message from said memory means, send said terminating message to said caller and terminate the connection to said caller, responding to a third control signal from said user to recall a leave-a-message signal, transmitting said leave-a-message signal to said caller and storing the caller's message in said memory means, and responding to a fourth control signal from said user to recall a predetermined phone number from said memory means, call said number and connect said caller to said predetermined number.

14. The control system of claim 1 including a meet-me mode wherein the electronic processing means further comprises means for: storing as a user mode control signal a meet-me mode signal and, upon recalling said meet-me mode signal in processing an incoming call, recalling from said memory means a pager access control procedure, controlling a paging system to page the user with an indication that he has a call waiting, identifying a call to said system from said user responsive to said page and, in the event the caller has waited on the line, switching the caller to the user.

15. The control system of claim 14 wherein the electronic processing means further comprises means for: in the event the caller has not waited on the line, so notifying the user by recalling a predetermined courtesy message and transmitting said courtesy message to the user.

16. The control system of claim 14 wherein the electronic processing means further comprises means for: recalling from said memory means a courtesy signal notifying the caller that the system must page the user and informing the caller that by transmitting a command the caller would be allowed to record a message, transmitting said courtesy signal to the caller before initiating the page to the user and, responsive to receipt of said command from the caller, recording the caller's message.

17. The control system of claim 15 wherein the electronic processing means further comprises means for: recalling from said memory means a courtesy signal notifying the caller that the system must page the user and informing the caller that by entering a command the caller would be allowed to record a message, transmitting said courtesy message to the caller before initiating the page to the user and, responsive to receipt of said command from the caller, recording the caller's message.

18. The control system of claim 1 in combination with a paging system wherein each user carries a paging device adapted to receive radio frequency signals broadcast from a central paging system with a unique identification code assigned to each paging device, and wherein: each paging device includes: a radio frequency transmitter; and control means for controlling said radio frequency transmitter such that a data signal may be transmitted to the control system to revise said control system memory means.

19. The combination of claim 18 wherein said controller means comprises a keypad and associated electronics allowing the user to manually revise said control system memory means stored signals.

20. The combination of claim 18 in further combination with a locator system wherein said locator system comprises a plurality of predeterminedly located locator transmitters, with each locator transmitter transmitting to a proximate paging device a signal corresponding to the telephone number of a nearby phone, and wherein said control means controls said radio frequency transmitter to transmit a signal related to said telephone number signal to said control system to revise said control system

memory means, whereby the control system will automatically forward incoming calls to a telephone near said user.

5 21. The combination of claim 20 wherein: each locator transmitter transmits an ultrasonic signal; and wherein: each paging device includes an ultrasonic receiver for receiving said ultrasonic signal.

22. The combination of claim 21 wherein each locator transmitter transmits an ultrasonic signal of approximately 40 kiloHertz modulated by said locator signal at a rate of approximately 75 baud.

10 23. The control system of claim 18 wherein each paging device includes a keypad for entry of commands by the user.

24. The control system of any one of claims 1 through 23 wherein a command from said user is entered via the user's telephone keypad.

25. The control system of any one of claims 1 through 23 wherein a command from said user is entered via a user voice command.

15 26. The control system of claim 1 wherein the electronic processing means further comprises means for: identifying a call to said system from a specific user requesting the present mode by which the system processes incoming calls directed to said specific user, recalling from said memory means the current mode by which the system processes incoming calls directed to said specific user, recalling from said
20 memory means a courtesy message which indicates said current mode and informs the user as to how to enter a mode command to change said mode, transmitting said courtesy message to said user, and responding to said user transmitting a specific mode command to appropriately change the mode by which the system processes subsequent incoming calls directed to said user.

25 27. The control system of claim 26 wherein said user mode commands are entered via the user's telephone keypad.

28. The control system of claim 26 wherein said user mode commands are entered via voice commands from said user.

30 29. The control system of claim 1 including a schedule mode wherein said electronic processing means further comprises means for: responding to said user

transmitting a sequence of schedule command modes and corresponding times for each such command mode to appropriately automatically change to the commanded modes at the commanded times.

5 30. The control system of claim 1 including a timer mode wherein said electronic processing means further comprises means for: responding to said user entering a timer command mode and a corresponding time interval command to appropriately change to the commanded mode for said commanded interval, thereafter reverting to a predetermined default mode.

10 31. The control system of claim 1 wherein said telephone exchange provides an automatic number identification of a caller (ANI) to said control system, and wherein the electronic processing means further comprises means for: identifying a call to said system by a user; and utilizing said ANI as said user's memory means stored forwarding number, whereby the user can update his forwarding number without manually entering the number of the telephone at his present location.

15 32. The control system of claim 31 wherein calls to said system are made by dialing a sequence which includes digits to identify one of a plurality of call processing modes and wherein the electronic processing means further comprises means for: identifying a call to said system by a specific user by matching the ANI with a memory means stored number for said user and processing said digits as a specific mode command control signal from said user.

20 33. The control system of claim 32 wherein said user's telephone station includes a telephone exchange provided speed calling service wherein multi-digit numbers can be recalled and dialed by the user entering a limited digit code, and wherein a sequence of said speed calling numbers are programmed as said specific mode command control signals, whereby a user can change the system mode control for processing his calls by entering the appropriate limited digit code.

25 34. The control system of claim 1 wherein said electronic processing means further includes means for: identifying a message center control signal from said caller and, regardless of the user's present call processing mode, permitting said caller to access the user's provided message center memory and store a message for
30

later access by the user.

5 35. The control system of claim 1 wherein said electronic processing means further includes means in implementing step c) for: upon implementing a call to said forwarding number, identifying if the user's number is busy or not answered and, in such event, disposing of said call in a predetermined manner.

10 36. The control system of claim 1 wherein said electronic processing means further includes means in implementing step c) for: upon implementing a call to said forwarding number, initiating a predetermined time-out interval, identifying the condition of the user's line not being busy or not ringing within said time-out interval to thereby implement step d), or identifying the condition of the user's phone ringing within said time-out interval to allow the user's phone to ring for a predetermined sequence and, if the user does not answer within said sequence, terminating the attempt to forward the call or identifying the condition of the user's phone being busy within said time-out interval to thereby terminate the attempt to forward the call.

15 37. The control system of claim 36 wherein the duration of said time-out interval is predeterminedly a function of whether the call from the caller is detected as local or long distance.

20 38. The control system of claim 36 wherein the electronic processing means further comprises means responsive to terminating the attempt to forward the call to recall from said memory means a courtesy message indicating that the caller can leave a message, transmitting said message to the caller, recording a message sent by the caller and allowing the user to call the system and access such message.

25 39. The control system of claim 1 wherein the electronic processing means further comprises means in implementing step for: identifying a command from said user requesting a desired call processing mode and responding to a predetermined help command from said user to recall from said memory means a courtesy message related to said specific call processing mode and transmitting said courtesy message to said user.

30 40. The control system of claim 1 wherein the electronic processing means further comprises means for: identifying a predetermined client service command

transmitted by said user and, responsive thereto, connecting said user to a client service operator.

5 41. The control system of claim 1 wherein the electronic processing means further comprises means following step e) for: identifying a command from said user indicating that the user desires to place a call to a predetermined number, calling said number, connecting said user to said called number while maintaining the user to system connection such that upon completion of said user's call the user is returned to the system to enter further commands.

10 42. The control system of claim 3 wherein the electronic processing means further comprises means for: upon said user calling the system and accessing a recorded message from a caller, identifying a command from said user indicating that the user desires to place a call to a predetermined number, calling said number, connecting the user to said called number while maintaining the user to system connection such that upon completion of said user's call the user is returned to his recorded messages in the system.

15 43. The control system of claim 1 wherein the electronic processing means step g) further comprises means for: implementing user call processing mode changes responsive to predetermined command sequences and further including user controls which, when transmitted, automatically implement said predetermined command sequences.

20 44. The control system of claim 1 wherein the electronic processing means further comprises means for: upon implementing call forwarding in accordance with steps b) through d), generating predetermined signals which to a caller indicate normal call processing operation but to a user indicate that the user can transmit his predetermined identification code to gain access to his system provided functions and, upon receipt of said predetermined identification code, terminating the call forwarding and transferring the user to the system's command mode.

25 45. The control system of claim 1 wherein the electronic processing means further comprises means for: upon implementing call forwarding in accordance with steps b) through d), recalling from said memory means a predetermined courtesy

30

message which directs the caller to ask for the called party by name upon completion of the call and transmitting said courtesy message to the caller.

5 46. The control system of claim 1 wherein the electronic processing means further comprises means for: upon implementing call forwarding in accordance with steps b) through d), recalling from said memory means a predetermined courtesy message which directs the caller to ask for the called party's extension upon completion of the call and transmitting said courtesy message to the caller.

10 47. The control system of either one of claims 45 or 46 wherein the particular courtesy message recalled from the memory means and transmitted to the caller is controllable by command from the user.

15 48. The control system of claim 1 wherein the electronic processing means further comprises means for: identifying a predetermined external message center command transmitted by said user and, responsive thereto, completing a call to a message center external of the control system and connecting the user to said external message center.

20 49. A control system for receiving and processing telephone calls from a caller to a user, the system comprising: detector means for detecting signals over a telephone line; signal generating means, responsive to control signals, for producing predetermined signals and transmitting said signals over a telephone line; memory means for controllably storing and recalling electronic signals; switching means for connecting a call on one line to another line; and central processing means for monitoring signals on a telephone line, accessing said memory means and controlling said signal generator means and switching means, said central processing means including means for:

- 25 a) identifying a call to said system directed to a user,
b) recalling from said memory means a user controlled call processing signal corresponding to a user selected one of a plurality of call processing modes and, responsive to said user controlled call processing signal dictating a voice-screen mode, proceeding by
30 c) recalling from said memory means a predetermined identification message

110

requesting caller identification information,

d) controlling said signal generating means to send said identification message to said caller,

5 e) storing in said memory means the caller's response to said identification message,

f) recalling the user's number from said memory means and controlling said signal generating means to call said user,

g) recalling from said memory means the caller's response and sending said response to said user, and

10 h) responding to a control command from said user to dispose of the call from the caller in a selected one of a plurality of options.

50. The control system of claim 49 wherein the central processing means further includes means for:

15 h) i) responding to a first control command from said user to connect said caller to said user.

51. The control system of claim 50 wherein the central processing means further includes means for:

20 h) ii) responding to an alternate control command from said user to recall a predetermined message from said memory means and send said message to said caller.

52. The control system of claim 50 wherein the central processing means further includes means for:

25 h) ii) responding to a second control command from said user to recall a terminating message from said memory means, send said terminating message to said caller and terminate the connection to said caller.

53. The control system of claim 50 wherein the central processing means further includes means for:

30 h) ii) responding to a second control command from said user to recall a leave-a-message signal, sending said leave-a-message signal to said caller and storing the caller's message in said memory means.

54. The control system of claim 50 wherein the central processing means further includes means for:

h) ii) responding to a second control command from said user to recall a predetermined phone number from said memory means, call said number and connect said user to said predetermined number.

55. The control system of claim 49 wherein the central processing means further includes means for:

a) i) recognizing a predetermined signal transmitted by the caller and, responsive thereto, immediately proceeding with step f) to call said user and then connect said caller to said user.

56. A control system for receiving and processing telephone calls from a caller to a user, the system comprising: detector means for detecting signals over a telephone line; signal generating means, responsive to control signals, for producing predetermined signals and transmitting said signals over a telephone line; memory means for controllably storing and recalling electronic signals; switching means for connecting a call on one line to another line; and electronic processing means for monitoring signals on a telephone line as detected by said detection means, accessing said memory means and producing and applying predetermined control signals to said signal generating means and switching means, said central processing means including means for:

a) identifying a call to said system directed to a user,

b) recalling from said memory means a predetermined paging system control procedure for paging said user,

c) causing said signal generating means to control said paging system to page said user with an indication that the user has a call waiting,

d) identifying a call to said system from said user,

e) in the event said caller has waited on the line, connecting the caller to the user, and

f) in the event the caller has not waited on the line, so notifying the user by recalling a predetermined message from said memory means and causing said signal

generating means to transmit said message to said user.

57. The control system of claim 56 wherein the electronic processing means further includes means for: recalling from said memory means a courtesy message notifying the caller that the system must page the user and allowing the user the option of recording a message in said memory means, transmitting said courtesy message to said caller and, responsive to said caller implementing the message option, recording said message in said memory means and allowing the user to access said message after responding to the page.

58. A paging system wherein each user carries a paging device adapted to receive radio frequency broadcast signals from a central paging system, with a unique identification code assigned to each paging device, characterized by:

a plurality of predeterminedly located ultrasonic transmitters, each transmitter transmitting an information signal; and

each paging device including:

an ultrasonic receiver for receiving the signal from a proximate ultrasonic transmitter, and

a radio frequency transmitter for transmitting to the central paging system a signal corresponding to the paging device received ultrasonic signal and the paging device assigned identification code,

whereby the paging system is provided with related information for each paging device.

59. The paging system of claim 58 wherein: said information signal is the phone number of a proximately located telephone, and said paging device radio frequency transmitter transmits said phone number related signal to said central paging system, whereby the central paging system is provided with the phone number of a phone proximate to said user.

60. The paging system of claim 59 in combination with a control system, wherein the control system comprises: means for detecting a call from a caller to said control system directed to a user, and processing means for accessing said central paging system and causing said central paging system to transmit a control signal to

the paging device of said user, which control signal causes said paging device to transmit back to said central paging system the proximate phone number signal, and implementing a call to said proximate phone number.

5 61. The system of claim 60 further comprising: means for connecting the caller to said proximate phone number.

62. The system of claim 60 wherein: each paging device includes user controllable means for transmitting telephone call processing control signals to said control system, and wherein each control system includes means responsive to said control signals to process incoming calls to said user in accordance therewith.

10 63. The system of claim 62 wherein one telephone call processing control signal causes said control system to forward to the user only selected calls.

64. The system of claim 59 wherein each locator transmitter transmits an ultrasonic signal of approximately 40 kiloHertz modulated by said locator signal at a rate of approximately 75 band.

15 65. A control system connected to the telephone exchange wherein each user of the system is assigned a unique telephone number and said control system routes a call to a user controlled number, the control system comprising:

input/output means adapted for connection to telephone exchange lines to input and output telephone calls;

20 switching control means for controllably connecting a call on one line to a different line;

memory means for controllably storing and recalling electronic signals; and

25 electronic processing means for accessing said memory means, switching control means and input/output means to direct the flow of input and output calls, said electronic processing means including means for responding to an incoming call to a specific user to recall from said memory means a courtesy message indicating to the caller that his call could be branched to any of a plurality of options responsive to the caller transmitting an appropriate command corresponding to the desired branch, transmitting said courtesy message to said caller and, responsive to the caller
30 transmitting said implementing the commanded option.

66. A paging system wherein each user carries a paging device adapted to receive radio frequency signals broadcast from a central paging system with a unique identification code assigned to each paging device, and characterized in that:

each paging device includes:

5 a radio frequency transmitter, and controller means for controlling said radio frequency transmitter, said controller means operable in at least two distinct user selectable modes, the first such mode being responsive to receiving a signal broadcast by the central paging system and responding by transmitting predetermined data back to said central paging system.

10 67. The system of claim 66 wherein said controller means comprises a keypad and associated electronics allowing a user to manually enter data.

15 68. The system of claim 66 in combination with a locator system comprising a plurality of predeterminedly located locator transmitters with each locator transmitter transmitting a unique locator signal including locating information, and wherein said controller means includes means for receiving the signal from a proximate locator transmitter and controlling said radio frequency transmitter to re-transmit said locating information to the central paging system.

20 69. The system of claim 68 wherein each locator transmitter locator signal corresponds to the number of a nearby telephone and wherein said controller controls said radio frequency transmitter to transmit said telephone number related signal to said central paging system.

25 70. The system of claim 68 in combination with a telephone control system for predeterminedly controlling incoming calls to a user in a selected one of at least two distinct modes responsive to a mode control signal wherein a locator transmitter transmits a predetermined mode signal and wherein said paging device transmits a signal responsive to said mode control signal through said paging system to said telephone control system to control the mode thereof.

30 71. A control system for receiving and processing telephone calls from a caller to a user, the system comprising: detector means for detecting signals over a telephone line; signal generating means, responsive to control signals, for producing

predetermined signals and transmitting said signals over a telephone line; memory means for controllably storing and recalling electronic signals; switching means for connecting a call on one line to another line; and central processing means for monitoring signals on a telephone line, accessing said memory means and controlling said signal generator means and switching means, said central processing means including means for:

- a) identifying a call to said system directed to a user,
- b) recognizing a predetermined signal transmitted by the caller and, responsive thereto, immediately proceeding with step g) to call said user, otherwise proceeding to step c);
- c) recalling from said memory means a user controlled call processing signal corresponding to a call processing mode and, responsive to said user controlled call processing signal dictating a voice-screen mode, proceeding by
- d) recalling from said memory means a predetermined identification message requesting caller identification information,
- e) controlling said signal generating means to send said identification message to said caller,
- f) storing in said memory means the caller's response to said identification message,
- g) recalling the user's number from said memory means and controlling said signal generating means to call said user,
- h) recalling from said memory means the caller's response and sending said response to said user, and
- i) responding to a control command from said user to dispose of the call from the caller in a selected one of a plurality of options.

72. The control system of claim 71 wherein the central processing means further includes means for:

- i) responding to a first control command from said user to connect said caller to said user.

73. The control system of claim 72 wherein the central processing means

further includes means for:

i) ii) responding to an alternate control command from said user to recall a predetermined message from said memory means and send said message to said caller.

5 74. The control system of claim 73 wherein the central processing means further includes means for:

i) ii) a) responding to a second control command from said user to recall a terminating message from said memory means, send said terminating message to said caller and terminate the connection to said caller.

10 75. The control system of claim 74 wherein the central processing means further includes means for:

i) ii) b) responding to a third control command from said user to recall a leave-a-message signal, sending said leave-a-message signal to said caller and storing the caller's message in said memory means.

15 76. The control system of claim 75 wherein the central processing means further includes means for:

i) ii) c) responding to a fourth control command from said user to recall a predetermined phone number from said memory means, call said number and connect said user to said predetermined number.

20 77. The combination of claim 18 in further combination with a locator system wherein said locator system comprises a plurality of predeterminedly located locator transmitters, with each locator transmitter transmitting to a proximate paging device a signal corresponding to a call processing mode, and wherein said control means controls said radio frequency transmitter to transmit a signal related to said call processing mode to said control system to revise said control system memory means, whereby the control system will automatically change a user's call processing mode.

25 78. The combination of claim 77 wherein: each locator transmitter transmits an ultrasonic signal; and wherein: each locator transmitter transmits an ultrasonic receiver for receiving said ultrasonic signal.

30 79. The combination of claim 78 wherein each locator transmitter transmits

117

an ultrasonic signal of approximately 40 kilohertz modulated by said locator signal at a rate of approximately 75 baud.

1/55

Fig. 1.

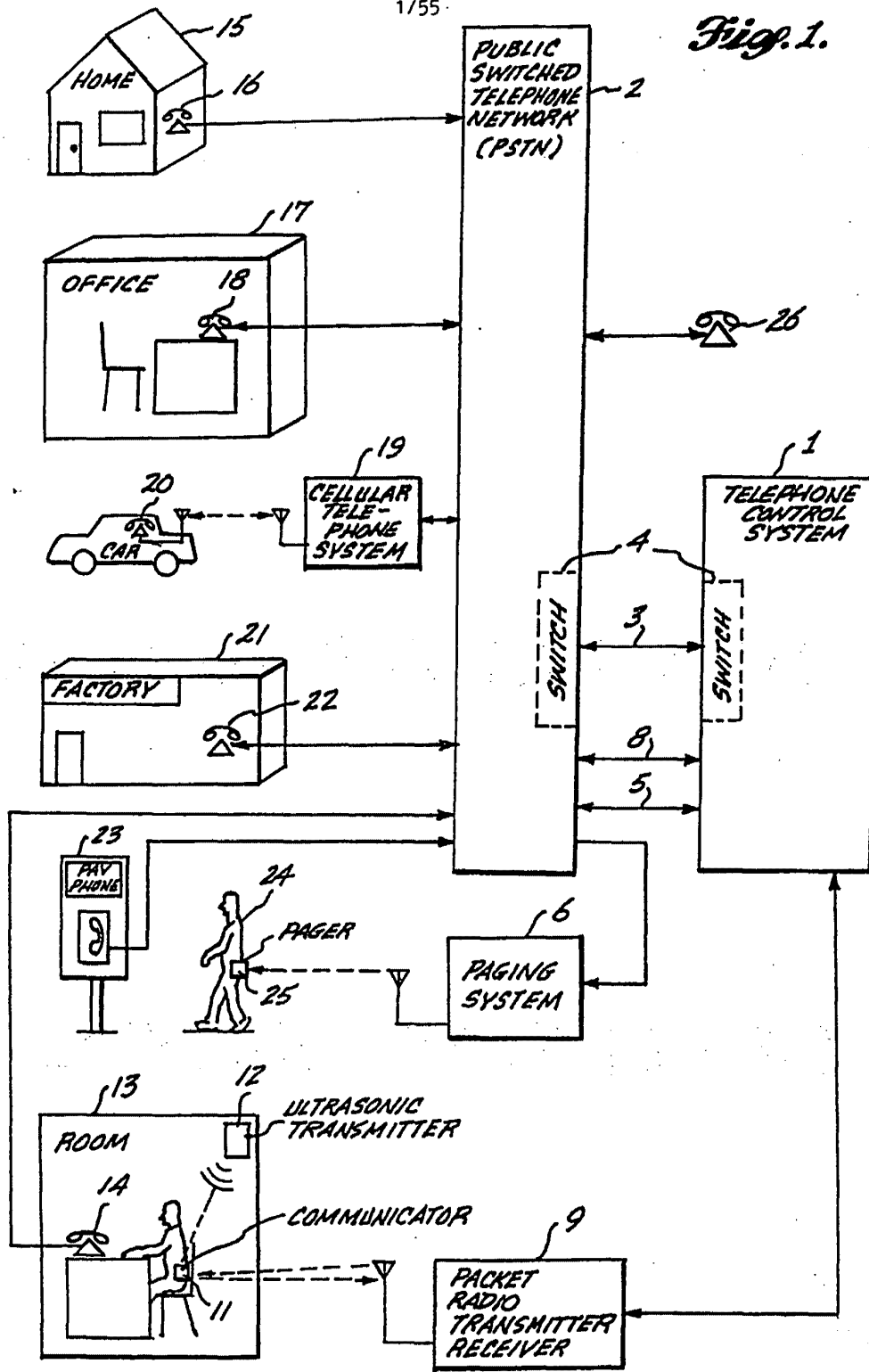

SUBSTITUTE SHEET

Fig. 2.
TELEPHONE CONTROL SYSTEM

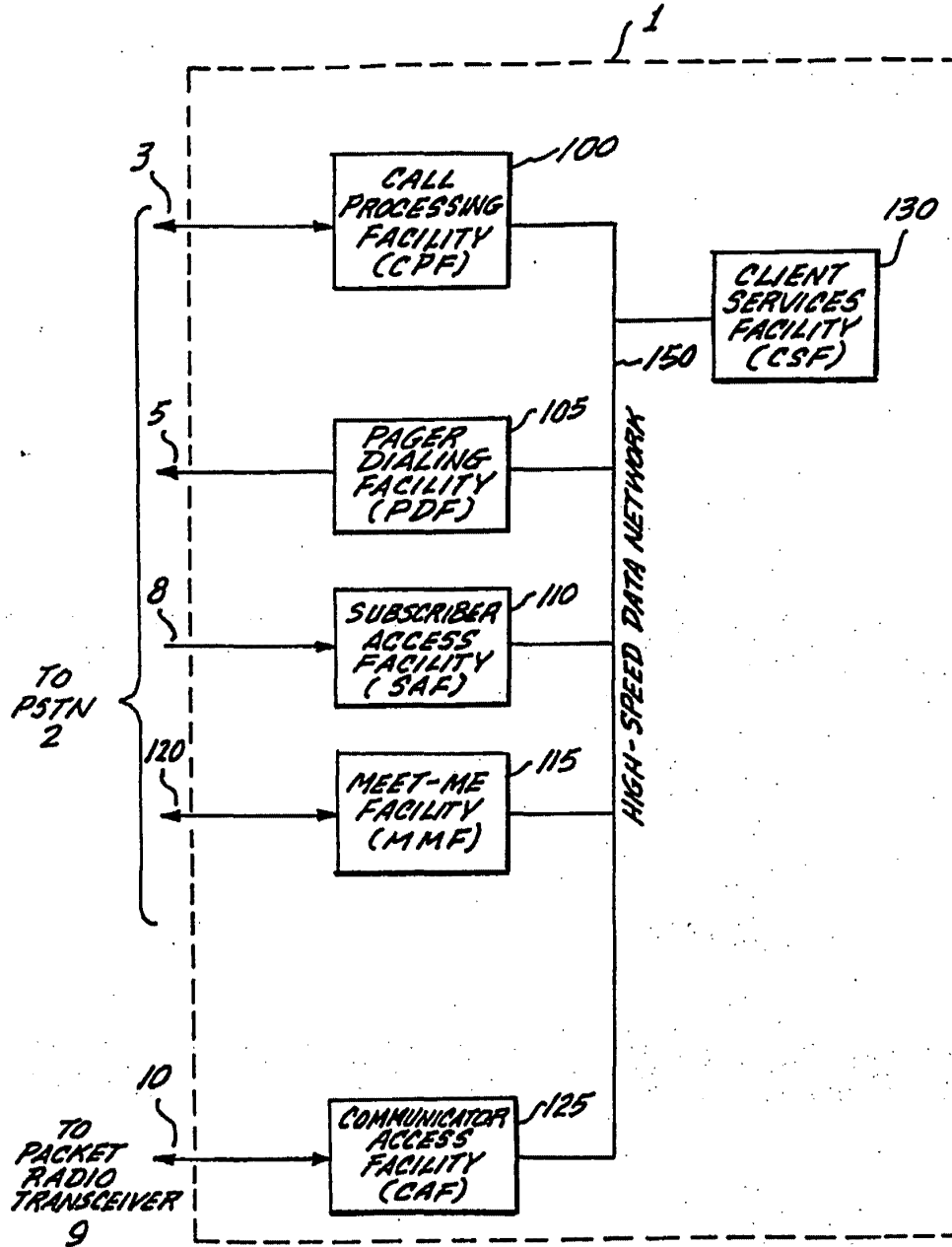

SUBSTITUTE SHEET

Fig. 3.

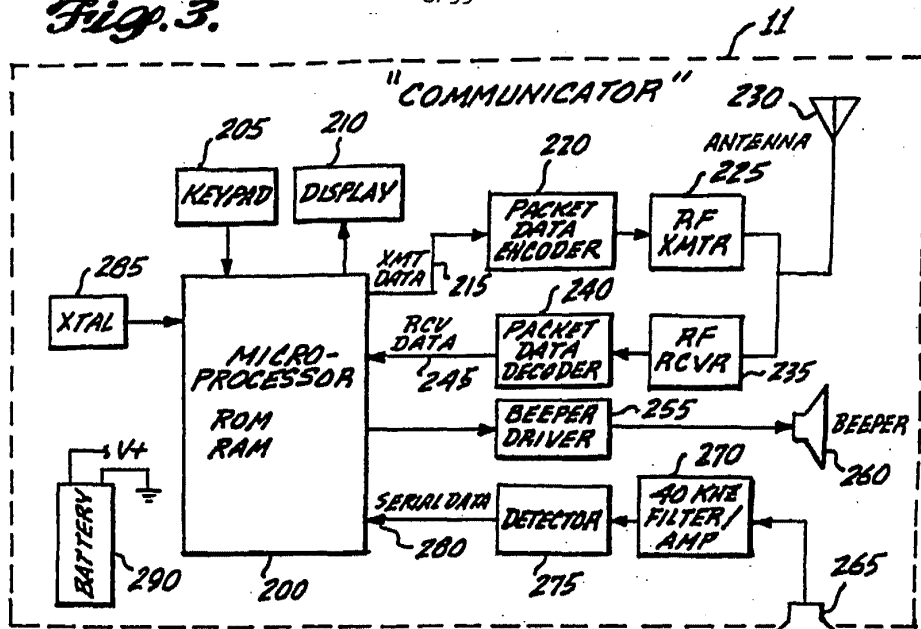
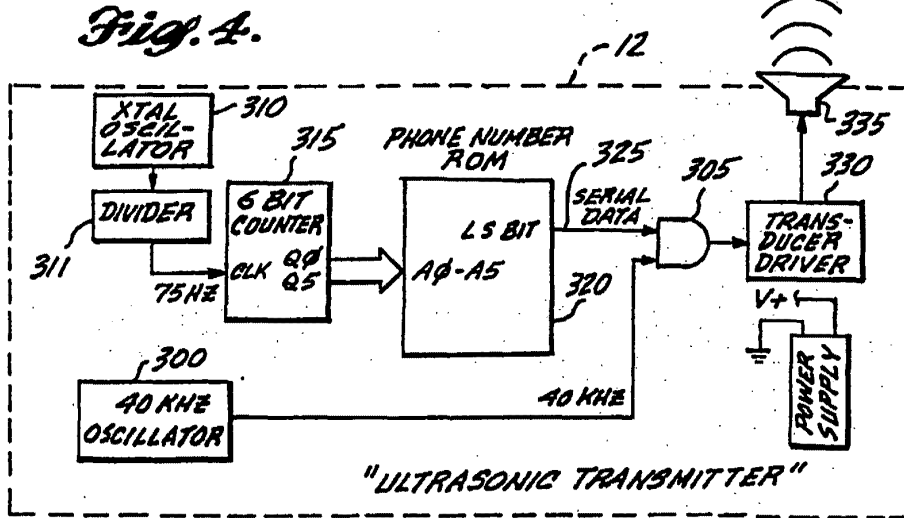

Fig. 4.



SUBSTITUTE SHEET

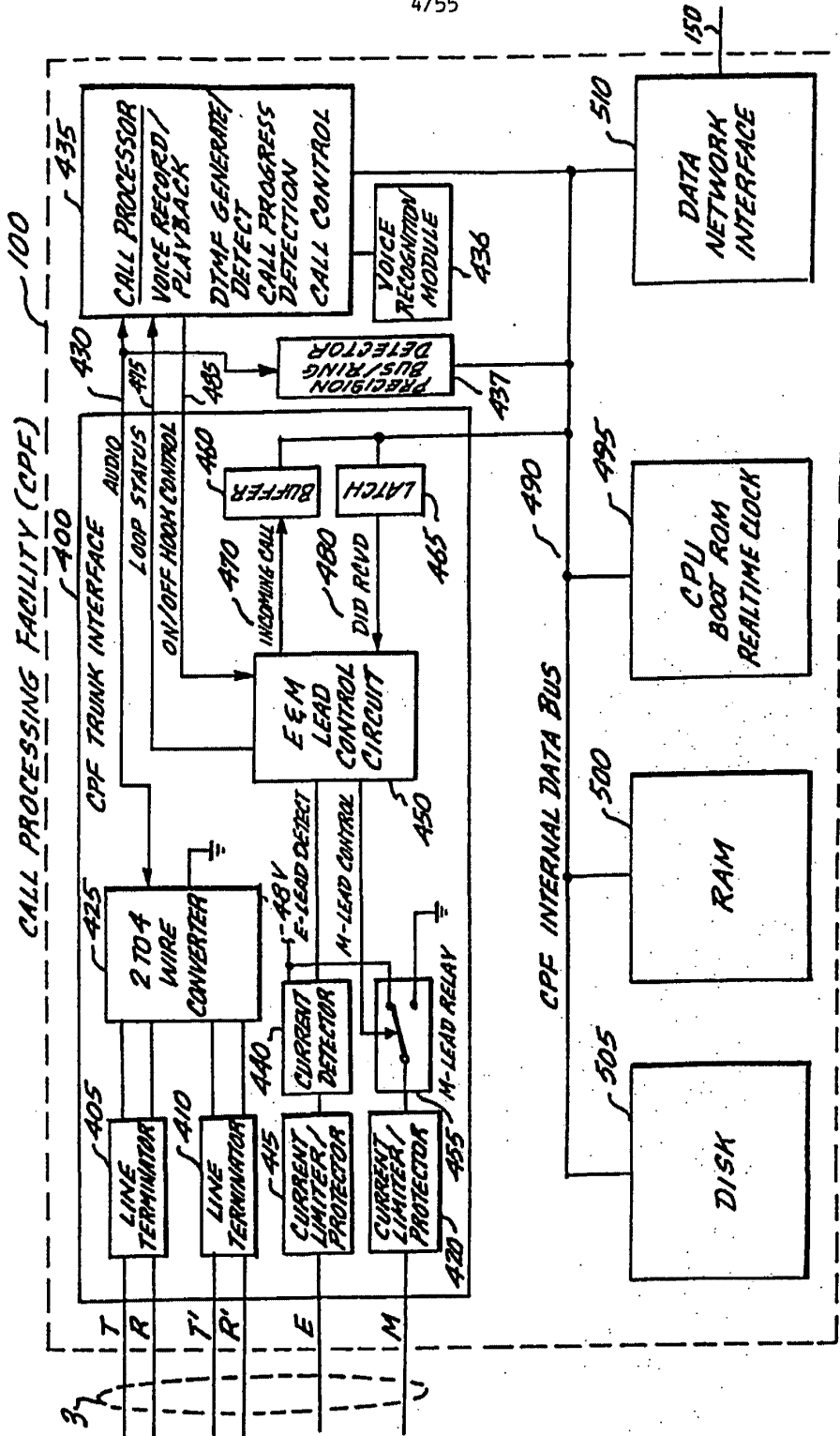

Fig. 5.

SUBSTITUTE SHEET

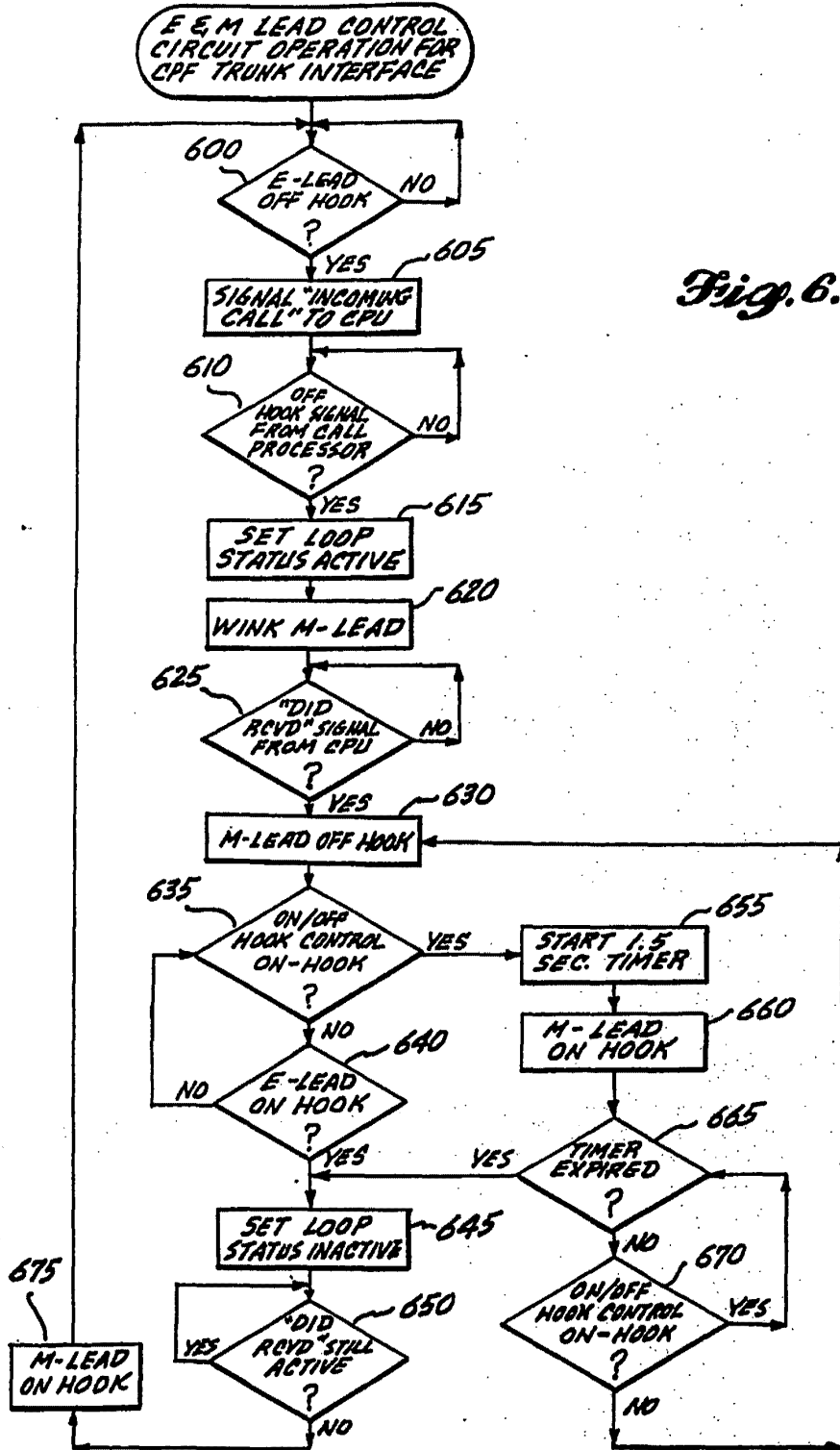

Fig. 6.

SUBSTITUTE SHEET

6/55

Fig. 7.

SUBSCRIBER MASTER RECORD 700

| | |
|-----|------------------------------------------|
| 701 | ACCESS (DID) NUMBER |
| 702 | P.I.N. CODE |
| 703 | CALL HANDLING MODE |
| 704 | STANDARD GREETING TYPE |
| 705 | OPTIONS |
| 706 | TRANSFER MESSAGE TYPE |
| 707 | TRANSFER NUMBER |
| 708 | EXTENSION NUMBER |
| 709 | MESSAGE CENTER NUMBER |
| 710 | PAGER NUMBER |
| 711 | OFFICE NUMBER |
| 712 | HOME NUMBER |
| 713 | MOBILE PHONE NUMBER |
| 714 | VIP SCREEN CODE |
| 715 | CURRENT MODE MEMORY NUMBER |
| 716 | PAGER MESSAGE CENTER DISPLAY NUMBER |
| 717 | PAGER FORWARDING DISPLAY NUMBER |
| 718 | COMMUNICATOR DYNAMIC MODE DISPLAY NUMBER |
| 719 | LAST MEET-ME ABANDON |
| 720 | LAST MEET-ME MESSAGE LEFT |
| 721 | EXTERNAL MSG CNTA TRANSFER COUNT |
| 722 | BRANCH ROUTING - NUMBER 0 |
| | BRANCH ROUTING - NUMBER 1 |
| | ⋮ |
| | BRANCH ROUTING - NUMBER 9 |
| 723 | BRANCH ROUTING - DEFAULT NUMBER |
| 724 | FEATURE TIMER - DURATION |
| 725 | FEATURE TIMER - TERMINATION MODE |
| 726 | WEEKLY SCHEDULE - STEP 1 TIME & DATE |
| | WEEKLY SCHEDULE - STEP 1 MODE |
| | ⋮ |
| | WEEKLY SCHEDULE - STEP 32 TIME & DATE |
| 727 | WEEKLY SCHEDULE - STEP 32 MODE |
| 728 | WEEKLY SCHEDULE - CURRENT STEP |
| 729 | WEEKLY SCHEDULE - ACTIVE |
| 729 | MULTIPLE OUTSIDE CALLS ALLOWED |
| 730 | DYNAMIC MODE ASSIGNMENT FLAG |
| 731 | CALL COUNT |

SUBSTITUTE SHEET

7/55

Fig. 8.
MODE MEMORY

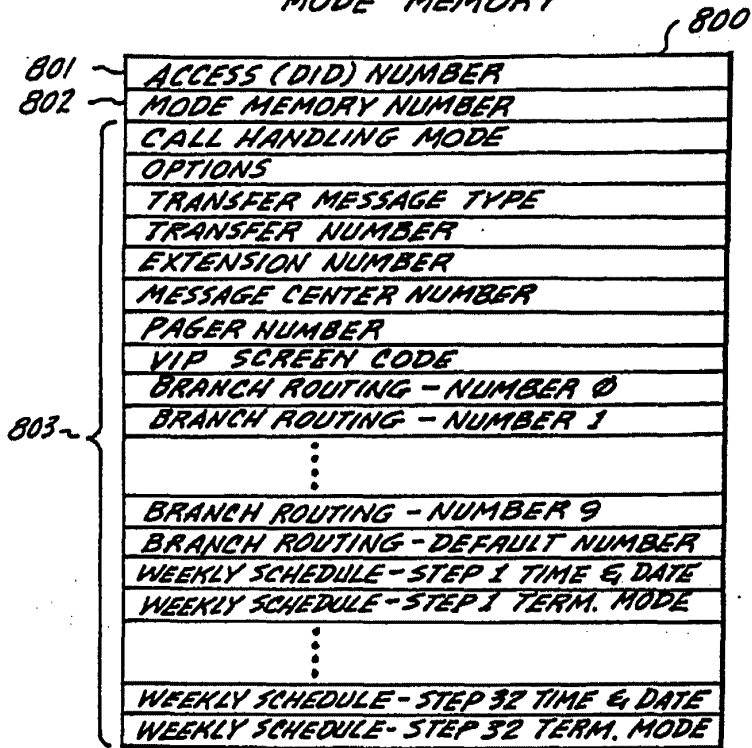

SUBSTITUTE SHEET

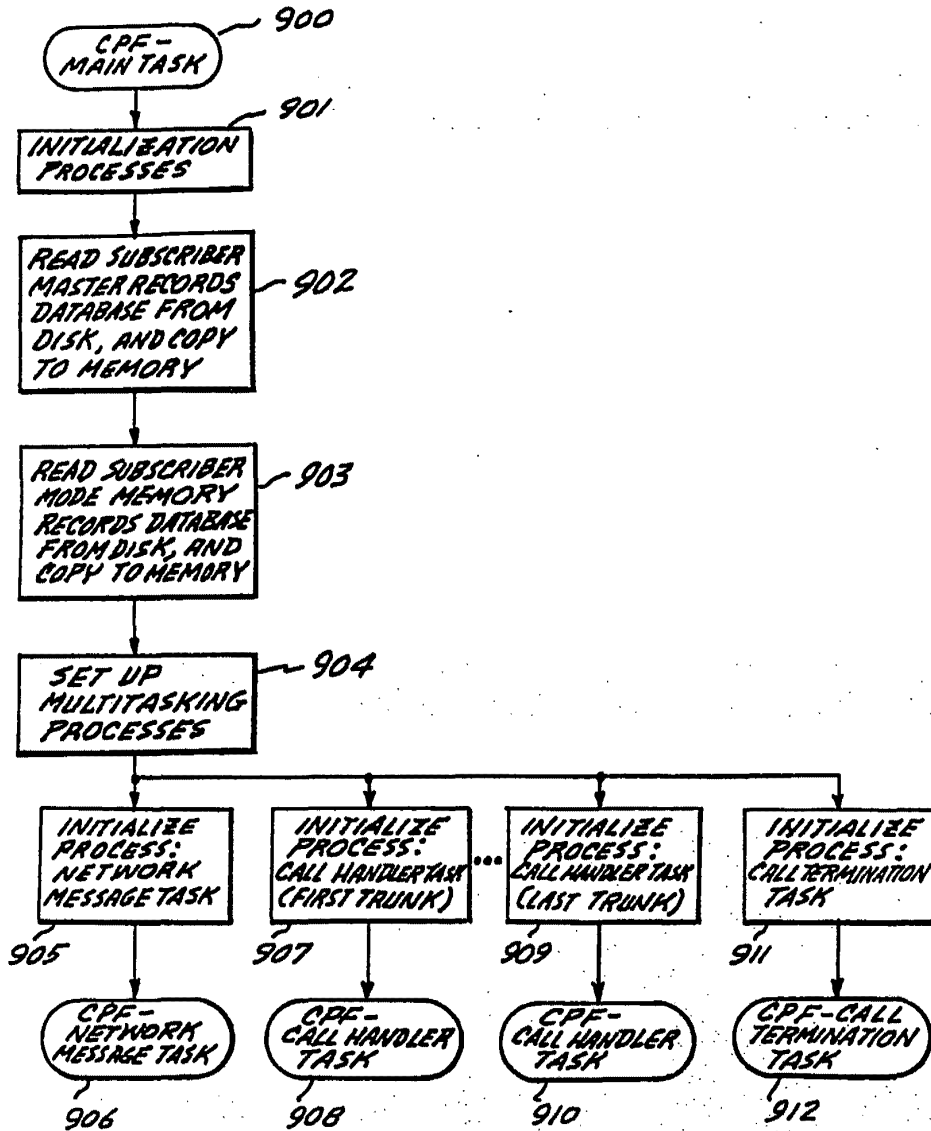
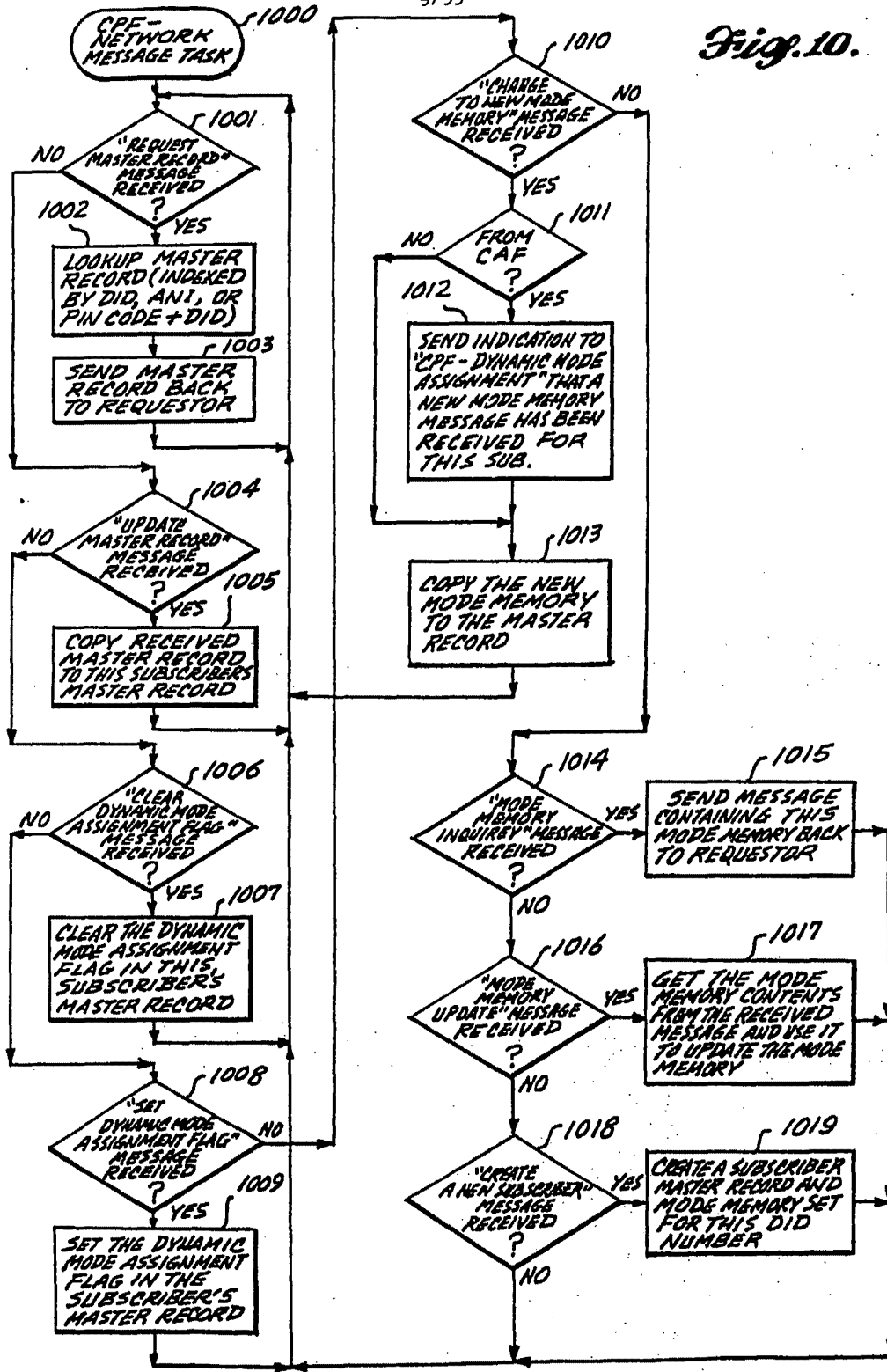

Fig. 9.

SUBSTITUTE SHEET

9/55

Fig. 10.



SUBSTITUTE SHEET

10/55

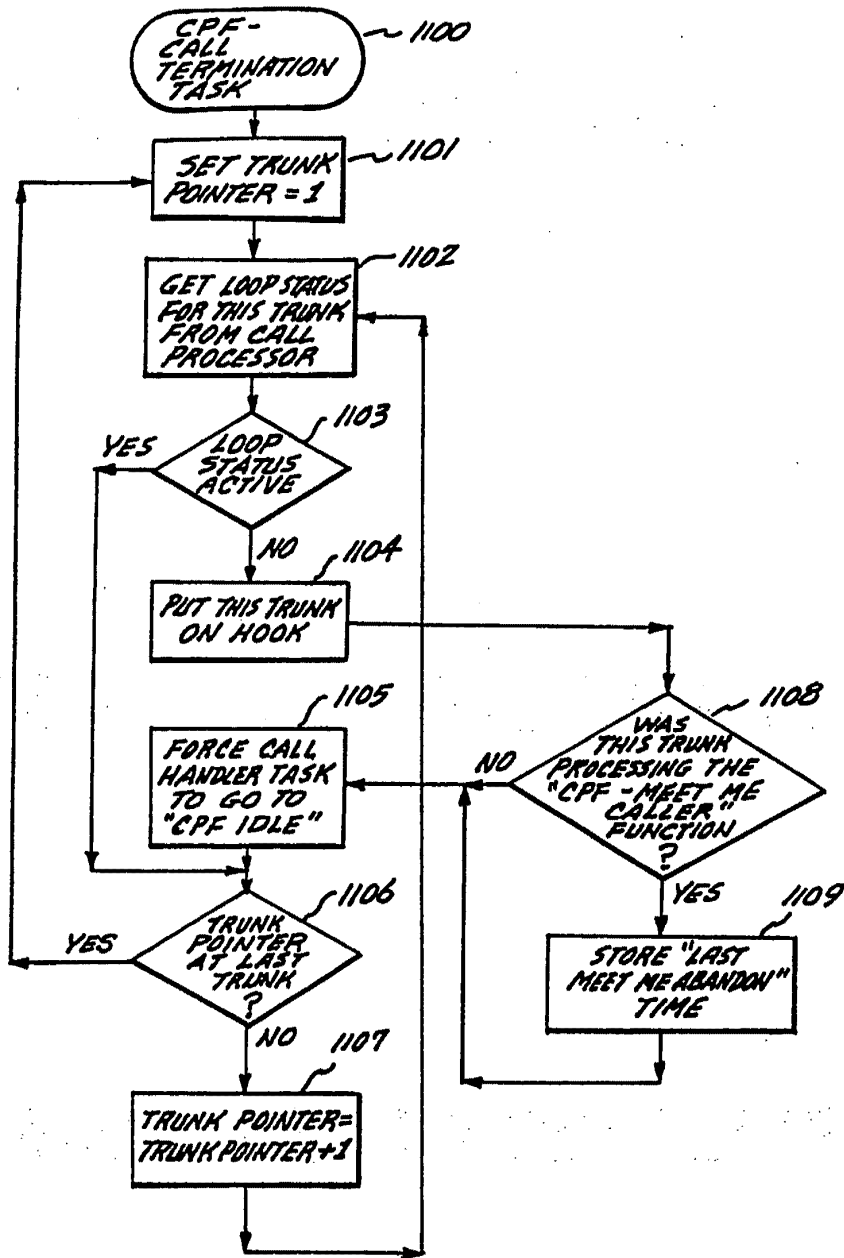

Fig. 11.

SUBSTITUTE SHEET

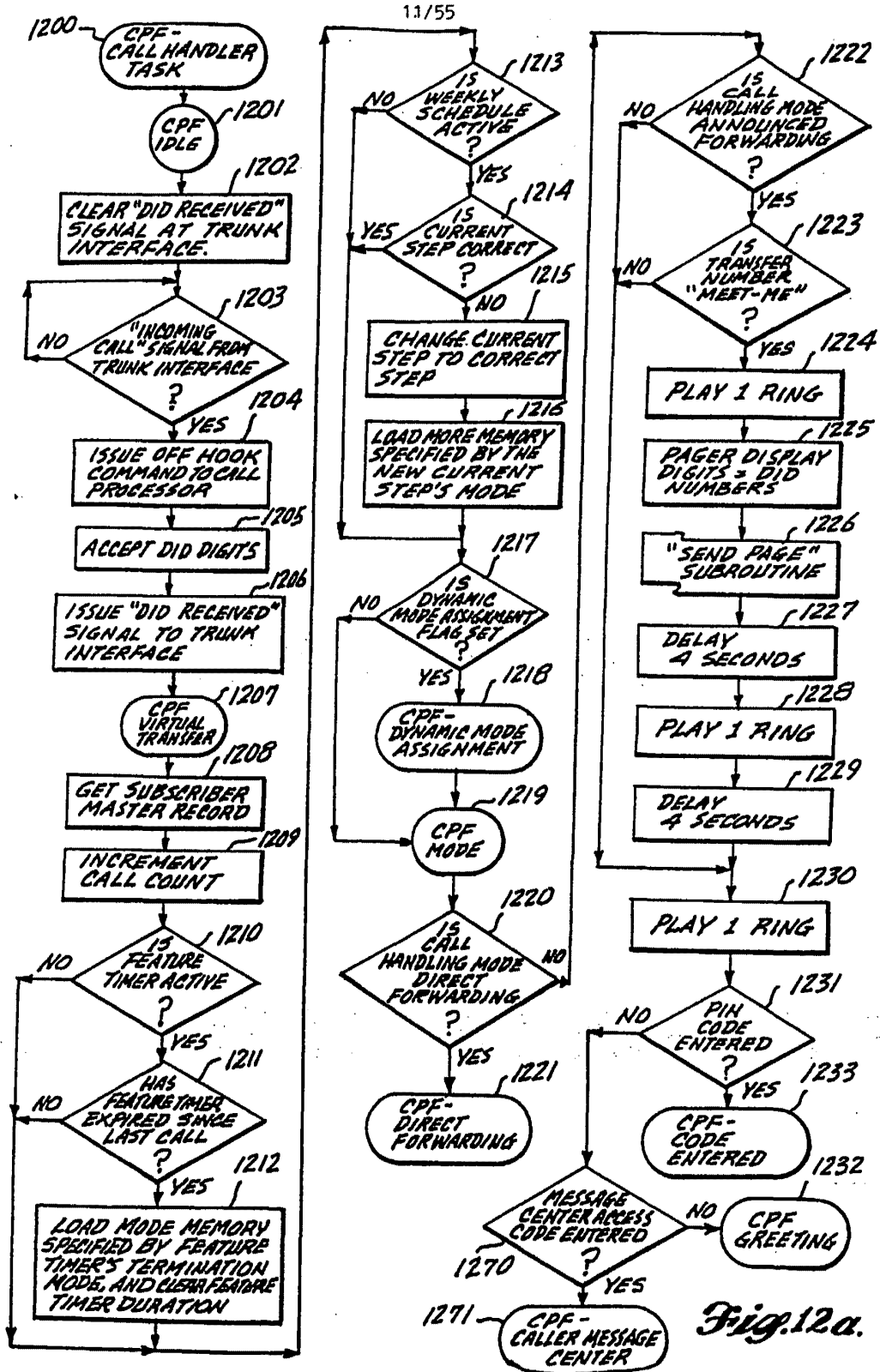
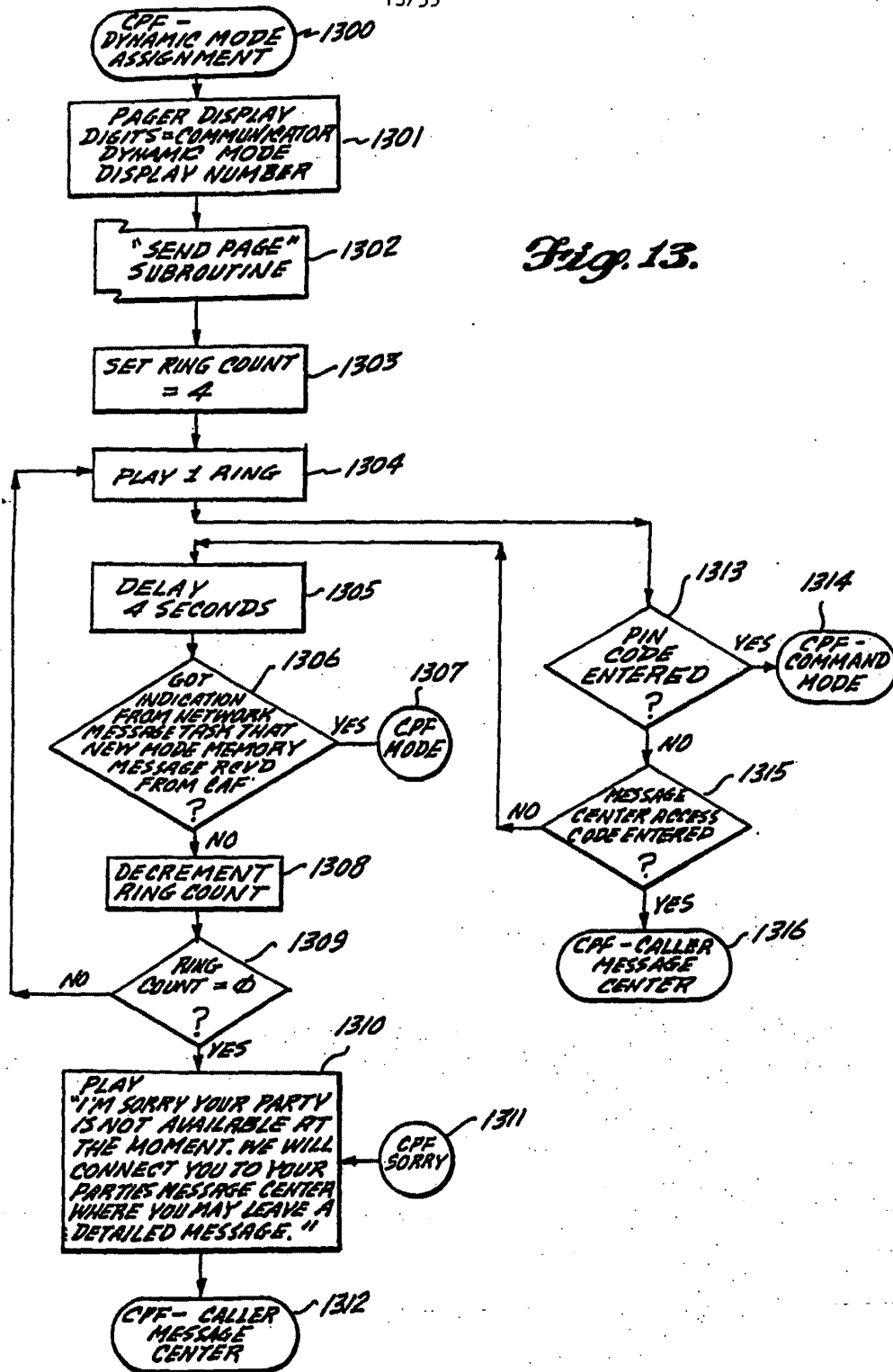

Fig. 12a.

SUBSTITUTE SHEET

13/55

Fig. 13.



SUBSTITUTE SHEET

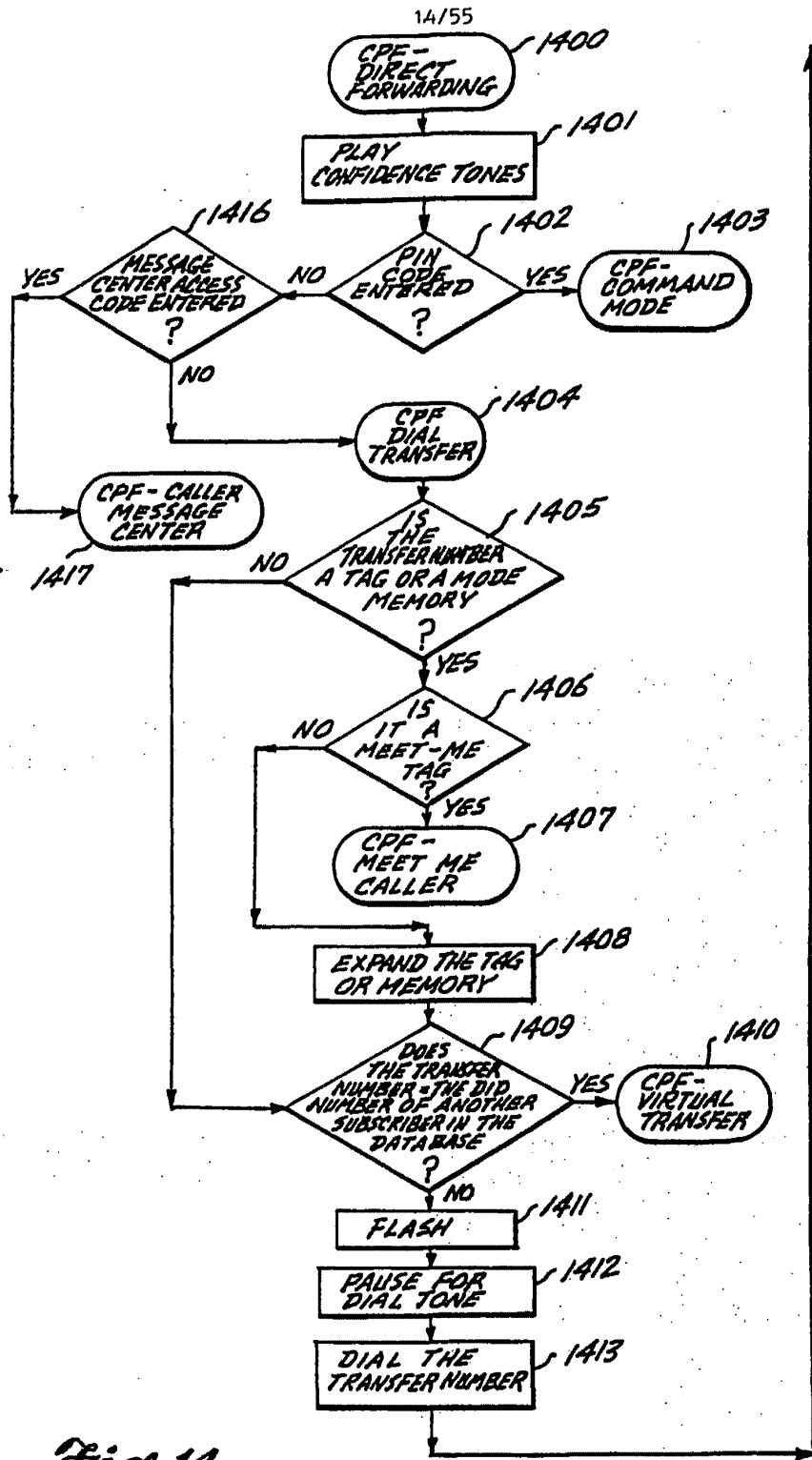
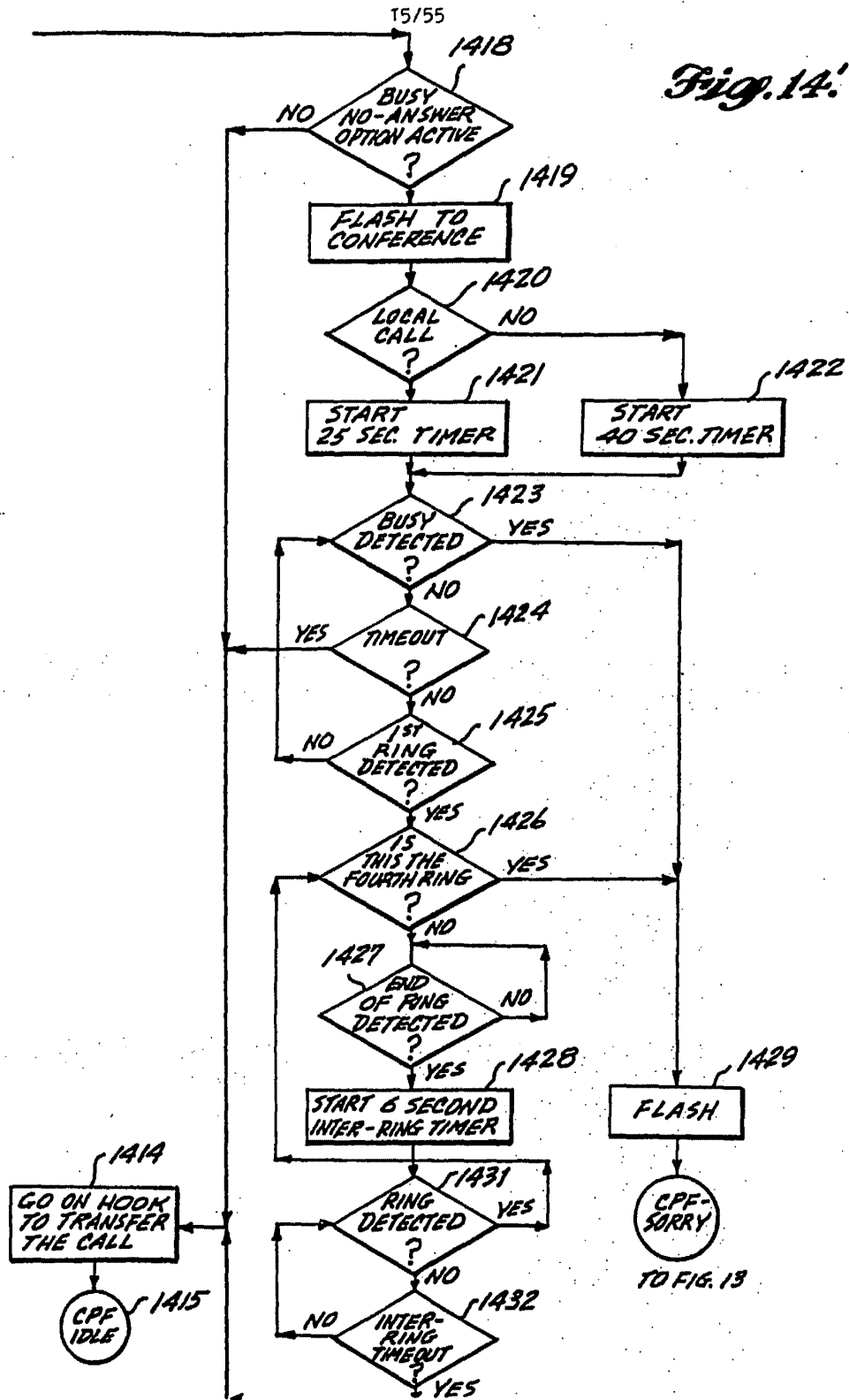

Fig. 14.

SUBSTITUTE SHEET

Fig. 14.



SUBSTITUTE SHEET

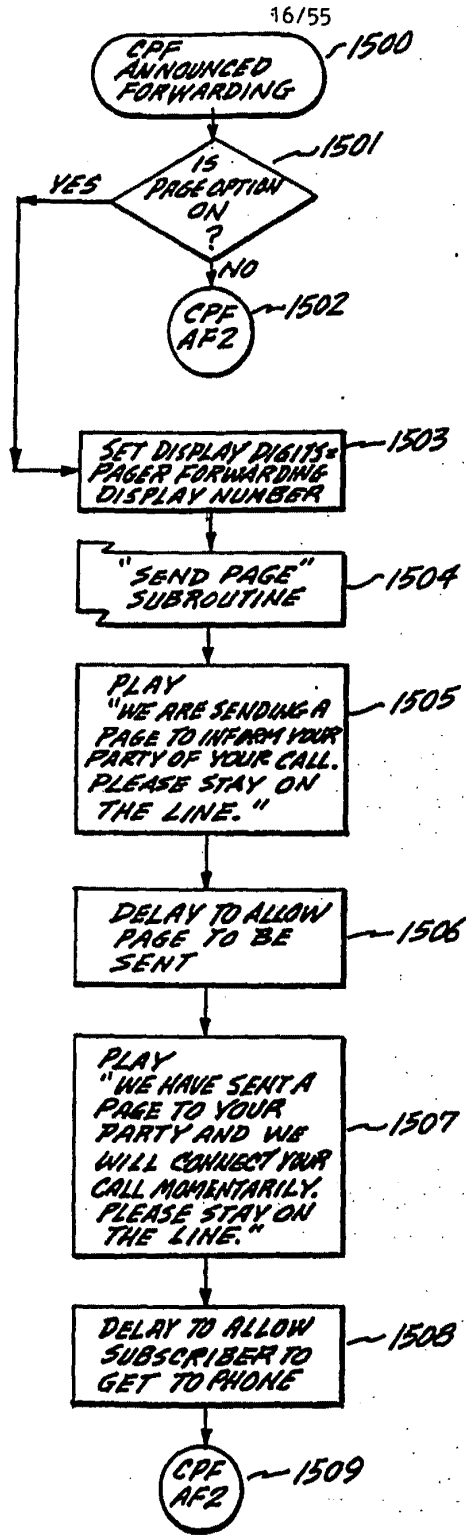

Fig. 15a.

SUBSTITUTE SHEET

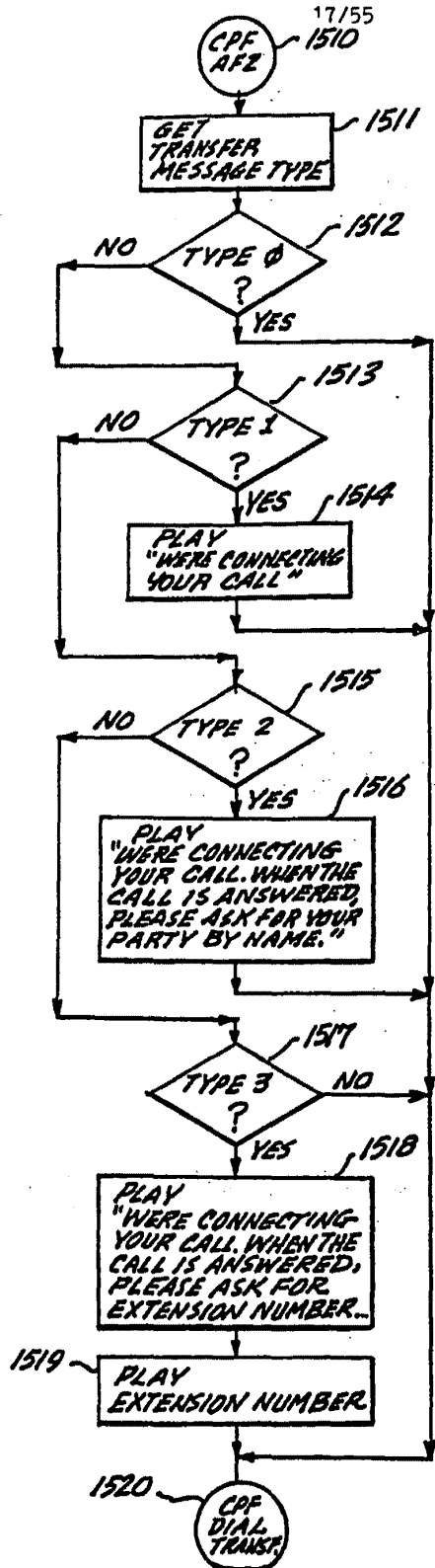

Fig. 15b.

SUBSTITUTE SHEET

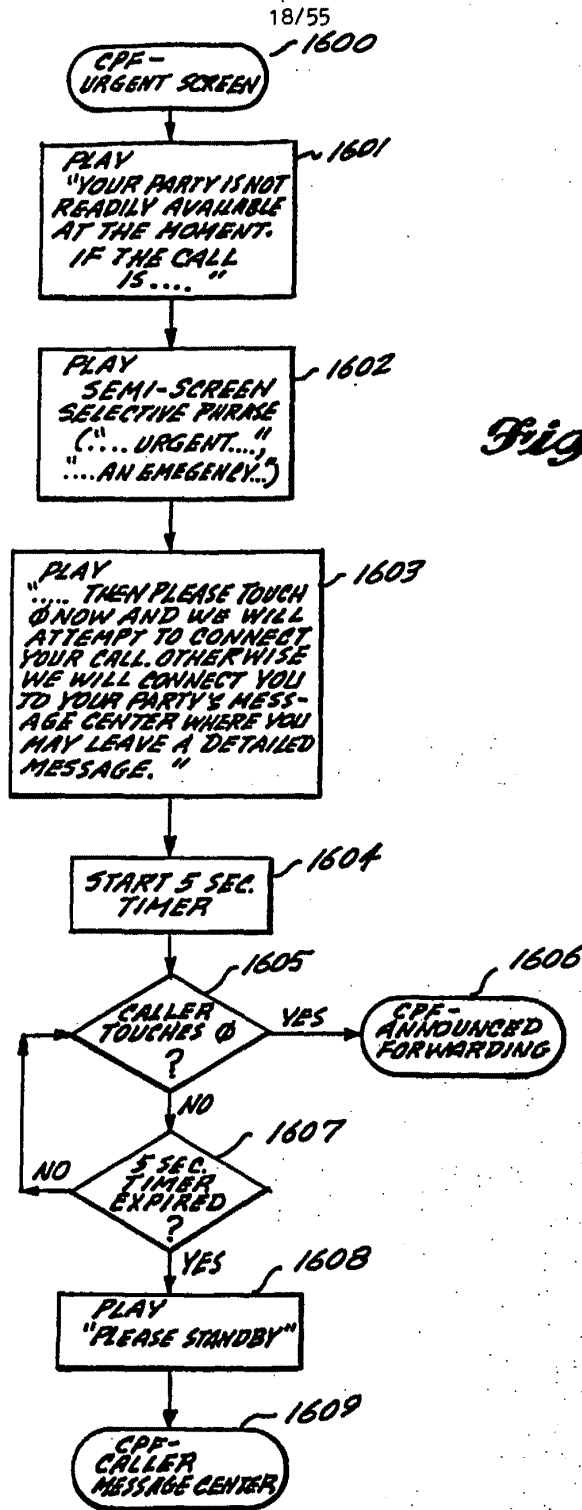

Fig. 16.

SUBSTITUTE SHEET

19/55

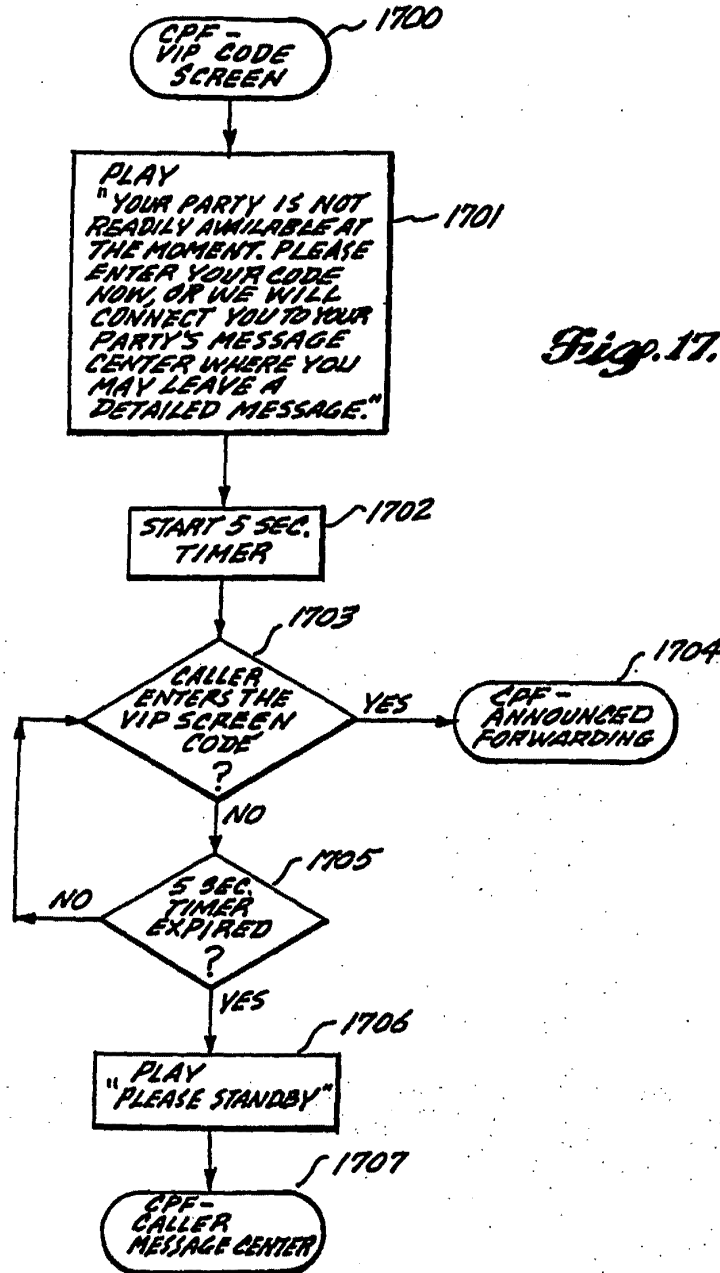

Fig. 17.

SUBSTITUTE SHEET

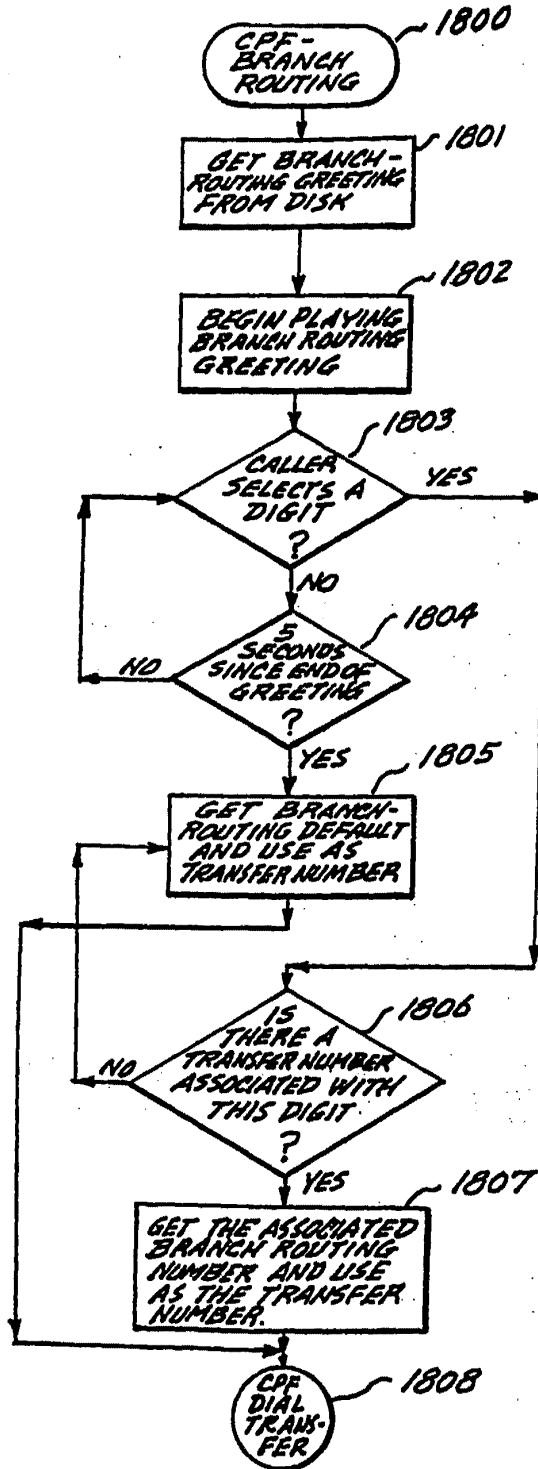

Fig. 18.

SUBSTITUTE SHEET

21/55

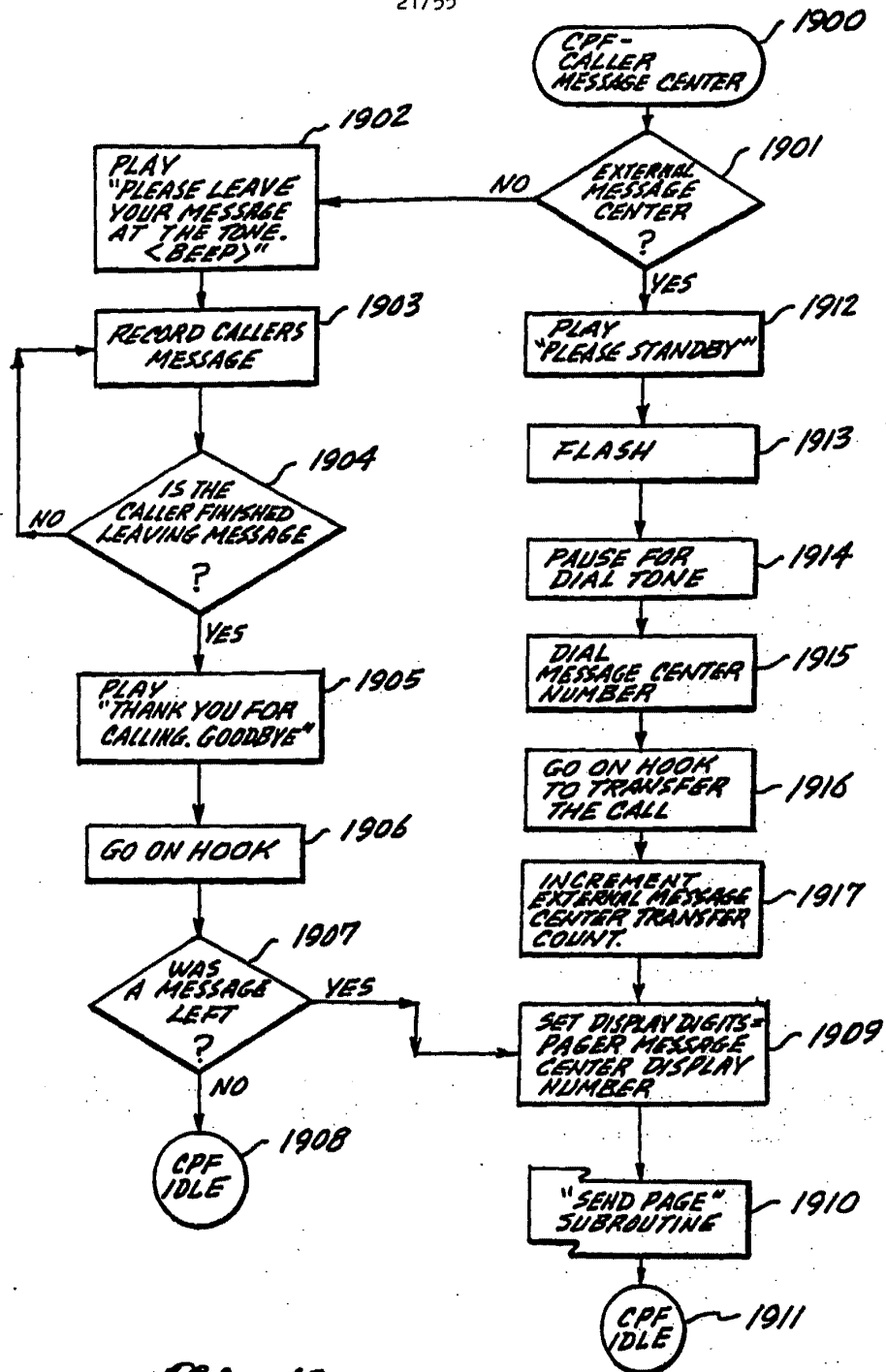

Fig. 19.

SUBSTITUTE SHEET

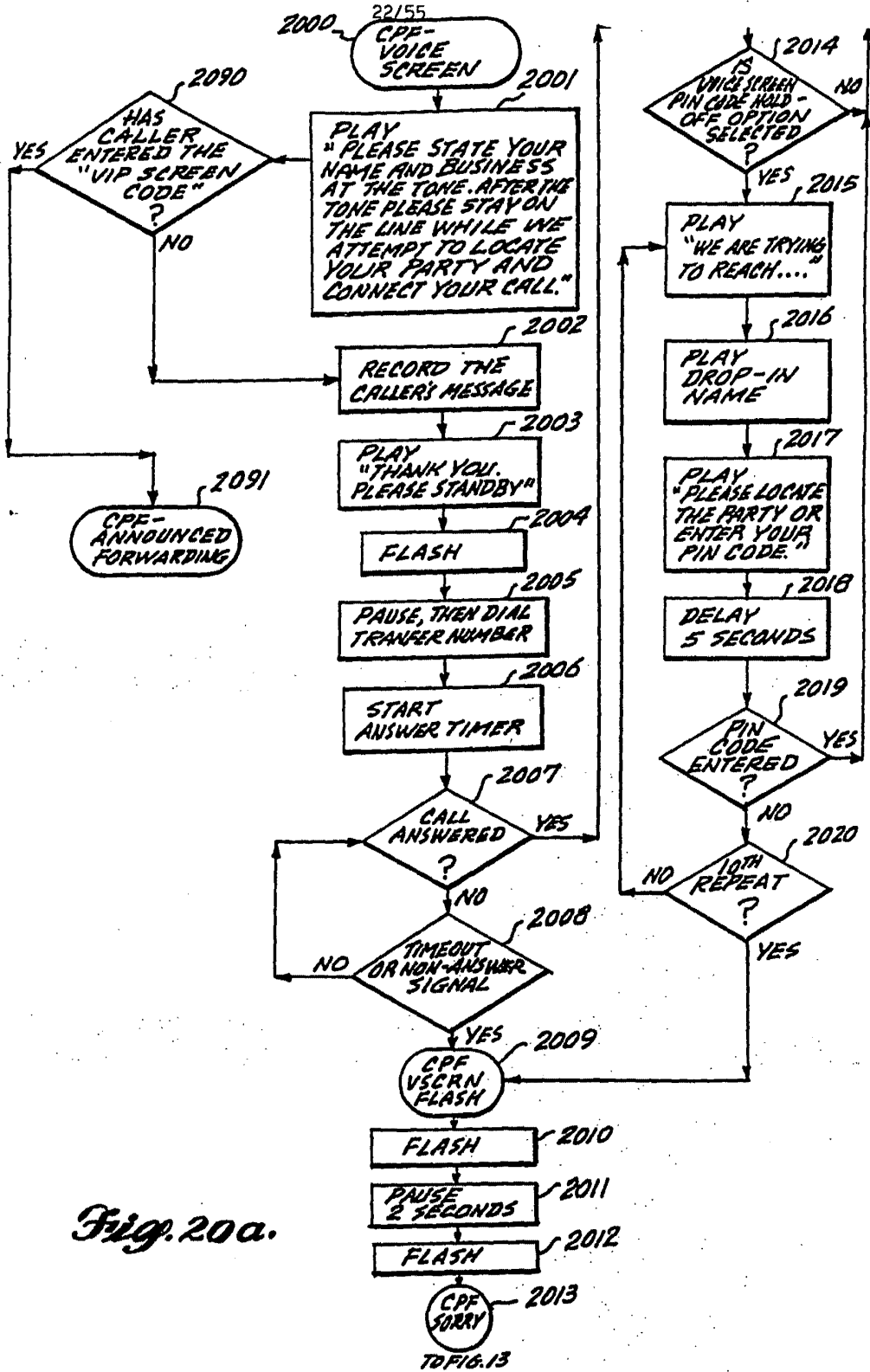

Fig. 20a.

TDFIG.13

SUBSTITUTE SHEET

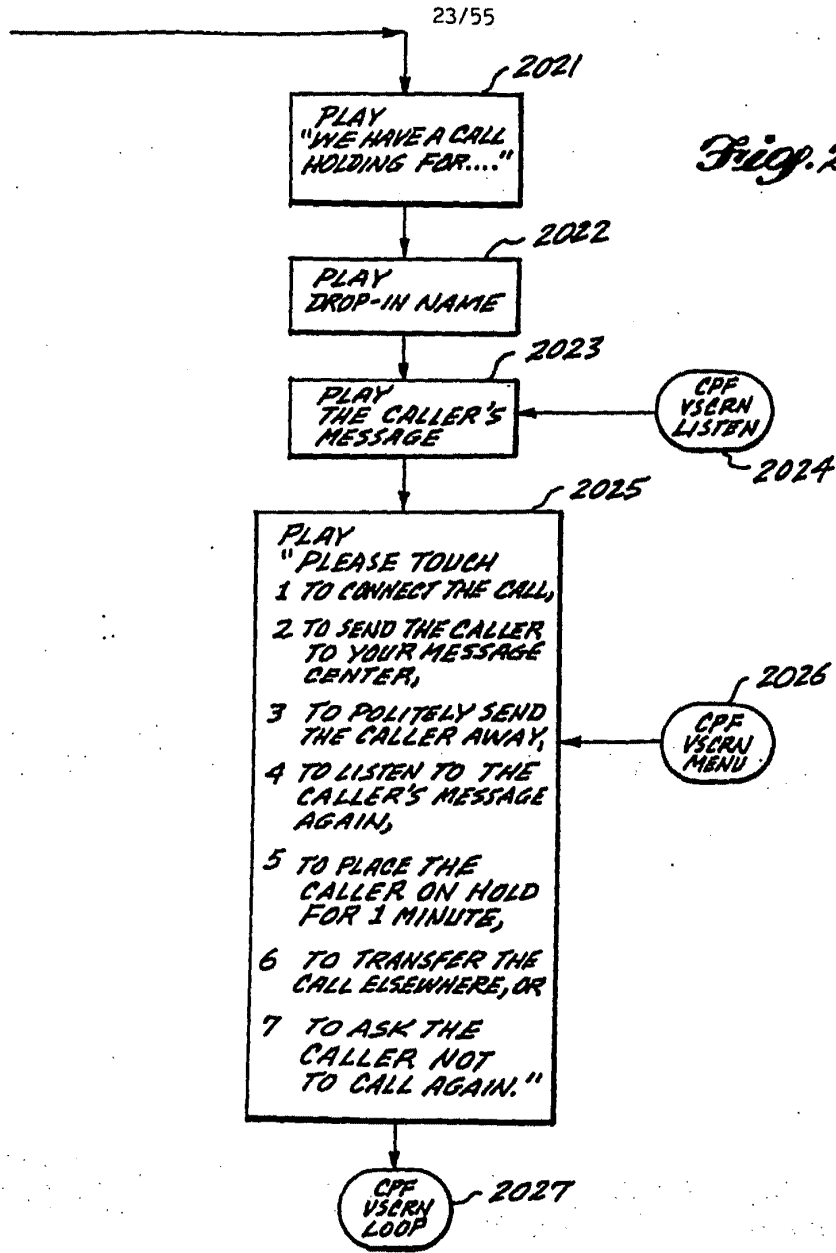

Fig. 20a.

SUBSTITUTE SHEET

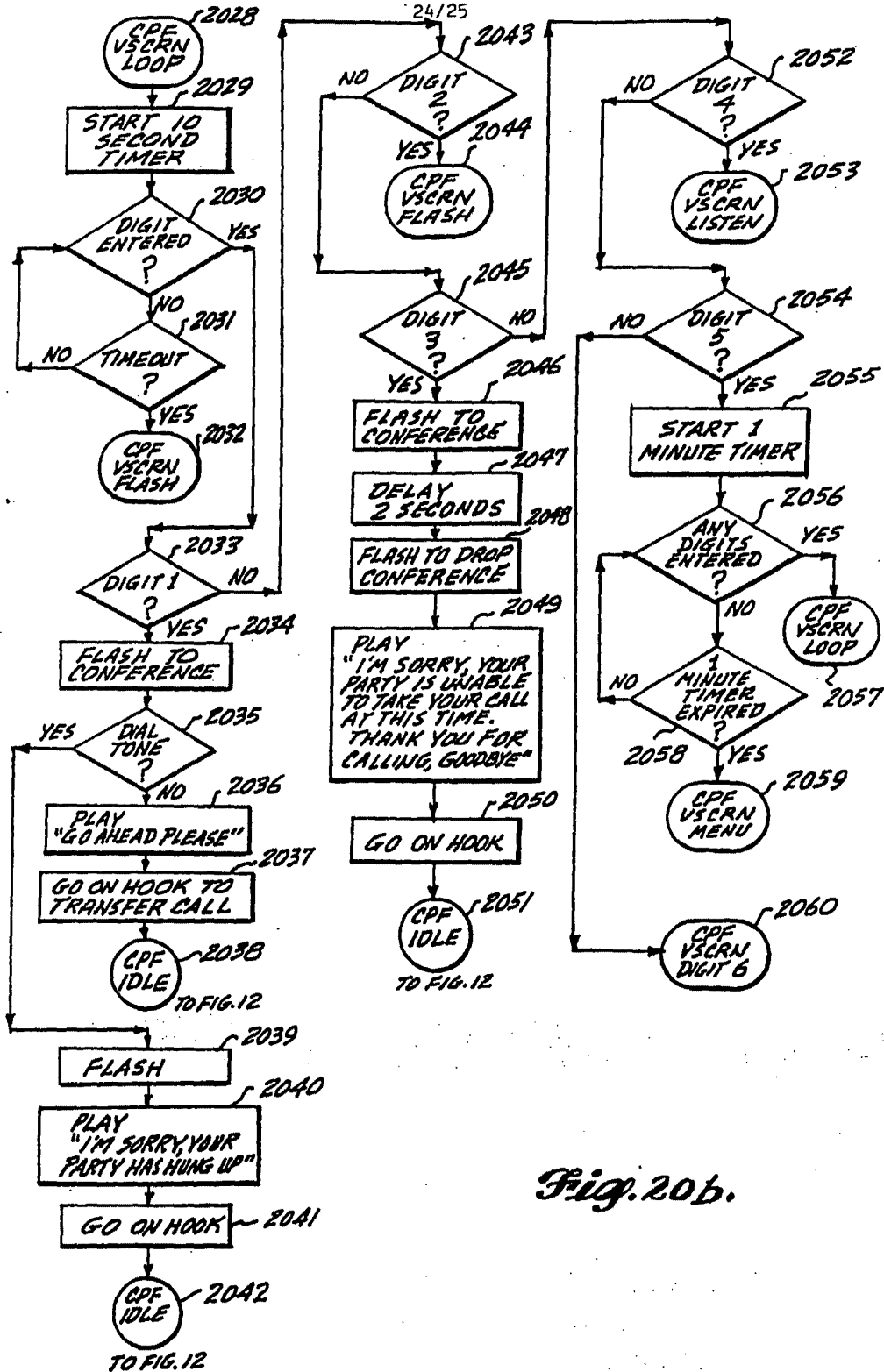

Fig. 20b.

SUBSTITUTE SHEET

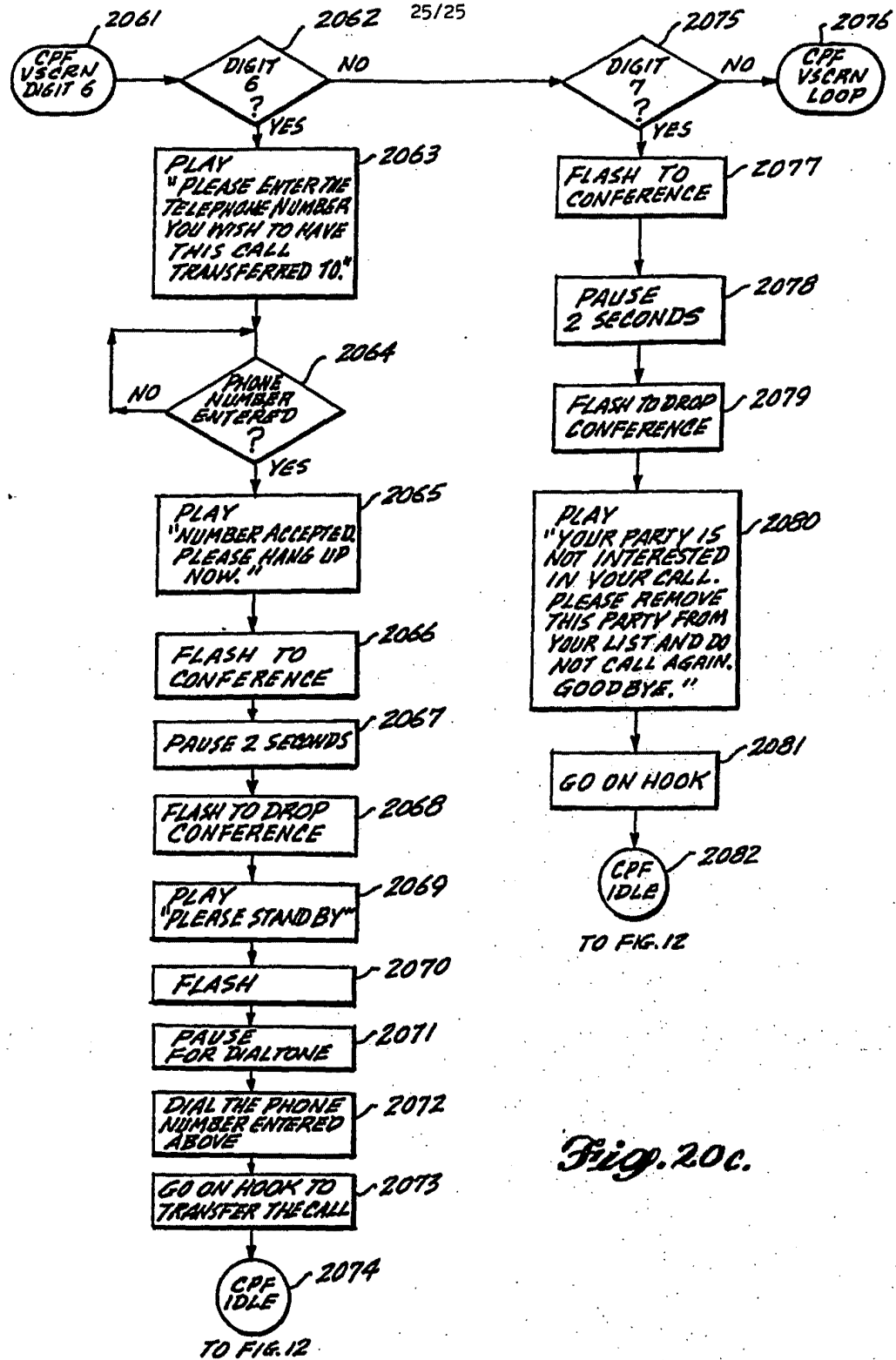

Fig. 20c.

SUBSTITUTE SHEET

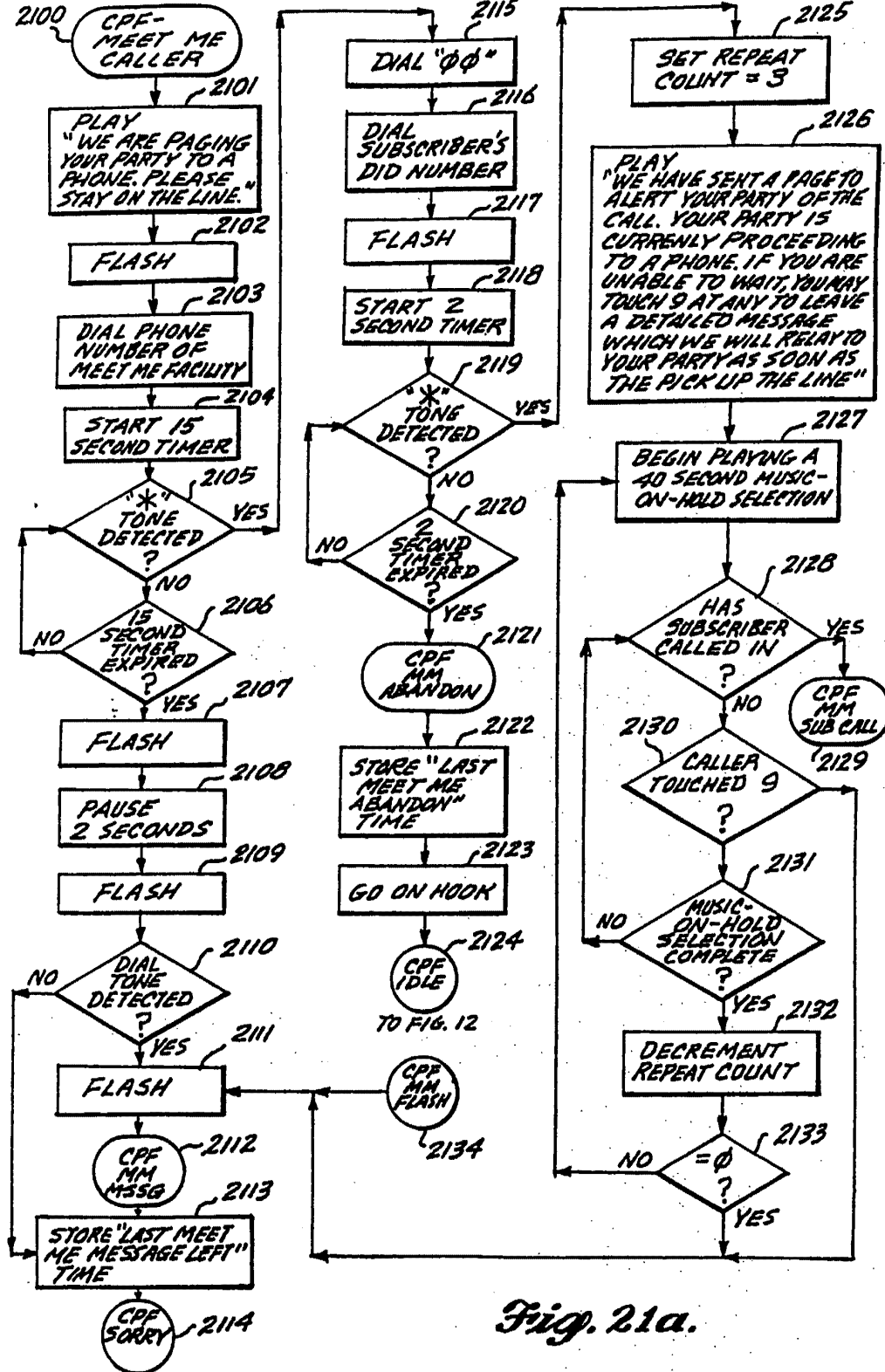

Fig. 21a.

SUBSTITUTE SHEET

27/55

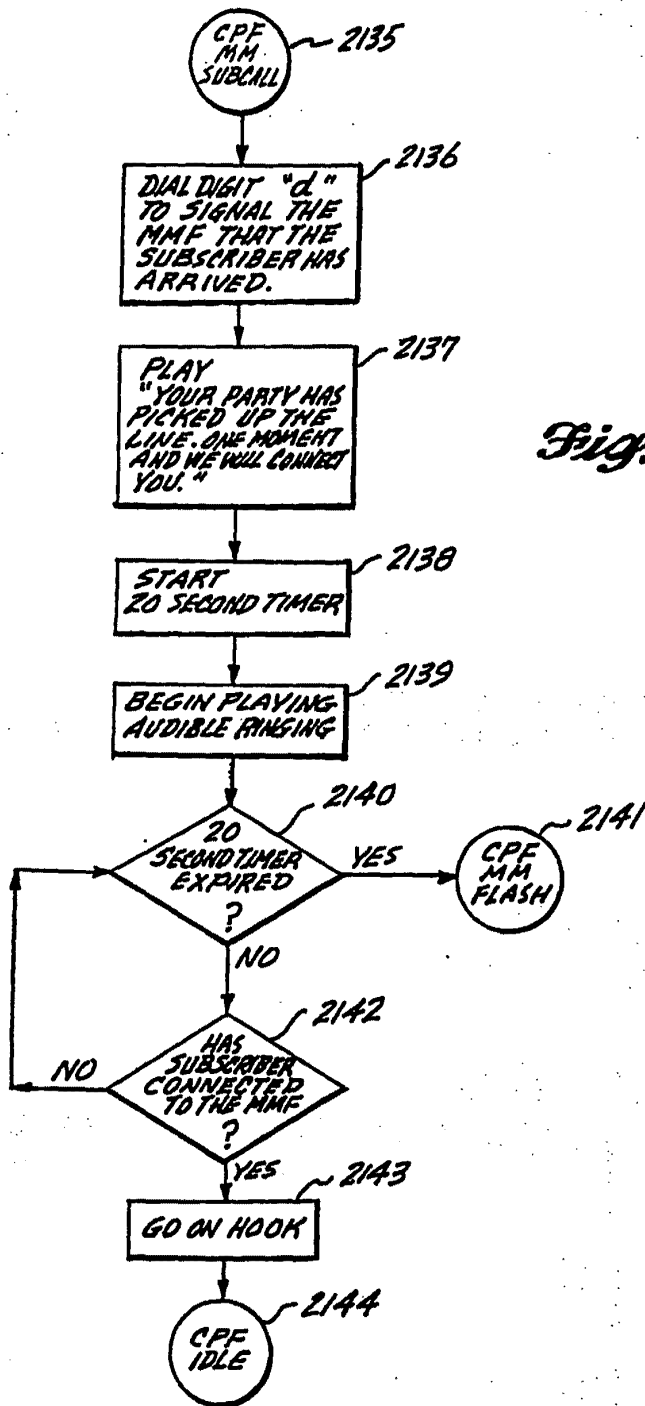

Fig. 21b.

TO FIG. 12

SUBSTITUTE SHEET

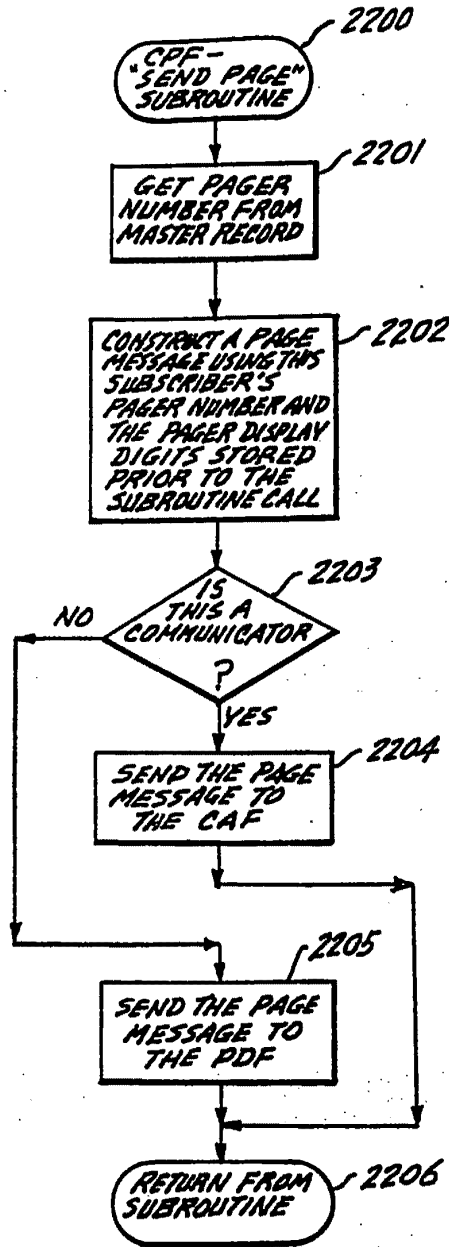

Fig. 22.

SUBSTITUTE SHEET

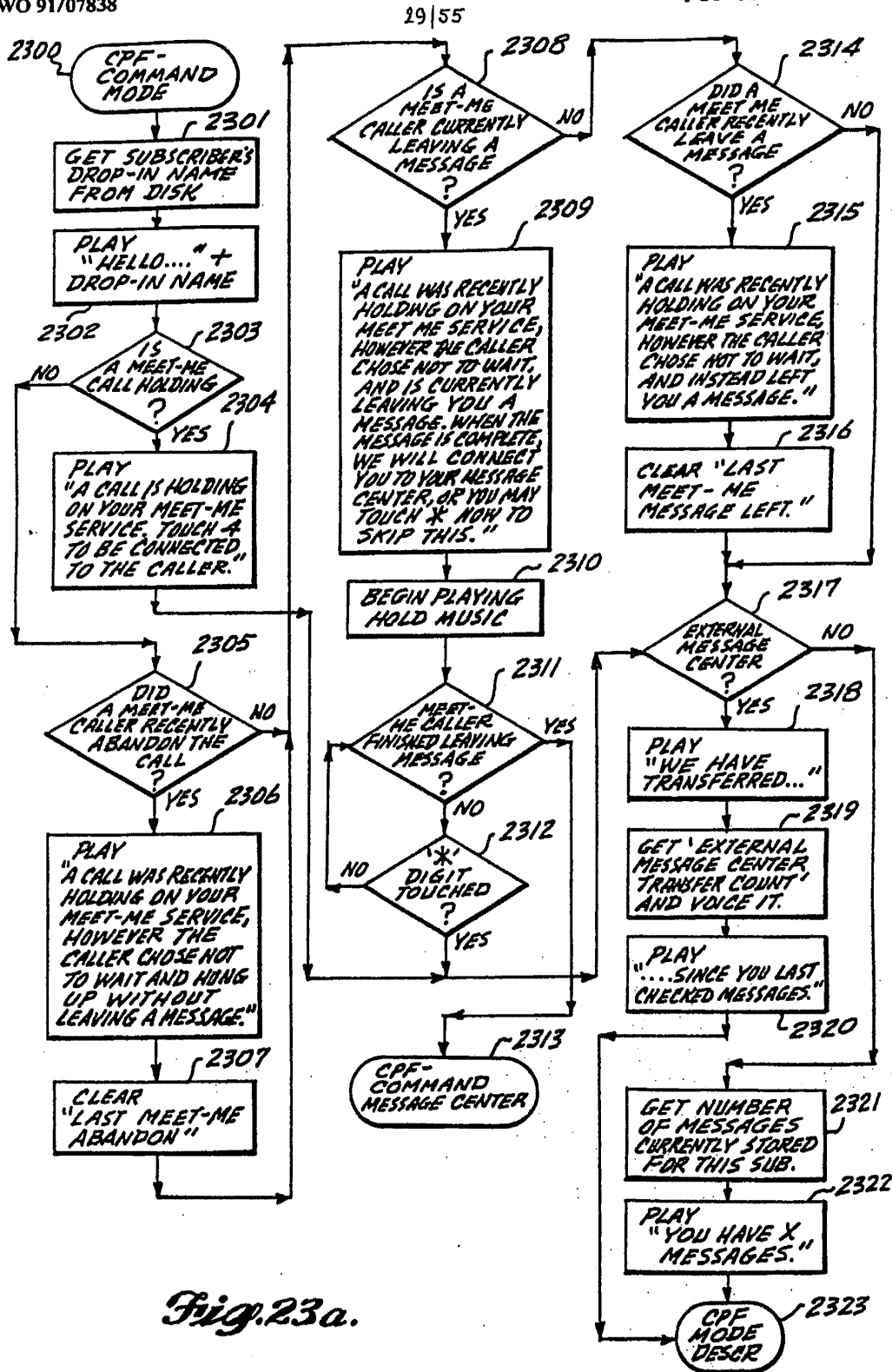

Fig. 23a.

SI INSTITUTE QUERT

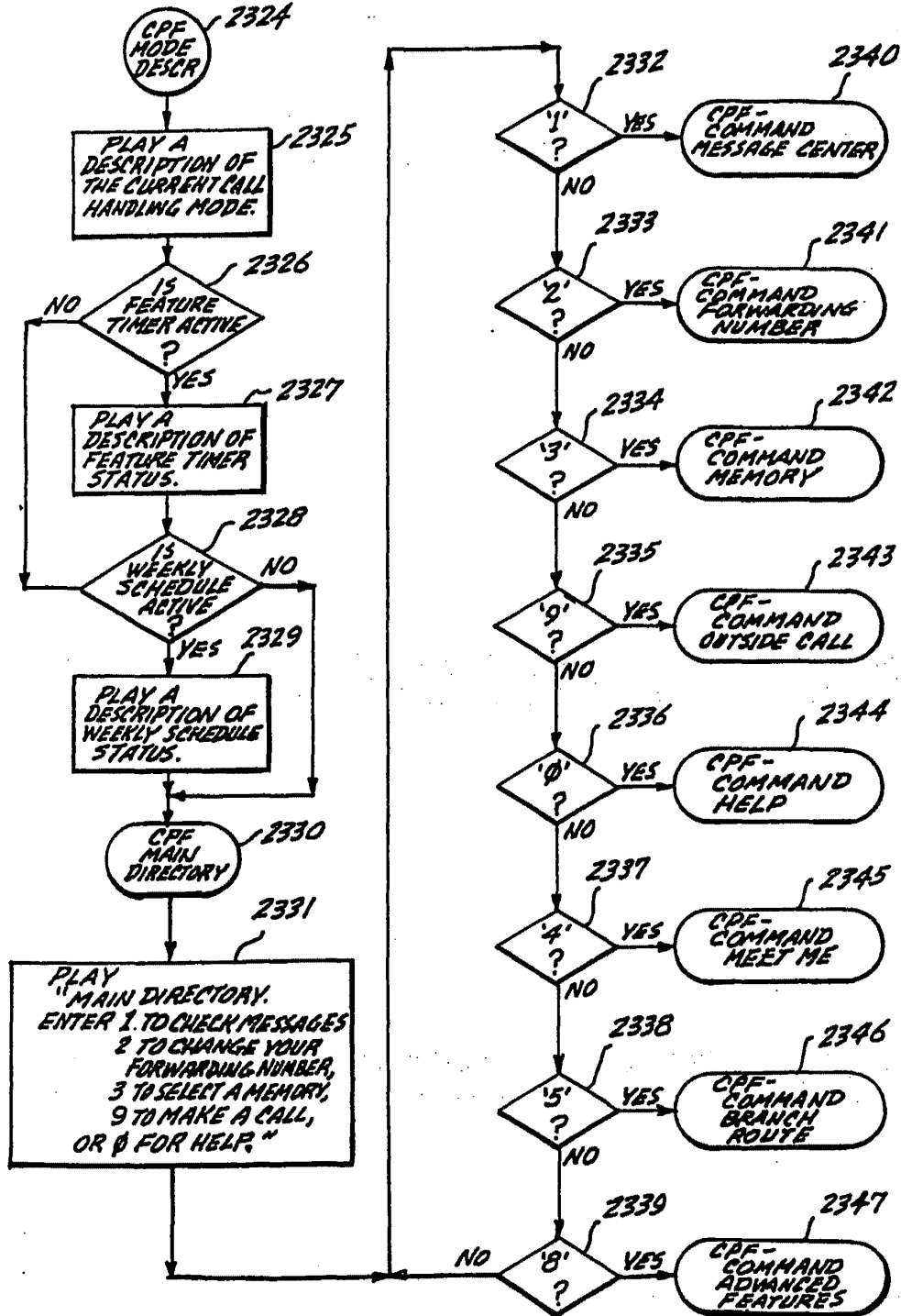

Fig. 23b.

SUBSTITUTE SHEET

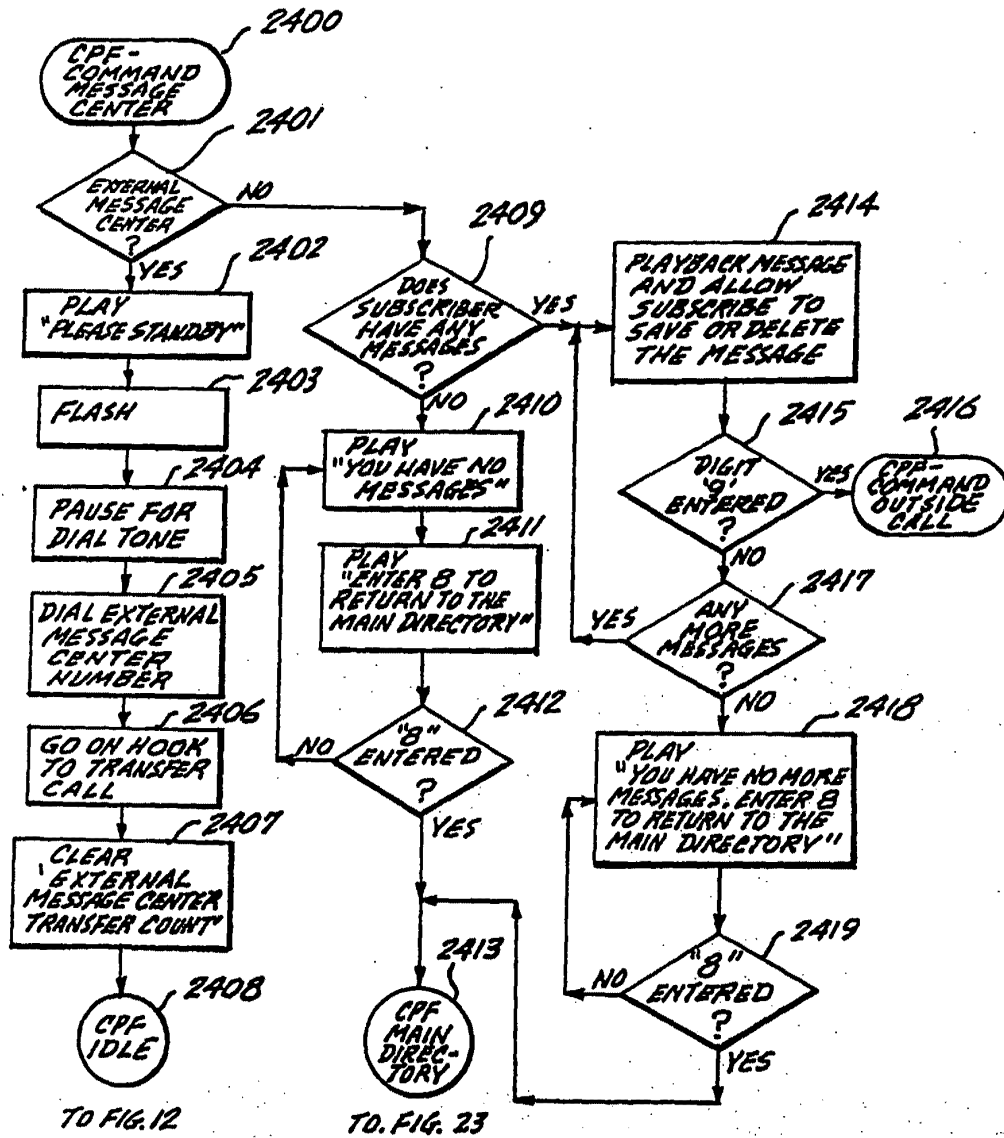

Fig. 24.

SUBSTITUTE SHEET

32/55

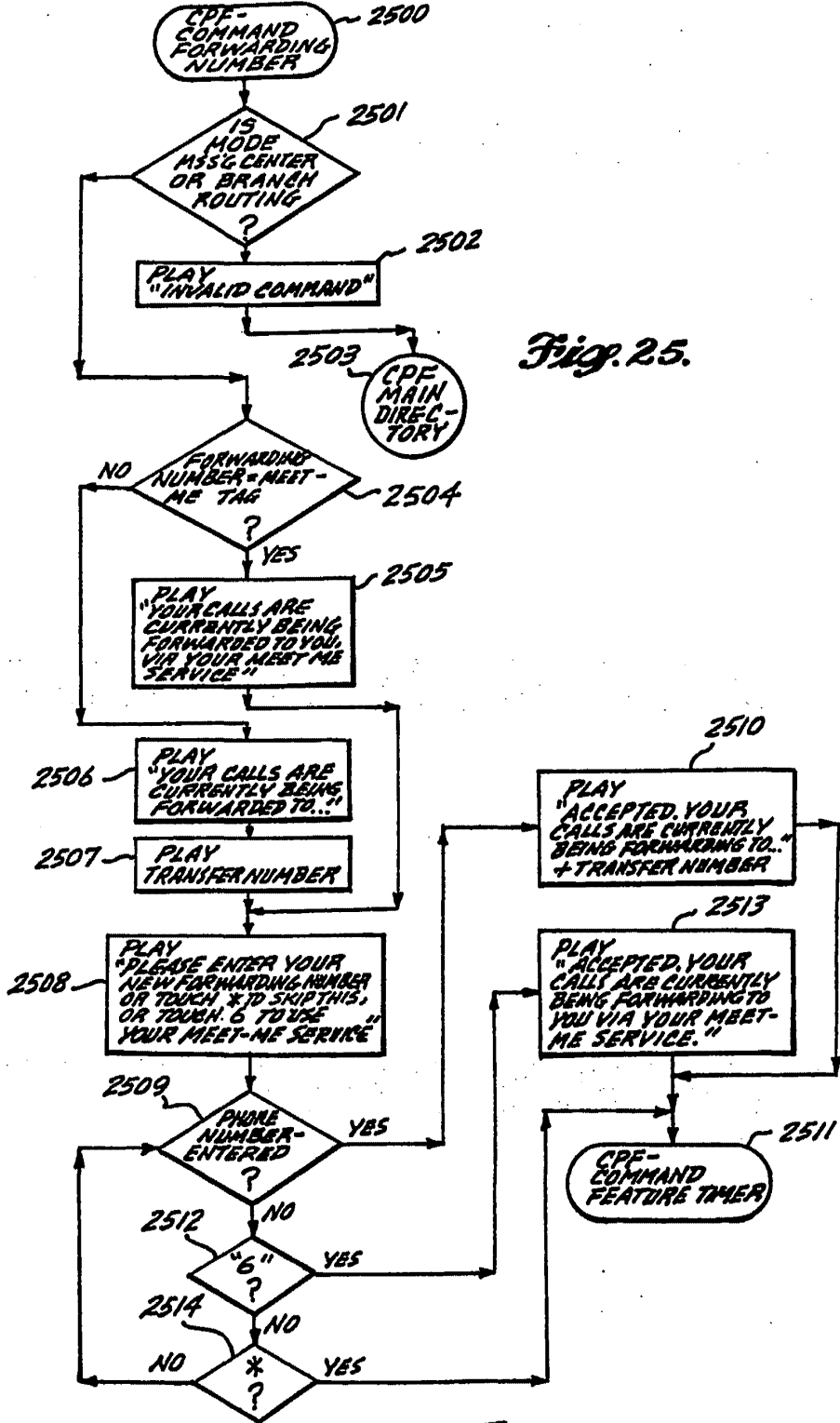

Fig. 25.

SUBSTITUTE SHEET

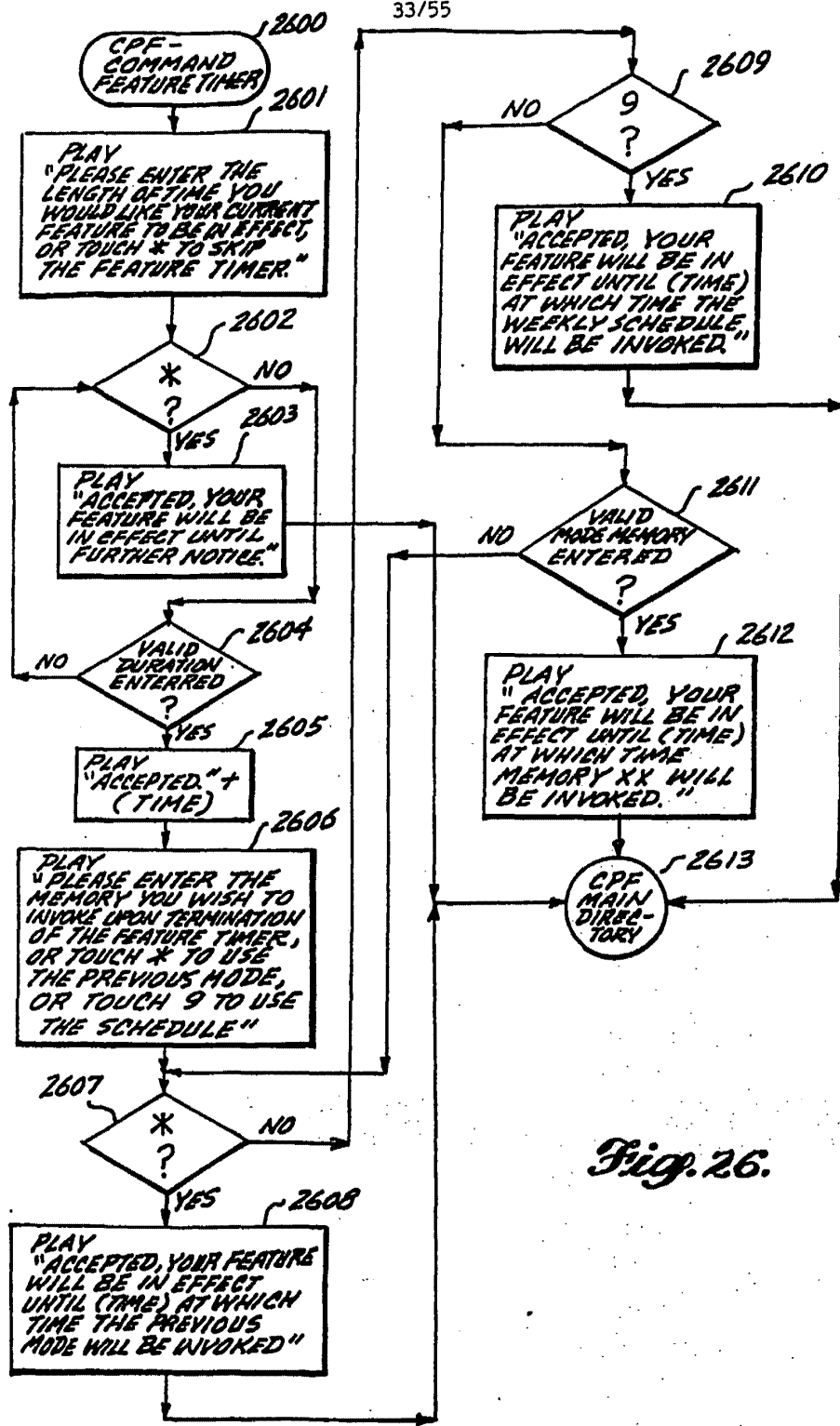

Fig. 26.

SUBSTITUTE SHEET

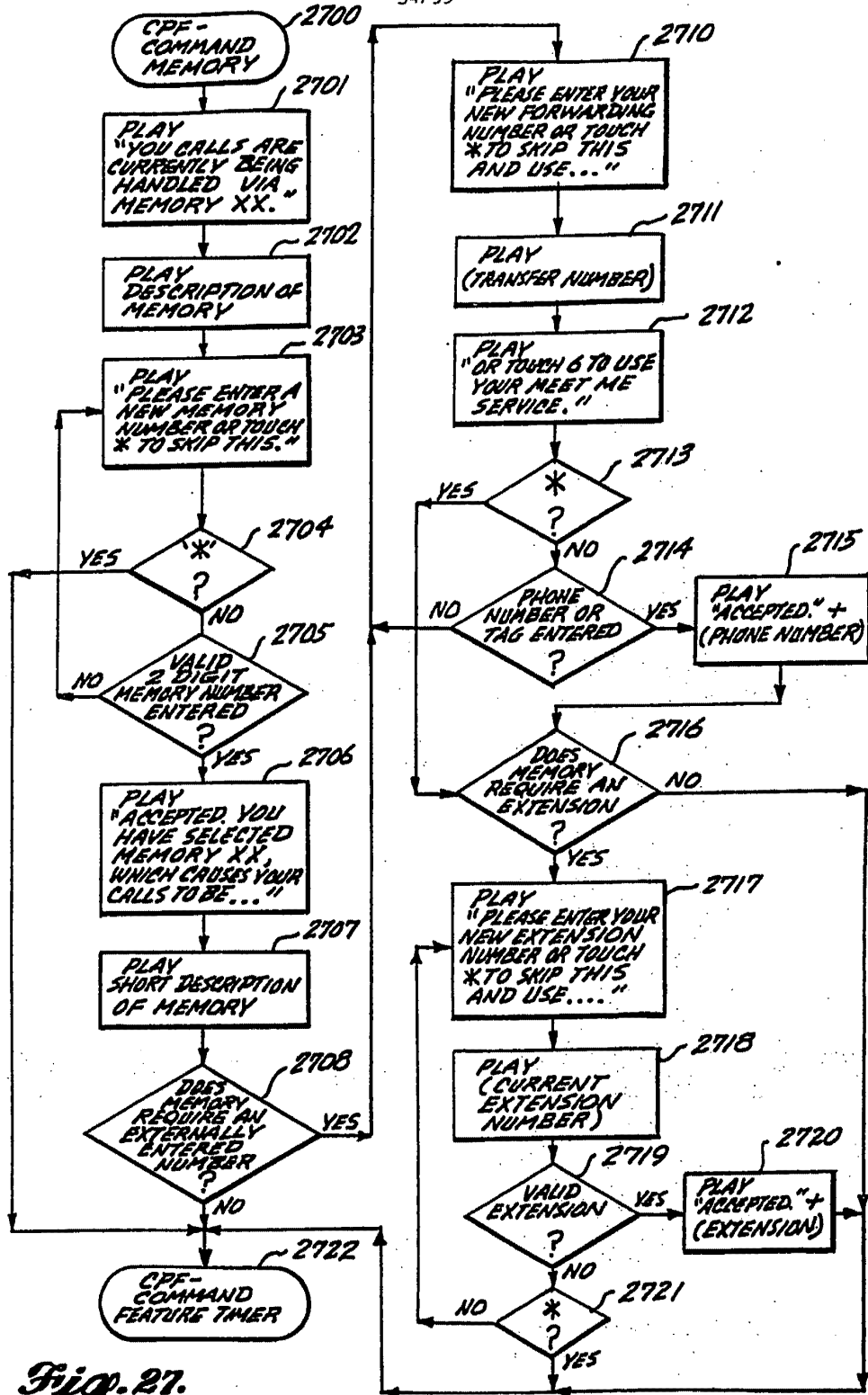
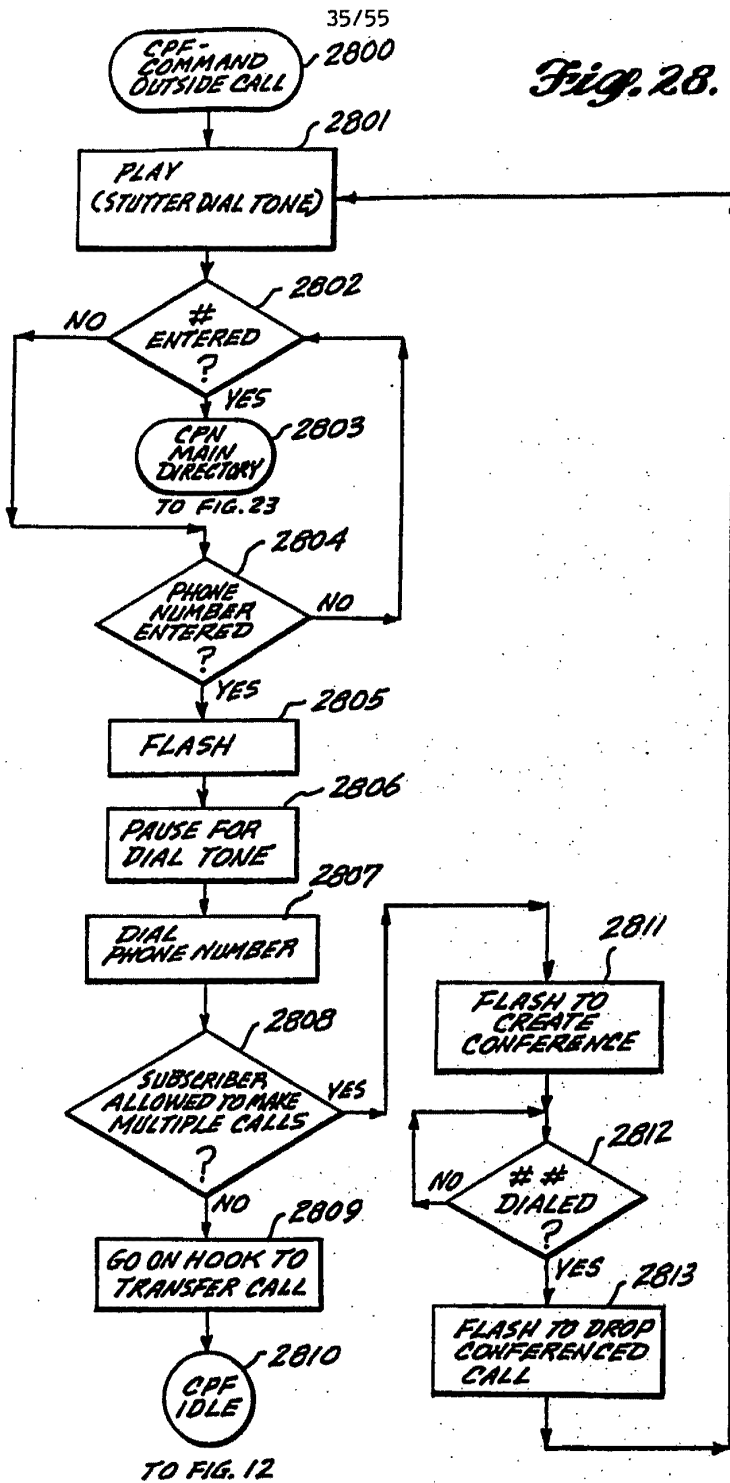

Fig. 27.

SUBSTITUTE SHEET

Fig. 28.



SUBSTITUTE SHEET

36/55

Fig. 29.

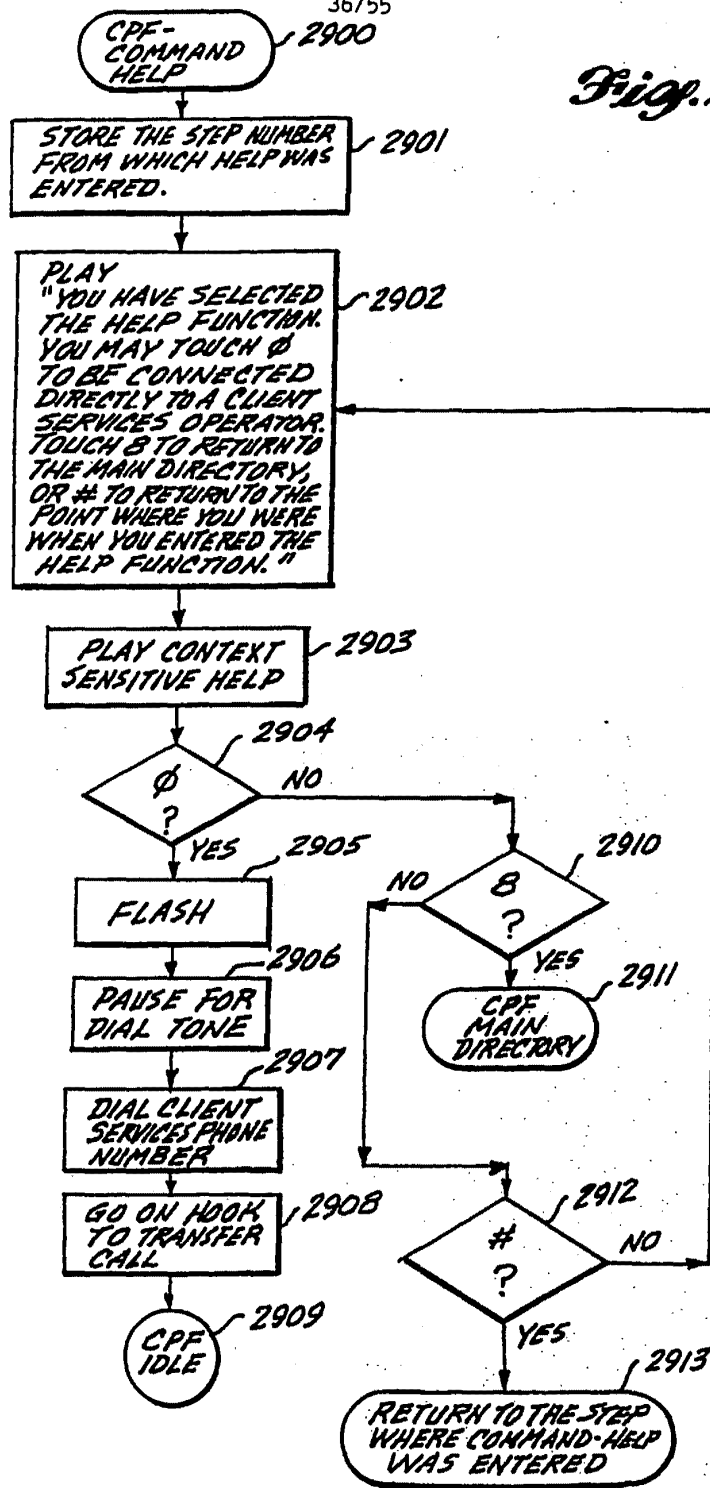

SUBSTITUTE SHEET

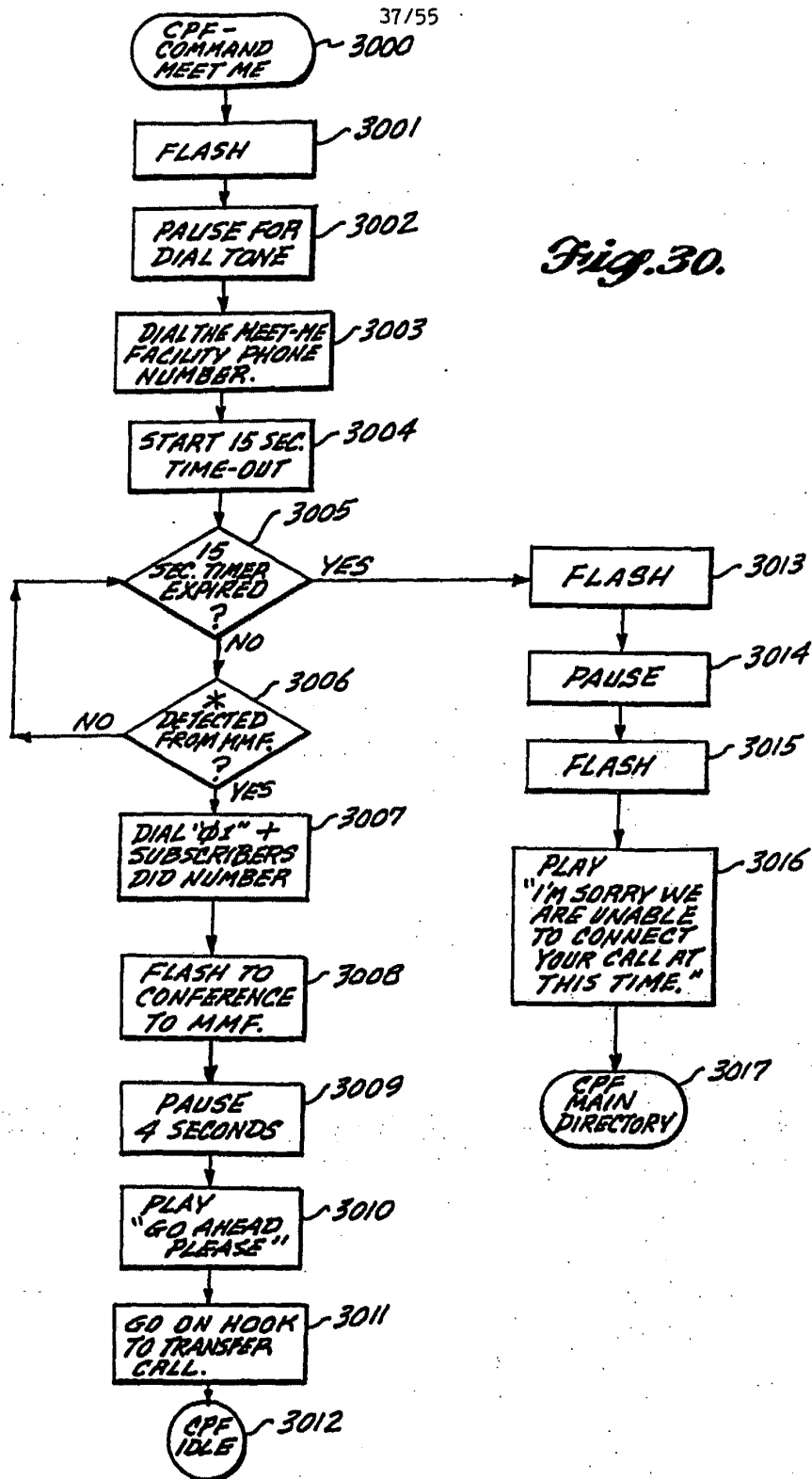

SUBSTITUTE SHEET

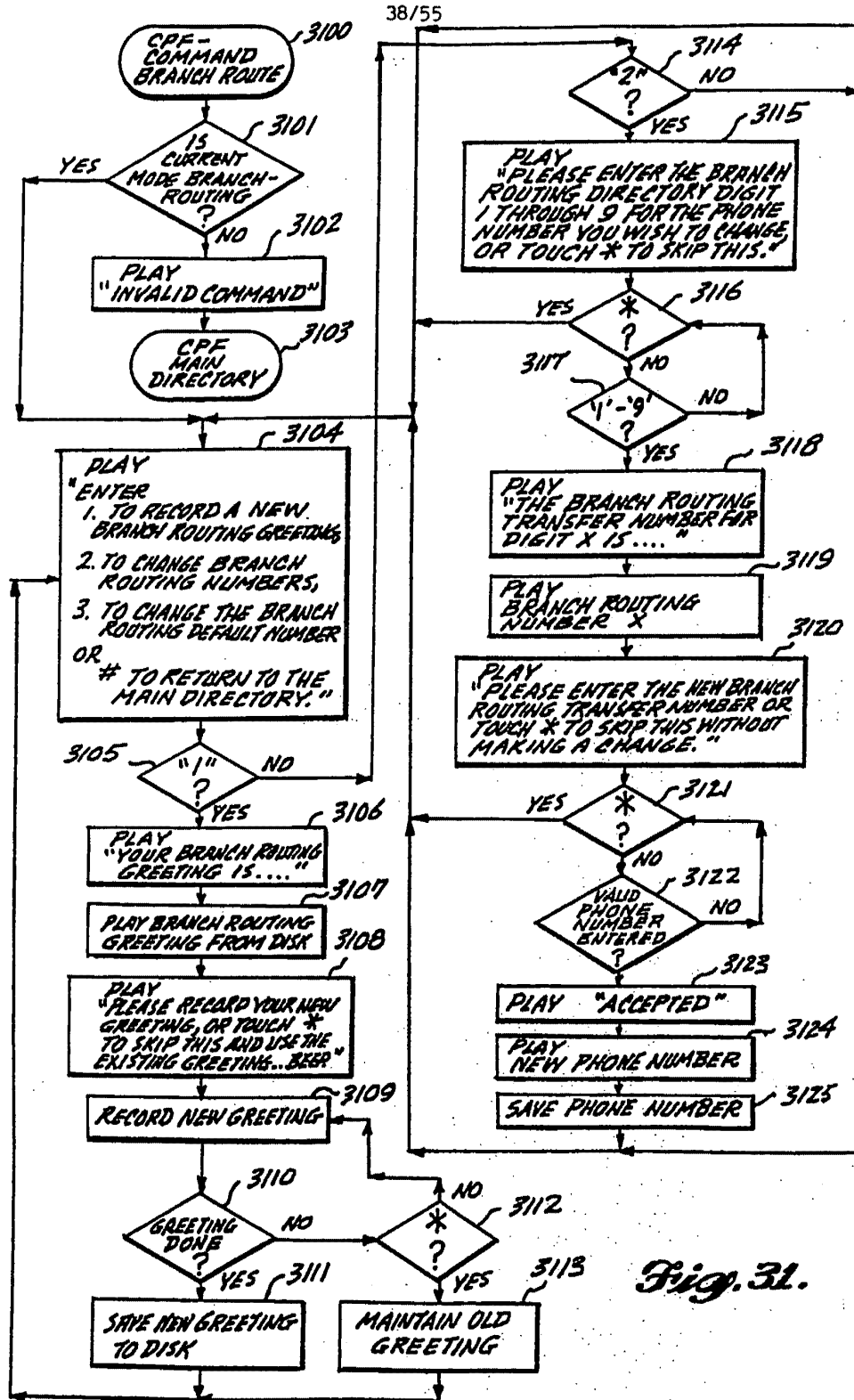

Fig. 31.

SUBSTITUTE SHEET

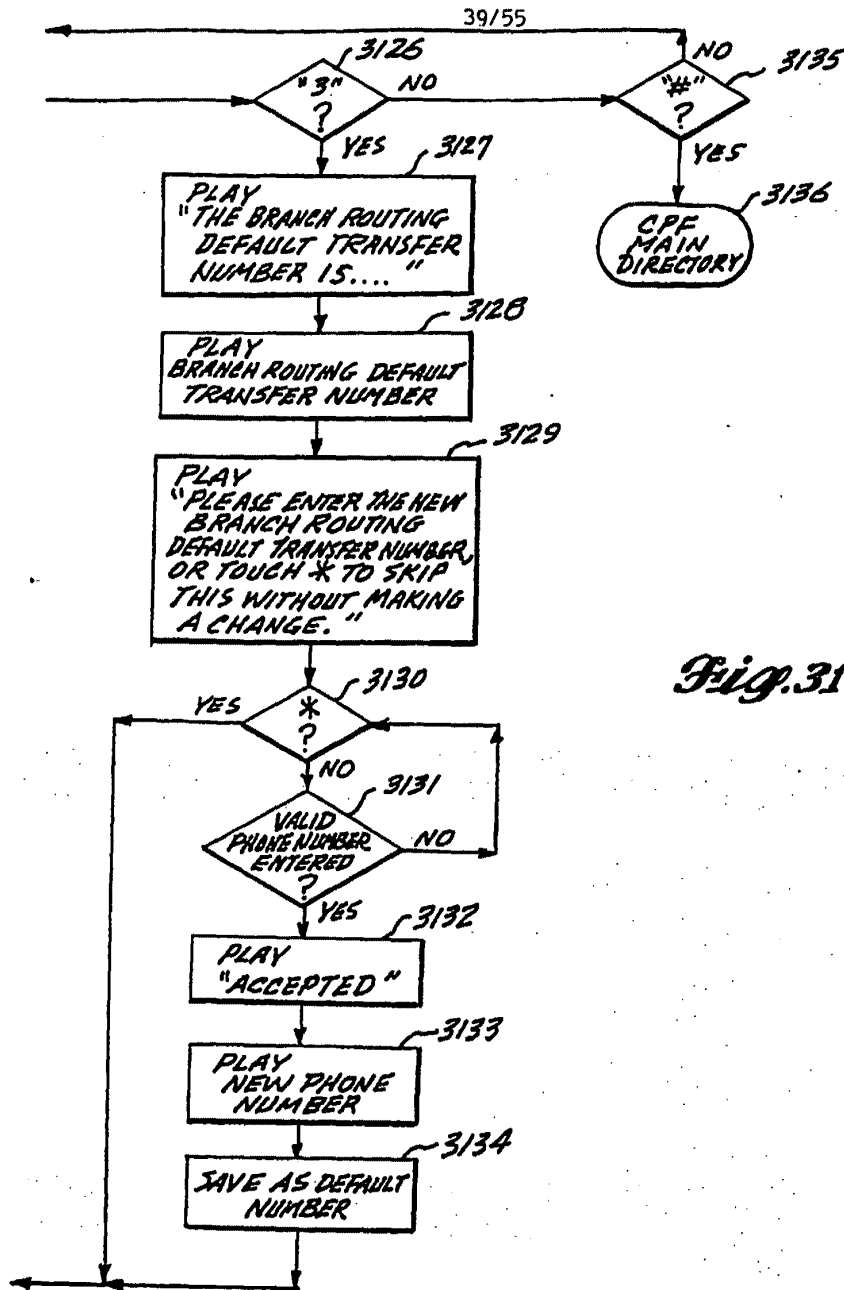

Fig. 31.

SUBSTITUTE SHEET

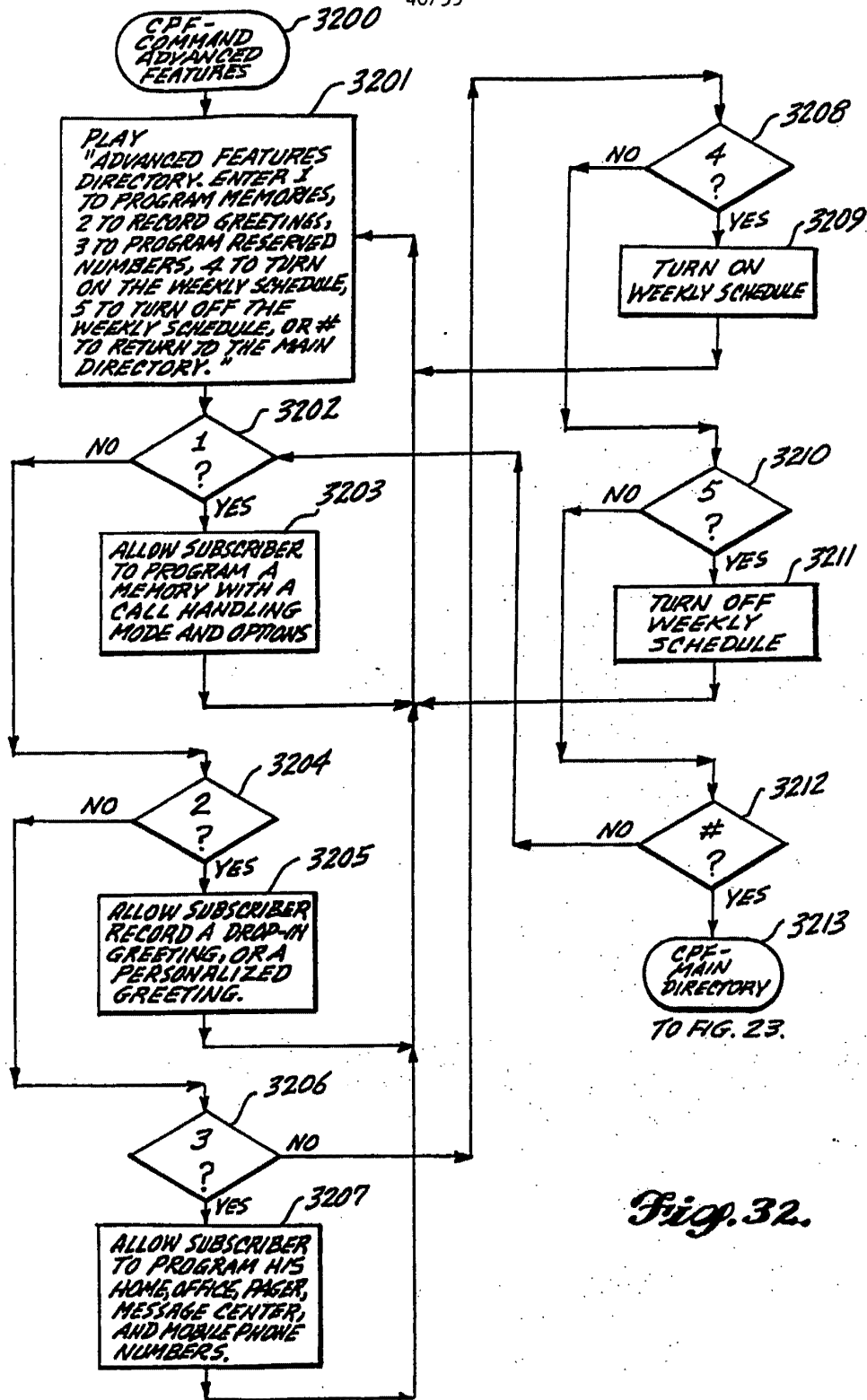

Fig. 32.

SUBSTITUTE SHEET

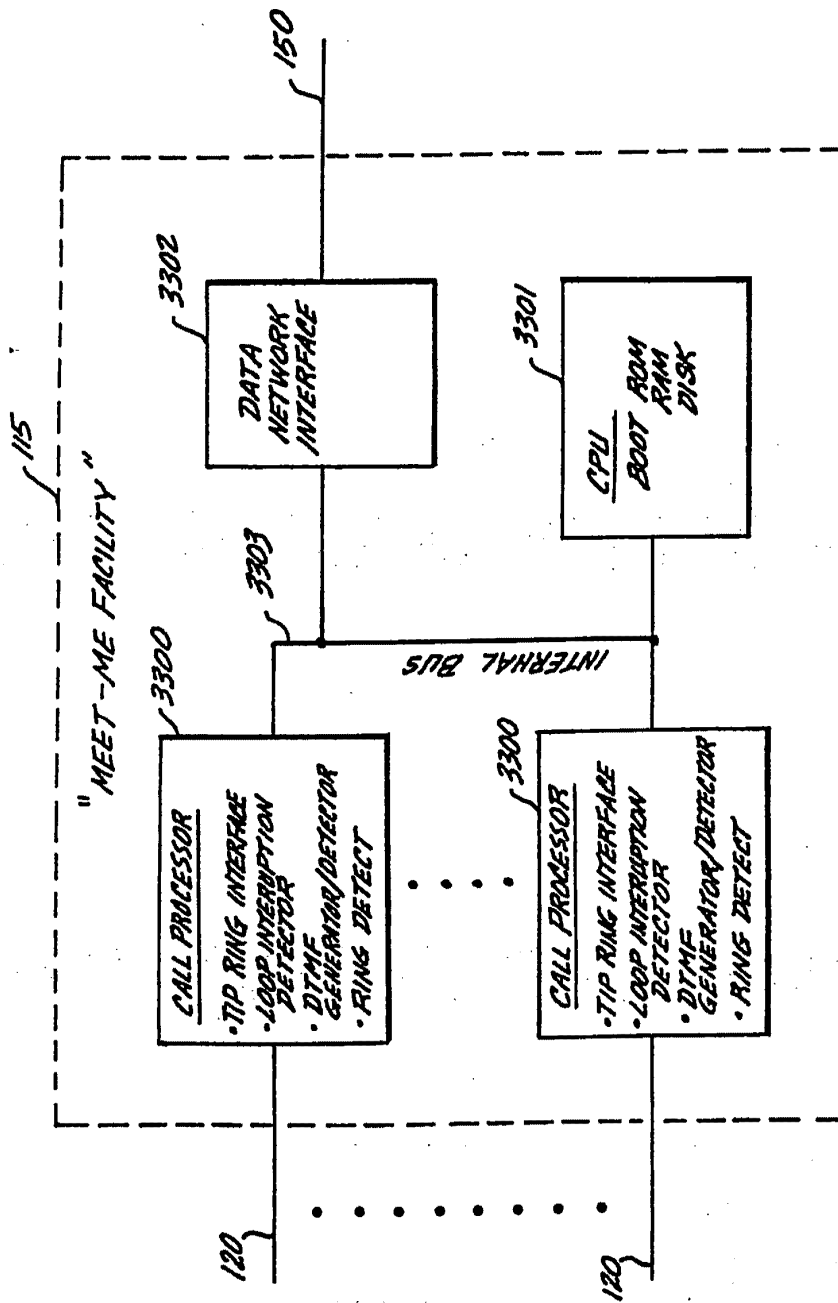

Fig. 33.

SUBSTITUTE SHEET

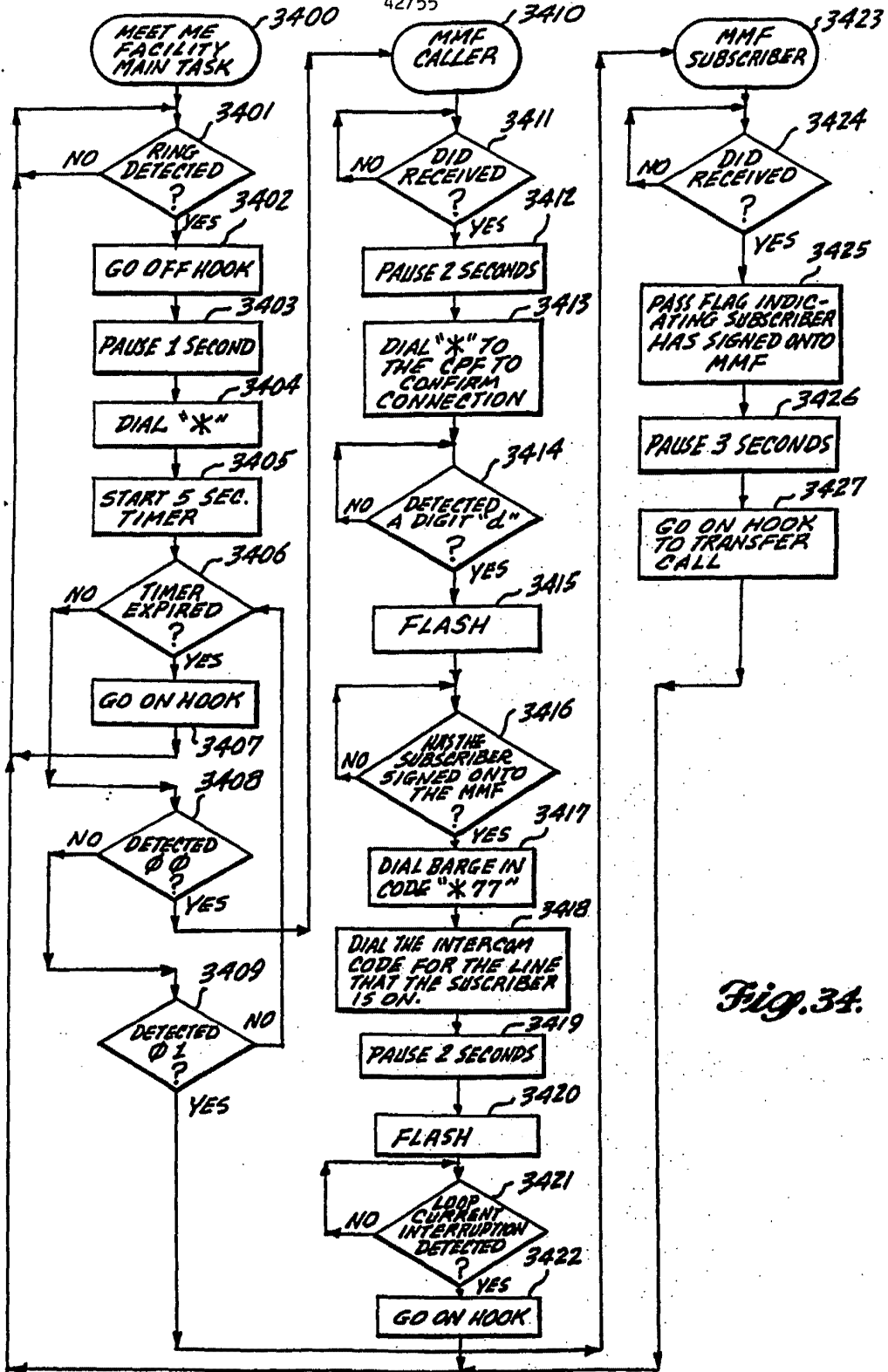

Fig. 34.

SUBSTITUTE SHEET

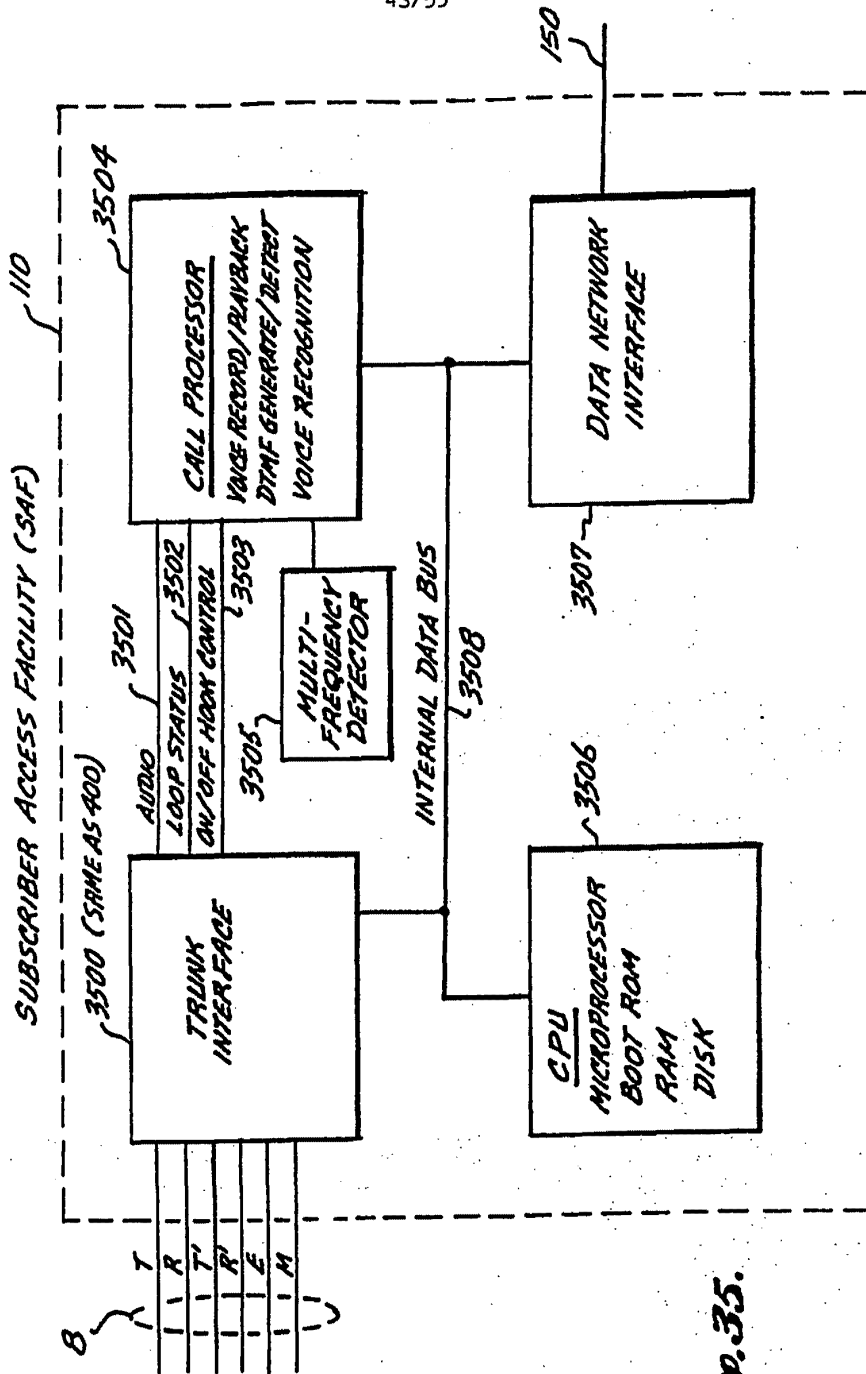
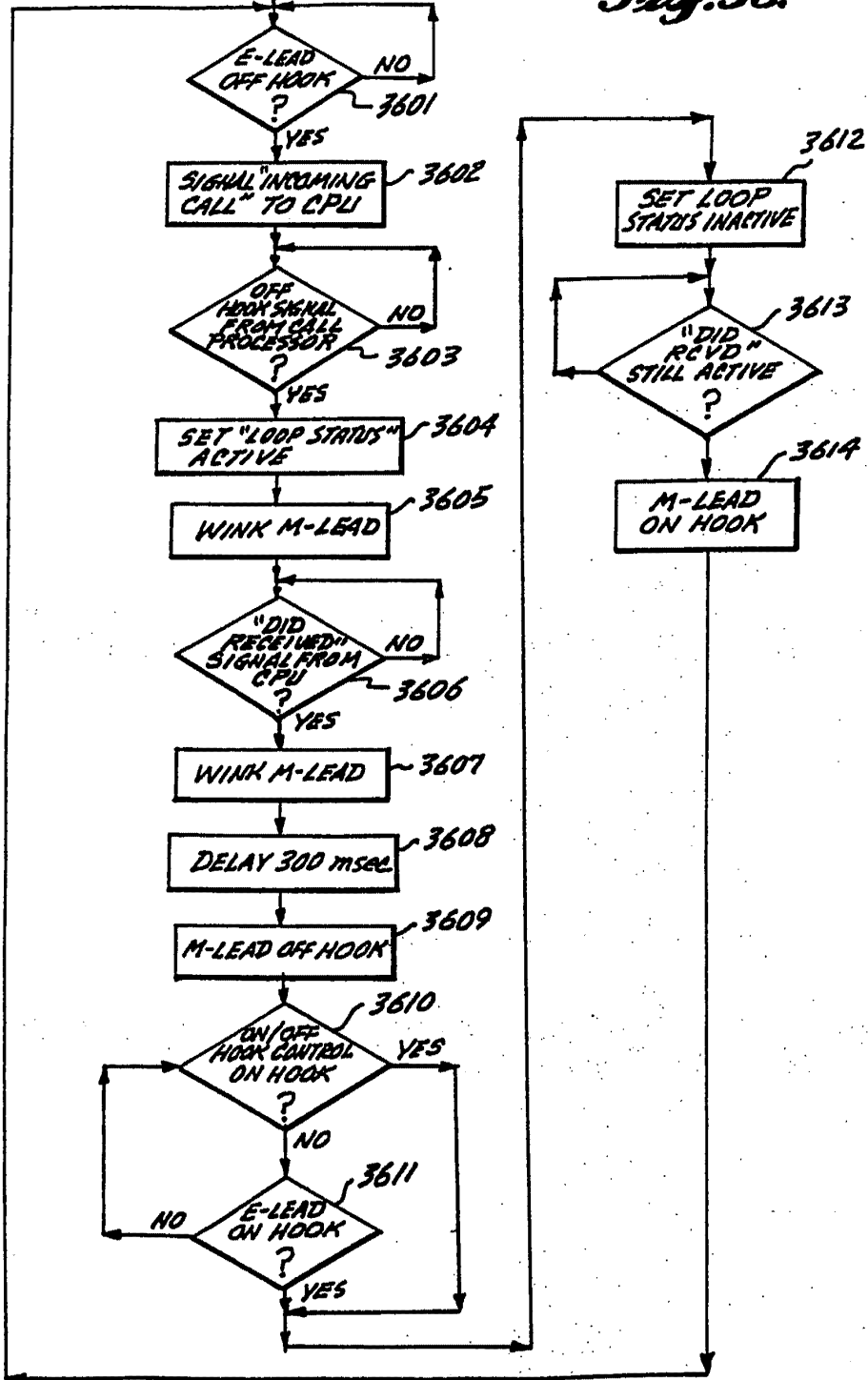

Fig. 35.

SUBSTITUTE SHEET

E & M LEAD CONTROL
CIRCUIT OPERATION FOR
SAF TRUNK INTERFACE ~ 3600

Fig. 36.



SUBSTITUTE SHEET

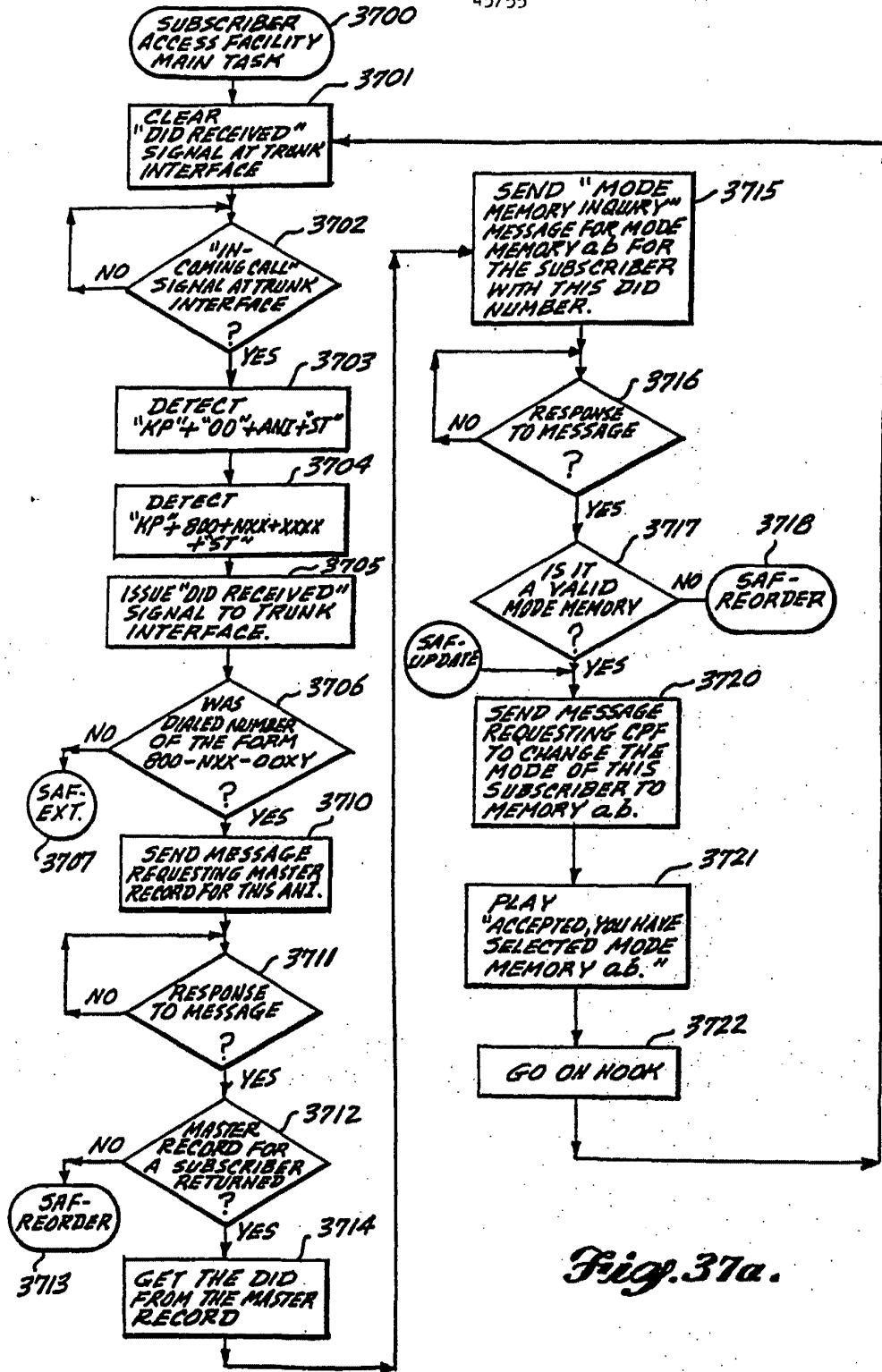

Fig. 37a.

SUBSTITUTE SHEET

46/55

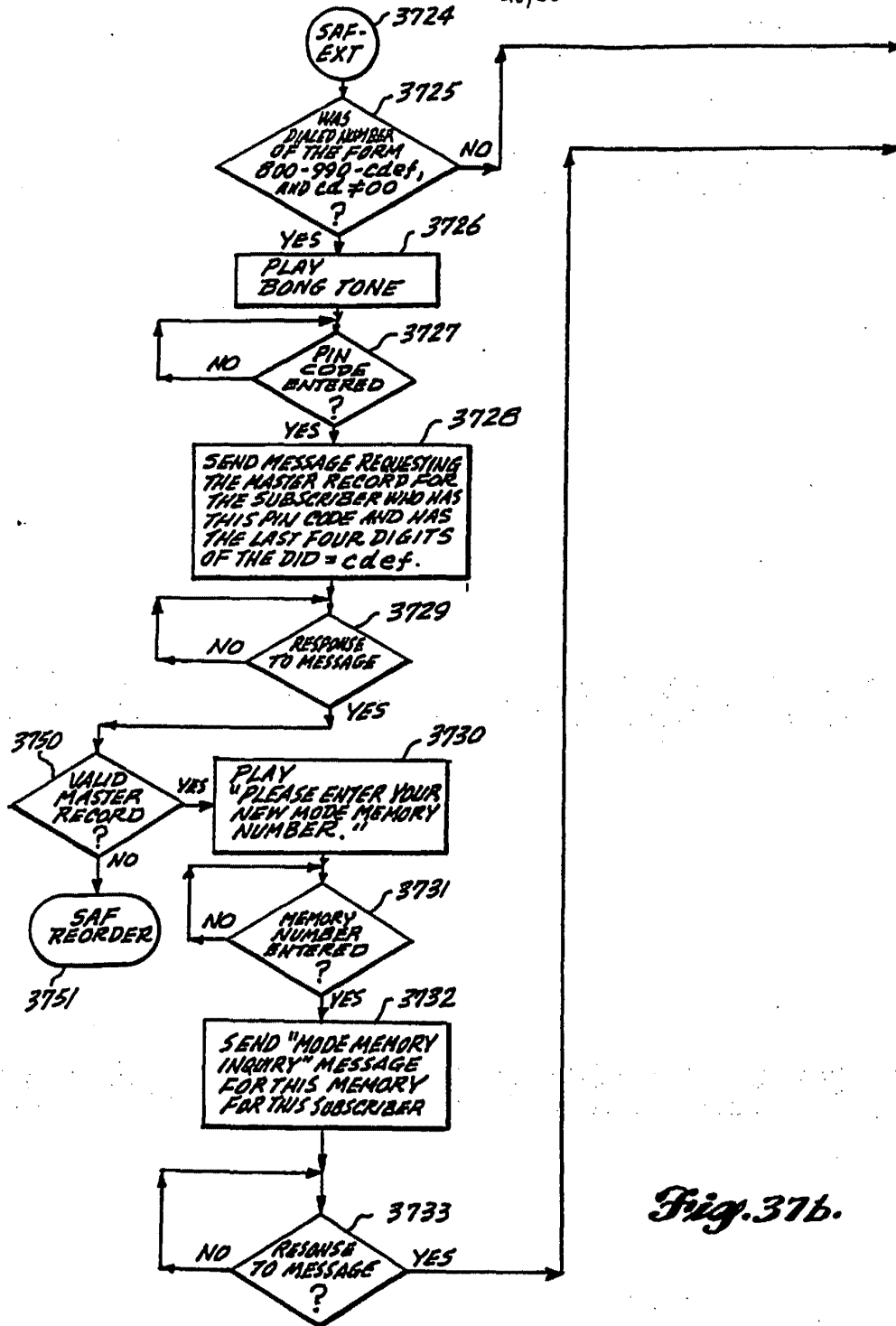

Fig.37b.

CONTINUATION SHEET

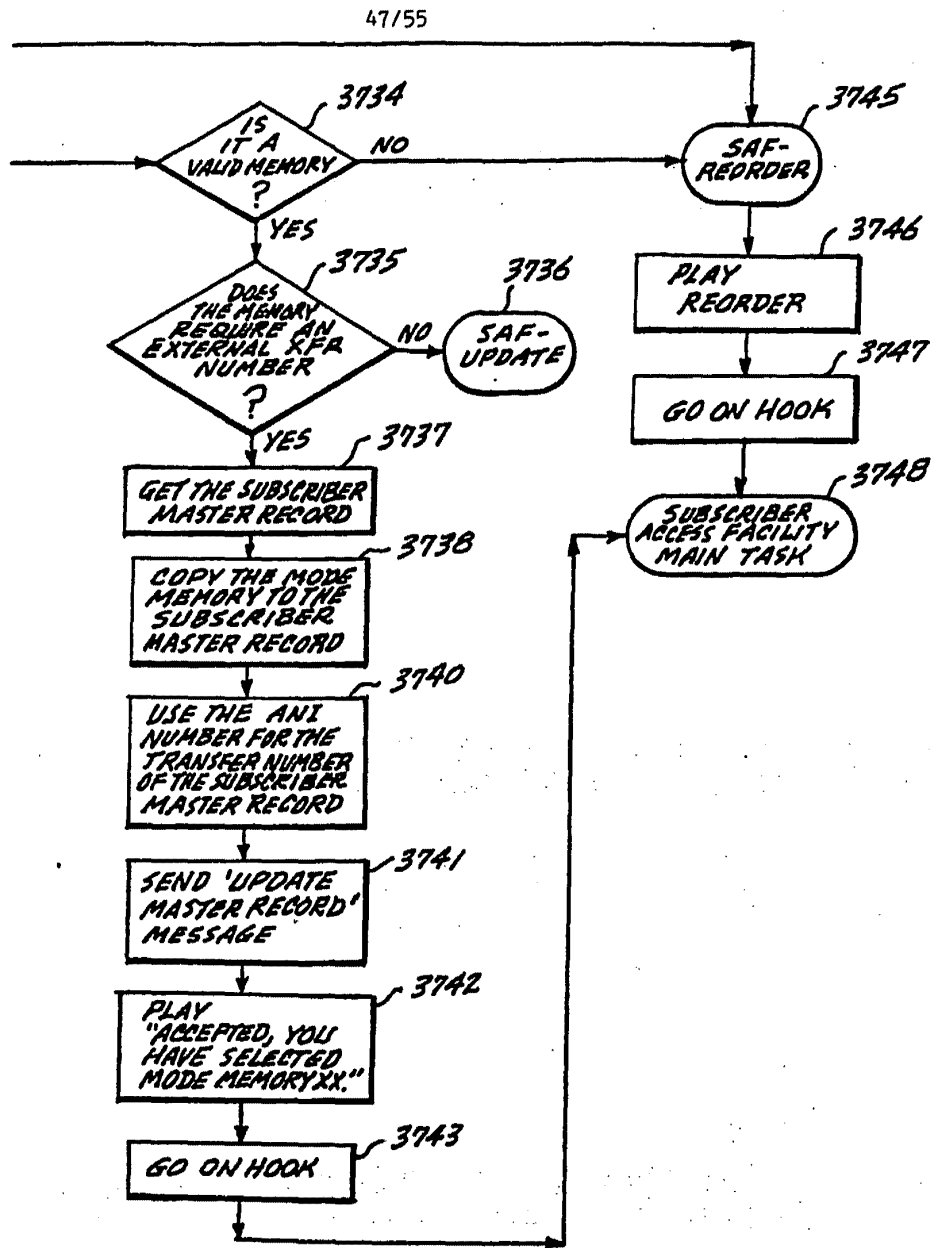

Fig. 37b.

SUBSTITUTE SHEET

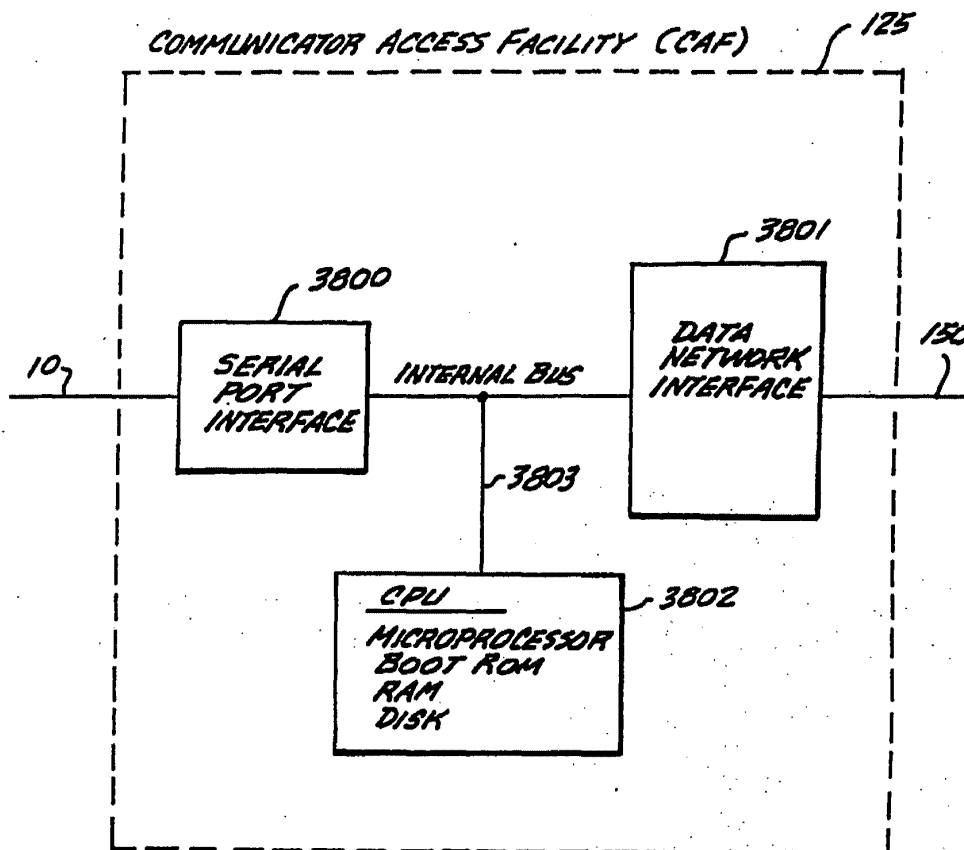

Fig. 38.

SUBSTITUTE SHEET

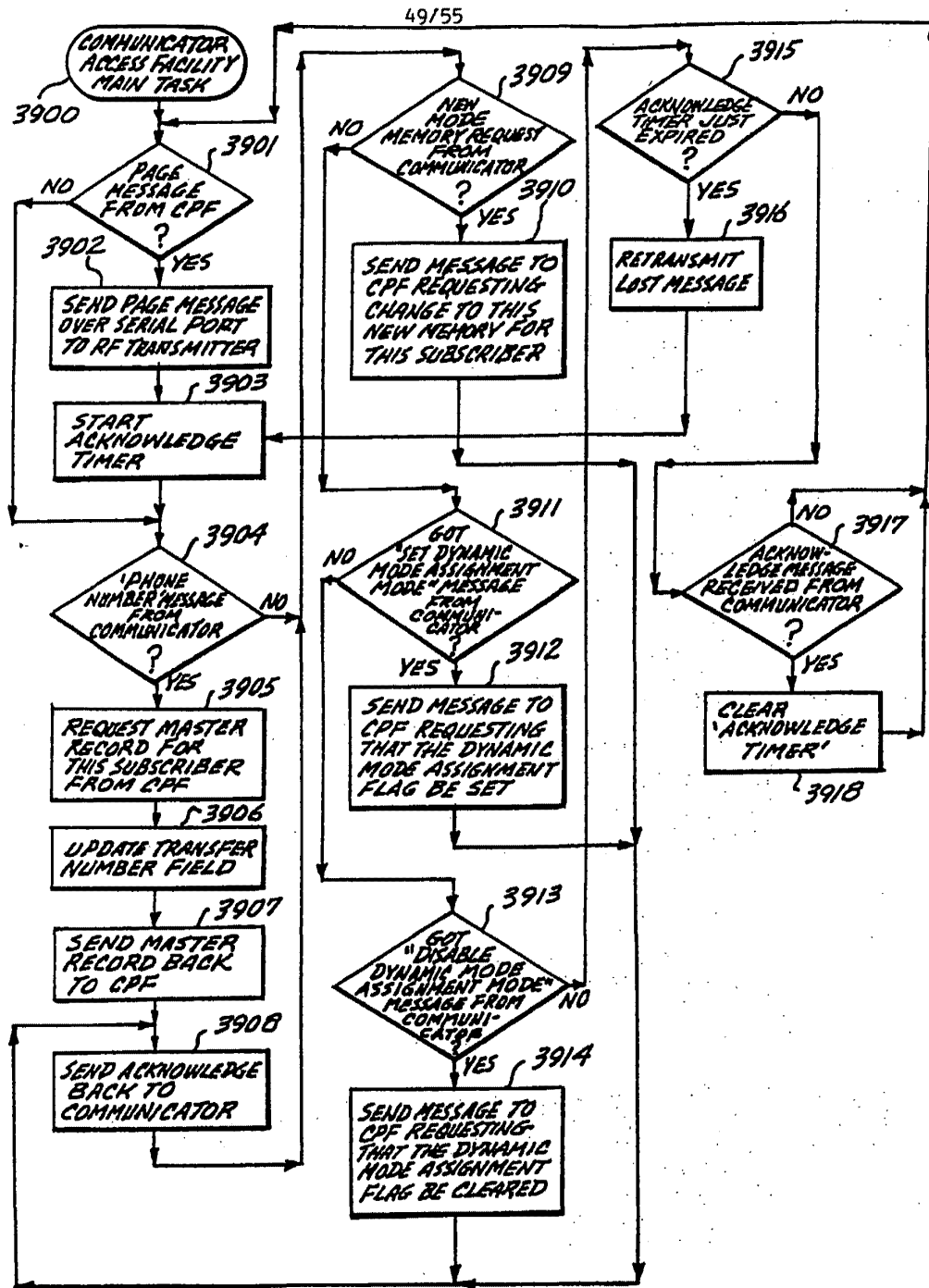

Fig. 39.

SUBSTITUTE SHEET

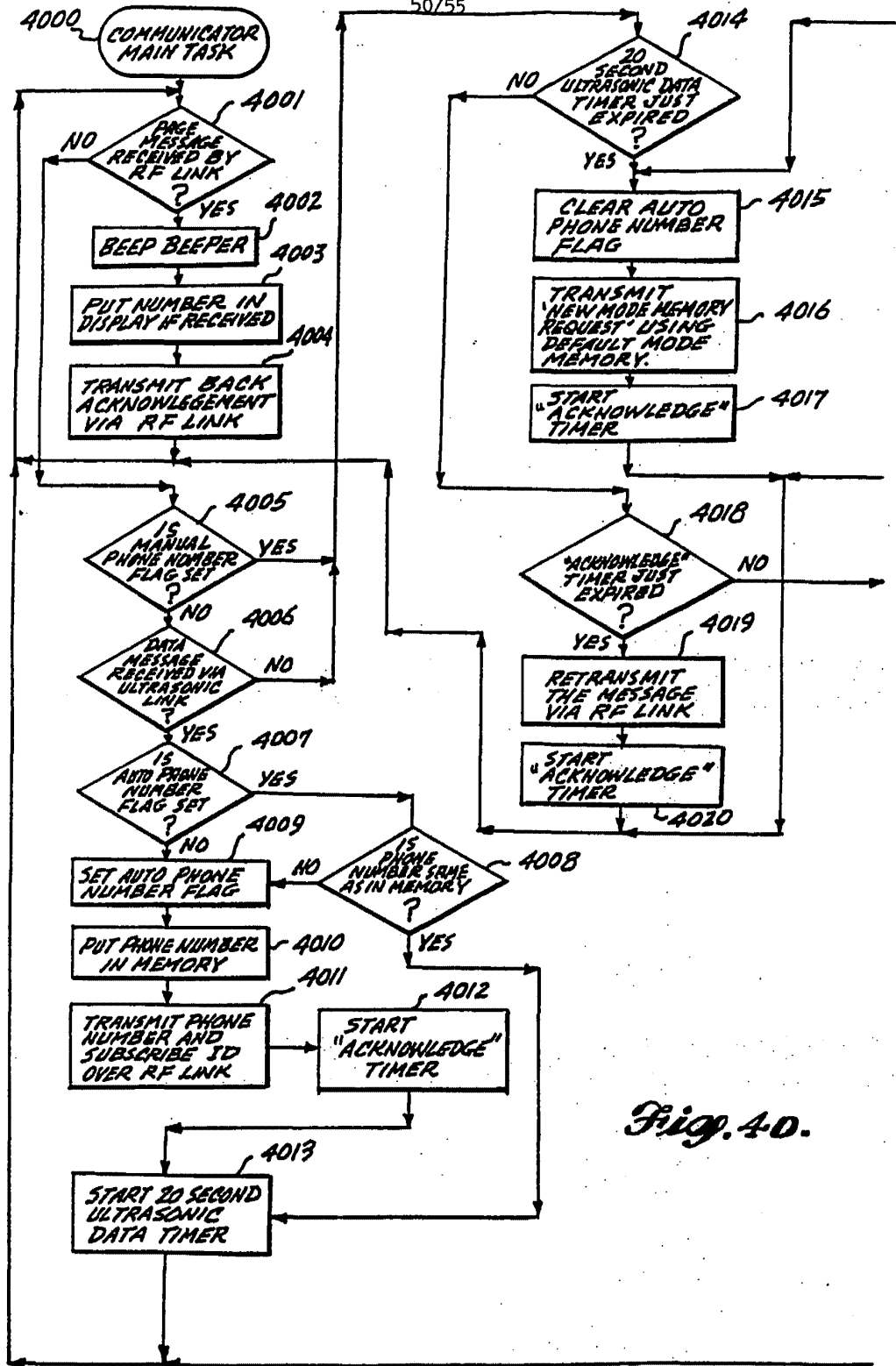

Fig. 40.

SUBSTITUTE SHEET

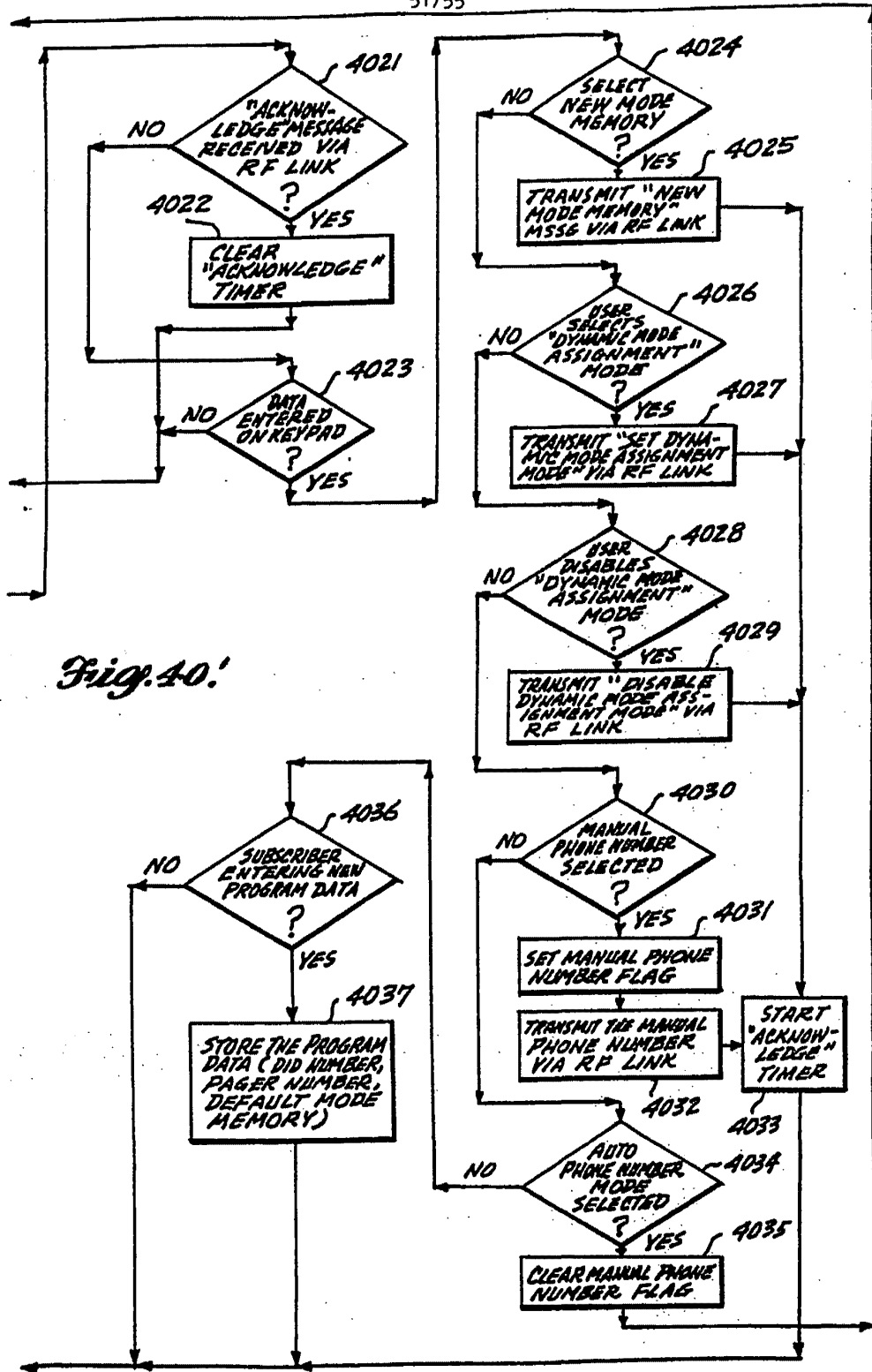

Fig. 40!

SUBSTITUTE SHEET

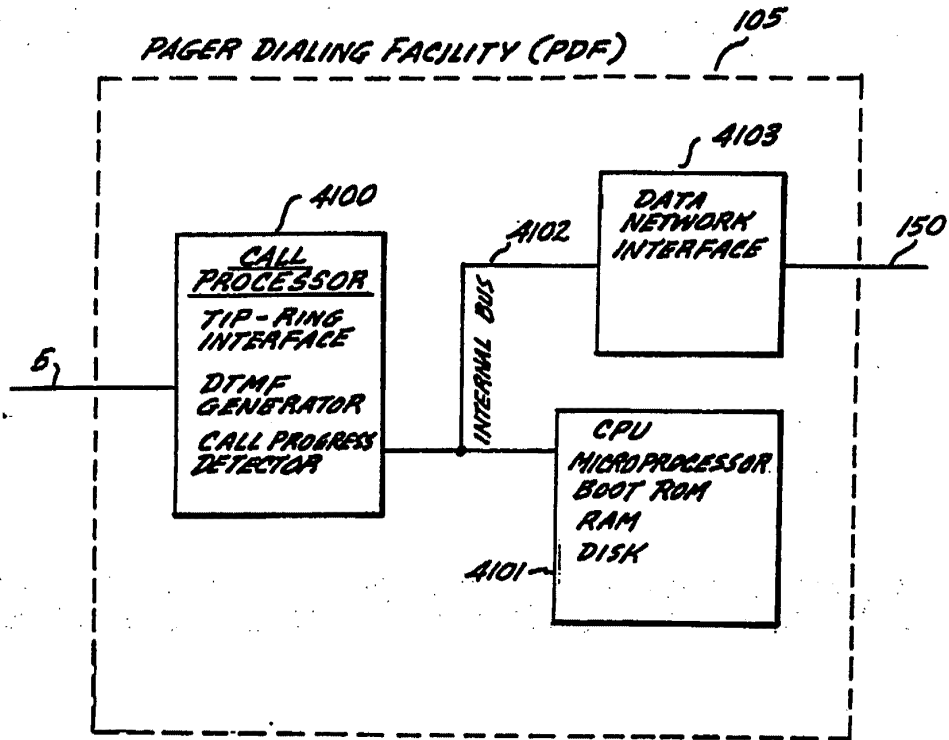
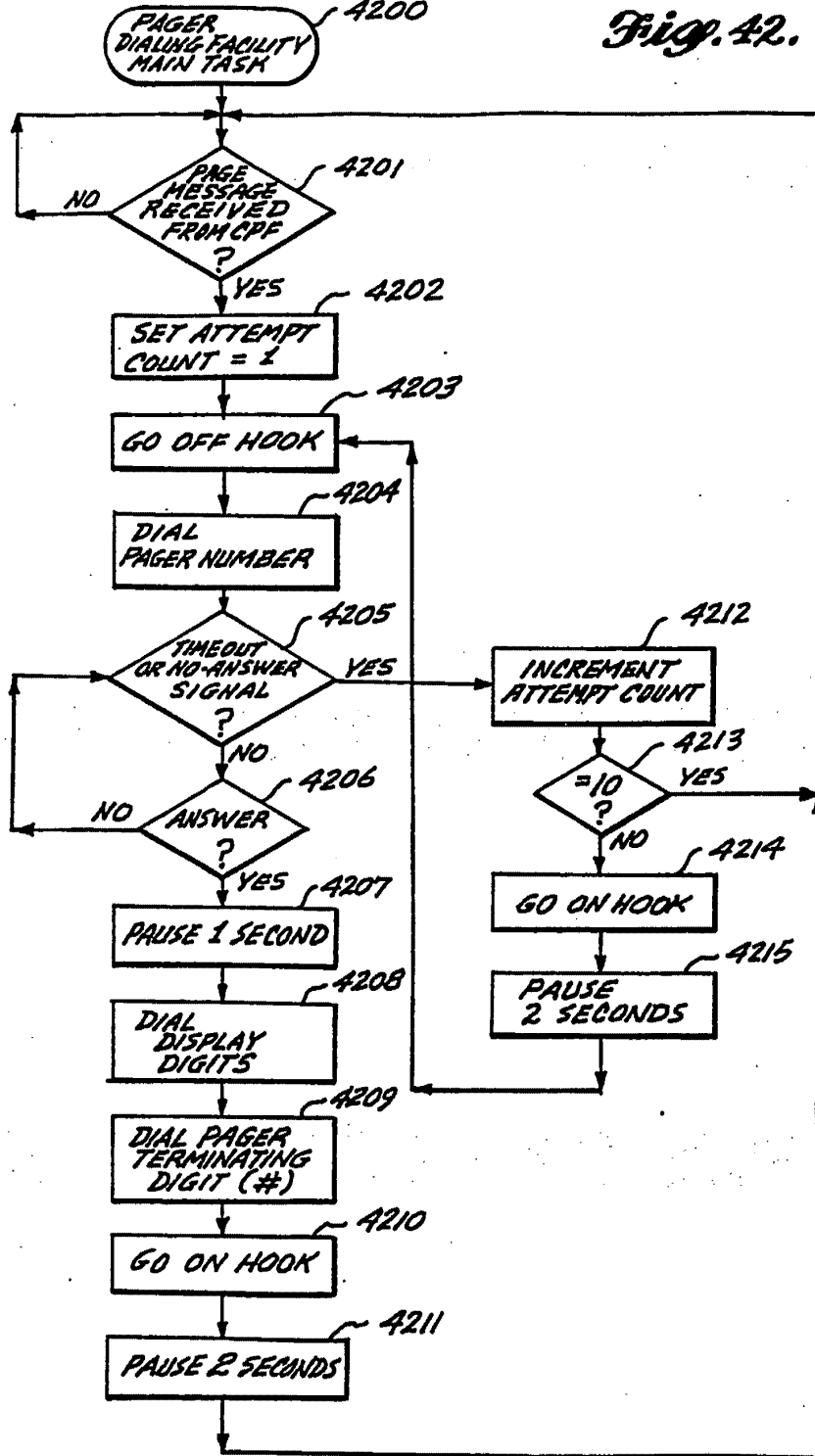

Fig. 41.

SUBSTITUTE SHEET

53/55
4200

Fig. 42.



SUBSTITUTE SHEET

Fig. 43.

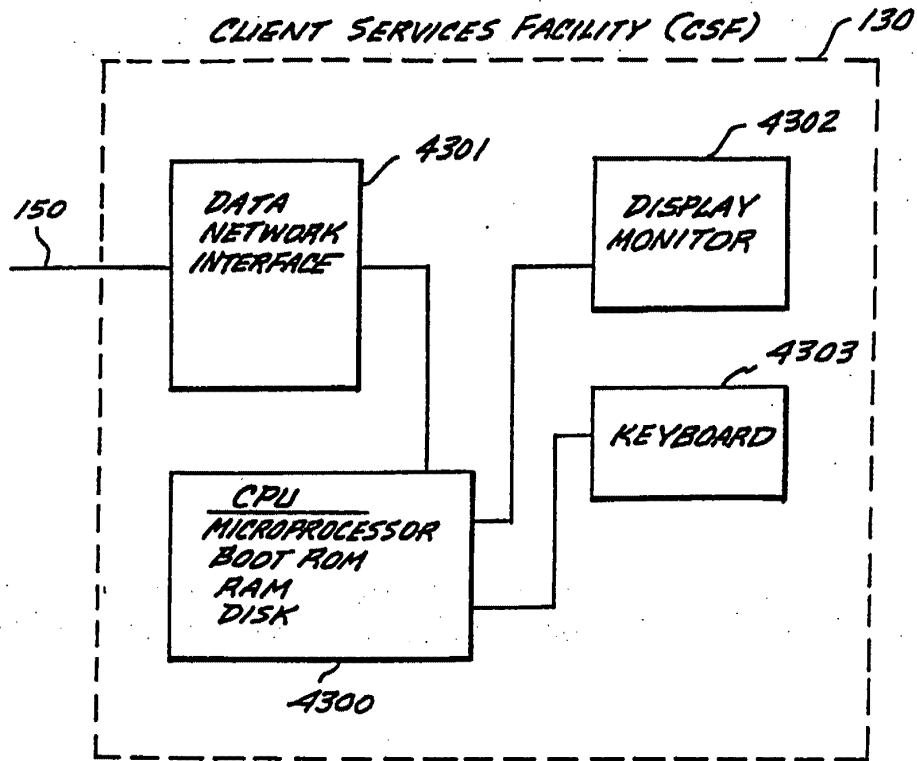

SUBSTITUTE SHEET

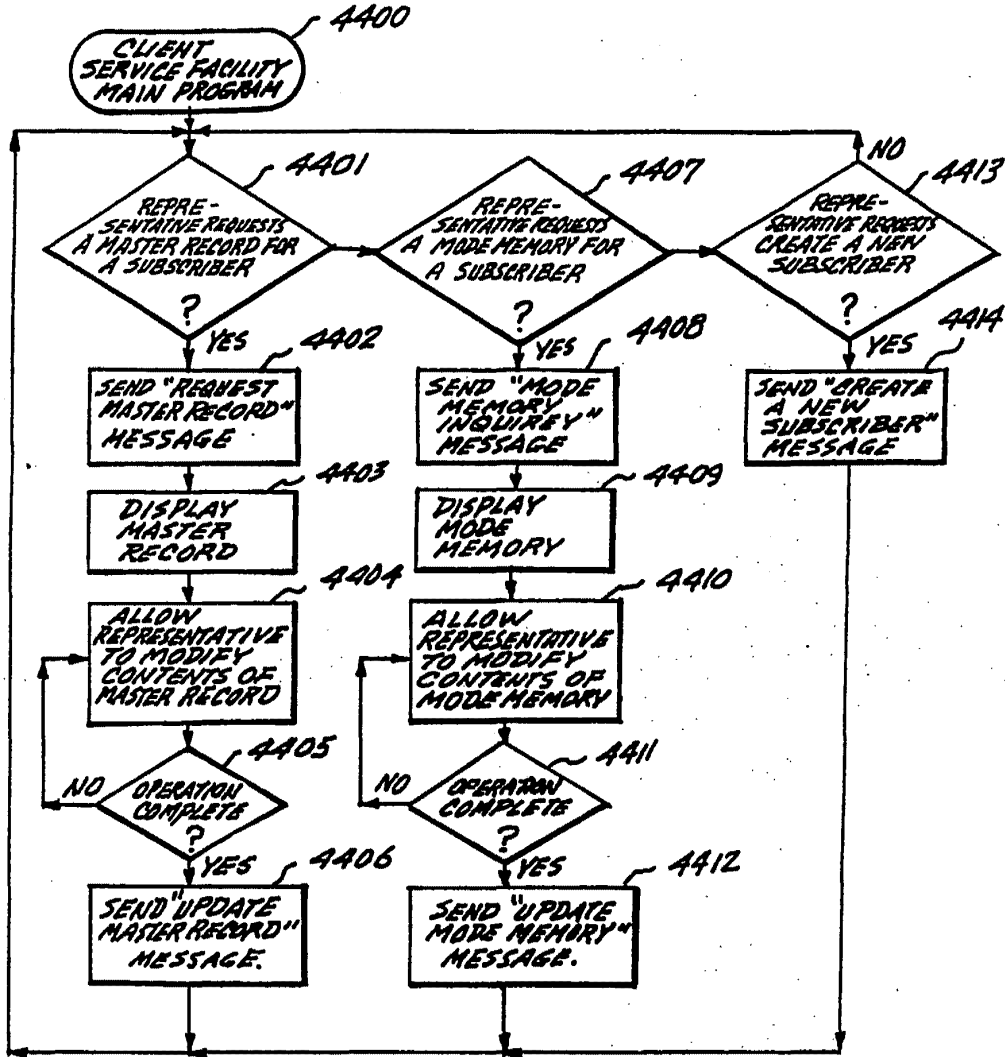
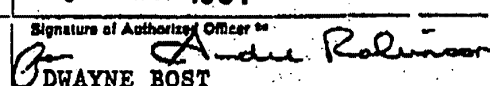

Fig. 44.

SUBSTITUTE SHEET

INTERNATIONAL SEARCH REPORT

International Application No **PCT/US90/06729**

| | | |
|------------------------------------------------------------------------------------------------------------------------------------------------------------------------------------------------------------------------------------------------------------------------------------------------------------------------------------------------------------------------------------------------------------------------------------------------------------------------------------------------------------------------------------------------------------------------------------------------------------------------------------------------------------------------------------------------------------------------------------------------------------------------------------------------------------------------------------------------------------------------------------------------------------------------------------------------------------------------------------------------------------------------------------------------------------------------------------------------------------------------------------------------------------------------------------------------------------------------------------------------------------------------------------------------------------------|---------------------------------------------------------------------------------------------------------------------------------------------------------------------------------------------------------------------------------------------------------------------|--------------------------------------|
| I. CLASSIFICATION OF SUBJECT MATTER (If several classification symbols apply, indicate all) * | | |
| According to International Patent Classification (IPC) or to both National Classification and IPC | | |
| IPC(5): HO4M 11/00, 1/64, 1/56, 1/66, 3/42 | | |
| U.S. Cl. 379/57, 88, 142, 199, 211 | | |
| II. FIELDS SEARCHED | | |
| Minimum Documentation Searched * | | |
| Classification System | Classification Symbols | |
| U.S. | 379/ 56, 57, 67, 88, 89, 142, 199, 200, 201, 210-212 | |
| Documentation Searched other than Minimum Documentation to the extent that such Documents are included in the Fields Searched * | | |
| | | |
| III. DOCUMENTS CONSIDERED TO BE RELEVANT ** | | |
| Category * | Citation of Document, 1 ^a with indication, where appropriate, of the relevant passages 1 ⁷ | Relevant to Claim No. 1 ⁴ |
| Y | US, A, 4,028,498 (Mehaffey et al.) 07 June 1977, See abstract; Fig. 1; col. 3, lines 13-18, 39-55; col. 11, lines 29-63; col. 13, lines 32-34, 48-51, 58, 59; col. 17, line 44-col. 118, line 12, 23-35. | 1-28,31-36, 38-57,65, 71-79 |
| Y | US, A, 4,313,035 (Jordan et al.) 26 January 1982, See col. 2, lines 29-39; col. 3, lines 16-31, 42-44; col. 6, lines 25-45, 60-63; col. 7, lines 15-22; col. 10, lines 1-10; col. 11, lines 43-46, line 62 through col. 12, line 25, 46-57; col. 13, lines 4-21. | 1-28,31-36, 38-48,56,57, 77-79 |
| Y | US, A, 4,625,081 (Lotito et al.) 25 November 1986, See abstract, lines 12-18; col. 3, lines 10-30, line 59 through col. 4, line 24; col. 7, lines 8-24. | 2,3,10,24-28, 31036,38-48 |
| Y | US, A, 4,674,115 (Kaleita et al.) 16 June 1987, See abstract; col. 1, lines 1-3, 27-32, 57-59; col. 2, lines 38-40; col. 5, lines 13-19; col. 6, lines 43-46; col. 10, lines 46-52. | 4-9,11-13, 49-55,71-76 |
| <p>* Special categories of cited documents:</p> <p>"A" document defining the general state of the art which is not considered to be of particular relevance</p> <p>"E" earlier document but published on or after the international filing date</p> <p>"L" document which may throw doubts on priority claim(s) or which is cited to establish the publication date of another citation or other special reason (as specified)</p> <p>"O" document referring to an oral disclosure, use, exhibition or other means</p> <p>"P" document published prior to the international filing date but later than the priority date claimed</p> <p>"T" later document published after the international filing date or priority date and not in conflict with the application but cited to understand the principle or theory underlying the invention</p> <p>"X" document of particular relevance; the claimed invention cannot be considered novel or cannot be considered to involve an inventive step</p> <p>"Y" document of particular relevance; the claimed invention cannot be considered to involve an inventive step when the document is combined with one or more other such documents, such combination being obvious to a person skilled in the art.</p> <p>"4" document member of the same patent family</p> | | |
| IV. CERTIFICATION | | |
| Date of the Actual Completion of the International Search * | Date of Mailing of this International Search Report * | |
| 28 FEBRUARY 1991 | 02 MAY 1991 | |
| International Searching Authority * | Signature of Authorized Officer ** | |
| ISA/US |  DWAYNE BOST | |

Form PCT/ISA/210 (second sheet) (May 1986)

| FURTHER INFORMATION CONTINUED FROM THE SECOND SHEET | | |
|-----------------------------------------------------|----------------------------------------------------------------------------------------------------------|---------------------------|
| Y,P | US, A, 4,893,329 (O'Brien) 09 January 1990, See abstract. | 4-9,11-13 |
| Y,P | US, A, 4,922,490 (Blakely) 01 May 1990, See Fig. 1; col. 5, lines 39-58; col. 6, lines 22-27. | 4-9,11-13, 49-55,71-76 |
| Y,P | US, A, 4,941,203 (Patsiokas et al.) 10 June 1990 See abstract. | 4-9,11-13, 49-55,71-76 |
| Y | US, A, 4,642,425 (Guinn, Jr. et al.) 10 February 1987, See abstract, col. 1, 2 and col. 3, lines 1-20 | 14-23,56,57, 77-79 |

V. OBSERVATIONS WHERE CERTAIN CLAIMS WERE FOUND UNSERCHABLE¹

This international search report has not been established in respect of certain claims under Article 17(2) (a) for the following reasons:

1. Claim numbers . . . because they relate to subject matter¹ not required to be searched by this Authority, namely:

2. Claim numbers . . . because they relate to parts of the international application that do not comply with the prescribed requirements to such an extent that no meaningful international search can be carried out¹, specifically:

3. Claim numbers . . . because they are dependent claims not drafted in accordance with the second and third sentences of PCT Rule 8.4(a).

VI. OBSERVATIONS WHERE UNITY OF INVENTION IS LACKING²

This International Searching Authority found multiple inventions in this international application as follows:

I. Claims 1-57, 65, 71-79 drawn to a telecommunication control system; class 379 subclass 201.

II. Claims 58-64, 66-70 drawn to a telephone paging system; class 379 subclass 57. SEE ATTACHMENT.

1. As all required additional search fees were timely paid by the applicant, this international search report covers all searchable claims of the international application.

2. As only some of the required additional search fees were timely paid by the applicant, this international search report covers only those claims of the international application for which fees were paid, specifically claims:

3. No required additional search fees were timely paid by the applicant. Consequently, this international search report covers only the invention first mentioned in the claims; it is covered by claim numbers:
1-57, 65, 71-79

4. As all searchable claims could be searched without effort justifying an additional fee, the International Searching Authority does not invite payment of any additional fee.

Remark on Protest

The additional search fees were accompanied by applicant's protest.

No protest accompanied the payment of additional search fees.

| III. DOCUMENTS CONSIDERED TO BE RELEVANT (CONTINUED FROM THE SECOND SHEET) | | |
|----------------------------------------------------------------------------|--------------------------------------------------------------------------------------------------------------|-----------------------------------|
| Category * | Citation of Document, ¹ with indication, where appropriate, of the relevant passages ¹ | Relevant to Claim No ¹ |
| Y | US, A, 4,748,655 (Thrower et al.) 31 May 1988 See abstract; col. 5, lines 23-35. | 14-23,77-79 |
| &P | US, A, 4,893,335 (Fuller et al.) 09 January 1990 See entire document. | |

Form PCT/ISA/210 (extra sheet) (May 1988)

DFW



PTO/SB/122 (09-03)
Approved for use through 11/30/2005. OMB 0651-0035
U.S. Patent and Trademark Office; U.S. DEPARTMENT OF COMMERCE

Under the Paperwork Reduction Act of 1995, no persons are required to respond to a collection of information unless it displays a valid OMB control number.

| | | |
|------------------------------------------------------------------------------------------------------------------------------------------------------------------------------------|------------------------|-----------------|
| <p align="center">CHANGE OF CORRESPONDENCE ADDRESS Application</p> <p>Address to: Commissioner for Patents P.O. Box 1450 Alexandria, VA 22313-1450.</p> | Application Number | 10/821,690 |
| | Filing Date | April 9, 2004 |
| | First Named Inventor | Alex Kurganov |
| | Art Unit | 2641 |
| | Examiner Name | Unknown |
| | Attorney Docket Number | 47242-00027USC1 |

Please change the Correspondence Address for the above-identified patent application to:

Customer Number :

OR

| | | | |
|-------------------------------------------------------------|-------------------------------------------------|-------|--------------|
| <input checked="" type="checkbox"/> Firm or Individual Name | Steve Z. Szczepanski - Kelley Drye & Warren LLP | | |
| Address | 333 West Wacker Drive, Suite 2600 | | |
| Address | | | |
| City | Chicago | State | IL |
| | | Zip | 60606 |
| Country | USA | | |
| Telephone | 312-857-7070 | Fax | 312-857-7095 |

This form cannot be used to change the data associated with a Customer Number. To change the data associated with an existing Customer Number use "Request for Customer Number Data Change" (PTO/SB/124).

I am the:

Applicant/Inventor

Assignee of record of the entire interest.
Statement under 37 CFR 3.73(b) is enclosed. (Form PTO/SB/96).

Attorney or Agent of record. Registration Number 27,957

Registered practitioner named in the application transmittal letter in an application without an executed oath or declaration. See 37 CFR 1.33(a)(1). Registration Number _____

Typed or Printed Name Steve Z. Szczepanski

Signature

Date July 1, 2004 Telephone 312-857-7070

NOTE: Signatures of all the inventors or assignees of record of the entire interest or their representative(s) are required. Submit multiple forms if more than one signature is required, see below*.

*Total of 1 forms are submitted.

This collection of information is required by 37 CFR 1.33. The information is required to obtain or retain a benefit by the public which is to file (and by the USPTO to process) an application. Confidentiality is governed by 35 U.S.C. 122 and 37 CFR 1.14. This collection is estimated to take 3 minutes to complete, including gathering, preparing, and submitting the completed application form to the USPTO. Time will vary depending upon the individual case. Any comments on the amount of time you require to complete this form and/or suggestions for reducing this burden, should be sent to the Chief Information Officer, U.S. Patent and Trademark Office, U.S. Department of Commerce, P.O. Box 1450, Alexandria, VA 22313-1450. DO NOT SEND FEES OR COMPLETED FORMS TO THIS ADDRESS. SEND TO: Commissioner for Patents, P.O. Box 1450, Alexandria, VA 22313-1450.

If you need assistance in completing the form, call 1-800-PTO-9199 and select option 2.

15750 U.S. PTO
040904

PTO/SB/05 (modified)

| | | |
|---------------------------------------------------------------------------------------------------------------------------------------------|------------------------|-------------------------------------------------------------------|
| UTILITY PATENT APPLICATION TRANSMITTAL <small>(Only for new nonprovisional applications under 37 CFR 1.53(b))</small> | Attorney Docket No. | 47242-00027USC1 |
| | First Inventor | Alex Kurganov |
| | Title | Robust Voice Browser System and Voice Activated Device Controller |
| | Express Mail Label No. | EV 284714429 US |

| | |
|--------------------------------------------------------------------------------------------------------------------|------------------------------------------------------------------------------------------------------------------------------|
| APPLICATION ELEMENTS <small>See MPEP chapter 600 concerning utility patent application contents.</small> | ADDRESS TO: Commissioner for Patents Mail Stop Patent Application P.O. Box 1450 Alexandria, VA 22313-1450 |
|--------------------------------------------------------------------------------------------------------------------|------------------------------------------------------------------------------------------------------------------------------|

| | |
|----------------------------------------------------------------------------------------------------------------------------------------------------------------------------------------------------------------------------------------------------------------------------------------------------------------------------------------------------------------------------------------------------------------------------------------------------------------------------------------------------------------------------------------------------------------------------------------------------------------------------------------------------------------------------------------------------------------------------------------------------------------------------------------------------------------------------------------------------------------------------------------------------------------------------------------------------------------------------------------------------------------------------------------------------------------------------------------------------------------------------------------------------------------------------------------------------------------------------------------------------------------------------------------------------------------------------------------------------------------------------------------------------------------------------------------------------------------------------|-----------------------------------------------------------------------------------------------------------------------------------------------------------------------------------------------------------------------------------------------------------------------------------------------------------------------------------------------------------------------------------------------------------------------------------------------------------------------------|
| 1. <input checked="" type="checkbox"/> Fee Transmittal Form (e.g., PTO/SB/17) <small>(Submit an original, and a duplicate for fee processing)</small> 2. <input checked="" type="checkbox"/> Applicant claims small entity status. <small>See 37 CFR 1.27.</small> 3. <input checked="" type="checkbox"/> Specification [Total Pages 34] <small>(preferred arrangement set forth below)</small> - Descriptive title of the Invention - Cross References to Related Applications - Statement Regarding Fed sponsored R & D - Reference to sequence listing, a table, or a computer program listing appendix - Background of the Invention - Brief Summary of the Invention - Brief Description of the Drawings (if filed) - Detailed Description - Claim(s) - Abstract of the Disclosure 4. <input checked="" type="checkbox"/> Drawing(s) (35 USC 113) [Total Sheets 4] 5. Oath or Declaration [Total Sheets 4] a. <input type="checkbox"/> Newly executed (original or copy) b. <input checked="" type="checkbox"/> Copy from a prior application (37 CFR 1.63(d)) <small>(for continuation/divisional with Box 18 completed)</small> i. <input type="checkbox"/> DELETION OF INVENTOR(S) <small>Signed statement attached deleting inventor(s) name in the prior application, see 37 CFR 1.63(d)(2) and 1.33(b).</small> 6. <input type="checkbox"/> Application Data Sheet. See 37 CFR 1.76 | 7. <input type="checkbox"/> CD-ROM or CD-R in duplicate, large table or Computer Program (Appendix) 8. Nucleotide and/or Amino Acid Sequence Submission (if applicable, all necessary) a. <input type="checkbox"/> Computer Reader Form (CRF) b. Specification Sequency Listing on: i. <input type="checkbox"/> CD ROM or CD-R (2 copies); or ii. <input type="checkbox"/> Paper c. <input type="checkbox"/> Statement verifying identity of above copies |
|----------------------------------------------------------------------------------------------------------------------------------------------------------------------------------------------------------------------------------------------------------------------------------------------------------------------------------------------------------------------------------------------------------------------------------------------------------------------------------------------------------------------------------------------------------------------------------------------------------------------------------------------------------------------------------------------------------------------------------------------------------------------------------------------------------------------------------------------------------------------------------------------------------------------------------------------------------------------------------------------------------------------------------------------------------------------------------------------------------------------------------------------------------------------------------------------------------------------------------------------------------------------------------------------------------------------------------------------------------------------------------------------------------------------------------------------------------------------------|-----------------------------------------------------------------------------------------------------------------------------------------------------------------------------------------------------------------------------------------------------------------------------------------------------------------------------------------------------------------------------------------------------------------------------------------------------------------------------|

| ACCOMPANYING APPLICATION PARTS | |
|-----------------------------------------------------------------------------------------------------------------------------------------------|--------------------------------------------------|
| 9. <input type="checkbox"/> Assignment Papers (cover sheet & document(s)) | |
| 10. <input type="checkbox"/> 37 CFR 3.73(b) Statement (when there is an assignee) | <input type="checkbox"/> Power of Attorney |
| 11. <input type="checkbox"/> English Translation Document (if applicable) | |
| 12. <input type="checkbox"/> Information Disclosure Statement (IDS)/PTO-1449 | <input type="checkbox"/> Copies of IDS Citations |
| 13. <input type="checkbox"/> Preliminary Amendment | |
| 14. <input type="checkbox"/> Return Receipt Postcard (MPEP 503) (Should be specifically itemized) | |
| 15. <input type="checkbox"/> Certified Copy of Priority Document(s) (if foreign priority is claimed) | |
| 16. <input type="checkbox"/> Nonpublication Request under 35 U.S.C. 122 (b)(2)(B)(i). Applicant must attach form PTO/SB/33 or its equivalent. | |
| 17. <input checked="" type="checkbox"/> Other: Check for \$335.00 | |

18. If a CONTINUING APPLICATION, check appropriate box and supply the requisite information below and in the first sentence of the specification following the title, or in an Application Data Sheet under 37 CFR 1.76:

Continuation Divisional Continuation-in-part (CIP) of prior application No.: 09/776,996

Prior application information: Examiner Susan McFadden Art Unit: 2641

For CONTINUATION OF DIVISIONAL APPS only; The entire disclosure of the prior application, from which an oath or declaration is supplied under Box 5b, is considered a part of the disclosure of the accompanying continuation or divisional application and is hereby incorporated by reference. The incorporation can only be relied upon when a portion has been inadvertently omitted from the submitted application parts.

19. CORRESPONDENCE ADDRESS

Customer Number or Bar Code Label **30223** OR Correspondence address below
(Insert Customer No. or Attach bar code label here)

| | | | |
|-------------------|---------------------------------------------------------------|-----------------------------------|------------------|
| Name | Russell J. Genet | | |
| Address | Jenkins & Gilchrist 225 West Washington Street, Suite 2600 | | |
| City | Chicago | State | IL |
| Country | USA | Zip Code | 60606-3418 |
| | Telephone | 312 425-8516 | Fax 312 425-3909 |
| Name (Print/Type) | Russell J. Genet | Registration No. (Attorney/Agent) | 42,571 |
| Signature | <i>Russell J. Genet</i> | Date | April 9, 2004 |

This collection of information is required by 37 CFR 1.53(b). The information is required to obtain or retain a benefit by the public which is to file (and by the USPTO to process) an application. Confidentiality is governed by 35 U.S.C. 122 and 37 CFR 1.14. This collection is estimated to take 12 minutes to complete, including gathering, preparing, and submitting the completed application form to the USPTO. Time will vary depending upon the individual case. Any comments on the amount of time you require to complete this form and/or suggestions for reducing this burden, should be sent to the Chief Information Officer, U.S. Patent and Trademark Office, U.S. Department of Commerce, P.O. Box 1450, Alexandria, VA 22313-1450. DO NOT SEND FEES OR COMPLETED FORMS TO THIS ADDRESS. SEND TO: Mail Stop Patent Application, Commissioner for Patents, P.O. Box 1450, Alexandria, VA 22313-1450.

If you need assistance in completing the form, call 1-800-PTO-9199 and select option 2.

FEE TRANSMITTAL for FY 2004

Effective 01/01/2003. Patent fees are subject to annual revision.

Applicant claims small entity status. See 37 CFR 1.27

TOTAL AMOUNT OF PAYMENT (\$) 385.00

Complete if Known

| | |
|----------------------|-----------------|
| Application Number | Unknown |
| Filing Date | April 9, 2004 |
| First Named Inventor | Alex Kurganov |
| Examiner Name | Unknown |
| Art Unit | Unknown |
| Attorney Docket No. | 47242-00027USC1 |

METHOD OF PAYMENT (check all that apply)

Check Credit card Money Order Other None

Deposit Account:

Deposit Account Number

10-0447/47242-00027USC1

Deposit Account Name

Jenkins & Gilchrist

The Commissioner is authorized to: (check all that apply)

Charge fee(s) indicated below Credit any overpayments
 Charge any additional fee(s) during the pendency of this application
 Charge fee(s) indicated below, except for the filing fee to the above-identified deposit account.

FEE CALCULATION

1. BASIC FILING FEE

| Large Entity | | Small Entity | | Fee Description | Fee Paid |
|---------------------|----------|--------------|----------|------------------------|--------------------|
| Fee Code | Fee (\$) | Fee Code | Fee (\$) | | |
| 1001 | 770 | 2001 | 385 | Utility filing fee | 385.00 |
| 1002 | 340 | 2002 | 170 | Design filing fee | |
| 1003 | 530 | 2003 | 265 | Plant filing fee | |
| 1004 | 770 | 2004 | 385 | Reissue filing fee | |
| 1005 | 160 | 2005 | 80 | Provisional filing fee | |
| SUBTOTAL (1) | | | | | (\$) 385.00 |

2. EXTRA CLAIM FEES FOR UTILITY AND REISSUE

| | Extra Claims | Fee from below | Fee Paid |
|--------------------|--------------|----------------|----------|
| Total Claims | 17 | - 20** = | 0.00 |
| Independent Claims | 1 | - 3** = | 0.00 |
| Multiple Dependent | | | |

| Large Entity | | Small Entity | | Fee Description | Fee Paid |
|---------------------|----------|--------------|----------|------------------------------------------------------------|------------------|
| Fee Code | Fee (\$) | Fee Code | Fee (\$) | | |
| 1202 | 18 | 2202 | 9 | Claims in excess of 20 | |
| 1201 | 86 | 2201 | 43 | Independent claims in excess of 3 | |
| 1203 | 290 | 2203 | 145 | Multiple dependent claim, if not paid | |
| 1204 | 86 | 2204 | 43 | ** Reissue independent claims over original patent | |
| 1205 | 18 | 2205 | 9 | ** Reissue claims in excess of 20 and over original patent | |
| SUBTOTAL (2) | | | | | (\$) 0.00 |

**or number previously paid, if greater; For Reissues, see above

FEE CALCULATION (continued)

3. ADDITIONAL FEES

| Large Entity | | Small Entity | | Fee Description | Fee Paid |
|------------------------------------|----------|--------------|----------|----------------------------------------------------------------------------|--------------------------|
| Fee Code | Fee (\$) | Fee Code | Fee (\$) | | |
| 1051 | 130 | 2051 | 65 | Surcharge - late filing fee or oath | |
| 1052 | 50 | 2052 | 25 | Surcharge - late provisional filing fee or cover sheet. | |
| 1053 | 130 | 1053 | 130 | Non-English specification | |
| 1812 | 2,520 | 1812 | 2,520 | For filing a request for <i>ex parte</i> reexamination | |
| 1804 | 920* | 1804 | 920* | Requesting publication of SIR prior to Examiner action | |
| 1805 | 1,840* | 1805 | 1,840* | Requesting publication of SIR after Examiner action | |
| 1251 | 110 | 2251 | 55 | Extension for reply within first month | |
| 1252 | 420 | 2252 | 210 | Extension for reply within second month | |
| 1253 | 950 | 2253 | 475 | Extension for reply within third month | |
| 1254 | 1,480 | 2254 | 740 | Extension for reply within fourth month | |
| 1255 | 2,010 | 2255 | 1,005 | Extension for reply within fifth month | |
| 1401 | 330 | 2401 | 165 | Notice of Appeal | |
| 1402 | 330 | 2402 | 165 | Filing a brief in support of an appeal | |
| 1403 | 290 | 2403 | 145 | Request for oral hearing | |
| 1451 | 1,510 | 1451 | 1,510 | Petition to institute a public use proceeding | |
| 1452 | 110 | 2452 | 55 | Petition to revive - unavoidable | |
| 1453 | 1,330 | 2453 | 665 | Petition to revive - unintentional | |
| 1501 | 1,330 | 2501 | 665 | Utility issue fee (or reissue) | |
| 1502 | 480 | 2502 | 240 | Design issue fee | |
| 1503 | 640 | 2503 | 320 | Plant issue fee | |
| 1460 | 130 | 1460 | 130 | Petitions to the Commissioner | |
| 1807 | 50 | 1807 | 50 | Processing fee under 37 CFR 1.17(q) | |
| 1806 | 180 | 1806 | 180 | Submission of Information Disclosure Stmt | |
| 8021 | 40 | 8021 | 40 | Recording each patent assignment per property (times number of properties) | |
| 1809 | 770 | 2809 | 385 | Filing a submission after final rejection (37 CFR 1.129(a)) | |
| 1810 | 770 | 2810 | 385 | For each additional invention to be examined (37 CFR 1.129(b)) | |
| 1801 | 770 | 2801 | 385 | Request for Continued Examination (RCE) | |
| 1802 | 900 | 1802 | 900 | Request for expedited examination of a design application | |
| Other fee (specify) _____ | | | | | |
| * Reduced by Basic Filing Fee Paid | | | | | SUBTOTAL (3) (\$) |

SUBMITTED BY

| | | | | | |
|-------------------|-------------------------------------------------------------------------------------|-----------------------------------|---------------|-----------|--------------|
| Name (Print/Type) | Russell J. Genet | Registration No. (Attorney/Agent) | 42,571 | Telephone | 312/425-8516 |
| Signature |  | Date | APRIL 9, 2004 | | |

WARNING: Information on this form may become public. Credit card information should not be included on this form. Provide credit card information and authorization on PTO-2038.

This collection of information is required by 37 CFR 1.17 and 1.27. The information is required to obtain or retain a benefit by the public which is to file (and by the USPTO to process) an application. Confidentiality is governed by 35 U.S.C. 122 and 37 CFR 1.14. This collection is estimated to take 12 minutes to complete, including gathering, preparing, and submitting the completed application form to the USPTO. Time will vary depending upon the individual case. Any comments on the amount of time you require to complete this form and/or suggestions for reducing this burden, should be sent to the Chief Information Officer, U.S. Patent and Trademark Office, U.S. Department of Commerce, P.O. Box 1450, Alexandria, VA 22313-1450. DO NOT SEND FEES OR COMPLETED FORMS TO THIS ADDRESS. SEND TO: Commissioner for Patents, P.O. Box 1450, Alexandria, VA 22313-1450.

If you need assistance in completing the form, call 1-800-PTO-9199 and select option 2.

Patent Application
Docket No.: 47242-00027USC1
Customer Number 30223

APPLICATION FOR UNITED STATES LETTERS PATENT

for

ROBUST VOICE BROWSER SYSTEM AND
VOICE ACTIVATED DEVICE CONTROLLER

INVENTORS:

Alexander Kurganov

Valery Zhukoff

| EXPRESS MAIL MAILING LABEL | |
|-------------------------------------------------------------------------------------------------------------------------------------------------------------------------------------------------------------------------------------------------------------------------------------------------------------------|-----------------|
| NUMBER: | EV 284714429 US |
| DATE: | April 9, 2004 |
| I hereby certify that this paper or fee is being deposited with the United States Postal Service "EXPRESS MAIL POST OFFICE TO ADDRESSEE" service under 37 C.F.R. 1.10 on the date indicated above and is addressed to: MS Patent Application, Commissioner for Patents, P.O. Box 1450, Alexandria, VA 22313-1450. | |
| <i>Maureen Hammonds</i> | |

**ROBUST VOICE BROWSER SYSTEM AND
VOICE ACTIVATED DEVICE CONTROLLER**

CROSS-REFERENCE TO RELATED APPLICATIONS

[001] This application is a continuation of U.S. Patent Application No. 09/776,996, filed February 5, 2001, now allowed, which claims priority to U.S. Provisional Application Serial No. 60/180,344, filed February 4, 2000 entitled "Voice-Activated Information Retrieval System" and U.S. Provisional Application Serial No. 60/233,068, filed September 15, 2000 entitled "Robust Voice Browser System and Voice Activated Device Controller" and these applications are incorporated by reference in their entirety into the present application.

FIELD OF THE INVENTION

[002] The present invention relates to a robust and highly reliable system that allows users to browse web sites and retrieve information by using conversational voice commands. Additionally, the present invention allows users to control and monitor other systems and devices that are connected the Internet or any other network by using voice commands.

BACKGROUND OF THE INVENTION

[003] Currently, three options exist for a user who wishes to gather information from a web site accessible over the Internet. The first option is to use a desktop or a laptop computer connected to a telephone line via a modem or connected to a network with Internet access. The second option is to use a Personal Digital Assistant (PDA) that has the capability of connecting to the Internet either through a modem or a wireless connection. The third option is to use one of the newly designed web-phones or web-pagers that are now being offered on the market. Although each of these options provide a user with access to the Internet to browse web sites, each of them have their own drawbacks.

[004] Desktop computers are very large and bulky and are difficult to transport. Laptop computers solve this inconvenience, but many are still quite heavy and are inconvenient to carry. Further, laptop computers cannot be carried and used everywhere a user travels. For instance, if a user wishes to obtain information from a remote location where no electricity or communication lines are installed, it would be nearly impossible to use a laptop computer. Oftentimes, information is needed on an immediate basis where a computer is

not accessible. Furthermore, the use of laptop or desktop computers to access the Internet requires either a direct or a dial-up connection tan an Internet Service Provider (ISP). Oftentimes, such connections are not available when a user desires to connect to the Internet to acquire information.

[005] The second option for remotely accessing web sites is the use of PDAs. These devices also have their own set of drawbacks. First, PDAs with the ability to connect to the Internet and access web sites are not readily available. As a result, these PDAs tend to be very expensive. Furthermore, users are usually required to pay a special service fee to enable the web browsing feature of the PDA. A further disadvantage of these PDAs is that web sites must be specifically designed to allow these devices to access information on the web site. Therefore, a limited number of web sites are available that are accessible by these web-enabled PDAs. Finally, it is very common today for users to carry cell phones, however, users must also carry a separate PDA if they require the ability to gather information from various web sites. Users are therefore subjected to added expenses since they must pay for both cellular telephone service and also for the web-enabling service for the PDA. This results in a very expensive alternative for the consumer.

[006] The third alternative mentioned above is the use of web-phones or web-pagers. These devices suffer many of the same drawbacks as PDAs. First, these devices are expensive to purchase. Further, the number of web sites accessible to these devices is limited since web sites must be specifically designed to allow access by these devices. Furthermore, users are often required to pay an additional fee in order to gain wireless web access. Again, this service is expensive. Another drawback of these web-phones or web-pagers is that as technology develops, the methods used by the various web sites to allow access by these devices may change. These changes may require users to purchase new web-phones or web-pagers or have the current device serviced in order to upgrade the firmware or operating system stored within the device. At the least, this would be inconvenient to users and may actually be quite expensive.

[007] Therefore, a need exists for a system that allows users to easily access and browse the Internet from any location. Such a system would only require users to have access to any type of telephone and would not require users to subscribe to multiple services.

[008] In the rapidly changing area of Internet applications, web sites change frequently. The design of the web site may change, the information required by the web site in order to

perform searches may change, and the method of reporting search results may change. Web browsing applications that submit search requests and interpret responses from these web sites based upon expected formats will produce errors and useless responses when such changes occur. Therefore, a need exists for a system that can detect modifications to web sites and adapt to such changes in order to quickly and accurately provide the information requested by a user through a voice enabled device, such as a telephone.

[009] When users access web sites using devices such as personal computers, delays in receiving responses are tolerated and are even expected, however, such delays are not expected when a user communicates with a telephone. Users expect communications over a telephone to occur immediately with a minimal amount of delay time. A user attempting to find information using a telephone expects immediate responses to his search requests. A system that introduces too much delay between the time a user makes a request and the time of response will not be tolerated by users and will lose its usefulness. Therefore, it is important that a voice browsing system that uses telephonic communications selects web sites that provide rapid responses since speed is an important factor for maintaining the system's desirability and usability. Therefore, a need exists for a system that accesses web sites based upon their speed of operation.

SUMMARY OF THE INVENTION

[0010] It is an object of an embodiment of the present invention to allow users to gather information from web sites by using voice enabled devices, such as wireline or wireless telephones.

[0011] An additional object of an embodiment of the present invention is to provide a system and method that allows the searching and retrieving of publicly available information by controlling a web browsing server using naturally spoken voice commands.

[0012] It is an object of another embodiment of the present invention to provide a robust voice browsing system that can obtain the same information from several web sites based upon a ranking order. The ranking order is automatically adjusted if the system detects that a given web site is not functioning, is too slow, or has been modified in such a way that the requested information cannot be retrieved any longer.

[0013] A still further object of an embodiment of the present invention is to allow users to gather information from web sites from any location where a telephonic connection can be

made.

[0014] Another object of an embodiment of the present invention is to allow users to browse web sites on the Internet using conversational voice commands spoken into wireless or wireline telephones or other voice enabled devices.

[0015] An additional object of an embodiment of the present invention is to provide a system and method for using voice commands to control and monitor devices connected to a network.

[0016] It is an object of an embodiment of the present invention to provide a system and method which allows devices connected to a network to be controlled by conversational voice commands spoken into any voice enabled device interconnected with the same network.

[0017] The present invention relates to a system for acquiring information from sources on a network, such as the Internet. A voice browsing system maintains a database containing a list of information sources, such as web sites, connected to a network. Each of the information sources is assigned a rank number which is listed in the database along with the record for the information source. In response to a speech command received from a user, a network interface system accesses the information source with the highest rank number in order to retrieve information requested by the user.

[0018] In a preferred embodiment of the present invention allows users to access and browse web sites when they do not have access to computers with Internet access. This is accomplished by providing a voice browsing system and method that allows users to browse web sites using conversational voice commands spoken into any type of voice enabled device (i.e., any type of wireline or wireless telephone, IP phone, wireless PDA, or other wireless device). These spoken commands are then converted into data messages by a speech recognition software engine running on a user interface system. These data messages are then sent to and processed by a network interface system. This network interface system then generates the proper requests that are transmitted to the desired web site over the Internet. Responses sent from the web site are received and processed by the network interface system and then converted into an audio message via a speech synthesis engine or a pre-recorded audio concatenation application and finally transmitted to the user's voice enabled device.

[0019] A preferred embodiment of the voice browser system and method uses a web site

polling and ranking methodology that allows the system to detect changes in web sites and adapt to those changes in real-time. This enables the voice browser system of a preferred embodiment to deliver highly reliable information to users over any voice enabled device. This ranking system also enables the present invention to provide rapid responses to user requests. Long delays before receiving responses to requests are not tolerated by users of voice-based systems, such as telephones. When a user speaks into a telephone, an almost immediate response is expected. This expectation does not exist for non-voice communications, such as email transmissions or accessing a web site using a personal computer. In such situations, a reasonable amount of transmission delay is acceptable. The ranking system of implemented by a preferred embodiment of the present invention ensures users will always receive the fastest possible response to their request.

[0020] An alternative embodiment of the present invention allows users to control and monitor the operation of a variety of household devices connected to a network using speech commands spoken into a voice enabled device.

BRIEF DESCRIPTION OF THE DRAWINGS

[0021] FIG. 1 is a depiction of the voice browsing system of the first embodiment of the present invention;

[0022] FIG. 2 is a block diagram of a database record used by the first preferred embodiment of the present invention;

[0023] FIG. 3 is a block diagram of a media server used by the preferred embodiment;

[0024] FIG. 4 is a block diagram of a web browsing server used by the preferred embodiment; and

[0025] FIG. 5 is a depiction of the device browsing system of the second embodiment of the present invention.

DETAILED DESCRIPTION OF THE PREFERRED EMBODIMENT

[0026] A first embodiment of the present invention is a system and method for allowing users to browse information sources, such as web sites, by using naturally spoken, conversational voice commands spoken into a voice enabled device. Users are not required to learn a

special language or command set in order to communicate with the voice browsing system of the present invention. Common and ordinary commands and phrases are all that is required for a user to operate the voice browsing system. The voice browsing system recognizes naturally spoken voice commands and is speaker-independent; it does not have to be trained to recognize the voice patterns of each individual user. Such speech recognition systems use phonemes to recognize spoken words and not predefined voice patterns.

[0027] The first embodiment allows users to select from various categories of information and to search those categories for desired data by using conversational voice commands. The voice browsing system of the first preferred embodiment includes a user interface system referred to as a media server. The media server contains a speech recognition software engine. This speech recognition engine is used to recognize natural, conversational voice commands spoken by the user and converts them into data messages based on the available recognition grammar. These data messages are then sent to a network interface system. In the first preferred embodiment, the network interface system is referred to as a web browsing server. The web browsing server then accesses the appropriate information source, such as a web site, to gather information requested by the user.

[0028] Responses received from the information sources are then transferred to the media server where speech synthesis engine converts the responses into audio messages that are transmitted to the user. A more detailed description of this embodiment will now be provided.

[0029] Referring to FIG. 1, a database 100 designed by Webley Systems Incorporated is connected to one or more web browsing servers 102 as well as to one or more media servers 106. The database may store information on magnetic media, such as a hard disk drive, or it may store information via other widely acceptable methods for storing data, such as optical disks. The database 100 contains a separate set of records for each web site accessible by the system. An example of a web site record is shown in FIG. 2. Each web site record 200 contains the rank number of the web site 202, the associated Uniform Resource Locator (URL) 204, and a command that enables the appropriate "extraction agent" 206 that is required in order to generate proper requests sent to and to format data received from the web site. The database record 200 also contains the timestamp 208

indicating the last time the web site was accessed. The extraction agent is described in more detail below. The database 100 categorizes each database record 200 according to the type of information provided by each web site. For instance, a first category of database records 200 may correspond to web sites that provide "weather" information. The database 100 may also contain a second category of records 200 for web sites that provide "stock" information. These categories may be further divided into subcategories. For instance, the "weather" category may contain subcategories depending upon type of weather information available to a user, such as "current weather" or "extended forecast". Within the "extended forecast" subcategory, a list of web site records may be stored that provide weather information for multiple days. The use of subcategories may allow the web browsing feature to provide more accurate, relevant, and up-to-date information to the user by accessing the most relevant web site. The number of records contained in each category or subcategory is not limited. In the preferred embodiment, three web site records are provided for each category.

[0030] Table 1 below depicts two database records 200 that are used with the preferred embodiment. These records also contain a field indicating the "category" of the record, which is "weather" in each of these examples.

TABLE 1

```
category: weather
URL: URL=http://cgi.cnn.com/cgi-
bin/weather/redirect?zip=_zip
rank: 1
command: web_dispatch.pl weather_cnn
browsingServer: wportal1
browsingServerBackup: wportal2
dateTime: Dec 21 2000 2:15PM
```

```
category: weather
URL: URL=http://weather.lycos.com/wcfiveday.asp?city=zip
rank: 2
command: web_dispatch.pl weather_lycos
browsingServer: wportal1
browsingServerBackup: wportal2
dateTime: Dec 21 2000 1:45PM
```

[0031] The database also contains a listing of pre-recorded audio files used to create

concatenated phrases and sentences. Further, database 100 may contain customer profile information, system activity reports, and any other data or software servers necessary for the testing or administration of the voice browsing system.

[0032] The operation of the media servers 106 will now be discussed in relation to FIG. 3. The media servers 106 function as user interface systems. In the preferred embodiment, the media servers 106 contain a speech recognition engine 300, a speech synthesis engine 302, an Interactive Voice Response (IVR) application 304, a call processing system 306, and telephony and voice hardware 308 required to communicate with the Public Switched Telephone Network (PSTN) 116. In the preferred embodiment, each media server is based upon Intel's Dual Pentium III 730 MHz microprocessor system.

[0033] The speech recognition function is performed by a speech recognition engine 300 that converts voice commands received from the user's voice enabled device 112 (i.e., any type of wireline or wireless telephone, Internet Protocol (IP) phones, or other special wireless units) into data messages. In the preferred embodiment, voice commands and audio messages are transmitted using the PSTN 116 and data is transmitted using the TCP/IP communications protocol. However, one skilled in the art would recognize that other transmission protocols may be used for either voice or data. Other possible transmission protocols would include SIP/VoIP (Session Initiation Protocol/Voice over IP), Asynchronous Transfer Mode (ATM) and Frame Relay. A preferred speech recognition engine is developed by Nuance Communications of 1380 Willow Road, Menlo Park, California 94025 (www.nuance.com). The Nuance engine capacity is measured in recognition units based on CPU type as defined in the vendor specification. The natural speech recognition grammars (i.e., what a user can say that will be recognized by the speech recognition engine) were developed by Webley Systems.

[0034] Table 2 below provides a partial source code listing of the recognition grammars used by the speech recognition engine of the preferred embodiment for obtaining weather information.

TABLE 2

```
?WHAT_IS ?the weather ?[info information report conditions]
      ? ( (?like in )
      [
```

UScities:n

```

{<param1 $n.zip> <param2 $n.city> <param3
$n.state>}
( (area code) AREA_CODE:n ) {<param1 $n>}
( AREA_CODE:n (area code) ) {<param1 $n>}
( (zip ?code) ZIP_CODE:n ) {<param1 $n>}
( ZIP_CODE:n (zip ?code) ) {<param1 $n>}
]
)

```

) {<menu 194>}

[0035] The media server 106 uses recognition results generated by the speech recognition engine 300 to retrieve a web site record 200 stored in the database 100 that can provide the information requested by the user. The media server 106 processes the recognition result data identifying keywords that are used to search the web site records 200 contained in the database 100. For instance, if the user's request was "What is the weather in Chicago?", the keywords "weather" and "Chicago" would be recognized. A web site record 200 with the highest rank number from the "weather" category within the database 100 would then be selected and transmitted to the web browsing server 102 along with an identifier indicating that Chicago weather is being requested.

[0036] The media servers 106 also contain a speech synthesis engine 302 that converts the data retrieved by the web browsing servers 102 into audio messages that are transmitted to the user's voice enabled device 112. A preferred speech synthesis engine is developed by Lernout and Hauspie Speech Products, 52 Third Avenue, Burlington, Massachusetts 01803 (www.lhsl.com).

[0037] A further description of the web browsing server 102 will be provided in relation to FIG. 4. The web browsing servers 102 provide access to any computer network such as the Internet 110. These servers are also capable of accessing databases stored on Local Area Networks (LANs) or Wide Area Networks (WANs). The web browsing servers receive responses from web sites and extract the data requested by the user. This task is also known as "content extraction." The web browsing servers 102 also perform the task of periodically polling or "pinging" various web sites and modifying the ranking numbers of these web sites depending upon their response and speed. This polling feature is further discussed below. The web browsing server 102 is comprised of a content

extraction agent 400, a content fetcher 402, a polling and ranking agent 404, and the content descriptor files 406. Each of these are software applications and will be discussed below.

[0038] Upon receiving a web site record 200 from the database 100 in response to a user request, the web browsing server 102 invokes the "content extraction agent" command 206 contained in the record 200. The content extraction agent 400 allows the web browsing server 102 to properly format requests and read responses provided by the web site 114 identified in the URL field 204 of the web site record 200. Each content extraction agent command 206 invokes the content extraction agent and identifies a content description file associated with the web page identified by the URL 204. This content description file directs the extraction agent where to extract data from the accessed web page and how to format a response to the user utilizing that data. For example, the content description file for a web page providing weather information would indicate where to insert the "city" name or ZIP code in order to retrieve Chicago weather information. Additionally, the content description file for each supported URL indicates the location on the web page where the response information is provided. The extraction agent 400 uses this information to properly extract from the web page the information requested by the user.

[0039] Table 3 below contains source code for a content extraction agent 400 used by the preferred embodiment.

TABLE 3

```
#!/usr/local/www/bin/sybperl5
#$Header:
/usr/local/cvsroot/webley/agents/service/web_dispatch.pl,v
1.6
# Dispatches all web requests

#http://wcorp.itn.net/cgi/flstat?carrier=ua&flight_no=155&mon_
abbr=jul&date=
6&stamp=OhLN~PdbuuE*itn/ord,itn/cb/sprint_hd
#http://cgi.cnnfn.com/flightview/rlm?airline=amt&number=300

require "config_tmp.pl";

# check parameters
die "Usage: $0 service [params]\n" if $#ARGV < 1;
#print STDERR @ARGV;
```

```

# get parameters
my ( $service, @param ) = @ARGV;

# check service
my %Services = (
    weather_cnn => 'webget.pl weather_cnn',
    weather_lycos => 'webget.pl
weather_lycos',
    weather_weather => 'webget.pl
weather_weather',
    weather_snap => 'webget.pl
weather_snap',
    weather_infospace => 'webget.pl
weather_infospace',
    stockQuote_yahoo => 'webget.pl stock',
    flightStatus_itn => 'webget.pl
flight_delay',
    yellowPages_yahoo => 'yp_data.pl',
    yellowPages_yahoo => 'yp_data.pl',
    newsHeaders_newsreal => 'news.pl',
    newsArticle_newsreal => 'news.pl',
);

# test param
my $date = 'date';
chop( $date );
my ( $short_date ) = $date =~ /\s+(\w{3}\s+\d{1,2})\s+/;
my %Test = (
    weather_cnn => '60053',
    weather_lycos => '60053',
    weather_weather => '60053',
    weather_snap => '60053',
    weather_infospace => '60053',
    stockQuote_yahoo => 'msft',
    flightStatus_itn => 'ua 155 ' .
$short_date,
    yellowPages_yahoo => 'tires 60015',
    newsHeaders_newsreal => '1',
    newsArticle_newsreal => '1 1',
);
die "$date: $0: error: no such service: $service (check this
script)\n"
unless $Services{$service };

# prepare absolute path to run other scripts
my ( $path, $script ) = $0 =~ m|^^(.*)\|^/|^*|;

# store the service to compare against datatable
my $service_stored = $service;

```

```

# run service
while( !( $response = '$path$Services{$service}@param' ) )
{
    # response failed
    # check with test parameters
    $response = '$path$Services{$service}$Test{$service}';
}';
# print "test: $path$Services{$service}$Test{$service}";
if ( $response ) {
    $service = &switch_service( $service );
# print "Wrong parameter values were supplied:
$service -
@param\n";
# die "$date: $0: error: wrong parameters: $service
-
@param\n";
}
else {
    # change priority and notify
    $service = &increase_attempt( $service );
}
}

# output the response :
print $response;

sub increase_attempt {
    my ( $service ) = @_ ;
    my ( $service_name ) = split( /_/, $service );
    print STDERR "$date: $0: attn: changing priority for
service:
$service\n";
    # update priority
    &db_query( "update mcServiceRoute "
        . "set priority = ( select max( priority )
from
mcServiceRoute "
        . "where service = '$service_name' ) + 1,
"
        . "date = getdate(), "
        . "attempt = attempt + 1 "
        . "where route = '$script $service'" );
# print "---$route===\n";
# find new route
my $route = @(&db_query( "select route from
mcServiceRoute "
        . "where service =
'$service_name' "
        . "and attempt < 5

```

```

"
                                . "order by
priority ")
                                }-> [ 0 ]{route };
    &db_query( "update mcServiceRoute "
              . "set attempt = 0 "
              . "where route = '$script $service'" )
    if ( $route eq "$script $service"
        or $route eq "$script $service_stored" );
    ( $service_name, $service ) = split( /\s+/, $route );
    die "$date: $0: error: no route for the service:
$service (add
more)\n"
        unless $service;
    return $service;
}
sub switch_service {
    my ( $service ) = @_;
    my ( $service_name ) = split( /_/, $service );
    print STDERR "$date: $0: attn: changing priority for
service:
$service\n";
    # update priority
    &db_query( "update mcServiceRoute "
              . "set priority = ( select max( priority )
from
mcServiceRoute "
              . "where service = '$service_name' ) + 1,
"
              . "date = getdate() "
              . "where route = '$script $service'" );
    # print "---$route===\n";
    # find new route
    my $route = @{&db_query( "select route from
mcServiceRoute "
                            . "where service =
'$service_name' "
                            . "and attempt < 5
"
                            . "order by
priority ")
                  }-> [ 0 ]{route };
    die "$date: $0: error: there is the only service:
$route (add
more)\n"
        if ( $route eq "$script $service"
            or $route eq "$script $service_stored" );
    ( $service_name, $service ) = split( /\s+/, $route );
    die "$date: $0: error: no route for the service:
$service (add

```

```

more)\n"
        unless $service;
        return $service;
    }
    -

```

[0074] Table 4 below contains source code of the content fetcher 402 used with the content extraction agent 400 to retrieve information from a web site.

TABLE 4

```

#!/usr/local/www/bin/sybperl5
#-T
# -w
# $Header:
# /usr/local/cvsroot/webley/agents/service/webget.pl,v 1.4
# Agent to get info from the web.
# Parameters: service_name [service_parameters], i.e. stock
# msft or weather
60645
# Configuration stored in files service_name.ini
# if this file is absent the configuration is received from
# mcServices table
# This script provides autoupdate to datatable if the .ini
# file is newer.

$debug = 1;
use URI::URL;
use LWP::UserAgent;
use HTTP::Request::Common;
use Vail::VarList;
use Sybase::CTlib;
use HTTP::Cookies;
#print "Sybase::CTlib $DB_USR, $DB_PWD, $DB_SRV;";
open( STDERR, ">>$0.log" ) if $debug;
#open( STDERR, ">&STDOUT" );
$log = `date`;
#$response = `./url.pl
"http://cgi.cnn.com/cgi-bin/weather/redirect?zip=60605"`;
#$response = `pwd`;
#print STDERR "pwd = $response\n";
#$response = `ls`;
#print STDERR "ls = $response\n";
chop( $log );
$log .= "pwd=" . `pwd`;
chop( $log );

#$debug2 = 1;

```



```

my $service = shift;
$log .= " $service: ". join( ':', @ARGV ) . "\n";
print STDERR $log if $debug;
#$response = `./url.pl
"http://cgi.cnn.com/cgi-bin/weather/redirect?zip=60605"`;
my @ini = &read_ini( $service );
chop( @ini );
my $section = "";
do { $section = &process_section( $section ) } while $section;
#$response = `./url.pl
"http://cgi.cnn.com/cgi-bin/weather/redirect?zip=60605"`;
exit;
#####
sub read_ini {
    my ( $service ) = @_;
    my @ini = ();
    # first, try to read file
    $0 =~ m|^(\.*/)[^/]*|;
    $service = $1 . $service;
    if ( open( INI, "$service.ini" ) ) {
        @ini = ( <INI> );
        return @ini unless ( $DB_SRV );
        # update datatable
        my $file_time = time - int( ( -M "$service.ini" )
* 24 *
3600 );
#
        print "time $file_time\n";
        my $dbh = new Sybase::CTlib $DB_USR, $DB_PWD,
$DB_SRV;
        unless ( $dbh ) {
            print STDERR "webget.pl: Cannot connect to
dataserver $DB_SRV:$DB_USR:$DB_PWD\n";
            return @ini;
        }
        my @row_refs = $dbh->ct_sql( "select lastUpdate
from
mcServices where service = '$service'", undef, 1 );
        if ( $dbh->{RC} == CS_FAIL ) {
            print STDERR "webget.pl: DB select from
mcServices
failed\n";
            return @ini;
        }
        unless ( defined @row_refs ) {
            # have to insert
            my ( @ini_escaped ) = map {
                ( my $x = $_ ) =~ s/\\/\\/\\/\\/g;
                $x;
            } @ini;
            $dbh->ct_sql( "insert mcServices values(

```

```

'$service',
'@ini_escaped', $file_time )" );
    if ( $dbh->{RC }== CS_FAIL ) {
        print STDERR "webget.pl: DB insert to
mcServices failed\n";
    }
    return @ini;
}
# print "time $file_time:". $row_refs[ 0 ]-
>{'lastUpdate'
}." \n";
    if ( $file_time > $row_refs[ 0 ]->{'lastUpdate' } )
{
    # have to update
    my ( @ini_escaped ) = map {
        ( my $x = $_ ) =~ s/\'/\\'/g;
        $x;
    }@ini;
    $dbh->ct_sql( "update mcServices set config =
'@ini_escaped', lastUpdate = $file_time where service =
'$service'" );
    if ( $dbh->{RC }== CS_FAIL ) {
        print STDERR "webget.pl: DB update to
mcServices failed\n";
    }
    return @ini;
}
else {
    print STDERR "$0: WARNING: $service.ini n/a in " .
'pwd'
        . "Try to read DB\n";
}
# then try to read datatable
die "webget.pl: Unable to find service $service\n"
unless ( $DB_SRV
);
    my $dbh = new Sybase::CTlib $DB_USR, $DB_PWD, $DB_SRV;
    die "webget.pl: Cannot connect to dataserer
$DB_SRV:$DB_USR:$DB_PWD\n" unless ( $dbh );
    my @row_refs = $dbh->ct_sql( "select config from
mcServices where
service = '$service'", undef, 1 );
    die "webget.pl: DB select from mcServices failed\n" if
$dbh->{RC }
== CS_FAIL;
    die "webget.pl: Unable to find service $service\n"
unless ( defined
@row_refs );
    $row_refs[ 0 ]->{'config' } =~ s/\n /\n\r/g;

```

```

@ini = split( /\r/, $row_refs[ 0 ]->'config' );
return @ini;
}
-
#####
sub process_section {
    my ( $prev_section ) = @_;
    my ( $section, $output, $content );
    my %Param;
    my %Content;
#   print"#####\n";
    foreach ( @ini ) {
#       print;
#       chop;
#       s/\s+$/;/;
#       s/^\s+//;
#       # get section name
#       if ( /^\[([.]*)\]/ ) {
#           print "$_: $section:$prev_section\n";
#           last if $section;
#           next if $1 eq "print";
#           next if $prev_section ne "" and $prev_section
ne $1;
#           if ( $prev_section eq $1 ) {
#               $prev_section = "";
#               next;
#           }
#           $section = $1;
#       }
#       # get parameters
#       push( @{$Param{$1}}, $2 ) if $section and
/([^\s=]+)=(.*)/;
#       }
#       print"+++++\n";
#       return 0 unless $section;
#       print "section $section\n";
#       # substitute parameters with values
#       map { $Param{URL }->[ 0 ] =~ s/$Param{Input }->[ $_
]/$ARGV[ $_
]/g
#       } 0 .. $#{$Param{Input }};

#       # get page content
#       ( $Content{'TIME'}, $content ) = &get_url_content(
#       ${ $Param{URL }
#       }[ 0 ] );

#       # filter it
#       map {
#           if ( /\["([^\"]+)\]"([^\"]*)"/ or
#           /\[/([^\/]+)\[/([^\/]+)\// )

```

```

{
    my $out = $2; $content =~ s/$1/$out/g;
}
}@{$Param{"Pre-filter" }};

#print STDERR $content;
# do main regular expression
unless( @values = $content =~
/`${Param{Regular_expression }}[ 0
]/ ) {
    &die_hard( `${Param{Regular_expression }}[ 0 ],
$content
);
    return $section;
}

%Content = map { ( $Param{Output }->[ $_ ], $values[ $_
] )
} 0 .. $#{$Param{Output }};

# filter it
map {
    if ( /(^[^"]+)\\"([^\"]+)\\"([^\"]*)\\"/
        or /(^[^\/]+\\"([^\\/]+)\\"([^\\/]*)\\"// ) {
        my $out = $3;
        $Content{$1 }=~ s/$2/$out/g;
    }
}@{$Param{"Post-filter" }};

# calculate it
map {
    if ( /(^[^=]+\\"(.*?)\\"/ ) {
        my $eval = $2;
        map { $eval =~ s/$_/$Content{$_ }/g
        }keys %Content;
        $Content{$1 }= eval( $eval );
    }
}@{$Param{Calculate }};

# read section [print]
foreach $i ( 0 .. $#ini ) {
    next unless $ini[ $i ] =~ /\^[print]\//;
    foreach ( $i + 1 .. $#ini ) {
        last if $ini[ $_ ] =~ /\^[.+\]\//;
        $output .= $ini[ $_ ] . "\n";
    }
    last;
}
}

```

```

# prepare output
map { $output =~ s/$_/$Content{$_ }/g
}keys %Content;
print $output;
return 0;
}
#####
sub get_url_content {
    my ( $url ) = @_;
    print STDERR $url if $debug;
#   $response = `./url.pl '$url'`;
#   $response = `./url.pl '$url'`;
    return( $time - time, $response );
    my $ua = LWP::UserAgent->new;
    $ua->agent( 'Mozilla/4.0 [en] (X11; I; FreeBSD 2.2.8-
STABLE i386)'
);
#   $ua->proxy( ['http', 'https'],
'http://proxy.webley:3128/' );
#   $ua->no_proxy( 'webley', 'vail' );
    my $cookie = HTTP::Cookies->new;
    $ua->cookie_jar( $cookie );
    $url = url $url;
    print "$url\n" if $debug2;
    my $time = time;
    my $res = $ua->request( GET $url );
    print "Response: " . ( time - $time ) . "sec\n" if
$debug2;
    return( $time - time, $res->content );
}
#####
sub die_hard {
    my( $re, $content ) = @_;
    my ( $re_end, $pattern );
    while( $content !~ /$re/ ) {
        if ( $re =~ s/(\[^\(\)]+\)[^\(\)]*$)// ) {
            $re_end = $1 . $re_end;
        }
        else {
            $re_end = $re;
            last;
        }
    }
    $content =~ /$re/;
    print STDERR "The regular expression did not match:\n
$re\n
Possible misuse:
$re_end:\n
Matched:
$&\n

```

```

Mismatched:
$\n
" if $debug;
    if ( $debug ) {
        print STDERR "Content:\n $content\n" unless
    }
$';
}

```

```
#####
```

[0075] Table 5 below contains the content descriptor file source code for obtaining weather information from the web site www.cnn.com that is used by the extraction agent 400 of the preferred embodiment.

TABLE 5

```

[cnn]
Input=_zip

URL=http://cgi.cnn.com/cgi-bin/weather/redirect?zip=_zip

Pre-filter="\n"
Pre-filter="<[^<>]+>"
Pre-filter=/\s+/
Pre-filter="[\\(\\)\\|]"

Output=_location
Output=first_day_name
Output=first_day_weather
Output=first_day_high_F
Output=first_day_high_C
Output=first_day_low_F
Output=first_day_low_C
Output=second_day_name
Output=second_day_weather
Output=second_day_high_F
Output=second_day_high_C
Output=second_day_low_F
Output=second_day_low_C
Output=third_day_name
Output=third_day_weather
Output=third_day_high_F
Output=third_day_high_C
Output=third_day_low_F
Output=third_day_low_C
Output=fourth_day_name
Output=fourth_day_weather

```

CHICAGO 283215v1 47242-00001

Output=fourth_day_high_F
Output=fourth_day_high_C
Output=fourth_day_low_F
Output=fourth_day_low_C
Output=undef
Output=_current_time
Output=_current_month
Output=_current_day
Output=_current_weather
Output=_current_temperature_F
Output=_current_temperature_C
Output=_humidity
Output=_wind
Output=_pressure
Output=_sunrise
Output=_sunset

Regular_expression=Author (.+) Four Day Forecast
(\S+) (\S+) HIGH
(\S+) F (\S+) C LOW (\S+) F (\S+) C (\S+) (\S+) HIGH (\S+) F
(\S+) C LOW
(\S+) F (\S+) C (\S+) (\S+) HIGH (\S+) F (\S+) C LOW (\S+) F
(\S+) C (\S+)
(\S+) HIGH (\S+) F (\S+) C LOW (\S+) F (\S+) C (.+) Current
Conditions(.+)
!local!, (\S+) (\S+) (.+) Temp: (\S+) F, (\S+) C Rel.
Humidity: (\S+) Wind:
(.+) Pressure: (.+) Sunrise: (.+) Sunset: (.+) Related Links

Post-filter=_current_weather"p/"partly "
Post-filter=_current_weather"l/"little "
Post-filter=_current_weather"m/"mostly "
Post-filter=_current_weather"t-/"thunder "
Post-filter=_wind"N"North "
Post-filter=_wind"E"East "
Post-filter=_wind"S"South "
Post-filter=_wind"W"West "
Post-filter=_wind/mph/miles per hour/
Post-filter=_wind/kph!/kilometers per hour/
Post-filter=_wind"\s+!", "

[print]
Current weather in _location is _current_weather.
Temperature is _current_temperature_F Fahrenheit,
_current_temperature_C
Celsius.
Humidity is _humidity.
Wind from the _wind.

[0076] Table 6 below contains the content descriptor file source code for obtaining weather information from the web site www.lycos.com that is used by the extraction agent 400 of the preferred embodiment.

TABLE 6

[lycos]

Input=zip
Input=_city

URL=http://weather.lycos.com/wcfiveday.asp?city=zip

Pre-filter="\n" "
Pre-filter="</TD>"td"
Pre-filter="<!.*?->" "
Pre-filter="
"_br_"
Pre-filter="/alt="/>alt="/
Pre-filter="<[^<>]+>" "
Pre-filter=" " "
Pre-filter="/\s+/" /

Output=_location
Output=_current_weather
Output=_current_temperature_F
Output=_humidity
Output=_winddir
Output=_windspeed
Output=_windmeasure
Output=_pressure
Output=first_day_name
Output=second_day_name
Output=third_day_name
Output=fourth_day_name
Output=fifth_day_name
Output=first_day_weather
Output=second_day_weather
Output=third_day_weather
Output=fourth_day_weather
Output=fifth_day_weather
Output=first_day_high_F
Output=first_day_low_F
Output=second_day_high_F
Output=second_day_low_F
Output=third_day_high_F
Output=third_day_low_F
Output=fourth_day_high_F
Output=fourth_day_low_F

CHICAGO 283215v1 47242-00001

```
Output=fifth_day_high_F
Output=fifth_day_low_F
Output=_windkmh
```

```
Regular_expression=Guide My Lycos (.+) Click image to
enlarge
alt=("[^"]+)"(?:.) Temp: (\d+)(?:.+)F _br_ Humidity:
(\S+)(?:.+) Wind: (.+?)
_br_
```

```
Output=_current_temperature_C
```

```
Post-filter=_location"_br_"
Post-filter=_current_weather"p/"partly "
Post-filter=_current_weather"m/"mostly "
Post-filter=_current_weather"t-/"thunder "
Post-filter=_winddir"@ " at "
Post-filter=_winddir/mpH/miles per hour/
Post-filter=_wind/kph!/kilometers per hour/
```

```
Calculate=_current_temperature_C=int((_current_temperature_F
-32)*5/9)
Calculate=_windkmh=int(_windspeed*1.6)
```

```
[print]
The current weather in _location is _current_weather.
The current temperature is _current_temperature_F Fahrenheit
_current_temperature_C Celcius.
Humidity is _humidity.
```

```
Winds _winddir.
```

[0077] Once the web browsing server 102 accesses the web site specified in the URL 204 and retrieves the requested information, the information is forwarded to the media server 106. The media server uses the speech synthesis engine 302 to create an audio message that is then transmitted to the user's voice enabled device 112. In the preferred embodiment, each web browsing server 102 is based upon Intel's Dual Pentium III 730 MHz microprocessor system.

[0078] Referring to FIG. 1, the operation of the robust voice browser system will be described. A user establishes a connection between his voice enabled device 112 and a media server 106. This may be done using the Public Switched Telephone Network

(PSTN) 116 by calling a telephone number associated with the voice browsing system 118. Once the connection is established, the media server 106 initiates an interactive voice response (IVR) application 304. The IVR application plays audio messages to the user presenting a list of options, such as, "stock quotes", "flight status", "yellow pages", "weather", and "news". These options are based upon the available web site categories and may be modified as desired. The user selects the desired option by speaking the name of the option into the voice enabled device 112.

[0079] As an example, if a user wishes to obtain restaurant information, he may speak into his telephone the phrase "yellow pages". The IVR application would then ask the user what he would like to find and the user may respond by stating "restaurants". The user may then be provided with further options related to searching for the desired restaurant. For instance, the user may be provided with the following restaurant options, "Mexican Restaurants", "Italian Restaurants", or "American Restaurants". The user then speaks into the telephone 112 the restaurant type of interest. The IVR application running on the media server 106 may also request additional information limiting the geographic scope of the restaurants to be reported to the user. For instance, the IVR application may ask the user to identify the zip code of the area where the restaurant should be located. The media server 106 uses the speech recognition engine 300 to interpret the speech commands received from the user. Based upon these commands, the media server 106 retrieves the appropriate web site record 200 from the database 100. This record and any additional data, which may include other necessary parameters needed to perform the user's request, are transmitted to a web browsing server 102. A firewall 104 may be provided that separates the web browsing server 102 from the database 100 and media server 106. The firewall provides protection to the media server and database by preventing unauthorized access in the event the firewall for web browsing server 108 fails or is compromised. Any type of firewall protection technique commonly known to one skilled in the art could be used, including packet filter, proxy server, application gateway, or circuit-level gateway techniques.

[0080] The web browsing server 102 then uses the web site record and any additional data and executes the extraction agent 400 and relevant content descriptor file 406 to retrieve the requested information.

[0081] The information received from the responding web site 114 is then processed by

the web browsing server 102 according to the content descriptor file 406 retrieval by the extraction agent. This processed response is then transmitted to the media server 106 for conversion into audio messages using either the speech synthesis software 302 or selecting among a database of prerecorded voice responses contained within the database 100.

[0082] As mentioned above, each web site record contains a rank number 202 as shown in FIG. 2. For each category searchable by a user, the database 100 may list several web sites, each with a different rank number 202. As an example, three different web sites may be listed as searchable under the category of "restaurants". Each of those web sites will be assigned a rank number such as 1, 2, or 3. The site with the highest rank (i.e., rank = 1) will be the first web site accessed by a web browsing server 102. If the information requested by the user cannot be found at this first web site, then the web browsing server 102 will search the second ranked web site and so forth down the line until the requested information is retrieved or no more web sites left to check.

[0083] The web site ranking method and system of the present invention provides robustness to the voice browser system and enables it to adapt to changes that may occur as web sites evolve. For instance, the information required by a web site 114 to perform a search or the format of the reported response data may change. Without the ability to adequately monitor and detect these changes, a search requested by a user may provide an incomplete response, no response, or an error. Such useless responses may result from incomplete data being provided to the web site 114 or the web browsing server 102 being unable to recognize the response data messages received from the searched web site 114.

[0084] The robustness and reliability of the voice browsing system of the present invention is further improved by the addition of a polling mechanism. This polling mechanism continually polls or "pings" each of the sites listed in the database 100. During this polling function, a web browsing server 102 sends brief data requests or "polling digital data" to each web site listed in database 100. The web browsing server 102 monitors the response received from each web site and determines whether it is a complete response and whether the response is in the expected format specified by the content descriptor file 406 used by the extraction agent 400. The polled web sites that provide complete responses in the format expected by the extraction agent 400 have their ranking established based on their "response time". That is, web sites with faster

response times will be assigned higher rankings than those with slower response times. If the web browsing server 102 receives no response from the polled web site or if the response received is not in the expected format, then the rank of that web site is lowered. Additionally, the web browsing server contains a warning mechanism that generates a warning message or alarm for the system administrator indicating that the specified web site has been modified or is not responsive and requires further review.

[0085] Since the web browsing servers 102 access web sites based upon their ranking number, only those web sites that produce useful and error-free responses will be used by the voice browser system to gather information requested by the user. Further, since the ranking numbers are also based upon the speed of a web site in providing responses, only the most time efficient sites are accessed. This system assures that users will get complete, timely, and relevant responses to their requests. Without this feature, users may be provided with information that is not relevant to their request or may not get any information at all. The constant polling and re-ranking of the web sites used within each category allows the voice browser of the present invention to operate efficiently. Finally, it allows the voice browser system of the present invention to dynamically adapt to changes in the rapidly evolving web sites that exist on the Internet.

[0086] It should be noted that the web sites accessible by the voice browser of the preferred embodiment may use any type of mark-up language, including Extensible Markup Language (XML), Wireless Markup Language (WML), Handheld Device Markup Language (HDML), Hyper Text Markup Language (HTML), or any variation of these languages.

[0087] A second embodiment of the present invention is depicted in FIG. 5. This embodiment provides a system and method for controlling a variety of devices 500 connected to a network 502 by using conversational speech commands spoken into a voice enabled device 504 (i.e., wireline or wireless telephones, Internet Protocol (IP) phones, or other special wireless units). The networked devices may include various household devices. For instance, voice commands may be used to control household security systems, VCRs, TVs, outdoor or indoor lighting, sprinklers, or heating and air conditioning systems.

[0088] Each of these devices 500 is connected to a network 502. These devices 500 may contain embedded microprocessors or may be connected to other computer equipment

that allow the device 500 to communicate with network 502. In the preferred embodiment, the devices 500 appear as "web sites" connected to the network 502. This allows a network interface system, such as a device browsing server 506, a database 508, and a user interface system, such as a media server 510, to operate similar to the web browsing server 102, database 100 and media server 106 described in the first preferred embodiment above. A network 502 interfaces with one or more network interface systems, which are shown as device browsing servers 506 in FIG. 5. The device browsing servers perform many of the same functions and operate in much the same way as the web browsing servers 102 discuss above in the first preferred embodiment. The device browsing servers 506 are also connected to a database 508.

[0089] Database 508 lists all devices that are connected to the network 502. For each device 500, the database 508 contains a record similar to that shown in FIG. 2. Each record will contain at least a device identifier, which may be in the form of a URL, and a command to "content extraction agent" contained in the device browsing server 506. Database 508 may also include any other data or software necessary to test and administer the device browsing system.

[0090] The content extraction agent operates similarly to that described in the first embodiment. A device descriptor file contains a listing of the options and functions available for each of the devices 500 connected on the network 502. Furthermore, the device descriptor file contains the information necessary to properly communicate with the networked devices 500. Such information would include, for example, communication protocols, message formatting requirements, and required operating parameters.

[0091] The device browsing server 506 receives messages from the various networked devices 500, appropriately formats those messages and transmits them to one or more media servers 510 which are part of the device browsing system. The user's voice enabled devices 504 can access the device browsing system by calling into a media server 510 via the Public Switched Telephone Network (PSTN) 512. In the preferred embodiment, the device browsing server is based upon Intel's Dual Pentium III 730 MHz microprocessor system.

[0092] The media servers 510 act as user interface systems and perform the functions of natural speech recognition, speech synthesis, data processing, and call handling. The

media server 510 operates similarly to the media server 106 depicted in FIG. 3. When data is received from the device browser server 506, the media server 510 will convert the data into audio messages via a speech synthesis engine that are then transmitted to the voice enabled device of the user 504. Speech commands received from the voice enabled device of the user 504 are converted into data messages via a speech recognition engine running on the media server 510. A preferred speech recognition engine is developed by Nuance Communications of 1380 Willow Road, Menlo Park, California 94025 (www.nuance.com). A preferred speech synthesis engine is developed by Lernout and Hauspie Speech Products, 52 Third Avenue, Burlington, Massachusetts 01803 (www.lhsl.com). The media servers 510 of the preferred embodiment are based on Intel's Dual Pentium III 730 MHz microprocessor system. A specific example for using the system and method of this embodiment of the invention will now be given.

[0093] First, a user may call into a media server 510 by dialing a telephone number associated with an established device browsing system. Once the user is connected, the IUR application of the media server 510 will provide the user with a list of available systems that may be monitored or controlled based upon information contained in database 508.

[0094] For example, the user may be provided with the option to select "Home Systems" or "Office Systems". The user may then speak the command "access home systems". The media server 510 would then access the database 508 and provide the user with a listing of the home subsystems or devices 500 available on the network 502 for the user to monitor and control. For instance, the user may be given a listing of subsystems such as "Outdoor Lighting System", "Indoor Lighting System", "Security System", or "Heating and Air Conditioning System". The user may then select the indoor lighting subsystem by speaking the command "Indoor Lighting System". The IUR application would then provide the user with a set of options related to the indoor lighting system. For instance the media server 510 may then provide a listing such as "Dining Room", "Living Room", "Kitchen", or "Bedroom". After selecting the desired room, the IUR application would provide the user with the options to hear the "status" of the lighting in that room or to "turn on", "turn off", or "dim" the lighting in the desired room. These commands are provided by the user by speaking the desired command into the users voice enabled device 504. The media server 510 receives this command and translates it into a data

message. This data message is then forwarded to the device browsing server 506 which routes the message to the appropriate device 500.

[0095] The device browsing system 514 of this embodiment of the present invention also provides the same robustness and reliability features described in the first embodiment. The device browsing system 514 has the ability to detect whether new devices have been added to the system or whether current devices are out-of-service. This robustness is achieved by periodically polling or "pinging" all devices 500 listed in database 508. The device browsing server 506 periodically polls each device 500 and monitors the response. If the device browsing server 506 receives a recognized and expected response from the polled device, then the device is categorized as being recognized and in-service. However, if the device browsing server 506 does not receive a response from the polled device 500 or receives an unexpected response, then the device 500 is marked as being either new or out-of-service. A warning message or a report may then be generated for the user indicating that a new device has been detected or that an existing device is experiencing trouble.

[0096] Therefore, this embodiment allows users to remotely monitor and control any devices that are connected to a network, such as devices within a home or office. Furthermore, no special telecommunications equipment is required for users to remotely access the device browser system. Users may use any type of voice enabled device (i.e., wireline or wireless telephones, IP phones, or other wireless units) available to them. Furthermore, a user may perform these functions from anywhere without having to subscribe to additional services. Therefore, no additional expenses are incurred by the user.

[0097] The descriptions of the preferred embodiments described above are set forth for illustrative purposes and are not intended to limit the present invention in any manner. Equivalent approaches are intended to be included within the scope of the present invention. While the present invention has been described with reference to the particular embodiments illustrated, those skilled in the art will recognize that many changes and variations may be made thereto without departing from the spirit and scope of the present invention. These embodiments and obvious variations thereof are contemplated as falling within the scope and spirit of the claimed invention.

CLAIMS

1. A system for gathering information from information sources connected to a network by using speech commands indicating specific actions to be performed, said system comprising:

a voice enabled device employed by users to communicate speech commands indicating specific actions to be performed;

said speech commands comprising information requests selectable by the user;

a database operatively connected with a computer said database containing stored digital-form commands for operating said system;

a speaker-independent speech recognition device for receiving from users said speech commands indicating specific actions to be performed, said speaker-independent speech recognition device configured to convert said speech commands to data messages;

a computer operatively connected with said database and said speech recognition device and configured to match said data messages with said stored digital-form commands and configured to carry out the specific actions indicated by said speech commands;

said computer further configured to search information sources connected to a network to gather information from said information sources connected to said network in response to said information requests.

2. The system of claim 1 wherein said network is the Internet.

3. The system of claim 1 wherein said information sources are web sites.

4. The system of claim 1 wherein the said voice enabled device is a standard telephone, an IP telephone, a cellular phone, a PDA, a personal computer, a DVD player, a television or other video display device, a CD player, a MP3 player, or any other device capable of audio playing an audio signal.

5. The system of claim 1 wherein said speaker-independent speech recognition device analyzes phonemes to recognize said speech commands.
6. The system of claim 1 wherein said speaker-independent speech recognition device recognizes naturally spoken speech commands.
7. The system of claim 1 wherein said database contains a stored list of said information sources connected to said network.
8. The system of claim 7 wherein said computer is further configured to periodically search said information sources contained in said stored list and also configured to assign ranks to said information sources to reflect the results of said periodic search.
9. The system of claim 7 wherein said computer is further configured to periodically search said network to identify new information sources and to add said new information sources to said stored list.
10. The system of claim 9 wherein said computer is further configured to periodically search said information sources contained in said stored list and also configured to assign ranks to said information sources to reflect the results of said periodic search.
11. The system of claim 8 wherein said ranks are established or modified based upon utility considerations of said information sources.
12. The system of claim 11 wherein said utility considerations comprise one or more of the following list: functionality of said information sources, speed of said information sources, or changes to said information sources that lower its utility for a specific information request.
13. The system in claim 8 wherein said computer searches said information sources with the highest rank in order to retrieve said information requested by said user.
14. The system of claim 1 wherein said information gathered by said system from said information sources in response to said information requests is stored by said

database and processed by said computer into a message, said system further configured to transmit said message to said voice enabled device or such other destination as designated by said user.

15. The system of claim 14 wherein said message is an audio message.

16. The system of claim 15 further comprising a speech synthesis engine configured to create said audio message.

17. The system of claim 15 further comprising a pre-recorded audio concatenation application configured to create said audio message.

ABSTRACT OF THE DISCLOSURE

The present invention relates to a system for acquiring information from sources on a network, such as the Internet. A voice browsing system maintains a database containing a list of information sources, such as web sites, connected to a network. Each of the information sources is assigned a rank number which is listed in the database along with the record for the information source. In response to a speech command received from a user, a network interface system accesses the information source with the highest rank number in order to retrieve information requested by the user.

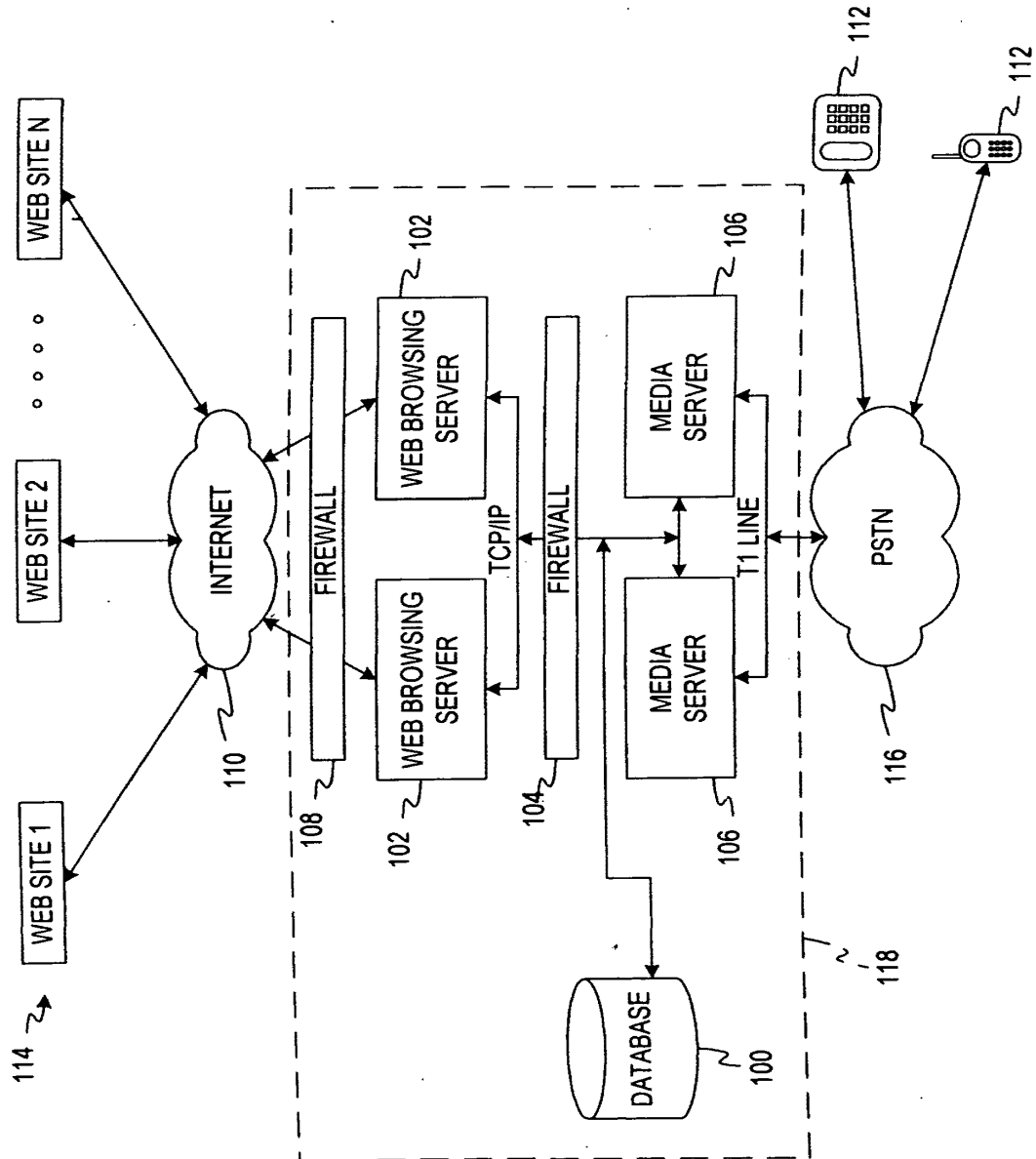

FIG. 1

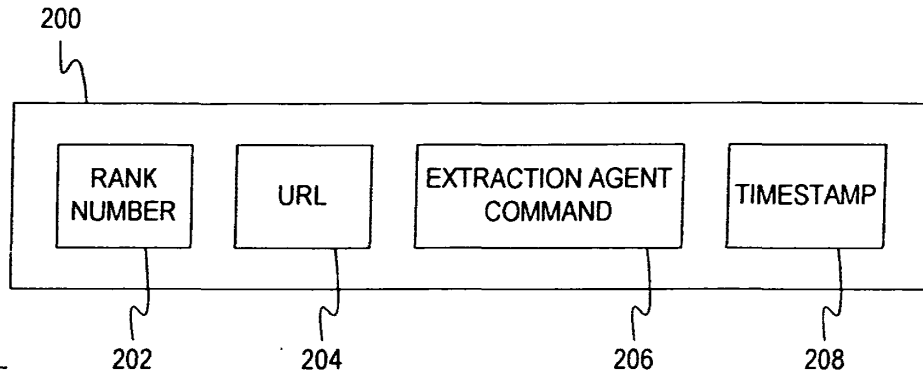

FIG. 2

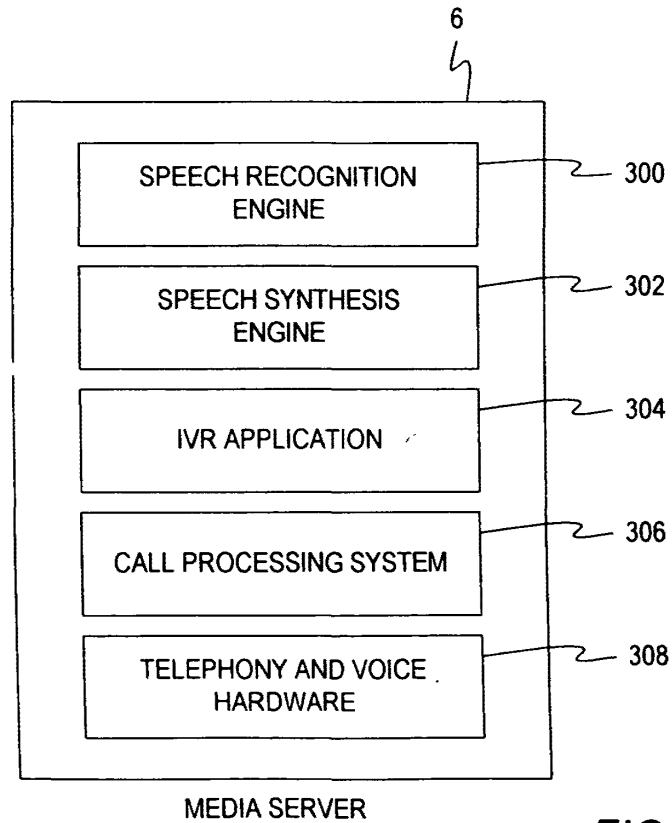

FIG. 3

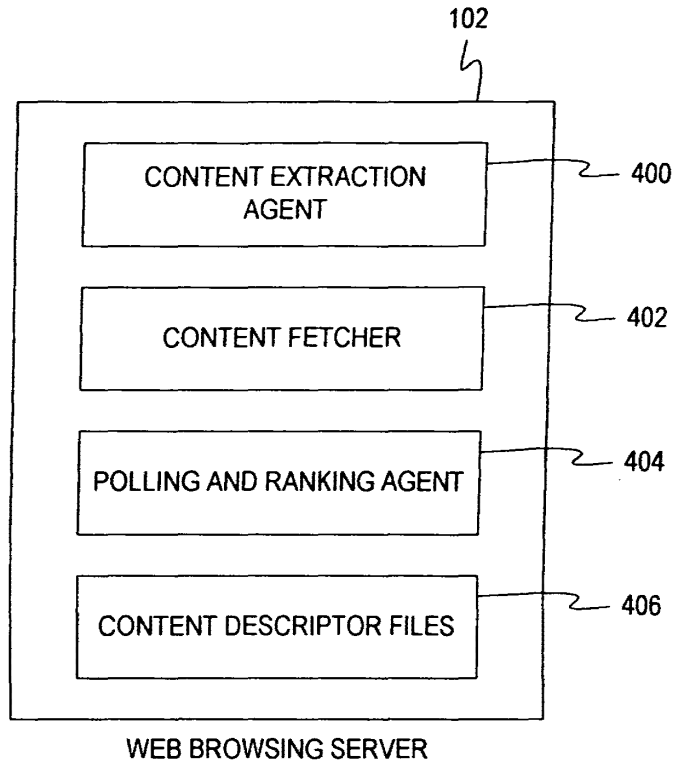

FIG. 4

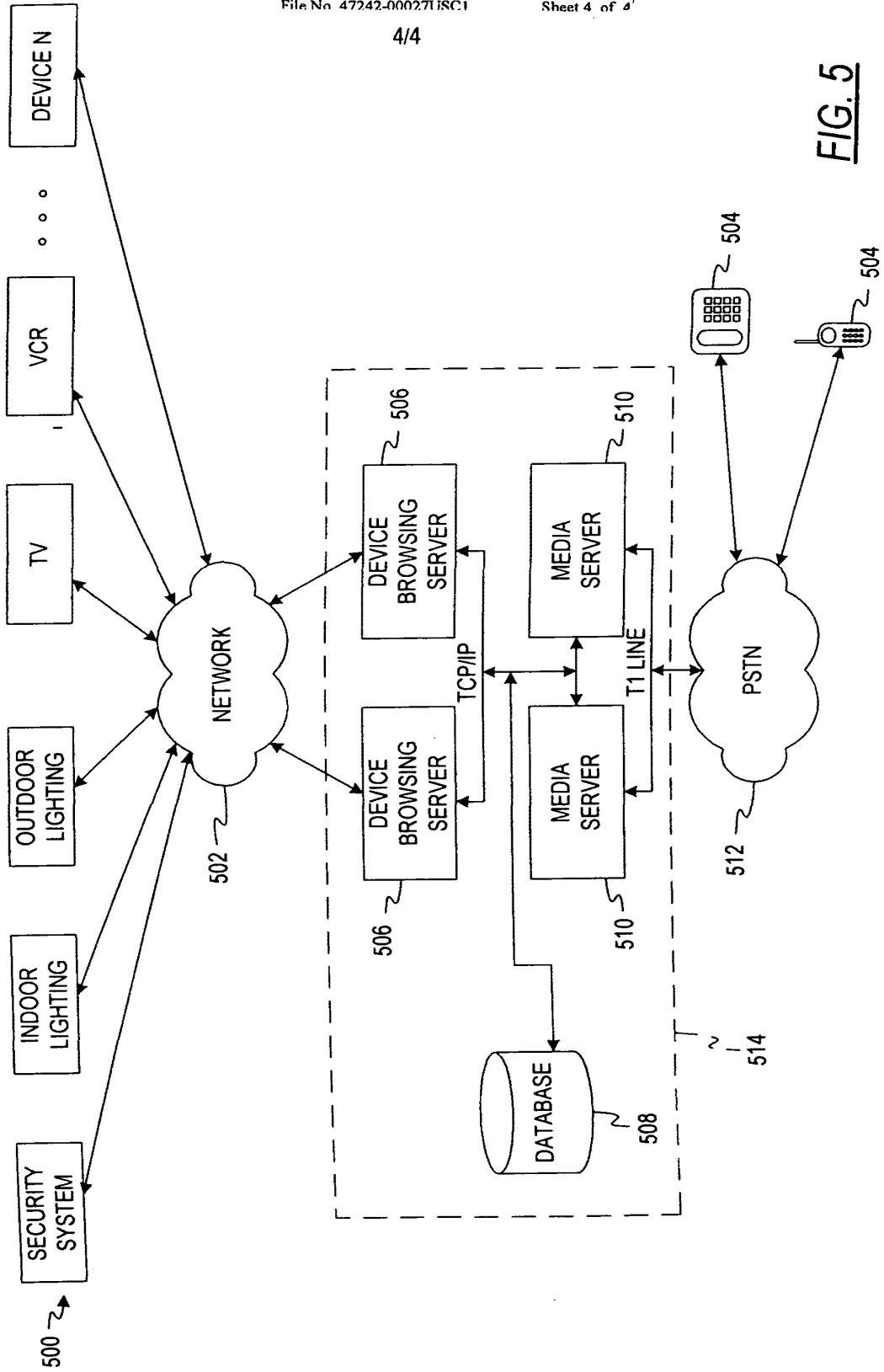

FIG. 5

**RULES 63 AND 67 (37 C.F.R. 1.63 and 1.67)
DECLARATION AND POWER OF ATTORNEY**

FOR UTILITY/DESIGN/CIP/PCT NATIONAL APPLICATIONS

As a below named inventor, I hereby declare that:

My residence, post office address and citizenship are as stated below next to my name,
and

I believe that I am an original, first and joint inventor of the subject matter which is claimed and for which a patent is sought on the invention entitled: **ROBUST VOICE BROWSER SYSTEM AND VOICE ACTIVATED DEVICE CONTROLLER**, the specification of which: (mark only one)

- (a) is attached hereto.
- (b) was filed on February 5, 2001 as Application Serial No. **09/776,996** and was amended on _____ (if applicable)
- (c) was filed as PCT International Application No. PCT/ _____ on _____ and was amended on _____ (if applicable).
- (d) was filed on _____ as Application Serial No. _____ and was issued a Notice of Allowance on _____.
- (e) was filed on _____ and bearing attorney docket number _____

I hereby state that I have reviewed and understand the contents of the above identified specification, including the claims as amended by any amendment referred to above or as allowed as indicated above.

I acknowledge the duty to disclose all information known to me to be material to the patentability of this application as defined in 37 CFR § 1.56. If this is a continuation-in-part (CIP) application, insofar as the subject matter of each of the claims of this application is not disclosed in the prior United States application in the manner provided by the first paragraph of 35 U.S.C. § 112, I acknowledge the duty to disclose to the Office all information known to me to be material to patentability of the application as defined in 37 CFR § 1.56 which became available between the filing date of the prior application and the national or PCT international filing date of this application.

I hereby claim foreign priority benefits under 35 U.S.C. § 119/365 of any foreign application(s) for patent or inventor's certificate listed below and have also identified below any foreign application for patent or inventor's certificate filed by me or my assignee

disclosing the subject matter claimed in this application and having a filing date (1) before that of the application on which my priority is claimed or, (2) if no priority is claimed, before the filing date of this application:

PRIOR FOREIGN PATENTS

| <u>Number</u> | <u>Country</u> | <u>Month/Day/Year Filed</u> | <u>Date first laid-open or Published</u> | <u>Date patented or Granted</u> | <u>Priority Claimed</u> | |
|---------------|----------------|-----------------------------|------------------------------------------|---------------------------------|-------------------------|-----------|
| | | | | | <u>Yes</u> | <u>No</u> |
| NONE | | | | | | |

I hereby claim the benefit under 35 U.S.C. § 120/365 of any United States application(s) listed below and PCT international applications listed above or below:

PRIOR U.S. OR PCT APPLICATIONS

| <u>Application No. (series code/serial no.)</u> | <u>Month/Day/Year Filed</u> | <u>Status(pending, abandoned, patented)</u> |
|-------------------------------------------------|-----------------------------|---------------------------------------------|
| 60/180,344 | February 4, 2000 | Pending |
| 60/233,068 | September 15, 2000 | Pending |

I hereby appoint:

| | | |
|----------------------------------------|-----------------------------------------|----------------------------------------|
| TIMOTHY G. ACKERMANN, Reg. No. 44,493 | GERALD H. GLANZMAN, Reg. No. 25,035 | SPENCER C. PATTERSON, Reg. No. 43,849 |
| BENJAMIN J. BAL, Reg. No. 43,481 | LEKHA GOPALAKRISHNAN, Reg. No. 46,733 | RUSSELL N. RIPPAMONTI, Reg. No. 39,521 |
| MICHAEL J. BLANKSTEIN, Reg. No. 37,097 | J. KEVIN GRAY, Reg. No. 37,141 | ROSS T. ROBINSON, Reg. No. 47,031 |
| MARY JO BOLDINGH, Reg. No. 34,713 | STEVEN R. GREENFIELD, Reg. No. 38,166 | STEPHEN G. RUDISILL, Reg. No. 20,087 |
| MARGARET A. BOULWARE, Reg. No. 28,708 | JOSHUA A. GRISWOLD, Reg. No. 46,310 | HOLLY L. RUDNICK, Reg. No. 43,065 |
| ARTHUR J. BRADY, Reg. No. 42,356 | J. PAT HEPTIG, Reg. No. 40,643 | J.L. JENNIE SALAZAR, Reg. No. 45,065 |
| MATTHEW O. BRADY, Reg. No. 44,554 | SHARON A. ISRAEL, Reg. No. 41,867 | KEITH W. SAUNDERS, Reg. No. 41,462 |
| DANIEL J. BURNHAM, Reg. No. 39,618 | JOHN R. KIRK JR., Reg. No. 24,477 | JERRY R. SELINGER, Reg. No. 26,582 |
| THOMAS L. CANTRELL, Reg. No. 20,849 | PAUL R. KITCH, Reg. No. 38,206 | JAMES O. SKARSTEN, Reg. No. 28,346 |
| RONALD B. COOLLEY, Reg. No. 27,187 | TIMOTHY M. KOWALSKI, Reg. No. 44,192 | ZACHARY J. SMOLINSKI, Reg. No. 47,100 |
| THOMAS L. CRISMAN, Reg. No. 24,846 | JAMES F. LEA III, Reg. No. 41,143 | GARY B. SOLOMON, Reg. No. 44,347 |
| STUART D. DWORK, Reg. No. 31,103 | HSIN-WEI LUANG, Reg. No. 44,213 | STEVE Z. SZCZEPANSKI, Reg. No. 27,957 |
| WILLIAM F. ESSER, Reg. No. 38,053 | ROBERT W. MASON, Reg. No. 42,848 | ANDRE M. SZUWALSKI, Reg. No. 35,701 |
| ROGER J. FRENCH, Reg. No. 27,786 | ROGER L. MAXWELL, Reg. No. 31,855 | ALAN R. THIELE, Reg. No. 30,694 |
| JANET M. GARETTO, Reg. No. 42,568 | LISA H. MEYERHOFF, Reg. No. 36,869 | TAMSEN VALOIR, Reg. No. 41,417 |
| MARK J. GATSCHET, Reg. No. 42,569 | STANLEY R. MOORE, Reg. No. 26,958 | RAYMOND VAN DYKE, Reg. No. 34,746 |
| JOHN C. GATZ, Reg. No. 41,774 | RICHARD J. MOURA, Reg. No. 34,883 | BRIAN D. WALKER, Reg. No. 37,751 |
| RUSSELL J. GENET, Reg. No. 42,571 | MARK V. MULLER, Reg. No. 37,509 | GERALD T. WELCH, Reg. No. 30,332 |
| | P. WESTON MUSSELMAN JR. Reg. No. 31,644 | HAROLD N. WELLS, Reg. No. 26,044 |
| | DANIEL G. NGUYEN, Reg. No. 42,933 | WILLIAM D. WIESE, Reg. No. 45,217 |

all of the firm of **JENKENS & GILCHRIST, a Professional Corporation**, 1445 Ross Avenue, Suite 3200, Dallas, Texas 75202-2799, as my attorneys and/or agents, with full power of substitution and revocation, to prosecute this application, provisionals thereof, continuations, continuations-in-part, divisionals, appeals, reissues, substitutions, and extensions thereof and to transact all business in the United States Patent and Trademark Office connected therewith, to appoint any individuals under an associate power of attorney and to file and prosecute any international patent application filed thereon before any international authorities, and I hereby authorize them to act and rely on instructions from and communicate directly with the person/assignee/attorney/firm/organization who/which first sent this case to them and by

CHICAGO 155885v1 47242-00027

whom/which I hereby declare that I have consented after full disclosure to be represented unless/until I instruct them in writing to the contrary.

Please address all correspondence and direct all telephone calls to:

S. Z. Szczepanski, Esq.
 Jenkens & Gilchrist, P.C.
 1445 Ross Avenue, Suite 3200
 Dallas, Texas 75202-2799
 312/425-8580
 312/425-3909 (fax)

I hereby declare that all statements made herein of my own knowledge are true and that all statements made on information and belief are believed to be true; and further that these statements were made with the knowledge that willful false statements and the like so made are punishable by fine or imprisonment, or both, under Section 1001 of Title 18 of the United States Code, and that such willful false statements may jeopardize the validity of the application or any patent issued thereon.

NAMED INVENTOR(S)

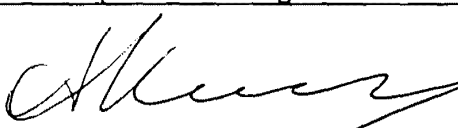
| | | | |
|---|-------------------------------------------------------------------------------------------------------------------------------------------|--------------------------------------------------------------------------------------|-----------------|
| 1 | Alexander Kurganov | | |
| | Full Name | Inventor's Signature | Date |
| | 2099 Sheridan Road Buffalo Grove, IL U.S.A. |  | U.S.A. 5/4/2001 |
| | Residence (city, state, country) 2099 Sheridan Road Buffalo Grove, IL 60089 Post Office Address (include zip code) | Citizenship | |

(FOR ADDITIONAL INVENTORS, check here X and add additional sheet for inventor information regarding signature, name, date, citizenship, residence and address)

| | | | |
|---|-----------------------------------------------------------------------------------------------------------------------------------------|-----------------------------|-------------------------------|
| 2 | Valery Zhukoff | | |
| | Full Name | Inventor's Signature | Date |
| | 821 Rosemary Terrace Deerfield, IL 60015 | <i>Valery Zhukoff</i> | 5/4/2001 USA |
| | Residence (city, state, country) 821 Rosemary Terrace Deerfield, IL 60015 Post Office Address (include zip code) | | Citizenship UKRAINE |

CHICAGO 155885v1 47242-00027

PATENT APPLICATION SERIAL NO. _____

U.S. DEPARTMENT OF COMMERCE
PATENT AND TRADEMARK OFFICE
FEE RECORD SHEET

04/13/2004 EAREGAY1 00000049 10821690

01 FC:2001 385.00 DP

PTO-1556
(5/87)

U.S. Government Printing Office: 2001 — 481-697/59173

PATENT APPLICATION FEE DETERMINATION RECORD
Effective October 1, 2003

Application or Docket Number

1082/690

CLAIMS AS FILED - PART I

(Column 1) (Column 2)

| | | |
|-----------------------------------------------------------|-----------------|--------------|
| TOTAL CLAIMS | 12 | |
| FOR | NUMBER FILED | NUMBER EXTRA |
| TOTAL CHARGEABLE CLAIMS | 12 minus 20 = * | 0 |
| INDEPENDENT CLAIMS | 1 minus 3 = * | 1 |
| MULTIPLE DEPENDENT CLAIM PRESENT <input type="checkbox"/> | | |

* If the difference in column 1 is less than zero, enter "0" in column 2

SMALL ENTITY TYPE

OR OTHER THAN SMALL ENTITY

| | |
|-----------|--------|
| RATE | FEE |
| BASIC FEE | 385.00 |
| X\$ 9= | |
| X43= | |
| +145= | |
| TOTAL | 385 |

| | |
|-----------|--------|
| RATE | FEE |
| BASIC FEE | 770.00 |
| X\$18= | |
| X86= | |
| +290= | |
| TOTAL | |

CLAIMS AS AMENDED - PART II

(Column 1) (Column 2) (Column 3)

| | | | | | |
|--------------------|-------------------------------------------------------------------------|----------------------------------|-------|------------------------------------|---------------|
| AMENDMENT A | | CLAIMS REMAINING AFTER AMENDMENT | | HIGHEST NUMBER PREVIOUSLY PAID FOR | PRESENT EXTRA |
| | Total | * | Minus | ** | = |
| | Independent | * | Minus | *** | = |
| | FIRST PRESENTATION OF MULTIPLE DEPENDENT CLAIM <input type="checkbox"/> | | | | |

SMALL ENTITY

OR OTHER THAN SMALL ENTITY

| | |
|------------------|-----------------|
| RATE | ADDI-TIONAL FEE |
| X\$ 9= | |
| X43= | |
| +145= | |
| TOTAL ADDIT. FEE | |

| | |
|------------------|-----------------|
| RATE | ADDI-TIONAL FEE |
| X\$18= | |
| X86= | |
| +290= | |
| TOTAL ADDIT. FEE | |

(Column 1) (Column 2) (Column 3)

| | | | | | |
|--------------------|-------------------------------------------------------------------------|----------------------------------|-------|------------------------------------|---------------|
| AMENDMENT B | | CLAIMS REMAINING AFTER AMENDMENT | | HIGHEST NUMBER PREVIOUSLY PAID FOR | PRESENT EXTRA |
| | Total | * | Minus | ** | = |
| | Independent | * | Minus | *** | = |
| | FIRST PRESENTATION OF MULTIPLE DEPENDENT CLAIM <input type="checkbox"/> | | | | |

| | |
|------------------|-----------------|
| RATE | ADDI-TIONAL FEE |
| X\$ 9= | |
| X43= | |
| +145= | |
| TOTAL ADDIT. FEE | |

| | |
|------------------|-----------------|
| RATE | ADDI-TIONAL FEE |
| X\$18= | |
| X86= | |
| +290= | |
| TOTAL ADDIT. FEE | |

(Column 1) (Column 2) (Column 3)

| | | | | | |
|--------------------|-------------------------------------------------------------------------|----------------------------------|-------|------------------------------------|---------------|
| AMENDMENT C | | CLAIMS REMAINING AFTER AMENDMENT | | HIGHEST NUMBER PREVIOUSLY PAID FOR | PRESENT EXTRA |
| | Total | * | Minus | ** | = |
| | Independent | * | Minus | *** | = |
| | FIRST PRESENTATION OF MULTIPLE DEPENDENT CLAIM <input type="checkbox"/> | | | | |

| | |
|------------------|-----------------|
| RATE | ADDI-TIONAL FEE |
| X\$ 9= | |
| X43= | |
| +145= | |
| TOTAL ADDIT. FEE | |

| | |
|------------------|-----------------|
| RATE | ADDI-TIONAL FEE |
| X\$18= | |
| X86= | |
| +290= | |
| TOTAL ADDIT. FEE | |

* If the entry in column 1 is less than the entry in column 2, write "0" in column 3.
 ** If the "Highest Number Previously Paid For" IN THIS SPACE is less than 20, enter "20."
 *** If the "Highest Number Previously Paid For" IN THIS SPACE is less than 3, enter "3."
 The "Highest Number Previously Paid For" (Total or Independent) is the highest number found in the appropriate box in column 1.