



US005831597A

United States Patent [19]

[11] Patent Number: **5,831,597**

West et al.

[45] Date of Patent: **Nov. 3, 1998**

[54] **COMPUTER INPUT DEVICE FOR USE IN CONJUNCTION WITH A MOUSE INPUT DEVICE**

Primary Examiner—Steven J. Saras
Assistant Examiner—Vincent Kovalick

[75] Inventors: **Michael S. West**, Austin, Tex.; **Jennifer S. Nyland**, North Vancouver; **Mitchell G. Burton**, Coquitlam, both of Canada

[57] **ABSTRACT**

[73] Assignee: **Tanisys Technology, Inc.**, Austin, Tex.

A computer input device is used in conjunction with a mouse input device. The computer input device of the invention comprises a body having a resilient layer covered by a surface layer textured throughout the entirety of the surface for operation of the mouse. A printed circuit card is incorporated in the body between the resilient layer and the upper surface layer and includes a plurality of capacitive touch sensor pads. The card further includes electronic circuitry for operating the touch sensor pads to detect when a capacitive object, such as a fingertip, is in the proximity of a sensor pad. A touch need not apply force to register. The printed circuit card includes a guard ring pad surrounding the touch pads which detects the presence of the mouse over the sensor pads and indicates that any detected outputs from the sensor pads are not valid, but instead are due to the presence of the mouse. The mouse can operate over the entirety of the surface of the device without interruption, including over the capacitive sensor pads. The input device can be connected to a personal computer through a mouse port, a keyboard port, a universal serial bus or any other available port of the computer. Other computer system components, such as a keyboard or mouse, can be connected directly or indirectly through this input device.

[21] Appl. No.: **653,589**

[22] Filed: **May 24, 1996**

[51] Int. Cl.⁶ **G09G 5/00**

[52] U.S. Cl. **345/163; 345/174; 345/156**

[58] Field of Search 345/156-158,
345/163-166, 173, 174; 248/918

[56] **References Cited**

U.S. PATENT DOCUMENTS

D. 352,278	11/1994	Sharpe, III et al.	D14/100
4,799,054	1/1989	House	340/710
4,989,819	2/1991	Sigler	248/476
5,022,170	6/1991	House	40/358
5,217,781	6/1993	Kuipers	428/85
5,231,380	7/1993	Logan	340/706
5,365,461	11/1994	Stein et al.	364/550
5,405,168	4/1995	Holt	281/2
5,414,420	5/1995	Puckette et al.	341/20
5,463,388	10/1995	Bale et al.	341/33

27 Claims, 6 Drawing Sheets

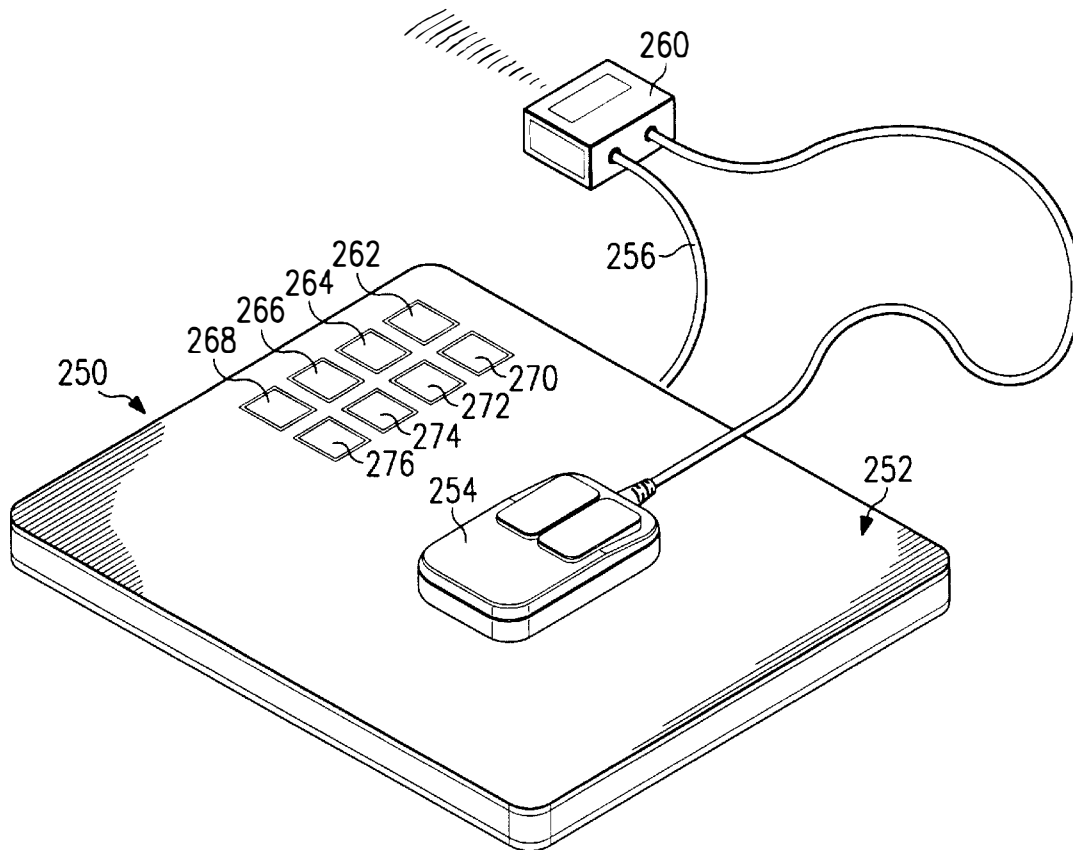

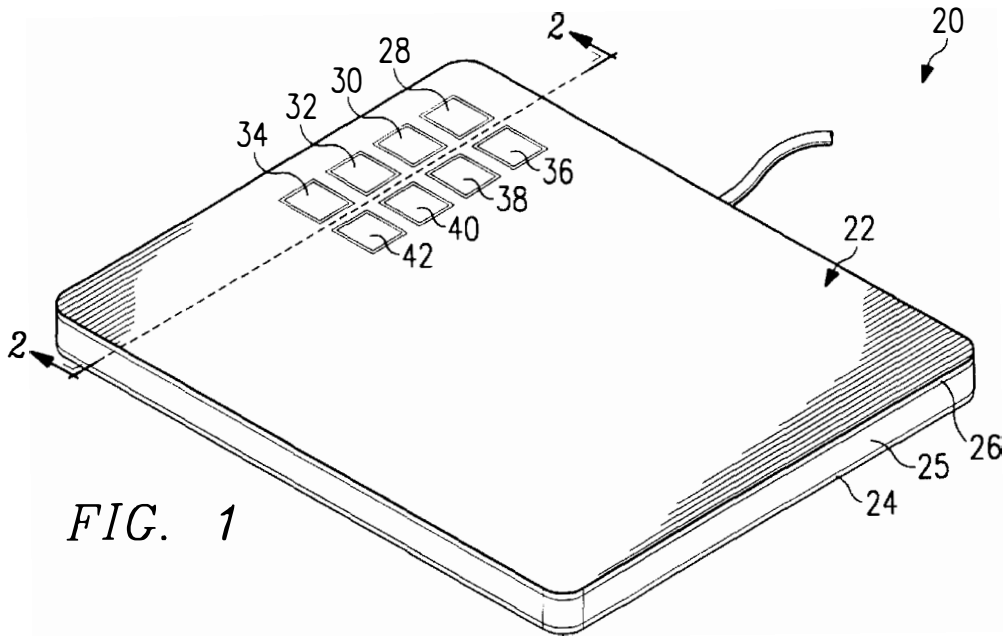

FIG. 1

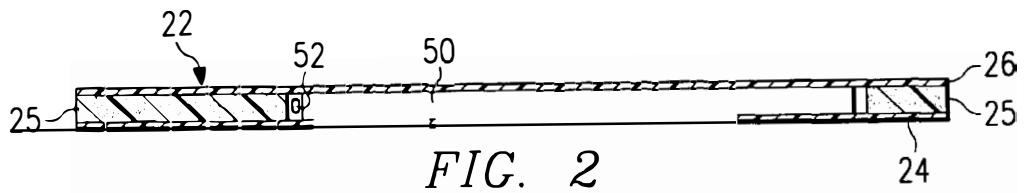

FIG. 2

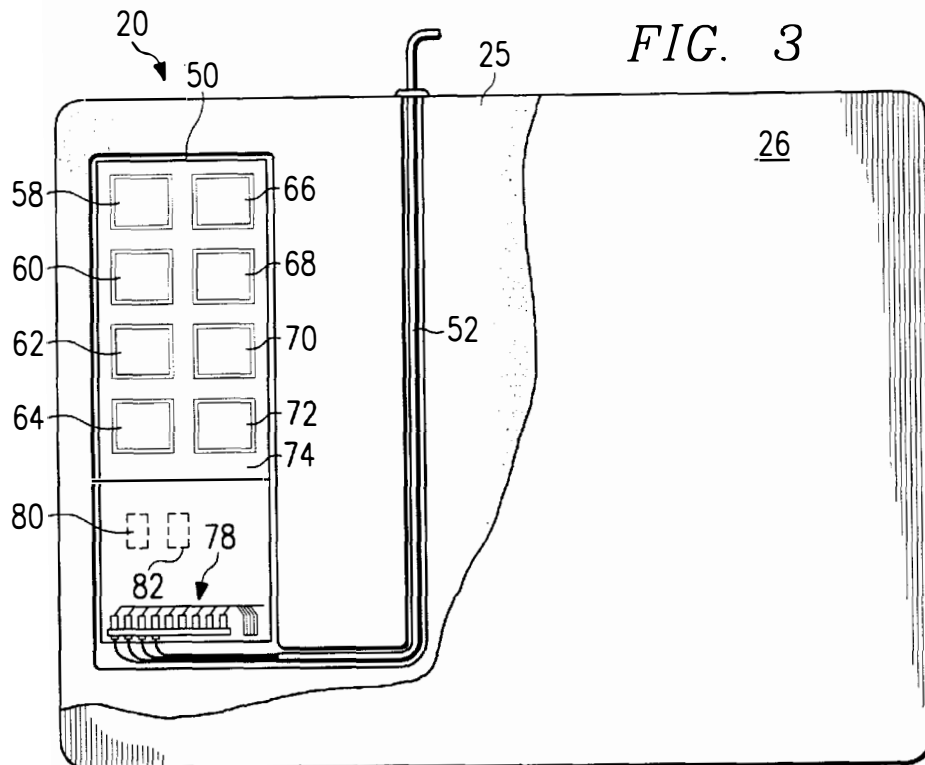

FIG. 3

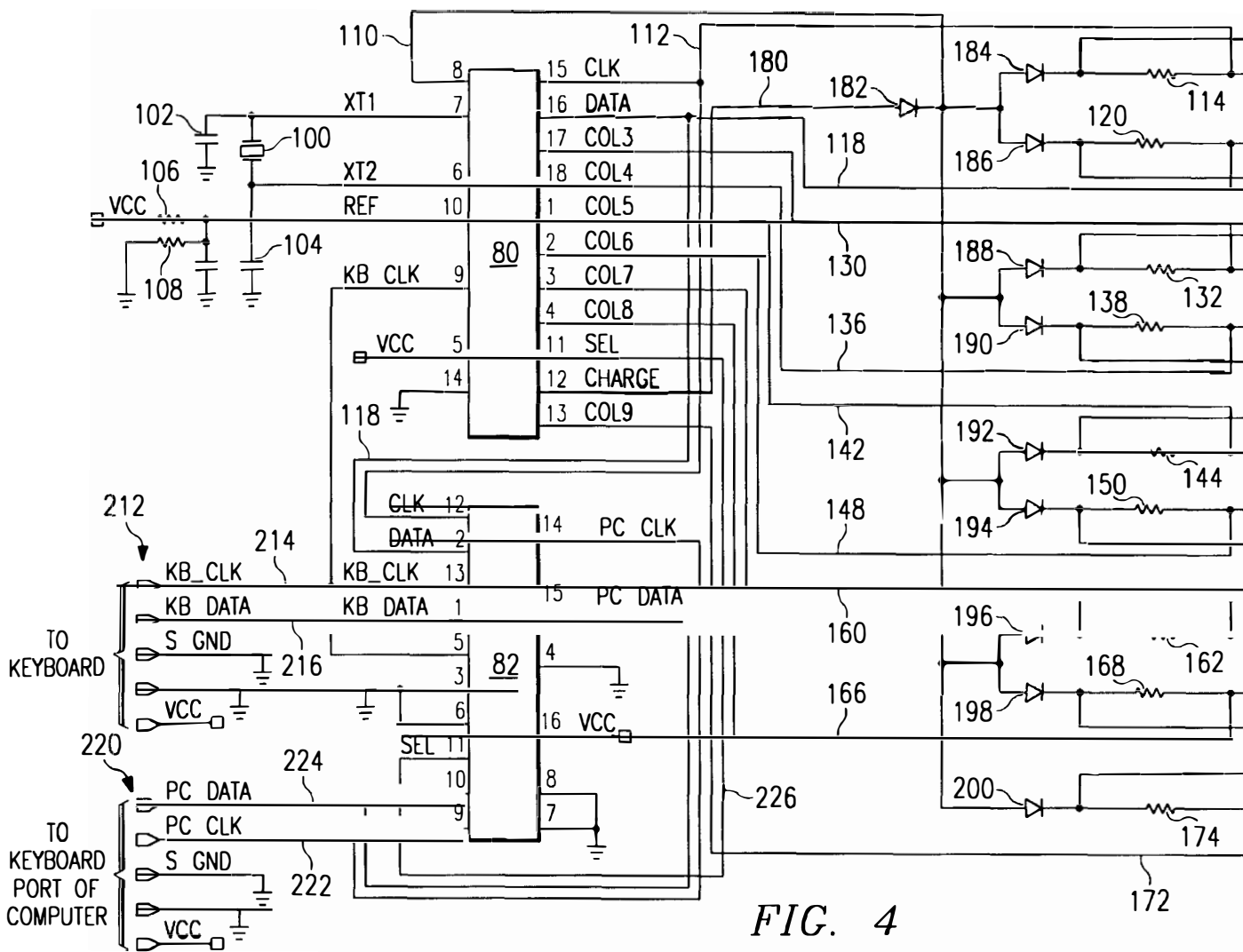

FIG. 4

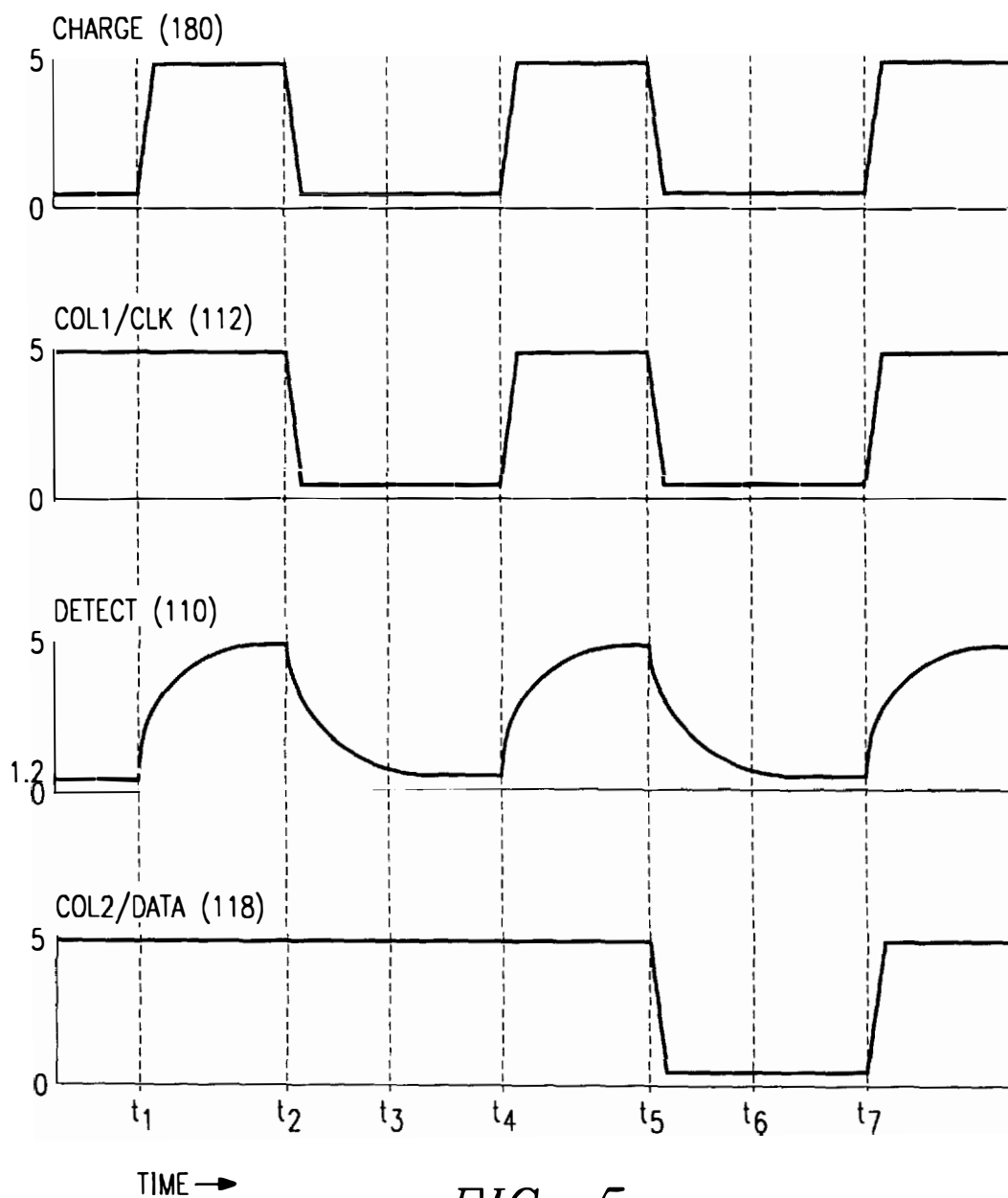

FIG. 5

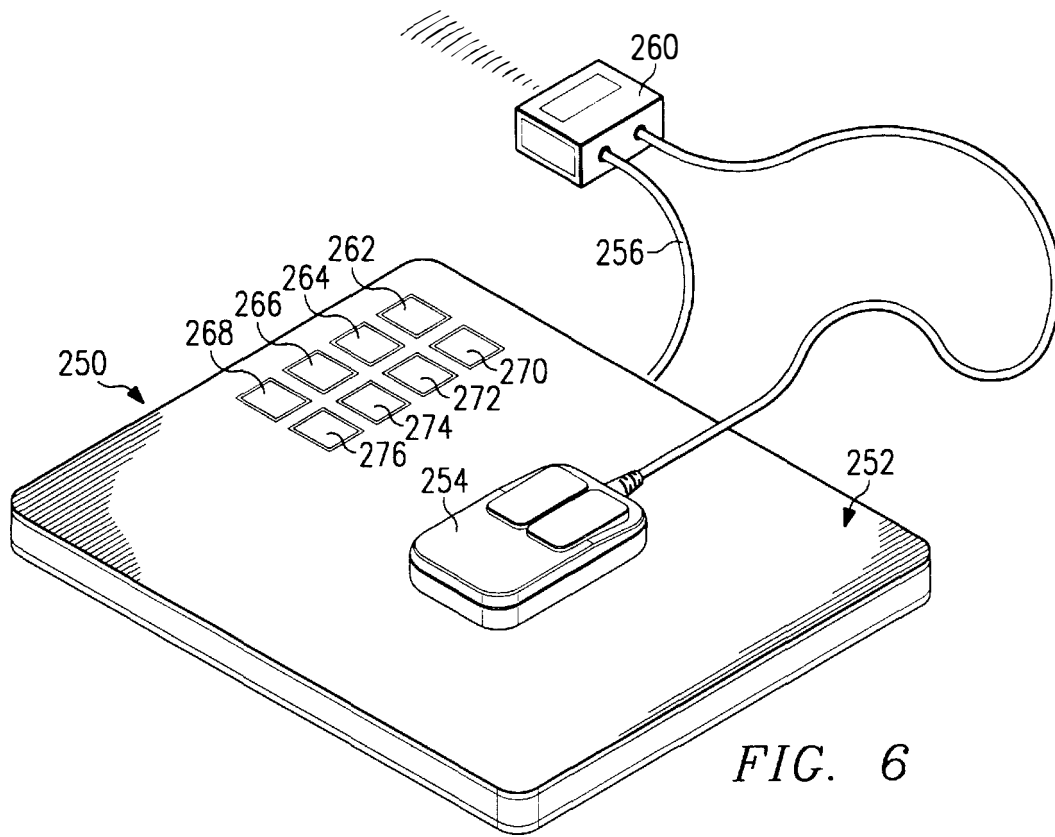

FIG. 6

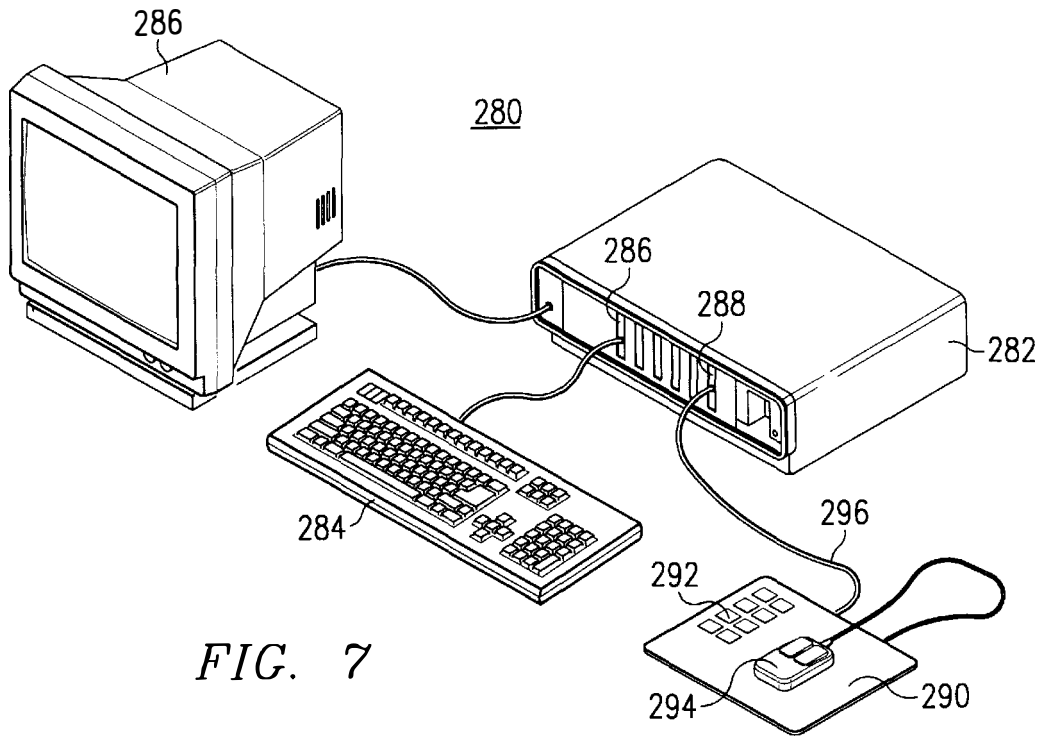

FIG. 7

Explore Litigation Insights

Docket Alarm provides insights to develop a more informed litigation strategy and the peace of mind of knowing you're on top of things.

Real-Time Litigation Alerts



Keep your litigation team up-to-date with **real-time alerts** and advanced team management tools built for the enterprise, all while greatly reducing PACER spend.

Our comprehensive service means we can handle Federal, State, and Administrative courts across the country.

Advanced Docket Research



With over 230 million records, Docket Alarm's cloud-native docket research platform finds what other services can't. Coverage includes Federal, State, plus PTAB, TTAB, ITC and NLRB decisions, all in one place.

Identify arguments that have been successful in the past with full text, pinpoint searching. Link to case law cited within any court document via Fastcase.

Analytics At Your Fingertips



Learn what happened the last time a particular judge, opposing counsel or company faced cases similar to yours.

Advanced out-of-the-box PTAB and TTAB analytics are always at your fingertips.

API

Docket Alarm offers a powerful API (application programming interface) to developers that want to integrate case filings into their apps.

LAW FIRMS

Build custom dashboards for your attorneys and clients with live data direct from the court.

Automate many repetitive legal tasks like conflict checks, document management, and marketing.

FINANCIAL INSTITUTIONS

Litigation and bankruptcy checks for companies and debtors.

E-DISCOVERY AND LEGAL VENDORS

Sync your system to PACER to automate legal marketing.