

Publications (Continued)

314. Ruffolo, R.R., Jr.: Adrenoceptors: Structure, Function and Pharmacology. Edited by R.R. Ruffolo, Jr., Harwood Academic Press, London, pp. 1-287, 1995.
315. Douglas, S.A., Vickery-Clark, L.M., Loudon, C., Ruffolo, R.R., Jr., Feuerstein, G.Z. and Ohlstein, E.O.: Acute pretreatment with carvedilol is sufficient for inhibition of neointima formation following rat carotid artery balloon angioplasty. Pharmacol. Communications 5: 65-72, 1994.
316. Autieri, M.V., Feuerstein, G.Z., Yue, T.L., Ruffolo, R.R., Jr., Ohlstein, E.H. and Douglas, S.A.: Differential gene expression associated with neointima formation induced by carotid artery balloon angioplasty in the rat. Circ. Res., submitted.
317. Feuerstein, G.Z. and Ruffolo, R.R., Jr.: Comparison of the ability of two vasodilating,  $\beta$ -blockers, carvedilol and celiprolol, to reduce infarct size in a pig model of acute myocardial infarction. Pharmacol. Communications 5: 57-63, 1994.
318. Feuerstein, G.Z., Yue, T.-L. and Ruffolo, R.R., Jr.: Carvedilol Update: A multiple action antihypertensive agent with antioxidant activity and the potential for myocardial and vascular protection (Japanese Translation). Drugs of Today 30 (Suppl. 1): 1-20, 1994.
319. Bril, A., Faivre, J.F., Forest, M.C., Cheval, B., Gout, B., Linee, Ph., Ruffolo, R.R., Jr. and Poyser, R.H.: Electrophysiological characteristics of BRL 32872, a novel antiarrhythmic agent with potassium and calcium channel blocking properties, in guinea pig cardiac isolated preparations. J. Pharmacol. Exp. Ther. 273: 1264-1272, 1995.
320. Ruffolo, R.R., Jr. and Poste, G.: A prescription for better prescriptions: A response. Issues in Science and Technology, Summer Supplement, page 9, 1994.
321. Feuerstein, G.Z. and Ruffolo, R.R., Jr.: The antiplatelet GPIIb/IIIa antibody, 7E3: A pioneer drug for the treatment of arterial thrombotic disorders. Expert Opinions in Investigational Drugs 3: 745-752, 1994.
322. Wang, X., Yue, T.-L., Barone, F.C., Ruffolo, R.R., Jr. and Feuerstein, G.Z.: Differential display of gene expression in rat focal brain ischemia. Neuroscience Protocols 95-020-02: 1-9, 1995.
323. The Contributors (Ruffolo, R.R., Jr. and 36 Other Contributors). The RBI Handbook of Receptor Classification. Edited by J.W. Kebabian and J.L. Neumeyer, Research Biochemicals International, Natick, 1994.
324. Ruffolo, R.R., Jr. and Hollinger, M.: G-Protein Coupled Transmembrane Signaling Mechanisms, edited by R.R. Ruffolo, Jr. and M. Hollinger, CRC Press, Boca Raton, pp. 1-204, 1995.

Publications (Continued)

325. Li, Y-O., Hieble, J.P., Bergma, D.J., Swift, A.M., Ganguli, S. and Ruffolo, R.R., Jr.: The  $\beta$ -hydroxyl group of catecholamines may interact with Ser<sup>90</sup> of the second transmembrane helix of the  $\alpha_2$ A-adrenoceptor. *Pharmacol. Commun.* 6: 125-131, 1995.
326. Wang, X., Yue, T.-L., Barone, F.C., Ruffolo, R.R., Jr. and Feuerstein, G.Z.: Identification of novel gene expression induced by focal ischemia using mRNA differential display. In: *Pharmacology of Cerebral Ischemia*, J. Kriegstein and H. Oberpichler-Schwenk, Editors, pp. 473-478, 1994.
327. Hieble, J.P. and Ruffolo, R.R., Jr.: Possible structural and functional relationships between imidazoline receptors and  $\alpha_2$ -adrenoceptors. *Ann. N.Y. Acad. Sci.* 763: 8-21, 1995.
328. Ruffolo, R.R., Jr.: G-Protein Coupled Transmembrane Signaling Mechanisms; Preface. in: G-Protein Coupled Transmembrane Signaling Mechanisms, edited by R.R. Ruffolo, Jr. and M. Hollinger. CRC Press, Boca Raton, pp. i-iii, 1995.
329. Bylund, D.B., Regan, J.W., Faber, J.E., Hieble, J.P., Triggle, C. and Ruffolo, R.R., Jr.: Vascular  $\alpha$ -adrenoceptors: From the gene to the human. *Can. J. Physiol. Pharmacol.* 73: 533-543, 1995.
330. Testa, R., Taddei, C., Poggesi, E., Destefani, C., Cotecchia, S., Hieble, J.P., Sulpizio, A.C., Naselsky, D., Bergsma, D., Ellis, C., Swift, A., Ganguly, S., Ruffolo, R.R., Jr. and Leonardi, A.: REC 15/2739 (SB 216469): A novel prostate selective  $\alpha_1$ -adrenoceptor antagonist. *Pharmacol. Commun.* 6: 79-86, 1995.
331. Ruffolo, R.R., Jr. and Hieble, J.P.: The Adrenoceptors: Historical perspectives, current status and future directions. *Pharmacol. Commun.* 6: 1-7, 1995.
332. Yue, T.L., Wang, X., Gu, J.L., Ruffolo, R.R., Jr. and Feuerstein, G.Z.: Carvedilol: A new vasodilating  $\beta$ -adrenoceptor blocker, inhibits oxidation of low density lipoproteins by vascular smooth muscle cells and prevents leukocyte adhesion to smooth muscle cells. *J. Pharmacol. Exp. Ther.* 273: 1442-1449, 1995.
333. Hieble, J.P., Ruffolo, R.R., Jr., Sulpizio, A.C., Naselsky, D.P., Conway, T.M., Ellis, C., Swift, A.M., Ganguly, S. and Bergsma, D.J.: Functional subclassification of  $\alpha_2$ -adrenoceptors. *Pharmacol. Commun.* 6: 91-97, 1995.
334. Li, Y-O., Hieble, J.P., Bergma, D.J., Swift, A.M., Ganguli, S. and Ruffolo, R.R., Jr.: The  $\beta$ -hydroxyl group of catecholamines may interact with Ser<sup>90</sup> of the second transmembrane helix of the  $\alpha_2$ A-adrenoceptor. In: Adrenoceptors: Structure, Function and Pharmacology, edited by R.R. Ruffolo, Jr., Harwood Academic Publishers, Reading, pp. 125-131, 1995.

Publications (Continued)

335. Testa, R., Taddei, C., Poggesi, E., Destefani, C., Cotecchia, S., Hieble, J.P., Sulpizio, A.C., Naselsky, D., Bergsma, D., Ellis, C., Swift, A., Ganguly, S., Ruffolo, R.R., Jr. and Leonardi, A.: REC 15/2739 (SB 216469): A novel prostate selective  $\alpha_1$ -adrenoceptor antagonist. In: Adrenoceptors: Structure, Function and Pharmacology, edited by R.R. Ruffolo, Jr., Harwood Academic Publishers, Reading, pp. 79-86, 1995.
336. Ruffolo, R.R., Jr. and Hieble, J.P.: The Adrenoceptors: Historical perspectives, current status and future directions. In: Adrenoceptors: Structure, Function and Pharmacology, edited by R.R. Ruffolo, Jr., Harwood Academic Publishers, Reading, pp. 1-7, 1995.
337. Hieble, J.P., Ruffolo, R.R., Jr., Sulpizio, A.C., Naselsky, D.P., Conway, T.M., Ellis, C., Swift, A.M., Ganguly, S. and Bergsma, D.J.: Functional subclassification of  $\alpha_2$ -adrenoceptors. In: Adrenoceptors: Structure, Function and Pharmacology, edited by R.R. Ruffolo, Jr., Harwood Academic Publishers, Reading, pp. 91-97, 1995.
338. Christopher, T.A., Yue, T.-L., Feuerstein, G.Z., Ruffolo, R.R., Jr., Lopez, B.L. and Ma, X.-L.: Carvedilol, a new  $\beta$ -adrenoceptor blocker, vasodilator and free radical scavenger, exerts an anti-shock and endothelial protective effect in rat splanchnic ischemia and reperfusion. *J. Pharmacol. Exp. Ther.* 273: 64-71, 1995.
339. Hieble, J.P., McCafferty, G.P., Naselsky, D.P., Bergsma, D.J. and Ruffolo, R.R., Jr.: Recent progress in the pharmacotherapy of diseases of the lower urinary tract. *European Journal of Medicinal Chemistry, Proceedings of the XIIIth International Symposium on Medicinal Chemistry*, edited by J.C. Muller, pp. 2705-2985, 1995.
340. Feuerstein, G.Z. and Ruffolo, R.R., Jr.: Ticlopidine: A novel antiplatelet drug for prevention of thrombotic disorders. *Expert Opinion in Investigational Drugs* 3: 1163-1169, 1994.
341. Hieble, J.P. and Ruffolo, R.R., Jr.: Subclassification of the  $\beta$ -adrenoceptors. *Pharmacol. Commun.* 6: 183-193, 1995.
342. Ruffolo, R.R., Jr.: Introduction. *Adrenoceptors: Structure, Function and Pharmacology*. *Pharmacol. Commun.*, page v, Volume 6 (No. 1-3), 1995.
343. Ruffolo, R.R., Jr.: *Adrenoceptors: Structure, Function and Pharmacology*; Preface. In: Adrenoceptors: Structure, Function and Pharmacology, edited by R.R. Ruffolo, Jr., Harwood Academic Publishers, Reading, pp. vii-ix, 1995.
344. Hieble, J.P. and Ruffolo, R.R., Jr.: Subclassification of the  $\beta$ -adrenoceptors. In: Adrenoceptors: Structure, Function and Pharmacology, edited by R.R. Ruffolo, Jr., Harwood Academic Publishers, Reading, pp. 183-193, 1995.

Publications (Continued)

345. Hieble, J.P., Bylund, D.B., Clarke, D.E., Eikenberg, D.C., Langer, S.Z., Lefkowitz, R.J., Minneman, K.P. and Ruffolo, R.R., Jr.: International Union of Pharmacology Nomenclature of Adrenoceptors. Recommendation for Nomenclature of  $\alpha_1$ -adrenoceptors: Consensus Update. *Pharmacol. Rev.* 47: 267-270, 1995.
346. Ruffolo, R.R., Jr.: Inflammation: Mediators and Pathways; Preface. In: Inflammation: Mediators and Pathways, edited by R.R. Ruffolo, Jr. and M. Hollinger, CRC Press, Boca Raton, pp. i-iii, 1995.
347. Lysko, P.G., Feuerstein, G.Z. and Ruffolo, R.R., Jr.: Carvedilol: A novel multiple action antihypertensive drug with multiple organ protective actions. *Pharmaceutical News* 2: 12-16, 1995.
348. Ruffolo, R.R., Jr., Bondinell, W., Ku, T., Naselsky, D.P. and Hieble, J.P.:  $\alpha_1$ -Adrenoceptors: Pharmacological classification and newer therapeutic applications. *Proc. West. Pharmacol. Soc.* 38: 121-126, 1995.
349. Feuerstein, G.Z. and Ruffolo, R.R., Jr.: Vascular restenosis: a disease in search of therapy. *Expert Opinion in Investigational Drugs* 4(3): 237-242, 1995.
350. Ruffolo, R.R., Jr.: Cardiovascular Drugs: Past, Present and Future. *Pharmaceutical News* 2(2): 13-15, 1995.
351. Yue, T-L., Gu, J-L., Lysko, P.M., Sponer, G., Cheng, H.Y., Ruffolo, R.R., Jr. and Feuerstein, G.Z.: Antioxidant activity of a  $\beta$ -adrenoceptor antagonist, Carazolol: Comparison with Propranolol and Carvedilol. *Pharmacol. Commun.* 7: 11-19, 1995.
352. Feuerstein, G.Z., Poste, G.P. and Ruffolo, R.R., Jr.: Carvedilol Update III. Rationale for Use in Congestive Heart Failure. *Drugs of Today* 31: 307-326, 1995.
353. Feuerstein, G.Z., Nichols, A.J. and Ruffolo, R.R., Jr.: Clopidogrel: A novel antiplatelet drug for prevention and treatment of thrombotic disorders. *Expert Opinion on Investigational New Drugs* 4: 425-430, 1995.
354. Bril, A., Gout, B., Bonhomme, M., Landais, L., Faiure, J.F., Linee, P., Poyser, R.P. and Ruffolo, R.R., Jr.: Combined potassium and calcium channel blocking activities as a basis for antiarrhythmic efficacy with low proarrhythmic risk: experimental profile of BRL 32872. *J. Pharmacol. Exp. Ther.*, in press.
355. Ruffolo, R.R., Jr.: Editor, Special Issue. Pharmacology of Adrenoceptors. *Pharmacol. Comm.*, Volume 6, Numbers 1-3, pp. 1-279, 1995.
356. Ruffolo, R.R., Jr. and Hollinger, M.A.: Inflammation: Mediators and Pathways. Edited by R.R. Ruffolo, Jr. and M.A. Hollinger, CRC Press, Boca Raton, pp. 1-206, 1995.

Publications (Continued)

357. Yue, T.L., Wang, X., Gu, J.L., Ruffolo, R.R., Jr. and Feuerstein, G.Z.: Carvedilol prevents low-density lipoprotein (LDL)-enhanced monocyte adhesion to endothelial cells by inhibition of LDL oxidation. *Eur. J. Pharmacol.* 294: 585-591, 1995.
358. Ma, X.L., Yue, T.L., Lopez, B.L., Barone, F.C., Christopher, T.A., Ruffolo, R.R., Jr. and Feuerstein, G.Z.: Carvedilol, a new  $\beta$ -adrenoceptor blocker and free radical scavenger, attenuates myocardial ischemia-reperfusion injury in hypercholesterolemic rabbits. *J. Pharmacol. Exp. Ther.* 227: 128-136, 1996.
359. Ruffolo, R.R., Jr. and Feuerstein, G.Z.: The Pharmacology of Carvedilol: Rationale for use in hypertension, coronary artery disease and congestive heart failure. *Cardiovasc. Drugs Ther.* 11: 247-256, 1997.
360. Hieble, J.P. and Ruffolo, R.R., Jr.: Subclassification and nomenclature of  $\alpha_1$ - and  $\alpha_2$ -adrenoceptors. In: Progress in Drug Research, Volume 47, edited by E. Jucker, Birkhauser Verlag, Basel, pp. 81-130, 1996.
361. Li, Y.-O., Hieble, J.P., Bergsma, D.J., Swift, A.M., Ganguly, S. and Ruffolo, R.R., Jr.: Identification of potential sites for interactions of catecholamines with the  $\alpha_2A$ -adrenoceptor by site-directed mutagenesis: The molecular basis for the Easson-Stedman Hypothesis. Submitted for publication.
362. Ohlstein, E.H., Elliott, J.P., Feuerstein, G.Z., and Ruffolo, R.R., Jr.: Endothelin receptors: Receptor classification, novel receptor antagonists and potential therapeutic targets. *Med. Res. Rev.* 16: 365-390, 1996.
363. Hieble, J.P., Ruffolo, R.R., Jr. and Starke, K. Identification, characterization and subclassification of  $\alpha_2$ -adrenoceptors: An overview. In:  $\alpha_2$ -Adrenergic Receptors: Structure, Function and Therapeutic Implications, Edited by S.M. Lanier and L. Limbird, Harwood Academic Publishers, Reading, pp. 1-18-, 1996.
364. Feuerstein, G.Z., Fisher, M., Nunnari, M. and Ruffolo, R.R., Jr.: Carvedilol inhibits aortic lipid deposition in the hypercholesterolemic rat. *Pharmacology* 54: 24-32, 1997.
365. Lukas, M.A., Ruffolo, R.R., Jr., Shusterman, N.H., Sponer, G. and Strein, K.: Method of treatment for decreasing mortality resulting from congestive heart failure. United States Patent #5,760,069, June 2, 1998.
366. Lopez, B.L., Christopher, T.A., Yue, T.L., Ruffolo, R.R., Jr., Feuerstein, G.Z. and Ma, X.L. Carvedilol, a new  $\beta$ -adrenoceptor blocker antihypertensive drug, protects against free-radical-induced endothelial dysfunction. *Pharmacology* 51: 165-173, 1995.

Publications (Continued)

367. Hieble, J.P., Hehr, A., Li, Y-O., Naselsky, D.P. and Ruffolo, R.R., Jr.: Characterization of stereoselective interactions of catecholamines with the  $\alpha_{2A}$ -adrenoceptor via site-directed mutagenesis. In:  $\alpha_2$ -Adrenergic Receptors: Structure, Function and Therapeutic Implications, Edited by S.M. Lanier and L. Limbird, Harwood Academic Publishers, Reading, pp. 43-51, 1996.
368. Feuerstein, G.Z. and Ruffolo, R.R., Jr.: Carvedilol: Preclinical profile and rationale for its use in hypertension, coronary syndromes and congestive heart failure. Cardiovascular Reviews and Reports 17: 27-38, 1996.
369. Wang, X., Ruffolo, R.R., Jr. and Feuerstein, G.Z.: mRNA Differential Display: A new technology for discovery of novel pharmacological targets. Trends Pharmacol. Sci. 17: 276-279, 1996.
370. Wang, X., Yue, T-L., Barone, F.C., White, R.F., Clark, R.K., Willette, R.N., Sulpizio, A.C., Aiyar, N.V., Ruffolo, R.R., Jr. and Feuerstein, G.Z.: Discovery of adrenomedullin in rat ischemic cortex and evidence for its role in exacerbating focal brain ischemic damage. Proc. Natl. Acad. Sci. 92: 11480-11484, 1995.
371. Hieble, J.P. and Ruffolo, R.R., Jr.: The use of  $\alpha$ -adrenoceptor antagonists in the pharmacological management of benign prostatic hypertrophy: an overview. Pharmacol. Res. 33: 145-160, 1996.
372. Feuerstein, G.Z. and Ruffolo, R.R., Jr.: Gene therapy for restenosis: status, issues and future directions. In: Coronary Restenosis: From Genetics and Therapeutics, edited by G.Z. Feuerstein, Marcel Dekker, New York, pp. 455-468, 1996.
373. Hehr, A., Hieble, J.P., Li, Y-O., Bergsma, D.J., Swift, A.M., Ganguly, S. and Ruffolo, R.R., Jr.: Serine<sup>185</sup> of transmembrane helix IV is not involved in the interaction of catecholamines with the  $\alpha_{2A}$ -adrenoceptor. Pharmacology 55:18-24, 1997.
374. Hieble, J.P., Naselsky, D.P., Arch, J.R.S., Chapman, H., Smith, S.A., Poyser, R.H. and Ruffolo, R.R., Jr.: Affinity of carvedilol for recombinant human adrenoceptors. Pharmacol. Rev. Commun. 10: 43-50, 1998.
375. Ruffolo, R.R., Jr., Trendelenburg, U. and Langer, S.Z.: Chemical Neurotransmission: Peripheral Autonomic Nervous System. In: Principles of Pharmacology. Edited by P.L. Munson, R.A. Mueller and G.R. Breese, Chapman and Hall, New York, in press.
376. Feuerstein, G.Z., Bril, A. and Ruffolo, R.R., Jr.: Sotalol and d-Sotalol: Apparent benefits of  $\beta$ -blocking activity for ventricular arrhythmias. Expert Opinion on Investigational Drugs 5: 575-580, 1996.

Publications (Continued)

377. Hieble, J.P. and Ruffolo, R.R., Jr.: Adrenergic pharmacology of carvedilol. In: Carvedilol: A Multiple Action Neurohormonal Antagonist. Edited by R.R. Ruffolo, Jr., G. Poste and C. Sohn, Harwood Academic Publishers, London, in press.
378. Gellai, M., Brooks, D.P., Bril, A. and Ruffolo, R.R., Jr.: Hemodynamic effects of carvedilol. In: Carvedilol: A Multiple Action Neurohormonal Antagonist. Edited by R.R. Ruffolo, Jr., G. Poste and C. Sohn, Harwood Academic Publishers, London, in press.
379. Feuerstein, G.Z., Yue, T-L. and Ruffolo, R.R., Jr.: Antioxidant activity of carvedilol. In: Carvedilol: A Multiple Action Neurohormonal Antagonist. Edited by R.R. Ruffolo, Jr., G. Poste and C. Sohn, Harwood Academic Publishers, London, in press.
380. Feuerstein, G.Z., Bril, A., Ohlstein, E.H., Brooks, D.P. and Ruffolo, R.R., Jr.: Major organ protection by carvedilol (heart/cardioprotection, kidneys/ renoprotection, de-emphasis blood vessels/remodeling, brain). In: Carvedilol: A Multiple Action Neurohormonal Antagonist. Edited by R.R. Ruffolo, Jr., G. Poste and C. Sohn, Harwood Academic Publishers, London, in press.
381. Feuerstein, G.Z., Ohlstein, E.H., Poste, G., Ma, X, Yue, T-L., Ruffolo, R.R., Jr.: Apoptosis, adhesion molecules, endothelial function, foam cells, gene expression - Additional actions of carvedilol. In: Carvedilol: A Multiple Action Neurohormonal Antagonist. Edited by R.R. Ruffolo, Jr., G. Poste and C. Sohn, Harwood Academic Publishers, London, in press.
382. Feuerstein, G.Z., Yue, T-L. and Ruffolo, R.R., Jr.: Emerging concepts in heart failure: Apoptosis in CHF. In: Carvedilol: A Multiple Action Neurohormonal Antagonist. Edited by R.R. Ruffolo, Jr., G. Poste and C. Sohn, Harwood Academic Publishers, London, in press.
383. Ruffolo, R.R., Jr., Feuerstein, G.Z., Poste, G. and Ma, X.: Introduction: Rationale for use of carvedilol in hypertension, coronary artery disease and congestive heart failure. In: Carvedilol: A Multiple Action Neurohormonal Antagonist. Edited by R.R. Ruffolo, Jr., G. Poste and C. Sohn, Harwood Academic Publishers, London, in press.
384. Feuerstein, G.Z., Shusterman, N.H., Poste, G. and Ruffolo, R.R., Jr.:  $\beta$ -Blockers and heart failure: Rationale and highlights from the Carvedilol Heart Failure Trials. Drug News and Perspectives 3: 18-22, 1996.
385. Ruffolo, R.R., Jr.: Carvedilol: an  $\alpha$ - and  $\beta$ -adrenoceptor antagonist that inhibits LDL oxidation. Proceedings from the International Symposium on Lipoprotein Oxidation and Atherosclerosis: Biological and Clinical Aspects, edited by G. Finardi, G. Bellomo and E. Maggi, Richelieu Press, pp. 19-23, 1996.

Publications (Continued)

386. Ruffolo, R.R., Jr. and Feuerstein, G.Z.: Carvedilol: Preclinical profile and mechanisms of action in preventing the progression of congestive heart failure. *Eur. Heart J.* 19 (Suppl. B): B19-B24, 1998.
387. Hieble, J.P. and Ruffolo, R.R., Jr.: Experimental and emerging drugs:  $\alpha$ -Adrenoceptor Agonists and Antagonists. In: Receptor-Based Drug Design, edited by P. Leff, Marcel Dekker, New York, pp. 231-252, 1998.
388. Ruffolo, R.R., Jr.: The role of  $\alpha$ - and  $\beta$ -adrenoceptors in cardiovascular diseases: Recent developments. In: Proceedings of Euro-Conference Symposium on the Role of Drug Receptors in Cardiovascular Disease. Edited by B. Verstig, 1996.
389. Bril, A., Feuerstein, G.Z. and Ruffolo, R.R., Jr.: Carvedilol, a new paradigm for the treatment of congestive heart failure. *Expert Opinion on Investigational Drugs* 5: 1523-1529, 1996.
390. Feuerstein, G. and Ruffolo, R.R., Jr.:  $\beta$ -Blockers in congestive heart failure. The pharmacology of carvedilol, a vasodilating  $\beta$ -blocker and antioxidant and its therapeutic utility in congestive heart failure. In: Catecholamines, Bridging Basic Science with Clinical Medicine. Edited by D.S. Goldstein, G. Eisenhofer and R. McCarthy, Academic Press, London. *Adv. Pharmacol.* 42: 611-615, 1998.
391. Feuerstein, G.Z., Poste, G., Shusterman, N.H. and Ruffolo, R.R., Jr.: The changing paradigm for pharmacotherapy of congestive heart failure. *Cardiovasc. Drugs Ther.* 11: 9S-14S, 1998.
392. Ruffolo, R.R., Jr., Feuerstein, G.Z. and Ohlstein, E.H.: Recent observations with  $\beta$ -adrenoceptor blockade: Beneficial effects in hypertension and heart failure. *Am. J. Hypertension* 11 (Suppl.):9S-14S, 1998.
393. Hieble, J.P. and Ruffolo, R.R., Jr.: Pharmacotherapy of benign prostatic hypertrophy with  $\alpha_1$ -adrenoceptor agonists. *Pharmacol. Rev. Commun.* 8:251-256, 1996.
394. Feuerstein, G.Z., Ruffolo, R.R., Jr. and Samanen, J.: The integrin  $\alpha$ II  $\beta_3$  (GPIIb/IIIa). A target for novel antiplatelet drugs. *Pharmacol. Rev. Commun.* 8: 257-265, 1996.
395. Hieble, J.P. and Ruffolo, R.R., Jr.: Recent advances in the identification of  $\alpha_1$ - and  $\alpha_2$ -adrenoceptor subtypes: Therapeutic implications. *Expert Opinion on Investigational Drugs* 6: 367-387, 1997.
396. Feuerstein, G.Z., Bril, A. and Ruffolo, R.R., Jr.: Pharmacology of  $\beta$ -Blockers: Protective effects of carvedilol in the myocardium. *Am. J. Cardiol.* 80(11A): 41L-45L, 1997.



Publications (Continued)

397. Feuerstein, G.Z., Ruffolo, R.R., Jr. and Yue, T-L.: Apoptosis and congestive heart failure. *Cardiovascular Medicine* 7: 249-255, 1997.
398. Feuerstein, G.Z., Shusterman, N., Ruffolo, R.R., Jr.: Carvedilol Update IV: Prevention of oxidative stress, cardiac remodeling and progression of congestive heart failure. *Drugs of Today* 33: 453-473, 1997.
399. Ruffolo, R.R., Jr.: Pharmacology of  $\beta$ -adrenoceptor blockade. *Perspectives in Cardiology* (Supplement, August 1997); *Proceedings of the International Meeting of the Canadian Cardiac Society Symposium on Evolution of Heart Failure Management: Emerging role of  $\beta$ -blockers*, pp. 11-14, 1997.
400. Ma, X.L., Lopez, B.L., Liu, G.L., Christopher, T.A., Gao, F., Guo, Y., Feuerstein, G.Z., Ruffolo, R.R., Jr., Barone, F.C. and Yue, T.L.: Hypercholesterolemia impairs a detoxification mechanism against peroxynitrite and renders the vascular tissue more susceptible to oxidative injury. *Circ. Res.* 80: 894-901, 1997.
401. Feuerstein, G.Z. and Ruffolo, R.R., Jr.: The Pharmacology of Carvedilol. *Trends Pharmacol. Sci.*, in press.
402. Gurbanov, K., Callanan, E., Feuerstein, G.Z., Ruffolo, R.R., Jr., Brodski, S., Hoffman, A., Haramati, A. and Winaver, J.: Effects of carvedilol on renal function in rats with experimental congestive heart failure. *International J. Science Medicine*, 2005.
403. Griswold, D., Ruffolo, R.R., Jr., Poste, G. and Torphy, T.J.: Prostaglandin H2 synthase isoforms and their relationship to gastrointestinal side effects. *Trends in Pharmacol. Sci.* 18: 311-313, 1997.
404. Yue, T-L., Ma, X-L., Wang, X., Romanic, A.M., Liu, G-L., Londen, C., Gu, J-L., Kumar, S., Poste, G., Ruffolo, R.R., Jr. and Feuerstein, G.Z.: Possible involvement of the stress-activated protein kinase signaling pathway and Fas receptor expression in prevention of ischemia/reperfusion induced cardiomyocyte apoptosis by carvedilol. *Circ. Res.* 82: 166-174, 1998.
405. Ruffolo, R.R., Jr., Poste, G.P. and Metcalf, B.W.: Preface to the Series. In: Cell Cycle Regulation. Edited by R. Ruffolo, Jr., G. Poste and B. Metcalf, Harwood Academic Publishers, London, pp. xi-xii, 1997.
406. Ruffolo, R.R., Jr., Poste, G. and Metcalf, B.W.: Preface to the Volume. In: Cell Cycle Regulation. Edited by R. Ruffolo, Jr., G. Poste and B. Metcalf, Harwood Academic Publishers, London, pp. xiii-xiv, 1997.
407. Ruffolo, R.R., Jr. and Feuerstein, G.Z.: Neurohormonal activation, oxygen free radicals and apoptosis in the pathogenesis of congestive heart failure. *J. Cardiovasc. Pharmacol.* 32 (Suppl. 1): S22-S30, 1998.

Publications (Continued)

408. Ohlstein, E.H., Brooks, D.P., Feuerstein, G.Z. and Ruffolo, R.R., Jr.: Inhibition of sympathetic outflow by the angiotensin II receptor antagonist, eprosartan, but not by losartan, valsartan and irbesartan: Possible relationship to differences in prejunctional angiotensin II receptor blockade. *Pharmacology* 55: 244-251, 1997.
409. Feuerstein, G.Z. and Ruffolo, R.R., Jr.: Congestive Heart Failure and genomic medicine: A look into the 21st Century. *Cardiovasc. Drugs Ther.* 11: 713-717, 1997.
410. Willette, R.N., Mitchell, M.P., Ohlstein, E.H., Lukas, M.A. and Ruffolo, R.R., Jr.: Evaluation of intrinsic sympathomimetic activity of bucindolol and carvedilol in rat heart. *Pharmacology* 56: 30-36, 1998.
411. Ruffolo, R.R., Jr., Poste, G. and Metcalf, B.W. Cell Cycle Regulation. Edited by R.R. Ruffolo, Jr., G. Poste and B.W. Metcalf, Harwood Academic Publishers, London, pp. 1-174, 1997.
412. Feuerstein, G.Z., Liu, G.L., Yue, T.L., Cheng, H.Y., Hieble, J.P., Arch, J., Ruffolo, R.R., Jr. and Ma, X.L.: Comparison of metoprolol and carvedilol pharmacology and cardioprotection in rabbit ischemia and reperfusion model. Proceedings from the XIIIth World Congress of Cardiology, Monduzzi Editore S.p.A., Bologna, Italy, pp. 959-963, 1998.
413. Yue, T.L., Ma, X.L., Gu, J.L., Ruffolo, R.R., Jr. and Feuerstein, G.Z.: Carvedilol inhibits activation of stress-activated protein kinase and reduces reperfusion injury in perfused rabbit heart. *Eur. J. Pharmacol.* 345: 61-65, 1998.
414. Brodsky, S., Gurbanov, K., Abassi, Z., Hoffman, A., Ruffolo, R.R., Jr., Feuerstein, G.Z. and Winaver, J.: Effect of eprosartan on renal function and cardiac hypertrophy in rats with experimental heart failure. *Hypertension* 32: 746-752, 1998.
415. Gellai, M., Schreiner, G.T., Ruffolo, R.R., Jr., Fletcher, T., DeWolf, R. and Brooks, D.P.: CVT-124, a novel adenosine A1 receptor antagonist with unique diuretic activities. *J. Pharmacol. Exp. Ther.* 286: 1191-1196, 1998.
416. Brunvand, H., Liu, G., Ma, X.L., Yue, T.L., Ruffolo, R.R., Jr. and Feuerstein, G.Z.: SB 211475, a metabolite of carvedilol, reduces infarct size after myocardial ischemic and reperfusion injury in rabbits. *Eur. J. Pharmacol.* 356: 193-198, 1998.
417. Ruffolo, R.R., Jr., Poste, G. and Metcalf, B.W.: Inflammatory cells and mediators in central nervous system diseases; Preface to the Series. In: Inflammatory Cells and Mediators in Central Nervous System Diseases. Edited by R.R. Ruffolo, Jr., G. Poste and B.W. Metcalf, Harwood Academic Publishers, London, pp. XI-XII, 1999.

Publications (Continued)

418. Edwards, R.M., Ruffolo, R.R., Jr. and Brooks, D.P.: Pharmacology of the angiotensin II receptor antagonist, eprosartan. *Expert Opinion on Investigational Drugs* 7: 463-469, 1998.
419. Christopher, T.A., Lopez, B.L., Ma, X.L., Feuerstein, G.Z., Ruffolo, R.R., Jr. and Yue, T.L.: Effects of a hydroxylated metabolite of the  $\beta$ -adrenoceptor antagonist, carvedilol, on post-ischemic splanchnic tissue injury. *Br. J. Pharmacol.* 123: 292-298, 1998.
420. Ruffolo, R.R., Jr.: Pharmacology of Carvedilol. Proceedings of the Canadian Cardiac Society Symposium on Congestive Heart Failure. *New Advances in the Treatment of Congestive Heart Failure*, pp. 9-10, 1998.
421. Humphrey, P.P.A. and Ruffolo, R.R., Jr.: The IUPHAR Compendium on Receptor Characterization and Classification: Preface. In: The IUPHAR Compendium of Receptor Characterization and Classification. Edited by P. Godfraind, P.M. Vanhoutte, R.R. Ruffolo, Jr. and P. Humphrey, IUPHAR Media, Burlington Press, Cambridge, pp. vii, 1998.
422. Hieble, J.P., Hehr, A., Li, Y.O. and Ruffolo, R.R., Jr.: Molecular basis for the stereoselective interactions of catecholamines with  $\alpha$ -adrenoceptors. *Proc. West. Pharmacol. Soc.* 41: 225-228, 1998.
423. Godfraind, T., Vanhoutte, P.M., Ruffolo, R.R., Jr. and Humphrey, P.: The IUPHAR Compendium of Receptor Characterization and Classification. IUPHAR Media, Burlington Press, Cambridge, 267 pages, 1998.
424. Hieble, J.P., Kolpak, D.C., McCafferty, G.P., Ruffolo, R.R., Jr., Testa, R. and Leonardi, A.: Effects of  $\alpha_1$ -adrenoceptor antagonists on agonist and tilt-induced changes in blood pressure: relationships to uroselectivity. *Eur. J. Pharmacol.* 373: 51-62, 1999.
425. Feuerstein, G.Z., Yue, T.L. and Ruffolo, R.R., Jr.: Novel mechanisms in the treatment of heart failure: Inhibition of oxygen radicals and apoptosis by carvedilol. *Prog. Cardiovasc. Dis.* 41(Suppl. 1), 17-24, 1998.
426. Gurbanov, K.G., Chandra, S., Schaffer, T., Freed, T., Sarkar, S.K., Ohlstein, E.H., Ruffolo, R.R., Jr. and Feuerstein, G.Z.: Use of serial cardiac-gated magnetic resonance imaging for analysis of cardiac function and structure in experimental congestive heart failure: studies with carvedilol. In press.
427. Brooks, D.P., Feuerstein, G.Z., Ohlstein, E.O. and Ruffolo, R.R., Jr.: Method for treating isolated systolic hypertension. United States Patent, P50667. 9.13.99.
428. Jobe, P.C., Adams-Curtis, L., Burks, T.F., Fuller, R.W., Peck, C.C., Ruffolo, R.R., Snead, O.C., Woosley, R.L.: The essential role of integrative biomedical sciences in protecting and contributing to the Health and Well Being of our Nation. *The Pharmacologist* 40: 32-37, 1998.

Publications (Continued)

429. Brodsky, S., Gurbanov, K., Abassi, Z., Hoffman, A., Ruffolo, R.R., Jr., Feuerstein, G.Z. and Winaver, J.: Effects of eprosartan on renal function and cardiac hypertrophy in rats with experimental heart failure. *Hypertension* 32: 746-752, 1998.
430. Ruffolo, R.R., Jr. and Hieble, J.P.: Adrenoceptor Pharmacology: Urogenital Applications. *Eur. Urology* 36 (Suppl. 1): 17-22, 1999.
431. Brooks, D.P. and Ruffolo, R.R., Jr.: Pharmacological mechanisms of angiotensin II receptor antagonists: implication for the treatment of elevated systolic blood pressure. *J. Hypertension* 17 (Suppl. 2): S27-S32, 1999.
432. Bylund, D.B., Bond, R.P., Clarke, D.E., Eikenburg, D.C., Hieble, J.P., Langer, S.Z., Lefkowitz, R.J., Minneman, K.P., Molinoff, P.B., Ruffolo, R.R., Strosberg, A.D. and Trendelenburg, U.G.: Adrenoceptors. In: The IUPHAR Compendium of Receptor Characterization and Classification. Edited by T. Godfraind, P.M. Vanhoutte, R.R. Ruffolo, Jr. and P. Humphrey. Published by IUPHAR Media, Burlington Press, Cambridge, pp. 58-74, 1998.
433. Douglas, S.A., Nambi, P., Gellai, M., Luengo, J.I., Xiang, J.N., Brooks, D.P., Ruffolo, R.R., Jr., Elliott, J.D. and Ohlstein, E.O.: Pharmacologic characterization of the novel, orally available endothelin-A-selective antagonist, SB 247083. *J. Cardiovasc. Pharmacol.* 31: S273-S276, 1998.
434. Ruffolo, R.R., Jr. and Feuerstein, G.Z.: Recent developments in the use of beta-blockers in the treatment of heart failure. *Pharmacol. and Toxicol.* 83 (Suppl. 1): 42-43, 1998.
435. Feuerstein, G., Liu, G.L., Yue, T.L., Cheng, H.Y., Hieble, J.P., Arch, J.R.S., Ruffolo, R.R., Jr. and Ma, X.L.: Comparison of metoprolol and carvedilol pharmacology and cardioprotection in rabbit ischemia and reperfusion model. *Eur. J. Pharmacol.* 351: 341-350, 1998.
436. Feuerstein, G.Z., Shusterman, N.H., Poste, G. and Ruffolo, R.R., Jr.: The changing paradigm for pharmacotherapy of congestive heart failure. *Internat. J. Cardiovasc. Med. Sci.* 1/2: 171-189, 1998.
437. Willette, R.N., Aiyar, N., Yue, T.L., Mitchell, M.P., Disa, J., Storer, B.L., Naselsky, D.P., Stadel, J.M., Ohlstein, E.O. and Ruffolo, R.R., Jr.: In vitro and in vitro characterization of intrinsic sympathomimetic activity in normal and heart failure rats. *J. Pharmacol. Exp. Ther.* 289: 48-53, 1999.
438. Gubanov, K.G., Schaffer, C.S., Freed, T., Ruffolo, R.R., Jr., Sarkar, S.K., Ohlstein, E.O. and Feuerstein, G.Z.: Utilization of Magnetic Resonance Imaging (MRI) for analysis of cardiac structure and function in rat: Studies with the cardioprotective drug carvedilol. *J. Cardiovasc. Med. Sci.*, submitted.

Publications (Continued)

439. Yue, T.L., Ruffolo, R.R., Jr. and Feuerstein, G.Z.: Antioxidant action of carvedilol. A potential role in the treatment of heart failure. *Heart Failure Reviews* 4: 39-51, 1999.
440. Ruffolo, R.R., Jr.: Inflammatory Cells and Mediators in CNS Diseases. Preface to the volume. In: Inflammatory Cells and Mediators in CNS Diseases, edited by, R.R. Ruffolo, Jr., G.Z. Feuerstein, A.J. Hunter, G. Poste and B.W. Metcalf. Harwood Academic Publishers, London, pp. XIII-XV, 1999.
441. Ruffolo, R.R., Jr., Feuerstein, G.Z., Hunter, A.J., Poste, G. and Metcalf, B.W.: Inflammatory Cells and Mediators in CNS Diseases. Harwood Academic Publishers, London, pp. 1-518, 1999.
442. Yue, T.L., Ohlstein, E.H. and Ruffolo, R.R., Jr.: Apoptosis: A potential target for discovering novel therapies for cardiovascular diseases. *Current Opinion in Chemical Biology* 3: 474-480, 1999.
443. Ruffolo, R.R., Jr.: Use of carbazole compounds for the treatment of congestive heart failure. U.S. Patent Number 5,902,821, May 11, 1999.
444. Ohlstein, E.H., Ruffolo, R.R., Jr. and Elliott, J.D.: Drug discovery in the next millennium. *Ann. Rev. Pharmacol. Toxicol.* 40: 177-191, 2000.
445. Ruffolo, R.R., Jr.: Apoptosis in Health and Disease; Preface to the Series. In: Apoptosis in Health and Disease, edited by R.R. Ruffolo, Jr. and F. Walsh, Harwood Academic Publishers, London, IX-X, 2000.
446. Ruffolo, R.R., Jr.: Apoptosis in Health and Disease; Preface to the Volume. In: Apoptosis in Health and Disease, edited by R.R. Ruffolo, Jr. and F. Walsh, Harwood Academic Publishers, London, XI-XII, 2000.
447. Brooks, D.P., Ohlstein, E.H. and Ruffolo, R.R., Jr.: Pharmacology of eprosartan, an angiotensin II receptor antagonist: Exploring hypotheses from clinical data. *Am. Heart J.* 138: S246-S251, 1999.
448. Ruffolo, R.R., Jr. and Walsh, F.: Apoptosis in Health and Disease. Harwood Academic Publishers, London, 2000 (249 pages).
449. Gao, F., Chen, J., Lopez, B.L., Christopher, T.A., Gu, J., Lysko, P., Ruffolo, R.R., Jr., Ohlstein, E.O., Ma, X.L. and Yue, T.L.: Comparison of Bisoprolol and Carvedilol cardioprotection in a rabbit ischemia and reperfusion model. *Eur. J. Pharmacol.* 406: 109-116, 2000.
450. Spedding, M. and Ruffolo, R.R., Jr.: Current Status of the International Union of Pharmacology Committee on Receptor Nomenclature and Drug Classification (NC-IUPHAR). In: The IUPHAR Compendium of Receptor Characterization and Classification, edited by R.R. Ruffolo and NC-IUPHAR, IUPHAR Media, London, pp. 1-8, 2000.

Publications (Continued)

451. Humphrey, P.P.A., Barnard, E.A., Bonner, T.I., Catterall, W., Dollery, C.T., Fredholm, B.B., Godfraind, T., Han, Q., Harmar, T.J., Langer, S.Z., Laudet, V., Limbird, L., Ruffolo, R.R., Jr., Spedding, M., Vanhoutte, P. and Watson, S.: The IUPHAR Receptor Code. In: The IUPHAR Compendium of Receptor Characterization and Classification, edited by R.R. Ruffolo and NC-IUPHAR, IUPHAR Media, London, pp. 10-23, 2000.
452. Ruffolo, R.R., Jr., et al.: The IUPHAR Compendium of Receptor Characterization and Classification. Edited by R.R. Ruffolo and NC-IUPHAR, IUPHAR Media, London, 396 pages, 2000.
453. Torphy, T. and Ruffolo, R.R., Jr.: Biology: The new rate-limiting step in Drug Discovery. *Pharmaceutical News* **8**: 50-53, 2001.
454. Bylund, D.B., Bond, R.A., Bouvier, M., Clarke, D.E., Eikenburg, D.C., Hieble, J.P., Kobilka, B.K., Langer, S.Z., Lefkowitz, R.J., Minneman, K.P., Ruffolo, R.R., Jr. and Strosberg, A.D.: Adrenoceptor. In: The IUPHAR Compendium of Receptor Characterization and Classification, edited by R.R. Ruffolo and NC-IUPHAR, IUPHAR Media, London, pp. 88-103, 2000.
455. Humphrey, P.P.A., Spedding, M. and Ruffolo, R.R., Jr., Spedding, M. and Watson, S.P.: Preface: The Second IUPHAR Compendium on Receptor Characterization and Classification. In: The IUPHAR Compendium of Receptor Characterization and Classification. IUPHAR Media, London, p. vii, 2000.
456. Lysko, P.G., Webb, C.L., Gu, J-L., Ohlstein, E.O., Ruffolo, R.R., Jr. and Yue, T.L.: A comparison of carvedilol and metoprolol antioxidant activities in vitro. *J. Cardiovasc. Pharmacol.* **36**: 277-281, 2000.
457. Bril, A., Rouanet, S., Berrebi-Bertrand, I., Ohlstein, E.H. and Ruffolo, R.R., Jr.: Anti-hypertrophic effect of Carvedilol in neonatal rat ventricular myocytes: Role of p42/44 and p38 mitogen-activated protein kinases. *J. Cardiovasc. Pharmacol.* Submitted for publication.
458. Naselsky, D.P., Ashton, D., Ruffolo, R.R., Jr. and Hieble, J.P.: Rabbit  $\alpha_2$ -adrenoceptors: Both platelets and adipocytes have  $\alpha_{2A}$ -pharmacology. *J. Pharmacol. Exp. Ther.* **298**: 219-225, 2001.
459. Davenport, A.P., Godfraind, T., Luscher, T.F., Ohlstein, E.O., Rubanyi, G.M. and Ruffolo, R.R., Jr.: Endothelin Receptors In: The IUPHAR Compendium of Receptor Characterization and Classification. Edited by R.R. Ruffolo and NC IUPHAR, IUPHAR Media, London, pp. 182-188, 2000.
460. Hieble, J.P. and Ruffolo, R.R., Jr.: Adrenergic Receptors. In: Understanding G-Protein Coupled Receptors and their role in the Central Nervous System. Edited by M. Pangalos and C. Davies. Oxford University Press, Oxford, pp. 205-220, 2002.

Publications (Continued)

461. Spedding, M. and Ruffolo, R.R., Jr.: Receptor Closure? The effects of publishing the human genome on receptor nomenclature, pharmacology and drug discovery. *Nature Pharmacology*, 2002.
462. Abernethy, D.R. and Ruffolo, R.R., Jr.: International Union of Pharmacology Nomenclature and Pharmacological Reviews. *Pharmacological Reviews* 54: 159, 2002.
463. Redmond, C.M. and Ruffolo, R.R., Jr.: Building Brands through R&D and Commercial Collaboration. *Pharmaceutical Executive*, September, 2002, p. 46.
464. Ruffolo, R.R., Jr. and Spedding, M.: The International Union of Pharmacology Committee on Receptor Nomenclature and Drug Classification. In: The IUPHAR Compendium of Voltage Gated Ion Channels. Edited by W.A. Catterall, K.G. Chandy and G.A. Gutman, IUPHAR Media, London, pp. 1-7, 2002.
465. Ruffolo, R.R., Jr. and Boath, D.: Re-engineering R&D: Wyeth's Challenge. *Scrip*, November 5, 2003, 2899.
466. Ruffolo, R.R., Jr.: Research and Development Productivity: A New Way of Working at Wyeth. *American Pharmaceutical Review* 7: 2-4, 2004.
467. Ruffolo, R.R., Jr.: World Health is Headed for a Day of Reckoning. In preparation.
468. Ruffolo, R.R., Jr.: Use of an mTOR inhibitor in treatment of uterine leiomyoma. U.S. Patent # 7,528,145, 8 pages, 2009.
469. Ruffolo, R.R., Jr. and Feuerstein, G.Z.: Carvedilol: Historical case study of the first beta-adrenoceptor blocker ( $\beta$ -blocker) approved for treatment of heart failure. In: Comprehensive Medicinal Chemistry II. Edited by D.J. Triggle, J.B. Taylor, Elsevier Ltd., Oxford, pp. 137-147, 2006.
470. Bowery, N., Headley, E. and Ruffolo, R.R., Jr.: Happy 5<sup>th</sup> Birthday Current Opinion in Pharmacology. *Curr. Opin. Pharmacol.* 5: 1-4, 2006.
471. Feuerstein, G.Z. and Ruffolo, R.R. Jr.: Translational Medicine. In: *Handbook of Translational Medicine*, Birkhauser Verlag, Basel. In press.
472. Gurbanov, K., Callanan, E., Feuerstein, G.Z., Ruffolo, R.R., Jr., Brodsky, S., Hoffman, A., Haramati, A. and Winaver, J.: Effects of carvedilol and renal function in rats with experimental congestive heart failure. *Intl. J. Cardiovasc. Med. and Sci.* 5: 61-67, 2005.
473. Ruffolo, R.R., Jr.: The Rhythm of Drug Development. *Drug Discovery Today* 9: 631-635, 2004.

Publications (Continued)

474. Gurbanov, K.G., Chandra, S., Strittmatter, R., Schaeffer, T., Freed, T., Ohlstein, E.O., Ruffolo, R.R., Jr., Feuerstein, G.Z. and Sarkar, S.K.: Serial characterization of an experimental model of cardiac dysfunction using magnetic resonance imaging. *Intl. J. Cardiovasc. Med. Sci.* 5: 97-100, 2005.
475. Ruffolo, R.R. Jr.: Why has R&D productivity declined in the pharmaceutical industry? *Expert Opin. Drug Discov.* 1: 99-102, 2006.
476. Ruffolo, R.R. Jr. and Feuerstein, G.Z.: Carvedilol Case History. The discovery and development of the first  $\beta$ -blocker for the treatment of congestive heart failure. *Expert Opin. Drug Discov.* 1: 85-89, 2006.
477. Feuerstein, G.Z., Ruffolo, R.R., Coughlin, C., Wang, J. and Miller, J.: Inflammation. In: Encyclopedia of Stress, 2<sup>nd</sup> Edition, Editor-in-Chief, George Fink, Academic Press (San Diego), pp. 530-539, 2007.
478. Feuerstein, G.Z., Ruffolo, R.R. and David, B.N.: Viruses and Stress. In: Encyclopedia of Stress, 2<sup>nd</sup> Edition, Editor-in-Chief, George Fink, Academic Press (San Diego), pp. 850-853, 2007.
479. Feuerstein, G.Z., Ruffolo, R.R. and Rutkowski, J.L.: Neuroinflammation. In: Encyclopedia of Stress, 2<sup>nd</sup> Edition, Editor-in-Chief, George Fink, Academic Press (San Diego), pp. 889-894, 2007.
480. Feuerstein, G.Z., Rutkowski, J.L., Walsh, F.L. and Ruffolo, R.R. Jr.: The role of translational medicine and biomarker research in drug discovery and development. *Am. Drug Disc.* 2: 23-28, 2007.
481. Ruffolo, R.R. Jr., Walsh, F.W. and Feuerstein, G.Z.: Drug Discovery. In: Pharmacology. Ed. by H. Majewski, UNESCO EOLSS Publishers, Paris, in press.
482. Feuerstein, G.Z., Zaleska, M.M., Krams, M., Wang, X., Day, M., Rutkowski, J.L., Finkelstein, S.P., Pangalos, M.N., Poole, M., Stiles, G.L., Ruffolo, R.R. Jr. and Walsh, F.L.: Missing Steps in the STAIR Case: A Translational Medicine Perspective on the Development of NXX-059 for Treatment of Acute Ischemic Stroke. *J. Cerebral Blood Flow and Metab.* In press.
483. Feuerstein, G.Z., Dormer, C., Ruffolo, R.R., Jr., Stiles, G., Walsh, F.W. and Rutkowski, J.L.: Translational medicine perspectives of biomarkers in drug discovery and development. Part I: Target selection and validation- Biomarkers take center stage. In: Training and Education in Translational Medicine. In press.



Publications (Continued)

484. Brooks, D., Feuerstein, G., Ohlstein, E.H. and Ruffolo, R. R., Jr.: Method of Treating Isolated Systolic Hypertension. U. S. Patent Application No. 20070129415 Issued June 7, 2007
485. Brooks, D., Feuerstein, G., Ohlstein, E.O. and Ruffolo, R. R., Jr: Method of Treating Isolated Systolic Hypertension. U. S. Patent Application No. 20050113431, Issued May 26, 2004.
486. Lukas-Laskey, Ruffolo, R. R., Jr., Shusterman, N. H., Sponer, G. and Strein, K.: Method of Treatment for Decreasing Mortality Resulting from Congestive Heart Failure. U. S Patent Application No. 20030105138, Issued June 5, 2003,
487. Feuerstein, G.Z. and Ruffolo, R.R. Jr.: Discontinued drugs in 2006: Cardiovascular Drugs Translational Medicine Perspective. *Expert Opin. Investig. Drugs* 16: 1315-1326, 2007.
488. Feuerstein, G.Z., Gill, D., Dormer, C., Ruffolo, R.R. Jr., Rutkowski, L., Walsh, F.S. and Hurko, O.: Translational Medicine Perspectives in Drug Discovery and Development. Part II: Target compound interaction - The vastly neglected biomarkers contributing to early clinical development failure. *American Drug Discovery* 3: 48-53, 2008.
489. Feuerstein, G.Z. and Ruffolo, R.R., Jr.: Cardiogenic Shock. In: Encyclopedia of Molecular Mechanisms of Disease, Springer-Verlag, Berlin, 2009
490. Feuerstein, G.Z., Caughlin, C., Ruffolo, R.R., Jr., Dormer, C., Walsh, F.W., Hurko, O. and Rutkowski, J.L. Translational Medicine Perspectives in Drug Discovery and Development. Part III: Disease biomarkers-setting the lexicon straight for drug registration, drug labeling and commercial opportunities. *American Drug Discovery*, in press.
491. Feuerstein, G.Z. and Ruffolo, R.R, Jr. Hypovolemic Shock. In: Encyclopedia of Molecular Mechanisms of Disease, Springer-Verlag, Berlin, pp. 1011-1012, 2009.
492. Feuerstein, G.Z., Keith, J.C. and Ruffolo, R.R., Jr. Septic Shock. In: Encyclopedia of Molecular Mechanisms of Disease, Springer Verlag, Berlin, p 1920, 2009.
493. Feuerstein, G.Z., Walsh, F.S., Ruffolo, R.R., Jr., Goddard, C., Rutkowski, J.L., Parsons, S., Coughlin, C. Wan, H.I., Alesci, S., Lee, J.H., Wolfgang, K.W. and Smith, M.F.Jr. Translational medicine perspectives in drug discovery and development-Part IV: Surrogate diseases pave the way for successful proof of concept studies towards investment decisions in large morbidity and mortality outcome studies in major diseases. *American Drug Discovery* 2/4: 36-41, 2008.

Publications (Continued)

494. Lukas-Laskey, Ruffolo, R. R., Jr., Shusterman, N. H., Sponer, G. and Strein, K.: Method of Treatment for Decreasing Mortality Resulting from Congestive Heart Failure. U. S. Patent No. 5760069, Issued June 2, 1998.
495. Lukas-Laskey, Ruffolo, R. R., Jr., Shusterman, N. H., Sponer, G and Strein, K: Method of Treatment for Decreasing Mortality Resulting from Congestive Heart Failure. U. S. Patent. No. RE400000, Issued January 8, 2008.
496. Lukas-Laskey, Ruffolo, R. R., Jr., Shusterman, N. H., Sponer, G and Strein, K.: Use of Carbazole Compounds for the Treatment of Congestive Heart Failure. U. S. Patent. No. RE40707, Issued May 5, 2009.
497. Feuerstein, G.Z., Alesci, S., Walsh, F.W., Rutkowski, J.L. and Ruffolo, R.R., Jr.: Translational Medicine - A Paradigm Shift in Modern Drug Discovery and Development: The Role of Biomarkers. In: Biomarkers in Drug Development: A Handbook of Practice, Application and Strategy, Ed. By M. R. Bleavins, C. Carini, M. Jurimar-Romet and Ramin Rahbari, John Wiley and Sons, pp. 361-373, 2010.

Abstracts

Over 200 Abstracts Published

UNITED STATES PATENT AND TRADEMARK OFFICE

---

BEFORE THE PATENT TRIAL AND APPEAL BOARD

---

THE SCOTTS COMPANY LLC  
Petitioner

v.

ENCAP, LLC  
Patent Owner

---

Case IPR2013-00110  
Patent 6,209,259

---

Before MICHAEL P. TIERNEY, LORA M. GREEN, and RAMA G. ELLURU,  
*Administrative Patent Judges.*<sup>1</sup>

PER CURIAM.

FINAL WRITTEN DECISION  
*35 U.S.C. § 318(a) and 37 C.F.R. § 42.73*

---

<sup>1</sup> Floyd, Administrative Patent Judge, who participated in the oral hearing held on January 30, 2014, has left the Board; accordingly, Tierney, Administrative Patent Judge, has been added to the panel.

## I. BACKGROUND

Petitioner, The Scotts Company LLC (“Scotts Company”), filed a Petition on January 10, 2013, for an *inter partes* review of claims 1-5, 7-11, 13, and 14 (“the challenged claims”) of U.S. Patent No. 6,209,259 (“the ’259 patent”) pursuant to 35 U.S.C. §§ 311-319. Paper 2. On April 15, 2013, Patent Owner, Encap, LLC (“Encap”), filed a Preliminary Response. Paper 9. On July 3, 2013, the Board granted an *inter partes* review for all challenged claims on less than all of the grounds of unpatentability alleged in the Petition. Paper 12, (“Dec.”). The Board also stayed concurrent reexamination of the ’259 patent. Paper 10.

After institution of trial, Encap filed a Corrected Patent Owner’s Response. Paper 48. Encap also filed a Corrected Contingent Motion to Amend Claims that requests substituting proposed new claims 15-24 for claims 2-5, 8-11, 13, and 14, respectively—contingent upon a determination of unpatentability. Paper 47. Scotts Company filed a Reply to Patent Owner’s Response (Paper 30), and an Opposition to Encap’s Motion to Amend Claims (Paper 33). Encap then filed a Corrected Reply to Scotts Company’s Opposition to Encap’s Motion to Amend Claims. Paper 49.

Additionally, Scotts Company filed a Motion to Exclude Evidence (Paper 52), to which Encap responded (Paper 64) and submitted supplemental evidence (Paper 58). Scotts Company filed a Reply in further support of its Motion to Exclude. Paper 68.

Encap also filed a Motion to Exclude Evidence (Paper 54) to which Scotts Company responded (Paper 60). Encap, with authorization (Paper 70), filed a Supplement to its Motion to Exclude (Paper 66), as well as a Reply (Paper 67).

Oral hearing was held on January 30, 2014.<sup>2</sup>

The Board has jurisdiction under 35 U.S.C. § 6(c). This Final Written Decision is issued pursuant to 35 U.S.C. § 318(a) and 37 C.F.R. § 42.73.

Scotts Company has shown by a preponderance of the evidence that claims 1-5, 7-11, 13, and 14 of the '259 patent are unpatentable. Encap's Motion to Amend Claims is denied.

*A. The '259 Patent*

The '259 patent is directed to a combination seed capsule, comprising at least one viable seed, a coating of a composition comprising a soil conditioning material mounted proximate and disposed outwardly of the outer surface of the seed, and optionally including one or more of inorganic chemical fertilizers, growth enhancer, binder, and/or an anti-fungal agent. Ex. 1001, Abstract, 4:5-11. According to the '259 patent Specification, the primary object of the invention is to "provide solid plant seed capsule products that supply both soil conditioning properties and the seed, which can benefit from such conditioned soil, in a given seed capsule particle." *Id.* at 3:28-31.

*B. Illustrative Claim*

Claims 1 and 7 are the only independent claims in the '259 patent, and are directed to a "[a] combination seed capsule." The only difference between these claims is that claim 7 additionally states that the seed coating is applied by an agglomeration process. The remaining challenged claims depend from either claim 1 or 7. Claim 1 is illustrative of the claimed subject matter, and is reproduced below.

---

<sup>2</sup> A transcript of the oral hearing is included in the record as Paper 78.

1. A combination seed capsule comprising:
  - one viable seed;
  - said seed acting as a core or pseudo core of said combination seed capsule;
  - a coating of a composition comprising soil conditioning materials;
  - said soil conditioning materials being in a solid state at time of coating.

*C. Prior Art Supporting the Instituted Challenges*

Name	Reference	Issue or Publication	Exhibit
Schreiber	U.S. Patent No. 3,698,133	Oct. 17, 1972	Ex. 1002
Roth	U.S. Patent No. 4,065,287	Dec. 27, 1977	Ex. 1003
Lowe	U.S. Patent No. 5,019,564	May 28, 1991	Ex. 1004
Matthews	GB670,461	Apr. 16, 1952	Ex. 1007

*D. The Instituted Challenges of Unpatentability*

References	Grounds	Claims
Schreiber	§ 102(b)	Claims 1, 7, and 13
Schreiber and Roth	§ 103(a)	Claims 2, 5, 8, 11, and 14
Schreiber and Lowe	§ 103(a)	Claims 3, 4, 9, and 10
Matthews	§ 102(b)	Claims 1, 2, 7, 8, 13, and 14
Roth	§ 102(b)	Claims 1, 2, 5, 7, 8, 11, 13, and 14
Roth and Lowe	§ 103(a)	Claims 1-5, 7-11, 13, and 14

## II. DISCUSSION

### A. Evidentiary Matters

#### 1. Scotts Company's Reply (Paper 30)

In a conference call held on December 3, 2013, Encap asserted that Scotts Company had raised new arguments and evidence in its Reply to Patent Owner's Response to Decision to Institute. Order (Paper 37), 2. The Board denied Encap's request to file a surreply, or to enlarge the page limit of Encap's Reply in support of its Motion to Amend. *Id.* We indicated, however, that we would determine whether Scotts Company's Reply and supporting evidence contain material exceeding the proper scope of a reply. *Id.*

We find that Scotts Company's Reply, and in particular, the supporting Declarations of Mr. Fredrick Sundstrom (Ex. 1039) and Mr. Krishna Pagilla (Ex. 1040) contain material outside the proper scope of a reply. 37 C.F.R. § 42.23(b) (reply is limited to arguments raised in Patent Owner's Response). Specifically, both Declarations contain materials in support of Scotts Company's Petition, and therefore, untimely filed. For example, Mr. Sundstrom includes analyses of claim construction (e.g., Ex. 1039 ¶¶ 7-9), as well as analyses of the Schreiber (e.g., *id.* at ¶¶ 10-13), Matthews (e.g., *id.* at ¶¶ 28, 29), Roth (e.g., *id.* at ¶ 34), Simmons (*id.* at ¶¶ 36, 38), and Evans (*id.* at ¶¶ 43, 44, 46, 48) references. Likewise, Mr. Pagilla addresses claim construction, as well as the references upon which Scotts Company sought institution. *See, e.g.*, Ex. 1040 ¶¶ 9-13, 23-27, 32, 33, 36-38. Specifically, we hold that the new evidence could have been included with the motion. By waiting to serve this evidence on Encap in Scotts Company's Reply, Encap was denied the opportunity to file responsive evidence. Thus, we



have not considered the untimely Declarations of Mr. Sundstrom and Mr. Pagilla, nor the arguments based thereon.<sup>3</sup>

2. *Scotts Company's Motion to Exclude*

Scotts Company filed a Motion to exclude: portions of the deposition testimony of Mr. Michael Krysiak taken by Encap on November 6, 2013 (Ex. 2002) and December 23, 2013 (Ex. 1038); and the Second Krysiak Declaration, which includes Attachments A and B (Ex. 2016). Pet. Mot. Excl. (Paper 52), 1. Mr. Krysiak, Encap's witness, submitted a second Declaration (Ex. 2012) in support of its Reply to Petitioner's Opposition to Encap's Motion to Amend (Paper 49). Encap responded to Scotts Company's Motion to Exclude and filed supplemental evidence. PO Resp. Mot. Excl. (Paper 64); PO Supp. Evid. (Paper 58), respectively. Scotts Company filed a Reply. Paper 68. We grant-in-part Scotts Company's Motion to Exclude Evidence.

Scotts Company asserts that Mr. Krysiak's deposition testimony in response to two questions (i.e., Ex. 2002, 207, 1. 9; Ex. 1038, 209, 11. 7-8) should be excluded. Pet. Mot. Excl. 9-10. As we did not rely upon this deposition testimony that Scotts Company seeks to exclude, Scotts Company's Motion is moot with respect to such testimony.

Scotts Company also moves to exclude the Second Declaration of Mr. Krysiak (Ex. 2012). Scotts Company's primary objection is that the Declaration is untimely, as it should have been submitted with Encap's Motion to

---

<sup>3</sup> The fact that two declarations may contain some material appropriate for a response does not require our consideration of them, as the Board will not attempt to sort the proper from the improper portions. *See Office Patent Trial Practice Guide*, 77 Fed. Reg. 48,756, 48,767 (Aug. 14, 2012).

Amend (Paper 47). Pet. Mot. Excl., 11-14; *see* 37 C.F.R. § 42.23(b) (“All arguments for the relief requested in a motion must be made in the motion. A reply may only respond to arguments raised in the corresponding opposition or patent owner response.”). In support of Scotts Company’s Opposition to Encap’s Motion to Amend (Paper 33), it relied upon the Declaration of Mr. Sundstrom (Ex. 1039), which was not considered, as discussed above. Encap asserts that Mr. Krysiak’s Second Declaration is in rebuttal to Declarations and deposition testimony of Mr. Sundstrom and Mr. Pagilla. PO Resp. Mot. Excl. 10-11. Encap proffers supplemental evidence—a revised Second Declaration of Mr. Krysiak with citations to the Declaration and deposition of Mr. Sundstrom. Paper 58; Ex. 2016.

Reading Mr. Krysiak’s Second Declaration, it is clear that the majority of the Declaration is in support of Encap’s Motion to Amend rather than in rebuttal to Scotts Company’s Opposition to Encap’s Motion to Amend or the Declarations and deposition testimony<sup>4</sup> of Mr. Sundstrom and Mr. Pagilla, and is thus, untimely. For example, paragraphs 2-3 relate to written description and claim construction, which Encap has the burden of proving in its Motion to Amend. Additionally, paragraphs 6-12 describe the background of the technology, which could have been submitted with Encap’s Motion to Amend opening brief, and thus, are not in rebuttal to testimony from Mr. Sundstrom or Mr. Pagilla. Likewise, paragraphs 25-53 and Schedule A attempt to distinguish over Matthews and Schreiber, which Encap should have done in Patent Owner’s Motion to Amend. Furthermore, to the extent that portions of Mr. Krysiak’s Second Declaration are in response to the

---

<sup>4</sup> While not addressed, we do not suggest that filing a declaration in rebuttal to deposition testimony is appropriate.

Declarations of Mr. Sundstrom and Mr. Pagilla, which were excluded, they should likewise be excluded. Those errors were not corrected in the Supplemental Evidence (i.e., Ex. 2016) submitted by Encap.

In addition, Encap attempts to incorporate Mr. Krysiak's Second Declaration into its Reply to Scott's Opposition to the Motion to Amend by merely stating, "The proposed claims define over the prior art succinctly. *Id.* [Mr. Krysiak's Second Declaration] at ¶¶ 14-53." Reply Mot. Amend 5. In our Order of August 27, 2013, we admonished Encap to refrain from attempting to use an expert declaration in such fashion. We stated, "Encap's motion to amend may be supported by an expert declaration, but that the motion itself should set forth the arguments and explanations with appropriate pinpoint citations to the expert declaration, rather than incorporating by reference the expert declaration." Paper 17, 2-3. Thus, Scotts Company's Motion to Exclude Mr. Krysiak's Second Declaration (Ex. 2012) is granted, as Mr. Krysiak's Corrected Second Declaration (Ex. 2016) did not remedy the issues, it is not considered.

*3. Encap's Motion to Exclude*

Encap moves to exclude the Declaration of Mr. Sundstrom (Ex. 2014), Scott Company's witness who provided a declaration in support of Scott Company's Reply to Patent Owner's Response to Decision to Institute (Paper 30), on the basis that the declarant refused to answer certain questions during his deposition on the basis of confidentiality, even though a protective order was in place. PO Mot. Excl. (Paper 54), 5. Having found that Mr. Sundstrom's Declaration was untimely submitted, and thus, not considered, Encap's Motion to Exclude is dismissed as moot.

*B. Claim Construction*

Consistent with the statute and the legislative history of the AIA, the Board interprets claims by applying the broadest reasonable construction in the context of the specification in which the claims reside. 37 C.F.R. § 42.100(b); *see Office Patent Trial Practice Guide*, 77 Fed. Reg. 48,756, 48,766 (Aug. 14, 2012). Claim terms also are given their ordinary and customary meaning, as would be understood by one of ordinary skill in the art in the context of the entire disclosure. *In re Translogic Tech., Inc.*, 504 F.3d 1249, 1257 (Fed. Cir. 2007).

Two exceptions to the general rule that a claim term is given its ordinary meaning are: 1) when a patentee sets out a definition and acts as his own lexicographer; or 2) when the patentee disavows the full scope of a claim term either in the specification or during prosecution. *See In re Paulsen*, 30 F.3d 1475, 1480 (Fed. Cir. 1994). If an inventor acts as his or her own lexicographer, the definition must be set forth in the specification with reasonable clarity, deliberateness, and precision. *Id.*

*1. “soil conditioning materials”*

All of the challenged claims require “a coating of a composition comprising soil conditioning materials.” The ’259 patent Specification states that “*all soil conditioning materials contemplated herein* beneficially modify soil to which they are applied, in some way other than direct provision of nitrogen, phosphorous, and/or potassium or other plant nutrients.” Ex. 1001, col. 8, ll. 41-44 (emphasis added). The Specification further provides specific examples of soil conditioning materials, such as municipal or other sewage sludge, paper mill sludge, fly ash, and dust. *Id.* at col. 7, ll. 21-23. Accordingly, in the Decision to Institute, the Board construed “soil conditioning materials” as “materials that beneficially modify soil

to which they are applied, in some way other than direct provision of nitrogen, phosphorous, and/or potassium or other plant nutrients, including for example, municipal or other sewage sludge, paper mill sludge, fly ash, and dust.” Dec. 6-7.

Although Scotts Company agrees with the Board’s preliminary construction (Pet. Reply, 1-2), Encap asserts the construction is overly broad in view of the Specification (PO Resp., 8-9). Specifically, Encap asserts the construction should be amended to include that the soil conditioner not only enhances soil condition of the growth medium/soil to which it is applied, it also provides soil conditioning value to the seed so coated irrespective of the general tilth condition of the growth medium. *Id.* (citing Ex. 1001, col. 8, ll. 42-52,<sup>5</sup> Abstract). Encap does not assert that its construction is the plain and ordinary meaning of “soil conditioning materials,” but rather, that the Specification defines the phrase. PO Resp. at 8. Specifically, Encap asserts the following portion of the Specification defines “soil conditioning materials:”

However, all soil conditioning materials contemplated herein beneficially modify soil to which they are applied, in some way other than direct provision of nitrogen, phosphorous, and/or potassium or other plant nutrients. By use of soil conditioner in intimate association with the seed, this invention not only enhances soil condition of the growth medium/soil to which it is applied, it also provides soil conditioning value to the seed so coated, and in intimate association with the seed, irrespective of the general tilth condition of the growth medium into or onto which the seed capsule is applied.

Ex. 1001, col. 8, ll. 42-52.

Through the inclusion of “all soil conditioning materials contemplated herein,” the first sentence requires the soil conditioning material to beneficially

---

<sup>5</sup> Encap mistakenly refers to col. 15, l. 29–col. 16, l. 6.

modify the soil in some way, other than directly providing plant nutrients. The second sentence is an observation of benefits provided by “this invention;” it does not *require* the invention provide the observed benefits; much less require *just* the soil conditioning material of the invention provide such benefits.

Encap relies upon its experts, Mr. John Katers, Mr. Daniel Madigan, and Mr. Michael Krysiak, all of whom provide identical claim constructions, in support of its position. Ex. 2007 ¶ 11; Ex. 1020 ¶ 10; Ex. 1022 ¶ 13. The experts provide, however, no credible analysis in support of their claim constructions, and thus, are unpersuasive.

Encap asserts also that the examples included in the Board’s preliminary claim construction should be omitted, because not *all* municipal or other sewage sludge, paper mill sludge, fly ash, or dust, necessarily modify the soil in a beneficial manner. PO Resp. 9. The Board’s preliminary construction, however, requires the soil conditioning materials “modify soil to which they are applied, in some way other than direct provision of nitrogen, phosphorous, and/or potassium or other plant nutrients.” The inclusion of the examples is intended to clarify, not modify, this requirement.

Accordingly, the Board maintains its construction of “soil conditioning materials” as:

Materials that beneficially modify soil to which they are applied, in some way other than direct provision of nitrogen, phosphorous, and/or potassium or other plant nutrients, including for example, municipal or other sewage sludge, paper mill sludge, fly ash, and dust.

2. “combination seed capsule”

The phrase “combination seed capsule” appears in the preamble of claims 1 and 7. Encap asserts that the Abstract of the ’259 patent defines “combination seed capsule.” PO Resp. 10-11. The Abstract reads:

This invention pertains to combination seed capsules wherein each seed capsule includes both moieties of at least one soil conditioner and at least one seed, and optionally, one or more inorganic chemical fertilizer, growth enhancer, binder, and/or anti-fungal agent. The combination seed capsules are made by physically combining the respective soil conditioner and seed with one other, in the absence of any requirement for chemical reactions in the process of so combining the respective materials. The combination seed capsules *provide cooperative and beneficial effects of the soil conditioner and the optional inorganic fertilizer, working together in controlled intimate relation with the seed, to enhance the germination and growth processes of the seed, and the plant emergent therefrom, greater than when the soil conditioner and seed, and optionally inorganic chemical fertilizer, are applied to the soil separately; the improvement being a result of the intimate relationship of the respective materials in the combination seed capsule, whereby the respective materials cooperate with each other in support of germination and plant growth.*

Ex. 1001, Abstract (emphases added). Encap asserts that the text that has been italicized is the definition of a “combination seed capsule.” PO Resp. 11. Encap also relies upon its technical experts, Messrs. Baker, Madigan, and Krysiak. *Id.* at 11-12. The experts, however, provide no credible analysis in support of their claim constructions and are thus, unpersuasive.

Scotts Company asserts that the term “combination seed capsule” appears in the preamble of both independent claims (i.e., claims 1 and 7), and thus, is not limiting. Pet. Reply 2. Scotts Company also asserts that in 1998, when the application that matured into the ’259 patent was filed, the rules prohibited relying

on the Abstract “for interpreting the scope of the claims.” *Id.* at 3 (quoting 37 C.F.R. § 1.72(b)). Lastly, Scotts Company asserts that Encap is attempting to improperly import limitations into the claims. *Id.*

First, the Abstract does not provide a definition for a “combination seed capsule,” but rather observes the benefits of the combination seed capsule. Second, the preamble term “combination seed capsule” is not limiting because the claim body describes a structurally complete invention. *Catalina Mktg. Int’l v. Coolsavings.com Inc.*, 62 USPQ2d 1781, 1785 (Fed. Cir. 2002). Thus, we need not construe “combination seed capsule,” as it does not limit the claim.

3. “being in a solid state at time of coating”

Independent claim 1 recites, “being in a solid state at time of coating.” Similarly, independent claim 7 recites, “are in a solid state at time of coating.” Additionally, claim 7 recites, “said coating being applied to said viable seed by an agglomeration operation.” Due to the inclusion of these three limitations, claims 1 and 7 were determined to be product-by-process claims in the Decision to Institute. Dec. 7-8.

Encap asserts that “in a solid state at time of coating” should be construed as “solid material in the form of particulate, fibrous, or a suspension of a particulate or fibrous material in a liquid carrier to form an agglomeration of said particulate and/or fibers.” PO Resp. 12-13 (citing Ex. 1001, col. 8, ll. 1-5<sup>6</sup>). Scotts Company points out that the Specification reads, the soil conditioning raw material “*may* be a particulate powder, or *may* be fibrous, or *may* be a suspension of a powder or fibrous material in a liquid carrier, and is preferably coated onto the substrate seed

---

<sup>6</sup> Encap erroneously cites to col. 14, ll. 24-28.



to form a seed capsule or other agglomeration of particles, fibers, *or the like*,” and thus, does not support Encap’s construction. Pet. Reply 3 (quoting Ex. 1001, col. 8, ll. 1-5 with emphasis added). We agree that the Specification does not support Encap’s proposed construction.

Encap further asserts that during prosecution of the ’259 patent application, Mr. Krysiak had discussions with the Examiner relating to “being in a solid state at the time of coating.” PO Resp. 12 (citing Ex. 1022 ¶ 15). Encap’s description of events does not provide support for its proposed claim construction. That is, it does not follow that adding the limitation to overcome Roth, defines the limitation to require “solid material in the form of particulate, fibrous, or a suspension of a particulate or fibrous material in a liquid carrier to form an agglomeration of said particulate and/or fibers.” As before, Mr. Krysiak’s opinion as to how the phrase should be construed includes no analysis, and thus, is unpersuasive.

Encap does establish that it disavowed claim scope, however, by adding the limitation “in a solid state at time of coating” to overcome Roth. That clear and unambiguous disavowal of claim scope causes us to modify the claim construction from that set forth in the Decision to Institute. Specifically, Encap narrowed the “in a solid state at time of coating” limitation to require the soil conditioning material be in a solid state at the time of coating the seed. Encap did not narrow “in a solid state at time of coating,” however, to further require a particulate, fibrous, or a suspension of a particulate or fibrous material in a liquid carrier to form an agglomeration of said particulate and/or fibers, as suggested by Encap.

The Federal Circuit has addressed the issue of determining whether a claim has been narrowed in the related context of prosecution history estoppel.

In order to give due deference to public notice considerations under the *Warner–Jenkinson* framework, a patent holder seeking to establish

the reason for an amendment must base his arguments solely upon the public record of the patent's prosecution, i.e., the patent's prosecution history. To hold otherwise—that is, to allow a patent holder to rely on evidence not in the public record to establish a reason for an amendment—would undermine the public notice function of the patent record.

*Festo Corp. v. Shoketsu Kinzoku Kogyo Kabushiki Co.*, 234 F.3d 558, 586 (Fed. Cir. 2000), *vacated on other grounds*, 535 U.S. 722 (2002).

An examination of the prosecution history of record reveals the following events which support our determination that Encap clearly disavowed the full scope of claims 1 and 7. On May 10, 2000, the Examiner issued a rejection to claim 77 as anticipated by Roth, and further rejected claims 77 and 85 as being obvious in view of Roth in combination with two other references. Ex. 1008, 171, 175.<sup>7</sup> On August 8, 2000, the Examiner issued an interview summary, which indicates that a proposed claim amendment was discussed. Specifically, the Examiner stated that adding, “wherein said soil conditioning material, when added to the seed, are in a dry, solid form,” to the claims would overcome Roth. The Examiner suggested “that the claims be written in a product by process form to clearly distinguish over Roth.” *Id.* at 203. On September 8, 2000, the Examiner issued an Interview Summary indicating that claims 77 and 85 were discussed, and that “[b]ased on the proposed draft amendment and arguments recited therein, the prior art was overcome.” *Id.* at 204. The record clearly shows that the only amendment made to claim 77 was the addition of the limitation, “said soil conditioning materials being in a solid state at time of coating.” *Id.* at 200. Claim 85 was amended in similar fashion to recite, “wherein said soil conditioning

---

<sup>7</sup> Claims 77 and 85, ultimately issued as claims 1 and 7, respectively.

materials are in a solid state at time of coating.” *Id.* at 201. Claims 77 and 85 ultimately issued as claims 1 and 7, respectively.

Thus, Encap successfully overcame Roth by adding the “in a solid state at the time of coating” limitation to claims 1 and 7. Construing the phrase as a product-by-process limitation would not result in distinguishing over Roth, as no discussion was had, nor evidence provided, to suggest the end product of Roth had different characteristics than the claimed composition. The disavowal of claim scope is clear. The limitation “in a product by process form,” therefore, must be construed to require the soil conditioning material be in a solid state at the time of coating. *See Tempo Lighting, Inc. v. Tivoli, LLC*, 742 F.3d 973, 978 (Fed. Cir. 2014).

Furthermore, Roth discloses a spray application of a MAS material that contains 0.1% to 2.5% solids at the time of coating. Ex. 1003, col. 3, ll. 50-51. Thus, the limitation “in a solid state at the time of coating” must further be construed to require more than 2.5% solids. Therefore, we construe “in a solid state at the time of coating” to mean that more than 2.5% of the soil conditioning material must be in a solid state at the time of coating the seed.

4. “*agglomeration operation*”

Independent claim 7 requires an “agglomeration operation,” which we construed in our Decision to Institute to be a product-by-process limitation. Dec. 8. Patent Owner concedes that claim 7 is a product-by-process claim. PO Resp. 16. Patent Owner, however, takes issue with the Board’s “holding” that an agglomeration operation means using water and heat to bind a plurality of particles. *Id.* at 13.

We did not construe “agglomeration operation,” other than to note that it is a product-by-process limitation. *In re Thorpe*, 777 F.2d 695, 698 (Fed. Cir. 1985). The structure implied by the process steps should be considered when assessing the patentability of product-by-process claims over the prior art. *See, e.g., In re Garnero*, 412 F.2d 276, 279 (CCPA 1969). That is especially true where the product can only be defined by the process steps by which the product is made, or where the manufacturing process steps would be expected to impart distinctive structural characteristics to the final product. *Id.* Thus, the issue is not focused on what “agglomeration operation” means, but rather on what properties would be embodied in a product made by an agglomeration operation (i.e., an agglomerate). Here, the parties are in near agreement on the properties of an agglomerate.

Encap states that an agglomerate is an assemblage of particles adhering to each other, and thus, a magnified image of an agglomerate would reveal that the product is comprised of particulate. PO Resp. 13-16. Without credible explanation, Encap in its conclusion limits its final description of an agglomerate to an assemblage of *fine* particles. *Id.* at 16. Evidence cited by Encap that may support this additional limitation is an article by Wolfgang B. Pietsch, titled “The Agglomerative Behavior of Fine Particles.” *Id.* at 13-14 (citing Ex. 1020 ¶ 11, Attachment A). As the title suggests, however, the article is specifically directed to agglomerates of fine particles. There is no credible suggestion in Mr. Madigan’s Declaration (Ex. 1020) that an “agglomerate” is limited to fine particles. *See* Ex. 1020 ¶¶ 11-17.

Scotts Company appears to accept Encap’s description of an agglomerate, but takes exception, as we do, with the limitation to fine particles. Pet. Reply 3-4.

Thus, we determine that an agglomerate is an assemblage of particles adhering to each other. The “agglomeration operation” limitation of claim 7 implies that the claimed “combination seed capsule” has a coating of a composition comprising soil conditioning materials comprised of particulate. As such, to satisfy the limitation of an “agglomeration operation,” a reference must disclose a product with the structural limitation of being comprised of particulate, irrespective of the process used to make the product.

*C. Anticipation by Roth—Claims 1, 2, 5, 7, 8, 11, 13, and 14*

Roth explains that the MAS coating is “solid” after application. Roth, however, does not disclose the soil conditioning materials “being in a solid state at time of coating,” because Roth discloses a spray application of a MAS material that is 97.5% to 99.9% liquid with the remainder “solids content.” PO Resp. 31-32 (citing Ex. 1003, col. 3, ll. 50-51). While a tiny amount (i.e., 0.1% to 2.5%) of the soil conditioning material is in solid state at the time of coating, as discussed above, this is not enough to satisfy the limitation “in a solid state at time of coating,” recited in claims 1 and 7. As such, Scotts Company has not shown, by a preponderance of the evidence, that Roth anticipates 1, 2, 5, 7, 8, 11, 13, and 14.

*D. Obviousness over Roth and Lowe—Claims 1-5, 7-11, 13, and 14*

Roth teaches the claimed “seed acting as a core or pseudo core” with a “coating of a composition comprising soil conditioning materials,” as required by claims 1 and 7. Specifically, Roth describes coating seeds with a methanol treated “sludge” carrier having one or more agricultural chemicals dispersed therein, wherein the source material is “municipal sewage,” as required by dependent claims 2, 5, 8, and 11. *See, e.g.*, Ex. 1003, col. 3, ll. 23-26. Roth also discloses that its coating may include a “binder,” e.g., polyvinyl alcohol, starch derivatives,

and further may include a fertilizer, as recited in claims 13 and 14. *Id.* at col. 2, ll. 3-5, 48-51; col. 5, ll. 49-52. Thus, we determine that Roth discloses all the limitations of claims 1, 2, 5, 7, 8, 11, 13, and 14 with the exception of “in a solid state at time of coating,” as required by independent claims 1 and 7.

Lowe discloses coating a seed with de-inked paper sludge having a “fiber content of the solids in the mixture should exceed at least 10%-15% by weight,” thereby teaching “in a solid state at time of coating.” Ex. 1004, col. 3, ll. 17-21. Lowe also discloses using “agglomeration” to combine the fibers to form individual granules. *Id.* at Abstract; col. 3, ll. 21-22. Thus, as discussed in greater detail below, Lowe in combination with Roth satisfies the limitations of independent claims 1 and 7 as the combination involves the use of known components for their known purpose to achieve a predictable result.

Lowe further teaches coating a seed with a material that is a byproduct of a “paper making process,” and specifically that the byproduct is “paper sludge,” as required by dependent claims 3, 4, 9, and 10. Lowe describes an agricultural granule for carrying and releasing agricultural chemicals that resembles a clay-based granule. *Id.* at Abstract. The agricultural granule is made from using waste materials from paper manufacture, referred to as paper sludge. *Id.* at col. 1, l. 68–col. 2, l. 1; col. 2, ll. 40-44.

Scotts Company asserts that because Roth teaches a MAS carrier for agricultural chemicals that can coat a seed, and because Lowe likewise teaches an agricultural carrier consisting of paper sludge, a person of ordinary skill in the art would have had reason to substitute Lowe’s paper mill sludge for Roth’s MAS coating. Pet. 57.

Encap asserts that the proposed combination runs contrary to the disclosure of Roth. PO Resp. 43. In particular, Encap asserts that Lowe requires the fiber content of the finished particle be above 10%, which means, therefore, that the material is 90% or less filler. *Id.* (citing Ex. 1004, col. 4, ll. 65-66; col. 6, ll. 53-63). On the other hand, Roth discloses MAS that is 97.5%-99.9% liquid. *Id.* (citing Ex. 1003, col. 3, ll. 50-51). Encap asserts that a product that is 97.5% or more liquid could not be replaced by a product with 10% or more fiber content and still be sprayed. *Id.* (citing Ex. 1020 ¶ 22). We do not find Encap's argument persuasive because Roth is not limited to spray-on coatings. The MAS, and presumably Lowe's paper sludge, can be applied to the seeds "by dipping, soaking, spraying, or other conventional mode of application." Ex. 1003, col. 4, ll. 48-50.

Encap also asserts that Roth's disclosure of a coating with 0.1% to 2.5% solids teaches away from using Lowe's coating containing over 10% solids. PO Resp. 43. Roth, however, "does not criticize, discredit, or otherwise discourage" the use of a higher percentage of solids. *In re Fulton*, 391 F.3d 1195, 1201 (Fed. Cir. 2004). Thus, Encap's argument is not persuasive.

Encap further asserts that paper sludge and MAS have very different characteristics. PO Resp. 44-45. In particular, Encap asserts that attempting to coat a seed with paper sludge, using the agglomeration process disclosed in Lowe, would not have a reasonable likelihood of success. *Id.* at 46. In support of its assertion, Encap submits the Declaration of Mr. Madigan (Ex. 1020) who testifies as to the difficulties associated with coating seeds with paper sludge utilizing the agglomeration process of Lowe. *Id.* We do not credit Mr. Madigan's declaration as it fails to provide the underlying basis for his conclusions. For example, Mr. Madigan cites an attachment that purports to show what a final product of Lowe

would look like if seed is introduced into the agglomeration process of Lowe. Ex. 1020, ¶ 23 and Attachment 5. Mr. Madigan, however, does not provide sufficient details regarding the underlying testing upon which he appears to rely. 37 C.F.R. § 42.65. Further, Scotts Company combined the paper sludge of Lowe (not its agglomeration process) with Roth. *See, e.g.,* Pet. 57.

As to Encap’s assertion that Roth in view of Lowe does not disclose a “combination seed capsule,” as discussed above, the preamble recitation “combination seed capsule” is not an additional structural limitation on the claim. PO Resp. 47.

Lastly, Encap asserts that Lowe’s paper sludge is not a “soil conditioning material.” *Id.* (citing Ex. 2007 ¶ 19). Paragraph 19 of Mr. Katers’ Declaration, however, does not support Encap’s contention. Mr. Katers merely states that “[n]ot all paper sludge material would benefit the soil to which it is applied;” he does not state that Lowe’s paper sludge is not beneficial to the soil. Ex. 2007 ¶ 19.

We, therefore, conclude that the ordinary artisan would have combined Roth and Lowe to arrive at the claimed composition.

*E. Anticipation by Schreiber—Claims 1, 7, and 13*

Schreiber discloses the limitations of claims 1 and 7. For example, Schreiber discloses a plant seed having multiple coatings thereon, which satisfies the claimed “seed acting as a core or pseudo core.” Ex. 1002, col. 1, ll. 4-6; col. 9, ll. 38-43. Schreiber further discloses the claimed “coating of a composition comprising soil conditioning materials.” Specifically, Schreiber describes a seed coating made of a composition comprising solid particulate coating material, such as ground peat moss, thereby satisfying the claimed “being in a solid state at time of coating,” of claims 1 and 7. *Id.* at col. 2, ll. 34-49; col. 10, ll. 40-42. Schreiber



explains that its invention permits the tailoring of seed coatings for achieving optimum germination and growth, while allowing early planting within a wide time period. Schreiber also explains that other advantages also accrue from the invention. Schreiber, thus, satisfies our construction of “soil conditioning materials” because its coating provides better root development and drought resistance. *Id.* at col. 2, ll. 15-19; col. 9, ll. 44-49. Schreiber also discloses that the coating is an “agglomeration” of a plurality of types of materials, as Schreiber explains that the coating composition includes a “binder,” required by claim 13, or a plasticizer, and that the coating layers may coalesce, thereby satisfying the agglomeration requirement of claim 7. *Id.* at col. 2, ll. 37-39, 55-56; col. 3, ll. 35-42; col. 6, ll. 23-32.

Encap asserts that Schreiber does not disclose a “combination seed capsule.” PO Resp. 18-23. For the reasons discussed above, a “combination seed capsule” found in the preamble of claims 1 and 7 does not further limit the claim. Encap also asserts that Schreiber does not disclose a “soil conditioning material.” *Id.* at 23-26. Schreiber, however, discloses peat moss, limestone, gypsum, and vermiculite. Ex. 1002, col. 2, ll. 44-49. Those materials are known to beneficially modify the soil in some way other than direct provision of plant nutrients, and are, thus, “soil conditioning materials,” as recited in claims 1 and 7. *See, e.g.*, Exs. 1028-1031. Encap’s expert, Mr. Baker, acknowledged that peat moss, limestone, gypsum, and vermiculite are all soil conditioning materials. Baker Depo., Ex. 2005, 88, l. 22– 90, l. 9.<sup>8</sup>

---

<sup>8</sup> We reference page numbers found in the lower right corner of the exhibit.

Encap seeks to distinguish Schreiber on a purported difference in the function of the Schreiber coating and those disclosed in the '259 patent. Specifically, Encap asserts that Schreiber discloses using a water-insoluble coating with a water-soluble binder (e.g., peat moss) to delay germination until growing conditions are favorable, whereas, the soil conditioning materials of the '259 patent enhance germination and plant growth. PO Resp. 25. For the reasons already discussed, the claim limitation “soil conditioning materials” does not require the material also provide soil conditioning value to the seed. Moreover, the '259 patent explicitly discloses that the coating may be used to delay germination. Ex. 1001, col. 4, ll. 12-20; col. 25, ll. 8-17. Just because Schreiber’s coating also serves to delay germination does not mean that it is not a “soil conditioning material,” so long as it beneficially modifies the soil, in some way other than direct provision of plant nutrients.

In summary, we hold that Scotts Company has shown, by a preponderance of the evidence, that claims 1, 7, and 13 are anticipated by Schreiber, under 35 U.S.C. § 102(b).

*F. Obviousness over Schreiber and Roth—Claims 2, 5, 8, 11, and 14<sup>9</sup>*

As discussed above, Schreiber discloses the elements of independent claims 1 and 7. Scotts Company proposes using Roth’s MAS in place of Schreiber’s peat moss. Pet. 38-39. Scotts Company’s proposed combination would result in a seed coated with Roth’s MAS, and as discussed above, MAS does not satisfy the claim limitation that the soil conditioning material be “in a solid state at the time of coating.”

---

<sup>9</sup> In its Response, Encap references claim 15 instead of 14. We have interpreted Encap’s reference as intended to be to claim 14. PO Resp. 26-27.

Therefore, we hold that Scotts Company has not shown, by a preponderance of the evidence, that claims 2, 5, 8, 11, and 14 are unpatentable over Schreiber and Roth, under 35 U.S.C. § 103(a).

*G. Obviousness over Schreiber and Lowe—Claims 3, 4, 9, and 10*

As discussed above, Schreiber discloses the elements of independent claims 1 and 7. Lowe further teaches a material that is a byproduct of a “paper making process,” and specifically that the byproduct is “paper sludge” as required by dependent claims 3, 4, 9, and 10. Lowe describes an agricultural granule for carrying and releasing agricultural chemicals that resembles a clay-based granule. Ex. 1004, Abstract. The agricultural granule is made from using waste materials from paper manufacture, referred to as paper sludge. *Id.* at col. 1, l. 68–col. 2, ll. 1, 40-44. Scotts Company asserts that because Lowe teaches an agricultural granule made from paper sludge for carrying and releasing incorporated agricultural chemicals that resembles a clay-based granule (*id.* at Abstract; col. 2, l. 1), a person of ordinary skill would have had reason to substitute Schreiber’s water-insoluble, solid, clay-like, agricultural inner coating material with Lowe’s paper sludge materials. Pet. 40.

Schreiber discloses that its inner coating controls permeability of water and is typically water insoluble. Ex. 1002, col. 2, ll. 34-39. Encap asserts that there is no evidence that Lowe’s material, derived from paper sludge, would operate to control water permeability (i.e., is water insoluble)—a trait important to the teachings of Schreiber. PO Resp. 28. Scotts Company does not respond to Encap’s argument, and fails to provide any evidence that Lowe’s agricultural granule is water insoluble. If Lowe’s material is water soluble, it would not be a

suitable replacement for Schreiber's inner coating, as it would frustrate Schreiber's objective of delayed germination.

In summary, we hold that Scotts Company has failed to show, by a preponderance of the evidence, that claims 3, 4, 9, and 10 are unpatentable over Schreiber and Lowe under 35 U.S.C. § 103(a).

*H. Anticipation by Matthews—Claims 1, 2, 7, 8, 13, and 14*

Matthews discloses the claimed “seed acting as a core or pseudo core” with a “solid” “coating of a composition comprising soil condition materials,” as required by claims 1 and 7. Ex. 1007, 2, ll. 41-89. Specifically, Matthews describes a seed pellet product coated with “fly ash,” as required by dependent claims 2 and 8. *Id.* at 2, ll. 10-12, 61-64. Matthews further describes alternately spraying and dusting the seed with the coating until the desired thickness is reached, after which the seed pellets are dried. *Id.* at 2, ll. 81-84, 88-89. Matthews also discloses that the coating is an “agglomeration” of a plurality of types of materials, as required by claim 7, because Matthews explains that the coating of dust particles is bound by an adhesive water-soluble plastic, such as polyvinyl alcohol or methyl cellulose, around and about the original seed particle. *Id.* at 2, ll. 42-45, 50-54; 3, ll. 5-9. Matthews describes applying a “binder,” as required by dependent claim 13, to the seed capsule, e.g., polyvinyl alcohol, to hold the coating substances firmly on the seed. *Id.* at 2, ll. 42-45; 3, ll. 5-9. Further, the Matthews seed coating may include “fertilizer,” thus satisfying dependent claim 14. *Id.* at 5, ll. 25-27.

Encap asserts that Matthews does not disclose a “combination seed capsule.” PO Resp. 38. As discussed above, the preamble recitation “combination seed capsule” does not further limit the claim. In addition, Encap unpersuasively asserts

that Matthews' fly ash may not be necessarily beneficial to the seed (*id.*)—a requirement lacking from our claim construction of “soil conditioning material.” Relying upon Messrs. Baker and Katers, Encap asserts that Matthews' fly ash does not *necessarily* modify the soil in a beneficial manner, and hence, has not been proved to be a soil conditioning material. *Id.* at 39-42 (citing Ex. 2011 ¶ 21; Ex. 2007 ¶ 24). Essentially, Encap's argument is that while fly ash is specifically identified in the '259 patent as a soil conditioning material (*see, e.g.*, Ex. 1001, col. 7, ll. 21-25), not *all* fly ash is suitable—indeed, some types of fly ash are toxic. *Id.* Matthews, however, states that “[e]ach material must be stable and non-toxic.” Ex. 1007, 8, ll. 9-10. Moreover, Mr. Baker also acknowledged that a person of ordinary skill would have understood that a non-toxic fly ash could be used to coat a seed as a soil condition material, and that using toxic materials harmful to the seed should be avoided. Ex. 2005, 150, l. 18–151, l. 20. Lastly, Matthews also discloses that the use of its coating materials “aid in germination” and “growth of the plant.” Ex. 1007, 2, ll. 33-39. Thus, we determine that a person of ordinary skill would interpret Matthews as using non-toxic fly ash, beneficial to the soil.

Matthews also discloses using lime (*id.* at 5, ll. 28-35), which Mr. Krysiak admitted was a soil condition material (Ex. 2002, 148, ll. 18-23).

Therefore, we hold that Scotts Company has shown, by a preponderance of the evidence, that claims 1, 2, 7, 8, 13, and 14 are anticipated by Matthews under 35 U.S.C. § 102(b).

#### *I. Secondary Considerations*

Before we can determine that the combination of Roth and Lowe (*see* Section D, above), renders the challenged claims unpatentable as obvious, we must consider the evidence of obviousness anew in light of any evidence of secondary

considerations of nonobviousness presented by Encap. *See Graham v. John Deere Co.*, 383 U.S. 1, 17-18 (1966) (“Such secondary considerations as commercial success, long felt but unsolved needs, failure of others, etc., might be utilized to give light to the circumstances surrounding the origin of the subject matter sought to be patented. As indicia of obviousness or nonobviousness, these inquiries may have relevancy.”); *Transocean Offshore Deepwater Drilling, Inc. v. Maersk Drilling USA, Inc.*, 699 F.3d 1340, 1349 (Fed. Cir. 2012) (“This objective evidence must be ‘considered as part of all the evidence, not just when the decisionmaker remains in doubt after reviewing the art.’”) (quoting *Stratoflex, Inc. v. Aeroquip Corp.*, 713 F.2d 1530, 1538-39 (Fed. Cir. 1983)).

Encap alleges copying by others, long felt need, and commercial success as secondary considerations of non-obviousness. PO Resp. 48-49. Encap, however, fails to provide sufficient credible evidence to support its allegations.

Encap alleges that Scotts Company’s Miracle-Gro<sup>®</sup> Turf Builder Grass Seed with Water Smart<sup>®</sup> is a copy of the product of the ’259 patent. *Id.* at 48. To support its allegations, Encap submits a copy of marketing brochures for EncapSeed<sup>™</sup> products (Ex. 1009, 89-97), a copy of the packaging from Scotts Company’s Turf Builder Grass Seed with Water Smart<sup>®</sup> (*id.* at 98-101; Ex. 2013, 342-43, 346-47), a copy of a website print out pertaining to Scotts Company’s TurfBuilder (Ex. 2013, 344-45), a Declaration by Mr. Krysiak dated October 31, 2012 and submitted during an *ex parte* reexamination (Ex. 1009, 118-131), and a Declaration by Mr. Krysiak (Ex. 1022 ¶¶ 41, 42). None of the evidence submitted by Encap, however, demonstrates that Scotts Company’s Miracle-Gro<sup>®</sup> Turf Builder Grass Seed with Water Smart<sup>®</sup> product falls within the scope of any claim of the ’259 patent, that Scotts Company was aware of the ’259 patent prior to

developing its product, or that Scotts Company developed its product by copying the '259 patent.

Encap also asserts that there was a long-felt need for invention disclosed in the '259 patent. PO Resp. 48-49. Specifically, Encap asserts that many homeowners could not get their grass seed to grow because of inappropriate watering. *Id.* at 48. Encap, however, presents no credible evidence this need was satisfied by the '259 patented invention.

Lastly, Encap asserts commercial success because Meadowland took a license to the '259 patent. *Id.* at 49. Encap, however, does not allege that Meadowland's licensed product was commercially successful, or that any such commercial success was attributable to the patented features of the product. Encap also asserts that Scotts Company's product was commercially successful. *Id.* Encap, however, does not provide persuasive evidence that Scotts Company's product is covered by any claim of the '259 patent, that such product was commercially successful, or that such success was attributable to the patented feature.

After weighing all the evidence of obviousness and nonobviousness of record, on balance, we conclude that the strong evidence of obviousness outweighs the weak evidence of nonobviousness. For the foregoing reasons, we conclude that Scotts Company has shown, by a preponderance of the evidence, that claims 1-5, 7-11, 13, and 14 are unpatentable under 35 U.S.C. § 103(a) over Roth and Lowe.

*J. Encap's Corrected Motion to Amend Claims*

Encap filed a Motion to Amend Claims (Paper 24), which was later corrected (Paper 47) ("Mot."). In the Corrected Motion, Encap proposes substitute

IPR2013-00110  
Patent 6,209,259

claims 15-24, to replace claims 2-5, 8-11, 13, and 14,<sup>10</sup> respectively. Mot. 1. The Corrected Motion is contingent, meaning that a proposed substitute claim is at issue and would be considered only if “the original claims of the ’259 patent are found unpatentable.” *Id.* While somewhat ambiguous, we interpret Encap’s motion as proposing a substitute claim if the claim it replaces is found unpatentable, as opposed to being contingent on all of the challenged claims being found unpatentable. Scotts Company has demonstrated the unpatentability of claims 1-5, 7-11, 13, and 14. Therefore, the contingency has materialized, and thus, we consider the Corrected Motion on the merits.

As the moving party, Encap bears the burden of proof to establish that it is entitled to the relief requested. 37 C.F.R. § 42.20(c). The proposed amendment is not entered automatically, but only upon Encap’s having demonstrated the patentability of those substitute claims. Here, we find that Encap has failed to demonstrate that the added limitations distinguish over the known prior art, for example, Roth in combination with Lowe. Hence, Encap’s Motion to Amend is denied.

In a conference call on August 26, 2013, we provided Encap guidance on filing a motion to amend the claims, and specifically directed the parties to the analysis in *Idle Free Sys. v. Bergstrom, Inc.*, IPR2012-00027, Paper 26 (PTAB June 11, 2013). The summary of the call is reflected in Paper 17 of the record. *Idle Free* holds that a patent owner should specifically identify features added to

---

<sup>10</sup> Encap later identifies the substitution as claims 15-24 in place of claims 2-5 and 11-13. Mot. 2-5. Thus, it is unclear whether claims 23-24 are proposed as replacement for claims 13 and 14, or for claims 12 and 13. However, as we discuss below, the issue is moot.



each substitute claim, and come forward with technical facts and reasoning about those features, including construction of new claim terms. *Idle Free*, slip op. at 7. The patent owner should also discuss the “significance and usefulness” of the added features “from the perspective of one with ordinary skill in the art.” *Id.* We agree with the reasoning in *Idle Free*, and conclude that Encap has failed to satisfy its burden to demonstrate the patentability of the proposed substitute claims by a preponderance of the evidence.

While Encap identifies nineteen separate “structural limitations,” presumed to be new, it does not identify how each of these structural limitations differs from what is previously recited in the claims. 37 C.F.R. § 42.221(b) (“A motion to amend claims must . . . show the changes clearly . . .”). Specifically, Encap’s listing of proposed claims 15-24 does not show, by redline or discussion, how the claims being replaced have been modified. Mot. 1-5. Moreover, Encap fails to construe any new claim limitation, and also fails to proffer any technical facts and reasoning about the amended features. *Idle Free*, slip op. at 7. Encap’s failure to comply with the Board’s directive places Scotts Company in the unfair position of having to ascertain the claim amendments and then make assumptions about which of the amendments are considered by Encap to be significant. For amended claims, however, the burden “is not on the petitioner to show unpatentability;” it is “on the patent owner to show patentable distinction over the prior art.” *Id.* at 7. Encap has not met its burden.

For example, to determine the differences between original claim 2 and its proposed substitute, claim 15, the following comparison was created, with bracketed text indicating material deleted from claim 2, and underlined text indicating material inserted into claim 2 (paragraphing added).

[2] 15. The combination seed capsule of claim 1 wherein [material of said soil conditioning materials are comprised of sludge or fly ash] said combination seed capsules provides cooperative and beneficial effects of said soil conditioning material working together in controlled intimate relation with said seed, to enhance the germination and growth processes of said seed and the plant emergent therefrom, said effects being greater than when said soil conditioning material and said seed are applied to the soil separately; wherein said effects result from an intimate relationship of said soil conditioning materials in said combination seed capsule, whereby said materials cooperate with each other in support of said germination and growth processes;

said soil conditioning material is a material that beneficially modifies soil in some way other than direct provision of fertilizer, used with said seed to provide soil conditioning value to said seed so coated, irrespective of general tilth condition of the growth medium into or onto which the seed capsule is applied;

said solid state at time of coating comprising materials in form of a particulate material, fibrous material, a suspension of said particulate and/or fibrous material in a liquid suspension, or any combination thereof; said soil conditioning value of said soil conditioning material to said seed comprises the enhanced control of moisture about said seed; said enhanced control consists of absorbing and holding water;

said coating of said combination seed capsule comprises a plurality of particles.

Encap does not explain why each new feature is “significant and useful,” does not construe any of the new claim limitations, nor proffer any technical facts and reasoning about the amended features. Instead, Encap provides conclusory statements only, such as “Roth does not provide the cooperative and beneficial

effects of this structural limitation.” Mot. 6. Encap does not provide a proposed interpretation of the recited “cooperative and beneficial effects” of proposed substitute claim 15, nor does it explain whether Roth provides some of the “effects of this structural limitation,” and not others or why.

Encap asserts that the structural limitations themselves provide the technical facts and reasoning, as well as the significance and usefulness of the limitations. Pet. Reply 3. Encap asserts also that the “[c]laim construction of the structural limitations is found within the limitations themselves.” *Id.* We disagree. Providing “cooperative and beneficial effects” is vague and not self-defining, in any meaningful way. Consequently, the usefulness and significance of the limitation is not self-evident. The same can be said of, “working together in controlled intimate relation.”

Encap also fails to “provide meaningful reasons” for making additional changes to dependent claims. *Idle Free*, slip op. at 9. For example, claim 18, which depends from claim 15, adds three new limitations. *See* Mot. at 3; *see also id.* at 3-4 (claims 19 and 20 both depend from claim 17, and only differ by inclusion of a fungicide in claim 19). But Encap fails to explain why the additional features were added to these dependent claims. *Idle Free*, slip op. at 9-10 (“Adding features for no meaningful reason is . . . not responsive to an alleged ground of unpatentability.”).

In addition, *Idle Free* further instructs patent owners to consider and distinguish “prior art,” both “of record” and “not of record but known to the patent owner.” *Id.* at 7. Moreover, we specifically explained to Encap that “[a] conclusory statement that no prior art is known to the patent owner . . . is insufficient.” IPR2013-00110, Paper 17, 2. On page 1 of its Motion (Paper 47),

Encap states, “No closer art than the prior art cited in the underlying *inter partes* review is known to PO.” Encap, however, was aware of additional relevant prior art, including Simmons and Evans, which were cited in Scotts Company’s request for *inter partes* review, but which were deemed cumulative of the adopted grounds of rejection. *See* Pet. at 41-49; Prelim. Resp. at 25. While those references may have been cumulative over the original claims, they are not be cumulative in view of Encap’s proposed substitute claims, and should be addressed. Encap’s proposed claim 15 recites that the soil conditioning material “comprises enhanced control of moisture about said seed” consisting of “absorbing and holding water.” Encap distinguishes the prior art in this *inter partes* review by arguing that it does not teach enhancing moisture about the seed. Mot. at 9-10. Simmons and Evans specifically disclose coating a seed with a water-absorbable polymer. Yet, Encap failed to distinguish its proposed claims over those two material prior art references.

Encap attempts to correct some of its errors by filing an expert declaration with its Corrected Reply to Motion to Amend. Paper 49; Ex. 2012. As already addressed, however, we exclude this Declaration as untimely and improperly incorporated by reference into Encap’s Motion. In addition, as discussed above, the proffered “corrected” Second Declaration of Mr. Krysiak does not overcome Scotts Company’s objections, and is thus, excluded.

For the above reasons, Encap’s Corrected Motion to Amend Claims is denied as it fails to distinguish over the prior art, for example, Roth in combination with Lowe.

### III. CONCLUSION

Scotts Company has shown by a preponderance of the evidence that: (1) claims 1, 7, and 13 of the '259 patent are unpatentable under 35 U.S.C. § 102(b) as anticipated by Schreiber; (2) claims 1, 2, 7, 8, 13, and 14 are unpatentable under 35 U.S.C. § 102(b) as anticipated by Matthews; and (3) claims 1-5, 7-11, 13, and 14 are unpatentable under 35 U.S.C. § 103(a) as obvious over Roth and Lowe.

Scotts Company has not shown by a preponderance of the evidence that: (1) claims 1, 2, 5, 7, 8, 11, 13, and 14 of the '259 patent are unpatentable under 35 U.S.C. § 102(b) as anticipated by Roth; (2) claims 2, 5, 8, 11, and 14 are unpatentable under 35 U.S.C. § 103(a) as obvious over Schreiber and Roth; or (3) claims 3, 4, 9, and 10 are unpatentable under 35 U.S.C. § 103(a) as obvious over Schreiber and Lowe.

Encap has not shown by a preponderance of the evidence that its proposed substitute claims 15-24 are patentable over the prior art.

### IV. ORDER

In consideration of the foregoing, it is hereby ORDERED that:

Scotts Company's Motion to Exclude Mr. Krysiak's Second Declaration (Ex. 2016) is granted and all other relief requested in the motion is denied;

Encap's Motion to Exclude Mr. Sundstrom's Declaration (Ex. 1039) is dismissed as moot;

Claims 1-5, 7-11, 13, and 14 of the '259 patent are determined to be unpatentable; and

Encap's Corrected Motion to Amend Claims is denied.

IPR2013-00110  
Patent 6,209,259

This is a final decision. Parties to the proceeding seeking judicial review of the decision must comply with the notice and service requirements of 37 C.F.R. § 90.2.

IPR2013-00110  
Patent 6,209,259

Petitioner:

Robert Schulman  
[rschulman@hunton.com](mailto:rschulman@hunton.com)

Jeff Vockrodt  
[jvockrodt@hunton.com](mailto:jvockrodt@hunton.com)

Patent Owner:

Philip Weiss  
[weissandweiss@aol.com](mailto:weissandweiss@aol.com)

Aaron Olejniczak  
[aarono@andruslaw.com](mailto:aarono@andruslaw.com)

UNITED STATES PATENT AND TRADEMARK OFFICE

---

BEFORE THE PATENT TRIAL AND APPEAL BOARD

---

THE SCOTTS COMPANY LLC  
Petitioner

v.

ENCAP, LLC  
Patent Owner

---

Case IPR2013-00110  
Patent 6,209,259

---

Before MICHAEL P. TIERNEY, LORA M. GREEN, and RAMA G. ELLURU,  
*Administrative Patent Judges.*<sup>1</sup>

PER CURIAM.

FINAL WRITTEN DECISION  
*35 U.S.C. § 318(a) and 37 C.F.R. § 42.73*

---

<sup>1</sup> Floyd, Administrative Patent Judge, who participated in the oral hearing held on January 30, 2014, has left the Board; accordingly, Tierney, Administrative Patent Judge, has been added to the panel.



## I. BACKGROUND

Petitioner, The Scotts Company LLC (“Scotts Company”), filed a Petition on January 10, 2013, for an *inter partes* review of claims 1-5, 7-11, 13, and 14 (“the challenged claims”) of U.S. Patent No. 6,209,259 (“the ’259 patent”) pursuant to 35 U.S.C. §§ 311-319. Paper 2. On April 15, 2013, Patent Owner, Encap, LLC (“Encap”), filed a Preliminary Response. Paper 9. On July 3, 2013, the Board granted an *inter partes* review for all challenged claims on less than all of the grounds of unpatentability alleged in the Petition. Paper 12, (“Dec.”). The Board also stayed concurrent reexamination of the ’259 patent. Paper 10.

After institution of trial, Encap filed a Corrected Patent Owner’s Response. Paper 48. Encap also filed a Corrected Contingent Motion to Amend Claims that requests substituting proposed new claims 15-24 for claims 2-5, 8-11, 13, and 14, respectively—contingent upon a determination of unpatentability. Paper 47. Scotts Company filed a Reply to Patent Owner’s Response (Paper 30), and an Opposition to Encap’s Motion to Amend Claims (Paper 33). Encap then filed a Corrected Reply to Scotts Company’s Opposition to Encap’s Motion to Amend Claims. Paper 49.

Additionally, Scotts Company filed a Motion to Exclude Evidence (Paper 52), to which Encap responded (Paper 64) and submitted supplemental evidence (Paper 58). Scotts Company filed a Reply in further support of its Motion to Exclude. Paper 68.

Encap also filed a Motion to Exclude Evidence (Paper 54) to which Scotts Company responded (Paper 60). Encap, with authorization (Paper 70), filed a Supplement to its Motion to Exclude (Paper 66), as well as a Reply (Paper 67).

Oral hearing was held on January 30, 2014.<sup>2</sup>

The Board has jurisdiction under 35 U.S.C. § 6(c). This Final Written Decision is issued pursuant to 35 U.S.C. § 318(a) and 37 C.F.R. § 42.73.

Scotts Company has shown by a preponderance of the evidence that claims 1-5, 7-11, 13, and 14 of the '259 patent are unpatentable. Encap's Motion to Amend Claims is denied.

*A. The '259 Patent*

The '259 patent is directed to a combination seed capsule, comprising at least one viable seed, a coating of a composition comprising a soil conditioning material mounted proximate and disposed outwardly of the outer surface of the seed, and optionally including one or more of inorganic chemical fertilizers, growth enhancer, binder, and/or an anti-fungal agent. Ex. 1001, Abstract, 4:5-11. According to the '259 patent Specification, the primary object of the invention is to "provide solid plant seed capsule products that supply both soil conditioning properties and the seed, which can benefit from such conditioned soil, in a given seed capsule particle." *Id.* at 3:28-31.

*B. Illustrative Claim*

Claims 1 and 7 are the only independent claims in the '259 patent, and are directed to a "[a] combination seed capsule." The only difference between these claims is that claim 7 additionally states that the seed coating is applied by an agglomeration process. The remaining challenged claims depend from either claim 1 or 7. Claim 1 is illustrative of the claimed subject matter, and is reproduced below.

---

<sup>2</sup> A transcript of the oral hearing is included in the record as Paper 78.

1. A combination seed capsule comprising:
  - one viable seed;
  - said seed acting as a core or pseudo core of said combination seed capsule;
  - a coating of a composition comprising soil conditioning materials;
  - said soil conditioning materials being in a solid state at time of coating.

*C. Prior Art Supporting the Instituted Challenges*

Name	Reference	Issue or Publication	Exhibit
Schreiber	U.S. Patent No. 3,698,133	Oct. 17, 1972	Ex. 1002
Roth	U.S. Patent No. 4,065,287	Dec. 27, 1977	Ex. 1003
Lowe	U.S. Patent No. 5,019,564	May 28, 1991	Ex. 1004
Matthews	GB670,461	Apr. 16, 1952	Ex. 1007

*D. The Instituted Challenges of Unpatentability*

References	Grounds	Claims
Schreiber	§ 102(b)	Claims 1, 7, and 13
Schreiber and Roth	§ 103(a)	Claims 2, 5, 8, 11, and 14
Schreiber and Lowe	§ 103(a)	Claims 3, 4, 9, and 10
Matthews	§ 102(b)	Claims 1, 2, 7, 8, 13, and 14
Roth	§ 102(b)	Claims 1, 2, 5, 7, 8, 11, 13, and 14
Roth and Lowe	§ 103(a)	Claims 1-5, 7-11, 13, and 14

## II. DISCUSSION

### A. Evidentiary Matters

#### 1. Scotts Company's Reply (Paper 30)

In a conference call held on December 3, 2013, Encap asserted that Scotts Company had raised new arguments and evidence in its Reply to Patent Owner's Response to Decision to Institute. Order (Paper 37), 2. The Board denied Encap's request to file a surreply, or to enlarge the page limit of Encap's Reply in support of its Motion to Amend. *Id.* We indicated, however, that we would determine whether Scotts Company's Reply and supporting evidence contain material exceeding the proper scope of a reply. *Id.*

We find that Scotts Company's Reply, and in particular, the supporting Declarations of Mr. Fredrick Sundstrom (Ex. 1039) and Mr. Krishna Pagilla (Ex. 1040) contain material outside the proper scope of a reply. 37 C.F.R. § 42.23(b) (reply is limited to arguments raised in Patent Owner's Response). Specifically, both Declarations contain materials in support of Scotts Company's Petition, and therefore, untimely filed. For example, Mr. Sundstrom includes analyses of claim construction (e.g., Ex. 1039 ¶¶ 7-9), as well as analyses of the Schreiber (e.g., *id.* at ¶¶ 10-13), Matthews (e.g., *id.* at ¶¶ 28, 29), Roth (e.g., *id.* at ¶ 34), Simmons (*id.* at ¶¶ 36, 38), and Evans (*id.* at ¶¶ 43, 44, 46, 48) references. Likewise, Mr. Pagilla addresses claim construction, as well as the references upon which Scotts Company sought institution. *See, e.g.*, Ex. 1040 ¶¶ 9-13, 23-27, 32, 33, 36-38. Specifically, we hold that the new evidence could have been included with the motion. By waiting to serve this evidence on Encap in Scotts Company's Reply, Encap was denied the opportunity to file responsive evidence. Thus, we

have not considered the untimely Declarations of Mr. Sundstrom and Mr. Pagilla, nor the arguments based thereon.<sup>3</sup>

2. *Scotts Company's Motion to Exclude*

Scotts Company filed a Motion to exclude: portions of the deposition testimony of Mr. Michael Krysiak taken by Encap on November 6, 2013 (Ex. 2002) and December 23, 2013 (Ex. 1038); and the Second Krysiak Declaration, which includes Attachments A and B (Ex. 2016). Pet. Mot. Excl. (Paper 52), 1. Mr. Krysiak, Encap's witness, submitted a second Declaration (Ex. 2012) in support of its Reply to Petitioner's Opposition to Encap's Motion to Amend (Paper 49). Encap responded to Scotts Company's Motion to Exclude and filed supplemental evidence. PO Resp. Mot. Excl. (Paper 64); PO Supp. Evid. (Paper 58), respectively. Scotts Company filed a Reply. Paper 68. We grant-in-part Scotts Company's Motion to Exclude Evidence.

Scotts Company asserts that Mr. Krysiak's deposition testimony in response to two questions (i.e., Ex. 2002, 207, l. 9; Ex. 1038, 209, ll. 7-8) should be excluded. Pet. Mot. Excl. 9-10. As we did not rely upon this deposition testimony that Scotts Company seeks to exclude, Scotts Company's Motion is moot with respect to such testimony.

Scotts Company also moves to exclude the Second Declaration of Mr. Krysiak (Ex. 2012). Scotts Company's primary objection is that the Declaration is untimely, as it should have been submitted with Encap's Motion to

---

<sup>3</sup> The fact that two declarations may contain some material appropriate for a response does not require our consideration of them, as the Board will not attempt to sort the proper from the improper portions. *See Office Patent Trial Practice Guide*, 77 Fed. Reg. 48,756, 48,767 (Aug. 14, 2012).

Amend (Paper 47). Pet. Mot. Excl., 11-14; *see* 37 C.F.R. § 42.23(b) (“All arguments for the relief requested in a motion must be made in the motion. A reply may only respond to arguments raised in the corresponding opposition or patent owner response.”). In support of Scotts Company’s Opposition to Encap’s Motion to Amend (Paper 33), it relied upon the Declaration of Mr. Sundstrom (Ex. 1039), which was not considered, as discussed above. Encap asserts that Mr. Krysiak’s Second Declaration is in rebuttal to Declarations and deposition testimony of Mr. Sundstrom and Mr. Pagilla. PO Resp. Mot. Excl. 10-11. Encap proffers supplemental evidence—a revised Second Declaration of Mr. Krysiak with citations to the Declaration and deposition of Mr. Sundstrom. Paper 58; Ex. 2016.

Reading Mr. Krysiak’s Second Declaration, it is clear that the majority of the Declaration is in support of Encap’s Motion to Amend rather than in rebuttal to Scotts Company’s Opposition to Encap’s Motion to Amend or the Declarations and deposition testimony<sup>4</sup> of Mr. Sundstrom and Mr. Pagilla, and is thus, untimely. For example, paragraphs 2-3 relate to written description and claim construction, which Encap has the burden of proving in its Motion to Amend. Additionally, paragraphs 6-12 describe the background of the technology, which could have been submitted with Encap’s Motion to Amend opening brief, and thus, are not in rebuttal to testimony from Mr. Sundstrom or Mr. Pagilla. Likewise, paragraphs 25-53 and Schedule A attempt to distinguish over Matthews and Schreiber, which Encap should have done in Patent Owner’s Motion to Amend. Furthermore, to the extent that portions of Mr. Krysiak’s Second Declaration are in response to the

---

<sup>4</sup> While not addressed, we do not suggest that filing a declaration in rebuttal to deposition testimony is appropriate.

IPR2013-00110  
Patent 6,209,259

Declarations of Mr. Sundstrom and Mr. Pagilla, which were excluded, they should likewise be excluded. Those errors were not corrected in the Supplemental Evidence (i.e., Ex. 2016) submitted by Encap.

In addition, Encap attempts to incorporate Mr. Krysiak's Second Declaration into its Reply to Scott's Opposition to the Motion to Amend by merely stating, "The proposed claims define over the prior art succinctly. *Id.* [Mr. Krysiak's Second Declaration] at ¶¶ 14-53." Reply Mot. Amend 5. In our Order of August 27, 2013, we admonished Encap to refrain from attempting to use an expert declaration in such fashion. We stated, "Encap's motion to amend may be supported by an expert declaration, but that the motion itself should set forth the arguments and explanations with appropriate pinpoint citations to the expert declaration, rather than incorporating by reference the expert declaration." Paper 17, 2-3. Thus, Scotts Company's Motion to Exclude Mr. Krysiak's Second Declaration (Ex. 2012) is granted, as Mr. Krysiak's Corrected Second Declaration (Ex. 2016) did not remedy the issues, it is not considered.

3. *Encap's Motion to Exclude*

Encap moves to exclude the Declaration of Mr. Sundstrom (Ex. 2014), Scott Company's witness who provided a declaration in support of Scott Company's Reply to Patent Owner's Response to Decision to Institute (Paper 30), on the basis that the declarant refused to answer certain questions during his deposition on the basis of confidentiality, even though a protective order was in place. PO Mot. Excl. (Paper 54), 5. Having found that Mr. Sundstrom's Declaration was untimely submitted, and thus, not considered, Encap's Motion to Exclude is dismissed as moot.

*B. Claim Construction*

Consistent with the statute and the legislative history of the AIA, the Board interprets claims by applying the broadest reasonable construction in the context of the specification in which the claims reside. 37 C.F.R. § 42.100(b); *see Office Patent Trial Practice Guide*, 77 Fed. Reg. 48,756, 48,766 (Aug. 14, 2012). Claim terms also are given their ordinary and customary meaning, as would be understood by one of ordinary skill in the art in the context of the entire disclosure. *In re Translogic Tech., Inc.*, 504 F.3d 1249, 1257 (Fed. Cir. 2007).

Two exceptions to the general rule that a claim term is given its ordinary meaning are: 1) when a patentee sets out a definition and acts as his own lexicographer; or 2) when the patentee disavows the full scope of a claim term either in the specification or during prosecution. *See In re Paulsen*, 30 F.3d 1475, 1480 (Fed. Cir. 1994). If an inventor acts as his or her own lexicographer, the definition must be set forth in the specification with reasonable clarity, deliberateness, and precision. *Id.*

*1. "soil conditioning materials"*

All of the challenged claims require "a coating of a composition comprising soil conditioning materials." The '259 patent Specification states that "*all soil conditioning materials contemplated herein* beneficially modify soil to which they are applied, in some way other than direct provision of nitrogen, phosphorous, and/or potassium or other plant nutrients." Ex. 1001, col. 8, ll. 41-44 (emphasis added). The Specification further provides specific examples of soil conditioning materials, such as municipal or other sewage sludge, paper mill sludge, fly ash, and dust. *Id.* at col. 7, ll. 21-23. Accordingly, in the Decision to Institute, the Board construed "soil conditioning materials" as "materials that beneficially modify soil



to which they are applied, in some way other than direct provision of nitrogen, phosphorous, and/or potassium or other plant nutrients, including for example, municipal or other sewage sludge, paper mill sludge, fly ash, and dust.” Dec. 6-7.

Although Scotts Company agrees with the Board’s preliminary construction (Pet. Reply, 1-2), Encap asserts the construction is overly broad in view of the Specification (PO Resp., 8-9). Specifically, Encap asserts the construction should be amended to include that the soil conditioner not only enhances soil condition of the growth medium/soil to which it is applied, it also provides soil conditioning value to the seed so coated irrespective of the general tilth condition of the growth medium. *Id.* (citing Ex. 1001, col. 8, ll. 42-52,<sup>5</sup> Abstract). Encap does not assert that its construction is the plain and ordinary meaning of “soil conditioning materials,” but rather, that the Specification defines the phrase. PO Resp. at 8. Specifically, Encap asserts the following portion of the Specification defines “soil conditioning materials:”

However, all soil conditioning materials contemplated herein beneficially modify soil to which they are applied, in some way other than direct provision of nitrogen, phosphorous, and/or potassium or other plant nutrients. By use of soil conditioner in intimate association with the seed, this invention not only enhances soil condition of the growth medium/soil to which it is applied, it also provides soil conditioning value to the seed so coated, and in intimate association with the seed, irrespective of the general tilth condition of the growth medium into or onto which the seed capsule is applied.

Ex. 1001, col. 8, ll. 42-52.

Through the inclusion of “all soil conditioning materials contemplated herein,” the first sentence requires the soil conditioning material to beneficially

---

<sup>5</sup> Encap mistakenly refers to col. 15, l. 29–col. 16, l. 6.

modify the soil in some way, other than directly providing plant nutrients. The second sentence is an observation of benefits provided by “this invention;” it does not *require* the invention provide the observed benefits; much less require *just* the soil conditioning material of the invention provide such benefits.

Encap relies upon its experts, Mr. John Katers, Mr. Daniel Madigan, and Mr. Michael Krysiak, all of whom provide identical claim constructions, in support of its position. Ex. 2007 ¶ 11; Ex. 1020 ¶ 10; Ex. 1022 ¶ 13. The experts provide, however, no credible analysis in support of their claim constructions, and thus, are unpersuasive.

Encap asserts also that the examples included in the Board’s preliminary claim construction should be omitted, because not *all* municipal or other sewage sludge, paper mill sludge, fly ash, or dust, necessarily modify the soil in a beneficial manner. PO Resp. 9. The Board’s preliminary construction, however, requires the soil conditioning materials “modify soil to which they are applied, in some way other than direct provision of nitrogen, phosphorous, and/or potassium or other plant nutrients.” The inclusion of the examples is intended to clarify, not modify, this requirement.

Accordingly, the Board maintains its construction of “soil conditioning materials” as:

Materials that beneficially modify soil to which they are applied, in some way other than direct provision of nitrogen, phosphorous, and/or potassium or other plant nutrients, including for example, municipal or other sewage sludge, paper mill sludge, fly ash, and dust.

2. “combination seed capsule”

The phrase “combination seed capsule” appears in the preamble of claims 1 and 7. Encap asserts that the Abstract of the ’259 patent defines “combination seed capsule.” PO Resp. 10-11. The Abstract reads:

This invention pertains to combination seed capsules wherein each seed capsule includes both moieties of at least one soil conditioner and at least one seed, and optionally, one or more inorganic chemical fertilizer, growth enhancer, binder, and/or anti-fungal agent. The combination seed capsules are made by physically combining the respective soil conditioner and seed with one other, in the absence of any requirement for chemical reactions in the process of so combining the respective materials. The combination seed capsules *provide cooperative and beneficial effects of the soil conditioner and the optional inorganic fertilizer, working together in controlled intimate relation with the seed, to enhance the germination and growth processes of the seed, and the plant emergent therefrom, greater than when the soil conditioner and seed, and optionally inorganic chemical fertilizer, are applied to the soil separately; the improvement being a result of the intimate relationship of the respective materials in the combination seed capsule, whereby the respective materials cooperate with each other in support of germination and plant growth.*

Ex. 1001, Abstract (emphases added). Encap asserts that the text that has been italicized is the definition of a “combination seed capsule.” PO Resp. 11. Encap also relies upon its technical experts, Messrs. Baker, Madigan, and Krysiak. *Id.* at 11-12. The experts, however, provide no credible analysis in support of their claim constructions and are thus, unpersuasive.

Scotts Company asserts that the term “combination seed capsule” appears in the preamble of both independent claims (i.e., claims 1 and 7), and thus, is not limiting. Pet. Reply 2. Scotts Company also asserts that in 1998, when the application that matured into the ’259 patent was filed, the rules prohibited relying

on the Abstract “for interpreting the scope of the claims.” *Id.* at 3 (quoting 37 C.F.R. § 1.72(b)). Lastly, Scotts Company asserts that Encap is attempting to improperly import limitations into the claims. *Id.*

First, the Abstract does not provide a definition for a “combination seed capsule,” but rather observes the benefits of the combination seed capsule. Second, the preamble term “combination seed capsule” is not limiting because the claim body describes a structurally complete invention. *Catalina Mktg. Int’l v. Coolsavings.com Inc.*, 62 USPQ2d 1781, 1785 (Fed. Cir. 2002). Thus, we need not construe “combination seed capsule,” as it does not limit the claim.

3. “*being in a solid state at time of coating*”

Independent claim 1 recites, “being in a solid state at time of coating.” Similarly, independent claim 7 recites, “are in a solid state at time of coating.” Additionally, claim 7 recites, “said coating being applied to said viable seed by an agglomeration operation.” Due to the inclusion of these three limitations, claims 1 and 7 were determined to be product-by-process claims in the Decision to Institute. Dec. 7-8.

Encap asserts that “in a solid state at time of coating” should be construed as “solid material in the form of particulate, fibrous, or a suspension of a particulate or fibrous material in a liquid carrier to form an agglomeration of said particulate and/or fibers.” PO Resp. 12-13 (citing Ex. 1001, col. 8, ll. 1-5<sup>6</sup>). Scotts Company points out that the Specification reads, the soil conditioning raw material “*may* be a particulate powder, or *may* be fibrous, or *may* be a suspension of a powder or fibrous material in a liquid carrier, and is preferably coated onto the substrate seed

---

<sup>6</sup> Encap erroneously cites to col. 14, ll. 24-28.

to form a seed capsule or other agglomeration of particles, fibers, *or the like*,” and thus, does not support Encap’s construction. Pet. Reply 3 (quoting Ex. 1001, col. 8, ll. 1-5 with emphasis added). We agree that the Specification does not support Encap’s proposed construction.

Encap further asserts that during prosecution of the ’259 patent application, Mr. Krysiak had discussions with the Examiner relating to “being in a solid state at the time of coating.” PO Resp. 12 (citing Ex. 1022 ¶ 15). Encap’s description of events does not provide support for its proposed claim construction. That is, it does not follow that adding the limitation to overcome Roth, defines the limitation to require “solid material in the form of particulate, fibrous, or a suspension of a particulate or fibrous material in a liquid carrier to form an agglomeration of said particulate and/or fibers.” As before, Mr. Krysiak’s opinion as to how the phrase should be construed includes no analysis, and thus, is unpersuasive.

Encap does establish that it disavowed claim scope, however, by adding the limitation “in a solid state at time of coating” to overcome Roth. That clear and unambiguous disavowal of claim scope causes us to modify the claim construction from that set forth in the Decision to Institute. Specifically, Encap narrowed the “in a solid state at time of coating” limitation to require the soil conditioning material be in a solid state at the time of coating the seed. Encap did not narrow “in a solid state at time of coating,” however, to further require a particulate, fibrous, or a suspension of a particulate or fibrous material in a liquid carrier to form an agglomeration of said particulate and/or fibers, as suggested by Encap.

The Federal Circuit has addressed the issue of determining whether a claim has been narrowed in the related context of prosecution history estoppel.

In order to give due deference to public notice considerations under the *Warner–Jenkinson* framework, a patent holder seeking to establish

the reason for an amendment must base his arguments solely upon the public record of the patent's prosecution, i.e., the patent's prosecution history. To hold otherwise—that is, to allow a patent holder to rely on evidence not in the public record to establish a reason for an amendment—would undermine the public notice function of the patent record.

*Festo Corp. v. Shoketsu Kinzoku Kogyo Kabushiki Co.*, 234 F.3d 558, 586 (Fed. Cir. 2000), *vacated on other grounds*, 535 U.S. 722 (2002).

An examination of the prosecution history of record reveals the following events which support our determination that Encap clearly disavowed the full scope of claims 1 and 7. On May 10, 2000, the Examiner issued a rejection to claim 77 as anticipated by Roth, and further rejected claims 77 and 85 as being obvious in view of Roth in combination with two other references. Ex. 1008, 171, 175.<sup>7</sup> On August 8, 2000, the Examiner issued an interview summary, which indicates that a proposed claim amendment was discussed. Specifically, the Examiner stated that adding, “wherein said soil conditioning material, when added to the seed, are in a dry, solid form,” to the claims would overcome Roth. The Examiner suggested “that the claims be written in a product by process form to clearly distinguish over Roth.” *Id.* at 203. On September 8, 2000, the Examiner issued an Interview Summary indicating that claims 77 and 85 were discussed, and that “[b]ased on the proposed draft amendment and arguments recited therein, the prior art was overcome.” *Id.* at 204. The record clearly shows that the only amendment made to claim 77 was the addition of the limitation, “said soil conditioning materials being in a solid state at time of coating.” *Id.* at 200. Claim 85 was amended in similar fashion to recite, “wherein said soil conditioning

---

<sup>7</sup> Claims 77 and 85, ultimately issued as claims 1 and 7, respectively.

materials are in a solid state at time of coating.” *Id.* at 201. Claims 77 and 85 ultimately issued as claims 1 and 7, respectively.

Thus, Encap successfully overcame Roth by adding the “in a solid state at the time of coating” limitation to claims 1 and 7. Construing the phrase as a product-by-process limitation would not result in distinguishing over Roth, as no discussion was had, nor evidence provided, to suggest the end product of Roth had different characteristics than the claimed composition. The disavowal of claim scope is clear. The limitation “in a product by process form,” therefore, must be construed to require the soil conditioning material be in a solid state at the time of coating. *See Tempo Lighting, Inc. v. Tivoli, LLC*, 742 F.3d 973, 978 (Fed. Cir. 2014).

Furthermore, Roth discloses a spray application of a MAS material that contains 0.1% to 2.5% solids at the time of coating. Ex. 1003, col. 3, ll. 50-51. Thus, the limitation “in a solid state at the time of coating” must further be construed to require more than 2.5% solids. Therefore, we construe “in a solid state at the time of coating” to mean that more than 2.5% of the soil conditioning material must be in a solid state at the time of coating the seed.

4. “agglomeration operation”

Independent claim 7 requires an “agglomeration operation,” which we construed in our Decision to Institute to be a product-by-process limitation. Dec. 8. Patent Owner concedes that claim 7 is a product-by-process claim. PO Resp. 16. Patent Owner, however, takes issue with the Board’s “holding” that an agglomeration operation means using water and heat to bind a plurality of particles. *Id.* at 13.

We did not construe “agglomeration operation,” other than to note that it is a product-by-process limitation. *In re Thorpe*, 777 F.2d 695, 698 (Fed. Cir. 1985). The structure implied by the process steps should be considered when assessing the patentability of product-by-process claims over the prior art. *See, e.g., In re Garner*, 412 F.2d 276, 279 (CCPA 1969). That is especially true where the product can only be defined by the process steps by which the product is made, or where the manufacturing process steps would be expected to impart distinctive structural characteristics to the final product. *Id.* Thus, the issue is not focused on what “agglomeration operation” means, but rather on what properties would be embodied in a product made by an agglomeration operation (i.e., an agglomerate). Here, the parties are in near agreement on the properties of an agglomerate.

Encap states that an agglomerate is an assemblage of particles adhering to each other, and thus, a magnified image of an agglomerate would reveal that the product is comprised of particulate. PO Resp. 13-16. Without credible explanation, Encap in its conclusion limits its final description of an agglomerate to an assemblage of *fine* particles. *Id.* at 16. Evidence cited by Encap that may support this additional limitation is an article by Wolfgang B. Pietsch, titled “The Agglomerative Behavior of Fine Particles.” *Id.* at 13-14 (citing Ex. 1020 ¶ 11, Attachment A). As the title suggests, however, the article is specifically directed to agglomerates of fine particles. There is no credible suggestion in Mr. Madigan’s Declaration (Ex. 1020) that an “agglomerate” is limited to fine particles. *See* Ex. 1020 ¶¶ 11-17.

Scotts Company appears to accept Encap’s description of an agglomerate, but takes exception, as we do, with the limitation to fine particles. Pet. Reply 3-4.



Thus, we determine that an agglomerate is an assemblage of particles adhering to each other. The “agglomeration operation” limitation of claim 7 implies that the claimed “combination seed capsule” has a coating of a composition comprising soil conditioning materials comprised of particulate. As such, to satisfy the limitation of an “agglomeration operation,” a reference must disclose a product with the structural limitation of being comprised of particulate, irrespective of the process used to make the product.

*C. Anticipation by Roth—Claims 1, 2, 5, 7, 8, 11, 13, and 14*

Roth explains that the MAS coating is “solid” after application. Roth, however, does not disclose the soil conditioning materials “being in a solid state at time of coating,” because Roth discloses a spray application of a MAS material that is 97.5% to 99.9% liquid with the remainder “solids content.” PO Resp. 31-32 (citing Ex. 1003, col. 3, ll. 50-51). While a tiny amount (i.e., 0.1% to 2.5%) of the soil conditioning material is in solid state at the time of coating, as discussed above, this is not enough to satisfy the limitation “in a solid state at time of coating,” recited in claims 1 and 7. As such, Scotts Company has not shown, by a preponderance of the evidence, that Roth anticipates 1, 2, 5, 7, 8, 11, 13, and 14.

*D. Obviousness over Roth and Lowe—Claims 1-5, 7-11, 13, and 14*

Roth teaches the claimed “seed acting as a core or pseudo core” with a “coating of a composition comprising soil conditioning materials,” as required by claims 1 and 7. Specifically, Roth describes coating seeds with a methanol treated “sludge” carrier having one or more agricultural chemicals dispersed therein, wherein the source material is “municipal sewage,” as required by dependent claims 2, 5, 8, and 11. *See, e.g.*, Ex. 1003, col. 3, ll. 23-26. Roth also discloses that its coating may include a “binder,” e.g., polyvinyl alcohol, starch derivatives,

and further may include a fertilizer, as recited in claims 13 and 14. *Id.* at col. 2, ll. 3-5, 48-51; col. 5, ll. 49-52. Thus, we determine that Roth discloses all the limitations of claims 1, 2, 5, 7, 8, 11, 13, and 14 with the exception of “in a solid state at time of coating,” as required by independent claims 1 and 7.

Lowe discloses coating a seed with de-inked paper sludge having a “fiber content of the solids in the mixture should exceed at least 10%-15% by weight,” thereby teaching “in a solid state at time of coating.” Ex. 1004, col. 3, ll. 17-21. Lowe also discloses using “agglomeration” to combine the fibers to form individual granules. *Id.* at Abstract; col. 3, ll. 21-22. Thus, as discussed in greater detail below, Lowe in combination with Roth satisfies the limitations of independent claims 1 and 7 as the combination involves the use of known components for their known purpose to achieve a predictable result.

Lowe further teaches coating a seed with a material that is a byproduct of a “paper making process,” and specifically that the byproduct is “paper sludge,” as required by dependent claims 3, 4, 9, and 10. Lowe describes an agricultural granule for carrying and releasing agricultural chemicals that resembles a clay-based granule. *Id.* at Abstract. The agricultural granule is made from using waste materials from paper manufacture, referred to as paper sludge. *Id.* at col. 1, l. 68–col. 2, l. 1; col. 2, ll. 40-44.

Scotts Company asserts that because Roth teaches a MAS carrier for agricultural chemicals that can coat a seed, and because Lowe likewise teaches an agricultural carrier consisting of paper sludge, a person of ordinary skill in the art would have had reason to substitute Lowe’s paper mill sludge for Roth’s MAS coating. Pet. 57.

Encap asserts that the proposed combination runs contrary to the disclosure of Roth. PO Resp. 43. In particular, Encap asserts that Lowe requires the fiber content of the finished particle be above 10%, which means, therefore, that the material is 90% or less filler. *Id.* (citing Ex. 1004, col. 4, ll. 65-66; col. 6, ll. 53-63). On the other hand, Roth discloses MAS that is 97.5%-99.9% liquid. *Id.* (citing Ex. 1003, col. 3, ll. 50-51). Encap asserts that a product that is 97.5% or more liquid could not be replaced by a product with 10% or more fiber content and still be sprayed. *Id.* (citing Ex. 1020 ¶ 22). We do not find Encap's argument persuasive because Roth is not limited to spray-on coatings. The MAS, and presumably Lowe's paper sludge, can be applied to the seeds "by dipping, soaking, spraying, or other conventional mode of application." Ex. 1003, col. 4, ll. 48-50.

Encap also asserts that Roth's disclosure of a coating with 0.1% to 2.5% solids teaches away from using Lowe's coating containing over 10% solids. PO Resp. 43. Roth, however, "does not criticize, discredit, or otherwise discourage" the use of a higher percentage of solids. *In re Fulton*, 391 F.3d 1195, 1201 (Fed. Cir. 2004). Thus, Encap's argument is not persuasive.

Encap further asserts that paper sludge and MAS have very different characteristics. PO Resp. 44-45. In particular, Encap asserts that attempting to coat a seed with paper sludge, using the agglomeration process disclosed in Lowe, would not have a reasonable likelihood of success. *Id.* at 46. In support of its assertion, Encap submits the Declaration of Mr. Madigan (Ex. 1020) who testifies as to the difficulties associated with coating seeds with paper sludge utilizing the agglomeration process of Lowe. *Id.* We do not credit Mr. Madigan's declaration as it fails to provide the underlying basis for his conclusions. For example, Mr. Madigan cites an attachment that purports to show what a final product of Lowe

would look like if seed is introduced into the agglomeration process of Lowe. Ex. 1020, ¶ 23 and Attachment 5. Mr. Madigan, however, does not provide sufficient details regarding the underlying testing upon which he appears to rely. 37 C.F.R. § 42.65. Further, Scotts Company combined the paper sludge of Lowe (not its agglomeration process) with Roth. *See, e.g.,* Pet. 57.

As to Encap's assertion that Roth in view of Lowe does not disclose a "combination seed capsule," as discussed above, the preamble recitation "combination seed capsule" is not an additional structural limitation on the claim. PO Resp. 47.

Lastly, Encap asserts that Lowe's paper sludge is not a "soil conditioning material." *Id.* (citing Ex. 2007 ¶ 19). Paragraph 19 of Mr. Katers' Declaration, however, does not support Encap's contention. Mr. Katers merely states that "[n]ot all paper sludge material would benefit the soil to which it is applied;" he does not state that Lowe's paper sludge is not beneficial to the soil. Ex. 2007 ¶ 19.

We, therefore, conclude that the ordinary artisan would have combined Roth and Lowe to arrive at the claimed composition.

*E. Anticipation by Schreiber—Claims 1, 7, and 13*

Schreiber discloses the limitations of claims 1 and 7. For example, Schreiber discloses a plant seed having multiple coatings thereon, which satisfies the claimed "seed acting as a core or pseudo core." Ex. 1002, col. 1, ll. 4-6; col. 9, ll. 38-43. Schreiber further discloses the claimed "coating of a composition comprising soil conditioning materials." Specifically, Schreiber describes a seed coating made of a composition comprising solid particulate coating material, such as ground peat moss, thereby satisfying the claimed "being in a solid state at time of coating," of claims 1 and 7. *Id.* at col. 2, ll. 34-49; col. 10, ll. 40-42. Schreiber

IPR2013-00110  
Patent 6,209,259

explains that its invention permits the tailoring of seed coatings for achieving optimum germination and growth, while allowing early planting within a wide time period. Schreiber also explains that other advantages also accrue from the invention. Schreiber, thus, satisfies our construction of “soil conditioning materials” because its coating provides better root development and drought resistance. *Id.* at col. 2, ll. 15-19; col. 9, ll. 44-49. Schreiber also discloses that the coating is an “agglomeration” of a plurality of types of materials, as Schreiber explains that the coating composition includes a “binder,” required by claim 13, or a plasticizer, and that the coating layers may coalesce, thereby satisfying the agglomeration requirement of claim 7. *Id.* at col. 2, ll. 37-39, 55-56; col. 3, ll. 35-42; col. 6, ll. 23-32.

Encap asserts that Schreiber does not disclose a “combination seed capsule.” PO Resp. 18-23. For the reasons discussed above, a “combination seed capsule” found in the preamble of claims 1 and 7 does not further limit the claim. Encap also asserts that Schreiber does not disclose a “soil conditioning material.” *Id.* at 23-26. Schreiber, however, discloses peat moss, limestone, gypsum, and vermiculite. Ex. 1002, col. 2, ll. 44-49. Those materials are known to beneficially modify the soil in some way other than direct provision of plant nutrients, and are, thus, “soil conditioning materials,” as recited in claims 1 and 7. *See, e.g.,* Exs. 1028-1031. Encap’s expert, Mr. Baker, acknowledged that peat moss, limestone, gypsum, and vermiculite are all soil conditioning materials. Baker Depo., Ex. 2005, 88, l. 22– 90, l. 9.<sup>8</sup>

---

<sup>8</sup> We reference page numbers found in the lower right corner of the exhibit.

• IPR2013-00110  
• Patent 6,209,259

Encap seeks to distinguish Schreiber on a purported difference in the function of the Schreiber coating and those disclosed in the '259 patent. Specifically, Encap asserts that Schreiber discloses using a water-insoluble coating with a water-soluble binder (e.g., peat moss) to delay germination until growing conditions are favorable, whereas, the soil conditioning materials of the '259 patent enhance germination and plant growth. PO Resp. 25. For the reasons already discussed, the claim limitation “soil conditioning materials” does not require the material also provide soil conditioning value to the seed. Moreover, the '259 patent explicitly discloses that the coating may be used to delay germination. Ex. 1001, col. 4, ll. 12-20; col. 25, ll. 8-17. Just because Schreiber’s coating also serves to delay germination does not mean that it is not a “soil conditioning material,” so long as it beneficially modifies the soil, in some way other than direct provision of plant nutrients.

In summary, we hold that Scotts Company has shown, by a preponderance of the evidence, that claims 1, 7, and 13 are anticipated by Schreiber, under 35 U.S.C. § 102(b).

*F. Obviousness over Schreiber and Roth—Claims 2, 5, 8, 11, and 14<sup>9</sup>*

As discussed above, Schreiber discloses the elements of independent claims 1 and 7. Scotts Company proposes using Roth’s MAS in place of Schreiber’s peat moss. Pet. 38-39. Scotts Company’s proposed combination would result in a seed coated with Roth’s MAS, and as discussed above, MAS does not satisfy the claim limitation that the soil conditioning material be “in a solid state at the time of coating.”

---

<sup>9</sup> In its Response, Encap references claim 15 instead of 14. We have interpreted Encap’s reference as intended to be to claim 14. PO Resp. 26-27.

Therefore, we hold that Scotts Company has not shown, by a preponderance of the evidence, that claims 2, 5, 8, 11, and 14 are unpatentable over Schreiber and Roth, under 35 U.S.C. § 103(a).

*G. Obviousness over Schreiber and Lowe—Claims 3, 4, 9, and 10*

As discussed above, Schreiber discloses the elements of independent claims 1 and 7. Lowe further teaches a material that is a byproduct of a “paper making process,” and specifically that the byproduct is “paper sludge” as required by dependent claims 3, 4, 9, and 10. Lowe describes an agricultural granule for carrying and releasing agricultural chemicals that resembles a clay-based granule. Ex. 1004, Abstract. The agricultural granule is made from using waste materials from paper manufacture, referred to as paper sludge. *Id.* at col. 1, l. 68—col. 2, ll. 1, 40-44. Scotts Company asserts that because Lowe teaches an agricultural granule made from paper sludge for carrying and releasing incorporated agricultural chemicals that resembles a clay-based granule (*id.* at Abstract; col. 2, l. 1), a person of ordinary skill would have had reason to substitute Schreiber’s water-insoluble, solid, clay-like, agricultural inner coating material with Lowe’s paper sludge materials. Pet. 40.

Schreiber discloses that its inner coating controls permeability of water and is typically water insoluble. Ex. 1002, col. 2, ll. 34-39. Encap asserts that there is no evidence that Lowe’s material, derived from paper sludge, would operate to control water permeability (i.e., is water insoluble)—a trait important to the teachings of Schreiber. PO Resp. 28. Scotts Company does not respond to Encap’s argument, and fails to provide any evidence that Lowe’s agricultural granule is water insoluble. If Lowe’s material is water soluble, it would not be a

suitable replacement for Schreiber's inner coating, as it would frustrate Schreiber's objective of delayed germination.

In summary, we hold that Scotts Company has failed to show, by a preponderance of the evidence, that claims 3, 4, 9, and 10 are unpatentable over Schreiber and Lowe under 35 U.S.C. § 103(a).

*H. Anticipation by Matthews—Claims 1, 2, 7, 8, 13, and 14*

Matthews discloses the claimed “seed acting as a core or pseudo core” with a “solid” “coating of a composition comprising soil condition materials,” as required by claims 1 and 7. Ex. 1007, 2, ll. 41-89. Specifically, Matthews describes a seed pellet product coated with “fly ash,” as required by dependent claims 2 and 8. *Id.* at 2, ll. 10-12, 61-64. Matthews further describes alternately spraying and dusting the seed with the coating until the desired thickness is reached, after which the seed pellets are dried. *Id.* at 2, ll. 81-84, 88-89. Matthews also discloses that the coating is an “agglomeration” of a plurality of types of materials, as required by claim 7, because Matthews explains that the coating of dust particles is bound by an adhesive water-soluble plastic, such as polyvinyl alcohol or methyl cellulose, around and about the original seed particle. *Id.* at 2, ll. 42-45, 50-54; 3, ll. 5-9. Matthews describes applying a “binder,” as required by dependent claim 13, to the seed capsule, e.g., polyvinyl alcohol, to hold the coating substances firmly on the seed. *Id.* at 2, ll. 42-45; 3, ll. 5-9. Further, the Matthews seed coating may include “fertilizer,” thus satisfying dependent claim 14. *Id.* at 5, ll. 25-27.

Encap asserts that Matthews does not disclose a “combination seed capsule.” PO Resp. 38. As discussed above, the preamble recitation “combination seed capsule” does not further limit the claim. In addition, Encap unpersuasively asserts



that Matthews' fly ash may not be necessarily beneficial to the seed (*id.*)—a requirement lacking from our claim construction of “soil conditioning material.” Relying upon Messrs. Baker and Katers, Encap asserts that Matthews' fly ash does not *necessarily* modify the soil in a beneficial manner, and hence, has not been proved to be a soil conditioning material. *Id.* at 39-42 (citing Ex. 2011 ¶ 21; Ex. 2007 ¶ 24). Essentially, Encap's argument is that while fly ash is specifically identified in the '259 patent as a soil conditioning material (*see, e.g.*, Ex. 1001, col. 7, ll. 21-25), not *all* fly ash is suitable—indeed, some types of fly ash are toxic. *Id.* Matthews, however, states that “[e]ach material must be stable and non-toxic.” Ex. 1007, 8, ll. 9-10. Moreover, Mr. Baker also acknowledged that a person of ordinary skill would have understood that a non-toxic fly ash could be used to coat a seed as a soil condition material, and that using toxic materials harmful to the seed should be avoided. Ex. 2005, 150, l. 18–151, l. 20. Lastly, Matthews also discloses that the use of its coating materials “aid in germination” and “growth of the plant.” Ex. 1007, 2, ll. 33-39. Thus, we determine that a person of ordinary skill would interpret Matthews as using non-toxic fly ash, beneficial to the soil.

Matthews also discloses using lime (*id.* at 5, ll. 28-35), which Mr. Krysiak admitted was a soil condition material (Ex. 2002, 148, ll. 18-23).

Therefore, we hold that Scotts Company has shown, by a preponderance of the evidence, that claims 1, 2, 7, 8, 13, and 14 are anticipated by Matthews under 35 U.S.C. § 102(b).

#### *I. Secondary Considerations*

Before we can determine that the combination of Roth and Lowe (*see* Section D, above), renders the challenged claims unpatentable as obvious, we must consider the evidence of obviousness anew in light of any evidence of secondary

IPR2013-00110  
Patent 6,209,259

considerations of nonobviousness presented by Encap. *See Graham v. John Deere Co.*, 383 U.S. 1, 17-18 (1966) (“Such secondary considerations as commercial success, long felt but unsolved needs, failure of others, etc., might be utilized to give light to the circumstances surrounding the origin of the subject matter sought to be patented. As indicia of obviousness or nonobviousness, these inquiries may have relevancy.”); *Transocean Offshore Deepwater Drilling, Inc. v. Maersk Drilling USA, Inc.*, 699 F.3d 1340, 1349 (Fed. Cir. 2012) (“This objective evidence must be ‘considered as part of all the evidence, not just when the decisionmaker remains in doubt after reviewing the art.’”) (quoting *Stratoflex, Inc. v. Aeroquip Corp.*, 713 F.2d 1530, 1538-39 (Fed. Cir. 1983)).

Encap alleges copying by others, long felt need, and commercial success as secondary considerations of non-obviousness. PO Resp. 48-49. Encap, however, fails to provide sufficient credible evidence to support its allegations.

Encap alleges that Scotts Company’s Miracle-Gro<sup>®</sup> Turf Builder Grass Seed with Water Smart<sup>®</sup> is a copy of the product of the ’259 patent. *Id.* at 48. To support its allegations, Encap submits a copy of marketing brochures for EncapSeed<sup>™</sup> products (Ex. 1009, 89-97), a copy of the packaging from Scotts Company’s Turf Builder Grass Seed with Water Smart<sup>®</sup> (*id.* at 98-101; Ex. 2013, 342-43, 346-47), a copy of a website print out pertaining to Scotts Company’s TurfBuilder (Ex. 2013, 344-45), a Declaration by Mr. Krysiak dated October 31, 2012 and submitted during an *ex parte* reexamination (Ex. 1009, 118-131), and a Declaration by Mr. Krysiak (Ex. 1022 ¶¶ 41, 42). None of the evidence submitted by Encap, however, demonstrates that Scotts Company’s Miracle-Gro<sup>®</sup> Turf Builder Grass Seed with Water Smart<sup>®</sup> product falls within the scope of any claim of the ’259 patent, that Scotts Company was aware of the ’259 patent prior to

developing its product, or that Scotts Company developed its product by copying the '259 patent.

Encap also asserts that there was a long-felt need for invention disclosed in the '259 patent. PO Resp. 48-49. Specifically, Encap asserts that many homeowners could not get their grass seed to grow because of inappropriate watering. *Id.* at 48. Encap, however, presents no credible evidence this need was satisfied by the '259 patented invention.

Lastly, Encap asserts commercial success because Meadowland took a license to the '259 patent. *Id.* at 49. Encap, however, does not allege that Meadowland's licensed product was commercially successful, or that any such commercial success was attributable to the patented features of the product. Encap also asserts that Scotts Company's product was commercially successful. *Id.* Encap, however, does not provide persuasive evidence that Scotts Company's product is covered by any claim of the '259 patent, that such product was commercially successful, or that such success was attributable to the patented feature.

After weighing all the evidence of obviousness and nonobviousness of record, on balance, we conclude that the strong evidence of obviousness outweighs the weak evidence of nonobviousness. For the foregoing reasons, we conclude that Scotts Company has shown, by a preponderance of the evidence, that claims 1-5, 7-11, 13, and 14 are unpatentable under 35 U.S.C. § 103(a) over Roth and Lowe.

*J. Encap's Corrected Motion to Amend Claims*

Encap filed a Motion to Amend Claims (Paper 24), which was later corrected (Paper 47) ("Mot."). In the Corrected Motion, Encap proposes substitute

claims 15-24, to replace claims 2-5, 8-11, 13, and 14,<sup>10</sup> respectively. Mot. 1. The Corrected Motion is contingent, meaning that a proposed substitute claim is at issue and would be considered only if “the original claims of the ’259 patent are found unpatentable.” *Id.* While somewhat ambiguous, we interpret Encap’s motion as proposing a substitute claim if the claim it replaces is found unpatentable, as opposed to being contingent on all of the challenged claims being found unpatentable. Scotts Company has demonstrated the unpatentability of claims 1-5, 7-11, 13, and 14. Therefore, the contingency has materialized, and thus, we consider the Corrected Motion on the merits.

As the moving party, Encap bears the burden of proof to establish that it is entitled to the relief requested. 37 C.F.R. § 42.20(c). The proposed amendment is not entered automatically, but only upon Encap’s having demonstrated the patentability of those substitute claims. Here, we find that Encap has failed to demonstrate that the added limitations distinguish over the known prior art, for example, Roth in combination with Lowe. Hence, Encap’s Motion to Amend is denied.

In a conference call on August 26, 2013, we provided Encap guidance on filing a motion to amend the claims, and specifically directed the parties to the analysis in *Idle Free Sys. v. Bergstrom, Inc.*, IPR2012-00027, Paper 26 (PTAB June 11, 2013). The summary of the call is reflected in Paper 17 of the record. *Idle Free* holds that a patent owner should specifically identify features added to

---

<sup>10</sup> Encap later identifies the substitution as claims 15-24 in place of claims 2-5 and 11-13. Mot. 2-5. Thus, it is unclear whether claims 23-24 are proposed as replacement for claims 13 and 14, or for claims 12 and 13. However, as we discuss below, the issue is moot.

each substitute claim, and come forward with technical facts and reasoning about those features, including construction of new claim terms. *Idle Free*, slip op. at 7. The patent owner should also discuss the “significance and usefulness” of the added features “from the perspective of one with ordinary skill in the art.” *Id.* We agree with the reasoning in *Idle Free*, and conclude that Encap has failed to satisfy its burden to demonstrate the patentability of the proposed substitute claims by a preponderance of the evidence.

While Encap identifies nineteen separate “structural limitations,” presumed to be new, it does not identify how each of these structural limitations differs from what is previously recited in the claims. 37 C.F.R. § 42.221(b) (“A motion to amend claims must . . . show the changes clearly . . .”). Specifically, Encap’s listing of proposed claims 15-24 does not show, by redline or discussion, how the claims being replaced have been modified. Mot. 1-5. Moreover, Encap fails to construe any new claim limitation, and also fails to proffer any technical facts and reasoning about the amended features. *Idle Free*, slip op. at 7. Encap’s failure to comply with the Board’s directive places Scotts Company in the unfair position of having to ascertain the claim amendments and then make assumptions about which of the amendments are considered by Encap to be significant. For amended claims, however, the burden “is not on the petitioner to show unpatentability;” it is “on the patent owner to show patentable distinction over the prior art.” *Id.* at 7. Encap has not met its burden.

For example, to determine the differences between original claim 2 and its proposed substitute, claim 15, the following comparison was created, with bracketed text indicating material deleted from claim 2, and underlined text indicating material inserted into claim 2 (paragraphing added).

[2] 15. The combination seed capsule of claim 1 wherein [material of said soil conditioning materials are comprised of sludge or fly ash] said combination seed capsules provides cooperative and beneficial effects of said soil conditioning material working together in controlled intimate relation with said seed, to enhance the germination and growth processes of said seed and the plant emergent therefrom, said effects being greater than when said soil conditioning material and said seed are applied to the soil separately; wherein said effects result from an intimate relationship of said soil conditioning materials in said combination seed capsule, whereby said materials cooperate with each other in support of said germination and growth processes;

said soil conditioning material is a material that beneficially modifies soil in some way other than direct provision of fertilizer, used with said seed to provide soil conditioning value to said seed so coated, irrespective of general tilth condition of the growth medium into or onto which the seed capsule is applied;

said solid state at time of coating comprising materials in form of a particulate material, fibrous material, a suspension of said particulate and/or fibrous material in a liquid suspension, or any combination thereof; said soil conditioning value of said soil conditioning material to said seed comprises the enhanced control of moisture about said seed; said enhanced control consists of absorbing and holding water;

said coating of said combination seed capsule comprises a plurality of particles.

Encap does not explain why each new feature is “significant and useful,” does not construe any of the new claim limitations, nor proffer any technical facts and reasoning about the amended features. Instead, Encap provides conclusory statements only, such as “Roth does not provide the cooperative and beneficial

effects of this structural limitation.” Mot. 6. Encap does not provide a proposed interpretation of the recited “cooperative and beneficial effects” of proposed substitute claim 15, nor does it explain whether Roth provides some of the “effects of this structural limitation,” and not others or why.

Encap asserts that the structural limitations themselves provide the technical facts and reasoning, as well as the significance and usefulness of the limitations. Pet. Reply 3. Encap asserts also that the “[c]laim construction of the structural limitations is found within the limitations themselves.” *Id.* We disagree. Providing “cooperative and beneficial effects” is vague and not self-defining, in any meaningful way. Consequently, the usefulness and significance of the limitation is not self-evident. The same can be said of, “working together in controlled intimate relation.”

Encap also fails to “provide meaningful reasons” for making additional changes to dependent claims. *Idle Free*, slip op. at 9. For example, claim 18, which depends from claim 15, adds three new limitations. *See* Mot. at 3; *see also id.* at 3-4 (claims 19 and 20 both depend from claim 17, and only differ by inclusion of a fungicide in claim 19). But Encap fails to explain why the additional features were added to these dependent claims. *Idle Free*, slip op. at 9-10 (“Adding features for no meaningful reason is . . . not responsive to an alleged ground of unpatentability.”).

In addition, *Idle Free* further instructs patent owners to consider and distinguish “prior art,” both “of record” and “not of record but known to the patent owner.” *Id.* at 7. Moreover, we specifically explained to Encap that “[a] conclusory statement that no prior art is known to the patent owner . . . is insufficient.” IPR2013-00110, Paper 17, 2. On page 1 of its Motion (Paper 47),

IPR2013-00110  
Patent 6,209,259

Encap states, “No closer art than the prior art cited in the underlying *inter partes* review is known to PO.” Encap, however, was aware of additional relevant prior art, including Simmons and Evans, which were cited in Scotts Company’s request for *inter partes* review, but which were deemed cumulative of the adopted grounds of rejection. *See* Pet. at 41-49; Prelim. Resp. at 25. While those references may have been cumulative over the original claims, they are not be cumulative in view of Encap’s proposed substitute claims, and should be addressed. Encap’s proposed claim 15 recites that the soil conditioning material “comprises enhanced control of moisture about said seed” consisting of “absorbing and holding water.” Encap distinguishes the prior art in this *inter partes* review by arguing that it does not teach enhancing moisture about the seed. Mot. at 9-10. Simmons and Evans specifically disclose coating a seed with a water-absorbable polymer. Yet, Encap failed to distinguish its proposed claims over those two material prior art references.

Encap attempts to correct some of its errors by filing an expert declaration with its Corrected Reply to Motion to Amend. Paper 49; Ex. 2012. As already addressed, however, we exclude this Declaration as untimely and improperly incorporated by reference into Encap’s Motion. In addition, as discussed above, the proffered “corrected” Second Declaration of Mr. Krysiak does not overcome Scotts Company’s objections, and is thus, excluded.

For the above reasons, Encap’s Corrected Motion to Amend Claims is denied as it fails to distinguish over the prior art, for example, Roth in combination with Lowe.



### III. CONCLUSION

Scotts Company has shown by a preponderance of the evidence that:

(1) claims 1, 7, and 13 of the '259 patent are unpatentable under 35 U.S.C. § 102(b) as anticipated by Schreiber; (2) claims 1, 2, 7, 8, 13, and 14 are unpatentable under 35 U.S.C. § 102(b) as anticipated by Matthews; and (3) claims 1-5, 7-11, 13, and 14 are unpatentable under 35 U.S.C. § 103(a) as obvious over Roth and Lowe.

Scotts Company has not shown by a preponderance of the evidence that:

(1) claims 1, 2, 5, 7, 8, 11, 13, and 14 of the '259 patent are unpatentable under 35 U.S.C. § 102(b) as anticipated by Roth; (2) claims 2, 5, 8, 11, and 14 are unpatentable under 35 U.S.C. § 103(a) as obvious over Schreiber and Roth; or (3) claims 3, 4, 9, and 10 are unpatentable under 35 U.S.C. § 103(a) as obvious over Schreiber and Lowe.

Encap has not shown by a preponderance of the evidence that its proposed substitute claims 15-24 are patentable over the prior art.

### IV. ORDER

In consideration of the foregoing, it is hereby ORDERED that:

Scotts Company's Motion to Exclude Mr. Krysiak's Second Declaration (Ex. 2016) is granted and all other relief requested in the motion is denied;

Encap's Motion to Exclude Mr. Sundstrom's Declaration (Ex. 1039) is dismissed as moot;

Claims 1-5, 7-11, 13, and 14 of the '259 patent are determined to be unpatentable; and

Encap's Corrected Motion to Amend Claims is denied.

IPR2013-00110  
Patent 6,209,259

This is a final decision. Parties to the proceeding seeking judicial review of the decision must comply with the notice and service requirements of 37 C.F.R. § 90.2.

IPR2013-00110  
Patent 6,209,259

Petitioner:

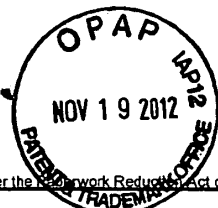
Robert Schulman  
[rschulman@hunton.com](mailto:rschulman@hunton.com)

Jeff Vockrodt  
[jvockrodt@hunton.com](mailto:jvockrodt@hunton.com)

Patent Owner:

Philip Weiss  
[weissandweiss@aol.com](mailto:weissandweiss@aol.com)

Aaron Olejniczak  
[aarono@andruslaw.com](mailto:aarono@andruslaw.com)



*fu*

PTO/SB/123 (11-08)  
 Approved for use through 11/30/2011. OMB 0651-0035  
 U.S. Patent and Trademark Office; U.S. DEPARTMENT OF COMMERCE

Under the Paperwork Reduction Act of 1995, no persons are required to respond to a collection of information unless it displays a valid OMB control number.

<b>CHANGE OF CORRESPONDENCE ADDRESS</b> <b>Patent</b>  Address to: Mail Stop Post Issue Commissioner for Patents P.O. Box 1450 Alexandria, VA 22313-1450	Patent Number	6,209,259
	Issue Date	4/3/01
	Application Number	09/113,254 ✓
	Filing Date	7/10/98
	First Named Inventor	D. Madigan
	Attorney Docket Number	P/35-145 RE

Please change the Correspondence Address for the above-identified patent to:

The address associated with Customer Number:

OR

**Firm or Individual Name** Philip M. Weiss, WEISS & WEISS

410 Jericho Turnpike  
 Suite 105  
 Address

City Jericho State NY ZIP 11753

Country US

Telephone 516-739-1500 Email 516-739-2189

This form cannot be used to change the data associated with a Customer Number. To change the data associated with an existing Customer Number use "Request for Customer Number Data Change" (PTO/SB/124).

This form will not affect any "fee address" provided for the above-identified patent. To change a "fee address" use the "Fee Address Indication Form" (PTO/SB/47).

I am the:

Patentee.

Assignee of record of the entire interest. See 37 CFR 3.71. Statement under 37 CFR 3.73(b) is enclosed. (Form PTO/SB/96).

Attorney or agent of record. Registration Number 34,751

Signature *Philip Weiss*

Typed or Printed Name Philip M. Weiss

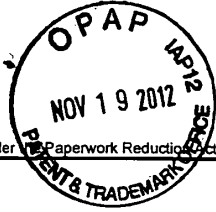
Date November 14, 2012 Telephone 516-739-1500

NOTE: Signatures of all the inventors or assignees of record of the entire interest or their representative(s) are required. Submit multiple forms if more than one signature is required, see below\*.

\*Total of 1 forms are submitted.

This collection of information is required by 37 CFR 1.33. The information is required to obtain or retain a benefit by the public which is to file (and by the USPTO to process) an application. Confidentiality is governed by 35 U.S.C. 122 and 37 CFR 1.11 and 1.14. This collection is estimated to take 3 minutes to complete, including gathering, preparing, and submitting the completed application form to the USPTO. Time will vary depending upon the individual case. Any comments on the amount of time you require to complete this form and/or suggestions for reducing this burden, should be sent to the Chief Information Officer, U.S. Patent and Trademark Office, U.S. Department of Commerce, P.O. Box 1450, Alexandria, VA 22313-1450. DO NOT SEND FEES OR COMPLETED FORMS TO THIS ADDRESS. SEND TO: Mail Stop Post Issue, Commissioner for Patents, P.O. Box 1450, Alexandria, VA 22313-1450.

If you need assistance in completing the form, call 1-800-PTO-9199 and select option 2.



Under Paperwork Reduction Act of 1995, no persons are required to respond to a collection of information unless it contains a valid OMB control number.

### Certificate of Mailing under 37 CFR 1.8

I hereby certify that this correspondence is being deposited with the United States Postal Service with sufficient postage as first class mail in an envelope addressed to:

Commissioner for Patents  
P.O. Box 1450  
Alexandria, VA 22313-1450

on 11/14/12  
Date

Signature

Debbie Broderick

Typed or printed name of person signing Certificate

516-739-1500

Telephone Number

Registration Number, if applicable

Note: Each paper must have its own certificate of mailing, or this certificate must identify each submitted paper.

This collection of information is required by 37 CFR 1.8. The information is required to obtain or retain a benefit by the public which is to file (and by the USPTO to process) an application. Confidentiality is governed by 35 U.S.C. 122 and 37 CFR 1.11 and 1.14. This collection is estimated to take 1.8 minutes to complete, including gathering, preparing, and submitting the completed application form to the USPTO. Time will vary depending upon the individual case. Any comments on the amount of time you require to complete this form and/or suggestions for reducing this burden, should be sent to the Chief Information Officer, U.S. Patent and Trademark Office, U.S. Department of Commerce, P.O. Box 1450, Alexandria, VA 22313-1450. DO NOT SEND FEES OR COMPLETED FORMS TO THIS ADDRESS. SEND TO: Commissioner for Patents, P.O. Box 1450, Alexandria, VA 22313-1450.

If you need assistance in completing the form, call 1-800-PTO-9199 and select option 2.



Patent No. 6,209,259

**NOTICE OF *EX PARTE* REEXAMINATION**

Notice is hereby given that a request for *ex parte* reexamination of U.S. Patent No. 6,209,259 was filed on 03/09/12 under 35 U.S.C. § 302 and 37 C.F.R. § 1.510(a).

The reexamination proceeding has been assigned Control No. 90/012,183

This Notice incorporates by reference into the patent file, all papers entered into the reexamination file.

**Note: This Notice should be entered into the patent file.**

TO: <b>Mail Stop 8</b> <b>Director of the U.S. Patent and Trademark Office</b> <b>P.O. Box 1450</b> <b>Alexandria, VA 22313-1450</b>	<b>REPORT ON THE</b> <b>FILING OR DETERMINATION OF AN</b> <b>ACTION REGARDING A PATENT OR</b> <b>TRADEMARK</b>
-----------------------------------------------------------------------------------------------------------------------------------------------	-------------------------------------------------------------------------------------------------------------------------

In Compliance with 35 U.S.C. § 290 and/or 15 U.S.C. § 1116 you are hereby advised that a court action has been filed in the U.S. District Court Eastern District of Wisconsin on the following  
 Trademarks or  Patents. (  the patent action involves 35 U.S.C. § 292.):

DOCKET NO. 11-C-685	DATE FILED 7/18/2011	U.S. DISTRICT COURT Eastern District of Wisconsin
PLAINTIFF Encap LLC		DEFENDANT The Scotts Company LLC et al
PATENT OR TRADEMARK NO.	DATE OF PATENT OR TRADEMARK	HOLDER OF PATENT OR TRADEMARK
1 6,209,259	4/3/2001	ENCAP LLC
2 7,412,878	8/19/2008	ENCAP LLC
3 6,745,513	6/8/2004	ENCAP LLC
4		
5		

In the above—entitled case, the following patent(s)/ trademark(s) have been included:

DATE INCLUDED	INCLUDED BY	<input type="checkbox"/> Amendment <input type="checkbox"/> Answer <input type="checkbox"/> Cross Bill <input type="checkbox"/> Other Pleading
PATENT OR TRADEMARK NO.	DATE OF PATENT OR TRADEMARK	HOLDER OF PATENT OR TRADEMARK
1		
2		
3		
4		
5		

In the above—entitled case, the following decision has been rendered or judgement issued:

DECISION/JUDGEMENT
--------------------

CLERK JON W. SANFILIPPO	(BY) DEPUTY CLERK A. Wachtendonck	DATE 7/19/2011
----------------------------	--------------------------------------	-------------------

Copy 1—Upon initiation of action, mail this copy to Director    Copy 2—Upon filing document adding patent(s), mail this copy to Director    Copy 3—Upon termination of action, mail this copy to Director    Copy 4—Case file copy



COMPLETED

DS D

P/35-5

IN THE UNITED STATES PATENT AND TRADEMARK OFFICE

In re Patent Application of: Michael Krysiak  
 Serial No.: 09/113,254 Date: July 10, 1998  
 Patent No.: 6,209,259 Issued: April 3, 2001  
 For: SEEDING TREATMENTS

Commissioner for Patents  
 P.O. Box 1450  
 Alexandria, VA 22313

CHANGE OF CORRESPONDENCE ADDRESS

Sir:

Please amend the correspondence address for the above-identified patent application  
 to: Philip M. Weiss, Esq.  
 Weiss & Weiss  
 300 Old Country Road, Suite 251  
 Mineola, New York 11501  
 Telephone: (516) 739-1500  
 Telefax: (516) 739-2189

Applicant requests that all future correspondence be mailed to the above-address.

June 29, 2005

Respectfully submitted,

Philip M. Weiss  
 Registration No. 34,751  
 Attorney for Applicant  
 WEISS AND WEISS  
 300 Old Country Road, Ste. 251  
 Mineola, New York 11501  
 Telephone: (516) 739-1500  
 Telefax: (516) 739-2189

Certificate of Mailing Under 37 C.F.R. §1.8(a)

I hereby certify that this correspondence and any documents attached herewith is being deposited with the U.S. postal service as first class mail in an envelope addressed to the Commissioner for Patents, P.O. Box 1450, Alexandria, VA 22313 on the date indicated below.  
 Dated: June 29, 2005

  
 Maureen P. Herbst



PHILIP M WEISS  
WEISS & WEISS  
500 OLD COUNTRY ROAD  
GARDEN CITY NY 11530

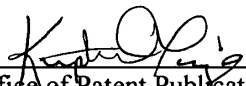
Mail Date: February 26, 2001  
Serial Number: 09/113254  
Applicant: MADIGAN

### NOTICE TO PAY BALANCE OF ISSUE FEE

Your issue fee payment filed on 12/21/00 has been received. However, new patent fees went into effect on October 1, 2000. The final rule entitled "Revision of Patent Fees for Fiscal Year 2001" was published in the *Federal Register*/Vol. 65, No. 156/Friday, August 11, 2000 [49193-49199] and in the U.S. Patent and Trademark Office *Official Gazette*, August 29, 2000 [1237 OG 131-138]. As stated in the final rule, "Any fee amount that is paid on or after the effective date of the fee increase will be subject to the new fees then in effect." The Notice of Allowance and Issue Fee Due (Form PTOL-85) that was mailed to you prior to October 1, 2000, stated an issue fee amount that was in effect prior to October 1, 2000. However, inasmuch as your issue fee was paid on or after October 1, 2000, the new issue fee amount was due.

In accordance with 37 CFR 1.317, you are given a time period of **THREE (3) MONTHS** from the mailing date of this notice during which to pay the **BALANCE DUE** indicated below. This three-month time period may not be extended. **If your patent issues before the expiration of the three-month period and if you do not pay the balance due before the expiration of the three-month period, your patent will lapse at the termination of the three-month period.**

TYPE OF ISSUE FEE PAID	Column A ISSUE FEE IN EFFECT AS OF OCT. 1, 2000 large entity / small entity	Column B ISSUE FEE PAID	BALANCE DUE [Col. A minus Col. B]
UTILITY	\$1,240.00 / \$620.00	\$ 605.00	\$ 15.00
DESIGN	\$440.00 / \$220.00	\$	\$
PLANT	\$600.00 / \$300.00	\$	\$

  
Office of Patent Publication  
Tel: 703-305-8263

**You MUST return a copy of this Notice with your payment.**

#### CERTIFICATE OF MAILING

I hereby certify that this notice and the required additional fee are being deposited with the United States Postal Service with sufficient postage for first class mail in an envelope addressed to Box ISSUE FEE, Commissioner for Patents, Washington, D.C. 20231 on the date indicated below.

Printed Name: \_\_\_\_\_ Signature: \_\_\_\_\_

Date: \_\_\_\_\_

P135-5

PART B ISSUE FEE TRANSMITTAL 12-22-00

CB

Complete and mail this form, together with the fee, to: Box ISSUE FEE Assistant Commissioner for Patents Washington, D.C. 20231

DEC 21 2000

EL 636894151US V6

MAILING INSTRUCTIONS: This form should be used for transmitting the ISSUE FEE. Blocks 1 through 4 should be completed where appropriate. All further correspondence including the Issue Fee Receipt, the Patent, advance orders and notification of maintenance fees will be mailed to the current correspondence address as indicated unless corrected below or directed otherwise in Block 1, by (a) specifying a new correspondence address; and/or (b) indicating a separate "FEE ADDRESS" for maintenance fee notifications.

Note: The certificate of mailing below can only be used for domestic mailings of the Issue Fee Transmittal. This certificate cannot be used for any other accompanying papers. Each additional paper, such as an assignment or formal drawing, must have its own certificate of mailing.

Express Certificate of Mailing

I hereby certify that this Issue Fee Transmittal is being deposited with the United States Postal Service with sufficient postage for first class mail in an envelope addressed to the Box Issue Fee address above on the date indicated below.

CURRENT CORRESPONDENCE ADDRESS (Note: Legibly mark-up with any corrections or use Block 1)

HM12/0926

PHILIP M. WEISS WEISS & WEISS 500 OLD COUNTRY ROAD GARDEN CITY NY 11530

Nelly Bronnberg (Depositor's name) Nelly Bronnberg (Signature) December 21, 2000 (Date)

Table with columns: APPLICATION NO., FILING DATE, TOTAL CLAIMS, EXAMINER AND GROUP ART UNIT, DATE MAILED. Row 1: 09/113,254, 07/10/98, 014, GRUNBERG, A, 1661, 09/26/00. Row 2: First Named Applicant: MADIGAN, 35 USC 154(b) term ext. = 0 Days.

TITLE OF INVENTION SEEDING TREATMENTS

Table with columns: ATTY'S DOCKET NO., CLASS-SUBCLASS, BATCH NO., APPLN. TYPE, SMALL ENTITY, FEE DUE, DATE DUE. Row 1: 3, 29214, 047-057.600, S82 UTILITY, YES, \$1210.00, 12/26/00

- 1. Change of correspondence address or indication of " Fee Address" (37 CFR 1.363). Use of PTO form(s) and Customer Number are recommended, but not required. [ ] Change of correspondence address (or Change of Correspondence Address form PTO/SB/122) attached. [ ] "Fee Address" indication (or "Fee Address" Indication form PTO/SB/47) attached.

- 2. For printing on the patent front page, list (1) the names of up to 3 registered patent attorneys or agents OR, alternatively, (2) the name of a single firm (having as a member a registered attorney or agent) and the names of up to 2 registered patent attorneys or agents. If no name is listed, no name will be printed. 1 Philip M. Weiss, Esq. 2 Weiss and Weiss PC 3

3. ASSIGNEE NAME AND RESIDENCE DATA TO BE PRINTED ON THE PATENT (print or type) PLEASE NOTE: Unless an assignee is identified below, no assignee data will appear on the patent. Inclusion of assignee data is only appropriate when an assignment has been previously submitted to the PTO or is being submitted under separate cover. Completion of this form is NOT a substitute for filing an assignment. (A) NAME OF ASSIGNEE Encap, LLC (B) RESIDENCE: (CITY & STATE OR COUNTRY) Green Bay, WI Please check the appropriate assignee category indicated below (will not be printed on the patent) [ ] individual [X] corporation or other private group entity [ ] government

4a. The following fees are enclosed (make check payable to Commissioner of Patents and Trademarks): [X] Issue Fee [ ] Advance Order - # of Copies 4b. The following fees or deficiency in these fees should be charged to: DEPOSIT ACCOUNT NUMBER (ENCLOSE AN EXTRA COPY OF THIS FORM) [ ] Issue Fee [ ] Advance Order - # of Copies

The COMMISSIONER OF PATENTS AND TRADEMARKS IS requested to apply the Issue Fee to the application identified above.

(Authorized Signature) Philip M. Weiss-RN: 34,751 (Date) 12/21/00

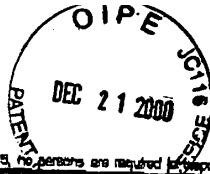
NOTE: The Issue Fee will not be accepted from anyone other than the applicant; a registered attorney or agent; or the assignee or other party in interest as shown by the records of the Patent and Trademark Office.

Burden Hour Statement: This form is estimated to take 0.2 hours to complete. Time will vary depending on the needs of the individual case. Any comments on the amount of time required to complete this form should be sent to the Chief Information Officer, Patent and Trademark Office, Washington, D.C. 20231. DO NOT SEND FEES OR COMPLETED FORMS TO THIS ADDRESS. SEND FEES AND THIS FORM TO: Box Issue Fee, Assistant Commissioner for Patents, Washington D.C. 20231

12/26/2000 MFANAEI1 00000008 09113254 01 FC:631 605.00 0P

Under the Paperwork Reduction Act of 1995, no persons are required to respond to a collection of information unless it displays a valid OMB control number.

TRANSMIT THIS FORM WITH FEE SteadyMed v. United Therapeutics Patent and Trademark Office



Approved for use through 09/30/2000. OMB 0801-0031  
Patent and Trademark Office, U.S. DEPARTMENT OF COMMERCE

Under the Paperwork Reduction Act of 1995, no persons are required to respond to a collection of information unless it displays a valid OMB control number.

#14  
CX3  
(-30-01)

**STATEMENT CLAIMING SMALL ENTITY STATUS  
(37 CFR 1.9(f) & 1.27(e))—SMALL BUSINESS CONCERN**

Docket Number (Optional)  
P/35-5

Applicant, Patentee, or Identifier: Encap LLC.  
Application or Patent No.: 09/113,254  
Filed or Issued: July 10, 1998  
Title: SEEDING TREATMENTS

I hereby state that I am  
 the owner of the small business concern identified below.  
 an official of the small business concern empowered to act on behalf of the concern identified below:

NAME OF SMALL BUSINESS CONCERN Encap LLC.

ADDRESS OF SMALL BUSINESS CONCERN 3921 Algoma Road  
Green Bay, WI 54311

I hereby state that the above identified small business concern qualifies as a small business concern as defined in 13 CFR Part 121 for purposes of paying reduced fees to the United States Patent and Trademark Office. Questions related to size standards for a small business concern may be directed to: Small Business Administration, Size Standards Staff, 409 Third Street, SW, Washington, DC 20416.

I hereby state that rights under contract or law have been conveyed to and remain with the small business concern identified above with regard to the invention described in:

- the specification filed herewith with title as listed above.
- the application identified above.
- the patent identified above.

If the rights held by the above identified small business concern are not exclusive, each individual, concern, or organization having rights in the invention must file separate statements as to their status as small entities, and no rights to the invention are held by any person, other than the inventor, who would not qualify as an independent inventor under 37 CFR 1.9(e) if that person made the invention, or by any concern which would not qualify as a small business concern under 37 CFR 1.9(d), or a nonprofit organization under 37 CFR 1.9(e).

Each person, concern, or organization having any rights in the invention is listed below:  
 no such person, concern, or organization exists.  
 each such person, concern, or organization is listed below.

Separate statements are required from each named person, concern or organization having rights to the invention stating their status as small entities. (37 CFR 1.27)

I acknowledge the duty to file, in this application or patent, notification of any change in status resulting in loss of entitlement to small entity status prior to paying, or at the time of paying, the earliest of the issue fee or any maintenance fee due after the date on which status as a small entity is no longer appropriate. (37 CFR 1.29(b))

NAME OF PERSON SIGNING Michael Krysiak

TITLE OF PERSON IF OTHER THAN OWNER President

ADDRESS OF PERSON SIGNING 3921 Algoma Road, Green Bay, WI 54311

SIGNATURE Michael Krysiak DATE 12-21-00

Speedy Hour Statement: This form is estimated to take 0.2 hours to complete. Time will vary depending upon the needs of the individual case. Any comments on the amount of time you are required to complete this form should be sent to the Chief Information Officer, Patent and Trademark Office, Washington, DC 20411. DO NOT SEND FEE OR COMPLETED FORMS TO THIS ADDRESS. SEND TO: Assistant Commissioner for Patents, Washington, DC 20221.

#15KS



P/35-5

IN THE UNITED STATES PATENT AND TRADEMARK OFFICE

In re Application of: Encap LLC.

Serial No.: 09/113,254

Filing Date: July 10, 1998

For: SEEDING TREATMENTS

Assistant Commissioner for Patents  
Washington, D.C. 20231

BOX ISSUE FEE

SUBMISSION OF FORMAL DRAWINGS

Sir:

In response to the Notice of Allowability dated September 26, 2000, please find enclosed six (6) sheets of formal drawings containing Figures 1-8.

Application should now proceed to issuance.

Respectfully Submitted,

Philip M. Weiss, Esq.  
Attorney for Applicant  
Reg. No. 34,751  
Weiss & Weiss  
500 Old Country Road  
Suite 305  
Garden City, New York 11530

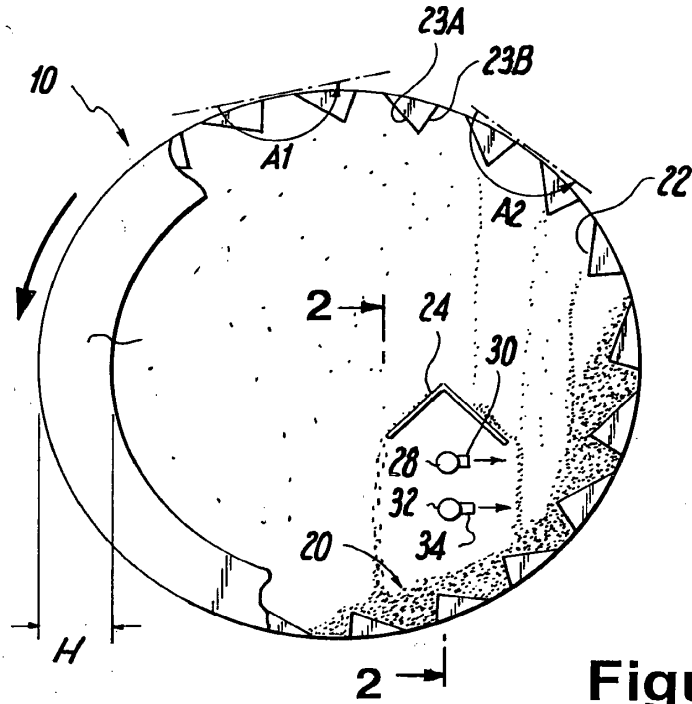


Figure 1

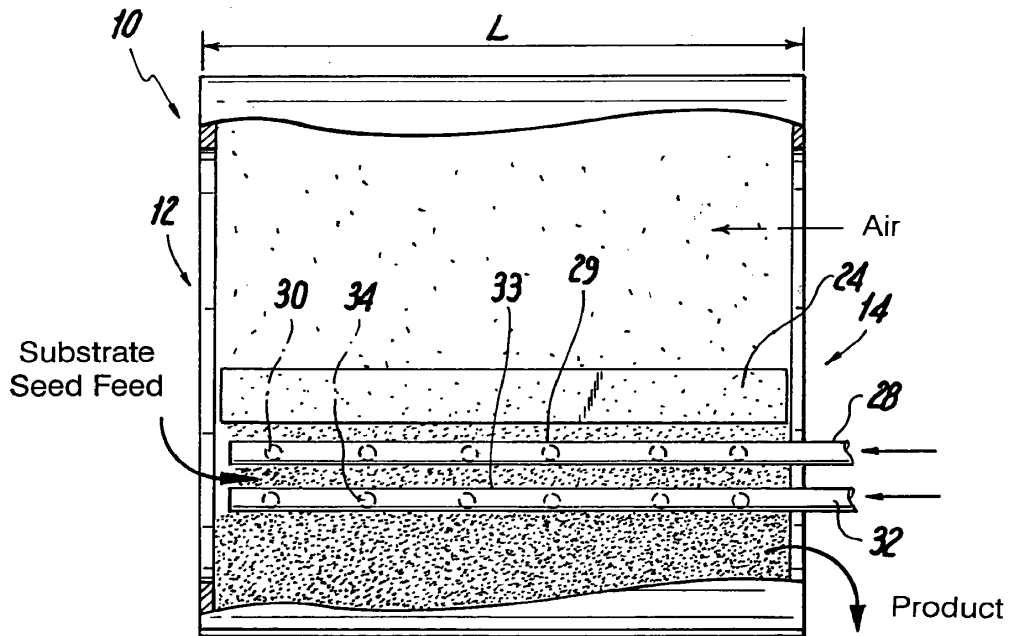
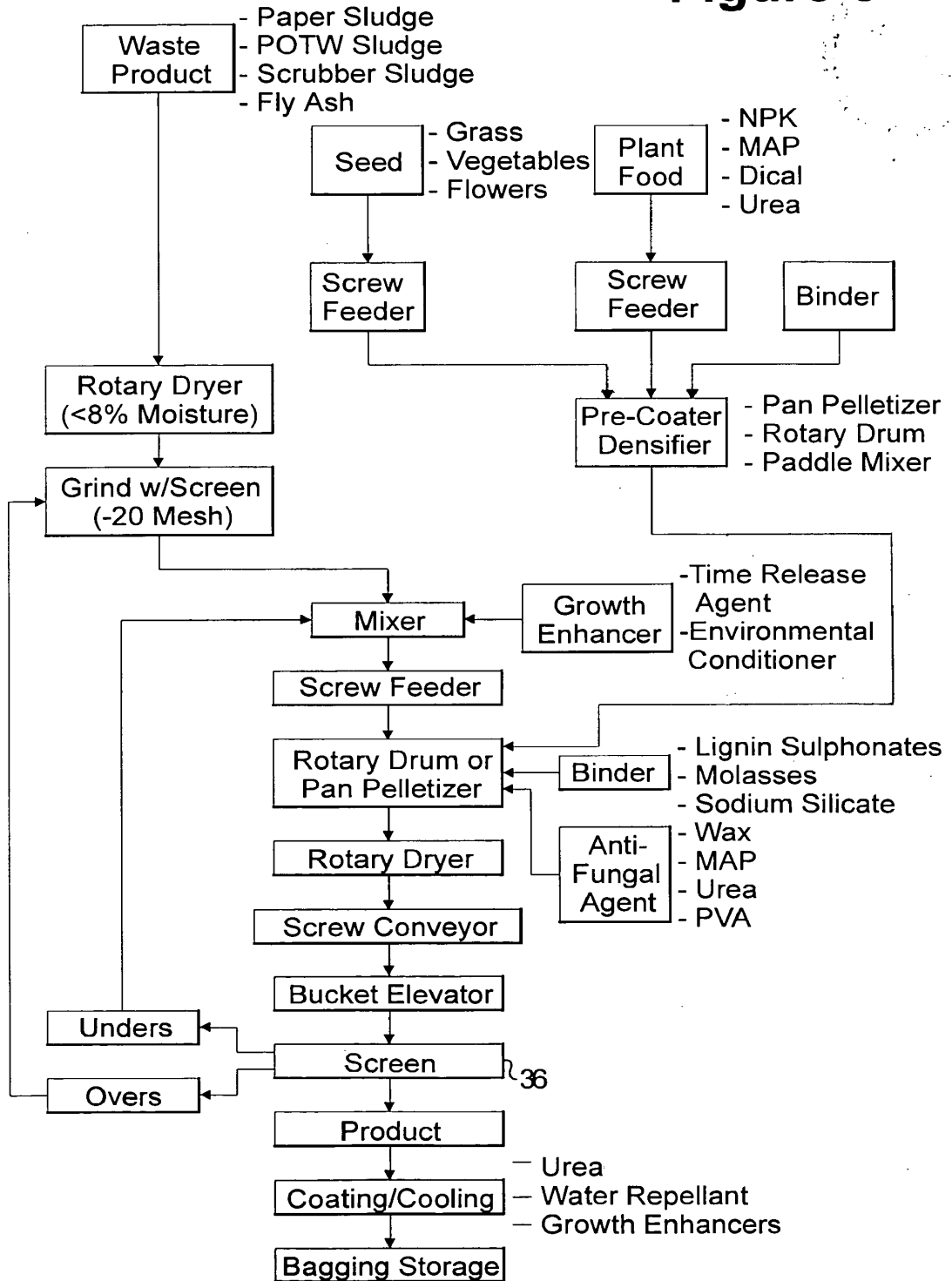


Figure 2

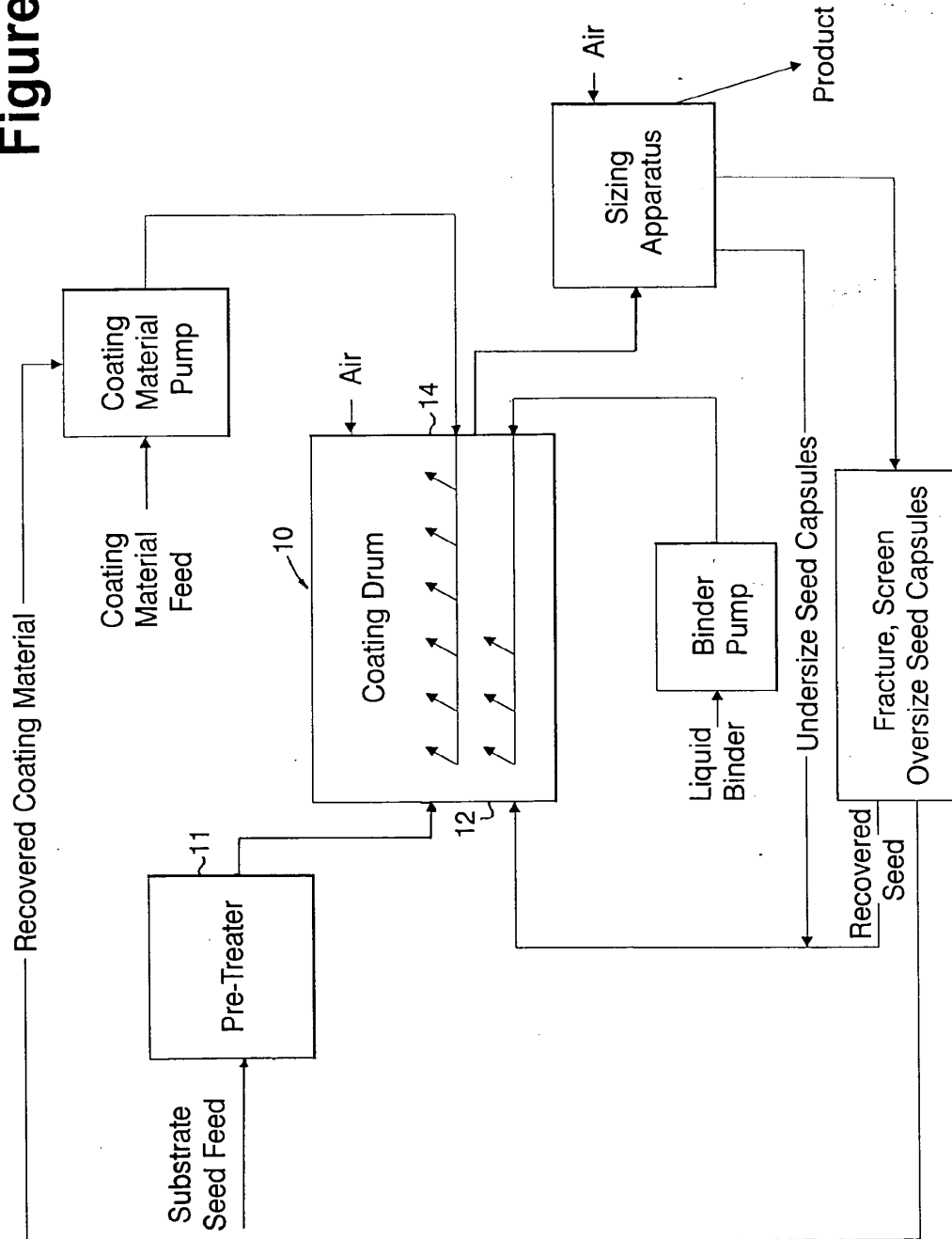
**Figure 3**



P. 47

UT Ex. 2025  
 SteadyMed v. United Therapeutics  
 IPR2016-00006

Figure 4



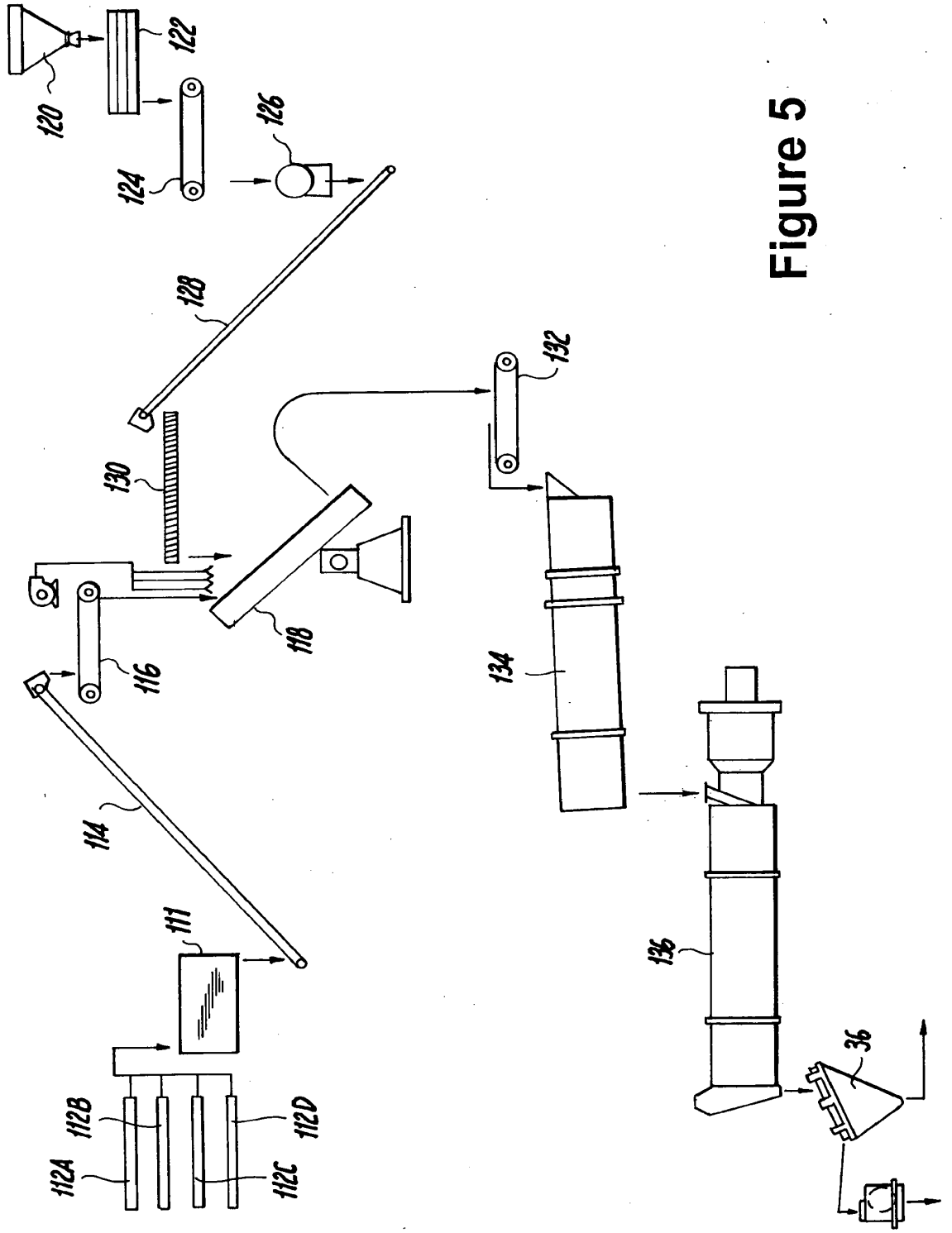
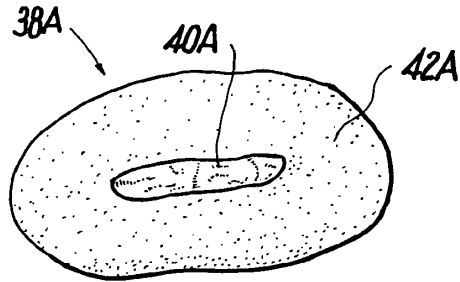
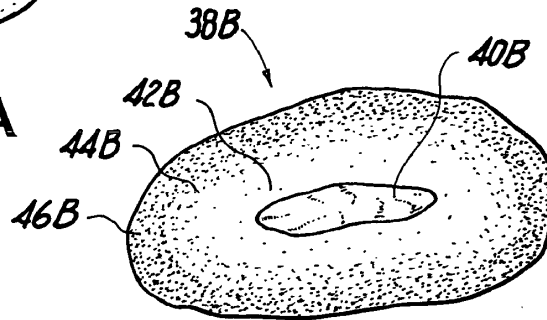


Figure 5

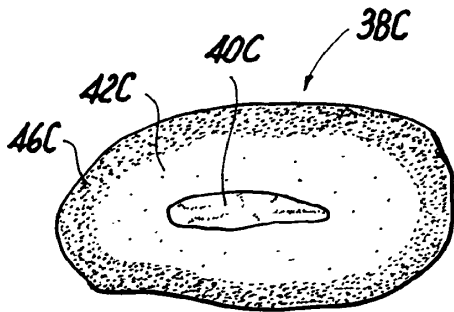




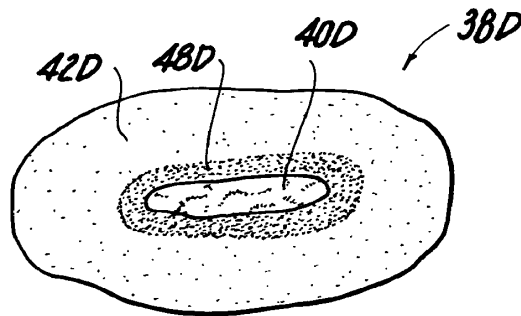
**Figure 6A**



**Figure 6B**



**Figure 6C**



**Figure 6D**

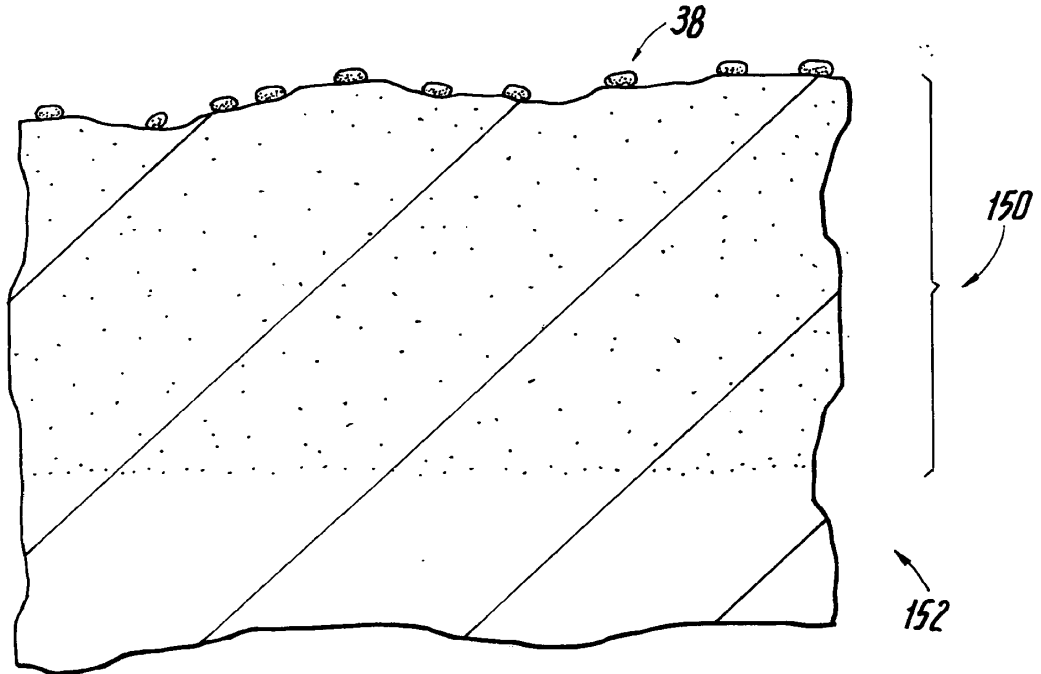


Figure 7

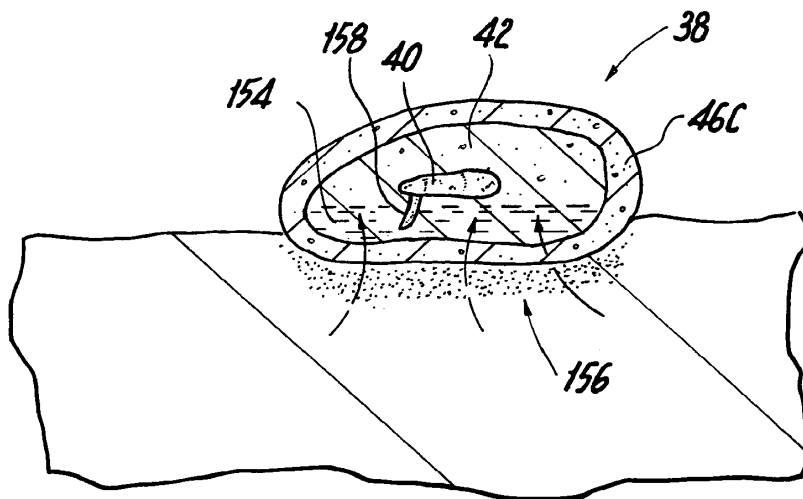


Figure 8



UNITED STATES DEPARTMENT OF COMMERCE  
Patent and Trademark Office

Vb

**NOTICE OF ALLOWANCE AND ISSUE FEE DUE**

HM12/0926

PHILIP M. WEISS  
WEISS & WEISS  
500 OLD COUNTRY ROAD  
GARDEN CITY NY 11630

APPLICATION NO.	FILING DATE	TOTAL CLAIMS	EXAMINER AND GROUP ART UNIT	DATE MAILED
09/113,254	07/10/98	014	GRUNBERG, A	1661 09/26/00
First Named Applicant	MADIGAN,	35 USC 154(b) term ext. =		0 Days.

TITLE OF INVENTION SEEDING TREATMENTS

ATTYS DOCKET NO.	CLASS-SUBCLASS	BATCH NO.	APPLN. TYPE	SMALL ENTITY	FEE DUE	DATE DUE
3 29214		047-057.600	S82 UTILITY	NO	\$1210.00	12/26/00

**THE APPLICATION IDENTIFIED ABOVE HAS BEEN EXAMINED AND IS ALLOWED FOR ISSUANCE AS A PATENT. PROSECUTION ON THE MERITS IS CLOSED.**

**THE ISSUE FEE MUST BE PAID WITHIN THREE MONTHS FROM THE MAILING DATE OF THIS NOTICE OR THIS APPLICATION SHALL BE REGARDED AS ABANDONED. THIS STATUTORY PERIOD CANNOT BE EXTENDED.**

**HOW TO RESPOND TO THIS NOTICE:**

I. Review the SMALL ENTITY status shown above.

If the SMALL ENTITY is shown as YES, verify your current SMALL ENTITY status:

- A. If the status is changed, pay twice the amount of the FEE DUE shown above and notify the Patent and Trademark Office of the change in status, or
- B. If the status is the same, pay the FEE DUE shown above.

If the SMALL ENTITY is shown as NO:

- A. Pay FEE DUE shown above, or
- B. File verified statement of Small Entity Status before, or with, payment of 1/2 the FEE DUE shown above.

II. Part B-Issue Fee Transmittal should be completed and returned to the Patent and Trademark Office (PTO) with your ISSUE FEE. Even if the ISSUE FEE has already been paid by charge to deposit account, Part B Issue Fee Transmittal should be completed and returned. If you are charging the ISSUE FEE to your deposit account, section "4b" of Part B-Issue Fee Transmittal should be completed and an extra copy of the form should be submitted.

III. All communications regarding this application must give application number and batch number. Please direct all communications prior to issuance to Box ISSUE FEE unless advised to the contrary.

**IMPORTANT REMINDER: Utility patents issuing on applications filed on or after Dec. 12, 1980 may require payment of maintenance fees. It is patentee's responsibility to ensure timely payment of maintenance fees when due.**

PATENT AND TRADEMARK OFFICE COPY

UT Ex. 2025

PTOL-85 (REV. 10-96) Approved for use through 06/30/99. (0651-0033)

SteadyMed v. United Therapeutics

IPR2016-00006

IPR2020-00769

United Therapeutics EX2006

Page 4271 of 7113

File

<b>Notice of Allowability</b>	Application No. <b>09/113,254</b>	Applicant(s) <b>Madigan et al.</b>
	Examiner <b>Anne Marie Grunberg</b>	Group Art Unit <b>1661</b>

All claims being allowable, PROSECUTION ON THE MERITS IS (OR REMAINS) CLOSED in this application. If not included herewith (or previously mailed), a Notice of Allowance and Issue Fee Due or other appropriate communication will be mailed in due course.

- This communication is responsive to papers faxed 8/21/2000
- The allowed claim(s) is/are 77, 79-81, 83-88, 90-93 (renumbered as 1-14)
- The drawings filed on \_\_\_\_\_ are acceptable.
- Acknowledgement is made of a claim for foreign priority under 35 U.S.C. § 119(a)-(d).
  - All  Some\*  None of the CERTIFIED copies of the priority documents have been
    - received.
    - received in Application No. (Series Code/Serial Number) \_\_\_\_\_
    - received in this national stage application from the International Bureau (PCT Rule 17.2(a)).
- \*Certified copies not received: \_\_\_\_\_
- Acknowledgement is made of a claim for domestic priority under 35 U.S.C. § 119(e).

A SHORTENED STATUTORY PERIOD FOR RESPONSE to comply with the requirements noted below is set to EXPIRE **THREE MONTHS** FROM THE "DATE MAILED" of this Office action. Failure to timely comply will result in ABANDONMENT of this application. Extensions of time may be obtained under the provisions of 37 CFR 1.136(a).

- Note the attached EXAMINER'S AMENDMENT or NOTICE OF INFORMAL APPLICATION, PTO-152, which discloses that the oath or declaration is deficient. A SUBSTITUTE OATH OR DECLARATION IS REQUIRED.
  - Applicant **MUST** submit **NEW FORMAL DRAWINGS**
    - because the originally filed drawings were declared by applicant to be informal.
    - including changes required by the Notice of Draftsperson's Patent Drawing Review, PTO-948, attached hereto or to Paper No. 5.
    - including changes required by the proposed drawing correction filed on \_\_\_\_\_, which has been approved by the examiner.
    - including changes required by the attached Examiner's Amendment/Comment.
- Identifying indicia such as the application number (see 37 CFR 1.84(c)) should be written on the reverse side of the drawings. The drawings should be filed as a separate paper with a transmittal letter addressed to the Official Draftsperson.**

- Note the attached Examiner's comment regarding REQUIREMENT FOR THE DEPOSIT OF BIOLOGICAL MATERIAL.

Any response to this letter should include, in the upper right hand corner, the APPLICATION NUMBER (SERIES CODE/SERIAL NUMBER). If applicant has received a Notice of Allowance and Issue Fee Due, the ISSUE BATCH NUMBER and DATE of the NOTICE OF ALLOWANCE should also be included.

- Attachment(s)**
- Notice of References Cited, PTO-892
  - Information Disclosure Statement(s), PTO-1449, Paper No(s). \_\_\_\_\_
  - Notice of Draftsperson's Patent Drawing Review, PTO-948
  - Notice of Informal Patent Application, PTO-152
  - Interview Summary, PTO-413
  - Examiner's Amendment/Comment
  - Examiner's Comment Regarding Requirement for Deposit of Biological Material
  - Examiner's Statement of Reasons for Allowance

*Bruce Campell*  
**BRUCE R. CAMPPELL, PH.D**  
**SUPERVISORY PATENT EXAMINER**  
**TECHNOLOGY CENTER 1600**

Art Unit: 1661

The Group and/or Art Unit location of your application in the PTO has changed. To aid in correlating any papers for this application, all further correspondence regarding this application should be directed to Group Art Unit 1661.

**DETAILED ACTION**

**Examiner's Amendment**

1. An Examiner's Amendment to the record appears below. Should the changes and/or additions be unacceptable to Applicant, an amendment may be filed as provided by 37 CFR 1.312. To ensure consideration of such an amendment, it **MUST** be submitted no later than the payment of the Issue Fee.

**IN THE CLAIMS**

~~1~~. (Amended)

A combination seed capsule comprising:

one viable seed;

said seed acting as a core or pseudo core of said combination seed capsule;

a coating of a composition comprising soil conditioning materials;

said soil conditioning materials being in a solid state at time of coating.--

c1

55  
p. 54

~~7~~  
7. (Amended)

A combination seed capsule comprising:

one viable seed;

said seed acting as a core or pseudo core of said combination seed capsule;

a coating of a composition comprising soil conditioning materials;

said coating being applied to said viable seed by an agglomeration

operation;

wherein said soil conditioning materials are in a solid state at time of

coating.

C2

The above changes were authorized by attorney Phillip Weiss in a telephone interview with Examiner Grünberg on September 8, 2000.

*Drawings*

2. In order to avoid abandonment, the drawing informalities noted in Paper No. 5, on the Notice of Draftsperson's Patent Drawing Review, and the Office Action, mailed on 18 June, 1999, must now be corrected. Correction can only be effected in the manner set forth in the above noted paper.

560  
P. 95

Art Unit: 1661

2. Any inquiry concerning this or any previous communication from the examiner should be directed to Anne Marie Grünberg whose telephone number is (703) 305-0805. The Examiner can normally be reached Monday through Thursday from 6:30 am to 4:00 pm. The Examiner can also be reached on alternate Fridays from 7:30 am to 4:00 pm.

If attempts to reach the Examiner by telephone are unsuccessful, the Examiner's supervisor, Bruce Campell, can be reached at (703) 308-4205. The fax phone number for the group is (703) 305-3014.

Any inquiry of a general nature or relating to the status of this application should be directed to THE MATRIX CUSTOMER SERVICE CENTER whose telephone number is (703) 308-0196.



**BRUCE R. CAMPPELL, PH.D  
SUPERVISORY PATENT EXAMINER  
TECHNOLOGY CENTER 1600**

Anne Marie Grünberg



<b>Interview Summary</b>	Application No. <b>09/113,254</b>	Applicant(s) <b>Madigan et al.</b>
	Examiner <b>Anne Marie Grunberg</b>	Group Art Unit <b>1661</b>

All participants (applicant, applicant's representative, PTO personnel):

(1) Anne Marie Grunberg (3) \_\_\_\_\_

(2) Phillip Weiss (4) \_\_\_\_\_

Date of Interview Aug 8, 2000

Type:  Telephonic  Personal (copy is given to  applicant  applicant's representative).

Exhibit shown or demonstration conducted:  Yes  No. If yes, brief description:

Agreement  was reached.  was not reached.

Claim(s) discussed: 76-94

Identification of prior art discussed:

Roth

Description of the general nature of what was agreed to if an agreement was reached, or any other comments:

Claim language was discussed, in particular it was discussed if "wherein said soil conditioning material, when added to the seed, are in a dry, solid form: and," if inserted into the independent claims, would be enough to overcome Roth. It was suggested that the claims be written in a product by process form to clearly distinguish over Roth.

(A fuller description, if necessary, and a copy of the amendments, if available, which the examiner agreed would render the claims allowable must be attached. Also, where no copy of the amendments which would render the claims allowable is available, a summary thereof must be attached.)

1.  It is not necessary for applicant to provide a separate record of the substance of the interview.

Unless the paragraph above has been checked to indicate to the contrary, A FORMAL WRITTEN RESPONSE TO THE LAST OFFICE ACTION IS NOT WAIVED AND MUST INCLUDE THE SUBSTANCE OF THE INTERVIEW. (See MPEP Section 713.04). If a response to the last Office action has already been filed, APPLICANT IS GIVEN ONE MONTH FROM THIS INTERVIEW DATE TO FILE A STATEMENT OF THE SUBSTANCE OF THE INTERVIEW.

2.  Since the Examiner's interview summary above (including any attachments) reflects a complete response to each of the objections, rejections and requirements that may be present in the last Office action, and since the claims are now allowable, this completed form is considered to fulfill the response requirements of the last Office action. Applicant is not relieved from providing a separate record of the interview unless box 1 above is also checked.

Examiner Note: You must sign and stamp this form unless it is an attachment to a signed Office action.



<u>DB Name</u>	<u>Query</u>	<u>Hit Count</u>	<u>Set Name</u>
JPAB,EPAB	l20	0	<u>L21</u>
USPT	l17 and l19	108	<u>L20</u>
USPT	@py<1998	6129483	<u>L19</u>
USPT	l17@py<1998	4294967295	<u>L18</u>
USPT	l16 and l13	120	<u>L17</u>
USPT	((47/57.6)!.CCLS. )	379	<u>L16</u>
USPT	((47/ )!.CCLS. )	0	<u>L15</u>
USPT	47.ccls	0	<u>L14</u>
USPT	l8 and l12	1209	<u>L13</u>
USPT	l3 same l4	1298	<u>L12</u>
USPT	l5 and l10	3711	<u>L11</u>
USPT	l3 and l8	5346	<u>L10</u>
USPT	l3 and l8	5346	<u>L9</u>
USPT	l6 or l7	1004442	<u>L8</u>
USPT	powder or powdery or dust or dusty	363204	<u>L7</u>
USPT	dry or solid	889500	<u>L6</u>
USPT	l3 and l4	4196	<u>L5</u>
USPT	soil or earth or ground	568955	<u>L4</u>
USPT	l1 same l2	6208	<u>L3</u>
USPT	coat or coating or coated or agglomerate or agglomeration or agglomerated	533284	<u>L2</u>
USPT	seed	64826	<u>L1</u>

<b>Interview Summary</b>	Application No. <b>09/113,254</b>	Applicant(s) <b>Madigan et al.</b>
	Examiner <b>Anne Marie Grunberg</b>	Group Art Unit <b>1661</b>

All participants (applicant, applicant's representative, PTO personnel):

(1) Anne Marie Grunberg (3) \_\_\_\_\_

(2) Philip Weiss (4) \_\_\_\_\_

Date of Interview Sep 8, 2000

Type:  Telephonic  Personal (copy is given to  applicant  applicant's representative).

Exhibit shown or demonstration conducted:  Yes  No. If yes, brief description:

Agreement  was reached.  was not reached.

Claim(s) discussed: 77 and 85

Identification of prior art discussed:

Roth

Description of the general nature of what was agreed to if an agreement was reached, or any other comments:

Based on the proposed draft amendment and arguments recited therein, the prior art was overcome.

(A fuller description, if necessary, and a copy of the amendments, if available, which the examiner agreed would render the claims allowable must be attached. Also, where no copy of the amendments which would render the claims allowable is available, a summary thereof must be attached.)

1.  It is not necessary for applicant to provide a separate record of the substance of the interview.

Unless the paragraph above has been checked to indicate to the contrary, A FORMAL WRITTEN RESPONSE TO THE LAST OFFICE ACTION IS NOT WAIVED AND MUST INCLUDE THE SUBSTANCE OF THE INTERVIEW. (See MPEP Section 713.04). If a response to the last Office action has already been filed, APPLICANT IS GIVEN ONE MONTH FROM THIS INTERVIEW DATE TO FILE A STATEMENT OF THE SUBSTANCE OF THE INTERVIEW.

2.  Since the Examiner's interview summary above (including any attachments) reflects a complete response to each of the objections, rejections and requirements that may be present in the last Office action, and since the claims are now allowable, this completed form is considered to fulfill the response requirements of the last Office action. Applicant is not relieved from providing a separate record of the interview unless box 1 above is also checked.

Examiner Note: You must sign and stamp this form unless it is an attachment to a signed Office action.



P/23-3

Handwritten initials and date: 11 B 7/27/00

IN THE UNITED STATES PATENT AND TRADEMARK OFFICE

In re Application: Madigan et al.

Serial No.: 09/113,254

Group Art Unit: 1638

Filed: July 10, 1998

Examiner: A. Grunberg

For: SEEDING TREATMENTS

Box Response  
Assistant Commissioner for Patents  
Washington, D.C. 20231

RESPONSE TO OFFICE ACTION

The following is in response to the Office Action mailed May 10, 2000.

In the Claims:

Cancel claims 70-73, 76, 78, 82, 89 and 94-100.

Claim 77 (amended) A combination seed capsule comprising:

[at least] one viable seed;

said seed acting as a core or pseudo core of said combination seed capsule;

[coatings] a coating of a composition comprising [a growth enhancer and material

finer] soil conditioning materials;

said coating being an integral part of said seed.

[Claim 79 lines 1-2 change "material fines" to] soil conditioning materials--;

Claim 79 line 2 change "industrial byproduct" to -- sludge or fly ash --;

Claim 80 line 1 change "79" to -77--;

Claim 80 line 2 before "byproduct" insert -- fiber containing --;

Claim 81 line 1 change "79" to -80--;

Claim 83 line 1 change "material fines" to -- soil conditioning materials --;

Claim 84 line 1 change "material fines" to -- soil conditioning materials --;

Claim 84 line 2 change "grassy/woody substances" to -- sawdust --;

Claim 85 line 2 delete "at least";

Claim 85 line 4 change "material fines" to -- soil conditioning materials --;

Claim 85 line 5 change "a lifting and mixing" to -- an --;

Claim 86 lines 1-2 change "material fines" to -- soil conditioning materials --;

Claim 86 line 2 change "industrial byproduct" to -- sludge or fly ash --;

Claim 87 line 2 before "byproduct" insert -- fiber containing --;

Claim 88 line 1 change "86" to --87--;

Claim 90 line 1 change "material fines" to -- soil conditioning materials --;

Claim 91 line 1 change "material fines" to -- soil conditioning materials --;

Claim 91 line 2 "grassy/woody substances" to -- sawdust --;

Claim 93 line 2 change "material fines" to -- soil conditioning materials --;

Claim 93 line 1 change "85" to -- 92 --.

**Response**

Applicant has canceled claims 70-73, 76, 78, 82, 89 and 94. Applicant has amended the claims as requested by the Examiner.

Examiner has rejected claim 77 under 35 U.S.C. §102 as being anticipated by Gerber. Claim 77 has been amended to add the element that the coating being an integral part of said seed. Further, claim 77 has been amended to claim only one viable seed. Gerber teaches a seed capsule having a number of seeds. Paragraph 7 of Krysiak Declaration. Gerber describes a mixture of seeds and loess which are pressed together.

They form a thistle ball. This differs from the encapsulated seed of the present invention because the thistle ball of Gerber includes multiple seeds, loess and the ball is not an integral part of the seed. Further, Gerber does not describe an agglomeration process. Paragraph 8 of Krysiak Declaration.

Examiner has rejected claims 76-78 and 83 under 35 U.S.C. §102 as being anticipated by Roth. Applicant has canceled claim 76 and amended claim 77, 78 and 83. Roth differs from the encapsulated seed of the present invention because Roth does not describe the coating to be an integral part of the seed. Rather, Roth teaches a novel means for releasing sludge into the surrounding soil. In addition, Roth describes the sprayed-on coating as a film with film forming properties. The process described in Roth does not teach the agglomeration process of the present invention. The coating of Roth is described as a thin continuous film. Paragraphs 10 and 11 of Krysiak Declaration.

Examiner has rejected claims 77, 79-81 and 84 under 35 U.S.C. §102 as being anticipated by Nilsson. Nilsson describes the introduction of the seed or seeds into a cover. The cover may be made into halves or parts, at least one part or half of which comprises a suitable recess for the seed or seeds. After introducing the seed into the recess, the capsule parts are secured to each other. Paragraph 13 of the Krysiak Declaration.

Nilsson differs from the present invention because Nilsson does not describe a coating, which is an integral part of the seed. Nilsson describes a shell of paper where the seed is placed within the shell. The shell has spaces which allow gas and liquid to penetrate. Further, Nilsson does not describe an agglomeration process. Paragraph 14 of the Krysiak Declaration.

Examiner has rejected claims 77, 79-81, 84-88 and 91-94 under 35 U.S.C §102 as being anticipated by Loperfido. Loperfido describes coated seeds having a coating comprising non-porous, hydrophobic, non-phytotoxic particles which are adhered to each other and to the seeds by a hydrophilic binder in such a manner that the coating is highly porous and provides facile gas and water exchange between the seed and its environment. Due to the hydrophilic nature of the binder, it will be dissolved readily by soil moisture. Dissolution of the binder destroys the mechanical integrity of the coating. The coating allows the maximum amount of air space in the coated seed. Paragraphs 16-18 of the Krysiak Declaration.

Loperfido differs from the encapsulated seed of the present invention because Loperfido does not teach a coating being an integral part of the seed. Loperfido teaches a binder added to the seed that does not uniformly coat the seed. The coating forms beads that then collect around the seed. The coating formed around the seed is of a highly porous nature. Loperfido describes allowing a maximum amount of air space between the coating and the seed. Paragraph 19 of the Krysiak Declaration.

Examiner has rejected claims 76-94 under 35 U.S.C. §103 as being unpatentable over Loperfido in view of Roth and further in view of Nelson. None of these references describes the coating as being an integral part of these seed.

None of the products described in the prior art patents have ever been made commercially. Paragraph 20 of the Krysiak Declaration. The present invention provides a soil conditioner in intimate association with the seed. The present invention provides a uniformity of coating or coating thickness so that the seed is not on or immediately adjacent an outside surface of the capsule such that the seed may fall out, or be easily

broken out, of the capsule, or easily removed by dissolution of materials at and near the surface of the seed capsule. Paragraph 22 of the Krysiak Declaration.

The present invention applies a seed in a seed capsule wherein the seed is intimately combined with a soil conditioning material in a common particle. This was not taught prior to the present invention. After a review of the prior art provided by the Examiner, this statement is still true. Paragraph 24 of the Krysiak Declaration.

Figures 6A-6D of the present invention illustrate the seed in intimate association with the soil conditioning material. The present invention comprises a combination seed capsule having a viable seed acting as a core or pseudo core. A coating of a composition comprising a soil conditioning material is an integral part of the seed. None of the prior art describes these elements. Further, where the coating is applied in an agglomeration operation is also not described in the prior art. Paragraph 29 and 30 of the Krysiak Declaration.

Enclosed is a sample of EncapSeed which was prepared according to the method described in the present invention. As shown by the enclosed EncapSeed, the coating is an integral part of the seed. The seed (an all-purpose grass seed mixture) comprises 32% of the overall product weight. The blanket that is wrapped around the seed is comprised of dicalcium phosphate (.8%) and dried, ground paper sludge (67.2%). The dried, ground paper fines range in size from approximately 30 mesh to approximately 200 mesh. Of this total material, 68.5% is comprised of inert material. The EncapSeed coating has no visible spaces between the coating and the seed is designed to act as the microenvironment for the seed for the germination process. Field tests by the University

of Wisconsin-Madison's Horticultural Department have shown that the EncapSeed blanket helps to enhance turf establishment. Paragraph 31 of the Krysiak Declaration.

Applicant now believes that the application is in condition for allowance.

Respectfully submitted,



Philip M. Weiss, Esq.  
Reg. No.: 34,751





07-14-00 MD EIA 41638  
Box 588

P/23-3

**IN THE UNITED STATES PATENT AND TRADEMARK OFFICE**

In re Application: Madigan et al.

Serial No.: 09/113,254

Group Art Unit: 1638

Filed: July 10, 1998

Examiner: A. Grunberg

For: SEEDING TREATMENTS

Box Response  
Assistant Commissioner for Patents  
Washington, D.C. 20231

RECEIVED  
JUL 19 2000  
TECH. CL. DIV. 2900

RECEIVED  
JUL 20 2000  
TECH CENTER 1600/2900

Enclosed please Response to Office Action, Declaration of Michael Krysiak,  
Seed Sample. Please stamp postcard and return.

Respectfully submitted,

Philip M. Weiss, Esq.  
Reg. No.: 34,751

Express Mail mailing label No.: EL636894240US

Date of Deposit: July 13, 2000

I hereby certify that this paper or fee is being deposited with the United States Postal Service "Express Mail Post Office to Addressee" service under 37 CFR 1.10 on the date indicated above and is addressed to the Assistant Commissioner of Patents, Washington, DC 20231

  
Date



#12  
7-27-00

P/23-3

**IN THE UNITED STATES PATENT AND TRADEMARK OFFICE**

**In re Application: Madigan et al.**

**Serial No.: 09/113,254**

**Group Art Unit: 1638**

**Filed: July 10, 1998**

**Examiner: A. Grunberg**

**For: SEEDING TREATMENTS**

**DECLARATION OF MICHAEL KRYSIAK**

**Assistant Commissioner for Patents  
Washington, D.C. 20231**

I, Mike Krysiak, residing at 3554 Highland Center Drive, Green Bay, Wisconsin, 54311 declares as follows;

1. I graduated from the University of Wisconsin-Milwaukee majoring in Industrial Engineering.
2. I have given various presentations relating to seed encapsulation, green building, quality and service throughout the United States.
3. I worked for FEECO International, Inc. as Manager of Quality and Service for six years. FEECO designs, builds and installs material processing equipment for companies in the environmental and fertilizer markets. During my last two years at FEECO I worked on the development of the EncapSeed products in our Pilot Lab. Prior to FEECO, I worked at Krueger International (KI) as an Industrial/Quality Engineer.
4. I presently am the President and CEO of Encap. Encap is in the business of encapsulating seeds.
5. I am a named inventor of the 09/113,254 patent application. I have reviewed the Office Action dated May 10, 2000.
6. I have reviewed the Examiner's rejection regarding Gerber and have reviewed the Gerber Patent.
7. Gerber teaches a seed capsule having a number of seeds not more than 4 percent of the total weight of the capsule. Col. 5 lines 23-27.

8. Gerber describes a mixture of seeds and loess which are pressed together. They form a thistle ball. This differs from the encapsulated seed of the present invention because the thistle ball of Gerber includes multiple seeds, loess and the ball is not an integral part of the seed. Further, Gerber does not describe an agglomeration process.

9. I have reviewed the Examiner's rejection over Roth and have reviewed the Roth patent.

10. Roth describes coating crop seeds with an MAS carrier having one or more agricultural chemicals dispersed therein. The process of coating is described as dipping, soaking, spraying, or other conventional mode of application. Col. 4 lines 46-50. Crop seeds described are corn, sorghum and soy. Col. 4 lines 60-62. The coating is described as a thin continuous film. Col. 4 lines 3-5.

11. Roth differs from the encapsulated seed of the present invention because Roth only describes spraying sludge on seeds. The spray does not become an integral part of the seed. Nor does the spraying describe an agglomeration process.

12. I have reviewed the Examiner's rejection over Nilsson and have reviewed the Nilsson patent.

13. Nilsson describes the introduction of the seed or seeds into a cover. The cover may be made into halves or parts, at least one part or half of which comprises a suitable recess for the seed or seeds. After introducing the seed into the recess, the capsule parts are secured to each other. Col. 2 lines 11-25, Col. 3 lines 45-52.

14. Nilsson differs from the present invention because Nilsson does not describe a coating which is an integral part of the seed. Nilsson describes a shell of paper where the seed is placed within the shell. The shell has spaces which allow gas and liquid to penetrate. Further, Nilsson does not describe an agglomeration process.

15. I have reviewed the Examiners rejection over Loperfido and have reviewed the Loperfido patent.

16. Loperfido describes coated seeds having a coating comprising non-porous, hydrophobic, non-phytotoxic particles which are adhered to each other and to the seeds by a hydrophilic binder in such a manner that the coating is highly porous and provides facile gas and water exchange between the seed and its environment. Abstract of the Invention.

17. Due to the hydrophilic nature of the binder, it will be dissolved readily by soil moisture. Dissolution of the binder destroys the mechanical integrity of the coating. Col. 5 lines 4-6.

18. The coating allows the maximum amount of air space in the coated seed. Col. 4 lines 21-22 .

19. Loperfido differs from the encapsulated seed of the present invention because Loperfido does not teach a coating being an integral part of the seed. Loperfido teaches a binder added to the seed that does not uniformly coat the seed. The coating forms beads that then collect around the seed. The coating formed around the seed is of a highly porous nature. Loperfido describes allowing a maximum amount of air space between the coating and the seed.

20. None of the products described in the prior art patents have ever been made commercially.

21. The present invention provides a soil conditioner in intimate association with the seed. Specification Pg. 15 lines 32-33.

22. The present invention provides a uniformity of coating or coating thickness so that the seed is not on or immediately adjacent an outside surface of the capsule such that the seed may fall out, or be easily broken out, of the capsule, or easily removed by dissolution of materials at and near the surface of the seed capsule. Specification Pg. 17 line 31 – Pg. 18 line 3.

23. The present invention prepares a seed that becomes generally uniformly coated with one or more layers of the coating material such that the coating material becomes an integral part of the respective seed capsule. As the coating material solidifies on the seed, the coating material tightly bonds to the respective portions of the seeds. Specification Pg. 22 lines 14-22.

24. The present invention applies a seed in a seed capsule wherein the seed is intimately combined with a soil conditioning material in a common particle. Specification Pg. 35 lines 23-25. This was not taught prior to the present invention. After a review of the prior art provided by the Examiner, this statement is still true.

25. The prior art does not show the soil conditioning material nor the inorganic fertilizer intimately associated in a common capsule or other particle as in the present invention. Specification Pg. 38 lines 30-33.

26. Where the soil conditioning and fertilizer materials are applied separate from the seed, the potential cooperative benefit of the soil conditioning material as relates to solution and up-take of soil moisture and or of the inorganic chemical fertilizer by the seed are not obtained, and/or are not obtained in controlled close association with the seed. Specification Pg. 32 lines 1-10.

27. When applied separately to the soil, the seed and the soil conditioner are not necessarily in intimate contact with each other as they are when both materials are combined into a single combined seed capsule product as in the present invention. Specification Pg. 39 lines 19-23.

28. In the present invention, soil conditioning material and optionally chemical fertilizer, are inherently bound to each other, and to the seed, as by the agglomeration process, and inherently assist the seed in achieving desired germination and strong early growth. Specification Pg. 42 lines 27-31.

29. Figures 6A-6D of the present invention illustrate the seed in intimate association with the soil conditioning material.

30. The present invention comprises a combination seed capsule having a viable seed acting as a core or pseudo core. A coating of a composition comprising a soil conditioning material is an integral part of the seed. None of the prior art describes these elements. Further, where the coating is applied in an agglomeration operation is also not described in the prior art.

31. Enclosed is a sample of EncapSeed which was prepared according to the method described in the present invention. As shown by the enclosed EncapSeed, the coating is an integral part of the seed. The seed (an all-purpose grass seed mixture) comprises 32% of the overall product weight. The blanket that is wrapped around the seed is comprised of dicalcium phosphate (.8%) and dried, ground paper sludge (67.2%). The dried, ground paper fines range in size from approximately 30 mesh to approximately 200 mesh. Of this total material, 68.5% is comprised of inert material. The EncapSeed coating has no visible spaces between the coating and the seed is designed to act as the microenvironment for the seed for the germination process. Field tests by the University of Wisconsin-Madison's Horticultural Department have shown that the EncapSeed blanket helps to enhance turf establishment.

I declare under the penalty of perjury that the foregoing is true and correct.

Date: June 27, 2000

  
Michael Krysiak



**UNITED STATES DEPARTMENT OF COMMERCE  
Patent and Trademark Office**

Address: COMMISSIONER OF PATENTS AND TRADEMARKS  
Washington, D.C. 20231

kd

APPLICATION NO.	FILING DATE	FIRST NAMED INVENTOR	ATTORNEY DOCKET NO.
09/113,254	07/10/98	MADIGAN	D 29214

PHILIP M. WEISS  
WEISS & WEISS  
500 OLD COUNTRY ROAD  
GARDEN CITY NY 11630

HM12/0510

EXAMINER

GRUNBERG, A

ART UNIT	PAPER NUMBER
1638	10


DATE MAILED: 05/10/00

**Please find below and/or attached an Office communication concerning this application or proceeding.**

**Commissioner of Patents and Trademarks**

# Office Action Summary

Application No. <b>09/113,254</b>	Applicant(s) <b>Madigan et al.</b>
Examiner <b>Anne Marie Grunberg</b>	Group Art Unit <b>1638</b>



Responsive to communication(s) filed on Dec 14, 1999

This action is FINAL.

Since this application is in condition for allowance except for formal matters, **prosecution as to the merits is closed** in accordance with the practice under *Ex parte Quayle*, 35 C.D. 11; 453 O.G. 213.

A shortened statutory period for response to this action is set to expire three month(s), or thirty days, whichever is longer, from the mailing date of this communication. Failure to respond within the period for response will cause the application to become abandoned. (35 U.S.C. § 133). Extensions of time may be obtained under the provisions of 37 CFR 1.136(a).

### Disposition of Claim

- Claim(s) 70-73 and 76-100 is/are pending in the application.
- Of the above, claim(s) 70-73 and 95-100 is/are withdrawn from consideration.
- Claim(s) \_\_\_\_\_ is/are allowed.
- Claim(s) 76-94 is/are rejected.
- Claim(s) \_\_\_\_\_ is/are objected to.
- Claims \_\_\_\_\_ are subject to restriction or election requirement.

### Application Papers

- See the attached Notice of Draftsperson's Patent Drawing Review, PTO-948.
- The drawing(s) filed on \_\_\_\_\_ is/are objected to by the Examiner.
- The proposed drawing correction, filed on \_\_\_\_\_ is  approved  disapproved.
- The specification is objected to by the Examiner.
- The oath or declaration is objected to by the Examiner.

### Priority under 35 U.S.C. § 119

- Acknowledgement is made of a claim for foreign priority under 35 U.S.C. § 119(a)-(d).
- All  Some\*  None of the CERTIFIED copies of the priority documents have been
- received.
- received in Application No. (Series Code/Serial Number) \_\_\_\_\_.
- received in this national stage application from the International Bureau (PCT Rule 17.2(a)).

\*Certified copies not received: \_\_\_\_\_

- Acknowledgement is made of a claim for domestic priority under 35 U.S.C. § 119(e).

### Attachment(s)

- Notice of References Cited, PTO-892
- Information Disclosure Statement(s), PTO-1449, Paper No(s) \_\_\_\_\_
- Interview Summary, PTO-413
- Notice of Draftsperson's Patent Drawing Review, PTO-948
- Notice of Informal Patent Application, PTO-152

— SEE OFFICE ACTION ON THE FOLLOWING PAGES —

Art Unit: 1638

### DETAILED ACTION

The Group and/or Art Unit location of your application in the PTO has changed. To aid in correlating any papers for this application, all further correspondence regarding this application should be directed to Group Art Unit 1638.

The text of those sections of Title 35, U.S. Code not included in this action can be found in a prior Office action.

Originally withdrawn claims 70-73 are still pending. Since they were not elected in response to the original restriction requirement, they should be canceled.

Newly submitted claims 95-100 are directed to an invention that is independent or distinct from the invention originally claimed for the following reasons: Claims 95-100 are drawn to a method of making capsules; Group II as set forth in the last office action, whereas the elected invention was drawn to a seed capsule and methods of use, Group I as set forth in the last office action.

Since applicant has received an action on the merits for the originally presented invention, this invention has been constructively elected by original presentation for prosecution on the merits. Accordingly, claims 95-100 are withdrawn from consideration as being directed to a non-elected invention. See 37 CFR 1.142(b) and MPEP § 821.03.

Applicant's election of Group I in Paper No. 5 is acknowledged. Because applicant did not distinctly and specifically point out the supposed errors in the restriction requirement, the election has been treated as an election without traverse (MPEP § 818.03(a)).



Art Unit: 1638

*Claim Rejections*

1. The following is a quotation of the second paragraph of 35 U.S.C. 112:

The specification shall conclude with one or more claims particularly pointing out and distinctly claiming the subject matter which the applicant regards as his invention.

2. Claims 77, 83-86, 90-91 and 93 are rejected under 35 U.S.C. 112, second paragraph, as being indefinite for failing to particularly point out and distinctly claim the subject matter which applicant regards as the invention.

Claims 77, 83-86, 90-91 and 93 are indefinite for the terminology “material fines”. This term is not defined in the specification and the metes and bounds of the claim can not be readily determined by one skilled in the art. This rejection may be obviated by deletion of “material fines” and substituting the term --soil conditioning materials-- as is described on page 13, lines 16-19 of the specification.

Similarly claims 79 and 86 are vague and indefinite in the use of “industrial byproduct”. Changing this term to --sludge-- or --fly ash-- as described on page 13, lines 17-19 of the specification, would obviate this rejection.

In addition, claims 80 and 87 are vague and indefinite in the terminology “byproduct of a paper making process” as a byproduct could be anything, including for example, contaminated water. Insertion of --fiber-containing-- before “byproduct” as described on page 9, line 9 of the specification, would obviate this rejection.

Art Unit: 1638

Claim 84 is vague and indefinite in the terminology “grassy/woody substances”. This rejection may be obviated by changing the term to state --sawdust--.

Claim 85 is vague and indefinite in the terminology “lifting and mixing agglomeration operation”. The phrase is not defined in the specification and it is not clear as to what exactly constitutes a lifting and mixing agglomeration operation. As a result, the metes and bounds of the claim can not be adequately determined. This rejection may be obviated by deleting “a lifting and mixing” and substituting --an-- in its stead to reflect terminology used on page 28, line 20 of the specification.

Claim 94 is vague and indefinite in the terminology “binder contains lignin”. This term is not defined in the specification, nor is there support to clarify what the terminology encompasses. As a result, the metes and bounds of the claim can not be determined by one skilled in the art. It is suggested that Applicant cancel this claim.

3. Claim 93 recites the limitation "said binder" in reference to claim 85. There is insufficient antecedent basis for this limitation in the claim. This rejection may be obviated by amending the claim to delete “claim 85” and change it to read --claim 92--.

4. The following is a quotation of the first paragraph of 35 U.S.C. 112:

The specification shall contain a written description of the invention, and of the manner and process of making and using it, in such full, clear, concise, and exact terms as to enable any person skilled in the art to which it pertains, or with which it is most nearly connected, to

Art Unit: 1638

make and use the same and shall set forth the best mode contemplated by the inventor of carrying out his invention.

Claims 77,83-86, 90-91 and 93-94 are rejected under 35 U.S.C. 112, first paragraph, as containing subject matter which was not described in the specification in such a way as to reasonably convey to one skilled in the relevant art that the inventor(s), at the time the application was filed, had possession of the claimed invention.

The specification provides no guidance in identifying “material fines”, or a “binder [that] contains lignin”. The specification does not contain guidance as to what a material fine would be, nor is it understood what form of lignin would be contained in what type of binder. In contrast, the claims are broadly drawn to any material fine, and any binder that contains lignin. In addition, these phrases are considered to be new matter since the specification as originally filed does not contain these items. The terms “grassy/woody substances” and “lifting and mixing agglomeration operation” are also considered to be new matter since they are not in the specification as originally filed.

The use of any type of material fine, or a binder which contains lignin is unpredictable due to the environmental impacts associated with certain material fines, and the germination characteristics of the seed and sensitivity of the seed to adhesive compounds, as set forth below.

Nelson teaches in column 2, lines 12-16, for example, that certain flue gas desulfurization wastes are not appropriate for soil amendments, owing to their high solubilities in water.

Art Unit: 1638

Porter et al teach in column 2, lines 21-30, for example, that selection of a suitable adhesive or binder, must take into account the germination characteristics of the seed and the sensitivity of the seed to damage caused by harsh chemicals that might be present in adhesive compounds.

Given the claim breadth, unpredictability, and lack of guidance as discussed above, undue experimentation would have been required by one skilled in the art to determine what type of material fines, and what type of lignin-containing binder could be used. Undue experimentation would also be required to identify appropriate grassy/woody substances and lifting and mixing agglomeration operations.

This rejection may be obviated by amending the claims as suggested in the section dealing with the second paragraph of 35 U.S.C. 112.

5. New claim 77 is rejected under the previously applied 35 U.S.C. 102(b) as being anticipated by Gerber.

Claim 77 is drawn to a combination seed capsule comprising at least one viable seed which acts as a core or pseudo-core of the seed capsule, and seed coatings comprising a growth enhancer and material fines.

Gerber teaches a combination seed capsule comprising at least one viable seed; said seed acting as a core or pseudo-core of said combination seed capsule (column 1, lines 61-63). Gerber

Art Unit: 1638

also teaches seed coatings comprising a growth enhancer and material fines (column 2, line 7; column 2, lines 52-56; column 3, lines 22-41).

This rejection may be obviated by inserting at the end of the claim --; said seed capsule having an inner layer comprising a soil conditioning material selected from the group consisting of municipal or sewage sludge, scrubber sludge, paper mill sludge, sawdust, fly ash, dust and animal waste;

and said seed capsule having an outer layer comprising a material selected from the group consisting of urea, an inorganic form of a plant nutrient, herbicides, fungicides, and ingredients effective to reduce susceptibility of the seed capsule to deleterious effects of animals;

wherein the inner-layer is agglomerated onto the seed.--

6. New claims 76-78 and 83 are rejected under the previously applied 35 U.S.C. 102(b) as being anticipated by Roth.

Claims 76-78 and 83 are drawn to a combination seed capsule comprising at least one viable seed which acts as a core or pseudo-core of the seed capsule, and a seed coating comprising dicalcium phosphate. Additionally, the claims are drawn to seed coatings comprising a growth enhancer and material fines such as municipal sewage.

Roth teaches a combination seed capsule comprising at least one viable seed; said seed acting as a core or pseudo-core of said combination seed capsule (column 4, lines 31-50). Roth

Art Unit: 1638

also teaches a coating comprising “the phosphates,” which although it does not specifically state dicalcium phosphate, certainly includes dicalcium phosphate (column 3, line 10). Additionally Roth teaches coatings comprising a growth enhancer and material fines (column 3, lines 5-16). Roth also teaches material fines comprised of municipal sewage (column 4, lines 46-50).

This rejection may be obviated by inserting at the end of the claim --; said seed capsule having an inner layer comprising a soil conditioning material selected from the group consisting of municipal or sewage sludge, scrubber sludge, paper mill sludge, sawdust, fly ash, dust and animal waste;

and said seed capsule having an outer layer comprising a material selected from the group consisting of urea, an inorganic form of a plant nutrient, herbicides, fungicides, and ingredients effective to reduce susceptibility of the seed capsule to deleterious effects of animals;

wherein the inner layer is agglomerated onto the seed.--

7. New claims 77, 79-81 and 84 are rejected under the previously applied 35 U.S.C. 102(b) as being anticipated by Nilsson.

Claims 77, 79-81 and 84 are drawn to a combination seed capsule comprising at least one viable seed which acts as a core or pseudo-core of the seed capsule, and seed coatings comprising a growth enhancer and material fines. Additionally, the claims are drawn to material fines such as industrial byproducts, byproducts of a paper making process, paper sludge, and grassy/woody substances.

Art Unit: 1638

Nilsson teaches a combination seed capsule comprising at least one viable seed; said seed acting as a core or pseudo-core of said combination seed capsule (column 1, lines 38-49).

Nilsson also teaches seed coatings comprising a growth enhancer and material fines (column 1, lines 60-68; column 4, line 23). Additionally Nilsson teaches material fines comprised of industrial byproducts (column 1, line 65). Nilsson also teaches material fines which are byproducts of a paper making process (column 1, line 65), such as paper sludge (column 1, line 65). Nilsson also teaches material fines comprised of grassy/woody substances (column 1, lines 65).

This rejection may be obviated by inserting at the end of the claim --; said seed capsule having an inner layer comprising a soil conditioning material selected from the group consisting of municipal or sewage sludge, scrubber sludge, paper mill sludge, sawdust, fly ash, dust and animal waste;

and said seed capsule having an outer layer comprising a material selected from the group consisting of urea, an inorganic form of a plant nutrient, herbicides, fungicides, and ingredients effective to reduce susceptibility of the seed capsule to deleterious effects of animals;

wherein the inner layer is agglomerated onto the seed.--

8. Claims 77, 79-81, 84-88, and 91-94 are rejected under 35 U.S.C. 102(b) as being anticipated by Loperfido (newly applied).

Art Unit: 1638

Claims 77, 79-81, 84-88, and 91-94 are drawn to a combination seed capsule comprising at least one viable seed which acts as a core or pseudo-core of the seed capsule, and seed coatings comprising a growth enhancer and material fines. Additionally, the claims are drawn to material fines such as industrial byproducts, byproducts of a paper making process, paper sludge, grassy/woody substances. The claims are also drawn to a binder which may include fertilizer and which contains lignin.

Loperfido teaches a combination seed capsule comprising at least one viable seed which acts as a core or pseudo-core of the seed capsule (abstract, for example). The seed coatings comprise a growth enhancer (column 6, lines 37-46) and material fines (column 2, lines 63-66, for example). Loperfido teaches material fines such as cellulose derivatives, which would include byproducts of a paper making process, paper sludge, or grassy/woody substances (column 4, lines 13-14). Byproducts of a paper making process are industrial byproducts since paper making is an industry. The coating is applied by a lifting and mixing agglomeration operation (column 6, lines 65-67; column 7, lines 1-19, for example). Loperfido teaches a binder that is applied to the seed capsule (column 5, lines 26-30, for example). Additionally, Loperfido teaches a fertilizer as part of the material fines (column 6, lines 35-47). Loperfido also teaches a binder that contains lignin (column 5, line 1, for example).

This rejection may be obviated by inserting at the end of the claim --; said seed capsule having an inner layer comprising a soil conditioning material selected from the group consisting



Art Unit: 1638

of municipal or sewage sludge, scrubber sludge, paper mill sludge, sawdust, fly ash, dust and animal waste;

and said seed capsule having an outer layer comprising a material selected from the group consisting of urea, an inorganic form of a plant nutrient, herbicides, fungicides, and ingredients effective to reduce susceptibility of the seed capsule to deleterious effects of animals;

wherein the inner layer is agglomerated onto the seed.--

Additionally, the term "at least" in line 2 of claims 76, 77 and 85, should be deleted.

Applicant may attempt to distinguish the claimed invention by supplying a declaration which sufficiently shows that the seed capsule of the instant invention is distinct from a seed capsule made by the process of Loperfido. No commitment to patentability will be made prior to receipt and review of the declaration.

9. Claims 76-94 are rejected under 35 U.S.C. 103(a) as being unpatentable over Loperfido in view of Roth, and further in view of Nelson (newly applied).

Claims 76-94 are drawn to a combination seed capsule comprising at least one viable seed which acts as a core or pseudo-core of the seed capsule, and a seed coating comprising dicalcium phosphate. Additionally, the claims are drawn to seed coatings comprising a growth enhancer and material fines such as municipal sewage, an industrial byproduct, paper sludge, fly ash, and grassy/woody substances. The claims are also drawn to the coating being applied by a lifting and mixing agglomeration operation.

Art Unit: 1638

Loperfido has been discussed previously.

Loperfido does not teach a coating or growth enhancer comprising dicalcium phosphate, nor does Loperfido teach material fines comprising fly ash or municipal sewage.

Roth teaches a coating comprising “the phosphates,” which although it does not specifically state dicalcium phosphate, certainly includes dicalcium phosphate (column 3, line 10). Roth also teaches material fines comprised of municipal sewage (column 4, lines 46-50).

Nelson teaches environmentally beneficial soil amendments such as fly ash (column 3, lines 60-63).

It would have been *prima facie* obvious to a person of ordinary skill in the art at the time the invention was made to utilize the combination seed capsules as taught by Loperfido, and to modify the capsules to include the fertilizer dicalcium phosphate, given the advantages of including fertilizers into the seed capsule as taught by Loperfido. It would also have been obvious to use material fines comprising municipal sewage or industrial byproducts such as fly ash, given the benefits of a low-cost carrier additive derived from sewage sludge as described by Roth (column 2, lines 1-45), and given the benefits of growth enhancing industrial byproducts such as fly ash as described by Nelson (column 3, lines 45-57).

This rejection may be obviated by inserting at the end of the claim --; said seed capsule having an inner layer comprising a soil conditioning material selected from the group consisting of municipal or sewage sludge, scrubber sludge, paper mill sludge, sawdust, fly ash, dust and animal waste;

Art Unit: 1638

and said seed capsule having an outer layer comprising a material selected from the group consisting of urea, an inorganic form of a plant nutrient, herbicides, fungicides, and ingredients effective to reduce susceptibility of the seed capsule to deleterious effects of animals;

wherein the inner layer is agglomerated onto the seed.--

Additionally, the term "at least" in line 2 of claims 76, 77 and 85, should be deleted.

Applicant may attempt to distinguish the claimed invention by supplying a declaration which sufficiently shows that the seed capsule of the instant invention is distinct from a seed capsule made by the process of Loperfido. No commitment to patentability will be made prior to receipt and review of the declaration.

Applicant's arguments filed 12/14/1999 have been fully considered but they are not persuasive.

The references supplied by the Applicant teach different coating and agglomeration techniques. The terminology in the art appears to be used interchangeably for different techniques. For example, on page 21 of Perry's Chemical Engineers' Handbook, liquid methods are characterized by spray or fluid bed agglomeration, whereas Hovmand appears to describe the same process on page 11, as a coating process. As a result, the previously applied art of Gerber, Roth and Nelson could be characterized as a coating or an agglomeration procedure.

No claim is allowed.

Art Unit: 1638

**CLOSING REMARKS**

Any inquiry concerning this or earlier communications from the examiner should be directed to Anne Marie Grünberg whose telephone number is (703) 305-0805. The examiner can normally be reached on Monday through Thursday from 7:30 to 5:00, and on alternate Fridays from 7:30 to 4:00.

If attempts to reach the examiner by telephone are unsuccessful, the examiner's supervisor, Lynette Smith, can be reached on (703) 308-3909. The fax phone number for this Group is (703) 305-3014.

Any inquiry of a general nature or relating to the status of this application or proceeding should be directed to the Group receptionist whose telephone number is (703) 308-0196.

Anne Marie Grünberg

May 8, 2000

DAVID T. FOX  
PRIMARY EXAMINER  
GROUP ~~130~~ 1638



**Notice of References Cited**

Application No. 09/113,254	Applicant(s) Madigan et al.	
Examiner Anne Marie Grunberg	Group Art Unit 1638	Page 1 of 1

**U.S. PATENT DOCUMENTS**

*		DOCUMENT NO.	DATE	NAME	CLASS	SUBCLASS
	A	5,627,133	5/1997	Nelson	504	116
	B	3,905,152	9/1975	Loperfido	47	57.6
	C					
	D					
	E					
	F					
	G					
	H					
	I					
	J					
	K					
	L					
	M					

**FOREIGN PATENT DOCUMENTS**

*		DOCUMENT NO.	DATE	COUNTRY	NAME	CLASS	SUBCLASS
	N						
	O						
	P						
	Q						
	R						
	S						
	T						

**NON-PATENT DOCUMENTS**

*		DOCUMENT (Including Author, Title, Source, and Pertinent Pages)	DATE
X	U	Hovmand, Granulation and agglomeration by fluidized bed and spray drying technology, pages 1, 10-11.	1982
X	V	Briquetting, pelletizing, extrusion & fluid bed/spray granulation, table of contents, table 8-52.	1998
X	W	Perry' Chemical Engineers' Handbook, 8-61	1978
X	X	Briquetting, Pelletizing, Extrusion and Fluid Bed/Spray Granulation, Engelleitner, tables 23-24, page 21 and 23.	1998

\* A copy of this reference is not being furnished with this Office action.  
(See Manual of Patent Examining Procedure, Section 707.05(a).)

<b>Interview Summary</b>	Application No. <b>09/113,254</b>	Applicant(s) <b>Madigan et al.</b>
	Examiner <b>Anne Marie Grunberg</b>	Group Art Unit <b>1638</b>

All participants (applicant, applicant's representative, PTO personnel):

(1) Anne Marie Grunberg (3) \_\_\_\_\_

(2) Philip Weiss (4) \_\_\_\_\_

Date of Interview May 4, 2000

Type:  Telephonic  Personal (copy is given to  applicant  applicant's representative).

Exhibit shown or demonstration conducted:  Yes  No. If yes, brief description:

Agreement  was reached.  was not reached.

Claim(s) discussed: claims 70-73 and 76-100

Identification of prior art discussed:

Discussed prior art in general terms and more thoroughly discussed Roth, Gerber, and Nilsson among others.

Description of the general nature of what was agreed to if an agreement was reached, or any other comments:

Discussed the general state of the prior art and how Applicant's invention differs from the prior art. Additionally, agglomeration methods were discussed.

(A fuller description, if necessary, and a copy of the amendments, if available, which the examiner agreed would render the claims allowable must be attached. Also, where no copy of the amendments which would render the claims allowable is available, a summary thereof must be attached.)

1.  It is not necessary for applicant to provide a separate record of the substance of the interview.

Unless the paragraph above has been checked to indicate to the contrary, A FORMAL WRITTEN RESPONSE TO THE LAST OFFICE ACTION IS NOT WAIVED AND MUST INCLUDE THE SUBSTANCE OF THE INTERVIEW. (See MPEP Section 713.04). If a response to the last Office action has already been filed, APPLICANT IS GIVEN ONE MONTH FROM THIS INTERVIEW DATE TO FILE A STATEMENT OF THE SUBSTANCE OF THE INTERVIEW.

2.  Since the Examiner's interview summary above (including any attachments) reflects a complete response to each of the objections, rejections and requirements that may be present in the last Office action, and since the claims are now allowable, this completed form is considered to fulfill the response requirements of the last Office action. Applicant is not relieved from providing a separate record of the interview unless box 1 above is also checked.

Examiner Note: You must sign and stamp this form unless it is an attachment to a signed Office action.

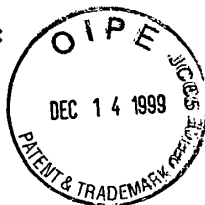
IN THE UNITED STATES PATENT AND TRADEMARK OFFICE

In re Patent Application of :  
Madigan

Serial No.: 09/113,254

Filed: July 10, 1998

Title: SEEDING TREATMENTS



Date: 12/14/99  
Group Art Unit: 1649  
Examiner: Grunberg

*J. [Signature]*  
w/ [Signature]  
3/3/99

RESPONSE TO OFFICE ACTION:

Sir:

In response to the Office Action mailed June 18, 1999 please amend the application as follows:

In the Specification

Pg. 8 Line 22 after "comprise" add --urea or--;

Line 24 delete "urea"

Line 26 change "micronutrient" to --nutrient--;

Pg. 9 Line 5 change "micronutrient" to--nutrient--;

Pg.10 Line 14 change "micronutrient" to --nutrient--;

Line 17 change "micronutrient" to --nutrient--;

Pg.14 Line 8 change "Inorganic chemical" to --chemical--;

Line 17 delete "inorganic";

Line 19 change "micronutrients" to --nutrients--;

Pg.18 Line 15 delete "inorganic";

Pg.19 Line 23 change "In" to --Referring to--;

Pg.34 Line 9 delete "inorganic";

*A*

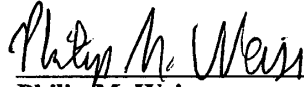
Further, during the interview, applicant discussed that there was a difference between the agglomeration process described in the present application and the coating process described in the prior art. The Examiner requested publications which describe such a difference. These publications are attached along with this response. For example, the publications describe the difference between a tumbling and mixer agglomeration which is similar to the method described in the patent application verses spraying methods which are similar to the coating methods described in the prior art. The article, "Granulation and Agglomeration by Fluidized Bed and Spray Drying Technology" specifically describes the difference between "agglomeration technology" and "the technology of coating particles". Table 8-52 from the notes from "Briquetting, Pelletizing, Extrusion of Fluid Bed/Spray Granulation" April 1998 show the difference between tumbling and mixer agglomeration and other techniques, such as, spray methods. This same table is found in "Perry's Chemical Engineers Handbook". In "Briquetting, Pelletizing, Extrusion of Fluid Bed/Spray Granulation" 1995 describes the difference in Table 23 between "tumble agglomeration", the method described in the present patent application versus "coating techniques" which are described as a totally separate technique. The notes further described these two techniques as differing between agitation methods and liquid methods.

The present claims specifically refer to an agglomeration method which is different than a coating methods described in the prior art.



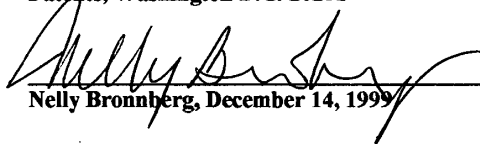


Therefore, the application is now in condition for allowance.

  
Philip M. Weiss  
Reg. No. 34,751



“Express Mail” mailing label number: *EL52478332345*  
Date of Deposit: December 14, 1999  
I hereby certify that this paper or fee is being deposited  
with the United States Postal Service  
“Express Mail Post Office to Addressee” service  
under 37 CFR 1.10 on the date indicated above and  
is addressed to BOX Response,  
Assistant Commissioner for  
Patents, Washington D.C. 20231

  
Nelly Bronnberg, December 14, 1999

Line 15 delete "inorganic";

Pg.37 Line 23 change "micronutrients" to --nutrients--;

In the Claims:

Delete Claims 1-69, 74 and 75

Add the following claims:

76. A combination seed capsule comprising:  
at least one viable seed;  
said seed acting as a core or pseudo-core of said combination  
seed capsule;

a coating comprising dicalcium phosphate.

77. A combination seed capsule comprising:  
at least one viable seed;  
said seed acting as a core or pseudo-core of said combination  
seed capsule;  
coatings comprising a growth enhancer and material fines.

78. The combination seed capsule of claim 77 wherein said growth enhancer is  
dicalcium phosphate.

<sup>2</sup>  
~~79.~~ The combination seed capsule of claim ~~77~~<sup>1</sup> wherein material of said <sup>soil conditioning</sup> material ~~fines~~<sup>sludge or fly ash</sup> are comprised of industrial byproduct.

<sup>3</sup>  
~~80.~~ The combination seed capsule of claim ~~79~~<sup>2</sup> wherein the material is a <sup>fiber containing</sup> byproduct of a paper making process.

<sup>4</sup>  
~~81.~~ The combination seed capsule of claim ~~79~~<sup>3</sup> wherein the byproduct is paper  
sludge.

52  
PST

82. The combination seed capsule of claim 79 wherein the byproduct is fly ash.

~~5~~ ~~83.~~ The combination seed capsule of claim 77 wherein the material <sup>1 Soil conditioning s</sup> fines is comprised of municipal sewage.

~~6~~ ~~84.~~ The combination seed capsule of claim 78 wherein the material <sup>1 Soil conditioning s</sup> fines are comprised of <sup>sawdust</sup> grassy/woody substances.

*Sub C2*  
*A'*  
85. A combination seed capsule comprising:  
~~at least one viable seed; said seed acting as a core or pseudo-core of said combination seed capsule;~~  
<sup>Soil conditioning s</sup>  
a coating of a composition comprising material fines;  
said coating being applied to said viable seed by a ~~lifting and mixing~~ <sup>an</sup> agglomeration operation.

~~8~~ ~~86.~~ The combination seed capsule of claim 85 wherein material of said material <sup>7 Soil conditioning</sup> fines are comprised of industrial byproduct. <sup>Sludge or fly ash</sup>

~~9~~ ~~87.~~ The combination seed capsule of claim 86 wherein the material is a <sup>8</sup> fiber containing byproduct of a paper making process.

~~10~~ ~~88.~~ The combination seed capsule of claim 86 wherein the byproduct is paper <sup>9</sup> sludge.

89. The combination seed capsule of claim 86 wherein the byproduct is fly ash.

~~11~~ ~~90.~~ The combination seed capsule of claim 85 wherein the material <sup>7 Soil conditioning s</sup> fines is comprised of municipal sewage.

~~12~~ ~~91.~~ The combination seed capsule of claim 85 wherein the material <sup>Soil conditioning s</sup> fines are comprised of <sup>sawdust</sup> grassy/woody substances.

53  
p. 92

~~13~~  
~~92.~~ The combination seed capsule of claim ~~85~~<sup>7</sup> wherein a binder is applied to said seed capsule.

~~14~~  
~~93.~~ The combination seed capsule of claim ~~85~~<sup>13</sup> wherein a fertilizer is part of said <sup>soil conditioning</sup> material <sup>s</sup> fines, said binder or its own layer.

- A
94. The combination seed capsule of claim 92 wherein said binder contains lignin.
95. A method of making seed capsules by an agglomeration operation comprising:  
spraying a binder on said seed;  
lifting and mixing said seeds with material fines.
96. The method of claim 95 wherein said seed capsules are coated with a growth enhancer.
97. The method of claim 96 wherein said growth enhancer is dicalcium phosphate. B
98. The method of claim 95 wherein said material fines are comprised of industrial byproduct fines.
99. The method of claim 95 wherein said binder is a liquid fertilizer.
100. The method of claim 95 wherein said binder contains lignin.

Response to Office Action

Applicant has canceled the original claims in the application and has added new claims 76-100. Applicant's attorney had a telephone interview with the examiner which discussed the use of dicalcium phosphate as a seed coating, and that this was not described in the prior art presently before the Examiner.

54  
p. 93

*Attach to  
#8*



**Granulation and Agglomeration by Fluidized Bed  
and Spray Drying Technology  
DR. SVEND HOVMAND  
NIRO ATOMIZER INC.**

**INTRODUCTION**

The methods to be described do not involve any mechanical agitation or compaction of the powder to be agglomerated but are agglomeration techniques derived from fluid bed dryer and spray dryer technology. With these methods, the drying and agglomeration of a product can be combined in one step in many cases. The agglomerated or granulated products from a Fluid Bed Granulator or Fluidized Spray Dryer are normally less dense and more fragile than the products agglomerated by the methods described previously in this course; however, stable and well defined agglomerates or granulates, that easily disperse in water can be produced in many applications without the addition of binder. The technology of coating particles in a fluid bed will also be described.

*3*

An overview of the techniques described here can be presented as follows:

The starting materials can influence the product characteristic. Granulation is initiated by formulation of liquid bridges. Accordingly, increasing particle surface area and absorption of water result in incomplete wetting of the surface of the particles and this will therefore result in decreasing granule size.


Granule size is directly proportional to droplet size for a given binder solution and varying the droplet size might therefore be the most suitable way of controlling the granule size.

The atomization of the liquid binder can either be performed by pressure nozzles or two fluid nozzles. Two fluid nozzles are often preferred in batch operations as they reduce the tendency to form wet agglomerates and of blockage of the nozzles. Further the position of the nozzle is an important parameter in the granulation process. Nozzles can be placed above the fluidized layer spraying downward, in the side of the fluidized layer, or at the bottom of fluidized layer near the distributor spraying upwards. Each position has advantages and disadvantages, however, no clear conclusions can be drawn from the available literature.

After granulation the granules can be dried in the fluid bed at elevated inlet gas temperatures in order to reduce the drying time.

C. Batch Fluid Bed Coating

Following the drying, the granules can be conveniently spray coated in the same equipment, as experience has shown that the fluidized bed is ideal for spray coating and is giving constant and reproducible coatings of the granules. Fluid



bed coating is an extreme example of fluid bed granulation. The layering mechanisms are made to dominate totally by applying very low liquid feed rates and keeping the fluidized layer dry; thus the drying rate rapid (16), (17), (18).

Coating is important in a number of industries such as pharmaceutical, agrochemical, seed treatment, food, and confectionery.

The reasons for coating are usually:

- appearance
- taste masking
- moisture protection or isolation from other ingredients
- enteric coating
- sustained release
- gastric release

The ideal fluid bed coater will ensure an even coating of each discrete granule/tablet's surface and thus ensure a perfect mix of the particles throughout the whole fluidized layer, by avoiding any dead zones in the fluid bed coater. It is crucial that each particle to be coated passes through the spray zone, preferably without being in contact with other particles and that the applied polymer is dried as rapidly as possible to prevent superficial sticking and picking off one surface to another.

The Wurster Process, Fig. 6, a spray coating process in a fluid bed where the granules are circulated up through the center while being coated, has specially being developed for coating of small and medium sized granules (10) (19).

**Briquetting, Pelletizing, Extrusion  
& Fluid Bed/Spray Granulation  
April 20-23, 1998  
Chicago, IL**

**TABLE OF CONTENTS**

	<b>SECTION</b>
<b>Selection of the Proper Agglomeration Process .....</b>	<b>A</b>
<b>Fundamentals of Agglomeration.....</b>	<b>B</b>
<b>Cost of Agglomeration.....</b>	<b>C</b>
<b>Pressure Agglomeration.....</b>	<b>D</b>
<b>The Pelletizing of Chemicals and Industrial Products .....</b>	<b>E</b>
<b>Granulation by Extrusion and Shaping by Spheronization.....</b>	<b>F</b>
<b>Granulation and Agglomeration by Fluidized Bed and Spray Drying Technology .....</b>	<b>G</b>
<b>Pelletizing.....</b>	<b>H</b>
<b>Laboratory Testing: Agglomerate Strength .....</b>	<b>I</b>
<b>Binders .....</b>	<b>J*</b>
<b>Appendix.....</b>	<b>K*</b>

**\*Optional Day Notes To Be Distributed**

**Optional Reading**

**Koerner, Robert M. and John MacDougall. *Elements II, Briquetting and Agglomeration.*  
Hudson: Institute for Briquetting and Agglomeration.**





TABLE 8-52 Size-Enlargement Methods and Applications\*

Method	Equipment	Representative applications
Pressure compaction	Piston or molding press	Plastic preforms, small machine parts from metal powders (cams, gears, gaskets), metal borings and turnings Pharmaceuticals, catalysts, industrial chemicals, ceramics, metal powders Clay-type minerals, potassium chloride, sodium chloride, organic compounds, metal powders, ores, charcoal, lime, magnesia, titanium sponge, phosphate rock Pharmaceuticals, plastics, clays, carbon, charcoal, industrial chemicals, fertilizers, rubber products, animal feeds Bauxite, plastics, rare-earth fluorides, clays, catalysts
	Tableting press	
	Roll-type press	
	Pellet mill	
Tumbling and mixer agglomeration	Screw extruder	Fertilizers, iron ores, nonferrous ores, mineral and clay products, carbon black, various finely divided solid-waste products Fertilizers, premixing for balling, conditioning steel-plant fines "Instant" foods, detergent granulation
	Inclined pan or disk; rotary-drum agglomerator	
	Paddle mixer; horizontal pan	
Thermal processes	Powder blenders; flow-jet mixing	Ferrous and nonferrous ores, minerals, cement clinker, solid-waste products Sulfur slates, urea, ammonium nitrate, caustic, various resins, hot-melt adhesives
	Sintering and heat hardening in traveling grate, rotary kiln, grate-kiln, shaft furnace	
Spray methods	Drying and solidification in drum dryers, bakers, endless-belt systems	Instant foods, washing powders, dyestuffs, press feeds Urea, ammonium nitrate, resins, coal-tar pitch, etc. Fertilizers, clays, sulfur, nuclear and other wastes Clays, diatomaceous earths, starch, waste by-products Coal fines, soot and oil removal from water
	Spray dryers	
	Prilling towers	
	Fluidized and spouted beds	
Liquid systems	Flash dryers	Metal dicarbide spheroids Waste sludge, mud and clay slurries, sewage sludge
	Immiscible-liquid wetting in various high-shear and turbine mixers	
	Sol-gel process in spray column Pellet flocculation in drums and stirred vessels	

\*Cf. Browning, *Chem. Eng.*, 74(25), 147 (1967).

From Ref. 7

FILE NO. 765 11/18 '99 21:28 IP:REC'D INTERNATIONAL I

T 920 400 0000 0000 0000

PAGE 10

# PERRY'S CHEMICAL ENGINEERS' HANDBOOK

SIXTH  
EDITION

McGraw-Hill Book Company

New York  
St. Louis  
San Francisco  
Auckland  
Bogotá  
Hamburg  
London  
Madrid  
Mexico  
Montreal  
New Delhi  
Panama  
Paris  
São Paulo  
Singapore  
Sydney  
Tokyo  
Toronto

Prepared by a staff of specialists  
under the editorial direction of

Late Editor  
**Robert H. Perry**

Editor  
**Don W. Green**  
Conger-Gabel Professor of Chemical  
and Petroleum Engineering,  
University of Kansas

Assistant Editor  
**James O. Maloney**  
Professor of Chemical Engineering,  
University of Kansas

P. 99

UT Ex. 2025  
SteadyMed v. United Therapeutics  
IPR2016-00006

IPR2020-00769  
United Therapeutics EX2006  
Page 4318 of 7113

**STRENGTH OF AGGLOMERATES 8-61**

**TABLE 8-52 Size-Enlargement Methods and Applications\***

Method	Equipment	Representative applications
Pressure compaction	Piston or molding press	Plastic preforms, small machine parts from metal powders (cams, gears, gaskets), metal borings and turnings Pharmaceuticals, catalysts, industrial chemicals, ceramics, metal powders Clay-type minerals, potassium chloride, sodium chloride, organic compounds, metal powders, ores, charcoal, lime, magnesite, titanium sponge, phosphate rock Pharmaceuticals, plastics, clays, carbon, charcoal, industrial chemicals, fertilizers, rubber products, animal feeds Bauxite, plastics, rare-earth fluorides, clays, catalysts
	Tableting press	
	Roll-type press	
Tumbling and mixer agglomeration	Pellet mill	Fertilizers, iron ores, nonferrous ores, mineral and clay products, carbon black, various finely divided solid-waste products Fertilizers, premixing for balling, conditioning stock-pile fines "Instant" foods, detergent granulation Ferrous and nonferrous ores, minerals, cement clinker, solid-waste products Sulfur slates, urea, ammonium nitrate, caustic, various resins, hot-melt adhesives Instant foods, washing powders, dyestuffs, press feeds Urea, ammonium nitrates, resins, coal-tar pitch, etc. Fertilizers, clays, sulfur, nuclear and other wastes Clays, diatomaceous earths, starch, waste by-products Coal fines, snot and oil removal from water
	Screw extruder	
	Inclined pan or disk, rotary-drum agglomerator	
	Paddle mixer; horizontal pan	
Thermal processes	Powder blenders; flow-jet mixing	Metal dicarbide spheruloids Waste sludge, mud and clay slurries, sewage sludge
	Sintering and heat hardening in traveling grate, rotary kiln, grate-kiln, shaft furnace	
Spray methods	Drying and solidification in drum dryers, bakers, endless-belt systems	Sol-gel process in spray column Pellet flocculation in drums and stirred vessels
	Spray dryers	
Liquid systems	Prilling towers	Flash dryers
	Fluidized and spouted beds	
	Flash dryers	

\* Cf. Browning, *Chem. Eng.*, 74(25), 147 (1967).

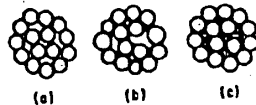


FIG. 8-64 Three states of liquid content for an assembly of spherical particles. (a) Pendular state. (b) Funicular state. (c) Capillary state. [Newitt and Conway-Jones, *Trans. Inst. Chem. Eng. (London)*, 36, 422 (1958).]

**Calculation of Agglomerate Strength** For an agglomerate composed of equal-sized spherical particles, the tensile strength  $t$  is [Rumpf, in Knepper (ed.), *Agglomeration*, op. cit., p. 379]

$$t = \frac{9}{8} \left( \frac{1 - \epsilon}{\pi X^2} \right) NF \quad (8-38)$$

where  $X$  is the particle diameter;  $F$  is the bonding force per point of contact;  $N$  is the mean coordination number, i.e., average number of points of contact between one sphere and its neighbors; and  $\epsilon$  is the volume fraction of voids in the agglomerate. Values of  $X$  and  $\epsilon$  can be obtained from a size-distribution analysis of the powder and the bulk density of the packed particles. As an approximation, the coordination number  $N$  is  $\pi/\epsilon$  (Rumpf, loc. cit.) or  $N = 2 \exp 2.4(1 - \epsilon)$  [Melsner, *Ind. Eng. Chem. Process Des. Dev.*, 3, 202 (1964)].  
For mobile liquid binders in the pendular state

$$t = 2.8 \left( \frac{1 - \epsilon}{\pi X^2} \right) \frac{\sigma}{X f(\theta)} \quad (8-39)$$

where  $\sigma$  is the surface tension of the binding liquid and  $f(\theta)$  is a function of the angle of contact [Newitt and Conway-Jones, *Trans. Inst. Chem. Eng. (London)*, 36, 422 (1958)].

If wetting is complete,  $f(\theta) = 1$ . For the capillary state

$$t = 8.0 \left( \frac{1 - \epsilon}{\pi X^2} \right) \frac{\sigma}{X f(\theta)} \quad (8-40)$$

The tensile strength of an agglomerate in the pendular state is about one-third of that in the capillary state, while the funicular state has intermediate strengths. A decrease in particle size and porosity yields greater strength. To improve agglomerate strength, the importance of correct particle-size distribution in attaining minimum porosity should be recognized [Ridgway and Tarback, *Chem. Process Eng. (February 1968)*].

For the other binding mechanisms calculated values of tensile strength shown in Fig. 8-65 indicate the strength to be expected in various size-enlargement processes.

**Strength-Testing Methods** Concepts of fracture mechanics (see subsection "Properties of Solids") are applicable to the methods of testing the strength of agglomerates.

Compression tests, in which agglomerates are crushed between parallel platens, are used for quick production checking. Various means of distributing the applied force uniformly over the agglomerate surface are used, including shaving off opposite sides, fitting them with hardening plastic, or covering the platen surface with compressive board.

A log-log plot of load at failure against pellet diameter for approximately spherically pellets produced under the same conditions often yields a straight line with slope approximately equal to 2. The intercept of such a plot at unit diameter yields a compressive-strength factor.

by various

material, used over product size per product, temperatures, abrasion, and attrition used. Attrition

ing of ores, as in the agents such

Interfacial ished in an Fig. 8-64), rings at the ate. As the continuous ular state, etely filled, uld bridge ie adhesion

hly viscous he weakest plotted, and

no particles responsible ter to form r particles, nterbalance

ing the agi- it is prob- most cases.

**The CENTER for  
PROFESSIONAL ADVANCEMENT**

144 Tices Lane, East Brunswick, New Jersey 08816

Academic Center, Two Tower Center, Ninth Floor,  
New Jersey Turnpike (Exit 9), East Brunswick, New Jersey 08816

*Administrative Offices*

Telephone 908-238-1600 • FAX 908-238-9113 • Telex 139303 (CENPRO EBRW).

**Briquetting,  
Pelletizing, Extrusion and Fluid  
Bed/Spray Granulation**

MARCH 27-29, 1995  
East Brunswick, NJ

W.H. ENGELLEITNER  
Course Director



continuing education through total involvement

DALE LEE  
RASMUSSEN

Table 23. Review of the most important size enlargement processes and some of their typical applications

Technology	Method	Applications (typical)
Tumble agglomeration	Balling drum, pan, and cone	Iron ores, other ores, cement raw mix, fertilizers, dusts from dust collectors, fine particulate waste materials, ceramics, clay, finely divided minerals, etc.
	Mixer	Ceramic materials, fertilizers, minerals, chemicals, pharmaceuticals, foodstuffs, detergents, etc.
	Fluidized bed (gas)	Fertilizers, pharmaceutical materials, filter cakes, foodstuffs, chemicals
	Suspension (liquid)	Solids, e.g. coal, from suspensions
Induration	Shaft furnace	Iron ores, other ores, minerals, waste materials, e.g. metal-bearing dusts, etc.
	Rotary kiln	
	Straight grate	
	Grate-Kiln Calciners	
Pressure agglomeration	Extrusion presses	Coals, ceramic materials, clays, polymers, plastics
	Pelleting machines	Animal feeds, rubber raw materials, catalysts, lubricants, stabilizers, pigments, polymers, clay, chemicals, pharmaceutical products, insecticides, herbicides, fungicides, etc.
	Piston presses (tableting)	Pharmaceutical products, catalysts, metal powders, ceramic materials, chemicals, pigments, plastic powders
	Roller presses (briquetting, compacting)	Coals, coke, salts, minerals, ores, fertilizers, chemicals, metal powders, animal feeds, polymers, refractories, waste materials, metal-bearing fines, pharmaceutical products, sponge iron, etc.
Other agglomeration methods	Agglomeration by heat	Ores, specifically iron ores, metal-bearing wastes and dusts, mill scale, etc.
	Spray solidification	Urea, other fertilizers, pitches, asphalt, waxes, resins, sulfur, inorganic salts, etc.
	Direct capillary action	Powders, chemicals, coal (spherical agglomeration)
	Alternative sources of particle movement	Finely divided particulate solids, pharmaceuticals, chemicals, food extracts (instant characteristics)
	Coating techniques	Pharmaceuticals, food, fertilizers and agricultural chemicals (control of release), microencapsulation of pigments, etc.
	Flocculation in gases and liquids	Environmental protection, aggregation of solids in gases, flocculation of solids in liquids, selective flocculation, etc.

Table 24. Wanted and unwanted agglomeration in various processes

Product area	Process	
	Wanted	Unwanted
Aggregate (+3 mm)	Briquetting, compacting + crushing and screening	-
Agricultural chemicals	Tumble agglomeration (disc and drum), mixer agglomeration, briquetting, compacting + crushing and screening	Caking, bag set, build-up, flow problems, segregation due to selective agglomeration
Alumina	Granulation (tumble/pressure), calcining	Build-up, caking, flow problems
Animal feed	Pelleting, mixer agglomeration, briquetting	Caking
Carbon black	Fluid bed, mixer agglomeration, granulation by compaction	Build-up, caking, flow problems
Ceramics	Precipitation, sol-gel, spray drying and granulation, compaction + crushing and screening, tableting	Build-up, caking
(China) clay	Tumble agglomeration, extrusion	Lumping, caking
Coal	Calcining, briquetting, tumble agglomeration, spherical agglomeration	Build-up
Detergents	Spray drying or granulation, micropelletization (drum, disc, mixer), tableting, pelleting	Caking, lumping, build-up
Dust (-0.5 mm)	Tumble agglomeration (disc, drum, fluid bed), briquetting, compacting, pelletizing (extrusion)	Build-up, caking
Fertilizers	Drum or disc granulation, compaction + crushing and screening, drop solidification	Caking, build-up, bag set
Filter cakes	Tumble agglomeration, briquetting, pelleting	Caking
Fumes (micrometer and submicrometer)	Fluid bed (with and without binder), disc and drum agglomeration	Build-up, caking, flow problems

(continued)

FILE NO. 100 11/10 20 21 22 23 24 25 26 27 28 29 30 31 32 33 34 35 36 37 38 39 40 41 42 43 44 45 46 47 48 49 50

several types of agglomeration equipment can be identified. A description and list of equipment for each method follows:

Agitation methods are characterized by tumbling or particle-growth mixing, usually in the presence of a liquid. Available equipment includes disc pelletizers, drum pelletizers, cone pelletizers, paddle mixers, plow mixers, mixer-mullers, mixer-granulators, pin mixers, coating pans, vertical mixers, cone blenders, vibrating screens, and vibrating conveyor-processors.

Pressure methods are characterized by force, as with compaction techniques. Available equipment includes briquetters, compactors, extruders, pellet mills, tableting machines, and isostatic compaction presses.

Thermal methods are characterized by applied heat, as in sintering or fusion and melt crystallization techniques. Available equipment includes heat-hardening devices, sinter strands or grates, indurating kilns, nodulizing kilns, drying and solidifying equipment, drum dryers, belt dryers, and hot-melt drum or pan granulators.

Liquid methods are characterized by spray or fluid bed agglomeration and agglomeration from liquid media. Available equipment includes spray dryers, prilling towers, spray granulators, and immiscible liquid-wetting devices.

**Selection Factors for Choosing an Agglomeration Method**

Selecting an agglomeration process or method depends on several factors, including the kind of raw material, the type of equipment, the intended use of the end product or agglomerate, and the use of a binder or binders. In many cases, there is a trade-off or compromise not necessarily determined by one factor alone.

**Kind of Raw Material**

In some instances, the selection of a method can be entirely dependent on the raw material's size or size range and uniformity of size. For example, a raw material that is 100 percent minus 325 mesh has different process requirements than a granular-fine stream ranging from 10 mesh to 325 mesh with a uniform size distribution curve.

The material's feed moisture, bulk density, angle of repose, flow characteristics, chemical composition, and toxicity can also effect the selection process. Table 1 lists the material characteristics of typical agglomerator feed streams, as well as the agglomeration methods suitable for these materials. The table shows the influence of the condition, size, handling characteristics, and moisture content of the raw material on process selection.

It should be noted, however, that there are exceptions to these guidelines. For instance, a pasty material may have to be extruded to utilize the flowability, viscosity, and moldability characteristics of the material as it flows through the auger and extruder die. In another case, a relatively coarse, but dry feed-

stock with the consistency of sand may not be pelletized by agitation and pellet growth alone; pressure, induced by a double-roll briquetter, may be required to compact the particles. Other feed materials, such as wood chips, are elastic and, at times, have a rather amorphous shape and size. Pelletizing and briquetting are poor agglomeration choices for these materials. A pellet mill or pellet press that applies pressure and friction and has a certain retention time in the die is a better choice.

In many cases, it is necessary to test a representative sample of a particular material in the laboratory before one or several agglomeration methods can be selected. Regardless of whether there is a previous application history, many materials are somewhat different, even within the same species, and should be tested.

**Type of Equipment**

The selection of an agglomeration method may not involve as wide a range of possibilities and variables as the field of equipment suggests. (See Table 2) When selecting agglomeration equipment, the processes before, during, and after the actual particle size enlargement step must also be considered. The total system, including storing feed, metering, proportioning, conveying, pretreating, binder-

Table 2  
Agglomeration Capacity

Method	Maximum Capacity (tph)	Retention Time	Typical Applications
Briquetter	30	seconds	Coal, Lime, Magnesite
Compactor-Granulator	75	seconds	Fertilizer, Puzosh, Salt
Extruder (Auger, Screw)	30	5-10 min.	Clay, Fertilizer, Plastics
Flexible Mixer-Agglomerator	40	seconds	Chemicals, Flue Dust
Fluid Bed Granulator	30	1-10 min.	Chemicals, Fertilizer, Pharmaceuticals
Mixer-Granulator	10	+30 min.	Ceramics, Chemicals
Nodulizing Kiln	1,000	+30 min.	Cement, Lime, Gypsum
Pelletizer (Disc, Drum)	130	1-5 min.	Cement, Coal, Flue Dust
Pellet Mill	50	1-5 min.	Biomass, Plastics
Pin Mixer	25	0-5 min.	Carbon Black, Chemicals, Flue Dust
Platen Press (Ram Extruder)	5	1-10 min.	Metal chips or fines
Prill Tower	30	0-5 min.	Nitrates, Sulfur, Urea
Pugmill	300	5-10 min.	Clay, Fertilizer, Fly Ash
Sinter Strand	1,000	+30 min.	Ferrous & Nonferrous Ores
Zip-Zag Blender	30	1-10 min.	Ceramics, Chemicals, Flue Dust

\*Batch units: 0.5-1 tph  
\*Retention time = 1 sec.

adding, product handling, post-treating, screening, packaging, and shipping can influence the selection of an agglomeration device.

For example, almost all continuous agglomeration equipment requires a uniform and controllable feed, by either a volumetric or

ft. height, if the actual handling of the product is reasonable, not severe, and the end use is feedstock within the plant?

The physical specifications for some agglomerates are very strict, particularly if industry practice, market standards, or competitive pressures require adherence to a code. For instance, iron ore pellets, compacted potash granules, molecular sieves, catalyst supports, and metal briquettes for furnace charge require very high product strength. On the other hand, many other agglomerates have no fixed or known standards. A realistic basis for determining the desired physical specifications reduces investing and operating costs and makes the task of the equipment supplier and test engineer much easier.

#### Binder Use

Binderless agglomeration, using only the natural or induced bonding forces of the particulate and the optimum densification (packing) at lowest porosity, is the most desirable and economical agglomeration method. If a liquid needs to be added to induce particle flow and compaction, water is the first choice. If binderless agglomeration or water alone cannot produce a permanent bond with high tensile strength, then additional binder materials must be added to increase the final product strength.

The method of binder classification first proposed by P.I. Waters<sup>4</sup> and further described by K.R. Komarek,<sup>5</sup> distinguishes binders by type, physicals, function, and chemical composition. Binder materials are either liquid (water, alcohol, oil, silicate, acid), solid (clay, dry starch, bentonite) or semi-solid (tar, pitch). Some binders act upon the product as film between solid particles (water, starch, silicate); others act as a matrix, filling voids between the particulates and becoming part of the dense mass of the agglomerate (tar, pitch). Those classified as chemical binders rely on the chemical reaction within the binder upon curing or heating, or between the binder and the raw material. Two binders can also be added—such as cement and water, lime and water, and lime and molasses—to produce a chemical reaction and induce bonding strength in the agglomerate.

The use of a binder is often limited by the specifications of the agglomerate. Some agglomerates can or cannot use organic binders, inorganic binders, or binders containing ash-form constituents, sulphur, or toxic materials. Cost can also limit the use of a binder. The purchase cost can make the use of an otherwise excellent binder uneconomical, or the transportation cost may be higher than the binder cost at origin.

When selecting a binder, emphasis should be placed on the proper test procedures. The selection of a binder can influence the agglomerate's post-treatment process, including

the type of equipment to be used for curing, drying, heating, and firing.<sup>6</sup> For the best results, laboratory results should be optimized and bench-tests qualified with at least one larger run in a prototype machine.

#### Wrapping Up the Selection Process

As this article has shown, selection of the proper agglomeration method and equipment depends on the characteristics of the raw material, the limitations of the equipment, the specifications of the desired agglomerate, and, in some instances, the choice of a binder or binders.

To help make process comparison and selection easier once this information is known, it is also useful to: study prior agglomeration applications for the same or similar raw material; review technical documentation on agglomeration methods or types of equipment made by professional societies, industry trade groups, or independent research organizations; consult industry standards on agglomerate product quality; and, compare vendor information and budget proposals. 2353

#### Endnotes

1. W.H. Engelleitner, *Selection of the Proper Agglomeration Process*, XVII, Institute for Briquetting & Agglomeration (1981).
2. W. Pietsch, "Pressure Agglomeration, The State of The Art," *Agglomeration*, 2, AIME (1977).
3. *Ibid.*
4. P.I. Waters, *Briquette Binders, A Reappraisal*, XII, Institute for Briquetting & Agglomeration, (1971).
5. K.R. Komarek, "Selecting Binders and Lubricants for Agglomeration Processes," *Chemical Engineering*, (1987).
6. J. MacDougall and V. Vellella, "Elements II: Briquetting and Agglomeration," Introduction, Institute for Briquetting and Agglomeration, (1983).



W.H. Engelleitner is a consultant specializing in agglomeration technology. He has more than twenty-five years experience in particle size enlargement by pelletizing, pressure compaction, extrusion, and other methods. Mr. Engelleitner is an executive and past president of the Institute for Briquetting and Agglomeration, a member of the Society of Mining Engineers, and a lecturer on briquetting, pelletizing, and extrusion at the Center for Professional Advancement, East Brunswick, NJ. In addition, he has authored many papers on agglomeration technology and holds several patents in this field. Mr. Engelleitner is currently manager of agglomeration for Teledyne Readco, York, PA.

For more information contact:

**TELEDYNE READCO**

801 South Richmond Avenue  
York, PA 17405  
717/940-2501 Telex: 84-0430

23

Equipment and Systems for Mixing and Agglomeration

UT Ex. 2025

SteadyMed v. United Therapeutics

IPR2016-00006

IPR2020-00769

United Therapeutics EX2006

Page 4323 of 7113

12/15/99 OAU 1649/#  
#7

**IN THE UNITED STATES PATENT AND TRADEMARK OFFICE**

In re Application of: Madigan

SERIAL NO.: 09/113,254



ART UNIT: 1649

FILED: July 10, 1998

EXAMINER: Grunberg

FOR: SEEDING TREATMENTS

RECEIVED

DEC 21 1999

TECH CENTER 1600/2900

Assistant Commissioner for Patents  
Washington, D.C. 20231

Sir:

**PETITION FOR EXTENSION OF TIME**

Applicants hereby petition the commissioner that the time now set for responding to the Official Action of June 18, 1999, be extended for three months to expire on December 18, 1999.

Our check for \$435.00 is enclosed to cover the extension fee set in 37 CFR §1.136. A duplicate copy of this petition is enclosed.

Respectfully submitted,

Per: Philip M. Weiss  
Philip M. Weiss  
Reg. No.: 34,751

12/16/1999 HPRASASD 00000037 09113254

01 FC:217

435.00 0P





**UNITED STATES DEPARTMENT OF COMMERCE**  
**Patent and Trademark Office**  
 Address: COMMISSIONER OF PATENTS AND TRADEMARKS  
 Washington, D.C. 20231

APPLICATION NUMBER	FILING DATE	FIRST NAMED APPLICANT	ATTORNEY DOCKET NO.
--------------------	-------------	-----------------------	---------------------

09/113,254

EXAMINER
----------

ART UNIT	PAPER NUMBER
----------	--------------

6 1/2

DATE MAILED:

**INTERVIEW SUMMARY**

All participants (applicant, applicant's representative, PTO personnel):

- (1) Anne Marie Grünberg (3) \_\_\_\_\_  
 (2) Philip Weiss (4) \_\_\_\_\_

Date of Interview 12/1999

Type:  Telephonic  Personal (copy is given to  applicant  applicant's representative).

Exhibit shown or demonstration conducted:  Yes  No If yes, brief description: \_\_\_\_\_

Agreement  was reached.  was not reached.

Claim(s) discussed: \_\_\_\_\_

Identification of prior art discussed: \_\_\_\_\_

Description of the general nature of what was agreed to if an agreement was reached, or any other comments: \_\_\_\_\_

Philip Weiss, attorney for applicant, called to determine whether a declaration was appropriate. The examiner felt that a declaration at this time was not necessary, but art supporting definitions may be helpful.

(A fuller description, if necessary, and a copy of the amendments, if available, which the examiner agreed would render the claims allowable must be attached. Also, where no copy of the amendments which would render the claims allowable is available, a summary thereof must be attached.)

1.  It is not necessary for applicant to provide a separate record of the substance of the interview.

Unless the paragraph above has been checked to indicate to the contrary, A FORMAL WRITTEN RESPONSE TO THE LAST OFFICE ACTION IS NOT WAIVED AND MUST INCLUDE THE SUBSTANCE OF THE INTERVIEW. (See MPEP Section 713.04). If a response to the last Office action has already been filed, APPLICANT IS GIVEN ONE MONTH FROM THIS INTERVIEW DATE TO FILE A STATEMENT OF THE SUBSTANCE OF THE INTERVIEW.

2.  Since the Examiner's interview summary above (including any attachments) reflects a complete response to each of the objections, rejections and requirements that may be present in the last Office action, and since the claims are now allowable, this completed form is considered to fulfill the response requirements of the last Office action. Applicant is not relieved from providing a separate record of the interview unless box 1 above is also checked.

Examiner Note: You must sign this form unless it is an attachment to another form.

*Anne Marie Grünberg*

FORM PTOL-413 (REV.1-98)

P. 106

UT Ex. 2025  
 SteadyMed v. United Therapeutics  
 IPR2016-00006

IPR2020-00769  
 United Therapeutics EX2006  
 Page 4325 of 7113

## Manual of Patent Examining Procedure, Section 713.04 Substance of Interview must Be Made of Record

A complete written statement as to the substance of any face-to-face or telephone interview with regard to an application must be made of record in the application, whether or not an agreement with the examiner was reached at the interview.

### § 1.133 Interviews

(b) In every instance where reconsideration is requested in view of an interview with an examiner, a complete written statement of the reasons presented at the interview as warranting favorable action must be filed by the applicant. An interview does not remove the necessity for response to Office action as specified in §§ 1.111, 1.135. (35 U.S.C. 132)

§ 1.2. Business to be transacted in writing. All business with the Patent or Trademark Office should be transacted in writing. The personal attendance of applicants or their attorneys or agents at the Patent and Trademark Office is unnecessary. The action of the Patent and Trademark Office will be based exclusively on the written record in the Office. No attention will be paid to any alleged oral promise, stipulation, or understanding in relation to which there is disagreement or doubt.

The action of the Patent and Trademark Office cannot be based exclusively on the written record in the Office if that record is itself incomplete through the failure to record the substance of interviews.

It is the responsibility of the applicant or the attorney or agent to make the substance of an interview of record in the application file, unless the examiner indicates he or she will do so. It is the examiner's responsibility to see that such a record is made and to correct material inaccuracies which bear directly on the question of patentability.

Examiners must complete a two-sheet carbon interleaf Interview Summary Form for each interview held after January 1, 1978 where a matter of substance has been discussed during the interview by checking the appropriate boxes and filling in the blanks in neat handwritten form using a ball point pen. Discussions regarding only procedural matters, directed solely to restriction requirements for which interview recordation is otherwise provided for in Section 812.01 of the Manual of Patent Examining Procedure, or pointing out typographical errors or unreadable script in Office actions or the like, are excluded from the interview recordation procedures below.

The Interview Summary Form shall be given an appropriate paper number, placed in the right hand portion of the file, and listed on the "Contents" list on the file wrapper. The docket and serial register cards need not be updated to reflect interviews. In a personal interview, the duplicate copy of the Form is removed and given to the applicant (or attorney or agent) at the conclusion of the interview. In the case of a telephonic interview, the copy is mailed to the applicant's correspondence address either with or prior to the next official communication. If additional correspondence from the examiner is not likely before an allowance or if other circumstances dictate, the Form should be mailed promptly after the telephonic interview rather than with the next official communication.

The Form provides for recordation of the following information:

- Serial Number of the application
- Name of applicant
- Name of examiner
- Date of interview
- Type of interview (personal or telephonic)
- Name of participant(s) (applicant, attorney or agent, etc.)
- An indication whether or not an exhibit was shown or a demonstration conducted
- An identification of the claims discussed
- An identification of the specific prior art discussed
- An indication whether an agreement was reached and if so, a description of the general nature of the agreement (may be by attachment of a copy of amendments or claims agreed as being allowable). (Agreements as to allowability are tentative and do not restrict further action by the examiner to the contrary)
- The signature of the examiner who conducted the interview
- Names of other Patent and Trademark Office personnel present.

The Form also contains a statement reminding the applicant of his responsibility to record the substance of the interview.

It is desirable that the examiner orally remind the applicant of his obligation to record the substance of the interview in each case unless both applicant and examiner agree that the examiner will record same. Where the examiner agrees to record the substance of the interview, or when it is adequately recorded on the Form or in an attachment to the Form, the examiner should check a box at the bottom of the Form informing the applicant that he need not supplement the Form by submitting a separate record of the substance of the interview.

It should be noted, however, that the Interview Summary Form will not normally be considered a complete and proper recordation of the interview unless it includes, or is supplemented by the applicant or the examiner to include, all of the applicable items required below concerning the substance of the interview:

A complete and proper recordation of the substance of any interview should include at least the following applicable items:

- 1) A brief description of the nature of any exhibit shown or any demonstration conducted,
- 2) an identification of the claims discussed,
- 3) an identification of specific prior art discussed,
- 4) an identification of the principal proposed amendments of a substantive nature discussed, unless these are already described on the Interview Summary Form completed by the examiner,
- 5) a brief identification of the general thrust of the principal arguments presented to the examiner. The identification of arguments need not be lengthy or elaborate. A verbatim or highly detailed description of the arguments is not required. The identification of the arguments is sufficient if the general nature or thrust of the principal arguments made to the examiner can be understood in the context of the application file. Of course, the applicant may desire to emphasize and fully describe those arguments which he feels were or might be persuasive to the examiner,
- 6) a general indication of any other pertinent matters discussed, and
- 7) if appropriate, the general results or outcome of the interview unless already described in the Interview Summary Form completed by the examiner.

Examiners are expected to carefully review the applicant's record of the substance of an interview. If the record is not complete or accurate, the examiner will give the applicant one month from the date of the notifying letter or the remainder of any period for response, whichever is longer, to complete the response and thereby avoid abandonment of the application (37 CFR 1.135(c)).

#### Examiner to Check for Accuracy

Applicant's summary of what took place at the interview should be carefully checked to determine the accuracy of any argument or statement attributed to the examiner during the interview. If there is an inaccuracy and it bears directly on the question of patentability, it should be pointed out in the next Office letter. If the claims are allowable for other reasons of record, the examiner should send a letter setting forth his or her version of the statement attributed to him. If the record is complete and accurate, the examiner should place the indication "Interview record OK" on the paper recording the substance of the interview along with the date and the examiner's initials.

GROUP 1600

Please type a plus sign (+) inside this box --

<b>REVOCAION OF POWER OF ATTORNEY OR AUTHORIZATION OF AGENT</b>	Application Number	08/113,254
	Filing Date	July 10, 1998
	First Named Inventor	Madigan
	Group Art Unit	1849
	Examiner Name	A. Grunberg
	Attorney Docket Number	29214

I hereby revoke all previous powers of attorney or authorizations of agent given in the above-identified application:

A Power of Attorney or Authorization of Agent is submitted herewith.

OR

Please change the correspondence address for the above-identified application to:

Customer Number  →

Place Customer Number Bar Code Label here

OR

<input checked="" type="checkbox"/> Firm or Individual Name	Weiss & Weiss Attn: Philip M. Weiss				
Address	500 Old Country Road				
Address					
City	Garden City				
Country	U.S.A.	State	New York	Zip	11630
Telephone	516-739-1500	Fax	516-739-2189		

I am the:

Applicant.

Assignee of record of the entire interest  
Certificate under 37 CFR 3.73(b) is enclosed

**SIGNATURE of Applicant or Assignee of Record**

Name	Fesco International by Daniel Madigan
Signature	<i>Daniel P. Madigan</i>
Date	10/20/99

511/07298.01  
101389/2281/00054.00001

OCT-18-1999 12:19

P.04/04

IN THE UNITED STATES PATENT AND TRADEMARK OFFICE

<p>In re Application of: Madigan</p> <p>Serial No.: 08/113,254</p> <p>Filed: July 10, 1998</p> <p>For: SEEDING TREATMENTS</p>
-------------------------------------------------------------------------------------------------------------------------------

Group Art No: 1649

Attorney:

BOX RESPONSES NO FEE  
Assistant Commissioner for Trademarks  
2900 Crystal Drive  
Arlington, VA 22202-3513

POWER OF ATTORNEY AND APPOINTMENT  
OF DOMESTIC REPRESENTATIVE

Sir:


Applicant hereby appoints Philip M. Weiss, Reg. No. 34,751; attorney of the firm WEISS & WEISS, located at 500 Old Country Road, Garden City, New York 11530, to prosecute this application to register, to transact all business in the Patent and Trademark Office in connection therewith and to receive the Certificate of Registration.

Philip M. Weiss, Esq., of Weiss & Weiss, whose postal address is 500 Old Country Road, Garden City, New York 11530, Telephone (516) 739-1500, is hereby designated as applicant's representative upon whom notices or process in proceedings affecting the mark may be served.

Respectfully submitted,

Fecco International

By: WEISS & WEISS

Per:   
 Daniel Paul Madigan  
 3913 Algoma Road  
 Green Bay, WI 54311

811/87286.01

TOTAL P.04

Under the Paperwork Reduction Act of 1996, no persons are required to respond to a collection of information unless it displays a valid OMB control number.

**STATEMENT UNDER 37 CFR 3.73(b)**

Applicant/Patent Owner: Fesco International

Application No./Patent No.: 08/113,254 Filed/Issue Date: July 10, 1998

Entitled: SEEDING TREATMENTS

Fesco International, a Corporation  
(name of Assignee) (Type of Assignee e.g., corporation, partnership, university, government agency, etc.)

states that it is:

- 1.  the assignee of the entire right, title, and interest; or
- 2.  an assignee of an undivided part interest

In the patent application/patent identified above by virtue of either:

A.  An assignment from the inventor(s) of the patent application/patent identified above. The assignment was recorded in the Patent and Trademark Office at Reel 8631, Frame 0624, or for which a copy thereof is attached;

OR

B.  A chain of title from the inventor(s), of the patent application/patent identified above, to the current assignee as shown below:

- 1. From: \_\_\_\_\_ To: \_\_\_\_\_  
The document was recorded in the Patent and Trademark Office at Reel \_\_\_\_\_, Frame \_\_\_\_\_, or for which a copy thereof is attached.
- 2. From: \_\_\_\_\_ To: \_\_\_\_\_  
The document was recorded in the Patent and Trademark Office at Reel \_\_\_\_\_, Frame \_\_\_\_\_, or for which a copy thereof is attached.
- 3. From: \_\_\_\_\_ To: \_\_\_\_\_  
The document was recorded in the Patent and Trademark Office at Reel \_\_\_\_\_, Frame \_\_\_\_\_, or for which a copy thereof is attached.

Additional documents in the chain of title are listed on a supplemental sheet.

Copies of assignment or other documents in the chain of title are attached.  
**NOTE:** A separate copy (i.e., the original assignment document or a true copy of the original document) must be submitted to Assignment Division in accordance with 37 CFR part 3, if the assignment is to be recorded in the records of the PTO. See MPEP 302-302.8

The undersigned (whose title is supplied below) is empowered to sign this statement on behalf of assignee.

\_\_\_\_\_  
Date

Daniel P. Madigan  
Signature

Daniel P. Madigan  
Type or print name

President  
Title

Burden Hour Statement: This form is estimated to take 0.2 hours to complete. Time will vary depending upon the needs of the individual case. Any comment on the amount of time you are required to complete this form should be sent to the Chief Information Officer, Patent and Trademark Office, Washington, DC 20231. DO NOT SEND FEES OR COMPLETED FORMS TO THIS ADDRESS. SEND TO: Assistant Commissioner for Patents, Washington, DC 20231

TOTAL P.02

FROM : LAW OFFICES

PHONE NO. : 516-739-2189

OCT 28 1999 04:16 PM P1

FAX RECEIVED

OCT 29 1999

GROUP 1600

GROUP 1600

**WEISS & WEISS**

Attorneys At Law

500 Old Country Road, Suite 305, Garden City, NY 11530  
Phone No. 516-739-1500 / Fax No. 516-739-2189

TO: Ann Marie Grunberg

FAX NO. 703-308-4242

DATE: October 28, 1999

FROM: Philip M. Weiss, Esq.

FAX NO. (516) 739-2189

NUMBER OF PAGES (INCLUDING COVER SHEET): 4

RE: \_\_\_\_\_

NOTE: \_\_\_\_\_

\_\_\_\_\_

\_\_\_\_\_

\_\_\_\_\_

\_\_\_\_\_

\_\_\_\_\_

**CONFIDENTIALITY NOTICE**

The information transmitted in this facsimile message is sent by an attorney and/or his agent, is intended to be confidential and for the use of the individual or entity named above. If the recipient is a client, this message may also be for the purpose of rendering legal advice and thereby privileged. If the reader of this message is not the intended recipient, you are hereby advised that any retention, dissemination, distribution or copying of this telecopy is strictly prohibited. If you have received this facsimile in error, please immediately notify us by telephone so that we can arrange for the retrieval of these original documents at no cost to you.



**UNITED STATES DEPARTMENT OF COMMERCE  
Patent and Trademark Office**

Address: COMMISSIONER OF PATENTS AND TRADEMARKS  
Washington, D.C. 20231

APPLICATION NO. 09/113,254	FILING DATE 07/10/98	FIRST NAMED INVENTOR MADIGAN	ATTORNEY DOCKET NO. 29214
-------------------------------	-------------------------	---------------------------------	------------------------------

THOMAS D WILHELM  
WILHELM LAW SERVICE  
100 W LAWRENCE STREET  
THIRD FLOOR  
APPLETON WI 54911

HM22/0618


EXAMINER GRUNBERG, A
-------------------------

ART UNIT 1849	PAPER NUMBER
------------------	--------------

DATE MAILED: 06/18/99

Please find below and/or attached an Office communication concerning this application or proceeding.

Commissioner of Patents and Trademarks

<b>Office Action Summary</b>	Application No. <b>09/113,254</b>	Applicant(s) <b>Madigan et al.</b>	
	Examiner <b>Anne Marie Grunberg</b>	Group Art Unit <b>1649</b>	

- Responsive to communication(s) filed on Jul 10, 1998
- This action is **FINAL**.
- Since this application is in condition for allowance except for formal matters, **prosecution as to the merits is closed** in accordance with the practice under *Ex parte Quayle*, 1935 C.D. 11; 453 O.G. 213.

A shortened statutory period for response to this action is set to expire three month(s), or thirty days, whichever is longer, from the mailing date of this communication. Failure to respond within the period for response will cause the application to become abandoned. (35 U.S.C. § 133). Extensions of time may be obtained under the provisions of 37 CFR 1.136(a).

**Disposition of Claims**

- Claim(s) 1-75 is/are pending in the application.
- Of the above, claim(s) 70-73 is/are withdrawn from consideration.
- Claim(s) \_\_\_\_\_ is/are allowed.
- Claim(s) 1-69, 74, and 75 is/are rejected.
- Claim(s) \_\_\_\_\_ is/are objected to.
- Claims \_\_\_\_\_ are subject to restriction or election requirement.

**Application Papers**

- See the attached Notice of Draftsperson's Patent Drawing Review, PTO-948.
- The drawing(s) filed on Jul 10, 1998 is/are objected to by the Examiner.
- The proposed drawing correction, filed on \_\_\_\_\_ is  approved  disapproved.
- The specification is objected to by the Examiner.
- The oath or declaration is objected to by the Examiner.

**Priority under 35 U.S.C. § 119**

- Acknowledgement is made of a claim for foreign priority under 35 U.S.C. § 119(a)-(d).
- All  Some\*  None of the CERTIFIED copies of the priority documents have been
- received.
- received in Application No. (Series Code/Serial Number) \_\_\_\_\_
- received in this national stage application from the International Bureau (PCT Rule 17.2(a)).
- \*Certified copies not received: \_\_\_\_\_
- Acknowledgement is made of a claim for domestic priority under 35 U.S.C. § 119(e).

**Attachment(s)**

- Notice of References Cited, PTO-892
- Information Disclosure Statement(s), PTO-1449, Paper No(s). 3
- Interview Summary, PTO-413
- Notice of Draftsperson's Patent Drawing Review, PTO-948
- Notice of Informal Patent Application, PTO-152

--- SEE OFFICE ACTION ON THE FOLLOWING PAGES ---



Art Unit: 1649

**DETAILED ACTION**

The Group and/or Art Unit location of your application in the PTO has changed. To aid in correlating any papers for this application, all further correspondence regarding this application should be directed to Group Art Unit 1649.

*Election/Restriction*

1. Restriction to one of the following inventions is required under 35 U.S.C. 121:
  - I. Claims 1- 69, and 74-75, drawn to a seed capsule and methods of use, classified in class 47, subclass 58.1, for example.
  - II. Claims 70-73, drawn to a method of making capsules, classified in class 47, subclass 57.6, for example.

2. The inventions are distinct, each from the other because of the following reasons:

Inventions II and I are related as process of making and product made. The inventions are distinct if either or both of the following can be shown: (1) that the process as claimed can be used to make other and materially different product or (2) that the product as claimed can be made by another and materially different process (MPEP § 806.05(f)). In the instant case the capsules can be made by a method involving different sequences of steps than that claimed in Group II.

Art Unit: 1649

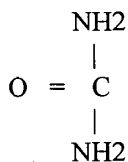
Because these inventions are distinct for the reasons given above and have acquired a separate status in the art as shown by their different classification or by their recognized divergent subject matter and because the search required for Invention I is not required in Inventions II, restriction for examination purposes as indicated is proper.

During a telephone conversation with Attorney Thomas Wilhelm on June 8, 1999 a provisional election was made with traverse to prosecute the invention of Group I, claims 1-69, and 74-75.

Applicant is reminded that upon the cancellation of claims to a non-elected invention, the inventorship must be amended in compliance with 37 CFR 1.48(b) if one or more of the currently named inventors is no longer an inventor of at least one claim remaining in the application. Any amendment of inventorship must be accompanied by a petition under 37 CFR 1.48(b) and by the fee required under 37 CFR 1.17(I).

3. The disclosure is objected to because of the following informalities:

a. Throughout the specification, as on page 8, lines 22-24, for example, urea is described as inorganic. However urea has the following structure which clearly has a carbon and makes urea an organic substance;



Art Unit: 1649

b. Throughout the specification, as on page 9, lines 5-7, for example, sulfur, magnesium and chromium are characterized as being micronutrients. However, according to Biology of Plants (Raven et al., 1992), sulfur and magnesium are macroelements, and chromium is not listed as a micronutrient.

c. The figures are described in a confusing manner in the specification. For example, on page 19, lines 23-28, Figure 1 and 2 are said to contain a numbered "12", "14", and "16". However, Figure 1 does not seem to contain a "12" or "14", and Figure 2 does not contain a "16". The description of all the figures should be reviewed for such errors.

d. The drawings are objected to because Figure 1 has a number appearing under the labeled number "28" that is unreadable.

Appropriate correction is required. No new matter should be added.

***Claim Rejections - 35 USC § 112***

4. The following is a quotation of the second paragraph of 35 U.S.C. 112:

The specification shall conclude with one or more claims particularly pointing out and distinctly claiming the subject matter which the applicant regards as his invention.

Art Unit: 1649

5. Claims 1-2, 4-5, 7, 9, 12-13, 18, 22, 26-28, 30-31, 33, 35-36, 39, 43, 45-48, 51-52, 54-55, 58, 61-62, and 67-68, and dependent claims 3, 6, 8, 10-11, 14-17, 19-21, 23-25, 29, 32, 34, 37-38, 40, 56-57, 59-60, 63-66, and 69 are rejected under 35 U.S.C. 112, second paragraph, as being indefinite for failing to particularly point out and distinctly claim the subject matter which applicant regards as the invention.

Claim 1 is unduly narrative in the recitation of “having an outer surface”, and is vague and indefinite in the recitation of “mounted proximate, including disposed outwardly of the outer surface”. It is unclear what the object of “mounted” is, nor is it clear what the second part of the phrase is referring to.

Claims 2, 28, 43, and 55 are vague and indefinite in the recitation of “enhancing”, “reducing”, “affects”, and “assisting”. This rejection may be obviated by changing the above to --enhanced--, --reduced--, --effects--, and --assistance--. Additionally, “ones of” is unclear (line 1 of iv.), and “flight” gives the impression that the seeds can fly. Since “flight” does not seem to be defined in the specification, it should be deleted.

Claim 4 is vague and indefinite in the recitation of “affect” as it is unclear what is intended. This rejection may be obviated by inserting --effects-- in its stead.

Claims 4 and 7 are vague and indefinite in the recitation of “animals, weeds, and spore-formers” for employing improper Markush terminology. See MPEP 2173.05(h). This rejection may be obviated by changing the phrase to --animals, weeds, or spore-formers.--

Art Unit: 1649

Claim 5 is vague and indefinite in the recitation “bitter substance”. This terminology does not appear to be defined in the specification and it is subjective language that is open to interpretation.

Claims 9 and 58 are vague and indefinite in the recitation “and generally displaced from said seed” or “and generally displaced from the seeds” because it is not clear what is meant.

The recitation of “urea” in claim 12 is not in accordance with the term “inorganic” which precedes it. Urea is not an inorganic plant nutrient.

Claim 13 is vague and indefinite in grammatical composition. This rejection may be obviated by inserting --which-- before “is”.

The recitation of “sulfur” and “chromium” in claim 18 is not in accordance with the term “micronutrient”. According to the Biology of Plants (Raven et al., Ed, page 596), sulfur is a macronutrient, and chromium is not listed as a micronutrient.

Claim 22 is vague and indefinite in the recitation of “ones, but less than all”, and in “for germination thereof” which are unduly narrative and confusing. This claim should be reworded to better reflect the intended meaning of the claim.

Claim 26 is vague and indefinite in the recitation of “having a first overall soil condition and texture”, and “disposed outwardly of the outer surfaces of said seeds”. The recitation “having outer surfaces,” and “said coatings of said seed capsules.....in the root zone of said plant growing medium.” is unduly narrative.

Art Unit: 1649

Claim 27 is vague and indefinite in the recitation “until respective ones of said seeds germinate.” It is unclear what “ones” is referring to.

Claims 30-31 are vague and indefinite in the recitation of “affect” or “effect” and “animals, weeds, and spore-formers” for reasons stated above. This rejection may be obviated by changing the above to --effects--, and --animals, weeds, or spore-formers.--

Claims 33 and 45 are vague and indefinite in the recitation “and generally displaced from said seeds” because it is not clear what is meant.

Claims 35 and 61 are vague and indefinite in the recitation of “uncoated ones of”.

Claims 36, 48, and 62 are vague and indefinite in the recitation of “including” which is not U.S. recognized terminology since it is not possible to distinguish whether it is an open or closed term. This rejection may be obviated by replacing “including” with --further compromising--.

Claims 39, 51 and 67 are vague and indefinite in the recitation of “agglomerating said coatings onto said inner layers.” It is unclear how the coatings can be agglomerated onto their own inner layers.

Claim 46 is vague and indefinite in the recitation of “nitrogen, phosphorus, and potassium” which employs improper Markush terminology. This rejection may be obviated by changing the above to --nitrogen, phosphorus, or potassium.--

Claim 47 is vague and indefinite in the recitation of “chromium” Chromium is not a recognized plant nutrient as taught by Biology of Plants (Raven et al., Ed, page 596).

Art Unit: 1649

Claim 52 is vague and indefinite in the recitation of "comprising" which is grammatically incorrect. This rejection may be overcome by deleting "comprising" and inserting --comprises--.

Claim 54 is unduly narrative in part '(a)'. It is unclear what applicant is claiming.

Claim 68 is vague and indefinite in the recitation of "the soil conditioners and plant nutrients" which lacks antecedent basis in claims 54. This rejection may be obviated by deleting "the" in line 2 of claim 68.

Clarification is required. No new matter should be added.

***Claim Rejections - 35 USC § 102***

6. The following is a quotation of the appropriate paragraphs of 35 U.S.C. 102 that form the basis for the rejections under this section made in this Office action:

A person shall be entitled to a patent unless --

(b) the invention was patented or described in a printed publication in this or a foreign country or in public use or on sale in this country, more than one year prior to the date of application for patent in the United States.

7. Claims 1-5, 7-10, 12, 14-15, 17, 21, 23-35, 39-41, 43-45, 47-48, 51-59, 61, 63, 66-69, and 74-75, are rejected under 35 U.S.C. 102(b) as being anticipated by Gerber.

Claims 1-5, 7-10, 12, 14-15, 17, 21, 23-35, 39-41, 43-45, 47-48, 51-59, 61, 63, 66-69, and 74-75, are drawn to a combination seed capsule which can be easily broadcast, and which protects the seed from the weather and pests, thus increasing germination rate, and prolonging the

Art Unit: 1649

range during which the seed may germinate. Additionally, the seed capsule may comprise two coats and may contain nutrients, herbicides, pesticides, and a bitter substance. Moisture retaining substances and other additives, enhance the germination microenvironment of the seed and act as a soil conditioner.

Gerber teaches a seed pellet having a core containing seed, organic substrates, loess, organic fertilizers, fungicides, pesticides, and a wetting agent which promotes surface wettability (abstract, first 4 lines). At least one bitter substance may also be present to deter animals from eating the seed capsules (column 4, lines 13-28). A second, outer coat may be applied to the core and should be semipermeable to allow water to penetrate but which keeps the water-soluble constituents from leaving the core (column 4, lines 29-48). The seed capsule inhibits germination during storage (column 7, lines 62-65). The pellets allow an increase in germination to occur (column 6, lines 48-49) and allow seeds to better be dispersed from an airplane (column 7, lines 65-66).

8. Claims 1-5, 8, 19, 21-30, 32, 35, 37, 39-41, 43-44, 47, 49, 51-57, 61, 64, 66-69, and 74-75 are rejected under 35 U.S.C. 102(b) as being anticipated by Roth.

Claims 1-5, 8, 19, 21-30, 32, 35, 37, 39-41, 43-44, 47, 49, 51-57, 61, 64, 66-69, and 74-75 are drawn to a combination seed capsule which can be easily broadcast, and which protects the seed from the weather and pests, thus increasing germination rate, and prolonging the range during which the seed may germinate. Additionally, the seed capsule may comprise two coats



Art Unit: 1649

and may contain nutrients, herbicides, pesticides, and a bitter substance. Moisture retaining substances and other additives, enhance the germination microenvironment of the seed and act as a soil conditioner. Additionally, the soil conditioning material comprises a sludge composition.

Roth teaches a methanol treated activated sludge carrier that acts as a means for sustaining the release of agricultural chemicals and can be used as a seed pelleting composition (abstract). The sludge acts as a carrier for all types of chemicals including pesticides, fertilizers, plant growth regulators, attractants and repellants (column 2, lines 48-52). Compounds such as urea, and iron are discussed in column 3, lines 1-22. Crop seeds are coated with the pelleting composition (column 4, lines 46-48, claims 9, and 16-17) which is stable under adverse weather conditions, and although hydrating in water, does not dissolve and wash off the substrate (column 2, lines 41-44).

It is well known in the art, that seed coatings or encapsulations increase the size of the seed to make broadcasting easier and to improve flowability. Trace elements, nutrients, pesticides, and wettable substances serve to protect the seed and increase germinability, thus increasing the health and survival rate of young plants. Thus, these features are inherent properties of the coated seeds taught by Roth.

9. Claims 1-4, 7-9, 14, 20-21, 24-32, 35,38-45, 47, 50-58, 61, 65-68, and 74-75 are rejected under 35 U.S.C. 102(b) as being anticipated by Nilsson.

Art Unit: 1649

Claims 1-4, 7-9, 14, 20-21, 24-32, 35,38-45, 47, 50-58, 61, 65-68, and 74-75 are drawn to a combination seed capsule which can be easily broadcast, and which protects the seed from the weather and pests, thus increasing germination rate, and prolonging the range during which the seed may germinate. Additionally, the seed capsule may comprise two coats and may contain nutrients, herbicides, pesticides, and a bitter substance. Moisture retaining substances and other additives, enhance the germination microenvironment of the seed and act as a soil conditioner. Additionally, the soil conditioning material comprises a fiber-containing by-product of a paper making operation.

Nilsson teaches a seed germination improving capsule having a water absorbing ability (abstract) which may be made from paper pulp or paper fibers (column 1, lines 60-65). The capsule material may be provided with additives such as nutrients, wetting agents, and germination inhibitors, etc ( column 3, lines 18-23) The capsule may also be dyed blue in order to discourage animals from eating them (column 3, lines 23-25). An additional outer material may be applied as a wetting agent (column 3, lines 36-44). Seed capsules disperse well and due to the dispersal properties and protective properties of the seed capsule, not as many seeds need to be dispersed (column 3, lines 26-35, column 6, lines 64-68, table 1 in column 7).

***Claim Rejections - 35 USC § 103***

Art Unit: 1649

This application currently names joint inventors. In considering patentability of the claims under 35 U.S.C. 103(a), the examiner presumes that the subject matter of the various claims was commonly owned at the time any inventions covered therein were made absent any evidence to the contrary. Applicant is advised of the obligation under 37 CFR 1.56 to point out the inventor and invention dates of each claim that was not commonly owned at the time a later invention was made in order for the examiner to consider the applicability of 35 U.S.C. 103© and potential 35 U.S.C. 102(f) or (g) prior art under 35 U.S.C. 103(a).

10. The following is a quotation of 35 U.S.C. 103(a) which forms the basis for all obviousness rejections set forth in this Office action:

(a) A patent may not be obtained though the invention is not identically disclosed or described as set forth in section 102 of this title, if the differences between the subject matter sought to be patented and the prior art are such that the subject matter as a whole would have been obvious at the time the invention was made to a person having ordinary skill in the art to which said subject matter pertains. Patentability shall not be negated by the manner in which the invention was made.

11. Claims 1-69, and 74-75 are rejected under 35 U.S.C. 103(a) as being unpatentable over Schreiber in view of Aswell and Roth.

Claims 1-69, and 74-75 are drawn to a combination seed capsule which can be easily broadcast, and which protects the seed from the weather and pests, thus increasing germination rate, and prolonging the range during which the seed may germinate. Additionally, the seed capsule may comprise two coats and may contain a soil conditioning substance, nutrients, herbicides, pesticides, and a bitter substance. Moisture retaining substances and other additives,

Art Unit: 1649

enhance the germination microenvironment of the seed and act as a soil conditioner.

Additionally, the soil conditioning material comprises a sludge composition or a fiber-containing by-product of a paper making operation.

Schreiber teaches a seed having a multiple layered coating (column 3, lines 35-39) in which the outer coating controls water imbibition of the seed to the extent necessary to delay germination until environmental factors are conducive to growth (claim 1).

Schreiber does not teach a combination seed capsule which can be easily broadcast, and contains nutrients, herbicides, pesticides, a bitter substance, and a soil conditioning substance.

Aswell teaches a waste paper soil conditioning and fertilizing pellet (column 1, lines 14-19). The densified pellets have greater water absorption and retention qualities than do most soils (column 3, lines 10-14) and may contain fertilizing ingredients (claims 5, 7).

Roth teaches an activated sludge that acts as an agricultural chemical carrier and suggests its use for seed pellets (abstract), as stated above.

It would have been *prima facie* obvious to a person of ordinary skill in the art at the time the invention was made to use the method of coating seeds as taught by Schreiber, and to modify that method by using the waste paper soil conditioning and fertilizing pellet as taught by Aswell to contain the seeds, given that it would have been obvious to want to fertilize and condition the soil in order to realize healthy seedlings. Additionally, it would have been obvious to use the activated sludge as taught by Roth to plug the hollow pellets taught by Aswell in order to minimize any contact to herbicides included within the capsules, and to increase fertilizing

Art Unit: 1649

(Roth, column 2, lines 25-27) and water retention values. Choice of fungicides, pesticides and animal repellents would have been the optimization of process parameters.

No claim is allowed.

12. Any inquiry concerning this communication or earlier communications from the examiner should be directed to Anne Marie Grunberg whose telephone number is (703) 305-0805. The examiner can normally be reached from Monday through Thursday from 7:30 until 5:00, and every other Friday from 7:30 until 4:00.

If attempts to reach the examiner are unsuccessful, the examiner's supervisor, Lynette Smith, can be reached at (703) 308-3909. The fax number for the unit is (703) 308-4242.

Any inquiry of a general nature or relating to the status of this application or proceeding should be directed to the Group receptionist whose telephone number is (703) 308-0196.

AMG

Application/Control Number: 09/113,254

Page 15

Art Unit: 1649

June 16, 1999

DAVID T. FOX  
PRIMARY EXAMINER

GROUP ~~180~~ 1649



P. 127

UT Ex. 2025  
SteadyMed v. United Therapeutics  
IPR2016-00006

IPR2020-00769  
United Therapeutics EX2006  
Page 4346 of 7113

**Notice of References Cited**

Application No. <b>09/113,254</b>	Applicant(s) <b>Madigan et al.</b>	
Examiner <b>Anne Marie Grunberg</b>	Group Art Unit <b>1649</b>	Page 1 of 1

**U.S. PATENT DOCUMENTS**

	DOCUMENT NO.	DATE	NAME	CLASS	SUBCLASS
A	4,759,151	7/26/1988	Gerber	47	57.6
B	4,628,633	12/16/86	Nilsson	47	57.6
<i>Part of Part 3</i>	3,269,824	<del>10/25/63</del> <i>8/1966</i>	Aswell	47	57.6
D	3,698,133	10/17/72	Schreiber	47	57.6
E	4,065,287	12/27/77	Roth	71	13
F					
G					
H					
I					
J					
K					
L					
M					

**FOREIGN PATENT DOCUMENTS**

	DOCUMENT NO.	DATE	COUNTRY	NAME	CLASS	SUBCLASS
N						
O						
P						
Q						
R						
S						
T						

**NON-PATENT DOCUMENTS**

	DOCUMENT (Including Author, Title, Source, and Pertinent Pages)	DATE
U	Biology of Plants, Raven et al., Worth Publishers, page 596	1992
V		
W		
X		

NOTICE OF DRAFTSPERSON'S PATENT DRAWING REVIEW

The drawing(s) filed (insert date) 7-10-98 are:

- A.  approved by the Draftsperson under 37 CFR 1.84 or 1.152.
- B.  objected to by the Draftsperson under 37 CFR 1.84 or 1.152 for the reasons indicated below. The Examiner will require submission of new, corrected drawings when necessary. Corrected drawings must be submitted according to the instructions on the back of this notice.

<p>1. DRAWINGS. 37 CFR 1.84(a): Acceptable categories of drawings:  <input checked="" type="checkbox"/> Color drawings are not acceptable until a petition is granted.  <input checked="" type="checkbox"/> Pencil and non-black ink not permitted. Fig(s) _____</p> <p>2. PHOTOGRAPHS. 37 CFR 1.84 (b)  <input type="checkbox"/> 1 full-tone set is required. Fig(s) _____  <input type="checkbox"/> Photographs not properly mounted (must use bristol board or photographic double-weight paper). Fig(s) _____  <input type="checkbox"/> Poor quality (half-tone). Fig(s) _____</p> <p>3. TYPE OF PAPER. 37 CFR 1.84(e)  <input checked="" type="checkbox"/> Paper not flexible, strong, white, and durable; nitrocellulose, rayon, or other fibers; or paper with a surface coating of plastic, wax, or other material. Fig(s) _____  <input type="checkbox"/> Erasures, alterations, overwritings, interlineations, folds, copy-machine marks not accepted. Fig(s) _____  <input type="checkbox"/> Mylar, velum paper is not acceptable (too thin). Fig(s) _____</p> <p>4. SIZE OF PAPER. 37 CFR 1.84(f): Acceptable sizes:  <input type="checkbox"/> 21.0 cm by 29.7 cm (DIN size A4)  <input type="checkbox"/> 21.6 cm by 27.9 cm (8 1/2 x 11 inches)  <input checked="" type="checkbox"/> All drawing sheets not the same size. Fig(s) _____  <input type="checkbox"/> Sheet(s) _____  <input type="checkbox"/> Drawings sheets not an acceptable size. Fig(s) _____</p> <p>5. MARGINS. 37 CFR 1.84(g): Acceptable margins:  <input type="checkbox"/> Top 2.5 cm Left 2.5 cm Right 1.5 cm Bottom 1.0 cm  <input type="checkbox"/> SIZE, A4 Size  <input type="checkbox"/> Top 2.5 cm Left 2.5 cm Right 1.5 cm Bottom 1.0 cm  <input checked="" type="checkbox"/> Margins not acceptable. Fig(s) <u>1-3, 5, 6</u>  <input type="checkbox"/> Top (T) _____ Left (L) _____  <input type="checkbox"/> Right (R) _____ Bottom (B) _____</p> <p>6. VIEWS. 37 CFR 1.84(h)  REMINDER: Specification may require revision to correspond to drawing changes.  Partial views. 37 CFR 1.84(h)(2)  <input type="checkbox"/> Brackets needed to show figure as one entity. Fig(s) _____  <input type="checkbox"/> Views not labeled separately or properly. Fig(s) _____  <input type="checkbox"/> Enlarged view not labeled separately or properly. Fig(s) _____</p> <p>7. SECTIONAL VIEWS. 37 CFR 1.84 (h)(3)  <input type="checkbox"/> Hatching not indicated for sectional portions of an object. Fig(s) _____  <input type="checkbox"/> Sectional designation should be noted with Arabic or Roman numbers. Fig(s) _____</p>	<p>8. ARRANGEMENT OF VIEWS. 37 CFR 1.84(f)  <input type="checkbox"/> Views do not appear in a horizontal, left-to-right fashion when pages are either upright or turned so that the top becomes the right side, except for graphs. Fig(s) _____</p> <p>9. SCALE. 37 CFR 1.84(c)  <input type="checkbox"/> Scale not large enough to show mechanism without crowding when drawing is reduced in size to two-thirds in reproduction. Fig(s) _____</p> <p>10. CHARACTER OF LINES, NUMBERS, &amp; LETTERS. 37 CFR 1.84(f)  <input type="checkbox"/> Lines numbers &amp; letters not uniformly thick and well defined, clean, durable, and black (poor line quality). Fig(s) <u>1-8</u>  <input type="checkbox"/> SHADING. 37 CFR 1.84(m)  <input type="checkbox"/> Solid black areas pale. Fig(s) _____  <input type="checkbox"/> Solid black shading not permitted. Fig(s) _____  <input type="checkbox"/> Shade lines, pale, rough and blurred. Fig(s) _____</p> <p>12. NUMBERS, LETTERS, &amp; REFERENCE CHARACTERS. 37 CFR 1.84(p)  <input type="checkbox"/> Numbers and reference characters not plain and legible. Fig(s) <u>1-8</u>  <input type="checkbox"/> Figure legends are poor. Fig(s) <u>1-8</u>  <input type="checkbox"/> Numbers and reference characters not oriented in the same direction as the view. 37 CFR 1.84(p)(1)  <input type="checkbox"/> English alphabet not used. 37 CFR 1.84(p)(2)  <input type="checkbox"/> Numbers, letters and reference characters must be at least 32 cm (1/8 inch) in height. 37 CFR 1.84(p)(3)  <input type="checkbox"/> Fig(s) _____</p> <p>13. LEAD LINES. 37 CFR 1.84(q)  <input type="checkbox"/> Lead lines cross each other. Fig(s) _____  <input type="checkbox"/> Lead lines missing. Fig(s) _____</p> <p>14. NUMBERING OF SHEETS OF DRAWINGS. 37 CFR 1.84(t)  <input type="checkbox"/> Sheets not numbered consecutively, and in Arabic numerals beginning with number 1. Sheet(s) _____</p> <p>15. NUMBERING OF VIEWS. 37 CFR 1.84(u)  <input type="checkbox"/> Views not numbered consecutively, and in Arabic numerals, beginning with number 1. Fig(s) _____</p> <p>16. CORRECTIONS. 37 CFR 1.84(w)  <input type="checkbox"/> Corrections not made from prior PTO-948 dated _____</p> <p>17. DESIGN DRAWINGS. 37 CFR 1.152  <input type="checkbox"/> Surface shading shown not appropriate. Fig(s) _____  <input type="checkbox"/> Solid black shading not used for color contrast. Fig(s) _____</p>
<p>COMMENTS</p>	

REVIEWER CHASS DATE 6-17-99 TELEPHONE NO. 703 305 8430

ATTACHMENT TO PAPER NO. 5



**INFORMATION DISCLOSURE CITATION**  
(Use several sheets if necessary)

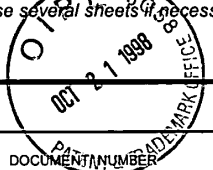
ATTY DOCKET NO.  
29214

SERIAL NO.  
09/113,254

APPLICANT (S)  
Daniel Paul Madigan et al

FILING DATE.  
07/10/98

GROUP  
Unassigned- 1649



**U.S. PATENT DOCUMENTS**

*EXAMINER INITIAL	DOCUMENT NUMBER	DATE	NAME	CLASS	SUBCLASS	FILING DATE IF APPROPRIATE
Amc	56,140	07/1866	Blessing	—	—	
Amc	2,664,350	12/1953	Hale et al	71	1	
Amc	3,545,129	12/1970	Schreiber et al	47	57.6	
Amc	3,621,612	11/1971	Porter	47	58	
Amc	3,698,133	10/1972	Schreiber	47	57.6	
Amc	3,936,976	02/1976	Porter et al	47	57.6	
Amc	3,947,996	04/1976	Watts	47	57.6	
Amc	3,950,891	04/1976	Hinkes	47	57.6	
Amc	4,116,666	09/1978	Willard, Sr.	71	77	
Amc	4,192,095	03/1980	Haslam et al	47	58	
Amc	4,272,417	06/1981	Barke et al	260	22 R	

**FOREIGN PATENT DOCUMENTS**

	DOCUMENT NUMBER	DATE	COUNTRY	CLASS	SUBCLASS	TRANSLATION	
						YES	NO
Amc	2354101	05/1974	Germany	A 01 c	07/00		✓

**OTHER DOCUMENTS (Including Author, Title, Date, Pertinent Pages, Etc.)**

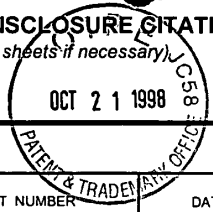
Amc		Pietsch, Wolfgang, "Part 2. Agglomerate Bonding and Strength," Date unknown. (Reprinted from W. Pietsch (98)).
Amc		Staub-Reinhalt, Luft, "Part 3, THE AGGLOMERATIVE BEHAVIOR OF FINE PARTICLES," (Reprinted from W. Pietsch (7), English edition). Vol. 27, No. 1, January 1967.

EXAMINER  
*Anne Marie Gumbert*

DATE CONSIDERED  
13 June 99

\*EXAMINER: Initial if reference considered, whether or not citation is in conformance with MPEP 609; Draw line through citation if not in conformance and not considered. Include copy of this form with next communication to applicant.

<b>INFORMATION DISCLOSURE CITATION</b> (Use several sheets if necessary)	ATTY DOCKET NO. 29214	SERIAL NO. 09/113,254
	APPLICANT (S) Daniel Paul Madigan et al	
	FILING DATE 07/10/98	GROUP Unassigned 1649



**U.S. PATENT DOCUMENTS**

*EXAMINER INITIAL	DOCUMENT NUMBER	DATE	NAME	CLASS	SUBCLASS	FILING DATE IF APPROPRIATE
AMG	4,344,979	08/1982	Gago et al	427	4	
AMG	4,438,593	03/1984	McNew et al	47	57.6	
AMG	4,452,008	06/1984	Sandhu et al	47	57.6	
AMG	4,493,162	01/1985	Langan et al	47	57.6	
AMG	4,752,319	06/1988	DelliColli	71	77	
AMG	4,759,151	07/1988	Gerber	47	57.6	
AMG	5,044,116	09/1991	Gago et al	47	57.6	
AMG	5,087,475	02/1992	Bazin et al	427	4	
AMG	5,106,648	04/1992	Williams	427	3	
AMG	5,127,185	07/1992	Kojimoto et al	47	57.6	
AMG	5,300,127	04/1994	Williams	47	57.6	

**FOREIGN PATENT DOCUMENTS**

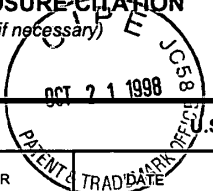
	DOCUMENT NUMBER	DATE	COUNTRY	CLASS	SUBCLASS	TRANSLATION	
						YES	NO

**OTHER DOCUMENTS (Including Author, Title, Date, Pertinent Pages, Etc.)**


EXAMINER <i>Anne Marie Gimbey</i>	DATE CONSIDERED 13 June 1999
--------------------------------------	---------------------------------

\*EXAMINER: Initial if reference considered, whether or not citation is in conformance with MPEP 609; Draw line through citation if not in conformance and not considered. Include copy of this form with next communication to applicant.

<b>INFORMATION DISCLOSURE CITATION</b> (Use several sheets if necessary)	ATTY DOCKET NO. 29214	SERIAL NO. 09/113,254
	APPLICANT (S) Daniel Paul Madigan et al	
	FILING DATE 07/10/98	GROUP Unassigned Key



**U.S. PATENT DOCUMENTS**

*EXAMINER INITIAL	DOCUMENT NUMBER	TRAD. DATE	NAME	CLASS	SUBCLASS	FILING DATE IF APPROPRIATE
AMB	5,368,626	11/1994	Schnuda	71	23	
AMB	5,525,131	06/1996	Asano	47	57.6	
AMB	5,623,781	04/1997	Legro	47	576	

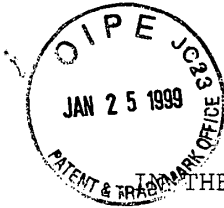
**FOREIGN PATENT DOCUMENTS**

DOCUMENT NUMBER	DATE	COUNTRY	CLASS	SUBCLASS	TRANSLATION	
					YES	NO

**OTHER DOCUMENTS (Including Author, Title, Date, Pertinent Pages, Etc.)**


EXAMINER <i>Anne Marie Gruber</i>	DATE CONSIDERED 13 June 1999
--------------------------------------	---------------------------------

\*EXAMINER: Initial if reference considered, whether or not citation is in conformance with MPEP 609; Draw line through citation if not in conformance and not considered. Include copy of this form with next communication to applicant.



Receipt #4  
29214

THE UNITED STATES PATENT AND TRADEMARK OFFICE

In re the application of:  
Daniel Paul Madigan et al

Group Art Unit: 3616

Serial Number: 09/113,254

Examiner: Unknown

Filed: 07/10/98

For: SEEDING TREATMENTS

REQUEST FOR CORRECTION TO FILING RECEIPT

Application Processing Division  
Customer Correction Branch  
Assistant Commissioner for Patents  
Washington, D.C. 20231

Sir:

Applicants note that the subject application has an incorrect city name for RONALD DEAN EICHHORN on the Filing Receipt (PTO-103X).

The correct city for RONALD D. EICHHORN should be "GREEN BAY".

Applicants respectfully request that the city of the inventor be corrected. These corrections have been noted on the copy of the **Filing Receipt** enclosed herewith. A copy of the title page as originally submitted is also enclosed.

Respectfully submitted,  
Daniel Paul Madigan et al

By: Thomas D. Wilhelm  
Thomas D. Wilhelm  
Attorney for Applicants  
(Reg. No. 28,794)

RECEIVED

January 22, 1999  
Appleton, Wisconsin 54911  
(920) 831-0100  
(920) 831-0101 FAX

FEB 08 1999

MATRIX CUSTOMER SERVICE CENTER

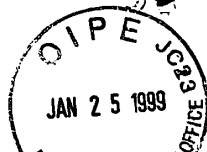
I HEREBY CERTIFY THAT THIS CORRESPONDENCE IS BEING DEPOSITED WITH THE UNITED STATES POSTAL SERVICE AS FIRST CLASS MAIL IN AN ENVELOPE ADDRESSED TO APPLICATION PROCESSING DIVISION, CUSTOMER CORRECTION BRANCH, ASSISTANT COMMISSIONER FOR PATENTS, WASHINGTON, D.C. 20231

ON January 22, 1999.  
Kerri Bruchs  
(Typed name of person mailing paper or fee)  
Kerri Bruchs  
(Signature)  
1/22/99  
(Date Of Signature)

PTO-103  
(Rev. 8-95)

RECEIVED JAN 1 1999

FILING RECEIPT  
CORRECTED



UNITED STATES DEPARTMENT OF COMMERCE  
Patent and Trademark Office  
ASSISTANT SECRETARY AND COMMISSIONER  
OF PATENTS AND TRADEMARKS  
Washington, D.C. 20231

APPLICATION NUMBER	FILING DATE	GRP ART UNIT	FIL FEE REC'D	ATTORNEY DOCKET NO.	DRWGS	TOT CL	IND CL
09/113,254	07/10/98	3616	\$1,147.00	29214	6	75	5

THOMAS D WILHELM  
WILHELM LAW SERVICE  
100 W LAWRENCE STREET  
THIRD FLOOR  
APPLETON WI 54911

Receipt is acknowledged of this nonprovisional Patent Application. It will be considered in its order and you will be notified as to the results of the examination. Be sure to provide the U.S. APPLICATION NUMBER, FILING DATE, NAME OF APPLICANT, and TITLE OF INVENTION when inquiring about this application. Fees transmitted by check or draft are subject to collection. Please verify the accuracy of the data presented on this receipt. If an error is noted on this Filing Receipt, please write to the Application Processing Division's Customer Correction Branch within 10 days of receipt. Please provide a copy of the Filing Receipt with the changes noted thereon.

Applicant(s)

DANIEL PAUL MADIGAN, GREEN BAY, WI; MICHAEL DENNIS  
KRYSIK, GREEN BAY, WI; RONALD DEAN EICHHORN, ~~EICHHORN,~~  
WI; GLEN H. WESENBERG, GREEN BAY, WI. GREEN BAY

FOREIGN FILING LICENSE GRANTED 07/28/98  
TITLE  
SEEDING TREATMENTS

PRELIMINARY CLASS: 047

RECEIVED

FEB 08 1999

MATRIX-CUSTOMER  
SERVICE CENTER

DATA ENTRY BY: WHITE, JACKIE P. 134 TEAM: 03 DATE: 01/07/99T Ex. 2025

SteadyMed v. United Therapeutics

IPR2016-00006

(see reverse)

IPR2020-00769

United Therapeutics EX2006

Page 4353 of 7113

LICENSE FOR FOREIGN FILING UNDER  
Title 35, United States Code, Section 184  
Title 37, Code of Federal Regulations, 5.11 & 5.15

GRANTED

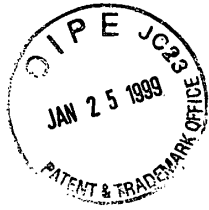
The applicant has been granted a license under 35 U.S.C. 184, if the phrase "FOREIGN FILING LICENSE GRANTED" followed by a date appears on the reverse side of this form. Such licenses are issued in all applications where the conditions for issuance of a license have been met, regardless of whether or not a license may be required as set forth in 37 CFR 5.11. The scope and limitations of this license are set forth in 37 CFR 5.15(a) unless an earlier license has been issued under 37 CFR 5.15(b). The license is subject to revocation upon written notification. The date indicated is the effective date of the license, unless an earlier license of similar scope has been granted under 37 CFR 5.13 or 5.14.

This license is to be retained by the licensee and may be used at any time on or after the effective date thereof unless it is revoked. This license is automatically transferred to any related application(s) filed under 37 CFR 1.62 which meets the provisions of 37 CFR 5.15(a). This license is not retroactive.

The grant of a license does not in any way lessen the responsibility of a licensee for the security of the subject matter as imposed by any Government contract or the provisions of existing laws relating to espionage and the national security or the export of technical data. Licensees should apprise themselves of current regulations, especially with respect to certain countries, of other agencies, particularly the Office of Defense Trade Controls, Department of State (with respect to Arms, Munitions and Implements of War (22 CFR Parts 121-128) ); the Office of Export Administration, Department of Commerce (15 CFR 370.10 (j) ); the Office of Foreign Assets Control, Department of Treasury (31 CFR Parts 500+) and the Department of Energy.

NOT GRANTED

No license under 35 U.S.C. 184 has been granted at this time, if the phrase "FOREIGN FILING LICENSE GRANTED" DOES NOT appear on the reverse side of this form. Applicant may still petition for a license under 37 CFR 5.12, if a license is desired before the expiration of 6 months from the filing date of the application. If 6 months has lapsed from the filing date of this application and the licensee has not received any indication of a secrecy order under 35 U.S.C. 181, the licensee may foreign file the application pursuant to 37 CFR 5.15(b).



RECEIVED

PATENT APPLICATION

FEB 08 1999

TITLE: SEEDING TREATMENTS

MAILING CUSTOMER SERVICE CENTER

By: Daniel Paul Madigan  
804 S. Madison  
Green Bay, WI 54301  
Citizenship: USA

Michael Dennis Krysiak  
3554 Highland Center Drive  
Green Bay, WI 54311  
Citizenship: USA

Ronald Dean Eichhorn  
1524 1/2 Cedar Street  
Green Bay, WI 54302  
Citizenship: USA

Glen H. Wesenberg  
920 Laverne Drive  
Green Bay, WI 54311  
Citizenship: USA

"Express Mail" mailing number  
EM 469 259 847 US

Date of Deposit June 10, 1998

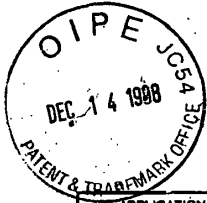
I hereby certify that this paper or fee is being deposited with the United States Postal Service "Express Mail Post Office to Addressee" service under 37 CFR 1.10 on the date indicated above and is addressed to the Assistant Commissioner of Patents, Washington, D.C. 20231.

Jerry F. Janssen

(Typed or printed name of person mailing paper or fee)

(Signature of person mailing paper or fee)

TDW, JSK



Sector #

UNITED STATES DEPARTMENT OF COMMERCE  
 Patent and Trademark Office  
 Address: COMMISSIONER OF PATENTS AND TRADEMARKS  
 Washington, D.C. 20231

APPLICATION NUMBER	FILING/RECEIPT DATE	FIRST-NAMED APPLICANT	ATTORNEY DOCKET NO./TITLE
--------------------	---------------------	-----------------------	---------------------------

097113,254 07/10/98 MADIGAN D 29214

0232,0810

THOMAS D. WILHELM  
 WILHELM LAW SERVICE  
 100 W. LAWRENCE STREET  
 THIRD FLOOR  
 APPLETON WI 54911

NOT ASSIGNED

3616

DATE MAILED:

08/13/98

**NOTICE TO FILE MISSING PARTS OF APPLICATION**  
*Filing Date Granted*

An Application Number and Filing Date have been assigned to this application. The items indicated below, however, are missing. Applicant is given **TWO MONTHS FROM THE DATE OF THIS NOTICE** within which to file all required items and pay fees required below to avoid abandonment. Extensions of time may be obtained by filing a petition accompanied by the extension fee under the provisions of 37 CFR 1.136(a). If any of items 1 or 3 through 5 are indicated as missing, the SURCHARGE set forth in 37 CFR 1.16(e) of  \$65.00 for a small entity in compliance with 37 CFR 1.27, or  \$130.00 for a non-small entity, must also be timely submitted in reply to this NOTICE to avoid abandonment.

If all required items on this form are filed within the period set above, the total amount owed by applicant as a  small entity (statement filed)  non-small entity is \$ 1374

- 1. The statutory basic filing fee is:
  - missing.
  - insufficient.
 Applicant must submit \$ 790 to complete the basic filing fee and/or file a small entity statement claiming such status (37 CFR 1.27).
- 2. Additional claim fees of \$ 1374, including any multiple dependent claim fees, are required.
  - \$ 164 for 2 independent claims over 3.
  - \$ 1210 for 55 dependent claims over 20.
  - \$ \_\_\_\_\_ for multiple dependent claim surcharge.
 Applicant must either submit the additional claim fees or cancel additional claims for which fees are due.
- 3. The oath or declaration:
  - is missing or unexecuted.
  - does not cover the newly submitted items.
  - does not identify the application to which it applies.
  - does not include the city and state or foreign country of applicant's residence.
 An oath or declaration in compliance with 37 CFR 1.63, including residence information and identifying the application by the above Application Number and Filing Date is required.
- 4. The signature(s) to the oath or declaration is/are by a person other than inventor or person qualified under 37 CFR 1.42, 1.43 or 1.47.  
 A properly signed oath or declaration in compliance with 37 CFR 1.63, identifying the application by the above Application Number and Filing Date, is required.
- 5. The signature of the following joint inventor(s) is missing from the oath or declaration:

An oath or declaration in compliance with 37 CFR 1.63 listing the names of all inventors and signed by the inventor(s), identifying this application by the above Application Number and Filing Date, is required.

- 6. A \$50.00 processing fee is required since your check was returned without payment (37 CFR 1.22(m)).
- 7. Your filing receipt was mailed in error because your check was returned without payment.
- 8. The application does not comply with the Sequence Rules.  
 See attached "Notice to Comply with Sequence Rules 37 CFR 1.821-1.825."
- 9. OTHER:

Direct the reply and any questions about this notice to "Attention: Box Missing Parts."

**A copy of this notice MUST be returned with the reply**

Customer Service Center  
 Initial Patent Examination Division (703) 308-1202

P. 137

PART 3 - OFFICE COPY

SteadyMed v. United Therapeutics

097113254  
 0000010 23210  
 12/1/98 CHANG  
 0205  
 0202  
 0203  
 0201  
 139.00 CH





DECLARATION FOR PATENT APPLICATION

As a below named inventor, I hereby declare that:

My residence, post office address, and citizenship are as stated below next to my name. I believe I am the original, first and sole inventor (if only one name is listed below) or an original, first and joint inventor (if plural names are listed below) of the subject matter which is claimed and for which a patent is sought on the invention entitled SEEDING TREATMENTS, the specification of which

(check one)  is filed herewith.  
 was filed on July 10, 1998  
 Application Serial No. 09/113,254  
and was amended on \_\_\_\_\_  
(if applicable)

I hereby state that I have reviewed and understand the contents of the above identified specification, including the claims, as amended by any amendment referred to above.

I acknowledge the duty to disclose information which is material to the examination of this application in accordance with Title 37, Code of Federal Regulations, §1.56 (a).

I hereby claim foreign priority benefits under Title 35, United States Code, §119 of any foreign application(s) for patent or inventor's certificate listed below and have also identified below any foreign application for patent or inventor's certificate having a filing date before that of the application on which priority is claimed:

Prior Foreign Application(s)		Priority Claimed	
(Number)	(Country)	(Day/Month/Year Filed)	(Yes) (No)

I hereby claim the benefit under Title 35, United States Code, §120 of any United States application(s) listed below and, insofar as the subject matter of each of the claims of this application is not disclosed in the prior United States application in the manner provided by the first paragraph of Title 35, United States Code, §112, I acknowledge the duty to disclose material information as defined in Title 37, Code of Federal Regulations, §1.56(a) which occurred between the filing date of the prior application and the national or PCT international filing date of this application:

<u>60/052,287</u>	<u>07/11/97</u>	<u>Provisional</u>
(Application Serial No.)	(Filing Date)	(Status-Patented, Pending, Abandoned)

I hereby appoint the following attorney(s) and/or agent(s) to prosecute this application and to transact all business in the Patent and Trademark Office connected therewith:

THOMAS D. WILHELM (REG. NO. 28794), JERRY F. JANSSEN (REG. NO. 29175), JASBIR S. KINDRA (REG. NO. 41115)  
Address all telephone calls to THOMAS D. WILHELM at telephone no. 920-831-0100  
Address all correspondence to THOMAS D. WILHELM at the following address:  
100 W. LAWRENCE ST. FLOOR 3  
APPLETON, WI 54911 USA

I hereby declare that all statements made herein of my own knowledge are true and that all statements made on information and belief are believed to be true; and further that these statements were made with the knowledge that willful false statements and the like so made are punishable by fine or imprisonment or both, under Section 1001 of Title 18 of the United States Code and that such willful false statements may jeopardize the validity of the application or any patent issued thereon.

Full name of sole or first inventor Daniel Paul Madigan  
Inventor's signature Daniel Paul Madigan Date 10/13/98  
Residence 804 S. Madison, Green Bay, Wisconsin 54301 Citizen USA  
Post Office Address 804 S. Madison, Green Bay, Wisconsin 54301 USA

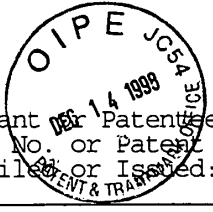
Full name of second joint inventor, if any Michael Dennis Krysiak  
Second Inventor's signature Michael Dennis Krysiak Date 10/19/98  
Residence 3554 Highland Center Drive, Green Bay, Wisconsin 54311 Citizen USA  
Post Office Address 3554 Highland Center Drive, Green Bay, Wisconsin 54311 USA

Additional inventors are named on sheet 2 of 3 sheets.

UT Ex. 2025  
SteadyMed v. United Therapeutics  
IPR2016-00006

Full name of third joint inventor, if any Ronald Dean Eichhorn  
Third Inventor's signature *Ronald D Eichhorn* Date 10/19/98  
Residence 1524 1/2 Cedar Street, Green Bay, Wisconsin 54302 Citizen USA  
Post Office Address 1524 1/2 Cedar Street, Green Bay, Wisconsin 54302 USA

Full name of fourth joint inventor, if any Glen H. Wesenberg  
Inventor's signature *Glen H Wesenberg* Date 20 Oct 98  
Residence 920 Laverne Drive, Green Bay, Wisconsin 54311 Citizen USA  
Post Office Address 920 Laverne Drive, Green Bay, Wisconsin 54311 USA



Applicant or Patentee: DANIEL PAUL MADIGAN ET AL Attorney's  
 Serial No. or Patent No.: 09/113,254 Docket No. 29214  
 Date Filed or Issued: July 10, 1998  
 For: SEEDING TREATMENTS

VERIFIED STATEMENT (DECLARATION) CLAIMING SMALL ENTITY STATUS (37 CFR 1.9(f) AND 1.27(b)) - INDEPENDENT INVENTOR

As a below named inventor, I hereby declare that I qualify as an independent inventor as defined in 37 CFR 1.9(c) for purposes of paying reduced fees under section 41(a) and (b) of Title 35, United States Code, to the Patent and Trademark Office with regard to the invention entitled SEEDING TREATMENTS and described in

- the specification filed herewith
- application serial no. 09/113,254, filed 07/10/98
- patent no. \_\_\_\_\_, issued \_\_\_\_\_

I have not assigned, granted, conveyed or licensed and am under no obligation under contract or law to assign, grant, convey or license, any rights in the invention to any person who could not be classified as an independent inventor under 37 CFR 1.9(c) if that person had made the invention, or to any concern which would not qualify as a small business concern under 37 CFR 1.9(d) or a nonprofit organization under 37 CFR 1.9(e).

Each person, concern or organization to which I have assigned, granted, conveyed, or licensed or am under an obligation under contract or law to assign, grant, convey, or license any rights in the invention is listed below:

- no such person, concern, or organization
- persons, concerns or organizations listed below\*

\*NOTE: Separate verified statements are required from each named person, concern or organization having rights to the invention averring to their status as small entities. (37 CFR 1.27)

FULL NAME FEECO International Inc.  
 ADDRESS 3913 Algoma Road, Green Bay, Wisconsin 54311  
 INDIVIDUAL  SMALL BUSINESS CONCERN  NONPROFIT ORGANIZATION

FULL NAME \_\_\_\_\_  
 ADDRESS \_\_\_\_\_  
 INDIVIDUAL  SMALL BUSINESS CONCERN  NONPROFIT ORGANIZATION

FULL NAME \_\_\_\_\_  
 ADDRESS \_\_\_\_\_  
 INDIVIDUAL  SMALL BUSINESS CONCERN  NONPROFIT ORGANIZATION

I acknowledge the duty to file, in this application or patent, notification of any change in status resulting in loss of entitlement to small entity status prior to paying, or at the time of paying, the earliest of the issue fee or any maintenance fee due after the date on which status as a small entity is no longer appropriate. (37 CFR 1.28(b)).

I hereby declare that all statements made herein of my own knowledge are true and that all statements made on information and belief are believed to be true; and further that these statements were made with the knowledge that willful false statements and the like so made are punishable by fine or imprisonment, or both, under section 1001 of Title 18 of the United States Code, and that such willful false statements may jeopardize the validity of the application, any patent issuing thereon, or any patent to which this verified statement is directed.

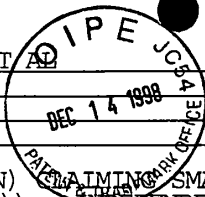
Daniel Paul Madigan  
 TYPED NAME OF INVENTOR  
*Daniel Paul Madigan*  
 Signature of Inventor  
10/13/98  
 Date

Michael Dennis Krysiak  
 TYPED NAME OF INVENTOR  
*Michael Dennis Krysiak*  
 Signature of Inventor  
10-15-98  
 Date

Ronald Dean Eichhorn  
 TYPED NAME OF INVENTOR  
*Ronald Dean Eichhorn*  
 Signature of Inventor  
10-19-98  
 Date

UT Ex. 2025  
 SteadyMed v. United Therapeutics  
 IPR2016-00006

Applicant or Patentee: DANIEL PAUL MADIGAN ET AL Attorney's  
 Serial No. or Patent No.: 09/113,254 Docket No. 29214  
 Date Filed or Issued: July 10, 1998  
 For: SEEDING TREATMENTS



VERIFIED STATEMENT (DECLARATION)  
 STATUS (37 CFR 1.9(f) AND 1.27(b)) - SMALL ENTITY INDEPENDENT INVENTOR

As a below named inventor, I hereby declare that I qualify as an independent inventor as defined in 37 CFR 1.9(c) for purposes of paying reduced fees under section 41(a) and (b) of Title 35, United States Code, to the Patent and Trademark Office with regard to the invention entitled SEEDING TREATMENTS and described in

- the specification filed herewith
- application serial no. 09/113,254, filed 07/10/98
- patent no. \_\_\_\_\_, issued \_\_\_\_\_.

I have not assigned, granted, conveyed or licensed and am under no obligation under contract or law to assign, grant, convey or license, any rights in the invention to any person who could not be classified as an independent inventor under 37 CFR 1.9(c) if that person had made the invention, or to any concern which would not qualify as a small business concern under 37 CFR 1.9(d) or a nonprofit organization under 37 CFR 1.9(e).

Each person, concern or organization to which I have assigned, granted, conveyed, or licensed or am under an obligation under contract or law to assign, grant, convey, or license any rights in the invention is listed below:

- no such person, concern, or organization
- persons, concerns or organizations listed below\*

\*NOTE: Separate verified statements are required from each named person, concern or organization having rights to the invention averring to their status as small entities. (37 CFR 1.27)

FULL NAME FEECO International Inc.  
 ADDRESS 3913 Algoma Road, Green Bay, Wisconsin 54311  
 INDIVIDUAL  SMALL BUSINESS CONCERN  NONPROFIT ORGANIZATION

FULL NAME \_\_\_\_\_  
 ADDRESS \_\_\_\_\_  
 INDIVIDUAL  SMALL BUSINESS CONCERN  NONPROFIT ORGANIZATION

FULL NAME \_\_\_\_\_  
 ADDRESS \_\_\_\_\_  
 INDIVIDUAL  SMALL BUSINESS CONCERN  NONPROFIT ORGANIZATION

I acknowledge the duty to file, in this application or patent, notification of any change in status resulting in loss of entitlement to small entity status prior to paying, or at the time of paying, the earliest of the issue fee or any maintenance fee due after the date on which status as a small entity is no longer appropriate. (37 CFR 1.28(b)).

I hereby declare that all statements made herein of my own knowledge are true and that all statements made on information and belief are believed to be true; and further that these statements were made with the knowledge that willful false statements and the like so made are punishable by fine or imprisonment, or both, under section 1001 of Title 18 of the United States Code, and that such willful false statements may jeopardize the validity of the application, any patent issuing thereon, or any patent to which this verified statement is directed.

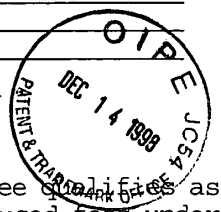
Glen H. Wesenberg TYPED NAME OF INVENTOR TYPED NAME OF INVENTOR TYPED NAME OF INVENTOR

Glen H. Wesenberg Signature of Inventor Signature of Inventor Signature of Inventor

20 Oct 98 Date Date P. 141 Date UT Ex. 2025

SteadyMed v. United Therapeutics  
 IPR2016-00006

Applicant or Patentee: DONIE PAUL MADIGAN ET AL Attorney's  
 Serial or Patent No.: 09/113,254 Docket No. 29214  
 Date Filed or Issued: July 10, 1998  
 For: SEEDING TREATMENTS



VERIFIED STATEMENT (DECLARATION) CLAIMING SMALL ENTITY STATUS (37 CFR 1.9(f) AND 1.27(b)) - SMALL ENTITY

As a representative of the assignee, I hereby declare that the assignee United Therapeutics is a small entity as defined in 37 CFR 1.9(d) for purposes of paying reduced fees under Section 41(a) and (b) of Title 35 United States Code, to the Patent and Trademark Office with regard to the invention entitled SEEDING TREATMENTS and described in

- the Provisional Patent Application filed herewith
- application serial no. 09/113,254, filed 07/10/98
- patent no. \_\_\_\_\_, issued \_\_\_\_\_.

The assignee has not signed, granted, conveyed, or licensed and is under no obligation under contract of law to assign, grant, convey, or license any rights in the invention to any person who could not be classified as an independent inventor under 37 CFR 1.9(c) if that person had made the invention, or to any concern which would not qualify as a small business concern under 37 CFR 1.9(d) or a nonprofit organization under 37 CFR 1.9(e).

Each person, concern, or organization to which the assignee has assigned, granted, conveyed, or licensed or is under an obligation under contract or law to assign, grant, convey, or license any rights in the invention is listed below:

- no such person, concern, or organization
- person, concerns or organizations listed below\*

\*NOTE: Separate verified statements are required from each named person, concern, or organization having rights to the invention averring to their status as small entities. (37 CFR 1.27)

FULL NAME \_\_\_\_\_  
 ADDRESS \_\_\_\_\_  
 INDIVIDUAL  SMALL BUSINESS CONCERN  NONPROFIT ORGANIZATION

I acknowledge the duty to file, in this application or patent, notification of any change in status resulting in loss of entitlement to small entity status prior to paying, or at the time of paying, the earliest of the issue fee or any maintenance fee due after the date on which status as a small entity is no longer appropriate. (37 CFR 1.28(b)).

I hereby declare that all statements made herein of my own knowledge are true and that all statements made on information and belief are believed to be true; and further that these statements were made with knowledge that willful false statements and the like so made are punishable by fine or imprisonment, or both, under section 1001 of Title 18 of the United States Code, and that such willful false statements may jeopardize the validity of the application, any patent issuing thereon, or any patent to which this verified statement is directed.

Dan Madigan, President  
 TYPED NAME OF PERSON SIGNING TITLE  
FEECO International Green Bay, Wisconsin  
 IDENTITY OF ASSIGNEE BEING REPRESENTED ASSIGNEE'S CITY AND STATE

Don Madigan P. 142 10/13/98 UT Ex. 2025  
 SIGNATURE DATE SIGNED United Therapeutics  
 IPR2016-00006



29214  
Patent

IN THE UNITED STATES PATENT AND TRADEMARK OFFICE

In re the application of:  
Daniel Paul Madigan et al

Serial Number: 09/113,254

Filed: 07/10/98

For: SEEDING TREATMENTS

Group Art Unit: 3616

Examiner: Unassigned

RESPONSE TO NOTICE TO FILE MISSING PARTS

Attention: Box Missing Parts  
Assistant Commissioner for Patents  
Washington, D.C. 20231

Sir:

This paper is submitted in response to the Notice To File Missing Parts dated 08/13/98 in the above-identified application. The Missing Parts required are the Surcharge and Filing Fees.

Applicants enclose herewith the following documents:

- Petition For Extension of Time - two months;
- copy of Notice to File Missing Parts of Application;
- Declaration, signed 10/13/98, 10/19/98 and 10/20/98 (2 sheets);
- Inventors' Small Entity Statement, signed 10/13/98, 10/15/98, 10/19/98, and 10/20/98 respectively (2 sheets);
- Assignee Small Entity Statement, signed 10/13/98 (1 sheet);
- Check #5283 for \$65.00, for the Missing Parts Fee;
- Check #5284 for \$953.00, for the Filing Fee; and
- Check #5285 for \$190.00, for the Petition for Extension Fee

I HEREBY CERTIFY THAT THIS CORRESPONDENCE IS BEING DEPOSITED WITH THE UNITED STATES POSTAL SERVICE AS FIRST CLASS MAIL IN AN ENVELOPE ADDRESSED TO BOX MISSING PARTS, ASSISTANT COMMISSIONER FOR PATENTS, WASHINGTON, D.C. 20231

ON December 11, 1998.

Kerri Bruchs

(Typed name of person mailing paper or fee)

Kerri Bruchs  
(SIGNATURE)

12/11/98

(DATE OF SIGNATURE)

Applicants submit that all parts of the application are now present in the PTO, and request that the Official Receipt be issued forthwith.

Should any additional fee be properly due, kindly charge same to Deposit Account 23-2130.

Respectfully submitted,  
Daniel Paul Madigan et al

By: Thomas D. Wilhelm  
Thomas D. Wilhelm,  
Attorney for Applicants  
(Reg. No. 28,794)

December 9, 1998  
Appleton, Wisconsin  
920-831-0100  
920-831-0101 FAX

<b>PETITION FOR EXTENSION OF TIME UNDER 37 CFR 1.136(a)</b> <b>(Small Entity)</b>	Docket No. 29214
--------------------------------------------------------------------------------------	---------------------

In Re Application Of: **Daniel Paul Madigan et al**

Serial No. 09/113,254	Filing Date 07/10/98	Examiner Unassigned	Group Art Unit 3616
--------------------------	-------------------------	------------------------	------------------------

Invention: **SEEDING TREATMENTS**



TO THE ASSISTANT COMMISSIONER FOR PATENTS:

This is a request under the provisions of 37 CFR 1.136(a) to extend the period for filing a response to the Office Action of 08/13/98 in the above-identified application.  
*Date*

The requested extension is as follows (check time period desired):

- One month     Two months     Three months     Four months     Five months

from: 10/13/98 until: 12/13/98  
*Date* *Date*

A verified statement of small entity status as a small entity under 37 CFR 1.27:

- is enclosed.  
 has already been filed in this application.

The fee for the extension of time is **\$190** and is to be paid as follows:

- A check in the amount of the fee is enclosed.  
 The Commissioner is hereby authorized to charge any fees which may be required, or credit any overpayment, to Deposit Account No. 23-2130  
A duplicate copy of this sheet is enclosed.  
 If an additional extension of time is required, please consider this a petition therefor and charge any additional fees which may be required to Deposit Account No. 23-2130      A duplicate copy of this sheet is enclosed.

*Thomas D. Wilhelm*  
*Signature*

Dated: December 11, 1998

**Thomas D. Wilhelm (Reg. No. 28,794)**  
Wilhelm Law Service  
100 W. Lawrence St., Third Floor  
Appleton, WI 54911

I certify that this document and fee is being deposited on <b>December 11, 1998</b> with the U.S. Postal Service as first class mail under 37 C.F.R. 1.8 and is addressed to the Assistant Commissioner for Patents, Washington, D.C. 20231.
<i>Kerri Bruchs</i> <i>Signature of Person Mailing Correspondence</i>
<b>Kerri Bruchs</b> <i>Typed or Printed Name of Person Mailing Correspondence</i>

12/21/1998 CHDMS 00000010 232130 09113254  
01 FC:216 200.00 00

CC:





0300

29214  
Patent

#3/Y.R.  
01/22/99

IN THE UNITED STATES PATENT AND TRADEMARK OFFICE

In re the application of:  
Daniel Paul Madigan et al

Group Art Unit: Unassigned

Serial Number: 09/113,254

Examiner: Unassigned

Filed: 07/10/98

For: SEEDING TREATMENTS

INFORMATION DISCLOSURE STATEMENT

Hon. Assistant Commissioner for Patents  
Washington, D.C. 20231

Sir:

Pursuant to Applicants' duty of disclosure set forth in 37 C.F.R. § 1.56, the Applicants wish to bring to the Examiner's attention the references listed here and on the attached PTO Form 1449.

No representation is made, and no representation is intended, that more relevant material does not exist or that the order of presentation of these materials in any way reflects their relative pertinence. The references cited on the attached PTO Form 1449 are not intended to constitute an admission of any kind. Specifically, this presentation is not an admission that any of the items listed on the attached PTO Form 1449 are properly citable against the above-identified application.

In accordance with the provisions of 37 C.F.R. § 1.98, the references are listed on the attached PTO Form 1449 and copies

I HEREBY CERTIFY THAT THIS CORRESPONDENCE IS BEING DEPOSITED WITH THE UNITED STATES POSTAL SERVICE AS FIRST CLASS MAIL IN AN ENVELOPE ADDRESSED TO ASSISTANT COMMISSIONER FOR PATENTS, WASHINGTON, D.C. 20231

ON October 19, 1998.

Kerri Bruchs  
(TYPED NAME OF PERSON MAILING PAPER OR FEE)

Kerri Bruchs  
(SIGNATURE)

October 19, 1998  
(DATE OF SIGNATURE)

are submitted herewith. The attached copies have been pulled from the Applicants' or assignee's file. Accordingly, some of the references may have written indicia thereon. It is requested that the Examiner ignore all such written indicia as such indicia may not be relevant to the instant case or may not be an accurate characterization of the reference.

This Information Disclosure Statement is being filed before issuance of a first Office Action or within three months of the filing date of the referenced patent application. Accordingly, no fee is due. Nevertheless, the Commissioner is hereby authorized to charge payment of any additional fees due under 37 C.F.R. § 1.17 or credit any overpayment to Deposit Account No. 23-2130. It is Applicants' desire to have these references available in the record for both the Examiner and the public to review. Applicants, therefore, request that the Examiner review the entire disclosure of each reference and make all references of record.

U.S. Patent Documents

56,140	Blessing
2,664,350	Hale et al
3,545,129	Schreiber et al
3,621,612	Porter
3,698,133	Schreiber
3,936,976	Porter et al
3,947,996	Watts
3,950,891	Hinkes
4,116,666	Willard, Sr.
4,192,095	Haslam et al
4,272,417	Barke et al
4,344,979	Gago et al
4,438,593	McNew et al
4,452,008	Sandhu et al
4,493,162	Langan et al
4,752,319	DelliColli
4,759,151	Gerber
5,044,116	Gago et al
5,087,475	Bazin et al
5,106,648	Williams
5,127,185	Kojimoto et al
5,300,127	Williams
5,368,626	Schnuda

5,525,131 Asano  
5,623,781 Legro

Foreign Patent Document

2354101 Germany

Other Documents

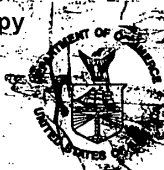
Pietsch, Wolfgang, "Part 2. Agglomerate Bonding and Strength," Date unknown. (Reprinted from W. Pietsch (98)).

Staub-Reinhalt, Luft, "Part 3, THE AGGLOMERATIVE BEHAVIOR OF FINE PARTICLES," (Reprinted from W. Pietsch (7), English edition). Vol. 27, No. 1, January 1967.

Respectfully submitted,  
Daniel Paul Madigan et al

By: Thomas D. Wilhelm  
Thomas D. Wilhelm,  
Attorney for Applicants  
(Reg. No. 28,794)

October 19, 1998  
Appleton, Wisconsin  
920-831-0100  
920-831-0101 FAX



APPLICATION NUMBER	FILING/RECEIPT DATE	FIRST NAMED APPLICANT	ATTORNEY DOCKET NO./TITLE
097413, 264	07/10/98	MADIGAN	D 29214
		0232/0813	
THOMAS D. WILHELM WILHELM LAW SERVICE 100 W. LAWRENCE STREET THIRD FLOOR APPLETON WI 54911		NOT ASSIGNED	
		3616	
		DATE MAILED:	08/13/98

**NOTICE TO FILE MISSING PARTS OF APPLICATION**  
**Filing Date Granted**

An Application Number and Filing Date have been assigned to this application. The items indicated below, however, are missing. Applicant is given TWO MONTHS FROM THE DATE OF THIS NOTICE within which to file all required items and pay fees required below to avoid abandonment. Extensions of time may be obtained by filing a petition accompanied by the extension fee under the provisions of 37 CFR 1.136(a). If any of items 1 or 3 through 5 are indicated as missing, the SURCHARGE set forth in 37 CFR 1.16(e) of  \$65.00 for a small entity in compliance with 37 CFR 1.27 or  \$130.00 for a non-small entity, must also be timely submitted in reply to this NOTICE to avoid abandonment.

If all required items on this form are filed within the period set above, the total amount owed by applicant as a  small entity (statement filed)  non-small entity is \$ 990.85 + 299.10

- 1. The statutory basic filing fee is:
  - missing.
  - insufficient.
 Applicant must submit \$ 790 to complete the basic filing fee and/or file a small entity statement claiming such status (37 CFR 1.27).
- 2. Additional claim fees of \$ 1374, including any multiple dependent claim fees, are required.
  - \$ 164 for 2 independent claims over 2.
  - \$ 120 for 5 dependent claims over 20.
  - \$ \_\_\_\_\_ for multiple dependent claim surcharge.
 Applicant must either submit the additional claim fees or cancel additional claims for which fees are due.
- 3. The oath or declaration:
  - is missing or unexecuted.
  - does not cover the newly submitted items.
  - does not identify the application to which it applies.
  - does not include the city and state or foreign country of applicant's residence.
 An oath or declaration in compliance with 37 CFR 1.63, including residence information and identifying the application by the above Application Number and Filing Date is required.
- 4. The signature(s) to the oath or declaration is/are by a person other than inventor or person qualified under 37 CFR 1.42, 1.43 or 1.47.  
A properly signed oath or declaration in compliance with 37 CFR 1.63, identifying the application by the above Application Number and Filing Date, is required.
- 5. The signature of the following joint inventor(s) is missing from the oath or declaration:

An oath or declaration in compliance with 37 CFR 1.63 listing the names of all inventors and signed by the omitted inventor(s), identifying this application by the above Application Number and Filing Date is required.

- 6. A processing fee is required since your check was returned without payment (37 CFR 1.4(m)).
- 7. A mailing receipt was mailed in error because your check was returned without payment.
- 8. The application does not comply with the Sequence Rules.  
See attached "Notice to Comply with Sequence Rules 37 CFR 1.821-1.825."
- 9. OTHER: None

Direct the reply and any questions about this notice to "Attention: Box Missing Parts."

**A copy of this notice MUST be returned with the reply.**

A

07/10/98  
605 U.S. Pro

# UTILITY PATENT APPLICATION TRANSMITTAL (Small Entity)

(Only for new nonprovisional applications under 37 CFR 1.53(b))

Docket No.  
29214

Total Pages in this Submission  
82

**TO THE ASSISTANT COMMISSIONER FOR PATENTS**

**Box Patent Application  
Washington, D.C. 20231**

Transmitted herewith for filing under 35 U.S.C. 111(a) and 37 C.F.R. 1.53(b) is a new utility patent application for an invention entitled:

**SEEDING TREATMENTS**

and invented by:

**DANIEL PAUL MADIGAN  
MICHAEL DENNIS KRYSIAK  
RONALD DEAN EICHHORN  
GLEN H. WESENBERG**

If a **CONTINUATION APPLICATION**, check appropriate box and supply the requisite information:

Continuation  Divisional  Continuation-in-part (CIP) of prior application No.: \_\_\_\_\_

Which is a:

Continuation  Divisional  Continuation-in-part (CIP) of prior application No.: \_\_\_\_\_

Which is a:

Continuation  Divisional  Continuation-in-part (CIP) of prior application No.: \_\_\_\_\_

Enclosed are:

### Application Elements

1.  Filing fee as calculated and transmitted as described below
2.  Specification having 70 pages and including the following:
  - a.  Descriptive Title of the Invention
  - b.  Cross References to Related Applications (if applicable)
  - c.  Statement Regarding Federally-sponsored Research/Development (if applicable)
  - d.  Reference to Microfiche Appendix (if applicable)
  - e.  Background of the Invention
  - f.  Brief Summary of the Invention
  - g.  Brief Description of the Drawings (if drawings filed)
  - h.  Detailed Description
  - i.  Claim(s) as Classified Below
  - j.  Abstract of the Disclosure

605 U.S. Pro  
09/11/254  
07/10/98

**UTILITY PATENT APPLICATION TRANSMITTAL  
(Small Entity)**

*(Only for new nonprovisional applications under 37 CFR 1.53(b))*

Docket No.  
29214

Total Pages in this Submission  
82

**Application Elements (Continued)**

3.  Drawing(s) *(when necessary as prescribed by 35 USC 113)*  
a.  Formal      b.  Informal      Number of Sheets         6
4.  Oath or Declaration  
a.  Newly executed *(original or copy)*       Unexecuted  
b.  Copy from a prior application (37 CFR 1.63(d)) *(for continuation/divisional application only)*  
c.  With Power of Attorney       Without Power of Attorney  
d.  DELETION OF INVENTOR(S)  
Signed statement attached deleting inventor(s) named in the prior application,  
see 37 C.F.R. 1.63(d)(2) and 1.33(b).
5.  Incorporation By Reference *(usable if Box 4b is checked)*  
The entire disclosure of the prior application, from which a copy of the oath or declaration is supplied  
under Box 4b, is considered as being part of the disclosure of the accompanying application and is hereby  
incorporated by reference therein.
6.  Computer Program in Microfiche
7.  Genetic Sequence Submission *(if applicable, all must be included)*  
a.  Paper Copy  
b.  Computer Readable Copy  
c.  Statement Verifying Identical Paper and Computer Readable Copy

**Accompanying Application Parts**

8.  Assignment Papers *(cover sheet & documents)*
9.  37 CFR 3.73(b) Statement *(when there is an assignee)*
10.  English Translation Document *(if applicable)*
11.  Information Disclosure Statement/PTO-1449       Copies of IDS Citations
12.  Preliminary Amendment
13.  Acknowledgment postcard
14.  Certificate of Mailing  
 First Class       Express Mail *(Specify Label No.):* EM 469 259 847 US

**UTILITY PATENT APPLICATION TRANSMITTAL  
(Small Entity)**

*(Only for new nonprovisional applications under 37 CFR 1.53(b))*

Docket No.  
29214

Total Pages in this Submission  
82

**Accompanying Application Parts (Continued)**

15.  Certified Copy of Priority Document(s) *(if foreign priority is claimed)*
16.  Small Entity Statement(s) - Specify Number of Statements Submitted: \_\_\_\_\_
17.  Additional Enclosures *(please identify below)*:

Correspondence Address

**Fee Calculation and Transmittal**

**CLAIMS AS FILED**

For	#Filed	#Allowed	#Extra	Rate	Fee
<b>Total Claims</b>	75	- 20 =	55	x \$11.00	\$605.00
<b>Indep. Claims</b>	5	- 3 =	2	x \$41.00	\$82.00
<b>Multiple Dependent Claims (check if applicable)</b> <input type="checkbox"/>					\$0.00
<b>BASIC FEE</b>					\$395.00
<b>OTHER FEE (specify purpose)</b> _____					\$0.00
<b>TOTAL FILING FEE</b>					\$1,082.00

- A check in the amount of \_\_\_\_\_ to cover the filing fee is enclosed.
- The Commissioner is hereby authorized to charge and credit Deposit Account No. \_\_\_\_\_ as described below. A duplicate copy of this sheet is enclosed.
- Charge the amount of \_\_\_\_\_ as filing fee.
  - Credit any overpayment.
  - Charge any additional filing fees required under 37 C.F.R. 1.16 and 1.17.
  - Charge the issue fee set in 37 C.F.R. 1.18 at the mailing of the Notice of Allowance, pursuant to 37 C.F.R. 1.311(b).

Dated: *July 10, 1998*

*Thomas D. Wilhelm*  
Signature

Thomas D. Wilhelm (Reg. No. 28,794)

cc:

IN THE UNITED STATES PATENT AND TRADEMARK OFFICE

In re the application of:  
Daniel Paul Madigan et al

Group Art Unit: Unassigned

Serial Number: Unassigned

Examiner: Unassigned

Filed: July 10, 1998

For: SEEDING TREATMENTS

CORRESPONDENCE ADDRESS

Hon. Assistant Commissioner for Patents  
Washington, D.C. 20231

Sir:

Kindly address all correspondence regarding the above-referenced Application to the following address:

Thomas D. Wilhelm  
Wilhelm Law Service, S.C.  
100 W. Lawrence Street  
Third Floor  
Appleton, WI 54911

Phone 920-831-0100  
FAX 920-831-0101

Respectfully submitted,  
Daniel Paul Madigan et al

By Thomas D. Wilhelm  
Thomas D. Wilhelm  
Attorney for Applicants  
(Reg. No. 28,794)

July 10, 1998  
Appleton, Wisconsin



PATENT APPLICATION

TITLE: SEEDING TREATMENTS

By: Daniel Paul Madigan  
804 S. Madison  
Green Bay, WI 54301  
Citizenship: USA

Michael Dennis Krysiak  
3554 Highland Center Drive  
Green Bay, WI 54311  
Citizenship: USA

Ronald Dean Eichhorn  
1524 1/2 Cedar Street  
Green Bay, WI 54302  
Citizenship: USA

Glen H. Wesenberg  
920 Laverne Drive  
Green Bay, WI 54311  
Citizenship: USA

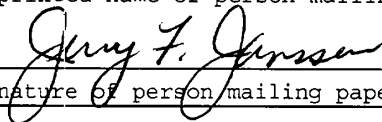
"Express Mail" mailing number  
EM 469 259 847 US

Date of Deposit June 10, 1998

I hereby certify that this paper or fee is being deposited with the United States Postal Service "Express Mail Post Office to Addressee" service under 37 CFR 1.10 on the date indicated above and is addressed to the Assistant Commissioner of Patents, Washington, D.C. 20231.

Jerry F. Janssen

(Typed or printed name of person mailing paper or fee)



(Signature of person mailing paper or fee)

TDW, JSK

SEEDING TREATMENTSField of the Invention

5 This present invention relates to improvements in seed and  
seed-related products, processes for making such products and  
processes for establishing and improving seed beds and seed bed  
germination. As additional benefits, this invention is directed at  
improving soil productivity through enhancements in soil fertility,  
soil condition/tilth, and control of soil moisture. Further, the  
10 invention relates to productive use of certain types of abundantly  
available manufacturing waste, which waste is currently being  
disposed of in landfills.

Background of the Invention

15 Agricultural growers, gardeners, landscape operators, flower  
growers, and the like produce a wide variety of cultivated crops.  
Many such crops are grown from seed. The sizes, shapes, and  
physical characteristics of the various kinds of seeds are as  
varied as the number of crops produced therefrom.  
20

Producers of such cultivated crops encounter a variety of  
challenges in handling and distributing such seed, as well as with  
sowing of such seed in suitable growing media. Certain seed may  
desirably be sowed by a broadcast method if the seed were  
25 compatible with broadcast application. For example, grass seed for  
lawns is desirably broadcast, but the low density and generally  
non-aerodynamic shape of some grass seed can limit the range of  
such broadcast, and make such seed susceptible to being blown about

by wind, or washed away by surface water, even if initially well placed in a good seeding application.

5 Another difficulty encountered in sowing seed is that the seed may be so small as to be difficult to handle, thereby to place properly-spaced seeds at a desired spacing as to make cost-effective use of the seed, thereby to produce a crop of the related plants without using any more seed than necessary, thus to gain maximum benefit from the amount of seed used.

10 While small seed may be efficiently handled by industrial equipment especially designed for handling such seed, typically the user of such seed also handles various other types of seed; and may be unable to justify the cost of such specialty seed-handling equipment. Rather, the seed user typically has a limited range of seed handling equipment which must be capable of being used and/or  
15 adapted to handle and apply all the types of seeds being used by that user. Where the seed itself can be adapted to the equipment, specialty seed can be handled without need for any specialized equipment.

20 Even where the seed may be sown by hand, such as in seedling or bedding trays or pots, some seeds are so small as to be difficult for the sower/user to effectively manipulate and control by hand. Typical of such difficult-to-handle seeds are seeds of lettuce, carrots, the cabbage family, ground cherries, and alfalfa. Many flower seeds are equally small and/or difficult to handle  
25 and/or manipulate, for example poppy seed.

30 When seed is planted, the seed has immediate use for moisture to aid in germination of the seed, and subsequent early development of the resulting young plant. Where moisture is not readily available to the seed when planted, the seed may lie in a dormant state for some period of time before germinating. While the seed is thus dormant, awaiting suitable moisture, the seed is subject to a variety of hazards which may destroy its viability. The seed may be attacked by worms, parasites, and other pests. The seed may be

eaten by foraging animals including insects and larvae. The seed may be overheated by a hot sun. The seed may lie dormant without germinating for so long that any plant emerging therefrom will have insufficient time to mature before the end of the growing season.

5           If and when the seed does germinate, the seedling plant has a continuing need for a proper balance of moisture and oxygen, as well as for such plant nutrients as nitrogen, phosphorous, and potash, as well as the micronutrients, in relatively predictable quantities. To the extent the proper balance of such materials is available to the young plant, a healthy young plant may be produced, with optimum potential for maximum crop production, assuming germination occurs at a seasonably-desirable time.

10           To the extent one or more such materials is not available to the seed and/or the young plant, plant growth, plant health, and ultimately maturity, may be adversely affected. For example, the soil may be too dry to support germination, or optimum germination. Or while the soil may in general have a desired moisture content, moisture content at a macro level can vary widely. Thus, while the soil in general may have a desirable moisture content, the microcosm of the soil adjacent an individual seed may be too dry, or too wet, to support any germination, or optimum germination.

15           Similarly, the soil may be generally depleted of one or more plant nutrients needed by the germinated seedling. Or while the soil may in general have desired nutrient levels, the nutrient levels at a macro level can vary widely. Thus, the microcosm of the soil adjacent an individual seed may be too low in one or more nutrients to support a desired level of plant growth, or so high as to be toxic to a desired level of plant growth.

20           Further, plant nutrient chemicals may be present in the soil, but so tied up chemically in the soil as to be unavailable, or poorly available, relative to the quantities and use rates needed for desired plant growth. Or the soil may become so hard, dry, and/or caked shortly after the seed germinates that the seedling

plant has difficulty penetrating such soil, difficulty becoming associated suitable nutrients, and/or difficulty taking up such nutrients because of insufficient moisture availability.

5 After the plant has further developed such that the plant roots extend deeper into the soil, conditions of the soil near the surface are less critical. However, until such time as the roots so penetrate, conditions of the soil at and near the top surface of the soil may be critical.

10 Soil fertility generally relates to uptake of plant nutrients from the soil by plants. Uptake is generally the result of two factors, the presence of plant nutrients in the soil, and the availability of the plant nutrients for plant uptake. Presence of plant nutrients in the soil is generally a function of the combination of (a) the basic level of soil fertility, (b) depletion by previous crop production and (c) replenishment with fertilizer. Availability of a plant nutrient physically present in the soil for plant uptake is in general related to solubility of the respective nutrient or nutrient combination in a solvent for the nutrient, which solvent is present in the soil, such solvent as water, along with any other material affecting solvation of the plant nutrient into the water or other solvent.

15 Plant nutrients are routinely depleted from the soil by crop production, and are routinely added back, or otherwise replenished, to the soil by conventional inorganic fertilizers.

25 In order for plant nutrients in the soil to be available for uptake by plants, the nutrients must be held in the soil without excessive leaching, but must not be held so tightly that the nutrients cannot be released for plant uptake. Thus, nutrient availability requires a balance between holding tightly enough to retain the nutrient in the root zone, without leaching, but not so tight as to make the nutrient unavailable for plant uptake. Thus, 30 the general "condition" or "tilth" of the soil is instrumental in

determining the efficiency with which plant nutrients are utilized for plant nutrition.

5 A properly conditioned soil has advantageous soil chemistry in combination with advantageous soil texture. Thus, in addition to providing specific plant nutrients, soil users also use products that modify basic soil chemistry, and soil texture.

Basic soil chemistry is modified by adding to the soil, for example, calcium products to provide pH control, and flyash or like products to provide pH control as well as micronutrients.

10 Soil texture is generally modified by adding to the soil organic matter such as manures, sludges, wood and other plant products and by-products, and the like. While such materials have good soil conditioning properties, plant nutrient value of such materials is fixed and is generally so low that other "fertilizer"-  
15 type products must in general be used in addition to the organic matter in order to preserve plant nutrient values in the soil.

The primary object of this invention is to provide solid plant seed capsule products that supply both soil conditioning properties and the seed, which can benefit from such conditioned soil, in a  
20 given seed capsule particle.

It is a further object to provide a plant nutrient material, in the seed capsule particle, in amount beneficial to the seedling emerging from the seed, and higher than a naturally-occurring amount of such nutrient in such soil conditioning material, so as  
25 to have enhanced chemical nutrient qualities over use of the soil conditioning material alone.

In another aspect, a further object is to provide soil conditioning and optionally nutrient qualities to seed products that reach the soil as the result of fulfilling objectives separate  
30 from providing soil fertility or soil conditioning.

Still another object is to provide seed capsules containing fertility-enhancing elements having a high level of plant food

nutrients in combination with a high level of soil conditioning properties.

5 Still another object is to encapsulate a seed in a soil conditioning material using materials rich in plant nutrients as part of the encapsulating agent.

Yet another object is to provide a seed product which reduces the tendency for light weight seeds to be washed away by surface water runoff.

10 Still another object is to provide a seed product which obviates the typical practice of adding straw as a mulch over e.g. grass seed, to protect the seed from being washed away by surface water, from heat of the sun, and to hold moisture in the soil.

15 A further object is to provide products wherein a single seed capsule product particle provides enhanced soil texture and enhanced soil nutrient value at nutrient levels traditionally needed by newly-germinated seedlings, optionally with higher levels of plant nutrient suitably spaced from the seed itself so as to not be toxic to seedling growth, optionally in combination with time-release technology.

20 Yet another object is to provide fertility-enhancing seed capsule products having a suitable level of plant food nutrients in combination with a high level of organic matter as soil conditioning material.

Summary of the Invention

5 The invention generally addresses a combination seed capsule, comprising at least one viable seed, having an outer surface and acting as a core or pseudo-core of said combination seed capsule; and a coating of a composition comprising a soil conditioning material mounted proximate, including disposed outwardly of the outer surface of said seed.

10 In general, the coating provides at least one of (i) enhancing broadcast flight properties of the combination seed capsule; (ii) reducing susceptibility to deleterious affects of weather on the combination seed capsule; (iii) enhancing resistance of the combination seed capsule to attack by animals, weeds, or spore-formers; (iv) staged germination of ones of the seed capsules, 15 having seeds, under a given set of conditions, over a period of time longer than the range of germination times inherent in the seeds; (v) enhancing control of moisture about the seed thereby to assist in seed germination; (vi) release of plant nutrients into soil onto which the combination seed capsule is placed; (vii) soil 20 conditioning effect to soil onto which the combination seed capsule is placed; (viii) staged release of plant nutrients into soil onto which said combination seed capsule is placed, over a period of time longer than the range of times inherent in the chemical composition so released; (ix) higher embryo emergence and survival 25 rate in a population of the seed capsules, thereby reducing required seed planting density for a desired plant population density; and (x) assisting in stabilizing moisture content in soil on which such seed capsule is disposed.

30 While a wide variety of seeds may be used, in general such seeds are selected from the group consisting of grass, vegetables, grains, and flowers.

Preferably, the coating comprises the soil conditioning material in combination with at least one ingredient effective to



reduce susceptibility of the seed capsule to deleterious affect of at least one of animals, weeds, and spore-formers. In some embodiments, the ingredient for reducing such susceptibility of the seed capsule is selected from the group consisting of herbicides, fungicides, for example metalaxyl, and a bitter substance.

In some embodiments, the combination seed capsule further comprises a second coating, separate from the first coating, and comprising at least one ingredient effective to reduce susceptibility of the seed capsule to deleterious effect of at least one of animals, weeds, and spore-formers.

Some embodiments are effective to provide a plant nutrient at a desirable controlled distance from a plant seedling emerging from the seed, in an amount beneficial to the plant seedling.

In other embodiments, the second coating material is intermingled with the first coating material in an outer portion of the first coating, and generally displaced from the seed.

The second coating material can comprise a plant nutrient, beneficial in location and in amount of availability, to a plant seedling emerging from the seed. The second coating composition can comprise an inorganic form of a plant nutrient and can be selected from the group consisting of nitrogen, phosphorus, and potassium. The second coating composition can comprise an inorganic form of a plant nutrient and can be selected from the group consisting of e.g. urea, monammonium phosphate, diammonium phosphate, superphosphate, triple superphosphate, dicalcium phosphate, and potash or a micronutrient such as sulfur, manganese, copper, boron, iron, magnesium, or chromium.

A population of the seed capsules can comprise coatings having a range of properties affecting germination rate of the seeds, thereby to stage germination of the seeds in the population over a period of time longer than the range of germination times inherent in uncoated ones of the seeds. Such properties can be, for

example, a range of hardnesses, or a range of thicknesses, of the coatings.

The coating can comprise a first layer of the soil conditioning material, and a second layer comprising an inorganic, and/or organic, fertilizer, and/or at least one micronutrient, such as, for example, sulfur, manganese, copper, boron, iron, magnesium, or chromium.

A preferred soil conditioning material is a sludge composition, such as a fiber-containing by-product of a paper making operation, or sewage sludge.

The seed capsule can comprise a water-leachable plant nutrient, and/or a leach-retardant composition, such as wax, effective to retard leaching of the leachable plant nutrient out of the combination seed capsule.

In some embodiments, in a population of the combination seed capsules, the coatings in ones, but less than all, of the population, comprise ingredients effective to retard effective penetration of a seed-germinating environment to the seed for germination thereof.

In embodiments preferred for some applications, the seed capsule comprises an inner layer on the outer surface of the seed, and an outer layer, the inner layer enhancing properties of the seed for acting as nucleus in an agglomeration operation agglomerating the coating onto the inner layer.

In some embodiments, the coating comprises an admixture of the soil conditioner and a plant nutrient.

In preferred embodiments, the coating remains generally disposed about the seed, and preferably but not necessarily remains generally intact about the seed, until the seed germinates.

The invention further comprises a plant growing medium extending over an area, the plant growing medium having a root zone, and a top surface of the root zone generally corresponding with a top surface of the plant growing medium, the plant growing

5 medium having a first overall soil condition and texture; and a population of seed capsules disposed over the top surface of the plant growing medium, the seed capsules comprising individual seeds, having outer surfaces, and coatings of soil conditioning material disposed outwardly of the outer surfaces of the seeds, the coatings of the seed capsules providing localized germination and growth environments, at and adjacent the seeds, having texture, and nutrient and water holding properties for supporting seedling health, superior to respective properties as provided overall in the root zone of the plant growing medium.

10 The invention yet further comprises a method of providing plant micronutrients to soil, the method comprising placing onto the soil a population of combination seed capsules, each comprising at least one seed, and a coating comprising a plant micronutrient material.

15 The coating can comprise a first coating comprising the plant micronutrient, and a second coating, separate and distinct from the first coating, and comprising a soil conditioning material.

20 The invention yet further comprehends a method of providing a seed bed having enhanced growing conditions for growing seed, the method comprising coating a population of the seeds with a coating material, and thereby providing coatings thereon of such material, the material tending to stabilize, in the seed capsules, or in soil on which the seed capsules are disposed coating compositions which tend to hold, moisture adjacent the seeds in the seed capsules or in soil adjacent the seed capsules, in such quantities and for such times as to enhance growing conditions for the seeds; and placing the population of seeds on soil effective to support germination of the seeds which are in the seed capsules.

25 In some embodiments, the seed capsules comprise inner layers on the outer surfaces of the seeds, and outer layers, the inner layers enhancing properties of the seeds for acting as nuclei in

agglomeration operations agglomerating the coatings onto the inner layers.

5 The invention yet further comprehends a method of making a population of combination seed capsules, each comprising a seed, and a coating of a soil conditioning material, the method comprising pre-coating the seed with a material which enhances the ability of the seed to act as a nucleus in an agglomeration operation, to form a pre-coated substrate; and subsequently coating the pre-coated substrate with a soil conditioning material.  
10 A preferred pre-coating material comprises dicalcium phosphate.

In general, the pre-coating step typically results in an overall increase in the density of pre-coated seed combination. The pre-coating step can be accomplished by, for example, spraying the pre-coating material onto the seed, and subsequently driving off such as by drying, as necessary, any solvent or other liquid carrier used for application of the coating material to the seed.  
15

In yet other expressions, the invention comprehends a method of providing an enhanced seed germination environment in combination with placement of a controlled amount of plant nutrients in controlled proximity to each seed, the method comprising providing a population of seeds, coated with a soil conditioning material which tends to enhance germination of the seeds, and with plant nutrient composition effective to enhance growth of plant embryos emerging from the seeds; and placing the population of seeds on soil effective to support germination of the seeds. In such method, the coating material can include a second ingredient comprising plant nutrient moieties.  
20  
25

Brief Description of the Drawings

FIGURE 1 is a transverse cross-sectional view of a coating drum suitable for spray-coating substrate seed according to the present invention.

FIGURE 2 is a partially cut away view showing a length of the drum of FIGURE 1.

FIGURE 3 is a schematic representative flow diagram illustrating a first manufacturing process for producing combination seed capsule product of the invention.

FIGURE 4 is a block diagram illustrating a second manufacturing process for producing combination seed capsule product of the invention.

FIGURE 5 is a schematic representative flow diagram illustrating a third manufacturing process for producing combination seed capsule product of the invention.

FIGURES 6A, 6B, 6C, and 6D show cross sections of seed capsules of the invention.

FIGURE 7 illustrates a cross-section of the soil root zone, and a representative population of seed capsules at the top surface of the soil.

FIGURE 8 illustrates a single seed capsule on the soil surface, and the micro-environment developing about the seed capsule.

DESCRIPTION OF THE ILLUSTRATED EMBODIMENTS

5 The following is a detailed description of the illustrated  
embodiments of the present invention which provides combination  
seed capsule products that provide for a combination of efficient  
and proper seed placement in the soil, soil conditioning properties  
at the specific site of the seed, plant nutrients at or near the  
specific site of the seed, ingredients effective to reduce  
deleterious effects of spore-formers and animals, and/or other  
10 various physical benefits/properties of the combination seed  
capsule not previously available in a single product.

15 In general, at least one seed substrate and at least one soil  
conditioning material are selected as raw materials, and are  
combined to make a combination soil conditioning seed capsule  
product of the invention.

20 The invention can operate with any of a wide variety of soil  
conditioning materials such as municipal or other sewage sludge,  
scrubber sludge, paper mill sludge, fly ash, dust, animal waste,  
other organic materials, and mineral soil conditioning materials.

25 The soil conditioning material can be a solid material having  
a melting temperature so high that handling such material in the  
melt state is impractical and/or undesirable in view of the limited  
temperatures at which the seed will remain viable. For example,  
the soil conditioning material may be combustible at a temperature  
lower than its melt temperature, or will melt only above  
temperatures which can be tolerated by the seed, such that  
viability of the seed would be destroyed if melting were attempted  
in an environment which exposed the seed to such temperatures.  
Thus, handling such material in the melt state is impractical,  
30 whereby other methods of handling the soil conditioning material  
may be desired.

Solid sewage sludge, sawdust, and solid animal waste are  
representative of soil conditioning materials which cannot be

readily melted. In the alternative, some soil conditioning materials such as sewage sludge, paper mill sludge, sawdust, and solid animal waste can be suitably comminuted and then dissolved or suspended in water or other solvent composition for processing purposes, optionally along with other soil conditioning materials and/or inorganic chemical fertilizer materials, and the solvent subsequently driven off to make a resulting solid product.

Inorganic chemical fertilizers generally are distributed in commerce as solid state materials. Such material is generally produced in manufacturing steps either in solution or in the melt state to meet a specified narrow range of size, hardness, and plant nutritional characteristics, distinct to the application of each such product. Examples of such fertilizers include nitrogen, phosphorus, and potassium containing products such as urea, monoammonium phosphate, diammonium phosphate, superphosphate, triple super phosphate, dicalcium phosphate, potash, and the like. The inorganic chemical fertilizer can be a mixture or other physical combination of known inorganic fertilizer chemicals, and may include desired amounts of micronutrients such as sulfur, manganese, copper, boron, iron, zinc, and the like.

In preferred embodiments of this invention, a precursor seed capsule, having one or more coatings of the soil conditioning and/or other material thereon may first be prepared as a solid or semi-solid particle or agglomerate. The soil conditioning raw material may be a particulate powder, or may be fibrous, or may be a suspension of a powder or fibrous material in a liquid carrier, and is preferably coated onto the substrate seed to form a seed capsule or other agglomeration of particles, fibers, or the like. Where the soil conditioning material is, for example, sewage sludge, the sewage sludge raw material can be obtained as a slurry that may be bound together as with a binder, preferably an organic binder, when dried. The slurry may be spray-applied to the substrate seeds, for example to a rolling bed of such seeds, in

combination with a flow of air to evaporate water from the thus-applied coating. Such sewage sludge, or paper mill sludge, need not be reacted or otherwise treated with any acid, caustic, or any other chemical before being applied and/or dried, or partially dried, either in preparation for, or after, the slurry application of the sludge to the seed substrate.

Specifically, the sewage sludge or paper mill sludge used herein as soil conditioning raw material need not be treated to transform such sludge into colloidal form. Thus, the sludge preferred for use herein is generally non-colloidal in nature, and is distinguished by its non-colloidal nature from conventional sludges which are specifically treated to provide the colloidal characteristics thereto.

Natural lignin, lignosulfonates, and the like, may serve as suitable binders where the soil conditioning material is, for example, paper mill sludge, raw wood, sewage sludge, or other organic or inorganic material. In the case of, for example, calcium chloride or other inorganic additives, such materials may be added to the primary coating, e.g. onto or into the sludge coating, by well-known processes.

Soil conditioning material used herein may be devoid of such conventional plant nutrients as nitrogen, potassium, and phosphorous, or may have such limited plant nutrient value, or may be so unbalanced in nitrogen, phosphorous, and potassium content, that the soil conditioning material may not, by itself, be a desirably complete material for use as the only ingredient in the seed coating. Thus, such soil conditioning material may have limited application herein where basic level of soil fertility is seriously degraded. However, all soil conditioning materials contemplated herein beneficially modify soil to which they are applied, in some way other than direct provision of nitrogen, phosphorous, and/or potassium or other plant nutrients. By use of soil conditioner in intimate association with the seed, this



invention not only enhances soil condition of the growth medium/soil to which it is applied, it also provides soil conditioning value to the seed so coated, and in intimate association with the seed, irrespective of the general tilth condition of the growth medium into or onto which the seed capsule is applied.

Further to preferred embodiments, typically a first coating material (e.g. soil conditioning material) is readily converted into liquid state such as liquid suspension, and is provided to the process as a liquid. As a general statement, the first coating material may be sprayed onto the substrate seed, then is converted back to solid state on the thus-created seed capsules or seed capsule precursors. In the alternative, the coating material may be mixed with the seed in an (e.g. ribbon) blender, or may be otherwise coated onto the substrate seed in an agglomeration process according to well-known conventional agglomeration principles.

Regarding the coating process, the coating material can accumulate as a single or multiple layer coating on the outside of the seeds to form a population of combination seed capsules. The layer or layers of coating material can be a homogeneous or heterogeneous mixture of the desired elements. Further, such population of combination seed capsules can have a range of hardnesses and thicknesses for improved seeding treatments.

Cooperating inner and/or outer layers may be used e.g. to control direct contact between the seed and moisture. Suitable materials and processes therefore are taught in USA Patent 3,698,133 Schreiber and 4,759,151 Gerber, and are thus well known in the art.

In some embodiments, a second coating material may penetrate into the layer of soil conditioning coating material. Such penetration may comprise a generally uniform distribution of the second coating material throughout the first coating material, or

may represent a more stratified or otherwise heterogeneous distribution of second coating material in or on the first coating material.

5 In other embodiments, the coating materials may be mixed into a heterogenous layer. Such layer or layers of heterogenous material can then be coated upon the outside surface of the seed.

10 Where the liquid state of a coating material was obtained by slurring or otherwise combining the coating material with water, the liquid fraction is reduced after application of the liquid-state material to the substrate seed, or to the growing seed capsule, to effect solidifying of the coating material after application of the coating material to the substrate seed. The liquid fraction is reduced by driving off the liquid carrier, as by  
15 medium or low temperature air, or vacuum or other flash drying, after or during application of the coating material to the substrate seed. The resulting solid seed capsule, comprising the seed coated with the e.g. sludge coating material, is then recovered as a combined soil conditioning seed capsule product of the invention.

20 Spraying of the liquid coating material can be accomplished by a variety of known processes such as, but not limited to, pneumatic, hydraulic, or electrostatic spraying processes. The temperature and pressure of the material being sprayed depends on the material selected, and the viscosity and other parameters of  
25 the respective material in the respective liquid state. While high atomization is desired, such is not critical. The liquid coating material need only be atomized sufficiently to provide a generally uniform coating on the substrate seeds, as determined after the coating and solidification steps in fabricating the seed capsule  
30 product are completed.

Indeed, the uniformity of coating or coating thickness about the seed is typically not critical so long as the seed is not on or immediately adjacent an outside surface of the capsule such that

the seed may fall out, or be easily broken out, of the capsule, or easily removed by dissolution of materials at and near the surface of the seed capsule. In addition, the seed should not be so near the outside surface of the capsule as to be in a nutrient layer having such high concentration of nutrient as to be toxic or otherwise detrimental to viability or growth of a plant emergent from the seed.

Spray application of the coating is suitably controlled to achieve the required addition of the spray material, liquid and/or powder, coating to the substrate seed or precursor seed capsule. An illustrated method of applying the liquid material to the substrate seed or precursor seed capsule is by using a rotating drum spray-coating apparatus. Other apparatus and methods, for example a tilted pan coating process, can be used to apply the soil conditioning material and optionally an inorganic chemical fertilizer material onto the substrate seed. The coating operations can be batch operations or continuous operations.

As illustrated in FIGURES 1, 2, and 4, spray apparatus can operate within a rotating drum disposed in a generally horizontal orientation. The drum may incorporate internal lifting flights which lift free-flowing (e.g. seed and growing seed capsule) particles in the drum and then let the particles fall to the bottom of the drum as a continuously falling curtain or cascade. In some embodiments, the interior of the drum is either clean and free from any flighting, or has only mixing fingers or flights that expand the area covered by the bed, that keep the bed rolling as the drum rotates, and that generally improve mixing, rather than lifting particles to the top of the drum and then releasing them in a falling cascade. However, such lifting of particles to the top of the drum, and corresponding falling cascade or falling curtain, are not excluded from processes of the invention. Rather, both such finger mixing, and such lifting coupled with falling cascade or curtain, are included within the scope of the invention.

Stationary spray nozzles are positioned within the drum to project the sprayed material onto the rolling bed, and optionally onto any curtain or cascade of falling particles. For a continuous process, the drum is preferably inclined at a small angle from horizontal, such as, without limitation, about 0.25 inch to about 0.38 inch from the horizontal for each foot of length of the drum, so that rotation of the drum causes the particles to move from the inlet end of the drum to the discharge end, while maintaining a relatively uniform bed thickness. The optimum degree of incline varies with each set-up and may thus be outside the above range. The important parameter is that the incline contribute to maintaining a bed of seed and seed capsule particles having sufficient uniformity that the spray material can be effectively applied to the particles passing through the drum. The particles are then discharged at the discharge end of the drum.

FIGURES 1 and 2 show schematically a first embodiment of processing equipment which may be used to produce seed capsules of the invention. Such processing equipment includes a drum and sprayer combination suitable for continuously producing coated seed capsules in accord with the invention. Use of the illustrated drum and sprayer combination is not critical, however, as other drum and sprayer combinations, or other coating methods such as pan coating methods, are also suitable. In FIGURES 1 and 2, drum **10** has an inlet end **12** for receiving the substrate seed material or materials, or partially formed or pre-coated seed capsule precursors. Drum **10** has a discharge end **14** through which agglomerated or otherwise coated seed capsule product particles are discharged over discharge retaining ring **16**. A variable speed rotary drive (not shown) is provided for supporting and rotating the drum **10** in a counterclockwise direction as viewed in FIGURE 1 at controlled, and changeable drive speeds. Conventional slope adjustment apparatus (not shown) is provided for routine and ongoing adjustment the slope of the drum from horizontal.

5 Air is preferably supplied from discharge end **14** as shown in  
FIGURE 2, and flows countercurrent to the direction of travel of  
the seed substrate material. Since the contemplated coating  
materials are generally applied to the seed in liquid, or semi-  
liquid, or other moist form, and since some coating materials may  
thus tend to form clumps or otherwise self-agglomerate when exposed  
to ambient moisture conditions, air supplied at discharge end **14**,  
and elsewhere in the process for contact with the coated seed and  
seed capsules, is preferably dried in order to cost-effectively  
10 remove an optimum amount of the moisture from the coating material  
and to assist in maintaining suitably low moisture content in the  
thus coated and dried seed capsules.

15 A first stationary spray assembly **28** extends longitudinally  
within drum **10** above and adjacent the bed **20** of seed and/or seed  
capsules. First spray assembly **28** includes pipe **29** and nozzles **30**.  
A second spray assembly **32** extends longitudinally within drum **10**  
generally adjacent first spray assembly **28**. Second stationary  
spray assembly **32** includes pipe **33** and nozzles **34**, which transport  
the material to be sprayed. Nozzles **30** and **34** are connected to  
20 pipes **29** and **33** respectively, and project sprays of liquid or  
otherwise particulate coating material toward the bed of seeds  
and/or seed capsule precursors. The description of spray  
assemblies **28**, **32** as stationary means that the spray assemblies do  
not rotate with drum **10**. However, the positions of either nozzles  
25 **30**, **34** or pipes **29**, **33**, or both, can be adjusted within the drum  
for proper direction of the respective spray or sprays onto the bed  
of seeds and/or seed capsules or seed capsule precursors.

30 A stationary protective cover **24** is mounted over the spray  
assemblies. Seeds and/or seed capsules falling from the inner  
surface of the drum and the flights, above the spray assemblies,  
fall onto the cover, and are deflected away from the spray  
assemblies, as shown in FIGURE 1. Thus, cover **24** protects the

pipes and nozzles from the falling seeds and seed capsules falling onto and fouling the pipes and spray nozzles.

5 As drum **10** rotates, flights **22** lift and mix the seeds, seed capsule precursors, and seed capsules, but do not generally carry the bulk of the seeds and seed capsules up to the top of the drum. Some small amount of seeds, seed capsule precursors, and seed capsules will be carried upwardly to the top of the drum by even a drum devoid of any flights. Thus, all drums experience some amount of seeds and seed capsules falling from the upper part of the rotating drum whereby cover **24** is beneficial for protecting spray assemblies **28** and **32**.

10 Preferred flights **22** are primarily directed toward enhancing mixing of the bed **20** of seeds and seed capsules, continually refreshing the surface of the bed with a newly-emergent supply of seeds and seed capsules, rather than lifting and subsequently dropping the seeds and seed capsules which may be fragile when initially coated. To that end, each flight **22** preferably, but without limitation, has a leading surface **23A** extending at an obtuse angle "A1" of at least 90 degrees with respect to the inner surface of the drum. A more preferred angle "A1" is about 100 degrees to about 150 degrees. Trailing surface **23B** of flight **22** can be virtually any angle, with the inner surface of the drum, which angle does not interfere with the operation of adjacent leading surfaces **23A**.

15  
20  
25 Additional retaining rings can be added to the assemblage shown in the drawings, in order to provide that height "H" to the retaining ring which will provide and maintain the optimum configuration of bed **20** inside drum **10**.

30 As noted above, inlet end **12** of the drum may be raised above discharge end **14**. When in use, the drum rotates continuously. Seeds or previously thinly-coated or partially-coated seed capsules are continuously fed into inlet end **12** and thus added to rolling bed **20**. Flights **22** continuously mix the bed as the drum rotates,

refreshing the bed surface with newly fed seeds, or seeds and seed capsules newly brought to the surface by the continuous rotation of the drum in combination with the mixing action of the flights. Spray assembly **28** sprays the desired coating material (e.g. sewage sludge, paper mill sludge, or other coating composition, onto the continuously moving and mixing surface of bed **20** from a plurality of nozzles **30** distributed along the length of pipe **29**, and similarly along the length of drum **10**, adding the sprayed material to the seeds and seed capsules in bed **20**. After receiving the spray coating from spray assembly **28**, the seed capsules are discharged through discharge end **14**. In some embodiments, the seed capsules pass through a cooling chamber, not shown, integral in drum **10**, before being discharged through discharge end **14**.

In general, as the seeds traverse the drum, from inlet to discharge, nozzles **30** atomize the liquid or other coating material and spray such atomized coating material as e.g. droplets of the coating material onto the seeds in the bed. The result is that the seeds become generally uniformly coated with one or more layers of the coating material such that the coating material becomes an integral part of the respective seed capsules fabricated in the drum. As the coating material solidifies on the seeds, the coating material tightly bonds to the respective portions of the seeds.

As the seeds and seed capsules roll and mix with rotation of the drum, the incline of the drum causes the seeds and seed capsules to travel from inlet end **12** toward discharge end **14**.

In the alternative, or where a coating material is not readily self-bonding to the seed material, a binder material can be provided toward the inlet end of the drum at spray assembly **32**, through pipe **33** and nozzles **34**. In such embodiment, the binder is preferably sprayed onto the seeds closer to inlet end **12** rather than along the entire length "L" of the drum. The coating material is then preferably sprayed onto the seeds downstream from the inlet end, and preferably relatively downstream of nozzles **34**. Thus, the

seeds receive a first coating of the binder, and a subsequent second coating of e.g. liquid soil conditioning coating material overlying the binder.

Binder material applied as e.g. through spray assembly **32** may contain additional coating components such as e.g. flyash, lime, gypsum, or the like, as one or more components for assisting in adding bulk and thickness to an inner binder layer prior to any, or the majority of, the application of the organic coating material (e.g. sewage sludge or paper mill sludge).

In some embodiments, binder and liquid soil conditioning coating material are applied at similar locations along length "L" of the drum whereby binder and soil conditioning coating material may become intermingled/mixed before reaching the seeds, or on the seeds. For example, liquid soil conditioning coating material may be sprayed onto the seeds along the full length of the coating chamber in drum **10** while spraying of the binder material onto the substrate seeds is done relatively closer to or adjacent the inlet end of the coating chamber of the drum. Thus, a first binder layer may underlie or be mixed with the soil conditioning coating material, and may be overlain by a second layer of the soil conditioning coating material. Thus, in this embodiment, the binder layer may typically be a combination of binder material and coating material.

Further, it is contemplated that the soil conditioning coating may be applied first, followed by application of binder or inorganic fertilizer or sealer coating, in which case the binder or inorganic fertilizer or sealer may serve as an outer shell, temporarily trapping the inwardly-disposed materials inside the seed capsule. In the alternative, the soil conditioning coating may be applied first, followed by application of the binder, and wherein the binder penetrates through the soil conditioning coating, either physically or chemically, to the underlying substrate seed and there provides the binding property.



Additional spray assemblies can be provided, spraying additional materials (e.g. inorganic fertilizer materials) onto the substrate seed. Thus, e.g. 6 spray assemblies can spray 6 different coating materials onto the substrate seed. For example, 5 a first spray material can be a binder or primer material intended primarily to enhance bonding of subsequent sprays to the substrate seed. Continuing the example, a second spray can be a combination of binder and finely comminuted particulate material such as lime and/or flyash. A third spray may be a soil conditioning material 10 such as a paper mill sludge or a municipal sewage sludge. Fourth, fifth, and/or sixth sprays can add nitrogen, phosphorous, and/or potassium plant nutrient ingredients, alone or in combination, or as combinations. In this manner, the soil conditioning properties of the seed capsule can be established, and the plant nutrient level of the seed capsule can be enhanced to provide substantially 15 any level of major and/or minor plant nutrients desired in the seed capsule, at substantially any relative ratios of the respective plant nutrients, and wherein the preferably primarily soil conditioning coating provides desired soil conditioning properties in the resulting product, initially for use by the specific seed 20 contained therein, and ultimately as additive to the overall tilth of the growth medium such as soil into or onto which the seed capsule is eventually planted.

A preferred, and rather simplistic, embodiment of the 25 invention is provided by spraying a soil conditioning liquid suspension of sewage sludge or paper mill sludge onto seeds to be encapsulated to make seed capsules. By controlling the amount of the soil conditioning sludge, or by controlling the residence time of the seeds in the drum, a desired thickness of soil conditioning 30 coating can be provided in the resulting coated product.

Typical dried sewage sludge, as a raw material, contains about 2-6% nitrogen, up to about 2% phosphorous, and generally no potassium, and thus has little or no market value as a fertilizer

(plant food) product per se. However, by adding e.g. urea, the nitrogen content can be raised if desired, especially as a coating on or adjacent the outside surface of the seed capsule, whereby the combination fertility-enhanced, soil conditioning, seed capsule product has real market value as a comprehensive, self-contained, value-added, seed capsule product. Such product thus contains the seed, a soil conditioning composition which operates somewhat as a seed incubator providing a beneficial germination environment, and a starter quantity of fertilizer selected in quantity and placed in location so as to provide improved, ideally optimum, amounts of plant nutrients at optimum location for use by the newly-emerged embryonic plant at the germination stage of seed development.

Starting with a sludge coating having 2% by weight nitrogen, sufficient urea may be added to bring the nitrogen content to, for example, 5%, 7%, 8% or 10% nitrogen, or more, depending what analysis is desired. Starting with a sludge coating having 6% nitrogen, sufficient urea may be added to bring nitrogen content to, for example, 10%, or whatever other analysis is desired. Phosphorous and/or potassium components and/or materials having combinations of plant nutrient elements (e.g. NPK) can, similarly, be added to the sludge, either before, after, or during addition of the urea. In addition, nitrogen, potassium, and/or phosphorous-containing materials can be combined with the sludge prior to the sludge being applied to the seed.

It should be understood that the more porous the established soil conditioning coating, or e.g. the outer surface of such coating, the more any subsequent spray material penetrates the established coating. All such penetration is contemplated in use of the term "coating" herein.

In some preferred embodiments, the overall coated combination seed capsule product comprises seed capsules wherein substantially the entirety of the soil conditioning material is confined to a contiguously-defined portion of the seed capsule. In such

embodiments, the structures of the finished product seed capsules comprise coatings of contiguously arranged elements of the soil conditioning material, generally arrayed entirely or substantially entirely about the seed, which coatings may be overlain by an additional layer, optionally discontinuous, of organic or inorganic chemical fertilizer. Further coating layers of either soil conditioning material or organic or inorganic chemical fertilizer can be applied over the additional layer.

In addition, or in the alternative, other layers of other materials whether soil conditioning materials, organic or inorganic fertilizers, or other materials, can be applied to the substrate seed before applying the above mentioned layer of soil conditioning sludge. Thus, the substrate seed can be coated with a layer of a calcium compound e.g. calcium chloride, calcium carbonate, or dicalcium phosphate, or with a sulfur moiety, and/or a further layer of urea, all with optional use of binder materials.

Further to the structure of the seed capsules of the invention, the coatings on the seed capsules need not generally represent a uniform mixture of the inorganic chemical fertilizer and the soil conditioner. Rather, in a typical seed capsule a core substrate seed is overlain or encapsulated by a soil conditioning material, and is generally free from a second overlying soil conditioning coating material, and wherein the inorganic fertilizer content at the seed/coating interface is relatively higher so as to represent a second coating material such as an inorganic fertilizer coating, as compared to the inorganic fertilizer content at locations at and adjacent the seed.

The second coating can, and preferably does, in some embodiments, penetrate into voids or other interstices in an underlying e.g. soil conditioning coating. However, preferably most if not all elements of the underlying e.g. soil conditioning coating material are generally interconnected with each other without intervening coating material of the second layer, except

for an optional binder used to hold the first coating material together as a unitary structure, separate from any structure and bonding provided by the second coating material.

5 While the combination seed capsule can comprise discontinuities in the soil conditioning sludge coating layer, in combination with an inorganic fertilizer material in such seed capsules, such compositions are less preferred.

10 Regarding the coating process, FIGURE 4 illustrates in flow sheet form a manufacturing process for producing seed capsules of the invention, using the coating drum 10 as described above. It should be understood, however, that other equipment such as a pan pelletizer, a paddle mixer, or the like can be used in place of the rotary drum to obtain combination seed capsules of the invention.

15 The coating process operates according to conventional and generally well known agglomeration principles, as described by Wolfgang B. Pietsch in an article entitled "The Agglomerative Behavior Of Fine Particles." Such coating process uses water and heat, along with physical and/or chemical adhesives and like properties, to bind or agglomerate a plurality of types of particles and/or materials into coated seed capsules, each typically containing an individual seed.

20 To obtain agglomerates from relatively smaller particles of raw materials, binding forces must act within the individual developing agglomerate particles. According to known agglomeration principles, five different binding mechanisms are known to be  
25 useful for building agglomerate particles including solid bridges, interfacial attractions and capillary pressure, adhesion and cohesion, attraction between solid particles, and form-closed bonds.

30 At elevated temperatures, solid bridges can form by diffusion of molecules from one particle to another at the points of contact. Heat can be introduced from an external, secondary source or created during agglomeration by friction and/or energy conversion.

Solid bridges can also be built up by chemical reaction, crystallization of dissolved substances, hardening binders, and solidification of melted components.

5 Capillary pressure and interfacial attraction forces in liquid bridges can create strong bonds that disappear if the liquid evaporates and no other binding mechanisms take over.

10 Highly viscous bonding media such as tar and other high molecular weight organic liquids can form adhesive and/or cohesive bonds very similar to those of solid bridges. Thin adsorption layers are immobile and can contribute to such bonding together of fine particles under certain circumstances.

15 Typical short-range forces of the van der Waals electrostatic or magnetic type can cause attraction between solid particles whereby the particles stick together if such particles are sufficiently close to each other. Decreasing particle size clearly favors such attraction between solid particles.

Fibers, little platelets or bulky particles can interlock or fold about each other resulting in "form-closed" bonds.

20 Now referring to FIGURE 3, in some embodiments of the coating/agglomeration process, it is desirable to pre-coat the seeds prior to implementing agglomeration principles to produce the above described coating of soil conditioning material. Such embodiments comprise light-weight and/or elongate shaped seeds (i.e. grass seeds), or other similar type of seed which may not  
25 readily or inherently serve as a nucleating agent in a conventional agglomeration process with the respective soil conditioning material which is desired to be coated on the seed. Pre-coating the grass seed, for example, enhances the agglomeration of paper sludge as a coating material, of binder and/or of other coating  
30 substances, by increasing the weight of the pre-coated grass seed and by providing a more filled in, more rounded shape to such long and narrow seeds. The increased weight and more filled in shape of the grass seed enables more effective, more efficient, processing

of the seed in coating apparatus such as that illustrated in FIGURES 3 and 4.

Referring to FIGURE 3, the form and composition of such pre-coating, when needed, can vary according to the weight, shape, composition, and surface properties of the seeds, and according to the binder, if any, the soil conditioning coating or coating materials to be applied, and any other inorganic or organic coating material to be applied.

The seeds, whether pre-coated or not, are received within the rotary drum where the soil conditioning material is spray coated onto the substrate seeds to obtain combination seed capsules.

Before coating the seeds with a soil conditioner, the organic soil conditioner material (e.g. paper sludge) is preferably processed through a dryer such as a rotary drum dryer, as needed, to reduce the amount of moisture in the organic soil conditioner material to less than about 8% water by weight. Such drying is an essential step where the material is otherwise above the nominal 8% effective water content, to enable grinding the sludge to a size less than US Standard 20 mesh screen, and to prevent the particles from agglomerating with each other. Certain of the coating materials, e.g. fly ash, because of their physical properties, need not be dried before being ground to a suitable size for participating in the agglomeration operation.

The seeds, whether pre-coated or not pre-coated, and the one or more soil conditioners, are received within a mixer where growth enhancers such as time release agents and/or other environmental conditioners may be added to form a combination seed capsule. The thus pre-coated seeds are then received into a pan pelletizer, a rotary drum, or the like, where binders such as lignin, lignosulphonates, molasses, sodium silicate, wax, monammonium phosphate, or urea can be added and thereby coated onto the pre-coated seeds. Other materials which can be added to the seed capsule at the e.g. rotary drum include anti-fungal coatings such

as with metalaxyl fungicide, for example, Apron® and/or Subdue®, available from Novartis, Inc. of Greensboro, North Carolina.

5 The such-coated seeds are then passed into a rotary or other dryer in order to obtain a seed capsule containing 5% or less water. The maximum water fraction in the coating can vary according to the composition of the coating material, so long as the resultant seed capsules remain suitably structurally strong and so long as a population of such coated seed capsules remains free flowing in solid condition. The process for fabricating the seed capsules must maintain a temperature sufficiently low that the seeds are not heated so hot that viability of the seeds, for germination purposes, is not dramatically compromised. It is generally preferred that the temperature of the seeds be suitably controlled such that any binder and/or coating material, or other materials applied to the seeds, cool at a controlled rate while bonds form between the seeds, or seed capsule precursors and the one or more soil conditioning and/or other coating materials. Such temperatures of all materials are suitably controlled to avoid decomposition of the respective materials, loss of viability of the seeds, or breakage of seed capsules or seed capsule precursors, or coatings or coating or other materials during such processing. The temperature at the rolling seed bed inside drum 10 generally can range from about 130 degrees F to up to at least 230 degrees F for seed residence times up to at least 1 hour. At drum operating temperatures of less than 130 degrees F, drying time can become excessive. At temperatures above 230 F, the viability of the seed may be at risk, depending on the sensitivity of the seed, residence time, and other influential parameters.

15  
20  
25  
30 The above stated temperature range is illustrative and not limiting, and will vary depending on the seed, the coating materials, and the specific process parameters of a particular coating system and coating operation. Thus, maximum e.g. drum coating temperatures can be less than 130 degrees F or more than

230 degrees F. However, the stated range is preferred, including all temperatures within such range such as, for example, 150 degrees F, 180 degrees F, 210 degrees F, and the like.

5 Referring to the drum of FIGURES 1 and 2, and to the pan pelletizer block in FIGURE 3, the seeds are fed continuously to an inlet as at inlet end **12** of drum **10**. Combination seed capsules, produced as described above, are released from a discharge locus such as discharge end **14** of the drum to a sizing apparatus **36** in which the seed capsules are sized through conventional sizing  
10 elements. Suitably-sized seed capsules are discharged from the sizing apparatus as product for distribution. Undersize seed capsules are fed back into mixer as shown in FIGURE 3. Oversized seed capsules are fractured and screened for reprocessing.

15 The recovered seed product can be further coated with any of the coating materials described above, such as urea or other inorganic or organic fertilizer, and/or with growth enhancers or other desirable materials. Further, other types of coating materials such as water repellants can be coated onto the discharged seed capsules for the purpose of imparting additional  
20 desirable properties to the seed capsules.

In the process of coating porous organic materials such as sewage sludge or paper mill sludge as is optional in the invention, with a second material which is applied for other than imparting soil conditioning properties, for example an inorganic fertilizer,  
25 the general size of the coated seed capsule may be the same after applying the second material (e.g. inorganic fertilizer) as the size of the previously-coated seed capsule, or may be similar in size. Namely, the quantity of coating material added to the seed capsule can be so small as to not materially affect seed capsule  
30 size, or the coating material can be received into an e.g. porous interior of the soil conditioning coating of the seed capsule, or both.



It is contemplated that the operation and functions of the invention have become fully apparent from the foregoing description of elements, but for completeness of disclosure, the usage of the invention will be briefly described.

5

## EXAMPLE 1

10 A coating drum as illustrated in FIGURES 1, 2 and 4 is used to place a coating of paper mill sludge on grass seed. Raw material grass seed about 4-6 millimeters long and about 0.5-1.0 millimeter thick, is continuously fed to pre-treater **11**, where the seed is blended with powdered lime, powdered flyash, and a lignosulfonate binder, to form partially-developed seed capsules comprising seeds coated with relatively thinner coatings of the recited mixture of coating materials. The partially-developed seed capsules are continuously fed to inlet end **12** of drum **10**, to form a bed **20** of the partially-developed seed capsules. The drum rotates continuously. The rolling of the drum, and the associated mixing affect of the flights, provide a constantly changing top surface of the bed. A paper mill sludge slurry is supplied in pipe **28** at pressure sufficient to atomize the liquid sludge slurry. A liquid sludge slurry is thus sprayed from nozzles **30** onto the top surface of the bed of partially-developed seed capsules, applying a sludge coating on those partially-developed seed capsules which are at the upper surface of the bed at any given point in time.

25

The resulting seed capsules, of paper mill sludge coated seeds, have a coating of soil conditioning sludge thick enough to make the material a product marketable for its soil conditioning content as well as for the seeds contained therein. Increased levels of nitrogen and/or other plant nutrients can be added by, without limitation, providing sprays of the other desired materials, preferably subsequent to at least the initial sludge slurry spray. Other materials can be included in one or more of

30

the sprays e.g. to retard or enhance moisture permeation into or out of the combination product in accord with the anticipated storage and/or use environment of the product.

5

## EXAMPLE 2

FIGURE 5 illustrates the equipment used in this EXAMPLE 2. As seen therein, grass seed, lime, flyash, and calcium lignosulfonate binder are fed to ribbon blender **111** by respective screw feeders **112A**, **112B**, **112C**, **112D** respectively. Ribbon blender **111** encapsulates the seed with a thin layer of the mixture of lime, flyash, and lignosulfonate to thereby make partially-formed seed capsules. The partially-formed seed capsules are discharged from the ribbon blender and conveyed by conveyor **114** and belt feeder **116** to a tilted-pan pelletizer **118**, which rotates about a fixed axis.

10

15

20

25

30

Paper mill sludge is received into a weigh hopper **120** at about 60% by weight water, and is fed by screw feeder **122** and belt **124** to pin mixer **126**. The pin mixer breaks down the fiber and fiber clusters of the sludge into loose separate fibers, and discharges the resultant material onto conveyor **128** which transports the material to screw feeder **130**, and thence into the tilted pan pelletizer.

35

40

45

50

55

60

65

70

75

80

85

90

95

100

105

110

115

120

125

130

135

140

145

150

155

160

165

170

175

180

185

190

195

200

205

210

215

220

225

230

235

240

245

250

255

260

265

270

275

280

285

290

295

300

305

310

315

320

325

330

335

340

345

350

355

360

365

370

375

380

385

390

395

400

405

410

415

420

425

430

435

440

445

450

455

460

465

470

475

480

485

490

495

500

505

510

515

520

525

530

535

540

545

550

555

560

565

570

575

580

585

590

595

600

605

610

615

620

625

630

635

640

645

650

655

660

665

670

675

680

685

690

695

700

705

710

715

720

725

730

735

740

745

750

755

760

765

770

775

780

785

790

795

800

805

810

815

820

825

830

835

840

845

850

855

860

865

870

875

880

885

890

895

900

905

910

915

920

925

930

935

940

945

950

955

960

965

970

975

980

985

990

995

1000

In the tilted pan pelletizer, the partially-formed seed capsules, (seeds being coated with lime, flyash, and lignosulfonate) are mixed with the comminuted paper mill sludge and thereby coated with the sludge. By operation of the tilted rotating pan pelletizer, the larger seed capsules generally rise to the top of the bed of seed capsules in the pan, and as additional material (sludge and partially-formed seed capsules) are added to the pan, the larger seed capsules overflow the lower edge of the rotating pan, onto vibrating feeder conveyor **132**.

The vibrating feeder conveyor feeds the seed capsules into granulator **134** (e.g. rotating drum) where the seed capsules may be

(e.g. spray) coated with inorganic fertilizer or other desired material.

5 From the granulator, the seed capsules flow into dryer 136 and are dried to a final product moisture of about 2-3% by weight water. The resultant product is then screened and sized as before, with undersized and oversized product seed capsules being recycled for further processing.

10 Urea and other liquid inorganic chemical fertilizers can, as indicated, be used as binders to bind together soil conditioning coatings which are not readily self-bonded together. In such embodiments, the urea or other liquid fertilizer composition serves as the binder or glue which holds together the soil conditioning material which is used as the coating. Other binding materials may  
15 be used either alone or in combination with the inorganic chemical fertilizer. Any plant nutrient components of the binder/glue composition contribute to the plant nutrient value, e.g. nitrogen, phosphorous, and/or potassium, provided by the so-made seed capsules. Thus, a binder/glue, or a multiplicity of binders/glues,  
20 properly selected as to nutrient value can provide, in the finished product, significant contribution to any desired fertility analysis.

25 A primary purpose of soil conditioning products is to condition the soil in terms of properties other than direct provision of plant nutrients.

30 The primary purpose of conventional inorganic chemical fertilizer products is to directly provide plant nutrients. It is well known that highly purified forms of inorganic chemical materials are more concentrated than desired in close or intimate proximity with seed, in the growing medium. Thus, inorganic chemical fertilizers can be diluted in concentration and still have sufficient nutrient content to be highly useful additives in soil conditioning seed capsules of the invention. It is common practice

to modify and thus dilute inorganic chemical fertilizer products with filler materials that do not provide plant nutrients, in order to provide less concentrated fertilizer products. To the inventor's knowledge, such diluents, however, do not include soil conditioning products, especially not organic soil conditioning products.

It is conventionally known to apply commercially available soil conditioning materials and inorganic fertilizers, in separate applications, to a given common plot of soil to assist the soil in growing a crop. For example, it is known to make a first broadcast or other placement of lime to control pH of the soil, followed by a second broadcast and/or row-applied placement of granular inorganic chemical fertilizer. It is also known to make sequential applications of a soil conditioning material such as fresh or aged manure followed by inorganic fertilizer, all of which may be separate from the step of applying seed. And where seed is indeed applied in the same step, the seed and soil conditioner are not intimately bound in controlled positioning with respect to each other in common in individual particles of the product so applied, as in the invention.

To the inventor's knowledge, it is not known to apply soil conditioning material and inorganic chemical fertilizer in a common carrier/particle. Nor is it known to apply seed in a seed capsule wherein the seed is intimately combined with a soil conditioning material in a common particle, optionally with an inorganic fertilizer component in controlled positioning with respect to the seed in the same capsule as a seed-soil conditioning particle.

In those embodiments of the invention comprehending both soil conditioning and inorganic fertilizer in the same seed capsule/particle, the ratio of soil conditioning material to inorganic chemical fertilizer material can vary, from, for example, about 80% by weight up to less than 100% by weight soil conditioning material, with corresponding greater than 0% up to

about 20% by weight inorganic chemical fertilizer. Generally, the invention as practically applied, however, is somewhat more narrowly defined, because the practical benefits of the invention are achieved at more balanced combinations of the soil conditioning material and the inorganic chemical fertilizer.

Thus, a preferred amount of soil conditioning material is about 90% by weight to about 98% by weight soil conditioning material, in combination with about 2% by weight to about 10% by weight inorganic chemical fertilizer. To the extent the soil conditioning material is present in amount less than about 80% by weight, the corresponding 20% by weight organic fertilizer in such close and intimate proximity to the seed may be toxic to the seed. To the extent the inorganic fertilizer is present in an amount of less than 2% by weight, the beneficial fertility affects of the fertilizer may not be perceived.

To the extent the inorganic fertilizer can be confined in a layer displaced from the seed, a higher level of inorganic fertilizer may be used while limiting risk of a toxic response from the seed. Referring now to FIGURES 6A-6D, in the embodiment of FIGURE 6A, seed capsule **38A** comprises a seed **40A** coated with a single generally homogeneous coating **42A**. Coating **42A**, as illustrated in FIGURE 6A, may comprise only the soil conditioning material (e.g. paper mill sludge or sewage sludge), or may comprise both the soil conditioning material and an inorganic fertilizer or other inorganic material generally dispersed in coating **42A**.

In FIGURE 6B, seed capsule **38B** comprises a seed **40B** coated with a first layer **42B** of soil conditioning material. A second coating material is shown penetrated part-way through the first layer **42B**, thus to make a combination outer layer **44B** comprising the combination of the material of layer **42A** and the material of the second material, such as inorganic fertilizer.

In FIGURE 6C, seed capsule **38C** comprises a seed **40C** coated with a first layer **42C** of soil conditioning material. A second

generally separate and distinct layer **46C** of a second coating material (e.g. inorganic fertilizer) is disposed outwardly on the underlying first layer **42C**. Layer **46C** generally does not penetrate layer **42C**, whereby higher levels of inorganic fertilizer may be used because of the effective displacement distance between the seed and the second layer **46C**. The second layer may be prevented from penetrating the first layer by applying e.g. an intervening layer which repels the second layer, for example wax, lignin, or the like.

In FIGURE 6D, seed capsule **38D** comprises a seed **40D** coated with a pre-coating layer **48D** of dicalcium phosphate to densify and configure the seed capsule precursor for the primary coating steps in drum **10** or pan pelletizer **118**. Layer **42D** of soil conditioning material is disposed outwardly of pre-coating layer **48D**. Other materials such as at layers **44B** or **46C** can be added to any of the embodiments, including that of FIGURE 6D to provide the properties associated therewith.

In alternative embodiments, seed capsules can comprise a seed coated with at least one heterogenous layer. The heterogenous layer comprises at least two different materials substantially commingled, uniformly or non-uniformly, within a single layer. Such materials can include, for example, soil conditioning material and inorganic fertilizer, micronutrients, herbicides, fungicides, binders and/or any other layer material contemplated by the present invention.

While the soil conditioning material/sewage sludge or paper mill sludge may contain a nominal amount of nitrogen and lesser quantities of phosphorous, potassium, and micronutrients, these small levels of plant nutrient content are generally not high enough for the plant nutrients to be considered a primary commercial asset. Yet only small nutrient amounts are desired so close to the seed. Thus, in some uses, the nutrient content of the sludge may be fully acceptable as the sole coating material on the

seed in making suitable and acceptable seed capsules of the invention.

5 Products of the invention offer a new combination of properties, namely readily available excellent soil conditioning properties in combination with the seed in a seed capsule wherein size and density of the seed capsule are controlled to the desired size and weight.

10 One of the properties offered by soil texture conditioners such as sewage sludge and paper mill sludge is that of maintaining soil condition by retaining moisture in the soil, retarding leaching of soil nutrients from the root zone, and attenuating hardening, clumping, or other hard agglomeration characteristics of the soil, which harder soils are more difficult for plant roots to penetrate than are softer soils. Thus, improving the soil texture  
15 condition, soil tith, increases the efficiency with which plant nutrients are retained and used for plant nutrition, as well as generally improving the environment of the soil to accommodate, and readily receive, root growth.

20 When soil conditioning materials and plant nutrients are applied separately to the soil, as in the prior art, the ratio of applied plant nutrients to applied soil conditioning material typically varies widely according to variations in the uniformity of the two applications of the two materials. Further, the soil conditioning material is generally not closely associated with the  
25 plant nutrient-containing fertilizer in the soil, and certainly neither soil conditioner nor the fertilizer are controllably-closely associated with the seed, such that nutrient absorption benefits provided by the soil conditioning material are not assuredly associated with respective particles of inorganic  
30 chemical fertilizer materials, and neither the soil conditioning material nor the inorganic fertilizer is controllably and intimately associated with the seed as in a common capsule or other particle as in the invention.

5 Rather, where soil conditioning and fertilizer materials are applied in separate applications and/or in applications separate from the application of the seed, the bulk of the soil conditioning material and the bulk of the inorganic chemical fertilizer are generally at least somewhat separated from each other in space, and physically separated from the seeds, such that potential cooperative benefit of the soil conditioning material as relates to solvation and up-take of soil moisture and/or of the inorganic chemical fertilizer by the seed are not obtained, and/or are not  
10 obtained in controlled close association with the seed.

15 When the soil conditioning material, the inorganic chemical fertilizer materials, and the seed are separately applied to soil with different sets of equipment, the respective rates of application vary such that the desired ratios between the quantities of the several materials are applied somewhat non-uniformly. The variances from uniformity will be different for each of the applications, thus adversely skewing the relative ratios of the materials with respect to each other at different locations in the e.g. field. Further, when applied separately to  
20 the soil, the seed and the soil conditioner are not necessarily in intimate contact with each other as they are when both materials are combined into a single combined seed capsule product as in the invention. Nor is the seed in closely controlled proximity (e.g. within the same capsule) with the inorganic fertilizer. In  
25 reality, then, any fertilizer added to the soil but not in close proximity to the seed applied to the same soil during e.g. the same growing season, is of reduced value or no value to that application of seed, whereby little or no value is realized, during that growing season, from the application of such material to the soil.

30 The amounts of soil conditioning material and inorganic fertilizer added to the soil at any given time represent a small fraction of the "soil" in the plant growing zone (root zone). Thus, in the conventional practice of providing separate



applications of plant nutrients and soil conditioning material, in addition to the seed, only small fractions of the newly applied soil conditioning material and plant nutrient come into proximate cooperating relationship with each other and with the seed. Thus, the seed and any plant newly emergent from the seed are benefitted only to the extent the overall average root zone of the soil is benefitted by the applied soil conditioning material

Even were combinations of soil conditioner, inorganic chemical fertilizer, and seed are to be applied as separate and distinct physical product particles, using a single application apparatus and a single application process, the individual particles of soil conditioner, individual particles of inorganic chemical fertilizer, and individual particles of seed would be separated from each other to a significant degree, during the application process, such that the benefits of intimate association with each other in the soil would be lost. Indeed, the seed benefits from intimate contact with a substantial quantity of soil conditioner, but can tolerate intimate contact with only limited concentrations of fertilizer chemicals. Rather, fertilizer chemicals should in general be displaced from, but controllably located close to the seed.

In an uncontrolled application of fertilizer by an application separate from application of the seed, as in the prior art, some of the seed might be expected to be placed so close to some of the inorganic fertilizer as to be damaged by the toxic affect of such close association. Thus, the benefit of intimate contact between organic soil conditioning material, inorganic chemical fertilizer, and seed, is reduced and largely lost because of low levels of intimate association between the soil conditioning material and the seed, and unpredictable, uncontrolled levels of association between the seed and the inorganic chemical fertilizer, outside the combination of the invention, of soil conditioning coating of the seed, and optional addition of inorganic fertilizer at controlled

location with respect to the seed, all in the same seed capsule, as taught herein.

By combining an organic soil conditioning material in the same seed capsule with the seed, highly effective levels of soil conditioner are assuredly associated with the seed as the seed germinates and begins to grow. Where suitable levels of plant nutrient fertilizer are incorporated into the same seed capsule, growth of the newly-germinated plant is further enhanced. In either case, the soil conditioning materials can and do tend to retain moisture and nutrients in the soil in the defined area of the seed capsule by a variety of mechanisms, providing an extended time period during which nutrients can be taken up by the plants. For example, organic soil conditioning material may retain moisture, reducing moisture drainage from the soil, such that the rate of leaching of the nutrients is, in general, reduced. Further, the soil conditioning material may absorb or otherwise physically or chemically attach to plant nutrient materials in the chemical fertilizer material, thus further retarding leaching of the plant nutrient away from the seed.

While applicant cannot place an exact time period on the increase in the extent to which the soil conditioning materials retard leaching of the plant nutrients from proximity with the seed, thereby holding the plant nutrients available for up-take by the plant, any increase in time during which the nutrients are held in the soil proximate the newly-emerging plant is beneficial to meeting the nutritional needs of the plant being so fed.

By incorporating soil conditioning materials and optionally plant nutrient fertilizers, in the seed capsules, the invention offers an efficiency of application of soil conditioning materials in proximity to the seeds most beneficially affected thereby, in a beneficial association never before available. Optional addition of plant nutrients to the same seed capsule provides a largely self-contained microcosm of seed, soil conditioner, and inorganic

fertilizer in intimate yet controlled spatial relationship with each other, whereby the controlled spacings provide enhanced plant growth benefit. Namely, soil conditioning materials and plant nutrients are somewhat beneficial to each other for the overall cooperative achievement of soil fertility in the presence of the newly emerging plant which is dependent on such plant nutrients, and on moisture retained by the soil conditioner for uptake of such plant nutrients.

While soil conditioning materials do perform a number of highly interdependent tasks, one such task is in assisting in maintaining the plant nutrients in the root zone where they can be effectively used by the plants when needed. Another such task is in assisting in making the soil soft and friable in the root zone whereby the newly-emerged and very tender plant roots more readily penetrate the soil as they grow.

Where both soil conditioner and fertilizer are incorporated with the seed into the seed capsule, the soil conditioner assists in strategically maintaining the combination of soil conditioner and plant nutrients in close and controlled proximity to each other and to the seed in the soil. Such strategic placement virtually assures that the soil conditioning material and inorganic chemical fertilizer are bound to each other, in proximate relationship with the seed, for a time, such that wherever the seed capsule may land when the seed is sown, the seed will have the initial benefit of both soil conditioner and plant nutrients in intimate proximity with itself, irrespective of any condition of the surrounding growth medium. Thus, in the invention, soil conditioning material and optionally inorganic chemical fertilizer, are inherently bound to each other, and to the seed, as by the coating process, and inherently assist the seed in achieving desired germination and strong early growth.

By incorporating the soil conditioning material in the same seed capsule with the seed, the invention ensures that the seed has

benefit of intimate relationship with a beneficial amount of soil conditioner material. The seed thus receives the advantage of the beneficial amount of soil conditioner material irrespective of the overall tilth of the soil and irrespective of the overall level of soil conditioner, e.g. soil texture conditioner, in the root zone of the soil with which the seed capsule becomes associated for seed and plant growth purposes.

Referring to FIGURE 7, a population of seed capsules **38** are disposed at the top surface of a cross section of soil. Root zone **150** of the soil is generally defined to that depth of the soil which typically receives roots of growing plants, and is generally defined within 20-30 inches of the top surface of the soil. Generally, and preferably, the root zone should have a soft texture, rich in organic and/or other soil conditioning material in order to provide good tilth, and desirable moisture and nutrient holding properties. Underlying root zone **150** is subsoil **152** which typically contains little organic matter.

It is a well known agricultural phenomenon that, in soil used for intensive crop production, the root zone tends, over time, to become relatively depleted of organic soil conditioning material, illustrated at **154** in FIGURE 7, negatively affecting soil tilth and texture. While wholesale addition of organic soil conditioning material can improve the overall tilth of the soil, FIGURE 7 illustrates application of the invention wherein the texture of the material immediately adjacent the seed, namely coating **42**, provides beneficial properties attributable to soil having desirable texture.

FIGURE 8 illustrates that coating **42** draws moisture **154** from the soil, into the capsule, where the moisture is available to assist in germination of seed **40**. In the process, traverse of the moisture through second coating **46C** releases plant nutrient material into the moisture, as well as downwardly into the soil adjacent the seed capsule, as illustrated at **156**. Thus, the root

158 emerging from the seed emerges into an initial growth medium, coating 42, having texture, moisture, and plant nutrient highly advantageous to early plant growth. As root 158 advances further downward, the upper portion of the underlying soil under the capsule where the seed first enters the soil, has also been beneficially affected to the good of the plant by plant nutrients 156, and by moisture attracted or held in the vicinity of the capsule, as a result of the presence of the soil conditioning material in the capsule.

The relative amounts of the soil conditioning material and the inorganic chemical fertilizer material in the seed capsule vary significantly in accord with the specific application, and any specific interactivity desired of the soil conditioning material and inorganic chemical fertilizer. For example, in a particular combination of soil conditioning material and inorganic fertilizer a particular plant crop to be nourished by the product may require a higher amount of plant nutrient, or a specific analysis of plant nutrients, in order to be properly fed at and shortly after the stage of germination.

Thus, for a given specific application of combination seed capsule (with fertilizer) product of the invention, the relative amount of inorganic chemical fertilizer, and the fertilizer analysis, may be increased or decreased from some "standard" in the interest of achieving a functionally adequate feeding of the newly germinated seedlings. Namely, the NPK etc. nutrient levels provided in a given seed capsule product of the invention can be set and controlled at the fertilizer manufacturing plant in accord with the respective NPK etc. nutrient needs of the seed to be supported, or of the soil or other growth medium to which the combination fertilizer of the invention is to be applied.

In any embodiments, whether or not specifically discussed here, the fabricated seed capsules are kept sufficiently cool, and are kept sufficiently dry, to avoid the seed capsules sticking to

each other, caking, and the like, and to prevent premature germination of the seed. Where liquid is used to obtain the coating material in liquid state, sufficient liquid is removed during or shortly after the coating step to avoid the seed capsules sticking to each other, or caking, or the like. Where the seed capsules are made by process other than the process described here, the details of the process will determine proper cooling, drying, or other steps to provide a finished, dry, solid seed capsule or like product. A dry such product generally has moisture content less than 10% by weight, preferably less than 5% by weight, most preferably less than 3% by weight.

As suggested by the description hereinabove, the processes of the invention are generally carried out to make combination seed improvement products solely by using physical processes such as coating and drying. While some minor chemical reactions may inadvertently accompany such physical processes, the invention does not rely on any chemical reaction for achievement of the objectives thereof. Rather the invention is focused on a physical combination of starting materials, which physical combination results in mutual benefits of the two starting materials (seed and soil conditioner, and optional inorganic chemical fertilizer) functioning intimately together, in primarily physical and physico-chemical relationship, to produce an overall increase in benefits of plant germination and early plant growth with such combination seed improvement products.

The relative amounts of seed and coating material depend on the overall benefits desired to be achieved from the coating operations. In general, the seed will comprise from about 0.1% to about 75% of the overall weight of the seed capsule. the coating material thus represents about 25% to about 99.9% by weight of the seed capsule. Where the seed content is low, the general benefit of the product is that of soil conditioning, with some seed application. Such product is well suited for application to e.g.

a healthy lawn for general improvement of soil condition, and modest fill-in of bare spots with seed.

Another benefit of low seed content by weight, especially with quite small seeds, is in creating a larger size seed capsule, and thereby facilitating the handling of such seed in commonly-used seed handling machines such as grain drills or seed broadcast machines.

Typically, however, a higher seed content is preferred so as to have major impact on the number of plants which are caused to germinate by application of such product. Thus, for a seed about 0.5-1.0 mm thick and about 4-7 mm long, a preferred fraction of seed is about 1% to about 50%, preferably about 1.5% to about 20%, more preferably about 2% to about 10% by weight seed, with respective amount of soil conditioner and optionally fertilizer. For example, in a preferred product of the invention, an above mentioned grass seed about 0.5-1.0 mm thick and about 4-7 mm long, when coated produces a seed capsule about 4 mm across and about 6-9 mm long. Smaller, or larger, seed capsules may be made and used as desired.

The size and density of the seed capsules can be readily controlled using conventional sizing equipment and processing parameters of the coating process, so as to provide a uniform product of a wide range of sizes and densities. With the size and density of any seed thus controllable, the size and density may be selected and specified for enhancing control and efficiency of seed handling and/or distribution. For example, tiny seeds such as lettuce, carrots, cabbage, and alfalfa, may be sized and weighted for easy and assured handling and distribution, whether by hand or by machine. Seeds which are non-aerodynamic, or which are so light as to be blown around, such as grass seed, can be made heavy and compact enough as to assuredly remain on location where sown after being planted. For example, non-aerodynamic seeds, after treatment according to the invention, can be broadcast-applied using

conventional equipment such as is used to broadcast apply granular fertilizer over e.g. 40 foot wide application paths.

5 Where time controlled germination is desirable, a population of combination seed capsules, having at least one soil conditioner and one or more nutrients, can be planted in conjunction with non-coated seeds. As a result, non-coated seeds will germinate at an earlier stage than the population of combination seed capsules. Such staggering of germination times allows, for example, the non-coated seeds to use the available soil nutrients with less competition (i.e. less seeds using limited nutrient supply). At a later time, when the coated seeds germinate, such seeds can use the nutrients leached from their combination seed capsules to germinate.

10 Where e.g. small such seeds are desirably planted in close proximity with each other, and wherein a relatively larger size seed capsule is desired for ease of handling such that the large size seed capsule would potentially interfere with such close placement of the seeds with respect to each other, then and in such situation, multiple seeds may be employed in individual seed capsules, e.g. generally uniformly distributed throughout the seed capsule, so as to provide for sufficiently close spacing of the seeds from each other.

15 Paper mill sludge, as is suggested as a coating material herein, is a resultant by-product of papermaking, typically from e.g. a de-inking process in the paper mill.

20 By utilizing paper mill sludge and/or sewage sludge as taught herein, one contemplates beneficially and suitably disposing of significant quantities of industrial waste which otherwise is disposed of by landfilling.

25 Where the product of the invention is applied as to a residential or like lawn, as in an agricultural field, the seed is applied to the soil in intimate combination (seed capsule) with the soil conditioner, such that the soil conditioner serves as moisture



retainer and sun shield. In addition, the seed capsule is much heavier and dense than the seed itself, whereby the seed capsule provides substantial protection against the seed being washed away in surface water run-off. Thus, the coating about the seed serves many of the functions typically performed by the conventionally-used straw mulch. Accordingly, product of the invention can be used to seed new lawns without any need for use of straw or any other mulch material.

Where seed is desirably used to fill in bare spots in the lawn, such seed, especially fertility-enhanced seed capsules, may be applied desirably in one of two ways. First, the coated seed capsule product may be applied only to perceived bare spots, without use of straw. The soil conditioner in the seed capsules serve the functions of the straw as described above, but perform better than straw because of the close association between the seed and the soil conditioner.

In the alternative, the coated seed capsule product may be broadcast generally over the entire lawn. Where the lawn is already healthy with thick grass growth, the soil conditioner and fertilizer will benefit the existing grasses, with minimal germination and growth of new seed from the seed capsules. Where the existing grass is thinner, the seeds in the seed capsules will have room and light to grow, whereby the combined properties of seed, soil conditioner, and fertilizer, in intimate relationship with one another, will be efficaciously used.

Where seed capsules of the invention are used to establish a new lawn, the soil conditioner in the seed capsules serve the functions of the straw as described above, obviating the need for straw in establishing the lawn seeding.

Those skilled in the art will now see that certain modifications can be made to the apparatus and methods herein disclosed with respect to the illustrated embodiments, without departing from the spirit of the instant invention. And while the

invention has been described above with respect to the preferred embodiments, it will be understood that the invention is adapted to numerous rearrangements, modifications, and alterations

5 To the extent the following claims use means plus function language, it is not meant to include there, or in the instant specification, anything not structurally equivalent to what is shown in the embodiments disclosed in the specification.

0  
1  
2  
3  
4  
5  
6  
7  
8  
9  
10  
11  
12  
13  
14  
15  
16  
17  
18  
19  
20  
21  
22  
23  
24  
25

CLAIMS

Having thus described the invention, what is claimed is:

1. A combination seed capsule, comprising:
  - (a) at least one viable seed, having an outer surface and acting as a core or psuedo-core of said combination seed capsule; and
  - (b) a coating of a composition comprising a soil conditioning material mounted proximate, including disposed outwardly of the outer surface of said seed.
  
2. A combination seed capsule as in Claim 1, said coating providing at least one of
  - (i) enhancing broadcast flight properties of said combination seed capsule;
  - (ii) reducing susceptibility to deleterious affects of weather on said combination seed capsule;
  - (iii) enhancing resistance of said combination seed capsule to attack by animals or spore-formers;
  - (iv) staged germination of ones of said seed capsules, having seeds, under a given set of conditions, over a period of time longer than the range of germination times inherent in said seeds;

- (v) enhancing control of moisture about said seed thereby to assist in seed germination;
- (vi) release of plant nutrients into soil onto which said combination seed capsule is placed;
- (vii) soil conditioning effect to soil onto which said combination seed capsule is placed;
- (viii) staged release of plant nutrients into soil onto which said combination seed capsule is placed, over a period of time longer than the range of times inherent in the chemical composition so released;
- (ix) higher embryo emergence and survival rate in a population of said seed capsules, thereby reducing required seed planting density for a desired plant population density; and
- (x) assisting in stabilizing moisture content in soil on which such seed capsule is disposed.

3. A combination seed capsule as in Claim 1 wherein said seed is selected from the group consisting of grass, vegetables, grains, and flowers.

4. A combination seed capsule as in Claim 1, said coating further comprising said soil conditioning material in combination with at least one ingredient effective to reduce susceptibility of

said seed capsule to deleterious affect of at least one of animals, weeds, and spore-formers.

5. A combination seed capsule as in Claim 4 wherein said at least one ingredient to reduce susceptibility of the seed capsule is selected from the group consisting of herbicides, fungicides, and a bitter substance.

6. A combination seed capsule as in Claim 5 wherein said fungicide comprises metalaxyl.

7. A combination seed capsule as in Claim 1, said coating comprising a first coating, said combination seed capsule further comprising a second coating, separate from said first coating, and comprising at least one ingredient effective to reduce susceptibility of said seed capsule to deleterious effect of at least one of animals, weeds, and spore-formers.

8. A combination seed capsule as in Claim 1, effective to provide a plant nutrient at a desirable controlled distance from a plant seedling emerging from said seed, in an amount beneficial to said plant seedling.

9. A combination seed capsule as in Claim 1, said coating comprising a first coating, said combination seed capsule further comprising a second coating of a second coating material intermingled with said first coating material in an outer portion of said first coating, and generally displaced from said seed.

10. A combination seed capsule as in Claim 9 wherein said second coating material comprises a plant nutrient, beneficial in location and in amount of availability, to plant seedling emerging from said seed.

11. A combination seed capsule as in Claim 9 wherein said second coating composition comprises an inorganic form of a plant nutrient and is selected from the group consisting of nitrogen, phosphorus, and potassium.

12. A combination seed capsule as in Claim 9 wherein said second coating composition comprises an inorganic form of a plant nutrient and is selected from the group consisting of urea, monammonium phosphate, diammonium phosphate, superphosphate, triple superphosphate, dicalcium phosphate, and potash.

13. A combination seed capsule as in Claim 9 wherein said second coating composition comprises an inorganic form of a plant nutrient is selected from the group consisting of sulfur, manganese, copper, boron, iron, magnesium and chromium.

14. A population of combination seed capsules of Claim 1, said population of seed capsules comprising coatings having a range of properties affecting germination rate of said seeds, thereby to stage germination of said seeds in said population over a period of time longer than the range of germination times inherent in uncoated ones of said seeds.

15. A population of combination seed capsules as in Claim 14 wherein said range of properties comprises at least one of (i) a range of hardnesses and (ii) a range of thicknesses, of said coatings.

16. A combination seed capsule as in Claim 1, said coating comprising a first layer of said soil conditioning material, and including a second layer comprising an inorganic fertilizer.

17. A combination seed capsule as in Claim 1, said coating comprising a first layer of said soil conditioning material, and including a second layer comprising at least one micronutrient.

18. A combination seed capsule as in Claim 17 wherein said micronutrient is selected from the group consisting of sulfur, manganese, copper, boron, iron, magnesium and chromium.

19. A combination seed capsule as in Claim 1, said soil conditioning material comprising a sludge composition.

20. A combination seed capsule as in Claim 1, said soil conditioning material comprising a fiber-containing by-product of a paper making operation.

21. A combination seed capsule as in Claim 1, said seed capsule comprising a water-leachable plant nutrient, and a leach-

retardant composition effective to retard leaching of said leachable plant nutrient out of said combination seed capsule.

22. A population of combination seed capsules of Claim 1, said coating in ones, but less than all, of said population, comprising an ingredient effective to retard effective penetration of a seed-germinating environment to said seed for germination thereof.

23. A combination seed capsule as in Claim 1, said seed capsule comprising an inner layer on the outer surface of said seed, and an outer layer, said inner layer enhancing properties of said seed for acting as nucleus in an agglomeration operation agglomerating said coating onto said inner layer.

24. A combination seed capsule as in Claim 1 wherein said coating comprises an admixture of said soil conditioner and a plant nutrient.

25. A combination seed capsule as in Claim 1 wherein said coating remains generally disposed about said seed until said seed germinates.

26. A plant growing system, comprising:

- (a) a plant growing medium extending over an area, said plant growing medium having a root zone, and a top surface of said root zone generally corresponding with a top surface



of said plant growing medium, said plant growing medium having a first overall soil condition and texture; and

- (b) a population of seed capsules disposed over the top surface of said plant growing medium, said seed capsules comprising individual seeds, having outer surfaces, and coatings of soil conditioning material disposed outwardly of the outer surfaces of said seeds,

said coatings of said seed capsules providing localized germination and growth environments, at and adjacent said seeds, having texture, and nutrient and water holding properties for supporting seedling health, superior to respective said properties as provided overall in the root zone of said plant growing medium.

27. A growing system as in Claim 26, said coatings remaining generally disposed about said seeds until respective ones of said seeds germinate.

28. A growing system as in Claim 26, said coatings providing at least one of

- (i) enhancing broadcast flight properties of said combination seed capsule;
- (ii) reducing susceptibility to deleterious affects of weather on said combination seed capsule;
- (iii) enhancing resistance of said combination seed capsule to attack by animals or spore-formers;

- (iv) staged germination of ones of said seed capsules, having seeds, under a given set of conditions, over a period of time longer than the range of germination times inherent in said seeds;
- (v) enhancing control of moisture about said seed thereby to assist in seed germination;
- (vi) release of plant nutrients into soil onto which said combination seed capsule is placed;
- (vii) soil conditioning effect to soil onto which said combination seed capsule is placed;
- (viii) staged release of plant nutrients into soil onto which said combination seed capsule is placed, over a period of time longer than the range of times inherent in the chemical composition so released;
- (ix) higher embryo emergence and survival rate in a population of said seed capsules, thereby reducing required seed planting density for a desired plant population density; and
- (x) assisting in stabilizing moisture content in soil on which such seed capsule is disposed.

29. A growing system as in Claim 26 wherein said seeds are selected from the group consisting of grass, vegetables, grains, and flowers.

30. A growing system as in Claim 26, said coatings further comprising said soil conditioning material in combination with at least one ingredient effective to reduce susceptibility of said seed capsules to deleterious affect of at least one of animals, weeds, and spore-formers.

31. A growing system as in Claim 26, said coating comprising a first coating, said combination seed capsules further comprising a second coating, separate from said first coating, and comprising at least one ingredient effective to reduce susceptibility of said seed capsules to deleterious effect of at least one of animals, weeds, and spore-formers.

32. A growing system as in Claim 26, effective to provide plant nutrients at desirable controlled distances from plant seedlings emerging from said seeds, in amounts beneficial to said plant seedlings.

33. A growing system as in Claim 26, said coatings comprising first coatings, said combination seed capsules further comprising second coatings of second coating materials intermingled with said first coating materials in outer portions of said first coatings, and generally displaced from said seeds.

34. A growing system as in Claim 33 wherein said second coating materials comprise plant nutrients, beneficial in location and in amount of availability, to plant seedlings emerging from said seeds.

35. A growing system as in Claim 26, said population of seed capsules comprising coatings having a range of properties affecting germination rates of said seeds, thereby to stage germination of said seeds in said population over a period of time longer than the range of germination times inherent in uncoated ones of said seeds.

36. A growing system as in Claim 26, said coatings comprising first layers of said soil conditioning material, and including second layers comprising inorganic fertilizer.

37. A growing system as in Claim 26, said soil conditioning material comprising a sludge composition.

38. A growing system as in Claim 26, said soil conditioning material comprising a fiber-containing by-product of a paper making operation.

39. A growing system as in Claim 26, said seed capsules comprising inner layers on the outer surfaces of said seeds, said inner layers enhancing properties of said seeds for acting as nucleus in an agglomeration operation agglomerating said coatings onto said inner layers.

40. A growing system as in Claim 26 wherein said coatings comprise admixtures of said soil conditioner and plant nutrient.

41. A method of providing plant micronutrients to soil, the method comprising placing onto the soil a population of combination seed capsules, each comprising at least one seed, and a coating comprising a plant micronutrient material.

42. A method as in Claim 41, the coating comprising a first coating comprising the plant micronutrient, and a second coating, separate and distinct from the first coating, and comprising a soil conditioning material.

43. A method as in Claim 41, the coating providing at least one of

- (i) enhancing broadcast flight properties of said combination seed capsule;
- (ii) reducing susceptibility to deleterious affects of weather on said combination seed capsule;
- (iii) enhancing resistance of said combination seed capsule to attack by animals or spore-formers;
- (iv) staged germination of ones of said seed capsules, having seeds, under a given set of conditions, over a period of time longer than the range of germination times inherent in said seeds;
- (v) enhancing control of moisture about said seed thereby to assist in seed germination;
- (vi) release of plant nutrients into soil onto which said combination seed capsule is placed;

- (vii) soil conditioning effect to soil onto which said combination seed capsule is placed;
- (viii) staged release of plant nutrients into soil onto which said combination seed capsule is placed, over a period of time longer than the range of times inherent in the chemical composition so released;
- (ix) higher embryo emergence and survival rate in a population of said seed capsules, thereby reducing required seed planting density for a desired plant population density; and
- (x) assisting in stabilizing moisture content in soil on which such seed capsule is disposed.

44. A method as in Claim 41, the coating providing a plant nutrient at a desirable controlled distance from a plant seedling emerging from the seed, in an amount beneficial to the plant seedling.

45. A method as in Claim 41, the coating comprising a first coating, the combination seed capsule further comprising a second coating of a second coating material intermingled with the first coating material in an outer portion of the first coating, and generally displaced from the seed.

46. A method as in Claim 45 wherein the first coating comprises plant micronutrient material and the second coating

comprises plant nutrient material comprising at least one of nitrogen, phosphorus, and potassium.

47. A method as in Claim 41 wherein the micronutrient composition comprises a plant nutrient selected from the group consisting of sulfur, manganese, copper, boron, iron, magnesium and chromium.

48. A method as in Claim 41, the coating comprising a first layer of the soil conditioning material, and including a second layer comprising an inorganic fertilizer.

49. A method as in Claim 41, the coating comprising a sludge composition.

50. A method as in Claim 41, the coating comprising a fiber-containing by-product of a paper making operation.

51. A method as in Claim 41, the seed capsule comprising an inner layer on an outer surface of the seed, and an outer layer, the inner layer enhancing properties of the seed for acting as nucleus in an agglomeration operation agglomerating the coating onto the inner layer.

52. A method as in Claim 41 wherein the coating comprising an admixture of soil conditioner and a plant nutrient.

53. A method as in Claim 41 wherein the coating remains generally disposed about the seed until the seed germinates.

54. A method of providing a seed bed having enhanced growing conditions for growing seed, the method comprising:

- (a) coating a population of the seeds with material, and thereby providing coatings thereon of such material, tending to stabilize, in the seed capsules, or in soil on which the seed capsules are disposed coating compositions which tend to hold, moisture adjacent the seeds in the seed capsules or in soil adjacent the seed capsules, in such quantities and for such times as to enhance growing conditions for the seeds; and
- (b) placing the population of seeds on soil effective to support germination of the seeds which are in the seed capsules.

55. A method as in Claim 54, the coatings providing at least one of

- (i) enhancing broadcast flight properties of said combination seed capsule;
- (ii) reducing susceptibility to deleterious affects of weather on said combination seed capsule;
- (iii) enhancing resistance of said combination seed capsule to attack by animals or spore-formers;



- (iv) staged germination of ones of said seed capsules, having seeds, under a given set of conditions, over a period of time longer than the range of germination times inherent in said seeds;
- (v) release of plant nutrients into soil onto which said combination seed capsule is placed;
- (vi) soil conditioning effect to soil onto which said combination seed capsule is placed;
- (vii) staged release of plant nutrients into soil onto which said combination seed capsule is placed, over a period of time longer than the range of times inherent in the chemical composition so released; and
- (viii) higher embryo emergence and survival rate in a population of said seed capsules, thereby reducing required seed planting density for a desired plant population density.

56. A method as in Claim 54 wherein the seeds are selected from the group consisting of grass, vegetables, grains, and flowers.

57. A method as in Claim 54, effective to provide a plant nutrient at desirable controlled distances from plant seedlings emerging from the seeds, in amounts beneficial to the plant seedlings.

58. A method as in Claim 54, the coatings comprising first coatings, the combination seed capsules further comprising second coatings of second coating materials intermingled with the first coating materials in outer portions of the first coatings, and generally displaced from the seeds.

59. A method as in Claim 58 wherein the second coating materials comprise plant nutrients, beneficial in location and in amount of availability, to plant seedlings emerging from the seeds.

60. A method as in Claim 58 wherein the second coating compositions comprise inorganic forms of plant nutrients and are selected from the group consisting of nitrogen, phosphorus, and potassium.

61. A method as in Claim 54, the population of seed capsules comprising coatings having a range of properties affecting germination rate of the seeds, thereby to stage germination of the seeds in the population over a period of time longer than the range of germination times inherent in uncoated ones of the seeds.

62. A method as in Claim 54, the coatings comprising first layers of the soil conditioning material, and including second layers comprising inorganic fertilizer.

63. A method as in Claim 54, the coatings comprising first layers of the soil conditioning materials, and including second layers comprising micronutrients.

64. A method as in Claim 54, the soil conditioning materials comprising sludge compositions.

65. A method as in Claim 54, the soil conditioning materials comprising fiber-containing by-products of paper making.

66. A method as in Claim 54, the seed capsules comprising water-leachable plant nutrients, and leach-retardant compositions effective to retard leaching of the leachable plant nutrients out of the combination seed capsules.

67. A method as in Claim 54, the seed capsules comprising inner layers on the outer surfaces of the seeds, and outer layers, the inner layers enhancing properties of the seeds for acting as nuclei in agglomeration operations agglomerating the coatings onto the inner layers.

68. A method as in Claim 54 wherein the coatings comprise admixtures of the soil conditioners and plant nutrients.

69. A method as in Claim 54 wherein the coatings remain generally disposed about the seeds until the seeds germinate.

70. A method of making a population of combination seed capsules, each comprising a seed, and a coating of a soil conditioning material, the method comprising:

- (a) pre-coating the seed with a material which enhances the ability of the seed to act as a nucleus in an agglomeration operation, to form a pre-coated substrate; and
- (b) subsequently coating the pre-coated substrate with a soil conditioning material.

71. A method as in Claim 70 wherein the pre-coating material comprises dicalcium phosphate.

72. A method as in Claim 70 wherein the pre-coating step results in an overall increase in the density of pre-coated seed combination.

73. A method as in Claim 70 wherein the pre-coating is accomplished by spraying the pre-coating material onto the seed.

74. A method of providing an enhanced seed germination environment in combination with placement of a controlled amount of plant nutrients in controlled proximity to each seed, the method comprising:

- (a) providing a population of seeds, coated with a soil conditioning material which tends to enhance germination of the seeds, and with plant nutrient composition effective to enhance growth of plant embryos emerging from the seeds; and

(b) placing the population of seeds on soil effective to support germination of the seeds.

75. A method as in Claim 74 wherein the coating material includes therein a second ingredient comprising plant nutrient moieties.

0  
1  
2  
3  
4  
5  
6  
7  
8  
9  
10  
11  
12  
13  
14  
15  
16  
17  
18  
19  
20  
21  
22  
23  
24  
25  
26  
27  
28  
29  
30  
31  
32  
33  
34  
35  
36  
37  
38  
39  
40  
41  
42  
43  
44  
45  
46  
47  
48  
49  
50  
51  
52  
53  
54  
55  
56  
57  
58  
59  
60  
61  
62  
63  
64  
65  
66  
67  
68  
69  
70  
71  
72  
73  
74  
75  
76  
77  
78  
79  
80  
81  
82  
83  
84  
85  
86  
87  
88  
89  
90  
91  
92  
93  
94  
95  
96  
97  
98  
99  
100

ABSTRACT OF THE DISCLOSURE

This invention pertains to combination seed capsules wherein each seed capsule includes both moieties of at least one soil conditioner and at least one seed, and optionally, one or more inorganic chemical fertilizer, growth enhancer, binder, and/or anti-fungal agent. The combination seed capsules are made by physically combining the respective soil conditioner and seed with one other, in the absence of any requirement for chemical reactions in the process of so combining the respective materials. The combination seed capsules provide cooperative and beneficial effects of the soil conditioner and the optional inorganic fertilizer, working together in controlled intimate relation with the seed, to enhance the germination and growth processes of the seed, and the plant emergent therefrom, greater than when the soil conditioner and seed, and optionally inorganic chemical fertilizer, are applied to the soil separately; the improvement being a result of the intimate relationship of the respective materials in the combination seed capsule, whereby the respective materials cooperate with each other in support of germination and plant growth.

000000000000000000

<b>CERTIFICATE OF MAILING BY "EXPRESS MAIL" (37 CFR 1.10)</b>		Docket No.
Applicant(s): Daniel Paul Madigan et al		29214

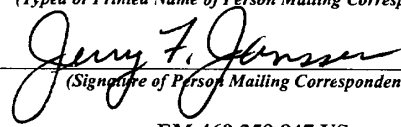
Serial No. Unassigned	Filing Date 07/10/98	Examiner Unassigned	Group Art Unit Unassigned
--------------------------	-------------------------	------------------------	------------------------------

Invention: SEEDING TREATMENTS

I hereby certify that this Informal Drawings (6)  
*(Identify type of correspondence)*

is being deposited with the United States Postal Service "Express Mail Post Office to Addressee" service under 37 CFR 1.10 in an envelope addressed to: The Assistant Commissioner for Patents, Washington, D.C. 20231 on July 10, 1998  
*(Date)*

Jerry F. Janssen  
*(Typed or Printed Name of Person Mailing Correspondence)*

  
*(Signature of Person Mailing Correspondence)*

EM 469 259 847 US  
*("Express Mail" Mailing Label Number)*

**Note: Each paper must have its own certificate of mailing.**

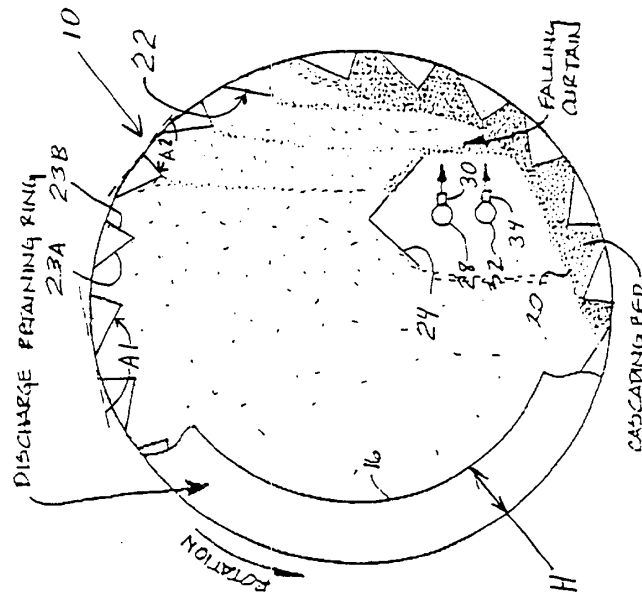


Fig. 1

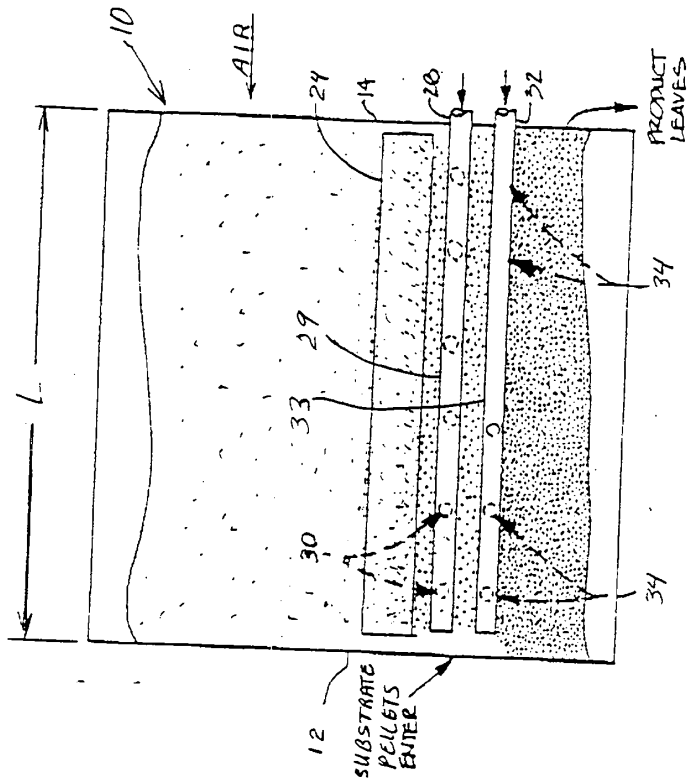


Fig. 2



## Seed/Paper Sludge Agglomeration Process

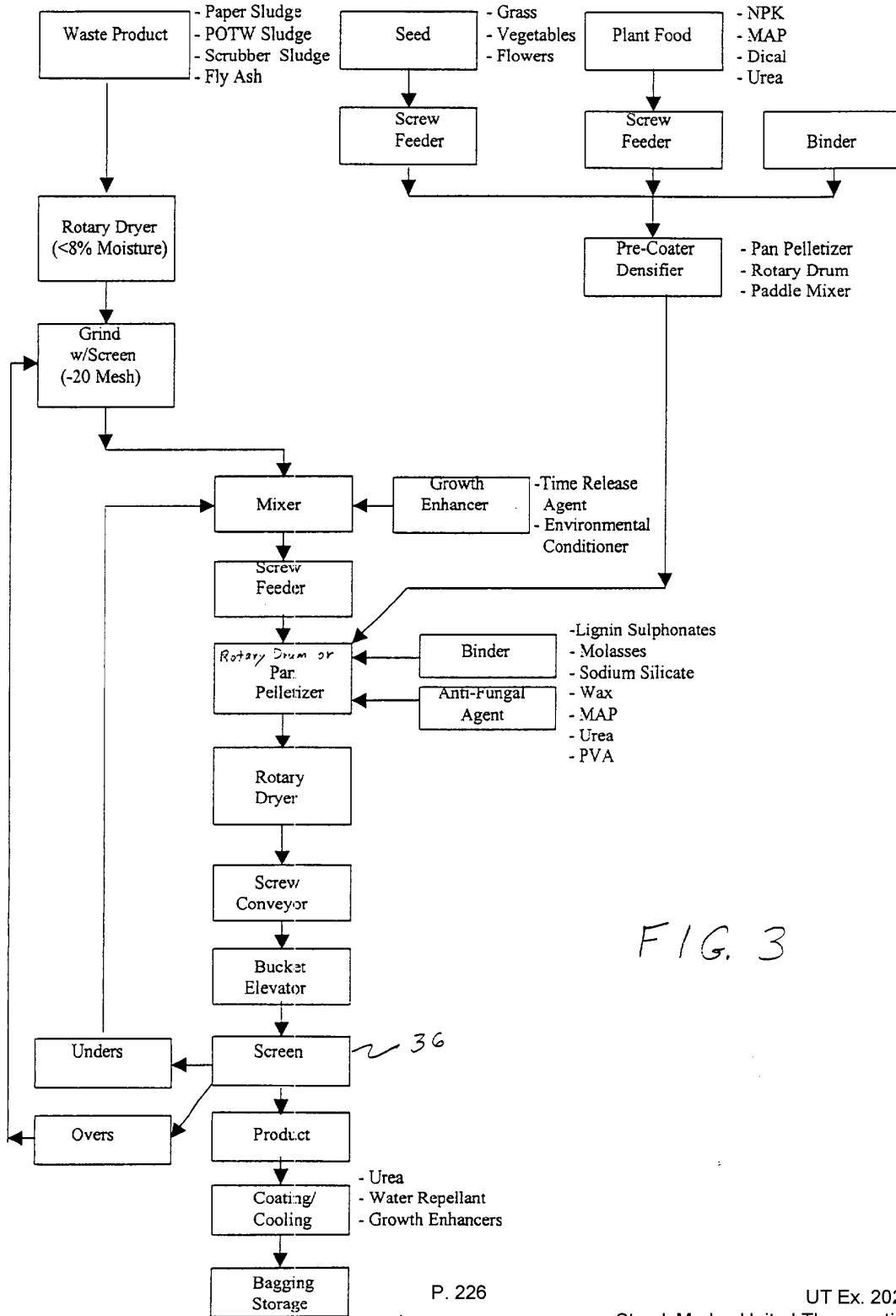


FIG. 3

SECRET

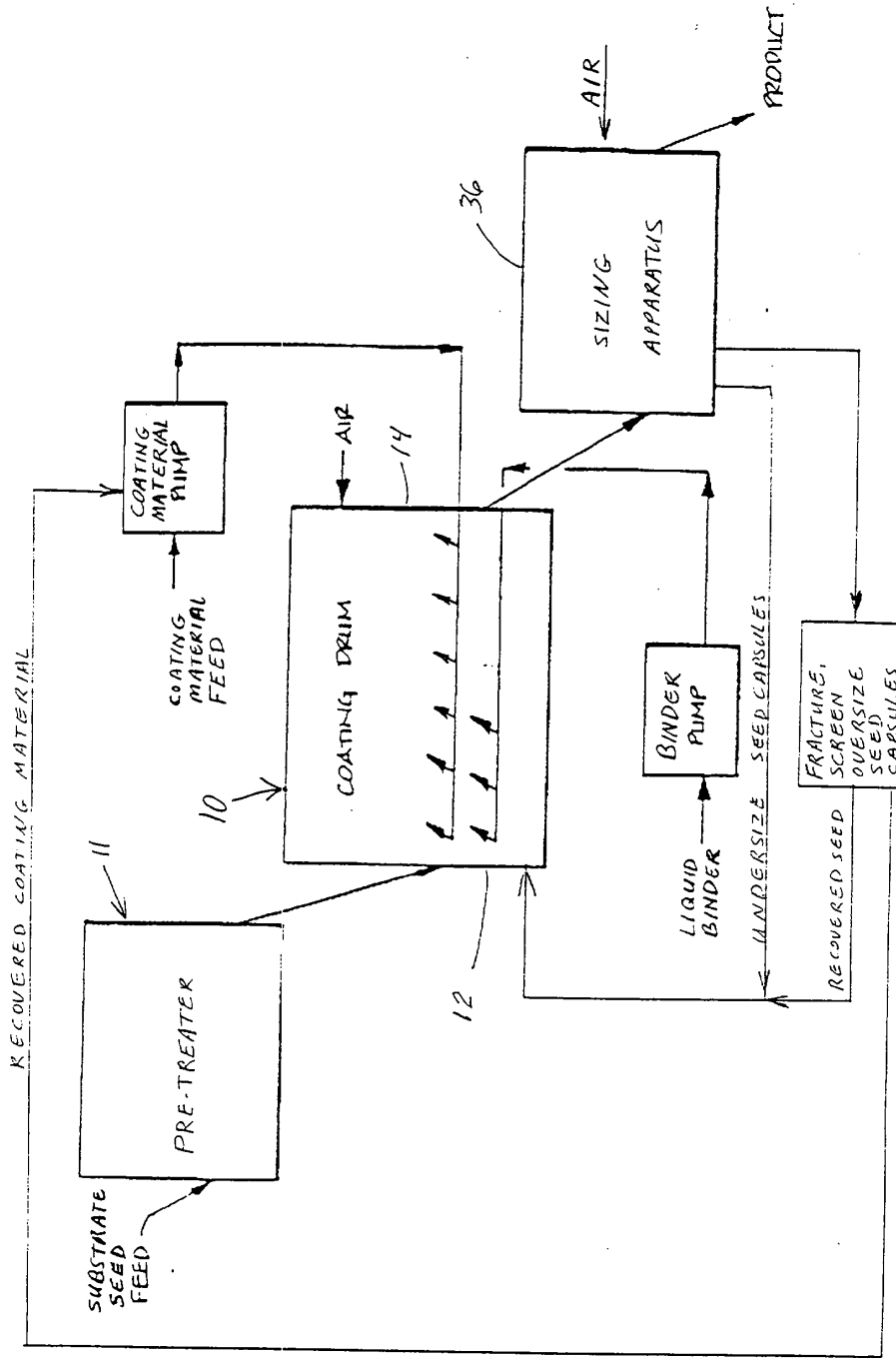
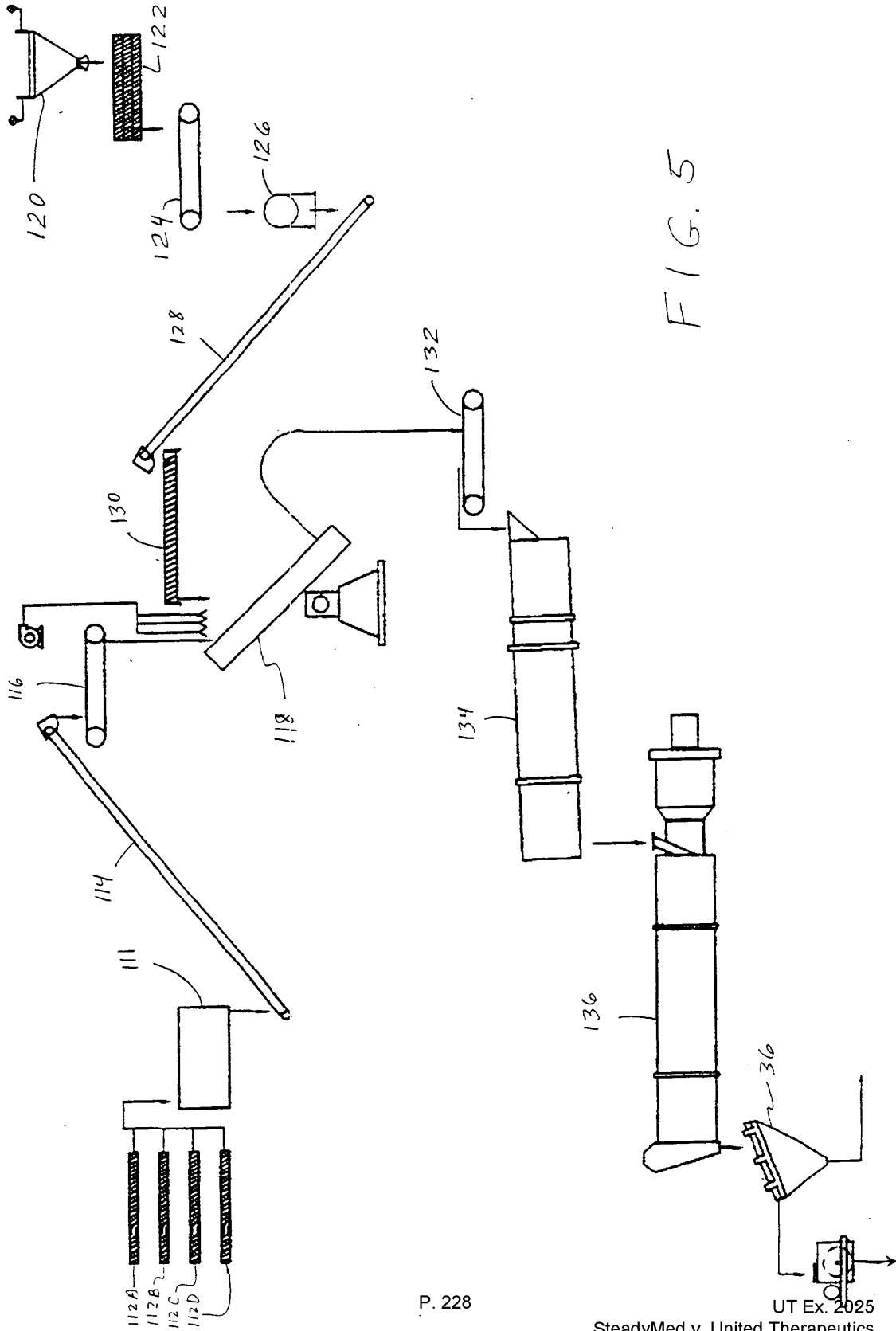


FIG. 4



001134 071006

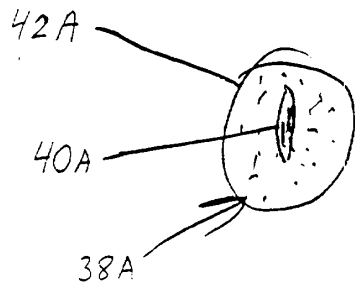


FIG. 6A

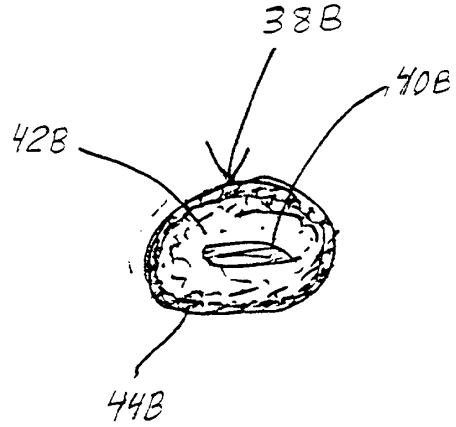


FIG. 6B

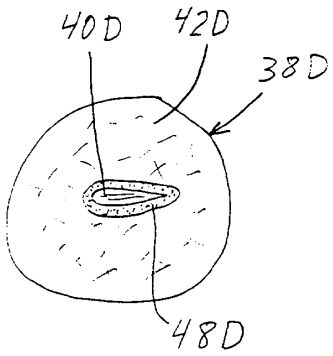


FIG. 6D

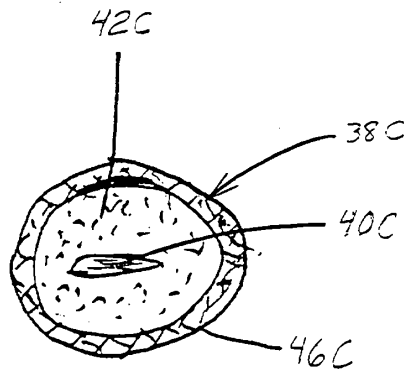
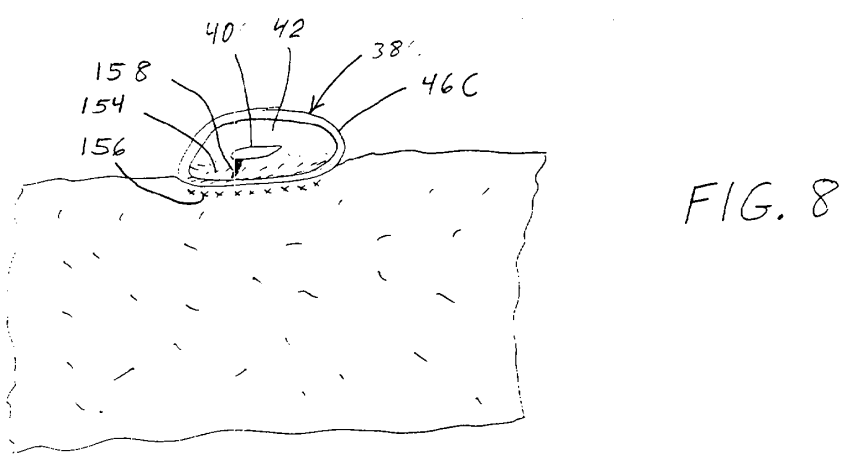
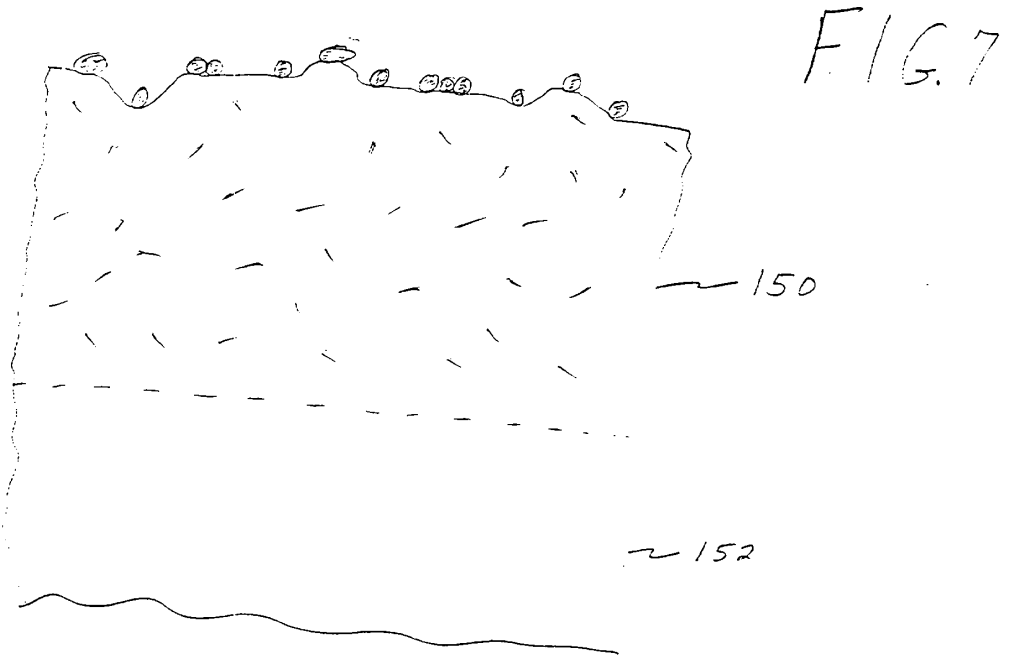
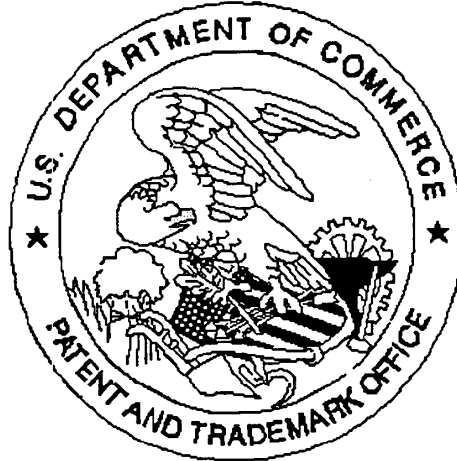


FIG. 6C

2024 RELEASE UNDER E.O. 14176



United States Patent & Trademark Office  
Office of Initial Patent Examination -- Scanning Division



Application deficiencies found during scanning:

1. Application papers are not suitable for scanning and are not in compliance with 37 CFR 1.52 because:
- All sheets must be the same size and either A4 (21 cm x 29.7 cm) or 8-1/2" x 11". Pages \_\_\_\_\_ do not meet these requirements.
  - Papers are not flexible, strong, smooth, non-shiny, durable, and white.
  - Papers are not typewritten or mechanically printed in permanent ink on one side.
  - Papers contain improper margins. Each sheet must have a left margin of at least 2.5 cm (1") and top, bottom and right margins of at least 2.0 cm (3/4").
  - Papers contain hand lettering.
2. Drawings are not in compliance and were not scanned because:
- The drawings or copy of drawings are not suitable for electronic reproduction.
  - All drawings sheets are not the same size. Pages must be either A4 (21 cm x 29.7 cm) or 8-1/2" x 11".
  - Each sheet must include a top and left margin of at least 2.5 cm (1"), a right margin of at least 1.5 cm (9/16") and a bottom margin of at least 1.0 cm (3/8").
3. Page(s) \_\_\_\_\_ are not of sufficient clarity, contrast and quality for electronic reproduction.
4. Page(s) \_\_\_\_\_ are missing.
5. OTHER: No Declarations Enclosed

00113234-071000

07/10/98

USPS U.S. PTO

# UTILITY PATENT APPLICATION TRANSMITTAL (Small Entity)

(Only for new nonprovisional applications under 37 CFR 1.53(b))

Docket No.  
29214

Total Pages in this Submission  
82

## TO THE ASSISTANT COMMISSIONER FOR PATENTS

Box Patent Application  
Washington, D.C. 20231

Transmitted herewith for filing under 35 U.S.C. 111(a) and 37 C.F.R. 1.53(b) is a new utility patent application for an invention entitled:

SEEDING TREATMENTS

and invented by:

DANIEL PAUL MADIGAN  
MICHAEL DENNIS KRYSIAK  
RONALD DEAN EICHHORN  
GLEN H. WESENBERG

If a CONTINUATION APPLICATION, check appropriate box and supply the requisite information:

Continuation  Divisional  Continuation-in-part (CIP) of prior application No.: \_\_\_\_\_

Which is a:

Continuation  Divisional  Continuation-in-part (CIP) of prior application No.: \_\_\_\_\_

Which is a:

Continuation  Divisional  Continuation-in-part (CIP) of prior application No.: \_\_\_\_\_

Enclosed are:

### Application Elements

1.  Filing fee as calculated and transmitted as described below
2.  Specification having 70 pages and including the following:
  - a.  Descriptive Title of the Invention
  - b.  Cross References to Related Applications (if applicable)
  - c.  Statement Regarding Federally-sponsored Research/Development (if applicable)
  - d.  Reference to Microfiche Appendix (if applicable)
  - e.  Background of the Invention
  - f.  Brief Summary of the Invention
  - g.  Brief Description of the Drawings (if drawings filed)
  - h.  Detailed Description
  - i.  Claim(s) as Classified Below
  - j.  Abstract of the Disclosure

**UTILITY PATENT APPLICATION TRANSMITTAL  
(Small Entity)**

*(Only for new nonprovisional applications under 37 CFR 1.53(b))*

Docket No.  
29214

Total Pages in this Submission  
82

**Application Elements (Continued)**

3.  Drawing(s) *(when necessary as prescribed by 35 USC 113)*  
a.  Formal      b.  Informal      Number of Sheets         6
4.  Oath or Declaration  
a.  Newly executed *(original or copy)*       Unexecuted  
b.  Copy from a prior application (37 CFR 1.63(d)) *(for continuation/divisional application only)*  
c.  With Power of Attorney       Without Power of Attorney  
d.  DELETION OF INVENTOR(S)  
Signed statement attached deleting inventor(s) named in the prior application,  
see 37 C.F.R. 1.63(d)(2) and 1.33(b).
5.  Incorporation By Reference *(usable if Box 4b is checked)*  
The entire disclosure of the prior application, from which a copy of the oath or declaration is supplied  
under Box 4b, is considered as being part of the disclosure of the accompanying application and is hereby  
incorporated by reference therein.
6.  Computer Program in Microfiche
7.  Genetic Sequence Submission *(if applicable, all must be included)*  
a.  Paper Copy  
b.  Computer Readable Copy  
c.  Statement Verifying Identical Paper and Computer Readable Copy

**Accompanying Application Parts**

8.  Assignment Papers *(cover sheet & documents)*
9.  37 CFR 3.73(b) Statement *(when there is an assignee)*
10.  English Translation Document *(if applicable)*
11.  Information Disclosure Statement/PTO-1449       Copies of IDS Citations
12.  Preliminary Amendment
13.  Acknowledgment postcard
14.  Certificate of Mailing  
 First Class       Express Mail *(Specify Label No.):* EM 469 259 847 US

P. 233

UT Ex. 2025



**UTILITY PATENT APPLICATION TRANSMITTAL  
(Small Entity)**

*(Only for new nonprovisional applications under 37 CFR 1.53(b))*

Docket No.  
29214

Total Pages in this Submission  
82

**Accompanying Application Parts (Continued)**

15.  Certified Copy of Priority Document(s) *(if foreign priority is claimed)*
16.  Small Entity Statement(s) - Specify Number of Statements Submitted: \_\_\_\_\_
17.  Additional Enclosures *(please identify below):*

Correspondence Address

**Fee Calculation and Transmittal**

**CLAIMS AS FILED**

For	#Filed	#Allowed	#Extra	Rate	Fee
<b>Total Claims</b>	75	- 20 =	55	x \$11.00	\$605.00
<b>Indep. Claims</b>	5	- 3 =	2	x \$41.00	\$82.00
<b>Multiple Dependent Claims (check if applicable)</b> <input type="checkbox"/>					\$0.00
<b>BASIC FEE</b>					\$395.00
<b>OTHER FEE (specify purpose)</b> _____					\$0.00
<b>TOTAL FILING FEE</b>					\$1,082.00

- A check in the amount of \_\_\_\_\_ to cover the filing fee is enclosed.
- The Commissioner is hereby authorized to charge and credit Deposit Account No. \_\_\_\_\_ as described below. A duplicate copy of this sheet is enclosed.
- Charge the amount of \_\_\_\_\_ as filing fee.
  - Credit any overpayment.
  - Charge any additional filing fees required under 37 C.F.R. 1.16 and 1.17.
  - Charge the issue fee set in 37 C.F.R. 1.18 at the mailing of the Notice of Allowance, pursuant to 37 C.F.R. 1.311(b).

Dated: *July 10, 1998*

*Thomas D. Wilhelm*  
Signature

**Thomas D. Wilhelm (Reg. No. 28,794)**

cc:

P. 234

UT Ex 2025

Page 3 of 3

SteadyMed v. United Therapeutics  
IPR2016-00006

IPR2020-00769  
United Therapeutics EX2006  
Page 4453 of 7113

**CERTIFICATE OF MAILING BY "EXPRESS MAIL" (37 CFR 1.10)**

Applicant(s): Daniel Paul Madigan et al

Docket No.

29214

Serial No.  
Unassigned

Filing Date  
07/10/98

Examiner  
Unassigned

Group Art Unit  
Unassigned

Invention: SEEDING TREATMENTS

I hereby certify that this Correspondence Address

*(Identify type of correspondence)*

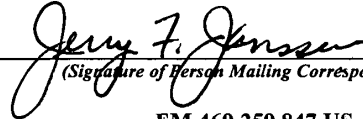
is being deposited with the United States Postal Service "Express Mail Post Office to Addressee" service under 37 CFR 1.10 in an envelope addressed to: The Assistant Commissioner for Patents, Washington, D.C. 20231 on

July 10, 1998

*(Date)*

Jerry F. Janssen

*(Typed or Printed Name of Person Mailing Correspondence)*



*(Signature of Person Mailing Correspondence)*

EM 469 259 847 US

*("Express Mail" Mailing Label Number)*

**Note: Each paper must have its own certificate of mailing.**

P. 235

UT Ex. 2025

**CERTIFICATE OF MAILING BY "EXPRESS MAIL" (37 CFR 1.10)**

Applicant(s): Daniel Paul Madigan et al

Docket No.

29214

Serial No. Unassigned	Filing Date 07/10/98	Examiner Unassigned	Group Art Unit Unassigned
--------------------------	-------------------------	------------------------	------------------------------

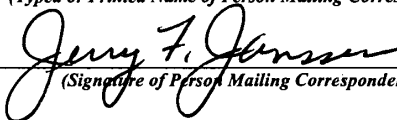
Invention: SEEDING TREATMENTS

I hereby certify that this Informal Drawings (6)  
*(Identify type of correspondence)*

is being deposited with the United States Postal Service "Express Mail Post Office to Addressee" service under 37 CFR 1.10 in an envelope addressed to: The Assistant Commissioner for Patents, Washington, D.C. 20231 on July 10, 1998  
*(Date)*

Jerry F. Janssen

*(Typed or Printed Name of Person Mailing Correspondence)*



*(Signature of Person Mailing Correspondence)*

EM 469 259 847 US

*("Express Mail" Mailing Label Number)*

Note: Each paper must have its own certificate of mailing.

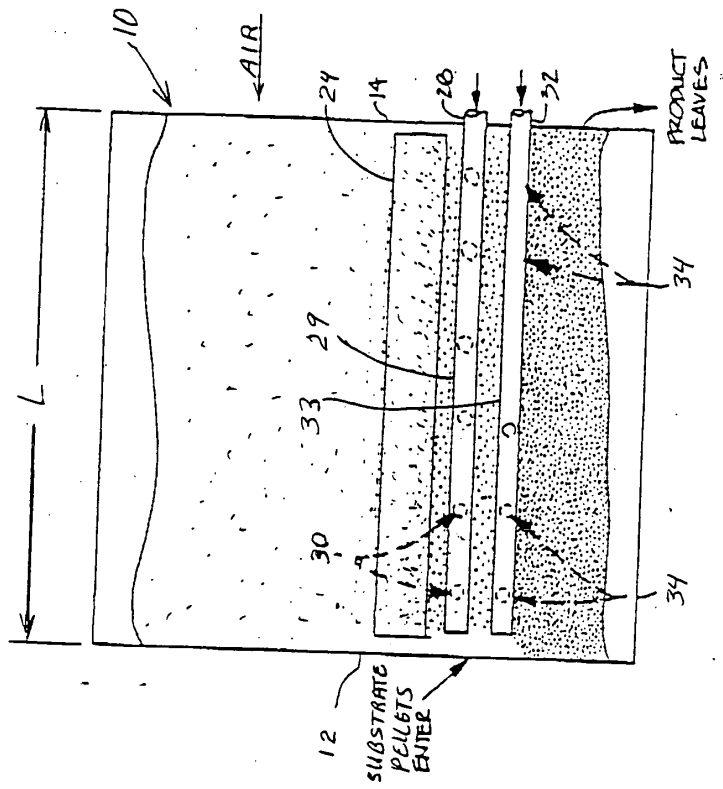


Fig. 1

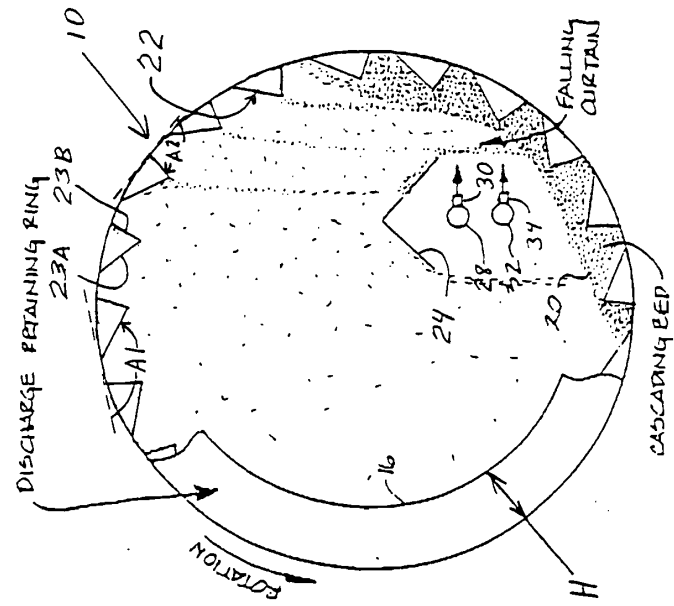


Fig. 2

# Seed/Paper Sludge Agglomeration Process

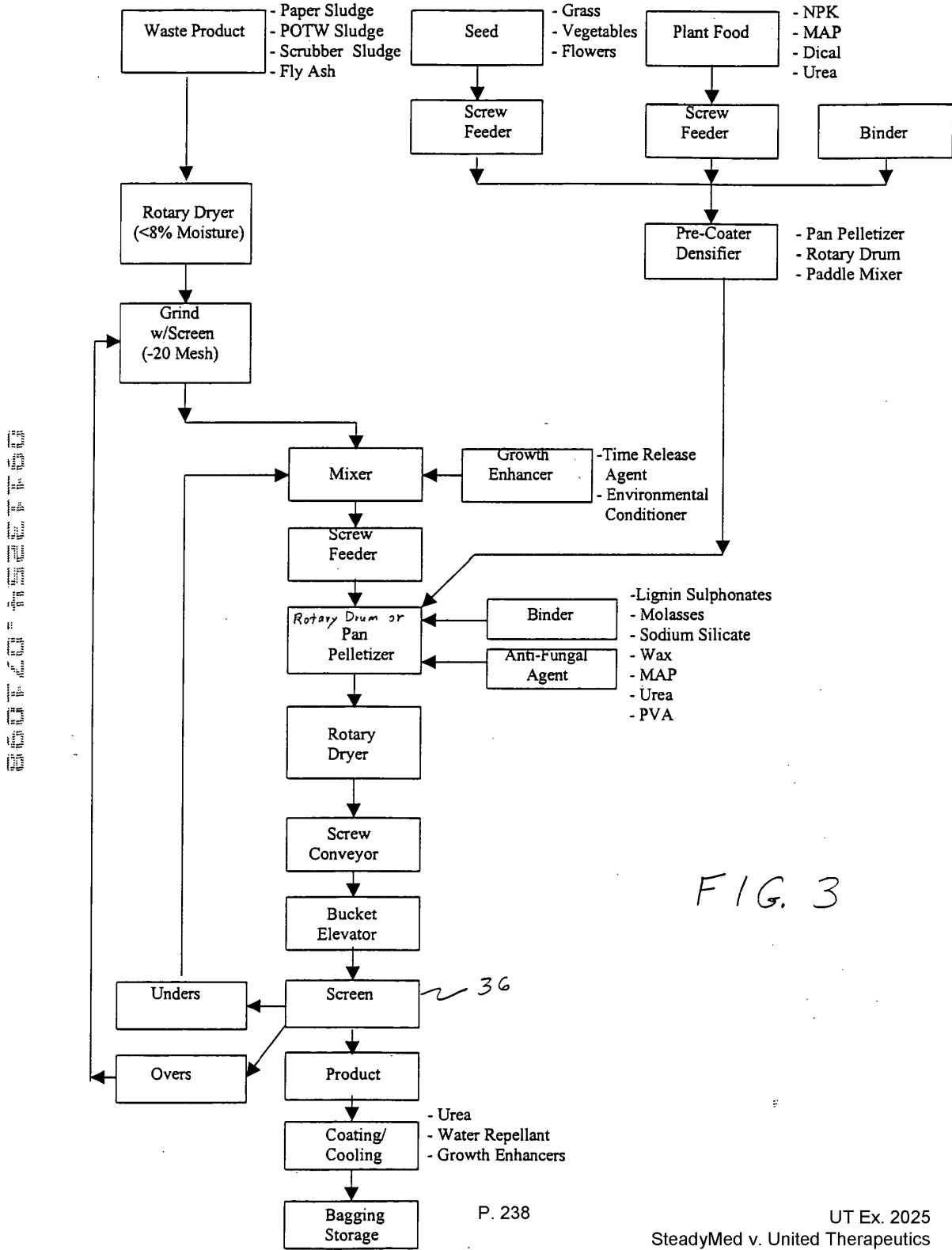


FIG. 3

FIG. 4

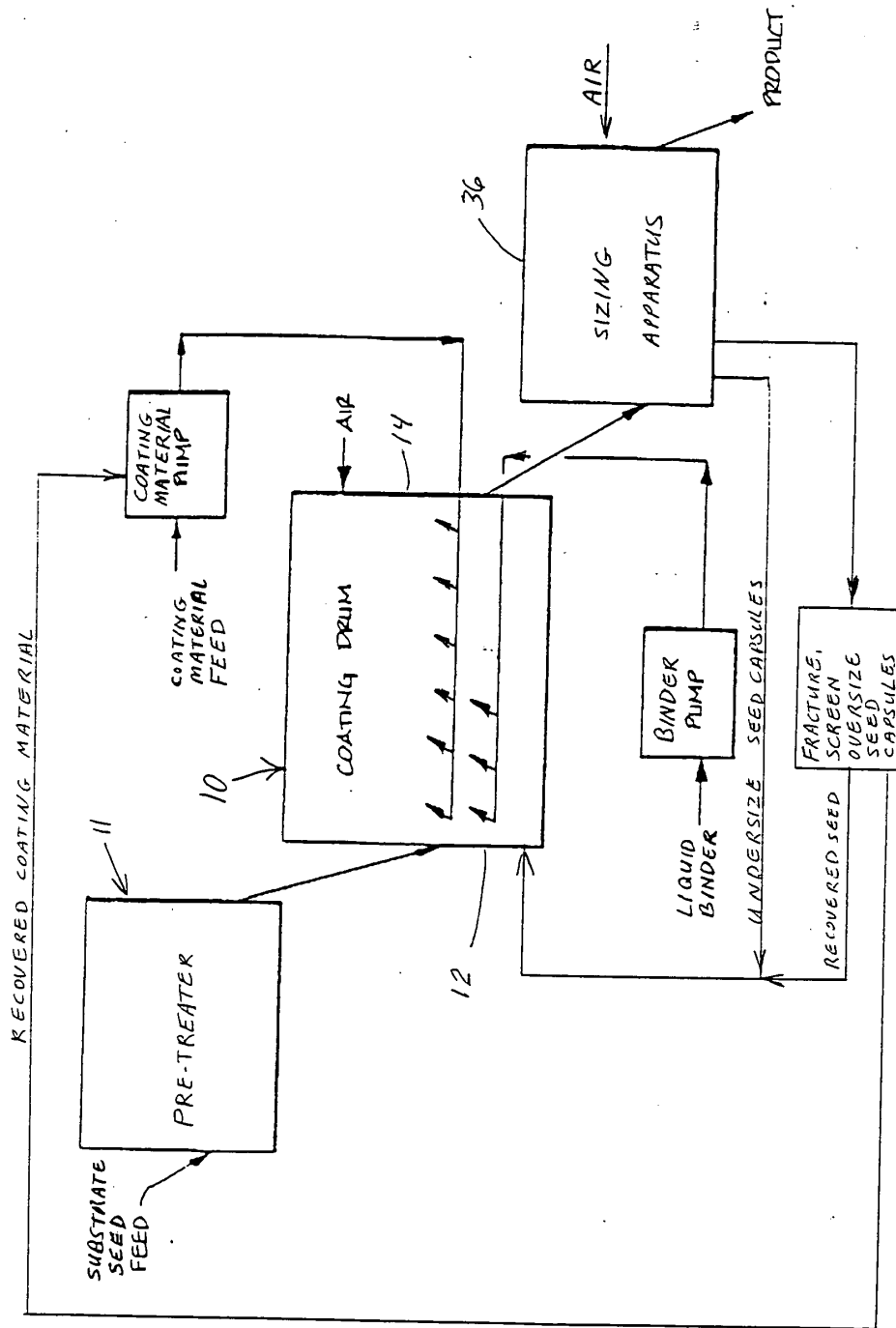
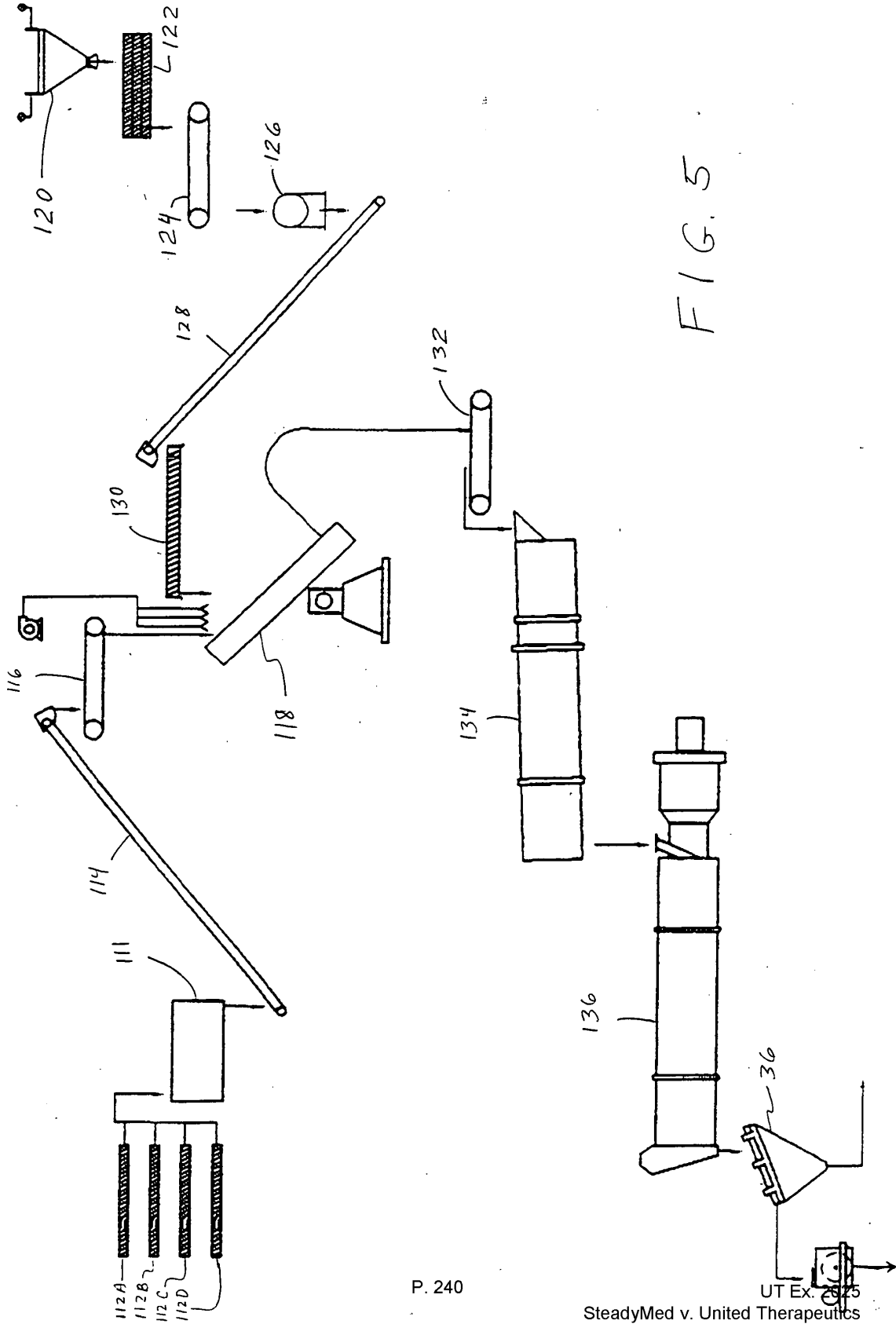


FIG. 4

FIG. 5



P. 240

UT Ex. 375  
SteadyMed v. United Therapeutics  
IPR2016-00006

SECRET FOR OFFICIAL USE

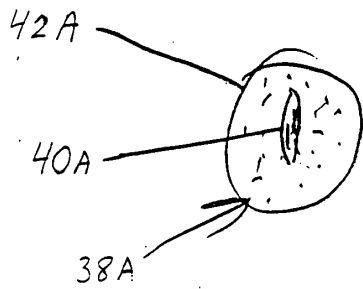


FIG. 6A

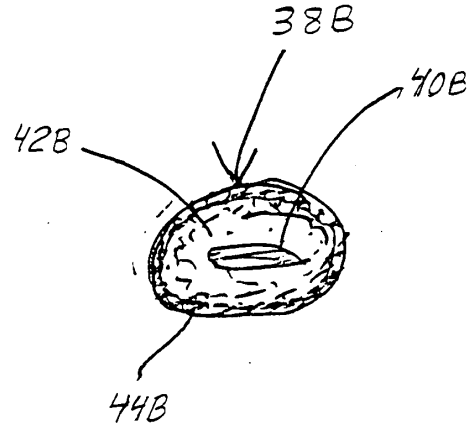


FIG. 6B

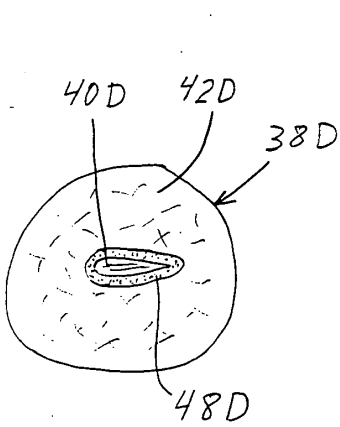


FIG. 6D

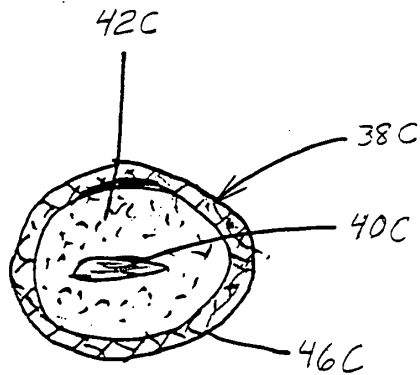


FIG. 6C



300 400 500 600 700 800 900 1000

FIG. 7

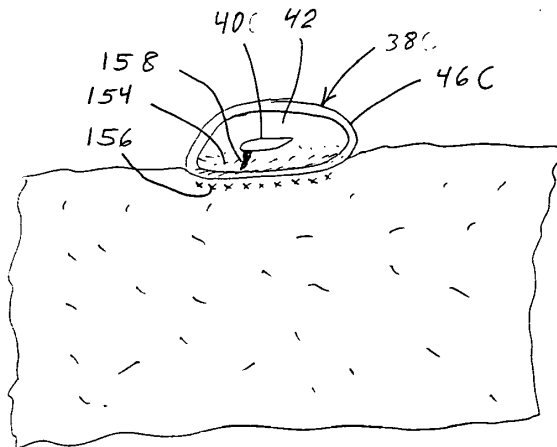
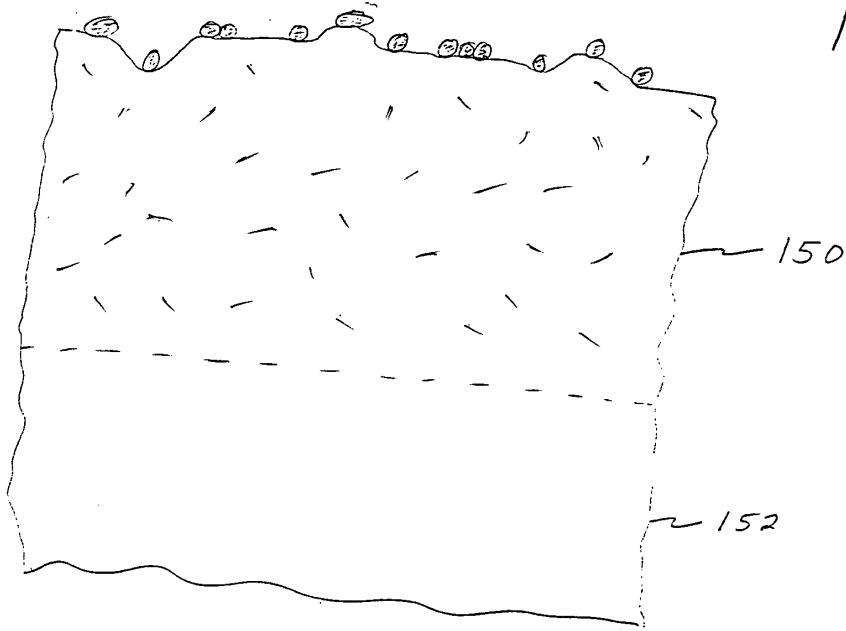


FIG. 8

PATENT APPLICATION

TITLE: SEEDING TREATMENTS

By: Daniel Paul Madigan  
804 S. Madison  
Green Bay, WI 54301  
Citizenship: USA

Michael Dennis Krysiak  
3554 Highland Center Drive  
Green Bay, WI 54311  
Citizenship: USA

Ronald Dean Eichhorn  
1524 1/2 Cedar Street  
Green Bay, WI 54302  
Citizenship: USA

Glen H. Wesenberg  
920 Laverne Drive  
Green Bay, WI 54311  
Citizenship: USA

"Express Mail" mailing number

EM 469 259 847 US

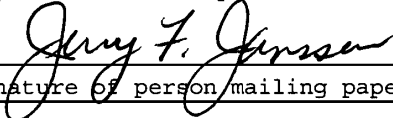
Date of Deposit June 10, 1998

2020-00769

I hereby certify that this paper or fee is being deposited with the United States Postal Service "Express Mail Post Office to Addressee" service under 37 CFR 1.10 on the date indicated above and is addressed to the Assistant Commissioner of Patents, Washington, D.C. 20231.

Jerry F. Janssen

(Typed or printed name of person mailing paper or fee)



(Signature of person mailing paper or fee)

TDW, JSK

*Also application claims benefit to US provisional 67052,287 filed 11-97.*

29214

SEEDING TREATMENTS

Field of the Invention

5 This present invention relates to improvements in seed and  
seed-related products, processes for making such products and  
processes for establishing and improving seed beds and seed bed  
germination. As additional benefits, this invention is directed at  
improving soil productivity through enhancements in soil fertility,  
soil condition/tilth, and control of soil moisture. Further, the  
10 invention relates to productive use of certain types of abundantly  
available manufacturing waste, which waste is currently being  
disposed of in landfills.

Background of the Invention

15 Agricultural growers, gardeners, landscape operators, flower  
growers, and the like produce a wide variety of cultivated crops.  
Many such crops are grown from seed. The sizes, shapes, and  
physical characteristics of the various kinds of seeds are as  
varied as the number of crops produced therefrom.

20 Producers of such cultivated crops encounter a variety of  
challenges in handling and distributing such seed, as well as with  
sowing of such seed in suitable growing media. Certain seed may  
desirably be sowed by a broadcast method if the seed were  
25 compatible with broadcast application. For example, grass seed for  
lawns is desirably broadcast, but the low density and generally  
non-aerodynamic shape of some grass seed can limit the range of  
such broadcast, and make such seed susceptible to being blown about

2 P. 244

UT Ex. 2025  
SteadyMed v. United Therapeutics  
IPR2016-00006

IPR2020-00769  
United Therapeutics EX2006  
Page 4463 of 7113

by wind, or washed away by surface water; even if initially well placed in a good seeding application.

Another difficulty encountered in sowing seed is that the seed may be so small as to be difficult to handle, thereby to place properly-spaced seeds at a desired spacing as to make cost-effective use of the seed, thereby to produce a crop of the related plants without using any more seed than necessary, thus to gain maximum benefit from the amount of seed used.

While small seed may be efficiently handled by industrial equipment especially designed for handling such seed, typically the user of such seed also handles various other types of seed; and may be unable to justify the cost of such specialty seed-handling equipment. Rather, the seed user typically has a limited range of seed handling equipment which must be capable of being used and/or adapted to handle and apply all the types of seeds being used by that user. Where the seed itself can be adapted to the equipment, specialty seed can be handled without need for any specialized equipment.

Even where the seed may be sown by hand, such as in seedling or bedding trays or pots, some seeds are so small as to be difficult for the sower/user to effectively manipulate and control by hand. Typical of such difficult-to-handle seeds are seeds of lettuce, carrots, the cabbage family, ground cherries, and alfalfa. Many flower seeds are equally small and/or difficult to handle and/or manipulate, for example poppy seed.

When seed is planted, the seed has immediate use for moisture to aid in germination of the seed, and subsequent early development of the resulting young plant. Where moisture is not readily available to the seed when planted, the seed may lie in a dormant state for some period of time before germinating. While the seed is thus dormant, awaiting suitable moisture, the seed is subject to a variety of hazards which may destroy its viability. The seed may be attacked by worms, parasites, and other pests. The seed may be

- 2 -

3 P. 245

UT Ex. 2025  
SteadyMed v. United Therapeutics  
IPR2016-00006

IPR2020-00769  
United Therapeutics EX2006  
Page 4464 of 7113

eaten by foraging animals including insects and larvae. The seed may be overheated by a hot sun. The seed may lie dormant without germinating for so long that any plant emerging therefrom will have insufficient time to mature before the end of the growing season.

5 If and when the seed does germinate, the seedling plant has a continuing need for a proper balance of moisture and oxygen, as well as for such plant nutrients as nitrogen, phosphorous, and potash, as well as the micronutrients, in relatively predictable quantities. To the extent the proper balance of such materials is  
10 available to the young plant, a healthy young plant may be produced, with optimum potential for maximum crop production, assuming germination occurs at a seasonably-desirable time.

To the extent one or more such materials is not available to the seed and/or the young plant, plant growth, plant health, and  
15 ultimately maturity, may be adversely affected. For example, the soil may be too dry to support germination, or optimum germination. Or while the soil may in general have a desired moisture content, moisture content at a macro level can vary widely. Thus, while the soil in general may have a desirable moisture content, the  
20 microcosm of the soil adjacent an individual seed may be too dry, or too wet, to support any germination, or optimum germination.

Similarly, the soil may be generally depleted of one or more plant nutrients needed by the germinated seedling. Or while the soil may in general have desired nutrient levels, the nutrient  
25 levels at a macro level can vary widely. Thus, the microcosm of the soil adjacent an individual seed may be too low in one or more nutrients to support a desired level of plant growth, or so high as to be toxic to a desired level of plant growth.

30 Further, plant nutrient chemicals may be present in the soil, but so tied up chemically in the soil as to be unavailable, or poorly available, relative to the quantities and use rates needed for desired plant growth. Or the soil may become so hard, dry, and/or caked shortly after the seed germinates that the seedling

plant has difficulty penetrating such soil, difficulty becoming associated suitable nutrients, and/or difficulty taking up such nutrients because of insufficient moisture availability.

5 After the plant has further developed such that the plant roots extend deeper into the soil, conditions of the soil near the surface are less critical. However, until such time as the roots so penetrate, conditions of the soil at and near the top surface of the soil may be critical.

10 Soil fertility generally relates to uptake of plant nutrients from the soil by plants. Uptake is generally the result of two factors, the presence of plant nutrients in the soil, and the availability of the plant nutrients for plant uptake. Presence of plant nutrients in the soil is generally a function of the combination of (a) the basic level of soil fertility, (b) depletion by previous crop production and (c) replenishment with fertilizer. Availability of a plant nutrient physically present in the soil for plant uptake is in general related to solubility of the respective nutrient or nutrient combination in a solvent for the nutrient, which solvent is present in the soil, such solvent as water, along with any other material affecting solvation of the plant nutrient into the water or other solvent.

15  
20 Plant nutrients are routinely depleted from the soil by crop production, and are routinely added back, or otherwise replenished, to the soil by conventional inorganic fertilizers.

25 In order for plant nutrients in the soil to be available for uptake by plants, the nutrients must be held in the soil without excessive leaching, but must not be held so tightly that the nutrients cannot be released for plant uptake. Thus, nutrient availability requires a balance between holding tightly enough to retain the nutrient in the root zone, without leaching, but not so tight as to make the nutrient unavailable for plant uptake. Thus, the general "condition" or "tilth" of the soil is instrumental in

determining the efficiency with which plant nutrients are utilized for plant nutrition.

5 A properly conditioned soil has advantageous soil chemistry in combination with advantageous soil texture. Thus, in addition to providing specific plant nutrients, soil users also use products that modify basic soil chemistry, and soil texture.

Basic soil chemistry is modified by adding to the soil, for example, calcium products to provide pH control, and flyash or like products to provide pH control as well as micronutrients.

10 Soil texture is generally modified by adding to the soil organic matter such as manures, sludges, wood and other plant products and by-products, and the like. While such materials have good soil conditioning properties, plant nutrient value of such materials is fixed and is generally so low that other "fertilizer"-type products must in general be used in addition to the organic matter in order to preserve plant nutrient values in the soil.

15 The primary object of this invention is to provide solid plant seed capsule products that supply both soil conditioning properties and the seed, which can benefit from such conditioned soil, in a given seed capsule particle.

20 It is a further object to provide a plant nutrient material, in the seed capsule particle, in amount beneficial to the seedling emerging from the seed, and higher than a naturally-occurring amount of such nutrient in such soil conditioning material, so as to have enhanced chemical nutrient qualities over use of the soil conditioning material alone.

25 In another aspect, a further object is to provide soil conditioning and optionally nutrient qualities to seed products that reach the soil as the result of fulfilling objectives separate from providing soil fertility or soil conditioning.

30 Still another object is to provide seed capsules containing fertility-enhancing elements having a high level of plant food

- 5 -



P. 248

UT Ex. 2025  
SteadyMed v. United Therapeutics  
IPR2016-00006

IPR2020-00769  
United Therapeutics EX2006  
Page 4467 of 7113

nutrients in combination with a high level of soil conditioning properties.

5 Still another object is to encapsulate a seed in a soil conditioning material using materials rich in plant nutrients as part of the encapsulating agent.

Yet another object is to provide a seed product which reduces the tendency for light weight seeds to be washed away by surface water runoff.

10 Still another object is to provide a seed product which obviates the typical practice of adding straw as a mulch over e.g. grass seed, to protect the seed from being washed away by surface water, from heat of the sun, and to hold moisture in the soil.

15 A further object is to provide products wherein a single seed capsule product particle provides enhanced soil texture and enhanced soil nutrient value at nutrient levels traditionally needed by newly-germinated seedlings, optionally with higher levels of plant nutrient suitably spaced from the seed itself so as to not be toxic to seedling growth, optionally in combination with time-release technology.

20 Yet another object is to provide fertility-enhancing seed capsule products having a suitable level of plant food nutrients in combination with a high level of organic matter as soil conditioning material.

7 P. 249



Summary of the Invention

5 The invention generally addresses a combination seed capsule, comprising at least one viable seed, having an outer surface and acting as a core or pseudo-core of said combination seed capsule; and a coating of a composition comprising a soil conditioning material mounted proximate, including disposed outwardly of the outer surface of said seed.

10 In general, the coating provides at least one of (i) enhancing broadcast flight properties of the combination seed capsule; (ii) reducing susceptibility to deleterious affects of weather on the combination seed capsule; (iii) enhancing resistance of the combination seed capsule to attack by animals, weeds, or spore-formers; (iv) staged germination of ones of the seed capsules, having seeds, under a given set of conditions, over a period of time longer than the range of germination times inherent in the seeds; (v) enhancing control of moisture about the seed thereby to assist in seed germination; (vi) release of plant nutrients into soil onto which the combination seed capsule is placed; (vii) soil conditioning effect to soil onto which the combination seed capsule is placed; (viii) staged release of plant nutrients into soil onto which said combination seed capsule is placed, over a period of time longer than the range of times inherent in the chemical composition so released; (ix) higher embryo emergence and survival rate in a population of the seed capsules, thereby reducing required seed planting density for a desired plant population density; and (x) assisting in stabilizing moisture content in soil on which such seed capsule is disposed.

25 While a wide variety of seeds may be used, in general such seeds are selected from the group consisting of grass, vegetables, grains, and flowers.

30 Preferably, the coating comprises the soil conditioning material in combination with at least one ingredient effective to

- 7 -



P. 250

UT Ex. 2025  
SteadyMed v. United Therapeutics  
IPR2016-00006

IPR2020-00769  
United Therapeutics EX2006  
Page 4469 of 7113

reduce susceptibility of the seed capsule to deleterious affect of at least one of animals, weeds, and spore-formers. In some embodiments, the ingredient for reducing such susceptibility of the seed capsule is selected from the group consisting of herbicides, fungicides, for example metalaxyl, and a bitter substance.

In some embodiments, the combination seed capsule further comprises a second coating, separate from the first coating, and comprising at least one ingredient effective to reduce susceptibility of the seed capsule to deleterious effect of at least one of animals, weeds, and spore-formers.

Some embodiments are effective to provide a plant nutrient at a desirable controlled distance from a plant seedling emerging from the seed, in an amount beneficial to the plant seedling.

In other embodiments, the second coating material is intermingled with the first coating material in an outer portion of the first coating, and generally displaced from the seed.

The second coating material can comprise a plant nutrient, beneficial in location and in amount of availability, to a plant seedling emerging from the seed. The second coating composition can comprise an inorganic form of a plant nutrient and can be selected from the group consisting of nitrogen, phosphorus, and potassium. The second coating composition can comprise <sup>urea or</sup> an inorganic form of a plant nutrient and can be selected from the group consisting of e.g. ~~urea~~, monammonium phosphate, diammonium phosphate, superphosphate, triple superphosphate, dicalcium phosphate, and potash or a ~~micro~~ nutrient such as sulfur, manganese, copper, boron, iron, magnesium, or chromium.

A population of the seed capsules can comprise coatings having a range of properties affecting germination rate of the seeds, thereby to stage germination of the seeds in the population over a period of time longer than the range of germination times inherent in uncoated ones of the seeds. Such properties can be, for

example, a range of hardnesses, or a range of thicknesses, of the coatings.

5 The coating can comprise a first layer of the soil conditioning material, and a second layer comprising an inorganic, and/or organic, fertilizer, and/or at least one ~~micro~~ nutrient, such as, for example, sulfur, manganese, copper, boron, iron, magnesium, or chromium.

10 A preferred soil conditioning material is a sludge composition, such as a fiber-containing by-product of a paper making operation, or sewage sludge.

The seed capsule can comprise a water-leachable plant nutrient, and/or a leach-retardant composition, such as wax, effective to retard leaching of the leachable plant nutrient out of the combination seed capsule.

15 In some embodiments, in a population of the combination seed capsules, the coatings in ones, but less than all, of the population, comprise ingredients effective to retard effective penetration of a seed-germinating environment to the seed for germination thereof.

20 In embodiments preferred for some applications, the seed capsule comprises an inner layer on the outer surface of the seed, and an outer layer, the inner layer enhancing properties of the seed for acting as nucleus in an agglomeration operation agglomerating the coating onto the inner layer.

25 In some embodiments, the coating comprises an admixture of the soil conditioner and a plant nutrient.

In preferred embodiments, the coating remains generally disposed about the seed, and preferably but not necessarily remains generally intact about the seed, until the seed germinates.

30 The invention further comprises a plant growing medium extending over an area, the plant growing medium having a root zone, and a top surface of the root zone generally corresponding with a top surface of the plant growing medium, the plant growing

5 medium having a first overall soil condition and texture; and a population of seed capsules disposed over the top surface of the plant growing medium, the seed capsules comprising individual seeds, having outer surfaces, and coatings of soil conditioning material disposed outwardly of the outer surfaces of the seeds, the coatings of the seed capsules providing localized germination and growth environments, at and adjacent the seeds, having texture, and nutrient and water holding properties for supporting seedling health, superior to respective properties as provided overall in the root zone of the plant growing medium.

10 The invention yet further comprises a method of providing plant micronutrients to soil, the method comprising placing onto the soil a population of combination seed capsules, each comprising at least one seed, and a coating comprising a plant ~~micro~~ nutrient material.

15 The coating can comprise a first coating comprising the plant ~~micro~~ nutrient, and a second coating, separate and distinct from the first coating, and comprising a soil conditioning material.

20 The invention yet further comprehends a method of providing a seed bed having enhanced growing conditions for growing seed, the method comprising coating a population of the seeds with a coating material, and thereby providing coatings thereon of such material, the material tending to stabilize, in the seed capsules, or in soil on which the seed capsules are disposed coating compositions which tend to hold, moisture adjacent the seeds in the seed capsules or in soil adjacent the seed capsules, in such quantities and for such times as to enhance growing conditions for the seeds; and placing the population of seeds on soil effective to support germination of the seeds which are in the seed capsules.

25 In some embodiments, the seed capsules comprise inner layers on the outer surfaces of the seeds, and outer layers, the inner layers enhancing properties of the seeds for acting as nuclei in

agglomeration operations agglomerating the coatings onto the inner layers.

5 The invention yet further comprehends a method of making a population of combination seed capsules, each comprising a seed, and a coating of a soil conditioning material, the method comprising pre-coating the seed with a material which enhances the ability of the seed to act as a nucleus in an agglomeration operation, to form a pre-coated substrate; and subsequently coating the pre-coated substrate with a soil conditioning material.  
10 A preferred pre-coating material comprises dicalcium phosphate.

In general, the pre-coating step typically results in an overall increase in the density of pre-coated seed combination. The pre-coating step can be accomplished by, for example, spraying the pre-coating material onto the seed, and subsequently driving off such as by drying, as necessary, any solvent or other liquid carrier used for application of the coating material to the seed.

15  
20  
25  
In yet other expressions, the invention comprehends a method of providing an enhanced seed germination environment in combination with placement of a controlled amount of plant nutrients in controlled proximity to each seed, the method comprising providing a population of seeds, coated with a soil conditioning material which tends to enhance germination of the seeds, and with plant nutrient composition effective to enhance growth of plant embryos emerging from the seeds; and placing the population of seeds on soil effective to support germination of the seeds. In such method, the coating material can include a second ingredient comprising plant nutrient moieties.

Brief Description of the Drawings

FIGURE 1 is a transverse cross-sectional view of a coating drum suitable for spray-coating substrate seed according to the present invention.

FIGURE 2 is a partially cut away view showing a length of the drum of FIGURE 1.

FIGURE 3 is a schematic representative flow diagram illustrating a first manufacturing process for producing combination seed capsule product of the invention.

FIGURE 4 is a block diagram illustrating a second manufacturing process for producing combination seed capsule product of the invention.

FIGURE 5 is a schematic representative flow diagram illustrating a third manufacturing process for producing combination seed capsule product of the invention.

FIGURES 6A, 6B, 6C, and 6D show cross sections of seed capsules of the invention.

FIGURE 7 illustrates a cross-section of the soil root zone, and a representative population of seed capsules at the top surface of the soil.

FIGURE 8 illustrates a single seed capsule on the soil surface, and the micro-environment developing about the seed capsule.

DESCRIPTION OF THE ILLUSTRATED EMBODIMENTS


5 The following is a detailed description of the illustrated  
embodiments of the present invention which provides combination  
seed capsule products that provide for a combination of efficient  
and proper seed placement in the soil, soil conditioning properties  
at the specific site of the seed, plant nutrients at or near the  
specific site of the seed, ingredients effective to reduce  
deleterious effects of spore-formers and animals, and/or other  
10 various physical benefits/properties of the combination seed  
capsule not previously available in a single product.

15 In general, at least one seed substrate and at least one soil  
conditioning material are selected as raw materials, and are  
combined to make a combination soil conditioning seed capsule  
product of the invention.

20 The invention can operate with any of a wide variety of soil  
conditioning materials such as municipal or other sewage sludge,  
scrubber sludge, paper mill sludge, fly ash, dust, animal waste,  
other organic materials, and mineral soil conditioning materials.

25 The soil conditioning material can be a solid material having  
a melting temperature so high that handling such material in the  
melt state is impractical and/or undesirable in view of the limited  
temperatures at which the seed will remain viable. For example,  
the soil conditioning material may be combustible at a temperature  
lower than its melt temperature, or will melt only above  
30 temperatures which can be tolerated by the seed, such that  
viability of the seed would be destroyed if melting were attempted  
in an environment which exposed the seed to such temperatures.  
Thus, handling such material in the melt state is impractical,  
whereby other methods of handling the soil conditioning material  
may be desired.

Solid sewage sludge, sawdust, and solid animal waste are  
representative of soil conditioning materials which cannot be

  
P. 256

readily melted. In the alternative, some soil conditioning materials such as sewage sludge, paper mill sludge, sawdust, and solid animal waste can be suitably comminuted and then dissolved or suspended in water or other solvent composition for processing purposes, optionally along with other soil conditioning materials and/or inorganic chemical fertilizer materials, and the solvent subsequently driven off to make a resulting solid product.

~~Inorganic~~ chemical fertilizers generally are distributed in commerce as solid state materials. Such material is generally produced in manufacturing steps either in solution or in the melt state to meet a specified narrow range of size, hardness, and plant nutritional characteristics, distinct to the application of each such product. Examples of such fertilizers include nitrogen, phosphorus, and potassium containing products such as urea, monoammonium phosphate, diammonium phosphate, superphosphate, triple super phosphate, dicalcium phosphate, potash, and the like. The ~~inorganic~~ chemical fertilizer can be a mixture or other physical combination of known inorganic fertilizer chemicals, and may include desired amounts of ~~micro~~nutrients such sulfur, manganese, copper, boron, iron, zinc, and the like.

In preferred embodiments of this invention, a precursor seed capsule, having one or more coatings of the soil conditioning and/or other material thereon may first be prepared as a solid or semi-solid particle or agglomerate. The soil conditioning raw material may be a particulate powder, or may be fibrous, or may be a suspension of a powder or fibrous material in a liquid carrier, and is preferably coated onto the substrate seed to form a seed capsule or other agglomeration of particles, fibers, or the like. Where the soil conditioning material is, for example, sewage sludge, the sewage sludge raw material can be obtained as a slurry that may be bound together as with a binder, preferably an organic binder, when dried. The slurry may be spray-applied to the substrate seeds, for example to a rolling bed of such seeds, in

15 R 257

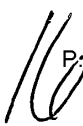


5 combination with a flow of air to evaporate water from the thus-applied coating. Such sewage sludge, or paper mill sludge, need not be reacted or otherwise treated with any acid, caustic, or any other chemical before being applied and/or dried, or partially dried, either in preparation for, or after, the slurry application of the sludge to the seed substrate.

10 Specifically, the sewage sludge or paper mill sludge used herein as soil conditioning raw material need not be treated to transform such sludge into colloidal form. Thus, the sludge preferred for use herein is generally non-colloidal in nature, and is distinguished by its non-colloidal nature from conventional sludges which are specifically treated to provide the colloidal characteristics thereto.

15 Natural lignin, lignosulfonates, and the like, may serve as suitable binders where the soil conditioning material is, for example, paper mill sludge, raw wood, sewage sludge, or other organic or inorganic material. In the case of, for example, calcium chloride or other inorganic additives, such materials may be added to the primary coating, e.g. onto or into the sludge coating, by well-known processes.

20 Soil conditioning material used herein may be devoid of such conventional plant nutrients as nitrogen, potassium, and phosphorous, or may have such limited plant nutrient value, or may be so unbalanced in nitrogen, phosphorous, and potassium content, that the soil conditioning material may not, by itself, be a desirably complete material for use as the only ingredient in the seed coating. Thus, such soil conditioning material may have limited application herein where basic level of soil fertility is seriously degraded. However, all soil conditioning materials contemplated herein beneficially modify soil to which they are applied, in some way other than direct provision of nitrogen, phosphorous, and/or potassium or other plant nutrients. By use of soil conditioner in intimate association with the seed, this

 Pg 258

invention not only enhances soil condition of the growth medium/soil to which it is applied, it also provides soil conditioning value to the seed so coated, and in intimate association with the seed, irrespective of the general tilth condition of the growth medium into or onto which the seed capsule is applied.

Further to preferred embodiments, typically a first coating material (e.g. soil conditioning material) is readily converted into liquid state such as liquid suspension, and is provided to the process as a liquid. As a general statement, the first coating material may be sprayed onto the substrate seed, then is converted back to solid state on the thus-created seed capsules or seed capsule precursors. In the alternative, the coating material may be mixed with the seed in an (e.g. ribbon) blender, or may be otherwise coated onto the substrate seed in an agglomeration process according to well-known conventional agglomeration principles.

Regarding the coating process, the coating material can accumulate as a single or multiple layer coating on the outside of the seeds to form a population of combination seed capsules. The layer or layers of coating material can be a homogeneous or heterogeneous mixture of the desired elements. Further, such population of combination seed capsules can have a range of hardnesses and thicknesses for improved seeding treatments.

Cooperating inner and/or outer layers may be used e.g. to control direct contact between the seed and moisture. Suitable materials and processes therefore are taught in USA Patent 3,698,133 Schreiber and 4,759,151 Gerber, and are thus well known in the art.

In some embodiments, a second coating material may penetrate into the layer of soil conditioning coating material. Such penetration may comprise a generally uniform distribution of the second coating material throughout the first coating material, or

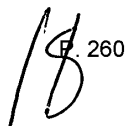
may represent a more stratified or otherwise heterogeneous distribution of second coating material in or on the first coating material.

5 In other embodiments, the coating materials may be mixed into a heterogenous layer. Such layer or layers of heterogenous material can then be coated upon the outside surface of the seed.

10 Where the liquid state of a coating material was obtained by slurring or otherwise combining the coating material with water, the liquid fraction is reduced after application of the liquid-state material to the substrate seed, or to the growing seed capsule, to effect solidifying of the coating material after application of the coating material to the substrate seed. The liquid fraction is reduced by driving off the liquid carrier, as by  
15 medium or low temperature air, or vacuum or other flash drying, after or during application of the coating material to the substrate seed. The resulting solid seed capsule, comprising the seed coated with the e.g. sludge coating material, is then recovered as a combined soil conditioning seed capsule product of the invention.

20 Spraying of the liquid coating material can be accomplished by a variety of known processes such as, but not limited to, pneumatic, hydraulic, or electrostatic spraying processes. The temperature and pressure of the material being sprayed depends on the material selected, and the viscosity and other parameters of  
25 the respective material in the respective liquid state. While high atomization is desired, such is not critical. The liquid coating material need only be atomized sufficiently to provide a generally uniform coating on the substrate seeds, as determined after the coating and solidification steps in fabricating the seed capsule  
30 product are completed.


Indeed, the uniformity of coating or coating thickness about the seed is typically not critical so long as the seed is not on or immediately adjacent an outside surface of the capsule such that

 260

the seed may fall out, or be easily broken out, of the capsule, or easily removed by dissolution of materials at and near the surface of the seed capsule. In addition, the seed should not be so near the outside surface of the capsule as to be in a nutrient layer having such high concentration of nutrient as to be toxic or otherwise detrimental to viability or growth of a plant emergent from the seed.

Spray application of the coating is suitably controlled to achieve the required addition of the spray material, liquid and/or powder, coating to the substrate seed or precursor seed capsule. An illustrated method of applying the liquid material to the substrate seed or precursor seed capsule is by using a rotating drum spray-coating apparatus. Other apparatus and methods, for example a tilted pan coating process, can be used to apply the soil conditioning material and optionally an ~~inorganic~~ chemical fertilizer material onto the substrate seed. The coating operations can be batch operations or continuous operations.

As illustrated in FIGURES 1, 2, and 4, spray apparatus can operate within a rotating drum disposed in a generally horizontal orientation. The drum may incorporate internal lifting flights which lift free-flowing (e.g. seed and growing seed capsule) particles in the drum and then let the particles fall to the bottom of the drum as a continuously falling curtain or cascade. In some embodiments, the interior of the drum is either clean and free from any flighting, or has only mixing fingers or flights that expand the area covered by the bed, that keep the bed rolling as the drum rotates, and that generally improve mixing, rather than lifting particles to the top of the drum and then releasing them in a falling cascade. However, such lifting of particles to the top of the drum, and corresponding falling cascade or falling curtain, are not excluded from processes of the invention. Rather, both such finger mixing, and such lifting coupled with falling cascade or curtain, are included within the scope of the invention.

 261

Stationary spray nozzles are positioned within the drum to project the sprayed material onto the rolling bed, and optionally onto any curtain or cascade of falling particles. For a continuous process, the drum is preferably inclined at a small angle from horizontal, such as, without limitation, about 0.25 inch to about 0.38 inch from the horizontal for each foot of length of the drum, so that rotation of the drum causes the particles to move from the inlet end of the drum to the discharge end, while maintaining a relatively uniform bed thickness. The optimum degree of incline varies with each set-up and may thus be outside the above range. The important parameter is that the incline contribute to maintaining a bed of seed and seed capsule particles having sufficient uniformity that the spray material can be effectively applied to the particles passing through the drum. The particles are then discharged at the discharge end of the drum.

FIGURES 1 and 2 show schematically a first embodiment of processing equipment which may be used to produce seed capsules of the invention. Such processing equipment includes a drum and sprayer combination suitable for continuously producing coated seed capsules in accord with the invention. Use of the illustrated drum and sprayer combination is not critical, however, as other drum and sprayer combinations, or other coating methods such as pan coating methods, are also suitable. <sup>Referring to</sup> FIGURES 1 and 2, drum **10** has an inlet end **12** for receiving the substrate seed material or materials, or partially formed or pre-coated seed capsule precursors. Drum **10** has a discharge end **14** through which agglomerated or otherwise coated seed capsule product particles are discharged over discharge retaining ring **16**. A variable speed rotary drive (not shown) is provided for supporting and rotating the drum **10** in a counterclockwise direction as viewed in FIGURE 1 at controlled, and changeable drive speeds. Conventional slope adjustment apparatus (not shown) is provided for routine and ongoing adjustment the slope of the drum from horizontal.

5 Air is preferably supplied from discharge end **14** as shown in  
FIGURE 2, and flows countercurrent to the direction of travel of  
the seed substrate material. Since the contemplated coating  
materials are generally applied to the seed in liquid, or semi-  
liquid, or other moist form, and since some coating materials may  
thus tend to form clumps or otherwise self-agglomerate when exposed  
to ambient moisture conditions, air supplied at discharge end **14**,  
and elsewhere in the process for contact with the coated seed and  
seed capsules, is preferably dried in order to cost-effectively  
10 remove an optimum amount of the moisture from the coating material  
and to assist in maintaining suitably low moisture content in the  
thus coated and dried seed capsules.

15 A first stationary spray assembly **28** extends longitudinally  
within drum **10** above and adjacent the bed **20** of seed and/or seed  
capsules. First spray assembly **28** includes pipe **29** and nozzles **30**.  
A second spray assembly **32** extends longitudinally within drum **10**  
generally adjacent first spray assembly **28**. Second stationary  
spray assembly **32** includes pipe **33** and nozzles **34**, which transport  
the material to be sprayed. Nozzles **30** and **34** are connected to  
20 pipes **29** and **33** respectively, and project sprays of liquid or  
otherwise particulate coating material toward the bed of seeds  
and/or seed capsule precursors. The description of spray  
assemblies **28**, **32** as stationary means that the spray assemblies do  
not rotate with drum **10**. However, the positions of either nozzles  
25 **30**, **34** or pipes **29**, **33**, or both, can be adjusted within the drum  
for proper direction of the respective spray or sprays onto the bed  
of seeds and/or seed capsules or seed capsule precursors.

30 A stationary protective cover **24** is mounted over the spray  
assemblies. Seeds and/or seed capsules falling from the inner  
surface of the drum and the flights, above the spray assemblies,  
fall onto the cover, and are deflected away from the spray  
assemblies, as shown in FIGURE 1. Thus, cover **24** protects the

pipes and nozzles from the falling seeds and seed capsules falling onto and fouling the pipes and spray nozzles.

As drum **10** rotates, flights **22** lift and mix the seeds, seed capsule precursors, and seed capsules, but do not generally carry the bulk of the seeds and seed capsules up to the top of the drum. Some small amount of seeds, seed capsule precursors, and seed capsules will be carried upwardly to the top of the drum by even a drum devoid of any flights. Thus, all drums experience some amount of seeds and seed capsules falling from the upper part of the rotating drum whereby cover **24** is beneficial for protecting spray assemblies **28** and **32**.

Preferred flights **22** are primarily directed toward enhancing mixing of the bed **20** of seeds and seed capsules, continually refreshing the surface of the bed with a newly-emergent supply of seeds and seed capsules, rather than lifting and subsequently dropping the seeds and seed capsules which may be fragile when initially coated. To that end, each flight **22** preferably, but without limitation, has a leading surface **23A** extending at an obtuse angle "A1" of at least 90 degrees with respect to the inner surface of the drum. A more preferred angle "A1" is about 100 degrees to about 150 degrees. Trailing surface **23B** of flight **22** can be virtually any angle, with the inner surface of the drum, which angle does not interfere with the operation of adjacent leading surfaces **23A**.

Additional retaining rings can be added to the assemblage shown in the drawings, in order to provide that height "H" to the retaining ring which will provide and maintain the optimum configuration of bed **20** inside drum **10**.

As noted above, inlet end **12** of the drum may be raised above discharge end **14**. When in use, the drum rotates continuously. Seeds or previously thinly-coated or partially-coated seed capsules are continuously fed into inlet end **12** and thus added to rolling bed **20**. Flights **22** continuously mix the bed as the drum rotates,

- 21 -

*JS* 264

UT Ex. 2025  
SteadyMed v. United Therapeutics  
IPR2016-00006

IPR2020-00769  
United Therapeutics EX2006  
Page 4483 of 7113

refreshing the bed surface with newly fed seeds, or seeds and seed capsules newly brought to the surface by the continuous rotation of the drum in combination with the mixing action of the flights. Spray assembly **28** sprays the desired coating material (e.g. sewage sludge, paper mill sludge, or other coating composition, onto the continuously moving and mixing surface of bed **20** from a plurality of nozzles **30** distributed along the length of pipe **29**, and similarly along the length of drum **10**, adding the sprayed material to the seeds and seed capsules in bed **20**. After receiving the spray coating from spray assembly **28**, the seed capsules are discharged through discharge end **14**. In some embodiments, the seed capsules pass through a cooling chamber, not shown, integral in drum **10**, before being discharged through discharge end **14**.

In general, as the seeds traverse the drum, from inlet to discharge, nozzles **30** atomize the liquid or other coating material and spray such atomized coating material as e.g. droplets of the coating material onto the seeds in the bed. The result is that the seeds become generally uniformly coated with one or more layers of the coating material such that the coating material becomes an integral part of the respective seed capsules fabricated in the drum. As the coating material solidifies on the seeds, the coating material tightly bonds to the respective portions of the seeds.

As the seeds and seed capsules roll and mix with rotation of the drum, the incline of the drum causes the seeds and seed capsules to travel from inlet end **12** toward discharge end **14**.

In the alternative, or where a coating material is not readily self-bonding to the seed material, a binder material can be provided toward the inlet end of the drum at spray assembly **32**, through pipe **33** and nozzles **34**. In such embodiment, the binder is preferably sprayed onto the seeds closer to inlet end **12** rather than along the entire length "L" of the drum. The coating material is then preferably sprayed onto the seeds downstream from the inlet end, and preferably relatively downstream of nozzles **34**. Thus, the

*23* P. 265



seeds receive a first coating of the binder, and a subsequent second coating of e.g. liquid soil conditioning coating material overlying the binder.

5 Binder material applied as e.g. through spray assembly **32** may contain additional coating components such as e.g. flyash, lime, gypsum, or the like, as one or more components for assisting in adding bulk and thickness to an inner binder layer prior to any, or the majority of, the application of the organic coating material (e.g. sewage sludge or paper mill sludge).

10 In some embodiments, binder and liquid soil conditioning coating material are applied at similar locations along length "L" of the drum whereby binder and soil conditioning coating material may become intermingled/mixed before reaching the seeds, or on the seeds. For example, liquid soil conditioning coating material may be sprayed onto the seeds along the full length of the coating chamber in drum **10** while spraying of the binder material onto the substrate seeds is done relatively closer to or adjacent the inlet end of the coating chamber of the drum. Thus, a first binder layer may underlie or be mixed with the soil conditioning coating material, and may be overlain by a second layer of the soil conditioning coating material. Thus, in this embodiment, the binder layer may typically be a combination of binder material and coating material.

15  
20  
25 Further, it is contemplated that the soil conditioning coating may be applied first, followed by application of binder or inorganic fertilizer or sealer coating, in which case the binder or inorganic fertilizer or sealer may serve as an outer shell, temporarily trapping the inwardly-disposed materials inside the seed capsule. In the alternative, the soil conditioning coating may be applied first, followed by application of the binder, and wherein the binder penetrates through the soil conditioning coating, either physically or chemically, to the underlying substrate seed and there provides the binding property.

30

24

Additional spray assemblies can be provided, spraying additional materials (e.g. inorganic fertilizer materials) onto the substrate seed. Thus, e.g. 6 spray assemblies can spray 6 different coating materials onto the substrate seed. For example, a first spray material can be a binder or primer material intended primarily to enhance bonding of subsequent sprays to the substrate seed. Continuing the example, a second spray can be a combination of binder and finely comminuted particulate material such as lime and/or flyash. A third spray may be a soil conditioning material such as a paper mill sludge or a municipal sewage sludge. Fourth, fifth, and/or sixth sprays can add nitrogen, phosphorous, and/or potassium plant nutrient ingredients, alone or in combination, or as combinations. In this manner, the soil conditioning properties of the seed capsule can be established, and the plant nutrient level of the seed capsule can be enhanced to provide substantially any level of major and/or minor plant nutrients desired in the seed capsule, at substantially any relative ratios of the respective plant nutrients, and wherein the preferably primarily soil conditioning coating provides desired soil conditioning properties in the resulting product, initially for use by the specific seed contained therein, and ultimately as additive to the overall tilth of the growth medium such as soil into or onto which the seed capsule is eventually planted.

A preferred, and rather simplistic, embodiment of the invention is provided by spraying a soil conditioning liquid suspension of sewage sludge or paper mill sludge onto seeds to be encapsulated to make seed capsules. By controlling the amount of the soil conditioning sludge, or by controlling the residence time of the seeds in the drum, a desired thickness of soil conditioning coating can be provided in the resulting coated product.

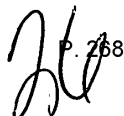
Typical dried sewage sludge, as a raw material, contains about 2-6% nitrogen, up to about 2% phosphorous, and generally no potassium, and thus has little or no market value as a fertilizer

(plant food) product per se. However, by adding e.g. urea, the nitrogen content can be raised if desired, especially as a coating on or adjacent the outside surface of the seed capsule, whereby the combination fertility-enhanced, soil conditioning, seed capsule product has real market value as a comprehensive, self-contained, value-added, seed capsule product. Such product thus contains the seed, a soil conditioning composition which operates somewhat as a seed incubator providing a beneficial germination environment, and a starter quantity of fertilizer selected in quantity and placed in location so as to provide improved, ideally optimum, amounts of plant nutrients at optimum location for use by the newly-emerged embryonic plant at the germination stage of seed development.

Starting with a sludge coating having 2% by weight nitrogen, sufficient urea may be added to bring the nitrogen content to, for example, 5%, 7%, 8% or 10% nitrogen, or more, depending what analysis is desired. Starting with a sludge coating having 6% nitrogen, sufficient urea may be added to bring nitrogen content to, for example, 10%, or whatever other analysis is desired. Phosphorous and/or potassium components and/or materials having combinations of plant nutrient elements (e.g. NPK) can, similarly, be added to the sludge, either before, after, or during addition of the urea. In addition, nitrogen, potassium, and/or phosphorous-containing materials can be combined with the sludge prior to the sludge being applied to the seed.

It should be understood that the more porous the established soil conditioning coating, or e.g. the outer surface of such coating, the more any subsequent spray material penetrates the established coating. All such penetration is contemplated in use of the term "coating" herein.

In some preferred embodiments, the overall coated combination seed capsule product comprises seed capsules wherein substantially the entirety of the soil conditioning material is confined to a contiguously-defined portion of the seed capsule. In such



embodiments, the structures of the finished product seed capsules comprise coatings of contiguously arranged elements of the soil conditioning material, generally arrayed entirely or substantially entirely about the seed, which coatings may be overlain by an additional layer, optionally discontinuous, of organic or inorganic chemical fertilizer. Further coating layers of either soil conditioning material or organic or inorganic chemical fertilizer can be applied over the additional layer.

In addition, or in the alternative, other layers of other materials whether soil conditioning materials, organic or inorganic fertilizers, or other materials, can be applied to the substrate seed before applying the above mentioned layer of soil conditioning sludge. Thus, the substrate seed can be coated with a layer of a calcium compound e.g. calcium chloride, calcium carbonate, or dicalcium phosphate, or with a sulfur moiety, and/or a further layer of urea, all with optional use of binder materials.

Further to the structure of the seed capsules of the invention, the coatings on the seed capsules need not generally represent a uniform mixture of the inorganic chemical fertilizer and the soil conditioner. Rather, in a typical seed capsule a core substrate seed is overlain or encapsulated by a soil conditioning material, and is generally free from a second overlying soil conditioning coating material, and wherein the inorganic fertilizer content at the seed/coating interface is relatively higher so as to represent a second coating material such as an inorganic fertilizer coating, as compared to the inorganic fertilizer content at locations at and adjacent the seed.

The second coating can, and preferably does, in some embodiments, penetrate into voids or other interstices in an underlying e.g. soil conditioning coating. However, preferably most if not all elements of the underlying e.g. soil conditioning coating material are generally interconnected with each other without intervening coating material of the second layer, except

for an optional binder used to hold the first coating material together as a unitary structure, separate from any structure and bonding provided by the second coating material.

5 While the combination seed capsule can comprise discontinuities in the soil conditioning sludge coating layer, in combination with an inorganic fertilizer material in such seed capsules, such compositions are less preferred.

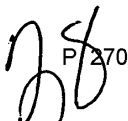
10 Regarding the coating process, FIGURE 4 illustrates in flow sheet form a manufacturing process for producing seed capsules of the invention, using the coating drum 10 as described above. It should be understood, however, that other equipment such as a pan pelletizer, a paddle mixer, or the like can be used in place of the rotary drum to obtain combination seed capsules of the invention.

15 The coating process operates according to conventional and generally well known agglomeration principles, as described by Wolfgang B. Pietsch in an article entitled "The Agglomerative Behavior Of Fine Particles." Such coating process uses water and heat, along with physical and/or chemical adhesives and like properties, to bind or agglomerate a plurality of types of particles and/or materials into coated seed capsules, each typically containing an individual seed.

20 To obtain agglomerates from relatively smaller particles of raw materials, binding forces must act within the individual developing agglomerate particles. According to known agglomeration principles, five different binding mechanisms are known to be useful for building agglomerate particles including solid bridges, interfacial attractions and capillary pressure, adhesion and cohesion, attraction between solid particles, and form-closed bonds.

25 At elevated temperatures, solid bridges can form by diffusion of molecules from one particle to another at the points of contact. Heat can be introduced from an external, secondary source or created during agglomeration by friction and/or energy conversion.

- 27 -

 P. 270

UT Ex. 2025  
SteadyMed v. United Therapeutics  
IPR2016-00006

IPR2020-00769  
United Therapeutics EX2006  
Page 4489 of 7113

Solid bridges can also be built up by chemical reaction, crystallization of dissolved substances, hardening binders, and solidification of melted components.

5 Capillary pressure and interfacial attraction forces in liquid bridges can create strong bonds that disappear if the liquid evaporates and no other binding mechanisms take over.

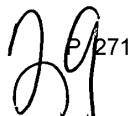
10 Highly viscous bonding media such as tar and other high molecular weight organic liquids can form adhesive and/or cohesive bonds very similar to those of solid bridges. Thin adsorption layers are immobile and can contribute to such bonding together of fine particles under certain circumstances.

15 Typical short-range forces of the van der Waals electrostatic or magnetic type can cause attraction between solid particles whereby the particles stick together if such particles are sufficiently close to each other. Decreasing particle size clearly favors such attraction between solid particles.

Fibers, little platelets or bulky particles can interlock or fold about each other resulting in "form-closed" bonds.

20 Now referring to FIGURE 3, in some embodiments of the coating/agglomeration process, it is desirable to pre-coat the seeds prior to implementing agglomeration principles to produce the above described coating of soil conditioning material. Such embodiments comprise light-weight and/or elongate shaped seeds (i.e. grass seeds), or other similar type of seed which may not readily or inherently serve as a nucleating agent in a conventional agglomeration process with the respective soil conditioning material which is desired to be coated on the seed. Pre-coating the grass seed, for example, enhances the agglomeration of paper sludge as a coating material, of binder and/or of other coating substances, by increasing the weight of the pre-coated grass seed and by providing a more filled in, more rounded shape to such long and narrow seeds. The increased weight and more filled in shape of the grass seed enables more effective, more efficient, processing

25  
30

A handwritten signature in black ink, appearing to be '29', with the number '271' written next to it.

of the seed in coating apparatus such as that illustrated in FIGURES 3 and 4.

Referring to FIGURE 3, the form and composition of such pre-coating, when needed, can vary according to the weight, shape, composition, and surface properties of the seeds, and according to the binder, if any, the soil conditioning coating or coating materials to be applied, and any other inorganic or organic coating material to be applied.

The seeds, whether pre-coated or not, are received within the rotary drum where the soil conditioning material is spray coated onto the substrate seeds to obtain combination seed capsules.

Before coating the seeds with a soil conditioner, the organic soil conditioner material (e.g. paper sludge) is preferably processed through a dryer such as a rotary drum dryer, as needed, to reduce the amount of moisture in the organic soil conditioner material to less than about 8% water by weight. Such drying is an essential step where the material is otherwise above the nominal 8% effective water content, to enable grinding the sludge to a size less than US Standard 20 mesh screen, and to prevent the particles from agglomerating with each other. Certain of the coating materials, e.g. fly ash, because of their physical properties, need not be dried before being ground to a suitable size for participating in the agglomeration operation.

The seeds, whether pre-coated or not pre-coated, and the one or more soil conditioners, are received within a mixer where growth enhancers such as time release agents and/or other environmental conditioners may be added to form a combination seed capsule. The thus pre-coated seeds are then received into a pan pelletizer, a rotary drum, or the like, where binders such as lignin, lignosulphonates, molasses, sodium silicate, wax, monammonium phosphate, or urea can be added and thereby coated onto the pre-coated seeds. Other materials which can be added to the seed capsule at the e.g. rotary drum include anti-fungal coatings such

A handwritten signature in black ink, appearing to be 'JD', is written over the page number '29'.

as with metalaxyl fungicide, for example, Apron® and/or Subdue®, available from Novartis, Inc. of Greensboro, North Carolina.

5 The such-coated seeds are then passed into a rotary or other dryer in order to obtain a seed capsule containing 5% or less water. The maximum water fraction in the coating can vary according to the composition of the coating material, so long as the resultant seed capsules remain suitably structurally strong and so long as a population of such coated seed capsules remains free flowing in solid condition. The process for fabricating the seed capsules must maintain a temperature sufficiently low that the seeds are not heated so hot that viability of the seeds, for germination purposes, is not dramatically compromised. It is generally preferred that the temperature of the seeds be suitably controlled such that any binder and/or coating material, or other materials applied to the seeds, cool at a controlled rate while bonds form between the seeds, or seed capsule precursors and the one or more soil conditioning and/or other coating materials. Such temperatures of all materials are suitably controlled to avoid decomposition of the respective materials, loss of viability of the seeds, or breakage of seed capsules or seed capsule precursors, or coatings or coating or other materials during such processing. The temperature at the rolling seed bed inside drum 10 generally can range from about 130 degrees F to up to at least 230 degrees F for seed residence times up to at least 1 hour. At drum operating temperatures of less than 130 degrees F, drying time can become excessive. At temperatures above 230 F, the viability of the seed may be at risk, depending on the sensitivity of the seed, residence time, and other influential parameters.

25 The above stated temperature range is illustrative and not limiting, and will vary depending on the seed, the coating materials, and the specific process parameters of a particular coating system and coating operation. Thus, maximum e.g. drum coating temperatures can be less than 130 degrees F or more than



230 degrees F. However, the stated range is preferred, including all temperatures within such range such as, for example, 150 degrees F, 180 degrees F, 210 degrees F, and the like.

5 Referring to the drum of FIGURES 1 and 2, and to the pan pelletizer block in FIGURE 3, the seeds are fed continuously to an inlet as at inlet end 12 of drum 10. Combination seed capsules, produced as described above, are released from a discharge locus such as discharge end 14 of the drum to a sizing apparatus 36 in which the seed capsules are sized through conventional sizing elements. Suitably-sized seed capsules are discharged from the 10 sizing apparatus as product for distribution. Undersize seed capsules are fed back into mixer as shown in FIGURE 3. Oversized seed capsules are fractured and screened for reprocessing.

15 The recovered seed product can be further coated with any of the coating materials described above, such as urea or other inorganic or organic fertilizer, and/or with growth enhancers or other desirable materials. Further, other types of coating materials such as water repellants can be coated onto the discharged seed capsules for the purpose of imparting additional desirable properties to the seed capsules. 20

In the process of coating porous organic materials such as sewage sludge or paper mill sludge as is optional in the invention, with a second material which is applied for other than imparting soil conditioning properties, for example an inorganic fertilizer, 25 the general size of the coated seed capsule may be the same after applying the second material (e.g. inorganic fertilizer) as the size of the previously-coated seed capsule, or may be similar in size. Namely, the quantity of coating material added to the seed capsule can be so small as to not materially affect seed capsule size, or the coating material can be received into an e.g. porous 30 interior of the soil conditioning coating of the seed capsule, or both.

*BA* 274

It is contemplated that the operation and functions of the invention have become fully apparent from the foregoing description of elements, but for completeness of disclosure, the usage of the invention will be briefly described.

5

## EXAMPLE 1

10 A coating drum as illustrated in FIGURES 1, 2 and 4 is used to place a coating of paper mill sludge on grass seed. Raw material grass seed about 4-6 millimeters long and about 0.5-1.0 millimeter thick, is continuously fed to pre-treater **11**, where the seed is blended with powdered lime, powdered flyash, and a lignosulfonate binder, to form partially-developed seed capsules comprising seeds coated with relatively thinner coatings of the recited mixture of coating materials. The partially-developed seed capsules are continuously fed to inlet end **12** of drum **10**, to form a bed **20** of the partially-developed seed capsules. The drum rotates continuously. The rolling of the drum, and the associated mixing affect of the flights, provide a constantly changing top surface of the bed. A paper mill sludge slurry is supplied in pipe **28** at pressure sufficient to atomize the liquid sludge slurry. A liquid sludge slurry is thus sprayed from nozzles **30** onto the top surface of the bed of partially-developed seed capsules, applying a sludge coating on those partially-developed seed capsules which are at the upper surface of the bed at any given point in time.

25

The resulting seed capsules, of paper mill sludge coated seeds, have a coating of soil conditioning sludge thick enough to make the material a product marketable for its soil conditioning content as well as for the seeds contained therein. Increased levels of nitrogen and/or other plant nutrients can be added by, without limitation, providing sprays of the other desired materials, preferably subsequent to at least the initial sludge slurry spray. Other materials can be included in one or more of

30

- 32 -

33  
F 275UT Ex. 2025  
SteadyMed v. United Therapeutics  
IPR2016-00006IPR2020-00769  
United Therapeutics EX2006  
Page 4494 of 7113

the sprays e.g. to retard or enhance moisture permeation into or out of the combination product in accord with the anticipated storage and/or use environment of the product.

5

## EXAMPLE 2

FIGURE 5 illustrates the equipment used in this EXAMPLE 2. As seen therein, grass seed, lime, flyash, and calcium lignosulfonate binder are fed to ribbon blender **111** by respective screw feeders **112A**, **112B**, **112C**, **112D** respectively. Ribbon blender **111** encapsulates the seed with a thin layer of the mixture of lime, flyash, and lignosulfonate to thereby make partially-formed seed capsules. The partially-formed seed capsules are discharged from the ribbon blender and conveyed by conveyor **114** and belt feeder **116** to a tilted-pan pelletizer **118**, which rotates about a fixed axis.

Paper mill sludge is received into a weigh hopper **120** at about 60% by weight water, and is fed by screw feeder **122** and belt **124** to pin mixer **126**. The pin mixer breaks down the fiber and fiber clusters of the sludge into loose separate fibers, and discharges the resultant material onto conveyor **128** which transports the material to screw feeder **130**, and thence into the tilted pan pelletizer.

In the tilted pan pelletizer, the partially-formed seed capsules, (seeds being coated with lime, flyash, and lignosulfonate) are mixed with the comminuted paper mill sludge and thereby coated with the sludge. By operation of the tilted rotating pan pelletizer, the larger seed capsules generally rise to the top of the bed of seed capsules in the pan, and as additional material (sludge and partially-formed seed capsules) are added to the pan, the larger seed capsules overflow the lower edge of the rotating pan, onto vibrating feeder conveyor **132**.

The vibrating feeder conveyor feeds the seed capsules into granulator **134** (e.g. rotating drum) where the seed capsules may be

- 33 -

UT Ex. 2025  
SteadyMed v. United Therapeutics  
IPR2016-00006

IPR2020-00769  
United Therapeutics EX2006  
Page 4495 of 7113

(e.g. spray) coated with inorganic fertilizer or other desired material.

5 From the granulator, the seed capsules flow into dryer 136 and are dried to a final product moisture of about 2-3% by weight water. The resultant product is then screened and sized as before, with undersized and oversized product seed capsules being recycled for further processing.

10 Urea and other liquid ~~inorganic~~ chemical fertilizers can, as indicated, be used as binders to bind together soil conditioning coatings which are not readily self-bonded together. In such  
15 embodiments, the urea or other liquid fertilizer composition serves as the binder or glue which holds together the soil conditioning material which is used as the coating. Other binding materials may be used either alone or in combination with the ~~inorganic~~  
20 fertilizer. Any plant nutrient components of the binder/glue composition contribute to the plant nutrient value, e.g. nitrogen, phosphorous, and/or potassium, provided by the so-made seed capsules. Thus, a binder/glue, or a multiplicity of binders/glues, properly selected as to nutrient value can provide, in the finished  
25 product, significant contribution to any desired fertility analysis.

A primary purpose of soil conditioning products is to condition the soil in terms of properties other than direct  
30 provision of plant nutrients.

The primary purpose of conventional inorganic chemical fertilizer products is to directly provide plant nutrients. It is well known that highly purified forms of inorganic chemical materials are more concentrated than desired in close or intimate  
35 proximity with seed, in the growing medium. Thus, inorganic chemical fertilizers can be diluted in concentration and still have sufficient nutrient content to be highly useful additives in soil conditioning seed capsules of the invention. It is common practice



to modify and thus dilute inorganic chemical fertilizer products with filler materials that do not provide plant nutrients, in order to provide less concentrated fertilizer products. To the inventor's knowledge, such diluents, however, do not include soil conditioning products, especially not organic soil conditioning products.

It is conventionally known to apply commercially available soil conditioning materials and inorganic fertilizers, in separate applications, to a given common plot of soil to assist the soil in growing a crop. For example, it is known to make a first broadcast or other placement of lime to control pH of the soil, followed by a second broadcast and/or row-applied placement of granular inorganic chemical fertilizer. It is also known to make sequential applications of a soil conditioning material such as fresh or aged manure followed by inorganic fertilizer, all of which may be separate from the step of applying seed. And where seed is indeed applied in the same step, the seed and soil conditioner are not intimately bound in controlled positioning with respect to each other in common in individual particles of the product so applied, as in the invention.

To the inventor's knowledge, it is not known to apply soil conditioning material and inorganic chemical fertilizer in a common carrier/particle. Nor is it known to apply seed in a seed capsule wherein the seed is intimately combined with a soil conditioning material in a common particle, optionally with an inorganic fertilizer component in controlled positioning with respect to the seed in the same capsule as a seed-soil conditioning particle.

In those embodiments of the invention comprehending both soil conditioning and inorganic fertilizer in the same seed capsule/particle, the ratio of soil conditioning material to inorganic chemical fertilizer material can vary, from, for example, about 80% by weight up to less than 100% by weight soil conditioning material, with corresponding greater than 0% up to



P. 278

about 20% by weight inorganic chemical fertilizer. Generally, the invention as practically applied, however, is somewhat more narrowly defined, because the practical benefits of the invention are achieved at more balanced combinations of the soil conditioning material and the inorganic chemical fertilizer.

Thus, a preferred amount of soil conditioning material is about 90% by weight to about 98% by weight soil conditioning material, in combination with about 2% by weight to about 10% by weight inorganic chemical fertilizer. To the extent the soil conditioning material is present in amount less than about 80% by weight, the corresponding 20% by weight organic fertilizer in such close and intimate proximity to the seed may be toxic to the seed. To the extent the inorganic fertilizer is present in an amount of less than 2% by weight, the beneficial fertility affects of the fertilizer may not be perceived.

To the extent the inorganic fertilizer can be confined in a layer displaced from the seed, a higher level of inorganic fertilizer may be used while limiting risk of a toxic response from the seed. Referring now to FIGURES 6A-6D, in the embodiment of FIGURE 6A, seed capsule **38A** comprises a seed **40A** coated with a single generally homogeneous coating **42A**. Coating **42A**, as illustrated in FIGURE 6A, may comprise only the soil conditioning material (e.g. paper mill sludge or sewage sludge), or may comprise both the soil conditioning material and an inorganic fertilizer or other inorganic material generally dispersed in coating **42A**.

In FIGURE 6B, seed capsule **38B** comprises a seed **40B** coated with a first layer **42B** of soil conditioning material. A second coating material is shown penetrated part-way through the first layer **42B**, thus to make a combination outer layer **44B** comprising the combination of the material of layer **42A** and the material of the second material, such as inorganic fertilizer.

In FIGURE 6C, seed capsule **38C** comprises a seed **40C** coated with a first layer **42C** of soil conditioning material. A second

generally separate and distinct layer **46C** of a second coating material (e.g. inorganic fertilizer) is disposed outwardly on the underlying first layer **42C**. Layer **46C** generally does not penetrate layer **42C**, whereby higher levels of inorganic fertilizer may be used because of the effective displacement distance between the seed and the second layer **46C**. The second layer may be prevented from penetrating the first layer by applying e.g. an intervening layer which repels the second layer, for example wax, lignin, or the like.

In FIGURE 6D, seed capsule **38D** comprises a seed **40D** coated with a pre-coating layer **48D** of dicalcium phosphate to densify and configure the seed capsule precursor for the primary coating steps in drum **10** or pan pellitizer **118**. Layer **42D** of soil conditioning material is disposed outwardly of pre-coating layer **48D**. Other materials such as at layers **44B** or **46C** can be added to any of the embodiments, including that of FIGURE 6D to provide the properties associated therewith.

In alternative embodiments, seed capsules can comprise a seed coated with at least one heterogenous layer. The heterogenous layer comprises at least two different materials substantially commingled, uniformly or non-uniformly, within a single layer. Such materials can include, for example, soil conditioning material and inorganic fertilizer, ~~micro~~nutrients, herbicides, fungicides, binders and/or any other layer material contemplated by the present invention.

While the soil conditioning material/sewage sludge or paper mill sludge may contain a nominal amount of nitrogen and lesser quantities of phosphorous, potassium, and micronutrients, these small levels of plant nutrient content are generally not high enough for the plant nutrients to be considered a primary commercial asset. Yet only small nutrient amounts are desired so close to the seed. Thus, in some uses, the nutrient content of the sludge may be fully acceptable as the sole coating material on the

seed in making suitable and acceptable seed capsules of the invention.

5

Products of the invention offer a new combination of properties, namely readily available excellent soil conditioning properties in combination with the seed in a seed capsule wherein size and density of the seed capsule are controlled to the desired size and weight.

10

One of the properties offered by soil texture conditioners such as sewage sludge and paper mill sludge is that of maintaining soil condition by retaining moisture in the soil, retarding leaching of soil nutrients from the root zone, and attenuating hardening, clumping, or other hard agglomeration characteristics of the soil, which harder soils are more difficult for plant roots to penetrate than are softer soils. Thus, improving the soil texture condition, soil tilth, increases the efficiency with which plant nutrients are retained and used for plant nutrition, as well as generally improving the environment of the soil to accommodate, and readily receive, root growth.

15

20

25

30

When soil conditioning materials and plant nutrients are applied separately to the soil, as in the prior art, the ratio of applied plant nutrients to applied soil conditioning material typically varies widely according to variations in the uniformity of the two applications of the two materials. Further, the soil conditioning material is generally not closely associated with the plant nutrient-containing fertilizer in the soil, and certainly neither soil conditioner nor the fertilizer are controllably-closely associated with the seed, such that nutrient absorption benefits provided by the soil conditioning material are not assuredly associated with respective particles of inorganic chemical fertilizer materials, and neither the soil conditioning material nor the inorganic fertilizer is controllably and intimately associated with the seed as in a common capsule or other particle as in the invention.



5 Rather, where soil conditioning and fertilizer materials are applied in separate applications and/or in applications separate from the application of the seed, the bulk of the soil conditioning material and the bulk of the inorganic chemical fertilizer are generally at least somewhat separated from each other in space, and physically separated from the seeds, such that potential cooperative benefit of the soil conditioning material as relates to solvation and up-take of soil moisture and/or of the inorganic chemical fertilizer by the seed are not obtained, and/or are not  
 10 obtained in controlled close association with the seed.

15 When the soil conditioning material, the inorganic chemical fertilizer materials, and the seed are separately applied to soil with different sets of equipment, the respective rates of application vary such that the desired ratios between the quantities of the several materials are applied somewhat non-uniformly. The variances from uniformity will be different for each of the applications, thus adversely skewing the relative ratios of the materials with respect to each other at different locations in the e.g. field. Further, when applied separately to  
 20 the soil, the seed and the soil conditioner are not necessarily in intimate contact with each other as they are when both materials are combined into a single combined seed capsule product as in the invention. Nor is the seed in closely controlled proximity (e.g. within the same capsule) with the inorganic fertilizer. In  
 25 reality, then, any fertilizer added to the soil but not in close proximity to the seed applied to the same soil during e.g. the same growing season, is of reduced value or no value to that application of seed, whereby little or no value is realized, during that growing season, from the application of such material to the soil.

30 The amounts of soil conditioning material and inorganic fertilizer added to the soil at any given time represent a small fraction of the "soil" in the plant growing zone (root zone). Thus, in the conventional practice of providing separate

applications of plant nutrients and soil conditioning material, in addition to the seed, only small fractions of the newly applied soil conditioning material and plant nutrient come into proximate cooperating relationship with each other and with the seed. Thus, the seed and any plant newly emergent from the seed are benefitted only to the extent the overall average root zone of the soil is benefitted by the applied soil conditioning material

5

Even were combinations of soil conditioner, inorganic chemical fertilizer, and seed are to be applied as separate and distinct physical product particles, using a single application apparatus and a single application process, the individual particles of soil conditioner, individual particles of inorganic chemical fertilizer, and individual particles of seed would be separated from each other to a significant degree, during the application process, such that the benefits of intimate association with each other in the soil would be lost. Indeed, the seed benefits from intimate contact with a substantial quantity of soil conditioner, but can tolerate intimate contact with only limited concentrations of fertilizer chemicals. Rather, fertilizer chemicals should in general be displaced from, but controllably located close to the seed.

10

15

20

25

In an uncontrolled application of fertilizer by an application separate from application of the seed, as in the prior art, some of the seed might be expected to be placed so close to some of the inorganic fertilizer as to be damaged by the toxic affect of such close association. Thus, the benefit of intimate contact between organic soil conditioning material, inorganic chemical fertilizer, and seed, is reduced and largely lost because of low levels of intimate association between the soil conditioning material and the seed, and unpredictable, uncontrolled levels of association between the seed and the inorganic chemical fertilizer, outside the combination of the invention, of soil conditioning coating of the seed, and optional addition of inorganic fertilizer at controlled

30

location with respect to the seed, all in the same seed capsule, as taught herein.

5 By combining an organic soil conditioning material in the same seed capsule with the seed, highly effective levels of soil conditioner are assuredly associated with the seed as the seed germinates and begins to grow. Where suitable levels of plant nutrient fertilizer are incorporated into the same seed capsule, growth of the newly-germinated plant is further enhanced. In either case, the soil conditioning materials can and do tend to  
10 retain moisture and nutrients in the soil in the defined area of the seed capsule by a variety of mechanisms, providing an extended time period during which nutrients can be taken up by the plants. For example, organic soil conditioning material may retain moisture, reducing moisture drainage from the soil, such that the  
15 rate of leaching of the nutrients is, in general, reduced. Further, the soil conditioning material may absorb or otherwise physically or chemically attach to plant nutrient materials in the chemical fertilizer material, thus further retarding leaching of the plant nutrient away from the seed.

20 While applicant cannot place an exact time period on the increase in the extent to which the soil conditioning materials retard leaching of the plant nutrients from proximity with the seed, thereby holding the plant nutrients available for up-take by the plant, any increase in time during which the nutrients are held  
25 in the soil proximate the newly-emerging plant is beneficial to meeting the nutritional needs of the plant being so fed.

30 By incorporating soil conditioning materials and optionally plant nutrient fertilizers, in the seed capsules, the invention offers an efficiency of application of soil conditioning materials in proximity to the seeds most beneficially affected thereby, in a beneficial association never before available. Optional addition of plant nutrients to the same seed capsule provides a largely self-contained microcosm of seed, soil conditioner, and inorganic

- 41 -



P. 284

UT Ex. 2025  
SteadyMed v. United Therapeutics  
IPR2016-00006

IPR2020-00769  
United Therapeutics EX2006  
Page 4503 of 7113

fertilizer in intimate yet controlled spatial relationship with each other, whereby the controlled spacings provide enhanced plant growth benefit. Namely, soil conditioning materials and plant nutrients are somewhat beneficial to each other for the overall cooperative achievement of soil fertility in the presence of the newly emerging plant which is dependent on such plant nutrients, and on moisture retained by the soil conditioner for uptake of such plant nutrients.

While soil conditioning materials do perform a number of highly interdependent tasks, one such task is in assisting in maintaining the plant nutrients in the root zone where they can be effectively used by the plants when needed. Another such task is in assisting in making the soil soft and friable in the root zone whereby the newly-emerged and very tender plant roots more readily penetrate the soil as they grow.

Where both soil conditioner and fertilizer are incorporated with the seed into the seed capsule, the soil conditioner assists in strategically maintaining the combination of soil conditioner and plant nutrients in close and controlled proximity to each other and to the seed in the soil. Such strategic placement virtually assures that the soil conditioning material and inorganic chemical fertilizer are bound to each other, in proximate relationship with the seed, for a time, such that wherever the seed capsule may land when the seed is sown, the seed will have the initial benefit of both soil conditioner and plant nutrients in intimate proximity with itself, irrespective of any condition of the surrounding growth medium. Thus, in the invention, soil conditioning material and optionally inorganic chemical fertilizer, are inherently bound to each other, and to the seed, as by the coating process, and inherently assist the seed in achieving desired germination and strong early growth.

By incorporating the soil conditioning material in the same seed capsule with the seed, the invention ensures that the seed has

benefit of intimate relationship with a beneficial amount of soil conditioner material. The seed thus receives the advantage of the beneficial amount of soil conditioner material irrespective of the overall tilth of the soil and irrespective of the overall level  
 5 soil conditioner, e.g. soil texture conditioner, in the root zone of the soil with which the seed capsule becomes associated for seed and plant growth purposes.

Referring to FIGURE 7, a population of seed capsules **38** are disposed at the top surface of a cross section of soil. Root zone  
 10 **150** of the soil is generally defined to that depth of the soil which typically receives roots of growing plants, and is generally defined within 20-30 inches of the top surface of the soil. Generally, and preferably, the root zone should have a soft texture, rich in organic and/or other soil conditioning material in  
 15 order to provide good tilth, and desirable moisture and nutrient holding properties. Underlying root zone **150** is subsoil **152** which typically contains little organic matter.

It is a well known agricultural phenomenon that, in soil used for intensive crop production, the root zone tends, over time, to become relatively depleted of organic soil conditioning material, illustrated at **154** in FIGURE 7, negatively affecting soil tilth and texture. While wholesale addition of organic soil conditioning  
 20 material can improve the overall tilth of the soil, FIGURE 7 illustrates application of the invention wherein the texture of the material immediately adjacent the seed, namely coating **42**, provides  
 25 beneficial properties attributable to soil having desirable texture.

FIGURE 8 illustrates that coating **42** draws moisture **154** from the soil, into the capsule, where the moisture is available to  
 30 assist in germination of seed **40**. In the process, traverse of the moisture through second coating **46C** releases plant nutrient material into the moisture, as well as downwardly into the soil adjacent the seed capsule, as illustrated at **156**. Thus, the root

158 emerging from the seed emerges into an initial growth medium, coating 42, having texture, moisture, and plant nutrient highly advantageous to early plant growth. As root 158 advances further downward, the upper portion of the underlying soil under the capsule where the seed first enters the soil, has also been beneficially affected to the good of the plant by plant nutrients 156, and by moisture attracted or held in the vicinity of the capsule, as a result of the presence of the soil conditioning material in the capsule.

10 The relative amounts of the soil conditioning material and the inorganic chemical fertilizer material in the seed capsule vary significantly in accord with the specific application, and any specific interactivity desired of the soil conditioning material and inorganic chemical fertilizer. For example, in a particular combination of soil conditioning material and inorganic fertilizer a particular plant crop to be nourished by the product may require a higher amount of plant nutrient, or a specific analysis of plant nutrients, in order to be properly fed at and shortly after the stage of germination.

20 Thus, for a given specific application of combination seed capsule (with fertilizer) product of the invention, the relative amount of inorganic chemical fertilizer, and the fertilizer analysis, may be increased or decreased from some "standard" in the interest of achieving a functionally adequate feeding of the newly germinated seedlings. Namely, the NPK etc. nutrient levels provided in a given seed capsule product of the invention can be set and controlled at the fertilizer manufacturing plant in accord with the respective NPK etc. nutrient needs of the seed to be supported, or of the soil or other growth medium to which the combination fertilizer of the invention is to be applied.

30 In any embodiments, whether or not specifically discussed here, the fabricated seed capsules are kept sufficiently cool, and are kept sufficiently dry, to avoid the seed capsules sticking to

each other, caking, and the like, and to prevent premature germination of the seed. Where liquid is used to obtain the coating material in liquid state, sufficient liquid is removed during or shortly after the coating step to avoid the seed capsules sticking to each other, or caking, or the like. Where the seed capsules are made by process other than the process described here, the details of the process will determine proper cooling, drying, or other steps to provide a finished, dry, solid seed capsule or like product. A dry such product generally has moisture content less than 10% by weight, preferably less than 5% by weight, most preferably less than 3% by weight.

As suggested by the description hereinabove, the processes of the invention are generally carried out to make combination seed improvement products solely by using physical processes such as coating and drying. While some minor chemical reactions may inadvertently accompany such physical processes, the invention does not rely on any chemical reaction for achievement of the objectives thereof. Rather the invention is focused on a physical combination of starting materials, which physical combination results in mutual benefits of the two starting materials (seed and soil conditioner, and optional inorganic chemical fertilizer) functioning intimately together, in primarily physical and physico-chemical relationship, to produce an overall increase in benefits of plant germination and early plant growth with such combination seed improvement products.

The relative amounts of seed and coating material depend on the overall benefits desired to be achieved from the coating operations. In general, the seed will comprise from about 0.1% to about 75% of the overall weight of the seed capsule. the coating material thus represents about 25% to about 99.9% by weight of the seed capsule. Where the seed content is low, the general benefit of the product is that of soil conditioning, with some seed application. Such product is well suited for application to e.g.

- 45 -

4/6 P. 288

UT Ex. 2025  
SteadyMed v. United Therapeutics  
IPR2016-00006

IPR2020-00769  
United Therapeutics EX2006  
Page 4507 of 7113

a healthy lawn for general improvement of soil condition, and modest fill-in of bare spots with seed.

5 Another benefit of low seed content by weight, especially with quite small seeds, is in creating a larger size seed capsule, and thereby facilitating the handling of such seed in commonly-used seed handling machines such as grain drills or seed broadcast machines.

10 Typically, however, a higher seed content is preferred so as to have major impact on the number of plants which are caused to germinate by application of such product. Thus, for a seed about 0.5-1.0 mm thick and about 4-7 mm long, a preferred fraction of seed is about 1% to about 50%, preferably about 1.5% to about 20%, more preferably about 2% to about 10% by weight seed, with respective amount of soil conditioner and optionally fertilizer. For example, in a preferred product of the invention, an above mentioned grass seed about 0.5-1.0 mm thick and about 4-7 mm long, when coated produces a seed capsule about 4 mm across and about 6-9 mm long. Smaller, or larger, seed capsules may be made and used as desired.

20 The size and density of the seed capsules can be readily controlled using conventional sizing equipment and processing parameters of the coating process, so as to provide a uniform product of a wide range of sizes and densities. With the size and density of any seed thus controllable, the size and density may be selected and specified for enhancing control and efficiency of seed handling and/or distribution. For example, tiny seeds such as lettuce, carrots, cabbage, and alfalfa, may be sized and weighted for easy and assured handling and distribution, whether by hand or by machine. Seeds which are non-aerodynamic, or which are so light as to be blown around, such as grass seed, can be made heavy and compact enough as to assuredly remain on location where sown after being planted. For example, non-aerodynamic seeds, after treatment according to the invention, can be broadcast-applied using



conventional equipment such as is used to broadcast apply granular fertilizer over e.g. 40 foot wide application paths.

5 Where time controlled germination is desirable, a population of combination seed capsules, having at least one soil conditioner and one or more nutrients, can be planted in conjunction with non-coated seeds. As a result, non-coated seeds will germinate at an earlier stage than the population of combination seed capsules. Such staggering of germination times allows, for example, the non-coated seeds to use the available soil nutrients with less competition (i.e. less seeds using limited nutrient supply). At a later time, when the coated seeds germinate, such seeds can use the nutrients leached from their combination seed capsules to germinate.

10 Where e.g. small such seeds are desirably planted in close proximity with each other, and wherein a relatively larger size seed capsule is desired for ease of handling such that the large size seed capsule would potentially interfere with such close placement of the seeds with respect to each other, then and in such situation, multiple seeds may be employed in individual seed capsules, e.g. generally uniformly distributed throughout the seed capsule, so as to provide for sufficiently close spacing of the seeds from each other.

15 20 25 Paper mill sludge, as is suggested as a coating material herein, is a resultant by-product of papermaking, typically from e.g. a de-inking process in the paper mill.

By utilizing paper mill sludge and/or sewage sludge as taught herein, one contemplates beneficially and suitably disposing of significant quantities of industrial waste which otherwise is disposed of by landfilling.

30 Where the product of the invention is applied as to a residential or like lawn, as in an agricultural field, the seed is applied to the soil in intimate combination (seed capsule) with the soil conditioner, such that the soil conditioner serves as moisture

retainer and sun shield. In addition, the seed capsule is much heavier and dense than the seed itself, whereby the seed capsule provides substantial protection against the seed being washed away in surface water run-off. Thus, the coating about the seed serves many of the functions typically performed by the conventionally-used straw mulch. Accordingly, product of the invention can be used to seed new lawns without any need for use of straw or any other mulch material.

Where seed is desirably used to fill in bare spots in the lawn, such seed, especially fertility-enhanced seed capsules, may be applied desirably in one of two ways. First, the coated seed capsule product may be applied only to perceived bare spots, without use of straw. The soil conditioner in the seed capsules serve the functions of the straw as described above, but perform better than straw because of the close association between the seed and the soil conditioner.

In the alternative, the coated seed capsule product may be broadcast generally over the entire lawn. Where the lawn is already healthy with thick grass growth, the soil conditioner and fertilizer will benefit the existing grasses, with minimal germination and growth of new seed from the seed capsules. Where the existing grass is thinner, the seeds in the seed capsules will have room and light to grow, whereby the combined properties of seed, soil conditioner, and fertilizer, in intimate relationship with one another, will be efficaciously used.

Where seed capsules of the invention are used to establish a new lawn, the soil conditioner in the seed capsules serve the functions of the straw as described above, obviating the need for straw in establishing the lawn seeding.

Those skilled in the art will now see that certain modifications can be made to the apparatus and methods herein disclosed with respect to the illustrated embodiments, without departing from the spirit of the instant invention. And while the

invention has been described above with respect to the preferred embodiments, it will be understood that the invention is adapted to numerous rearrangements, modifications, and alterations

5 To the extent the following claims use means plus function language, it is not meant to include there, or in the instant specification, anything not structurally equivalent to what is shown in the embodiments disclosed in the specification.

501207926



CLAIMS

Having thus described the invention, what is claimed is:

1. A combination seed capsule, comprising:
- (a) at least one viable seed, having an outer surface and acting as a core or psuedo-core of said combination seed capsule; and
  - (b) a coating of a composition comprising a soil conditioning material mounted proximate, including disposed outwardly of the outer surface of said seed.
2. A combination seed capsule as in Claim 1, said coating providing at least one of
- (i) enhancing broadcast flight properties of said combination seed capsule;
  - (ii) reducing susceptibility to deleterious affects of weather on said combination seed capsule;
  - (iii) enhancing resistance of said combination seed capsule to attack by animals or spore-formers;
  - (iv) staged germination of ones of said seed capsules, having seeds, under a given set of conditions, over a period of time longer than the range of germination times inherent in said seeds;

2025 RELEASED

- (v) enhancing control of moisture about said seed thereby to assist in seed germination;
- (vi) release of plant nutrients into soil onto which said combination seed capsule is placed;
- (vii) soil conditioning effect to soil onto which said combination seed capsule is placed;
- (viii) staged release of plant nutrients into soil onto which said combination seed capsule is placed, over a period of time longer than the range of times inherent in the chemical composition so released;
- (ix) higher embryo emergence and survival rate in a population of said seed capsules, thereby reducing required seed planting density for a desired plant population density; and
- (x) assisting in stabilizing moisture content in soil on which such seed capsule is disposed.

3. A combination seed capsule as in Claim 1 wherein said seed is selected from the group consisting of grass, vegetables, grains, and flowers.

4. A combination seed capsule as in Claim 1, said coating further comprising said soil conditioning material in combination with at least one ingredient effective to reduce susceptibility of

said seed capsule to deleterious affect of at least one of animals, weeds, and spore-formers.

5. A combination seed capsule as in Claim 4 wherein said at least one ingredient to reduce susceptibility of the seed capsule is selected from the group consisting of herbicides, fungicides, and a bitter substance.

6. A combination seed capsule as in Claim 5 wherein said fungicide comprises metalaxyl.

7. A combination seed capsule as in Claim 1, said coating comprising a first coating, said combination seed capsule further comprising a second coating, separate from said first coating, and comprising at least one ingredient effective to reduce susceptibility of said seed capsule to deleterious effect of at least one of animals, weeds, and spore-formers.

8. A combination seed capsule as in Claim 1, effective to provide a plant nutrient at a desirable controlled distance from a plant seedling emerging from said seed, in an amount beneficial to said plant seedling.

9. A combination seed capsule as in Claim 1, said coating comprising a first coating, said combination seed capsule further comprising a second coating of a second coating material intermingled with said first coating material in an outer portion of said first coating, and generally displaced from said seed.

20250720 14:56:16

10. A combination seed capsule as in Claim 9 wherein said second coating material comprises a plant nutrient, beneficial in location and in amount of availability, to plant seedling emerging from said seed.

11. A combination seed capsule as in Claim 9 wherein said second coating composition comprises an inorganic form of a plant nutrient and is selected from the group consisting of nitrogen, phosphorus, and potassium.

12. A combination seed capsule as in Claim 9 wherein said second coating composition comprises an inorganic form of a plant nutrient and is selected from the group consisting of urea, monammonium phosphate, diammonium phosphate, superphosphate, triple superphosphate, dicalcium phosphate, and potash.

13. A combination seed capsule as in Claim 9 wherein said second coating composition comprises an inorganic form of a plant nutrient is selected from the group consisting of sulfur, manganese, copper, boron, iron, magnesium and chromium.

14. A population of combination seed capsules of Claim 1, said population of seed capsules comprising coatings having a range of properties affecting germination rate of said seeds, thereby to stage germination of said seeds in said population over a period of time longer than the range of germination times inherent in uncoated ones of said seeds.

15. A population of combination seed capsules as in Claim 14 wherein said range of properties comprises at least one of (i) a range of hardnesses and (ii) a range of thicknesses, of said coatings.

16. A combination seed capsule as in Claim 1, said coating comprising a first layer of said soil conditioning material, and including a second layer comprising an inorganic fertilizer.

17. A combination seed capsule as in Claim 1, said coating comprising a first layer of said soil conditioning material, and including a second layer comprising at least one micronutrient.

18. A combination seed capsule as in Claim 17 wherein said micronutrient is selected from the group consisting of sulfur, manganese, copper, boron, iron, magnesium and chromium.

19. A combination seed capsule as in Claim 1, said soil conditioning material comprising a sludge composition.

20. A combination seed capsule as in Claim 1, said soil conditioning material comprising a fiber-containing by-product of a paper making operation.

21. A combination seed capsule as in Claim 1, said seed capsule comprising a water-leachable plant nutrient, and a leach-



retardant composition effective to retard leaching of said leachable plant nutrient out of said combination seed capsule.

22. A population of combination seed capsules of Claim 1, said coating in ones, but less than all, of said population, comprising an ingredient effective to retard effective penetration of a seed-germinating environment to said seed for germination thereof.

23. A combination seed capsule as in Claim 1, said seed capsule comprising an inner layer on the outer surface of said seed, and an outer layer, said inner layer enhancing properties of said seed for acting as nucleus in an agglomeration operation agglomerating said coating onto said inner layer.

24. A combination seed capsule as in Claim 1 wherein said coating comprises an admixture of said soil conditioner and a plant nutrient.

25. A combination seed capsule as in Claim 1 wherein said coating remains generally disposed about said seed until said seed germinates.

26. A plant growing system, comprising:

- (a) a plant growing medium extending over an area, said plant growing medium having a root zone, and a top surface of said root zone generally corresponding with a top surface

of said plant growing medium, said plant growing medium having a first overall soil condition and texture; and

- (b) a population of seed capsules disposed over the top surface of said plant growing medium, said seed capsules comprising individual seeds, having outer surfaces, and coatings of soil conditioning material disposed outwardly of the outer surfaces of said seeds,

said coatings of said seed capsules providing localized germination and growth environments, at and adjacent said seeds, having texture, and nutrient and water holding properties for supporting seedling health, superior to respective said properties as provided overall in the root zone of said plant growing medium.

27. A growing system as in Claim 26, said coatings remaining generally disposed about said seeds until respective ones of said seeds germinate.

28. A growing system as in Claim 26, said coatings providing at least one of

- (i) enhancing broadcast flight properties of said combination seed capsule;
- (ii) reducing susceptibility to deleterious affects of weather on said combination seed capsule;
- (iii) enhancing resistance of said combination seed capsule to attack by animals or spore-formers;

- (iv) staged germination of ones of said seed capsules, having seeds, under a given set of conditions, over a period of time longer than the range of germination times inherent in said seeds;
- (v) enhancing control of moisture about said seed thereby to assist in seed germination;
- (vi) release of plant nutrients into soil onto which said combination seed capsule is placed;
- (vii) soil conditioning effect to soil onto which said combination seed capsule is placed;
- (viii) staged release of plant nutrients into soil onto which said combination seed capsule is placed, over a period of time longer than the range of times inherent in the chemical composition so released;
- (ix) higher embryo emergence and survival rate in a population of said seed capsules, thereby reducing required seed planting density for a desired plant population density; and
- (x) assisting in stabilizing moisture content in soil on which such seed capsule is disposed.

29. A growing system as in Claim 26 wherein said seeds are selected from the group consisting of grass, vegetables, grains, and flowers.

30. A growing system as in Claim 26, said coatings further comprising said soil conditioning material in combination with at least one ingredient effective to reduce susceptibility of said seed capsules to deleterious affect of at least one of animals, weeds, and spore-formers.

31. A growing system as in Claim 26, said coating comprising a first coating, said combination seed capsules further comprising a second coating, separate from said first coating, and comprising at least one ingredient effective to reduce susceptibility of said seed capsules to deleterious effect of at least one of animals, weeds, and spore-formers.

32. A growing system as in Claim 26, effective to provide plant nutrients at desirable controlled distances from plant seedlings emerging from said seeds, in amounts beneficial to said plant seedlings.

33. A growing system as in Claim 26, said coatings comprising first coatings, said combination seed capsules further comprising second coatings of second coating materials intermingled with said first coating materials in outer portions of said first coatings, and generally displaced from said seeds.

34. A growing system as in Claim 33 wherein said second coating materials comprise plant nutrients, beneficial in location and in amount of availability, to plant seedlings emerging from said seeds.

20250716 14:52:16

35. A growing system as in Claim 26, said population of seed capsules comprising coatings having a range of properties affecting germination rates of said seeds, thereby to stage germination of said seeds in said population over a period of time longer than the range of germination times inherent in uncoated ones of said seeds.

36. A growing system as in Claim 26, said coatings comprising first layers of said soil conditioning material, and including second layers comprising inorganic fertilizer.

37. A growing system as in Claim 26, said soil conditioning material comprising a sludge composition.

38. A growing system as in Claim 26, said soil conditioning material comprising a fiber-containing by-product of a paper making operation.

39. A growing system as in Claim 26, said seed capsules comprising inner layers on the outer surfaces of said seeds, said inner layers enhancing properties of said seeds for acting as nucleus in an agglomeration operation agglomerating said coatings onto said inner layers.

40. A growing system as in Claim 26 wherein said coatings comprise admixtures of said soil conditioner and plant nutrient.

41. A method of providing plant micronutrients to soil, the method comprising placing onto the soil a population of combination seed capsules, each comprising at least one seed, and a coating comprising a plant micronutrient material.

42. A method as in Claim 41, the coating comprising a first coating comprising the plant micronutrient, and a second coating, separate and distinct from the first coating, and comprising a soil conditioning material.

43. A method as in Claim 41, the coating providing at least one of

- (i) enhancing broadcast flight properties of said combination seed capsule;
- (ii) reducing susceptibility to deleterious affects of weather on said combination seed capsule;
- (iii) enhancing resistance of said combination seed capsule to attack by animals or spore-formers;
- (iv) staged germination of ones of said seed capsules, having seeds, under a given set of conditions, over a period of time longer than the range of germination times inherent in said seeds;
- (v) enhancing control of moisture about said seed thereby to assist in seed germination;
- (vi) release of plant nutrients into soil onto which said combination seed capsule is placed;

- (vii) soil conditioning effect to soil onto which said combination seed capsule is placed;
- (viii) staged release of plant nutrients into soil onto which said combination seed capsule is placed, over a period of time longer than the range of times inherent in the chemical composition so released;
- (ix) higher embryo emergence and survival rate in a population of said seed capsules, thereby reducing required seed planting density for a desired plant population density; and
- (x) assisting in stabilizing moisture content in soil on which such seed capsule is disposed.

44. A method as in Claim 41, the coating providing a plant nutrient at a desirable controlled distance from a plant seedling emerging from the seed, in an amount beneficial to the plant seedling.

45. A method as in Claim 41, the coating comprising a first coating, the combination seed capsule further comprising a second coating of a second coating material intermingled with the first coating material in an outer portion of the first coating, and generally displaced from the seed.

46. A method as in Claim 45 wherein the first coating comprises plant micronutrient material and the second coating

comprises plant nutrient material comprising at least one of nitrogen, phosphorus, and potassium.

47. A method as in Claim 41 wherein the micronutrient composition comprises a plant nutrient selected from the group consisting of sulfur, manganese, copper, boron, iron, magnesium and chromium.

48. A method as in Claim 41, the coating comprising a first layer of the soil conditioning material, and including a second layer comprising an inorganic fertilizer.

49. A method as in Claim 41, the coating comprising a sludge composition.

50. A method as in Claim 41, the coating comprising a fiber-containing by-product of a paper making operation.

51. A method as in Claim 41, the seed capsule comprising an inner layer on an outer surface of the seed, and an outer layer, the inner layer enhancing properties of the seed for acting as nucleus in an agglomeration operation agglomerating the coating onto the inner layer.

52. A method as in Claim 41 wherein the coating comprising an admixture of soil conditioner and a plant nutrient.



53. A method as in Claim 41 wherein the coating remains generally disposed about the seed until the seed germinates.

54. A method of providing a seed bed having enhanced growing conditions for growing seed, the method comprising:

- (a) coating a population of the seeds with material, and thereby providing coatings thereon of such material, tending to stabilize, in the seed capsules, or in soil on which the seed capsules are disposed coating compositions which tend to hold, moisture adjacent the seeds in the seed capsules or in soil adjacent the seed capsules, in such quantities and for such times as to enhance growing conditions for the seeds; and
- (b) placing the population of seeds on soil effective to support germination of the seeds which are in the seed capsules.

55. A method as in Claim 54, the coatings providing at least one of

- (i) enhancing broadcast flight properties of said combination seed capsule;
- (ii) reducing susceptibility to deleterious affects of weather on said combination seed capsule;
- (iii) enhancing resistance of said combination seed capsule to attack by animals or spore-formers;

- (iv) staged germination of ones of said seed capsules, having seeds, under a given set of conditions, over a period of time longer than the range of germination times inherent in said seeds;
- (v) release of plant nutrients into soil onto which said combination seed capsule is placed;
- (vi) soil conditioning effect to soil onto which said combination seed capsule is placed;
- (vii) staged release of plant nutrients into soil onto which said combination seed capsule is placed, over a period of time longer than the range of times inherent in the chemical composition so released; and
- (viii) higher embryo emergence and survival rate in a population of said seed capsules, thereby reducing required seed planting density for a desired plant population density.

56. A method as in Claim 54 wherein the seeds are selected from the group consisting of grass, vegetables, grains, and flowers.

57. A method as in Claim 54, effective to provide a plant nutrient at desirable controlled distances from plant seedlings emerging from the seeds, in amounts beneficial to the plant seedlings.

58. A method as in Claim 54, the coatings comprising first coatings, the combination seed capsules further comprising second coatings of second coating materials intermingled with the first coating materials in outer portions of the first coatings, and generally displaced from the seeds.

59. A method as in Claim 58 wherein the second coating materials comprise plant nutrients, beneficial in location and in amount of availability, to plant seedlings emerging from the seeds.

60. A method as in Claim 58 wherein the second coating compositions comprise inorganic forms of plant nutrients and are selected from the group consisting of nitrogen, phosphorus, and potassium.

61. A method as in Claim 54, the population of seed capsules comprising coatings having a range of properties affecting germination rate of the seeds, thereby to stage germination of the seeds in the population over a period of time longer than the range of germination times inherent in uncoated ones of the seeds.

62. A method as in Claim 54, the coatings comprising first layers of the soil conditioning material, and including second layers comprising inorganic fertilizer.

63. A method as in Claim 54, the coatings comprising first layers of the soil conditioning materials, and including second layers comprising micronutrients.

64. A method as in Claim 54, the soil conditioning materials comprising sludge compositions.

65. A method as in Claim 54, the soil conditioning materials comprising fiber-containing by-products of paper making.

66. A method as in Claim 54, the seed capsules comprising water-leachable plant nutrients, and leach-retardant compositions effective to retard leaching of the leachable plant nutrients out of the combination seed capsules.

67. A method as in Claim 54, the seed capsules comprising inner layers on the outer surfaces of the seeds, and outer layers, the inner layers enhancing properties of the seeds for acting as nuclei in agglomeration operations agglomerating the coatings onto the inner layers.

68. A method as in Claim 54 wherein the coatings comprise admixtures of the soil conditioners and plant nutrients.

69. A method as in Claim 54 wherein the coatings remain generally disposed about the seeds until the seeds germinate.

70. A method of making a population of combination seed capsules, each comprising a seed, and a coating of a soil conditioning material, the method comprising:

- (a) pre-coating the seed with a material which enhances the ability of the seed to act as a nucleus in an agglomeration operation, to form a pre-coated substrate; and
- (b) subsequently coating the pre-coated substrate with a soil conditioning material.

71. A method as in Claim 70 wherein the pre-coating material comprises dicalcium phosphate.

72. A method as in Claim 70 wherein the pre-coating step results in an overall increase in the density of pre-coated seed combination.

73. A method as in Claim 70 wherein the pre-coating is accomplished by spraying the pre-coating material onto the seed.

74. A method of providing an enhanced seed germination environment in combination with placement of a controlled amount of plant nutrients in controlled proximity to each seed, the method comprising:

- (a) providing a population of seeds, coated with a soil conditioning material which tends to enhance germination of the seeds, and with plant nutrient composition effective to enhance growth of plant embryos emerging from the seeds; and

(b) placing the population of seeds on soil effective to support germination of the seeds.

A

75. A method as in Claim 74 wherein the coating material includes therein a second ingredient comprising plant nutrient moieties.

add  
A'

UNITED STATES PATENT AND TRADEMARK OFFICE

ABSTRACT OF THE DISCLOSURE

This invention pertains to combination seed capsules wherein each seed capsule includes both moieties of at least one soil conditioner and at least one seed, and optionally, one or more inorganic chemical fertilizer, growth enhancer, binder, and/or anti-fungal agent. The combination seed capsules are made by physically combining the respective soil conditioner and seed with one other, in the absence of any requirement for chemical reactions in the process of so combining the respective materials. The combination seed capsules provide cooperative and beneficial effects of the soil conditioner and the optional inorganic fertilizer, working together in controlled intimate relation with the seed, to enhance the germination and growth processes of the seed, and the plant emergent therefrom, greater than when the soil conditioner and seed, and optionally inorganic chemical fertilizer, are applied to the soil separately; the improvement being a result of the intimate relationship of the respective materials in the combination seed capsule, whereby the respective materials cooperate with each other in support of germination and plant growth.

- 69 -

P. 312

UT Ex. 2025  
SteadyMed v. United Therapeutics  
IPR2016-00006

IPR2020-00769  
United Therapeutics EX2006  
Page 4531 of 7113



UNITED STATES PATENT AND TRADEMARK OFFICE

COMMISSIONER FOR PATENTS  
 UNITED STATES PATENT AND TRADEMARK OFFICE  
 WASHINGTON, D. C. 20231  
 www.uspto.gov



Bib Data Sheet

<b>SERIAL NUMBER</b> 09/113,254	<b>FILING DATE</b> 07/10/1998 <b>RULE</b> -	<b>CLASS</b> 047	<b>GROUP ART UNIT</b> 1649	<b>ATTORNEY DOCKET NO.</b> 29214
------------------------------------	---------------------------------------------------	---------------------	-------------------------------	-------------------------------------

**APPLICANTS**  
 DANIEL PAUL MADIGAN, GREEN BAY, WI ;  
 MICHAEL DENNIS KRYSIAK, GREEN BAY, WI ;  
 RONALD DEAN EICHHORN, GREEN BAY, WI ;  
 GLEN H. WESENBERG, GREEN BAY, WI ;

**\*\* CONTINUING DATA \*\*\*\*\***  
 THIS APPLN CLAIMS BENEFIT OF 60/052,287 07/11/1997

**\*\* FOREIGN APPLICATIONS \*\*\*\*\***

**IF REQUIRED, FOREIGN FILING LICENSE**  
**GRANTED \*\* 07/28/1998**

Foreign Priority claimed <input type="checkbox"/> yes <input checked="" type="checkbox"/> no	35 USC 119 (a-d) conditions met <input type="checkbox"/> yes <input checked="" type="checkbox"/> no <input type="checkbox"/> Met after Allowance	Verified and Acknowledged Examiner's Signature _____ Initials _____	<b>STATE OR COUNTRY</b> WI	<b>SHEETS DRAWING</b> 6	<b>TOTAL CLAIMS</b> 75	<b>INDEPENDENT CLAIMS</b> 5
-------------------------------------------------------------------------------------------------	-----------------------------------------------------------------------------------------------------------------------------------------------------	------------------------------------------------------------------------	-------------------------------	----------------------------	---------------------------	--------------------------------

**ADDRESS**  
 PHILIP M. WEISS  
 WEISS & WEISS  
 500 OLD COUNTRY ROAD  
 GARDEN CITY, NY ~~11630~~ 11530

**TITLE**  
 SEEDING TREATMENTS

<b>FILING FEE RECEIVED</b> 1542	FEES: Authority has been given in Paper No. _____ to charge/credit DEPOSIT ACCOUNT No. _____ for following:	<input type="checkbox"/> All Fees
		<input type="checkbox"/> 1.16 Fees ( Filing )
		<input type="checkbox"/> 1.17 Fees ( Processing Ext. of time )
		<input type="checkbox"/> 1.18 Fees ( Issue )
		<input type="checkbox"/> Other _____
		<input type="checkbox"/> Credit



SERIAL NUMBER 09/113,254	FILING DATE 07/10/98	CLASS 047	GROUP ART UNIT <del>1649</del> 1661	ATTORNEY DOCKET NO. 29214
-----------------------------	-------------------------	--------------	----------------------------------------	------------------------------

APPLICANT

DANIEL PAUL MADIGAN, GREEN BAY, WI; MICHAEL DENNIS KRYSIAK, GREEN BAY, WI; RONALD DEAN EICHORN, GREEN BAY, WI; GLEN H. WESENBERG, GREEN BAY, WI.

\*\*CONTINUING DOMESTIC DATA\*\*\*\*\*

VERIFIED

Amc

*Revised*

\*\*371 (NAT'L STAGE) DATA\*\*\*\*\*

VERIFIED

Amc

\*\*FOREIGN APPLICATIONS\*\*\*\*\*

VERIFIED

Amc

I. REQUIRED, FOREIGN FILING LICENSE GRANTED 07/28/98

Foreign Priority claimed 35 USC 119 (a-d) conditions met	<input type="checkbox"/> yes <input checked="" type="checkbox"/> no <input type="checkbox"/> yes <input checked="" type="checkbox"/> no	<input type="checkbox"/> Met after Allowance	STATE OR COUNTRY WI	SHEETS DRAWING 6	TOTAL CLAIMS 75	INDEPENDENT CLAIMS 5
Verified and Acknowledged	<u>Amc</u>	Examiner's Initials	Initials			

ADDRESS	THOMAS D WILHELM WILHELM LAW SERVICE 100 W LAWRENCE STREET THIRD FLOOR APPLETON WI 54911	Philip M. Weiss Weiss & Weiss 500 Old Country Road Garden City, New York	34751
---------	------------------------------------------------------------------------------------------------------	-----------------------------------------------------------------------------------	-------

TITLE	SEEDING TREATMENTS
-------	--------------------

FILING FEE RECEIVED \$1,147	FEES: Authority has been given in Paper: No. _____ to charge/credit DEPOSIT ACCOUNT NO. _____ for the following: P. 314	<input type="checkbox"/> All Fees <input type="checkbox"/> 1.16 Fees (Filing) <input type="checkbox"/> 1.17 Fees (Processing Ext. of time) <input type="checkbox"/> 1.18 Fees (Issue) <input type="checkbox"/> Other _____ UI Ex. 2025 <input type="checkbox"/> Credit Med v. United Therapeutics
--------------------------------	----------------------------------------------------------------------------------------------------------------------------------	------------------------------------------------------------------------------------------------------------------------------------------------------------------------------------------------------------------------------------------------------------------------------------------------------------------

IPR2016-00006



UNITED STATES DEPARTMENT OF COMMERCE  
 Patent and Trademark Office  
 ASSISTANT SECRETARY OF COMMERCE AND  
 COMMISSIONER OF PATENTS AND TRADEMARKS  
 Washington, D.C. 20231

**NOTICE OF FILING/CLAIM FEE(S) DUE**  
 TO ENSURE PROPER CREDIT OF FEES, PLEASE RETURN A COPY OF THIS  
 FEE CALCULATION SHEET WITH YOUR RESPONSE.

APPLICATION NUMBER: 113 254

**Total Fee Calculation**

Fee Code	Total # Claims	Number Extra	X	Fee	Fee =	Total
Sm./Lg.				Sm. Entity	Lg. Entity	
Basic Filing Fee	<u>201/101</u>					<u>790</u>
Total Claims >20	<u>203/103</u>	<u>75</u> -20 =	<u>55</u>	X		<u>1210</u>
Independent Claims >3	<u>202/102</u>	<u>5</u> -3 =	<u>2</u>	X		<u>164</u>
Mult. Dep Claim Present	<u>204/104</u>					
Surcharge	<u>205/105</u>					<u>130</u>
English Translation	<u>139</u>					<u>0</u>
<b><u>TOTAL FEE CALCULATION</u></b>						<b><u>2294</u></b>

Fees due upon filing the application:

Total Filing Fees Due = \$ 2294

Less Filing Fees Submitted - \$ 0

BALANCE DUE = \$ 2294

P. 315

UT Ex. 2025  
 SteadyMed v. United Therapeutics  
 IPR2016-00006

Office of Initial Patent Examination

IPR2020-00769  
 United Therapeutics EX2006  
 Page 4534 of 7113

**PATENT APPLICATION FEE DETERMINATION RECORD**

Effective October 1, 1997

Application or Docket Number

713254

**CLAIMS AS FILED - PART I**

FOR	(Column 1) NUMBER FILED	(Column 2) NUMBER EXTRA
BASIC FEE		
TOTAL CLAIMS	75 minus 20 =	* 55
INDEPENDENT CLAIMS	5 minus 3 =	* 2
MULTIPLE DEPENDENT CLAIM PRESENT		

\* If the difference in column 1 is less than zero, enter "0" in column 2

SMALL ENTITY TYPE <input type="checkbox"/>		OR	OTHER THAN SMALL ENTITY	
RATE	FEE		RATE	FEE
	395.00	OR		790.00
x\$11=		OR	x\$22=	120
x41=		OR	x82=	164
+135=		OR	+270=	
TOTAL		OR	TOTAL	2164

**CLAIMS AS AMENDED - PART II**

	(Column 1)	(Column 2)	(Column 3)	
AMENDMENT A	CLAIMS REMAINING AFTER AMENDMENT		HIGHEST NUMBER PREVIOUSLY PAID FOR	PRESENT EXTRA
	Total	*	Minus **	=
	Independent	*	Minus ***	=
	FIRST PRESENTATION OF MULTIPLE DEPENDENT CLAIM			

SMALL ENTITY		OR	OTHER THAN SMALL ENTITY	
RATE	ADDITIONAL FEE		RATE	ADDITIONAL FEE
x\$11=		OR	x\$22=	
x41=		OR	x82=	
+135=		OR	+270=	
TOTAL ADDIT. FEE		OR	TOTAL ADDIT. FEE	

	(Column 1)	(Column 2)	(Column 3)	
AMENDMENT B	CLAIMS REMAINING AFTER AMENDMENT		HIGHEST NUMBER PREVIOUSLY PAID FOR	PRESENT EXTRA
	Total	*	Minus **	=
	Independent	*	Minus ***	=
	FIRST PRESENTATION OF MULTIPLE DEPENDENT CLAIM			

SMALL ENTITY		OR	OTHER THAN SMALL ENTITY	
RATE	ADDITIONAL FEE		RATE	ADDITIONAL FEE
x\$11=		OR	x\$22=	
x41=		OR	x82=	
+135=		OR	+270=	
TOTAL ADDIT. FEE		OR	TOTAL ADDIT. FEE	

	(Column 1)	(Column 2)	(Column 3)	
AMENDMENT C	CLAIMS REMAINING AFTER AMENDMENT		HIGHEST NUMBER PREVIOUSLY PAID FOR	PRESENT EXTRA
	Total	*	Minus **	=
	Independent	*	Minus ***	=
	FIRST PRESENTATION OF MULTIPLE DEPENDENT CLAIM			

SMALL ENTITY		OR	OTHER THAN SMALL ENTITY	
RATE	ADDITIONAL FEE		RATE	ADDITIONAL FEE
x\$11=		OR	x\$22=	
x41=		OR	x82=	
+135=		OR	+270=	
TOTAL ADDIT. FEE		OR	TOTAL ADDIT. FEE	25

\* If the entry in column 1 is less than the entry in column 2, write "0" in column 3.  
 \*\* If the "Highest Number Previously Paid For" IN THIS SPACE is less than 20, enter "20."  
 \*\*\* If the "Highest Number Previously Paid For" IN THIS SPACE is less than 3, enter "3."  
 The "Highest Number Previously Paid For" (Total or Independent) is the highest number found in the space provided.

IN THE UNITED STATES PATENT AND TRADEMARK OFFICE

In re the application of:  
Daniel Paul Madigan et al

Group Art Unit: Unassigned

Serial Number: Unassigned

Examiner: Unassigned

Filed: July 10, 1998

For: SEEDING TREATMENTS

CORRESPONDENCE ADDRESS

Hon. Assistant Commissioner for Patents  
Washington, D.C. 20231

Sir:

Kindly address all correspondence regarding the above-referenced Application to the following address:

Thomas D. Wilhelm  
Wilhelm Law Service, S.C.  
100 W. Lawrence Street  
Third Floor  
Appleton, WI 54911

Phone 920-831-0100  
FAX 920-831-0101

Respectfully submitted,  
Daniel Paul Madigan et al

By Thomas Wilhelm  
Thomas D. Wilhelm  
Attorney for Applicants  
(Reg. No. 28,794)

July 10, 1998  
Appleton, Wisconsin

ISSUE CLASSIFICATION

47	57.6
Class	Subclass

PATENT NUMBER

6209259

U.S. UTILITY PATENT APPLICATION

O.I.P.E. *300* PATENT DATE APR 03 2007

SCANNED *ch* O.A. *AA*

SECTOR	CLASS	SUBCLASS	ART UNIT	EXAMINER
	47	57.6	1658 <i>3572</i>	Grünberg

FILED WITH:  DISK (CRF)  FICHE  
(Attached in pocket on right inside flap)

PREPARED AND APPROVED FOR ISSUE

ISSUING CLASSIFICATION			
ORIGINAL		CROSS REFERENCE(S)	
CLASS	SUBCLASS	CLASS	SUBCLASS (ONE SUBCLASS PER BLOCK)
47	57.6	47	58.1
INTERNATIONAL CLASSIFICATION			
A01K	1/06		
A01K	21/00		

Continued on Issue Slip Inside File Jacket

<input type="checkbox"/> <b>TERMINAL DISCLAIMER</b>	DRAWINGS			CLAIMS ALLOWED	
	Sheets Drwg.	Figs. Drwg.	Print Fig.	Total Claims	Print Claim for O.G.
	6	118	NA	14	1
<input type="checkbox"/> a) The term of this patent subsequent to _____ (date) has been disclaimed.	Ann. Marie Grünberg 9/13/00 (Assistant Examiner) (Date)			NOTICE OF ALLOWANCE MAILED	
<input type="checkbox"/> b) The term of this patent shall not extend beyond the expiration date of U.S. Patent. No. _____	BRUCE R. CAMPBELL, Ph.D. SUPERVISORY PATENT EXAMINER TECHNOLOGY CENTER 1800 Bruce Campbell 7/18/00 (Primary Examiner) (Date)			9126100	
<input type="checkbox"/> c) The terminal _____ months of this patent have been disclaimed.	9/29/00 (Legal Instruments Examiner) (Date)			ISSUE FEE	
				Amount Due	Date Paid
				\$ 1210	12-21-00
				ISSUE BATCH NUMBER	
				582	

WARNING: The information disclosed herein may be restricted. Unauthorized disclosure is prohibited by the United States Code Title 35, Sections 122, 181 and 366. Possession outside the U.S. Patent & Trademark Office is restricted to employees and contractors only.

Form PTO-436A (Rev. 10/97)

(LABEL AREA) ISSUE FEE IN FILE *RS*

(FACE)

2025  
beutics  
00006

SEARCHED			
Class	Sub.	Date	Exmr.
47	65	6/12/99	Amr
	65.5		
	74		
	57.6		
	58.1		
updated search 5/3/00			Amr
47	57.6	9/11/00	Amr
1	58.1		

INTERFERENCE SEARCHED			
Class	Sub.	Date	Exmr.
47	57.6	9/11/00	Amr
1	58.1		

SEARCH NOTES (INCLUDING SEARCH STRATEGY)		
	Date	Exmr.
BIOSIS, CABA,	6/1/99	Amr
CAPLUS,		
Agricola,		
Derwent,		
GPI web of		
US Patents		
S seed (10-)		
(capsul? or		
encapsul?		
or coat?)		
S sludge		
S broadcast?		
updated search 5/3/00 Amr		
S West	9/11/00	Amr
S seed		
S Coat or		
Coating or		
Control or		
agglomerate?		
or 9.1mH		
S dry or solid		
or powder or		
dust?		
S fines or sludge		
or sand or waste		

(RIGHT OUTSIDE)

k. 2025  
 beutics  
 00006

ISSUE SLIP STAPLE AREA (for additional cross references)

POSITION	INITIALS	ID NO.	DATE
FEE DETERMINATION			
O.J.P.E. CLASSIFIER			
FORMALITY REVIEW		6076	7-2-31

INDEX OF CLAIMS

- ✓ ..... Rejected
- ..... Allowed
- (Through numeral) Canceled
- + ..... Restricted
- N ..... Non-elected
- I ..... Interference
- A ..... Appeal
- O ..... Objected

Claim	Final	Original	Date	Claim	Final	Original	Date	Claim	Final	Original	Date
1				51				110			
2				52				112			
3				53				113			
4				54				114			
5				55				115			
6				56				116			
7				57				117			
8				58				118			
9				59				119			
10				60				120			
11				61				121			
12				62				122			
13				63				123			
14				64				124			
15				65				125			
16				66				126			
17				67				127			
18				68				128			
19				69				129			
20				70				130			
21				71				131			
22				72				132			
23				73				133			
24				74				134			
25				75				135			
26				76				136			
27				77				137			
28				78				138			
29				79				139			
30				80				140			
31				81				141			
32				82				142			
33				83				143			
34				84				144			
35				85				145			
36				86				146			
37				87				147			
38				88				148			
39				89				149			
40				90				150			
41				91							
42				92							
43				93							
44				94							
45				95							
46				96							
47				97							
48				98							
49				99							
50				100							

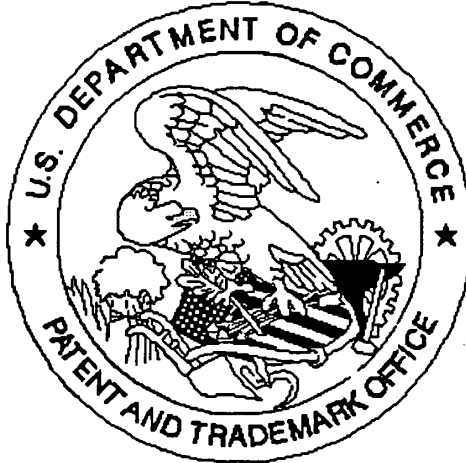
If more than 150 claims or 10 actions  
staple additional sheet here

(LEFT INSIDE)

2025  
beutics  
00006

# United States Patent & Trademark Office

Office of Initial Patent Examination -- Scanning Division



500720452460

## Application deficiencies found during scanning:

1. Application papers are not suitable for scanning and are not in compliance with 37 CFR 1.52 because:
  - All sheets must be the same size and either A4 (21 cm x 29.7 cm) or 8-1/2" x 11". Pages \_\_\_\_\_ do not meet these requirements.
  - Papers are not flexible, strong, smooth, non-shiny, durable, and white.
  - Papers are not typewritten or mechanically printed in permanent ink on one side.
  - Papers contain improper margins. Each sheet must have a left margin of at least 2.5 cm (1") and top, bottom and right margins of at least 2.0 cm (3/4").
  - Papers contain hand lettering.
2. Drawings are not in compliance and were not scanned because:
  - The drawings or copy of drawings are not suitable for electronic reproduction.
  - All drawings sheets are not the same size. Pages must be either A4 (21 cm x 29.7 cm) or 8-1/2" x 11".
  - Each sheet must include a top and left margin of at least 2.5 cm (1"), a right margin of at least 1.5 cm (9/16") and a bottom margin of at least 1.0 cm (3/8").
3. Page(s) \_\_\_\_\_ are not of sufficient clarity, contrast and quality for electronic reproduction.
4. Page(s) \_\_\_\_\_ are missing.
5. OTHER: No Declarations Enclosed



## Asymmetric, Stereocontrolled Total Synthesis of Paraherquamide A

Robert M. Williams,\* Jianhua Cao, Hidekazu Tsujishima, and Rhona J. Cox

Contribution from the Department of Chemistry, Colorado State University, Fort Collins, Colorado 80523

Received June 16, 2003; E-mail: rmw@chem.colostate.edu

**Abstract:** The first total synthesis of paraherquamide A, a potent anthelmintic agent isolated from various *Penicillium* sp. with promising activity against drug-resistant intestinal parasites, is reported. Key steps in this asymmetric, stereocontrolled total synthesis include a new enantioselective synthesis of  $\alpha$ -alkylated- $\beta$ -hydroxyproline derivatives to access the substituted proline nucleus and a highly diastereoselective intramolecular  $S_N2'$  cyclization to generate the core bicyclo[2.2.2]diazaoctane ring system.

## Introduction

The paraherquamides<sup>1–4</sup> are an unusual family of fungal natural products which contain a bicyclo[2.2.2]diazaoctane core structure, a *spiro*-oxindole, and a substituted proline moiety. The parent member, paraherquamide A (1), was first isolated from cultures of *Penicillium paraherquei* by Yamazaki and co-workers in 1981.<sup>1</sup> Since then, paraherquamides B–G,<sup>2</sup> VM55595, VM55596, and VM55597,<sup>3</sup> SB203105 and SB200437,<sup>4</sup> and sclerotamide<sup>5</sup> have been isolated from various *Penicillium* and *Aspergillus* species. Marefortines A–C are structurally similar, containing a pimelic acid unit in place of proline.<sup>6</sup> Also closely related are VM55599,<sup>3</sup> aspergamides A and B,<sup>7</sup> avrainvillamide (CJ-17,665),<sup>8</sup> and the most recently isolated members of this family, stephacidins A and B.<sup>9</sup> These last six compounds contain a 2,3-disubstituted indole in place of the *spiro*-oxindole. Brevianamides A and B,<sup>10</sup> which contain a *spiro*-indoxyl rather

than a *spiro*-oxindole, and the asperparalines, which contain a *spiro*-succinimide,<sup>11</sup> are also structurally comparable (Figure 1).

The paraherquamides have attracted considerable attention due to their molecular complexity, intriguing biogenesis,<sup>12,13</sup> and biological activity. Some members, most notably paraherquamide A, display potent anthelmintic activity and antinematodal properties.<sup>14</sup> Due to the appearance of drug resistance developed by helminths, broad spectrum anthelmintic agents such as the macrocyclic endectocides, benzimidazoles, tetrahydropyrimidines, and imidazothiazoles are beginning to lose efficacy and there has arisen an urgent need to discover new families of antiparasitic agents. The paraherquamides represent an entirely new structural class of anthelmintic compounds, and as such, they hold great potential as drugs for the treatment of intestinal parasites in animals.<sup>15</sup> The mode of action of the paraherquamides is, as yet, incompletely characterized, but recent work suggests that they are selective competitive cholinergic antagonists.<sup>16</sup>

- (1) Yamazaki, M.; Okuyama, E.; Kobayashi, M.; Inoue, H. *Tetrahedron Lett.* **1981**, *22*, 135–136.
- (2) (a) Ondeyka, J. G.; Goegelman, R. T.; Schaeffer, J. M.; Kelemen, L.; Zitano, L. *J. Antibiot.* **1990**, *43*, 1375–1379. (b) Liesch, J. M.; Wichmann, C. F. *J. Antibiot.* **1990**, *43*, 1380–1386. (c) Blanchflower, S. E.; Banks, R. M.; Everett, J. R.; Manger, B. R.; Reading, C. *J. Antibiot.* **1991**, *44*, 492–497.
- (3) Blanchflower, S. E.; Banks, R. M.; Everett, J. R.; Reading, C. *J. Antibiot.* **1993**, *46*, 1355–1363.
- (4) Banks, R. M.; Blanchflower, S. E.; Everett, J. R.; Manger, B. R.; Reading, C. *J. Antibiot.* **1997**, *50*, 840–846.
- (5) Whyte, A. C.; Gloer, J. B.; Wicklow, D. T.; Dowd, P. F. *J. Nat. Prod.* **1996**, *59*, 1093–1095.
- (6) (a) Polonsky, J.; Merrien, M.-A.; Prangé, T.; Pascard, C.; Moreau, S. *J. Chem. Soc., Chem. Commun.* **1980**, 601–602. (b) Prangé, T.; Billion, M.-A.; Vuilhorgne, M.; Pascard, C.; Polonsky, J.; Moreau, S. *Tetrahedron Lett.* **1981**, *22*, 1977–1980.
- (7) Fuchser, Jens. Beeinflussung der Sekundärstoffbildung bei *Aspergillus ochraceus* durch Variation der Kulturbedingungen sowie Isolierung, Strukturklärung und Biosynthese der neuen Naturstoffe. Ph.D. Thesis, University of Göttingen, Germany, 1995. K. Bielefeld Verlag: Friedland, 1996 (Prof. A. Zeeck).
- (8) (a) Fencical, W.; Jensen, P. R.; Cheng, X. C. U.S. Patent 6,066,635, 2000. (b) Sugie, Y.; Hirai, H.; Inagaki, T.; Ishiguro, M.; Kim, Y.-J.; Kojima, Y.; Sakakibara, T.; Sakemi, S.; Sugiuma, A.; Suzuki, Y.; Brennan, L.; Dugnan, J.; Huang, L. H.; Sutcliffe, J.; Kojima, N. *J. Antibiot.* **2001**, *54*, 911–916.
- (9) Qian-Citrone, J.; Huang, S.; Shu, Y.-Z.; Vyas, D.; Fairchild, C.; Menendez, A.; Krampitz, K.; Dalterio, R.; Klobner, S. E.; Gao, Q. *J. Am. Chem. Soc.* **2002**, *124*, 14556–14557.
- (10) (a) Birch, A. J.; Wright, J. J. *J. Chem. Soc., Chem. Commun.* **1969**, 644–645. (b) Birch, A. J.; Wright, J. J. *Tetrahedron* **1970**, *26*, 2329–2344. (c) Birch, A. J.; Russell, R. A. *Tetrahedron* **1972**, *28*, 2999–3008.
- (11) (a) Hayashi, H.; Nishimoto, Y.; Nozaki, H. *Tetrahedron Lett.* **1997**, *38*, 5655–5658. (b) Hayashi, H.; Nishimoto, Y.; Akiyama, K.; Nozaki, H. *Biosci. Biotechnol. Biochem.* **2000**, *64*, 111–115.
- (12) (a) Porter, A. E. A.; Sammes, P. G. *J. Chem. Soc., Chem. Commun.* **1970**, 1103. (b) Baldas, J.; Birch, A. J.; Russell, R. A. *J. Chem. Soc., Perkin Trans. 1* **1974**, 50–52. (c) Birch, A. J. *J. Agric. Food Chem.* **1971**, *19*, 1088–1092. (d) Kuo, M. S.; Wiley, V. H.; Cialdella, J. I.; Yurek, D. A.; Whaley, H. A.; Marshall, V. P. *J. Antibiot.* **1996**, *49*, 1006–1013.
- (13) (a) Stocking, E. M.; Sanz-Cervera, J. F.; Williams, R. M.; Unkefer, C. J. *J. Am. Chem. Soc.* **1996**, *118*, 7008–7009. (b) Williams, R. M.; Sanz-Cervera, J. F.; Sancenón, F.; Marco, J. A.; Halligan, K. M. *Bioorg. Med. Chem.* **1998**, *6*, 1233–1241. (c) Stocking, E. M.; Williams, R. M.; Sanz-Cervera, J. F. *J. Am. Chem. Soc.* **2000**, *122*, 9089–9098. (d) Stocking, E. M.; Martinez, R. A.; Silks, L. A.; Sanz-Cervera, J. F.; Williams, R. M. *J. Am. Chem. Soc.* **2001**, *123*, 3391–3392. (e) Stocking, E. M.; Sanz-Cervera, J. F.; Unkefer, C. J.; Williams, R. M. *Tetrahedron* **2001**, *57*, 5303–5320. (f) Stocking, E. M.; Sanz-Cervera, J. F.; Williams, R. M. *Angew. Chem., Int. Ed.* **2001**, *40*, 1296–1298.
- (14) (a) Ostlund, D. A.; Mickle, W. G.; Ewanciw, D. V.; Andrioli, F. J.; Campbell, W. C.; Hernandez, S.; Mochales, S.; Munguira, E. *Res. Vet. Sci.* **1990**, *48*, 260–261. (b) Shoop, W. L.; Egerton, J. R.; Eary, C. H.; Suhayda, D. *J. Parasitol.* **1990**, *76*, 349–351. (c) Shoop, W. L.; Eary, C. H.; Michael, H. W.; Haines, H. W.; Seward, R. L. *Vet. Parasitol.* **1991**, *40*, 339–341. (d) Shoop, W. L.; Michael, B. F.; Haines, H. W.; Eary, C. H. *Vet. Parasitol.* **1992**, *43*, 259–263. (e) Shoop, W. L.; Haines, H. W.; Eary, C. H.; Michael, B. F. *Am. J. Vet. Res.* **1992**, *53*, 2032–2034. (f) Schaeffer, J. M.; Blizard, T. A.; Ondeyka, J.; Goegelman, R.; Sinclair, P. J.; Mrazik, H. *Biochem. Pharmacol.* **1992**, *43*, 679–684. For a review, see: (g) Geary, T. G.; Sangster, N. C.; Thompson, D. P. *Vet. Parasitol.* **1999**, *84*, 275–295.

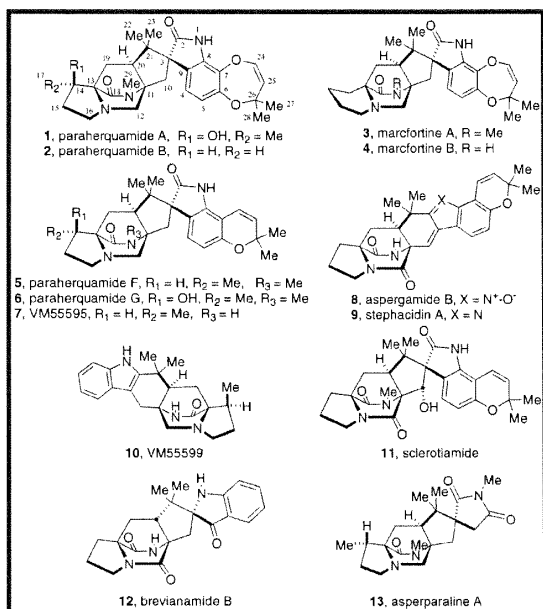
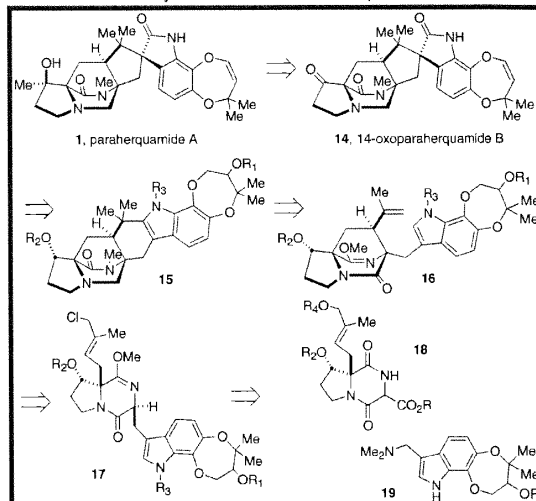


Figure 1. Structures of some paraherquamides and related compounds.

The small quantities of paraherquamide A that can be isolated from cultures for biological study have slowed the development of these agents. Recently, Lee and Clothier reported the interesting semisynthetic conversion of marcfortine A (3), a metabolite more readily available by fermentation, into paraherquamide A via paraherquamide B (2).<sup>17</sup> Following synthetic studies on brevianamide B (12),<sup>18</sup> our laboratory reported the first total synthesis of a member of the paraherquamide family, *ent*-paraherquamide B, in 1993, in which a diastereoselective intramolecular  $\text{S}_{\text{N}}2'$  cyclization reaction was used to construct the core bicyclo[2.2.2]diazaoctane ring system.<sup>19</sup> We have further exploited this reaction strategy, and we described the first total synthesis of paraherquamide A in 2000.<sup>20</sup> Herein, we detail a full account of this work.

### Scheme 1. Retrosynthetic Plan for Paraherquamide A



### Synthesis of an $\alpha$ -Alkylated- $\beta$ -Hydroxyproline

Despite the apparent similarity in the structures of paraherquamides A and B, synthesis of the former turned out to be a significantly more challenging endeavor owing to the presence of the unusual  $\beta$ -hydroxy- $\beta$ -methyl proline residue. In the semisynthesis of paraherquamide A from marcfortine A (3), the final step was addition of methylmagnesium bromide to 14-oxoparaherquamide B (14).<sup>17</sup> We planned to use this same methodology to complete our total synthesis and to construct 14 using a similar strategy to that used for paraherquamide B, that is, coupling of suitably functionalized indole (19) and diketopiperazine (18) units and then an intramolecular  $\text{S}_{\text{N}}2'$  cyclization followed by palladium-mediated closure of the seventh ring, and finally oxidation and rearrangement of the 2,3-disubstituted indole to the *spiro*-oxindole of 14-oxoparaherquamide B<sup>19</sup> (Scheme 1).

New methodology was now required to prepare a suitably functionalized  $\alpha$ -alkylated- $\beta$ -hydroxyproline residue. A variety of methods were investigated for the asymmetric construction of this class of compound, leading to the development of a potentially general synthetic method which uses dianion alkylation of the readily available *N*-*t*-BOC- $\beta$ -hydroxyproline ethyl ester derivative 12 with net retention of stereochemistry.<sup>21</sup> This methodology has now successfully been applied to a concise asymmetric and stereocontrolled total synthesis of paraherquamide A.

Epoxide 20, which is commercially available or made by epoxidation of isoprene with *m*CPBA, was treated with *n*-Bu<sub>4</sub>Nl and TBSCl to provide iodide 21 as a mixture of geometrical isomers (*E*:*Z*  $\approx$  6:1) in 58% overall yield. Diester 22 was prepared in two steps from ethyl glycinate and ethyl acrylate, and then a Dieckmann cyclization was conducted, using a slight modification of the procedure described by Rapoport.<sup>22</sup>

- (15) (a) Blizzard, T. A.; Marino, G.; Mrozik, H.; Fisher, M. H.; Hoogsteen, K.; Springer, J. P. *J. Org. Chem.* **1989**, *54*, 2657–2663. (b) Blizzard, T. A.; Mrozik, H.; Fisher, M. H.; Schaeffer, J. M. *J. Org. Chem.* **1990**, *55*, 2256–2259. (c) Blizzard, T. A.; Margiatto, G.; Mrozik, H.; Schaeffer, J. M.; Fisher, M. H. *Tetrahedron Lett.* **1991**, *32*, 2437–2440. (d) Blizzard, T. A.; Margiatto, G.; Mrozik, H.; Schaeffer, J. M.; Fisher, M. H. *Tetrahedron Lett.* **1991**, *32*, 2441–2444. (e) Lee, B. H.; Clothier, M. F.; Johnson, S. S. *Bioorg. Med. Chem. Lett.* **2001**, *11*, 553–554. (f) Lee, B. H.; Clothier, M. F.; Dutton, F. E.; Nelson, S. J.; Johnson, S. S.; Thompson, D. P.; Geary, T. G.; Whaley, H. D.; Haber, C. L.; Marshall, V. P.; Kornis, G. I.; McNally, P. L.; Ciadella, J. I.; Martin, D. G.; Bowman, J. W.; Baker, C. A.; Coscarelli, E. M.; Alexander-Bowman, S. J.; Davis, J. P.; Zinser, E. W.; Wiley, V.; Lipton, M. F.; Mauragis, M. A. *Curr. Top. Med. Chem.* **2002**, *2*, 779–793. (g) Lee, B. H.; Clothier, M. F. U.S. Patent 5,750,695, 1998.
- (16) (a) Robertson, A. P.; Clark, C. L.; Burns, T. A.; Thompson, D. P.; Geary, T. G.; Trailovic, S. M.; Martin, R. J. *J. Pharmacol. Exp. Ther.* **2002**, *302*, 853–860. (b) Zinser, E. W.; Wolfe, M. L.; Alexander-Bowman, S. J.; Thomas, E. M.; Davis, J. P.; Groppi, V. E.; Lee, B. H.; Thompson, D. P.; Geary, T. G. *J. Vet. Pharmacol. Ther.* **2002**, *25*, 241–250.
- (17) (a) Lee, B. H.; Clothier, M. F. *J. Org. Chem.* **1997**, *62*, 1795–1798. (b) Lee, B. H.; Clothier, M. F.; Pickering, D. A. *J. Org. Chem.* **1997**, *62*, 7836–7840.
- (18) Williams, R. M.; Glinka, T.; Kwast, E.; Coffinan, H.; Stille, J. K. *J. Am. Chem. Soc.* **1990**, *112*, 808–821.
- (19) Cushing, T. D.; Sanz-Cervera, J. F.; Williams, R. M. *J. Am. Chem. Soc.* **1996**, *118*, 557–579.
- (20) Williams, R. M.; Cao, J.; Tsujishima, H. *Angew. Chem., Int. Ed.* **2000**, *39*, 2540–2544.

- (21) Williams, R. M.; Cao, J. *Tetrahedron Lett.* **1996**, *37*, 5441–5444.
- (22) (a) Blake, J.; Willson, C. D.; Rapoport, H. *J. Am. Chem. Soc.* **1964**, *86*, 5293–5299. For more regioselective methods, see: (b) Yamada, Y.; Ishii, T.; Kimura, M.; Hosaka, K. *Tetrahedron Lett.* **1981**, *22*, 1353–1354. (c) Sibi, M. P.; Christensen, J. W.; Kim, S.-G.; Eggen, M.; Stessman, C.; Oien, L. *Tetrahedron Lett.* **1995**, *36*, 6209–6212.

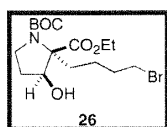
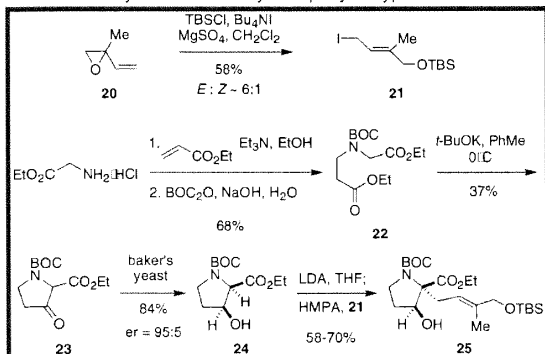


Figure 2. Assignment of relative stereochemistry of **25**.

Scheme 2. Synthesis of  $\alpha$ -Alkylated- $\beta$ -Hydroxyproline **25**



to yield racemic  $\beta$ -ketoester **23** (Scheme 2). Baker's yeast reduction afforded the optically active  $\beta$ -hydroxyester **24** with an enantiomeric ratio of ca. 95:5 as described by Knight et al.<sup>23</sup> Alkylation of the dianion of **24** with substituted allyl iodide **21** proceeded with retention of stereochemistry and excellent diastereoselectivity under the conditions previously developed.<sup>21</sup> The desired  $\alpha$ -alkylated product **25** was obtained in 58–70% isolated yield with little or no *O*-monoalkylation or *O*,*C*-dialkylation taking place. It was interesting to note during large scale synthesis of **25** that the amount of HMPA required in the alkylation reaction ranged from 1.4 to 13.6 equiv depending on the batch of **24** that was used, despite the batches being apparently identical by <sup>1</sup>H NMR, IR, TLC, and optical rotation. The reasons for this phenomenon are presently unclear.<sup>24</sup>

The assignment of the relative stereochemistry of **25** was obtained by comparison of the <sup>1</sup>H NMR and optical rotation data of **25** to those of **26**, which was obtained by alkylation of **24** with 1,4-dibromobutane. The relative stereochemistry of **26** was assigned unambiguously through single-crystal X-ray analysis (Figure 2).<sup>21</sup> The absolute stereochemistry of **25** was confirmed by Barton deoxygenation and conversion to diketopiperazine (+)-**29** as illustrated in Scheme 3. This same diketopiperazine could be obtained, as the enantiomer, from **30**. This compound has previously been converted to (+)-paraherquamide B, a substance whose absolute stereochemistry has been confirmed.<sup>19</sup>

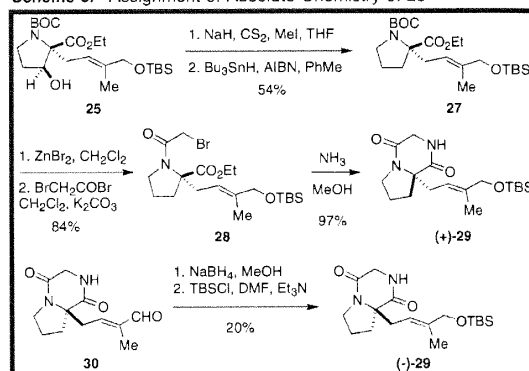
#### Synthesis of a Functionalized Diketopiperazine

It was necessary to convert the substituted proline (**25**) into a suitably functionalized diketopiperazine for a similar Somei–Kametani coupling reaction to that used in our total synthesis of paraherquamide B. Initial studies on this system were carried out with the secondary alcohol protected as a benzyl ether.

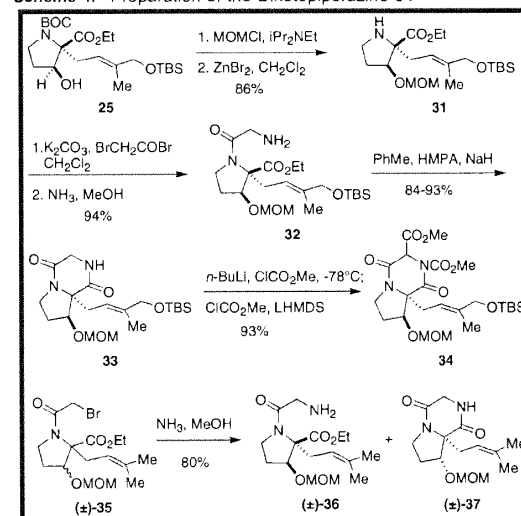
(23) (a) Cooper, J.; Gallagher, P. T.; Knight, D. W. *J. Chem. Soc., Perkin Trans. I* **1993**, 1313–1317. For alternative baker's yeast reductions, see: (b) Sibi, M. P.; Christensen, J. W. *Tetrahedron Lett.* **1990**, *31*, 5689–5692. (c) Blide, R.; Mortezaei, R.; Seilimati, A.; Sih, C. J. *Tetrahedron Lett.* **1990**, *31*, 4827–4830.

(24) Seebach, D. *Angew. Chem., Int. Ed. Engl.* **1988**, *27*, 1624–1654.

Scheme 3. Assignment of Absolute Chemistry of **25**



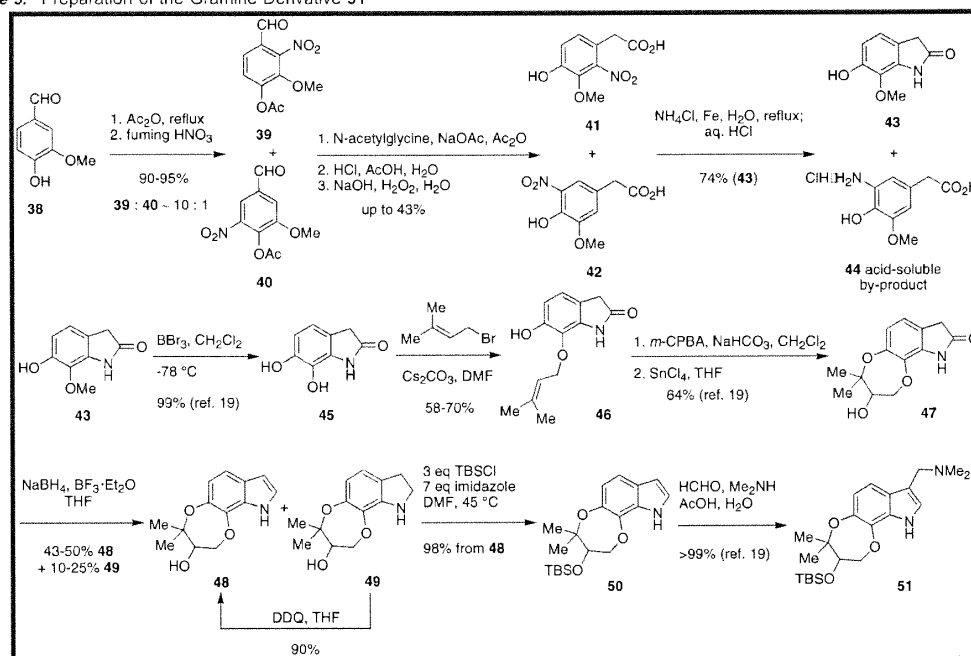
Scheme 4. Preparation of the Diketopiperazine **34**



However, because of problems with selectivity and purification later in the synthesis, the less bulky and more polar methoxymethyl (MOM) protecting group was used in the final synthetic route. After MOM protection of the alcohol, the *N*-*t*-BOC group was smoothly removed with ZnBr<sub>2</sub> in dichloromethane<sup>25</sup> and the exposed secondary amine (**31**) was acetylated with bromoacetyl bromide under Schotten–Baumann conditions (Scheme 4). Treatment of the bromoacetamide with methanolic ammonia afforded the corresponding glycineamide (**32**) which was directly subjected to cyclization in the presence of sodium hydride in toluene/HMPA to afford the bicyclic compound **33** in 75% overall yield from **25**. An interesting observation about the ease of closure of hydroxylated diketopiperazines was made during this study. When there is no hydroxyl substituent (e.g., in **28**) or the protected hydroxyl group is *trans* to the ester, the diketopiperazine typically forms spontaneously from the aminoester in methanol at room temperature. On the other hand, a *cis*-isomer such as **31** can be isolated as the aminoester from the amination reaction, and formation of the diketopiperazine requires much more forcing conditions. On amination of a

(25) Nigam, S. C.; Mann, A.; Taddei, M.; Wermuth, C.-G. *Synth. Commun.* **1989**, *19*, 3139–3142.

Scheme 5. Preparation of the Gramine Derivative 51



mixture of diastereomeric bromoacetamides **35**, the aminoester **36** and the diketopiperazine **37** are produced. This is presumably because the *cis*-diketopiperazine is significantly more sterically hindered. After diketopiperazine formation, a one-pot double carbomethoxylation reaction was performed by the sequential addition of *n*-BuLi in THF followed by addition of methylchloroformate, which carbomethoxylates the amide nitrogen. Subsequent addition of more methylchloroformate followed by LHMDS afforded **34** in 93% yield as an ~6:1 mixture of *E* and *Z* isomers, with the newly created stereogenic center as a single stereoisomer (relative configuration was not assigned).

#### Improved Synthesis of the Gramine Derivative

With this functionalized diketopiperazine in hand, we turned our attention to improvement of the synthesis of the dioxepin-containing indole fragment that we originally described in 1990.<sup>26</sup> The original route provides compound **51** in 14 steps with no chromatography required until the ninth step. However, further optimization was necessary to achieve a more rapid and efficient large-scale synthesis. The route we have developed is illustrated in Scheme 5. Vanillin (**38**) was acetylated with acetic anhydride and then treated with fuming nitric acid to afford **39**, the desired regioisomer, and **40**, the undesired isomer, in an ~10:1 ratio. Initially, these regioisomers were separated by hydrolysis of the acetate group and isolation of the desired phenol isomer by crystallization.<sup>27</sup> Analysis of the product mixture by TLC revealed that **39** had a lower *R<sub>f</sub>* and **40** had exactly the same *R<sub>f</sub>* as that of the starting material, and it was possible to isolate **39** by flash chromatography. However, neither purification method proved optimal for a large-scale protocol. The new

approach circumvents these problems. Instead, we directly used the mixture of nitrobenzaldehydes **39** and **40**. After a three-step transformation,<sup>28</sup> **39** provided the desired acid **41**, and **40** provided the undesired acid **42**. Reduction of the nitro group was originally carried out in 95% yield by hydrogenation over palladium on carbon at 40 psi and 80 °C. However, this protocol could prove awkward on a large scale, so an alternative approach was developed using iron and NH<sub>4</sub>Cl<sup>29</sup> which, while the yield (74%) is more moderate, proved easier to scale-up. On reduction to the corresponding amines, the amine intermediate from **41** cyclized to oxindole **43**, but **42** was simply reduced to amino acid **44**, which cannot undergo an intramolecular cyclization reaction due to geometric restriction. On extraction of the reaction mixture, the amino acid (**44**) was removed with aqueous acid leaving the oxindole (**43**) in the organic phase. Demethylation then proceeded smoothly as already described to give **45**.<sup>30</sup>

Prenylation of **45** is partially selective for the 7-hydroxy position due to the greater acidity of this hydroxyl group. However, under the prenylation conditions originally developed for paraherquamide B, small amounts of the 6-prenyloxy and 6,7-diprenyloxy isomers were also formed, and the three compounds are difficult to separate by flash chromatography. In this modification of our original route, replacement of the base with Cs<sub>2</sub>CO<sub>3</sub> improves the selectivity and yield of **46**.

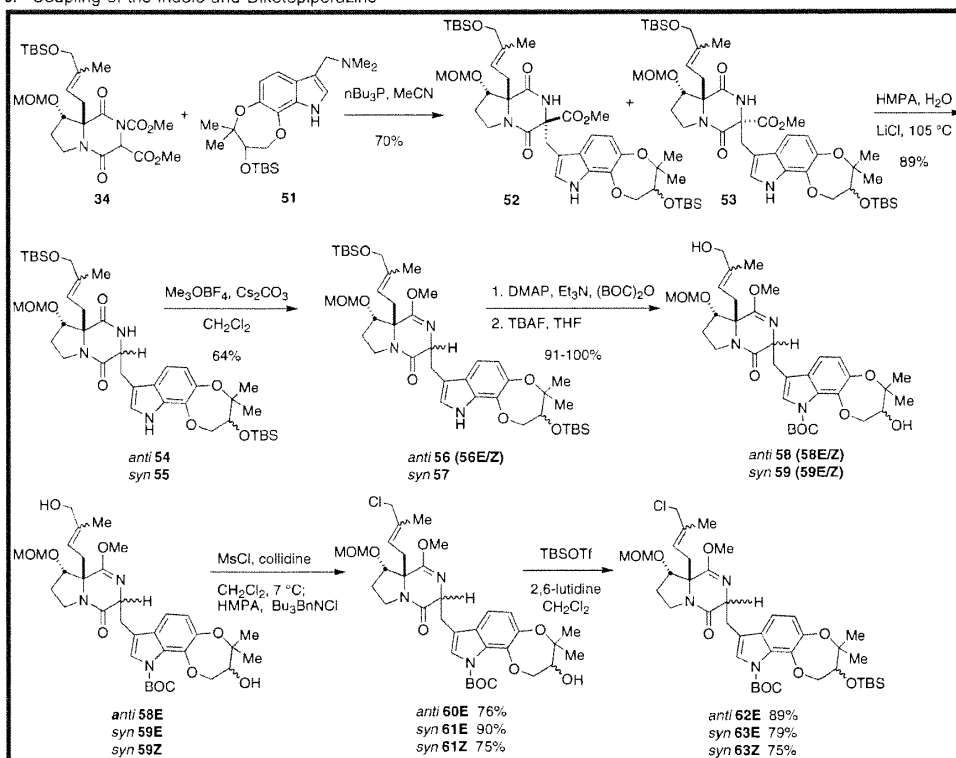
(28) (a) MacDonald, S. F. *J. Chem. Soc.* **1948**, 376–378. (b) Beer, R. J. S.; Clarke, K.; Davenport, H. F.; Robertson, A. *J. Chem. Soc.* **1951**, 2029–2032.

(29) Wissner, A.; Berger, D. M.; Boschelli, D. H.; Floyd, M. B., Jr.; Greenberger, L. M.; Gruber, B. C.; Johnson, B. D.; Mamuya, N.; Nilakantan, R.; Reich, M. F.; Shen, R.; Tsou, H.-R.; Upeslakis, E.; Wang, Y. F.; Wu, B.; Ye, F.; Zhang, N. *J. Med. Chem.* **2000**, *43*, 3244–3256.

(30) Since this route was developed, McWhorter and Savall have published a route to **45** which is shorter and higher yielding, but the applicability of their synthesis on a large scale has not yet been demonstrated. Savall, B. M.; McWhorter, W. W. *J. Org. Chem.* **1996**, *61*, 8696–8697.

(26) Williams, R. M.; Cushing, T. D. *Tetrahedron Lett.* **1990**, *31*, 6325–6328.  
(27) Raiford, L. C.; Stoesser, W. C. *J. Am. Chem. Soc.* **1928**, *50*, 2556–2563.

Scheme 6. Coupling of the Indole and Diketopiperazine



Extraction into base during the workup procedure also removes the diprenylated byproduct which allowed for easier purification.

A major problem in our first generation synthesis of the gramine derivative was during reduction of the oxindole to the indole, when over-reduction to the indoline occurred in variable quantities giving a ratio of 4:1 to 2:1 of indole/indoline. Attempts were made, without success, to effect a more selective reduction of the oxindole. However, the problem was solved in an indirect fashion as it proved possible to oxidize the indoline byproduct to the indole with DDQ<sup>31</sup> in greater than 90% yield.

Formation of TBS ethers on hindered alcohols is known to be very sensitive to the concentration of the reaction mixture. The silylation reaction was optimized by concentrating the reaction mixture to give an improved yield of 95% from 82%. Finally indole **50** was converted to the gramine derivative **51** under standard conditions. The advantages of this new approach are significant in terms of increased yield, lower cost, and faster synthesis on a large scale.

### Coupling of the Indole and Diketopiperazine

Somei–Kametani coupling<sup>32</sup> of diketopiperazine **34** with the gramine derivative **51** in the presence of tri-*n*-butylphosphine gave a separable mixture of two diastereomers **52** and **53** in a

3:1 ratio, each as a mixture of four diastereomers (Scheme 6).<sup>33</sup> Decarboxylation was effected by treatment of **52** and **53** individually with LiCl in hot, aqueous HMPA to provide, in both cases, a mixture of **54** (*anti*-isomer) and **55** (*syn*-isomer), which could now be separated into the *E* and *Z* isomers, each of which as a mixture of two diastereomers (epimeric at the dioxepin secondary alcohol). However, as separation of the geometric isomers proved to be difficult, the compounds were usually carried through the synthetic sequence as a mixture and separated only for analytical purposes. Protection of the secondary amide as the corresponding methyl lactim ether was accomplished by treating **54** and **55** with trimethyloxonium tetrafluoroborate and Cs<sub>2</sub>CO<sub>3</sub> in dichloromethane. Model studies had shown that Cs<sub>2</sub>CO<sub>3</sub> was a more efficient base than Na<sub>2</sub>CO<sub>3</sub> for this reaction, as it leads to a lower incidence of TBS cleavage and *N*-methylation. Next, the indole nitrogen was protected as the corresponding *N*-*t*-BOC derivative by treatment with di-*tert*-butyl dicarbonate in the presence of DMAP, and then the silyl ethers were removed with tetrabutylammonium fluoride (TBAF) to provide **58** (*anti*) and **59** (*syn*). From this point onward, the *E* and *Z* isomers were utilized separately. Unfortunately, the Corey procedure,<sup>34</sup> which had been successful

(31) He, F.; Foxman, B. M.; Snider, B. B. *J. Am. Chem. Soc.* **1998**, *120*, 6417–6418.

(32) (a) Somei, M.; Karasawa, Y.; Kaneko, C. *Heterocycles* **1981**, *16*, 941–949. (b) Kametani, T.; Kanaya, N.; Ihara, M. *J. Chem. Soc., Perkin Trans. 1* **1981**, 959–963.

(33) The stereochemistry at the newly formed stereogenic centers in **52** and **53**, and in all subsequent compounds, was assigned on the basis of <sup>1</sup>H NMR data. In compounds where the indole substituent is on the same face of the diketopiperazine as the MOM ether, the signal for the methoxy group is at significantly higher field than in the situation where these two substituents are on opposite faces. This is due to the proximity of the methoxy group to the shielding effects of the aromatic system.

(34) Corey, E. J.; Kim, C. U.; Takeda, M. *Tetrahedron Lett.* **1972**, *13*, 4339–4342.

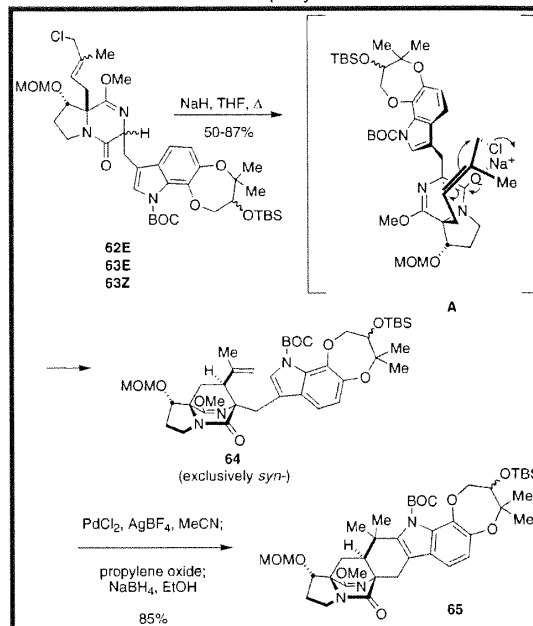
in the synthesis of paraherquamide B for conversion of an allylic alcohol to the corresponding chloride, proved unreliable when applied to the paraherquamide A system. Under the conditions used previously, cleavage of the lactim ether and chlorination at the 2-position of the indole were observed. Extensive investigation into suitable conditions was carried out, and it was eventually found that selective conversion of the primary alcohols **58** and **59** to the corresponding mesylates was possible in the presence of the hindered base collidine. Displacement of mesylate by a chloride ion under these reaction conditions was very slow so  $\text{Bu}_3\text{BnNCl}$  (as an external chloride source) and a polar solvent were added to accelerate the reaction, allowing formation of the allylic chlorides (**60** and **61**) in up to 90% yield. This is a simple, practical, and reproducible method for preparing allylic chlorides in molecules bearing labile functional groups. Finally, careful reprotection of the secondary alcohols with *tert*-butyldimethylsilyl triflate in the presence of 2,6-lutidine afforded the key allylic chlorides **62** and **63**.

### $\text{S}_{\text{N}}2'$ Cyclization and Closure of the Seventh Ring

The stage was now set for the critical intramolecular  $\text{S}_{\text{N}}2'$  cyclization, that sets the relative stereochemistry at C-20 during formation of the bicyclo[2.2.2]diazaoctane ring nucleus. Based on precedent from the paraherquamide B synthesis,<sup>19</sup> **63E** was treated with NaH in refluxing benzene. However, the reaction was very slow and gave the desired cyclization product **64** in only 25% yield, accompanied by products from competing pathways. The acidic proton in **63E** is more sterically hindered than in the corresponding substrate for the paraherquamide B synthesis, due to the presence of the MOM ether. Since NaH likely exists as heterogeneous clusters in benzene, it was expected that use of a more coordinating solvent may break up the clusters and render deprotonation more facile. Conveniently, use of NaH in refluxing THF afforded the desired  $\text{S}_{\text{N}}2'$  cyclization product **64** in 87% yield from **63E** exclusively as the desired *syn*-isomer.<sup>35</sup> This remarkably diastereoselective intramolecular  $\text{S}_{\text{N}}2'$  cyclization reaction proceeds, in a nonpolar solvent like THF, via a tight, intramolecular ion-pair driven cyclization ("closed" transition state)<sup>36</sup> as shown in Scheme 7. Compound **62E** also underwent the same transformation to give **64** in 82% yield. In both cases, the product was sometimes accompanied by a small amount of Boc-protected cyclized product which could be reprotected under standard conditions. In addition, it was interesting to note that the *Z*-isomer, **63Z**, provides the same cyclization product, again with exclusive *syn* selectivity, in 50% yield.

Closure of the seventh ring was attempted using  $\text{PdCl}_2$  and  $\text{AgBF}_4$  in acetonitrile followed by  $\text{NaBH}_4$  to reduce the incipient heptacyclic *o*-palladium adduct,<sup>37</sup> reaction conditions which had

Scheme 7. Formation of the Heptacycle



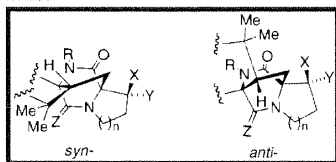
been successful in the paraherquamide B synthesis.<sup>19</sup> However, the only products isolated under the same conditions with **64** were those appearing to arise from removal of the *N*-*t*-BOC, MOM and other protecting groups, presumably by  $\text{HBF}_4$  generated in situ. To buffer the reaction mixture, propylene oxide was added as an acid scavenger and the reaction now proceeded to give the desired 2,3-disubstituted indole (**65**) in 85% yield.

### Completion of the Synthesis

Conditions could not be found which would allow direct and high-yielding conversion of the lactim ether (**65**) to the amide. However, use of 0.1 M aqueous HCl in THF gave the corresponding ring-opened amine methyl ester (**66**) which was recycled to the bicyclo[2.2.2]diazaoctane (**67**) by treatment of **66** with catalytic 2-hydroxypyridine in hot toluene. Chemo-selective reduction of the tertiary amide in the presence of the secondary amide to give **68** could be effected by treatment of the diamide **67** with the  $\text{AlH}_3\text{-Me}_2\text{NEt}$  complex followed by quenching with sodium cyanoborohydride, methanol, and acetic acid, as used in the synthesis of paraherquamide B. However, use of excess diisobutylaluminum hydride (DIBAL-H) in dichloromethane was a simpler experimental procedure and gave improved yields of **68**.<sup>38</sup> *N*-Methylation of the secondary amide proceeded smoothly and was followed by cleavage of the MOM ether with bromocatecholborane.<sup>39</sup> Oxidation of the secondary alcohol with Dess–Martin periodinane<sup>40</sup> and concomitant removal of the *N*-*t*-BOC group and TBS ether with TFA gave ketone **70** (Scheme 8).

The final critical oxidative spirocyclization of the 2,3-disubstituted indole was effected by a two-step procedure.

(35) The *syn/anti* relationship in this case refers to the relative stereochemistry between the C-20 stereogenic center (see paraherquamide numbering) and the proline residue.



(36) (a) Denmark, S. E.; Henke, B. R. *J. Am. Chem. Soc.* **1989**, *111*, 8032–8034. (b) Denmark, S. E.; Henke, B. R. *J. Am. Chem. Soc.* **1991**, *113*, 2177–2194.

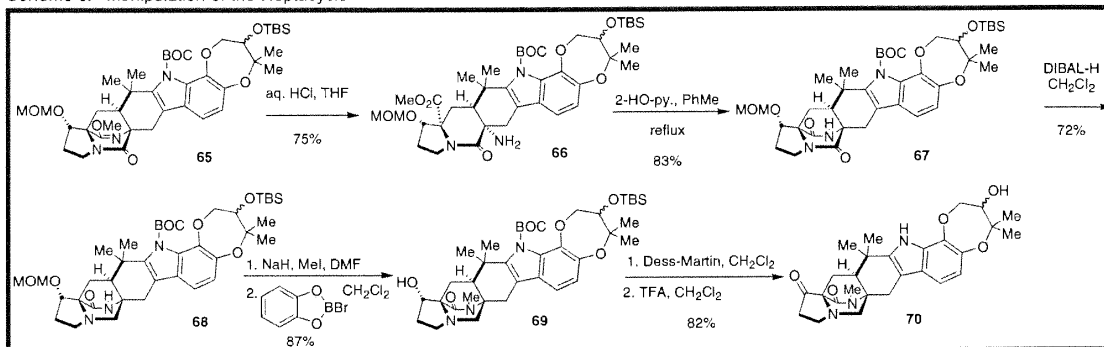
(37) Trost, B. M.; Fortunak, J. M. D. *Organometallics* **1982**, *1*, 7–13.

(38) Fukuyama, T.; Liu, G. *Pure Appl. Chem.* **1997**, *69*, 501–505.

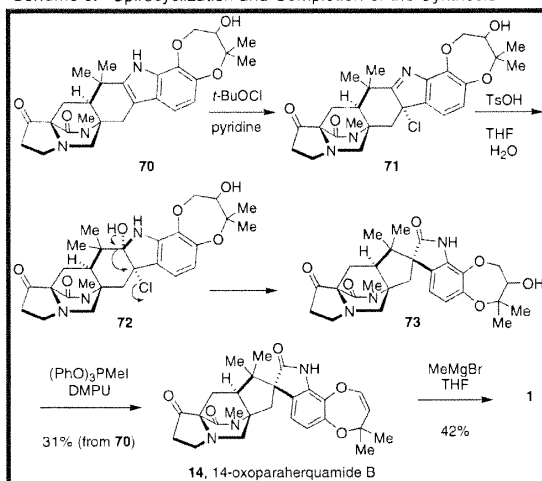
(39) Boeckman, R. K., Jr.; Potenza, J. C. *Tetrahedron Lett.* **1985**, *26*, 1411–1414.

(40) (a) Dess, D. B.; Martin, J. C. *J. Org. Chem.* **1983**, *48*, 4155–4156. (b) Dess, D. B.; Martin, J. C. *J. Am. Chem. Soc.* **1991**, *113*, 7277–7287.

Scheme 8. Manipulation of the Heptacycle



Scheme 9. Spirocyclization and Completion of the Synthesis



Treatment of **70** with *tert*-butyl hypochlorite in pyridine provided a labile 3-chloroindolenine, from which it was found necessary to rigorously remove, by azeotrope with benzene, all of the pyridine prior to the next step. Pinacol-type rearrangement with TsOH in aqueous THF then generated the desired *spiro*-oxindole (**73**). From our investigations during the pararherquamide B synthesis, it was found that use of a sterically demanding amine such as pyridine gives the best stereoselectivity during the chlorination reaction. It is assumed that addition of chlorine to **70** proceeds from the least hindered face of the indole giving the  $\alpha$ -chloroindolenine **71**. Hydration of the imine functionality, interestingly, must also occur from the same  $\alpha$ -face, that is, *syn*-to the relatively large chlorine atom, to furnish the *syn*-chlorohydrin **72** which subsequently rearranges stereospecifically to the desired *spiro*-oxindole **73** (Scheme 9).

Dehydration of the seven-membered ring in **73** with methyltriphenoxyphosphonium iodide (MTPI) in DMPU afforded 14-oxopararherquamide B (**14**) in moderate yield.<sup>17</sup> This intermediate has been previously obtained semisynthetically from marfortine A by a group from Pharmacia–Upjohn, and comparison of the authentic and synthetic materials confirmed the identity of this substance. Addition of methylmagnesium bromide to the ketone group of **14** has been previously described to give pararherquamide A along with the corresponding C-14 epimer in around 50% yield.<sup>17a</sup> Employment of this protocol using

MeMgBr with our synthetic ketone gave (–)-pararherquamide A (**1**) as the exclusive product (the C-14 epimer was not detected) in 42% yield. This product was identical to a natural sample of pararherquamide A by <sup>1</sup>H NMR, <sup>13</sup>C NMR, IR, exact mass, and mobility on TLC (*R<sub>f</sub>*). A synthetic sample was recrystallized from ether and had mp 250 °C (dec), [ $\alpha$ ]<sub>D</sub><sup>25</sup> = –22 (*c* = 0.2, MeOH). Natural pararherquamide A recrystallized from ether under the same conditions yielded a sample with mp 250 °C (dec) and [ $\alpha$ ]<sub>D</sub><sup>25</sup> = –21 (*c* = 0.2, MeOH). All intermediates up to the final product have an enantiomeric ratio of approximately 97.5:2.5; the final synthetic pararherquamide A upon recrystallization from ether is approximately optically pure.

We have reported here the first total synthesis of pararherquamide A, the most biologically potent member of this family of compounds. This asymmetric synthesis proceeds in 46 steps from commercially available materials, with the longest linear sequence being 34 steps.

The approach developed in this study makes it feasible to examine the design and synthesis of other members of the pararherquamide family and should also permit access to structurally unique pararherquamides that may have significant biological properties. The application of this methodology to the asymmetric, stereocontrolled total synthesis of other members of the pararherquamide family, and evaluation of their properties is currently under study in these laboratories.

**Acknowledgment.** This work was supported by the NIH (Grant CA 70375). The Japanese Society for the Promotion of Science (JSPS) is acknowledged for providing fellowship support to H.T. Mass spectra were obtained on instruments supported by the NIH Shared Instrumentation Grant GM49631. We also wish to thank Dr. Timothy Blizzard of Merck & Co. for providing an authentic sample of natural pararherquamide A. We also wish to acknowledge Dr. Byung H. Lee of the Pharmacia–Upjohn Co. (now Pfizer) for providing NMR spectra and an authentic specimen of 14-oxopararherquamide B. We also wish to thank Dr. Alfredo Vazquez for assistance with purification and characterization of synthetic pararherquamide A.

**Supporting Information Available:** Complete experimental procedures and spectroscopic and analytical data for all new compounds. This material is available free of charge via the Internet at <http://pubs.acs.org>.

JA036713+

Stereocontrolled Total Synthesis of (+)-Paraherquamide B<sup>1</sup>Timothy D. Cushing,<sup>‡</sup> Juan F. Sanz-Cervera,<sup>†</sup> and Robert M. Williams\*Contribution from the Department of Chemistry, Colorado State University,  
Fort Collins, Colorado 80523Received August 7, 1995<sup>®</sup>

**Abstract:** The convergent stereocontrolled, asymmetric total synthesis of (+)-paraherquamide B is described. Key features of this synthesis include (1) an improved procedure to effect reduction of unprotected oxindoles to indoles; (2) a complex application of the Somei/Kametani coupling reaction; (3) a high-yielding and entirely stereocontrolled intramolecular S<sub>N</sub>2' cyclization reaction that constructs the core bicyclo[2.2.2] ring system; (4) a mild Pd(II)-mediated cyclization reaction that constructs a complex tetrahydrocarbazole; and (5) the chemoselective reduction of a highly hindered tertiary lactam in the presence of an unhindered secondary lactam, utilizing precoordination of the more reactive secondary lactam to triethylaluminum.

## Introduction

The paraherquamides are complex, heptacyclic, toxic mold metabolites with potent anthelmintic activity isolated from various *Penicillium* sp. The parent and most potent derivative, paraherquamide A (**1**), was first isolated from *Penicillium parherquei* in 1980 by Yamazaki.<sup>1</sup> The simplest member, paraherquamide B (**2**), plus five other structurally related paraherquamides C–G (**3–9**) were isolated from *Penicillium charlesii* (*fellutanum*) (ATCC 20841) in 1990 at Merck & Co.<sup>2,3</sup> and concomitantly at SmithKline Beecham.<sup>4</sup> More recently three additional related compounds were discovered by the same group at SmithKline.<sup>5</sup> Interest in the paraherquamides has come from the finding that this class of alkaloids displays potent anthelmintic and antinematodal properties.<sup>6,7</sup>

There are essentially three classes of broad-spectrum anthelmintics currently in use: the benzimidazoles, the levamisoles/morantels, and the avermectins/milbemycins. Unfortunately, the first two groups have lost much of their utility due to the recent appearance of drug resistance built up by the helminths.<sup>7a,8</sup> More

recently drug resistance to the avermectins has been observed in various parasites.<sup>9</sup> The paraherquamides represent an entirely new structural class of antiparasitic agents, which promise to play a significant role in the near future. The relatively low culture yields of paraherquamide obtained for biological study have slowed the development and potential commercialization of these agents (Figure 1).

As part of our ongoing efforts to elucidate the biosynthesis of the core bicyclo[2.2.2] ring system of the related alkaloids the brevianamides,<sup>10</sup> we have applied methodology originally developed for the stereocontrolled total synthesis of (–)-brevianamide B<sup>11</sup> to complete the first stereocontrolled total synthesis of (+)-paraherquamide B (**12**);<sup>12</sup> the results of this study are described in full herein.

The paraherquamides are structurally very similar to brevianamides A and B (**17** and **16**)<sup>13</sup> and marcfortines A–C (**13–15**)<sup>14</sup> with respect to the common core bicyclo[2.2.2] ring system that is derived from the cycloaddition of an isoprene unit across the amino acid α-carbons. This close structural similarity might imply a related biogenesis, and the structural features of these substances shall be described briefly from this standpoint. The paraherquamides and brevianamides A and B (**17** and **16**) appear to be derived from the condensation of tryptophan and proline, while the marcfortines are formed from the condensation of tryptophan and pipercolic acid. The origin of the methyl group in the pyrrolidine ring of paraherquamides A and C–E and VM55595-7 could in principle come from the methylation of proline, but it seems more likely that this amino acid residue is derived from isoleucine. The very low fermentation yield of paraherquamide B may be a manifestation of poor incorporation of cyclo-L-trp-L-pro into the subsequent biosynthetic machinery

<sup>1</sup> Dedicated to Professor Ei-ichi Negishi on the occasion of his 60th birthday.

<sup>†</sup> On leave from the Department of Organic Chemistry of the University of Valencia, Spain.

<sup>‡</sup> Present address: Tularik Inc., 270 East Grand Ave., South San Francisco, CA 94080.

<sup>®</sup> Abstract published in *Advance ACS Abstracts*, December 1, 1995.

(1) (a) Yamazaki, M.; Fujimoto, H.; Okuyama, E.; Ohta, Y. *Proc. Jpn. Assoc. Mycotoxicol.* **1980**, *10*, 27. (b) Yamazaki, M.; Okuyama, E.; Kobayashi, M.; Inoue, H. *Tetrahedron Lett.* **1981**, *22*, 135.

(2) (a) Blizzard, T. A.; Marino, G.; Mrozik, H.; Fisher, M. H.; Hoogsteen, K.; Springer, J. P. *J. Org. Chem.* **1989**, *54*, 2657. (b) Blizzard, T. A.; Mrozik, H.; Fisher, M. H.; Schaeffer, J. M. *J. Org. Chem.* **1990**, *55*, 2256. (c) Blizzard, T. A.; Margiatio, G.; Mrozik, H.; Schaeffer, J. M.; Fisher, M. H. *Tetrahedron Lett.* **1991**, *32*, 2437. (d) Blizzard, T. A.; Margiatio, G.; Mrozik, H.; Schaeffer, J. M.; Fisher, M. H. *Tetrahedron Lett.* **1991**, *32*, 2441. (e) Blizzard, T. A.; Rosegay, A.; Mrozik, H.; Fisher, M. H. *J. Labelled Compd. Radiopharm.* **1990**, *28*, 461.

(3) (a) Ondeyka, J. D.; Goegelman, R. T.; Schaeffer, J. M.; Kelemen, L. *J. Antibiot.* **1990**, *43*, 1375. (b) Liesch, J. M.; Wichman, C. F. *J. Antibiot.* **1990**, *43*, 1380.

(4) Blanchflower, S. E.; Banks, R. M.; Everett, J. R.; Manger, B. R.; Reading, C. *J. Antibiot.* **1991**, *44*, 492.

(5) Blanchflower, S. E.; Banks, R. M.; Everett, J. R.; Reading, C. *J. Antibiot.* **1993**, *46*, 1355.

(6) Ostlund, D. A.; Mickle, W. G.; Ewaneiw, D. V.; Andriuli, F. J.; Campbell, W. C.; Hernandez, S.; Mochaes, S.; Munguira, E. *Res. Vet. Sci.* **1990**, *48*, 260.

(7) (a) Shoop, W. L.; Egerton, J. R.; Eary, C. H.; Suhayda, D. *J. Parasitol.* **1990**, *76* (2) 186. (b) Shoop, W. L.; Michael, B. F.; Haines, H. W.; Eary, C. H. *Vet. Parasitol.* **1992**, *43*, 259. (c) Schaeffer, J. M.; Blizzard, T. A.; Ondeyka, J.; Goegelman, R.; Sinclair, P. J.; Mrozik, H. *Biochem. Pharmacol.* **1992**, *43*, 679. (d) Shoop, W. L.; Haines, H. W.; Eary, C. H.; Michael, B. F. *Am. J. Vet. Res.* **1992**, *53*, 2032.

(8) Coles, G. C. *Pestic. Sci.* **1977**, *8*, 536.

(9) (a) Van Wyk, J. A.; Malan, F. S. *Vet. Rec.* **1988**, *123*, 226. (b) Echevarria, F. A. M.; Trindade, N. P. *Vet. Rec.* **1989**, *124*, 147.

(10) (a) Sanz-Cervera, J. F.; Glinka, T.; Williams, R. M. *J. Am. Chem. Soc.* **1993**, *115*, 347. (b) Sanz-Cervera, J. F.; Glinka, T.; Williams, R. M. *Tetrahedron* **1993**, *49*, 8471.

(11) (a) Williams, R. M.; Glinka, T.; Kwast, E. *J. Am. Chem. Soc.* **1988**, *110*, 5927. (b) Williams, R. M.; Glinka, T.; Kwast, E.; Coffman, H.; Stille, J. K. *J. Am. Chem. Soc.* **1990**, *112*, 808. (c) Williams, R. M.; Glinka, T.; Kwast, E. *Tetrahedron Lett.* **1989**, *30*, 5575.

(12) A preliminary account of this work has appeared: Cushing, T. D.; Sanz-Cervera, J. F.; Williams, R. M. *J. Am. Chem. Soc.* **1993**, *115*, 9323.

(13) (a) Birch, A. J.; Wright, J. J. *J. Chem. Soc., Chem. Commun.* **1969**, 644. (b) Birch, A. J.; Wright, J. J.; *Tetrahedron* **1970**, *26*, 2339. (c) Birch, A. J.; Russell, R. A. *Tetrahedron* **1972**, *28*, 2999. (d) Baldas J.; Birch, A. J.; Russell, R. A. *J. Chem. Soc., Perkin Trans. 1* **1974**, 50.

(14) (a) Polonsky, J.; Merrien, M. A.; Prange, T.; Pascard, C. *J. Chem. Soc., Chem Commun.* **1980**, 601. (b) Prange, T.; Billion, M.-A.; Vuilhorgne, M.; Pascard, C.; Polonsky, J. *Tetrahedron Lett.* **1981**, *22*, 1977.



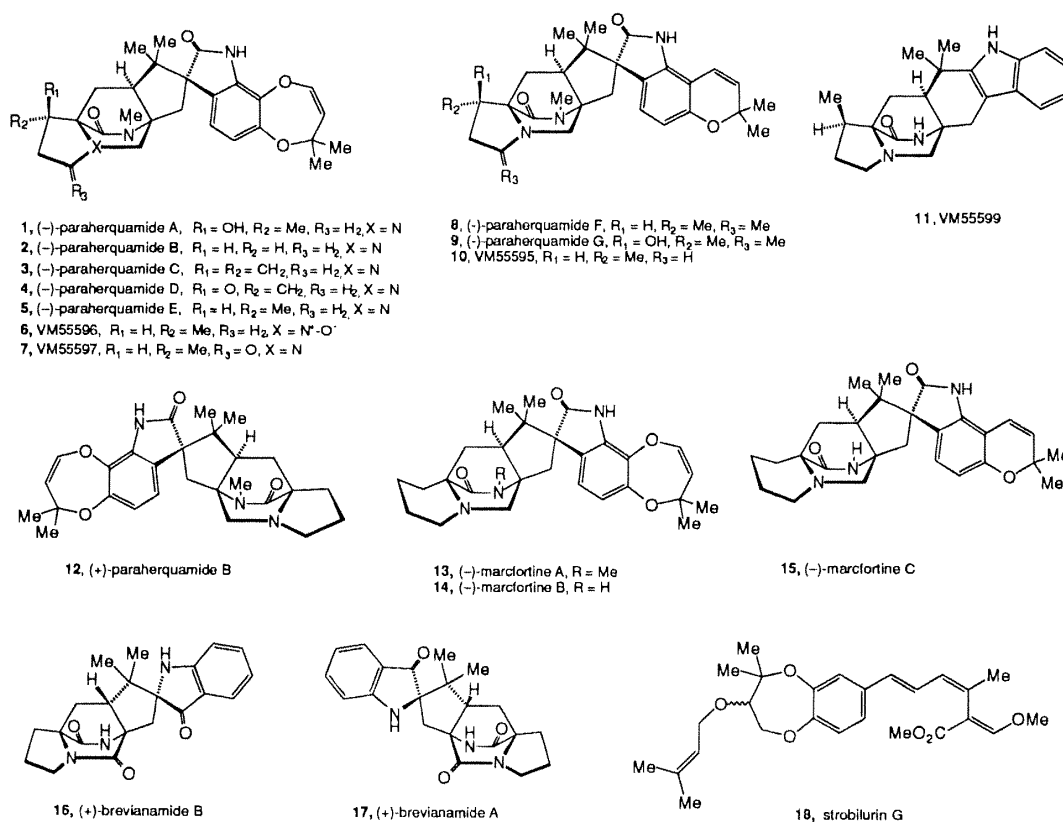


Figure 1.

or may be the result of inefficient demethylation of the isoleucine-derived amino acid precursor.

The oxidation state of the amino acid-derived dioxopiperazine moiety remains unchanged in the case of the brevianamides, but for the paraherquamides and the marcfortines the tertiary amide residue is enzymatically reduced to a monooxopiperazine, a process that is known.<sup>15</sup> The tryptophan-derived indolyl side chain of the paraherquamides and marcfortines is oxidized to spiro-oxindoles while the indolyl side chain of the brevianamides oxidize to spiro-indoxyls. The paraherquamides, marcfortines, and brevianamides all incorporate one isoprene unit that forms the bridging bicyclo[2.2.2] ring structure. The paraherquamides and marcfortines differ from the brevianamides in that a second isoprene unit coupled with an oxidized form of tryptophan gives the dioxepin (or pyran) moiety. This is one of the most interesting and unique features of these compounds. The gem-dimethyl dioxepin ring found in paraherquamides A–E (1–5) and marcfortines A and B (13 and 14) is a unique ring system among natural products. A similar structural feature was discovered in the antifungal natural product strobilurin G (18),<sup>16</sup> but this dioxepin moiety lacks the double bond found in the other metabolites (Figure 1).

As outlined in Scheme 1, a convergent synthesis of the enantiomer of paraherquamide B (12)<sup>17</sup> was envisioned to contain four key carbon–carbon bond-forming reactions. The

first task would involve the construction of a suitably  $\alpha$ -alkylated proline derivative.<sup>11</sup> The second important coupling would be the Somei/Kametani-type alkylation<sup>18</sup> of a suitably protected gramine derivative (20) and the requisite piperazine-dione (19). The third and perhaps most crucial C–C bond-forming reaction, providing the core bicyclo[2.2.2] ring system, was a stereofacially controlled intramolecular  $S_N2'$  cyclization reaction that sets the stereochemistry at C-20 (paraherquamide numbering) and concomitantly installs the isopropenyl group that will be utilized in the fourth C–C bond-forming reaction. This isopropenyl group, in turn, would be conscripted for an olefin–cation cyclization to provide the heptacyclic tetrahydrocarbazole. Standard procedures to effect this transformation involve strong protic acids,<sup>11,19</sup> and there was reason for concern about the reactivity of the more highly oxygenated indole (22) as a practical synthetic precursor to 23. The penultimate step, a regio- and stereofacially controlled oxidative spirocyclization reaction, must be accomplished to construct the desired spiro-oxindole. A number of these transformations were explored during the course of the investigations on the synthesis of (-)-brevianamide B,<sup>11</sup> including a simple oxindole model study,<sup>11c</sup> which set a firm foundation for addressing some of the

(18) (a) Somei, M.; Karasawa, Y.; Kaneko, C. *Heterocycles* **1981**, *16*, 941. (b) Kametani, T.; Kanaya, N.; Ihara, M. *J. Am. Chem. Soc.* **1980**, *102*, 3974.

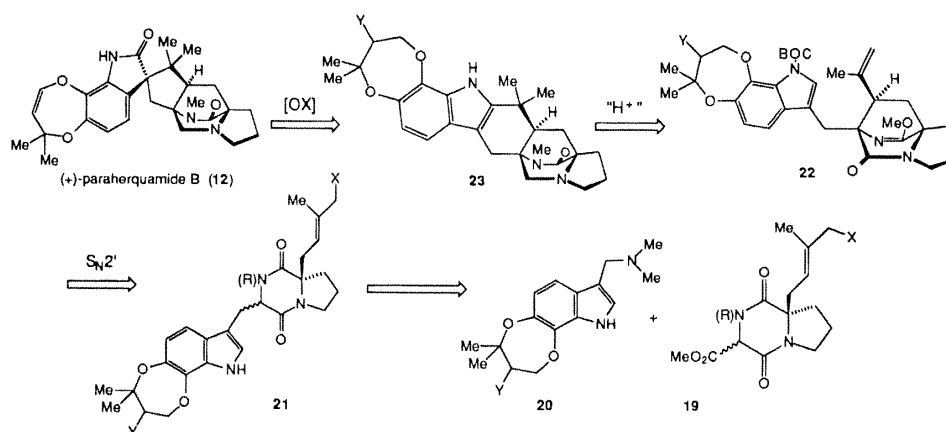
(19) (a) Stoermer, D.; Heathcock, C. H. *J. Org. Chem.* **1993**, *58*, 564. (b) Guller, R.; Dobler, M.; Borschberg, H.-J. *Helv. Chim. Acta* **1991**, *74*, 1636. (c) Darbre, T.; Nussbaumer, C.; Borschberg, H.-J. *Helv. Chim. Acta* **1984**, *67*, 1040. (d) Delpech, B.; Khuong-Huu, Q. *J. Org. Chem.* **1978**, *43*, 4898.

(15) Bond, R. F.; Boeyens, J. C. A.; Holzappel, C. V.; Steyn, P. S. *J. Chem. Soc., Perkin Trans. 1* **1979**, 1751.

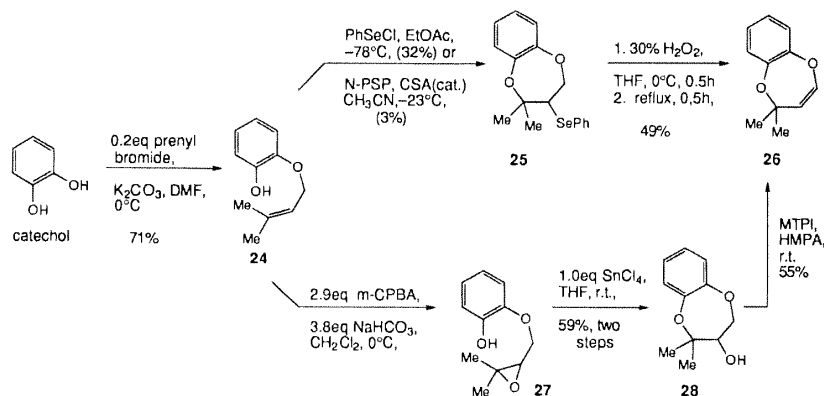
(16) Fredenhagen, A.; Hug, P.; Peter, H. H. *J. Antibiot.* **1990**, *48*, 661.

(17) The enantiomer of the natural product was selected as the target due to the large relative cost difference between (*S*)- and (*R*)-proline.

Scheme 1



Scheme 2



stereochemical and regiochemical issues that would be faced in attacking the paraherquamide ring system.

## Results and Discussion

**Construction of the Dioxepinooxindole Ring System.** The prenylated catechol ring system of the paraherquamides is an unusual oxidative cyclization product that previously has not been observed to occur in metabolites of mixed biogenetic origin. Although the parent 2*H*-1,5-benzodioxepin has been synthesized previously,<sup>20</sup> to the best of our knowledge there has been no reported synthesis of the corresponding isoprenyl dioxepin ring system of paraherquamide. The synthesis of this ring system was explored in a simple model study employing prenylated catechol **24** (Scheme 2).<sup>21</sup> It was speculated that the requisite 7-*endo-tet* cyclization reaction would be facilitated by a stabilized tertiary carbocation provided by the prenyl substituent.

The first attempt at effecting this cyclization reaction

(20) Guillaumet, G.; Coudert, G.; Loubinoux, B. *Angew. Chem., Int. Ed. Engl.* **1983**, *22*, 64.



2*H*-1,5-benzodioxepin

(21) Williams, R. M.; Cushing, T. D. *Tetrahedron Lett.* **1990**, *31*, 6325.

employed a phenylselenoetherification.<sup>22</sup> Following a procedure of Clive,<sup>23</sup> **24** cyclized to **25** with either PhSeCl or *N*-phenylselenophthalimide (N-PSP),<sup>24</sup> although in very low yield. The main byproducts came from the electrophilic addition across the double bond, electrophilic aromatic substitution of the phenyl ring by the phenyl selenide, and phenolic attack at the methylene producing the six-membered-ring product. The selenide **25** was treated with H<sub>2</sub>O<sub>2</sub> and the resulting selenoxide thermally eliminated providing the unique dioxepin **26** in 49% yield.

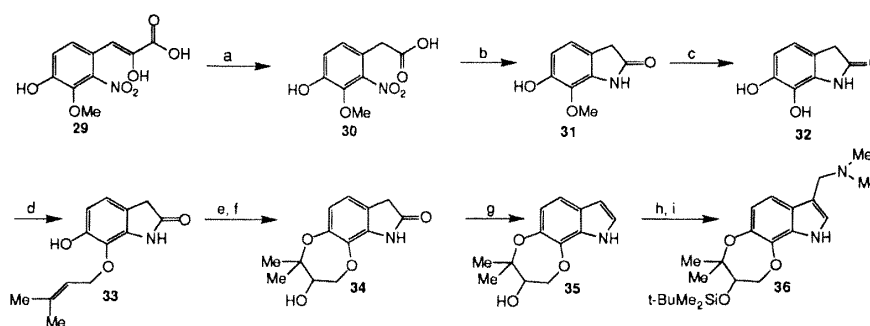
Due to the low yield of the phenylselenoetherification, an alternative procedure involving epoxidation followed by a Lewis acid-mediated ring closure was investigated.<sup>25</sup> The prenylated catechol **24** was epoxidized with buffered *m*-CPBA to provide epoxide **27**, which was treated with stannic chloride to give the dioxepin **28**. A major side product in this reaction was a ketone,

(22) (a) Nicolaou, K. C. *Tetrahedron* **1981**, *37*, 4097. (b) Nicolaou, K. C.; Magolda, R. L.; Sipio, W. J.; Barnette, W. E.; Lysenko, Z.; Joullie, M. M. *J. Am. Chem. Soc.* **1980**, *102*, 3784. (c) Clive, D. L. *J. Tetrahedron* **1978**, *34*, 1049–1132.

(23) (a) Clive, D. J. L.; Chiiattu, G.; Curtis, N. J.; Kiel, W. A.; Wong, C. K. *J. Chem. Soc., Chem. Commun.* **1977**, 725. See also: (b) Liotta, D.; Zima, G. *Tetrahedron Lett.* **1978**, *50*, 4977. (c) Tiecco, M.; Testaferri, L.; Tingoli, M.; Bartoli, D.; Balducci, R. *J. Org. Chem.* **1990**, *55*, 429.

(24) Nicolaou, K. C.; Claremon, D. A.; Barnette, W. E.; Seitz, S. P. *J. Am. Chem. Soc.* **1979**, *101*, 3704.

(25) (a) Cookson, R. C.; Liverton, N. J. *J. Chem. Soc., Perkin Trans. 1* **1985**, 1589. (b) Kocienski, P.; Love, C.; Whitby, R.; Roberts, D. A. *Tetrahedron Lett.* **1988**, *29*, 2867. See also: (c) Nicolaou, K. C.; Prasad, C. V. C.; Somers, P. K.; Hwang, C.-K. *J. Am. Chem. Soc.* **1989**, *111*, 5335.

Scheme 3<sup>a</sup>

<sup>a</sup> Reagents and conditions: (a) 4.0 equiv of NaOH, 1.0 equiv of 30% H<sub>2</sub>O<sub>2</sub>, 81–93%; (b) H<sub>2</sub>, Pd/C, AcOH, 92%; (c) 2.5 equiv of BBr<sub>3</sub>, CH<sub>2</sub>Cl<sub>2</sub>, –78 °C, 99%; (d) 1.2 equiv of prenyl bromide, 1.1 equiv of K<sub>2</sub>CO<sub>3</sub>, DMF, 0 °C to room temperature, 52%; (e) *m*-CPBA, NaHCO<sub>3</sub>, CH<sub>2</sub>Cl<sub>2</sub>; (f) 1.2 equiv of SnCl<sub>4</sub>, THF, 64%; (g) 1.6 equiv of NaBH<sub>4</sub>, 3.5 equiv of BF<sub>3</sub>·OEt<sub>2</sub>, THF, 44–50%; (h) *t*-BuMe<sub>2</sub>SiCl, im, DMF, 40 °C, 83%; (i) CH<sub>2</sub>O, HNMe<sub>2</sub>, AcOH, H<sub>2</sub>O, 99%.

resulting from a 1,2 hydride shift.<sup>26</sup> A number of methods were explored to effect the dehydration of the secondary alcohol of dioxepin **28**; the best result was realized with methyltriphenoxyphosphonium iodide (MTPI) in HMPA to provide **26**.<sup>27</sup>

With a proven method accessible for the construction of the dioxepin ring system, attention was focused on constructing the requisite gramine derivative. Oxygenated indoles are notoriously unstable and undergo facile autoxidation,<sup>28</sup> photooxidation,<sup>29</sup> dimerization, and polymerization.<sup>30</sup> In light of this problematic reactivity, our plan called for formation of the dioxepin ring system prior to indole (gramine) formation. The approach employed involved the formation of a suitably substituted oxindole (essentially a protected indole), followed by the construction of the dioxepin and final elaboration into the gramine derivative.

The known pyruvic acid **29** (Scheme 3)<sup>31</sup> (prepared in five steps from vanillin) was oxidatively decarboxylated<sup>32</sup> to afford the phenylacetic acid **30**, which was reductively cyclized to give the required oxindole **31**<sup>33</sup> in nearly quantitative yield.

At this point, a method was needed to differentiate between the two phenolic substituents for the prenylation reaction. A number of attempted selective protecting group strategies were

explored, but nothing satisfactory was found; it was thus decided to forgo any protecting group for the 6-hydroxy position. Oxindole **31** was cleanly demethylated upon treatment with (clear) boron tribromide. The resulting oxindole **32** was subjected to the prenylation conditions, and the desired alkylated product **33** was obtained in 52% yield.<sup>34,35</sup> Both of the methods discussed above for the formation of the seven-membered ring were examined. The phenylselenoetherification procedure failed on this substrate, and only products resulting from electrophilic aromatic substitution were formed.

The alternative epoxidation/Lewis acid-mediated cyclization again proved to be successful on this substrate. The epoxidation reaction (*m*-CPBA) had to be buffered with NaHCO<sub>3</sub> to prevent the formation of the six-membered-ring tertiary alcohol. In most cases, the reaction was worked up and taken on to the next step without purification (the labile epoxide tended to cyclize to the six-membered tertiary alcohol upon contact with silica gel). The incipient epoxide product was directly treated with SnCl<sub>4</sub> in THF to provide the desired seven-membered-ring alcohol **34** (64% overall yield from **33**).

*N*-Alkylated oxindoles have been reported to be reduced to indoles by the use of DIBAL or LiAlH<sub>4</sub>;<sup>36</sup> however, in the case of unsubstituted oxindoles, this reduction either fails or requires

(26) For a related observation, see: Taylor, S. T.; Davisson, M. E.; Hissom, B. R., Jr.; Brown, S. J.; Pristach, H. A.; Schramm, S. B.; Harvey, S. M. *J. Org. Chem.* **1987**, *52*, 425.

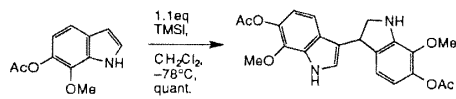
(27) Hutchins, R. O.; Hutchins, M. G.; Milewski, C. A. *J. Org. Chem.* **1972**, *37*, 4191.

(28) Houlihan, W. J.; Remers, W. A.; Brown, R. K. *Indoles, Part one, The Chemistry of Heterocycles*; John Wiley & Sons, Inc.: New York, 1972.

(29) (a) Chan, A. C.; Hilliard, P. R., Jr. *Tetrahedron Lett.* **1989**, *30*, 6483.

(b) d'Ischia, M.; Prota, G. *Tetrahedron* **1987**, *43*, 431.

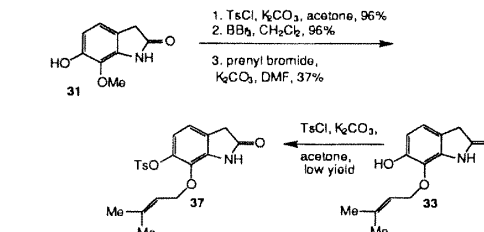
(30) This difficulty was observed in a short synthesis of the known 6-acetoxy-7-methoxyindole (**1**). The unstable substance **1** was treated with TMSI, producing the dimer **11** as the sole product.



See: (a) Walker, G. N. *J. Am. Chem. Soc.* **1955**, *77*, 3844. (b) Burton, H.; Duffield, J. A.; Prail, P. F. G. *J. Chem. Soc.* **1950**, 1062. (c) Beer, R. J. S.; Megrath, L.; Robertson, A.; Woodier, A. B. *J. Chem. Soc.* **1949**, 2061. (d) Beer, R. J. S.; Clarke, K.; Khorana, H. G.; Robertson, A. *J. Chem. Soc.* **1948**, 2223. (e) Chan, A. C.; Hilliard, P. R., Jr. *Tetrahedron Lett.* **1989**, *30*, 6483. (f) d'Ischia, M.; Prota, G. *Tetrahedron* **1987**, *43*, 431. (g) Deibel, R. M. B.; Chedelkel, M. R. *J. Am. Chem. Soc.* **1984**, *106*, 5884. (h) Hencock, R. A. *Chem. Rev.* **1959**, *59*, 181.

(31) (a) Beer, R. J. S.; Clarke, K.; Davenport, H. F.; Robertson, A. *J. Chem. Soc.* **1951**, 2029. (b) Bennington, F.; Morin, R. D.; Clark, L. C., Jr. *J. Org. Chem.* **1959**, *24*, 917.

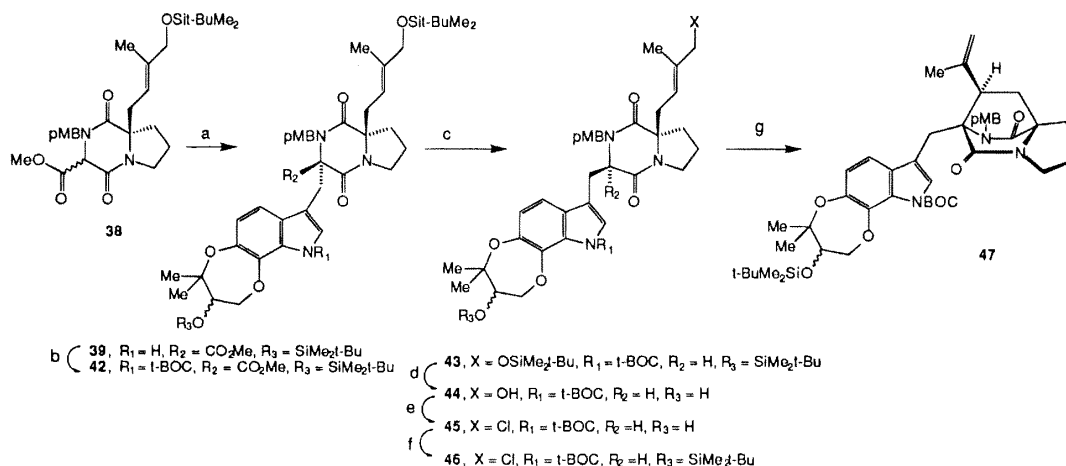
(32) Kosuge, T.; Ishida, H.; Inabe, A.; Nukaya, H. *Chem. Pharm. Bull.* **1985**, *33*, 1414.



(36) (a) Kishi, Y.; Nakatsuka, S.; Fukuyama, T.; Havel, M. *J. Am. Chem. Soc.* **1973**, *95*, 6494. (b) Robinson, B. *Chem. Rev.* **1969**, *69*, 785.

P. 4

UT Ex. 2027  
SteadyMed v. United Therapeutics  
IPR2016-00006

Scheme 4<sup>a</sup>

<sup>a</sup> Reagents and conditions: (a) 36, 0.5 equiv of  $\text{PBu}_3$ , MeCN, 51%; (b) DMAP,  $\text{Et}_3\text{N}$ ,  $\text{BOC}_2\text{O}$ ,  $\text{CH}_2\text{Cl}_2$ , 90%; (c) 5 equiv of LiCl, 1.5 equiv of  $\text{H}_2\text{O}$ , HMPA, 100 °C, 66%; (d) 3.0 equiv of *n*- $\text{Bu}_4\text{NF}$ , THF, 79%; (e) 1.9 equiv of LiCl, 4.0 equiv of collidine, 4.0 equiv of MsCl, DMF, 86%; (f) *t*- $\text{BuMe}_2\text{SiOTf}$ , 2,6-lutidine,  $\text{CH}_2\text{Cl}_2$ , 76%; (g) 10 equiv of NaH, benzene, 11%.

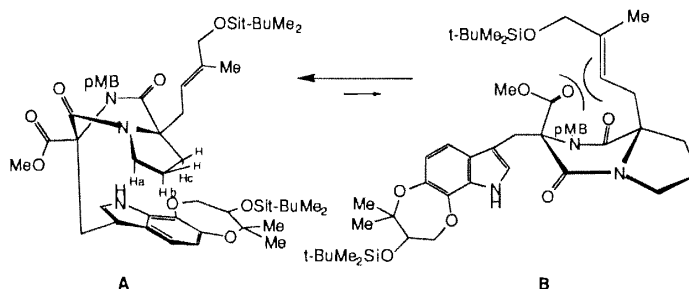


Figure 2.

more vigorous conditions. In 1972 it was reported<sup>37</sup> that substituted and unsubstituted oxindoles could be reduced to the corresponding indole in high yields with borane in THF at 0 °C. Oxindole **34** was subjected to these conditions (1.0 M  $\text{BH}_3/\text{THF}$ , Aldrich), but with no reaction. However, when oxindole **34** was treated with 1.6 equiv of  $\text{NaBH}_4$  and 3.5 equiv of  $\text{BF}_3\cdot\text{OEt}_2$  in THF for 1 day (0 °C to room temperature), the desired indole **35** was obtained in 43–50% yield. The indole **35** was treated with a warm solution of TBDMSCl and imidazole in DMF, to provide the required O-silylated indole, which was easily converted to the gramine **36** through the well-known Mannich procedure (Scheme 3).

**Construction of the Bicyclo[2.2.2] Ring System.** To probe the stability of the dioxepin–indole in subsequent transformations, a model study involving the previously synthesized racemic piperazinedione **38**<sup>38</sup> was investigated (Scheme 4). Indole **36** was condensed with the piperazinedione **38** following the Somei/Kametani conditions<sup>18</sup> to give the desired *syn* product **39** (a racemic mixture of two diastereomers) in 51% yield. The relative stereochemistry of this substance was evident by an examination of the <sup>1</sup>H NMR spectrum. There is a large upfield shift of the proline ring protons of **39** ( $\delta$  Ha, Hb, Hc; 0.03–0.19 (m), 0.43–0.52 (m), 0.62–0.72 (m) ppm). It is well-known that N-alkylated piperazinediones prefer to adopt a boat-like conformation due to the planar geometry of the amides and A-1,3 steric interactions of *N*-alkyl residues. This forces the

substituents on the amino acid  $\alpha$ -carbons to adopt either pseudoaxial or pseudoequatorial dispositions. In conformer **B** (Figure 2) the carbomethoxy group is sterically congested by the bulky isopentenyl group, favoring the alternate boat conformer (**A**), which positions the indole ring under the piperazinedione, positioning the two pyrrolidine protons Ha and Hb directly over the shielding cone of the aromatic indole ring system; the corresponding *anti*-isomer cannot adopt this type of conformation. Furthermore, a consideration of the mechanism of the Somei/Kametani reaction<sup>18</sup> supports the expectation that the *syn*-isomer (**39**) should be the major product. The gramine derivative (**36**) reacts with tributylphosphine to form a bulky (tributylphosphino)indole intermediate that can only approach from the less congested face of the piperazinedione enolate, away from the isopentenyl moiety.

A similar phenomenon was observed when **39** was subjected to the decarbomethoxylation procedure (LiCl,  $\text{H}_2\text{O}$ , HMPA) directly. The two main products isolated were the *syn*-isomer **40** and the *anti*-isomer **41**, in a ratio of 3.3:1.0 (Figure 3). These stereochemical assignments were made by comparing the <sup>1</sup>H NMR spectral data of **40** and **41**. There was a pronounced upfield shift of three pyrrolidine ring protons in compound **41**, a shift that is not observed for diastereomer **40**.

Piperazinedione **39** was first converted to the BOC-protected indole **42**, which was subsequently subjected to a decarbomethoxylation reaction supplying the *syn*-diastereomer **43** as

(37) Sirowej, H.; Khan, S. A.; Plieninger, H. *Synthesis* 1972, 84.(38) Williams, R. M.; Glinka, T. *Tetrahedron Lett.* 1986, 27, 3581.

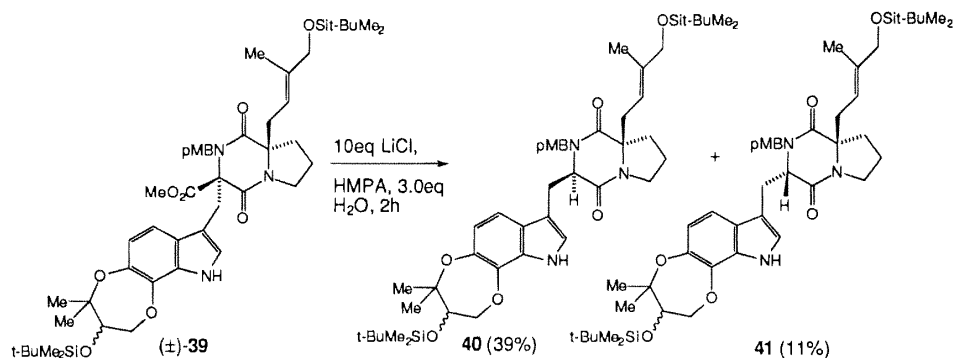
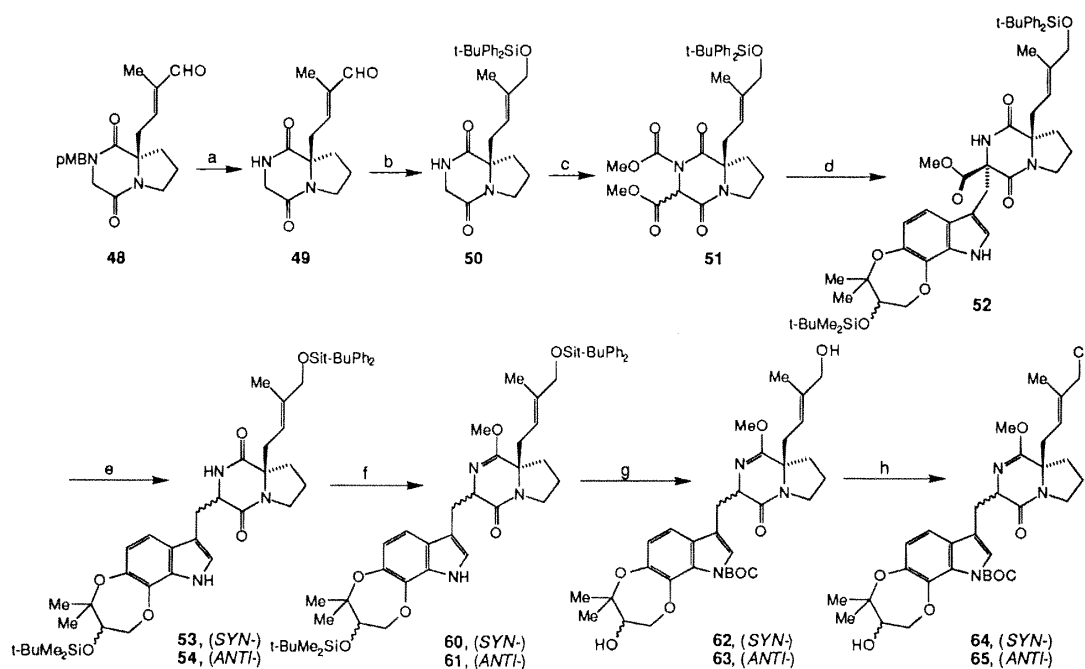


Figure 3.

Scheme 5<sup>a</sup>

<sup>a</sup> Reagents and conditions: (a) 3.8 equiv of CAN (0.33 M), 2:1 CH<sub>3</sub>CN/H<sub>2</sub>O, 2 h, 79%; (b) (i) 2 equiv of NaBH<sub>4</sub>, EtOH; (ii) *t*-BuPh<sub>2</sub>SiCl, im, DMF, 75%; (c) (i) 1.0 equiv of *n*-BuLi, 1.1 equiv of MeOCOCl, -78 °C; (ii) 2.2 equiv of LiN(SiMe<sub>3</sub>)<sub>2</sub>, 1.1 equiv of MeOCOCl, THF, -100 °C, 93%; (d) 36, 0.5 equiv of PBu<sub>3</sub>, CH<sub>3</sub>CN, reflux, 73%; (e) LiCl, HMPA, 100 °C (*syn/anti* 3:1), 89%; (f) Me<sub>3</sub>OBF<sub>4</sub>, Na<sub>2</sub>CO<sub>3</sub>, CH<sub>2</sub>Cl<sub>2</sub> (*syn*, 81%; *anti*, 62–71%); (g) (i) BOC<sub>2</sub>O, DMAP, Et<sub>3</sub>N, CH<sub>2</sub>Cl<sub>2</sub>; (ii) *n*-Bu<sub>4</sub>NF, THF (*syn*, 90%; *anti*, 85%); (h) NCS, Me<sub>2</sub>S (*syn*, 74–81%; *anti*, 86%).

the major product. Compound **43** (the minor, *anti*-diastereomer was not utilized) was desilylated to provide the diol **44**, which was converted to the allylic chloride **45**. Careful treatment of **45** with *t*-BuMe<sub>2</sub>SiOTf, to prevent transesterification of the BOC groups,<sup>39</sup> gave the desired product **46** in 76% yield. Allylic chloride **46** was subjected to 10 equiv of NaH in refluxing benzene, but the reaction proved extremely sluggish. After 5 days, the desired product **47** was obtained in a poor 11% yield (19% based on recovered **46**; accompanied by extensive decomposition). The *syn*-isomer **47** was the only stereoisomer formed in this reaction; the corresponding *anti*-isomer was not detected. While this reaction demonstrated the potential viability of the stereoselective intramolecular S<sub>N</sub>2' reaction, work on the racemic model system was halted, due to the low yield in this

key transformation coupled with perceived difficulties associated with removing the *N*-*p*-methoxybenzyl group.

**Total Synthesis of (+)-Paraherquamide B.** Starting from the known piperazinedione **48** (prepared in eight steps from (S)-proline),<sup>11</sup> the enal **49** was obtained in 79% yield by treatment of **48** with a 0.33 M solution of ceric ammonium nitrate (Scheme 5).<sup>40</sup> The resulting product (**49**) was reduced with NaBH<sub>4</sub> and protected with *t*-BuPh<sub>2</sub>SiCl in a two-step process to give the silyl ether **50** in 75% yield. Compound **50** was then subjected to a two-step, one-pot acylation providing the required substrate **51** in 93% yield. The crude material was a mixture of epimers in a ratio of approximately 4:1 (*syn/anti*). Interestingly this mixture had a tendency to epimerize during column chroma-

(39) Sakaitani, M.; Ohfun, Y. *J. Am. Chem. Soc.* 1990, 112, 1150.

(40) Yoshimura, J.; Yamaura, M.; Suzuki, T.; Hashimoto, H. *Chem. Lett.* 1983, 1001.

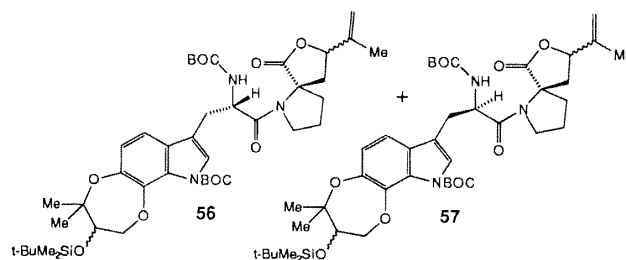
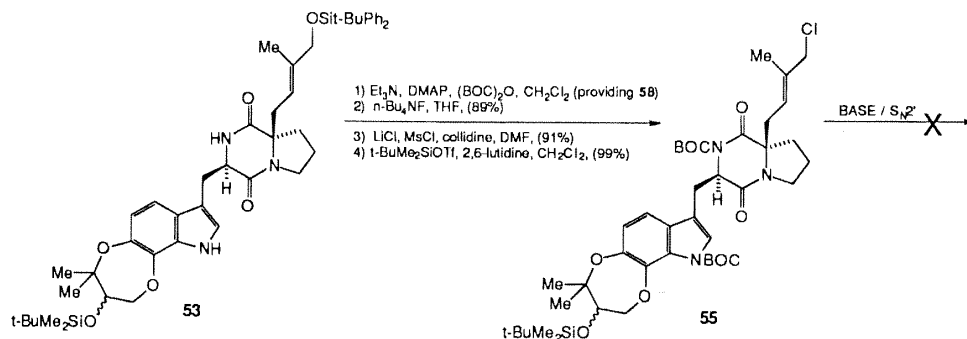


Figure 4.

Scheme 6



tography, resulting in an increase in the proportion of the *syn*-isomer. The two products were combined and condensed with the gramine **36** providing the indole **52** in 73% yield as a mixture of two diastereomers (epimeric at the secondary alcohol stereogenic center). Interestingly, the imidic carbamate group was also cleaved in the course of this reaction. Compound **52** was subjected to the decarbomethoxylation procedure, affording a 3:1 mixture of **53** (*syn*) and **54** (*anti*) in 89% combined yield.

The lactam **53** could be converted to the *N*-BOC-protected allylic chloride **55** in four steps and in good overall yield (Scheme 6), but numerous attempts to effect the  $S_N2'$  reaction on this substrate failed. These reactions were capricious and were accompanied by the occasional appearance of the spiro-lactones **56** and **57**, formed in low yield <5% (Figure 4). It seems likely that the failure of **55** to cyclize in the desired fashion can be attributed to nonbonding interactions between the *tert*-butoxycarbonyl group and the pendant dioxepin indole.<sup>41,42</sup>

These observations dictated that a suitable amide protecting group would have to be selected that was less electron withdrawing and less sterically demanding than both the *tert*-butoxycarbonyl and the *p*-methoxybenzyl groups. The loss of the lactam methoxycarbonyl group in the alkylation of **51** with the gramine **36** was presumably due to  $N \rightarrow N$  acyl transfer to dimethylamine, a byproduct of the Somei/Kametani reaction. This appears to be a general reaction that was used to selectively deprotect the *N*-*tert*-butoxycarbonyl group of **58** without deblocking the *N*-*tert*-BOC-protected indole. Thus, refluxing a

solution of **58** and  $Me_2NH$  in  $CH_3CN$  furnished compound **59** in 92% yield<sup>43</sup> (Scheme 7).

The strategy planned for the reduction of the tertiary amide called for the protection of the secondary lactam as a lactim ether,<sup>44</sup> and this group seemed suitable for use earlier in the synthesis and appeared compatible with the  $S_N2'$  cyclization. Thus, *syn*-isomer **53** was treated with 20 equiv (optimum) of  $Na_2CO_3$  and 5 equiv of  $Me_3OBF_4$  in dichloromethane for 4 h, to yield 81% of compound **60**. Even though the next two reactions could be carried out in a stepwise fashion, it proved most convenient to convert **60** directly to the protected diol **62** in a one-pot, two-step sequence. Diol **62** was then subjected to the chlorination procedure successfully used in the conversion of diol **44** to the allylic chloride **45**. Unfortunately, under these conditions, the reaction failed and the lactim ether was cleanly deblocked back to the lactam. This problem was finally solved by following the procedure of Corey,<sup>45</sup> which called for the addition of compound **62** to a mixture of *N*-chlorosuccinimide and dimethyl sulfide, which yielded the chloride **64** in 81% yield.

Allylic chloride **64** was reprotected with *t*-BuPh<sub>2</sub>SiOTf to provide **66** in 77–82% yield. The stage was now set to effect the  $S_N2'$  reaction. Compound **66** was refluxed in benzene with 20 equiv of sodium hydride, resulting in a very clean and high-yielding cyclization reaction furnishing the desired product **68** in 93% yield (Scheme 8).

(43) This result is noteworthy, especially in light of a report that *tert*-butoxycarbonyl-protected amides are cleaved to the *tert*-butoxycarbonyl-protected amines with DEAEA (2-(*N,N*-diethylamino)ethylamine) in  $CH_3CN$  at room temperature; see: Grehn, L.; Gummarsson, K.; Ragnarsson, U. *Acta Chem. Scand. B* **1987**, *41*, 18. However, the substrates examined in that report were all open-chain amides. Interestingly it is known that BOC-protected lactams can be cleaved by base but it is the amide bond that is broken as was observed on substrate **55**. Recently it has been reported that  $Mg(OMe)_2$  will also cleave lactam carbamates including BOC-protected lactams; see: Wei, Z.-Y.; Knaus, E. E.; *Tetrahedron Lett.* **1994**, *35*, 847.

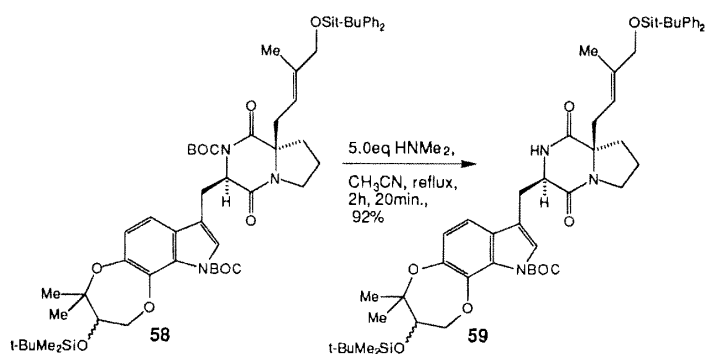
(44) Williams, R. M.; Brunner, E. J.; Sabol, M. R. *Synthesis* **1988**, 963.

(45) Corey, E. J.; Kim, C. U.; Takeda, M. *Tetrahedron Lett.* **1972**, *13*, 4339.

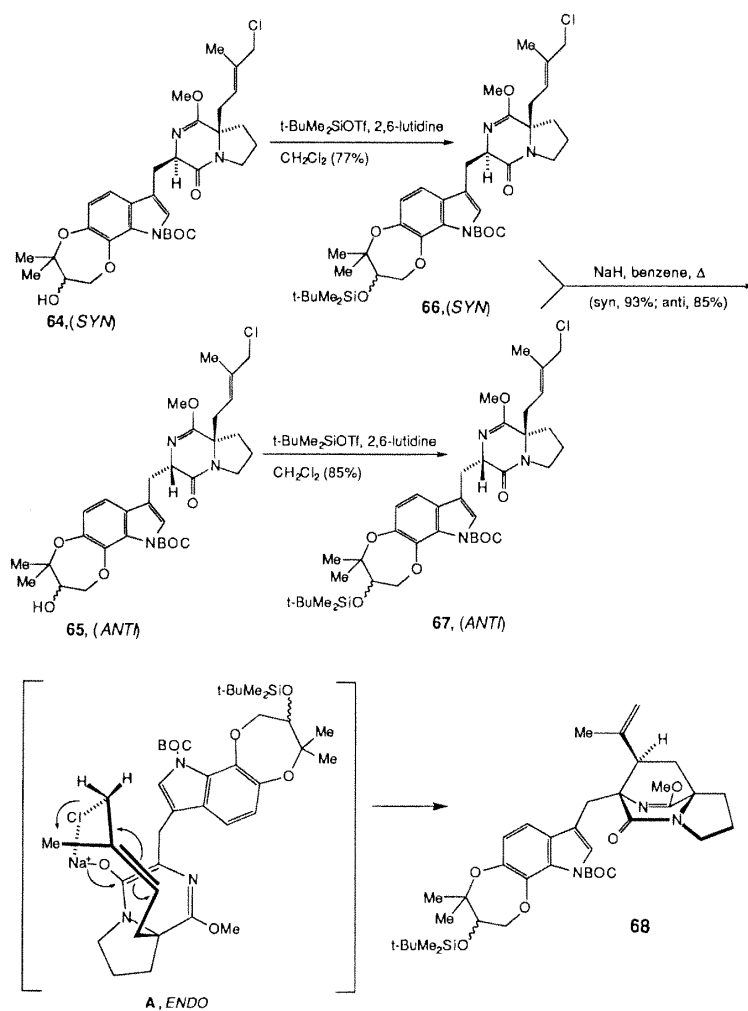
(41) The formation of the two spiro compounds **56** and **57** is presumably due to the increased electrophilicity of the *N*-acylated amide. Apparently, trace moisture in the reaction mixture caused the production of hydroxide, which then hydrolyzed the reactive amide bond. The resulting carboxylic acid cyclized in an  $S_N2'$  fashion, furnishing the spiro lactones.

(42) (a) Giovannini, A.; Savoia, D.; Umani-Ronchi, A. *J. Org. Chem.* **1989**, *54*, 228. (b) Flynn, D. L.; Zelle, R. E.; Grieco, P. A. *J. Org. Chem.* **1983**, *48*, 2424.

## Scheme 7



## Scheme 8



This last series of reactions was also carried out in parallel on the *anti*-isomer **54**. Following the same sequence (five steps) we obtained the fully protected chloride **67** in good yield. The chloride **67** was then refluxed in benzene with the required amount of sodium hydride to yield the same product (**68**, 85%

yield) as that obtained from **66**. The yields of **68** from both routes were very high, and the undesired *anti*-diastereomer was not detected. The high degree of facial selectivity observed in the cyclizations to **68** and **47** is quite interesting and warrants some comments. It is generally accepted that  $\text{S}_{\text{N}}2'$  reactions

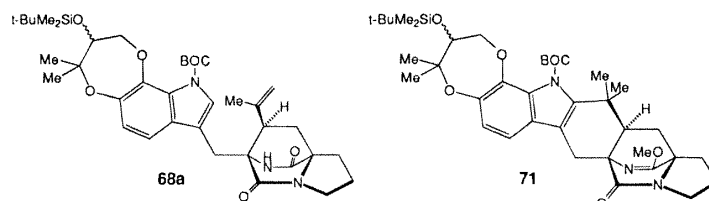


Figure 5.

favor a *syn* orientation<sup>46</sup> (i.e., the incoming nucleophile attacks the  $\pi$ -electrons from the same face as the departing leaving group, polarizing the  $\pi$ -system in the proper orientation for a “backside” displacement on the C–Cl bond). Alternatively, a frontier molecular orbital analysis has indicated<sup>46a</sup> that the stabilization imparted by a HOMO<sub>Nuc</sub>–LUMO<sub>allylic</sub> interaction is greater for the *syn* overlap. While the greatest level of diastereoselectivity was observed with a nonpolar aprotic solvent (benzene), a fairly significant change in the relative amounts of the *syn*- and *anti*-diastereomers can be realized by simply changing the solvent to a more polar solvent such as DMF.<sup>11</sup> In the present system, additional stabilization for the *endo* transition state may be due to the formation of a tight contact ion pair between the chlorine atom and sodium atom of the enolate species (see A, Scheme 8) in the transition state for the formation of the C–C bond.<sup>47</sup> The poor ligating solvent benzene is not capable of effectively solvating the enolate cation nor the developing chloride anion in the transition state. It is reasonable that this type of association favors the rotamer that positions the allylic chloride moiety over the enolate, resulting in the desired *syn* stereochemistry.

With the bicyclo[2.2.2] ring system constructed in a reliable and high-yielding sequence, attention was turned to the final C–C bond-forming reaction on the indole. Due to the strongly acidic conditions that were used previously for a related cyclization reaction in the brevianamide synthesis, it was assumed that the silyl ether, the *tert*-butoxycarbonyl protecting group, and the lactim ether would be removed during this cyclization reaction. Subjecting compound **68** to the standard conditions (dilute, aqueous HCl in dioxane at 10 °C)<sup>11,19,48</sup> resulted in extensive decomposition, and none of the desired cyclized product was ever detected. The reaction conditions were extensively varied using different acids and temperatures, but the only recognizable products were those stemming from the loss of protecting groups. The problem might be attributed to the enhanced basicity of the indole at the 2-position (indole numbering) caused by the electron-donating oxygen atoms in the aromatic ring. If protonation at the 2-position is kinetically competitive with olefin protonation, cyclization would be precluded.

A search of the literature revealed a 1982 Trost and Fortunak paper<sup>49</sup> wherein PdCl<sub>2</sub> and AgBF<sub>4</sub> were utilized to effect the

Heck-type cyclialkylations of various isoquinuclidine model compounds. Compound **68** was exposed to these conditions, affording the heptacycle **69** in 63–82% yields. During the course of the reaction, the lactim ether moiety was cleaved, restoring the free, secondary amide.<sup>50</sup> The main byproduct of this reaction was the uncyclized free lactam **68a** (Figure 5), which curiously did not cyclize to **69** when subjected to the same conditions. It was also observed that the lactim ether protected heptacycle **71** could not be deblocked to the free lactam **69** with PdCl<sub>2</sub> and AgBF<sub>4</sub> alone, implying that the cleavage of the lactim ether is due to the tetrafluoroboric acid produced in the cyclization, and that the cyclization occurs *prior* to lactim ether cleavage.

Trost and Fortunak speculated<sup>49</sup> that the cyclization mechanism was either a Heck-type arylation or the electrophilic aromatic substitution of a palladium-complexed olefin, and there was evidence to support both mechanistic possibilities. It is possible that the palladium chloride and the silver tetrafluoroborate react to form a powerful Lewis acid, since an incubation period involving these two reagents is needed prior to the introduction of the substrate. It was reported<sup>49</sup> that there is no reaction with other mixed-metal systems involving palladium chloride (e.g., boron trifluoride, aluminum chloride, stannous chloride, stannic chloride, titanium trichloride). The enhanced basicity (nucleophilicity) at the 2-position of indole **68** renders this substance perfectly disposed to undergo a Heck-type arylation reaction.

There are several reports of methods that will selectively reduce a tertiary amide in the presence of a secondary amide.<sup>51</sup> The secondary lactam of **69** was protected as the lactim ether **71** and treated with diborane; however, the spectral characteristics of the major products isolated were consistent with reduction of both the tertiary amide and the lactim ether. In 1991 Martin *et al.*<sup>52</sup> successfully used alane to reduce a tertiary amide in the presence of an oxindole (secondary amide) relying on the known rate difference for reduction between these two groups.<sup>53</sup> However, initial experiments with this reagent gave poor results, with the secondary amide undergoing reduction along with the tertiary amide. Compound **69** (and **71**) is sufficiently twisted such that the *gem*-dimethyl groups effectively block the  $\beta$ -face of the tertiary amide (Figure 6),

(46) (a) Magid, R. M.; Fruchey, O. S.; Johnson, W. L.; Allen, T. G. *J. Org. Chem.* **1979**, *44*, 359. (b) Magid, R. A. *Tetrahedron* **1980**, *36*, 1901.

(47) The idea that the stereochemical outcome of an intramolecular enolate alkylation is determined by chelation in the transition state was recently demonstrated by Denmark and Henke, who observed a marked preference for a “closed” transition state (coordination of the cationic counterion to an enolate and the developing alcohol) resulting in a *syn* product. For example, the highest *syn:anti* ratio (89:11) was obtained in toluene and the lowest *syn:anti* ratio (2:98) was obtained with a crown ether. These observations parallel the facial selectivities described herein and in ref 11 on the intramolecular S<sub>N</sub>2' reaction; see: (a) Denmark, S. A.; Henke, B. R. *J. Am. Chem. Soc.* **1991**, *113*, 2177. (b) Denmark, S. A.; Henke, B. R. *J. Am. Chem. Soc.* **1989**, *111*, 8022.

(48) (a) Hutchison, A. J.; Kishi, Y. *J. Am. Chem. Soc.* **1979**, *101*, 6786. (b) Guller, R.; Borschberg, H.-J. *Tetrahedron Lett* **1994**, *35*, 865.

(49) Trost, B. M.; Fortunak, J. M. D. *Organometallics* **1982**, *1*, 7.

(50) (a) Ashimori, A.; Overman, L. E. *J. Org. Chem.* **1992**, *57*, 4571. (b) Karabelas, K.; Westerlund, C.; Hallberg, A. *J. Org. Chem.* **1985**, *50*, 3896. (c) Cava, M. P.; Kevinson, M. I. *Tetrahedron* **1985**, *41*, 5061 and literature cited therein.

(51) In a recently reported synthesis of gelsemine, a tertiary lactam was reduced in the presence of a secondary lactam with DIBALH. However, this reagent failed on substrates **69**; see: Dutton, J. K.; Steel, R. W.; Tasker, A. S.; Popsavin, V.; Johnson, A. P. *J. Chem. Soc., Chem. Commun.* **1994**, 765.

(52) Martin, S. F.; Benage, B.; Geraci, L. S.; Hunter, J. E.; Mortimore, M. *J. Am. Chem. Soc.* **1991**, *113*, 6161.

(53) (a) Yoon, N. M.; Brown, H. C. *J. Am. Chem. Soc.* **1968**, *90*, 2927. (b) Marlett, E. M.; Park, W. S.; *J. Org. Chem.* **1990**, *55*, 2968. (c) Jorgenson, M. J. *Tetrahedron Lett.* **1962**, 559. (d) Another very recent synthesis of gelsemine reported the reduction of the same gelsemine precursor (as in ref 51) with AlH<sub>3</sub>; Newcombe, N. J.; Fang, Y.; Vijn, R. J.; Hiemstra, H.; Speckamp, W. N. *J. Chem. Soc., Chem. Commun.* **1994**, 767.



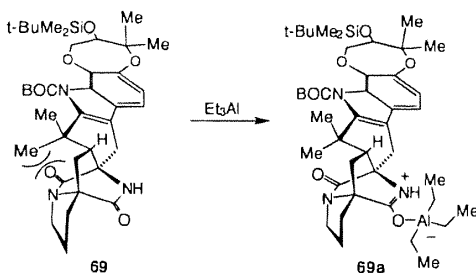


Figure 6.

leaving the  $\alpha$ -face relatively unencumbered. However, a modification of the alane procedure<sup>52</sup> proved satisfactory for this transformation. The piperazinedione **69** was pretreated with  $\text{AlEt}_3$ , with the expectation that this Lewis acid would form a complex with the more exposed secondary lactam (**69a**, Figure 6) and leave the tertiary lactam accessible for reduction.

Following 10 min of precomplexation with  $\text{AlEt}_3$ , 5 equiv of  $\text{AlH}_3\text{-Me}_2\text{NEt}$  complex was added, followed by quenching with  $\text{NaCNBH}_3$ , acetic acid, and methanol to provide the desired amine **70** in 63% yield. Compound **70** was smoothly alkylated with methyl iodide, affording the *N*-methylated product **72** in 95–98% yield. Compound **72** was subsequently deblocked with 80 equiv of TFA in  $\text{CH}_2\text{Cl}_2$  to yield the penultimate heptacycle **73** in 97% (Scheme 9).

The stage was now set for the final transformations involving the oxidative pinacol-type rearrangement and dehydration. Due to the difficulties encountered in the attempted cationic cyclization on the indole (cf. **68**  $\rightarrow$  **69**), there was concern about the reactivity of the indole ring toward the electrophilic reagents that would be utilized in the oxidative pinacol-type reaction. There was the possibility that the electron-donating oxygen atoms on the indole ring would hinder the acid-catalyzed rearrangement of, for example, an intermediate chloroindolenine,<sup>54</sup> similarly to the way that strong acid hindered the cationic cyclization.<sup>55</sup> When compound **73** was treated with *tert*-butyl hypochlorite and triethylamine, there was an almost instantaneous reaction resulting in the total disappearance of starting material and the appearance of two new components ( $\approx 1:2$  ratio as evidenced by  $^1\text{H}$  NMR analysis) that were presumed to be the expected diastereomeric chloroindolenines. When this mixture was subjected to the standard rearrangement procedure employing a refluxing solution of acetic acid, water, and methanol, these substances slowly decomposed (many bands in the PTLC).<sup>56</sup>

Since the tertiary amine of **73** might react with the chlorinating reagent and was thus considered to be a possible culprit in these oxidations, an attempt to effect the pinacol-type rear-

angement before the amide reduction step was investigated. Thus, piperazinedione **69** was readily deblocked with TFA to provide the amide **76** in 95% yield (Scheme 10). This substance was treated with *t*-BuOCl and  $\text{Et}_3\text{N}$  in the same manner as before, producing two products **77/78** ( $\approx 1:4$  ratio). Using a milder  $\text{MeOH}/\text{H}_2\text{O}/\text{AcOH}$  system (stirring at room temperature), an oxindole compound **79** was formed in 29% yield. Although this result was encouraging, this substance appeared to possess the incorrect relative stereochemistry at the spiro-ring juncture. This assignment was supported by comparing the  $^1\text{H}$  NMR spectra of **79** and an authentic sample of (–)-paraherquamide B (**1**). The *gem*-dimethyl signals of **79** were shifted upfield, indicating that one methyl group is in the shielding cone of the oxindole carbonyl.

After a careful reexamination of the decomposition products obtained from the attempted pinacol-type rearrangement of **73**, it was determined that there were mainly two decomposition pathways, and that they were in direct competition with the desired process. These two pathways involve the intermediacy of an oxonium-stabilized tertiary carbocation (at C-3 of the indole) that decomposes to quinone-type products. Additionally, products were isolated whose spectral characteristics were consistent with an elimination process followed by nucleophilic reaction with the solvent at the tryptophan benzylic carbon.

In the classical pinacol rearrangement there is a distinct carbonium ion intermediate, but recent studies have shown that this may in fact be more of a concerted process<sup>57</sup> and, furthermore, that the nature of the solvent can have an impact on which of the two processes, concerted or stepwise, will predominate. There have been conflicting reports in the literature on whether this type of rearrangement is, at all times, stereospecific.<sup>58,59</sup> A detailed study<sup>59c</sup> involving the isolation and separation of the two diastereomeric chloroindolenines derived from yohimbine demonstrated that this reaction can be entirely stereospecific. Alternatively, by increasing the solvating power of the reaction medium, each of these chloroindolenines formed two rearranged products, indicating that the reaction went (at least in part) by way of a carbocationic intermediate. This is consistent with the observed production of **79** from **77** and **78**. A less polar solvent system should minimize the side reactions involving carbocation intermediates and, at the same time, should increase the stereospecific nature of the pinacol-type rearrangement. Thus, treatment of **73** with *t*-BuOCl and  $\text{Et}_3\text{N}$  in  $\text{CH}_2\text{Cl}_2$  provided the two chloroindolenines **74** and **75** ( $\approx 2.25:1$  ratio, respectively). The solvent was removed, and the crude reaction mixture was refluxed with a solution of 95% THF, 4%  $\text{H}_2\text{O}$ , and 1% TFA, giving a 62% yield of oxindole products (43% of the desired **80** and 19% of the epi product **81**).<sup>60</sup> The C-3-epi-isomer (**81**) was easily distinguishable from the desired isomer (**80**) by the upfield shift of the *gem*-dimethyl signals in the  $^1\text{H}$  NMR spectrum. The relative amounts of products (**80** and **81**) indicate that the cyclization was stereospecific under these conditions. It was thus deduced that an increase in the ratio of the desired oxindole **80** to the undesired

(54) (a) Gaskell, A. J.; Radunz, H. -E.; Winterfeldt, E. *Tetrahedron Lett.* **1970**, 5361. (b) Winterfeldt, E.; Gaskell, A. J.; Korth, T.; Radunz, H. -E.; Walkowiak, M. *Chem. Ber.* **1969**, *102*, 3558. (c) Hollinshead, S. P.; Grubisha, D. S.; Bennett, D. W.; Cook, J. M. *Heterocycles* **1989**, *29*, 529.

(55) Concern about this possible difficulty was somewhat ameliorated by the knowledge of an alternative procedure that employed  $\text{OsO}_4$ -pyridine. See: (a) Takayama, H.; Kitajima, M.; Ogata, K.; Sakai, S. *J. Org. Chem.* **1992**, *57*, 4583. (b) Takayama, H.; Odaka, H.; Aimi, N.; Sakai, S. *Tetrahedron Lett.* **1990**, *38*, 5483. (c) Takayama, H.; Masubuchi, K.; Kitajima, M.; Aimi, N.; Sakai, S. *Tetrahedron* **1989**, *45*, 1327. (d) Fu, X.; Cook, J. M. *J. Org. Chem.* **1993**, *58*, 661. See also: (e) Takayama, H.; Tomimaga, Y.; Kitajima, M.; Aimi, N.; Sakai, S. *J. Org. Chem.* **1994**, *59*, 4381.

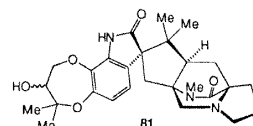
(56) Similar problems were observed during the total synthesis of isopteropodine and pteropodine; see: Martin, S. F.; Mortimore, M. *Tetrahedron Lett.* **1990**, *31*, 4557. In this system, the solution involved treating the chloroindolenines with silver perchlorate in methanolic perchloric acid. This method was attempted on substrate **73**, but unfortunately it failed to produce any desired product.

(57) Osamura, Y.; Nakamura, K. *J. Am. Chem. Soc.* **1993**, *115*, 9112.

(58) Parker, A. J. *Chem. Rev.* **1969**, *69*, 1.

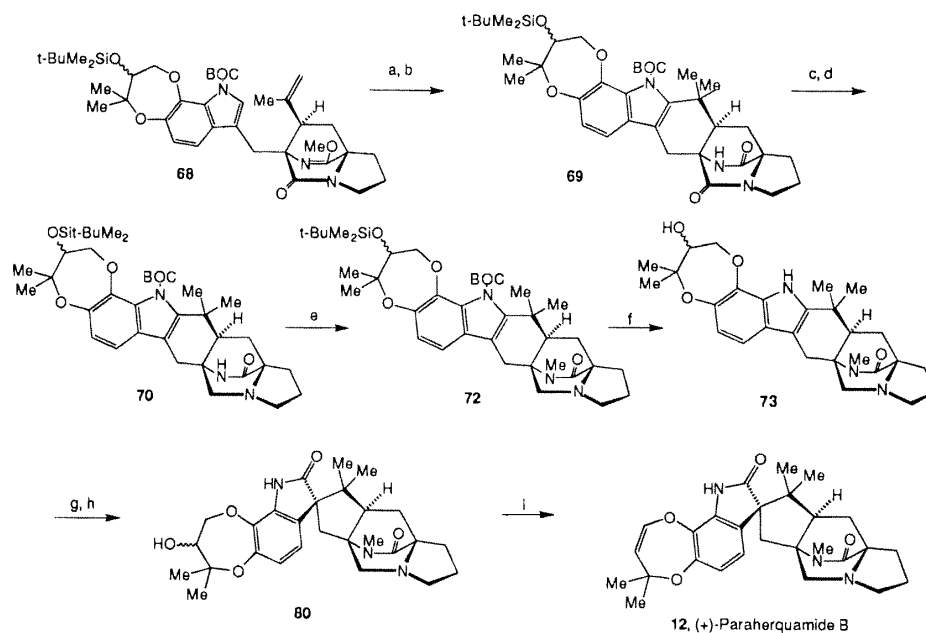
(59) (a) Owellen, R. J.; Hartke, C. *J. Org. Chem.* **1976**, *41*, 102. (b) Kuehne, M. E.; Roland, D. M.; Hafter, R. *J. Org. Chem.* **1978**, *43*, 3703. (c) Awang, D. V. C.; Vincent, A.; Kidack, D. *Can. J. Chem.* **1984**, *62*, 2667.

(60)



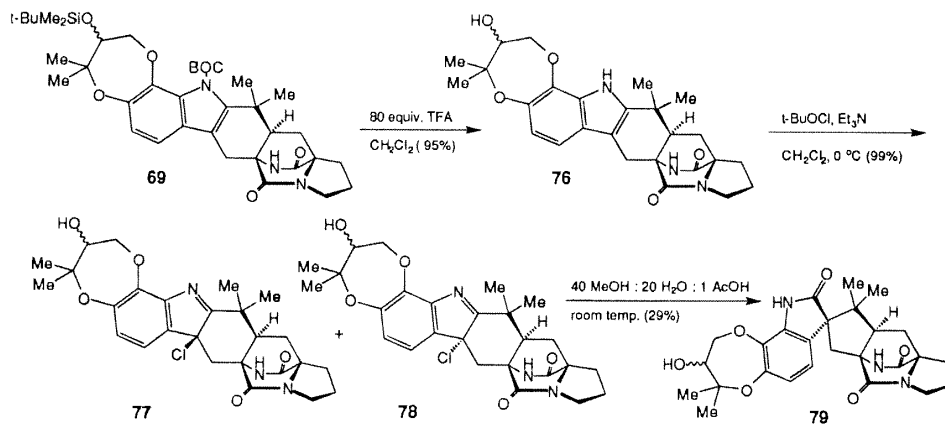
P. 10

 UT Ex. 2027  
 SteadyMed v. United Therapeutics  
 IPR2016-00006

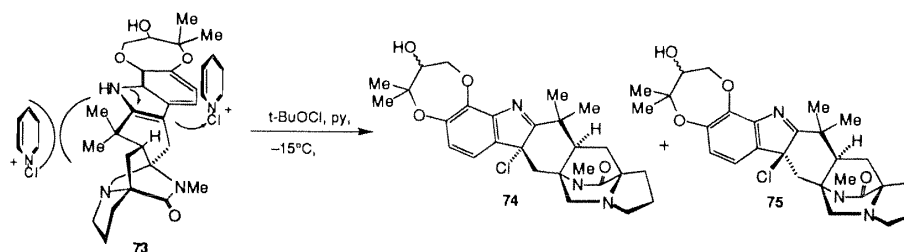
Scheme 9<sup>a</sup>

<sup>a</sup> Reagents and conditions: (a) PdCl<sub>2</sub>, AgBF<sub>4</sub>, MeCN; (b) NaBH<sub>4</sub> (63–82% from **68**); (c) 1.1 equiv of Et<sub>3</sub>Al, 5.0 equiv of AlH<sub>3</sub>-DMEA, THF, toluene; (d) 2.0 equiv of NaCNBH<sub>3</sub>, AcOH, MeOH (65% from **69**); (e) 2.5 equiv of NaH, 2.0 equiv of MeI, DMF (98%); (f) 80 equiv of TFA, CH<sub>2</sub>Cl<sub>2</sub> (96%); (g) *t*-BuOCl, pyridine, -15 °C; (h) 90% THF, 10% H<sub>2</sub>O, pTsoH (76%); (i) MTPI, DMPU (79%).

## Scheme 10



## Scheme 11



isomer **81** could be achieved simply by finding a method that would increase the ratio of chloroindolenines (**74**:**75**). The  $\alpha$ -face of **73** is considerably more hindered than the  $\beta$ -face, a

supposition that was supported by the difficulties encountered in the reduction of **71** and **69**. Increasing the steric bulk of the chlorinating agent should favor attack on the  $\beta$ -face of **73**, thus

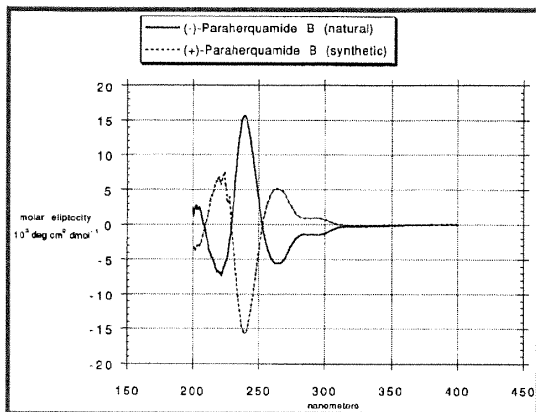


Figure 7.

providing a greater relative amount of chloroindolenine **74**. When **73** was treated with *t*-BuOCl in pyridine instead of triethylamine, the desired chloroindolenine **74** was produced in a much more stereoselective fashion. It can be speculated that *tert*-butyl hypochlorite forms a bulky complex with pyridine, delivering the chlorine more selectively to the least hindered  $\alpha$ -face of **73** (only a small amount,  $\approx 5\%$ , of the undesired isomer **75** was formed under these conditions (Scheme 11)).

Employing a minor modification of the solvent system, the crude mixture of **74/75** was refluxed with a solution of 90% tetrahydrofuran, 10% H<sub>2</sub>O containing 15 equiv of *p*-toluenesulfonic acid to give the desired oxindole **80** in 76% yield (from **73**), with only 4% of the undesired **81** being formed.

The stereospecific conversion of the chloroindolenines into the corresponding oxindoles requires that the water molecule attack the imine from the same face as the chlorine atom. *Anti* attack on the imine is not as likely because of certain stereoelectronic effects.<sup>59c</sup> The addition of water to the  $\beta$ -face of **74** situates the six-membered ring adjacent to the indole ring in a stable chair conformation that would also place the C–Cl bond and the migrating (CH<sub>3</sub>)<sub>2</sub>CC group in an unfavorable *syn* alignment. Conversely, the addition of water to the  $\alpha$ -face of compound **75** would result in an unfavorable boat conformation that would also place the C–Cl bond and the migrating (CH<sub>3</sub>)<sub>2</sub>CC group in an unfavorable *syn* alignment. Thus, the major isomer **74** must either (1) suffer kinetically controlled attack by water on the same face of **74** as the chlorine atom, which aligns the migrating group and the C–Cl bond in a stereoelectronically favorable *anti* orientation, or (2) undergo reversible attack by water from either face, with only the correct carbinolamine, which aligns the migrating group and the C–Cl bond in a stereoelectronically favorable *anti* orientation, rearranging irreversibly to the oxindole.

The final dehydration reaction (MTPI, DMPU, 18 h) on the alcohol **80** produced (+)-paraherquamide B (**12**) in 79% yield (Scheme 9). This substance proved to be identical to the natural product by comparison of the <sup>1</sup>H and <sup>13</sup>C NMR spectra, mobility on TLC, IR spectra, mass spectra, and UV spectra. Comparison of the CD spectra of the natural (–)-paraherquamide B (**2**) and the synthetic (+)-paraherquamide B (**12**) (Figure 7) confirmed the expected enantiomeric relationship between these two products.

## Conclusion

The first stereocontrolled, asymmetric total synthesis of (+)-paraherquamide B has been completed. The synthesis is

convergent, starting from (S)-proline and vanillin with an overall yield of 1.4% from (S)-proline.

Key features of this synthesis include (1) a new method to effect reduction of unprotected oxindoles to indoles; (2) a complex application of the Somei/Kametani reaction that concomitantly effected a desired decarbomethoxylation; (3) a high-yielding and entirely stereocontrolled intramolecular S<sub>N</sub>2' cyclization reaction; (4) a mild Pd(II)-mediated cyclization reaction that concomitantly deblocked a lactim ether protecting group; and (5) the chemoselective reduction of a highly hindered tertiary lactam in the presence of an unhindered secondary lactam, utilizing precoordination of the more reactive secondary lactam to triethylaluminum.

## Experimental Section

**General information.** Melting points were determined in open-ended capillary tubes and are uncorrected. <sup>1</sup>H and <sup>13</sup>C NMR spectra were recorded on either a Bruker WP-270SY 270 MHz or a Bruker AC300P 300 MHz NMR spectrometer. Chemical shifts are reported in ppm relative to CHCl<sub>3</sub> at  $\delta$  7.24 or TMS at  $\delta$  0.0. IR spectra were recorded on a Perkin-Elmer 1600 FT IR spectrometer. Mass spectra were obtained on a V. G. Micromass Ltd. Model 16F spectrometer. The CD spectrum was obtained on a Jasco J710 spectropolarimeter. High-resolution mass spectra were obtained from the Midwest Center for Mass Spectrometry Department of Chemistry, University of Nebraska—Lincoln, Lincoln, NE. Elemental analyses were obtained from M-H-W Laboratories, Phoenix, AZ. Optical rotations were recorded on a Perkin-Elmer 24 polarimeter at a wavelength of 589 nm using a 1.0 dm cell of 1.0 mL total volume.

Column chromatography and flash column chromatography were performed with silica gel grade 60 (230–400 mesh). Radial chromatography was performed with a Harrison Research Chromatotron Model 7924 using E. Merck silica gel 60 PF-254 containing gypsum; 1, 2, 4, and 8 mm plates were used as needed. Preparatory thin layer chromatography (PTLC) was carried out with Merck Kieselgel 60 F<sub>254</sub> precoated glass plates (either 0.25 or 0.50 mm); visualization was carried out with ultraviolet light and/or heating with a solution of 5–7% phosphomolybdic acid; staining with I<sub>2</sub>; vanillin; or Dragendorff.

All solvents were commercial grade and were distilled and dried as follows: tetrahydrofuran (THF) from sodium benzophenone ketyl; diethyl ether from sodium benzophenone ketyl; carbon tetrachloride from calcium hydride; dioxane from sodium; benzene from sodium benzophenone ketyl; dichloromethane from calcium hydride; acetonitrile from P<sub>2</sub>O<sub>5</sub>; DMF was dried and stored over 3 Å molecular sieves, as were benzene and toluene. HMPA was dried and stored over 4 Å molecular sieves. Dimethyl sulfide, 2,6-lutidine, triethylamine, and pyridine were all distilled prior to use. Phenylselenium chloride was purified by sublimation. *N*-Chlorosuccinimide (NCS) was recrystallized from benzene. LiCl was dried and stored in the oven. All other reagents were commercial grade and used without further treatment. Abbreviations are used throughout: *N,N*-dimethylformamide (DMF); acetic acid (AcOH); di-*tert*-butyl dicarbonate ((BOC)<sub>2</sub>O); methyltriphenoxyphosphonium iodide (MTPI); ethyl acetate (EtOAc); *m*-chloroperoxybenzoic acid (*m*-CPBA); (*N,N*-dimethylamino)pyridine (DMAP); hexamethylphosphoramide (HMPA); ceric ammonium nitrate (CAN); methanesulfonyl chloride (MsCl); *N*-chlorosuccinimide (NCS); trifluoroacetic acid (TFA); dimethylethylamine (DMEA); imidazole (im); 1,3-dimethyl-3,4,5,6-tetrahydro-2(1*H*)-pyrimidinone (DMPU).

**2-[(3-Methyl-2-butenyl)oxy]phenol (**24**).** To a stirred, cold (0 °C), dark solution of catechol (2.07 g, 18.8 mmol, 5.0 equiv) in DMF (65 mL) in a reaction vessel that had been flushed with Ar was added anhydrous K<sub>2</sub>CO<sub>3</sub> (0.520 g, 3.76 mmol, 1.0 equiv). After 5 min, prenyl bromide (0.441 mL, 3.76 mmol, 1.0 equiv) was added dropwise. The reaction mixture was kept at 0 °C for  $\sim 6$  h and stirred at room temperature for an additional 18 h. The mixture was then poured into a separatory funnel, diluted with H<sub>2</sub>O (100 mL), and extracted five times with CH<sub>2</sub>Cl<sub>2</sub>. The organic layer was washed with brine, dried over MgSO<sub>4</sub>, and evaporated to dryness. The residue was purified by radial chromatography (eluted with 1% ethyl acetate/hexanes) to give 479 mg (71%) of **24** as a colorless oil. An analytical sample was obtained by PTLC on silica gel (eluted with hexanes).

<sup>1</sup>H NMR (300 MHz) (CDCl<sub>3</sub>): δ TMS 1.74 (3H, s), 1.80 (3H, s), 4.57 (2H, d, *J* = 6.8 Hz), 5.49 (1H, m), 5.70 (1H, s, D<sub>2</sub>O exch), 6.82–6.92 (4H, m). IR (NaCl, neat): 3533, 2932, 1612, 1502, 1467, 1385, 1259, 1221, 1106, 997, 743 cm<sup>-1</sup>. Mass spectrum (EI): *m/e* (relative intensity) 178 (11), 161 (11), 110 (78), 69 (67), 32 (100). Microanalysis calcd for C<sub>11</sub>H<sub>14</sub>O<sub>2</sub>: C, 74.13; H, 7.92. Found: C, 73.88; H, 8.00.

(±)-3,4-Dihydro-2,2-dimethyl-3-(phenylseleno)-2H-benzodioxepin (**25**). A solution of phenylselenenyl chloride (117.8 mg, 0.615 mmol, 1.05 equiv) in EtOAc (4.1 mL, 0.15 M) was slowly added (~1 mmol/h) to a stirred solution of **24** (104.4 mg, 0.58 mmol, 1.0 equiv) in EtOAc (3.90 mL, 0.15 M) at -75 °C under Ar. This mixture was allowed to warm to room temperature and was stirred for a total of 17 h. The solution was poured into a separatory funnel and washed twice with H<sub>2</sub>O and once with brine. The organic layer was dried over MgSO<sub>4</sub> and evaporated to dryness. The residue was purified by PTLC (eluted with 1:3 hexanes/benzene) to afford 62.1 mg (32%) of **25**. An analytical sample was obtained by PTLC (eluted with hexanes, and then distilled under reduced pressure).

<sup>1</sup>H NMR (300 MHz) (CDCl<sub>3</sub>): δ TMS 1.28 (3H, s), 1.76 (3H, s), 3.62 (1H, dd, *J* = 3.4, 10.3 Hz), 4.17 (1H, dd, *J* = 10.3, 12.6 Hz), 4.40 (1H, dd, *J* = 3.5, 12.6 Hz), 6.94–6.98 (4H, m), 7.30–7.34 (3H, m), 7.59–7.62 (2H, m). IR (NaCl, neat): 2986, 1491, 1256, 1088, 1000 cm<sup>-1</sup>. HRMS (EI): *m/e* 334.0473 (C<sub>17</sub>H<sub>18</sub>O<sub>2</sub>Se requires 334.0472).

2,2-Dimethyl-2H-1,5-benzodioxepin (**26**). To a stirred solution of **25** (61.7 mg, 0.185 mmol, 1.0 equiv) in THF (3 mL) was added H<sub>2</sub>O<sub>2</sub> (0.21 mL, 0.5 mmol, 10 equiv) at 0 °C. The resulting solution was stirred for 0.5 h and then brought to reflux temperature for 0.5 h. The mixture was poured into a separatory funnel, diluted with water, and extracted with ether. The ethereal solution was washed with brine, dried over MgSO<sub>4</sub>, and evaporated to dryness. The residue was purified by PTLC (eluted with 1:3 hexanes/EtOAc) to afford 16.0 mg (49%) of **26** as a pale yellow oil (see data below).

Compound **26** was also obtained from **28** as follows: To a solution of **28** (76.2 mg, 0.39 mmol, 1.0 equiv) in HMPA (2 mL) under N<sub>2</sub> at room temperature was added MTPI (291.5 mg, 0.64 mmol, 1.6 equiv) all at once. After being stirred for 1 day, the mixture was poured into a separatory funnel containing 1 M NaOH and was extracted with ether. The organic layer was washed with brine and dried over MgSO<sub>4</sub>. Evaporation gave a crude yield of 163.5 mg. The crude product was purified by radial chromatography (eluted with 1:10 EtOAc/hexanes, then 1:5 EtOAc/hexanes) to afford 46 mg (66%) of **26**.

<sup>1</sup>H NMR (300 MHz) (CDCl<sub>3</sub>): δ TMS 1.42 (6H, s), 4.81 (1H, d, *J* = 7.8 Hz), 6.30 (1H, d, *J* = 7.8 Hz), 6.95–7.06 (4H, m). IR (neat): 2978, 1654, 1587, 1495, 1311, 1242, 750 cm<sup>-1</sup>. HRMS (EI): *m/e* 176.0835 (C<sub>11</sub>H<sub>12</sub>O<sub>2</sub> requires 176.0837).

(±)-2-[(3,3-Dimethyloxiranyl)methoxy]phenol (**27**). To a solution of **24** (1.31 g, 7.35 mmol, 1.0 equiv) in CH<sub>2</sub>Cl<sub>2</sub> (40.0 mL) under N<sub>2</sub> at 0 °C was added NaHCO<sub>3</sub> (803 mg, 9.56 mmol, 1.3 equiv) followed by *m*-CPBA (1.27 g, 7.35 mmol, 1.0 equiv). After 1.5 h additional NaHCO<sub>3</sub> (812 mg, 9.66 mmol, 1.21 equiv) and *m*-CPBA (1.26 g, 7.35 mmol, 0.99 equiv) were added. This mixture was kept stirring at 0 °C for 2 h, when more NaHCO<sub>3</sub> (778 mg, 9.27 mmol, 1.3 equiv) and *m*-CPBA (1.12 g, 6.49 mmol, 0.88 mmol) were added. After 2 h, the cold mixture was filtered to remove the solids. The filtrate was washed three times with 10% Na<sub>2</sub>S<sub>2</sub>O<sub>3</sub> and three times with brine, dried over MgSO<sub>4</sub>, and evaporated to dryness to afford 1.41 g (99%) of **27**. An analytical sample was recrystallized from toluene to give a glassy solid, mp 36–37 °C.

<sup>1</sup>H NMR (270 MHz) (CDCl<sub>3</sub>): δ TMS 1.37 (3H, s), 1.41 (3H, s), 3.18 (1H, dd, *J* = 4.2, 6.3 Hz), 4.07 (1H, dd, *J* = 6.4, 11.0 Hz), 4.28 (1H, dd, *J* = 4.2, 11.0 Hz), 5.78 (1H, s, D<sub>2</sub>O exch), 6.81–6.97 (4H, m). IR (NaCl, neat): 3413, 2966, 1590, 1502, 1267, 744 cm<sup>-1</sup>. Microanal. Calcd for C<sub>11</sub>H<sub>14</sub>O<sub>3</sub>: C, 68.02; H, 7.26. Found: C, 67.91; H, 7.39.

(±)-3,4-Dihydro-2,2-dimethyl-2H-1,5-benzodioxepin-3-ol (**28**). A flame-dried flask, flushed with Ar, was charged with dry THF (85.4 mL). Tin tetrachloride (0.85 mL, 7.3 mmol, 1.0 equiv) was then added dropwise in 5 min. After 10 min a solution of **27** (1.41 g, 7.26 mmol, 1.0 equiv) in dry THF (13.8 mL) was added slowly (dropwise) to the mixture. The reaction mixture was stirred at room temperature for 20 min, poured into saturated NaHCO<sub>3</sub>, washed with brine, dried over

MgSO<sub>4</sub>, and evaporated to dryness. The crude product was purified by radial chromatography (eluted with 1:7 EtOAc/hexanes) to afford 842 mg (60% or 59% for two steps) of **28** as an oil. An analytical sample was obtained by PTLC (eluted with 5:1 EtOAc/hexanes, and then distilled under reduced pressure).

<sup>1</sup>H NMR (300 MHz) (CDCl<sub>3</sub>): δ TMS 1.20 (3H, s), 1.53 (3H, s), 2.96 (1H, d, *J* = 11.3 Hz, D<sub>2</sub>O exch), 3.58 (1H, ddd, *J* = 1.1, 4.0, 11.3 Hz), 4.08 (1H, dd, *J* = 1.1, 12.6 Hz), 4.20 (1H, dd, *J* = 4.0, 12.6 Hz), 6.98–7.02 (4H, m). IR (NaCl, neat): 3448, 2978, 1596, 1490, 1261 cm<sup>-1</sup>. Mass spectrum (EI): *m/e* (relative intensity) 194 (41), 176 (19), 136 (57), 121 (100), 59 (63). HRMS (EI) *m/e* 194.0943 (C<sub>11</sub>H<sub>14</sub>O<sub>3</sub> requires 194.0943).

4-Hydroxy-3-methoxy-2-nitrophenylacetic Acid (**30**). To a flask containing **29** (101 g, 397 mmol, 1.0 equiv) at 0 °C was added a solution of NaOH (63.5 g, 1.59 mol, 4.0 equiv) in H<sub>2</sub>O (1.4 L). After 10 min, hydrogen peroxide (49.5 mL, 437 mmol, 1.1 equiv, 30% solution in water) was added dropwise. The deep purple solution slowly turned brown during the addition. The mixture was allowed to reach room temperature and stirred for 24 h. The reaction mixture was then acidified with concentrated HCl until pH ≈ 3, during which CO<sub>2</sub> was released and a fine yellow crystalline product precipitated. The mixture was filtered, washed with cold H<sub>2</sub>O, and dried to yield 72.6 g (81%) of **30**. An analytical sample was recrystallized from H<sub>2</sub>O to give bright yellow needles, mp 161–162 °C (when the reaction was carried out with 11.9 g of the phenylacetic acid, the yield was 93%).

<sup>1</sup>H NMR (300 MHz) (acetone-*d*<sub>6</sub>): δ TMS 2.83 (2H, br s, D<sub>2</sub>O exch), 3.62 (2H, s), 3.91 (3H, s), 7.10 (2H, s). IR (KBr): 3488, 2958, 2641, 1668, 1533, 1399, 1344, 1296, 1225, 1051, 825 cm<sup>-1</sup>. Mass spectrum (EI): *m/e* (relative intensity) 228 (M<sup>+</sup>, 0.7), 227 (5.8), 166 (10.0), 106 (13.6), 44 (100). Microanal. Calcd for C<sub>9</sub>H<sub>9</sub>NO<sub>6</sub>: C, 47.58; H, 3.99; N, 6.16. Found: C, 47.56; H, 4.06; N, 6.25.

1,3-Dihydro-6-hydroxy-7-methoxy-2H-indol-2-one (**31**). A mixture of **30** (23.0 g, 101 mmol, 1.0 equiv) in glacial acetic acid (100 mL) and Pd/C (10%, 1.5 g) was hydrogenated at 40 psi of H<sub>2</sub> in an oil bath (80 °C) for 5 h. The mixture was immediately filtered through a Celite plug and washed with a small amount of warm AcOH. The flask was kept under suction (cold) until a large quantity of white product had precipitated. This was filtered to collect the product, when an additional quantity of product precipitated under suction. This was collected, and the two crops of white flakes were combined and dried under reduced pressure to yield 17.2 g (95%) of **31**. An analytical sample was recrystallized from H<sub>2</sub>O to give white crystals, mp 210–211 °C.

<sup>1</sup>H NMR (300 MHz) (CDCl<sub>3</sub>): δ TMS 3.50 (2H, d, *J* = 1.0 Hz), 3.87 (3H, s), 5.49 (1H, s, D<sub>2</sub>O exch), 6.60 (1H, d, *J* = 8.1 Hz), 6.86 (1H, d, *J* = 8.0 Hz), 7.94 (1H, s, D<sub>2</sub>O exch). IR (KBr): 3287, 3014, 2953, 1686, 1633, 1504, 1466, 1315, 1163, 637 cm<sup>-1</sup>. Microanal. Calcd for C<sub>9</sub>H<sub>9</sub>NO<sub>3</sub>: C, 60.33; H, 5.06; N, 7.82. Found: C, 60.51; H, 5.05; N, 7.60.

1,3-Dihydro-7-methoxy-6-[(tolylsulfonyl)oxy]-2H-indol-2-one. To a stirred mixture of **31** (321.6 mg, 1.795 mmol, 1.0 equiv) in acetone (7 mL) at 0 °C under Ar were added K<sub>2</sub>CO<sub>3</sub> (740.5 mg, 5.358 mmol, 2.98 equiv) and *p*-toluenesulfonyl chloride (376.4 mg, 1.974 mmol, 1.1 equiv). The mixture was stirred for 5 h at 0 °C and 1 h at room temperature. The reaction mixture was diluted with water and extracted with EtOAc. The organic layer was washed three times with 1 M NaOH and once with brine, dried over MgSO<sub>4</sub>, and concentrated to dryness. The product, 572.3 mg (96%), was obtained as a rust-colored, amorphous solid.

<sup>1</sup>H NMR (270 MHz) (CDCl<sub>3</sub>): δ 2.47 (3H, s), 3.52 (2H, s), 3.81 (3H, s), 6.70 (1H, d, *J* = 8.2 Hz), 6.86 (1H, d, *J* = 8.1 Hz), 7.34 (2H, d, *J* = 8.1 Hz), 7.79 (2H, d, *J* = 8.3 Hz), 7.85 (1H, s, D<sub>2</sub>O exch). IR (KBr): 3172 (br), 1709, 1616, 1496, 1458, 1371, 1338, 1175, 1093, 1050, 1000, 848, 815, 728, 662, 548, cm<sup>-1</sup>. Mass spectrum (EI): *m/e* (relative intensity) 333 (5.0), 269 (1.4), 178 (40), 91 (77), 28 (100).

1,3-Dihydro-7-hydroxy-6-[(tolylsulfonyl)oxy]-2H-indol-2-one. Boron tribromide (1.1 mL, 1.1 mmol, 2.0 equiv, 1 M/CH<sub>2</sub>Cl<sub>2</sub>) was added to a stirred mixture of 1,3-dihydro-7-methoxy-6-[(tolylsulfonyl)oxy]-2H-indol-2-one obtained above (181.5 mg, 0.54 mmol, 1.0 equiv) in CH<sub>2</sub>Cl<sub>2</sub> (4.3 mL) under Ar, at -78 °C. The mixture was stirred for 8 h and stored at -20 °C for 12 h. The mixture was poured into ice/<sup>U</sup>TEx. 2027

water, stirred for 0.5 h, and extracted with EtOAc. The organic layer was washed with brine, dried over MgSO<sub>4</sub>, and concentrated to dryness to give 164.7 mg (95%) of a red solid.

<sup>1</sup>H NMR (270 MHz) (acetone-*d*<sub>6</sub>): δ TMS 2.45 (3H, s), 3.43 (2H, d, *J* = 0.8 Hz), 6.61 (1H, d, *J* = 8.1 Hz), 6.71 (1H, d, *J* = 8.1 Hz), 7.46 (2H, d, *J* = 8.6 Hz), 7.79 (2H, d, *J* = 8.3 Hz), 8.50 (1H, s, D<sub>2</sub>O exch), 9.28 (1H, s, D<sub>2</sub>O exch). IR (NaCl, neat): 3259 (br), 2921, 1698, 1365, 1175, 1142, 728 cm<sup>-1</sup>. Mass spectrum (EI): *m/e* (relative intensity) 319 (3.4), 278 (6.0), 246 (6.7), 163 (49), 139 (73), 91 (100).

**1,3-Dihydro-7-[(3-methyl-2-butenyl)oxy]-6-[(tolylsulfonyl)oxy]-2*H*-indol-2-one (37).** To a stirred solution of 1,3-dihydro-7-hydroxy-6-[(tolylsulfonyl)oxy]-2*H*-indol-2-one obtained above (159.4 mg, 0.49 mmol, 1.0 equiv) in DMF (1.5 mL) at 0 °C was added K<sub>2</sub>CO<sub>3</sub> (103.5 mg, 0.75 mmol, 1.5 equiv) followed by prenyl bromide (0.09 mL, 0.75 mmol, 1.5 equiv). After 4 h the mixture was poured into water, extracted with EtOAc, washed with brine, dried over MgSO<sub>4</sub>, and concentrated to dryness. The product was purified by radial chromatography (eluted with 3:2 hexanes/EtOAc) to afford 71.9 mg (37%) of 37 as a red solid.

<sup>1</sup>H NMR (270 MHz) (CDCl<sub>3</sub>): δ TMS 1.58 (3H, s), 1.70 (3H, s), 2.45 (3H, s), 3.52 (2H, s), 4.47 (2H, d, *J* = 7.3 Hz), 5.35 (1H, t, *J* = 7.3 Hz), 6.74 (1H, d, *J* = 8.2 Hz), 6.87 (1H, d, *J* = 8.1 Hz), 7.32 (2H, d, *J* = 8.0 Hz), 7.79 (2H, d, *J* = 8.3 Hz), 8.61 (1H, s, D<sub>2</sub>O exch). IR (NaCl, neat): 3194 (br), 1714, 1627, 1464, 1376, 1196, 1175, 837, 728 cm<sup>-1</sup>. Mass spectrum (EI): *m/e* (relative intensity) 387 (16), 319 (16), 164 (37), 91 (91), 67 (100).

**1,3-Dihydro-6,7-dihydroxy-2*H*-indol-2-one (32).** Boron tribromide (800 mL, 800 mmol, 2.5 equiv, 1M/CH<sub>2</sub>Cl<sub>2</sub>) was added dropwise to a stirred mixture of 31 (57.3 g, 320 mmol, 1.0 equiv) in CH<sub>2</sub>Cl<sub>2</sub> (640 mL) under N<sub>2</sub> at -78 °C. The reaction mixture was stirred at -78 °C for 8 h and was then poured into a large (4 L) beaker containing 1.5 L of ice/water, stirred for 10 min, and filtered to remove undissolved product. The remaining liquid was extracted with EtOAc, washed with brine, and dried over MgSO<sub>4</sub>. The organic layer was evaporated to yield the pure product 32, which was combined with the filter cake, total yield 52.3 g (99%). An analytical sample was recrystallized from H<sub>2</sub>O (three times) to give a faint pink crystalline solid, mp 245 °C dec.

<sup>1</sup>H NMR (300 MHz) (DMSO-*d*<sub>6</sub>): δ TMS 3.32 (2H, s), 6.36 (1H, d, *J* = 7.9 Hz), 6.48 (1H, d, *J* = 2.9 Hz), 8.80 (2H, br s, D<sub>2</sub>O exch), 10.0 (1H, br s, D<sub>2</sub>O exch). IR (KBr): 3366–3123 (br), 1672, 1649, 1618, 1359, 1265, 1178, 786 cm<sup>-1</sup>. Microanal. Calcd for C<sub>8</sub>H<sub>7</sub>NO: C, 58.18; N, 4.27; O, 8.48. Found: C, 58.34; H, 4.44; N, 8.25.

**1,3-Dihydro-6-hydroxy-7-[(3-methyl-2-butenyl)oxy]-2*H*-indol-2-one (33).** To a stirred solution of 6,7-dihydroxyindole (32) (19.0 g, 115 mmol, 1.0 equiv) in DMF (230 mL) at 0 °C under Ar was added K<sub>2</sub>CO<sub>3</sub> (15.9 g, 115 mmol, 1.0 equiv). After 8 min prenyl bromide (14.8 mL, 127 mmol, 1.1 equiv) was added dropwise. The reaction mixture was stirred at 0 °C for 6.5 h, poured into a separatory funnel, diluted with H<sub>2</sub>O, and extracted with ether. The ethereal solution was washed with brine, dried over Na<sub>2</sub>SO<sub>4</sub>, and evaporated to dryness. The product was purified by column chromatography (eluted with 3:1 hexanes/EtOAc, then 1:1 hexanes/EtOAc) to yield 14.5 g (54%) of 33. An analytical sample was recrystallized from toluene to give a red-white solid, mp 111 °C.

<sup>1</sup>H NMR (300 MHz) (CDCl<sub>3</sub>): δ TMS 1.65 (3H, s), 1.80 (3H, s), 3.50 (2H, s), 4.47 (1H, d, *J* = 7.4 Hz), 5.50–5.55 (1H, m), 5.57 (1H, s, D<sub>2</sub>O exch), 6.59 (1H, d, *J* = 8.1 Hz), 6.84 (1H, d, *J* = 8.0 Hz), 7.77 (1H, s, D<sub>2</sub>O exch). IR (KBr): 3367, 3192, 2971, 1694, 1664, 1635, 1461, 1356, 1286, 1199, 1047 cm<sup>-1</sup>. Microanal. Calcd for C<sub>13</sub>H<sub>15</sub>NO: C, 65.14; H, 6.83; N, 6.33. Found: C, 65.16; H, 6.52; N, 6.07.

**(±)-1,3-Dihydro-7-[(3,3-dimethyloxirany)methoxy]-6-hydroxy-2*H*-indol-2-one.** To a stirred solution of 33 (14.5 g, 62.1 mmol, 1.0 equiv) in CH<sub>2</sub>Cl<sub>2</sub> (620 mL) were added NaHCO<sub>3</sub> (5.7 g, 68.3 mmol, 1.1 equiv) and *m*-CPBA (10.7 g, 62.1 mmol, 1.0 equiv). The mixture was stirred for 1 h, and an additional amount of each reagent was added, NaHCO<sub>3</sub> (5.7 g, 68.3 mmol, 1.1 equiv) and *m*-CPBA (10.7 g, 62.1 mmol, 1.0 equiv). The mixture was stirred for an additional 1 h, and a third portion each of NaHCO<sub>3</sub> (5.7 g, 68.3 mmol, 1.1 equiv) and *m*-CPBA (10.7 g, 62.1 mmol, 1.0 equiv) was added. The resulting mixture was stirred for 3 h, while the temperature was maintained at 0 °C. The reaction mixture was filtered into a flask containing 10%

Na<sub>2</sub>S<sub>2</sub>O<sub>3</sub> and 10% NaHCO<sub>3</sub>. The organic layer was isolated, diluted with CH<sub>2</sub>Cl<sub>2</sub>, and washed with 10% Na<sub>2</sub>S<sub>2</sub>O<sub>3</sub> and saturated NaHCO<sub>3</sub>, and finally with brine. The organic layer was dried over Na<sub>2</sub>SO<sub>4</sub>, filtered, concentrated under reduced pressure, and dried in vacuo to yield 17 g of the product, which was used directly for the next step. An analytical sample was recrystallized from toluene to give a white solid, mp 122–123 °C.

<sup>1</sup>H NMR (300 MHz) (CDCl<sub>3</sub>): δ TMS 1.38 (3H, s), 1.42 (3H, s), 3.25 (1H, dd, *J* = 2.9, 8.5 Hz), 3.47–3.49 (2H, m), 3.80 (1H, dd, *J* = 8.5, 12.0 Hz), 4.54 (1H, dd, *J* = 2.9, 12.0 Hz), 6.25 (1H, s, D<sub>2</sub>O exch), 6.58 (1H, d, *J* = 8.1 Hz), 6.84 (1H, d, *J* = 8.1 Hz), 8.44 (1H, s, D<sub>2</sub>O exch). IR (KBr): 3495, 3146, 2982, 1717, 1694, 1635, 1501, 1466, 1321, 1187, 1047, 861 cm<sup>-1</sup>. Microanal. Calcd for C<sub>13</sub>H<sub>15</sub>NO<sub>4</sub>: C, 62.64; H, 6.06; N, 5.62. Found: C, 62.70; H, 6.15; N, 5.66.

**(±)-3,4,8,10-Tetrahydro-3-hydroxy-4,4-dimethyl-2*H*,9*H*-[1,4]dioxepino[2,3-*g*]indol-9-one (34).** SnCl<sub>4</sub> (9.6 mL, 81.8 mmol, 1.2 equiv) was slowly added dropwise to a flame-dried flask, which had been flushed with Ar and charged with dry THF (960 mL). After 10 min a solution of (±)-1,3-dihydro-7-[(3,3-dimethyloxirany)methoxy]-6-hydroxy-2*H*-indol-2-one obtained above (17 g, 62 mmol, 1.0 equiv) in THF (73 mL) was added dropwise to the reaction vessel and stirred for 2 h. Approximately one-half of the solvent was removed under reduced pressure and the remaining solution poured into a separatory funnel containing saturated NaHCO<sub>3</sub> and H<sub>2</sub>O (~50:50), which was then exhaustively extracted with CH<sub>2</sub>Cl<sub>2</sub>. The organic layer was washed with brine, dried over Na<sub>2</sub>SO<sub>4</sub>, and evaporated to give a dark crude product. The product was purified by column chromatography (eluted with 1:2 hexanes/EtOAc) to yield 10 g (64% for two steps) of 34. An analytical sample was recrystallized from toluene to give a yellow crystalline solid, mp 194 °C.

<sup>1</sup>H NMR (300 MHz) (CDCl<sub>3</sub>): δ TMS 1.24 (3H, s), 1.54 (3H, s), 2.94 (1H, d, *J* = 11.2 Hz, D<sub>2</sub>O exch), 3.51 (2H, s), 3.63 (1H, ddd, *J* = 1.0, 4.0, 11.2 Hz), 4.12 (1H, dd, *J* = 1.0, 12.4 Hz), 4.24 (1H, dd, *J* = 4.0, 12.5 Hz), 6.64 (1H, d, *J* = 8.0 Hz), 6.83 (1H, d, *J* = 7.9 Hz), 7.64 (1H, s, D<sub>2</sub>O exch). IR (KBr): 3460, 3320, 3169, 2982, 1711, 1682, 1461, 1327, 1216, 1047 cm<sup>-1</sup>. Microanal. Calcd for C<sub>13</sub>H<sub>15</sub>NO<sub>4</sub>: C, 62.64; H, 6.08; N, 5.61. Found: C, 62.28; H, 6.21; N, 5.56.

**(±)-3-Hydroxy-4,4-dimethyl-3,4-dihydro-2*H*,10*H*-[1,4]dioxepino[2,3-*g*]indole (35).** To a stirred solution of 34 (11.2 g, 44.8 mmol, 1.0 equiv) in THF (225 mL) under Ar at 0 °C was added BF<sub>3</sub>·OEt<sub>2</sub> (19.3 mL, 157 mmol, 3.5 equiv). After 10 min, NaBH<sub>4</sub> (2.71 g, 71.8 mmol, 1.6 equiv) was added at once, and the mixture was stirred for 8 h at 0 °C and then at room temperature for 40 h. The reaction was completed by the slow addition of water (1 L) and was stirred for 0.5 h. HCl (concentrated) was added until pH = 1, and the mixture was stirred for an additional 0.5 h. The mixture was treated with 1 M NaOH until pH = 14 and stirred for 0.5 h. The mixture was poured into a separatory funnel and extracted with EtOAc/ether. The organic layer was washed with brine, dried over Na<sub>2</sub>SO<sub>4</sub>, and evaporated to leave 10 g of a crude solid. The product was purified by column chromatography (eluted with 2:1 hexanes/EtOAc) to yield 4.5 g (43%) of 35. An analytical sample was recrystallized from benzene to afford a white crystalline solid, mp 202–205 °C.

<sup>1</sup>H NMR (300 MHz) (CDCl<sub>3</sub>): δ TMS 1.22 (3H, s), 1.56 (3H, s), 3.03 (1H, d, *J* = 11.4 Hz, D<sub>2</sub>O exch), 3.63 (1H, ddd, *J* = 4.0, 0.9, 11.3 Hz), 4.19 (1H, dd, *J* = 0.9, 12.3 Hz), 4.31 (1H, dd, *J* = 4.0, 12.3 Hz), 6.49 (1H, dd, *J* = 2.2, 3.1 Hz), 6.78 (1H, d, *J* = 8.4 Hz), 7.16–7.19 (2H, m), 8.29 (1H, s, D<sub>2</sub>O exch). IR (KBr): 3340, 2984, 1580, 1504, 1444, 1338, 1224, 1133, 1057, 814, 753 cm<sup>-1</sup>. Microanal. Calcd for C<sub>13</sub>H<sub>15</sub>NO<sub>3</sub>: C, 66.94; H, 6.48; N, 6.00. Found: C, 67.16; H, 6.63; N, 5.79.

**(±)-3-[[[1,1-Dimethylethyl]dimethylsilyl]oxy]-4,4-dimethyl-3,4-dihydro-2*H*,10*H*-[1,4]dioxepino[2,3-*g*]indole.** To a stirred solution of 35 (11.6 g, 49.7 mmol, 1.0 equiv) in DMF (124 mL) at room temperature under N<sub>2</sub> was added *tert*-butyldimethylsilyl chloride (15.0 g, 99.4 mmol, 2.0 equiv) immediately followed by imidazole (23.7 g, 348 mmol, 7.0 equiv). The solution was slowly heated to 40 °C, stirred overnight, poured into a separatory funnel, and extracted with EtOAc. The organic layer was washed with brine and dried over Na<sub>2</sub>SO<sub>4</sub>. The solvent was removed and the crude solid purified by column chromatography (eluted with 5:1 hexanes/EtOAc) to yield 14.2 g (82%) of

the product. An analytical sample was recrystallized from cyclohexane to give a white solid, mp 118–119 °C.

<sup>1</sup>H NMR (300 MHz) (CDCl<sub>3</sub>): δ TMS 0.14 (6H, s), 0.89 (9H, s), 1.12 (3H, s), 1.48 (3H, s), 3.88 (1H, dd, *J* = 9.2, 11.5 Hz), 3.98 (1H, dd, *J* = 3.2, 9.2 Hz), 4.22 (1H, dd, *J* = 3.2, 11.5 Hz), 6.48 (1H, dd, *J* = 2.2, 3.1 Hz), 6.76 (1H, d, *J* = 8.4 Hz), 7.14 (2H, ddd, *J* = 2.4, 3.4, 3.5 Hz), 8.21 (1H, s, D<sub>2</sub>O exch). IR (neat): 3412, 2936, 1500, 1438, 1234, 1093, 833 cm<sup>-1</sup>. Microanal. Calcd for C<sub>19</sub>H<sub>29</sub>NO<sub>3</sub>Si: C, 65.66; H, 8.41; N, 4.03. Found: C, 65.59; H, 8.20; N, 3.90.

(±)-3-[[[(1,1-Dimethylethyl)dimethylsilyl]oxy]-4,4-dimethyl-8-(*N,N*-dimethylamino)methyl]-3,4-dihydro-2*H*,10*H*-[1,4]dioxepino[2,3-*g*]indole (36). To a flask charged with acetic acid (136 mL) under Ar were added formaldehyde (3.4 mL, 45 mmol, 1.1 equiv, 37%/H<sub>2</sub>O) and dimethylamine (20.5 mL, 163 mmol, 4.0 equiv, 40% solution in H<sub>2</sub>O) followed by (±)-3-[[[(1,1-dimethylethyl)dimethylsilyl]oxy]-4,4-dimethyl-3,4-dihydro-2*H*,10*H*-[1,4]dioxepino[2,3-*g*]indole obtained above (14.2 g, 40.9 mmol, 1.0 equiv) over a 10 min period. The reaction mixture was stirred for 1 day when 10% K<sub>2</sub>CO<sub>3</sub> was added until pH ≈ 8; then 2 M NaOH was added. The mixture was extracted with ether/EtOAc, washed with brine, and dried over Na<sub>2</sub>SO<sub>4</sub>. The solvent was removed under reduced pressure, leaving 17.3 g (quantitative) of the pure product 36. An analytical sample was recrystallized from toluene to give a white flaky solid, mp 152 °C.

<sup>1</sup>H NMR (300 MHz) (CDCl<sub>3</sub>): δ TMS 0.15 (6H, s), 0.90 (9H, s), 1.13 (3H, s), 1.48 (3H, s), 2.28 (6H, s), 3.58 (2H, s), 3.58 (2H, s), 3.82 (1H, dd, *J* = 9.2, 11.4 Hz), 3.98 (1H, dd, *J* = 3.2, 9.1 Hz), 4.21 (1H, dd, *J* = 3.2, 11.5 Hz), 6.76 (1H, d, *J* = 8.4 Hz), 8.44 (1H, s, D<sub>2</sub>O exch). IR (NaCl, neat): 2932, 1502, 1458, 1360, 1251, 1218, 1093, 837, 777 cm<sup>-1</sup>. Microanal. Calcd for C<sub>22</sub>H<sub>36</sub>N<sub>2</sub>O<sub>3</sub>Si: C, 65.31; H, 8.97; N, 6.92. Found: C, 65.09; H, 8.77; N, 6.73.

(±)-6(*R*)-(2*E*)-Methyl 3-[[[(1,1-Dimethylethyl)dimethylsilyl]oxy]-3,4-dihydro-4,4-dimethyl-2*H*,10*H*-[1,4]dioxepino[2,3-*g*]indol-8-yl)methyl]-8a-[4-[[[(1,1-dimethylethyl)dimethylsilyl]oxy]-3-methyl-2-butenyl]-2-[(4-methoxyphenyl)methyl]octahydro-1,4-dioxopyrrolo[1,2-*a*]pyrazine-3-carboxylate (39). To a stirred solution of 38 (23.0 mg, 0.043 mmol, 1.0 equiv) in CH<sub>3</sub>CN (0.3 mL) and PBu<sub>3</sub> (5.4 μL, 0.022 mmol, 0.5 equiv) was added a solution of 36 (19.3 mg, 0.048 mmol, 1.1 equiv) in CH<sub>3</sub>CN (0.3 mL). The mixture was refluxed for 5.5 h and stirred at room temperature overnight. The reaction mixture was then diluted with ether, washed with water, dilute HCl, and brine, and dried over MgSO<sub>4</sub>. The solvent was removed and the crude oily solid purified by PTLC on silica gel (eluted with 1:4 EtOAc/hexanes) to yield 19.8 mg (51%) of 39. An analytical sample was recrystallized from cyclohexane to give a white crystalline solid, mp 168–168.5 °C.

<sup>1</sup>H NMR (300 MHz) (CDCl<sub>3</sub>) (a racemic mixture of two diastereomers): δ TMS 0.00 (6H, s), 0.01 (6H, s), 0.13 (6H, s), 0.14 (6H, s), 0.034–0.19 (2H, m), 0.43–0.52 (2H, m), 0.62–0.72 (2H, m), 0.84 (9H, s), 0.85 (9H, s), 0.86 (9H, s), 0.88 (9H, s), 1.05 (3H, s), 1.1 (3H, s), 1.45 (3H, s), 1.49 (3H, s), 1.537 (3H, s), 1.544 (3H, s), 1.33–1.67 (2H, m), 2.14–2.25 (2H, m), 2.52–2.60 (2H, m), 2.87–3.03 (2H, m), 3.27 (6H, s), 3.36–3.52 (2H, m), 3.66 (1H, 1/2 ABq, *J* = 15.0 Hz), 3.66 (1H, 1/2 ABq, *J* = 15.0 Hz), 3.75 (6H, s), 3.77–3.96 (12H, m), 4.14–4.20 (2H, m), 5.25–5.31 (2H, m); 5.48 (2H, 1/2 ABq, *J* = 14.6 Hz), 6.70–6.89 (8H, m), 7.15–7.22 (6H, m), 8.29 (1H, s, D<sub>2</sub>O exch), 8.32 (1H, s, D<sub>2</sub>O exch). IR (NaCl, neat): 3303, 2954, 2856, 1752, 1660, 1512, 1447, 1251, 1098, 1049, 837, 777 cm<sup>-1</sup>. Microanal. Calcd for C<sub>48</sub>H<sub>71</sub>N<sub>3</sub>O<sub>5</sub>Si<sub>2</sub>: C, 64.76; H, 8.04; N, 4.72. Found: C, 64.95; H, 8.09; N, 4.53.

[(±)-[3α,8αβ(*E*)]]-8-[[2-[(4-Methoxyphenyl)methyl]-8a-[4-[[[(1,1-dimethylethyl)dimethylsilyl]oxy]-3-methyl-2-butenyl]octahydro-1,4-dioxopyrrolo[1,2-*a*]pyrazin-3-yl)methyl]-3-[[[(1,1-dimethylethyl)dimethylsilyl]oxy]-3,4-dihydro-4,4-dimethyl-2*H*,10*H*-[1,4]dioxepino[2,3-*g*]indole (40). [(±)-[3β,8αα(*E*)]]-8-[[2-[(4-Methoxyphenyl)methyl]-8a-[4-[[[(1,1-dimethylethyl)dimethylsilyl]oxy]-3-methyl-2-butenyl]octahydro-1,4-dioxopyrrolo[1,2-*a*]pyrazin-3-yl)methyl]-3-[[[(1,1-dimethylethyl)dimethylsilyl]oxy]-3,4-dihydro-4,4-dimethyl-2*H*,10*H*-[1,4]dioxepino[2,3-*g*]indole (41). A dry flask containing 39 (24.4 mg, 0.027 mmol, 1.0 equiv) and lithium chloride (11.6 mg, 0.27 mmol, 10 equiv) under N<sub>2</sub> was charged with HMPA (0.21 mL) and water (1.5 × 10<sup>-3</sup> mL, 0.082 mmol, 3.0 equiv). This mixture was heated to 100–105 °C for 2 h. The resulting solution

was diluted with 1:1 EtOAc/hexanes and washed with water (5×) and brine. The organic layer was dried over MgSO<sub>4</sub> and concentrated to dryness. The product was purified by PTLC on silica gel (eluted with 1:3 EtOAc/hexanes) to yield 8.9 mg (39%) of 40 (oil) and 2.7 mg (12%) of 41 (oil). Total yield: 51%.

<sup>1</sup>H NMR (300 MHz) (CDCl<sub>3</sub>) (a racemic mixture of two diastereomers) (40): δ 0.036 (12H, s), 0.12 (6H, s), 0.13 (6H, s), 0.84 (9H, s), 0.87 (9H, s), 0.88 (9H, s), 0.882 (9H, s), 1.10 (3H, s), 1.11 (3H, s), 1.458 (9H, s), 1.463 (3H, s), 1.72–2.04 (10H, m), 2.12–2.23 (2H, m), 3.24–3.51 (8H, m), 3.72 (3H, s), 3.73 (3H, s), 3.79–3.82 (6H, m), 3.83 (2H, s), 3.86 (2H, s), 4.15–4.20 (4H, m), 5.15 (1H, 1/2 ABq, *J* = 14.2 Hz), 5.20 (1H, 1/2 ABq, *J* = 14.2 Hz), 5.28 (1H, m), 5.45 (1H, m), 6.67–6.71 (4H, m), 6.76 (2H, d, *J* = 8.5 Hz), 6.81–6.90 (6H, m), 7.16 (2H, d, *J* = 8.5 Hz), 8.12 (2H, s, D<sub>2</sub>O exch). IR (NaCl, neat): 2920, 1655, 1508, 1449, 1250, 1220, 1091, 838 cm<sup>-1</sup>.

<sup>1</sup>H NMR (300 MHz) (CDCl<sub>3</sub>) (a racemic mixture of two diastereomers) (41): δ -0.18 (12H, s), 0.12 (6H, s), 0.13 (6H, s), 0.26–0.41 (2H, m), 0.47–0.58 (2H, m), 0.62–0.72 (2H, m), 0.84 (18H, s), 0.87 (9H, s), 0.89 (9H, s), 1.06 (3H, s), 1.44 (6H, s), 1.47 (3H, s), 1.48 (3H, s), 1.63–1.67 (2H, m), 2.10–2.17 (2H, m), 2.44–2.52 (2H, m), 2.89–3.05 (2H, m), 3.20–3.28 (2H, m), 3.40–3.52 (4H, m), 3.71–3.97 (16H, m), 4.08 (2H, br s), 4.14–4.21 (2H, m), 5.05 (2H, br s), 5.56 (1H, 1/2 ABq, *J* = 14.2 Hz), 5.57 (1H, 1/2 ABq, *J* = 14.5 Hz), 6.71 (1H, d, *J* = 8.6 Hz), 6.73 (1H, d, *J* = 8.6 Hz), 6.83–6.88 (6H, m), 7.14 (1H, d, *J* = 8.6 Hz), 7.18 (1H, d, *J* = 8.6 Hz), 7.22–7.23 (4H, m), 8.34 (2H, s, D<sub>2</sub>O exch). IR (anti) (neat): 2932, 1649, 1508, 1455, 1250, 1220, 1103, 838 cm<sup>-1</sup>. HRMS (EI) (anti): 831.46765 (C<sub>46</sub>H<sub>69</sub>N<sub>3</sub>O<sub>5</sub>Si<sub>2</sub> requires 831.4674).

[(±)-[3α,8αα(*E*)]]-1,1-Dimethylethyl 8-[[3-(Methoxycarbonyl)-2-[[4-methoxyphenyl)methyl]-8a-[4-[[[(1,1-dimethylethyl)dimethylsilyl]oxy]-3-methyl-2-butenyl]octahydro-1,4-dioxopyrrolo[1,2-*a*]pyrazin-3-yl)methyl]-3-[[[(1,1-dimethylethyl)dimethylsilyl]oxy]-3,4-dihydro-4,4-dimethyl-2*H*,10*H*-[1,4]dioxepino[2,3-*g*]indole-10-carboxylate (42). To a stirred solution of 39 (260.0 mg, 0.292 mmol, 1.0 equiv) in CH<sub>2</sub>Cl<sub>2</sub> (1.5 mL) at 0 °C under Ar were added DMAP (35.7 mg, 0.292 mmol, 1.0 equiv) and Et<sub>3</sub>N (0.041 mL, 0.29 mmol, 1.0 equiv). After 5 min (BOC)<sub>2</sub>O (191.2 mg, 0.876 mmol, 3.0 equiv) was added in one portion. The resulting solution was stirred for 20 h, poured into water, and extracted with EtOAc. The organic layer was washed with brine, dried over Na<sub>2</sub>SO<sub>4</sub>, and concentrated under reduced pressure. The crude solid was purified by radial chromatography (eluted with 1:5 EtOAc/hexanes) to yield 260.4 mg (90%) of 42 as a white crystalline solid, mp 74–75 °C.

<sup>1</sup>H NMR (300 MHz) (CDCl<sub>3</sub>): δ -0.01 (6H, s), 0.00 (6H, s), 0.113 (6H, s), 0.12 (6H, s), 0.58–0.68 (2H, m), 0.80–0.92 (38H, m), 1.06 (6H, s), 1.45–1.63 (2H, m), 1.47 (6H, s), 1.53 (6H, s), 1.60 (18H, s), 1.59–1.81 (2H, m), 2.22–2.34 (2H, m), 2.60 (2H, dd, *J* = 8.1, 15.0 Hz), 2.91–3.08 (2H, m), 3.26 (6H, s), 3.26–3.42 (2H, m), 3.56 (1H, 1/2 ABq, *J* = 14.8 Hz), 3.59 (1H, 1/2 ABq, *J* = 14.8 Hz), 3.71–3.80 (4H, m), 3.74 (6H, s), 3.83 (2H, s), 3.84 (2H, s), 3.90–3.97 (4H, m), 4.13–4.17 (2H, m), 3.32 (2H, m), 5.34 (1H, 1/2 ABq, *J* = 14.8 Hz), 5.42 (1H, 1/2 ABq, *J* = 14.8 Hz), 6.75–6.79 (4H, m), 6.88 (1H, d, *J* = 8.4 Hz), 6.89 (1H, d, *J* = 8.4 Hz), 7.03 (2H, s), 7.12–7.20 (6H, m). IR (NaCl, neat): 2943, 1752, 1660, 1507, 1496, 1464, 1463, 1404, 1365, 1251, 1153, 1109, 1082, 837, 772 cm<sup>-1</sup>. HRMS (EI): 989.5249 (C<sub>53</sub>H<sub>79</sub>N<sub>3</sub>O<sub>7</sub>Si<sub>2</sub> requires 989.5253).

[(±)-[3β,8αβ(*E*)]]-1,1-Dimethylethyl 8-[[8a-[4-[[[(1,1-dimethylethyl)dimethylsilyl]oxy]-3-methyl-2-butenyl]-2-[(4-methoxyphenyl)methyl]octahydro-1,4-dioxopyrrolo[1,2-*a*]pyrazin-3-yl)methyl]-3-[[[(1,1-dimethylethyl)dimethylsilyl]oxy]-3,4-dihydro-4,4-dimethyl-2*H*,10*H*-[1,4]dioxepino[2,3-*g*]indole-10-carboxylate (*syn*-43). [(±)-[3α,8αβ(*E*)]]-1,1-Dimethylethyl 8-[[8a-[4-[[[(1,1-dimethylethyl)dimethylsilyl]oxy]-3-methyl-2-butenyl]-2-[(4-methoxyphenyl)methyl]octahydro-1,4-dioxopyrrolo[1,2-*a*]pyrazin-3-yl)methyl]-3-[[[(1,1-dimethylethyl)dimethylsilyl]oxy]-3,4-dihydro-4,4-dimethyl-2*H*,10*H*-[1,4]dioxepino[2,3-*g*]indole-10-carboxylate (*anti*-43). A flask containing 42 (126.6 mg, 0.128 mmol, 1.0 equiv) and LiCl (27.1 mg, 0.64 mmol, 5.0 equiv) under N<sub>2</sub> was charged with HMPA (0.78 mL) and H<sub>2</sub>O (3.4 × 10<sup>-3</sup> mL, 1.9 × 10<sup>-4</sup> mmol, 1.5 equiv). The solution was heated (100–105 °C) for 1.25 h and then poured into water and extracted with ether. The organic layer was washed with water and brine, dried over MgSO<sub>4</sub>, and concentrated, leaving a crude oily solid. The product

was purified by radial chromatography (eluted with 1:5 EtOAc/hexanes) to yield 79.2 mg (66%) of *syn*-**43** (an analytical sample was obtained by PTLC, eluted with 1:5 EtOAc/hexanes, to give an oil) and 3.1 mg (2.6%) of the *anti*-isomer (oil).

<sup>1</sup>H NMR (300 MHz) (CDCl<sub>3</sub>) (*syn*-**43**): δ 0.026 (6H, s), 0.32 (6H, s), 0.127 (6H, s), 0.14 (6H, s), 0.867 (9H, s), 0.873 (9H, s), 0.878 (9H, s), 0.883 (9H, s), 1.10 (6H, s), 1.48 (3H, s), 1.49 (3H, s), 1.55 (3H, s), 1.57 (3H, s), 1.610 (9H, s), 1.613 (9H, s), 1.83–1.96 (6H, s), 2.22–2.35 (4H, m), 2.46 (2H, dd, *J* = 6.0, 15.0 Hz), 3.11–3.21 (2H, m), 3.31–3.85 (2H, m), 3.37 (1H, <sup>1</sup>/<sub>2</sub>ABq, *J* = 14.5 Hz), 3.48 (1H, <sup>1</sup>/<sub>2</sub>ABq, *J* = 14.6 Hz), 3.71 (3H, s), 3.72 (3H, s), 3.76–3.98 (8H, m), 3.99 (2H, m), 4.02 (2H, s), 4.15–4.21 (4H, m), 5.17 (1H, <sup>1</sup>/<sub>2</sub>ABq, *J* = 14.5 Hz), 5.20 (1H, <sup>1</sup>/<sub>2</sub>ABq, *J* = 14.6 Hz), 5.35 (1H, m), 5.48 (1H, m), 6.62–6.70 (6H, m), 6.79 (2H, m), 6.91 (2H, d, *J* = 8.3 Hz), 7.14 (1H, d, *J* = 8.4 Hz), 7.16 (1H, d, *J* = 8.3 Hz), 7.22 (1H, s), 7.23 (1H, s). IR (NaCl, neat) (*syn*): 2932, 1755, 1661, 1455, 1367, 1250, 1156, 1114, 1091, 838 cm<sup>-1</sup>. HRMS (EI) (*syn*): 931.51955 (C<sub>51</sub>H<sub>77</sub>N<sub>3</sub>O<sub>9</sub>Si<sub>2</sub> requires 931.5198). Microanal. Calcd for C<sub>51</sub>H<sub>77</sub>N<sub>3</sub>O<sub>9</sub>Si<sub>2</sub>: C, 65.70; H, 8.32; N, 4.51. Found: C, 65.37; H, 8.37; N, 4.54.

<sup>1</sup>H NMR (300 MHz) (CDCl<sub>3</sub>) (*anti*): δ -0.02 (6H, s), -0.01 (6H, s), 0.03–0.22 (2H, m), 0.12 (6H, s), 0.13 (6H, s), 0.146–0.62 (4H, m), 0.84 (9H, s), 0.85 (9H, s), 0.87 (18H, s), 1.05 (3H, s), 1.07 (3H, s), 1.43 (3H, s), 1.47 (3H, s), 1.49 (3H, s), 1.52 (3H, s), 1.55 (9H, s), 1.60 (9H, s), 1.80–1.91 (2H, m), 2.19–2.22 (2H, m), 2.50–2.61 (2H, m), 3.09–3.23 (2H, m), 3.29–3.52 (4H, m), 3.63–3.96 (18H, m), 4.13–4.20 (4H, m), 5.04–5.10 (1H, m), 5.28–5.32 (1H, m), 5.48 (1H, <sup>1</sup>/<sub>2</sub>ABq, *J* = 14.3 Hz), 5.52 (1H, <sup>1</sup>/<sub>2</sub>ABq, *J* = 14.3 Hz), 6.71–6.90 (6H, m), 7.04–7.22 (8H, m). IR (NaCl, neat) (*anti*): 3295 (br), 1753, 1657, 1510, 1447, 1249, 1152, 1090, 1034, 836, 773 cm<sup>-1</sup>.

**1,1-Dimethylethyl 8-[[8a-[4-Hydroxy-3-methyl-2-butenyl]-2-[(4-methoxyphenyl)methyl]octahydro-1,4-dioxopyrrolo[1,2-*a*]pyrazin-3-yl]methyl]-3-hydroxy-3,4-dihydro-4,4-dimethyl-2*H*,10*H*-[1,4]dioxepino[2,3-*g*]indole-10-carboxylate (44).** To a stirred solution of **43** (36.3 mg, 0.04 mmol, 1.0 equiv) under N<sub>2</sub> in THF (1.0 mL) was added *n*-Bu<sub>4</sub>NF (0.12 mL, 0.12 mmol, 3.0 eq, 1.0M/THF). The solution was heated (~40 °C) for 3 h. At this time the solution was diluted with water and extracted with ethyl acetate. The organic layer was washed with brine and dried over MgSO<sub>4</sub>. The residue was purified by PTLC on silica gel (eluted with EtOAc) to yield 24.9 mg (79%) of **44**.

<sup>1</sup>H NMR (300 MHz) (CDCl<sub>3</sub>): δ 1.19 (3H, s), 1.22 (3H, s), 1.52 (3H, s), 1.53 (3H, s), 1.56 (3H, s), 1.57 (3H, s), 1.59 (9H, s), 1.60 (9H, s), 1.72–2.21 (12H, m), 2.71 (2H, br s, D<sub>2</sub>O exch), 3.18–3.49 (4H, m), 3.51 (2H, <sup>1</sup>/<sub>2</sub>ABq, *J* = 14.5 Hz), 3.56 (1H, s, D<sub>2</sub>O exch), 3.61 (1H, s, D<sub>2</sub>O exch), 3.72 (3H, s), 3.74 (3H, s), 3.75–3.94 (6H, s), 4.18–4.30 (4H, s), 4.26–4.27 (4H, m), 4.44 (2H, m), 5.25 (2H, <sup>1</sup>/<sub>2</sub>ABq, *J* = 14.5 Hz), 5.25 (2H, <sup>1</sup>/<sub>2</sub>ABq, *J* = 14.4 Hz), 6.70 (2H, d, *J* = 8.7 Hz), 6.77 (2H, d, *J* = 8.6 Hz), 6.83 (2H, d, *J* = 8.6 Hz), 6.927 (1H, d, *J* = 8.4 Hz), 6.932 (1H, d, *J* = 8.3 Hz), 7.03 (2H, d, *J* = 8.6 Hz), 7.12 (1H, d, *J* = 8.3 Hz), 7.15 (1H, d, *J* = 8.4 Hz), 7.21 (1H, s), 7.23 (1H, s). IR (NaCl, neat): 3422, 2976, 1753, 1649, 1513, 1496, 1457, 1371, 1333, 1251, 1153, 1033, 733 cm<sup>-1</sup>. Mass spectrum (EI): *m/e* (relative intensity) 703 (M<sup>+</sup>, 8), 604 (37), 603 (100). HRMS (EI): 703.3461 (C<sub>39</sub>H<sub>49</sub>N<sub>3</sub>O<sub>9</sub> requires 703.3472).

**1,1-Dimethylethyl 8-[[8a-[4-Chloro-3-methyl-2-butenyl]-2-[(4-methoxyphenyl)methyl]octahydro-1,4-dioxopyrrolo[1,2-*a*]pyrazin-3-yl]methyl]-3-hydroxy-3,4-dihydro-4,4-dimethyl-2*H*,10*H*-[1,4]dioxepino[2,3-*g*]indole-10-carboxylate (45).** To **44** (24.9 mg, 0.035 mmol, 1.0 equiv) in DMF (0.35 mL) at 0 °C under Ar were added dry LiCl (2.9 mg, 0.07 mmol, 1.9 equiv) and collidine (7 μL, 0.05 mmol, 1.5 equiv). After stirring for 10 min, methanesulfonyl chloride (4 μL, 0.05 mmol, 1.5 equiv) was added dropwise. The ice bath was removed and the mixture stirred at room temperature for 24 h. At this time additional collidine (2.5 equiv) and methanesulfonyl chloride (2.5 equiv) were added, and the mixture was stirred for 2 h. It was then diluted with water and extracted with EtOAc. The organic layer was washed with brine, dried over MgSO<sub>4</sub>, and concentrated to dryness. The product was purified by PTLC on silica gel (eluted with 2:1 EtOAc/hexanes) to yield 21.9 mg (86%) of **45** as an oil.

<sup>1</sup>H NMR (300 MHz) (CDCl<sub>3</sub>): δ TMS 1.22 (3H, s), 1.23 (3H, s), 1.57 (3H, s), 1.58 (3H, s), 1.62 (9H, s), 1.63 (9H, s), 1.66 (3H, s), 1.73 (3H, s), 1.83–1.93 (8H, m), 2.05–2.37 (4H, m), 3.06 (2H, dd, *J* = 3.8, 11.4 Hz), 3.35–3.42 (6H, m, 1H, D<sub>2</sub>O exch), 3.46–3.69 (4H, m), 3.75 (3H, s), 3.77 (3H, s), 3.86–3.94 (2H, m), 3.96 (2H, s), 4.02 (2H, s), 4.21–4.29 (6H, m), 5.20–5.29 (3H, m), 5.53 (1H, m), 6.69–6.81 (6H, m), 6.94–6.99 (4H, m), 7.18–7.21 (4H, m). IR (NaCl, neat): 3433, 2976, 1752, 1654, 1513, 1496, 1453, 1371, 1251, 1153 cm<sup>-1</sup>.

**1,1-Dimethylethyl 8-[[8a-[4-Hydroxy-3-methyl-2-butenyl]-2-[(4-methoxyphenyl)methyl]octahydro-1,4-dioxopyrrolo[1,2-*a*]pyrazin-3-yl]methyl]-3-[[[1,1-dimethylethyl]dimethylsilyloxy]-3,4-dihydro-4,4-dimethyl-2*H*,10*H*-[1,4]dioxepino[2,3-*g*]indole-10-carboxylate (46).** To a solution of **45** (28.2 mg, 0.04 mmol, 1.0 equiv) in CH<sub>2</sub>Cl<sub>2</sub> (0.3 mL) at 0 °C under Ar was added *tert*-butyldimethylsilyl triflate (9.0 μL, 0.047 mmol, 1.2 equiv) followed immediately by 2,6-lutidine (6.0 μL, 0.047 mmol, 1.4 equiv). The mixture was stirred for 2 h, then diluted with EtOAc, washed with water and brine, dried over MgSO<sub>4</sub>, and concentrated under reduced pressure. The product was purified by radial chromatography (eluted with 1:1 EtOAc/hexanes) to yield 24.9 mg (76%) of **46** as an oil.

<sup>1</sup>H NMR (300 MHz) (CDCl<sub>3</sub>): δ 0.12 (6H, s), 0.13 (6H, s), 0.87 (9H, s), 0.88 (9H, s), 1.08 (3H, s), 1.10 (3H, s), 1.48 (6H, s), 1.61 (9H, s), 1.63 (9H, s), 1.69 (3H, s), 1.79 (3H, s), 1.82–2.03 (8H, m), 2.16–2.24 (4H, m), 3.19 (2H, dd, *J* = 7.2, 8.5 Hz), 3.25–3.39 (4H, m), 3.49 (1H, <sup>1</sup>/<sub>2</sub>ABq, *J* = 14.5 Hz), 3.65 (1H, <sup>1</sup>/<sub>2</sub>ABq, *J* = 14.5 Hz), 3.72 (3H, s), 3.76 (3H, s), 3.79–3.99 (8H, m), 4.15–4.22 (4H, m), 5.19–5.28 (4H, m), 5.49 (2H, m), 6.67–6.81 (6H, m), 6.92 (4H, dd, *J* = 1.9, 8.4 Hz), 7.13 (1H, d, *J* = 8.4 Hz), 7.14 (1H, d, *J* = 8.4 Hz), 7.20 (1H, s), 7.24 (1H, s). IR (NaCl, neat): 2932, 1752, 1654, 1512, 1491, 1447, 1365, 1251, 1153, 1088, 837 cm<sup>-1</sup>.

**(±)-[3α,8α,10(R\*)]-1,1-Dimethylethyl 8-[[Tetrahydro-2-[(4-methoxyphenyl)methyl]-10-(1-methylethenyl)-1,4-dioxo-6*H*-3,8a-ethanopyrrolo[1,2-*a*]pyrazin-3(4*H*)-yl]methyl]-3-[[[1,1-dimethylethyl]dimethylsilyloxy]-3,4-dihydro-4,4-dimethyl-2*H*,10*H*-[1,4]dioxepino[2,3-*g*]indole-10-carboxylate (47).** To **46** (24.0 mg, 0.028 mmol, 1.0 equiv) in a flask equipped with a magnetic stir bar were added NaH (12.3 mg, 0.3 mmol, 10.8 equiv) and benzene (3.5 mL). The flask was fitted with a condenser and gently refluxed for 59 h (additional benzene (1.5 mL) was added during this time). The solution was stirred at room temperature for 8 days, after which NaI (10.8 mg, 0.072 mmol, 2.5 equiv) was added. The mixture was then stirred at reflux temperature for an additional 2 days. The resulting mixture was diluted with EtOAc, washed with water and brine, dried over MgSO<sub>4</sub>, and concentrated under reduced pressure. The product was purified by PTLC on silica gel (eluted with 1:1 hexanes/EtOAc) to afford 2.5 mg (11% or 19% based on recovered **46**) of **47** as an amorphous yellow solid.

<sup>1</sup>H NMR (300 MHz) (CDCl<sub>3</sub>): δ 0.12 (6H, s), 0.14 (6H, s), 0.882 (9H, s), 0.885 (9H, s), 1.10 (3H, s), 1.13 (3H, s), 1.48 (3H, s), 1.49 (3H, s), 1.55 (3H, s), 1.56 (3H, s), 1.59 (18H, s), 1.80 (2H, dd, *J* = 5.7, 13.3 Hz), 1.90 (2H, dd, *J* = 13.2 Hz), 2.03–2.08 (4H, m), 2.22 (2H, dd, *J* = 10.4, 13.4 Hz), 2.85–2.98 (4H, m), 3.08 (2H, <sup>1</sup>/<sub>2</sub>ABq, *J* = 17.1 Hz), 3.29 (2H, <sup>1</sup>/<sub>2</sub>ABq, *J* = 17.6 Hz), 3.56–3.62 (4H, m), 3.72 (3H, s), 3.73 (3H, s), 3.74–3.83 (2H, dd, *J* = 9.4, 12.5 Hz), 3.91–3.96 (2H, m), 4.18 (2H, dd, *J* = 3.6, 12.2 Hz), 4.28 (1H, <sup>1</sup>/<sub>2</sub>ABq, *J* = 15.9 Hz), 4.37 (1H, <sup>1</sup>/<sub>2</sub>ABq, *J* = 15.9 Hz), 4.54–4.74 (6H, m), 6.62–6.75 (8H, m), 6.89–6.94 (2H, m), 6.99–7.04 (2H, m), 7.25 (1H, s), 7.28 (1H, s). IR (NaCl, neat): 2932, 1687, 1365, 1251, 1158, 1088 cm<sup>-1</sup>. HRMS (EI): 799.4252 (C<sub>45</sub>H<sub>61</sub>N<sub>3</sub>O<sub>9</sub>Si requires 799.4228).

**(*R*)-(E)-8a-[3-Methyl-4-oxo-2-buten-yl]hexahydro-1,2-*a*]pyrazine-1,4-dione (49).** To a stirred solution of **48** (17.25 g, 48.45 mmol, 1.0 equiv) in a 2:1 solution of CH<sub>3</sub>CN (343 mL) and H<sub>2</sub>O (171 mL) was added, in one portion, CAN (93 g, 170 mmol, 3.8 equiv). After stirring for 2 h, the orange solution was poured into a large separatory funnel and exhaustively extracted with CHCl<sub>3</sub>. The organic layer was washed with brine, dried over Na<sub>2</sub>SO<sub>4</sub>, and concentrated under reduced pressure. The product was purified by column chromatography (eluted with 95:4:1 CH<sub>2</sub>Cl<sub>2</sub>/MeOH/AcOH) to yield 9.0 g (79%) of **49** as a yellow oil. An analytical sample was obtained by PTLC (silica gel, eluted with 1:1 hexanes/EtOAc).

<sup>1</sup>H NMR (300 MHz) (CDCl<sub>3</sub>): δ TMS 1.76 (3H, s), 1.99–2.10 (2H, br s), 2.17–2.26 (2H, m), 2.78 (1H, dd, *J* = 7.3, 14.5 Hz), 2.90 (1H, s).

dd,  $J = 8.0, 14.8$  Hz), 3.54–3.63 (1H, m), 3.84 (1H, dt,  $J = 12.3, 8.4$  Hz), 3.95 (1H, d  $\frac{1}{2}$  ABq,  $J = 3.4, 17.6$  Hz), 4.10 (1H,  $\frac{1}{2}$  ABq,  $J = 17.6$  Hz), 6.55 (1H, t,  $J = 7.2$  Hz), 7.96 (1H, br s, D<sub>2</sub>O exch), 9.45 (1H, s). IR (NaCl, neat): 3246, 1684, 1448, 1326, 1107 cm<sup>-1</sup>.  $[\alpha]_D^{25} = -1.51/1.92 \times 10^{-3}$ ° = -78.4° (CH<sub>2</sub>Cl<sub>2</sub>,  $c = 0.164$ ). Microanal. Calcd: C, 61.00; H, 6.83; N, 11.86. Found: C, 60.88; H, 6.66; N, 11.71. HRMS (EI): 236.1155 (C<sub>12</sub>H<sub>16</sub>N<sub>2</sub>O<sub>3</sub> requires 236.11609).

**(R)-(E)-8a-[4-[[[(1,1-Dimethylethyl)diphenylsilyl]oxy]-3-methyl-2-butenyl]hexahydro-2H-pyrrolo[1,2-a]pyrazine-1,4-dione (50).** To a stirred solution of **49** (9.0 g, 37 mmol, 1.0 equiv) in absolute ethanol (742 mL) at room temperature was added NaBH<sub>4</sub> (2.85 g, 75.5 mmol, 2.0 equiv). After 2 h the excess hydride was quenched with water (500 mL) and the pH adjusted to 3–4 by the slow addition of 1 M HCl. Fifteen minutes later, the water and ethanol were removed under reduced pressure and the crude residue was dried in vacuo overnight. The resulting mass (10.87 g) was triturated (1:4 CH<sub>3</sub>OH/CH<sub>2</sub>Cl<sub>2</sub>) and filtered to remove the salts. The remaining solution was concentrated to yield 9.1 g of the crude allylic alcohol, which was immediately utilized for the next step without additional purification. The crude allylic alcohol (9.1 g, 38 mmol, 1.0 equiv) was dissolved in DMF (191 mL) under Ar, and to this mixture was added imidazole (11.9 g, 175.3 mmol, 4.6 equiv) followed by *tert*-butyldiphenylsilyl chloride (12.9 mL, 49.5 mmol, 1.3 equiv). After 2 days the reaction mixture was diluted with water (1 L) and extracted with a 1:1 solution of hexanes and EtOAc. The organic layer was washed with brine, dried over Na<sub>2</sub>SO<sub>4</sub>, and concentrated to dryness. The crude solid was recrystallized (ethyl acetate, two crops) to give 10.5 g of the product. The remaining mother liquor was chromatographed (eluted with EtOAc) to give 3.0 g of the pure product. Total yield of **50**: 13.5 g (75% from the enone, two steps). An analytical sample was recrystallized from acetone to provide a white crystalline solid, mp 132 °C.

<sup>1</sup>H NMR (300 MHz) (CDCl<sub>3</sub>): δ 1.03 (9H, s), 1.54 (3H, s), 1.92–2.19 (4H, m), 2.49 (1H, dd,  $J = 8.6, 14.1$  Hz), 2.58 (1H, dd,  $J = 7.5, 14.1$  Hz), 3.44–3.53 (1H, m), 3.73 (1H, d  $\frac{1}{2}$  ABq,  $J = 4.1, 16.9$  Hz), 3.78–3.85 (1H, m), 4.01 (2H, s), 4.06 (1H,  $\frac{1}{2}$  ABq,  $J = 16.9$  Hz), 5.56–5.62 (1H, m), 6.38 (1H, d,  $J = 3.7$  Hz, D<sub>2</sub>O exch), 7.32–7.43 (6H, m), 7.62 (4H, dd,  $J = 1.8, 7.6$  Hz). IR (NaCl, neat): 3232 (br), 2930, 2857, 1664, 1446, 1435, 1113, 822, 733, 702 cm<sup>-1</sup>.  $[\alpha]_D^{25} = -63.3$ ° (CDCl<sub>3</sub>,  $c = 0.0822$ ). Microanal. Calcd for C<sub>28</sub>H<sub>36</sub>N<sub>2</sub>O<sub>5</sub>Si: C, 70.55; H, 7.61; N, 5.88. Found C, 70.60; H, 7.56; N, 5.91.

**[(R)-[3α,8αβ(E)]]-Methyl 8a-[4-[[[(1,1-Dimethylethyl)diphenylsilyl]oxy]-3-methyl-2-butenyl]octahydro-2-(methoxycarbonyl)-1,4-dioxopyrrolo[1,2-a]pyrazine-3-carboxylate (51).** To a stirred solution of **50** (8.12 g, 17.0 mmol, 1.0 equiv) in THF (208 mL) at -78 °C, was added a solution of *n*-BuLi (10.65 mL, 17.03 mmol, 1.0 equiv, 1.6 M/hexanes) dropwise. After 25 min methyl chloroformate (1.45 mL, 18.7 mmol, 1.1 equiv) was added dropwise to the reaction mixture and stirred for 25 min. The solution was then transferred via cannula to a cold (-100 °C) flask charged with LiN[Si(CH<sub>3</sub>)<sub>2</sub>]<sub>2</sub> (37.47 mL, 37.47 mmol, 2.2 equiv, 1.0 M/THF) and methyl chloroformate (1.45 mL, 18.7 mmol, 1.1 equiv). The resulting solution was stirred for 45 min, diluted with EtOAc, and washed with saturated aqueous NH<sub>4</sub>Cl and brine. The organic layer was dried over MgSO<sub>4</sub> and concentrated under reduced pressure. The residue was purified by flash column chromatography (eluted with 2:1 hexanes/EtOAc) to yield 9.4 g (93%) of **51** (as a mixture of two diastereomers, *anti/syn*). An analytical sample (oil) was obtained by PTLC (eluted with 2:1 hexanes/EtOAc).

<sup>1</sup>H NMR (300 MHz) (CDCl<sub>3</sub>): δ 1.04 (9H, s), 1.40 (3H, s), 1.86–2.03 (2H, m), 2.12–2.31 (2H, m), 2.55 (1H, d,  $J = 7.4$  Hz), 3.43–3.52 (2H, m), 3.74–3.82 (1H, m), 3.83 (3H, s), 3.88 (3H, s), 4.03 (2H, br s), 5.48–5.53 (2H, m), 7.34–7.41 (6H, m), 7.57–7.66 (4H, m). IR (NaCl, neat): 2960, 1790, 1740, 1681, 1430, 1366, 1272, 1223, 1109, 735, 705 cm<sup>-1</sup>. Microanal. Calcd for C<sub>32</sub>H<sub>40</sub>N<sub>2</sub>O<sub>7</sub>Si: C, 68.06; H, 7.14; N, 4.96. Found: C, 67.87; H, 7.27; N, 4.77.

**[3β,8αβ(E)]-Methyl 3-[[[(1,1-Dimethylethyl)dimethylsilyl]oxy]-3,4-dihydro-4,4-dimethyl-2H,10H-[1,4]dioxepino[2,3-g]indol-8-yl]methyl]-8a-[4-[[[(1,1-dimethylethyl)diphenylsilyl]oxy]-3-methyl-2-butenyl]octahydro-1,4-dioxopyrrolo[1,2-a]pyrazine-3-carboxylate (52).** To a flask containing **51** (5.89 g, 14.56 mmol, 1.0 equiv) and **36** (8.64 g, 14.56 mmol, 1.1 equiv) were added CH<sub>3</sub>CN (291 mL) and tributylphosphine (1.82 mL, 7.28 mmol, 0.5 equiv). The resulting mixture was gently refluxed for 3.5 h and then stirred at room

temperature overnight. The solvent was removed *in vacuo*, and the residue was purified by column chromatography (eluted with 1:2 EtOAc/hexanes) to yield 9.56 g (73%) of **52**. An analytical sample was purified by PTLC on silica gel (eluted with 1:2 EtOAc/hexanes) to give a white crystalline solid, mp 106–108 °C.

<sup>1</sup>H NMR (300 MHz) (CDCl<sub>3</sub>) (mixture of two diastereomers): δ 0.10 (6H, s), 0.115 (3H, s), 0.12 (3H, s), 0.87 (9H, s), 0.88 (9H, s), 1.02 (18H, s), 1.096 (3H, s), 1.10 (3H, s), 1.45 (3H, s), 1.46 (3H, s), 1.54 (6H, s), 1.60–1.88 (6H, m), 2.02–2.11 (2H, m), 2.92 (2H, dd,  $J = 7.1, 14.4$  Hz), 2.44 (2H, dd,  $J = 8.1, 14.5$  Hz), 3.32–3.44 (4H, m), 3.60 (3H, s), 3.62 (3H, s), 3.72–3.93 (8H, m), 3.98 (4H, br s), 4.18 (2H, dd,  $J = 2.9, 8.4$  Hz), 5.43 (2H, m), 6.38 (1H, s, D<sub>2</sub>O exch), 6.41 (1H, s, D<sub>2</sub>O exch), 6.74 (1H, d,  $J = 8.5$  Hz), 6.75 (1H, d,  $J = 8.5$  Hz), 6.89 (1H, d,  $J = 2.3$  Hz), 6.92 (1H, d,  $J = 2.3$  Hz), 7.08 (2H, d,  $J = 8.5$  Hz), 7.33–7.41 (12H, m), 7.61–7.63 (8H, m), 8.43 (1H, d,  $J = 2.9$  Hz, D<sub>2</sub>O exch), 8.64 (1H, d,  $J = 1.9$  Hz, D<sub>2</sub>O exch). <sup>13</sup>C NMR (75.5 MHz) (CDCl<sub>3</sub>) (mixture of two diastereomers): δ 4.8, 4.2, 9.5, 17.9, 19.2, 19.3, 19.5, 20.3, 25.7, 26.8, 28.0, 28.3, 29.7, 33.7, 35.6, 46.1, 46.2, 53.3, 66.9, 68.0, 71.6, 76.3, 80.7, 80.8, 108.2, 112.9, 117.1, 117.9, 118.0, 123.5, 123.6, 125.5, 127.6, 129.1, 129.2, 129.6, 133.6, 135.5, 138.8, 141.6, 141.8, 161.4, 169.7, 170.5, 170.6. IR (NaCl, neat): 3281 (br), 2954, 2932, 2856, 1747, 1670, 1665, 1649, 1431, 1251, 1224, 1109, 1088, 733, 706 cm<sup>-1</sup>. HRMS (EI): 893.4457 (C<sub>50</sub>H<sub>67</sub>N<sub>3</sub>O<sub>8</sub>Si<sub>2</sub> requires 893.4467). Microanal. Calcd for C<sub>50</sub>H<sub>67</sub>N<sub>3</sub>O<sub>8</sub>Si<sub>2</sub>: C, 67.16; H, 7.55; N, 4.70. Found: C, 66.93; H, 7.36; N, 4.51.

**[3β,8αβ(E)]-8-[[8a-[4-[[[(1,1-Dimethylethyl)diphenylsilyl]oxy]-3-methyl-2-butenyl]octahydro-1,4-dioxopyrrolo[1,2-a]pyrazin-3-yl]methyl]-3-[[[(1,1-dimethylethyl)dimethylsilyl]oxy]-3,4-dihydro-4,4-dimethyl-2H,10H-[1,4]dioxepino[2,3-g]indole (53).** **[3α,8αβ(E)]-8-[[8a-[4-[[[(1,1-Dimethylethyl)diphenylsilyl]oxy]-3-methyl-2-butenyl]octahydro-1,4-dioxopyrrolo[1,2-a]pyrazin-3-yl]methyl]-3-[[[(1,1-dimethylethyl)dimethylsilyl]oxy]-3,4-dihydro-4,4-dimethyl-2H,10H-[1,4]dioxepino[2,3-g]indole (54).** A flask containing **52** (9.56 g, 10.7 mmol, 1.0 equiv) and LiCl (2.26 g, 53.45 mmol, 5.0 equiv) under Ar was charged with HMPA (82 mL) and water (0.29 mL, 16.0 mmol, 1.5 equiv). This mixture was gently heated (100–105 °C) for 9 h and then diluted with 1:1 hexanes/EtOAc. The resulting solution was washed with water. The organic layer was washed with brine, dried over Na<sub>2</sub>SO<sub>4</sub>, and evaporated to dryness. The residue was purified by column chromatography (eluted with 1:2 EtOAc/hexanes) to yield 5.90 g (66%) of **53** (two diastereomers; an analytical sample was recrystallized from CCl<sub>4</sub>, mp (*syn*) 167–168 °C) and 2.10 g (23%) of **54** (two diastereomers); an analytical sample was obtained by PTLC on silica gel (eluted with 1:2 EtOAc/hexanes, mp (*anti*) 95–99 °C, white crystalline solid). Total combined yield: 8.00 g (89%).

<sup>1</sup>H NMR (300 MHz) (CDCl<sub>3</sub>) (**53**, mixture of two diastereomers): δ TMS 0.12 (6H, s), 0.13 (6H, s), 0.90 (18H, s), 1.0 (18H, s), 1.126 (3H, s), 1.13 (3H, s), 1.48 (6H, s), 1.64 (6H, s), 1.94–2.06 (6H, m), 2.20–2.24 (2H, m), 2.36–2.46 (2H, m), 2.60–2.72 (2H, m), 2.98 (2H, dd,  $J = 11.6, 14.1$  Hz), 3.44–3.57 (4H, m), 3.88 (2H, dd,  $J = 6.7, 9.2$  Hz), 3.97 (2H, dd,  $J = 3.1, 9.1$  Hz), 4.02–4.06 (2H, m), 4.10 (4H, s), 4.17–4.25 (4H, m), 5.58 (2H, m), 5.68 (2H, br s, D<sub>2</sub>O exch), 6.75 (2H, d,  $J = 8.5$  Hz), 6.86 (1H, d,  $J = 2.2$  Hz), 6.88 (1H,  $J = 2.2$  Hz), 7.14 (2H, d,  $J = 8.4$  Hz), 7.26–7.44 (12H, m), 7.60–7.64 (8H, m), 8.04 (1H, s, D<sub>2</sub>O exch), 8.06 (1H, s, D<sub>2</sub>O exch).

The analytical samples of the *syn*-diastereomers were separable by PTLC.

<sup>1</sup>H NMR (300 MHz) (CDCl<sub>3</sub>) (**53a**, less polar): δ TMS 0.12 (3H, s), 0.13 (3H, s), 0.88 (9H, s), 1.03 (9H, s), 1.11 (3H, s), 1.46 (3H, s), 1.63 (3H, s), 1.92–2.04 (3H, m), 2.18–2.23 (1H, m), 2.39 (1H, dd,  $J = 7.2, 14.2$  Hz), 2.64 (1H, dd,  $J = 8.7, 14.2$  Hz), 2.99 (1H, dd,  $J = 11.4, 14.2$  Hz), 3.42–3.46 (1H, m), 3.51 (1H, dd,  $J = 2.7, 14.2$  Hz), 3.85 (1H, dd,  $J = 9.2, 11.3$  Hz), 3.94 (1H, dd,  $J = 3.0, 9$  Hz), 3.99–4.06 (1H, m), 4.08 (2H, s), 4.11–4.15 (1H, m), 4.19 (1H, dd,  $J = 3.0, 11.3$  Hz), 5.58 (1H, t,  $J = 7.8$  Hz), 5.76 (1H, d,  $J = 2.7$  Hz, D<sub>2</sub>O exch), 6.73 (1H, d,  $J = 8.4$  Hz), 6.85 (1H, d,  $J = 2.1$  Hz), 7.11 (1H, d,  $J = 8.5$  Hz), 7.26–7.42 (6H, m), 7.57–7.63 (4H, m), 8.15 (1H, s, D<sub>2</sub>O exch).

<sup>1</sup>H NMR (300 MHz) (CDCl<sub>3</sub>) (**53b**, more polar): δ TMS 0.12 (3H, s), 0.14 (3H, s), 0.88 (9H, s), 1.03 (9H, s), 1.11 (3H, s), 1.46 (3H, s), 1.62 (3H, s), 1.91–2.04 (3H, m), 2.18–2.22 (1H, m), 2.36 (1H, dd,  $J =$



= 7.3, 14.2 Hz), 2.60 (1H, dd,  $J = 8.6, 14.3$  Hz), 2.97 (1H, dd,  $J = 11.3, 14.2$  Hz), 3.41–3.44 (1H, m), 3.50 (1H, dd,  $J = 3.1, 14.2$  Hz), 3.86 (1H, dd,  $J = 9.3, 11.3$  Hz), 3.95 (1H, dd,  $J = 3.0, 9.1$  Hz), 3.99–4.03 (1H, m), 4.08 (2H, s), 4.14–4.16 (1H, m), 4.20 (1H, dd,  $J = 2.9, 11.6$  Hz), 5.56 (1H, t,  $J = 7.5$  Hz), 5.72 (1H, d,  $J = 2.6$  Hz, D<sub>2</sub>O exch), 6.73 (1H, d,  $J = 8.4$  Hz), 6.84 (1H, d,  $J = 2.1$  Hz), 7.11 (1H, d,  $J = 8.4$  Hz), 7.26–7.42 (6H, m), 7.57–7.62 (4H, m), 8.07 (1H, s, D<sub>2</sub>O exch). IR (NaCl, neat) (*syn*): 3274 (br), 2929, 2858, 1666, 1651, 1453, 1428, 1250, 1224, 1112, 1052, 858, 838, 777 cm<sup>-1</sup>. Microanal. Calcd for C<sub>49</sub>H<sub>65</sub>N<sub>3</sub>O<sub>6</sub>Si<sub>2</sub> (*syn*): C, 68.94; H, 7.84; N, 5.02. Found: C, 69.06; H, 7.76; N, 5.03.

<sup>1</sup>H NMR (300 MHz) (CDCl<sub>3</sub>) (**54**, mixture of two diastereomers): δ TMS 0.14 (6H, s), 0.16 (6H, s), 0.90 (18H, s), 1.04 (9H, s), 1.045 (9H, s), 1.09 (3H, s), 1.13 (3H, s), 1.47 (6H, s), 1.53 (3H, m), 1.54 (3H, m), 1.97–2.17 (8H, m), 2.47–2.62 (4H, m), 2.78–2.88 (2H, m), 3.54–3.65 (4H, m), 3.82–3.99 (6H, m), 4.02 (4H, s), 4.21 (2H, dd,  $J = 3.1, 11.0$  Hz), 4.35–4.39 (2H, m), 5.52–5.54 (2H, m), 5.69 (2H, br s, D<sub>2</sub>O exch), 6.60 (2H, d,  $J = 8.4$  Hz), 6.63 (2H, d,  $J = 8.4$  Hz), 6.89 (2H, d,  $J = 2.1$  Hz), 6.98 (2H, d,  $J = 8.4$  Hz), 7.36–7.42 (10H, m), 7.62–7.69 (8H, m), 8.08 (2H, br s, D<sub>2</sub>O exch). IR (NaCl, neat) (*anti*): 3289 (br), 2929, 2855, 1666, 1444, 1428, 1254, 1222, 1111, 857, 836, 704 cm<sup>-1</sup>. Mass spectrum (EI) (*anti*): *m/e* (relative intensity) 833 (M<sup>+</sup>, 0.1), 512 (6.4), 361 (26), 360 (100), 199 (47). Microanal. Calcd for C<sub>48</sub>H<sub>65</sub>N<sub>3</sub>O<sub>6</sub>Si<sub>2</sub> (*anti*): C, 68.94; H, 7.84; N, 5.02. Found: C, 68.76; H, 7.60; N, 4.82.

**[3β,8αβ(E)]-1,1-Dimethylethyl 8-[[2-[(1,1-Dimethylethoxy)carbonyl]-8a-[4-[(1,1-dimethylethyl)diphenylsilyloxy]-3-methyl-2-butenyl]octahydro-1,4-dioxopyrrolo[1,2-*a*]pyrazin-3-yl]methyl]-3-[[1,1-dimethylethyl]dimethylsilyloxy]-3,4-dihydro-4,4-dimethyl-2H,10H-[1,4]dioxepino[2,3-*g*]indole-10-carboxylate (**58**). To a stirred solution of **53** (310 mg, 0.37 mmol, 1.0 equiv) at 0 °C under Ar in CH<sub>2</sub>Cl<sub>2</sub> (7.4 mL) were added Et<sub>3</sub>N (0.1 mL, 0.74 mmol, 2.0 equiv) and DMAP (90.7 mg, 0.74 mmol, 2.0 equiv). After 5 min, (BOC)<sub>2</sub>O (486.2 mg, 2.2 mmol, 6.0 equiv) was added in one portion. The resulting solution was stirred for 8.5 h, poured into water, and extracted with EtOAc. The organic layer was washed with 10% CuSO<sub>4</sub> and brine, dried over MgSO<sub>4</sub>, and concentrated under reduced pressure. The residue was purified by radial chromatography (eluted with 1:2 EtOAc/hexanes) to yield 375 mg (97%) of **58** as an amorphous solid.**

<sup>1</sup>H NMR (300 MHz) (CDCl<sub>3</sub>) (mixture of two diastereomers): δ 0.12 (6H, s), 0.13 (6H, s), 0.879 (9H, s), 0.880 (9H, s), 1.01 (18H, s), 1.05 (3H, s), 1.07 (3H, s), 1.14 (9H, s), 1.18 (9H, s), 1.55 (6H, s), 1.47 (6H, s), 1.57 (18H, s), 1.88–2.16 (6H, m), 2.17–2.26 (2H, m), 2.28–2.36 (2H, m), 2.50 (2H, dd,  $J = 8.1, 14.5$  Hz), 3.22 (2H, m), 3.32–3.45 (4H, m), 3.71–3.81 (2H, m), 3.84–3.96 (4H, m), 4.00 (4H, br s), 4.13–4.18 (2H, m), 5.02–5.07 (2H, m), 5.42 (1H, t,  $J = 7.3$  Hz), 5.53 (1H, t,  $J = 7.5$  Hz), 6.91 (2H, d,  $J = 8.3$  Hz), 7.16 (1H, d,  $J = 8.0$  Hz), 7.19 (1H, d,  $J = 8.2$  Hz), 7.22 (1H, s), 7.24 (1H, s), 7.30–7.40 (12H, m), 7.57–7.61 (8H, m). IR (NaCl, neat): 2932, 1752, 1730, 1660, 1371, 1251, 1153, 1109, 1088, 706 cm<sup>-1</sup>. HRMS (EI): 1035.5481 (C<sub>58</sub>H<sub>81</sub>N<sub>3</sub>O<sub>6</sub>Si<sub>2</sub> requires 1035.5461).

**[3β,8αβ(E)]-1,1-Dimethylethyl 8-[[2-[(1,1-Dimethylethoxy)carbonyl]-8a-[4-hydroxy-3-methyl-2-butenyl]octahydro-1,4-dioxopyrrolo[1,2-*a*]pyrazin-3-yl]methyl]-3,4-dihydro-4,4-dimethyl-3-hydroxy-2H,10H-[1,4]dioxepino[2,3-*g*]indole-10-carboxylate. To a stirred solution of **53** (511 mg, 0.61 mmol, 1.0 equiv) at 0 °C under Ar in CH<sub>2</sub>Cl<sub>2</sub> (12.2 mL) were added DMAP (149.4 mg, 1.2 mmol, 2.0 equiv) and Et<sub>3</sub>N (0.17 mL, 1.2 mmol, 2.0 equiv). After 5 min, (BOC)<sub>2</sub>O (801.0 mg, 3.67 mmol, 6.0 equiv) was added in one portion. The resulting solution was stirred for 2.7 h, and reaction was found to be complete by TLC analysis; during this period, the reaction temperature slowly reached 15 °C. The reaction flask was then charged with THF (12 mL) and the CH<sub>2</sub>Cl<sub>2</sub> removed by evaporation (until the volume of the flask was approximately 12 mL). The solution was stirred at room temperature and *n*-Bu<sub>4</sub>NF (1.96 mL, 1.96 mmol, 3.2 eq, 1.0 M/THF) added quickly. After 22 h, additional *n*-Bu<sub>4</sub>NF (1.0 mL, 1.0 mmol, 1.6 equiv, 1.0 M/THF) was added to the reaction flask and stirred for 24 h. The reaction was complete by TLC and was poured into water and extracted with EtOAc. The organic layer was washed with 10% CuSO<sub>4</sub> and brine, dried over MgSO<sub>4</sub>, and concentrated under reduced pressure. The residue was purified by radial chromatography (eluted**

with EtOAc) to yield 369 mg (89%) of the diol (obtained as a pale yellow, amorphous solid).

<sup>1</sup>H NMR (300 MHz) (CDCl<sub>3</sub>) (mixture of two diastereomers): δ 1.21 (3H, s), 1.24 (3H, s), 1.29 (9H, s), 1.35 (9H, s), 1.47 (6H, s), 1.52 (6H, s), 1.56 (18H, s), 1.63–2.21 (14H, m), 3.21–3.38 (8H, m), 3.54 (1H, br s, D<sub>2</sub>O exch), 3.58 (1H, br s, D<sub>2</sub>O exch), 3.81–3.87 (6H, m, 2H D<sub>2</sub>O exch), 4.22 (4H, d,  $J = 8.0$  Hz), 4.62 (1H, t,  $J = 8.4$  Hz), 4.96–5.01 (2H, m), 5.07 (1H, t,  $J = 7.2$  Hz), 6.90 (1H, d,  $J = 8.4$  Hz), 6.91 (1H, d,  $J = 8.4$  Hz), 7.13 (1H, d,  $J = 8.4$  Hz), 7.18 (1H, d,  $J = 8.4$  Hz), 7.22 (1H, s), 7.23 (1H, s). IR (NaCl, neat): 3436, 2978, 1755, 1649, 1367, 1249, 1149, 732 cm<sup>-1</sup>.

**[3β,8αβ(E)]-1,1-Dimethylethyl 8-[[2-[(1,1-Dimethylethoxy)carbonyl]-8a-[4-chloro-3-methyl-2-butenyl]octahydro-1,4-dioxopyrrolo[1,2-*a*]pyrazin-3-yl]methyl]-3,4-dihydro-4,4-dimethyl-3-hydroxy-2H,10H-[1,4]dioxepino[2,3-*g*]indole-10-carboxylate. To a stirred solution of the diol obtained above (50.0 mg, 0.0725 mmol, 1.0 equiv) in DMF (0.73 mL) at 0 °C under Ar were added collidine (0.014 mL, 0.11 mmol, 1.5 equiv) and LiCl (5.27 mg, 0.12 mmol, 1.7 equiv). After 15 min, MsCl (8.4 μL, 0.11 mmol, 1.5 equiv) was added and the reaction mixture allowed to reach room temperature in the course of 16 h. At this time an additional amount (1.0 equiv) of each reagent was added in the same manner as above. After 8.5 h there was little change by TLC, so a large excess of MsCl (0.06 mL, 0.775 mmol, 10.7 equiv) was added at 0 °C and stirred for ~12 h until only the desired product was apparent by TLC. The solution was diluted with 1:1 hexanes/EtOAc, washed with water and brine, dried over MgSO<sub>4</sub>, and concentrated, under reduced pressure. The residue was purified by radial chromatography, 1:1 EtOAc/hexanes, to yield 45.5 mg (91%) of the product allylic chloride (obtained as a foamy glass).**

<sup>1</sup>H NMR (300 MHz) (CDCl<sub>3</sub>) (mixture of two diastereomers): δ 1.18 (3H, s), 1.20 (3H, s), 1.24 (9H, s), 1.30 (9H, s), 1.51 (3H, s), 1.54 (3H, s), 1.58 (18H, s), 1.64 (3H, s), 1.66 (3H, s), 1.74–2.18 (10H, m), 2.27 (2H, dd,  $J = 8.1, 15.0$  Hz), 3.02 (2H, br s, D<sub>2</sub>O exch), 3.19 (2H, dd,  $J = 7.2, 14.8$  Hz), 3.27–3.44 (4H, m), 3.56 (2H, br s), 3.81–3.89 (2H, m), 3.91 (2H, s), 3.94 (2H, s), 4.18–4.30 (4H, m), 4.99–5.06 (2H, m), 5.21 (1H, t,  $J = 8.3$  Hz), 5.38–5.43 (1H, m), 6.93 (2H, d,  $J = 8.3$  Hz), 7.17 (1H, d,  $J = 8.3$  Hz), 7.20 (1H, d,  $J = 8.3$  Hz), 7.21 (1H, s), 7.24 (1H, s). IR (NaCl, neat): 3384, 2920, 1750, 1736, 1657, 1367, 1250, 1149 cm<sup>-1</sup>.

**[3β,8αβ(E)]-1,1-Dimethylethyl 8-[[2-[(1,1-Dimethylethoxy)carbonyl]-8a-[4-chloro-3-methyl-2-butenyl]octahydro-1,4-dioxopyrrolo[1,2-*a*]pyrazin-3-yl]methyl]-3-[[1,1-dimethylethyl]dimethylsilyloxy]-3,4-dihydro-4,4-dimethyl-2H,10H-[1,4]dioxepino[2,3-*g*]indole-10-carboxylate (**55**). To a stirred solution of the allylic chloride obtained above (96.2 mg, 0.37 mmol, 1.0 equiv) in CH<sub>2</sub>Cl<sub>2</sub> (0.5 mL) under Ar were added 2,6-lutidine (0.016 mL, 0.14 mmol, 0.38 equiv) and *tert*-butyldimethylsilyl triflate (0.03 mL, 0.14 mmol, 0.38 equiv). After 1 h an additional amount (0.5 equiv) of the two reagents was added. The mixture was stirred for 1 h, and another portion (0.5 equiv) of each reagent was added. The solution was stirred for 75 min and was then poured into water and extracted with EtOAc. The organic layer was washed with brine, dried over MgSO<sub>4</sub>, and concentrated under reduced pressure. The residue was purified by radial chromatography (eluted with 1:2 EtOAc/hexanes) to yield 106.5 mg (99%) of **55** as a white crystalline solid, mp 70–73 °C.**

<sup>1</sup>H NMR (300 MHz) (CDCl<sub>3</sub>) (mixture of two diastereomers): δ 0.10 (3H, s), 0.11 (6H, s), 0.12 (3H, s), 0.877 (18H, s), 1.04 (3H, s), 1.06 (3H, s), 1.22 (9H, s), 1.29 (9H, s), 1.44 (3H, s), 1.46 (3H, s), 1.58 (18H, s), 1.62 (3H, s), 1.65 (3H, s), 1.76–2.13 (10H, m), 2.22 (2H, dd,  $J = 8.4, 14.8$  Hz), 3.19 (2H, dd,  $J = 7.1, 14.7$  Hz), 3.26–3.42 (4H, m), 3.68–3.78 (2H, m), 3.81–3.87 (4H, m), 3.90 (2H, s), 3.94 (2H, s), 4.10–4.17 (2H, m), 5.00–5.05 (2H, m), 5.22 (1H, t,  $J = 7.6$  Hz), 5.41 (1H, t,  $J = 7.6$  Hz), 6.91 (2H, d,  $J = 8.3$  Hz), 7.14 (1H, d,  $J = 8.3$  Hz), 7.16 (1H, d,  $J = 8.3$  Hz), 7.21 (1H, s), 7.24 (1H, s). <sup>13</sup>C NMR (75.5 MHz) (CDCl<sub>3</sub>) (mixture of two diastereomers): δ -5.0, -4.1, -4.0, 14.3, 17.8, 18.3, 19.7, 19.8, 25.6, 27.3, 27.4, 27.9, 28.5, 29.6, 30.1, 34.5, 34.7, 36.1, 45.2, 45.32, 51.3, 51.4, 60.5, 68.1, 68.2, 70.9, 70.9, 75.7, 80.2, 83.1, 84.2, 84.2, 113.6, 113.8, 114.1, 114.2, 120.0, 120.1, 122.6, 122.7, 126.9, 127.1, 127.8, 127.9, 129.0, 135.6, 135.8, 140.43, 146.3, 146.4, 148.3, 148.4, 150.3, 150.5, 164.4, 164.5, 168.6, 168.7. IR (NaCl, neat): 2936, 1754, 1729, 1663, 1496, 1456, 1370.

1248, 1152, 1086, 838  $\text{cm}^{-1}$ . HRMS (EI): 815.3973 ( $\text{C}_{42}\text{H}_{62}\text{N}_3\text{O}_9$ -SiCl requires 815.3944).

**[3 $\beta$ ,8 $\alpha\beta$ (E)]-1,1-Dimethylethyl 8-[[8 $\alpha$ -[4-[[1,1-Dimethylethyl)diphenylsilyloxy]-3-methyl-2-butenyl]octahydro-1,4-dioxopyrrolo[1,2-*a*]pyrazin-3-yl]methyl]-3-[[1,1-dimethylethyl)dimethylsilyloxy]-3,4-dihydro-4,4-dimethyl-2*H*,10*H*-[1,4]dioxepino[2,3-*g*]indole-10-carboxylate (59).** To a flask fitted with a reflux condenser was added **58** (799 mg, 0.771 mmol, 1.0 equiv) followed by  $\text{CH}_3\text{CN}$  (15.4 mL) and dimethylamine (0.53 mL, 3.85 mmol, 5.0 equiv, 40% solution in water). The resulting solution was refluxed for 2 h and 20 min. The solvent was removed under reduced pressure and the residue purified by radial chromatography (eluted with 1:2 EtOAc/hexanes) to yield 657 mg (92%) of **59**. An analytical sample was obtained by PTLC, on silica gel (eluted with 1:2 EtOAc/hexanes) (foamy oil).

$^1\text{H}$  NMR (300 MHz) ( $\text{CDCl}_3$ ) (mixture of two diastereomers):  $\delta$  0.14 (6H, s), 0.23 (6H, s), 0.88 (18H, s), 1.01 (18H, s), 1.10 (6H, s), 1.48 (6H, d), 1.59 (18H, s), 1.62 (6H, s), 1.98–2.05 (6H, m), 2.07–2.19 (2H, m), 2.37–2.47 (2H, m), 2.64–2.75 (2H, m), 2.94 (2H, dd,  $J = 11.6, 14.1$  Hz), 3.41–3.47 (4H, m), 3.82 (2H, dd,  $J = 9.6, 12.2$  Hz), 3.93–4.03 (4H, m), 4.07 (4H, br s), 4.10–4.15 (2H, m), 4.20 (2H, dd,  $J = 2.7, 12.4$  Hz), 5.56–5.61 (2H, m), 5.78 (1H, d,  $J = 3.0$  Hz,  $\text{D}_2\text{O}$  exch), 5.81 (1H, d,  $J = 2.8$  Hz,  $\text{D}_2\text{O}$  exch), 6.877 (1H, d,  $J = 8.4$  Hz), 6.884 (1H, d,  $J = 8.4$  Hz), 7.09 (2H, d,  $J = 8.4$  Hz), 7.20–7.40 (14H, m), 7.56–7.61 (8H, m).  $^{13}\text{C}$  NMR (75.5 MHz) ( $\text{CDCl}_3$ ) (mixture of two diastereomers):  $\delta$  -5.0, -4.1, 13.7, 14.0, 17.8, 18.6, 18.8, 19.1, 19.6, 22.5, 25.7, 26.7, 28.0, 28.4, 28.4, 31.4, 31.6, 31.7, 34.9, 35.8, 44.81, 57.5, 67.5, 68.2, 71.0, 75.8, 76.6, 77.0, 77.4, 80.3, 83.3, 83.1, 113.3, 114.6, 116.6, 120.1, 126.3, 126.3, 127.5, 127.6, 128.1, 128.2, 128.4, 128.4, 128.6, 133.1, 133.2, 135.4, 139.2, 140.5, 140.6, 146.4, 146.5, 148.4, 164.4, 169.6, 169.7. IR (NaCl, neat): 3246, 2960, 2861, 1750, 1676, 1662, 1430, 1366, 1252, 1159, 1109, 1090  $\text{cm}^{-1}$ . HRMS (EI): 935.48955 ( $\text{C}_{53}\text{H}_{73}\text{N}_3\text{O}_8\text{Si}_2$  requires 935.4936). Microanal. Calcd for  $\text{C}_{53}\text{H}_{73}\text{N}_3\text{O}_8\text{Si}_2$ : C, 67.57; H, 7.96; N, 4.54. Found: C, 67.62; H, 7.94; N, 4.32.

**[3 $\beta$ ,8 $\alpha\beta$ (E)]-1,1-Dimethylethyl 8-[[3,4,6,7,8,8a-Hexahydro-8a-[4-[[1,1-dimethylethyl)diphenylsilyloxy]-3-methyl-2-butenyl]-1-methoxy-4-oxopyrrolo[1,2-*a*]pyrazin-3-yl]methyl]-3-[[1,1-dimethylethyl)dimethylsilyloxy]-3,4-dihydro-4,4-dimethyl-2*H*,10*H*-[1,4]dioxepino[2,3-*g*]indole-10-carboxylate (60).** To a stirred solution of **53** (3.87 g, 4.63 mmol, 1.0 equiv) in  $\text{CH}_2\text{Cl}_2$  (46 mL) under Ar at 0 °C was added  $\text{Na}_2\text{CO}_3$  (9.8 g, 92.6 mmol, 20.0 equiv). After 10 min,  $\text{Me}_3\text{OBF}_4$  (3.42 g, 23.15 mmol, 5.0 equiv) was added in one portion. The mixture was stirred for 4.0 h at room temperature, poured into water, and extracted with EtOAc. The organic layer was washed with brine, dried over  $\text{Na}_2\text{SO}_4$ , and concentrated to dryness under reduced pressure. The residue was purified by flash column chromatography (eluted with 1:2 hexanes/EtOAc; then 1:1 hexanes/EtOAc) to yield 3.20 g (81%) of **60**. An analytical sample was obtained by PTLC on silica gel (eluted with EtOAc) (isolated as a white solid, mp 74–76 °C).

$^1\text{H}$  NMR (300 MHz) ( $\text{CDCl}_3$ ) (mixture of two diastereomers):  $\delta$  0.120 (12H, s), 0.875 (18H, s), 1.02 (18H, s), 1.06 (3H, s), 1.07 (3H, s), 1.45 (12H, s), 1.65–2.08 (14H, m), 3.07–3.15 (2H, m), 3.26 (2H, dd,  $J = 6.2, 12.6$  Hz), 3.32–3.40 (2H, m), 3.61 (6H, s), 3.70–3.86 (2H, m), 3.91–3.95 (4H, m), 3.99 (2H, s), 4.15 (2H, dd,  $J = 3.6, 11.7$  Hz), 4.36–4.40 (2H, m), 5.37–5.44 (2H, br m), 6.69 (2H, d,  $J = 8.4$  Hz), 7.01 (2H, d,  $J = 1.7$  Hz), 7.15 (2H, d,  $J = 8.4$  Hz), 7.26–7.41 (12H, m), 7.58–7.62 (8H, m), 8.06 (2H, s,  $\text{D}_2\text{O}$  exch). IR (NaCl, neat): 3292, 2932, 1687, 1643, 1447, 1251, 1218, 1109, 837  $\text{cm}^{-1}$ . Mass spectrum (EI):  $m/e$  (relative intensity) 849 ( $\text{M}^+$ , 8.9), 361 (26), 360 (95), 167 (100). Microanal. Calcd for  $\text{C}_{49}\text{H}_{57}\text{N}_3\text{O}_8\text{Si}_2$ : C, 69.02; H, 7.94; N, 4.94. Found: C, 69.02; H, 7.88; N, 4.79.

**[3 $\alpha$ ,8 $\alpha\beta$ (E)]-1,1-Dimethylethyl 8-[[3,4,6,7,8,8a-Hexahydro-8a-[4-[[1,1-dimethylethyl)diphenylsilyloxy]-3-methyl-2-butenyl]-1-methoxy-4-oxopyrrolo[1,2-*a*]pyrazin-3-yl]methyl]-3-[[1,1-dimethylethyl)dimethylsilyloxy]-3,4-dihydro-4,4-dimethyl-2*H*,10*H*-[1,4]dioxepino[2,3-*g*]indole-10-carboxylate (61).** To a stirred solution of **54** (8.47 g, 10.13 mmol, 1.0 equiv) in  $\text{CH}_2\text{Cl}_2$  (101 mL) at 0 °C under Ar was added  $\text{Na}_2\text{CO}_3$  (21.26 g, 202.6 mmol, 20.0 equiv). After 15 min  $\text{Me}_3\text{OBF}_4$  (7.49 g, 50.64 mmol, 5.0 equiv) was added in one portion. The mixture was stirred for 5 min, the ice bath was removed, and the reaction mixture was stirred for 4.5 h. The mixture was then

poured into water and extracted with EtOAc. The organic layer was washed with brine, dried over  $\text{Na}_2\text{SO}_4$ , and concentrated to dryness under reduced pressure. The residue was purified by column chromatography (eluted with 1:2 EtOAc/hexanes) to yield 5.30 g (62%) of **61**. [The yield of **61** was 365 mg (71%) from 508 mg of **54**.] An analytical sample was obtained by PTLC on silica gel (eluted with 1:2 EtOAc/hexanes) and obtained as a white crystalline solid, mp 54–58 °C).

$^1\text{H}$  NMR (300 MHz) ( $\text{CDCl}_3$ ) (mixture of two diastereomers):  $\delta$  0.13 (3H, s), 0.14 (9H, s), 0.89 (18H, s), 1.03 (9H, s), 1.04 (9H, s), 1.087 (3H, s), 1.093 (3H, s), 1.28–1.43 (4H, m), 1.48 (6H, s), 1.50 (6H, s), 1.79–1.89 (4H, m), 2.24–2.38 (4H, m), 3.22–3.42 (6H, m), 3.60 (3H, s), 3.62 (3H, s), 3.68–3.76 (2H, m), 3.79–3.87 (2H, m), 3.94 (2H, d,  $J = 3.4$  Hz), 3.97 (4H, br s), 4.15–4.20 (2H, m), 4.26–4.32 (2H, m), 5.41 (2H, t,  $J = 7.8$  Hz), 6.701 (1H, d,  $J = 8.5$  Hz), 6.703 (1H, d,  $J = 8.4$  Hz), 6.96 (1H, d,  $J = 2.6$  Hz), 6.97 (1H, d,  $J = 2.6$  Hz), 7.28 (2H, d,  $J = 8.5$  Hz), 7.32–7.44 (12H, m), 7.60–7.64 (8H, m), 7.97 (2H, br s,  $\text{D}_2\text{O}$  exch). IR (NaCl, neat): 3304, 2930, 1695, 1645, 1447, 1249, 1221, 836  $\text{cm}^{-1}$ . HRMS (EI): 849.4550 ( $\text{C}_{49}\text{H}_{57}\text{N}_3\text{O}_8\text{Si}_2$  requires 849.4568). Microanal. Calcd for  $\text{C}_{49}\text{H}_{57}\text{N}_3\text{O}_8\text{Si}_2$ : C, 69.22; H, 7.94; N, 4.94. Found: C, 59.06; H, 8.04; N, 4.89.

**[3 $\beta$ ,8 $\alpha\beta$ (E)]-1,1-Dimethylethyl 8-[[3,4,6,7,8,8a-Hexahydro-8a-(4-hydroxy-3-methyl-2-butenyl)-1-methoxy-4-oxopyrrolo[1,2-*a*]pyrazin-3-yl]methyl]-3,4-dihydro-3-hydroxy-4,4-dimethyl-2*H*,10*H*-[1,4]dioxepino[2,3-*g*]indole-10-carboxylate (62).** To a stirred solution of **60** (5.45 g, 6.41 mmol, 1.0 equiv) in  $\text{CH}_2\text{Cl}_2$  (32 mL) under Ar at 0 °C were added  $\text{Et}_3\text{N}$  (0.89 mL, 6.41 mmol, 1.0 equiv) and DMAP (783.1 mg, 6.41 mmol, 1.0 equiv). After 10 min ( $\text{BOC}_2\text{O}$  (4.20 g, 19.2 mmol, 3.0 equiv) was added in one portion. The reaction mixture was stirred for 6 h and diluted with THF (45 mL). The remaining  $\text{CH}_2\text{Cl}_2$  was removed by evaporation under reduced pressure (until the volume in the flask was 45 mL). The flask was charged with  $n\text{-Bu}_4\text{NF}$  (19.2 mL, 19.2 mmol, 3.0 equiv, 1.0 M/THF), and the mixture was stirred at room temperature for approximately 12 h. The solution was diluted with water and extracted with EtOAc. The organic layer was washed with brine, dried over  $\text{Na}_2\text{SO}_4$ , and concentrated to dryness under reduced pressure. The residue was purified by column chromatography (eluted with 1:2 EtOAc/hexanes; then 2:1 EtOAc/hexanes) to yield 3.45 g (90%) of **62**. [The yield of **62** was 243 mg (97%) from 355 mg of **60**.] An analytical sample was obtained by PTLC on silica gel (eluted with 2:1 EtOAc/hexanes) to afford a white solid, mp 72–85 °C.

$^1\text{H}$  NMR (300 MHz) ( $\text{CDCl}_3$ ) (mixture of two diastereomers):  $\delta$  1.18 (6H, s), 1.52 (3H, s), 1.53 (3H, s), 1.56 (3H, s), 1.57 (21H, s), 1.61–2.07 (10H, m), 2.14 (2H, dd,  $J = 8.6, 14.5$  Hz), 2.85 (2H, br s,  $\text{D}_2\text{O}$  exch), 2.92–3.01 (2H, m), 3.18–3.35 (6H, m), 3.56 (2H, br s,  $\text{D}_2\text{O}$  exch), 3.62 (3H, s), 3.64 (3H, s), 3.88 (4H, br s), 3.91–4.00 (2H, m), 4.25 (4H, br s), 4.30–4.39 (2H, m), 4.98–5.01 (2H, m), 6.87 (1H, d,  $J = 8.3$  Hz), 6.88 (1H, d,  $J = 8.3$  Hz), 7.16 (1H, d,  $J = 8.3$  Hz), 7.17 (1H, d,  $J = 8.3$  Hz), 7.34 (1H, s), 7.35 (1H, s).  $^{13}\text{C}$  NMR (75.5 MHz) ( $\text{CDCl}_3$ ) (mixture of two diastereomers):  $\delta$  13.4, 19.5, 19.7, 23.5, 23.6, 25.1, 25.3, 27.9, 30.3, 30.5, 34.4, 34.8, 35.1, 35.3, 43.4, 43.6, 52.6, 52.7, 62.0, 62.4, 65.3, 65.4, 67.7, 67.8, 70.6, 75.4, 82.6, 82.6, 114.5, 114.7, 116.8, 116.9, 118.2, 118.3, 119.0, 119.1, 126.3, 128.0, 128.1, 129.9, 130.0, 138.6, 138.7, 140.7, 146.2, 148.5, 161.32, 161.5, 168.5, 168.7. IR (NaCl, neat): 3390 (br), 2976, 1752, 1692, 1632, 1491, 1453, 1371, 1251, 1158, 733  $\text{cm}^{-1}$ . Microanal. Calcd for  $\text{C}_{32}\text{H}_{43}\text{N}_3\text{O}_8$ : C, 64.30; H, 7.25; N, 7.03. Found: C, 64.12; H, 7.41; N, 6.88. HRMS (EI):  $m/e$  597.3065 ( $\text{C}_{32}\text{H}_{43}\text{N}_3\text{O}_8$  requires 597.3050).

**[3 $\alpha$ ,8 $\alpha\beta$ (E)]-1,1-Dimethylethyl 8-[[3,4,6,7,8,8a-Hexahydro-8a-(4-hydroxy-3-methyl-2-butenyl)-1-methoxy-4-oxopyrrolo[1,2-*a*]pyrazin-3-yl]methyl]-3,4-dihydro-3-hydroxy-4,4-dimethyl-2*H*,10*H*-[1,4]dioxepino[2,3-*g*]indole-10-carboxylate (63).** To a stirred solution of **61** (5.30 g, 5.65 mmol, 1.0 equiv) under Ar in  $\text{CH}_2\text{Cl}_2$  (1.5 mL) at 0 °C were added  $\text{Et}_3\text{N}$  (0.79 mL, 5.65 mmol, 1.0 equiv) and DMAP (689.7 mg, 5.65 mmol, 1.0 equiv). After 5 min ( $\text{BOC}_2\text{O}$  (3.70 g, 16.94 mmol, 3.0 equiv) was added in one portion. The reaction mixture was stirred for 4.5 h and diluted with THF (40 mL). The remaining  $\text{CH}_2\text{Cl}_2$  was removed under reduced pressure (until the reaction volume was 40 mL). The flask was charged with  $n\text{-Bu}_4\text{NF}$  (17.0 mL, 17.0 mmol, 3.0 equiv, 1.0 M/THF), and the mixture was stirred at room temperature for ~12 h. The solution was diluted with water and extracted with EtOAc.

The organic layer was washed with brine, dried over  $\text{Na}_2\text{SO}_4$ , and concentrated to dryness. The residue was purified by column chromatography (eluted with EtOAc) to yield 3.16 g (85%) of **63** as a white, amorphous solid, mp 72–80 °C [The yield of **63** was 179 mg (98%) with 260 mg of **61**].

$^1\text{H}$  NMR (300 MHz) ( $\text{CDCl}_3$ ) (mixture of two diastereomers):  $\delta$  1.16 (3H, s), 1.18 (3H, s), 1.51 (3H, s), 1.52 (3H, s), 1.55 (6H, s), 1.57 (18H, s), 1.60–2.14 (10H, m, 2H  $\text{D}_2\text{O}$  exch), 2.22–2.37 (4H, m), 3.06–3.18 (3H, m, 1H  $\text{D}_2\text{O}$  exch), 3.26–3.36 (5H, m, 1H  $\text{D}_2\text{O}$  exch), 3.55 (3H, s), 3.56 (2H, br s), 3.60 (3H, s), 3.63–3.72 (2H, m), 3.89 (4H, m), 4.18–4.23 (2H, m), 4.25 (4H, br s), 5.21–5.27 (2H, m), 6.857 (1H, d,  $J = 8.3$  Hz), 6.861 (1H, d,  $J = 8.3$  Hz), 7.22 (2H, d,  $J = 8.3$  Hz), 7.24 (2H, s). IR (NaCl, neat): 3401 (br), 2976, 1747, 1692, 1632, 1496, 1436, 1371, 1251, 1158, 733  $\text{cm}^{-1}$ . HRMS (EI): 597.3050 ( $\text{C}_{32}\text{H}_{43}\text{N}_3\text{O}_5$  requires 597.3050).

**[3 $\beta$ ,8 $\alpha\beta$ (E)]-1,1-Dimethylethyl 8-[[3,4,6,7,8,8a-Hexahydro-8a-(4-chloro-3-methyl-2-butenyl)-1-methoxy-4-oxopyrrolo[1,2-a]pyrazin-3-yl]methyl]-3,4-dihydro-3-hydroxy-4,4-dimethyl-2H,10H-[1,4]dioxepino[2,3-g]indole-10-carboxylate (64).** Dimethyl sulfide (0.67 mL, 9.13 mmol, 8.0 equiv) was added dropwise to a stirred solution of NCS (1.22 g, 9.13 mmol, 8.0 equiv) in  $\text{CH}_2\text{Cl}_2$  (51 mL) at 0 °C under Ar. The resulting mixture was stirred for 10 min and then cooled to –23 °C. After 10 min, **62** (682.4 mg, 1.14 mmol, 1.0 equiv) was added to the flask in one portion and stirring continued for 6 h. At this time the reaction flask was placed in a freezer (–35 °C) for 16 h, followed by an additional 10 h of stirring at –23 °C. The mixture was then diluted with EtOAc, washed with water and brine, dried over  $\text{Na}_2\text{SO}_4$ , and concentrated under reduced pressure. The residue was purified by radial chromatography (eluted with 1:2 hexanes/EtOAc) to yield 565.8 mg (81%) of **64** as a white amorphous solid. [The yield of **64** was 2.12 g (37% or 74% based on recovered **62**) with 5.60 g of **62**.] An analytical sample was obtained by PTLC on silica gel (eluted with 2:1 EtOAc/hexanes).

$^1\text{H}$  NMR (300 MHz) ( $\text{CDCl}_3$ ) (mixture of two diastereomers):  $\delta$  1.17 (6H, s), 1.52 (6H, s), 1.57 (18H, s), 1.65 (6H, s), 1.73–2.20 (10H, m), 2.84 (2H, dd,  $J = 9.0, 14.4$  Hz), 3.06 (1H, br s,  $\text{D}_2\text{O}$  exch), 3.10 (1H, br s,  $\text{D}_2\text{O}$  exch), 3.26–3.36 (4H, m), 3.55–3.58 (4H, m), 3.62 (3H, s), 3.63 (3H, s), 3.91 (4H, s), 3.95–4.05 (2H, m), 4.24–4.25 (4H, m), 4.30–4.36 (2H, m), 5.28 (2H, m), 6.88 (2H, d,  $J = 8.3$  Hz), 7.14 (1H, d,  $J = 8.3$  Hz), 7.15 (1H, d,  $J = 8.3$  Hz), 7.376 (1H, s), 7.384 (1H, s). IR (NaCl, neat): 3403, 2979, 1750, 1716, 1642, 1348, 1154  $\text{cm}^{-1}$ . HRMS (EI): 615.2709 ( $\text{C}_{32}\text{H}_{42}\text{N}_3\text{O}_7\text{Cl}$  requires 615.2711). Microanal. Calcd for  $\text{C}_{32}\text{H}_{42}\text{N}_3\text{O}_7\text{Cl}$ : C, 62.38; H, 6.87; N, 6.82. Found: C, 62.53; H, 6.86; N, 6.67.

**[3 $\alpha$ ,8 $\alpha\beta$ (E)]-1,1-Dimethylethyl 8-[[3,4,6,7,8,8a-Hexahydro-8a-(4-chloro-3-methyl-2-butenyl)-1-methoxy-4-oxopyrrolo[1,2-a]pyrazin-3-yl]methyl]-3,4-dihydro-3-hydroxy-4,4-dimethyl-2H,10H-[1,4]dioxepino[2,3-g]indole-10-carboxylate (65).** To a stirred solution of NCS (5.67 g, 42.4 mmol, 8.0 equiv) at 0 °C under Ar in  $\text{CH}_2\text{Cl}_2$  (206 mL) was added dimethyl sulfide (3.12 mL, 42.4 mmol, 8.0 equiv) dropwise. After 0.5 h the mixture was cooled (–23 °C) and stirred for an additional 0.5 h. At this time the lactim ether–diol **63** (3.17 g, 5.30 mmol, 1.0 equiv) was added [approximately 3 g was added as a solid; the remaining amount was added as a solution in  $\text{CH}_2\text{Cl}_2$  (30 mL) via cannula]. The white mixture was stirred for 12 h, diluted with EtOAc, washed with water and brine, dried over  $\text{Na}_2\text{SO}_4$ , and concentrated under reduced pressure. The residue was purified by flash column chromatography (eluted with 2:1 hexanes/EtOAc; then 1:1 hexanes/EtOAc) to afford 2.80 g (86%) of **65** as a glass.

$^1\text{H}$  NMR (300 MHz) ( $\text{CDCl}_3$ ) (mixture of two diastereomers):  $\delta$  1.17 (3H, s), 1.18 (3H, s), 1.52 (3H, s), 1.54 (3H, s), 1.57 (18H, s), 1.65 (6H, s), 1.71–1.92 (8H, m), 2.24–2.39 (4H, m), 3.03–3.19 (4H, m, 2H  $\text{D}_2\text{O}$  exch), 3.28–3.37 (4H, m), 3.56 (3H, s), 3.60 (3H, s), 3.59–3.75 (4H, m), 3.89 (4H, s), 4.21–4.29 (6H, m), 5.35 (2H, t,  $J = 7.5$  Hz), 6.86 (1H, d,  $J = 8.3$  Hz), 6.87 (1H, d,  $J = 8.3$  Hz), 7.23 (2H, d,  $J = 8.3$  Hz), 7.22 (1H, s), 7.27 (1H, s). IR (NaCl, neat): 3412 (br), 2976, 1752, 1698, 1638, 1365, 1251, 1158  $\text{cm}^{-1}$ . HRMS (EI): 615.2714 ( $\text{C}_{32}\text{H}_{42}\text{N}_3\text{O}_7\text{Cl}$  requires 615.2711).

**[3 $\beta$ ,8 $\alpha\beta$ (E)]-1,1-Dimethylethyl 8-[[3,4,6,7,8,8a-Hexahydro-8a-(4-chloro-3-methyl-2-butenyl)-1-methoxy-4-oxopyrrolo[1,2-a]pyrazin-3-yl]methyl]-3-[[[(1,1-dimethylethyl)dimethylsilyloxy]-3,4-dihydro-4,4-dimethyl-2H,10H-[1,4]dioxepino[2,3-g]indole-10-carboxylate (66).**

To a stirred solution of **64** (3.55 g, 5.76 mmol, 1.0 equiv) in  $\text{CH}_2\text{Cl}_2$  (23 mL) at 0 °C under Ar was added 2,6-lutidine (0.74 mL, 6.34 mmol, 1.1 equiv) followed by *tert*-butyldimethylsilyl triflate (1.08 mL, 6.34 mmol, 1.1 equiv). After 3 h an additional amount (1.1 equiv) of each reagent was added to the reaction flask; after stirring for 2 h, an additional amount (1.1 equiv) of each reagent was added. The mixture was stirred for 1 h, diluted with EtOAc, washed four times with water and once with brine, dried over  $\text{Na}_2\text{SO}_4$ , and concentrated under reduced pressure. The residue was purified by column chromatography (eluted with 1:1 hexanes/EtOAc) to yield 3.23 g (77%) of **66** as an amorphous, white solid. An analytical sample was obtained by PTLC on silica gel (eluted with 1:1 hexanes/EtOAc).

$^1\text{H}$  NMR (300 MHz) ( $\text{CDCl}_3$ ) (mixture of two diastereomers):  $\delta$  0.12 (6H, s), 0.13 (6H, s), 0.88 (18H, s), 1.06 (6H, s), 1.47 (6H, s), 1.59 (18H, s), 1.65 (6H, s), 1.78–1.98 (8H, s), 2.02–2.12 (2H, m), 2.86 (2H, dd,  $J = 9.0, 14.6$  Hz), 3.31–3.34 (2H, m), 3.33 (2H, dd,  $J = 4.0, 13.6$  Hz), 3.62 (3H, s), 3.64 (3H, s), 3.71–3.79 (2H, m), 3.73 (1H, dd,  $J = 4.2, 9.8$  Hz), 3.77 (1H, dd,  $J = 4.4, 9.7$  Hz), 3.92 (4H, s), 3.94–4.01 (4H, m), 4.15 (2H, dd,  $J = 3.8, 12.4$  Hz), 4.32–4.37 (2H, m), 5.28–5.30 (2H, m), 6.87 (2H, d,  $J = 8.3$  Hz), 7.12 (1H, d,  $J = 8.3$  Hz), 7.13 (1H, d,  $J = 8.3$  Hz), 7.38 (2H, s). IR (NaCl, neat): 2930, 1750, 1691, 1652, 1494, 1424, 1366, 1248, 1159, 1088  $\text{cm}^{-1}$ . Mass spectrum (EI): *m/e* (relative intensity) 729 ( $\text{M}^+$ , 4.2), 731 ( $\text{M} + 2$ , 2.1), 629 (9.4), 361 (24.1), 360 (100), 167 (94.8), 57.2 (63). Microanal. Calcd for  $\text{C}_{38}\text{H}_{56}\text{N}_3\text{O}_7\text{SiCl}$ : C, 62.49; H, 7.73; N, 5.75. Found: C, 62.57; H, 7.71; N, 5.55.

**[3 $\alpha$ ,8 $\alpha\beta$ (E)]-1,1-Dimethylethyl 8-[[3,4,6,7,8,8a-Hexahydro-8a-(4-chloro-3-methyl-2-butenyl)-1-methoxy-4-oxopyrrolo[1,2-a]pyrazin-3-yl]methyl]-3-[[[(1,1-dimethylethyl)dimethylsilyloxy]-3,4-dihydro-4,4-dimethyl-2H,10H-[1,4]dioxepino[2,3-g]indole-10-carboxylate (67).** To a stirred solution of **65** (2.73 g, 4.43 mmol, 1.0 equiv) under Ar at 0 °C in  $\text{CH}_2\text{Cl}_2$  (18 mL) was added 2,6-lutidine (0.57 mL, 4.87 mmol, 1.1 equiv) followed by *tert*-butyldimethylsilyl triflate (0.87 mL, 4.87 mmol, 1.1 equiv). After 1 h, 1.1 equiv of each reagent was added and stirred for 3 h. The solution was diluted with EtOAc, washed with water and brine, dried over  $\text{Na}_2\text{SO}_4$ , and concentrated under reduced pressure. The residue was purified by column chromatography (eluted with 1:2 EtOAc/hexanes) to yield 2.76 g (85%) of **67** as a white amorphous solid. An analytical sample was obtained by PTLC on silica gel (eluted with 1:2 EtOAc/hexanes).

$^1\text{H}$  NMR (300 MHz) ( $\text{CDCl}_3$ ) (mixture of two diastereomers):  $\delta$  0.12 (6H, s), 0.13 (6H, s), 0.87 (18H, s), 1.05 (3H, s), 1.06 (3H, s), 1.47 (6H, s), 1.50–1.53 (2H, m), 1.58 (18H, s), 1.65 (6H, s), 1.72–1.91 (6H, m), 2.21–2.37 (4H, m), 3.06–3.19 (2H, m), 3.28–3.36 (4H, m), 3.56 (3H, s), 3.60 (3H, s), 3.63–3.87 (4H, m), 3.89 (4H, s), 3.93 (2H, dd,  $J = 3.9, 9.8$  Hz), 4.13–4.18 (2H, m), 4.22–4.35 (2H, m), 5.30–5.40 (2H, m), 6.85 (1H, d,  $J = 8.3$  Hz), 6.86 (1H, d,  $J = 8.3$  Hz), 7.19–7.26 (4H, m). IR (NaCl, neat): 2949, 1751, 1693, 1652, 1493, 1424, 1369, 1250, 1156, 1086  $\text{cm}^{-1}$ . Microanal. Calcd for  $\text{C}_{38}\text{H}_{56}\text{N}_3\text{O}_7\text{SiCl}$ : C, 62.49; H, 7.73; N, 5.75. Found: C, 62.29; H, 7.61; N, 5.76. HRMS (EI): 729.3555 ( $\text{C}_{38}\text{H}_{56}\text{N}_3\text{O}_7\text{SiCl}$  requires 729.3576).

**1,1-Dimethylethyl 8-[[7,8-Dihydro-1-methoxy-10-(1-methylethenyl)-4-oxo-6H-3,8a-ethanopyrrolo[1,2-a]pyrazin-3(4H)-yl]methyl]-3-[[[(1,1-dimethylethyl)dimethylsilyloxy]-3,4-dihydro-4,4-dimethyl-2H,10H-[1,4]dioxepino[2,3-g]indole-10-carboxylate (68).** To a stirred solution of **66** (1.43 g, 1.96 mmol, 1.0 equiv) in benzene (300 mL) was added NaH (939 mg, 39.16 mmol, 20.0 equiv, freshly washed in pentane). This mixture was gently stirred at reflux temperature for 8.25 h, diluted with EtOAc, and washed with water and dilute HCl. The organic layer was isolated, washed with brine, dried over  $\text{Na}_2\text{SO}_4$ , and concentrated under reduced pressure. The residue was purified by radial chromatography (eluted with 1:3 EtOAc/hexanes) to yield 1.26 g of **68** (93%). [The yield of **68** was 2.52 g (86%) from 3.10 g of **66**.]

To a stirred solution of **67** (1.60 g, 2.19 mmol, 1.0 equiv) in benzene (313 mL) was added NaH (1.05 g, 43.8 mmol, 20.0 equiv, freshly washed in pentane). This mixture was gently stirred at reflux temperature for 5.5 h and stirred at room temperature overnight. At this time, a small sample was removed, washed with water, and extracted with EtOAc. A crude proton NMR (in  $\text{CDCl}_3$ ) indicated that the reaction was complete. The remaining mixture was diluted with EtOAc and washed with water. The organic layer was washed with

brine, dried over  $\text{Na}_2\text{SO}_4$ , and concentrated under reduced pressure. The two samples were combined and purified by radial chromatography (eluted with 1:3 EtOAc/hexanes) to yield 1.29 g of **68** (85%). An analytical sample was obtained by PTLC on silica gel (eluted with 1:3 EtOAc/hexanes); the product was obtained as a white solid, mp 105–108 °C.

$^1\text{H}$  NMR (300 MHz) ( $\text{CDCl}_3$ ) (mixture of two diastereomers):  $\delta$  0.12 (6H, s), 0.13 (6H, s), 0.872 (9H, s), 0.875 (9H, s), 1.06 (3H, s), 1.07 (3H, s), 1.46 (6H, s), 1.58 (18H, s), 1.61 (3H, s), 1.64 (3H, s), 1.72–2.03 (8H, m), 2.25–2.42 (2H, m), 2.47 (2H, dd,  $J = 5.1, 9.7$  Hz), 2.54 (2H, dd,  $J = 5.8, 9.7$  Hz), 3.05 (1H,  $^1/2$  ABq,  $J = 15.0$  Hz), 3.07 (1H,  $^1/2$  ABq,  $J = 15.0$  Hz), 3.31–3.53 (6H, m), 3.57 (3H, s), 3.64 (3H, s), 3.73–3.89 (2H, m), 3.94 (2H, dd,  $J = 3.7, 9.7$  Hz), 4.17 (2H, dd,  $J = 3.1, 11.6$  Hz), 4.62 (1H, s), 4.75 (1H, s), 4.78 (1H, s), 4.85 (1H, s), 6.82 (2H, d,  $J = 8.4$  Hz), 7.31 (1H, d,  $J = 8.4$  Hz), 7.38 (1H, d,  $J = 8.4$  Hz), 7.44 (1H, s), 7.52 (1H, s). IR (NaCl, neat): 2935, 1752, 1684, 1637, 1496, 1418, 1365, 1350, 1250, 1220, 1156, 1083  $\text{cm}^{-1}$ . HRMS (EI):  $m/e$  693.3834 ( $\text{C}_{38}\text{H}_{55}\text{N}_3\text{O}_7\text{Si}$  requires 693.3809). Microanal. Calcd for  $\text{C}_{38}\text{H}_{55}\text{N}_3\text{O}_7\text{Si}$ : C, 65.77; H, 7.99; N, 6.05. Found: C, 65.85; H, 7.99; N, 5.91.

**1,1-Dimethylethyl 3-[[[(1,1-Dimethylethyl)dimethylsilyloxy]-3,4,8-12,13,14,14a,15-octahydro-4,4,15,15-tetramethyl-9,17-dioxo-11H,16H-8a,13a-(iminomethano)-2H,9H-[1,4]dioxepino[2,3-*a*]indolizino[6,7-*h*]carbazole-16-carboxylate (69).** To a flask charged with  $\text{PdCl}_2$  (827.9 mg, 4.67 mmol, 3.0 equiv) and  $\text{AgBF}_4$  (605.3 mg, 3.11 mmol, 2.0 equiv) was added dry  $\text{CH}_3\text{CN}$  (50 mL). The mixture was stirred for 6.5 h, when a solution of **68** (1.08 g, 1.56 mmol, 1.0 equiv) in  $\text{CH}_3\text{CN}$  (5.0 mL) was syringed into the flask. The reaction mixture was stirred for 48 h, and EtOH (55 mL) was added, followed by small portions of  $\text{NaBH}_4$  (590 mg, 15.6 mmol, 10.0 equiv) at 0 °C. The addition was complete in 0.5 h, and the mixture was stirred for an additional 0.5 h. The black mixture was filtered to remove palladium and the solvent evaporated under reduced pressure. The residue was dissolved in EtOAc, washed with dilute aqueous HCl (0.01 M) and brine, dried over  $\text{Na}_2\text{SO}_4$ , and concentrated under reduced pressure. The residue was purified by radial chromatography (eluted with 25:25:1  $\text{CH}_2\text{Cl}_2/\text{Et}_2\text{O}/\text{MeOH}$ ) to afford 676.3 mg (63%) of **69** as a white amorphous solid. An analytical sample was obtained by PTLC on silica gel (eluted with 25:25:1  $\text{CH}_2\text{Cl}_2/\text{Et}_2\text{O}/\text{MeOH}$ ).

$^1\text{H}$  NMR (300 MHz) ( $\text{CDCl}_3$ ) (mixture of two diastereomers):  $\delta$  0.081 (6H, s), 0.11 (6H, s), 0.87 (9H, s), 0.88 (9H, s), 1.08 (3H, s), 1.17 (3H, s), 1.26 (3H, s), 1.27 (3H, s), 1.34 (3H, s), 1.35 (3H, s), 1.44 (3H, s), 1.46 (3H, s), 1.56 (9H, s), 1.58 (9H, s), 1.81–1.90 (2H, m), 1.96–2.06 (6H, m), 2.20 (2H, dd,  $J = 10.3, 13.5$  Hz), 2.52–2.60 (4H, m), 2.78 (2H, dt,  $J = 6.5, 12.9$  Hz), 3.36–3.49 (2H, m), 3.51–3.57 (2H, m), 3.63–3.84 (4H, m), 3.88–3.92 (2H, m), 4.04–4.16 (2H, m), 6.24 (1H, s,  $\text{D}_2\text{O}$  exch), 6.26 (1H, s,  $\text{D}_2\text{O}$  exch), 6.78 (1H, d,  $J = 8.3$  Hz), 6.80 (1H, d,  $J = 8.5$  Hz), 6.98 (1H, d,  $J = 8.2$  Hz), 6.99 (1H, d,  $J = 8.4$  Hz).  $^{13}\text{C}$  NMR (75.5 MHz) ( $\text{CDCl}_3$ ) (mixture of two diastereomers):  $\delta$  -5.2, -5.1, -5.0, -4.5, -4.3, 17.6, 18.7, 19.3, 19.7, 19.9, 24.3, 25.5, 25.6, 26.9, 26.2, 27.2, 27.8, 27.9, 28.3, 28.5, 29.1, 31.1, 36.2, 43.8, 50.5, 50.6, 53.3, 54.8, 55.7, 59.4, 60.2, 60.2, 66.3, 67.6, 71.1, 72.7, 75.9, 78.0, 80.5, 84.1, 84.3, 108.3, 112.4, 112.5, 113.6, 117.9, 118.5, 124.6, 124.9, 128.7, 128.9, 129.4, 137.7, 138.3, 139.4, 139.6, 143.0, 143.2, 152.9, 153.0, 168.3, 174.1. IR (neat): 3214, 2928, 2856, 1745, 1556, 1496, 1443, 1368, 1252, 1233, 1154, 1141, 1091, 1052, 994, 859, 838, 777, 733. Microanal. Calcd for  $\text{C}_{37}\text{H}_{53}\text{N}_3\text{O}_7\text{Si}$ : C, 65.36; H, 7.86; N, 6.18. Found: C, 65.18; H, 7.77; N, 6.18. MS (EI):  $m/e$  (relative intensity) 679 ( $\text{M}^+$ , 0.3), 580 (20.4), 579 (51), 73 (100). HRMS (EI):  $m/e$  679.3661 ( $\text{C}_{37}\text{H}_{53}\text{N}_3\text{O}_7\text{Si}$  requires 679.3653).

**1,1-Dimethylethyl 3-[[[(1,1-Dimethylethyl)dimethylsilyloxy]-3,4,8-12,13,14,14a,15-octahydro-4,4,15,15-tetramethyl-17-methoxy-9-oxo-11H,16H-8a,13a-(iminomethano)-2H,9H-[1,4]dioxepino[2,3-*a*]indolizino[6,7-*h*]carbazole-16-carboxylate (71).** To a stirred solution of **69** (26.1 mg, 0.38 mmol, 1.0 equiv) in  $\text{CH}_2\text{Cl}_2$  (1 mL) under Ar at 0 °C was added  $\text{Na}_2\text{CO}_3$  (81.0 mg, 0.76 mmol, 20.0 equiv). After 10 min  $\text{Me}_3\text{OBF}_4$  (28.3 mg, 0.191 mmol, 5.0 equiv) was added in one portion. The mixture was stirred for 4 h at room temperature, poured into water, and extracted with EtOAc. The organic layer was washed with brine, dried over  $\text{Na}_2\text{SO}_4$ , and concentrated to dryness under reduced pressure. The residue was purified by PTLC on silica gel

(eluted with 1:2 hexanes/EtOAc) to afford 19.6 mg (74%) of **71** as a white amorphous solid.

$^1\text{H}$  NMR (300 MHz) ( $\text{CDCl}_3$ ) (mixture of two diastereomers):  $\delta$  TMS 0.10–0.15 (12H, m), 0.89 (9H, s), 0.90 (9H, s), 1.09 (6H, s), 1.26 (3H, s), 1.29 (3H, s), 1.33 (3H, s), 1.36 (3H, s), 1.46 (3H, s), 1.48 (3H, s), 1.58 (9H, s), 1.60 (9H, s), 1.76–2.51 (10H, m), 2.23–2.31 (2H, m), 2.60–2.70 (2H, m), 3.027 (1H,  $^1/2$  ABq,  $J = 16.4$  Hz), 3.032 (1H,  $^1/2$  ABq,  $J = 16.4$  Hz), 3.31–3.41 (2H, m), 3.46–3.54 (2H, m), 3.68 (2H, dd,  $J = 9.1, 12.1$  Hz), 3.77 (6H, s), 3.87–3.94 (2H, m), 3.90 (2H,  $^1/2$  ABq,  $J = 16.3$  Hz), 4.08 (2H, dd,  $J = 3.5, 11.9$  Hz), 6.79 (1H, d,  $J = 8.3$  Hz), 6.80 (1H, d,  $J = 8.3$  Hz), 7.063 (1H, d,  $J = 8.3$  Hz), 7.061 (1H, d,  $J = 8.3$  Hz). IR (NaCl, neat): 2952, 2886, 1745, 1683, 1640, 1496, 1412, 1355, 1252, 1232, 1156, 1140, 1111, 1090, 1052, 992, 838, 770  $\text{cm}^{-1}$ . HRMS (EI):  $m/e$  693.3810 ( $\text{C}_{38}\text{H}_{55}\text{N}_3\text{O}_7\text{Si}$  requires 693.3810).

**3-(Hydroxy)-3,4,8,12,13,14,14a,15-octahydro-4,4,15,15-tetramethyl-9,17-dioxo-11H,16H-8a,13a-(iminomethano)-2H,9H-[1,4]dioxepino[2,3-*a*]indolizino[6,7-*h*]carbazole (76).** To a stirred solution of **69** (150 mg, 0.22 mmol, 1.0 equiv) in  $\text{CH}_2\text{Cl}_2$  (4.4 mL) under  $\text{N}_2$  at 0 °C was added TFA (1.4 mL, 17.8 mmol, 80 equiv) dropwise. The reaction mixture was allowed to reach room temperature overnight. The solution was concentrated and the residue taken up in EtOAc. The resulting solution was washed with 10%  $\text{Na}_2\text{CO}_3$  and brine. The organic layer was dried over  $\text{Na}_2\text{SO}_4$  and concentrated to dryness under reduced pressure. The residue was purified by radial chromatography (eluted with EtOAc) to yield 102 mg (95%) of **76**. An analytical sample was obtained by PTLC on silica gel (eluted with 1:1 EtOAc/hexanes) as a white amorphous solid.

$^1\text{H}$  NMR (300 MHz) ( $\text{CDCl}_3$ ) (mixture of two diastereomers):  $\delta$  1.06 (3H, s), 1.08 (3H, s), 1.18 (3H, s), 1.20 (3H, s), 1.23 (3H, s), 1.29 (3H, s), 1.49 (3H, s), 1.55 (3H, s), 1.79–2.04 (8H, m), 2.17 (2H, td,  $J = 5.1, 11.9$  Hz), 2.43 (1H, m), 2.43 (1H,  $^1/2$  ABq,  $J = 15.5$  Hz), 2.51 (1H, dd,  $J = 4.8, 10.2$  Hz), 2.59 (1H,  $^1/2$  ABq,  $J = 15.5$  Hz), 2.78 (2H, dt,  $J = 6.5, 12.9$  Hz), 3.21 (1H, br s,  $\text{D}_2\text{O}$  exch), 3.33–3.41 (3H, m), 3.41–3.56 (3H, m), 3.60 (1H, br s,  $\text{D}_2\text{O}$  exch), 3.70 (1H,  $^1/2$  ABq,  $J = 15.4$  Hz), 3.78 (1H,  $^1/2$  ABq,  $J = 15.4$  Hz), 4.12 (2H, dd,  $J = 8.4, 12.0$  Hz), 4.25 (2H, td,  $J = 4.0, 12.2$  Hz), 6.65 (2H, s,  $\text{D}_2\text{O}$  exch), 6.72 (1H, d,  $J = 8.3$  Hz), 6.73 (1H, d,  $J = 8.3$  Hz), 7.02 (1H, d,  $J = 7.9$  Hz), 7.05 (1H, d,  $J = 8.1$  Hz), 7.98 (1H, s,  $\text{D}_2\text{O}$  exch), 8.10 (1H, s,  $\text{D}_2\text{O}$  exch). IR (NaCl, neat): 3308, 1684, 1679, 1402, 1367, 1232, 1044, 733  $\text{cm}^{-1}$ . HRMS (EI):  $m/e$  465.2248 ( $\text{C}_{26}\text{H}_{31}\text{N}_3\text{O}_5$  requires 465.2264).

**14-Deoxy-29-demethyl-24,25-dihydro-25-hydroxy-12-oxo-17-norparaherquamide (79).** To a stirred mixture of **76** (16.5 mg, 0.035 mmol, 1.0 equiv) in  $\text{CH}_2\text{Cl}_2$  (0.7 mL) at 0 °C under  $\text{N}_2$  was added  $\text{Et}_3\text{N}$  (4.6  $\mu\text{L}$ , 0.04 mmol, 1.1 equiv) followed by *t*-BuOCl (5.4  $\mu\text{L}$ , 0.04 mmol, 1.1 equiv). After 0.5 h, the resulting clear, yellow solution was concentrated to dryness (the flask being kept cold). The residue was immediately subjected to a solution of  $\text{MeOH}/\text{H}_2\text{O}/\text{AcOH}$  (40:20:1) and stirred under  $\text{N}_2$  at room temperature for 0.5 h. The solution was diluted with saturated  $\text{NaHCO}_3$ , and the organic layer was washed three times with saturated  $\text{NaHCO}_3$ , washed with brine, dried over  $\text{Na}_2\text{SO}_4$ , and concentrated to dryness under reduced pressure. The residue was purified by PTLC on silica gel (eluted with 20:1  $\text{CH}_2\text{Cl}_2/\text{MeOH}$ ) to yield 5.0 mg (29%) of **79** as an amorphous solid.

$^1\text{H}$  NMR (300 MHz) ( $\text{CDCl}_3$ ) (mixture of two diastereomers):  $\delta$  0.46 (3H, s), 0.48 (3H, s), 0.93 (6H, s), 1.22 (3H, s), 1.23 (3H, s), 1.45 (3H, s), 1.51 (3H, s), 1.65–2.09 (14H, m), 2.71–2.79 (2H, m), 2.87 (2H, td,  $J = 3.2, 9.3$  Hz), 3.40–4.99 (2H, m), 3.56–3.66 (6H, m, 2H  $\text{D}_2\text{O}$  exch), 4.08–4.26 (4H, m), 6.56 (1H, d,  $J = 8.1$  Hz), 6.61 (1H, d,  $J = 8.1$  Hz), 6.80 (1H, d,  $J = 7.7$  Hz), 6.82 (1H, d,  $J = 7.8$  Hz), 6.96 (1H, s,  $\text{D}_2\text{O}$  exch), 7.09 (1H, s,  $\text{D}_2\text{O}$  exch), 8.03 (1H, s,  $\text{D}_2\text{O}$  exch), 8.11 (1H, s,  $\text{D}_2\text{O}$  exch). IR (NaCl, neat): 3411, 3237, 1698, 1632, 1496, 1404, 1333, 1213, 728  $\text{cm}^{-1}$ . Mass spectrum ( $\text{M}^+$  relative intensity) 481 ( $\text{M}^+$ , 23.9), 412 (15.2), 249 (12.7), 220 (100), 149 (60.6). HRMS (EI):  $m/e$  481.2194 ( $\text{C}_{26}\text{H}_{31}\text{N}_3\text{O}_6$  requires 481.2213).

**1,1-Dimethylethyl 3-[[[(1,1-Dimethylethyl)dimethylsilyloxy]-3,4,8-12,13,14,14a,15-octahydro-4,4,15,15-tetramethyl-17-oxo-11H,16H-8a,13a-(iminomethano)-2H,9H-[1,4]dioxepino[2,3-*a*]indolizino[6,7-*h*]carbazole-16-carboxylate (70).** To a stirred solution of **69** (164 mg, 0.24 mmol, 1.0 equiv) in THF (4.9 mL) at -78 °C under Ar was added  $\text{Et}_3\text{Al}$  (0.14 mL, 0.26 mmol, 1.1 equiv, 1.9 M in toluene)

dropwise. After 10 min the solution was warmed to 0 °C and AlH<sub>3</sub>-DMEA (6.0 mL, 1.20 mmol, 5.0 equiv, 0.2 M in toluene) was added dropwise. The ice bath was removed and the solution stirred for 1 h and 20 min at room temperature. At this time MeOH (4.7 mL) and AcOH (0.31 mL) were syringed into the flask, followed by NaCNBH<sub>3</sub> (179 mg, 2.85 mmol, 11.9 equiv). This mixture was stirred for 10 min, and the solvent was removed under reduced pressure and replaced with ethyl acetate. The resulting solution was washed with NaHCO<sub>3</sub> (saturated) and brine, dried over Na<sub>2</sub>SO<sub>4</sub>, and concentrated under reduced pressure. The residue was purified by radial chromatography (eluted with 1:1 hexanes/EtOAc) to yield 102 mg (65%) of **70** as a white amorphous solid. An analytical sample was obtained by PTLC on silica gel (eluted with 1:1 EtOAc/hexanes).

<sup>1</sup>H NMR (300 MHz) (CDCl<sub>3</sub>) (mixture of two diastereomers): δ 0.085 (6H, s), 0.11 (6H, s), 0.87 (9H, s), 0.88 (9H, s), 1.12 (3H, s), 1.15 (3H, s), 1.23 (3H, s), 1.24 (3H, s), 1.36 (3H, s), 1.37 (3H, s), 1.45 (6H, s), 1.59 (9H, s), 1.61 (9H, s), 1.88–1.92 (6H, s), 1.97–2.10 (2H, m), 2.17–2.26 (2H, m), 2.54–2.63 (2H, m), 2.70 (2H, <sup>1</sup>/<sub>2</sub> ABq, *J* = 15.5 Hz), 2.829 (1H, <sup>1</sup>/<sub>2</sub> ABq, *J* = 15.4 Hz), 2.835 (1H, <sup>1</sup>/<sub>2</sub> ABq, *J* = 15.6 Hz), 3.06–3.09 (2H, m), 3.45–3.49 (4H, m), 3.67–3.85 (4H, m), 3.90 (2H, dd, *J* = 3.4, 8.7 Hz), 4.09–4.18 (4H, m), 6.03 (2H, s, D<sub>2</sub>O exch), 6.78 (1H, d, *J* = 8.3 Hz), 6.79 (1H, d, *J* = 8.3 Hz), 6.89 (2H, d, *J* = 8.3 Hz). IR (NaCl, neat): 3227, 2928, 1746, 1683, 1597, 1371, 1254, 1233, 1154, 1138, 1090, 836 cm<sup>-1</sup>. Mass spectrum (EI): *m/e* (relative intensity) 665 (M<sup>+</sup>, 0.3), 565 (30.6), 521 (40.1), 164 (100). Microanal. Calcd for C<sub>27</sub>H<sub>35</sub>N<sub>3</sub>O<sub>6</sub>Si: C, 66.73; H, 8.32; N, 6.31. Found: C, 66.50; H, 8.18; N, 6.33. HRMS (EI): *m/e* 665.38365 (C<sub>27</sub>H<sub>35</sub>N<sub>3</sub>O<sub>6</sub>Si requires 665.3860).

**1,1-Dimethylethyl 3-[[[(1,1-Dimethylethyl)dimethylsilyl]oxy]-3,4,8-, 12,13,14,14a,15-octahydro-4,4,15,15,18-pentamethyl-17-oxo-11*H*-, 16*H*-8*a*,13*a*-(iminomethano)-2*H*,9*H*-[1,4]dioxepino[2,3-*a*]indolizino[6,7-*h*]carbazole-16-carboxylate (72).** To a stirred solution of **70** (147.5 mg, 0.22 mmol, 1.0 equiv) in DMF (2.2 mL) under Ar at 0 °C was added NaH (13.3 mg, 0.55 mmol, 2.5 equiv). After 5 min, MeI (27.6 μL, 0.44 mmol, 2.0 equiv) was syringed in dropwise. The mixture was stirred for 4 h, when a small amount of water and mercaptoethanol (21.6 μL) were added. After a few minutes, the mixture was diluted with water and extracted with 1:1 hexanes/EtOAc. The organic layer was washed with brine, dried over Na<sub>2</sub>SO<sub>4</sub>, and concentrated under reduced pressure. The residue was purified by radial chromatography (eluted with 1:2 hexanes/EtOAc) to yield 146.9 mg (98%) of **72** as a white amorphous solid. An analytical sample was obtained by PTLC on silica gel (eluted with 1:1 EtOAc/hexanes).

<sup>1</sup>H NMR (300 MHz) (CDCl<sub>3</sub>) (mixture of two diastereomers): δ 0.089 (6H, s), 0.11 (6H, s), 0.87 (9H, s), 0.88 (9H, s), 1.13 (3H, s), 1.15 (3H, s), 1.25 (6H, s), 1.36 (3H, s), 1.37 (3H, s), 1.46 (6H, s), 1.59 (9H, s), 1.61 (9H, s), 1.86–2.06 (10H, m), 2.09–2.20 (6H, m), 2.61–2.70 (2H, m), 2.747 (1H, <sup>1</sup>/<sub>2</sub> ABq, *J* = 15.4 Hz), 2.754 (1H, <sup>1</sup>/<sub>2</sub> ABq, *J* = 15.4 Hz), 2.30–3.05 (2H, m), 3.05 (6H, s), 3.14 (2H, <sup>1</sup>/<sub>2</sub> ABq, *J* = 15.4 Hz), 3.39 (2H, d, *J* = 10.5 Hz), 3.74–3.85 (2H, m), 3.89–3.93 (2H, m), 4.07–4.18 (2H, m), 6.797 (1H, d, *J* = 8.3 Hz), 6.804 (1H, d, *J* = 8.3 Hz), 6.93 (2H, d, *J* = 8.3 Hz). IR (NaCl, neat): 2921, 1747, 1665, 1496, 1371, 1251, 1235, 1158, 1142, 1108, 1093, 837, 755 cm<sup>-1</sup>. Mass spectrum (EI): *m/e* (relative intensity) 679 (M<sup>+</sup>, 2.1), 579 (4.2), 520 (4.2), 178 (100). Microanal. Calcd for C<sub>38</sub>H<sub>57</sub>N<sub>3</sub>O<sub>6</sub>Si: C, 67.12; H, 8.45; N, 6.18. Found: C, 67.33; H, 8.27; N, 6.44. HRMS (EI): *m/e* 679.4008 (C<sub>38</sub>H<sub>57</sub>N<sub>3</sub>O<sub>6</sub>Si requires 679.4017).

**3-Hydroxy-3,4,8,12,13,14,14a,15-octahydro-4,4,15,15,18-pentamethyl-17-oxo-11*H*,16*H*-8*a*,13*a*-(iminomethano)-2*H*,9*H*-[1,4]dioxepino[2,3-*a*]indolizino[6,7-*h*]carbazole (73).** To a stirred solution of **72** (294.7 mg, 0.43 mmol, 1.0 equiv) in CH<sub>2</sub>Cl<sub>2</sub> (8.7 mL) at 0 °C under Ar was added TFA (2.77 mL, 34.7 mmol, 80.0 equiv) dropwise. The solution was stirred for 15 h, the temperature being maintained at 15 °C. At this time the solution was concentrated under reduced pressure, diluted with EtOAc, washed with saturated NaHCO<sub>3</sub> and brine, dried over Na<sub>2</sub>SO<sub>4</sub>, and concentrated under reduced pressure. The residue was purified by radial chromatography (eluted with EtOAc) to yield 194.8 mg (96%) of **73** as a white amorphous solid. An analytical sample was obtained by PTLC on silica gel (eluted with 1:1 EtOAc/hexanes).

<sup>1</sup>H NMR (300 MHz) (CDCl<sub>3</sub>) (mixture of two diastereomers): δ 1.21 (3H, s), 1.23 (3H, s), 1.29 (3H, s), 1.32 (3H, s), 1.42 (3H, s), 1.45

(3H, s), 1.54 (6H, s), 1.88–2.00 (10H, m), 2.07–2.22 (6H, m), 2.63–2.72 (2H, m), 2.79 (1H, <sup>1</sup>/<sub>2</sub> ABq, *J* = 15.1 Hz), 2.80 (1H, <sup>1</sup>/<sub>2</sub> ABq, *J* = 15.1 Hz), 3.01–3.07 (4H, m, 2H D<sub>2</sub>O exch), 3.07 (6H, s), 3.17 (1H, <sup>1</sup>/<sub>2</sub> ABq, *J* = 15.1 Hz), 3.19 (1H, <sup>1</sup>/<sub>2</sub> ABq, *J* = 15.4 Hz), 3.37–3.43 (2H, m), 3.62 (2H, br s), 4.20 (2H, dd, *J* = 4.4, 12.3 Hz), 4.29 (1H, dd, *J* = 4.0, 12.3 Hz), 4.31 (1H, dd, *J* = 4.0, 12.3 Hz), 6.750 (1H, d, *J* = 8.4 Hz), 6.753 (1H, d, *J* = 8.3 Hz), 7.01 (2H, d, *J* = 8.4 Hz), 8.01 (2H, s, D<sub>2</sub>O exch). <sup>13</sup>C NMR (75.5 MHz) (CDCl<sub>3</sub>) (mixture of two diastereomers): δ 14.0, 20.8, 22.6, 23.9, 24.4, 24.5, 24.7, 25.1, 27.7, 27.9, 30.2, 30.3, 31.3, 34.4, 45.9, 54.3, 57.4, 60.0, 60.2, 64.0, 71.0, 75.5, 76.6, 77.0, 77.4, 79.5, 104.6, 112.2, 116.17, 116.22, 125.0, 129.2, 137.2, 140.4, 141.6, 171.0, 174.3. IR (NaCl, neat): 3324, 2954, 1654, 1507, 1474, 1365, 1235, 1071, 1049, 908, 733 cm<sup>-1</sup>. Microanal. Calcd for C<sub>27</sub>H<sub>35</sub>N<sub>3</sub>O<sub>4</sub>Si: C, 69.65; H, 7.58; N, 9.02. Found: C, 69.54; H, 7.66; N, 8.89. Mass spectrum (EI): *m/e* (relative intensity) 465 (M<sup>+</sup>, 9.7), 406 (14.5), 287 (11.8), 178 (100). HRMS (EI): *m/e* 465.2625 (C<sub>27</sub>H<sub>35</sub>N<sub>3</sub>O<sub>4</sub>Si requires 465.2628).

**14-Deoxy-24,25-dihydro-25-hydroxy-17-norparaherquamide (80).** To a stirred solution of **73** (99 mg, 0.21 mmol, 1.0 equiv) in pyridine (4 mL) at -15 °C under Ar was added *t*-BuOCl (37 μL, 0.32 mmol, 1.5 equiv). After 2 h the solvent was removed under reduced pressure to give 106 mg (quantitative) of the crude chloroindolenines (**74/75**) as a mixture of epimers. The majority of the crude chloroindolenines, **74/75** (71 mg, 0.14 mmol, 1.0 equiv), was dissolved in THF (10 mL) and water (1 mL), and *p*-toluenesulfonic acid monohydrate (135 mg, 0.41 mmol, 15 equiv) was added. The resulting yellow solution was stirred at reflux temperature for 20 min and diluted with EtOAc and aqueous K<sub>2</sub>CO<sub>3</sub>. The organic layer was isolated, washed with brine, dried over Na<sub>2</sub>SO<sub>4</sub>, and concentrated to dryness under reduced pressure. The residue was purified by PTLC on silica gel (eluted with 20:1 CH<sub>2</sub>Cl<sub>2</sub>/MeOH) to yield (from the chloroindolenines) 52 mg (76%) of **80** and 2.7 mg (4%) of **81**.

<sup>1</sup>H NMR (300 MHz) (CDCl<sub>3</sub>) (**80** mixture of two diastereomers): δ TMS 0.80 (3H, s), 0.83 (3H, s), 1.08 (3H, s), 1.10 (3H, s), 1.22 (3H, s), 1.26 (3H, s), 1.50 (3H, s), 1.52 (3H, s), 1.40–1.60 (8H, m), 1.77–1.93 (8H, m), 2.05–2.21 (2H, m), 2.55–2.71 (4H, m), 3.02–3.10 (4H, m), 3.06 (6H, s), 3.63 (4H, br s, 2H D<sub>2</sub>O exch), 4.05–4.24 (4H, m), 6.60 (1H, d, *J* = 8.1 Hz), 6.62 (1H, d, *J* = 8.2 Hz), 6.78 (1H, d, *J* = 8.1 Hz), 6.79 (1H, d, *J* = 8.2 Hz), 7.42 (1H, s, D<sub>2</sub>O exch), 7.45 (1H, s, D<sub>2</sub>O exch). IR (NaCl, neat): 3333, 2974, 2933, 1703, 1651, 1646, 1631, 1456, 1395, 1323, 1200, 1046, 903, 728 cm<sup>-1</sup>. Mass spectrum (EI): *m/e* (relative intensity) 481 (M<sup>+</sup>, 0.7), 422 (20.7), 421 (15), 135 (48), 133 (100). HRMS (CI): *m/e* 481 (C<sub>27</sub>H<sub>35</sub>N<sub>3</sub>O<sub>5</sub> requires 481.2578), [M + H] 482.2645 (C<sub>27</sub>H<sub>36</sub>N<sub>3</sub>O<sub>5</sub> requires 482.2655).

<sup>1</sup>H NMR (500 MHz) (CDCl<sub>3</sub>) (**81** mixture of two diastereomers): δ TMS 0.53 (3H, s), 0.56 (3H, s), 0.84 (3H, s), 0.86 (3H, s), 1.22 (3H, s), 1.25 (3H, s), 1.50 (3H, s), 1.52 (3H, s), 1.41–1.73 (8H, m), 1.83–1.90 (8H, m), 2.09–2.13 (2H, m), 2.28–2.41 (6H, m), 2.51–2.58 (2H, m), 3.00 (3H, s), 3.01 (3H, s), 3.63 (2H, br s), 3.78 (1H, D<sub>2</sub>O exch), 3.81 (1H, s, D<sub>2</sub>O exch), 4.05–4.24 (4H, m), 6.60 (2H, d, *J* = 8.0 Hz), 6.62 (2H, d, *J* = 7.4 Hz), 7.42 (2H, s, D<sub>2</sub>O exch). IR (NaCl, neat): 3271, 2924, 2854, 1714, 1644, 1496, 1464, 1393, 1375, 1211, 1142, 1066 cm<sup>-1</sup>.

**(+)-Paraherquamide B (12).** To a stirred solution of **80** (22.5 mg, 0.047 mmol, 1.0 equiv) in DMPU (500 μL) under Ar at room temperature was added MTPI (90 mg, 0.20 mmol, 4.0 equiv). After 16 h KOH (10 mL, 1 M) was added, and the mixture was stirred for an additional 10 min. The pH was adjusted to 2 (addition of HCl) and the mixture extracted with EtOAc. The mixture was diluted with 1:1 hexanes/EtOAc and washed with water and brine. The organic layer was dried over Na<sub>2</sub>SO<sub>4</sub> and concentrated under reduced pressure. The residue was purified by PTLC on silica gel (eluted with 20:1 CH<sub>2</sub>Cl<sub>2</sub>/MeOH) to afford 17.1 mg (79%) of (+)-paraherquamide B (**12**) as a white, amorphous solid. This material proved to be identical to an authentic sample of natural (-)-paraherquamide B by <sup>1</sup>H NMR, <sup>13</sup>C NMR, TLC mobility, IR, mass spectrum, and UV (see text for CD spectrum, Figure 7).

<sup>1</sup>H NMR (300 MHz) (CDCl<sub>3</sub>): δ TMS 0.82 (3H, s), 1.09 (3H, s), 1.40 (3H, s), 1.41 (3H, s), 1.64 (1H, dd, *J* = 9.7, 12.4 Hz), 1.73–1.92 (4H, m), 1.82 (1H, <sup>1</sup>/<sub>2</sub> ABq, *J* = 15.5 Hz), 2.16 (1H, dd, *J* = 8.6, 17.8 Hz), 2.54–2.59 (1H, m), 2.61 (1H, <sup>1</sup>/<sub>2</sub> ABq, *J* = 11.1 Hz), 2.66 (1H, <sup>1</sup>/<sub>2</sub> ABq, *J* = 15.5 Hz), 3.03–3.10 (2H, m), 3.05 (3H, s), 3.60 (1H, <sup>1</sup>/<sub>2</sub> ABq, *J* = 15.5 Hz).

ABq,  $J = 11.1$  Hz), 4.87 (1H, d,  $J = 7.7$  Hz), 6.30 (1H, d,  $J = 7.7$  Hz), 6.64 (1H, d,  $J = 8.2$  Hz), 6.78 (1H, d,  $J = 8.2$  Hz), 8.5 (1H, br s, D<sub>2</sub>O exch). <sup>13</sup>C NMR (75.5 MHz) (CDCl<sub>3</sub>):  $\delta$  20.7 (q), 23.8 (q), 26.2 (q), 28.2 (q), 28.8 (t), 29.8 (t), 29.9 (q), 37.2 (t), 46.1 (s), 52.8 (d), 53.8 (t), 59.5 (t), 63.0 (s), 65.2 (s), 67.4 (s), 79.7 (s), 115.0 (d), 117.2 (d), 120.3 (d), 125.3 (s), 132.5 (s), 135.3 (s), 139.0 (d), 146.0 (s), 172.9 (s), 183.1 (s). IR (NaCl, neat): 3190, 2974, 2933, 1703, 1697, 1651, 1631, 1503, 1456, 1328, 1195, 1046 728 cm<sup>-1</sup>. UV:  $\lambda_{\max}$  226 nm ( $\epsilon = 30$  200).  $[\alpha]_D^{25} = (+0.4/7.75 \times 10^{-3})^\circ = +51.6^\circ$  (CHCl<sub>3</sub>,  $c = 0.008$ ). Mass spectrum (EI):  $m/e$  (relative intensity) 463 (M<sup>+</sup>, 0.5), 404 (15.6), 135 (41.5), 133 (100). HRMS (EI):  $m/e$  463.2456 (C<sub>27</sub>H<sub>33</sub>N<sub>3</sub>O<sub>4</sub> requires 463.2471).

**Spiro Product 56.** <sup>1</sup>H NMR (300 MHz) (acetone-*d*<sub>6</sub>) (mixture of two diastereomers):  $\delta$  TMS 0.21 (12H, s), 0.93 (18H, s), 1.13 (6H, s), 1.41 (18H, s), 1.48 (6H, s), 1.62 (18H, s), 1.82 (6H, s), 1.88–2.15 (6H, m), 2.54 (2H, t,  $J = 11.3$  Hz), 2.81–2.83 (4H, m), 3.02–3.06 (4H, m), 3.36–3.42 (2H, m), 3.62–3.64 (2H, m), 3.88 (2H, dd,  $J = 9.3, 12.2$  Hz), 3.99 (2H, dd,  $J = 3.5, 9.3$  Hz), 4.21 (2H, dd,  $J = 3.5, 12.2$  Hz), 4.61–4.83 (4H, m), 4.96 (2H, br s), 5.07 (2H, br s), 5.94 (2H, d,  $J = 8.5$  Hz, D<sub>2</sub>O exch), 6.92 (2H, d,  $J = 8.3$  Hz), 7.25 (2H, d,  $J = 8.3$  Hz), 7.41 (2H, s). <sup>13</sup>C NMR (75.5 MHz) (CDCl<sub>3</sub>) (mixture of two diastereomers):  $\delta$  -4.9 (q), -4.0 (q), 16.5 (q), 17.9 (s), 18.4 (q), 24.1 (t), 25.7 (q), 28.0 (q), 28.3 (q), 28.6 (q), 29.4 (t), 29.7 (d), 35.6 (t), 36.6 (t), 47.9 (t), 51.7 (d), 66.6 (s), 70.9 (t), 75.9 (d), 76.6 (s), 79.8 (d), 80.4 (s), 83.1 (s), 113.7 (d), 113.9 (t), 114.6 (s), 120.3 (d), 126.4 (d), 127.9 (s), 129.3 (s), 140.4 (s), 141.8 (s), 146.6 (s), 148.5 (s), 155.0 (s), 169.7 (s), 176.6 (s). IR (NaCl, neat): 2932, 1780, 1752, 1714, 1649, 1496, 1425, 1365, 1251, 1229, 1158, 1088 cm<sup>-1</sup>.

**Spiro Product 57.** <sup>1</sup>H NMR (300 MHz) (acetone-*d*<sub>6</sub>) (mixture of two diastereomers):  $\delta$  TMS 0.21 (12H, s), 0.94 (18H, s), 1.14 (6H, s), 1.41 (18H, s), 1.47 (6H, s), 1.62 (18H, s), 1.80 (6H, s), 1.96–2.07 (6H, m), 2.58 (2H, t,  $J = 11.3$  Hz), 2.84 (4H, br s), 2.98–3.13 (4H, m), 3.48–3.50 (2H, m), 3.51–3.52 (2H, m), 3.88 (2H, dd,  $J = 9.3, 12.1$  Hz), 4.00 (2H, dd,  $J = 3.4, 9.1$  Hz), 4.22 (2H, dd,  $J = 3.4, 12.2$  Hz), 4.72 (2H, dd,  $J = 6.6, 15.0$  Hz), 4.84 (2H, dd,  $J = 6.3, 10.7$  Hz), 4.96 (2H, br s), 5.08 (2H, br s), 5.95 (2H, d,  $J = 8.6$  Hz, D<sub>2</sub>O exch), 6.91 (2H, d,  $J = 8.3$  Hz), 7.23 (2H, d,  $J = 8.3$  Hz), 7.38 (2H, s). <sup>13</sup>C NMR (75.5 MHz) (CDCl<sub>3</sub>) (mixture of two diastereomers):  $\delta$  -4.9 (q), -4.0 (q), 16.5 (q), 17.9 (s), 18.8 (q), 24.1 (t), 25.7 (q), 28.0 (q),

28.3 (q), 29.0 (t), 29.7 (d), 35.6 (t), 36.7 (t), 48.0 (t), 52.4 (d), 66.7 (s), 71.0 (t), 75.8 (d), 76.6 (s), 79.8 (d), 80.4 (s), 83.1 (s), 113.6 (d), 113.8 (t), 114.7 (s), 120.0 (d), 126.1 (d), 127.8 (s), 129.3 (s), 140.4 (s), 141.7 (s), 146.4 (s), 148.6 (s), 155.0 (s), 169.8 (s), 175.7 (s). IR (neat): 2926, 1783, 1754, 1715, 1652, 1494, 1457, 1367, 1250, 1160, 1087 cm<sup>-1</sup>.

**Acknowledgment.** This work was supported in part by the National Institutes of Health (Grant CA 43969) and the National Science Foundation (CHE 9320010). Acknowledgment is made to the donors of the Petroleum Research Fund, administered by the American Chemical Society, and The Colorado State University Agricultural Experiment Station (USDA SAES Western Project W-122) for partial support of this work. Mass spectra were obtained on instruments supported by the National Institutes of Health Shared Instrumentation Grant GM49631. We would like to thank Dr. Chris Rithner of Colorado State University for technical assistance with several 2D NMR experiments. Narashima Sreerama and Prof. Robert W. Woody (Department of Biochemistry and Molecular Biology, Colorado State University) are gratefully acknowledged for help in obtaining CD spectra. We would also like to acknowledge Dr. Dusan Stanojevic and Prof. Gregory L. Verdine (Department of Chemistry, Harvard University) for their assistance in obtaining CD spectra of paraherquamide B. We are grateful to Dr. John Ondeyka of Merck & Co. for furnishing NMR spectra of natural paraherquamide B. J.F.S.-C. thanks the Conselleria de Educacio i Ciencia de la Generalitat Valenciana (Spain) for a fellowship. We also wish to acknowledge Renee Gallegos (Colorado State University), Felix Sancenon (University of Valencia), and M. Eugenia Martinez (University of Valencia) for valuable assistance in isolating natural (-)-paraherquamide B from *P. fellutanum*. Mr. Dan Bond is gratefully acknowledged for providing synthetic chemical technical assistance.

JA952666C

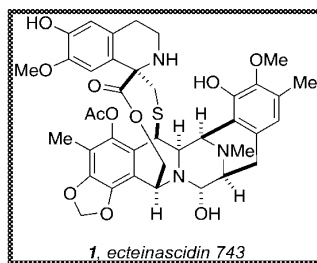
## Synthetic Studies on Et-743. Assembly of the Pentacyclic Core and a Formal Total Synthesis

Dan Fishlock<sup>†</sup> and Robert M. Williams<sup>\*†‡</sup>

Department of Chemistry, Colorado State University, Fort Collins, Colorado 80523, and University of Colorado Cancer Center, Aurora, Colorado 80045

rmw@lamar.colostate.edu

Received May 30, 2008



A formal total synthesis of the potent anticancer agent Et-743 is described. The tetrahydroisoquinoline core is stereoselectively constructed using a novel radical cyclization of a glyoxalimine. Further elaboration of this core rapidly accessed the pentacyclic core of Et-743, but a mixture of regioisomers was obtained in the key Pictet–Spengler ring closure. A known advanced intermediate in the synthesis of Et-743 was intercepted, constituting a formal synthesis of the molecule.

### Introduction

Members of the tetrahydroisoquinoline family of alkaloids display a wide range of biological properties such as antitumor and antimicrobial activities.<sup>1</sup> Of particular significance within this family is Ecteinascidin 743 (Et-743, **1**, Figure 1), which has been demonstrated to possess extremely potent cytotoxic activity with in vitro IC<sub>50</sub> values in the 0.1–1 ng/mL range in several cell lines (as a measure of RNA, DNA, and protein synthesis inhibition).<sup>2</sup> Et-743 is currently in phase II/III clinical trials for the treatment of ovarian, endometrial, and breast cancers and several sarcoma lines.<sup>3</sup> The scarcity of the natural product from marine sources renders Et-743 an important target for synthesis. Corey and co-workers reported the first total synthesis of Et-743 in 36 steps with an overall yield of 0.72%.<sup>4a</sup>

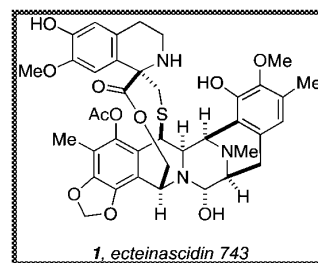


FIGURE 1. Ecteinascidin 743 (**1**).

A second-generation synthesis improved the overall yield to 2.04%, but still required 36 steps.<sup>4b</sup> Fukuyama and co-workers achieved a total synthesis of Et-743 in 50 steps and 0.56% overall yield.<sup>5</sup> More recently, Zhu and co-workers reported a 31 step synthesis in 1.7% overall yield.<sup>6</sup> Most recently, Danishefsky and co-workers reported a formal total synthesis<sup>7</sup> via a pentacyclic compound that intercepted a late-stage intermediate of Fukuyama's route.<sup>5</sup> Despite the advancements in the state-of-the-art in total synthetic approaches to Et-743, the clinical supply of this complex drug is semisynthetically derived from natural cyanosafraicin B, obtained by fermentation as reported by PharmaMar.<sup>8</sup>

Our laboratory has been developing methodology for the assembly of tetrahydroisoquinoline natural products and has

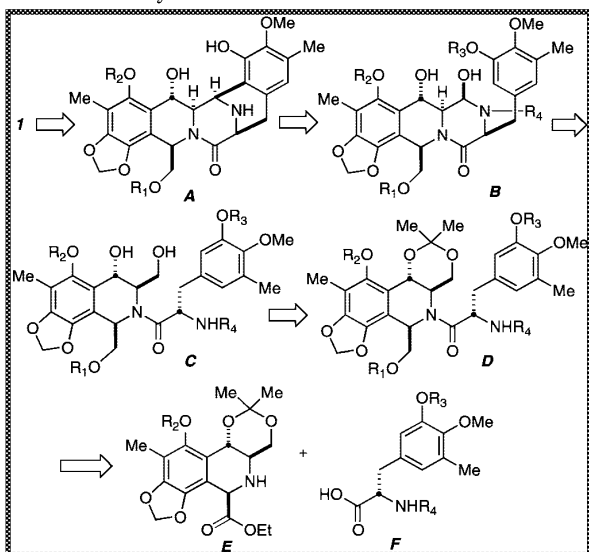
<sup>†</sup> Colorado State University.

<sup>‡</sup> University of Colorado Cancer Center.

(1) Scott, J. D.; Williams, R. M. *Chem. Rev.* **2002**, *102*, 1669–1730.

(2) (a) Rinehart, K. L.; Holt, T. G.; Fregeau, N. L.; Keifer, P. A.; Wilson, G. R.; Perun, T. J.; Sakai, R.; Thompson, A. G.; Stroh, J. G.; Shield, L. S.; Seigler, D. S. *J. Nat. Prod.* **1990**, *53*, 771–792. (b) Rinehart, K. L.; Holt, T. G.; Fregeau, N. L.; Stroh, J. G.; Keifer, P. A.; Sun, F.; Li, L. H.; Martin, D. G. *J. Org. Chem.* **1990**, *55*, 4512–4515. (c) Wright, A. E.; Forleo, D. A.; Gunawardana, G. P.; Gunasekera, S. P.; Koehn, F. E.; McConnell, O. J. *J. Org. Chem.* **1990**, *55*, 4508–4512. (d) Guan, Y.; Sakai, R.; Rinehart, K. L.; Wang, A. H.-J. *J. Biomol. Struct. Dyn.* **1993**, *10*, 793–818. (e) Aune, G. J.; Furuta, T.; Pommier, Y. *Anti-Cancer Drugs* **2002**, *13*, 545–555. (f) Rinehart, K. L. *Med. Drug Rev.* **2000**, *1*–27.

SCHEME 1. Synthetic Plan



reported syntheses of D,L-quinocarcinamide,<sup>9</sup> (–)-tetrazomine,<sup>10</sup> (–)-renieramycin G,<sup>11</sup> (–)-jorumycin,<sup>11</sup> and cribrastatin 4 (renieramycin H).<sup>12</sup> As a part of this program, we have targeted Et-743 by a convergent route that envisioned coupling of a suitably functionalized tyrosine derivative<sup>13</sup> with the complete tetrahydroisoquinoline core (Scheme 1.) We have successfully deployed this strategy, with the present objective of construction of pentacycle A, in the synthesis of (–)-renieramycin G and (–)-jorumycin.<sup>11,12</sup>

We have previously reported a concise and highly diastereoselective synthesis of the tetrahydroisoquinoline core of Et-743

(E).<sup>14</sup> This was achieved via an intramolecular 6-endo radical closure on a glyoxalimine, and the desired 1,3-*cis*-diastereomer was obtained exclusively. The synthesis of a tetrahydroisoquinoline such as E can be problematic because of the acid sensitivity of the benzylic hydroxyl, particularly because it is *ortho* to the phenolic hydroxyl of the aromatic ring and thus has a high propensity for *ortho*-quinonemethide formation. Herein, we report a formal total synthesis of Et-743 as part of our ongoing efforts to devise a practical and scalable synthesis of this potent antitumor antibiotic that would be amenable to the construction of analogues with anticipated potent cytotoxic activity.

## Results and Discussion

The synthesis began with Borchardt's catechol 3<sup>15</sup> that was regioselectively brominated to generate 4 (92% yield) (Scheme 2.) Conversion of catechol 4 to the methylenedioxy aldehyde 5 was accomplished using bromochloromethane in a sealed vessel (69% yield). Baeyer–Villiger oxidation using *m*-CPBA provided bromophenol 6 as an off-white solid following hydrolysis of the resulting formate intermediate (73% yield). Stereoselective aldol condensation of the titanium phenolate of 6 with (*R*)-Garner's aldehyde (7)<sup>16</sup> using a modification of Casiraghi's method<sup>17</sup> provided the *anti*-product 8 followed by allyl protection of the phenolic oxygen delivering 9 (65% yield, two steps). Subsequent hydrolysis of the oxazolidine and formation of the *trans*-acetonide (84% yield, two steps) provided 10 as an oil that cleanly underwent *N*-Boc deprotection using Ohfuné's protocol<sup>18</sup> (76% yield) to afford free amine 11 as a stable crystalline solid. From 11, the glyoxalimine intermediate 13 (see Scheme 3) was readily obtained by condensation with ethyl glyoxalate. Following isolation by filtration through Celite and concentration, the radical ring closure commenced with slow addition of Bu<sub>3</sub>SnH and AIBN via syringe pump to a refluxing dilute solution of the glyoxalimine (13). Concentration and KF/silica chromatography<sup>19</sup> of the crude reaction mixture provided solid 12 as a single diastereomer (58% yield, two steps). The relative stereochemistry of 12 was secured <sup>1</sup>H NMR data and corroborated by X-ray crystallography. Examination of the crude <sup>1</sup>H NMR revealed the formation of a single diastereomer in the radical closure and exclusive 6-endo regioselectivity. In addition to 12 and tin impurities visible in the <sup>1</sup>H NMR spectrum, an aromatic proton arising from hydride quenching of the aryl radical revealed a ~6.6:1 ratio of 12 to reduced substrate. Slower addition rates (over 18 or 36 h) did not improve the isolated yield of 12.

(3) (a) Zelek, L.; Yovine, A.; Etienne, B.; Jimeno, J.; Taamma, A.; Martín, C.; Spielmann, M.; Cvitkovic, E.; Misset, J. L. *Ecteinacidin-743 in Taxane/Antracycline Pretreated Advanced/Metastatic Breast Cancer Patients: Preliminary Results with the 24 h Continuous Infusion Q3 Week Schedule*; 36th Annual Meeting of the American Society of Clinical Oncology, New Orleans, May 20–23, 2000; Abstract number 592. (b) Delalogue, S.; Yovine, A.; Taamma, A.; Cottu, P.; Riofrio, M.; Raymond, E.; Brain, E.; Marty, M.; Jimeno, J.; Cvitkovic, E.; Misset, J. L. *Preliminary Evidence of Activity Of Ecteinacidin-743 (ET-743) in Heavily Pretreated Patients with Bone and Soft Tissue Sarcomas*; 36th Annual Meeting of the American Society of Clinical Oncology, New Orleans, May 20–23, 2000; Abstract number 2181. (c) Le Cesne, A.; Judson, I.; Blay, J. Y.; Radford, J.; an Oosterom, A.; Lorigan, P.; Rodenhuis, E.; Donato Di Paoula, E.; Van Glabbeke, M.; Jimeno, J.; Verweij, J. *Phase II of ET-743 in Advance Soft Tissue Sarcoma in Adult: A STBSG-EORTC Trial*; 36th Annual Meeting of the American Society of Clinical Oncology, New Orleans, May 20–23, 2000; Abstract number 2182. (d) Aune, G. J.; Furuta, T.; Pommier, Y. *Anti-Cancer Drugs* **2002**, *13*, 545–555.

(4) (a) Corey, E. J.; Gin, D. Y.; Kania, R. S. *J. Am. Chem. Soc.* **1996**, *118*, 9202–9203. (b) Martínez, E. J.; Corey, E. J. *Org. Lett.* **2000**, *2*, 993–996.

(5) Endo, A.; Yanagisawa, A.; Abe, M.; Tohima, S.; Kan, T.; Fukuyama, T. *J. Am. Chem. Soc.* **2002**, *124*, 6552–6554.

(6) Chen, J.; Chen, X.; Bois-Choussy, M.; Zhu, J. *J. Am. Chem. Soc.* **2006**, *128*, 87–89.

(7) Zheng, S.; Chan, C.; Furuuchi, T.; Wright, B. J. D.; Zhou, B.; Guo, J.; Danishefsky, S. J. *Angew. Chem., Int. Ed.* **2006**, *45*, 1754–1759.

(8) Cuevas, C.; Pérez, M.; Martín, M. J.; Chicharro, J. L.; Fernández-Rivas, C.; Flores, M.; Francesch, A.; Gallego, P.; Zarzuelo, M.; de la Calle, F.; Garcia, J.; Polanco, C.; Rodríguez, I.; Manzanares, I. *Org. Lett.* **2000**, *2*, 2545–2548. (9) Flanagan, M. E.; Williams, R. M. *J. Org. Chem.* **1995**, *60*, 6791–6797.

(10) (a) Scott, J. D.; Williams, R. M. *Angew. Chem., Int. Ed.* **2001**, *40*, 1463–1465. (b) Scott, J. D.; Williams, R. M. *J. Am. Chem. Soc.* **2002**, *124*, 2951–2956.

(11) (a) Lane, J. W.; Chen, Y.; Williams, R. M. *J. Am. Chem. Soc.* **2005**, *127*, 12684–12690. (b) Lane, J. W.; Estevez, A.; Mortara, K.; Callan, O.; Spencer, J. R.; Williams, R. M. *Bioorg. Med. Chem. Lett.* **2006**, *16*, 3180–3183. (c) Vincent, G.; Lane, J. W.; Williams, R. M. *Tetrahedron Lett.* **2007**, *48*, 3719–3722. (d) Jin, W.; Metobo, S.; Williams, R. M. *Org. Lett.* **2003**, *5*, 2095–2098.

(12) (a) Vincent, G.; Williams, R. M. *Angew. Chem., Int. Ed.* **2007**, *46*, 1517–1520. (b) Vincent, G.; Chen, Y.; Lane, J. W.; Williams, R. M. *Heterocycles* **2007**, *72*, 385–398.

(13) Jin, W.; Williams, R. M. *Tetrahedron Lett.* **2003**, *44*, 4635–4639.

(14) Fishlock, D.; Williams, R. M. *Org. Lett.* **2006**, *8*, 3299–3301.

(15) Prep a red from 2,3-dimethoxytoluene according to: Shinhababu, A. K.; Ghosh, A. K.; Borchardt, R. T. *J. Med. Chem.* **1985**, *28*, 1273–1279.

(16) (*R*)-Garner's aldehyde was synthesized from D-serine according to: Garner, P.; Park, J. M. *Org. Synth.* **1992**, *70*, 18–28.

(17) Casiraghi, G.; Comia, M.; Rasso, G. *J. Org. Chem.* **1988**, *53*, 4919–4922. In our case, sonication was not required as described in the original paper.

(18) Sakaitani, M.; Ohfuné, Y. *J. Org. Chem.* **1990**, *55*, 870–876.

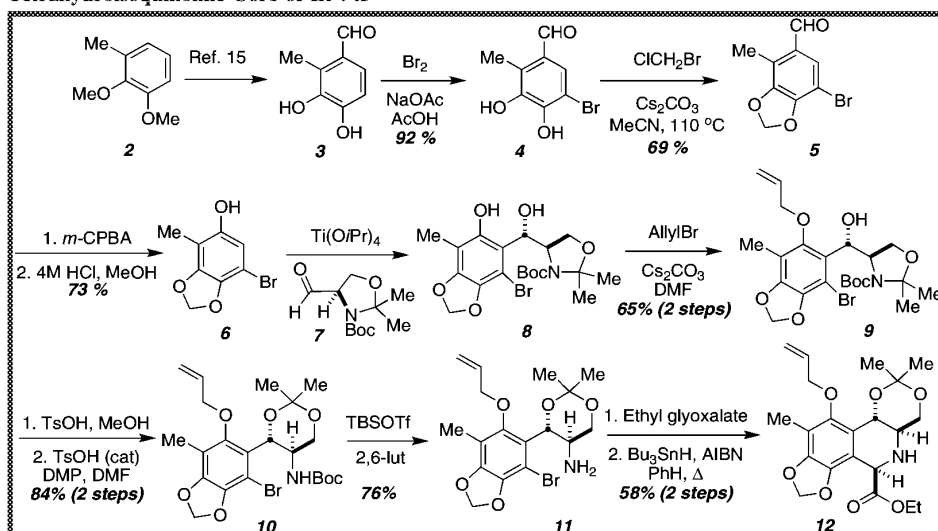
(19) Effective removal of tin impurities from Bu<sub>3</sub>SnH-mediated reactions: Harrowen, D. C.; Guy, J. L. *Chem. Commun.* **2004**, 1968–1969.

(20) (a) De Paolis, M.; Chiaroni, A.; Zhu, J. *Chem. Commun.* **2003**, 2896–2897. (b) Chen, X.; Chen, J.; De Paolis, M.; Zhu, J. *J. Org. Chem.* **2005**, *70*, 4397–4408.

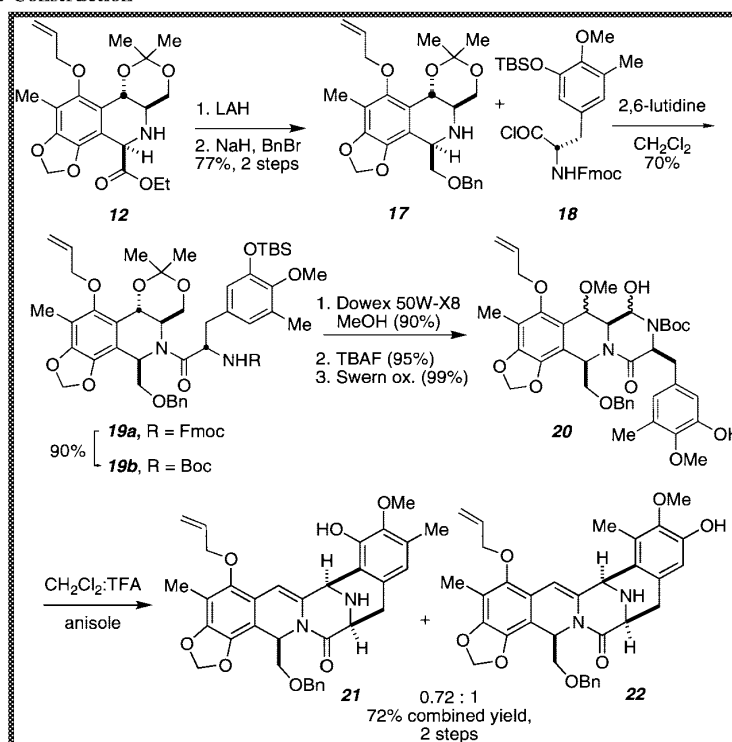
(21) (a) Herberich, B.; Kinugawa, M.; Vazquez, A.; Williams, R. M. *Tetrahedron Lett.* **2001**, *42*, 543–546. (b) Jin, W.; Metobo, S.; Williams, R. M. *Org. Lett.* **2003**, *5*, 2095–2098.



SCHEME 2. Tetrahydroisoquinoline Core of Et-743



SCHEME 3. Pentacycle Construction



The diastereoselectivity of this reaction stands apart from numerous Pictet–Spengler cyclizations on related substrates that provide tetrahydroisoquinolines exclusively as the 1,3-*trans*-diastereomers.<sup>11,20,21</sup> We qualitatively rationalize the *cis*-diastereoselectivity of this radical process using the Beckwith–Houk chairlike transition state model for intramolecular radical ring closures (Figure 2).<sup>22</sup> The lowest-energy chair conformation (**A**)

adopted by the *trans*-acetonide of the substrate (**13**) results in both the glyoxalimine and aryl substituent being in an equatorial disposition. In this conformation, 1,3-diaxial steric effects and allylic strain interactions are minimized in the ring-forming transition state. To further examine the stereocontrol imparted by the acetonide ring, the *cis*-acetonide substrate **14** was prepared (using Casiraghi's method from the magnesium phenolate of **6**).<sup>17</sup> Substrate **14** resulted in a 1:1 mixture of 1,3-

(22) (a) Beckwith, A. L. J.; Schiesser, C. H. *Tetrahedron* **1985**, *41*, 3925–3941. (b) Spellmeyer, D. C.; Houk, K. N. *J. Org. Chem.* **1987**, *52*, 959–974.

(23) Chen, X.; Zhu, J. *Angew. Chem., Int. Ed.* **2007**, *46*, 3962–3965.

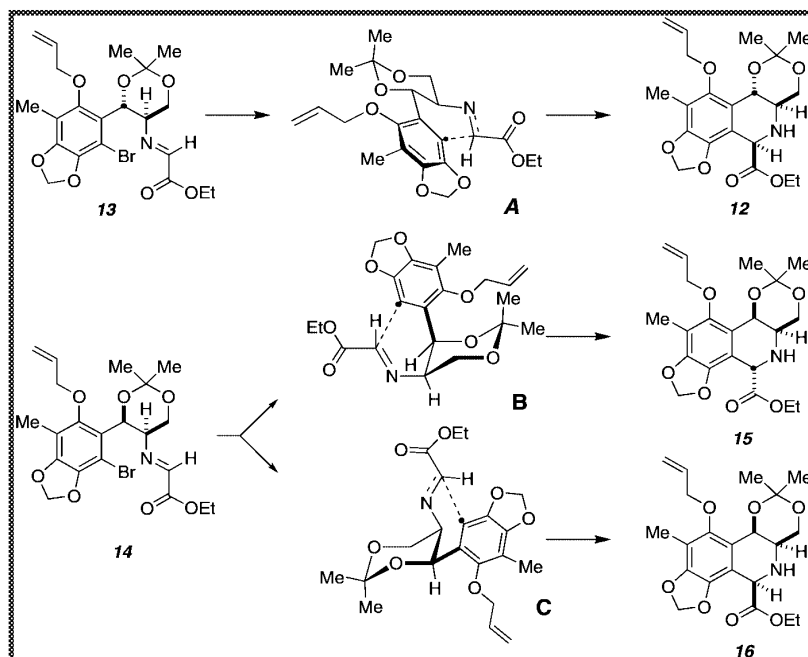


FIGURE 2. Transition state models to rationalize the observed 1,3 relative stereochemistry in the tetrahydroisoquinoline radical ring closure.

*trans*- and 1,3-*cis*-tetrahydroisoquinolines (**15** and **16**, both are known compounds),<sup>20</sup> which suggests the energy difference between transition state conformations **B** and **C** (axial aryl group versus axial glyoxalimine) is negligible.

As shown in Scheme 3, reduction of the tetrahydroisoquinoline ester (**12**)<sup>14</sup> with LAH, followed by immediate protection as the benzyl ether (**17**), proceeded cleanly in 77% yield over two steps. The substituted tyrosine amino acid component (**18**) has been previously reported by us, utilizing the oxazinone template technology developed in our laboratory that was benzylated with the advanced aromatic side chain.<sup>13</sup> Thus, acylation of the tetrahydroisoquinoline (**17**) was achieved via the *N*-Fmoc-protected amino acid chloride (**18**) to give amide **19a** without epimerization. The use of the *N*-Boc free acid with a variety of coupling agents (DCC, HOBt, HATU) all resulted in very sluggish reactions with poor isolated yields, as did the attempted use of the *N*-Boc acid fluoride.

Treatment of **19a** with diethylamine provided the free amine, which was not isolated in favor of immediate evaporation of excess base and solvent and subsequent Boc protection of the crude material. Isolation following chromatography provided compound **19b** in 90% yield. Removal of the acetonide from **19b** was accomplished using the extremely mild, albeit slow, method of stirring with Dowex 50W-X8 cationic resin in methanol. Complete deprotection took 8–12 h, but the yield was quantitative following simple filtration and concentration. Instead of providing the usual diol product, this substrate incorporated methanol at the benzylic position thus providing the methyl ether as a ~1:1 mixture of diastereomers. Not unexpectedly, the benzylic stereogenic center loses stereochemical integrity since the methanol is incorporated via the incipient *ortho*-quinonemethide species arising from the acidic deprotection conditions.

Alternatively, we found that the use of water/dichloromethane with cationic resin on **19b** could provide the corresponding free

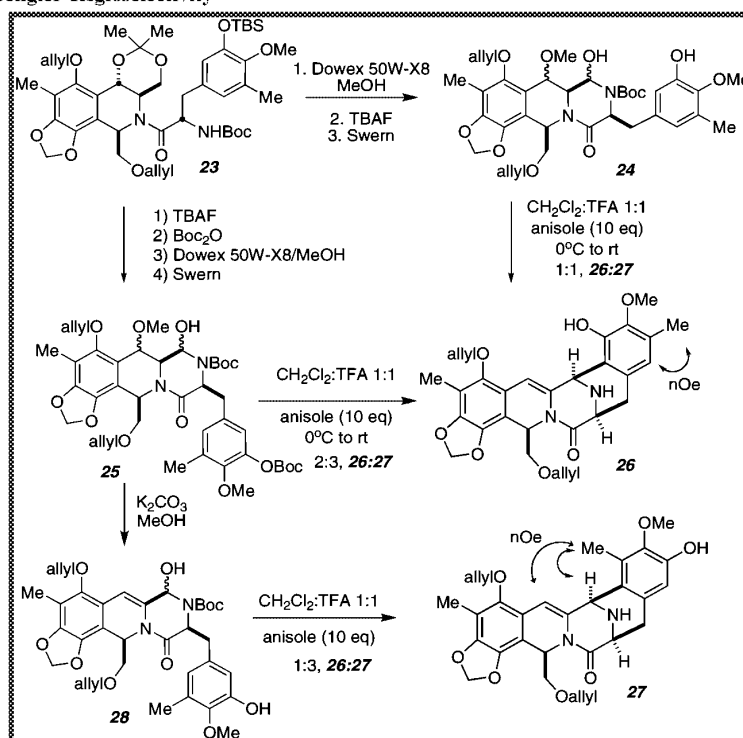
diol, but oxidation of the primary alcohol (in the presence of the free benzylic alcohol) could not, in our hands, be cleanly accomplished. The methyl ether was thus a fortuitous selective protection of the benzylic alcohol, ultimately simplifying the subsequent manipulations.

Facile deprotection of the *O*-TBS-protected phenol using TBAF was followed by oxidation of the primary alcohol using Swern conditions in high yield. This oxidation product (**20**) existed as an equilibrium mixture of the aldehyde and the corresponding hemiaminal species (illustrated) as observed by <sup>1</sup>H NMR, which was otherwise additionally complicated by amide and carbamate rotamers. The attempted oxidation using either Dess–Martin periodinane or TPAP/NMO both failed, leading to extensive decomposition. Following filtration of crude **20** through a plug of silica gel, this substance was immediately subjected to the Pictet–Spengler conditions.

The objective at this stage was to achieve the Pictet–Spengler reaction via *N*-Boc deprotection, iminium ion formation, and electrophilic aromatic substitution to provide the desired pentacyclic core of Et-743. This meant that the aromatic substitution must occur *ortho* to the free phenol, and the benzylic methyl ether must survive these conditions. Unfortunately, it had already been demonstrated above that the electron-rich aromatic ring of the tetrahydroisoquinoline component was highly sensitive to protic conditions, leading to *ortho*-quinonemethide formation.

Indeed, when substrate **20** was treated with trifluoroacetic acid in methylene chloride, it cleanly underwent the expected pentacycle formation furnishing **21** + **22** as a ~0.72:1 *ortho*:*para* mixture of regioisomers in 72% combined yield. As anticipated, the benzylic methoxy group was eliminated presumably via the incipient *ortho*-quinonemethide species that forms under these conditions. In a fruitless effort to circumvent the vexing olefin formation, pentacycle formation with TFA in dry methanol resulted in extensive decomposition of the substrate.

SCHEME 4. Pictet–Spengler Regioselectivity



As part of these synthetic investigations, the intermediate **23** was prepared (in parallel with the *O*-benzyl-protected synthesis) bearing an *O*-allyl-protected hydroxymethyl at C1 of the THIQ core. This substrate was used to examine the regioselectivity of the pentacycle-forming ring closure and was utilized to acquire detailed <sup>1</sup>H NMR data, while the *O*-benzyl material **21** was carried forward in the synthesis. One interesting observation was the behavior of compound **25** containing the *O*-Boc carbonate-protected phenolic oxygen. Treatment of **25** under the same reaction conditions provided the pentacycles **26** + **27** in a 2:3 ratio of *ortho:para* regioisomers. The *O*-Boc carbonate would presumably be deprotected quickly under these conditions to reveal the free phenol-containing reactive species, thus resulting in a comparable regioselectivity as observed with substrate **20** (beginning with a free phenol on the aryl nucleophile moiety). Notably, however, when substrate **25** was treated with K<sub>2</sub>CO<sub>3</sub>/MeOH, the *O*-Boc carbonate was selectively removed (**28**) with apparent olefin formation prior to the Pictet–Spengler reaction and pentacycle formation. Treatment of **28** with TFA in dichloromethane produced the pentacycles **26** + **27** in a 1:3 ratio of *ortho:para* regioisomers, supporting the hypothesis that some regioselectivity in the closure might arise from an intramolecular H bond with a heteroatom at the benzylic position.<sup>11c</sup>

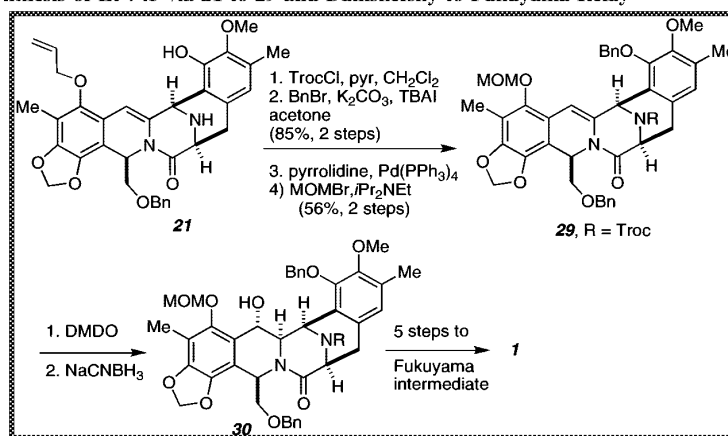
In their synthesis of renieramycin H, the Zhu group has interestingly reported control of Pictet–Spengler regioselectivity in a related system by variation of acid concentration (Scheme 4).<sup>23</sup> It was found in that case that lowering the concentration of methanesulfonic acid to 0.01% in CH<sub>2</sub>Cl<sub>2</sub> could invert the *ortho:para* selectivity from 3.4:1 to 2:3. Furthermore, the use of acetonitrile as the solvent instead of dichloromethane favored the undesired isomer, giving *ortho:para* selectivity of 1:10. Our

attempt to reproduce the Zhu conditions on substrate **24** using 0.01% methanesulfonic acid in CH<sub>2</sub>Cl<sub>2</sub> did not affect the regioselectivity of this reaction. The substrate was consumed to provide some material that appeared to still contain the *N*-Boc protecting group, but the <sup>1</sup>H NMR of the crude product was prohibitively complex. Subsequent treatment of this reaction crude with a TFA/anisole/CH<sub>2</sub>Cl<sub>2</sub> mixture provided the pentacycles **26** + **27** with ~1:1 regioselectivity. The same ratio is obtained if the TFA/anisole conditions are used directly on substrate **24**.

In order to redeem the synthetic utility of the olefinic products (**21** or **26**), our attention was captured by the recent formal synthesis of Et-743 reported by the Danishefsky group<sup>7</sup> in which the olefin (**29**, Scheme 5) underwent facile oxidation using DMDO and immediate hydride reduction delivering the benzylic alcohol **30**. With the availability of this methodology in the literature, our efforts were briefly redirected to convert our synthetic pentacycle **21** into compound **29** which would constitute a formal total synthesis of Et-743 by relay through the Danishefsky<sup>7</sup> and then Fukuyama<sup>5</sup> syntheses, respectively.

In the event, the desired pentacycle **21** (Scheme 3) was *N*-protected as the trichloroethyl carbamate (Troc), and the phenolic residue was protected as the corresponding *O*-benzyl ether in 85% yield for the two steps (Scheme 5). Removal of the *O*-allyl group under standard conditions followed by reprotection as the corresponding MOM ether provided compound **29** (56% yield for the two steps). Compound **29** perfectly matched Danishefsky's substrate by <sup>1</sup>H, <sup>13</sup>C NMR, and optical rotation, confirming the structure of compound **29**.

Since Danishefsky has previously converted<sup>7</sup> compound **29** into a late-stage intermediate in Fukuyama's total synthesis<sup>5</sup> (namely, compound **30**, Scheme 5), this two-stage relay of our

SCHEME 5. Formal Synthesis of Et-743 via **21** to **29** and Danishefsky to Fukuyama Relay

synthetic **21** thus constitutes a formal total synthesis of Et-743 and provides firm structural corroboration of our synthetic material and methods.

While the present formal synthesis reveals that our glyoxal-imine radical cyclization technology<sup>14</sup> holds considerable potential for the efficient total synthesis of Et-743 and congeners, we are currently endeavoring to improve the regioselectivity of the key pentacycle formation (**20** to **21**) as well as refining the overall synthetic efficiency of our approach. These objectives are currently under study in our laboratory and will be reported in due course.

### Experimental Section

For general methods and considerations, see Supporting Information.

**Compound 19.** The Fmoc-amino acid (410 mg, 0.727 mmol, 1.2 equiv) was dissolved in dry toluene and concentrated ( $\times 2$ ), and then dried under high vacuum. This oil was dissolved in dry  $\text{CH}_2\text{Cl}_2$  (4 mL) to which was added oxalyl chloride (1 mL) at room temperature, followed by dry DMF (20  $\mu\text{L}$ ). After stirring for 20 min, the solution was concentrated and reconstituted from dry toluene ( $\times 2$ ) and then dried under high vacuum. This acid chloride **18** was dissolved in  $\text{CH}_2\text{Cl}_2$  (4 mL) and cooled to 0 °C. THIQ(OBn) **17** (275 mg, 0.61 mmol, 1 equiv) was dissolved in dry  $\text{CH}_2\text{Cl}_2$  (2 mL) and 2,6-lutidine (77  $\mu\text{L}$ , 0.67 mmol, 1.1 equiv). This solution was transferred into the acid chloride solution slowly dropwise, and the resulting mixture was warmed to rt and stirred 7 h (TLC showed consumption of the THIQ(OBn) starting material). The reaction was quenched with saturated  $\text{NH}_4\text{Cl}$  (aq) and then extracted to EtOAc ( $\times 3$ ). The combined organic fractions were dried ( $\text{Na}_2\text{SO}_4$ ), filtered, and concentrated to provide a crude orange oil. Purification by flash chromatography (hexanes:EtOAc 5:1, silica gel) gave the peptide **19a** as a pale yellow oil (426 mg, 70%);  $R_f = 0.34$  (3:1 hexanes:EtOAc, UV, CAM);  $[\alpha]_D^{25} = -22.8$  (c 1.14,  $\text{CH}_2\text{Cl}_2$ ); IR (thin film) 3289, 2929, 2858, 1717, 1634  $\text{cm}^{-1}$ ;  $^1\text{H}$  and  $^{13}\text{C}$  NMR spectra are extremely complex due to amide and carbamate rotamers. See the rt ( $\text{CDCl}_3$ ) and 373 K ( $\text{DMSO}-d_6$ )  $^1\text{H}$  spectra and rt ( $\text{CDCl}_3$ )  $^{13}\text{C}$  spectra in the Supporting Information; HRMS(ESI/APCI+)  $m/z$  calcd for  $\text{C}_{58}\text{H}_{68}\text{N}_2\text{O}_{11}\text{NaSi}$  ( $M + \text{Na}$ )<sup>+</sup> 1019.4485, found 1019.4499.

**Compound 19b.** Fmoc (OBn) peptide **19a** (146 mg, 0.146 mmol) was dissolved in a 20% v/v solution of  $\text{Et}_2\text{NH}$  in  $\text{CH}_2\text{Cl}_2$  [ $\text{CH}_2\text{Cl}_2$  (2.5 mL) and diethylamine (0.6 mL)]. After stirring for 6 h, the solution was concentrated and then reconstituted from toluene and dried under high vacuum. The crude material was dissolved in EtOH: $\text{CH}_2\text{Cl}_2$  (2:0.5 mL) to which was added Boc<sub>2</sub>O (370 mg, 10

equiv). After stirring for 12 h, the reaction was concentrated and immediately purified by flash chromatography (9:1 to 5:1 hexanes:EtOAc, silica gel) to provide **19b** as a clear colorless oil (115 mg, 90% over 2 steps);  $R_f = 0.43$  (3:1 hexanes:EtOAc, UV, CAM);  $[\alpha]_D^{25} = -26.6$  (c 1.0,  $\text{CH}_2\text{Cl}_2$ ); IR (thin film) 3319, 2930, 2858, 1711, 1646  $\text{cm}^{-1}$ ;  $^1\text{H}$  and  $^{13}\text{C}$  NMR spectra are extremely complex due to amide and carbamate rotamers; see the  $^1\text{H}$  spectra ( $\text{CDCl}_3$ , rt) and ( $\text{DMSO}-d_6$ , 373 K) and  $^{13}\text{C}$  spectrum ( $\text{CDCl}_3$ , rt) in the Supporting Information; HRMS(ESI/APCI+)  $m/z$  calcd for  $\text{C}_{48}\text{H}_{66}\text{N}_2\text{O}_{11}\text{NaSi}$  ( $M + \text{Na}$ )<sup>+</sup> 897.4328, found 897.4310.

**Compounds 21 and 22.** Boc (OBn) peptide **19b** (115 mg, 0.132 mmol) was dissolved in dry MeOH (5 mL), and Dowex 50W-X8 cationic resin (100 mg) was added (the resin was first rinsed with dry methanol and dried under a stream of argon). After 65 h, the reaction was complete by TLC and a single streak was observed (during the course of the reaction, two streaks initially arise due to a mixture of diol and methyl ether/alcohol products). The reaction was filtered through a plug of Celite, eluting with dry MeOH, and the filtrate was combined to provide the methyl ether as clear, colorless oil (100 mg, 90% yield);  $R_f = 0$  to 0.35 streak (3:1 hexanes:EtOAc, UV, CAM); HRMS(FAB+)  $m/z$  calcd for  $\text{C}_{46}\text{H}_{65}\text{N}_2\text{O}_{11}\text{Si}$  ( $M + \text{H}$ )<sup>+</sup> 849.4358, found 849.4354. The methyl ether (100 mg) was dissolved in THF (3 mL), and TBAF (1 M in THF, 125  $\mu\text{L}$ , 1.06 equiv) was added in one portion. After 20 min, the reaction was concentrated by rotary evaporation and passed through a silica plug (eluting with 3:1 to 1:1 hexanes:EtOAc) to provide the free phenol as a clear, colorless oil (82 mg, 95% yield);  $R_f = 0$  to 0.43 streak (3:1 hexanes:EtOAc, UV, CAM); HRMS(FAB+)  $m/z$  calcd for  $\text{C}_{40}\text{H}_{51}\text{N}_2\text{O}_{11}$  ( $M + \text{H}$ )<sup>+</sup> 735.3493, found 735.3490. Oxalyl chloride (15  $\mu\text{L}$ , 1.5 equiv) was added carefully to a solution of DMSO (25  $\mu\text{L}$ , 3.2 equiv) in  $\text{CH}_2\text{Cl}_2$  (1 mL) previously cooled to  $-78$  °C. A solution of the above alcohol (82 mg, 0.11 mmol) in  $\text{CH}_2\text{Cl}_2$  (2 mL) was added dropwise, and the resulting mixture was stirred at  $-78$  °C for 40 min. The reaction was quenched with  $\text{Et}_3\text{N}$  (125  $\mu\text{L}$ , 8 equiv) and then allowed to warm to rt. The reaction was diluted with  $\text{CH}_2\text{Cl}_2$  and washed with brine, and then the combined organic fractions were dried ( $\text{Na}_2\text{SO}_4$ ), filtered, and concentrated. The crude material was passed through a silica gel plug (eluting with hexanes:EtOAc 1:1) to provide a yellow oil/foam (82 mg, quant.) of hemiaminal **20** which was used without further purification;  $R_f = 0.5$  (hexanes:EtOAc 1:1, UV, CAM). Hemiaminal **20** (232 mg, 0.32 mmol) was dissolved in  $\text{CH}_2\text{Cl}_2$  (3 mL) to which were added TFA (3 mL) and anisole (0.350 mL) at rt. The reaction was stirred for 14 h and then concentrated to remove TFA, then redissolved in  $\text{CH}_2\text{Cl}_2$  and washed with saturated aq  $\text{NaHCO}_3$ . The organic fraction was dried ( $\text{Na}_2\text{SO}_4$ ), filtered, and concentrated. Crude  $^1\text{H}$  NMR shows 0.72:1 *ortho* (**21**) to *para* (**22**) regioisomers. Purification by PTLC (2% MeOH in

EtOAc) provided the *ortho* (63 mg) and *para* products (69 mg) for a combined yield of 72%. Data for **21**:  $R_f = 0.61$  (EtOAc:MeOH 95:5, UV, CAM);  $[\alpha]_D^{25} -18.0$  (c 1.0, CH<sub>2</sub>Cl<sub>2</sub>); IR (thin film) 3295, 2932, 1672, 1632, 1455, 1428 cm<sup>-1</sup>; <sup>1</sup>H NMR (400 MHz, CDCl<sub>3</sub>)  $\delta$  7.14–7.30 (m, 3H), 6.98 (s, 1H), 6.97 (s, 1H), 6.24 (s, 1H), 6.19 (s, 1H), 6.12 (dddd,  $J = 16.0, 11.0, 5.4, 5.4$  Hz, 1H), 6.05 (dd,  $J = 7.2, 5.0$  Hz, 1H), 5.85 (br s, 1H), 5.82 (br s, 1H), 5.78 (v br s, 1H), 5.45 (app dd,  $J = 17.1, 1.1$  Hz, 1H), 5.29 (app dd,  $J = 10.3, 0.8$  Hz, 1H), 4.9 (s, 1H), 4.30 (app d of AB quartet,  $J = 12.3, 5.4$  Hz, 2H), 4.03 (d,  $J = 6.1$  Hz, 1H), 3.87 (AB quartet,  $J = 12.1$  Hz, 2H), 3.63 (s, 3H), 2.95–3.2 (m, 5H), 2.11 (s, 3H), 2.09 (s, 3H); <sup>13</sup>C NMR (100 MHz, CDCl<sub>3</sub>)  $\delta$  168.8, 147.6, 145.6 ( $\times 2$ ), 143.4, 139.7, 138.7, 134.5, 133.9, 129.4, 128.8, 128.0 ( $\times 2$ ), 127.1, 126.8 ( $\times 2$ ), 122.5, 119.3, 117.7, 117.5, 113.0, 108.7, 101.5, 100.2, 75.3, 72.6, 70.0, 60.8, 54.4, 50.0, 46.9, 33.4, 15.9, 9.4. HRMS(ESI/APCI+)  $m/z$  calcd for C<sub>34</sub>H<sub>35</sub>N<sub>2</sub>O<sub>7</sub> (M + H)<sup>+</sup> 583.2439, found 583.2441. Data for **22**:  $R_f = 0.5$  (EtOAc:MeOH 95:5, UV, CAM);  $[\alpha]_D^{25} +47.8$  (c 1.45, CH<sub>2</sub>Cl<sub>2</sub>); IR (thin film) 3298, 2931, 1671, 1631, 1430, 1409 cm<sup>-1</sup>; <sup>1</sup>H NMR (400 MHz, CDCl<sub>3</sub>)  $\delta$  7.11–7.22 (m, 3H), 6.94 (s, 1H), 6.92 (s, 1H), 6.41 (s, 1H), 6.11 (dddd,  $J = 16.1, 10.6, 5.5, 5.5$  Hz, 1H), 6.08 (s, 1H), 6.03 (dd,  $J = 6.6, 5.1$  Hz, 1H), 5.86 (br s, 1H), 5.83 (br s, 1H), 5.45 (app dd,  $J = 17.1, 1.1$  Hz, 1H), 5.30 (app dd,  $J = 10.4, 0.8$  Hz, 1H), 4.65 (s, 1H), 4.36 (app d of A of AB quartet,  $J = 12.5, 5.5$  Hz, 1H), 4.24 (app d of B of AB quartet,  $J = 12.5, 5.5$  Hz, 2H), 4.01 (d,  $J = 6.0$  Hz, 1H), 3.91 (AB quartet,  $J = 12.2$  Hz, 1H), 3.56 (s, 3H), 2.95–3.24 (m, 5H), 2.27 (s, 3H), 2.12 (s, 3H); <sup>13</sup>C NMR (100 MHz, CDCl<sub>3</sub>)  $\delta$  168.7, 148.0, 147.6, 145.9, 144.3, 139.7, 138.4, 134.6, 133.7, 129.6, 128.7, 128.1 ( $\times 2$ ), 127.2, 126.9 ( $\times 2$ ), 124.9, 117.8, 117.1, 113.8, 113.0, 108.8, 101.5, 100.5, 75.4, 72.8, 70.1, 61.0, 54.3, 52.6, 46.8, 35.4, 12.0, 9.4; HRMS (ESI/APCI+)  $m/z$  calcd for C<sub>34</sub>H<sub>35</sub>N<sub>2</sub>O<sub>7</sub> (M + H)<sup>+</sup> 583.2439, found 583.2429.

**Preparation of Compound 29.** The desired *ortho*-regioisomer **21** (55 mg, 0.095 mmol) was dissolved in CH<sub>2</sub>Cl<sub>2</sub> (2 mL) and pyridine (11  $\mu$ L, 0.14 mmol, 1.5 equiv) at 0 °C. TrocCl (13.5  $\mu$ L, 0.1 mmol, 1.0 equiv) was added and the reaction maintained at 0 °C for 2 h, and then diluted with CH<sub>2</sub>Cl<sub>2</sub> and washed with saturated aq NH<sub>4</sub>Cl. The organic layer was dried (Na<sub>2</sub>SO<sub>4</sub>), filtered, and then concentrated. The crude oil was passed through a plug of silica gel eluting with EtOAc, and then concentrated and dried under vacuum. The resulting oil was dissolved in CH<sub>2</sub>Cl<sub>2</sub> (600  $\mu$ L), and MeOH (200  $\mu$ L) and K<sub>2</sub>CO<sub>3</sub> (52 mg, 0.38 mmol, 4 equiv) were added followed by benzyl bromide (22  $\mu$ L, 0.19 mmol, 2 equiv) and a catalytic amount of tetrabutylammonium iodide. The resulting mixture was stirred at rt for 13.5 h then filtered through a pad of Celite, rinsing with CH<sub>2</sub>Cl<sub>2</sub>. Flash chromatography (5:1 hexanes:EtOAc) provided the *N*-Troc/*O*-benzyl product as a pale yellow oil (68 mg, 85% over 2 steps);  $R_f = 0.46$  (hexanes:EtOAc 3:1, UV, CAM);  $[\alpha]_D^{25} +58.1$  (c 1.7, CH<sub>2</sub>Cl<sub>2</sub>); IR (thin film) 2927, 1724, 1681, 1434, 1371 cm<sup>-1</sup>; <sup>1</sup>H NMR (400 MHz, CDCl<sub>3</sub>, mixture of carbamate rotamers)  $\delta$  7.30–7.56 (m, 3H), 7.14–7.25 (m, 4H), 6.92–7.00 (m, 2H), 6.45 (d,  $J = 9.9$  Hz, 1H), 6.22 (d,  $J = 4.1$  Hz, 1H), 6.12 ( $J = 16.1$  Hz, 1H), 6.01–6.08 (m, 1H), 5.79–5.90 (m, 3H), 4.98–5.29 (m, 5H), 4.85 (d,  $J = 12.0, 2.8$  Hz, 1H), 4.60 (d,  $J = 11.9, 6.5$  Hz, 1H), 3.97–4.11 (m, 3H), 2.85 (app d,  $J = 12.1$  Hz, 1H), 3.70 (s, 3H), 3.04–3.30 (m, 4H), 2.10 (s, 3H), 2.07 (s, 3H); <sup>13</sup>C NMR (100 MHz, CDCl<sub>3</sub>, mixture of carbamate rotamers)  $\delta$  166.1/166.0, 151.5/151.4, 149.9, 148.9, 148.4, 148.3/148.2, 146.2, 139.6, 138.5, 137.6/137.5, 133.8/133.7, 132.6/132.5, 131.3/131.2, 128.9 ( $\times 2$ ), 128.3, 128.1 ( $\times 2$ ), 128.0, 127.2, 126.8, 126.6/126.5, 125.4/125.0, 117.6, 117.3, 116.9, 113.3/113.3, 108.6/108.4, 103.3, 102.9, 101.6, 95.3/95.2, 75.4/75.3, 75.2/75.0, 74.6/74.4, 72.6, 69.9/

69.8, 60.5, 54.4/53.7, 50.9/50.1, 47.3/47.2, 32.8/32.4, 16.0, 9.5; HRMS(ESI/APCI+)  $m/z$  calcd for C<sub>44</sub>H<sub>42</sub>N<sub>2</sub>O<sub>9</sub>Cl<sub>3</sub> (M + H)<sup>+</sup> 847.1950, found 847.1949.

The allyl-protected pentacycle obtained above (20 mg, 0.024 mmol) was dissolved in CH<sub>2</sub>Cl<sub>2</sub> (400  $\mu$ L), and pyrrolidine (6  $\mu$ L, 3 eq) was added, followed by Pd(PPh<sub>3</sub>)<sub>4</sub> (2 mg, 0.002 mmol) under Ar. After 16 h, the reaction was still not complete, so additional portions of pyrrolidine and palladium catalyst were added. After stirring an additional 4 h (20 h total), the dark green reaction was applied directly to flash chromatography (silica gel, hexanes:EtOAc 3:1). The pure fractions were combined to provide the phenol as yellow oil (11 mg 56%), used without characterization;  $R_f = 0.26$  (hexanes:EtOAc 3:1, UV, CAM). Phenol (11 mg, 0.014 mmol) was dissolved in CH<sub>2</sub>Cl<sub>2</sub> (200  $\mu$ L) to which were added iPr<sub>2</sub>NEt (12  $\mu$ L, 0.07 mmol, 5 equiv) and MOMBr (3.3  $\mu$ L, 0.042 mmol, 3 equiv). The mixture was stirred for 30 min at rt and then quenched with water and extracted with CH<sub>2</sub>Cl<sub>2</sub> ( $\times 3$ ). The combined organic fractions were dried (Na<sub>2</sub>SO<sub>4</sub>), filtered, and concentrated. Flash chromatography (hexanes:EtOAc 3:1) provided the protected pentacycle **29** (11.5 mg, quant.);  $R_f = 0.41$  (hexanes:EtOAc 3:1, UV, CAM);  $[\alpha]_D^{25} +45.4$  (c 0.8, CHCl<sub>3</sub>) [lit. +50 (c 1.0, CHCl<sub>3</sub>)]; IR (thin film) 2932, 1723, 1681, 1654, 1432, 1371 cm<sup>-1</sup>. <sup>1</sup>H and <sup>13</sup>C NMR spectra perfectly match the data provided by the Danishefsky group for this intermediate in their formal synthesis (copies of their spectra included in the Supporting Information); <sup>1</sup>H NMR (400 MHz, CDCl<sub>3</sub>, mixture of carbamate rotamers)  $\delta$  7.56–7.31 (m, 5H), 7.13–7.23 (m, 3H), 6.96 (app br d,  $J = 6.9$  Hz, 2H), 6.46 (d,  $J = 9.4$  Hz, 1H), 6.01–6.15 (m, 3H), 5.86 (app d,  $J = 3.0$  Hz, 2H), 5.82 (br s, 1H), 4.97–5.19 (m, 4H), 4.86 (d,  $J = 11.9$  Hz, 1H), 4.79 (A of AB quart,  $J = 12.0$  Hz, 1H), 4.68 (B of AB quart,  $J = 11.9$  Hz, 1H), 4.49–4.60 (m, 2H), 4.43 (app d,  $J = 6.1$  Hz, 1H), 4.01 (d of A of AB quart,  $J = 11.8, 4.4$  Hz, 1H), 3.85 (B of AB quart,  $J = 12.1$  Hz, 1H), 3.71 (app d,  $J = 10.6$  Hz, 3H), 3.38 (rotomeric s, 3H), 3.03–3.29 (m, 5H), 2.11 (s, 6H); <sup>13</sup>C NMR (100 MHz, CDCl<sub>3</sub>, mixture of carbamate rotamers)  $\delta$  166.0/165.9, 151.6/151.4, 149.9, 148.7/148.2, 147.3, 146.2/146.1, 139.8, 138.4/138.4, 137.8/137.7, 132.6/132.5, 131.1/131.1, 128.8, 128.2, 127.9, 127.2, 126.8, 126.6/126.5, 125.2/125.0, 117.0/116.8, 113.7/113.6, 108.5/108.4, 103.3/102.7, 101.6, 100.4/100.4, 95.3/95.2, 75.4/75.3, 74.4/74.0, 72.6/72.6, 69.9/69.9, 60.4, 57.6/57.5, 54.4/53.7, 50.8/50.1, 47.4/47.3, 32.7/32.3, 16.0, 9.9; HRMS(ESI/APCI+)  $m/z$  calcd for C<sub>43</sub>H<sub>42</sub>N<sub>2</sub>O<sub>10</sub>Cl<sub>3</sub> (M + H)<sup>+</sup> 851.1900, found 851.1897.

**Acknowledgment.** This paper is fondly dedicated to the memory of the late Professor A.I. Meyers. We gratefully acknowledge financial support from the National Institutes of Health (Grant CA85419). We are grateful to Prof. Samuel J. Danishefsky of the Memorial Sloan-Kettering Cancer Research Institute for kindly providing characterization data for compound **29**.

**Note Added after ASAP Publication.** Reference 6 contained an incorrect publication date and the description of the conditions used by Zhu et al. (below Scheme 4) was erroneous in the version published ASAP August 8, 2008; the corrected version was published ASAP September 17, 2008.

**Supporting Information Available:** Complete experimental procedures and spectroscopic data. This material is available free of charge via the Internet at <http://pubs.acs.org>.

JO801159K

# A Pauson–Khand Approach to the Synthesis of Ingenol

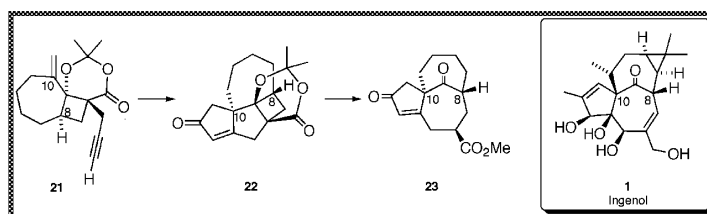
Jeffrey D. Winkler,\* Esther C. Y. Lee, and LaToya I. Nevels

Department of Chemistry, University of Pennsylvania,  
Philadelphia, Pennsylvania 19104

winkler@sas.upenn.edu

Received January 18, 2005

## ABSTRACT



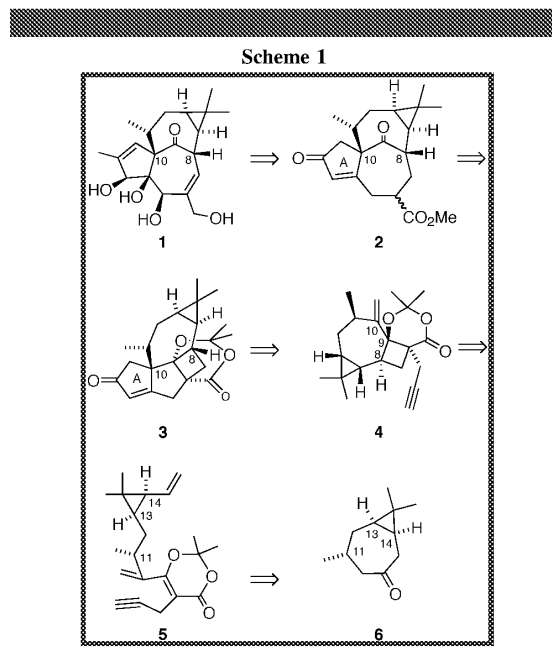
Pauson–Khand cyclization of dioxanone photoadduct **21** leads to the formation of a single product in good yield. However, retro-aldol fragmentation of the pentacyclic cyclopentenone **22** leads to the formation of **23**, with *cis*-C-8/C-10 intrabridgehead stereochemistry, unlike the target compound ingenol **1**, which possesses C-8/C-10 *trans* intrabridgehead stereochemistry.

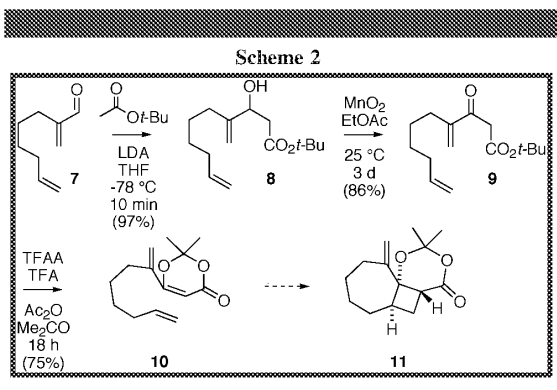
The therapeutic importance of C-3 esters of ingenol **1** and the dearth of exploration of structure–activity relationship data for this class of compounds make the development of efficient pathways for the synthesis of ingenol and analogues an important goal. Of particular note in the synthesis of ingenol is the establishment of the C-8/C-10 *trans* intrabridgehead stereochemistry, which is critical for the biological activity of **1**. In 2002, we reported the first total synthesis of racemic **1**, in which the *trans* intrabridgehead stereochemistry was established via intramolecular dioxenone photoaddition. The total synthesis proceeded in 42 steps from commercially available starting materials in an overall yield of 0.042%.<sup>1</sup> Since that time, two other total syntheses have appeared by: Tanino and Kuwajima (2003) and Wood (2004), which proceeded in ca. 45 and 38 steps, respectively.<sup>2</sup>

In an effort to develop a more efficient approach to the synthesis of ingenol, we have examined the strategy outlined in Scheme 1 for the synthesis of **1**, in which the C-8/C-10 intrabridgehead stereochemical relationship is established via

(1) Winkler, J. D.; Rouse, M. B.; Greaney, M. F.; Harrison, S. J.; Jeon, Y. T. *J. Am. Chem. Soc.* **2002**, *124*, 9726–9728.

(2) a) Tanino, K.; Onuki, K.; Miyashita, M.; Nakamura, T.; Takahashi, Y.; Kuwajima, I. *J. Am. Chem. Soc.* **2003**, *125*, 1498–1500. (b) Nickel, A.; Maruyama, T.; Tang, H.; Murphy, P.; Greene, B.; Yusuf, N.; Wood, J. L. *J. Am. Chem. Soc.* **2004**, *126*, 16300–16301.

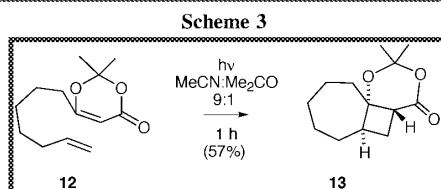




Pauson–Khand cyclization of **4** to give **3**. The A-ring cyclopentenone moiety in retroaldol product **2** would then be used to complete the synthesis of **1**. The Pauson–Khand substrate **4** should be available by the intramolecular dioxenone photocycloaddition of **5**. We envisioned that the C-11 methyl group (ingenol numbering) and the *gem*-dimethylcyclopropane in **5** would be derived from **6**, the preparation of which has been described from (+)-carene.<sup>3</sup> We report herein the results of our model study for this new reaction sequence.

To determine the viability of the route outlined in Scheme 1, we examined the irradiation of **10** (Scheme 2) as a model system for the photocycloaddition of methylene dioxenone **5** (Scheme 1). The synthesis of **10** is outlined in Scheme 2. Unsaturated aldehyde **7** was prepared in a one-pot procedure by Swern oxidation of 7-octen-1-ol followed by reaction of the intermediate aldehyde with Eschenmoser's salt.<sup>4</sup> Reaction of **7** with the conjugate base of *tert*-butyl acetate then gave **8**, which on  $\text{MnO}_2$  oxidation afforded ketoester **9**. Exposure of **9** to dioxenone-forming conditions (TFAA, TFA,  $\text{Ac}_2\text{O}$ ,  $\text{Me}_2\text{CO}$ ) led to the formation of the dioxenone photosubstrate **10** in 75% yield. However, irradiation of **10** (3.0 mM in 10%  $\text{Me}_2\text{CO}/\text{MeCN}$ , 450 W Hanovia mercury lamp, 3 h) resulted only in the recovery of unreacted **10** without formation of the desired photoadduct **11**.

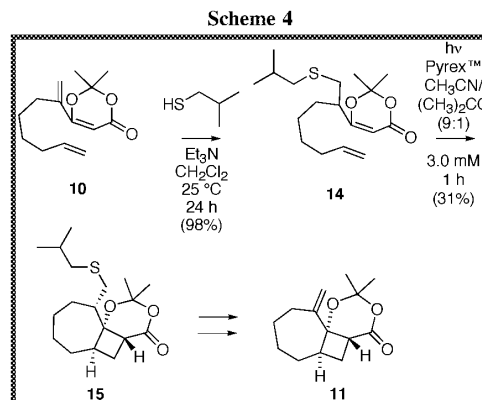
While we have shown that irradiation of **12** leads to the formation of **13** in good yield (Scheme 3),<sup>5</sup> irradiation of a



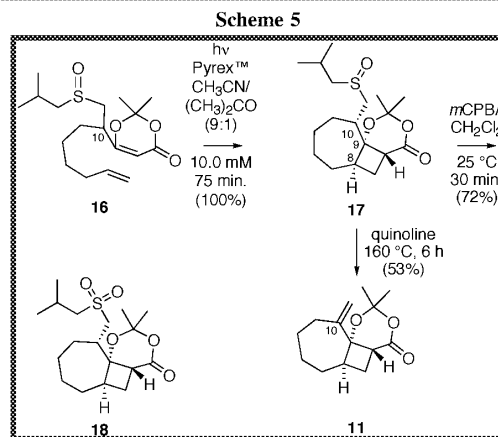
1:1 mixture of **10** and **12** led to the formation of none of the desired photoadduct **13**, a result that is consistent with quenching of the dioxenone triplet (of both **10** and **12**) by the diene moiety present in **10**.

(3) Satoh, T.; Kaneko, Y.; Okuda, T.; Uwaya, S.; Yamakawa, K. *Chem. Pharm. Bull.* **1984**, *32*, 3452–3460.

We therefore turned our attention to sulfide **14** as a protecting group for the offending diene functionality in **10** (Scheme 4). Oxidative elimination of **15**, the photoadduct obtained from **14**, would then lead to the formation of **11**. Conjugate addition of isobutylthiol to **10** gave **14**. While



irradiation of **14** does lead to the formation of the desired photoadduct **15**, the irradiation of the corresponding sulfoxide **16** (Scheme 5), obtained by reaction of **14** with *m*-CPBA



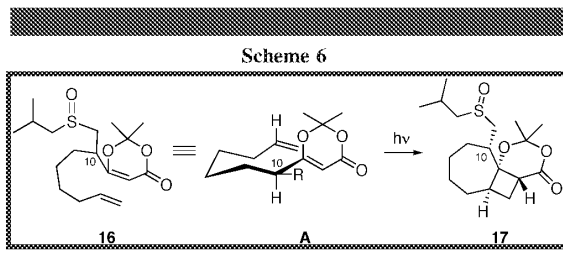
( $-78$  °C, 97% yield, as a ca. 1:1 ratio of sulfoxide diastereomers), gave a cleaner reaction and higher yields.

Irradiation of **16** led to the formation of a ca. 1:1 mixture of diastereomeric photoadducts **17**. Oxidation of the mixture of diastereomeric products to a single sulfone (*m*-CPBA, 72% yield) confirmed that the photocycloaddition of **16** proceeded with a unique sense of induction from the C-10 stereocenter.

(4) Takano, S.; Inomata, K.; Samizu, K.; Tomita, S.; Yanase, M.; Suzuki, M.; Iwabuuchi, Y.; Sugihara, F.; Ogasawara, K. *Chem. Lett.* **1989**, 1283–1284.

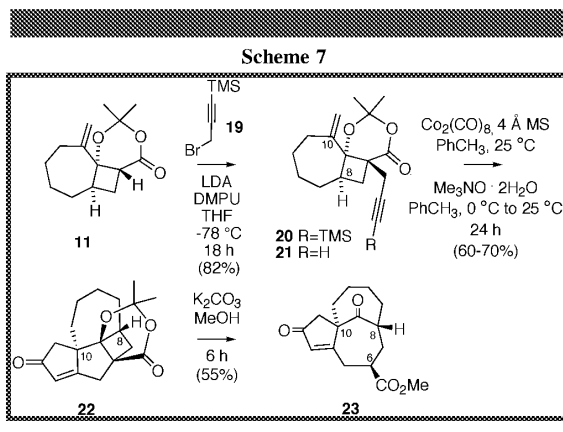
(5) Winkler, J. D.; Hey, J. P.; Hannon, F. J. *Heterocycles* **1987**, *25*, 55–60.

The stereochemical outcome of the photocycloaddition of **16** can be attributed to allylic strain effects. Selective formation of **17** is consistent with reaction via the conformation shown in **A** [Scheme 6; R = CH<sub>2</sub>S(O)*i*-Bu], in which



the C-10 hydrogen eclipses the dioxenone ring. The structure of **18**, the sulfone derived from **17**, was confirmed by X-ray crystallographic analysis. Heating sulfoxide photoadduct **17** to 160 °C in quinoline led to the formation of the desired methylene photoadduct **11**, the formal product of [2 + 2] cycloaddition of **10** (Scheme 4) in good yield.

The Pauson–Khand substrate **21** was then prepared via alkylation of the conjugate base of **11** (LDA, THF, DMPU, –78 °C) with 3-trimethylsilylpropargyl bromide **19** to give **20**, followed by desilylation with TBAF (THF, 100%) to give **21** (Scheme 7). Reaction of **21** with Co<sub>2</sub>(CO)<sub>8</sub> and 4 Å



molecular sieves in toluene at room temperature for 2 h followed by slow addition of a suspension of trimethylamine *N*-oxide dihydrate in toluene at 0 °C led to the formation of **22** as a single diastereomer in 60–70% yield.<sup>6</sup> It is noteworthy that the Pauson–Khand reaction of **21** in the

presence of the trimethylamine *N*-oxide dihydrate was considerably more efficient than the reaction using anhydrous trimethylamine *N*-oxide. This pronounced difference could be attributed to the attenuation of the nucleophilicity of the hydrated amine oxide ligand, which could retard decomplexation of the initially formed cobalt–alkyne complex.<sup>7</sup>

The structure and stereochemistry of **22** was confirmed by X-ray crystallographic analysis, which revealed that it did not contain the requisite C-8/C-10 relative stereochemistry for the synthesis of ingenol. Retro-aldol fragmentation of **22** led to the formation of **23**, with *cis* intrabridgehead stereochemistry, which was verified by X-ray crystallographic analysis. While the fragmentation product was initially formed as a single C-6 epimer (C-6 $\beta$  ester as shown in **23**), prolonged exposure of **23** to the basic reaction conditions (K<sub>2</sub>CO<sub>3</sub>, MeOH) led to the formation of a mixture of C-6 epimeric products.

While the C-8/C-10 intrabridgehead stereochemical relationship in **22** is established in the Pauson–Khand reaction in **21**, that relationship is indirectly established in **21**, since the propargyl moiety in **21** can only approach the C-10 exocyclic methylene from the  $\beta$ -face as shown to give **22**.

In the retrosynthetic plan outlined in Scheme 1, the C-8/C-9 ring fusion stereochemistry in **4** is *trans*, which forces the approach of the propargyl moiety in **4** to the  $\alpha$ -face of the C-10 methylene, thereby generating the requisite C-8/C-10 *trans* intrabridgehead stereochemistry shown in **3**. However, irradiation of **16** led to the exclusive formation of the *cis*-fused bicyclo[5.2.0]nonane moiety as shown in **17** (Scheme 5). The successful implementation of the retrosynthetic plan in Scheme 1 therefore depends on the preparation of a *trans*-fused photoadduct or its equivalent from **16**. Studies directed toward the construction of the requisite *trans*-fused photoadduct are currently in progress, and our results will be reported in due course.

**Acknowledgment.** We would like to thank the National Institutes of Health (CA40250), GlaxoSmithKline, Amgen, and Merck for their generous support of this program.

**Supporting Information Available:** Spectral data and experimental procedures for **8–11**, **14–18**, and **20–23** and X-ray data for **18**, **22**, and **23**. This material is available free of charge via the Internet at <http://pubs.acs.org>.

OL050103S

(6) Perez-Serrano, L.; Casarrubios, L.; Dominguez, G.; Perez-Castells, J. *Org. Lett.* **1999**, *1*, 1187–1188.

(7) (a) Shen, J.; Shi, Y.; Gao, Y.; Shi, Q.; Basolo, F. *J. Am. Chem. Soc.* **1988**, *110*, 2414–2418. (b) Shojaie, A.; Atwood, J. D. *Organometallics* **1985**, *4*, 187–190.



## Crystal modification of dipyrindamole using different solvents and crystallization conditions

R. Adhiyaman<sup>a,1</sup>, Sanat Kumar Basu<sup>b,\*</sup>

<sup>a</sup> Department of Pharmaceutics, Bapatla College of Pharmacy, Bapatla, Andhra Pradesh, India

<sup>b</sup> Division of Pharmaceutics, Department of Pharmaceutical Technology, Jadavpur University, Kolkata, India

Received 21 March 2005; received in revised form 10 April 2006; accepted 17 April 2006

Available online 13 May 2006

### Abstract

Dipyrindamole crystals having different types of habits, improved dissolution rate were prepared by recrystallization from selected solvents, such as acetonitrile, benzene and methanol (Method I); crystals have also been made by solvent change using methanolic solution of dipyrindamole in the presence of 2% solutions of Tween-80, Povidone K<sub>30</sub> and polyethylene glycol (PEG) 4000 (Method II). Scanning electron microscopy, X-ray powder diffractometry, IR spectrometry and differential scanning calorimetry were used to investigate the physicochemical characteristics of the crystals. The comparative dissolution behavior of the newly developed crystals and that of the untreated dipyrindamole were also studied. It was found that the newly developed crystals were different from each other with respect to physical properties but are chemically identical. The crystals, obtained (Method I) from benzene and acetonitrile, produced needle shaped crystals and that obtained from methanol produced rectangular shaped crystals. But the crystals obtained (Method II) with the methanolic solution of the drug in the presence of Tween-80, Povidone K<sub>30</sub> and PEG-4000 produced smooth needle shaped crystals. X-ray diffraction spectra and differential scanning calorimetry study of the newly developed crystals, clearly indicate that dipyrindamole exist in different crystal modification. The dissolution rate of newly developed crystals was found to be greater than the pure drug dipyrindamole. Stability studies at 40 °C (75% RH) for 1 month for the modified crystals as well as the pure drug did show some changes in the XRD and DSC but not in IR studies.

© 2006 Elsevier B.V. All rights reserved.

**Keywords:** Dipyrindamole; Recrystallization; Physicochemical characterization

### 1. Introduction

Different physiological and formulation factors are responsible for the bioavailability of drug from the dosage form. One of the most important physical factors, which affect the bioavailability and therapeutic efficacy of drug, is the existence of active ingredients in various crystal forms having different internal structure and physical properties (Kapoor et al., 1998). The different crystal form of a drug have different physicochemical characteristics, namely crystal shape, crystal size, melting point, density, flow properties solubility pattern, dissolution characteristics and XRD pattern, though they are chemically identical. A physical form having improved dissolution rate and solubil-

ity is useful for improving the bioavailability of a drug (Burt and Mitchell, 1980; Watanable et al., 1982). The crystal habit is an important variable in pharmaceutical manufacturing, where some factors, such as the polarity of crystallization solvent and the presence of impurities in the solvent, affect crystallization (Chow et al., 1985; Femi-Oyewo and Spring, 1994; Garekani et al., 2000). Among them, solvent strongly affects the habit of crystalline materials; however, the role-played by solvent interactions in enhancing or inhibiting crystal growth is still not completely understood (Lahra and Leiserowitz, 2001). The drug dipyrindamole used herein is practically insoluble in water. Its main use in therapy as antiplatelet aggregating and peripheral vasodilating effect is well known. But the water insolubility and the poor bioavailability are the limitations of its effective use clinically. Keeping this in view, crystal modification of dipyrindamole has been undertaken to improve dissolution and bioavailability. Dipyrindamole is a derivative of 1,3,5,7-tetra azanaphthalene and used mainly for cardiovascular diseases for the above-mentioned purposes. It has been recrystallized

\* Corresponding author.

E-mail addresses: [eskebee@yahoo.com](mailto:eskebee@yahoo.com) (R. Adhiyaman), [basusanat.kumar@hotmail.com](mailto:basusanat.kumar@hotmail.com) (S.K. Basu).

<sup>1</sup> Present address: J.S.S. College of Pharmacy, The Rocklands, Ootacamund-643001, Tamil Nadu, India.

from selected solvents and solvent system. The newly developed dipyrnidamole crystals were characterized by some physicochemical approaches.

## 2. Materials and methods

### 2.1. Materials

Dipyridamole was obtained as generous gift from German Remedies (Mumbai, India). The solvents used for the present work were acetone, benzene, methanol, obtained from Ranbaxy Chemical Laboratories (S.A.S. Nagar, India) and Tween-80, Povidone K<sub>30</sub> and polyethylene glycol (PEG) 4000 were obtained from SDS Chemical Limited (Boisar, India).

### 2.2. Preparation of dipyrnidamole crystals

Two different methods used in this study to observe the effect of solvents on the development of crystal habits in the changed environment are given below.

#### 2.2.1. Method I

One gram of dipyrnidamole was dissolved separately in 50 ml of selected solvents in a conical flask. The solution was heated at the boiling point of the respective solvents and filtered, concentrated and the solution was left at room temperature (28–30 °C) until the solvent was completely evaporated. The crystals were further dried under vacuum at room temperature and stored in appropriate airtight container for further use.

#### 2.2.2. Method II

One gram of dipyrnidamole was dissolved in 40 ml of methanol in a conical flask and the solution was heated and filtered. The resultant solution was concentrated at 60 °C and then cooled down at room temperature (28–30 °C). The clear solution, thus obtained, was rapidly added to equal volume of cold water (5 °C) containing 2% solution of Tween-80, PVP K<sub>30</sub> and PEG-4000, separately under agitation by means of a glass rod and then left for 1 h at 10–15 °C. The crystals were then recovered by filtration under vacuum using a sintered glass funnel. They were then kept in airtight container for further use.

### 2.3. Stability studies

One month's accelerated stability test was carried out for each sample after preparation, when the crystals were kept in humidity chambers (75% RH) and at a temperature 40 °C and the physicochemical changes of the crystals as observed are compared with that of the drug dipyrnidamole under identical conditions. The results are summarized in Figs. 9 (XRD) and 10 (DSC), respectively.

### 2.4. Scanning electron microscopy

Electron micrograph of crystals was obtained using a scanning electron microscope (JEOL JSM—5200) operating between 5 and 24 kV. The specimens were mounted on a metal

stub (with double side adhesive tape) and coated under vacuum with gold in an argon atmosphere prior to observation.

### 2.5. X-ray powder diffraction

The cavity of the metal sample holder of X-ray diffractometer was filled with ground sample powder and then smoothed out with a spatula. X-ray diffraction pattern of dipyrnidamole crystals were obtained using the X-ray diffractometer (Rich Seifert Model 3000P) at 30 kV, 30 mA over a range of 10–100 2 $\theta$ , using Cu K $\alpha$  radiation wavelength 1.5405 Å.

### 2.6. Infrared spectroscopy

The spectra were recorded on an IR spectrophotometer (PERKIN-ELMER USA MODEL—248), after respective samples were mixed with dried KBr powder and compressed to a 12 mm disc by a hydraulic press at 10 tonnes compression for 30 s.

### 2.7. Thermal analysis

Differential scanning calorimetry (DSC) of the samples, 10 mg, was carried out using a thermal analysis system (METTLER TA 4000 System). Calibration with standard was undertaken prior to subjecting the samples, which were heated at 10 °C/min in an aluminum pan under a nitrogen atmosphere and a similar empty pan was used as the reference. The instrument automatically calculated onsets of melting points and enthalpy of fusion.

### 2.8. Dissolution studies

Dipyridamole and its crystals, 25 mg in each case were accurately weighed and dissolution profile of the drug was determined in a USP Type II Dissolution test apparatus at 37 °C, with basket (100 mesh) with a stirring speed of 50 rpm. The dissolution medium was 600 ml of phosphate buffer pH 4.0, I.P. (Indian Pharmacopoeia). Samples were withdrawn from the dissolution vessels at selected time intervals and analyzed for dipyrnidamole content at 285 nm on a UV spectrophotometer (BECKMAN-UM-64). The results are shown as the graphical plots in Figs. 7 and 8, respectively.

## 3. Results and discussion

### 3.1. Morphology of crystals

Fig. 1 shows the scanning electron micrographs (SEM) of untreated and recrystallized dipyrnidamole from different solvents under solvent evaporation method (Method I). It is clear from the figure that the untreated dipyrnidamole is having small irregular needle shaped crystals (Fig. 1d), whereas the crystals obtained from acetonitrile is needle shaped (Fig. 1c) and that from benzene is rod shaped (Fig. 1b). Recrystallization of dipyrnidamole from methanol solution with the same method produced

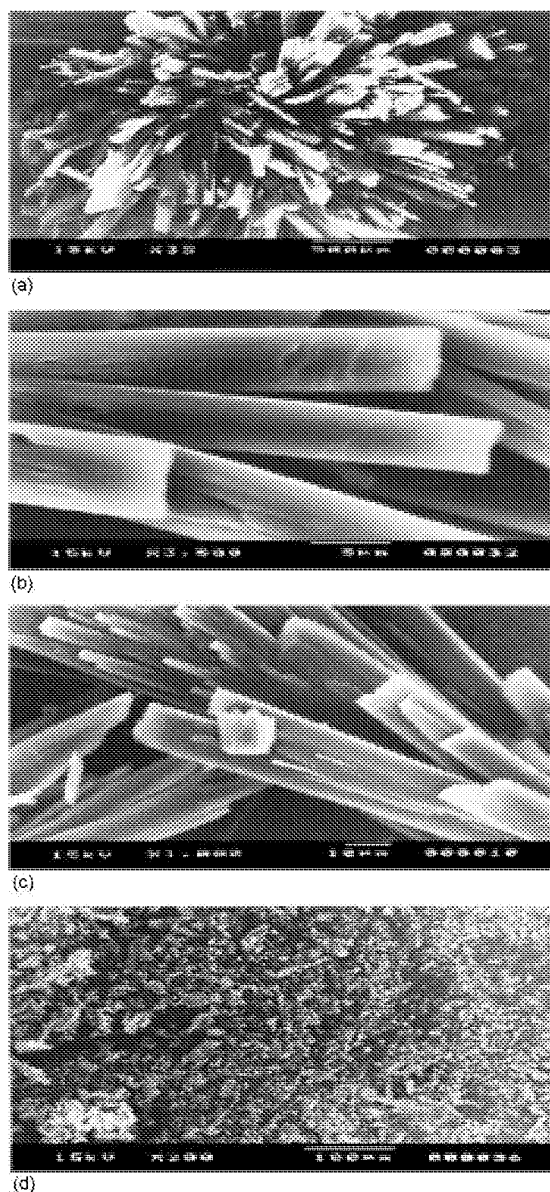


Fig. 1. Scanning electron micrographs of dipyrindamole recrystallized from (a) methanol, (b) benzene, (c) acetonitrile and (d) untreated dipyrindamole.

rectangular needle shaped crystals (Fig. 1a), while using solvent change method (Method II), the shape of crystals changes to fine needles (Fig. 2a–c). The results also showed that the size of crystals produced from Methods I and II are somewhat different from the size of untreated dipyrindamole and follows the order, i.e. Method I > Method II (compare the magnification of the SEM in Figs. 1 and 2). Therefore, it can be concluded that cooling rate decreases the crystal size due to incomplete growth of large number of small crystals (Garekani et al., 1999).

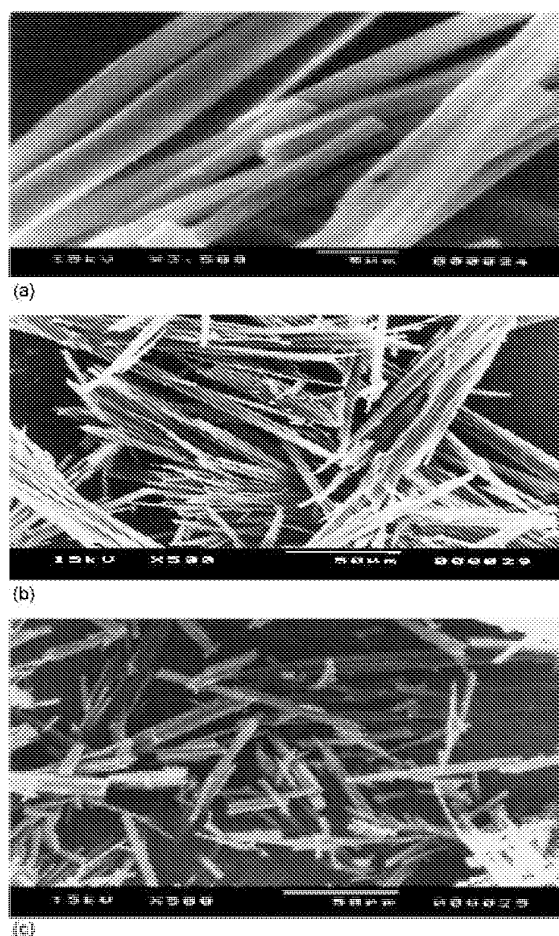


Fig. 2. Scanning electron micrographs of dipyrindamole recrystallized from methanol with 2% solutions of (a) Tween-80 (SCT); (b) PEG-4000 (SCPEG); (c) PVPK<sub>30</sub> (SCPVP).

### 3.2. X-ray diffraction

To obtain information on the physicochemical characteristics of the prepared crystals, X-ray powder diffraction measurements were conducted.

XRD spectra for all crystals are presented in Figs. 3 and 4. In the powder diffractogram sharp peak at diffraction angle ( $2\theta$ ) 30.04, 20.74, 20.81, 12.33, 17.45, 10.25, and 20.93 were obtained in case of drug dipyrindamole and the modified crystals obtained from methanol, benzene, acetonitrile, Tween-80, PEG-400, PVP K<sub>30</sub>, respectively. The presences of these sharp peaks are clearly evident in the comparative diffractogram presented in Figs. 3 and 4 and the data recorded therein. From the data recorded, it is clearly evident that there is significant difference in the entire diffraction pattern or  $d$ -spacing values between treated and untreated dipyrindamole samples. The intensity of the peak in methanol is the highest than that of all other modified crystals reported herein. This is probably due to higher crystal

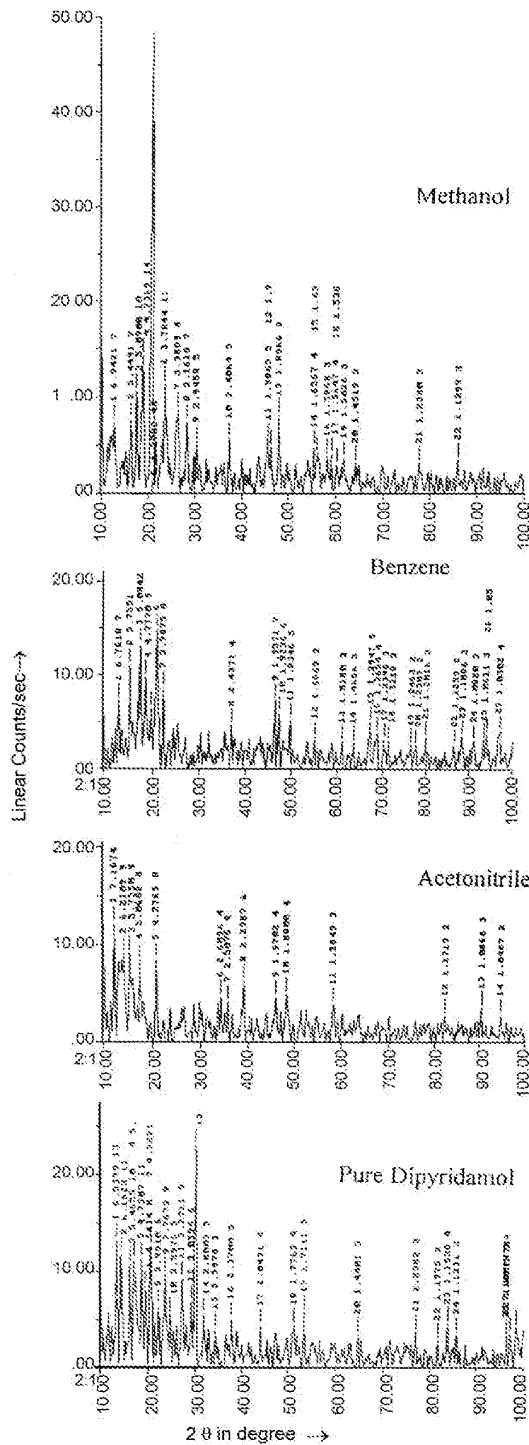


Fig. 3. X-ray powder diffraction pattern of pure dipyrnidamole and dipyrnidamole recrystallized from methanol; benzene; acetonitrile.

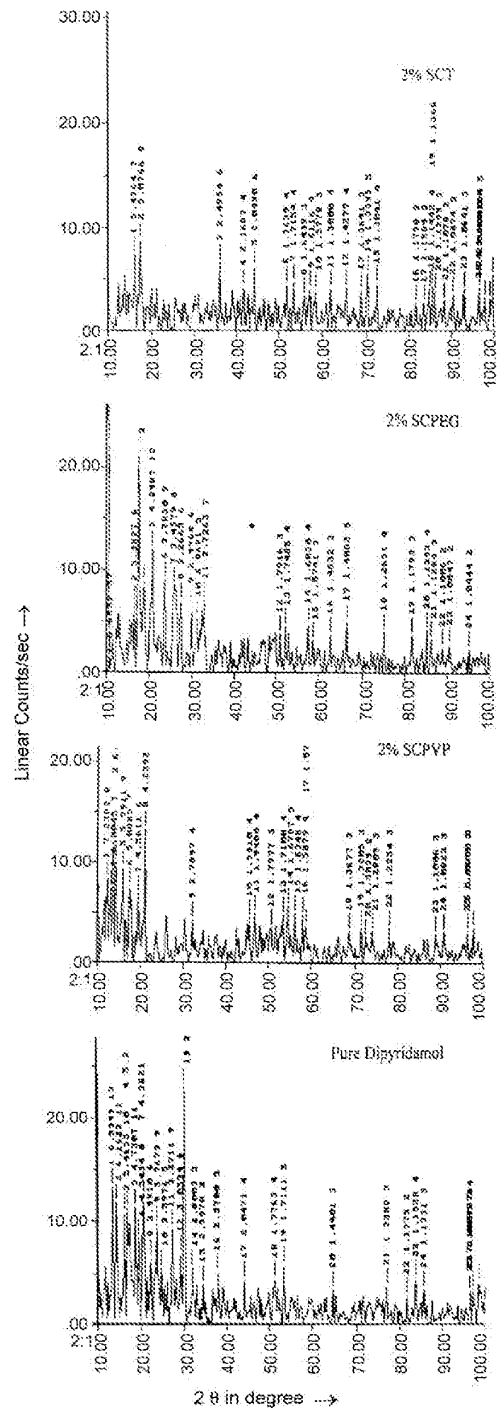


Fig. 4. X-ray powder diffraction pattern of pure dipyrnidamole and dipyrnidamole recrystallized from methanol with 2% solutions of Tween-80 (SCT); PEG-4000 (SCPEG); PVP K<sub>30</sub> (SCPVP).

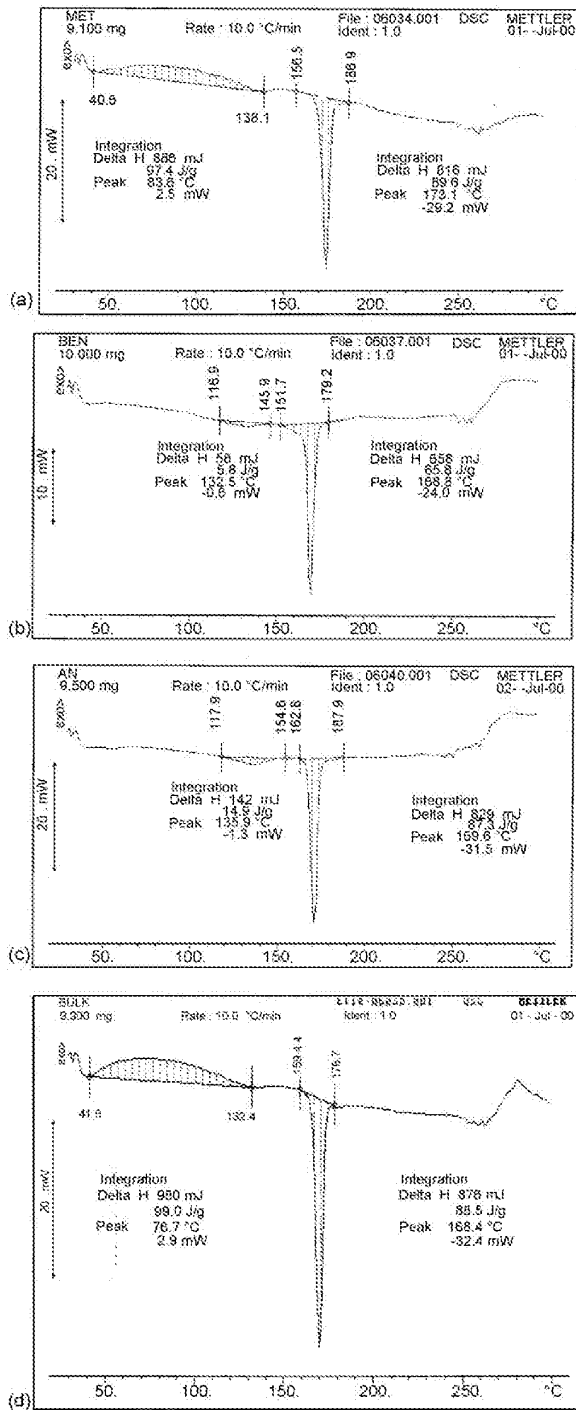


Fig. 5. Differential scanning calorimetric thermographs of dipyridamole recrystallized from (a) methanol; (b) benzene; (c) acetonitrile; (d) untreated dipyridamole.

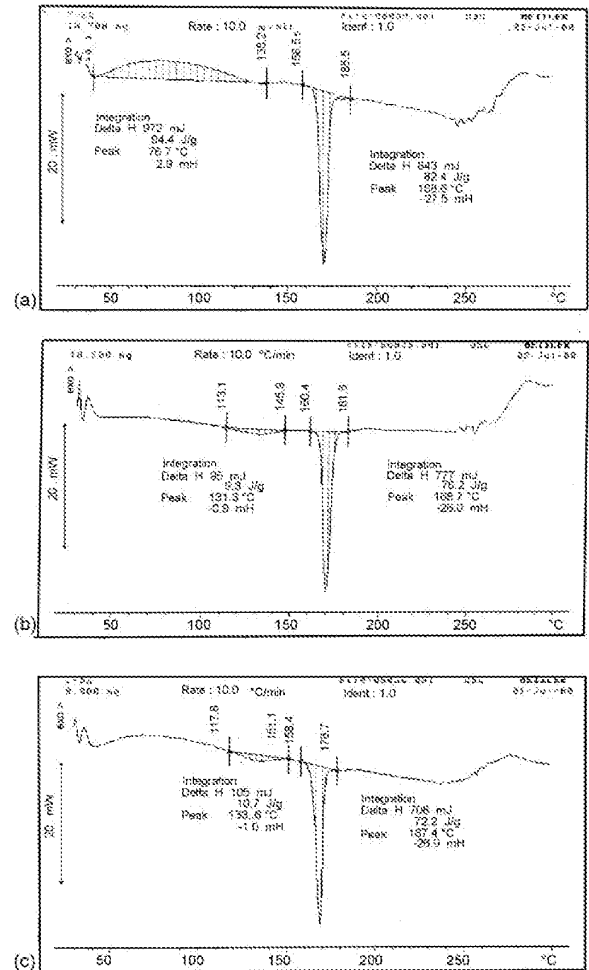


Fig. 6. Differential Scanning Calorimetric thermographs of dipyridamole recrystallized from methanol with 2% solution of (a) Tween-80(SCT); (b) PEG-4000 (SCPEG); (c) PVP K<sub>30</sub> (SCPVP).

perfection in this condition of crystallization (Nokhodchi et al., 2003).

### 3.3. Infrared spectroscopy

The spectra of all modified crystals were identical and the main absorption bands of dipyridamole appeared in all of the spectra. This indicates that there were no difference between the internal structure and conformations of these samples, because these were not associated with changes at molecular level.

### 3.4. Thermal analysis

The DSC data for drug dipyridamole (untreated) and the modified crystals are shown in Figs. 5 and 6. It should be noted that the DSC thermo grams (Figs. 5 and 6) of all modified crystals showed only slight variation. However, the modified crystal

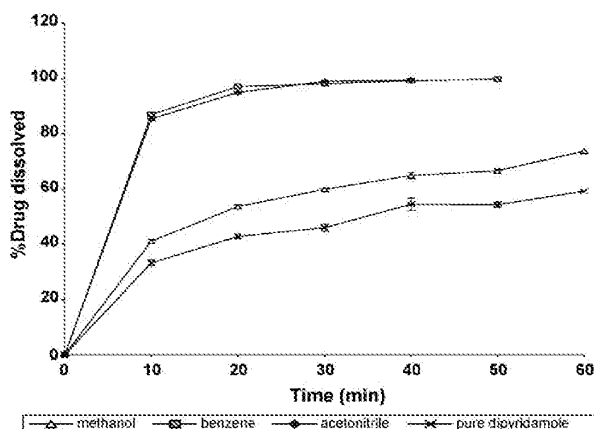


Fig. 7. Dissolution profile of pure Dipyridamole and modified crystals obtained using various solvents in phosphate buffer pH 4.0. (I.P). (a) Methanol; (b) benzene; (c) acetonitrile; (d) untreated dipyridamole.

obtained from methanol shows significant changes due to high crystal perfection.

The DSC curve of crystals from SCT (2%, v/v) and methanol shows broad exothermic peaks and very slight but insignificant variation in transition temperature and a little difference (not significant) in enthalpy of fusion. This may be due to oxidation or phase transformation. Crystals obtained by using acetonitrile, benzene, SCPVP (2%, w/v) and SCPEG (2%, w/v) show a weak endothermic peak and there is no significant variation in transition temperature, but significant difference in enthalpy of fusion is observed in case of acetonitrile, SCPEG (2%, w/v) and SCPVP (2%, w/v) while compared with the thermo gram obtained in case of benzene. The appearance of weak endothermic peaks in this case may be due to solvation of the crystals (Gordon and Chow, 1992).

Results from IR spectroscopy, X-ray diffraction analysis and DSC taken together led to the conclusion that only habit modifi-

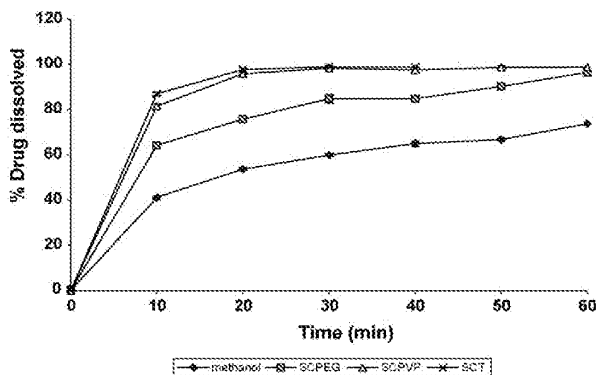


Fig. 8. Dissolution profile of modified crystals of dipyridamole from methanol and also from methanol with 2% solutions of PEG-4000, PVP K<sub>30</sub>, and Tween-80 in phosphate buffer pH 4.0. (I.P). (a) Methanol; (b) Tween-80 (SCT); (c) PEG-4000 (SCPEG); (d) PVP K<sub>30</sub> (SCPVP).

cations were observed during recrystallization of dipyridamole under various conditions of the crystallization.

### 3.5. Dissolution studies

The dissolution profile of dipyridamole and its modified crystals from different solvents are shown in Figs. 7 and 8, respectively.

Recrystallization of the parent drug from various solvents, given earlier (Method I), resulted in the increase of the dissolution rate of different modified crystals than dipyridamole. Especially, crystals obtained from benzene and acetonitrile, show higher dissolution rate than untreated dipyridamole because of the better crystallinity of the modified crystals in these cases. Crystals obtained using only methanol show lower dissolution rate than other crystals obtained (Method II). However, it is evident that after the addition of Tween-80 and other polymer solution, the dissolution rates were increased. This may be due to

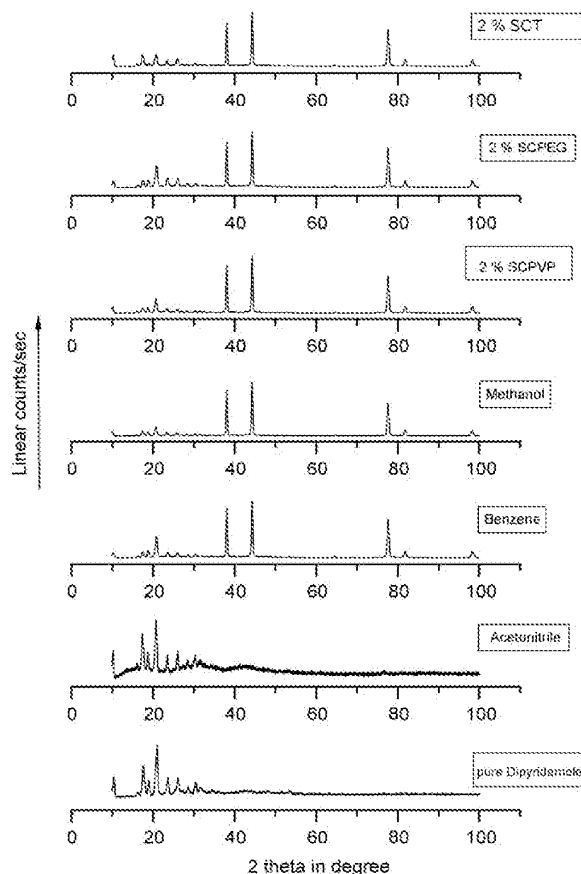


Fig. 9. Comparative X-ray powder diffraction pattern of pure dipyridamole and dipyridamole recrystallized from acetonitrile; benzene; methanol and dipyridamole recrystallized from methanol with 2% solutions of PEG-4000 (SCPEG), PVPK<sub>30</sub> (SCPVP), Tween-80 (SCT) and kept at elevated temperature (40 °C) and 75% RH for one month.

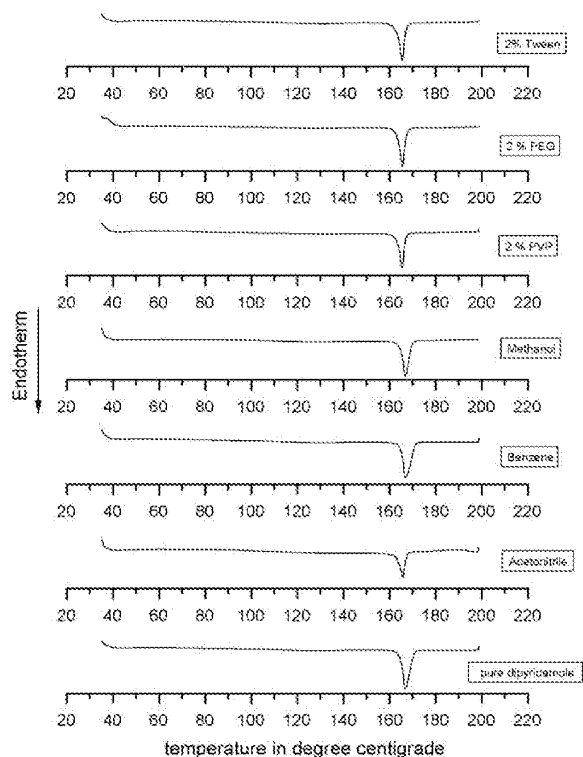


Fig. 10. Comparative Differential scanning calorimetric thermographs of pure dipyrindamole and dipyrindamole recrystallized from acetonitrile; benzene; methanol and dipyrindamole recrystallized from methanol with 2% solutions of PEG-4000 (SCPEG), PVPK<sub>30</sub> (SCPVP), Tween-80 (SCT) and kept under elevated temperature (40 °C) and 75% RH for one month.

the adsorption of surfactant and polymers on the crystal surface (Majumdar et al., 1992).

### 3.6. Stability studies

The results obtained in the stability test showed slight changes in XRD, DSC data for all samples under investigation. XRD spectra for all the crystals kept at the elevated temperature (40 °C) are presented in Fig. 9. In the powder diffractogram of dipyrindamole and the modified crystals, sharp peak at diffraction angle ( $2\theta$ ), 20.98, 20.79 and 44.25, respectively were obtained in case of drug dipyrindamole and crystals from acetonitrile and benzene. But in the case of crystals obtained from methanol (Method I) and other crystals obtained (Method II), all of them showed the sharp peak at diffraction angle ( $2\theta$ ), 44.5. These clearly indicate that under the circumstance all retain the same state. However, there is significant difference in the  $d$ -spacing values between the freshly prepared crystals and the crystals obtained after storing at elevated temperature including pure drug. This is probably due to the existence of different crystal habits in the crystalline materials at elevated temperature. The DSC data for drug dipyrindamole (untreated) and the modified crystals kept at elevated temperature are shown in Fig. 10. It

is clearly evident from the DSC thermo grams for all the samples including pure dipyrindamole under investigation that the modified crystals (Methods I and II) showed slight change in the value of enthalpy and the heat of fusion. However, the DSC curve of crystals from SCT (2%, v/v) and PEG (2%, w/v), very weak exothermic peaks were seen in a position significantly different from the samples, studied under ambient conditions, leading to significant variation in transition temperature and in enthalpy of fusion. This may probably be due to oxidation or phase transformation under such stress condition. But it is very much interesting to note that none of the samples studied under such stress condition did show any change in the IR spectrum confirming the presence of its chemical identity.

## 4. Conclusion

In conclusion, it can be said that the crystallization conditions and the medium used have major effect on dipyrindamole crystals habit modification under ambient conditions. The crystals showed significant changes in the shape, size, melting points, dissolution rate, XRD patterns and DSC curves. This suggests that the newly developed crystals of dipyrindamole under ambient conditions exist in different crystalline modification facilitating significantly improved dissolution rate as compared to dipyrindamole. There are enough references (Dalton et al., 2001; el-Yazigi and Sawchuk, 1985) available in the literature wherein it has been proved that in vitro dissolution data are good predictor of in vivo performance in reality. Therefore, it can be safely concluded that the improvement obtained in the present study in the modified crystals will give better bioavailability and better therapeutic activity clinically. But the stability study undertaken at 40 °C and a relative humidity of 75% shows some physical changes probably due to some phase transitions but retaining the chemical identity. The effect of such changes in reality needs to be explored in actual situations, if any.

## Acknowledgements

The authors thank Indian Association for the Cultivation of Science, Kolkata, India; Bengal Engineering and Science University, Shibpur, Howrah, India; University Science and Instrumentation Centre, Jadavpur University, Kolkata, India for their help during instrumental analysis of samples.

## References

- Burt, H.M., Mitchell, A.G., 1980. Effect of habit modification on dissolution rate. *Int. J. Pharm.* 5, 239–251.
- Chow, A.H.L., Chow, P.K.K., Wang, Z., Grant, D.G.W., 1985. Modification of acetaminophen crystals; influence of growth in aqueous solutions containing *p*-acetoxyacetanilide on crystal properties. *Int. J. Pharm.* 23, 239–258.
- Dalton, J.T., Straughn, A.B., Dickason, D.A., Grandolfi, G.P., 2001. Predictive ability of level A in vitro–in vivo correlation for ringcap controlled-release acetaminophen tablets. *Pharm. Res.* 18, 1729–1734.
- el-Yazigi, A., Sawchuk, R.J., 1985. In vitro–in vivo correlation and dissolution studies with oral theophylline dosage forms. *J. Pharm. Sci.* 74, 161–164.
- Femi-Oyewo, M.N., Spring, M.S., 1994. Studies on paracetamol crystals produced by growth in aqueous solutions. *Int. J. Pharm.* 112, 17–28.

- Garekani, H.A., Ford, J.L., Rubinstein, M.H., Rajabi-Siah-boomi, A.P., 1999. Formation and compression characteristics of prismatic polyhedral crystal and thin plate like crystals of paracetamol. *Int. J. Pharm.* 187, 77–89.
- Garekani, H.A., Ford, J.L., Rubinstein, M.H., Rajabi-Siah-boomi, A.P., 2000. Highly compressible paracetamol; compression properties. *Int. J. Pharm.* 208, 101–110.
- Gordon, J.D., Chow, A.H.L., 1992. Modification of phenytoin crystals: influence of 3-propanolozymethyl-5,5-diphenyl-hydantoin on solution-phase crystallization and related crystal properties. *Int. J. Pharm.* 79, 171–181.
- Kapoor, A., Majumdar, D.K., Yadav, M.R., 1998. Crystal forms of nimesulide – a sulfonanilide (non-steroidal anti inflammatory drug). *Indian J. Chem.* 37B, 572–575.
- Lahra, M., Leiserowitz, L., 2001. The effect of solvent on crystal growth and morphology. *Chem. Eng. Sci.* 56, 2245–2253.
- Nokhodchi, A., Bolourtchian, W., Dinarvand, R., 2003. Crystal modification of phenytoin using different solvents and crystallization conditions 250, 85–97.
- Watanabe, A., Yamaoka, Y., Takada, K., 1982. Crystal habits and dissolution behavior of aspirin. *Chem. Pharm. Bull.* 30, 2958–2963.



## PURITY DETERMINATION BY DIFFERENTIAL SCANNING CALORIMETRY

ERWIN E. MARTI

*Central Research Services Department, Ciba-Geigy Ltd., Basel (Switzerland)*

(Received April 3rd, 1972; revised June 23rd, 1972)

### ABSTRACT

A review of the literature on the DSC method for purity determination is presented, with a discussion of the most important aspects, *i.e.* theory, sample handling, calibration of the instrument, evaluation of melting curves, and the conditions and accuracy of the measurement of eutectic impurities.

A number of mathematical descriptions of the solid–liquid equilibrium for eutectic binary systems is applied to the calculation of theoretical phase diagrams and specific heat functions, which are then compared with experimental phase diagrams and melting curves. The applicability of the DSC method to systems of solid solutions is discussed.

Both the experimental procedure and the evaluation by computer methods required to obtain accurate impurity determinations by DSC are presented. A number of practical examples is included.

### INTRODUCTION

The measurement of the melting point of a substance as a method of identification dates back to the early days of chemistry. Many different observations on organic and inorganic substances were made during the thermal treatment necessary for a melting point determination.

The observations were summarized and interpreted in terms of phenomena like polymorphism, sublimation, thermal decomposition, solid solutions, eutectic systems, congruently-melting compounds, glass transitions and others. Kofler<sup>1</sup> turned the melting point determination by microscopic observation into an extremely useful method in the field of analytical chemistry. Kofler's treatise on purity determinations is excellent, but of course, today, it is not easy to agree with the statement in *Thermomikromethoden*: "The method of purity determination with the microscopical observation of the melting point, however, will finally replace all the others". Somehow, the development of the analytical methods for purity determination since 1950 has appeared to prove the opposite, namely that all the other analytical methods would replace the melting point determinations. Kofler's melting point method is nowadays performed with many different types of apparatus. The method is used

because it is the simplest analytical method for getting information about the purity and about the crystal form of the sample under investigation. The melting point method is based on the determination of the absolute temperature of the substance assuming an infinitely small amount of solid substance in the solid-liquid equilibrium. A reference standard of a high purity is required to make the temperature measurement only a relative one. This high purity standard is also used for the relation between the purity and the melting point difference given in Eqn. (1)

$$\Delta T = T_1 - T_s = x_0 \cdot k_r \quad (1)$$

where  $\Delta T$  is the melting point difference in °K,  $T_1$  is the melting point of the high purity standard in °K,  $T_s$  is the melting point of the sample in °K,  $x_0$  is the mole fraction of the impurity, and  $k_r$  is the cryoscopic constant in °K.

The cryoscopic constant is defined as

$$k_r = \frac{RT_1^2}{\Delta H_{f,1}} \quad (2)$$

where  $R$  is the gas constant and  $\Delta H_{f,1}$  is the molar heat of fusion of the high purity standard, and is experimentally determined by means of Eqn. (1) or with a measurement of the heat of fusion  $\Delta H_{f,1}$  and the melting point of the reference standard.

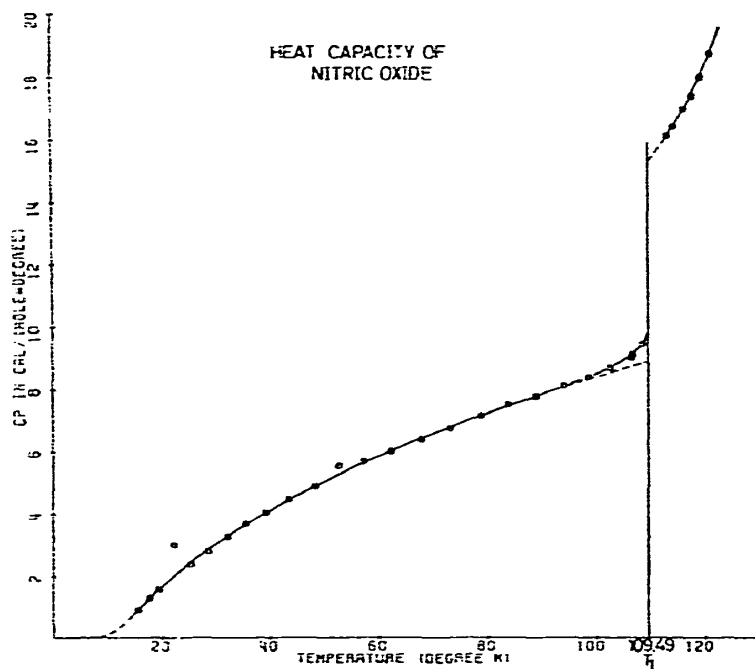


Fig. 1. Heat capacity of nitric oxide measured by Johnston and Giauque<sup>3</sup>. (Melting point  $T_1 = 109.49^\circ\text{K}$ .)

Today, a second method seems to replace at least partially the microscopic observation of the melting point. This second method is known as differential scanning calorimetry (DSC). The DSC method measures the endothermic amount of energy which is afforded by the premelting process of substances. The method of premelting as a purity determination dates back to the 1920's in a form used by Eucken and Karwat<sup>2</sup> and Johnston and Giaque<sup>3</sup> for the measurement of the heat capacity of nitric oxide in the melting point region. In 1929, Johnston and Giaque<sup>3</sup> reported from the Chemical Laboratory of the University of California in Berkeley on the heat capacity of nitric oxide from 14°K to the boiling point.

The paper of Johnston and Giaque is interesting enough for a brief discussion. In Fig. 1, the heat capacity of nitric oxide is shown as a function of temperature, according to the measurements of Johnston and Giaque. The extremely sharp melting region of the nitric oxide sample at about 110°K should be noted. The nitric oxide used by Johnston and Giaque was produced by the reaction of potassium nitrite and potassium iodide in distilled water. The generated nitric oxide was purified over several distillation steps.

As an example, the same purified sample, containing  $n_0 = 3.769$  moles of nitric oxide, was used for the premelting measurements and also the measurements of the heat capacity, the heat of fusion, and the melting point. Johnston and Giaque measured the following values for this sample of nitric oxide: molar heat of fusion,  $\Delta H_{f,1} = 549.5 \pm 1.0 \text{ cal.mole}^{-1}$ ; melting point,  $T_1 \cong T_s = 109.49 \pm 0.05^\circ\text{K}$ .

The purity of the nitric oxide was calculated by applying Eqn. (3), which holds for low concentration of impurities

$$x_{0,2} = \frac{\Delta H_{f,1}}{RT_1^2} (T_1 - T)r \quad (3)$$

where  $x_{0,2}$  is the eutectic impurity of the sample as mole fraction,  $\Delta H_{f,1}$  is the molar heat of fusion of the pure nitric oxide,  $T_1$  is the melting point of the pure nitric oxide,  $T$  is the temperature of the solid-liquid equilibrium,  $r$  is the molten fraction of the system at temperature  $T$ , and  $R$  is the gas constant.

The heat of premelting  $\Delta q_p$ , necessary for a temperature rise of the solid-liquid equilibrium from  $T'$  to  $T''$ , is related to the corresponding molten fractions of the sample  $r'$  and  $r''$ . We can write the equation

$$\Delta q_p = \Delta H_{f,1} n_0 (r'' - r') \quad (4)$$

The method of Johnston and Giaque enables the measurement of the total amount of heat  $\Delta q$  for a temperature rise of the substance from  $T'$  to  $T''$ . This total amount of heat is the sum of the heat of premelting  $\Delta q_p$  and an amount  $\Delta q_c$  given by the specific heat of the substance and the known temperature interval  $\Delta T = T'' - T'$

$$\Delta q = \Delta q_p + \Delta q_c \quad (5)$$

The calculation of the heat of premelting ( $\Delta q_p$ ) is possible from Eqn. (5), with the

measurement of the heat capacity of nitric oxide ( $\Delta q$ ) and with an extrapolation of the specific heat from a region with practically no premelting into the selected region of premelting. The eutectic impurity of the nitric oxide is calculated for a corresponding set of temperatures and molten fractions ( $T', r'$ ;  $T'', r''$ ) and with the aid of Eqns. (3) and (4).

$$x_{0.2} = \frac{\Delta q_p}{n_0 R T_1^2} \cdot \frac{(T_1 - T'')(T_1 - T')}{T'' - T'} \quad (6)$$

With Eqn. (6) and the values of the measurements on nitric oxide, it is possible to calculate exactly the same values of eutectic impurities as found by Johnston and Giaque. The values and results are presented in Table I.

TABLE I  
PREMELTING MEASUREMENTS ON NITRIC OXIDE

<i>Temperatures (°K)</i>		<i>Heat of premelting between <math>T'</math> and <math>T''</math>, <math>q_p</math> (cal)</i>	<i>Eutectic impurities <math>x_{0.2}</math> (mole fraction)</i>
$T'$	$T''$		
104.71	108.59	0.171	$7.9 \times 10^{-6}$
107.63	109.15	0.365	$6.4 \times 10^{-6}$

Johnston and Giaque came to the conclusion that the nitric oxide used in their measurements contained less than  $10^{-3}$  mole percent of eutectic impurities, or, the so-called purity is of the order of 99.999%. The authors excluded the possibility of noneutectic impurities because of the method of preparation of the nitric oxide used for these investigations. Johnston and Giaque explained that no analyses of the purified gas were made since accurate melting point and heat capacity data provide a more sensitive test of impurity than that given by chemical analysis. Johnston and Giaque made an equivalent statement to Kofler's about the measurement of impurities by the melting point method. It seems to be clear that such excellent investigators as Giaque and Kofler did not emphasize the melting point and premelting method in such a way without being deeply impressed by the possibilities of these two methods.

If we want to compare the excellent work from the low temperature laboratory at the University of California in Berkeley (the laboratory was named Giaque Hall in 1967) with the premelting measurements, mainly DSC and DTA, performed in the 1970's, we have to consider several points. The difference between the calorimetric method of Johnston and Giaque and the DSC or DTA method is not in thermodynamics but rather in the instrumentation and in the properties of the methods of measurement.

In Table II we compare some of the aspects of the two methods, selecting the DSC-IB of the Perkin-Elmer Corporation for the second group.

TABLE II  
COMPARISON OF THE PREMELTING METHOD OF JOHNSTON AND GIAUQUE  
AND THE PURITY DETERMINATION WITH THE DSC-1B

<i>Condition or property measured</i>	<i>Calorimetric method of Johnston and Giaque<sup>3</sup></i>	<i>DSC-1B (Perkin-Elmer Corp.)</i>
Weight of the sample	100 g	3 mg
Accuracy of the absolute temperatures	$\pm 10^{-2} \text{ }^\circ\text{K}$	$\pm 3 \times 10^{-1} \text{ }^\circ\text{K}$
Accuracy of the relative temperatures	$\pm 2 \times 10^{-3} \text{ }^\circ\text{K}$	$\pm 10^{-2} \text{ }^\circ\text{K}$
Accuracy of the measured heat of fusion	$\pm 2 \times 10^{-1} \%$	$\pm 5\%$
Accuracy in the purity value for high-purity substances	$\pm 10^{-4} \%$	$\pm 5 \times 10^{-2} \%$
Time for a premelting measurement	2-4 days	20 min

The great disadvantage of the calorimetric method developed by Johnston and Giaque, especially in industrial use, is the extremely long running time required for one measurement which is of course due to the enormous sample weights and the necessity for an equilibrium between the liquid and solid phases of the sample at all temperature points<sup>4</sup>. It is also clear, however, that somehow one has to pay for such a high accuracy in purity measurements. Between the measurements on purity with thermoanalytical methods of the 1920's and the 1970's, a great number of papers were published on purity measurements by the freezing point method. We mention only one paper, which we regard as representative of all the papers on thermoanalytical purity measurements produced during this period: Determination of Purity by Measurement of Freezing Points, by Glasgow, Krouskop, Beadle, Axilrod and Rossini<sup>5</sup>.

Following these preliminary and historical remarks, we will concentrate on purity work performed with the DSC-1B, an instrument of the Perkin-Elmer Corporation. The development of new DSC- and DTA-systems will certainly change the issue of the purity determination, *e.g.* enhance the accuracy of the measurement of eutectic impurities and solid solutions without increasing the running time for one measurement.

#### DISCUSSION ON THE DSC LITERATURE ON PURITY

In this discussion we shall not attempt a complete report of the DSC literature. We will arrange our discussion according to theoretical and experimental points of the DSC-purity method.

##### (a) *Theory of the purity measurements*

As far as we know, all DSC results on purity in the literature are calculated

according to the following equation

$$T = T_1 - \frac{x_{0,2} RT_1^2}{\Delta H_{f,1}} \cdot \frac{1}{r} \quad (7)$$

[for symbols see Eqn. (3)].

Eqn. (7) is derived under the following approximations and conditions: (i) The components form a eutectic phase diagram; (ii) the system is at constant pressure; (iii) the impurity or impurities form ideal solutions with the molten part of the main component; (iv) the impurity is restricted to low concentrations; and (v) the heat of fusion is independent of temperature.

A second equation discussed by Driscoll and coworkers<sup>6</sup> describes systems containing eutectic impurities and impurities forming solid solutions with the main component. The systems of solid solutions are characterized according to Driscoll by a partition coefficient, this being the ratio of the concentrations of the impurity between the solid and liquid phases.

$$K = \frac{k'}{k} \quad (8)$$

leading with Eqn. (7) to the relationship

$$T = T_1 - \frac{x_{0,2} \cdot RT_1^2}{\Delta H_{f,1}} \frac{1}{\frac{K}{1-K} + r} \quad (9)$$

The discussion of systems with eutectic impurities and impurities forming solid solutions is rather inconsistent.

With regard to this relationship, Driscoll *et al.* state: "Systems which form true solid solutions, however, cannot be handled by this method of analysis". Joy and coworkers<sup>7</sup> declare in their abstract: "Because the DSC technique is "blind" to equilibrium solid solution formation, DSC values should not be used as a sole criterion of purity". Mastrangelo and Dornte<sup>8</sup> reported on a mixture of 2,2-dimethylbutane and 2,3-dimethylbutane. These two substances are known to form solid solutions. Mastrangelo and Dornte find a reasonable agreement between the theoretical temperature relation of Eqn. (9) and the experimental findings.

We have found no complete experimental proof of Eqn. (9) in the literature. Such a proof would require the independent determination of the parameters and thermodynamic constants such as temperature  $T$ , mole fractions of the main component and the impurities, molten fraction  $r$ , the partition coefficient  $K$ , the melting point  $T_1$ , and the heat of fusion of the main component  $\Delta H_{f,1}$ . Investigations of this kind should result in an assessment of the equilibrium with respect to temperature and concentrations.

Reconsidering Eqn. (7), we find the limitation of this equation discussed by several authors with respect to the allowable concentration of impurities. The limit is not properly defined because the definition would require the introduction of an absolute deviation between the theoretical amount of eutectic impurities and the sum of eutectic impurities as determined by DSC. With the lack of such a definition it is not surprising that the limitation of Eqn. (7) is estimated with considerable differences: Davis and Porter<sup>10</sup> assumed a limitation of Eqn. (7), with respect to the concentration of eutectic impurities, of 5%; De Angelis and Papariello<sup>11</sup> assumed a limitation of 1%; and Joy *et al.*<sup>7</sup>, one of 2%.

These limitations on the amount of eutectic impurities for the premelting method can be overcome by a method suggested by De Angelis and Papariello<sup>11</sup>. Samples of high impurity concentration (>1%) are diluted with the pure main component to extend the limit of the applicability of the DSC method. Such a dilution method was applied by De Angelis and Papariello to 4 different organic systems with actual purities of 95.5–97.0 mole-%. The DSC purity values of these samples without dilution gave results in a narrow range from 97.4 to 97.8 mole-%. The absolute differences between the true and the experimental purity values were, therefore, of the order of 1–2 mole-%. DSC results with such high inaccuracies are not sufficient for analytical purposes. The experiments of De Angelis and Papariello performed with the same compounds, but with a dilution of the main impurities with the corresponding main component to a purity level above 99 mole-%, resulted in excellent agreement between DSC values and the actual purity. Schumacher and Felder<sup>12</sup> present similar results in DSC purity values determined directly and after dilution with a substituted benzotriazole as the main component.

The differences between the actual purity and the experimental values determined without dilution are explained by the authors of both papers<sup>11,12</sup> in terms of an inconsistency between Eqn. (7) and the actual melting behaviour of organic substances in a purity region below 99 mole-%. We found that such an explanation of the differences of theoretical and experimental purities appears to be, however, only one of several possibilities. Another possible explanation for the differences is that the DSC method without dilution, used by Papariello and Schumacher, is only applicable to substances with a purity of at least 99 mole-%. In contrary to the findings of Papariello and Schumacher, we observed for many substances that the method without dilution gave correct values for impurities in the case of samples with substantially higher concentrations of impurities. We found that highly accurate purity values can only be achieved by selecting a scan speed appropriate to both the impurity concentration and the evaluation procedure. Thus, using the simplest Perkin–Elmer type of evaluation<sup>13</sup>, a scan speed of  $0.625^{\circ}\text{C min}^{-1}$  will yield valid results only in the purity range above 98 mole-%. The accuracy of a melting curve evaluation is improved by a data collection and evaluation at more than the 5–7 points within the important melting region, as suggested by Perkin–Elmer<sup>13</sup>. The more sophisticated the data collection and evaluation, the less important are the experimental conditions—scan speed, weight of sample and sensitivity—for getting a purity value of a high accuracy.

If one observes differences between the experimental and the actual purity values one has to check the experimental conditions, including the type of sample pan used, the data collection, the evaluation procedure of the melting curve, and the melting behaviour of the substance. If after all these investigations the differences in the experimental and the actual purity persist, an inconsistency between Eqn. (7) and the melting behaviour of this specific system is highly probable.

The dilution method introduced by Papariello<sup>11</sup> is excellent for the solution of special problems. Its practical use in an analytical laboratory is, however, limited by the amount of work involved. Therefore, the question of the limitation of the DSC method to a region of high purity substances (*e.g.* to a purity better than 98 mole-%) has to be reexamined because such a strong limitation would diminish the value of the whole method. Such an investigation of the purity region, in which the DSC method is a useful analytical tool, should be performed with binary systems. It would be very helpful if the phase diagrams of the selected binary systems were known from literature. With such a binary system, all kinds of possible parameters and conditions have to be varied; the ratio of the two compounds, the sample weight, the sample pan, the scan speed, the sensitivity, the first, second and following melting curves of the same sample if possible, and the data collection and evaluation. The results thus obtained may be discussed with respect to discrepancies between theoretical and experimental values of the purity, the heat of fusion, and the melting points. They can, moreover, reveal properties of the two components such as thermal stability, high vapor pressure in the melting region for one or both of the compounds, polymorphism, and anomalous behaviours demonstrated by the phase diagram and by the melting curve. Having completed these investigations on some binary systems one could perform a similar program on multi-component systems. All these results should give us information on the limitation of Eqn. (7).

*(b) Handling of the samples*

Gray<sup>13</sup> suggested the use of the volatile sample pan with an inside cover. This inside cover is made from aluminum to fit into the bottom part of the volatile pan. Driscoll *et al.*<sup>6</sup>, Barral and Diller<sup>14</sup>, Reubke and Mollica<sup>15</sup>, and others regard the volatile sample pan with an inside cover as the best solution to avoid volatilization. The sample handling and the variation of the temperature treatment are most important for substances with polymorphism, in the presence of impurities with a high vapor pressure in the melting region of the main component, and with substances which are unstable in the melting region.

Difficulties also arise with the sample holders of the DSC-IB. The sample pans, the aluminum dome lids and the outside cover of the sample holders have to be carefully placed in the correct positions<sup>14,16</sup>.

Barral and Diller<sup>14</sup> make a good point on the preparation of samples whereby great care has to be taken in selecting test samples or in mixing of low concentration standards, because the sample size in DSC measurements has to be in the region of a few milligrams. For quantitative work with the DSC-IB, the sample size should be



between 1 and 5 mg. Results with a high reproducibility are only possible with special care in the handling procedure.

(c) *Calibration of the DSC apparatus*

The calibration of the temperature axis of the DSC with high purity standards should be performed in the way indicated by Barrall and Diller<sup>14</sup>. The calibration of the sensitivity of the DSC in calories per unit area presents no problems. Important for high purity measurements is the careful calibration of the thermal resistance between the sample pan holder and the sample pan with standards like indium, tin and lead; this is also shown in the interesting investigations performed by Barrall and Diller<sup>14</sup>.

The question arises whether or not one is allowed to use inorganic materials as standards for the measurement of the thermal resistance, which can then be used in the purity determination of organic substances. However, the DSC-IB is nearly independent of the thermal resistance of the sample, as long as the sample consists of crystals of a rather small size<sup>17</sup>.

(d) *Instrumental conditions for a purity determination*

The instrumental conditions for a purity determination are sensitivity or the calorimetric range, the scan speed, and the sample pan. There are mutual relationships between these experimental conditions and some of the properties of the instrumentation and the sample. As an example, the appropriate calorimetric range used in a purity determination depends on several conditions, *i.e.* heat of fusion of the main component, sample size, scan speed, concentration of impurities, and recording system or data collection.

The scan speed, as indicated in the literature<sup>6,7,14</sup>, is in general kept at the lower end of the range, *i.e.* 0.625 or 1.25°C/min. Such low values of the scan speed are

TABLE III  
EFFECT OF SAMPLE SIZE AND HEATING RATE ON CALCULATED PURITY  
(BARRALL AND DILLER<sup>14</sup>)

Mixture	Sample size (mg)	Heating rate (°C/min)	Purity (mole-%)	
			Found <sup>a</sup>	Known <sup>b</sup>
Lead in tin	3.084	1.25	0.425	0.419
Lead in tin	3.084	5.0	0.185	0.419
Lead in tin	3.084	20.0	0.0828	0.419
Lead in tin	4.300	1.25	0.321	0.419
Lead in tin	6.284	5.0	0.857	1.16
Lead in tin	6.284	1.25	0.871	1.16
Lead in tin	6.284	0.625	0.890	1.16

<sup>a</sup>Calculated with partial areas considered to the vertex of the endotherm. <sup>b</sup>Determined by atomic absorption of lead with a Perkin-Elmer Model 303 spectrophotometer, using nitrous oxide as oxidizing agent to dissociate the tin compounds.

required for high purity measurements. Low values of the scan speed are necessary as the sample is probably not at thermal equilibrium during rapid rates of heating, according to Barrall and Diller<sup>14</sup>. The effects of sample size and heating rate on the measured purity in mixtures of lead in tin<sup>14</sup> are presented in Table III.

Three parameters are varied in Table III; sample size, scan speed, and purity level. The mixture with the lower concentration of lead seems to be strongly sensitive to changes of the heating rate with respect to the concentrations of lead calculated from melting curves. Conclusions from Table III are only typical for the applied conditions, such as the data collection and evaluation procedure. Generalizations are only possible after performing the investigations mentioned in part (a).

(e) *Evaluation of the melting curves*

The calibration of the instrument, the handling of the samples, and the determination of the correct instrumental conditions for obtaining a melting curve which may be easily handled by an evaluation procedure, are all possible with some care in the experimental work. However, understanding and performing the purity calculations from melting curves is rather complicated. Therefore, the literature about this subject is quite extensive. No review of evaluation methods is available in the literature.

A given procedure for the evaluation of a melting curve can be checked in several different ways; there are a great many internal and external checks possible. We will discuss here the external checks which are performed with the values resulting from a normal evaluation of a melting curve; *i.e.* (i) the melting point of the sample, (ii) the melting point of the pure main component, (iii) the heat of fusion of the pure main component, and (iv) the purity value of the sample. The melting point and the heat of fusion of the sample calculated by the evaluation procedure may be compared with the values measured directly on the melting curve by applying the calibration factors. The melting point and the heat of fusion of the pure main component can probably be found in the literature. Such literature values permit a comparison with the results from the evaluation of melting curves.

For test substances, the measured DSC purity value may be compared with the actual purity value known from mixing. A second method is to compare the DSC purity value with the purity information obtained from a separate analytical procedure. In the case of disagreement between the DSC purity value and the actual purity value, several points must be considered with regard to the DSC method; *i.e.* the instrumental conditions used in getting the melting curve; the physical and chemical behaviour of the main component and the impurities; and the evaluation procedure, and the use of the thermodynamic relationship for the description of the solid-liquid equilibrium.

All the considerations given in this section, which are necessary in case of discrepancies between the values evaluated from melting curves (*i.e.* purity, melting points, heat of fusion) and values found in the literature, receive practically no mention in the published work on DSC-purity determination.

The evaluation of melting curves by hand, suggested by Perkin-Elmer<sup>13</sup>, is practicable but too cumbersome for routine work. Computer programs used in the evaluation give higher accuracies in purity and thermodynamic values, and are much faster. Programs were developed by Driscoll *et al.*<sup>6</sup>, Scott and Gray<sup>18</sup>, Barrall and Diller<sup>14</sup>, Davis and Porter<sup>10</sup>, Heuvel and Lind<sup>19</sup>, Gent<sup>20</sup>, and others.

The basic problems of the evaluation of melting curves by computer or by hand are the same. Referring to Eqn. (7), one has to fit the experimental DSC-curve to a straight line in the  $(1/r, T)$ -diagram, as it was first shown by Pitzer and Scott<sup>21</sup>.

The evaluation procedures cited above consist of: (1) the fit of the experimental points from a melting curve to a given thermodynamic function, together with the determination of the true heat of fusion of the main component<sup>6,10</sup>; (2) the linearization with an appropriate mathematical method<sup>6,18</sup>; and (3) the calculation of the purity value and the thermodynamic constants of the sample and of the corresponding main component. It is not always possible to separate a given evaluation procedure into these three parts. However, the literature of the evaluation procedures is more easily discussed by such a partition.

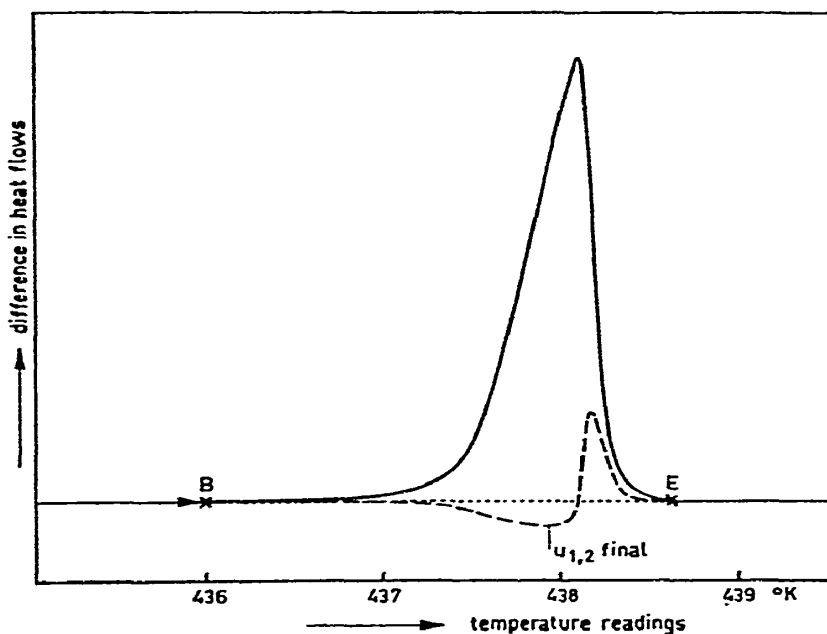


Fig. 2. Melting trace of benzanilide with a baseline  $u_{1,2} \text{ final}$  calculated by Heuvel and Lind<sup>19</sup>.

The problem of evaluating the true heat of fusion exists because the DSC is measuring the difference in the heat necessary to maintain a given and constant temperature rise in the reference and the sample cell. The baseline of the instrument during an exothermic or endothermic change of the sample can only be determined

approximately by a connection of the recorder lines before and after such an energy change. Heuvel and Lind<sup>19</sup> stated, "Under certain conditions of instrument operation, *e.g.* fast scanning rates, the course of the base line deviates to a large extent from simple interpolation between pre-transition and post-transition baselines". Fig. 2 shows the melting trace of benzanilide from the paper of Heuvel and Lind. The indicated baselines are given by (i) a straight line from point B to E, and (ii)  $U_{1,2}$  final; a function of the heating rate, the heat capacity of the sample, and the thermal resistance from the sample holder to the sample<sup>17</sup> according to the calculations of Heuvel and Lind<sup>19</sup>.

For a sharp transition, as shown in Fig. 2, both baselines give the same calculated value for the heat of fusion, which is a conclusion of the paper of Heuvel and Lind<sup>19</sup>.

The discussion of the heat of fusion is presented in two parts: (1) with high purity substances, and (2) with substances having lower purity values.

Table IV shows the heats of fusion for several high-purity substances. The values are directly calculated from melting curves in applying a straight baseline, as shown in Fig. 2.

TABLE IV  
HEAT OF FUSION FROM DSC MELTING CURVES FOR SUBSTANCES OF  
A HIGH PURITY VALUE

Substances	DSC purity (mole %)	Heat of fusion		$\frac{\Delta H_{f,DSC} - \Delta H_{f,Lit.}}{\Delta H_{f,Lit.}} \times 100$ (%)
		DSC uncorrected baseline $\Delta H_{f,DSC}$ (cal.mole <sup>-1</sup> )	Lit. values $H_{f,Lit.}$ (cal.mole <sup>-1</sup> )	
Benzene	99.8	2352 <sup>a</sup>	2349 (Ref. 22)	+0.1
Benzene	99.05	2237 <sup>a</sup>	2349 (Ref. 22)	-4.8
Benzamide	99.25	4590 <sup>b</sup>	4899 (Ref. 23)	-6.3
Benzoic acid		3945 <sup>b</sup>	4300 (Ref. 24)	-8.3
Anthrachinon	99.94	7725 <sup>b</sup>	7830 (Ref. 25)	-1.3
Potassium nitrate		2370 <sup>b</sup>	2295 (Ref. 26)	+3.3
Distilled water	99.97	1400 <sup>b</sup>	1434 (Ref. 27)	-2.4
Butazolidine	99.56 $\pm 0.28^c$	5710 <sup>b</sup> $\pm 680^{b,c}$		

<sup>a</sup>DSC values by Driscoll *et al.*<sup>6</sup>. <sup>b</sup>DSC values by Marti and Heiber (unpublished). <sup>c</sup>Error in a single measurement on 95% confidence limits.

The agreement of the DSC with the literature values for the heat of fusion is reasonable in the case of high purity substances. The reproducibility of the heat of fusion, according to measurements on butazolidine, is indicative of a normal-precision, and certainly not of a high-precision instrument. A better precision in the determination of energies are expected from new instruments, *e.g.* Mettler DTA 2000<sup>28</sup> and Perkin-Elmer DSC-2<sup>29</sup>.

The determination of the heat of fusion from melting curves of samples with low purity values reveals a completely different picture compared to that presented in Table IV. The results are presented in Table V. The measurements were performed by Driscoll *et al.*<sup>6</sup> for an impurity content of  $\leq 2.80$  mole-%, and for highest value of impurities by a measurement in our laboratory. The determination of the heat of fusion was performed with an uncorrected baseline, as described in Fig. 2.

TABLE V  
HEAT OF FUSION FROM DSC MELTING CURVES FOR BENZENE WITH  
VARIOUS AMOUNTS OF EUTECTIC IMPURITIES

Substance	DSC purity (mole-%)	Heat of fusion DSC, uncorrected baseline $\Delta H_{f,DSC}$ (cal.mole <sup>-1</sup> )	$\frac{\Delta H_{f,DSC} - \Delta H_{f,Lit.}}{\Delta H_{f,Lit.}} \times 100$ (%)
Benzene	99.8	2352	+0.1
	99.05	2237	-4.8
	99.10	2131	-9.3
	97.14	1788	-23.9
	91.5	1293	-49.2

A correction of the heat of fusion for substances with purities below 99% is absolutely necessary. For example (see Table V, benzene, purity 91.5%), the eutectic impurity calculated in applying Eqn. (7) would be too low by as much as 50% for the theoretical impurity value of 8.5 mole-%. A similar picture of the difference between the heat of fusion according to the literature values and the DSC measurements was shown by Davis and Porter<sup>10</sup>. The difference in the values of the heats of fusion can be explained by (i) the fact that the instrument has a limited sensitivity, and (ii) a eutectic and premelting region which is unrecorded because the eutectic point may be far below the melting point of the main component.

The incorrect baseline measured by the DSC has not only an influence on the heat of fusion, but also on the evaluation procedure. The melting curve allows a calculation of the fraction of the substance melted as a function of temperature. The temperature indicated on the DSC-IB must be corrected to the temperature of the sample. The correction is performed with a temperature calibration curve of the instrument and with calibration measurements on the thermal lag between the sample holder and the sample<sup>30</sup>. The plot of the temperature of the sample as a function of the reciprocal molten fraction—the  $1/r$ , ( $T$ )-diagram—should give a straight line according to Eqn. (7). A straight line in the ( $1/r$ ,  $T$ )-diagram can be observed occasionally for substances with an extremely high purity. All other substances give only a straight line after a trial and error correction of the baseline, the so called linearization<sup>13</sup>. A new position of the baseline yields a new value of the heat of fusion. The linearization procedure corrects, at least partially, for the energy unrecorded

through the instrument's limitation and for the premelting region which is not observed. The linearization procedure leads to a more accurate determination of the heat of fusion of the main component.

The linearization in the  $(1/r, T)$ -diagram is only possible within a certain region of the melting curve. The limits of the linearization region are discussed in the paper by Driscoll *et al.*<sup>6</sup>. They used for their linearization a constant value for the lower limit of the fraction melted with 2% and for the upper limit, a value based on the fraction melted at the point where the rate of heat input reaches half of its maximum value. This defines the upper limit from about 12.5% for a pure sample to about 40% for a sample with approximately 2 mole-% of eutectic impurities. The influence of the limits of the linearization interval on the calculated impurity values is shown in Table VI, taken from the work of Driscoll *et al.*<sup>6</sup>.

TABLE VI  
CALCULATED IMPURITY VALUES FOR NBS OCTANE WITH A  
CERTIFIED IMPURITY OF  $0.06 \pm 0.04\%$

<i>Linearization limits, fraction melted (%)</i>		<i>Calculated impurity (mole-%)</i>
<i>Lower limit</i>	<i>Upper limit</i>	
2	10	0.016
2	18	0.23
2.5	36	0.52
2.5	40	0.59
2.5	50	0.78
10	50	2.69

Driscoll and coworkers emphasized the importance of the linearization limits, which are applied for the calculation of impurity values. Only with a comprehensive investigation on melting curves of substances which are close to an ideal melting behaviour, is one able to find proper values for the linearization limits. The necessity for an investigation of the linearization limits is clearly demonstrated in comparing the values of the linearization limits and the calculated impurities in Table VI. These calculated impurity values differ by two orders of magnitude from the NBS value.

In general, the performance of the linearization permits the calculation of the heat of fusion of the main component  $\Delta H_{r,1}$ ; the melting point of the main component  $T_1$ , obtained from the intercept of the  $T$ -axis with the straight line of the corrected data for the melting curve in the  $(1/r, T)$ -diagram; and the melting point of the sample  $T_0$  as the temperature value where  $r = 1$ . The calculation of the eutectic impurity using Eqn. (7) can then be made without any difficulty.

Apart from the computing procedures for the determination of the concentration of eutectic impurity, there is another method suggested by Plato and Glasgow<sup>31</sup>. These two authors reported their experiences with 95 different organic compounds analyzed with the DSC: "An experienced analyst can estimate the purity of an

unweighed sample to within about 0.2 mole-% by visual inspection of the DSC curve produced in a 3-min scan". This remark can be regarded as the introduction of a new evaluation method. However, this new evaluation method of melting curves would demand, in our opinion, the following procedure, especially to reach the goal of an accuracy in eutectic impurities of  $\pm 0.2$  mole-%: (1) Preparation of a set of reference melting curves; the range of eutectic impurities and the instrumental conditions required to set up reference curves should be appropriate to the samples which have to be measured for analytical purposes. (2) Measurement of the melting curves of samples with the same instrumental conditions as used for the reference curves. (3) Comparison of the melting curves and the reference curves. Using the improved method of Plato and Glasgow the computer program for the calculation of purity values can be partially replaced.

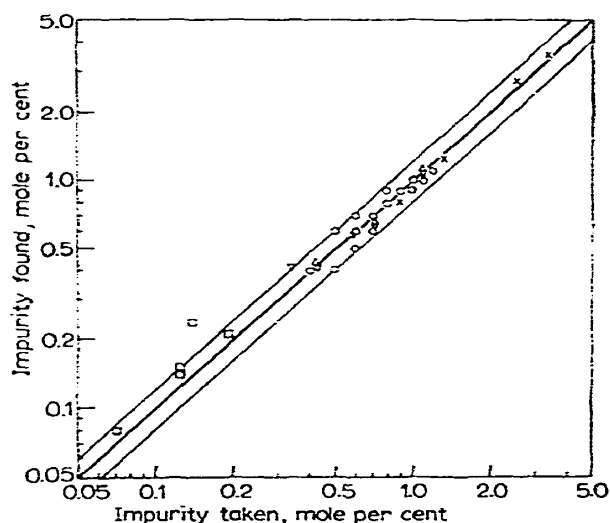


Fig. 3. Relation between actual and experimental impurity value (Joy *et al.*<sup>7</sup>).

(f) *Accuracy of measurements of eutectic impurities with DSC*

All authors agree that the accuracy of the impurity values measured with DSC decreases with increasing content of eutectic impurities. Barrali and Diller<sup>14</sup> claim a high relative accuracy of  $\pm 3\%$  with respect to the eutectic impurity, but only in case of high-purity substances. Reubke and Mollica<sup>15</sup> reported on substances in the purity region of 99 to 100%. These authors claim an absolute error in the eutectic impurities of 0.1%, which means more than 10% relative to the amount of impurities. Joy and coworkers<sup>7</sup> make the interesting remark that the upper limit in purity measurements with DSC are 99.95 mole-%. Higher numerical values of the purity seem to bear no significance. The statement of Joy and coworkers of the existence of an absolute error in eutectic impurities of only 0.05 mole-% is quite close to the value given by Reubke and Mollica. This minimum value of the absolute error of the

impurity measurements is of course typical for the DSC-IB. An extensive comparison of theoretical and measured DSC values is presented in Fig. 3. The substances are selected by Joy *et al.* and the purity of most of these substances is in the region of  $99.0 \pm 0.5\%$ .

The upper and lower lines on the graph indicate the +20% and -20% relative error limit. It should be added, however, that only substances with no problems in melting (*e.g.* suspected solid solution formation, incomplete solubility of the impurities in the melt, or other disturbances) were chosen by Joy for presentation in Fig. 3. De Angelis and Papariello<sup>11</sup> give examples of organic substances with absolute errors between the actual and DSC purity values of 0.5 mole-% at the 98-% purity level and 2.5 mole-% at the 95-% level. The actual values of the purity are given by dry mixing the main component and the impurity. Dry mixing of substances in the purity range of less than 99% should be without any problems. Therefore actual values of the purity known from mixing of the main component and impurities are expected to be very close to the true purity values. The relative accuracies of eutectic impurities, according to the measurements and calculations of De Angelis and Papariello, are within 25% for the 98-% purity level and 50% for the 95-% level. De Angelis and Papariello explain, "We have not yet encountered any system in which accurate results were obtained beyond 1.5 mole-% impurity and it is indicated that DSC purity values of less than 99% are likely to be in error". From statements in the literature on accuracy in the determination of eutectic impurities the following conclusion can be made. There are two regions of purity with an arbitrary separation limit of 99 mole-%. The probability of a good agreement of actual and measured impurity values is high in the high-purity region, and low in the low-purity region. A first step to a clearer situation in the low-purity region could be reached by an extensive study on any system which shows great differences in actual and experimental purity values.

*(g) Application of the purity determination to substances which are unstable in the melting region*

Reubke and Mollica<sup>15</sup> reported, "Samples were selected which would melt without decomposition". Plato and Glasgow<sup>31</sup> stated, "Purity of chemicals that decompose near their melting points cannot be determined by the DSC method". Throughout the literature one can find the statement that the DSC method is unable to handle substances which decompose during melting.

**THEORY OF THE PURITY DETERMINATION USING THE METHOD OF PREMELTING ON BINARY SYSTEMS WITH A EUTECTIC PHASE DIAGRAM**

The theory of the purity determination with the method of premelting was discussed by Marti *et al.*<sup>32</sup> for a binary system with a eutectic phase diagram. A binary system is the simplest system for a theoretical discussion of the purity determination by DSC, also for experimental work it is easy to collect all the necessary information from the literature or by measurements. The understanding of the



melting behaviour of a binary system from a theoretical and experimental point of view is certainly the most important part of the attempt to understand the melting behaviour of a multicomponent system.

The melting behaviour of a eutectic system consisting of only two components is commonly described approximately by a thermodynamic relationship in the region of solid-liquid equilibria. Such a description is given in Eqn. (10)<sup>33</sup> for an ideal mixture of non-electrolytes under isobaric conditions with a heat of fusion independent of temperature.

$$\ln(x_i) = \frac{\Delta H_{f,i}}{R} \left( \frac{1}{T_i} - \frac{1}{T} \right) \quad (i = 1, 2) \quad (10)$$

where  $x_i$  is the mole fraction of the component  $i$  in the liquid phase,  $\Delta H_{f,i}$  is the heat of fusion of the pure component  $i$  at the melting point,  $R$  is the gas constant,  $T_i$  is the melting point of the pure component  $i$  in °K, and  $T$  is the temperature in °K.

The mole fractions for a binary mixture are connected by the equation

$$x_1 + x_2 = 1 \quad (11)$$

At low values of one of the components, *e.g.* component 2, we can write Eqn. (10) in the form

$$x_2 = \frac{\Delta H_{f,1}}{R} \left( \frac{1}{T} - \frac{1}{T_1} \right) \quad (12)$$

More exactly, the solubility equilibrium (Eqn. 10) is found by introducing a heat of fusion,  $\Delta H_i$ , which is a function of temperature<sup>34</sup>. In this case we can write

$$\Delta H_i = \Delta H_{f,i} + \Delta C_{0,i}(T - T_i) \quad (13)$$

where  $\Delta C_{0,i}$  is the difference of the molar heat capacities of the pure component  $i$  at constant pressure for the liquid and the solid phase.

Eqn. (13), applied to the solubility equilibrium of an ideal mixture, leads to the following relationship

$$\ln(x_i) = \frac{\Delta H_{f,i}}{R} \left( \frac{1}{T_i} - \frac{1}{T} \right) - \frac{\Delta C_{0,i}}{R} \left( 1 - \frac{T_i}{T} + \ln \frac{T_i}{T} \right) \quad (14)$$

The following abbreviation will be used for Eqn. (14)

$$\ln(x_i) = A(T) \quad (15)$$

Eqns. (10), (12) and (14) enable us to construct the isobaric melting point diagram for binary systems, which are ideal mixtures on the basis of the properties of the main components alone (namely melting points, heats of fusion, and heat capacities).

A mixture of phenacetin and benzamide was chosen as an example of a binary system. The thermodynamic values used for the calculation of the phase diagram are given in Table VII.

TABLE VII  
THERMODYNAMIC PROPERTIES OF PHENACETIN AND BENZAMIDE

Thermodynamic values	Phenacetin		Benzamide	
	Author's values by DSC	Lit. values	Author's values by DSC	Lit. values
Melting point $T_f$ (°K)	407 ± 0.3	407–408 <sup>35</sup>	400 ± 0.3	400–400.7 <sup>36</sup>
Heat of fusion $\Delta H_{f,t}$ (cal/mole)	7750 ± 600	7880 <sup>a</sup>	4900 ± 600	4900 <sup>37</sup>
Difference between the molar heat capacities in the liquid and the solid phase $\Delta C_{p,t}$ (cal/mole °K)	12.5 ± 0.5		13.3 ± 0.5	

<sup>a</sup>Calculated from the heat of sublimation ( $\Delta H_s = 27.60 \text{ kcal mole}^{-1}$ )<sup>38</sup> and the heat of evaporation ( $\Delta H_v = 19.72 \text{ kcal mole}^{-1}$ )<sup>39</sup>.

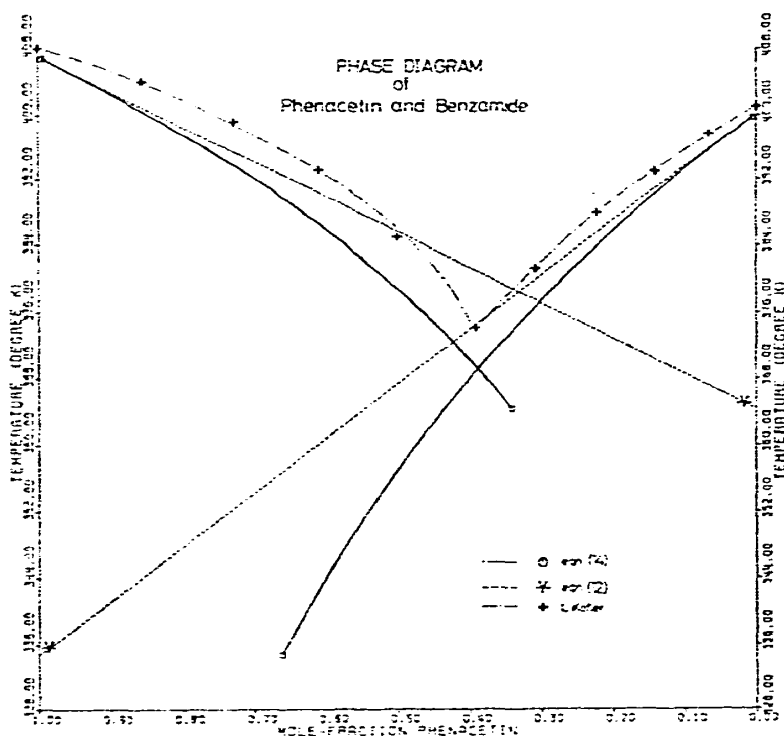


Fig. 4. Comparison of theoretical and experimental phase diagrams for phenacetin and benzamide (Kofler, Marti *et al.*<sup>32</sup>).

In Fig. 4, the melting point diagrams calculated from Eqns. (12) and (14) are compared with a diagram from measurements by Kofler<sup>40</sup>. The differences between the two theoretical phase diagrams are easily understood by the two levels of approximation applied to Eqns. (12) and (14). However, the differences between the theoretical

phase diagram calculated with Eqn. (14) and the experimental phase diagram are certainly caused by the difference between the activities of the components, and the concentration itself. A smaller part of the differences may be due to experimental conditions. A discussion of the activity can be attempted by introducing the relation<sup>41</sup>

$$a_i = x_i f_i \quad (16)$$

where  $a_i$  is the activity of the component  $i$  in the liquid phase, and  $f_i$  is the activity coefficient of the component  $i$ .

The activity coefficient,  $f_i$ , of a binary liquid mixture of non-electrolytes is defined by Eqn. (17)

$$\mu_i = \mu_i^\circ + RT \ln(x_i f_i) \quad (i = 1, 2) \quad (17)$$

where  $\mu_i$  is the chemical potential of component  $i$  in the liquid phase and  $\mu_i^\circ$  is the chemical potential of pure liquid component  $i$  at the same pressure and temperature.

A relationship exists between the activity coefficients  $f_1$  and  $f_2$  because of the mutual interaction of the substances in a binary system and because of the equilibrium between the phases of a heterogeneous system. The equilibrium condition demands that all the phases must have the same temperature  $T$ , the same pressure  $P$ , and the chemical potential of each component must have the same value of  $\mu_i$  in all the phases.

The relationship between the activity coefficients follows from a combination of Eqns. (11) and (17) and in the application of the Gibbs–Duhem relationship

$$x_1 \left( \frac{\delta \ln f_1}{\delta x_1} \right)_{T,P} + (1-x_1) \left( \frac{\delta \ln f_2}{\delta x_1} \right)_{T,P} = 0 \quad (18)$$

The activity coefficient  $f_i$  is a function of temperature, pressure and the mole fraction of the components; it is determined by a solubility measurement of each component at the temperature  $T$  and at isobaric conditions according to Eqn. (19), which follows from Eqns. (14) and (16)

$$\ln(x_i f_i) = \frac{\Delta H_{f,i}}{R} \left( \frac{1}{T_i} - \frac{1}{T} \right) - \frac{\Delta C_{0,i}}{R} \left( 1 - \frac{T_i}{T} + \ln \frac{T_i}{T} \right) \quad (19)$$

The point-to-point determination of the activity coefficient is cumbersome. The problem may be solved relatively easily if we can specify the form of the function of the activity coefficient  $f_i(T, x_i)$ . This function is then found, to a certain approximation, by combining only a few solubility data from Eqn. (19) along with the temperature dependence of the activity coefficient. The temperature dependence at a given concentration  $x_1$  is related to the temperature dependence of the chemical potential by

$$\left( \frac{\delta \ln f_1}{\delta T} \right)_{P,x_1} = - \frac{\Delta H_1^*}{RT^2} \quad (20)$$

where  $\Delta H_1^*$  is the differential heat of mixing given by the following equation

$$\Delta H_1^* = H_1 - H_1^\circ \quad (21)$$

where  $H_1^0$  is the molar enthalpy of the pure liquid component 1 and  $H_1$  is the partial molar enthalpy of component 1 in the mixture.

With the determination of the function  $f_1(T, x_1)$  from measurements on a binary system, the function  $f_2(T, x_2)$  is also known according to Eqn. (18). Each branch of the melting point diagram of a binary system under isobaric conditions is described to a good approximation by Eqn. (19) and the thermodynamic constants of the corresponding main component known from the literature or from the measurements of heat of fusion, melting point, difference of the molar heat capacities for the liquid and the solid phase, and the activity coefficient.

Next, theoretical melting curves for different values of the ratio of the components for a given binary system are calculated. The calculation is based on the Eqns. (12) and (14) under the restriction to ideal mixtures. A melting curve can be defined by the rate of heat flow to the sample which, in a solid-liquid equilibrium, is a function of the temperature. The melting curve is further dependent on the ratio of the components and on the phase diagram of the binary system. Such a representation of the melting curves by the rate of heat flow as a function of temperature is experimentally obtained by the DSC method. In contrast to the paper by O'Neill<sup>17</sup>, which presents a fusion analysis with the rate of heat flow, our discussion of the melting curves is based on the specific heat function. The relation between rate of heat flow, specific heat function and scan speed is given in Eqn. (22)

$$\frac{dH}{dT} = \frac{dH}{dt} \cdot \frac{dt}{dT} \quad (22)$$

where  $dH/dT$  is the specific heat function at constant pressure ( $\text{cal } ^\circ\text{K}^{-1} \text{ mole}^{-1}$ ),  $dH/dt$  is the rate of heat flow ( $\text{cal sec}^{-1} \text{ mole}^{-1}$ ), and  $dT/dt$  is the scan speed in  $^\circ\text{K sec}^{-1}$ . There is no difference, in principle, in discussing the melting behaviour with the rate of heat flow or the specific heat function.

One branch of the phase diagram is selected with the condition for component 2 of

$$x_{0,2} < x_{e,2} \quad (23)$$

where  $x_{0,2}$  is the mole fraction of component 2 in the binary mixture and  $x_{e,2}$  is the mole fraction of the component 2 at the eutectic point.

The condition in Eqn. (23) defines component 1 as the main component of the mixture. The eutectic melting at the eutectic temperature  $T_e$  is neglected by setting the temperature limits for Eqns. (12) and (14)

$$T_1 > T > T_e \quad (24)$$

The relation between the mole fraction  $x_2$  of component 2 in the liquid phase and the mole fraction of this component in the given system ( $x_{e,2}$ ) is

$$x_2 = \frac{x_{0,2}}{r} \quad (25)$$

where  $r$  is the molten fraction of the mixture.

By inserting Eqn. (25) into the equation for the solubility equilibrium in Eqn. (12), we obtain

$$\frac{x_{0,2}}{r} = \frac{\Delta H_{f,1}}{R} \cdot \left( \frac{1}{T} - \frac{1}{T_1} \right) \quad (26)$$

The introduction of the molten fraction  $r$  enables us to write the specific heat function as

$$\frac{dH}{dT} = \frac{dH}{dr} \cdot \frac{dr}{dT} \quad (27)$$

The derivative  $dr/dT$  is calculated from Eqn. (26). The other derivative  $dH/dr$  can be formed using the following relation

$$H_r = \Delta H_{f,1} \cdot r \quad (28)$$

The relation in Eqn. (28) holds because of the limitation to eutectic systems and because of the restriction to ideal mixtures. Insertion of  $dH/dr$  and  $dr/dT$  into Eqn. (27) leads to the specific heat function

$$\left( \frac{dH}{dT} \right)_1 = x_{0,2} \cdot \frac{RT_1^2}{(T_1 - T)^2} \quad (29)$$

The integration of Eqn. (29) can be performed between the limits  $T_a$  and  $T_{s,1}$

$$\int_{T_a}^{T_{s,1}} \left( \frac{dH}{dT} \right)_1 dT = x_{0,2} \cdot RT_1^2 \int_{T_a}^{T_{s,1}} \frac{dT}{(T_1 - T)^2} \quad (30)$$

The upper limit  $T_{s,1}$  is the melting point of the given mixture and is approximated [see Eqn. (26),  $r = 1$ ] by

$$T_{s,1} = T_1 - x_{0,2} \cdot \frac{RT_1^2}{\Delta H_{f,1}} \quad (31)$$

The lower limit is more or less arbitrarily chosen as

$$T_a = T_1 - \frac{RT_1^2}{\Delta H_{f,1}} \quad (32)$$

defining  $r$  as equal to  $x_{0,2}$  for this lower limit.

The definition of the lower limit of the specific heat functions excludes the energetic change of binary systems at the eutectic points. There is no continuity between the eutectic point and the melting region which would demand a mutual discussion of both phenomena.

By repeating the procedure, which gave Eqn. (29) from Eqn. (26), with the solubility equilibrium from Eqn. (14) we obtain the specific heat function

$$\left(\frac{dH}{dT}\right)_1 = \frac{x_{0,2}}{RT^2} \cdot [\Delta H_{r,1} + \Delta C_{0,1}(T - T_1)]^2 \cdot \frac{1}{e^{A(T)} + e^{-A(T)} - 2} \quad (33)$$

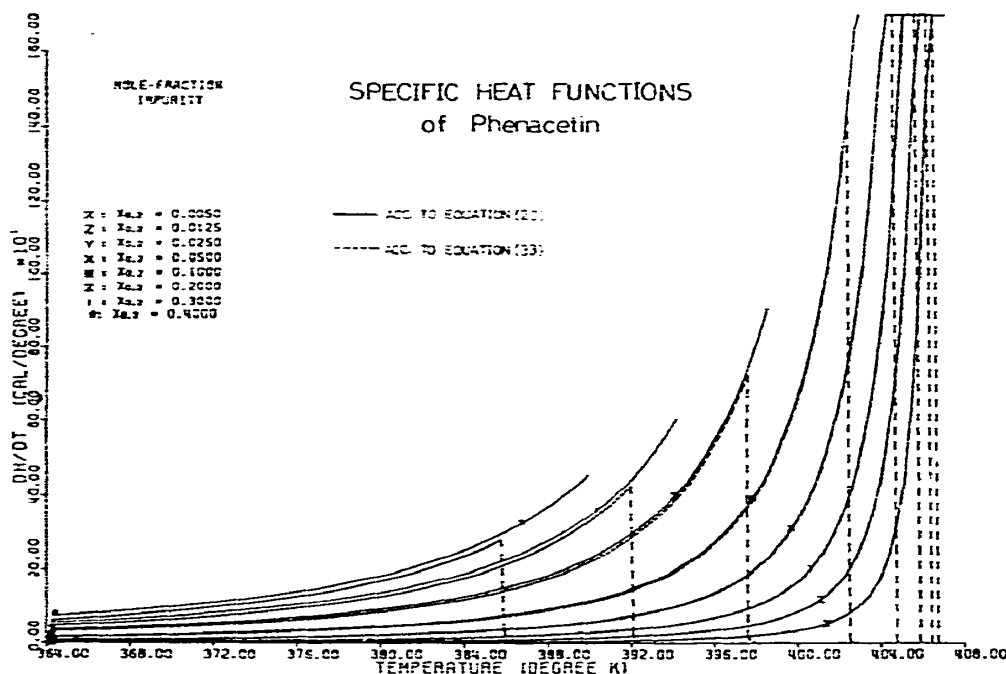


Fig. 5. Specific heat functions of phenacetin from Eqns. (29) and (33).

For a given mole fraction, the theoretical specific heat functions according to Eqns. (29) and (33) depend only on the properties of the main components. Specific heat functions of phenacetin and benzamide are presented in Figs. 5 and 6. The sets of specific heat functions for phenacetin are calculated according to Eqns. (29) and (33), whereas for benzamide, only one set of curves from Eqn. (29) is shown. The thermodynamic values of the main components used for our calculations are shown in Table VII. The following mole fractions of component 2 (impurity) were used for the presentation of the specific heat functions in the case of phenacetin and benzamide;  $x_{0,2} = 0.005, 0.0125, 0.025, 0.05, 0.10, 0.20, 0.30$ . In addition, for phenacetin as the main component, a curve with  $x_{0,2} = 0.40$  was also plotted. The upper and lower limits of the specific heat functions calculated according to Eqn. (29) are determined by Eqns. (31) and (32). In Figs. 5 and 6, the curves are plotted between these limits if the selected range of the specific heat of  $1600 \text{ cal } ^\circ\text{K}^{-1}$  allows such a presentation. As

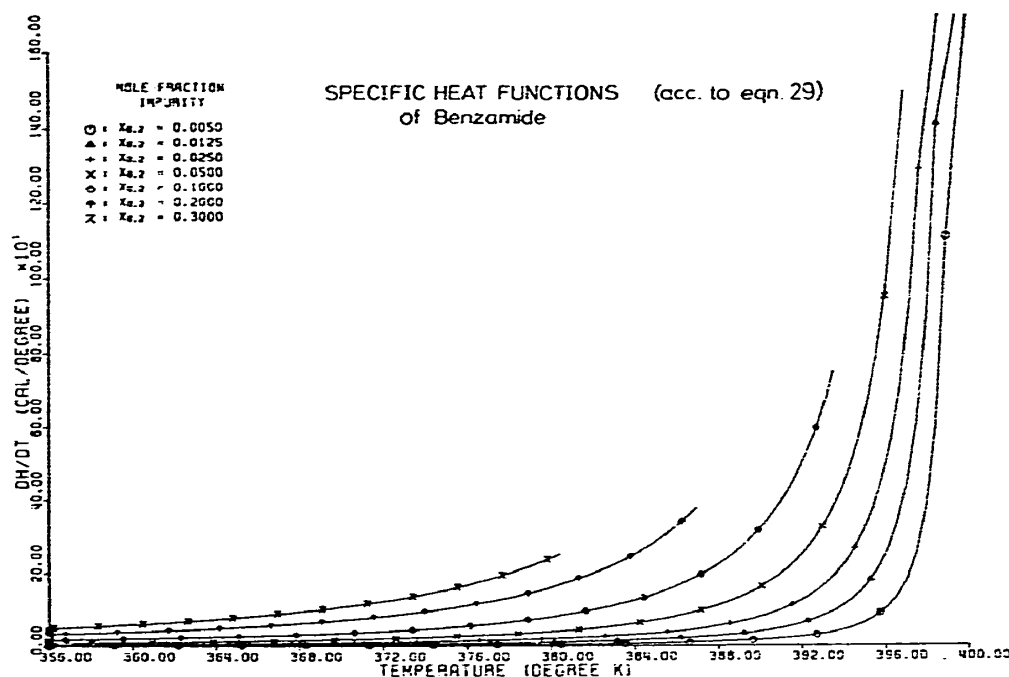


Fig. 6. Specific heat functions of benzamide from Eqn. (29) (Marti *et al.*<sup>32</sup>).

an example, a comparison of the specific heat functions for phenacetin and benzamide with a mole fraction of component 2 ( $x_{0,2} = 0.3$ ) shows differences caused mainly by the difference in the melting points and the heat of fusions. Among other subjects, there is an investigation in a subsequent part of this paper into the difference of specific heat functions calculated using Eqn. (29) for main components which differ in their thermodynamic constants.

The differences of the specific heat functions from Eqns. (29) and (33) are shown in Fig. 5. Significant differences between the specific heat functions (shape of curves and upper limits) are only seen for extremely high impurity values (component 2). For the specific heat functions of Eqn. (29) the upper limits (melting points) were evaluated from Eqn. (31). Eqn. (31) is only a poor approximation in a region of the mole fraction of component 2 between 0.4 and 0.1. The absolute values and relative differences of the specific heat functions of phenacetin as main component, calculated from Eqns. (29) and (33), are presented for selected temperature values and mole fractions in Table VIII.

The relative differences of the specific heat functions calculated with Eqns. (29) and (33) are strongly dependent on temperature but are practically independent of the mole fraction of the main component. Table VIII clearly shows that the differences in the assumptions used for the calculation of specific heat functions are not really

TABLE VIII  
COMPARISON OF SPECIFIC HEAT FUNCTIONS CALCULATED FROM  
EQN. (29) OR EQN. (33)

Temperature	Mole fraction of component 2	(dH/dT) from Eqn. (29)	(dH/dT) from Eqn. (33)	$\frac{(dH/dT)_{29} - (dH/dT)_{33}}{(dH/dT)_{29}} \times 100$
364.3	0.30	54.4	46.0	15.5
391.8	0.30	428.2	412.8	3.8
364.3	0.05	9.1	7.7	15.4
391.8	0.05	71.5	68.9	3.6

essential for the shape of the curves and, therefore, calculated impurity values in mole fractions change only a little when using either Eqn. (29) or (33).

It is even possible to go one step further in saying that to a certain approximation the specific heat function is only dependent on the mole fraction of the second component (impurity) as long as the restriction of eutectic systems holds. To explain this statement and to show the closeness of this approximation, Eqn. (29) may be written in the transformed form

$$\left(\frac{dH}{dT}\right)_1 = x_{0,2} \frac{R}{1 - 2\frac{T}{T_1} + \left(\frac{T}{T_1}\right)^2} \quad (34)$$

Now, two mixtures with different main components and melting points of the pure substances  $T_1$  and  $T_2$ , respectively can be compared. The following temperature difference,  $\Delta T$ , is introduced

$$\Delta T = T_2 - T_1 \quad (35)$$

The specific heat function of mixture number 2 is represented on a shifted scale, namely

$$T' = T - \Delta T \quad (36)$$

The specific heat functions are indicated with the indices 1 and 2 and the mole fraction of the impurity in both cases is made the same. The ratio of the two specific heat functions formed with Eqn. (34) can be written as

$$\frac{\left(\frac{dH}{dT}\right)_1}{\left(\frac{dH}{dT}\right)_2} = \frac{1}{\left(1 + \frac{\Delta T}{T_1}\right)^2} \quad (37)$$

Obviously, the ratio of the specific heat functions taken at corresponding temperatures is constant.



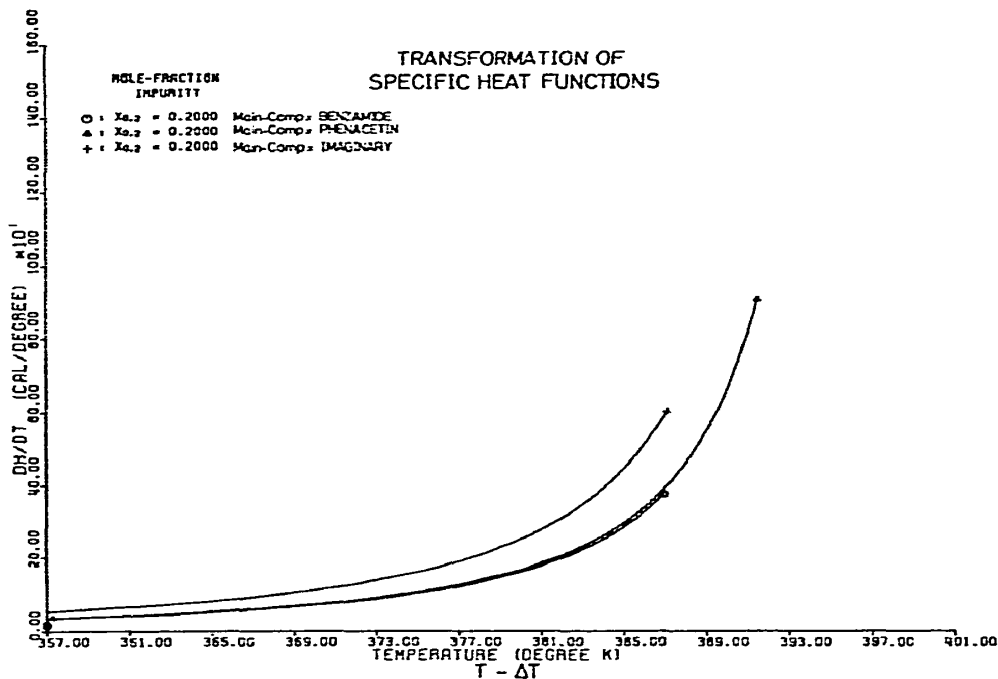


Fig. 7. Transformation of specific heat functions (Marti *et al.*<sup>32</sup>).

As an example, three specific heat functions on a transformed temperature scale are represented in Fig. 7 with a constant mole fraction  $x_{0,2} = 0.2$ . The substances and thermodynamic values used in these examples are shown in Table IX.

TABLE IX  
THERMODYNAMIC PROPERTIES OF THE COMPOUNDS USED FOR FIG. 7

Substance	Heat of fusion $\Delta H_{r,1}$ (cal/mole)	Melting point $T_1$ ( $^{\circ}K$ )	Temp. shift $T$ ( $^{\circ}K$ )
1. Benzamide	4900	400	0
2. Phenacetin	7750	407	7
3. Imaginary substance	7750	500	100

Eqn. (37) and the values in Table IX give the ratios

$$\frac{\left(\frac{dH}{dT}\right)_1}{\left(\frac{dH}{dT}\right)_2} = 0.966 \quad \text{and} \quad \frac{\left(\frac{dH}{dT}\right)_1}{\left(\frac{dH}{dT}\right)_3} = 0.64$$

which agree fully with the ratios taken directly from the specific heat functions in Fig. 7.

A second point observed in Fig. 7 is the position of the upper limit of the specific heat functions. This limit is given by Eqn. (31) and, for a constant mole fraction of the impurity, depends only on the cryoscopic constant of the main component.

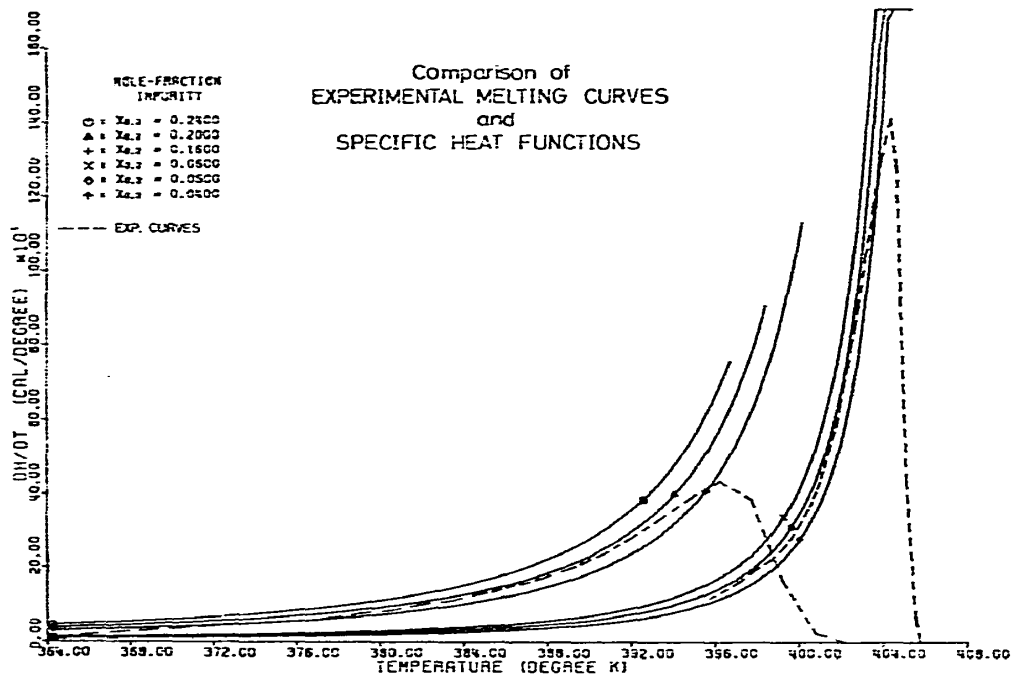


Fig. 8. Comparison of experimental melting curves and specific heat functions for phenacetin as main component and benzamide as impurity (Marti *et al.*<sup>3,2</sup>). The actual impurity values in mole fraction of the two mixtures are  $x_{0,2}^{exp} = 0.2$  and  $0.05$ .

In Fig. 8, theoretical specific heat functions for phenacetin calculated with Eqn. (29) and experimental curves recorded with the DSC-IB instrument of the Perkin-Elmer Corp. are compared. The samples were carefully mixed from phenacetin OAS (main component) and crystalline benzamide (impurity). The purities of both components used for the preparation of the mixtures were determined with the DSC-IB and evaluated with a computer program. The mean values of eutectic impurities of the two components are: phenacetin OAS,  $0.25 \pm 0.05$  mole %; benzamide cryst.  $0.66 \pm 0.10$  mole %.

The mixtures under investigation can be regarded as pseudo-binary systems with components of such a purity level, especially for the chosen mole fractions of the components. In Fig. 8, the experimental curves for  $x_{0,2} = 0.2$  and  $0.05$  (concentration

of the impurity) are presented after transforming the ordinates  $Y_{\text{exp}}$  with a factor  $f_{\text{DSC}}$  to reach the same scale as applied for the theoretical curves.

$$Y = Y_{\text{exp}} \cdot f_{\text{DSC}} \quad (38)$$

The factor is determined by the equation

$$f_{\text{DSC}} = \frac{B}{\dot{T}} \cdot R_f \cdot \frac{M}{m} \quad (39)$$

where  $B$  = recorder speed ( $\text{cm min}^{-1}$ ),  $\dot{T}$  = scan speed ( $^{\circ}\text{K min}^{-1}$ ),  $R_f$  = range factor ( $\text{cal cm}^{-2}$ ),  $M$  = molecular weight of the main component (g), and  $m$  = sample weight of main component (g).

The temperature scale was only shifted according to a temperature calibration curve used for the measurements with the DSC-IB. No correction of the experimental curves for the thermal resistance of the DSC instrument were applied. Correction is certainly necessary for  $\tan \alpha$  values (thermal resistance) of less than 20.

The experimental conditions for the melting curves presented in Fig. 8 are as follows:

<i>Mole fraction of benzamide</i>	<i>Sample weight (mg)</i>	<i>Range (mcal sec<sup>-1</sup>)</i>	<i>Scan speed (°K min<sup>-1</sup>)</i>
0.2	3.09	4	16
0.05	3.20	4	4

Fig. 8 shows the agreement between the theoretical and experimental curves at least for the important melting region used for the determination of purity values.

#### DISCUSSION OF THE MEASUREMENTS OF SYSTEMS WITH IMPURITIES FORMING SOLID SOLUTIONS WITH THE MAIN COMPONENT

The two basic forms of phase diagrams are eutectic systems and systems with a complete range of solid solutions. One observes, normally, in the region of low concentration of one component either the form of a eutectic system or a solid solution. All other effects are restricted mainly to a mole-fraction region from about 0.1 to 0.9. As an example one is unlikely to find a congruently- or incongruently-melting compound in the concentration range of 0–0.1.

A theoretical representation of the melting curves for systems of solid solutions is not as easy as in the case of substances with a eutectic phase diagram. This difficulty arises because the concentrations of the components are normally a function of temperature, (i) in eutectic systems only in the liquid phase, and (ii) in systems of solid solutions in the liquid phase as well as in the solid phase. We shall now discuss a

temperature change for a eutectic system and a system of a solid solution within the temperature region of the solid-liquid equilibrium.

A system at equilibrium conditions at a given temperature is brought to a non-equilibrium condition by an infinitely-fast temperature change. The system will recover from these non-equilibrium conditions with two relaxation processes, a heat flow and a mass transport. The mass transport is caused by the temperature change and, therefore, the mass transport is consecutive to the heat flow. Equilibrium concentrations of the components are attained anew by diffusion of the components inside the phase. In eutectic systems, the diffusion is restricted to the liquid phase. In systems of solid solutions the diffusion of components occurs in the liquid and in the solid phase. The difference in the relaxation processes for eutectic systems and systems of solid solutions is mainly due to the difference in the diffusion rates in the liquid or in the solid phase. Therefore these diffusion rates which determine the relaxation times differ in order of magnitude.

Another difficulty in systems of solid solutions is caused by the crystallization of the substances. The crystallization conditions have an influence on the crystals formed. The solid phase may consist of so-called "zone crystals", which differ according to the conditions of crystallization in their concentration profile over cross-sections of any single crystal. Melting curves of zone crystals, which are measured at different non-equilibrium conditions are influenced by the actual concentration profile of the crystals.

Investigations into equilibrium or non-equilibrium conditions during the melting of systems of solid solutions are important for a similar treatment of purity determination in eutectic systems and systems of solid solutions. A similar purity determination for systems of solid solutions does not exist on the same level as in the case of eutectic systems.

The systems of solid solutions are only discussed phenomenologically and the possibilities of the DSC method are explained for a specific system, namely benzene-thiophene. The measurements published by Driscoll *et al.*<sup>6</sup> on benzene-thiophene are presented in Table X. The measurements were made on a pseudobinary system, of

TABLE X  
DSC MEASUREMENTS OF SOLID SOLUTIONS IN THE BENZENE-THIOPHENE SYSTEM BY DRISCOLL *et al.*<sup>6</sup>

Sample	Impurity	Added impurity (mole-%)	True impurity (mole-%)	Measured impurity (mole-%)	$\Delta H_f$ (cal/mole)
Benzene	Thiophene	0		0.11	2352
		0.07	0.18	0.21	2209
		0.20	0.31	0.13	2364
		0.44	0.55	0.13	2370
		1.27	1.38	0.30	2438
		3.04	3.15	0.43	2291
		5.27	5.38	0.97	2468

benzene and thiophene. These two compounds are known to form solid solutions. The added impurity in Table X refers to thiophene. The true impurity is the added impurity (thiophene), corrected with the eutectic impurity (benzene), and could be measured with the DSC if benzene and thiophene could form a eutectic system.

The measured impurity, the impurity of benzene, and the heat of fusion of the samples were determined with the DSC apparatus. The measured impurity is only about 13% of the value of the true impurity, at least for the addition of more than 1 mole-% of thiophene. From the investigations by Driscoll *et al.*, one can calculate a distribution ratio of the impurity between the solid and the liquid phase of about  $K \approx 4$ . The calculation is, of course, only a rough approximation. We do not know if the distribution ratio is a function of the conditions prevalent during the measurements.

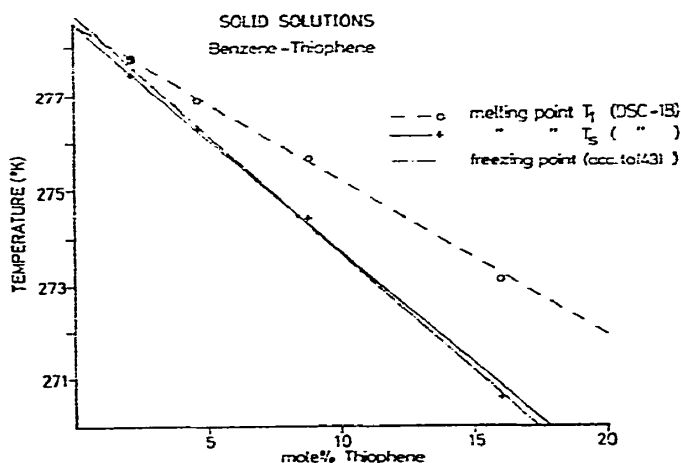


Fig. 9. Solid solutions of benzene-thiophene. Presentation of melting point *vs.* concentration of thiophene in the measured systems.

The heat of fusion is, in contrast to eutectic systems, practically constant with increasing amounts of impurity. As reported at the Perkin-Elmer meeting in Zurich<sup>42</sup>, in 1969, we obtained similar values for the impurity and heat of fusion for the same system as reported by Driscoll *et al.*<sup>6</sup>. With careful calibration of the temperature scale of the DSC-IB, we were able to get absolute values of the melting points within  $\pm 0.3^\circ\text{C}$  of the benzene-thiophene samples. In Fig. 9 the melting points of the samples calculated with a computer program based on Eqn. (7) are presented as a function of the thiophene concentration. The melting points of the samples,  $T_s$ , agree with literature values found from freezing point measurements by Fawcett and Rasmussen<sup>43</sup>. The decrease of the melting point of the pure component,  $T_1$ , is incompatible with the assumption of a eutectic system.

The decrease of  $T_1$  with an increasing concentration of thiophene is explained by the phase diagram of a complete series of solid solutions of benzene-thiophene.

From our measurements, we conclude that a temperature accuracy of the DSC-IB in the order of  $\pm 0.3^\circ\text{C}$  enables the detection of at least 1 mole-% of thiophene. In order to measure the amount of impurity forming solid solutions in a binary system, one has to determine, with test measurements on the same binary system, the shift of the melting point as a function of the concentration of the impurity. For binary and multicomponent systems with unknown impurities, a significant change of the melting point  $T_f$  indicates one or several possible effects, *e.g.* solid solutions, polymorphism, salt or solvate formation of the main component, decomposition, etc.

In conclusion, we can state that in a great number of pseudobinary systems, it is possible to measure impurities forming solid solutions with the main component but with the restriction that the impurities are known. At present, one is not able to measure absolute amounts of impurities in systems of solid solutions with unknown components.

#### THE PRACTICAL ASPECTS OF DSC PURITY MEASUREMENTS

##### (a) *Experimental technique*

The experimental procedure for a purity determination with the DSC apparatus, in the case of a substance investigated for the first time, is as follows.

DSC curves of the substance under investigation are recorded from room temperature, or from at least  $30^\circ\text{C}$  below the melting region up to  $100^\circ\text{C}$  above the melting point in the case of low-melting substances. The curves are measured with a high scan speed (*e.g.*  $dT/dt = 16^\circ\text{C min}^{-1}$ ) in the volatile as well as in the open sample pan. This procedure enables energy changes to be observed in addition to the heat of fusion, caused by effects such as; modification changes, eutectic points, evaporation of impurities, loss of crystal water, and decompositions. The measured DSC curves enable us to form the substances into three groups: (1) Substances with no effect observed other than the melting in the given temperature region; (2) substances with effects clearly separated from the melting region; and (3) substances with effects interfering with the melting region.

This discussion is restricted to substances without effects interfering with the melting region; such an effect is one that occurs within the linearization region used in the computing procedure of the purity value. The investigation of effects other than the melting observed with the DSC apparatus is an analytical problem involving thermogravimetical analysis, X-ray and spectroscopical methods and other appropriate methods.

The same samples used for the first DSC curves are cooled down for recrystallization and heated up again to get a second melting curve, if possible. The second melting curve yields information about a modification change which could occur during the recrystallization, about the stability of the substance in the temperature region scanned, and about effects which can be observed by a comparison of the curves from the first and second melts.

If a second melting curve cannot be obtained because the substance has

decomposed during melting or did not recrystallize, the stability is determined by keeping a sample at constant temperature for 3–30 minutes at about 10°C below the melting point. Such a procedure, with respect to the thermal treatment, is not completely equivalent to a second melting.

If such a thermal treatment indicates a decomposition of the substance, the samples are enclosed in volatile sample pans inside a glove box filled with nitrogen gas. The measurements in a nitrogen atmosphere reveal the answer to the question of the oxygen sensitivity of the substance under investigation.

Finally, some melting curves are selected for an evaluation with the computer. The results of the computer program are listed and then compared with the corresponding melting curve and with the information available from other analytical methods. After following this procedure there is a strong basis for setting up an instruction for routine work on the same substance.

Routine analyses are normally performed with one or two melting curves under appropriate conditions. In the case of routine substances without any anomaly, the evaluation of the melting curve is performed according to the method suggested by Plato and Glasgow<sup>31</sup> or with a computer program.

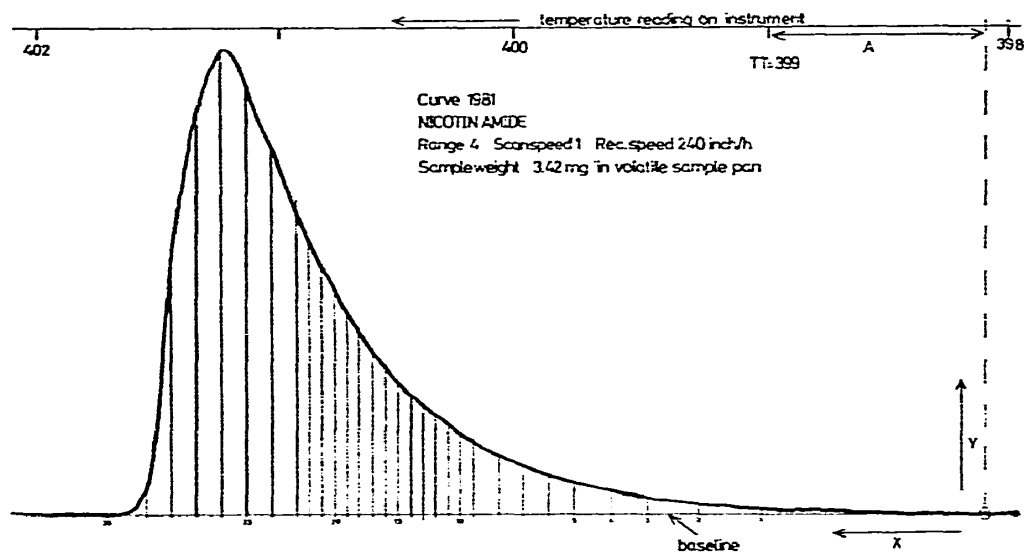


Fig. 10. DSC melting curve of nicotinamide (number of curve 2, 1981).

*(b) The evaluation of melting curves in this laboratory*

The evaluation of melting curves and the basic computer program for the purity determination will be discussed in some detail because of the importance of the evaluation with respect to the whole issue of the purity determination by DSC. The evaluation of melting curves will be discussed with nicotinamide as an example. A

typical melting curve of a sample of nicotinamide measured with the DSC-IB is shown in Fig. 10. The conditions for this melting curve are: sample weight, 3.42 mg; range, 4 mcal sec<sup>-1</sup>; scan speed, 1 °C min<sup>-1</sup>; and recorder speed, 240 in. h<sup>-1</sup>.

The evaluation of the melting curve starts with the drawing of a baseline, as shown in Fig. 10. The baseline connects the pretransition to the posttransition region with a straight line. The points 0–30 are marked on the baseline, observing the rule that the density of the points should be greater in the expected linearization region than in the other parts of the melting curve. The temperature  $TT$  (399 °K in the case of nicotinamide) and the distance  $A$  are necessary for the connection of the points on the  $x$ -axis (see Fig. 10) to the temperature marking of the instrument. The point number zero is the zero point for both the  $x$ - and  $y$ -ordinates. The values  $(x_i, y_i)$  for the points  $i = 0$ –30 are used as a representation of the melting curve in the computer program. The main program calls up the subroutines. Each of the subroutines can be briefly described as follows:

*Subroutine INPUT:* Reads and writes experimental data.

*Subroutine DATEN:* Contains the calibration factors of the instrument and calculates the constants for the temperature correction.

*Subroutine INTGR:* Performs the integration of the melting curves and corrects the temperature for all experimental points.

*Subroutine SUBXQ:* Calculates the molten fraction  $r$  using the values obtained from subroutine INTGR.

The molten fraction  $r_i$  is given by

$$r_i = \frac{\sum_{n=1}^i a_n}{\sum_{n=1}^{30} a_n} = \frac{a_{0,i}}{a_{0,30}} \quad (40)$$

where  $a_n$  is the area bounded by the baseline, the melting curve and the lines perpendicular to the baseline through the points  $i$  and  $i-1$  ( $i = 1$ –30). The baseline is shifted with the parameter  $ax$  set to zero at the beginning of the linearization and set to 10 cm<sup>2</sup> for the first linearization step. The molten fraction  $r'_i$  is calculated according to the equation

$$r'_i = \frac{a_{0,i} + ax}{a_{0,30} + ax} \quad (41)$$

The variation of the parameter  $ax$  within the linearization procedure is performed in subroutine VORFIT.

*Subroutine VORFIT:* This subroutine tests the curvature of the transformed melting curve in the  $(1/r, T)$ -diagram inside the given linearization region (for a molten fraction of about 10–40%). The curvature is determined with segments between transformed points  $i$  and  $i+j$ , with  $i$  and  $i+j$  restricted inside the linearization region, and for  $j = 2, 3, 4, 5, 6$ , etc.



When the curvature of the transformed melting curve is convex downwards, the distance between the curve and segments (calculated only for the transformed experimental points) is positive according to our definition, and is counted as an element of class  $N1$ . When the curvature is convex upwards, all the points are counted as class  $N2$ . The predominant curvature inside the linearization region is proportional to the absolute value of  $\Delta N = N1 - N2$  and the sign of  $\Delta N$  indicates whether the curvature is convex upwards or downwards. The sign of the parameter  $ax$  for the first linearization step is the same as the sign of  $\Delta N$  calculated at the beginning of the linearization. Again, the values of  $N1$ ,  $N2$  and  $\Delta N$  are determined with the shifted values of the molten fraction according to Eqn. (41). If the sign of  $\Delta N$  is not changing, the parameter  $2ax$  is used for the second linearization step. If the sign of  $\Delta N$  changes in the second linearization step, the parameter  $0.5ax$  is applied to the next linearization. The linearization with the diminution of the parameter  $ax$  is performed until one of the following conditions is reached: (i)  $|N1 - N2| \leq 1$ ; (ii)  $|ax_{old} - ax_{new}| \leq 0.5 \text{ cm}^2$ ; or (iii) the number of steps is greater than 50.

The value of the parameter  $ax$  for the last linearization step is called POPTA, given in the printout as the value relative to the total area of the melting curve  $a_{0,30}$

$$\text{POPT} = \frac{\text{POPTA}}{a_{0,30}} \times 100 \quad (42)$$

With a parameter value of  $ax = 10 \text{ cm}^2$  at the beginning of the linearization, condition (ii) can be fulfilled within 5 linearization steps.

*Subroutine FIT:* The linearization in this subroutine starts with the last parameter value POPTA taken from the subroutine VORFIT. The subroutine performs a least-square fit with the parameter values POPTA,  $\text{POPTA} \pm AX$ . The parameter value  $AX$  is set to  $0.5 \text{ cm}^2$  at the beginning. The sum of the squares of the deviation of the transformed points with respect to the regression line is minimised by changing the parameter  $AX$ . The least-square fit terminates under any of the following conditions: (i)  $AX \leq 10^{-2} \text{ cm}^2$ ; (ii) when the number of steps is greater than 30; or (iii) when the sum of the squares of the deviation of the transformed points from the regression lines is  $\leq 10^{-5}$ .

*Subroutine KONZ:* The subroutine KONZ calculates with the aid of Eqn. (7) the information which one can get from the regression line and the conditions of the last linearization step.

*Subroutine CHECK:* The subroutine CHECK calculates the distance between the transformed points and the regression line. The greatest distance within the linearization region is called DTMAX. The distance of transformed points outside the linearization region is compared with DTMAX. Any point with a distance less than DTMAX is added to the linearization region. The first point, beginning with the linearization limits, with a distance greater than DTMAX interrupts the enlargement of the region in this specific direction. If the distances of the points adjacent to the limits of linearization are greater than DTMAX, the enlargement of the linearization region is attempted by multiplying DTMAX by a factor  $f$ . The values of the factor  $f$

```

2 1981      NICOTINAMIDREAME10
-----
FITZWAUGE      = 3.4200 (IN MGR)
HOLFKUI ABGRIECHT  = 122.1300 (IN GR)
RANGE          = 4.0000 (IN MCAL/SEC)
RANGE-FAKTOR    = 0.9440 (IN MCAL/CM**2)
SCAN SPEED     = 1.0000 (IN GRAD/MIN)
NTMAX          = 0.488E-07 GRAD

          TG-ALPHA = 3.1200
          ALPHA   = -0.1030 (IN GRAD)
          BETA    = 41.2900 (IN CM)
          A       = 8.9000 (IN CM)
          B       = 9.8000 (IN CM)
          TT      = 399.0000 (IN GRAD KELVIN)
          ZVDR   = 240.0000 (IN INCH/H)
          NPDT   = 1 (1=FLUSSIGKEITS-,2=NORMALREAKTYER)

RESULTATE DES FIT-PROGRAMMS (MIT 00DTMAX):
GRENZEN J1 = 10 1 J2 = 27
NPDT      = 2.06 %
SCHMELZTEMPERATUR (T0) = 127.27 GRAD CELSIUS
SCHMELZTEMPERATUR (TS) = 127.22 GRAD CELSIUS
STYFUNG DER GERADEN (S) = -0.0541 +- 0.0016
Q.-SUMME DER Y-ABWEICHUNGEN: W-1/R GRDSS = 0.1214E-03
.....
          SCHMELZBEREICH P(J1) = 12.18 % R(J2) = 38.04 % CM**2
          VON FN(10)           = 160.74
          DELTA-H-HF          = 1647.40
          KONZENTRATION DER VERUNREINIGUNG = 0.0953 +- 0.0020 MOL-%
          KRYOSKOPISCHE KONSTANTE = -0.17
          W-1/R KLEIN = 0.4095E-04
          .....

RESULTATE DES FIT-PROGRAMMS (MIT 10DTMAX):
GRENZEN J1 = 10 1 J2 = 26
NPDT      = -0.03 %
SCHMELZTEMPERATUR (T0) = 127.24 GRAD CELSIUS
SCHMELZTEMPERATUR (TS) = 127.20 GRAD CELSIUS
STYFUNG DER GERADEN (S) = -0.0427 +- 0.0047
Q.-SUMME DER Y-ABWEICHUNGEN: W-1/R GRDSS = 0.2045E-03
.....
          SCHMELZBEREICH R(J1) = 10.34 % R(J2) = 73.43 % CM**2
          VON FN(10)           = 160.74
          DELTA-H-HF          = 5531.76
          KONZENTRATION DER VERUNREINIGUNG = 0.0737 +- 0.0041 MOL-%
          KRYOSKOPISCHE KONSTANTE = -0.58
          W-1/R KLEIN = 0.5659E-03
          .....

RESULTATE DES FIT-PROGRAMMS (MIT 50DTMAX):
GRENZEN J1 = 9 1 J2 = 26
NPDT      = 0.82 %
SCHMELZTEMPERATUR (T0) = 127.24 GRAD CELSIUS
SCHMELZTEMPERATUR (TS) = 127.20 GRAD CELSIUS
STYFUNG DER GERADEN (S) = -0.0443 +- 0.0090
Q.-SUMME DER Y-ABWEICHUNGEN: W-1/R GRDSS = 0.4241E-03
.....
          SCHMELZBEREICH R(J1) = 10.04 % R(J2) = 73.65 % CM**2
          VON FN(10)           = 160.74
          DELTA-H-HF          = 5378.55
          KONZENTRATION DER VERUNREINIGUNG = 0.0788 +- 0.0047 MOL-%
          KRYOSKOPISCHE KONSTANTE = -0.57
          W-1/R KLEIN = 0.5953E-03
          .....

RESULTATE DES FIT-PROGRAMMS (MIT 100DTMAX):
GRENZEN J1 = 8 1 J2 = 26
NPDT      = 1.83 %
SCHMELZTEMPERATUR (T0) = 127.24 GRAD CELSIUS
SCHMELZTEMPERATUR (TS) = 127.20 GRAD CELSIUS
STYFUNG DER GERADEN (S) = -0.0448 +- 0.0093
Q.-SUMME DER Y-ABWEICHUNGEN: W-1/R GRDSS = 0.6271E-03
.....
          SCHMELZBEREICH R(J1) = 9.18 % R(J2) = 73.91 % CM**2
          VON FN(10)           = 160.74
          DELTA-H-HF          = 5634.80
          KONZENTRATION DER VERUNREINIGUNG = 0.0857 +- 0.0044 MOL-%
          KRYOSKOPISCHE KONSTANTE = -0.57
          W-1/R KLEIN = 0.6623E-03
          .....
    
```

Fig. 11. Nicotinamide, printout for curve 2, 1981.

are specified in the program as  $f = 5, 10, 15, 20$ , etc. The linearization procedure (subroutine VORFIT, FIT and KONZ) is performed again in each linearization region, which is found by enlargement. In routine work the computer program is restricted to three enlargements of the linearization region.

In Fig. 11 the printout for nicotinamide is shown together with the experimental conditions and the calibration factors of the instrument. The distance DTMAX is calculated as  $4.8 \times 10^{-3} \text{ } ^\circ\text{C}$ . The first linearization region covers the melting region from 12.18 to 38.04% or from point 10 to point 22. The parameter POPT is 2.06%, which means that the baseline is shifted slightly downwards. The melting points are:  $T_1 = 127.27^\circ\text{C}$  and  $T_s = 127.22^\circ\text{C}$ . The melting points yield a slope of the regression line of  $-0.05^\circ\text{C}$ . The heat of fusion is  $5650 \text{ cal mole}^{-1}$ . The concentration of the impurity is  $0.095 \pm 0.003 \text{ mole-}\%$  and the cryoscopic constant according to Eqn. (2) is  $0.57^\circ\text{C mole-}\%^{-1}$ . The enlargement of the linearization region to a linearization region from 9.16 to 73.91% indicates only small variations in the melting points, heats of fusion and concentrations of impurity.

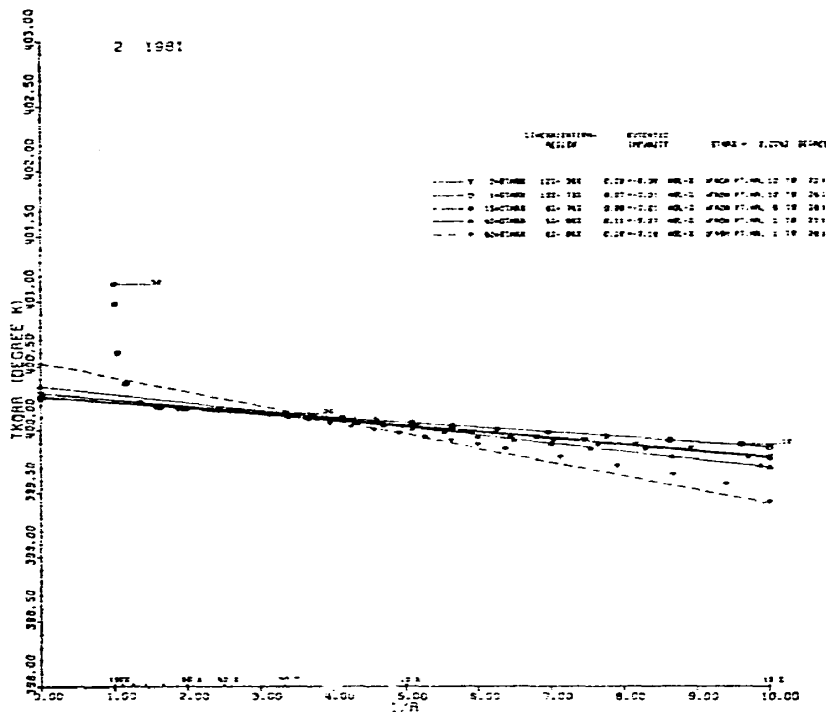


Fig. 12.  $(1/r, T)$ -diagram for nicotinamide.

The  $(1/r, T)$ -diagram of nicotinamide is presented in Fig. 12. The transformed points of the melting curve of nicotinamide are shown and also the regression lines

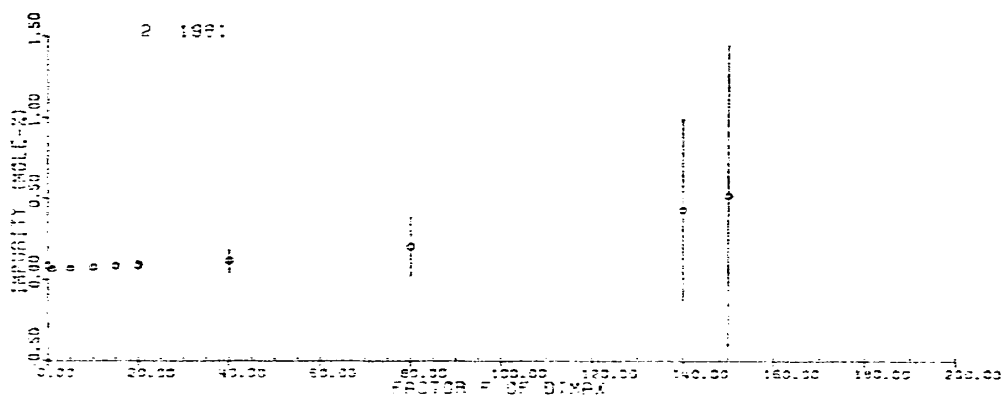


Fig. 13. Presentation of the impurity content of nicotinamide (number of curve 2, 1981) *vs.* the factor *f* of DTMAX.

calculated with points inside the linearization regions. In Fig. 13 the concentration of the impurity as a function of the distance *f* (DTMAX) is presented. The errors of the impurity concentration with 65% confidence limits, calculated with the regression line within the linearization region, are shown as lines through the corresponding points. The linearization region for the *f*-factor of 80 covers the molten fraction from 8 to 96% with a concentration of the impurity of  $0.20 \pm 0.18$  mole-%; a value which is consistent with the result from the first linearization region. The molten fraction from 8 to 96% covers a part of the melting curve from point 1 to point 28 (see Fig. 10). The point 26 is certainly an upper limit for the linearization region, which in the presented evaluation of the melting curve for nicotinamide implies an *f*-factor of 15 as an upper limit. The agreement between the results for these restricted linearization regions is even better.

The conclusion from such results on impurity values and thermodynamic constants, which are nearly independent of the melting region selected for the calculation, are a necessary but not sufficient condition for an ideal melting behaviour of a substance.

#### EXPERIMENTS AND DISCUSSION

##### (a) High purity substances

A few high purity substances are listed in Table XI. The melting curves of these substances were measured in volatile sample pans and the evaluation was performed according to the method explained in the preceding section, part (b). The cryoscopic constants of substances measured with the DSC-IB differ by less than 14% from literature values.

The difference is mainly caused by the heat of fusion measured with the DSC-IB. For high purity substances a 10% error in the evaluated heat of fusion will lead to only a negligible error in the eutectic impurity.

TABLE XI  
PROPERTIES OF SOME HIGH PURITY SUBSTANCES

Substance	Melting points ( $^{\circ}\text{K}$ )		Difference in melting points $\Delta T = T_1 - T_2$ ( $^{\circ}\text{C}$ )	Heat of fusion $\Delta H_{f,1}$ ( $\text{cal mole}^{-1}$ )	Cryoscopic constant $k_f$ ( $^{\circ}\text{C mole}^{-1}$ )	Eutectic impurity ( $\text{mole}\%$ )
	$T_1$	$T_2$				
<i>Deionized water</i>						
DSC	273.261	273.230	0.031	1650	0.90	0.035
Lit.	273.16			1434	1.04	
<i>Benzene (Merck)</i>						
DSC	278.561	278.490	0.071	2180	0.71	0.10
Lit.	278.66			2350	0.67	
<i>Anthraquinone</i>						
DSC	557.9	557.7	0.043	8400	0.75	0.06
Lit.	558.6			7800	0.86	
<i>Carbazole</i>						
DSC	517.51	517.38	0.013	6500	0.82	0.15
Lit.	518.5			7040	0.86	
4-Acetaminophenol	441.67	441.62	0.051	7280	0.53	0.09
Nicotinamide	400.42	400.37	0.05	5650	0.57	0.09
Irgafen	481.117	481.110	0.007	7140	0.70	0.01
<i>Development compounds</i>						
MA 731, Batch 2	372.55	372.53	0.02	6710	0.33	0.06
MA 849, Batch 1	392.52	392.48	0.04	7770	0.40	0.10

(b) *Mixtures of standard substances*

Experiments with mixtures of standard substances are discussed. The mixtures were prepared in a laboratory type ball-mill grinder. In Table XII the actual and measured impurity values for the system phenacetin-*p*-aminobenzoic acid (*p*-ABA) are compared.

TABLE XII  
COMPARISON OF THE ACTUAL AND MEASURED IMPURITY VALUES FOR THE  
PHENACETIN-*p*-AMINOBENZOIC ACID SYSTEM

Main component	Scan speed $\dot{T}$ ( $^{\circ}\text{C min}^{-1}$ )	Added <i>p</i> -ABA (% by weight)	Actual impurity $n_{r,a}$ (mole-%)	Measured impurity $n_{r,m}$ (mole-%)	$\frac{n_{r,a} - n_{r,m}}{n_{r,a}} \times 100$ (%)
Phenacetin	1	0.2	0.43	0.38	+12
	1	0.4	0.70	0.59	+16
	1	0.6	0.96	1.06	-10
	1	0.8	1.23	1.29	-5
	1	1.0	1.50	1.79	-19
	2	1.0	1.50	1.52	-1
	2	1.0	1.50	1.49	+1

The impurities were measured in normal sample pans and the evaluation was performed by the simplest method suggested by Perkin-Elmer<sup>13</sup>. The agreement between actual and measured impurity is reasonable.

*Impurity with a high vapor pressure* — In the next step, measurements in different sample pans were carried out in the melting region with an impurity of high vapor pressure. The system chosen was phenacetin-acetanilide (ACD), the results are presented in Table XIII. This system was chosen to emphasize the importance of the type of sample pan used for analytical purposes.

TABLE XIII

INFLUENCE OF AN OPEN AND CLOSED SAMPLE PAN ON THE MEASURED IMPURITY IN THE CASE OF AN IMPURITY WITH A HIGH VAPOR PRESSURE

<i>Substance</i>	<i>Sample pan</i>	<i>Number of melt</i>	<i>Actual impurity (mole-%)</i>	<i>Measured impurity (mole-%)</i>	<i>Weight loss of sample pan during melting <math>\times 10^{-6}</math> g</i>
Phenacetin	normal	1		0.20	-7
OAS		2		0.36	-20
		3		0.29	-30
Phenacetin	volatile	1		0.46	-1
OAS		2		0.35	-1
		3		0.28	0
Phenacetin	normal	1	2.4	1.27	-15
OAS		2		1.11	-31
+ 1.6% (w/w) ACD		3		0.97	-46
		4		0.86	-62
Phenacetin	volatile	1	2.4	1.51	+1
OAS	sample pan	2		1.23	+2
+ 1.6% (w/w) ACD	without inside cover	3		1.36	+2
		4		1.44	-2
Phenacetin	volatile	1	2.4	1.73	0
OAS	sample pan	2		1.27	0
+ 1.6% (w/w) ACD	with inside cover				

Compared with the sample weight of about 3 mg, a remarkable loss of weight from the normal pans is observed. The measurements of the weights of the pans were carried out with a Cahn Electrobalance before and after the melting of the samples. The measured impurity for the pure main component, phenacetin OAS, taken as a mean value of the three consecutive melts, is in the volatile sample pan only 0.1 mole-% higher than in the normal pan. With the absolute value of about 0.4 mole-% for the impurity measured in the volatile sample pan for phenacetin OAS, it was calculated as a rough approximation (setting mole-% equal to % by weight) that the total amount of impurities in a sample was about  $12 \times 10^{-6}$  g. The total amount of impurities is, as may be seen from Table XIII, about equal to the weight loss from a normal pan during each melting run. A loss from the sample pan of  $4 \times 10^{-6}$  g of impurity would have a remarkable influence on the melting curve. No shift of the

eutectic impurities to lower values with increasing number of melts was observed. The conclusion is that the vapor pressure of all the eutectic impurities of phenacetin OAS must be very small compared with the main component. This condition must be fulfilled over the whole temperature range in the region of melting.

The pseudobinary system of phenacetin OAS and acetanilide melted in the normal pan shows a measured value for the eutectic impurity of only 50% of the actual impurity for the first melt, and only 36% for the melt number 4. The total amount of ACD in a sample is  $48 \times 10^{-6}$  g. A loss of 50% of ACD as eutectic impurity during the first melt is equal to  $24 \times 10^{-6}$  g. This amount has to be compared with a total loss out of the sample pan of  $15 \times 10^{-6}$  g. The loss out of the sample pan consists mainly of ACD. Such a conclusion may be drawn from the vapor pressure data of phenacetin and ACD. The vapor pressure of phenacetin for 115°C is  $3.2 \times 10^{-2}$  torr according to the measurements of Wiedemann<sup>38</sup>. For ACD, Cramer<sup>39</sup> has reported a vapor pressure at 115°C of  $6.3 \times 10^{-1}$  torr. If we make the assumption that the loss out of the sample pan is only caused by ACD, we would have to explain the difference between the loss of ACD from the melt and the total loss from the sample pan. There are two possible explanations: (1) The heat of evaporation caused by the loss of ACD from the sample pan is superimposed upon the heat of fusion. (2) The ACD evaporates from the liquid phase onto positions inside the sample pan which have a lower temperature compared to the melt.

Explanation 1 can be excluded by a rough calculation of the heat necessary for the loss of about  $24 \times 10^{-6}$  g ACD measured from the first melt, when compared with the heat of fusion necessary for the melting of a 3 mg sample; in our example the heat of evaporation is about 2% of the heat of fusion. This energy of evaporation is further spread over the whole temperature region of the melting process. Therefore, the calculated eutectic impurity is influenced only to a rather small extent.

In contrast, point 2 is somewhat more reasonable, because of the great temperature gradient inside the sample pan, caused by the construction of the DSC-IB sample pan holder.

The transport of the ACD inside the sample pans is also indicated by the measurements in the volatile sample pans with and without an inside cover. However, the difference between the actual and the measured impurity is least in the volatile sample pan with an inside cover.

*(c) Different evaluation procedures applied to systems of phenacetin and benzamide*

In the next experiments, several evaluation procedures on systems of phenacetin and benzamide are discussed. Phenacetin was chosen as the main component and benzamide as the so-called impurity. The evaluation procedures of the melting curves are compared with the results of the actual and the measured impurity, with the melting points, and with the heats of fusion. The evaluation procedures applied to each of the melting curves are described briefly.

*Evaluation procedure "Normal" (N)* — This evaluation procedure is based on Eqn. (7) and is explained in detail in the preceding section, part (b).

*Evaluation procedure "Square Root" (SR)* — The evaluation procedure SR uses the following equation

$$T = \frac{T_1}{2} + \frac{T_1}{2} \left[ 1 + \frac{4RT_1}{\Delta H_{f,1}} \left( \ln \left( 1 - \frac{1}{r} x_{0,2} \right) \right) \right]^{1/2} \quad (43)$$

Eqn. (43) is obtained from Eqn. (14) by the approximation  $\Delta c_{0,i} = 0$ . The evaluation procedure SR performs a trial and error method in varying the parameters  $T_1$ ,  $\Delta H_{f,1}$ , and  $x_{0,2}$ .

With a set of parameters  $T_1$ ,  $\Delta H_{f,1}$ , and  $x_{0,2}$ , together with chosen experimental values of the molten fraction  $r$ , values of  $T_c$  may be determined. These calculated temperature values,  $T_c$ , are compared with the experimentally obtained values of  $T$ , and the sum of the squares of deviation  $T_c - T$  is computed for all experimental points within a given region of the molten fraction. With a three-parameter reiteration procedure, the sum of the squares of deviation is brought to a certain small limit, chosen from experience.

*Evaluation procedure "heat of fusion" (HF)* — The evaluation and linearization of the melting curve is performed with the evaluation procedure "Normal". The only deviation from the evaluation procedure "Normal" is within the subroutine KONZ. In the calculations of the eutectic impurity, using Eqn. (7), the heat of fusion of the main component is taken from the literature or from a measurement of a high-purity sample, whereas in the evaluation procedure "Normal", the heat of fusion used in Eqn. (7) is calculated from the melting curve of the sample under investigation.

*Evaluation procedure "correction to the weight of the main component" (CMC)* — The evaluation is performed with the procedure "Normal". In the subroutine KONZ we do not use the weight of the sample, but only the weight of the main component.

The results of the measurements on the phenacetin-benzamide system are presented in Table XIV.

In Table XIV are tabulated the concentration of the impurity; the actual impurity, which is known from the benzamide added plus the eutectic impurity of phenacetin OAS; the melting points; the heats of fusion; and the eutectic impurity calculated with the evaluation procedures described, N, SR, HF, and CMC. The measured eutectic impurity  $x_{0,2}$  is a function of two parameters; the evaluation procedure and the concentration of the impurity itself.

The melting points will be discussed first. The melting points of the main component,  $T_1$ , are nearly constant up to a concentration of 10 mole-% of benzamide. For higher values of the impurity concentration,  $T_1$  is about 3°C too low, but the correction of the thermal lag, caused by a scan speed of 16°C min<sup>-1</sup>, is not easy. The melting point of the sample,  $T_s$ , decreases with increasing impurity content because of the melting point depression. The shift of  $T_1$  for high impurity values, which was explained by experimental reasons, should have practically the same influence on  $T_s$ . Therefore, the temperature difference  $\Delta T = T_1 - T_s$ , which is important for the



TABLE XIV  
RESULTS OF SEVERAL EVALUATION PROCEDURES ON THE  
PHENACETIN OAS-BENZAMIDE SYSTEM  
Main component, phenacetin OAS; impurity, benzamide.

Benzamide added (mole-%)	Actual impurity (mole-%)	$T_1$	$T_s$	Evaluation procedure							
				N		SR		HF		CMC	
				$\Delta H_{f,1}$	$x_{0,2}$	$\Delta H_{f,1}$	$x_{0,2}$	$\Delta H_{f,1}$	$x_{0,2}$	$\Delta H_{f,1}$	$x_{0,2}$
0		133.7	133.6	7860	0.22	7270	0.14	7750	0.21	7860	0.22
1.25	1.47	133.2	133.5	7330	1.39	7300	1.34	7750	1.47	7400	1.40
2.5	2.72	133.2	132.2	7040	2.0	7035	1.9	7750	2.2	7150	2.1
					$\pm 0.4$		$\pm 0.3$		$\pm 0.3$		$\pm 0.3$
5.0	5.22	133.5	131.4	6960	4.5	7120	4.5	7750	4.9	7190	4.6
					$\pm 1.0$		$\pm 1.1$		$\pm 0.8$		$\pm 1.0$
10.0	10.2	132.5	129.0	6535	6.9	6710	6.6	7750	8.2	7050	7.5
					$\pm 1.0$		$\pm 1.4$		$\pm 0.6$		$\pm 1.0$
20.0	20.2	130.7	123.8	6100	13.0	6585	12.7	7750	16.5	7170	15.5
					$\pm 1.4$		$\pm 1.0$		$\pm 1.3$		$\pm 1.8$
30.0	30.2	130.7	119.0	5896	21.2	6710	20.5	7750	27.8	7570	27.3
					$\pm 1.8$		$\pm 1.8$		$\pm 1.9$		$\pm 2.3$

calculation of the impurity, should only be affected very slightly by the shift in  $T_1$  and  $T_s$ .

The results of the eutectic impurities calculated according to the different evaluation procedures are practically constant for the high-purity substance phenacetin OAS (see Table XIV). The calculated eutectic impurities for systems with concentrations of 1.25, 2.5, and 5 mole-% of benzamide are all well within a normal error limit compared to the actual eutectic impurity (error limit up to  $\pm 10\%$  relative to the impurity value).

The differences in eutectic impurities calculated with four different evaluation procedures in the concentration region of 10–30 mole-% of benzamide are remarkable. With the normal evaluation procedure N, also with the evaluation SR, the eutectic impurities are found to be about 30% too low compared with the actual eutectic impurities. In contrast, the evaluation procedures HF and CMC show relative differences of only 10–20% between measured and actual eutectic impurities. The conclusion is that the normal and the square root evaluation methods are only capable of yielding good results in an impurity region up to 5 mole-%. The differences between the two procedures (N, SR) are so small that we do not use the square root method, which requires a much longer computing time than the evaluation procedure "Normal". The heat of fusion method is as easy as the "Normal" evaluation but one needs a high-purity standard or a literature value of the heat of fusion of the main component. The procedure "correction to the weight of the main component" can only be performed with known values of the weight of the main component. The CMC method is of theoretical interest, and the application to systems with unknown impurities would only be a rough approximation.

(d) *Variation of scan speed and the use of two different data collection systems for melting curves*

Measurements were performed on two systems: (1) Diphenyl as a high-purity substance; and (2) phenacetin OAS and 2.5 mole-% of benzamide. Also two systems for the collection of data were used for the measurements: (1) ERA, Digital Data Acquisition system; (2) Mauerhofer system by Ciba-Geigy, Basel. The ERA system collects data in the premelting, melting and postmelting range on magnetic tape. The data collection rate for our measurements was chosen as 20 points  $\text{sec}^{-1}$ . The Mauerhofer system was built by Ciba-Geigy, Basel. Here the data are collected on paper tape. The data collection rate for this system is 2 points  $\text{sec}^{-1}$ .

The experimental data collected from melting curves with both of the systems replace the 31 experimental points ( $x_i, y_i$ ) in the evaluation procedure "Normal". The baseline of the melting curves, which is drawn by hand in the procedure "Normal", is calculated, in the case of the data systems, from points in the premelting and the postmelting ranges. If the number of experimental points in the melting region is too high (ERA system), a reduction in the number of points is obtained by forming a mean value from 10 or 20 adjacent points. Such a data reduction has a smoothing effect on the experimental curve.

The eutectic impurities calculated from melting curves recorded either with the ERA or the Mauerhofer system are presented in Table XV. The experimentally varied parameter in the table is the scan speed.

TABLE XV  
EUTECTIC IMPURITY AS A FUNCTION OF SCAN SPEED FROM MELTING CURVES RECORDED WITH THE TWO DIFFERENT DATA COLLECTION SYSTEMS

Scan speed ( $^{\circ}\text{C min}^{-1}$ )	Eutectic impurity (mole-%)		
	ERA system	Mauerhofer system	Mettler DTA-2000 and CT system <sup>c</sup>
Diphenyl			
0.5	0.13	0.08	0.12
1	0.20	0.05	0.13
2	0.16	0.07	0.12
4	0.23	0.05	0.25
8	0.20	*	0.88
Phenacetin OAS-2.5 mole-% Benzamide <sup>b</sup>			
4	2.4	2.7	
8	2.2	2.2	
16	2.3	2.2	
32	2.6	*	

\*No evaluation possible. <sup>b</sup>Actual eutectic impurity, 2.7 mole-%. <sup>c</sup> Values added in proof.

The melting of diphenyl is extremely sharp because of the purity level; on the other hand, the melting region of phenacetin-benzamide is rather broad. Equilibrium conditions between temperature and the molten fraction are calculated from Eqn. (7)

and used in the computing procedure. Non-equilibrium conditions, which would be expected at high scan speeds and for high-purity substances, should have an influence on the eutectic impurity calculated with Eqn. (7) with the aid of a linearization in the  $(1/r, T)$ -diagram. The variations of the calculated impurities with the scan speed for each of the substances within each of the data collection systems are rather small, and there is no significant shift of these eutectic impurities as a function of the applied scan speed.

For diphenyl, the mean value of the eutectic impurity for the scan speed in the range  $0.5\text{--}8^\circ\text{C min}^{-1}$  is  $0.18 \pm 0.04$  in using the ERA system for the data collection, and  $0.06 \pm 0.02$  in the scan speed range  $0.5\text{--}4^\circ\text{C min}^{-1}$  for the Mauerhofer data system. The difference is rather large, but one has to take into consideration that the melting curves were measured with two different DSC-IB instruments and two different data collection systems. In the case of the phenacetine-benzamide system, the agreement between the actual and the measured eutectic impurities is reasonable for all the scan speeds applied.

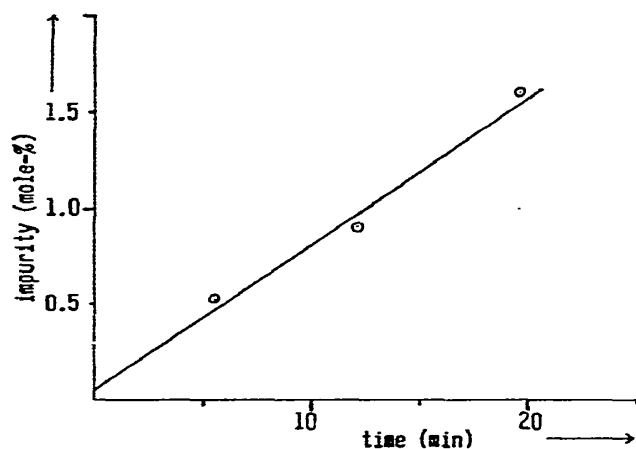


Fig. 14. Presentation of the decomposition of a sample of the development compound MA 1219 in a nitrogen atmosphere.

(e) *Purity measurements on substances which decompose in the melting region*

In the preceding section, part (a), we explained the necessary investigations on a substance which decomposes in the melting region. Melting curves are measured on the same substance with different thermal treatments. The calculated eutectic impurities of such melting curves are presented as a function of the time for which the substance was kept at a temperature close to the melting point with, of course, a correction for the time necessary for the melting. The measurements are performed in a nitrogen atmosphere in almost every case. An example is given in Fig. 14. The decomposition of this substance in a nitrogen atmosphere is calculated to be

TABLE XVI  
COMPARISON OF PURITY VALUES

Substance	Batch No.	Sum of Impurities		DSC	TLC (%)	GLC (%)	Titration (%)	NMR
		Thermobalance (weight-%)	Volatiles sample pan (mole-%)					
Chlorpromazine-HCl	1	0.40	2.7	1.0	2.0			
Chlorpromazine-HCl	2	0.40	2.8	1.8	2.6			
Diazepam (1. Provenance)			0.4	0.10-0.15				
Diazepam (2. Provenance)			4.0	4.5-5.0	4.4			
Ethacrynic acid	1	0.05	1.6	1.1				
Ethacrynic acid	2	0.15	2.4	0.2				
Tolbutamide	1		1.8	1.6				
Cyclohexenylamine-HCl	1		0.6	pure	0.1			
Cyclohexenylamine-HCl	2		0.7	pure	0.1			
4-Acetaminophenol	1		0.09	0.1				
Nicotinamide	1		0.09	pure	0.02			
MA 731	1		0.9	0.6				
MA 731	2		0.4	0.2				
MA 956	1		0.2	0.05				
MA 956	2		0.1	0.05				
MA 1219	1		1.6	0.2				0.5 H <sub>2</sub> O
MA 587	1	1.2	0.8	2-5			1.8-2.3	
MA 1017	2		1.0	pure				
MA 1017	2		1.0	pure	1.05			
MA 1017	4		1.5	0.15	1.2			
MA 1017	5		0.6	0.2	0.07			
MA 1469	3		0.2	0.02	pure			
MA 1769	3		0.4	pure	0.04			

0.075 mole-% min<sup>-1</sup>. The eutectic impurity of the substance without thermal treatment (extrapolation of the thermal treatment to zero time) is  $0.1 \pm 0.1$  mole-%. With air as the atmosphere for the melting, we observed a similar decomposition of the substance. This example shows the possibility of measuring impurity values of substances which are unstable in the melting region.

COMPARISON OF PURITY INFORMATION ON SEVERAL SUBSTANCES ACCORDING TO  
DSC, THERMOBALANCE, TLC, GLC, NMR-SPECTROSCOPY AND TITRATION

In Table XVI, a comparison of impurity values on substances obtained from several analytical methods is presented. The values headed "thermobalance" in Table XVI give the loss of weight of the substance up to the melting point. With a high amount of impurities of high vapor pressure in the melting region, one may expect quite a difference in the DSC values measured in the volatile and the open sample pan, as is seen for chlorpromazine-HCl. For many substances shown in Table XVI we see quite a reasonable agreement between the DSC values of impurities compared with the values from other analytical methods. However, there are substances like MA 1219 with a remarkable difference between the given impurity values. Such differences in impurity values obtained by several analytical methods provide a wide spectrum of problems to be solved with the appropriate investigations.

SUMMARY

The identification of substances and the determination of the purity of organic and inorganic substances by measurement of the melting point dates back to the early days of chemistry. In the 1920's Johnston and Giauque<sup>3</sup> introduced another thermal method for the purity determination of substances: the method of premelting. The method of Johnston and Giauque is based on a measurement of the heat of premelting of a substance as a function of temperature. The calorimeters used for the determination of the heat of premelting were built for sample weights up to several hundred grams. Relaxation times for the thermal equilibrium and the equilibrium of mass in the order of hours resulted from the large mass and the geometry of the calorimeters used in these investigations. In the 1960's a calorimeter (DSC) was developed by the Perkin-Elmer Corporation, which allowed the measurement of heats of premelting of a substance for samples of a few milligrams. The relaxation time for the DSC is in the order of parts of a second. The new instrument brought a fast development and a broad application of the method of premelting especially for purity measurements of pharmaceutical and agrochemical substances. Perkin-Elmer improved the DSC with the development of two further instruments: the DSC-IB and the DSC-2. All these three instruments are constructed according to the same basic principle, *i.e.* the measurement of temperature and heat of premelting, but differ in features such as: calorimetric sensitivity, baseline stability, temperature range, temperature calibration linearity and performance of the temperature programmer. Other instruments like

the DTA 2000 from Mettler Corporation, the Du Pont 900 can also be used for purity determinations.

In the literature mainly results on high purity substances are reported. A limitation of the purity region from 95 or even from 99 to 100% is claimed. These limitations of the method are substantiated by several authors because of marked differences between the actual and measured purity values. The discrepancies are explained in literature in terms of an inconsistency between the simplest equation for the solubility equilibrium and the melting behaviour of organic substances. We found that this explanation appears to be only one of several possibilities; other reasons may be the following: anomalous behaviour of main component and impurities, experimental conditions, recording system and data collection, and evaluation procedure—including the chosen equation for the description of the solid-liquid equilibrium—applied to the measured melting curve.

An investigation of these alternative reasons are rather cumbersome in the case of multi-component systems because of the multiplicity of the physical and chemical properties of all the components. Furthermore, the following aspects affecting the purity values should be considered: (i) the measurement of melting curves in open and closed sample pans, (ii) the use of different scan speeds, (iii) the measurement of a first and a second melting curve of the same sample, (iv) the influence of oxygen on the chemical stability of a substance in the melting region, (v) the proof of the ideality of a melting curve, and (vi) the evaluation of melting curves with a high enough number of data points and with the appropriate evaluation procedure.

It may be concluded from statements in the literature on the accuracy of purity values that there are two regions of purity with an arbitrary separation limit of 99 mole-%. The probability of a good agreement of actual and measured purity values is high in the high-purity region, and low in the low-purity region.

The work in our laboratory was concerned with a thorough investigation of effects causing these inconsistencies. Binary eutectic mixtures were selected as test systems, because phase diagrams, physical and chemical properties are easily found in literature. Using different equations for the description of the solubility equilibrium we have calculated theoretical phase diagrams and theoretical melting curves. The comparison of theoretical and experimental phase diagrams gives a measure of the quality of the approximation attained by the chosen equation for the solubility equilibrium. The study should be extended to include the influence of the activity coefficient on theoretical phase diagrams. Theoretical melting curves are useful for a proof of the ideality of experimental curves which is important for the reliability of calculated purity values.

Another application of theoretical melting curves is the determination of purity values by comparison of the experimental curves with a set of theoretical curves. These are calculated by selecting an equation for the solubility equilibrium, and transforming it into a function describing the theoretical melting curve (a so-called specific heat function). Thermal constants of the corresponding main component and a purity value are then inserted into the equation of the specific heat function.

Calculation and presentation of the specific heat functions for a set of purity values can be executed by computer. The comparison of the experimental curve with specific heat functions is performed either visually or by a least-square fit.

The transformation of theoretical melting curves calculated from the simplest equation of the solubility equilibrium on a temperature scale,  $T - \Delta T$ , is also of theoretical importance. The temperature difference  $\Delta T = T_i - T_1$  is given by the difference of the melting point of the corresponding main component  $T_i$  and an arbitrarily chosen reference temperature  $T_1$ . The ratio of a transformed theoretical melting curve and a reference melting curve with the same concentration of eutectic impurities taken at corresponding temperatures is constant and equal to  $[1 + (\Delta T / T_1)]^{-2}$ . The transformation reveals the fact, that melting curves of different main components with different melting points but equal concentrations of eutectic impurities are rather similar in their shape.

Systems with a complete series of solid solutions are treated at the present time by the measurement of melting or freezing points. A strong restriction in the quantitative determination of solid solutions is the necessity of knowing the melting point of the impurity forming solid solutions with the main component. Of course, it would be even better to know the phase diagram of the main component and the impurity. The accuracy of the purity measurements of solid solutions is related to the accuracy of the temperature measurement of the instrument. The determination of solid solutions is impossible in most of the systems with more than one impurity forming solid solutions.

In the evaluation procedure of melting curves for eutectic impurities one should consider the importance of the following: (i) the evaluation of melting curves measured with scan speeds up to  $32^\circ\text{C min}^{-1}$  is only possible in connection with a fast data collection system, (ii) the linearization with a least square fit is not without problems in case of practical melting curves, (iii) the first linearization should be performed in a linearization interval from about 15 to 35% of the substance melted and the interval should be extended for a succeeding linearization, and (iv) the evaluation procedures suggested by several authors (*e.g.* Scott and Gray<sup>18</sup>) are limited to a high purity region. Melting curves of substances with low purity must be treated by an evaluation procedure which corrects among others for the heat of fusion of the main component.

Ten thousand melting curves for more than 500 different compounds were measured and evaluated in our laboratories with three DSC-IB calorimeters since 1968. Several test systems were investigated for an evaluation of practical and theoretical aspects of the purity determination by DSC. Results from other analytical methods, especially for pharmaceutical and agrochemical substances, have been compared with results from the DSC method.

#### ACKNOWLEDGMENTS

The author wishes to express his thanks to the following persons for collaboration in experimental and theoretical work: O. Heiber, G. Tonn, W. Huber, A.

Geoffroy, B. Humpert and U. Rudolf. The author is also grateful for many helpful discussions with: S. G. Lawrence, J. Meier, H. C. Mez, P. Moser, G. Rihs, K. Wunder and R. Zbinden.

## REFERENCES

- 1 L. Kofler and A. Kofler, *Thermomikromethoden zur Kennzeichnung organischer Stoffe und Stoffgemische*, Verlag Chemie, Weinheim (1954).
- 2 A. Eucken and E. Karwat, *Z. Phys. Chem.*, 112 (1924) 467.
- 3 H. L. Johnston and W. F. Giauque, *J. Amer. Chem. Soc.*, 51 (1929) 3194.
- 4 G. Pilcher, *Anal. Chim. Acta*, 17 (1957) 144.
- 5 A. R. Glasgow, N. C. Krouskop, J. Beadle, G. D. Axilrod, and F. D. Rossini, *Anal. Chem.*, 20 (1948) 410.
- 6 G. L. Driscoll, L. N. Duling, and F. Magnotta, *Proc. ACSS on Analytical Calorimetry, San Francisco*, 1968, p. 271.
- 7 E. F. Joy, J. D. Bonn, and A. J. Barnard Jr., *Thermochim. Acta*, 2 (1971) 57.
- 8 S. V. R. Mastrangelo and R. W. Dornte, *J. Amer. Chem. Soc.*, 77 (1955) 6200.
- 9 B. Wunderlich and St. M. Wolpert, *Therm. Anal., Proc. Int. Conf., 3rd, Davos*, 1 (1971) 17.
- 10 G. J. Davis and R. S. Porter, *J. Therm. Anal.*, 1 (1969) 449.
- 11 N. J. De Angelis and G. J. Papariello, *J. Pharm. Sci.*, 57 (1968) 1868.
- 12 R. Schumacher and B. Felder, *Z. Anal. Chem.*, 254 (1971) 265.
- 13 *Thermal Analysis Newsletter, Nos. 5 and 6*, Analytical Division, Perkin-Elmer Corp., Norwalk, Conn., U. S. A.
- 14 E. M. Barrall II and R. D. Diller, *Thermochim. Acta*, 1 (1970) 509.
- 15 R. Reubke and A. Mollica Jr., *J. Pharm. Sci.*, 56 (1967) 822.
- 16 R. N. Rogers and E. D. Morris Jr., *Anal. Chem.*, 38 (1966) 410.
- 17 M. J. O'Neill, *Anal. Chem.*, 36 (1964) 1238.
- 18 L. A. Scott and A. P. Gray, *DSC-Purity and the DSC-4 Computer Program for Purity Analysis*, Norwalk, Conn., U. S. A., 1969.
- 19 H. M. Heuvel and K. C. J. B. Lind, *Anal. Chem.*, 42 (1970) 1044.
- 20 W. L. Gent, *J. Sci. Instrum.*, 2 (1969) 69.
- 21 K. S. Pitzer and D. W. Scott, *J. Amer. Chem. Soc.*, 63 (1941) 2419.
- 22 D'Ans-Lax, *Taschenbuch für Chemiker und Physiker*, 2 (1964) 1076.
- 23 *Ibid.*, 2 (1964) 1076.
- 24 *Ibid.*, 2 (1964) 1075.
- 25 *Ibid.*, 2 (1964) 1085.
- 26 *Ibid.*, 1 (1964) 380.
- 27 *Ibid.*, 1 (1964) 350.
- 28 W. Perron, *Therm. Anal., Proc. Int. Conf., 3rd, Davos*, 1 (1971) 35.
- 29 M. J. O'Neill and A. P. Gray, *ibid.*, 1 (1971) 279.
- 30 A. P. Gray, *Proc. ACSS on Analytical Calorimetry, San Francisco*, 1968, p. 209.
- 31 C. Plato and A. R. Glasgow Jr., *Anal. Chem.*, 42 (1969) 330.
- 32 E. Marti, O. Heiber, W. Huber, and G. Tonn, *Therm. Anal., Proc. Int. Conf., 3rd, Davos*, 3 (1971) 83.
- 33 F. D. Rossini, *Chemical Thermodynamics*, Wiley, New York, (1950) 298.
- 34 J. H. Hildebrand and R. L. Scott, *The Solubility of Nonelectrolytes*, Dover, New York, (1964) 13.
- 35 *Beilsteins Handbuch der Organischen Chemie*, 13 (1930) 461.
- 36 *Ibid.*, 9E1 (1932) 96.
- 37 H. Staude, *Physikalisch-Chemisches Taschenbuch*, 2 (1949) 1179.
- 38 H. G. Wiedemann, *Thermochim. Acta*, 3 (1972) 355.
- 39 J. S. N. Cramer, *Rec. Trav. Chim. Pays-Bas*, 62 (1943) 606.
- 40 L. Kofler, *Z. Anal. Chem.*, 128 (1948) 533.
- 41 R. Haase and H. Schönert, *Solid-Liquid Equilibrium*, Pergamon Press, Glasgow, (1969) 60.
- 42 E. Marti and O. Heiber, *Meet. on the Purity Determination with the DSC-1B*, Perkin-Elmer Corp., Zürich, 1969.
- 43 F. S. Fawcett and H. E. Rasmussen, *J. Amer. Chem. Soc.*, 67 (1945) 1705.



- [54] **COMPOSITION AND PROCESS**  
[75] Inventor: **Paul A. Aristoff**, Portage, Mich.  
[73] Assignee: **The Upjohn Company**, Kalamazoo, Mich.  
[21] Appl. No.: **219,210**  
[22] Filed: **Dec. 22, 1980**

**Related U.S. Application Data**

- [63] Continuation-in-part of Ser. No. 135,055, Mar. 28, 1980, abandoned.  
[51] **Int. Cl.**<sup>3</sup> ..... **C07C 177/00**  
[52] **U.S. Cl.** ..... **560/56; 568/734; 568/807; 260/239 BF; 568/808; 260/326.45; 260/465 F; 260/465 D; 260/326.5 C; 544/154; 544/171; 544/176; 544/336; 544/386; 546/203; 546/205; 546/285; 546/314; 546/309; 546/337; 548/250; 560/28; 562/466; 562/451; 562/452; 562/455; 564/80; 564/172; 564/174; 564/88; 564/90; 564/95; 564/158; 568/632; 568/633; 568/634**  
[58] **Field of Search** ..... **560/56, 28; 562/466, 562/451, 452, 455; 260/239 BF, 326.4 V, 465 F, 465 D, 326.5 C; 544/154, 171, 176, 336, 386; 546/203, 205, 285, 314, 309, 337; 548/280; 564/80, 172, 174, 88, 90, 95, 158; 568/632, 633, 634, 734, 807, 808**

- [56] **References Cited**  
**FOREIGN PATENT DOCUMENTS**  
2017699 10/1979 United Kingdom ..... 810/56

**OTHER PUBLICATIONS**

- Derwent Abstract 48154B/26 J 54063059 05/21/79.  
*Primary Examiner*—Paul J. Killos  
*Attorney, Agent, or Firm*—L. Ruth Hattan; Robert A. Armitage

[57] **ABSTRACT**

The present specification provides novel analogs of carbacyclin (CBA<sub>2</sub>), 6a-carba-prostacyclin (6a-carba-PGI<sub>2</sub>), which have pronounced prostacyclin-like pharmacological activity, e.g., as platelet antiaggregatory agents. Specifically the novel chemical analogs of CBA<sub>2</sub> are those substituted by fluoro (C-5), alkyl (C-9), interphenylene (C-5), and methano (C-6a,9). Further provided are benzindene analogs of CBA<sub>2</sub> and substituted forms thereof, i.e., 9-deoxy-2',9-methano (or 2',9-metheno)-3-oxa-4,5,6-trinor-3,7-(1',3'-interphenylene)-PGF<sub>1</sub> compounds. Also provided are a variety of novel chemical intermediates, e.g., substituted bicyclo[3.3.0]octane intermediates, and chemical process utilizing such intermediates which are useful in the preparation of the novel CBA<sub>2</sub> analogs.

**13 Claims, No Drawings**

## COMPOSITION AND PROCESS

This application is a continuation-in-part of Ser. No. 135,055, filed Mar. 28, 1980, now abandoned.

## BACKGROUND OF THE INVENTION

The present invention relates to novel compositions of matter and novel processes for preparing these compositions of matter. Moreover, there are provided novel methods by which certain of these novel compositions of matter are employed for pharmacologically useful purposes. Further there are provided novel chemical intermediates for preparing these compositions of matter.

The present invention is specifically concerned with novel analogs of prostacyclin or PGI<sub>2</sub>. Specifically, the present invention is concerned with analogs of carbacyclin modified at the C-5 or C-9 position, e.g., C-5 interphenylene analogs of carbacyclin, 5-fluoro analogs of carbacyclin, 9β-alkyl analogs of carbacyclin, C-6a,9 tricyclic (cyclopropyl) analogs of carbacyclin, and combinations thereof as well as novel benzidine analogs thereof.

Prostacyclin is an endogenously produced compound in mammalian species, being structurally and biosynthetically related to the prostaglandins (PG's). In particular, prostacyclin exhibits the structure and carbon atom numbering of formula I when the C-5,6 positions are unsaturated. For convenience, prostacyclin is often referred to simply as "PGI<sub>2</sub>". Carbacyclin, 6a-carba-PGI<sub>2</sub>, exhibits the structure and carbon atom numbering indicated in formula II when the C-5,6 positions are unsaturated. Likewise, for convenience, carbacyclin is referred to simply as "CBA<sub>2</sub>".

A stable partially saturated derivative of PGI<sub>2</sub> is PGI<sub>1</sub> or 5,6-dihydro-PGI<sub>2</sub> when the C-5,6 positions are saturated, depicted with carbon atom numbering in formula II when the C-5,6 positions are saturated. The corresponding 5,6-dihydro-CBA<sub>2</sub> is CBA<sub>1</sub>, depicted in formula II.

As is apparent from inspection of formulas I and II, prostacyclin and carbacyclin may be trivially named as derivatives of PGF-type compounds, e.g., PGF<sub>2α</sub> of formula III. Accordingly, prostacyclin is trivially named 9-deoxy-6,9α-epoxy-(5Z)-5,6-didehydro-PGF<sub>1</sub> and carbacyclin is named 9-deoxy-6,9α-methano-(5E)-5,6-didehydro-PGF<sub>1</sub>. For description of prostacyclin and its structural identification, see Johnson, et al., Prostaglandins 12:915 (1976).

For convenience, the novel prostacyclin or carbacyclin analogs will be referred to by the trivial, art-recognized system of nomenclature described by N. A. Nelson, J. Med. Chem. 17:911 (1974) for prostaglandins. Accordingly, all of the novel prostacyclin derivatives herein will be named as 9-deoxy-PGF<sub>1</sub>-type compounds, PGI<sub>2</sub> derivatives, or preferably as CBA<sub>1</sub> or CBA<sub>2</sub> derivatives.

In the formulas herein, broken line attachments to a ring indicate substituents in the "alpha" (α) configuration, i.e., below the plane of said ring. Heavy solid line attachments to a ring indicate substituents in the "beta" (β) configuration, i.e., above the plane of said ring. The use of wavy lines (~) herein will represent attachment of substituents in the alpha or beta configuration or attached in a mixture of alpha and beta configurations. Alternatively wavy lines will represent either an E or Z

geometric isomeric configuration or the mixture thereof.

A side chain hydroxy at C-15 in the formulas herein is in the S or R configuration as determined by the Cahn-Ingold-Prelog sequence rules, J. Chem. Ed. 41:16 (1964). See also Nature 212:38 (1966) for discussion of the stereochemistry of the prostaglandins which discussion applies to the novel prostacyclin or carbacyclin analogs herein. Molecules of prostacyclin and carbacyclin each have several centers of asymmetry and therefore can exist in optically inactive form or in either of two enantiomeric (optically active) forms, i.e., the dextrorotatory and laevorotatory forms. As drawn, the formula for PGI<sub>2</sub> corresponds to that endogenously produced in the mammalian species. In particular, refer to the stereochemical configuration at C-8 (α), C-9 (α), C-11 (α) and C-12 (β) of endogenously produced prostacyclin. The mirror image of the above formula for prostacyclin represents the other enantiomer. The racemic form of prostacyclin contains equal numbers of both enantiomeric molecules.

For convenience, reference to prostacyclin and carbacyclin will refer to the optically active form thereof. Thus, with reference to prostacyclin, reference is made to the form thereof with the same absolute configuration as that obtained from the mammalian species.

The term "prostacyclin-type" product, as used herein, refers to any cyclopentane derivative herein which is useful for at least one of the same pharmacological purposes for which prostacyclin is employed. A formula as drawn herein which depicts a prostacyclin-type product or an intermediate useful in the preparation thereof, represents that particular stereoisomer of the prostacyclin-type product which is of the same relative stereochemical configuration as prostacyclin obtained from mammalian tissues or the particular stereoisomer of the intermediate which is useful in preparing the above stereoisomer of the prostacyclin type product.

The term "prostacyclin analog" or "carbacyclin analog" represents that stereoisomer of a prostacyclin-type product which is of the same relative stereochemical configuration as prostacyclin obtained from mammalian tissues or a mixture comprising stereoisomer and the enantiomers thereof. In particular, where a formula is used to depict a prostacyclin type product herein, the term "prostacyclin analog" or "carbacyclin analog" refers to the compound of that formula or a mixture comprising that compound and the enantiomer thereof.

## PRIOR ART

Carbacyclin and closely related compounds are known in the art. See Japanese Kokia 63,059 and 63,060, also abstracted respectively as Derwent Farmdoc CPI Numbers 48154B/26 and 48155B/26. See also British published specifications 2,012,265 and German Offenlegungsschrift 2,900,352, abstracted as Derwent Farmdoc CPI Number 54825B/30. See also British published application Nos. 2,017,699, 2,014,143 and 2,013,661.

The synthesis of carbacyclin and related compounds is also reported in the chemical literature, as follows: Morton, D. R., et al., J. Organic Chemistry, 44:2880 (1979); Shibasaki, M., et al. Tetrahedron Letters, 433-436 (1979); Kojima, K., et al., Tetrahedron Letters, 3743-3746 (1978); Nicolaou, K. C., et al., J. Chem. Soc., Chemical Communications, 1067-1068 (1978); Sugie, A., et al., Tetrahedron Letters 2607-2610 (1979); Shibasaki, M., Chemistry Letters, 1299-1300 (1979).

and Hayashi, M., Chem. Lett. 1437-1440 (1979); and Li, Tsung-tee, "A Facile Synthesis of 9(0)-Methano-prostacyclin", Abstract No. 378, (Organic Chemistry), and P. A. Aristoff, "Synthesis of 6a-Carbaprostacyclin I<sub>2</sub>", Abstract No. 236 (Organic Chemistry) both at Abstract of Papers (Part II) Second Congress of the North American Continent, San Francisco, California (Las Vegas, Nevada), USA, 24-29 August 1980.

7-Oxo and 7-hydroxy-CBA<sub>2</sub> compounds are apparently disclosed in U.S. Pat. No. 4,192,891. 19-Hydroxy-CBA<sub>2</sub> compounds are disclosed in U.S. Ser. No. 54,811, filed 5 July 1979. CBA<sub>2</sub> aromatic esters are disclosed in U.S. Pat. No. 4,180,657. 11-Deoxy-Δ<sup>10</sup>- or Δ<sup>11</sup>-CBA<sub>2</sub> compounds are described in Japanese Kokai No. 77/24,865, published 24 Feb. 1979.

### SUMMARY OF THE INVENTION

The present specification particular by provides:

- (a) a carbacyclin intermediate of formula IV, V, VI, VII, VIII, or IX; and
- (b) a carbacyclin analog of formula X or XI; wherein g is 0, 1, 2, or 3; wherein n is one or 2; wherein L<sub>1</sub> is α-R<sub>3</sub>:β-R<sub>4</sub>, α-R<sub>4</sub>:β-R<sub>3</sub>, or a mixture of α-R<sub>3</sub>:β-R<sub>4</sub> and α-R<sub>4</sub>:β-R<sub>3</sub>, wherein R<sub>3</sub> and R<sub>4</sub> are hydrogen, methyl, or fluoro, being the same or different, with the proviso that one of R<sub>3</sub> and R<sub>4</sub> is fluoro only when the other is hydrogen or fluoro; wherein M<sub>1</sub> is α-OH:β-R<sub>5</sub> or α-R<sub>5</sub>:β-OH, wherein R<sub>5</sub> is hydrogen or methyl; wherein M<sub>6</sub> is α-OR<sub>10</sub>:β-R<sub>5</sub> or α-R<sub>5</sub>:β-OR<sub>10</sub>, wherein R<sub>5</sub> is hydrogen or methyl and R<sub>10</sub> is an acid hydrolyzable protective group; wherein R<sub>7</sub> is
  - (1) —C<sub>m</sub>H<sub>2m</sub>—CH<sub>3</sub>, wherein m is an integer from one to 5, inclusive,
  - (2) phenoxy optionally substituted by one, two or three chloro, fluoro, trifluoromethyl, (C<sub>1</sub>-C<sub>3</sub>)alkyl, or (C<sub>1</sub>-C<sub>3</sub>)alkoxy, with the proviso that not more than two substituents are other than alkyl, with the proviso that R<sub>7</sub> is phenoxy or substituted phenoxy, only when R<sub>3</sub> and R<sub>4</sub> are hydrogen or methyl, being the same or different,
  - (3) phenyl, benzyl, phenylethyl, or phenylpropyl optionally substituted on the aromatic ring by one, two or three chloro, fluoro, trifluoromethyl, (C<sub>1</sub>-C<sub>3</sub>)alkyl, or (C<sub>1</sub>-C<sub>3</sub>)alkoxy, with the proviso that not more than two substituents are other than alkyl,
  - (4) cis—CH=CH—CH<sub>2</sub>—CH<sub>3</sub>,
  - (5) —(CH<sub>2</sub>)<sub>2</sub>—CH(OH)—CH<sub>3</sub>, or
  - (6) —(CH<sub>2</sub>)<sub>3</sub>—CH=C(CH<sub>3</sub>)<sub>2</sub>;
 wherein —C(L<sub>1</sub>)-R<sub>7</sub> taken together is
  - (1) (C<sub>4</sub>-C<sub>7</sub>)cycloalkyl optionally substituted by one to 3 (C<sub>1</sub>-C<sub>5</sub>) alkyl;
  - (2) 2-(2-furyl)ethyl,
  - (3) 2-(3-thienyl)ethoxy, or
  - (4) 3-thienyloxymethyl;
 wherein R<sub>8</sub> is hydroxy, hydroxymethyl, or hydrogen; wherein R<sub>15</sub> is hydrogen or fluoro; wherein R<sub>16</sub> is hydrogen or R<sub>16</sub> and R<sub>17</sub> taken together are —CH<sub>2</sub>— or R<sub>16</sub> and R<sub>17</sub> taken together form a second valence bond between C-6a and C-9 or are —CH<sub>2</sub>—; wherein R<sub>17</sub> is as defined above or is
  - (1) hydrogen, or
  - (2) (C<sub>1</sub>-C<sub>4</sub>)alkyl;

wherein R<sub>18</sub> is hydrogen, hydroxy, hydroxymethyl, —OR<sub>10</sub> or —CH<sub>2</sub>OR<sub>10</sub>, wherein R<sub>10</sub> is an acid-hydrolyzable protective group; wherein

- (1) R<sub>20</sub>, R<sub>21</sub>, R<sub>22</sub>, R<sub>23</sub>, and R<sub>24</sub> are all hydrogen with R<sub>22</sub> being either α-hydrogen or β-hydrogen,
- (2) R<sub>20</sub> is hydrogen, R<sub>21</sub> and R<sub>22</sub> taken together form a second valence bond between C-9 and C-6a, and R<sub>23</sub> and R<sub>24</sub> taken together form a second valence bond between C-8 and C-9 or are both hydrogen, or
- (3) R<sub>22</sub>, R<sub>23</sub>, and R<sub>24</sub> are all hydrogen, with R<sub>22</sub> being either α-hydrogen or β-hydrogen, and
  - (a) R<sub>20</sub> and R<sub>21</sub> taken together are oxo, or
  - (b) R<sub>20</sub> is hydrogen and R<sub>21</sub> is hydroxy, being α-hydroxy or β-hydroxy;
 wherein R<sub>27</sub> is the same as R<sub>7</sub> except that —(CH<sub>2</sub>)<sub>2</sub>—CH(OH)—CH<sub>3</sub> is —(CH<sub>2</sub>)—CH(OR<sub>11</sub>)—CH<sub>3</sub>; wherein R<sub>32</sub> is hydrogen or R<sub>31</sub>, wherein R<sub>31</sub> is a hydroxyl hydrogen replacing group; wherein R<sub>33</sub> is —CHO or —CH<sub>2</sub>OR<sub>32</sub>, wherein R<sub>32</sub> is as defined above; wherein R<sub>47</sub> is as defined above or is
  - (1) (C<sub>1</sub>-C<sub>4</sub>)alkyl, or
  - (2) —CH<sub>2</sub>OH;
 wherein X<sub>1</sub> is
  - (1) —COOR<sub>1</sub>, wherein R<sub>1</sub> is
    - (a) hydrogen,
    - (b) (C<sub>1</sub>-C<sub>12</sub>)alkyl,
    - (c) (C<sub>3</sub>-C<sub>10</sub>)cycloalkyl,
    - (d) (C<sub>7</sub>-C<sub>12</sub>)aralkyl,
    - (e) phenyl, optionally substituted with one, 2 or 3 chloro or (C<sub>1</sub>-C<sub>3</sub>)alkyl,
    - (f) phenyl substituted in the para position by
      - (i) —NH—CO—R<sub>25</sub>,
      - (ii) —CO—R<sub>26</sub>,
      - (iii) —O—CO—R<sub>54</sub>, or
      - (iv) —CH=N—NH—CO—NH<sub>2</sub> wherein R<sub>25</sub> is methyl, phenyl, acetamidophenyl, benzamidophenyl, or —NH<sub>2</sub>; R<sub>26</sub> is methyl, phenyl, —NH<sub>2</sub>, or methoxy; and R<sub>54</sub> is phenyl or acetamidophenyl; inclusive, or
    - (g) a pharmacologically acceptable cation;
  - (2) —CH<sub>2</sub>OH,
  - (3) —COL<sub>4</sub>, wherein L<sub>4</sub> is
    - (a) amino of the formula —NR<sub>51</sub>R<sub>52</sub>, wherein R<sub>51</sub> and R<sub>52</sub> are
      - (i) hydrogen,
      - (ii) (C<sub>1</sub>-C<sub>12</sub>)alkyl,
      - (iii) (C<sub>3</sub>-C<sub>10</sub>)cycloalkyl,
      - (iv) (C<sub>7</sub>-C<sub>12</sub>)aralkyl,
      - (v) phenyl, optionally substituted with one, 2 or 3 chloro, (C<sub>1</sub>-C<sub>3</sub>)alkyl, hydroxy, carboxy, (C<sub>2</sub>-C<sub>5</sub>)alkoxycarbonyl, or nitro,
      - (vi) (C<sub>2</sub>-C<sub>5</sub>)carboxyalkyl,
      - (vii) (C<sub>2</sub>-C<sub>5</sub>)carbamoylalkyl,
      - (viii) (C<sub>2</sub>-C<sub>5</sub>)cyanoalkyl,
      - (ix) (C<sub>3</sub>-C<sub>6</sub>)acetylalkyl,
      - (x) (C<sub>7</sub>-C<sub>11</sub>)benzoalkyl, optionally substituted by one, 2 or 3 chloro, (C<sub>1</sub>-C<sub>3</sub>)alkyl, hydroxy, (C<sub>1</sub>-C<sub>3</sub>)alkoxy, carboxy, (C<sub>2</sub>-C<sub>5</sub>)alkoxycarbonyl, or nitro,
      - (xi) pyridyl, optionally substituted by one, 2 or 3 chloro, (C<sub>1</sub>-C<sub>3</sub>)alkyl, or (C<sub>1</sub>-C<sub>3</sub>)alkoxy,
      - (xii) (C<sub>6</sub>-C<sub>9</sub>)pyridylalkyl optionally substituted by one, 2 or 3 chloro, (C<sub>1</sub>-C<sub>3</sub>)alkyl, hydroxy, or (C<sub>1</sub>-C<sub>3</sub>)alkyl,
      - (xiii) (C<sub>1</sub>-C<sub>4</sub>)hydroxyalkyl,
      - (xiv) (C<sub>1</sub>-C<sub>4</sub>)dihydroxyalkyl,

(xv) (C<sub>1</sub>-C<sub>4</sub>)trihydroxyalkyl, with the further proviso that not more than one of R<sub>51</sub> and R<sub>52</sub> is other than hydrogen or alkyl,

(b) cycloamino selected from the group consisting of pyrrolidino, piperidino, morpholino, piperazino, hexamethyleimino, pyrrolino, or 3,4-didehydropiperidinyl optionally substituted by one or 2 (C<sub>1</sub>-C<sub>12</sub>)alkyl of one to 12 carbon atoms, inclusive,

(c) carbonylamino of the formula —NR<sub>53</sub>COR<sub>51</sub>, wherein R<sub>23</sub> is hydrogen or (C<sub>1</sub>-C<sub>4</sub>)alkyl and R<sub>51</sub> is other than hydrogen, but otherwise as defined above,

(d) sulfonylamino of the formula —NR<sub>53</sub>SO<sub>2</sub>R<sub>51</sub>, wherein R<sub>21</sub> and R<sub>23</sub> are as defined in (c),

(4) —CH<sub>2</sub>NL<sub>2</sub>L<sub>3</sub>, wherein L<sub>2</sub> and L<sub>3</sub> are hydrogen or (C<sub>1</sub>-C<sub>4</sub>)alkyl, being the same or different, or the pharmacologically acceptable acid addition salts thereof when X<sub>1</sub> is —CH<sub>2</sub>NL<sub>2</sub>L<sub>3</sub>, wherein Y<sub>1</sub> is trans—CH=CH—, cis—CH=CH—, —CH<sub>2</sub>CH<sub>2</sub>—, or —C≡C—;

wherein Z<sub>1</sub> is

(1) —CH<sub>2</sub>—(CH<sub>2</sub>)<sub>f</sub>—C(R<sub>2</sub>)<sub>2</sub>, wherein R<sub>2</sub> is hydrogen or fluoro and f is zero, one, 2, or 3;

(2) trans—CH<sub>2</sub>—CH=CH—,

(3) —(Ph)—(CH<sub>2</sub>)<sub>g</sub>—, wherein (Ph) is 1,2-, 1,3-, or 1,4-phenylene and g is zero, one, 2, or 3;

wherein Z<sub>4</sub> is —CH<sub>2</sub>— or —(CH<sub>2</sub>)<sub>f</sub>—CF<sub>2</sub>, wherein f is as defined above;

with the overall proviso that

(1) R<sub>15</sub>, R<sub>16</sub>, and R<sub>17</sub> are all hydrogen only when Z<sub>1</sub> is —(Ph)—(CH<sub>2</sub>)<sub>g</sub>—, and

(2) Z<sub>1</sub> is —(Ph)—(CH<sub>2</sub>)<sub>g</sub>— only when R<sub>15</sub> is hydrogen.

With regard to the divalent substituents described above (e.g., L<sub>1</sub> and M<sub>1</sub>), these divalent radicals are defined as α-R<sub>i</sub>:β-R<sub>j</sub>, wherein R<sub>i</sub> represents the substituent of the divalent moiety in the alpha configuration with respect to the plane of the C-8 to C-12 cyclopentane ring and R<sub>j</sub> represents the substituent of the divalent moiety in the beta configuration with respect to the plane of the ring. Accordingly, when M<sub>1</sub> is defined as α-OH:β-R<sub>5</sub>, the hydroxy of the M<sub>1</sub> moiety is in the alpha configuration, i.e., as in PGI<sub>2</sub> above, and the R<sub>5</sub> substituent is in the beta configuration.

The carbon atom content of various hydrocarbon-containing moieties is indicated by a prefix designating the minimum and maximum number of carbon atoms in the moiety, i.e., the prefix (C<sub>i</sub>-C<sub>j</sub>) indicates a moiety of the integer "i" to the integer "j" carbon atoms, inclusive. Thus (C<sub>1</sub>-C<sub>3</sub>)alkyl refers to alkyl of one to 3 carbon atoms, inclusive, or methyl, ethyl, propyl, and isopropyl.

Certain novel prostacyclin analogs herein, i.e., formula X compounds, are all named as CBA<sub>1</sub> or CBA<sub>2</sub> compounds, respectively, by virtue of the substitution of methylene for oxo in the heterocyclic ring of prostacyclin and the substitution. CBA<sub>2</sub> compounds are those exhibiting the olefinic double bond at C-5,6, while CBA<sub>1</sub> compounds are those saturated at C-5,6. Formula XI compounds are named as PGE<sub>1</sub> or PGF<sub>1</sub> derivatives as hereinafter described.

Novel compounds wherein Z<sub>1</sub> is (Ph)-(CH<sub>2</sub>)<sub>g</sub> are designated inter-o-, inter-m-, or inter-p-phenylene depending on whether the attachment between C-5 and the —(CH<sub>2</sub>)<sub>g</sub>— moiety is ortho, meta, or para, respectively.

For those compounds wherein g is zero, one, 2 or 3, the carbacyclin analogs so described are further characterized as 2,3,4-trinor-, 3,4-dinor-, or 4-nor, since in this event the X<sub>1</sub>-terminated side chain contains (not including the phenylene) 2, 3, or 4 carbon atoms, respectively, in place of the five carbon atoms contained in PGI<sub>2</sub>. The missing carbon atom or atoms are considered to be at the C-4 to C-2 positions such that the phenylene is connected to the C-5 and C-1 to C-3 positions. Accordingly these compounds are named as 1,5-, 2,5-, 3,5-, and 4,5-inter-phenylene CBA compounds when g is zero, one, 2, or 3, respectively.

Those CBA analogs wherein Z<sub>1</sub> is —CH<sub>2</sub>—(CH<sub>2</sub>)<sub>f</sub>—CF<sub>2</sub>— are characterized as "2,2-difluoro—" compounds. For those compounds wherein f is zero, 2, or 3, the carbacyclin analogs so described are further characterized as 2-nor, 2a-homo, or 2a,2b-dihomo, since in this event the X<sub>1</sub>-terminated side chain contains 4, 6, or 7 carbon atoms, respectively, in place of the five carbon atoms contained in CBA<sub>2</sub>. The missing carbon atom is considered to be at the C-2 position such that the C-1 carbon atoms is connected to the C-3 position. The additional carbon atom or atoms are considered as though they were inserted between the C-2 and C-3 positions. Accordingly these additional carbon atoms are referred to as C-2a and C-2b, counting from the C-2 to the C-3 position.

Those CBA analogs wherein Z<sub>1</sub> is trans—CH<sub>2</sub>—CH=CH— are described as "trans-2,3-didehydro-CBA" compounds.

Those novel compounds where n is 2 are further characterized as 7a-homo-CBA compounds by virtue of the cyclohexyl ring replacing the heterocyclic ring of prostacyclin.

Further, the novel compounds are named as 9β-alkyl-CBA compounds when R<sub>17</sub> is alkyl.

When R<sub>16</sub> and R<sub>17</sub> taken together are —CH<sub>2</sub>—(methylene), the novel compounds so described are "6αβ,9β-methano-CBA" compounds by virtue of the methylene bridge between C-6a and C-9.

When R<sub>15</sub> is fluoro, "5-fluoro-CBA" compounds are described.

The formula XI CBA analogs wherein R<sub>20</sub>, R<sub>21</sub>, R<sub>22</sub>, R<sub>23</sub>, and R<sub>24</sub> are all hydrogen with R<sub>22</sub> being β-hydrogen are characterized as "9-deoxy-2',9α-methano-3-oxa-4,5,6-trinor-3,7-(1',3'-inter-phenylene)-PGF<sub>1</sub>" compounds. Corresponding compounds wherein R<sub>22</sub> is α-hydrogen are characterized as "9-deoxy-2',9β-methano-3-oxa-4,5,6-trinor-3,7-(1',3'-inter-phenylene)-PGF<sub>1</sub>" compounds. CBA analogs wherein R<sub>20</sub>, R<sub>23</sub>, and R<sub>24</sub> are all hydrogen and R<sub>21</sub> and R<sub>22</sub> taken together form a valence bond between C-9 and C-6a are characterized as "9-deoxy-2',9-metheno-3-oxo-3,4,5-trinor-3,7-(1',3'-inter-phenylene)-PGF<sub>1</sub>" compounds. CBA analogs wherein R<sub>20</sub> is hydrogen and R<sub>21</sub> and R<sub>22</sub> taken together form a second valence bond between C-9 and C-6a and R<sub>23</sub> and R<sub>24</sub> taken together form a second valence bond between C-7 and C-8 are characterized as "9-deoxy-2',9-metheno-3-oxa-3,4,5-trinor-3,7-(1',3'-inter-phenylene)-7,8-didehydro-PGE<sub>1</sub>" compounds. The formula XI CBA analogs wherein R<sub>22</sub>, R<sub>23</sub>, and R<sub>24</sub> are all hydrogen and R<sub>20</sub> and R<sub>21</sub> taken together are oxo are characterized as "6a-oxo-9-deoxy-2',9α-methano-3-oxa-4,5,6-trinor-3,7-(1',3'-inter-phenylene)-PGF<sub>1</sub>" or "6a-oxo-9-deoxy-2',9β-methano-3-oxa-4,5,6-trinor-3,7-(1',3'-inter-phenylene)-PGF<sub>1</sub>" depending on whether R<sub>22</sub> is α-hydrogen or β-hydrogen, respectively. Formula XI CBA analogs wherein R<sub>20</sub>, R<sub>22</sub>, R<sub>23</sub>, and R<sub>24</sub>

are all hydrogen and R<sub>21</sub> is  $\alpha$ -hydroxy are characterized as "6 $\alpha$ -hydroxy-9-deoxy-2',9 $\alpha$ -methano-3-oxa-4,5,6-trinor-3,7-(1',3'-inter-phenylene)-PGF<sub>1</sub>" or "6 $\alpha$ -hydroxy-9-deoxy-2',9 $\beta$ -methano-3-oxa-4,5,6-trinor-3,7-(1',3'-inter-phenylene)-PGF<sub>1</sub>" compounds depending on whether R<sub>22</sub> is  $\alpha$ -hydrogen or  $\beta$ -hydrogen, respectively. Finally, formula XI TXA analogs wherein R<sub>20</sub>, R<sub>22</sub>, R<sub>23</sub>, and R<sub>24</sub> are all hydrogen and R<sub>21</sub> is  $\beta$ -hydroxy are characterized as "6 $\alpha\beta$ -hydroxy-9-deoxy-2',9 $\beta$ -methano-3-oxa-4,5,6-trinor-3,7-(1',3'-inter-phenylene)-PGF<sub>1</sub>" or "6 $\alpha\beta$ -hydroxy-9-deoxy-2',9 $\alpha$ -methano-3-oxa-4,5,6-trinor-3,7-(1',3'-inter-phenylene)-PGF<sub>1</sub>" compounds depending on whether R<sub>22</sub> is  $\alpha$ -hydrogen or  $\beta$ -hydrogen, respectively. When Z<sub>4</sub> is  $-(CH_2)_f-CF_2$  and f is zero, the formula XI CBA analogs are additionally characterized as "2,2-difluoro" compounds. When f is one, 2, or 3, such compounds are additionally characterized as "2a-homo", "2a,2b-dihomo" or "2a,2b,2c-trihomo" compounds.

When R<sub>5</sub> is methyl, the carbacyclin analogs are all named as "15-methyl-CBA" compounds. Further, except for compounds wherein Y<sub>1</sub> is  $cis-CH=CH-$ , compounds wherein the M<sub>1</sub> moiety contains an hydroxyl in the beta configuration are additionally named as "15-epi-CBA" compounds.

For the compounds wherein Y<sub>1</sub> is  $cis-CH=CH-$ , then compounds wherein the M<sub>1</sub> moiety contains an hydroxyl in the alpha configuration are named as "15-epi-CBA" compounds. For a description of this convention of nomenclature for identifying C-15 epimers, see U.S. Pat. No. 4,016,184, issued 5 Apr. 1977, particularly columns 24-27 thereof.

The novel carbacyclin analogs herein which contain  $-(CH_2)_2-$ ,  $cis-CH=CH-$ , or  $-C\equiv C-$  as the Y<sub>1</sub> moiety, are accordingly referred to as "13,14-dihydro", "cis-13", or "13,14-didehydro" compounds, respectively.

When R<sub>7</sub> is straight chained  $-C_mH_{2m}-CH_3$ , wherein m is as defined above, the compounds so described are named as "19,20-dinor", "20-nor", "20-methyl" or "20-ethyl" compounds when m is one, 2, 4 or 5, respectively. When R<sub>7</sub> is branched chain  $-C_mH_{2m}-CH_3$ , then the compounds so described are "17-, 18-, 19-, or 20-alkyl" or "17,17-, 17,18-, -17,19-, 17,20-, 18,18-, 18,19-, 18,20-, 19,19-, or 19,20-dialkyl" compounds when m is 4 or 5 and the unbranched portion of the chain is at least n-butyl, e.g., "17,20-dimethyl" compounds are described when m is 5 (1-methylpentyl).

When R<sub>7</sub> is phenyl and neither R<sub>3</sub> and R<sub>4</sub> is methyl, the compounds so described are named as "16-phenyl-17,18,19,20-tetranor" compounds. When R<sub>7</sub> is substituted phenyl, the corresponding compounds are named as "16-(substituted phenyl)-17,18,19,20-tetranor" compounds. When one and only one of R<sub>3</sub> and R<sub>4</sub> is methyl or both R<sub>3</sub> and R<sub>4</sub> are methyl, then the corresponding compounds wherein R<sub>7</sub> is as defined in this paragraph are named as "16-phenyl or 16-(substituted phenyl)-18,19,20-trinor" compounds or "16-methyl-16-phenyl- or 16-(substituted phenyl)-18,19,20-trinor" compounds respectively.

When R<sub>7</sub> is benzyl, the compounds so described are named as "17-phenyl-18,19,20-trinor" compounds. When R<sub>7</sub> is substituted benzyl, the corresponding compounds are named as "17-(substituted phenyl)-18,19,20-trinor" compounds.

When R<sub>7</sub> is phenylethyl, the compounds so described are named as "18-phenyl-19,20-dinor" compounds. When R<sub>7</sub> is substituted phenylethyl, the corresponding

compounds are named as "18-(substituted phenyl)-19,20-dinor" compounds.

When R<sub>7</sub> is phenylpropyl, the compounds so described are named as "19-phenyl-20-nor" compounds. When R<sub>7</sub> is substituted phenylpropyl the corresponding compounds are named as "19-(substituted phenyl)-20-nor" compounds.

When R<sub>7</sub> is phenoxy and neither R<sub>3</sub> nor R<sub>4</sub> is methyl, the compounds so described are named as "16-phenoxy-17,18,19,20-tetranor" compounds. When R<sub>7</sub> is substituted phenoxy, the corresponding compounds are named as "16-(substituted phenoxy)-17,18,19,20-tetranor" compounds. When one and only one of R<sub>3</sub> and R<sub>4</sub> is methyl or both R<sub>3</sub> and R<sub>4</sub> are methyl, then the corresponding compounds wherein R<sub>7</sub> is as defined in this paragraph are named as "16-phenoxy or 16-(substituted phenoxy)-18,19,20-trinor" compounds or "16-methyl-16-phenoxy- or 16-(substituted phenoxy)-18,19,20-trinor" compounds, respectively.

When R<sub>7</sub> is  $cis-CH=CH-CH_2CH_3$ , the compounds so described are named as "cis-17,18-didehydro" compounds.

When R<sub>7</sub> is  $-(CH_2)_2-CH(OH)-CH_3$ , the compounds so described are named as "19-hydroxy" compounds.

When R<sub>7</sub> is  $-(CH_2)_3-CH=C(CH_3)_2$ , the compounds so described are named as "20-isopropylidene" compounds.

When  $-C(L_1)-R_7$  is optionally substituted cycloalkyl, 2-(2-furyl)ethyl, 2-(3-thienyl)ethyl, or 3-thienyloxymethyl, the compounds so described are respectively 15-cycloalkyl-16,17,18,19,20-pentanor compounds, 17-(2-furyl)-18,19,20-trinor-CBA compounds, 17-(3-thienyl)-18,19,20-trinor compounds, or 16-(3-thienyloxy)-17,18,19,20-tetranor compounds.

When at least one of R<sub>3</sub> and R<sub>4</sub> is not hydrogen then (except for the 16-phenoxy or 16-phenyl compounds discussed above) there are described the "16-methyl" (one and only one of R<sub>3</sub> and R<sub>4</sub> is methyl), "16,16-dimethyl" (R<sub>3</sub> and R<sub>4</sub> are both methyl), "16-fluoro" (R<sub>3</sub> or R<sub>4</sub> is fluoro), "16,16-difluoro" (R<sub>3</sub> and R<sub>4</sub> are both fluoro) compounds. For those compounds wherein R<sub>3</sub> and R<sub>4</sub> are different, the prostaglandin analogs so represented contain an asymmetric carbon atom at C-16. Accordingly, two epimeric configurations are possible: "(16S)" and "(16R)". Further, there is described by this invention the C-16 epimeric mixture: "(16RS)".

When X<sub>1</sub> is  $-CH_2OH$ , the compounds so described are named as "2-decarboxy-2-hydroxymethyl" compounds.

When X<sub>1</sub> is  $-CH_2NL_2L_3$ , the compounds so described are named as "2-decarboxy-2-aminomethyl" or "2-(substituted amino)methyl" compounds.

When X<sub>1</sub> is  $-COL_4$ , the novel compounds herein are named as CBA-type amides. Further, when X<sub>1</sub> is  $-COOR_1$ , the novel compounds herein are named as CBA-type esters and CBA-type salts.

Examples of phenyl esters substituted in the para position (i.e., X<sub>1</sub> is  $-COOR_1$ , R<sub>1</sub> is p-substituted phenyl) include p-acetamidophenyl ester, p-benzamidophenyl ester, p-(p-acetamidobenzamido)phenyl ester, p-(p-benzamidobenzamido)phenyl ester, p-aminocarbonylamino phenyl ester, p-acetylphenyl ester, p-benzylphenyl ester, p-amidocarbonylphenyl ester, p-methoxycarbonylphenyl ester, p-benzoyloxyphenyl ester, p-(p-acetamidobenzoyloxy)phenyl ester, and p-hydroxybenzaldehyde semicarbazone ester.

Examples of novel amides herein (i.e.,  $X_1$  is  $-\text{COL}_4$ ) include the following:

(1) Amides within the scope of alkylamino groups of the formula  $-\text{NR}_{51}\text{R}_{52}$  are methylamide, ethylamide, n-propylamide, n-butylamide, n-pentylamide, n-hexylamide, n-heptylamide, n-octylamide, n-nonylamide, n-decylamide, n-undecylamide, and n-dodecylamide, and isomeric forms thereof. Further examples are dimethylamide, diethylamide, di-n-propylamide, di-n-butylamide, methylethylamide, methylpropylamide, methylbutylamide, ethylpropylamide, ethylbutylamide, and propylbutylamide. Amides within the scope of cycloalkylamino are cyclopropylamide, cyclobutylamide, cyclopentylamide, 2,3-dimethylcyclopentylamide, 2,2-dimethylcyclopentylamide, 2-methylcyclopentylamide, 3-tert-butylcyclopentylamide, cyclohexylamide, 4-tert-butylcyclohexylamide, 3-isopropylcyclohexylamide, 2,2-dimethylcyclohexylamide, cycloheptylamide, cyclooctylamide, cyclononylamide, cyclodecylamide, N-methyl-N-cyclobutylamide, N-methyl-N-cyclopentylamide, N-methyl-N-cyclohexylamide, N-ethyl-N-cyclopentylamide, and N-ethyl-N-cyclohexylamide. Amides within the scope of aralkylamino are benzylamide, 2-phenylethylamide, and N-methyl-N-benzylamide. Amides within the scope of substituted phenylamide are p-chloroanilide, m-chloroanilide, 2,4-dichloroanilide, 2,4,6-trichloroanilide, m-nitroanilide, p-nitroanilide, p-methoxyanilide, 3,4-dimethoxyanilide, 3,4,5-trimethoxyanilide, p-hydroxymethylanilide, p-methylanilide, m-methyl anilide, p-ethylanilide, t-butylanilide, p-carboxyanilide, p-methoxycarbonyl anilide, p-carboxyanilide and o-hydroxyanilide. Amides within the scope of carboxyalkylamino are carboxyethylamide, carboxypropylamide and carboxymethylamide, carboxybutylamide. Amides within the scope of carbamoylalkylamino are carbamoylmethylamide, carbamoylethylamide, carbamoylpropylamide, and carbamoylbutylamide. Amides within the scope of cyanoalkylamino are cyanomethylamide, cyanoethylamide, cyanopropylamide, and cyanobutylamide. Amides within the scope of acetylalkylamino are acetylme-  
thylamide, acetylethylamide, acetylpropylamide, and acetylbutylamide. Amides within the scope of benzoylalkylamino are benzoylmethylamide, benzoylethylamide, benzoylpropylamide, and benzoylbutylamide. Amides within the scope of substituted benzoylalkylamino are p-chlorobenzoylmethylamide, m-chlorobenzoylmethylamide, 2,4-dichlorobenzoylmethylamide, 2,4,6-trichlorobenzoylmethylamide, m-nitrobenzoylmethylamide, p-nitrobenzoylmethylamide, p-methoxybenzoylmethylamide, 2,4-dimethoxy benzoylmethylamide, 3,4,5-trimethoxybenzoylmethylamide, p-hydroxymethylbenzoylmethylamide, p-methylbenzoylmethylamide, m-methylbenzoylmethylamide, p-ethylbenzoylmethylamide, t-butylbenzoylmethylamide, p-carboxybenzoylmethylamide, m-methoxycarbonylbenzoylmethylamide, o-carboxybenzoylmethylamide, o-hydroxybenzoylmethylamide, p-chlorobenzoylethylamide, m-chlorobenzoylethylamide, 2,4-dichlorobenzoylethylamide, 2,4,6-trichlorobenzoylethylamide, m-nitrobenzoylethylamide, p-nitrobenzoylethylamide, p-methoxybenzoylethylamide, 2,4-dimethoxybenzoylethylamide, 3,4,5-trimethoxybenzoylethylamide, p-hydroxymethylbenzoylethylamide, p-methylbenzoylethylamide, m-methylbenzoylethylamide, p-ethylbenzoylethylamide, t-butylbenzoylethylamide, p-carboxybenzoylethylamide, m-methoxycarbonylbenzoylethylamide, o-car-

boxybenzoylethylamide, o-hydroxybenzoylethylamide, p-chlorobenzoylpropylamide, m-chlorobenzoylpropylamide, 2,4-dichlorobenzoylpropylamide, 2,4,6-trichlorobenzoylpropylamide, m-nitrobenzoylpropylamide, p-nitrobenzoylpropylamide, p-methoxybenzoylpropylamide, 2,4-dimethoxybenzoylpropylamide, 3,4,5-trimethoxybenzoylpropylamide, p-hydroxymethylbenzoylpropylamide, p-methylbenzoylpropylamide, m-methylbenzoylpropylamide, p-ethylbenzoylpropylamide, t-butylbenzoylpropylamide, p-carboxybenzoylpropylamide, m-methoxycarbonylbenzoylpropylamide, o-carboxybenzoylpropylamide, o-hydroxybenzoylpropylamide, p-chlorobenzoylbutylamide, m-chlorobenzoylbutylamide, 2,4-dichlorobenzoylbutylamide, 2,4,6-trichlorobenzoylbutylamide, m-nitrobenzoylmethylamide, p-nitrobenzoylbutylamide, p-methoxybenzoylbutylamide, 2,4-dimethoxybenzoylbutylamide, 3,4,5-trimethoxybenzoylbutylamide, p-hydroxymethylbenzoylbutylamide, p-methylbenzoylbutylamide, m-methylbenzoylbutylamide, p-ethylbenzoylbutylamide, t-butylbenzoylbutylamide, p-carboxybenzoylbutylamide, m-methoxycarbonylbenzoylbutylamide, o-carboxybenzoylbutylamide, o-hydroxybenzoylmethylamide. Amides within the scope of pyridylamino are  $\alpha$ -pyridylamide,  $\beta$ -pyridylamide, and  $\gamma$ -pyridylamide. Amides within the scope of substituted pyridylamino are 4-methyl- $\alpha$ -pyridylamide, 4-methyl- $\beta$ -pyridylamide, 4-chloro- $\alpha$ -pyridylamide, and 4-chloro- $\beta$ -pyridylamide. Amides within the scope of pyridylalkylamino are  $\alpha$ -pyridylmethylamide,  $\beta$ -pyridylmethylamide,  $\gamma$ -pyridylmethylamide,  $\alpha$ -pyridylethylamide,  $\beta$ -pyridylethylamide,  $\gamma$ -pyridylethylamide,  $\alpha$ -pyridylpropylamide,  $\beta$ -pyridylpropylamide,  $\gamma$ -pyridylpropylamide,  $\alpha$ -pyridylbutylamide,  $\beta$ -pyridylbutylamide, and  $\gamma$ -pyridylbutylamide. Amides within the scope of substituted pyridylalkylamido are 4-methyl- $\alpha$ -pyridylmethylamide, 4-methyl- $\beta$ -pyridylmethylamide, 4-chloro- $\alpha$ -pyridylmethylamide, 4-chloro- $\beta$ -pyridylmethylamide, 4-methyl- $\alpha$ -pyridylpropylamide, 4-methyl- $\beta$ -pyridylpropylamide, 4-chloro- $\alpha$ -pyridylpropylamide, 4-chloro- $\beta$ -pyridylpropylamide, 4-methyl- $\alpha$ -pyridylbutylamide, 4-methyl- $\beta$ -pyridylbutylamide, 4-chloro- $\alpha$ -pyridylbutylamide, 4-chloro- $\beta$ -pyridylbutylamide, 4-chloro- $\gamma$ -pyridylbutylamide. Amides within the scope of hydroxyalkylamino are hydroxymethylamide,  $\beta$ -hydroxyethylamide,  $\beta$ -hydroxypropylamide,  $\gamma$ -hydroxypropylamide, 1-(hydroxymethyl)ethylamide, 1-(hydroxymethyl)propylamide, (2-hydroxymethyl)propylamide, and  $\alpha,\alpha$ -dimethyl-hydroxyethylamide. Amides within the scope of dihydroxyalkylamino are dihydroxymethylamide,  $\beta,\gamma$ -dihydroxypropylamide, 1-(hydroxymethyl)-2-hydroxymethylamide,  $\beta,\gamma$ -dihydroxybutylamide,  $\beta,\delta$ -dihydroxybutylamide,  $\gamma,\delta$ -dihydroxybutylamide, and 1,1-bis(hydroxymethyl)ethylamide. Amides within the scope of trihydroxyalkylamino are tris(hydroxymethyl)methylamide and 1,3-dihydroxy-2-hydroxymethylpropylamide.

(2) Amides within the scope of cycloamino groups described above are pyrrolidylamide, piperidylamide, morpholinylamide, hexamethylenimineylamide, piperazinylamide, pyrrolinylamide, and 3,4-dihydrodropiperidinyllamide.

(3) Amides within the scope of carbonylamino of the formula  $-\text{NR}_{53}\text{COR}_{51}$  are methylcarbonylamide, ethylcarbonylamide, phenylcarbonylamide, and benzylcarbonylamide.

(4) Amides within the scope of sulfonylamino of the formula  $-\text{NR}_{53}\text{SO}_2\text{R}_{51}$  are methylsulfonylamide, ethylsulfonylamide, phenylsulfonylamide, p-tolylsulfonylamide, benzylsulfonylamide.

Examples of alkyl of one to 12 carbon atoms, inclusive, are methyl, ethyl, propyl, butyl, pentyl, hexyl, heptyl, octyl, nonyl, decyl, undecyl, dodecyl, isomeric forms thereof.

Examples of  $(\text{C}_3-\text{C}_{10})$ cycloalkyl which includes alkyl-substituted cycloalkyl, are cyclopropyl, 2-methylcyclopropyl, 2,2-dimethylcyclopropyl, 2,3-diethylcyclopropyl, 2-butylcyclopropyl, cyclobutyl, 2-methylcyclobutyl, 3-propylcyclobutyl, 2,3,4-triethylcyclobutyl, cyclopentyl, 2,2-dimethylcyclopentyl, 2-pentylcyclopentyl, 3-tert-butylcyclopentyl, cyclohexyl, 4-tert-butylcyclohexyl, 3-isopropylcyclohexyl, 2,2-dimethylcyclohexyl, cycloheptyl, cyclooctyl, cyclononyl, and cyclodecyl.

Examples of  $(\text{C}_7-\text{C}_{12})$ aralkyl are benzyl, 2-phenylethyl, 1-phenylethyl, 2-phenylpropyl, 4-phenylbutyl, 3-phenylbutyl, 2-(1-naphthylethyl), and 1-(2-naphthylmethyl).

Examples of phenyl substituted by one to 3 chloro or alkyl of one to 4 carbon atoms, inclusive, are p-chlorophenyl, m-chlorophenyl, 2,4-dichlorophenyl, 2,4,6-trichlorophenyl, p-tolyl, m-tolyl, o-tolyl, p-ethylphenyl, p-tert-butylphenyl, 2,5-dimethylphenyl, 4-chloro-2-methylphenyl, and 2,4-dichloro-3-methylphenyl.

Examples of  $(\text{C}_5-\text{C}_7)$ cycloalkyl optionally substituted by  $(\text{C}_1-\text{C}_4)$ alkyl are cyclobutyl, 1-propylcyclobutyl, 1-butylcyclobutyl, 1-pentylcyclobutyl, 2-methylcyclobutyl, 2-propylcyclobutyl, 3-ethylcyclobutyl, 3-propylcyclobutyl, 2,3,4-triethylcyclobutyl, cyclopentyl, 2,2-dimethylcyclopentyl, 3-ethylcyclopentyl, 3-propylcyclopentyl, 3-butylcyclopentyl, 3-tert-butylcyclopentyl, 1-methyl-3-propylcyclopentyl, 2-methyl-3-propylcyclopentyl, 2-methyl-4-propylcyclopentyl, cyclohexyl, 3-ethylcyclohexyl, 3-isopropylcyclohexyl, 4-methylcyclohexyl, 4-ethylcyclohexyl, 4-propylcyclohexyl, 4-butylcyclohexyl, 4-tert-butylcyclohexyl, 2,6-dimethylcyclohexyl, 2,2-dimethylcyclohexyl, 2,6-dimethyl-4-propylcyclohexyl, and cycloheptyl.

Examples of substituted phenoxy, phenylmethyl, phenylethyl, or phenylpropyl of the  $\text{R}_7$  moiety are (o-, m-, or p-)tolyl, (o-, m-, or p-)ethylphenyl, 4-ethyl-o-tolyl, 5-ethyl-m-tolyl, (o-, m-, or p-)propylphenyl, 2-propyl-(m- or p-)tolyl, 4-isopropyl-2,6-xylyl, 3-propyl-4-ethylphenyl, (2,3,4-, 2,3,5-, 2,3,6-, or 2,4,5-)trimethylphenyl, (o-, m-, or p-)fluorophenyl, 2-fluoro-(m- or p-)tolyl, 4-fluoro-2,5-xylyl, (2,4-, 2,5-, 2,6-, 3,4-, or 3,5-)difluorophenyl, (o-, m-, or p-)chlorophenyl, 2-chloro-p-tolyl, (3-, 4-, 5-, or 6-)chloro-o-tolyl, 4-chloro-2-propylphenyl, 2-isopropyl-4-chlorophenyl, 4-chloro-3,5-xylyl, (2,3-, 2,4-, 2,5-, 2,6-, 3,4-, or 3,5-)dichlorophenyl, 4-chloro-3-fluorophenyl, (3- or 4-)chloro-2-fluorophenyl, (o-, m-, or p-)trifluoromethylphenyl, (o-, m-, or p-)methoxyphenyl, (o-, m-, or p-)ethoxyphenyl, (4- or 5-)chloro-2-methoxyphenyl, 2,4-dichloro-(4- or 6-)methylphenyl, (o-, m-, or p-)tolyl, (o-, m-, or p-)ethylphenyl, 4-ethyl-o-tolyl, 5-ethyl-m-tolyl, (o-, m-, or p-)propylphenyl, 2-propyl-(m- or p-)tolyl, 4-isopropyl-2,6-xylyl, 3-propyl-4-ethylphenyl, (2,3,4-, 2,3,5-, 2,3,6-, or 2,4,5-)trimethylphenyl, (o-, m-, or p-)fluorophenoxy, 2-fluoro-(m- or p-)tolyl, 4-fluoro-2,5-xylyl, (2,4-, 2,5-, 2,6-, 3,4-, or 3,5-)difluorophenoxy, (o-, m-, or p-)chlorophenoxy, 2-chloro-p-tolyl, (3, 4, 5, or 6-)chloro-o-tolyl, 4-chloro-2-propylphenyl, 2-isopropyl-4-chlorophenoxy, 4-chloro-3,5-xylyl, (2,3-, 2,4-, 2,5-, 2,6-, 3,4-, or 3,5-)dichlorophenoxy, (3- or 4-)chloro-2-fluorophenoxy, (o-, m-, or p-)trifluoromethylphenyl, (o-, m-, or p-)methoxyphenyl, (o-, m-, or p-)ethoxyphenyl, (4- or 5-)chloro-2-methoxyphenyl, and 2,4-dichloro-(4- or 6-)methoxyphenyl.

4-chloro-2-propylphenyl, 2-isopropyl-4-chlorophenoxy, 4-chloro-3,5-xylyl, (2,3-, 2,4-, 2,5-, 2,6-, 3,4-, or 3,5-)dichlorophenoxy, 4-chloro-3-fluorophenoxy, (3- or 4-)chloro-2-fluorophenoxy, (o-, m-, or p-)trifluoromethylphenyl, (o-, m-, or p-)methoxyphenyl, (o-, m-, or p-)ethoxyphenyl, (4- or 5-)chloro-2-methoxyphenyl, 2,4-dichloro-(5- or 6-)methylphenyl, (o-, m-, or p-)tolylmethyl, (o-, m-, or p-)ethylphenyl methyl, 4-ethyl-o-tolylmethyl, 5-ethyl-m-tolylmethyl, (o-, m-, or p-)propylphenylmethyl, 2-propyl-(m-, or p-)tolylmethyl, 4-isopropyl-2,6-xylylmethyl, 3-propyl-4-ethylphenylmethyl, (2,3,4-, 2,3,5-, 2,3,6-, or 2,4,5-)trimethylphenylmethyl, (o-, m-, or p-)fluorophenylmethyl, 2-fluoro-(m- or p-)tolylmethyl, 4-fluoro-2,5-xylylmethyl, (2,4-, 2,5-, 2,6-, 3,4-, or 3,5-)difluorophenyl, (o-, m-, or p-)chlorophenylmethyl, 2-chloro-p-tolylmethyl, (3, 4, 5, or 6-)chloro-o-tolylmethyl, 4-chloro-2-propylphenylmethyl, 2-isopropyl-4-chlorophenylmethyl, 4-chloro-3,5-xylylmethyl, (2,3-, 2,4-, 2,5-, 2,6-, 3,4-, or 3,5-)dichlorophenylmethyl, 4-chloro-3-fluorophenylmethyl, (3- or 4-)chloro-2-fluorophenylmethyl, (o-, m-, or p-)trifluoromethylphenylmethyl, (o-, m-, or p-)methoxyphenylmethyl, (o-, m-, or p-)ethoxyphenylmethyl, (4- or 5-)chloro-2-methoxyphenylmethyl, and 2,4-dichloro-(4- or 6-)methoxyphenylmethyl.

The novel CBA analogs disclosed herein produce certain prostacyclin-like pharmacological responses.

Accordingly, the novel formula X and XI CBA analogs are used as agents in the study, prevention, control, and treatment of diseases, and other undesirable physiological conditions, in mammals, particularly humans, valuable domestic animals, pets, zoological specimens, and laboratory animals (e.g., mice, rats, rabbits and monkeys). In particular, these compounds have useful application as antithrombotic agents, anti-ulcer agents, and anti-asthma agents, as indicated below.

#### (a) Platelet Aggregation Inhibition

These novel CBA analogs disclosed herein are useful whenever it is desired to inhibit platelet aggregation, to reduce the adhesive character of platelets, or to remove or prevent the formation of thrombi in mammals, including man. For example, these compounds are useful in the treatment and prevention of myocardial infarcts, to treat and prevent post-operative thrombosis, to promote patency of vascular grafts following surgery, to treat peripheral vascular diseases, and to treat conditions such as atherosclerosis, arteriosclerosis, blood clotting defects due to lipemia, and other clinical conditions in which the underlying etiology is associated with lipid imbalance or hyperlipidemia. Other *in vivo* applications include geriatric patients to prevent cerebral ischemic attacks and long term prophylaxis following myocardial infarcts and strokes. For these purposes, these compounds are administered systemically, e.g., intravenously, subcutaneously, intramuscularly, and in the form of sterile implants for prolonged action. For rapid response, especially in emergency situations, the intravenous route of administration is preferred. Doses in the range about 0.01 to about 10 mg per kg of body weight per day are used, the exact dose depending on the age, weight, and condition of the patient or animal, and on the frequency and route of administration.

The preferred dosage form for these compounds is oral, although other non-parenteral routes (e.g., buccal, rectal, sublingual) are likewise employed in preference to parenteral routes. Oral dosage forms are conventionally formulated (tablets, capsules, et cetera) and admin-

13

istered 2-4 times daily. Doses in the range of about 0.05 to 100 mg per kg of body weight per day are effective.

The addition of these compounds to whole blood provides in vitro applications such as storage of whole blood to be used in heart-lung machines. Additionally whole blood containing these compounds can be circulated through organs, e.g., heart and kidneys, which have been removed from a donor prior to transplant. They are also useful in preparing platelet rich concentrates for use in treating thrombocytopenia, chemotherapy, and radiation therapy. In vitro applications utilize a dose of 0.001-1.0  $\mu\text{g}$  per ml of whole blood. For treatment of peripheral vascular diseases, see U.S. Pat. No. 4,103,026.

(b) Gastric Secretion Reduction

These novel CBA analogs disclosed herein are also useful in mammals, including man and certain useful animals, e.g., dogs and pigs, to reduce and control gastric secretion, thereby to reduce or avoid gastrointestinal ulcer formation, and accelerate the healing of such ulcers already present in the gastrointestinal tract. For this purpose, these compounds are injected or infused intravenously, subcutaneously, or intramuscularly in an infusion dose range about 0.1  $\mu\text{g}$  to about 20  $\mu\text{g}$  per kg of body weight per minute, or in a total daily dose by injection or infusion in the range about 0.01 to about 10 mg per kg of body weight per day, the exact dose depending on the age, weight, and condition of the patient or animal, and on the frequency and route of administration.

Preferably, however, these novel compounds are administered orally or by other non-parenteral routes. As employed orally, one to 6 administrations daily in a dosage range of about 1.0 to 100 mg per kg of body weight per day is employed. Once healing of the ulcers has been accomplished the maintenance dosage required to prevent recurrence is adjusted downward so long as the patient or animals remains asymptomatic.

(c) NOSAC-Induced Lesion Inhibition

These novel CBA analogs disclosed herein are also useful in reducing the undesirable gastrointestinal effects resulting from systemic administration of anti-inflammatory prostaglandin synthetase inhibitors, and are useful for that purpose by concomitant administration of the prostaglandin derivative and the anti-inflammatory prostaglandin synthetase inhibitor. See Partridge, et al., U.S. Pat. No. 3,781,429, for a disclosure that the ulcerogenic effect induced by certain non-steroidal anti-inflammatory agents in rats is inhibited by concomitant oral administration of certain prostaglandins. Accordingly these novel CBA analogs herein are useful, for example, in reducing the undesirable gastrointestinal effects resulting from systemic administration of indomethacin, phenylbutazone, and aspirin. These are substances specifically mentioned in Partridge, et al. as non-steroidal, anti-inflammatory agents. These are also known to be prostaglandin synthetase inhibitors.

The anti-inflammatory synthetase inhibitor, for example, indomethacin, aspirin, or phenylbutazone is administered in any of the ways known in the art to alleviate an inflammatory conditions, for example, in any dosage regimen and by any of the known routes of systemic administration.

(d) Bronchodilation (Anti-asthma)

These novel analogs disclosed herein are also useful in the treatment of asthma. For example, these compounds are useful as bronchodilators or as inhibitors of mediator-induced bronchoconstriction, such as SRS-A,

14

and histamine which are released from cells activated by an antigen-antibody complex. Thus, these compounds control spasm and facilitate breathing in conditions such as bronchial bronchitis, bronchiectasis, pneumonia and emphysema. For these purposes, these compounds are administered in a variety of dosage forms, e.g., orally in the form of tablets, capsules, or liquids; rectally in the form of suppositories, parenterally, subcutaneously, or intramuscularly, with intravenous administration being preferred in emergency situations; by inhalation in the form of aerosols or solutions for nebulizers; or by insufflation in the form of powder. Doses in the range of about 0.01 to 5 mg per kg of body weight are used 1 to 4 times a day, the exact dose depending on the age, weight, and condition of the patient and on the frequency and route of administration. For the above use these CBA analogs can be combined advantageously with other anti-asthmatic agents, such as sympathomimetics (isoproterenol, phenylephrine, ephedrine, etc.); xanthine derivatives (theophylline and aminophylline); and corticosteroids (ACTH and prednisolone).

These compounds are effectively administered to human asthma patients by oral inhalation. For administration by the oral inhalation route with conventional nebulizers or by oxygen aerosolization it is convenient to provide the instant active ingredient in dilute solution, preferably at concentrations of about one part of medicament to from about 100 to 200 parts by weight of total solution. Entirely conventional additives may be employed to stabilize these solutions or to provide isotonic media, for example, sodium chloride, sodium citrate, citric acid, sodium bisulfite, and the like can be employed. For administration as a self-propelled dosage unit for administering the active ingredient in aerosol form suitable for inhalation therapy the composition can comprise the active ingredient suspended in an inert propellant (such as a mixture of dichlorodifluoromethane and dichlorotetrafluoroethane) together with a co-solvent, such as ethanol, flavoring materials and stabilizers. Suitable means to employ the aerosol inhalation therapy technique are described fully in U.S. Pat. No. 3,868,691, for example.

When  $X_1$  is  $-\text{COOR}_1$ , the novel CBA analogs so described are used for the purposes described above in the free acid form, in ester form, or in pharmacologically acceptable salt form. When the ester form is used, the ester is any of those within the above definition of  $R_1$ . However, it is preferred that the ester be alkyl of one to 12 carbon atoms, inclusive. Of the alkyl esters, methyl and ethyl are especially preferred for optimum absorption of the compound by the body or experimental animal system; and straight-chain octyl, nonyl, decyl, undecyl, and dodecyl are especially preferred for prolonged activity.

Pharmacologically acceptable salts of the novel prostaglandin analogs of this invention for the purposes described above are those with pharmacologically acceptable metal cations, ammonia, amine cations, or quaternary ammonium cations.

Especially preferred metal cations are those derived from the alkali metals, e.g., lithium, sodium, and potassium, and from the alkaline earth metals, e.g., magnesium and calcium, although cationic forms of other metals, e.g., aluminum, zinc, and iron are within the scope of this invention.

Pharmacologically acceptable amine cations are those derived from primary, secondary, and tertiary

P. 8

Ex. 2032

SteadyMed v. United Therapeutics  
IPR2016-00006

IPR2020-00769

United Therapeutics EX2006

Page 4644 of 7113



amines. Example of suitable amines are methylamine, dimethylamine, trimethylamine, ethylamine, dibutylamine, triisopropylamine, N-methylhexylamine, decylamine, dodecylamine, allylamine, crotylamine, cyclopentylamine, dicyclohexylamine, benzylamine, dibenzylamine,  $\alpha$ -phenylethylamine,  $\beta$ -phenylethylamine, ethylenediamine, diethylenetriamine, adamantylamine, and the like aliphatic, cycloaliphatic, araliphatic amines containing up to and including about 18 carbon atoms, as well as heterocyclic amines, e.g., piperidine, morpholine, pyrrolidine, piperazine, and lower-alkyl derivatives thereto, e.g., 1-methylpiperidine, 4-ethylmorpholine, 1-isopropylpyrrolidine, 2-methylpyrrolidine, 1,4-dimethylpiperazine, 2-methylpiperidine, and the like as well as amines containing water-solubilizing or hydrophilic groups, e.g., mono-, di-, and triethanolamine, ethyldiethanolamine, N-butylethanolamine, 2-amino-1-butanol, 2-amino-2-ethyl-1,3-propanediol, 2-amino-2-methyl-1-propanol, tris(hydroxymethyl) aminomethane, N-phenylethanolamine, N-(p-tert-amyphenyl)-diethanolamine, galactamine, N-methylglycamine, N-methylglucosamine, ephedrine, phenylephrine, epinephrine, procaine, and the like. Further useful amine salts of the basic amino acid salts, e.g., lysine and arginine.

Examples of suitable pharmacologically acceptable quaternary ammonium cations are tetramethylammonium, tetraethylammonium, benzyltrimethylammonium, phenyltriethylammonium, and the like.

When  $X_1$  is  $-\text{CH}_2\text{NL}_2\text{L}_3$ , the novel CBA analogs so described are used for the purposes described in either free base or pharmacologically acceptable acid addition salt form.

The acid addition salts of the 2-decarboxy-2-aminomethyl- or 2-(substituted aminomethyl)-CBA analogs provided by this invention are the hydrochlorides, hydrobromides, hydriodides, sulfates, phosphates, cyclohexanesulfamates, methanesulfonates, ethanesulfonates, benzenesulfonates, toluenesulfonates and the like, prepared by reacting the CBA analog with the stoichiometric amount of the acid corresponding to the pharmacologically acceptable acid addition salt.

To obtain the optimum combination of biological response specificity, potency, and duration of activity, certain compounds within the scope of this invention are preferred.

It is preferred that in the  $X_1$ -terminated side chain for inter-p-phenylene-CBA compounds,  $g$  be zero, for inter-m-phenylene-CBA compounds  $g$  be zero or one (especially zero), and for inter-o-phenylene CBA compounds  $g$  be zero, one, or 2 (especially one). Inter-o- and inter-m-phenylene-CBA compounds, especially inter-m-phenylene-CBA compounds are preferred. Moreover when  $Z_1$  is  $-\text{CH}_2-(\text{CH}_2)_f-\text{C}(\text{R}_2)_2$ ,  $f$  is preferably one and  $\text{R}_2$  is preferably hydrogen. When  $\text{R}_{17}$  is  $(\text{C}_1-\text{C}_4)$ -alkyl,  $\text{R}_{17}$  is preferably methyl. Further, when the C-12 side chain contains  $-\text{C}_m\text{H}_{2m}-\text{CH}_3$ , it is preferred that  $m$  be 3, 4, or 5, most preferably 3. When  $m$  is 5, more straight chain isomeric forms are preferred, especially methyl-substituted butyl. Further, it is preferred that, when  $\text{R}_7$  is aromatic,  $\text{R}_7$  be phenoxy, phenyl, or benzyl, including substituted forms thereof. For those compounds wherein  $\text{R}_7$  is substituted phenoxy or phenylalkyl, it is preferred there be only one or 2 substituents selected from the group consisting of chloro, fluoro, or trifluoromethyl. Further, for those compounds wherein  $\text{R}_7$  is aromatic, it is preferred that  $\text{R}_3$  and  $\text{R}_4$  both be hydrogen.

Most especially preferred to biological potency are formula X CBA<sub>2</sub> analogs exhibiting the same C-5 isomeric configuration as CBA<sub>2</sub> itself.

Especially preferred are those compounds which satisfy two or more of the above preferences. Further, the above preferences are expressly intended to describe the preferred compounds within the scope of any generic formula of novel CBA analogs disclosed herein.

Those protective groups within the scope of  $\text{R}_{10}$  are any group which replaces a hydroxy hydrogen and is neither attacked by nor is reactive to the reagents used in the transformations used herein as a hydroxy is and which is subsequently replaceable by acid hydrolysis with hydrogen in the preparation of the prostaglandin-type compounds. Several such protective groups are known in the art, e.g., tetrahydropyranyl and substituted tetrahydropyranyl. See for reference E. J. Corey, Proceedings of the Robert A. Welch Foundation Conferences on Chemical Research, XII Organic Synthesis, pgs. 51-79 (1969). Those blocking groups which have been found useful include:

(a) tetrahydropyranyl;

(b) tetrahydrofuranlyl;

(c) a group of the formula  $-\text{C}(\text{OR}_{11})(\text{R}_1)_2-\text{CH}(\text{R}_{13})(\text{R}_{14})$ , wherein  $\text{R}_{11}$  is alkyl of one to 18 carbon atoms, inclusive, cycloalkyl of 3 to 10 carbon atoms, inclusive, aralkyl of 7 to 12 carbon atoms, inclusive, phenyl or phenyl substituted with one to 3 alkyl of one to 4 carbon atoms, inclusive, wherein  $\text{R}_{12}$  and  $\text{R}_{13}$  are alkyl of one to 4 carbon atoms, inclusive, phenyl, phenyl substituted with one, 2 or 3 alkyl of one to 4 carbon atoms, inclusive, or when  $\text{R}_{12}$  and  $\text{R}_{13}$  are taken together  $-(\text{CH}_2)_a-$  or when  $\text{R}_{12}$  and  $\text{R}_{13}$  are taken together  $-(\text{CH}_2)_b-\text{O}-(\text{CH}_2)_c$ , wherein  $a$  is 3, 4, or 5 and  $b$  is one, 2, or 3, and  $c$  is one, 2, or 3, with the proviso that  $b$  plus  $c$  is 2, 3, or 4, with the further proviso that  $\text{R}_{12}$  and  $\text{R}_{13}$  may be the same or different, and wherein  $\text{R}_{14}$  is hydrogen or phenyl; and

(d) silyl groups according to  $\text{R}_{28}$ , as qualified herein-after.

When the protective group  $\text{R}_{10}$  is tetrahydropyranyl, the tetrahydropyranyl ether derivative of any hydroxy moieties of the CBA-type intermediates herein is obtained by reaction of the hydroxy-containing compound with 2,3-dihydropyran in an inert solvent, e.g., dichloromethane, in the presence of an acid condensing agent such as p-toluenesulfonic acid or pyridine hydrochloride. The dihydropyran is used in large stoichiometric excess, preferably 4 to 100 times the stoichiometric amount. The reaction is normally complete in less than an hour at 20°-50° C.

When the protective group is tetrahydrofuranlyl, 2,3-dihydrofuran is used, as described in the preceding paragraph, in place of the 2,3-dihydropyran.

When the protective group is of the formula  $-\text{C}(\text{OR}_{11})(\text{R}_{12})-\text{CH}(\text{R}_{13})(\text{R}_{14})$ , wherein  $\text{R}_{11}$ ,  $\text{R}_{12}$ ,  $\text{R}_{13}$ , and  $\text{R}_{14}$  are as defined above; a vinyl ether or an unsaturated cyclic or heterocyclic compound, e.g., 1-cyclohexen-1-yl methyl ether, or 5,6-dihydro-4-methoxy-2H-pyran is employed. See C. B. Reese, et al., J. American Chemical Society 89, 3366 (1967). The reaction conditions for such vinyl ethers and unsaturated compounds are similar to those for dihydropyran above.

$\text{R}_{28}$  is a silyl protective group of the formula  $-\text{Si}(\text{G})_3$ . In some cases, such silylations are general, in that they silylate all hydroxyls of a molecule, while in other cases they are selective, in that while one or more

hydroxyls are silylated at least one other hydroxyl remains unaffected. For any of these silylations, silyl groups within the scope of  $-\text{Si}(\text{G}_1)_3$  include trimethylsilyl, dimethylphenylsilyl, triphenylsilyl, t-butyl-dimethylsilyl, or methylphenylbenzylsilyl. With regard to  $\text{G}_1$ , examples of alkyl are methyl, ethyl, propyl, isobutyl, butyl, sec-butyl, tert-butyl, pentyl, and the like. Examples of aralkyl are benzyl, phenethyl,  $\alpha$ -phenylethyl, 3-phenyl propyl,  $\alpha$ -naphthylmethyl, and 2-( $\alpha$ -naphthyl)ethyl. Examples of phenyl substituted with halo or alkyl are p-chlorophenyl, m-fluorophenyl, o-tolyl, 2,4-dichlorophenyl, p-tert-butylphenyl, 4-chloro-2-methylphenyl, and 2,4-dichloro-3-methylphenyl.

These silyl groups are known in the art. See for example, Pierce "Silylation of Organic Compounds," Pierce Chemical Company, Rockford, Ill. (1968). When silylated products of the charts below are intended to be subjected to chromatographic purification, then the use of silyl groups known to be unstable to chromatography (e.g. trimethylsilyl) is to be avoided. Further, when silyl groups are to be introduced selectively, silylating agents which are readily available and known to be useful in selective silylations are employed. For example, t-butyl-dimethylsilyl groups are employed when selective introduction is required. Further, when silyl groups are to be selectively hydrolyzed in the presence of protective groups according to  $\text{R}_{10}$  or acyl protective groups, then the use of silyl groups which are readily available and known to be easily hydrolyzable with tetra-n-butylammonium fluoride are employed. A particularly useful silyl group for this purpose is t-butyl-dimethylsilyl, while other silyl groups (e.g. trimethylsilyl) are not employed when selective introduction and/or hydrolysis is required.

The protective groups as defined by  $\text{R}_{10}$  are otherwise removed by mild acidic hydrolysis. For example, by reaction with (1) hydrochloric acid in methanol; (2) a mixture of acetic acid, water, and tetrahydrofuran, or (3) aqueous citric acid or aqueous phosphoric acid in tetrahydrofuran, at temperatures below  $55^\circ\text{C}$ ., hydrolysis of the blocking group is achieved.

$\text{R}_{31}$  is a hydroxy-hydrogen protective group, as indicated above. As such,  $\text{R}_{31}$  may be an acyl protective group according to  $\text{R}_9$ , an acid hydrolyzable protective group according to  $\text{R}_{10}$ , a silyl protective group according to  $\text{R}_{28}$ , or an arylmethyl hydroxy hydrogen replacing group according to  $\text{R}_{34}$ .

Acyl protective groups according to  $\text{R}_9$  include:

- (a) benzoyl;
- (b) benzoyl substituted with one to 5 alkyl of one to 4 carbon atoms, inclusive, or phenylalkyl of 7 to 12 carbon atoms, inclusive, or nitro, with the proviso that not more than two substituents are other than alkyl, and that the total number of carbon atoms in the substituents does not exceed 10 carbon atoms, with the further proviso that the substituents are the same or different;
- (c) benzoyl substituted with alkoxycarbonyl of 2 to 5 carbon atoms, inclusive;
- (d) naphthoyl;
- (e) naphthoyl substituted with one to 9, inclusive, alkyl of one to 4 carbon atoms, inclusive, phenylalkyl of 7 to 10 carbon atoms, inclusive, or nitro, with the proviso that not more than two substituents on either of the fused aromatic rings are other than alkyl and that the total number of carbon atoms in the substituents on either of the fused aromatic rings does not exceed 10

carbon atoms, with the further proviso that the various substituents are the same or different; or

(f) alkanoyl of 2 to 12 carbon atoms, inclusive.

In preparing these acyl derivatives of a hydroxy-containing compound herein, methods generally known in the art are employed. Thus, for example, an aromatic acid of the formula  $\text{R}_9\text{OH}$ , wherein  $\text{R}_9$  is as defined above (e.g., benzoic acid), is reacted with the hydroxy-containing compound in the presence of a dehydrating agent, e.g. p-toluensulfonyl chloride or dicyclohexylcarbodiimide; or alternatively an anhydride of the aromatic acid of the formula  $(\text{R}_9)_2\text{O}$ , e.g., benzoic anhydride, is used.

Preferably, however, the process described in the above paragraph proceeds by use of the appropriate acyl halide, e.g.,  $\text{R}_9\text{Hal}$ , wherein Hal is chloro, bromo, or iodo. For example, benzoyl chloride is reacted with the hydroxy-containing compound in the presence of a hydrogen chloride scavenger, e.g. a tertiary amine such as pyridine, triethylamine or the like. The reaction is carried out under a variety of conditions, using procedures generally known in the art. Generally mild conditions are employed:  $0^\circ$ – $60^\circ\text{C}$ ., contacting the reactants in a liquid medium (e.g., excess pyridine or an inert solvent such as benzene, toluene, or chloroform). The acylating agent is used either in stoichiometric amount or in substantial stoichiometric excess.

As examples of  $\text{R}_9$ , the following compounds are available as acids ( $\text{R}_9\text{OH}$ ),  $(\text{R}_9)_2\text{O}$ , or acyl chlorides ( $\text{R}_9\text{Cl}$ ): benzoyl; substituted benzoyl, e.g., (2-, 3-, or 4-)methylbenzoyl, (2-, 3-, or 4-)ethylbenzoyl, (2-, 3-, or 4-)isopropylbenzoyl, (2-, 3-, or 4-)tert-butylbenzoyl, 2,4-dimethylbenzoyl, 3,5-dimethylbenzoyl, 2-isopropyl-toluy, 2,4,6-trimethylbenzoyl, pentamethylbenzoyl, phenyl(2-, 3-, or 4-)toluy, (2-, 3-, or 4-)phenethylbenzoyl, (2-, 3-, or 4-)nitrobenzoyl, (2,4, 2,5-, or 2,3-)dinitrobenzoyl, 2,3-dimethyl-2-nitrobenzoyl, 4,5-dimethyl-2-nitrobenzoyl, 2-nitro-6-phenylethylbenzoyl, 3-nitro-2-phenethylbenzoyl, 2-nitro-6-phenethylbenzoyl, 3-nitro-2-phenethylbenzoyl; mono esterified phthaloyl, isophthaloyl, or terephthaloyl; 1- or 2-naphthoyl; substituted naphthoyl, e.g., (2-, 3-, 4-, 5-, 6-, or 7-)methyl-1-naphthoyl, (2- or 4-)ethyl-1-naphthoyl, 2-isopropyl-1-naphthoyl, 4,5-dimethyl-1-naphthoyl, 6-isopropyl-4-methyl-1-naphthoyl, 8-benzyl-1-naphthoyl, (3-, 4-, 5-, or 8-)nitro-1-naphthoyl, 4,5-dinitro-1-naphthoyl, (3-, 4-, 6-, 7-, or 8-)methyl-1-naphthoyl, 4-ethyl-2-naphthoyl, and (5- or 8-)nitro-2-naphthoyl and acetyl.

There may be employed, therefore, benzoyl chloride, 4-nitrobenzoyl chloride, 3,5-dinitrobenzoyl chloride, or the like, i.e.  $\text{R}_9\text{Cl}$  compounds corresponding to the above  $\text{R}_9$  groups. If the acyl chloride is not available, it is prepared from the corresponding acid and phosphorus pentachloride as is known in the art. It is preferred that the  $\text{R}_9\text{OH}$ ,  $(\text{R}_9)_2\text{O}$ , or  $\text{R}_9\text{Cl}$  reactant does not have bulky hindering substituents, e.g. tert-butyl on both of the ring carbon atoms adjacent to the carbonyl attaching site.

The acyl protective groups, according to  $\text{R}_9$ , are removed by deacylation. Alkali metal carbonate or hydroxide are employed effectively at ambient temperature for this purpose. For example, potassium carbonate or hydroxide in aqueous methanol at about  $25^\circ\text{C}$  is advantageously employed.

$\text{R}_{34}$  is defined as any arylmethyl group which replaces the hydroxy hydrogen of the intermediates in the preparation of the various CBA analogs herein which is subsequently replaceable by hydrogen in the processes

herein for preparation of these respective prostacyclin analogs, being stable with respect to the various reactions to which R<sub>34</sub>-containing compounds are subjected and being introduced and subsequently removed by hydrogenolysis under conditions which yield substantially quantitative yields of desired products.

Examples of arylmethyl hydroxy-hydrogen replacing groups are

- (a) benzyl;
- (b) benzyl substituted by one to 5 alkyl of one to 4 carbon atoms, inclusive, chloro, bromo, iodo, fluoro, nitro, phenylalkyl of 7 to 12 carbon atoms, inclusive, with the further proviso that the various substituents are the same or different;
- (c) benzhydryl;
- (d) benzhydryl substituted by one to 10 alkyl of one to 4 carbon atoms, inclusive, chloro, bromo, iodo, fluoro, nitro, phenylalkyl of 7 to 12 carbon atoms, inclusive, with the further proviso that the various substituents are the same or different on each of the aromatic rings;
- (e) trityl;
- (f) trityl substituted by one to 15 alkyl of one to 4 carbon atoms, inclusive, chloro, bromo, iodo, fluoro, nitro, phenylalkyl of 7 to 12 carbon atoms, inclusive, with the further proviso that the various substituents are the same or different on each of the aromatic rings.

The introduction of such ether linkages to the hydroxy-containing compounds herein, particularly the benzyl or substituted benzyl ether proceeds by methods known in the art, for example by reaction of the hydroxy-containing compound with the benzyl or substituted benzyl halide (chloride, bromide, or iodide) corresponding to the desired ether. This reaction proceeds in the presence of an appropriate condensing agent (e.g., silver oxide). The mixture is stirred and heated to 50°-80° C. Reaction times of 4 to 20 hours are ordinarily sufficient.

The Charts herein describe the methods whereby the novel intermediates and end products of the present specification are prepared by the novel processes herein. With respect to these charts, g, n, L<sub>1</sub>, M<sub>1</sub>, M<sub>6</sub>, R<sub>7</sub>, R<sub>8</sub>, R<sub>10</sub>, R<sub>15</sub>, R<sub>16</sub>, R<sub>17</sub>, R<sub>18</sub>, R<sub>20</sub>, R<sub>21</sub>, R<sub>22</sub>, R<sub>23</sub>, and R<sub>24</sub>, R<sub>28</sub>, R<sub>31</sub>, X<sub>1</sub>, Y<sub>1</sub>, Z<sub>1</sub>, and Z<sub>4</sub> are as defined above. R<sub>37</sub> is the same as R<sub>47</sub>, but other than —CH<sub>2</sub>OH. R<sub>38</sub> is —OR<sub>31</sub>, hydrogen, or —CH<sub>2</sub>OR<sub>31</sub>, wherein R<sub>31</sub> is defined as above. R<sub>27</sub> is same as R<sub>7</sub> except that —(CH<sub>2</sub>)<sub>2</sub>—CH(OH)—CH<sub>3</sub> is —(CH<sub>2</sub>)<sub>2</sub>—CH(OR<sub>10</sub>)—CH<sub>3</sub>. R<sub>37</sub> is the same as R<sub>17</sub>, but other than hydrogen. Ac is acetyl. Z<sub>2</sub> is the same as Z<sub>1</sub> but not —(Ph)—(CH<sub>2</sub>)<sub>g</sub>—. Z<sub>3</sub> is the same as Z<sub>1</sub>, but not trans—CH<sub>2</sub>—CH=CH—.

With respect to Chart A, a method is provided whereby the known formula XXI bicyclic lactone is transformed to the carbacyclin intermediate of formula XXV useful in the preparation of formula X CBA compounds wherein R<sub>17</sub> is alkyl or R<sub>16</sub> and R<sub>17</sub> taken together are methano or a second valence bond between C-6a and C-9. With respect to Chart A, the formula XXI compound is transformed to the formula XXII compound by treatment with the anion of dimethyl methylphosphonate. Methods for such a reaction are known in the art. See Dauben, W. G., et al., JACS, 97:4973 (1975), describing a reaction of this type.

The formula XXII lactol is transformed to the formula XXIII diketone by oxidation methods known in the art. For example, Collins reagent or Jones reagent is employed in this oxidative transformation.

The formula XXIII diketone is cyclized to the formula XXIV compound by an intramolecular Horner-Emmons reaction. The chemical methodology for analogous transformations is known in the art. See Piers, E., et al., Tetrahedron Letters, 3279 (1979) and Clark, R. D., et al., Synthetic Communications 5:1 (1975).

The formula XXIV compound is transformed to the novel formula XXV compound wherein R<sub>16</sub> is hydrogen and R<sub>37</sub> is alkyl by treatment with lithium dialkyl cuprate. The lithium dialkyl cuprate is prepared by conventional means, e.g., reaction of anhydrous copper iodide in diethyl ether with an alkyllithium in diethyl ether, and thereafter reacted with the formula XXIV compounds, e.g., in diethyl ether.

The formula XXIV compound is transferred to the novel formula XXV compound wherein R<sub>16</sub> and R<sub>37</sub> taken together are methylene (—CH<sub>2</sub>—) by one of two methods. By the first method, the formula XXV compound is prepared by treatment of the formula XXIV compound with the anion of trimethyloxosulfonium iodide. See for reference E. J. Corey, et al., JACS 87:1353 (1965). By this method, the anion is conveniently generated by treatment of trimethyloxosulfonium iodide in sodium hydride.

By a second method, the formula XXIV compound is converted to the formula XXV compound wherein R<sub>16</sub> and R<sub>37</sub> taken together are methylene by first converting the formula XXIV compound to the corresponding formula XXXVI hydroxymethyl compound by photochemical addition of methanol (e.g., see G. L. Bundy, Tetr. Lett. 1957, 1975), thereafter treating the resulting hydroxymethyl compound with an excess (e.g., two equivalents) of p-toluenesulfonyl chloride in a tertiary amine base to yield the corresponding formula XXVII tosylate, and finally treating the resulting formula XXVII tosylate with base (e.g., potassium t-butoxide) to yield the formula XXV cyclopropyl compound.

With respect to Chart B, a method is provided whereby the formula XXXI compound prepared in accordance with methods of Chart A is transformed to the novel CBA<sub>2</sub> analogs of formula XXXVI.

The formula XXXI compound is transformed to the formula XXXVI compound by methods known in the art for preparing carbacyclin. See for example, British published applications referred to above. Alternatively, the formula XXXI compound is reacted with formula XXXII compound and thereby successively transformed to the formula XXXIII, formula XXXIV and formula XXXV compounds.

The reaction of the formula XXXI compound employing the formula XXXII compound is accomplished by methods known in the art. See Moersch, G. W., J. Organic Chemistry, 36:1149 (1971) and Mulzer, J. et al., Tetrahedron Letters, 2949 (1978). The formula XXXII reactants are known in the art or are prepared by methods known in the art. See Example 4 describing one such method of preparation of a formula XXXII compound.

The formula XXXIII compound is then transformed to the formula XXXIV compound by decarboxylative dehydration. Procedures for this reaction are known in the art. See Eschenmoser, A., et al., Helv. Chim. Acta. 58:1450 (1975), Hara, S., et al., Tetrahedron Letters, 1545 (1975) and Mulzer, J., et al., Tetrahedron Letters, 2953 (1978) and 1909 (1979).

Finally, the formula XXXV compound is prepared from formula XXXIV compound by selective desilylation. Such procedures are known in the art and typi-

cally employ the use of tetra-n-butyl ammonium fluoride and tetrahydrofuran. See Corey, E. J., et al., JACS 94:6190 (1972).

The formula XXXV compound is transformed to various acids, esters, amides, and amines of a formula XXXVI by methods known in the art. Particularly useful in this regard are methods described in the aforementioned British published specifications describing the preparation of carbacyclin analogs.

The preparation of formula XXXVI compounds from the formula XXXV compounds proceeds by, for example, oxidation to the corresponding carboxylic acid, followed by hydrolysis of any protective groups at the C-11 or C-15 position of the molecule. Such carboxylic acids are then esterified by conventional means or amidized by conventional means. Such amides may, for example, then be reduced to corresponding amines ( $X_1$  is  $-\text{CH}_2\text{NL}_2\text{L}_3$ ) by reduction by lithium aluminum hydride. See U.S. Pat. No. 4,073,808. In a preparation of the primary alcohols according to formula XXXVI from the formula XXXV compound, hydrolysis of any protective groups at C-11 or C-15 yields such products directly. Hydrolysis is accomplished by procedures described above, e.g., mild acidic conditions at elevated temperatures.

Chart C provides a method whereby the known formula XLI compounds are transformed to the formula XLIV aldehydes employed in Chart D in the preparation of inter-phenylene-CBA<sub>2</sub> compounds therein.

With respect to Chart C, the formula XLII compound is prepared from the formula XLI compounds by reduction. Conventional methods known in the art for the transformation of carboxylic acids to corresponding primary alcohols are employed. For example, one extremely useful conventional means for this reduction is employing lithium aluminum hydride as a reducing agent.

The formula XLIII compound is then prepared from the formula XLII compound by monosilylation. Particularly, formula XLIII compounds are prepared wherein R<sub>28</sub> represents a relatively stable silyl group, most preferably being t-butyl-dimethylsilyl or phenyl-dimethylsilyl. Other silyl groups, particularly trimethylsilyl (TMS) are not preferred for use in connection with the methods of Chart C.

The formula XLIII monosilyl derivatives are prepared from the formula XLII compound by reacting the formula XLII compounds with about an equal molar amount of the silylating agent. For example, when R<sub>28</sub> is t-butyl-dimethylsilyl, a single equivalent of t-butyl-dimethylsilyl chloride is employed in the transformation. Accordingly, there are prepared both monosilyl derivatives of the formula XLII compound as well as the bis-silyl derivatives corresponding to formula XLII. From this mixture of products, the formula XLIII compound is recovered by conventional means, e.g., column chromatography. Otherwise, the silylation proceeds under conditions conventionally employed for silylating hydroxyl groups. Refer to the discussion hereinabove.

The formula XLIV compound is then prepared from the formula XLIII compound by oxidation of the formula XLIII alcohol to the corresponding aldehyde. Conventional oxidizing agents are employed, e.g., manganese dioxide.

Chart D provides a method whereby the known formula LI ketones are transformed to the formula LX inter-phenylene CBA<sub>2</sub> analogs disclosed herein.

In accordance with Chart D the formula LII compound is prepared from the formula LI compound by reduction of the formula LI ketone to the corresponding secondary alcohol. This reduction proceeds by conventional means, employing readily available reducing agents. Accordingly, sodium, potassium, or lithium borohydride is conveniently employed in this reduction.

Thereafter, the formula LII alcohol is transformed to the corresponding mesylate (methanesulfonate). Conventional methods for the transformation of alcohols to corresponding mesylates are employed. Thus, the formula LII alcohol is reacted with methane-sulfonyl chloride in the presence of a tertiary amine (e.g., triethylamine) in the preparation of the formula LIII compound.

Other sulfonyl derivatives corresponding to the formula LII alcohol may be employed in place of the formula LIII compound in the transformations of Chart D. These other sulfonyl derivatives are preferably those derived from readily available sulfonylating reagents, i.e., the corresponding sulfonyl chlorides. One especially important alternative to the formula LIII compound is the tosylate (toluenesulfonate) corresponding to the formula LII compound.

The formula LIII compound, or an alternate sulfonate corresponding thereto, is transformed to the formula LIV compound by treatment with sodium lithium or potassium thiophenoxide. The thiophenoxide is conveniently prepared just prior to the transformation by mixing approximately equal molar amounts of thiophenol and base, e.g., potassium t-butoxide.

This formula LIV compound is then oxidized to the corresponding formula LV compound by oxidation with a readily available oxidizing agent such as m-chloroperbenzoic acid.

The formula LV compound is then condensed with the formula XLIV compound prepared according to Chart C by first treatment of the formula LV compound with a strong base, e.g., n-butyllithium, to generate the anion corresponding to the formula LV compound, treatment of the corresponding anion with the aldehyde of formula XLIV and finally treating the resulting adduct with acetic anhydride to yield the formula LVI acetyl compound.

The formula LVI compound is then transformed to the formula LVII compound by reaction with a sodium amalgam. Methods by which the formula LVII olefin is formed from the formula LV compound are analogous to known methods described by Kocienski, P. J., et al., "Scope and Stereochemistry of an Olefin Synthesis from  $\beta$ -Hydroxysulphones", JCS Perkin I, 829-834 (1978).

The formula LVII compound is then transformed to the formula LVIII compound by selective hydrolysis of the silyl group according to R<sub>28</sub>. Conventional means for this hydrolysis are employed, e.g., tetra-n-butyl ammonium fluoride. Refer to the discussion above for a description of this hydrolysis.

The formula LVIII C-5 diastereomers thusly prepared are conveniently purified into (5-E) and (5-Z) isomeric forms. This transformation proceeds by conventional means, e.g., column chromatography.

Thereafter either the (5E) or (5Z) isomer of formula LVIII is transformed to the formula LIX carboxylic acid or ester by conventional oxidation, followed by optional esterification. One especially convenient means of oxidation is employing the Jones reagent, although

other oxidizing agents are employed. Esterification then proceeds by methods hereinafter described.

Finally, the formula LX products are prepared from the formula LIX compound by first hydrolyzing the protective groups under acidic conditions, e.g., mixtures of water, tetrahydrofuran, and acetic acid. Thereafter, the formula LIX acids and esters are transformed to various other C-1 derivatives by methods hereinafter described.

One especially convenient means of preparing the formula LX compound as a free carboxylic acid ( $X_1$  is  $-\text{COOH}$ ), is by purification of the corresponding methyl ester, followed by saponification under basic conditions (e.g., the treatment with potassium carbonate or sodium or potassium hydroxide).

Charg E provides a method whereby the known formula LXI compound is transformed into formula LXIII intermediate useful in the preparation of the novel  $\text{CBA}_2$  analogs.

The procedures for the transformation of the formula LXI compound to the formula LXIII compound are analogous to those describing the transformation in Charts A, B, and D of the formula XXI compound to the formula XXXVI and LX compounds (i.e., corresponding to the transformation of formula LXI compound to the formula LXII compound is the transformation in Chart A of the formula XXI compound to the formula XXV compound and corresponding to the transformation of the formula LXII compound to the formula LXIII compound is the transformation in Chart D of the formula LI compound to the formula LX compound.). For convenience, the protective groups  $\text{R}_{31}$  and  $\text{R}_{38}$  may be the same or different, although preferably such protective groups are different, whereby the hydrolysis of a protective group according to  $\text{R}_{31}$  is accomplished in the presence of a protective group according to  $\text{R}_{38}$ .

Chart F then provides a method whereby the formula LXXI compound prepared according to Chart E is transformed to the formula LXXII carbacyclin analog in accordance with the present invention. With respect to Chart F, the formula LXXI compound is transformed to the formula LXXII compound by selective hydrolysis of the protective group according to  $\text{R}_{31}$ . Thereafter, the formula LXXII compound is transformed to formula LXXIII compound by methods known in the art, e.g., oxidation of the formula LXXII primary alcohol to the corresponding aldehyde, Wittig oxyacylating the aldehyde, and reduction of the resulting ketone to the secondary or tertiary alcohol corresponding to  $\text{M}_1$ . For an example of the various transformations employed according to Chart F, see Chart A (part VI) of U.S. Pat. No. 4,107,427, issued Aug. 15 1978.

Chart G provides a method whereby the novel formula LXXXI intermediate, prepared according to Chart A, is transformed to the formula LXXXVIII and LXXXIX isomers of the novel C-6a- and /or C-9-substituted  $\text{CBA}_2$  analogs.

With respect to Chart G, the formula LXXXIII compound is prepared from the formula LXXXI ketone by a Wittig  $\omega$ -carboxyalkylation employing a formula LXXXII triphenylphosphonium compound. The Wittig reaction is undertaken under conventional reaction conditions for preparing prostaglandin-type substances. The formula LXXXIII compound is then optionally hydrolyzed to yield the formula X carboxylic acid

products or employed in the further transformations of Chart G in ester form.

The formula LXXXIII compound thusly prepared is thereafter preferably separated directly into C-5 isomers of formulas LXXXVIII and LXXXIX (e.g., by chromatographic means followed by hydrolysis of and protective groups at C-11 or C-15 position of the molecule), or is alternatively transformed to the formula LXXXIV ester by conventional esterification techniques, e.g., ethereal diazomethane treatment or treatment with methyl iodide. The formula LXXXIV ester is then reduced to the corresponding primary alcohol by reduction with a suitable reducing agent, e.g., lithium aluminum hydride, by methods known in the art for preparing prostaglandin-type primary alcohols from corresponding prostaglandin esters.

The formula LXXXV compound represents an especially convenient intermediate for the facile separation of the C-5 diastereomers. Accordingly, the formula LXXXV compound may be separated by conventional means of separation of diastereomeric mixtures, e.g., column chromatography, whereby the formula LXXXVI and formula LXXXVII compounds are prepared in isomerically pure form. These primary alcohols are then conveniently transformed to the formula LXXXVIII and LXXXIX products by methods described above. Refer to the transformations of the formula XXXV compound to the formula XXXVI compound in Chart B.

Chart H provides a method whereby the formula XCVII 5-fluoro- $\text{CBA}_2$  compounds are prepared from the formula XCIII  $\text{CBA}_2$  intermediates known in the art. See, for example, British Published Application No. 2,014,143, especially the discussion relative to step (b) of Chart A therein. This formula XCI sulfoximine is transformed to the formula XCII fluorinated sulfoximine by first generating an anion of the formula XCII compound, e.g., by treatment with *n*-butyllithium in hexane, and treating the resulting anion with a fluorine source. Particularly preferred as a source of fluorine is perchloryl fluoride ( $\text{FC10}_3$ ).

The formula XCII compound thusly prepared and the known formula XCIII compound described above are then employed in the preparation of the formula XCIV compound by known methods. Refer again to step (b) of Chart A of British Published Application No. 2,014,143.

The formula XCIV compound thusly prepared is then transformed to the formula XCV primary alcohol by hydrolysis under mild acidic conditions (e.g., mixtures of acetic acid, water, and tetrahydrofuran) as is known in the art. Thereafter, the formula XCV primary alcohol is oxidized to the corresponding formula XCVI carboxylic acid employing conventional means. For example, treatment with oxygen and an aqueous suspension of platinum oxide hydrogenated at ambient temperature and pressure yields the formula LXXVI carboxylic acid. Thereafter, the formula XCVI compound is transformed into the various formula XCVII products by derivatization or transformation of the carboxyl group of the formula XCVI compound.

The C-5 isomers of the formula XCIV to formula XCVII compounds are conveniently separate at any step during the process of Chart H, but are most conveniently and preferably separated from the formula XCIV diastereomeric mixture. Conventional means, e.g., column chromatography, are employed in the separation.

Chart I provides an optional method whereby the known formula CI compound is transformed to the formula CIII products herein. With respect to Chart I, the formula XCII is prepared from the formula XCI compound by the procedure described in Chart H for the preparation of the formula XCVII compound from the formula XCIII compound. This formula CII CBA<sub>2</sub> intermediate is then transformed to the formula CIII compound by the procedures described in Chart F for the transformation of the formula LXXI to the formula LXXIII compound.

Chart J provides the preferred methods for preparing the formula X CBA analogs wherein Z<sub>1</sub> is trans—CH<sub>2</sub>—CH=CH—. With respect to Chart J, R<sub>1</sub> therein is other than hydrogen or a cation, preferably being lower alkyl. The formula CXIV is prepared from the formula CXI compound by first preparing the  $\alpha$ -phenylselenyl derivative thereof, dehydrophenylselenizing, whereby the formula CXIII  $\alpha,\beta$ -unsaturated ester is prepared. This ester is then transformed to the formula CXIV free acid (X<sub>1</sub> is —COOH) by saponification and this free acid is transformed to the various other formula CXIV compounds as indicated in Chart H (refer to the transformation of the formula XCVI compound to the formula XCVII compound).

Chart K provides the preferred method whereby the formula VI CBA intermediates wherein Z<sub>1</sub> is trans—CH<sub>2</sub>—CH=CH— are prepared. With respect to Chart K, the formula CXXI compound is transformed to the formula CXXIII compound by methods analogous to those described in Chart J for the preparation of the formula CXIV compound from the formula CXI compound.

For a detailed description of the methodology employed in Charts J–K, refer to the discussion in British Pat. No. 2,014,143, and references cited therein.

Charts L–O provide methods whereby CBA<sub>2</sub> intermediates and analogs are employed in the synthesis of corresponding CBA<sub>1</sub> intermediates and analogs.

Charts L provides the preferred method for preparing the formula VII CBA<sub>1</sub> intermediates wherein Z<sub>1</sub> is trans—CH<sub>2</sub>—CH=CH—. With respect to Chart L the formula CXXXI compound, prepared as the formula CXXXII compound of Chart K, is reduced to the formula CXXXII compound by conventional methods. For a discussion of such methods, and general methodologies for transforming CBA<sub>2</sub> intermediates and analogs to corresponding CBA<sub>1</sub> intermediates and analogs, refer to British Published Application No. 2,017,699. For example, catalytic hydrogenation with conventional catalysts under atmospheric pressure is employed.

Thereafter, this formula CXXXII compound is successively transformed to the formula CXXXIII  $\alpha,\beta$ -unsaturated ester and the formula CXXXIV CBA<sub>1</sub> intermediate by methods described in Charts J–K (i.e., the transformation of the formula CXII compound to the corresponding formula CXIV compounds and the transformation of the formula CXXII compound to the formula CXXIII compound).

Otherwise, the formula VII CBA<sub>1</sub> intermediates are prepared according to the method of Chart M, wherein the formula CXLI compound, prepared above, is reduced to the formula CXLII intermediates by techniques described in Chart L and references cited therein.

Chart N describes the preparation of the various CBA<sub>1</sub> analogs from the formula CLI compounds pre-

pared in Charts L and M. Procedures employed in Chart N are those described in Chart F above.

Finally, Chart O provides an alternative method for the preparation of the formula CLXII CBA<sub>1</sub> analogs directly from formula CLXI CBA<sub>2</sub> analogs. This transformation of Chart O proceeds by direct reduction of the formula CLXI compound by methods described in Chart M and references cited therein. Chart O is an especially convenient method for the preparation of CBA<sub>1</sub> analogs wherein Y<sub>1</sub> is —CH<sub>2</sub>CH<sub>2</sub>—.

The formula XI CBA analogs are prepared according to the methods described in Charts P–U. With respect to Chart P, the formula CLXXI compound is known in the art or prepared by methods known in the art. See U.S. Pat. No. 4,181,789. This compound is conveniently transformed to the corresponding formula CLXXII methylene and formula CLXXIII hydroxymethyl compounds by methods known in the art. Such procedures are particularly and especially described in U.S. Pat. No. 4,012,467 and 4,060,534.

The formula CLXXIII compound thusly prepared is thereafter converted to the formula CLXXIV mesylate by methods known in the art, e.g., reaction with methanesulfonyl chloride in a tertiary amine base. Alternatively, other sulfonated derivatives corresponding to the formula CLXXIV compound are prepared such as those described in connection with formula LIII in Chart D.

Thereafter, the formula CLXXIV mesylate (or other sulfonate) is selectively hydrolyzed to yield the formula CLXXV phenol derivatives. Selective hydrolysis of R<sub>28</sub> silyl ether groups in the presence of protected R<sub>18</sub> or M<sub>6</sub> hydroxyl groups is accomplished by methods hereinabove described, i.e., the use of tetra-n-butyl ammonium fluoride by methods known in the art and hereinabove described. The formula CLXXV phenol derivative is then cyclized to yield the formula CLXXVI compounds. Cyclization proceeds most conveniently by treatment of the formula XVI compound with base at elevated temperatures. For example, n-butyllithium, sodium hydride, or potassium hydride are conveniently employed at reflux temperatures in organic solvent such as tetrahydrofuran or glyme.

The cyclized formula CLXXVI compound is then transformed to the formula CLXXVII compound by  $\omega$ -carboxyalkylation. Methods known in the art are employed, e.g., methods for preparing 3,7-inter-phenylene-PGF $\alpha$  compounds and corresponding phenolic intermediates. For example, the preparation of the formula CLXXVII compound proceeds by reaction of the formula CLXXVI compound with sodium hydride and the alkyl bromoalkanoate corresponding to the —Z<sub>4</sub>—COOR<sub>1</sub> group to be introduced into the molecule. Thereafter, the formula CLXXVIII compound is prepared by deprotection, i.e., hydrolysis under mild acidic conditions of the protective groups, followed by transformation to various other C-1 derivatives by methods hereinafter described.

Chart Q provides a method whereby further formula XI CBA analogs in accordance with the present invention are prepared. In particular, formula XI compounds wherein at least one of R<sub>20</sub>, R<sub>21</sub>, R<sub>23</sub>, or R<sub>24</sub> is not hydrogen are prepared. In accordance with Chart Q, the formula CLXXXI compound, referred to above in the discussion pertaining to Chart P, is oxidized to the corresponding formula CLXXXII aldehyde by methods known in the art. For example, Collins reagent is employed in this oxidation. When conversion of one C-9

stereoisomer of formula CLXXXIII to the other is described, refer to the procedure in Chart R.

Thereafter the formula CLXXXII aldehyde is hydrolyzed to the corresponding formula CLXXXIII phenol derivative by methods described above for the preparation of the formula CLXXV compound from the formula CLXXXIV compound of Chart P.

Thereafter, cyclization of the formula CLXXXIII to the corresponding formula CLXXXIV compound is accomplished by heating at reflux in an organic solvent the phenoxide anion of the formula CLXXXIII compound. See for reference Casiraghi, G., et al., J.C.S. Perkin I, 2027 (1979). The C-9 isomers of the formula CLXXXIV compound are conveniently separated by conventional techniques, e.g., column chromatography. Thereafter, the formula CLXXXIV compound is transformed to the formula CLXXXV compound by methods described in Chart P for the preparation of the formula CLXXXVII compound from the formula CLXXVI compound. This alcohol is then oxidized to the corresponding formula CLXXXVI ketone (e.g., by methods described above for the preparation of the formula CLXXXII compound from the formula CLXXXI compound) or dehydrated to yield the formula CLXXXVIII compound. Such dehydrations proceed by methods known in the art and include first preparing the mesylate corresponding to the formula CLXXXV compound following by treatment with base.

Thereafter, the formula CLXXXVI or CLXXXVIII compound is transformed, respectively, to the formula CLXXXVII or CLXXXIX compound by methods hereinafter described.

Finally, the formula CLXXXIX compound thusly prepared is dehydrogenated to yield the formula CXC compound by conventional means, e.g., catalytic dehydrogenation (palladium-on-carbon catalyst) or treatment with DDQ (2,3-dichloro-5,6-dicyano-1,4-benzoquinone).

Chart R provides a method whereby the C-9 epimeric forms of compounds prepared according to the Chart P are prepared. With respect to Chart R, the formula CXCI aldehyde, prepared as the formula CLXXXII compound of Chart Q is isomerized by treatment under basic conditions (i.e., the use of an organic base such as 1,8-diazobicyclo[5.4.0]-undec-7-ene in an organic solvent (e.g., methylene chloride)). Thereafter this  $\beta$ -aldehyde is reduced to the corresponding formula CXCI alcohol by treatment with a suitable reducing agent, such as a borohydride reducing agent. (e.g., sodium, lithium, or potassium borohydride). Thereafter, the formula CXCI alcohol thusly prepared is transformed to the corresponding  $\beta$ -CBA analogs by methods described in Chart P, e.g., the transformation of the formula CLXXXIII to the formula CLXXXVIII compound.

Optionally, the various formula XI CBA analogs prepared according to Charts P, Q, and R are prepared by the procedure of Chart S. The procedure of Chart S employs the formula CCI starting material described in chart P which is thereafter converted to the formula CCII compound prepared in accordance with methods described for the preparation of the formula CLXXXVIII compound from the formula CLXXI compound of Chart P, the formula CLXXXVII, formula CLXXXIX, formula CXC compounds from the formula CLXXXI compound of Chart Q and the formula CXCI compounds from the formula CXCI compound

of Chart R. The formula CCII compound thusly prepared is then transformed to the formula CCIII compounds by methods hereinabove described, e.g., the transformation of the formula LXXI compound to the formula LXXIII compound of Chart F.

Chart T provides a preferred method whereby the 9-deoxo-2',9-metheno-3-oxa-4,5,6-trinor-3,7-(1,3-interphenylene)-PGE<sub>1</sub> compounds of formula CCXIII are prepared. In accordance with Chart T the formula CCXI compound, prepared as the formula CLXXXIII compound of Chart Q, is treated with a methyl Grignard reagent, methyl magnesium bromide and heated at reflux in an organic solvent (e.g., glyme).

The formula CCXII thusly prepared is then transformed to the formula CCXIII product by the method described in Chart P for the preparation of the formula CLXXXVIII product from the formula CLXXVI phenol intermediate.

Chart U provides a convenient method whereby formula XI compounds wherein Y<sub>1</sub> is trans-CH=CH-, the formula CCXXI compound of Chart U, are transformed to corresponding formula CCXXII aldehyde intermediates. This transformation is accomplished by ozonolysis by methods otherwise known in the art.

The formula CCXXII intermediate is then conveniently transformed to various formula XI products (the Formula CCXXIII compound of Chart U) by methods described above, i.e., reaction of the formula CCXXII compound with the appropriate Wittig reagent followed by reduction and hydrolysis. Accordingly by the procedure described in Chart U the C-12 side chains of the various formula CCXXI compounds is conveniently modified by the formula CCXXII aldehyde intermediates. As discussed above, the processes herein described lead variously to carboxylic acids (X<sub>1</sub> is —COOR<sub>1</sub> and R<sub>1</sub> is hydrogen) or to esters or primary alcohols (X<sub>1</sub> is —CH<sub>2</sub>OH).

When the alkyl ester has been obtained and an acid is desired, saponification procedures, as known in the art for PGF-type compounds are employed.

When an acid has been prepared and an alkyl, cycloalkyl, or aralkyl ester is desired, esterification is advantageously accomplished by interaction of the acid with appropriate diazohydrocarbon. For example, when diazomethane is used, the methyl ester is produced. Similar use of diazoethane, diazobutane, and 1-diazo-2-ethylhexane, and diazodecane, for example, gives the ethyl, butyl, and 2-ethylhexyl and decyl esters, respectively. Similarly, diazocyclohexane and phenyl-diazomethane yield cyclohexyl and benzyl esters, respectively.

Esterification with diazohydrocarbons is carried out by mixing a solution of the diazohydrocarbon in a suitable inert solvent, preferably diethyl ether, with the acid reactant, advantageously in the same or a different inert diluent. After the esterification reaction is complete the solvent is removed by evaporation, and the ester purified if desired by conventional methods, preferably by chromatography. It is preferred that contact of the acid reactants with the diazohydrocarbon be no longer than necessary to effect the desired esterification, preferably about one to about 10 min, to avoid undesired molecular changes. Diazohydrocarbons are known in the art or can be prepared by methods known in the art. See, for example, Organic Reactions, John Wiley and Sons, Inc., New York, N.Y., Vol. 8, pp. 389-394 (1954).

An alternative method for alkyl, cycloalkyl or aralkyl esterification of the carboxy moiety of the acid compounds comprises transformation of the free acid to the corresponding substituted ammonium salt, followed by interaction of that salt with an alkyl iodide. Examples of suitable iodides are methyl iodide, ethyl iodide, butyl iodide, isobutyl iodide, tert-butyl iodide, cyclopropyl iodide, cyclopentyl iodide, benzyl iodide, phenethyl iodide, and the like.

Various methods are available for preparing phenyl or substituted phenyl esters within the scope of the invention from corresponding aromatic alcohols and the free acid, differing as to yield and purity of product.

With regard to the preparation of the phenyl, particularly p-substituted phenyl esters disclosed herein (i.e.,  $X_1$  is  $-\text{COOR}_1$  and  $R_1$  is p-substituted phenyl), such compounds are prepared by the method described in U.S. Pat. No. 3,890,372. Accordingly, by the preferred method described therein, the p-substituted phenyl ester is prepared first by forming a mixed anhydride, particularly following the procedures described below for preparing such anhydrides as the first step in the preparation of amido and cycloamido derivatives.

This anhydride is then reacted with a solution of the phenol corresponding to the p-substituted phenyl ester to be prepared. This reaction proceeds preferably in the presence of a tertiary amine, such as pyridine. When the conversion is complete, the p-substituted phenyl ester has been recovered by conventional techniques.

A preferred method for substituted phenyl esters is that disclosed in U.S. Pat. No. 3,890,372 in which a mixed anhydride is reacted with an appropriate phenol or naphthol. The anhydride is formed from the acid with isobutylchloroformate in the presence of a tertiary amine.

Phenacyl-type esters are prepared from the acid using a phenacyl bromide, for example p-phenylphenacyl bromide, in the presence of a tertiary amine. See, for example, U.S. Pat. No. 3,984,454, German Offenlegungsschrift No. 2,535,693, and Derwent Farmdoc No. 16828X.

Carboxyamides ( $X_1$  is  $-\text{COL}_4$ ) are prepared by one of several amidation methods known in the prior art. See, for example, U.S. Pat. No. 3,981,868, issued 21 Sept. 1976 for a description of the preparation of the present amido and cycloamido derivatives of prostaglandin-type free acids and U.S. Pat. No. 3,954,741 describing the preparation of carbonylamido and sulfonylamido derivatives of prostaglandin-type free acids.

The preferred method by which the present amido and cycloamido derivatives of the acids are prepared is, first, by transformation of such free acids to corresponding mixed acid anhydrides. By this procedure, the prostaglandin-type free acid is first neutralized with an equivalent of an amide base, and thereafter reacted with a slight stoichiometric excess of a chloroformate corresponding to the mixed anhydride to be prepared.

The amine base preferred for neutralization is triethylamine, although other amines (e.g., pyridine, methyl-diethylamine) are likewise employed. Further, a convenient, readily available chloroformate for use in the mixed anhydride production is isobutyl chloroformate.

The mixed anhydride formation proceeds by conventional methods and accordingly the free acid is mixed with both the tertiary amine base and the chloroformate in a suitable solvent (e.g., aqueous tetrahydrofuran), allowing the reaction to proceed at  $-10^\circ\text{C}$ . to  $20^\circ\text{C}$ .

Thereafter, the mixed anhydride is converted to the corresponding amido or cycloamido derivatives by reaction with the amine corresponding to the amide to be prepared. In the case where the simple amide ( $-\text{NH}_2$ ) is to be prepared, the transformation proceeds by the addition of ammonia. Accordingly, the corresponding amine (or ammonia) is mixed with the mixed anhydride at or about  $-10^\circ$  to  $+10^\circ\text{C}$ ., until the reaction is shown to be complete.

Thereafter, the novel amido or cycloamido or cycloamido derivative is recovered from the reaction mixture by conventional techniques.

The carbonylamido and sulfonylamido derivative of the presently disclosed PG-type compounds are likewise prepared by known methods. See, for example, U.S. Pat. No. 3,954,741 for description of the methods by which such derivatives are prepared. By this known method the acid is reacted with a carboxyacyl or sulfonyl isocyanate, corresponding to the carbonylamido or sulfonylamido derivative to be prepared.

By another, more preferred method the sulfonylamido derivatives of the present compounds are prepared by first generating the PG-type mixed anhydride, employing the method described above for the preparation of the amido and cycloamido derivatives. Thereafter, the sodium salt of the corresponding sulfonamide is reacted with the mixed anhydride and hexamethylphosphoramide. The pure PG-type sulfonylamido derivative is then obtained from the resulting reaction mixture by conventional techniques.

The sodium salt of the sulfonamide corresponding to the sulfonylamido derivative to be prepared is generated by reacting the sulfonamide with alcoholic sodium methoxide. Thus, by a preferred method methanolic sodium methoxide is reacted with an equal molar amount of the sulfonamide. The sulfonamide salt is then reacted, as described above, with the mixed anhydride, using about four equivalents of the sodium salt per equivalent of anhydride. Reaction temperatures at or about  $0^\circ\text{C}$ . are employed.

The compounds of this invention prepared by the processes of this invention, in free acid form, are transformed to pharmacologically acceptable salts by neutralization with appropriate amounts of the corresponding inorganic or organic base, examples of which correspond to the cations and amines listed hereinabove. These transformations are carried out by a variety of procedures known in the art to be generally useful for the preparation of inorganic, i.e., metal or ammonium salts. The choice of procedure depends in part upon the solubility characteristics of the particular salt to be prepared. In the case of the inorganic salts, it is usually suitable to dissolve an acid of this invention in water containing the stoichiometric amount of a hydroxide, carbonate, or bicarbonate corresponding to the inorganic salt desired. For example, such use of sodium hydroxide, sodium carbonate, or sodium bicarbonate gives a solution of the sodium salt. Evaporation of the water or addition of a water-miscible solvent of moderate polarity, for example, a lower alkanol or a lower alkanone, gives the solid inorganic salt if that form is desired.

To produce an amine salt, an acid of this invention is dissolved in a suitable solvent of either moderate or low polarity. Examples of the former are ethanol, acetone, and ethyl acetate. Examples of the latter are diethyl ether and benzene. At least a stoichiometric amount of the amine corresponding to the desired cation is then



added to that solution. If the resulting salt does not precipitate, it is usually obtained in solid form by evaporation. If the amine is relatively volatile, any excess can easily be removed by evaporation. It is preferred to use stoichiometric amounts of the less volatile amines.

Salts wherein the cation is quaternary ammonium are produced by mixing an acid of this invention with the stoichiometric amount of the corresponding quaternary ammonium hydroxide in water solution, followed by evaporation of the water.

#### DESCRIPTION OF THE PREFERRED EMBODIMENTS

The present invention is more completely understood by the operation of the following examples:

##### EXAMPLE 1

3-oxo-7 $\alpha$ -tetrahydropyran-2-yloxy-6 $\beta$ [(3'S)-3'-tetrahydropyran-2-yloxy-trans-1'-octenyl]-bicyclo[3.3.0]oct-1-ene

(Formula XXIV: R<sub>18</sub> is tetrahydropyranyloxy; Y<sub>1</sub> is trans—CH=CH—, M<sub>6</sub> is  $\alpha$ -tetrahydropyranyloxy; $\beta$ -H, L<sub>1</sub> is  $\alpha$ -H; $\beta$ -H, R<sub>27</sub> is n-butyl; and n is the integer one).

Refer to Chart A.

A. To a stirred solution of 19 ml (170 mmoles) dimethyl methylphosphonate and 600 ml of dry tetrahydrofuran at  $-78^{\circ}$  C. under an argon atmosphere is added dropwise over 5 min 110 ml (172 mmoles) of 1.56 M n-butyllithium in hexane. The resulting solution is stirred for 30 min at  $-78^{\circ}$  C., treated with 25.4 g of 3 $\alpha$ ,5 $\alpha$ -dihydroxy-2 $\beta$ -(3 $\alpha$ -hydroxy-trans-1-octenyl)-1 $\alpha$ -cyclopentaneacetic acid, lactone, bis(tetrahydropyranyl)ether, in 100 ml of dry tetrahydrofuran dropwise over one hr, and stirred for one hr at  $-78^{\circ}$  C. and four hr at room temperature. The reaction is then quenched by addition of 10 ml glacial acetic acid, diluted with 700 ml of brine, and extracted with diethyl ether (3 $\times$ 700 ml). The combined ethereal layers are washed with 200 ml bicarb and 500 ml brine and dried over anhydrous sodium sulfate and concentrated under reduced pressure to yield 37 g of formula XXII compound as oily white solid: 3-dimethylphosphonomethyl-3-hydroxy-2-oxa-7 $\alpha$ -tetrahydropyran-2-yloxy-6 $\beta$ [(3'S)-3'-tetrahydropyran-2-yloxy-trans-1'-octenyl]-bicyclo[3.3.0]octane. Crystallization of the crude product from hexane and ether yields 22.1 g of purified formula XXII product. Silica gel TLC R<sub>f</sub> is 0.22 in ethyl acetate. The melting range is 89°–93° C. NMR absorptions are observed at 3.72 (doublet, J=11 Hz) and 3.83 (doublet, J=11 Hz) $\delta$ . Characteristic infrared absorptions are 3340, 1250, 1185, 1130, 1075, and 1030 cm<sup>-1</sup>.

B. To a solution of 10.0 g of the product of Part A in 75 ml acetone stirring under a nitrogen atmosphere at  $-10^{\circ}$  C. is added over 30 min 9.0 ml of Jones reagent. The resulting suspension is stirred for 30 min at  $-10^{\circ}$  C. and then quenched with 4 ml 2-propanol. The solvents are decanted away from the green residue and most of the acetone removed at reduced pressure. The acetone concentrate is then taken up in ethyl acetate and washed with saturated aqueous sodium bicarbonate and then with brine and dried over anhydrous sodium sulfate. Concentration under reduced pressure yields 8.2 g of formula XXIII product: 2-decarboxy-6-desbutyl-6-dimethylphosphonomethyl-6-keto-PGE<sub>1</sub>, 11,15-bis(tetrahydropyranyl ether). Chromatography of formula XXIII product on 600 g silica gel eluting with 20% acetone in methylene chloride yields 4.95 g of pure formula XXIII product. Silica gel TLC R<sub>f</sub> (in 20%

acetone in methylene chloride) is 0.22. Characteristic NMR absorptions are observed at 3.14 (doublet, J=23 Hz) and 3.80 (doublet, J=11 Hz), 5.4–5.8 (m) $\delta$ . Characteristic infrared absorptions are observed at 1745, 1715, 1260, 1200, 1185, 1130, 1030, 970, 870 cm<sup>-1</sup>.

C. A suspension of 5.37 g of the product of Example 1, Part B, 1.33 g anhydrous potassium carbonate, and 5.37 g 18-Crown-6 ether in 200 ml toluene is heated at 75° C. for six hr under a nitrogen atmosphere, cooled to 0° C., and washed with 200 ml brine, 200 ml of 3:1 water:brine, and 200 ml brine, and dried over anhydrous sodium sulfate. Most of the solvents are removed under reduced pressure and the residue is filtered through 50 g silica gel eluting with 250 ml ethyl acetate to give 3.9 g of formula XXIV product: 3-oxo-7 $\alpha$ -tetrahydropyranyl-2-yloxy-6 $\beta$ [(3'S)-3'-tetrahydropyran-2-yl-trans-1'-octenyl]bicyclo[3.3.0]oct-1-ene. The crude product is chromatographed on 300 g silica gel eluting with 60:40 hexane:ethyl acetate to give 2.39 g of pure title product. Silica gel TLC R<sub>f</sub> is 0.22 in 60:40 hexane:ethyl acetate. NMR absorptions are observed at 5.18–5.86 (m) and 5.94 (broad singlet) $\delta$ . Infrared absorptions are observed at 1710 and 1632 cm<sup>-1</sup>.

Following the procedure of Example 1, but employing the various 3 $\alpha$ ,5 $\alpha$ -hydroxy-2-substituted-1 $\alpha$ -cyclopentaneacetic acid  $\delta$ -lactones of formula XXI, there are prepared each of the various corresponding formula XXIV products wherein n is one.

Further, following the procedure of Example 1, but employing each of the various 3 $\alpha$ ,5 $\alpha$ -dihydroxy-2-substituted-1 $\alpha$ -cyclopentaneacetic acid,  $\delta$ -lactones of formula XXI, there are prepared each of the various formula XXIV compounds wherein n is 2.

Further, following the procedure of Example 1, but employing each of the various 5 $\alpha$ -hydroxy-2-substituted-1 $\alpha$ -cyclopentanealkanoic acid lactones of formula XXI, there are prepared each of the various formula XXIV compounds wherein R<sub>18</sub> is hydrogen. Finally, following the procedure of Example 1, but employing each of the various 3 $\alpha$ -hydroxymethyl-5 $\alpha$ -hydroxy-2-substituted-1 $\alpha$ -cyclopentanealkanoic acid lactones of formula XXI, there are prepared each of the various formula XXIV compounds wherein R<sub>18</sub> is —CH<sub>2</sub>OR<sub>10</sub>.

##### EXAMPLE 2

3-oxo-8 $\alpha$ -tetrahydropyran-2-yloxy-7 $\beta$ [(3'S)-3'-tetrahydropyran-2-yloxy-trans-1'-octenyl]bicyclo[4.3.0]non-1-ene

(Formula XXIV: R<sub>18</sub>, Y<sub>1</sub>, M<sub>6</sub>, R<sub>7</sub> are defined in Example 1 and n is the integer 2).

Refer to Chart A.

A. A solution of 2.05 ml (18.9 mmoles) of dimethyl methylphosphonate and 100 ml of dry tetrahydrofuran is stirred at  $-78^{\circ}$  C. under a nitrogen atmosphere and treated dropwise with 11.8 ml (18.9 mmoles) of 1.6 molar n-butyllithium in hexane. After stirring for 30 min at  $-78^{\circ}$  C., the resulting mixture is treated dropwise over 25 min with 4.25 g of 3 $\alpha$ ,5 $\alpha$ -dihydroxy-2 $\beta$ -(3 $\alpha$ -hydroxy-trans-1-octenyl) 1 $\alpha$ -cyclopentane propionic acid,  $\delta$ -lactone, 11,15-bis(tetrahydropyranyl ether), in 30 ml of dry tetrahydrofuran. The resulting mixture is then stirred for one hr at 78° C. The solution is then allowed to stir at ambient temperature for 2 hr and is quenched by addition of 1.2 ml of acetic acid. The mixture is then added to 250 ml of brine and 200 ml of diethyl ether. The aqueous and organic layers are then separated and the aqueous layer extracted twice with

diethyl ether. The ethereal extracts are then washed with brine, dried over anhydrous sodium sulfate, and concentrated to yield 5.6 g of crude formula XXII compound, as an oil: 3-(dimethylphosphonomethyl)-3-hydroxy-2-oxo-8 $\alpha$ -tetrahydropyran-2-yl-oxy-7 $\beta$ [(3'S)-3'-tetrahydropyran-2-yloxy-trans-1'-octenyl]-bicyclo[4.3.0]nonane. Chromatography on silica gel eluting with 4:1 ethyl acetate:acetone yields 4.1 g of purified formula XXII product. Characteristic NMR absorption is observed at 5.15–5.65 (multiplet) $\delta$ . Silica gel TLC  $R_f$  is 0.34 in 4:1 ethyl acetate:acetone. Characteristic infrared absorptions are observed at 3350, 1235, and 1030  $\text{cm}^{-1}$ .

B. A suspension of 3.42 g of chromium trioxide and 80 ml of methylene chloride is treated with 5.8 ml of pyridine, stirred at ambient temperature under a nitrogen atmosphere for 30 min, and combined with 3 scoops of dry diatomaceous earth. The resulting mixture is then treated with 3.25 g of the reaction product of Part A and 8 ml of dry dichloromethane, stirred for 30 min at ambient temperature under nitrogen, filtered through 30 g of silica gel (eluting with 200 ml of ethylacetate and acetone, 2:1) and concentrated under reduced pressure. Chromatographing the residue (3.73 g) on 120 g of silica gel, eluting with ethyl acetate and acetone (4:1) yields 2.07 g of formula XXIII product: 2-decarboxy-5-despropyl-6-dimethylphosphonomethyl-5-keto-PFE<sub>1</sub>, 11,15-bis(tetrahydropyranyl ether). Characteristic infrared absorptions are observed at 1740 and 1715  $\text{cm}^{-1}$ .

Characteristic NMR absorptions are observed at 3.1 (doublet,  $J=23$  Hz) and 3.8 (doublet,  $J=11$  Hz) $\delta$ .

C. A suspension of 12 mg of 50% sodium hydride in mineral oil and 3 ml of diglyme is stirred at 0° C. under an argon atmosphere. The suspension is then treated with 150 mg of the product of Part B in 3 ml of diglyme. After 1 hr, the cooling bath is removed and the resulting solution is stirred at ambient temperature under argon. After a total of 20 hr from addition of the formula XXIII reactant, the resulting solution is then added to 30 ml of water and extracted with 90 ml of diethyl ether. The ethereal extract is washed with brine (30 ml), dried over anhydrous sodium sulfate, concentrated under reduced pressure to a brown oil (110 mg) and chromatographed on 10 g of silica gel eluting with hexane and ethyl acetate (1:1). There is accordingly prepared 15 mg of formula XXIV compound: 3-oxo-8 $\alpha$ -tetrahydropyran-2-yloxy-7 $\beta$ [(3'S)-3'-tetrahydropyran-2-yloxy-trans-1'-octenyl]bicyclo[4.3.0]non-1-ene. NMR absorptions are observed at 4.7 (broad singlet) and 5.3–6.0 (multiplet) $\delta$ . IR absorption is observed at 1670  $\text{cm}^{-1}$ .

Alternatively, the formula XXIV compound above is prepared as follows:

A solution of 150 mg of the product of Part B and 5 ml of dry tetrahydrofuran at 0° C. under an argon atmosphere is treated dropwise with 0.5 ml of 0.52 M potassium hydride and 18-crown-6 ether (Aldrich Chemical Co. Catalog Handbook of Fine Chemicals 1979–1980, Milwaukee, Wisconsin, p. 133; Pedersen, J. C., JACS 92:386 (1970) in tetrahydrofuran (prepared from 800 mg potassium hydride and 1.0 g 18-crown-6 ether in 8.7 ml of dry tetrahydrofuran). After stirring for one hr at 0° C. under argon, the mixture is added to 30 ml of water, extracted with 90 mg of diethyl ether and the ethereal extract is washed with brine, dried over anhydrous sodium sulfate, concentrated under reduced pressure, and chromatographed on 9 g of silica gel eluting with ethyl acetate and hexane. Formula XXIV product (40

mg) is thereby obtained. Silica gel TLC  $R_f$  is 0.30 in ethyl acetate and hexane (1:1).

#### EXAMPLE 3

1 $\beta$ -Methyl-3-oxo-7 $\alpha$ -tetrahydropyran-2-yl-oxy-6 $\beta$ -[(3'S)-3'-tetrahydropyran-2-yloxy-trans-1'-octenyl]-bicyclo-[3.3.0]octane

(Formula XXV: R<sub>18</sub>, Y<sub>1</sub>, M<sub>6</sub>, n, L<sub>1</sub>, R<sub>7</sub> are as defined in Example 1, R<sub>16</sub> is hydrogen and R<sub>37</sub> is methyl).

Refer to Chart A.

A suspension of 2.70 g of anhydrous copper iodide is stirred in 100 ml of anhydrous diethyl ether at –20° C. under an argon atmosphere and is treated dropwise with 20.0 ml of 1.4 M ethereal methyllithium. The resulting solution is then stirred for 15 min at –20° C. and treated over 2.5 hr at –20° C. with a solution of 2.00 g of the title product of Example 1 in 100 ml of anhydrous diethyl ether. Stirring is continued for an additional 1.5 hr at –20° C. and the resulting mixture added to 200 ml of 1 M aqueous ammonium chloride. The aqueous and organic layers are then separated and the aqueous layer extracted with diethylether (400 ml). The combined organic extracts are then washed with 200 ml of brine, dried over anhydrous sodium sulfate, concentrated under reduced pressure to yield 2.4 g of title product as a pale green oil. Chromatography on 25 g of silica gel eluting with hexane in ethyl acetate (3:1) yields 2.0 g of title product as a colorless oil. Characteristic NMR absorptions (CDCl<sub>3</sub>) are observed at 1.18, 3.20–4.43, 4.70, and 5.2–5.9 $\delta$ . Characteristic infrared absorptions are observed at 1745, 1665, 1200, 1130, 1110, 1075, 1035, 1020, 980, and 870  $\text{cm}^{-1}$ . Silica gel  $R_f$  is 0.26 in ethyl acetate and hexane (1:3).

By procedures known in the art, each of the various novel formula XXV intermediates is transformed to a 9 $\beta$ -methyl-CBA<sub>2</sub> or CBA<sub>1</sub> compound by methods exemplified hereinafter or known from British Published Specification Nos. 2,013,661, 2,014,143, and 2,017,699.

#### EXAMPLE 4

5-Carboxypentanol, t-butyl(dimethylsilyl) ether

A solution of 4 g of sodium hydroxide in 100 ml of methanol and water (4:1) is treated with 10 ml of caprolactone and stirred at ambient temperature under a nitrogen atmosphere. After 20 hr, solvent is evaporated following addition of toluene, yielding 15 g of solid, crude 5-carboxypentanol.

The above solid is suspended in 300 ml of dimethylformamide under a nitrogen atmosphere, cooled to 0° C., treated with 35 g of imidazole, stirred for 15 min at 0° C. and 15 min at ambient temperature, cooled to 0° C. and treated with 39 g of t-butyl(dimethylsilyl)chloride. The resulting solution is then allowed to warm to ambient temperature under a nitrogen atmosphere. After 26 hr, the resulting solution is treated with 8 g of sodium hydroxide in 40 ml of water and 40 ml of methanol, with stirring maintained under a nitrogen atmosphere. After 13 hr, the suspension is acidified to pH 4 with 500 ml of 1 N aqueous hydrogen chloride, then saturated with sodium chloride and extracted with ethyl acetate. The ethyl acetate extracts are then washed with 1 N aqueous sodium hydroxide. The basic extracts are then acidified to pH 4 with concentrated hydrochloric acid, saturated with brine, and extracted with ethyl acetate. The ethyl acetate extracts are then washed with brine, dried over sodium sulfate, and concentrated under reduced pressure to yield 22.6 g of a yellow liquid, 5-carboxypen-

tanol, t-butyltrimethylsilyl ether. Chromatography on 800 g of silica gel eluting with ethyl acetate and hexane (1:9 to 1:1) yields 14.8 g of 5-carboxypentanol, t-butyltrimethylsilyl ether. NMR absorptions are observed at 0.05 (singlet) and 0.90 (singlet) $\delta$ . Infrared absorptions are observed at 3000 (broad) and 1700  $\text{cm}^{-1}$ .

Following the procedure of Example 4, but employing each of the various lactones corresponding to the  $\omega$ -carboxyalkanol compounds of formula XXXII there are prepared each of the various formula XXXII products.

## EXAMPLE 5

2-Decarboxy-2-(t-butyltrimethylsilyloxy)methyl-5-carboxy-6-hydroxy-9 $\beta$ -methyl-CBA<sub>1</sub>,  
11,15-bis(tetrahydropyran)ether

(Formula XXXIII: R<sub>28</sub> is t-butyltrimethylsilyl, Z<sub>2</sub> is  $-(\text{CH}_2)_3-$ , n is 1, and R<sub>16</sub>, R<sub>18</sub>, R<sub>37</sub>, M<sub>6</sub>, L<sub>1</sub>, and R<sub>4</sub> are as defined in Example 3).

Refer to Chart B.

A solution of 0.58 ml of dry diisopropylamine and 20 ml of dry tetrahydrofuran at 0° C. under an argon atmosphere is treated with 2.6 ml of 1.56 M n-butyllithium in hexane, stirred for 5 to 10 min at 0° C., treated with 0.50 g of the title product of Example 4 in 5 ml of tetrahydrofuran, stirred for 15 min at 0° C. and 1 hr at ambient temperature, cooled to 0° C., treated with 0.91 g of the title product of Example 3 in 5 ml of tetrahydrofuran, and allowed to slowly warm to ambient temperature under an argon atmosphere. Thereafter, 130 ml of water and 20 ml of brine are added and the mixture extracted with diethyl ether. The ethereal extracts are then washed with 4 ml of 1 N aqueous hydrochloric acid and 150 ml of brine and dried over sodium sulfate, and concentrated under reduced pressure to yield title product.

Following the procedure of Example 5, but employing each of the various formula XXXI compounds described following Example 1, there are prepared each of the various formula XXXIII compounds wherein R<sub>28</sub> t-butyltrimethylsilyl and Z<sub>2</sub> is  $-(\text{CH}_2)_3-$ .

## EXAMPLE 6

2-Decarboxy-2-(t-butyltrimethylsilyloxy)methyl-9 $\beta$ -methyl-CBA<sub>2</sub>, 11,15-bis(tetrahydropyran)ether

(Formula XXXIV: R<sub>28</sub>, Z<sub>2</sub>, n, R<sub>18</sub>, Y<sub>1</sub>, M<sub>6</sub>, L<sub>1</sub> and R<sub>7</sub> are as defined for Examples 1 and 5).

The reaction product of Example 5 (1.37 g) and 16 ml of methylene chloride is treated with 2.9 ml of dimethylformamide dineopentyl acetal, stirred for 3 hr at ambient temperature under nitrogen, added to 160 ml of ice water and 40 ml of brine, and extracted with diethyl ether. The ethereal extracts are then washed with 150 ml of sodium bicarbonate and 150 ml of brine, dried over sodium sulfate, and concentrated under reduced pressure to yield crude title product. Chromatography on 100 g of silica gel eluting with 10% ethyl acetate in hexane yields pure title product.

Following the procedure of Example 6, but employing each of the various formula XXXIII compounds described following Example 5, there are prepared each of the various corresponding formula XXXIV products wherein R<sub>28</sub> is t-butyltrimethylsilyl and Z<sub>2</sub> is  $-(\text{CH}_2)_3-$ .

## EXAMPLE 7

2-Decarboxy-2-hydroxymethyl-9 $\beta$ -methyl-CBA<sub>2</sub>,  
11,15-bis(tetrahydropyran)ether

(Formula XXXV: Z<sub>2</sub>, n, R<sub>16</sub>, R<sub>37</sub>, R<sub>18</sub>, Y<sub>1</sub>, M<sub>6</sub>, L<sub>1</sub>, and R<sub>7</sub> are as defined in Examples 1 and 5).

Refer to Chart B.

A solution of 0.71 g of the title product of Example 6 and 16 ml of dry tetrahydrofuran at 0° C. under a nitrogen atmosphere is treated with 3.2 ml of 0.75 molar tetra-n-butylammoniumfluoride and tetrahydrofuran. After allowing the reaction mixture to slowly warm to ambient temperature overnight with stirring, 150 ml of brine is added and the resulting mixture extracted with ethyl acetate. The ethyl acetate extracts are then washed with 0.5 N aqueous potassium bisulfate, 100 ml of sodium bicarbonate, and 100 ml of brine, dried over sodium sulfate, and concentrated under reduced pressure to yield crude title product. Filtering through 25 g of silica gel with 200 ml of ethyl acetate and hexane yields 0.61 g of further purified product. Chromatography on silica gel eluting with 35% ethyl acetate in hexane yields pure title product.

Following the procedure of Example 7, but employing each of the various formula XXXIV compounds described in and following Example 6, there are prepared each of the various formula XXXV compounds wherein Z<sub>2</sub> is  $-(\text{CH}_2)_3-$ .

Following the procedure of Examples 5, 6, and 7, and employing the various starting materials described in and following these examples and each of the various formula XXXII compounds described in and following Example 4, there are prepared each of the various formula XXXV compounds.

## EXAMPLE 8

2-Decarboxy-2-hydroxymethyl-9 $\beta$ -methyl-CBA<sub>2</sub>

(Formula XXXVI: X<sub>1</sub> is  $-\text{CH}_2\text{OH}$ , Z<sub>2</sub> is  $-(\text{CH}_2)_3-$ , R<sub>8</sub> is hydroxy, Y<sub>1</sub> is trans- $\text{CH}=\text{CH}-$ , M<sub>1</sub> is  $\alpha\text{-OH}:\beta\text{-H}$ , L<sub>1</sub> is  $\alpha\text{-H}:\beta\text{-H}$  and R<sub>7</sub> is n-butyl).

Refer to Chart B.

The title product of Example 7 (0.25 g) is combined with 9 ml of acetic acid, water and tetrahydrofuran (6:3:1) and heated to 37°-40° C. for two hr. Thereafter the resulting mixture is cooled and extracted with diethyl ether. The ethereal extracts are then washed with brine, dried over sodium sulfate and concentrated to yield crude title product. Chromatography on silica gel yields pure title product.

Following the procedure of Example 7, but employing each of the various formula XXXV primary alcohols described in and following Example 7 there are prepared each of the various corresponding formula XXXVI products wherein X<sub>1</sub> is  $-\text{CH}_2\text{OH}$ .

## EXAMPLE 9

o-(t-Butyltrimethylsilyloxyethyl)benzaldehyde

(Formula XLIV: R<sub>28</sub> is t-butyltrimethylsilyloxy and g is one).

Refer to Chart C.

A. To a mixture of 7.6 g of lithium aluminum hydride and 400 ml of dry tetrahydrofuran under a nitrogen atmosphere is added dropwise with stirring 18 g of homophthalic acid (Aldrich Chemical Company) in 250 ml of dry tetrahydrofuran. Dropwise addition rate is adjusted such that mild reflux is maintained during the

course of the exothermic reaction. The resulting mixture is then heated at reflux for 5 hr, cooled to 0° C., and 7.6 g of water in 50 ml of tetrahydrofuran is added dropwise with stirring. Thereafter 27 ml of 10% aqueous sodium hydroxide is added and the resulting mixture is stirred at ambient temperature for 20 min, filtered, and the filter solids washed with 150 ml of tetrahydrofuran. The filtrate and tetrahydrofuran wash are then concentrated under reduced pressure to yield 14.0 g of crude formula XXXII diol, 2-(*o*-hydroxymethylphenyl)ethanol. Chromatography on 1.2 kg of silica gel, deactivated by addition of 240 ml of ethyl acetate, eluting with ethyl acetate, yields 13.5 g of formula XLII product. Melting range is 41.5°–43° C.

B. To a solution of 13.5 g of the reaction product of Part A in 50 ml of dry tetrahydrofuran under a nitrogen atmosphere is added with stirring 9.05 g of imidazole. The resulting solution is then cooled to –5° C. and 13.9 g of *t*-butyldimethylsilyl chloride is added. The resulting mixture is then maintained for 20 min and thereafter allowed to warm to ambient temperature. After 1 hr, the resulting mixture is then shaken with 500 ml of hexane and diethylether (2:1) and 250 ml of water and brine (1:1). The organic layer is then washed with water and brine, dried over magnesium sulfate, and concentrated under reduced pressure to yield a crude mixture of mono- and bis-silyl ethers corresponding to the starting material of Part A. This mixture of products is then chromatographed on 2 kg of silica gel, deactivated with 400 ml of ethyl acetate and eluted with 25% ethyl acetate and Skellysolve B to yield 6.82 g of formula XLIII product, *o*-(*t*-butyldimethylsilyloxyethyl)phenylmethanol. NMR absorptions are observed at 7.20–7.52, 4.57, 3.91 (t, J G.1), 2.93 (t, J 6.1), 0.82, and –0.08δ. Silica gel TLC  $R_f$  is 0.54 in 25% ethyl acetate and hexane.

C. A mixture of 5.0 g of the reaction product of Part B, 100 ml of trichloromethane, and 25 g of activated manganese dioxide (MnO<sub>2</sub>) is stirred at ambient temperature for 4 hr. Chloroform (100 ml) is then added and the resulting mixture filtered through diatomaceous earth. After washing filter solids with 200 ml of trichloromethane, the resulting filtrate and wash is then concentrated under reduced pressure to yield a residue containing title product. Chromatography on 400 g of silica gel, deactivated with 80 ml of ethyl acetate and elution with 25% ethyl acetate and hexane yields 2.93 g of pure title product. Silica gel TLC  $R_f$  is 0.74 in 25% ethyl acetate and hexane. NMR absorptions are observed at 10.34, 7.25–8.00, 3.89 (t, J 6.0), 3.27 (t, J 6.0), 0.83 and –0.09δ. The mass spectrum exhibits a peak at 265 (M+1) and other peaks of decreasing intensity at *m/e* 75, 207, 73, 133, 223, 208, 77, 177, 76 and 105.

Following the procedure described in Chart C, but employing each of the various formula XXXI acids, there is prepared each of the various corresponding formula XXXIV aldehydes wherein R<sub>28</sub> is *t*-butyldimethylsilyl.

#### EXAMPLE 10

*m*-(*t*-Butyldimethylsilyloxymethyl)benzaldehyde

(Formula XLIV: *g* is zero and R<sub>28</sub> is *t*-butyldimethylsilyl).

Refer to Chart C.

A. To a solution of 10.0 g of *m*-(hydroxymethyl)phenylmethanol in 40 ml of dry tetrahydrofuran under a nitrogen atmosphere is added with stirring 7.35 g imidazole. The resulting solution is then cooled to 0° C.

and 11.3 g of *t*-butyldimethylsilyl is added. The resulting mixture is then stirred with cooling for 15 min and thereafter allowed to warm to ambient temperature. After 90 min, the resulting mixture is then shaken in 400 ml of hexane and diethyl ether (2:1) and 200 ml of water and brine (1:1). The organic layer is then washed successively with water and brine (1:1, 300 ml) and brine (150 ml), dried over magnesium sulfate and concentrated under reduced pressure to yield a mixture of mono- and bis-*t*-butyldimethylsilyloxy ether corresponding to the formula XXXII compound. This mixture of products is then chromatographed on 1.4 kg of silica gel, deactivated by addition of 280 ml of ethyl acetate and eluted with 25–40% ethyl acetate in hexane to yield 7.65 kg of pure formula XLIII product, *m*-(*t*-butyldimethylsilyloxymethyl)phenylmethanol. Silica gel TLC  $R_f$  is 0.46 in 25% ethyl acetate and hexane. NMR absorptions are observed at 7.25, 4.72, 4.60, 2.23, 0.92, and 0.09δ. The mass spectrum exhibits a peak at 251 (M+1) and other peaks of decreasing intensity at *m/e* 235, 121, 195, 237, 105, 133, 75, 89, 236, and 119.

B. A mixture of 5.0 g of the reaction product of Part A and 100 ml of trichloromethane and 25 g of activated manganese dioxide (MnO<sub>2</sub>) is stirred at ambient temperature for 4 hr. Chloroform (100 ml) is then added and the resulting mixture filtered through diatomaceous earth. The filter solids are washed with 200 ml of trichloromethane and the filtrate and trichloromethane wash are then concentrated under reduced pressure to yield 5.2 g of crude title product. Chromatography on 400 g of silica gel, deactivated with 80 ml of ethyl acetate and elution with ethyl acetate and hexane (1:3) yields 3.65 g of pure title product. Silica gel TLC  $R_f$  is 0.46 in 10% ethyl acetate and hexane. NMR absorptions are observed at 10.00, 7.26–7.86, 4.81, 0.95, and 0.11δ.

#### EXAMPLE 11

3-Phenylsulfonyl-7 $\alpha$ -tetrahydropyran-2-yloxy-6 $\beta$ -[(3'S)-3'-tetrahydropyran-2-yloxy-trans-1'-octenyl]-bicyclo-[3.3.0]octane

(Formula LV: *n* is the integer one, R<sub>18</sub> is tetrahydropyran-yloxy, Y<sub>1</sub> is trans—CH=CH—, M<sub>6</sub> is  $\alpha$ -tetrahydropyran-yloxy: $\beta$ -hydrogen, L<sub>1</sub> is  $\alpha$ -hydrogen: $\beta$ -hydrogen, R<sub>16</sub> and R<sub>17</sub> are both hydrogen, and R<sub>27</sub> is *n*-butyl).

Refer to Chart D.

A. Sodium borohydride (0.38 g) is added with stirring to a solution of 2.90 g of 3-oxo-7 $\alpha$ -tetrahydropyran-2-yloxy-6 $\beta$ -[(3'S)-3'-tetrahydropyran-2-yloxy-trans-1'-octenyl]-bicyclo[3.3.0]octane in 25 ml of 95% aqueous ethanol. The resulting mixture is then stirred at ambient temperature for 20 min. Thereafter the resulting mixture is shaken in 100 ml of brine and 200 ml of ethyl acetate. The organic layer is then immediately washed in brine, dried over magnesium sulfate, and concentrated under reduced pressure to yield 2.94 g of formula LII alcohol: (3RS)-3-hydroxy-7 $\alpha$ -tetrahydropyran-2-yloxy-6 $\beta$ -[(3'S)-3'-tetrahydropyran-2-yloxy-trans-1'-octenyl]bicyclo[3.3.0]octane. Infrared absorptions are observed at 3600 and 3450 cm<sup>-1</sup> and no carbonyl absorption. Silica gel TLC  $R_f$  is 0.63 and 0.67 in ethyl acetate and hexane (1:1).

B. To a solution of 2.9 g of the reaction product of Part A in 25 ml of dry dichloromethane and 1.4 ml (1.02 g) of triethylamine at 0° C. is added with stirring 0.57 ml of (0.848 g) of methanesulfonyl chloride over 5 min. The resulting is then stirred an additional 20 min and

shaken with 160 ml of diethyl ether and 80 ml of cold (0° C.) dilute aqueous hydrochloric acid. The organic layer is then washed successively in brine, dilute aqueous potassium bicarbonate, and brine, dried over sodium sulfate, and concentrated under reduced pressure to yield 3.5 g of crude formula LIII compound: (3R,S)-3-hydroxy-7 $\alpha$ -tetrahydropyran-2-yloxy-6 $\beta$ -[(3'S)-3'-tetrahydropyran-2-yloxy-trans-1'-octenyl]bicyclo[3.3.0]octane, 3-methylsulfonate.

C. Thiophenol (1.13 ml, 1.21 g) is added to a mixture of 1.12 g of potassium t-butoxide in 15 ml of dry dimethylsulfoxide (DMSO) under a nitrogen atmosphere. To the solution of potassium thiophenoxide thus prepared is added 3.5 g of the reaction product of Part B in 8 ml of dimethylsulfoxide. The resulting mixture is then stirred at ambient temperature for 16 hr, whereupon additional potassium t-butoxide is added so as to transform the solution to a distinct yellow color. The resulting mixture is then stirred an additional 4 hr at ambient temperature, diluted with 100 ml of diethyl ether and 100 ml of hexane, washed with 5% aqueous potassium hydroxide (200 ml) and brine (200 ml), dried over magnesium sulfate, and concentrated under reduced pressure to yield 5 g of a residue of crude formula LIV compound: 3-phenylthio-7 $\alpha$ -tetrahydropyran-2-yloxy-6 $\beta$ -[(3'S)-3'-tetrahydropyran-2-yloxy-trans-1'-ocenyl]bicyclo[3.3.0]octane. Chromatography on 300 g of silica gel, deactivated with 40 ml of diethyl ether and 40 ml of trichloromethane and eluted with 5% diethyl ether in trichloromethane yields 3.1 g of pure product. Silica gel TLC R<sub>f</sub> is 0.75 in 10% ethyl acetate in dichloromethane.

D. To a solution of 3.1 g of the reaction product of Part C and 50 ml of dichloromethane at 0° C. is added with stirring over 10 min 2.43 g of 85% m-chloroperbenzoic acid. The resulting mixture is then stirred at 0° C. for 30 min, diluted with 150 ml of dry ethyl ether, washed with ice cold dilute aqueous potassium hydroxide and brine, dried over magnesium sulfate, and concentrated under reduced pressure to yield 3.4 g of crude title product. Chromatography on 350 g of silica gel, deactivated with 70 ml of ethyl acetate and elution with 500 ml of 30–50% ethyl acetate in hexane yields 2.90 g of pure title product as a mixture of C-6 isomers. Silica gel TLC R<sub>f</sub>'s are 0.41, 0.45 and 0.48 in 30% ethyl acetate in hexane (stereoisomers). NMR absorptions are observed at 7.52–8.02, 5.30–5.67, 4.70, and 3.30–4.13 $\delta$ .

Following the procedure of Example 11, each of the formula LI compounds is transformed to the corresponding formula LV 3-phenylsulfonyl compound.

#### EXAMPLE 12

##### (5E)-2,5-inter-o-phenylene-3,4-dinor-CBA<sub>2</sub>

(Formula LX: X<sub>1</sub> is —COOH, g is one, n is one, R<sub>16</sub> and R<sub>17</sub> are hydrogen, R<sub>8</sub> is hydroxy, Y<sub>1</sub> is trans—CH=CH—, M<sub>1</sub> is  $\alpha$ -OH: $\beta$ -H, L<sub>1</sub> is  $\alpha$ -H: $\beta$ -H, and R<sub>7</sub> is n-butyl), its methyl ester and the corresponding (5Z) isomers thereof.

Refer to Chart C.

A. To a solution of 1.26 g of the title product of Example 11 in 15 ml of dry tetrahydrofuran at —78° C. under a nitrogen atmosphere is added dropwise with stirring 1.48 ml of 1.6 M n-butyllithium in hexane over 1 min. After 10 min 0.66 g of title product of Example 4 in 5 ml of dry tetrahydrofuran is added. After 45 min 0.26 ml of distilled acetic anhydride is added. Stirring is then continued at —78° C. for 3 hr and at ambient temperature for an additional 2 hr. The resulting mixture is then shaken with 120 ml of diethyl ether and 80 ml of

saturated aqueous ammonium chloride. The organic layer is then washed with 15 ml of brine, dried over magnesium sulfate, and concentrated under reduced pressure to yield 2.21 g of formula LVI product as a mixture of isomers: 3-[ $\alpha$ -acetoxy-o-(t-butylidimethylsilyloxyethyl)- $\alpha$ -tolyl]-3-phenylsulfonyl-7 $\alpha$ -(tetrahydropyran-2-yl)oxy-6 $\beta$ -[(3'S)-3'-(tetrahydropyran-2-yl)oxy-trans-1'-ocenyl]bicyclo[3.3.0]octane. R<sub>28</sub>, g, R<sub>17</sub>, n, R<sub>18</sub>, Y<sub>1</sub>, M<sub>6</sub>, L<sub>1</sub>, and R<sub>27</sub> are defined in Examples 9 and 11. Silica gel TLC R<sub>f</sub> range is 0.30–0.53 (8 spots) (stereoisomers) in 25% ethyl acetate and hexane.

B. The mixture of isomeric products of Part A (2.21 g) and 40 ml of methanol and 20 ml of ethyl acetate is stirred at —20° C. with chips of 5.6% sodium amalgam for 60 min. After decanting liquid, excess amalgam and solids are rinsed by decantation employing 200 ml of diethyl ether. The organic solutions are then combined, washed with brine, dried, and concentrated under reduced pressure to yield 1.8 g of crude 2-decarboxy-2-(t-butylidimethylsilyloxymethyl)-2,5-inter-o-phenylene-3,4-dinor-CBA<sub>2</sub>, 11,15-bis(tetrahydropyranyl ether). Chromatography on 250 g of silica gel, deactivated with 50 ml of diethyl ether and eluted with 30% diethyl ether in hexane yields 1.06 g of pure product. Silica gel TLC R<sub>f</sub>'s are 0.49, 0.56, and 0.62 (stereoisomers) in 30% diethyl ether and hexane. NMR absorptions are observed at 7.20, 6.54, 5.22–5.80, 4.72, 3.38–4.16 and 2.74–3.00 $\delta$ .

C. A solution of 1.06 g of the reaction product of Part B in 10 ml of dry tetrahydrofuran is treated with 3.2 ml of 0.75 N tetra-n-butylammonium fluoride in tetrahydrofuran at ambient temperature for 40 min. The resulting mixture is then diluted with 125 ml of diethyl ether. The resulting solution is then washed with brine, dried over magnesium sulfate, and concentrated under reduced pressure to yield a residue of isomeric formula LVIII products: (5E)- and (5Z)-2-decarboxy-2-hydroxymethyl-2,5-inter-o-phenylene-3,4-dinor-CBA<sub>2</sub>, 11,15-bis-(tetrahydropyranyl ether). Chromatography on 100 g of silica gel, deactivated with 20 ml of ethyl acetate and eluted with 25–50% ethyl acetate in hexane yields 0.40 g of (5Z) isomer and 0.51 g of (5E) isomer. For the (5Z) isomer silica gel TLC R<sub>f</sub>'s are 0.31 and 0.35 (stereoisomers) in 25% ethyl acetate and hexane. NMR absorptions are observed at 7.20, 6.51, 5.10–5.72, 4.69, 3.32–4.16, and 2.76–3.00 $\delta$ . For the (5E) isomer silica gel TLC R<sub>f</sub>'s are 0.20 and 0.24 (stereoisomers) in 25% ethyl acetate and hexane. NMR absorptions are observed at 7.19, 6.50, 5.10–5.64, 4.70, 3.32–4.10, and 2.88–3.01 $\delta$ .

D. To a solution of 400 mg of the (5Z) reaction product of Part C in 20 ml of dry acetone at —50° C. is added with stirring 1.0 ml of Jones reagent (prepared as follows: 26.72 g of chromium trioxide in 23 ml of concentrated sulfuric acid diluted with water to a volume of 100 ml). The resulting mixture is then allowed to warm to —20° C. over a 20 min period and stirred at —20° C. for 30 min. Excess Jones reagent is then destroyed by addition of 0.5 ml of isopropanol. After 5 min the reaction mixture is then shaken in 100 ml of ethyl acetate and 80 ml of brine containing 0.5 ml of concentrated hydrochloric acid. The organic layer is then washed twice in 50 ml of water containing a trace (10 drops) of concentrated hydrochloric acid, twice in 50 ml of water and in brine. The organic layer is then dried over magnesium sulfate and concentrated under reduced pressure to yield 360 mg of crude (5Z)-2,5-inter-o-phenylene-3,4-dinor-CBA<sub>2</sub>, 11,15-bis(tetrahy-

dropranyl ether), a formula LIX compound. Crude formula LIX compound is then taken up in 30 ml of diethyl ether and extracted in the mixture of 15 ml of water and 5 ml of methanol containing a trace amount (10 drops) of 45% aqueous potassium hydroxide. The extraction is repeated 6 times, until the acid is completely extracted from the ethereal solution. The aqueous extracts are then acidified to pH2 and extracted with ethyl acetate. The organic extract is then washed with brine, dried over magnesium sulfate, and concentrated under reduced pressure to yield a residue of pure title product. Silica gel TLC is a streak to about  $R_f$  0.50 in ethyl acetate and hexane (1:1). Purified acid is then converted to the corresponding ethyl ester by treatment with excess ethereal diazomethane for 10 min. Following esterification, the resulting reaction mixture is treated with ethyl acetate and washed with dilute aqueous potassium hydroxide and brine. After drying and concentrating to a residue, chromatography on 20 g of silica gel deactivated with 4 ml of ethyl acetate and elution with 10% ethyl acetate in trichloromethane yields 210 mg of (5Z)-2,5-inter-o-phenylene-3,4-dinor-CBA<sub>2</sub>, methyl ester, 11,15-bis(tetrahydropyranyl ether). Silica gel TLC  $R_f$ 's are 0.52, 0.56, and 0.60 (stereoisomers) in 25% ethyl acetate and hexane. NMR absorptions are observed at 7.20, 6.45, 5.34-5.78, 4.70, 3.68, and 3.30-4.28 $\delta$ .

E. A mixture of 200 mg of methyl ester of Part D, 5 ml of acetic acid, 2.5 ml of water, and 1 ml of tetrahydrofuran is heated to 40° C. and stirred for 4 hr. The resulting mixture is then diluted with 100 ml of ethyl acetate and washed with a mixture of 6 g of 85% aqueous potassium hydroxide in 20 ml of water and 30 g of ice, washed with brine (40 ml), dried over magnesium sulfate, and concentrated under reduced pressure to yield 180 mg of crude (5Z)-2,5-inter-o-phenylene-3,4-dinor-CBA<sub>2</sub>, methyl ester. Chromatography on 20 g of silica gel deactivated with 4 ml of ethyl acetate and elution with 100 ml of 50% ethyl acetate in trichloromethane and 100 ml of 50% acetone in trichloromethane yields 105 mg of pure product. Silica gel TLC  $R_f$ 's are 0.57 in 40% acetone and trichloromethane and 0.52 in ethyl acetate. NMR absorptions are observed at 7.20, 6.43, 5.45-5.59, 3.65, 3.40-4.20, and 3.18 $\delta$ . The mass spectrum of the bis TMS derivative exhibits peaks of decreasing intensity at  $m/e$  73, 75, 74, 147, 43, 129, 41, 45, 167, 59, and an  $M^+ - C_5H_{11}$  peak at 485.2513.

F. To a solution of 105 mg of the reaction product of Part E in 5 ml of methanol and 2.5 ml of water under a nitrogen atmosphere is added 0.33 g of potassium carbonate. The resulting mixture is stirred at ambient temperature for 20 hr whereupon a small quantity (5 drops) of 45% aqueous potassium hydroxide is added. The resulting mixture is stirred for an additional 4 hr at ambient temperature. Thereupon the mixture is shaken with 100 ml of ethyl acetate and excess cold dilute aqueous hydrochloric acid. The organic layer is then washed with brine, dried, and concentrated under reduced pressure to yield 100 mg of pure (5Z)-2,5-inter-o-phenylene-3,4-dinor-CBA<sub>2</sub>. Silica gel TLC  $R_f$ 's are 0.56 in the A-IX solvent system (the organic phase of an equilibrated mixture of ethyl acetate, acetic acid, cyclohexane, and water, 9:2:9:10). The mass spectrum of the tris TMS derivative exhibits peak of decreasing intensity at  $m/e$  73, 75, 129, 167, 74, 55, 69, 57, 147, and 45 and an  $M^+ - CH_3$  peak at 599.3418.

G. Following the procedure of Part D, 510 mg of the (5E) reaction product of Part C is transformed to 310

mg of (5E)-2,5-inter-o-phenylene-3,4-dinor-CBA<sub>2</sub>, 11,15-bis(tetrahydropyranyl ether). Silica gel TLC  $R_f$ 's are 0.41 in 25% ethyl acetate and hexane containing 1% acetic acid, and 220 mg of (5E)-2,5-inter-o-phenylene-3,4-dinor-CBA<sub>2</sub>, 11,15-bis(tetrahydropyranyl ether)-methyl ester. Silica gel TLC  $R_f$ 's are 0.48, 0.51, and 0.56 (stereoisomers) in 25% ethyl acetate and hexane. NMR absorptions are observed at 7.20, 6.43, 5.26-5.64, 4.70, 3.65, and 3.30-4.10 $\delta$ .

H. Following the procedure of Part E, the reaction product of Part G (210 mg) is transformed to 110 mg of (5E)-2,5-inter-o-phenylene-3,4-dinor-CBA<sub>2</sub>, methyl ester. Silica gel TLC  $R_f$  is 0.57 in 40% acetone and trichloromethane and 0.46 in ether acetate. NMR absorptions are observed at 7.22, 6.44, 5.32-5.47, 3.68, 3.50-4.08, and 3.10 $\delta$ . The mass spectrum of the bis TMS derivative exhibits peaks of decreasing intensity at  $m/e$  73, 75, 129, 227, 167, 55, 57, 173, 74, 466 and an  $M^+ - CH_3$  peak at 541.3198.

I. Following the procedure of Part F, the reaction product of Part H (110 mg) is transformed to 102 mg of (5E)-2,5-inter-o-phenylene-3,4-dinor-CBA<sub>2</sub>. Silica gel TLC  $R_f$  is 0.50 in the A-IX solvent system. The mass spectrum of the tris TMS derivative exhibits peaks of decreasing intensity at  $m/e$  73, 75, 167, 129, 524, 453, 285, 147, 434, 213, and an  $M^+ - CH_3$  peak at 599.3424.

#### EXAMPLE 13

(5E)-1,5-inter-m-phenylene-2,3,4-trinor -CBA<sub>2</sub>

its methyl ester, and the corresponding (5Z) isomers.

Refer to Chart D.

A. Following the procedure of Example 12, Part A, a solution of 1.26 g of the title product of Example 6 and 0.62 g of the title product of Example 5 are transformed to 2.3 g of formula LVI compound. Silica gel TLC  $R_f$  range is 0.37-0.56 (7 spots) (stereoisomers) in 25% ethyl acetate in hexane.

B. Following the procedure of Example 12, Part B, the reaction product of Part A (2.3 g) is transformed to 1.0 g of isomeric formula LVII compounds: (5E)- and (5Z)-2-decarboxy-2-(t-butylidimethylsilyloxymethyl)-1,5-inter-m-phenylene-2,3,4-trinor-CBA<sub>2</sub>, 11,15-bis(tetrahydropyranyl ether). Silica gel TLC  $R_f$ 's are 0.47, 0.54 and 0.58 (stereoisomers) in 30% diethyl ether and hexane.

C. Following the procedure of Example 12, Part C, 1.0 g of the isomerically mixed reaction product of Part B is transformed to 0.51 g of (5Z)-2-decarboxy-2-hydroxymethyl-1,5-inter-m-phenylene-2,3,4-trinor-CBA<sub>2</sub>, 11,15-bis(tetrahydropyranyl ether) and 0.40 g of (5E)-2-decarboxy-2-hydroxymethyl-1,5-inter-m-phenylene-2,3,4-trinor-CBA<sub>2</sub>, 11,15-bis(tetrahydropyranyl ether). For the (5Z)-isomer, silica gel TLC  $R_f$ 's are 0.31 and 0.35 (stereoisomers) in 25% ethyl acetate and hexane. NMR absorptions are observed at 7.18, 6.36, 5.19-5.65, 4.63, 4.58, 3.31-4.08, and 2.92 $\delta$ . For the (5E)-isomer, silica gel TLC  $R_f$ 's are 0.23 and 0.27 (stereoisomers) in 25% ethyl acetate and hexane. NMR absorptions are observed at 7.19, 6.37, 5.29-5.72, 4.67, 4.60, 3.30-4.17, and 2.78 $\delta$ .

D. Following the procedure of Example 12, Part D, 510 mg of the (5Z) reaction product of Part C is transformed to 310 mg of (5Z)-1,5-inter-m-phenylene-2,3,4-trinor-CBA<sub>2</sub>, 11,15-bis(tetrahydropyranyl ether) and 240 mg of (5Z)-1,5-inter-m-phenylene-2,3,4-trinor-CBA<sub>2</sub>, methyl ester, 11,15-bis(tetrahydropyranyl ether). For the acid, silica gel TLC streak to about  $R_f$

0.54 in 50% ethyl acetate and hexane. For the methyl ester, silica gel TLC  $R_f$ 's are 0.58, 0.63, and 0.68 (stereoisomers) in 25% ethyl acetate and hexane. NMR absorptions are observed at 7.28–8.00, 6.40, 5.13–5.73, 4.71, 3.89, and 3.28–4.08 $\delta$ .

E. Following the procedure of Example 12, Part E, 240 mg of the methyl ester product of Part D is transformed to 140 mg of (5Z)-1,5-inter-m-phenylene-2,3,4-trinor-CBA<sub>2</sub>, methyl ester. Silica gel TLC  $R_f$  is 0.49 in ethyl acetate. NMR absorptions are observed at 7.28–7.93, 6.40, 5.34–5.48, 3.88, and 3.32 $\delta$ . The mass spectrum of the bis TMS derivative exhibits peaks of decreasing intensity at  $m/e$  83, 85, 73, 47, 213, 75, 129, 48, 87, 77, and an  $M^+ - CH_3$  peak at 527.2996.

F. To a solution of 140 mg of the reaction product of Part E in 6 ml of methanol under a nitrogen atmosphere is added a solution of 0.20 g of 85% potassium hydroxide in 2 ml of water. The resulting mixture is then stirred at ambient temperature for 7 hr, shaken with 200 ml of ethyl acetate and excess cold dilute aqueous hydrochloric acid. The organic layer is then washed with brine, dried over magnesium sulfate, concentrated under reduced pressure to yield 110 g of pure (5Z)-1,5-inter-m-phenylene-2,3,4-trinor-CBA<sub>2</sub>. Silica gel TLC  $R_f$  is 0.60 in the A-IX solvent system. The mass spectrum of the tris TMS derivative exhibits peaks of decreasing intensity at  $m/e$  73, 271, 394, 129, 420, 510, 75, 147, 32, 74, and an  $M^+ - CH_3$  peak at 585.3234.

G. Following the procedure of Example 12, Part D, 400 mg of the (5E) reaction product of Part C is transformed to 260 mg of (5E)-1,5-inter-m-phenylene-2,3,4-trinor-CBA<sub>2</sub>, 11,15-bis(tetrahydropyranyl ether) and 190 mg of (5E)-1,5-inter-m-phenylene-2,3,4-trinor-CBA<sub>2</sub>, methyl ester, 11,15-bis(tetrahydropyranyl ether). For the acid silica gel TLC streak to about  $R_f$  0.36 in 50% ethyl acetate and hexane. For the methyl ester, silica gel TLC  $R_f$ 's are 0.50, 0.53, and 0.57 (stereoisomers) in 25% ethyl acetate and hexane. NMR absorptions are observed at 7.38–7.95, 6.42, 5.13–5.75, 4.68, 3.89, and 3.30–4.09 $\delta$ .

H. Following the procedure of Example 12, Part E, 190 mg of the reaction product of Part G is transformed to 81 mg of (5E)-1,5-inter-m-phenylene-2,3,4-trinor-CBA<sub>2</sub>, methyl ester. Silica gel TLC  $R_f$  is 0.51 in ethyl acetate. NMR absorptions are observed at 7.30–7.93, 6.43, 5.45–5.59, 3.89, 3.50–4.14, and 3.09 $\delta$ . The mass spectrum of the bis TMS derivative exhibits peaks of decreasing intensity at  $m/e$  73, 213, 129, 75, 83, 452, 173, 85, 262, 362, and an  $M^+ - CH_3$  peak at 527.2996.

I. Following the procedure of Example 13, Part F, 81 mg of the reaction product of Part H is transformed to 65 mg of (5E)-1,5-inter-m-phenylene-2,3,4-trinor-CBA<sub>2</sub>. Silica gel TLC  $R_f$  is 0.60 in the A-IX solvent system. The mass spectrum of the tris TMS derivative exhibits peaks of decreasing intensity at  $m/e$  73, 271, 394, 75, 510, 129, 420, 147, 173, 395, and an  $M^+ - CH_3$  peak at 585.3227.

Following the procedure of Examples 12–13, but employing each of the various formula LV compounds described in and following Example 11 in each of the various formula XLIV described in and following Examples 9 and 10, there are prepared each of the various formula L compounds in free acid or methyl ester form.

## EXAMPLE 14

9 $\beta$ -methyl-CBA<sub>2</sub>, methyl ester,  
11,15-bis(tetrahydropyranyl ether)

(Formula LXXXIV:  $R_{16}$  is hydrogen,  $R_{37}$  is methyl,  $Z_2$  is  $-(CH_2)_3-$  and  $R_{18}$ ,  $Y_1$ ,  $M_6$ ,  $L_1$ , and  $R_7$  are as defined in Example 3) and the corresponding (5E) and (5Z) free acids (Formula LXXXIII).

Refer to Chart G.

A. A suspension of 57% sodium hydride in mineral oil (1.90 g) is washed with hexane and treated with 130 ml of dry dimethyl sulfoxide (DMSO). The resulting suspension is heated at 65° C. for 1 hr under a nitrogen atmosphere and the resulting solution cooled to 15° C. and treated dropwise over 15 min with 10.0 g of 4-carboxybutyltriphenylphosphonium bromide. The resulting orange solution is stirred for 15 min at 10° C. and then treated dropwise over 15 min with a solution of 2.12 g of the title product of Example 3 in 20 ml of dry DMSO. The resulting solution is then stirred at ambient temperature under a nitrogen atmosphere for 60 hr, treated with 15 ml of water, stirred for 30 min at ambient temperature, added to 200 ml of ice water and 100 ml of brine, acidified with 1 N aqueous hydrochloric acid, and extracted with 900 ml of diethyl ether. The ethereal extracts are then washed with 1 l of water and 200 ml of brine, dried over sodium sulfate, and concentrated under reduced pressure to yield 4.8 g of a yellow oil, the formula LXXXIII carboxylic acid.

B. The formula LXXXIII product and 42 ml of diisopropylethylamine in 120 ml of acetonitrile at 10° C. under a nitrogen atmosphere is treated with 15 ml of methyl iodide and allowed to warm slowly to ambient temperature. The resulting suspension is then stirred for 16 hr, treated with 3.0 ml of methyl iodide, stirred for an additional 2 hr, added to 500 ml of brine, and extracted with 1 l of ethyl acetate. The organic extracts are then washed with 250 ml of 0.5 N potassium bisulfate, 250 ml of saturated aqueous sodium bicarbonate, 250 ml of brine, dried over anhydrous sodium sulfate, and concentrated under reduced pressure to yield a solid residue. The residue is then chromatographed on 500 g silica gel, eluting with 8% acetone in hexane to yield 2.25 g of title formula LXXXIV product. NMR absorptions ( $CDCl_3$ ) are observed at 0.9, 1.05, 1.08, 3.66, 3.02–4.35, 4.70, and 4.95 $\delta$ . Infrared absorptions are observed at 1730, 1670, 1645, 1200, 1165, 1135, 1080, 1035, 1020, 980, and 870  $cm^{-1}$ . Silica gel TLC  $R_f$  is 0.46 in ethyl acetate and hexane (1:3) and 0.26 in ethyl acetate and hexane (1:6).

C. Alternatively the isomeric formula LXXXIII reaction products of Part A are separated into the (5E) and (5Z) title free acid products by chromatography on acid washed silica gel eluting with 10–30% ethyl acetate in hexane.

Following the procedure of Example 9, but employing each of the various formula LXXXI ketones in place of the Example 3 product, there are prepared each of the various formula LXXXIV methyl esters wherein  $Z_2$  is  $-(CH_2)_3-$ .

Further following the procedure of Example 14, but employing a formula LXXXII  $\omega$ -carboxytriphenylphosphonium compound wherein  $Z_2$  is other than  $-(CH_2)_3-$ , each of the various formula LXXXI ketones is transformed to corresponding formula LXXXIV ester wherein  $Z_2$  is other than  $-(CH_2)_3-$ .

## EXAMPLE 15

(5Z)-2-Decarboxy-2-hydroxymethyl-9 $\beta$ -methyl-CBA<sub>2</sub>,  
11,15-bis(tetrahydropyranyl ether)

(Formula LXXXVI: R<sub>16</sub>, R<sub>37</sub>, Z<sub>2</sub>, R<sub>18</sub>, M<sub>6</sub>, L<sub>1</sub>, and R<sub>7</sub>  
are as defined in Example 14) and its (5E) isomer (for-  
mula LXXXVII).

Refer to Chart G.

A suspension of 0.16 g of lithium aluminum hydride  
in 45 ml of dry tetrahydrofuran at 0° C. under a nitrogen  
atmosphere is treated dropwise with 1.98 g of the title  
product of Example 14 in 15 ml of dry tetrahydrofuran.  
The resulting suspension is stirred for 1 hr at 0° C. and  
thereafter for 1 hr at ambient temperature. The resulting  
mixture is then cooled to 0° C., quenched by addition of  
0.16 ml of water, 0.16 ml of 15% aqueous sodium hydro-  
xide. After stirring for 1 hr at ambient temperature,  
treatment with magnesium sulfate and filtration with  
diatomaceous earth, rinsing with diethyl ether, yields a  
mixture which is concentrated under reduced pressure.  
The resulting product, 0.25 g, is chromatographed on  
180 g of silica gel, eluting with 30% ethyl acetate in  
hexane to yield 1.03 g of formula LXXXVII product and  
1.06 g of formula LXXXVI product. For the formula  
LXXXVI product NMR absorptions (CDCl<sub>3</sub>) are  
observed at 0.90, 1.09, 3.2-4.4, 4.72, 5.0-5.9 $\delta$ . Infrared  
absorptions are observed at 3470, 1760, 1200, 1135,  
1120, 1075, 1035, 1020, and 980 cm<sup>-1</sup>. Silica gel TLC  
R<sub>f</sub> is 0.29 in ethyl acetate and hexane (35:65). For the  
formula LXXXVII product NMR absorptions (CDCl<sub>3</sub>)  
are observed at 0.90, 1.05, 3.2-4.4, 4.6-4.95, 5.05-5.97 $\delta$ .  
Infrared absorptions are observed at 3470, 1670, 1200,  
1125, 1110, 1080, 1035, 1020, and 985 cm<sup>-1</sup>. Silica gel  
TLC R<sub>f</sub> is 0.36 in ethyl acetate and hexane (35:65).

Following the procedure of Example 15, but employ-  
ing each of the various formula LXXXIV esters de-  
scribed following Example 14, there are prepared each  
of the respective formula LXXXVI and formula  
LXXXVII primary alcohols.

## EXAMPLE 16

(5Z)-9 $\beta$ -methyl-CBA<sub>2</sub>, methyl ester

(Formula LXXXVIII: X<sub>1</sub> is -COOCH<sub>3</sub>, R<sub>8</sub> is hydroxy,  
M<sub>1</sub> is  $\alpha$ -OH: $\beta$ -H, and R<sub>16</sub>, R<sub>17</sub>, L<sub>1</sub>, R<sub>7</sub>, Y<sub>1</sub>, and Z<sub>2</sub> are as  
defined in Example 15).

Refer to Chart G.

A. A solution of the formula LXXXVI title product  
of Example 15 in 38 ml of acetone at -20° C. under a  
nitrogen atmosphere is treated over 5 min with 1.9 ml of  
Jones reagent (prepared by dissolving 133.6 g of chro-  
mium trioxide in 115 ml concentrated sulfuric acid and  
diluting with water to a volume of 500 ml), stirred for 2  
hr at -20° C., quenched by addition of 2.3 ml of isopro-  
panol, stirred for 40 min at -20° C., diluted with 200 ml  
of brine, extracted with 400 ml of ethyl acetate, washed  
with 600 ml of brine, dried over sodium sulfate, and  
concentrated under reduced pressure to yield 1.01 g  
carboxylic acid corresponding to the formula LXXXVI  
primary alcohol as a pale green oil.

B. A solution of the product of Part A in 11 ml of  
acetonitrile at 15° C. under a nitrogen atmosphere is  
treated with 4.1 ml of diisopropylethylamine and 1.5 ml  
of methyl iodide. The resulting suspension is then  
stirred at ambient temperature for 17 hr, treated with  
0.3 ml of methyl iodide, stirred for 2 hr at ambient tem-  
perature, diluted with 50 ml of brine, extracted with 100  
ml of ethyl acetate, washed with 50 ml of 0.5 M potas-  
sium bisulfate, 50 ml of aqueous sodium bicarbonate and

50 ml of brine, dried over anhydrous sodium sulfate, and  
concentrated under reduced pressure to yield 1.02 g of  
the methyl ester corresponding to the carboxylic acid  
product of Part A.

C. A solution of the product of Part B in 56 ml of a  
mixture of tetrahydrofuran, water, and acetic acid  
(1:2:4) is heated to 45° C. under a nitrogen atmosphere  
for 3 hr, cooled, diluted with 200 ml of brine, and ex-  
tracted with 400 ml of diethyl acetate. The organic  
extracts are then washed with 600 ml of saturated  
aqueous sodium bicarbonate and 400 ml of brine, dried  
over anhydrous sodium sulfate, and concentrated under  
reduced pressure to yield 0.9 g of crude title product as  
a yellow oil. Chromatographing on 100 g of silica gel,  
eluting with hexane and ethyl acetate (3:7) yields 0.39 g  
of pure title product as a colorless oil. NMR absorptions  
(CDCl<sub>3</sub>) are observed at 0.89, 1.08, 3.5-4.35, 3.66,  
5.0-5.7 $\delta$ . Infrared absorptions are observed at 3360,  
1740, 1670, 1455, 1435, 1370, 1240, 1225, 1195, 1170,  
1075, 1020, and 970 cm<sup>-1</sup>. Silica gel TLC R<sub>f</sub> is 0.22 in  
ethyl acetate and hexane (7:3).

Following the procedure of Example 16, but employ-  
ing each of the various formula LXXXVI compounds  
described following Example 15, there are prepared  
each of the various formula LXXXVIII 9 $\beta$ -methyl-  
CBA<sub>2</sub> compounds wherein X<sub>1</sub> is -COOR<sub>1</sub>.

## EXAMPLE 17

(5E)-9 $\beta$ -methyl-CBA<sub>2</sub>, methyl ester

(Formula LXXXIX: R<sub>16</sub>, R<sub>17</sub>, X<sub>1</sub>, Z<sub>2</sub>, R<sub>8</sub>, R<sub>1</sub>, M<sub>1</sub>, L<sub>1</sub>,  
and R<sub>7</sub> are as defined in Example 16).

Refer to Chart G.

A. Following the procedure of Example 16, Part A,  
0.60 g of the formula LXXXVII product of Example 15  
is transformed to the carboxylic acid corresponding to  
the formula LXXXVII primary alcohol, yielding 0.66 g  
of a green oil.

B. Following the procedure of Example 16, Part B,  
the product of Part A above (0.66 g) is transformed to  
the methyl ester corresponding to the carboxylic acid  
product of Part A, yielding 0.58 g of a yellow oil.

C. Following the procedure of Example 16, Part C,  
the product of Part B above (0.58 g) is transformed to  
0.25 g of title product as a colorless oil. NMR absorp-  
tions (CDCl<sub>3</sub>) are observed at 0.90, 1.05, 3.30, 3.66,  
3.75-4.25, 5.0-5.7 $\delta$ . Infrared absorptions are observed  
at 3360, 1740, 1670, 1455, 1435, 1250, 1225, 1195, 1170,  
1075, 1020, and 970 cm<sup>-1</sup>. Silica gel TLC R<sub>f</sub> is 0.22 in  
ethyl acetate and hexane (3:7).

Following the procedure of Example 17, but employ-  
ing each of the various formula LXXXVII compounds  
described following Example 15, there are prepared  
each of the various formula LXXXIX products wherein  
X<sub>1</sub> is -COOCH<sub>3</sub>.

## EXAMPLE 18

(5Z)-9 $\beta$ -methyl-CBA<sub>2</sub>

A solution of 0.28 g of the title product of Example 16  
in 8 ml of methanol is stirred at ambient temperature  
under a nitrogen atmosphere and treated with 1 ml of 8  
M aqueous sodium hydroxide. The resulting yellow  
solution is then stirred for 5 hr at ambient temperature  
under a nitrogen atmosphere, diluted with 90 ml of ice  
and brine, acidified to pH2 with 1 N hydrochloric acid,  
extracted with 360 ml of ethyl acetate, washed with 120  
ml of brine, dried over anhydrous sodium sulfate, and



concentrated under reduced pressure to yield 0.25 g of crude title product. Chromatography on 30 g of silica gel, eluting with the A-IX solvent system (the organic phase of an equilibrated mixture of ethyl acetate, acetic acid, cyclohexane, and water, 9:2:5:10), yields 0.235 g of pure title product as a colorless oil. NMR absorptions (CDCl<sub>3</sub>) are observed at 0.89, 1.08, 3.5-4.35, 5.0-5.7, 6.058. Infrared absorptions are observed at 3340, 2660, 1710, 1240, 1205, 1175, 1130, 1075, 1055, 1020, and 970 cm<sup>-1</sup>. Silica gel TLC R<sub>f</sub> is 0.25 in the A-IX solvent system.

Following the procedure of Example 18 each of the various methyl esters prepared following Example 16 is transformed to the corresponding carboxylic acid.

#### EXAMPLE 19

##### (5E)-9β-methyl-CBA<sub>2</sub>

Following the procedure of Example 18, 0.25 g of the title product of Example 17 is transformed to 0.21 g of title product as a colorless oil. NMR absorptions (CDCl<sub>2</sub>) are observed at 0.90, 1.06, 3.5-4.3, 5.0-5.7, and 5.938. Infrared absorptions are observed at 3340, 2660, 1710, 1300, 1240, 1175, 1130, 1075, 1055, 1020, and 970 cm<sup>-1</sup>. Silica gel TLC R<sub>f</sub> is 0.27 in the A-IX solvent system.

Each of the various carboxylic acids corresponding to LXXXVIII and LXXXIX wherein X<sub>1</sub> is —COOH— can be prepared from the corresponding formula LXXXIII reaction products by acid hydrolysis of the tetrahydropyranyl ether protecting groups of C-11 and C-15. [The (5Z) LXXXIII reaction products from Example 14, Part C go to formula LXXXVIII products; and the (5E) LXXXIII reaction products from Example 14, Part C go to formula LXXXIX products.]

Following the procedure of Example 19, but employing each of the various formula LXXXIX methyl esters described following Example 17, there are prepared each of the various corresponding carboxylic acids.

#### EXAMPLE 20

2β-(t-butyl dimethylsilyloxymethyl)-5β-methyl-7-oxo-3α-tetrahydropyran-2-yl-oxy-bicyclo[3.3.0]octane (Formula LXII: n is the integer one, R<sub>31</sub> is t-butyl dimethylsilyl, and R<sub>38</sub> is tetrahydropyranyloxy).

Refer to Chart E.

A. A solution of 40.6 g of 3α-benzoyloxy-5α-hydroxy-2β-hydroxymethyl-1α-cyclopentaneacetic acid, ω-lactone in 250 ml of dimethylformamide, stirring at 0° C. under a nitrogen atmosphere, is treated with 25 g of imidazole in 28 g of t-butyl dimethylsilyl chloride. The resulting solution is then stirred for 67 hr at ambient temperature, added to 500 ml of water, extracted with three 500 ml portions of diethyl ether, washed with 500 ml of 10% aqueous potassium bisulfate, 500 ml of aqueous sodium bicarbonate and 500 ml of brine, dried over sodium sulfate, and concentrated under reduced pressure to yield 59.9 g of 3α-benzoyloxy-5α-hydroxy-2β-(t-butyl dimethylsilyloxymethyl)-1α-cyclopentaneacetic acid, ω lactone as a white solid. NMR absorptions (CDCl<sub>3</sub>) are observed at 0.06, 0.91, 2.1-3.12, 3.74, 4.94-5.54, 7.24-7.67, and 7.9-8.28. Infrared absorptions are observed at 1780, 1720, 1600, 1585, 1490, 1270, 1255, 1180, 1115, 1100, 1070, 1050, 830, 790, and 710 cm<sup>-1</sup>. Silica gel TLC R<sub>f</sub> is 0.20 in ethyl acetate and hexane (1:4).

B. A solution of 59.1 g of the reaction product of Part A and 500 ml of absolute methanol, stirring at ambient temperature under a nitrogen atmosphere, is treated

with 35 ml of a 25% solution of sodium methoxide and methanol. The resulting reaction mixture is then stirred for 90 min at ambient temperature and quenched by addition of 9.5 ml of glacial acetic acid. Methanol is removed under reduced pressure and the resulting residue diluted with 500 ml of saturated aqueous sodium bicarbonate. The resulting mixture is then extracted with two 500 ml portions of ethyl acetate, washed with 300 ml of saturated aqueous sodium bicarbonate in 200 ml of brine, dried over sodium sulfate, and concentrated under reduced pressure to yield 58 g of an oily solid, crude 3α,5α-dihydroxy-2β-(t-butyl dimethylsilyloxymethyl)-1α-cyclopentaneacetic acid, ω lactone. This crude product is then chromatographed in 800 g of silica gel, eluting with 20-75% ethyl acetate in hexane to yield pure title product as a white crystal solid. Melting range is 60.5° C. to 62° C. NMR absorptions (CDCl<sub>3</sub>) are observed at 0.06, 0.90, 1.7-3.0, 3.67, 3.9-4.4, and 4.7-5.138. Silica gel TLC R<sub>f</sub> is 0.3 in 50% ethyl acetate in hexane.

C. A solution of 37.3 g of reaction product of Part B in 400 ml of methylene chloride, stirring at 0° C. under a nitrogen atmosphere, is treated with 18 ml of dihydropyran and 0.14 g of pyridine hydrochloride. The resulting solution is stirred at ambient temperature for 13 hr, treated with an additional 3 ml of dihydropyran and 30 mg of pyridine hydrochloride, stirred for an additional 4 hr, washed with two 400 ml portions of saturated aqueous sodium bicarbonate and 400 ml of brine, dried over anhydrous sodium sulfate, and concentrated under reduced pressure to yield 49 g of a pale yellow oil, crude 5α-hydroxy-3α-tetrahydropyran-2-yloxy-2β-(t-butyl dimethylsilyloxymethyl)-1α-cyclopentaneacetic acid, ω lactone. Chromatography on 800 g of silica gel, eluting with 0-75% ethyl acetate in hexane yields 37 g of pure product as a colorless oil. NMR absorptions (CDCl<sub>3</sub>) are observed at 0.05, 0.90, 1.62, 2.0-3.0, 3.6, 3.2-4.4, 4.67, and 4.8-5.28. Infrared absorptions are observed at 1780, 1255, 1175, 1160, 1116, 1080, 1035, 1020, 1005, 975, 835, and 775 cm<sup>-1</sup>. Silica gel TLC R<sub>f</sub> is 0.25 in hexane and ethyl acetate (2:1).

D. A solution of 28 ml of dimethyl methylphosphonate in 800 ml of dry tetrahydrofuran at -70° C. under a nitrogen atmosphere is treated with 160 ml of 1.56 M n-butyllithium in hexane, stirred for 30 min at -70° C. The resulting mixture, maintained at -70° C., is then treated dropwise over 30 min with 41.7 g of reaction product of Part C in 200 ml of tetrahydrofuran. The resulting solution is then stirred at -70° C. for 1 hr, allowed to warm, stirred for an additional 2.5 hr at ambient temperature, quenched by addition of 14 ml of glacial acetic acid, added to 1 l of brine, extracted with three 700 ml portions of diethyl ether, washed with 500 ml of brine, dried over anhydrous sodium sulfate, and concentrated under reduced pressure to yield 63 g of a yellow oil, crude 6β-(t-butyl dimethylsilyloxymethyl)-3-dimethylphosphonomethyl-3-hydroxy-2-oxa-7α-tetrahydropyranyloxy-bicyclo[3.3.0]octane. Chromatography on 800 g of silica gel eluting with 50-75% ethyl acetate in hexane yields 44.2 g of pure title product as a colorless oil. NMR absorptions (CDCl<sub>3</sub>) are observed at 0.05, 0.89, 1.23-3.02, 2.2-4.37, 4.70, and 4.998. Infrared absorptions are observed at 3380, 1255, 2235, 1120, 1050, 1035, 835, and 775 cm<sup>-1</sup>. Silica gel TLC R<sub>f</sub> is 0.25 in ethyl acetate.

E. A suspension of 29.2 g of chromium trioxide in 700 ml of methylene chloride, stirring at ambient tempera-

ture under a nitrogen atmosphere, is treated rapidly with 50 ml of pyridine, treated with dry diatomaceous earth, stirred for 5 min, and then treated with 23.8 g of title product of Part D in 60 ml of methylene chloride. The resulting suspension is then stirred for 45 min at ambient temperature under a nitrogen atmosphere and filtered through 300 g of silica gel, eluting with 2 l of ethyl acetate in acetone (2:1). Concentration under reduced pressure yields 24 g of a brown yellow oil, crude 3 $\beta$ -(t-butylidimethylsilyloxymethyl)-2 $\alpha$ -(2'-dimethylphosphonomethyl-2'-oxoethyl)-4 $\alpha$ -tetrahydropyran-2-yl-oxy-pentanone. High pressure liquid chromatography of 12 g of the crude product on silica gel eluting with 20% acetone in methylene chloride yields 4.54 g of pure product as a colorless oil. NMR absorptions (CDCl<sub>3</sub>) are observed at 0.05, 0.88, 2.8–4.5, 3.77, and 4.86 $\delta$ . Infrared absorptions are observed at 1745, 1715, 1255, 1130, 1115, 1060, 1025, 835, 810, and 775 cm<sup>-1</sup>. Silica gel TLC R<sub>f</sub> is 0.27 in 20% acetone in methylene chloride and 0.3 in ethyl acetate.

F. A degassed suspension of 0.52 g reaction product of Part E, 0.15 g anhydrous potassium carbonate, and 0.59 g 18-crown-6 ether in 20 ml toluene are stirred at 75° C. for 6 hr under a nitrogen atmosphere and thereafter cooled to 0° C. The resulting solution is then washed successively with 20 ml brine, a solution of 15 ml water and 5 ml brine, and 20 ml brine, dried over anhydrous sodium sulfate, and concentrated to yield a brown residue crude 6 $\beta$ -t-butylidimethylsilyloxymethyl-7 $\alpha$ -tetrahydropyran-2-yl-oxy-bicyclo[3.3.0]oct-1-en-2-one, filtering through 7 g of silica gel and eluting with hexane and ethyl acetate (70 ml, 1:1) yields 0.31 g of product as an oil. High pressure liquid chromatography (10 ml fractions, 3.8 ml/minute flow rate) on silica gel, eluting with hexane and ethyl acetate (3:1) yields 0.20 g of pure product as a colorless oil. NMR absorption (CDCl<sub>3</sub>) of the trimethylsilyl derivative are observed at 0.06, 0.90, 1.20–3.20, 3.20–4.85, and 5.85–6.08. Infrared absorptions are observed at 1710, 1630, 1250, 1130, 1115, 1075, 1030, 965, 870, 835, 810, 775 cm<sup>-1</sup>. Silica gel TLC R<sub>f</sub> is 0.34 in hexane and ethyl acetate (2:1).

G. A suspension of 0.35 g of anhydrous copper iodide in 12 ml of anhydrous diethyl ether at -20° C. under an argon atmosphere is treated dropwise with 2.0 ml of 1.4 M methylolithium. The resulting solution is then stirred at -20° C. for 15 min, treated at -20° C. dropwise over 1.5 hr with a solution of 0.22 g of the reaction product of Part F in 12 ml of anhydrous diethyl ether. The resulting suspension is then stirred at -20° C. for 2 hr, added to 50 ml of 1 M aqueous ammonium chloride, extracted with 150 ml of diethyl ether, washed with 50 ml of brine, dried over anhydrous sodium sulfate, and concentrated under reduced pressure to yield 0.23 g of crude title product as a pale yellow oil. Chromatography on 30 g of silica gel, eluting with ethyl acetate and hexane (1:4) yields 0.22 g of pure title product as a colorless oil. NMR absorptions (CDCl<sub>3</sub>) are observed at 0.05, 0.90, 1.16, 1.3–2.9, 3.3–4.4, and 4.63 $\delta$ . Infrared absorptions are observed at 1745, 1255, 1135, 1110, 1095, 1075, 1035, 1020, 835, and 775 cm<sup>-1</sup>. Silica gel TLC R<sub>f</sub> is 0.32 in ethyl acetate and hexane (1:4).

#### EXAMPLE 21

N-methyl-(1-fluoro-5-tetrahydropyran-2-yl-oxy-pentyl)-phenylsulfoximine

(Formula XCII: Z<sub>2</sub> is -(CH<sub>2</sub>)<sub>3</sub>- and R<sub>10</sub> is tetrahydropyran-2-yl).

Refer to Chart H.

Diisopropylamine (0.59 g) is dissolved in 21 ml of tetrahydrofuran and the resulting mixture cooled to -78° C. with stirring under an argon atmosphere. Thereafter triphenylmethane is added, for use as an indicator, and a solution of n-butyllithium and hexane is added dropwise until the resulting mixture attains a pink color. After stirring for an additional 75 min, the resulting mixture is treated with 1.50 g of N-methyl-(5-tetrahydropyran-2-yl-oxy-pentyl)-phenylsulfoximine dissolved in 6 ml of dry tetrahydrofuran. The resulting mixture is then stirred for an additional 30 min at -78° C. Thereafter excess perchloryl fluoride (FC10<sub>3</sub>) is bubbled through the solution for 4–5 min, during which time a stream of argon is also bubbled through the mixture for safety reasons. The resulting mixture is then stirred at additional 90 min at -78° C. and then the reaction is quenched by addition of 5% aqueous sodium bicarbonate. After equilibration of the reaction mixture to ambient temperature, the mixture is diluted with additional 5% aqueous sodium bicarbonate and extracted with methylene chloride. The organic extracts are then washed with brine, dried over magnesium sulfate, and concentrated under reduced pressure to yield 1.64 g of a yellow oil. Chromatography on silica gel columns in a series, eluting with ethyl acetate and hexane (1:1) yields 0.18 g of the formula XCII title product as a mixture of diastereomers. Silica gel TLC R<sub>f</sub> in ethyl acetate and hexane (1:1) are 0.54 (less polar isomer) and 0.45 (more polar isomer). NMR absorptions (CDCl<sub>3</sub>) for the less polar isomer are 1.2–2.15, 3.65, 3.68, 3.1–4.1, 4.4–4.8, 5.5, and 7.4–8.1 $\delta$ . NMR absorptions (CDCl<sub>3</sub>) for the more polar isomer are 1.15–2.20, 3.63, 3.1–4.1, 4.45–4.65, 5.27, and 7.4–8.1 $\delta$ .

Following the procedure of Example 21, but employing each of the various formula XCI phenylsulfoxamines, there are prepared each of the various corresponding formula XCII fluorinated phenylsulfoxamines.

#### EXAMPLE 22

5-Fluoro-2-decarboxy-2-hydroxymethyl-CBA<sub>2</sub>, 1,11,15-tris(tetrahydropyran-2-yl ether)

(Formula XCIV: R<sub>16</sub> and R<sub>17</sub> are both hydrogen, R<sub>10</sub> is tetrahydropyran-2-yl, Z<sub>2</sub> is -(CH<sub>2</sub>)<sub>3</sub>-, n is the integer one, R<sub>18</sub> is tetrahydropyran-2-yl-oxy, Y<sub>1</sub> is trans-CH=CH-, M<sub>6</sub> is  $\alpha$ -tetrahydropyran-2-yl-oxy- $\beta$ -hydrogen, R<sub>3</sub> and R<sub>4</sub> of the L<sub>1</sub> moiety are both hydrogen, and R<sub>7</sub> is n-butyl).

Refer to Chart H.

Diisopropylamine (164 mg) and triphenylmethane (1.5 mg) are dissolved in 4 ml of dry tetrahydrofuran and the resulting solution is cooled to -78° C. under a nitrogen atmosphere. A solution of n-butyllithium and hexane is added until a faint pink color is attained. This solution is then stirred an additional 80 min. Thereafter, 0.488 g of the title product of Example 21 in 4 ml of dry tetrahydrofuran is added dropwise. Thereafter 608 mg of 7-oxo-3 $\alpha$ -tetrahydropyran-2-yl-oxy-2 $\beta$ -[(3'S)-3'-tetrahydropyran-2-yl-oxy-trans-1'-octenyl] bicyclo[3.3.0]octane (Formula XCV: R<sub>16</sub>, R<sub>17</sub>, n, R<sub>18</sub>, Y<sub>1</sub>, M<sub>6</sub>, L<sub>1</sub>, and R<sub>7</sub> are as defined for the title product) in 4 ml of tetrahydrofuran is added to the reaction mixture. After 4 min, the resulting mixture is quenched by addition of saturated aqueous ammonium chloride and ethyl acetate is thereafter added to the reaction mixture, which is maintained at -78° C. The resulting mixture is then allowed to warm until solids separate. Thereupon addi-

tional ethyl acetate is added, the reaction extracted with brine. The ethyl acetate layer is then dried over sodium sulfate and concentrated under reduced pressure.

An aluminum amalgam is then prepared by reacting 0.31 g of 20 mesh aluminum with 2.5 ml of aqueous mercuric chloride followed by washing with ethyl acetate and diethyl ether. The residue from the ethyl acetate layer (described in the preceding paragraph) is dissolved in 5 ml of tetrahydrofuran and the solution cooled to 0° C. This cooled solution is then treated with aluminum amalgam, 2 ml of water, and 1 ml of glacial acetic acid. The resulting mixture is then stirred for 2 hr at 0° C. and 16 hr at 20° C. The reaction is then diluted with ethyl acetate and filtered with diatomaceous earth. The ethyl acetate layer is then washed with 5% aqueous sodium bicarbonate and saturated brine, dried over sodium sulfate, and concentrated under reduced pressure to yield 0.96 g as an oily residue. Chromatographing over 100 g of silica gel and eluting with 500 ml of 15% ethyl acetate in mixed hexanes, 500 ml of 25% ethyl acetate in mixed hexanes, 300 ml of 50% ethyl acetate in mixed hexanes, and 800 ml of 50% acetone in methylene chloride, taking 20 ml fractions, yields a less polar isomer in fractions 22–26 (80 mg) and a more polar isomer in fractions 30–36 (74 mg). These isomers represent the C-5 diastereomers of the formula XCIV product. For the less polar isomer, NMR absorptions (CDCl<sub>3</sub>) are observed at 0.65–2.65, 3.15–4.15, 4.35–4.75, and 5.25–5.75δ. For the more polar isomer, NMR absorptions (CDCl<sub>3</sub>) are observed at 0.6–2.65, 3.10–4.15, 4.40–4.7, and 5.2–5.7δ. Silica gel TLC R<sub>f</sub> for the less polar isomer is 0.66 and for the more polar isomer is 0.57 in ethyl acetate and mixed hexanes (3:7).

Following the procedure of Example 22, but employing each of the various formula XCIII ketones, there are obtained each of the various formula XCIV intermediates wherein Z<sub>2</sub> is —(CH<sub>2</sub>)<sub>3</sub>—.

Further following the procedure of Example 22, but substituting each of the various fluorinated phenylsulfoximines described following Example 21, there are prepared from the various formula XCIII ketones each of the various formula XCIV products wherein Z<sub>2</sub> is other than —(CH<sub>2</sub>)<sub>3</sub>—.

#### EXAMPLE 23

5-Fluoro-2-Decarboxy-2-hydroxymethyl-CBA<sub>2</sub> (more polar isomer)

(Formula XCV: R<sub>16</sub>, R<sub>17</sub>, Z<sub>2</sub>, n, R<sub>8</sub>, M<sub>1</sub>, L<sub>1</sub>, and R<sub>7</sub> are as defined in Example 17).

Refer to Chart H.

The title product of Example 22 (74 mg) is dissolved in 2 ml of a mixture of tetrahydrofuran, water, and glacial acetic acid (2:2:1) and the resulting mixture stirred under a nitrogen atmosphere. The reaction mixture is maintained at ambient temperature for 17 hr, thereafter at 40° C. for 7 hr, and finally at 23° C. for an additional 24 hr. The resulting mixture is then diluted with ethyl acetate, washed with 5% aqueous sodium bicarbonate and saturated brine, dried over sodium sulfate, and concentrated under reduced pressure to yield 52 mg of crude title product. Chromatography over silica gel, eluting with acetone and methylene chloride (60:40) yields 19 mg of pure title product. NMR absorptions (CDCl<sub>3</sub>) are observed at 0.6–2.60, 2.60–3.30, 3.30–4.15, 5.1–5.9δ. <sup>13</sup>C-NMR absorptions (CDCl<sub>3</sub>) are observed at 135.8, 133.0, 117.5 (d J=18 Hz), 77.4, 73.3, 62.6, 57.6, 46.4, 41.1, 38.0, 37.2, 36.2 (d J=5 Hz), 31.9, 31.8, 31.2, 29.5 (d J=29 Hz), 25.2, 22.5,

14.0δ. Silica gel TLC R<sub>f</sub> is 0.280 in acetone and methylene chloride (1:1).

#### EXAMPLE 24

5-Fluoro-2-decarboxy-2-hydroxymethyl-CBA<sub>2</sub> (less polar isomer)

Following the procedure of Example 23, 85 mg of less polar title product of Example 22 are transformed to 25 mg of pure title product. NMR absorptions (CDCl<sub>3</sub>) are observed at 0.5–2.5, 3.1–4.75, and 5.05–5.8δ. <sup>13</sup>C-NMR absorptions (CDCl<sub>3</sub>) are observed at 137.0, 132.6, 77.0, 73.6, 62.3, 57.4, 45.5, 41.6, 36.9, 36.5, 34.4 (d J=3.1 Hz), 32.5 (d J=5.4 Hz), 31.8, 31.7, 29.2 (d J=28.9 Hz), 25.4, 22.6, 22.4, and 14.0δ. Silica gel TLC R<sub>f</sub> is 0.33 in acetone and methylene chloride.

Following the procedure of Examples 23 and 24, but employing the various diastereomeric products described following Example 22, there are prepared each of the various diastereomers corresponding to formula XCV.

#### EXAMPLE 25

5-fluoro-CBA<sub>2</sub> (more polar isomer)

(Formula LXXVI: Z<sub>2</sub>, n, R<sub>8</sub>, Y<sub>1</sub>, M<sub>1</sub>, L<sub>1</sub>, and R<sub>7</sub> are as defined in Example 23).

Refer to Chart H.

The platinum oxide catalyst is prepared by suspending 46 mg of 85% platinum oxide in 9 ml of water and hydrogenating the resulting mixture at ambient temperature and pressure for 34 min. To this suspension is added 58 mg of sodium bicarbonate and 18 mg of the title product of Example 23 dissolved in 2 ml of acetone. The resulting mixture is then warmed to 60° C. and oxygen bubbled therethrough for 80 min. The reaction mixture is then filtered through diatomaceous earth and the filter cake washed in water. The filtrate is then acidified to pH4 with 5% aqueous sodium hydrogen sulfate and extracted with ethyl acetate. The organic extracts are then dried over magnesium sulfate and concentrated under reduced pressure to yield 21 mg of pure title product. NMR absorptions (CDCl<sub>3</sub>) are observed at 0.6–2.8, 3.0–4.2, and 4.65–5.8δ. <sup>13</sup>C-NMR absorptions (CDCl<sub>3</sub>) are observed at 176.9, 135.5, 133.2, 118.5 (d J=17.5 Hz), 77.7, 73.5, 57.3, 46.5, 41.0, 38.2, 37.0, 36.2 (d J=4.8 Hz), 32.3, 31.7, 31.1 (d J=13.5 Hz), 28.5 (d J=28.3 Hz), 25.2, 22.6, 21.0, and 14.0δ. Silica gel TLC R<sub>f</sub> is 0.39 in the A-IX solvent system.

#### EXAMPLE 26

5-Fluoro-CBA<sub>2</sub> (less polar isomer)

Following the procedure of Example 25, 24 mg of the title product of Example 24 yields 23 mg of pure title product. NMR absorptions (CDCl<sub>3</sub>) are observed at 0.6–2.9, 3.3–4.2, 5.0–6.0δ. <sup>13</sup>C-NMR absorptions (CDCl<sub>3</sub>) are observed at 176.8, 135.4, 132.9, 118.3 (d J=18.2 Hz), 77.6, 73.4, 57.2, 46.3, 41.2, 37.8, 36.8, 34.6 (d J=2.7 Hz), 32.8, 32.4, 31.7, 28.7 (d J=28.4 Hz), 25.2, 22.6, 21.1, and 14.0δ. TLC R<sub>f</sub> is 0.50 in the A-IX solvent system.

The reaction products of Example 25–26 are obtained as diastereomeric mixtures of (5E) and (5Z) geometric isomers. These geometric isomers are characterized herein as “less polar” and “more polar” isomers based on TLC motilities. The isomers of these 5-fluoro-CBA<sub>2</sub> compounds correspond to the (5E) and (5Z) geometric isomers of CBA<sub>2</sub> itself. On the basis of relative biologi-

cal activities, the more polar 5-fluoro-CBA<sub>2</sub> isomer yields more potent pharmacological effects and on this basis could be assigned the (5Z) structure based on pharmacological considerations alone. However, the <sup>13</sup>C-NMR data suggests the more polar isomer corresponds to the (5E) structure of the 5-fluoro-CBA<sub>2</sub> compound.

Following the procedure of Examples 25-26, there are prepared each of the various formula XCVI 5-fluoro-CBA<sub>2</sub> diastereomers from the starting materials described following Example 24.

Further following the procedures known in the art, each of the various 5-fluoro-CBA<sub>2</sub> compounds described in and following Examples 24-25 is transformed to the corresponding formula XCVII 5-fluoro-CBA<sub>2</sub> analogs.

#### EXAMPLE 27

##### (5Z)-9β-methyl-CBA<sub>2</sub> adamantylamine salt

The title product of Example 18 (54 mg), (5Z)-9β-methyl-CBA<sub>2</sub> in 6 ml of diethyl ether is combined with 23 mg of adamantylamine. After 10 min the precipitate forms which is thereafter stirred for 12 hr, decanted, and concentrated under reduced pressure to yield 68 mg of a solid, pure title product. Melting range is 110°-114° C.

#### EXAMPLE 28

##### (5Z)-9β-methyl-CBA<sub>2</sub>, calcium salt hydrate

The title product of Example 18 (0.95 g), 9β-methyl-(5Z)-CBA<sub>2</sub>, calcium oxide (0.064 g), freshly boiled water (9.2 ml), and distilled tetrahydrofuran (6 ml), are combined by heating to 50° C. under a nitrogen atmosphere with stirring for 20 min. The resulting mixture is then filtered, washed with tetrahydrofuran, and concentrated under reduced pressure to yield a residue. The residue is then dissolved in tetrahydrofuran (10 ml) and concentrated 8 times to yield a cream-colored foam. This foam is then dissolved in 6 ml of tetrahydrofuran which is dripped into anhydrous diethyl ether (95 ml). The resulting suspension is then stirred for 15 min at ambient temperature under a nitrogen atmosphere and filtered. The filter cake is then washed with anhydrous diethyl ether and dried for 20 hr under reduced pressure at ambient temperature to yield 0.686 g of title product. Melting range is 101°-108° C. Following atmospheric equilibration melting range is 80°-117° C. Infrared absorptions are observed at 3330, 1670, 1555, 1455, 1345, 1310, 1270, 1075, 1020, 970 cm<sup>-1</sup>.

#### EXAMPLE 29

##### 8α-hydroxy-7β-(3α-hydroxy-trans-1-octenyl)-tricyclo-[4.3.1]nonan-4-one, 8,3'-bis(tetrahydropyranyl ether)

(Formula XXV: R<sub>18</sub>, Y<sub>1</sub>, M<sub>6</sub>, L<sub>1</sub>, R<sub>27</sub>, and n are as defined in Example 1, R<sub>16</sub> and R<sub>37</sub> taken together are -CH<sub>2</sub>-).

Refer to Chart A.

A. The formula XXIV title product of Example 1 (4.0 g) and benzophenone (2 g) in one liter of methanol is photolyzed (3500 Å lamp) for 3 hr while argon is bubbled through the solution. The methanol is then removed by concentration under reduced pressure and the residue chromatographed on 600 g of silica gel eluting with a mixture ranging from ethyl acetate in hexane (1:3) to 100% ethyl acetate. Compound XXVI, 1β-hydroxymethyl-7α-hydroxy-6β-(6'α-hydroxy-trans-1'-octenyl)bicyclo[3.3.0]octan-3-one, 7,3'-bis(tetrahy-

dropyranyl ether) is obtained as a white solid (3.45 g). Crystallization from ethyl acetate in hexane yields a white solid with melting range 65°-70° C. NMR absorptions (CDCl<sub>3</sub>) are observed at 0.89, 1.17-2.90, 2.92-4.40, 4.69, and 5.24-5.77δ. Infrared absorptions are observed at 3420, 1730, 1200, 1125, 1110, 1070, 1040, 1020, and 970 cm<sup>-1</sup>. Silica gel TLC R<sub>f</sub> is 0.29 in hexane and ethyl acetate (1:4).

B. A solution of 0.6 g of the reaction product of Part A and 0.49 g of p-toluenesulfonyl chloride in 30 ml of pyridine is cooled to 0° C. under argon for 70 hr, added to 100 ml of ice, diluted with 300 ml of water, and extracted with diethyl ether (800 ml). The ethereal extracts are then washed with brine, dried over magnesium sulfate, concentrated under reduced pressure, and chromatographed eluting with 50% to 80% hexane in ethyl acetate to yield 0.49 g of formula XXVII compound, 3-oxo-7α-tetrahydropyran-2-yloxy-6β-[(3's)-3'-tetrahydropyran-2-yloxy-trans-1'-octenyl]-1β-(p-toluenesulfonyl)-oxymethylbicyclo[3.3.0]octane, as a colorless oil. NMR absorptions (CDCl<sub>3</sub>) are observed at 0.88, 1.06-2.9, 2.45, 3.17-4.35, 4.52-4.83, 5.2-5.8, 7.37, and 7.81 δ. Infrared absorptions are observed at 1740, 1600, 1360, 1200, 1190, 1175, 1130, 1110, 1075, 1035, 1020, 970, and 820 cm<sup>-1</sup>. Silica gel TLC R<sub>f</sub> is 0.45 or 0.26 in ethyl acetate and hexane (1:1 or 1:2).

C. A degassed solution of 0.49 g of the reaction product of Part B and 1 ml of t-butanol in 50 ml of dry tetrahydrofuran at 0° C. under an argon atmosphere is treated with 0.8 ml of 1.7 M potassium t-butoxide in tetrahydrofuran. After 5 min the reaction is allowed to warm and the resulting brown solution stirred for 3 hr at ambient temperature. Thereafter 90 ml of brine is added and the mixture is extracted with 270 ml of ethyl acetate. The ethyl acetate extracts are then washed with 100 ml of saturated aqueous sodium bicarbonate, 100 ml of brine, dried over anhydrous magnesium sulfate, concentrated under reduced pressure, yielding 0.37 g of a brown oil, and chromatographed on 40 g of silica gel eluting with hexane and ethyl acetate (2:1) to yield 0.32 g of pure formula XXV title product as a colorless oil.

D. Alternatively, a suspension of 207 mg of 57% sodium hydride in mineral oil and 1.08 g of trimethylloxosulfonium iodide is treated dropwise under a nitrogen atmosphere with 6 ml of dimethylsulfoxide. The resulting grey slurry is then stirred at ambient temperature for 20 min, treated with 2.03 g of the title product of Example 1 in 4 ml of dry dimethylsulfoxide and stirred for 2 hr at ambient temperature. Thereafter stirring is continued for 1 hr at 50° C., the reaction mixture is cooled and diluted with 200 ml of water and thereafter extracted with three 100 ml portions of diethyl ether. The combined ethereal extracts are then washed with 200 ml of water, washed with 100 ml of brine, dried over anhydrous magnesium sulfate, concentrated under reduced pressure, yielding a brown oil, and chromatographed on 250 g of silica gel eluting with ethyl acetate and hexane (1:2) to yield 453 mg of pure title product.

E. For title product prepared according to Part C or Part D above, NMR absorptions (CDCl<sub>3</sub>) are observed at 0.25-2.75, 3.15-4.39, 4.68, and 5.2-5.8δ. Infrared absorptions are observed at 1725, 1665, 1135, 1080, 1040, 1020, 980 cm<sup>-1</sup>.

The mass spectrum exhibits a molecular ion at 446 and silica gel TLC R<sub>f</sub> is 0.30 in ethyl acetate and hexane.

## EXAMPLE 30

(5Z) and (5E)-6 $\alpha$ ,9 $\beta$ -methano-CBA<sub>2</sub>

(Formula X: X<sub>1</sub> is —COOH, Z<sub>1</sub> is —(CH<sub>2</sub>)<sub>3</sub>—, R<sub>15</sub> is hydrogen, R<sub>16</sub> and R<sub>17</sub> taken together are methano, n is one, R<sub>8</sub> is hydroxy, Y<sub>1</sub> is trans—CH=CH—, M<sub>1</sub> is  $\alpha$ -OH: $\beta$ -H, L<sub>1</sub> is  $\alpha$ -H: $\beta$ -H, R<sub>7</sub> is n-butyl, and the C-5, C-6 positions are unsaturated).

Refer to Chart G.

A. A suspension of 452 mg of 57% sodium hydride in mineral oil and 30 ml of dimethylsulfoxide is heated to 65° C. for 1 hr under a nitrogen atmosphere, cooled to 17° C. and thereafter treated over 15 min with 2.39 g of 4-carboxybutyltriphenylphosphonium bromide. The resulting red solution is then stirred for 15 min at 17°–20° C., treated with a solution of 716 mg of the title product of Example 29, 6 ml of dry dimethylsulfoxide, stirred for 43 hr at 40° C., cooled to 0° C., treated with 3.5 ml of water, stirred for 30 min at 0° C., added to 75 ml of water and brine (2:1), acidified with one N aqueous hydrochloric acid, and extracted with 225 ml of diethyl ether. The ethereal extracts are then washed with 375 ml of water and 75 ml of brine, dried over magnesium sulfate, concentrated under reduced pressure, and chromatographed on 150 g of acid-washed silica gel eluting with 10–25% ethyl acetate in hexane to yield 290 mg of (5Z)-6 $\alpha$ ,9 $\beta$ -methano-CBA<sub>2</sub>, 11,15-bis(tetrahydropyranyl ether), 70 mg of (5E)-6 $\alpha$ ,9 $\beta$ -methano-CBA<sub>2</sub>, 11,15-bis(tetrahydropyranyl ether), and 400 mg of a mixture of (5E) and (5Z) formula LXXXIII isomers. Rechromatographing the isomeric mixture on 150 g of acid-washed silica gel yields an additional 50 mg of (5E) isomer and 180 mg of (5Z) isomer.

For the (5Z) isomer NMR absorptions (CDCl<sub>3</sub>) are observed at 0.5–2.85, 3.22–4.4, 4.70, 4.9–5.75, and 10.1  $\delta$ . Infrared absorptions are observed at 3600–3000 (a broad band), 1740, 1710, 1240, 1210, 1135, 1080, 1035, 1020, 980, and 870 cm<sup>-1</sup>. Silica gel TLC R<sub>f</sub> is 0.27 in hexane, ethyl acetate, and acetic acid (65:34:1). For the (5E) isomer NMR absorptions are observed at 0.40–2.70, 3.2–4.4, 4.70, 5.0–5.8, and 8.82 $\delta$ . Infrared absorptions are observed at 3600–3000, 1740, 1710, 1460, 1445, 1200, 1135, 1075, 1035, 1020, and 980 and cm<sup>-1</sup>. Silica gel TLC R<sub>f</sub> is 0.32 in hexane, ethyl acetate, and acetic acid (65:34:1).

B. A solution of 446 mg of the (5Z) reaction product of Part A in 44 ml of acetic acid, water, and tetrahydrofuran (6:3:2) is heated at 45° C. under a nitrogen atmosphere for 3 hr, cooled, added to 200 ml of brine, extracted with 160 ml of ethyl acetate in hexane (3:2), washed with 500 ml of brine, extracted with 120 ml of ethyl acetate and hexane (3:2) dried over sodium sulfate, concentrated under reduced pressure, yielding 0.38 g of a yellow oil and chromatographed on 60 g of acid washed silica gel eluting with 70% ethyl acetate in hexane to yield 170 mg of pure (5Z) title product as a colorless oil. NMR absorptions are observed at 0.5–2.90, 0.89, 4.05, 4.85–5.8, and 6.13 $\delta$ . Infrared absorptions are observed at 3360, 2260, 1710, 1245, 1240, 1075, 1025, and 970 cm<sup>-1</sup>. The mass spectrum for the tris-trimethylsilyl derivative exhibits a high resolution peak at 578.3653. Silica gel TLC R<sub>f</sub> is 0.30 in the A–IX solvent system (the organic phase of an equilibrated mixture of ethyl acetate, acetic acid, cyclohexane, and water; 9:2:5:10).

C. Following the procedure of Part B above 90 mg of the (5E) reaction product of Part A is converted to 46

mg of (5E) title product as a colorless oil. NMR absorptions are observed at 4.40–2.8, 0.89, 4.06, and 5.0–5.85  $\delta$ . Infrared absorptions are observed at 3340, 2630, 1710, 1070, 970 cm<sup>-1</sup>. The mass spectrum exhibits a high resolution peak at 578.3664. Silica gel TLC R<sub>f</sub> is 0.32 in the A–IX solvent system.

Following the procedure of Examples 27–29, each of the various formula X products is prepared wherein R<sub>16</sub> and R<sub>17</sub> are methano from the corresponding formula LXXXI reactants of Chart G.

Accordingly, the above examples provide methods for preparing each of the various formula X CBA analogs of the present invention.

## EXAMPLE 31

9-deoxy-2',9 $\alpha$ -methano-3-oxa-4,5,6-trinor-3,7-(1',3'-inter-phenylene)-PGF<sub>1 $\alpha$</sub> 

(Formula XI: X<sub>1</sub> is COOH, R<sub>20</sub>, R<sub>21</sub>, R<sub>23</sub>, and R<sub>24</sub> are all hydrogen, Z<sub>4</sub> is —CH<sub>2</sub>—, R<sub>22</sub> is  $\beta$ -hydrogen, R<sub>8</sub>, Y<sub>1</sub>, M<sub>1</sub>, L<sub>1</sub>, and R<sub>7</sub> are as defined in Example 8) and its corresponding methyl ester (X<sub>1</sub> is —COOCH<sub>3</sub>).

Refer to Chart P.

A. A solution of methyl phenyl-N-methyl sulfoximine (3.39 g) in dry tetrahydrofuran (60 ml), is alternately degassed and flushed with nitrogen, cooled to –78° C. and treated dropwise over 7 min with 2.8 M methyl magnesium chloride (7.16 ml). The resulting solution is stirred at –78° C. for 30 min, then at 0° C. for 15 min. The reaction is cooled to –78° C. and treated with a solution of 3-oxa-1,2,4,5,6-pentanor-3,7-inter-m-phenylene-PGE<sub>1</sub>, 3-(t-butyl)dimethylsilyl ether, 11,15-bis(tetrahydropyranyl ether) (6.05 g), a formula CLXXXI compound, in dry tetrahydrofuran (35 ml). The resulting mixture is stirred for 1.75 hr while the temperature permitted to go from –78° C. to 0° C. and then stirred for one hr at 0° C. The reaction mixture is then diluted with brine (170 ml) and extracted with diethyl ether. The ethereal extracts are then washed successively with brine (170 ml), 0.5 M aqueous potassium bisulfate (170 ml), saturated aqueous sodium bicarbonate (170 ml) and brine (170 ml), dried over magnesium sulfate, filtered and concentrated to a yellow oil (8.0 g), 9-[(N-methyl)phenylsulfoximinoethyl]-3-oxa-1,2,4,5,6-pentanor-3,7-inter-m-phenylene-PGF<sub>1 $\alpha$</sub> , 3-(t-butyl)dimethylsilyl ether), 11,15-bis(tetrahydropyranyl ether). A degassed solution of 9-[(N-methyl)phenylsulfoximinomethyl]-3-oxa-1,2,4,5,6-pentanor-3,7-inter-m-phenylene-PGF<sub>1 $\alpha$</sub> , 3-(t-butyl)dimethylsilyl ether), 11,15-bis(tetrahydropyranyl ether) (8.0 g) in tetrahydrofuran (150 ml) is cooled to 0° C., treated with 50% acetic acid/water (45 ml) then immediately with aluminum amalgam under nitrogen. (The aluminum amalgam is prepared by washing 20 mesh aluminum, 8.00 g, with diethyl ether, 170 ml, methanol, 340 ml, mercuric chloride, 8.03 g, in water, 275 ml, methanol, 170 ml, and diethyl ether, 170 ml).

The resulting black suspension is stirred for 1.75 hr during which the reaction temperature is permitted to go from 0° to 15° C. (slowly) then cooled to 0°, treated with ethyl acetate (210 ml) and stirred for an additional 30 min at 0° C. The suspension is filtered through diatomaceous earth and the filter cake washed with ethyl acetate. The combined filtrate is then washed with brine (300 ml), 0.5 M aqueous potassium bisulfate (300 ml), saturated aqueous sodium bicarbonate (300 ml) and brine (300 ml), dried, filtered, and concentrated to a yellow oil, crude formula CLXXII compound (6.03 g), 9-deoxy-9-methylene-3-oxa-1,2,3,4,5,6-pentanor-3,7-

inter-*m*-phenylene-P GF<sub>1</sub>, 3-(*t*-butyldimethylsilyl ether), 11,15-bis(tetrahydropyranyl ether). The crude product is combined with that from a repeat preparation to yield 10.1 g of formula CLXXII product which is chromatographed on silica gel eluting with 5% ethyl acetate in Skellysolve B (SSB, isomeric hexanes) to yield 6.93 g of 9-deoxy-9-methylene-3-oxa-1,2,4,5,6-pentano-3,7-inter-*m*-phenylene-PGF<sub>1</sub>, 3-(*t*-butyldimethylsilyl ether), 11,15-bis(tetrahydropyranyl ether). NMR absorptions are observed at 4.52–5.12 and 6.53–7.30δ. Infrared absorptions are observed at 1600 and 1655 cm<sup>-1</sup>. Silica gel TLC R<sub>f</sub> is 0.39 in 10% ethyl acetate in hexane.

B. A degassed solution of 9-deoxy-9-methylene-3-oxa-1,2,4,5,6-pentano-3,7-inter-*m*-phenylene-PGF<sub>1</sub>, 3-(*t*-butyldimethylsilyl ether), 11,15-bis(tetrahydropyranyl ether), the reaction product of Part A, (1.33 g) in dry tetrahydrofuran (70 ml) is cooled to 0° C. and treated under nitrogen with 0.5 M 9-borabicyclo[3.3.1]nonane (14 ml), dropwise over 5 min. The colorless solution is stirred for 4.5 hr at 0° and treated with 30% hydrogen peroxide (6 ml) followed by 3 N potassium hydroxide (6 ml). The resulting suspension is stirred for an additional 30 min at 0° C. and for 75 min while warming to room temperature. The reaction mixture is transferred to a separatory funnel, diluted with brine (300 ml) and ethyl acetate (300 ml). The layers are separated, and the aqueous layer extracted with ethyl acetate (600 ml). The organic extracts are washed with brine (6 ml), dried, filtered, and contrasted to formula CLXXIII product, a colorless oil (3.3 g), 9-deoxy-9α-(hydroxymethyl)-3-oxa-1,2,4,5,6-pentano-3,7-inter-*m*-phenylene-PGF<sub>1</sub>, 3-(*t*-butyldimethylsilyl ether), 11,15-bis(tetrahydropyranyl ether). The crude formula CLXXIII product is chromatographed on silica gel (300 g) in 35% ethyl acetate in hexane to yield 1.26 g of 9-deoxy-9α-(hydroxymethyl)-3-oxa-1,2,4,5,6-pentano-3,7-inter-*m*-phenylene-PGF<sub>1</sub>, 3-(*t*-butyldimethylsilyl ether), 11,15-bis(tetrahydropyranyl ether) as a colorless oil. NMR absorptions are observed at 4.73, 5.12–5.70, 6.52–7.23δ. Infrared absorptions are observed at 3480 and 1670 cm<sup>-1</sup>. Silica gel TLC R<sub>f</sub> is 0.21 in 35% ethyl acetate in hexane.

C. A degassed solution of 9-deoxy-9α-hydroxymethyl-3-oxa-1,2,4,5,6-pentano-3,7-inter-*m*-phenylene-PGF<sub>1</sub>, 3-(*t*-butyldimethylsilyl ether), 11,15-bis(tetrahydropyranyl ether) (2.01 g), reaction product of Part B, in dry methylene chloride (45 ml) is cooled to -5° C. under nitrogen and treated with triethylamine (0.72 ml), then with methanesulfonyl chloride (0.76 ml). The resulting solution is stirred at -5° C. for 5 min then for 75 min while warming to ambient temperature. The reaction solution is poured over ice, and the resulting mixture swirled for a few minutes then transferred to a separatory funnel and partitioned between diethyl ether and brine. The layers are separated, and the aqueous layer extracted with ether (400 ml). The organic layer is washed with brine (200 ml) and saturated aqueous sodium bicarbonate (400 ml), dried, filtered, and concentrated to a formula CLXXIV product, a colorless oil (2.69 g), 9-deoxy-9α-mesyloxymethyl-3-oxa-1,2,4,5,6-pentano-3,7-inter-*m*-phenylene-PGF<sub>1</sub>, 3-(*t*-butyldimethylsilyl ether), 11,15-bis(tetrahydropyranyl ether). This product (2.69 g) is chromatographed on silica gel (185 g) eluting with 25% ethyl acetate in Skellysolve B to yield 1.99 g of 9-deoxy-9α'-mesyloxymethyl-3-oxa-1,2,4,5,6-pentano-3,7-inter-*m*-phenylene-PGF<sub>1</sub>, 11,15-bis(tetrahydropyranyl ether). NMR absorptions are

observed at 2.95, 4.70, 5.20–5.70, and 6.52–7.22δ. Silica gel TLC R<sub>f</sub> is 0.30 in 35% ethyl acetate in hexane.

D. A degassed solution of 9-deoxy-9α-mesyloxymethyl-3-oxa-1,2,4,5,6-pentano-3,7-inter-*m*-phenylene-PGF<sub>1</sub>, 3-(*t*-butyldimethylsilyl ether), 11,15-bis(tetrahydropyranyl ether) (0.971 g), the reaction product of Part C, in dry tetrahydrofuran (35 ml) is cooled to 0° C. and treated under nitrogen with 0.75 M tetrabutylammonium fluoride (2.6 ml). The resulting amber solution is stirred for 2.5 hr at 0°–5° C. and is partitioned between ethyl acetate (150 ml) and brine (150 ml). The layers are separated, and the aqueous layer extracted with ethyl acetate (300 ml). The organic layer is then washed with 0.5 M aqueous ammonium chloride (150 ml), saturated aqueous sodium bicarbonate (300 ml) and brine (150 ml), dried, filtered and concentrated to give 0.82 g of formula CLXXV product, 9-deoxy-9α-mesyloxymethyl-3-oxa-1,2,4,5,6-pentano-3,7-inter-*m*-phenylene-PGF<sub>1</sub>, 11,15-bis(tetrahydropyranyl ether). Infrared absorptions are observed at 3330 cm<sup>-1</sup>. Silica gel TLC R<sub>f</sub> is 0.37 in 50% ethyl acetate in hexane.

E. A degassed solution of 9-deoxy-9α-mesyloxymethyl-3-oxa-1,2,4,5,6-pentano-3,7-inter-*m*-phenylene-PGF<sub>1</sub>, 11,15-bis(tetrahydropyranyl ether) (0.82 g), reaction product of Part D, is cooled to -40° C. under argon and treated with 57% sodium hydride (0.67 g). The resulting suspension is then stirred for 40 min at -40° C. then 15 min at 0° C. The suspension is stirred for an additional 20 min while warming to room temperature and then stirred for 2.5 hr at reflux. The reaction is then cooled to 10° C., diluted with ice cold brine (200 ml) and extracted with ethyl acetate (450 ml). The ethyl acetate extracts are then washed with brine (300 ml), dried, filtered and concentrated to give 0.72 g of the formula CLXXVI crude product. The crude product is chromatographed in silica gel (175 g) in 25% ethyl acetate in Skellysolve B to yield 0.49 g of 9-deoxy-2',9α-methano-3-oxa-1,2,4,5,6-pentano-3,7-(1',3'-interphenylene)-PGF<sub>1</sub>, 11,15-bis(tetrahydropyranyl ether). NMR absorptions are observed at 4.77, 5.32–6.03, and 6.52–7.22δ. Infrared absorptions are observed at 3340 and 1670 cm<sup>-1</sup>. Silica gel TLC R<sub>f</sub> is 0.56 in 35% ethyl acetate in hexane.

F. A degassed solution of 9-deoxy-2',9α-methano-3-oxa-1,2,4,5,6-pentano-3,7-(1',3'-interphenylene)-PGF<sub>1</sub>, 11,15-bis(tetrahydropyranyl ether) (0.47 g), reaction product of Part E, in dry glyme (15 ml) is cooled to 0° C. and treated under nitrogen with methyl bromoacetate (0.26 ml) followed by 57% sodium hydride suspension (0.136 g). Following vigorous effervescence, a white precipitate is formed. The resulting suspension is stirred for 2.5 hr at 0°–5° C., diluted with ice cold brine (200 ml) and extracted with ethyl acetate (450 ml). The ethyl acetate extracts are washed with brine (300 ml), dried over magnesium sulfate, filtered and concentrated to a pale yellow oil (0.62 g), formula CLXXVII compound, 9-deoxy-2',9α-methano-3-oxa-4,5,6-trino-3,7-(1',3'-interphenylene)-PGF<sub>1</sub>, methyl ester, 11,15-bis(tetrahydropyranyl ether). Infrared absorptions are observed at 1765 and 1740 cm<sup>-1</sup>.

G. A solution of 9-deoxy-2',9α-methano-3-oxa-4,5,6-trino-3,7-(1',3'-interphenylene)-PGF<sub>1</sub>, methyl ester, 11,15-bis(tetrahydropyranyl ether) (0.62 g), reaction product of Part F, in acetic acid (15 ml), water (7.5 ml) and tetrahydrofuran (5 ml) is reacted at 45° C. under nitrogen for 2.75 hr, cooled and diluted with ice cold brine (200 ml). The resulting suspension is extracted with ethyl acetate (400 ml), and the organic extracts

washed with brine (400 ml), saturated aqueous sodium bicarbonate (600 ml) and brine (200 ml). The ethyl acetate extracts are then dried over magnesium sulfate, filtered and concentrated to give 0.44 g of pale yellow oil.

This crude product is chromatographed on silica gel (60 g) in 50% ethyl acetate in Skellysolve B to yield 0.37 g of product which was crystallized to yield 0.216 g of title product, 9-deoxy-2',9 $\alpha$ -methano-3-oxa-4,5,6-trinor-3,7-(1',3'-inter-phenylene)-PGF<sub>1</sub>, methyl ester. Melting range is 82°–84° C. NMR absorptions are observed at 3.77, 4.62, 5.42–5.63, and 6.53–7.25 $\delta$ . Infrared absorptions are observed at 3520, 3400, and 1735 cm<sup>-1</sup>. Silica gel TLC R<sub>f</sub> is 0.30 in 35% acetone in methylene chloride.

H. A solution of 9-deoxy-2',9 $\alpha$ -methano-3-oxa-4,5,6-trinor-3,7-(1',3'-inter-phenylene)-PGF<sub>1</sub>, methyl ester (0.15 g), reaction product of Part G, in 5% potassium hydroxide in 9:1 methanol-water (5.5 ml) is stirred at 0° C. under nitrogen. The solution is turbid initially and a precipitate forms within 5 min. The reaction is then stirred for one hr at 0° C., diluted with ice cold brine (90 ml), acidified with 1 N hydrochloric acid, and extracted with ethyl acetate (180 ml). The ethyl acetate extract is then washed with brine (270 ml), dried over magnesium sulfate, and concentrated under reduced pressure to yield a waxy, semi-solid (0.131 g), which is crystallized to yield 0.105 g of title product, 9-deoxy-2',9 $\alpha$ -methano-3-oxa-4,5,6-trinor-3,7-(1',3'-inter-phenylene)PGF<sub>1</sub>. Melting range is 131°–133° C. NMR absorptions are observed at 4.68, 5.48–5.72, 6.68–7.22. Infrared absorptions are observed at 3460, 3280, 1735, 1720, and 1700 cm<sup>-1</sup>.

I. The dosage at which the title compounds should be administered to achieve their effect, chiefly anti-platelet aggregation or blood pressure lowering, will vary according to the potency of the particular compound under study. When given orally, the compounds will show a desired effect in man at a dose from about 0.05 to about 50 mg/kg orally, preferably from about 0.1 to about 5 mg/kg. The compounds 9-deoxy-2',9 $\alpha$ -methano-3-oxa-4,5,6-trinor-3,7-(1',3'-interphenylene)-PGF<sub>1</sub>, methyl ester, given to a rat orally at a dose of 1 mg/kg lowered blood pressure 44 mmHg. After 52 min the blood pressure was still lower 14 mm. Intravenous dosages for the desired effect are from about 1 to about 500 ng/kg/min in man, preferably from about 10 to about 100 ng/kg/min.

#### EXAMPLE 32

9-Deoxy-2',9 $\alpha$ -methano-3-oxa-4,5,6-trinor-3,7-(1',3'-inter-phenylene)-16,16-difluoro-PGF<sub>1</sub>

(Formula XI: X<sub>1</sub> is —COOH, L<sub>1</sub> is  $\alpha$ -fluoro: $\beta$ -fluoro, R<sub>20</sub>, R<sub>21</sub>, R<sub>23</sub>, and R<sub>24</sub> are all hydrogen, Z<sub>4</sub> is —CH<sub>2</sub>—, R<sub>22</sub> is  $\beta$ -hydrogen, R<sub>8</sub>, Y<sub>1</sub>, M<sub>1</sub>, and R<sub>7</sub> are as defined in Example 8) and its corresponding methyl ester (X<sub>1</sub> is —COOCH<sub>3</sub>).

Refer to Chart P.

A. Diethyl ether (55 ml) tri-n-butylphosphine (2.28 g) and cuprous iodide (2.13 g) are combined with stirring with the resulting mixture being alternately degassed and flushed with nitrogen at 25° C. for 1 hr. The resulting solution is then cooled to —78° C. and is hereafter referred to as solution 32-I. Thereafter 60 ml of anhydrous diethyl ether and 6.47 g of m-bromo-phenol, t-butyl dimethylsilyl ether are combined and the resulting solution alternately degassed and flushed with nitrogen and cooled to —78° C. After cooling, the resulting

mixture is treated with 44.16 ml of a 1.02 M solution of t-butyllithium in n-pentane. This reaction mixture is then stirred at —78° C. for 1 hr and hereinafter referred to as solution 32-II. Solution 32-II is then transferred with stirring over 15 min to solution 32-I under a nitrogen atmosphere. The resulting solution changed in color from clear to yellow to an orange-brown to tan. The resulting mixture is then stirred at —78° C. for 30 min and labelled solution 32-III. Thereafter 4 $\alpha$ -hydroxy-3 $\beta$ -(4',4'-difluoro-3' $\alpha$ -hydroxy-trans-1'-octenyl)-2-methylene-cyclopentanone, 4,3'-bis(tetrahydropyran-2-yl ether), 4 g, Example 25 of U.S. Pat. No. 4,181,798, and 38 ml of anhydrous dry ethyl ether are combined with stirring and the resulting mixture alternately degassed and flushed with nitrogen and thereafter cooled to —78° C. The resulting solution is referred to herein as solution 32-IV. Solution 32-IV is then added to solution 32-III with vigorous stirring over 25 min at —78° C. under a nitrogen atmosphere. The reaction mixture is then stirred at —78° C. for 30 min and thereafter transferred to 100 ml of 8% glacial acetic acid in diethyl ether (—40° C.) with vigorous stirring under a nitrogen atmosphere. The resulting mixture is then diluted with brine and extracted with diethyl ether. The ethereal extracts are then washed with aqueous sodium bicarbonate in brine, dried over sodium sulfate, concentrated under reduced pressure, and chromatographed on silica gel eluting with 20% ethyl acetate in Skellysolve B to yield 5.56 g of pure formula CLXXI compound: 16,16-difluoro-3-oxa-1,2,4,5,6-pentanor-3,7-inter-m-phenylene-PGE<sub>1</sub>, 3-(t-butyl dimethylsilyl ether), 11,15-bis(tetrahydropyran-2-yl ether). NMR absorptions (CDCl<sub>3</sub>) are observed at 0.18, 3.1–5.0, 5.67, 6.52–6.88, and 6.88–7.2 $\delta$ . Infrared absorptions are observed at 1745, 1600, 1585, 1490, 1275, 1260, 1200, 1155, 1125, 1075, 1035, 1025, 975, 840, and 780 cm<sup>-1</sup>. Silica gel TLC R<sub>f</sub> is 0.36 and 0.41 in 25% ethyl acetate in Skellysolve B. Silica gel TLC R<sub>f</sub> is 0.5 in 5% acetone in methylene chloride.

B. Following the procedure of Example 31, Part A, 3.47 g of the reaction product of Part A of this example is converted to 2.98 g of formula CLXXII product as a colorless oil, 9-deoxy-9-methylene-3-oxa-1,2,4,5,6-pentanor-3,7-inter-m-phenylene-16,16-difluoro-PGF<sub>1</sub>, 3-(t-butylsilyl ether), 11,15-bis(tetrahydropyranyl ether). NMR absorptions are observed at 0.17, 0.97, 1.0–3.2, 3.2–4.4, 4.4–5.0, 5.3–6.0, and 6.4–7.3 $\delta$ . Infrared absorptions are observed at 1655, 1605, 1585, 1485, 1275, 1260, 1200, 1144, 1125, 1080, 1025, 970, 870, and 780 cm<sup>-1</sup>. Silica gel TLC R<sub>f</sub> is 0.31 and at 0.36 in 10% ethyl acetate in hexane.

C. Following the procedure of Example 31, Part B, 2.83 g of the reaction product of Part B of this example is converted to 2.5 g of formula CLXXIII product as a colorless oil, 9-deoxy-9 $\alpha$ -(hydroxymethyl)-3-oxa-1,2,4,5,6-pentanor-3,7-inter-m-phenylene-16,16-difluoro-PGF<sub>1</sub>, 3-(t-butyl dimethylsilyl ether), 11,15-bis(tetrahydropyranyl ether). NMR absorptions (CDCl<sub>3</sub>) are observed at 0.18, 0.98, 1.15–3.0, 3.0–4.5, 4.5–5.0, 5.3–5.9, and 6.4–7.3 $\delta$ . Infrared absorptions are observed at 3460, 1670, 1600, 1585, 1485, 1275, 1260, 1160, 1135, 1125, 1075, 1025, 975, 840, and 780 cm<sup>-1</sup>. Silica gel TLC R<sub>f</sub> is 0.28 in 35% ethyl acetate in hexane.

D. Following the procedure of Example 31, Part C, the reaction product of Part C of this example (2.29 g) is converted to 1.83 g of formula CLXXIV product as a colorless oil, 9-deoxy-9 $\alpha$ -mesyloxymethyl-3-oxa-

1,2,4,5,6-pentanor-3,7-inter-m-phenylene-16,16-difluoro-PGF<sub>1</sub>, 3-(t-butyltrimethylsilyl ether), 11,15-bis(tetrahydropyranyl ether). NMR absorptions are observed at 0.18, 0.98, 1.15-2.85, 2.95, 3.11-4.5, 4.5-5.0, 5.2-5.9, and 6.5-7.4δ. Infrared absorptions are observed at 2930, 2860, 1605, 1590, 1490, 1465, 1440, 1360, 1275, 1200, 1175, 1120, 1025, 975, and 840 cm<sup>-1</sup>. Silica gel TLC R<sub>f</sub> is 0.28 in 30% ethyl acetate and hexane.

E. Following the procedure of Example 31, Part D, 1.7 g of the reaction product of Part D of this example is converted to 1.6 g of formula CLXXV product as a yellow oil, 9-deoxy-9α-mesyloxymethyl-3-oxa-1,2,4,5,6-pentanor-3,7-inter-m-phenylene-16,16-difluoro-PGF<sub>1</sub>, 11,15-bis(tetrahydropyranyl ether). Silica gel TLC R<sub>f</sub> is 0.34 in ethyl acetate and hexane (1:1).

F. Following the procedure of Example 31, Part E, 1.52 g of the reaction product of Part D of this example is converted to 0.83 g of formula CLXXVI product as a white foam, 9-deoxy-2',9α-methano-3-oxa-1,2,4,5,6-pentanor-3,7-(1',3'-inter-phenylene)-16,16-difluoro-PGF<sub>1</sub>, 11,15-bis(tetrahydropyranyl ether). NMR absorptions are observed at 0.95, 1.05-2.95, 3.5-5.0, 5.3-6.0, and 6.5-7.2δ. Infrared absorptions are observed at 3350, 2930, 1670, 1615, 1590, 1465, 1280, 1200, 1120, 1070, and 975 cm<sup>-1</sup>. The mass spectrum exhibits peaks at 534, 451, 446, 402, and 348. Silica gel TLC R<sub>f</sub> is 0.26 in ethyl acetate and hexane (1:3) and 0.40 in acetone and methylene chloride (1:19).

G. Following the procedure of Example 31, Part F, 0.80 g of the reaction product of Part F of this example is converted to 1.06 g of formula CLXXVII product as a colorless oil, 9-deoxy-2',9α-methano-3-oxa-4,5,6-trinor-3,7-(1',3'-inter-phenylene)-16,16-difluoro-PGF<sub>1</sub>, methyl ester, 11,15-bis(tetrahydropyranyl ether). Silica gel TLC R<sub>f</sub> is 0.44 in 5% acetone and methylene chloride.

H. Following the procedure of Example 31, Part G, 1.0 g of the reaction product of Part G of this example is converted to 0.62 g of crystalline methyl ester title product, a Formula CLXXVIII white solid. Recrystallization from hexane in diethyl ether yields a material with melting range 93°-95° C. NMR absorptions are observed at 0.95, 1.10-2.90, 2.90-4.8, 5.4-5.8, and 6.4-7.3. Infrared absorptions are observed at 3560, 3400, 1765, 1750, 1735, 1720, 1675, 1605, 1585, 1270, 1215, 1205, 1120, 1105, 1080, 1010, 970, and 770 cm<sup>-1</sup>. The mass spectrum for the bis-trimethylsilyl derivative exhibits a high resolution peak at 582.2997. Silica gel TLC R<sub>f</sub> is 0.35 in hexane and ethyl acetate (1:4).

Following the procedure of Example 31, Part H, the reaction product of Part H of this example (0.25 g) is converted to the carboxylic acid title product (158 mg) as a crystalline solid. Melting range is 128°-130° C. NMR absorptions (COCD<sub>3</sub>) are observed at 0.9, 1.3-3.0, 3.0-4.6, 4.68, 4.8-5.5, 6.5-6.9, 5.5-5.9, and 6.6-7.3δ. Infrared absorptions are observed at 3570, 3480, 3370, 3220, 2800, 1740, 1720, 1605, 1585, 1235, 1210, 1125, 1105, 1080, 1000, and 970 cm<sup>-1</sup>. The mass spectrum for the tris-trimethylsilyl derivative exhibits a high resolution peak at 640.3232. Silica gel TLC R<sub>f</sub> is 0.18 in the A-IX solvent system.

Following the procedure of Examples 31 and 32, there are prepared each of the various formula CLXXVIII products in free acid or ester form from corresponding formula CLXXI reactants.

Formula CLXXVIII compounds wherein Y<sub>1</sub> is unsaturated (trans- or cis-CH=CH-) are transformed to corresponding formula CLXXVIII compounds

wherein Y is saturated (-CH<sub>2</sub>CH<sub>2</sub>-) by hydrogenation, as exemplified below:

## EXAMPLE 33

9-Deoxy-2',9α-methano-3-oxa-4,5,6-trinor-3,7-(1',3'-inter-phenylene)-13,14-dihydro-PGF<sub>1</sub>

(Formula XI: X<sub>1</sub> is COOH, Y<sub>1</sub> is -CH<sub>2</sub>CH<sub>2</sub>-, R<sub>20</sub>, R<sub>21</sub>, R<sub>23</sub>, and R<sub>24</sub> are all hydrogen, Z<sub>4</sub> is -CH<sub>2</sub>-, R<sub>22</sub> is β-hydrogen, R<sub>8</sub>, M<sub>1</sub>, L<sub>1</sub>, and R<sub>7</sub> are as defined in Example 8) and its corresponding methyl ester (X<sub>1</sub> is -COOCH<sub>3</sub>).

A. A solution of the methyl ester title product of Example 31 (0.341 g) in ethyl acetate (35 ml) is treated at ambient temperature with 5% palladium-on-charcoal and hydrogenated at atmospheric pressure. The resulting suspension is then stirred for 70 minutes with a hydrogen uptake of 20 ml (atmospheric pressure). The resulting suspension is then filtered through diatomaceous earth and the filter cake washed with ethyl acetate. The combined filtrate is then concentrated under reduced pressure to yield a colorless oil which is chromatographed on silica gel eluting with ethyl acetate in Skellysolve B to yield 0.306 g of title product (methyl ester), a colorless oil. NMR absorptions (CDCl<sub>3</sub>) are observed at 0.9, 0.107-1.23, 3.3-4.03, 3.77, 4.62, 6.52, and 7.27δ. Infrared absorptions are observed at 3350, 2930, 2855, 1760, 1740, 1605, 1585, 1467, 1435, 1275, 1205, 1120, 1080, 1025, and 775 cm<sup>-1</sup>. Silica gel TLC R<sub>f</sub> is 0.54 in ethyl acetate.

B. Following the procedure of Example 31, Part H, the title product of Part A of this example (0.177 g) is converted to 0.23 g of title product (free acid) as a solid. Recrystallization from ethyl acetate in hexane yields 0.096 g with melting range 121°-123° C. The mass spectrum for the tris-trimethylsilyl derivatives exhibits a high resolution peak at 606.3553 and other peaks at 591-535, 516, 427, 426, 275, 274, 173, and 157. Silica gel TLC R<sub>f</sub> is 0.27 in A-IX.

## EXAMPLE 34

9-Deoxy-2',9β-methano-3-oxa-4,5,6-trinor-3,7-(1',3'-inter-phenylene)-PGF<sub>1</sub>

(Formula XI: X<sub>1</sub> is COOH, R<sub>20</sub>, R<sub>21</sub>, R<sub>22</sub>, and R<sub>24</sub> are all hydrogen, Z<sub>4</sub> is -CH<sub>2</sub>-, R<sub>22</sub> is α-hydrogen, R<sub>8</sub>, Y<sub>1</sub>, M<sub>1</sub>, L<sub>1</sub>, and R<sub>7</sub> are as defined in Example 8) and its corresponding methyl ester (X<sub>1</sub> is -COOCH<sub>3</sub>).

Refer to Charts Q and R.

A. A solution of 0.82 g of the reaction product of Example 31, Part B, in 16 ml of methylene chloride is stirred at ambient temperature under nitrogen atmosphere and treated with diatomaceous earth followed by 26 ml of Collins reagent prepared from 2.5 ml of pyridine and 1.55 g of chromium trioxide in 50 ml of methylene chloride). The resulting suspension is then stirred for 35 min at ambient temperature under a nitrogen atmosphere and filtered through 30 g of silica gel, eluting with 150 ml of ethyl acetate. Concentration under reduced pressure yields 0.90 g of a pale yellow oil. Chromatographing on 85 g of silica gel eluting with 20% ethyl acetate in Skellysolve B yields 0.644 g of pure formula CLXXXII aldehyde as a colorless oil, 9-deoxy-9α-formyl-3-oxa-1,2,4,5,6-pentanor-3,7-inter-m-phenylene-PGE<sub>1</sub>, 3-(t-butyltrimethylsilyl ether), 11,15-bis(tetrahydropyranyl ether). NMR absorptions are observed at 0.18, 0.88, 0.98, 1.13-3.08, 3.23-4.35, 4.73, 5.25-5.75, 6.57-7.37, and 9.88δ. Infrared absorp-



tions are observed at 2730, 1720, 1600, 1585, 1485, 1275, 1260, 1075, 1035, 1030, 1020, 975, and 840  $\text{cm}^{-1}$ . Silica gel TLC  $R_f$  is 0.47 in ethyl acetate and hexane (1:3).

B. A degassed solution of 1.5 g of the reaction product of Part A and 0.36 ml of 1,8-diazobicyclo[5.4.0]undec-7-ene in 150 ml of methylene chloride is stirred for 40 hr at ambient temperature under a nitrogen atmosphere, washed with 100 ml of ice cold 0.15 M aqueous potassium bisulfate, 100 ml of saturated aqueous sodium carbonate, and 100 ml of brine, dried over anhydrous sodium sulfate and concentrated under reduced pressure to yield 1.5 g of formula CXCII product as a yellow oil, 9-deoxy-9 $\beta$ -formyl-3-oxa-1,2,4,5,6-pentanor-3,7-inter-phenylene-PGF<sub>1</sub>, 3-(*t*-butyldimethylsilyl ether), 11,15-bis(tetrahydropyranyl ether). NMR absorptions ( $\text{CDCl}_3$ ) are observed at 0.18, 0.89, 0.98, 1.1-3.2, 3.2-4.4, 4.68, 5.2-5.8, 6.58-7.4, and 9.22 $\delta$ . Infrared absorptions are observed at 1725, 1600, 1585, 1485, 1440, 1275, 1260, 1200, 1160, 1130, 1075, 1035, 1020, 975, 870, and 840  $\text{cm}^{-1}$ . Silica gel TLC  $R_f$  is 0.24 in ethyl acetate and hexane (1:3).

C. A solution of 1.5 g of the reaction product of Part B in 40 ml of methanol is treated with stirring at 20° C. under a nitrogen atmosphere over several minutes with 400 mg of sodium borohydride, stirred for 20 min at 20° C. The resulting mixture is then added to a cold solution of 200 ml of brine and 32 ml of 0.1 M aqueous potassium sulfate, extracted with 600 ml of ethyl acetate, washed with 200 ml of saturated aqueous sodium bicarbonate in 200 ml of brine, dried over anhydrous magnesium sulfate, concentrated under reduced pressure, and chromatographed on 200 g of silica gel eluting with 35% ethyl acetate in hexane to yield 1.37 g of formula CLCIII product as a colorless oil, 9-deoxy-9 $\beta$ -hydroxymethyl-3-oxa-1,2,4,5,6-pentanor-3,7-inter-*m*-phenylene-PGF<sub>1</sub>, 3-(*t*-butyldimethylsilyl ether), 11,15-(tetrahydropyranyl ether). NMR absorptions ( $\text{CDCl}_3$ ) are observed at 0.17, 0.88, 0.99, 1.1-3.0, 3.0-4.35, 4.7, 5.25-5.85, and 6.5-7.4 $\delta$ . Infrared absorptions are observed at 3460, 1665, 1605, 1685, 1490, 1275, 1260, 1200, 1160, 1135, 1115, 1075, 1020, 1005, 975, 840, and 780  $\text{cm}^{-1}$ . Silica gel TLC  $R_f$  is 0.20 in 35% ethyl acetate in hexane.

D. A degassed solution of 1.32 g of the reaction product of Part B in 0.47 ml of triethyl amine and 30 ml of methylene chloride at 20° C. under a nitrogen atmosphere is treated with 0.5 ml of methanesulfonyl chloride, stirred for 5 min at 0° C., warmed to 20° C. over 90 min, added to 50 g of ice, diluted with 150 ml of brine, extracted with 450 ml of diethyl ether, washed with 150 ml of brine and 300 ml of saturated aqueous sodium bicarbonate, dried over anhydrous magnesium sulfate, concentrated under reduced pressure to yield an oil, and filtered through 70 g of silica gel eluting with 30% ethyl acetate in hexane to yield 1.47 g of mesylate corresponding to the starting material, i.e., the 9 $\beta$  analog of formula CLXXIV. Silica gel TLC  $R_f$  is 0.23 in 30% ethyl acetate in hexane.

E. A degassed solution of 1.47 g of the reaction product of Part D and 50 ml of dry tetrahydrofuran at 0° C. under a nitrogen atmosphere is treated with 3.9 ml of 0.45 M tetra-*n*-butylammonium fluoride. The resulting solution is then stirred at 0° C. for 4 hr, treated with another 0.5 ml of tetra-*n*-butylammonium fluoride, stirred for 30 min at 0° C., diluted with 150 ml of brine, extracted with 450 ml of ethyl acetate, washed successively with 150 ml of 0.5 M aqueous ammonium chloride, 300 ml of saturated aqueous sodium bicarbonate,

and 150 ml of brine, dried over anhydrous sodium sulfate, and concentrated under reduced pressure to yield 1.3 g of a yellow oil, the phenol corresponding to the starting material, i.e., the 9 $\beta$  isomer of the formula CLXXV compound. Silica gel TLC  $R_f$  is 0.11 in 35% ethyl acetate in hexane.

F. A degassed solution of 1.3 g of the reaction product of Part E in 75 ml of dry glyme at -40° C. under a nitrogen atmosphere is treated with 90 mg of 57% sodium hydride dispersion in mineral oil, stirred at -40° to -30° C. for 40 min, stirred at 0° C. for 15 min, stirred at ambient temperature for 15 min, heated and refluxed for 5 hr, cooled to ambient temperature, added to 200 ml of ice cold glyme, extracted with 450 ml of ethyl acetate, washed with 300 ml of brine, dried over anhydrous sodium sulfate on 175 g of silica gel eluting with 25% ethyl acetate in hexane to yield 0.61 g of the 9 $\beta$  isomer corresponding to the formula CLXXVI compound as a viscous oil. NMR absorptions are observed at 0.90, 1.07-3.1, 3.1-4.4, 4.75, 5.33-6.16, and 6.5-7.2 $\delta$ . Infrared absorptions are observed at 3340, 1665, 1610, 1585, 1500, 1465, 1135, 1110, 1075, 1020, and 980  $\text{cm}^{-1}$ . Silica gel TLC  $R_f$  is 0.26 in 25% ethyl acetate in hexane and 0.23 in 5% acetone in methylene chloride.

G. A solution of 0.50 g of the reaction product of Part F in 28 ml of methyl bromoacetate in 16 ml of dry glyme at 0° C. under an argon atmosphere is treated with 0.14 g of a 57% mineral oil dispersion of sodium hydride. The resulting suspension is then stirred for 2.5 hr at 0° C., quenched with 200 ml of cold brine, extracted with 460 ml of ethyl acetate, washed with 300 ml of brine, dried over anhydrous sodium sulfate, and concentrated under reduced pressure to yield 0.68 g of an oil, the 9 $\beta$  isomer corresponding to the formula CLXXVII compound.

H. A solution of the reaction product of Part G (0.68 g) in 5 ml of tetrahydrofuran, 7.5 ml of water, and 15 ml of acetic acid is heated for 2.5 hr at 45° C., cooled, diluted with 200 ml of brine, extracted with 400 ml of ethyl acetate, washed with 400 ml of brine, washed with 200 ml of saturated aqueous sodium bicarbonate, and 200 ml of brine, dried over anhydrous sodium sulfate, concentrated under reduced pressure to yield an oil, chromatographed on 75 g of silica gel eluting with 30% hexane in ethyl acetate to 100% ethyl acetate to yield 0.32 g of title methyl ester as a white foam. Crystallization from hot diethyl ether in hexane yields 0.23 g of pure ester product as a white solid. Melting range is 85°-87° C. NMR absorptions ( $\text{CDCl}_3$ ) are observed at 0.90, 1.07-2.9, 2.9-4.5, 4.61, 5.4-5.8, and 6.38-7.34 $\delta$ . Infrared absorptions are observed at 3520, 3420, 1735, 1720, 1605, 1580, 1300, 1240, 1210, 1110, 1085, 1050, 1010, 970, 760, 720, and 710  $\text{cm}^{-1}$ . The mass spectrum of the bis-trimethylsilyl derivative exhibits a high resolution peak at 546.3182. Silica gel TLC  $R_f$  is 0.14 in 30% ethyl acetate in hexane.

I. Following the procedure of Example 31, Part H, the title product of Part H (158 mg) is transformed to the title free acid (129 mg) as a white solid. Melting range is 150°-154° C. NMR absorptions are observed at 0.90, 1.07-3.5, 3.85-4.35, 4.70, 5.09-5.9, and 6.5-7.3 $\delta$ . Infrared absorptions are observed at 3380, 2640, 2560, 1730, 1605, 1580, 1260, 1230, 1115, 1050, 1025, 970, and 770  $\text{cm}^{-1}$ .

Following the procedure of Example 34, each of the various formula XI compounds are prepared wherein  $R_{22}$  is  $\alpha$ -hydrogen. Further following the procedure of Example 33, the various 9 $\beta$ -methano isomers of Exam-

ple 34 and corresponding formula XI compounds wherein  $Y_1$  is *cis*- or *trans*- $CH=CH-$  are hydrogenated to corresponding 13,14-dihydro-PGF<sub>1</sub> compounds.

## EXAMPLE 35

9-Deoxy-2',9-metheno-3-oxa-4,5,6-trinor-3,7-(1',3'-inter-phenylene)-PGE<sub>1</sub>

(Formula XI:  $X_1$  is COOH,  $R_{20}$ ,  $R_{21}$ ,  $R_{23}$ , and  $R_{24}$  are all hydrogen,  $Z_4$  is  $-CH_2-$ ,  $R_{21}$  and  $R_{22}$  taken together form a valence bond,  $R_8$ ,  $Y_1$ ,  $M_1$ ,  $L_1$ , and  $R_7$  are as defined in Example 8) and its corresponding methyl ester ( $X_1$  is  $-COOCH_3$ ).

Refer to Chart T.

A. A degassed solution of the reaction product of Example 34, Part A, (1.68 g) in dry tetrahydrofuran (50 ml) is cooled to 0° C. and treated under a nitrogen atmosphere with 0.75 M tetrabutylammonium fluoride (4.37 ml). The resulting solution is then stirred at 0° C. for 2 hr, diluted with brine (300 ml), extracted with ethyl acetate, washed with brine, dried over magnesium sulfate, filtered, and concentrated under reduced pressure to yield 2.3 g of an oil. The oil is chromatographed on silica gel (160 g) in 25% ethyl acetate in Skellysolve B yielding 1.21 g of formula CCXI compound, 9-deoxy-9 $\alpha$ -formyl-1,2,4,5,6-pentanor-3,7-inter-*m*-phenylene-PGE<sub>1</sub>, 11,15-bis(tetrahydropyranyl ether). NMR absorptions (CDCl<sub>3</sub>) are observed at 0.88, 1.13-3.15, 3.27-4.47, 4.71, 6.10, 6.53-7.41, 9.27 $\delta$ . Infrared absorptions are observed at 3345, 2930, 2860, 2720, 1735, 1715, 1605, 1595, 1585, 1485, 1450, 1370, 1350, 1255, 1235, and 970 cm<sup>-1</sup>. Silica gel TLC  $R_f$  is 0.12 in 25% ethyl acetate and hexane and 0.39 in 50% ethyl acetate in hexane.

B. A degassed solution of 0.28 g of the reaction product of Part A in 33 ml of glyme is cooled to -40° C. under argon and treated with 2.95 N methylmagnesium chloride in tetrahydrofuran (0.2 ml). The reaction mixture is stirred at -40° C. for 15 min, stirred at 0° C. for 15 min, permitted to warm to ambient temperature, stirred at reflux for 115 hr under an argon atmosphere, cooled, diluted with ice cold brine (150 ml), extracted with ethyl acetate (300 ml), washed with brine (300 ml), dried over magnesium sulfate, filtered, concentrated under reduced pressure to yield 0.31 g of an oil, and chromatographed on silica gel eluting with 25% ethyl acetate in Skellysolve B to yield 0.16 g of the formula CCXII compound, 9-deoxy-2',9-metheno-3-oxa-1,2,4,5,6-pentanor-3,7-(1',3'-inter-phenylene)-PGE<sub>1</sub>, 11,15-bis(tetrahydropyranyl ether). The mass spectrum of the trimethylsilyl derivative exhibits a molecular peak at 568 and other peaks at 466, 382, 364, 314, 297, 267, 255, 243, 230, 270, 153, and 85. Silica gel TLC  $R_f$  is 0.25 in 25% ethyl acetate in hexane and 0.58 in 50% ethyl acetate in hexane.

C. A degassed solution of the reaction product of Part C (0.16 g) in dry glyme (5 ml) is cooled at -5° C. and treated with methylbromo acetate (0.04 ml) under a nitrogen atmosphere. The resulting solution is then treated with 50% sodium hydride dispersion in mineral oil (0.16 g). Precipitate forms in 5 min in the resulting suspension is stirred for 1.5 hr at 0° C., diluted with brine (100 ml), extracted with ethyl acetate (240 ml), washed with brine (100 ml), dried over magnesium sulfate, filtered, concentrated to yield a brown residue which solidifies on refrigeration, and chromatographed on 25 g of silica gel eluting with 20% ethyl acetate in Skellysolve B to yield 0.136 g of the bis(tetrahydropyranyl ether) of a formula CCXIII compound: 9-deoxy-

2',9-metheno-3-oxa-4,5,6-trinor-3,7-(1,3-inter-phenylene)-PGE<sub>1</sub>, methyl ester, 11,15-bis(tetrahydropyranyl ether). Melting range is 81°-83° C. The mass spectrum exhibits peaks at 366, 384, 364, 279, 247, 230, 215, 149, and 85. Silica gel TLC  $R_f$  is 0.45 in 5% acetone in methylene chloride.

D. A solution of the reaction product of Part C (0.12 g) in tetrahydrofuran (1 ml), water (2 ml) and acetic acid (4 ml) is heated at 45° C. under a nitrogen atmosphere for 2.25 hr, cooled, and partitioned between brine (100 ml) in ethyl acetate (90 ml). The layers are separated and the aqueous layer extracted with ethyl acetate (160 ml). The organic layers are then washed successively with brine (100 ml), water (100 ml), saturated aqueous sodium bicarbonate (300 ml) and brine (200 ml), dried over magnesium sulfate, filtered, concentrated to yield 0.97 g of a solid, and chromatographed on 30 g of silica gel, eluting with 85% ethyl acetate in hexane to yield 0.083 g of white crystalline formula CCXIII title product in methyl ester form. Recrystallization from diethyl ether in hexane yields 0.056 g of pure methyl ester title product. Melting range is 96°-98° C. NMR absorptions (CDCl<sub>3</sub>) are observed at 0.94, 3.86, 3.92-4.28, 4.72, 5.58-5.86, and 6.62-7.18 $\delta$ . Infrared absorptions are observed at 3420, 1765, 1665, 1600, 1575, 1465, 1440, 1275, 1215, 1190, 1105, 1085, 970, and 770 cm<sup>-1</sup>. The mass spectrum for the trimethylsilyl derivative exhibits a molecular ion at 554 and other peaks at 454, 383, 365, 364, 230, 229, 225. Silica gel TLC  $R_f$  is 0.41 in ethyl acetate.

E. Following the procedure of Example 31, Part H, the reaction product of Part D (0.19 g) is converted to 76 mg of crystalline title product in free acid form. Melting range is 150°-152° C. NMR absorptions (CDCl<sub>3</sub>) are observed at 0.91, 1.2-3.48, 3.88-4.15, 4.70, 5.62-4.66, and 6.63-7.11. The mass spectrum for the trimethylsilyl derivative exhibits a high resolution peak at 602.3251 and other peaks at 512, 422, 287, 225, 174, and 173. Silica gel TLC  $R_f$  is 0.23 in the A-IX solvent system.

## EXAMPLE 36

9-Deoxy-2',9 $\alpha$ -methano-3-oxa-4,5,6,13,14,15,16,17,18,19,20-undecanor-3,7-(1',3'-inter-phenylene)-12-formyl-PGF<sub>1</sub>, methyl ester

(formula CCXXII:  $X_1$  is  $-COOCH_3$ ,  $Z_4$  is  $-CH_2-$ ,  $R_{20}$ ,  $R_{21}$ , and  $R_{23}$  are hydrogen,  $R_{22}$  is  $\beta$ -hydrogen, and  $R_{18}$  is tetrahydropyran-2-yl-oxy).

Refer to Chart U.

Ozone is bubbled through a solution of 0.72 g of the reaction product of Example 31, Part F, in 50 ml of absolute methanol at -78° C. for 5 min. Thereafter oxygen is bubbled through the resulting solution for 5 min and the solution is treated with 16 ml of dimethyl sulfide. After standing at 16 hr for 0° C. under a nitrogen atmosphere and 2½ hr at ambient temperature, the solution is diluted with 200 ml of ethyl acetate, washed successively with 100 ml of brine, 100 ml of saturated aqueous sodium bicarbonate and 100 ml of brine, dried over anhydrous sodium sulfate, concentrated under reduced pressure, and chromatographed on 175 g of silica gel eluting with 35% ethyl acetate in hexane to yield 367 mg of title product as a colorless oil. NMR absorptions (CDCl<sub>3</sub>) are observed at 1.0-3.0, 3.1-4.5, 3.63, 6.45-7.34, and 9.77 $\delta$ . The mass spectrum exhibits peaks at 388 and 304. Silica gel TLC  $R_f$  is 0.19 and 0.22 in 25% and 30% ethyl acetate in hexane.

## EXAMPLE 37

9-Deoxy-2',9 $\alpha$ -methano-20-methyl-3-oxa-4,5,6-trinor-3,7-(1',3'-inter-phenylene)-PGF<sub>1</sub>

(Formula XI: X<sub>1</sub>, Z<sub>4</sub>, R<sub>8</sub>, R<sub>20</sub>, R<sub>21</sub>, R<sub>22</sub>, R<sub>23</sub>, R<sub>24</sub>, Y<sub>1</sub>, M<sub>1</sub>, and L<sub>1</sub> are as defined in Example 31 and R<sub>7</sub> is n-pentyl) its methyl ester (Z<sub>1</sub> is —COOCH<sub>3</sub>), its 15-epimer (M<sub>1</sub> is  $\alpha$ -H: $\beta$ -OH), and 15-epimer methyl ester (M<sub>1</sub> is  $\alpha$ -H: $\beta$ -OH and Z<sub>1</sub> is —COOCH<sub>3</sub>).

Refer to Chart U.

A. A suspension of 56 mg of a 57% sodium hydride dispersion in mineral oil and 4 ml of tetrahydrofuran at 0° C. under a nitrogen atmosphere is treated with a solution of 286 mg of dimethyl-2-octylphosphonate in 4 ml of tetrahydrofuran, stirred for 5 min at 0° C., stirred for 1 hr at ambient temperature, cooled to 0° C., treated with a solution of 0.39 g of title product of Example 36 and 4 ml of tetrahydrofuran, stirred for 2½ hr at ambient temperature, cooled in 0° C., added to a solution of 40 ml of ethyl acetate containing several drops of acetic acid, extracted with 120 ml of ethyl acetate, washed with 30 ml of saturated aqueous sodium bicarbonate, washed with 30 ml of brine, dried over anhydrous sodium sulfate, concentrated under reduced pressure to yield an oil, and chromatographed on 60 g of silica gel eluting with 25% ethyl acetate in hexane to yield 0.42 g of a colorless oil, 9,15-dideoxy-15-keto-2',9 $\alpha$ -methano-20-methyl-4,5,6-trinor-3,7-(1',3'-inter-phenylene)-PGF<sub>1</sub>, methyl ester, 11-tetrahydropyranyl ether. NMR absorptions are observed at 0.89, 1.05–3.0, 3.5–4.37, 4.62, and 5.97–7.30 $\delta$ . The mass spectrum exhibits peaks at 414, 396, 323, 311, and 301. Silica gel TLC R<sub>f</sub> is 0.26 in 25% ethyl acetate in hexane.

B. A degassed solution of 42 mg of sodium borohydride and 4 ml of absolute methanol at –30° C. under a nitrogen atmosphere is treated dropwise with a solution of 391 mg of the title reaction product of Part A in 0.3 ml of methylene chloride and 3 ml of methanol, stirred for 1½ hr at –30° C., quenched by careful addition of 0.2 ml of glacial acetic acid, diluted with 70 ml of brine, extracted with 210 ml of ethyl acetate, washed with 70 ml of saturated aqueous sodium bicarbonate, washed with 70 ml of brine, dried over anhydrous sodium sulfate, concentrated under reduced pressure to yield 0.42 g of a colorless oil, and chromatographed on 60 g of silica gel eluting with 40% ethyl acetate in hexane to yield 0.36 g of an epimeric mixture of C-15 alcohols. Silica gel TLC R<sub>f</sub> is 0.20 in 40% ethyl acetate in hexane.

C. A solution of the reaction products of Part B above in 3 ml of tetrahydrofuran, 4.5 ml of water, and 9 ml of acetic acid is heated to 45° C. under a nitrogen atmosphere for 2.5 hrs, cooled, diluted washed with 100 ml of brine, extracted with 200 ml of ethyl acetate, washed with 100 ml of brine, washed with 300 ml of saturated aqueous sodium bicarbonate and 100 ml of brine, dried over anhydrous sodium sulfate, concentrated under reduced pressure to a yellow oil, and chromatographed on 60 g of silica gel eluting with 20% ethyl acetate in methylene chloride to yield 96 mg of 9-deoxy-2',9 $\alpha$ -methano-20-methyl-3-oxa-4,5,6-trinor-3,7-(1,3-inter-phenylene)-15-epi-PGF<sub>1</sub>, methyl ester as a colorless oil and 159 mg of 9-deoxy-2',9 $\alpha$ -methano-20-methyl-3-oxa-4,5,6-trinor-3,7-(1,3-inter-phenylene)-PGF<sub>1</sub>, methyl ester as a white solid. Recrystallization of the 15 $\alpha$ -hydroxy compound from hot hexane in diethyl ether yields 140 mg as a white solid. Melting range is 79°–82° C. For the title product methyl ester, NMR absorptions are observed at 0.92, 1.08–3.0, 3.38–4.5,

4.64, 5.33–5.70, and 6.5–7.4. The mass spectrum of the trimethylsilyl derivative exhibits a high resolution peak at 560.3375. Silica gel TLC R<sub>f</sub> is 0.19 in 20% ethyl acetate in methylene chloride and 0.31 in 20% hexane in ethyl acetate. For the 15-epi compound, NMR absorptions (CDCl<sub>3</sub>) are observed at 0.89, 1.07–3.0, 3.7–4.33, 4.63, 5.5–5.8, and 6.55–7.37 $\delta$ . Infrared absorptions are observed at 3360, 1765, 1750, 1735, 1605, 1585, 1470, 1440, 1205, 1120, 1080, 970, and 770 cm<sup>-1</sup>. The mass spectrum for the trimethylsilyl derivative exhibits a high resolution peak at 560.3385. Silica gel TLC R<sub>f</sub> is 0.35 in 20% acetone and methylene chloride and 0.45 in 20% hexane and ethyl acetate.

D. Following the procedure of Example 31, Part H, the 15 $\alpha$ -hydroxy title product of Part C (94 mg) is transformed to 9-deoxy-2',9 $\alpha$ -methano-20-methyl-3-oxa-4,5,6-trinor-3,7-(1,3-inter-phenylene)-PGF<sub>1</sub>, title free acid, as a white solid, 81 mg. Melting range is 144°–146° C. NMR absorptions (CD<sub>3</sub>COCD<sub>3</sub>) are observed at 0.8, 1.05–2.9, 3.2–4.5, 4.65, 5.38–5.56, and 6.6–7.2 $\delta$ . The mass spectrum of the trimethylsilyl derivative exhibits a high resolution peak at 618.3576. Silica gel TLC R<sub>f</sub> is 0.14 in the A-IX solvent system.

E. Further following the procedure of Example 31, Part H, the 15-epi title product of Part C (93 mg) is converted to 9-deoxy-2',9 $\alpha$ -methano-20-methyl-3-oxa-4,5,6-trinor-3,7-(1,3-inter-phenylene)-15-epi-PGF<sub>1</sub>, a white solid, 72 mg. Melting range is 105°–108° C. MMR absorptions (CD<sub>3</sub>COCD<sub>3</sub>) are observed at 0.90, 1.05–2.9, 3.2–4.3, 4.71, 5.0–5.84, and 6.5–7.34 $\delta$ . Silica gel TLC R<sub>f</sub> is 0.19 in the A-IX solvent system.

Following the procedures of Examples 36 and 37, there are substituted C-12 side chains according to the procedure of Chart U for each of the various formula XI compounds.

Thus, according to procedures described above, there are prepared

(5E)-9 $\beta$ -methyl-CBA<sub>2</sub> compounds,  
 (5Z)-9 $\beta$ -methyl-CBA<sub>2</sub> compounds,  
 (5E)-5-fluoro-9 $\beta$ -methyl-CBA<sub>2</sub> compounds,  
 (5Z)-5-fluoro-9 $\beta$ -methyl-CBA<sub>2</sub> compounds,  
 (5E)-5-fluoro-CBA<sub>2</sub> compounds,  
 (5Z)-5-fluoro-CBA<sub>2</sub> compounds,  
 (5E)-9 $\beta$ -methyl-2,5-inter-o-phenylene-3,4-dinor-CBA<sub>2</sub> compounds,  
 (5Z)-9 $\beta$ -methyl-2,5-inter-o-phenylene-3,4-dinor-CBA<sub>2</sub> compounds,  
 (5E)-9 $\beta$ -methyl-1,5-inter-o-phenylene-2,3,4-trinor-CBA<sub>2</sub> compounds,  
 (5E)-9 $\beta$ -methyl-1,5-inter-o-phenylene-3,4,5-trinor-CBA<sub>2</sub> compounds,  
 (5E)-2,5-inter-o-phenylene-3,4-dinor-CBA<sub>2</sub> compounds,  
 (5Z)-2,5-inter-o-phenylene-3,4-dinor-CBA<sub>2</sub> compounds,  
 (5E)-1,5-inter-m-phenylene-2,3,4-trinor-CBA<sub>2</sub> compounds,  
 (5Z)-1,5-inter-m-phenylene-2,3,4-trinor-CBA<sub>2</sub> compounds,  
 2,2-difluoro-(5E)-9 $\beta$ -methyl-CBA<sub>2</sub> compounds,  
 2,2-difluoro-(5Z)-9 $\beta$ -methyl-CBA<sub>2</sub> compounds,  
 2,2,5-trifluoro-(5E)-9 $\beta$ -methyl-CBA<sub>2</sub> compounds,  
 2,2,5-trifluoro-(5Z)-9 $\beta$ -methyl-CBA<sub>2</sub> compounds,  
 2,2,5-trifluoro-(5E)-CBA<sub>2</sub> compounds,  
 2,2,5-trifluoro-(5Z)-CBA<sub>2</sub> compounds,  
 2,2-difluoro-(5E)-9 $\beta$ -methyl-2,5-inter-o-phenylene-3,4-dinor-CBA<sub>2</sub> compounds,

2,2-difluoro-(5Z)-9 $\beta$ -methyl-2,5-inter-o-phenylene-3,4-dinor-CBA<sub>2</sub> compounds,  
 2,2-difluoro-(5E)-9 $\beta$ -methyl-1,5-inter-o-phenylene-2,3,4-trinor-CBA<sub>2</sub> compounds,  
 2,2-difluoro-(5E)-9 $\beta$ -methyl-1,5-inter-o-phenylene-3,4,5-trinor-CBA<sub>2</sub> compounds,  
 2,2-difluoro-(5E)-2,5-inter-o-phenylene-3,4-dinor-CBA<sub>2</sub> compounds,  
 2,2-difluoro-(5Z)-2,5-inter-o-phenylene-3,4-dinor-CBA<sub>2</sub> compounds,  
 2,2-difluoro-(5E)-1,5-inter-m-phenylene-2,3,4-trinor-CBA<sub>2</sub> compounds,  
 2,2-difluoro-(5Z)-1,5-inter-m-phenylene-2,3,4-trinor-CBA<sub>2</sub> compounds,  
 trans-2,3-didehydro-(5E)-9 $\beta$ -methyl-CBA<sub>2</sub> compounds,  
 trans-2,3-didehydro-(5Z)-9 $\beta$ -methyl-CBA<sub>2</sub> compounds,  
 trans-2,3-didehydro-(5E)-5-fluoro-9 $\beta$ -methyl-CBA<sub>2</sub> compounds,  
 trans-2,3-didehydro-(5Z)-5-fluoro-9 $\beta$ -methyl-CBA<sub>2</sub> compounds,  
 trans-2,3-didehydro-(5E)-5-fluoro-CBA<sub>2</sub> compounds,  
 trans-2,3-didehydro-(5Z)-5-fluoro-CBA<sub>2</sub> compounds,  
 trans-2,3-didehydro-(5E)-9 $\beta$ -methyl-2,5-inter-o-phenylene-3,4-dinor-CBA<sub>2</sub> compounds,  
 trans-2,3-didehydro-(5Z)-9 $\beta$ -methyl-2,5-inter-o-phenylene-3,4-dinor-CBA<sub>2</sub> compounds,  
 trans-2,3-didehydro-(5E)-9 $\beta$ -methyl-1,5-inter-o-phenylene-2,3,4-trinor-CBA<sub>2</sub> compounds,  
 trans-2,3-didehydro-(5Z)-9 $\beta$ -methyl-1,5-inter-o-phenylene-2,3,4-trinor-CBA<sub>2</sub> compounds,  
 trans-2,3-didehydro-(5E)-9 $\beta$ -methyl-1,5-inter-o-phenylene-3,4,5-trinor-CBA<sub>2</sub> compounds,  
 trans-2,3-didehydro-(5Z)-9 $\beta$ -methyl-1,5-inter-o-phenylene-3,4,5-trinor-CBA<sub>2</sub> compounds,  
 trans-2,3-didehydro-(5E)-2,5-inter-o-phenylene-3,4-dinor-CBA<sub>2</sub> compounds,  
 trans-2,3-didehydro-(5Z)-2,5-inter-o-phenylene-3,4-dinor-CBA<sub>2</sub> compounds,  
 trans-2,3-didehydro-(5E)-1,5-inter-m-phenylene-2,3,4-trinor-CBA<sub>2</sub> compounds,  
 trans-2,3-didehydro-(5Z)-1,5-inter-m-phenylene-2,3,4-trinor-CBA<sub>2</sub> compounds,  
 9-deoxy-2',9 $\alpha$ -methano-3-oxa-4,5,6-trinor-3,7-(1',3'-inter-phenylene)-PGF<sub>1</sub> compounds,  
 9-deoxy-2',9 $\beta$ -methano-3-oxa-4,5,6-trinor-3,7-(1',3'-inter-phenylene)-PGF<sub>1</sub> compounds,  
 9-deoxy-2',9-metheno-3-oxa-3,4,5-trinor-3,7-(1',3'-inter-phenylene)-7,8-didehydro-PGE<sub>1</sub> compounds,  
 9-deoxy-2',9-metheno-3-oxa-3,4,5-trinor-3,7-(1',3'-inter-phenylene)-PGE<sub>1</sub> compounds,  
 6 $\alpha$ -oxo-9-deoxy-2',9 $\alpha$ -methano-3-oxa-4,5,6-trinor-3,7-(1',3'-inter-phenylene)-PGF<sub>1</sub> compounds,  
 6 $\alpha$ -oxo-9-deoxy-2',9 $\beta$ -methano-3-oxa-4,5,6-trinor-3,7-(1',3'-inter-phenylene)-PGF<sub>1</sub> compounds,  
 6 $\alpha$ -hydroxy-9-deoxy-2',9 $\alpha$ -methano-3-oxa-4,5,6-trinor-3,7-(1',3'-inter-phenylene)-PGF<sub>1</sub> compounds,  
 6 $\alpha$ -hydroxy-9-deoxy-2',9 $\beta$ -methano-3-oxa-4,5,6-trinor-3,7-(1',3'-inter-phenylene)-PGF<sub>1</sub> compounds,  
 6 $\beta$ -hydroxy-9-deoxy-2',9 $\alpha$ -methano-3-oxa-4,5,6-trinor-3,7-(1',3'-inter-phenylene)-PGF<sub>1</sub>, and  
 6 $\beta$ -hydroxy-9-deoxy-2',9 $\beta$ -methano-3-oxa-4,5,6-trinor-3,7-(1',3'-inter-phenylene)-PGF<sub>1</sub> compounds,  
 in free acid or methyl ester form which exhibit the following side chain substituents:  
 15-cyclohexyl-16,17,18,19,20-pentanor-;  
 17-(2-furyl)-18,19,20-trinor-;  
 16-(3-thienyl)oxy-17,18,19,20-tetranor-;  
 17-(3-thienyl)-18,19,20-trinor-;  
 15-methyl-;  
 16-methyl-;  
 15,16-dimethyl-;  
 16,16-dimethyl-;

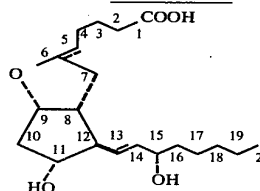
17,20-dimethyl-;  
 16-fluoro-;  
 15-methyl-16-fluoro-;  
 16,16-difluoro-;  
 5 15-methyl-16,16-difluoro-;  
 17-phenyl-18,19,20-trinor-;  
 17-(m-trifluoromethylphenyl)-18,19,20-trinor-;  
 17-(m-chlorophenyl)-18,19,20-trinor-;  
 17-(p-fluorophenyl)-18,19,20-trinor-;  
 10 15-methyl-17-phenyl-18,19,20-trinor-;  
 16-methyl-17-phenyl-18,19,20-trinor-;  
 16,16-dimethyl-17-phenyl-18,19,20-trinor-;  
 16-fluoro-17-phenyl-18,19,20-trinor-;  
 16,16-difluoro-17-phenyl-18,19,20-trinor-;  
 15 16-phenyl-17,18,19,20-tetranor-;  
 15-methyl-16-phenyl-17,18,19,20-tetranor-;  
 16-(m-trifluoromethylphenyl)-17,18,19,20-tetranor-;  
 16-(m-chlorophenyl)-17,18,19,20-tetranor-;  
 16-(p-fluorophenyl)-17,18,19,20-tetranor-;  
 20 16-phenyl-18,19,20-trinor-;  
 15-methyl-16-phenyl-18,19,20-trinor-;  
 16-methyl-16-phenyl-18,19,20-trinor-;  
 15,16-dimethyl-16-phenyl-18,19,20-trinor-;  
 16-phenoxy-17,18,19,20-tetranor-;  
 25 15-methyl-16-phenoxy-17,18,19,20-tetranor-;  
 16-(m-trifluoromethylphenoxy)-17,18,19,20-tetranor-;  
 16-(m-chlorophenoxy)-17,18,19,20-tetranor-;  
 16-(p-fluorophenoxy)-17,18,19,20-tetranor-;  
 16-phenoxy-18,19,20-trinor-;  
 30 15-methyl-16-phenoxy-18,19,20-trinor-;  
 16-methyl-16-phenoxy-18,19,20-trinor-;  
 15,16-dimethyl-16-phenoxy-18,19,20-trinor-;  
 13,14-didehydro-;  
 35 15-cyclohexyl-16,17,18,19,20-pentanor-13,14-didehydro-;  
 17-(2-furyl)-18,19,20-trinor-13,14-didehydro-;  
 16-(3-thienyl)oxy-17,18,19,20-tetranor-13,14-didehydro-;  
 40 17-(3-thienyl)-18,19,20-trinor-13,14-didehydro-;  
 15-methyl-13,14-didehydro-;  
 16-methyl-13,14-didehydro-;  
 15,16-dimethyl-13,14-didehydro-;  
 16,16-dimethyl-13,14-didehydro-;  
 45 17,20-dimethyl-13,14-didehydro-;  
 16-fluoro-13,14-didehydro-;  
 15-methyl-16-fluoro-13,14-didehydro-;  
 16,16-difluoro-13,14-didehydro-;  
 15-methyl-16,16-difluoro-13,14-didehydro-;  
 50 17-phenyl-18,19,20-trinor-13,14-didehydro-;  
 17-(m-trifluoromethylphenyl)-18,19,20-trinor-13,14-didehydro-;  
 17-(m-chlorophenyl)-18,19,20-trinor-13,14-didehydro-;  
 17-(p-fluorophenyl)-18,19,20-trinor-13,14-didehydro-;  
 55 15-methyl-17-phenyl-18,19,20-trinor-13,14-didehydro-;  
 16-methyl-17-phenyl-18,19,20-trinor-13,14-didehydro-;  
 16,16-dimethyl-17-phenyl-18,19,20-trinor-13,14-didehydro-;  
 16-fluoro-17-phenyl-18,19,20-trinor-13,14-didehydro-;  
 60 16,16-difluoro-17-phenyl-18,19,20-trinor-13,14-didehydro-;  
 16-phenyl-17,18,19,20-tetranor-13,14-didehydro-;  
 15-methyl-16-phenyl-17,18,19,20-tetranor-13,14-didehydro-;  
 16-(m-trifluoromethylphenyl)-17,18,19,20-tetranor-13,14-didehydro-;  
 65 16-(m-chlorophenyl)-17,18,19,20-tetranor-13,14-didehydro-;

16-(p-fluorophenyl)-17,18,19,20-tetranor-13,14-didehydro-;  
 16-phenyl-18,19,20-trinor-13,14-didehydro-;  
 15-methyl-16-phenyl-18,19,20-trinor-13,14-didehydro-;  
 16-methyl-16-phenyl-18,19,20-trinor-13,14-didehydro-;  
 15,16-dimethyl-16-phenyl-18,19,20-trinor-13,14-didehydro-;  
 16-phenoxy-17,18,19,20-tetranor-13,14-didehydro-;  
 15-methyl-16-phenoxy-17,18,19,20-tetranor-13,14-didehydro-;  
 16-(m-trifluoromethylphenoxy)-17,18,19,20-tetranor-13,14-didehydro-;  
 16-(m-chlorophenoxy)-17,18,19,20-tetranor-13,14-didehydro-;  
 16-(p-fluorophenoxy)-17,18,19,20-tetranor-13,14-didehydro-;  
 16-phenoxy-18,19,20-trinor-13,14-didehydro-;  
 15-methyl-16-phenoxy-18,19,20-trinor-13,14-didehydro-;  
 16-methyl-16-phenoxy-18,19,20-trinor-13,14-didehydro-;  
 15,16-dimethyl-16-phenoxy-18,19,20-trinor-13,14-didehydro-;  
 13,14-dihydro-;  
 15-cyclohexyl-16,17,18,19,20-pentanon-13,14-dihydro-;  
 17-(2-furyl)-18,19,20-trinor-13,14-dihydro-;  
 16-(3-thienyl)oxy-17,18,19,20-tetranor-13,14-dihydro-;  
 17-(3-thienyl)-18,19,20-trinor-13,14-dihydro-;  
 15-methyl-13,14-dihydro-;  
 16-methyl-13,14-dihydro-;  
 15,16-dimethyl-13,14-dihydro-;  
 16,16-dimethyl-13,14-dihydro-;  
 17,20-dimethyl-13,14-dihydro-;  
 16-fluoro-13,14-dihydro-;  
 15-methyl-16-fluoro-13,14-dihydro-;  
 16,16-difluoro-13,14-dihydro-;  
 15-methyl-16,16-difluoro-13,14-dihydro-;  
 17-phenyl-18,19,20-trinor-13,14-dihydro-;  
 17-(m-trifluoromethylphenyl)-18,19,20-trinor-13,14-dihydro-;  
 17-(m-chlorophenyl)-18,19,20-trinor-13,14-dihydro-;  
 17-(p-fluorophenyl)-18,19,20-trinor-13,14-dihydro-;  
 15-methyl-17-phenyl-18,19,20-trinor-13,14-dihydro-;  
 16-methyl-17-phenyl-18,19,20-trinor-13,14-dihydro-;  
 16,16-dimethyl-17-phenyl-18,19,20-trinor-13,14-dihydro-;  
 16-fluoro-17-phenyl-18,19,20-trinor-13,14-dihydro-;  
 16,16-difluoro-17-phenyl-18,19,20-trinor-13,14-dihydro-;  
 16-phenyl-17,18,19,20-tetranor-13,14-dihydro-;  
 15-methyl-16-phenyl-17,18,19,20-tetranor-13,14-dihydro-;  
 16-(m-trifluoromethylphenyl)-17,18,19,20-tetranor-13,14-dihydro-;  
 16-(m-chlorophenyl)-17,18,19,20-tetranor-13,14-dihydro-;  
 16-(p-fluorophenyl)-17,18,19,20-tetranor-13,14-dihydro-;  
 16-phenyl-18,19,20-trinor-13,14-dihydro-;  
 15-methyl-16-phenyl-18,19,20-trinor-13,14-dihydro-;  
 16-methyl-16-phenyl-18,19,20-trinor-13,14-dihydro-;  
 15,16-dimethyl-16-phenyl-18,19,20-trinor-13,14-dihydro-;  
 16-phenoxy-17,18,19,20-tetranor-13,14-dihydro-;  
 15-methyl-16-phenoxy-17,18,19,20-tetranor-13,14-dihydro-;  
 16-(m-trifluoromethylphenoxy)-17,18,19,20-tetranor-13,14-dihydro-;

16-(m-chlorophenoxy)-17,18,19,20-tetranor-13,14-dihydro-;  
 16-(p-fluorophenoxy)-17,18,19,20-tetranor-13,14-dihydro-;  
 16-phenoxy-18,19,20-trinor-13,14-dihydro-;  
 15-methyl-16-phenoxy-18,19,20-trinor-13,14-dihydro-;  
 16-methyl-16-phenoxy-18,19,20-trinor-13,14-dihydro-;  
 15,16-dimethyl-16-phenoxy-18,19,20-trinor-13,14-dihydro-;  
 13-cis-;  
 15-cyclohexyl-16,17,18,19,20-pentanon-13-cis-;  
 17-(2-furyl)-18,19,20-trinor-13-cis-;  
 16-(3-thienyl)oxy-17,18,19,20-tetranor-13-cis-;  
 17-(3-thienyl)-18,19,20-trinor-13-cis-;  
 15-methyl-13-cis-;  
 16-methyl-13-cis-;  
 15,16-dimethyl-13-cis-;  
 16,16-dimethyl-13-cis-;  
 17,20-dimethyl-13-cis-;  
 16-fluoro-13-cis-;  
 15-methyl-16-fluoro-13-cis-;  
 16,16-difluoro-13-cis-;  
 15-methyl-16,16-difluoro-13-cis-;  
 17-phenyl-18,19,20-trinor-13-cis-;  
 17-(m-trifluoromethylphenyl)-18,19,20-trinor-13-cis-;  
 17-(m-chlorophenyl)-18,19,20-trinor-13-cis-;  
 17-(p-fluorophenyl)-18,19,20-trinor-13-cis-;  
 15-methyl-17-phenyl-18,19,20-trinor-13-cis-;  
 16-methyl-17-phenyl-18,19,20-trinor-13-cis-;  
 16,16-dimethyl-17-phenyl-18,19,20-trinor-13-cis-;  
 16-fluoro-17-phenyl-18,19,20-trinor-13-cis-;  
 16,16-difluoro-17-phenyl-18,19,20-trinor-13-cis-;  
 16-phenyl-17,18,19,20-tetranor-13-cis-;  
 15-methyl-16-phenyl-17,18,19,20-tetranor-13-cis-;  
 16-(m-trifluoromethylphenyl)-17,18,19,20-tetranor-13-cis-;  
 16-(m-chlorophenyl)-17,18,19,20-tetranor-13-cis-;  
 16-(p-fluorophenyl)-17,18,19,20-tetranor-13-cis-;  
 16-phenyl-18,19,20-trinor-13-cis-;  
 15-methyl-16-phenyl-18,19,20-trinor-13-cis-;  
 16-methyl-16-phenyl-18,19,20-trinor-13-cis-;  
 15,16-dimethyl-16-phenyl-18,19,20-trinor-13-cis-;  
 16-phenoxy-17,18,19,20-tetranor-13-cis-;  
 15-methyl-16-phenoxy-17,18,19,20-tetranor-13-cis-;  
 16-(m-trifluoromethylphenoxy)-17,18,19,20-tetranor-13-cis-;  
 16-(m-chlorophenoxy)-17,18,19,20-tetranor-13-cis-;  
 16-(p-fluorophenoxy)-17,18,19,20-tetranor-13-cis-;  
 16-phenoxy-18,19,20-trinor-13-cis-;  
 15-methyl-16-phenoxy-18,19,20-trinor-13-cis-;  
 16-methyl-16-phenoxy-18,19,20-trinor-13-cis-;  
 15,16-dimethyl-16-phenoxy-18,19,20-trinor-13-cis-;

## FORMULAS

60



65

P. 37

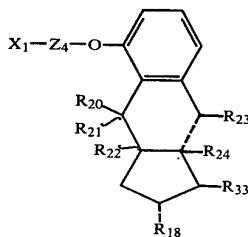
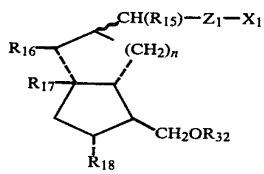
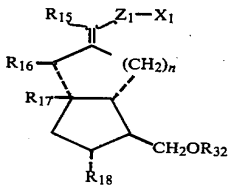
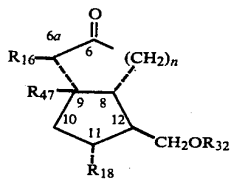
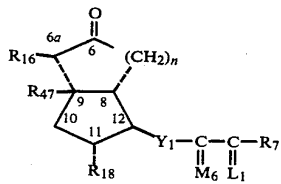
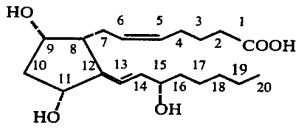
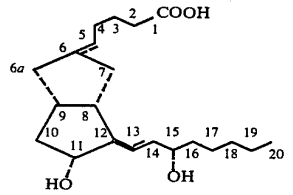
Ex. 2032

SteadyMed v. United Therapeutics  
IPR2016-00006

4,306,075

73

-continued  
FORMULAS

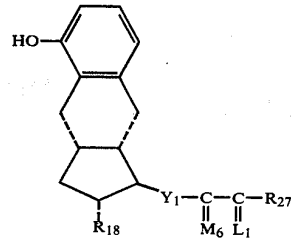


74

-continued  
FORMULAS

II

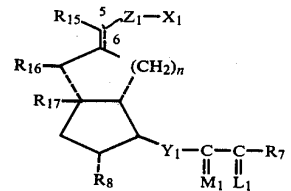
5



IX

III

15

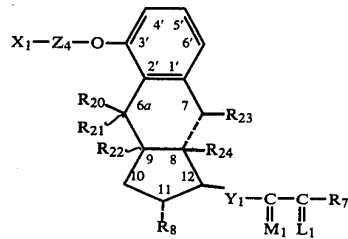


X

IV

20

25



XI

V

30

35

VI

40

45

VII

50

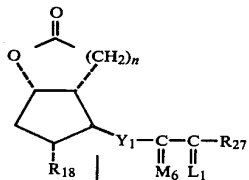
55

VIII

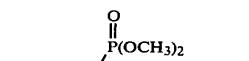
60

65

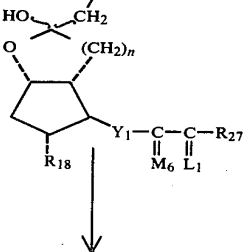
CHART A



XXI



XXII



P. 38

Ex. 2032

SteadyMed v. United Therapeutics  
IPR2016-00006

IPR2020-00769

United Therapeutics EX2006

Page 4674 of 7113

-continued

CHART A

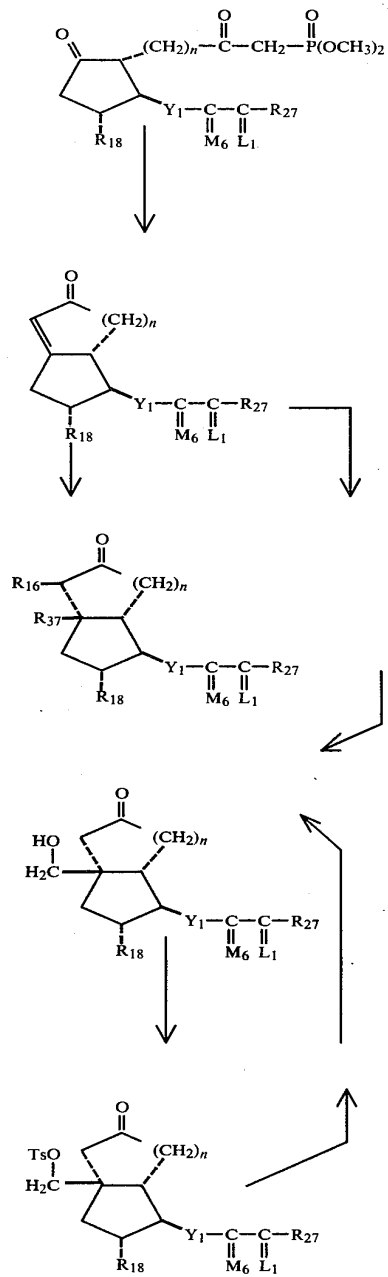


CHART B

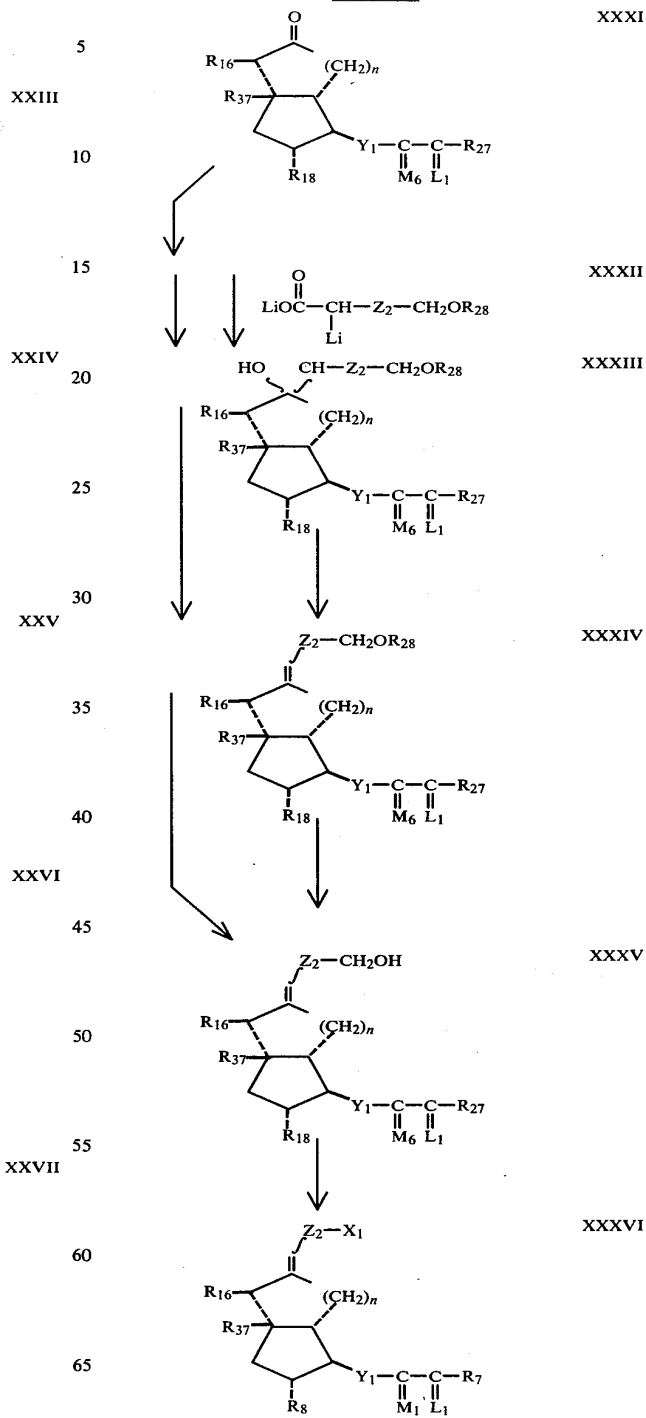


CHART C

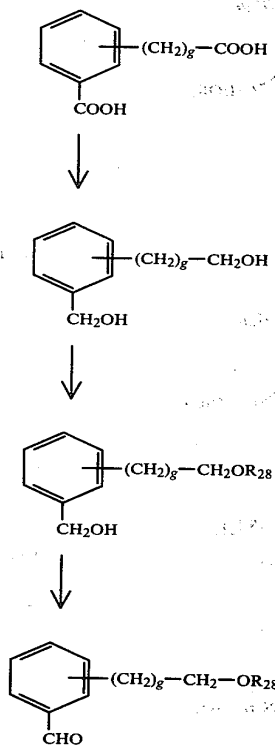
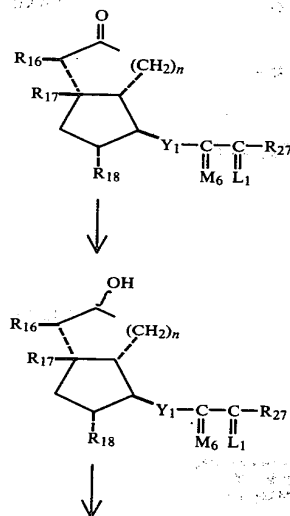
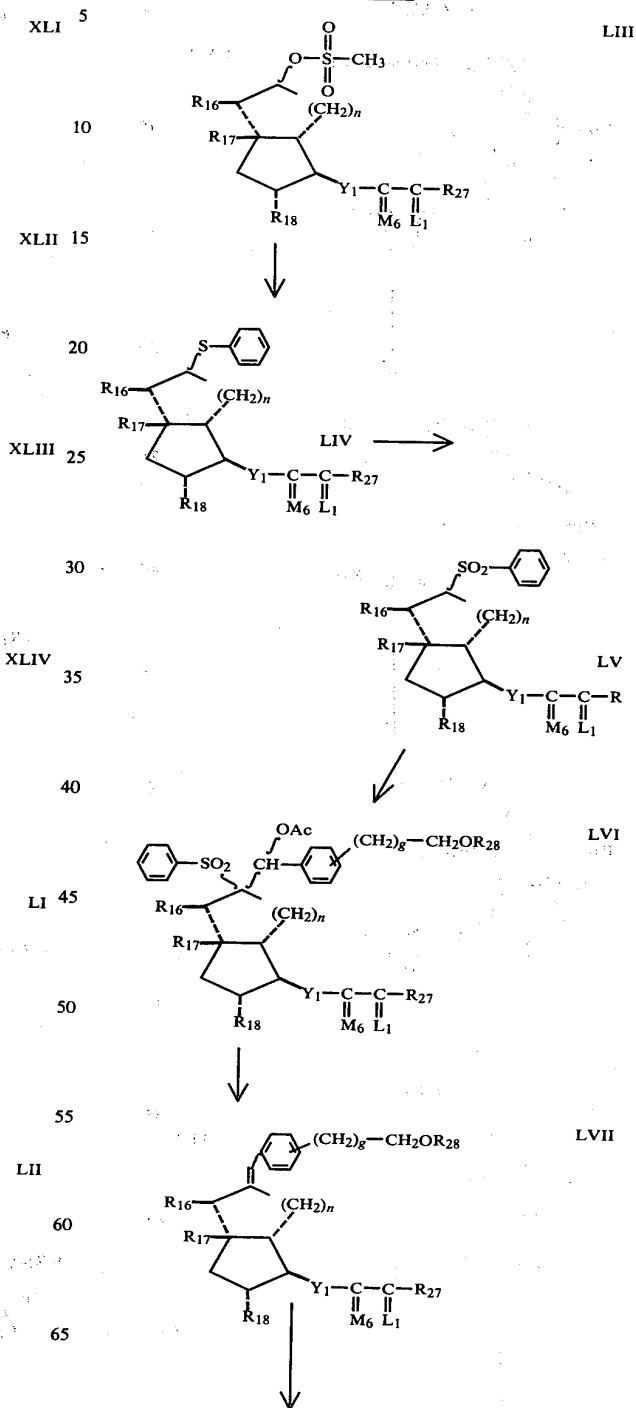


CHART D



-continued-

CHART D





79

-continued

CHART D

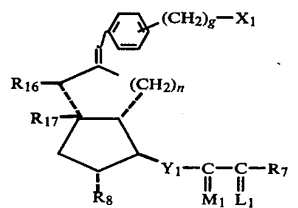
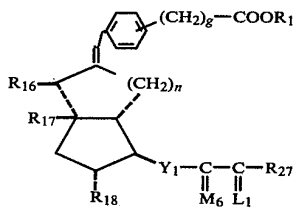
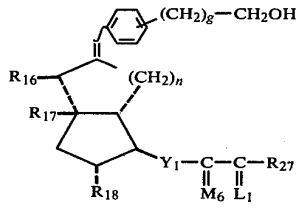
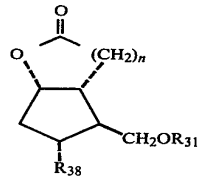


CHART E



80

-continued

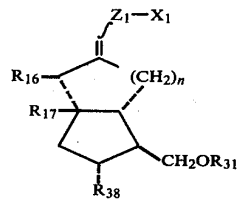
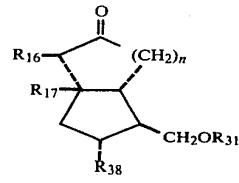
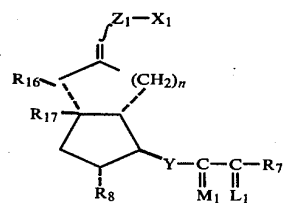
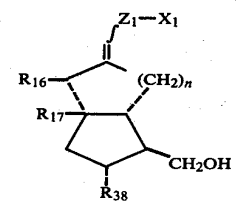
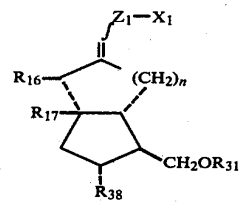


CHART F



LVIII

10

15

LIX

25

30

35

LX 40

45

50

55

LXI

60

65

LXII

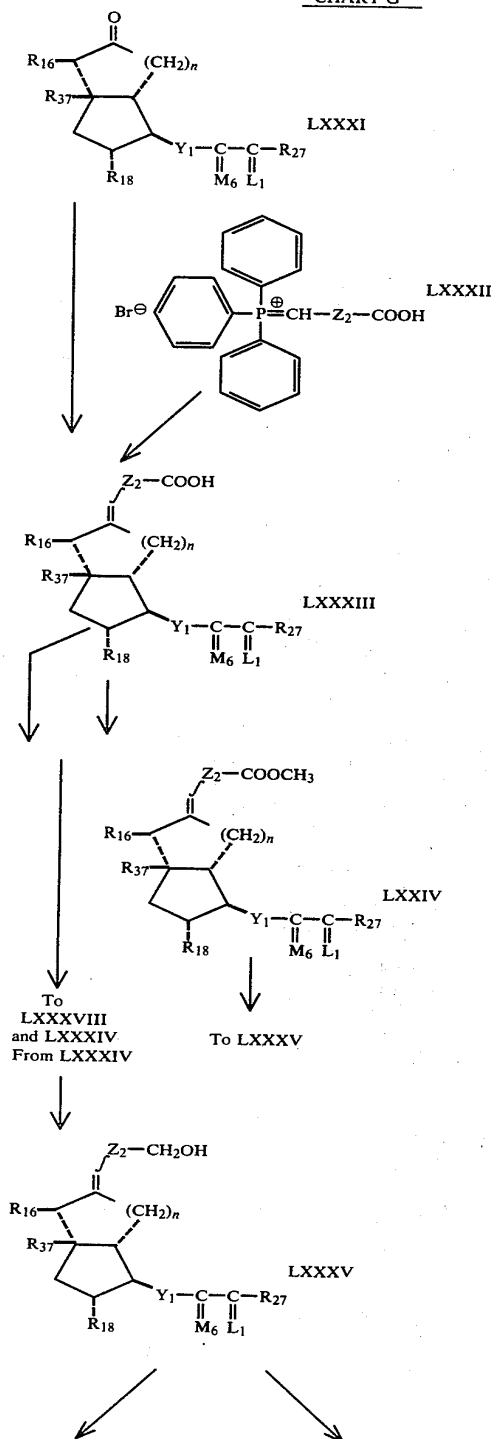
LXIII

LXXI

LXXII

LXXIII

## CHART G



-continued

CHART G

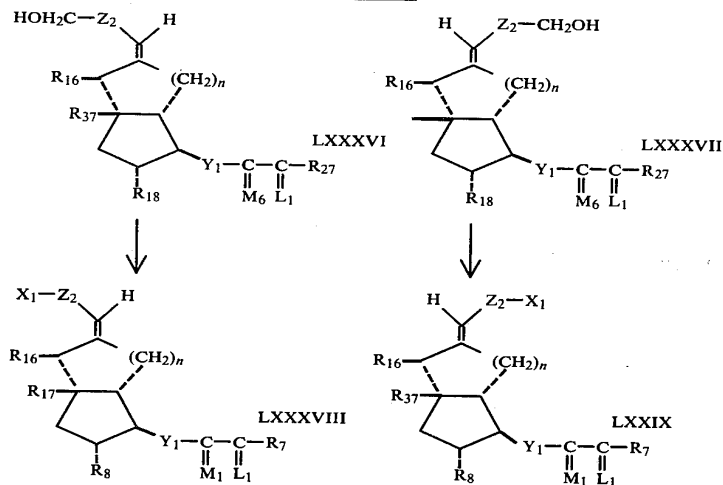
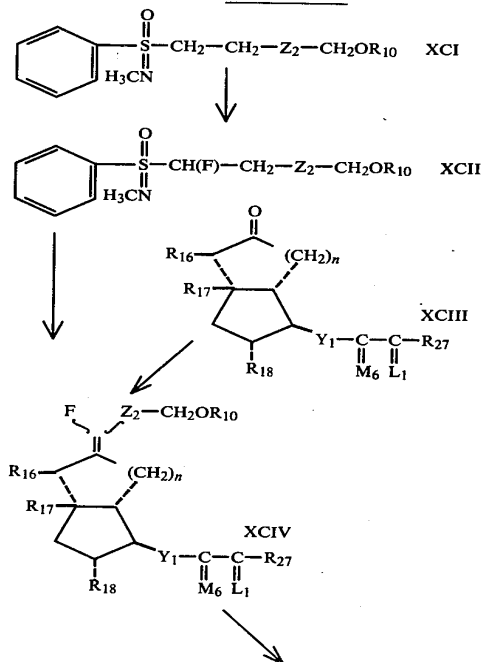
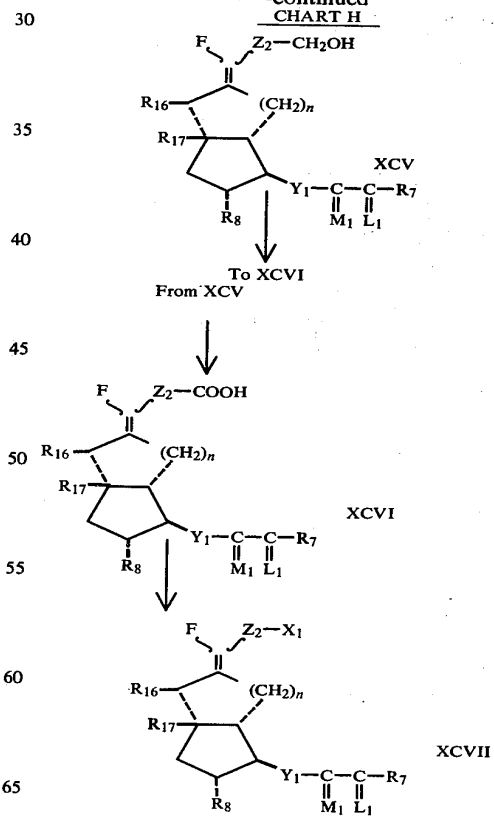


CHART H

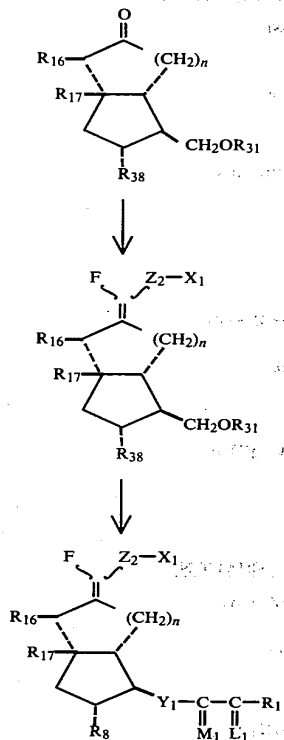
-continued  
CHART H

P. 43

Ex. 2032

SteadyMed v. United Therapeutics  
IPR2016-00006

CHART I



-continued

CHART J

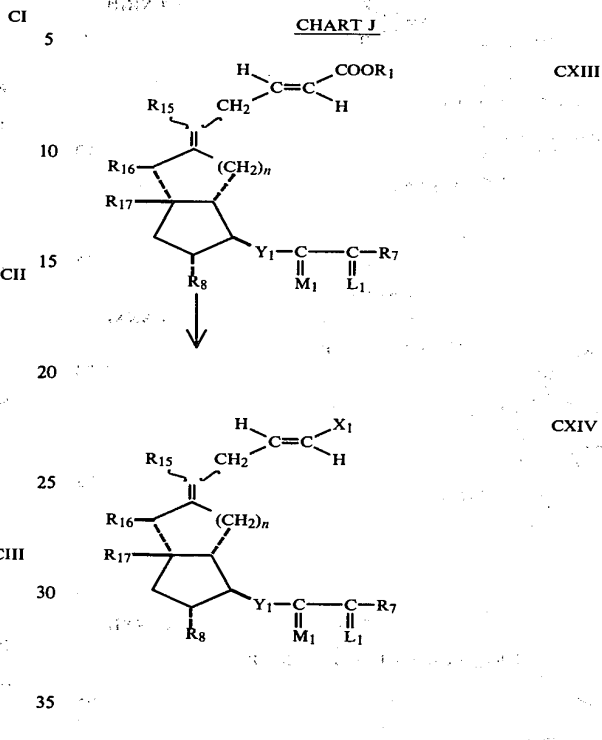
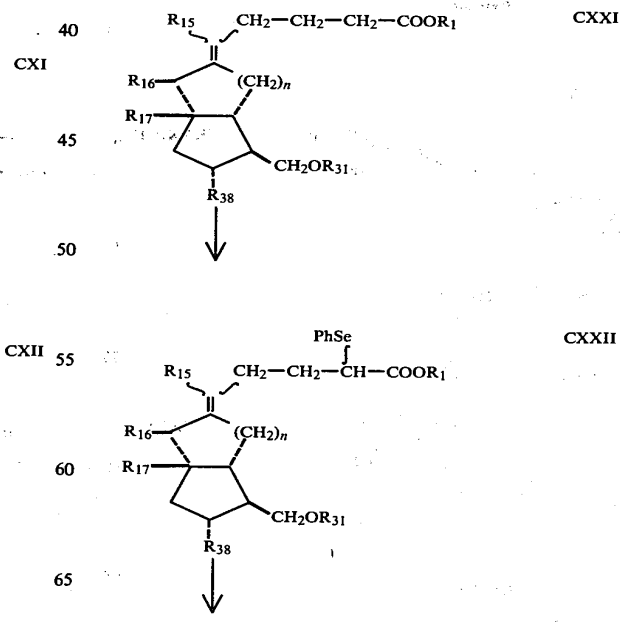
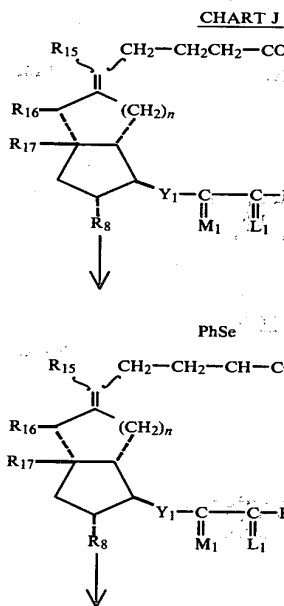


CHART K



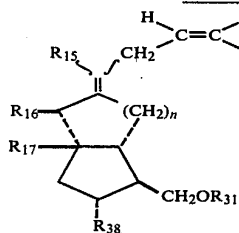
-continued  
CHART K

CHART L

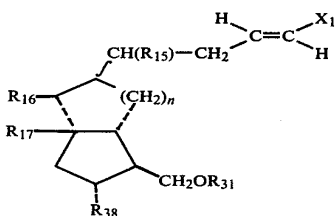
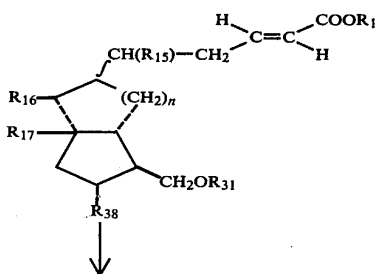
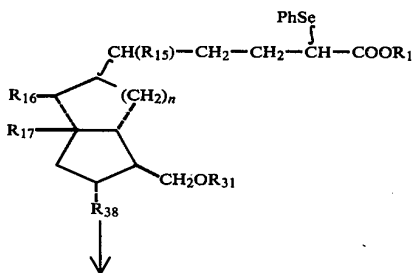
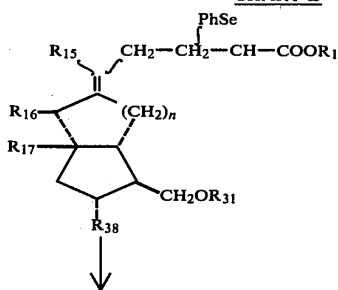
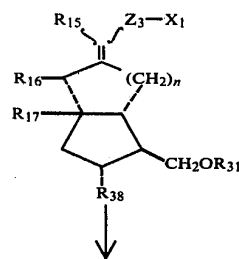


CHART M

CXXXIII

5



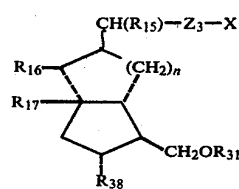
CXL I

10

15

CXXXI

20



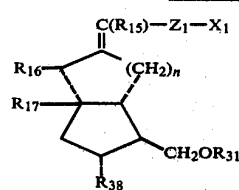
CXLII

25

CHART N

CXXXII

30



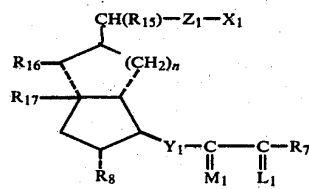
CL I

35

40

CXXXIII

45



CLII

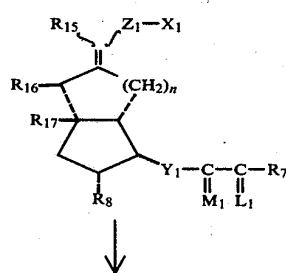
50

55

CHART O

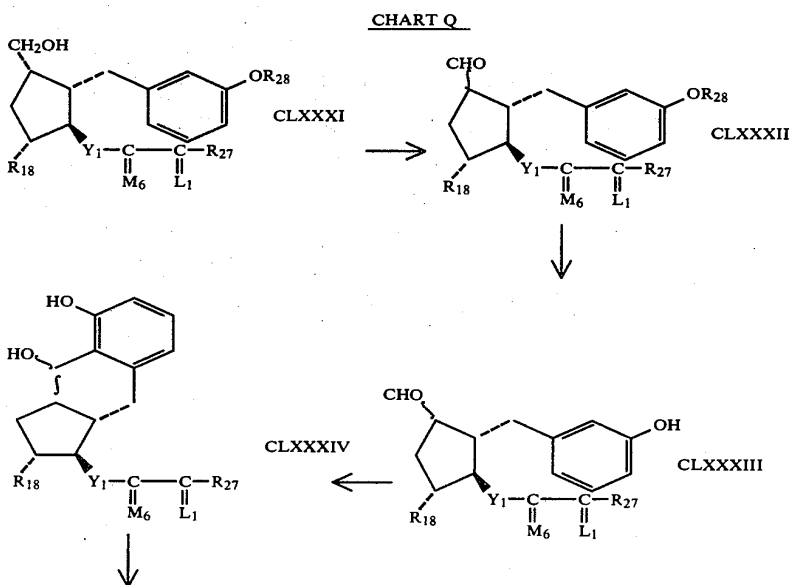
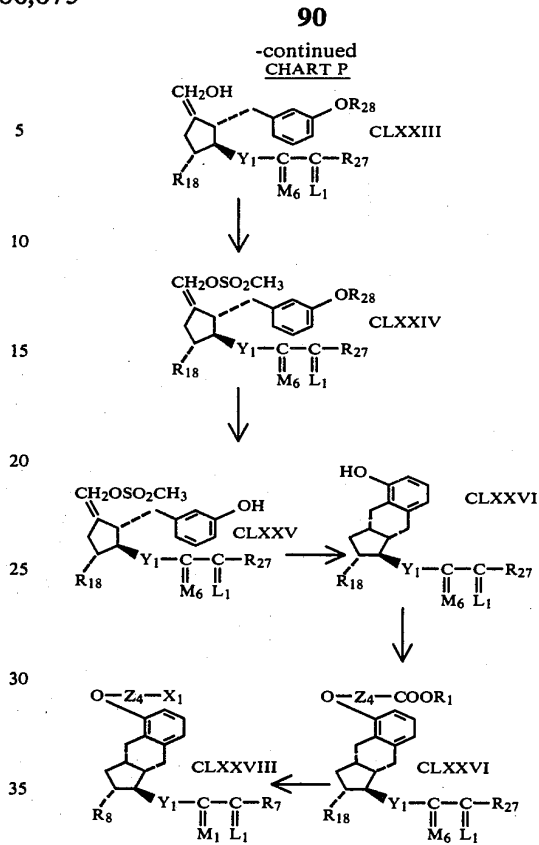
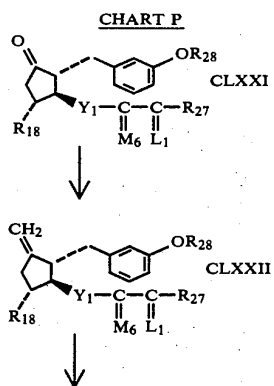
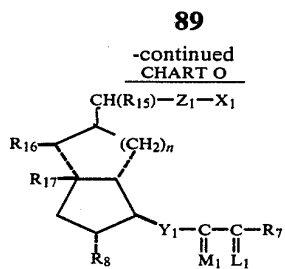
CXXXIV

60



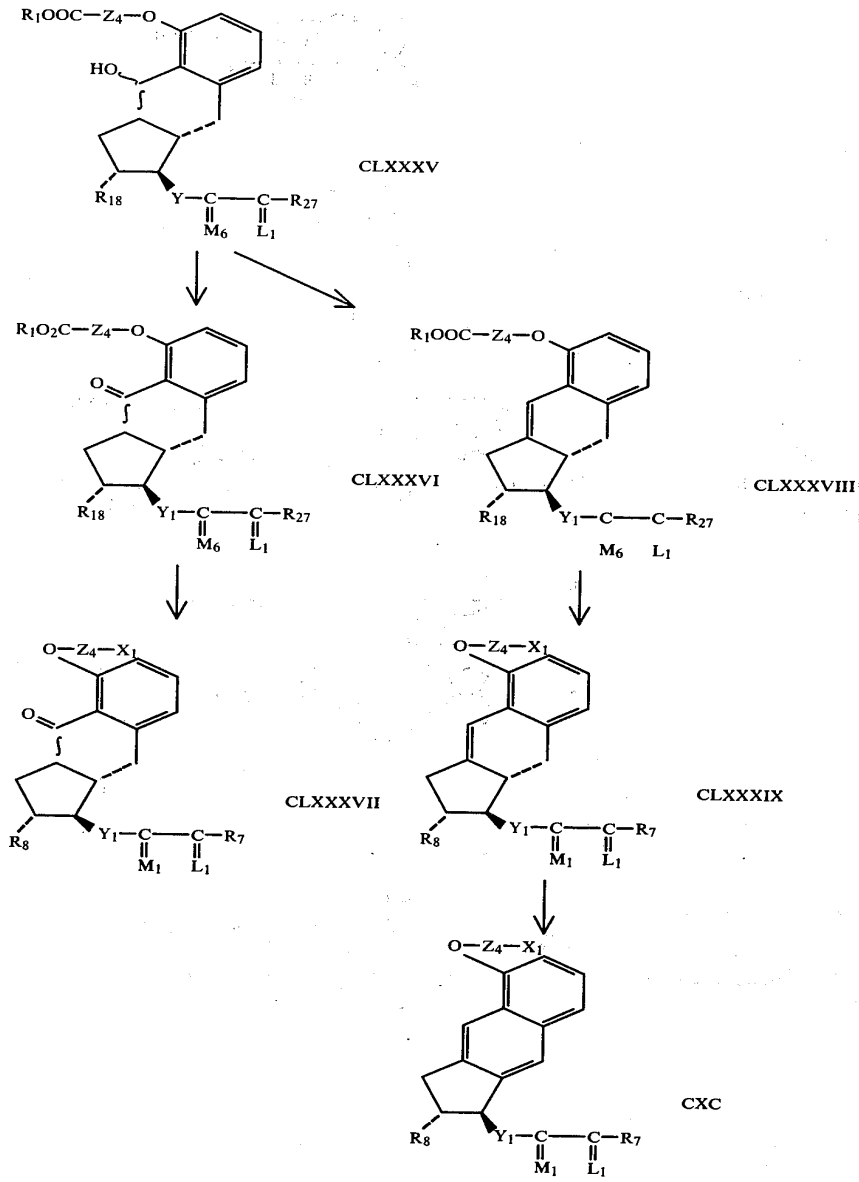
CLXI

65



-continued

## CHART Q



60

65

P. 47

Ex. 2032  
 SteadyMed v. United Therapeutics  
 IPR2016-00006

93

94

CHART R

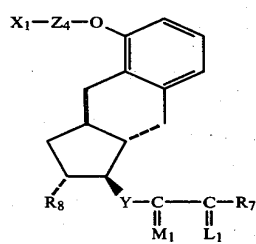
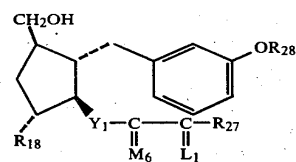
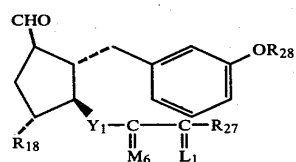
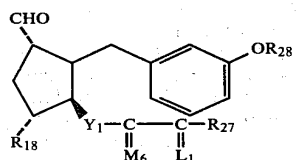
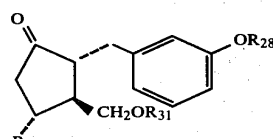


CHART S



-continued

CHART S

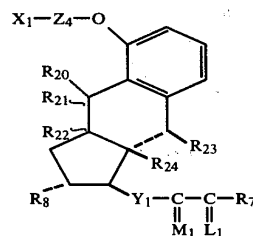
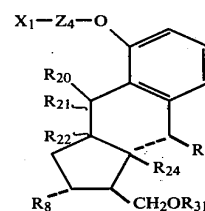
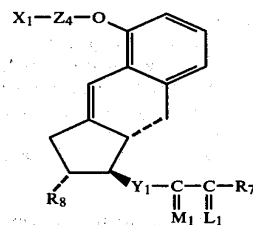
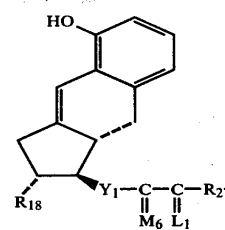
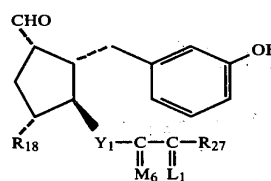


CHART T



CXCI

CXCII

CXCIII

CXCIV

CCI

CCII

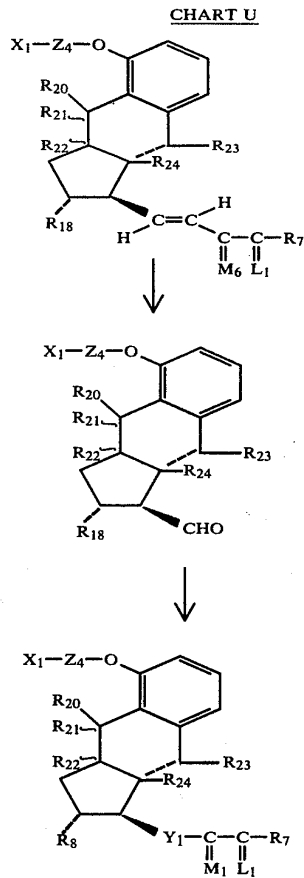
CCIII

CCXI

CCXII

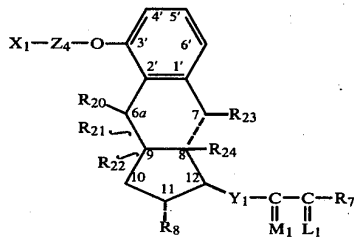
CCXIII





I claim:

1. A carbacyclin analog of formula XI:



wherein L<sub>1</sub> is α-R<sub>3</sub>:β-R<sub>4</sub>, α-R<sub>4</sub>:β-R<sub>3</sub>, or a mixture of α-R<sub>3</sub>:β-R<sub>4</sub> and α-R<sub>4</sub>:β-R<sub>3</sub>, wherein R<sub>3</sub> and R<sub>4</sub> are hydrogen, methyl, or fluoro, being the same or different, with the proviso that one of R<sub>3</sub> and R<sub>4</sub> is fluoro only when the other is hydrogen or fluoro; wherein M<sub>1</sub> is α-OH:β-R<sub>5</sub> or α-R<sub>5</sub>:β-OH, wherein R<sub>5</sub> is hydrogen or methyl;

wherein R<sub>7</sub> is

(1) -C<sub>m</sub>H<sub>2m</sub>-CH<sub>3</sub>, wherein m is an integer from one to 5, inclusive,

CCXXI

5

(2) phenoxy optionally substituted by one, two or three chloro, fluoro, trifluoromethyl, (C<sub>1</sub>-C<sub>3</sub>)alkyl, or (C<sub>1</sub>-C<sub>3</sub>)alkoxy, with the proviso that not more than two substituents are other than alkyl, with the proviso that R<sub>7</sub> is phenoxy or substituted phenoxy, only when R<sub>3</sub> and R<sub>4</sub> are hydrogen or methyl, being the same or different,

10

(3) phenyl, benzyl, phenylethyl, or phenylpropyl optionally substituted on the aromatic ring by one, two or three chloro, fluoro, trifluoromethyl, (C<sub>1</sub>-C<sub>3</sub>)alkyl, or (C<sub>1</sub>-C<sub>3</sub>)alkoxy, with the proviso that not more than two substituents are other than alkyl,

15

(4) cis-CH=CH-CH<sub>2</sub>-CH<sub>3</sub>,  
(5) -(CH<sub>2</sub>)<sub>2</sub>-CH(OH)-CH<sub>3</sub>, or  
(6) -(CH<sub>2</sub>)<sub>3</sub>-CH=C(CH<sub>3</sub>)<sub>2</sub>;

CCXXII

20

wherein -C(L<sub>1</sub>)-R<sub>7</sub> taken together is

(1) (C<sub>4</sub>-C<sub>7</sub>)cycloalkyl optionally substituted by one to 3 (C<sub>1</sub>-C<sub>5</sub>) alkyl;

(2) 2-(2-furyl)ethyl,

(3) 2-(3-thienyl)ethoxy, or

(4) 3-thienyloxymethyl;

wherein R<sub>8</sub> is hydroxy, hydroxymethyl, or hydrogen;

25

(1) R<sub>20</sub>, R<sub>21</sub>, R<sub>22</sub>, R<sub>23</sub>, and R<sub>24</sub> are all hydrogen with R<sub>22</sub> being either α-hydrogen or β-hydrogen,

(2) R<sub>20</sub> is hydrogen, R<sub>21</sub> and R<sub>22</sub> taken together form a second valence bond between C-9 and C-6a, and R<sub>23</sub> and R<sub>24</sub> taken together form a second valence bond between C-8 and C-9 or are both hydrogen, or

30

(3) R<sub>22</sub>, R<sub>23</sub>, and R<sub>24</sub> are all hydrogen, with R<sub>22</sub> being either α-hydrogen or β-hydrogen, and

(a) R<sub>20</sub> and R<sub>21</sub> taken together are oxo, or

(b) R<sub>20</sub> is hydrogen and R<sub>21</sub> is hydroxy, being α-hydroxy or β-hydroxy;

35

wherein X<sub>1</sub> is

(1) -COOR<sub>1</sub>, wherein R<sub>1</sub> is

(a) hydrogen,

(b) (C<sub>1</sub>-C<sub>12</sub>)alkyl,

(c) (C<sub>3</sub>-C<sub>10</sub>)cycloalkyl,

(d) (C<sub>6</sub>-C<sub>12</sub>)aralkyl,

(e) phenyl, optionally substituted with one, 2 or 3 chloro or (C<sub>1</sub>-C<sub>3</sub>)alkyl,

45

(f) phenyl substituted in the para position by

(i) -NH-CO-R<sub>25</sub>,

(ii) -CO-R<sub>26</sub>,

(iii) -O-CO-R<sub>54</sub>, or

(iv) -CH=N-NH-CO-NH<sub>2</sub> wherein R<sub>25</sub> is methyl, phenyl, acetamidophenyl, benzamidophenyl, or -NH<sub>2</sub>; R<sub>26</sub> is methyl, phenyl, -NH<sub>2</sub>, or methoxy; and R<sub>54</sub> is phenyl or acetamidophenyl; inclusive, or

50

(g) a pharmacologically acceptable cation;

(2) -CH<sub>2</sub>OH,

(3) -COL<sub>4</sub>, wherein L<sub>4</sub> is

55

(a) amino of the formula -NR<sub>51</sub>R<sub>52</sub>, wherein R<sub>51</sub> and R<sub>52</sub> are

(i) hydrogen,

(ii) (C<sub>1</sub>-C<sub>12</sub>)alkyl,

(iii) (C<sub>3</sub>-C<sub>10</sub>)cycloalkyl,

(iv) (C<sub>7</sub>-C<sub>12</sub>)aralkyl,

(v) phenyl, optionally substituted with one, 2 or 3 chloro, (C<sub>1</sub>-C<sub>3</sub>)alkyl, hydroxy, carboxy, (C<sub>2</sub>-C<sub>5</sub>)alkoxycarbonyl, or nitro,

(vi) (C<sub>2</sub>-C<sub>5</sub>)carboxyalkyl,

(vii) (C<sub>2</sub>-C<sub>5</sub>)carbamoylalkyl,

(viii) (C<sub>2</sub>-C<sub>5</sub>)cyanoalkyl,

97

- (ix) (C<sub>3</sub>-C<sub>6</sub>)acetylalkyl,  
 (x) (C<sub>7</sub>-C<sub>11</sub>)benzalkyl, optionally substituted by one, 2 or 3 chloro, (C<sub>1</sub>-C<sub>3</sub>)alkyl, hydroxy, (C<sub>1</sub>-C<sub>3</sub>)alkoxy, carboxy, (C<sub>2</sub>-C<sub>5</sub>)alkoxycarbonyl, or nitro,  
 (xi) pyridyl, optionally substituted by one, 2 or 3 chloro, (C<sub>1</sub>-C<sub>3</sub>)alkyl, or (C<sub>1</sub>-C<sub>3</sub>)alkoxy,  
 (xii) (C<sub>6</sub>-C<sub>9</sub>)pyridylalkyl optionally substituted by one, 2 or 3 chloro, (C<sub>1</sub>-C<sub>3</sub>)alkyl, hydroxy, or (C<sub>1</sub>-C<sub>3</sub>)alkyl,  
 (xiii) (C<sub>1</sub>-C<sub>4</sub>)hydroxyalkyl,  
 (xiv) (C<sub>1</sub>-C<sub>4</sub>)dihydroxyalkyl,  
 (xv) (C<sub>1</sub>-C<sub>4</sub>)trihydroxyalkyl,

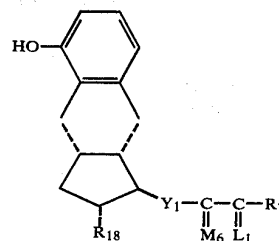
with the further proviso that not more than one of R<sub>51</sub> and R<sub>52</sub> is other than hydrogen or alkyl,

- (b) cycloamino selected from the group consisting of pyrrolidino, piperidino, morpholino, piperazino, hexamethyleneimino, pyrrolino, or 3,4-dihydropiperidinyl optionally substituted by one or 2 (C<sub>1</sub>-C<sub>12</sub>)alkyl of one to 12 carbon atoms, inclusive,  
 (c) carbonylamino of the formula —NR<sub>53</sub>COR<sub>51</sub>, wherein R<sub>53</sub> is hydrogen or (C<sub>1</sub>-C<sub>4</sub>)alkyl and R<sub>51</sub> is other than hydrogen, but otherwise as defined above,  
 (d) sulfonylamino of the formula —NR<sub>53</sub>SO<sub>2</sub>R<sub>51</sub>, wherein R<sub>51</sub> and R<sub>53</sub> are as defined in (c),  
 (4) —CH<sub>2</sub>NL<sub>2</sub>L<sub>3</sub>, wherein L<sub>2</sub> and L<sub>3</sub> are hydrogen or (C<sub>1</sub>-C<sub>4</sub>)alkyl, being the same or different, or the pharmacologically acceptable acid addition salts thereof when X<sub>1</sub> is —CH<sub>2</sub>NL<sub>2</sub>L<sub>3</sub>,

wherein Y<sub>1</sub> is trans—CH=CH—, cis—CH=CH—, —CH<sub>2</sub>CH<sub>2</sub>—, or —C≡C—; and wherein Z<sub>4</sub> is —CH<sub>2</sub>— or —(CH<sub>2</sub>)<sub>f</sub>—CF<sub>2</sub>, wherein f is zero, one, 2, or 3.

2. 9-Deoxy-2',9 $\alpha$ -methano-3-oxa-4,5,6-trinor-3,7-(1',3'-inter-phenylene)-PGF<sub>1</sub>, methyl ester, a compound according to claim 1.
  3. 9-Deoxy-2',9 $\alpha$ -methano-3-oxa-4,5,6-trinor-3,7-(1',3'-inter-phenylene)-PGF<sub>1</sub>, a compound according to claim 1.
  4. 9-Deoxy-16,16-difluoro-2',9 $\alpha$ -methano-3-oxa-4,5,6-trinor-3,7-(1',3'-inter-phenylene)-PGF<sub>1</sub> or its methyl ester, a compound according to claim 1.
  5. 9-Deoxy-13,14-dihydro-2',9 $\alpha$ -methano-3-oxa-4,5,6-trinor-3,7-(1',3'-inter-phenylene)-PGF<sub>1</sub> or its methyl ester, a compound according to claim 1.
  6. 9-Deoxy-2',9 $\alpha$ -methano-3-oxa-4,5,6-trinor-3,7-(1',3'-inter-phenylene)-PGF<sub>1</sub>, amide, a compound according to claim 1.
  7. (15R)-9-Deoxy-2',9 $\alpha$ -methano-3-oxa-4,5,6-trinor-3,7-(1',3'-inter-phenylene)-PGF<sub>1</sub> or its methyl ester, a compound according to claim 1.
  8. 9-Deoxy-2',9 $\alpha$ -methano-3-oxa-4,5,6-trinor-3,7-(1',3'-inter-phenylene)-PGE<sub>1</sub> or its methyl ester, a compound according to claim 1.
  9. 9-Deoxy-7,8-dihydro-2',9 $\alpha$ -methano-3-oxa-4,5,6-trinor-3,7-(1',3'-inter-phenylene)-PGE<sub>1</sub> or its methyl ester, a compound according to claim 1.
  10. 9-Deoxy-2',9-hydroxymethano-3-oxa-4,5,6-trinor-3,7-(1',3'-inter-phenylene)-PGF<sub>1</sub> or its methyl ester, a compound according to claim 1.
  11. 9-Deoxy-2',9 $\alpha$ -carbonyl-oxa-4,5,6-trinor-3,7-(1',3'-inter-phenylene)-PGF<sub>1</sub> or its methyl ester, a compound according to claim 1.
12. A compound according to formula IX:

98

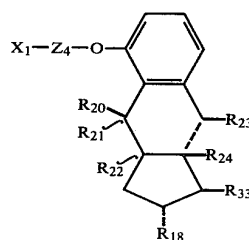


IX

wherein L<sub>1</sub> is  $\alpha$ -R<sub>3</sub>: $\beta$ -R<sub>4</sub>,  $\alpha$ -R<sub>4</sub>: $\beta$ -R<sub>3</sub>, or a mixture of  $\alpha$ -R<sub>3</sub>: $\beta$ -R<sub>4</sub> and  $\alpha$ -R<sub>4</sub>: $\beta$ -R<sub>3</sub>, wherein R<sub>3</sub> and R<sub>4</sub> are hydrogen, methyl, or fluoro, being the same or different, with the proviso that one of R<sub>3</sub> and R<sub>4</sub> is fluoro only when the other is hydrogen or fluoro;

wherein M<sub>6</sub> is  $\alpha$ -OR<sub>10</sub>: $\beta$ -R<sub>5</sub> or  $\alpha$ -R<sub>5</sub>: $\beta$ -OR<sub>10</sub>, wherein R<sub>5</sub> is hydrogen or methyl and R<sub>10</sub> is an acid hydrolyzable protective group;

- wherein R<sub>27</sub> is
- (1) —C<sub>m</sub>H<sub>2m</sub>—CH<sub>3</sub>, wherein m is an integer from one to 5, inclusive,
  - (2) phenoxy optionally substituted by one, two or three chloro, fluoro, trifluoromethyl, (C<sub>1</sub>-C<sub>3</sub>)alkyl, or (C<sub>1</sub>-C<sub>3</sub>)alkoxy, with the proviso that not more than two substituents are other than alkyl, with the proviso that R<sub>27</sub> is phenoxy or substituted phenoxy, only when R<sub>3</sub> and R<sub>4</sub> are hydrogen or methyl, being the same or different,
  - (3) phenyl, benzyl, phenylethyl, or phenylpropyl optionally substituted on the aromatic ring by one, two or three chloro, fluoro, trifluoromethyl, (C<sub>1</sub>-C<sub>3</sub>)alkyl, or (C<sub>1</sub>-C<sub>3</sub>)alkoxy, with the proviso that not more than two substituents are other than alkyl,
  - (4) cis—CH=CH—CH<sub>2</sub>—CH<sub>3</sub>,
  - (5) —(CH<sub>2</sub>)<sub>2</sub>—CH(OR<sub>10</sub>)—CH<sub>3</sub>, wherein R<sub>10</sub> is as defined above, or
  - (6) —(CH<sub>2</sub>)<sub>3</sub>—CH=C(CH<sub>3</sub>)<sub>2</sub>;
- wherein —C(L<sub>1</sub>)—R<sub>27</sub> taken together is
- (1) (C<sub>4</sub>-C<sub>7</sub>)cycloalkyl optionally substituted by one to 3 (C<sub>1</sub>-C<sub>5</sub>) alkyl;
  - (2) 2-(2-furyl)ethyl,
  - (3) 2-(3-thienyl)ethoxy, or
  - (4) 3-thienyloxymethyl;
- wherein R<sub>18</sub> is hydrogen, hydroxy, hydroxymethyl, —OR<sub>10</sub> or —CH<sub>2</sub>OR<sub>10</sub>, wherein R<sub>10</sub> is an acid-hydrolyzable protective group; and wherein Y<sub>1</sub> is trans—CH=CH—, cis—CH=CH—, —CH<sub>2</sub>CH<sub>2</sub>—, or —C≡C—.
13. A compound according to formula VIII:



VIII

P. 50

Ex. 2032  
 SteadyMed v. United Therapeutics  
 IPR2016-00006

wherein R<sub>18</sub> is hydrogen, hydroxy, hydroxymethyl, —OR<sub>10</sub> or —CH<sub>2</sub>OR<sub>10</sub>, wherein R<sub>10</sub> is an acid-hydrolyzable protective group;

wherein

- (1) R<sub>20</sub>, R<sub>21</sub>, R<sub>22</sub>, R<sub>23</sub>, and R<sub>24</sub> are all hydrogen with R<sub>22</sub> being either  $\alpha$ -hydrogen or  $\beta$ -hydrogen,
- (2) R<sub>20</sub> is hydrogen, R<sub>21</sub> and R<sub>22</sub> taken together form a second valence bond between C-9 and C-6a, and R<sub>23</sub> and R<sub>24</sub> taken together form a second valence bond between C-8 and C-9 or are both hydrogen, or
- (3) R<sub>22</sub>, R<sub>23</sub>, and R<sub>24</sub> are all hydrogen, with R<sub>22</sub> being either  $\alpha$ -hydrogen or  $\beta$ -hydrogen, and
  - (a) R<sub>20</sub> and R<sub>21</sub> taken together are oxo, or
  - (b) R<sub>20</sub> is hydrogen and R<sub>21</sub> is hydroxy, being  $\alpha$ -hydroxy or  $\beta$ -hydroxy;

wherein R<sub>33</sub> is —CHO or —CH<sub>2</sub>OR<sub>32</sub>, wherein R<sub>32</sub> is hydrogen or a hydroxyl hydrogen replacing group; wherein X<sub>1</sub> is

- (1) —COOR<sub>1</sub>, wherein R<sub>1</sub> is
  - (a) hydrogen,
  - (b) (C<sub>1</sub>–C<sub>12</sub>)alkyl,
  - (c) (C<sub>3</sub>–C<sub>10</sub>)cycloalkyl,
  - (d) (C<sub>7</sub>–C<sub>12</sub>)aralkyl,
  - (e) phenyl, optionally substituted with one, 2 or 3 chloro or (C<sub>1</sub>–C<sub>3</sub>)alkyl,
  - (f) phenyl substituted in the para position by
    - (i) —NH—CO—R<sub>25</sub>,
    - (ii) —CO—R<sub>26</sub>,
    - (iii) —O—CO—R<sub>54</sub>, or
    - (iv) —CH=N—NH—CO—NH<sub>2</sub> wherein R<sub>25</sub> is methyl, phenyl, acetamidophenyl, benzamidophenyl, or —NH<sub>2</sub>; R<sub>26</sub> is methyl, phenyl, —NH<sub>2</sub>, or methoxy; and R<sub>54</sub> is phenyl or acetamidophenyl; inclusive, or
  - (g) a pharmacologically acceptable cation;
- (2) —CH<sub>2</sub>OH,
- (3) —COL<sub>4</sub>, wherein L<sub>4</sub> is
  - (a) amino of the formula —NR<sub>51</sub>R<sub>52</sub>, wherein R<sub>51</sub> and R<sub>52</sub> are
    - (i) hydrogen,
    - (ii) (C<sub>1</sub>–C<sub>12</sub>)alkyl,

- (iii) (C<sub>3</sub>–C<sub>10</sub>)cycloalkyl,
- (iv) (C<sub>7</sub>–C<sub>12</sub>)aralkyl,
- (v) phenyl, optionally substituted with one, 2 or 3 chloro, (C<sub>1</sub>–C<sub>3</sub>)alkyl, hydroxy, carboxy, (C<sub>2</sub>–C<sub>5</sub>)alkoxycarbonyl, or nitro,
- (vi) (C<sub>2</sub>–C<sub>5</sub>)carboxyalkyl,
- (vii) (C<sub>2</sub>–C<sub>5</sub>)carbamoylalkyl,
- (viii) (C<sub>2</sub>–C<sub>5</sub>)cyanoalkyl,
- (ix) (C<sub>3</sub>–C<sub>6</sub>)acetylalkyl,
- (x) (C<sub>7</sub>–C<sub>11</sub>)benzoalkyl, optionally substituted by one, 2 or 3 chloro, (C<sub>1</sub>–C<sub>3</sub>)alkyl, hydroxy, (C<sub>1</sub>–C<sub>3</sub>)alkoxy, carboxy, (C<sub>2</sub>–C<sub>5</sub>)alkoxycarbonyl, or nitro,
- (xi) pyridyl, optionally substituted by one, 2 or 3 chloro, (C<sub>1</sub>–C<sub>3</sub>)alkyl, or (C<sub>1</sub>–C<sub>3</sub>)alkoxy,
- (xii) (C<sub>6</sub>–C<sub>9</sub>)pyridylalkyl optionally substituted by one, 2 or 3 chloro, (C<sub>1</sub>–C<sub>3</sub>)alkyl, hydroxy, or (C<sub>1</sub>–C<sub>3</sub>)alkyl,
- (xiii) (C<sub>1</sub>–C<sub>4</sub>)hydroxyalkyl,
- (xiv) (C<sub>1</sub>–C<sub>4</sub>)dihydroxyalkyl,
- (xv) (C<sub>1</sub>–C<sub>4</sub>)trihydroalkyl,

with the further proviso that not more than one of R<sub>51</sub> and R<sub>52</sub> is other than hydrogen or alkyl,

- (b) cycloamino selected from the group consisting of pyrrolidino, piperidino, morpholino, piperazino, hexamethyleneimino, pyrrolino, or 3,4-didehydropiperidinyl optionally substituted by one or 2 (C<sub>1</sub>–C<sub>12</sub>)alkyl of one to 12 carbon atoms, inclusive,

- (c) carbonylamino of the formula —NR<sub>53</sub>COR<sub>51</sub>, wherein R<sub>53</sub> is hydrogen or (C<sub>1</sub>–C<sub>4</sub>)alkyl and R<sub>51</sub> is other than hydrogen, but otherwise as defined above,

- (d) sulfonylamino of the formula —NR<sub>53</sub>SO<sub>2</sub>R<sub>51</sub>, wherein R<sub>51</sub> and R<sub>53</sub> are as defined in (c),

- (4) —CH<sub>2</sub>NL<sub>2</sub>L<sub>3</sub>, wherein L<sub>2</sub> and L<sub>3</sub> are hydrogen or (C<sub>1</sub>–C<sub>4</sub>)alkyl, being the same or different, or the pharmacologically acceptable acid addition salts thereof when X<sub>1</sub> is —CH<sub>2</sub>NL<sub>2</sub>L<sub>3</sub>; and

wherein Z<sub>4</sub> is —CH<sub>2</sub>— or —(CH<sub>2</sub>)<sup>f</sup>—CF<sub>2</sub>, wherein f is zero, one, 2, or 3.

\* \* \* \* \*

45

50

55

60

65

UNITED STATES PATENT OFFICE  
CERTIFICATE OF CORRECTION Page 1 of 3

Patent No. 4,306,075 Dated December 15, 1981

Inventor(s) Paul A. Aristoff

It is certified that error appears in the above-identified patent and that said Letters Patent are hereby corrected as shown below:

Column 3, line 63, "R<sub>47</sub>" should read -- R<sub>17</sub> --.

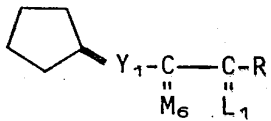
Column 33, line 11, "acetone:acetone" should read -- acetate:acetone --.

Column 33, line 27, "-dimethylphosphonom ethyl-5-keto-PFE<sub>1</sub>" should read -- -dimethylphosphonomethyl-5-keto-PGE<sub>1</sub> --.

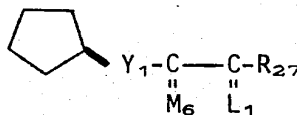
Column 36, line 55, "-CH<sub>3</sub>OH" should read -- -CH<sub>2</sub>OH --.

Column 49, line 67, "-(CH<sub>2</sub>)<sub>32</sub>" should read -- -(CH<sub>2</sub>)<sub>3</sub> --.

Column 78, lines 30-37, that portion of Formula LV reading



should read



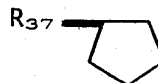
Column 81, Chart G, the fourth structural formula now labeled "LXXIV" should read -- LXXXIV --.

Column 81, Chart G, following the fourth structural formula, the instructions "To LXXXVIII and LXXXIV From LXXXIV" should read -- To LXXXVIII and LXXXIX From LXXXIV --.

Column 83, Chart G, that portion of Formula LXXXVII reading



should read



Column 83, Chart G, the fourth structural formula now labeled "LXXIX" should read -- LXXXIX --.

UNITED STATES PATENT OFFICE  
CERTIFICATE OF CORRECTION Page 2 of 3

Patent No. 4,306,075 Dated December 15, 1981

Inventor(s) Paul A. Aristoff

It is certified that error appears in the above-identified patent and that said Letters Patent are hereby corrected as shown below:

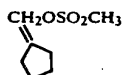
Column 90, Chart P, that portion of Formula CLXXIII reading



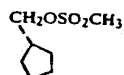
should read



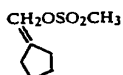
Column 90, Chart P, that portion of Formula CLXXIV reading



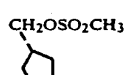
should read



Column 90, Chart P, that portion of Formula CLXXV reading

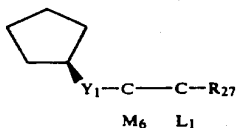


should read

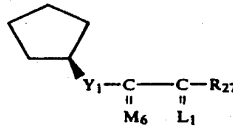


Column 90, Chart P, the fifth structural formula now labeled "CLXXVI" should read -- CLXXVII --.

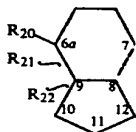
Column 91, Chart Q, that portion of Formula CLXXXVIII reading



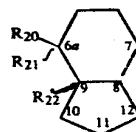
should read



Column 95, Claim 1, lines 47-57, that portion of Formula XI now reading



should read



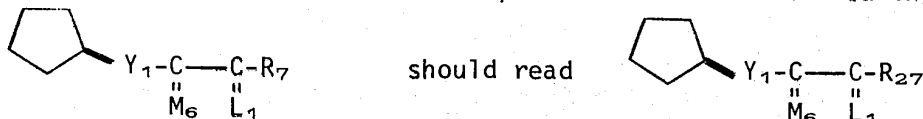
UNITED STATES PATENT OFFICE  
CERTIFICATE OF CORRECTION Page 3 of 3

Patent No. 4,306,075 Dated December 15, 1981

Inventor(s) Paul A. Aristoff

It is certified that error appears in the above-identified patent and that said Letters Patent are hereby corrected as shown below:

Column 96, line 42, "(C<sub>6</sub>-C<sub>12</sub>)" should read -- (C<sub>7</sub>-C<sub>12</sub>) --.  
Column 97, line 59, "-dihydro-" should read -- -didehydro- --.  
Column 98, lines 1-13, that portion of Formula IX reading



Column 100, line 21, "(C<sub>1</sub>-C<sub>4</sub>)trihydroalkyl" should read  
-- (C<sub>1</sub>-C<sub>4</sub>)trihydroxyalkyl --.

**Signed and Sealed this**

*Seventeenth* **Day of** *May* 1983

[SEAL]

*Attest:*

**GERALD J. MOSSINGHOFF**

*Attesting Officer*

*Commissioner of Patents and Trademarks*



US005153222A

**United States Patent** [19][11] **Patent Number:** 5,153,222

Tadepalli et al.

[45] **Date of Patent:** Oct. 6, 1992

- [54] **METHOD OF TREATING PULMONARY HYPERTENSION WITH BENZIDINE PROSTAGLANDINS**
- [75] **Inventors:** Anjaneyulu S. Tadepalli, Durham; Walker A. Long, Chapel Hill; James W. Crow, Raleigh; Kenneth B. Klein, Chapel Hill, all of N.C.
- [73] **Assignee:** Burroughs Wellcome Co., Research Triangle Park, N.C.
- [21] **Appl. No.:** 715,439
- [22] **Filed:** Jun. 14, 1991

**Related U.S. Application Data**

[62] Division of Ser. No. 367,090, Jun. 16, 1989, abandoned.

**Foreign Application Priority Data**

Jun. 17, 1988 [GB] United Kingdom ..... 8814438

[51] **Int. Cl.<sup>5</sup>** ..... A61K 31/19[52] **U.S. Cl.** ..... 514/571[58] **Field of Search** ..... 524/454, 569; 514/571**References Cited****U.S. PATENT DOCUMENTS**

5,028,628 7/1991 Tadepalli ..... 514/573  
 4,306,075 12/1981 Aristoff ..... 560/56  
 4,499,085 2/1985 Masuda ..... 514/58

**FOREIGN PATENT DOCUMENTS**

0005768A1 12/1979 European Pat. Off. .  
 0217419A2 4/1987 European Pat. Off. .  
 0229844A1 7/1987 European Pat. Off. .  
 0347243A1 12/1989 European Pat. Off. .

**OTHER PUBLICATIONS**

Aristoff, et al., J. Amer. Chem. Soc., vol. 107, No. 26, 1985, p. 7968, Total Synthesis of a Novel Antiulcer Agent via a Modification of the Intramolecular Wadsworth-Emmons-Wittig Reaction.  
 Abstract Supplement—R. J. Lambert, et al., Chest, 89, p. 459S, Jun. (1986).  
 Abstract—New England Journal of Medicine, vol. 312, No. 14, pp. 932-936 (1985).  
 Praveen Tyle, Review, Pharmaceutical Research, vol. 3, No. 6, 1986, Iontophoretic Devices for Drug Delivery, pp. 318-326.  
 Whittle, et al., Progress in Medicinal Chemistry, vol. 21, pp. 235-279, 1984, 6 Antithrombotic Assessment and Clinical Potential of Prostacyclin Analogs.  
 Rubin, et al., The American Heart Association, Circulation, vol. 66, No. 2, Aug., 1982, Prostacyclin-induced

Acute Pulmonary Vasodilation in Primary Pulmonary Hypertension, pp. 334-338.

Whittle, et al., The American Heart Association, Circulation, vol. 72, No. 6, Dec., 1985, Platelet Actions of Stable Carbocyclic Analogues of Prostacyclin, pp. 1219-1225.

Long, et al., Am. Rev. Respir. Cns, 1987, 136, pp. 773-776, Prostacyclin and Pge, Treatment of Pulmonary Hypertension.

Grossman, et al., Pulmonary Hypertension, 24, The Normal Pulmonary Circulation, pp. 835-851, 1981.

Aristoff et al., Advances in Prostaglandin, Thranboxane, and Leukotriene Research, vol. 15, pp. 275-277, 1985.

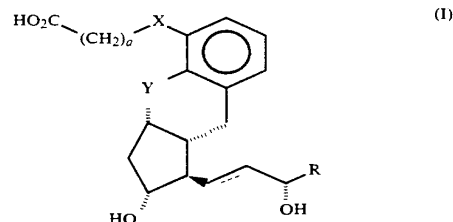
*Primary Examiner*—Frederick E. Waddell

*Assistant Examiner*—Kimberly R. Jordan

*Attorney, Agent, or Firm*—Donald Brown; Lawrence A. Nielsen

**[57] ABSTRACT**

The present invention is concerned with methods for the prophylaxis, treatment and diagnosis of pulmonary hypertension which comprise hte administrative of an effective amount of a compound of formula (I)



wherein a is an integer of from 1 to 3;

X and Y, which may be the same or different, are selected from —O— and —CH<sub>2</sub>—;

R is —(CH<sub>2</sub>)<sub>a</sub>R<sup>1</sup> wherein R<sup>1</sup> is hydrogen or methyl, or R is cyclohexyl, or

R is —CH(CH<sub>3</sub>)CH<sub>2</sub>C≡CCH<sub>3</sub>; and

the dotted line represents an optional double bond; or of a physiologically acceptable salt or acid derivative thereof.

Medicaments and diagnostic aids for use in the methods of the invention are also within the scope of the invention.

**2 Claims, No Drawings**

**METHOD OF TREATING PULMONARY  
HYPERTENSION WITH BENZIDINE  
PROSTAGLANDINS**

This is a divisional of copending application(s) Ser. No. 07/367,090 filed on Jun. 16, 1989, now abandoned.

The present invention is concerned with prostaglandins, specifically benzindene prostaglandins, for use in the treatment, or diagnosis of pulmonary hypertension. Their use in the manufacture of medicaments for the treatment of pulmonary hypertension and in the manufacture of diagnostic aids for identifying PPH patients having active pulmonary vasoconstriction and the medicaments and diagnostic aids obtained thereby are within the scope of the invention.

All blood is driven through the lungs via the pulmonary circulation in order, among other things, to replenish the oxygen which it dispenses in its passage around the rest of the body via the systemic circulation. The flow through both circulations is in normal circumstances equal, but the resistance offered to it in the pulmonary circulation is generally much less than that of the systemic circulation. When the resistance to pulmonary blood flow increases, the pressure in the circulation is greater for any particular flow. This is referred to as pulmonary hypertension. Generally, pulmonary hypertension is defined through observations of pressures above the normal range pertaining in the majority of people residing at the same altitude and engaged in similar activities.

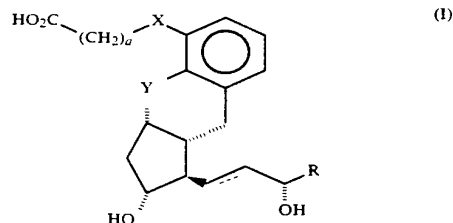
Most often pulmonary hypertension is a manifestation of an obvious or explicable increase in resistance, such as obstruction to blood flow by pulmonary emboli, malfunction of the heart's valves or muscle in handling blood after its passage through the lungs, diminution in pulmonary vessel calibre as a reflex response to hypoventilation and low oxygenation, or a mismatch of vascular capacity and essential blood flow, such as shunting of blood in congenital abnormalities or surgical removal of lung tissue. Such pulmonary hypertension is referred to as secondary hypertension.

There remain some cases of pulmonary hypertension where the cause of the increased resistance is as yet inexplicable. They are described as primary pulmonary hypertension (PPH) and are diagnosed by and after exclusion of the causes of secondary pulmonary hypertension. Despite the possibility of a varied aetiology, cases of primary pulmonary hypertension tend to comprise a recognisable entity. Approximately 65% are female and young adults are most commonly afflicted, though it has occurred in children and patients over 50. Life expectancy from the time of diagnosis is short, about 3 to 5 years, though occasional reports of spontaneous remission and longer survival are to be expected given the nature of the diagnostic process. Generally, however, progress is inexorable via syncope and right heart failure and death is quite often sudden. Until now, no successful treatment was known.

U.S. Pat. No. 4,306,075 describes novel benzindene prostaglandins which produce various pharmacological responses, such as inhibition of platelet aggregation, reduction of gastric secretion, and bronchodilation. It is indicated that the compounds have useful application as anti-thrombotic agents, anti-ulcer agents, and anti-asthma agents. There is no indication that these compounds may be used in the treatment of any form of hypertension.

We have now discovered that within the class of benzindene prostaglandins described in the U.S. Patent, there is a sub-class of compounds of formula (I) as defined hereinbefore which are suitable for use in the treatment of pulmonary hypertension. The term "pulmonary hypertension" is used herein to include both primary and secondary pulmonary hypertension as ordinarily understood by clinicians (*vide supra*). The compounds of the invention may also be used in the treatment of Raynaud's disease. PPH patients having active pulmonary vasoconstriction are considered suitable candidates for long-term oral vasodilator therapy (R J Lambert et al, *Chest* 89, 459S (1986)). The ability of the compounds of the invention to reduce pulmonary vascular resistance in such patients provides a useful diagnostic aid for identifying suitable candidates for long-term vasodilator therapy.

According to the present invention, therefore, there is provided a compound of formula (I)



for use in the treatment, or diagnosis of pulmonary hypertension

wherein a is an integer of from 1 to 3;

X and Y, which may be the same or different, are selected from —O— and —CH<sub>2</sub>—;

R is —(CH<sub>2</sub>)<sub>5</sub>R<sup>1</sup> wherein R<sup>1</sup> is hydrogen or methyl, or R is cyclohexyl, or

R is —CH(CH<sub>3</sub>)CH<sub>2</sub>C≡CCH<sub>3</sub>; and

the dotted line represents an optional double bond; and pharmaceutically acceptable salts and acid derivatives thereof.

The term "acid derivative" is used herein to describe C<sub>1-4</sub> alkyl esters and amides, including amides wherein the nitrogen is optionally substituted by one or two C<sub>1-4</sub> alkyl groups.

The invention also includes bioprecursors or "pro-drugs" of the above-defined compounds, that is, compounds which are converted in vivo to compounds of formula (I) or pharmaceutically active derivatives thereof.

Further aspects of the present invention are concerned with the use of a compound of formula (I), or a pharmaceutically acceptable salt or acid derivative thereof, in the manufacture of a medicament for the treatment of pulmonary hypertension or in the manufacture of a diagnostic aid for identifying PPH patients having active pulmonary vasoconstriction and with medicaments and diagnostic aids obtained thereby which may be administered when primary or secondary pulmonary hypertension is indicated.

Preferred compounds of formula (I) having particularly desirable pulmonary anti-hypertensive properties include those wherein

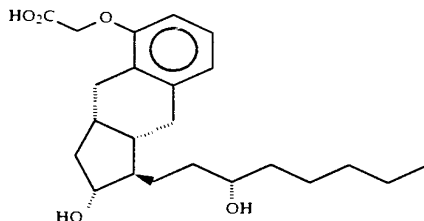
X is —O—;

Y is —CH<sub>2</sub>—; and

R is —(CH<sub>2</sub>)<sub>4</sub>CH<sub>3</sub>.



A particularly preferred compound of formula (I) having exceptional pulmonary anti-hypertensive properties is 9-deoxy-2',9 $\alpha$ -methano-3-oxa-4,5,6-trinor-3,7-(1',3'-interphenylene)-13,14-dihydro-prostaglandin F<sub>1</sub>, which has the following structure:



and pharmaceutically acceptable salts and acid derivatives thereof.

Other compounds of the invention which show pulmonary anti-hypertensive activity include:

9-Deoxy-2',9 $\alpha$ -methano-3-oxa-4,5,6-trinor-3,7-(1',3'-interphenylene)-prostaglandin F<sub>1</sub>

9-Deoxy-2',9 $\alpha$ -methano-3-oxa-4,5,6-trinor-3,7-(1',3'-interphenylene)-15-cyclohexylprostaglandin F<sub>1</sub>

9-Deoxy-2',9 $\alpha$ -methano-3-oxa-4,5,6-trinor-3,7-(1',3'-interphenylene)-20-methylprostaglandin F<sub>1</sub>

(15S,16RS)-9-Deoxy-2',9 $\alpha$ -methano-16-methyl-3-oxa-18,18,19,19-tetrahydro-4,5,6-trinor-3,7-(1',3'-interphenylene)prostaglandin F<sub>1</sub>

The present invention extends to non-physiologically acceptable salts of the compounds of formula (I) which may be used in the preparation of the pharmacologically active compounds of the invention. The physiologically acceptable salts of compounds of formula (I) include salts derived from bases. Base salts include ammonium salts, alkali metal salts such as those of sodium and potassium, alkaline earth metal salts such as those of calcium and magnesium, salts with organic bases such as dicyclohexylamine and N-methyl-D-glucamine, and salts with amino acids such as arginine and lysine.

Quaternary ammonium salts can be formed, for example, by reaction with lower alkyl halides, such as methyl, ethyl, propyl, and butyl chlorides, bromides, and iodides, with dialkyl sulphates, with long chain halides, such as decyl, lauryl, myristyl, and stearyl chlorides, bromides, and iodides, and with aralkyl halides, such as benzyl and phenethyl bromides.

The amount of a compound of formula (I), or a physiologically acceptable salt or acid derivative thereof, which is required in a medication or diagnostic aid according to the invention to achieve the desired effect will depend on a number of factors, in particular the specific application, the nature of the particular compound used, the mode of administration, and the condition of the patient. In general, a daily dose per patient for the treatment of pulmonary hypertension is in the range 25  $\mu$ g to 250 mg; typically from 0.5  $\mu$ g to 2.5 mg, preferably from 7  $\mu$ g to 285  $\mu$ g, per day per kilogram bodyweight. For example, an intravenous dose in the range 0.5  $\mu$ g to 1.5 mg per kilogram bodyweight per day may conveniently be administered as an infusion of from 0.5 ng to 1.0  $\mu$ g per kilogram bodyweight per minute. Infusion fluids suitable for this purpose contain, for example, from 10 ng to 10  $\mu$ g per milliliter. Ampoules for injection contain, for example, from 0.1  $\mu$ g to 1.0 mg and orally administrable unit dose formulations,

such as tablets or capsules, contain, for example, from 0.1 to 100 mg, typically from 1 to 50 mg. For diagnostic purposes, a single unit dose formulation may be administered. In the case of physiologically acceptable salts, the weights indicated above refer to the weight of the active compound ion, that is, the ion derived from the compound of formula (I).

In the manufacture of a medicament or diagnostic aid according to the invention, hereinafter referred to as a "formulation", the compounds of formula (I) and their physiologically acceptable salts and acid derivatives are typically admixed with, inter alia, an acceptable carrier. The carrier must, of course, be acceptable in the sense of being compatible with any other ingredients in the formulation and must not be deleterious to the patient. The carrier may be a solid or a liquid, or both, and is preferably formulated with the compound as a unit-dose formulation, for example, a tablet, which may contain from 0.05% to 95% by weight of the active compound. One or more compounds of formula (I) and/or their physiologically acceptable salts or acid derivatives may be incorporated in the formulations of the invention, which may be prepared by any of the well known techniques of pharmacy consisting essentially of admixing the components.

In addition to compounds of formula (I), other pharmacologically active substances may be present in the formulations of the present invention. For example, the compounds of the invention may be present in combination with tissue plasminogen activator, a substance known to dissolve the fibrin network of blood clots which has found utility in the treatment of thrombotic disorders (see, for example, *The New England Journal of Medicine*, 312(14), 932, (1985)).

The formulations of the invention include those suitable for oral, rectal, topical, buccal (e.g. sub-lingual), parenteral (e.g. subcutaneous, intramuscular, intradermal, or intravenous) and transdermal administration, although the most suitable route in any given case will depend on the nature and severity of the condition being treated and on the nature of the particular compound of formula (I), or the physiologically acceptable salt or acid derivative thereof, which is being used.

Formulations suitable for oral administration may be presented in discrete units, such as capsules, cachets, lozenges, or tablets, each containing a predetermined amount of a compound of formula (I) or a physiologically acceptable salt or acid derivative thereof; as a powder or granules; as a solution or a suspension in an aqueous or non-aqueous liquid; or as an oil-in-water or water-in-oil emulsion. Such formulations may be prepared by any suitable method of pharmacy which includes the step of bringing into association the active compound and a suitable carrier (which may contain one or more accessory ingredients). In general, the formulations of the invention are prepared by uniformly and intimately admixing the active compound with a liquid or finely divided solid carrier, or both, and then, if necessary, shaping the resulting mixture. For example, a tablet may be prepared by compressing or moulding a powder or granules containing the active compound, optionally with one or more accessory ingredients. Compressed tablets may be prepared by compressing, in a suitable machine, the compound in a free-flowing form, such as a powder or granules optionally mixed with a binder, lubricant, inert diluent, and/or surface active/dispersing agent(s). Moulded tablets may be

made by moulding, in a suitable machine, the powdered compound moistened with an inert liquid binder.

Formulations suitable for buccal (sub-lingual) administration include lozenges comprising a compound of formula (I), or a physiologically acceptable salt or acid derivative thereof, in a flavoured base, usually sucrose and acacia or tragacanth; and pastilles comprising the compound in an inert base such as gelatin and glycerin or sucrose and acacia.

Formulations of the present invention suitable for parenteral administration conveniently comprise sterile aqueous preparations of a compound of formula (I), or a physiologically acceptable salt or acid derivative thereof, which preparations are preferably isotonic with the blood of the intended recipient. These preparations are preferably administered intravenously, although administration may also be effected by means of subcutaneous, intramuscular, or intradermal injection. Such preparations may conveniently be prepared by admixing the compound with water or a glycine buffer and rendering the resulting solution sterile and isotonic with the blood. Injectable formulations according to the invention generally contain from 0.1 to 5% w/v of active compound and are administered at a rate of 0.1 ml/min/kg.

Formulations suitable for rectal administration are preferably presented as unit dose suppositories. These may be prepared by admixing a compound of formula (I), or a physiologically acceptable salt or acid derivative thereof, with one or more conventional solid carriers, for example, cocoa butter, and then shaping the resulting mixture.

Formulations suitable for topical application to the skin preferably take the form of an ointment, cream, lotion, paste, gel, spray, aerosol, or oil. Carriers which may be used include vaseline, lanoline, polyethylene glycols, alcohols, and combinations of two or more thereof. The active compound is generally present at a concentration of from 0.1 to 15% w/w, for example, from 0.5 to 2% w/w. Formulations for transdermal administration may be delivered by iontophoresis (see, for example, Pharmaceutical Research 3(6), 318, (1986)) and typically take the form of an optionally buffered aqueous solution of a compound of formula (I) or of a salt or acid derivative thereof. Suitable formulations comprise citrate or bis/tris buffer (pH 6) or ethanol/water and contain from 0.1 to 0.2M active ingredient.

The compounds of the present invention are conveniently prepared by methods the same as or analogous to those described in U.S. Pat. No. 4,306,075.

For a better understanding of the invention, the following Examples are given by way of illustration.

#### EXAMPLES

The effects of 9-deoxy-2', 9 $\alpha$ -methano-3-oxa-4,5,6-trinor-3,7-(1',3'-interphenylene)-13,14-dihydro-prostaglandin F<sub>1</sub> monitored in experimental pulmonary hypertension models. In Example 1, the model used was an open chest preparation of an anaesthetised cat (anaesthetic: chloralose and urethane). In Example 2, the model was a conscious spontaneously hypertensive rat.

#### EXAMPLE 1

A series of glycine buffer solutions of the test compound were successively administered to each animal by i.v. infusion at doses equivalent to 100 ng, 300 ng, 1  $\mu$ g, and 3  $\mu$ g/kg/min. Each solution was infused over a period of 20 minutes, hypoxia being induced in the animal during the last 5 minutes of infusion by ventilating with 10% oxygen in nitrogen. A 15-minute 'recovery' period was observed between successive infusions. Following surgery, the animal was allowed to stabilize for 30 minutes, after which two 5-minute hypoxic challenges were given 15 minutes apart which were averaged to obtain the control hypoxic responses. 15 minutes after the second control hypoxic challenge, the animal started to receive the test compound. The averaged control hypoxic responses were compared with those obtained during infusion of the test compound.

The following parameters were monitored during the course of each experiment: systemic arterial pressure (MAP), pulmonary arterial (PAP) and venous (PVP) pressure, and cardiac output (CO, aortic blood flow). From the values obtained, the systemic vascular resistance (MAP/CI where CI=CO/body weight in kg) and the pulmonary vascular resistance (PAP/CI) were calculated.

The test compound was found to reduce hypoxia-induced increase in pulmonary arterial pressure and pulmonary vascular resistance in a dose-related manner without appreciably affecting cardiac output or heart rate. At higher doses, the test compound reduced systemic arterial pressure and systemic vascular resistance. Thus hypoxia-induced pulmonary vasoconstriction could be reduced without disturbing the systemic haemodynamics by suitably adjusting the dose. The hypoxia-induced vasoconstriction did not return to its control value within 15 minutes of terminating the final infusion indicating a relatively long duration of action for the compound.

#### EXAMPLE 2

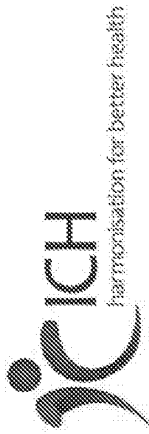
The test compound was administered to a series of animal at doses of 0.1, 0.3, 1.0 and 3.0 mg/kg P.O. and the systolic and diastolic pressures and heart rate of each animal were monitored for 24 hours after administration of the compound. At doses of 0.3 mg/kg P.O. and above, a dose-dependent fall in systolic and diastolic pressures were observed for a period of up to 8 hours after administration indicating that the compound had good oral bioavailability.

What is claimed:

1. A method of treating pulmonary hypertension in a patient, which comprises administering to said patient an effective pulmonary hypertension treatment amount of the compound 9-deoxy-2',9 $\alpha$ -methano-3-oxa-4,5,6-trinor-3,7-(1',3'-interphenylene)-13,14-dihydro-prostaglandin F<sub>1</sub>.

2. A method of treating pulmonary hypertension in a patient, which comprises administering to said patient an effective pulmonary hypertension treatment amount of a pharmaceutically acceptable salt of the compound 9-deoxy-2',9 $\alpha$ -methano-3-oxa-4,5,6-trinor-3,7-(1',3'-interphenylene)-13,14-dihydroprostaglandin F<sub>1</sub>.

\* \* \* \* \*



**Q7 Implementation Working Group**  
**ICH Q7 Guideline: Good Manufacturing Practice Guide for Active Pharmaceutical Ingredients**  
**Questions and Answers**

**Current version**  
**dated 10 June 2015**

---

**International Conference on Harmonisation of Technical Requirements for Registration of Pharmaceuticals for Human Use**

ICH Secretariat, Chemin des Mines 9, P.O. Box 195, 1211 Geneva 20, Switzerland

Telephone: +41 (0)22 538 32 16 • [secretariat@ich.org](mailto:secretariat@ich.org) • <http://www.ich.org>

P. 1

UT Ex. 2034  
SteadyMed v. United Therapeutics  
IPR2016-00006

**In order to facilitate the implementation of the Q7 Guidelines,  
the ICH Experts have developed a series of Q&As:**

**Q7 Q&As  
Document History**

Code	History	Date
Q7 Q&As	Approval by the ICH Steering Committee under Step 4	10 June 2015

**References**

These documents are published at [www.ich.org](http://www.ich.org).

ICH E2E	Pharmacovigilance Planning	November 2004
ICH Q1A(R2)	Stability testing of new drug substance and products February 2003	September 1999
ICH Q5A	Quality of Biotechnological Products: Viral Safety Evaluation of Biotechnology Products Derived from Cell Lines of Human or Animal Origin	November 2005
ICH Q5B	Quality of biotechnological products: Analysis of the construct in cells used for the production of r-DNA derived protein products	July 1997
ICH Q5D	Quality of Biotechnological Products: Derivation and Characterisation of Cell Substrates Used for Production of Biotechnological/Biological Products	March 1999
ICH Q6B	Specifications: Test Procedures and Acceptance Criteria for Biotechnological/Biological Products	November 2000
ICH Q7	Good Manufacturing Practice of APIs	August 2009
ICH Q8(R2)	Pharmaceutical Development	November 2006
	Part I: 'Pharmaceutical Development'	November 2008
	Part II: 'Annex to Pharmaceutical Development',	November 2005
ICH Q9	Quality Risk Management and the ICH Q9 Briefing pack	June 2008
ICH Q10	Pharmaceutical Quality Systems	November 2010
ICH Q-IWG	Training Programme for ICH Q8/Q9/Q10	May 2012
ICH Q11	Development and Manufacturing of Active Pharmaceutical Ingredients	

**Legal Notice:** This document is protected by copyright and may be used, reproduced, incorporated into other works, adapted, modified, translated or distributed under a public license provided that ICH's copyright in the document is acknowledged at all times. In case of any adaptation, modification or translation of the document, reasonable steps must be taken to clearly label, demarcate or otherwise identify that changes were made to or based on the original document. Any impression that the adaptation, modification or translation of the original document is endorsed or sponsored by the ICH must be avoided. The document is provided "as is" without warranty of any kind. In no event shall the ICH or the authors of the original document be liable for any claim, damages or other liability arising from the use of the document. The above-mentioned permissions do not apply to content supplied by third parties. Therefore, for documents where the copyright vests in a third party, permission for reproduction must be obtained from this copyright holder.

Table of Contents

PREFACE ..... 1

1. INTRODUCTION - SCOPE ..... 2

2. QUALITY MANAGEMENT ..... 2

3. PERSONNEL..... 3

4. BUILDINGS AND FACILITIES – CONTAINMENT ..... 4

5. PROCESS EQUIPMENT – CLEANING ..... 5

6. DOCUMENTATION AND RECORDS ..... 6

7. MATERIALS MANAGEMENT ..... 7

8. PRODUCTION AND IN-PROCESS CONTROLS..... 8

9. PACKAGING AND IDENTIFICATION LABELLING OF APIS AND INTERMEDIATES..... 8

10. STORAGE AND DISTRIBUTION ..... 8

11. LABORATORY CONTROLS..... 9

12. VALIDATION ..... 11

13. CHANGE CONTROL ..... 11

14. REJECTION AND REUSE OF MATERIALS ..... 12

15. COMPLAINTS AND RECALLS ..... 12

16. CONTRACT MANUFACTURERS (INCLUDING LABORATORIES) ..... 13

17. AGENTS, BROKERS, TRADERS, DISTRIBUTORS, REPACKERS, AND RELABELLERS ..... 14

18. SPECIFIC GUIDANCE FOR APIS MANUFACTURED BY CELL CULTURE/FERMENTATION..... 15

19. APIS FOR USE IN CLINICAL TRIALS ..... 15

20. GLOSSARY ..... 16

21. ANNEX: Q&AS LINKED TO THE RESPECTIVE SECTIONS OF ICH Q7 ..... 17

## **PREFACE**

Since the ICH Q7 Guidance was finalised, experience with implementing the guidance worldwide has given rise to requests for clarification of uncertainties due to the interpretation of certain sections. This Question and Answer (Q&A) document is intended to respond to those requests.

The ICH Q7 document should be read in its entirety regardless of the nature of the manufacturing activities being conducted to fully understand the linkages between certain sections and successfully implement appropriate Good Manufacturing practices (GMPs) at all stages of the Active Pharmaceutical Ingredients (API) supply chain, including distribution. A table is provided as an Annex of this document showing the link between each Q&A and the relevant Sections of ICH Q7 and other ICH Quality guidance.

ICH would like to acknowledge the work undertaken by the Pharmaceutical Inspection Co-operation Scheme (PIC/S). PIC/S contributed to this document by selecting and reviewing relevant Q&As that had been collected from training sessions since the implementation of Q7 and transferred the output of these reviews to the ICH Q7 IWG for consideration and consolidation, as appropriate. Additional questions were developed based on responses from an ICH survey. PIC/S further contributed to the development of the document as an ICH Interested Party.

Please note that ICH Q7 should be applied in combination with the principles laid down for development and manufacturing in ICH Q11 (see definition of API starting material; see also ICH Q8(R2) Part II), Quality Risk Management (ICH Q9), and Pharmaceutical Quality Systems (ICH Q10). GMP principles as described in ICH Q7 should be applied regardless which approach is taken in pharmaceutical development and manufacturing.

ICH Q7 also describes principles of GMPs to be applied in the manufacture of APIs for use in clinical trials (Section 19) and for APIs manufactured by cell culture/fermentation (Section 18).

**Q7 Questions and Answers**

**1. INTRODUCTION - SCOPE**

#	Date of Approval	Questions	Answers
1.1	June 2015	Should GMP according to ICH Q7 be applied for manufacturing Steps before the defined 'API starting material' i.e., Steps not identified in grey in Table 1?	ICH Q7 does not apply to Steps prior to the introduction of the API starting material. However, there is an expectation that an appropriate level of controls suitable for the production of the API starting material should be applied [ICH Q7, Section 1.3]. Normally, the 'API-starting material' is defined in the regulatory filing by the applicant and approved in the regulatory reviewing process. Additional guidance is provided to define and justify 'API starting material' derived from various sources [ICH Q1, Section 5]; for master cell banks, see [ICH Q5B; ICH Q5D].
1.2	June 2015	Does ICH Q7 apply to manufacturing Steps for the addition of substance(s) to an API (e.g., to stabilise the API)?	When a mixture is classified in the regulatory filing as an API in a region or country in which it is used in a drug product, ICH Q7 should be applied to the manufacturing of these mixtures [ICH Q7, Section 1.2, 2.0 – see Glossary for definition of 'API'].

**2. QUALITY MANAGEMENT**

#	Date of Approval	Questions	Answers
2.1	June 2015	What is meant by 'quality unit(s) independent from production'?	The intent of the term 'independent' is to prevent any conflict of interest and ensure unbiased decision-making regarding quality-related decisions in the organisation structure. The person in the quality unit who is responsible for final decision-making (e.g., batch release decision) should not have responsibilities for production activities [ICH Q7, Section 2.13].
2.2	June 2015	Does ICH Q7 expect that the quality unit performs API release testing?	While the quality unit has responsibility for the release of the API, which includes oversight of the testing and results, ICH Q7 does not prescribe specifically who performs testing. 'quality control' in the ICH Q7 Glossary [ICH Q7, Section 20] refers to the activities, not the organisational structure. For examples of quality responsibility related to testing and release, refer to [ICH Q7, Sections 2.13, 2.22, and 11.12]. Appropriate laboratory controls should be followed [ICH Q7, Sections 11.10, 16.10] regardless of who performs the testing.
2.3	June 2015	Can other departments outside of the quality unit be held responsible for	Yes. The quality unit is responsible for establishing a system to release or reject raw materials, intermediates, packaging, and labelling materials. This responsibility cannot be delegated [ICH Q7,

	releasing raw materials and intermediates?	Section 2.22(2)]. The system established by the quality unit may allow 'other departments' to release raw materials and intermediates (except intermediates that are for use outside the control of the manufacturer [ICH Q7, Section 2.22(1)] as long as oversight and the overall responsibility of this system remains with the quality unit.
2.4	Does ICH Q7 expect that sampling be performed by the quality unit?	No. ICH Q7 does not prescribe specifically who should perform the sampling [ICH Q7, Section 2.22]. However, the quality unit has responsibility for reviewing and approving sampling plans [ICH Q7, Section 11.12] and procedures. Sampling should be performed by adequately trained personnel [ICH Q7, Section 3.10] and be appropriately documented as per [ICH Q7, Section 6.52].
2.5	What should be the frequency of a product quality review?	A product quality review is generally expected annually. Review timeframes can be appropriately adjusted based upon manufacturing and campaign duration with adequate justification. Even if no manufacturing has occurred in the review period, the quality review should be conducted as per section [ICH Q7, Section 2.50] and include stability, returns, complaints, and recalls. For example, a product quality review may encompass more or less than 12 months depending upon product campaign duration [ICH Q7, Section 2.50; ICH Q10, Section 2.6].
2.6	Should the product quality review of results include trend analysis?	Trend analysis is usually an important element in verifying the consistency of the process as part of the product quality review [ICH Q7, Sections 2.50, 2.51]. Potential tools to use are described in [ICH Q9, Annex 1.9].

3. PERSONNEL

#	Date of Approval	Questions	Answers
3.1	June 2015	What is the intent of the statement in [ICH Q7, Section 3.12] 'training should be periodically assessed'?	In [ICH Q7, Section 3.12], the statement 'training should be periodically assessed' refers to a system to evaluate if personnel remain proficient and competent in their job tasks and responsibilities, and whether more frequent, additional, or new training is needed and recurring training is up to date.
3.2	June 2015	Does ICH Q7 expect the use of a consultant and can a company delegate tasks and/or responsibility to a consultant?	ICH Q7 does not expect the use of a consultant. Consultants may perform delegated tasks and/or provide advice. However, the ultimate responsibility for API quality must not be delegated [ICH Q10, Section 2.7, ICH Q7, Sections 2.2, 3.3].



**4. BUILDINGS AND FACILITIES – CONTAINMENT**

#	Date of Approval	Questions	Answers
4.1	June 2015	When are dedicated production areas expected?	<p>ICH Q7 expects dedicated production areas for highly sensitising materials such as penicillins and cephalosporins because of the patient risk (e.g., anaphylactic shock to penicillin-allergic patients) from trace amounts of these compounds in other medicines [ICH Q7, Section 4.40].</p> <p>For materials of an infectious nature or high pharmacological activity or toxicity, a risk-based approach should be used to determine appropriate containment measures, which may include validated inactivation, cleaning and/or dedicated production areas [ICH Q7, Section 4.41].</p> <p>While ICH Q7 does not define high pharmacological activity or toxicity, these are generally determined by evaluating relevant animal and human data collected during research and development. Important considerations in this evaluation of pharmacological activity or toxicity may include Occupational Exposure Limit (OEL), Permitted Daily Exposure (PDE), Acceptable Daily Exposure (ADE), Threshold for Toxicological Concerns (TTC), No Observed Adverse Effect Level (NOAEL) [ICH S Guidelines, ICH E2E, Section 2.1.1], and the consequences of cross-contamination [ICH Q9, Section 4.3].</p>
4.2	June 2015	To what extent can quality risk management be used in establishing appropriate containment measures to prevent cross-contamination?	<p>The principles of quality risk management [ICH Q9, Annex II.4] should be applied to the design of buildings, facilities and controls for the purpose of containment, taking into consideration the pharmacological/toxicological/chemical/biological properties of the raw material, intermediate and/or API to be handled or manufactured.</p> <p>Appropriate containment measures and controls [ICH Q7, Section 4.42] include but are not limited to the following:</p> <ul style="list-style-type: none"> <li>• Technical controls (e.g., dedicated production areas, closed/dedicated Heating Ventilation and Air Conditioning (HVAC) system, closed manufacturing systems, use of disposable technologies, design of facility and equipment for containment and ease of cleaning); and</li> <li>• Procedural (organisational) controls (e.g., cleaning, personnel flow, environmental monitoring and training).</li> </ul> <p>Monitoring systems are important to check the effectiveness of the containment controls.</p>

**5. PROCESS EQUIPMENT – CLEANING**

#	Date of Approval	Questions	Answers
5.1	June 2015	For dedicated equipment, is 'visually clean' acceptable for verification of cleaning effectiveness, (i.e., no expectation for specific analytical determination)?	'Visually clean' may be acceptable for dedicated equipment based on the ability to visually inspect and sufficient supporting data from cleaning studies (e.g., analytical determination to demonstrate cleaning effectiveness) [ICH Q7, Section 12.76]. Equipment should be cleaned at appropriate intervals (e.g., time or number of batches) to prevent build-up and carryover of contaminants (e.g., degradants or objectionable levels of microorganisms) so that they do not adversely alter the quality of the API [ICH Q7, Sections 5.23, 12.7].
5.2	June 2015	Should acceptance criteria for residues be defined for dedicated equipment?	Yes. Regardless of whether equipment is dedicated or not, it is expected that acceptance criteria for residues be defined and that the equipment be cleaned at appropriate intervals to prevent build-up and carry-over of contaminants. Intervals can be based on number of batches, product change-over, time, etc. [ICH Q7, Sections 5.22, 5.23, 5.24, 5.25, 8.50].  Cleaning intervals and acceptance criteria should be established based on an understanding of the process/reactions/degradation, taking into account solubility, potency, toxicity, etc. Establishment of acceptance criteria does not necessarily imply sampling and testing after every cleaning. Visual inspection of equipment for cleanliness is an expectation of [ICH Q7, Section 5.21]. Where validation data has confirmed effective cleaning, cleaning procedures should be monitored at appropriate intervals [ICH Q7, Section 12.76].
5.3	June 2015	Is it expected that equipment cleaning time limits be confirmed in cleaning validation?	Yes. Equipment cleaning is addressed in two sections in ICH Q7. While the cleaning validation [ICH Q7, Section 12.7] does not specifically address time limits for cleaning, [ICH Q7, Section 5.21] indicates that the maximum time between completion of processing and equipment cleaning (dirty hold time) should be established by the company. This maximum established dirty hold time is the time period for which evidence is available to demonstrate that the equipment can still be reliably cleaned. This maximum established dirty hold time is confirmed during the initial cleaning validation and can be extended with appropriate supporting data.  While ICH Q7 does not specify the need for time limits between equipment cleaning and use in the next process (clean hold time), [ICH Q7, Section 5.21] does state that written procedures should include instructions for the protection of clean equipment from contamination prior to use and inspection of equipment for cleanliness immediately before use, if practicable.
5.4	June 2015	Is it expected that campaign manufacturing be addressed in cleaning validation?	Yes. The cleaning validation section [ICH Q7, Section 12.7] does not specifically address campaign manufacture. However, sections [ICH Q7, Sections 5.23, 8.50] set forth the expectations that equipment be cleaned at appropriate intervals (e.g., time or number of batches) to prevent build-up and carryover

		of contaminants so that they do not adversely alter the quality of the API. The appropriate interval is confirmed during cleaning validation.
5.5	June 2015	At product changeover, are both visual examination and analytical testing necessary to verify that equipment is clean?  Appropriate cleaning validation verifies that the cleaning process is effective. During cleaning validation, both visual examination and analytical testing should be used to verify cleaning effectiveness [ICH Q7, Sections 12.72 to 75]. Once the cleaning process is validated, routine monitoring of cleanliness of equipment at product changeover should include visual inspection [ICH Q7, Section 12.76]. Frequency of analytical testing to verify ongoing effectiveness of the validated cleaning process is determined by the API manufacturer using a risk-based approach. In situations where the cleaning process is not yet validated, both visual examination and analytical testing are expected.

**6. DOCUMENTATION AND RECORDS**

#	Date of Approval	Questions	Answers
6.1	June 2015	What is meant by 'completely distributed' in [ICH Q7, Section 6.13], which states that 'records should be retained for at least 3 years after the batch is completely distributed'?	For APIs with a retest date, [ICH Q7, Section 6.13] states that records related to production, control and distribution should be retained for at least 3 years after the API batch is 'completely distributed', which is understood as the complete distribution of the entire batch of the API by the API manufacturer to the next party in the supply chain.  In the case of APIs handled by agents, brokers, traders, distributors, repackers, and relabellers [ICH Q7, Section 17], 'completely distributed' refers to distribution of the received quantity of the batch of API.  The intent of ICH Q7 is to retain records for the period of time that the API could be on the market in order to investigate any problems and/or product complaints. Based on accepted industry practice at the time ICH Q7 was written, it was not anticipated that a manufacturer would set a retest date longer than 3 years. However, the use of 'at least three years' in this section of ICH Q7 covers longer record retention periods, which is in alignment with the basic GMP principle and/or regional requirements that records be retained for the entire period the material is available on the market.  It is good industry practice to consider retaining records for the period of time the drug product(s) in which the API was used may be available on the market.
6.2	June 2015	Does a batch numbering system need to be sequential?	No, [ICH Q7, Section 6.51] says only that batch production records should have a unique batch or ID number.
6.3	June 2015	Who is responsible for the issuance of batch production records?	[ICH Q7, Section 2.3] does not specify who is responsible for the issuance of batch production records [ICH Q7, Section 6.5] as long as the issuance process is described in writing and approved by the quality unit [ICH Q7, Section 2.21].

**7. MATERIALS MANAGEMENT**

#	Date of Approval	Questions	Answers
7.1	June 2015	Does the phrase 'grouping of containers' have the same meaning in [ICH Q7, Sections 7.20 and 7.24]?	The phrase 'grouping of containers' should be read in the context of each sentence. A grouping of containers refers to multiple containers physically secured by the supplier (e.g., shrink-wrapped pallet, etc.) usually intended for ease of shipment and reconciliation. [ICH Q7, Section 7.20] is referring to incoming visual examination of materials before acceptance into the facility under quarantine. The phrase in [ICH Q7, Section 7.24], 'grouping of containers (batches)' contains an additional word 'batches' because this section is addressing the need to establish batch traceability for the incoming material.
7.2	June 2015	What is expected in terms of evaluation of suppliers of materials?	Different phrases are used to describe the expectation for evaluation of suppliers of materials [ICH Q7, Sections 7.11, 7.12, 7.31], including traders, if any. [ICH Q7, Section 7.12] states that all materials are purchased against a specification and from suppliers approved by the quality unit [ICH Q7, Section 7.31]. Prior to approval of any supplier, an evaluation should be conducted using a risk-based approach [ICH Q9, Appendix II.5; ICH Q7, Section 7.31]. More extensive evaluation is needed for suppliers of those materials classified as 'critical' [ICH Q7, Section 7.11].
7.3	June 2015	What is meant by 'full analysis' [ICH Q7, Section 7.31] on batches of raw materials to qualify a supplier?	A 'full analysis' should include all tests specified by the user of the raw material in the regulatory filing. In cases where no filing is required, the full analysis should include tests in other formal written specifications issued by the user of the raw material [ICH Q7, 7.31]. A raw material supplier's Certificate of Analysis (CoA) may not necessarily align with the user's specifications.
7.4	June 2015	Are on-site audits required in the evaluation of suppliers?	No. An on-site audit is not required; however, an on-site audit could be a useful tool in the evaluation of a supplier. A risk assessment of the material or the service provided can be used to develop an audit strategy and manage the ongoing evaluation of suppliers [ICH Q7, Sections 7.11, 7.31].
7.5	June 2015	Which tests are considered to be identity tests?	For incoming production materials, identity tests and related methods should be used as described in the relevant sections of a Pharmacopoeia monograph, in an approved regulatory filing or in an in-house specification (including method/analytical procedure) [ICH Q7, Section 7.30]. When available, a discriminating test should be considered for identification testing. The visual examination of a label or the material is not considered sufficient except in the cases described in [ICH Q7, Section 7.32].
7.6	June 2015	Is it possible to extend the expiry date or retest date of a raw material and what is the acceptable practice to	Manufacturing and labelling of raw materials for use by API manufacturers is outside the scope of ICH Q7. As such, retest and expiry dates, as defined in ICH Q7, do not strictly apply to raw materials and

	determine how long it may be extended for?	may be used in a different manner by the raw material supplier. Expiry date, as defined in the glossary of [ICH Q7, Section 20], applies specifically to the API. API manufacturers may re-evaluate [ICH Q7, Section 7.5] and then use a raw material after the 'expiry date' or 'retest date', based on an appropriate scientific and risk-based justification (e.g., understanding of material attributes, testing, and stability). Similar justifications may be used to extend the date by which the material should be re-evaluated. It is the responsibility of the API manufacturer to ensure the raw materials are appropriate for the intended use at the time of use.
--	--------------------------------------------	------------------------------------------------------------------------------------------------------------------------------------------------------------------------------------------------------------------------------------------------------------------------------------------------------------------------------------------------------------------------------------------------------------------------------------------------------------------------------------------------------------------------------------------------------------------------------------------------------------------------------------------------------------------------------------

**8. PRODUCTION AND IN-PROCESS CONTROLS**

#	Date of Approval	Questions	Answers
8.1	June 2015	Can yield ranges defined for the first batch differ from latter batches within a campaign?	Yes. Differing yield ranges [ICH Q7, Section 8.14] may be described and justified in the manufacturing procedure/master batch record explaining the ranges [ICH Q7, Section 6.41]. For example, the first batch in the series of production of batches of the same material (campaign) may leave residual material in the equipment, resulting in a low yield in the first batch and contributing to an increased yield in a subsequent batch of the campaign.
8.2	June 2015	What is meant by 'appropriate specifications (of each batch) prior to blending' [ICH Q7, Section 8.41]?	As a principle, no batches with Out of Specification (OOS) results should be blended [ICH Q7, Section 8.41]. Blending is defined in [ICH Q7, Section 8.40]. Individual intermediate and/or API batches should demonstrate conformance with the filed specifications prior to blending. In regions or circumstances where there are intermediates and/or APIs that do not require filing, conformance with the release specification should be demonstrated.

**9. PACKAGING AND IDENTIFICATION LABELLING OF APIS AND INTERMEDIATES**

No Q&A.

**10. STORAGE AND DISTRIBUTION**

#	Date of Approval	Questions	Answers
10.1	June 2015	What is meant by 'APIs and intermediates can be transferred under quarantine to another unit under the company's control when...'	[ICH Q7, Section 10.20] states 'APIs and intermediates should only be released for distribution to third parties after they have been released by the quality unit(s). APIs and intermediates can be transferred under quarantine to another unit under the company's control when authorised by the quality unit(s) and if appropriate controls and documentation are in place'.

	<p>and is this applicable to contract manufacturers?</p>	<p>The second sentence in [ICH Q7, Section 10.20] describes transport situations that are not considered distribution. It provides for physical movement (transfer but not release) of quarantined material to another unit. This unit can be on the same site, different site (within the same company), or a contract manufacturer (see final paragraph below).</p> <p>The goal of transfer under quarantine is to allow transportation and testing in parallel. Material that is transferred under quarantine is not to be used for further processing until all testing and quality review is complete and the material is released by the quality unit as defined in [ICH Q7, Section 2.22].</p> <p>This provision for transfer under quarantine is included in ICH Q7 for situations where a company is shipping APIs or intermediates from one unit to another and has both the need to expedite the shipping and the material management system in place to prevent use of the material before full release. Examples of circumstances where transfer under quarantine may be needed include extraordinary supply chain requirement(s) (e.g., short shelf-life), and materials with a lengthy timeframe for required test(s) (e.g., some microbiological tests, etc.).</p> <p>With appropriate oversight as described in [ICH Q10, Section 2.7], including a written agreement as described in [ICH Q7, Section 16.12], and appropriate ongoing controls, a contract manufacturer may be considered a 'unit under the company's control'. There is a joint responsibility by both parties to clearly justify and document the need to transfer the unreleased intermediate or API, and to ensure appropriate control is maintained to prevent use before full release.</p>
--	----------------------------------------------------------	------------------------------------------------------------------------------------------------------------------------------------------------------------------------------------------------------------------------------------------------------------------------------------------------------------------------------------------------------------------------------------------------------------------------------------------------------------------------------------------------------------------------------------------------------------------------------------------------------------------------------------------------------------------------------------------------------------------------------------------------------------------------------------------------------------------------------------------------------------------------------------------------------------------------------------------------------------------------------------------------------------------------------------------------------------------------------------------------------------------------------------------------------------------------------------------------------------------------------------------------------------------------------------------------------------------------------------------------------------------------------------------------------------------------------------------------------------------------------------------------------------------------------------------------------------------------------------------------------------------------------------------------------------------------------------------------------------------------------------------------------------------------------------

**11. LABORATORY CONTROLS**

#	Date of Approval	Questions	Answers
11.1	June 2015	What is expected in terms of impurities for APIs extracted from herbal or animal tissue origin [ICH Q7, Section 11.2]?	<p>In cases where the API itself is the extract from an herbal or animal tissue preparation, all constituents of this extract (concomitant constituents) might be considered to be part of the API. Therefore, a production process-related impurity profile (except, for example, solvents used in the process), would generally not be expected. However, for all APIs derived from herbal or animal sources, tests and limits for possible contaminants originating from these sources (e.g., pesticides, mycotoxins, viruses, herbicides, elemental impurities and wrong species) should be established, based on a risk assessment.</p> <p>In cases where herbal or animal sources provide material that is further processed to yield a chemically-defined API, all constituents other than the API are considered impurities. In this situation, the API manufacturer would be expected to establish an impurity profile as well as an API release specification that would include impurity limits.</p>

<p>In any case, it is the API manufacturer's responsibility to establish batch release specifications for APIs to ensure that they are safe and of high quality, consistent with appropriate regulatory requirements, applicable compendial specifications and regional expectations [ICH Q7, Section 11.21; ICH Q9; ICH Q11].</p>	
<p>The company should decide and justify the decision of which method to use. All test methods for stability studies [ICH Q1A] should be validated and demonstrated to be stability indicating prior to use [ICH Q7, Section 11.51].</p> <p>Any changes to stability test methods should be documented. Applicability of the changes to the existing stability studies should be assessed and may require filing in accordance with regional requirements for post-approval changes [ICH Q7, Section 13.11].</p>	<p>In cases where an API test method is changed, which method should be used for stability studies already in progress?</p>
<p>The purpose of a retest date is to ensure that the API is still suitable for use. The API manufacturer can extend the retest date of a specific batch based on good science and long-term stability results for that API and testing of the specific batch that has been stored according to the label conditions. In some regions, regulatory authority approval of the retest date extension for the batch may be required.</p> <p>If an API manufacturer wants to change (i.e., extend) the retest date for future batches of an API, then it should conduct stability testing sufficient to support the change, and include the new retest date and supporting data in a regulatory filing, as determined by regional requirements.</p>	<p>When is it acceptable for an API manufacturer to extend an API retest date [ICH Q7, Section 11.6]?</p>
<p>'Completely distributed' refers to the distribution of the entire batch of the API by the API manufacturer to the next party in the supply chain. It should be noted that this applies to all parties that physically process or repack the API [ICH Q7, Section 20 – see Glossary for definition of 'manufacture'].</p> <p>The intent of ICH Q7 is to retain samples for the period of time that the API could be in the market in order to investigate any problems and/or product complaints. Based on accepted industry practice at the time ICH Q7 was written, it was not anticipated that a manufacturer would set a retest date longer than 3 years. It is a basic GMP principle that reserve samples be retained for the entire period the material is available on the market. For example, if a company sets a retest date of 5 years and the API is completely distributed immediately after manufacturing, it was never intended that the reserve sample be destroyed before the 5 year retest date was reached.</p>	<p>What is meant by 'completely distributed' in [ICH Q7, Section 11.71], which indicates reserve/retention samples should be retained for 3 years after the batch is completely distributed by the manufacturer?</p>
<p>Unlike stability samples, the purpose of the reserve/retention sample is not to represent the quality of the batch in the market place but to allow future evaluation of the quality of the original API batch (e.g., in evaluation of potential counterfeits, etc.). Therefore, reserve/retention samples may be stored in packaging (and conditions) that better preserve the original state of the API.</p>	<p>Why does ICH Q7 permit the use of a packaging system for reserve/retention samples that is 'more protective than the marketed packaging system' [ICH Q7, Section 11.72]?</p>

**12. VALIDATION**

#	Date of Approval	Questions	Answers
12.1	June 2015	Is the lifecycle approach to process validation acceptable for APIs under ICH Q7?	Yes, ICH Q7 does not preclude the lifecycle approach [ICH Q7, Section 12.10, ICH Q10, ICH Q11].
12.2	June 2015	Can the range of a process parameter be expanded based only on a process deviation(s)?	No. However, information from the investigation into a process deviation(s) can be used to support expanding the range of a process parameter. Additional work and studies are normally needed to adequately demonstrate that the expanded range for the process parameter consistently produces API of the necessary quality [ICH Q7, Sections 2.16, 12.11, 13.13].
12.3	June 2015	Would additional process validation studies be needed to support a change in the source of an API starting material?	Any change in the API starting material should be assessed for impact on the API manufacturing process and the resulting API quality [ICH Q7, Section 7.14]. Additional validation studies of the API process may be warranted if the change in the API starting material is deemed significant. In most cases, validation would be expected for a different source of the starting material unless otherwise justified [ICH Q7, Sections 12.1, 13.13].
12.4	June 2015	Is a retrospective approach to validation still acceptable?	Prospective validation is normally expected for processes introduced since the publication of ICH Q7. The concept of retrospective validation remains acceptable as an exception for existing, well established products prior to the implementation of ICH Q7 [ICH Q7, Section 12.44]. If regulatory discussions redefine a step as critical, which had previously been considered non-critical, a protocol describing retrospective analysis of data together with the commitment for concurrent or prospective validation may be an option. Regardless of the type of validation, the quality system should confirm the ongoing robustness of the process (e.g., product quality review).

**13. CHANGE CONTROL**

#	Date of Approval	Questions	Answers
13.1	June 2015	Who is responsible for notifying the drug product manufacturer about relevant changes in API manufacturing?	Each party in the supply chain is responsible for transferring information related to quality or regulatory changes to the next customer in the supply chain. The intention is that the information is transferred



		along the supply chain to the drug product manufacturer in a timely manner [ICH Q7, Sections 13.17, 17.60].
--	--	-------------------------------------------------------------------------------------------------------------

**14. REJECTION AND REUSE OF MATERIALS**

#	Date of Approval	Questions	Answers
14.1	June 2015	Should rejected materials be stored under physical and secure segregation?	ICH Q7 does not specify a need for physical and secure segregation. Both [ICH Q7, Sections 4.14 and 10.11] include the provision for the use of alternative control systems for storage of rejected material. Whatever control system is used, the purpose should be to prevent the unintentional or unauthorised use of the rejected material [ICH Q7, Sections 7.44, 10.11, 14.1].
14.2	June 2015	Does the definition of expiry date in ICH Q7 preclude the rework or reprocess of an expired API?	According to the definition, material should not be used after the expiry date. The original intent of this definition in ICH Q7 was that expired API should not be used in drug product formulation. It may be acceptable to reprocess [ICH Q7, Section 14.2] or rework [ICH Q7, Section 14.3] the expired API where the API manufacturer has all related historical GMP documentation and additional stability data on the reworked or reprocessed API. There may be registration/filing considerations that are beyond the scope of ICH Q7 in addition to the GMP considerations.
14.3	June 2015	Is validation expected for the recovery of material from mother liquor?	It depends. Recovery of material(s) from mother liquor is a process and the need for validation should be assessed as for any other process step [ICH Q7, Section 14.40]. Recovery of material from mother liquor in any process step that must be controlled within predetermined criteria to ensure the API meets its specification is, by definition, a critical process step and should be validated. For example, recovery of API from mother liquor would be considered a critical process step and should be validated [ICH Q7, Sections 12.11, 12.12, 14.41, 14.43, 20 – see Glossary for definitions of ‘critical’, ‘materials’, ‘mother liquor’, and ‘validation’].

**15. COMPLAINTS AND RECALLS**

#	Date of Approval	Questions	Answers
15.1	June 2015	Can quality defects of released APIs that are identified by another entity belonging to the same company be handled outside of the API	Yes. After the release of an API for further use, any identified quality defect should be investigated and addressed according to the API manufacturer’s complaint system or equivalent (i.e., non-conformance, deviations, etc.) [ICH Q7, Sections 15.10 to 15.12]. Where equivalent systems are used, such defects should be categorised in a manner that provides clear visibility that the defect was discovered after being released by the API site.

		manufacturer's complaint procedure?	
15.2	June 2015	Must a quality related return, at the request of the API manufacturing site, from another site within the same company be recorded as a 'recall'?	No, provided that no portion of the batch left direct control of the company for sale or use. It must be clearly visible in the API site's Quality System as a return triggered by the API manufacturing site so this is clear in quality system trend reporting and in the Product Quality Review [ICH Q7, Sections 2.50, 15.13; and 15.14].

**16. CONTRACT MANUFACTURERS (INCLUDING LABORATORIES)**

#	Date of Approval	Questions	Answers
16.1	June 2015	Does ICH Q7 preclude a contract manufacturer's independent quality unit from performing the main responsibilities as described in [ICH Q7, Section 2.22]?	No. The original intent of Section 2.2 was to distinguish the main responsibilities (e.g., batch record review, review of non-conformances and investigations, sampling, testing, release or rejection of intermediate or API, etc.) of the independent quality unit from other departments within a company. Contract manufacturers are expected to have an independent quality unit that meet the responsibilities defined in [ICH Q7, Section 2.2] for all activities performed. Given the potential complexity of outsourcing contract manufacturing arrangements, GMP responsibilities should be clearly defined between both parties in detail in a written agreement [ICH Q7, Section 16.12]. However, the overall responsibility for API quality must not be delegated.
16.2	June 2015	Which outsourced activities are covered by ICH Q7?	In the context of ICH Q7, contract manufacturing is the outsourced activity. The term 'outsourced activities', as defined and described in [ICH Q10, Section 2.7, Glossary], aligns with the description of 'contract manufacturer' in [ICH Q7, Section 16]. ICH Q7 defines 'manufacture' as ' <i>all operations of receipt of materials, production, packaging, repackaging, labelling, relabelling, quality control, release, storage, and distribution of APIs and related controls.</i> ' 'Related controls' include any activities or services necessary to support production (e.g., maintenance, calibration, etc.). ICH Q7 applies to any activities performed by the original manufacturer or the company that is performing the activity on behalf of the original manufacturer.

16.3	June 2015	What is meant by 'where subcontracting is allowed' [ICH Q7, Section 16.14]?	Subcontracting as used in [ICH Q7, Section 16.14] refers to the contract acceptor further contracting out a specific activity to another party (third party). This should only be done when the written and approved contract, as described in [ICH Q7, Section 16.12], specifically allows for such subcontracting. Even when subcontracting is allowed, the original contract giver should approve specific subcontracting before it occurs as stated in [ICH Q7, Section 16.14].
------	-----------	-----------------------------------------------------------------------------	-------------------------------------------------------------------------------------------------------------------------------------------------------------------------------------------------------------------------------------------------------------------------------------------------------------------------------------------------------------------------------------------------------------------------------------------------------------------------------------

**17. AGENTS, BROKERS, TRADERS, DISTRIBUTORS, REPACKERS, AND RELABELLERS**

#	Date of Approval	Questions	Answers
17.1	June 2015	What does ICH Q7 mean by 'Agents, brokers, traders, distributors, repackers, or relabellers'?	Regardless of what they are referred to in different regions, ICH Q7 applies to all parties in the supply chain after the original API/intermediate manufacturer to the drug product manufacturer, in order to maintain the integrity, traceability, and transparency of the supply chain [ICH Q7, Section 17.1].
17.2	June 2015	Could a distributor of an API engage a contract manufacturer for production Steps?	No. If a distributor [ICH Q7, Section 17.1] of an API contracts out production Steps (e.g., drying, micronisation, milling, or sieving), then the distributor becomes a manufacturer and is subject to the entirety of ICH Q7.  This includes, but is not limited to, appropriate written agreements as stated in [ICH Q7, Section 16.12] defining responsibilities of each party. In addition, these contracted production steps must be described in registration documents, applications, or equivalent as per regional requirements.
17.3	June 2015	Is it acceptable to replace the original label, which contains the information of the original manufacturer?	Any relabeling operations are considered manufacturing by definition [ICH Q7, Section 20] and should be performed under appropriate GMP controls [ICH Q7, Section 17.40]. With appropriate justification, manufacturers including repackagers and relabellers may replace the original label. The new label should contain information as per [ICH Q7, Sections 9.42, 9.43]. However, distributors should not remove an original label, but only add additional labels. Information about the original manufacturer must be provided to the customers [ICH Q7, Section 17.61]. Overall, the traceability of the supply chain needs to be maintained [ICH Q7, Section 17.2].
17.4	June 2015	Who is considered to be the original manufacturer of the API for purposes of the Certificate of Analysis (CoA)?	The CoA should document the original manufacturer to support traceability throughout the supply chain [ICH Q7, Sections 11.4, 17.6].  The original manufacturer would be the facility where the final purified API/intermediate is produced. Further physical processing (e.g., drying, micronisation, milling, sieving) of an API would not make the manufacturer performing such operations the original manufacturer. All authentic CoAs including those of the original manufacturer should be available [ICH Q7, Section 17.20].

**18. SPECIFIC GUIDANCE FOR APIS MANUFACTURED BY CELL CULTURE/FERMENTATION**

#	Date of Approval	Questions	Answers
18.1	June 2015	Does ICH Q7 expect validation for viral removal/viral inactivation steps for biological/biotechnological products?	Yes. According to [ICH Q7, Section 18.51], viral inactivation/removal steps are considered critical for some processes (e.g., cell lines of human and animal origin [ICH Q5A, Section 1]. Parameters for validation should be established in accordance with [ICH Q5A, Q5D and Q6B]. Due to the potential for contamination [ICH Q5A, Section 2.B], viral inactivation studies should be performed in a separate and typically smaller laboratory facility [ICH Q11, Section 7.2] and not in a clinical or commercial manufacturing facility.
18.2	June 2015	Do [ICH Q7, Sections 18.14, 18.2] apply to classical fermentation and biotechnology?	For 'classical fermentation', the text from [ICH Q7, Section 18.14] ' <i>...this guide covers cell culture/fermentation from the point at which a vial of the cell bank is retrieved for use in manufacturing</i> ' refers to 'classical fermentation' and not to the 'biotechnology fermentation/cell culture'. Although the entire ICH Q7 Guideline does not apply prior to the introduction of cells into the classical fermentation process, as shown in Table 1 of [ICH Q7, Section 1.3], an appropriate level of GMP controls suitable for cell banks should be established. For 'biotechnology fermentation/cell culture' [ICH Q7, Section 18.2] on 'Cell Bank Maintenance and Record Keeping' applies specifically to biotechnology fermentation/cell culture because ICH Q7 starts with the maintenance of the working cell bank [ICH Q7, Section 1.3, Table 1]. Although for biotech products the entire ICH Q7 Guideline does not apply prior to the maintenance of the working cell bank, an appropriate level of GMP controls suitable for cell banks should be established. See also [ICH Q5B, ICH Q5D].

**19. APIS FOR USE IN CLINICAL TRIALS**

#	Date of Approval	Questions	Answers
19.1	June 2015	Is it permitted to use the same equipment to manufacture materials to be used in pre-clinical and clinical trials?	Yes. As long as operations are conducted under GMP conditions according to ICH Q7, including the establishment of effective cleaning methods, safe residue limits and appropriate containment measures [ICH Q7, Section 19.3].

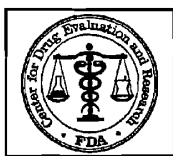
20. GLOSSARY

#	Date of Approval	Questions	Answers
20.1	June 2015	Are the terms 'deviation' and 'non-conformance' synonyms?	No. However, they are related. The term 'deviation', as used in ICH Q7, refers to a ' <i>departure from an approved instruction or established standard</i> ' that may or may not have an impact on the quality of the material. ' <i>Non-conformance</i> ' refers to a status as a result of a failure of the material to meet specifications or appropriately established standards that impacts the quality of the material [ICH Q7, Sections 2.50, 14.30, 20].

**21. ANNEX: Q&As linked to the respective Sections of ICH Q7**

Sections of ICH Q7	1: Introduction	2: Quality Management	3: Personnel	4: Buildings and Facilities	5: Process Equipment	6: Documentation and Records	7: Materials Management	8: Production and In-Process Controls	9: Packaging and Identification Labelling of APIs and Intermediates	10: Storage and Distribution	11: Laboratory Control	12: Validation	13: Change Control	14: Rejection and Re-use of Materials	15: Complaints and Recalls	16: Contract Manufacturer (including Laboratories)	17: Agents, Brokers, Traders, Distributors, Repackers, and Relabellers	18: Specific Guidance for APIs manufactured by Cell Culture/fermentation	19: APIs for Use in Clinical Trials	20: Glossary	Other ICH Guidelines
<b>1. Introduction – Scope</b>																					
1	1.3																				Q11 Q5B Q5D
2	1.2																			20	
<b>2. Quality Management</b>																					
1		2.13																			
2		2.13 2.22							11.12 11.10						16.10					20	
3		2.22																			
4		2.22	3.10			6.52				11.12											
5		2.50																			Q10
6		2.50 2.51																			Q9
<b>3. Personnel</b>																					
1			3.12																		
2		2.2	3.3																		Q10
<b>4. Buildings and Facilities – Containment</b>																					
1			4.40 4.41																		E2B Q9
2			4.42																		Q9
<b>5. Process Equipment – Cleaning</b>																					
1				5.23							12.76 12.7										
2				5.21 to 5.25			8.50				12.76										
3				5.21							12.7										
4				5.23			8.50				12.7										
5											12.72to 12.76										
<b>6. Documents and Records</b>																					
1						6.13											17				
2						6.51															
3		2.21 2.3				6.5															
<b>7. Materials Management</b>																					
1							7.20 7.24														
2							7.11 7.12 7.31														Q9
3							7.31														
4							7.11 7.31														
5							7.30 7.32														
6							7.5													20	
<b>8. Production and In-Process Control</b>																					
1						6.41		8.14													
2								8.40 8.41													
<b>9. Packaging and Identification Labelling of APIs and Intermediates</b>																					
<b>10. Storage and Distribution</b>																					

Sections of ICH Q7		1: Introduction	2: Quality Management	3: Personnel	4: Buildings and Facilities	5: Process Equipment	6: Documentation and Records	7: Materials Management	8: Production and In-Process Controls	9: Packaging and Identification Labelling of APIs and Intermediates	10: Storage and Distribution	11: Laboratory Control	12: Validation	13: Change Control	14: Rejection and Re-use of Materials	15: Complaints and Recalls	16: Contract Manufacturers (including Laboratories)	17: Agents, Brokers, Traders, Distributors, Repackers, and Relabellers	18: Specific Guidance for APIs manufactured by Cell Culture/Fermentation	19: APIs for Use in Clinical Trials	20: Glossary	Other ICH Guidelines
1			2.22								10.20						16.12					Q10
<b>11. Laboratory Controls</b>																						
1												11.2 11.21										Q9 Q11
2												11.51	13.11									Q1A
3												11.6										
4												11.71								20		
5												11.72										
<b>12. Validation</b>																						
1												12.10										Q10 Q11
2			2.16										12.11 12.1	13.13 13.13								
3							7.14						12.4									
4													12.44									
<b>13. Change Control</b>																						
1														13.17			17.60					
<b>14. Rejection and Re-use of Materials</b>																						
1				4.14				7.44			10.11				14.1							
2															14.2 14.3							
3												12.11 12.12			14.40 14.41 14.43				20			
<b>15. Complaints and Recalls</b>																						
1															15.10 to 15.12							
2			2.50												15.13 15.14							
<b>16. Contract Management (including Laboratories)</b>																						
1			2.2 2.22														16.12					
2																	16					Q10
3																	16.12 16.14					
<b>17. Agents, Brokers, Traders, Distributors, Repackers, and Relabellers</b>																						
1																	17.1					
2																	16.12	17.1				
3								9.42 9.43										17.2 17.40 17.61		20		
4										11.4								17.20 17.6				
<b>18. Specific Guidance for APIs Manufactured by Cell Culture/Fermentation</b>																						
1																			18.51			Q5A Q5D Q6B Q11
2			1.3																18.14 18.2			Q5B Q5D
<b>19. APIs for Use in Clinical Trials</b>																						
1																				19.3		
<b>20. Glossary</b>																						
1			2.50												14.30						20	



Center for Drug Evaluation  
and Research (CDER)

# Reviewer Guidance

## Validation of Chromatographic Methods

November 1994  
CMC 3

P. 1

UT Ex. 2035  
SteadyMed v. United Therapeutics  
IPR2016-00006

IPR2020-00769  
United Therapeutics EX2006  
Page 4716 of 7113



TABLE OF CONTENTS

I. INTRODUCTION ..... 1

II. TYPES OF CHROMATOGRAPHY ..... 2

    A. High Performance Liquid Chromatography (HPLC) ..... 2

        1. Chiral Chromatography ..... 2

        2. Ion-exchange Chromatography ..... 3

        3. Ion-pair/Affinity Chromatography ..... 3

        4. Normal Phase Chromatography ..... 3

        5. Reversed Phase Chromatography ..... 3

        6. Size Exclusion Chromatography ..... 4

    B. Gas Chromatography (GC) ..... 4

    C. Thin-Layer Chromatography (TLC) ..... 5

III. REFERENCE STANDARDS ..... 5

IV. PARAMETERS FOR VALIDATION OF HPL CHROMATOGRAPHIC METHODS FOR DRUG SUBSTANCE AND DRUG PRODUCT ..... 7

    A. Accuracy ..... 8

    B. Detection Limit and Quantitation Limit ..... 8

    C. Linearity ..... 11

    D. Precision ..... 13

        1. Repeatability ..... 13

            a. Injection Repeatability ..... 13

            b. Analysis Repeatability ..... 15

2.	Intermediate Precision .....	15
3.	Reproducibility .....	16
E.	Range .....	16
F.	Recovery .....	16
G.	Robustness .....	16
H.	Sample Solution Stability .....	17
I.	Specificity/selectivity .....	17
J.	System Suitability Specifications and Tests .....	21
1.	Capacity factor .....	22
2.	Precision/Injection repeatability .....	22
3.	Relative retention .....	22
4.	Resolution .....	22
5.	Tailing factor .....	23
6.	Theoretical plate number .....	26
K.	General Points to Consider .....	28
V.	COMMENTS AND CONCLUSIONS .....	29
VI.	ACKNOWLEDGEMENTS .....	29
VII.	REFERENCES .....	29

# REVIEWER GUIDANCE<sup>1</sup>

## VALIDATION OF CHROMATOGRAPHIC METHODS

### I. INTRODUCTION

The purpose of this technical review guide is to present the issues to consider when evaluating chromatographic test methods from a regulatory perspective. The document discusses the points to note and weaknesses of chromatography so that CDER reviewers can ensure that the method's performance claims are properly evaluated, and that sufficient information is available for the field chemist to assess the method. Analytical terms, as defined by the International Conference of Harmonization (ICH), 1993, have been incorporated in this guide.

Chromatographic methods are commonly used for the quantitative and qualitative analysis of raw materials, drug substances, drug products and compounds in biological fluids. The components monitored include chiral or achiral drug, process impurities, residual solvents, excipients such as preservatives, degradation products, extractables and leachables from container and closure or manufacturing process, pesticide in drug product from plant origin, and metabolites.

The objective of a test method is to generate reliable and accurate data regardless of whether it is for acceptance, release, stability or pharmacokinetics study. Data are generated for the qualitative and quantitative testing during development and post-approval of the drug products. The testing includes the acceptance of raw materials, release of the drug substances and products, in-process testing for quality assurance, and establishment of the expiration dating period.

Validation of a method is the process by which a method is tested by the developer or user for reliability, accuracy and preciseness of its intended purpose. Data thus

---

<sup>1</sup>This guidance has been prepared by the Analytical Methods Technical Committee of the Chemistry Manufacturing Controls Coordinating Committee (CMC CC) of the Center for Drug Evaluation and Research at the Food and Drug Administration. Although this guidance does not create or confer any rights for or on any person and does not operate to bind FDA or the industry, it does represent the agency's current thinking on the validation of chromatographic methods. For additional copies of this guidance, contact the Division of Communications Management, HFD-210, CDER, FDA, 5600 Fishers Lane, Rockville, MD 20857 (Phone: 301-594-1012). Send one self-addressed adhesive label to assist the offices in processing your request. An electronic version of this guidance is also available via Internet the World Wide Web (WWW) ( connect to the FDA Home Page at [WWW.FDA.GOV/CDER](http://WWW.FDA.GOV/CDER) and go to the "Regulatory Guidance" section).

generated become part of the methods validation package submitted to CDER.

Methods validation should not be a one-time situation to fulfil Agency filing requirements, but the methods should be validated and also designed by the developer or user to ensure ruggedness or robustness. Methods should be reproducible when used by other analysts, on other equivalent equipment, on other days or locations, and throughout the life of the drug product. Data that are generated for acceptance, release, stability, or pharmacokinetics will only be trustworthy if the methods used to generate the data are reliable. The process of validation and method design also should be early in the development cycle before important data are generated. Validation should be on-going in the form of re-validation with method changes.

## **II. TYPES OF CHROMATOGRAPHY**

Chromatography is a technique by which the components in a sample, carried by the liquid or gaseous phase, are resolved by sorption-desorption steps on the stationary phase.

### **A. High Performance Liquid Chromatography (HPLC)**

HPL chromatographic separation is based on interaction and differential partition of the sample between the mobile liquid phase and the stationary phase. The commonly used chromatographic methods can be roughly divided into the following groups, not necessarily in order of importance:

1. Chiral
2. Ion-exchange
3. Ion-pair/affinity
4. Normal phase
5. Reversed phase
6. Size exclusion

#### **1. Chiral Chromatography**

Separation of the enantiomers can be achieved on chiral stationary phases by formation of diastereomers via derivatizing agents or mobile phase additives on achiral stationary phases. When used as an impurity test method, the sensitivity is enhanced if the enantiomeric impurity elutes before the enantiomeric drug.

2. Ion-exchange Chromatography

Separation is based on the charge-bearing functional groups, anion exchange for sample negative ion ( $X^-$ ), or cation exchange for sample positive ion ( $X^+$ ). Gradient elution by pH is common.

3. Ion-pair/Affinity Chromatography

Separation is based on a chemical interaction specific to the target species. The more popular reversed phase mode uses a buffer and an added counter-ion of opposite charge to the sample with separation being influenced by pH, ionic strength, temperature, concentration of and type of organic co-solvent(s). Affinity chromatography, common for macromolecules, employs a ligand (biologically active molecule bonded covalently to the solid matrix) which interacts with its homologous antigen (analyte) as a reversible complex that can be eluted by changing buffer conditions.

4. Normal Phase Chromatography

Normal phase chromatography is a chromatographic technique that uses organic solvents for the mobile phase and a polar stationary phase. Here, the less polar components elute faster than the more polar components.

5. Reversed Phase Chromatography

The test method most commonly submitted to CDER is the reversed phase HPLC method. UV detection is the most common detection technique.

Reversed phase chromatography, a bonded phase chromatographic technique, uses water as the base solvent. Separation based on solvent strength and selectivity also may be affected by column temperature and pH. In general, the more polar components elute faster than the less polar components.

UV detection can be used with all chromatographic techniques. The concern for this type of detector is the loss of sensitivity with lamp aging, and varying sensitivity at the low level depending on design and/or manufacturer. A point to note is that observations on the HPL chromatograms, by UV detection in combination with reversed-phase HPLC, may not be a true indication of the facts for

the following reasons:

- Compounds much more polar than the compound of interest may be masked (elute together) in the solvent front/void volume.
- Compounds very less polar than the analyte may elute either late during the chromatographic run or are retained in the column.
- Compounds with lower UV extinction coefficients or different wavelength maxima may not be detectable at the low level relative to the visibility of the analyte since only one wavelength is normally monitored.

#### 6. Size Exclusion Chromatography

Also known as gel permeation or filtration, separation is based on the molecular size or hydrodynamic volume of the components. Molecules that are too large for the pores of the porous packing material on the column elute first, small molecules that enter the pores elute last, and the elution rates of the rest depend on their relative sizes.

#### B. Gas Chromatography (GC)

Gas chromatography is based on the volatilized sample transported by the carrier gas as the moving phase through the stationary phase of the column where separation takes place by the sorption/desorption process.

Samples for gas chromatographic analysis are normally low molecular weight compounds that are volatile and stable at high temperature. In this respect, residual solvents in drug substances and drug products are suitable for gas chromatographic analysis. Chemical derivatives can also be formed to achieve volatility and thermal stability.

Common detectors are flame ionization (FID) for carbon-containing compounds, electron capture (ECD) for halogenated compounds, flame photometric (FPD) for compounds containing sulphur or phosphorous and nitrogen-phosphorous (NPD) for compounds containing nitrogen or phosphorous. Chiral separation also can be achieved by gas chromatography. Separation by the packed column is rapidly being replaced by the capillary column that provides improved resolution and analysis speed. The location of the analyte on the gas chromatogram is

described by retention time ( $R_f$ ) which is similar to HPLC.

### C. Thin-Layer Chromatography (TLC)

Thin-layer chromatography is the simplest of the more common chromatographic techniques. Separation is based on migration of the sample spotted on a coated (stationary phase) plate with one edge dipped in a mixture of solvents (mobile phase). The whole system is contained in an enclosed tank.

Detection techniques include fluorescence, UV and sprays (universal and specific) for compounds that are not naturally colored. The location of the analyte on the TLC plate is described by the  $R_f$  value which is the ratio of the migration distance of the compound of interest to the mobile phase front.

Of the three techniques, gas, liquid and thin-layer, TLC is the most universal test method as all components are present on the plate and with appropriate detection techniques, all components can be observed. However, it normally is not as accurate or sensitive as HPLC. TLC has a higher analytical variation than HPLC, although one sees the "whole picture" when appropriate detection schemes are selected.

### III. REFERENCE STANDARDS

A reference standard is a highly purified compound that is well characterized. Chromatographic methods rely heavily on a reference standard to provide accurate data. Therefore the quality and purity of the reference standard is very important. Two types of reference standards, chemical and nuclidic, exist. With the latter, the radio-label purity should also be considered as well as the chemical purity.

As described in the Guideline for Submitting Samples and Analytical Data for Methods Validation, the two categories of chemical reference standards are as follows:

- USP/NF reference standard that does not need characterization, and
- non-compendial standard that should be of the highest purity that can be obtained by reasonable effort and should be thoroughly characterized to assure its identity, strength, quality and purity.

The points to note are:

- Most USP/NF reference standards do not state the purity of the compound.

- The purity correction factor for non-USP reference standards is recommended to be included in the calculation of the test method.
- In addition to structurally-related impurities from the synthesis process, other process impurities like heavy metals, residual solvents, moisture (bound and unbound), pesticides for products of plant origin, and degradation products can also contribute to the lack of purity in the reference standard.
- The drying of the reference standard before use, if stated in the method, will eliminate residual solvent(s), unbound moisture and sometimes bound moisture (depending on the drying conditions). The drying step is always included for hygroscopic compounds. On the other hand, drying can result in the loss of a hydrate or cause degradation in heat-sensitive compounds.

Chromatographic test methods use either external or internal standards for quantitation.

- A. An external standard method is used when the standard is analyzed on a separate chromatogram from the sample. Quantitation is based on a comparison of the peak area/height (HPLC or GC) or spot intensity (TLC) of the sample to that of a reference standard of the analyte of interest.

The external standard method is more appropriate for samples as follows:

1. Sample with a single target concentration and narrow concentration range, e.g., acceptance and release tests.
2. Simple sample preparation procedure.
3. Increased baseline time for detection of potential extraneous peaks, e.g., impurities test.

- B. With an internal standard method, compound of known purity that does not cause interference in the analysis is added to the sample mixture. Quantitation is based on the response ratio of compound of interest to the internal standard vs the response ratio of a similar preparation of the reference standard (HPLC or GC). This technique is rarely used for TLC methods.

The internal standard method is more appropriate for samples as follows:



1. Complex sample preparation procedures, e.g., multiple extractions.
2. Low concentration sample (sensitivity being an issue), e.g., pharmacokinetics studies.
3. Wide range of concentrations expected in the sample for analysis, e.g., pharmacokinetics studies.

Although CDER does not specify whether the method must use an internal or external standard for quantitation, it is commonly observed that HPLC methods for release and stability and TLC methods use external standards; and methods for biological fluids and GC methods use internal standards.

The working concentration is the target concentration of the compound of interest as described in the method. Keeping the concentrations of the sample and the standard close to each other for the external standard method improves the accuracy of the method.

**Recommendations:**

1. Include the purity correction factor, if known, of the reference standard in the calculation.
2. State the working concentrations of the standard and sample in the method.

**IV. PARAMETERS FOR VALIDATION OF HPL CHROMATOGRAPHIC METHODS FOR DRUG SUBSTANCE AND DRUG PRODUCT**

Though many types of HPL chromatographic techniques are available, the most commonly submitted method, the reversed-phase HPLC with UV detection, is selected to illustrate the parameters for validation. The criteria for the validation of this technique can be extrapolated to other detection methods and chromatographic techniques. For acceptance, release or stability testing, accuracy should be optimized since the need to show deviation from the actual or true value is of the greatest concern.

**A. Accuracy**

Accuracy is the measure of how close the experimental value is to the true value.

Accuracy studies for drug substance and drug product are recommended to be performed at the 80, 100 and 120% levels of label claim as stated in the Guideline for Submitting Samples and Analytical Data for Methods Validation.

For the drug product, this is performed frequently by the addition of known amounts of drug by weight or volume (dissolved in diluent) to the placebo formulation working in the linear range of detection of the analyte. This would be a true recovery for liquid formulations. For formulations such as tablet, suppository, transdermal patch, this could mean evaluating potential interaction of the active drug with the excipients in the diluent. From a practical standpoint, it is difficult to manufacture a single unit with known amount of active drug to evaluate recovery. This test evaluates the specificity of the method in the presence of the excipients under the chromatographic conditions used for the analysis of the drug product. It will pick up recovery problems that could be encountered during the sample preparation and the chromatographic procedures. However, it does not count the effect of the manufacturing process.

At each recommended level studied, replicate samples are evaluated. The RSD of the replicates will provide the analysis variation or how precise the test method is. The mean of the replicates, expressed as % label claim, indicates how accurate the test method is.

**Recommendations:**

Recovery data, at least in triplicate, at each level (80, 100 and 120% of label claim) is recommended. The mean is an estimate of accuracy and the RSD is an estimate of sample analysis precision.

**B. Detection Limit and Quantitation Limit**

These limits are normally applied to related substances in the drug substance or drug product. Specifications on these limits are submitted with the regulatory impurities method relating to release and stability of both drug substance and drug product. Detection limit is the lowest concentration of analyte in a sample that can be detected, but not necessarily quantitated, under the stated

experimental conditions. Quantitation limit is the lowest concentration of analyte in a sample that can be determined with acceptable precision and accuracy under the stated experimental conditions.

With UV detectors, it is difficult to assure the detection precision of low level compounds due to potential gradual loss of sensitivity of detector lamps with age, or noise level variation by detector manufacturer. At low levels, assurance is needed that the detection and quantitation limits are achievable with the test method each time. With no reference standard for a given impurity or means to assure detectability, extraneous peak(s) could "disappear/appear." A crude method to evaluate the feasibility of the extraneous peak detection is to use the percentage claimed for detection limit from the area counts of the analyte. For example, detection limit claim of 0.01% for the analyte integrated area count of 50,000 will give an area count of 5 that is not detectable.

Though USP expresses detection limit and quantitation limit in terms of 2 or 3, and 10 times noise level respectively, this concept is not very practical. Noise level on a detector during the method development phase may be different when samples are assayed on different detectors, etc. The use of standard(s) in the test method at the quantitation limit level (proposed by the applicant) is assurance that the impurity can be observed and quantitated.

Detector sensitivity can vary with the model number and/or manufacturer as illustrated in Table 1 for the analysis of a compound by two commercial detectors. The data should not be taken as the expected ratio of sensitivity of the two detectors. It is not known if other parameters which can also play a part, e.g., age of lamp, column, were considered when setting these limits.

9

**Table 1. Comparison of Detector Sensitivity Limits in Two Commercial Detectors.**

---

	Detector 1	Detector 2
Quantitation Limit	0.21%	0.07%
Detection Limit	0.16%	0.05%

---

One also should be cautious that baseline noise is not interpreted as extraneous peaks. Undulations may be observed at the void volume if the diluent for the sample is different from the solvents (proportion and type) used in the mobile phase.

If a reference standard for the compound of interest is available, a standard close to the quantitation limit or the specification could be used. For monitoring peak(s) with no reference standard for the impurity, a diluted reference standard of the drug substance is recommended. The method should then check that the high and low concentrations are operating in the linear range of detection of the drug substance. Otherwise the information that is expressed as % area or height of the drug substance peak from the same HPL chromatogram will be biased. It should also be noted that the extraneous peak using area count does not consider the detection response which depends on the UV extinction coefficient or absorptivity of the compound.

**Recommendations:**

1. Analysis repeatability and injection repeatability data at the quantitation limit.
2. Use of an additional reference standard at the quantitation limit level in the test method.

### C. Linearity

The linear range of detectability that obeys Beer's Law is dependent on the compound analyzed and detector used. The working sample concentration and samples tested for accuracy should be in the linear range.

Figures 1 and 2 illustrate the behavior of UV response vs. concentration of a (a) linear and (b) non-linear relationship. A point to note is that when monitoring impurity peaks expressed as percent area of the parent drug substance, the impurity observed may not be a true reflection of the theoretical amount if the non-linear section of the concentration curve is employed. In addition, the actual amount will be obtained only if the extinction coefficient or absorptivity values are the same for both impurity and parent compound. Impurity reference standards are often needed.

Figure 1. Concentrations vs. Peak Areas of Standards to Illustrate Linearity.

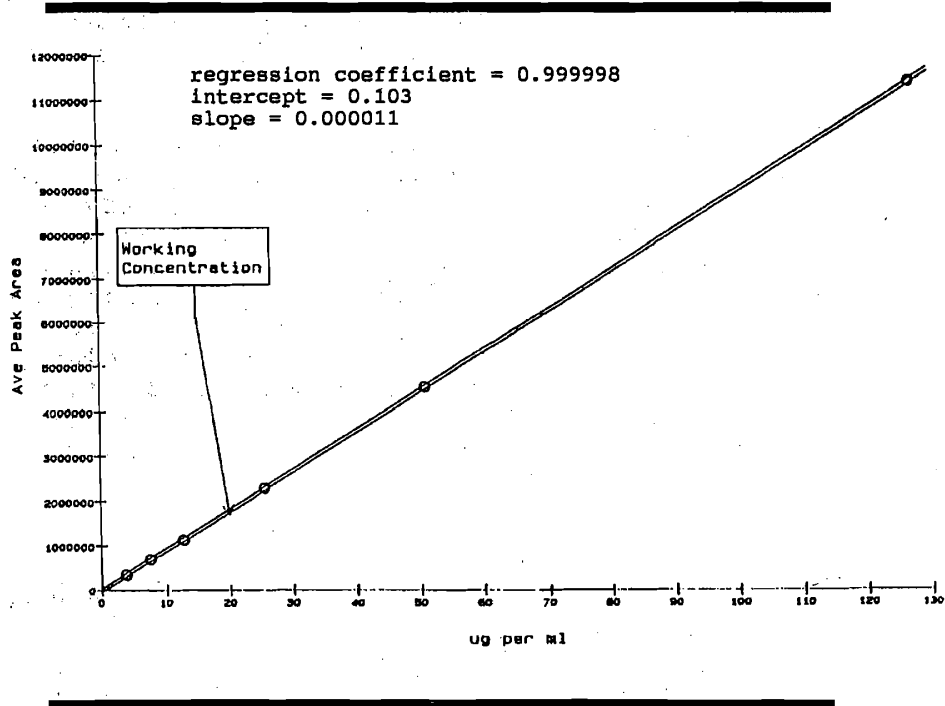
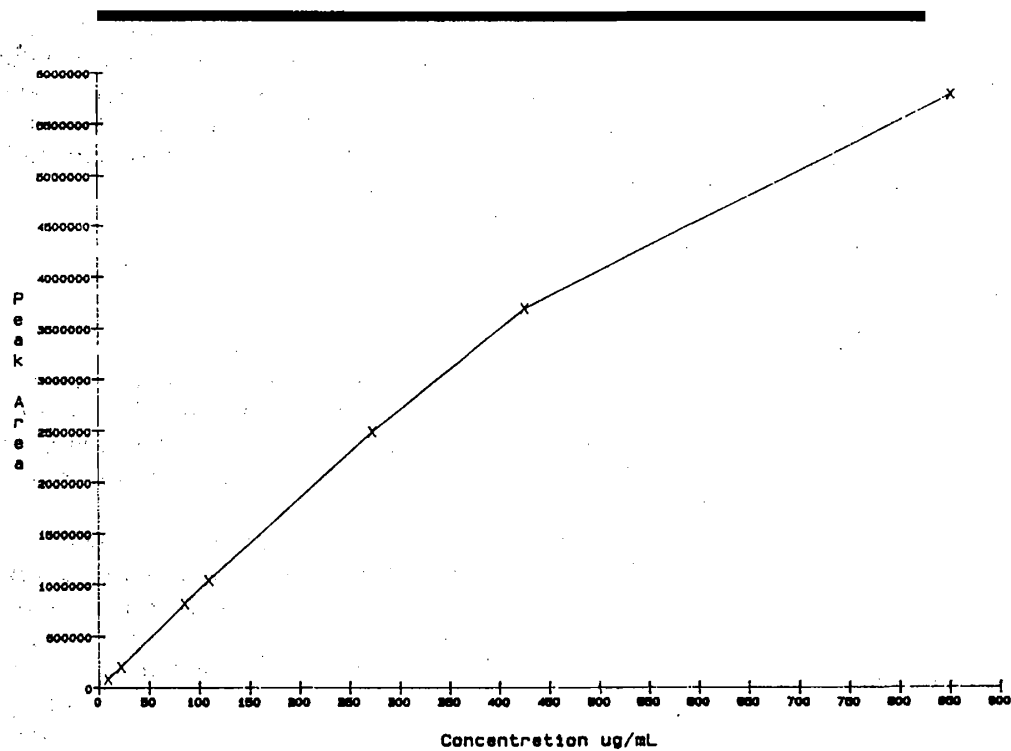


Figure 2. Concentrations vs. Peak Areas of Standards Outside the Linear Range.



**Recommendations:**

The linearity range for examination depends on the purpose of the test method. For example, the recommended range for an assay method for content would be  $NLT \pm 20\%$  and the range for an assay/impurities combination method based on area % (for impurities) would be  $+20\%$  of target concentration down to the limit of quantitation of the drug substance or impurity. Under most circumstances, regression coefficient ( $r$ ) is  $\geq 0.999$ . Intercept and slope should be indicated.

## D. Precision

Precision is the measure of how close the data values are to each other for a number of measurements under the same analytical conditions. ICH has defined precision to contain three components: repeatability, intermediate precision and reproducibility. Ruggedness as defined in USP XXII <1225>, 1990 incorporates the concepts described under the terms "intermediate precision", "reproducibility" and "robustness" of this guide.

### 1. Repeatability

#### a. Injection Repeatability

Sensitivity is the ability to detect small changes in the concentration of the analyte in the sample. Sensitivity can be partially controlled by monitoring the specification for injection reproducibility (system suitability testing).

The sensitivity or precision as measured by multiple injections of a homogeneous sample (prepared solution) indicates the performance of the HPLC instrument under the chromatographic conditions and day tested. The information is provided as part of the validation data and as a system suitability test. The specification, as the coefficient of variation in % or relative standard deviation (RSD), set here will determine the variation limit of the analysis. The tighter the value, the more precise or sensitive to variation one can expect the results. This assumes that the chromatograph does not malfunction after the system suitability testing has been performed. Keep in mind, however, that it does not consider variations due to the drug product manufacturing and laboratory sample preparation procedures. As an illustration for injection and  $R_t$  variation, Table 2 provides representative data collected when a leak developed in the chromatographic system during sampling. The set of four duplicate samples were injected sequentially. Variations in peak area and drift of retention times are noted. Sets of typical data from a well-behaved system for comparison are shown in Table 3.

**Table 2. Representative Injection Repeatability Data for an HPL Chromatographic System that Developed a Leak During Sampling.**

Sample	R <sub>t</sub>	Peak Area	Δ R <sub>t</sub>	Δ Peak Area
A1	5.62	2155699	0.04	35233
A2	5.66	2120466		
B1	5.87	2205659	0.26	82696
B2	6.13	2288355		
C1	6.21	2227066	0.27	38213
C2	6.48	2265279		
D1	6.73	2581888	0.26	20128
D2	6.99	2602016		

**Table 3. Representative Injection Repeatability Data for Select Formulations from a Normally Functional HPL Chromatographic System.**

---

Dosage Form	n	Mean ± SD	RSD
Inhalation Solution	10	1993162 ± 5029	0.25%
Solution for Inhalation	10	1722253 ± 6288	0.37%
Capsule	10	1744320 ± 3133	0.18%

---



**Recommendations:**

As part of methods validation, a minimum of 10 injections with an RSD of  $\leq 1\%$  is recommended. With the methods for release and stability studies, an RSD of  $\leq 1\%$  RSD for precision of the system suitability tests for at least five injections ( $n \geq 5$ ) for the active drug either in drug substance or drug product is desirable. For low level impurities, higher variations may be acceptable.

b. Analysis Repeatability

Determination, expressed as the RSD, consists of multiple measurements of a sample by the same analyst under the same analytical conditions. For practical purpose, it is often combined with accuracy and carried out as a single study. See section IV.A under Accuracy.

2. Intermediate Precision

Intermediate precision was previously known as part of ruggedness. The attribute evaluates the reliability of the method in a different environment other than that used during development of the method. The objective is to ensure that the method will provide the same results when similar samples are analyzed once the method development phase is over.

Depending on time and resources, the method can be tested on multiple days, analysts, instruments, etc.

Intermediate precision in the test method can be partly assured by good system suitability specifications. Thus, it is important to set tight, but realistic, system suitability specifications.

**Recommendations:**

As a minimum, data generated as described under section IV.A Accuracy, for two separate occasions, is recommended to indicate the intermediate precision of the test method.

### 3. Reproducibility

As defined by ICH, reproducibility expresses the precision between laboratories as in collaborative studies. Multiple laboratories are desirable but not always attainable because of the size of the firm.

#### **Recommendations:**

It is not normally expected if intermediate precision is accomplished.

### E. Range

Range is the interval between the high and low levels of analyte studied. See also sections IV.A and C under Accuracy and Linearity respectively.

The ranges recommended in sections IV.A and C under Accuracy and Linearity can be applied to other analytes, e.g., preservatives.

### F. Recovery

Recovery is expressed as the amount/weight of the compound of interest analyzed as a percentage to the theoretical amount present in the medium.

Full recovery should be obtained for the compound(s) of interest. During the sample preparation procedure, the compound of interest is recovered from excipients in the formulation matrix ranging from a simple aqueous solution to complex cream formulation, and from potential adhesion to container/closure components, e.g., glass vial, metered valve. In general, a simpler sample preparation procedure will result in a lower variation of recovery. Data collection for recovery are discussed in section IV.A under Accuracy.

### G. Robustness

ICH defines robustness as a measure of the method's capability to remain unaffected by small, but deliberate variations in method parameters. Robustness can be partly assured by good system suitability specifications. Thus, it is important to set tight, but realistic, system suitability specifications.

Testing varying some or all conditions, e.g., age of columns, column type, column temperature, pH of buffer in mobile phase, reagents, is normally performed.

**Recommendations:**

Data obtained from studies for robustness, though not usually submitted, are recommended to be included as part of method validation.

**H. Sample Solution Stability**

Solution stability of the drug substance or drug product after preparation according to the test method should be evaluated according to the test method. Most laboratories utilize autosamplers with overnight runs and the sample will be in solution for hours in the laboratory environment before the test procedure is completed. This is of concern especially for drugs that can undergo degradation by hydrolysis, photolysis or adhesion to glassware.

**Recommendations:**

Data to support the sample solution stability under normal laboratory conditions for the duration of the test procedure, e.g., twenty-four hours, should be generated. In exceptional cases where multiple days are needed for sample preparation or solution storage, an appropriate stability time should be selected.

**I. Specificity/selectivity**

The analyte should have no interference from other extraneous components and be well resolved from them. A representative HPL chromatogram or profile should be generated and submitted to show that the extraneous peaks either by addition of known compounds or samples from stress testing are baseline resolved from the parent analyte. Examples of the extraneous peaks are as follows:

- For the drug substance or raw material, the related substances to consider are process impurities (which include isomeric impurities) from the synthesis process, residual pesticides, solvents, and other extraneous components from extracts of natural origin.

- For the drug product, the related substances may be impurities present in the active drug, degradation products, interaction of the active drug with excipients, extraneous components, e.g., residual solvents from the excipients or manufacturing process, leachables or extractables from the container and closure system or from the manufacturing process.

Submission of data from stress testing of the drug substance using acid and base hydrolysis, temperature, photolysis and oxidation according to the Guideline for Submitting Samples and Analytical Data for Methods Validation is recommended. Representative HPL chromatograms are recommended for stressed and non-stressed samples that include test methods for impurities, preservatives, etc. and placebo sample. With the impurities test method, the HPL chromatogram should indicate the presence of impurities at the level of detection/quantitation claimed. The chromatograms should be legible, labeled, and the time or time scale and attenuation should be indicated.

Points to note are as follows:

1. The parent peak may be expanded, e.g., by increasing the concentration, attenuation change, so that extraneous peaks can be observed at a reasonable size to evaluate stability-indicating capability. See comments in section IV.B under Limits of Detection/Quantitation.
2. The baseline should be on-scale as off-scale baseline (observed as a flat straight line) can hide minor peaks.

Peak purity can be determined by the photo-diode array detector. Low level extraneous components present under the compound of interest, however, may not interfere or influence the UV spectrum of the analyte.

Figures 3 and 4 illustrate the combination of UV spectroscopy and HPL chromatography by photo-diode array detection using (a) 3-dimensional plot and (b) conventional HPL chromatogram. The analyte elutes at 4.7 minutes. It should be noted that the quality of the UV spectra for the low level components is poor.

Figure 3. A Representative 3-Dimensional Plot of the HPL Chromatogram with the UV Spectra.

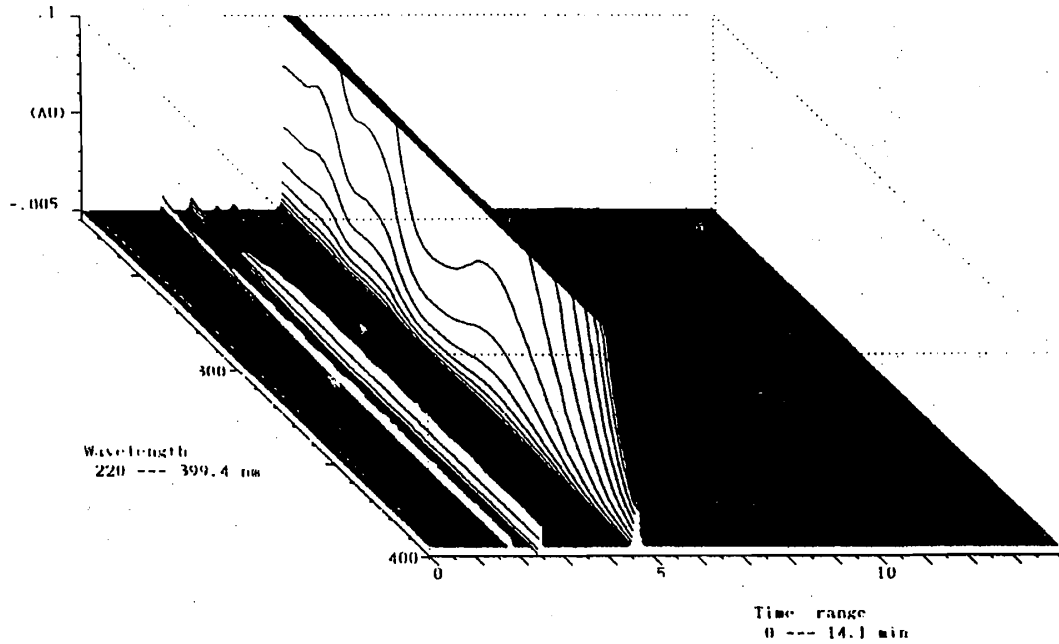
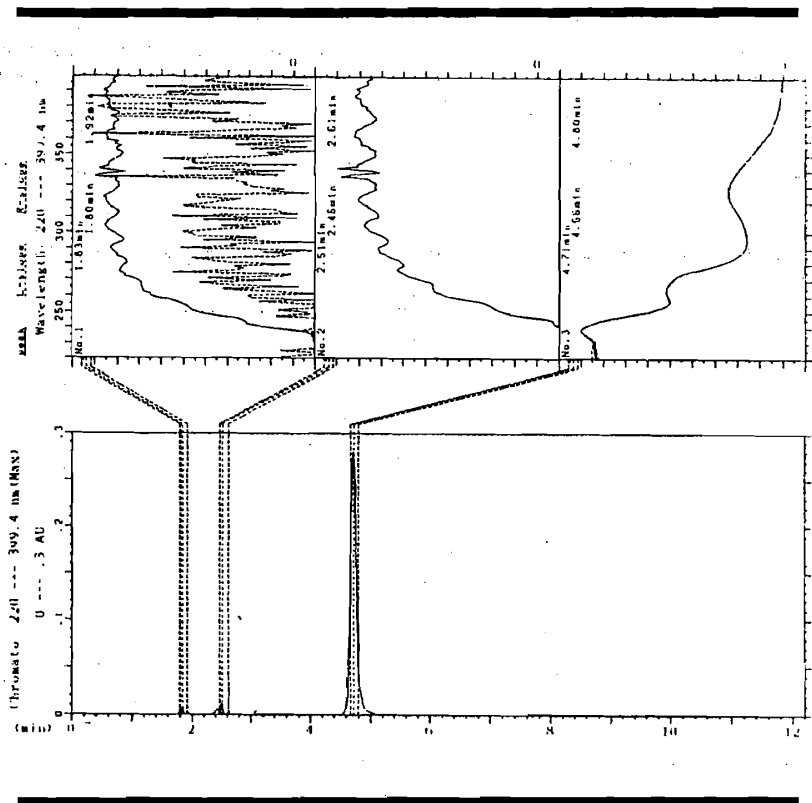


Figure 4. A Representative Conventional HPL Chromatogram with UV Spectra.



When stressed samples are used, an appropriate detector/integrator setting should be selected. For example, to be able to detect low levels, e.g., 0.1% degradation products, the parent peak should be of a size that at least a 0.1% detectability or area count is feasible.

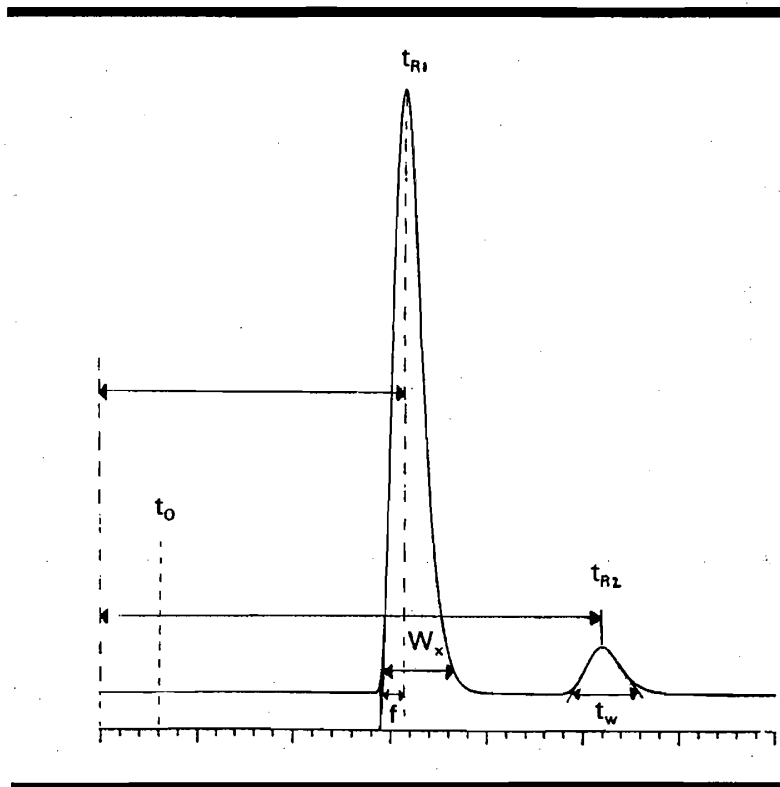
**Recommendations:**

Representative HPL chromatograms should be submitted for stressed and non-stressed samples that include impurities test method, preservative(s), etc. with the related placebo sample. Representative HPL chromatogram(s) to show selectivity by the addition of known extraneous compounds also should be submitted.

## J. System Suitability Specifications and Tests

The accuracy and precision of HPLC data collected begin with a well-behaved chromatographic system. The system suitability specifications and tests are parameters that provide assistance in achieving this purpose. This section explains the terms as indicated in Figure 5, and provides recommendations and illustrations.

Figure 5. Definition of Terms for the System Suitability Parameters.



Where

- $W_x$  = width of the peak determined at either 5% (0.05) or 10% (0.10) from the baseline of the peak height
- $f$  = distance between peak maximum and peak front at  $W_x$
- $t_0$  = elution time of the void volume or non-retained components
- $t_R$  = retention time of the analyte
- $t_w$  = peak width measured at baseline of the extrapolated straight sides to baseline

$t_R$  = retention time of the analyte  
 $t_W$  = peak width measured at baseline of the extrapolated straight sides to baseline

1. Capacity factor ( $k'$ )

$$k' = (t_R - t_0) / t_0$$

The capacity factor is a measure of where the peak of interest is located with respect to the void volume, i.e., elution time of the non-retained components.

**Recommendations:**

The peak should be well-resolved from other peaks and the void volume. Generally the value of  $k'$  is  $> 2$ .

2. Precision/Injection repeatability (RSD)

Injection precision expressed as RSD (relative standard deviation) indicates the performance of the HPL chromatograph which includes the plumbing, column, and environmental conditions, at the time the samples are analyzed. It should be noted that sample preparation and manufacturing variations are not considered.

**Recommendations:**

RSD of  $\leq 1\%$  for  $n \geq 5$  is desirable.

3. Relative retention ( $\alpha$ )

$$\alpha = k'_1 / k'_2$$

Relative retention is a measure of the relative location of two peaks. This is not an essential parameter as long as the resolution ( $R_s$ ) is stated.

4. Resolution ( $R_s$ )

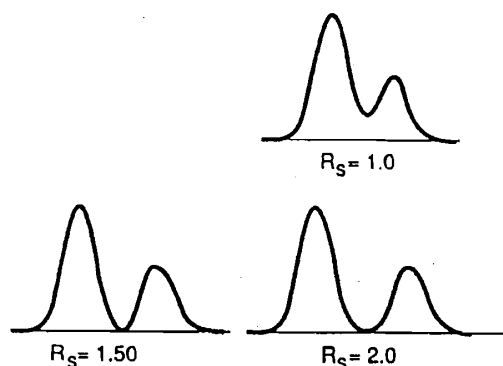
$$R_s = (t_{R2} - t_{R1}) / (1/2) (t_{W1} + t_{W2})$$

$R_s$  is a measure of how well two peaks are separated. For reliable quantitation, well-separated peaks are essential for quantitation. This is a very useful parameter if potential interference peak(s) may be of concern. The closest potential eluting peak to the



$R_s$  is minimally influenced by the ratio of the two compounds being measured. The resolution of peaks as indicated by the  $R_s$  values is shown in Figure 6.

Figure 6. Separation of Peaks as Indicated by  $R_s$  Values.



**Recommendations:**

$R_s$  of  $> 2$  between the peak of interest and the closest potential interfering peak (impurity, excipient, degradation product, internal standard, etc.) is desirable.

5. Tailing factor (T)

$$T = W_x / 2f$$

The accuracy of quantitation decreases with increase in peak tailing because of the difficulties encountered by the integrator in determining where/when the peak ends and hence the calculation of the area under the peak. Integrator variables are preset by the analyst for optimum calculation of the area for the

peak of interest. Figures 7 and 8 illustrate the tailing factors and the effect on quantitation. If the integrator is unable to determine exactly when an upslope or downslope occurs, accuracy drops.

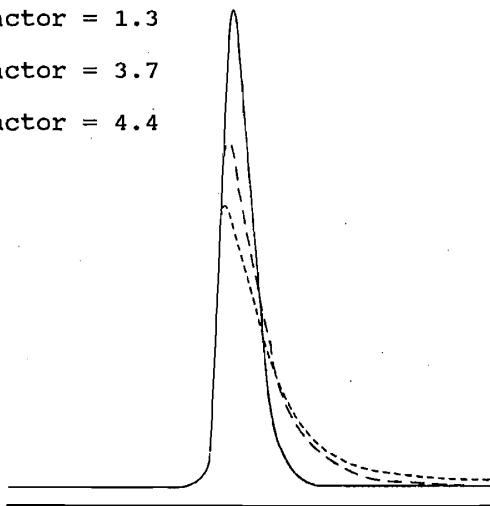
**Figure 7. HPLC Peak with Various Tailing Factors.**

---

Tailing factor = 1.3

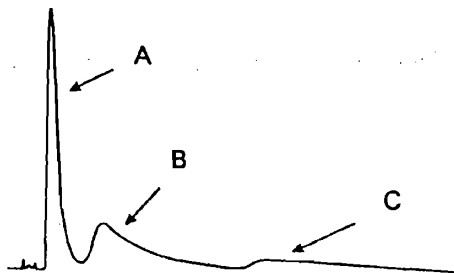
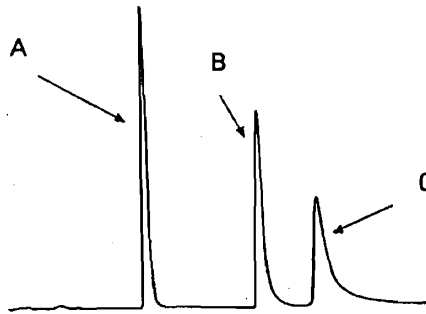
Tailing factor = 3.7

Tailing factor = 4.4



**Figure 8. Effect of Peak Tailing on Quantitation.**

---



---

**Recommendations:**

T of  $\leq 2$

6. Theoretical plate number (N)

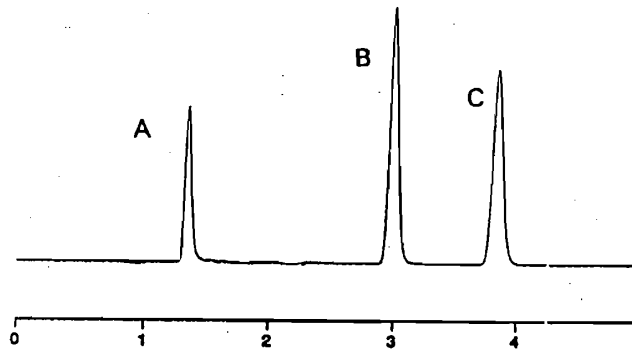
$$N = 16 (t_R / t_W)^2 = L / H$$

Theoretical plate number is a measure of column efficiency, that is, how many peaks can be located per unit run-time of the chromatogram.

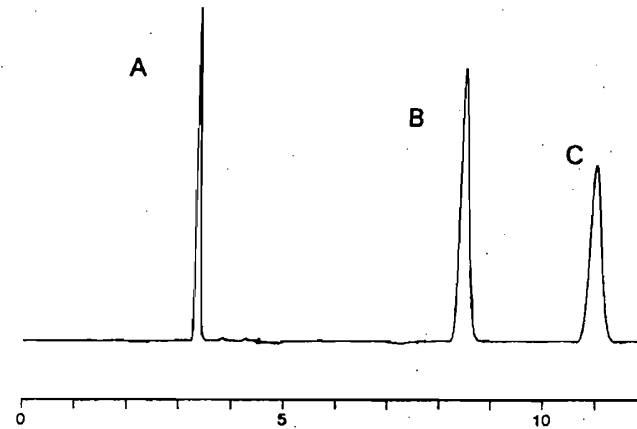
N is fairly constant for each peak on a chromatogram with a fixed set of operating conditions. H, or HETP, the height equivalent of a theoretical plate, measures the column efficiency per unit length (L) of the column. Parameters which can affect N or H include peak position, particle size in column, flow-rate of mobile phase, column temperature, viscosity of mobile phase, and molecular weight of the analyte. Figure 9 shows one set of compounds A, B, and C under two different chromatographic conditions resulting in, e.g.,  $R_s$  for B to be 3 and 8.5 minutes, respectively. An examination of peak B indicates that the theoretical plate values are different even though the peaks appear similar visually.

Figure 9. Effect of Retention Times on Theoretical Plates.

	$R_t$	N	$k'$
A	1.35	2007	0.51
B	3.00	4702	2.35
C	3.85	5929	3.29



	$R_t$	N	$k'$
A	3.36	5076	0.60
B	8.46	7175	3.03
C	10.99	8742	4.23



### **Recommendations:**

The theoretical plate number depends on elution time but in general should be > 2000.

### **General Recommendation:**

System suitability testing is essential for the assurance of the quality performance of the chromatographic system. The amount of testing required will depend on the purpose of the test method. For dissolution or release profile test methods using an external standard method, k', T and RSD are minimum recommended system suitability tests. For acceptance, release, stability, or impurities/degradation methods using external or internal standards, k', T, R<sub>s</sub> and RSD are recommended as minimum system suitability testing parameters. In practice, each method submitted for validation should include an appropriate number of system suitability tests defining the necessary characteristics of that system. Additional tests may be selected at the discretion of the applicant or the reviewer.

### **K. General Points to Consider**

Some basic points to note in the test method are:

1. The sample and standard should be dissolved in the mobile phase. If that is not possible, then avoid using too high a level of the organic solvent as compared to the level in the mobile phase.
2. The sample and standard concentrations should be close if not the same.
3. The samples should be bracketed by standards during the analytical procedure.
4. Filtration of the samples before injection is occasionally observed. Filtration will remove particulates (centrifugation performs the same function) that may clog columns. Adhesion of the analyte to the filter can also happen. This will be of importance especially for low level impurities. Data to validate this aspect should be submitted by the applicant.

## V. COMMENTS AND CONCLUSIONS

### HPL Chromatographic Methods for Drug Substance and Drug Product.

Methods should not be validated as a one-time situation, but methods should be validated and designed by the developer or user to ensure ruggedness or robustness throughout the life of the method.

The variations due to the drug product manufacturing process, the laboratory sample preparation procedure and the instrument performance contribute to the accuracy of the data obtained from the analysis. With proper validation and tight chromatographic performance (system suitability) criteria, an improvement in the reliability of the data can be obtained. Variations, except from the drug product manufacturing process, will be minimized. Only with good reliable validated methods, can data that are generated for release, stability, pharmacokinetics be trust-worthy.

## VI. ACKNOWLEDGEMENTS

Comments from Drs. Hoiberg, Poochikian, Blumenstein, Schroeder, Look, Tolgyesi (HFD-150); Dr. Layoff (HFH-300); Drs. Zimmerman and Piechocki (HFD-110); and the Analytical Methods Technical Committee: Dr. Sheinin, Mr. Shostak, Ms. Cunningham, Ms. Jongedyk, Mr. Leutzinger, Dr. Seggel, Ms. Sharkey and Mr. Smela are appreciated.

## VII. REFERENCES

1. Guideline for Submitting Samples and Analytical Data for Methods Validation, February 1987.
2. United States Pharmacopeia, XXII, 1990. <1225>.
3. Text on Validation of Analytical Procedures, International Conference on Harmonization, September 1993.

Submitted by:

---

Linda L. Ng, Ph.D.

Approved by CMC CC:

---

Charles Kumkumian, Ph.D.

---

Roger L. Williams, M.D.



PO Box 13341  
Research Triangle Park, NC  
27709  
Corporate (919)481-4855  
Facsimile (919)481-4908  
www.magellanlabs.com



*Certificate of Analysis*

September 2, 1999

Characterization of the Drug Substance UT-15		
TP No.: TP-LRR-0008 Phase: Phase 13	Company: United Therapeutics, Corporation Research and Development	Product: UT-15 Drug Substance
A 2-page testing summary is included for lot UT15-99H001.		

All data generated at Magellan Laboratories and described within this report were collected under the direction of the Study Director and were audited by the Quality Assurance Unit of Magellan Laboratories Incorporated for compliance with Good Laboratory Practices (21 CFR Part 58) and Good Manufacturing Practices (21 CFR Part 211). This report accurately reflects the raw data which have been stored in the Archives of Magellan Laboratories Incorporated.

Linda Carlisle                      9-3-99  
Quality Assurance                      Date

William E. Weiser, Ph.D.                      9/2/99  
Study Director                      Date

HIGHLY CONFIDENTIAL

P. 1

UT Ex. 2036  
SteadyMed v. United Therapeutics  
IPR2016-00006

Page 1 of 3 Page(s)

UTC-Sand-Rem01086357

IPR2020-00769  
United Therapeutics EX2006  
Page 4749 of 7113

PO Box 13341  
 Research Triangle Park, NC  
 27709  
 Corporate (919) 481-4855  
 Facsimile (919) 481-4908  
 www.magellanlabs.com



**Certificate of Analysis**  
**[[*(1R,2R,3aS,9aS)*-2,3,3a,4,9,9a-hexahydro-2-hydroxy-1-[[*(3S)*-3-hydroxyoctyl]-1*H*-benz[*f*]inden-5-yl]oxy]acetic acid**  
**Lot UT15-99H001**

<u>Test</u>	<u>Specifications</u>	<u>Results</u>
Physical Examination	A white to cream-colored powder	White powder
Identification		
IR	The infrared spectrum exhibits maxima which are only at the same wavenumbers as, and have similar relative intensities to, those in the reference standard spectrum of UT-15, similarly obtained.	Conforms
HPLC	The retention time for the principle peak in the sample chromatogram agrees with the retention time of the principle peak in the standard chromatogram, using the chromatographic purity method.	Conforms
Residue on Ignition	Not more than 0.3%, w/w	0.02%
Water (Karl Fischer)	Not more than 2.0%, w/w	0.8%, w/w
Residual Solvents by Gas Chromatography		
Ethyl Acetate	Not more than 1.0%, w/w	ND <sup>1</sup>
Ethanol	Not more than 0.5%, w/w	<0.1%
Acetic Acid	Not more than 1.0%, w/w	<0.1%
Total	Not more than 2.5%, w/w	<0.1%
Total Volatiles	Not more than 4.0%, w/w	0.8%, w/w
Melting Range	Not less than 118 °C and not more than 126 °C	122.2 - 125.1 °C
Specific Rotation	Not less than +31.0° and not more than +35.0° at 589 nm and 25°, volatiles-free basis	$[\alpha]_{589}^{25} = +32.4^\circ$ (volatiles-free basis)
Heavy Metals	Not more than 0.002%	Not more than 0.002%

<sup>1</sup>ND = Not Detected

PO Box 13341  
 Research Triangle Park, NC  
 27709  
 Corporate (919) 481-4855  
 Facsimile (919) 481-4908  
 www.magellanlabs.com



**Certificate of Analysis**  
**[[[(1R,2R,3aS,9aS)-2,3,3a,4,9,9a-hexahydro-2-hydroxy-1-[(3S)-3-hydroxyoctyl]-1H-benz[f]inden-5-yl]oxy]acetic acid**  
**Lot UT15-99H001**

<u>Test</u>	<u>Specifications</u>	<u>Results</u>
Chromatographic Purity (HPLC)		
1AU90	Not more than 0.5%	0.05%
2AU90	Not more than 1.0%	<0.05%
97W86 (Benzindene Triol)	Not more than 1.0%	ND <sup>1</sup>
3AU90	Not more than 2.0%	ND
UT-15 Methyl Ester	Not more than 1.0%	0.06%
98W86	Not more than 1.0%	<0.05%
UT-15 Ethyl Ester	Not more than 1.0%	0.1%
750W93	Not more than 2.0%	0.5%
751W93	Not more than 2.0%	0.3%
Total Unidentified Impurities	Not more than 2.0%	ND
Total Related Substances	Not more than 5.0%	1.0%
Assay (HPLC)	Not less than 94.0 and not more than 101.0%, w/w, on the volatiles-free basis	98.4%
Factor	Factor the material on the basis of assay and total volatiles content	1.024 parts UT-15 equivalent to 1.00 parts volatiles-free UT-15

<sup>1</sup>ND = Not Detected



**CardinalHealth**

**Certificate of Analysis**

February 17, 2004

Release Analysis of UT-15 Drug Substance		
<b>TTP:</b> TTP-LRR-M0239	<b>Company:</b> United Therapeutics Corporation 2225 W. Harrison Street Chicago, IL 60612 (312) 421-1819	<b>Product:</b> Treprostinil Drug Substance*
<b>Lot No:</b> UT15-031202		
<b>Date of Manufacture:</b> 12-23-03	<b>Storage/Packaging:</b> 5 °C/Ambient Amber HDPE bottle with NCR screw cap	<b>Phase:</b> Release Testing
<b>Retest Date:</b> 12-2005		
<b>Date Received:</b> 01-08-04		<b>Method:</b> ATM-LRR-M0002.18
<b>Date Testing Completed:</b> 01-25-04		
TEST/REFERENCE	SPECIFICATIONS	RESULTS <sup>1</sup>
Physical Examination NB 2, PDR 1	A white to cream-colored powder	White powder
Identification by IR NB 2, PDR 15	The infrared spectrum exhibits maxima which are only at the same wavenumbers as, and have similar relative intensities to, those in the reference standard spectrum of Treprostinil, similarly obtained.	Conforms
Identification by HPLC NB 1, PDR 8	The retention time for the principal peak in the sample chromatogram agrees with the retention time of the principal peak in the standard chromatogram, using the chromatographic purity method.	Conforms
Residue on Ignition NB 3, PDR 4	Not more than 0.2%, w/w	0.0%
Water (Karl Fischer) NB 2, PDR 8	Not more than 2.0%, w/w	0.1%
Residual Solvents by Gas Chromatography TTP-LRR-M0242, Sample Analysis NB 3, LDR 21	Ethyl Acetate Not more than 0.5%, w/w Ethanol Not more than 0.5%, w/w Acetic Acid Not more than 0.5%, w/w	Ethyl Acetate <0.1% Ethanol <0.1% Acetic Acid ND
Melting Range NB 2, PDR 11	Not less than 120.0 °C and not more than 126.0 °C	122.1 °C - 123.9 °C
Specific Rotation NB 2, PDR 12	Not less than +42.0° and not more than +49.0° at 589 nm and 25 °C, volatiles-free basis	+ 47.3 °
Heavy Metals NB 3, PDR 8	Not more than 0.002%	Not more than 0.002%
Microbial Limits Total Aerobic Count Total Yeast and Mold Count <i>Escherichia coli</i> <i>Salmonella</i> species <i>Pseudomonas aeruginosa</i> <i>Staphylococcus aureus</i> ATM-LRR-M0007.00 NB 6, PDR 6	NMT 10 CFU/g NMT 10 CFU/g Absent Absent Absent Absent	<2 CFU/g <2 CFU/g Absent Absent Absent Absent



**CardinalHealth**

**Certificate of Analysis**

February 17, 2004

Release Analysis of UT-15 Drug Substance		
<b>TTP:</b> TTP-LRR-M0239	<b>Company:</b> United Therapeutics Corporation 2225 W. Harrison Street Chicago, IL 60612 (312) 421-1819	<b>Product:</b> Treprostinil Drug Substance*
<b>Lot No:</b> UT15-031202		
<b>Date of Manufacture:</b> 12-23-03	<b>Storage/Packaging:</b> 5 °C/Ambient Amber HDPE bottle with NCR screw cap	<b>Phase:</b> Release Testing
<b>Retest Date:</b> 12-2005		<b>Method:</b> ATM-LRR-M0002.18
<b>Date Received:</b> 01-08-04		
<b>Date Testing Completed:</b> 01-25-04		
TEST/REFERENCE	SPECIFICATIONS	RESULTS <sup>1</sup>
Chromatographic Purity (HPLC) NB 1, LDR 68 - 72		
1AU90	Not more than 0.5%	ND
2AU90	Not more than 0.5%	ND
97W86 (Benzindene Triol)	Not more than 0.2%	ND
3AU90	Not more than 1.0%	0.2%
Treprostinil Methyl Ester	Not more than 0.2%	<0.05%
Treprostinil Ethyl Ester	Not more than 0.6%	0.2%
750W93	Not more than 1.5%	0.07%
751W93	Not more than 1.3%	<0.05%
Unidentified	Not more than 0.1% AUC each	ND
Total Related Substances NB 1, LDR 72	Not more than 3.0%	0.5%
Assay (HPLC) NB 1, LDR 67	Not less than 97.0 and not more than 101.0%, w/w, on the volatiles-free basis	99.7%
Factor NB 1, PDR 9	Factor the material on the basis of assay and total volatiles content	1.005
Endotoxins (1:2000 dilution) ATM-LRR-M0012.00 NB 5, PDR 5	Less than 104 EU/mg	< 60 EU/mg

NMT = Not more than

\*[[[(1R,2R,3aS,9aS)-2,3,3a,4,9,9a-hexahydro-2-hydroxy-1-[(3S)-3-hydroxyoctyl]-1H-benz[flinden-5-yl]oxy]acetic acid

<sup>1</sup>All results conform to specifications.

ND = None detected

All data generated at Cardinal Health and described within this report were collected under the direction of the Study Director and were reviewed for compliance with Good Manufacturing Practices (21 CFR Parts 210 and 211). This report accurately reflects the raw data which have been stored in the Archives of Cardinal Health.

Quality Assurance Date 17 Feb 2004

Wei Pan, Ph.D. Date 2/17/04  
Study Director



**CardinalHealth**

**Certificate of Analysis**

February 17, 2004

Release Analysis of UT-15 Drug Substance		
TTP: TTP-LRR-M0239	Company: United Therapeutics Corporation 2225 W. Harrison Street Chicago, IL 60612 (312) 421-1819	Product: Treprostinil Drug Substance*
Lot No: UT15-031201		
Date of Manufacture: 12-11-03	Storage/Packaging: 5 °C/Ambient Amber HDPE bottle with NCR screw cap	Phase: Release Testing
Retest Date: 12-2005		Method: ATM-LRR-M0002.18
Date Received: 01-08-04		
Date Testing Completed: 01-25-04		
TEST/REFERENCE	SPECIFICATIONS	RESULTS <sup>1</sup>
Physical Examination NB 2, PDR 1	A white to cream-colored powder	White powder
Identification by IR NB 2, PDR 15	The infrared spectrum exhibits maxima which are only at the same wavenumbers as, and have similar relative intensities to, those in the reference standard spectrum of Treprostinil, similarly obtained.	Conforms
Identification by HPLC NB 1, PDR 8	The retention time for the principal peak in the sample chromatogram agrees with the retention time of the principal peak in the standard chromatogram, using the chromatographic purity method.	Conforms
Residue on Ignition NB 3, PDR 4	Not more than 0.2%, w/w	0.0%
Water (Karl Fischer) NB 2, PDR 8	Not more than 2.0%, w/w	0.1%
Residual Solvents by Gas Chromatography TTP-LRR-M0242, Sample Analysis NB 3, LDR 20	Ethyl Acetate Not more than 0.5%, w/w Ethanol Not more than 0.5%, w/w Acetic Acid Not more than 0.5%, w/w	Ethyl Acetate <0.1% Ethanol <0.1% Acetic Acid ND
Melting Range NB 2, PDR 11	Not less than 120.0 °C and not more than 126.0 °C	122.5 °C - 123.9 °C
Specific Rotation NB 2, PDR 12	Not less than +42.0° and not more than +49.0° at 589 nm and 25 °C, volatiles-free basis	+ 47.3 °
Heavy Metals NB 3, PDR 8	Not more than 0.002%	Not more than 0.002%
Microbial Limits Total Aerobic Count Total Yeast and Mold Count <i>Escherichia coli</i> <i>Salmonella</i> species <i>Pseudomonas aeruginosa</i> <i>Staphylococcus aureus</i> ATM-LRR-M0007.00 NB 6, PDR 6	NMT 10 CFU/g NMT 10 CFU/g Absent Absent Absent Absent	<2 CFU/g <2 CFU/g Absent Absent Absent Absent



**CardinalHealth**

**Certificate of Analysis**

February 17, 2004

Release Analysis of UT-15 Drug Substance		
TTP: TTP-LRR-M0239	Company: United Therapeutics Corporation 2225 W. Harrison Street Chicago, IL 60612 (312) 421-1819	Product: Treprostinil Drug Substance*
Lot No: UT15-031201		
Date of Manufacture: 12-11-03	Storage/Packaging: 5 °C/Ambient Amber HDPE bottle with NCR screw cap	Phase: Release Testing
Retest Date: 12-2005		Method: ATM-LRR-M0002.18
Date Received: 01-08-04		
Date Testing Completed: 01-25-04		
TEST/REFERENCE	SPECIFICATIONS	RESULTS <sup>1</sup>
Chromatographic Purity (HPLC) NB 1, LDR 62 - 66		
1AU90	Not more than 0.5%	ND
2AU90	Not more than 0.5%	ND
97W86 (Benzindene Triol)	Not more than 0.2%	ND
3AU90	Not more than 1.0%	0.2%
Treprostinil Methyl Ester	Not more than 0.2%	<0.05%
Treprostinil Ethyl Ester	Not more than 0.6%	0.1%
750W93	Not more than 1.5%	0.09%
751W93	Not more than 1.3%	<0.05%
Unidentified	Not more than 0.1% AUC each	ND
Total Related Substances NB 1, LDR 66	Not more than 3.0%	0.4%
Assay (HPLC) NB 1, LDR 61	Not less than 97.0 and not more than 101.0%, w/w, on the volatiles-free basis	100.5%
Factor NB 1, PDR 9	Factor the material on the basis of assay and total volatiles content	0.9956
Endotoxins (1:2000 dilution) ATM-LRR-M0012.00 NB 5, PDR 5	Less than 104 EU/mg	< 60 EU/mg

NMT = Not more than

\*[[[(1R,2R,3aS,9aS)-2,3,3a,4,9,9a-hexahydro-2-hydroxy-1-[(3S)-3-hydroxyoctyl]-1H-benz[*f*]inden-5-yl]oxy]acetic acid

<sup>1</sup>All results conform to specifications.

ND = None detected

All data generated at Cardinal Health and described within this report were collected under the direction of the Study Director and were reviewed for compliance with Good Manufacturing Practices (21 CFR Parts 210 and 211). This report accurately reflects the raw data which have been stored in the Archives of Cardinal Health.

Quality Assurance      17 February  
Date

Wei Pan, Ph.D.  
Study Director      2/17/04  
Date



**CardinalHealth**

**Certificate of Analysis**

February 17, 2004

Release Analysis of UT-15 Drug Substance			
<b>TTP:</b> TTP-LRR-M0239	<b>Company:</b> United Therapeutics Corporation 2225 W. Harrison Street Chicago, IL 60612 (312) 421-1819	<b>Product:</b> Treprostinil Drug Substance*	
<b>Lot No:</b> UT15-031102			
<b>Date of Manufacture:</b> 12-02-03	<b>Storage/Packaging:</b> 5 °C/Ambient Amber HDPE bottle with NCR screw cap	<b>Phase:</b> Release Testing	
<b>Retest Date:</b> 12-2005		<b>Method:</b> ATM-LRR-M0002.18	
<b>Date Received:</b> 01-08-04			
<b>Date Testing Completed:</b> 02-05-04			
TEST/REFERENCE	SPECIFICATIONS	RESULTS <sup>3</sup>	
Physical Examination NB 2, PDR 1	A white to cream-colored powder	White powder	
Identification by IR NB 2, PDR 15	The infrared spectrum exhibits maxima which are only at the same wavenumbers as, and have similar relative intensities to, those in the reference standard spectrum of Treprostinil, similarly obtained.	Conforms	
Identification by HPLC NB 1, PDR 8	The retention time for the principal peak in the sample chromatogram agrees with the retention time of the principal peak in the standard chromatogram, using the chromatographic purity method.	Conforms	
Residue on Ignition NB 3, PDR 4	Not more than 0.2%, w/w	0.0%	
Water (Karl Fischer) NB 2, PDR 8	Not more than 2.0%, w/w	0.1%	
Residual Solvents by Gas Chromatography TTP-LRR-M0242, Sample Analysis NB 3, LDR 19	Ethyl Acetate Not more than 0.5%, w/w Ethanol Not more than 0.5%, w/w Acetic Acid Not more than 0.5%, w/w	Ethyl Acetate <0.1% Ethanol 0.1% Acetic Acid ND	
Melting Range NB 2, PDR 11	Not less than 120.0 °C and not more than 126.0 °C	121.8 °C - 124.0 °C	
Specific Rotation NB 2, PDR 12	Not less than +42.0° and not more than +49.0° at 589 nm and 25 °C, volatiles-free basis	+ 47.2 °	
Heavy Metals NB 3, PDR 8	Not more than 0.002%	Not more than 0.002%	
Microbial Limits Total Aerobic Count Total Yeast and Mold Count <i>Escherichia coli</i> <i>Salmonella</i> species <i>Pseudomonas aeruginosa</i> <i>Staphylococcus aureus</i> ATM-LRR-M0007.00 NB 6, PDR 6	NMT 10 CFU/g NMT 10 CFU/g Absent Absent Absent Absent	<2 CFU/g <2 CFU/g Absent Absent Absent	





**CardinalHealth**

**Certificate of Analysis**

February 17, 2004

Release Analysis of UT-15 Drug Substance			
<b>TTP:</b> TTP-LRR-M0239	<b>Company:</b> United Therapeutics Corporation 2225 W. Harrison Street Chicago, IL 60612 (312) 421-1819	<b>Product:</b> Treprostinil Drug Substance*	
<b>Lot No:</b> UT15-031102			
<b>Date of Manufacture:</b> 12-02-03	<b>Storage/Packaging:</b> 5 °C/Ambient Amber HDPE bottle with NCR screw cap	<b>Phase:</b> Release Testing	
<b>Retest Date:</b> 12-2005		<b>Method:</b> ATM-LRR-M0002.18	
<b>Date Received:</b> 01-08-04			
<b>Date Testing Completed:</b> 02-05-04			
TEST/REFERENCE	SPECIFICATIONS	RESULTS <sup>3</sup>	
Chromatographic Purity (HPLC) <sup>1</sup> NB 1, LDR 113 - 117			
1AU90	Not more than 0.5%	ND	
2AU90	Not more than 0.5%	ND	
97W86 (Benzidine Triol)	Not more than 0.2%	<0.05%	
3AU90	Not more than 1.0%	0.1%	
Treprostinil Methyl Ester	Not more than 0.2%	<0.05%	
Treprostinil Ethyl Ester	Not more than 0.6%	0.1%	
750W93	Not more than 1.5%	0.1%	
751W93	Not more than 1.3%	0.06%	
Unidentified	Not more than 0.1% AUC each		
Unidentified @ RRT 1.12		0.06%	
Total Related Substances NB 1, LDR 117	Not more than 3.0%	0.4%	
Assay (HPLC) <sup>1</sup> NB 1, LDR 55, 112	Not less than 97.0 and not more than 101.0%, w/w, on the volatiles-free basis	Prep 1 101.6% <sup>2</sup> Prep 2 102.8% <sup>2</sup> Avg. 102.2% <sup>2</sup>  Prep 1 99.9% Prep 2 100.6% Prep 3 100.2% Prep 4 100.5% Prep 5 100.4% Prep 6 99.9% Avg. 100.3%	
Factor <sup>1</sup> NB 1, PDR 18	Factor the material on the basis of assay and total volatiles content	0.9988	

<sup>1</sup> The assay, impurity, and factor results are the average of six sample preparations.

<sup>2</sup> The results were out of specification. After confirming the results by reanalysis, these results were investigated by preparing an additional three samples per preparation. Upon investigation, the cause was a suspected but unconfirmed preparation error. These results are not included in the calculation of the average result.



**CardinalHealth**

**Certificate of Analysis**

February 17, 2004

Release Analysis of UT-15 Drug Substance			
<b>TTP:</b> TTP-LRR-M0239	<b>Company:</b> United Therapeutics Corporation 2225 W. Harrison Street Chicago, IL 60612 (312) 421-1819	<b>Product:</b> Treprostinil Drug Substance*	
<b>Lot No:</b> UT15-031102			
<b>Date of Manufacture:</b> 12-02-03	<b>Storage/Packaging:</b> 5 °C/Ambient Amber HDPE bottle with NCR screw cap	<b>Phase:</b> Release Testing	
<b>Retest Date:</b> 12-2005		<b>Method:</b> ATM-LRR-M0002.18	
<b>Date Received:</b> 01-08-04			
<b>Date Testing Completed:</b> 02-05-04			
<b>TEST/REFERENCE</b>	<b>SPECIFICATIONS</b>	<b>RESULTS<sup>3</sup></b>	
Endotoxins (1:2000 dilution) ATM-LRR-M0012.00 NB 5, PDR 5	Less than 104 EU/mg	< 60 EU/mg	

NMT = Not more than

\*[[[(1R,2R,3aS,9aS)-2,3,3a,4,9,9a-hexahydro-2-hydroxy-1-[(3S)-3-hydroxyoctyl]-1H-benz[f]inden-5-yl]oxy]acetic acid

<sup>3</sup>All results, except assay, conform to specifications.

ND = None detected

All data generated at Cardinal Health and described within this report were collected under the direction of the Study Director and were reviewed for compliance with Good Manufacturing Practices (21 CFR Parts 210 and 211). This report accurately reflects the raw data which have been stored in the Archives of Cardinal Health.

  
Quality Assurance Date 17 Feb 2004

  
Wei Pan, Ph.D. Date 2/17/04  
Study Director



**CardinalHealth**

**Certificate of Analysis**

February 17, 2004

Release Analysis of UT-15 Drug Substance			
<b>TTP:</b> TTP-LRR-M0239	<b>Company:</b> United Therapeutics Corporation 2225 W. Harrison Street Chicago, IL 60612 (312) 421-1819	<b>Product:</b> Treprostinil Drug Substance*	
<b>Lot No:</b> UT15-031101			
<b>Date of Manufacture:</b> 11-18-03	<b>Storage/Packaging:</b> 5 °C/Ambient Amber HDPE bottle with NCR screw cap	<b>Phase:</b> Release Testing	
<b>Retest Date:</b> 11-2005		<b>Method:</b> ATM-LRR-M0002.18	
<b>Date Received:</b> 01-08-04			
<b>Date Testing Completed:</b> 01-25-04			
TEST/REFERENCE	SPECIFICATIONS	RESULTS <sup>1</sup>	
Physical Examination NB 2, PDR 1	A white to cream-colored powder	White powder	
Identification by IR NB 2, PDR 15	The infrared spectrum exhibits maxima which are only at the same wavenumbers as, and have similar relative intensities to, those in the reference standard spectrum of Treprostinil, similarly obtained.	Conforms	
Identification by HPLC NB 1, PDR 8	The retention time for the principal peak in the sample chromatogram agrees with the retention time of the principal peak in the standard chromatogram, using the chromatographic purity method.	Conforms	
Residue on Ignition NB 3, PDR 4	Not more than 0.2%, w/w	0.0%	
Water (Karl Fischer) NB 2, PDR 8	Not more than 2.0%, w/w	0.1%	
Residual Solvents by Gas Chromatography TTP-LRR-M0242, Sample Analysis NB 3, LDR 18	Ethyl Acetate Not more than 0.5%, w/w Ethanol Not more than 0.5%, w/w Acetic Acid Not more than 0.5%, w/w	Ethyl Acetate <0.1% Ethanol <0.1% Acetic Acid ND	
Melting Range NB 2, PDR 11	Not less than 120.0 °C and not more than 126.0 °C	122.6 °C - 124.2 °C	
Specific Rotation NB 2, PDR 12	Not less than +42.0° and not more than +49.0° at 589 nm and 25 °C, volatiles-free basis	+ 47.4 °	
Heavy Metals NB 3, PDR 8	Not more than 0.002%	Not more than 0.002%	
Microbial Limits Total Aerobic Count Total Yeast and Mold Count <i>Escherichia coli</i> <i>Salmonella</i> species <i>Pseudomonas aeruginosa</i> <i>Staphylococcus aureus</i> ATM-LRR-M0007.00 NB 6, PDR 6	NMT 10 CFU/g NMT 10 CFU/g Absent Absent Absent Absent	<2 CFU/g <2 CFU/g Absent Absent Absent Absent	



**CardinalHealth**

**Certificate of Analysis**

February 17, 2004

Release Analysis of UT-15 Drug Substance			
<b>TTP:</b> TTP-LRR-M0239	<b>Company:</b> United Therapeutics Corporation 2225 W. Harrison Street Chicago, IL 60612 (312) 421-1819	<b>Product:</b> Treprostinil Drug Substance*	
<b>Lot No:</b> UT15-031101			
<b>Date of Manufacture:</b> 11-18-03	<b>Storage/Packaging:</b> 5 °C/Ambient Amber HDPE bottle with NCR screw cap	<b>Phase:</b> Release Testing	
<b>Retest Date:</b> 11-2005		<b>Method:</b> ATM-LRR-M0002.18	
<b>Date Received:</b> 01-08-04			
<b>Date Testing Completed:</b> 01-25-04			
TEST/REFERENCE	SPECIFICATIONS	RESULTS <sup>1</sup>	
Chromatographic Purity (HPLC) NB 1, LDR 50 - 54 1AU90 2AU90 97W86 (Benzindene Triol) 3AU90 Treprostinil Methyl Ester Treprostinil Ethyl Ester 750W93 751W93 Unidentified Unidentified @ RRT 1.12	Not more than 0.5% Not more than 0.5% Not more than 0.2% Not more than 1.0% Not more than 0.2% Not more than 0.6% Not more than 1.5% Not more than 1.3% Not more than 0.1% AUC each	ND ND ND 0.2% ND 0.2% <0.05% <0.05% 0.06%	
Total Related Substances NB 1, LDR 54	Not more than 3.0%	0.5%	
Assay (HPLC) NB 1, LDR 49	Not less than 97.0 and not more than 101.0%, w/w, on the volatiles-free basis	100.0%	
Factor NB 1, PDR 9	Factor the material on the basis of assay and total volatiles content	1.001	
Endotoxins (1:2000 dilution) ATM-LRR-M0012.00 NB 5, PDR 5	Less than 104 EU/mg	< 60 EU/mg	

NMT = Not more than

\*[[[(1R,2R,3aS,9aS)-2,3,3a,4,9,9a-hexahydro-2-hydroxy-1-[(3S)-3-hydroxyoctyl]-1H-benz[f]inden-5-yl]oxy]acetic acid

<sup>1</sup>All results conform to specifications.

ND = None detected

All data generated at Cardinal Health and described within this report were collected under the direction of the Study Director and were reviewed for compliance with Good Manufacturing Practices (21 CFR Parts 210 and 211). This report accurately reflects the raw data which have been stored in the Archives of Cardinal Health.

Quality Assurance      Date  
17 Feb 2004

Wei Pan, Ph.D.  
Study Director      Date  
2/17/04



**CardinalHealth**

**Certificate of Analysis**

February 17, 2004

Release Analysis of UT-15 Drug Substance			
<b>TTP:</b> TTP-LRR-M0239	<b>Company:</b> United Therapeutics Corporation 2225 W. Harrison Street Chicago, IL 60612 (312) 421-1819	<b>Product:</b> Treprostinil Drug Substance*	
<b>Lot No:</b> UT15-031003			
<b>Date of Manufacture:</b> 11-07-03	<b>Storage/Packaging:</b> 5 °C/Ambient Amber HDPE bottle with NCR screw cap	<b>Phase:</b> Release Testing	
<b>Re-test Date:</b> 11-2005		<b>Method:</b> ATM-LRR-M0002.18	
<b>Date Received:</b> 01-08-04			
<b>Date Testing Completed:</b> 01-25-04			
TEST/REFERENCE	SPECIFICATIONS	RESULTS <sup>1</sup>	
Physical Examination NB 2, PDR 1	A white to cream-colored powder	White powder	
Identification by IR NB 2, PDR 15	The infrared spectrum exhibits maxima which are only at the same wavenumbers as, and have similar relative intensities to, those in the reference standard spectrum of Treprostinil, similarly obtained.	Conforms	
Identification by HPLC NB 1, PDR 8	The retention time for the principal peak in the sample chromatogram agrees with the retention time of the principal peak in the standard chromatogram, using the chromatographic purity method.	Conforms	
Residue on Ignition NB 3, PDR 4	Not more than 0.2%, w/w	0.0%	
Water (Karl Fischer) NB 2, PDR 8	Not more than 2.0%, w/w	0.1%	
Residual Solvents by Gas Chromatography TTP-LRR-M0242, Sample Analysis NB 3, LDR 17	Ethyl Acetate Not more than 0.5%, w/w Ethanol Not more than 0.5%, w/w Acetic Acid Not more than 0.5%, w/w	Ethyl Acetate <0.1% Ethanol 0.1% Acetic Acid ND	
Melting Range NB 2, PDR 11	Not less than 120.0 °C and not more than 126.0 °C	121.3 °C - 123.6 °C	
Specific Rotation NB 2, PDR 12	Not less than +42.0° and not more than +49.0° at 589 nm and 25 °C, volatiles-free basis	+ 47.7 °	
Heavy Metals NB 3, PDR 8	Not more than 0.002%	Not more than 0.002%	
Microbial Limits Total Aerobic Count Total Yeast and Mold Count <i>Escherichia coli</i> <i>Salmonella</i> species <i>Pseudomonas aeruginosa</i> <i>Staphylococcus aureus</i> ATM-LRR-M0007.00 NB 6, PDR 6	NMT 10 CFU/g NMT 10 CFU/g Absent Absent Absent Absent	<2 CFU/g <2 CFU/g Absent Absent Absent Absent	



**CardinalHealth**

**Certificate of Analysis**

February 17, 2004

Release Analysis of UT-15 Drug Substance		
TTP: TTP-LRR-M0239	Company: United Therapeutics Corporation 2225 W. Harrison Street Chicago, IL 60612 (312) 421-1819	Product: Treprostinil Drug Substance*
Lot No: UT15-031003		
Date of Manufacture: 11-07-03	Storage/Packaging: 5 °C/Ambient Amber HDPE bottle with NCR screw cap	Phase: Release Testing
Retest Date: 11-2005		Method: ATM-LRR-M0002.18
Date Received: 01-08-04		
Date Testing Completed: 01-25-04		
TEST/REFERENCE	SPECIFICATIONS	RESULTS <sup>1</sup>
Chromatographic Purity (HPLC) NB 1, LDR 44 - 48		
1AU90	Not more than 0.5%	ND
2AU90	Not more than 0.5%	ND
97W86 (Benzidine Triol)	Not more than 0.2%	<0.05%
3AU90	Not more than 1.0%	0.2%
Treprostinil Methyl Ester	Not more than 0.2%	<0.05%
Treprostinil Ethyl Ester	Not more than 0.6%	0.2%
750W93	Not more than 1.5%	0.1%
751W93	Not more than 1.3%	0.06%
Unidentified	Not more than 0.1% AUC each	
Unidentified @ RRT 1.12		0.07%
Total Related Substances NB 1, LDR 48	Not more than 3.0%	0.6%
Assay (HPLC) NB 1, LDR 43	Not less than 97.0 and not more than 101.0%, w/w, on the volatiles-free basis	100.4%
Factor NB 1, PDR 9	Factor the material on the basis of assay and total volatiles content	0.9981
Endotoxins (1:2000 dilution) ATM-LRR-M0012.00 NB 5, PDR 5	Less than 104 EU/mg	< 60 EU/mg

NMT = Not more than

\*[[[(1R,2R,3aS,9aS)-2,3,3a,4,9,9a-hexahydro-2-hydroxy-1-[(3S)-3-hydroxyoctyl]-1H-benz[*f*]inden-5-yl]oxy]acetic acid

<sup>1</sup>All results conform to specifications.

ND = None detected

All data generated at Cardinal Health and described within this report were collected under the direction of the Study Director and were reviewed for compliance with Good Manufacturing Practices (21 CFR Parts 210 and 211). This report accurately reflects the raw data which have been stored in the Archives of Cardinal Health.

Quality Assurance      Date      17 Feb 2004

Wei Pan, Ph.D.  
Study Director      Date      2/17/04



**CardinalHealth**

**Certificate of Analysis**

February 17, 2004

Release Analysis of UT-15 Drug Substance			
TTP: TTP-LRR-M0239	Company: <b>United Therapeutics Corporation</b> 2225 W. Harrison Street Chicago, IL 60612 (312) 421-1819	Product:  Treprostinil Drug Substance*	
Lot No: UT15-031002			
Date of Manufacture: 10-28-03	Storage/Packaging:  5 °C/Ambient Amber HDPE bottle with NCR screw cap	Phase: Release Testing	
Retest Date: 10-2005		Method: ATM-LRR-M0002.18	
Date Received: 01-08-04			
Date Testing Completed: 01-25-04			
TEST/REFERENCE	SPECIFICATIONS	RESULTS <sup>1</sup>	
Physical Examination NB 2, PDR 1	A white to cream-colored powder	White powder	
Identification by IR NB 2, PDR 15	The infrared spectrum exhibits maxima which are only at the same wavenumbers as, and have similar relative intensities to, those in the reference standard spectrum of Treprostinil, similarly obtained.	Conforms	
Identification by HPLC NB 1, PDR 8	The retention time for the principal peak in the sample chromatogram agrees with the retention time of the principal peak in the standard chromatogram, using the chromatographic purity method.	Conforms	
Residue on Ignition NB 3, PDR 4	Not more than 0.2%, w/w	0.0%	
Water (Karl Fischer) NB 2, PDR 8	Not more than 2.0%, w/w	0.1%	
Residual Solvents by Gas Chromatography TTP-LRR-M0242, Sample Analysis NB 3, LDR 16	Ethyl Acetate Not more than 0.5%, w/w Ethanol Not more than 0.5%, w/w Acetic Acid Not more than 0.5%, w/w	Ethyl Acetate <0.1% Ethanol 0.1% Acetic Acid ND	
Melting Range NB 2, PDR 11	Not less than 120.0 °C and not more than 126.0 °C	121.5 °C - 123.3 °C	
Specific Rotation NB 2, PDR 12	Not less than +42.0° and not more than +49.0° at 589 nm and 25 °C, volatiles-free basis	+ 47.7 °	
Heavy Metals NB 3, PDR 8	Not more than 0.002%	Not more than 0.002%	
Microbial Limits Total Aerobic Count Total Yeast and Mold Count <i>Escherichia coli</i> <i>Salmonella</i> species <i>Pseudomonas aeruginosa</i> <i>Staphylococcus aureus</i> ATM-LRR-M0007.00 NB 6, PDR 6	NMT 10 CFU/g NMT 10 CFU/g Absent Absent Absent Absent	<2 CFU/g <2 CFU/g Absent Absent Absent Absent	



**CardinalHealth**

**Certificate of Analysis**

February 17, 2004

Release Analysis of UT-15 Drug Substance			
<b>TTP:</b> TTP-LRR-M0239	<b>Company:</b> United Therapeutics Corporation 2225 W. Harrison Street Chicago, IL 60612 (312) 421-1819	<b>Product:</b> Treprostinil Drug Substance*	
<b>Lot No:</b> UT15-031002			
<b>Date of Manufacture:</b> 10-28-03	<b>Storage/Packaging:</b> 5 °C/Ambient Amber HDPE bottle with NCR screw cap	<b>Phase:</b> Release Testing	
<b>Retest Date:</b> 10-2005		<b>Method:</b> ATM-LRR-M0002.18	
<b>Date Received:</b> 01-08-04			
<b>Date Testing Completed:</b> 01-25-04			
TEST/REFERENCE	SPECIFICATIONS	RESULTS <sup>1</sup>	
Chromatographic Purity (HPLC) NB 1, LDR 38 - 42			
1AU90	Not more than 0.5%	ND	
2AU90	Not more than 0.5%	ND	
97W86 (Benzindene Triol)	Not more than 0.2%	ND	
3AU90	Not more than 1.0%	0.2%	
Treprostinil Methyl Ester	Not more than 0.2%	ND	
Treprostinil Ethyl Ester	Not more than 0.6%	0.1%	
750W93	Not more than 1.5%	<0.05%	
751W93	Not more than 1.3%	<0.05%	
Unidentified	Not more than 0.1% AUC each		
Unidentified @ RRT 1.12		0.08%	
Total Related Substances NB 1, LDR 42	Not more than 3.0%	0.4%	
Assay (HPLC) NB 1, LDR 37	Not less than 97.0 and not more than 101.0%, w/w, on the volatiles-free basis	100.5%	
Factor NB 1, PDR 9	Factor the material on the basis of assay and total volatiles content	0.9970	
Endotoxins (1:2000 dilution) ATM-LRR-M0012.00 NB 5, PDR 5	Less than 104 EU/mg	< 60 EU/mg	

NMT = Not more than

\*[[[(1R,2R,3aS,9aS)-2,3,3a,4,9,9a-hexahydro-2-hydroxy-1-[(3S)-3-hydroxyoctyl]-1H-benz[*f*]inden-5-yl]oxy]acetic acid

<sup>1</sup>All results conform to specifications.

ND = None detected

All data generated at Cardinal Health and described within this report were collected under the direction of the Study Director and were reviewed for compliance with Good Manufacturing Practices (21 CFR Parts 210 and 211). This report accurately reflects the raw data which have been stored in the Archives of Cardinal Health.

Quality Assurance      17 Feb 2004  
Date

Wei Pan, Ph.D.  
Study Director      2/17/04  
Date





**CardinalHealth**

**Certificate of Analysis**

February 17, 2004

Release Analysis of UT-15 Drug Substance			
<b>TTP:</b> TTP-LRR-M0239	<b>Company:</b> United Therapeutics Corporation 2225 W. Harrison Street Chicago, IL 60612 (312) 421-1819	<b>Product:</b> Treprostinil Drug Substance*	
<b>Lot No:</b> UT15-031001			
<b>Date of Manufacture:</b> 10-16-03	<b>Storage/Packaging:</b> 5 °C/Ambient Amber HDPE bottle with NCR screw cap	<b>Phase:</b> Release Testing	
<b>Retest Date:</b> 10-2005		<b>Method:</b> ATM-LRR-M0002.18	
<b>Date Received:</b> 01-08-04			
<b>Date Testing Completed:</b> 01-25-04			
TEST/REFERENCE	SPECIFICATIONS	RESULTS <sup>1</sup>	
Physical Examination NB 2, PDR 1	A white to cream-colored powder	White powder	
Identification by IR NB 2, PDR 15	The infrared spectrum exhibits maxima which are only at the same wavenumbers as, and have similar relative intensities to, those in the reference standard spectrum of Treprostinil, similarly obtained.	Conforms	
Identification by HPLC NB 1, PDR 8	The retention time for the principal peak in the sample chromatogram agrees with the retention time of the principal peak in the standard chromatogram, using the chromatographic purity method.	Conforms	
Residue on Ignition NB 3, PDR 4	Not more than 0.2%, w/w	0.0%	
Water (Karl Fischer) NB 2, PDR 8	Not more than 2.0%, w/w	0.1%	
Residual Solvents by Gas Chromatography TTP-LRR-M0242, Sample Analysis NB 3, LDR 15	Ethyl Acetate Not more than 0.5%, w/w Ethanol Not more than 0.5%, w/w Acetic Acid Not more than 0.5%, w/w	Ethyl Acetate <0.1% Ethanol 0.1% Acetic Acid ND	
Melting Range NB 2, PDR 11	Not less than 120.0 °C and not more than 126.0 °C	121.9 °C - 123.3 °C	
Specific Rotation NB 2, PDR 12	Not less than +42.0° and not more than +49.0° at 589 nm and 25 °C, volatiles-free basis	+ 45.6 °	
Heavy Metals NB 3, PDR 8	Not more than 0.002%	Not more than 0.002%	
Microbial Limits Total Aerobic Count Total Yeast and Mold Count <i>Escherichia coli</i> <i>Salmonella</i> species <i>Pseudomonas aeruginosa</i> <i>Staphylococcus aureus</i> ATM-LRR-M0007.00 NB 6, PDR 6	NMT 10 CFU/g NMT 10 CFU/g Absent Absent Absent Absent	<2 CFU/g <2 CFU/g Absent Absent Absent Absent	



**CardinalHealth**

**Certificate of Analysis**

February 17, 2004

Release Analysis of UT-15 Drug Substance			
<b>TTP:</b> TTP-LRR-M0239	<b>Company:</b> United Therapeutics Corporation 2225 W. Harrison Street Chicago, IL 60612 (312) 421-1819	<b>Product:</b> Trepstinil Drug Substance*	
<b>Lot No:</b> UT15-031001			
<b>Date of Manufacture:</b> 10-16-03	<b>Storage/Packaging:</b> 5 °C/Ambient Amber HDPE bottle with NCR screw cap	<b>Phase:</b> Release Testing	
<b>Retest Date:</b> 10-2005		<b>Method:</b> ATM-LRR-M0002.18	
<b>Date Received:</b> 01-08-04			
<b>Date Testing Completed:</b> 01-25-04			
TEST/REFERENCE	SPECIFICATIONS	RESULTS <sup>1</sup>	
Chromatographic Purity (HPLC) NB 1, LDR 32 - 36			
1AU90	Not more than 0.5%	ND	
2AU90	Not more than 0.5%	ND	
97W86 (Benzidine Triol)	Not more than 0.2%	< 0.05%	
3AU90	Not more than 1.0%	0.2%	
Trepstinil Methyl Ester	Not more than 0.2%	< 0.05%	
Trepstinil Ethyl Ester	Not more than 0.6%	0.1%	
750W93	Not more than 1.5%	0.2%	
751W93	Not more than 1.3%	0.08%	
Unidentified	Not more than 0.1% AUC each		
Unidentified @ RRT 1.12		0.05%	
Total Related Substances NB 1, LDR 36	Not more than 3.0%	0.6%	
Assay (HPLC) NB 1, LDR 31	Not less than 97.0 and not more than 101.0%, w/w, on the volatiles-free basis	100.4%	
Factor NB 1, PDR 9	Factor the material on the basis of assay and total volatiles content	0.9975	
Endotoxins (1:2000 dilution) ATM-LRR-M0012.00 NB 5, PDR 5	Less than 104 EU/mg	< 60 EU/mg	

NMT = Not more than

\*[[[(1R,2R,3aS,9aS)-2,3,3a,4,9,9a-hexahydro-2-hydroxy-1-[(3S)-3-hydroxyoctyl]-1H-benz[*h*]inden-5-yl]oxy]acetic acid

<sup>1</sup>All results conform to specifications.

ND = None detected

All data generated at Cardinal Health and described within this report were collected under the direction of the Study Director and were reviewed for compliance with Good Manufacturing Practices (21 CFR Parts 210 and 211). This report accurately reflects the raw data which have been stored in the Archives of Cardinal Health.

Quality Assurance      17 Feb 2004  
Date

Wei Pan, Ph.D.  
Study Director      2/17/04  
Date



CardinalHealth

**Revised Certificate of Analysis**

Supersedes Certificate of Analysis Dated August 14, 2003  
November 5, 2003

Release Testing for Commercial Lots of Treprostinil Drug Substance			
TTP: TTP-LRR-M0117	Company: United Therapeutics Corporation 2225 W. Harrison Street Chicago, IL 60612 (312) 421-1819	Product:  Treprostinil Drug Substance*	
Lot No: UT15-030602			
Date of Manufacture: 06-24-03	Storage/Packaging: 5 °C/Ambient Amber Nalgene bottle with amber Nalgene screw cap	Phase: RT-Phase 14	
Retest Date: 06-24-05		Method: ATM-LRR-M0002.17	
Date Testing Started: 07-21-03			
Date Testing Completed: 08-06-03			
TEST	SPECIFICATIONS	RESULTS <sup>1</sup>	
Physical Examination	A white to cream-colored powder	White powder	
Identification by IR	The infrared spectrum exhibits maxima which are only at the same wavenumbers as, and have similar relative intensities to, those in the reference standard spectrum of Treprostinil, similarly obtained.	Conforms	
Identification by HPLC	The retention time for the principle peak in the sample chromatogram agrees with the retention time of the principle peak in the standard chromatogram, using the chromatographic purity method.	Conforms	
Residue on Ignition	Not more than 0.2%, w/w	0.0%	
Water (Karl Fischer)	Not more than 2.0%, w/w	0.3%	
Residual Solvents by Gas Chromatography	Ethyl Acetate Not more than 0.5%, w/w Ethanol Not more than 0.5%, w/w Acetic Acid Not more than 0.5%, w/w	Ethyl Acetate <0.1% Ethanol <0.1% Acetic Acid ND	
Melting Range	Not less than 120.0 °C and not more than 126.0 °C	121.8 °C - 123.1 °C	
Specific Rotation	Not less than +42.0° and not more than +49.0° at 589 nm and 25 °C, volatiles-free basis	+ 45.7 °	
Heavy Metals	Not more than 0.002%	Not more than 0.002%	
Microbial Limits Total Aerobic Count Total Yeast and Mold Count <i>Escherichia coli</i> <i>Salmonella</i> species <i>Pseudomonas aeruginosa</i> <i>Staphylococcus aureus</i> ATM-LRR-M0007.00	NMT 10 CFU/g NMT 10 CFU/g Absent Absent Absent Absent	0 CFU/g 0 CFU/g Absent Absent Absent Absent	



CardinalHealth

**Revised Certificate of Analysis**

Supersedes Certificate of Analysis Dated August 14, 2003  
November 5, 2003

Release Testing for Commercial Lots of Treprostinil Drug Substance		
<b>TTP:</b> TTP-LRR-M0117	<b>Company:</b> United Therapeutics Corporation 2225 W. Harrison Street Chicago, IL 60612 (312) 421-1819	<b>Product:</b> Treprostinil Drug Substance*
<b>Lot No:</b> UT15-030602		
<b>Date of Manufacture:</b> 06-24-03	<b>Storage/Packaging:</b> 5 °C/Ambient	<b>Phase:</b> RT-Phase 14
<b>Retest Date:</b> 06-24-05	<b>Amber Nalgene bottle with amber Nalgene screw cap</b>	<b>Method:</b> ATM-LRR-M0002.17
<b>Date Testing Started:</b> 07-21-03		
<b>Date Testing Completed:</b> 08-06-03		
TEST	SPECIFICATIONS	RESULTS <sup>1</sup>
Chromatographic Purity (HPLC)		
1AU90	Not more than 0.5%, w/w	<0.05%
2AU90	Not more than 0.5%, w/w	<0.05%
97W86 (Benzidine Triol)	Not more than 0.2%, w/w	<0.05%
3AU90	Not more than 1.0%, w/w	0.2%
Treprostinil Methyl Ester	Not more than 0.2%, w/w	<0.05%
Treprostinil Ethyl Ester	Not more than 0.6%, w/w	0.1%
750W93	Not more than 1.5%, w/w	0.06%
751W93	Not more than 1.3%, w/w	<0.05%
Unidentified	Not more than 0.1% AUC each	NR
Total Related Substances	Not more than 3.0%	0.4%
Assay (HPLC)	Not less than 97.0 and not more than 101.0%, w/w, on the volatiles-free basis	100.1%
Factor	Factor the material on the basis of assay and total volatiles content	1.002
Endotoxins (1:2000 dilution) ATM-LRR-M0012.00	Less than 104 EU/mg	< 60 EU/mg

<sup>1</sup>All results conform to specifications.

NMT = Not more than

\*[[[(1R,2R,3aS,9aS)-2,3,3a,4,9,9a-hexahydro-2-hydroxy-1-[(3S)-3-hydroxyoctyl]-1H-benz[f]inden-5-yl]oxy]acetic acid

ND = None detected

NR = Not reportable

Total Related Substances value was calculated using unrounded numbers.

Note: Report revised to recalculate Assay and Factor results with the corrected reference standard purity. See memo dated 09-08-03.

All data generated at Cardinal Health and described within this report were collected under the direction of the Study Director and were reviewed for compliance with Good Manufacturing Practices (21 CFR Parts 210 and 211). This report accurately reflects the raw data which have been stored in the Archives of Cardinal Health.

Quality Assurance Date 5 Nov 2003

William E. Weiser, Ph.D. Date 5 Nov 2003  
Study Director



**CardinalHealth**

**Revised Certificate of Analysis**

Supersedes Certificate of Analysis Dated September 2, 2003  
November 5, 2003

Release Testing for Commercial Lots of Treprostinil Drug Substance		
TTP: TTP-LRR-M0117	Company: United Therapeutics Corporation 2225 W. Harrison Street Chicago, IL 60612 (312) 421-1819	Product:  Treprostinil Drug Substance*
Lot No: UT15-030601		
Date of Manufacture: 06-17-03	Storage/Packaging: 5 °C/Ambient Amber Nalgene bottle with amber Nalgene screw cap	Phase: RT-Phase 14
Retest Date: 06-17-05		
Date Testing Started: 07-21-03		Method: ATM-LRR-M0002.17
Date Testing Completed: 08-06-03		
TEST	SPECIFICATIONS	RESULTS <sup>1</sup>
Physical Examination	A white to cream-colored powder	White powder
Identification by IR	The infrared spectrum exhibits maxima which are only at the same wavenumbers as, and have similar relative intensities to, those in the reference standard spectrum of Treprostinil, similarly obtained.	Conforms
Identification by HPLC	The retention time for the principle peak in the sample chromatogram agrees with the retention time of the principle peak in the standard chromatogram, using the chromatographic purity method.	Conforms
Residue on Ignition	Not more than 0.2%, w/w	0.0%
Water (Karl Fischer)	Not more than 2.0%, w/w	0.3%
Residual Solvents by Gas Chromatography	Ethyl Acetate Not more than 0.5%, w/w Ethanol Not more than 0.5%, w/w Acetic Acid Not more than 0.5%, w/w	Ethyl Acetate <0.1% Ethanol <0.1% Acetic Acid ND
Melting Range	Not less than 120.0 °C and not more than 126.0 °C	120.5 °C - 122.8 °C
Specific Rotation	Not less than +42.0° and not more than +49.0° at 589 nm and 25 °C, volatiles-free basis	+ 46.5 °
Heavy Metals	Not more than 0.002%	Not more than 0.002%
Microbial Limits Total Aerobic Count Total Yeast and Mold Count <i>Escherichia coli</i> <i>Salmonella</i> species <i>Pseudomonas aeruginosa</i> <i>Staphylococcus aureus</i> ATM-LRR-M0007.00	NMT 10 CFU/g NMT 10 CFU/g Absent Absent Absent Absent	0 CFU/g 0 CFU/g Absent Absent Absent Absent

Cardinal Health  
P.O. Box 13341  
Research Triangle Park, NC 27709  
tel 919.481.4855

www.cardinal.com



**CardinalHealth**

**Revised Certificate of Analysis**

Supersedes Certificate of Analysis Dated September 2, 2003  
November 5, 2003

Release Testing for Commercial Lots of Treprostinil Drug Substance		
<b>TTP:</b> TTP-LRR-M0117	<b>Company:</b> United Therapeutics Corporation 2225 W. Harrison Street Chicago, IL 60612 (312) 421-1819	<b>Product:</b> Treprostinil Drug Substance*
<b>Lot No:</b> UT15-030601		
<b>Date of Manufacture:</b> 06-17-03	<b>Storage/Packaging:</b> 5 °C/Ambient Amber Nalgene bottle with amber Nalgene screw cap	<b>Phase:</b> RT-Phase 14
<b>Retest Date:</b> 06-17-05		<b>Method:</b> ATM-LRR-M0002.17
<b>Date Testing Started:</b> 07-21-03		
<b>Date Testing Completed:</b> 08-06-03		
TEST	SPECIFICATIONS	RESULTS <sup>1</sup>
Chromatographic Purity (HPLC)		
1AU90	Not more than 0.5%, w/w	<0.05%
2AU90	Not more than 0.5%, w/w	<0.05%
97W86 (Benzindene Triol)	Not more than 0.2%, w/w	<0.05%
3AU90	Not more than 1.0%, w/w	0.2%
Treprostinil Methyl Ester	Not more than 0.2%, w/w	<0.05%
Treprostinil Ethyl Ester	Not more than 0.6%, w/w	0.09%
750W93	Not more than 1.5%, w/w	<0.05%
751W93	Not more than 1.3%, w/w	<0.05%
Unidentified	Not more than 0.1% AUC each	NR
Total Related Substances	Not more than 3.0%	0.3%
Assay (HPLC)	Not less than 97.0 and not more than 101.0%, w/w, on the volatiles-free basis	100.1%
Factor	Factor the material on the basis of assay and total volatiles content	1.002
Endotoxins (1:2000 dilution) ATM-LRR-M0012.00	Less than 104 EU/mg	< 60 EU/mg

<sup>1</sup>All results conform to specifications.

NMT = Not more than

\*|[(1R,2R,3aS,9aS)-2,3,3a,4,9,9a-hexahydro-2-hydroxy-1-[(3S)-3-hydroxyoctyl]-1H-benz[ ]inden-5-yl]oxy]acetic acid

NR = None detected

NR = Not reportable

Total Related Substances value was calculated using unrounded numbers.

Note: Report revised to recalculate Assay and Factor results with the corrected reference standard purity. See memo dated 09-08-03.

All data generated at Cardinal Health and described within this report were collected under the direction of the Study Director and were reviewed for compliance with Good Manufacturing Practices (21 CFR Parts 210 and 211). This report accurately reflects the raw data which have been stored in the Archives of Cardinal Health.

Quality Assurance      5 Nov 2003      Date

William E. Weiser, Ph.D.      5 Nov 2003      Date  
Study Director



CardinalHealth

**Revised Certificate of Analysis**

Supersedes Certificate of Analysis Dated August 14, 2003  
November 5, 2003

Release Testing for Commercial Lots of Treprostinil Drug Substance		
TTP: TTP-LRR-M0117	Company: United Therapeutics Corporation 2225 W. Harrison Street Chicago, IL 60612 (312) 421-1819	Product: Treprostinil Drug Substance*
Lot No: UT15-030504		
Date of Manufacture: 06-10-03	Storage/Packaging: 5 °C/Ambient Amber Nalgene bottle with amber Nalgene screw cap	Phase: RT-Phase 14
Retest Date: 06-10-05		
Date Testing Started: 07-21-03		Method: ATM-LRR-M0002.17
Date Testing Completed: 08-06-03		
TEST	SPECIFICATIONS	RESULTS <sup>1</sup>
Physical Examination	A white to cream-colored powder	White powder
Identification by IR	The infrared spectrum exhibits maxima which are only at the same wavenumbers as, and have similar relative intensities to, those in the reference standard spectrum of Treprostinil, similarly obtained.	Conforms
Identification by HPLC	The retention time for the principle peak in the sample chromatogram agrees with the retention time of the principle peak in the standard chromatogram, using the chromatographic purity method.	Conforms
Residue on Ignition	Not more than 0.2%, w/w	0.0%
Water (Karl Fischer)	Not more than 2.0%, w/w	0.3%
Residual Solvents by Gas Chromatography	Ethyl Acetate Not more than 0.5%, w/w Ethanol Not more than 0.5%, w/w Acetic Acid Not more than 0.5%, w/w	Ethyl Acetate <0.1% Ethanol <0.1% Acetic Acid ND
Melting Range	Not less than 120.0 °C and not more than 126.0 °C	121.7 °C - 123.3 °C
Specific Rotation	Not less than +42.0° and not more than +49.0° at 589 nm and 25 °C, volatiles-free basis	+ 47.5 °
Heavy Metals	Not more than 0.002%	Not more than 0.002%
Microbial Limits Total Aerobic Count Total Yeast and Mold Count <i>Escherichia coli</i> <i>Salmonella</i> species <i>Pseudomonas aeruginosa</i> <i>Staphylococcus aureus</i> ATM-LRR-M0007.00	NMT 10 CFU/g NMT 10 CFU/g Absent Absent Absent Absent	2 CFU/g 0 CFU/g Absent Absent Absent Absent

Cardinal Health  
P.O. Box 13341  
Research Triangle Park, NC 27709  
tel 919.481.4855

www.cardinal.com



CardinalHealth

**Revised Certificate of Analysis**

Supersedes Certificate of Analysis Dated August 14, 2003  
November 5, 2003

Release Testing for Commercial Lots of Treprostinil Drug Substance		
TTP: <b>TTP-LRR-M0117</b>	Company: <b>United Therapeutics Corporation 2225 W. Harrison Street Chicago, IL 60612 (312) 421-1819</b>	Product: <b>Treprostinil Drug Substance*</b>
Lot No: <b>UT15-030504</b>		
Date of Manufacture: <b>06-10-03</b>	Storage/Packaging: <b>5 °C/Ambient</b>	Phase: <b>RT-Phase 14</b>
Retest Date: <b>06-10-05</b>	<b>Amber Nalgene bottle with amber Nalgene screw cap</b>	Method: <b>ATM-LRR-M0002.17</b>
Date Testing Started: <b>07-21-03</b>		
Date Testing Completed: <b>08-06-03</b>		
TEST	SPECIFICATIONS	RESULTS <sup>1</sup>
Chromatographic Purity (HPLC) 1AU90 2AU90 97W86 (Benzidine Triol) 3AU90 Treprostinil Methyl Ester Treprostinil Ethyl Ester 750W93 751W93 Unidentified	Not more than 0.5%, w/w Not more than 0.5%, w/w Not more than 0.2%, w/w Not more than 1.0%, w/w Not more than 0.2%, w/w Not more than 0.6%, w/w Not more than 1.5%, w/w Not more than 1.3%, w/w Not more than 0.1% AUC each	<0.05% <0.05% <0.05% 0.2% <0.05% 0.1% 0.06% <0.05% NR
Total Related Substances	Not more than 3.0%	0.4%
Assay (HPLC)	Not less than 97.0 and not more than 101.0%. w/w, on the volatiles-free basis	100.0%
Factor	Factor the material on the basis of assay and total volatiles content	1.003
Endotoxins (1:2000 dilution) ATM-LRR-M0012.00	Less than 104 EU/mg	< 60 EU/mg

<sup>1</sup>All results conform to specifications.

NMT = Not more than

\*[[1R,2R,3aS,9aS)-2,3,3a,4,9,9a-hexahydro-2-hydroxy-1-[(3S)-3-hydroxyoctyl]-1H-benz[flinden-5-yl]oxy]acetic acid

ND = None detected

NR = Not reportable

Total Related Substances value was calculated using unrounded numbers.

Note: Report revised to recalculate Assay and Factor results with the corrected reference standard purity. See memo dated 09-08-03.

All data generated at Cardinal Health and described within this report were collected under the direction of the Study Director and were reviewed for compliance with Good Manufacturing Practices (21 CFR Parts 210 and 211). This report accurately reflects the raw data which have been stored in the Archives of Cardinal Health.

Quality Assurance                      Date  
5 Nov 2003

William E. Weiser, Ph.D.                      Date  
Study Director                      5 Nov 2003





**CardinalHealth**

**Revised Certificate of Analysis**

Supersedes Certificate of Analysis Dated September 30, 2003  
February 17, 2004

Release Testing for Commercial Lots of Treprostinil Drug Substance		
<b>TTP:</b> TTP-LRR-M0117	<b>Company:</b> United Therapeutics Corporation 2225 W. Harrison Street Chicago, IL 60612 (312) 421-1819	<b>Product:</b> Treprostinil Drug Substance*
<b>Lot No:</b> UT15-030503		
<b>Date of Manufacture:</b> 05-30-03	<b>Storage/Packaging:</b> 5 °C/Ambient	<b>Phase:</b> RT-Phase 13
<b>Retest Date:</b> 05-30-05	Amber Nalgene bottle with amber Nalgene screw cap	<b>Method:</b> ATM-LRR-M0002.17
<b>Date Testing Started:</b> 06-04-03		
<b>Date Testing Completed:</b> 06-23-03		
TEST	SPECIFICATIONS	RESULTS <sup>1</sup>
Physical Examination	A white to cream-colored powder	White powder
Identification by IR	The infrared spectrum exhibits maxima which are only at the same wavenumbers as, and have similar relative intensities to, those in the reference standard spectrum of Treprostinil, similarly obtained.	Conforms
Identification by HPLC	The retention time for the principle peak in the sample chromatogram agrees with the retention time of the principle peak in the standard chromatogram, using the chromatographic purity method.	Conforms
Residue on Ignition	Not more than 0.2%, w/w	0.0%
Water (Karl Fischer)	Not more than 2.0%, w/w	0.2%
Residual Solvents by Gas Chromatography	Ethyl Acetate Not more than 0.5%, w/w Ethanol Not more than 0.5%, w/w Acetic Acid Not more than 0.5%, w/w	Ethyl Acetate 0.0% Ethanol 0.1% Acetic Acid 0.0%
Melting Range	Not less than 120.0 °C and not more than 126.0 °C	120.3 °C – 121.3°C
Specific Rotation	Not less than +42.0° and not more than +49.0° at 589 nm and 25 °C, volatiles-free basis	+ 44.4°
Heavy Metals	Not more than 0.002%	Not more than 0.002%
Microbial Limits Total Aerobic Count Total Yeast and Mold Count <i>Escherichia coli</i> <i>Salmonella</i> species <i>Pseudomonas aeruginosa</i> <i>Staphylococcus aureus</i> ATM-LRR-M0007.00	NMT 10 CFU/g NMT 10 CFU/g Absent Absent Absent Absent	2 CFU/g 2 CFU/g Absent Absent Absent Absent



**CardinalHealth**

**Revised Certificate of Analysis**

Supersedes Certificate of Analysis Dated September 30, 2003  
February 17, 2004

Release Testing for Commercial Lots of Treprostinil Drug Substance		
<b>TTP:</b> TTP-LRR-M0117	<b>Company:</b> United Therapeutics Corporation 2225 W. Harrison Street Chicago, IL 60612 (312) 421-1819	<b>Product:</b> Treprostinil Drug Substance*
<b>Lot No:</b> UT15-030503		<b>Phase:</b> RT-Phase 13
<b>Date of Manufacture:</b> 05-30-03	<b>Storage/Packaging:</b> 5 °C/Ambient Amber Nalgene bottle with amber Nalgene screw cap	<b>Method:</b> ATM-LRR-M0002.17
<b>Retest Date:</b> 05-30-05		
<b>Date Testing Started:</b> 06-04-03		
<b>Date Testing Completed:</b> 06-23-03		
TEST	SPECIFICATIONS	RESULTS <sup>1</sup>
Chromatographic Purity (HPLC)		
1AU90	Not more than 0.5%	ND
2AU90	Not more than 0.5%	ND
97W86 (Benzindene Triol)	Not more than 0.2%	<0.05%
3AU90	Not more than 1.0%	0.3%
Treprostinil Methyl Ester	Not more than 0.2%	<0.05%
Treprostinil Ethyl Ester	Not more than 0.6%	0.2%
750W93	Not more than 1.5%	0.2%
751W93	Not more than 1.3%	0.1%
Unidentified	Not more than 0.1% AUC each	
Unidentified at RRT 1.12		0.09%
Total Related Substances	Not more than 3.0%	0.9%
Assay (HPLC)	Not less than 97.0 and not more than 101.0%, w/w, on the volatiles-free basis	99.9%
Factor	Factor the material on the basis of assay and total volatiles content	1.004
Endotoxins (1:2000 dilution) ATM-LRR-M0012.00	Less than 104 EU/mg	< 60 EU/mg

<sup>1</sup>All results conform to specifications.

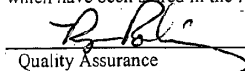
NMT = Not more than

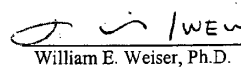
\*[[[(1R,2R,3aS,9aS)-2,3,3a,4,9,9a-hexahydro-2-hydroxy-1-[(3S)-3-hydroxyoctyl]-1H-benz[f]inden-5-yl]oxy]acetic acid

ND = None detected

Note: Report revised to correct Total Related Substances value to match current methodology.

All data generated at Cardinal Health and described within this report were collected under the direction of the Study Director and were reviewed for compliance with Good Manufacturing Practices (21 CFR Parts 210 and 211). This report accurately reflects the raw data which have been stored in the Archives of Cardinal Health.

  
Quality Assurance      Date 17 Feb 2004

  
William E. Weiser, Ph.D.      Date 2/17/04  
Study Director



**CardinalHealth**

**Revised Certificate of Analysis**

Supercedes Certificate of Analysis Dated September 30, 2003

February 17, 2004

Release Testing for Commercial Lots of Treprostinil Drug Substance		
<b>TTP:</b> TTP-LRR-M0117	<b>Company:</b> United Therapeutics Corporation 2225 W. Harrison Street Chicago, IL 60612 (312) 421-1819	<b>Product:</b> Treprostinil Drug Substance*
<b>Lot No:</b> UT15-030502		
<b>Date of Manufacture:</b> 05-23-03	<b>Storage/Packaging:</b> 5 °C/Ambient Amber Nalgene bottle with amber Nalgene screw cap	<b>Phase:</b> RT-Phase 13
<b>Retest Date:</b> 05-23-05		<b>Method:</b> ATM-LRR-M0002.17
<b>Date Testing Started:</b> 06-04-03		
<b>Date Testing Completed:</b> 06-23-03		
TEST	SPECIFICATIONS	RESULTS <sup>1</sup>
Physical Examination	A white to cream-colored powder	White powder
Identification by IR	The infrared spectrum exhibits maxima which are only at the same wavenumbers as, and have similar relative intensities to, those in the reference standard spectrum of Treprostinil, similarly obtained.	Conforms
Identification by HPLC	The retention time for the principle peak in the sample chromatogram agrees with the retention time of the principle peak in the standard chromatogram, using the chromatographic purity method.	Conforms
Residue on Ignition	Not more than 0.2%, w/w	0.0%
Water (Karl Fischer)	Not more than 2.0%, w/w	0.2%
Residual Solvents by Gas Chromatography	Ethyl Acetate Not more than 0.5%, w/w Ethanol Not more than 0.5%, w/w Acetic Acid Not more than 0.5%, w/w	Ethyl Acetate 0.0% Ethanol 0.1% Acetic Acid 0.0%
Melting Range	Not less than 120.0 °C and not more than 126.0 °C	120.7 °C – 121.5 °C
Specific Rotation	Not less than +42.0° and not more than +49.0° at 589 nm and 25 °C, volatiles-free basis	+46.2°
Heavy Metals	Not more than 0.002%	Not more than 0.002%
Microbial Limits Total Aerobic Count Total Yeast and Mold Count <i>Escherichia coli</i> <i>Salmonella</i> species <i>Pseudomonas aeruginosa</i> <i>Staphylococcus aureus</i> ATM-LRR-M0007.00	NMT 10 CFU/g NMT 10 CFU/g Absent Absent Absent Absent	0 CFU/g 2 CFU/g Absent Absent Absent Absent



**CardinalHealth**

**Revised Certificate of Analysis**

Supersedes Certificate of Analysis Dated September 30, 2003  
February 17, 2004

Release Testing for Commercial Lots of Treprostinil Drug Substance		
TTP: TTP-LRR-M0117	Company: United Therapeutics Corporation 2225 W. Harrison Street Chicago, IL 60612 (312) 421-1819	Product: Treprostinil Drug Substance*
Lot No: UT15-030502		
Date of Manufacture: 05-23-03	Storage/Packaging: 5 °C/Ambient Amber Nalgene bottle with amber Nalgene screw cap	Phase: RT-Phase 13
Retest Date: 05-23-05		
Date Testing Started: 06-04-03		Method: ATM-LRR-M0002.17
Date Testing Completed: 06-23-03		
TEST	SPECIFICATIONS	RESULTS <sup>1</sup>
Chromatographic Purity (HPLC)		
1AU90	Not more than 0.5%	ND
2AU90	Not more than 0.5%	ND
97W86 (Benzindene Triol)	Not more than 0.2%	ND
3AU90	Not more than 1.0%	0.3%
Treprostinil Methyl Ester	Not more than 0.2%	<0.05%
Treprostinil Ethyl Ester	Not more than 0.6%	0.1%
750W93	Not more than 1.5%	0.1%
751W93	Not more than 1.3%	0.06%
Unidentified	Not more than 0.1% AUC each	
Unidentified at RRT 1.12		0.08%
Total Related Substances	Not more than 3.0%	0.6%
Assay (HPLC)	Not less than 97.0 and not more than 101.0%, w/w, on the volatiles-free basis	99.5%
Factor	Factor the material on the basis of assay and total volatiles content	1.008
Endotoxins (1:2000 dilution) ATM-LRR-M0012.00	Less than 104 EU/mg	< 60 EU/mg

<sup>1</sup>All results conform to specifications.

NMT = Not more than

\*[[[(1R,2R,3aS,9aS)-2,3,3a,4,9,9a-hexahydro-2-hydroxy-1-[(3S)-3-hydroxyoctyl]-1H-benz[f]inden-5-yl]oxy]acetic acid

ND = None detected

Total Related Substances value was calculated using unrounded numbers.

Note: Report revised to correct Total Related Substances value to match current methodology.

All data generated at Cardinal Health and described within this report were collected under the direction of the Study Director and were reviewed for compliance with Good Manufacturing Practices (21 CFR Parts 210 and 211). This report accurately reflects the raw data which have been stored in the Archives of Cardinal Health.

Quality Assurance                      Date                      17 Feb 2004

William E. Weiser, Ph.D.                      Date                      2/17/04  
Study Director



**CardinalHealth**  
**Revised Certificate of Analysis**

Supersedes Certificate of Analysis dated September 30, 2003  
February 17, 2004

Release Testing for Commercial Lots of Treprostinil Drug Substance		
<b>TTP:</b> TTP-LRR-M0117	<b>Company:</b> United Therapeutics Corporation 2225 W. Harrison Street Chicago, IL 60612 (312) 421-1819	<b>Product:</b> Treprostinil Drug Substance*
<b>Lot No:</b> UT15-030501		
<b>Date of Manufacture:</b> 05-15-03	<b>Storage/Packaging:</b> 5 °C/Ambient Amber Nalgene bottle with amber Nalgene screw cap	<b>Phase:</b> RT-Phase 13
<b>Retest Date:</b> 05-15-05		
<b>Date Testing Started:</b> 06-04-03		<b>Method:</b> ATM-LRR-M0002.17
<b>Date Testing Completed:</b> 06-23-03		
TEST	SPECIFICATIONS	RESULTS <sup>3</sup>
Physical Examination	A white to cream-colored powder	White powder
Identification by IR	The infrared spectrum exhibits maxima which are only at the same wavenumbers as, and have similar relative intensities to, those in the reference standard spectrum of Treprostinil, similarly obtained.	Conforms
Identification by HPLC	The retention time for the principle peak in the sample chromatogram agrees with the retention time of the principle peak in the standard chromatogram, using the chromatographic purity method.	Conforms
Residue on Ignition	Not more than 0.2%, w/w	0.0%
Water (Karl Fischer)	Not more than 2.0%, w/w	0.2%
Residual Solvents by Gas Chromatography	Ethyl Acetate Not more than 0.5%, w/w Ethanol Not more than 0.5%, w/w Acetic Acid Not more than 0.5%, w/w	Ethyl Acetate 0.0% Ethanol 0.1% Acetic Acid 0.0%
Melting Range	Not less than 120.0 °C and not more than 126.0 °C	120.1 °C - 121.0 °C
Specific Rotation	Not less than +42.0° and not more than +49.0° at 589 nm and 25 °C, volatiles-free basis	+46.0°
Heavy Metals	Not more than 0.002%	Not more than 0.002%
Microbial Limits Total Aerobic Count Total Yeast and Mold Count <i>Escherichia coli</i> <i>Salmonella</i> species <i>Pseudomonas aeruginosa</i> <i>Staphylococcus aureus</i> ATM-LRR-M0007.00	NMT 10 CFU/g NMT 10 CFU/g Absent Absent Absent Absent	0 CFU/g <sup>1</sup> 2 CFU/g Absent Absent Absent

<sup>1</sup>This is the retest value. The original result was 12 CFU/g. Per sponsor request, sample was retested according to USP guidelines using 2.5 times the sample weight. Both values are being reported.



**CardinalHealth**  
**Revised Certificate of Analysis**

Supersedes Certificate of Analysis dated September 30, 2003  
February 17, 2004

Release Testing for Commercial Lots of Treprostinil Drug Substance		
<b>TTP:</b> TTP-LRR-M0117	<b>Company:</b> United Therapeutics Corporation 2225 W. Harrison Street Chicago, IL 60612 (312) 421-1819	<b>Product:</b> Treprostinil Drug Substance*
<b>Lot No:</b> UT15-030501		
<b>Date of Manufacture:</b> 05-15-03	<b>Storage/Packaging:</b> 5 °C/Ambient Amber Nalgene bottle with amber Nalgene screw cap	<b>Phase:</b> RT-Phase 13
<b>Retest Date:</b> 05-15-05		
<b>Date Testing Started:</b> 06-04-03		<b>Method:</b> ATM-LRR-M0002.17
<b>Date Testing Completed:</b> 06-23-03		
TEST	SPECIFICATIONS	RESULTS <sup>3</sup>
Chromatographic Purity (HPLC)		
1AU90	Not more than 0.5%	ND
2AU90	Not more than 0.5%	ND
97W86 (Benzidine Triol)	Not more than 0.2%	ND
3AU90	Not more than 1.0%	0.3%
Treprostinil Methyl Ester	Not more than 0.2%	<0.05%
Treprostinil Ethyl Ester	Not more than 0.6%	0.1%
750W93	Not more than 1.5%	0.1%
751W93	Not more than 1.3%	0.07%
Unidentified	Not more than 0.1% AUC each	
Unidentified at RRT 1.12		0.07%
Total Related Substances	Not more than 3.0%	0.6%
Assay (HPLC)	Not less than 97.0 and not more than 101.0%, w/w, on the volatiles-free basis	99.9%
Factor	Factor the material on the basis of assay and total volatiles content	1.004
Endotoxins (1:2000 dilution) ATM-LRR-M0012.00	Less than 104 EU/mg	< 60 EU/mg

NMT = Not more than

\*[[[(1R,2R,3aS,9aS)-2,3,3a,4,9a-hexahydro-2-hydroxy-1-[(3S)-3-hydroxyoctyl]-1H-benz[*h*]inden-5-yl]oxy]acetic acid

<sup>3</sup>All results conform to specifications.

ND = None detected

Note: Report revised to correct Total Related Substances value to match current methodology.

All data generated at Cardinal Health and described within this report were collected under the direction of the Study Director and were reviewed for compliance with Good Manufacturing Practices (21 CFR Parts 210 and 211). This report accurately reflects the raw data which have been stored in the Archives of Cardinal Health.

Quality Assurance      17 Feb 2004      Date

William E. Weiser, Ph.D.      2/17/04      Date  
Study Director



**CardinalHealth**

**Revised Certificate of Analysis**

Supersedes Certificate of Analysis Dated September 30, 2003  
February 17, 2004

Release Testing for Commercial Lots of Treprostinil Drug Substance		
<b>TTP:</b> TTP-LRR-M0117	<b>Company:</b> United Therapeutics Corporation 2225 W. Harrison Street Chicago, IL 60612 (312) 421-1819	<b>Product:</b> Treprostinil Drug Substance*
<b>Lot No:</b> UT15-030401		
<b>Date of Manufacture:</b> 05-09-03	<b>Storage/Packaging:</b> 5 °C/Ambient Amber Nalgene bottle with amber Nalgene screw cap	<b>Phase:</b> RT-Phase 13
<b>Retest Date:</b> 05-09-05		
<b>Date Testing Started:</b> 06-04-03		<b>Method:</b> ATM-LRR-M0002.17
<b>Date Testing Completed:</b> 06-23-03		
TEST	SPECIFICATIONS	RESULTS <sup>1</sup>
Physical Examination	A white to cream-colored powder	White powder
Identification by IR	The infrared spectrum exhibits maxima which are only at the same wavenumbers as, and have similar relative intensities to, those in the reference standard spectrum of Treprostinil, similarly obtained.	Conforms
Identification by HPLC	The retention time for the principle peak in the sample chromatogram agrees with the retention time of the principle peak in the standard chromatogram, using the chromatographic purity method.	Conforms
Residue on Ignition	Not more than 0.2%, w/w	0.0%
Water (Karl Fischer)	Not more than 2.0%, w/w	0.3%
Residual Solvents by Gas Chromatography	Ethyl Acetate Not more than 0.5%, w/w Ethanol Not more than 0.5%, w/w Acetic Acid Not more than 0.5%, w/w	Ethyl Acetate 0.0% Ethanol <0.1% Acetic Acid 0.0%
Melting Range	Not less than 120.0 °C and not more than 126.0 °C	121.3°C - 122.0 °C
Specific Rotation	Not less than +42.0° and not more than +49.0° at 589 nm and 25 °C, volatiles-free basis	+46.1°
Heavy Metals	Not more than 0.002%	Not more than 0.002%
Microbial Limits Total Aerobic Count Total Yeast and Mold Count <i>Escherichia coli</i> <i>Salmonella</i> species <i>Pseudomonas aeruginosa</i> <i>Staphylococcus aureus</i> ATM-LRR-M0007.00	NMT 10 CFU/g NMT 10 CFU/g Absent Absent Absent Absent	0 CFU/g 6 CFU/g Absent Absent Absent Absent



**CardinalHealth**

**Revised Certificate of Analysis**

Supersedes Certificate of Analysis Dated September 30, 2003  
February 17, 2004

Release Testing for Commercial Lots of Treprostinil Drug Substance		
<b>TTP:</b> TTP-LRR-M0117	<b>Company:</b> United Therapeutics Corporation 2225 W. Harrison Street Chicago, IL 60612 (312) 421-1819	<b>Product:</b> Treprostinil Drug Substance*
<b>Lot No:</b> UT15-030401		
<b>Date of Manufacture:</b> 05-09-03	<b>Storage/Packaging:</b> 5 °C/Ambient Amber Nalgene bottle with amber Nalgene screw cap	<b>Phase:</b> RT-Phase 13
<b>Retest Date:</b> 05-09-05		
<b>Date Testing Started:</b> 06-04-03		<b>Method:</b> ATM-LRR-M0002.17
<b>Date Testing Completed:</b> 06-23-03		
TEST	SPECIFICATIONS	RESULTS <sup>1</sup>
Chromatographic Purity (HPLC)		
1AU90	Not more than 0.5%	ND
2AU90	Not more than 0.5%	ND
97W86 (Benzindene Triol)	Not more than 0.2%	ND
3AU90	Not more than 1.0%	0.3%
Treprostinil Methyl Ester	Not more than 0.2%	<0.05%
Treprostinil Ethyl Ester	Not more than 0.6%	0.2%
750W93	Not more than 1.5%	0.06%
751W93	Not more than 1.3%	<0.05%
Unidentified	Not more than 0.1% AUC each	NR
Total Related Substances	Not more than 3.0%	0.6%
Assay (HPLC)	Not less than 97.0 and not more than 101.0%, w/w, on the volatiles-free basis	100.1%
Factor	Factor the material on the basis of assay and total volatiles content	1.002
Endotoxins (1:2000 dilution) ATM-LRR-M0012.00	Less than 104 EU/mg	< 60 EU/mg

<sup>1</sup>All results conform to specifications.

NMT = Not more than

\*[[[(1R,2R,3aS,9aS)-2,3,3a,4,9,9a-hexahydro-2-hydroxy-1-[(3S)-3-hydroxyoctyl]-1H-benz[f]inden-5-yl)oxy]acetic acid

ND = None detected

NR = Not reportable

Total Related Substances value was calculated using unrounded numbers.

Note: Report revised to correct Total Related Substances value to match current methodology.

All data generated at Cardinal Health and described within this report were collected under the direction of the Study Director and were reviewed for compliance with Good Manufacturing Practices (21 CFR Parts 210 and 211). This report accurately reflects the raw data which have been stored in the Archives of Cardinal Health.

Quality Assurance      17 Feb 2004  
Date

William E. Weiser, Ph.D.  
Study Director      2/17/04  
Date





Magellan Analytical  
 A Division Of Magellan Laboratories  
 Magellan Facility  
 P.O. Box 13341  
 Research Triangle Park, NC 27709  
 Corporate: (919) 481-4855  
 Facsimile: (919) 481-4908  
 www.magellanlabs.com

Certificate of Analysis  
 October 31, 2000

Release Testing for Commercial Lots of UT-15 Drug Substance		
TTP No.: TTP-LRR-M0117	Company: United Therapeutics, Corporation Research and Development	Product: UT-15 Drug Substance
Phase: RT-Phase 1		Method: ATM-LRR-M0002.13

[[[(1R,2R,3aS,9aS)-2,3,3a,4,9,9a-hexahydro-2-hydroxy-1-[(3S)-3-hydroxyoctyl]-1H-benz[f]indén-5-yl]oxy]acetic acid  
 Lot UT15-000901

Test	Specifications	Results
Physical Examination	A white to cream-colored powder	Conforms
Identification IR	The infrared spectrum exhibits maxima which are only at the same wavenumbers as, and have similar relative intensities to, those in the reference standard spectrum of UT-15, similarly obtained.	Conforms
HPLC	The retention time for the principle peak in the sample chromatogram agrees with the retention time of the principle peak in the standard chromatogram, using the chromatographic purity method.	Conforms
Residue on Ignition	Not more than 0.2%, w/w	0.16%, w/w
Water (Karl Fischer)	Not more than 2.0%, w/w	0.2%, w/w
Residual Solvents by Gas Chromatography Ethyl Acetate Ethanol Acetic Acid	Not more than 0.5%, w/w Not more than 0.5%, w/w Not more than 0.5%, w/w	Not Detected <0.1% Not Detected
Melting Range	Not less than 120.0 °C and not more than 126.0 °C	122.3 – 124.5 °C
Specific Rotation	Not less than +42.0° and not more than +49.0° at 589 nm and 25 °C, volatiles-free basis	$[\alpha]_{589}^{25} = +45.0^\circ$ (volatiles-free basis)
Heavy Metals	Not more than 0.002%	Not more than 0.002%



**Magellan Analytical**  
 A Division Of Magellan Laboratories  
 Magellan Facility  
 P.O. Box 13341  
 Research Triangle Park, NC 27709  
 Corporate: (919) 481-4855  
 Facsimile: (919) 481-4908  
 www.magellanlabs.com

**[[[(1R,2R,3aS,9aS)-2,3,3a,4,9,9a-hexahydro-2-hydroxy-1-[(3S)-3-hydroxyoctyl]-1H-benz[*f*]inden-5-yl]oxy]acetic acid**  
**Lot UT15-000901**

Test	Specifications	Results
<b>Chromatographic Purity (HPLC)</b>		
1AU90	Not more than 0.5%	Not Detected
2AU90	Not more than 0.5%	< 0.05%
97W86 (Benzindene Triol)	Not more than 0.5%	Not Detected
3AU90	Not more than 1.0%	0.3%
UT-15 Methyl Ester	Not more than 0.2%	< 0.05%
98W86 (Methoxy Diol)	Not more than 0.1%	< 0.05%
UT-15 Ethyl Ester	Not more than 0.6%	0.1%
750W93	Not more than 2.0%	0.05%
751W93	Not more than 2.0%	< 0.05%
Unidentified	Not more than 0.1% each	Not Detected
<b>Total Related Substances</b>	<b>Not more than 5.0%</b>	<b>0.5%</b>
<b>Assay (HPLC)</b>	<b>Not less than 95.0 and not more than 101.0%, w/w, on the volatiles-free basis</b>	<b>99.8%</b>
<b>Factor</b>	<b>Factor the material on the basis of assay and total volatiles content</b>	<b>1.004 parts UT-15 equivalent to 1.00 parts volatiles-free UT-15</b>

All data generated at Magellan Laboratories Incorporated and described within this report were collected under the direction of the Study Director and were audited by the Quality Assurance Unit of Magellan Laboratories Incorporated for compliance with Good Laboratory Practices (21 CFR Part 58) and Good Manufacturing Practices (21 CFR Part 211). This report accurately reflects the raw data which have been stored in the Archives of Magellan Laboratories Incorporated.

Markene E. Raseta      10/31/00  
 Quality Assurance      Date

William Edward Weiser      10/31/00  
 William Edward Weiser, Ph.D.      Date  
 Study Director



**Magellan Analytical**  
 A Division Of Magellan Laboratories  
 Magellan Facility  
 P.O. Box 13341  
 Research Triangle Park, NC 27709  
 Corporate: (919) 481-4855  
 Facsimile: (919) 481-4908  
 www.magellanlabs.com

*Certificate of Analysis*  
 November 22, 2000

Release Testing for Commercial Lots of UT-15 Drug Substance		
TTP No.: TTP-LRR-M0117	Company: United Therapeutics, Corporation Research and Development	Product: UT-15 Drug Substance Method: ATM-LRR-M0002.13
Phase: RT-Phase 2		

[[*(1R,2R,3aS,9aS)*-2,3,3a,4,9,9a-hexahydro-2-hydroxy-1-[(*(3S)*-3-hydroxyoctyl)]-1*H*-benz[*f*]inden-5-yl]oxy]acetic acid  
 Lot UT15-001001

Test	Specifications	Results
Physical Examination	A white to cream-colored powder	Conforms
Identification IR	The infrared spectrum exhibits maxima which are only at the same wavenumbers as, and have similar relative intensities to, those in the reference standard spectrum of UT-15, similarly obtained.	Conforms
HPLC	The retention time for the principle peak in the sample chromatogram agrees with the retention time of the principle peak in the standard chromatogram, using the chromatographic purity method.	Conforms
Residue on Ignition	Not more than 0.2%, w/w	0.01%, w/w
Water (Karl Fischer)	Not more than 2.0%, w/w	0.1%, w/w
Residual Solvents by Gas Chromatography		
Ethyl Acetate	Not more than 0.5%, w/w	<0.1%
Ethanol	Not more than 0.5%, w/w	<0.1%
Acetic Acid	Not more than 0.5%, w/w	<0.1%
Melting Range	Not less than 120.0 °C and not more than 126.0 °C	123.4 - 124.9 °C
Specific Rotation	Not less than +42.0° and not more than +49.0° at 589 nm and 25 °C, volatiles-free basis	$[\alpha]_{589}^{25} = +45.4^\circ$ (volatiles-free basis)
Heavy Metals	Not more than 0.002%	Not more than 0.002%



**Magellan Analytical**  
 A Division Of Magellan Laboratories  
 Magellan Facility  
 P.O. Box 13341  
 Research Triangle Park, NC 27709  
 Corporate: (919) 481-4855  
 Facsimile: (919) 481-4908  
 www.magellanlabs.com

[[ (1R,2R,3aS,9aS)-2,3,3a,4,9,9a-hexahydro-2-hydroxy-1-[(3S)-3-hydroxyoctyl]-  
 -1H-benz[*f*]inden-5-yl]oxy]acetic acid  
 Lot UT15-001001

Test	Specifications	Results
<b>Chromatographic Purity (HPLC)</b>		
1AU90	Not more than 0.5 %	< 0.05 %
2AU90	Not more than 0.5 %	< 0.05 %
97W86 (Benzindene Triol)	Not more than 0.5 %	Not Detected
3AU90	Not more than 1.0 %	0.2 %
UT-15 Methyl Ester	Not more than 0.2 %	< 0.05 %
98W86 (Methoxy Diol)	Not more than 0.1 %	< 0.05 %
UT-15 Ethyl Ester	Not more than 0.6 %	0.09 %
750W93	Not more than 2.0 %	0.09 %
751W93	Not more than 2.0 %	0.06 %
Unidentified	Not more than 0.1 % each	Not Detected
Total Related Substances	Not more than 5.0 %	0.4 %
Assay (HPLC)	Not less than 95.0 and not more than 101.0 %, w/w, on the volatiles-free basis	99.8 %
Factor	Factor the material on the basis of assay and total volatiles content	1.003 parts UT-15 equivalent to 1.00 parts volatiles-free UT-15

All data generated at Magellan Laboratories Incorporated and described within this report were collected under the direction of the Study Director and were audited by the Quality Assurance Unit of Magellan Laboratories Incorporated for compliance with Good Laboratory Practices (21 CFR Part 58) and Good Manufacturing Practices (21 CFR Part 211). This report accurately reflects the raw data which have been stored in the Archives of Magellan Laboratories Incorporated.

*Kimberly J. Yongue* 11/22/00  
 Quality Assurance Date

*William Edward Weiser* 11/22/00  
 William Edward Weiser, Ph.D. Date  
 Study Director



**Magellan Analytical**  
 A Division Of Magellan Laboratories  
 Magellan Facility  
 P.O. Box 13341  
 Research Triangle Park, NC 27709  
 Corporate: (919) 481-4855  
 Facsimile: (919) 481-4908  
 www.magellanlabs.com

**Revised Certificate of Analysis<sup>1,2</sup>**

May 7, 2001

Supersedes Certificate of Analysis dated March 26, 2001

Retest needed by March 26, 2002

Release Testing for Commercial Lots of UT-15 Drug Substance		
TTP No.: TTP-LRR-M0117	Company: United Therapeutics Corporation Research and Development	Product: UT-15 Drug Substance
Phase: RT-Phase 4		Method: ATM-LRR-M0002.15

**[[[(1R,2R,3aS,9aS)-2,3,3a,4,9,9a-hexahydro-2-hydroxy-1-[(3S)-3-hydroxyoctyl]-1H-benz[*f*]inden-5-yl)oxy]acetic acid  
 Lot UT15-010201**

Test	Specifications	Results
Physical Examination	A white to cream-colored powder	Conforms
Identification IR	The infrared spectrum exhibits maxima which are only at the same wavenumbers as, and have similar relative intensities to, those in the reference standard spectrum of UT-15, similarly obtained.	Conforms
HPLC	The retention time for the principle peak in the sample chromatogram agrees with the retention time of the principle peak in the standard chromatogram, using the chromatographic purity method.	Conforms
Residue on Ignition	Not more than 0.2%, w/w	0.0%
Water (Karl Fischer)	Not more than 2.0%, w/w	0.1%, w/w
Residual Solvents by Gas Chromatography		
Ethyl Acetate	Not more than 0.5%	<0.1%
Ethanol	Not more than 0.5%	<0.1%
Acetic Acid	Not more than 0.5%	<0.1%
Melting Range	Not less than 120.0 °C and not more than 126.0 °C	123.2 - 124.0 °C
Specific Rotation	Not less than +42.0° and not more than +49.0° at 589 nm and 25 °C, volatiles-free basis	$[\alpha]_{589}^{25} = +47.4^\circ$ (volatiles-free basis)
Heavy Metals	Not more than 0.002%	Conforms

<sup>1</sup>Revised to add endotoxin results, which were tested under TTP-LRR-M0117 RT-Phase 4 AT.

<sup>2</sup>Revised to add header on second page.



**Magellan Analytical**  
 A Division Of Magellan Laboratories  
 Magellan Facility  
 P.O. Box 13341  
 Research Triangle Park, NC 27709  
 Corporate: (919) 481-4855  
 Facsimile: (919) 481-4908  
 www.magellanlabs.com

*Revised Certificate of Analysis*<sup>1,2</sup>

May 7, 2001

Supersedes Certificate of Analysis dated March 26, 2001

Retest needed by March 26, 2002

Release Testing for Commercial Lots of UT-15 Drug Substance			
TTP No.:	TTP-LRR-M0117	Company:	United Therapeutics Corporation Research and Development
Phase:	RT-Phase 4	Product:	UT-15 Drug Substance
		Method:	ATM-LRR-M0002.15

[[[(1R,2R,3aS,9aS)-2,3,3a,4,9,9a-hexahydro-2-hydroxy-1-[(3S)-3-hydroxyoctyl]-1H-benz[*h*]inden-5-yl]oxy]acetic acid  
 Lot UT15-010201

Test	Specifications	Results
Chromatographic Purity (HPLC)		
1AU90	Not more than 0.5%	Not Detected
2AU90	Not more than 0.5%	<0.05%
97W86 (Benzindene Triol)	Not more than 0.2%	<0.05%
3AU90	Not more than 1.0%	0.2%
UT-15 Methyl Ester	Not more than 0.2%	Not Detected
98W86 (Methoxy Diol)	Not more than 0.1%	Not Detected
UT-15 Ethyl Ester	Not more than 0.6%	0.09%
750W93	Not more than 1.5%	0.06%
751W93	Not more than 1.3%	<0.05%
Unidentified	Not more than 0.1% each	Not Detected
Total Related Substances	Not more than 3.0%	0.4%
Assay (HPLC)	Not less than 97.0 and not more than 101.0%, w/w, on the volatiles-free basis	99.3%
Factor	Factor the material on the basis of assay and total volatiles content	1.007 parts UT-15 equivalent to 1.00 parts volatiles-free UT-15
Endotoxins (1:2000 dilution)	< 104 EU/mg	< 60 EU/mg

<sup>1</sup>Revised to add endotoxin results, which were tested under TTP-LRR-M0117 RT-Phase 4 AT.

<sup>2</sup>Revised to add header on second page.

All data generated at Magellan Laboratories Incorporated and described within this report were collected under the direction of the Study Director and were reviewed for compliance with Good Laboratory Practices (21 CFR Part 58) and Good Manufacturing Practices (21 CFR Part 211). This report accurately reflects the raw data which have been stored in the Archives of Magellan Laboratories Incorporated.

*A. Ashmore*  
 Quality Assurance

5/7/01  
 Date

*Jonathan S. Green*  
 Jonathan S. Green, Ph.D.  
 Study Director

5/7/01  
 Date



**Magellan Analytical**  
 A Division Of Magellan Laboratories  
 Magellan Facility  
 P.O. Box 13341  
 Research Triangle Park, NC 27709  
 Corporate: (919) 481-4855  
 Facsimile: (919) 481-4908  
 www.magellanlabs.com

*Revised Certificate of Analysis*<sup>1,2</sup>

May 7, 2001

Supersedes Certificate of Analysis dated March 26, 2001

Retest needed by March 26, 2002

Release Testing for Commercial Lots of UT-15 Drug Substance		
TTP No.: TTP-LRR-M0117	Company: United Therapeutics Corporation Research and Development	Product: UT-15 Drug Substance
Phase: RT-Phase 4		Method: ATM-LRR-M0002.15

[[[(1R,2R,3aS,9aS)-2,3,3a,4,9,9a-hexahydro-2-hydroxy-1-[(3S)-3-hydroxyoctyl]-1H-benz[f]inden-5-yl]oxy]acetic acid  
 Lot UT15-010202

Test	Specifications	Results
Physical Examination	A white to cream-colored powder	Conforms
Identification		
IR	The infrared spectrum exhibits maxima which are only at the same wavenumbers as, and have similar relative intensities to, those in the reference standard spectrum of UT-15, similarly obtained.	Conforms
HPLC	The retention time for the principle peak in the sample chromatogram agrees with the retention time of the principle peak in the standard chromatogram, using the chromatographic purity method.	Conforms
Residue on Ignition	Not more than 0.2%, w/w	0.0%
Water (Karl Fischer)	Not more than 2.0%, w/w	0.1%, w/w
Residual Solvents by Gas Chromatography		
Ethyl Acetate	Not more than 0.5%	<0.1%
Ethanol	Not more than 0.5%	<0.1%
Acetic Acid	Not more than 0.5%	<0.1%
Melting Range	Not less than 120.0 °C and not more than 126.0 °C	123.0 – 124.0 °C
Specific Rotation	Not less than +42.0° and not more than +49.0° at 589 nm and 25 °C, volatiles-free basis	$[\alpha]_{589}^{25} = +47.2^\circ$ (volatiles-free basis)
Heavy Metals	Not more than 0.002%	Conforms

<sup>1</sup>Revised to add endotoxin results, which were tested under TTP-LRR-M0117 RT-Phase 4 AT.

<sup>2</sup>Revised to add header on second page.



**Magellan Analytical**  
 A Division Of Magellan Laboratories  
 Magellan Facility  
 P.O. Box 13341  
 Research Triangle Park, NC 27709  
 Corporate: (919) 481-4855  
 Facsimile: (919) 481-4908  
 www.magellanlabs.com

*Revised Certificate of Analysis*<sup>1,2</sup>

May 7, 2001

Supersedes Certificate of Analysis dated March 26, 2001

Retest needed by March 26, 2002

Release Testing for Commercial Lots of UT-15 Drug Substance			
TTP No.: TTP-LRR-M0117	Company: United Therapeutics Corporation Research and Development	Product: UT-15 Drug Substance	Method: ATM-LRR-M0002.15
Phase: RT-Phase 4			

[[*(1R,2R,3aS,9aS)*-2,3,3a,4,9,9a-hexahydro-2-hydroxy-1-[(3*S*)-3-hydroxyoctyl]-1*H*-benz[*f*]inden-5-yl]oxy]acetic acid  
 Lot UT15-010202

Test	Specifications	Results
Chromatographic Purity (HPLC)		
1AU90	Not more than 0.5%	Not Detected
2AU90	Not more than 0.5%	<0.05%
97W86 (Benzindene Triol)	Not more than 0.2%	<0.05%
3AU90	Not more than 1.0%	0.2%
UT-15 Methyl Ester	Not more than 0.2%	<0.05%
98W86 (Methoxy Diol)	Not more than 0.1%	Not Detected
UT-15 Ethyl Ester	Not more than 0.6%	0.09%
750W93	Not more than 1.5%	0.06%
751W93	Not more than 1.3%	<0.05%
Unidentified	Not more than 0.1% each	Not Detected
Total Related Substances	Not more than 3.0%	0.4%
Assay (HPLC)	Not less than 97.0 and not more than 101.0%, w/w, on the volatiles-free basis	99.8%
Factor	Factor the material on the basis of assay and total volatiles content	1.002 parts UT-15 equivalent to 1.00 parts volatiles-free UT-15
Endotoxins (1:2000 dilution)	< 104 EU/mg	< 60 EU/mg

<sup>1</sup>Revised to add endotoxin results, which were tested under TTP-LRR-M0117 RT-Phase 4 AT.

<sup>2</sup>Revised to add header on second page.

All data generated at Magellan Laboratories Incorporated and described within this report were collected under the direction of the Study Director and were reviewed for compliance with Good Laboratory Practices (21 CFR Part 58) and Good Manufacturing Practices (21 CFR Part 211). This report accurately reflects the raw data which have been stored in the Archives of Magellan Laboratories Incorporated.

K. Ashmore                      5/7/01  
 Quality Assurance                      Date

Jonathan S. Green, Ph.D.                      5/7/01  
 Study Director                      Date





**Magellan Analytical**  
 A Division Of Magellan Laboratories  
 Magellan Facility  
 P.O. Box 13341  
 Research Triangle Park, NC 27709  
 Corporate: (919) 481-4855  
 Facsimile: (919) 481-4908  
 www.magellanlabs.com

*Revised Certificate of Analysis*<sup>1,2</sup>  
 May 7, 2001

Supersedes Certificate of Analysis dated March 26, 2001  
 Retest needed by March 26, 2002

Release Testing for Commercial Lots of UT-15 Drug Substance		
TTP No.: TTP-LRR-M0117	Company: United Therapeutics Corporation Research and Development	Product: UT-15 Drug Substance
Phase: RT-Phase 4		Method: ATM-LRR-M0002.15

[[[(1R,2R,3aS,9aS)-2,3,3a,4,9,9a-hexahydro-2-hydroxy-1-[(3S)-3-hydroxyoctyl]-1H-benz[f]inden-5-yl]oxy]acetic acid  
 Lot UT15-010203

Test	Specifications	Results
Physical Examination	A white to cream-colored powder	Conforms
Identification IR	The infrared spectrum exhibits maxima which are only at the same wavenumbers as, and have similar relative intensities to, those in the reference standard spectrum of UT-15, similarly obtained.	Conforms
HPLC	The retention time for the principle peak in the sample chromatogram agrees with the retention time of the principle peak in the standard chromatogram, using the chromatographic purity method.	Conforms
Residue on Ignition	Not more than 0.2%, w/w	0.0%
Water (Karl Fischer)	Not more than 2.0%, w/w	0.2%, w/w
Residual Solvents by Gas Chromatography Ethyl Acetate Ethanol Acetic Acid	Not more than 0.5% Not more than 0.5% Not more than 0.5%	<0.1% <0.1% Not Detected
Melting Range	Not less than 120.0 °C and not more than 126.0 °C	123.3 - 124.4 °C
Specific Rotation	Not less than +42.0° and not more than +49.0° at 589 nm and 25 °C, volatiles-free basis	$[\alpha]_{589}^{25} = +47.1^\circ$ (volatiles-free basis)
Heavy Metals	Not more than 0.002%	Conforms

<sup>1</sup>Revised to add endotoxin results, which were tested under TTP-LRR-M0117 RT-Phase 4 AT.

<sup>2</sup>Revised to add header on second page.



**Magellan Analytical**  
 A Division Of Magellan Laboratories  
 Magellan Facility  
 P.O. Box 13341  
 Research Triangle Park, NC 27709  
 Corporate: (919) 481-4855  
 Facsimile: (919) 481-4908  
 www.magellanlabs.com

*Revised Certificate of Analysis*<sup>1,2</sup>  
 May 7, 2001

Supersedes Certificate of Analysis dated March 26, 2001  
 Retest needed by March 26, 2002

Release Testing for Commercial Lots of UT-15 Drug Substance		
TTP No.: TTP-LRR-M0117	Company: United Therapeutics Corporation Research and Development	Product: UT-15 Drug Substance
Phase: RT-Phase 4		Method: ATM-LRR-M0002.15

[[*(1R,2R,3aS,9aS)*-2,3,3a,4,9,9a-hexahydro-2-hydroxy-1-[(*(3S)*-3-hydroxyoctyl)-1*H*-benz[*f*]inden-5-yl]oxy]acetic acid  
 Lot UT15-010203

Test	Specifications	Results
Chromatographic Purity (HPLC)		
1AU90	Not more than 0.5%	0.2%
2AU90	Not more than 0.5%	<0.05%
97W86 (Benzindene Triol)	Not more than 0.2%	0.08%
3AU90	Not more than 1.0%	0.3%
UT-15 Methyl Ester	Not more than 0.2%	<0.05%
98W86 (Methoxy Diol)	Not more than 0.1%	<0.05%
UT-15 Ethyl Ester	Not more than 0.6%	0.4%
750W93	Not more than 1.5%	0.3%
751W93	Not more than 1.3%	0.2%
Unidentified Unid @ RRT 0.59	Not more than 0.1% each	0.06%
Total Related Substances	Not more than 3.0%	1.5%
Assay (HPLC)	Not less than 97.0 and not more than 101.0%, w/w, on the volatiles-free basis	98.1%
Factor	Factor the material on the basis of assay and total volatiles content	1.021 parts UT-15 equivalent to 1.00 parts volatiles-free UT-15
Endotoxins (1:2000 dilution)	< 104 EU/mg	< 60 EU/mg

<sup>1</sup>Revised to add endotoxin results, which were tested under TTP-LRR-M0117 RT-Phase 4 AT.

<sup>2</sup>Revised to add header on second page.

All data generated at Magellan Laboratories Incorporated and described within this report were collected under the direction of the Study Director and were reviewed for compliance with Good Laboratory Practices (21 CFR Part 58) and Good Manufacturing Practices (21 CFR Part 211). This report accurately reflects the raw data which have been stored in the Archives of Magellan Laboratories Incorporated.

K. Ashmore      5/7/01  
 Quality Assurance      Date

Jonathan S. Green      5/7/01  
 Jonathan S. Green, Ph.D.      Date  
 Study Director



**Magellan Analytical**  
 A Division Of Magellan Laboratories  
 Magellan Facility  
 P.O. Box 13341  
 Research Triangle Park, NC 27709  
 Corporate: (919) 481-4855  
 Facsimile: (919) 481-4908  
 www.magellanlabs.com

**Revised Certificate of Analysis<sup>1</sup>**  
 August 30, 2001  
 Supersedes Certificate of Analysis issued  
 August 27, 2001

Release Testing for Commercial Lots of Treprostinil Drug Substance		
TTP No.: TTP-LRR-M0117	Company: United Therapeutics Corporation Research and Development	Product: Treprostinil Drug Substance
Phase: RT-Phase 5		Method: ATM-LRR-M0002.15

[[[(1R,2R,3aS,9aS)-2,3,3a,4,9,9a-hexahydro-2-hydroxy-1-[(3S)-3-hydroxyoctyl]-1H-benz[f]inden-5-yl]oxy]acetic acid  
 Lot UT15-010301  
 Manufactured 3/15/2001 and Retest 3/15/2002

Test	Specifications	Results
Physical Examination	A white to cream-colored powder	Conforms
Identification IR	The infrared spectrum exhibits maxima which are only at the same wavenumbers as, and have similar relative intensities to, those in the reference standard spectrum of Treprostinil, similarly obtained.	Conforms
HPLC	The retention time for the principle peak in the sample chromatogram agrees with the retention time of the principle peak in the standard chromatogram, using the chromatographic purity method.	Conforms
Residue on Ignition	Not more than 0.2%, w/w	0.0%
Water (Karl Fischer)	Not more than 2.0%, w/w	0.2%, w/w
Residual Solvents by Gas Chromatography		
Ethyl Acetate	Not more than 0.5%	<0.1%
Ethanol	Not more than 0.5%	<0.1%
Acetic Acid	Not more than 0.5%	<0.1%
Melting Range	Not less than 120.0 °C and not more than 126.0 °C	123.2 - 124.0 °C
Specific Rotation	Not less than +42.0° and not more than +49.0° at 589 nm and 25 °C, volatiles-free basis	$[\alpha]_{589}^{25} = +45.1^\circ$ (volatiles-free basis)
Heavy Metals	Not more than 0.002%	Not more than 0.002%

<sup>1</sup>Revised to include manufacturing dates and retest dates per Sponsor request and to change the drug substance name to Treprostinil.



**Magellan Analytical**  
 A Division Of Magellan Laboratories  
 Magellan Facility  
 P.O. Box 13341  
 Research Triangle Park, NC 27709  
 Corporate: (919) 481-4855  
 Facsimile: (919) 481-4908  
 www.magellanlabs.com

**Revised Certificate of Analysis<sup>1</sup>**  
 August 30, 2001  
 Supersedes Certificate of Analysis issued  
 August 27, 2001

Release Testing for Commercial Lots of Treprostinil Drug Substance			
TTP No.: TTP-LRR-M0117	Company: United Therapeutics Corporation Research and Development	Product: Treprostinil Drug Substance	Method: ATM-LRR-M0002.15
Phase: RT-Phase 5			

[[[(1R,2R,3aS,9aS)-2,3,3a,4,9,9a-hexahydro-2-hydroxy-1-[(3S)-3-hydroxyoctyl]-1H-benz[*f*]inden-5-yl]oxy]acetic acid  
 Lot UT15-010301  
 Manufactured 3/15/2001 and Retest 3/15/2002

Test	Specifications	Results
Chromatographic Purity (HPLC)		
1AU90	Not more than 0.5%	Not Detected
2AU90	Not more than 0.5%	Not Detected
97W86 (Benzindene Triol)	Not more than 0.2%	<0.05%
3AU90	Not more than 1.0%	0.3%
Treprostinil Methyl Ester	Not more than 0.2%	Not Detected
98W86 (Methoxy Diol)	Not more than 0.1%	<0.05%
Treprostinil Ethyl Ester	Not more than 0.6%	0.09%
750W93	Not more than 1.5%	0.07%
751W93	Not more than 1.3%	<0.05%
Unidentified	Not more than 0.1% each	Not Detected
Total Related Substances	Not more than 3.0%	0.5%
Assay (HPLC)	Not less than 97.0 and not more than 101.0%, w/w, on the volatiles-free basis	99.1%
Factor	Factor the material on the basis of assay and total volatiles content	1.011 parts Treprostinil equivalent to 1.00 parts volatiles-free Treprostinil
Endotoxins (1:2000 dilution)	< 104 EU/mg	< 60 EU/mg

<sup>1</sup>Revised to include manufacturing dates and retest dates per Sponsor request and to change the drug substance name to Treprostinil.

All data generated at Magellan Laboratories Incorporated and described within this report were collected under the direction of the Study Director and were reviewed for compliance with Good Laboratory Practices (21 CFR Part 58) and Good Manufacturing Practices (21 CFR Part 211). This report accurately reflects the raw data which have been stored in the Archives of Magellan Laboratories Incorporated.

Sean D. Mase 8/30/01  
 Quality Assurance Date

Jonathan S. Green, Ph.D. 30 Aug 2001  
 Study Director Date



**Magellan Analytical**  
 A Division Of Magellan Laboratories  
 Magellan Facility  
 P.O. Box 13341  
 Research Triangle Park, NC 27709  
 Corporate: (919) 481-4855  
 Facsimile: (919) 481-4908  
 www.magellanlabs.com

**Revised Certificate of Analysis<sup>1</sup>**

August 30, 2001

Supersedes Certificate of Analysis issued

August 27, 2001

Release Testing for Commercial Lots of Treprostinil Drug Substance		
TTP No.: TTP-LRR-M0117 Phase: RT-Phase 5	Company: United Therapeutics Corporation Research and Development	Product: Treprostinil Drug Substance Method: ATM-LRR-M0002.15

[[[(1R,2R,3aS,9aS)-2,3,3a,4,9,9a-hexahydro-2-hydroxy-1-[(3S)-3-hydroxyoctyl]-1H-benz[f]inden-5-yl]oxy]acetic acid  
 Lot UT15-010302  
 Manufactured 3/27/2001 and Retest 3/27/2002

Test	Specifications	Results
Physical Examination	A white to cream-colored powder	Conforms
Identification IR	The infrared spectrum exhibits maxima which are only at the same wavenumbers as, and have similar relative intensities to, those in the reference standard spectrum of Treprostinil, similarly obtained.	Conforms
HPLC	The retention time for the principle peak in the sample chromatogram agrees with the retention time of the principle peak in the standard chromatogram, using the chromatographic purity method.	Conforms
Residue on Ignition	Not more than 0.2%, w/w	0.0%
Water (Karl Fischer)	Not more than 2.0%, w/w	0.1%, w/w
Residual Solvents by Gas Chromatography		
Ethyl Acetate	Not more than 0.5%	<0.1%
Ethanol	Not more than 0.5%	<0.1%
Acetic Acid	Not more than 0.5%	<0.1%
Melting Range	Not less than 120.0 °C and not more than 126.0 °C	123.1 - 123.9 °C
Specific Rotation	Not less than +42.0° and not more than +49.0° at 589 nm and 25 °C, volatiles-free basis	$[\alpha]_{589}^{25} = +47.5^\circ$ (volatiles-free basis)
Heavy Metals	Not more than 0.002%	Not more than 0.002%

<sup>1</sup>Revised to include manufacturing dates and retest dates per Sponsor request and to change the drug substance name to Treprostinil.



**Magellan Analytical**  
 A Division Of Magellan Laboratories  
 Magellan Facility  
 P.O. Box 13341  
 Research Triangle Park, NC 27709  
 Corporate: (919) 481-4855  
 Facsimile: (919) 481-4908  
 www.magellanlabs.com

**Revised Certificate of Analysis<sup>1</sup>**

August 30, 2001

Supersedes Certificate of Analysis issued

August 27, 2001

Release Testing for Commercial Lots of Treprostinil Drug Substance		
TTP No.: TTP-LRR-M0117	Company: United Therapeutics Corporation Research and Development	Product: Treprostinil Drug Substance
Phase: RT-Phase 5		Method: ATM-LRR-M0002.15

[[[(1R,2R,3aS,9aS)-2,3,3a,4,9,9a-hexahydro-2-hydroxy-1-[(3S)-3-hydroxyoctyl]-1H-benz[*f*]inden-5-yl]oxy]acetic acid

Lot UT15-010302

Manufactured 3/27/2001 and Retest 3/27/2002

Test	Specifications	Results
Chromatographic Purity (HPLC)		
1AU90	Not more than 0.5%	<0.05%
2AU90	Not more than 0.5%	Not Detected
97W86 (Benzindene Triol)	Not more than 0.2%	<0.05%
3AU90	Not more than 1.0%	0.2%
Treprostinil Methyl Ester	Not more than 0.2%	Not Detected
98W86 (Methoxy Diol)	Not more than 0.1%	Not Detected
Treprostinil Ethyl Ester	Not more than 0.6%	0.08%
750W93	Not more than 1.5%	<0.05%
751W93	Not more than 1.3%	<0.05%
Unidentified	Not more than 0.1% each	Not Detected
Total Related Substances	Not more than 3.0%	0.3%
Assay (HPLC)	Not less than 97.0 and not more than 101.0%, w/w, on the volatiles-free basis	99.6%
Factor	Factor the material on the basis of assay and total volatiles content	1.005 parts Treprostinil equivalent to 1.00 parts volatiles-free Treprostinil
Endotoxins (1:2000 dilution)	< 104 EU/mg	< 60 EU/mg

<sup>1</sup>Revised to include manufacturing dates and retest dates per Sponsor request and to change the drug substance name to Treprostinil.

All data generated at Magellan Laboratories Incorporated and described within this report were collected under the direction of the Study Director and were reviewed for compliance with Good Laboratory Practices (21 CFR Part 58) and Good Manufacturing Practices (21 CFR Part 211). This report accurately reflects the raw data which have been stored in the Archives of Magellan Laboratories Incorporated.

Sean D. Mase 8/30/01  
 Quality Assurance Date

Jonathan S. Green, Ph.D. 30 Aug 2001  
 Study Director Date

Page 2 of 2 Page(s)



**Magellan Analytical**  
 A Division Of Magellan Laboratories  
 Magellan Facility  
 P.O. Box 13341  
 Research Triangle Park, NC 27709  
 Corporate: (919) 481-4855  
 Facsimile: (919) 481-4908  
 www.magellanlabs.com

**Revised Certificate of Analysis<sup>1</sup>**

August 30, 2001  
 Supersedes Certificate of Analysis issued  
 August 27, 2001

Release Testing for Commercial Lots of Treprostinil Drug Substance		
TTP No.: TTP-LRR-M0117 Phase: RT-Phase 5	Company: United Therapeutics Corporation Research and Development	Product: Treprostinil Drug Substance Method: ATM-LRR-M0002.15

[[[(1R,2R,3aS,9aS)-2,3,3a,4,9,9a-hexahydro-2-hydroxy-1-[(3S)-3-hydroxyoctyl]-1H-benz[f]indeno[5,6-b]pyridin-5-yl]oxy]acetic acid  
 Lot UT15-010303  
 Manufactured 4/10/2001 and Retest 4/10/2002

Test	Specifications	Results
Physical Examination	A white to cream-colored powder	Conforms
Identification IR	The infrared spectrum exhibits maxima which are only at the same wavenumbers as, and have similar relative intensities to, those in the reference standard spectrum of Treprostinil, similarly obtained.	Conforms
HPLC	The retention time for the principle peak in the sample chromatogram agrees with the retention time of the principle peak in the standard chromatogram, using the chromatographic purity method.	Conforms
Residue on Ignition	Not more than 0.2%, w/w	0.0%
Water (Karl Fischer)	Not more than 2.0%, w/w	0.2%, w/w
Residual Solvents by Gas Chromatography		
Ethyl Acetate	Not more than 0.5%	<0.1%
Ethanol	Not more than 0.5%	<0.1%
Acetic Acid	Not more than 0.5%	<0.1%
Melting Range	Not less than 120.0 °C and not more than 126.0 °C	123.0 - 123.9 °C
Specific Rotation	Not less than +42.0° and not more than +49.0° at 589 nm and 25 °C, volatiles-free basis	$[\alpha]_{589}^{25} = +47.5^\circ$ (volatiles-free basis)
Heavy Metals	Not more than 0.002%	Not more than 0.002%

<sup>1</sup>Revised to include manufacturing dates and retest dates per Sponsor request and to change the drug substance name to Treprostinil.



**Magellan Analytical**  
 A Division Of Magellan Laboratories  
 Magellan Facility  
 P.O. Box 13341  
 Research Triangle Park, NC 27709  
 Corporate: (919) 481-4855  
 Facsimile: (919) 481-4908  
 www.magellanlabs.com

**Revised Certificate of Analysis<sup>1</sup>**

August 30, 2001

Supersedes Certificate of Analysis issued

August 27, 2001

Release Testing for Commercial Lots of Treprostinil Drug Substance		
TTP No.: TTP-LRR-M0117	Company: United Therapeutics Corporation Research and Development	Product: Treprostinil Drug Substance
Phase: RT-Phase 5		Method: ATM-LRR-M0002.15

[[[(1R,2R,3aS,9aS)-2,3,3a,4,9,9a-hexahydro-2-hydroxy-1-[(3S)-3-hydroxyoctyl]-1H-benz[*f*]inden-5-yl]oxy]acetic acid

Lot UT15-010303

Manufactured 4/10/2001 and Retest 4/10/2002

Test	Specifications	Results
Chromatographic Purity (HPLC)		
1AU90	Not more than 0.5%	Not Detected
2AU90	Not more than 0.5%	Not Detected
97W86 (Benzindene Triol)	Not more than 0.2%	<0.05%
3AU90	Not more than 1.0%	0.2%
Treprostinil Methyl Ester	Not more than 0.2%	Not Detected
98W86 (Methoxy Diol)	Not more than 0.1%	Not Detected
Treprostinil Ethyl Ester	Not more than 0.6%	0.1%
750W93	Not more than 1.5%	<0.05%
751W93	Not more than 1.3%	<0.05%
Unidentified	Not more than 0.1% each	Not Detected
Total Related Substances	Not more than 3.0%	0.3%
Assay (HPLC)	Not less than 97.0 and not more than 101.0%, w/w, on the volatiles-free basis	100.0%
Factor	Factor the material on the basis of assay and total volatiles content	1.002 parts Treprostinil equivalent to 1.00 parts volatiles-free Treprostinil
Endotoxins (1:2000 dilution)	< 104 EU/mg	< 60 EU/mg

<sup>1</sup> Revised to include manufacturing dates and retest dates per Sponsor request and to change the drug substance name to Treprostinil.

All data generated at Magellan Laboratories Incorporated and described within this report were collected under the direction of the Study Director and were reviewed for compliance with Good Laboratory Practices (21 CFR Part 58) and Good Manufacturing Practices (21 CFR Part 211). This report accurately reflects the raw data which have been stored in the Archives of Magellan Laboratories Incorporated.

Sean D. Mase 8/30/01  
 Quality Assurance Date

Jonathan S. Green, Ph.D. 30 Aug 2001  
 Study Director Date





RPT-A-LRR-M0117-007-01.00

**Certificate of Analysis**  
**Release Testing for Commercial Lots of Treprostinil Drug**  
**Substance**

**Technical TP Number: TTP-LRR-M0117**  
**Study Phase: RT-Phase 6**  
**October 23, 2001**

---

**MAGELLAN LABORATORIES** Incorporated

*Where great minds come together*

P.O. Box 13341 · Research Triangle Park · North Carolina 27709  
Corporate (919) 481-4855 · Facsimile (919) 481-4908

P. 49

UT Ex. 2036

SteadyMed v. United Therapeutics

IPR2016-00006

**HIGHLY CONFIDENTIAL**

**UTC-Sand-Rem01102388**

IPR2020-00769  
United Therapeutics EX2006  
Page 4797 of 7113

Magellan Laboratories  
P.O. Box 13341  
Research Triangle Park, NC 27709  
Corporate: (919) 481-4855  
Facsimile: (919) 481-4908  
www.magellanlabs.com



**Certificate of Analysis**

October 15, 2001

Release Testing for Commercial Lots of Treprostinil Drug Substance			
TTP No.: TTP-LRR-M0117	Company: United Therapeutics Corporation Research and Development	Product: Treprostinil Drug Substance	
Phase: RT-Phase 6		Method: ATM-LRR-M0002.16	

[[[(1R,2R,3aS,9aS)-2,3,3a,4,9,9a-hexahydro-2-hydroxy-1-[(3S)-3-hydroxyoctyl]-1H-benz[f]inden-5-yl]oxy]acetic acid  
Lot UT15-010802

Manufactured 8/28/2001 and Retest 8/28/2002  
Testing started 9/24/01 and completed 10/10/01

Test	Specifications	Results
Physical Examination	A white to cream-colored powder	A white powder
Identification IR	The infrared spectrum exhibits maxima which are only at the same wavenumbers as, and have similar relative intensities to, those in the reference standard spectrum of Treprostinil, similarly obtained.	Conforms
HPLC	The retention time for the principle peak in the sample chromatogram agrees with the retention time of the principle peak in the standard chromatogram, using the chromatographic purity method.	Conforms
Residue on Ignition	Not more than 0.2%, w/w	0.0%, w/w
Water (Karl Fischer)	Not more than 2.0%, w/w	0.2%, w/w
Residual Solvents by Gas Chromatography		
Ethyl Acetate	Not more than 0.5%	<0.1%
Ethanol	Not more than 0.5%	<0.1%
Acetic Acid	Not more than 0.5%	<0.1%
Melting Range	Not less than 120.0 °C and not more than 126.0 °C	122.4 - 124.8 °C
Specific Rotation	Not less than +42.0° and not more than +49.0° at 589 nm and 25 °C, volatiles-free basis	[α] <sub>589</sub> <sup>25</sup> = +45.7° (volatiles-free basis)
Heavy Metals	Not more than 0.002%	Not more than 0.002%
Microbial Limits		
Total Aerobic Count	NMT 10 CFU/g	2 CFU/g
Total Yeast and Mold Count	NMT 10 CFU/g	2 CFU/g
<i>Escherichia coli</i>	Absent	Absent
<i>Salmonella</i> species	Absent	Absent
<i>Pseudomonas aeruginosa</i>	Absent	Absent
<i>Staphylococcus aureus</i>	Absent	Absent
ATM-LRR-M0007.00	Absent	Absent

Page 1 of 2 Page(s)

P. 50

UT Ex. 2036

SteadyMed v. United Therapeutics

IPR2016-00006

HIGHLY CONFIDENTIAL

UTC-Sand-Rem01102389

IPR2020-00769

United Therapeutics EX2006

Page 4798 of 7113

Magellan Laboratories  
P.O. Box 13341  
Research Triangle Park, NC 27709  
Corporate: (919) 481-4855  
Facsimile: (919) 481-4908  
www.magellanlabs.com



**Certificate of Analysis**

October 15, 2001

Release Testing for Commercial Lots of Treprostinil Drug Substance			
TTP No.: TTP-LRR-M0117	Company: United Therapeutics Corporation Research and Development	Product: Treprostinil Drug Substance	
Phase: RT-Phase 6		Method: ATM-LRR-M0002.16	

[[[(1R,2R,3aS,9aS)-2,3,3a,4,9,9a-hexahydro-2-hydroxy-1-[(3S)-3-hydroxyoctyl]-1H-benz[*f*]inden-5-yl]oxy]acetic acid  
Lot UT15-010802

Manufactured 8/28/2001 and Retest 8/28/2002  
Testing started 9/24/01 and completed 10/10/01

Test	Specifications	Results
Chromatographic Purity (HPLC)		
1AU90	Not more than 0.5%	< 0.05%
2AU90	Not more than 0.5%	< 0.05%
97W86 (Benzindene Triol)	Not more than 0.2%	Not Detected
3AU90	Not more than 1.0%	0.2%
Treprostinil Methyl Ester	Not more than 0.2%	< 0.05%
98W86 (Methoxy Diol)	Not more than 0.1%	< 0.05%
Treprostinil Ethyl Ester	Not more than 0.6%	< 0.05%
750W93	Not more than 1.5%	< 0.05%
751W93	Not more than 1.3%	< 0.05%
Unidentified	Not more than 0.1% each	Not Detected
Total Related Substances	Not more than 3.0%	0.2%
Assay (HPLC)	Not less than 97.0 and not more than 101.0%, w/w, on the volatiles-free basis	99.7%
Factor	Factor the material on the basis of assay and total volatiles content	1.005 parts Treprostinil equivalent to 1.00 parts volatiles-free Treprostinil
Endotoxins (1:2000 dilution)	< 104 EU/mg	< 60 EU/mg
ATM-LRR-M0012.00		

All data generated at Magellan Laboratories Incorporated and described within this report were collected under the direction of the Study Director and were reviewed for compliance with Good Laboratory Practices (21 CFR Part 58) and Good Manufacturing Practices (21 CFR Part 211). This report accurately reflects the raw data which have been stored in the Archives of Magellan Laboratories Incorporated.

Sean D. Mase 10/15/2001  
Quality Assurance Date

William E. Weiser 15 Oct 2001  
William E. Weiser, Ph.D. Date  
Study Director

Page 2 of 2 Page(s)

Magellan Laboratories  
 P.O. Box 13341  
 Research Triangle Park, NC 27709  
 Corporate: (919) 481-4855  
 Facsimile: (919) 481-4908  
 www.magellanlabs.com



**Certificate of Analysis**

October 15, 2001

Release Testing for Commercial Lots of Treprostinil Drug Substance		
TTP No.: TTP-LRR-M0117	Company: United Therapeutics Corporation Research and Development	Product: Treprostinil Drug Substance
Phase: RT-Phase 6		Method: ATM-LRR-M0002.16

[[[(1R,2R,3aS,9aS)-2,3,3a,4,9,9a-hexahydro-2-hydroxy-1-[(3S)-3-hydroxyoctyl]-1H-benz[*f*]inden-5-yl]oxy]acetic acid  
 Lot UT15-010803

Manufactured 9/13/2001 and Retest 9/13/2002

Testing started 9/24/01 and completed 10/10/01

Test	Specifications	Results
Physical Examination	A white to cream-colored powder	A white powder
Identification		
IR	The infrared spectrum exhibits maxima which are only at the same wavenumbers as, and have similar relative intensities to, those in the reference standard spectrum of Treprostinil, similarly obtained.	Conforms
HPLC	The retention time for the principle peak in the sample chromatogram agrees with the retention time of the principle peak in the standard chromatogram, using the chromatographic purity method.	Conforms
Residue on Ignition	Not more than 0.2% w/w	0.0% w/w
Water (Karl Fischer)	Not more than 2.0% w/w	0.2% w/w
Residual Solvents by Gas Chromatography		
Ethyl Acetate	Not more than 0.5%	<0.1%
Ethanol	Not more than 0.5%	0.1%
Acetic Acid	Not more than 0.5%	<0.1%
Melting Range	Not less than 120.0 °C and not more than 126.0 °C	122.6 - 124.6 °C
Specific Rotation	Not less than +42.0° and not more than +49.0° at 589 nm and 25 °C, volatiles-free basis	$[\alpha]_{589}^{25} = +45.2^\circ$ (volatiles-free basis)
Heavy Metals	Not more than 0.002%	Not more than 0.002%
Microbial Limits		
Total Aerobic Count	NMT 10 CFU/g	< 2 CFU/g
Total Yeast and Mold Count	NMT 10 CFU/g	< 2 CFU/g
<i>Escherichia coli</i>	Absent	Absent
<i>Salmonella</i> species	Absent	Absent
<i>Pseudomonas aeruginosa</i>	Absent	Absent
<i>Staphylococcus aureus</i>	Absent	Absent
ATM-LRR-M0007.00		

Page 1 of 2 Page(s)

P. 52

UT Ex. 2036

SteadyMed v. United Therapeutics

IPR2016-00006

HIGHLY CONFIDENTIAL

UTC-Sand-Rem01102391

IPR2020-00769

United Therapeutics EX2006

Page 4800 of 7113

Magellan Laboratories  
 P.O. Box 13341  
 Research Triangle Park, NC 27709  
 Corporate: (919) 481-4855  
 Facsimile: (919) 481-4908  
 www.magellanlabs.com



*Certificate of Analysis*  
 October 15, 2001

Release Testing for Commercial Lots of Treprostinil Drug Substance		
TTP No.: TTP-LRR-M0117	Company: United Therapeutics Corporation Research and Development	Product: Treprostinil Drug Substance
Phase: RT-Phase 6		Method: ATM-LRR-M0002.16

[[[(1R,2R,3aS,9aS)-2,3,3a,4,9,9a-hexahydro-2-hydroxy-1-[(3S)-3-hydroxyoctyl]-1H-benz[*f*]inden-5-yl]oxy]acetic acid  
 Lot UT15-010803

Manufactured 9/13/2001 and Retest 9/13/2002  
 Testing started 9/24/01 and completed 10/10/01

Test	Specifications	Results
Chromatographic Purity (HPLC)		
1AU90	Not more than 0.5%	<0.05%
2AU90	Not more than 0.5%	<0.05%
97W86 (Benzidine Triol)	Not more than 0.2%	Not Detected
3AU90	Not more than 1.0%	0.2%
Treprostinil Methyl Ester	Not more than 0.2%	<0.05%
98W86 (Methoxy Diol)	Not more than 0.1%	<0.05%
Treprostinil-Ethyl Ester	Not more than 0.6%	0.07%
750W93	Not more than 1.5%	0.1%
751W93	Not more than 1.3%	0.06%
Unidentified	Not more than 0.1% each	Not Detected
Total Related Substances	Not more than 3.0%	0.4%
Assay (HPLC)	Not less than 97.0 and not more than 101.0%, w/w, on the volatiles-free basis	99.7%
Factor	Factor the material on the basis of assay and total volatiles content	1.006 parts Treprostinil equivalent to 1.00 parts volatiles-free Treprostinil
Endotoxins (1:2000 dilution)	< 104 EU/mg	< 60 EU/mg
ATM-LRR-M0012.00		

All data generated at Magellan Laboratories Incorporated and described within this report were collected under the direction of the Study Director and were reviewed for compliance with Good Laboratory Practices (21 CFR Part 58) and Good Manufacturing Practices (21 CFR Part 211). This report accurately reflects the raw data which have been stored in the Archives of Magellan Laboratories Incorporated.

Stan D. Mase 10/15/2001  
 Quality Assurance Date

William E. Weiser, Ph.D. 15 Oct 2001  
 Study Director Date

Page 2 of 2 Page(s)

P. 53

UT Ex. 2036

SteadyMed v. United Therapeutics  
 IPR2016-00006

HIGHLY CONFIDENTIAL

UTC-Sand-Rem01102392

IPR2020-00769  
 United Therapeutics EX2006  
 Page 4801 of 7113



**Magellan Analytical**  
 A Division Of Magellan Laboratories  
 Magellan Facility  
 P.O. Box 13341  
 Research Triangle Park, NC 27709  
 Corporate: (919) 481-4855  
 Facsimile: (919) 481-4908  
 www.magellanlabs.com

*Certificate of Analysis*

November 20, 2001

Release Testing for Commercial Lots of Treprostinil Drug Substance		
TTP No.: TTP-LRR-M0117 Phase: RT-Phase 7	Company: United Therapeutics Corporation Research and Development	Product: Treprostinil Drug Substance Method: ATM-LRR-M0002.17

[[*(1R,2R,3aS,9aS)*-2,3,3a,4,9,9a-hexahydro-2-hydroxy-1-[(*3S*)-3-hydroxyoctyl]-*1H*-benz[*f*]inden-5-yl]oxy]acetic acid  
 Lot UT15-010901

Manufactured 9/20/2001 and Retest 9/20/2002  
 Testing started 10/30/01 and completed 11/14/01

Test	Specifications	Results
Physical Examination	A white to cream-colored powder	A white powder
Identification IR	The infrared spectrum exhibits maxima which are only at the same wavenumbers as, and have similar relative intensities to, those in the reference standard spectrum of Treprostinil, similarly obtained.	Conforms
HPLC	The retention time for the principle peak in the sample chromatogram agrees with the retention time of the principle peak in the standard chromatogram, using the chromatographic purity method.	Conforms
Residue on Ignition	Not more than 0.2%, w/w	0.0%, w/w
Water (Karl Fischer)	Not more than 2.0%, w/w	0.1%, w/w
Residual Solvents by Gas Chromatography Ethyl Acetate Ethanol Acetic Acid	Not more than 0.5%, w/w Not more than 0.5%, w/w Not more than 0.5%, w/w	<0.1% 0.1% Not Detected
Melting Range	Not less than 120.0 °C and not more than 126.0 °C	122.3 – 124.0 °C
Specific Rotation	Not less than +42.0° and not more than +49.0° at 589 nm and 25 °C, volatiles-free basis	+45.6° (volatiles-free basis)
Heavy Metals	Not more than 0.002%	Not more than 0.002%
Microbial Limits Total Aerobic Count Total Yeast and Mold Count <i>Escherichia coli</i> <i>Salmonella</i> species <i>Pseudomonas aeruginosa</i> <i>Staphylococcus aureus</i> ATM-LRR-M0007.00	NMT 10 CFU/g NMT 10 CFU/g Absent Absent Absent Absent Absent	<2 CFU/g 2 CFU/g Absent Absent Absent Absent

Page 1 of 2 Page(s)

P. 54

UT Ex. 2036

SteadyMed v. United Therapeutics

IPR2016-00006

HIGHLY CONFIDENTIAL

UTC-Sand-Rem01102393

IPR2020-00769

United Therapeutics EX2006

Page 4802 of 7113



**Magellan Analytical**  
A Division Of Magellan Laboratories  
Magellan Facility  
P.O. Box 13341  
Research Triangle Park, NC 27709  
Corporate: (919) 481-4855  
Facsimile: (919) 481-4908  
www.magellanlabs.com

*Certificate of Analysis*  
November 20, 2001

Release Testing for Commercial Lots of Treprostinil Drug Substance		
TTP No.: TTP-LRR-M0117 Phase: RT-Phase 7	Company: United Therapeutics Corporation Research and Development	Product: Treprostinil Drug Substance Method: ATM-LRR-M0002.17

[[*(1R,2R,3aS,9aS)*-2,3,3a,4,9,9a-hexahydro-2-hydroxy-1-[(*3S*)-3-hydroxyoctyl]-*1H*-benz[*f*]inden-5-yl]oxy]acetic acid  
Lot UT15-010901

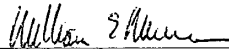
Manufactured 9/20/2001 and Retest 9/20/2002  
Testing started 10/30/01 and completed 11/14/01

Test	Specifications	Results
Chromatographic Purity (HPLC)		
1AU90	Not more than 0.5%	Not Detected
2AU90	Not more than 0.5%	<0.05%
97WS6 (Benzindene Triol)	Not more than 0.2%	0.07%
3AU90	Not more than 1.0%	0.2%
Treprostinil Methyl Ester	Not more than 0.2%	Not Detected
98WS6 (Methoxy Diol)	Not more than 0.1%	<0.05%
Treprostinil Ethyl Ester	Not more than 0.6%	0.09%
750W93	Not more than 1.5%	0.1%
751W93	Not more than 1.3%	0.08%
Unidentified RRT 1.12	Not more than 0.1% AUC each	0.08%
Total Related Substances	Not more than 3.0%	0.6%
Assay (HPLC)	Not less than 97.0 and not more than 101.0%, w/w, on the volatiles-free basis	99.1%
Factor	Factor the material on the basis of assay and total volatiles content	1.011 parts Treprostinil equivalent to 1.00 parts volatiles-free Treprostinil
Endotoxins (1:2000 dilution) ATM-LRR-M0012.00	< 104 EU/mg	< 60 EU/mg

All data generated at Magellan Laboratories Incorporated and described within this report were collected under the direction of the Study Director and were reviewed for compliance with Good Laboratory Practices (21 CFR Part 58) and Good Manufacturing Practices (21 CFR Part 211). This report accurately reflects the raw data which have been stored in the Archives of Magellan Laboratories Incorporated.

  
Quality Assurance

20-Nov-2001  
Date

  
William E. Weiser, Ph.D.  
Study Director

20 Nov 2001  
Date

Page 2 of 2 Page(s)

HIGHLY CONFIDENTIAL

P. 55

UT Ex. 2036

SteadyMed v. United Therapeutics  
IPR2016-00006

UTC-Sand-Rem01102394

IPR2020-00769  
United Therapeutics EX2006  
Page 4803 of 7113



**Magellan Analytical**  
 A Division Of Magellan Laboratories  
 Magellan Facility  
 P.O. Box 13341  
 Research Triangle Park, NC 27709  
 Corporate: (919) 481-4855  
 Facsimile: (919) 481-4908  
 www.magellanlabs.com

**Certificate of Analysis**

November 20, 2001

Release Testing for Commercial Lots of Treprostinil Drug Substance		
TTP No.: TTP-LRR-M0117 Phase: RT-Phase 7	Company: United Therapeutics Corporation Research and Development	Product: Treprostinil Drug Substance Method: ATM-LRR-M0002.17

[[*(1R,2R,3aS,9aS)*-2,3,3a,4,9,9a-hexahydro-2-hydroxy-1-[(3*S*)-3-hydroxyoctyl]-1*H*-benz[*f*]inden-5-yl]oxy]acetic acid  
 Lot UT15-010902

Manufactured 10/2/2001 and Retest 10/2/2002  
 Testing started 10/30/01 and completed 11/14/01

Test	Specifications	Results
Physical Examination	A white to cream-colored powder	A white powder
Identification IR	The infrared spectrum exhibits maxima which are only at the same wavenumbers as, and have similar relative intensities to, those in the reference standard spectrum of Treprostinil, similarly obtained.	Conforms
HPLC	The retention time for the principle peak in the sample chromatogram agrees with the retention time of the principle peak in the standard chromatogram, using the chromatographic purity method.	Conforms
Residue on Ignition	Not more than 0.2%, w/w	0.0%, w/w
Water (Karl Fischer)	Not more than 2.0%, w/w	0.1%, w/w
Residual Solvents by Gas Chromatography Ethyl Acetate Ethanol Acetic Acid	Not more than 0.5%, w/w Not more than 0.5%, w/w Not more than 0.5%, w/w	<0.1% <0.1% Not Detected
Melting Range	Not less than 120.0 °C and not more than 126.0 °C	122.6 – 124.4 °C
Specific Rotation	Not less than +42.0° and not more than +49.0° at 589 nm and 25 °C, volatiles-free basis	$[\alpha]_{589}^{25} = +45.7^\circ$ (volatiles-free basis)
Heavy Metals	Not more than 0.002%	Not more than 0.002%
Microbial Limits Total Aerobic Count Total Yeast and Mold Count <i>Escherichia coli</i> <i>Salmonella</i> species <i>Pseudomonas aeruginosa</i> <i>Staphylococcus aureus</i> ATM-LRR-M0007.00	NMT 10 CFU/g NMT 10 CFU/g Absent Absent Absent Absent	2 CFU/g <2 CFU/g Absent Absent Absent Absent

Page 1 of 2 Page(s)

P. 56

UT Ex. 2036

SteadyMed v. United Therapeutics

IPR2016-00006

HIGHLY CONFIDENTIAL

UTC-Sand-Rem01102395

IPR2020-00769

United Therapeutics EX2006

Page 4804 of 7113



**Magellan Analytical**  
 A Division Of Magellan Laboratories  
 Magellan Facility  
 P.O. Box 13341  
 Research Triangle Park, NC 27709  
 Corporate: (919) 481-4855  
 Facsimile: (919) 481-4908  
 www.magellanlabs.com



*Certificate of Analysis*  
 November 20, 2001

Release Testing for Commercial Lots of Treprostinil Drug Substance		
TTP No.: TTP-LRR-M0117 Phase: RT-Phase 7	Company: United Therapeutics Corporation Research and Development	Product: Treprostinil Drug Substance Method: ATM-LRR-M0002.17

[[*(1R,2R,3aS,9aS)*-2,3,3a,4,9,9a-hexahydro-2-hydroxy-1-[(*3S*)-3-hydroxyoctyl]-*1H*-benz[*f*]indene-5-yl]oxy]acetic acid  
 Lot UT15-010902

Manufactured 10/2/2001 and Retest 10/2/2002  
 Testing started 10/30/01 and completed 11/14/01

Test	Specifications	Results
Chromatographic Purity (HPLC)		
1AU90	Not more than 0.5%	Not Detected
2AU90	Not more than 0.5%	<0.05%
97W86 (Benzidine Triol)	Not more than 0.2%	Not Detected
3AU90	Not more than 1.0%	0.2%
Treprostinil Methyl Ester	Not more than 0.2%	Not Detected
98W86 (Methoxy Diol)	Not more than 0.1%	Not Detected
Treprostinil Ethyl Ester	Not more than 0.6%	0.1%
750W93	Not more than 1.5%	<0.05%
751W93	Not more than 1.3%	<0.05%
Unidentified	Not more than 0.1% AUC each	
RRT 1.12		0.07%
Total Related Substances	Not more than 3.0%	0.4%
Assay (HPLC)	Not less than 97.0 and not more than 101.0%, w/w, on the volatiles-free basis	99.5%
Factor	Factor the material on the basis of assay and total volatiles content	1.006 parts Treprostinil equivalent to 1.00 parts volatiles-free Treprostinil
Endotoxins (1:2000 dilution)	< 104 EU/mg	< 60 EU/mg
ATM-LRR-M0012.00		

All data generated at Magellan Laboratories Incorporated and described within this report were collected under the direction of the Study Director and were reviewed for compliance with Good Laboratory Practices (21 CFR Part 58) and Good Manufacturing Practices (21 CFR Part 211). This report accurately reflects the raw data which have been stored in the Archives of Magellan Laboratories Incorporated.

*C. B. [Signature]*  
 Quality Assurance

20 Nov 2001  
 Date

*[Signature]*  
 William E. Weiser, Ph.D.  
 Study Director

20 Nov 2001  
 Date

Page 2 of 2 Page(s)

P. 57

UT Ex. 2036

SteadyMed v. United Therapeutics  
 IPR2016-00006

HIGHLY CONFIDENTIAL

UTC-Sand-Rem01102396

IPR2020-00769  
 United Therapeutics EX2006  
 Page 4805 of 7113



**Magellan Analytical**  
 A Division Of Magellan Laboratories  
 Magellan Facility  
 P.O. Box 13341  
 Research Triangle Park, NC 27709  
 Corporate: (919) 481-4855  
 Facsimile: (919) 481-4908  
 www.magellanlabs.com

**Certificate of Analysis**

November 20, 2001

Release Testing for Commercial Lots of Treprostinil Drug Substance			
TTP No.: TTP-LRR-M0117	Company: United Therapeutics Corporation Research and Development	Product: Treprostinil Drug Substance	Method: ATM-LRR-M0002.17
Phase: RT-Phase 7			

[[[(1R,2R,3aS,9aS)-2,3,3a,4,9,9a-hexahydro-2-hydroxy-1-[(3S)-3-hydroxyoctyl]-1H-benz[*h*]inden-5-yl]oxy]acetic acid  
 Lot UT15-011001

Manufactured 10/11/2001 and Retest 10/11/2002  
 Testing started 10/30/01 and completed 11/14/01

Test	Specifications	Results
Physical Examination	A white to cream-colored powder	A white powder
Identification IR	The infrared spectrum exhibits maxima which are only at the same wavenumbers as, and have similar relative intensities to, those in the reference standard spectrum of Treprostinil, similarly obtained.	Conforms
HPLC	The retention time for the principle peak in the sample chromatogram agrees with the retention time of the principle peak in the standard chromatogram, using the chromatographic purity method.	Conforms
Residue on Ignition	Not more than 0.2%, w/w	0.0%, w/w
Water (Karl Fischer)	Not more than 2.0%, w/w	0.1%, w/w
Residual Solvents by Gas Chromatography Ethyl Acetate Ethanol Acetic Acid	Not more than 0.5%, w/w Not more than 0.5%, w/w Not more than 0.5%, w/w	<0.1% 0.1% Not Detected
Melting Range	Not less than 120.0 °C and not more than 126.0 °C	122.7 – 124.2 °C
Specific Rotation	Not less than +42.0° and not more than +49.0° at 589 nm and 25 °C, volatiles-free basis	$[\alpha]_{589}^{25} = +45.8^\circ$ (volatiles-free basis)
Heavy Metals	Not more than 0.002%	Not more than 0.002%
Microbial Limits Total Aerobic Count Total Yeast and Mold Count <i>Escherichia coli</i> <i>Salmonella</i> species <i>Pseudomonas aeruginosa</i> <i>Staphylococcus aureus</i> ATM-LRR-M0007.00	NMT 10 CFU/g NMT 10 CFU/g Absent Absent Absent Absent	< 2 CFU/g < 2 CFU/g Absent Absent Absent Absent

Page 1 of 2 Page(s)

P. 58

UT Ex. 2036

SteadyMed v. United Therapeutics

IPR2016-00006

HIGHLY CONFIDENTIAL

UTC-Sand-Rem01102397

IPR2020-00769

United Therapeutics EX2006

Page 4806 of 7113



Magellan Analytical  
 A Division Of Magellan Laboratories  
 Magellan Facility  
 P.O. Box 13341  
 Research Triangle Park, NC 27709  
 Corporate: (919) 481-4855  
 Facsimile: (919) 481-4908  
 www.magellanlabs.com

*Certificate of Analysis*

November 20, 2001

Release Testing for Commercial Lots of Treprostinil Drug Substance		
TTP No.: TTP-LRR-M0117 Phase: RT-Phase 7	Company: United Therapeutics Corporation Research and Development	Product: Treprostinil Drug Substance Method: ATM-LRR-M0002.17

[(1R,2R,3aS,9aS)-2,3,3a,4,9,9a-hexahydro-2-hydroxy-1-[(3S)-3-hydroxyoctyl]-1H-benz[f]inden-5-yl]oxy]acetic acid

Lot UT15-011001

Manufactured 10/11/2001 and Retest 10/11/2002

Testing started 10/30/01 and completed 11/14/01

Test	Specifications	Results
Chromatographic Purity (HPLC)		
1AU90	Not more than 0.5%	Not Detected
2AU90	Not more than 0.5%	<0.05%
97WS6 (Benzindene Triol)	Not more than 0.2%	<0.05%
3AU90	Not more than 1.0%	0.3%
Treprostinil Methyl Ester	Not more than 0.2%	Not Detected
98WS6 (Methoxy Diol)	Not more than 0.1%	Not Detected
Treprostinil Ethyl Ester	Not more than 0.6%	0.1%
750W93	Not more than 1.5%	0.08%
751W93	Not more than 1.3%	<0.05%
Unidentified RRT 1.12	Not more than 0.1% AUC each	0.07%
Total Related Substances	Not more than 3.0%	0.6%
Assay (HPLC)	Not less than 97.0 and not more than 101.0%, w/w, on the volatiles-free basis	99.4%
Factor	Factor the material on the basis of assay and total volatiles content	1.008 parts Treprostinil equivalent to 1.00 parts volatiles-free Treprostinil
Endotoxins (1:2000 dilution) ATM-LRR-M0012.00	< 104 EU/mg	< 60 EU/mg

All data generated at Magellan Laboratories Incorporated and described within this report were collected under the direction of the Study Director and were reviewed for compliance with Good Laboratory Practices (21 CFR Part 58) and Good Manufacturing Practices (21 CFR Part 211). This report accurately reflects the raw data which have been stored in the Archives of Magellan Laboratories Incorporated.

C.ESP  
 Quality Assurance  
 20-Nov-2001  
 Date

William E. Weiser  
 William E. Weiser, Ph.D.  
 Study Director  
 20 Nov 2001  
 Date

Page 2 of 2 Page(s)

P. 59

UT Ex. 2036

SteadyMed v. United Therapeutics

IPR2016-00006

HIGHLY CONFIDENTIAL

UTC-Sand-Rem01102398

IPR2020-00769

United Therapeutics EX2006

Page 4807 of 7113

Magellan Laboratories  
 P.O. Box 13341  
 Research Triangle Park, NC 27709  
 Corporate: (919) 481-4855  
 Facsimile: (919) 481-4908  
 www.magellanlabs.com



**Certificate of Analysis (Part 1)<sup>1</sup>**  
 March 14, 2002

Release Testing for Commercial Lots of Troprostiniil Drug Substance		
TTP No.: TTP-LRR-M0117	Company: United Therapeutics Corporation Research and Development	Product: Troprostiniil Drug Substance
Phase: RT-Phase 8		Method: ATM-LRR-M0002.17

[[[(1R,2R,3aS,9aS)-2,3,3a,4,9,9a-hexahydro-2-hydroxy-1-[(3S)-3-hydroxyoctyl]-1H-benz[*f*]inden-5-yl]oxy]acetic acid  
 Lot UT15-010801-RP

Manufactured 02/05/2002 and Retest 02/05/2003  
 Testing started 02/20/02 and completed 03/04/02

Test	Specifications	Results
Physical Examination	A white to cream-colored powder	A white powder
Identification IR	The infrared spectrum exhibits maxima which are only at the same wavenumbers as, and have similar relative intensities to, those in the reference standard spectrum of Troprostiniil, similarly obtained.	Conforms
HPLC	The retention time for the principle peak in the sample chromatogram agrees with the retention time of the principle peak in the standard chromatogram, using the chromatographic purity method.	Conforms
Residue on Ignition	Not more than 0.2%, w/w	0.0%, w/w
Water (Karl Fischer)	Not more than 2.0%, w/w	0.2%, w/w
Residual Solvents by Gas Chromatography		Average
Ethyl Acetate	Not more than 0.5%, w/w	ND
Ethanol	Not more than 0.5%, w/w	<0.1%
Acetic Acid	Not more than 0.5%, w/w	<0.1%
Melting Range	Not less than 120.0 °C and not more than 126.0 °C	122.4 – 124.6 °C
Specific Rotation	Not less than +42.0° and not more than +49.0° at 589 nm and 25 °C, volatiles-free basis	+46.7° (volatiles-free basis)
Heavy Metals	Not more than 0.002%	Not more than 0.002%
Microbial Limits		
Total Aerobic count	NMT 10 CFU/g	2 CFU/g
Total Yeast and Mold Count	NMT 10 CFU/g	2 CFU/g
<i>Escherichia coli</i>	Absent	Absent
<i>Salmonella</i> species	Absent	Absent
<i>Pseudomonas aeruginosa</i>	Absent	Absent
<i>Staphylococcus aureus</i>	Absent	Absent
(ATM-LRR-M0007.00)		

Page 1 of 2 Page(s)

P. 60

UT Ex. 2036

SteadyMed v. United Therapeutics

IPR2016-00006

HIGHLY CONFIDENTIAL

UTC-Sand-Rem01102399

IPR2020-00769

United Therapeutics EX2006

Page 4808 of 7113

Magellan Laboratories  
 P.O. Box 13341  
 Research Triangle Park, NC 27709  
 Corporate: (919) 481-4866  
 Facsimile: (919) 481-4908  
 www.magellanlabs.com



**Certificate of Analysis (Part 1)<sup>1</sup>**  
 March 14, 2002

Release Testing for Commercial Lots of Treprostinil Drug Substance		
TTP No.: TTP-LRR-M0117 Phase: RT-Phase 7	Company: United Therapeutics Corporation Research and Development	Product: Treprostinil Drug Substance Method: ATM-LRR-M0002.17

[[[(1R,2R,3aS,9aS)-2,3,3a,4,9,9a-hexahydro-2-hydroxy-1-[(3S)-3-hydroxyoctyl]-1H-benz[*f*]inden-5-yl]oxy]acetic acid  
 Lot UT15-010801-RP

Manufactured 02/05/2002 and Retest 02/05/2003  
 Testing started 02/20/02 and completed 03/04/02

Test	Specifications	Results
Chromatographic Purity (HPLC)		Average
1AU90	Not more than 0.5%	ND
2AU90	Not more than 0.3%	<0.05%
97W86 (Benzidine Triol)	Not more than 0.2%	<0.05%
3AU90	Not more than 1.0%	0.1%
Treprostinil Methyl Ester	Not more than 0.2%	ND
98W86 (Methoxy Diol)	Not more than 0.1%	ND
Treprostinil Ethyl Ester	Not more than 0.6%	0.2%
750W93	Not more than 1.5%	0.2%
751W93	Not more than 1.3%	0.1%
Unidentified	Not more than 0.1% AUC each	ND
Total Related Substances	Not more than 3.0%	0.6%
Assay (HPLC)	Not less than 97.0 and not more than 101.0%, w/w, on the volatiles-free basis	98.8%
Factor	Factor the material on the basis of assay and total volatiles content	1.014 parts Treprostinil equivalent to 1.00 parts volatiles-free Treprostinil
Endotoxins (1:2000 dilution) (ATM-LRR-M0012.00)	< 104 EU/mg	< 60 EU/mg

<sup>1</sup>Results for lot UT15-020101 will be reported in Part 2.  
 All data generated at Magellan Laboratories Incorporated and described within this report were collected under the direction of the Study Director and were reviewed for compliance with Good Laboratory Practices (21 CFR Part 58) and Good Manufacturing Practices (21 CFR Part 211). This report accurately reflects the raw data which have been stored in the Archives of Magellan Laboratories Incorporated.

Lisa M. Berger 3-14-2002  
 Quality Assurance Date

William E. Welsler 14 Mar 2002  
 William E. Welsler, Ph.D. Date  
 Study Director

Page 2 of 2 Page(s)

HIGHLY CONFIDENTIAL

P. 61

UT Ex. 2036  
 SteadyMed v. United Therapeutics  
 IPR2016-00006

UTC-Sand-Rem01102400

IPR2020-00769  
 United Therapeutics EX2006  
 Page 4809 of 7113

**Magellan Laboratories**  
P.O. Box 13341  
Research Triangle Park, NC 27709  
Corporate: (919) 481-4855  
Facsimile: (919) 481-4908  
www.magellanlabs.com



**Revised Certificate of Analysis**

April 25, 2002

Supersedes Certificate of Analysis dated April 11, 2002

Release Testing for Commercial Lots of Treprostinil Drug Substance		
TTP No.: TTP-LRR-M0117	Company: United Therapeutics Corporation 2225 W. Harrison Street Chicago, IL 60612 (312) 421-1819	Product: Treprostinil Drug Substance Method: ATM-LRR-M0002.17
Phase: RT-Phase 9		

[[[(1R,2R,3aS,9aS)-2,3,3a,4,9,9a-hexahydro-2-hydroxy-1-[(3S)-3-hydroxyoctyl]-1H-benz[*f*]inden-5-yl]oxy]acetic acid

Lot UT15-020202

Manufactured 02/26/2002 and Retest 02/26/2003

Testing started 03/22/02 and completed 04/04/02

Test	Specifications	Results
Physical Examination	A white to cream-colored powder	A white powder
Identification		
IR	The infrared spectrum exhibits maxima which are only at the same wavenumbers as, and have similar relative intensities to, those in the reference standard spectrum of Treprostinil, similarly obtained.	Conforms
HPLC	The retention time for the principle peak in the sample chromatogram agrees with the retention time of the principle peak in the standard chromatogram, using the chromatographic purity method.	Conforms
Residue on Ignition	Not more than 0.2%, w/w	0.0%, w/w
Water (Karl Fischer)	Not more than 2.0%, w/w	0.2%, w/w
Residual Solvents by Gas Chromatography		
Ethyl Acetate	Not more than 0.5%, w/w	<0.1%
Ethanol	Not more than 0.5%, w/w	<0.1%
Acetic Acid	Not more than 0.5%, w/w	<0.1%
Melting Range	Not less than 120.0 °C and not more than 126.0 °C	121.0 – 121.6 °C
Specific Rotation	Not less than +42.0° and not more than +49.0° at 589 nm and 25 °C, volatiles-free basis	+45.7° (volatiles-free basis)
Heavy Metals	Not more than 0.002%	Not more than 0.002%
Microbial Limits		
Total Aerobic Count	NMT 10 CFU/g	<2 CFU/g
Total Yeast and Mold Count	NMT 10 CFU/g	<2 CFU/g
<i>Escherichia coli</i>	Absent	Absent
<i>Salmonella</i> species	Absent	Absent
<i>Pseudomonas aeruginosa</i>	Absent	Absent
<i>Staphylococcus aureus</i>	Absent	Absent
ATM-LRR-M0007.00		

Page 1 of 2 Page(s)

P. 62

UT Ex. 2036

SteadyMed v. United Therapeutics

IPR2016-00006

**HIGHLY CONFIDENTIAL**

**UTC-Sand-Rem01102405**

IPR2020-00769

United Therapeutics EX2006

Page 4810 of 7113

**Magellan Laboratories**  
P.O. Box 13341  
Research Triangle Park, NC 27709  
Corporate: (919) 481-4855  
Facsimile: (919) 481-4908  
www.magellanlabs.com



**Revised Certificate of Analysis**

April 25, 2002

Supersedes Certificate of Analysis dated April 11, 2002

Release Testing for Commercial Lots of Treprostinil Drug Substance		
TTP No.: TTP-LRR-M0117 Phase: RT-Phase 9	Company: United Therapeutics Corporation 2225 W. Harrison Street Chicago, IL 60612 (312) 421-1819	Product: Treprostinil Drug Substance Method: ATM-LRR-M0002.17

[[[(1R,2R,3aS,9aS)-2,3,3a,4,9,9a-hexahydro-2-hydroxy-1-[(3S)-3-hydroxyoctyl]-1H-benz[*f*]inden-5-yl]oxy]acetic acid

Lot UT15-020202

Manufactured 02/26/2002 and Retest 02/26/2003

Testing started 03/22/02 and completed 04/04/02

Test	Specifications	Results
Chromatographic Purity (HPLC)		
1AU90	Not more than 0.5%	ND
2AU90	Not more than 0.5%	ND
97W86 (Benzindene Triol)	Not more than 0.2%	ND
3AU90	Not more than 1.0%	0.05%
Treprostinil Methyl Ester	Not more than 0.2%	<0.05%
98W86 (Methoxy Diol)	Not more than 0.1%	ND
Treprostinil Ethyl Ester	Not more than 0.6%	0.1%
750W93	Not more than 1.5%	<0.05%
751W93	Not more than 1.3%	<0.05%
Unidentified	Not more than 0.1% AUC each	ND
Total Related Substances	Not more than 3.0%	0.2%
Assay (HPLC)	Not less than 97.0 and not more than 101.0%, w/w, on the volatiles-free basis	98.8%
Factor	Factor the material on the basis of assay and total volatiles content	1.014 parts Treprostinil equivalent to 1.00 parts volatiles-free Treprostinil
Endotoxins (1:2000 dilution) ATM-LRR-M0012.00	< 104 EU/mg	< 60 EU/mg

Note: Revised Microbial and Endotoxin results.

All data generated at Magellan Laboratories Incorporated and described within this report were collected under the direction of the Study Director and were reviewed for compliance with Good Laboratory Practices (21 CFR Part 58) and Good Manufacturing Practices (21 CFR Part 211). This report accurately reflects the raw data which have been stored in the Archives of Magellan Laboratories Incorporated.

*Ken Eck*  
Quality Assurance  
Date: 25 Apr 02

*William E. Weiser*  
William E. Weiser, Ph.D.  
Study Director  
Date: 25 Apr 2002

Page 2 of 2 Page(s)

P. 63

UT Ex. 2036

SteadyMed v. United Therapeutics

IPR2016-00006

HIGHLY CONFIDENTIAL

UTC-Sand-Rem01102406

IPR2020-00769

United Therapeutics EX2006

Page 4811 of 7113



**CardinalHealth**

**Revised Certificate of Analysis**

February 4, 2003

Supersedes Certificate of Analysis dated April 25, 2002

Release Testing for Commercial Lots of Treprostinil Drug Substance		
TTP No.: TTP-LRR-M0117 Phase: RT-Phase 9	Company: United Therapeutics Corporation 2225 W. Harrison Street Chicago, IL 60612 (312) 421-1819	Product: Treprostinil Drug Substance Method: ATM-LRR-M0002.17

[[[(1R,2R,3aS,9aS)-2,3,3a,4,9,9a-hexahydro-2-hydroxy-1-[(3S)-3-hydroxyoctyl]-1H-benz[f]inden-5-yl]oxy]acetic acid  
Lot UT15-020203

Manufactured 03/07/2002 and Retest 03/07/2004

Testing started 03/22/02 and completed 04/04/02

Test	Specifications	Results
Physical Examination	A white to cream-colored powder	A white powder
Identification IR	The infrared spectrum exhibits maxima which are only at the same wavenumbers as, and have similar relative intensities to, those in the reference standard spectrum of Treprostinil, similarly obtained.	Conforms
HPLC	The retention time for the principle peak in the sample chromatogram agrees with the retention time of the principle peak in the standard chromatogram, using the chromatographic purity method.	Conforms
Residue on Ignition	Not more than 0.2%, w/w	0.0%, w/w
Water (Karl Fischer)	Not more than 2.0%, w/w	0.2%, w/w
Residual Solvents by Gas Chromatography Ethyl Acetate Ethanol Acetic Acid	Not more than 0.5%, w/w Not more than 0.5%, w/w Not more than 0.5%, w/w	<0.1% <0.1% <0.1%
Melting Range	Not less than 120.0 °C and not more than 126.0 °C	121.0 – 121.8 °C
Specific Rotation	Not less than +42.0° and not more than +49.0° at 589 nm and 25 °C, volatiles-free basis	+45.7° (volatiles-free basis)
Heavy Metals	Not more than 0.002%	Not more than 0.002%
Microbial Limits Total Aerobic Count Total Yeast and Mold Count <i>Escherichia coli</i> <i>Salmonella</i> species <i>Pseudomonas aeruginosa</i> <i>Staphylococcus aureus</i> ATM-LRR-M0007.00	NMT 10 CFU/g NMT 10 CFU/g Absent Absent Absent Absent	<2 CFU/g <2 CFU/g Absent Absent Absent Absent





**CardinalHealth**

**Revised Certificate of Analysis**

February 4, 2003

Supersedes Certificate of Analysis dated April 25, 2002

Release Testing for Commercial Lots of Treprostinil Drug Substance		
TTP No.: TTP-LRR-M0117 Phase: RT-Phase 9	Company: United Therapeutics Corporation 2225 W. Harrison Street Chicago, IL 60612 (312) 421-1819	Product: Treprostinil Drug Substance Method: ATM-LRR-M0002.17

[[*(1R,2R,3aS,9aS)*-2,3,3a,4,9,9a-hexahydro-2-hydroxy-1-[(*3S*)-3-hydroxyoctyl]-1*H*-benz[*f*]inden-5-yl]oxy]acetic acid  
Lot UT15-020203

Manufactured 03/07/2002 and Retest 03/07/2004  
Testing started 03/22/02 and completed 04/04/02

Test	Specifications	Results
Chromatographic Purity (HPLC)		
1AU90	Not more than 0.5%	ND
2AU90	Not more than 0.5%	ND
97W86 (Benzindene Triol)	Not more than 0.2%	ND
3AU90	Not more than 1.0%	0.05%
Treprostinil Methyl Ester	Not more than 0.2%	<0.05%
98W86 (Methoxy Diol)	Not more than 0.1%	ND
Treprostinil Ethyl Ester	Not more than 0.6%	0.1%
750W93	Not more than 1.5%	0.08%
751W93	Not more than 1.3%	<0.05%
Unidentified	Not more than 0.1% AUC each	ND
Total Related Substances	Not more than 3.0%	0.2%
Assay (HPLC)	Not less than 97.0 and not more than 101.0%, w/w, on the volatiles-free basis	98.9%
Factor	Factor the material on the basis of assay and total volatiles content	1.014 parts Treprostinil equivalent to 1.00 parts volatiles-free Treprostinil
Endotoxins (1:2000 dilution) ATM-LRR-M0012.00	< 104 EU/mg	< 60 EU/mg

Note: Revised to extend retest date for Lot UT15-020203 per Sponsor request.

All data generated at Cardinal Health and described within this report were collected under the direction of the Study Director and were reviewed for compliance with Good Laboratory Practices (21 CFR Part 58) and Good Manufacturing Practices (21 CFR Part 211). This report accurately reflects the raw data which have been stored in the Archives of Cardinal Health.

Don Poling 4 Feb 2003  
Quality Assurance Date

William E. Weiser, Ph.D. 4 Feb 2003  
Study Director Date



**CardinalHealth**

**Revised Certificate of Analysis**

February 4, 2003

Supersedes Certificate of Analysis dated April 26, 2002

Release Testing for Commercial Lots of Treprostinil Drug Substance		
TTP No.: TTP-LRR-M0117 Phase: RT-Phase 10	Company: United Therapeutics Corporation 2225 W. Harrison Street Chicago, IL 60612 (312) 421-1819	Product: Treprostinil Drug Substance Method: ATM-LRR-M0002.17

[[[(1R,2R,3aS,9aS)-2,3,3a,4,9,9a-hexahydro-2-hydroxy-1-[(3S)-3-hydroxyoctyl]-1H-benz[*f*]inden-5-yl]oxy]acetic acid  
Lot UT15-020301

Manufactured 03/19/2002 and Retest 3/19/2004  
Testing started 04/15/2002 and completed 04/22/2002

Test	Specifications	Results
Physical Examination	A white to cream-colored powder	A white powder
Identification IR	The infrared spectrum exhibits maxima which are only at the same wavenumbers as, and have similar relative intensities to, those in the reference standard spectrum of Treprostinil, similarly obtained.	Conforms
HPLC	The retention time for the principle peak in the sample chromatogram agrees with the retention time of the principle peak in the standard chromatogram, using the chromatographic purity method.	Conforms
Residue on Ignition	Not more than 0.2%, w/w	0.0%, w/w
Water (Karl Fischer)	Not more than 2.0%, w/w	0.3%, w/w
Residual Solvents by Gas Chromatography Ethyl Acetate Ethanol Acetic Acid	Not more than 0.5%, w/w Not more than 0.5%, w/w Not more than 0.5%, w/w	<0.1% <0.1% ND <sup>1</sup>
Melting Range	Not less than 120.0 °C and not more than 126.0 °C	121.5 – 123.5 °C
Specific Rotation	Not less than +42.0° and not more than +49.0° at 589 nm and 25 °C, volatiles-free basis	+45.6° (volatiles-free basis)
Heavy Metals	Not more than 0.002%	Not more than 0.002%
Microbial Limits Total Aerobic count Total Yeast and Mold Count <i>Escherichia coli</i> <i>Salmonella</i> species <i>Pseudomonas aeruginosa</i> <i>Staphylococcus aureus</i> (ATM-LRR-M0007.00)	NMT 10 CFU/g NMT 10 CFU/g Absent Absent Absent Absent	<2 CFU/g <2 CFU/g Absent Absent Absent Absent

Page 1 of 2 Page(s)



**CardinalHealth**

**Revised Certificate of Analysis**

February 4, 2003

Supersedes Certificate of Analysis dated April 26, 2002

Release Testing for Commercial Lots of Treprostinil Drug Substance		
<b>TTP No.:</b> TTP-LRR-M0117	<b>Company:</b> United Therapeutics Corporation 2225 W. Harrison Street Chicago, IL 60612 (312) 421-1819	<b>Product:</b> Treprostinil Drug Substance
<b>Phase:</b> RT-Phase 10		<b>Method:</b> ATM-LRR-M0002.17

[[**(1R,2R,3aS,9aS)-2,3,3a,4,9,9a-hexahydro-2-hydroxy-1-[(3S)-3-hydroxyoctyl]-1H-benz[*f*]inden-5-yl]oxy]acetic acid**  
**Lot UT15-020301**

**Manufactured 03/19/2002 and Retest 03/19/2004**  
**Testing started 04/15/2002 and completed 04/22/2002**

Test	Specifications	Results
Chromatographic Purity (HPLC)		Average
1AU90	Not more than 0.5%	ND
2AU90	Not more than 0.5%	<0.05%
97W86 (Benzindene Triol)	Not more than 0.2%	ND
3AU90	Not more than 1.0%	0.2%
Treprostinil Methyl Ester	Not more than 0.2%	ND
98W86 (Methoxy Diol)	Not more than 0.1%	ND
Treprostinil Ethyl Ester	Not more than 0.6%	0.1%
750W93	Not more than 1.5%	<0.05%
751W93	Not more than 1.3%	<0.05%
Unidentified	Not more than 0.1% AUC each	ND
Total Related Substances	Not more than 3.0%	0.3%
Assay (HPLC)	Not less than 97.0 and not more than 101.0%, w/w, on the volatiles-free basis	99.7%
Factor	Factor the material on the basis of assay and total volatiles content	1.006 parts Treprostinil equivalent to 1.00 parts volatiles-free Treprostinil
Endotoxins (1:2000 dilution) (ATM-LRR-M0012.00)	< 104 EU/mg	< 60 EU/mg

ND = Not Detected.

Note: Revised to extend retest date per Sponsor request.

All data generated at Cardinal Health and described within this report were collected under the direction of the Study Director and were reviewed for compliance with Good Laboratory Practices (21 CFR Part 58) and Good Manufacturing Practices (21 CFR Part 211). This report accurately reflects the raw data which have been stored in the Archives of Cardinal Health.

Don Poling 4 Feb 2003  
Quality Assurance Date

William E. Weiser 4 Feb 2003 (wsw)  
William E. Weiser, Ph.D. Date  
Study Director



**CardinalHealth**

**Revised Certificate of Analysis**

February 4, 2003

Supersedes Certificate of Analysis dated April 26, 2002

Release Testing for Commercial Lots of Treprostinil Drug Substance		
<b>TTP No.:</b> TTP-LRR-M0117	<b>Company:</b> United Therapeutics Corporation 2225 W. Harrison Street Chicago, IL 60612 (312) 421-1819	<b>Product:</b> Treprostinil Drug Substance
<b>Phase:</b> RT-Phase 10		<b>Method:</b> ATM-LRR-M0002.17

[[[(1R,2R,3aS,9aS)-2,3,3a,4,9,9a-hexahydro-2-hydroxy-1-[(3S)-3-hydroxyoctyl]-1H-benz[*l*]inden-5-yl]oxy]acetic acid

Lot UT15-020302

Manufactured 3/28/2002 and Retest 03/28/2004

Testing started 4/15/2002 and completed 04/22/2002

Test	Specifications	Results
Physical Examination	A white to cream-colored powder	A white powder
Identification IR	The infrared spectrum exhibits maxima which are only at the same wavenumbers as, and have similar relative intensities to, those in the reference standard spectrum of Treprostinil, similarly obtained.	Conforms
HPLC	The retention time for the principle peak in the sample chromatogram agrees with the retention time of the principle peak in the standard chromatogram, using the chromatographic purity method.	Conforms
Residue on Ignition	Not more than 0.2%, w/w	0.0%, w/w
Water (Karl Fischer)	Not more than 2.0%, w/w	0.3%, w/w
Residual Solvents by Gas Chromatography Ethyl Acetate Ethanol Acetic Acid	Not more than 0.5%, w/w Not more than 0.5%, w/w Not more than 0.5%, w/w	<0.1% <0.1% ND <sup>1</sup>
Melting Range	Not less than 120.0 °C and not more than 126.0 °C	121.6 – 124.2 °C
Specific Rotation	Not less than +42.0° and not more than +49.0° at 589 nm and 25 °C, volatiles-free basis	+45.6° (volatiles-free basis)
Heavy Metals	Not more than 0.002%	Not more than 0.002%
Microbial Limits Total Aerobic Count Total Yeast and Mold Count <i>Escherichia coli</i> <i>Salmonella</i> species <i>Pseudomonas aeruginosa</i> <i>Staphylococcus aureus</i> ATM-LRR-M0007.00	NMT 10 CFU/g NMT 10 CFU/g Absent Absent Absent Absent	<2 CFU/g <2 CFU/g Absent Absent Absent Absent



**CardinalHealth**

**Revised Certificate of Analysis**

February 4, 2003

Supersedes Certificate of Analysis dated April 26, 2002

Release Testing for Commercial Lots of Treprostinil Drug Substance		
TTP No.: TTP-LRR-M0117 Phase: RT-Phase 10	Company: United Therapeutics Corporation 2225 W. Harrison Street Chicago, IL 60612 (312) 421-1819	Product: Treprostinil Drug Substance Method: ATM-LRR-M0002.17

[[[(1R,2R,3aS,9aS)-2,3,3a,4,9,9a-hexahydro-2-hydroxy-1-[(3S)-3-hydroxyoctyl]-1H-benz[f]inden-5-yl]oxylacetic acid  
Lot UT15-020302

Manufactured 03/28/2002 and Retest 03/28/2004

Testing started 04/15/2002 and completed 04/22/2002

Test	Specifications	Results
Chromatographic Purity (HPLC)		
1AU90	Not more than 0.5%	ND
2AU90	Not more than 0.5%	<0.05%
97W86 (Benzindene Triol)	Not more than 0.2%	ND
3AU90	Not more than 1.0%	0.2%
Treprostinil Methyl Ester	Not more than 0.2%	ND
98W86 (Methoxy Diol)	Not more than 0.1%	ND
Treprostinil Ethyl Ester	Not more than 0.6%	0.1%
750W93	Not more than 1.5%	0.06%
751W93	Not more than 1.3%	<0.05%
Unidentified	Not more than 0.1% AUC each	ND
Total Related Substances	Not more than 3.0%	0.4%
Assay (HPLC)	Not less than 97.0 and not more than 101.0%, w/w, on the volatiles-free basis	99.6%
Factor	Factor the material on the basis of assay and total volatiles content	1.007 parts Treprostinil equivalent to 1.00 parts volatiles-free Treprostinil
Endotoxins (1:2000 dilution) ATM-LRR-M0012.00	< 104 EU/mg	< 60 EU/mg

ND = Not Detected

Note: Revised to extend retest date per Sponsor request.

All data generated at Cardinal Health and described within this report were collected under the direction of the Study Director and were reviewed for compliance with Good Laboratory Practices (21 CFR Part 58) and Good Manufacturing Practices (21 CFR Part 211). This report accurately reflects the raw data which have been stored in the Archives of Cardinal Health.

Ray Poling 4 Feb 2003  
Quality Assurance Date

William E. Weiser 4 Feb 2003  
William E. Weiser, Ph.D. Date  
Study Director



**CardinalHealth**

**Revised Certificate of Analysis**

February 4, 2003

Supersedes Certificate of Analysis dated April 26, 2002

Release Testing for Commercial Lots of Treprostinil Drug Substance		
TTP No.: TTP-LRR-M0117 Phase: RT-Phase 10	Company: United Therapeutics Corporation 2225 W. Harrison Street Chicago, IL 60612 (312) 421-1819	Product: Treprostinil Drug Substance Method: ATM-LRR-M0002.17

[[[(1R,2R,3aS,9aS)-2,3,3a,4,9,9a-hexahydro-2-hydroxy-1-[(3S)-3-hydroxyoctyl]-1H-benz[f]inden-5-yl]oxy]acetic acid  
Lot UT15-020303

Manufactured 04/09/2002 and Retest 04/09/2004  
Testing started 04/15/2002 and completed 04/22/2002

Test	Specifications	Results
Physical Examination	A white to cream-colored powder	A white powder
Identification IR	The infrared spectrum exhibits maxima which are only at the same wavenumbers as, and have similar relative intensities to, those in the reference standard spectrum of Treprostinil, similarly obtained.	Conforms
HPLC	The retention time for the principle peak in the sample chromatogram agrees with the retention time of the principle peak in the standard chromatogram, using the chromatographic purity method.	Conforms
Residue on Ignition	Not more than 0.2%, w/w	0.0%, w/w
Water (Karl Fischer)	Not more than 2.0%, w/w	0.3%, w/w
Residual Solvents by Gas Chromatography Ethyl Acetate Ethanol Acetic Acid	Not more than 0.5%, w/w Not more than 0.5%, w/w Not more than 0.5%, w/w	<0.1% <0.1% ND <sup>1</sup>
Melting Range	Not less than 120.0 °C and not more than 126.0 °C	121.6 – 123.1 °C
Specific Rotation	Not less than +42.0° and not more than +49.0° at 589 nm and 25 °C, volatiles-free basis	+45.6° (volatiles-free basis)
Heavy Metals	Not more than 0.002%	Not more than 0.002%
Microbial Limits Total Aerobic Count Total Yeast and Mold Count <i>Escherichia coli</i> <i>Salmonella</i> species <i>Pseudomonas aeruginosa</i> <i>Staphylococcus aureus</i> ATM-LRR-M0007.00	NMT 10 CFU/g NMT 10 CFU/g Absent Absent Absent Absent	<2 CFU/g <2 CFU/g Absent Absent Absent Absent



**CardinalHealth**

**Revised Certificate of Analysis**

February 4, 2003

Supersedes Certificate of Analysis dated April 26, 2002

Release Testing for Commercial Lots of Treprostinil Drug Substance		
<b>TTP No.:</b> TTP-LRR-M0117 <b>Phase:</b> RT-Phase 10	<b>Company:</b> United Therapeutics Corporation 2225 W. Harrison Street Chicago, IL 60612 (312) 421-1819	<b>Product:</b> Treprostinil Drug Substance <b>Method:</b> ATM-LRR-M0002.17

[[[(1R,2R,3aS,9aS)-2,3,3a,4,9,9a-hexahydro-2-hydroxy-1-[(3S)-3-hydroxyoctyl]-1H-benz[*f*]indene-5-yl]oxy]acetic acid  
Lot UT15-020303

Manufactured 04/09/2002 and Retest 04/09/2004

Testing started 04/15/2002 and completed 04/22/2002

Test	Specifications	Results
Chromatographic Purity (HPLC)		
1AU90	Not more than 0.5%	ND
2AU90	Not more than 0.5%	<0.05%
97W86 (Benzindene Triol)	Not more than 0.2%	ND
3AU90	Not more than 1.0%	0.2%
Treprostinil Methyl Ester	Not more than 0.2%	ND
98W86 (Methoxy Diol)	Not more than 0.1%	ND
Treprostinil Ethyl Ester	Not more than 0.6%	0.1%
750W93	Not more than 1.5%	<0.05%
751W93	Not more than 1.3%	<0.05%
Unidentified	Not more than 0.1% AUC each	ND
Total Related Substances	Not more than 3.0%	0.3%
Assay (HPLC)	Not less than 97.0 and not more than 101.0%, w/w, on the volatiles-free basis	99.3%
Factor	Factor the material on the basis of assay and total volatiles content	1.011 parts Treprostinil equivalent to 1.00 parts volatiles-free Treprostinil
Endotoxins (1:2000 dilution)	< 104 EU/mg	< 60 EU/mg
ATM-LRR-M0012.00		

ND = Not Detected

Note: Revised to extend retest date per Sponsor request.

All data generated at Cardinal Health and described within this report were collected under the direction of the Study Director and were reviewed for compliance with Good Laboratory Practices (21 CFR Part 58) and Good Manufacturing Practices (21 CFR Part 211). This report accurately reflects the raw data which have been stored in the Archives of Cardinal Health.

Debra Poling 4 Feb 2003  
Quality Assurance Date

William E. Weiser 4 Feb 2003  
William E. Weiser, Ph.D. Date  
Study Director



**CardinalHealth**  
**Certificate of Analysis**  
January 8, 2003

Release Testing for Commercial Lots of Treprostinil Drug Substance		
TTP No.: TTP-LRR-M0117	Company: United Therapeutics Corporation 2225 W. Harrison Street Chicago, IL 60612 (312) 421-1819	Product: Treprostinil Drug Substance
Phase: RT-Phase 11		Method: ATM-LRR-M0002.17

[[*(1R,2R,3aS,9aS)*-2,3,3a,4,9,9a-hexahydro-2-hydroxy-1-[(*3S*)-3-hydroxyoctyl]  
-1*H*-benz[*f*]inden-5-yl]oxy]acetic acid  
Lot UT15-021001

Manufactured 10/17/2002 and Retest 10/17/2004  
Testing started 11/21/2002 and completed 12/30/2002

Test	Specifications	Results
Physical Examination	A white to cream-colored powder	A white powder
Identification IR	The infrared spectrum exhibits maxima which are only at the same wavenumbers as, and have similar relative intensities to, those in the reference standard spectrum of Treprostinil, similarly obtained.	Conforms
HPLC	The retention time for the principle peak in the sample chromatogram agrees with the retention time of the principle peak in the standard chromatogram, using the chromatographic purity method.	Conforms
Residue on Ignition	Not more than 0.2%, w/w	0.0%
Water (Karl Fischer)	Not more than 2.0%, w/w	0.3%
Residual Solvents by Gas Chromatography		
Ethyl Acetate	Not more than 0.5%, w/w	<0.1%
Ethanol	Not more than 0.5%, w/w	0.1%
Acetic Acid	Not more than 0.5%, w/w	<0.1%
Melting Range	Not less than 120.0 °C and not more than 126.0 °C	122.1-123.7 °C
Specific Rotation	Not less than +42.0° and not more than +49.0° at 589 nm and 25 °C, volatiles-free basis	+46.3°
Heavy Metals	Not more than 0.002%	Not more than 0.002%
Microbial Limits		
Total Aerobic count	NMT <sup>1</sup> 10 CFU/g	2 CFU/g
Total Yeast and Mold Count	NMT 10 CFU/g	0 CFU/g
<i>Escherichia coli</i>	Absent	Absent
<i>Salmonella</i> species	Absent	Absent
<i>Pseudomonas aeruginosa</i>	Absent	Absent
<i>Staphylococcus aureus</i>	Absent	Absent
(ATM-LRR-M0007.00)		

<sup>1</sup>NMT = Not More Than

Page 1 of 2 Page(s)

P. 72

UT Ex. 2036

SteadyMed v. United Therapeutics

IPR2016-00006

HIGHLY CONFIDENTIAL

UTC-Sand-Rem01102415

IPR2020-00769

United Therapeutics EX2006

Page 4820 of 7113



Cardinal Health  
P.O. Box 13341  
Research Triangle Park, NC 27709  
tel 919.481.4855  
fax 919.481.4908

www.cardinal.com



**Cardinal Health**  
**Certificate of Analysis**  
January 8, 2003

Release Testing for Commercial Lots of Treprostinil Drug Substance		
TTP No.: TTP-LRR-M0117	Company: United Therapeutics Corporation 2225 W. Harrison Street Chicago, IL 60612 (312) 421-1819	Product: Treprostinil Drug Substance Method: ATM-LRR-M0002.17
Phase: RT-Phase 11		

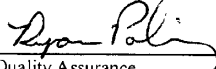
[[[(1R,2R,3aS,9aS)-2,3,3a,4,9,9a-hexahydro-2-hydroxy-1-[(3S)-3-hydroxyoctyl]-1H-benz[*f*]inden-5-yl]oxy]acetic acid  
Lot UT15-021001

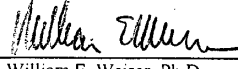
Manufactured 10/17/2002 and Retest 10/17/2004  
Testing started 11/21/2002 and completed 12/30/2002

Test	Specifications	Results
Chromatographic Purity (HPLC)		
1AU90	Not more than 0.5%	ND
2AU90	Not more than 0.5%	ND
97W86 (Benzindene Triol)	Not more than 0.2%	<0.05%
3AU90	Not more than 1.0%	0.4%
Treprostinil Methyl Ester	Not more than 0.2%	<0.05%
Treprostinil Ethyl Ester	Not more than 0.6%	0.1%
750W93	Not more than 1.5%	0.1%
751W93	Not more than 1.3%	0.08%
Unidentified	Not more than 0.1% AUC each Unidentified @ RRT 1.12	0.07%
Total Related Substances	Not more than 3.0%	0.8%
Assay (HPLC)	Not less than 97.0 and not more than 101.0%, w/w, on the volatiles-free basis	99.3%
Factor	Factor the material on the basis of assay and total volatiles content	1.011 Treprostinil equivalent to 1.00 parts volatiles-free Treprostinil
Endotoxins (1:2000 dilution) (ATM-LRR-M0012.00)	Less than 104 EU/mg	<60 EU/mg

ND = Not Detected

All data generated at Cardinal Health and described within this report were collected under the direction of the Study Director and were reviewed for compliance with Good Manufacturing Practices (21 CFR Part 211). This report accurately reflects the raw data which have been stored in the Archives of Cardinal Health.

 08 Jan 2003  
Quality Assurance Date

 8 Jan 2003  
William E. Weiser, Ph.D. Date  
Study Director

Page 2 of 2 Page(s)

HIGHLY CONFIDENTIAL

P. 73

UT Ex. 2036  
SteadyMed v. United Therapeutics  
IPR2016-00006

UTC-Sand-Rem01102416

IPR2020-00769  
United Therapeutics EX2006  
Page 4821 of 7113



**CardinalHealth**

**Revised Certificate of Analysis<sup>1</sup>**

January 23, 2003

Supersedes Certificate of Analysis dated January 8, 2003

Release Testing for Commercial Lots of Treprostinil Drug Substance		
<b>TTP No.:</b> TTP-LRR-M0117	<b>Company:</b> United Therapeutics Corporation 2225 W. Harrison Street Chicago, IL 60612 (312) 421-1819	<b>Product:</b> Treprostinil Drug Substance
<b>Phase:</b> RT-Phase 11	<b>Packaging/Storage:</b> Amber HDPE bottle with NCR screw cap 5 °C/Ambient RH	<b>Method:</b> ATM-LRR-M0002.17

[[*(1R,2R,3aS,9aS)*-2,3,3a,4,9,9a-hexahydro-2-hydroxy-1-[(*(3S)*-3-hydroxyoctyl)-*1H*-benz[*f*]inden-5-yl]oxy]acetic acid  
Lot UT15-021002

Manufactured 11/5/2002 and Retest 11/5/2004  
Testing started 11/21/2002 and completed 1/21/2003

Test	Specifications	Results <sup>2</sup>
Physical Examination	A white to cream-colored powder	White powder
Identification IR	The infrared spectrum exhibits maxima which are only at the same wavenumbers as, and have similar relative intensities to, those in the reference standard spectrum of Treprostinil, similarly obtained.	Conforms
HPLC	The retention time for the principle peak in the sample chromatogram agrees with the retention time of the principle peak in the standard chromatogram, using the chromatographic purity method.	Conforms
Residue on Ignition	Not more than 0.2%, w/w	0.1%
Water (Karl Fischer)	Not more than 2.0%, w/w	0.2%
Residual Solvents by Gas Chromatography Ethyl Acetate Ethanol Acetic Acid	Not more than 0.5%, w/w Not more than 0.5%, w/w Not more than 0.5%, w/w	<0.1% <0.1% <0.1%
Melting Range	Not less than 120.0 °C and not more than 126.0 °C	122.5 °C – 124.6 °C
Specific Rotation	Not less than +42.0° and not more than +49.0° at 589 nm and 25 °C, volatiles-free basis	+46.4 °
Heavy Metals	Not more than 0.002%	Not more than 0.002%

<sup>1</sup>Report revised to include investigation of high assay result of Assay prep 1.

<sup>2</sup>All results conform to specifications.



CardinalHealth

Cardinal Health  
P.O. Box 13341  
Research Triangle Park, NC 27709  
tel 919.481.4855

www.cardinal.com

**Revised Certificate of Analysis<sup>1</sup>**

January 23, 2003

Supersedes Certificate of Analysis dated January 8, 2003

Release Testing for Commercial Lots of Treprostinil Drug Substance		
TTP No.:  TTP-LRR-M0117	Company: United Therapeutics Corporation 2225 W. Harrison Street Chicago, IL 60612 (312) 421-1819	Product:  Treprostinil Drug Substance
Phase:  RT-Phase 11	Packaging/Storage: Amber HDPE bottle with NCR screw cap 5 °C/Ambient RH	Method:  ATM-LRR-M0002.17

[[[(1R,2R,3aS,9aS)-2,3,3a,4,9,9a-hexahydro-2-hydroxy-1-[(3S)-3-hydroxyoctyl]-1H-benz[*f*]inden-5-yl]oxy]acetic acid  
Lot UT15-021002

Manufactured 11/5/2002 and Retest 11/5/2004  
Testing started 11/21/2002 and completed 1/21/2003

Test	Specifications	Results <sup>2</sup>																		
Chromatographic Purity (HPLC) <sup>3</sup>																				
1AU90	Not more than 0.5%	ND <sup>4</sup>																		
2AU90	Not more than 0.5%	<0.05%																		
97W86 (Benzindene Triol)	Not more than 0.2%	<0.05%																		
3AU90	Not more than 1.0%	0.3%																		
Treprostinil Methyl Ester	Not more than 0.2%	<0.05%																		
Treprostinil Ethyl Ester	Not more than 0.6%	0.2%																		
750W93	Not more than 1.5%	0.06%																		
751W93	Not more than 1.3%	<0.05%																		
Unidentified	Not more than 0.1% AUC each Unidentified @ RRT 1.12	0.05%																		
Total Related Substances	Not more than 3.0%	0.6%																		
Assay (HPLC)	Not less than 97.0 and not more than 101.0%, w/w, on the volatiles-free basis	<table border="1"> <thead> <tr> <th>Prep<sup>5</sup></th> <th>Result</th> </tr> </thead> <tbody> <tr><td>1</td><td>101.2%<sup>6</sup></td></tr> <tr><td>2</td><td>99.8%</td></tr> <tr><td>3</td><td>99.9%</td></tr> <tr><td>4</td><td>100.1%</td></tr> <tr><td>5</td><td>99.9%</td></tr> <tr><td>6</td><td>100.0%</td></tr> <tr><td>7</td><td>100.1%</td></tr> <tr><td>Average(n=6)</td><td>100.0%</td></tr> </tbody> </table>	Prep <sup>5</sup>	Result	1	101.2% <sup>6</sup>	2	99.8%	3	99.9%	4	100.1%	5	99.9%	6	100.0%	7	100.1%	Average(n=6)	100.0%
Prep <sup>5</sup>	Result																			
1	101.2% <sup>6</sup>																			
2	99.8%																			
3	99.9%																			
4	100.1%																			
5	99.9%																			
6	100.0%																			
7	100.1%																			
Average(n=6)	100.0%																			

<sup>1</sup> Report revised to include investigation of high assay result of Assay prep 1.

<sup>2</sup> All results, except Assay (HPLC) Prep 1, conform to specifications.

<sup>3</sup> The impurities reported are the average of n=6.

<sup>4</sup> ND = Not detected.

<sup>5</sup> Preparations one and two were tested on 12-17-2002. Preparations three through seven were tested on 1-17-2003.

<sup>6</sup> This result is out of specifications. An investigation was conducted and an assignable cause was not determined. A laboratory error is suspected but unconfirmed. Five additional sample preps confirm the result of prep two. This result is not included in the reported average.



**CardinalHealth**

**Revised Certificate of Analysis<sup>1</sup>**

January 23, 2003

Supersedes Certificate of Analysis dated January 8, 2003

Release Testing for Commercial Lots of Treprostinil Drug Substance		
TTP No.: TTP-LRR-M0117	Company: United Therapeutics Corporation 2225 W. Harrison Street Chicago, IL 60612 (312) 421-1819	Product: Treprostinil Drug Substance
Phase: RT-Phase 11	Packaging/Storage: Amber HDPE bottle with NCR screw cap 5 °C/Ambient RH	Method: ATM-LRR-M0002.17

(((1R,2R,3aS,9aS)-2,3,3a,4,9,9a-hexahydro-2-hydroxy-1-[(3S)-3-hydroxyoctyl]-1H-benz[*f*]inden-5-yl)oxy)acetic acid  
Lot UT15-021002

Manufactured 11/5/2002 and Retest 11/5/2004  
Testing started 11/21/2002 and completed 1/21/2003

Test	Specifications	Results <sup>2</sup>
Factor	Factor the material on the basis of assay and total volatiles content	1.002 Treprostinil equivalent to 1.00 parts volatiles-free Treprostinil
Microbial Limits		
Total Aerobic Count	NMT <sup>3</sup> 10 CFU/g	2 CFU/g
Total Yeast and Mold Count	NMT 10 CFU/g	4 CFU/g
<i>Escherichia coli</i>	Absent	Absent
<i>Salmonella</i> species	Absent	Absent
<i>Pseudomonas aeruginosa</i>	Absent	Absent
<i>Staphylococcus aureus</i>	Absent	Absent
ATM-LRR-M0007.00		
Endotoxins (1:2000 dilution)	Less than 104 EU/mg	<60 EU/mg
ATM-LRR-M0012.00		

<sup>1</sup>Report revised to include investigation of high assay result of Assay prep 1.

<sup>2</sup>All results conform to specifications.

<sup>3</sup>NMT = Not More Than

All data generated at Cardinal Health and described within this report were collected under the direction of the Study Director and were reviewed for compliance with Good Manufacturing Practices (21 CFR Parts 210 and 211). This report accurately reflects the raw data which have been stored in the Archives of Cardinal Health.

Quality Assurance Date 23 Jan 2003

William E. Weiser, Ph.D. Date 1/23/03  
Study Director



RPT-A-LRR-M0117-012-01.01

**REVISED Certificate of Analysis**  
**Release Testing for Commercial Lots of Treprostinil Drug**  
**Substance**

**Technical TP Number: TTP-LRR-M0117**  
**Study Phase: RT-Phase 11**

**January 23, 2003**

---

**Cardinal Health**

P.O. Box 13341 · Research Triangle Park · North Carolina 27709  
Telephone (919) 481-4855 · Facsimile (919) 481-4908

P. 77

UT Ex. 2036

SteadyMed v. United Therapeutics

IPR2016-00006

**HIGHLY CONFIDENTIAL**

**UTC-Sand-Rem01102420**

**IPR2020-00769**

**United Therapeutics EX2006**

**Page 4825 of 7113**



**CardinalHealth**  
**Certificate of Analysis**  
January 8, 2003

Release Testing for Commercial Lots of Treprostinil Drug Substance		
TTP No.: TTP-LRR-M0117	Company: United Therapeutics Corporation 2225 W. Harrison Street Chicago, IL 60612 (312) 421-1819	Product: Treprostinil Drug Substance Method: ATM-LRR-M0002.17
Phase: RT-Phase 11		

[[[(1R,2R,3aS,9aS)-2,3,3a,4,9,9a-hexahydro-2-hydroxy-1-[(3S)-3-hydroxyoctyl]-1H-benz[*f*]inden-5-yl]oxy]acetic acid  
Lot UT15-021003

Manufactured 11/12/2002 and Retest 11/12/2004  
Testing started 11/21/2002 and completed 12/30/2002

Test	Specifications	Results
Physical Examination	A white to cream-colored powder	A white powder
Identification IR	The infrared spectrum exhibits maxima which are only at the same wavenumbers as, and have similar relative intensities to, those in the reference standard spectrum of Treprostinil, similarly obtained.	Conforms
HPLC	The retention time for the principle peak in the sample chromatogram agrees with the retention time of the principle peak in the standard chromatogram, using the chromatographic purity method.	Conforms
Residue on Ignition	Not more than 0.2%, w/w	0.0%
Water (Karl Fischer)	Not more than 2.0%, w/w	0.1%
Residual Solvents by Gas Chromatography Ethyl Acetate Ethanol Acetic Acid	Not more than 0.5%, w/w Not more than 0.5%, w/w Not more than 0.5%, w/w	<0.1% <0.1% <0.1%
Melting Range	Not less than 120.0 °C and not more than 126.0 °C	121.7-123.9 °C
Specific Rotation	Not less than +42.0° and not more than +49.0° at 589 nm and 25 °C, volatiles-free basis	+46.1°
Heavy Metals	Not more than 0.002%	Not more than 0.002%
Microbial Limits Total Aerobic Count Total Yeast and Mold Count <i>Escherichia coli</i> <i>Salmonella</i> species <i>Pseudomonas aeruginosa</i> <i>Staphylococcus aureus</i> ATM-LRR-M0007.00	NMT <sup>1</sup> 10 CFU/g NMT 10 CFU/g Absent Absent Absent Absent	2 CFU/g 0 CFU/g Absent Absent Absent Absent

<sup>1</sup>NMT = Not More Than



**CardinalHealth**  
**Certificate of Analysis**  
January 8, 2003

Release Testing for Commercial Lots of Treprostinil Drug Substance		
TTP No.: TTP-LRR-M0117	Company: United Therapeutics Corporation 2225 W. Harrison Street Chicago, IL 60612 (312) 421-1819	Product: Treprostinil Drug Substance
Phase: RT-Phase 11		Method: ATM-LRR-M0002.17


[[[(1R,2R,3aS,9aS)-2,3,3a,4,9,9a-hexahydro-2-hydroxy-1-[(3S)-3-hydroxyoctyl]-1H-benz[f]inden-5-yl]oxy]acetic acid  
Lot UT15-021003


Manufactured 11/12/2002 and Retest 11/12/2004  
Testing started 11/21/2002 and completed 12/30/2002

Test	Specifications	Results
Chromatographic Purity (HPLC)		
1AU90	Not more than 0.5%	ND <sup>1</sup>
2AU90	Not more than 0.5%	ND
97W86 (Benzindene Triol)	Not more than 0.2%	ND
3AU90	Not more than 1.0%	0.4%
Treprostinil Methyl Ester	Not more than 0.2%	<0.05%
Treprostinil Ethyl Ester	Not more than 0.6%	0.1%
750W93	Not more than 1.5%	<0.05%
751W93	Not more than 1.3%	<0.05%
Unidentified	Not more than 0.1% AUC each Unidentified @ RRT 1.12	0.07%
Total Related Substances	Not more than 3.0%	0.6%
Assay (HPLC)	Not less than 97.0 and not more than 101.0%, w/w, on the volatiles-free basis	100.8%
Factor	Factor the material on the basis of assay and total volatiles content	0.9929 Treprostinil equivalent to 1.00 parts volatiles-free Treprostinil
Endotoxins (1:2000 dilution)	Less than 104 EU/mg	<60 EU/mg
ATM-LRR-M0012.00		

ND = Not Detected

All data generated at Cardinal Health and described within this report were collected under the direction of the Study Director and were reviewed for compliance with Good Manufacturing Practices (21 CFR Part 211). This report accurately reflects the raw data which have been stored in the Archives of Cardinal Health.

 08 Jan 2003  
Quality Assurance Date

 8 Jan 2003  
William E. Weiser, Ph.D. Date  
Study Director



**CardinalHealth**

**Certificate of Analysis**

January 16, 2003

Release Testing for Commercial Lots of Treprostinil Drug Substance		
TTP No.:  TTP-LRR-M0117	Company: United Therapeutics Corporation 2225 W. Harrison Street Chicago, IL 60612 (312) 421-1819	Product:  Treprostinil Drug Substance
Phase:  RT-Phase 12	Packaging/Storage: Amber HDPE bottle with NCR screw cap 5 °C/Ambient RH	Method:  ATM-LRR-M0002.17

[[[(1R,2R,3aS,9aS)-2,3,3a,4,9,9a-hexahydro-2-hydroxy-1-[(3S)-3-hydroxyoctyl]  
-1H-benz[*f*]inden-5-yl]oxy]acetic acid  
Lot UT15-021101

Manufactured 11/21/2002 and Retest 11/21/2004  
Testing started 12/17/2002 and completed 1/3/2003

Test	Specifications	Results <sup>1</sup>
Physical Examination	A white to cream-colored powder	White powder
Identification IR	The infrared spectrum exhibits maxima which are only at the same wavenumbers as, and have similar relative intensities to, those in the reference standard spectrum of Treprostinil, similarly obtained.	Conforms
HPLC	The retention time for the principle peak in the sample chromatogram agrees with the retention time of the principle peak in the standard chromatogram, using the chromatographic purity method.	Conforms
Residue on Ignition	Not more than 0.2%, w/w	0.0%
Water (Karl Fischer)	Not more than 2.0%, w/w	0.1%
Residual Solvents by Gas Chromatography Ethyl Acetate Ethanol Acetic Acid	Not more than 0.5%, w/w Not more than 0.5%, w/w Not more than 0.5%, w/w	<0.1% <0.1% ND <sup>2</sup>
Melting Range	Not less than 120.0 °C and not more than 126.0 °C	122.1 °C – 124.6 °C
Specific Rotation	Not less than +42.0° and not more than +49.0° at 589 nm and 25 °C, volatiles-free basis	+45.0 °
Heavy Metals	Not more than 0.002%	Not more than 0.002%

<sup>1</sup>All results conform to specifications.

<sup>2</sup>ND = Not Detected





CardinalHealth

**Certificate of Analysis**

January 16, 2003

Release Testing for Commercial Lots of Treprostinil Drug Substance		
<b>TTP No.:</b>  TTP-LRR-M0117	<b>Company:</b> United Therapeutics Corporation 2225 W. Harrison Street Chicago, IL 60612 (312) 421-1819	<b>Product:</b>  Treprostinil Drug Substance
<b>Phase:</b>  RT-Phase 12	<b>Packaging/Storage:</b> Amber HDPE bottle with NCR screw cap 5 °C/Ambient RH	<b>Method:</b>  ATM-LRR-M0002.17

[[[(1R,2R,3aS,9aS)-2,3,3a,4,9,9a-hexahydro-2-hydroxy-1-[(3S)-3-hydroxyoctyl]-1H-benz[*f*]inden-5-yl]oxy]acetic acid  
Lot UT15-021101

Manufactured 11/21/2002 and Retest 11/21/2004  
Testing started 12/17/2002 and completed 1/3/2003

Test	Specifications	Results <sup>1</sup>
Microbial Limits Total Aerobic Count Total Yeast and Mold Count <i>Escherichia coli</i> <i>Salmonella</i> species <i>Pseudomonas aeruginosa</i> <i>Staphylococcus aureus</i> ATM-LRR-M0007.00	NMT <sup>2</sup> 10 CFU/g NMT 10 CFU/g Absent Absent Absent Absent	2 CFU/g 0 CFU/g Absent Absent Absent Absent
Chromatographic Purity (HPLC) 1AU90 2AU90 97W86 (Benzindene Triol) 3AU90 Treprostinil Methyl Ester Treprostinil Ethyl Ester 750W93 751W93 Unidentified	Not more than 0.5% Not more than 0.5% Not more than 0.2% Not more than 1.0% Not more than 0.2% Not more than 0.6% Not more than 1.5% Not more than 1.3% Not more than 0.1% AUC each	ND <sup>3</sup> ND ND 0.2% ND 0.1% 0.09% 0.06% ND
Total Related Substances	Not more than 3.0%	0.5%

<sup>1</sup>All results conform to specifications.

<sup>2</sup>NMT = Not More Than

<sup>3</sup>ND = Not Detected

Cardinal Health  
P.O. Box 13341  
Research Triangle Park, NC 27709  
tel 919.481.4855

www.cardinal.com



**Cardinal Health**

**Certificate of Analysis**

January 16, 2003

Release Testing for Commercial Lots of Treprostinil Drug Substance		
<b>TTP No.:</b>  TTP-LRR-M0117	<b>Company:</b> United Therapeutics Corporation 2225 W. Harrison Street Chicago, IL 60612 (312) 421-1819	<b>Product:</b>  Treprostinil Drug Substance
<b>Phase:</b>  RT-Phase 12	<b>Packaging/Storage:</b> Amber HDPE bottle with NCR screw cap 5 °C/Ambient RH	<b>Method:</b>  ATM-LRR-M0002.17

[[[(1R,2R,3aS,9aS)-2,3,3a,4,9,9a-hexahydro-2-hydroxy-1-[(3S)-3-hydroxyoctyl]-1H-benz[*f*]inden-5-yl]oxy]acetic acid  
Lot UT15-021101

Manufactured 11/21/2002 and Retest 11/21/2004  
Testing started 12/17/2002 and completed 1/3/2003

<u>Test</u>	<u>Specifications</u>	<u>Results<sup>1</sup></u>
Assay (HPLC)	Not less than 97.0 and not more than 101.0%, w/w, on the volatiles-free basis	99.6%
Factor	Factor the material on the basis of assay and total volatiles content	1.005
Endotoxins (1:2000 dilution) ATM-LRR-M0012.00	Less than 104 EU/mg	<60 EU/mg

<sup>1</sup>All results conform to specifications.

All data generated at Cardinal Health and described within this report were collected under the direction of the Study Director and were reviewed for compliance with Good Manufacturing Practices (21 CFR Parts 210 and 211). This report accurately reflects the raw data which have been stored in the Archives of Cardinal Health.

Quality Assurance      16 Jan 2003  
Date

/WEW      1/16/03  
William E. Weiser, Ph.D.      Date  
Study Director



**CardinalHealth**

**Certificate of Analysis**

January 16, 2003

Release Testing for Commercial Lots of Treprostinil Drug Substance		
<b>TTP No.:</b>  TTP-LRR-M0117	<b>Company:</b> United Therapeutics Corporation 2225 W. Harrison Street Chicago, IL 60612 (312) 421-1819	<b>Product:</b>  Treprostinil Drug Substance
<b>Phase:</b>  RT-Phase 12	<b>Packaging/Storage:</b> Amber HDPE bottle with NCR screw cap 5 °C/Ambient RH	<b>Method:</b>  ATM-LRR-M0002.17

[[[(1R,2R,3aS,9aS)-2,3,3a,4,9,9a-hexahydro-2-hydroxy-1-[(3S)-3-hydroxyoctyl]-1H-benz[*f*]inden-5-yl]oxy]acetic acid  
Lot UT15-021102

Manufactured 12/5/2002 and Retest 12/5/2004  
Testing started 12/17/2002 and completed 1/3/2003

Test	Specifications	Results <sup>1</sup>
Physical Examination	A white to cream-colored powder	White powder
Identification IR	The infrared spectrum exhibits maxima which are only at the same wavenumbers as, and have similar relative intensities to, those in the reference standard spectrum of Treprostinil, similarly obtained.	Conforms
HPLC	The retention time for the principle peak in the sample chromatogram agrees with the retention time of the principle peak in the standard chromatogram, using the chromatographic purity method.	Conforms
Residue on Ignition	Not more than 0.2%, w/w	0.0%
Water (Karl Fischer)	Not more than 2.0%, w/w	0.1%
Residual Solvents by Gas Chromatography Ethyl Acetate Ethanol Acetic Acid	Not more than 0.5%, w/w Not more than 0.5%, w/w Not more than 0.5%, w/w	<0.1% 0.1% ND <sup>2</sup>
Melting Range	Not less than 120.0 °C and not more than 126.0 °C	121.2 °C – 123.5 °C
Specific Rotation	Not less than +42.0° and not more than +49.0° at 589 nm and 25 °C, volatiles-free basis	+46.4 °
Heavy Metals	Not more than 0.002%	Not more than 0.002%

<sup>1</sup>All results conform to specifications.  
<sup>2</sup>ND = Not Detected



**CardinalHealth**

**Certificate of Analysis**

January 16, 2003

Release Testing for Commercial Lots of Treprostinil Drug Substance		
TTP No.:  TTP-LRR-M0117	Company: United Therapeutics Corporation 2225 W. Harrison Street Chicago, IL 60612 (312) 421-1819	Product:  Treprostinil Drug Substance
Phase:  RT-Phase 12	Packaging/Storage: Amber HDPE bottle with NCR screw cap 5 °C/Ambient RH	Method:  ATM-LRR-M0002.17

[[[(1R,2R,3aS,9aS)-2,3,3a,4,9,9a-hexahydro-2-hydroxy-1-[(3S)-3-hydroxyoctyl]-1H-benz[*f*]inden-5-yl]oxy]acetic acid  
Lot UT15-021102

Manufactured 12/5/2002 and Retest 12/5/2004  
Testing started 12/17/2002 and completed 1/3/2003

Test	Specifications	Results <sup>1</sup>
Microbial Limits		
Total Aerobic count	NMT <sup>2</sup> 10 CFU/g	0 CFU/g
Total Yeast and Mold Count	NMT 10 CFU/g	0 CFU/g
<i>Escherichia coli</i>	Absent	Absent
<i>Salmonella</i> species	Absent	Absent
<i>Pseudomonas aeruginosa</i>	Absent	Absent
<i>Staphylococcus aureus</i>	Absent	Absent
(ATM-LRR-M0007.00)		
Chromatographic Purity (HPLC)		
1AU90	Not more than 0.5%	ND <sup>3</sup>
2AU90	Not more than 0.5%	ND
97W86 (Benzindene Triol)	Not more than 0.2%	0.07%
3AU90	Not more than 1.0%	0.1%
Treprostinil Methyl Ester	Not more than 0.2%	ND
Treprostinil Ethyl Ester	Not more than 0.6%	0.1%
750W93	Not more than 1.5%	0.2%
751W93	Not more than 1.3%	0.1%
Unidentified	Not more than 0.1% AUC each	ND
Total Related Substances	Not more than 3.0%	0.6%

<sup>1</sup>All results conform to specifications.

<sup>2</sup>NMT = Not More Than

<sup>3</sup>ND = Not Detected



**CardinalHealth**

**Certificate of Analysis**

January 16, 2003

Release Testing for Commercial Lots of Treprostinil Drug Substance		
<b>TTP No.:</b>  TTP-LRR-M0117	<b>Company:</b> United Therapeutics Corporation 2225 W. Harrison Street Chicago, IL 60612 (312) 421-1819	<b>Product:</b>  Treprostinil Drug Substance
<b>Phase:</b>  RT-Phase 12	<b>Packaging/Storage:</b> Amber HDPE bottle with NCR screw cap 5 °C/Ambient RH	<b>Method:</b>  ATM-LRR-M0002.17

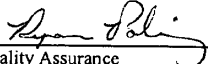
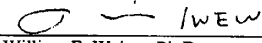
[[[(1R,2R,3aS,9aS)-2,3,3a,4,9,9a-hexahydro-2-hydroxy-1-[(3S)-3-hydroxyoctyl]-  
-1H-benz[*l*]inden-5-yl]oxy]acetic acid  
Lot UT15-021102

Manufactured 12/5/2002 and Retest 12/5/2004  
Testing started 12/17/2002 and completed 1/3/2003

<u>Test</u>	<u>Specifications</u>	<u>Results<sup>1</sup></u>
Assay (HPLC)	Not less than 97.0 and not more than 101.0%, w/w, on the volatiles-free basis	99.2%
Factor	Factor the material on the basis of assay and total volatiles content	1.011
Endotoxins (1:2000 dilution) (ATM-LRR-M0012.00)	Less than 104 EU/mg	<60 EU/mg

All results conform to specifications.

All data generated at Cardinal Health and described within this report were collected under the direction of the Study Director and were reviewed for compliance with Good Manufacturing Practices (21 CFR Parts 210 and 211). This report accurately reflects the raw data which have been stored in the Archives of Cardinal Health.

	16 Jan 2003		1/16/03
Quality Assurance	Date	William E. Weiser, Ph.D. Study Director	Date

**HIGHLY CONFIDENTIAL**

P. 86

UT Ex. 2036

SteadyMed v. United Therapeutics

IPR2016-00006

**UTC-Sand-Rem01102429**

**IPR2020-00769**

**United Therapeutics EX2006**

**Page 4834 of 7113**



RPT-A-LRR-M0107-001-03.00

**Certificate of Analysis**  
**Release and Stability Testing for Three Lots of UT-15**  
**Drug Substance**

**Technical TP Number: TTP-LRR-M0107**  
**Study Phase: RT-Phase 1**  
**September 29, 2000**

---

**MAGELLAN LABORATORIES Incorporated**      *Analytical resources for the pharmaceutical industry*

P. 87  
P.O. Box 13341 • Research Triangle Park • North Carolina 27709  
Corporate (919) 481-4600      **UT Ex 2036**  
Steady State      **United Therapeutics**

IPR2016-00006

**HIGHLY CONFIDENTIAL**

**UTC-Sand-Rem01117901**

**IPR2020-00769**  
**United Therapeutics EX2006**  
**Page 4835 of 7113**



**Magellan Analytical**  
 A Division Of Magellan Laboratories  
 Magellan Facility  
 P.O. Box 13341  
 Research Triangle Park, NC 27709  
 Corporate: (919) 481-4855  
 Facsimile: (919) 481-4908  
 www.magellanlabs.com

*Certificate of Analysis*  
 September 29, 2000

Release and Stability Testing for Three Lots of UT-15 Drug Substance		
TTP No.: TTP-LRR-M0107	Company: United Therapeutics, Corporation Research and Development	Product: UT-15 Drug Substance Method: ATM-LRR-M0002.13
Phase: RT-Phase 1		

[[*(1R,2R,3aS,9aS)*-2,3,3a,4,9,9a-hexahydro-2-hydroxy-1-[(*3S*)-3-hydroxyoctyl]-1*H*-benz[*f*]inden-5-yl]oxy]acetic acid  
 Lot UT15-000701

Test	Specifications	Results
Physical Examination	A white to cream-colored powder	Conforms
Identification IR	The infrared spectrum exhibits maxima which are only at the same wavenumbers as, and have similar relative intensities to, those in the reference standard spectrum of UT-15, similarly obtained.	Conforms
HPLC	The retention time for the principle peak in the sample chromatogram agrees with the retention time of the principle peak in the standard chromatogram, using the chromatographic purity method.	Conforms
Residue on Ignition	Not more than 0.2%, w/w	0.04%, w/w
Water (Karl Fischer)	Not more than 2.0%, w/w	0.2%, w/w
Residual Solvents by Gas Chromatography		
Ethyl Acetate	Not more than 0.5%, w/w	<0.1%
Ethanol	Not more than 0.5%, w/w	<0.1%
Acetic Acid	Not more than 0.5%, w/w	<0.1%
Melting Range	Not less than 120 °C and not more than 126 °C	123.1-124.7 °C
Specific Rotation	Not less than +42.0° and not more than +49.0° at 589 nm and 25 °C, volatiles-free basis	$[\alpha]_{589}^{25} = +44.1^\circ$ (volatiles-free basis)
Heavy Metals	Not more than 0.002%	Not more than 0.002%





**Magellan Analytical**  
 A Division Of Magellan Laboratories  
 Magellan Facility  
 P.O. Box 13341  
 Research Triangle Park, NC 27709  
 Corporate: (919) 481-4855  
 Facsimile: (919) 481-4908  
 www.magellanlabs.com

[[**(1R,2R,3aS,9aS)-2,3,3a,4,9,9a-hexahydro-2-hydroxy-1-[(3S)-3-hydroxyoctyl]-1H-benz[*f*]inden-5-yl]oxy]acetic acid**  
**Lot UT15-000701**

Test	Specifications	Results
<b>Chromatographic Purity (HPLC)</b>		
1AU90	Not more than 0.5%	ND <sup>1</sup>
2AU90	Not more than 0.5%	<0.05%
97W86 (Benzindene Triol)	Not more than 0.5%	ND
3AU90	Not more than 1.0%	0.1%
UT-15 Methyl Ester	Not more than 0.2%	<0.05%
98W86 (Methoxy Diol)	Not more than 0.1%	ND
UT-15 Ethyl Ester	Not more than 0.6%	0.08%
750W93	Not more than 2.0%	0.06%
751W93	Not more than 2.0%	<0.05%
Unidentified	Not more than 0.1% each	ND
<b>Total Related Substances</b>	Not more than 5.0%	0.2%
<b>Assay (HPLC)</b>	Not less than 95.0 and not more than 101.0%, w/w, on the volatiles-free basis	100.0%
<b>Factor</b>	Factor the material on the basis of assay and total volatiles content	1.003 parts UT-15 equivalent to 1.00 parts volatiles-free UT-15

<sup>1</sup>ND = Not Detected

All data generated at Magellan Laboratories Incorporated and described within this report were collected under the direction of the Study Director and were audited by the Quality Assurance Unit of Magellan Laboratories Incorporated for compliance with Good Laboratory Practices (21 CFR Part 58) and Good Manufacturing Practices (21 CFR Part 211). This report accurately reflects the raw data which have been stored in the Archives of Magellan Laboratories Incorporated.

*Colin St*  
 Quality Assurance

9/29/00  
 Date

*William E Weiser*  
 William Edward Weiser, Ph.D.  
 Study Director

9/29/2000  
 Date



RPT-A-LRR-M0107-001-03.00

**Certificate of Analysis**  
**Release and Stability Testing for Three Lots of UT-15**  
**Drug Substance**

**Technical TP Number: TTP-LRR-M0107**  
**Study Phase: RT-Phase 1**  
**September 29, 2000**

---

**MAGELLAN LABORATORIES** Incorporated

*Analytical resources for the pharmaceutical industry*

P. 90  
P.O. Box 13341 · Research Triangle Park · North Carolina 27709  
Corporate (919) 481-4600  
SteadyMed, United Therapeutics

UT Ex 2036

IPR2016-00006

**HIGHLY CONFIDENTIAL**

**UTC-Sand-Rem01117904**

IPR2020-00769  
United Therapeutics EX2006  
Page 4838 of 7113



**Magellan Analytical**  
 A Division Of Magellan Laboratories  
 Magellan Facility  
 P.O. Box 13341  
 Research Triangle Park, NC 27709  
 Corporate: (919) 481-4855  
 Facsimile: (919) 481-4908  
 www.magellanlabs.com

*Certificate of Analysis*  
 September 29, 2000

Release and Stability Testing for Three Lots of UT-15 Drug Substance		
TTP No.: TTP-LRR-M0107	Company: United Therapeutics, Corporation Research and Development	Product: UT-15 Drug Substance Method: ATM-LRR-M0002.13
Phase: RT-Phase 1		

[[*(1R,2R,3aS,9aS)*-2,3,3a,4,9,9a-hexahydro-2-hydroxy-1-[(*(3S)*-3-hydroxyoctyl)-1*H*-benz[*f*]inden-5-yl]oxy]acetic acid  
 Lot UT15-000801

Test	Specifications	Results
Physical Examination	A white to cream-colored powder	Conforms
Identification		
IR	The infrared spectrum exhibits maxima which are only at the same wavenumbers as, and have similar relative intensities to, those in the reference standard spectrum of UT-15, similarly obtained.	Conforms
HPLC	The retention time for the principle peak in the sample chromatogram agrees with the retention time of the principle peak in the standard chromatogram, using the chromatographic purity method.	Conforms
Residue on Ignition	Not more than 0.2%, w/w	0.01%, w/w
Water (Karl Fischer)	Not more than 2.0%, w/w	0.2%, w/w
Residual Solvents by Gas Chromatography		
Ethyl Acetate	Not more than 0.5%, w/w	<0.1%
Ethanol	Not more than 0.5%, w/w	<0.1%
Acetic Acid	Not more than 0.5%, w/w	<0.1%
Melting Range	Not less than 120 °C and not more than 126 °C	123.1-124.7 °C
Specific Rotation	Not less than +42.0° and not more than +49.0° at 589 nm and 25 °C, volatiles-free basis	$[\alpha]_{589}^{25} = +44.7^\circ$ (volatiles-free basis)
Heavy Metals	Not more than 0.002%	Not more than 0.002%

PO Box 13341  
 Research Triangle Park, NC  
 27709  
 Corporate (919) 481-4855  
 Facsimile (919) 481-4908  
 www.magellanlabs.com



[[[(1R,2R,3aS,9aS)-2,3,3a,4,9,9a-hexahydro-2-hydroxy-1-[(3S)-3-hydroxyoctyl]  
 -1H-benz[*h*]inden-5-yl]oxy]acetic acid  
 Lot UT15-000801

Test	Specifications	Results
<b>Chromatographic Purity (HPLC)</b>		
1AU90	Not more than 0.5%	ND <sup>1</sup>
2AU90	Not more than 0.5%	< 0.05%
97W86 (Benzindene Triol)	Not more than 0.5%	ND
3AU90	Not more than 1.0%	0.2%
UT-15 Methyl Ester	Not more than 0.2%	< 0.05%
98W86 (Methoxy Diol)	Not more than 0.1%	ND
UT-15 Ethyl Ester	Not more than 0.6%	0.1%
750W93	Not more than 2.0%	0.07%
751W93	Not more than 2.0%	< 0.05%
Unidentified Unid@RRT16.41	Not more than 0.1% each	0.05%
Total Related Substances	Not more than 5.0%	0.4%
Assay (HPLC)	Not less than 95.0 and not more than 101.0%, w/w, on the volatiles-free basis	100.0%
Factor	Factor the material on the basis of assay and total volatiles content	1.002 parts UT-15 equivalent to 1.00 parts volatiles-free UT-15

<sup>1</sup>ND = Not Detected

All data generated at Magellan Laboratories Incorporated and described within this report were collected under the direction of the Study Director and were audited by the Quality Assurance Unit of Magellan Laboratories Incorporated for compliance with Good Laboratory Practices (21 CFR Part 58) and Good Manufacturing Practices (21 CFR Part 211). This report accurately reflects the raw data which have been stored in the Archives of Magellan Laboratories Incorporated.

*C. B. SA*                      9/29/00  
 Quality Assurance                      Date

*William E. Weiser*                      9/29/2000  
 William Edward Weiser, Ph.D.                      Date  
 Study Director



RPT-A-LRR-M0107-001-03.00

**Certificate of Analysis**  
**Release and Stability Testing for Three Lots of UT-15**  
**Drug Substance**

**Technical TP Number: TTP-LRR-M0107**  
**Study Phase: RT-Phase 1**  
**September 29, 2000**

---

MAGELLAN LABORATORIES Incorporated<sup>93</sup>

Analytical resources for the pharmaceutical industry

SteadyMed v. United Therapeutics

P.O. Box 13344 • Research Triangle Park, North Carolina 27709

IPR2016-00006

**HIGHLY CONFIDENTIAL**

**UTC-Sand-Rem01117910**

IPR2020-00769

United Therapeutics EX2006

Page 4841 of 7113

PO Box 13341  
 Research Triangle Park, NC  
 27709  
 Corporate (919) 481-4855  
 Facsimile (919) 481-4908  
 www.magellanlabs.com



Certificate of Analysis  
 September 29, 2000

Release and Stability Testing for Three Lots of UT-15 Drug Substance		
TTP No.: TTP-LRR-M0107	Company: United Therapeutics, Corporation Research and Development	Product: UT-15 Drug Substance
Phase: RT-Phase 1		Method: ATM-LRR-M0002.13

[[[(1R,2R,3aS,9aS)-2,3,3a,4,9,9a-hexahydro-2-hydroxy-1-[(3S)-3-hydroxyoctyl]-1H-benz[*f*]inden-5-yl]oxy]acetic acid  
 Lot UT15-000802

Test	Specifications	Results
Physical Examination	A white to cream-colored powder	Conforms
Identification IR	The infrared spectrum exhibits maxima which are only at the same wavenumbers as, and have similar relative intensities to, those in the reference standard spectrum of UT-15, similarly obtained.	Conforms
HPLC	The retention time for the principle peak in the sample chromatogram agrees with the retention time of the principle peak in the standard chromatogram, using the chromatographic purity method.	Conforms
Residue on Ignition	Not more than 0.2%, w/w	0.00%, w/w
Water (Karl Fischer)	Not more than 2.0%, w/w	0.3%, w/w
Residual Solvents by Gas Chromatography Ethyl Acetate Ethanol Acetic Acid	Not more than 0.5%, w/w Not more than 0.5%, w/w Not more than 0.5%, w/w	<0.1% <0.1% <0.1%
Melting Range	Not less than 120 °C and not more than 126 °C	123.1-124.7 °C
Specific Rotation	Not less than +42.0° and not more than +49.0° at 589 nm and 25 °C, volatiles-free basis	$[\alpha]_{589}^{25} = +44.0^\circ$ (volatiles-free basis)
Heavy Metals	Not more than 0.002%	Not more than 0.002%

PO Box 13341  
 Research Triangle Park, NC  
 27709  
 Corporate (919) 481-4855  
 Facsimile (919) 481-4908  
 www.magellanlabs.com



[[*(1R,2R,3aS,9aS)*-2,3,3a,4,9,9a-hexahydro-2-hydroxy-1-[(3*S*)-3-hydroxyoctyl]  
 -1*H*-benz[*f*]inden-5-yl]oxy]acetic acid  
 Lot UT15-000802

Test	Specifications	Results
Chromatographic Purity (HPLC)		
1AU90	Not more than 0.5%	ND <sup>1</sup>
2AU90	Not more than 0.5%	<0.05%
97W86 (Benzindene Triol)	Not more than 0.5%	ND
3AU90	Not more than 1.0%	0.1%
UT-15 Methyl Ester	Not more than 0.2%	<0.05%
98W86 (Methoxy Diol)	Not more than 0.1%	ND
UT-15 Ethyl Ester	Not more than 0.6%	0.07%
750W93	Not more than 2.0%	0.1%
751W93	Not more than 2.0%	0.07%
Unidentified	Not more than 0.1% each	ND
Total Related Substances	Not more than 5.0%	0.3%
Assay (HPLC)	Not less than 95.0 and not more than 101.0%, w/w, on the volatiles-free basis	99.9%
Factor	Factor the material on the basis of assay and total volatiles content	1.004 parts UT-15 equivalent to 1.00 parts volatiles-free UT-15

<sup>1</sup>ND = Not Detected

All data generated at Magellan Laboratories Incorporated and described within this report were collected under the direction of the Study Director and were audited by the Quality Assurance Unit of Magellan Laboratories Incorporated for compliance with Good Laboratory Practices (21 CFR Part 58) and Good Manufacturing Practices (21 CFR Part 211). This report accurately reflects the raw data which have been stored in the Archives of Magellan Laboratories Incorporated.

*Col. St.*                      9/29/00  
 Quality Assurance                      Date

*William E. Weiser*                      9/29/2000  
 William Edward Weiser, Ph.D.                      Date  
 Study Director



RPT-A-LRR-M0113-001-02.00

**Certificate of Analysis**  
**Release and Stability Testing for Two Commercial Lots of**  
**UT-15 Drug Substance**

**Technical TP Number: TTP-LRR-M0113**  
**Study Phase: Release Testing**  
**October 31, 2000**

---

**MAGELLAN LABORATORIES** Incorporated

*Analytical resources for the pharmaceutical industry*

P. 96  
P.O. Box 13341 • Research Triangle Park • North Carolina 27709  
Corporate (919) 481-4800  
SteadyMed, United Therapeutics

UT Ex 2036  
IPR2016-00006

**HIGHLY CONFIDENTIAL**

**UTC-Sand-Rem01118722**

IPR2020-00769  
United Therapeutics EX2006  
Page 4844 of 7113





**Magellan Analytical**  
 A Division Of Magellan Laboratories  
 Magellan Facility  
 P.O. Box 13341  
 Research Triangle Park, NC 27709  
 Corporate: (919) 481-4855  
 Facsimile: (919) 481-4908  
 www.magellanlabs.com

*Certificate of Analysis*  
 October 31, 2000

Release and Stability Testing for Two Commercial Lots of UT-15 Drug Substance		
<b>TTP No.:</b> TTP-LRR-M0113	<b>Company:</b> United Therapeutics, Corporation Research and Development	<b>Product:</b> UT-15 Drug Substance
<b>Phase:</b> Release Testing		<b>Method:</b> ATM-LRR-M0002.13

**[[*(1R,2R,3aS,9aS)*-2,3,3a,4,9,9a-hexahydro-2-hydroxy-1-[(*3S*)-3-hydroxyoctyl]-1*H*-benz[*f*]inden-5-yl]oxy]acetic acid**  
**Lot UT15-000902**

<u>Test</u>	<u>Specifications</u>	<u>Results</u>
Physical Examination	A white to cream-colored powder	Conforms
Identification IR	The infrared spectrum exhibits maxima which are only at the same wavenumbers as, and have similar relative intensities to, those in the reference standard spectrum of UT-15, similarly obtained.	Conforms
HPLC	The retention time for the principle peak in the sample chromatogram agrees with the retention time of the principle peak in the standard chromatogram, using the chromatographic purity method.	Conforms
Residue on Ignition	Not more than 0.2%, w/w	0.07%, w/w
Water (Karl Fischer)	Not more than 2.0%, w/w	0.1%, w/w
Residual Solvents by Gas Chromatography Ethyl Acetate Ethanol Acetic Acid	Not more than 0.5%, w/w Not more than 0.5%, w/w Not more than 0.5%, w/w	<0.1% 0.1% <0.1%
Melting Range	Not less than 120.0 °C and not more than 126.0 °C	122.8 - 125.2 °C
Specific Rotation	Not less than +42.0° and not more than +49.0° at 589 nm and 25 °C, volatiles-free basis	$[\alpha]_{589}^{25} = +45.9^\circ$ (volatiles-free basis)
Heavy Metals	Not more than 0.002%	Not more than 0.002%



**Magellan Analytical**  
 A Division Of Magellan Laboratories  
 Magellan Facility  
 P.O. Box 13341  
 Research Triangle Park, NC 27709  
 Corporate: (919) 481-4855  
 Facsimile: (919) 481-4908  
 www.magellanlabs.com

[[[(1R,2R,3aS,9aS)-2,3,3a,4,9,9a-hexahydro-2-hydroxy-1-[(3S)-3-hydroxyoctyl]-1H-benz[f]inden-5-yl]oxy]acetic acid  
 Lot UT15-000902

<u>Test</u>	<u>Specifications</u>	<u>Results</u>
<b>Chromatographic Purity (HPLC)</b>		
1AU90	Not more than 0.5%	Not Detected
2AU90	Not more than 0.5%	<0.05%
97W86 (Benzindene Triol)	Not more than 0.5%	Not Detected
3AU90	Not more than 1.0%	0.2%
UT-15 Methyl Ester	Not more than 0.2%	<0.05%
98W86 (Methoxy Diol)	Not more than 0.1%	<0.05%
UT-15 Ethyl Ester	Not more than 0.6%	0.1%
750W93	Not more than 2.0%	0.1%
751W93	Not more than 2.0%	0.06%
Unidentified	Not more than 0.1% each	Not Detected
<b>Total Related Substances</b>	Not more than 5.0%	0.5%
<b>Assay (HPLC)</b>	Not less than 95.0 and not more than 101.0%, w/w, on the volatiles-free basis	99.8%
<b>Factor</b>	Factor the material on the basis of assay and total volatiles content	1.004 parts UT-15 equivalent to 1.00 parts volatiles-free UT-15

All data generated at Magellan Laboratories Incorporated and described within this report were collected under the direction of the Study Director and were audited by the Quality Assurance Unit of Magellan Laboratories Incorporated for compliance with Good Laboratory Practices (21 CFR Part 58) and Good Manufacturing Practices (21 CFR Part 211). This report accurately reflects the raw data which have been stored in the Archives of Magellan Laboratories Incorporated.

Marlene E. Paseta                      10/31/00  
 Quality Assurance                      Date

William Edward Weiser, Ph.D.                      10/31/00  
 Study Director                      Date



RPT-A-LRR-M0113-001-02.00

**Certificate of Analysis**  
**Release and Stability Testing for Two Commercial Lots of**  
**UT-15 Drug Substance**

**Technical TP Number: TTP-LRR-M0113**  
**Study Phase: Release Testing**  
**October 31, 2000**

---

**MAGELLAN LABORATORIES Incorporated**

*Analytical resources for the pharmaceutical industry*

P.O. Box 13341 • Research Triangle Park • North Carolina 27709  
Corporate (919) 481-4855 • Fax (919) 481-4888  
SteadyMed v. United Therapeutics

IPR2016-00006

**HIGHLY CONFIDENTIAL**

**UTC-Sand-Rem01118725**

IPR2020-00769  
United Therapeutics EX2006  
Page 4847 of 7113



**Magellan Analytical**  
 A Division Of Magellan Laboratories  
 Magellan Facility  
 P.O. Box 13341  
 Research Triangle Park, NC 27709  
 Corporate: (919) 481-4855  
 Facsimile: (919) 481-4908  
 www.magellanlabs.com

*Certificate of Analysis*  
 October 31, 2000

Release and Stability Testing for Two Commercial Lots of UT-15 Drug Substance		
TTP No.: TTP-LRR-M0113	Company: United Therapeutics, Corporation Research and Development	Product: UT-15 Drug Substance
Phase: Release Testing		Method: ATM-LRR-M0002.13

**[[[(1R,2R,3aS,9aS)-2,3,3a,4,9,9a-hexahydro-2-hydroxy-1-[(3S)-3-hydroxyoctyl]-1H-benz[f]inden-5-yl]oxy]acetic acid  
 Lot UT15-000803**

Test	Specifications	Results
Physical Examination	A white to cream-colored powder	Conforms
Identification IR	The infrared spectrum exhibits maxima which are only at the same wavenumbers as, and have similar relative intensities to, those in the reference standard spectrum of UT-15, similarly obtained.	Conforms
HPLC	The retention time for the principle peak in the sample chromatogram agrees with the retention time of the principle peak in the standard chromatogram, using the chromatographic purity method.	Conforms
Residue on Ignition	Not more than 0.2%, w/w	0.11%, w/w
Water (Karl Fischer)	Not more than 2.0%, w/w	0.2%, w/w
Residual Solvents by Gas Chromatography Ethyl Acetate Ethanol Acetic Acid	Not more than 0.5%, w/w Not more than 0.5%, w/w Not more than 0.5%, w/w	Not Detected 0.1% <0.1%
Melting Range	Not less than 120.0 °C and not more than 126.0 °C	122.4 - 124.9 °C
Specific Rotation	Not less than +42.0° and not more than +49.0° at 589 nm and 25 °C, volatiles-free basis	$[\alpha]_{589}^{25} = +46.2^\circ$ (volatiles-free basis)
Heavy Metals	Not more than 0.002%	Not more than 0.002%



**Magellan Analytical**  
 A Division Of Magellan Laboratories  
 Magellan Facility  
 P.O. Box 13341  
 Research Triangle Park, NC 27709  
 Corporate: (919) 481-4855  
 Facsimile: (919) 481-4908  
 www.magellanlabs.com

**[[ (1R,2R,3aS,9aS)-2,3,3a,4,9,9a-hexahydro-2-hydroxy-1-[(3S)-3-hydroxyoctyl]-1H-benz[f]inden-5-yl]oxy]acetic acid**  
**Lot UT15-000803**

<u>Test</u>	<u>Specifications</u>	<u>Results</u>
<b>Chromatographic Purity (HPLC)</b>		
1AU90	Not more than 0.5%	Not Detected
2AU90	Not more than 0.5%	<0.05%
97W86 (Benzindene Triol)	Not more than 0.5%	Not Detected
3AU90	Not more than 1.0%	0.2%
UT-15 Methyl Ester	Not more than 0.2%	<0.05%
98W86 (Methoxy Diol)	Not more than 0.1%	<0.05%
UT-15 Ethyl Ester	Not more than 0.6%	0.1%
750W93	Not more than 2.0%	0.2%
751W93	Not more than 2.0%	0.09%
Unidentified	Not more than 0.1% each	Not Detected
<b>Total Related Substances</b>	<b>Not more than 5.0%</b>	<b>0.6%</b>
<b>Assay (HPLC)</b>	<b>Not less than 95.0 and not more than 101.0%, w/w, on the volatiles-free basis</b>	<b>99.7%</b>
<b>Factor</b>	<b>Factor the material on the basis of assay and total volatiles content</b>	<b>1.006 parts UT-15 equivalent to 1.00 parts volatiles-free UT-15</b>

All data generated at Magellan Laboratories Incorporated and described within this report were collected under the direction of the Study Director and were audited by the Quality Assurance Unit of Magellan Laboratories Incorporated for compliance with Good Laboratory Practices (21 CFR Part 58) and Good Manufacturing Practices (21 CFR Part 211). This report accurately reflects the raw data which have been stored in the Archives of Magellan Laboratories Incorporated.

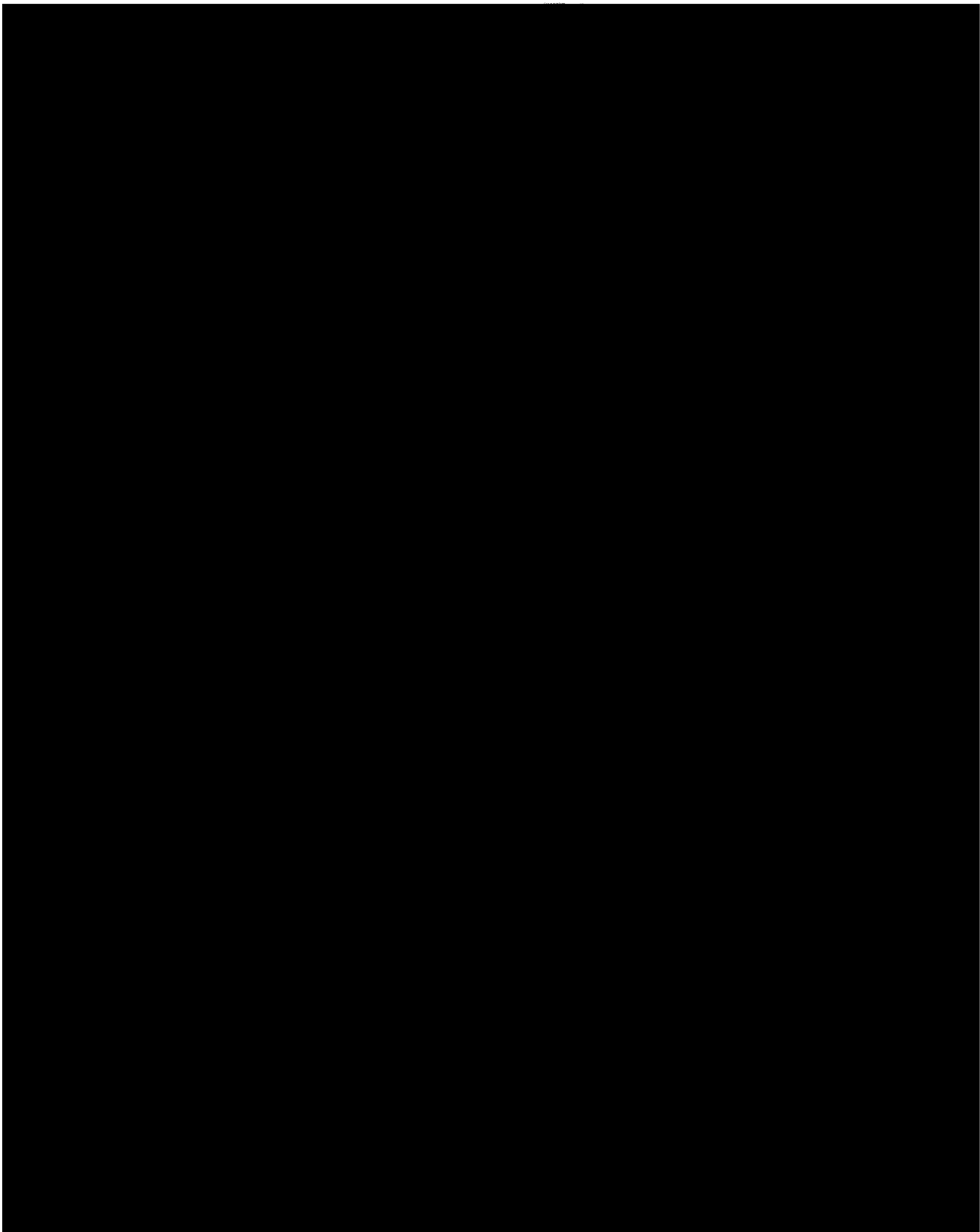
Marlene E. Raseta      10/31/00  
 Quality Assurance      Date

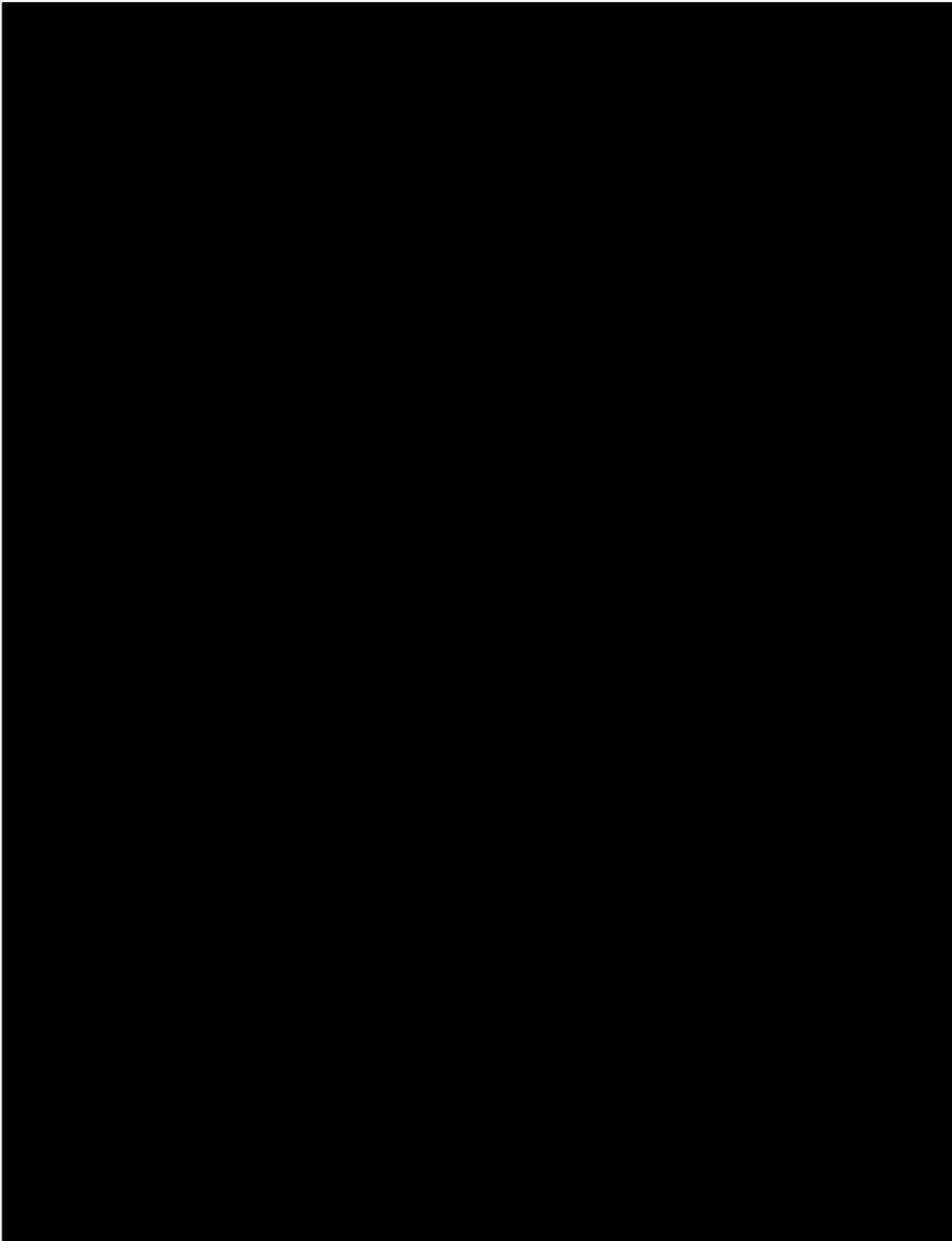
William Edward Weiser, Ph.D.      10/31/00  
 Study Director      Date

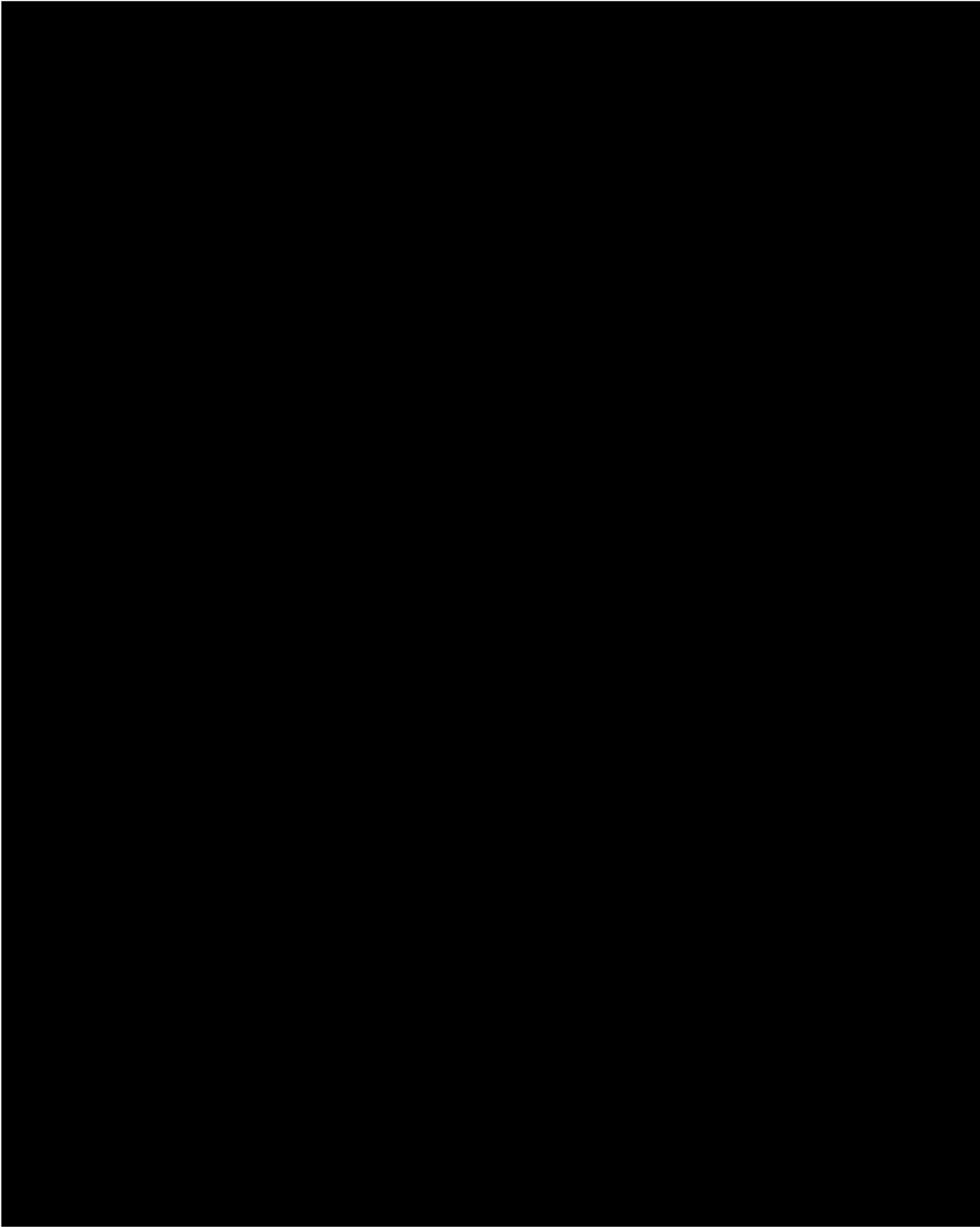
**HIGHLY CONFIDENTIAL**

**UTC-Sand-Rem01118727**

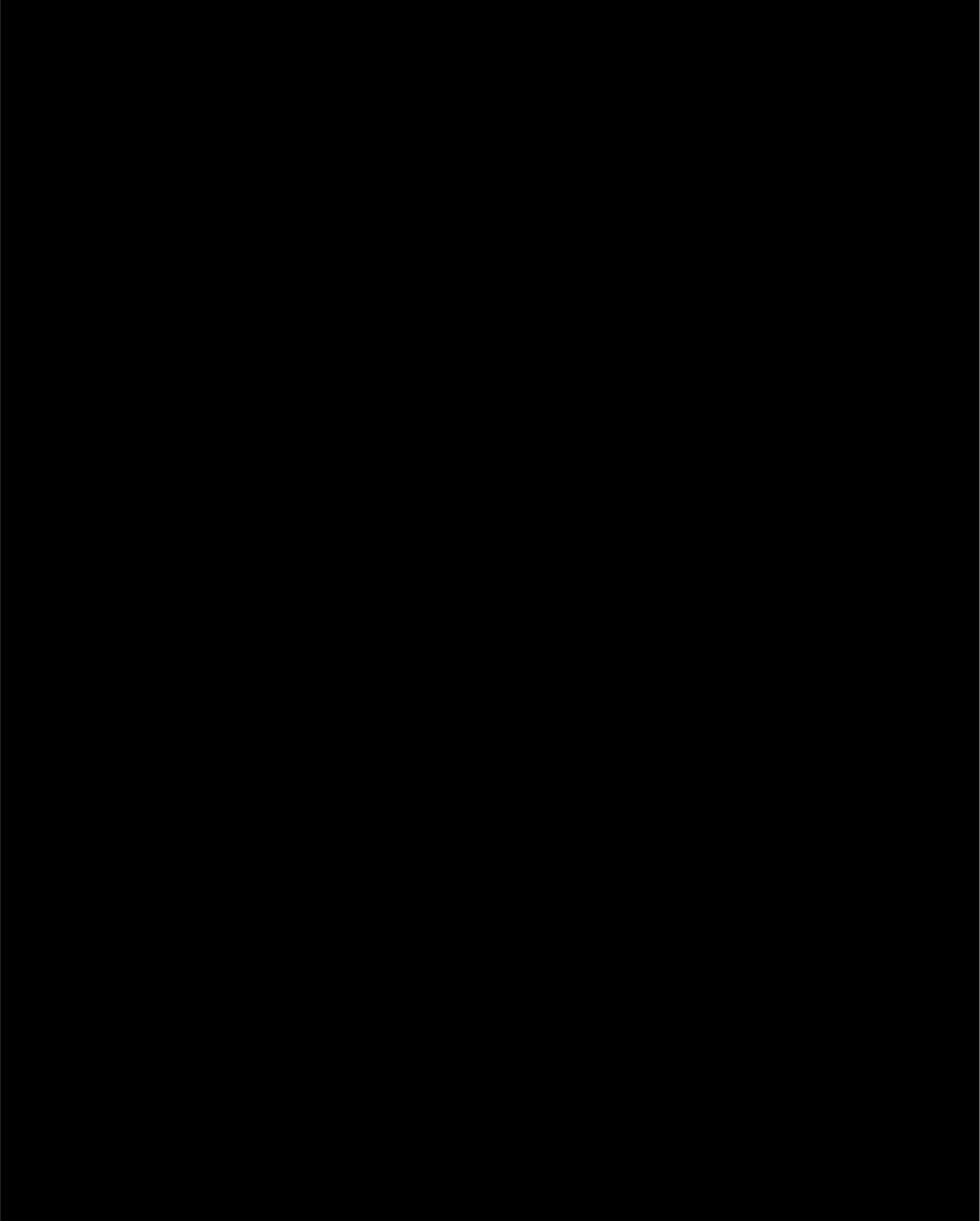
IPR2020-00769  
 United Therapeutics EX2006  
 Page 4849 of 7113

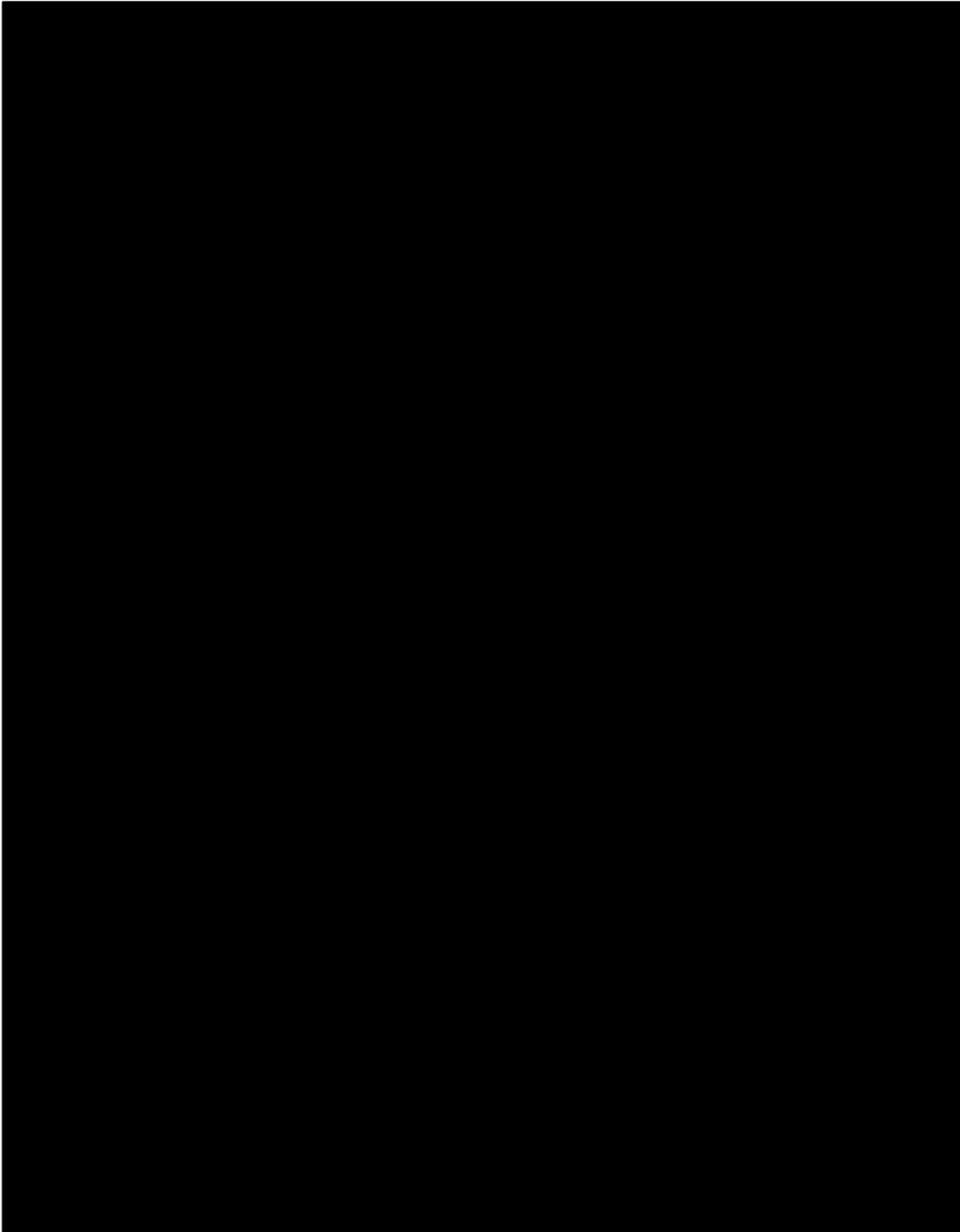


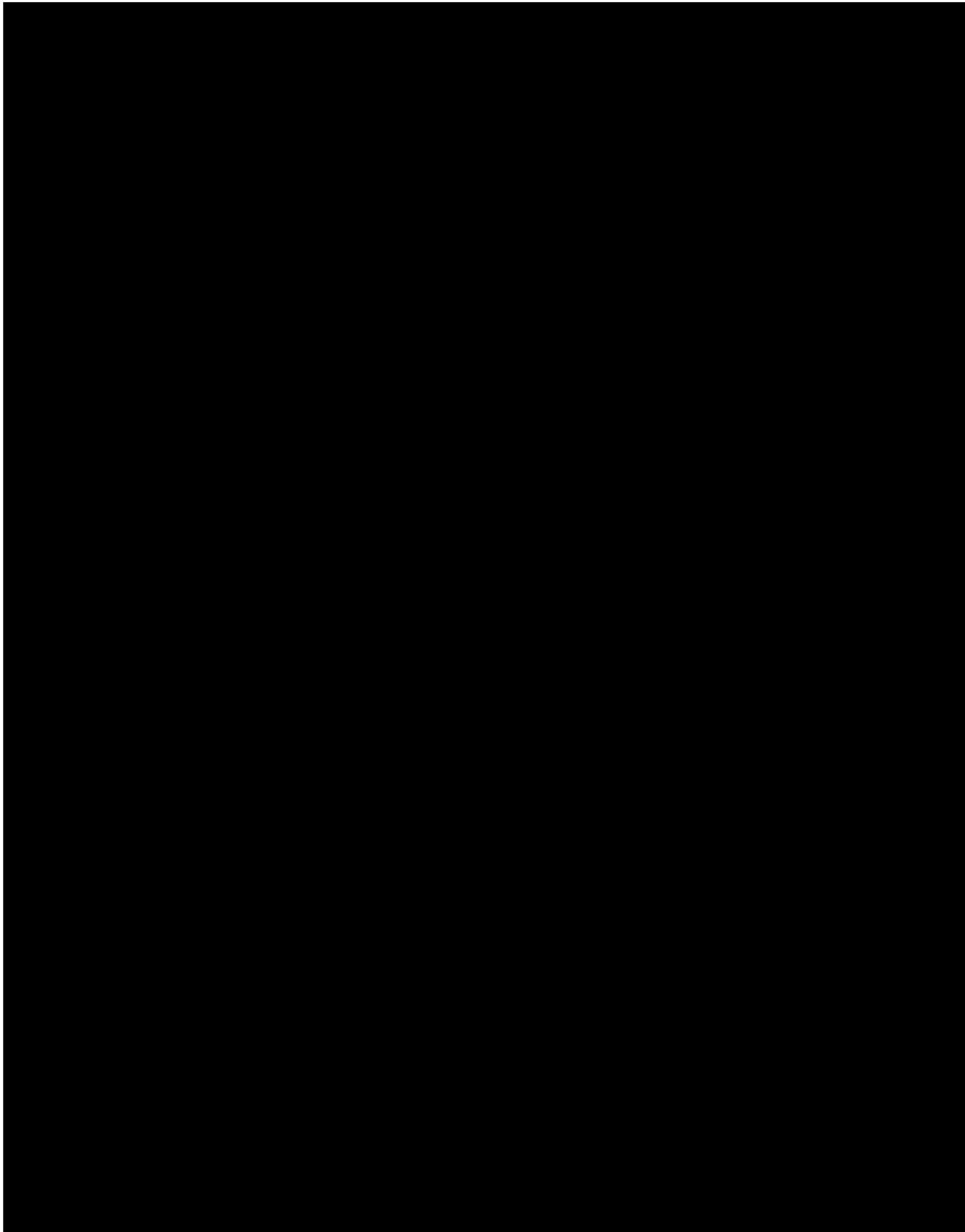


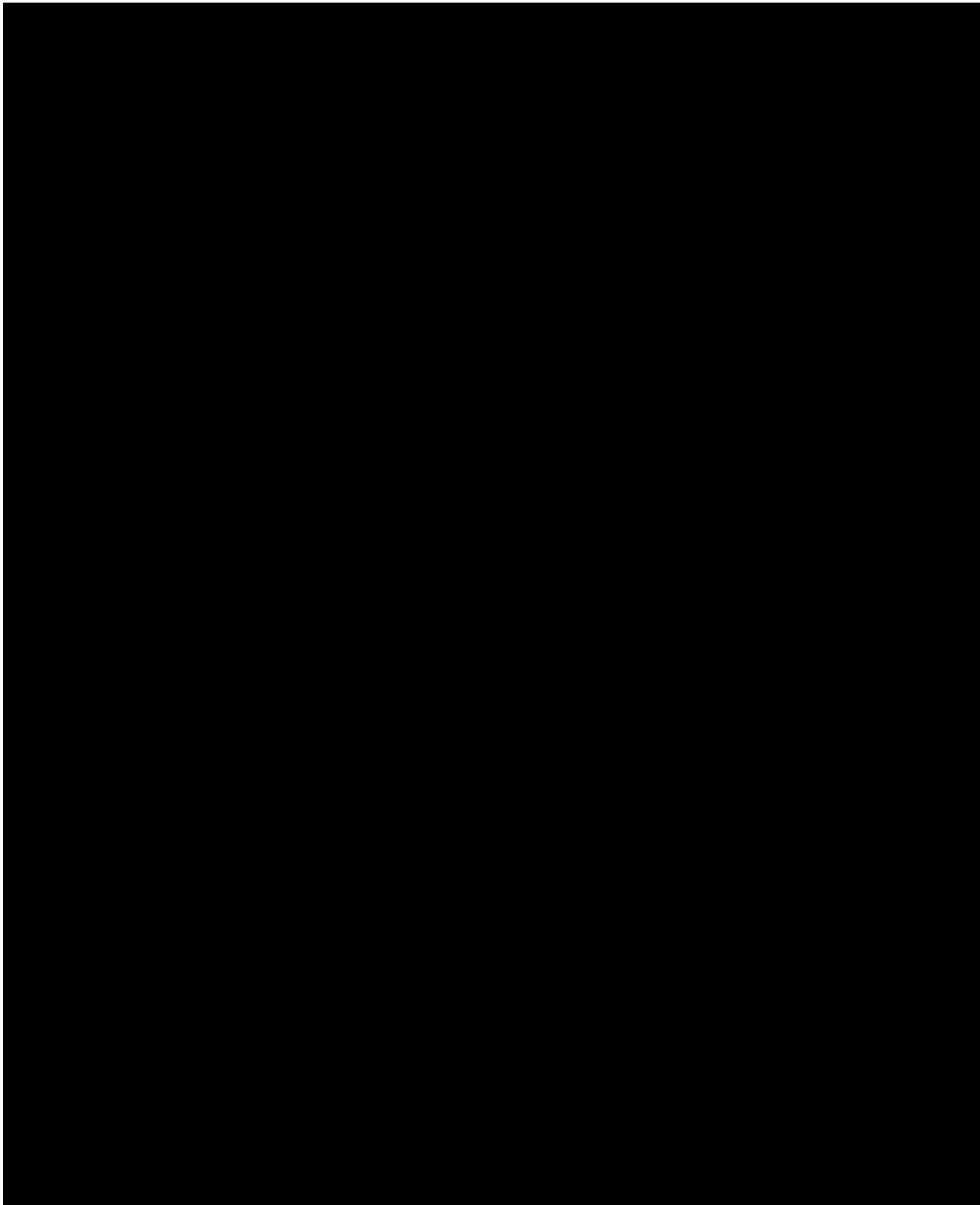












**HIGHLY CONFIDENTIAL**

P. 8  
SteadyMed v. United Therapeutics

UT Ex. 2037

UTC\_TV\_000017206

IPR2020-00769  
United Therapeutics EX2006  
Page 4857 of 7113

**HIGHLY CONFIDENTIAL**

P. 9 UT Ex. 2037 UTC\_TV\_000017207  
SteadyMed v. United Therapeutics

IPR2020-00769  
United Therapeutics EX2006  
Page 4858 of 7113

**HIGHLY CONFIDENTIAL**

P. 10  
SteadyMed v. United Therapeutics

UT Ex. 2037

UTC\_TV\_000017209

IPR2020-00769  
United Therapeutics EX2006  
Page 4859 of 7113

**HIGHLY CONFIDENTIAL**

P. 11 UT Ex. 2037 UTC\_TV\_000017210  
SteadyMed v. United Therapeutics

IPR2020-00769  
United Therapeutics EX2006  
Page 4860 of 7113



**HIGHLY CONFIDENTIAL**

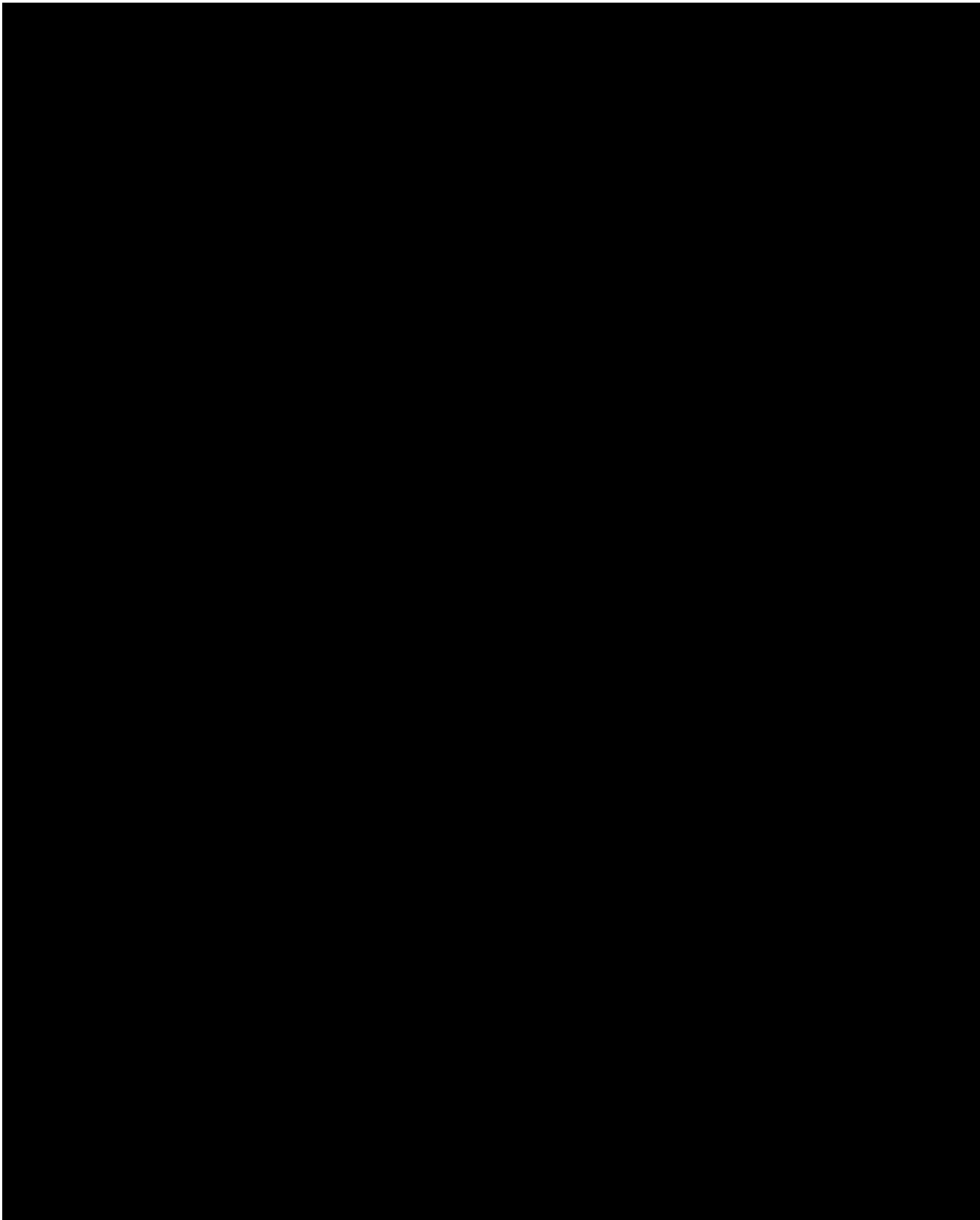
P. 12 UT Ex. 2037 UTC\_TV\_000017252  
SteadyMed v. United Therapeutics  
IPR2020-00769

IPR2020-00769  
United Therapeutics EX2006  
Page 4861 of 7113

**HIGHLY CONFIDENTIAL**

P. 13 UT Ex. 2037  
SteadyMed v. United Therapeutics **UTC\_TV\_000017253**  
IPR2020-00769

IPR2020-00769  
United Therapeutics EX2006  
Page 4862 of 7113



**HIGHLY CONFIDENTIAL**

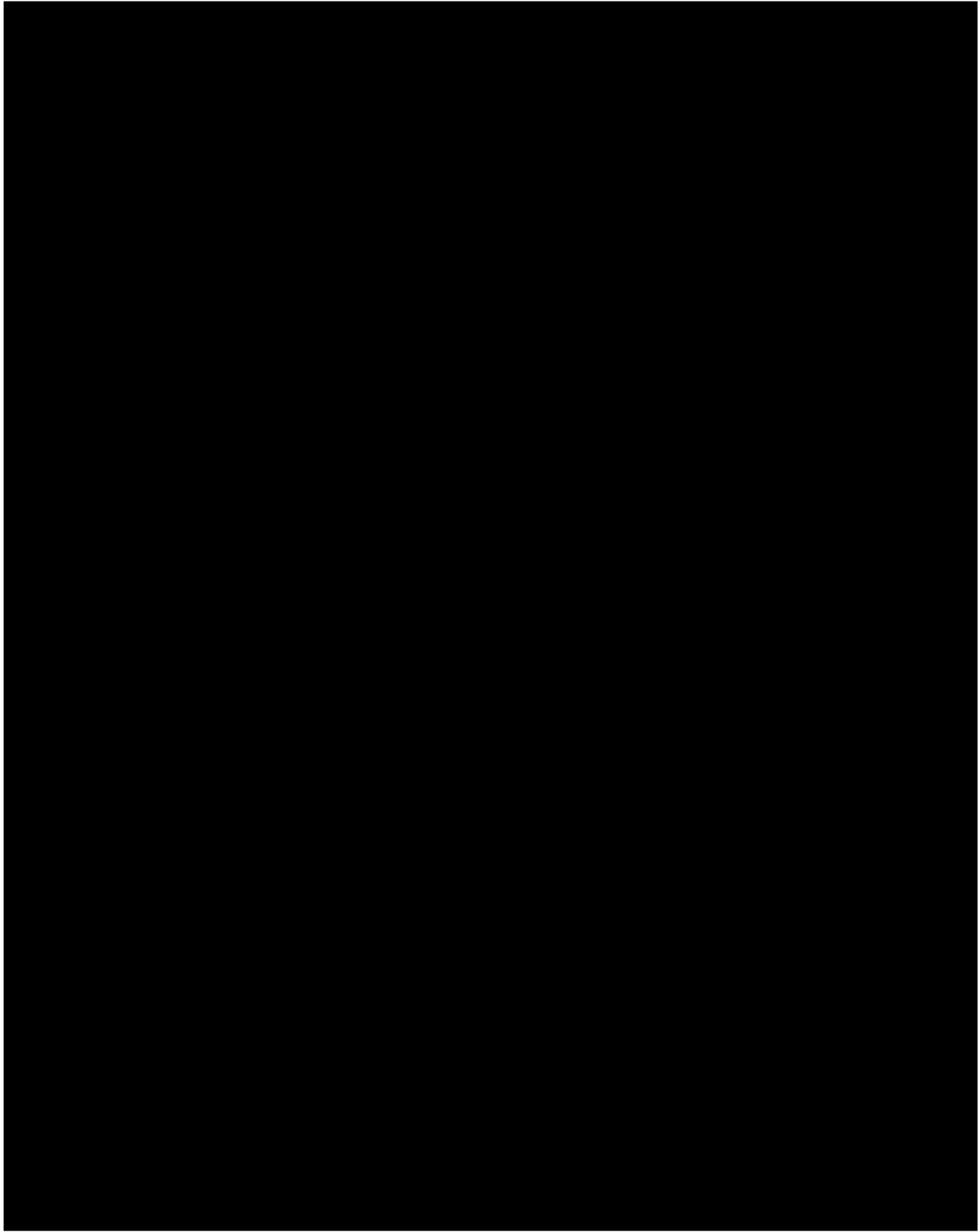
P. 14 UT Ex. 2037  
SteadyMed v. United Therapeutics UTC\_TV\_000017255

IPR2020-00769  
United Therapeutics EX2006  
Page 4863 of 7113

**HIGHLY CONFIDENTIAL**

P. 15 UT Ex. 2037  
SteadyMed v. United Therapeutics UTC\_TV\_000017256

IPR2020-00769  
United Therapeutics EX2006  
Page 4864 of 7113



**HIGHLY CONFIDENTIAL**

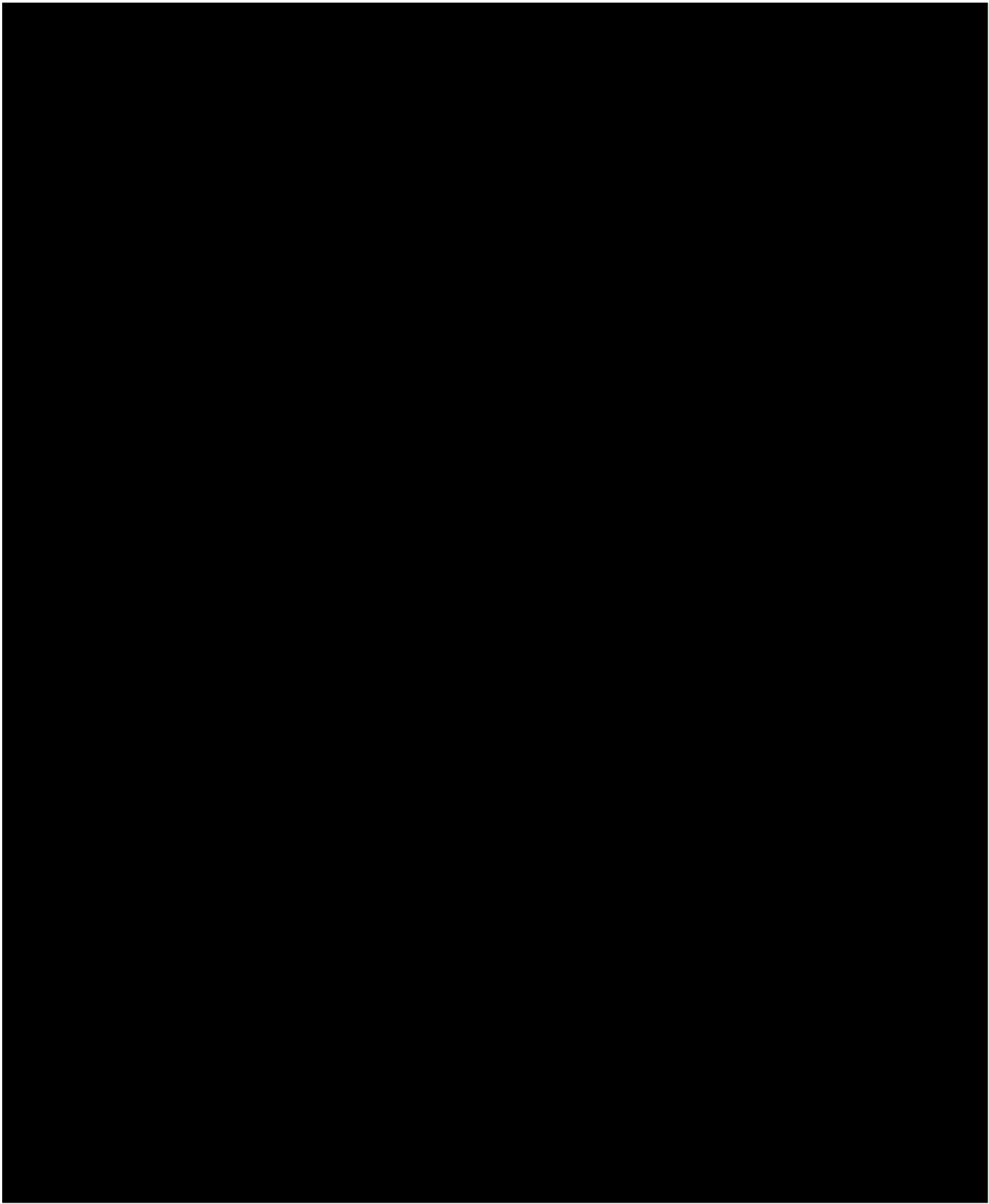
P. 16 UT Ex. 2037 UTC\_TV\_000017258  
SteadyMed v. United Therapeutics  
IPR2020-00769

IPR2020-00769  
United Therapeutics EX2006  
Page 4865 of 7113

**HIGHLY CONFIDENTIAL**

P. 17 UT Ex. 2037  
SteadyMed v. United Therapeutics **UTC\_TV\_000017259**  
IPR2020-00769

IPR2020-00769  
United Therapeutics EX2006  
Page 4866 of 7113



**HIGHLY CONFIDENTIAL**

P. 18 UT Ex. 2037  
SteadyMed v. United Therapeutics UTC\_TV\_000017264

IPR2020-00769  
United Therapeutics EX2006  
Page 4867 of 7113

**HIGHLY CONFIDENTIAL**

P. 19 UT Ex. 2037  
SteadyMed v. United Therapeutics **UTC\_TV\_000017265**

IPR2020-00769  
United Therapeutics EX2006  
Page 4868 of 7113



**HIGHLY CONFIDENTIAL**

P. 20 UT Ex. 2037 UTC\_TV\_000017267  
SteadyMed v. United Therapeutics

IPR2020-00769  
United Therapeutics EX2006  
Page 4869 of 7113

**HIGHLY CONFIDENTIAL**

P. 21 UT Ex. 2037  
SteadyMed v. United Therapeutics UTC\_TV\_000017268  
IPR2020-00769

IPR2020-00769  
United Therapeutics EX2006  
Page 4870 of 7113

**HIGHLY CONFIDENTIAL**

P. 22 UT Ex. 2037  
SteadyMed v. United Therapeutics **UTC\_TV\_000017270**

IPR2020-00769  
United Therapeutics EX2006  
Page 4871 of 7113

**HIGHLY CONFIDENTIAL**

P. 23

UT Ex. 2037  
SteadyMed v. United Therapeutics  
IPR2020-00769

**UTC\_TV\_000017271**

IPR2020-00769  
United Therapeutics EX2006  
Page 4872 of 7113

**HIGHLY CONFIDENTIAL**

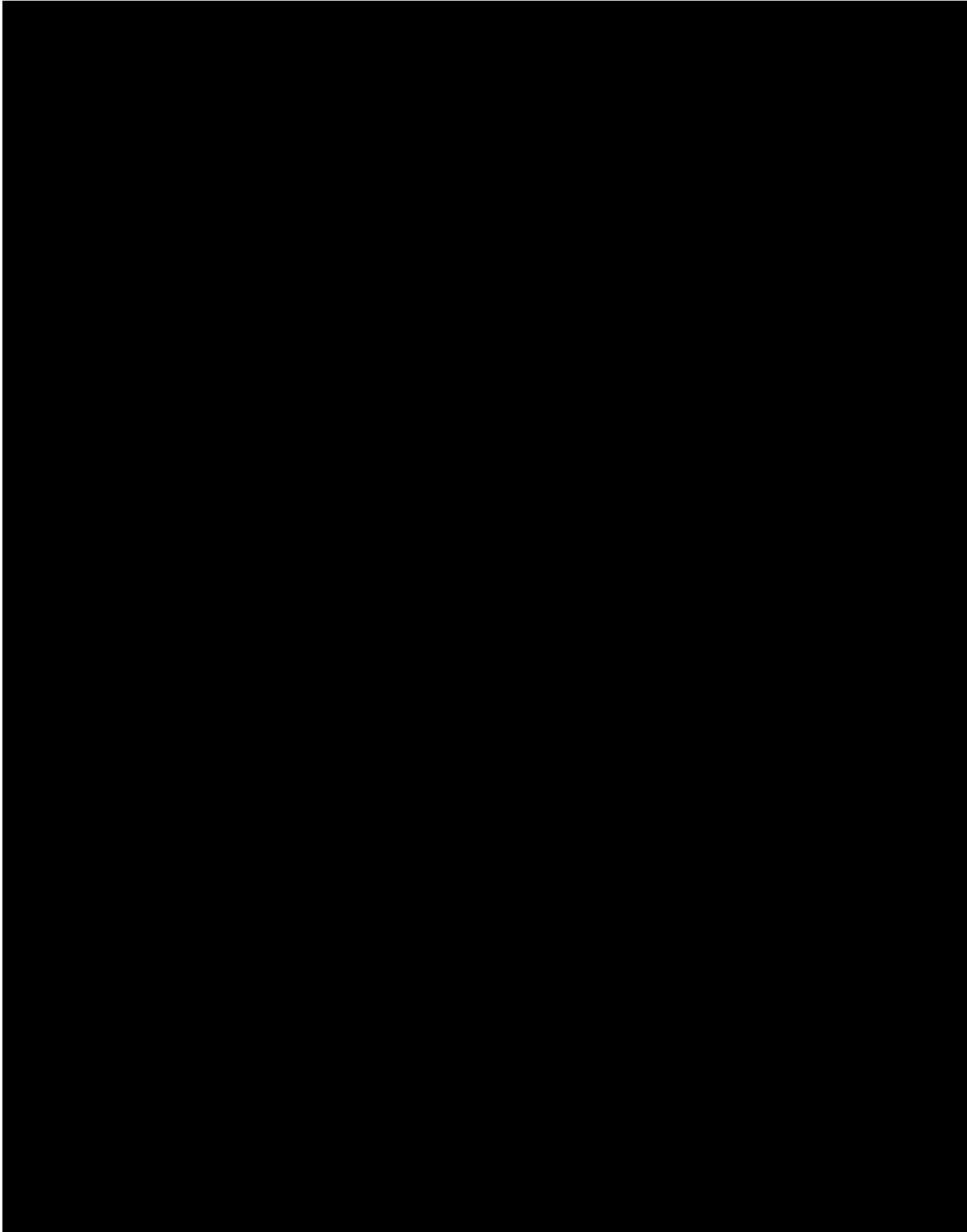
P. 24 UT Ex. 2037 UTC\_TV\_000017273  
SteadyMed v. United Therapeutics  
1700000 00000

IPR2020-00769  
United Therapeutics EX2006  
Page 4873 of 7113

HIGHLY CONFIDENTIAL

P. 25 UT Ex. 2037  
SteadyMed v. United Therapeutics UTC\_TV\_000017274

IPR2020-00769  
United Therapeutics EX2006  
Page 4874 of 7113



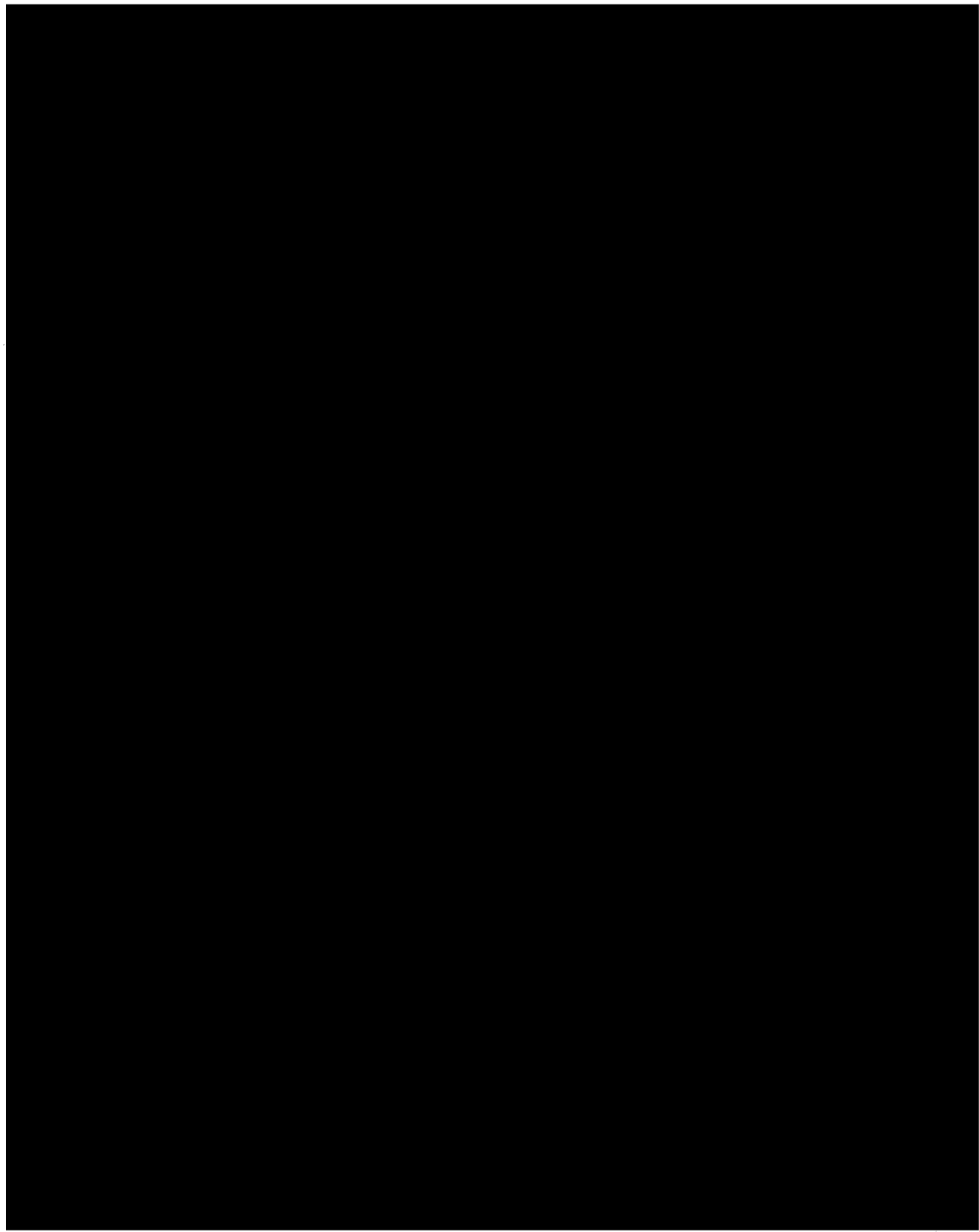
HIGHLY CONFIDENTIAL

P. 26  
SteadyMed v. United Therapeutics

UT Ex. 2037

UTC\_TV\_000017276

IPR2020-00769  
United Therapeutics EX2006  
Page 4875 of 7113



**HIGHLY CONFIDENTIAL**

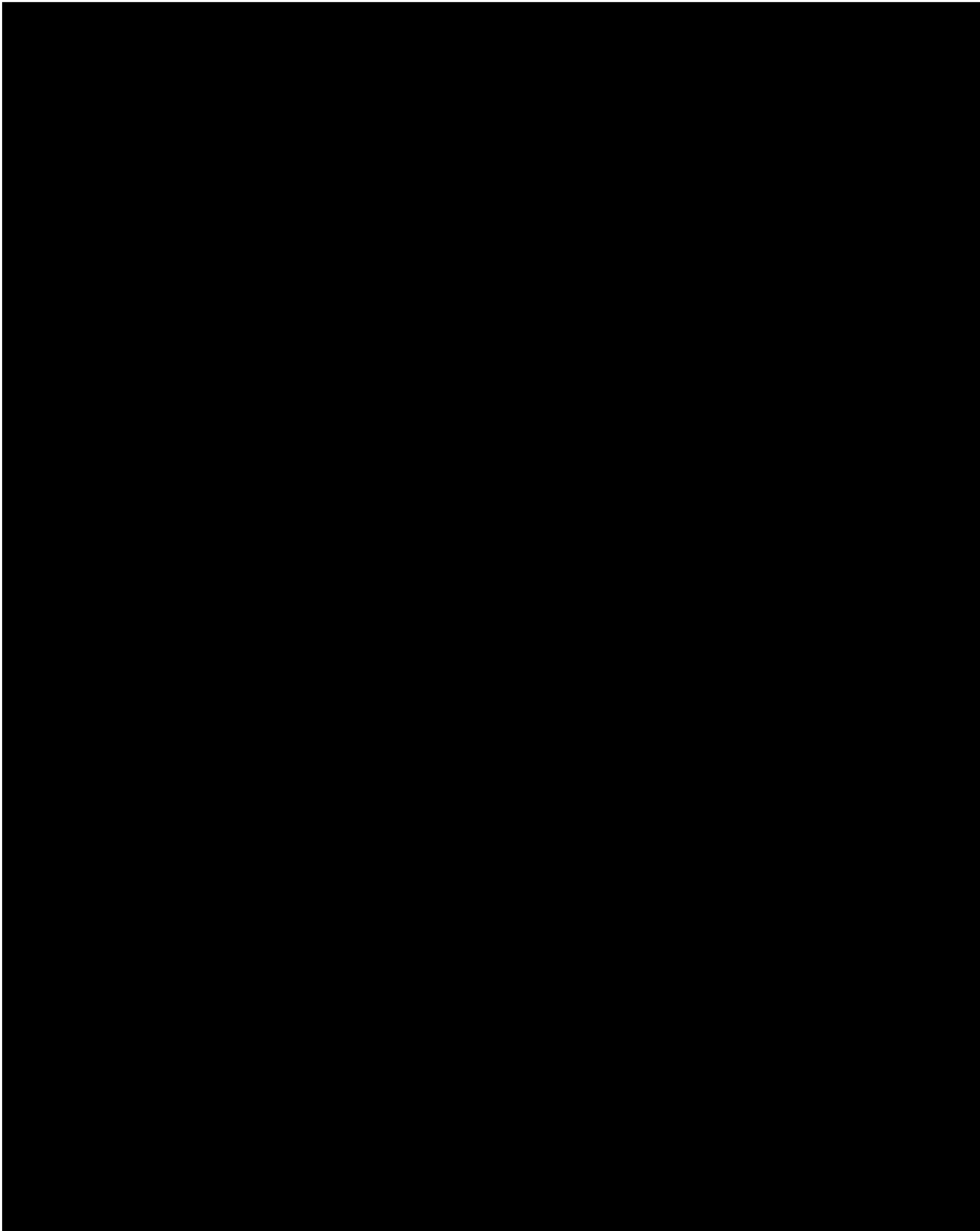
P. 27

UT Ex. 2037  
SteadyMed v. United Therapeutics

**UTC\_TV\_000017277**

IPR2020-00769  
United Therapeutics EX2006  
Page 4876 of 7113





HIGHLY CONFIDENTIAL

P. 28 UT Ex. 2037 UTC\_TV\_000017279  
SteadyMed v. United Therapeutics  
IPR2020-00769

IPR2020-00769  
United Therapeutics EX2006  
Page 4877 of 7113

**HIGHLY CONFIDENTIAL**

P. 29  
UT Ex. 2037  
SteadyMed v. United Therapeutics  
IPR2020-00769

**UTC\_TV\_000017280**

IPR2020-00769  
United Therapeutics EX2006  
Page 4878 of 7113

**HIGHLY CONFIDENTIAL**

P. 30  
SteadyMed v. United Therapeutics

UT Ex. 2037

**UTC\_TV\_000017294**

IPR2020-00769  
United Therapeutics EX2006  
Page 4879 of 7113

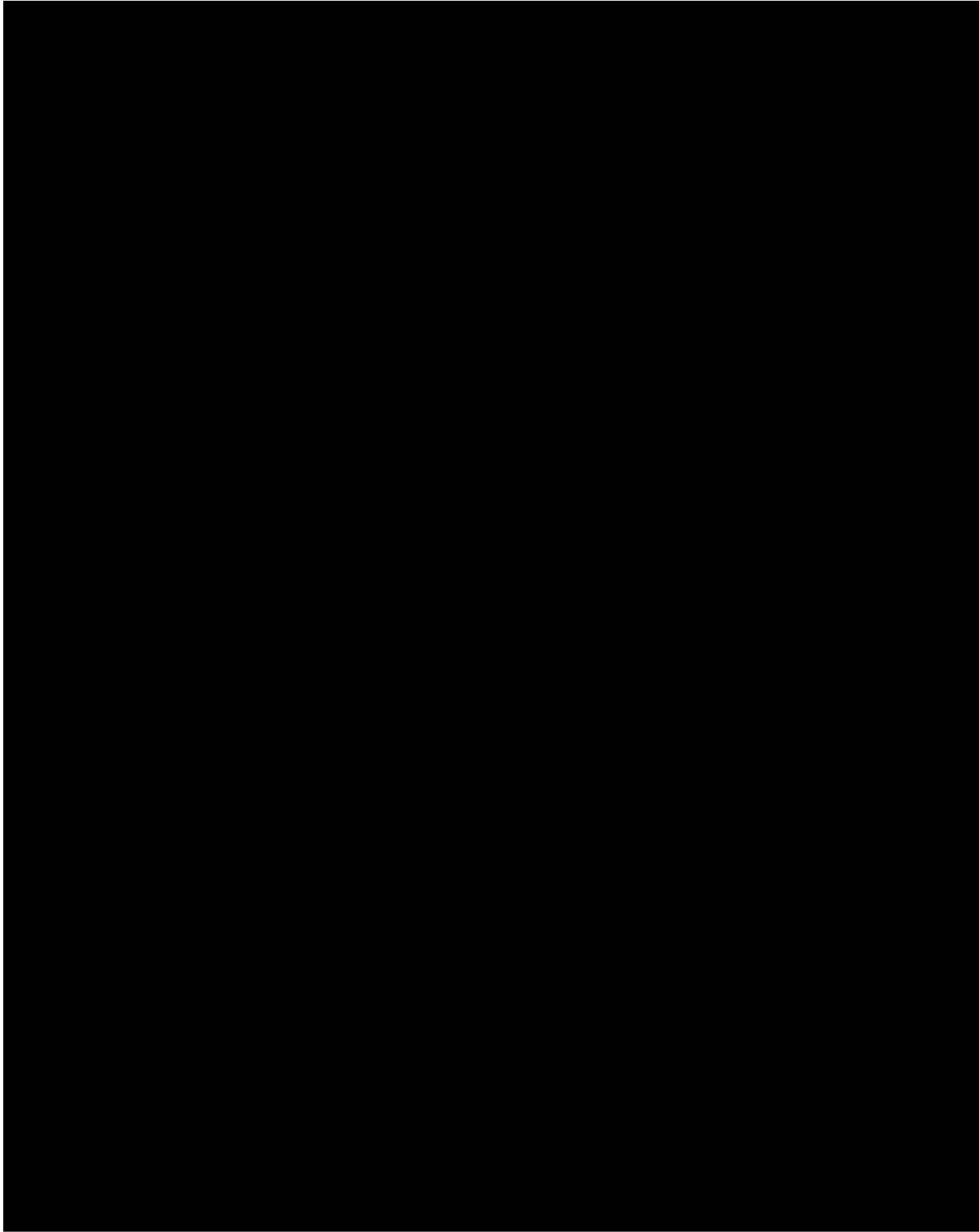
**HIGHLY CONFIDENTIAL**

P. 31  
SteadyMed v. United Therapeutics

UT Ex. 2037

**UTC\_TV\_000017295**

IPR2020-00769  
United Therapeutics EX2006  
Page 4880 of 7113



**HIGHLY CONFIDENTIAL**

P. 32  
SteadyMed v. United Therapeutics

UT Ex. 2037

UTC\_TV\_000021102

IPR2020-00769  
United Therapeutics EX2006  
Page 4881 of 7113



**HIGHLY CONFIDENTIAL**

P. 33  
SteadyMed v. United Therapeutics

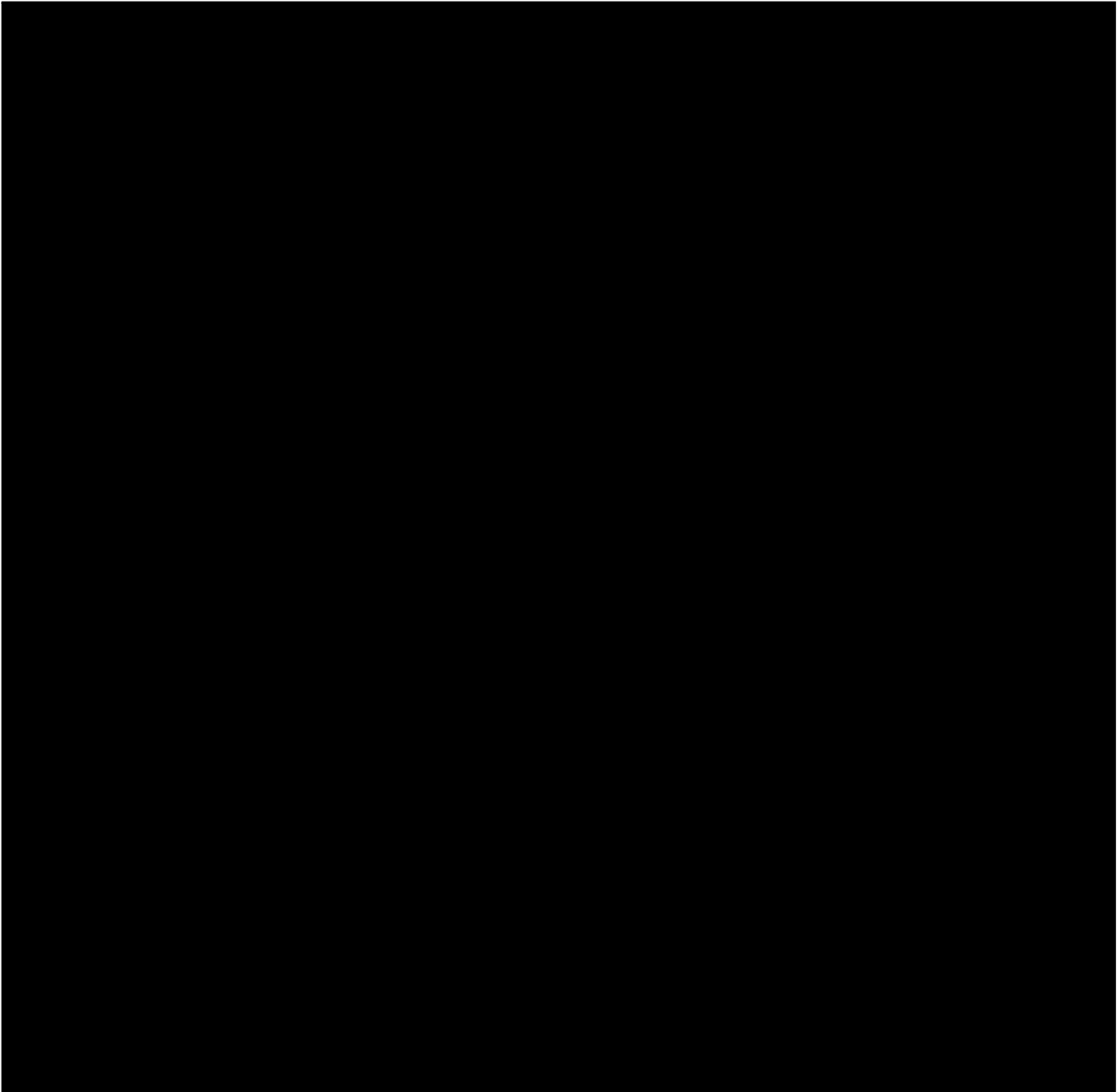
UT Ex. 2037

**UTC\_TV\_000021103**

IPR2020-00769  
United Therapeutics EX2006  
Page 4882 of 7113

HIGHLY CONFIDENTIAL

UTC\_TV\_000021112

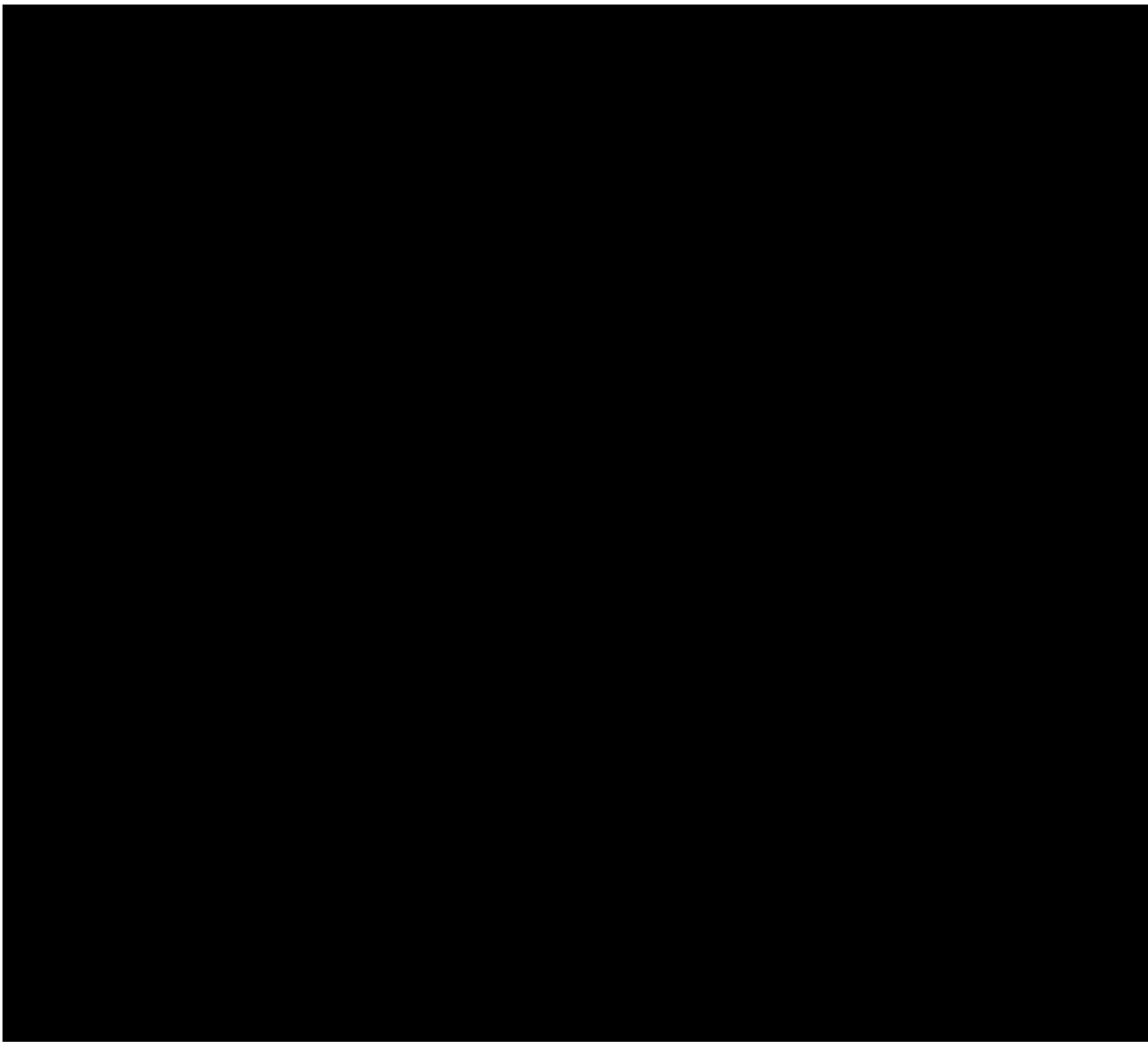


P. 34

SteadyMed v. United T  
IPR;

HIGHLY CONFIDENTIAL

UTC\_TV\_000021113



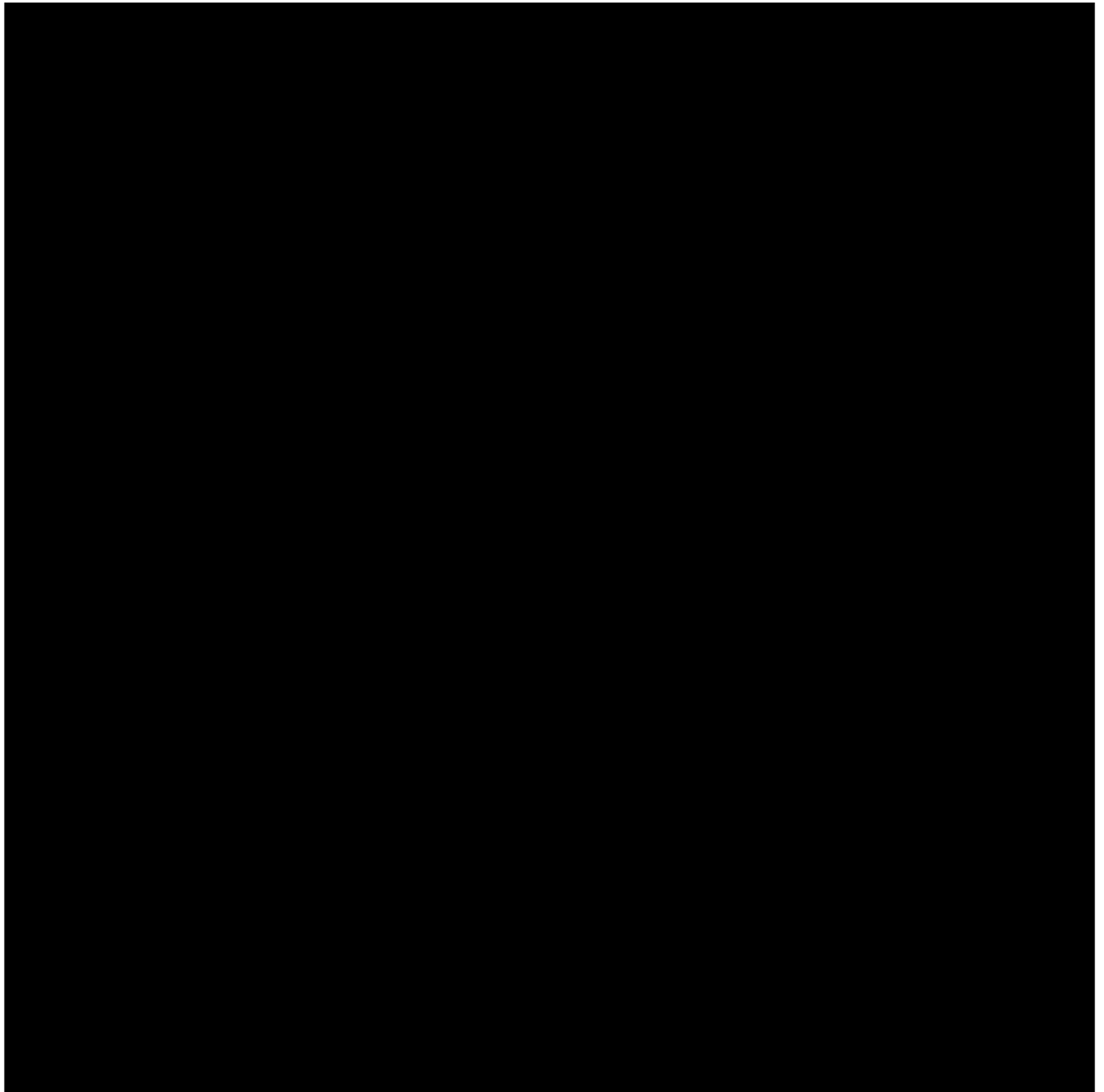
P. 35

SteadyMed v. United T  
IPR2



HIGHLY CONFIDENTIAL

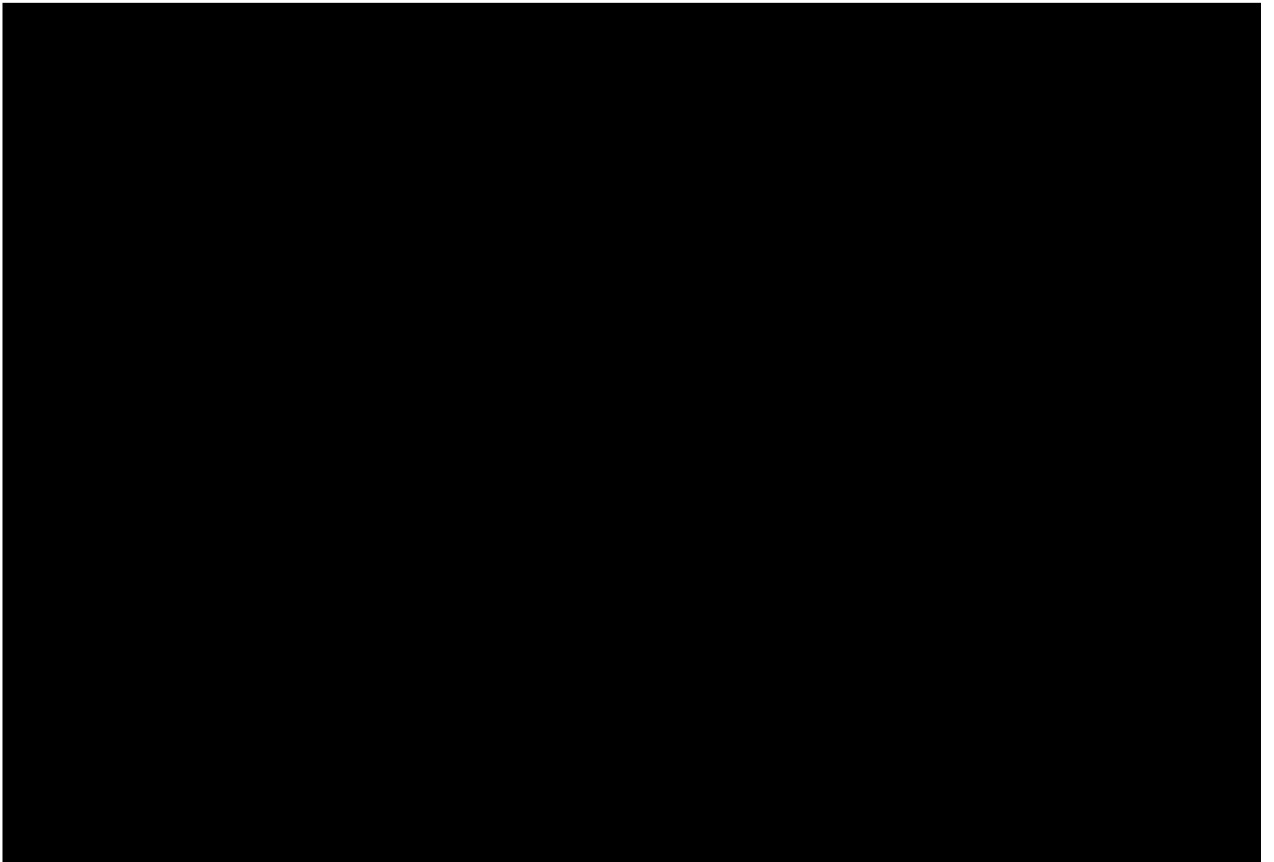
UTC\_TV\_000021114



P. 36

SteadyMed v. United T  
IPR:

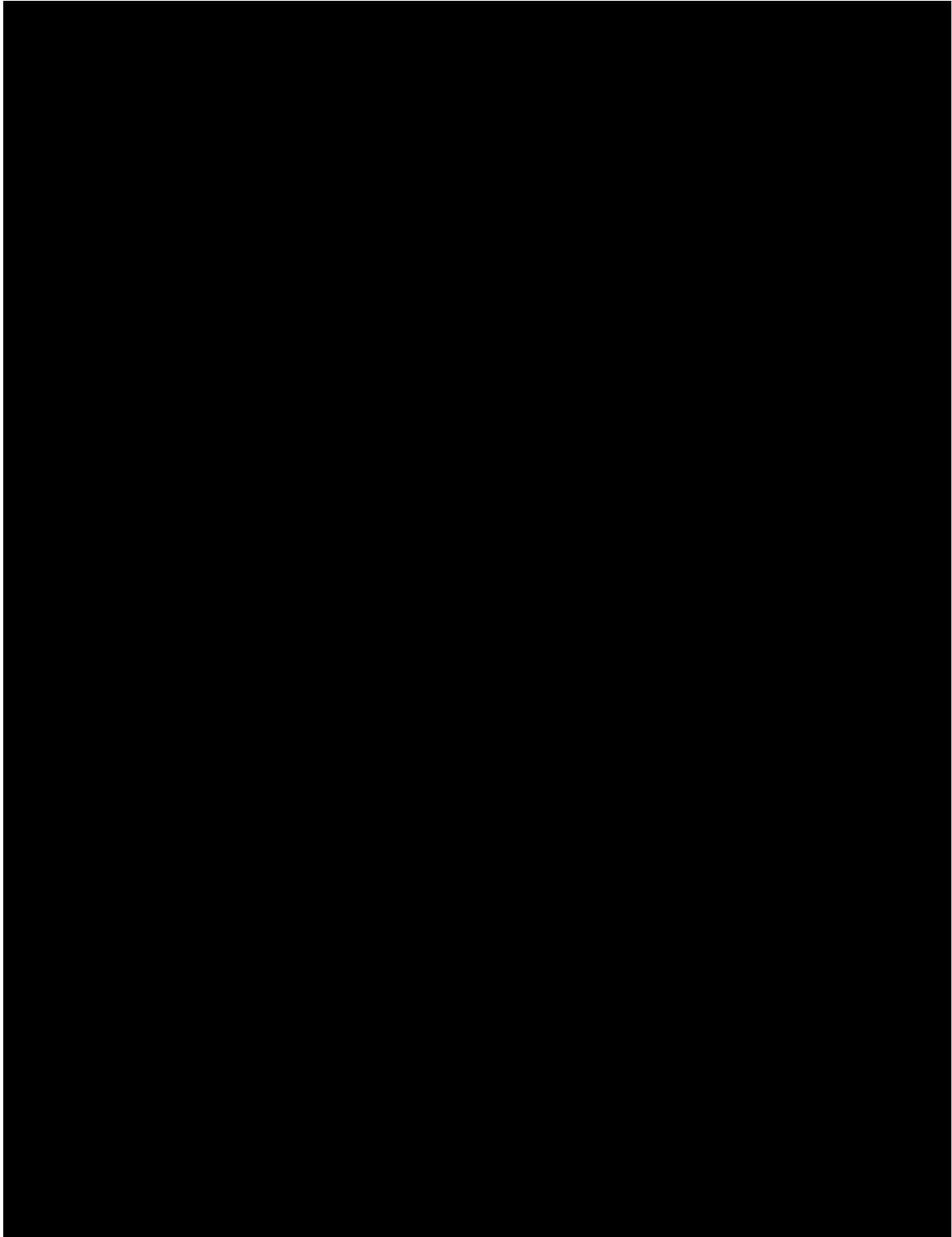
HIGHLY CONFIDENTIAL



UTC\_TV\_000021115

P. 37

SteadyMed v. United T  
IPR2



**HIGHLY CONFIDENTIAL**

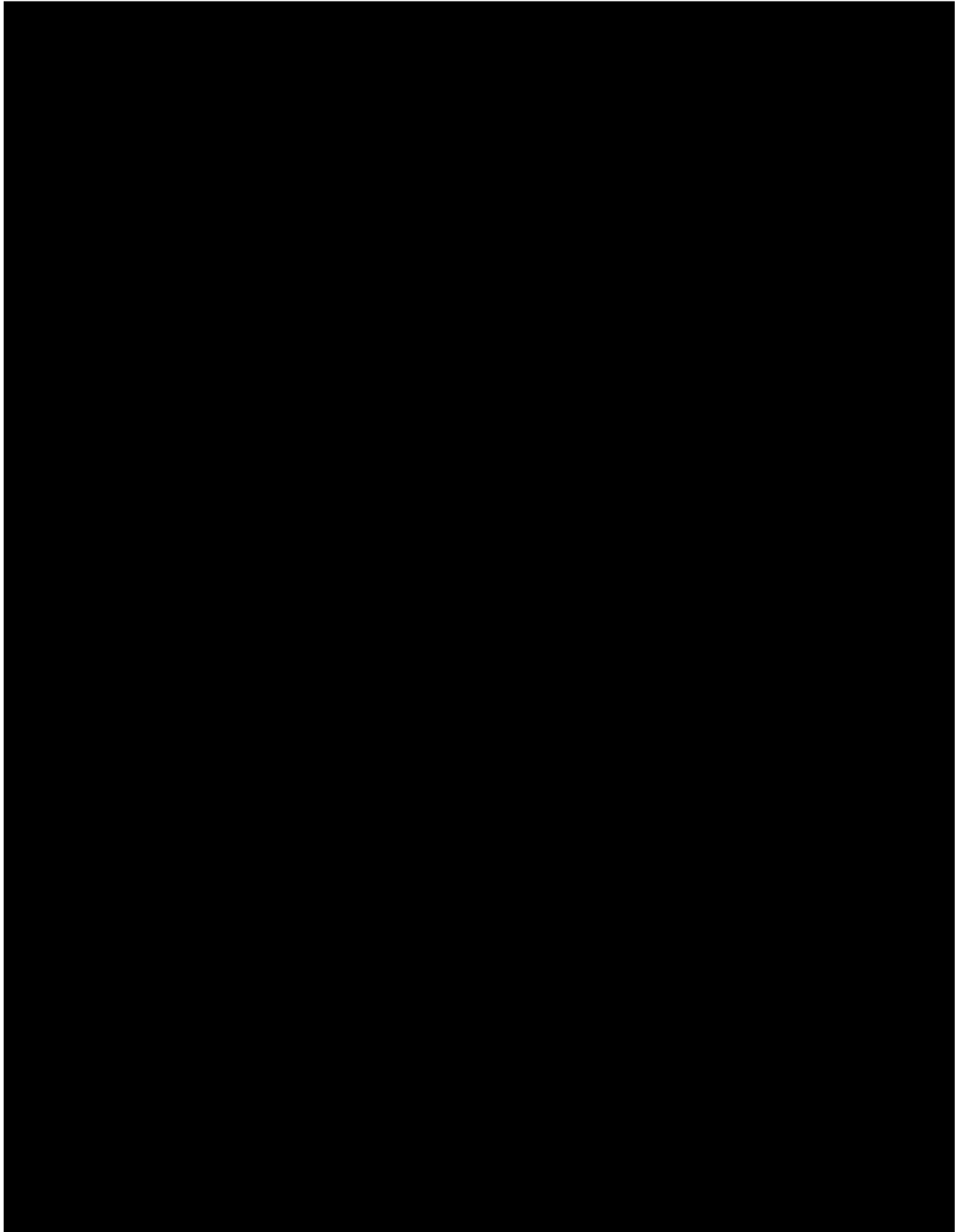
P. 38 UT Ex. 2037 UTC\_TV\_000021116  
SteadyMed v. United Therapeutics

IPR2020-00769  
United Therapeutics EX2006  
Page 4887 of 7113

**HIGHLY CONFIDENTIAL**

P. 39 UT Ex. 2037 UTC\_TV\_000021117  
SteadyMed v. United Therapeutics  
IPR2020-00769

IPR2020-00769  
United Therapeutics EX2006  
Page 4888 of 7113



**HIGHLY CONFIDENTIAL**

P. 40  
SteadyMed v. United Therapeutics

UT Ex. 2037

**UTC\_TV\_000021118**

IPR2020-00769  
United Therapeutics EX2006  
Page 4889 of 7113

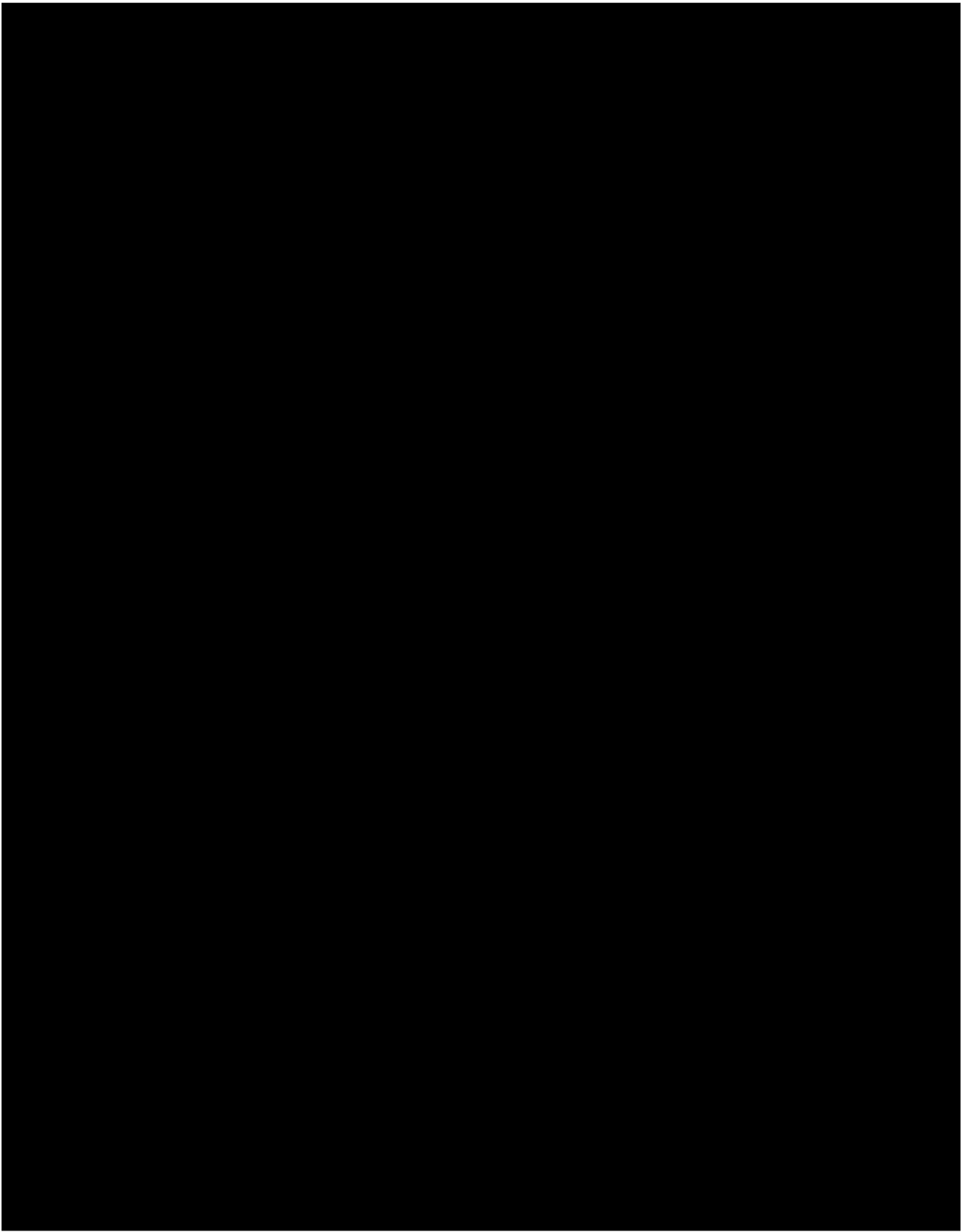
**HIGHLY CONFIDENTIAL**

P. 41

UT Ex. 2037  
SteadyMed v. United Therapeutics  
IPR2020-00769

**UTC\_TV\_000021119**

IPR2020-00769  
United Therapeutics EX2006  
Page 4890 of 7113



**HIGHLY CONFIDENTIAL**

P. 42 UT Ex. 2037 UTC\_TV\_000022755  
SteadyMed v. United Therapeutics  
IPR2020-00769

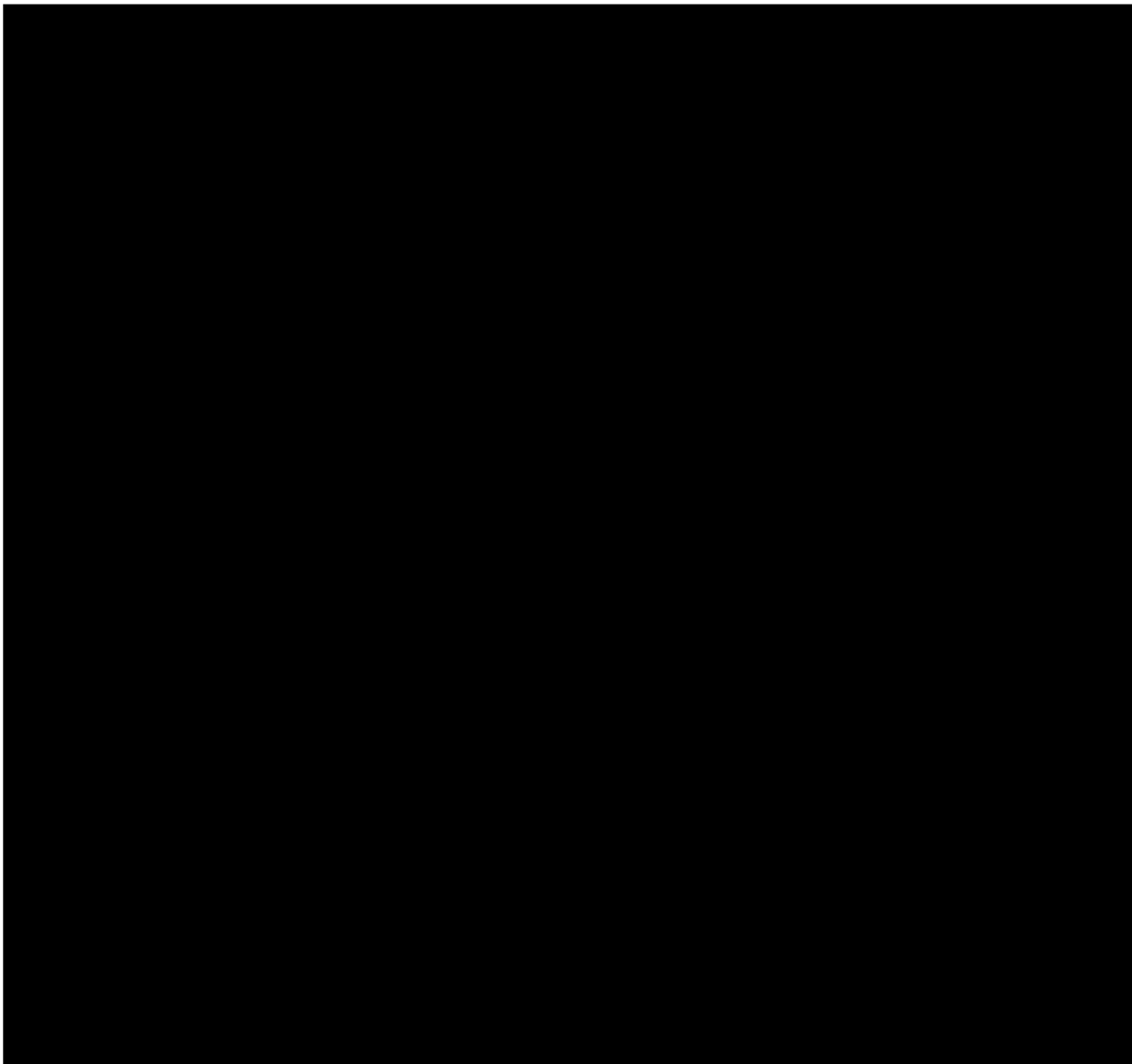
IPR2020-00769  
United Therapeutics EX2006  
Page 4891 of 7113

**HIGHLY CONFIDENTIAL**

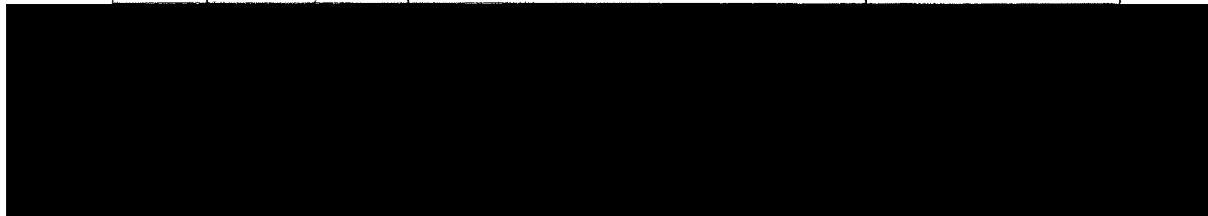
P. 43 UT Ex. 2037 UTC\_TV\_00022756  
SteadyMed v. United Therapeutics

IPR2020-00769  
United Therapeutics EX2006  
Page 4892 of 7113





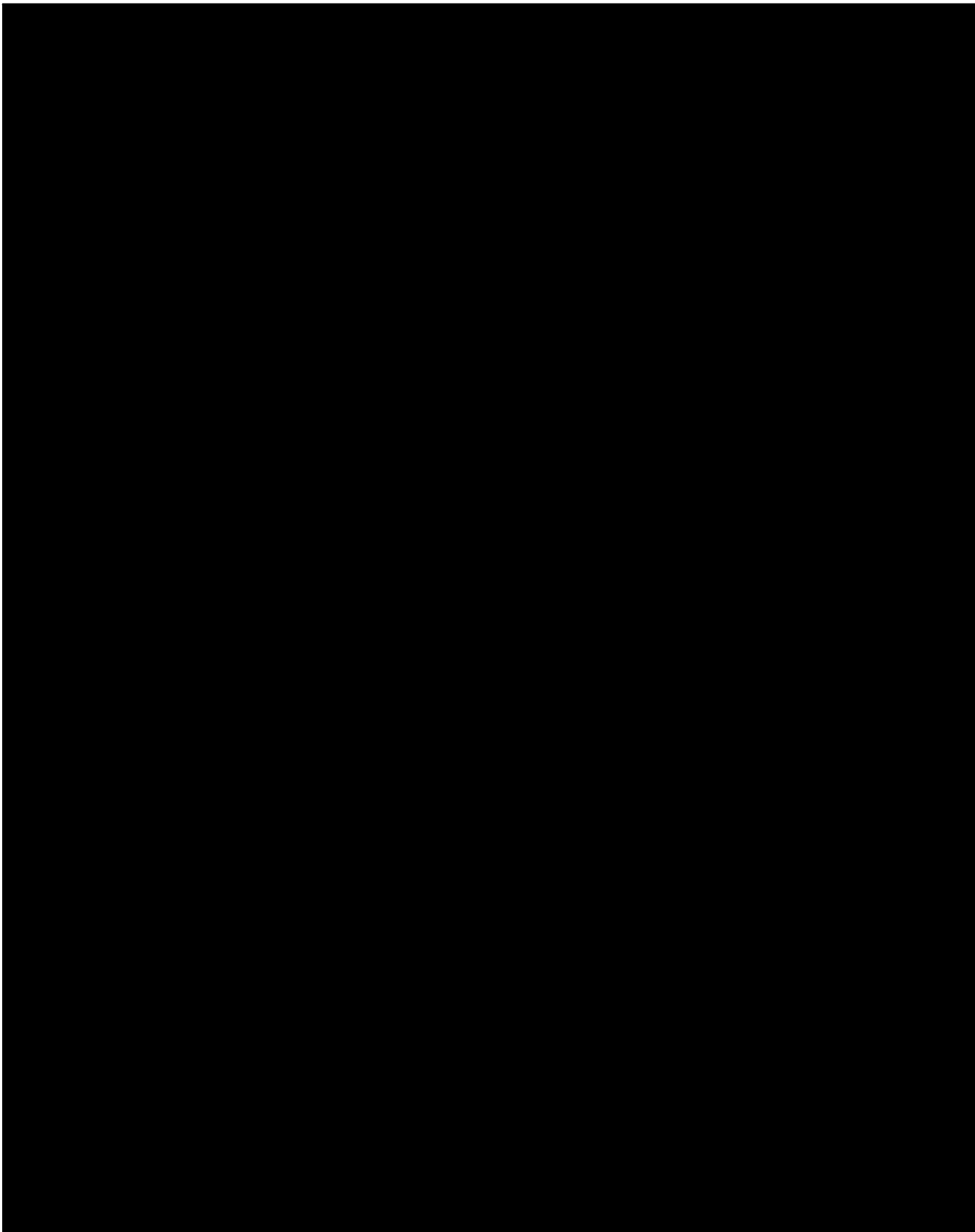
	<u>Compound</u>	<u>Specifications</u>	
Impurities (HPLC) [Known Impurities] (UTW-11-0327)	1AU90	Not more than 0.4 %	ND
	2AU90	Not more than 0.1 %	ND
	97W86	Not more than 0.2 %	ND
	3AU90	Not more than 0.5 %	< 0.05 % w/w
	Treprostinil Methyl Ester	Not more than 0.2 %	ND
	Treprostinil Ethyl Ester	Not more than 0.5 %	ND
	750W93	Not more than 0.5 %	ND
751W93	Not more than 0.3 %	ND	
Impurities (HPLC) [Unidentified Impurities] (UTW-11-0327)	Not more than 0.2 % AUC each		0.07 % AUC (RRT 0.28)
Impurities (HPLC) [Total Related Substances] (UTW-11-0327)	Not more than 1.5 %		0.1 % w/w



**HIGHLY CONFIDENTIAL**

P. 45 UT Ex. 2037 UTC\_TV\_00054835  
SteadyMed v. United Therapeutics

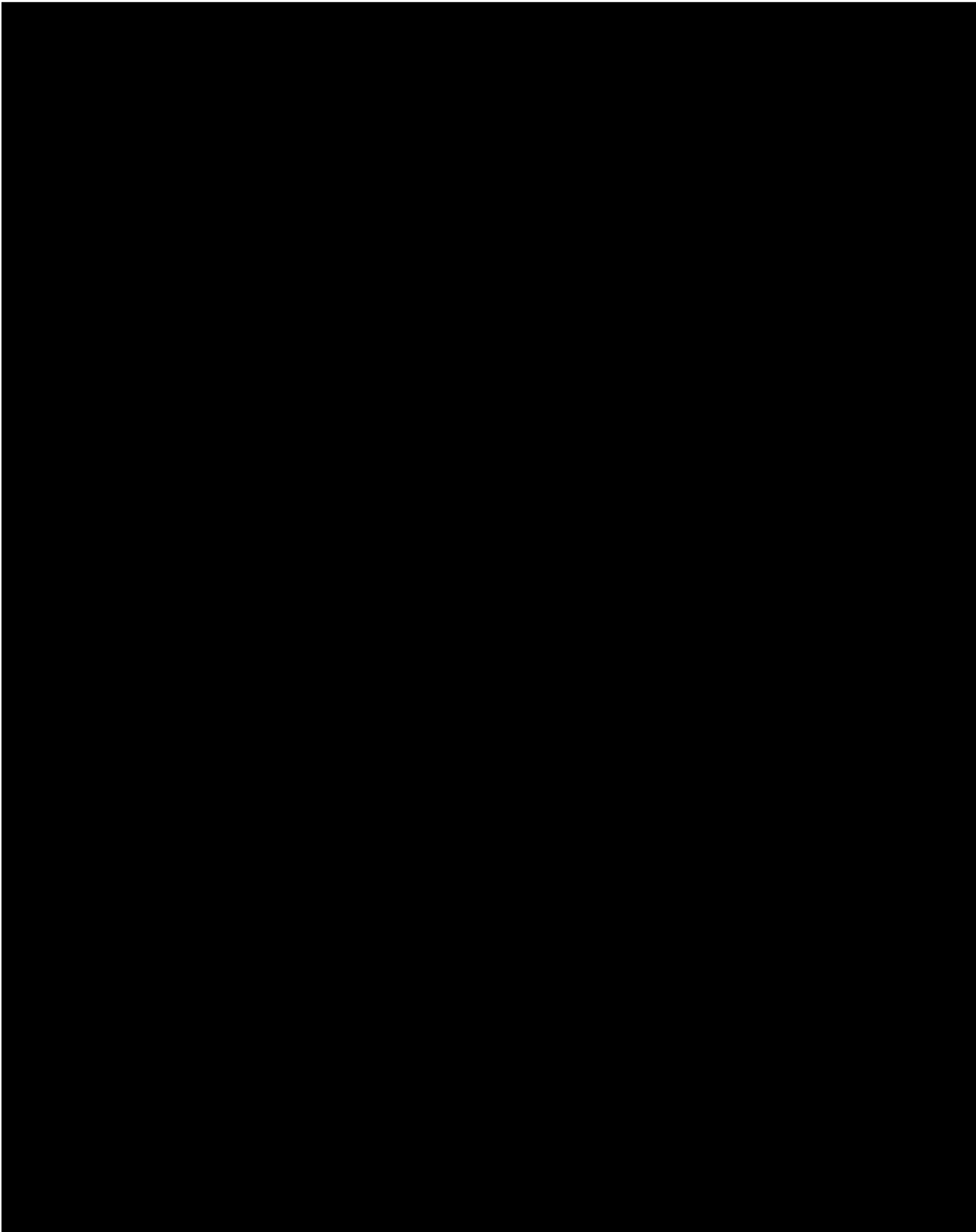
IPR2020-00769  
United Therapeutics EX2006  
Page 4894 of 7113



**HIGHLY CONFIDENTIAL**

P. 46 UT Ex. 2037 UTC\_TV\_00054836  
SteadyMed v. United Therapeutics

IPR2020-00769  
United Therapeutics EX2006  
Page 4895 of 7113



**HIGHLY CONFIDENTIAL**

P. 47 UT Ex. 2037 UTC\_TV\_000084779  
SteadyMed v. United Therapeutics

IPR2020-00769  
United Therapeutics EX2006  
Page 4896 of 7113



**HIGHLY CONFIDENTIAL**

P. 49

UT Ex. 2037

SteadyMed v. United Therapeutics

**UTC\_TV\_000087774**

IPR2020-00769  
United Therapeutics EX2006  
Page 4898 of 7113

**HIGHLY CONFIDENTIAL**

P. 50

UT Ex. 2037

SteadyMed v. United Therapeutics

**UTC\_TV\_000087775**

IPR2020-00769  
United Therapeutics EX2006  
Page 4899 of 7113

**HIGHLY CONFIDENTIAL**

P. 51

UT Ex. 2037

SteadyMed v. United Therapeutics

**UTC\_TV\_000087776**

IPR2020-00769  
United Therapeutics EX2006  
Page 4900 of 7113



**HIGHLY CONFIDENTIAL**

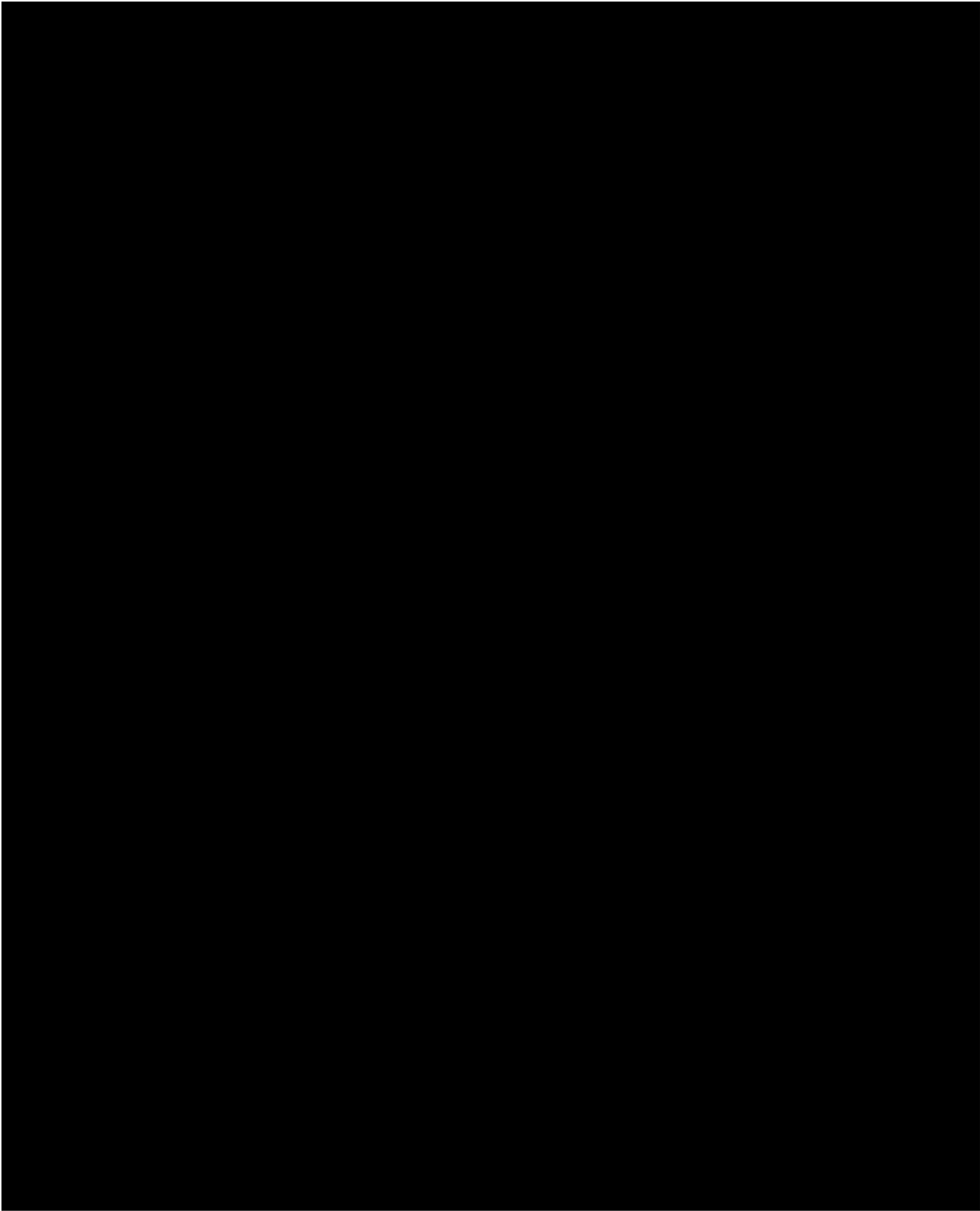
P. 52

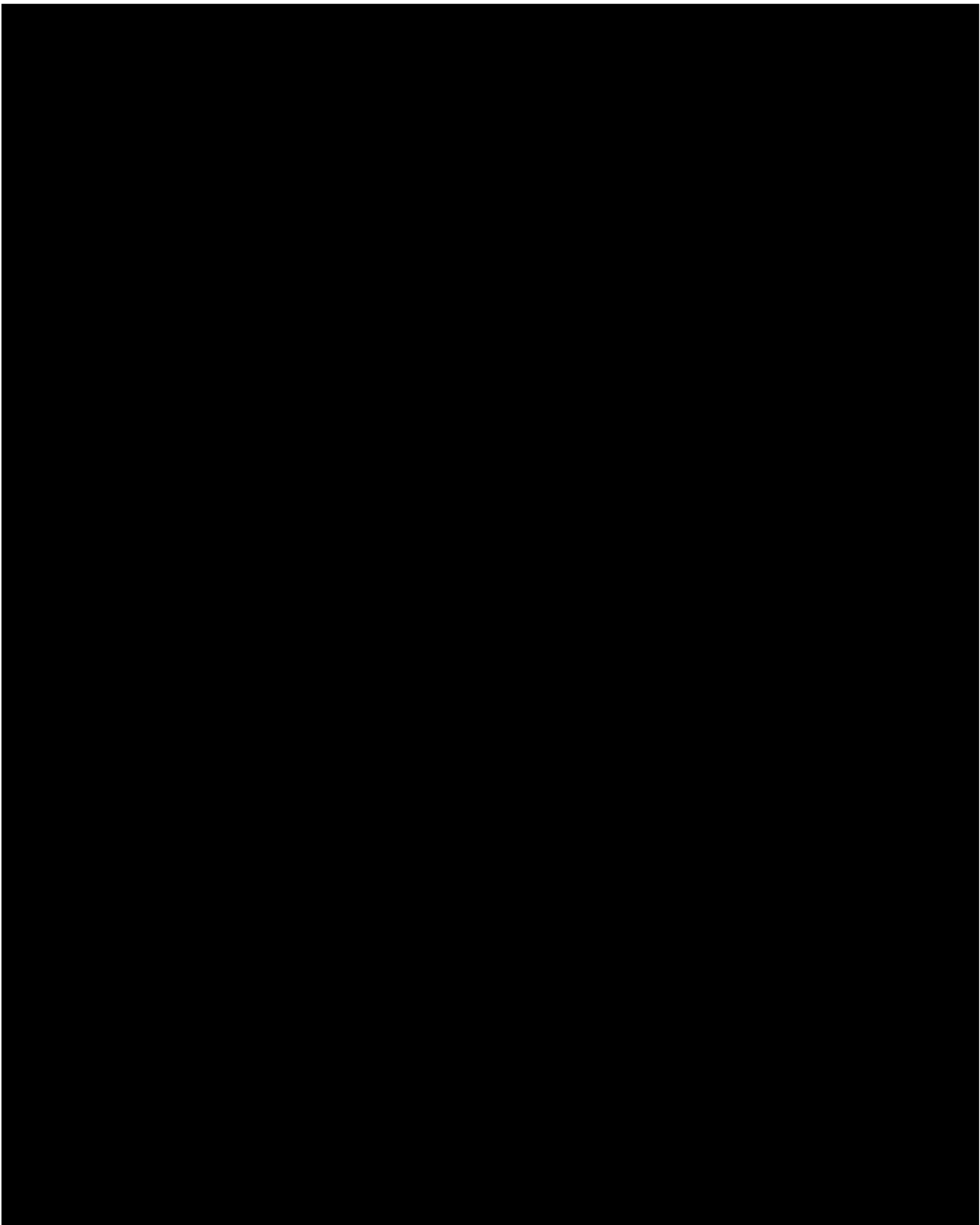
UT Ex. 2037

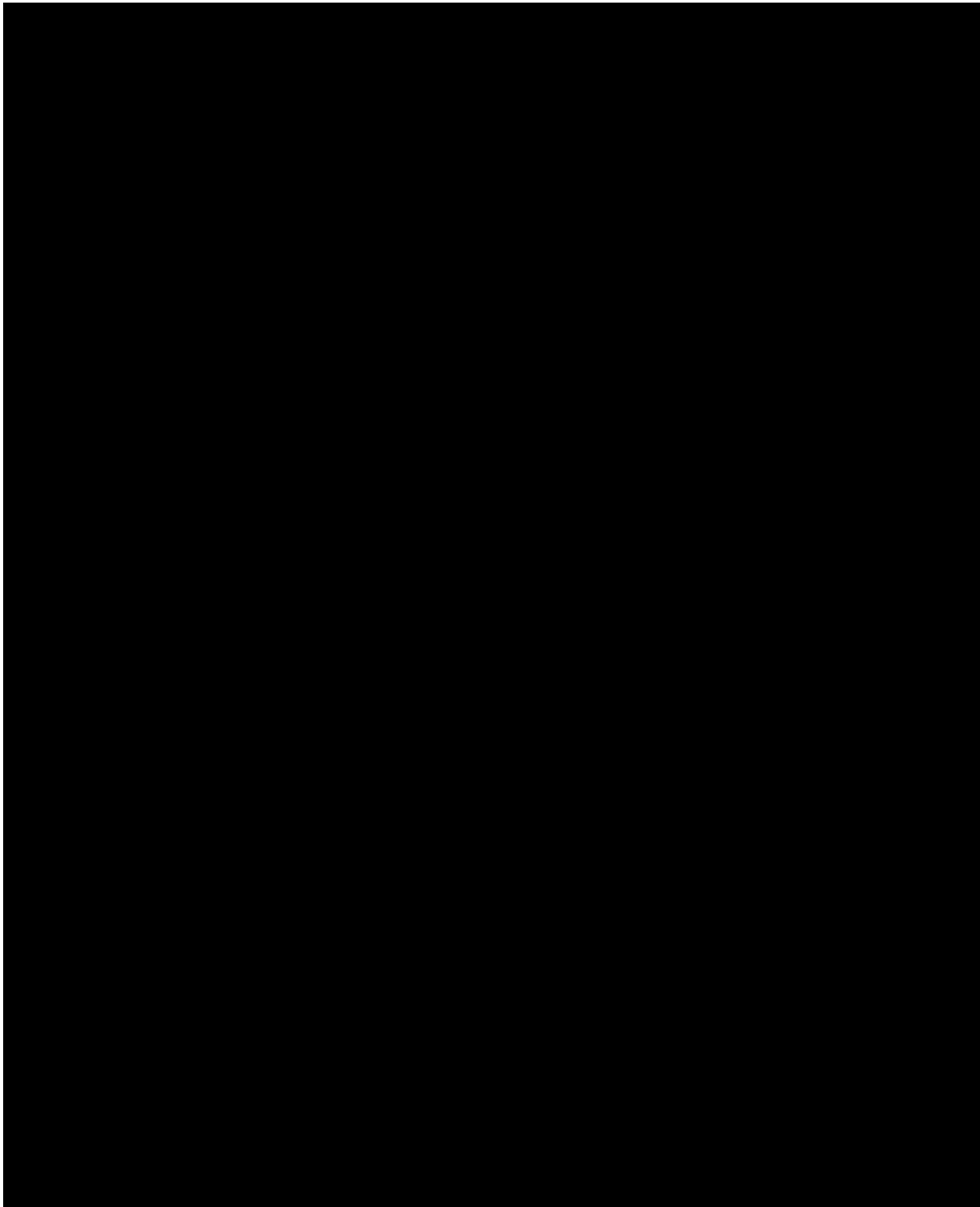
SteadyMed v. United Therapeutics

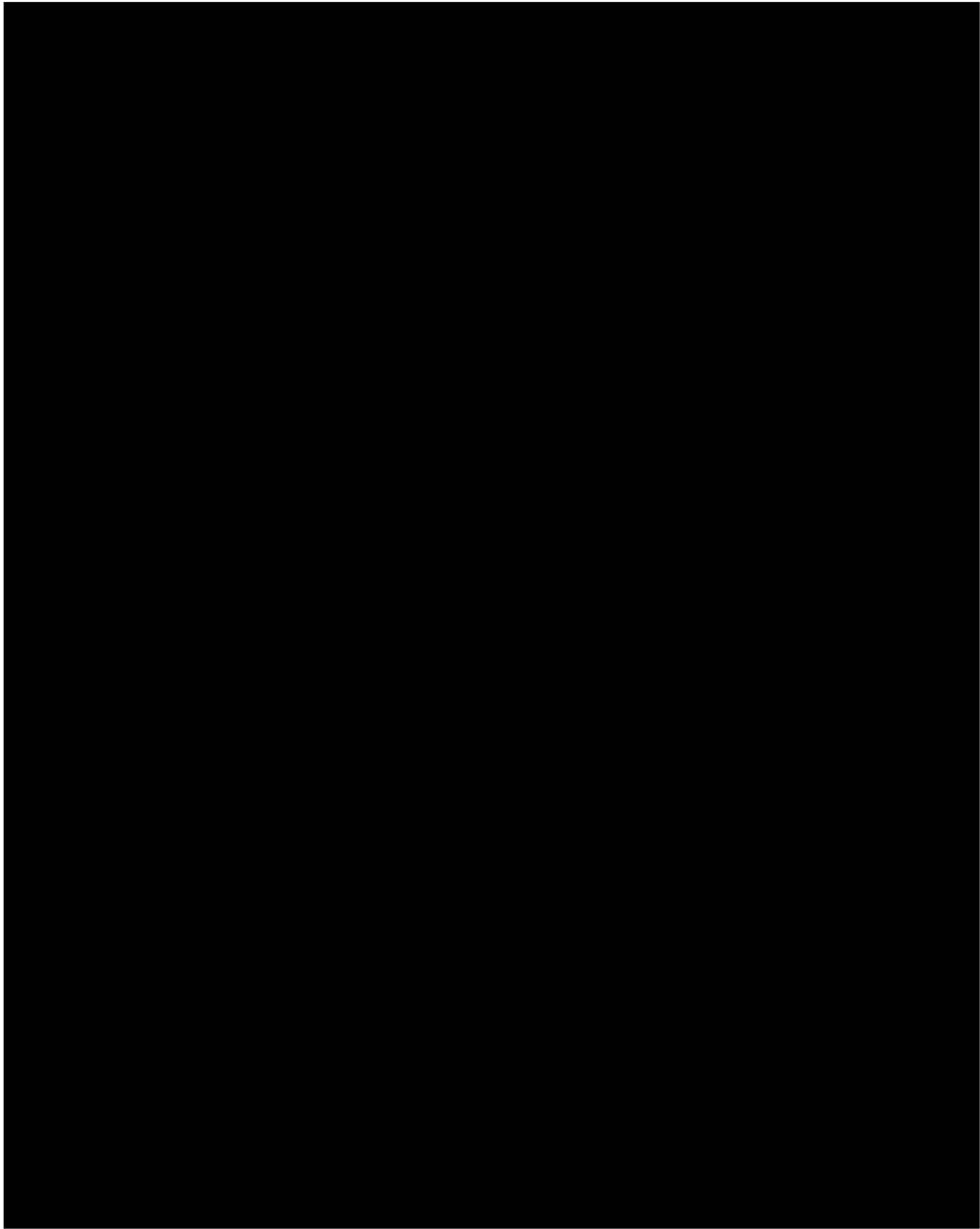
**UTC\_TV\_000087777**

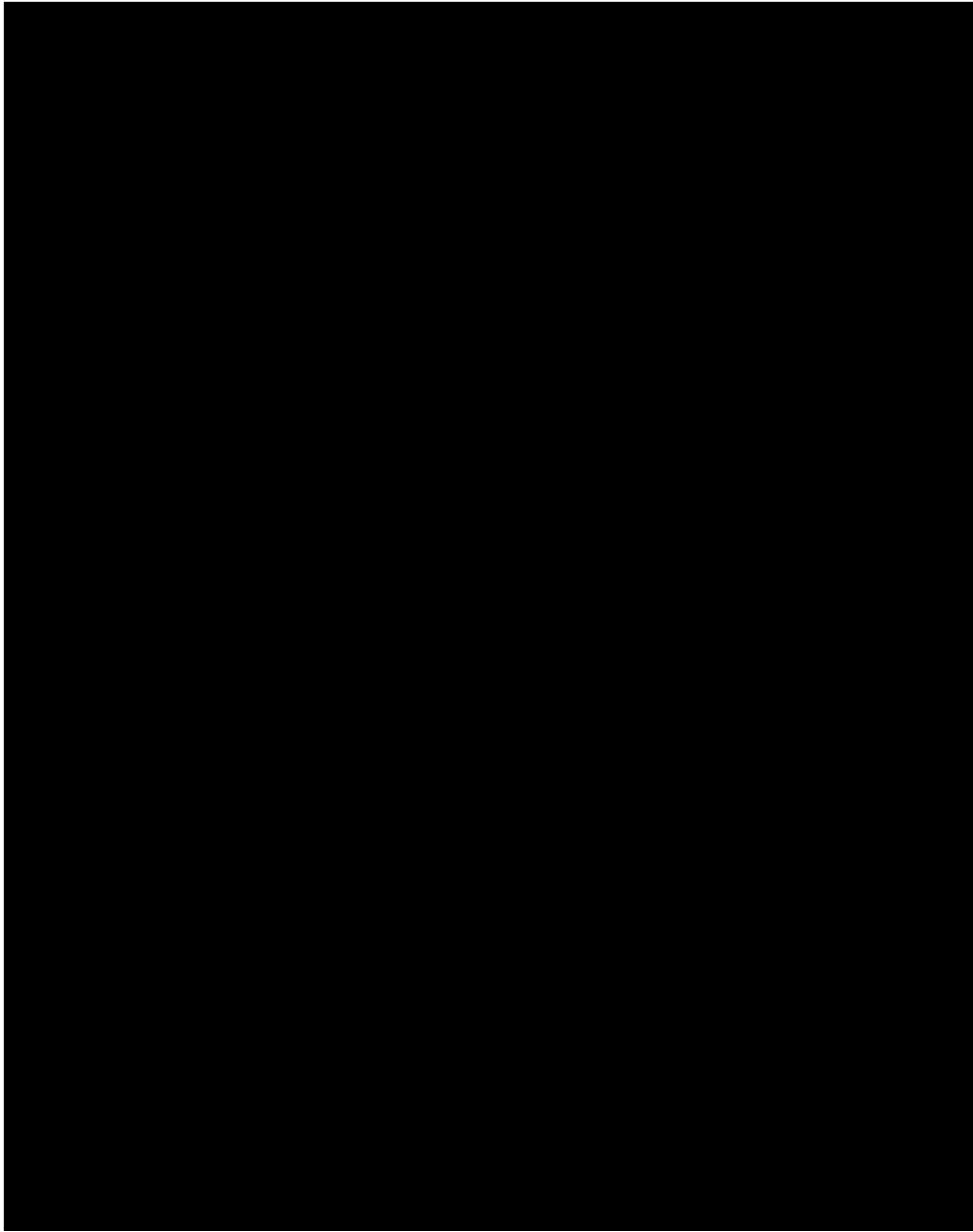
IPR2020-00769  
United Therapeutics EX2006  
Page 4901 of 7113

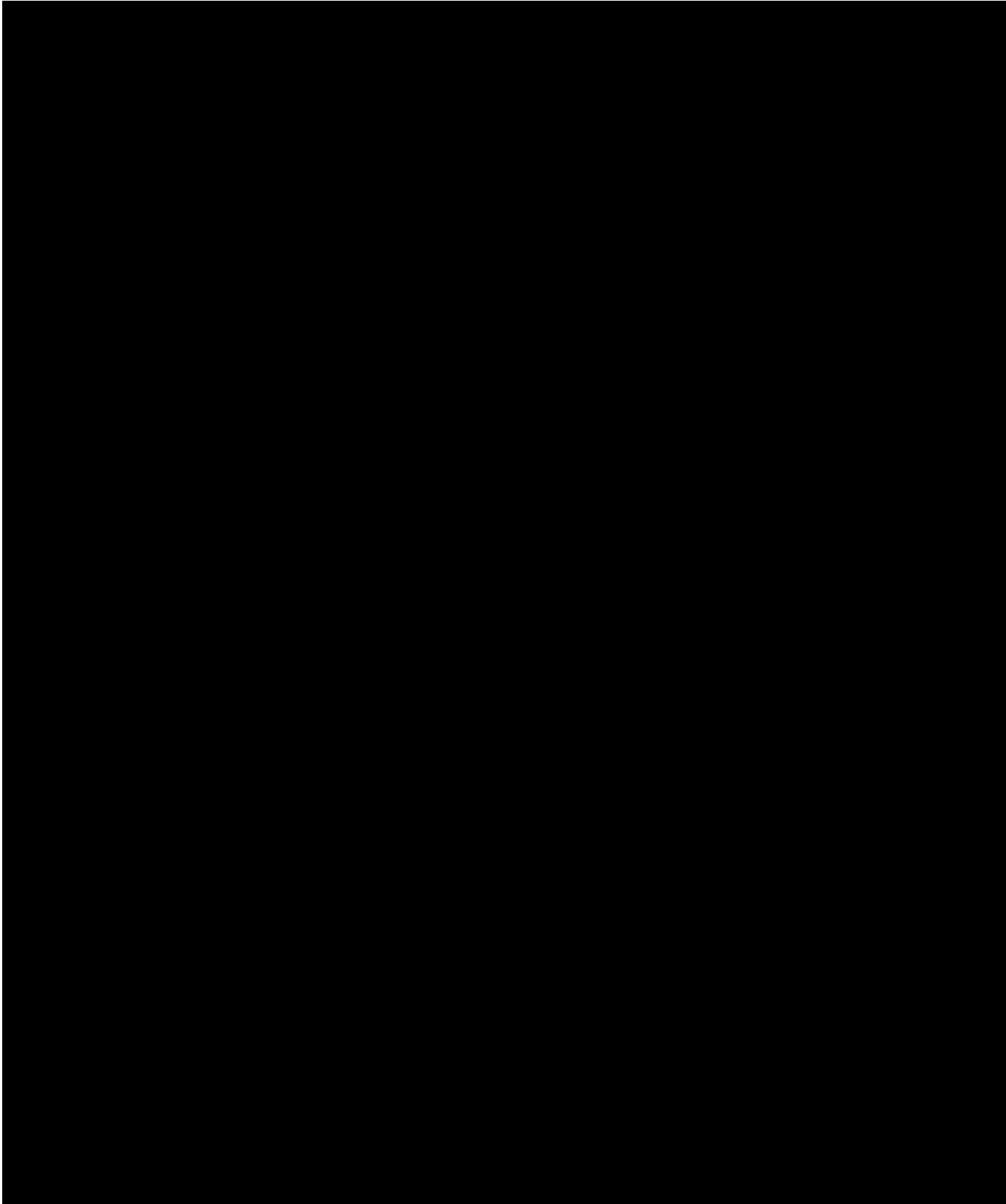


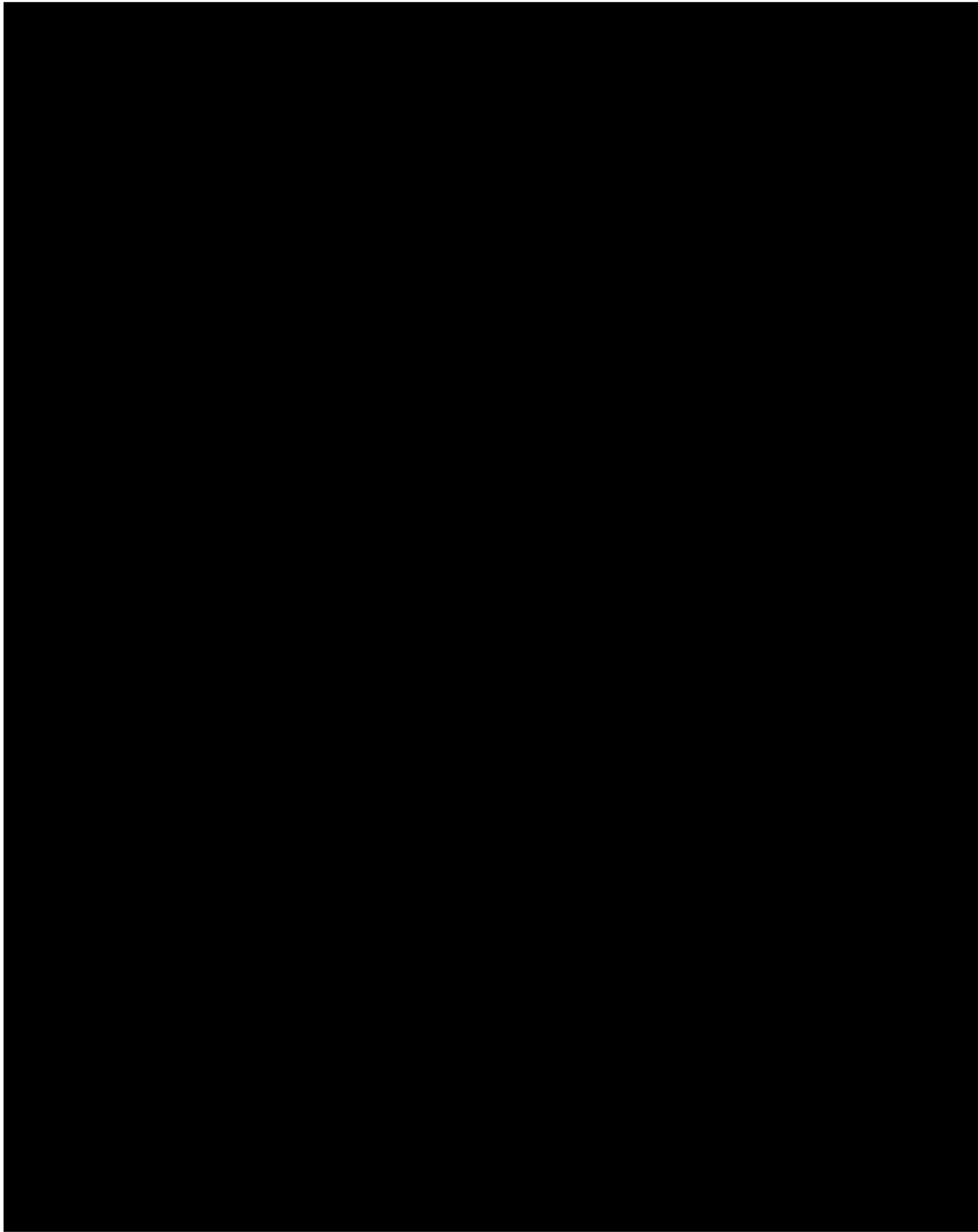




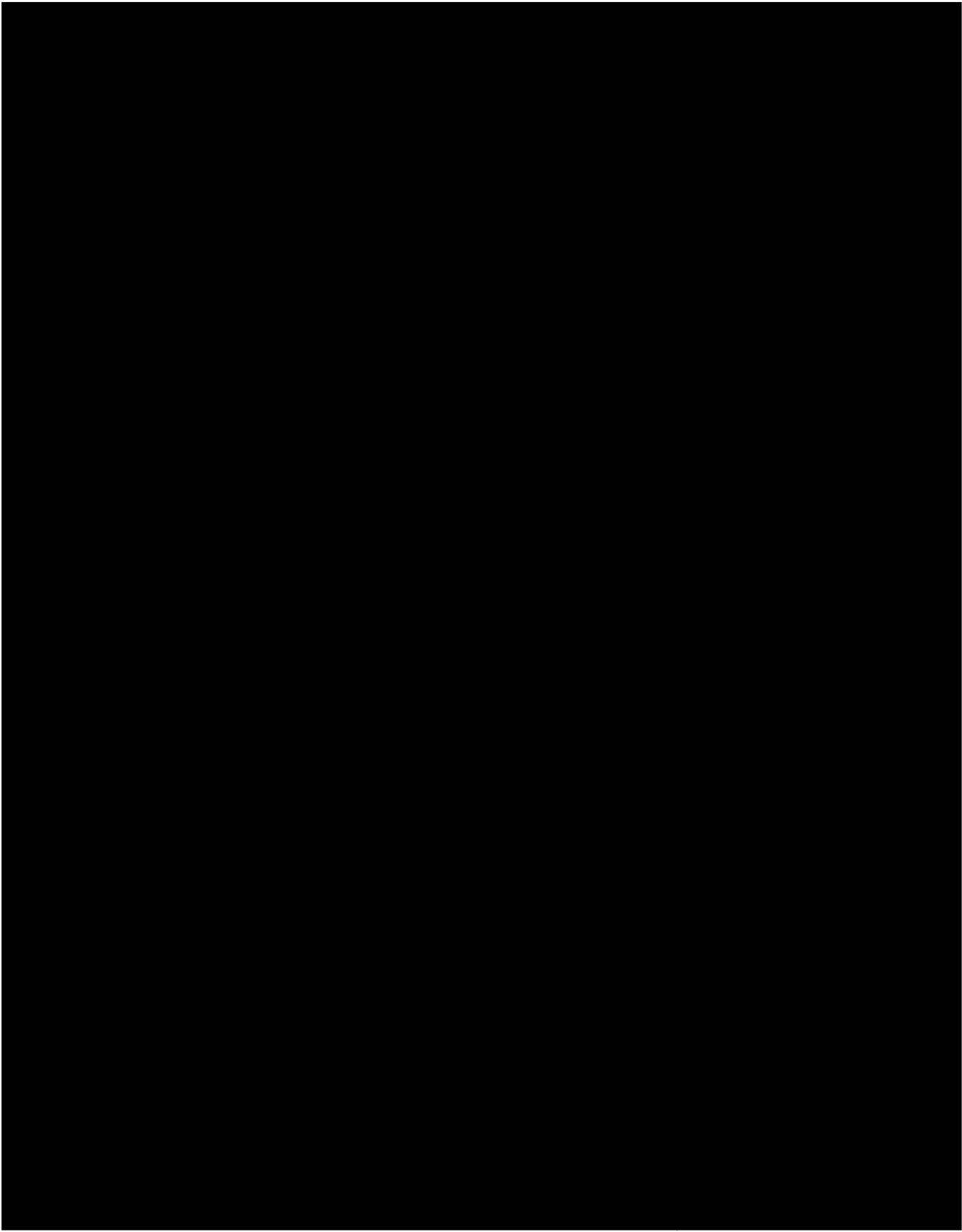


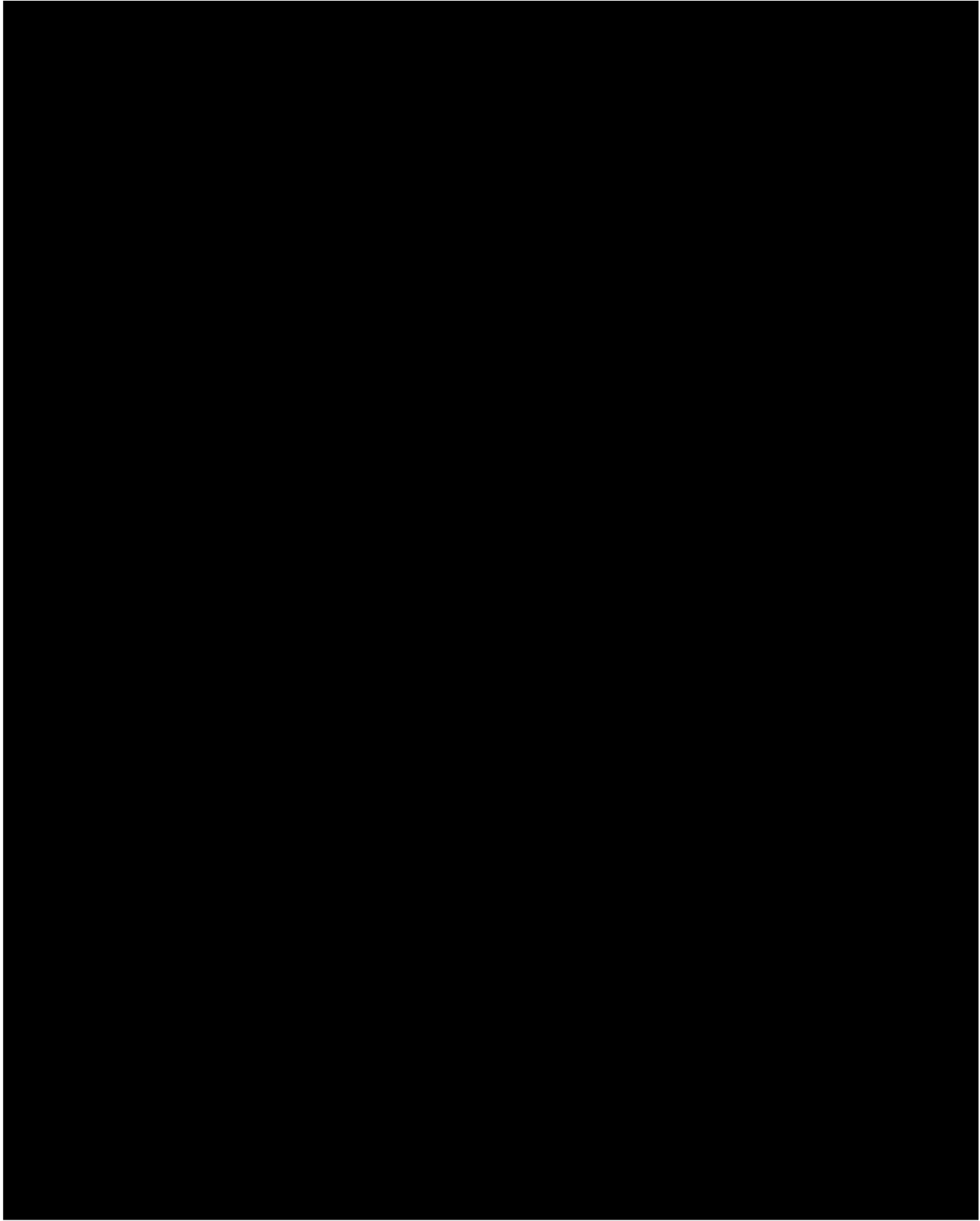


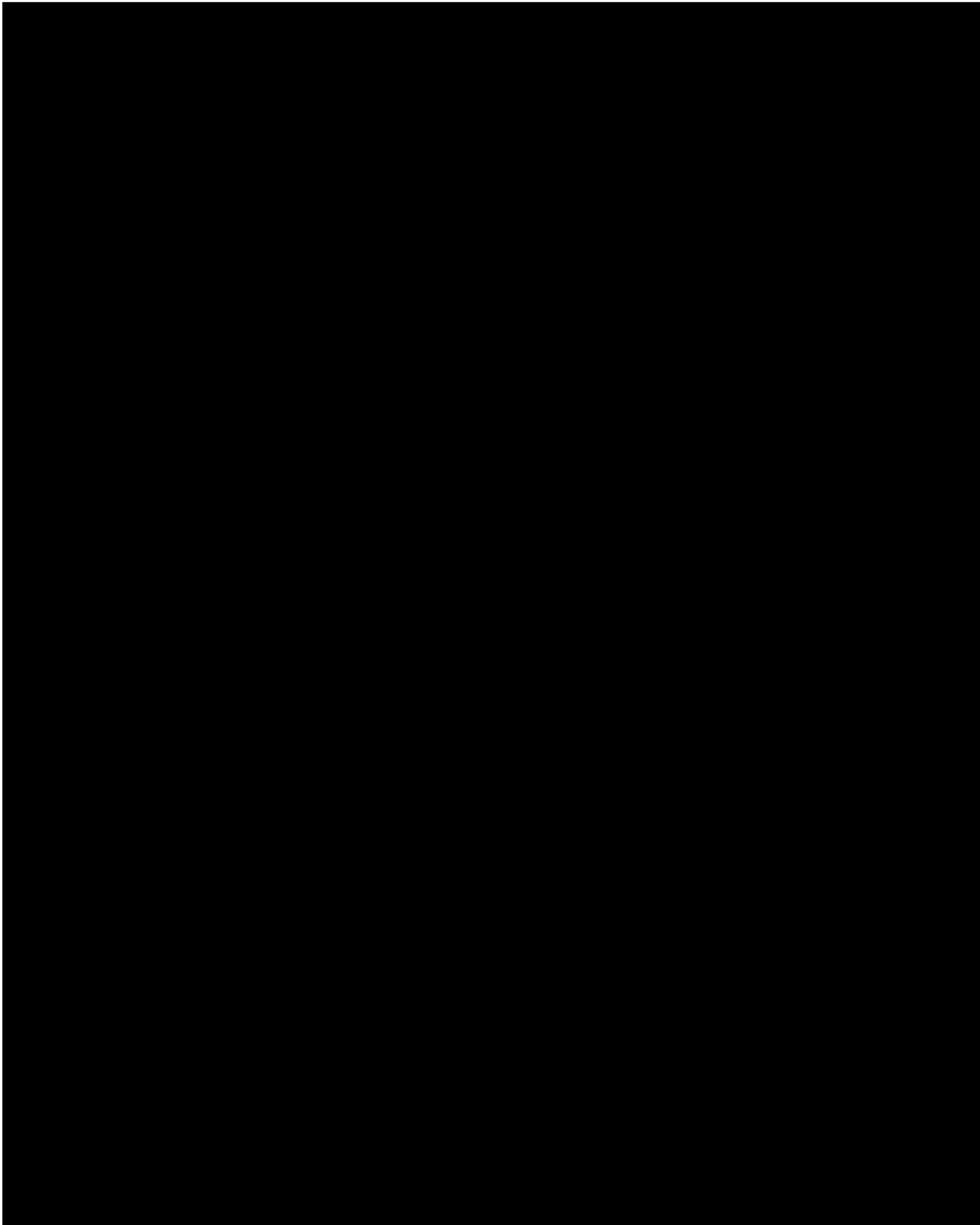


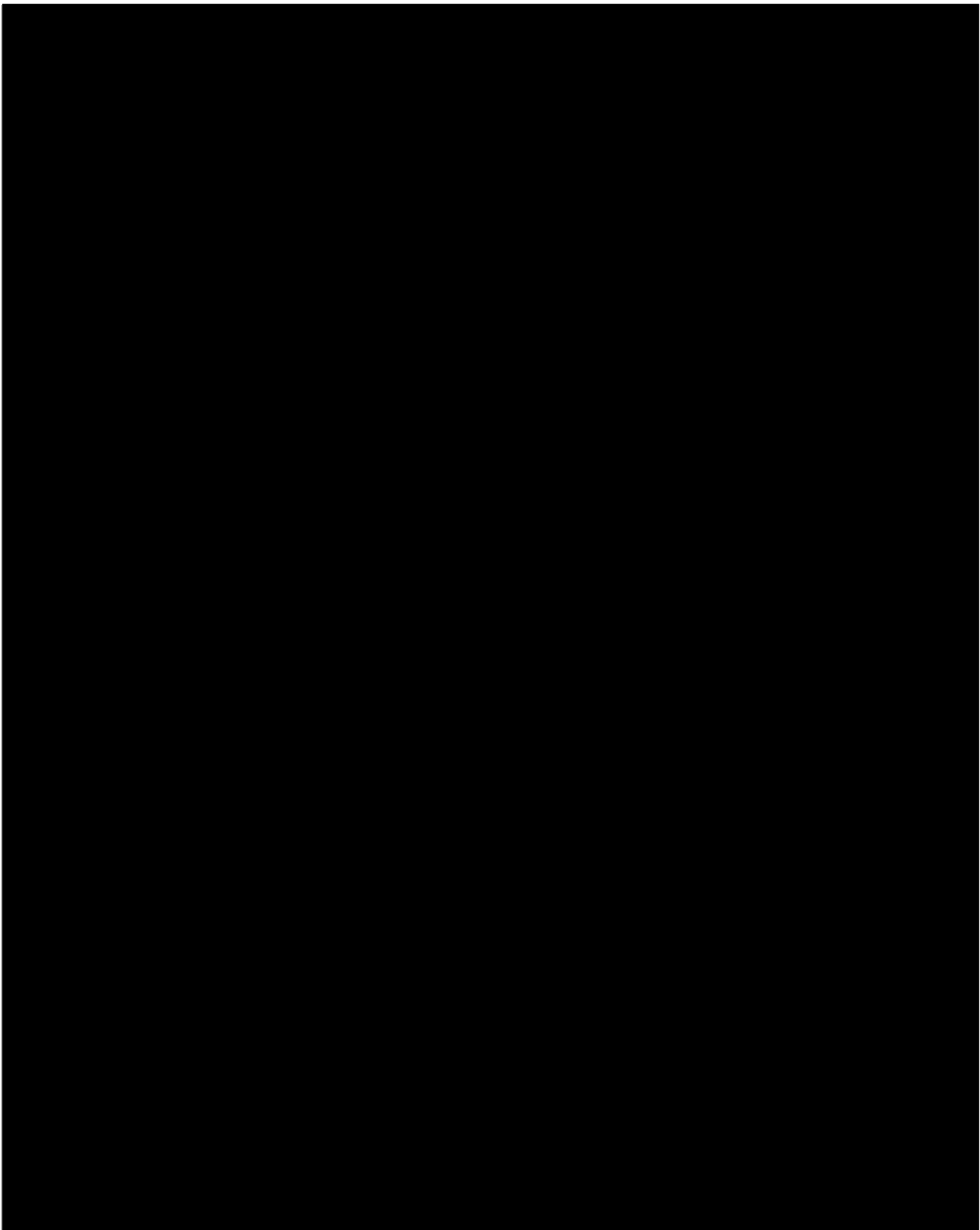


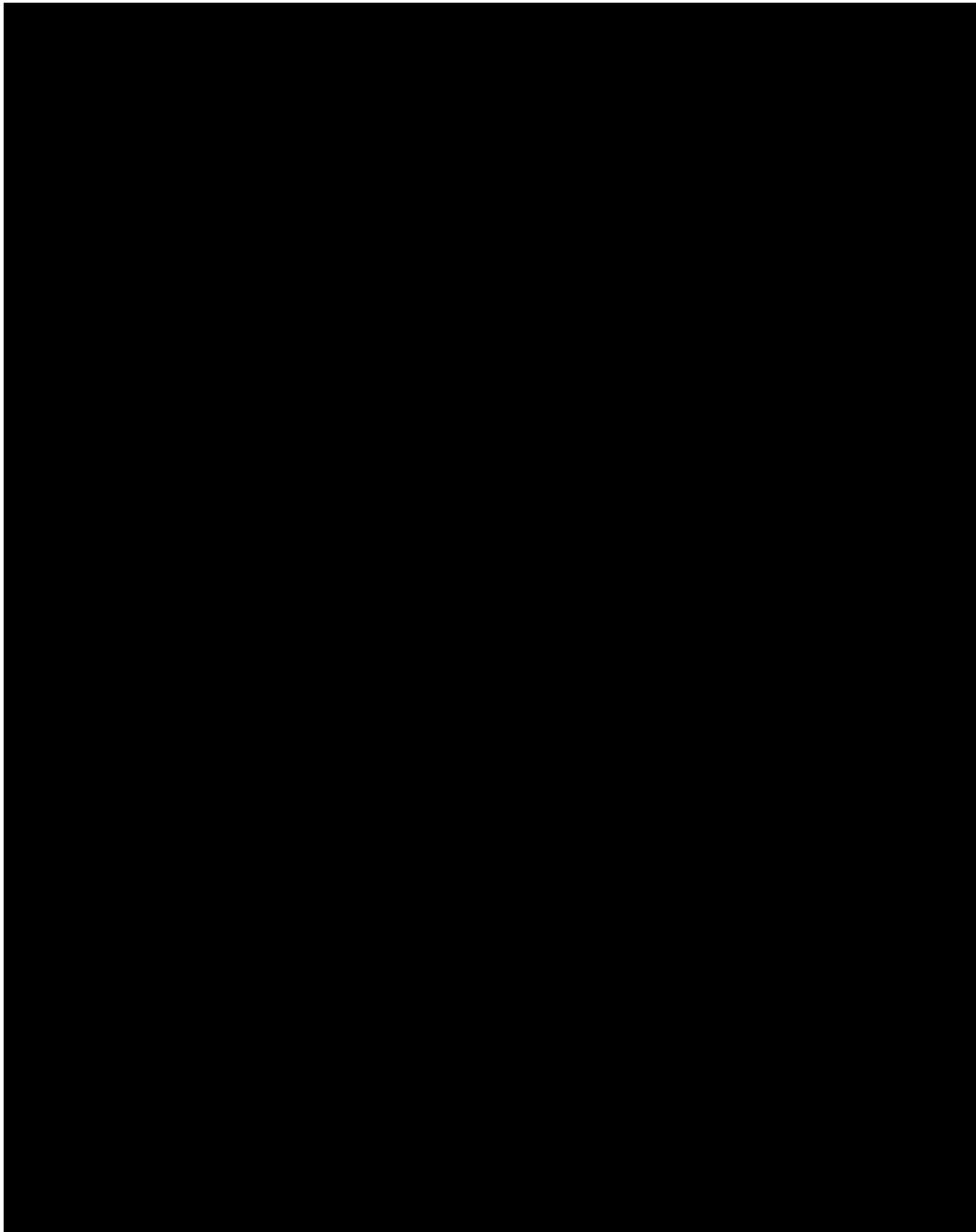


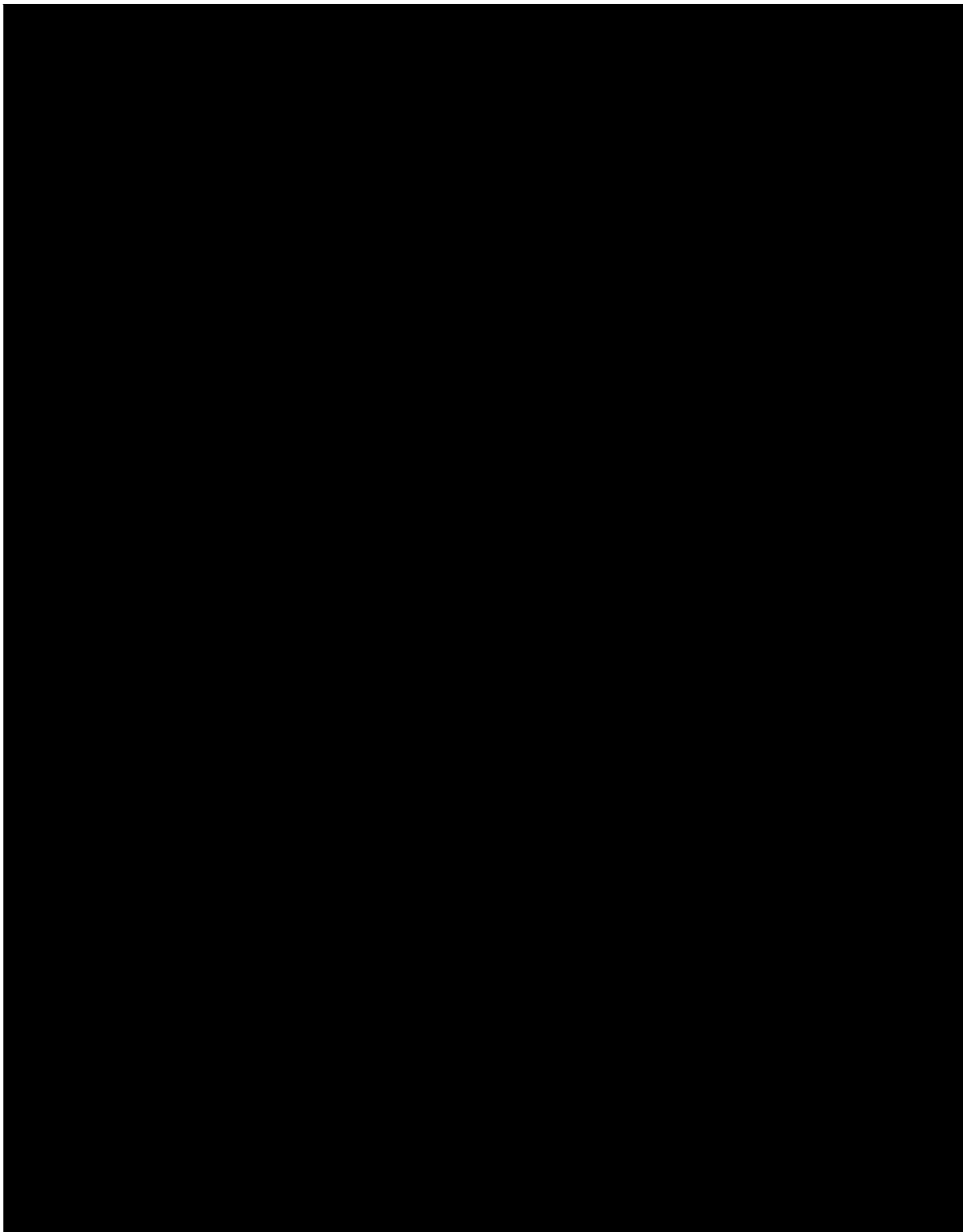


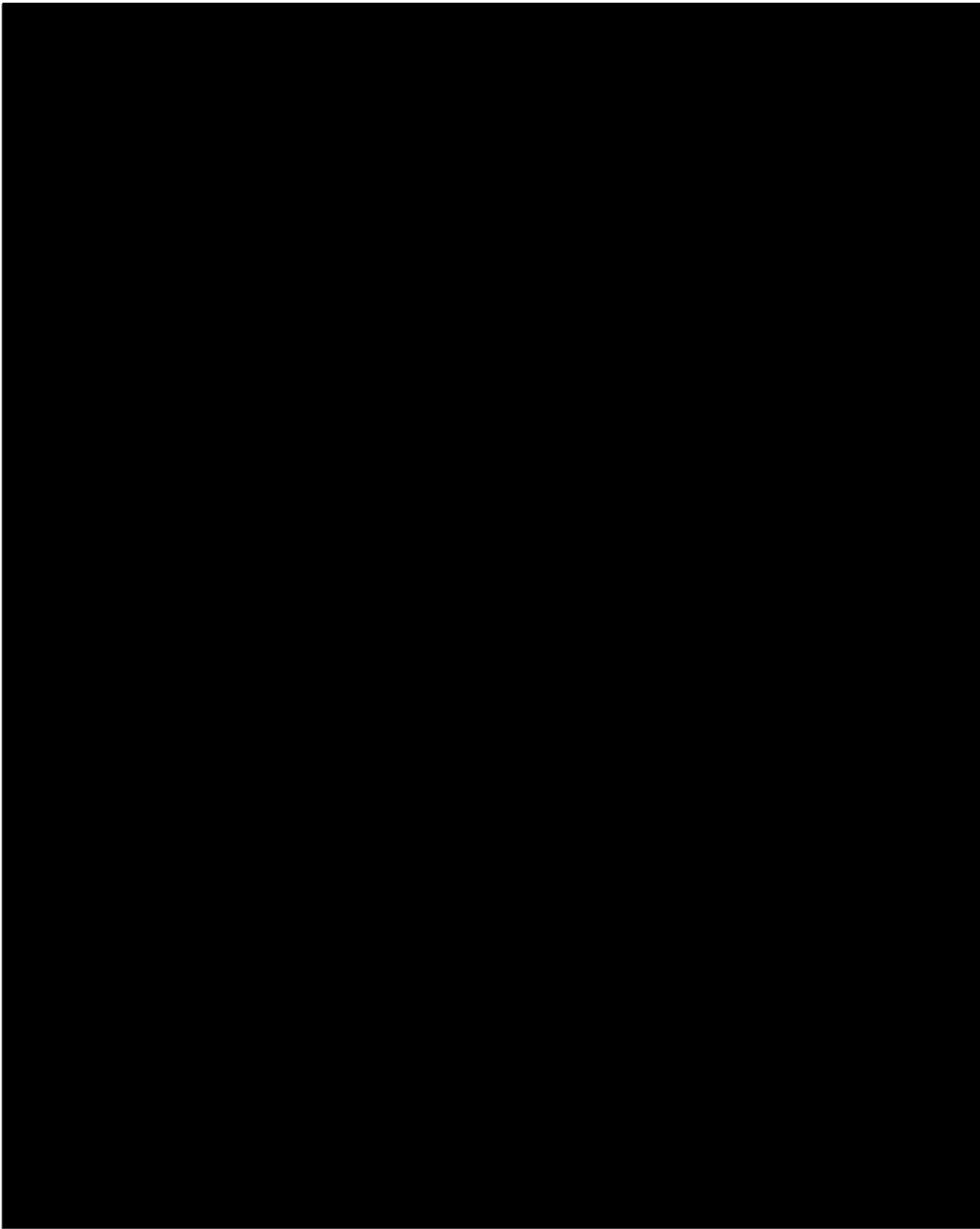


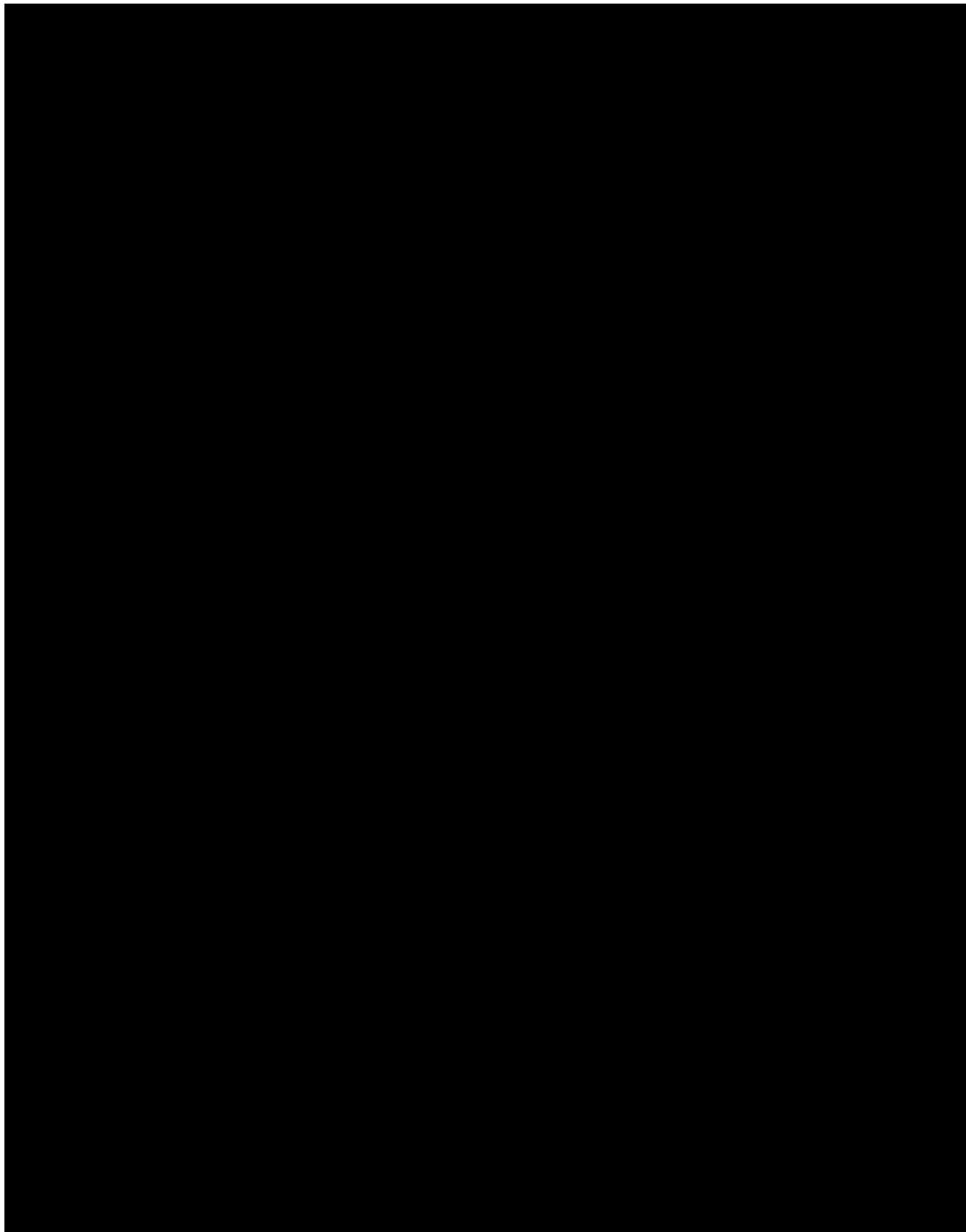




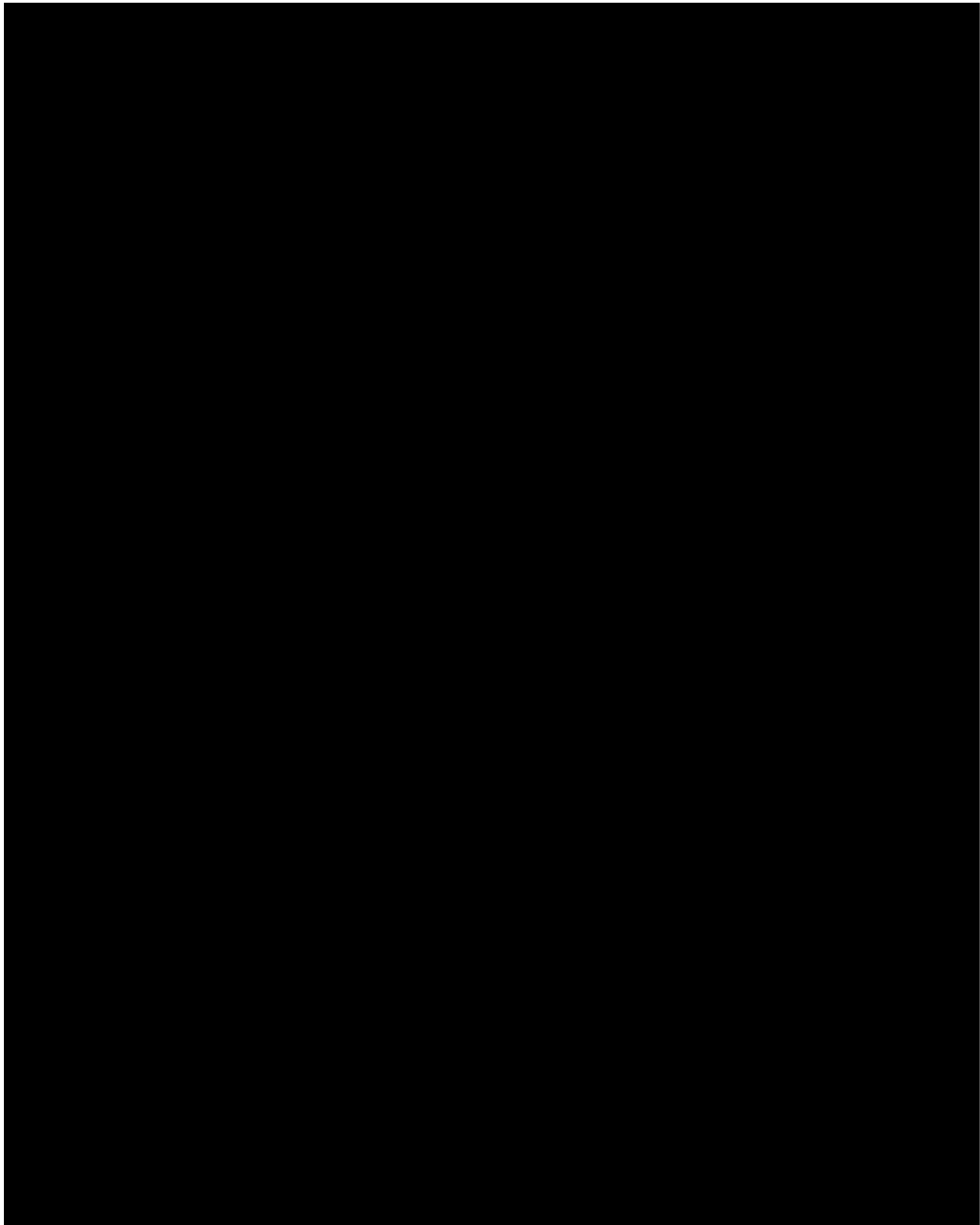


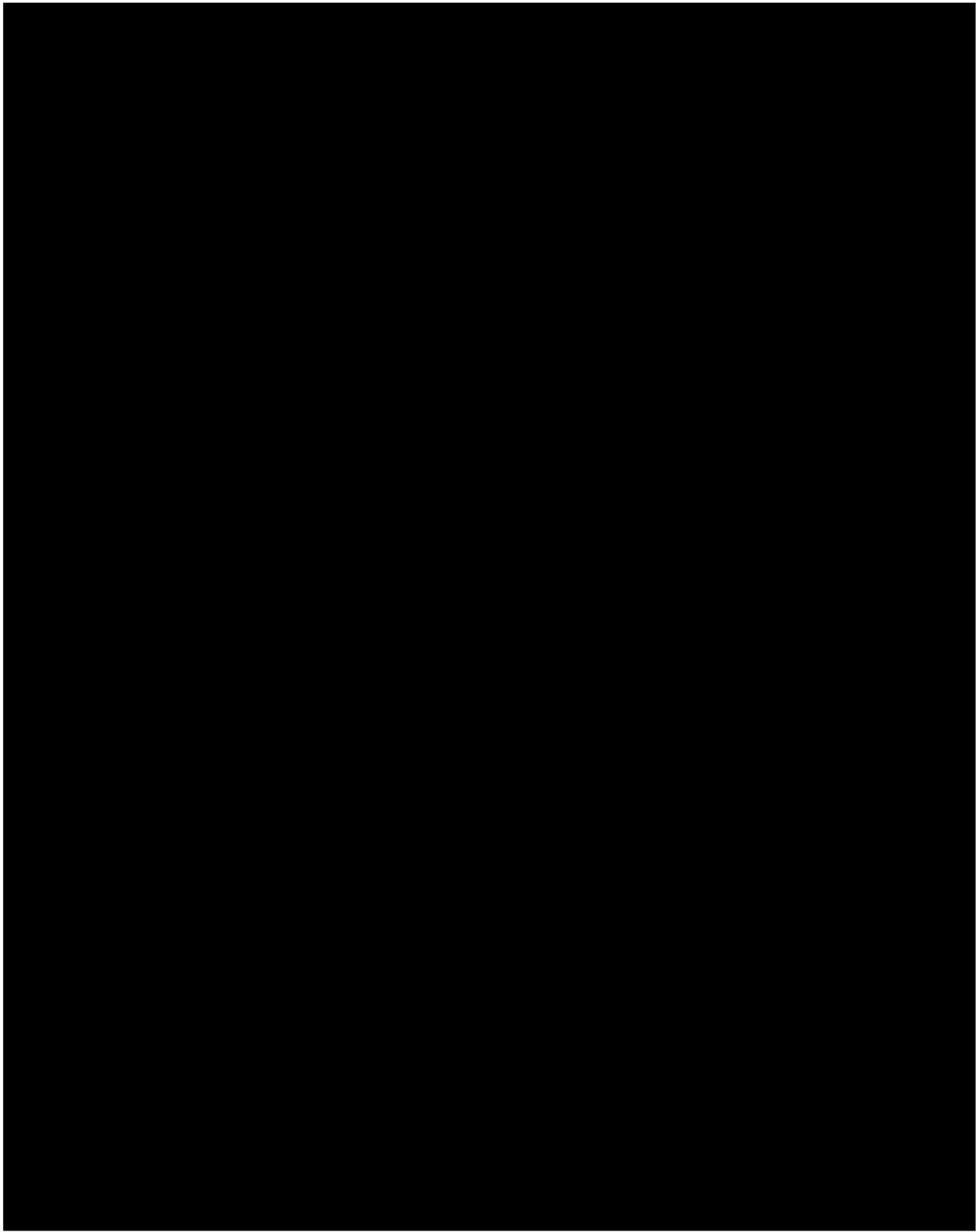


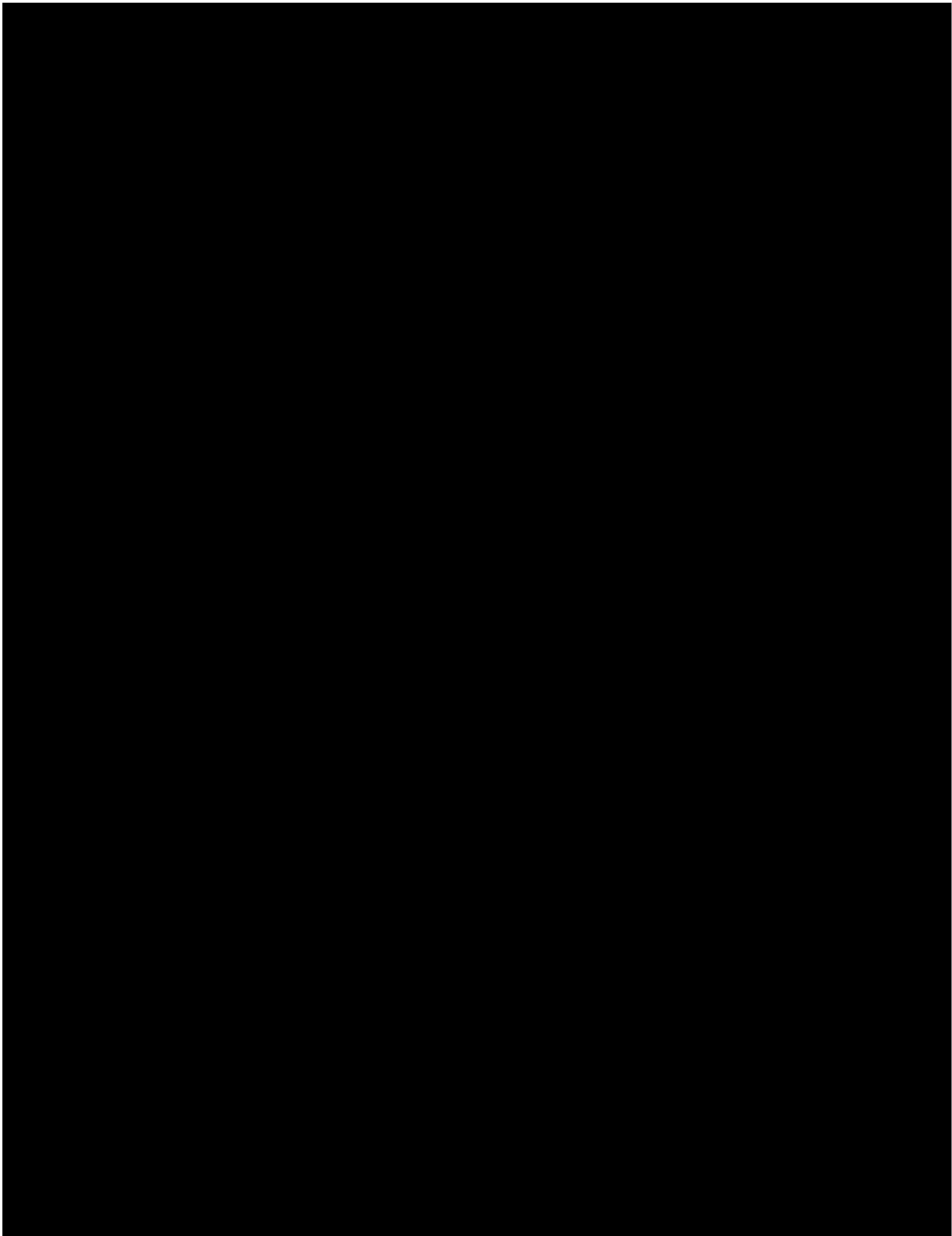


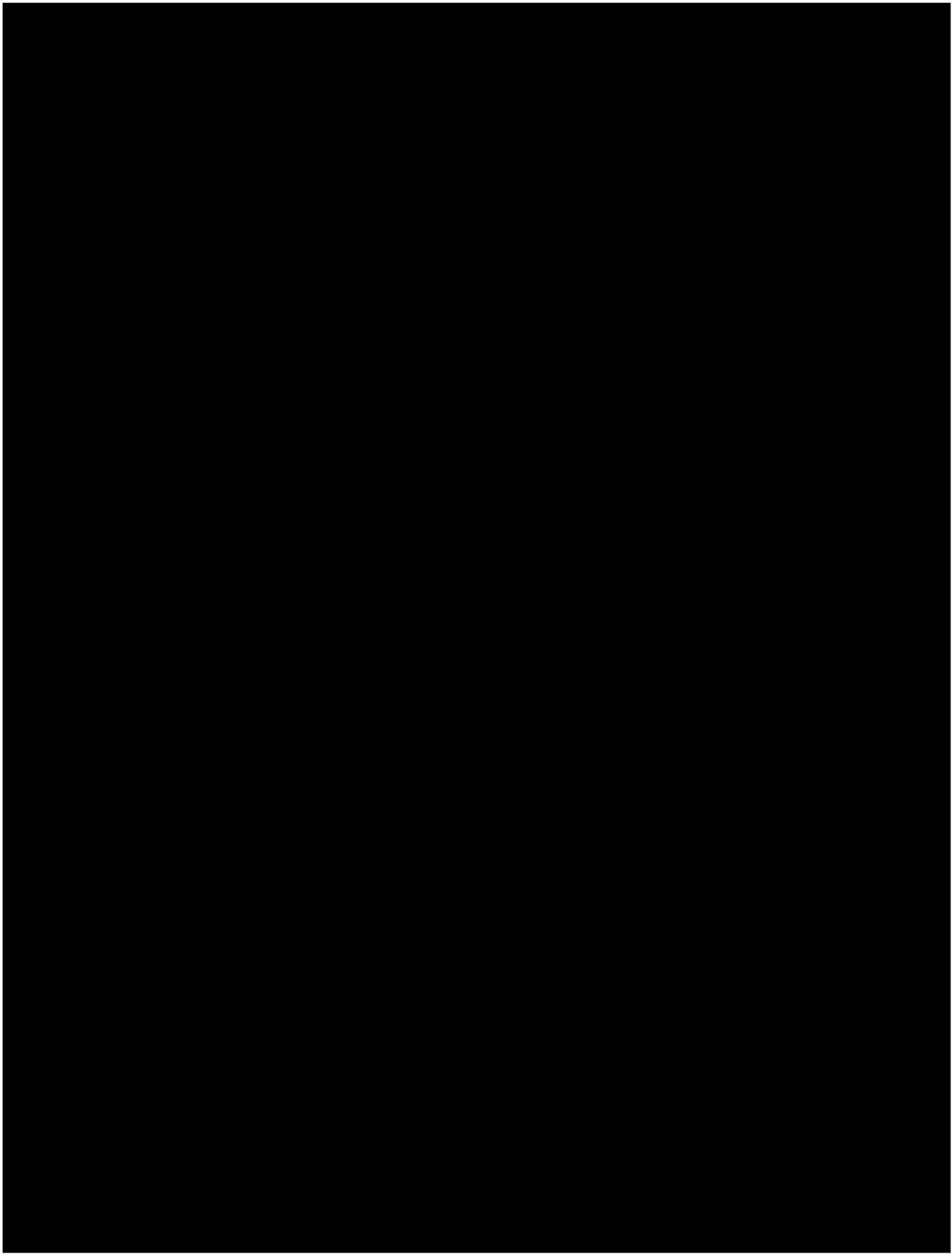


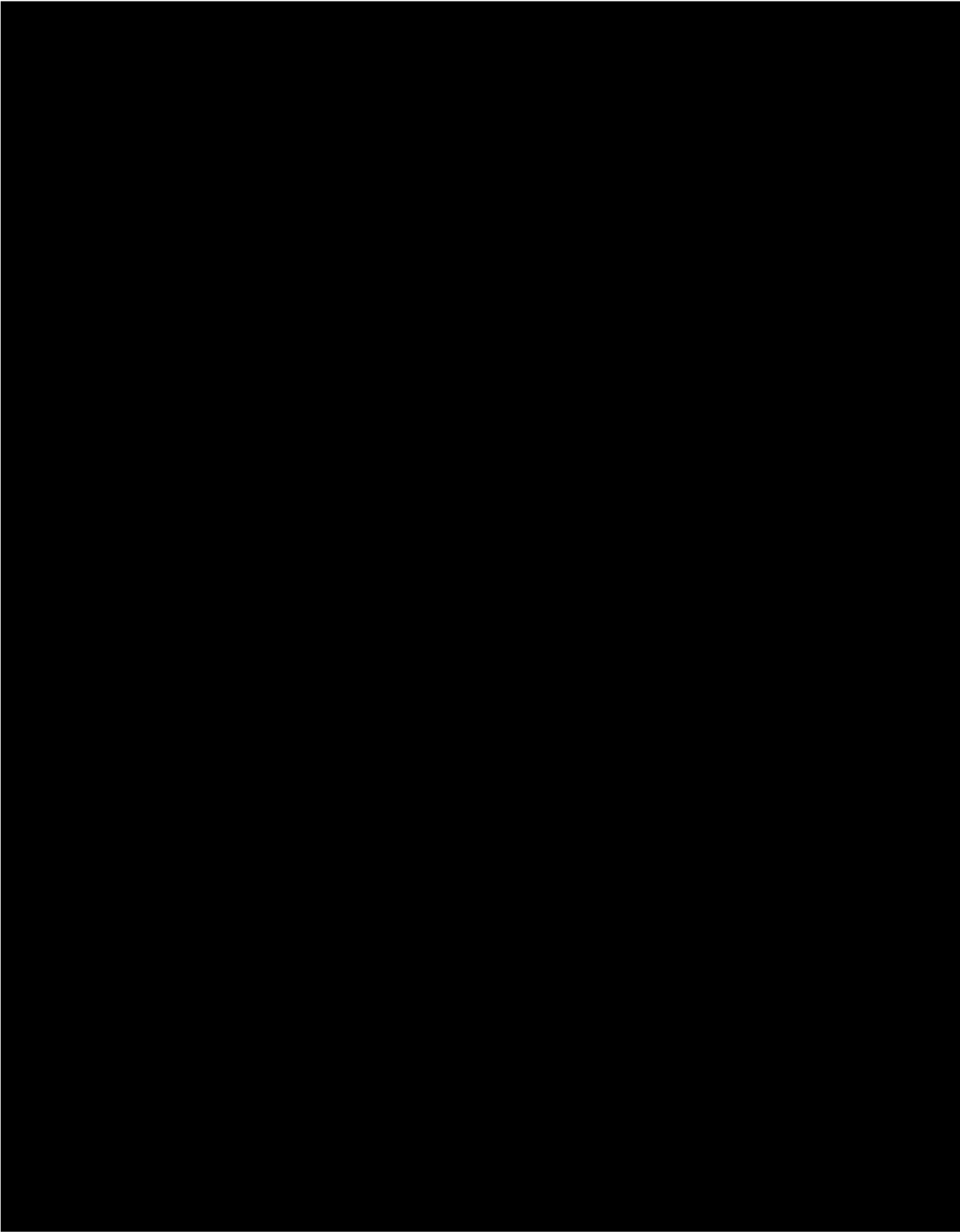


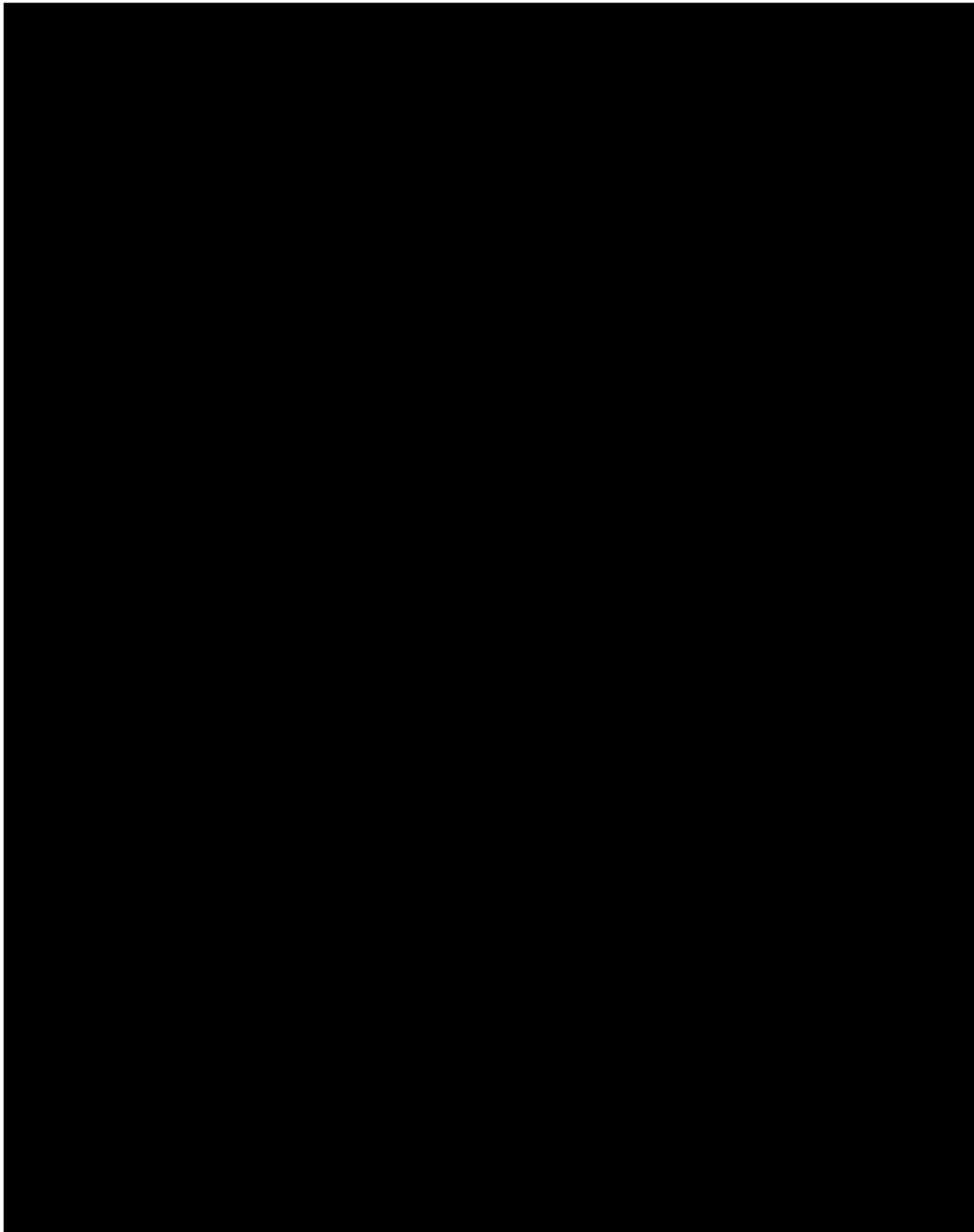


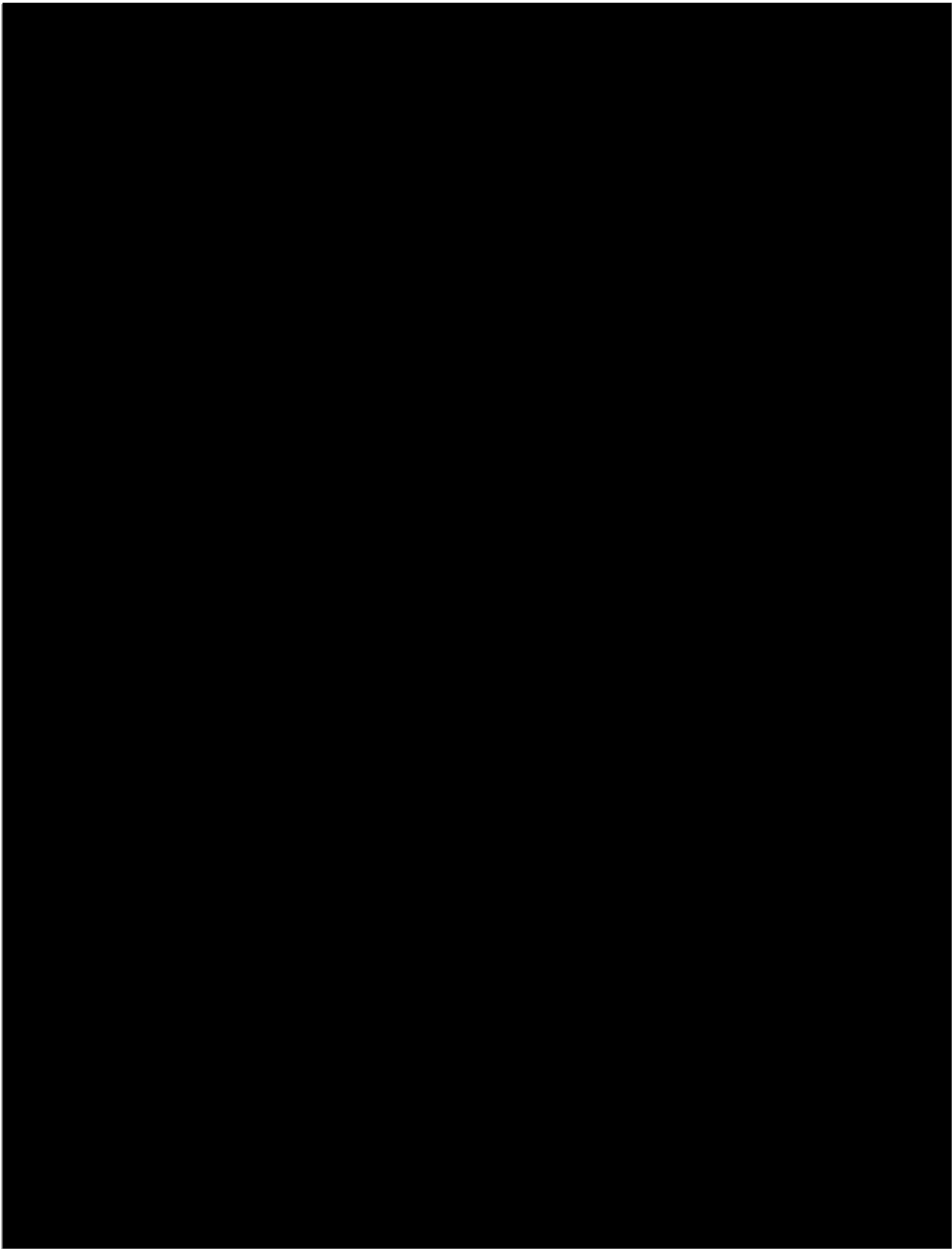


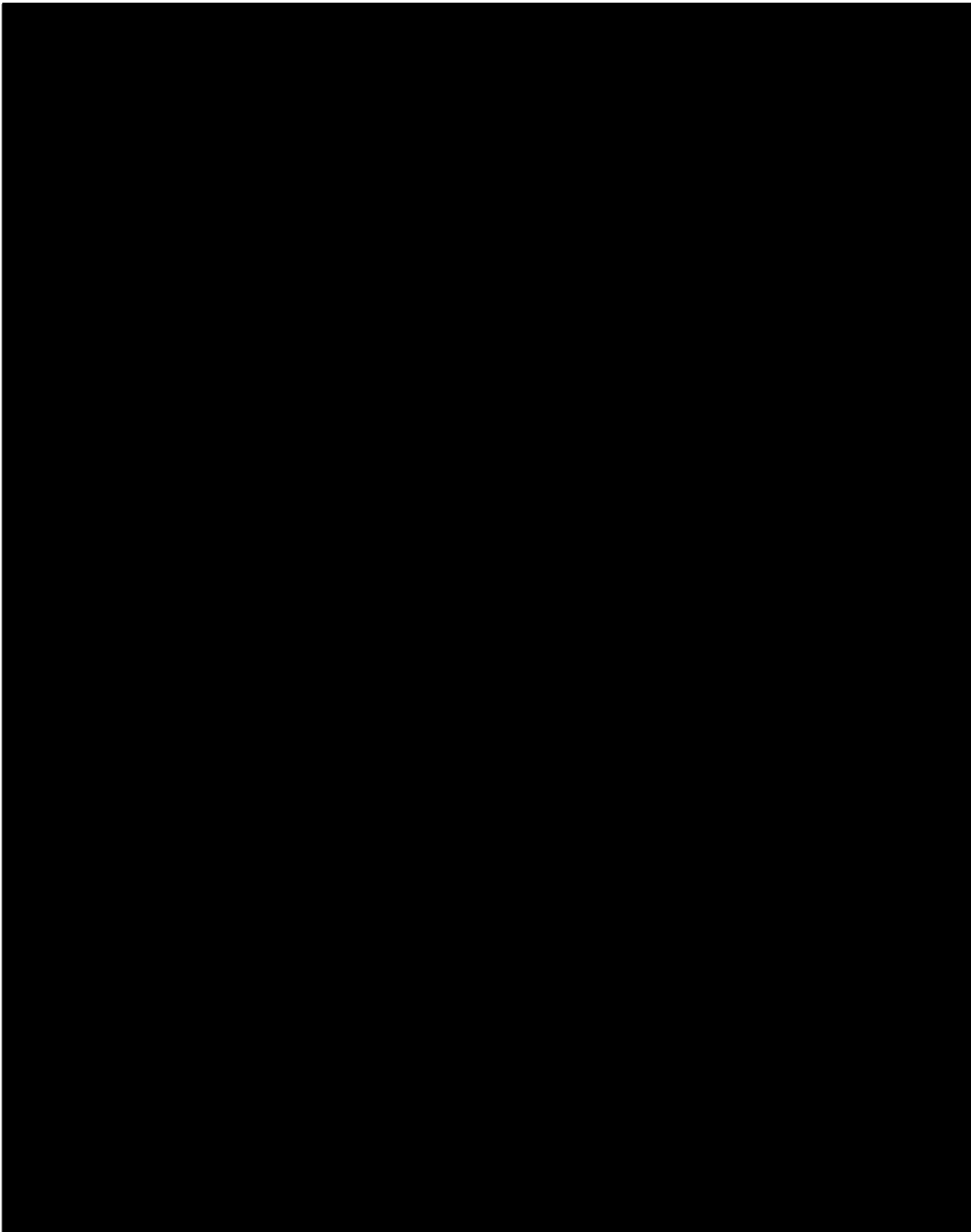




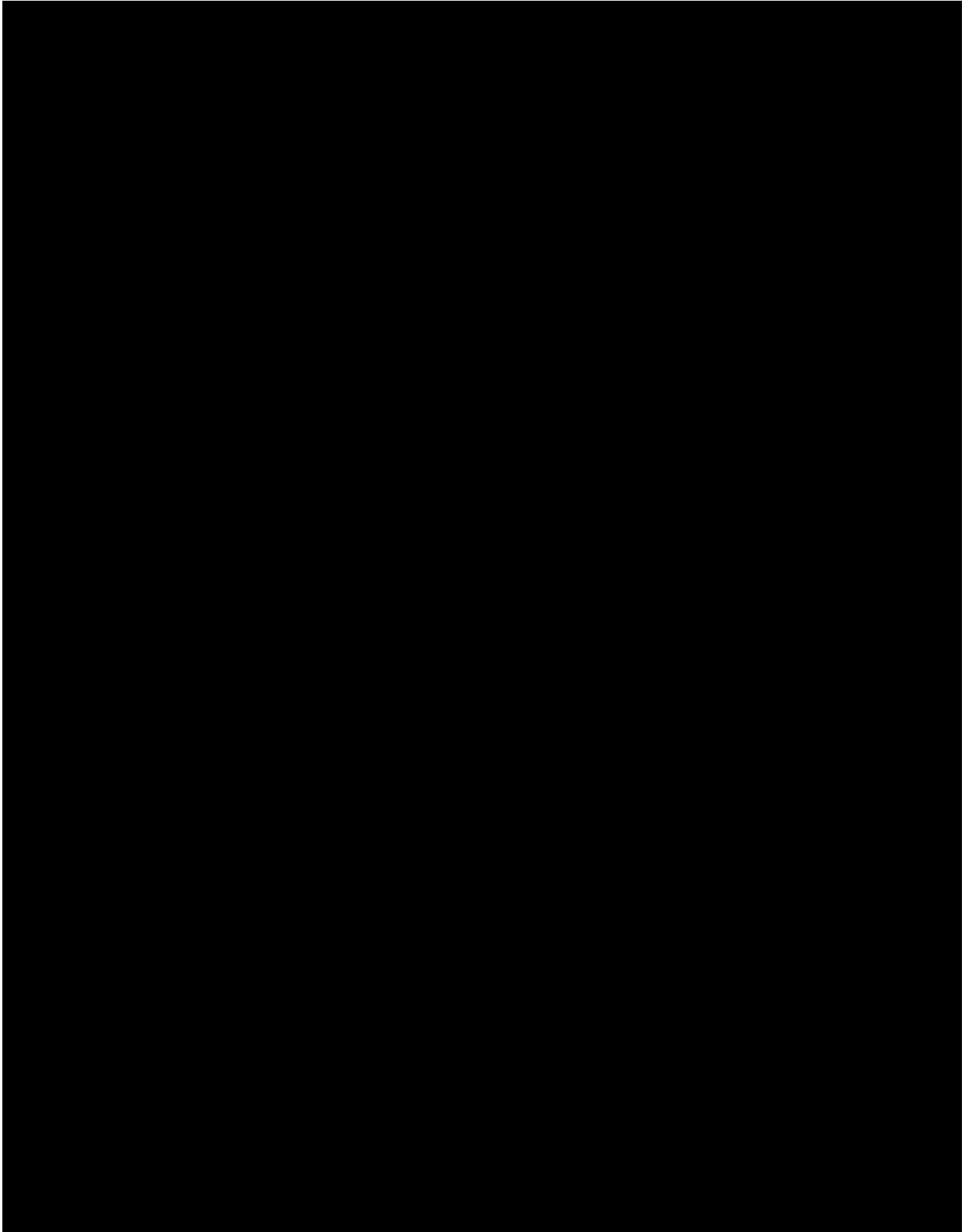


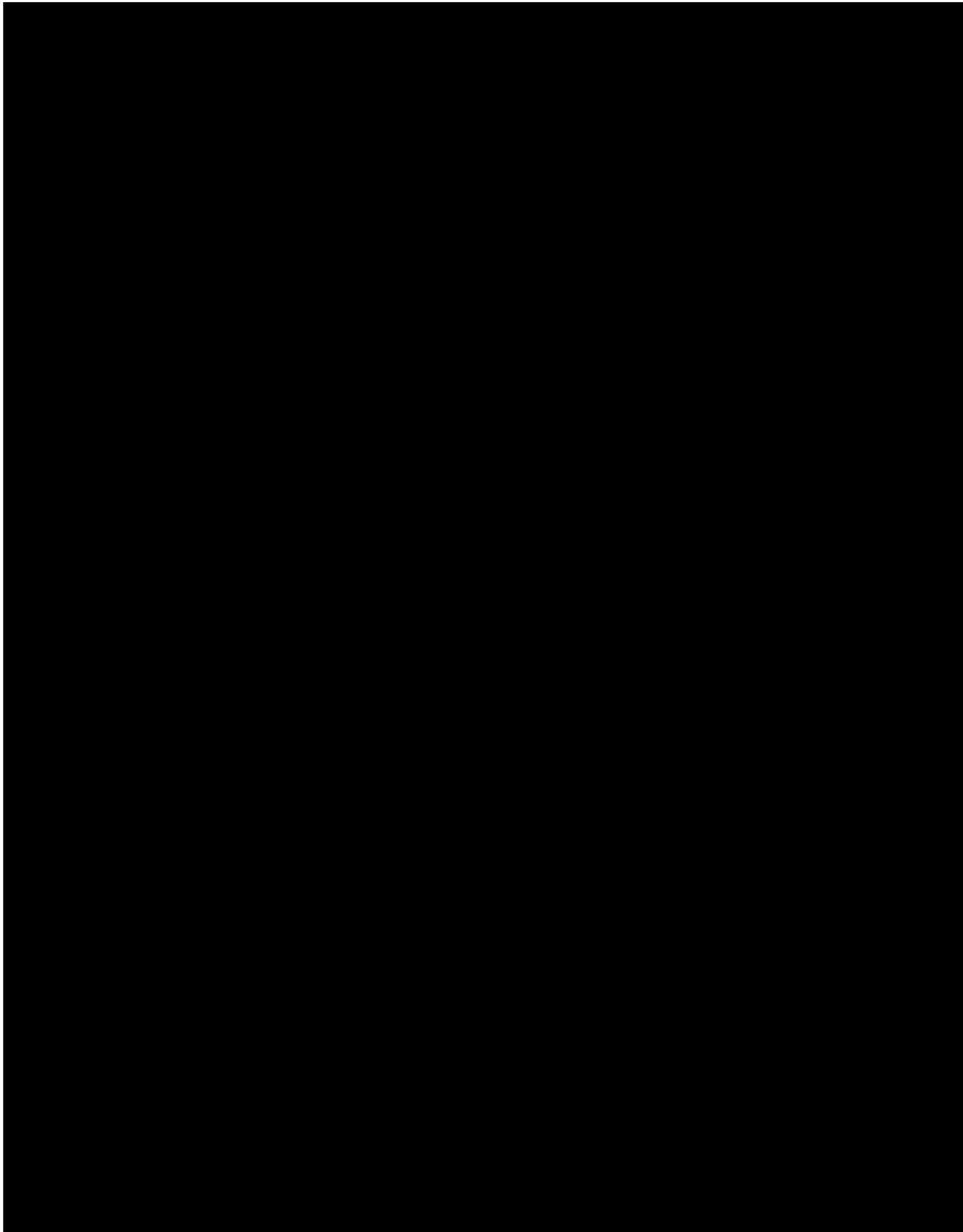


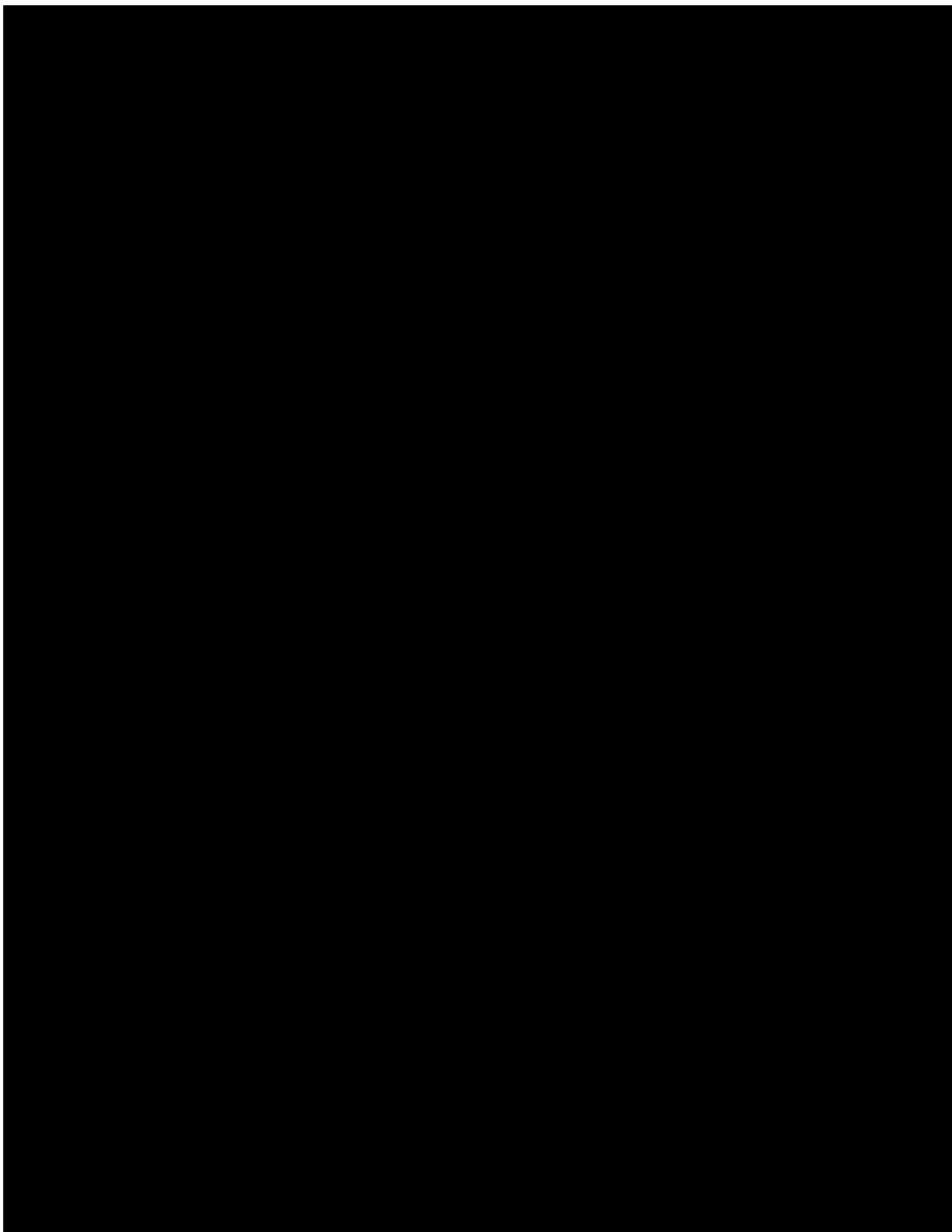


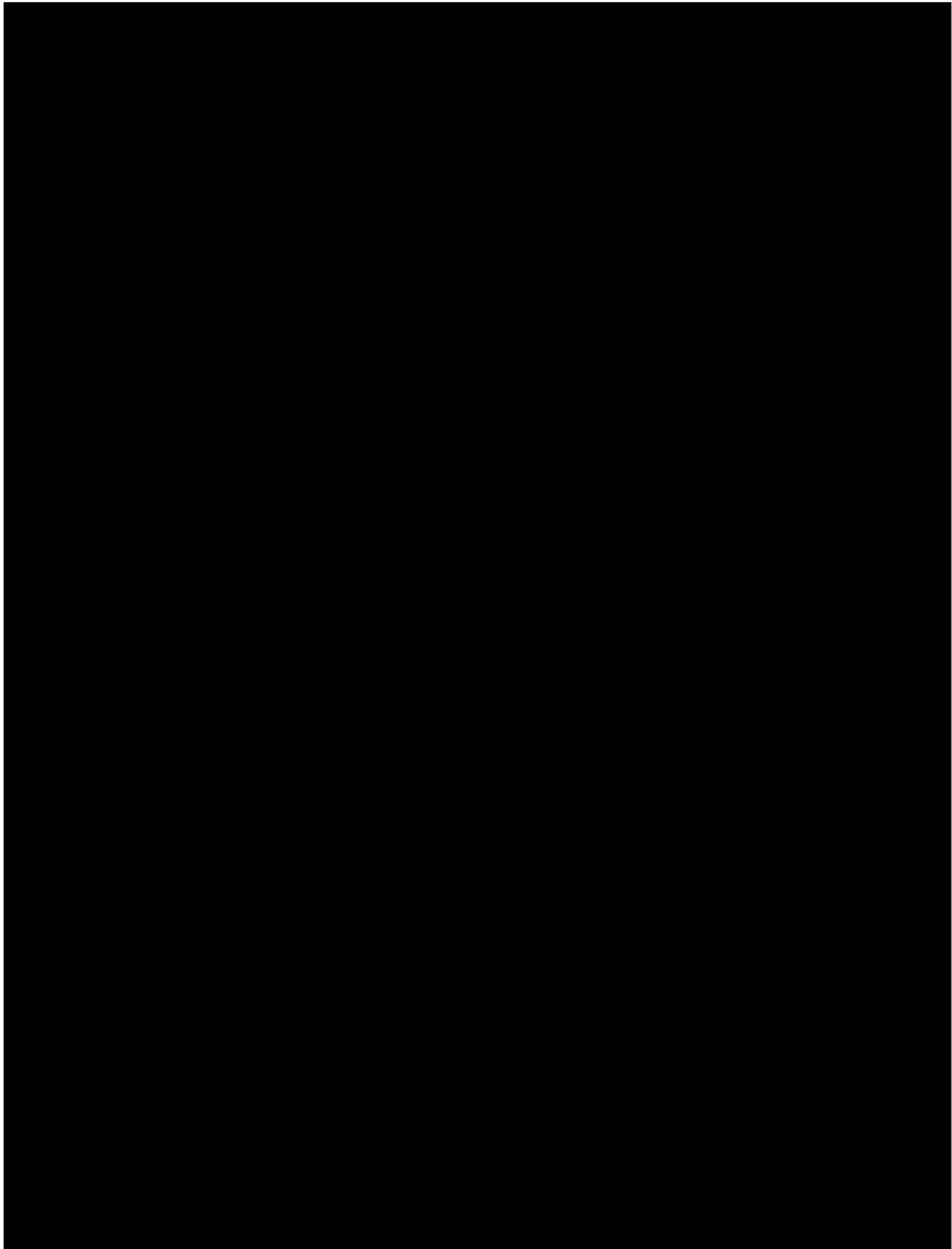


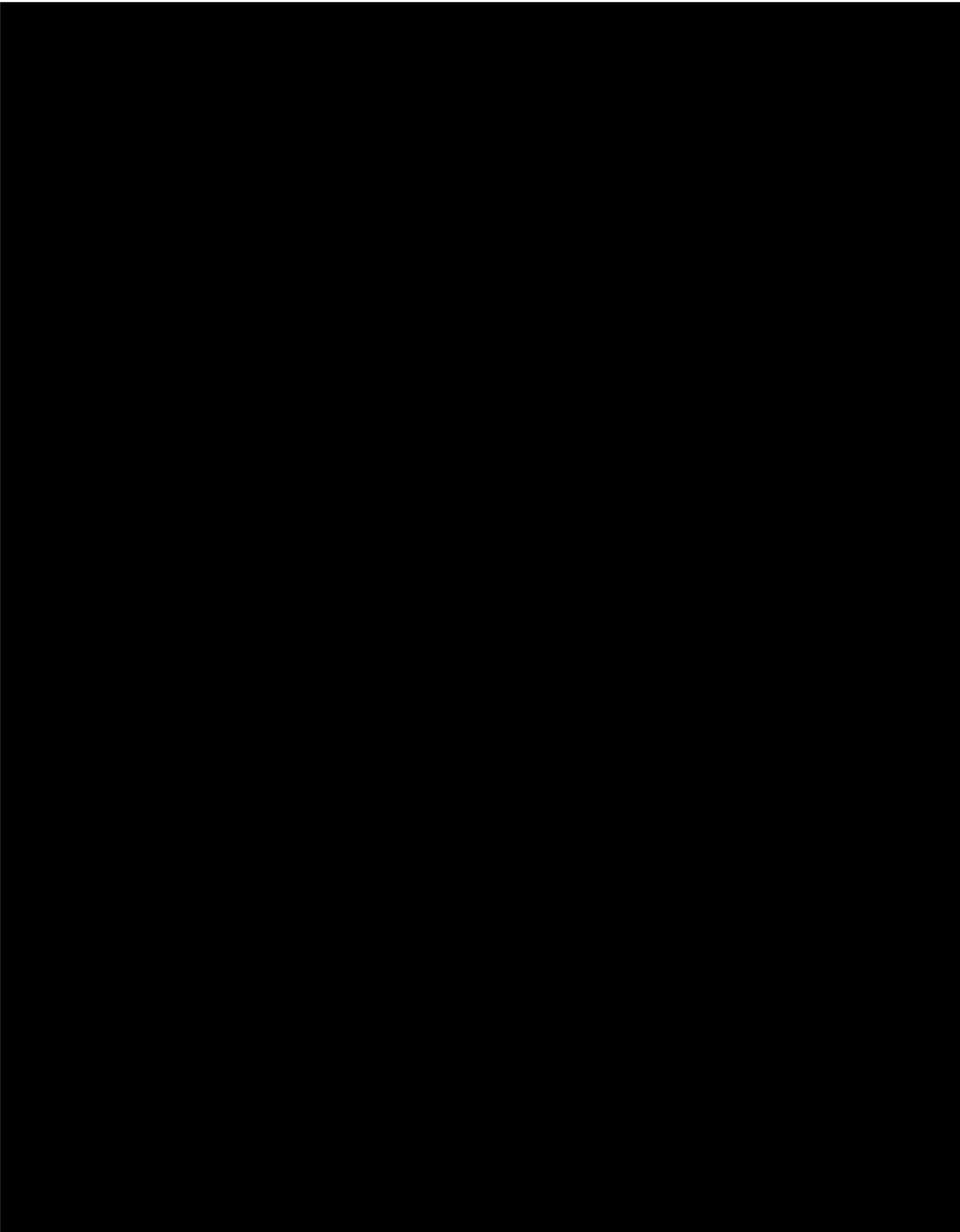


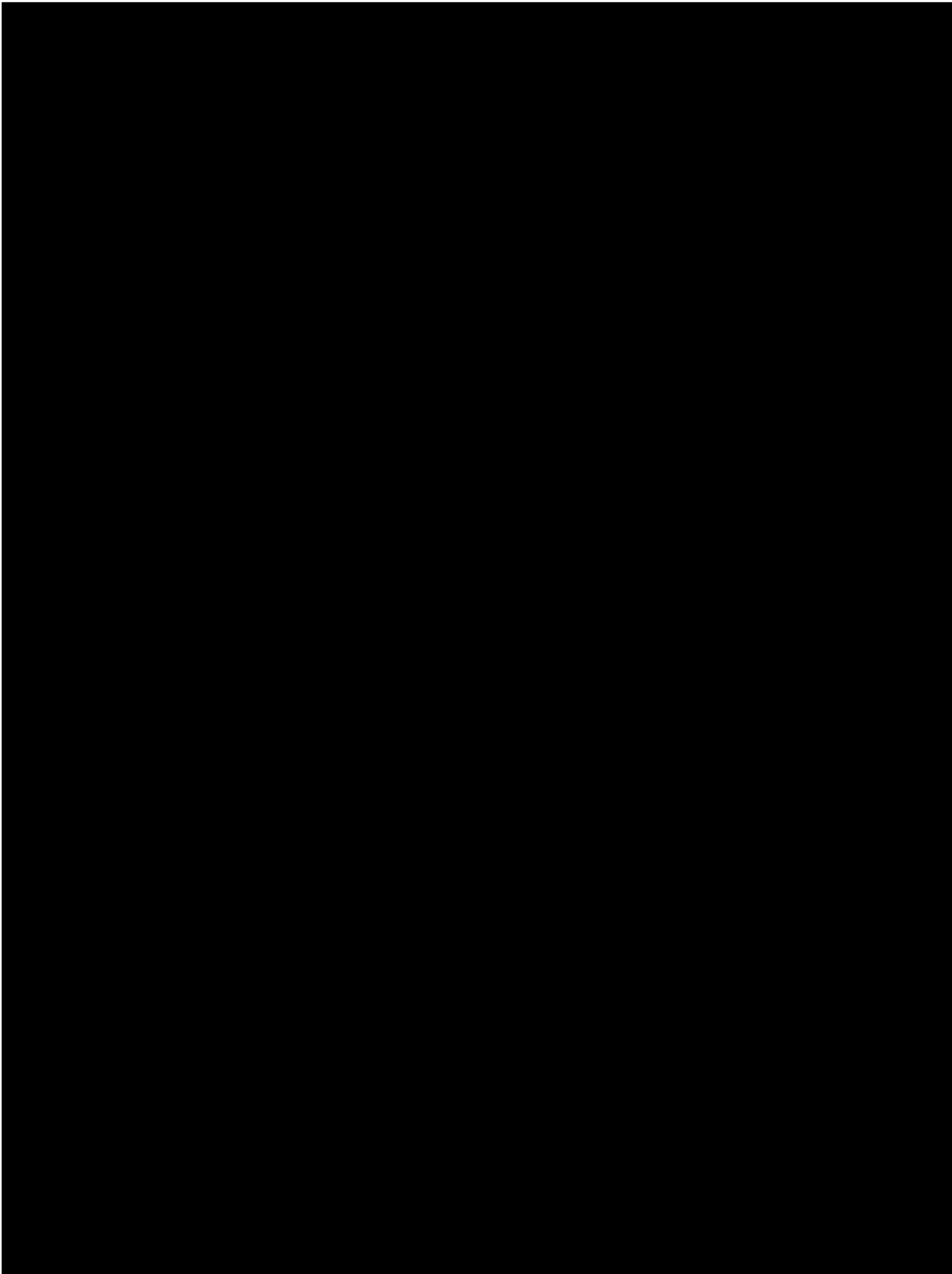


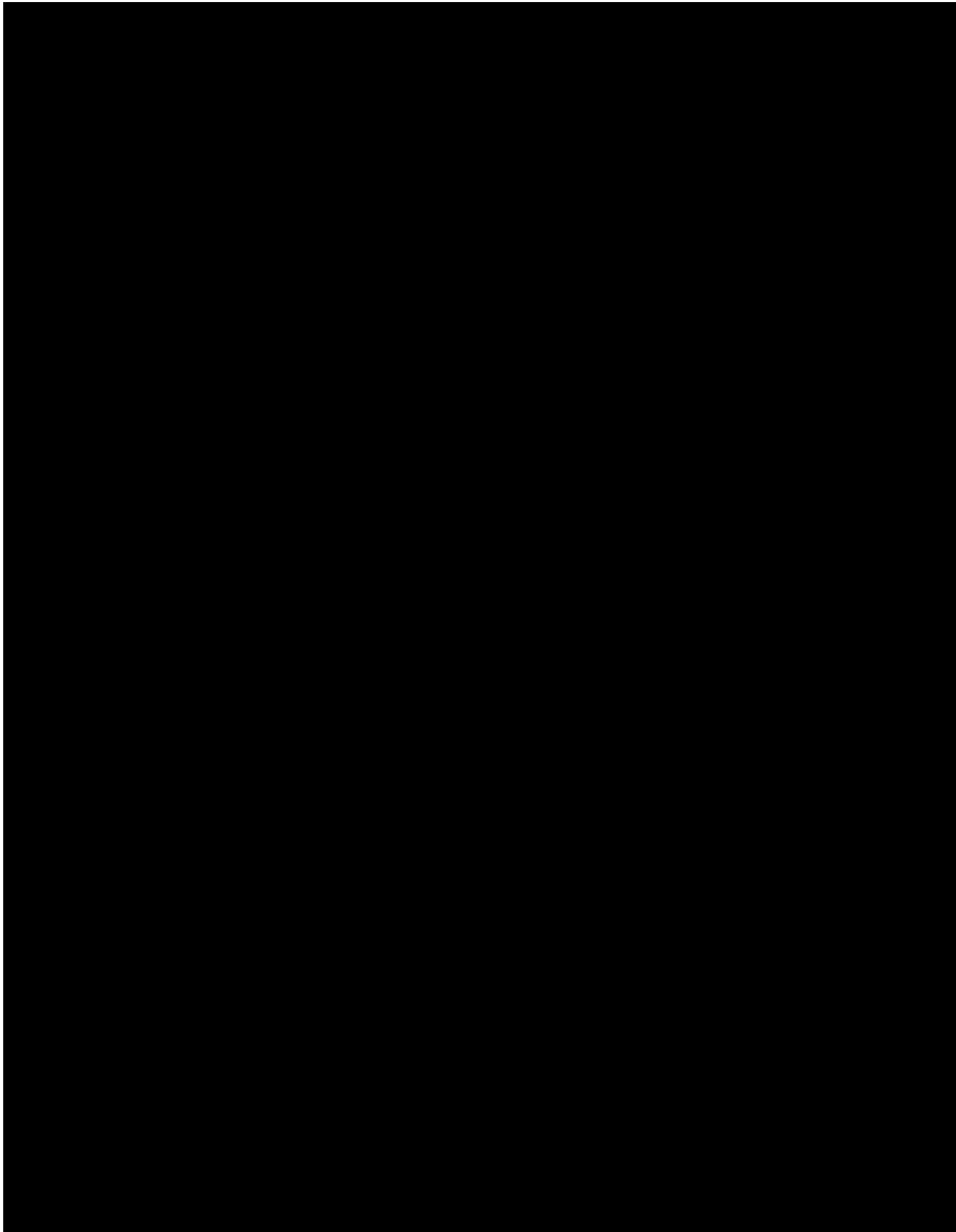


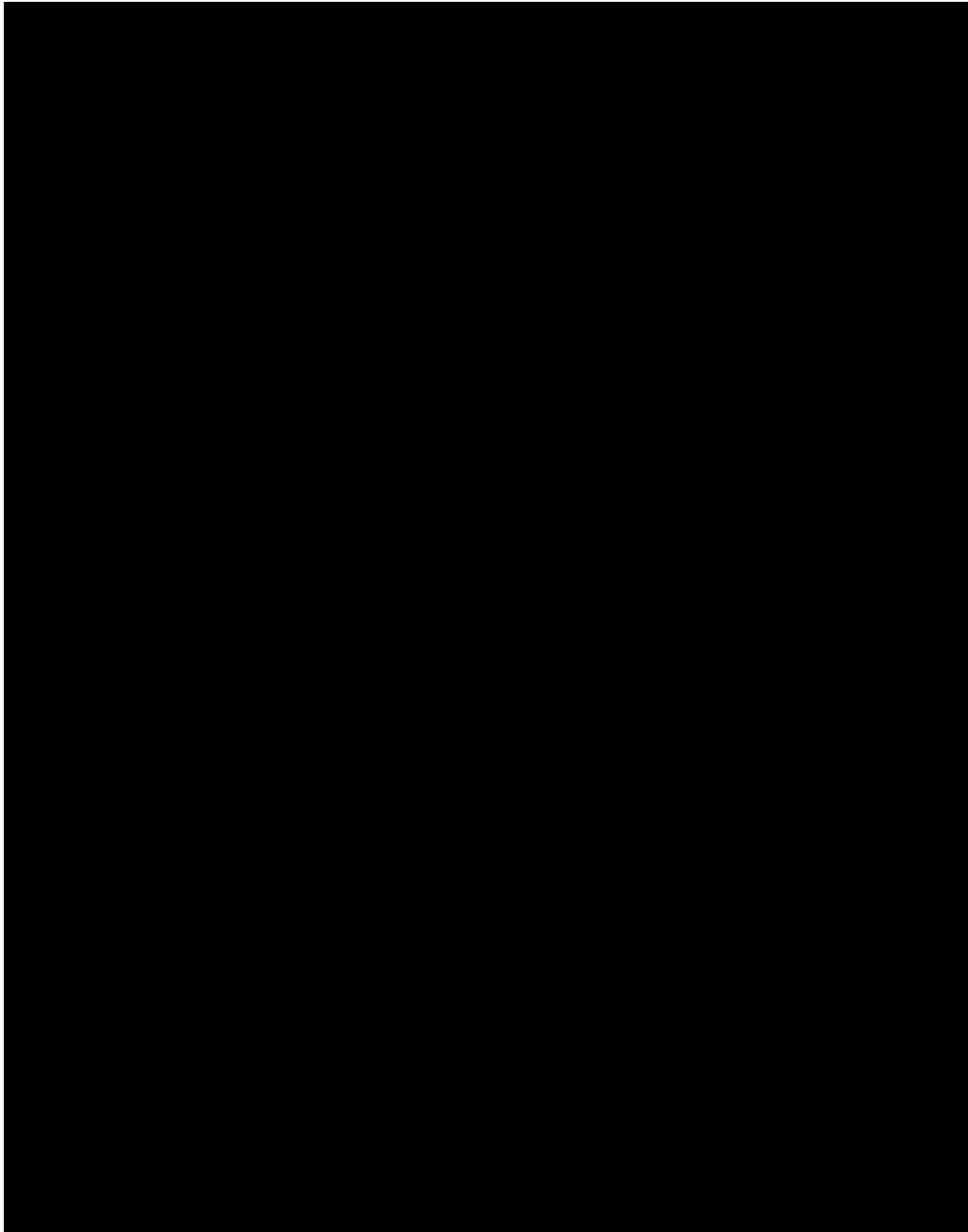




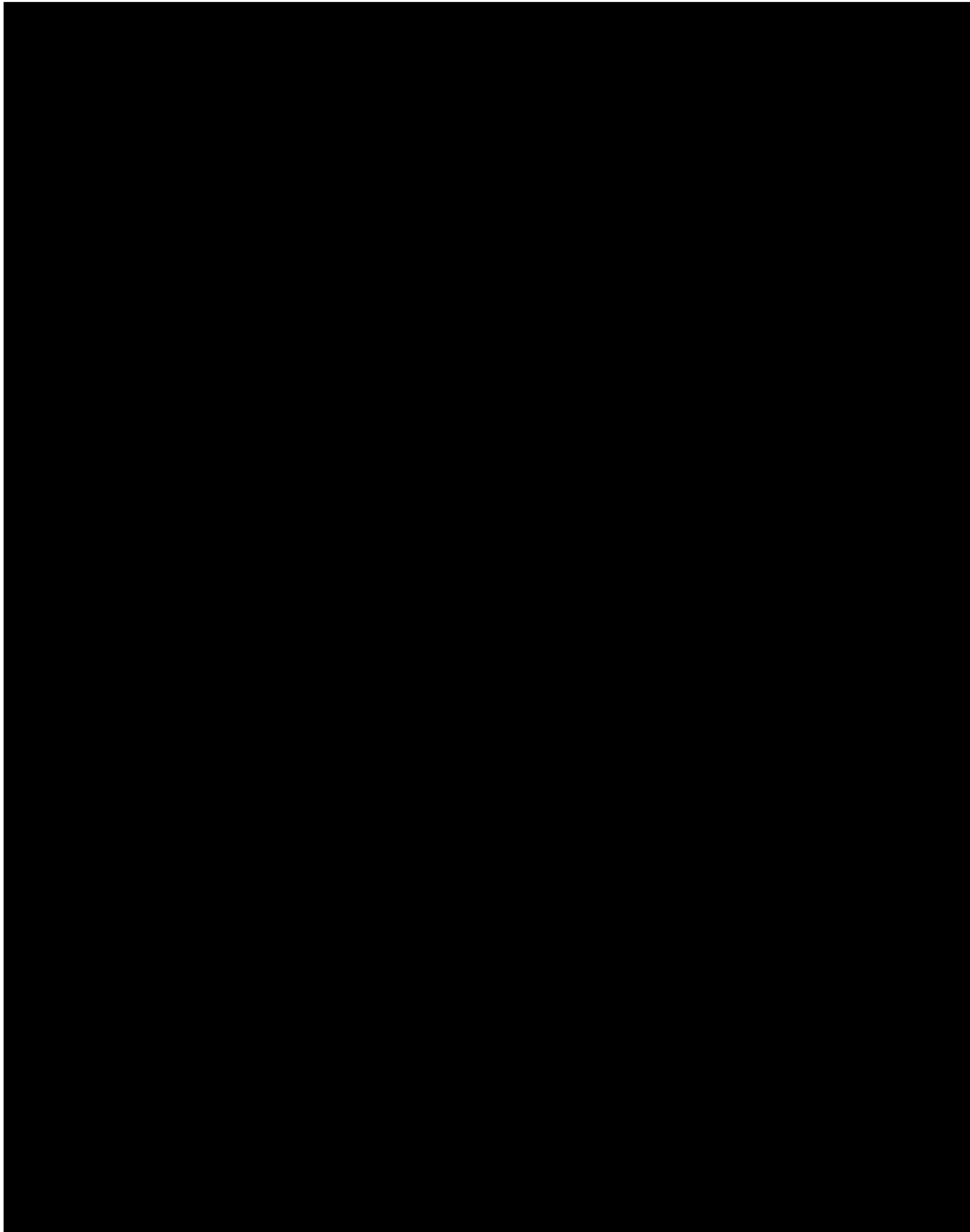


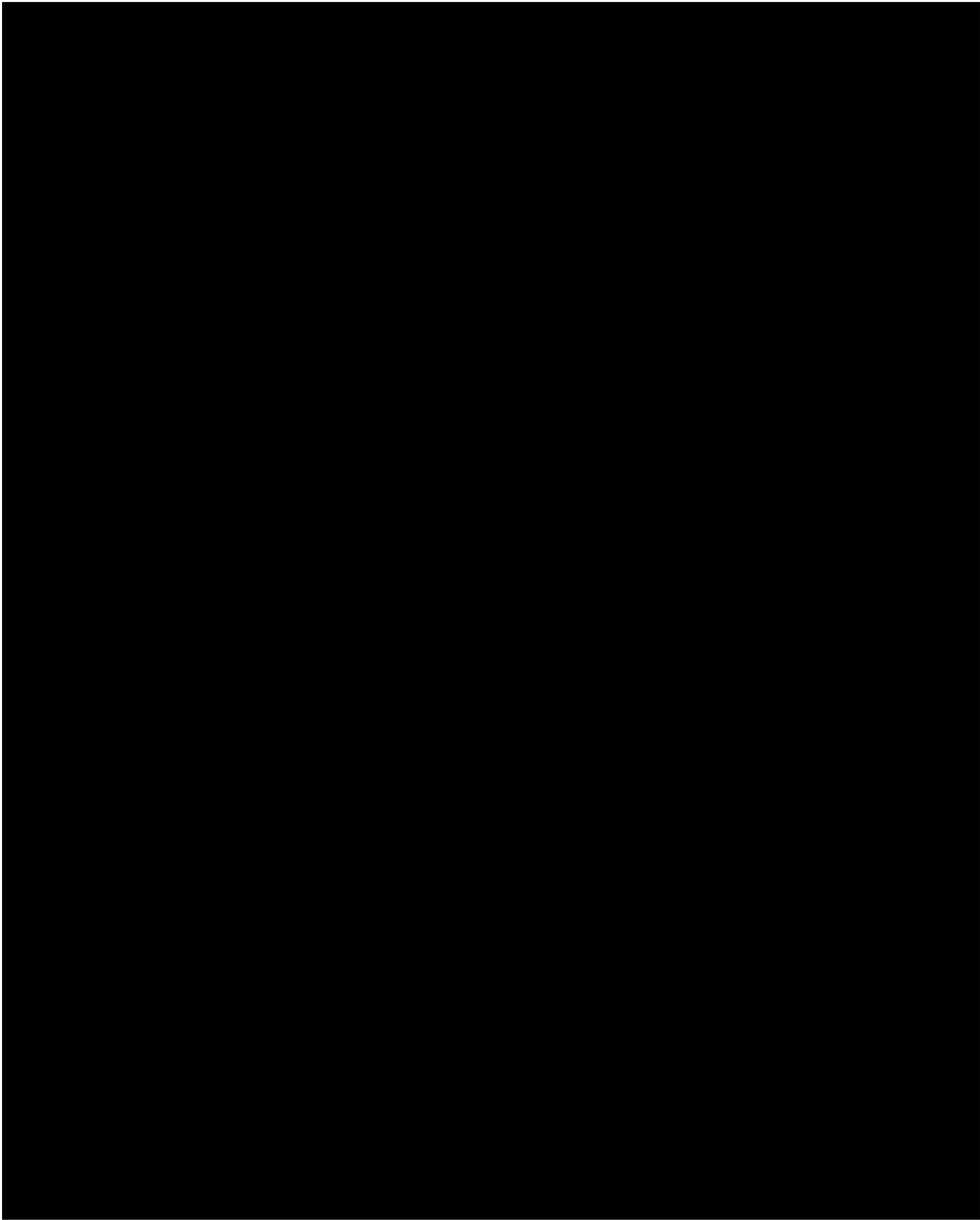


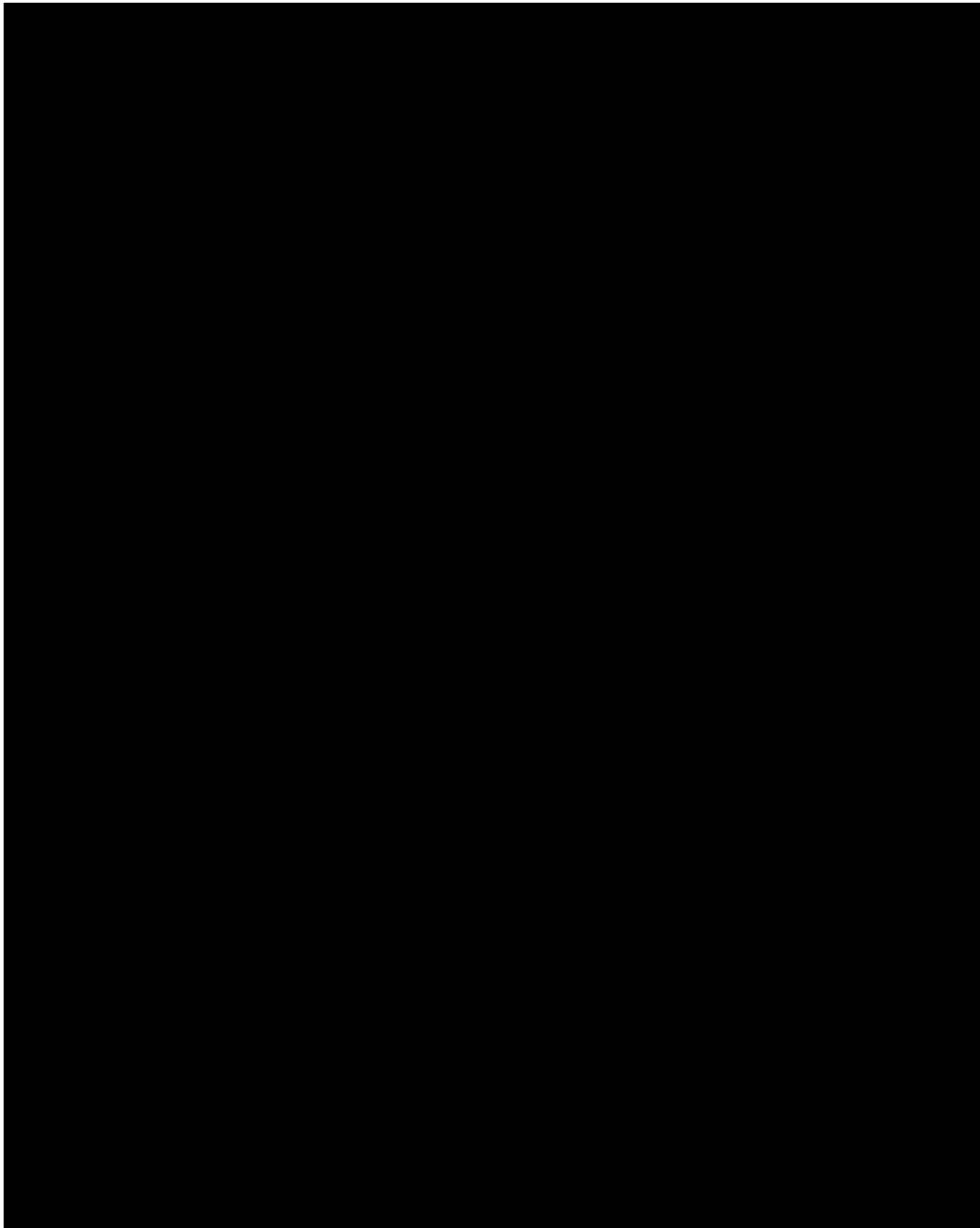


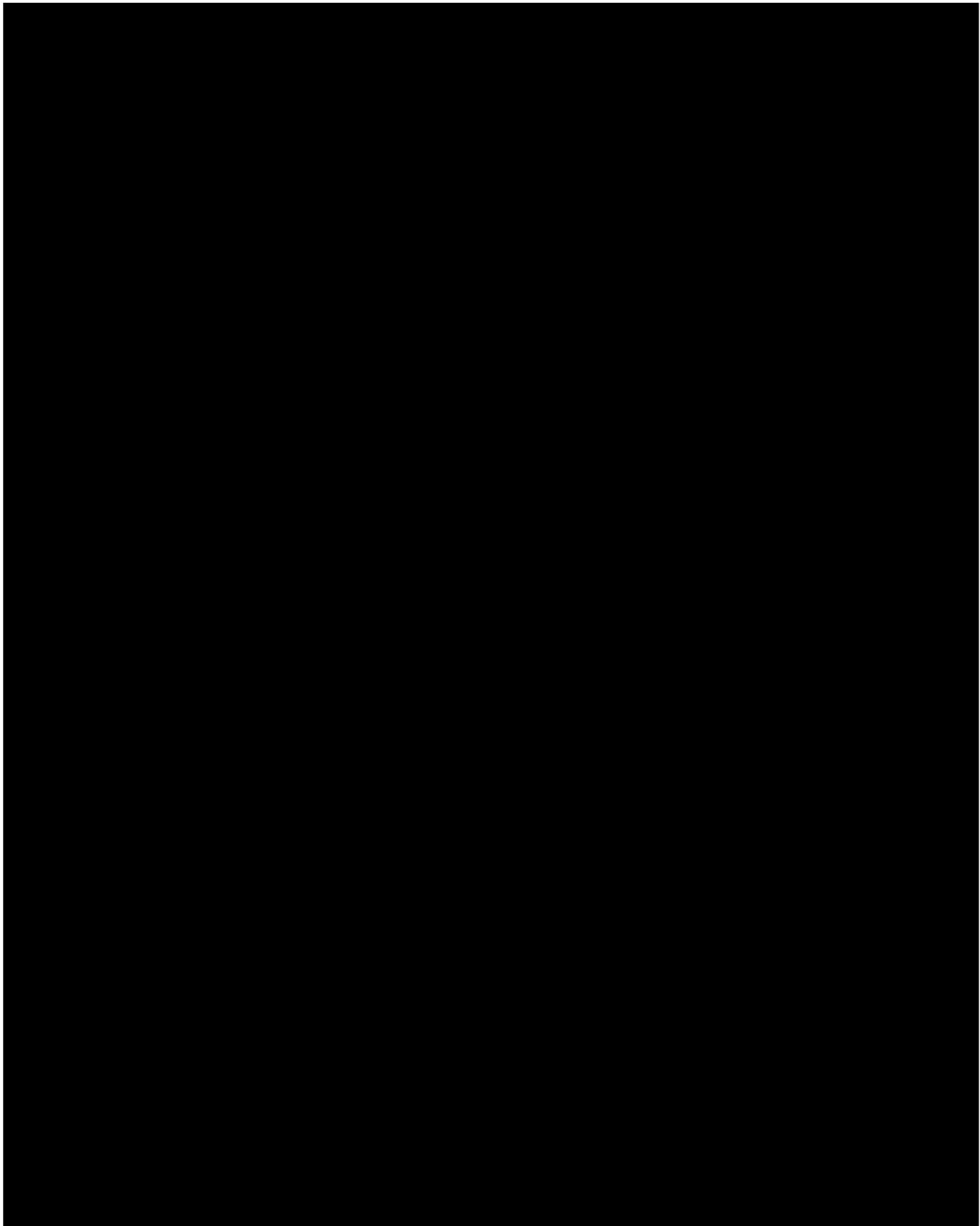


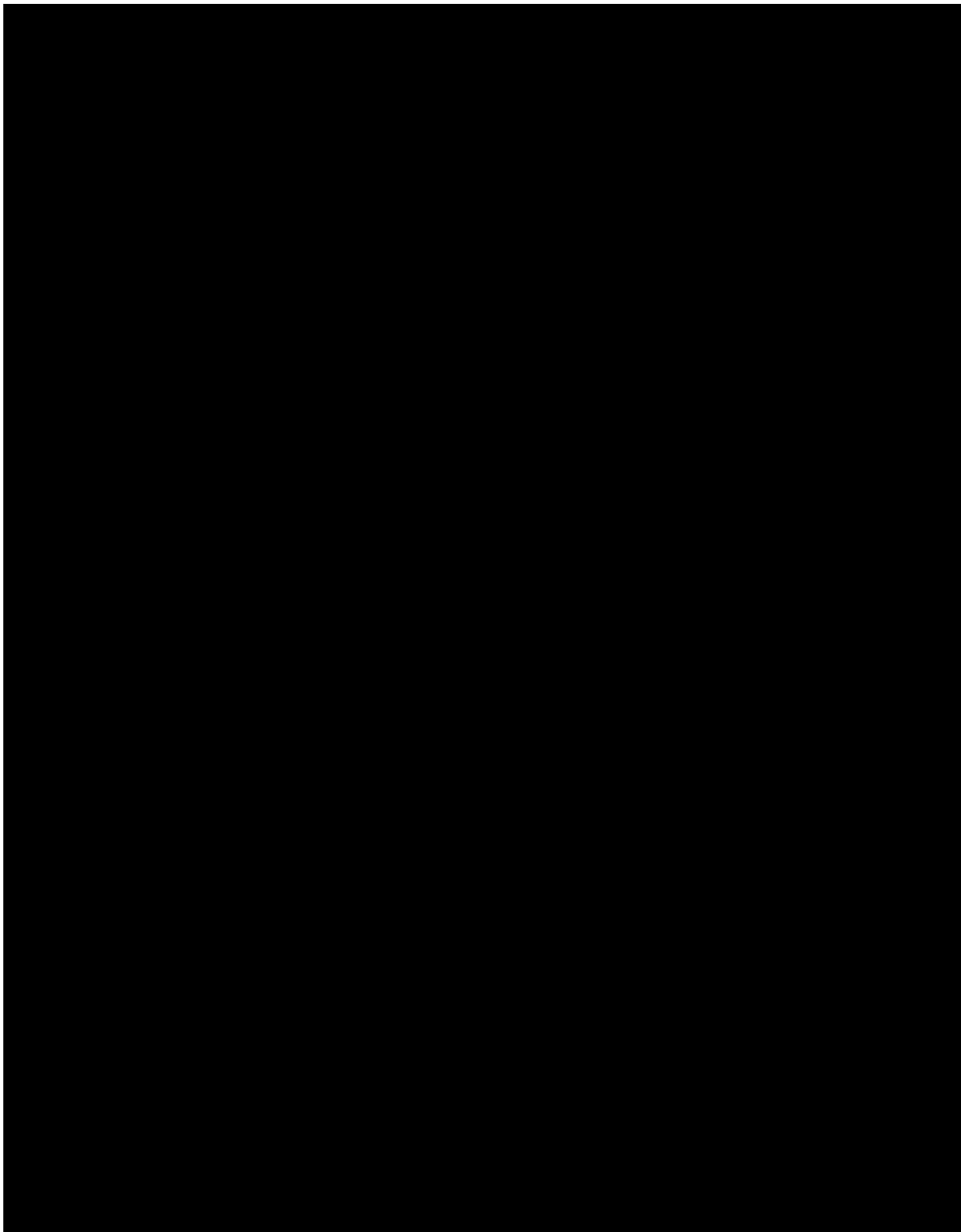


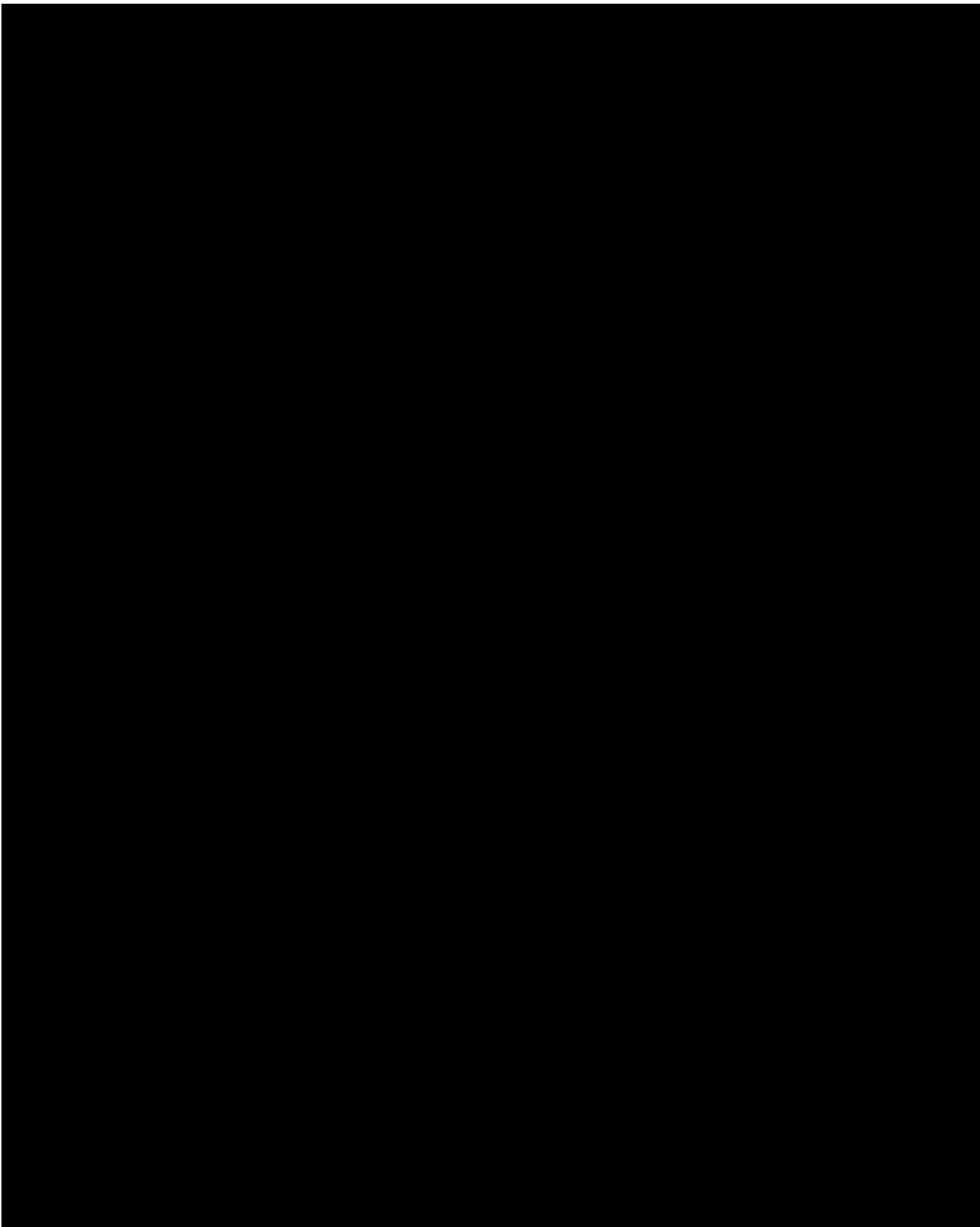


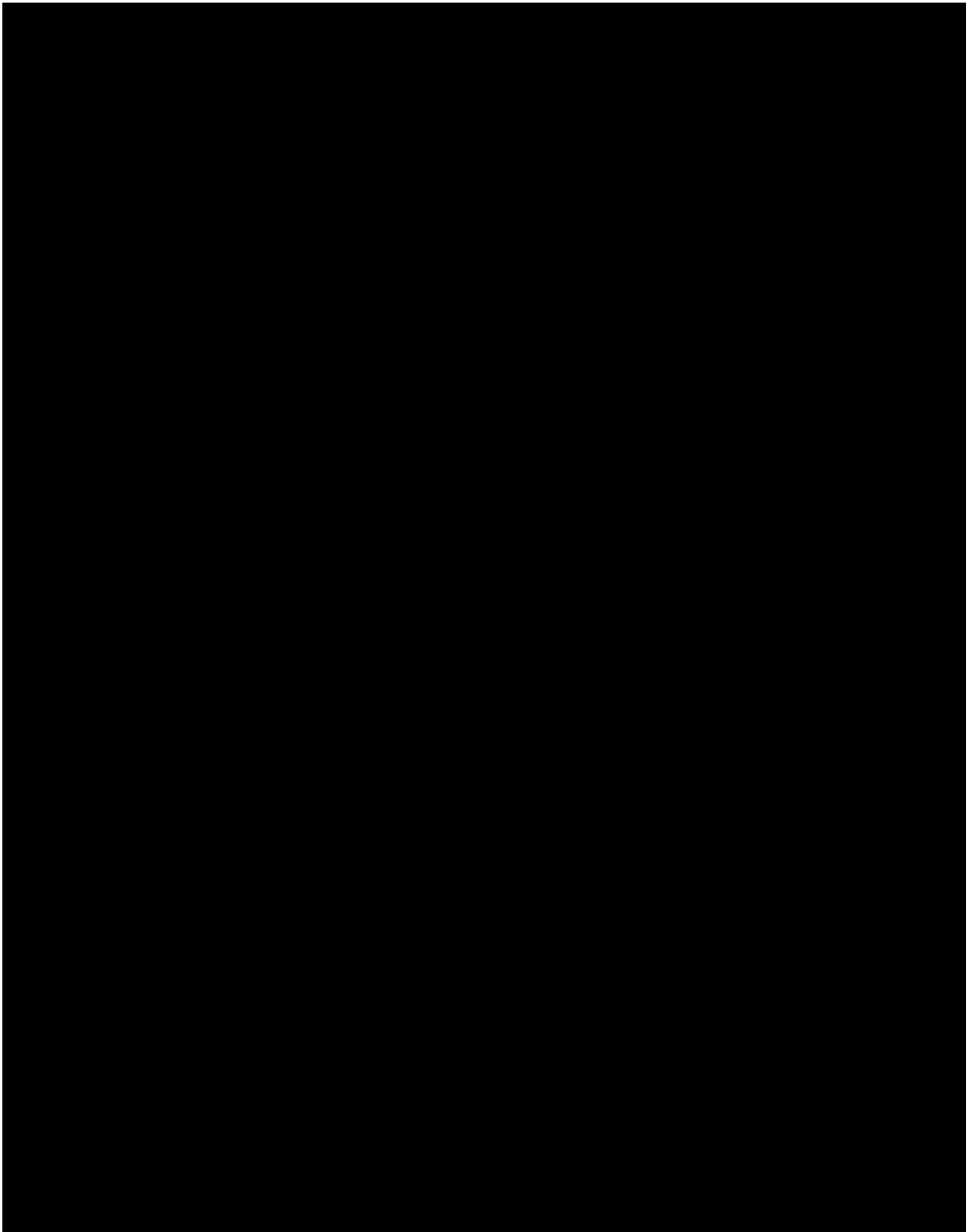


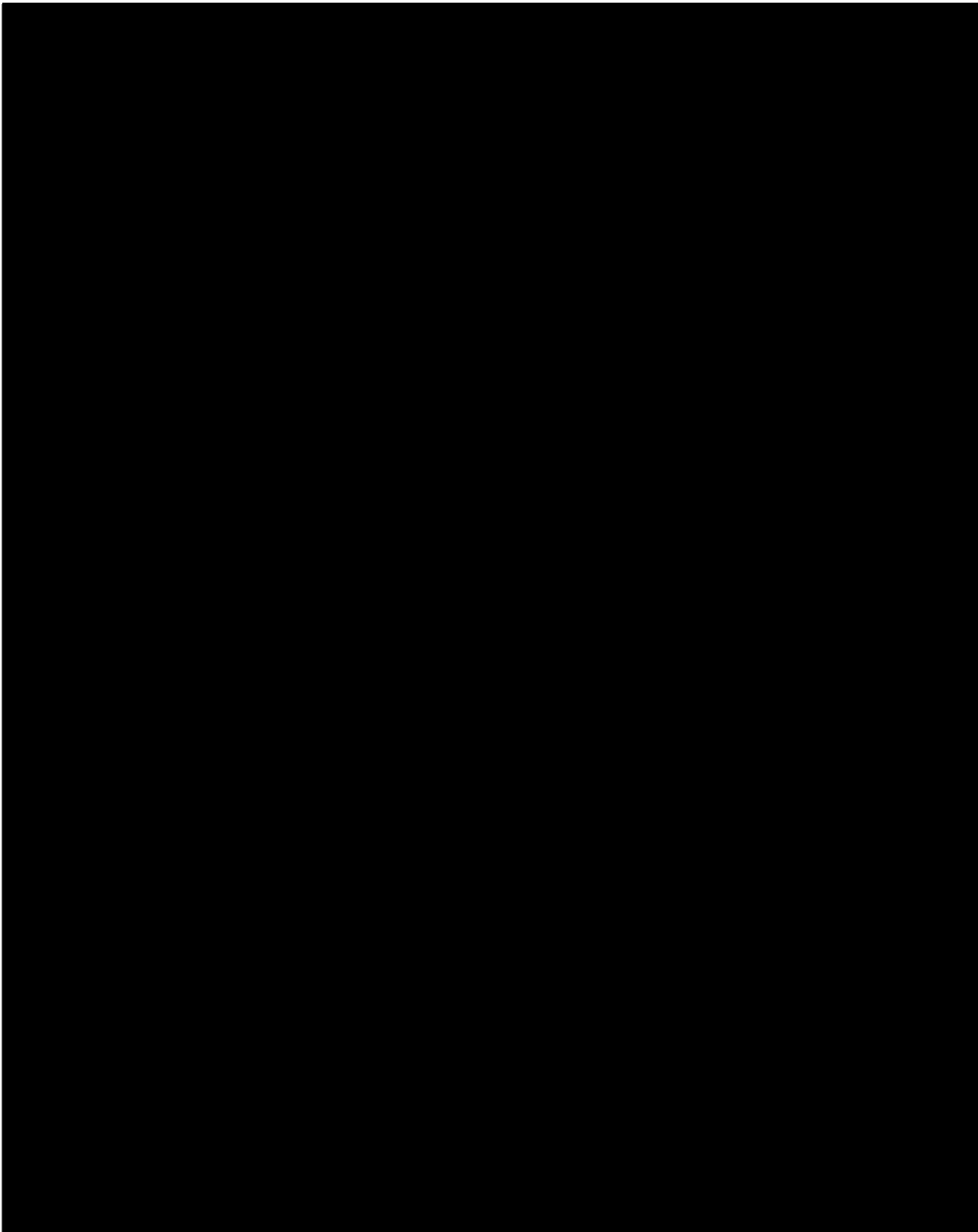




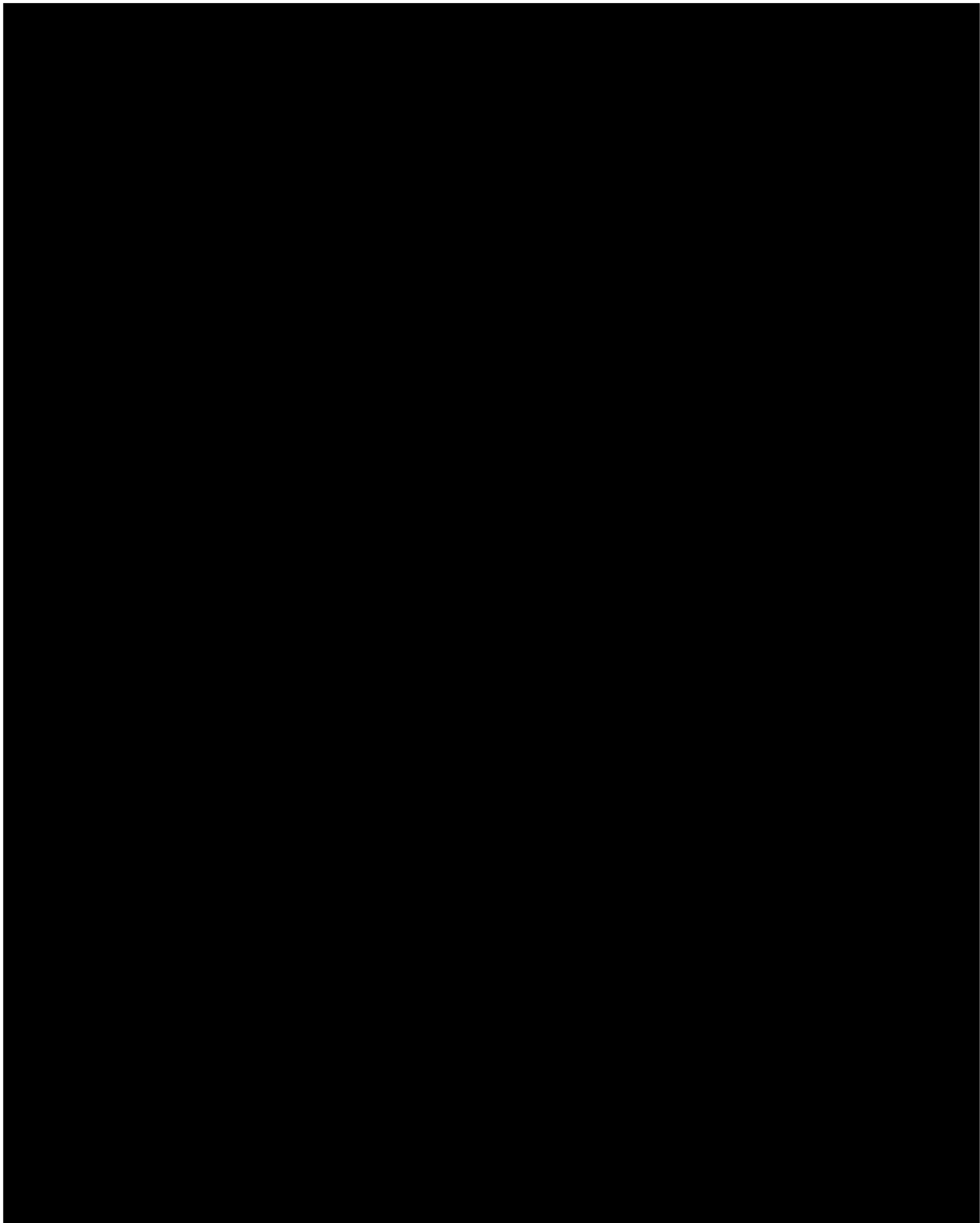


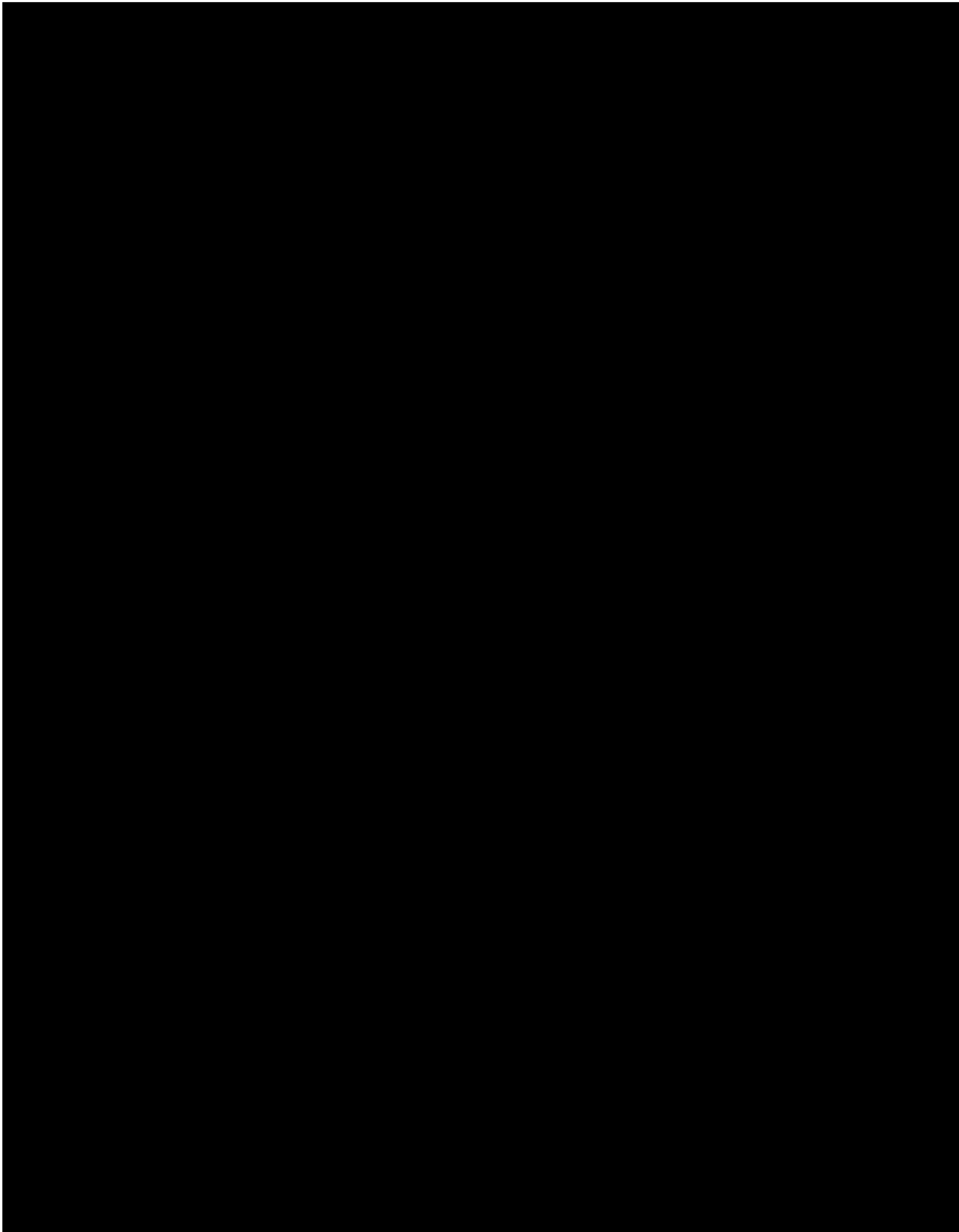


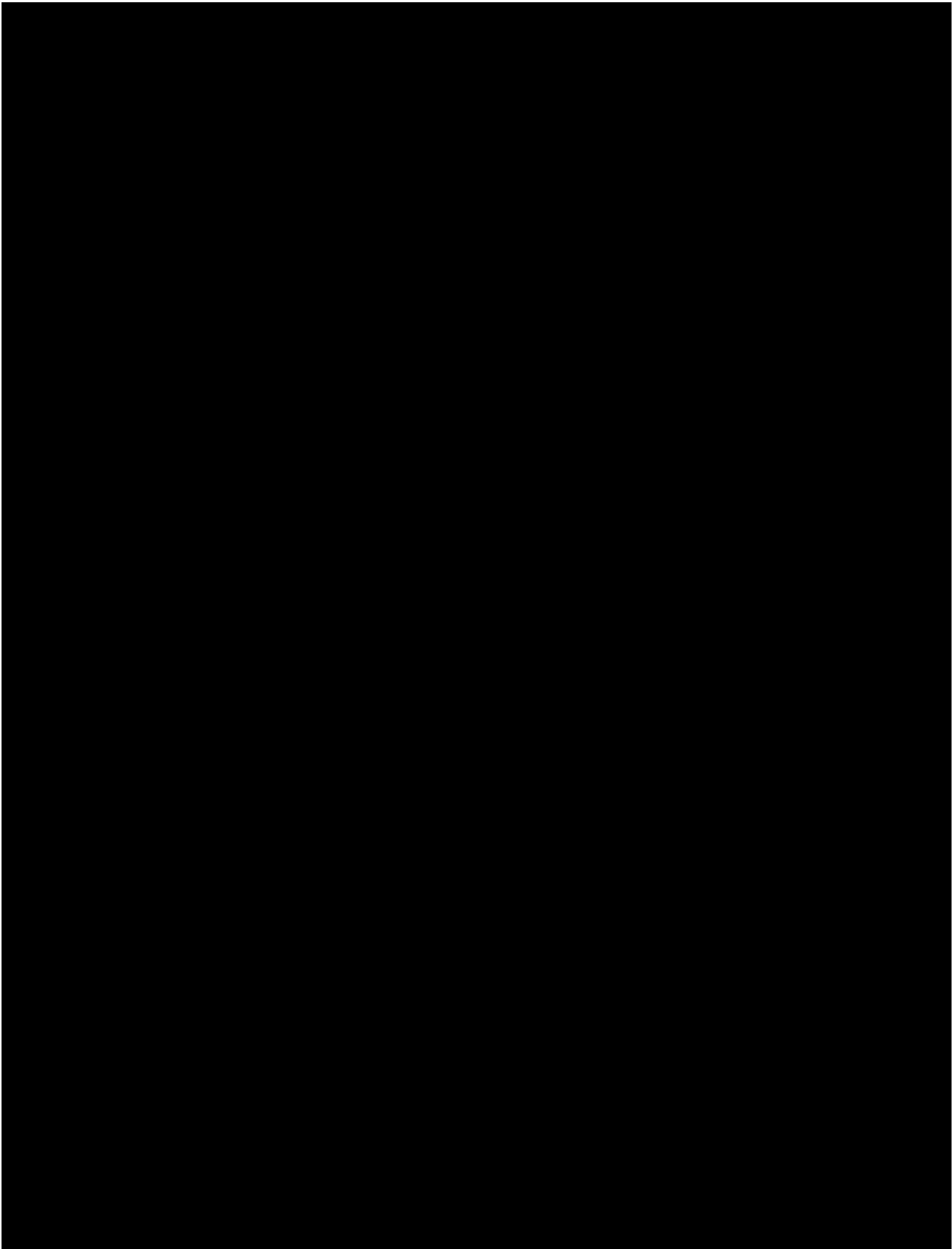


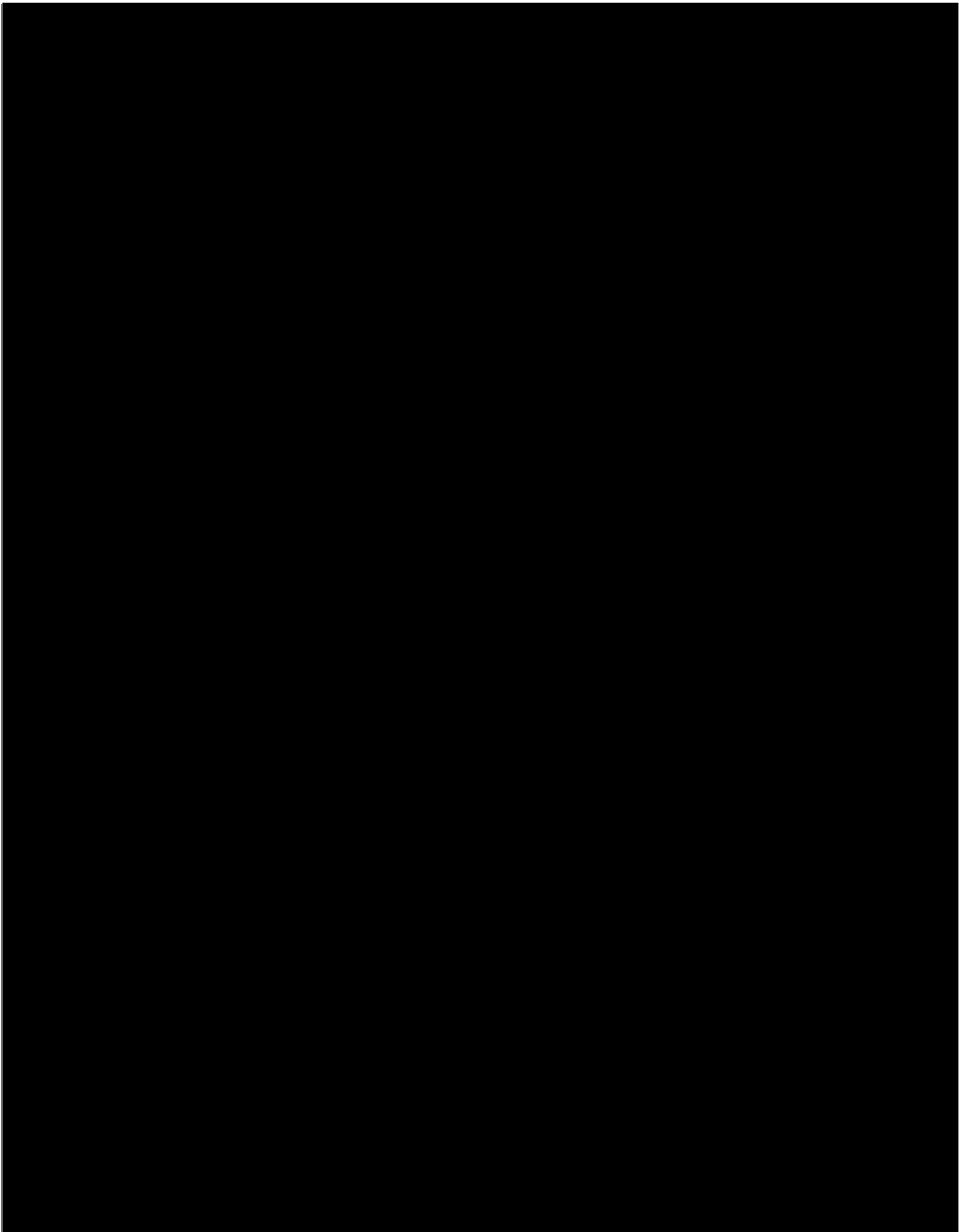


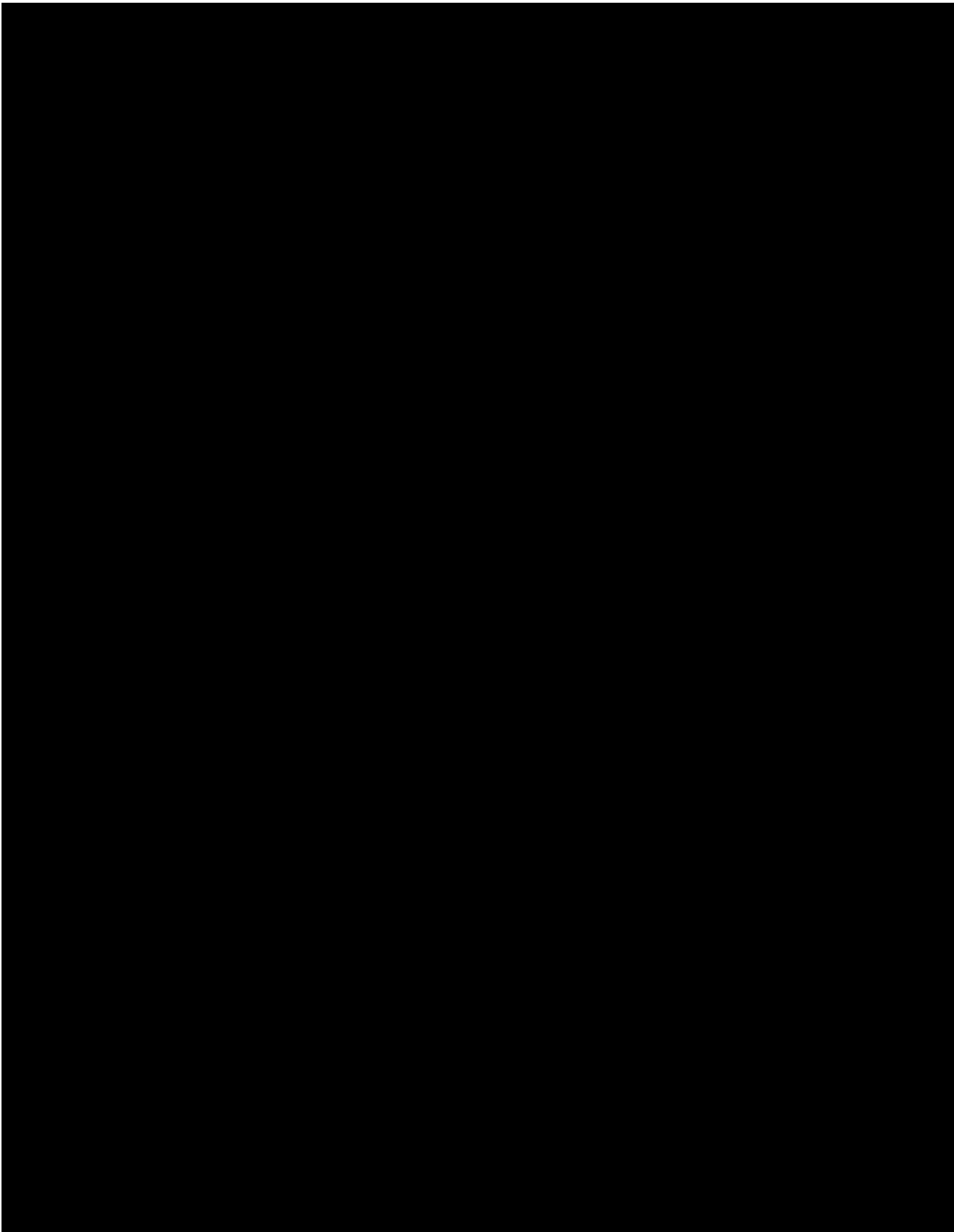


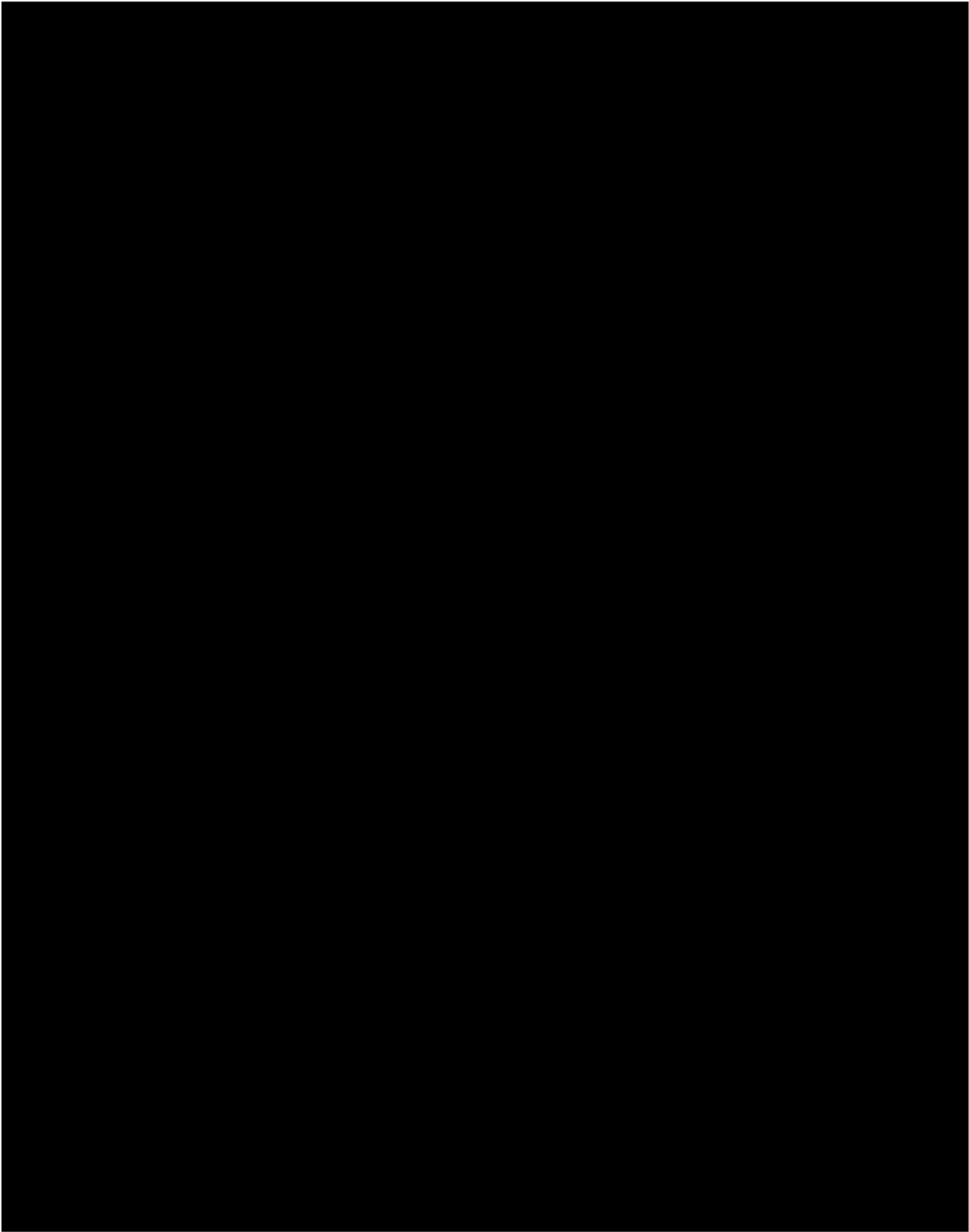


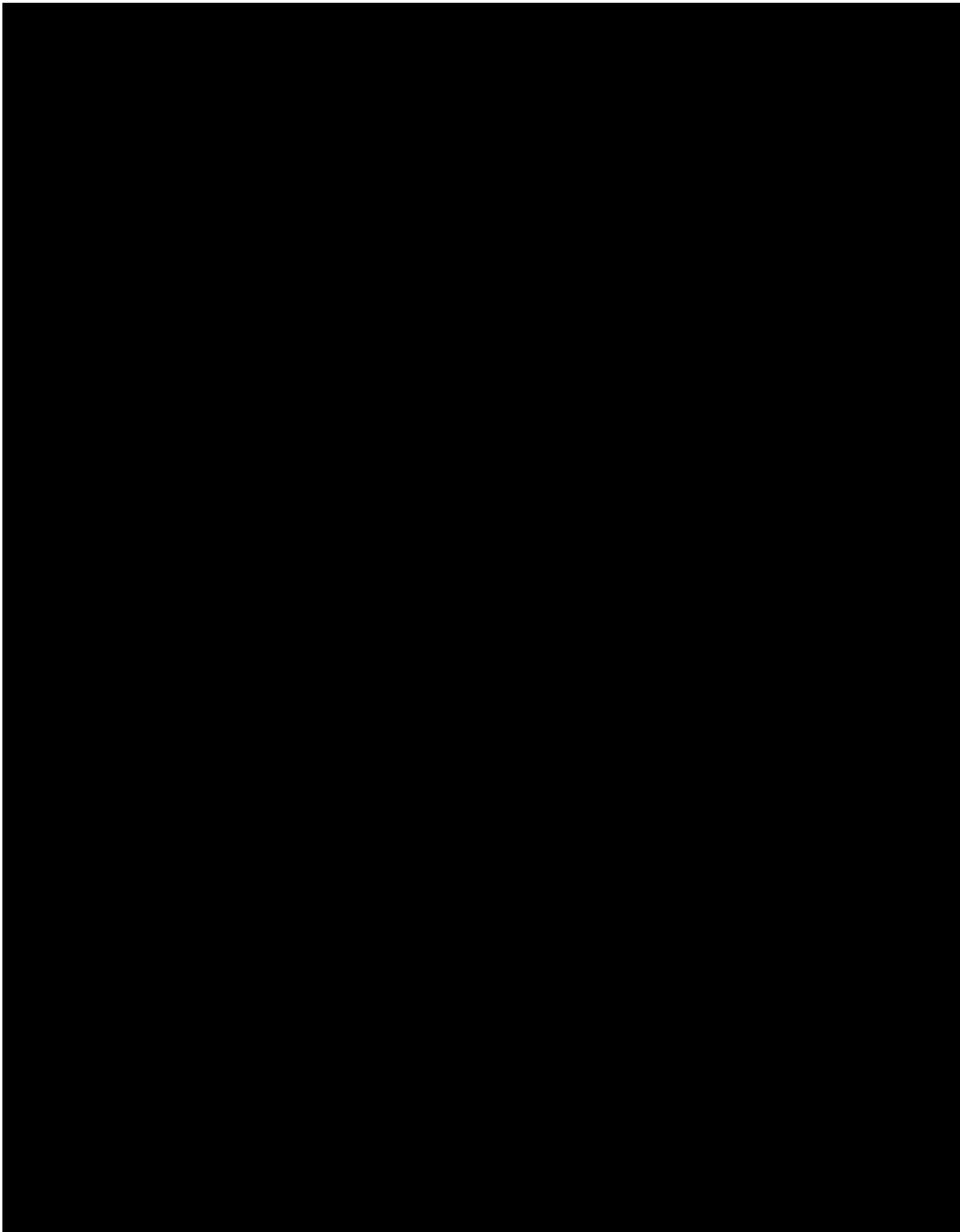


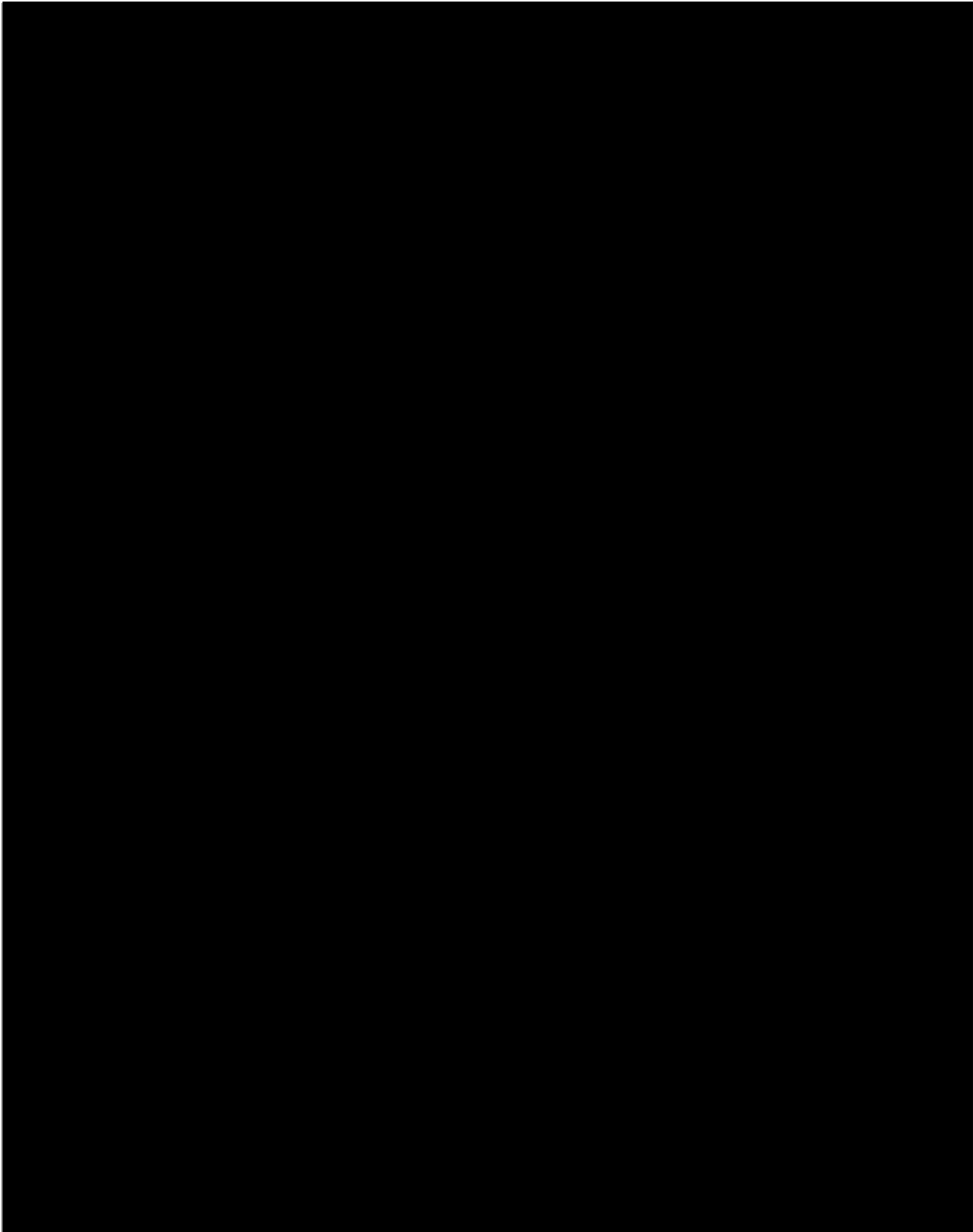




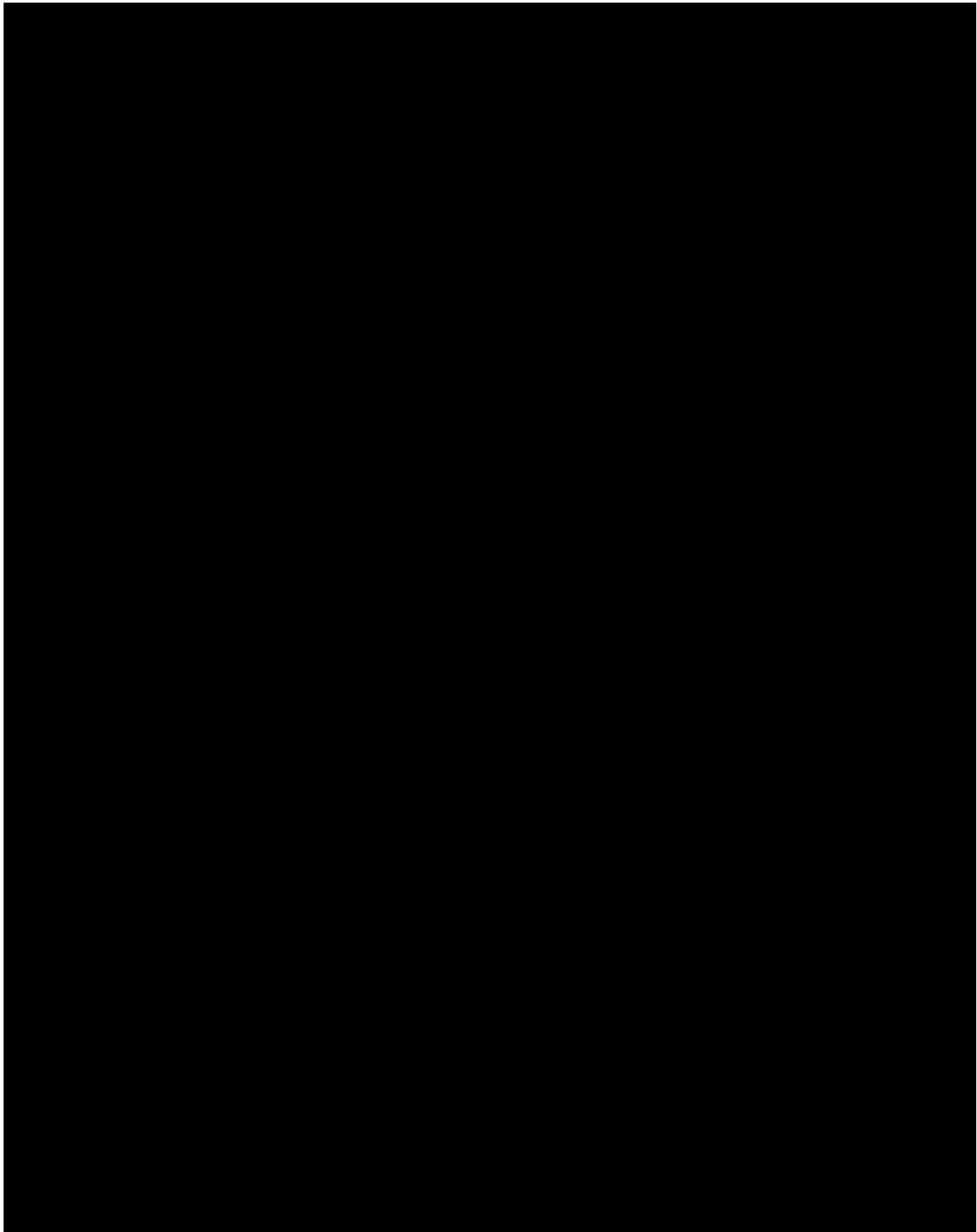


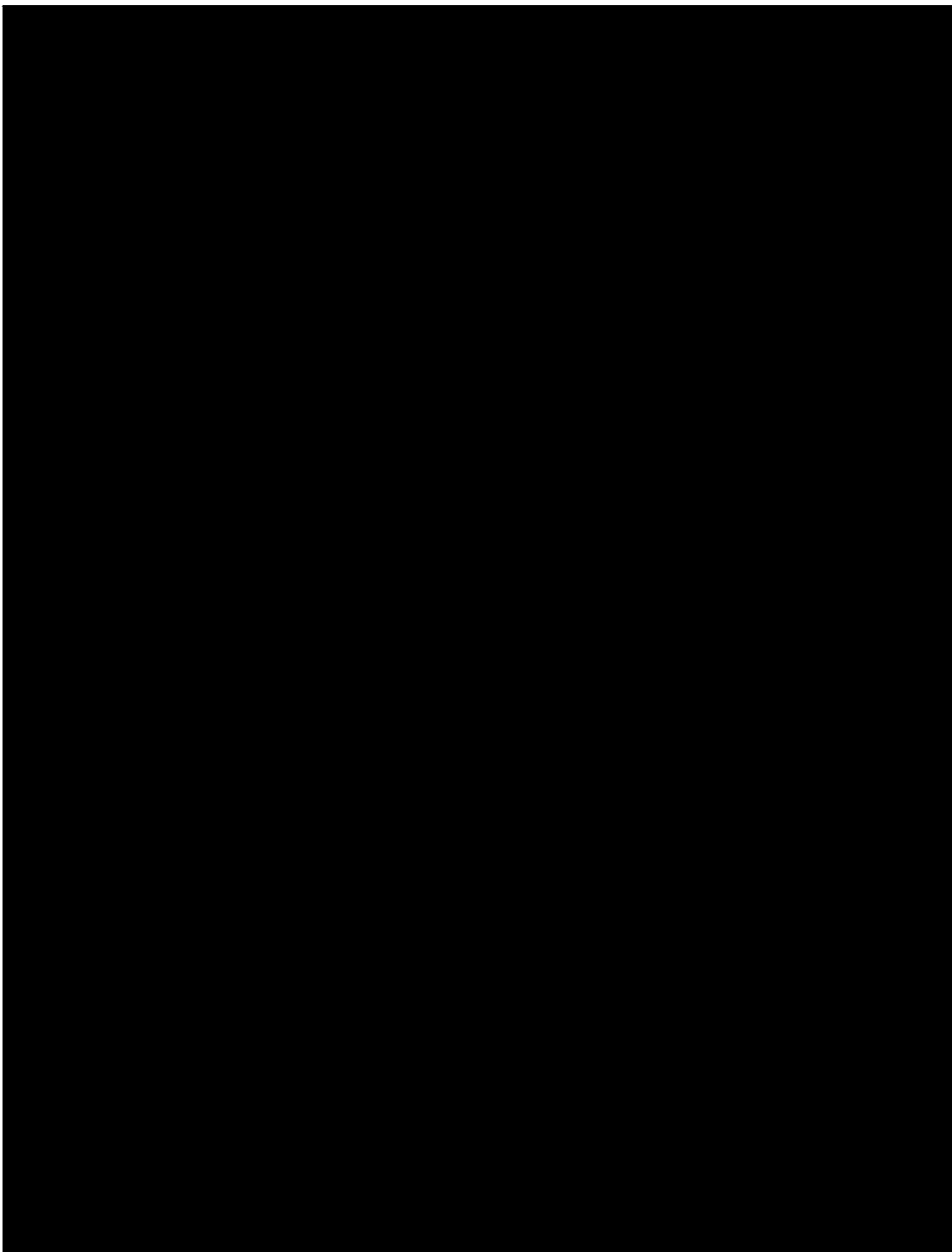


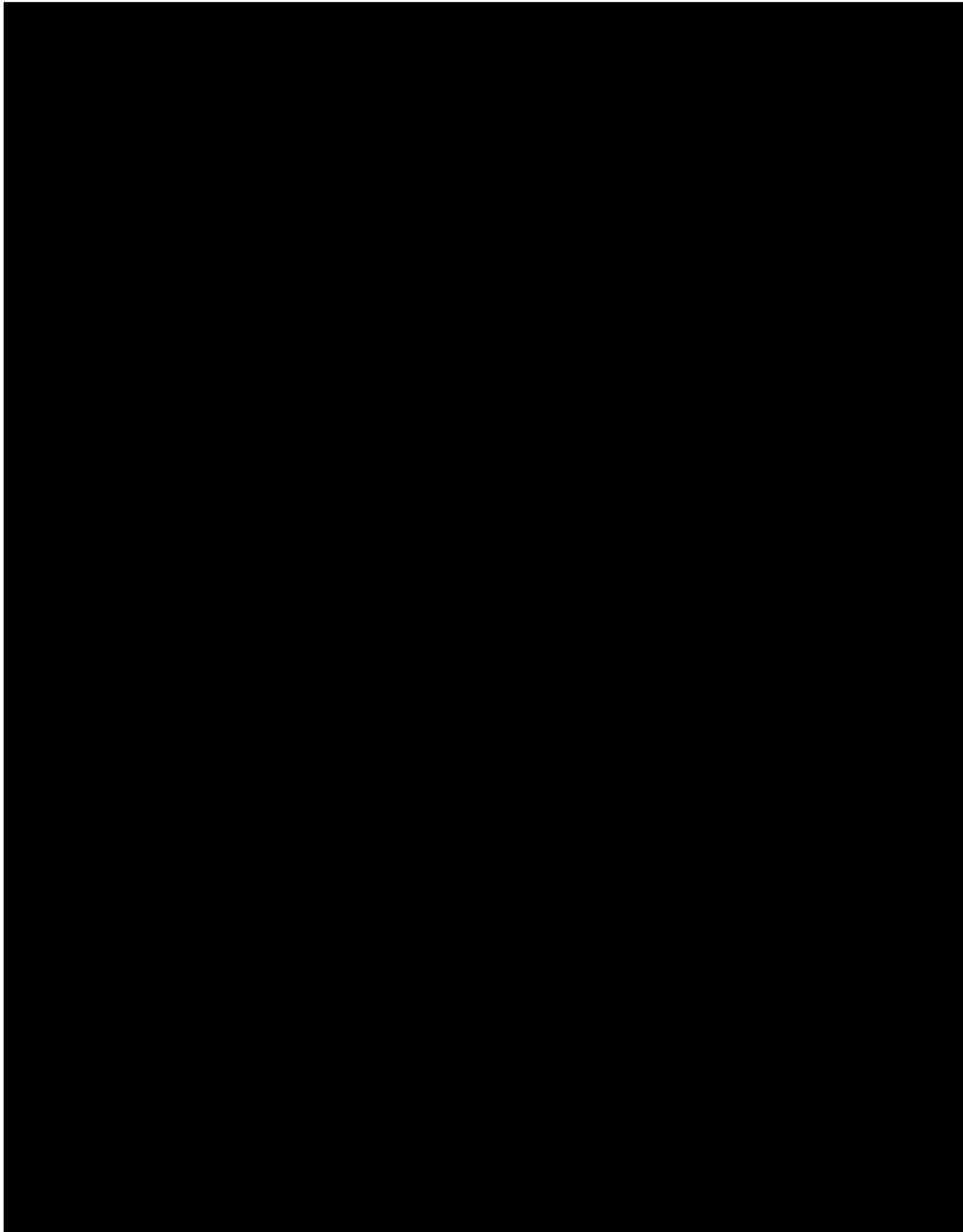


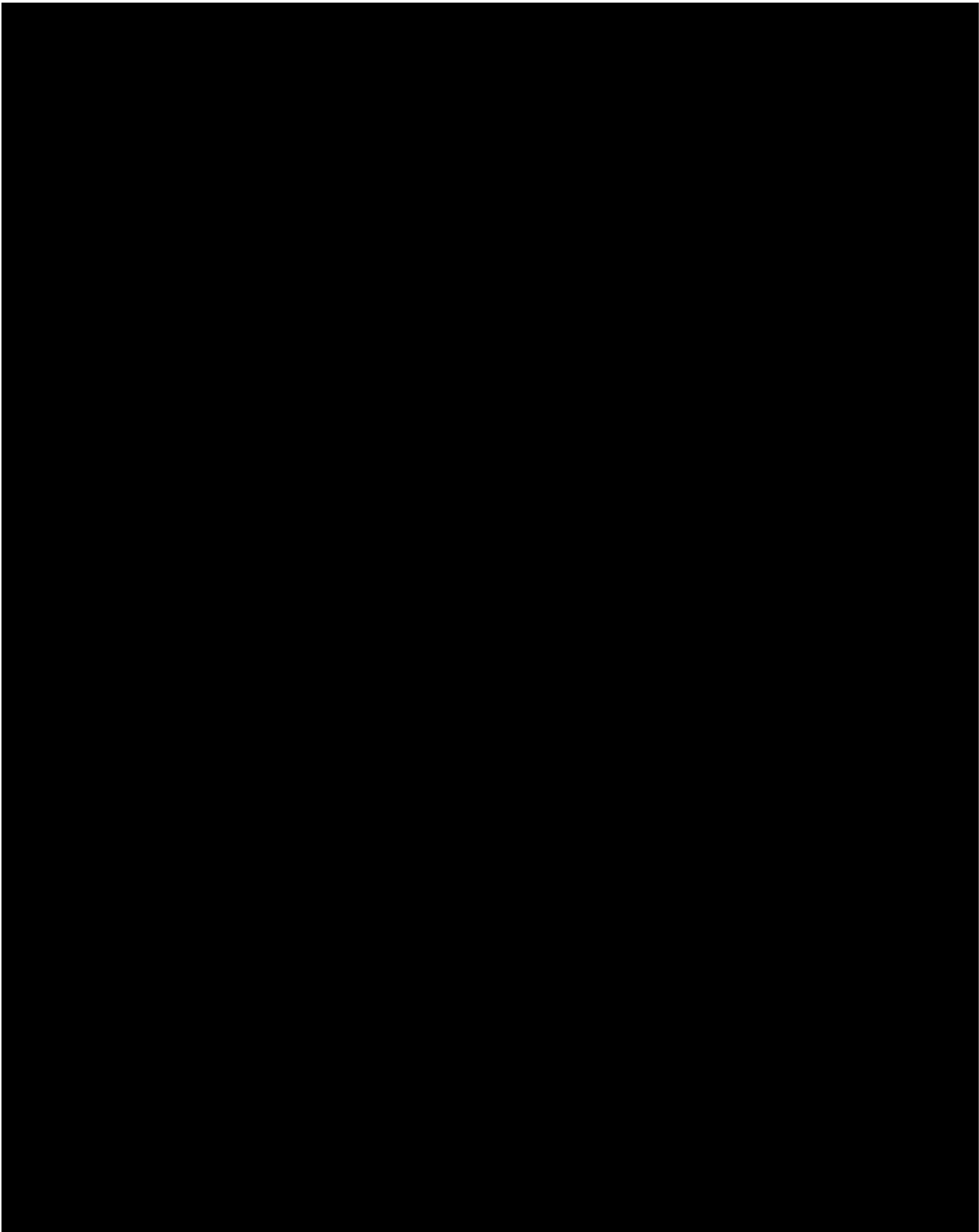


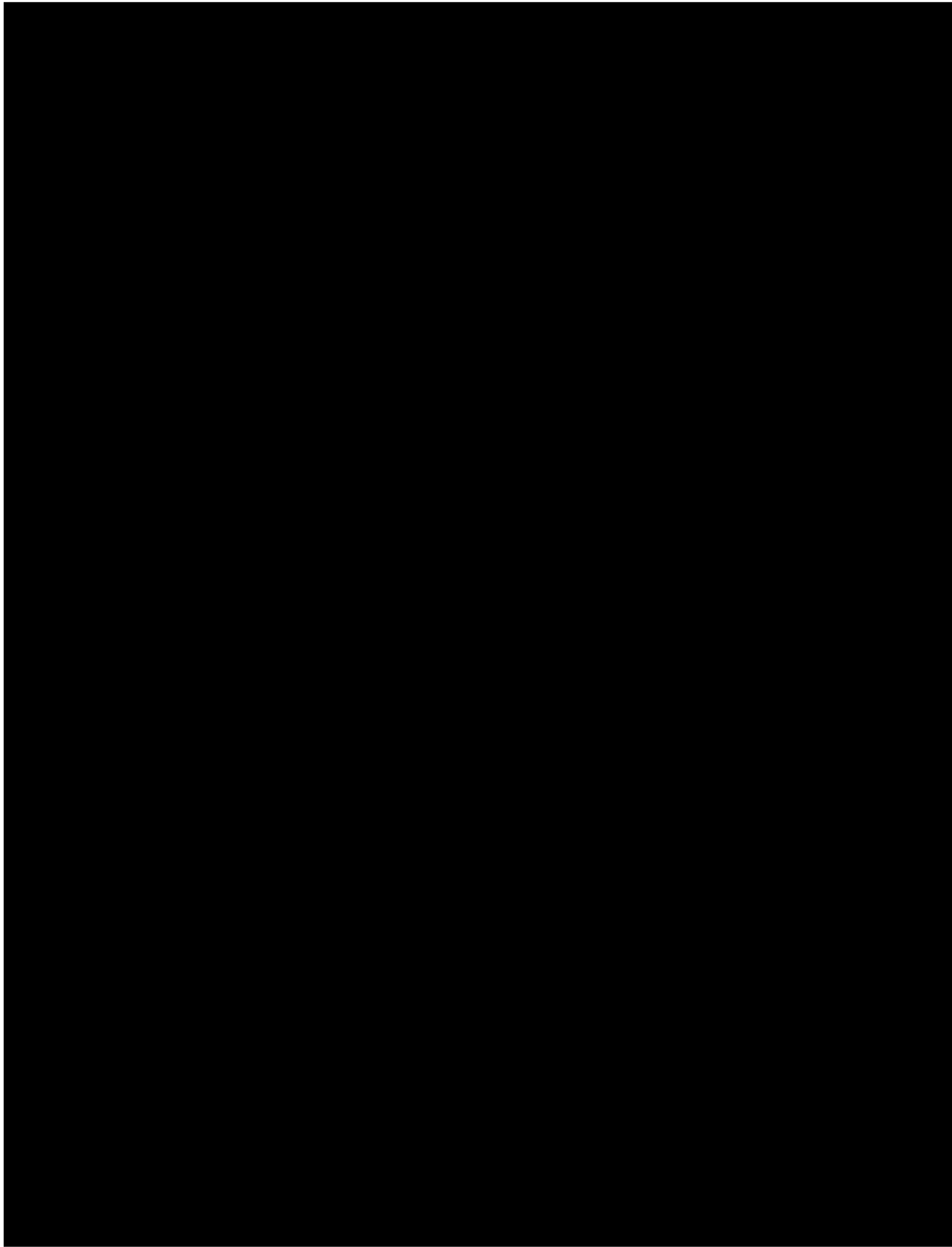


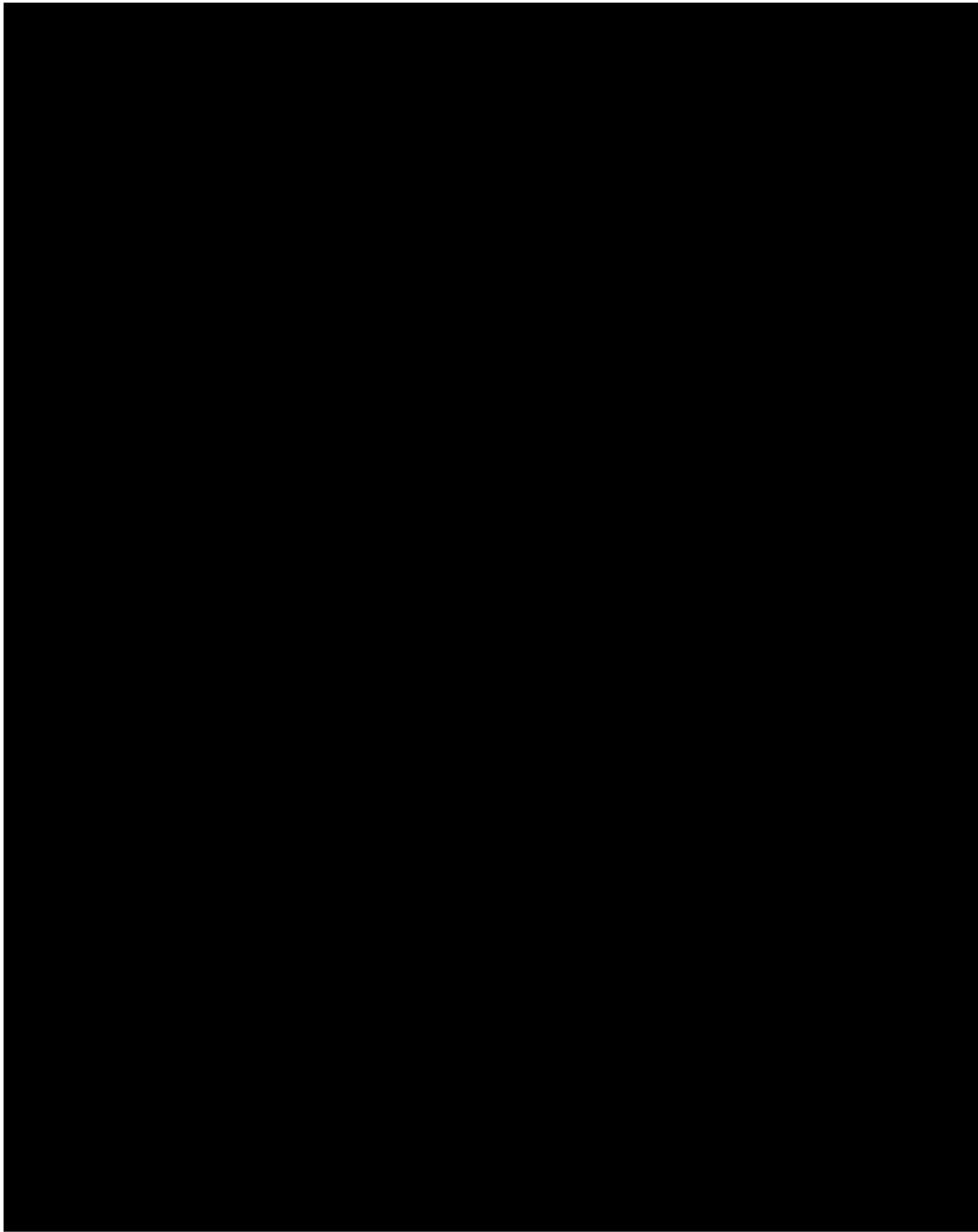


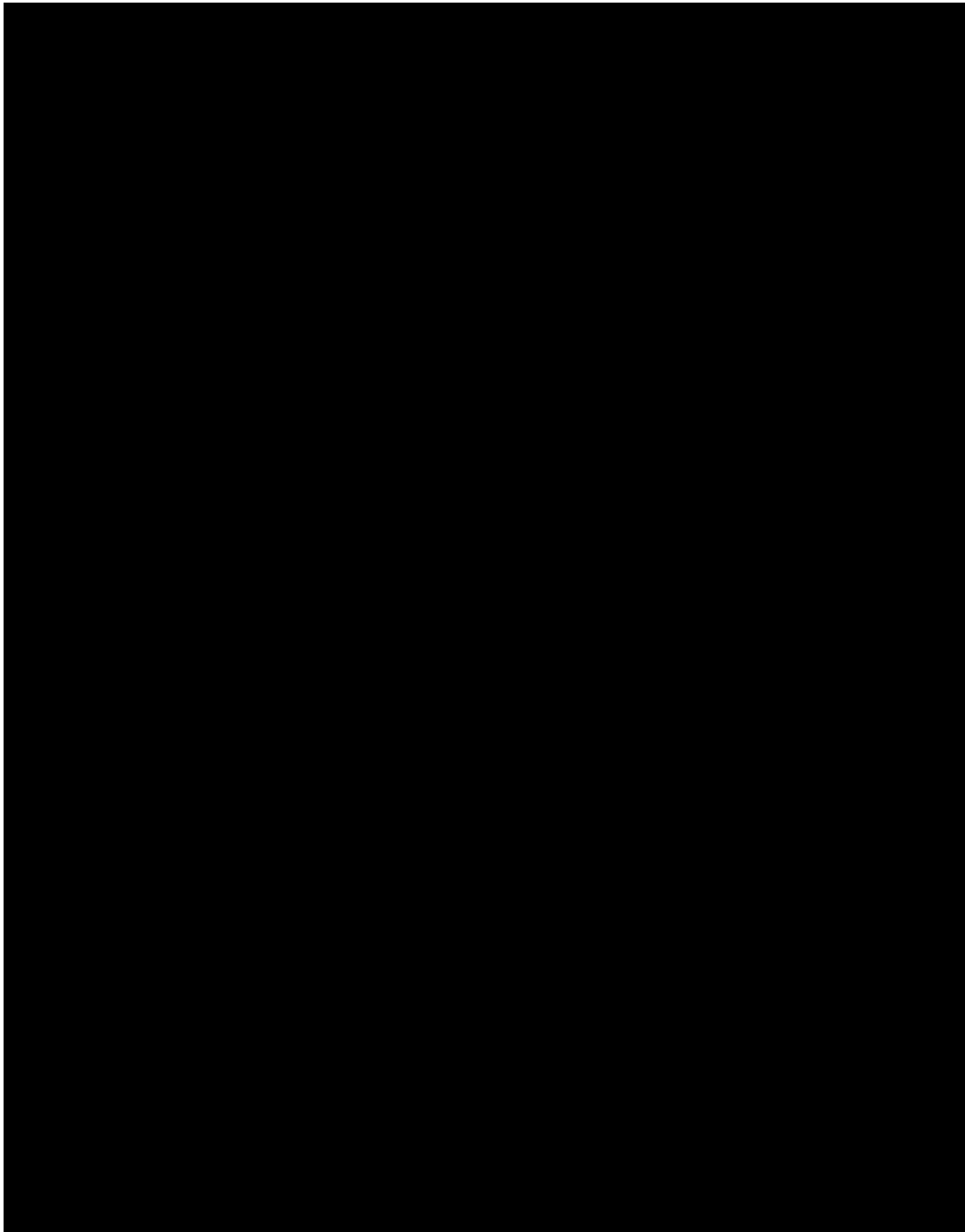


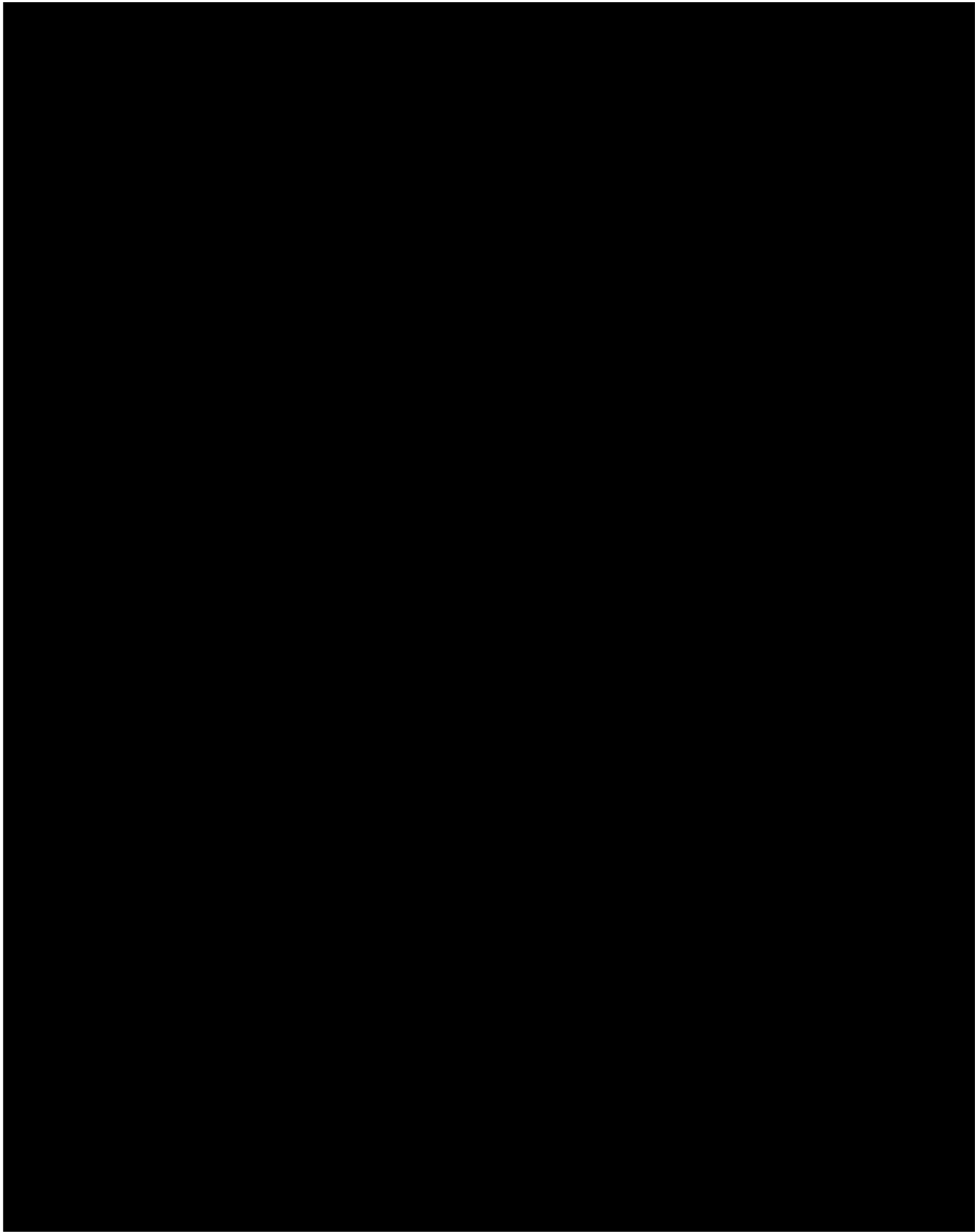




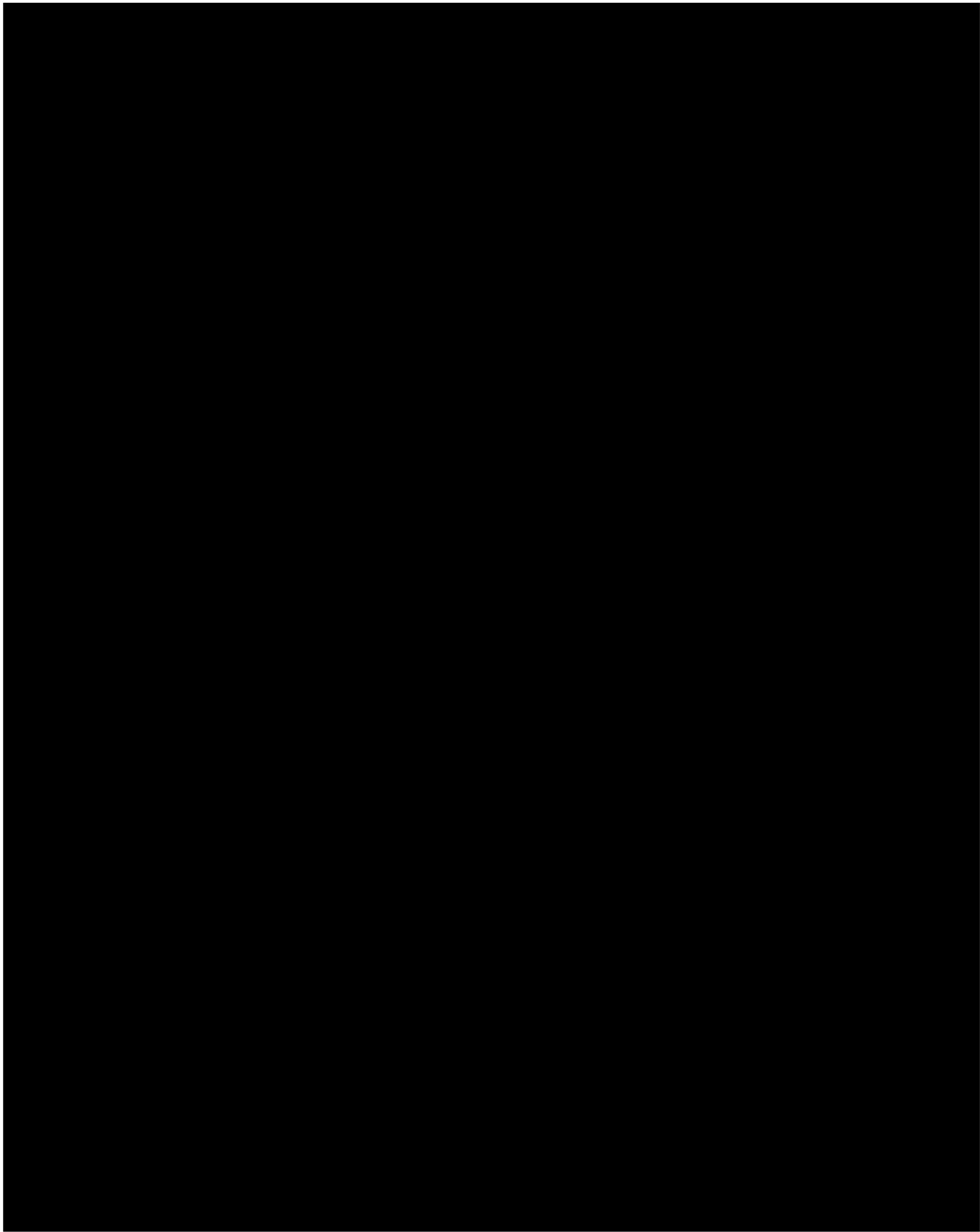


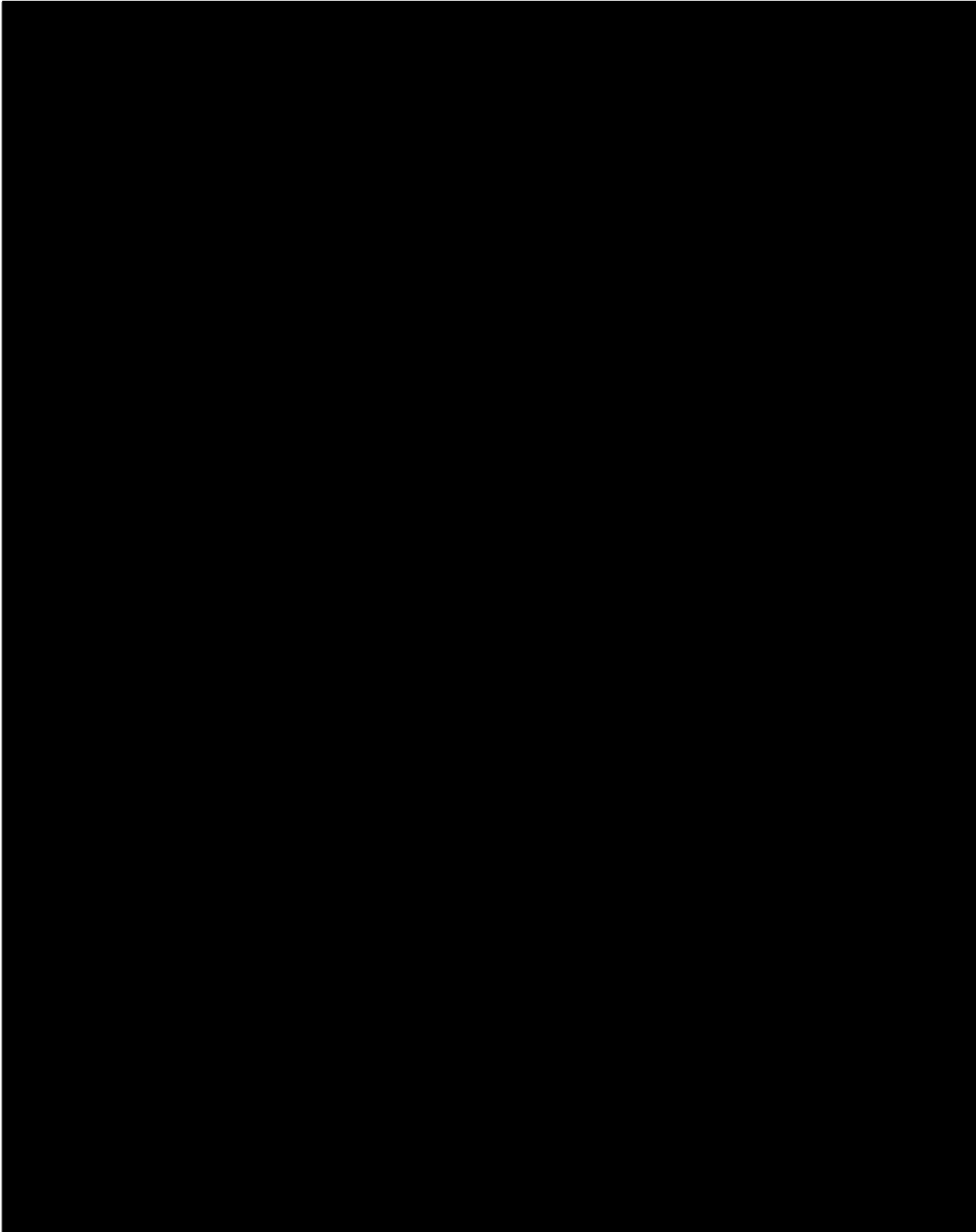


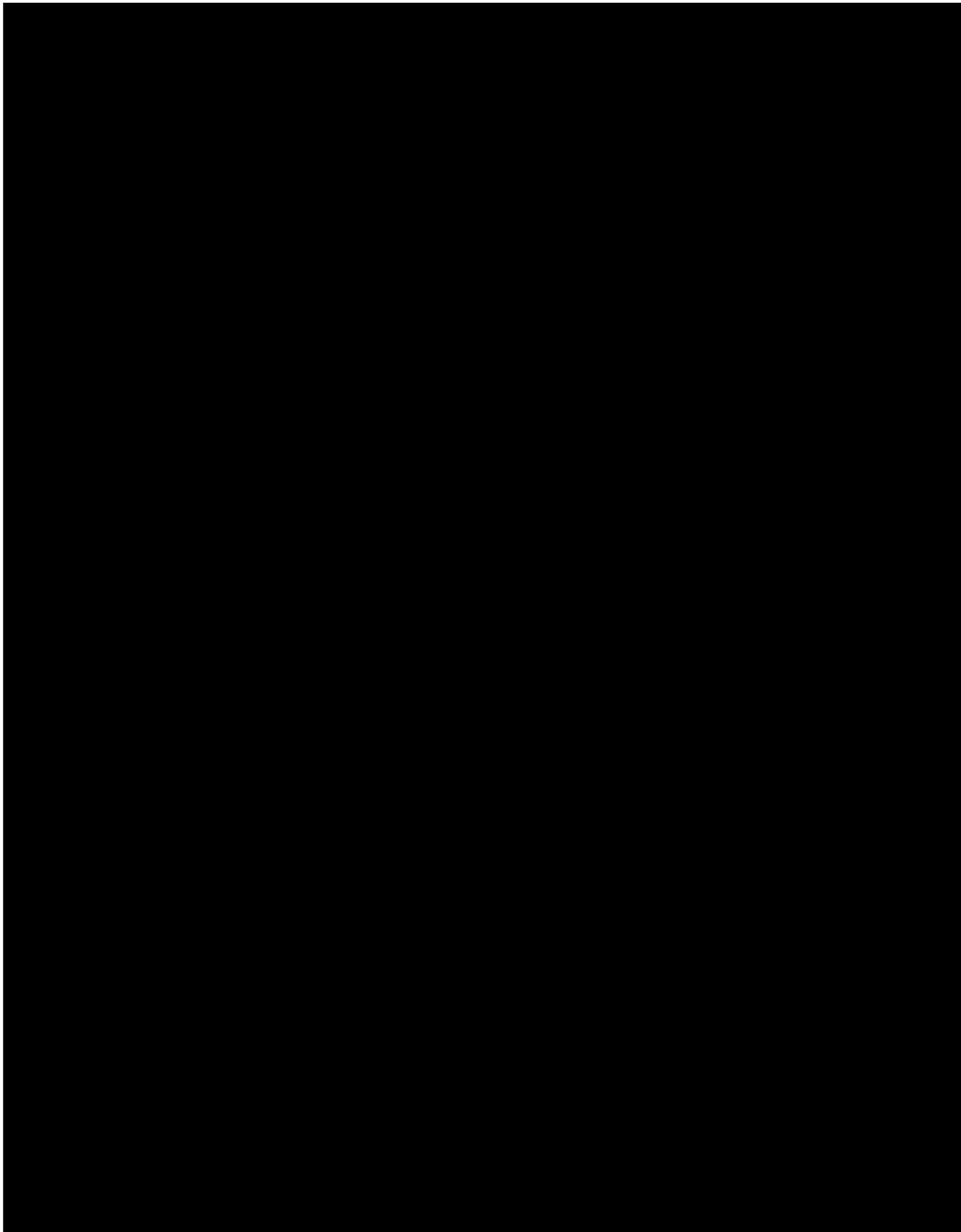


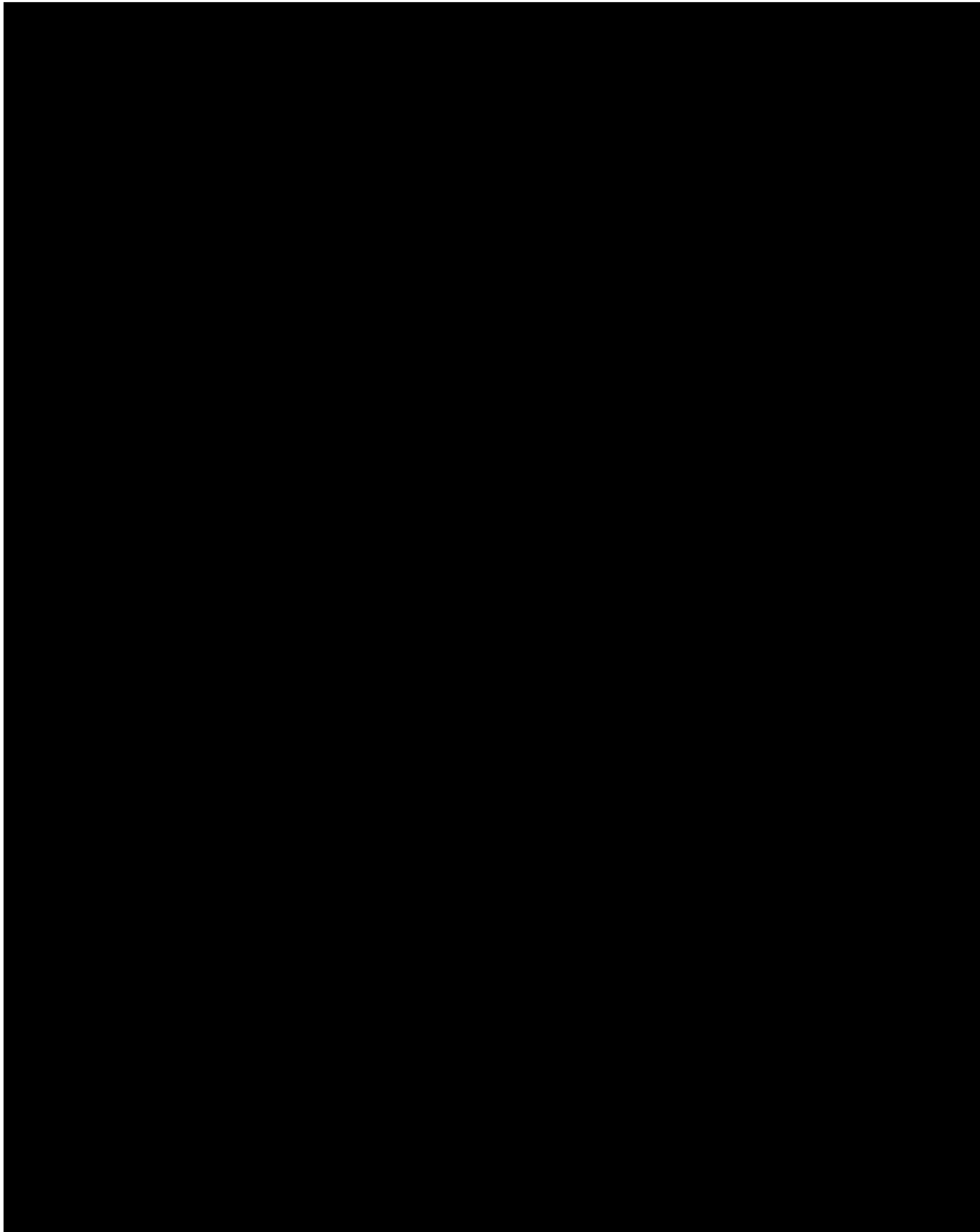


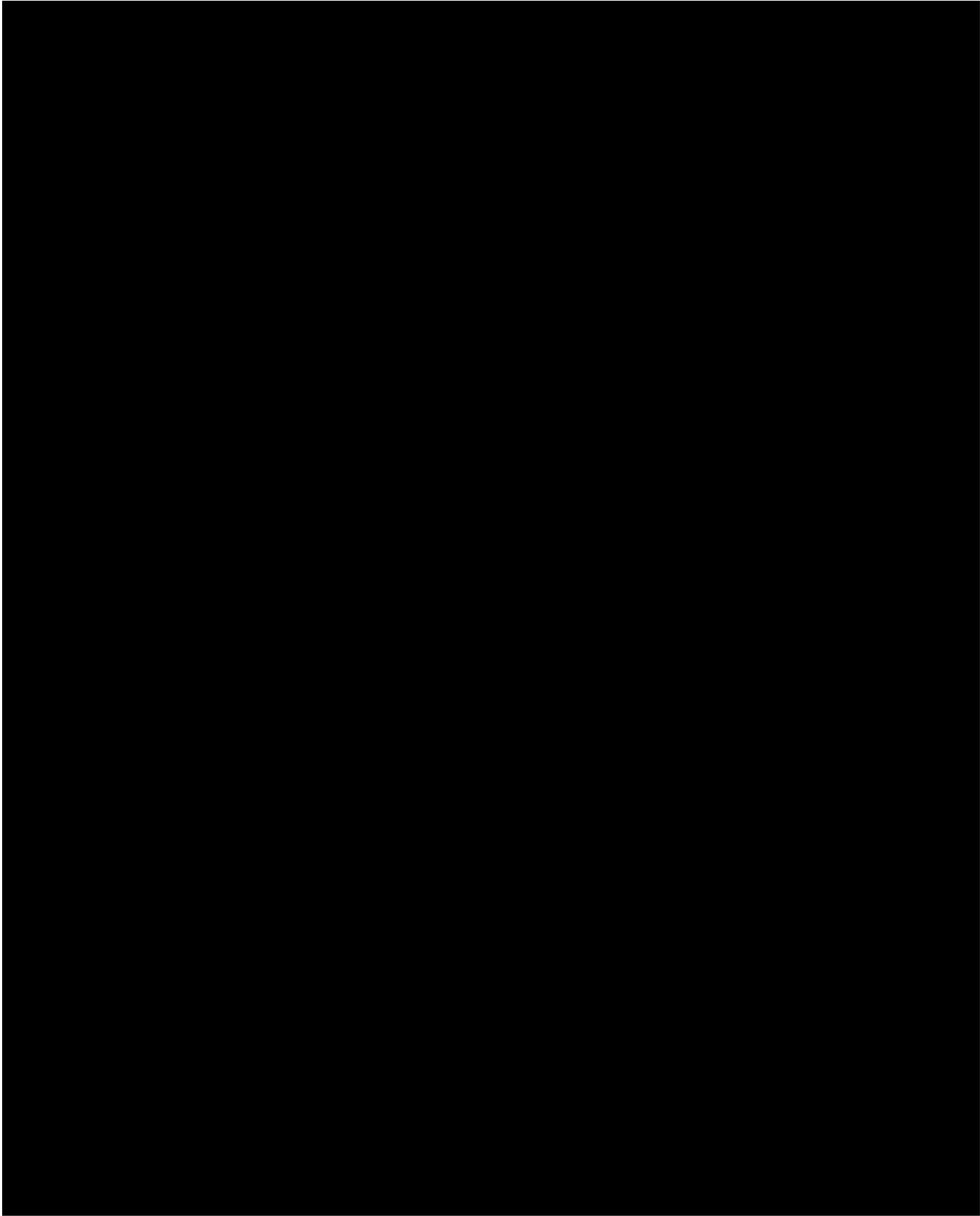


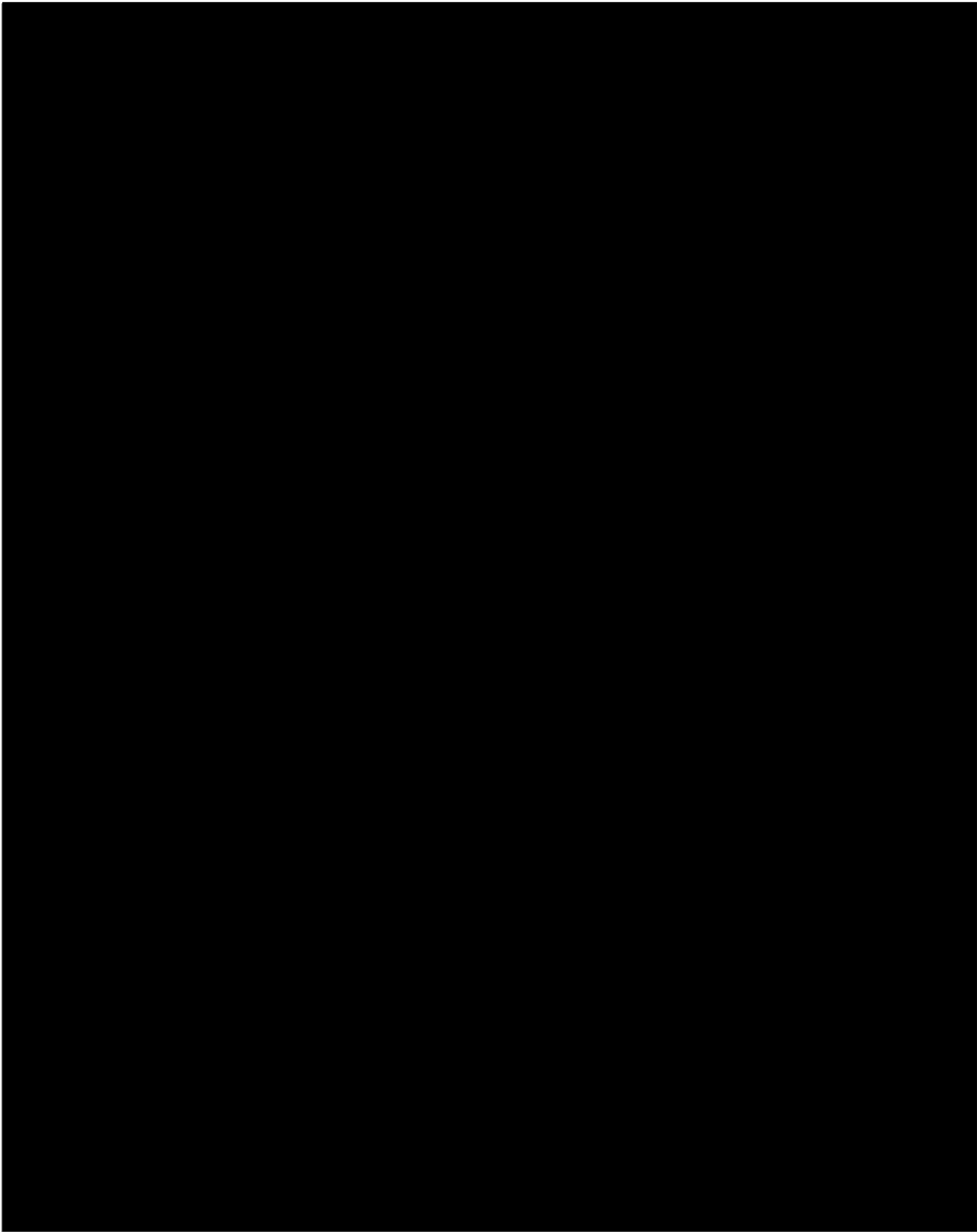


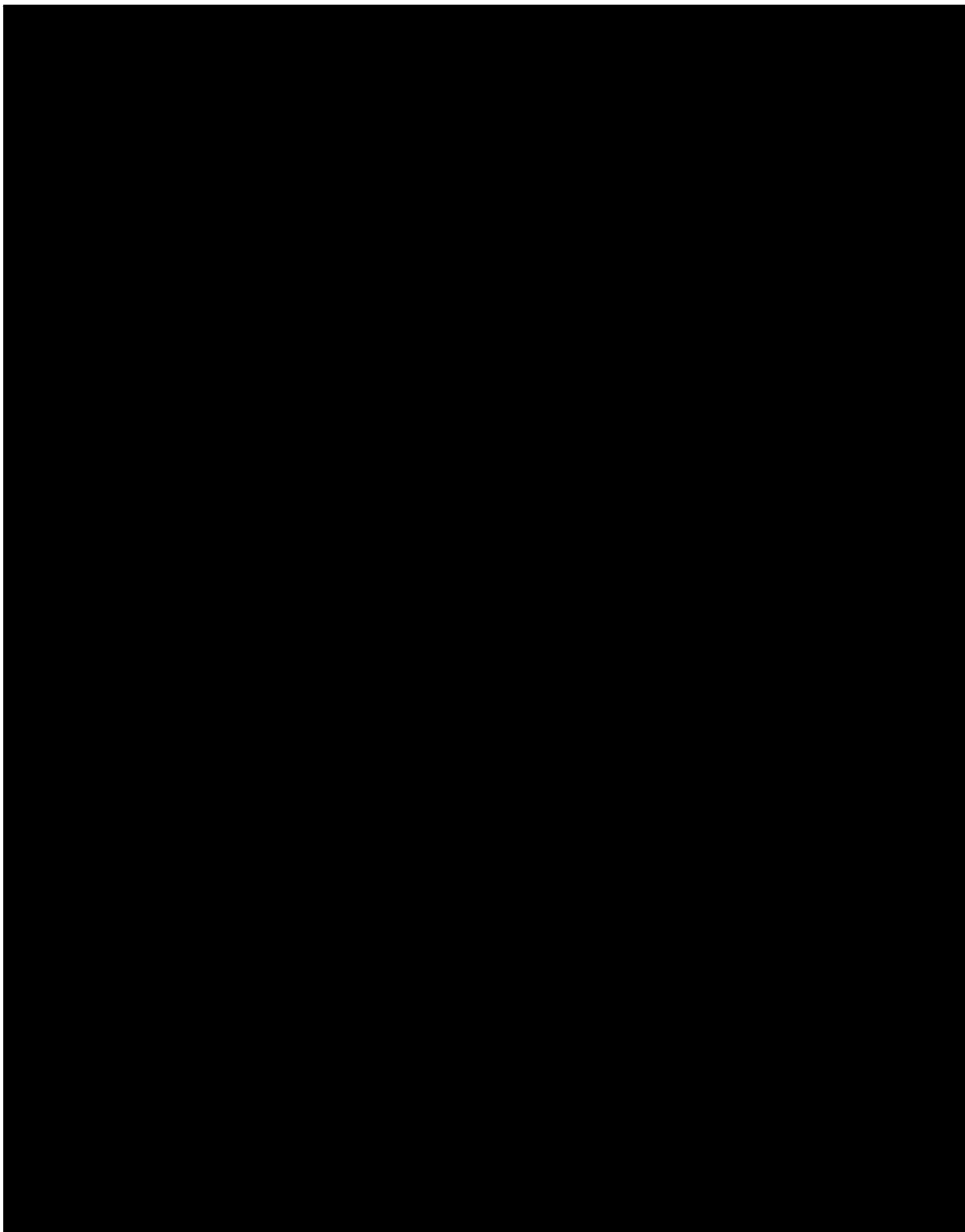




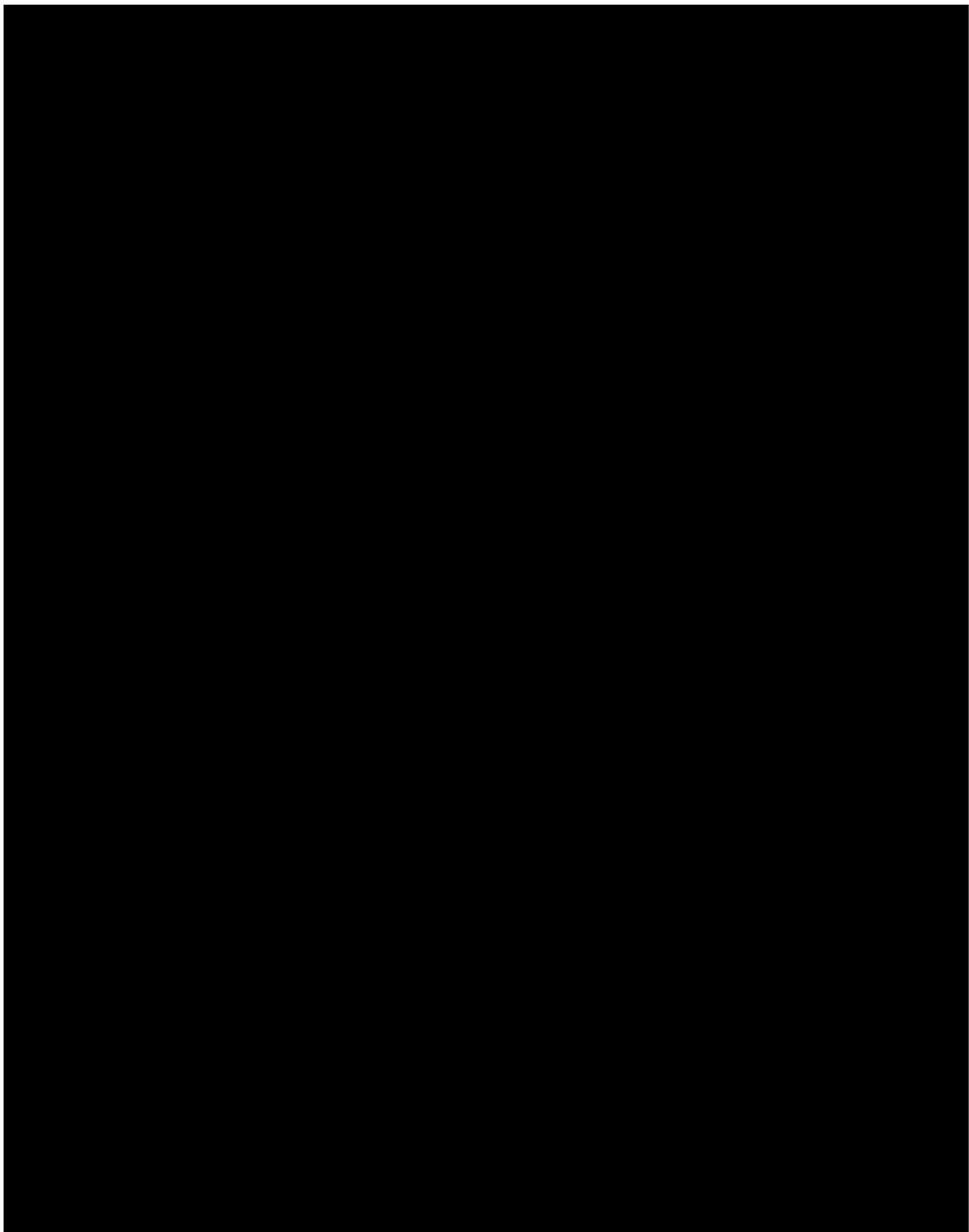




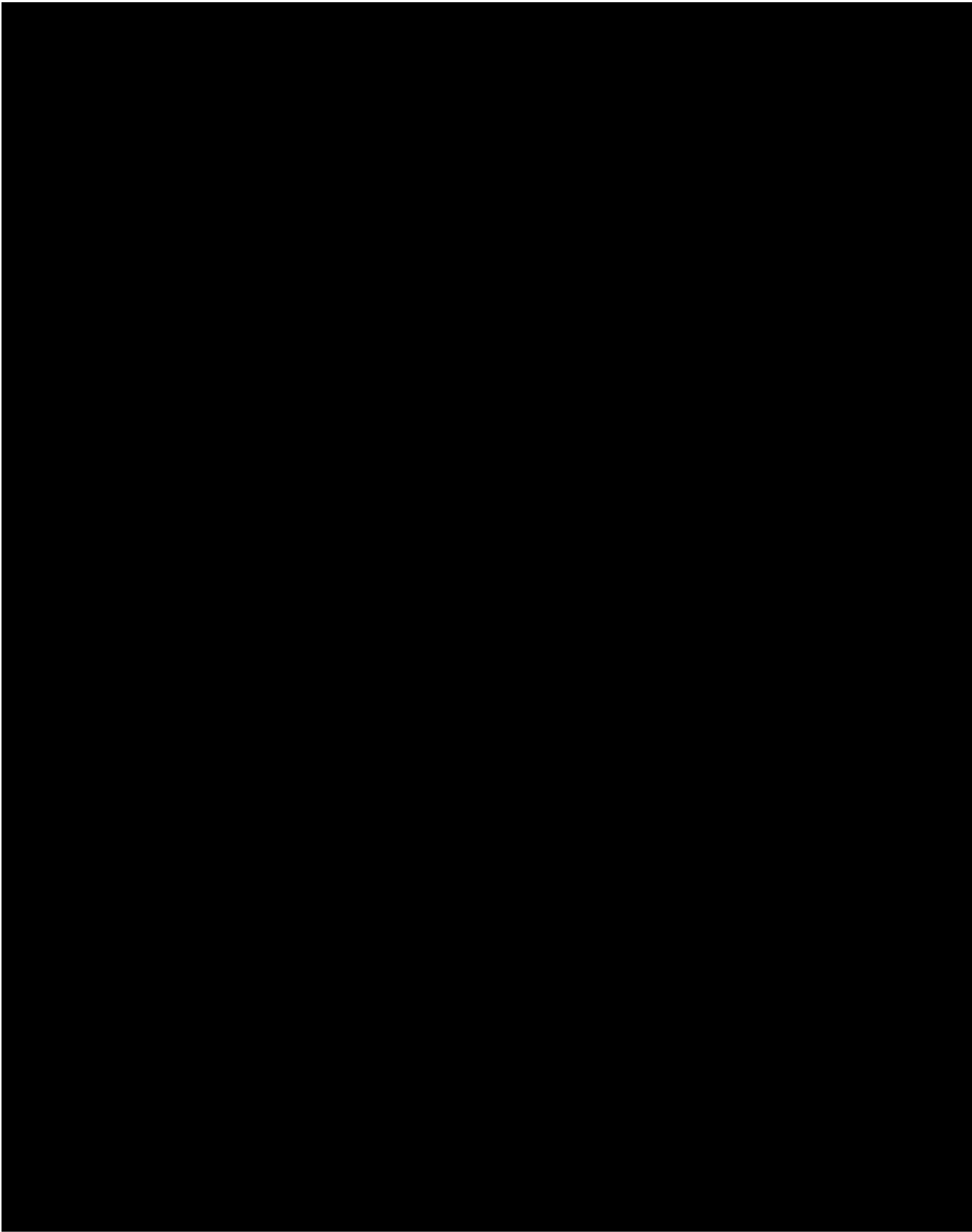


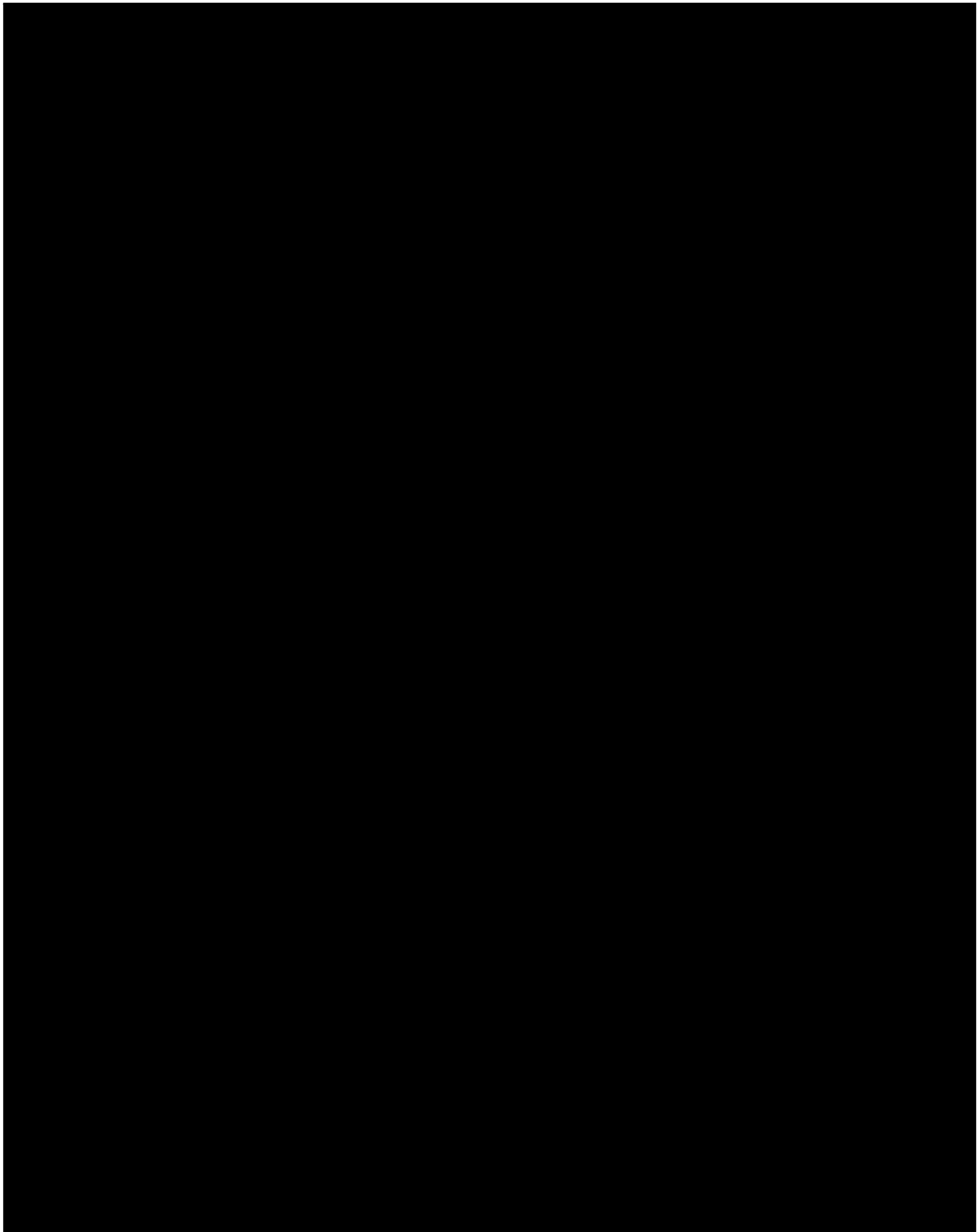


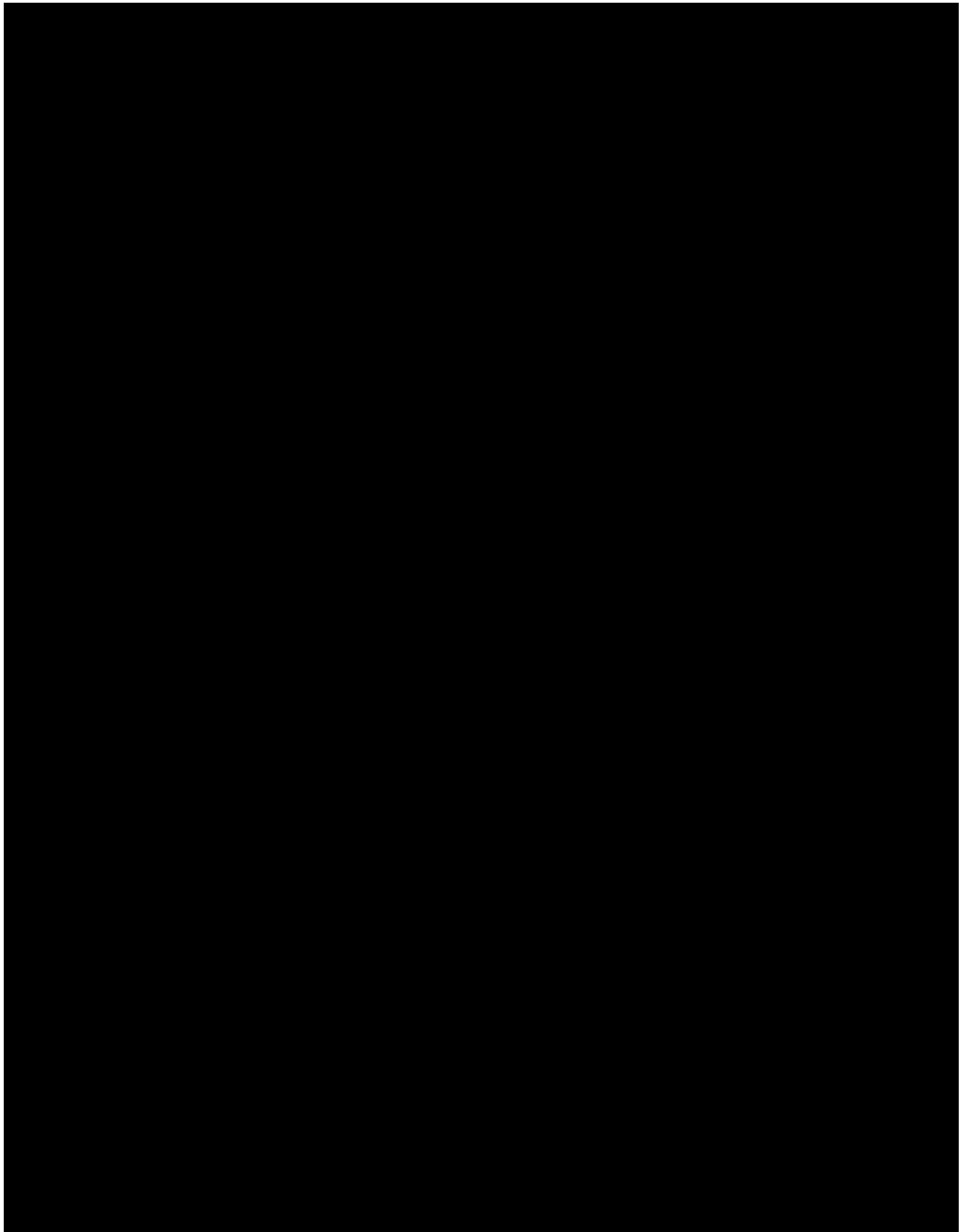
CONFIDENTIAL

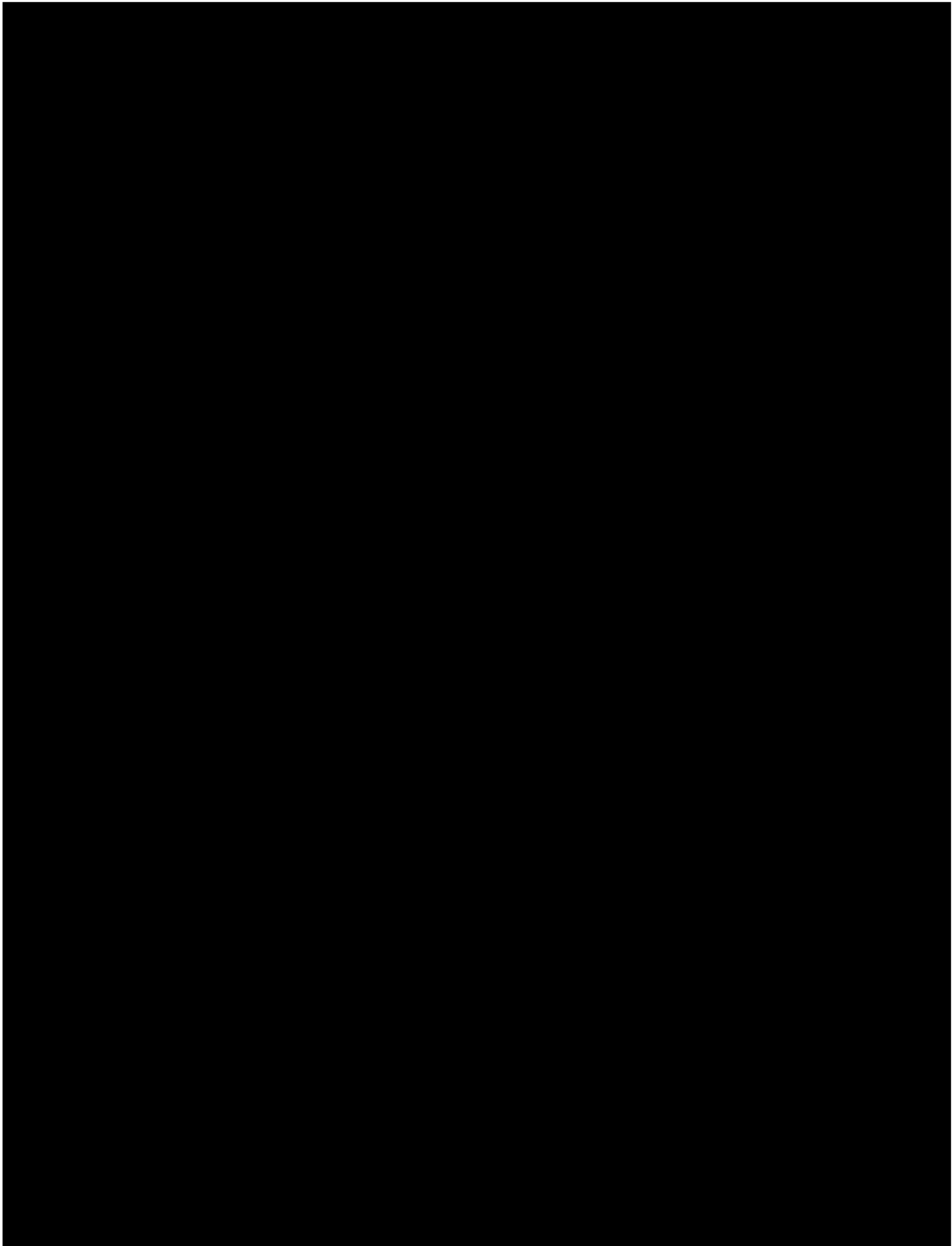


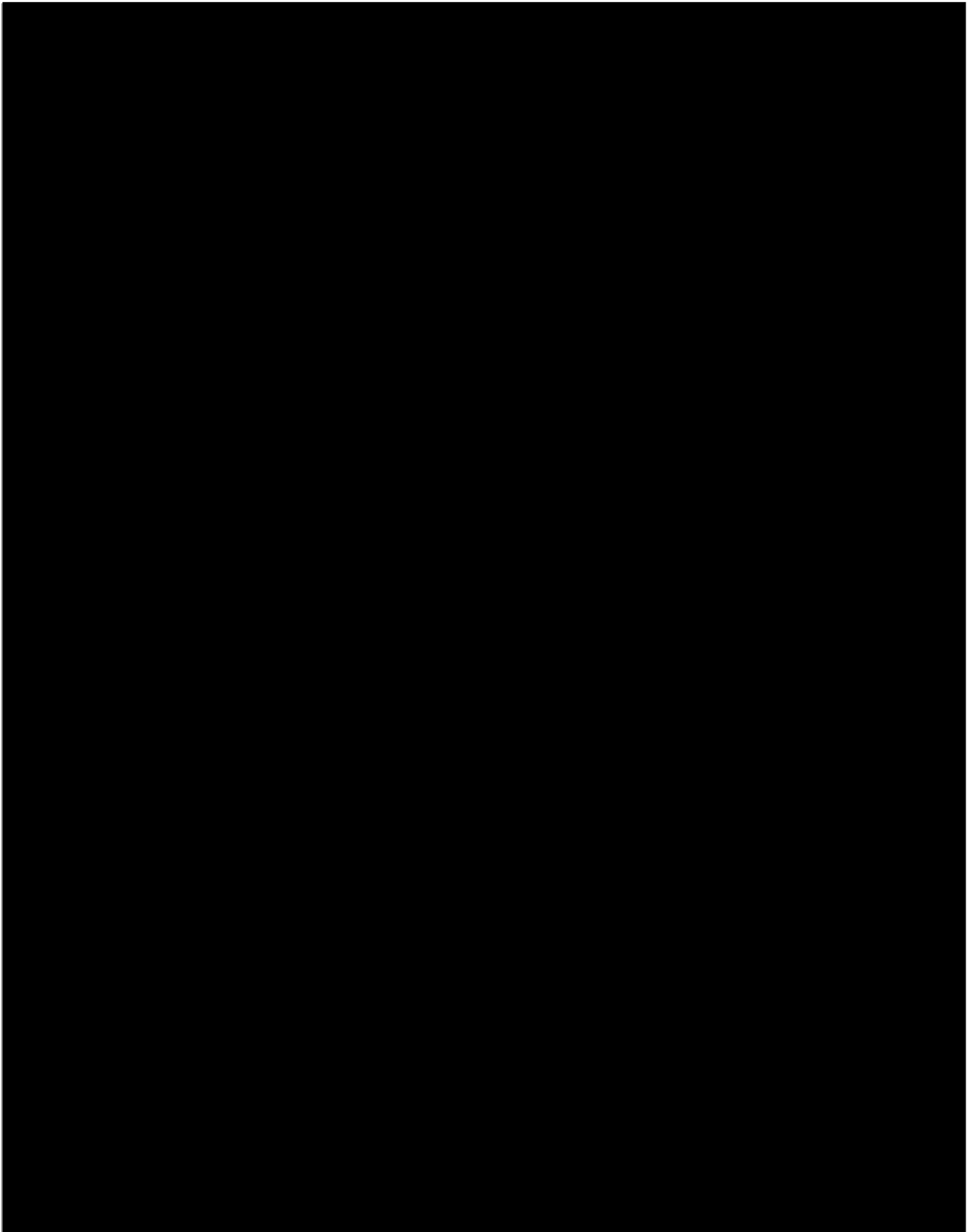


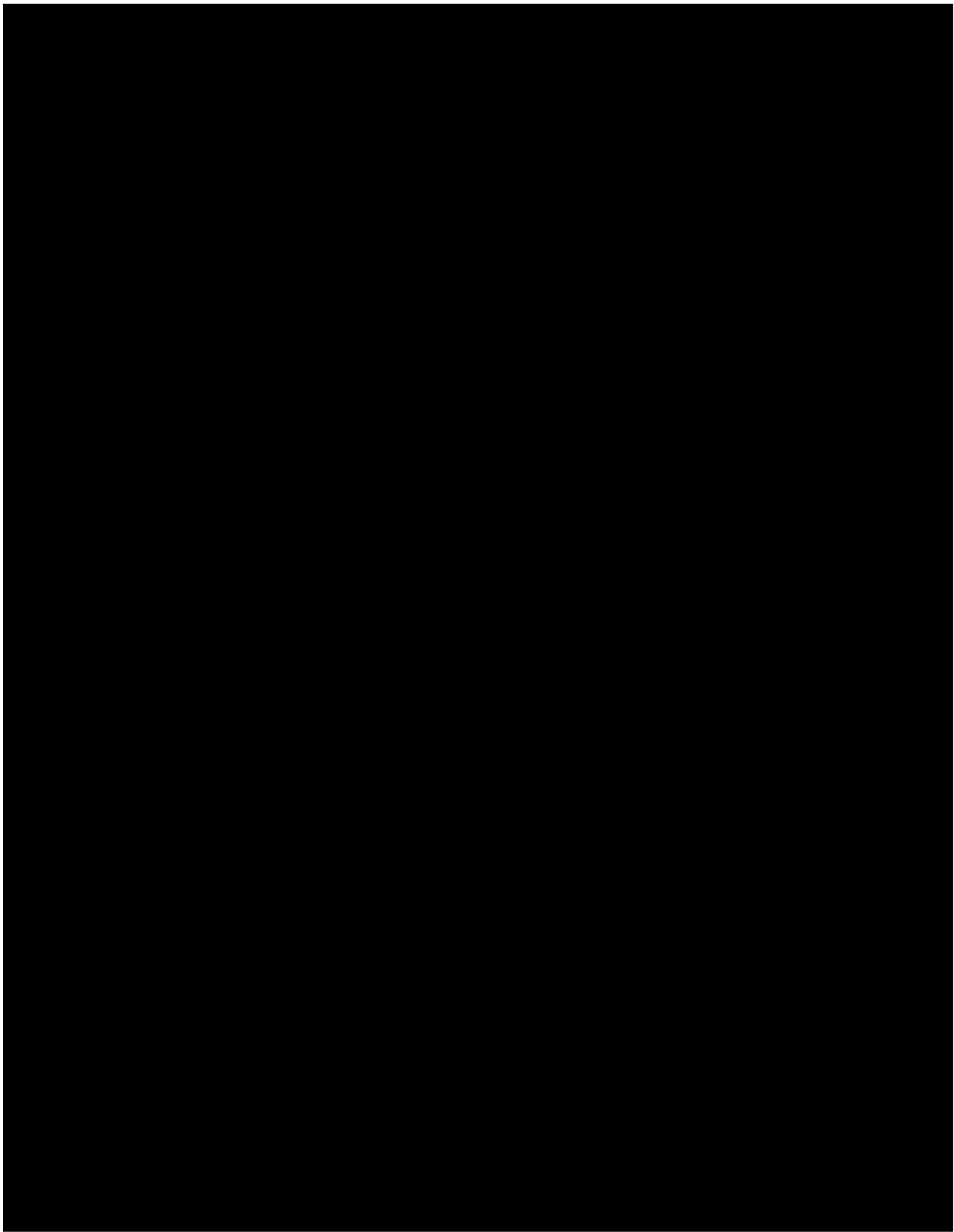


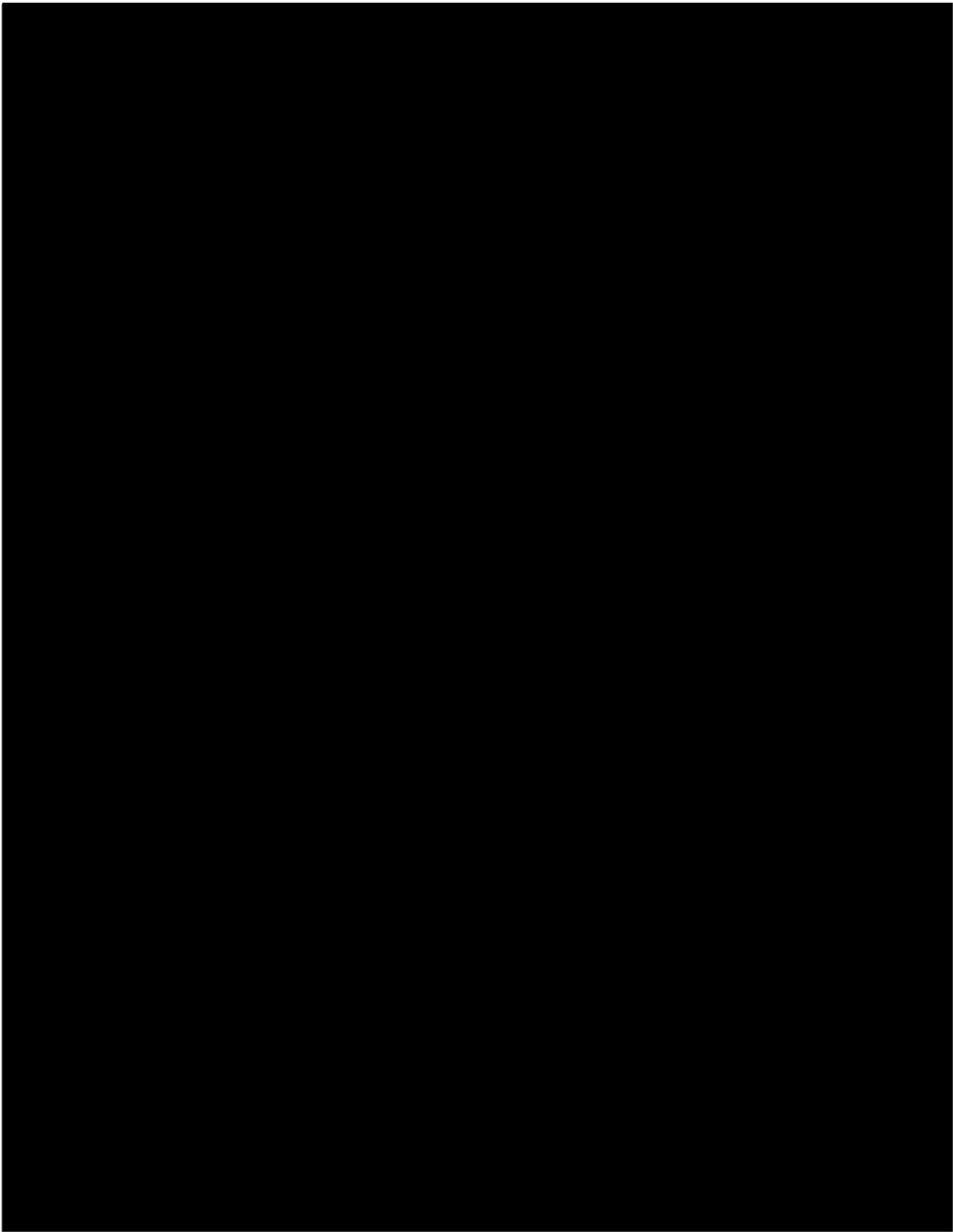


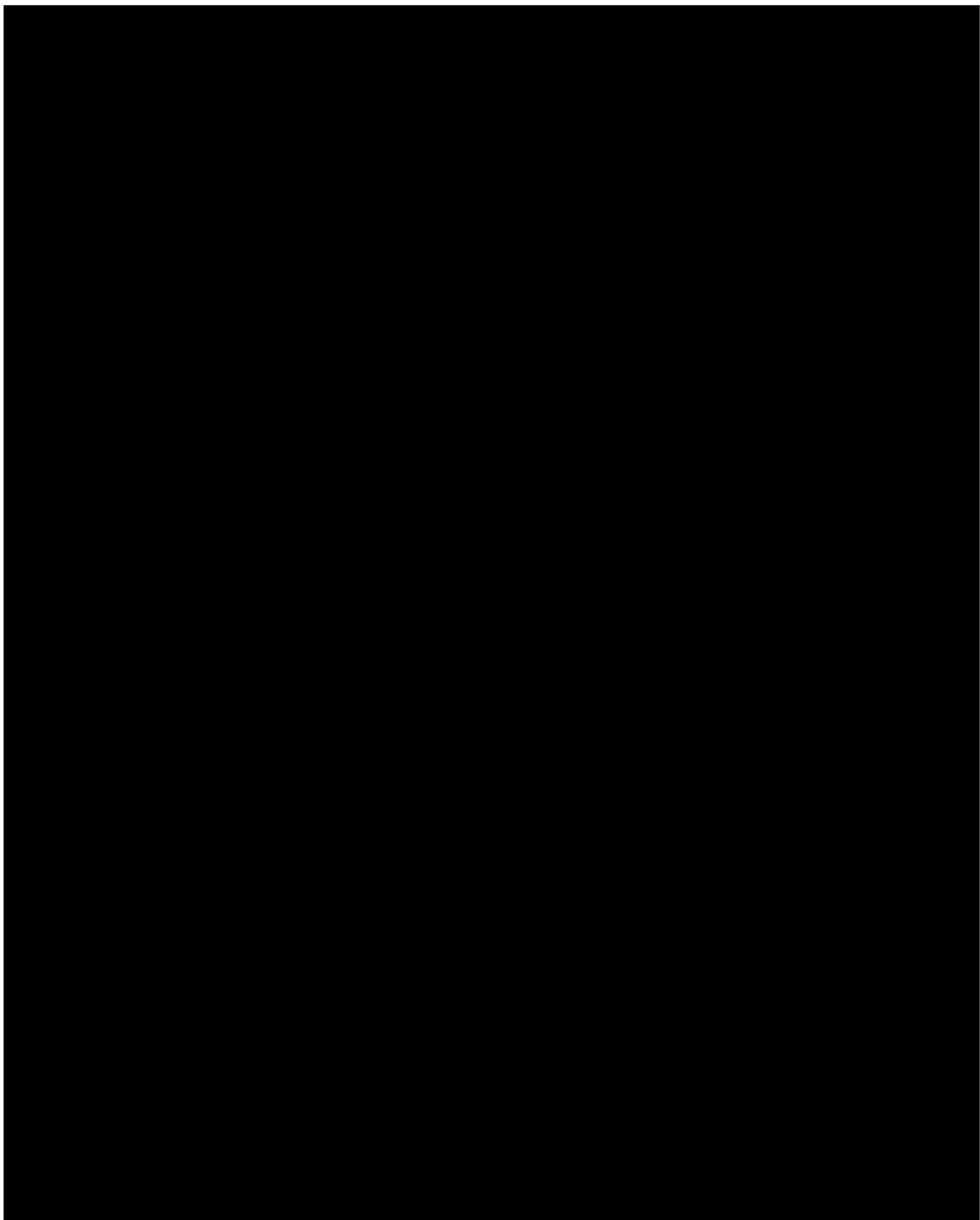




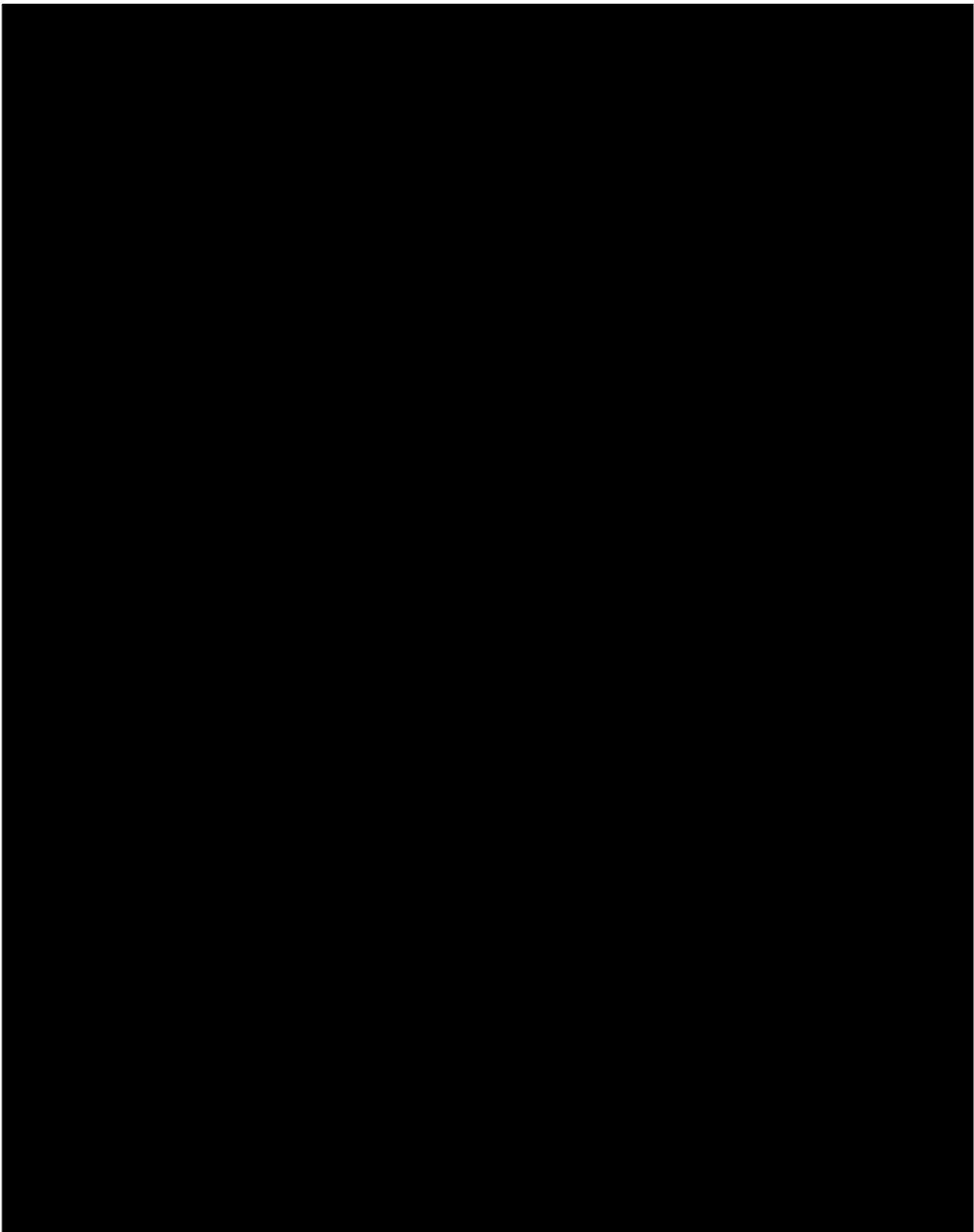


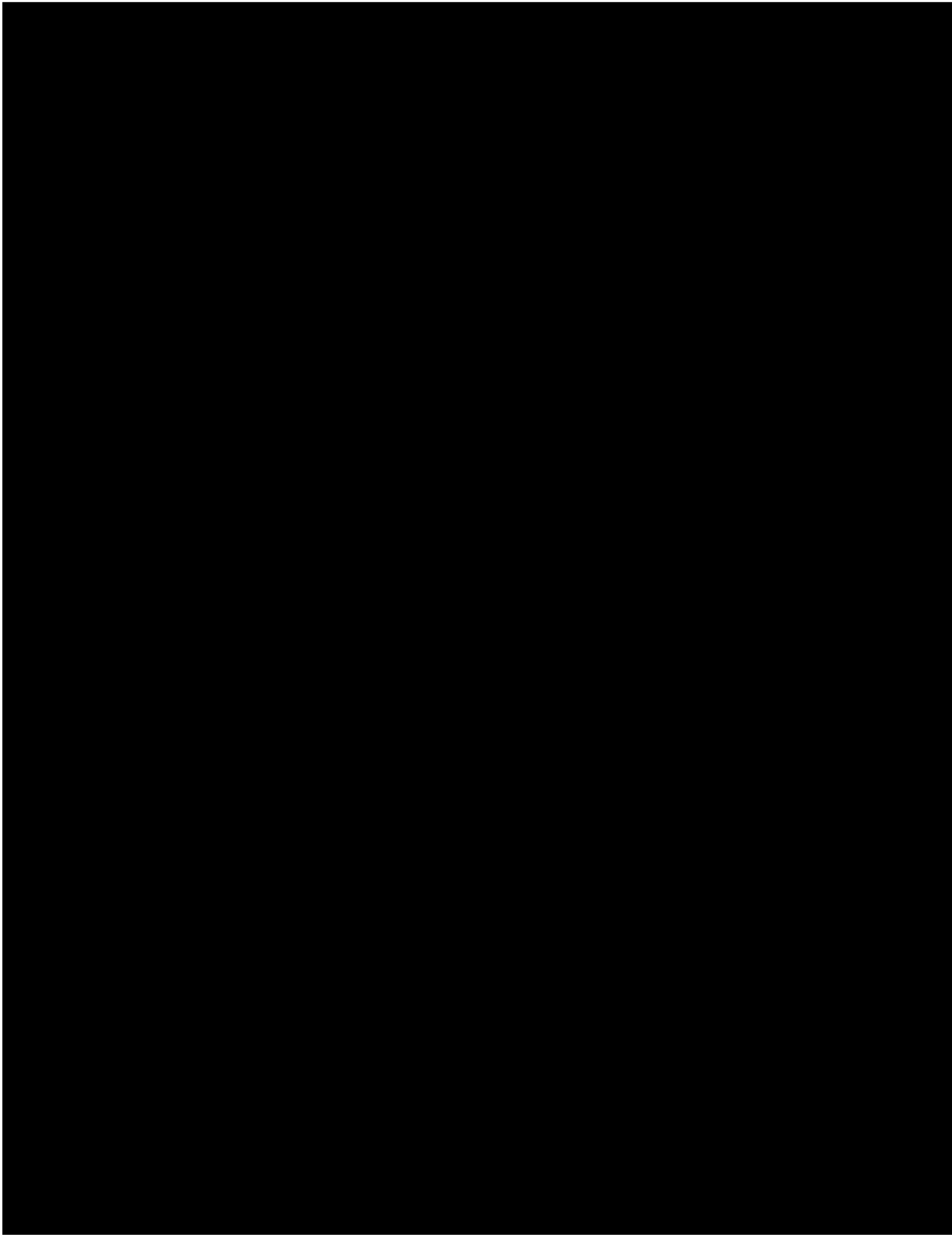


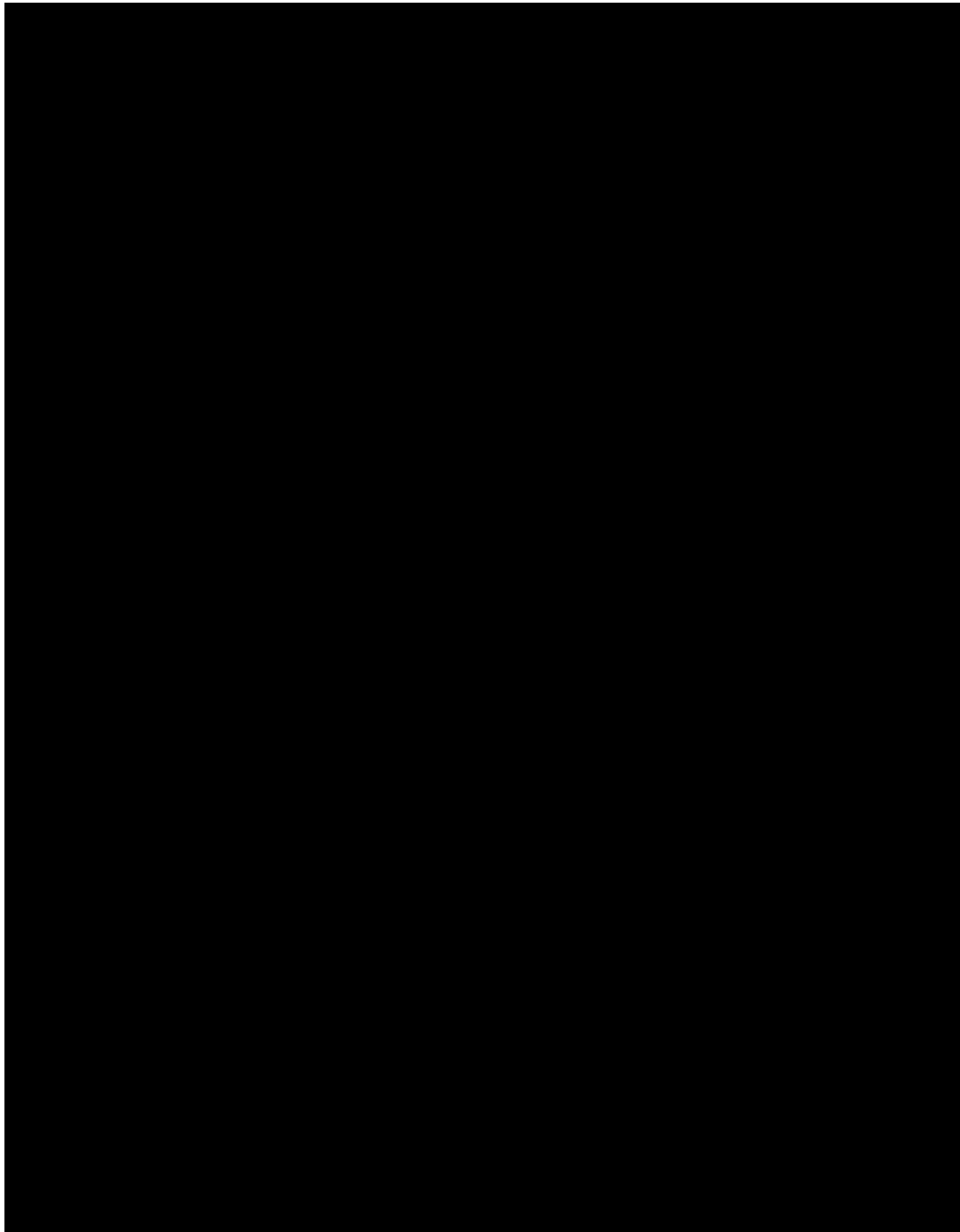


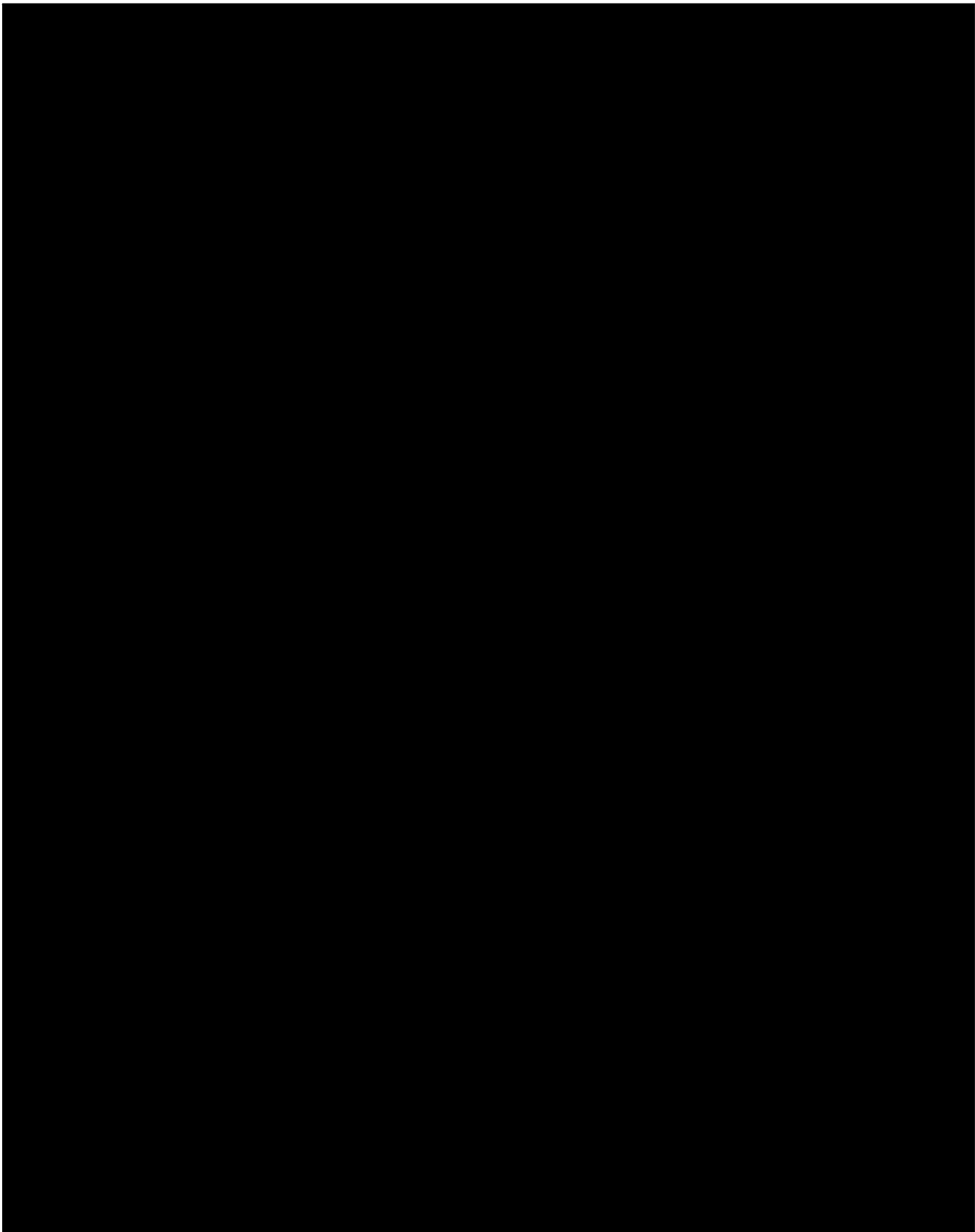


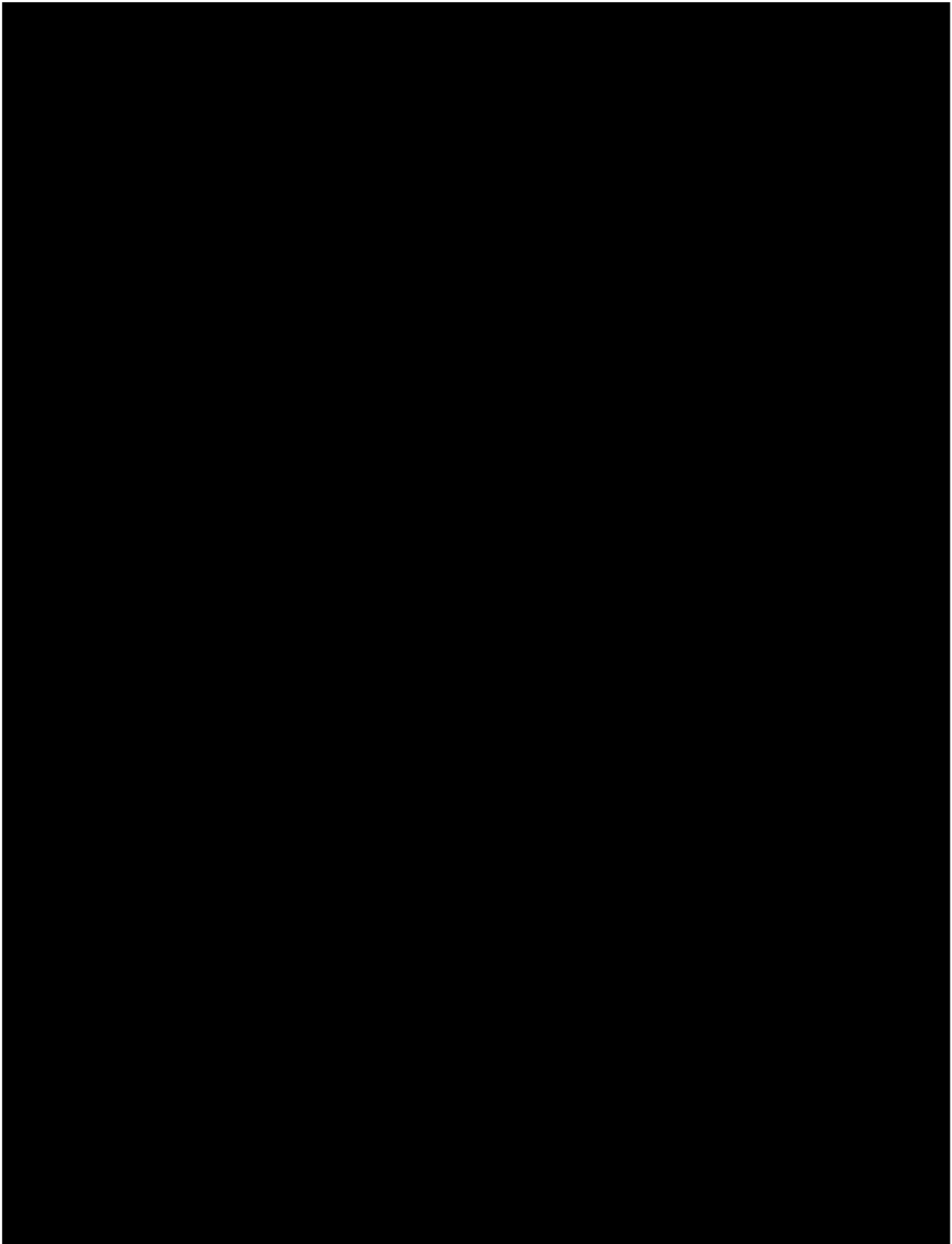


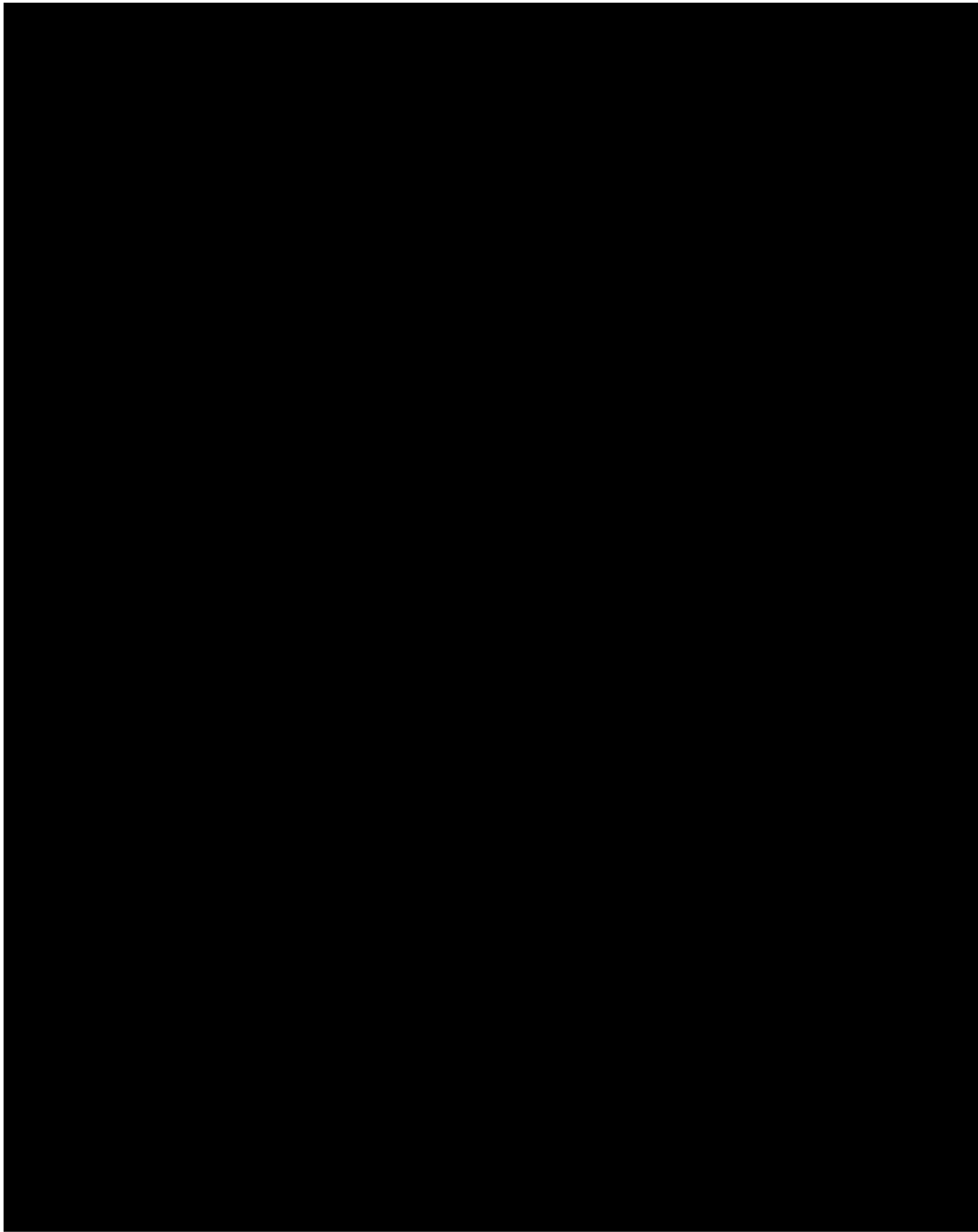


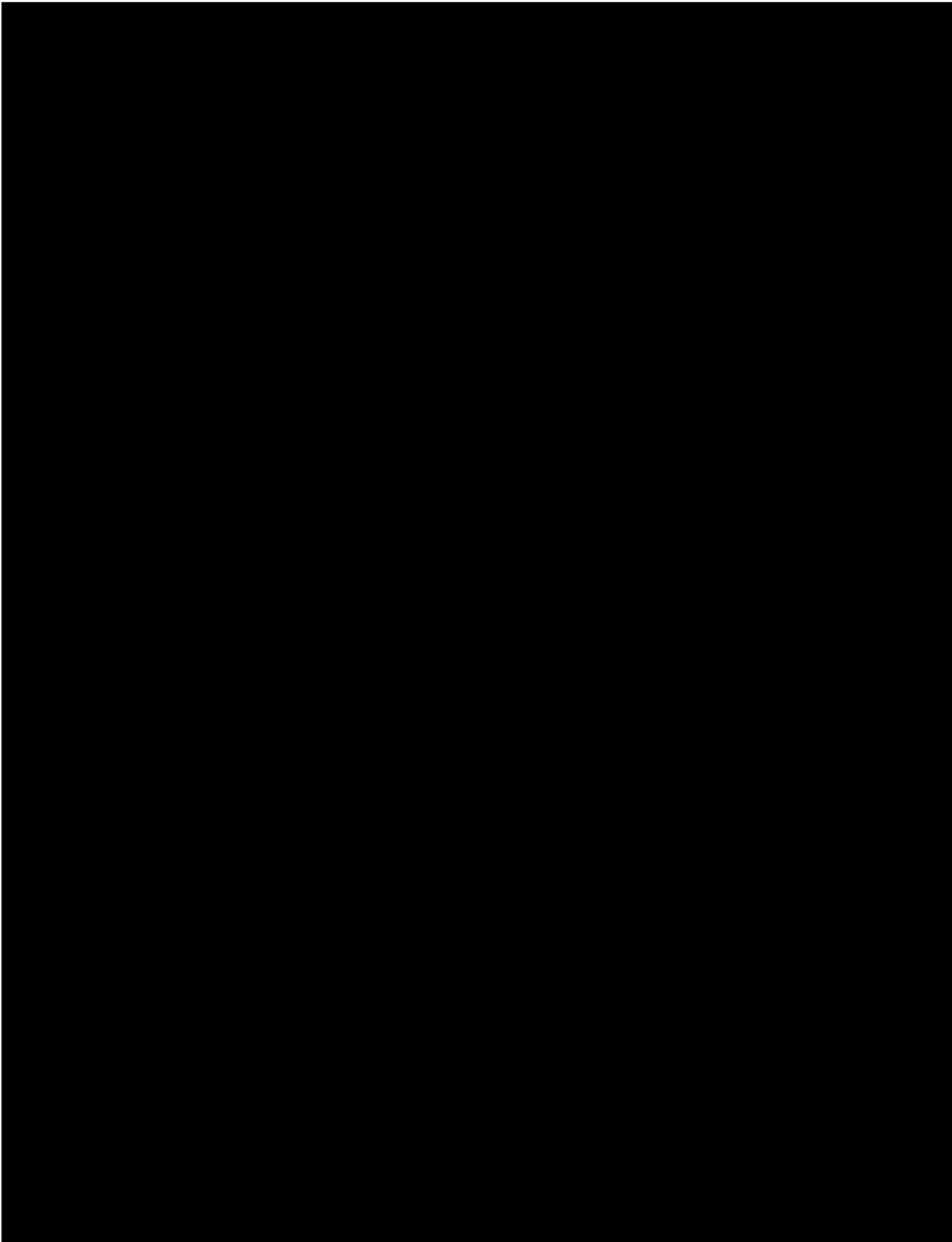


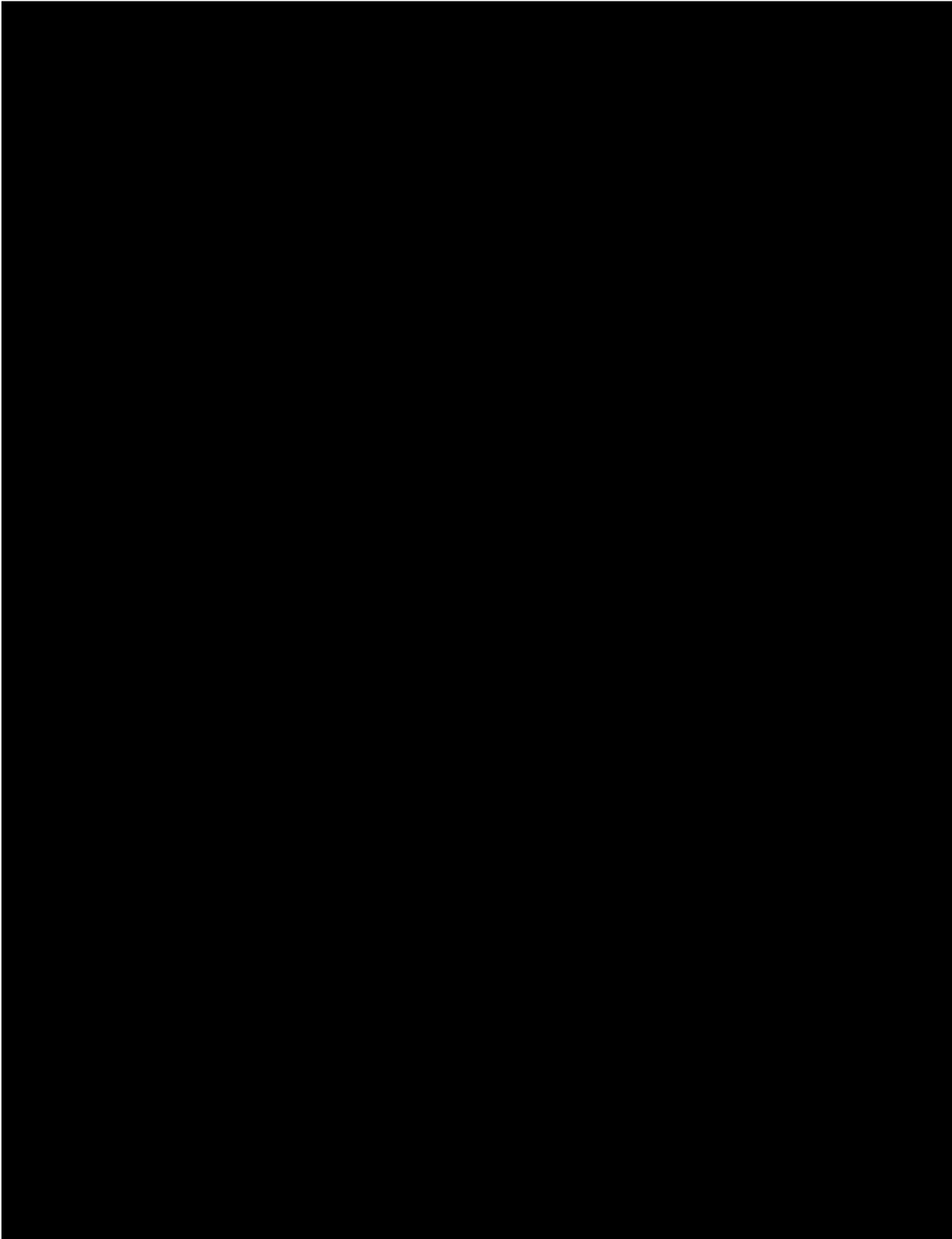




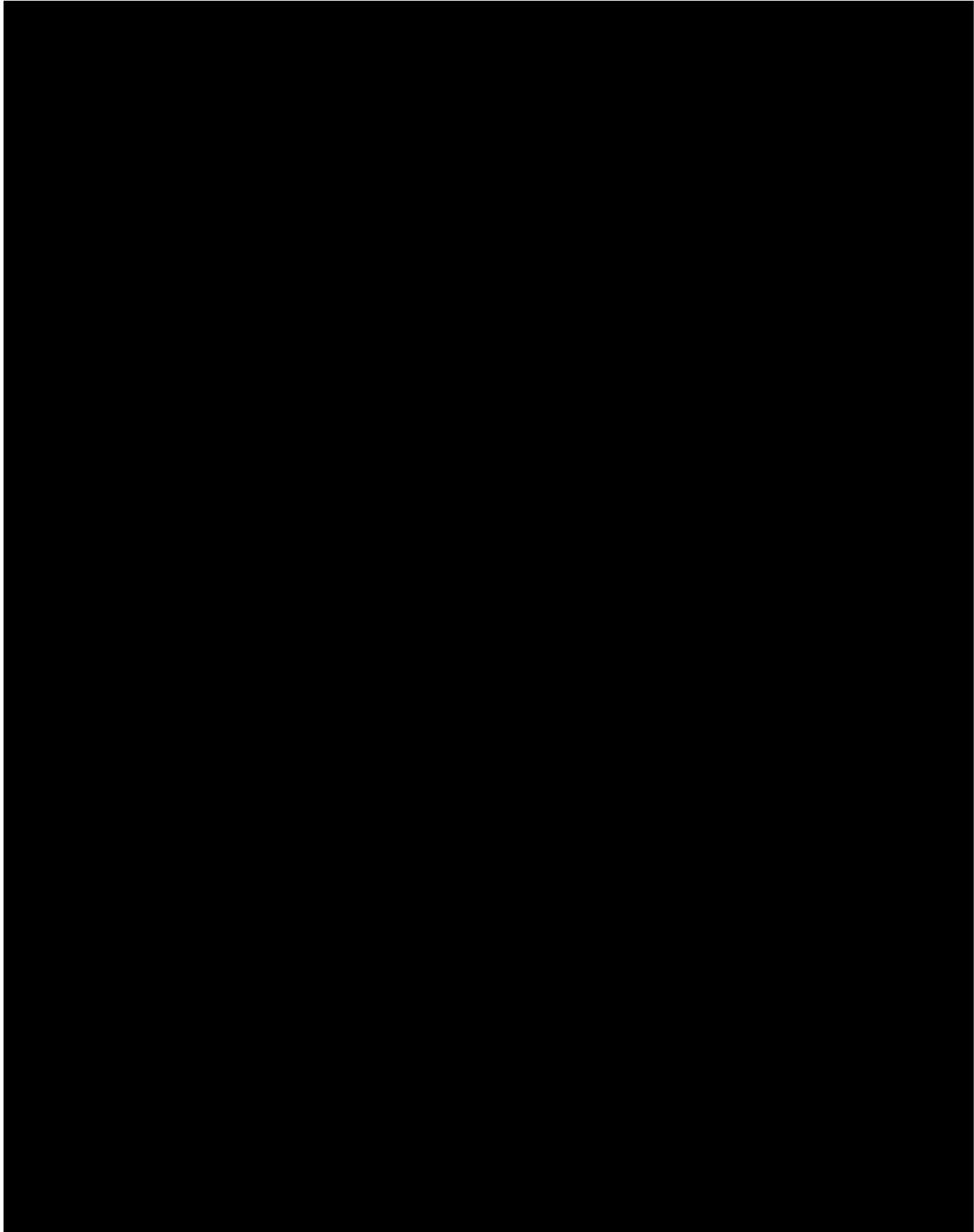


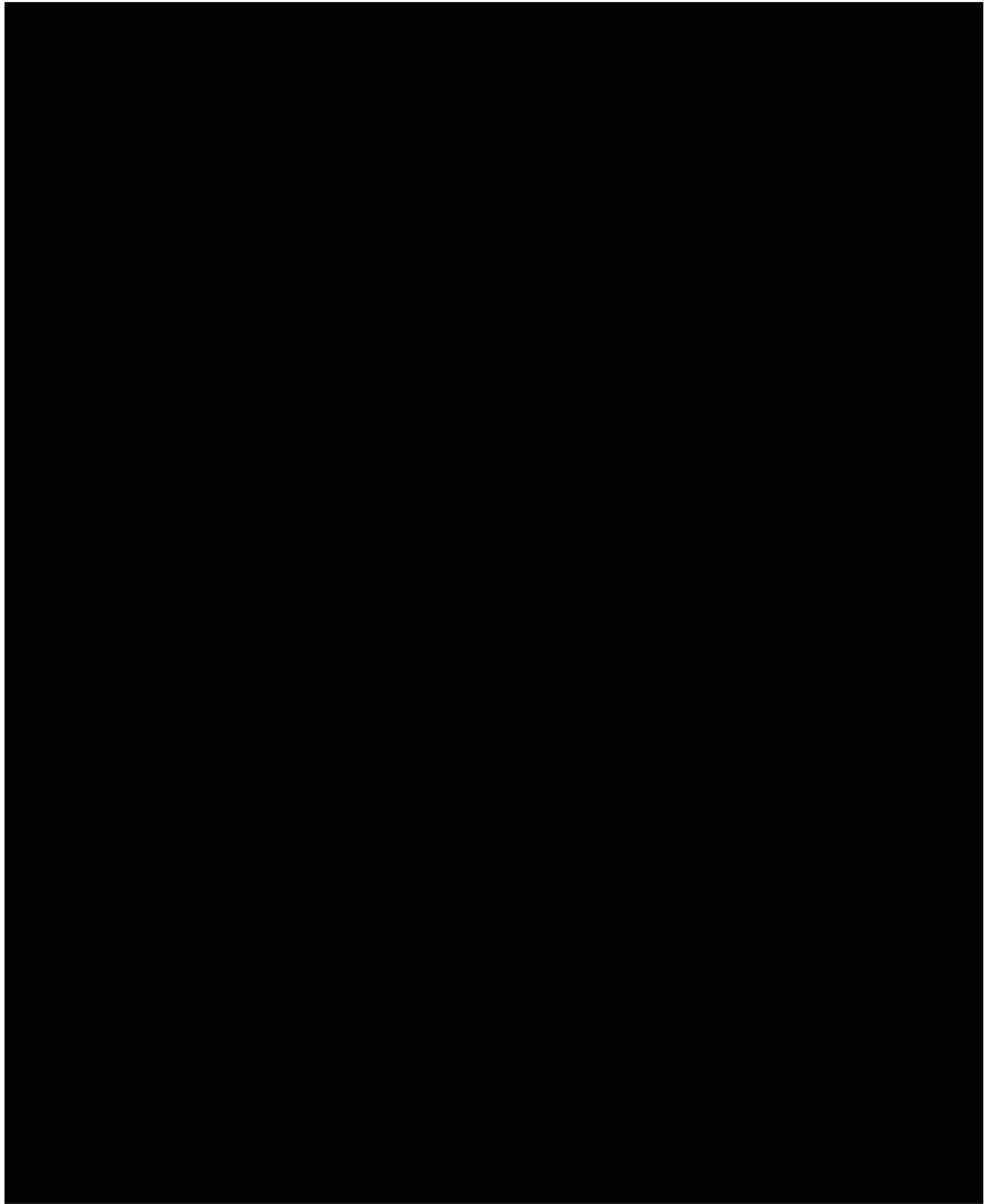


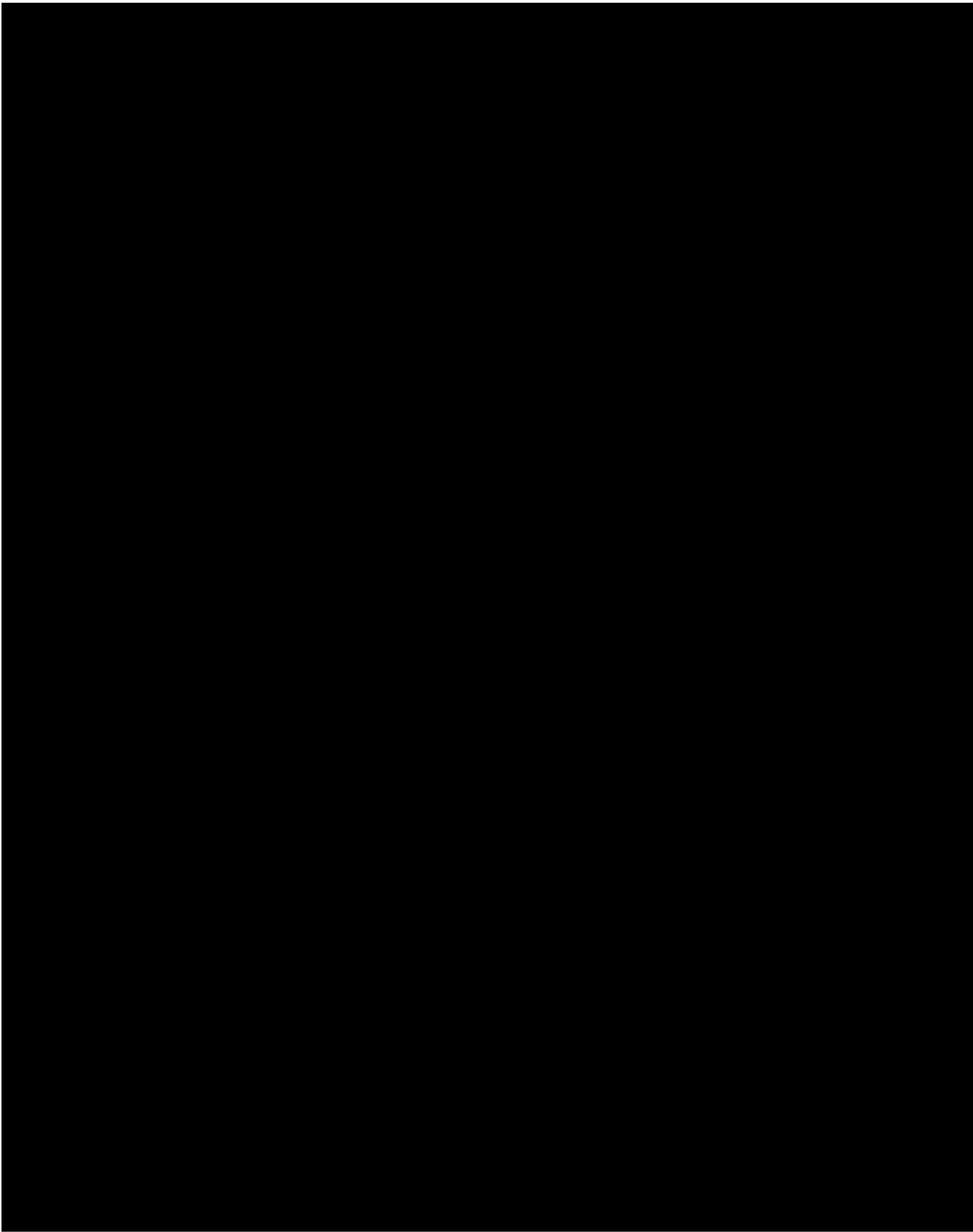


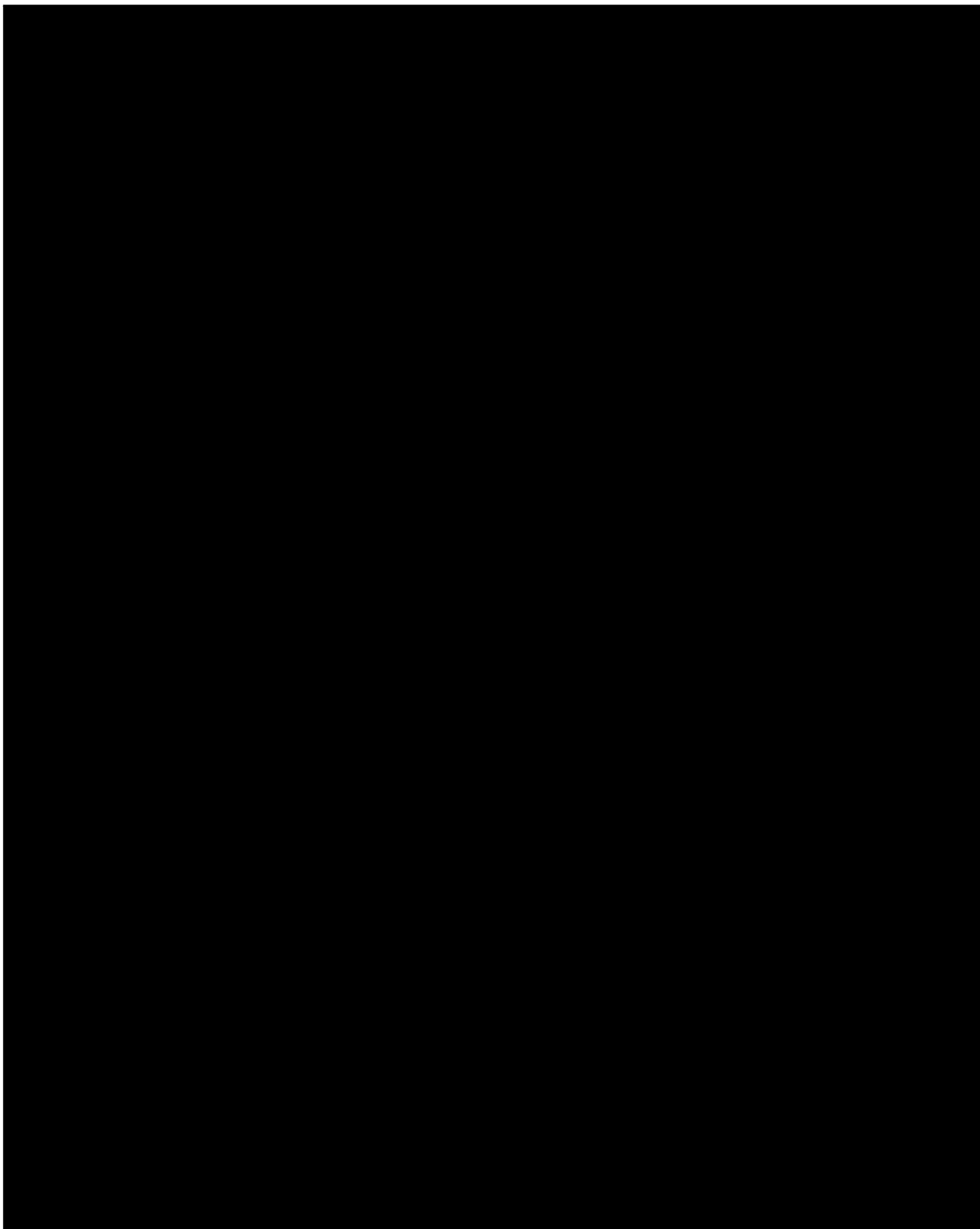


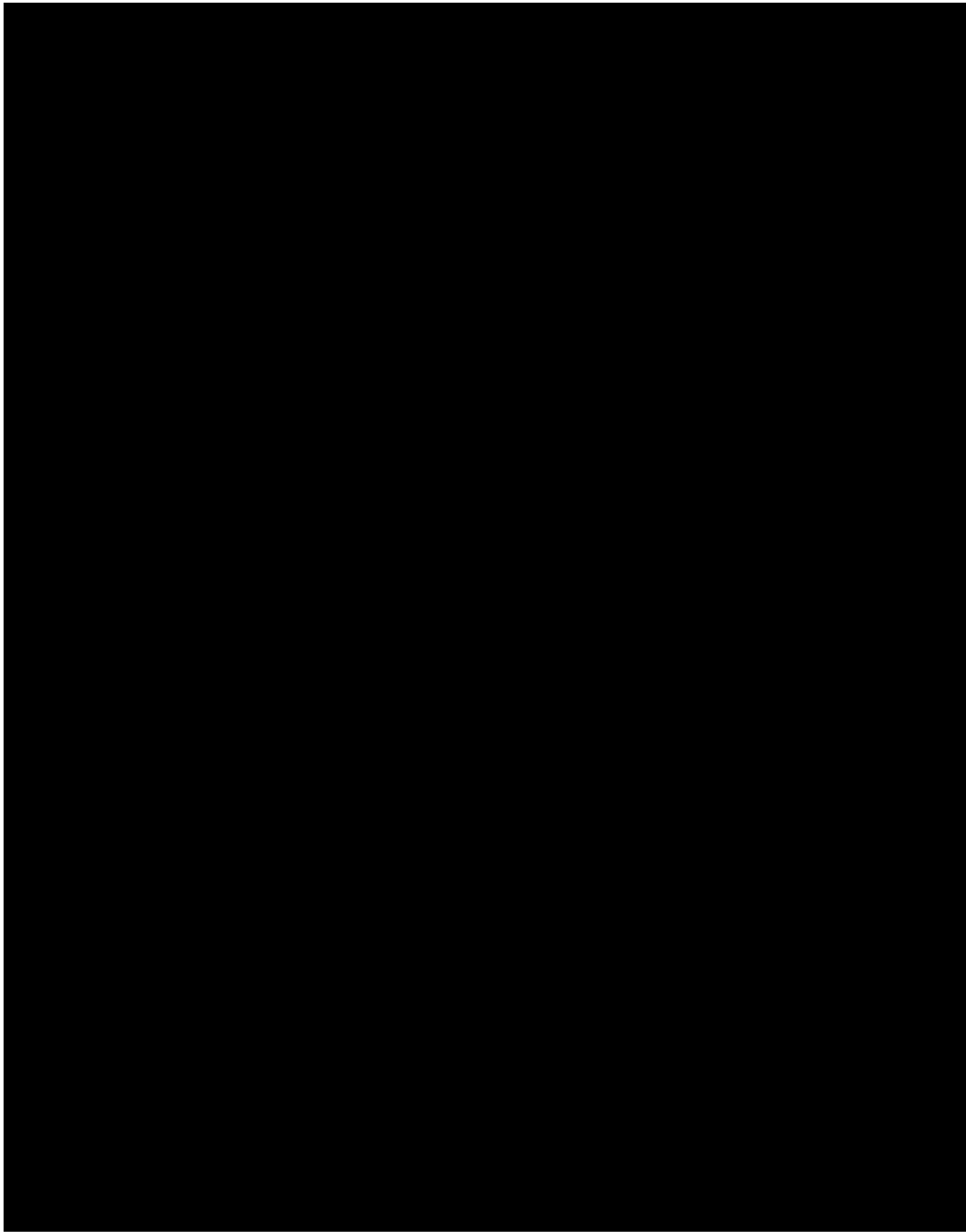


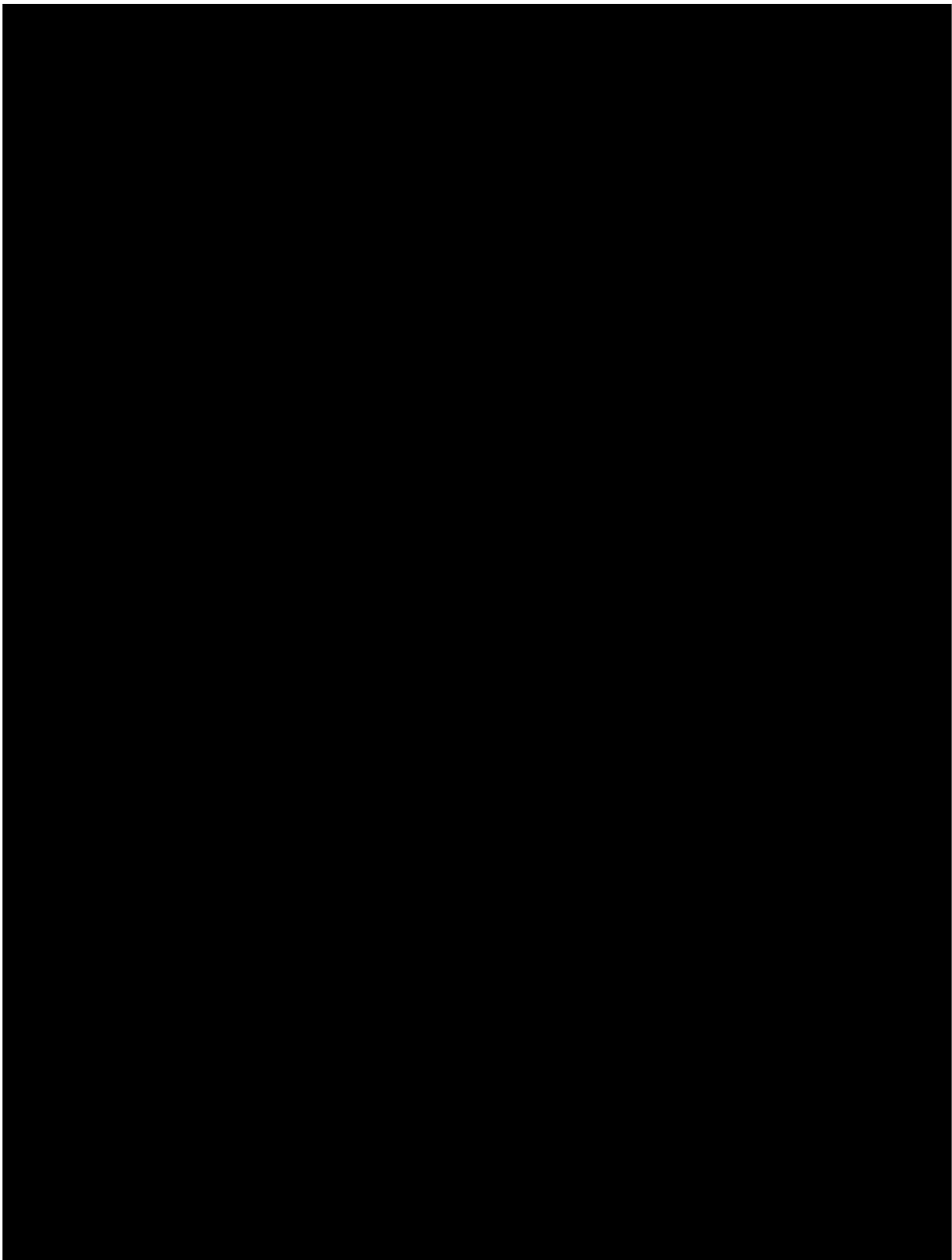


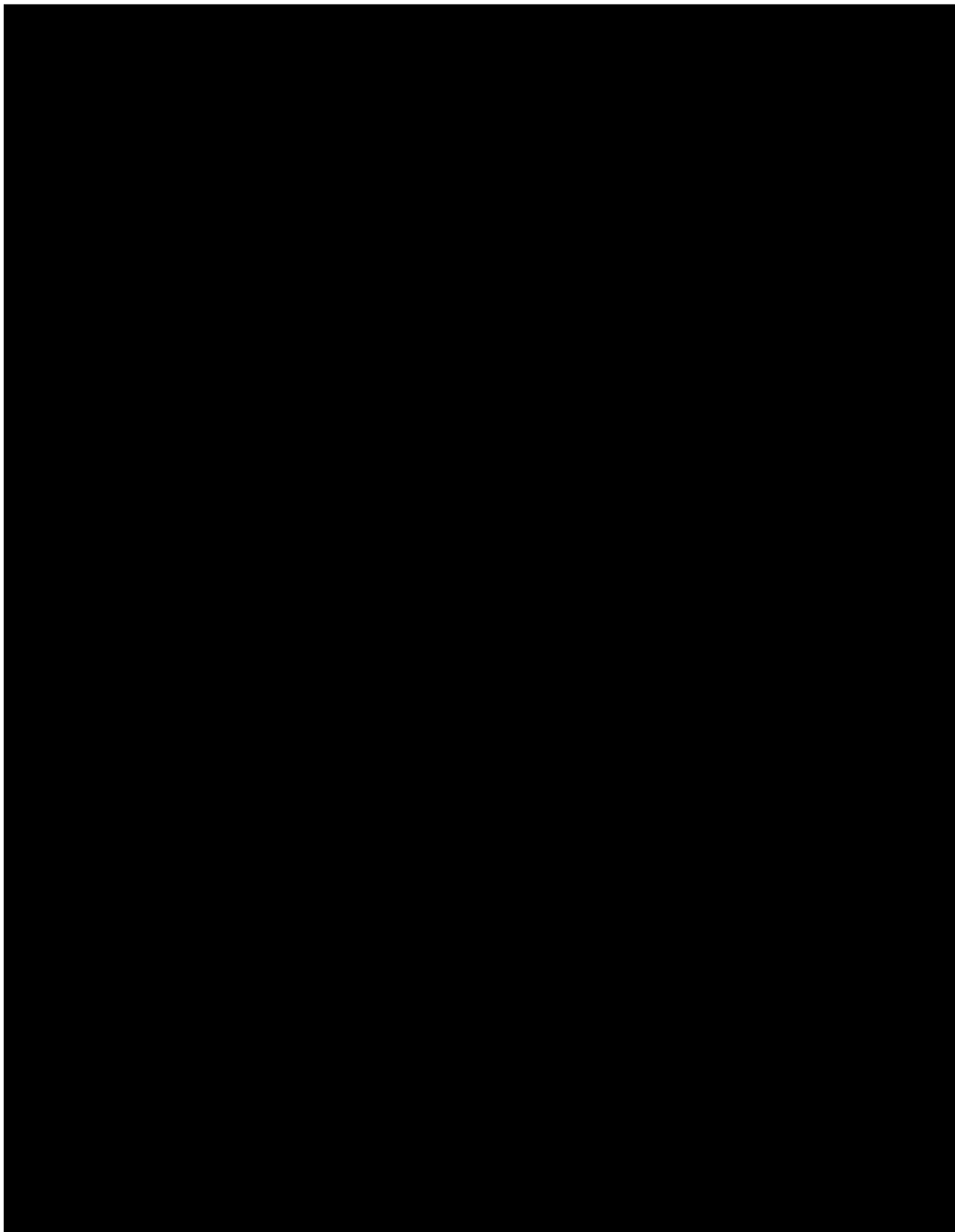


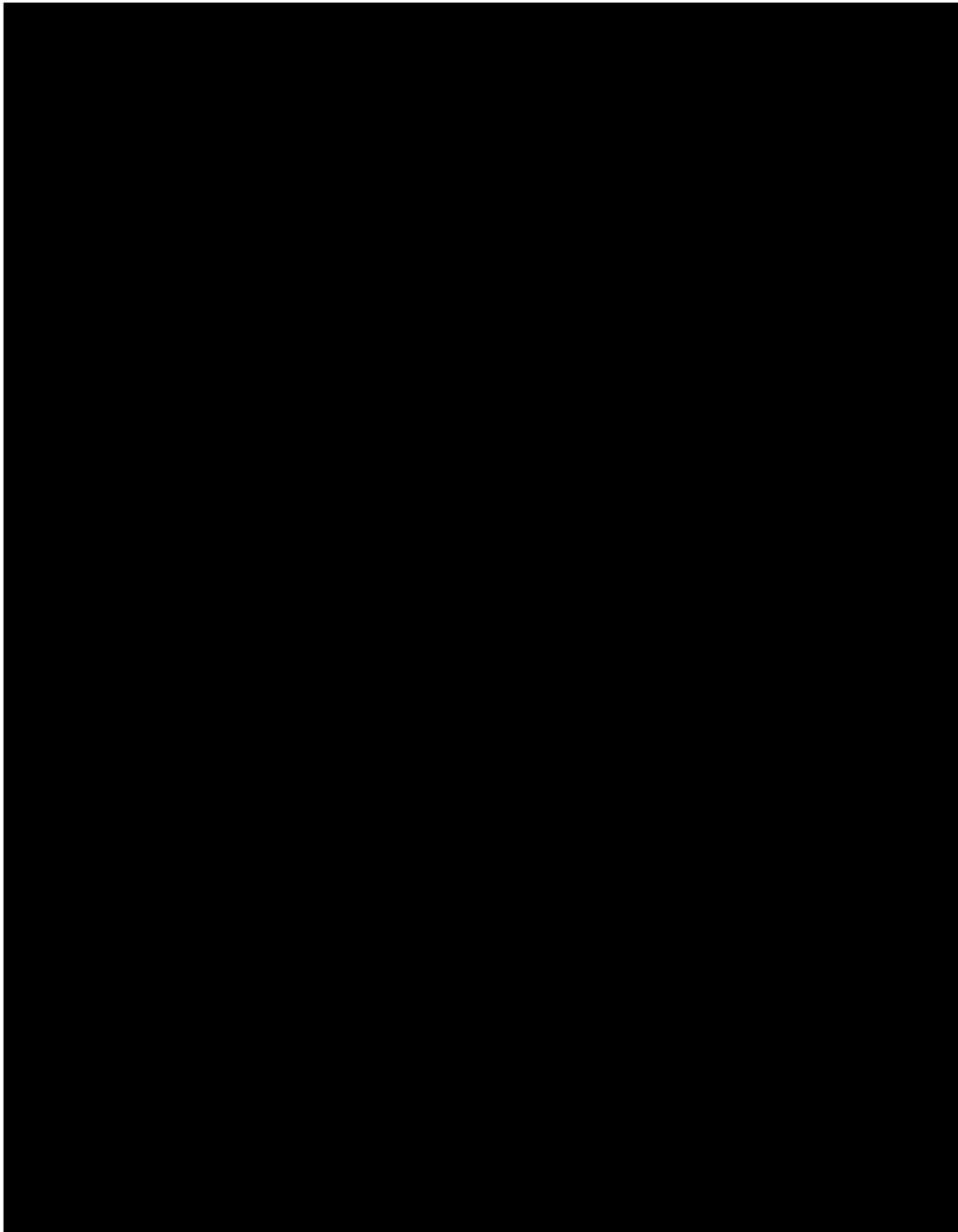






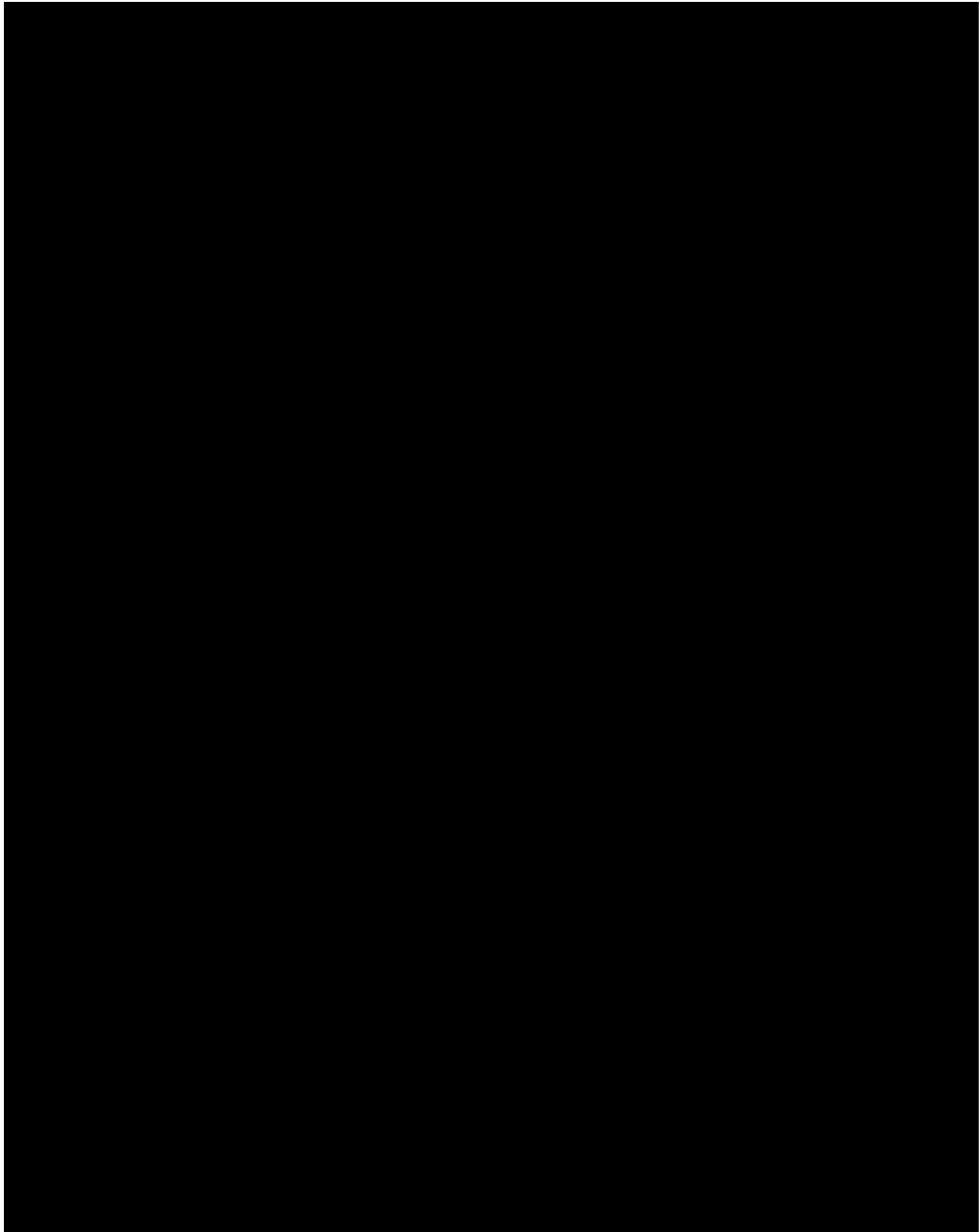


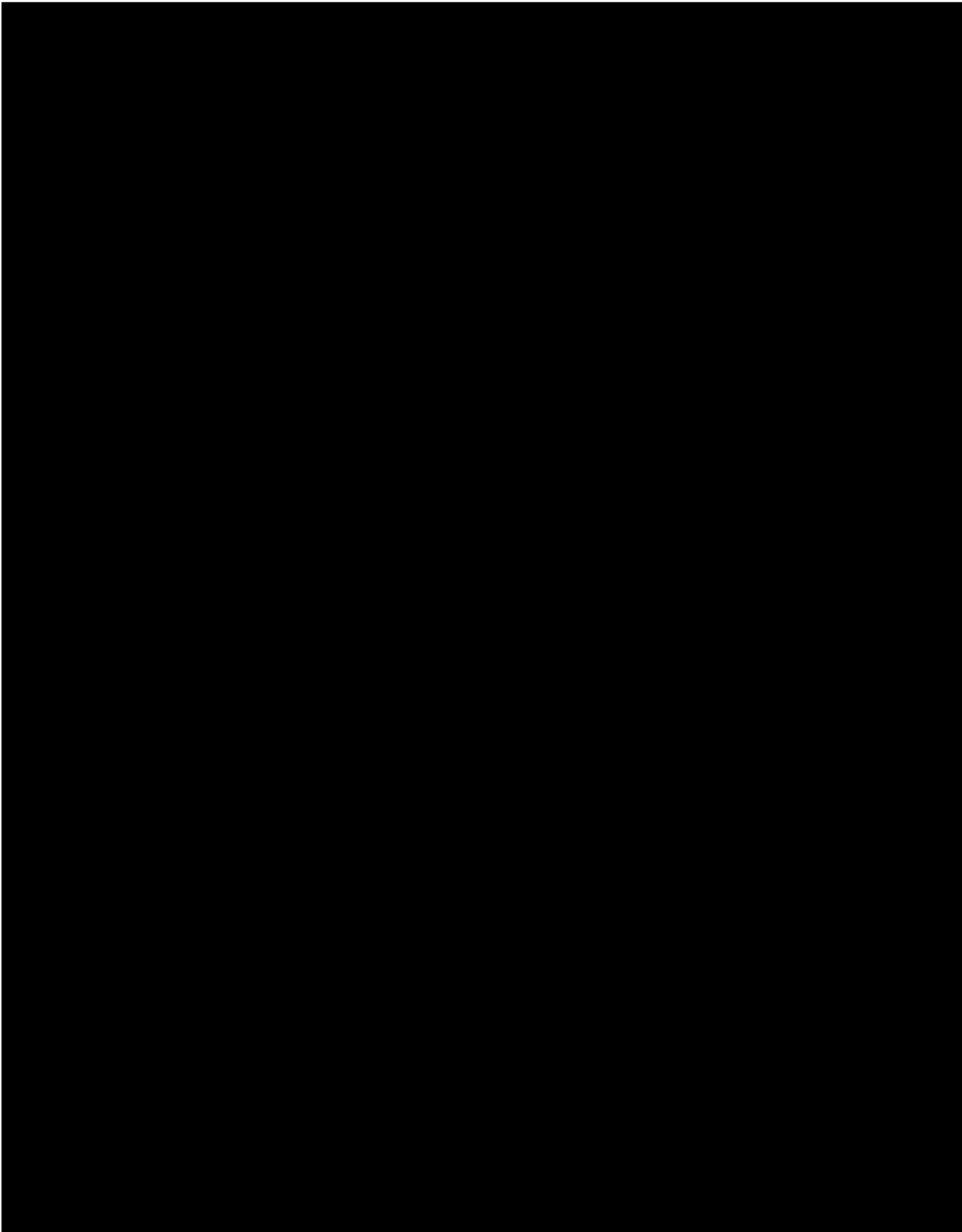


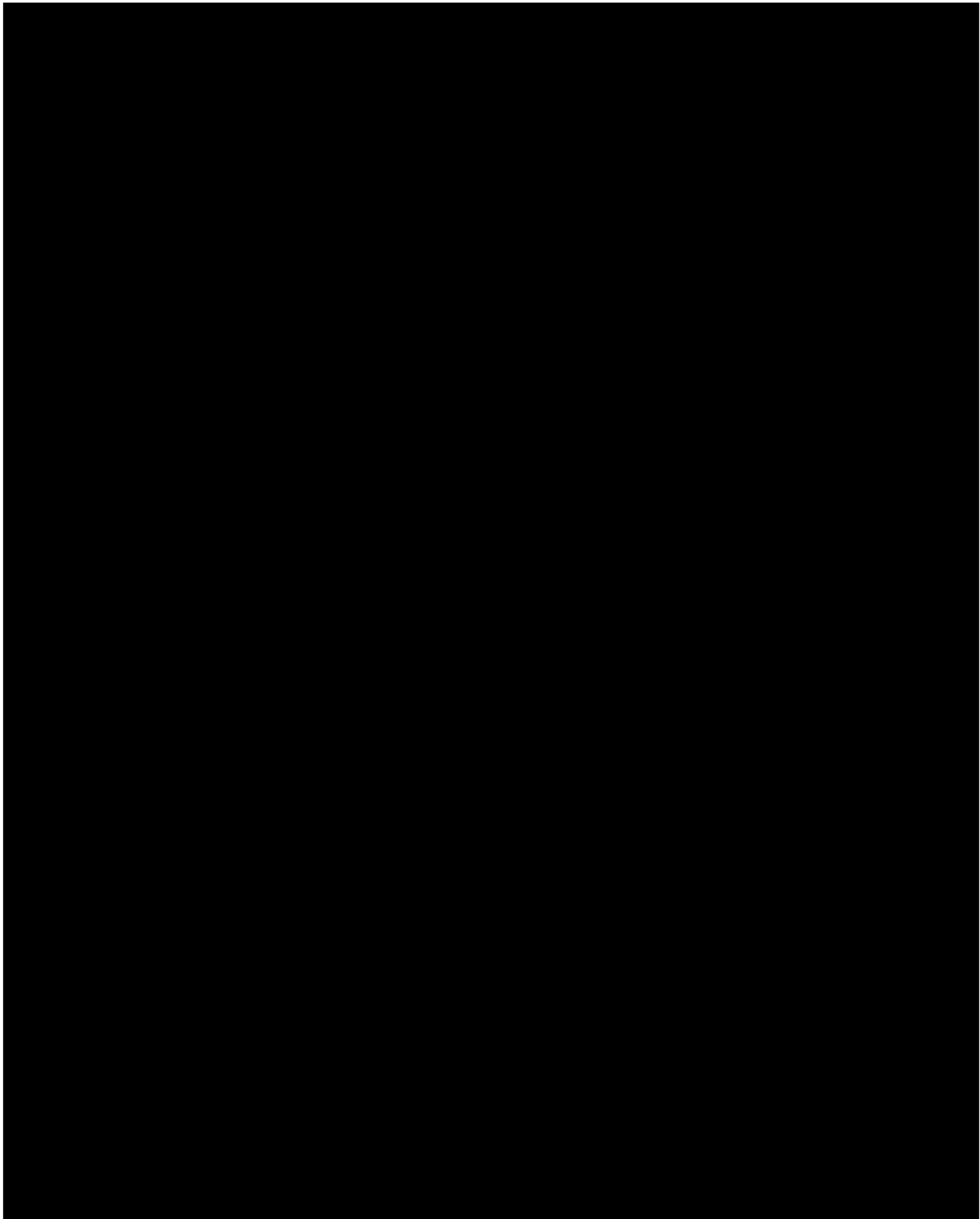


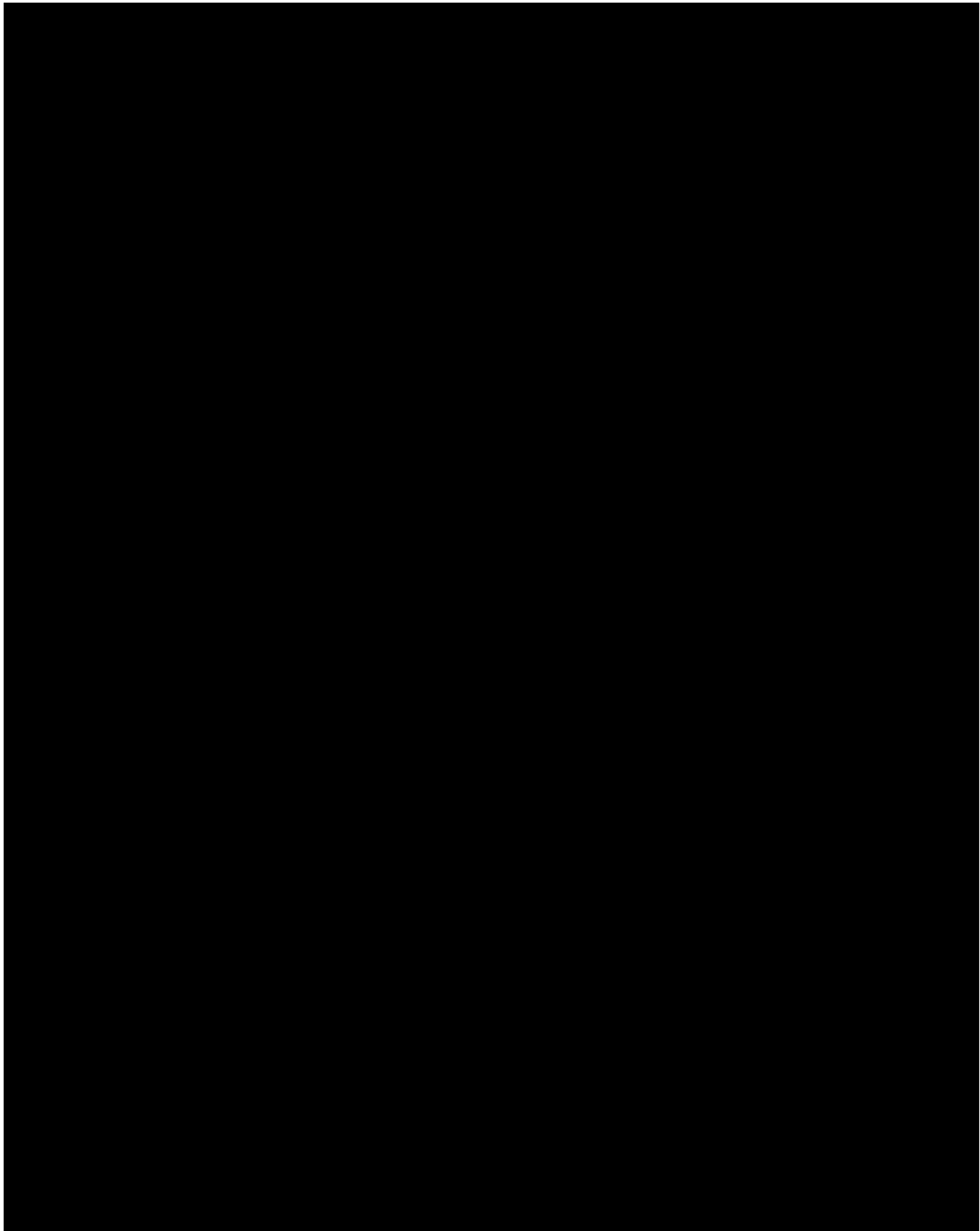


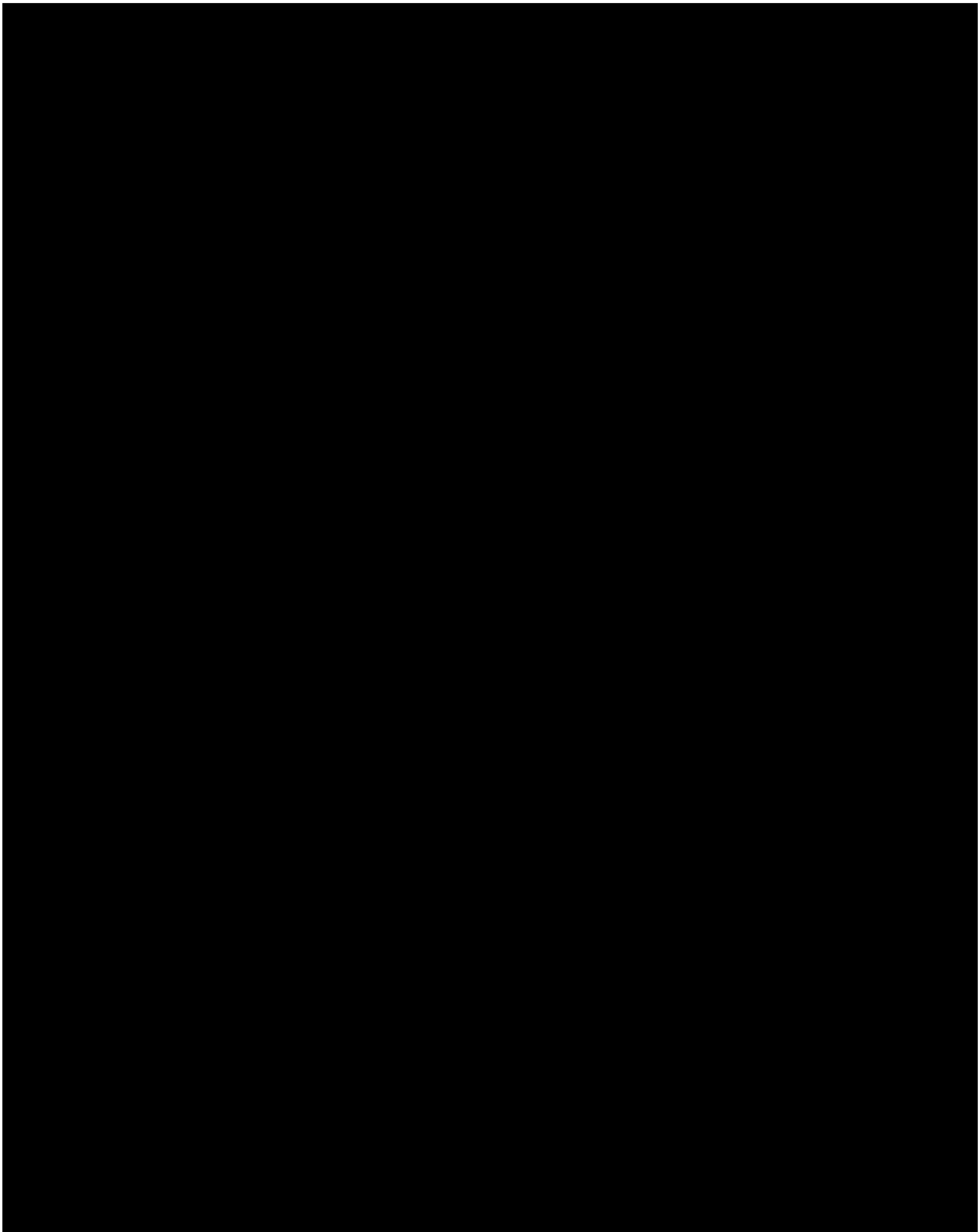


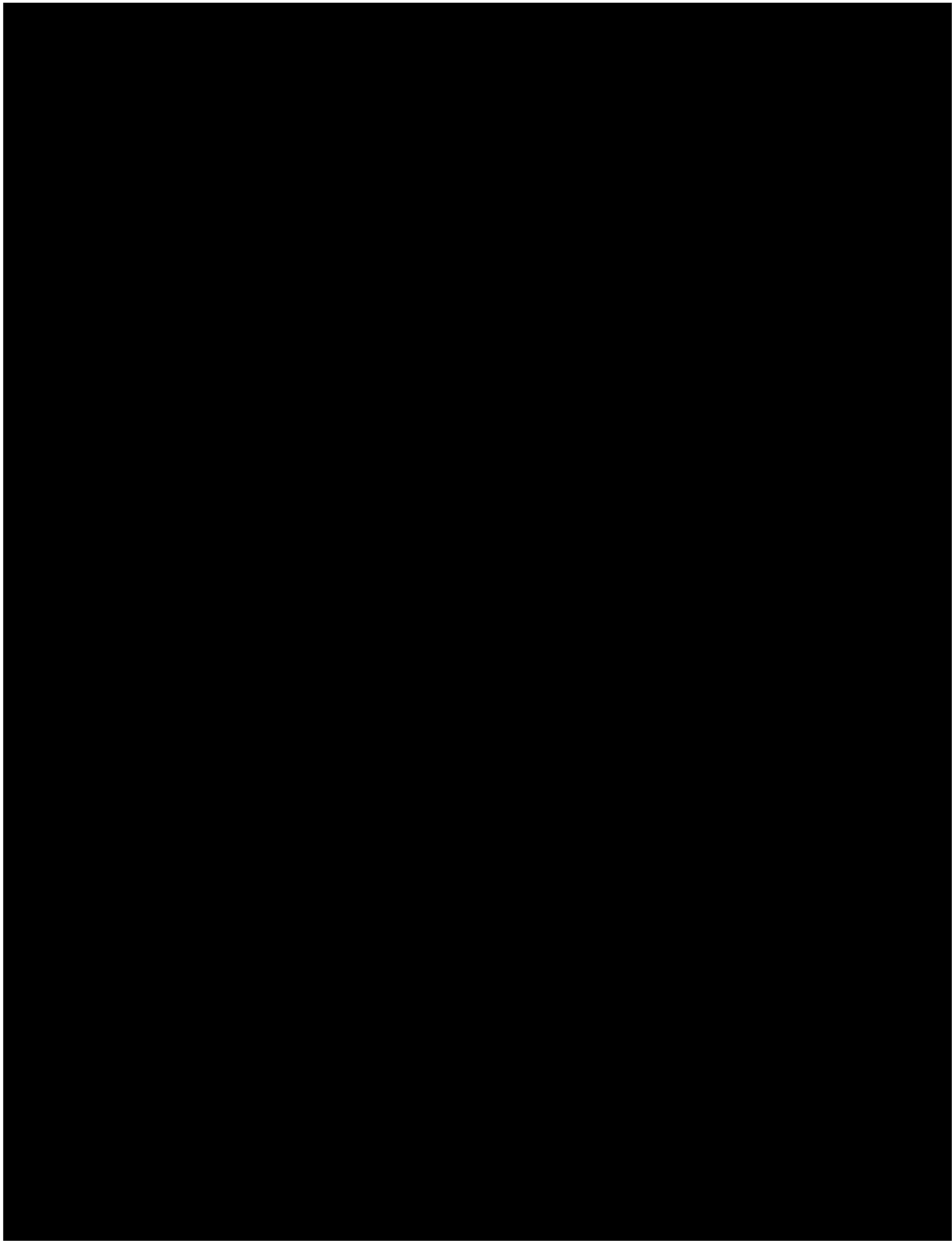


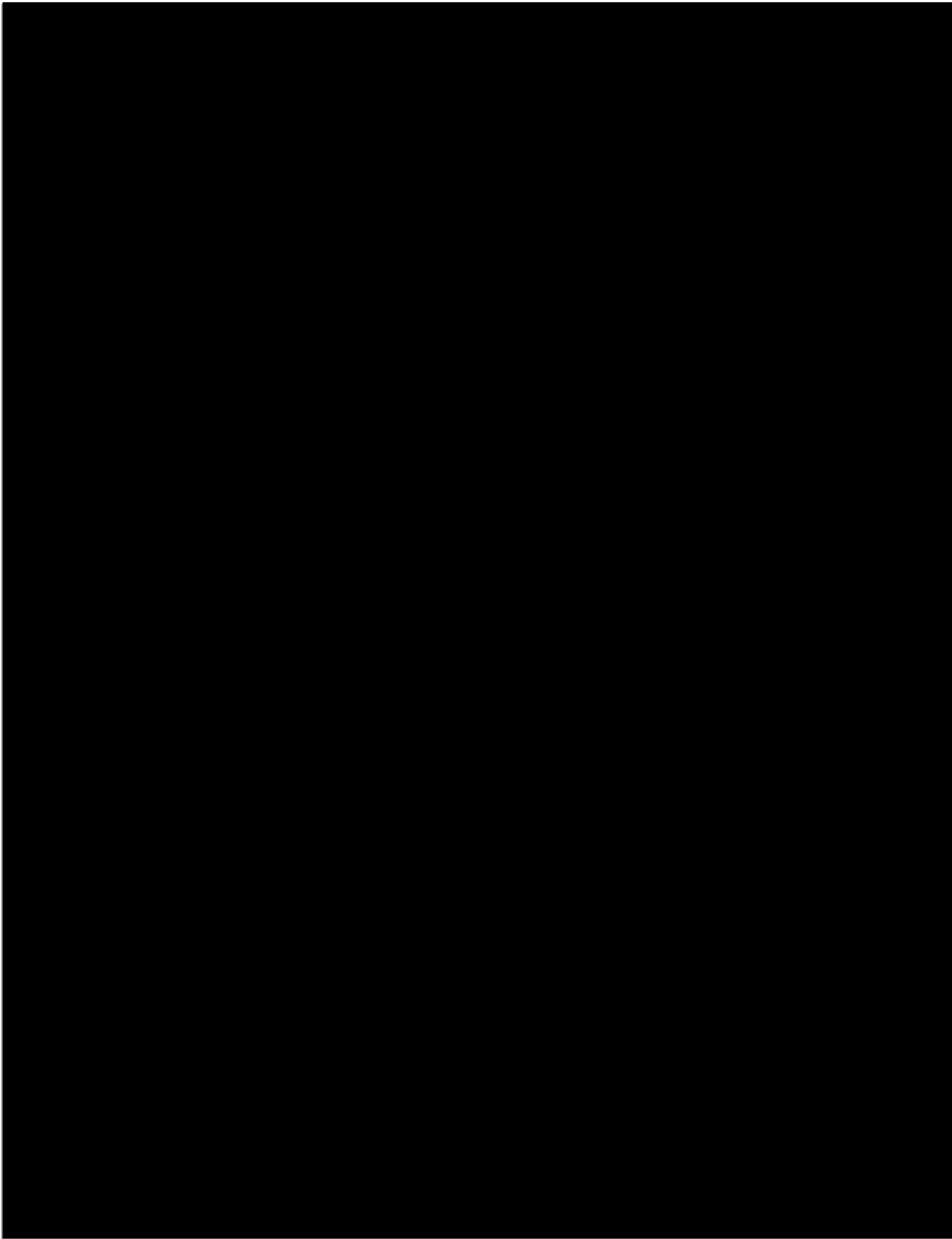




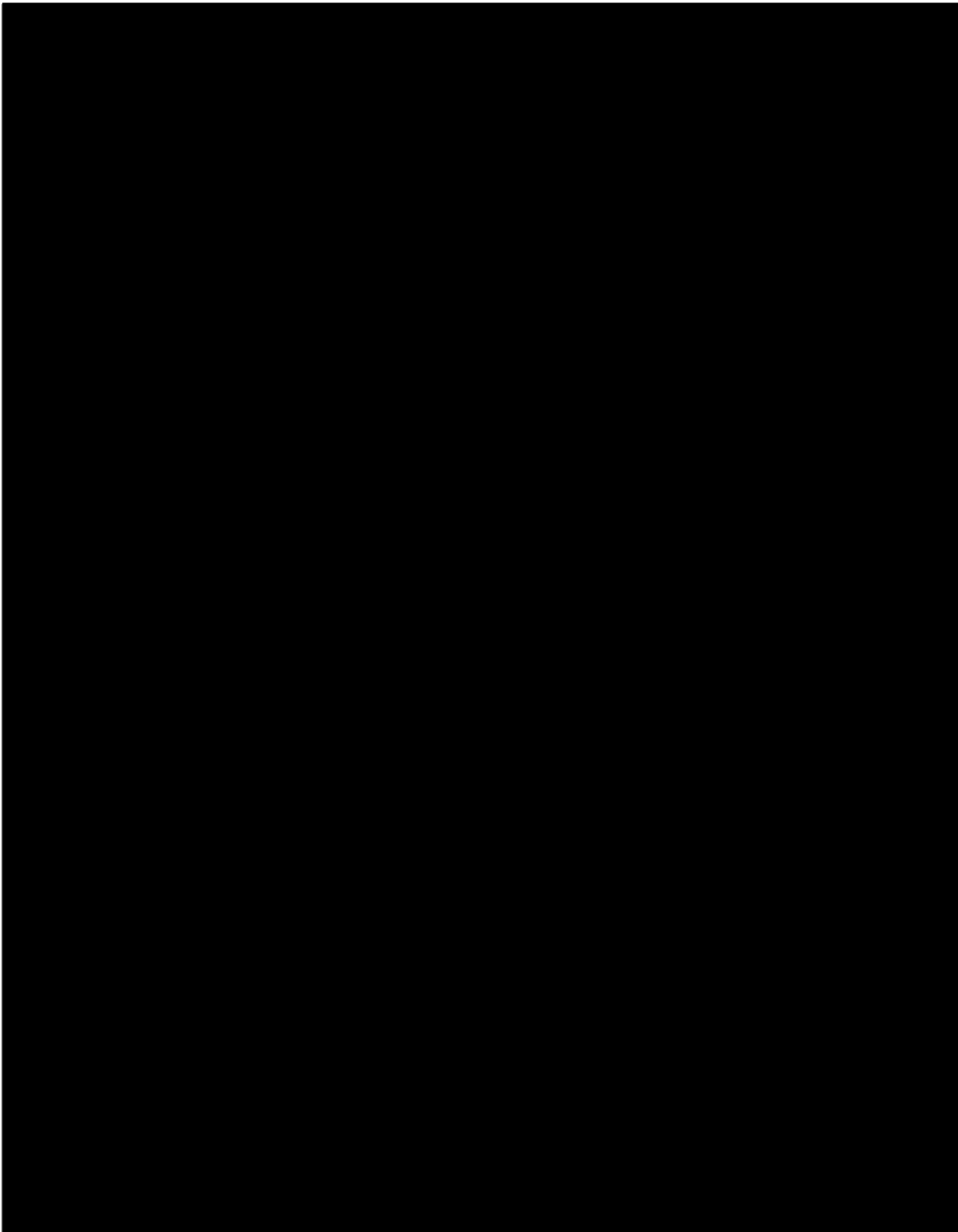


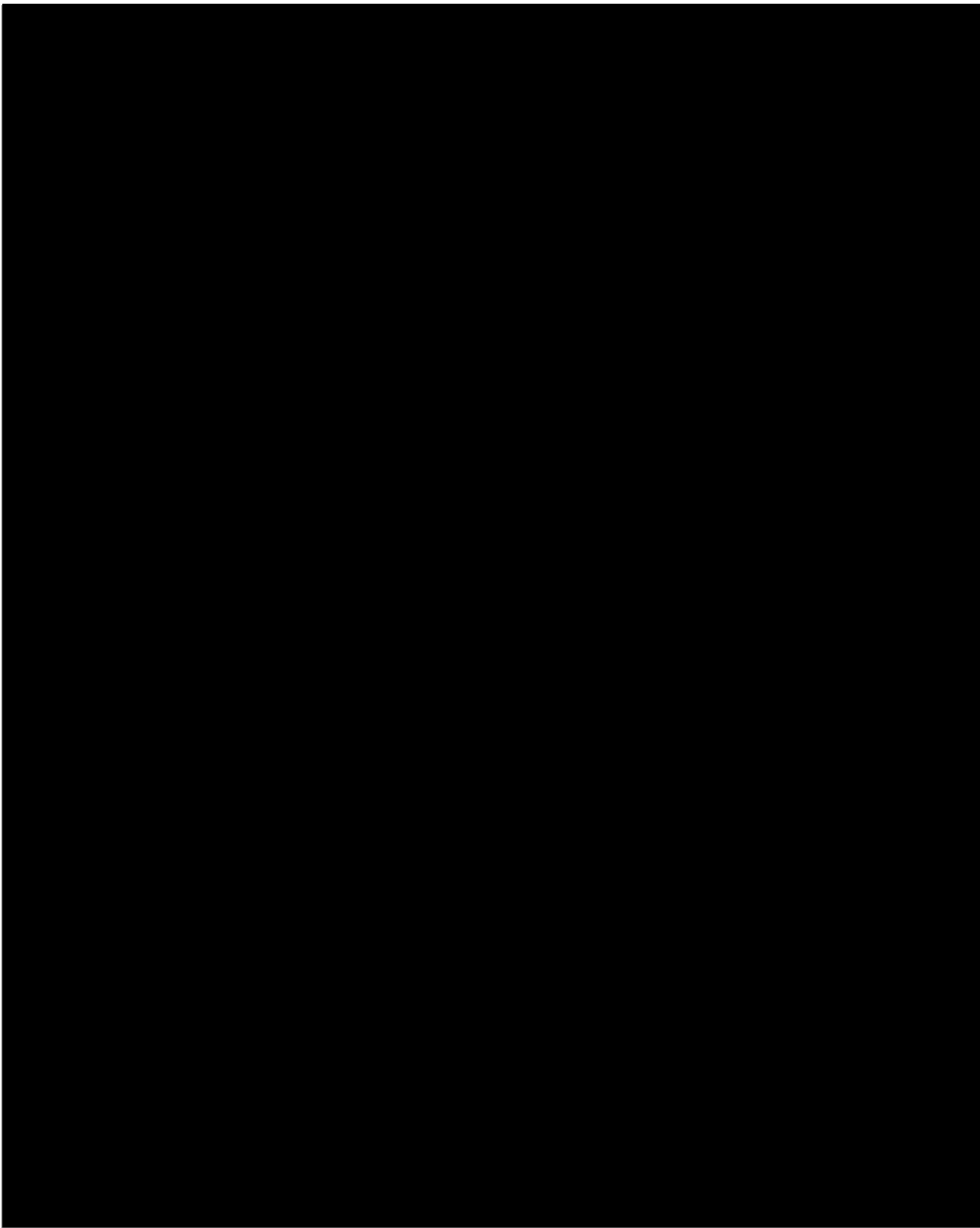


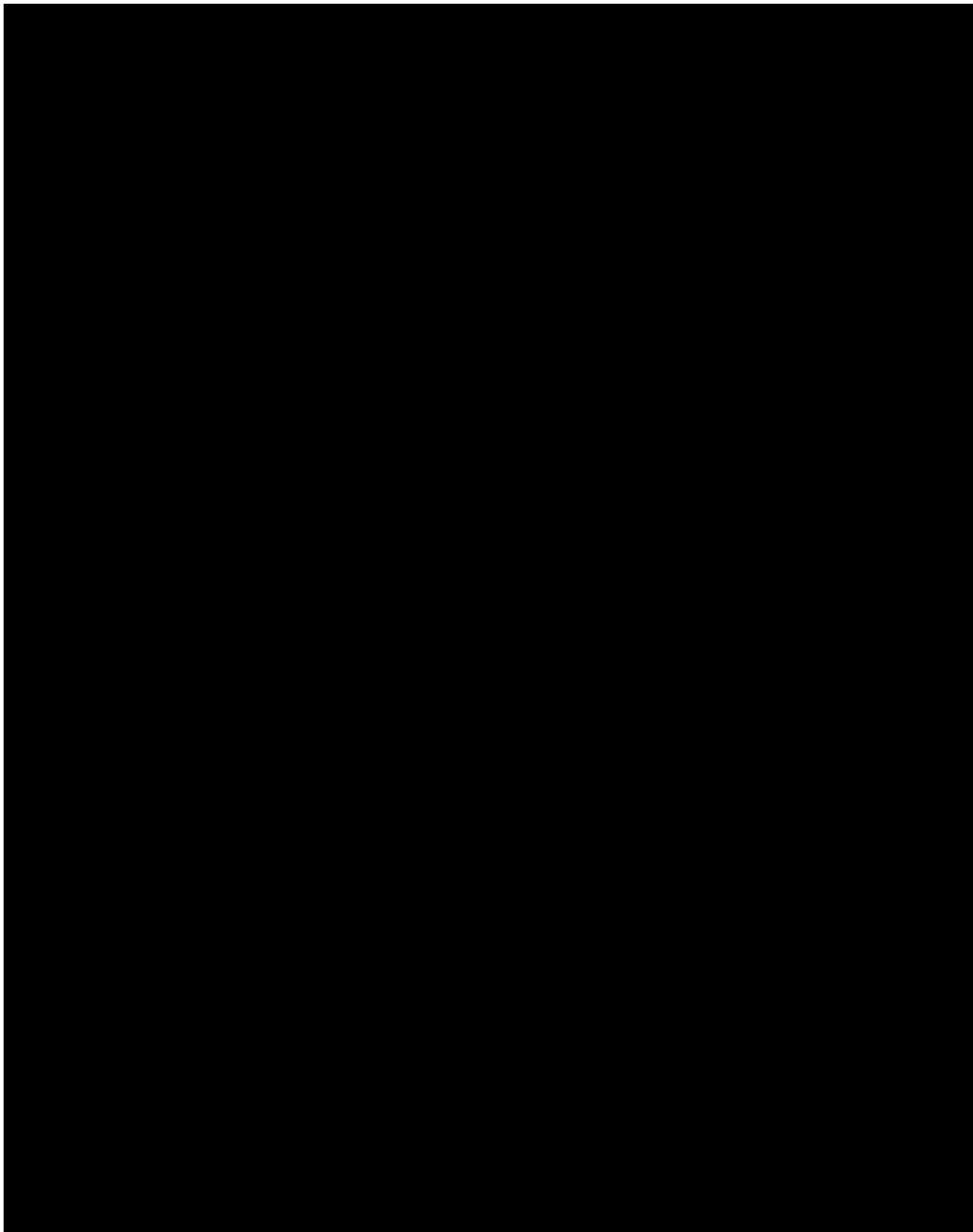


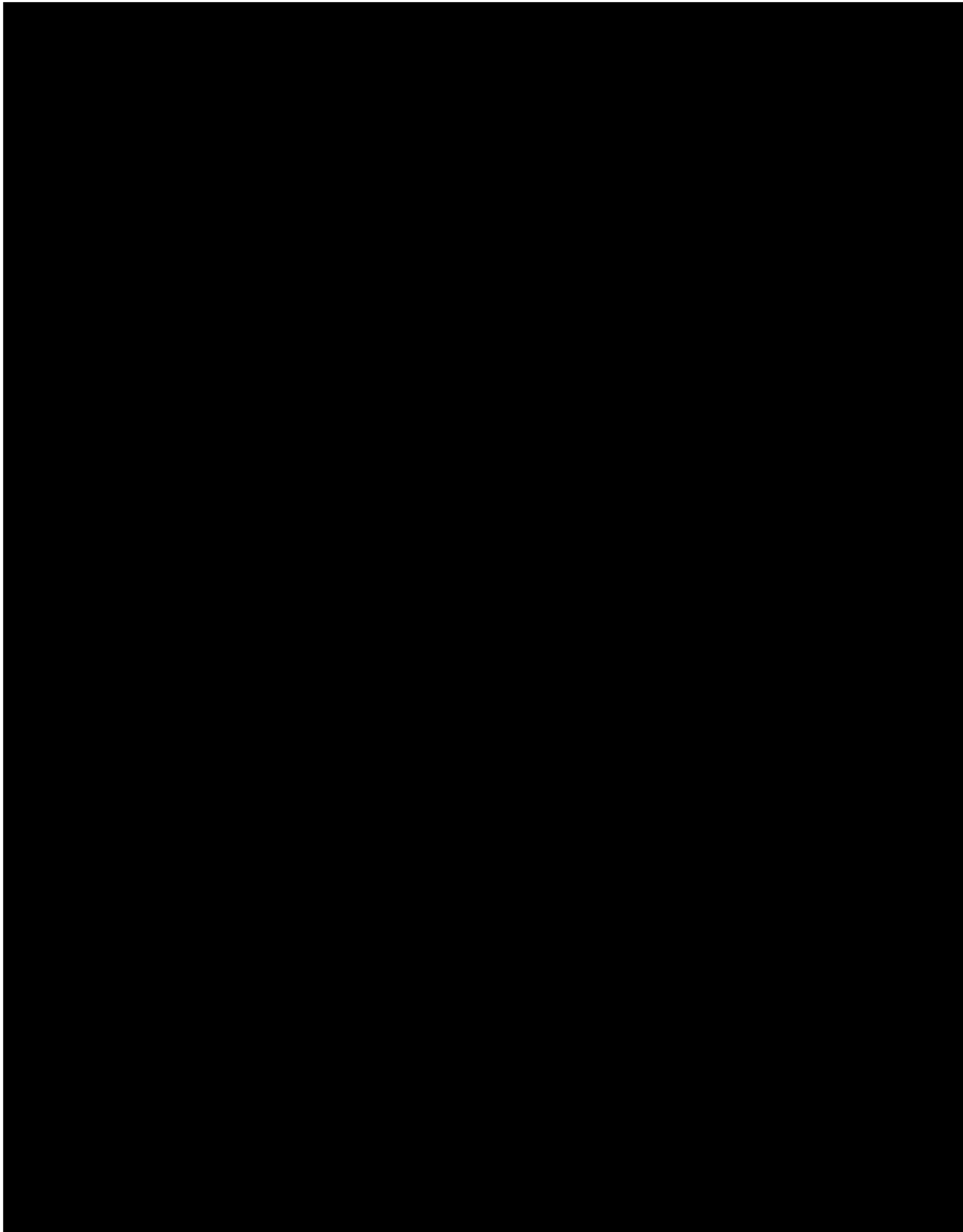


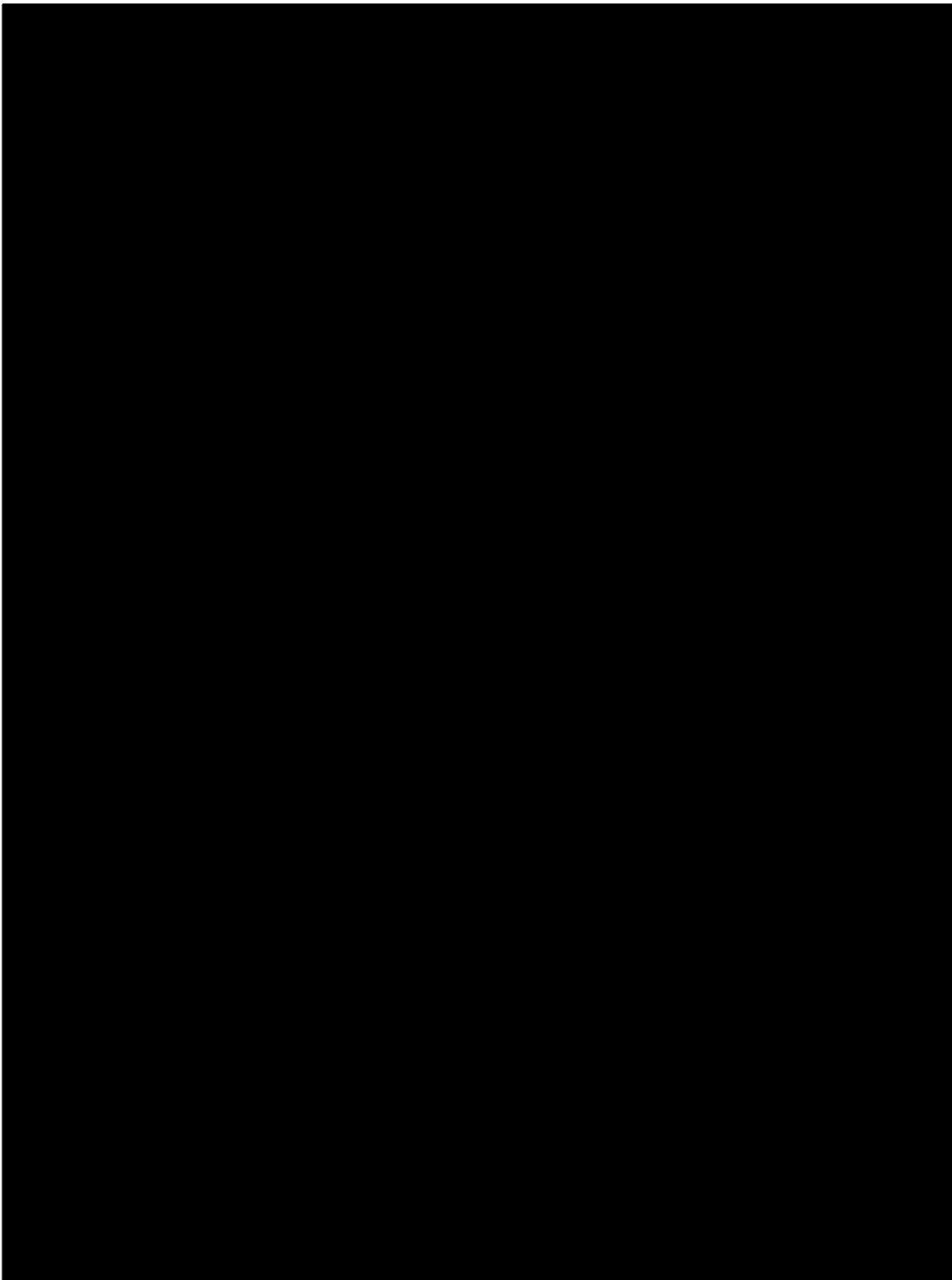


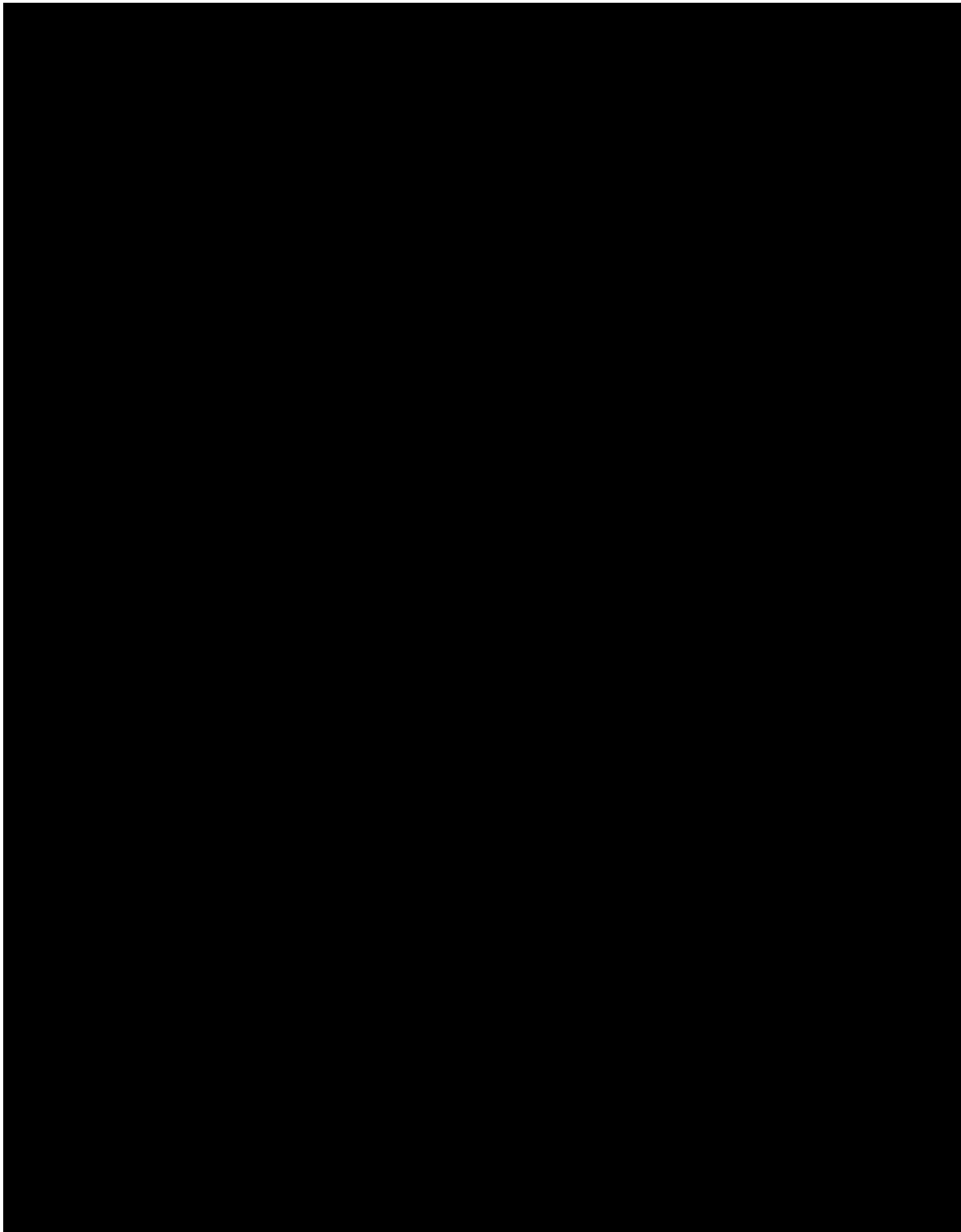


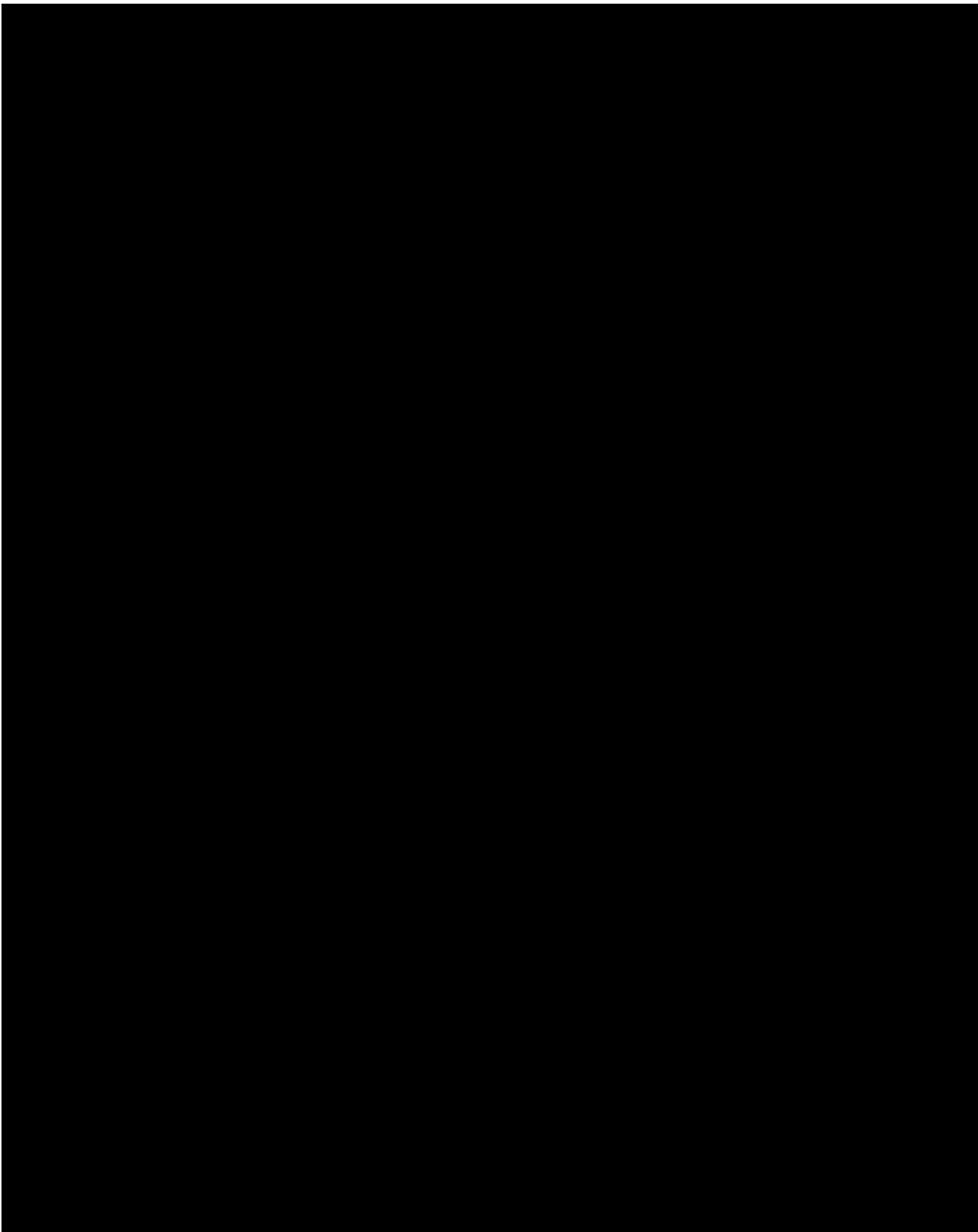


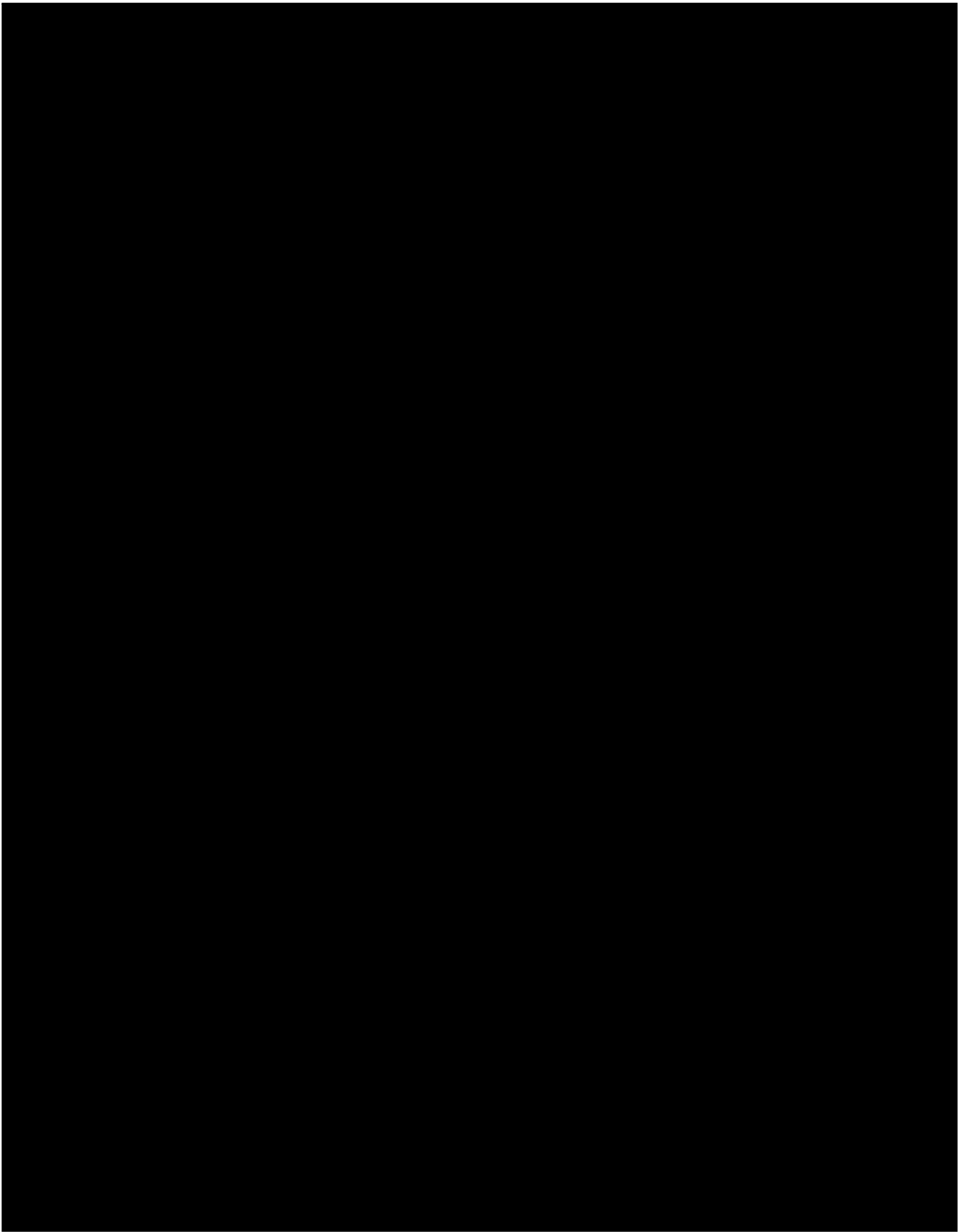




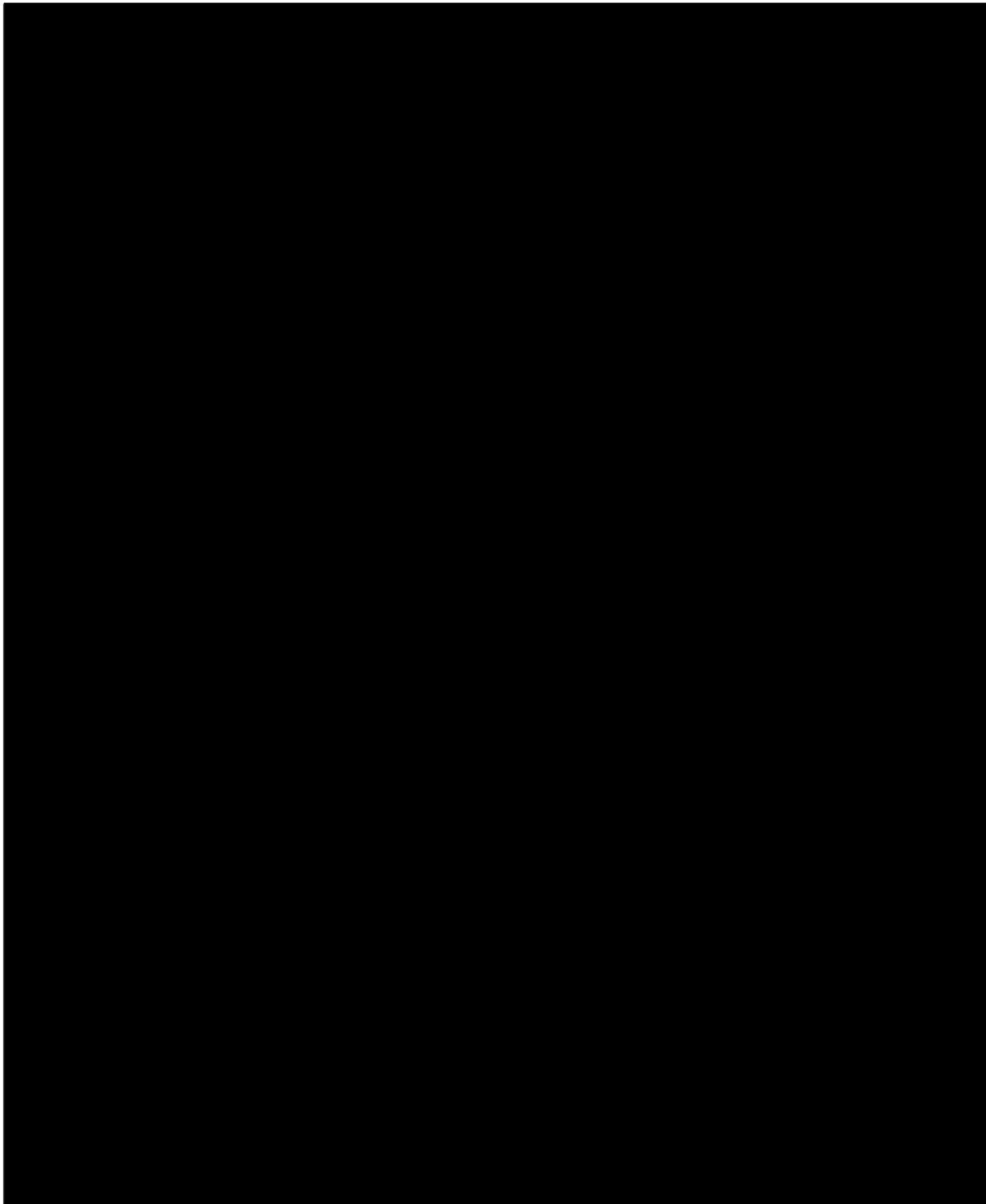












Lot # 01J11032

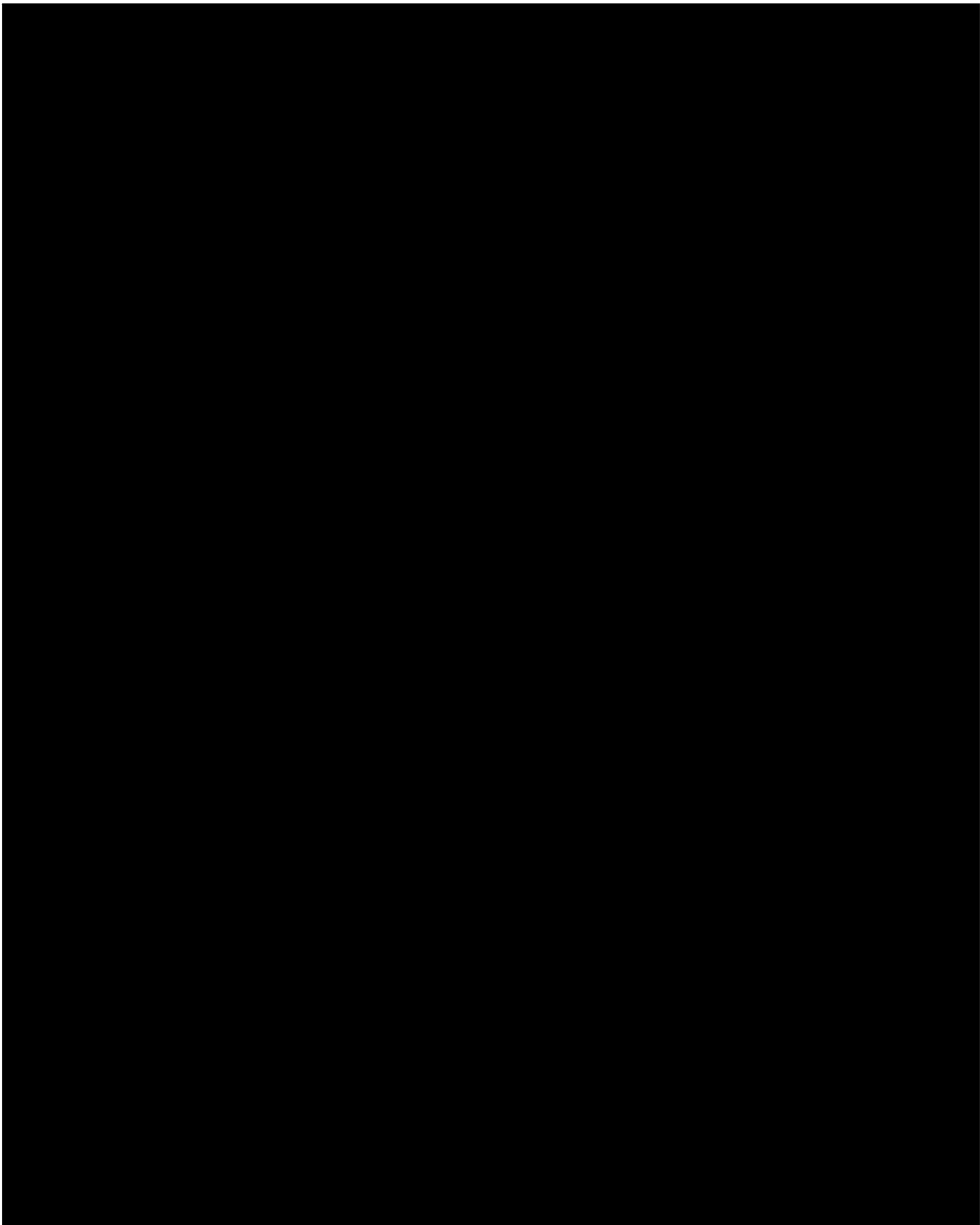
Page 1 of 2

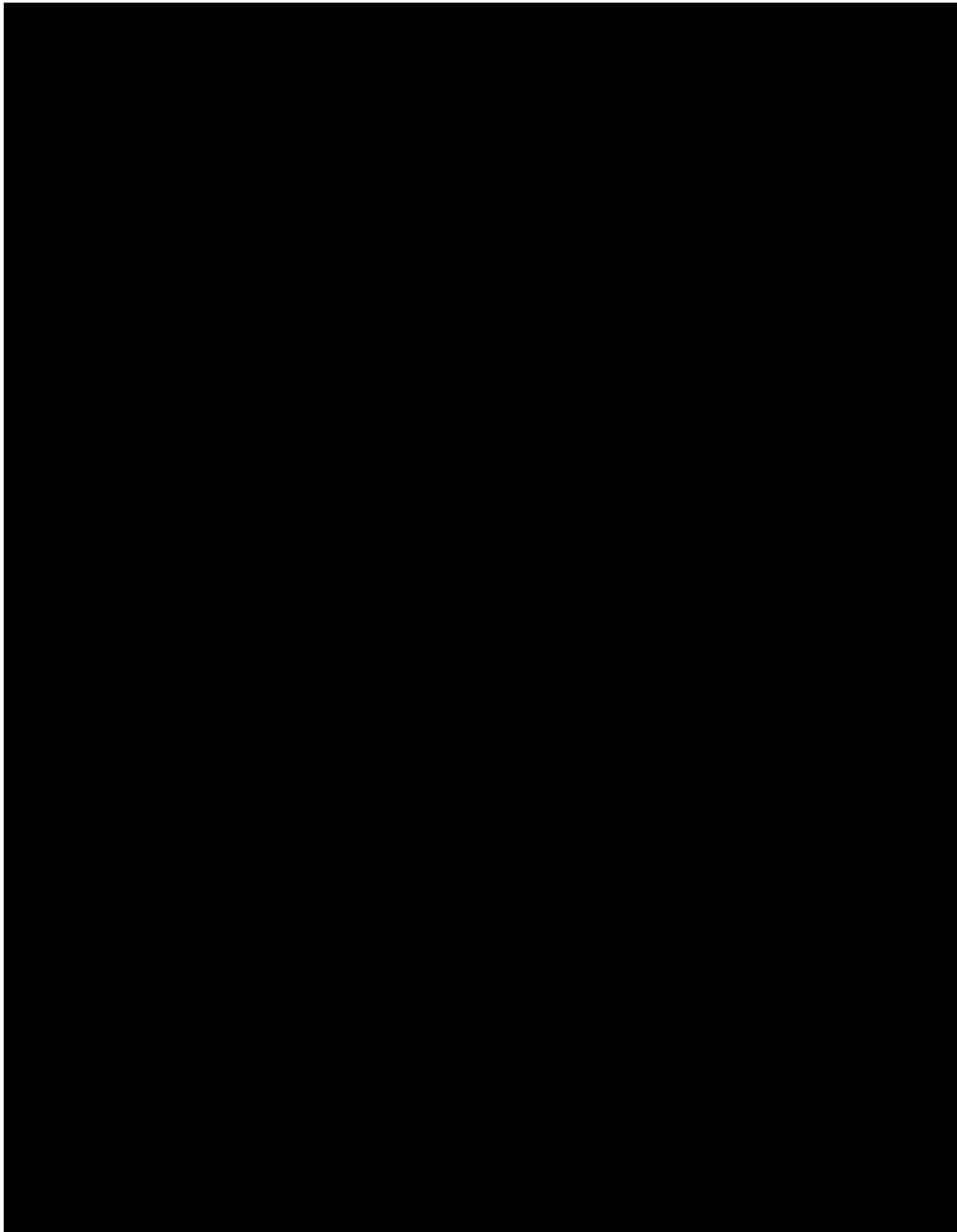
CONFIDENTIAL

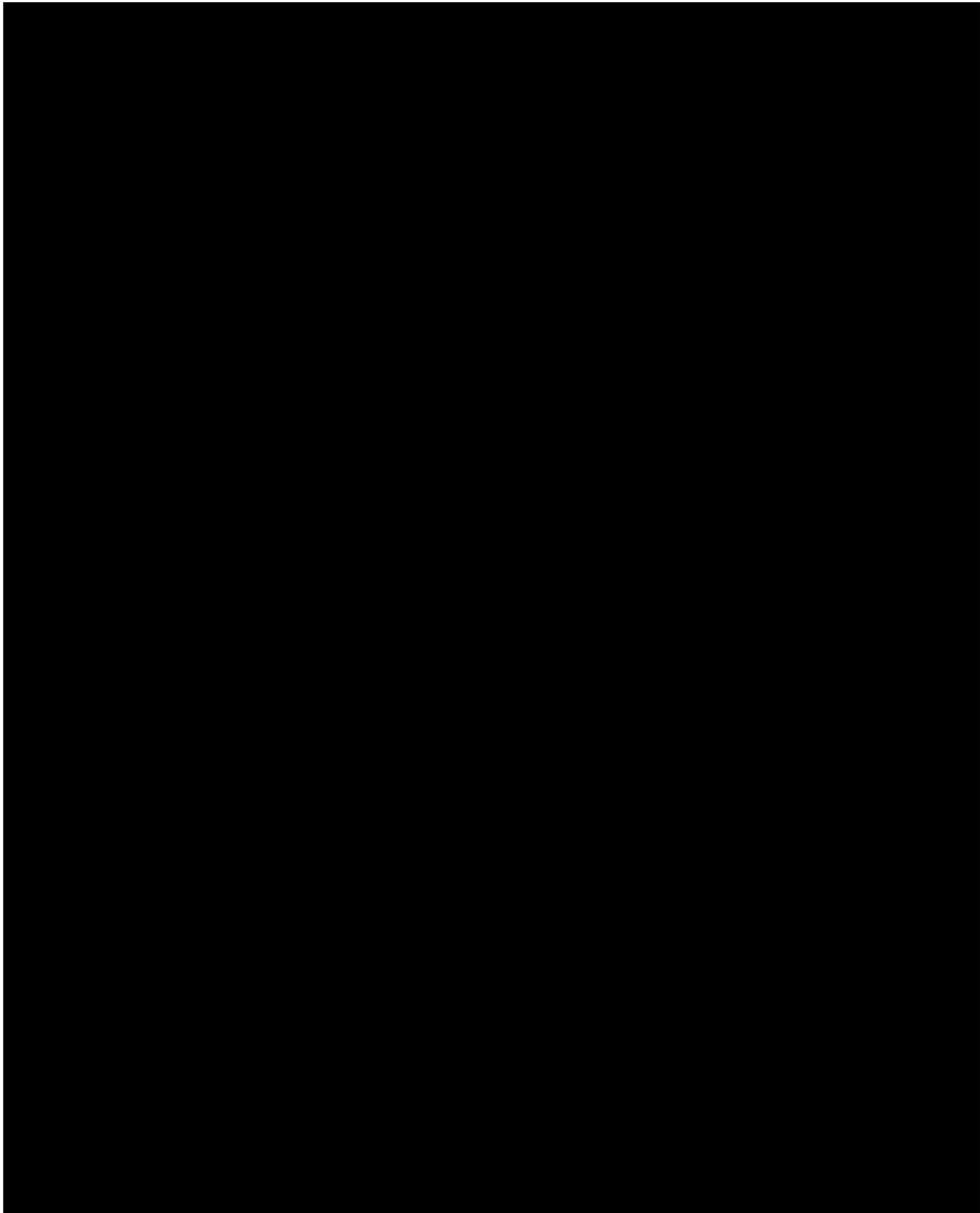
P. 156 UT Ex. 2037  
SteadyMed v. United Therapeutics

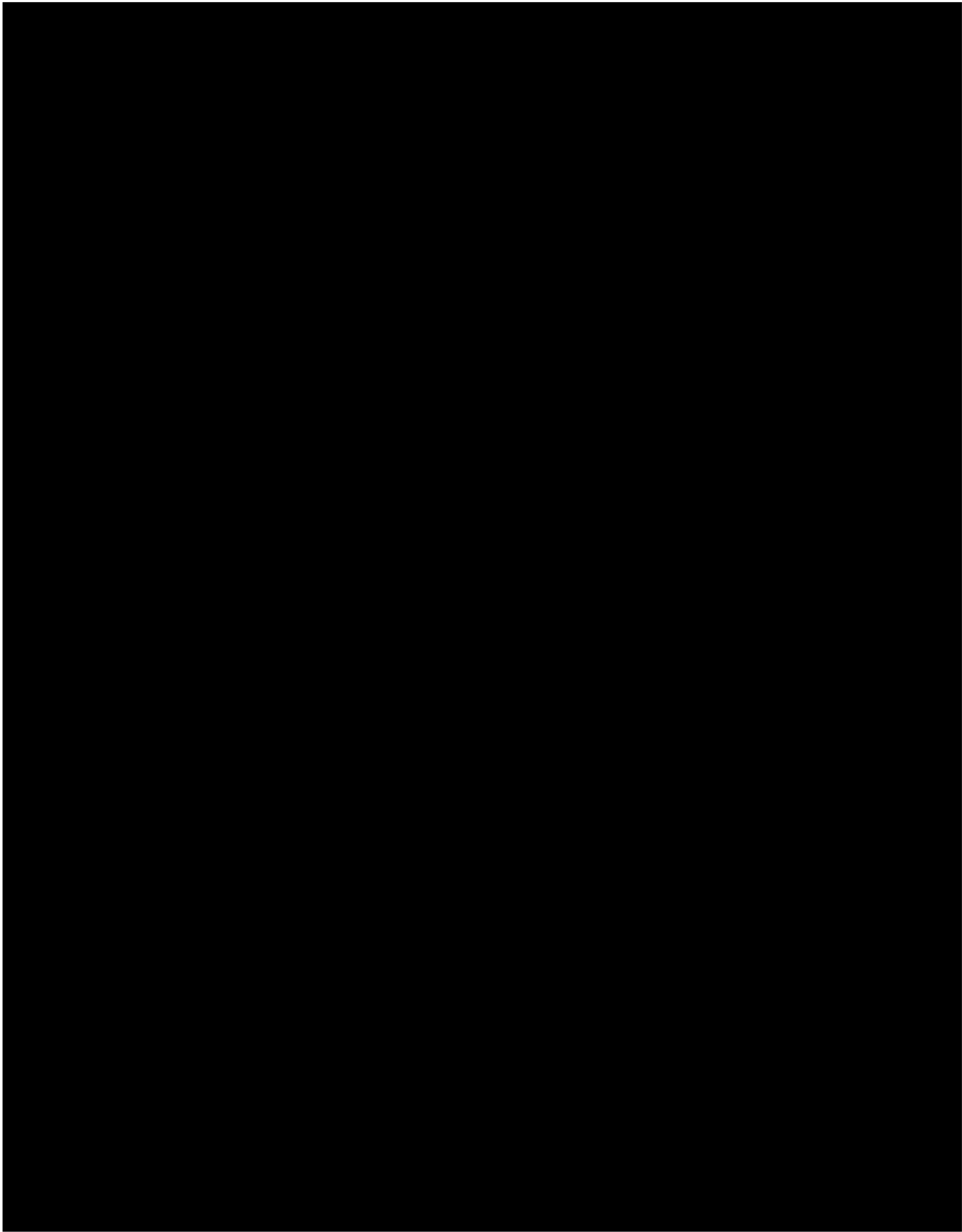
UTG Case # 2020-00769

IPR2020-00769  
United Therapeutics EX2006  
Page 5005 of 7113

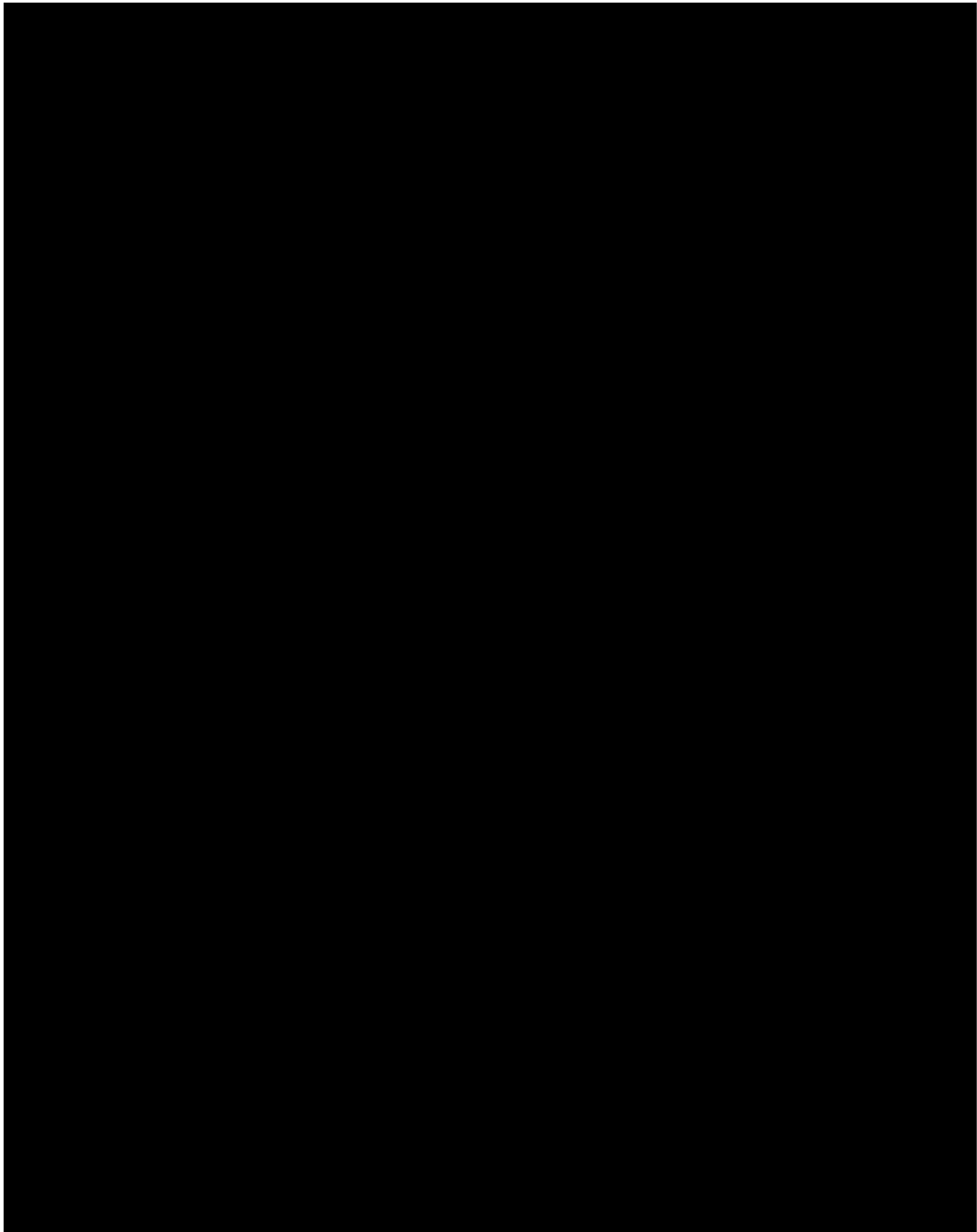


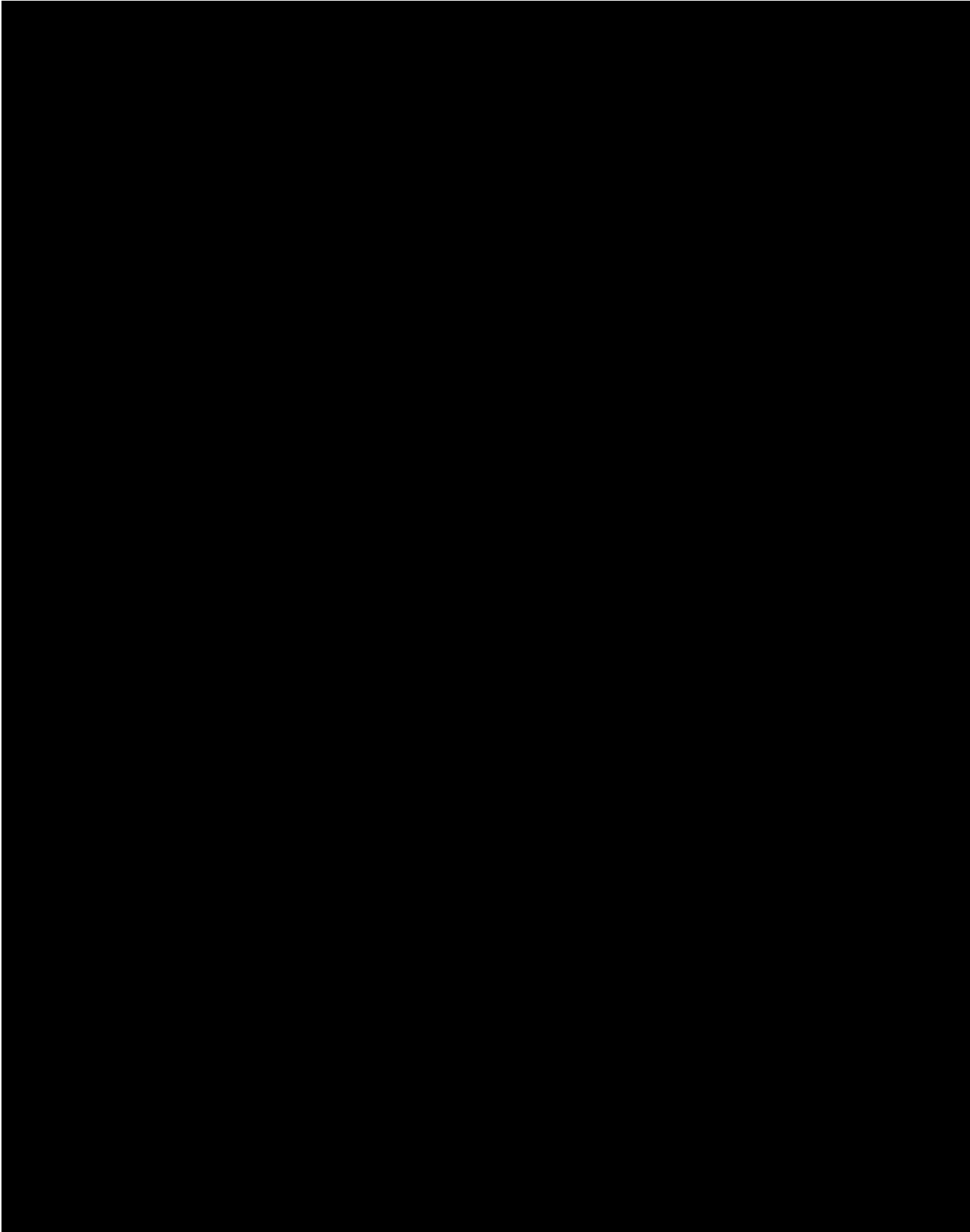




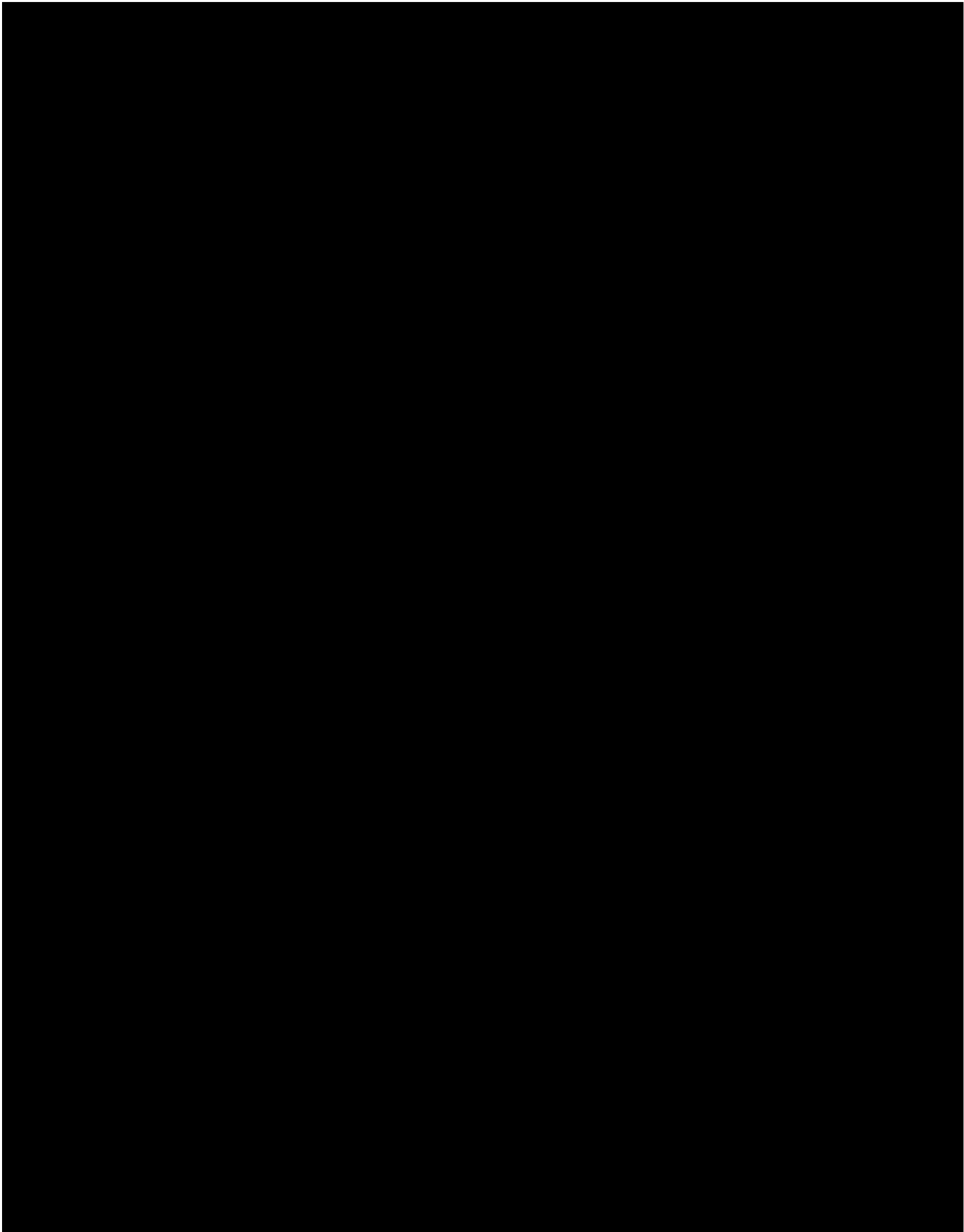




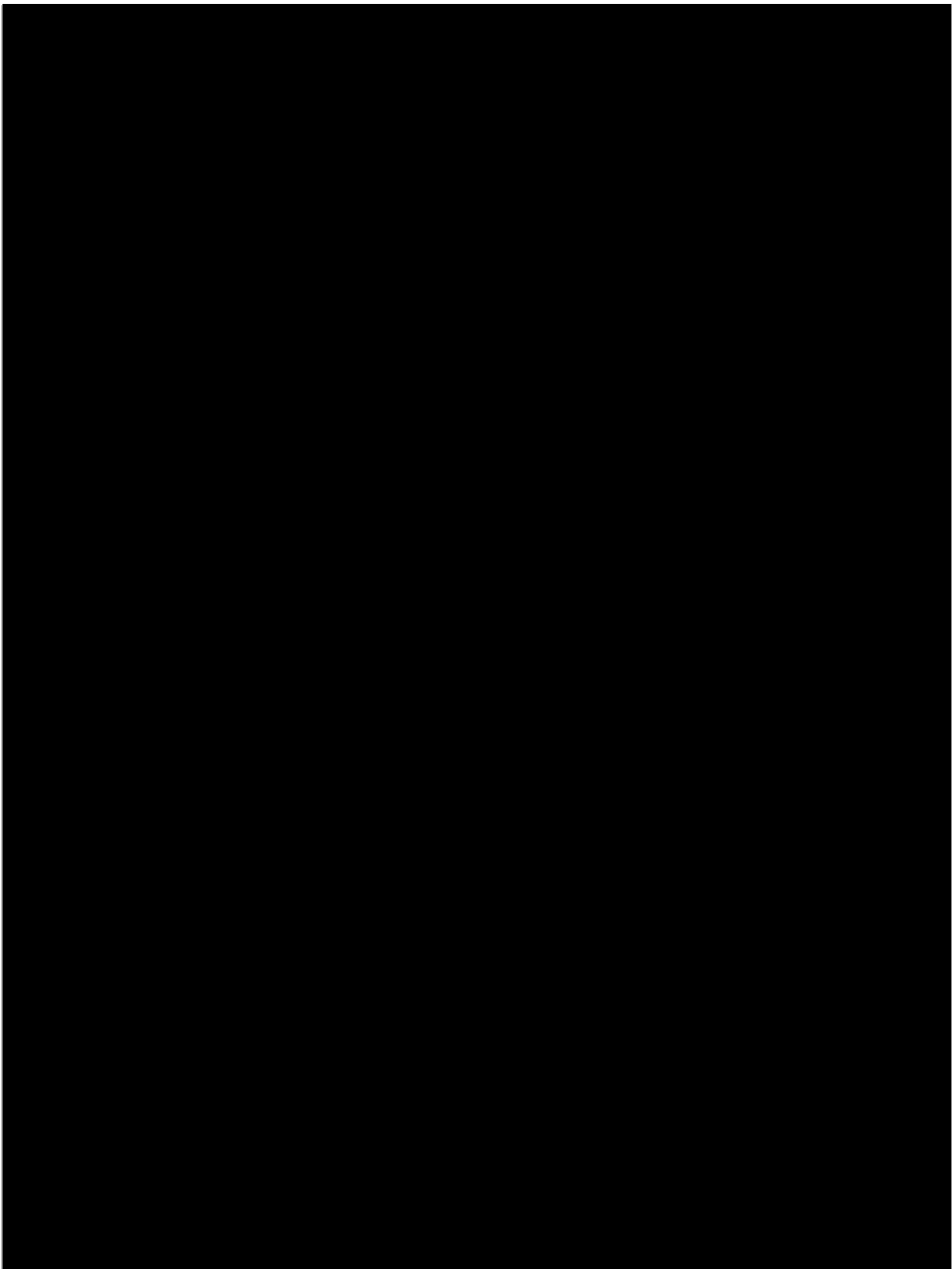


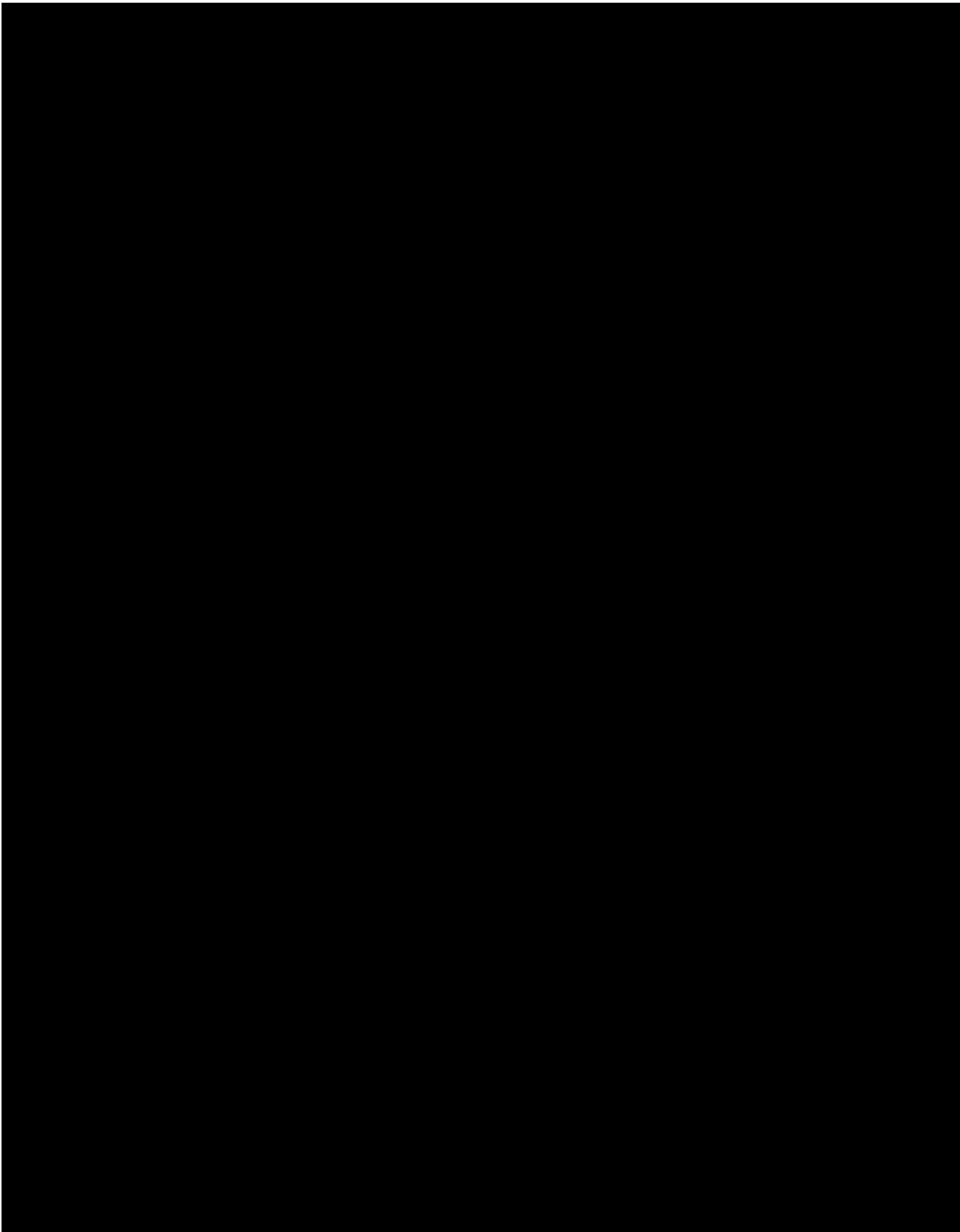


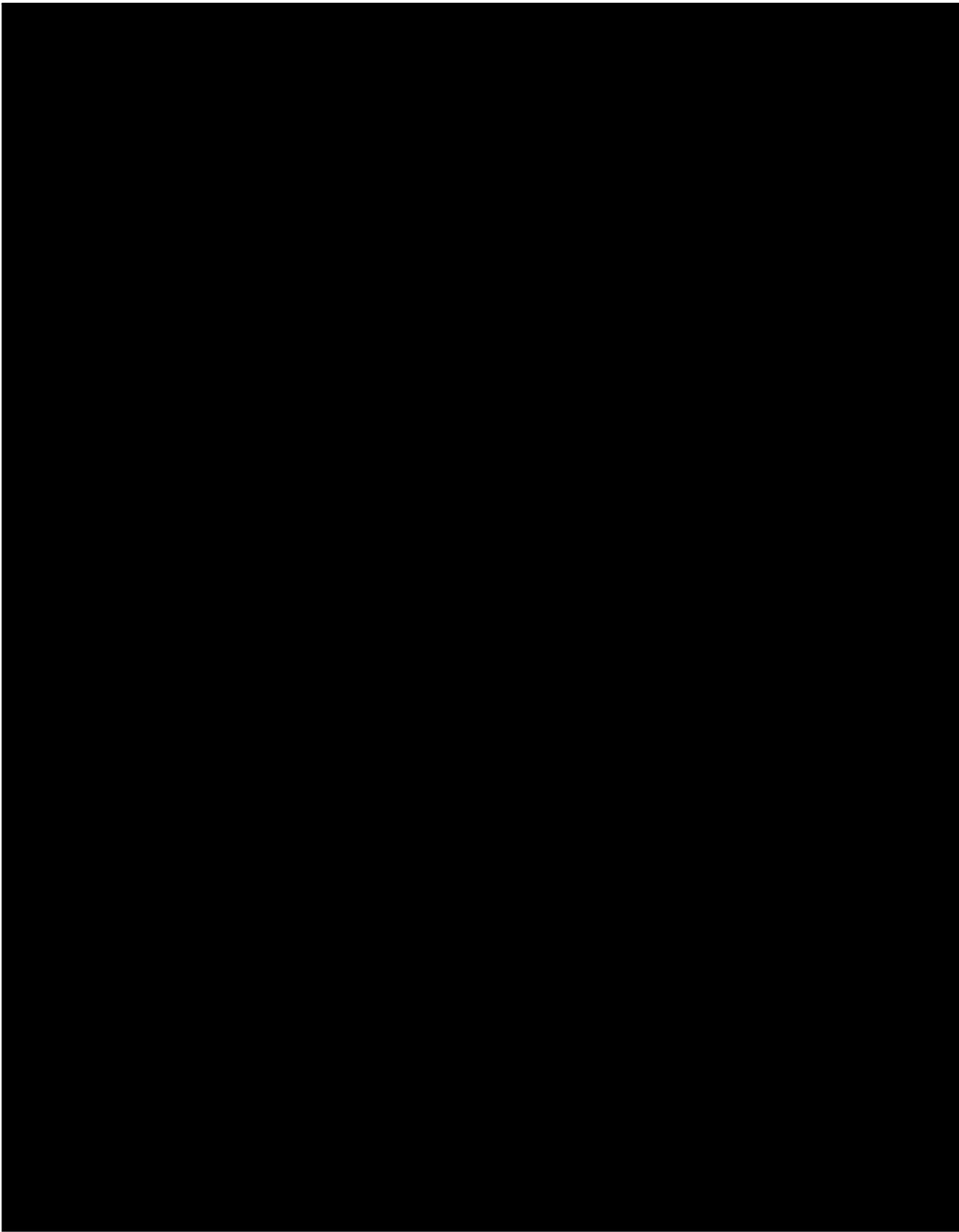


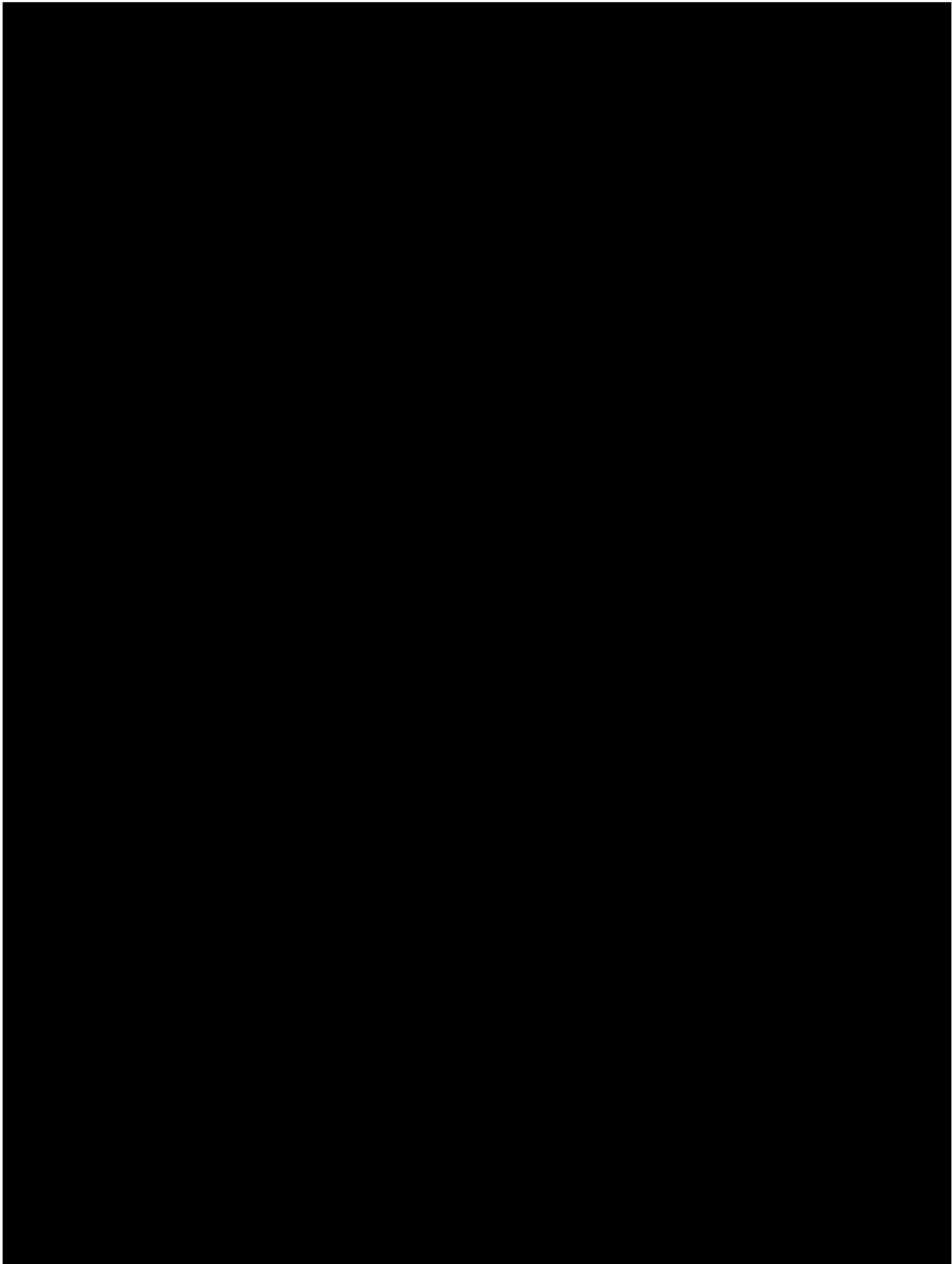


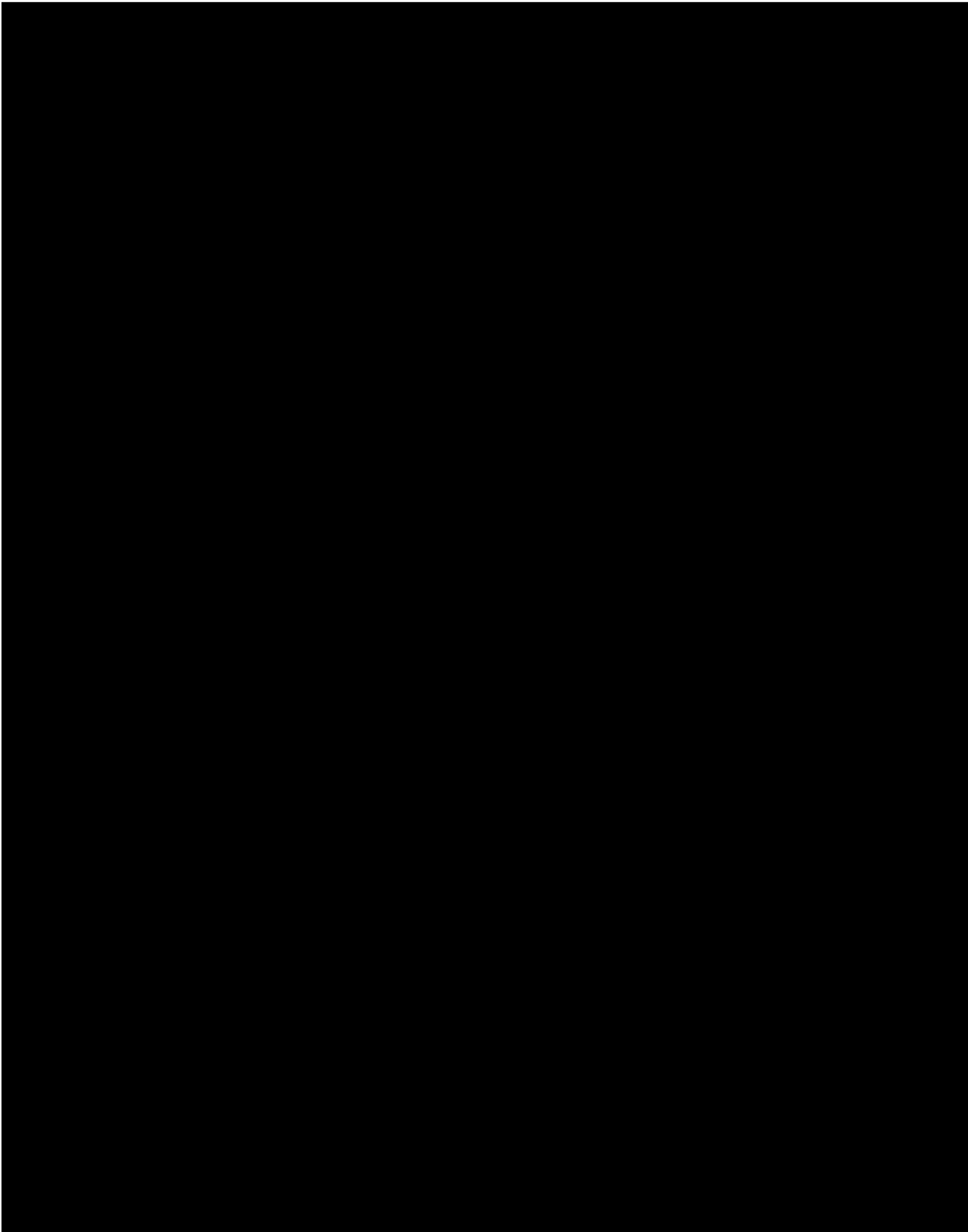


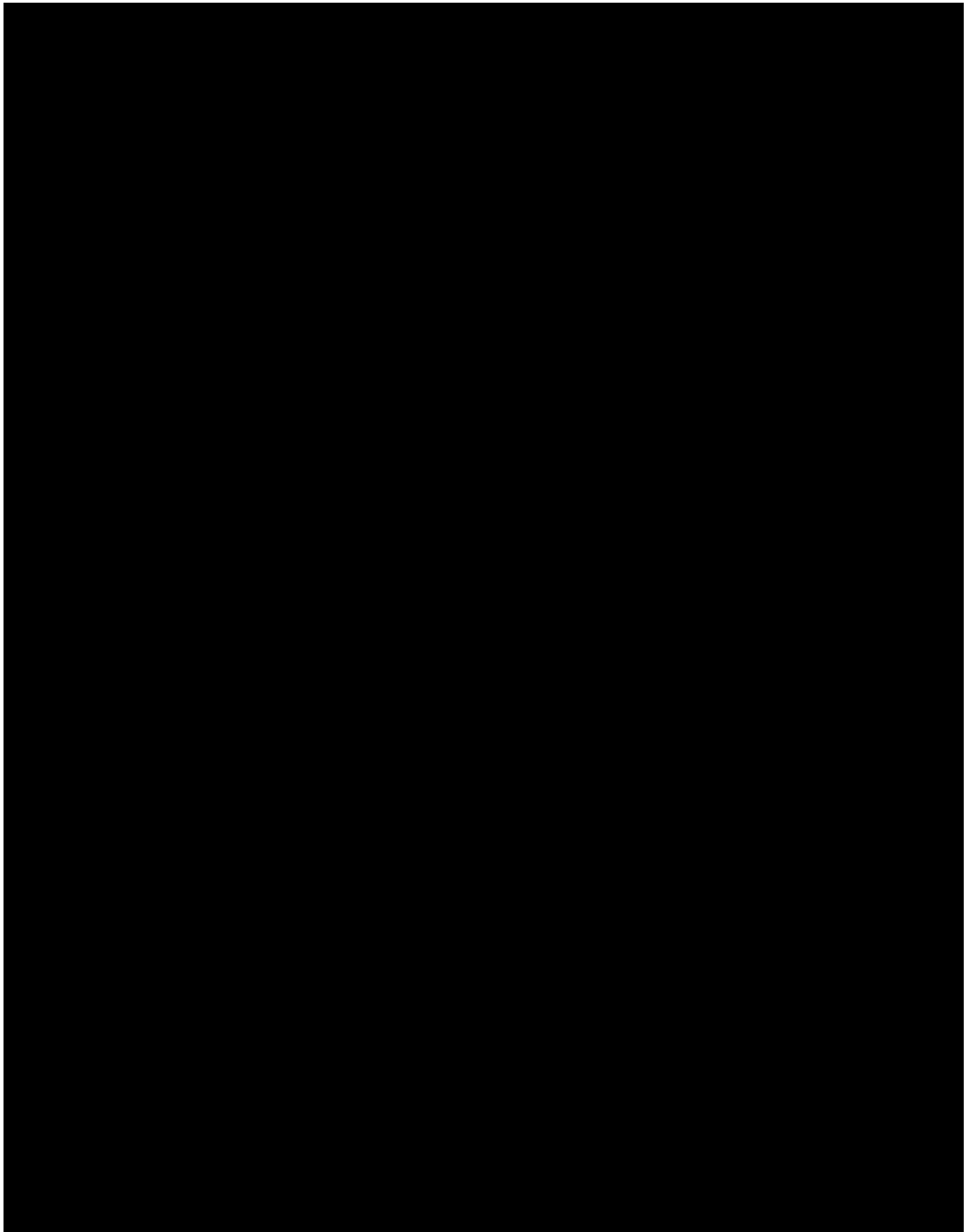




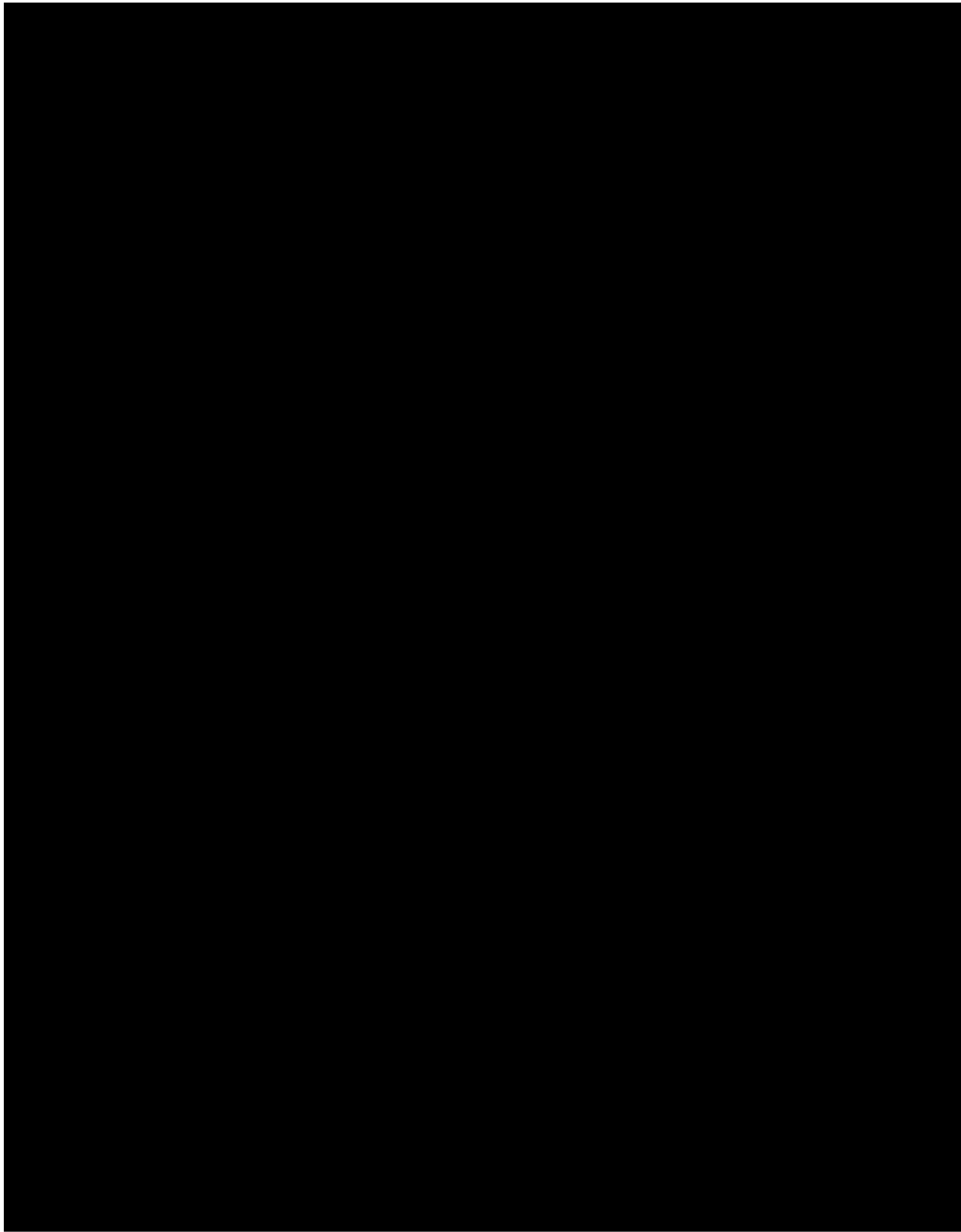


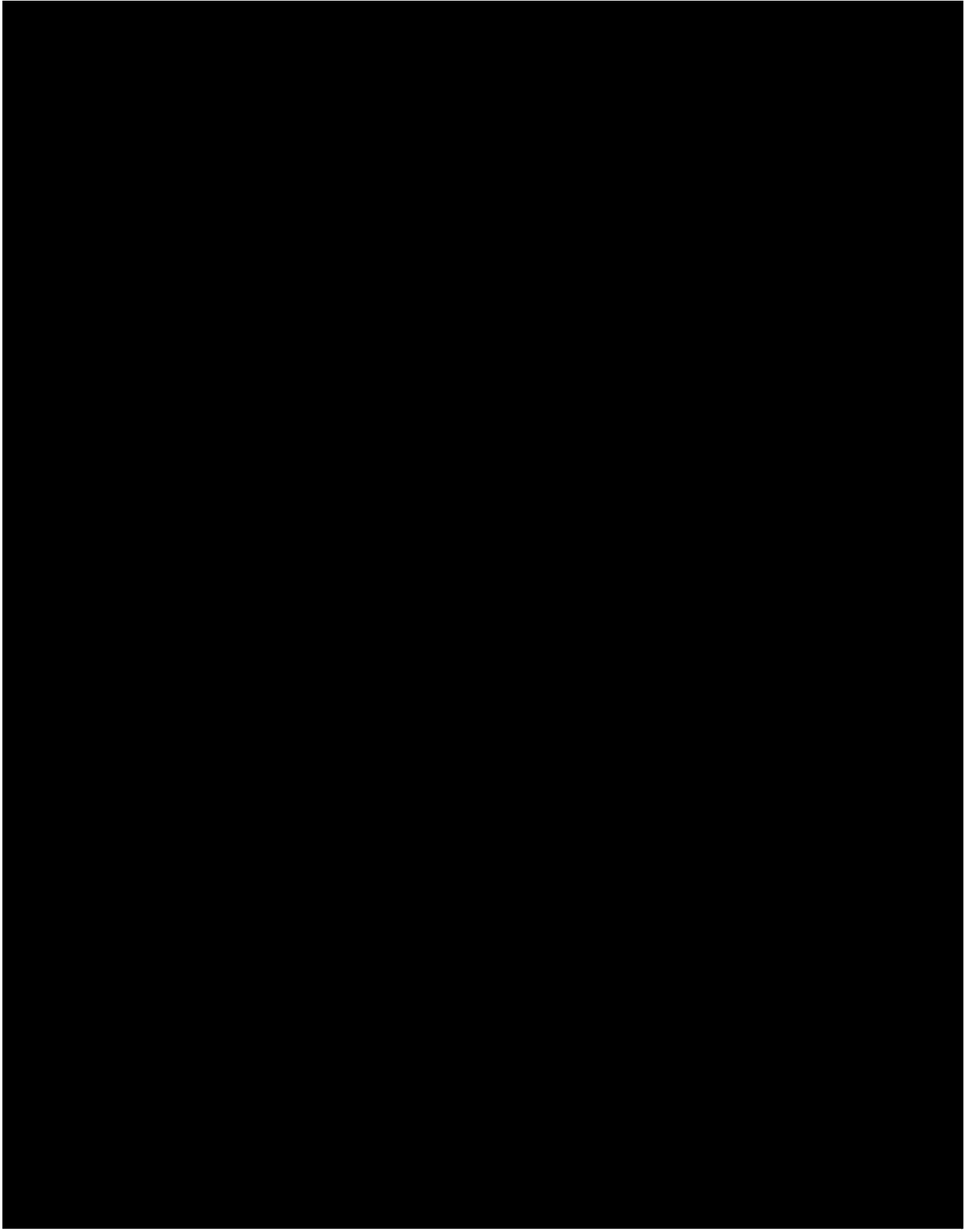


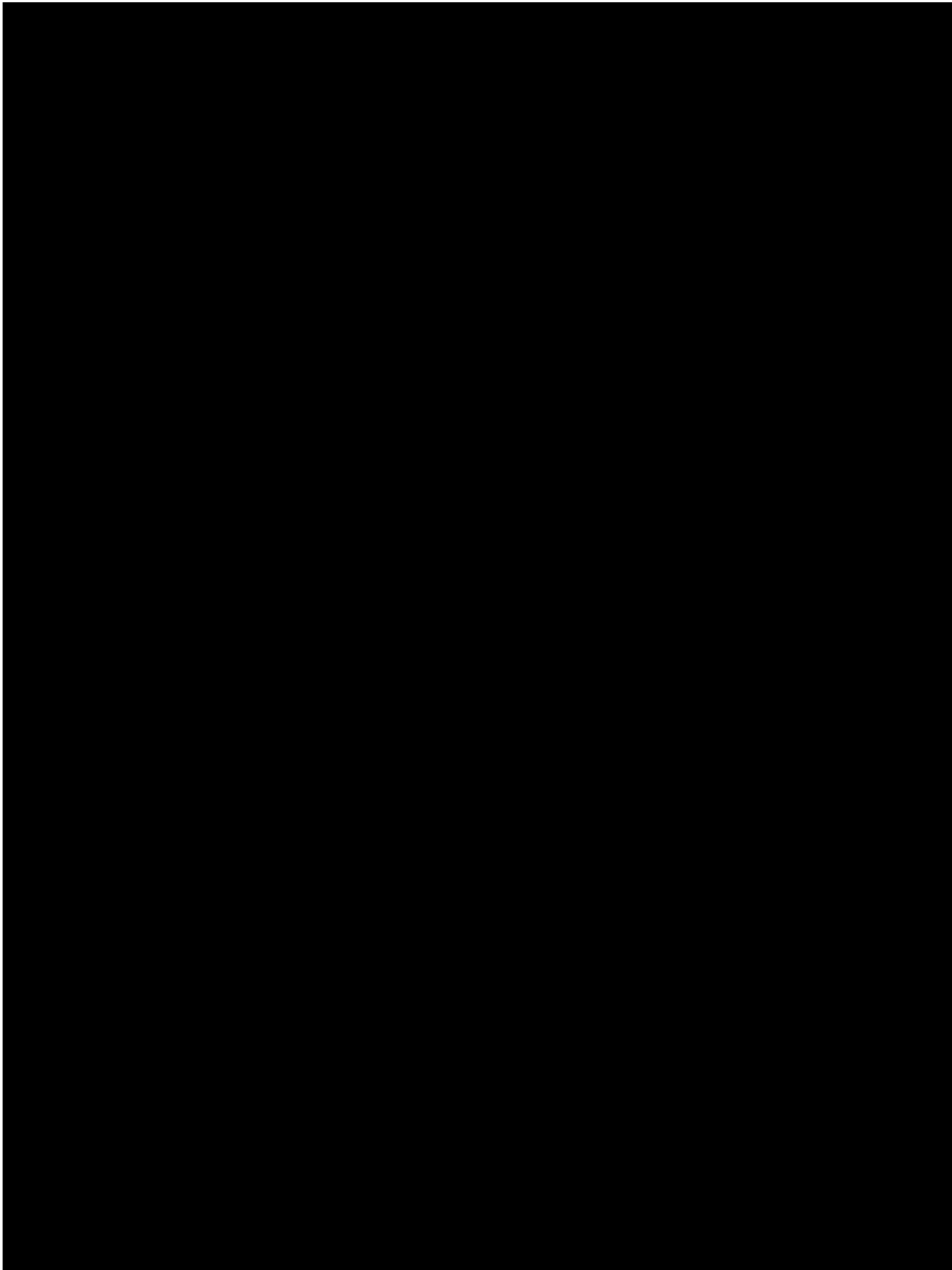


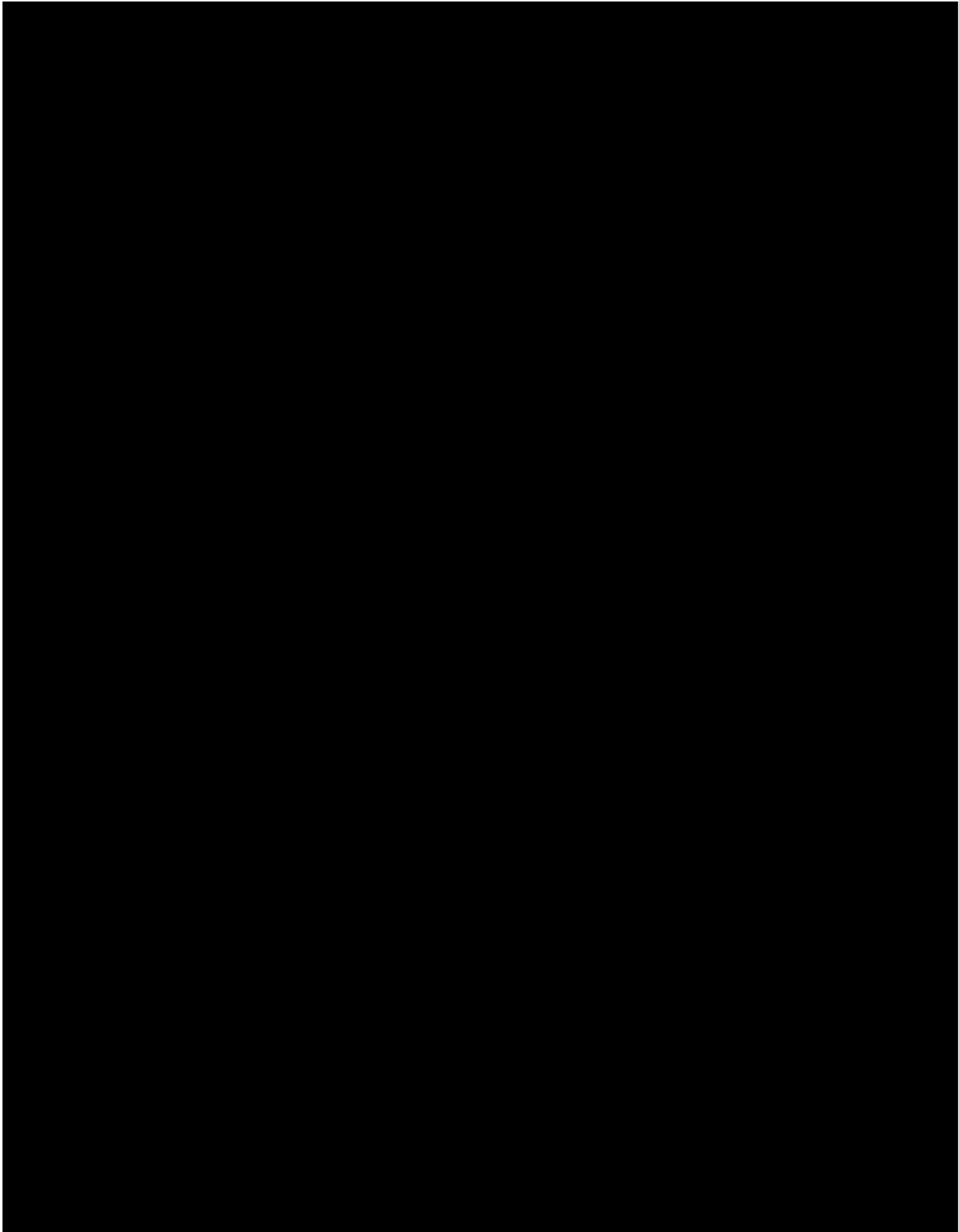


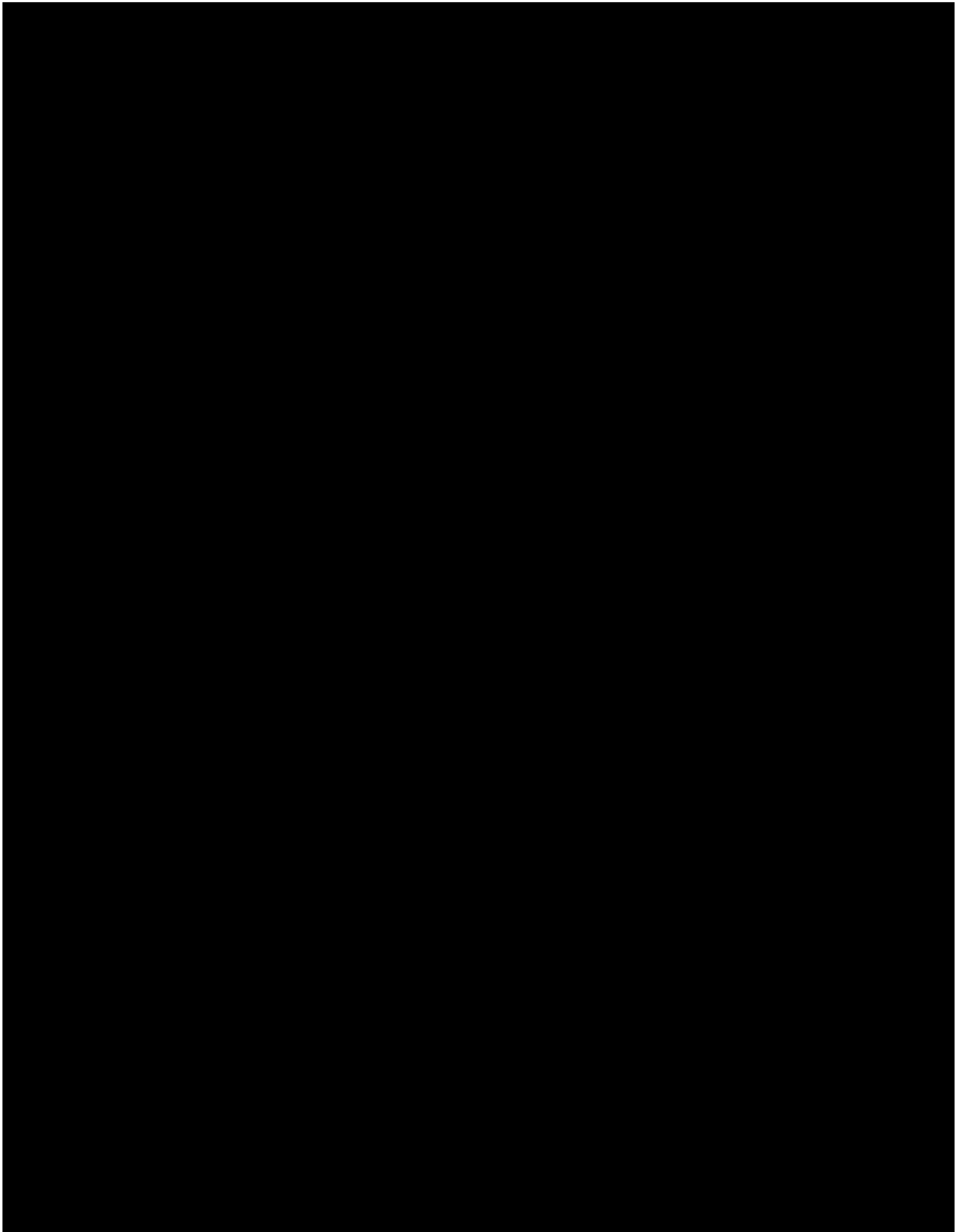


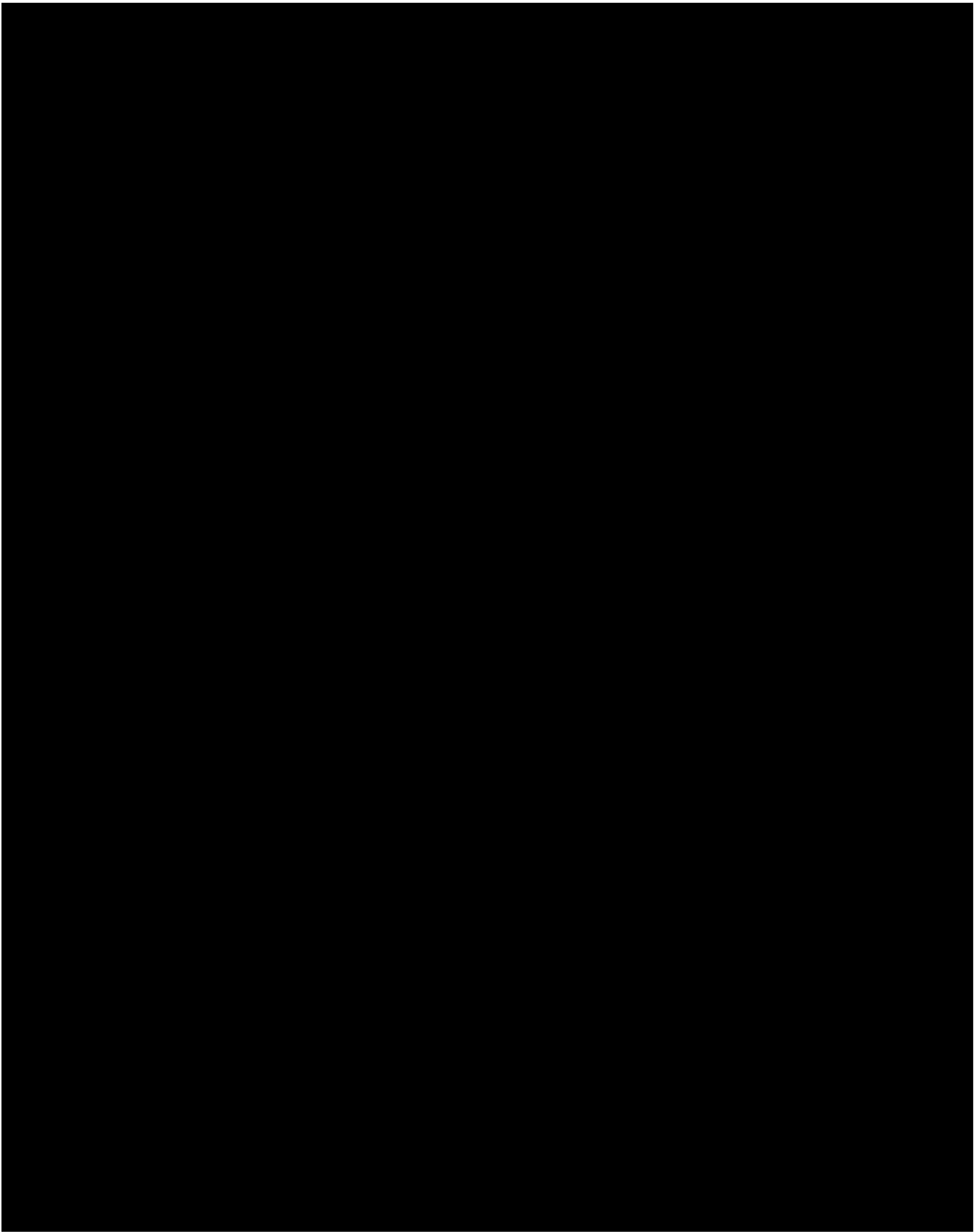


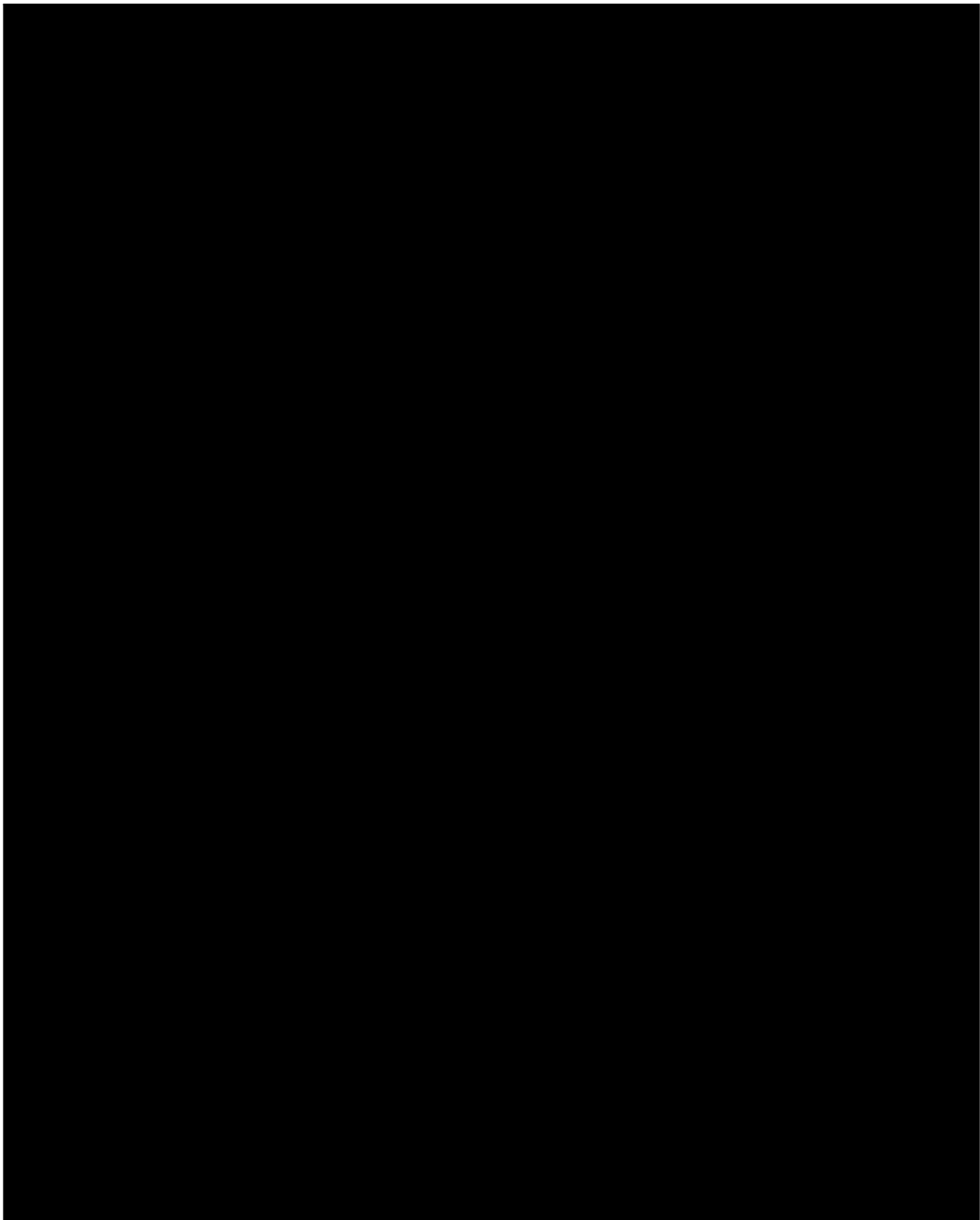


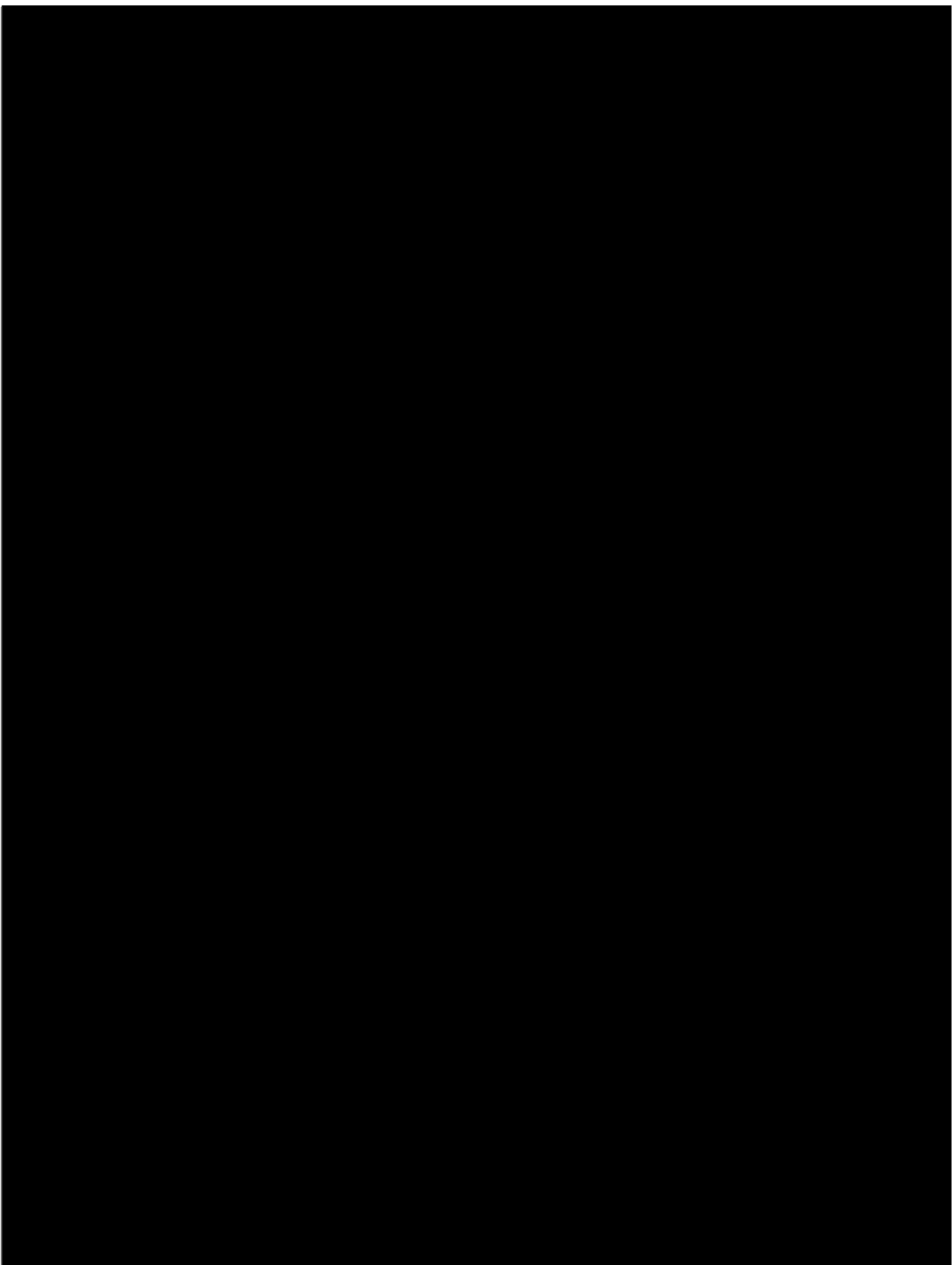




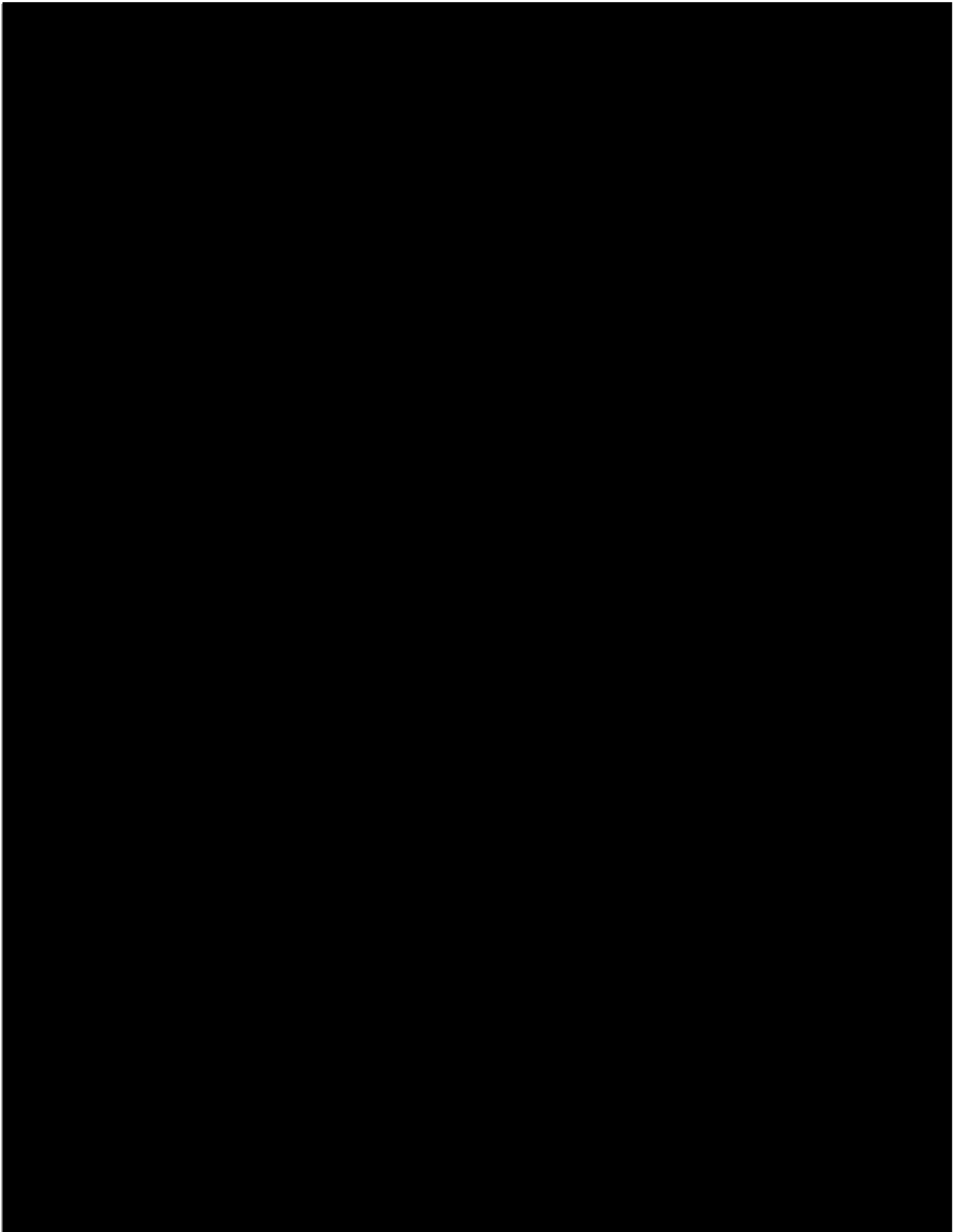


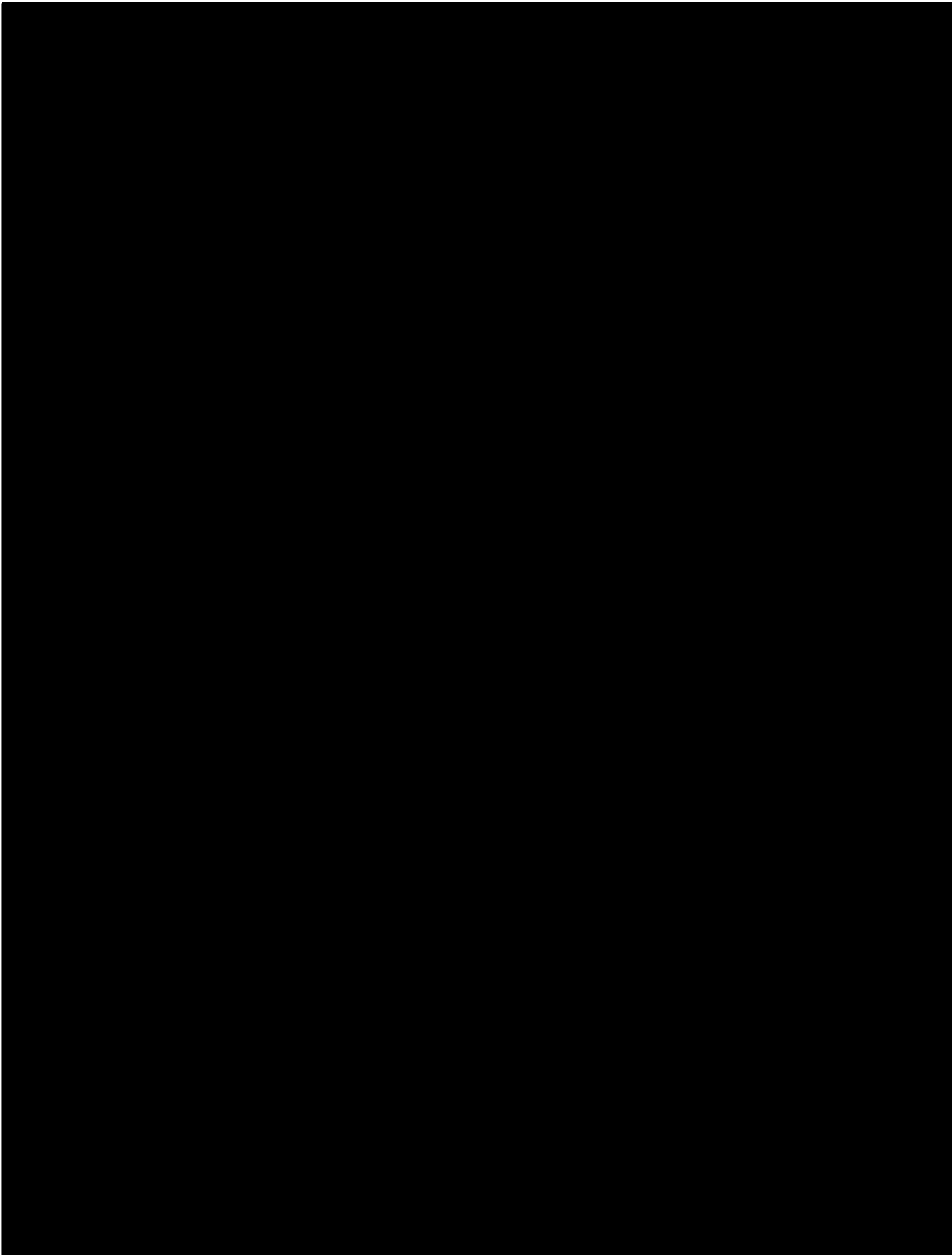


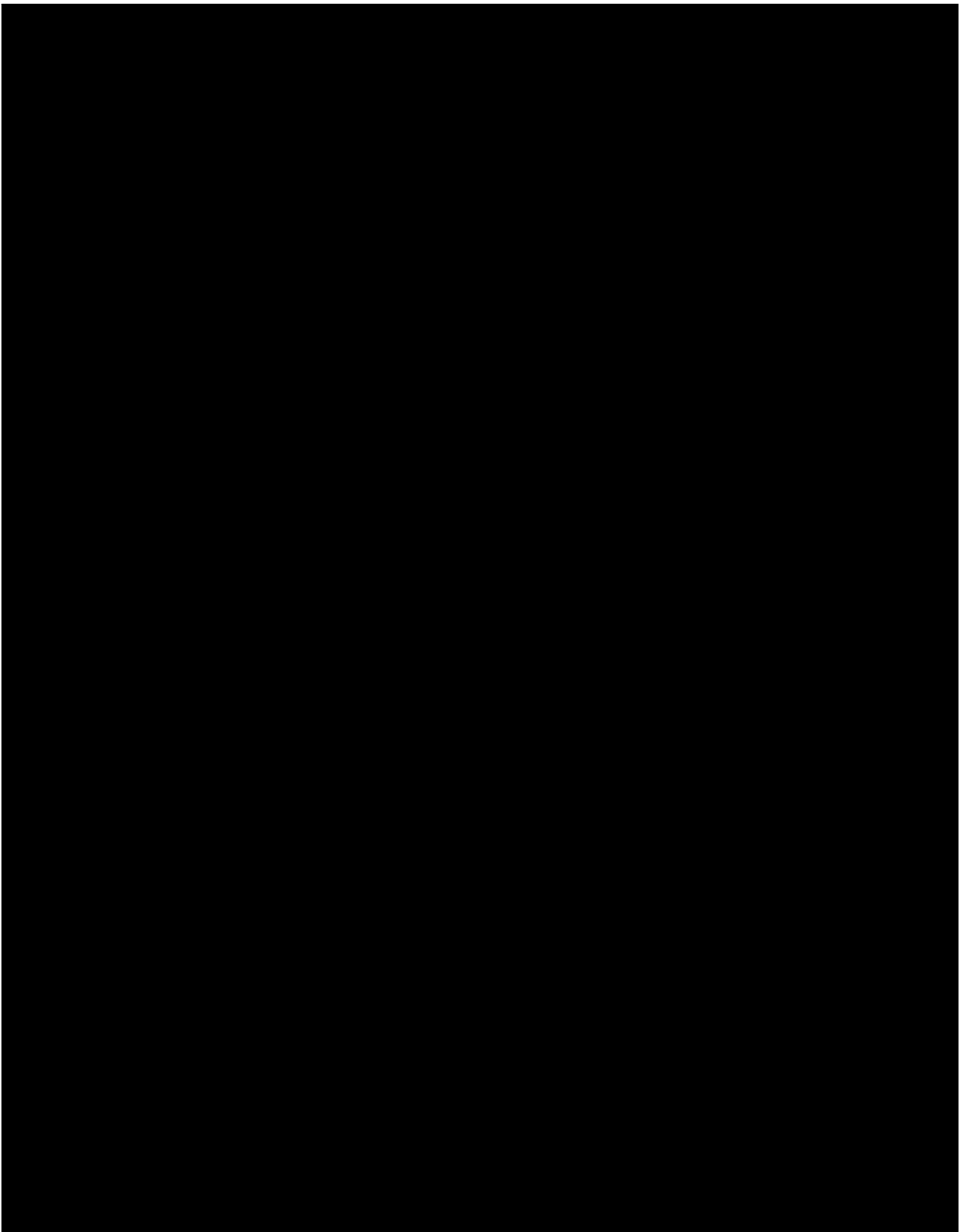


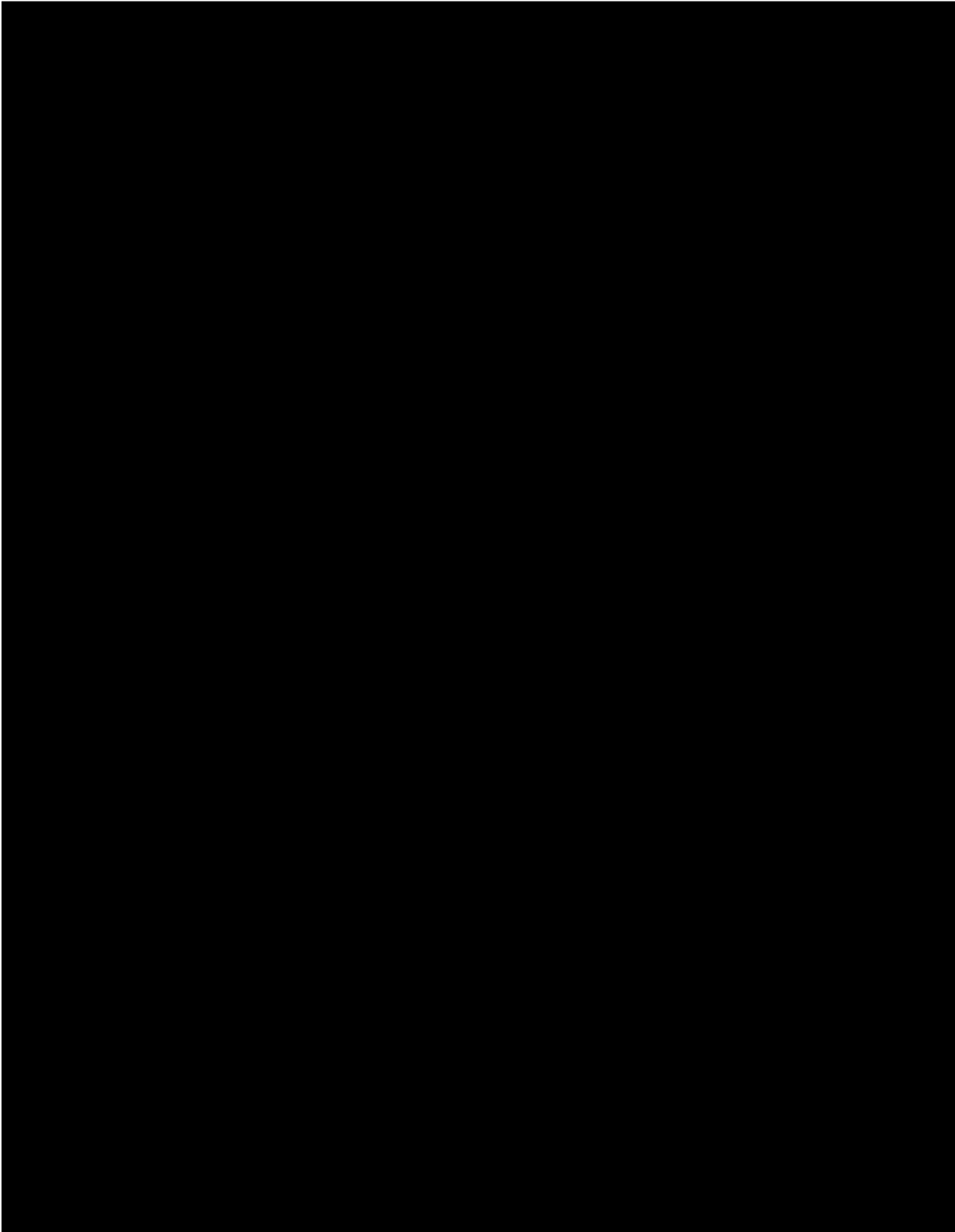


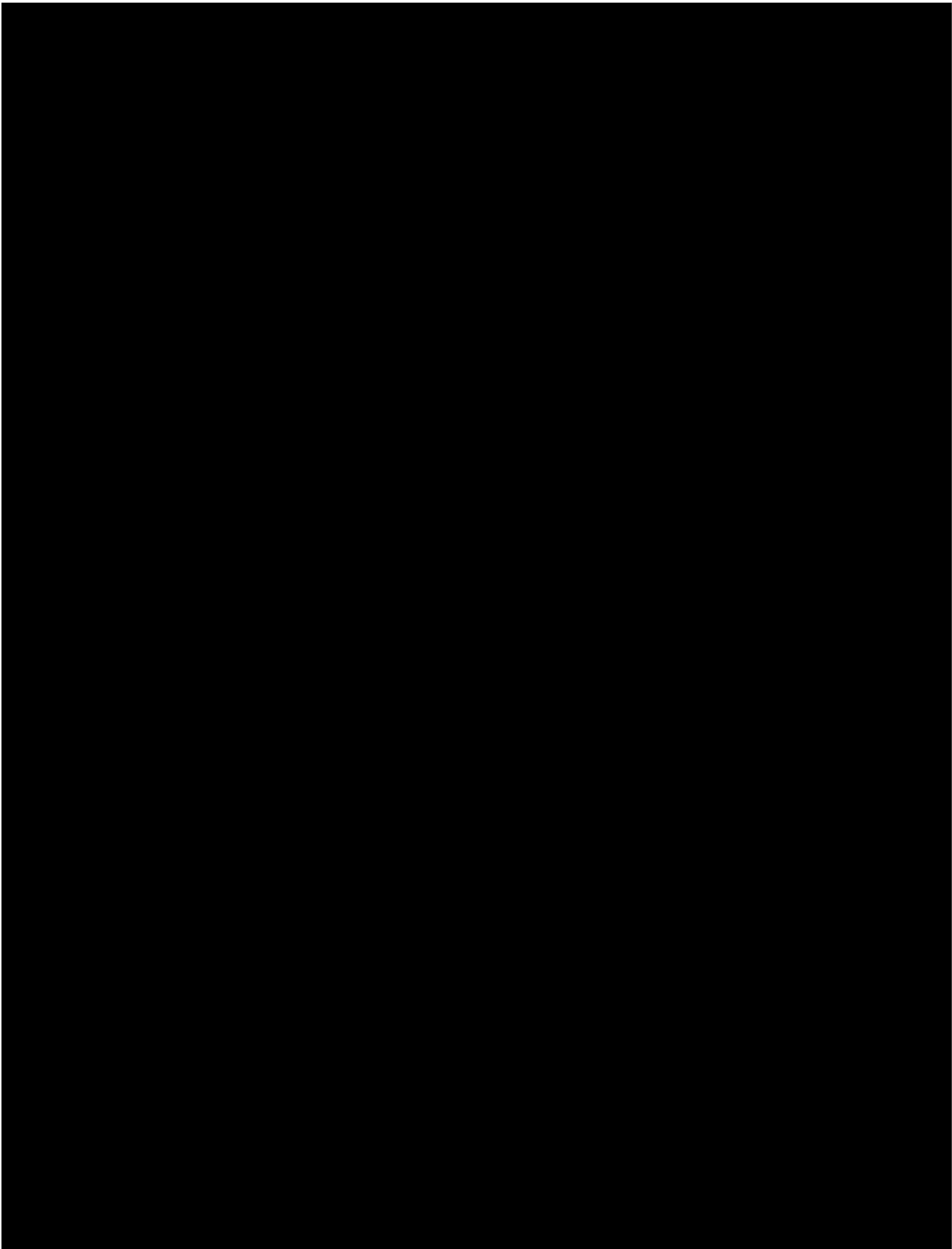


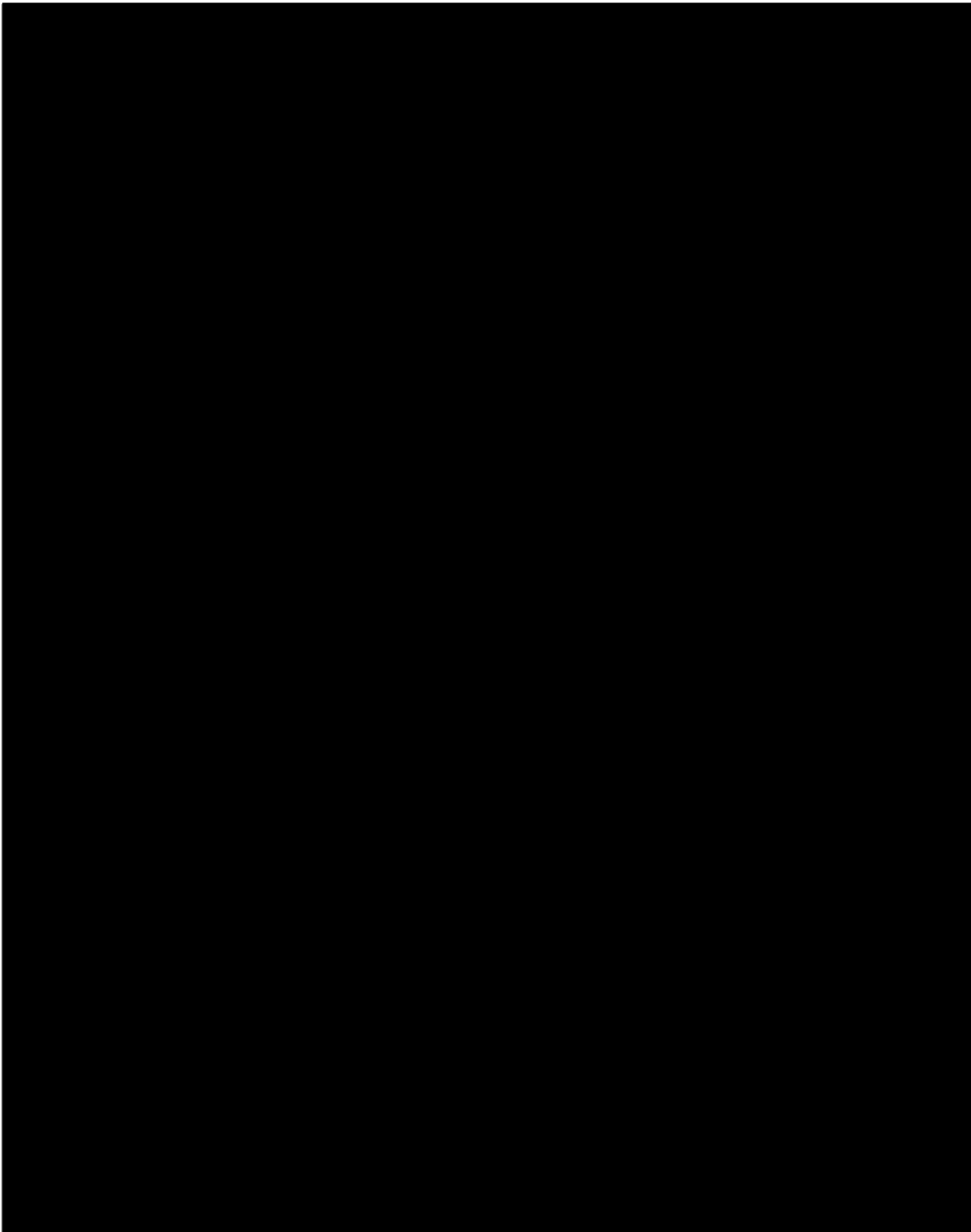


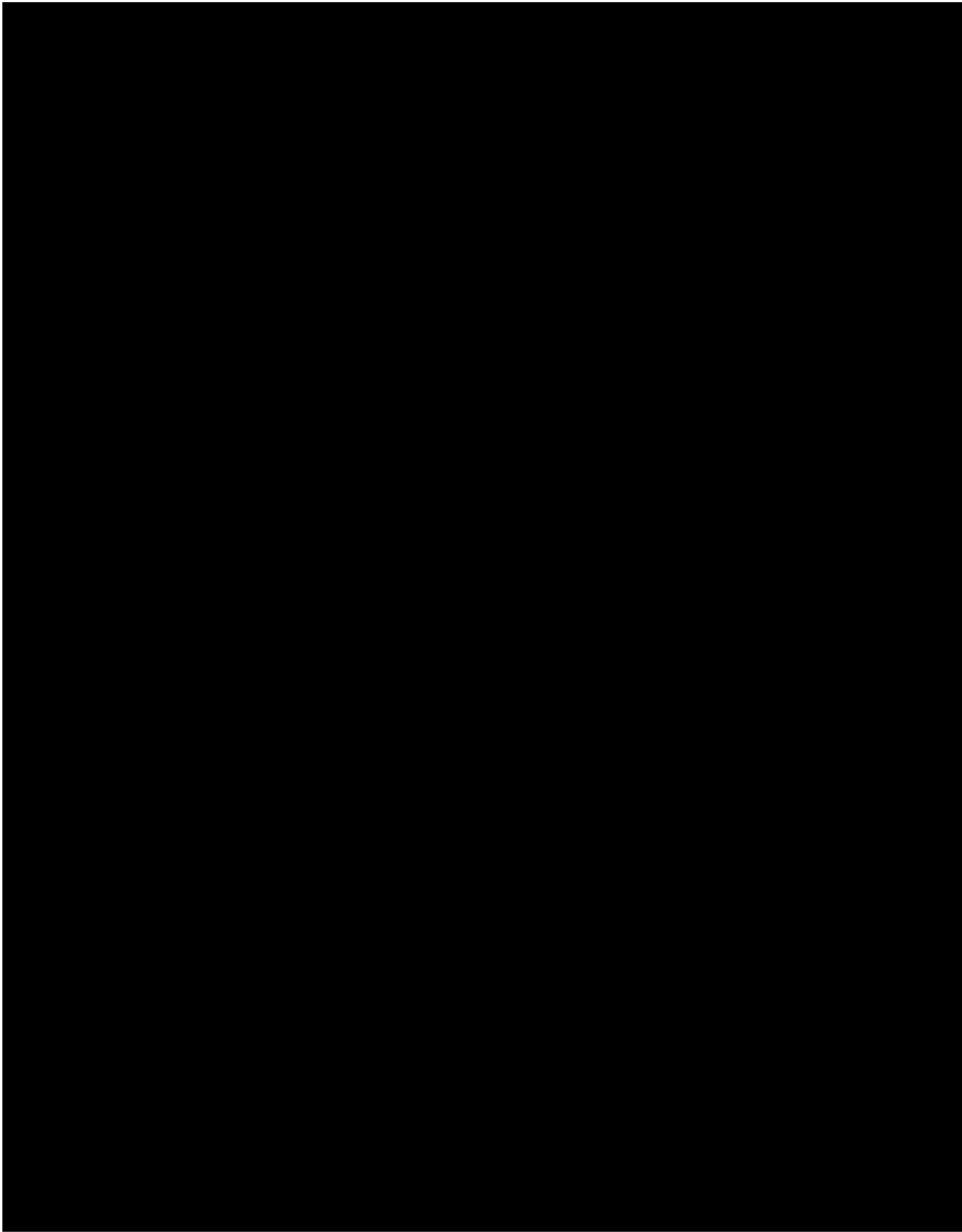


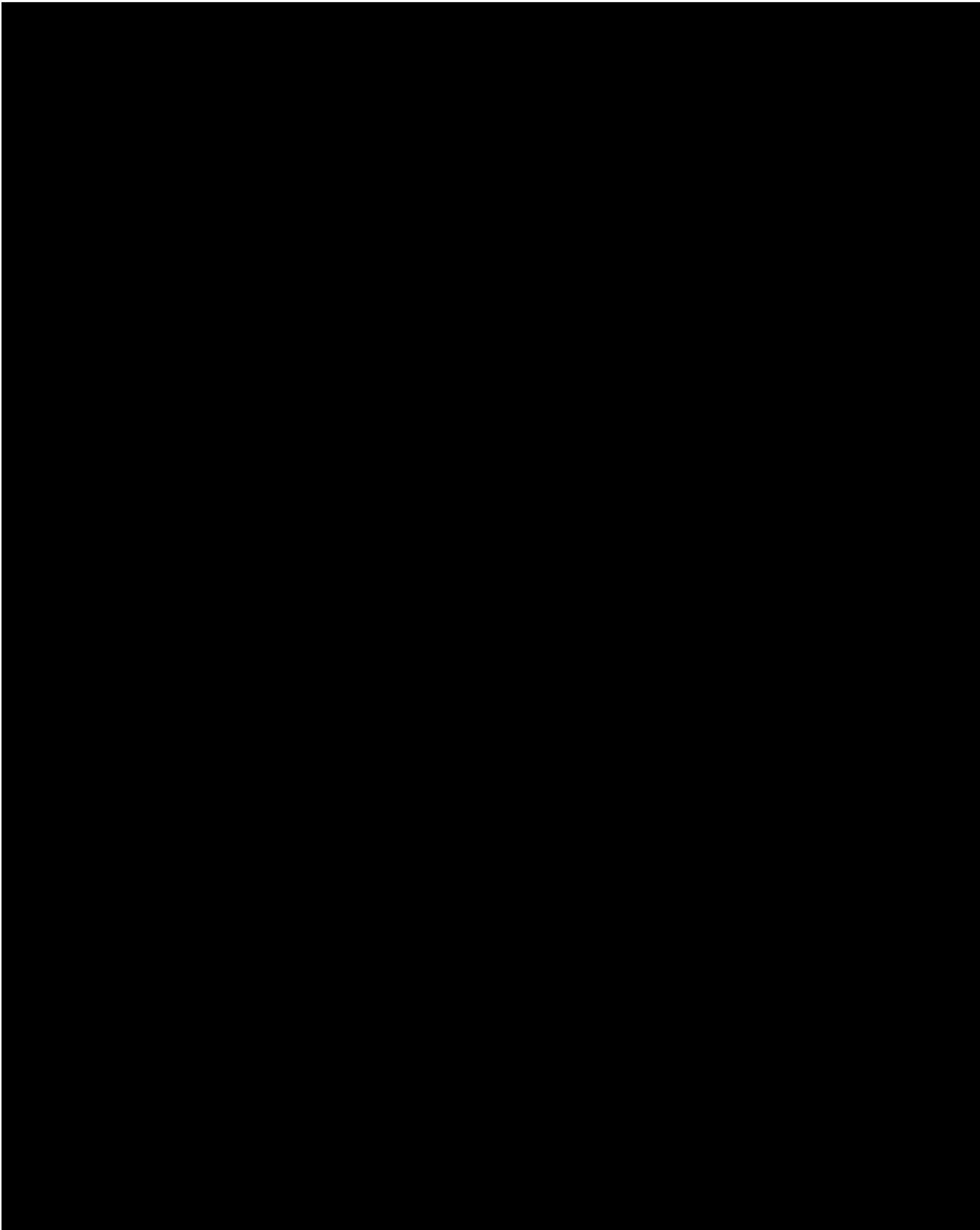




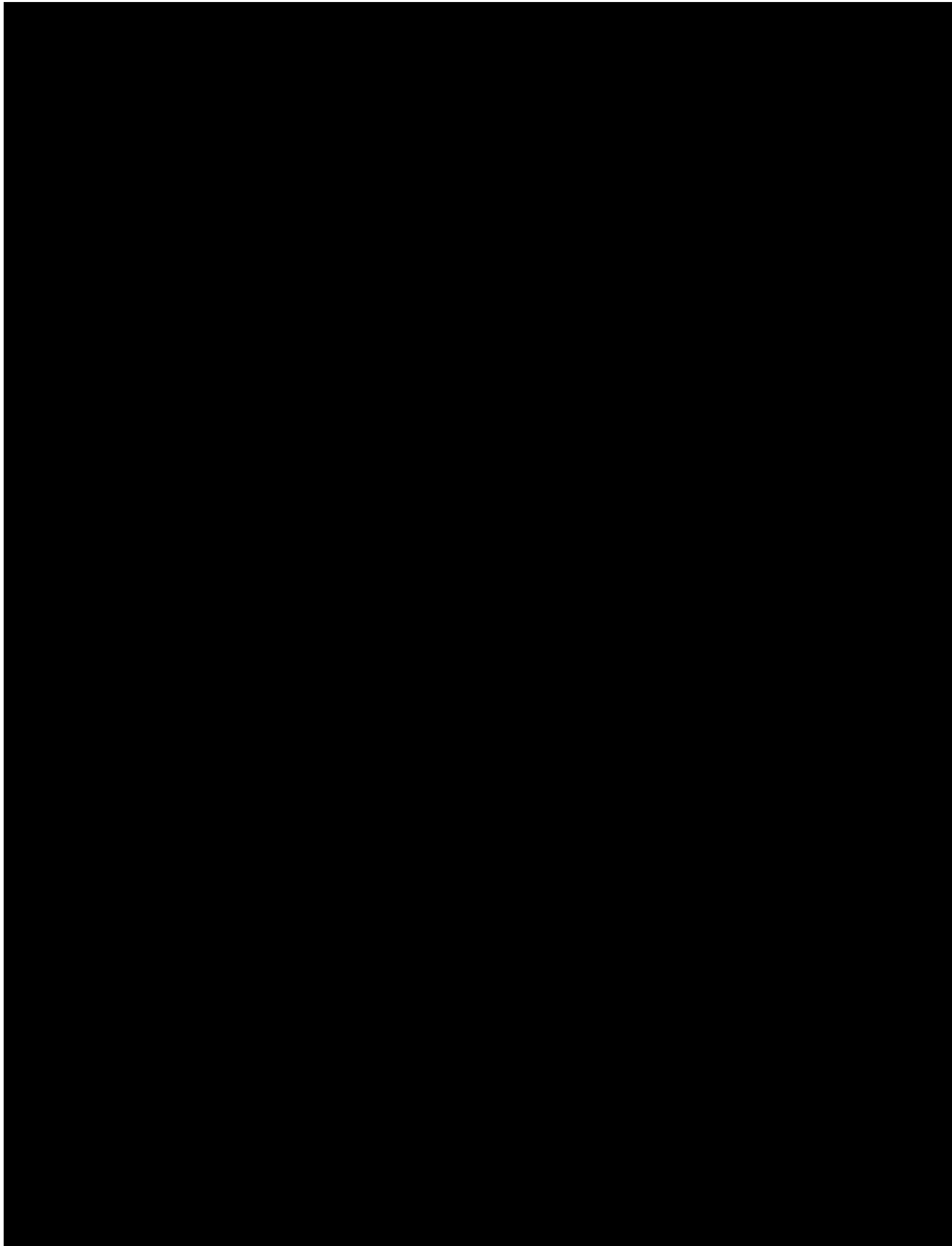


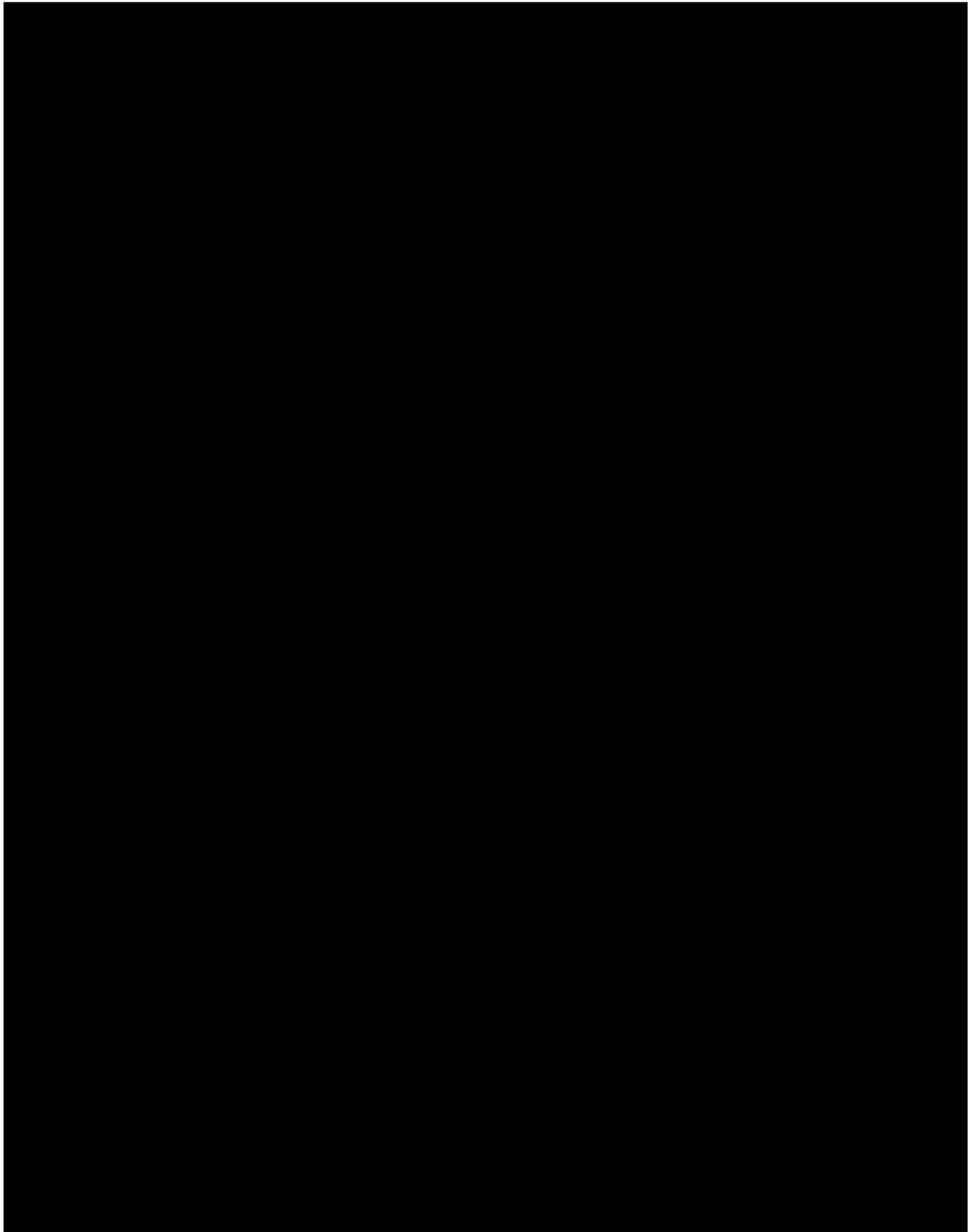


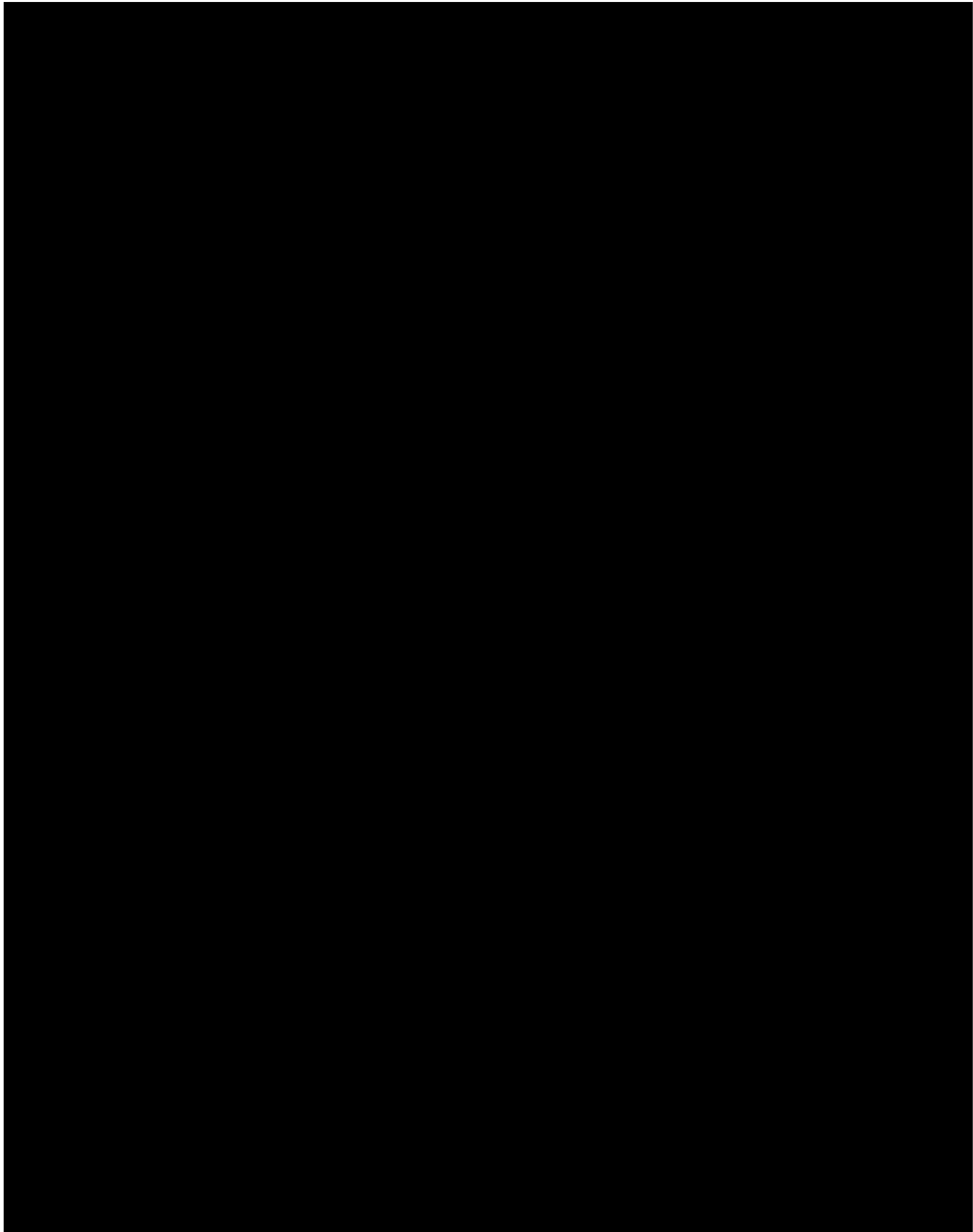


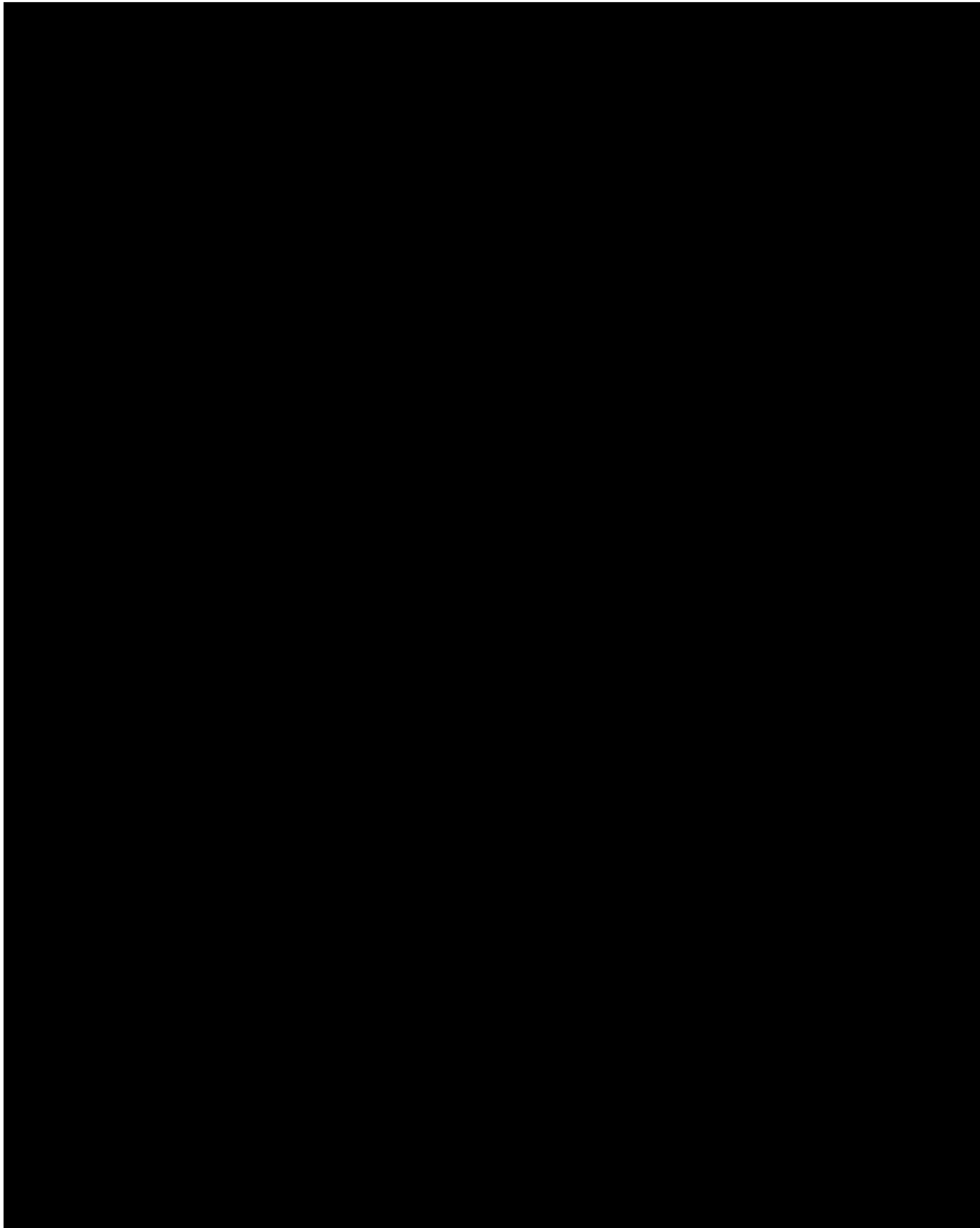


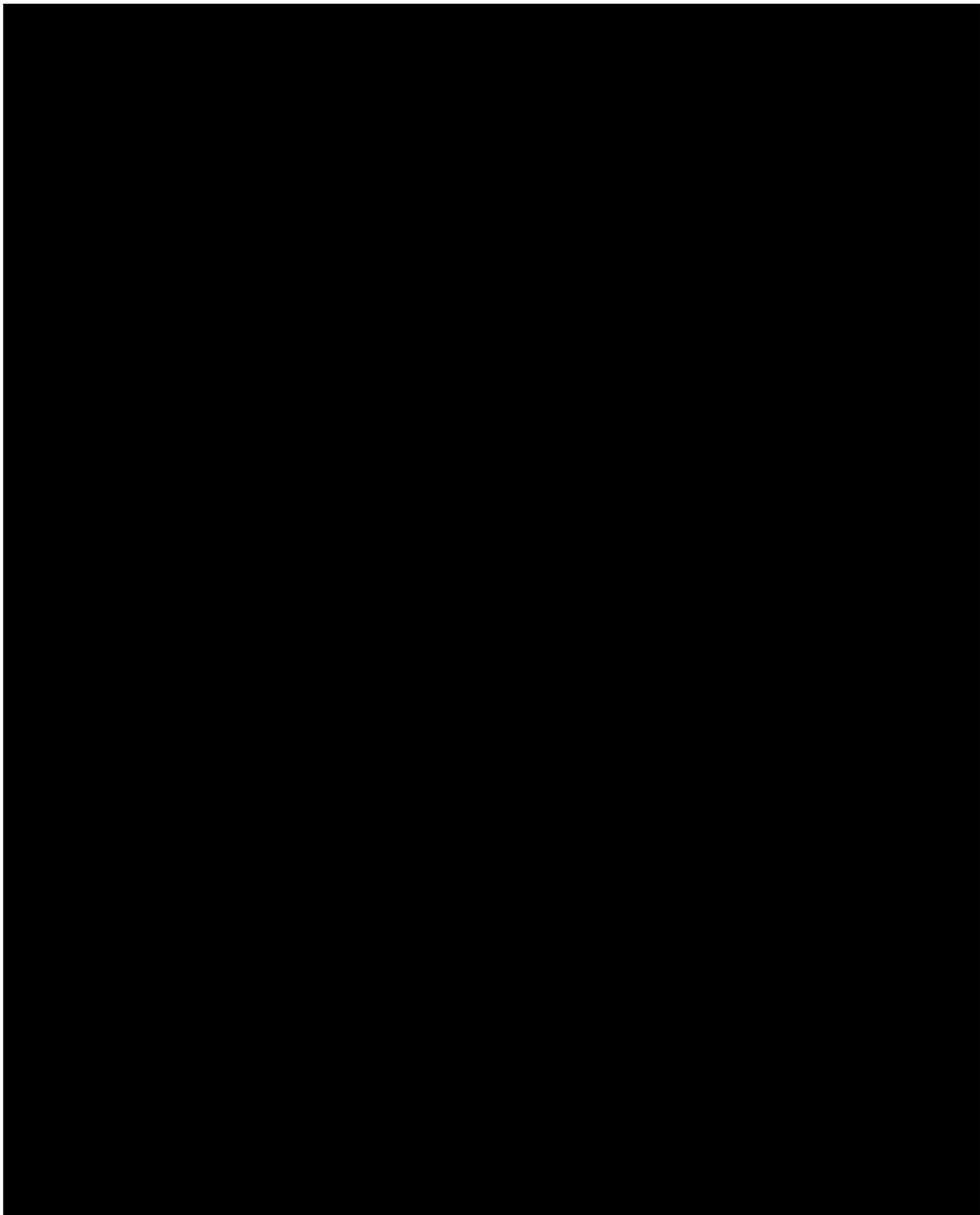


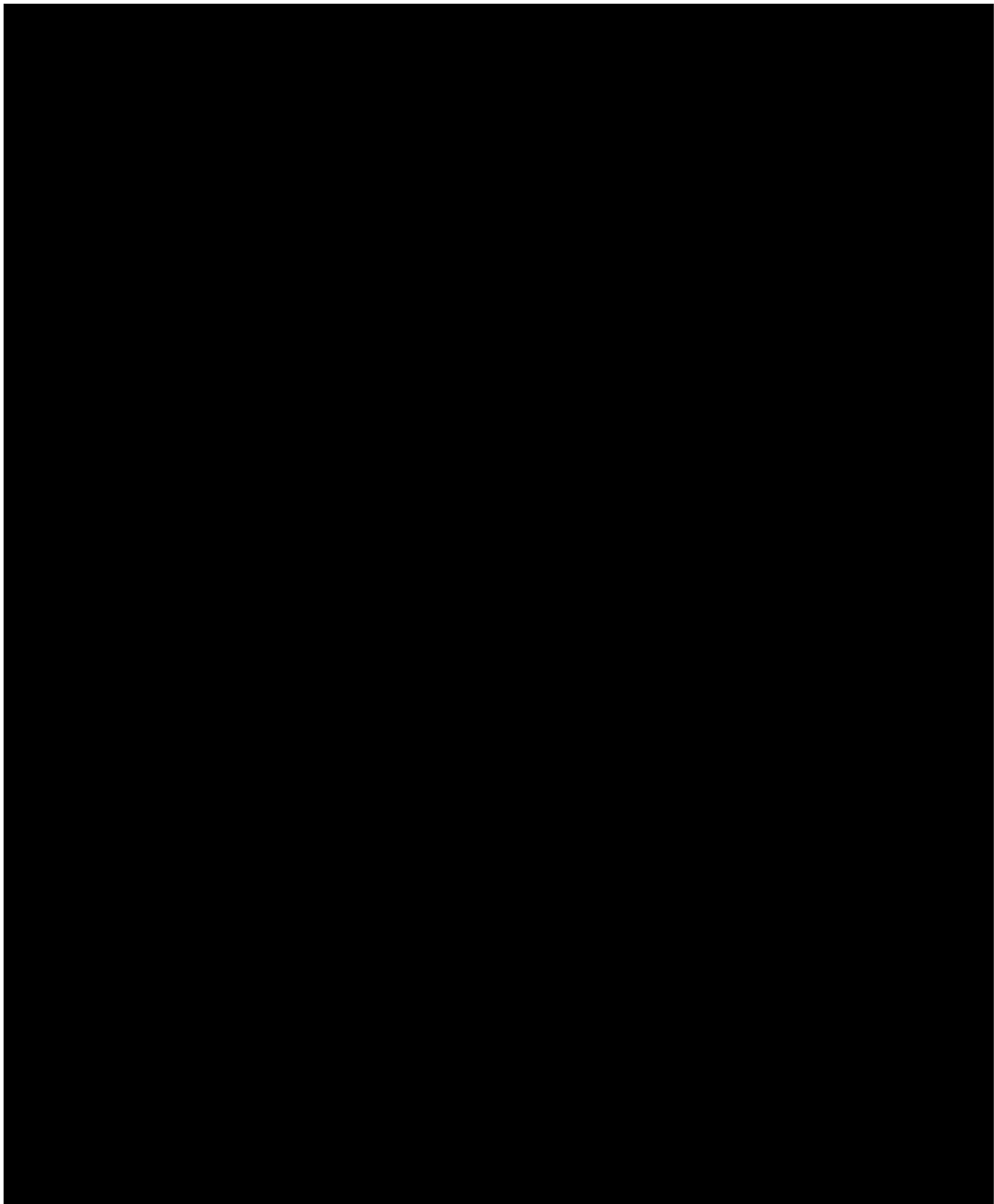


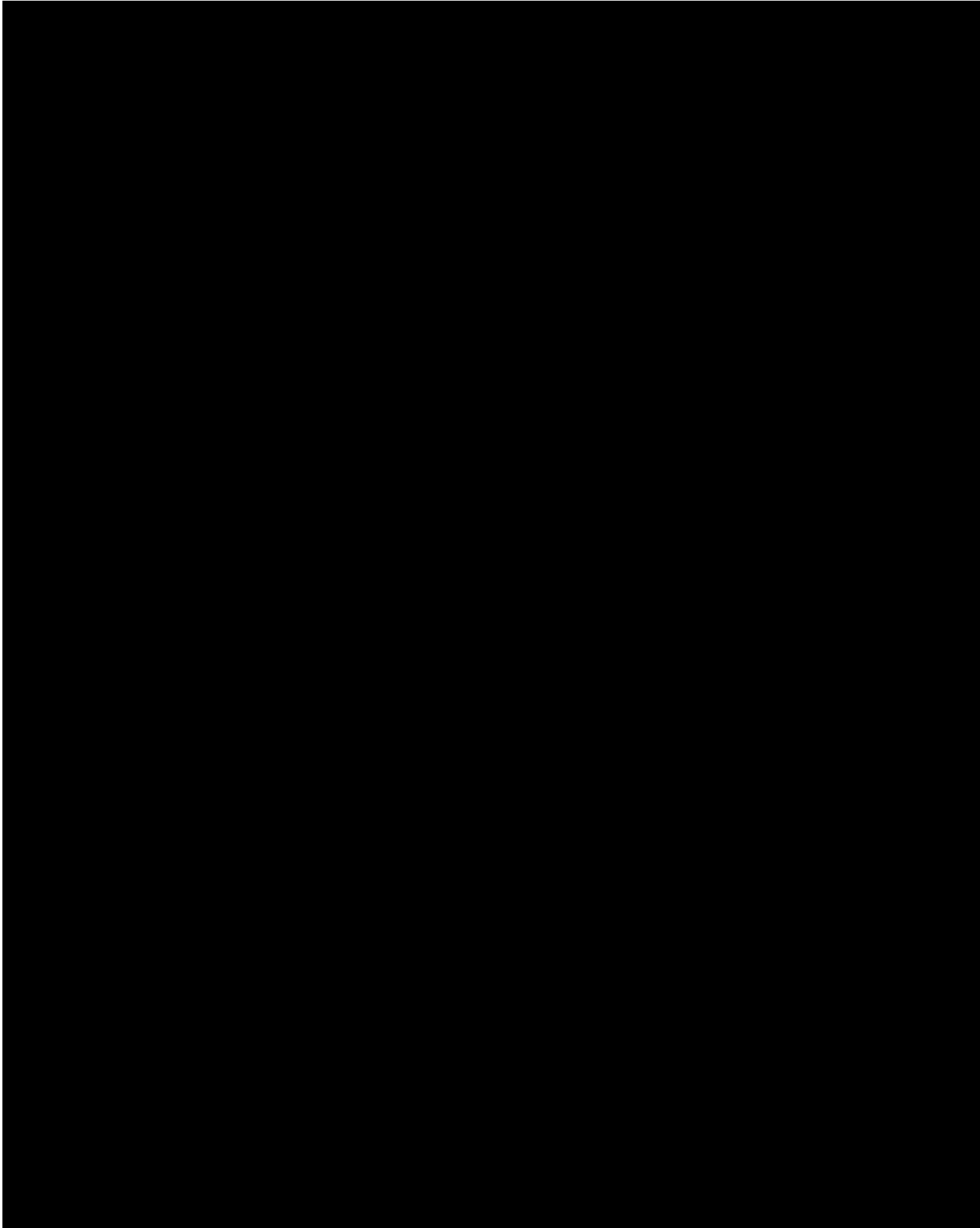


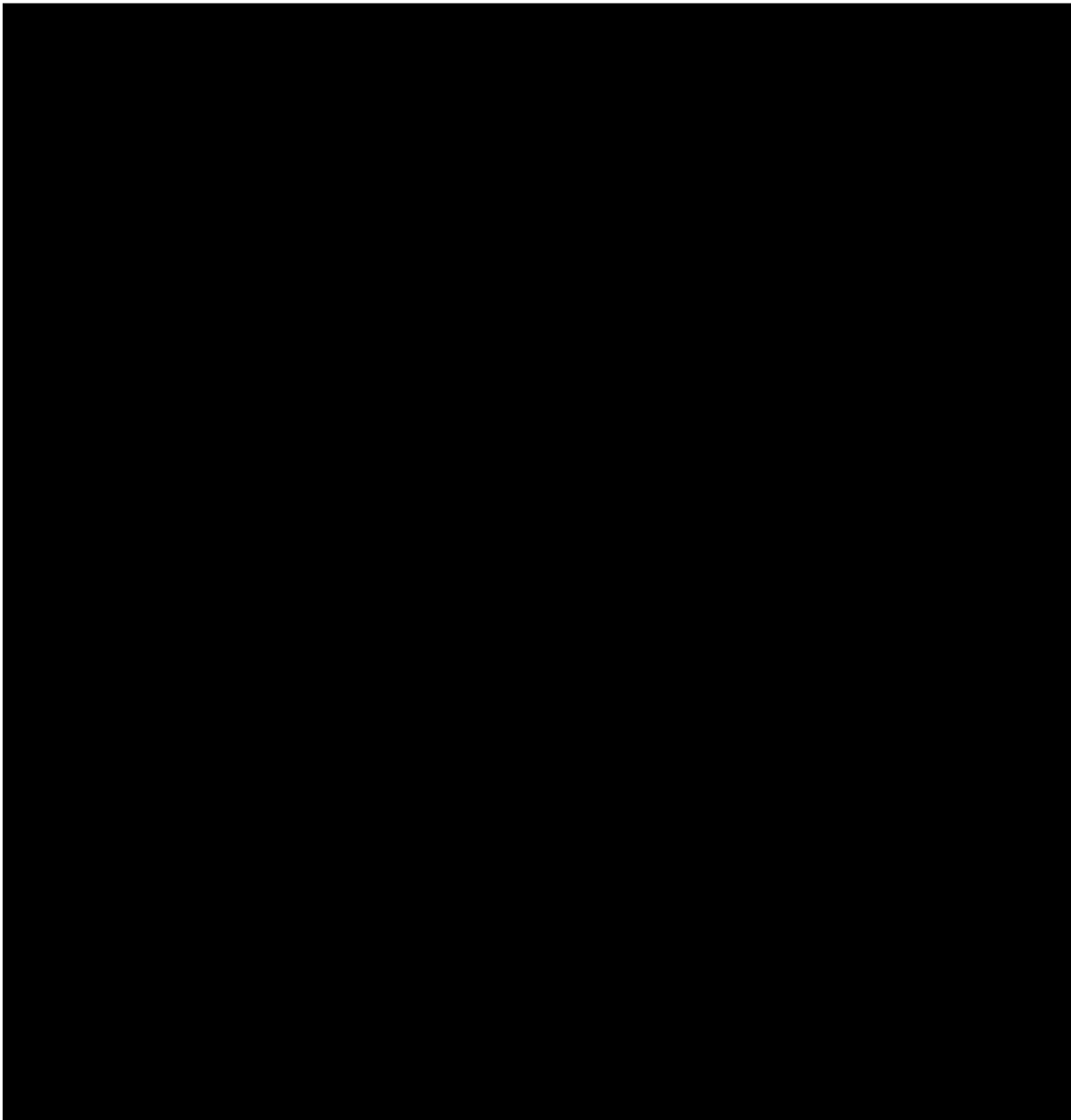




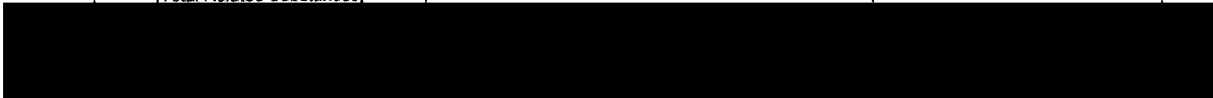




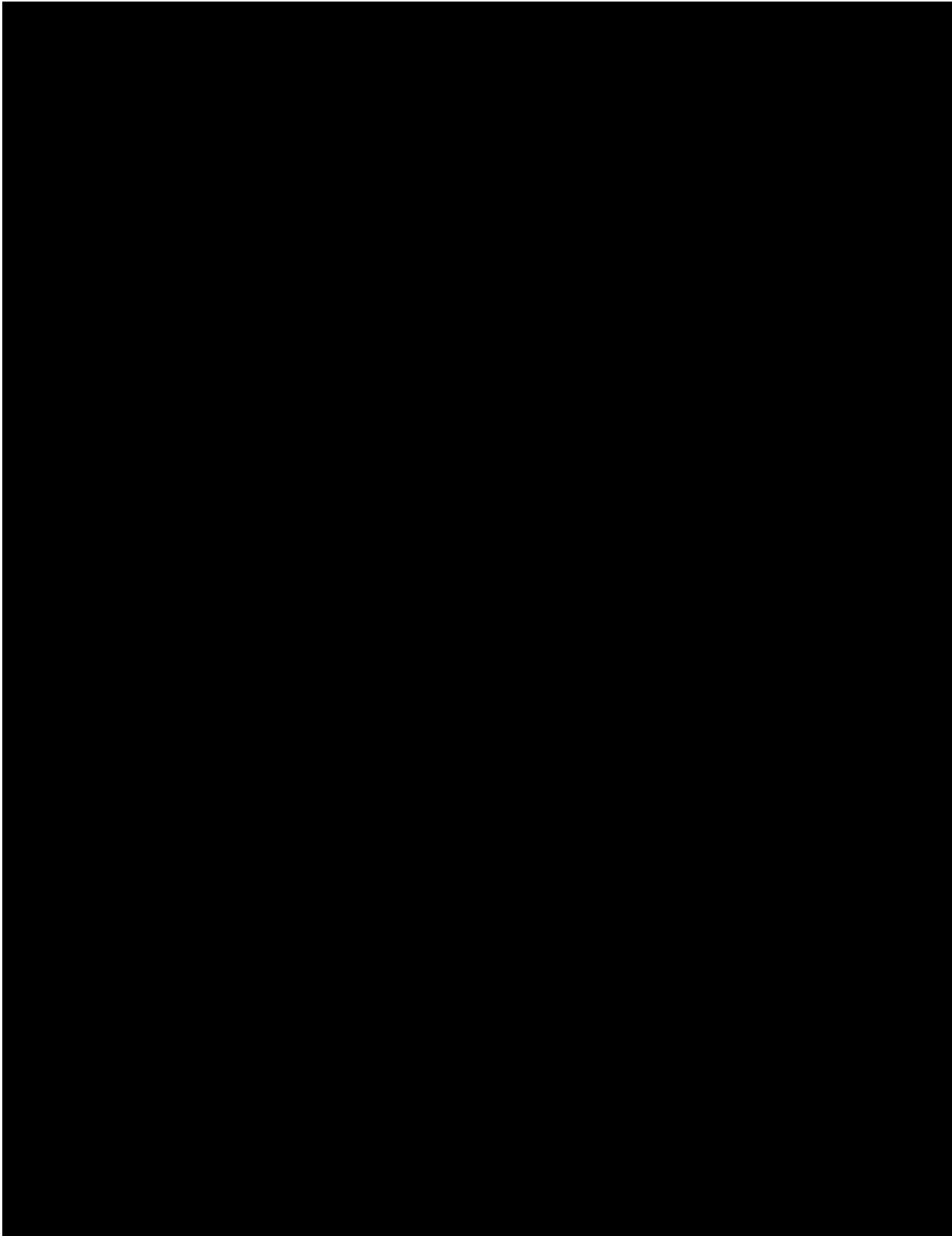


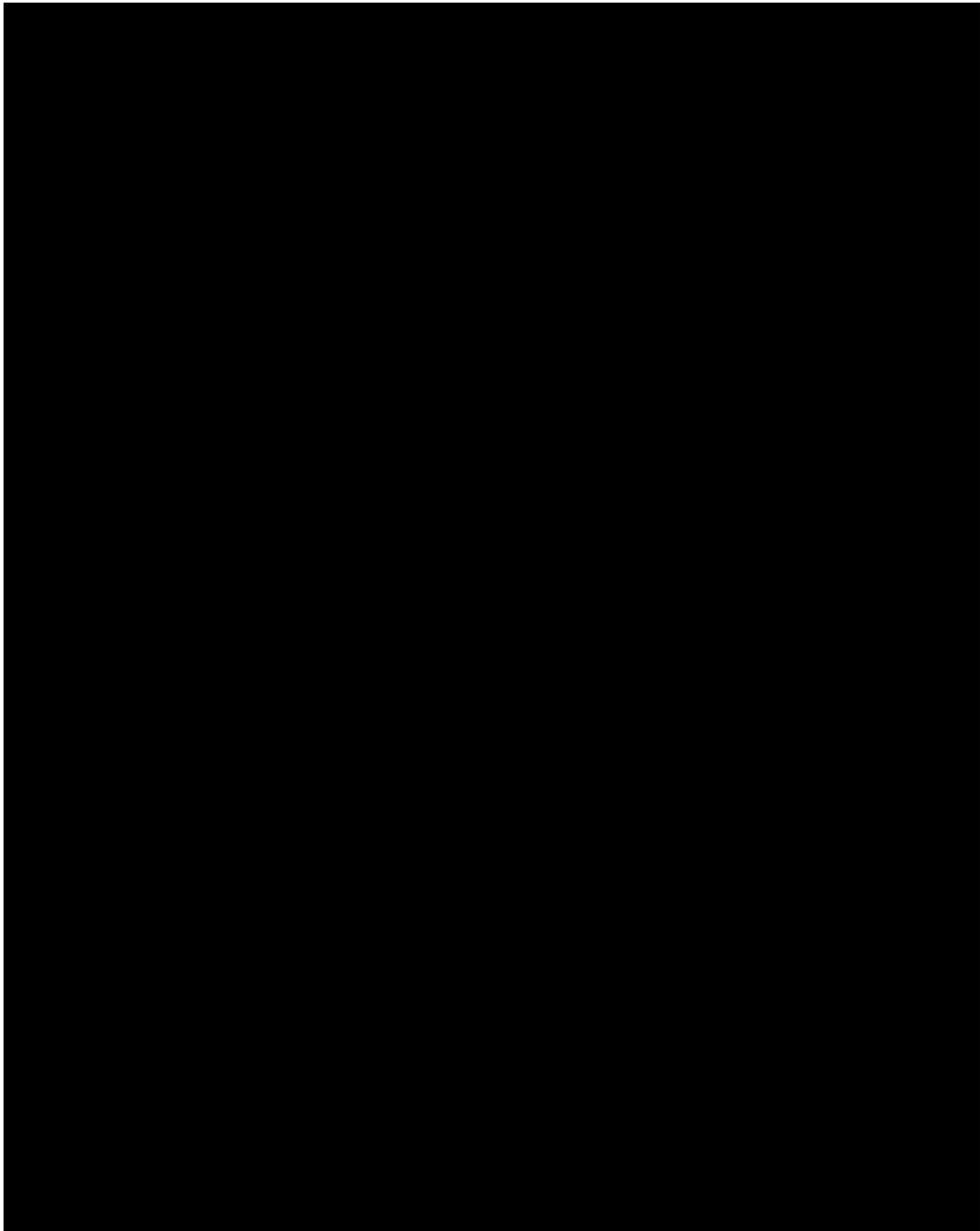


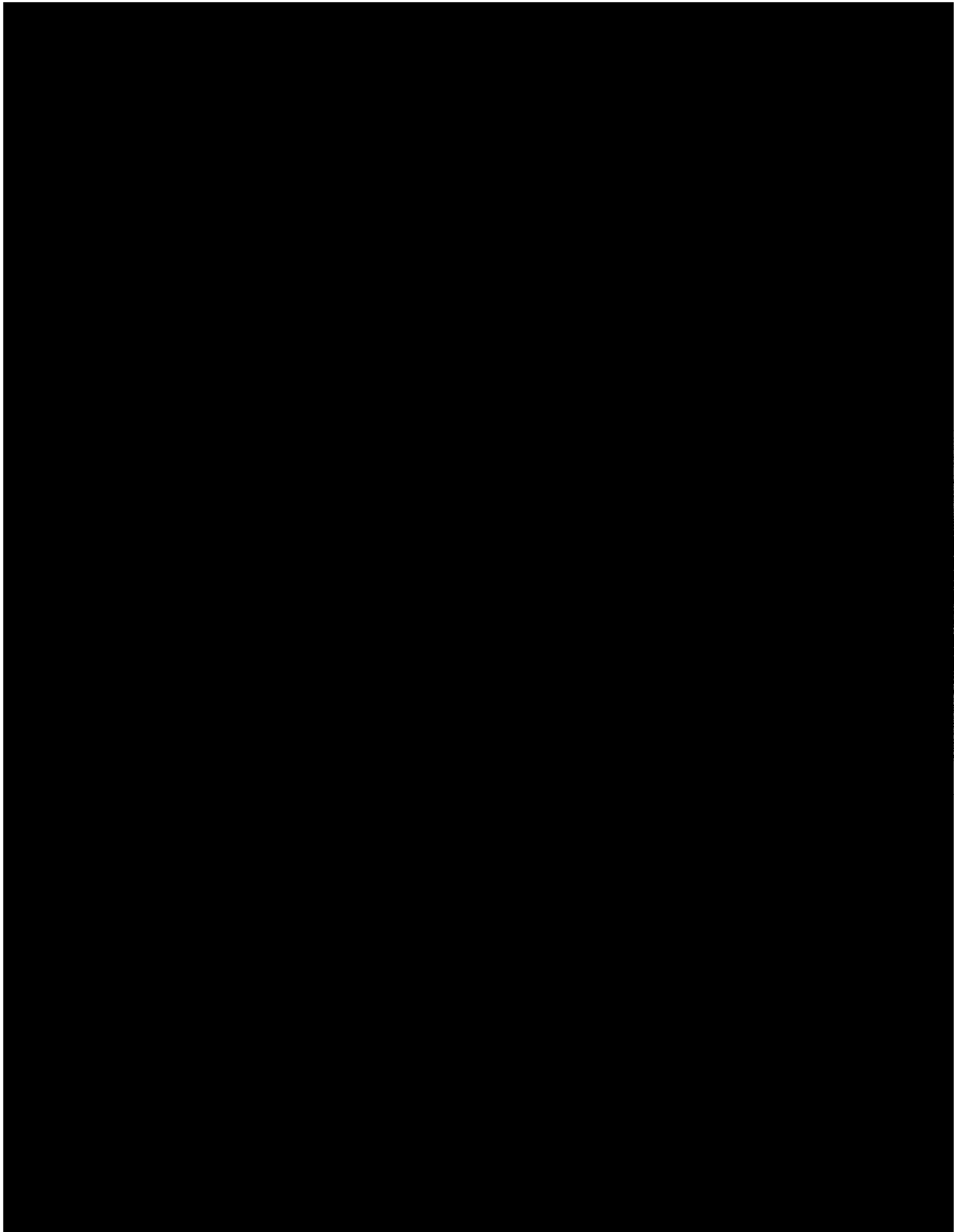
	Compound	Specifications	
Impurities (HPLC)	1AU90	Not more than 0.40%	ND
	2AU90	Not more than 0.10%	ND
	3AU90	Not more than 1.00%	ND
	750W93	Not more than 0.50%	0.06 % w/w
	751W93	Not more than 0.30%	< 0.05 % w/w
	97W86 (Benzindene Triol)	Not more than 0.20%	ND
	Treprostinil Ethyl Ester	Not more than 0.50%	0.13 % w/w
	Treprostinil Methyl Ester	Not more than 0.20%	ND
	Impurities (HPLC) [Unidentified Impurities]	Not more than 0.10% AUC each	
Impurities (HPLC) [Total Related Substances]	Not more than 3.00%		0.2 %

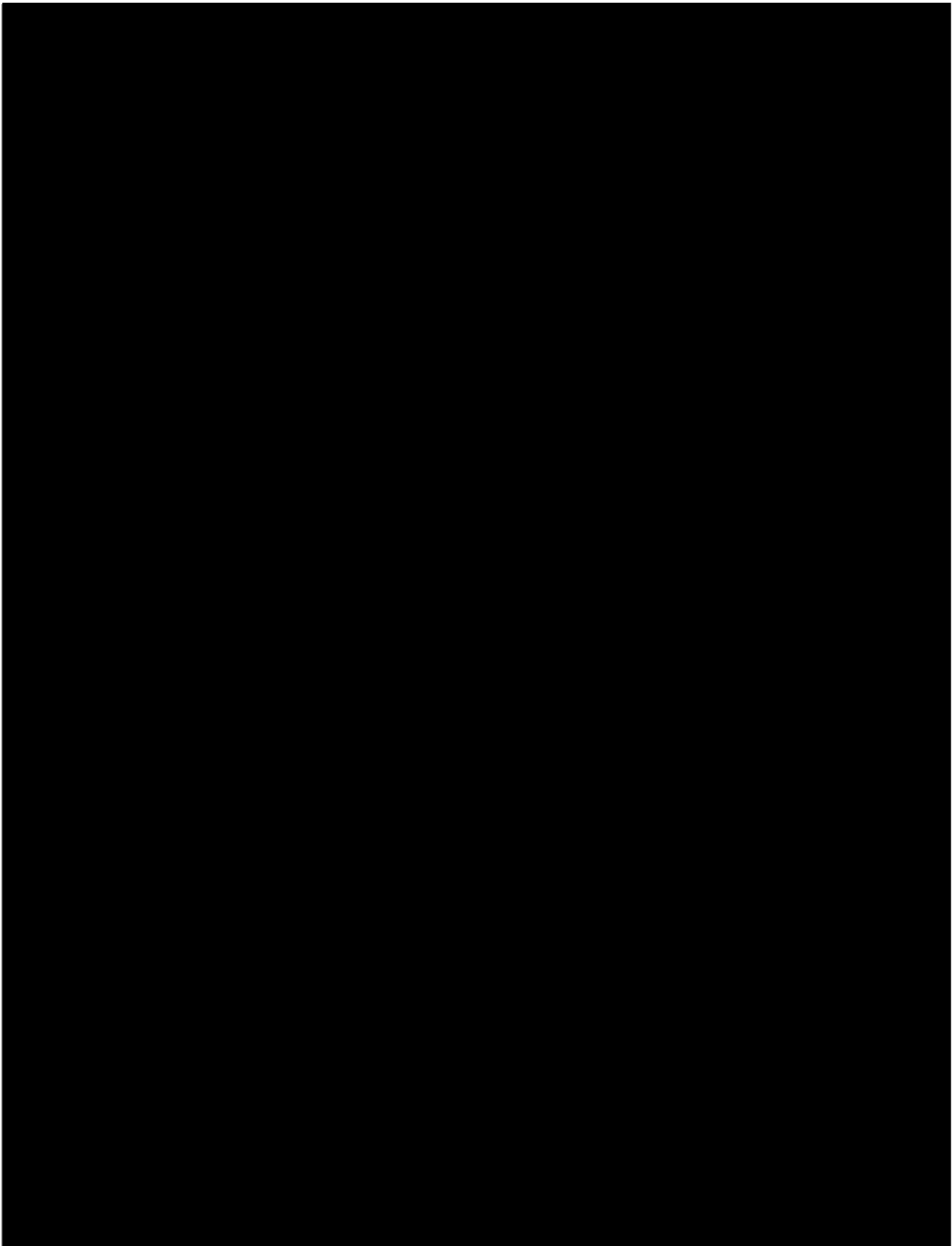


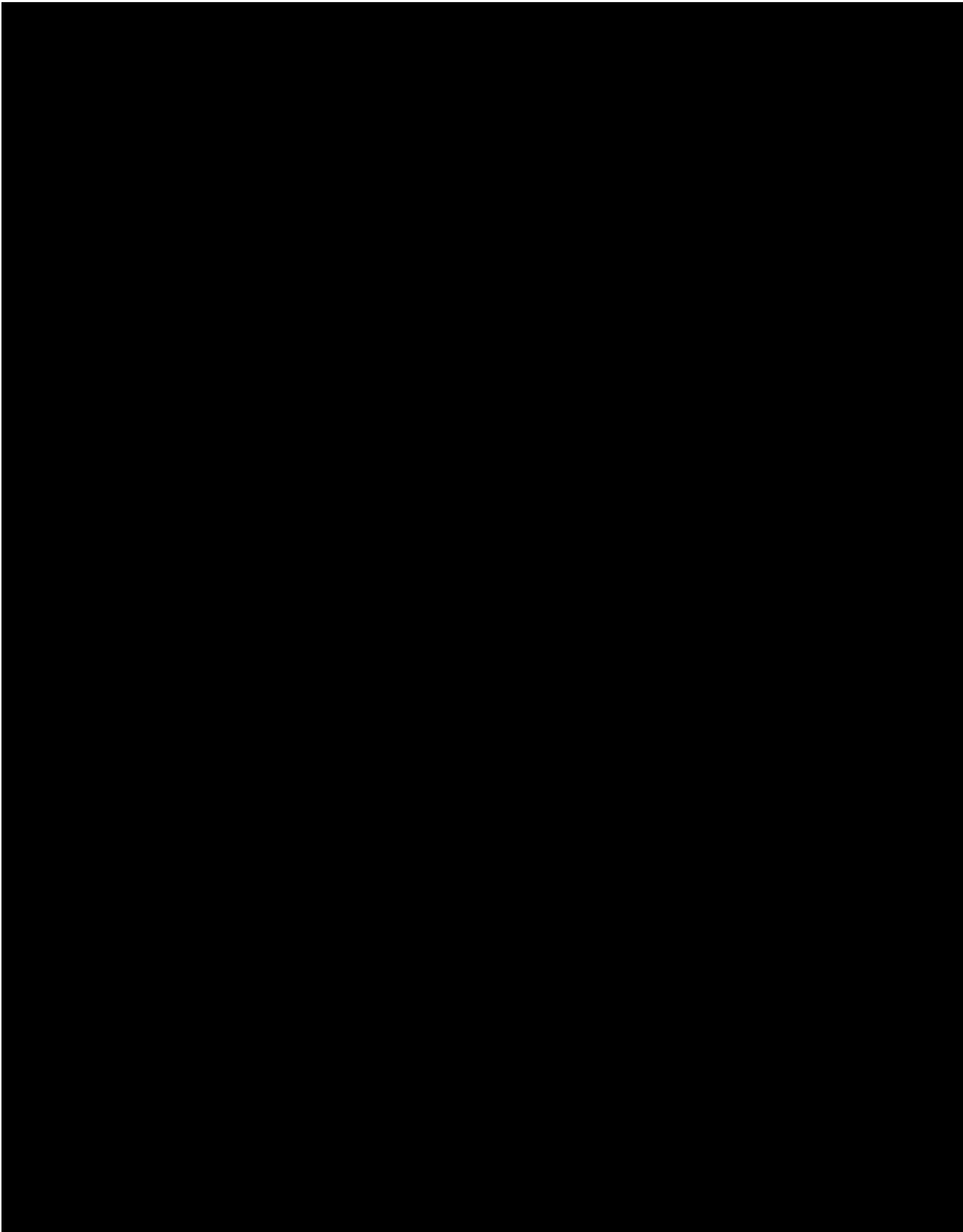


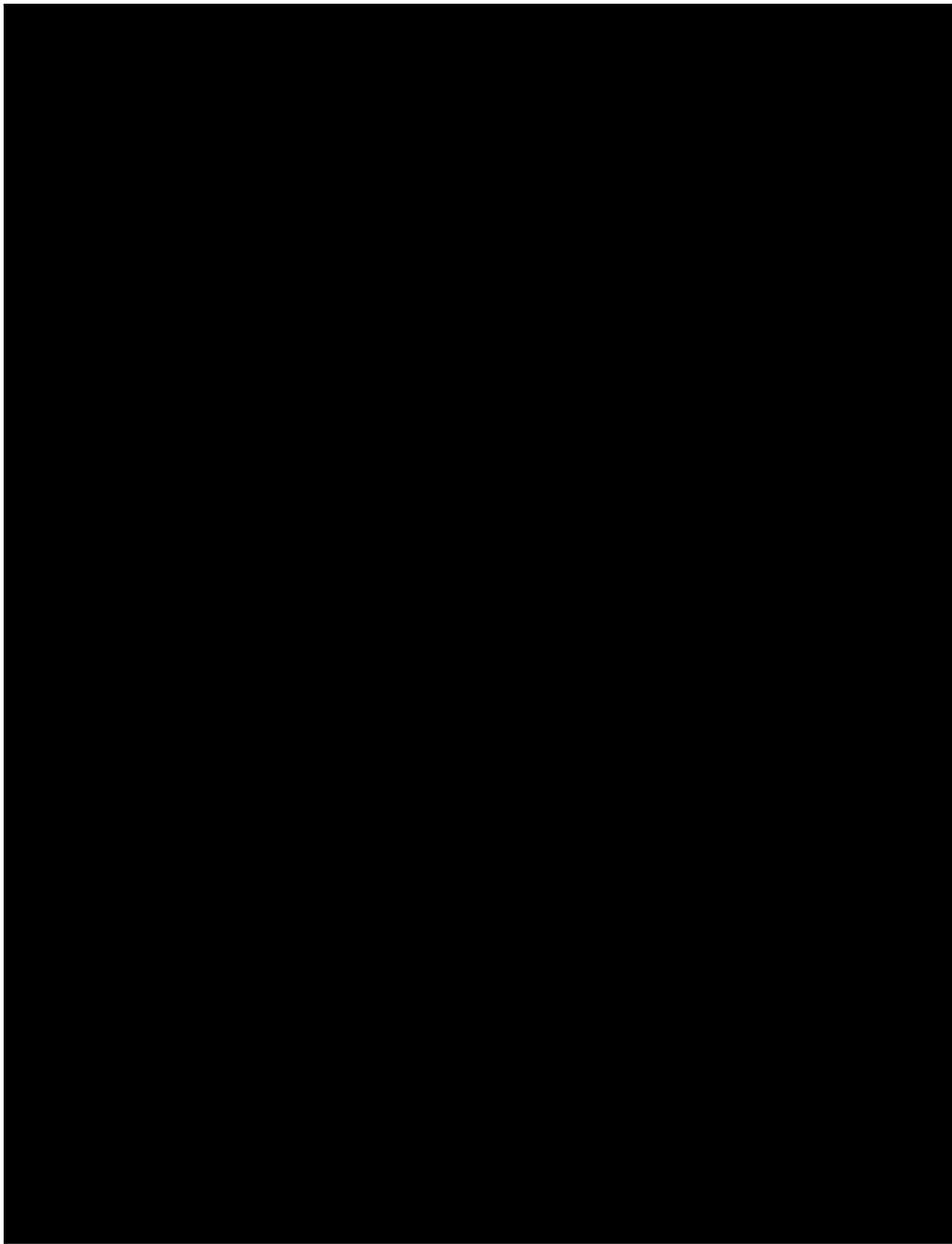


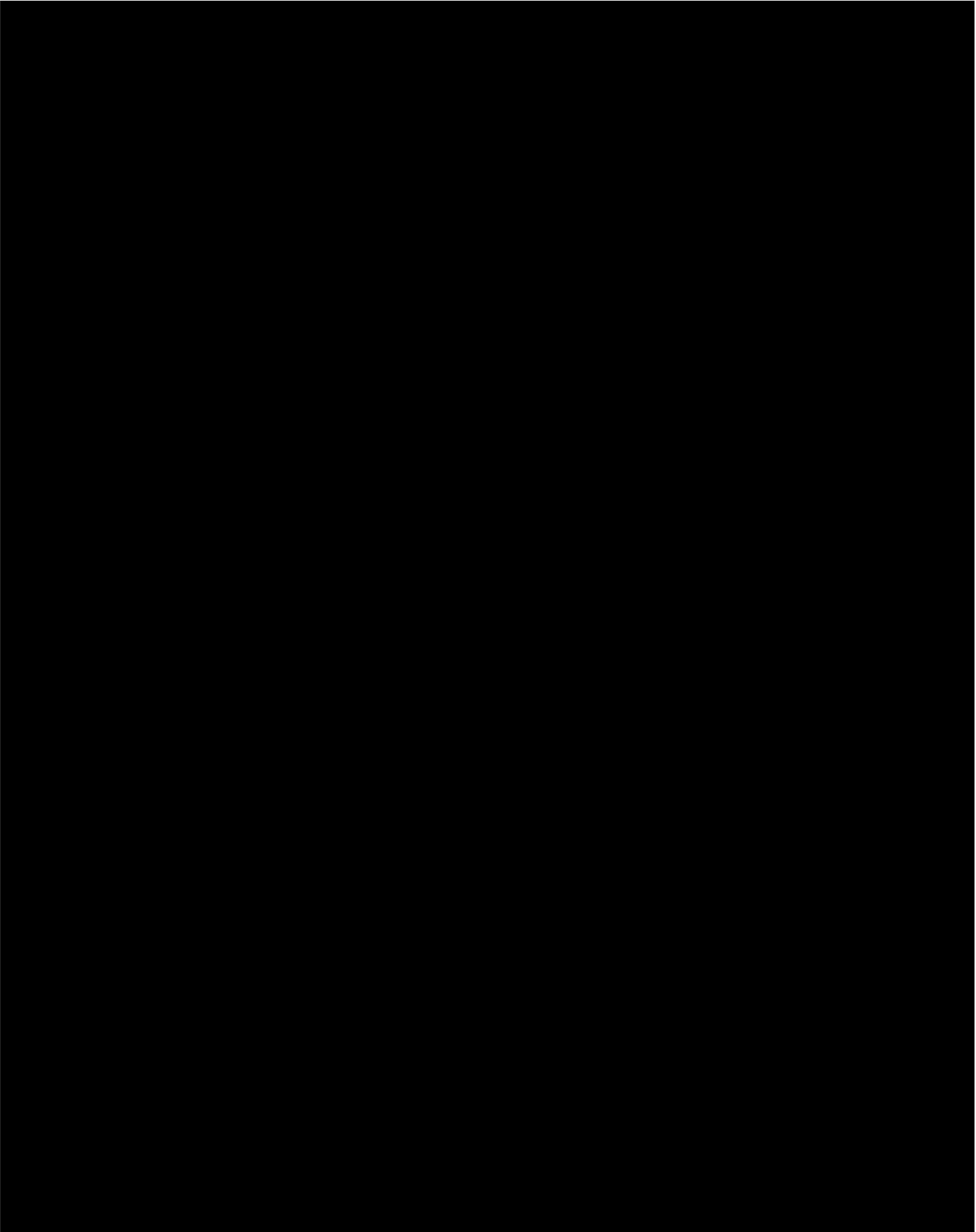


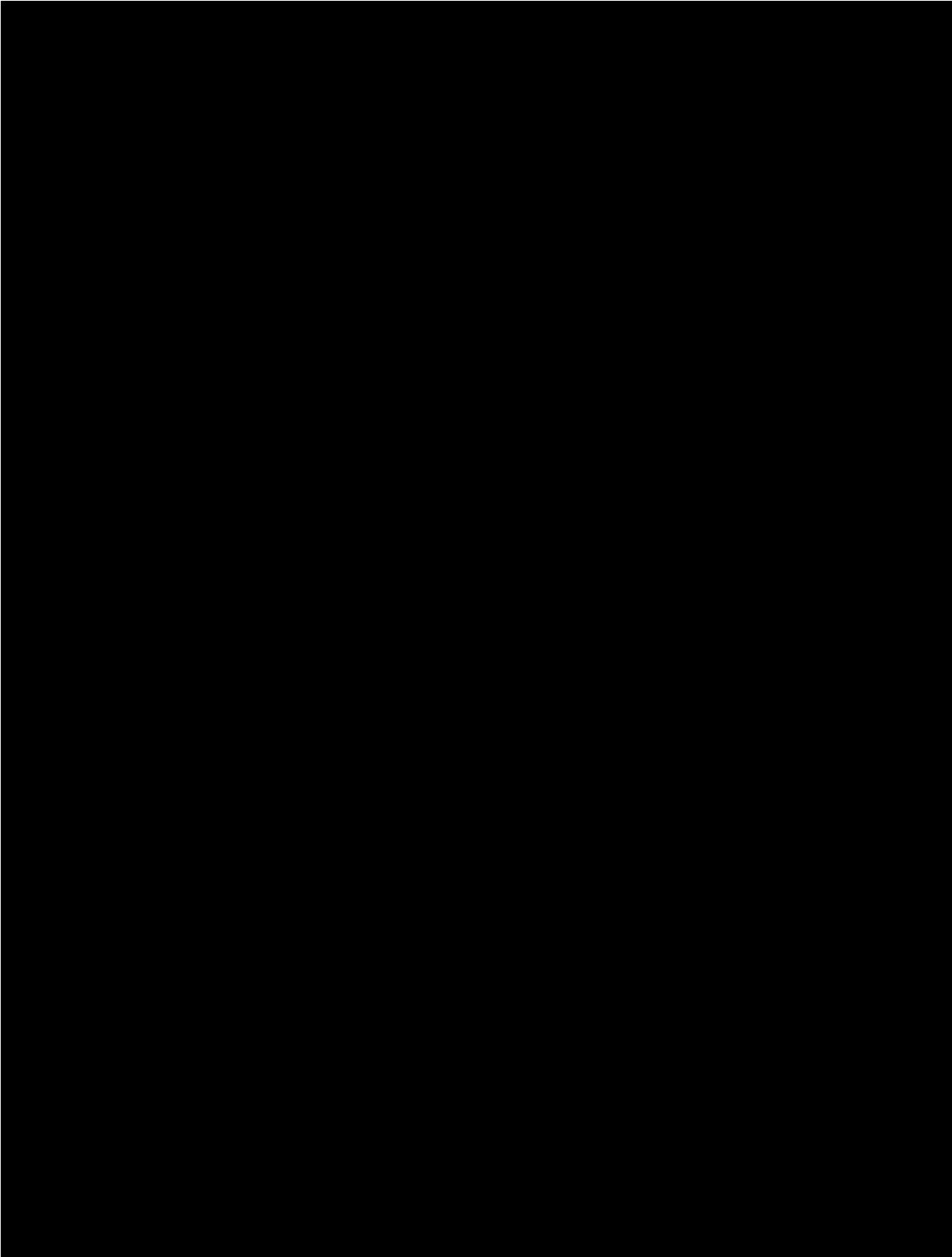




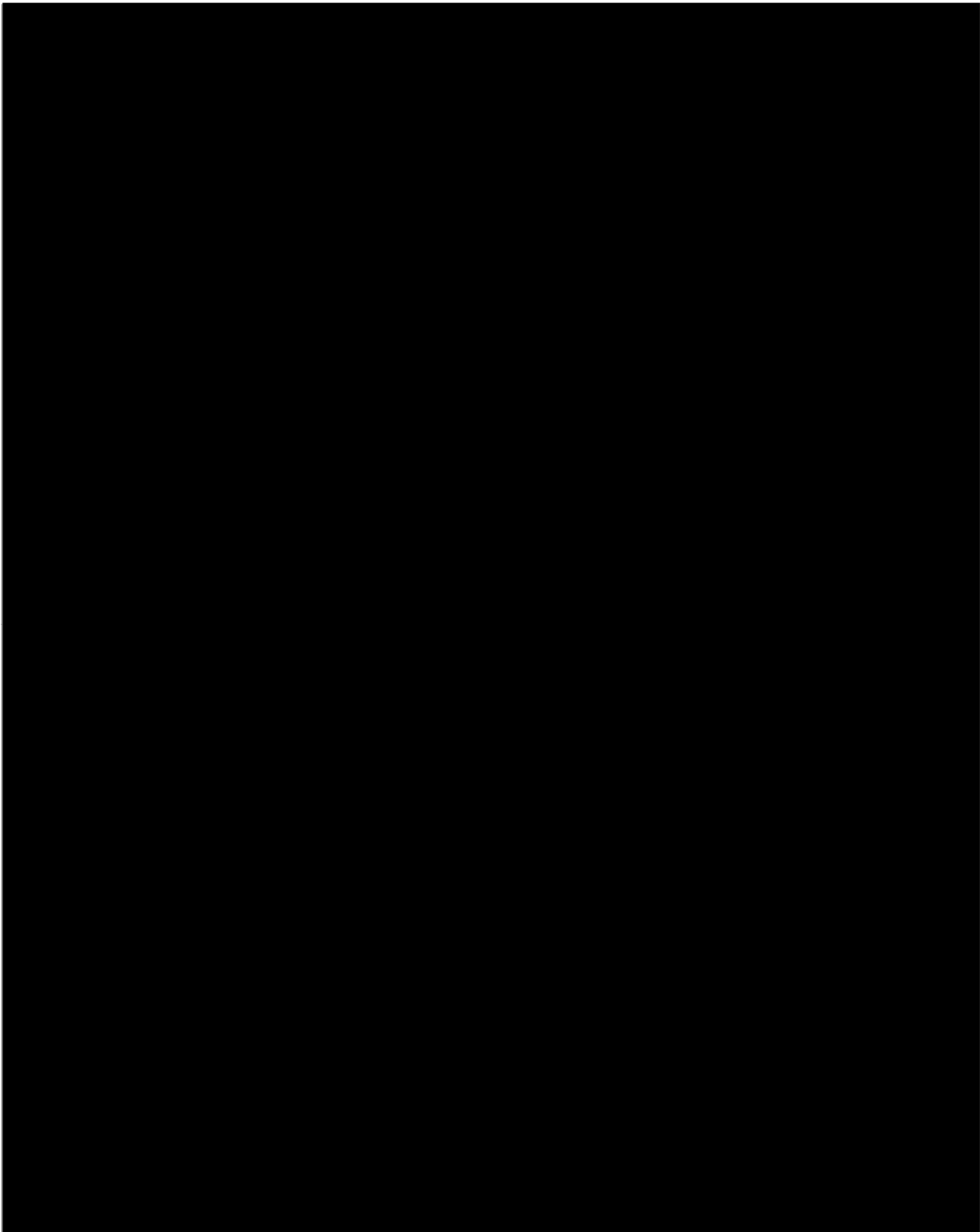


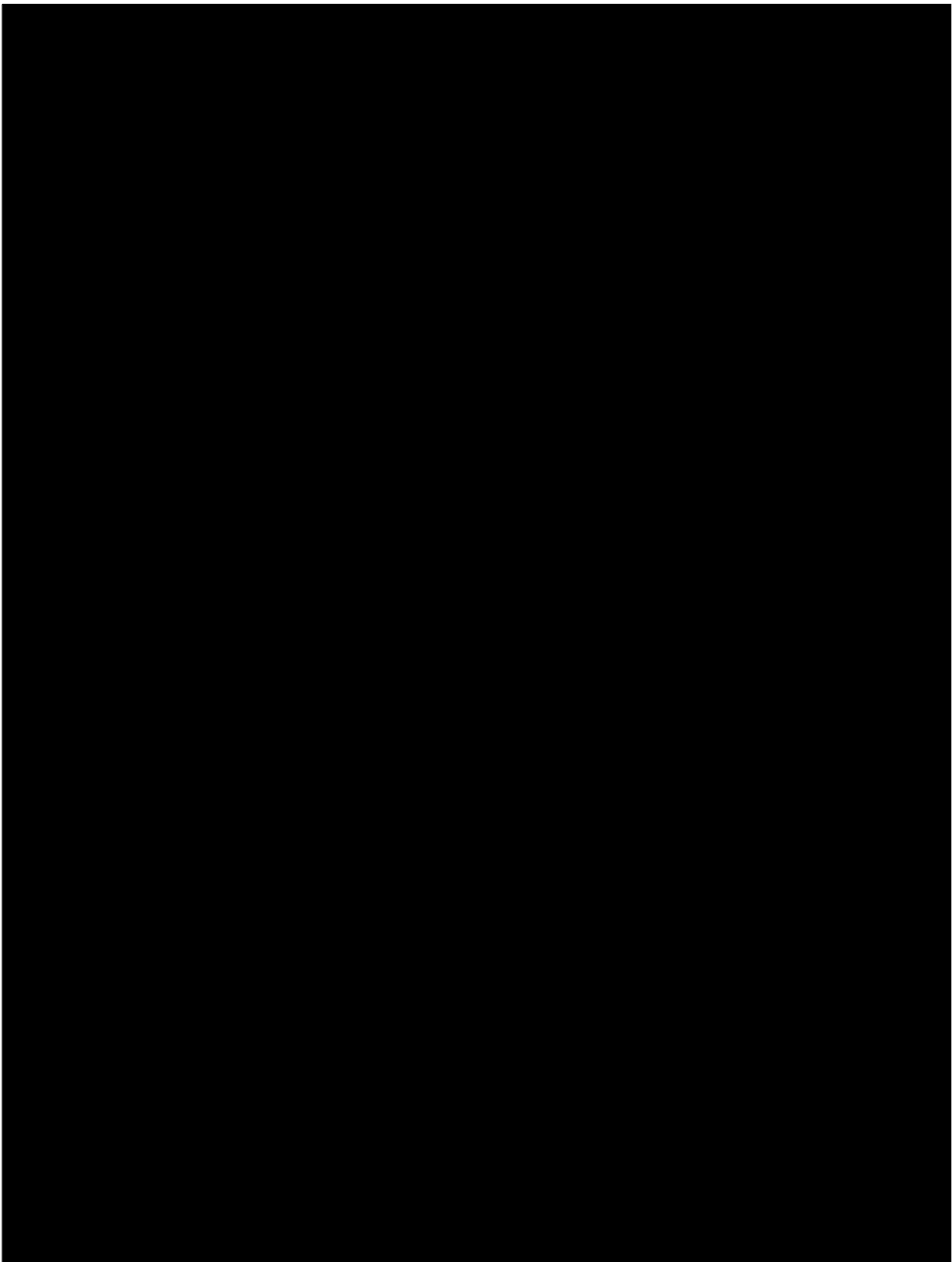


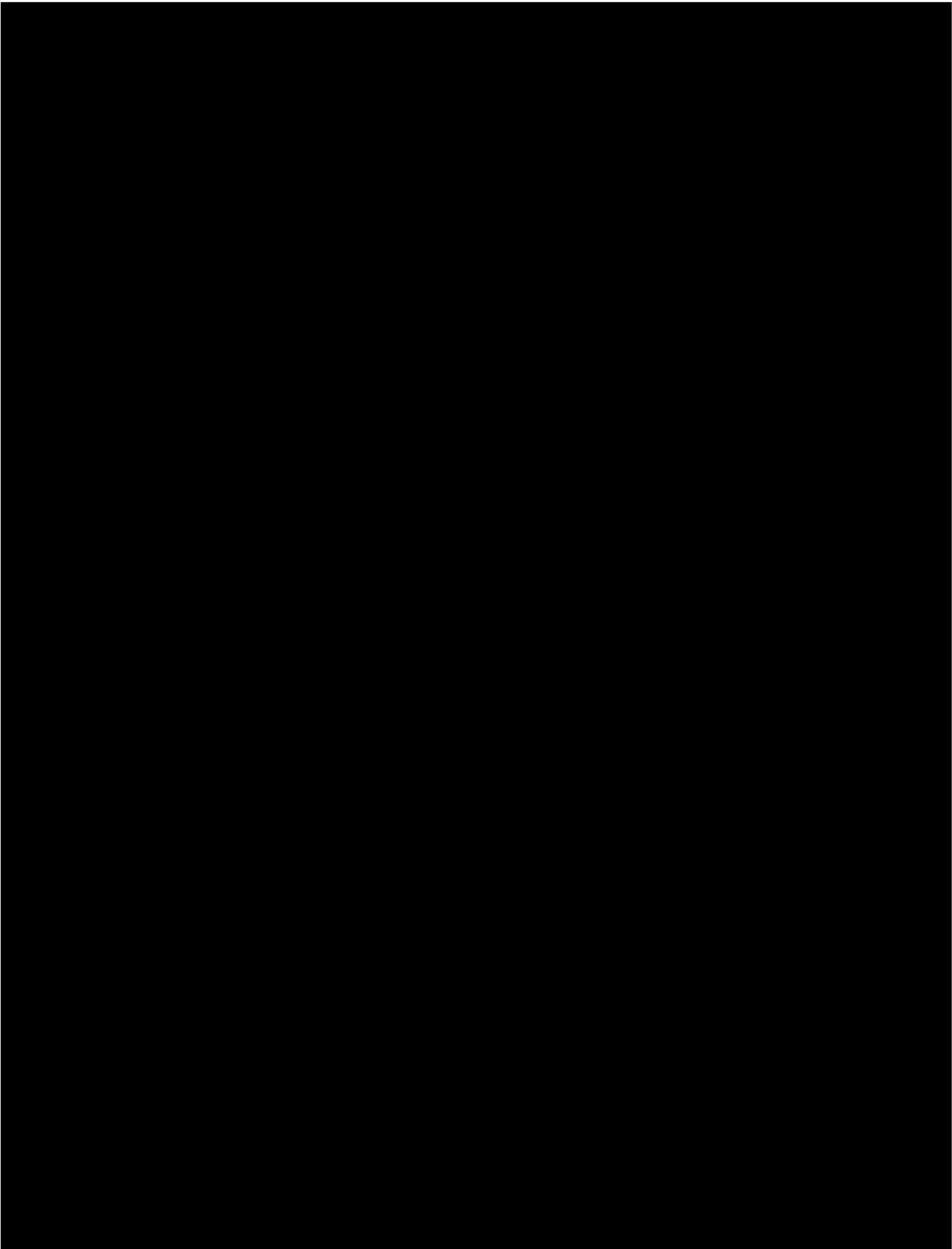


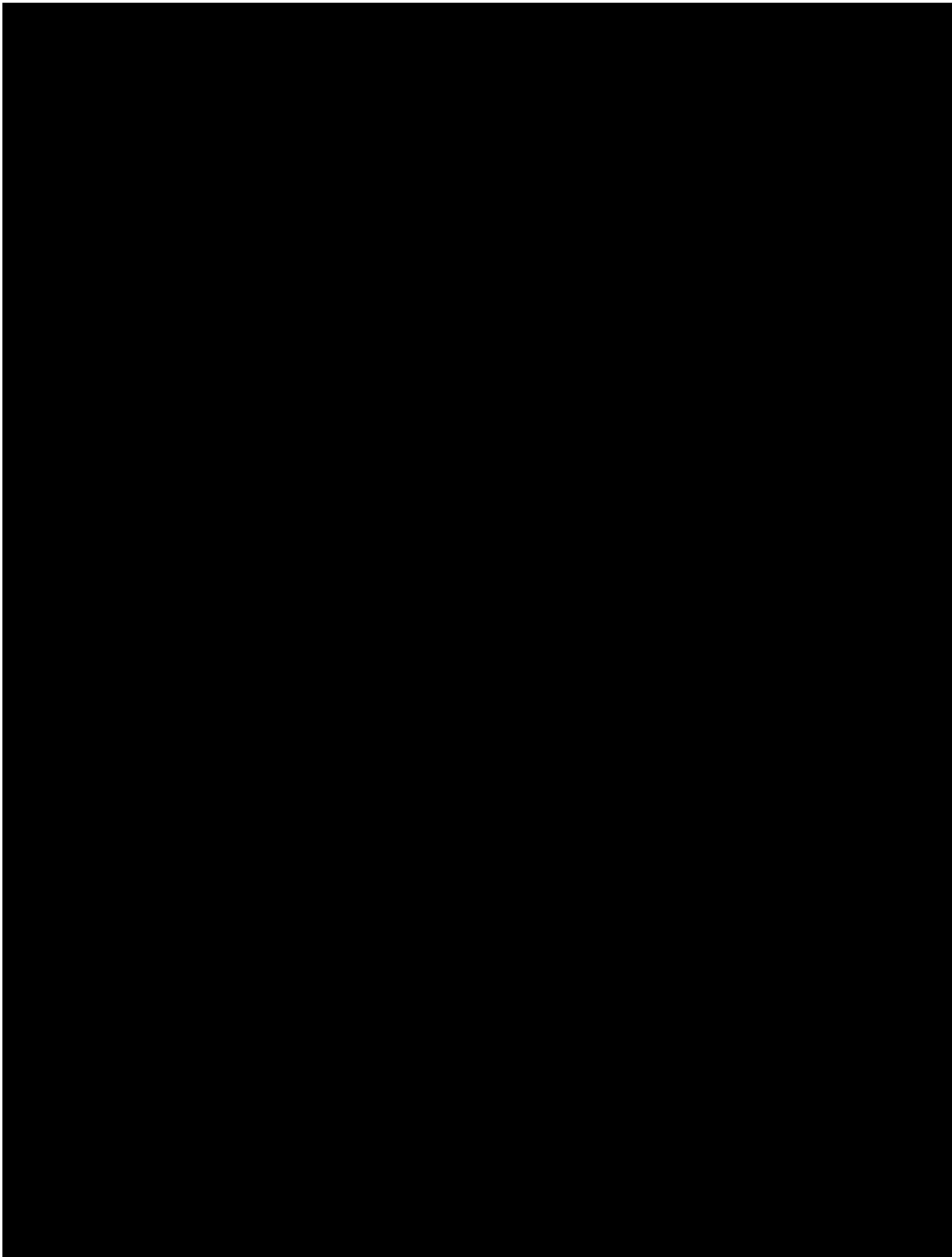


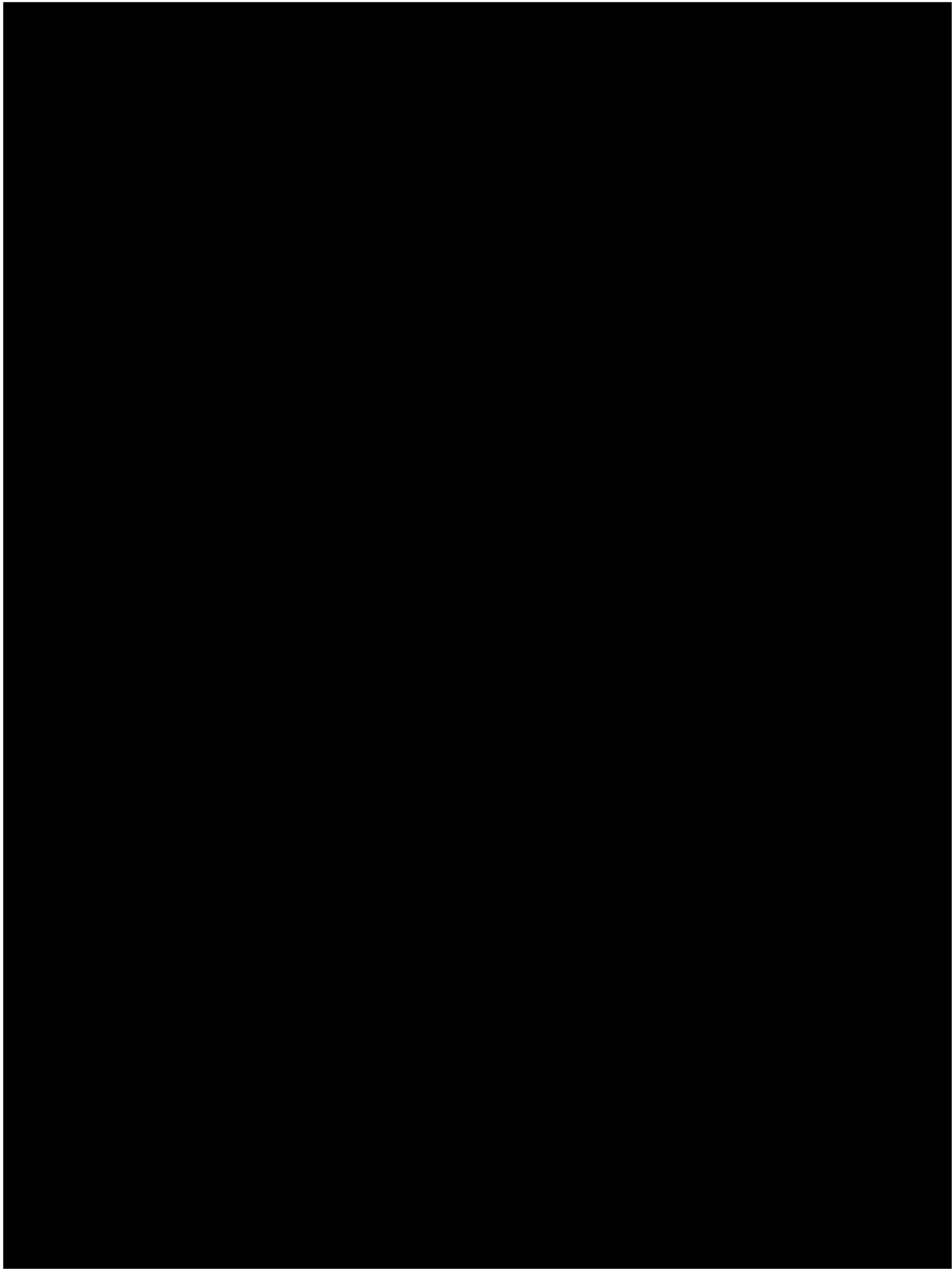


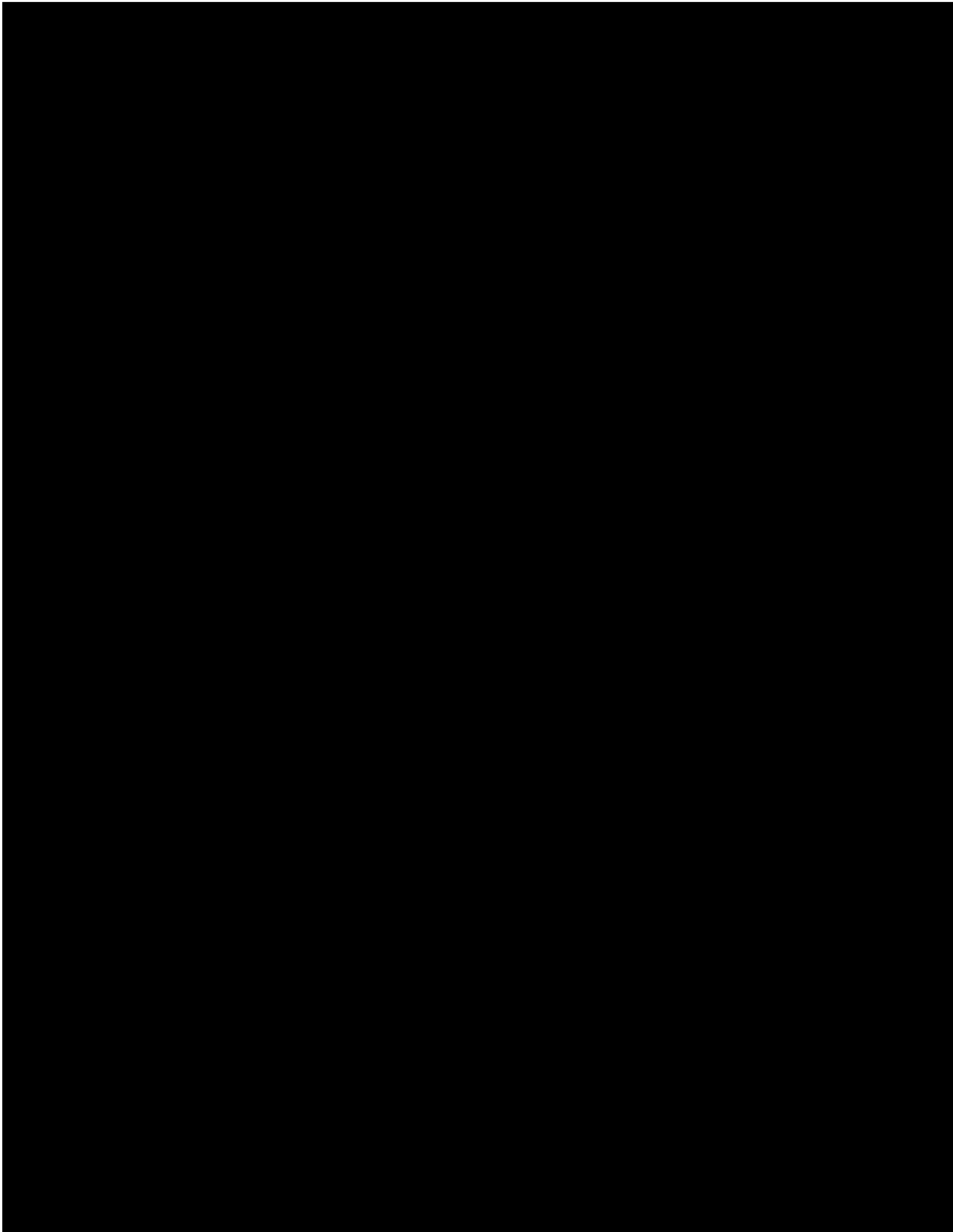


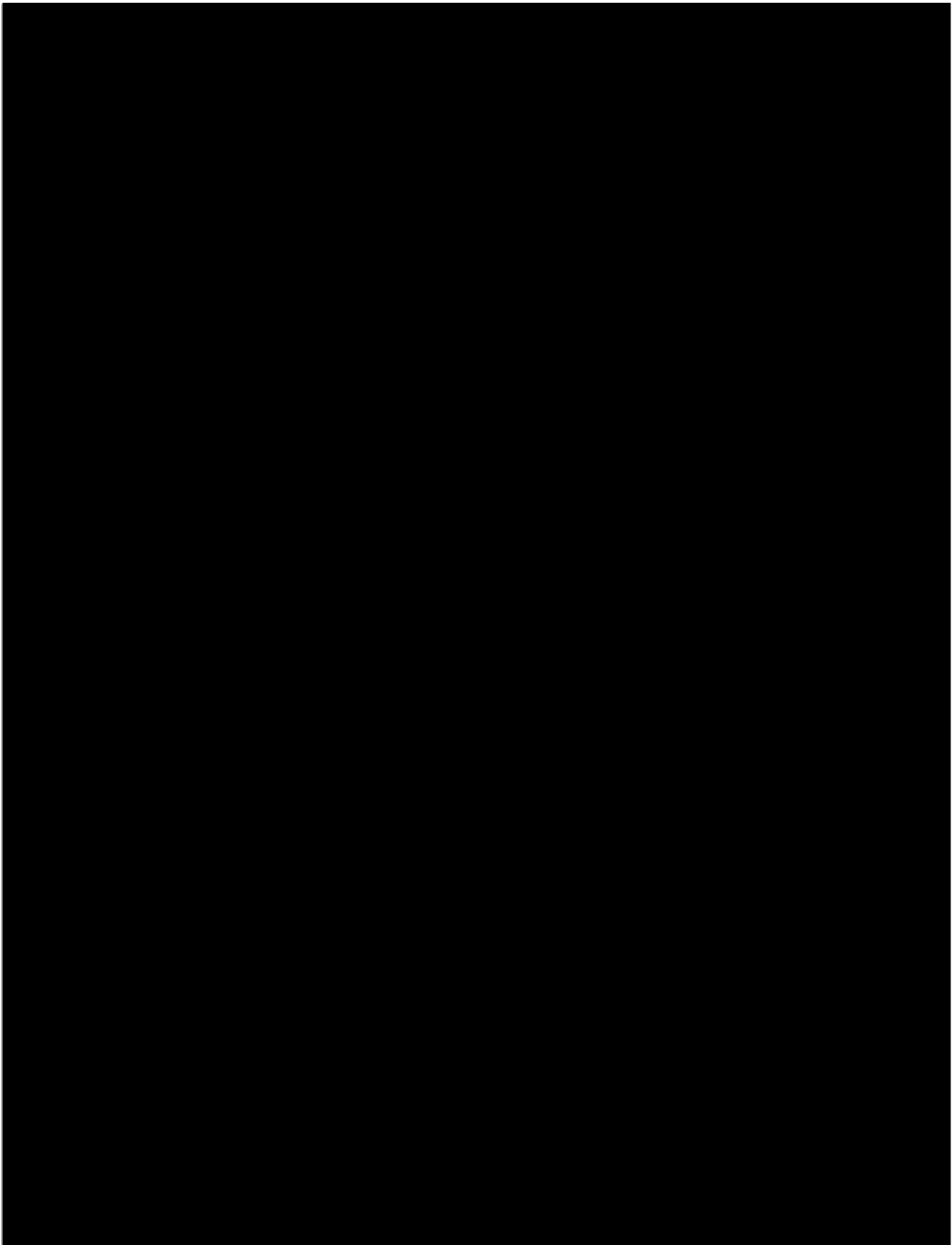


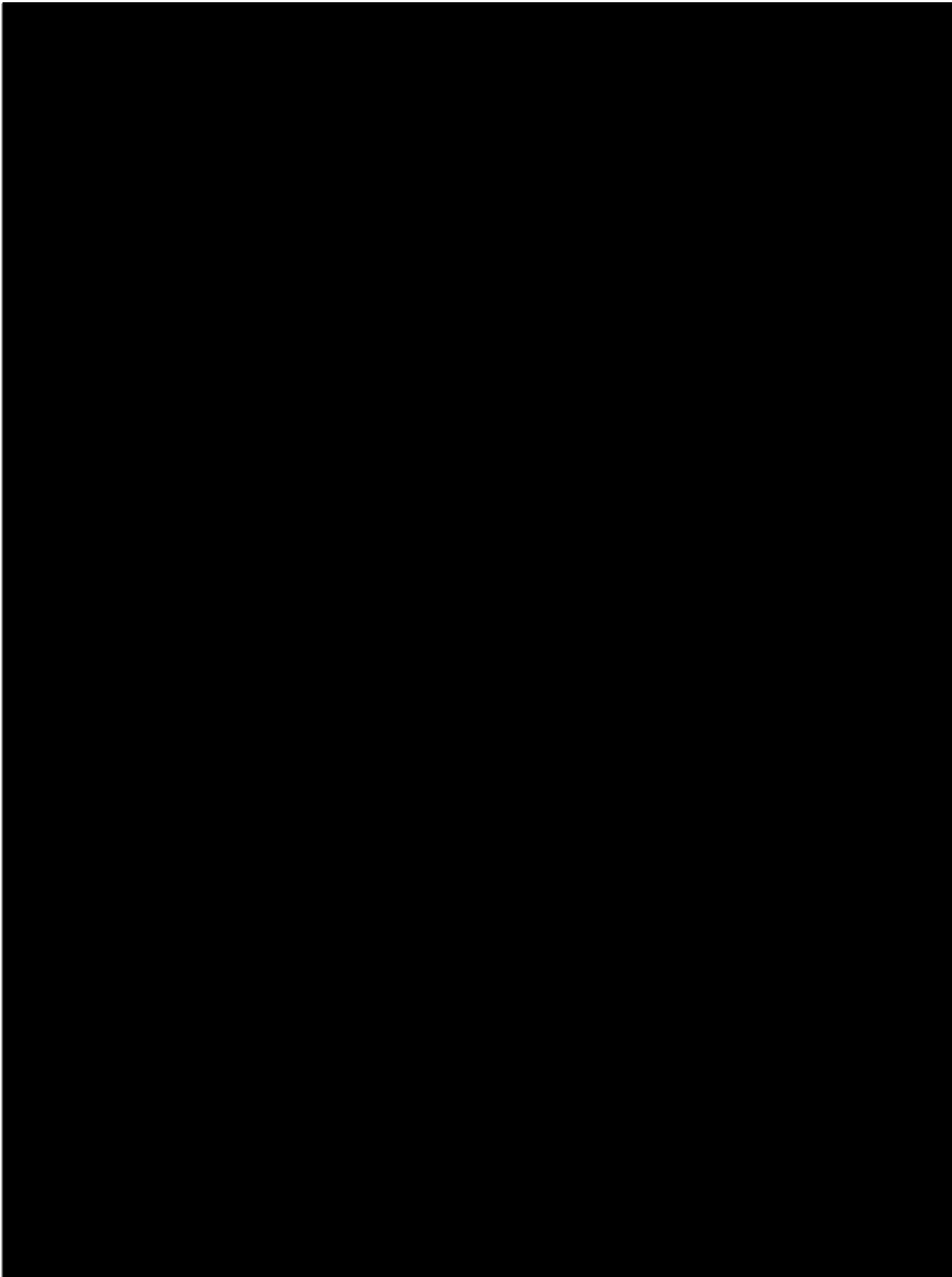




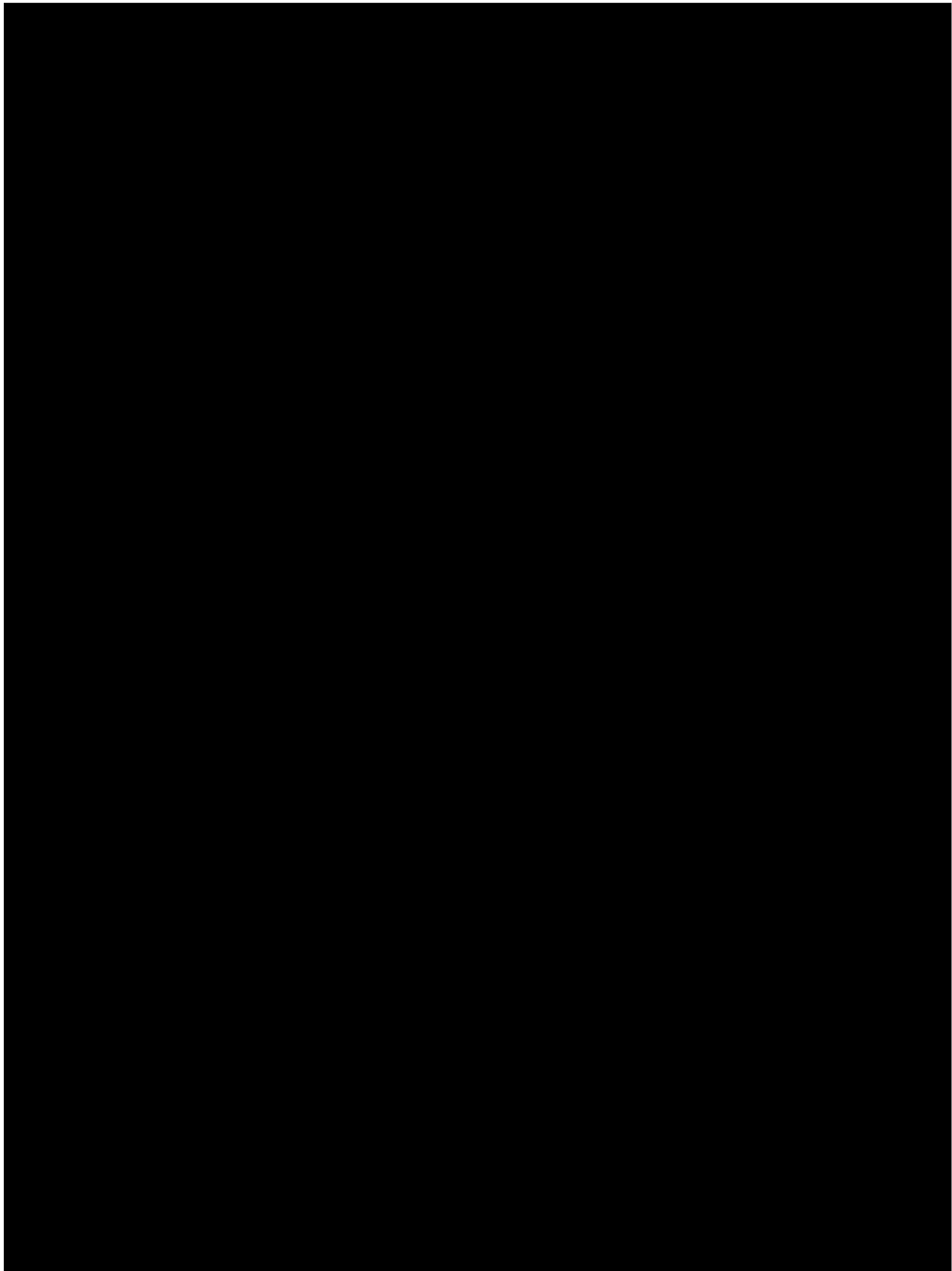


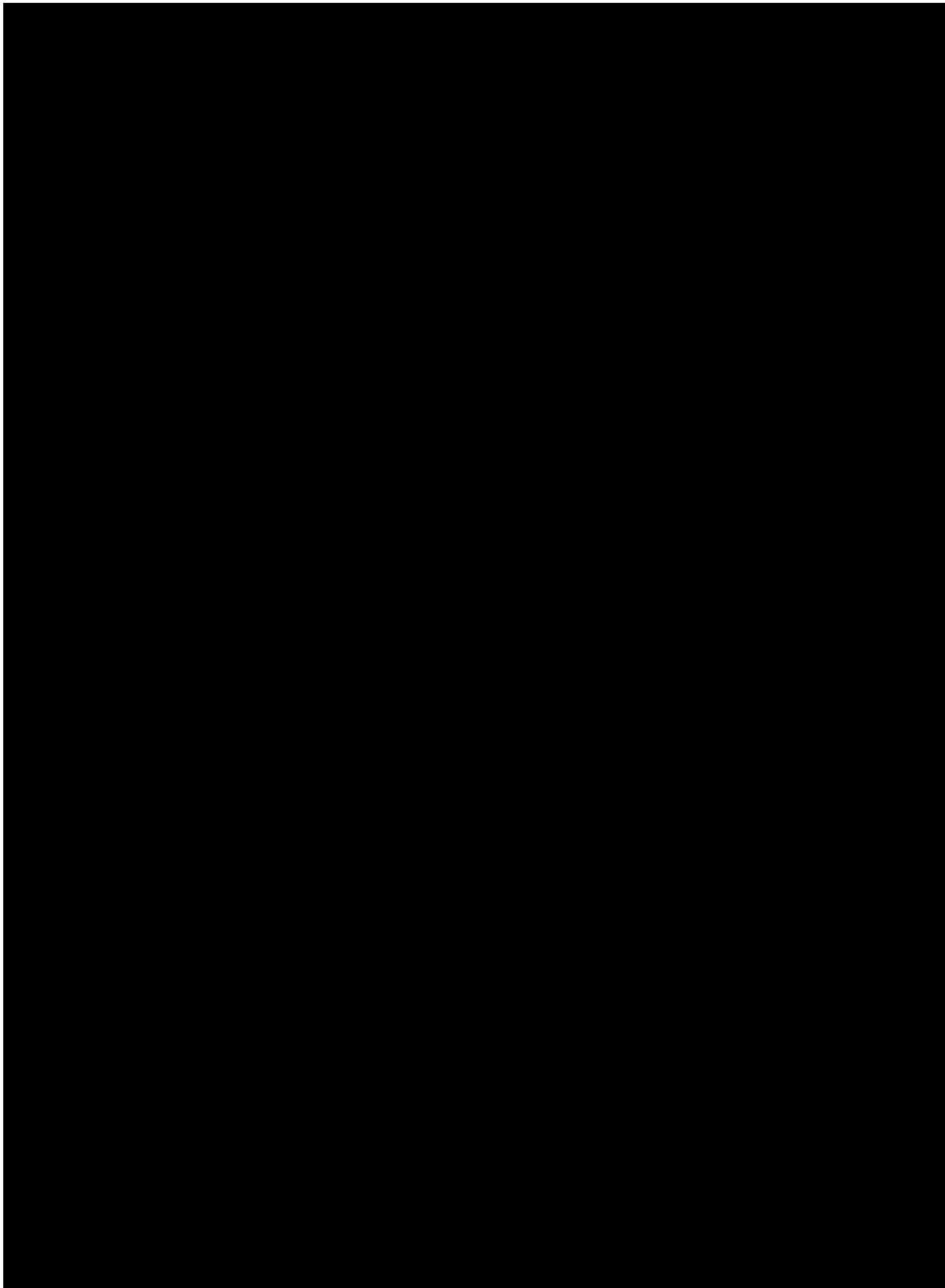


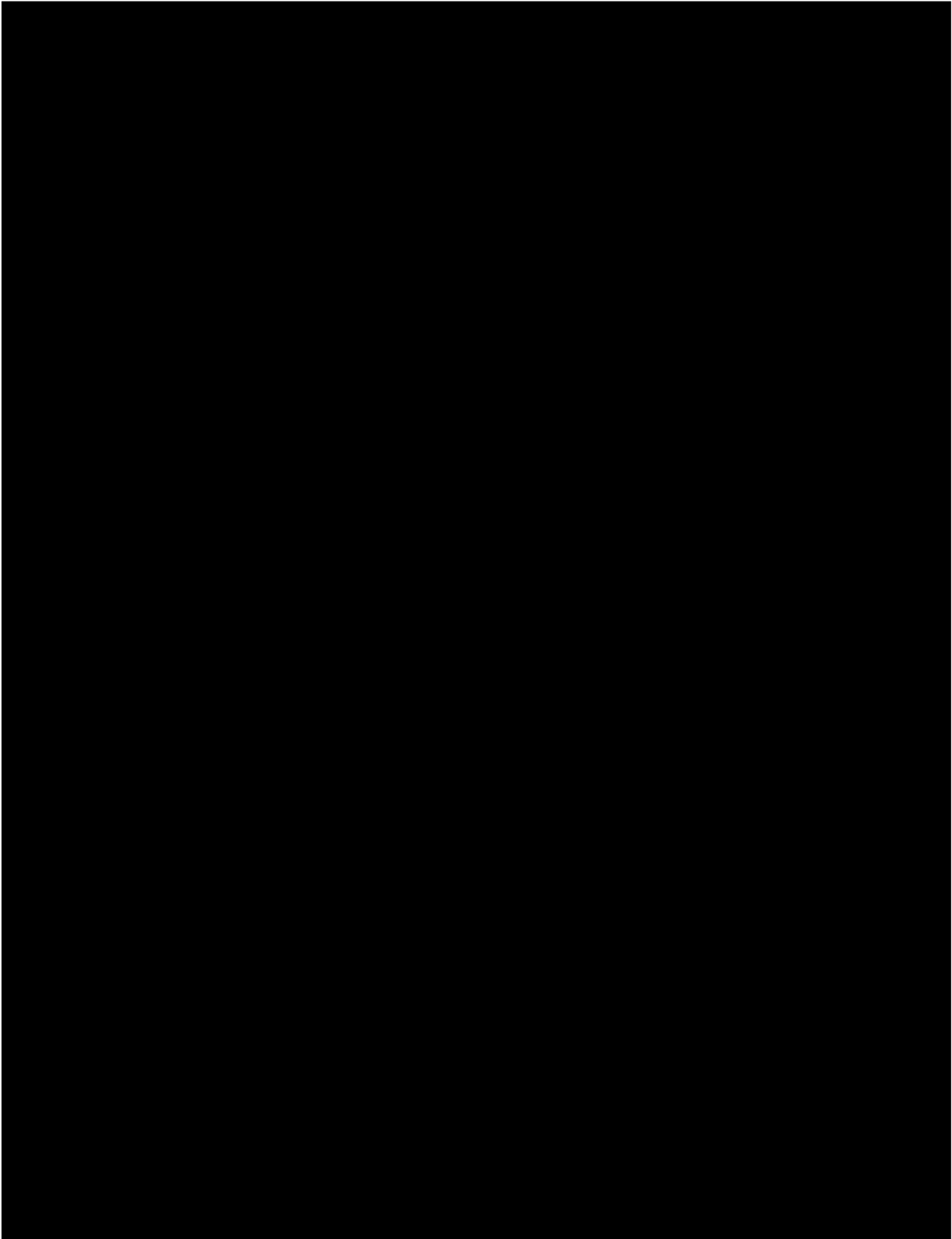


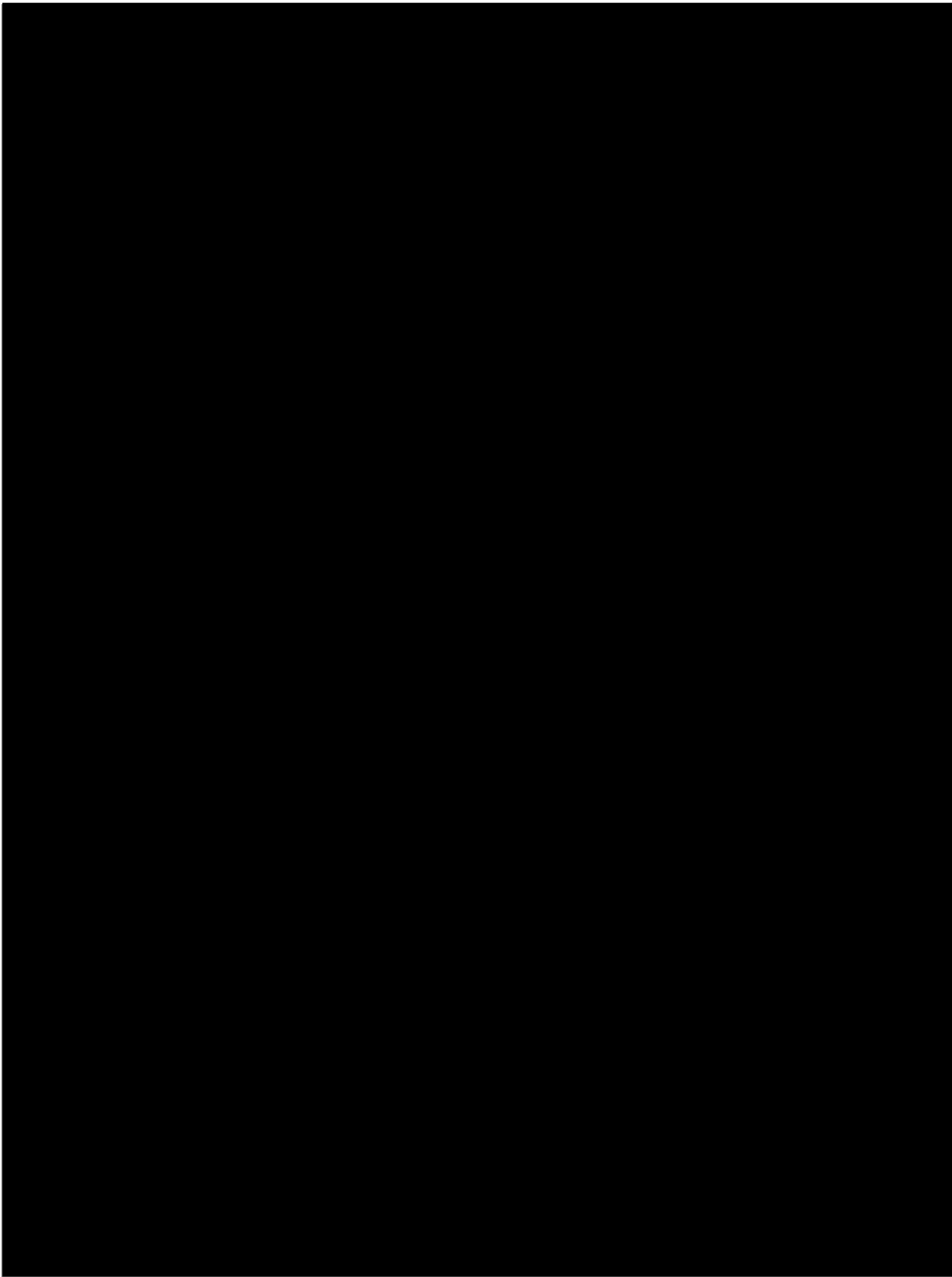


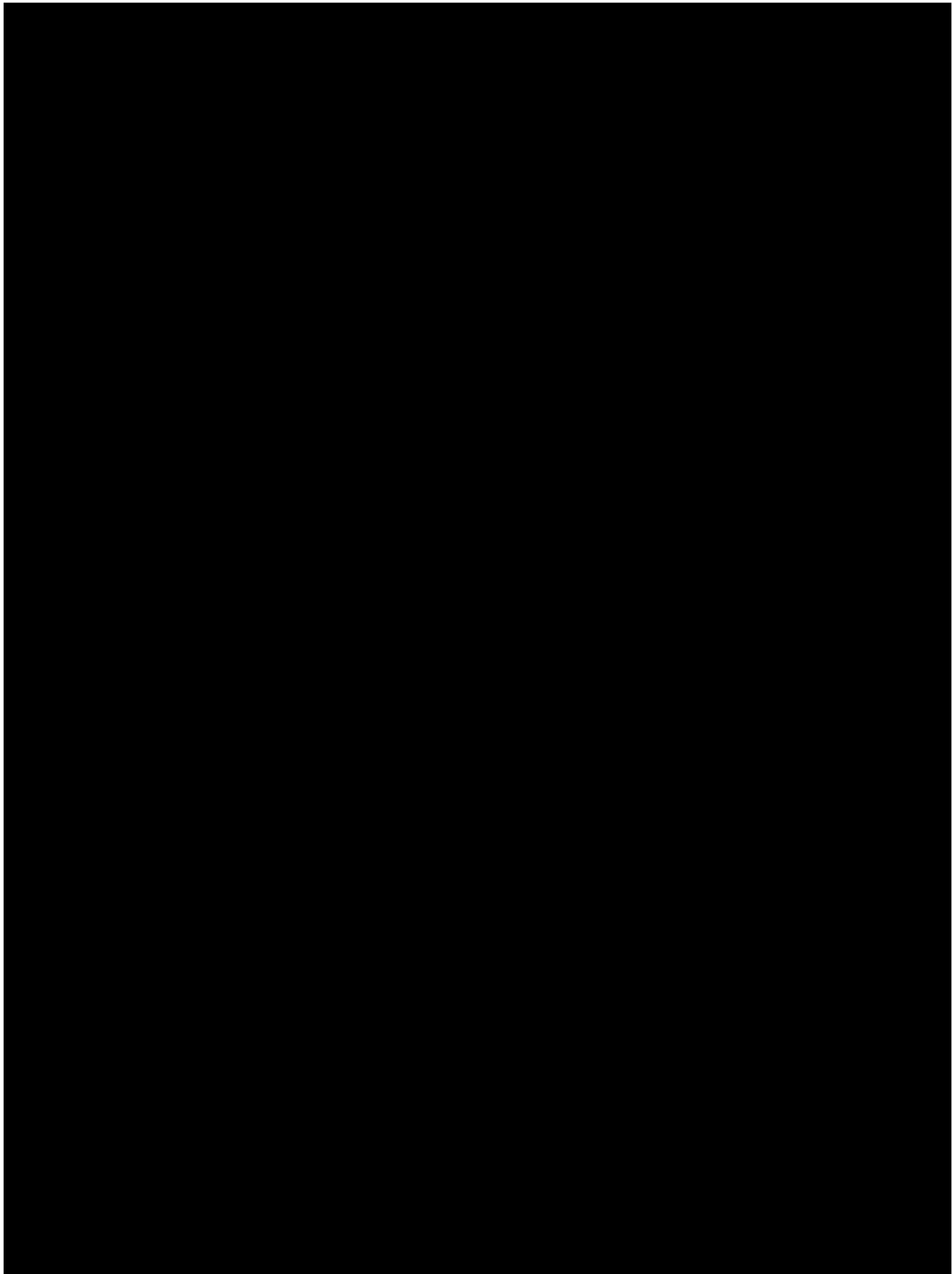


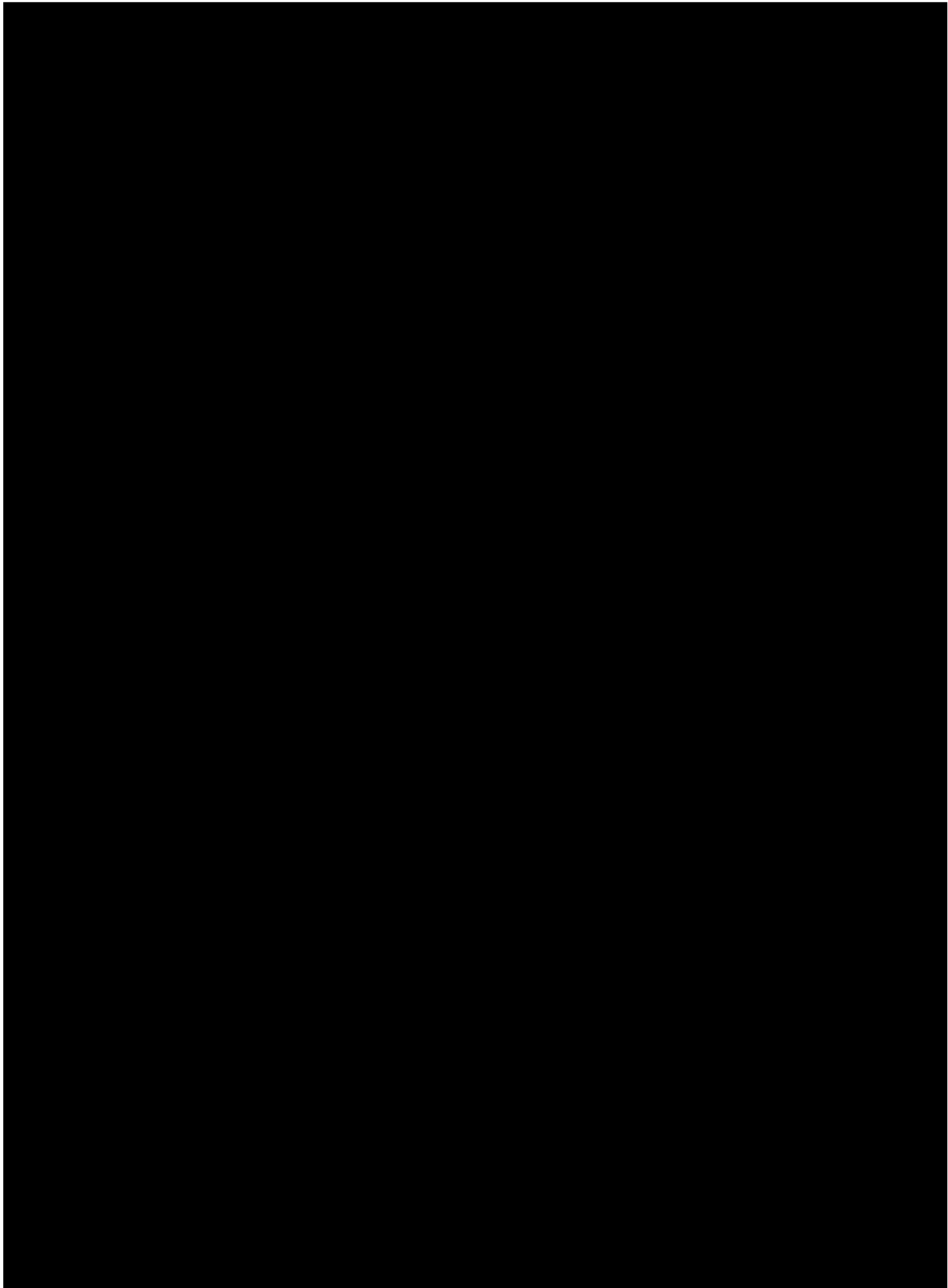


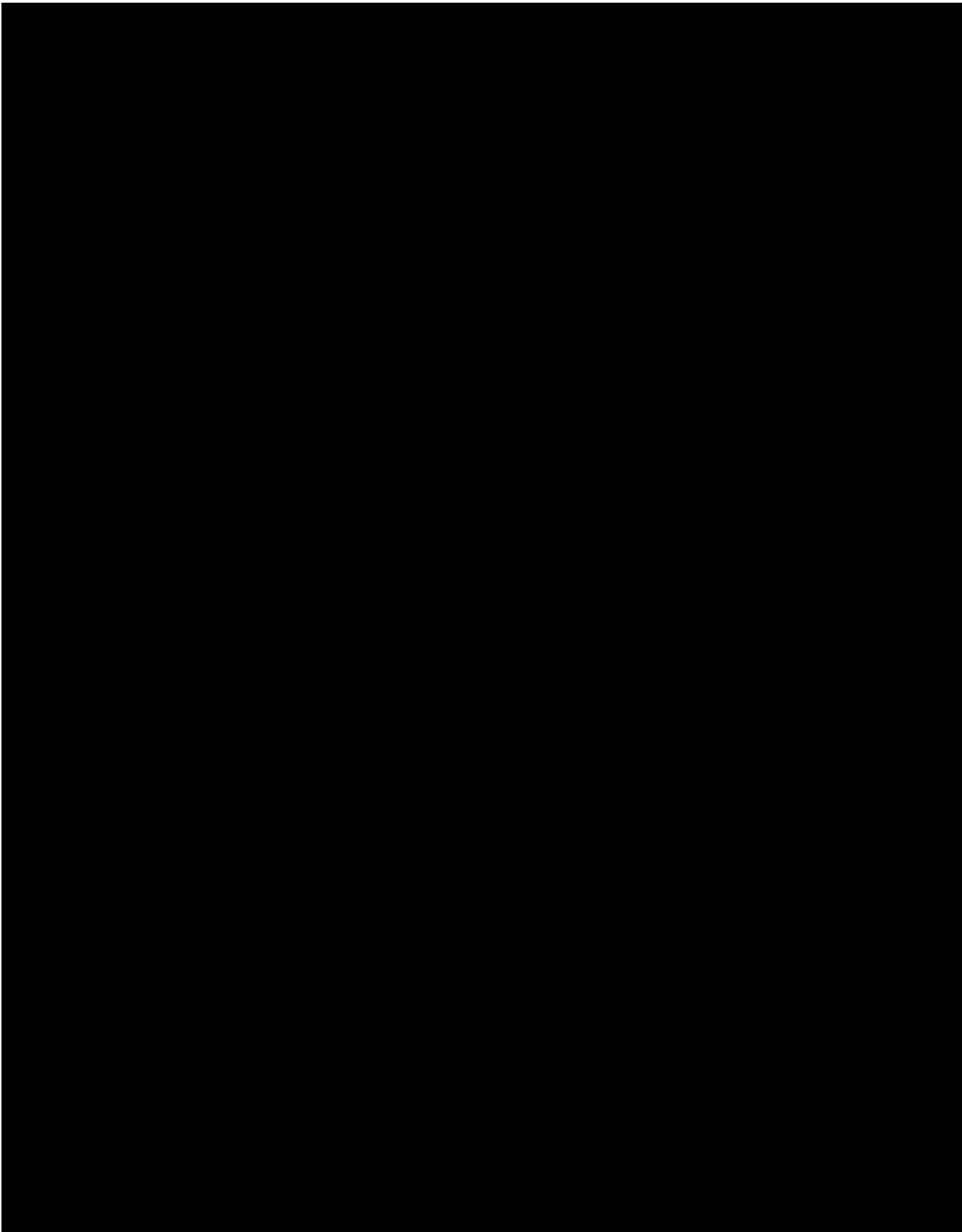


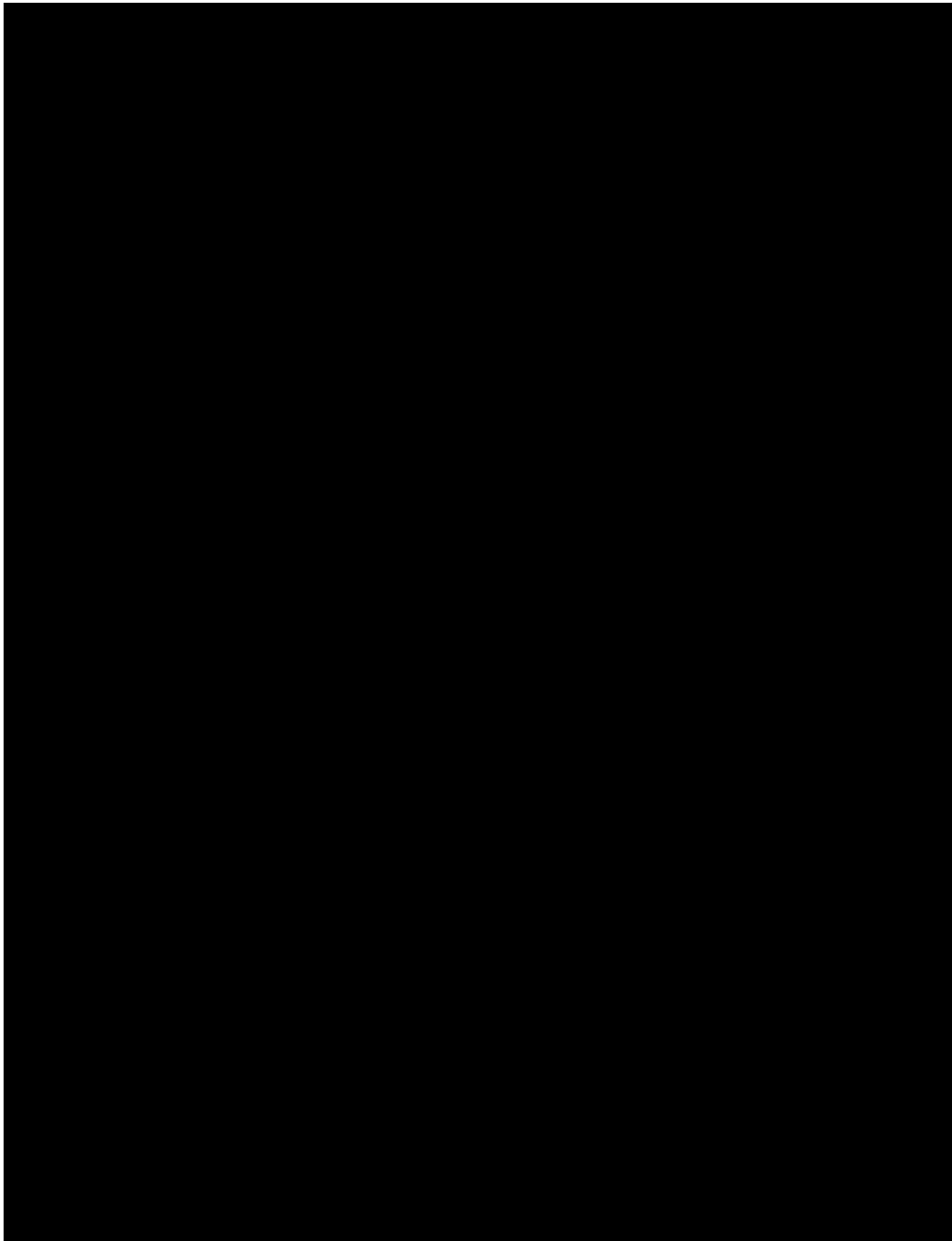




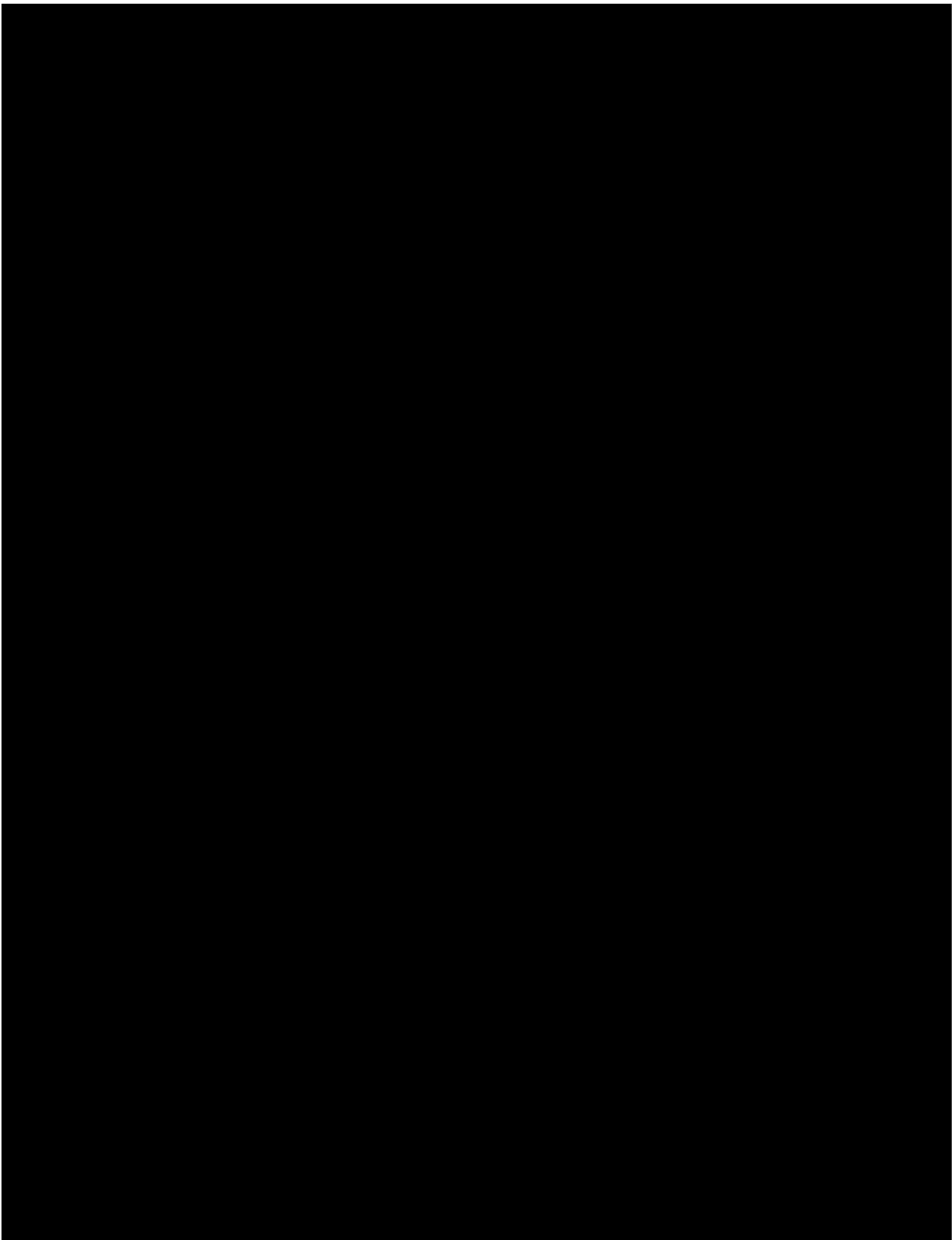


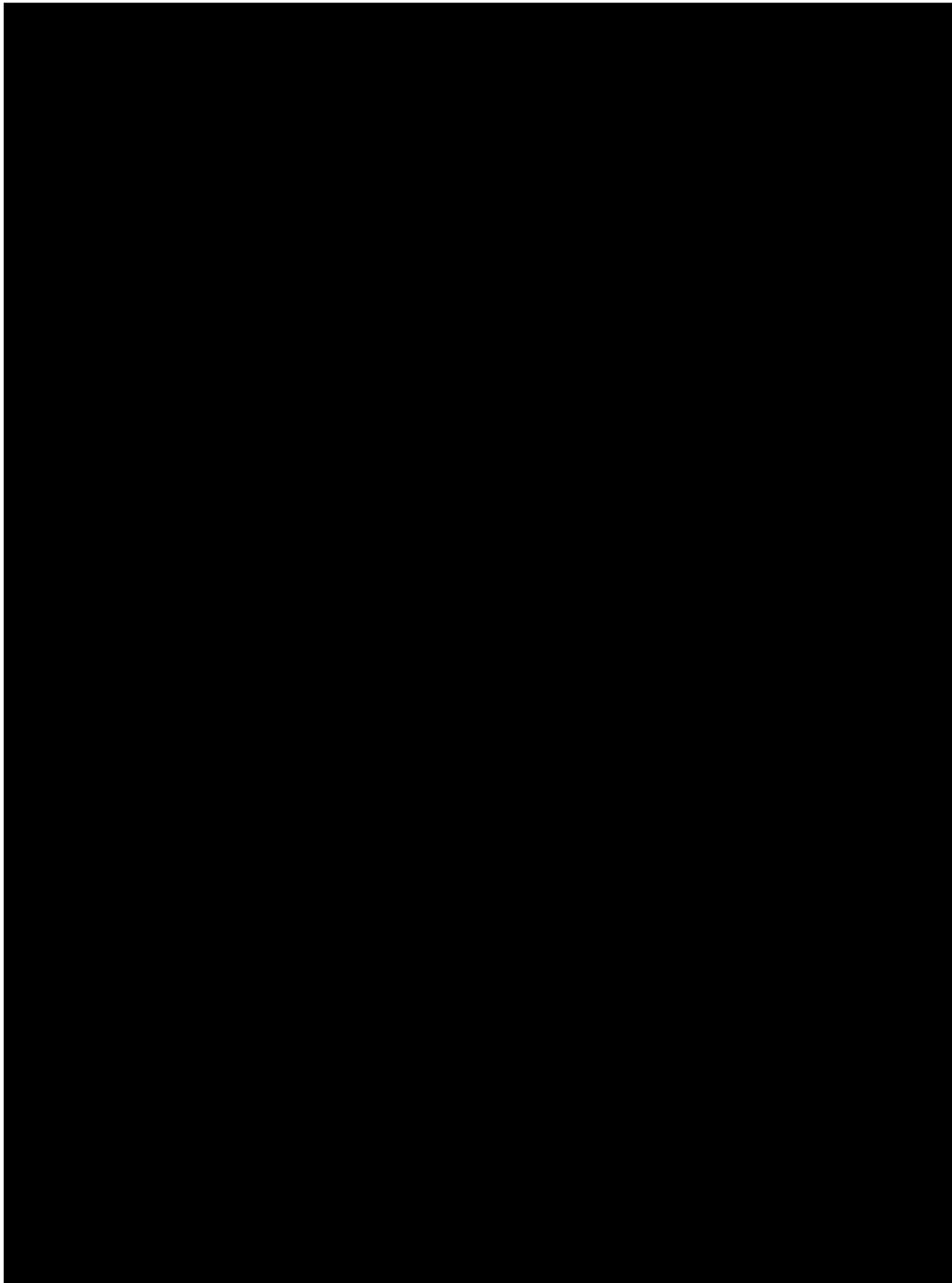


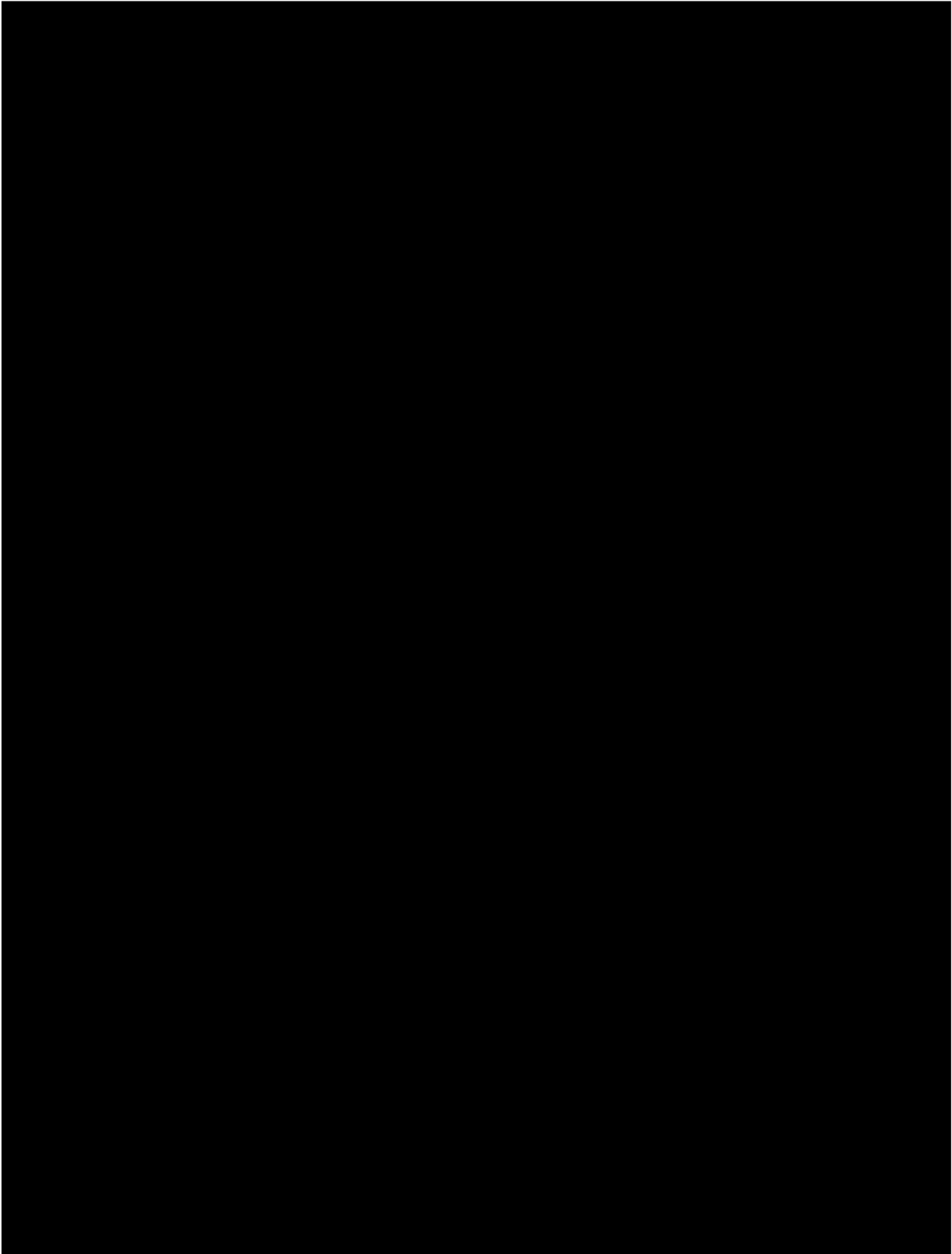


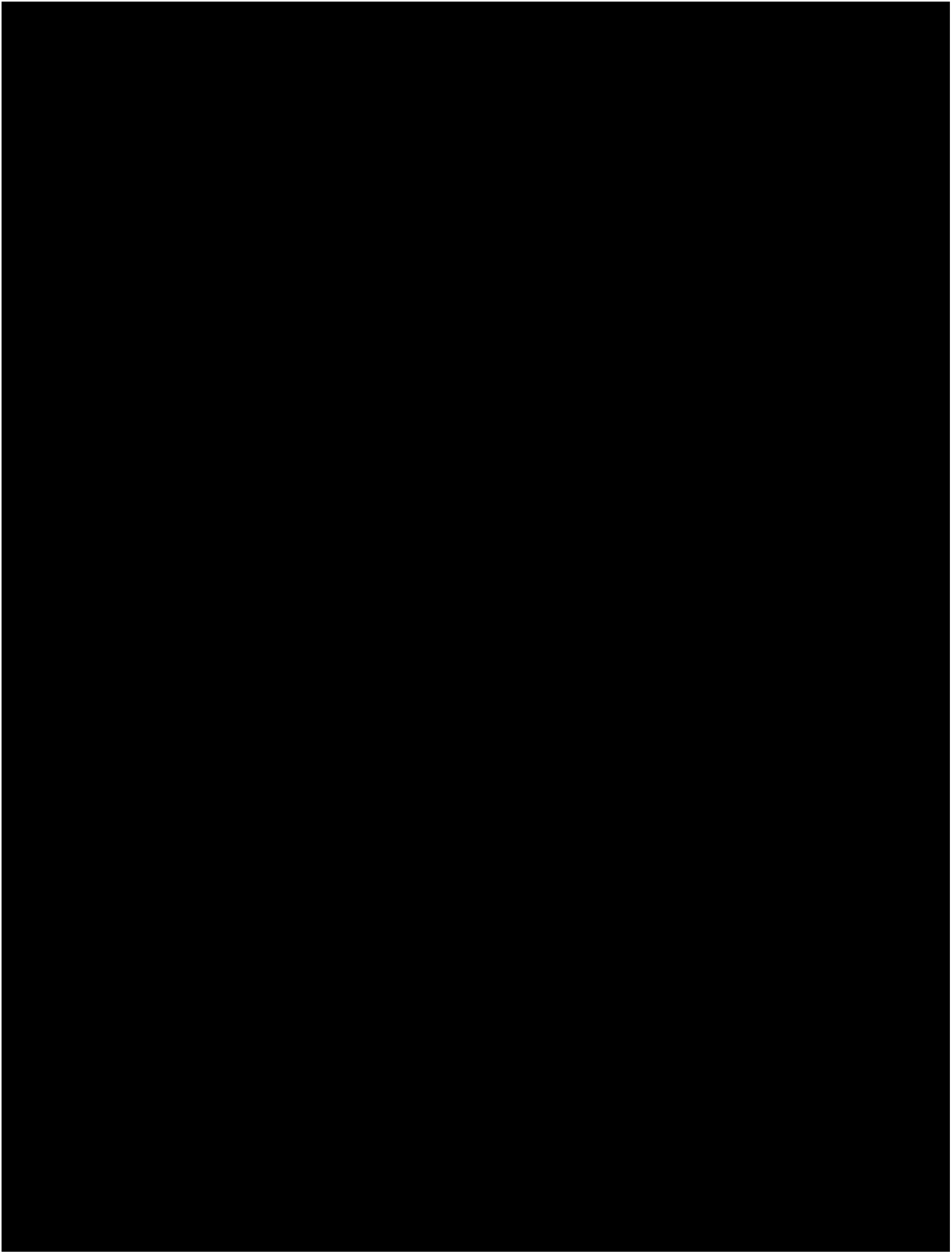


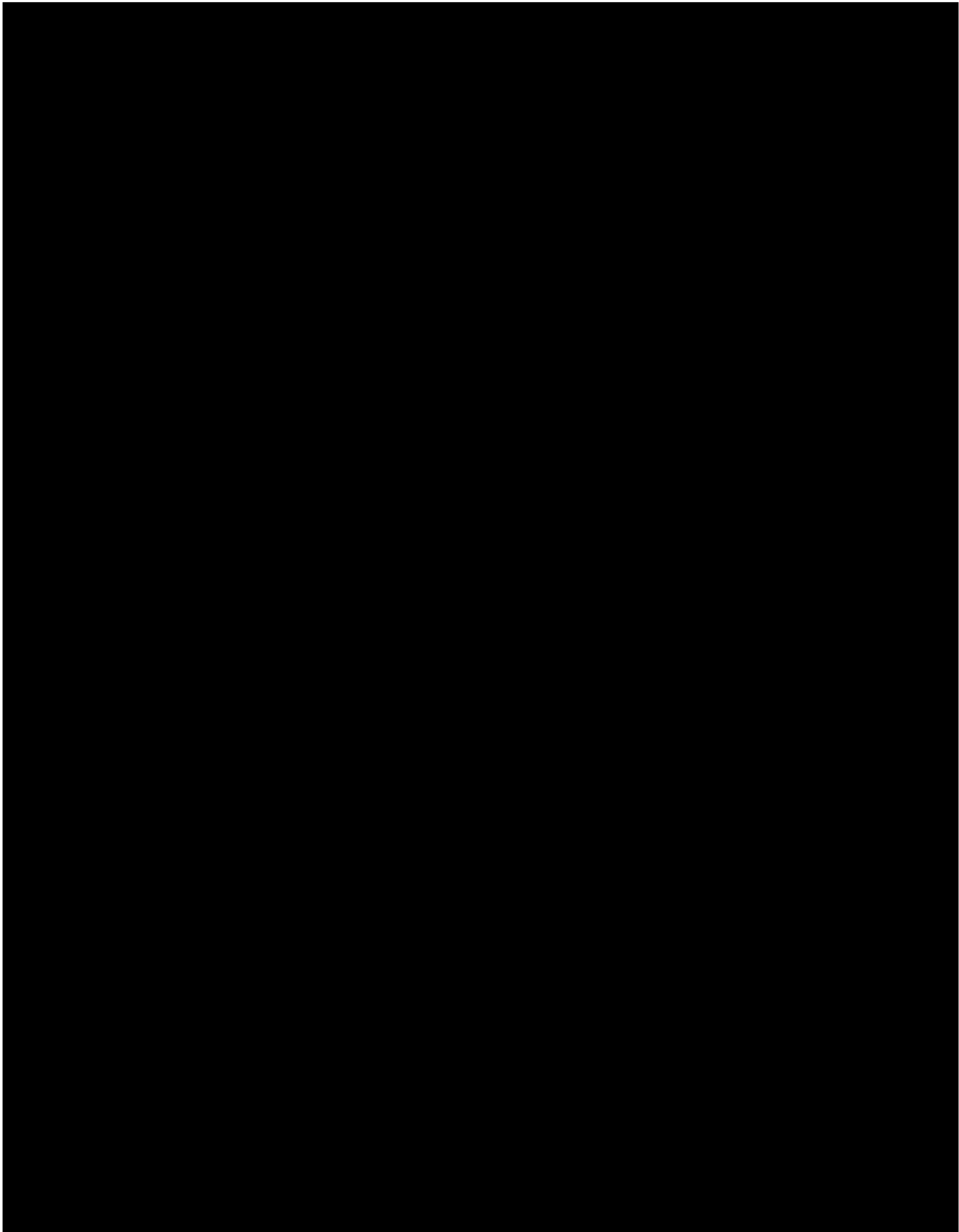


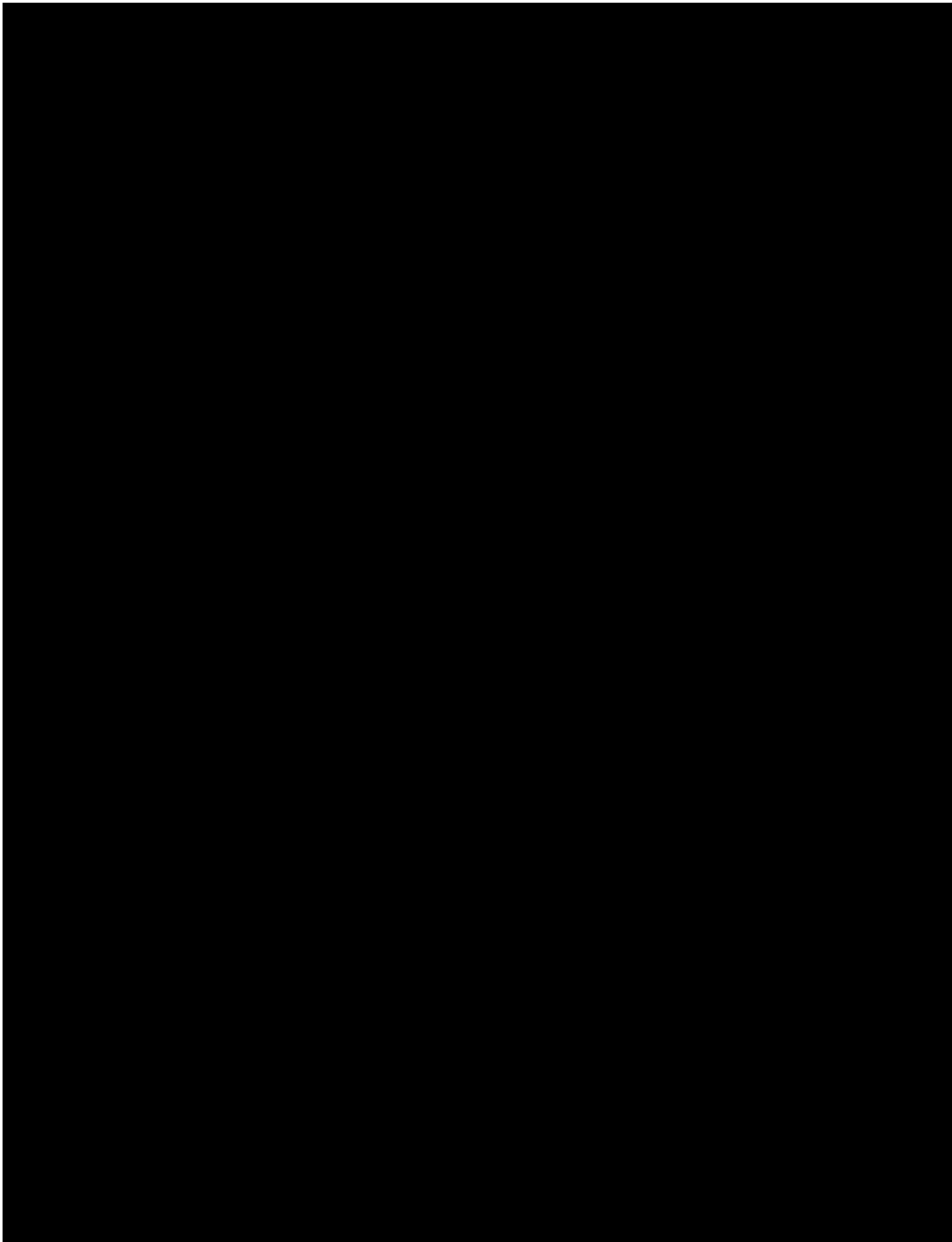


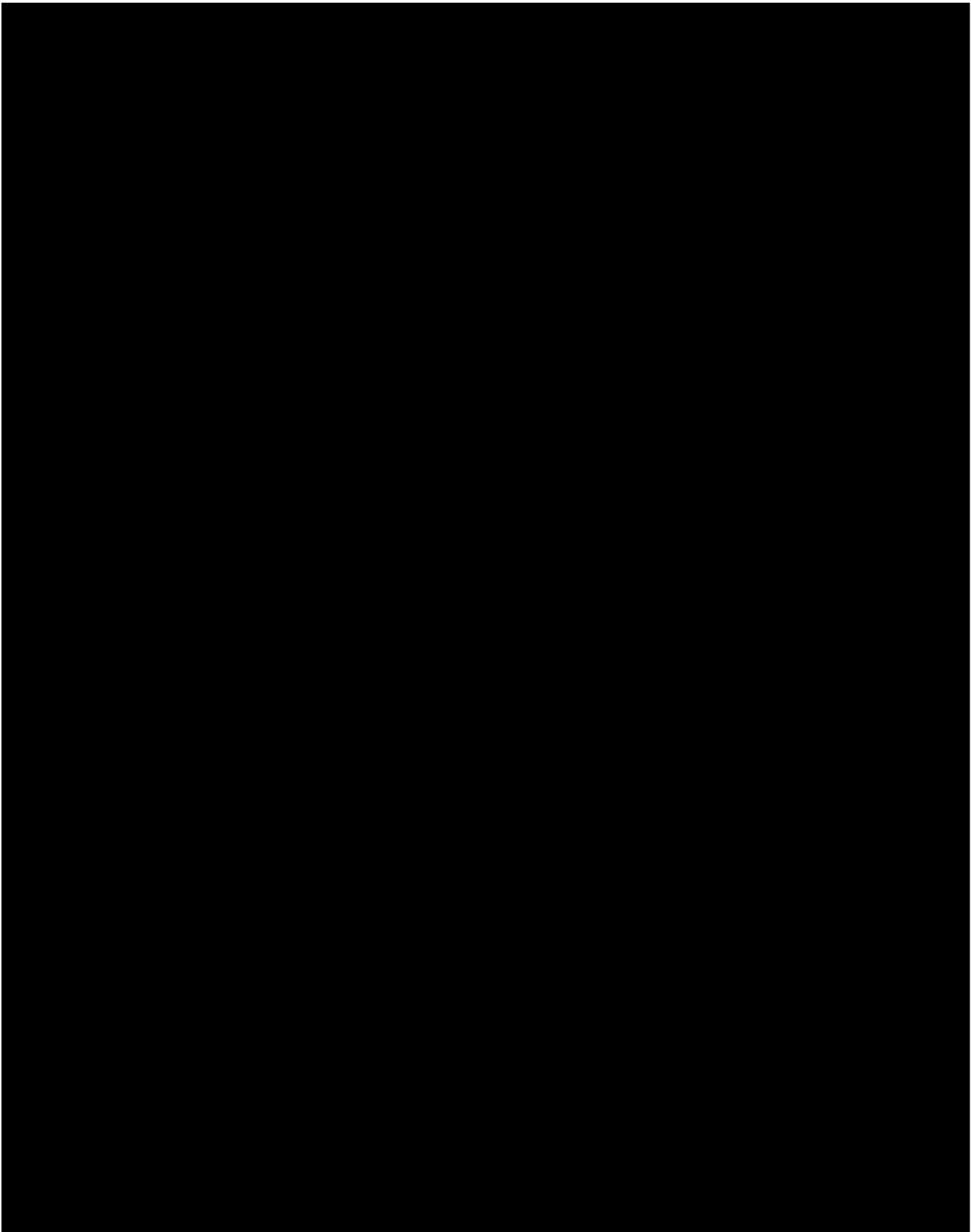


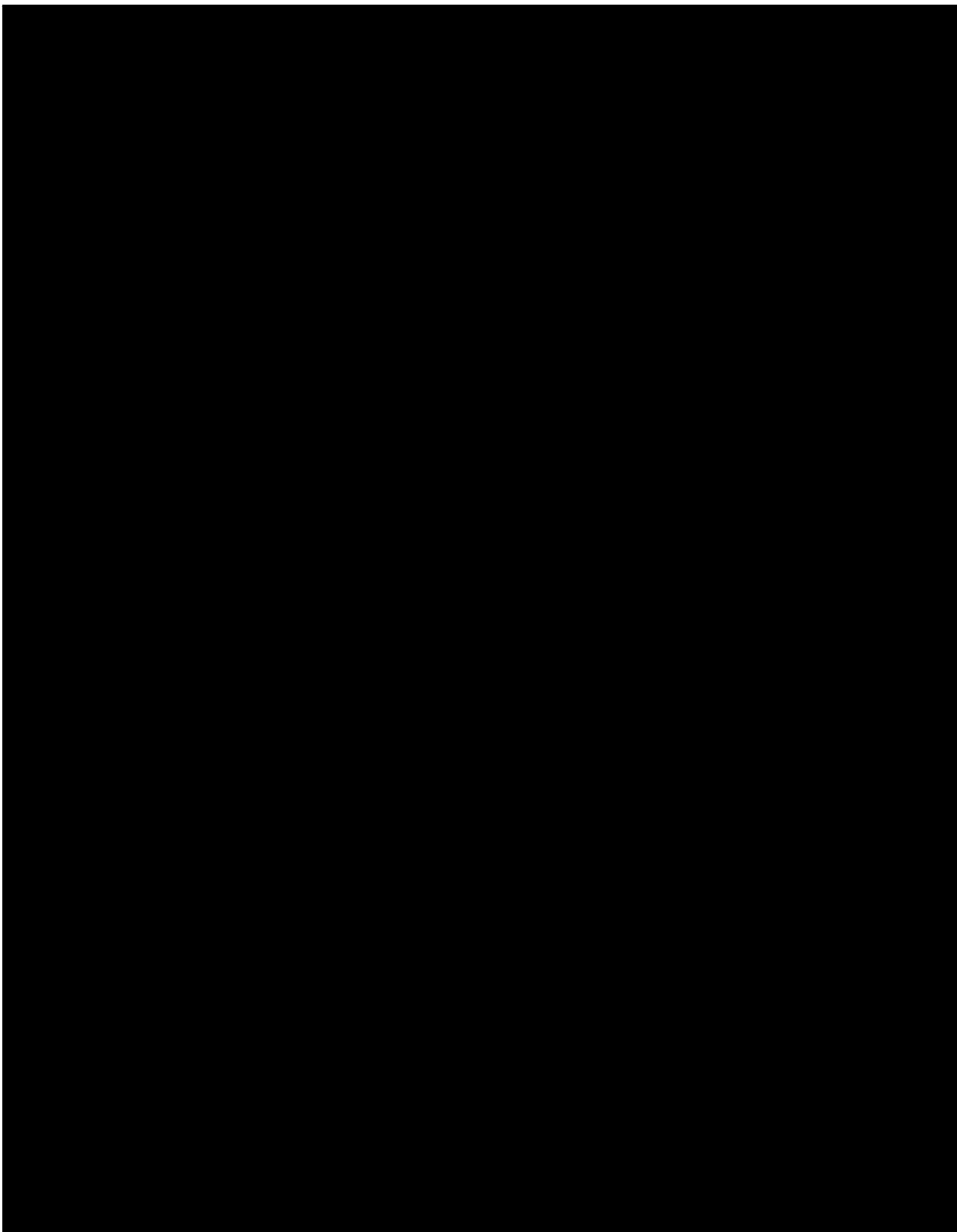




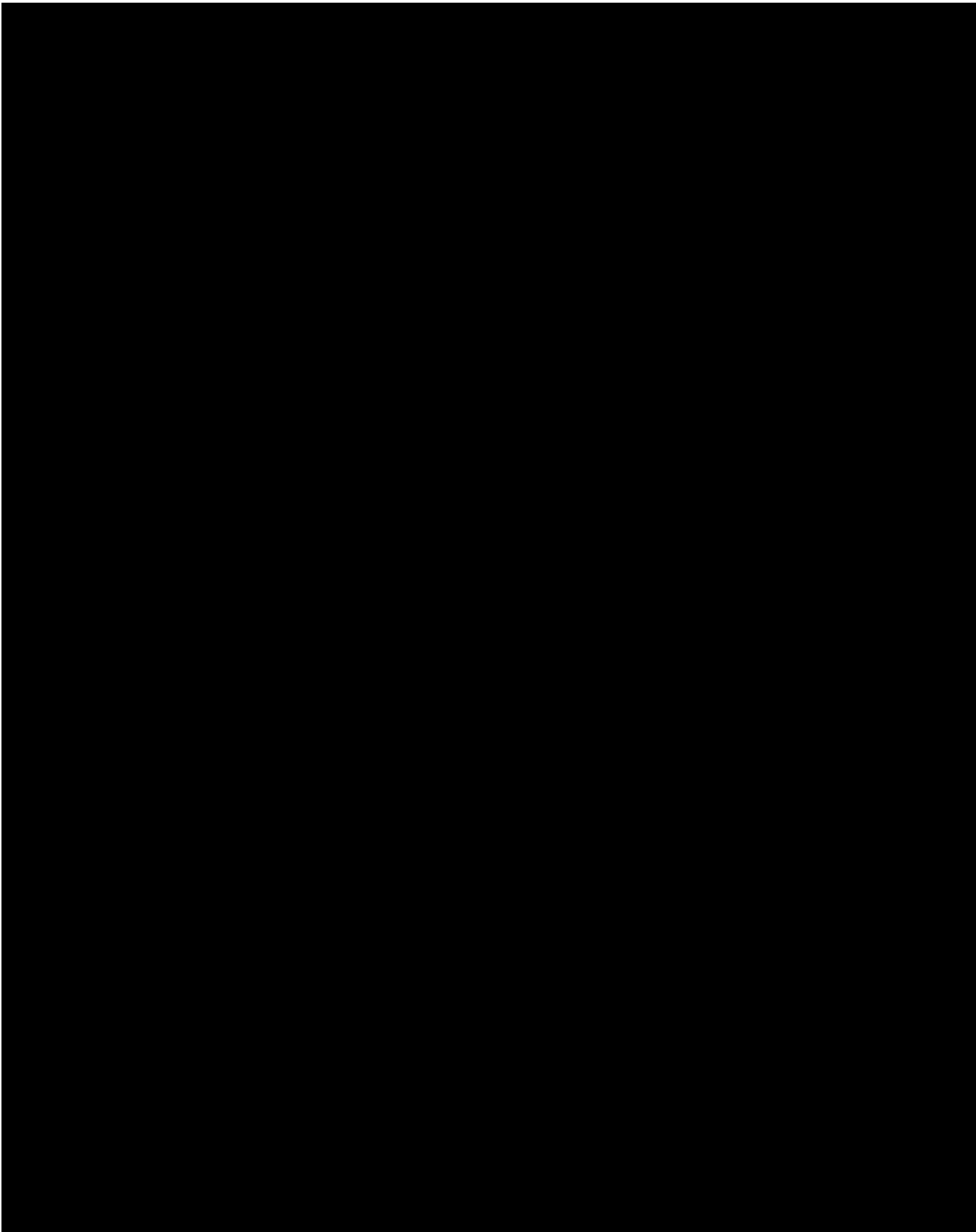




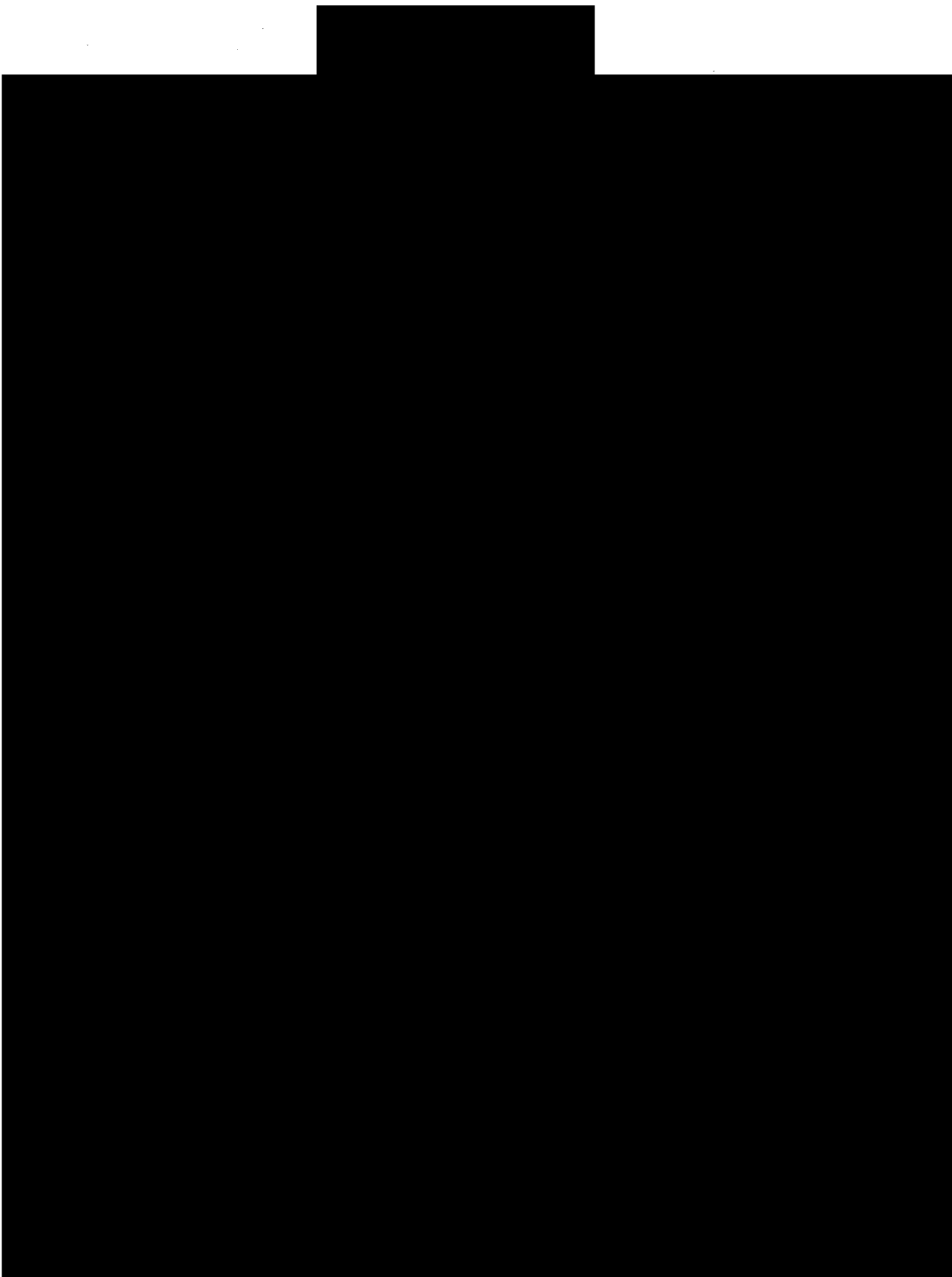


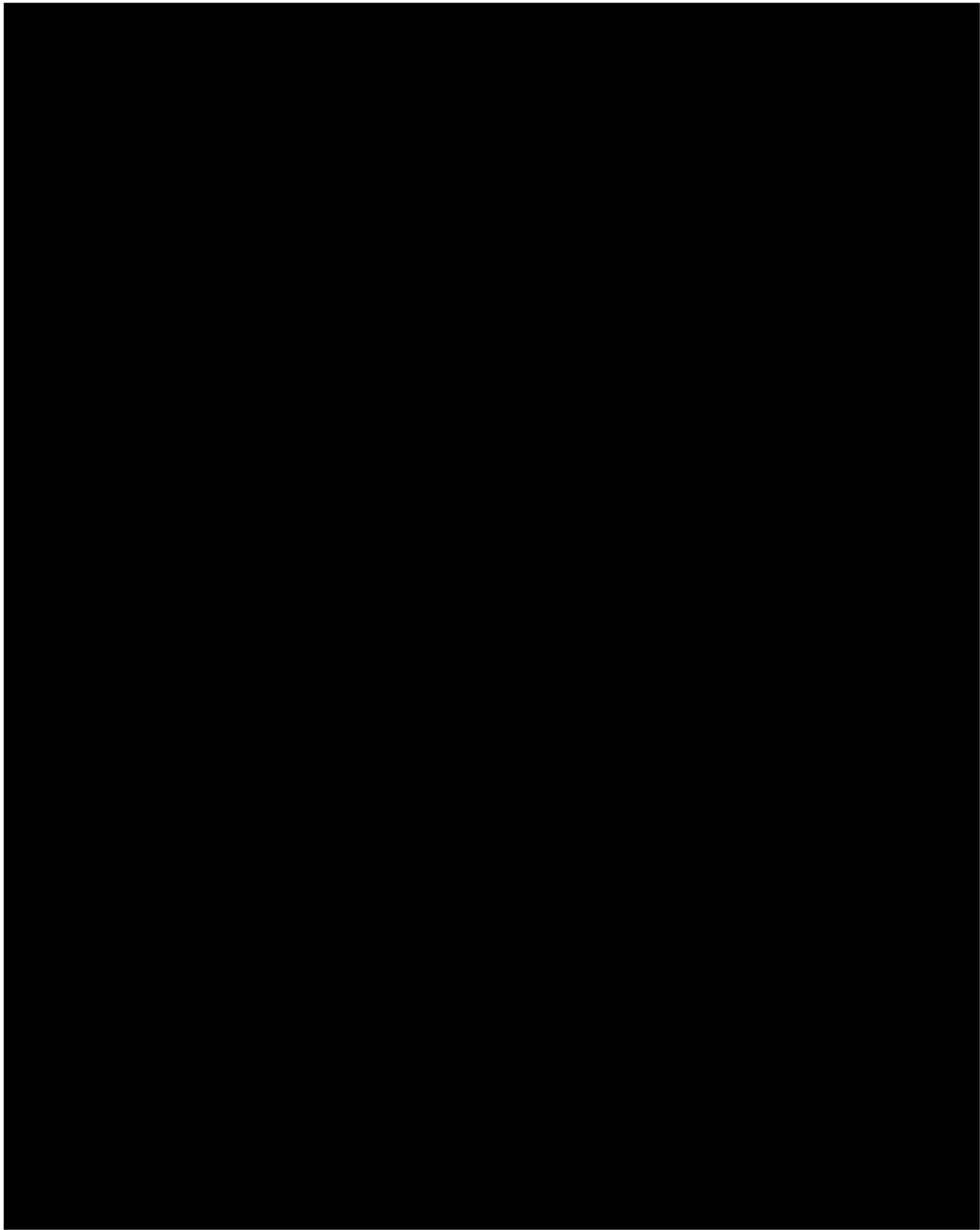


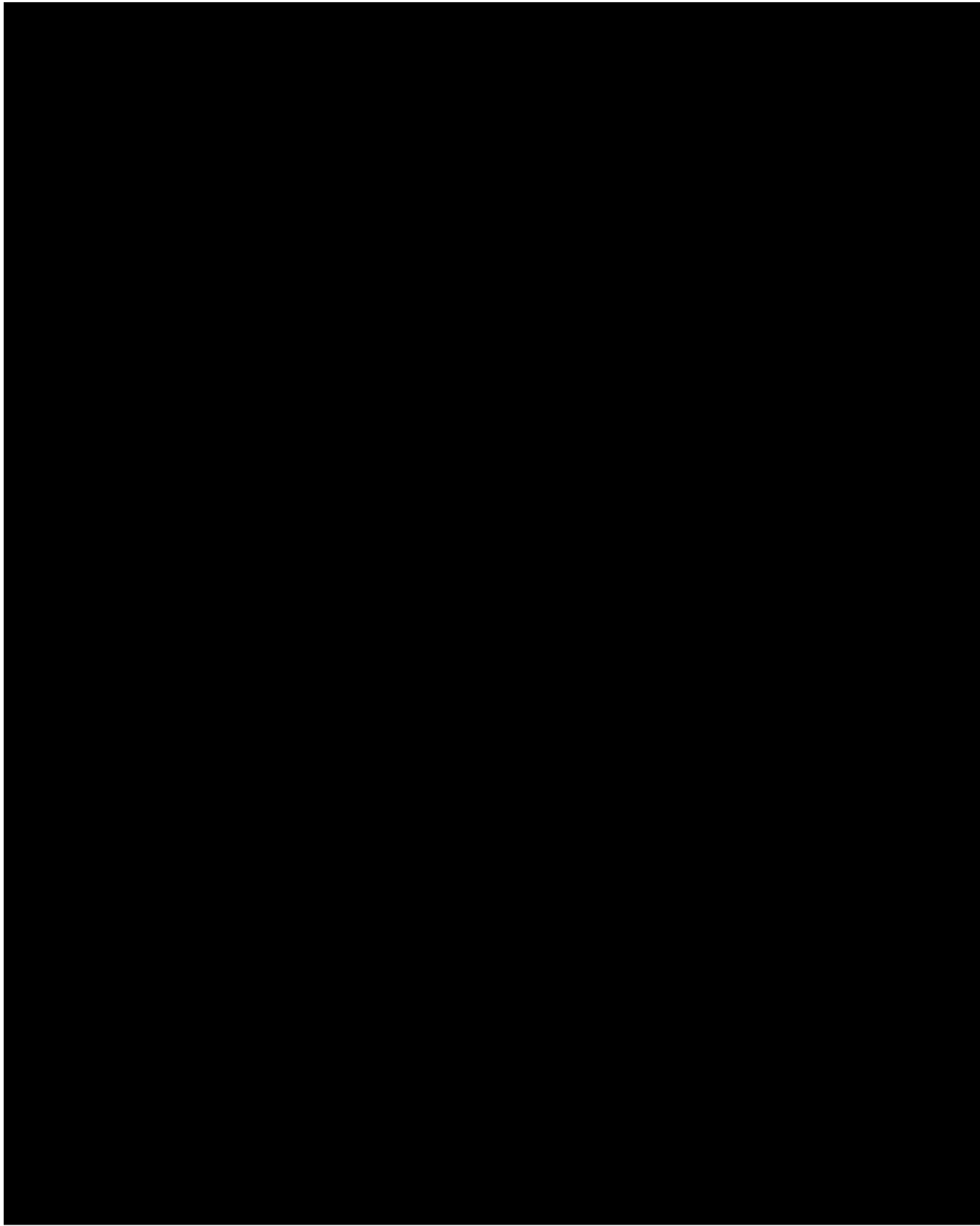


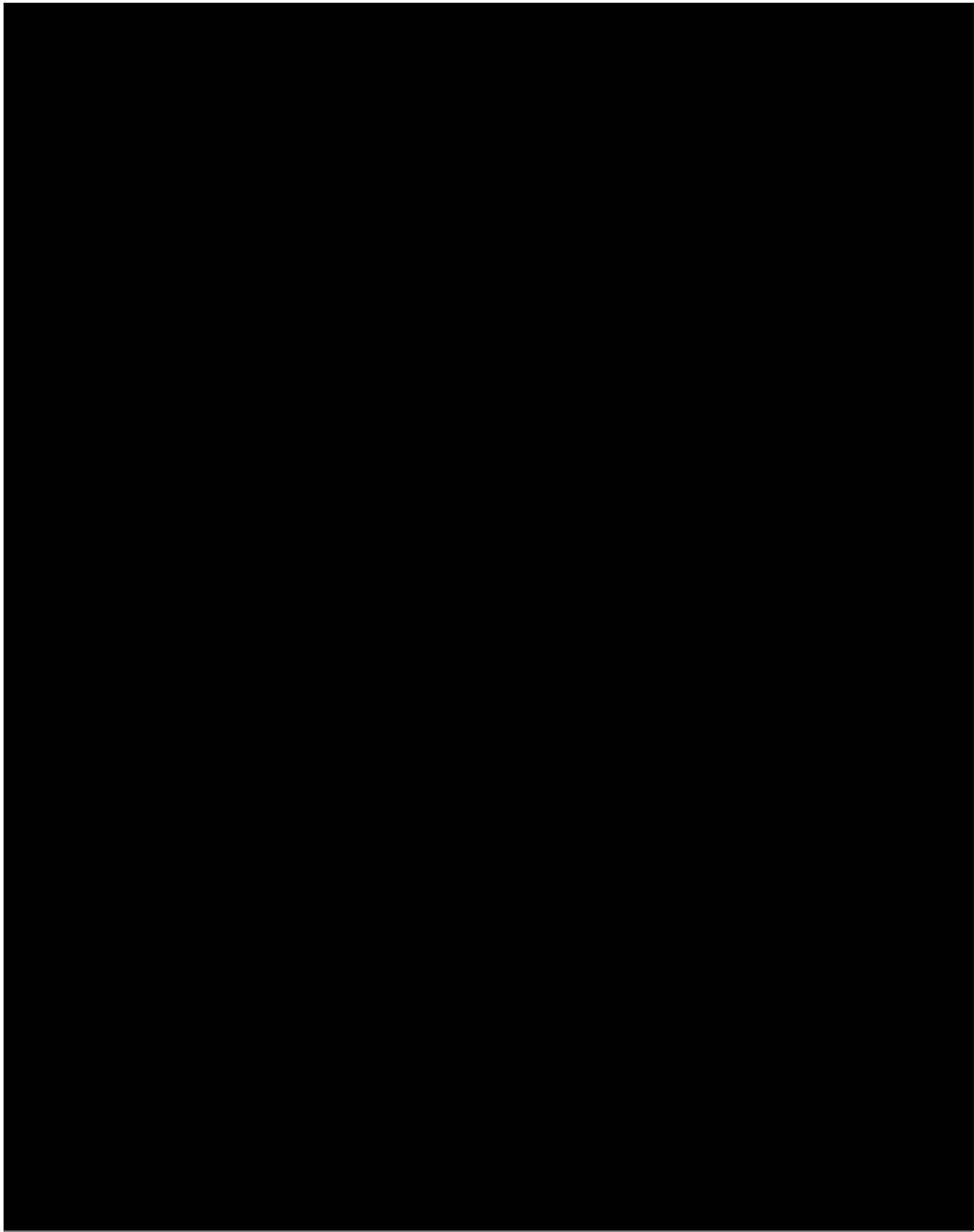


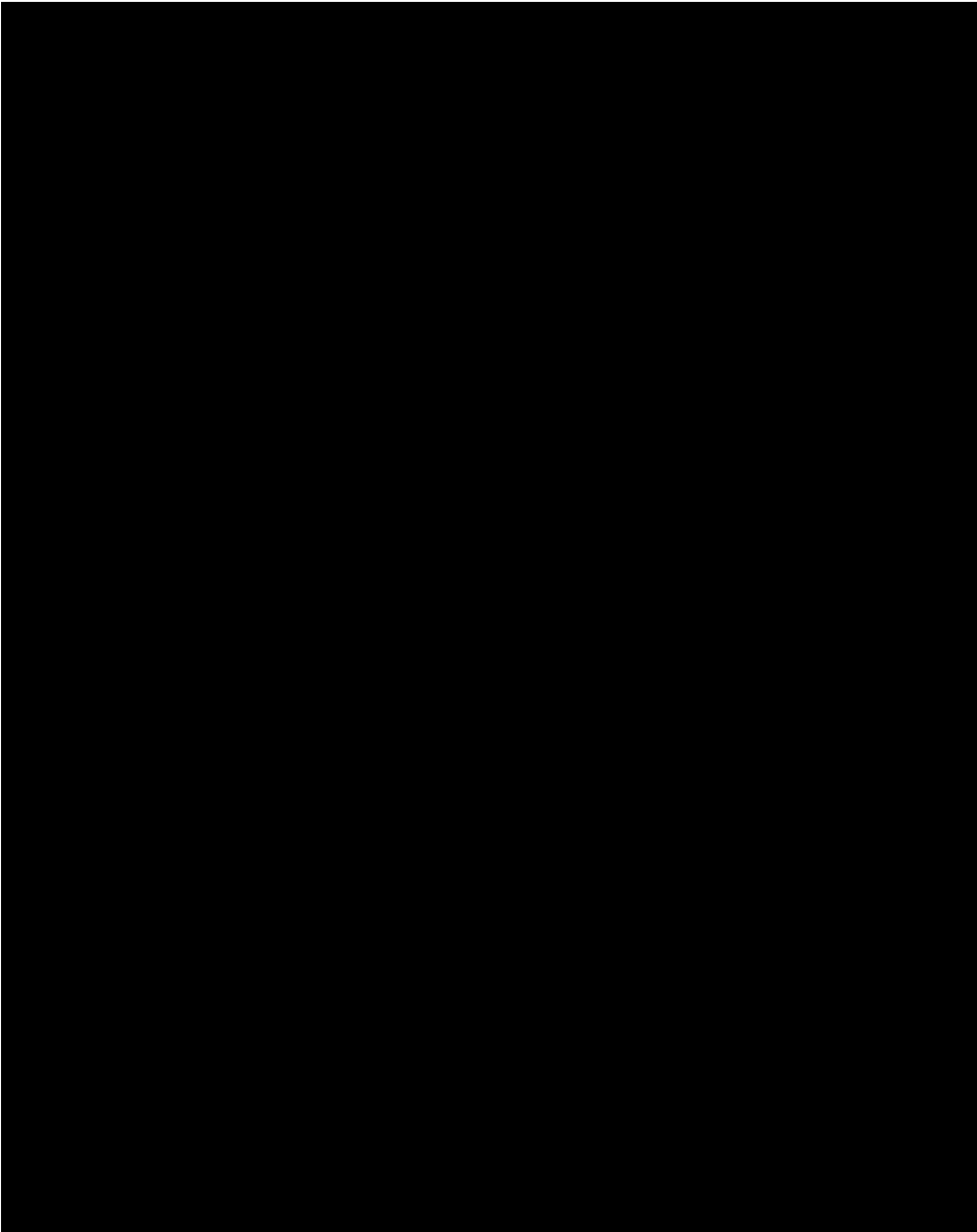
R  
E  
D  
A  
C  
T  
E  
D

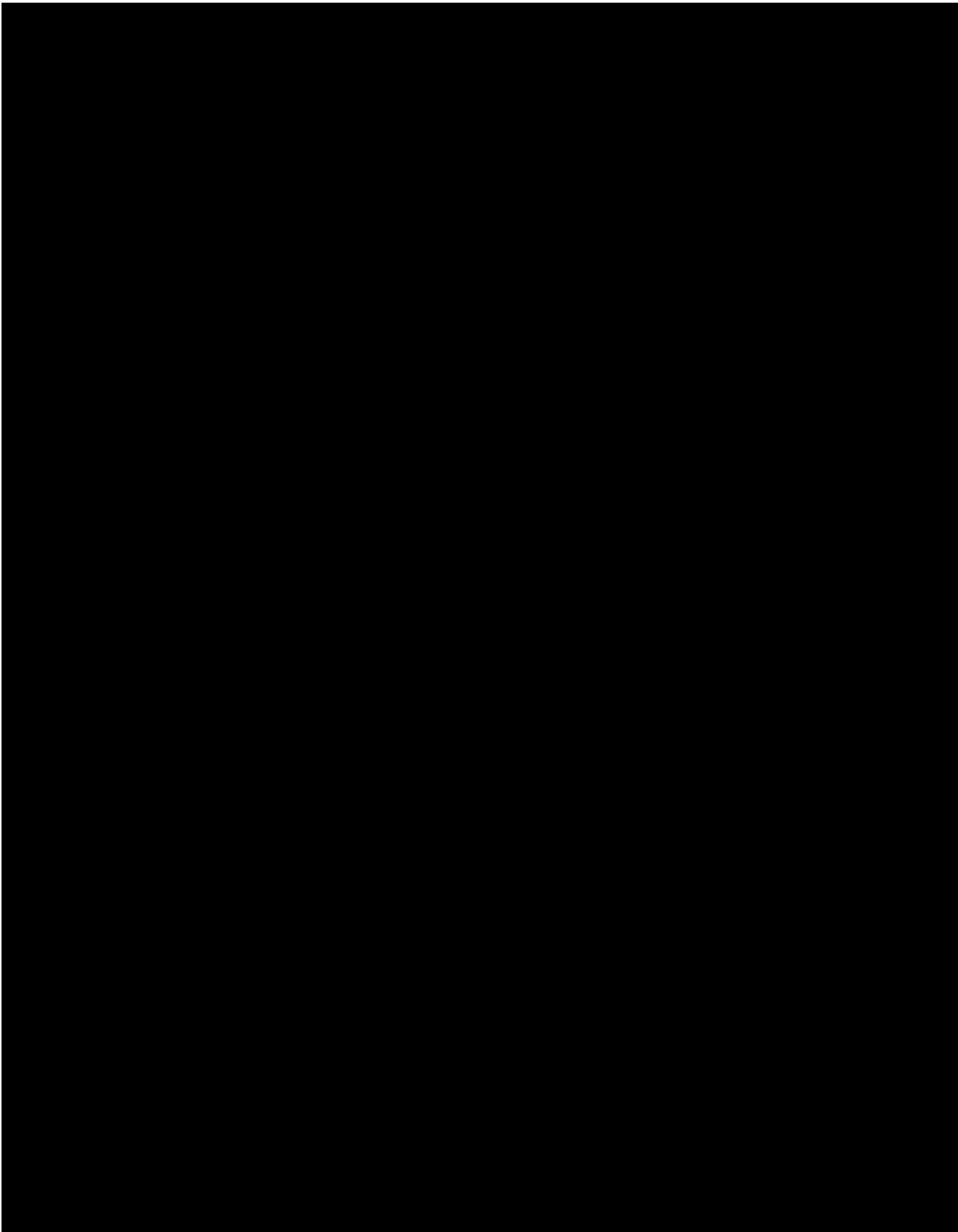


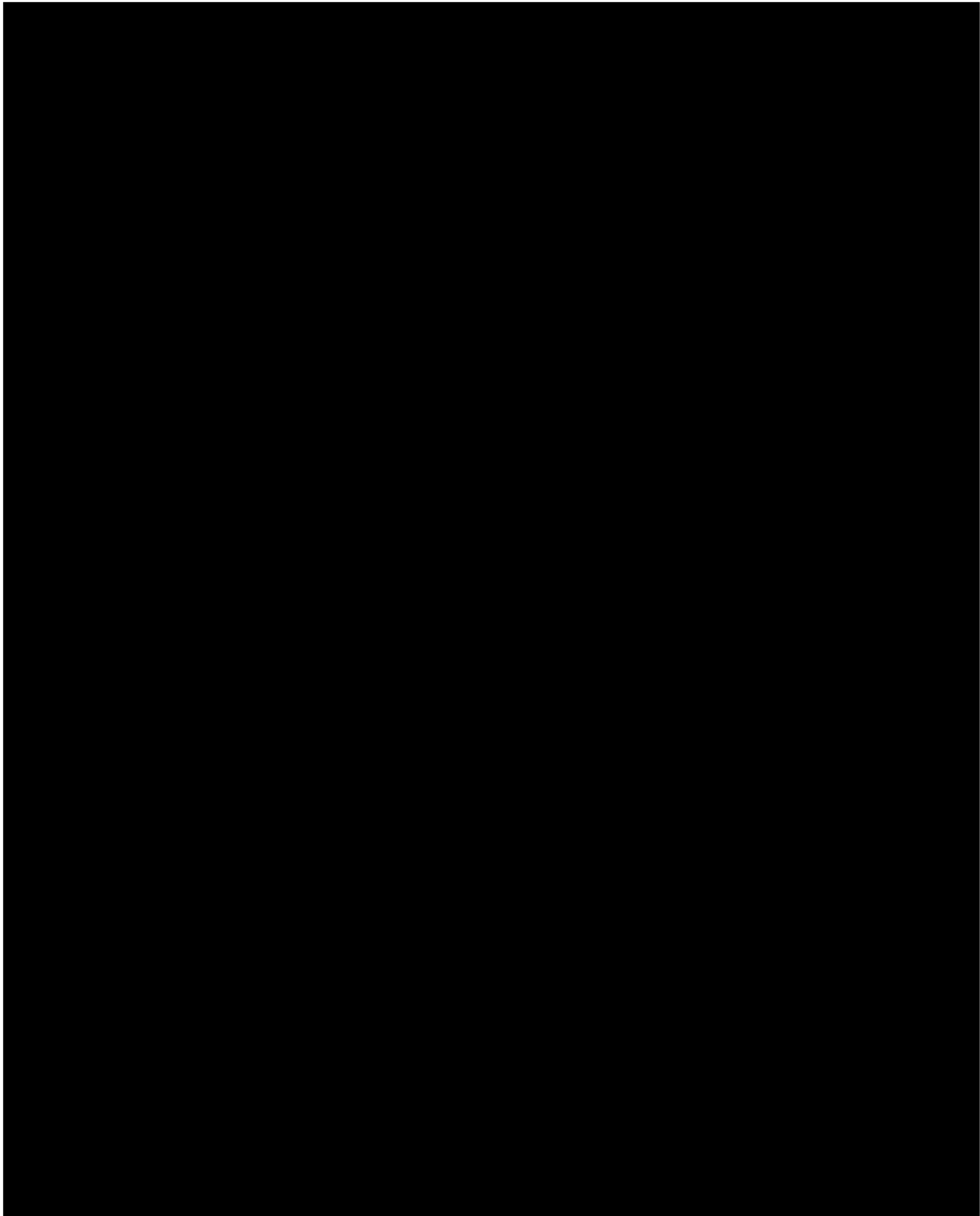




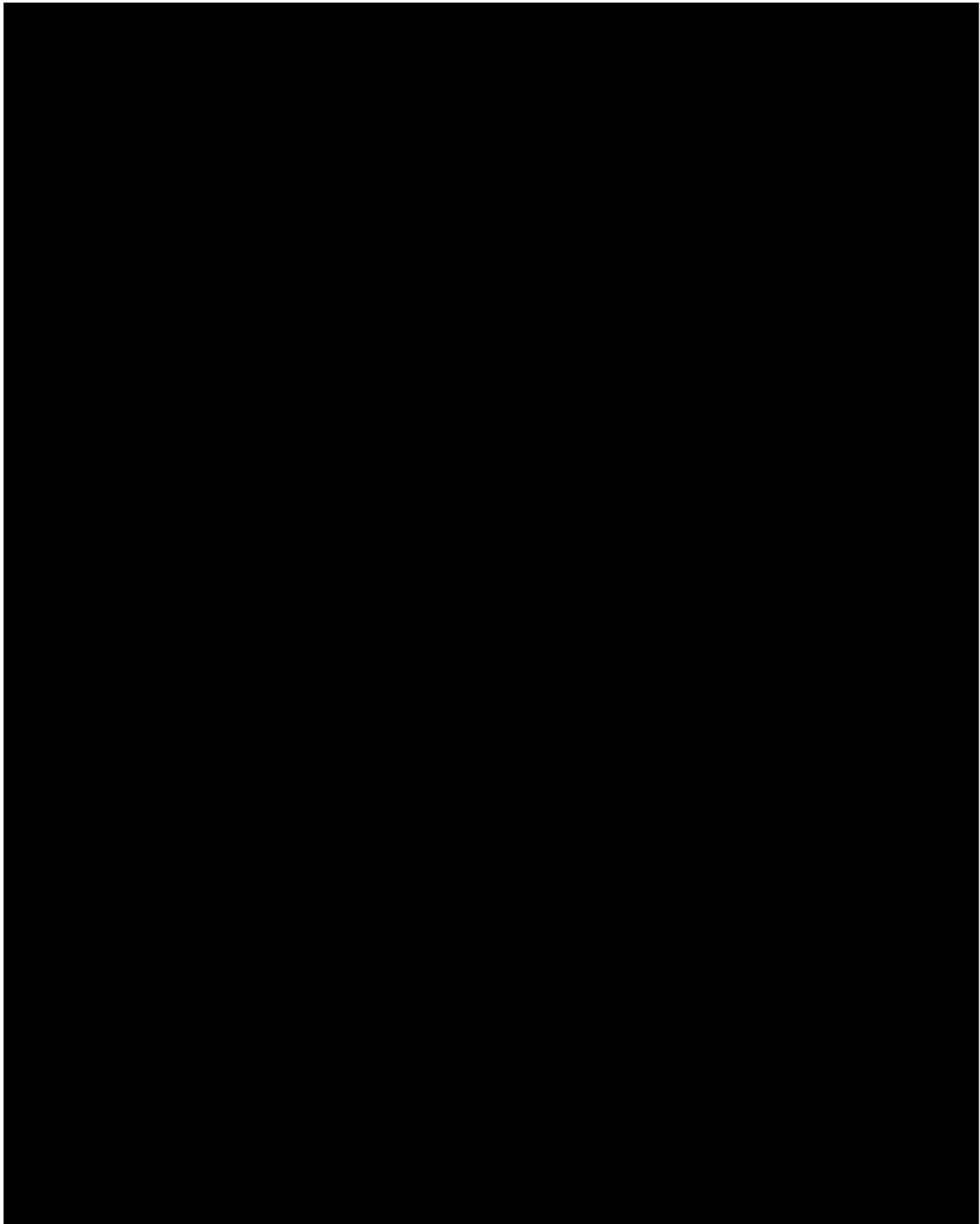


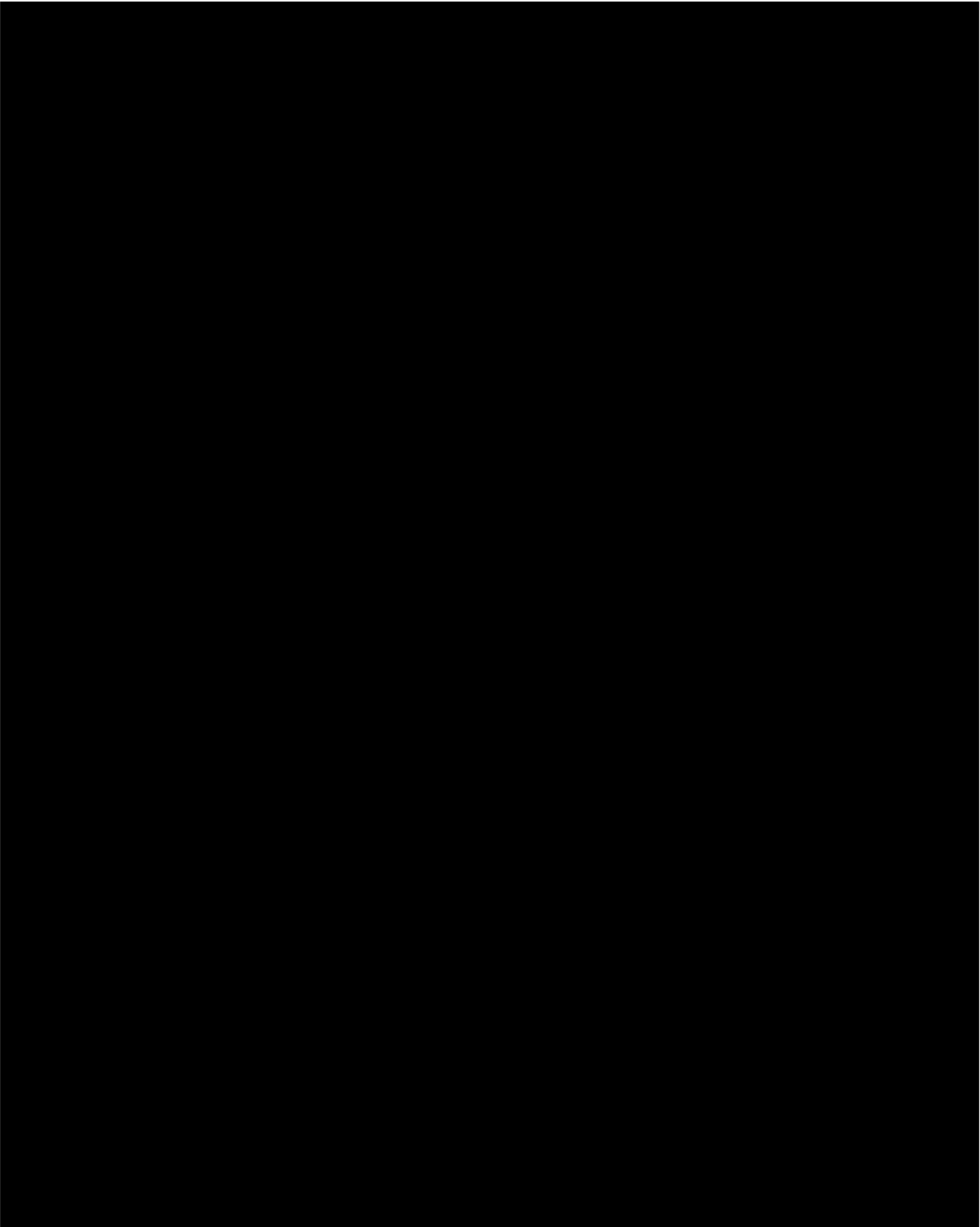


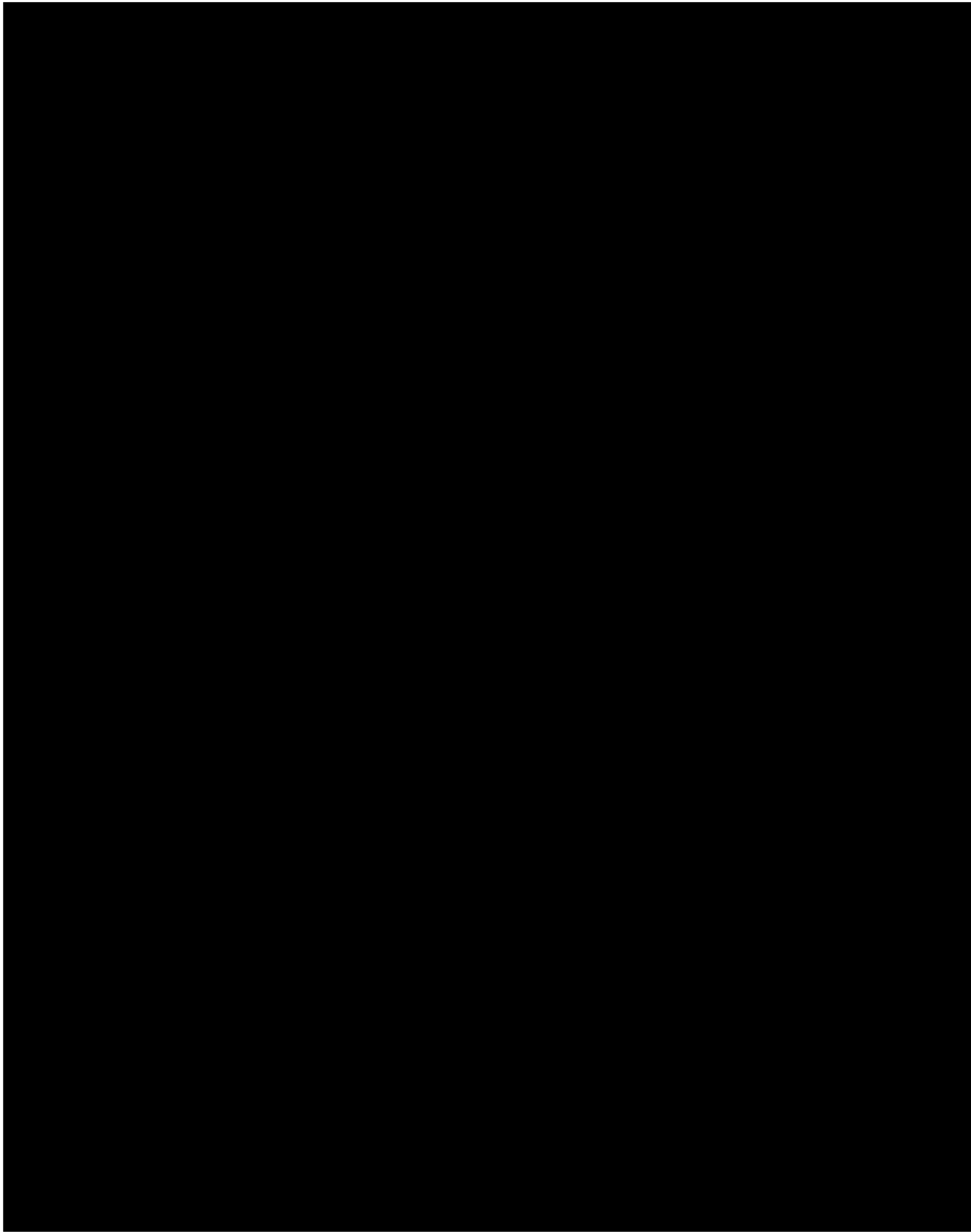


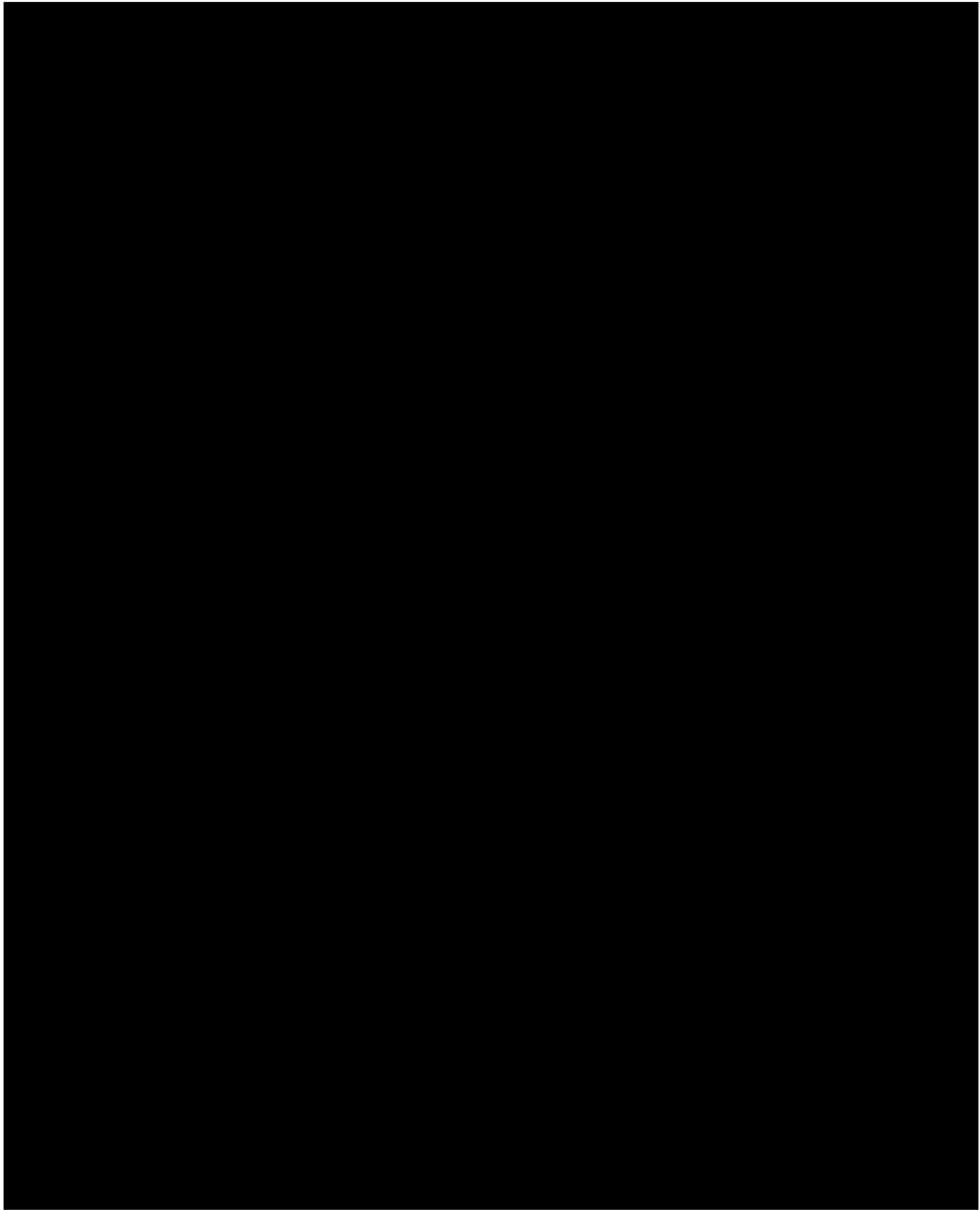


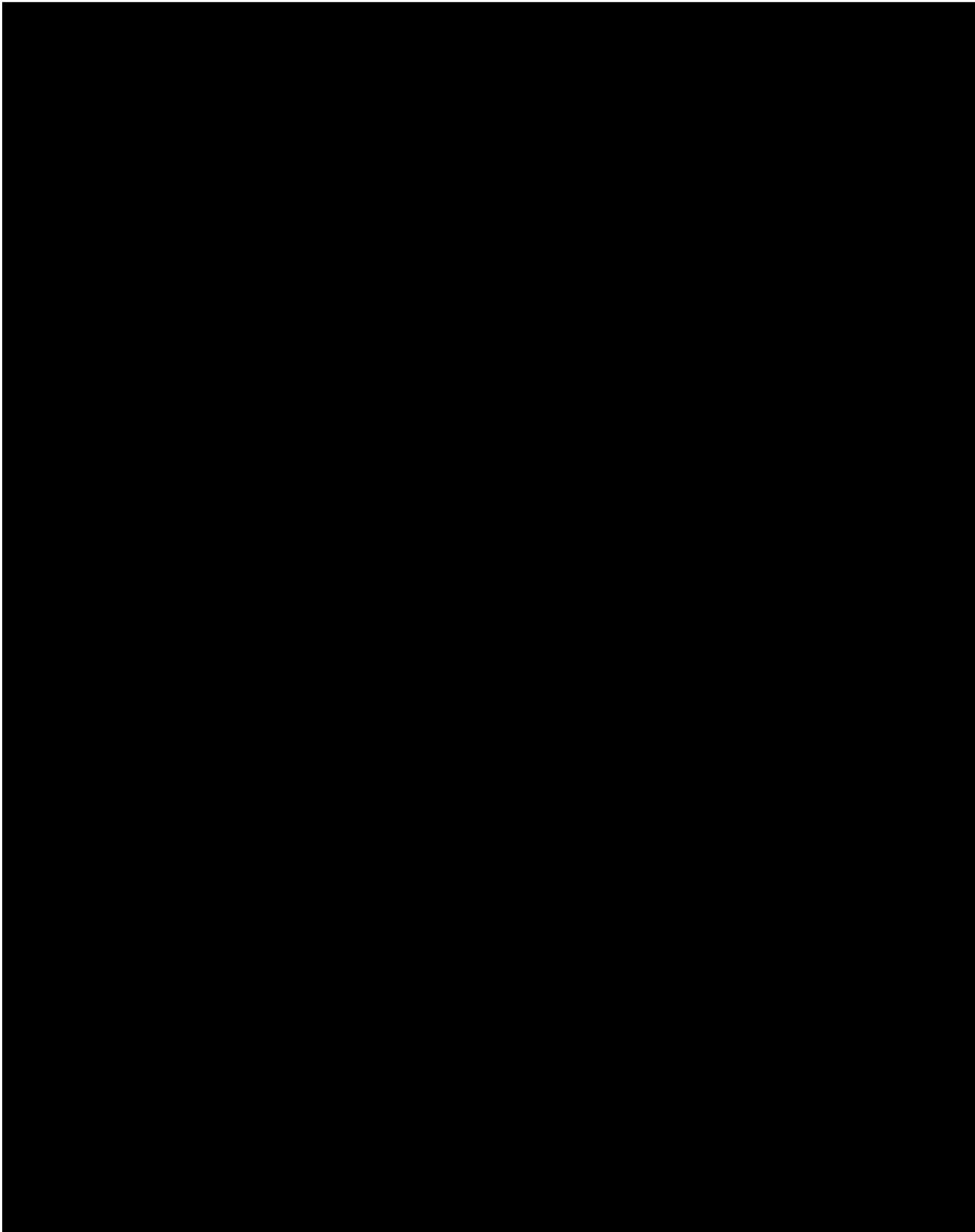


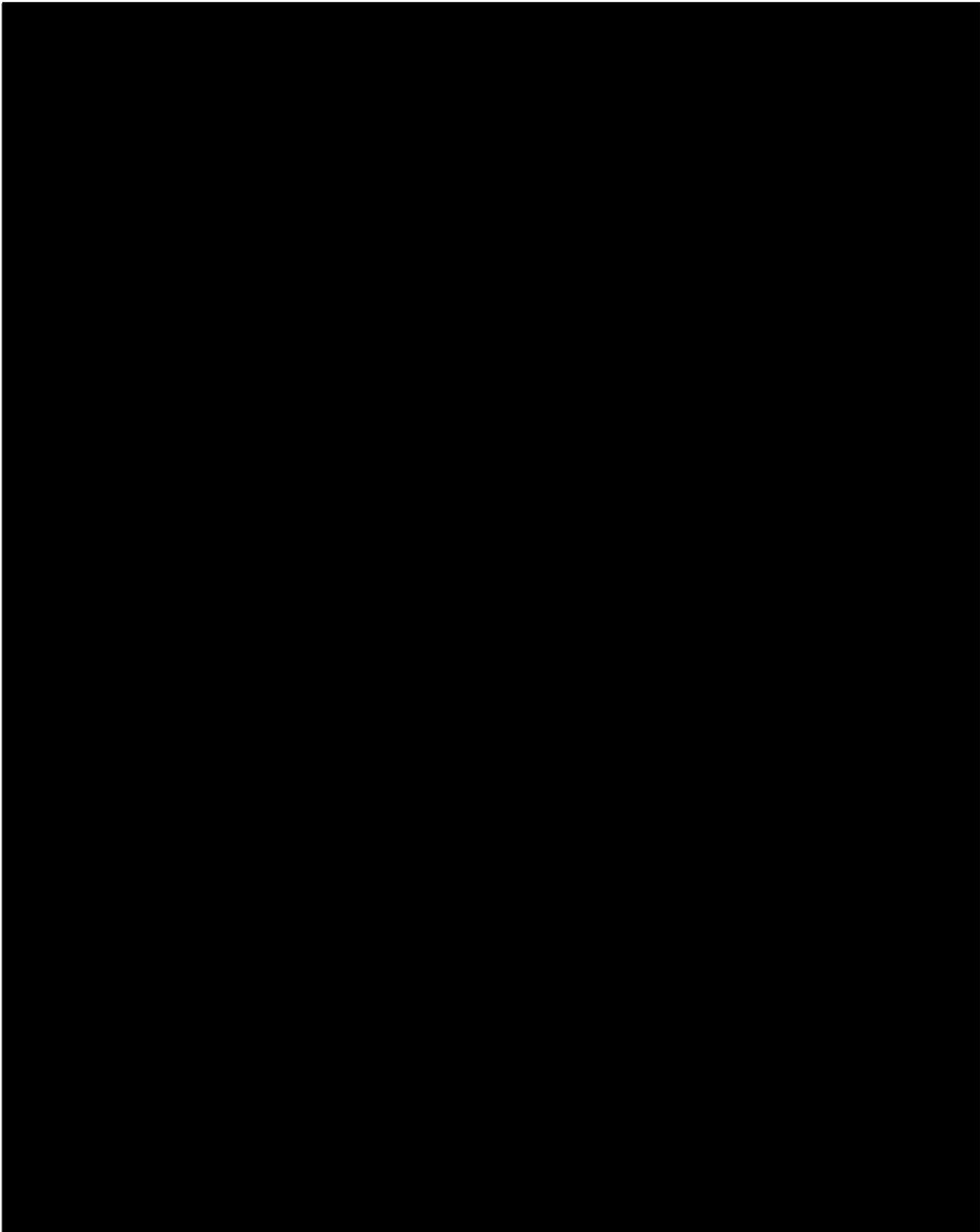


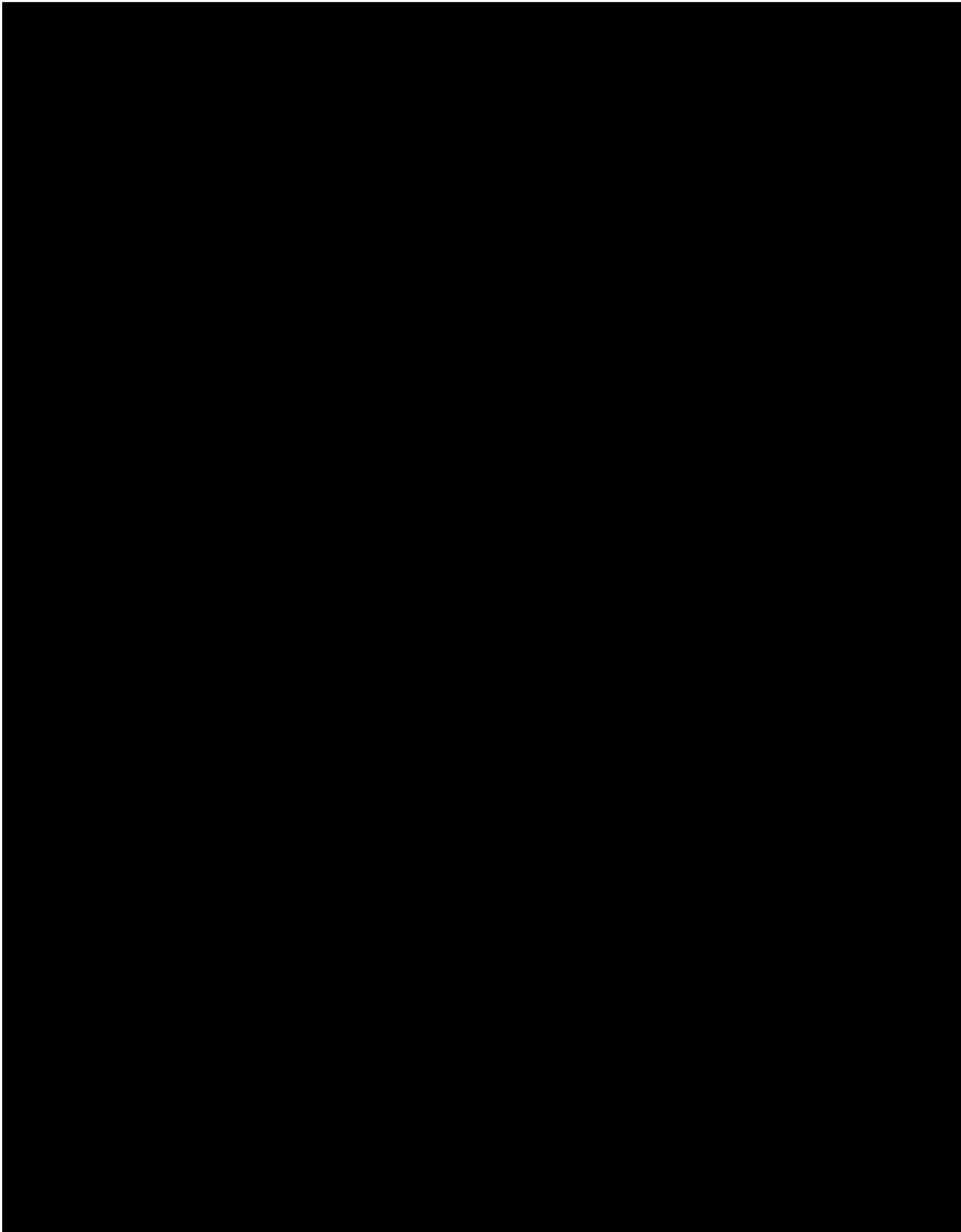












INTERNATIONAL CONFERENCE ON HARMONISATION OF TECHNICAL  
REQUIREMENTS FOR REGISTRATION OF PHARMACEUTICALS FOR HUMAN  
USE

**ICH HARMONISED TRIPARTITE GUIDELINE**

**IMPURITIES IN NEW DRUG SUBSTANCES  
Q3A(R2)**

Current *Step 4* version  
dated 25 October 2006

*This Guideline has been developed by the appropriate ICH Expert Working Group and has been subject to consultation by the regulatory parties, in accordance with the ICH Process. At Step 4 of the Process the final draft is recommended for adoption to the regulatory bodies of the European Union, Japan and USA.*



**Q3A(R2)**  
**Document History**

First Codification	History	Date	New Codification <b>November 2005</b>
Q3	Approval by the Steering Committee under <i>Step 2</i> and release for public consultation.	15 March 1994	Q3A
Q3A	Approval by the Steering Committee under <i>Step 4</i> and recommendation for adoption to the three ICH regulatory bodies.  Q3 was renamed Q3A.	30 March 1995	Q3A
Q3A(R)	Approval by the Steering Committee of the first Revision under <i>Step 2</i> and release for public consultation.	7 October 1999	Q3A(R1)
Q3A(R)	Approval by the Steering Committee of the first Revision under <i>Step 4</i> and recommendation for adoption to the three ICH regulatory bodies.	6 February 2002	Q3A(R1)

**Current *Step 4* version**

Q3A(R2)	Approval by the Steering Committee of the revision of the Attachment 2 directly under <i>Step 4</i> without further public consultation.	25 October 2006	Q3A(R2)
---------	------------------------------------------------------------------------------------------------------------------------------------------	--------------------	---------

# IMPURITIES IN NEW DRUG SUBSTANCES

## ICH Harmonised Tripartite Guideline

Having reached *Step 4* of the ICH Process at the ICH Steering Committee meeting on 7 February 2002, this guideline is recommended for adoption to the three regulatory parties to ICH.

Attachment 2 has been revised on 25 October 2006.

## TABLE OF CONTENTS

1. PREAMBLE .....	1
2. CLASSIFICATION OF IMPURITIES .....	1
3. RATIONALE FOR THE REPORTING AND CONTROL OF IMPURITIES .....	2
3.1 Organic Impurities .....	2
3.2 Inorganic Impurities.....	2
3.3 Solvents .....	3
4. ANALYTICAL PROCEDURES.....	3
5. REPORTING IMPURITY CONTENT OF BATCHES.....	3
6. LISTING OF IMPURITIES IN SPECIFICATIONS .....	4
7. QUALIFICATION OF IMPURITIES.....	5
8. GLOSSARY .....	6
ATTACHMENT 1.....	8
ATTACHMENT 2.....	9
ATTACHMENT 3.....	10



# IMPURITIES IN NEW DRUG SUBSTANCES

## 1. PREAMBLE

This document is intended to provide guidance for registration applications on the content and qualification of impurities in new drug substances produced by chemical syntheses and not previously registered in a region or member state. It is not intended to apply to new drug substances used during the clinical research stage of development. The following types of drug substances are not covered in this guideline: biological/biotechnological, peptide, oligonucleotide, radiopharmaceutical, fermentation product and semi-synthetic products derived therefrom, herbal products, and crude products of animal or plant origin.

Impurities in new drug substances are addressed from two perspectives:

*Chemistry Aspects* include classification and identification of impurities, report generation, listing of impurities in specifications, and a brief discussion of analytical procedures; and

*Safety Aspects* include specific guidance for qualifying those impurities that were not present, or were present at substantially lower levels, in batches of a new drug substance used in safety and clinical studies.

## 2. CLASSIFICATION OF IMPURITIES

Impurities can be classified into the following categories:

- Organic impurities (process- and drug-related)
- Inorganic impurities
- Residual solvents

Organic impurities can arise during the manufacturing process and/or storage of the new drug substance. They can be identified or unidentified, volatile or non-volatile, and include:

- Starting materials
- By-products
- Intermediates
- Degradation products
- Reagents, ligands and catalysts

Inorganic impurities can result from the manufacturing process. They are normally known and identified and include:

- Reagents, ligands and catalysts
- Heavy metals or other residual metals
- Inorganic salts
- Other materials (e.g., filter aids, charcoal)

Solvents are inorganic or organic liquids used as vehicles for the preparation of solutions or suspensions in the synthesis of a new drug substance. Since these are

generally of known toxicity, the selection of appropriate controls is easily accomplished (see ICH Guideline Q3C on Residual Solvents).

Excluded from this document are: (1) extraneous contaminants that should not occur in new drug substances and are more appropriately addressed as Good Manufacturing Practice (GMP) issues, (2) polymorphic forms, and (3) enantiomeric impurities.

### **3. RATIONALE FOR THE REPORTING AND CONTROL OF IMPURITIES**

#### **3.1 Organic Impurities**

The applicant should summarise the actual and potential impurities most likely to arise during the synthesis, purification, and storage of the new drug substance. This summary should be based on sound scientific appraisal of the chemical reactions involved in the synthesis, impurities associated with raw materials that could contribute to the impurity profile of the new drug substance, and possible degradation products. This discussion can be limited to those impurities that might reasonably be expected based on knowledge of the chemical reactions and conditions involved.

In addition, the applicant should summarise the laboratory studies conducted to detect impurities in the new drug substance. This summary should include test results of batches manufactured during the development process and batches from the proposed commercial process, as well as the results of stress testing (see ICH Guideline Q1A on Stability) used to identify potential impurities arising during storage. The impurity profile of the drug substance batches intended for marketing should be compared with those used in development, and any differences discussed.

The studies conducted to characterise the structure of actual impurities present in the new drug substance at a level greater than (>) the identification threshold given in Attachment 1 (e.g., calculated using the response factor of the drug substance) should be described. Note that any impurity at a level greater than (>) the identification threshold in any batch manufactured by the proposed commercial process should be identified. In addition, any degradation product observed in stability studies at recommended storage conditions at a level greater than (>) the identification threshold should be identified. When identification of an impurity is not feasible, a summary of the laboratory studies demonstrating the unsuccessful effort should be included in the application. Where attempts have been made to identify impurities present at levels of not more than ( $\leq$ ) the identification thresholds, it is useful also to report the results of these studies.

Identification of impurities present at an apparent level of not more than ( $\leq$ ) the identification threshold is generally not considered necessary. However, analytical procedures should be developed for those potential impurities that are expected to be unusually potent, producing toxic or pharmacological effects at a level not more than ( $\leq$ ) the identification threshold. All impurities should be qualified as described later in this guideline.

#### **3.2 Inorganic Impurities**

Inorganic impurities are normally detected and quantified using pharmacopoeial or other appropriate procedures. Carry-over of catalysts to the new drug substance should be evaluated during development. The need for inclusion or exclusion of inorganic impurities in the new drug substance specification should be discussed.

Acceptance criteria should be based on pharmacopoeial standards or known safety data.

### **3.3 Solvents**

The control of residues of the solvents used in the manufacturing process for the new drug substance should be discussed and presented according to the ICH Q3C Guideline for Residual Solvents.

## **4. ANALYTICAL PROCEDURES**

The registration application should include documented evidence that the analytical procedures are validated and suitable for the detection and quantification of impurities (see ICH Q2A and Q2B Guidelines for Analytical Validation). Technical factors (e.g., manufacturing capability and control methodology) can be considered as part of the justification for selection of alternative thresholds based on manufacturing experience with the proposed commercial process. The use of two decimal places for thresholds (See Attachment 1) does not necessarily reflect the precision of the analytical procedure used for routine quality control purposes. Thus, the use of lower precision techniques (e.g., thin-layer chromatography) can be acceptable where justified and appropriately validated. Differences in the analytical procedures used during development and those proposed for the commercial product should be discussed in the registration application.

The quantitation limit for the analytical procedure should be not more than ( $\leq$ ) the reporting threshold.

Organic impurity levels can be measured by a variety of techniques, including those that compare an analytical response for an impurity to that of an appropriate reference standard or to the response of the new drug substance itself. Reference standards used in the analytical procedures for control of impurities should be evaluated and characterised according to their intended uses. The drug substance can be used as a standard to estimate the levels of impurities. In cases where the response factors of the drug substance and the relevant impurity are not close, this practice can still be appropriate, provided a correction factor is applied or the impurities are, in fact, being overestimated. Acceptance criteria and analytical procedures used to estimate identified or unidentified impurities can be based on analytical assumptions (e.g., equivalent detector response). These assumptions should be discussed in the registration application.

## **5. REPORTING IMPURITY CONTENT OF BATCHES**

Analytical results should be provided in the application for all batches of the new drug substance used for clinical, safety, and stability testing, as well as for batches representative of the proposed commercial process. Quantitative results should be presented numerically, and not in general terms such as “complies”, “meets limit” etc. Any impurity at a level greater than ( $>$ ) the reporting threshold (see Attachment 1) and total impurities observed in these batches of the new drug substance should be reported with the analytical procedures indicated. Below 1.0%, the results should be reported to two decimal places (e.g., 0.06%, 0.13%); at and above 1.0%, the results should be reported to one decimal place (e.g., 1.3%). Results should be rounded using conventional rules (see Attachment 2). A tabulation (e.g., spreadsheet) of the data is recommended. Impurities should be designated by code number or by an appropriate descriptor, e.g., retention time. If a higher reporting threshold is proposed, it should

be fully justified. All impurities at a level greater than (>) the reporting threshold should be summed and reported as total impurities.

When analytical procedures change during development, reported results should be linked to the procedure used, with appropriate validation information provided. Representative chromatograms should be provided. Chromatograms of representative batches from analytical validation studies showing separation and detectability of impurities (e.g., on spiked samples), along with any other impurity tests routinely performed, can serve as the representative impurity profiles. The applicant should ensure that complete impurity profiles (e.g., chromatograms) of individual batches are available, if requested.

A tabulation should be provided that links the specific new drug substance batch to each safety study and each clinical study in which the new drug substance has been used.

For each batch of the new drug substance, the report should include:

- Batch identity and size
- Date of manufacture
- Site of manufacture
- Manufacturing process
- Impurity content, individual and total
- Use of batches
- Reference to analytical procedure used

## **6. LISTING OF IMPURITIES IN SPECIFICATIONS**

The specification for a new drug substance should include a list of impurities. Stability studies, chemical development studies, and routine batch analyses can be used to predict those impurities likely to occur in the commercial product. The selection of impurities in the new drug substance specification should be based on the impurities found in batches manufactured by the proposed commercial process. Those individual impurities with specific acceptance criteria included in the specification for the new drug substance are referred to as "specified impurities" in this guideline. Specified impurities can be identified or unidentified.

A rationale for the inclusion or exclusion of impurities in the specification should be presented. This rationale should include a discussion of the impurity profiles observed in the safety and clinical development batches, together with a consideration of the impurity profile of batches manufactured by the proposed commercial process. Specified identified impurities should be included along with specified unidentified impurities estimated to be present at a level greater than (>) the identification threshold given in Attachment 1. For impurities known to be unusually potent or to produce toxic or unexpected pharmacological effects, the quantitation/detection limit of the analytical procedures should be commensurate with the level at which the impurities should be controlled. For unidentified impurities, the procedure used and assumptions made in establishing the level of the impurity should be clearly stated. Specified, unidentified impurities should be referred to by an appropriate qualitative analytical descriptive label (e.g., "unidentified A", "unidentified with relative retention of 0.9"). A general acceptance criterion of not more than ( $\leq$ ) the identification threshold (Attachment 1) for any unspecified impurity and an acceptance criterion for total impurities should be included.

Acceptance criteria should be set no higher than the level that can be justified by safety data, and should be consistent with the level achievable by the manufacturing process and the analytical capability. Where there is no safety concern, impurity acceptance criteria should be based on data generated on batches of the new drug substance manufactured by the proposed commercial process, allowing sufficient latitude to deal with normal manufacturing and analytical variation and the stability characteristics of the new drug substance. Although normal manufacturing variations are expected, significant variation in batch-to-batch impurity levels can indicate that the manufacturing process of the new drug substance is not adequately controlled and validated (see ICH Q6A Guideline on Specifications, Decision Tree #1, for establishing an acceptance criterion for a specified impurity in a new drug substance). The use of two decimal places for thresholds (See Attachment 1) does not necessarily indicate the precision of the acceptance criteria for specified impurities and total impurities.

In summary, the new drug substance specification should include, where applicable, the following list of impurities:

*Organic Impurities*

- Each specified identified impurity
- Each specified unidentified impurity
- Any unspecified impurity with an acceptance criterion of not more than ( $\leq$ ) the identification threshold
- Total impurities

*Residual Solvents*

*Inorganic Impurities*

## **7. QUALIFICATION OF IMPURITIES**

Qualification is the process of acquiring and evaluating data that establishes the biological safety of an individual impurity or a given impurity profile at the level(s) specified. The applicant should provide a rationale for establishing impurity acceptance criteria that includes safety considerations. The level of any impurity present in a new drug substance that has been adequately tested in safety and/or clinical studies would be considered qualified. Impurities that are also significant metabolites present in animal and/or human studies are generally considered qualified. A level of a qualified impurity higher than that present in a new drug substance can also be justified based on an analysis of the actual amount of impurity administered in previous relevant safety studies.

If data are unavailable to qualify the proposed acceptance criterion of an impurity, studies to obtain such data can be appropriate when the usual qualification thresholds given in Attachment 1 are exceeded.

Higher or lower thresholds for qualification of impurities can be appropriate for some individual drugs based on scientific rationale and level of concern, including drug class effects and clinical experience. For example, qualification can be especially important when there is evidence that such impurities in certain drugs or therapeutic classes have previously been associated with adverse reactions in patients. In these instances, a lower qualification threshold can be appropriate. Conversely, a higher qualification threshold can be appropriate for individual drugs when the level of concern for safety is less than usual based on similar considerations (e.g., patient



population, drug class effects, clinical considerations). Proposals for alternative thresholds would be considered on a case-by-case basis.

The "Decision Tree for Identification and Qualification" (Attachment 3) describes considerations for the qualification of impurities when thresholds are exceeded. In some cases, decreasing the level of impurity to not more than the threshold can be simpler than providing safety data. Alternatively, adequate data could be available in the scientific literature to qualify an impurity. If neither is the case, additional safety testing should be considered. The studies considered appropriate to qualify an impurity will depend on a number of factors, including the patient population, daily dose, and route and duration of drug administration. Such studies can be conducted on the new drug substance containing the impurities to be controlled, although studies using isolated impurities can sometimes be appropriate.

Although this guideline is not intended to apply during the clinical research stage of development, in the later stages of development the thresholds in this guideline can be useful in evaluating new impurities observed in drug substance batches prepared by the proposed commercial process. Any new impurity observed in later stages of development should be identified if its level is greater than (>) the identification threshold given in Attachment 1 (see the "Decision Tree for Identification and Qualification" in Attachment 3). Similarly, the qualification of the impurity should be considered if its level is greater than (>) the qualification threshold given in Attachment 1. Safety assessment studies to qualify an impurity should compare the new drug substance containing a representative amount of the new impurity with previously qualified material. Safety assessment studies using a sample of the isolated impurity can also be considered.

## 8. GLOSSARY

**Chemical Development Studies:** Studies conducted to scale-up, optimise, and validate the manufacturing process for a new drug substance.

**Enantiomeric Impurity:** A compound with the same molecular formula as the drug substance that differs in the spatial arrangement of atoms within the molecule and is a non-superimposable mirror image.

**Extraneous Contaminant:** An impurity arising from any source extraneous to the manufacturing process.

**Herbal Products:** Medicinal products containing, exclusively, plant material and/or vegetable drug preparations as active ingredients. In some traditions, materials of inorganic or animal origin can also be present.

**Identified Impurity:** An impurity for which a structural characterisation has been achieved.

**Identification Threshold:** A limit above (>) which an impurity should be identified.

**Impurity:** Any component of the new drug substance that is not the chemical entity defined as the new drug substance.

**Impurity Profile:** A description of the identified and unidentified impurities present in a new drug substance.

**Intermediate:** A material produced during steps of the synthesis of a new drug substance that undergoes further chemical transformation before it becomes a new drug substance.

**Ligand:** An agent with a strong affinity to a metal ion.

**New Drug Substance:** The designated therapeutic moiety that has not been previously registered in a region or member state (also referred to as a new molecular entity or new chemical entity). It can be a complex, simple ester, or salt of a previously approved drug substance.

**Polymorphic Forms:** Different crystalline forms of the same drug substance. These can include solvation or hydration products (also known as pseudo-polymorphs) and amorphous forms.

**Potential Impurity:** An impurity that theoretically can arise during manufacture or storage. It may or may not actually appear in the new drug substance.

**Qualification:** The process of acquiring and evaluating data that establishes the biological safety of an individual impurity or a given impurity profile at the level(s) specified.

**Qualification Threshold:** A limit above (>) which an impurity should be qualified.

**Reagent:** A substance other than a starting material, intermediate, or solvent that is used in the manufacture of a new drug substance.

**Reporting Threshold:** A limit above (>) which an impurity should be reported. Reporting threshold is the same as reporting level in Q2B.

**Solvent:** An inorganic or an organic liquid used as a vehicle for the preparation of solutions or suspensions in the synthesis of a new drug substance.

**Specified Impurity:** An impurity that is individually listed and limited with a specific acceptance criterion in the new drug substance specification. A specified impurity can be either identified or unidentified.

**Starting Material:** A material used in the synthesis of a new drug substance that is incorporated as an element into the structure of an intermediate and/or of the new drug substance. Starting materials are normally commercially available and of defined chemical and physical properties and structure.

**Unidentified Impurity:** An impurity for which a structural characterisation has not been achieved and that is defined solely by qualitative analytical properties (e.g., chromatographic retention time).

**Unspecified impurity:** An impurity that is limited by a general acceptance criterion, but not individually listed with its own specific acceptance criterion, in the new drug substance specification.

**ATTACHMENT 1**  
**Thresholds**

<b>Maximum Daily Dose<sup>1</sup></b>	<b>Reporting Threshold<sup>2,3</sup></b>	<b>Identification Threshold<sup>3</sup></b>	<b>Qualification Threshold<sup>3</sup></b>
≤ 2g/day	0.05%	0.10% or 1.0 mg per day intake (whichever is lower)	0.15% or 1.0 mg per day intake (whichever is lower)
> 2g/day	0.03%	0.05%	0.05%

---

<sup>1</sup> The amount of drug substance administered per day

<sup>2</sup> Higher reporting thresholds should be scientifically justified

<sup>3</sup> Lower thresholds can be appropriate if the impurity is unusually toxic

**ATTACHMENT 2**

**Illustration of Reporting Impurity Results for Identification and Qualification in an Application**

The attachment is only illustrative and is not intended to serve as template how results on impurities should be presented in an application file. Normally raw data are not presented.

**Example 1: 0.5 g Maximum Daily Dose**

Reporting threshold = 0.05%  
 Identification threshold = 0.10%  
 Qualification threshold = 0.15%

"Raw" Result (%)	Reported Result (%) Reporting threshold =0.05%	Calculated Total Daily Intake (TDI) (mg) of the impurity (rounded result in mg)	Action	
			Identification (Threshold 0.10% exceeded?)	Qualification (Threshold 0.15% exceeded?)
0.044	Not reported	0.2	None	None
0.0963	0.10	0.5	None	None
0.12	0.12 <sup>1)</sup>	0.6	Yes	None <sup>1)</sup>
0.1649	0.16 <sup>1)</sup>	0.8	Yes	Yes <sup>1)</sup>

**Example 2: 0.8 g Maximum Daily Dose**

Reporting threshold = 0.05%  
 Identification threshold = 0.10%  
 Qualification threshold = 1.0 mg TDI

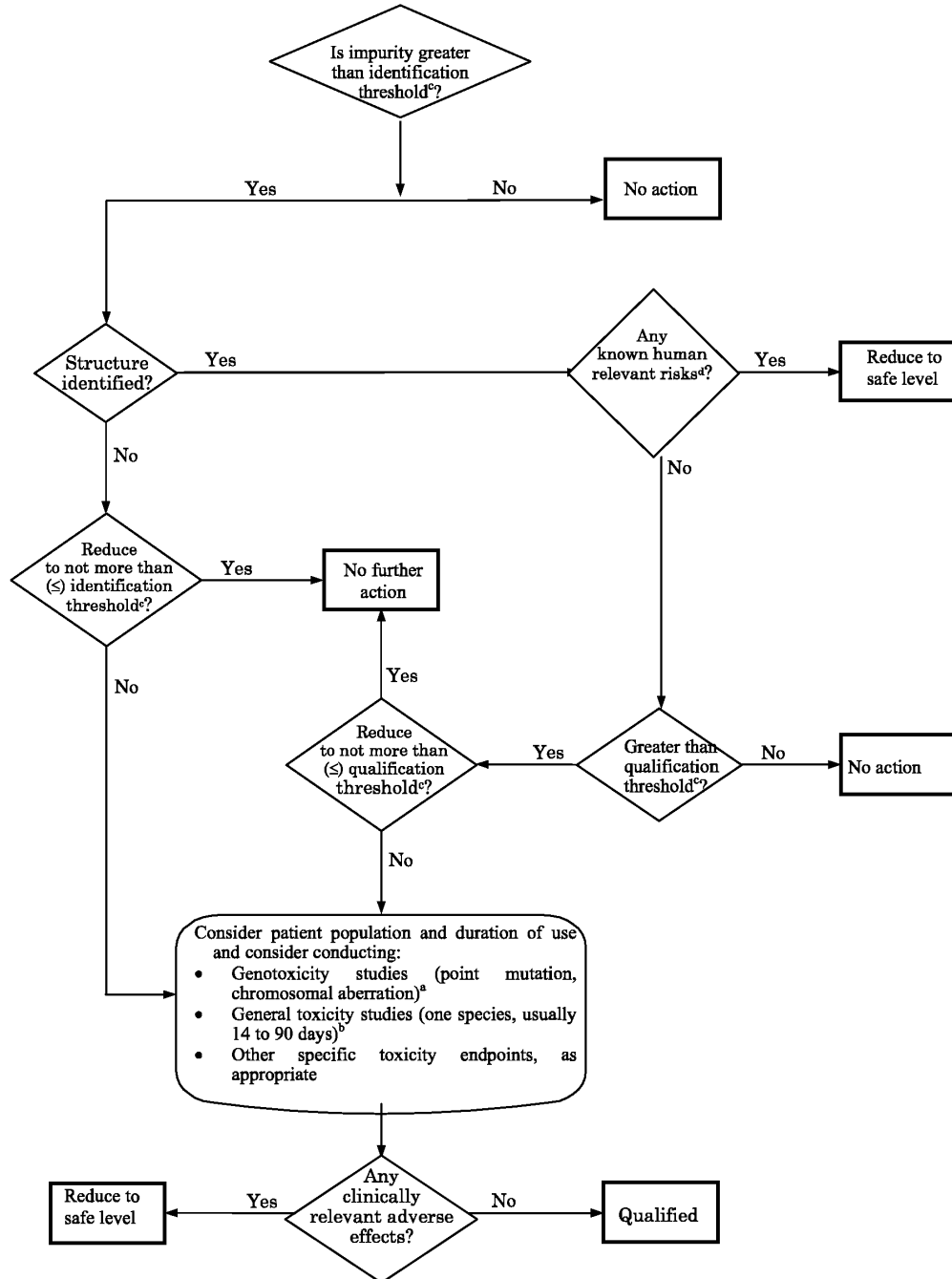
"Raw" Result (%)	Reported Result (%) Reporting threshold =0.05%	Calculated Total Daily Intake (TDI) (mg) of the impurity (rounded result in mg)	Action	
			Identification (Threshold 0.10% exceeded?)	Qualification (Threshold 1.0 mg TDI exceeded?)
0.066	0.07	0.6	None	None
0.124	0.12	1.0	yes	None <sup>1)2)</sup>
0.143	0.14	1.1	yes	Yes <sup>1)</sup>

1) After identification, if the response factor is determined to differ significantly from the original assumptions, it may be appropriate to re-measure the actual amount of the impurity present and re-evaluate against the qualification threshold (see Attachment 1).

2) To verify if a threshold is exceeded, a reported result has to be evaluated against the thresholds as follows: when the threshold is described in %, the reported result rounded to the same decimal place as the threshold should be compared directly to the threshold. When the threshold is described in TDI, the reported result should be converted to TDI, rounded to the same decimal place as the threshold and compared to the threshold. For example the amount of impurity at 0.12% level corresponds to a TDI of 0.96 mg (absolute amount) which is then rounded up to 1.0 mg; so the qualification threshold expressed in TDI (1.0 mg) is not exceeded.

ATTACHMENT 3

Decision Tree for Identification and Qualification



**Notes on Attachment 3**

- a) If considered desirable, a minimum screen (e.g., genotoxic potential), should be conducted.  
A study to detect point mutations and one to detect chromosomal aberrations, both in vitro, are considered an appropriate minimum screen.
- b) If general toxicity studies are desirable, one or more studies should be designed to allow comparison of unqualified to qualified material. The study duration should be based on available relevant information and performed in the species most likely to maximise the potential to detect the toxicity of an impurity. On a case-by-case basis, single-dose studies can be appropriate, especially for single-dose drugs. In general, a minimum duration of 14 days and a maximum duration of 90 days would be considered appropriate.
- c) Lower thresholds can be appropriate if the impurity is unusually toxic.
- d) For example, do known safety data for this impurity or its structural class preclude human exposure at the concentration present?

---

# M7 Assessment and Control of DNA Reactive (Mutagenic) Impurities in Pharmaceuticals to Limit Potential Carcinogenic Risk

## Guidance for Industry

**U.S. Department of Health and Human Services  
Food and Drug Administration  
Center for Drug Evaluation and Research (CDER)  
Center for Biologics Evaluation and Research (CBER)**

**May 2015  
ICH**

---

P. 1

UT Ex. 2039  
SteadyMed v. United Therapeutics  
IPR2016-00006

IPR2020-00769  
United Therapeutics EX2006  
Page 5107 of 7113

# M7 Assessment and Control of DNA Reactive (Mutagenic) Impurities in Pharmaceuticals to Limit Potential Carcinogenic Risk Guidance for Industry

*Additional copies are available from:*

*Office of Communications, Division of Drug Information  
Center for Drug Evaluation and Research  
Food and Drug Administration  
10001 New Hampshire Ave., Hillandale Bldg., 4<sup>th</sup> Floor  
Silver Spring, MD 20993-0002  
Phone: 855-543-3784 or 301-796-3400; Fax: 301-431-6353  
Email: [druginfo@fda.hhs.gov](mailto:druginfo@fda.hhs.gov)*

*<http://www.fda.gov/Drugs/GuidanceComplianceRegulatoryInformation/Guidances/default.htm>*

*or*

*Office of Communication, Outreach and Development  
Center for Biologics Evaluation and Research  
Food and Drug Administration  
10903 New Hampshire Ave., Bldg. 71, Room 3128  
Silver Spring, MD 20993-0002  
Phone: 800-835-4709 or 240-402-7800  
[ocod@fda.hhs.gov](mailto:ocod@fda.hhs.gov)*

*<http://www.fda.gov/BiologicsBloodVaccines/GuidanceComplianceRegulatoryInformation/Guidance/default.htm>*

**U.S. Department of Health and Human Services  
Food and Drug Administration  
Center for Drug Evaluation and Research (CDER)  
Center for Biologics Evaluation and Research (CBER)**

**May 2015  
ICH**

P. 2

UT Ex. 2039  
SteadyMed v. United Therapeutics  
IPR2016-00006

IPR2020-00769  
United Therapeutics EX2006  
Page 5108 of 7113



*Contains Nonbinding Recommendations*

TABLE OF CONTENTS

I. INTRODUCTION (1)..... 1

II. SCOPE OF GUIDANCE (2) ..... 2

III. GENERAL PRINCIPLES (3)..... 2

IV. CONSIDERATIONS FOR MARKETED PRODUCTS (4) ..... 4

    A. Post-Approval Changes to the Drug Substance Chemistry, Manufacturing, and Controls (4.1)..... 4

    B. Post-Approval Changes to the Drug Product Chemistry, Manufacturing, and Controls (4.2)..... 4

    C. Changes to the Clinical Use of Marketed Products (4.3)..... 5

    D. Other Considerations for Marketed Products (4.4)..... 5

V. DRUG SUBSTANCE AND DRUG PRODUCT IMPURITY ASSESSMENT (5)..... 5

    A. Synthetic Impurities (5.1)..... 5

    B. Degradation Products (5.2) ..... 6

    C. Considerations for Clinical Development (5.3) ..... 7

VI. HAZARD ASSESSMENT ELEMENTS (6)..... 7

VII. RISK CHARACTERIZATION (7)..... 8

    A. TTC-Based Acceptable Intakes (7.1)..... 8

    B. Acceptable Intakes Based on Compound-Specific Risk Assessments (7.2)..... 9

        1. Mutagenic Impurities With Positive Carcinogenicity Data (Class 1 in Table 1) (7.2.1)..... 9

        2. Mutagenic Impurities With Evidence for a Practical Threshold (7.2.2)..... 9

    C. Acceptable Intakes in Relation to Less-Than-Lifetime (LTL) Exposure (7.3)..... 9

        1. Clinical Development (7.3.1)..... 11

        2. Marketed Products (7.3.2)..... 11

    D. Acceptable Intakes for Multiple Mutagenic Impurities (7.4)..... 11

    E. Exceptions and Flexibility in Approaches (7.5)..... 12

VIII. CONTROL ..... 12

    A. Control of Process Related Impurities (8.1) ..... 13

    B. Considerations for Control Approaches (8.2) ..... 14

    C. Considerations for Periodic Testing (8.3) ..... 15

    D. Control of Degradation Products (8.4)..... 15

    E. Lifecycle Management (8.5) ..... 16

    F. Considerations for Clinical Development (8.6) ..... 17

IX. DOCUMENTATION..... 17

    A. Clinical Trial Applications (9.1) ..... 17

    B. Common Technical Document (Marketing Application) (9.2) ..... 17

*Contains Nonbinding Recommendations*

**NOTES..... 19**  
**GLOSSARY..... 24**  
**REFERENCES..... 26**  
**APPENDICES..... 28**

**M7 Assessment and Control of DNA Reactive (Mutagenic)  
Impurities in Pharmaceuticals to Limit Potential  
Carcinogenic Risk  
Guidance for Industry<sup>1</sup>**

This guidance represents the current thinking of the Food and Drug Administration (FDA or Agency) on this topic. It does not create any rights for any person and is not binding on FDA or the public. You can use an alternative approach if it satisfies the requirements of the applicable statutes and regulations. To discuss an alternative approach, contact the FDA staff responsible for this guidance as listed on the title page.

**I. INTRODUCTION (1)<sup>2</sup>**

The synthesis of drug substances involves the use of reactive chemicals, reagents, solvents, catalysts, and other processing aids. As a result of chemical synthesis or subsequent degradation, impurities reside in all drug substances and associated drug products. While ICH *Q3A Impurities in New Drug Substances* (Revision 2) (Q3A) and *Q3B(R2) Impurities in New Drug Products* (Q3B) (Refs. 1 and 2)<sup>3</sup> provide guidance for qualification and control for the majority of the impurities, limited guidance is provided for those impurities that are DNA reactive. The purpose of this guidance is to provide a practical framework that is applicable to the identification, categorization, qualification, and control of these mutagenic impurities to limit potential carcinogenic risk. This guidance is intended to complement ICH Q3A, Q3B (Note 1), and *M3(R2) Nonclinical Safety Studies for the Conduct of Human Clinical Trials and Marketing Authorization for Pharmaceuticals* (Ref. 3).

This guidance emphasizes considerations of both safety and quality risk management in establishing levels of mutagenic impurities that are expected to pose negligible carcinogenic risk. It outlines recommendations for assessment and control of mutagenic impurities that reside or are reasonably expected to reside in final drug substance or product, taking into consideration the intended conditions of human use.

<sup>1</sup>This guidance was developed within the Expert Working Group (Multidisciplinary) of the International Conference on Harmonisation of Technical Requirements for Registration of Pharmaceuticals for Human Use (ICH) and has been subject to consultation by the regulatory parties, in accordance with the ICH process. This document has been endorsed by the ICH Steering Committee at Step 4 of the ICH process, June 2014. At Step 4 of the process, the final draft is recommended for adoption to the regulatory bodies of the European Union, Japan, and the United States.

<sup>2</sup> Arabic numbers reflect the organizational breakdown in the document endorsed by the ICH Steering Committee at Step 4 of the ICH process, June 2014.

<sup>3</sup> We update guidances periodically. To make sure you have the most recent version of a guidance, check the FDA Drugs guidance Web page at <http://www.fda.gov/Drugs/GuidanceComplianceRegulatoryInformation/Guidances/default.htm> or the Vaccines, Blood & Biologics Web page at <http://www.fda.gov/BiologicsBloodVaccines/GuidanceComplianceRegulatoryInformation/Guidances/default.htm>.

### ***Contains Nonbinding Recommendations***

In general, FDA's guidance documents do not establish legally enforceable responsibilities. Instead, guidances describe the Agency's current thinking on a topic and should be viewed only as recommendations, unless specific regulatory or statutory requirements are cited. The use of the word *should* in Agency guidances means that something is suggested or recommended, but not required.

## **II. SCOPE OF GUIDANCE (2)**

This document is intended to provide guidance for new drug substances and new drug products during their clinical development and subsequent applications for marketing. It also applies to post-approval submissions of marketed products, and to new marketing applications for products with a drug substance that is present in a previously approved product – in both cases, only where:

- Changes to the drug substance synthesis result in new impurities or increased acceptance criteria for existing impurities;
- Changes in the formulation, composition or manufacturing process result in new degradation products or increased acceptance criteria for existing degradation products;
- Changes in indication or dosing regimen are made which significantly affect the acceptable cancer risk level.

Assessment of the mutagenic potential of impurities as described in this guidance is not intended for the following types of drug substances and drug products: biological/biotechnological, peptide, oligonucleotide, radiopharmaceutical, fermentation, herbal, and crude products of animal or plant origin.

This guidance does not apply to drug substances and drug products intended for advanced cancer indications as defined in the scope of ICH S9 (Ref. 4). Additionally, there may be some cases where a drug substance intended for other indications is itself genotoxic at therapeutic concentrations and may be expected to be associated with an increased cancer risk. Exposure to a mutagenic impurity in these cases would not significantly add to the cancer risk of the drug substance. Therefore, impurities could be controlled at acceptable levels for non-mutagenic impurities.

Assessment of the mutagenic potential of impurities as described in this guidance is not intended for excipients used in existing marketed products, flavoring agents, colorants, and perfumes. Application of this guidance to leachables associated with drug product packaging is not intended, but the safety risk assessment principles outlined in this guidance for limiting potential carcinogenic risk can be used if warranted. The safety risk assessment principles of this guidance can be used if warranted for impurities in excipients that are used for the first time in a drug product and are chemically synthesized.

## **III. GENERAL PRINCIPLES (3)**

The focus of this guidance is on DNA reactive substances that have a potential to directly cause DNA damage when present at low levels leading to mutations and therefore, potentially causing cancer. This type of mutagenic carcinogen is usually detected in a bacterial reverse

### *Contains Nonbinding Recommendations*

mutation (mutagenicity) assay. Other types of genotoxicants that are non-mutagenic typically have threshold mechanisms and usually do not pose carcinogenic risk in humans at the level ordinarily present as impurities. Therefore, to limit a possible human cancer risk associated with the exposure to potentially mutagenic impurities, the bacterial mutagenicity assay is used to assess the mutagenic potential and the need for controls. Structure-based assessments are useful for predicting bacterial mutagenicity outcomes based upon the established knowledge. There are a variety of approaches to conduct this evaluation, including a review of the available literature and/or computational toxicology assessment.

A Threshold of Toxicological Concern (TTC) concept was developed to define an acceptable intake for any unstudied chemical that poses a negligible risk of carcinogenicity or other toxic effects. The methods upon which the TTC is based are generally considered to be very conservative since they involve a simple linear extrapolation from the dose giving a 50% tumor incidence (TD<sub>50</sub>) to a 1 in 10<sup>6</sup> incidence, using TD<sub>50</sub> data for the most sensitive species and most sensitive site of tumor induction. For application of a TTC in the assessment of acceptable limits of mutagenic impurities in drug substances and drug products, a value of 1.5 micrograms (µg)/day corresponding to a theoretical 10<sup>-5</sup> excess lifetime risk of cancer can be justified. Some structural groups were identified to be of such high potency that intakes even below the TTC would theoretically be associated with a potential for a significant carcinogenic risk. This group of high potency mutagenic carcinogens, referred to as the *cohort of concern*, comprises aflatoxin-like-, N-nitroso-, and alkyl-azoxy compounds.

During clinical development, it is expected that control strategies and approaches will be less developed in earlier phases where overall development experience is limited. This guidance bases acceptable intakes for mutagenic impurities on established risk assessment strategies. Acceptable risk during the early development phase is set at a theoretically calculated level of approximately one additional cancer per million. For later stages in development and for marketed products, acceptable increased cancer risk is set at a theoretically calculated level of approximately 1 in 100,000. These risk levels represent a small theoretical increase in risk when compared to human overall lifetime incidence of developing any type of cancer, which is greater than 1 in 3. It is noted that established cancer risk assessments are based on lifetime exposures. Less-Than-Lifetime (LTL) exposures both during development and marketing can have higher acceptable intakes of impurities and still maintain comparable risk levels. The use of a numerical cancer risk value (1 in 100,000) and its translation into risk-based doses (TTC) is a highly hypothetical concept that should not be regarded as a realistic indication of the actual risk. Nevertheless, the TTC concept provides an estimate of safe exposures for any mutagenic compound. However, exceeding the TTC is not necessarily associated with an increased cancer risk given the conservative assumptions employed in the derivation of the TTC value. The most likely increase in cancer incidence is actually much less than 1 in 100,000. In addition, in cases where a mutagenic compound is a non-carcinogen in a rodent bioassay, there would be no predicted increase in cancer risk. Based on all the above considerations, any exposure to an impurity that is later identified as a mutagen is not necessarily associated with an increased cancer risk for patients already exposed to the impurity. A risk assessment would determine whether any further actions would be taken.

Where a potential risk has been identified for an impurity, an appropriate control strategy leveraging process understanding and/or analytical controls should be developed to ensure that the mutagenic impurity is at or below the acceptable cancer risk level.

### *Contains Nonbinding Recommendations*

There may be cases when an impurity is also a metabolite of the drug substance. In such cases, the risk assessment that addresses mutagenicity of the metabolite can qualify the impurity.

#### **IV. CONSIDERATIONS FOR MARKETED PRODUCTS (4)**

This guidance is not intended to be applied retrospectively (i.e., to products marketed prior to adoption of this guidance). However, some types of post-approval changes warrant a reassessment of safety relative to mutagenic impurities. This section applies to these post-approval changes for products marketed prior to, or after, the adoption of this guidance. Section VIII.E (8.5) (Lifecycle Management) contains additional recommendations for products marketed after adoption of this guidance.

##### **A. Post-Approval Changes to the Drug Substance Chemistry, Manufacturing, and Controls (4.1)**

Post-approval submissions involving the drug substance chemistry, manufacturing, and controls should include an evaluation of the potential risk impact associated with mutagenic impurities from changes to the route of synthesis, reagents, solvents, or process conditions after the starting material. Specifically, changes should be evaluated to determine whether the changes result in any new mutagenic impurities or higher acceptance criteria for existing mutagenic impurities. Reevaluation of impurities not impacted by changes is not recommended. For example, when only a portion of the manufacturing process is changed, the assessment of risk from mutagenic impurities should be limited to whether any new mutagenic impurities result from the change, whether any mutagenic impurities formed during the affected step are increased, and whether any known mutagenic impurities from upstream steps are increased. Regulatory submissions associated with such changes should describe the assessment as outlined in Section IX.B (9.2). Changing the site of manufacture of drug substance, intermediates, or starting materials or changing raw materials supplier will not require a reassessment of mutagenic impurity risk.

When a new drug substance supplier is proposed, evidence that the drug substance produced by this supplier using the same route of synthesis as an existing drug product marketed in the assessor's region is considered to be sufficient evidence of acceptable risk/benefit regarding mutagenic impurities and an assessment per this guidance is not required. If this is not the case, then an assessment per this guidance is strongly recommended.

##### **B. Post-Approval Changes to the Drug Product Chemistry, Manufacturing, and Controls (4.2)**

Post-approval submissions involving the drug product (e.g., change in composition, manufacturing process, dosage form) should include an evaluation of the potential risk associated with any new mutagenic degradation products or higher acceptance criteria for existing mutagenic degradation products. If appropriate, the regulatory submission should include an updated control strategy. Reevaluation of the drug substance associated with drug products is not recommended or expected provided there are no changes to the drug substance. Changing the site of manufacture of drug product will not require a reassessment of mutagenic impurity risk.

## ***Contains Nonbinding Recommendations***

### **C. Changes to the Clinical Use of Marketed Products (4.3)**

Changes to the clinical use of marketed products that can warrant a reevaluation of the mutagenic impurity limits include a significant increase in clinical dose, an increase in duration of use (in particular when a mutagenic impurity was controlled above the lifetime acceptable intake for a previous indication that may no longer be appropriate for the longer treatment duration associated with the new indication), or a change in indication from a serious or life-threatening condition where higher acceptable intakes were justified (Section VII.E (7.5)) to an indication for a less serious condition where the existing impurity acceptable intakes may no longer be appropriate. Changes to the clinical use of marketed products associated with new routes of administration or expansion into patient populations that include pregnant women and/or pediatrics will not warrant a reevaluation, assuming no increases in daily dose or duration of treatment.

### **D. Other Considerations for Marketed Products (4.4)**

Application of this guidance to marketed products may be warranted if there is specific cause for concern. The existence of impurity structural alerts alone is considered insufficient to trigger follow-up measures, unless it is a structure in the cohort of concern (Section III (3)). However a specific cause for concern would be new relevant impurity hazard data (classified as Class 1 or 2, Section 6) generated after the overall control strategy and specifications for market authorization were established. This new relevant impurity hazard data should be derived from high-quality scientific studies consistent with relevant regulatory testing guidelines, with data records or reports readily available. Similarly, a newly discovered impurity that is a known Class 1 or Class 2 mutagen that is present in a marketed product could also be a cause for concern. In both of these cases when the applicant becomes aware of this new information, an evaluation per this guidance should be conducted.

## **V. DRUG SUBSTANCE AND DRUG PRODUCT IMPURITY ASSESSMENT (5)**

Actual and potential impurities that are likely to arise during the synthesis and storage of a new drug substance, and during manufacturing and storage of a new drug product, should be assessed.

The impurity assessment is a two-stage process:

- Actual impurities that have been identified should be considered for their mutagenic potential.
- An assessment of potential impurities likely to be present in the final drug substance is carried out to determine whether further evaluation of their mutagenic potential is warranted.

The steps as applied to synthetic impurities and degradation products are described in Sections V.A (5.1) and V.B (5.2), respectively.

### **A. Synthetic Impurities (5.1)**

Actual impurities include those observed in the drug substance above the ICH Q3A reporting thresholds. Identification of actual impurities is expected when the levels exceed the

### ***Contains Nonbinding Recommendations***

identification thresholds outlined by ICH Q3A. It is acknowledged that some impurities below the identification threshold may also have been identified.

Potential impurities in the drug substance can include starting materials, reagents, and intermediates in the route of synthesis from the starting material to the drug substance.

The risk of carryover into the drug substance should be assessed for identified impurities that are present in starting materials and intermediates, and impurities that are reasonably expected by-products in the route of synthesis from the starting material to the drug substance. As the risk of carryover may be negligible for some impurities (e.g., those impurities in early synthetic steps of long routes of synthesis), a risk-based justification could be provided for the point in the synthesis after which these types of impurities should be evaluated for mutagenic potential.

For starting materials that are introduced late in the synthesis of the drug substance (and where the synthetic route of the starting material is known), the final steps of the starting material synthesis should be evaluated for potential mutagenic impurities.

Actual impurities where the structures are known and potential impurities as defined above should be evaluated for mutagenic potential as described in Section VI (6).

#### **B. Degradation Products (5.2)**

Actual drug substance degradation products include those observed above the ICH Q3A reporting threshold during storage of the drug substance in the proposed long-term storage conditions and primary and secondary packaging. Actual degradation products in the drug product include those observed above the ICH Q3B reporting threshold during storage of the drug product in the proposed long-term storage conditions and primary and secondary packaging, and also include those impurities that arise during the manufacture of the drug product. Identification of actual degradation products is expected when the levels exceed the identification thresholds outlined by ICH Q3A/Q3B. It is acknowledged that some degradation products below the identification threshold may also have been identified.

Potential degradation products in the drug substance and drug product are those that may be reasonably expected to form during long-term storage conditions. Potential degradation products include those that form above the ICH Q3A/Q3B identification threshold during accelerated stability studies (e.g., 40°C/75% relative humidity for 6 months) and confirmatory photostability studies as described in ICH Q1B (Ref. 5), but are yet to be confirmed in the drug substance or drug product under long-term storage conditions in the primary packaging.

Knowledge of relevant degradation pathways can be used to help guide decisions on the selection of potential degradation products to be evaluated for mutagenicity, e.g., from degradation chemistry principles, relevant stress testing studies, and development stability studies.

Actual and potential degradation products likely to be present in the final drug substance or drug product and where the structure is known should be evaluated for mutagenic potential as described in Section VI (6).



***Contains Nonbinding Recommendations***

**C. Considerations for Clinical Development (5.3)**

It is expected that the impurity assessment described in Sections V.A (5.1) and V.B (5.2) applies to products in clinical development. However, it is acknowledged that the available information is limited. For example, information from long-term stability studies and photostability studies may not be available during clinical development and thus information on potential degradation products may be limited. Additionally, the thresholds outlined in ICH Q3A/Q3B do *not* apply to products in clinical development and, consequently, fewer impurities will be identified.

**VI. HAZARD ASSESSMENT ELEMENTS (6)**

Hazard assessment involves an initial analysis of actual and potential impurities by conducting database and literature searches for carcinogenicity and bacterial mutagenicity data in order to classify them as Class 1, 2, or 5 according to Table 1. If data for such a classification are not available, an assessment of Structure-Activity Relationships (SAR) that focuses on bacterial mutagenicity predictions should be performed. This could lead to a classification into Class 3, 4, or 5.

**Table 1: Impurities Classification With Respect to Mutagenic and Carcinogenic Potential and Resulting Control Actions**

<b>Class</b>	<b>Definition</b>	<b>Proposed action for control (details in Section VII (7) and VIII (8))</b>
<b>1</b>	Known mutagenic carcinogens	Control at or below compound-specific acceptable limit
<b>2</b>	Known mutagens with unknown carcinogenic potential (bacterial mutagenicity positive,* no rodent carcinogenicity data)	Control at or below acceptable limits (appropriate TTC)
<b>3</b>	Alerting structure, unrelated to the structure of the drug substance; no mutagenicity data	Control at or below acceptable limits (appropriate TTC) or conduct bacterial mutagenicity assay; If non-mutagenic = Class 5 If mutagenic = Class 2
<b>4</b>	Alerting structure, same alert in drug substance or compounds related to the drug substance (e.g., process intermediates) which have been tested and are non-mutagenic	Treat as non-mutagenic impurity
<b>5</b>	No structural alerts, or alerting structure with sufficient data to demonstrate lack of mutagenicity or carcinogenicity	Treat as non-mutagenic impurity

\*Or other relevant positive mutagenicity data indicative of DNA-reactivity-related induction of gene mutations (e.g., positive findings in in vivo gene mutation studies)

### ***Contains Nonbinding Recommendations***

A computational toxicology assessment should be performed using Quantitative Structure-Activity Relationship ((Q)SAR) methodologies that predict the outcome of a bacterial mutagenicity assay (Ref. 6). Two (Q)SAR prediction methodologies that complement each other should be applied. One methodology should be expert rule-based, and the second methodology should be statistical-based. (Q)SAR models utilizing these prediction methodologies should follow the general validation principles set forth by the Organisation for Economic Co-operation and Development (OECD).

The absence of structural alerts from two complementary (Q)SAR methodologies (expert rule-based and statistical) is sufficient to conclude that the impurity is of no mutagenic concern, and no further testing is recommended (Class 5 in Table 1).

If warranted, the outcome of any computer system-based analysis can be reviewed with the use of expert knowledge in order to provide additional supportive evidence on relevance of any positive, negative, conflicting, or inconclusive prediction and to provide a rationale to support the final conclusion.

To follow up on a relevant structural alert (Class 3 in Table 1), either adequate control measures could be applied or a bacterial mutagenicity assay with the impurity alone can be conducted. An appropriately conducted negative bacterial mutagenicity assay (Note 2) would overrule any structure-based concern, and no further genotoxicity assessments would be recommended (Note 1). These impurities should be considered non-mutagenic (Class 5 in Table 1). A positive bacterial mutagenicity result would warrant further hazard assessment and/or control measures (Class 2 in Table 1). For instance, when levels of the impurity cannot be controlled at an appropriate acceptable limit, it is recommended that the impurity be tested in an in vivo gene mutation assay in order to understand the relevance of the bacterial mutagenicity assay result under in vivo conditions. The selection of other in vivo genotoxicity assays should be scientifically justified based on knowledge of the mechanism of action of the impurity and expected target tissue exposure (Note 3). In vivo studies should be designed taking into consideration existing ICH genotoxicity guidances. Results in the appropriate in vivo assay may support setting compound specific impurity limits.

An impurity with a structural alert that is shared (e.g., same structural alert in the same position and chemical environment) with the drug substance or related compounds can be considered as non-mutagenic (Class 4 in Table 1) if the testing of such material in the bacterial mutagenicity assay was negative.

## **VII. RISK CHARACTERIZATION (7)**

As a result of hazard assessment described in Section VI (6), each impurity will be assigned to one of the five classes in Table 1. For impurities belonging in Classes 1, 2, and 3, the principles of risk characterization used to derive acceptable intakes are described in this section.

### **A. TTC-Based Acceptable Intakes (7.1)**

A TTC-based acceptable intake of a mutagenic impurity of 1.5 µg per person per day is considered to be associated with a negligible risk (theoretical excess cancer risk of <1 in 100,000 over a lifetime of exposure) and can, in general, be used for most pharmaceuticals as a default to derive an acceptable limit for control. This approach would usually be used for

### ***Contains Nonbinding Recommendations***

mutagenic impurities present in pharmaceuticals for long-term treatment (> 10 years) and where no carcinogenicity data are available (Classes 2 and 3).

#### **B. Acceptable Intakes Based on Compound-Specific Risk Assessments (7.2)**

##### ***1. Mutagenic Impurities With Positive Carcinogenicity Data (Class 1 in Table 1) (7.2.1)***

Compound-specific risk assessments to derive acceptable intakes should be applied instead of the TTC-based acceptable intakes where sufficient carcinogenicity data exist. For a known mutagenic carcinogen, a compound-specific acceptable intake can be calculated based on carcinogenic potency and linear extrapolation as a default approach. Alternatively, other established risk assessment practices such as those used by international regulatory bodies may be applied either to calculate acceptable intakes or to use already existing values published by regulatory authorities (Note 4).

Compound-specific calculations for acceptable intakes can be applied case-by-case for impurities which are chemically similar to a known carcinogen compound class (class-specific acceptable intakes) provided that a rationale for chemical similarity and supporting data can be demonstrated (Note 5).

##### ***2. Mutagenic Impurities With Evidence for a Practical Threshold (7.2.2)***

The existence of mechanisms leading to a dose response that is non-linear or has a practical threshold is increasingly recognized, not only for compounds that interact with non-DNA targets but also for DNA-reactive compounds, whose effects may be modulated by, for example, rapid detoxification before coming into contact with DNA, or by effective repair of induced damage. The regulatory approach to such compounds can be based on the identification of a No-Observed Effect Level (NOEL) and use of uncertainty factors (see ICH Q3C(R5), Ref. 7) to calculate a permissible daily exposure (PDE) when data are available.

The acceptable intakes derived from compound-specific risk assessments (Section VII.B (7.2)) can be adjusted for shorter duration of use in the same proportions as defined in the following sections (Section VII.C.1 (7.3.1) and VII.C.2 (7.3.2)) or should be limited to not more than 0.5%, whichever is lower. For example, if the compound-specific acceptable intake is 15 µg/day for lifetime exposure, the less than lifetime limits (Table 2) can be increased to a daily intake of 100 µg (> 1-10 years treatment duration), 200 µg (> 1-12 months) or 1200 µg (< 1 month). However, for a drug with a maximum daily dose of, for instance, 100 milligrams (mg), the acceptable daily intake for the < 1-month duration, would be limited to 0.5% (500 µg) rather than 1200 µg.

#### **C. Acceptable Intakes in Relation to Less-Than-Lifetime (LTL) Exposure (7.3)**

Standard risk assessments of known carcinogens assume that cancer risk increases as a function of cumulative dose. Thus, cancer risk of a continuous low dose over a lifetime would be equivalent to the cancer risk associated with an identical cumulative exposure averaged over a shorter duration.

***Contains Nonbinding Recommendations***

The TTC-based acceptable intake of 1.5 µg/day is considered to be protective for a lifetime of daily exposure. To address LTL exposures to mutagenic impurities in pharmaceuticals, an approach is applied in which the acceptable cumulative lifetime dose (1.5 µg/day x 25,550 days = 38.3 mg) is uniformly distributed over the total number of exposure days during LTL exposure. This would allow higher daily intake of mutagenic impurities than would be the case for lifetime exposure and still maintain comparable risk levels for daily and non-daily treatment regimens. Table 2 is derived from the above concepts and illustrates the acceptable intakes for LTL to lifetime exposures for clinical development and marketing. In the case of intermittent dosing, the acceptable daily intake should be based on the total number of dosing days instead of the time interval over which the doses were administered and that number of dosing days should be related to the relevant duration category in Table 2. For example, a drug administered once per week for 2 years (i.e., 104 dosing days) would have an acceptable intake per dose of 20 µg.

*Contains Nonbinding Recommendations*

**Table 2: Acceptable Intakes for an Individual Impurity**

Duration of treatment	≤ 1 month	>1 - 12 months	>1 - 10 years	>10 years to lifetime
Daily intake [µg/day]	120	20	10	1.5

1. *Clinical Development (7.3.1)*

Using this LTL concept, acceptable intakes of mutagenic impurities are recommended for limited treatment periods during clinical development of up to 1 month, 1 to 12 months and more than 1 year up to completion of Phase 3 clinical trials (Table 2). These adjusted acceptable intake values maintain a  $10^{-6}$  risk level in early clinical development when benefit has not yet been established and a  $10^{-5}$  risk level for later stages in development (Note 6).

An alternative approach to the strict use of an adjusted acceptable intake for any mutagenic impurity could be applied for Phase 1 clinical trials for dosing up to 14 days. For this approach, only impurities that are known mutagenic carcinogens (Class 1) and known mutagens of unknown carcinogenic potential (Class 2), as well as impurities in the cohort of concern chemical class, should be controlled (see Section VIII (8)) to acceptable limits as described in Section VII (7). All other impurities would be treated as non-mutagenic impurities. This includes impurities which contain structural alerts (Class 3), which alone would not trigger action for an assessment for this limited Phase 1 duration.

2. *Marketed Products (7.3.2)*

The treatment duration categories with acceptable intakes in Table 2 for marketed products are intended to be applied to anticipated exposure durations for the great majority of patients. The proposed intakes, along with various scenarios for applying those intakes, are described in Note 7, Table 4. In some cases, a subset of the population of patients may extend treatment beyond the marketed drug's categorical upper limit (e.g., treatment exceeding 10 years for an acceptable intake of 10 µg/day, perhaps receiving 15 years of treatment). This would result in a negligible increase (in the example given, a fractional increase to 1.5/100,000) compared to the overall calculated risk for the majority of patients treated for 10 years.

**D. Acceptable Intakes for Multiple Mutagenic Impurities (7.4)**

The TTC-based acceptable intakes should be applied to each individual impurity. When there are two Class 2 or Class 3 impurities, individual limits apply. When there are three or more Class 2 or Class 3 impurities specified on the drug substance specification, total mutagenic impurities should be limited as described in Table 3 for clinical development and marketed products.

For combination products, each active ingredient should be regulated separately.

***Contains Nonbinding Recommendations***

**Table 3: Acceptable Total Daily Intakes for Multiple Impurities**

Duration of treatment	≤ 1 month	>1 - 12 months	>1 - 10 years	>10 years to lifetime
Total Daily intake [µg/day]	120	60	30	5

Only specified Class 2 and 3 impurities on the drug substance specification should be included in the calculation of the total limit. However, impurities with compound-specific or class-related acceptable intake limits (Class 1) should not be included in the total limits of Class 2 and Class 3 impurities. Also, degradation products that form in the drug product would be controlled individually and a total limit would not be applied.

**E. Exceptions and Flexibility in Approaches (7.5)**

- Higher acceptable intakes may be justified when human exposure to the impurity will be much greater from other sources, e.g., food, or endogenous metabolism (e.g., formaldehyde).
- Case-by-case exceptions to the use of the appropriate acceptable intake can be justified in cases of severe disease, reduced life expectancy, late onset but chronic disease, or limited therapeutic alternatives.
- Compounds from some structural classes of mutagens can display extremely high carcinogenic potency (cohort of concern), i.e., aflatoxin-like-, N-nitroso-, and alkyl-azoxy structures. If these compounds are found as impurities in pharmaceuticals, acceptable intakes for these high-potency carcinogens would likely be significantly lower than the acceptable intakes defined in this guidance. Although the principles of this guidance can be used, a case-by-case approach, using, e.g., carcinogenicity data from closely related structures, if available, should usually be developed to justify acceptable intakes for pharmaceutical development and marketed products.

The above risk approaches described in Section VII (7) are applicable to all routes of administration, and no corrections to acceptable intakes are generally warranted. Exceptions to consider may include situations where data justify route-specific concerns that should be evaluated case by case. These approaches are also applicable to all patient populations based upon the conservative nature of the risk approaches being applied.

**VIII. CONTROL**

A control strategy is a planned set of controls derived from current product and process understanding that assures process performance and product quality (ICH Q10, Ref. 8). A control strategy can include, but is not limited to, the following:

- Controls on material attributes (including raw materials, starting materials, intermediates, reagents, solvents, primary packaging materials);

### ***Contains Nonbinding Recommendations***

- Facility and equipment operating conditions;
- Controls implicit in the design of the manufacturing process;
- In-process controls (including in-process tests and process parameters);
- Controls on drug substance and drug product (e.g., release testing).

When an impurity has been characterized as Class 1, 2, or 3 in Table 1, it is important to develop a control strategy that assures that the level of this impurity in the drug substance and drug product is below the acceptable limit. A thorough knowledge of the chemistry associated with the drug substance manufacturing process, and of the drug product manufacturing process, along with an understanding of the overall stability of the drug substance and drug product is fundamental to developing the appropriate controls.

Developing a strategy to control mutagenic impurities in the drug product is consistent with risk management processes identified in ICH Q9 (Ref. 9). A control strategy that is based on product and process understanding and utilization of risk management principles will lead to a combination of process design and control and appropriate analytical testing, which can also provide an opportunity to shift controls upstream and minimize the need for end-product testing.

#### **A. Control of Process Related Impurities (8.1)**

There are 4 potential approaches to development of a control strategy for drug substance:

##### **Option 1**

Include a test for the impurity in the drug substance specification with an acceptance criterion at or below the acceptable limit using an appropriate analytical procedure.

For an Option 1 control approach, it is possible to apply periodic verification testing per ICH Q6A (Ref 10). Periodic verification testing is justified when it can be shown that levels of the mutagenic impurity in the drug substance are less than 30% of the acceptable limit for at least 6 consecutive pilot scale or 3 consecutive production scale batches. If this condition is not fulfilled, a routine test in the drug substance specification is recommended. See Section VIII.C (8.3) for additional considerations.

##### **Option 2**

Include a test for the impurity in the specification for a raw material, starting material or intermediate, or as an in-process control, with an acceptance criterion at or below the acceptable limit using an appropriate analytical procedure.

##### **Option 3**

Include a test for the impurity in the specification for a raw material, starting material or intermediate, or as an in-process control, with an acceptance criterion above the acceptable limit of the impurity in the drug substance, using an appropriate analytical procedure coupled with demonstrated understanding of fate and purge and associated process controls that assure the level in the drug substance is below the acceptable limit without the need for any additional testing later in the process.

### ***Contains Nonbinding Recommendations***

This option can be justified when the level of the impurity in the drug substance will be less than 30% of the acceptable limit by review of data from laboratory scale experiments (spiking experiments are encouraged) and, where warranted, is supported by data from pilot scale or commercial scale batches. See Appendix 2, Case Examples 1 and 2. Alternative approaches can be used to justify Option 3.

#### **Option 4**

Understand process parameters and impact on residual impurity levels (including fate and purge knowledge) with sufficient confidence that the level of the impurity in the drug substance will be below the acceptable limit such that no analytical testing is recommended for this impurity (i.e., the impurity does not need to be listed on any specification).

A control strategy that relies on process controls in lieu of analytical testing can be appropriate if the process chemistry and process parameters that have an impact on the levels of mutagenic impurities are understood and the risk of an impurity residing in the final drug substance above the acceptable limit is determined to be negligible. In many cases, justification of this control approach based on scientific principles alone is sufficient. Elements of a scientific risk assessment can be used to justify an option 4 approach. The risk assessment can be based on physicochemical properties and process factors that influence the fate and purge of an impurity, including chemical reactivity, solubility, volatility, ionizability, and any physical process steps designed to remove impurities. The result of this risk assessment might be shown as an estimated purge factor for clearance of the impurity by the process (Ref. 11).

Option 4 is especially useful for those impurities that are inherently unstable (e.g., thionyl chloride that reacts rapidly and completely with water) or for those impurities that are introduced early in the synthesis and are effectively purged.

In some cases an Option 4 approach can be appropriate when the impurity is known to form, or is introduced late in the synthesis; however, process-specific data should then be provided to justify this approach.

#### **B. Considerations for Control Approaches (8.2)**

For Option 4 approaches where justification based on scientific principles alone is not considered sufficient, as well as for Option 3 approaches, analytical data to support the control approach is strongly recommended. This could include, as appropriate, information on the structural changes to the impurity caused by downstream chemistry (*fate*); analytical data on pilot scale batches; and, in some cases, laboratory scale studies with intentional addition of the impurity (*spiking studies*). In these cases, it is important to demonstrate that the fate/purge argument for the impurity is robust and will consistently assure a negligible probability of an impurity residing in the final drug substance above the acceptable limit. Where the purge factor is based on developmental data, it is important to address the expected scale-dependence or independence. In the case that the small scale model used in the development stage is considered to not represent the commercial scale, confirmation of suitable control in pilot scale and/or initial commercial batches is generally appropriate. The need for data from pilot/commercial batches is influenced by the magnitude of the purge factor calculated from laboratory or pilot scale data, point of entry of the impurity, and knowledge of downstream process purge points.



### ***Contains Nonbinding Recommendations***

If Options 3 and 4 cannot be justified, then a test for the impurity on the specification for a raw material, starting material or intermediate, or as an in-process control (Option 2) or drug substance (Option 1) at the acceptable limit should be included. For impurities introduced in the last synthetic step, an Option 1 control approach would normally be expected unless otherwise justified.

The application of *As Low As Reasonably Practicable* (ALARP) is not necessary if the level of the mutagenic impurity is below acceptable limits. Similarly, it is not necessary to demonstrate that alternate routes of synthesis have been explored.

In cases where control efforts cannot reduce the level of the mutagenic impurity to below the acceptable limit and levels are as low as reasonably practical, a higher limit may be justified based on a risk/benefit analysis.

#### **C. Considerations for Periodic Testing (8.3)**

The above options include situations where a test is recommended to be included in the specification, but where routine measurement for release of every batch may not be necessary. This approach, referred to as *periodic or skip testing* in ICH Q6A could also be called *Periodic Verification Testing*. This approach may be appropriate when it can be demonstrated that processing subsequent to impurity formation/introduction clears the impurity. It should be noted that allowance of Periodic Verification Testing is contingent upon use of a process that is under a state of control (i.e., produces a quality product that consistently meets specifications and conforms to an appropriately established facility, equipment, processing, and operational control regimen). If upon testing, the level of the mutagenic impurity fails to meet the acceptance criteria established for the periodic test, the drug producer should immediately commence full testing (i.e., testing of every batch for the attribute specified) until the cause of the failure has been conclusively determined, corrective action has been implemented, and the process is again documented to be in a state of control. As noted in ICH Q6A, regulatory authorities should be notified of a periodic verification test failure to evaluate the risk/benefit of previously released batches that were not tested.

#### **D. Control of Degradation Products (8.4)**

For a potential degradation product that has been characterized as mutagenic, it is important to understand if the degradation pathway is relevant to the drug substance and drug product manufacturing processes and/or their proposed packaging and storage conditions. A well-designed accelerated stability study (e.g., 40°C/75% relative humidity, 6 months) using the proposed packaging, with appropriate analytical procedures, is recommended to determine the relevance of the potential degradation product. Alternatively, well-designed kinetically equivalent shorter-term stability studies at higher temperatures using the proposed commercial packaging may be used to determine the relevance of the degradation pathway prior to initiating longer-term stability studies. This type of study would be especially useful to understand the relevance of those potential degradation products that are based on knowledge of potential degradation pathways but not yet observed in the product.

Based on the result of these accelerated studies, if it is anticipated that the degradation product will form at levels approaching the acceptable limit under the proposed packaging and storage conditions, then efforts to control formation of the degradation product is

### *Contains Nonbinding Recommendations*

recommended. In these cases, monitoring for the drug substance or drug product degradation in long-term primary stability studies at the proposed storage conditions (in the proposed commercial pack) is expected unless otherwise justified. Whether or not a specification limit for the mutagenic degradation product is appropriate will generally depend on the results from these stability studies.

If it is anticipated that formulation development and packaging design options are unable to control mutagenic degradation product levels to less than the acceptable limit and levels are as low as reasonably practicable, a higher limit can be justified based on a risk/benefit analysis.

#### **E. Lifecycle Management (8.5)**

This section is intended to apply to those products approved after the issuance of this guidance.

The quality system elements and management responsibilities described in ICH Q10 are intended to encourage the use of science-based and risk-based approaches at each lifecycle stage, thereby promoting continual improvement across the entire product lifecycle. Product and process knowledge should be managed from development through the commercial life of the product up to and including product discontinuation.

The development and improvement of a drug substance or drug product manufacturing process usually continues over its lifecycle. Manufacturing process performance, including the effectiveness of the control strategy, should be periodically evaluated. Knowledge gained from commercial manufacturing can be used to further improve process understanding and process performance and to adjust the control strategy.

Any proposed change to the manufacturing process should be evaluated for the impact on the quality of drug substance and drug product. This evaluation should be based on understanding of the manufacturing process and should determine whether appropriate testing to analyze the impact of the proposed changes is warranted. Additionally, improvements in analytical procedures may lead to structural identification of an impurity. In those cases, the new structure would be assessed for mutagenicity as described in this guidance.

Throughout the lifecycle of the product, it will be important to reassess if testing is recommended when intended or unintended changes occur in the process. This applies when there is no routine monitoring at the acceptable limit (Option 3 or Option 4 control approaches), or when applying periodic rather than batch-by-batch testing. This testing should be performed at an appropriate point in the manufacturing process.

In some cases, the use of statistical process control and trending of process measurements can be useful for continued suitability and capability of processes to provide adequate control on the impurity. Statistical process control can be based on process parameters that influence impurity formation or clearance, even when that impurity is not routinely monitored (e.g., Option 4).

All changes should be subject to internal change management processes as part of the quality system (ICH Q10). Changes to information filed and approved in a dossier should be reported to regulatory authorities in accordance with regional regulations and guidelines.

## ***Contains Nonbinding Recommendations***

### **F. Considerations for Clinical Development (8.6)**

It is recognized that product and process knowledge increases over the course of development and therefore it is expected that data to support control strategies in the clinical development trial phases will be less than at the marketing registration phase. A risk-based approach based on process chemistry fundamentals is encouraged to prioritize analytical efforts on those impurities with the highest likelihood of being present in the drug substance or drug product. Analytical data may not be expected to support early clinical development when the likelihood of an impurity being present is low, but in a similar situation analytical data may be appropriate to support the control approach for the marketing application. It is also recognized that commercial formulation design occurs later in clinical development and therefore efforts associated with drug product degradation products will be limited in the earlier phases.

### **IX. DOCUMENTATION**

Information relevant to the application of this guidance should be provided at the following stages:

#### **A. Clinical Trial Applications (9.1)**

- It is expected that the number of structures assessed for mutagenicity and the collection of analytical data will both increase throughout the clinical development period.
- For Phase 1 studies of 14 days or less, a description of efforts to mitigate risks of mutagenic impurities focused on Class 1 and Class 2 impurities and those in the cohort of concern as outlined in Section VII (7) should be included. For Phase 1 clinical trials of more than 14 days and for Phase 2a clinical trials as well, Class 3 impurities that have analytical controls should also be included.
- For Phase 2b and Phase 3 clinical development trials, a list of the impurities assessed by (Q)SAR should be included, and any Class 1, 2, or 3 actual and potential impurities should be described along with plans for control. The *in silico* (Q)SAR systems used to perform the assessments should be described. The results of bacterial mutagenicity tests of actual impurities should be reported.
- Chemistry arguments may be appropriate instead of analytical data for potential impurities that present a low likelihood of being present as described in Section VIII.F (8.6).

#### **B. Common Technical Document (Marketing Application) (9.2)**

- For actual and potential process related impurities and degradation products where assessments according to this guidance are conducted, the mutagenic impurity classification and rationale for this classification should be provided:
  - This would include the results and description of *in silico* (Q)SAR systems used and, as appropriate, supporting information to arrive at the overall conclusion for Class 4 and 5 impurities.

***Contains Nonbinding Recommendations***

- When bacterial mutagenicity assays were performed on impurities, study reports should be provided for bacterial mutagenicity assays on impurities.
- Justification for the proposed specification and the approach to control should be provided (e.g., ICH Q11 example 5b, Ref. 12). For example, this information could include the acceptable intake, the location, and sensitivity of relevant routine monitoring. For Option 3 and Option 4 control approaches, a summary of knowledge of the purge factor, and identification of factors providing control (e.g., process steps, solubility in wash solutions), is important.

**Contains Nonbinding Recommendations**

**NOTES**

- Note 1* The ICH M7 Guidance recommendations provide a state-of-the-art approach for assessing the potential of impurities to induce point mutations and ensure that such impurities are controlled to safe levels so that below or above the ICH Q3A/Q3B qualification threshold, no further qualification for mutagenic potential is required. This includes the initial use of (Q)SAR tools to predict bacterial mutagenicity. In cases where the amount of the impurity exceeds 1 mg daily dose for chronic administration, evaluation of genotoxic potential as recommended in ICH Q3A/Q3B could be considered. In cases where the amount of the impurity is less than 1 mg, no further genotoxicity testing is required regardless of other qualification thresholds.
- Note 2* To assess the mutagenic potential of impurities, a single bacterial mutagenicity assay can be carried out with a fully adequate protocol according to ICH S2(R1) and OECD 471 guidelines (Refs. 13 and 14). The assays should be performed in compliance with Good Laboratory Practices (GLP) regulations; however, lack of full GLP compliance does not necessarily mean that the data cannot be used to support clinical trials and marketing authorizations. Such deviations should be described in the study report. For example, the test article may not be prepared or analyzed in compliance with GLP regulations. In some cases, the selection of bacterial tester strains may be limited to those proven to be sensitive to the identified alert. For impurities that are not feasible to isolate or synthesize or when compound quantity is limited, it may not be possible to achieve the highest test concentrations recommended for an ICH-compliant bacterial mutagenicity assay according to the current testing guidelines. In this case, bacterial mutagenicity testing could be carried out using a miniaturized assay format with proven high concordance to the ICH-compliant assay to enable testing at higher concentrations with justification.
- Note 3* Tests to Investigate the in vivo Relevance of in vitro Mutagens (Positive Bacterial Mutagenicity)

In vivo test	Factors to justify choice of test as fit-for-purpose
Transgenic mutation assays	<ul style="list-style-type: none"> <li>• For any bacterial mutagenicity positive. Justify selection of assay tissue/organ</li> </ul>
<i>Pig-a</i> assay (blood)	<ul style="list-style-type: none"> <li>• For directly acting mutagens (bacterial mutagenicity positive without S9)*</li> </ul>
Micronucleus test (blood or bone marrow)	<ul style="list-style-type: none"> <li>• For directly acting mutagens (bacterial mutagenicity positive without S9) and compounds known to be clastogenic*</li> </ul>
Rat liver Unscheduled DNA Synthesis (UDS) test	<ul style="list-style-type: none"> <li>• In particular for bacterial mutagenicity positive with S9 only</li> <li>• Responsible liver metabolite known                             <ul style="list-style-type: none"> <li>○ to be generated in test species used</li> <li>○ to induce bulky adducts</li> </ul> </li> </ul>
Comet assay	<ul style="list-style-type: none"> <li>• Justification should be provided (chemical class specific mode of action to form alkaline labile sites or single-strand breaks as preceding DNA damage that can</li> </ul>

***Contains Nonbinding Recommendations***

	potentially lead to mutations
	• Justify selection of assay tissue/organ
Others	• With convincing justification

\*For indirect acting mutagens (requiring metabolic activation), adequate exposure to metabolite(s) should be demonstrated.

**Note 4** Example of linear extrapolation from the TD<sub>50</sub>

It is possible to calculate a compound-specific acceptable intake based on rodent carcinogenicity potency data such as TD<sub>50</sub> values (doses giving a 50% tumor incidence equivalent to a cancer risk probability level of 1:2). Linear extrapolation to a probability of 1 in 100,000 (i.e., the accepted lifetime risk level used) is achieved by simply dividing the TD<sub>50</sub> by 50,000. This procedure is similar to that employed for derivation of the TTC.

Calculation example: Ethylene oxide

TD<sub>50</sub> values for ethylene oxide according to the Carcinogenic Potency Database are 21.3 mg/kg body weight/day (rat) and 63.7 mg/kg body weight/day (mouse). For the calculation of an acceptable intake, the lower (i.e., more conservative) value of the rat is used.

To derive a dose to cause tumors in 1 in 100,000 animals, divide by 50,000:

$$21.3 \text{ mg/kilograms (kg)} \div 50,000 = 0.42 \text{ } \mu\text{g/kg}$$

To derive a total human daily dose:

$$0.42 \text{ } \mu\text{g/kg/day} \times 50 \text{ kg body weight} = 21.3 \text{ } \mu\text{g/person/day}$$

Hence, a daily life-long intake of 21.3  $\mu\text{g}$  ethylene oxide would correspond to a theoretical cancer risk of  $10^{-5}$  and therefore be an acceptable intake when present as an impurity in a drug substance.

Alternative methods and published regulatory limits for cancer risk assessment

As an alternative of using the most conservative TD<sub>50</sub> value from rodent carcinogenicity studies irrespective of its relevance to humans, an in-depth toxicological expert assessment of the available carcinogenicity data can be done in order to initially identify the findings (e.g., species, organ) with highest relevance to human risk assessment as a basis for deriving a reference point for linear extrapolation. Also, in order to better take into account directly the shape of the dose-response curve, a benchmark dose such as a benchmark dose lower confidence limit 10% (BMDL10, an estimate of the lowest dose which is 95% certain to cause no more than a 10% cancer incidence in rodents) may be used instead of TD<sub>50</sub> values as a numerical index for carcinogenic potency. Linear extrapolation to a probability of 1 in 100,000 (i.e., the accepted lifetime risk level used) is then achieved by simply dividing the BMDL10 by 10,000.

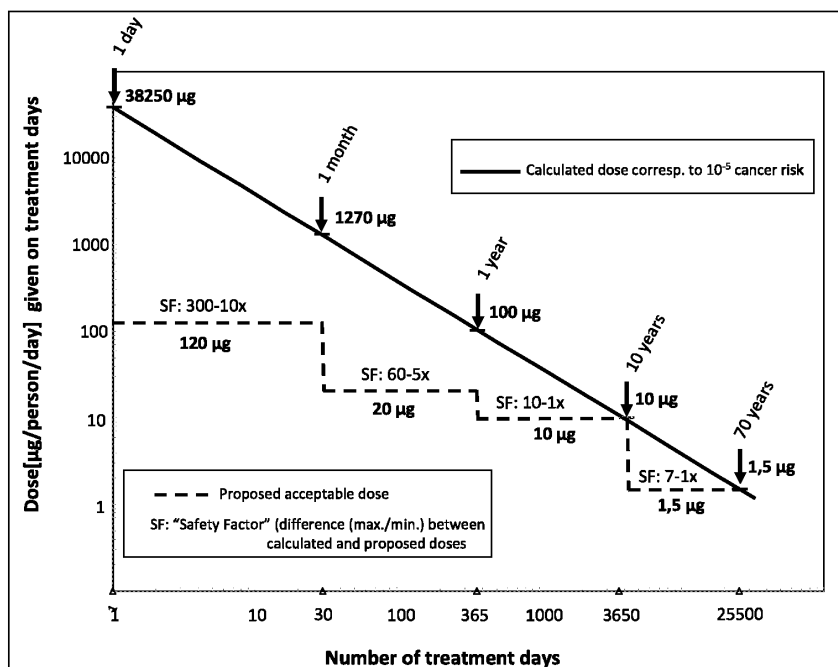
### *Contains Nonbinding Recommendations*

Compound-specific acceptable intakes can also be derived from published recommended values from internationally recognized bodies such as World Health Organization (WHO, International Program on Chemical Safety [IPCS] Cancer Risk Assessment Programme) and others using the appropriate  $10^{-5}$  lifetime risk level. In general, a regulatory limit that is applied should be based on the most current and scientifically supported data and/or methodology.

*Note 5* A compound-specific calculation of acceptable intakes for mutagenic impurities may be applied for mutagenic impurities (without carcinogenicity data) which are structurally similar to a chemically defined class of known carcinogen. For example, factors that are associated with the carcinogenic potency of monofunctional alkyl chlorides have been identified (Ref. 15) and can be used to modify the safe acceptable intake of monofunctional alkyl chlorides, a group of alkyl chlorides commonly used in drug synthesis. Compared to multifunctional alkyl chlorides, the monofunctional compounds are much less potent carcinogens with  $TD_{50}$  values ranging from 36 to 1810 mg/kg/day ( $n=15$ ; epichlorohydrin with two distinctly different functional groups is excluded). A  $TD_{50}$  value of 36 mg/kg/day can thus be used as a still very conservative class-specific potency reference point for calculation of acceptable intakes for monofunctional alkyl chlorides. This potency level is at least 10-fold lower than the  $TD_{50}$  of 1.25 mg/kg/day corresponding to the default lifetime TTC (1.5  $\mu$ g/day) and therefore justifies lifetime and less-than-lifetime daily intakes for monofunctional alkyl chlorides 10 times the default ones.

*Note 6* Establishing less-than-lifetime acceptable intakes for mutagenic impurities in pharmaceuticals has precedence in the establishment of the staged TTC limits for clinical development (Ref. 16). The calculation of less-than-lifetime Acceptable Intakes (AI) is predicated on the principle of Haber's rule, a fundamental concept in toxicology where concentration (C) x time (T) = a constant (k). Therefore, the carcinogenic effect is based on both dose and duration of exposure.

*Contains Nonbinding Recommendations*



**Figure 1:** Illustration of calculated daily dose of a mutagenic impurity corresponding to a theoretical 1:100,000 cancer risk as a function of duration of treatment in comparison to the acceptable intake levels as recommended in Section VII.C (7.3).

The solid line in Figure 1 represents the linear relationship between the amount of daily intake of a mutagenic impurity corresponding to a  $10^{-5}$  cancer risk and the number of treatment days. The calculation is based on the TTC level as applied in this guidance for life-long treatment, i.e., 1.5 µg per person per day using the formula:

$$\text{Less-than-lifetime AI} = \frac{1.5 \mu\text{g} \times (365 \text{ days} \times 70 \text{ years lifetime} = 25,550)}{\text{Total number of treatment days}}$$

The calculated daily intake levels would thus be 1.5 µg for treatment duration of 70 years, 10 µg for 10 years, 100 µg for 1 year, 1270 µg for 1 month and approximately 38.3 mg as a single dose, all resulting in the same cumulative intake and therefore theoretically in the same cancer risk (1 in 100,000).

The dashed step-shaped curve represents the actual daily intake levels adjusted to less-than-lifetime exposure as recommended in Section VII (7) of this guidance for products in clinical development and marketed products. These proposed levels, are, in general, significantly lower than the calculated values thus providing safety factors that increase with shorter treatment durations.

The proposed accepted daily intakes are also in compliance with a  $10^{-6}$  cancer risk level if treatment durations are not longer than 6 months and are therefore applicable in early clinical trials with volunteers/patients where benefit has not yet



**Contains Nonbinding Recommendations**

been established. In this case, the safety factors as shown in the upper graph would be reduced by a factor of 10.

*Note 7*

**Table 4:** Examples of clinical use scenarios with different treatment durations for applying acceptable intakes

<b>Scenario<sup>1</sup></b>	<b>Acceptable Intake (µg/day)</b>
<b>Treatment duration of ≤ 1 month:</b> e.g., drugs used in emergency procedures (antidotes, anesthesia, acute ischemic stroke), actinic keratosis, treatment of lice	120
<b>Treatment duration of &gt; 1-12 months:</b> e.g., anti-infective therapy with maximum up to 12 months treatment (Hepatitis C Virus), parenteral nutrients, prophylactic flu drugs (~ 5 months), peptic ulcer, Assisted Reproductive Technology (ART), pre-term labor, preeclampsia, pre-surgical (hysterectomy) treatment, fracture healing (these are acute use but with long half-lives)	20
<b>Treatment duration of &gt;1-10 years:</b> e.g., stage of disease with short life expectancy (severe Alzheimer's), non-genotoxic anticancer treatment being used in a patient population with longer-term survival (breast cancer, Chronic Myelogenous Leukemia), drugs specifically labeled for less than 10 years of use, drugs administered intermittently to treat acute recurring symptoms <sup>2</sup> (chronic Herpes, gout attacks, substance dependence such as smoking cessation), macular degeneration, Human Immunodeficiency Virus (HIV) <sup>3</sup>	10
<b>Treatment duration of &gt;10 years to lifetime:</b> e.g., chronic use indications with high likelihood for lifetime use across broader age range (hypertension, dyslipidemia, asthma, Alzheimer's Disease (AD) (except severe AD), hormone therapy (e.g., Growth Hormone, Thyroid Hormone, Para Thyroid Hormone), lipodystrophy, schizophrenia, depression, psoriasis, atopic dermatitis, Chronic Obstructive Pulmonary Disease (COPD), cystic fibrosis, seasonal and perennial allergic rhinitis	1.5

<sup>1</sup> This table shows general examples; each example should be examined on a case-by-case basis. For example, 10 µg/day may be acceptable in cases where the life expectancy of the patient may be limited, e.g., severe Alzheimer's disease, even though the drug use could exceed 10-year duration.

<sup>2</sup> Intermittent use over a period >10 yrs., but based on calculated cumulative dose, it falls under the >1-10 yr. category.

<sup>3</sup> HIV is considered a chronic indication, but resistance develops to the drugs after 5-10 years and the therapy is changed to other HIV drugs.

*Contains Nonbinding Recommendations*

**GLOSSARY**

**Acceptable intake:**

In the context of this guidance, an intake level that poses negligible cancer risk, or for serious/life-threatening indications where risk and benefit are appropriately balanced.

**Acceptable limit:**

Maximum acceptable concentration of an impurity in a drug substance or drug product derived from the acceptable intake and the daily dose of the drug.

**Acceptance criterion:**

Numerical limits, ranges, or other suitable measures for acceptance of the results of analytical procedures.

**Control strategy:**

A planned set of controls, derived from current product and process understanding that ensures process performance and product quality. The controls can include parameters and attributes related to drug substance and drug product materials and components, facility and equipment operating conditions, in-process controls, finished product specifications, and the associated methods and frequency of monitoring and control.

**Cumulative intake:**

The total intake of a substance that a person is exposed to over time.

**Degradation Product:**

A molecule resulting from a chemical change in the drug molecule brought about over time and/or by the action of light, temperature, pH, water, or by reaction with an excipient and/or the immediate container/closure system.

**DNA-reactive:**

The potential to induce direct DNA damage through chemical reaction with DNA.

**Expert knowledge:**

In the context of this guidance, expert knowledge can be defined as a review of pre-existing data and the use of any other relevant information to evaluate the accuracy of an *in silico* model prediction for mutagenicity.

**Genotoxicity:**

A broad term that refers to any deleterious change in the genetic material regardless of the mechanism by which the change is induced.

**Impurity:**

Any component of the drug substance or drug product that is not the drug substance or an excipient.

**Mutagenic impurity:**

An impurity that has been demonstrated to be mutagenic in an appropriate mutagenicity test model, e.g., bacterial mutagenicity assay.

### ***Contains Nonbinding Recommendations***

**Periodic verification testing:**

Also known as *periodic or skip testing* in ICH Q6A.

**(Q)SAR and SAR:**

In the context of this guidance, refers to the relationship between the molecular (sub) structure of a compound and its mutagenic activity using (Quantitative) Structure-Activity Relationships derived from experimental data.

**Purge factor:**

Purge reflects the ability of a process to reduce the level of an impurity, and the purge factor is defined as the level of an impurity at an upstream point in a process divided by the level of an impurity at a downstream point in a process. Purge factors may be measured or predicted.

**Structural alert:**

In the context of this guidance, a chemical grouping or molecular (sub) structure which is associated with mutagenicity.

***Contains Nonbinding Recommendations***

**REFERENCES**

1. ICH guidance for industry, 2006, Q3A Impurities in New Drug Substances (Revision 2).
2. ICH guidance for industry, 2006, Q3B(R2) Impurities in New Drug Products.
3. ICH guidance for industry, 2010, M3(R2) Nonclinical Safety Studies for the Conduct of Human Clinical Trials and Marketing Authorization for Pharmaceuticals.
4. ICH guidance for industry, 2010, S9 Nonclinical Evaluation for Anticancer Pharmaceuticals.
5. ICH guidance for industry, 1996, Q1B Photostability Testing of New Drug Substances and Products.
6. Sutter A, Amberg A, Boyer S, Brigo A, Contrera JF, Custer LL, Dobo KL, Gervais V, Glowienke S, van Gompel J, Greene N, Muster W, Nicolette J, Reddy MV, Thybaud V, Vock E, White AT, Müller L (2013). Use of in silico systems and expert knowledge for structure-based assessment of potentially mutagenic impurities. *Regul Toxicol Pharmacol* 2013 67:39-52.
7. International Conference on Harmonisation, 2011, Q3C(R5): Impurities: Guideline for Residual Solvents, available at [http://www.ich.org/fileadmin/Public\\_Web\\_Site/ICH\\_Products/Guidelines/Quality/Q3C/Step4/Q3C\\_R5\\_Step4.pdf](http://www.ich.org/fileadmin/Public_Web_Site/ICH_Products/Guidelines/Quality/Q3C/Step4/Q3C_R5_Step4.pdf).
8. ICH guidance for industry, 2009, Q10 Pharmaceutical Quality System.
9. ICH guidance for industry, 2006, Q9 Quality Risk Management.
10. ICH guidance for industry, 2000, Q6A Specifications: Test Procedures and Acceptance Criteria for New Drug Substances and New Drug Products: Chemical Substances.
11. Teasdale A, Elder D, Chang S-J, Wang S, Thompson R, Benz N, Sanchez Flores I, (2013). Risk assessment of genotoxic impurities in new chemical entities: strategies to demonstrate control. *Org Process Res Dev* 17:221–230.
12. ICH guidance for industry, 2012, Q11 Development and Manufacture of Drug Substances.
13. ICH guidance for industry, 2012, S2(R1) Genotoxicity Testing and Data Interpretation for Pharmaceuticals Intended for Human Use.
14. Test 471. Bacterial Reverse Mutation Test, OECD Guideline for Testing of Chemicals, Section, 4 July 1997.
15. Brigo, A and Müller, L (2011). Development of the Threshold of Toxicological Concern Concept and Its Relationship to Duration of Exposure, in *Genotoxic Impurities* (Ed. A.

***Contains Nonbinding Recommendations***

Teasdale), John Wiley & Sons, Inc., Hoboken, NJ, USA. doi:  
10.1002/9780470929377.ch2.

16. Müller L, Mauthe RJ, Riley CM, Andino MM, De Antonis D, Beels C, DeGeorge J, De Knaep AGM, Ellison D, Fagerland J, Frank R, Fritschel B, Galloway S, Harpur E, Humfrey CDN, Jacks ASJ, Jagota N, Mackinnon J, Mohan G, Ness DK, O'Donovan MR, Smith MD, Vudathala G, Yotti L (2006). A rationale for determining, testing, and controlling specific impurities in pharmaceuticals that possess potential for genotoxicity. *Regul Toxicol Pharmacol* 44:198-211.

*Contains Nonbinding Recommendations*

**APPENDICES**

**Appendix 1: Scope Scenarios for Application of the ICH M7 Guidance**

<b>Scenario</b>	<b>Applies to Drug Substance</b>	<b>Applies to Drug Product</b>	<b>Comments</b>
Registration of new drug substances and associated drug product	Yes	Yes	Primary intent of the M7 Guidance
Clinical trial applications for new drug substances and associated drug product	Yes	Yes	Primary intent of the M7 Guidance
Clinical trial applications for new drug substances for an anti-cancer drug per ICH S9	No	No	Out of scope of M7 Guidance
Clinical trial applications for new drug substances for an orphan drug	Yes	Yes	There may be exceptions on a case-by-case basis for higher impurity limits
Clinical trial application for a new drug product using an existing drug substance where there are no changes to the drug substance manufacturing process	No	Yes	Retrospective application of the M7 Guidance is not intended for marketed products unless there are changes made to the synthesis. Since no changes are made to the drug substance synthesis, the drug substance would not require reevaluation. Since the drug product is new, application of this guidance is expected.
A new formulation of an approved drug substance is filed	No	Yes	See Section IV.B (4.2)
A product that is previously approved in a member region is filed for the first time in a different member region. The product is unchanged.	Yes	Yes	As there is no mutual recognition, an existing product in one member region filed for the first time in another member region would be considered a new product.
A new supplier or new site of the drug substance is registered. There are no changes to the manufacturing process used in this registered application.	No	No	As long as the synthesis of the drug substance is consistent with previously approved methods, then reevaluation of mutagenic impurity risk is not necessary. The applicant would need to demonstrate that no changes have been made to a previously approved process/product. Refer to Section IV.A (4.1).

***Contains Nonbinding Recommendations***

An existing product (approved after the issuance of ICH M7 with higher limits based on ICH S9) associated with an advanced cancer indication is now registered for use in a non-life threatening indication	Yes	Yes	Since the patient population and acceptable cancer risk have changed, the previously approved impurity control strategy and limits will require reevaluation. See Section IV.C (4.3).
New combination product is filed that contains one new drug substance and an existing drug substance	Yes (new drug substance) No (existing drug substance)	Yes	M7 would apply to the new drug substance. For the existing drug substance, retrospective application of M7 to existing products is not intended. For the drug product, this would classify as a new drug product so the guidance would apply to any new or higher levels of degradation products.

**Appendix 2: Case Examples to Illustrate Potential Control Approaches**

**Case 1: Example of an Option 3 Control Strategy**

An intermediate X is formed two steps away from the drug substance and impurity A is routinely detected in intermediate X. The impurity A is a stable compound and carries over to the drug substance. A spike study of the impurity A at different concentration levels in intermediate X was performed at laboratory scale. As a result of these studies, impurity A was consistently removed to less than 30% of the TTC-based limit in the drug substance even when impurity A was present at 1% in intermediate X. Since this intermediate X is formed only two steps away from the drug substance and the impurity A level in the intermediate X is relatively high, the purging ability of the process has also been confirmed by determination of impurity A in the drug substance in multiple pilot-scale batches and results were below 30% of the TTC-based limit. Therefore, control of the impurity A in the intermediate X with an acceptance limit of 1.0% is justified and no test is warranted for this impurity in the drug substance specification.

**Case 2: Example of an Option 3 Control Strategy: Based on Predicted Purge From a Spiking Study Using Standard Analytical Methods**

A starting material Y is introduced in step 3 of a 5-step synthesis, and an impurity B is routinely detected in the starting material Y at less than 0.1% using standard analytical methods. In order to determine whether the 0.1% specification in the starting material is acceptable, a purge study was conducted at laboratory scale where impurity B was spiked into starting material Y with different concentration levels up to 10% and a purge factor of > 500 fold was determined across the final three processing steps. This purge factor applied to a 0.1% specification in starting material Y would result in a predicted level of impurity B in the drug substance of less than 2 parts per million (ppm). As this is below the TTC-based limit of 50 ppm for this impurity in the drug substance, the 0.1% specification of impurity B

### *Contains Nonbinding Recommendations*

in starting material Y is justified without the need for providing drug substance batch data on pilot scale or commercial scale batches.

#### **Case 3: Example of an Option 2 and 4 Control Strategy: Control of Structurally Similar Mutagenic Impurities**

The Step 1 intermediate of a 5-step synthesis is a nitroaromatic compound that may contain low levels of impurity C, a positional isomer of the step 1 intermediate and also a nitroaromatic compound. The amount of impurity C in the step 1 intermediate has not been detected by ordinary analytical methods, but it may be present at lower levels. The step 1 intermediate is positive in the bacterial mutagenicity assay. The step 2 hydrogenation reaction results in a 99% conversion of the step 1 intermediate to the corresponding aromatic amine. This is confirmed via in-process testing. An assessment of purge of the remaining step 1 nitroaromatic intermediate was conducted, and a high purge factor was predicted based on purge points in the subsequent step 3 and 4 processing steps. Purge across the step 5 processing step is not expected and a specification for the step 1 intermediate at the TTC-based limit was established at the step 4 intermediate (Option 2 control approach). The positional isomer impurity C would be expected to purge via the same purge points as the step 1 intermediate and therefore will always be much lower than the step 1 intermediate itself; therefore, no testing is required and an Option 4 control strategy for impurity C can be supported without the need for any additional laboratory or pilot scale data.

#### **Case 4: Example of an Option 4 Control Strategy: Highly Reactive Impurity**

Thionyl chloride is a highly reactive compound that is mutagenic. This reagent is introduced in step 1 of a 5-step synthesis. At multiple points in the synthesis, significant amounts of water are used. Since thionyl chloride reacts instantaneously with water, there is no chance of any residual thionyl chloride to be present in the drug substance. An Option 4 control approach is suitable without the need for any laboratory or pilot scale data.



### *Contains Nonbinding Recommendations*

#### **Implementation of Guidance:**

Implementation of M7 is encouraged after publication; however, because of the complexity of the guidance, application of M7 is not expected prior to 18 months after ICH publication. The following exceptions to the 18-month timeline apply.

1. Ames tests should be conducted according to M7 upon ICH publication. However, Ames tests conducted prior to publication of M7 need not be repeated.
2. When development programs have started Phase 2b and Phase 3 clinical trials prior to publication of M7, these programs can be completed up to and including marketing application submission and approval, with the following exceptions to M7:
  - No need for two (Q)SAR assessments as outlined in Section VI (6).
  - No need to comply with the scope of product impurity assessment as outlined in Section V (5).
  - No need to comply with the documentation recommendations as outlined in Section IX (9).
3. Given the similar challenges for development of a commercial manufacturing process, application of the aspects of M7 listed above to new marketing applications that do not include Phase 2b and Phase 3 clinical trials would not be expected until 36 months after ICH publication of M7.

---

# **What's New with Impurities in Pharmaceuticals?**

**Southern California Pharmaceutical Discussion Group**

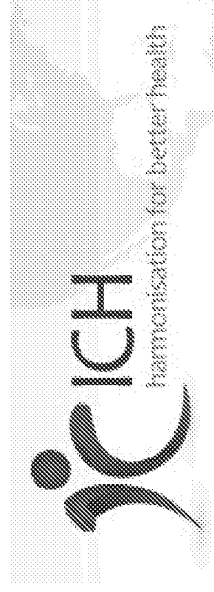
**January 15, 2015**

**Bernard A. Olsen, Ph.D**

**Olsen Pharmaceutical Consulting, LLC  
bolsen@comcast.net**

# ICH Q3 Impurities

---



- Q3A Drug Substances– 1995 (step 4), R1 (2002), R2 (2006)
- Q3B Drug Products– 1996 (step 4), R1 (2003), R2 (2006)
- Q3C Residual Solvents– 1997, R1-5 (2002, 2005, 2009, 2011)
- Most ICH guidelines on impurities in drug substances and drug products are >15 years old
- What else is there to say?

# Filling the Gaps

---

- M7 – Genotoxic Impurities – Step 4 (June 2014)
  - changes from EMA and FDA guidance
- Q3D Elemental Impurities – Step 4 (Dec. 2014)
  - USP <232>, <233>
- Other gaps?
- Revisions needed?

# ICH M7 – Genotoxic Impurities

---

Filling the ICH Q3 A/B gap for “impurities that are expected to be unusually potent, producing toxic or pharmacological effects at a level not more than ( $\leq$ ) the identification threshold.”

- Identification of "unusually potent" impurities not described
- No threshold of concern given

EMA\* guideline and FDA\*\* draft guidance:

*Threshold of Toxicological Concern (TTC), 1.5 µg/day*

\*[http://www.ema.europa.eu/docs/en\\_GB/document\\_library/Scientific\\_guideline/2009/09/WC500002903.pdf](http://www.ema.europa.eu/docs/en_GB/document_library/Scientific_guideline/2009/09/WC500002903.pdf)

\*\*<http://www.fda.gov/downloads/Drugs/GuidanceComplianceRegulatoryInformation/Guidances/ucm079235.pdf>

# Assessing Impurities – ICH M7

---

All impurities (actual and potential), where the structures are known, should be evaluated for mutagenic potential.

.

# Classifying impurities – PhRMA paper recommendation\*, adopted in M7

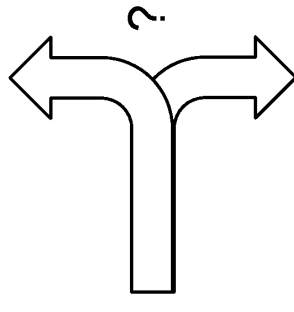
---

All identified or predicted impurities should be classified into one of five classes:

**Class 1.** Known to be genotoxic and carcinogenic



**Class 2.** Known to be genotoxic but with unknown carcinogenic potential



**Class 3.** With a unique alerting structure and of unknown genotoxic potential

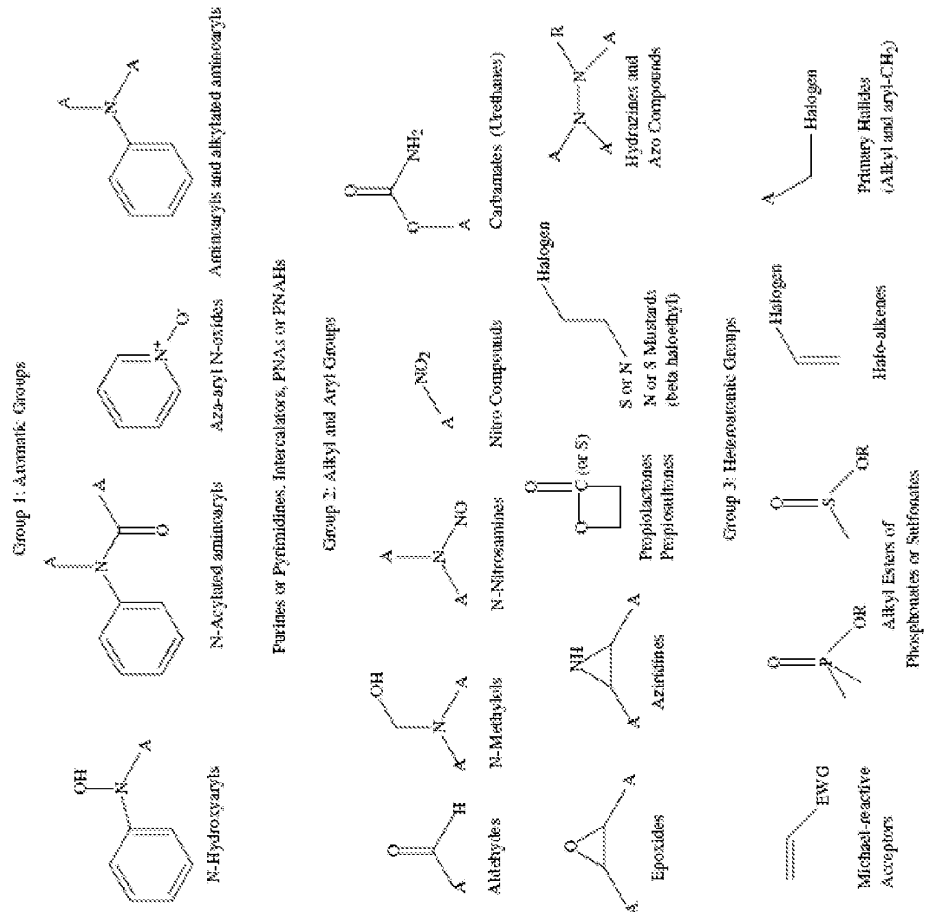
**Class 4.** With an alerting structure related to the parent API

**Class 5.** With no structural alert



\*Müller et al., *Reg. Tox. Pharmacol.* 44, 198-211 (2006);

# Alerting Structures – examples



Legend: A = Alkyl, Aryl, or H  
 Halogen = F, Cl, Br, I  
 EWG = Electron withdrawing group (CN, C=O, ester, etc.)

Müller et al.

UT Ex. 2040  
 IPR2016-00006

SteadyMed v. United Therapeutics  
 P. 7

B.A. Olsen  
 SCPDG January 15, 2015



# Assessing Impurities – ICH M7, cont.

---

## Is an impurity potentially genotoxic?

Search databases and literature for carcinogenicity and bacterial mutagenicity data in order to classify impurity as Class 1, 2, or 5

## When data are not available:

Use Structure-Activity Relationships (SAR) that focus on bacterial mutagenicity predictions. This could lead to a classification into Class 3, 4, or 5.

# (Q)SAR/in silico assessments

---

Two (Q)SAR prediction methodologies that complement each other should be applied.

- Expert rule-based
- Statistical-based
- follow Organisation for Economic Co-operation and Development (OECD) validation principles
  - review with expert knowledge

Absence of structural alerts from 2 Q(SAR) predictions = normal impurity

# Toxicity Prediction Software

---

## Freely available software

Caesar models

Lazar

OncoLogic

PASS

EPI Suite  
OECD QSAR Application Toolbox  
Toxtree  
T.E.S.T

## Commercially available software

ACD/Tox Suite

BioEpisteme

HazardExpert

MDL QSAR

MultiCASE

TOPKAT

q-Tox

ADMET Predictor

DEREK

Leadscope

Molcode Toolbox

OASIS TIMES

ToxAlert

CSGenoTox

**Review of Software Tools for Toxicity Prediction**, M. F. Gatnik and A. Worth, European Commission Joint Research Centre, Institute for Health and Consumer Protection  
[https://eurl-ecvam.jrc.ec.europa.eu/laboratories-research/predictive\\_toxicology/doc/EUR\\_24489\\_EN.pdf](https://eurl-ecvam.jrc.ec.europa.eu/laboratories-research/predictive_toxicology/doc/EUR_24489_EN.pdf)

**Industry Survey:** Dobo et al., Reg. Tox. Pharmacol. 62 (2012) 449–455

# Ames testing

---

- Negative result classifies compound as normal ICH impurity and overrides a positive *in silico* prediction for genotoxicity
- Test on the isolated impurity preferred vs. impurity in drug substance;  $\geq 250$   $\mu\text{g}/\text{plate}$  needed for compound of interest
- GLP studies expected but test article characterization may not comply fully; exceptions also allowed for compounds difficult to prepare or isolate

# ICH M7 - TTC-based acceptable limits

Acceptable Daily Intakes* for an Individual Impurity, µg/day Clinical trials or marketed product								
	Single Dose	< 14 days	≤ 1 mo.	≤ 3 mo.	≤ 6 mo.	≤ 12 mo.	> 1 – 10 years	> 10 years to lifetime
M7	**	**	120	20	20	20	10	1.5
EMA	120	60	60	30	10	5	1.5 (marketed)	1.5

\*Compound-specific risk assessments to derive acceptable intakes should be applied instead of the TTC-based acceptable intakes where sufficient carcinogenicity data exist.

\*\*Clinical trials of up to 14 days – class 3 impurities can be treated as normal impurities

UT Ex. 2040

SteadyMed v. United Therapeutics

IPR2016-00006

# Mitigating factors in application of TTC

---

- Indication – life-saving therapy
- Exposure from other sources, e.g., foods or endogenous metabolism (e.g., formaldehyde)
- Reduced life expectancy
- Late onset but chronic disease
- Limited therapeutic alternatives

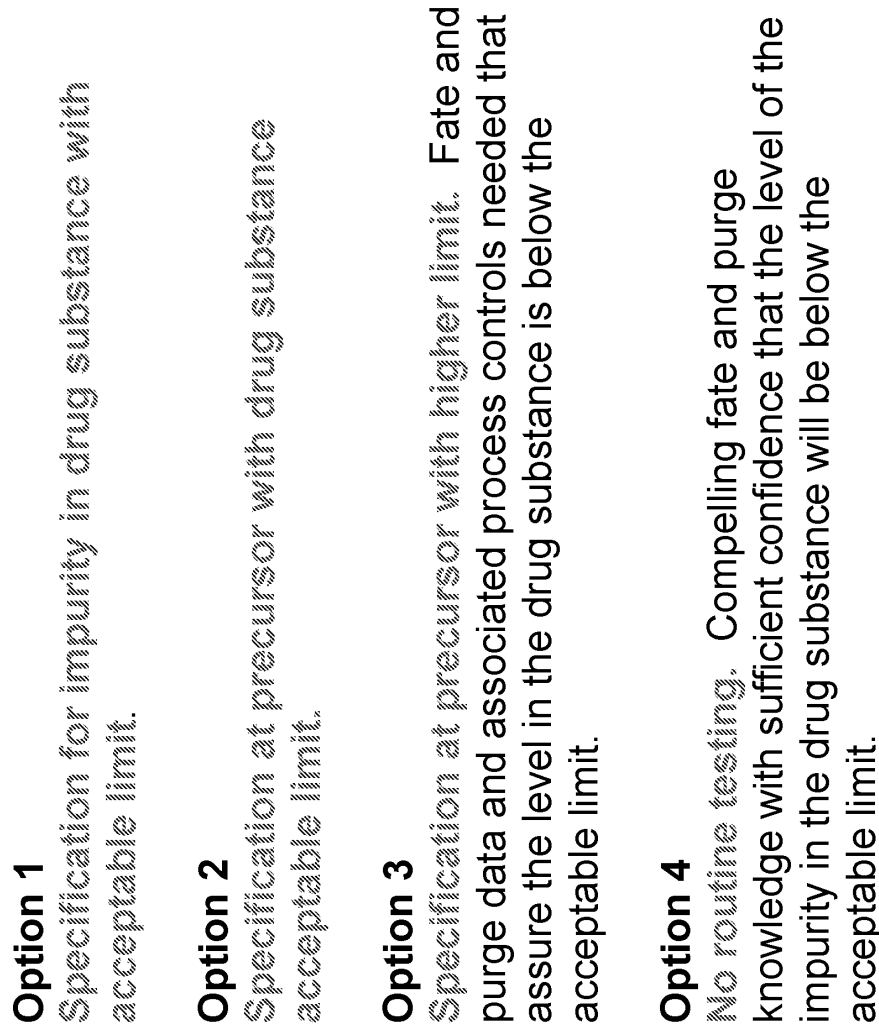
# Strategies to Address GTIs

---

- Modify synthesis to remove compounds of concern or move them as early in the synthesis as possible
- Purification – provide rationale and/or data to demonstrate that GTI has negligible risk of being in drug substance
- Specification – commit to analytical testing and acceptance limit at intermediate (higher levels?) or drug substance (staged TTC levels)
- Degradation product GTI – packaging and storage to prevent formation, implement specification through shelf-life

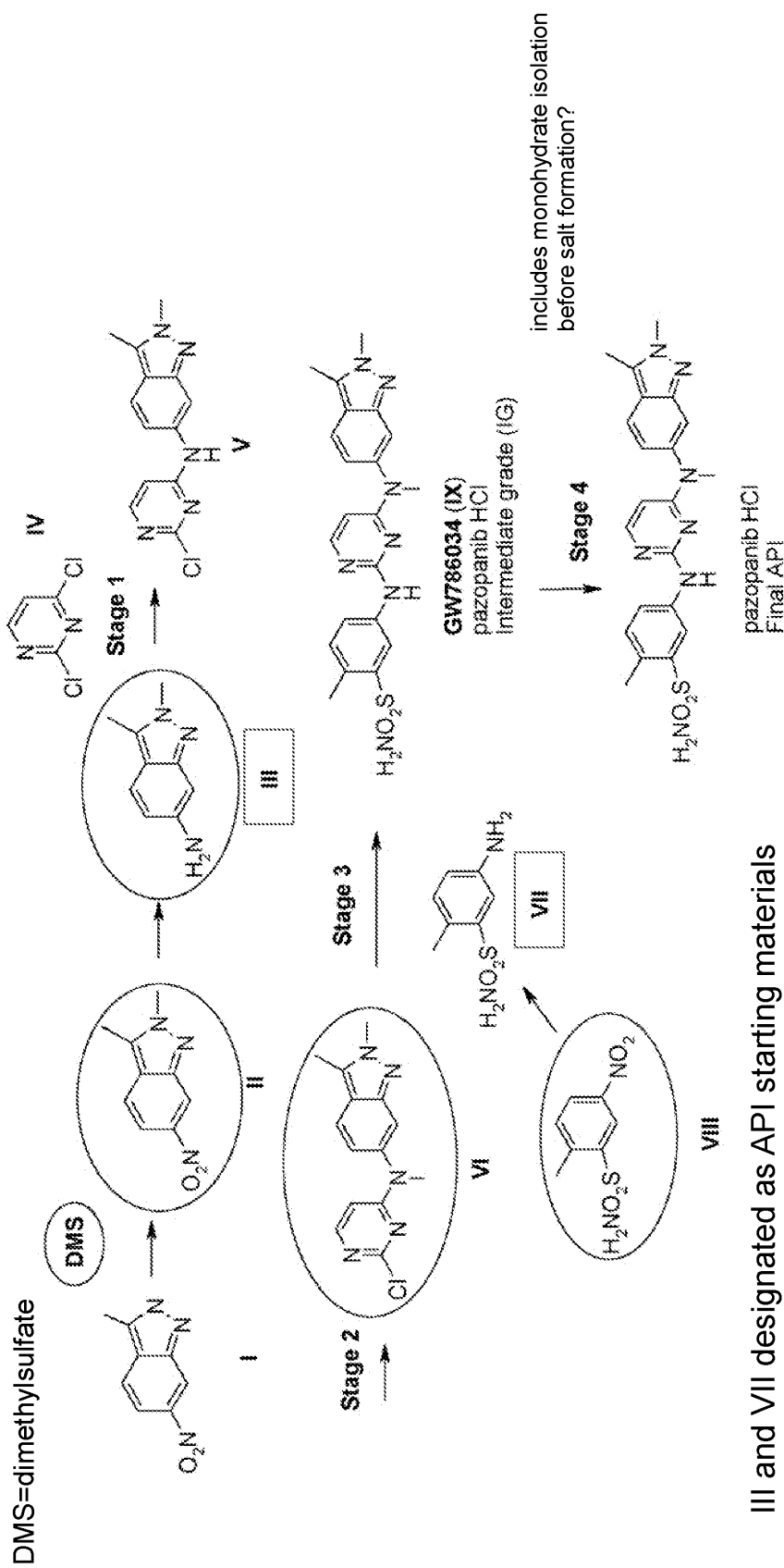
# ICH M7 Control Options for Process Impurities

---





# Example – GSK, pazopanib HCl



III and VII designated as API starting materials

D.Q. Liu, T.K. Chen, M.A. McGuire, A.S. Kord, J. Pharm. Biomed. Anal. 50 (2009) 144-150

UT Ex. 2040  
SteadyMed v. United Therapeutics  
IPR2016-00006

B.A. Olsen  
SCPDG January 15, 2015

P. 16

16

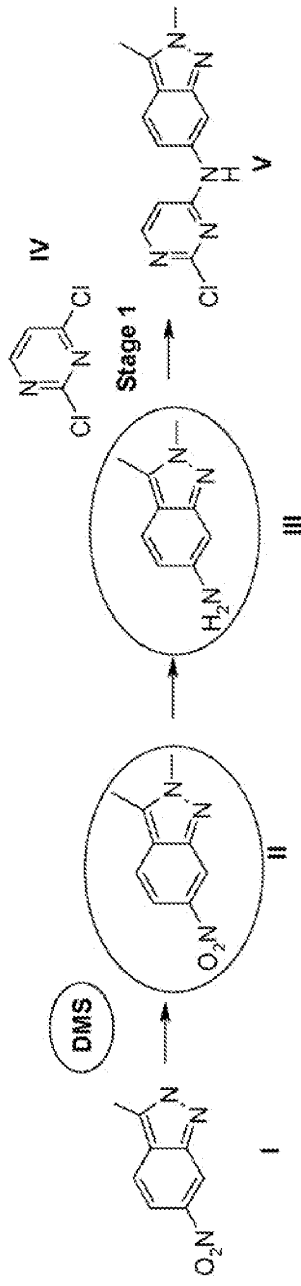
# Strategy

---

- Develop TTC-level LC-MS method for GTIs
- Analyze materials throughout process to show lack of carry-through (up to 79 batches of API)
- Perform impurity rejection studies to show process capability
- Establish tests for GTIs at levels higher than TTC using LC methods at starting materials or intermediates

Note: Pazopanib HCl (Votrient) is a tyrosine kinase inhibitor approved for the treatment of renal cell carcinoma

# Impurity rejection efficiency - DMS



DMS introduced 2 steps back from starting material III  
20 batches of III showed <1.7 ppm DMS  
79 batches of API showed <1.7 ppm DMS

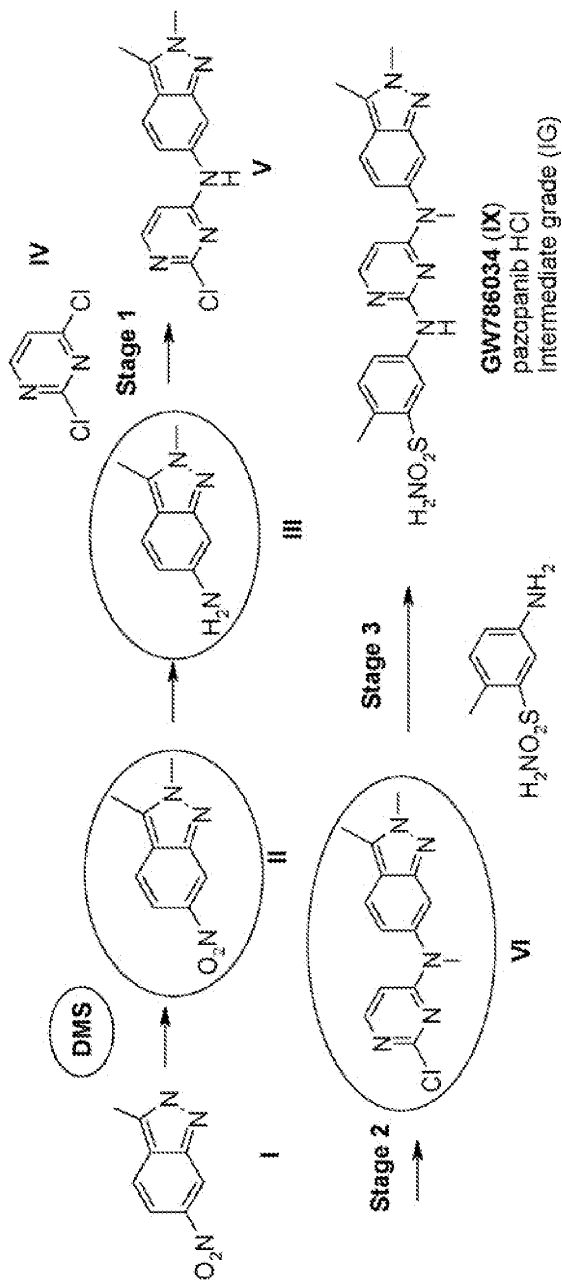
50,000 ppm DMS spiked in III → <1.7 ppm in V

>29,000 fold rejection in step 1 followed by 4 subsequent steps

0.1% acceptance criterion set for DMS in starting material III

IS ROUTINE TESTING FOR DMS NEEDED?

# Impurity rejection efficiency – compound II

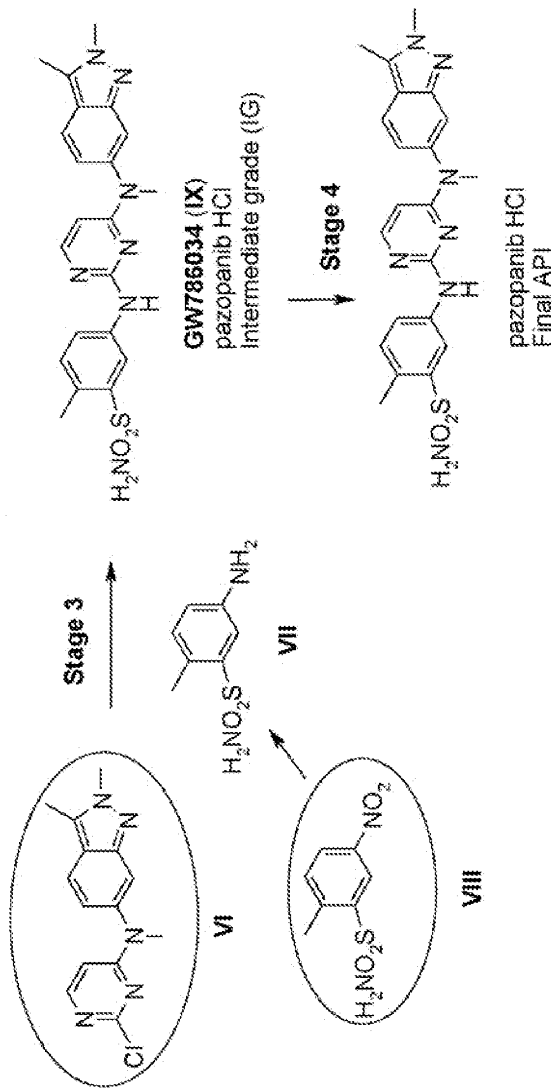


79 batches of API showed <1.7 ppm II  
 16 batches of III showed <24 ppm II

50,000 ppm in III	→	670 ppm in V	75 fold rejection
670 ppm in V	→	23 ppm in VI	29 fold rejection
23 ppm in VI	→	<1.7 ppm in IX	>13 fold rejection

0.1% limit set for II in III

# Higher Upstream limits for VI and VIII



limit of NMT 0.1% set for VIII in VII

limit of NMT 0.6% set for VI in IX

# Genotoxic degradation products

---

- Identify potential degradation product GTIs during predictive stress testing
- Does degradation product GTI form with time under normal storage conditions?
- Can degradation product GTI formation be prevented through formulation design, packaging, or storage conditions?
- Establish specification if necessary

# Risk of Producing an Alerting Structure from Drug Degradation\*

---

- Analysis of over 1100 known degradation products from more than 350 drugs suggests that degradation of drugs may lead to unique structure alerting functional groups in about 5-8% of the degradation products.
- Roughly 50% or less of these alerting structures can be expected to be Ames positive
- An average of 8-9 major deg products are observed in stress testing for a typical drug, so most drugs will have zero or one deg product for follow-up as a potential GTI

\*S.W. Baertschi et al., Stress Testing and Degradation-Derived Genotoxic Impurities: Scientific, Practical and Regulatory Considerations, Conference on Small Molecule Science, August 2, 2011, Chapel Hill, NC

# ICH M7- Control for degradants

---

Is degradant relevant?

- check accelerated stability study data (e.g., 40°C/75% relative humidity, 6 months)
- kinetically equivalent shorter term stability studies at higher temperatures in the proposed commercial package may be used to determine the relevance of the degradation pathway prior to initiating longer term stability studies.

S.W. Baertschi et al., “Stress testing as a predictive tool for the assessment of potential genotoxic degradants”, in Pharmaceutical Stress Testing, 2<sup>nd</sup> Ed., S.W. Baertschi, K.M. Alsante, R. A. Reed, 2011, Informa, London.



# ICH M7 – Other Considerations

---

- Not applied to products for advanced cancer indications (see ICH S9)
- Not applied to drug substances that are themselves genotoxic
- Will be applied to changes in existing authorizations if new or greater levels of previous impurities are present
- Assess potentially genotoxic impurities which may be present at levels below the Q3 A/B ID thresholds (same as current guidelines)
- Previous data from similar compounds may be used with justification to discharge risk

# Elemental Impurities

---

USP <232> Limits  
USP <233> Procedures  
replacing <231> Heavy Metals

ICH Q3D



# Disclaimer

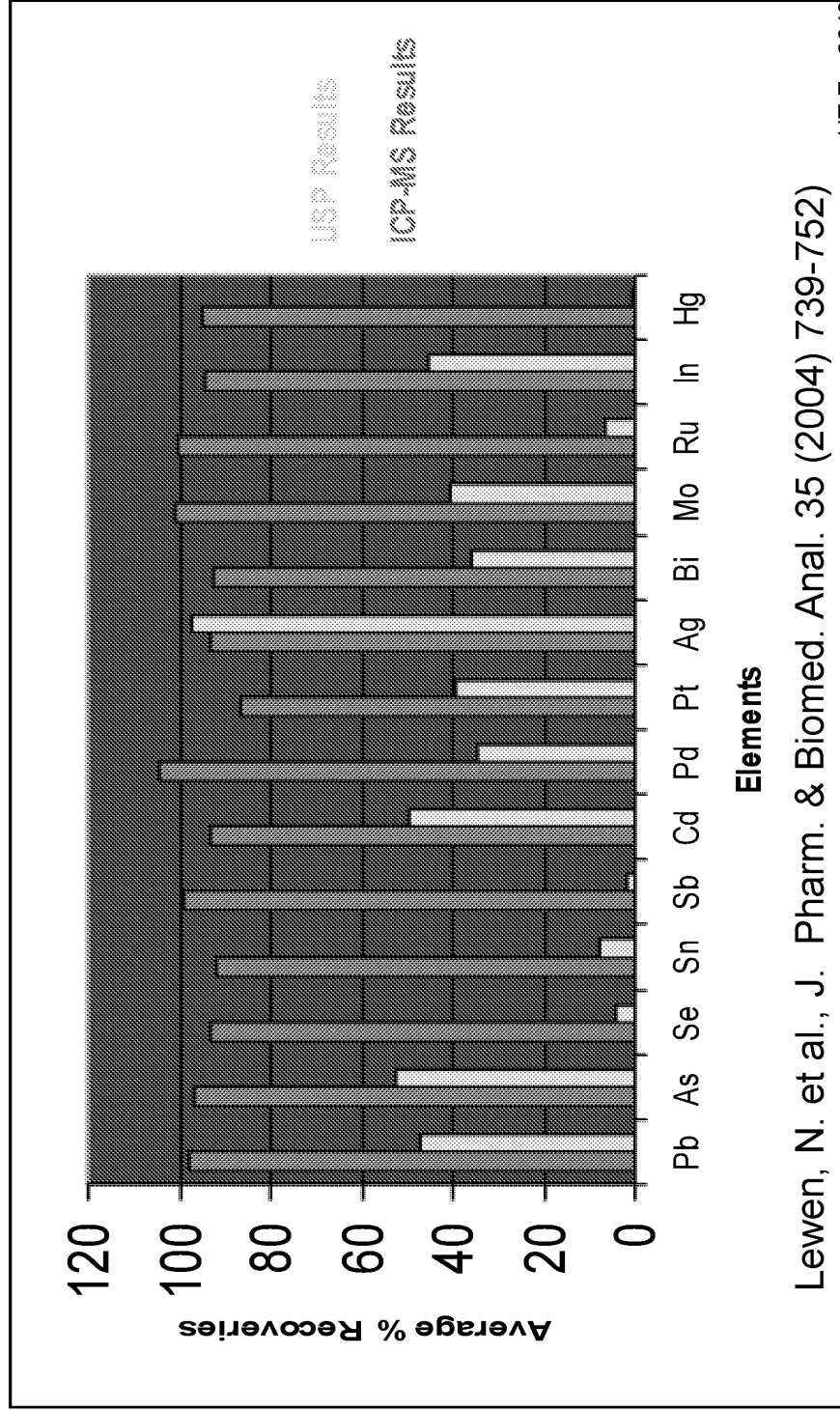
---

Information in this presentation related to USP Elemental Impurities is from publically-available sources.

The speaker does not represent official USP positions or policy on Elemental Impurities or any other topic.

# USP <231> Heavy Metals

<231> has been in use for many years. What's the problem?



Lewen, N. et al., J. Pharm. & Biomed. Anal. 35 (2004) 739-752

# USP key issue – elemental impurities

---

<232> Elemental Impurities – Limits

<233> Elemental Impurities – Procedures

Revisions proposed in PF 40(2)

<http://www.usp.org/usp-nf/key-issues/elemental-impurities>

Implementation date when chapters apply to drug product monographs: ~~December 1, 2015~~

**BUT, what about ICH Q3D?**

◦ Elemental Impurities Key Issues Page Updated (14--Jan--2015)

**January 14, 2015:** USP is announcing plans to establish January 1, 2018 as the new date of applicability of General Chapters <232> Elemental Impurities—Limits and <233> Elemental Contaminants in Dietary Supplements.

# Heavy metals limits – USP proposal

Table 1. Elemental Impurities for Drug Products

Element	Oral Daily Dose PDE <sup>a</sup> (µg/day)	Parenteral Daily Dose PDE (µg/day)	Inhalational Daily Dose PDE (µg/day)	LVP Component Limit (µg/g)
Cadmium	<del>25</del> <sup>5</sup> 5.0 <sub>1S</sub> (USP38)	2.5	<del>45</del> <sup>3</sup> 3.4 <sub>1S</sub> (USP38)	0.25
Lead	<del>5</del> <sup>5</sup> 5.0 <sub>1S</sub> (USP38)	<del>5</del> <sup>5</sup> 5.0 <sub>1S</sub> (USP38)	<del>5</del> <sup>5</sup> 5.0 <sub>1S</sub> (USP38)	0.5
Inorganic arsenic <sup>b</sup>	<del>45</del> <sup>15</sup> 15 <sub>1S</sub> (USP38)	<del>45</del> <sup>15</sup> 15 <sub>1S</sub> (USP38)	<del>45</del> <sup>15</sup> 15 <sub>1S</sub> (USP38)	<del>8.45</del> <sup>1.5</sup> 1.5 <sub>1S</sub> (USP38)
Inorganic mercury <sup>b</sup>	15	1.5	<del>45</del> <sup>12</sup> 12 <sub>1S</sub> (USP38)	0.15
Iridium	100	10	1.5	1.0
Osmium	100	10	1.5	1.0
Palladium	100	10	<del>45</del> <sup>10</sup> 10 <sub>1S</sub> (USP38)	1.0
Platinum	100	10	1.5	1.0
Rhodium	100	10	1.5	1.0
Ruthenium	100	10	1.5	1.0

PDE = permitted daily exposure

# Limits, cont.

	$\frac{g}{g}$	$\frac{g}{g}$	$\frac{g}{g}$	$\frac{g}{g}$
Chromium				<del>25</del> <sup>29</sup> .1S (USP38)
Molybdenum	<del>400</del> <sup>180</sup> .1S (USP38)	<del>40</del> <sup>90</sup> .1S (USP38)		<del>40</del> <sup>90</sup> .1S (USP38)
Nickel	<del>500</del> <sup>600</sup> .1S (USP38)	<del>50</del> <sup>60</sup> .1S (USP38)		<del>50</del> <sup>60</sup> .1S (USP38)
Vanadium	<del>400</del> <sup>120</sup> .1S (USP38)	<del>40</del> <sup>12</sup> .1S (USP38)		<del>40</del> <sup>12</sup> .1S (USP38)
Copper	<del>4000</del> <sup>1300</sup> .1S (USP38)	<del>400</del> <sup>130</sup> .1S (USP38)		<del>40</del> <sup>13</sup> .1S (USP38)

# Options for compliance

---

Drug product analysis (Q3D option 3)

*Daily Dose PDE  $\geq$  measured value ( $\mu\text{g/g}$ )  $\times$  maximum daily dose (g/day)*

*Summation option (add metals present in each component, Q3D option 2b)*

*Daily Dose PDE  $\geq$   $[\sum^M_1(CM \times WM)] \times DD$*

*M = each ingredient used to manufacture a dosage unit  
CM = element concentration in component (drug substance or excipient) ( $\mu\text{g/g}$ )  
WM = weight of component in a dosage unit (g/dosage unit)  
DD = number of units in the maximum daily dose (unit/day)*

*Individual component option (Large volume parenterals only)*

*API and excipients meet limits given in Table 1 for LVP components*



# Testing

---

If, by validated processes and supply-chain control, manufacturers can demonstrate the absence of impurities, then further testing is not needed.

# USP Updates – stay tuned

---

October 2014 expert panel recommendation: Limits be revised to align with the ICH Q3D Step 4 document to the extent possible.

Separately, USP is considering potential adjustments to the elemental impurities implementation timeline as specified in General Notices 5.60.30 (Dec.1, 2015) based on developments related to the anticipated ICH Q3D Step 4 document.

<http://www.usp.org/usp-nf/key-issues/elemental-impurities>

# ICH Q3D – Guideline for Elemental Impurities

---

- Focus is on risk assessment for occurrence of and limits for elemental impurities
- Step 4 guideline published December 16, 2014

[http://www.ich.org/fileadmin/Public\\_Web\\_Site/ICH\\_Products/Guidelines/Quality/Q3D/Q3D\\_Step\\_4.pdf](http://www.ich.org/fileadmin/Public_Web_Site/ICH_Products/Guidelines/Quality/Q3D/Q3D_Step_4.pdf)

# ICH Q3D: Risk-based assessment of need for control of metal impurities

Table 5.1: Elements to be Considered in the Risk Assessment

Element	Class	If intentionally added (all routes)	If not intentionally added		
			Oral	Parenteral	Inhalation
Cd	1	yes	yes	yes	yes
Pb	1	yes	yes	yes	yes
As	1	yes	yes	yes	yes
Hg	1	yes	yes	yes	yes
Co	2A	yes	yes	yes	yes
V	2A	yes	yes	yes	yes
Ni	2A	yes	yes	yes	yes
Tl	2B	yes	no	no	no
Au	2B	yes	no	no	no
Pd	2B	yes	no	no	no
Ir	2B	yes	no	no	no
Os	2B	yes	no	no	no
Rh	2B	yes	no	no	no
Ru	2B	yes	no	no	no
Se	2B	yes	no	no	no
Ag	2B	yes	no	no	no
Pt	2B	yes	no	no	no
Li	3	yes	no	yes	yes
Sb	3	yes	no	yes	yes
Ba	3	yes	no	no	yes
Mo	3	yes	no	no	yes
Cu	3	yes	no	yes	yes
Sn	3	yes	no	no	yes
Cr	3	yes	no	no	yes

UT Ex. 2040

SteadyMed v. United Therapeutics  
IPR2016-00006

P. 35

B.A. Olsen  
SCPDG January 15, 2015

# ICH Q3D – Risk assessment

---

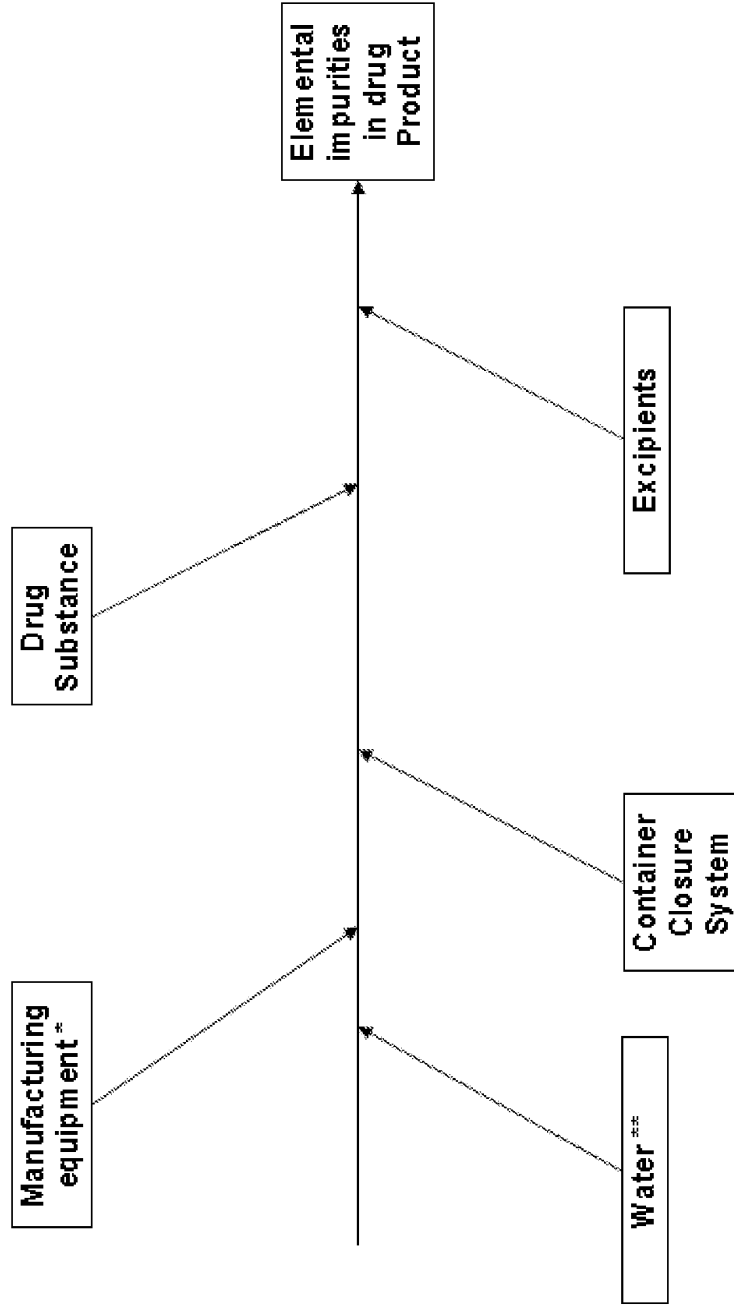
**Identify:** Identify known and potential sources of elemental impurities that may find their way into the drug product.

**Evaluate:** Evaluate the presence of a particular elemental impurity in the drug product by determining the observed or predicted level of the impurity and comparing with the established PDE.

**Control:** Summarize and document the risk assessment. Identify if controls built into the process are sufficient or identify additional controls to be considered to limit elemental impurities in the drug product.

# Sources of Elemental Impurities

---



# ICH Q3D: Limits for Elemental Impurities

Table A.2.1: Permitted Daily Exposures for Elemental Impurities<sup>1</sup>

Element	Class <sup>2</sup>	Oral PDE µg/day	Parenteral PDE, µg/day	Inhalation PDE, µg/day
Cd	1	5	2	2
Pb	1	5	5	5
As	1	15	15	2
Hg	1	30	3	1
Co	2A	50	5	3
V	2A	100	10	1
Ni	2A	200	20	5
Tl	2B	8	8	8
Au	2B	100	100	1
Pd	2B	100	10	1
Ir	2B	100	10	1
Os	2B	100	10	1
Rh	2B	100	10	1
Ru	2B	100	10	1
Se	2B	150	80	130
Ag	2B	150	10	7
Pt	2B	100	10	1
Li	3	550	250	25
Sb	3	1200	90	20
Ba	3	1400	700	300
Mo	3	3000	1500	10
Cu	3	3000	300	30
Sn	3	6000	600	60
Cr	3	11000	1100	3

Red = USP <232> PDEs

Option 1: Assume 10 g/day dose. If all components meet PDE concentration, they may be used in any proportion

Option 2a: Use the actual dose to calculate PDE concentration. If all components meet the PDE, they may be used in any proportion.

Option 2b: Use the amounts of each component present and data on metals present to set limits for individual components.

Option 3: Drug product analysis with limits based on daily dose

UT Ex. 2040

## Q3D – Other Limit Considerations

---

- When PDEs are necessary for other routes of administration, the concepts described in the guideline may be used to derive PDEs.
  - Consider local effects, bioavailability, quality considerations
- Higher PDEs may be permitted for:
  - Intermittent dosing;
  - Short term dosing (i.e., 30 days or less);
  - Specific indications (e.g., life-threatening, unmet medical needs, rare diseases).



# ICH Q3D Implementation

---

- Application of Q3D to existing products is not expected prior to 36 months after publication of the guideline by ICH. December 2017?
- Will USP implementation timing be revised to December 2017? -----  
January 1, 2018
- Q3D implementation plan 21 Oct 2014
  - Training materials
  - FAQ document

[http://www.ich.org/fileadmin/Public\\_Web\\_Site/ICH\\_Products/Guidelines/Quality/Q3D/Q3D\\_IWG\\_Final\\_Concept\\_Paper\\_October\\_21\\_2014.pdf](http://www.ich.org/fileadmin/Public_Web_Site/ICH_Products/Guidelines/Quality/Q3D/Q3D_IWG_Final_Concept_Paper_October_21_2014.pdf)  
[http://www.ich.org/fileadmin/Public\\_Web\\_Site/ICH\\_Products/Guidelines/Quality/Q3D/Q3D\\_IWG\\_Final\\_Business\\_Plan\\_October\\_21\\_2014.pdf](http://www.ich.org/fileadmin/Public_Web_Site/ICH_Products/Guidelines/Quality/Q3D/Q3D_IWG_Final_Business_Plan_October_21_2014.pdf)

# USP <233> Method Proposal

---

*Procedure 1 can be used for elemental impurities generally amenable to detection by inductively coupled plasma–atomic (optical) emission spectroscopy (ICP–AES or ICP–OES).*

*Procedure 2 can be used for elemental impurities generally amenable to detection by inductively coupled plasma–mass spectrometry (ICP–MS).*

# Performance-based method

---

Analysts are free to select a method/procedure that works for their samples

The method selected may include plasma spectrochemistry, atomic absorption spectroscopy, **OR ANY OTHER METHOD** that displays adequate accuracy, sensitivity and specificity.

# Other ICH Impurity Questions

---

- Other gaps?
- Thresholds and limits
- Impurity control in
  - multisource products
  - starting materials
  - reagents
- Depth of impurity investigations

# Products not covered by ICH

---

## Excluded product types:

- biological/biotechnological (ICH Q6B)
- peptide (PhEur general monograph 2034)
- oligonucleotide
- radiopharmaceutical
- fermentation product and semi-synthetic products (EMA guideline for antibiotics)
- herbal products
- crude products of animal or plant origin

# Extractable and Leachable Impurities

---

**Multitude of guidelines, but lack of harmonized expectations, focus has been on inhaled and nasal products**

- Metered Dose Inhaler (MDI) and Dry Powder Inhaler (DPI) Drug Products; FDA Draft Guidance for Industry
- Nasal Spray and Inhalation Solution, Suspension, and Spray Drug Products – Chemistry, Manufacturing, and Controls Documentation; FDA Guidance for Industry
- CHMP Guideline on the Pharmaceutical Quality of Inhalation and Nasal Products
- PQRI: Safety Thresholds and Best Practices for Extractables and Leachables in Orally Inhaled and Nasal Drug Products

# Threshold limit disconnects

---

## Drug substance process impurity:

- 0.2% in a drug substance with 0.5 mg maximum daily dose requires identification and qualification
- Patient exposure - Total daily intake (TDI) of impurity: 1 µg
- TDI is less than 1.5 µg/day limit for a potentially genotoxic impurity

## Residual solvent:

- A drug substance with benzene at 2 ppm meets Q3C(R5) limit, but for a dose of 2 g/day, TDI is 4 µg
- A drug substance with benzene present at 5 ppm exceeds limit, but for a dose of 2 mg/day, TDI is 0.01 µg

D.J. Snodin, S.D. McCrossen, "Guidelines and pharmacopoeial standards for pharmaceutical impurities: Overview and critical assessment", Reg. Tox. Pharmacol. 63 (2012) 298–312

# Degradation impurities threshold concerns

---

Degradation impurity in drug substance

Dose:	<u>1 mg</u>	<u>10 mg</u>	<u>100 mg</u>
ID threshold (TDI)	1 µg	10 µg	100 µg
Qual threshold (TDI)	1.5 µg	15 µg	150 µg

Degradation impurity in drug product

Dose:	<u>1 mg</u>	<u>10 mg</u>	<u>100 mg</u>
ID threshold (TDI)	5 µg	20 µg	200 µg
Qual threshold (TDI)	10 µg	50 µg	200 µg

Should thresholds for degradation impurities in a drug substance be consistent with those for the drug product?



# Other Threshold Considerations

---

Should more latitude in application of Q3 thresholds be allowed based on:

- Chronic vs. limited-duration therapy
- Indication
- Population

Should *in silico*, literature, or other structure-based rationale be acceptable for impurity qualification in lieu of additional animal studies?

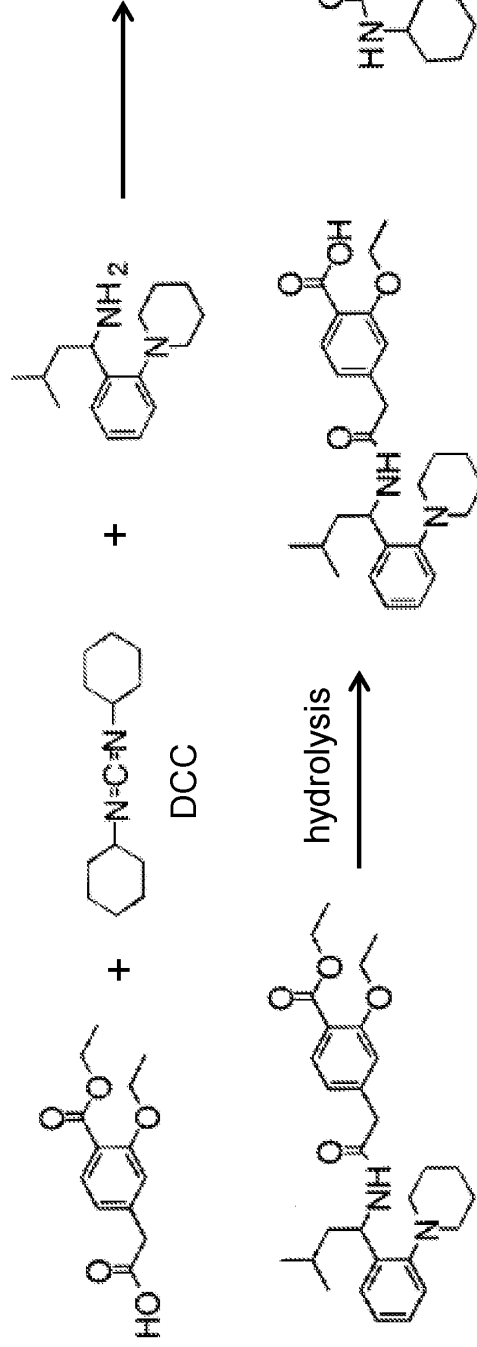
# Risk assessment for impurities in multi-sourced materials (starting materials, reagents)

---

- What method(s) are used to prepare the material?
- What impurities could be introduced with the material?
- What is the likelihood QC methods will detect new impurities?
- Does supplier's change control for manufacturing changes evaluate the potential for new impurities?
- Does buyer's change control evaluate potential for new impurities from a different supplier?

# Example: Impurity from reagent

## Repaglinide synthesis



Impurity derived from  
cyclohexylamine in DCC

K.V.S.R. Krishna Reddy et al., J. Pharm. Biomed. Anal. 32 (2003) 461-467

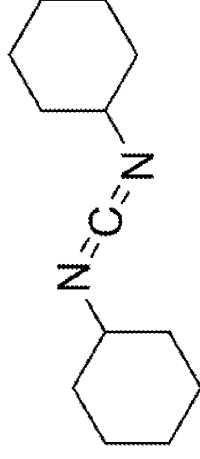
# DCC Quality?

---

74 suppliers (52 from China)

Quality range: 98.0-99.5%

Unknown control of cyclohexylamine impurity



Switching suppliers without knowledge of the impact of cyclohexylamine as an impurity could generate a new impurity in the drug substance

Do suppliers control cyclohexylamine levels?  
What levels are acceptable for regalinide process?  
Would the QC impurities test for repaginide detect the cyclohexylamine-derived impurity?

# Ambiguity in Impurity Investigation

## How much is enough?

---

### Q3A(R2)

... summarise the *actual and potential impurities most likely to arise* during the synthesis, purification, and storage of the new drug substance.

This discussion can be limited to those impurities that *might reasonably be expected* based on knowledge of the chemical reactions and conditions involved.

Potential Impurity: An impurity that *theoretically* can arise during manufacture or storage. It may or may not actually appear in the new drug substance.

?????

How are “most likely to arise” and “might reasonably be expected” interpreted?

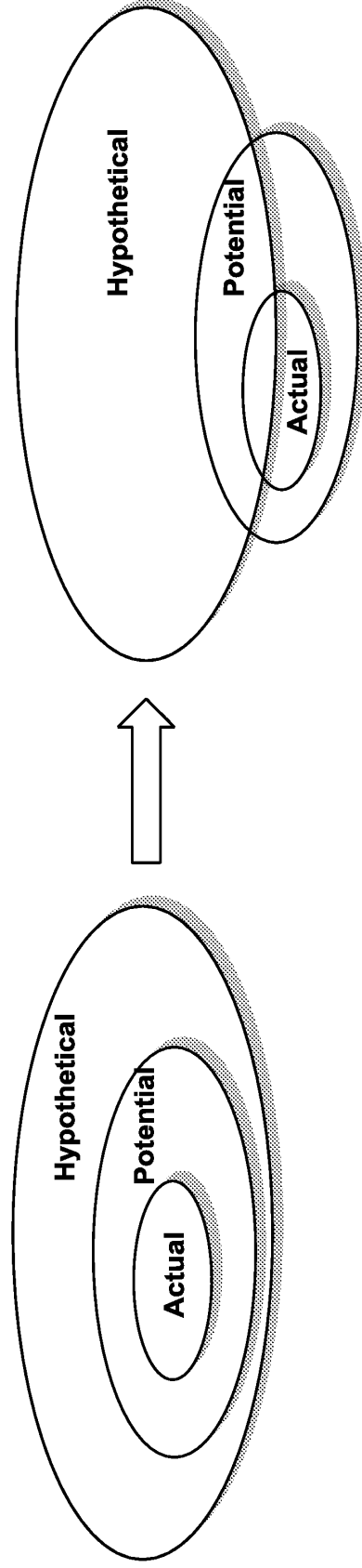
“Theoretical” impurities can encompass an unreasonably large number of compounds, especially if genotoxicity thresholds are considered.

# In Practice...

---

Focus investigation on potential, not hypothetical/theoretical impurities

- Theoretical/hypothetical: based on *in cerebro* or *in silico* predictions of synthetic by-products or degradation chemistry
- Potential: used in process, found during process development, or formed as major degradation products during stress testing
- Actual or relevant: impurities present in drug or with a high likelihood of being present



**Idealized**

**Realistic**

---

\*S. Baertschi et al., Conference on Small Molecule Science UNC-Chapel Hill, NC, August 2, 2011

UT Ex. 2040

B.A. Olsen  
SCP DG January 15, 2015

SteadyMed v. United Therapeutics  
IPR2016-00006

P. 53

53

# Summary

---

Despite ongoing questions, ICH impurity guidelines have provided harmonized expectations for drug development.

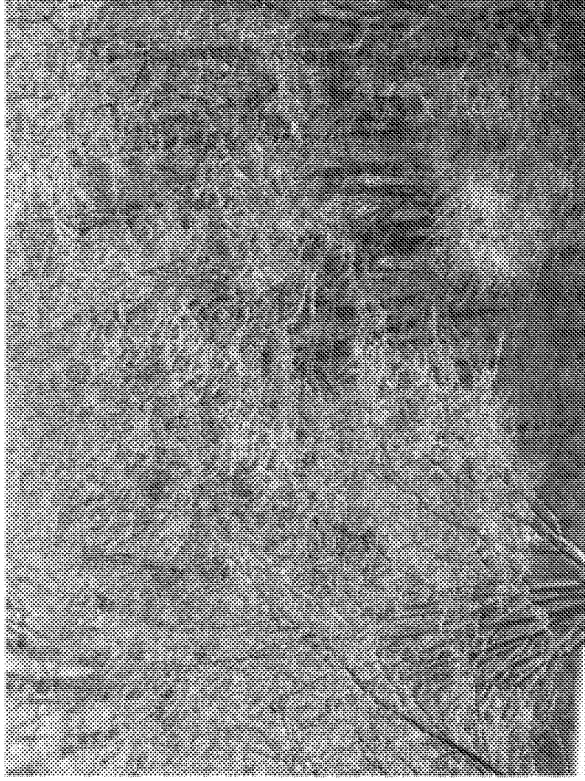
Changes being effected:

- Genotoxic impurities
- Elemental impurities


Opportunities for improvement:

- guidance for other product types
- greater flexibility when justified
- reexamination of threshold rationale and inconsistency

# Thank You!



West Lafayette, IN (47906) Weather  
4:38 AM EST

 **-5<sup>°</sup>F**  
Feels Like: 1°  
**Partly Cloudy**  
*Bitterly cold.*





**Biotech**

## Janet Woodcock - FDA

---

by *Damian Garde* |



**The gatekeeper of biopharma's biggest market**

**Name:** Janet Woodcock

**Title:** Director of the FDA's Center for Drug Evaluation and Research

FDA meetings have made for intriguing theater over the past year. Advocates chastise the agency for its perceived gender bias. Pharma execs squabble about safety data that happen to defend their multi-billion-dollar products. Parents of children with rare diseases read tearful entreaties for the agency to approve new drugs with debatable supporting evidence.

Each, wittingly or otherwise, is trying to get through to Janet Woodcock, a 20-plus-year FDA veteran who runs the agency's drug-approval arm and has the power to alter the course of the industry.

Woodcock is director of the FDA's Center for Drug Evaluation and Research, a division tasked with vetting new drug applications. Under her leadership, the agency is approving more and more new drugs each year--45 last year and 41 in 2014--all the while facing mounting criticism from critics who say the FDA is too close to the business it regulates, industry insiders who claim the process is still too slow, and patient advocates who argue the agency needs to rethink its approach to rare diseases.

Case in point: Duchenne muscular dystrophy.

Two companies, BioMarin Pharmaceuticals (\$BMRN) and Sarepta Therapeutics (\$SRPT), are petitioning the agency to approve treatments that could help about 13% of boys with the deadly, muscle-wasting disease. Each is armed with data from small studies in which their candidate drugs charted only intermittent efficacy, below the standard usually required to win FDA approval. There are no approved treatments for the disease, and parents of DMD patients are clamoring for anything that might improve and extend the lives of their children, even if it's a long shot.

The question facing Woodcock becomes: Should the FDA bend its standards in response to unmet need, or would relenting open up a loophole that biopharma companies could later exploit to the detriment of patients?

Woodcock always stays on-message in her public comments, sticking to the point that the agency makes its decisions based solely on safety and efficacy data. But the FDA, under her watch, has been increasingly flexible in the approval process.

CDER's cancer division, led by Richard Pazdur, has repeatedly approved new cancer medications with shallow efficacy records, clearing them to treat only the most desperate patients until companies come back with enough data to justify broader use. And the agency seemed to cave to public pressure last year when it approved Addyi, a twice-rejected female libido treatment whose scant effectiveness didn't outweigh its side effects in the eyes of many critics.

Each case boils down to the same fundamental issue: What makes a drug approvable? Woodcock, as gatekeeper of the world's biggest drug market, plays a sizable role answering that question, giving her the power to shift the dynamics of biopharma.

-- Damian Garde (email | Twitter)

**For more:**

**Special Report:** The biggest winners--and losers--in the 2015 race for new drug approvals

Sarepta gets creative in bolstering its case for quick eteplirsen approval

FDA slaps down BioMarin's Duchenne's drug as rival nears a moment of truth

FDA clears a controversial female libido drug despite 'modest' effects and dangerous risks

Read More:

Anne Wojcicki - 23andMe

Up

# The Political Economy Of FDA Drug Review: Processing, Politics, And Lessons For Policy

Patients, more than pharmaceutical firms, shape the political costs to the FDA of delaying drug approval.

by Daniel P. Carpenter

**ABSTRACT:** U.S. Food and Drug Administration (FDA) drug review bears a structural similarity to many decisions made by other regulatory agencies: high uncertainty, low reversibility, avoidance of observable error, and high political stakes that induce lobbying by interested parties. This paper explores the policy lessons to be learned from viewing FDA drug review as a politically shaped exercise in information processing. I argue that the incentives facing regulators induce limits on the degree to which drug review can be accelerated, that the same incentives could render privatization initiatives problematic, and that political pressures could play a useful role in identifying priority drugs.

CONSIDER TWO HYPOTHETICAL CONSUMERS, one a pharmaceutical consumer (“patient”) who wishes to try a new drug for some ailment, the other a vitamin consumer who wishes to take zinc supplements to ward off a cold or flu. There are few institutional restrictions upon the consumption decisions of the vitamin consumer, at least in the United States. She is free to purchase vitamin products over the counter, and the vitamin manufacturer is free to sell them without prior authorization or licensing.

Not so with pharmaceuticals. The marketplace for pharmaceuticals is one of the most highly regulated industries in the U.S. economy.<sup>1</sup> To use any new pharmaceutical product, the patient must secure the approval of two agents: a licensed physician and the U.S. Food and Drug Administration (FDA).<sup>2</sup>

No discussion of the past, present, or future of the pharmaceutical industry can ignore the critical role played by the FDA in its evolution. The agency’s drug review decisions are essentially final (contesting them is extremely difficult and costly) and immensely consequential (regulators in other nations frequently cue off of the FDA’s decisions). If the FDA so chooses, it can materially impede the flow of new products to the pharmaceutical marketplace, or it can help accelerate that

.....  
*Dan Carpenter is a professor of government at Harvard University, in Cambridge, Massachusetts, and a fellow in residence at the Center for Advanced Study in the Behavioral Sciences, Stanford University, in Stanford, California.*

*“FDA officials want good press but also to preserve a reputation for scientific rigor among academics and medical professionals.”*

flow. Just as important, major changes are now occurring at the FDA—including the merger of its drugs and biologics review divisions—that will shape the future of the marketplace.

In this essay I use some lessons from political science to illuminate the way the FDA operates. My central claim is that FDA drug review is an exercise in learning shaped by organized interests. Both the learning and the politics have some peculiar features. The learning—more specifically, “optimal stopping” (deciding not just if but when to terminate drug review and approve an application)—is driven by the FDA’s desire to safeguard its reputation for protecting the public’s health.<sup>3</sup> The politics involves the mobilization of drug-specific lobbies—mainly the firm submitting the drug and the patients for whom the drug is intended.

The learning incentive and the politics incentive combine to form a trade-off. The FDA will highly prize new information on a drug and will often delay approval to obtain that information. In most cases, however, there is a political cost to delay, and in recent years that cost has been shaped even more by patients and their lobbies than by pharmaceutical firms.

FDA officials seem keenly aware of these trade-offs and of the political difficulties that rejection of a new drug application (NDA) can cause, especially when few or no existing therapies exist for a given disease. In 1991 Paul Leber (then director of the FDA’s Division of Neuropharmacological Drug Products) read the initial drug application for Burroughs-Wellcome’s Lamictal (lamotrigine) for partial epileptic seizures. He found the NDA to be “disorganized” and poorly keyed to protocols for clinical trials. He considered a “refuse-to-file” (RTF) action, a major embarrassment for the pharmaceutical firm in which the FDA returns the NDA without reviewing it. Yet Leber decided against an RTF, reasoning that since “no new anti-epileptic product had been marketed over the previous 12 years...a refuse to file action, although justified, could have untoward political consequences.”<sup>4</sup>

In this essay I consider the lessons and policy implications of this trade-off. My argument and evidence here are both taken from a larger project on the evolution of pharmaceutical regulation at the FDA over the past half-century. This project entails a massive empirical enterprise, including collection of data on more than 17,000 pharmaceutical products (and more than 2,000 new chemical entities, or NCEs) developed over the past fifty years; more than 250 companies that have submitted NDAs; the epidemiology of more than 250 medical conditions (“primary indications”) for which NDAs have been submitted; more than 3,000 disease and patient advocacy groups representing medical conditions for which NDAs have been submitted; and more than 4,000 personnel who have served in the FDA from 1980 to the present.

## Protecting Reputation

I posit that the FDA behaves in ways that enhance its reputation for protecting consumer safety and public health. As gauged by public opinion polls, the FDA remains one of the most popular agencies in government, regularly securing 70 percent or greater “approval” of its performance among sampled respondents.<sup>5</sup> But-tressing this popularity are powerful symbolic lessons of history: The FDA is widely credited with saving thousands of American lives in its response to the sul-fanilamide tragedy of 1937 and the thalidomide scandal of 1959–1961.<sup>6</sup> Congress dramatically strengthened pharmaceutical regulations after each of these events. In short, whether or not the agency deserves it, the FDA clearly possesses a reputa-tion for protecting public health and consumer safety.

This reputation did not arise by accident but is the result of refined bureau-cratic strategies. FDA officials have labored for years to craft and guard their orga-nizational legitimacy. They have done so through frequent contact with their vari-ous constituents: attending professional meetings; giving lectures to ensure that the FDA’s perspective on a given issue is heard; and cultivating the advice of aca-demic and medical scientists, particularly on FDA advisory committees.<sup>7</sup>

Bureaucratic reputations often have multiple audiences. The FDA’s reputation is no exception; it has scientific, political, and popular facets. FDA officials want good press (or no bad press) in the news media but also want to preserve a reputa-tion for scientific rigor among academics and medical professionals. As Alison Lawton, a long-time FDA observer, noted recently, “The FDA is very responsive to what I would call ‘opinion leaders’ in the scientific and medical communities. It cares very much about what these people think as to how the agency is doing.”<sup>8</sup>

Another critical audience lies in Congress, particularly in the committees that oversee the FDA. For much of the FDA’s history, these bodies have launched criti-cisms at the agency for approving drugs too frequently and too quickly, and the FDA appears to sense these criticisms acutely. Commissioner Alexander Schmidt offered some testimony to this effect in 1974:

In all of the FDA’s history, I am unable to find a single instance where a Congressional committee investigated the failure of FDA to approve a new drug. But, the times when hearings have been held to criticize our ap-proval of new drugs have been so frequent that we aren’t able to count them.. The message to FDA staff could not be clearer. Whenever a controversy over a new drug is resolved by its approval, the Agency and the indi-viduals involved likely will be investigated. Whenever such a drug is disapproved, no inquiry will be made.<sup>9</sup>

Contrary to the claims of some analysts, there is nothing inherently “selfish” or “inefficient” about reputation protection.<sup>10</sup> Reputation is simply a currency of bu-reaucratic politics. Agencies with strong reputations can more easily attract de-sired personnel; fend off budget cuts; and lobby for the programs, funds, and other things they desire. There are other things that bureaucracies protect and “maxi-mize,” but for many agencies such as the FDA, reputation protection serves as the simplest and most powerful dynamic governing their behavior.<sup>11</sup>

## Drug Review As A Stopping Problem

In reviewing NDAs, the FDA must choose not only whether to approve, but when to approve. Every time the FDA reviews a new drug, it “invests” (takes a chance with) its reputation. There are three critical aspects of this decision.

■ **Inherent uncertainty.** FDA officials know that even the most successful clinical trials cannot eliminate the possibility that a drug will turn out to be unsafe or ineffective. Consider, for example, the 1996 review of SmithKline Beecham’s Requip (ropinerole) for idiopathic Parkinson’s disease. In his summary memorandum, FDA official Paul Leber discussed Requip’s safety data and added an important cautionary note:

Because no pharmacologically active drug substance is entirely free of risk, the conclusion that a drug has been shown to be “safe for use,” is actually no more than an opinion. Accordingly, risk to benefit assessments are inherently arguable, all the more so because each turns not only on personal sentiments about the nature of risks and benefits of a drug, but upon incomplete and imperfect information concerning the drug’s risks.<sup>12</sup>

Similarly, in 1997 FDA official Rudolph Widmark summarized safety data from Wyeth’s Duract (bromfenac sodium) for postoperative pain relief and cautioned:

In our safety review of NDA study we usually do not get definitive answers based on unequivocal data but are forced to interpret “flagging” events. We think that in the case of bromfenac, we have seen a “liver flag” that can be only fully explored through responsible marketing of the drug.<sup>13</sup>

Some uncertainty will always remain in drug review, and the marginal benefit of more trials and more delay tends to decline as the drug review gets longer.

■ **Asymmetric observability of error.** In the language of decision theory, a “Type I error” occurs when a decisionmaker accepts as true a hypothesis that is in fact false. A “Type II error” occurs when a decisionmaker rejects a hypothesis that is in fact true. The FDA, then, may be said to commit a Type I error when it approves a “bad” drug and a Type II error when it fails to approve a drug that should have been approved. For most of the FDA’s history, Type I errors have been more visible than Type II errors.<sup>14</sup> As the remarks from former Commissioner Schmidt illustrate, the FDA has often been excoriated for approving a bad drug (or approving it too quickly) and only recently has been criticized for approving drugs too slowly.

■ **Low (reputational) reversibility.** Finally, the damage of a faulty approval decision is difficult to undo. Of course, the FDA can always secure a recall of a faulty product or compel the manufacturer to attach a “black box warning.” Yet these steps will only publicize the error that the agency has made. Even though drug approvals are procedurally reversible, the FDA views drug approval as irreversible from the standpoint of reputation.

My model of drug review, then, is one in which agency reviewers are conducting a “cost-benefit” analysis of the drug at each moment in the review process. The costs of approval can be thought of as the publicly observable hazards of the drug (the FDA rarely gets criticized for approving a safe but ineffective drug, again because safety errors are much more visible than efficacy errors). The benefit of

approval is to reduce the political pressure that patients, medical professionals, and pharmaceutical firms can apply directly or indirectly upon the FDA (witness the AIDS lobby of the late 1980s and early 1990s).

There is a hitch, however, and the problem is not as simple as it might seem. When the FDA sees approval as irreversible, probability decision theory predicts that the FDA will approve a drug only when the benefits of approval exceed both the costs of approval and the benefits of waiting further.<sup>15</sup> We can think of the benefits of waiting as the amount of information gleaned from another look at the file, or perhaps another test conducted by the drug company. As it turns out, this “value of waiting” is highest during the earliest stages of review, when the least is known about the drug.<sup>16</sup>

### **The Politics Of Review: New Factors In The Policy Arena**

If neither doctors, patients, nor drug firms could apply public pressure for FDA approvals, the agency would find it much easier to delay drugs indefinitely. The costs of delay are not simply scientific; they are political. That is, they are subject to how well those who demand drugs can press their case before the agency, Congress, the media, and other public fora. Before the 1980s it was rare for anyone outside of clinical or academic circles to criticize the FDA for delay. Put differently, few in the media or in Congress were complaining of the agency’s Type II errors.

Today the situation is much different, and the political power of patients matters as much as or more than the political power of firms. The best evidence for this proposition comes in two strategies that are now widely adopted by pharmaceutical firms: (1) Firms themselves have in the past six to eight years created, fostered, and subsidized a number of patient advocacy groups; and (2) firms regularly seek alliances with patient advocates in pressing the case for priority status, accelerated approval, or simply approval before the FDA. The second of these is a much more common, and much more successful, strategy. Put differently, politically strategic pharmaceutical firms know that industry lobbying is less successful than patient advocacy, and their regulatory behavior adapts to this fact.

FDA drug approval has in recent years been powerfully shaped by two related factors: the increase of patient advocacy groups and the increasing visibility of Type II errors.

■ **Patient advocacy groups.** The past two decades have witnessed an explosion of interest groups and in no field more dramatically than in health.<sup>17</sup> Several studies have shown that the increase is largely attributable to nonprofit and citizens’ groups. As part of the FDA project, my research team and I have tracked the evolution of disease-advocacy groups over the past half-century. As of 2000 we aggregated more than 3,100 disease-specific advocacy groups with at least some involvement in political issues. We were able to find founding dates for more than half of these groups. We found evidence of an explosion of high-specificity health groups in the 1970s and especially the 1980s.<sup>18</sup>

■ **Type II errors.** The rise in patient advocacy has led to a balancing of the visibility of Type II versus Type I errors. Before the 1980s it was rare for the public's attention to be drawn to a drug that the FDA had not approved or was reviewing slowly. The AIDS epidemic changed this, less because AIDS protestors changed the FDA than because FDA officials foresaw the extraordinary politics of AIDS and rushed HIV treatments to approval.<sup>19</sup> Yet AIDS was only the beginning of a much larger story of disease-based political mobilization in the United States. To a degree never before witnessed, disease-specific lobbies now press Congress for medical research funding, insurers and state governments for favorable coverage rulings, and the FDA for quick approvals (Exhibit 1).

*Asthma versus arthritis.* Although people affected by a variety of diseases generally have begun to mobilize and lobby, not all are organized equally. Consider two examples. By just about any measure of public health, asthma is a more severe problem in the United States than arthritis (including rheumatoid arthritis). Exhibit 1 provides some raw figures. The annual death rate from asthma and related illnesses averaged nine times that for arthritis in the 1990s. Or consider that in 1997 hospitalization data from the federal government's Healthcare Cost and Utilization Project (HCUP), there are twice as many hospitalizations for asthma than for osteoarthritis. In addition, the average age of those hospitalized for arthritis was 69, but for asthma, 23.4; hence, when quality-adjusted life years (QALYs) are accounted for, asthma poses an even more costly public health burden.<sup>20</sup>

Yet arthritis receives far more media coverage than asthma does. If we examine coverage in the *Washington Post* for a given year in the 1990s, there were 105 (nonobituary) stories mentioning asthma that year, but almost twice as many (204) mentioning arthritis. Similarly, during 1967–1997 there were 117 arthritis-related stories on the nightly newscasts of the three major networks (ABC, NBC,

**EXHIBIT 1**  
**Epidemiology, Media Coverage, And FDA Drug Approval Times**

	Death rate per 10,000	Total hospitalizations (1997)	Average days per hospitalization	Washington Post stories (1998)	TV news stories (1967– 1998)	Median FDA approval time (1983– 2000)
Arthritis versus asthma						
Arthritis	0.0027	356,405	0.00 <sup>a</sup>	204	117	15.6
Asthma	0.0203	599,591	3.08	105	78	32.6
Three common cancers						
Breast	0.19	120,834	1.95	387	523	11.1
Lung	0.39	133,734	6.80	271	253	14.3
Prostate	0.14	134,882	3.04	165	111	19.3

**SOURCES:** Hospitalization data from the Healthcare Cost and Utilization Project (HCUP), 1997; and author-collected data on news coverage and Food and Drug Administration (FDA) approval times.

<sup>a</sup>Negligible number.



and CBS), but only 78 asthma-related stories.<sup>21</sup> Perhaps this is not surprising, since the early 1980s arthritis drugs have consistently been approved with much greater speed (an average of twenty months) than have drugs for asthma (an average of thirty-two months, or a full year more).

*Certain cancers.* Consider also the most common and deadly forms of cancer—breast, lung, and prostate. Prostate cancer is the most prevalent of these conditions, and lung cancer is by far the deadliest, but breast cancer has far more organizations, research dollars, media coverage, and quick drug approvals (Exhibit 1).

*Advocacy groups' slow rise.* One puzzle is why it took so long for patient and disease advocacy groups to become better organized, given that some have been around a long time. I can only hazard two educated guesses. First, political scientists have characterized the period before the 1970s as one dominated by industry, labor, and trade associations. In the 1980s and 1990s citizens' groups came to the fore. Disease and patient advocacy groups thus might be part of a larger trend. Second, the rise of disease advocacy groups could present an example of organizational learning. Many unorganized disease communities, witnessing the political and economic successes of the AIDS and breast cancer advocacy coalitions, have been motivated to form their own groups and to enter the political arena.<sup>22</sup>

*Examples of patients' power.* As illustrative evidence of the power of patient advocates in publicizing possible Type II errors, consider the recent approval of AstraZeneca's Iressa (gefitinib) for Stage III non-small-cell lung cancer patients. Despite strong skepticism from the Center for Drug Evaluation and Research (CDER) statistical reviewer and from industry watchers, the FDA approved Iressa in May 2003, in part for two reasons. First, the *Wall Street Journal* ran several editorials urging the FDA to approve it (the most vocal on 24 September 2002). So strong and visible was this pressure that FDA officials are reported to have complained to AstraZeneca about the editorials, worried of a link between the company and the editorial page. Second and more important, lung cancer patient advocates strongly supported approval, and several representatives of the groups offered robust and emotional testimony for the drug at a critical FDA advisory committee meeting in September 2002. As one journalist wrote following the meeting, "These patients—all of whom took Iressa through a compassionate use program—seemed to be the wild card that really helped AstraZeneca in the end. The company has allowed more than 18,000 patients access to Iressa outside its clinical trials, creating a very vocal and persuasive lobbying voice in the drug's favor."<sup>23</sup>

■ **Resources.** Perhaps the most pervasive influence upon FDA drug approval times has been the presence or absence of plentiful FDA staff to review new applications. One important reason that FDA drug approval times slowed in the 1970s, engendering complaints of a "drug lag," is that the 1962 Amendments to the 1938 Food, Drug, and Cosmetic Act piled many new responsibilities onto the FDA without a proportionate increase in personnel. The median FDA review time for new molecular entities (NMEs) submitted in 1978 was 30.8 months, and 30.0 months in 1983. In

other words, the average drug was taking two and a half years to get approved; many others took considerably longer.

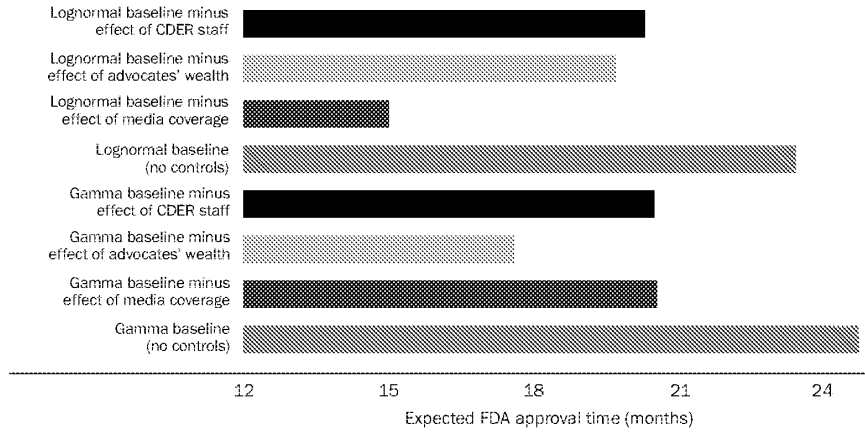
In recent years this situation has begun to change, particularly with the enactment of the Prescription Drug User Fee Act (PDUFA) of 1992 and subsequent renewals of this legislation. PDUFA is a more complicated law than I can assay here, but its most important provisions create (1) a system of per application “user fees” that fund increases in the reviewer staff at CDER, and (2) an incentive structure whereby the legislation is renewed only if the FDA meets specified performance goals.<sup>24</sup> In part because of PDUFA and in part because CDER staff totals began to rise five years before PDUFA, the average review time for NMEs has greatly declined, to thirteen months in 2002. The key here is that FDA staff began to increase appreciably five years before PDUFA was enacted and that the long-run effect of resources on review times is negative and large (with an elasticity of  $-1.6$  to  $-2.2$ , meaning that a 10 percent increase in CDER personnel yields a 16–22 percent decrease in expected drug approval time).

■ **Some statistical evidence.** Iressa’s approval points to two factors: organized patients and media coverage of the disease. One way of assessing the influence of media and patient groups is to conduct a duration analysis of drug review times in which measures for these constructs are included as explanatory variables. Using data on 540 NCEs reviewed by the FDA over the past twenty-five years, I conducted a set of maximum likelihood duration analyses, regressing the approval time for a drug upon (1) a measure of the wealth of advocacy groups that existed for the primary indication disease of the drug; (2) a measure of the amount of news coverage the primary indication disease received in the three years before the NDA was submitted; and (3) a set of controls, including epidemiological variables, fixed effects for the submitting firms, a set of “shared frailties” (akin to random effects) for the primary indications of the drugs, and proxies for the number of previously existing therapies for the drug’s primary indication and the staff resources of the FDA.<sup>25</sup>

Exhibit 2 shows the reduction in expected FDA approval time from a one-standard-deviation increase in the variable in question. Begin with the “baseline” predictions of the two models estimated, lognormal and gamma. These are 23.7 and 24.1 months, respectively. If all other covariates of FDA review times are held at their means, the marginal effect of a one-standard-deviation increase in *Washington Post* stories ranges from 4.2 to 8.4 months’ reduction in expected approval time from the baseline. Similarly, marginal effects of a standardized increase in group wealth range from 3.7 to 7.1 months’ reduction in expected review time. Finally, a one-standard-deviation increase in CDER staff (200 full-time equivalents, or FTEs) yields a reduction of three to four months in approval time for all drugs. Note that since the models include disease-specific frailty parameters, these observed associations cannot be attributed to unmeasured disease-level heterogeneity in drugs.

In short, there is considerable evidence—from anecdote, from factual inspec-

**EXHIBIT 2**  
**Marginal Effects Of FDA Staff, Advocates' Wealth, And Media Coverage On New Molecular Entity (NME) Approval Times**



**SOURCE:** Author's maximum likelihood duration analyses of Food and Drug Administration (FDA) approval times.  
**NOTES:** Estimates from lognormal and gamma duration models. Effect of one-standard-deviation increase in each item depicted. See text for details. CDER is Center for Drug Evaluation and Research, FDA.

tion of the FDA's behavior, and from statistical analyses of drug review times—that the political organization and newsworthiness of patients is negatively associated with drug review times (that is, it causes these review times to get shorter). This should come as little surprise to readers aware of the FDA's response to the AIDS epidemic. The statistical analyses reported here suggest that the FDA's responsiveness to disease politics is by no means an artifact of AIDS, but extends to other diseases as well.

**What Does The Future Hold?**

■ **Further cuts in approval times?** While approval times for NMEs (especially priority drugs) have become shorter during the past fifteen years, one implication of the perspective presented here is that further reductions (if they can be generated at all) are likely to come at a much higher marginal cost. Trimming two months from the median approval time when yearly averages were thirty to thirty-six months was much easier; now that CDER reviewers commonly crank through priority drugs in six months or less, further reductions will likely come only through dramatic procedural change. As CDER official Kenneth Edmunds recently cautioned, “My fear is that there is a law of diminishing returns setting in. It may be expensive to wring that last 5 percent of improvement out of the FDA without some things giving way. All the easy water has been drained out of the system. All the fat is near the bone now.”<sup>26</sup>

■ **Third-party review and privatization?** There have been several proposals to rely on non-FDA (“third party”) reviewers or to privatize the FDA’s review processes. Among these are actual provisions for occasional third-party review in recent legislation (for medical devices in the 1997 FDA Modernization Act, or FDAMA) and proposals from the Hoover Institution to make the FDA a certifier of private reviewers.<sup>27</sup> In both cases, reformers wish to exploit interorganizational competition among reviewers to reduce approval times and increase the likelihood of approval.

The form and likely effects of privatization are far too complex a subject to be tackled here. Still, it is difficult to believe that the incentives facing FDA drug reviewers would not materialize under privatization. In the simplest case, third-party reviewers would rationally decide to compete not just over quickness in review but also over minimization of visible errors. In the presence of any tort liability, moreover, the procedural conservatism of third-party reviewers might be greater than that under the FDA status quo.<sup>28</sup> Whether privatization would still be preferable to the status quo is another issue, but the limits posed by the incentives of drug review ought to be kept in mind.

■ **Disease politics as usual?** Patient advocacy groups and media attention can accelerate drug review, particularly for diseases that have well-organized advocates and are newsworthy. The problem, as often in politics, is one of inequality: Better-organized and more publicly salient groups get a disproportionate share of the “benefits” (quicker approvals). From a policy standpoint, there are at least two ways of looking at this pattern. One steady conclusion is that it represents an unfortunate (perhaps indefensible) result of distributive politics. Another interpretation would see these political patterns as more benign. With scarce resources, the FDA cannot avoid privileging one disease over another in its drug approval decisions. Moreover, more highly organized and “newsworthy” medical conditions are likely to be (but might not always be) more prevalent, deadlier ones. In short, the FDA must make tough (moral) choices, and disease politics could provide crucial information and guidance in doing so.

**P**HARMACEUTICAL REGULATION is an immensely complex process, and no combination of theoretical modeling and empirical analysis can ever do it full explanatory justice. There is also much that the FDA does in drug regulation that I have not covered here, including labeling and advertising regulation, the promotion of good manufacturing practices, and the regulation of clinical trials. Nonetheless, viewing FDA drug review as a learning exercise shaped by organized interests sheds illumination upon the process and its policy implications. The FDA protects its reputation, views its approval decisions as irreversible, and responds dramatically to patient advocacy groups and their coverage in the media because they make the consequences of delay and rejection more visible.

The author acknowledges the National Science Foundation (Grant no. SES-0076452) for research support and thanks the editor and three anonymous reviewers for criticisms and suggestions. He also acknowledges responsibility for all characterizations, errors, and omissions.

NOTES

1. The stringency of regulation is arguably higher in other nations, because the United States does not (at this writing) directly constrain pharmaceutical prices.
2. This is a very simplified representation of the pharmaceutical marketplace. For more, see the FDA's Web site, www.fda.gov/cder.
3. For a general theory and empirical investigation of how agencies engage in "reputation-maximization," see D.P. Carpenter, *The Forging of Bureaucratic Autonomy: Reputations, Networks, and Policy Innovation in Executive Agencies, 1862-1928* (Princeton, N.J.: Princeton University Press, 2001).
4. "Lamictal Efficacy Comparable to Carbamazepine in First-Line Epilepsy, Glasgow Study; Lamotrigine in Phase III for Monotherapy, Pediatrics," *Pharmaceutical Approvals Monthly*, F-D-C Reports (January 1996): 29.
5. See Pew Research Center, *Deconstructing Distrust: How Americans View Government* (Washington: Pew Research Center, 1998), 33. This is an imperfect measure, used here only for heuristic purposes. Such "approval ratings" could simply signify public agreement with the agency's mission and not its performance. Still, it is worth noting that all but a handful of other agencies score materially lower in these polls.
6. P.J. Hilts, *Protecting America's Health: The FDA, Business, and One Hundred Years of Regulation* (New York: Alfred A. Knopf, 2003), chaps. 5 and 10.
7. I acknowledge Susan Moffitt, a doctoral candidate in the University of Michigan Department of Political Science who is writing a dissertation about federal advisory committees, for some of the insight on FDA advisory committees.
8. Alison Lawton, vice-president for regulatory affairs, Genzyme Corporation, interview, 11 June 2003.
9. A. Schmidt, "The FDA Today: Critics, Congress, and Consumerism" (Speech given at the National Press Club, Washington, D.C., 29 October 1974), quoted in H. Grabowski, *Drug Regulation and Innovation* (Washington: AEI Press, 1976), 76.
10. In their book on FDA "founder" Harvey Wiley, Hugh Coppin and Jack High (*The Politics of Purity* [Ann Arbor: University of Michigan Press, 1999]) seem to equate reputation enhancement with selfish, inefficient behavior, and Hilts (*Protecting America's Health*, p. 346) disparages them for criticizing Wiley as selfish. All of these authors fall into the same trap of assuming that altruism cannot possibly have any relation to self-interested behavior. In regulation as in many other fields, reputation enhancement incentives may lead to cooperative, altruistic behavior, and more efficient outcomes.
11. Analysts such as William Niskanen have argued that bureaucracies attempt to maximize their budgets (*Bureaucracy and Representative Government* [Chicago: Aldine-Atherton, 1971]), while others (including myself) have argued that agencies maximize their discretion or autonomy. Although agencies such as the FDA will usually prefer more budget to less, they will generally value reputation over resources. Among the reasons for this are that (1) regulators' personal income is only weakly related to the agency's budget; and (2) budget increases can increase the workload or task diversity of agencies in a way that leaves them "worse off" See J.Q. Wilson, *Bureaucracy: What Government Departments Do and Why They Do It* (New York: Basic Books, 1989), 118-119, 180-181. In addition, statistical tests of the budget maximization hypothesis have not supported Niskanen's theory. See D.P. Carpenter, "Adaptive Signal Processing, Hierarchy, and Budgetary Control in Federal Regulation," *American Political Science Review* (June 1996): 283-302.
12. Memorandum from Paul Leber, director, Division of Neuropharmacological Drugs, to Robert Temple, director, Office of New Drug Evaluation I, Subject: "NDA 20-658, Requip [ropinerole HCl tablets]," 6-7, NDA Public File 20-658, FDA Center for Drug Evaluation and Research.
13. R. Widmark, "Memo regarding Hepatotoxicity of Bromfenac," undated [December 1995], 3, NDA File 20-535, FDA CDER. See also "Wyeth-Ayerst Duract Hepatotoxicity Warning Was Suggested during NDA Review," *Pharmaceutical Approvals Monthly*, F-D-C Reports (April 1998): 34.
14. This is not necessarily the case. If the hazards of drug products are easily discerned and newsworthy, then the assumption is safe. But solid knowledge about product hazards often emerges only many years after market entry and is disseminated more in academic discussions than in the popular news media (the thousands of lost lives attributable to malprescription of arrhythmia drugs such as Tambocor and Encaid). See Hilts, *Protecting America's Health*, 231-232; and C.F.L. Heimann, *Acceptable Risks: Politics, Policy and Risky*

- Technologies* (Ann Arbor: University of Michigan Press, 1997).
15. See D.P. Carpenter, "Why Do Bureaucrats Delay? Lessons from a Stochastic Optimal Stopping Model," in *Policy, Politics, and Organizations: Scientific Approaches to Bureaucratic Politics*, ed. G. Krause and K. Meier (Ann Arbor: University of Michigan Press, forthcoming).
  16. See D.P. Carpenter, "Protection without Capture: Product Approval by a Politically Responsive, Learning Regulator," Robert Wood Johnson Foundation Scholars in Health Policy Working Paper no. 13 (Princeton, N.J.: RWJF, 2000).
  17. F.R. Baumgartner and B.D. Jones, *Agendas and Instability in American Politics* (Chicago: University of Chicago Press, 1993); and J. Walker, *The Mobilization of Interest Groups in America* (Ann Arbor: University of Michigan Press, 1991).
  18. As far as one can discern from the data (including Jack Walker's careful 1991 study), the vast majority of these groups neither are for-profit groups nor are funded by the pharmaceutical industry; indeed, most groups diligently avoid the label of "front group" for drug companies. In their analysis of Walker's data, Baumgartner and Jones find that just 26 percent of groups in the health policy field were "for-profit," 43 percent were nonprofit, and another 31 percent were citizens' groups. Only foreign affairs, education, and civil rights had lower ratios of profit-to-citizen involvement. Baumgartner and Jones, *Agendas and Instability in American Politics*, 183.
  19. Hilts, *Protecting America's Health*, 246.
  20. Agency for Healthcare Research and Quality, *Statistics from the HCUP-3 Nationwide Inpatient Sample for 1997: Principal Diagnoses* (Rockville, Md.: AHRQ, 1998).
  21. The *Washington Post* and the Vanderbilt TV News database both have electronically searchable archives. For the methodology used to aggregate stories, see D.P. Carpenter, "Groups, the Media, Agency Waiting Costs, and FDA Drug Approval," *American Journal of Political Science* (July 2002): 490-505.
  22. I thank an anonymous reviewer for suggesting this puzzle.
  23. A. Feuerstein, "AstraZeneca Scores Comeback Victory on Iressa," [www.thestreet.com/\\_yahoo/tech/adamfeuerstein/10044113.html](http://www.thestreet.com/_yahoo/tech/adamfeuerstein/10044113.html) (12 November 2003). I gathered similar impressions from an interview with Philip Crooker, regulatory affairs director, AstraZeneca, 19 May 2003.
  24. R.A. Merrill, "Modernizing the FDA: An Incremental Revolution," *Health Affairs* (Mar/Apr 1999): 96-111.
  25. One drawback of the estimations here is that we "observe" only those drugs that have been submitted to the FDA. Strategic firms are likely to anticipate likely regulatory outcomes, and so the sample is highly selected. I am trying to address this problem in ongoing theoretical and empirical research. See D.P. Carpenter and M.M. Ting, "Product Approval with Endogenous Submissions" (Unpublished manuscript, Harvard University, 2003).
  26. Kenneth Edmunds, director of electronic submissions, CDER Information Technology Group, interview, May 2002.
  27. H.I. Miller, *To America's Health: A Proposal to Reform the Food and Drug Administration* (Stanford, Calif.: Hoover Institution Press, 2000).
  28. Consider the possibility that when third-party reviewers commit a Type I error, private or corporate parties could bring suit against them. Whereas Type I errors are more observable than Type II errors now, they would undoubtedly become much more observable under a tort system because the financial payoff to revealing such errors would rise. Hence, privatized review might well suffer from a greater procedural conservatism than FDA review. Although well-functioning insurance markets could smooth this risk, privatized reviewers would still face strong incentives to limit Type I errors.

INTERNATIONAL CONFERENCE ON HARMONISATION OF TECHNICAL  
REQUIREMENTS FOR REGISTRATION OF PHARMACEUTICALS FOR HUMAN USE

**DRAFT CONSENSUS GUIDELINE**

## **GUIDELINE FOR ELEMENTAL IMPURITIES**

**Q3D**

Current *Step 2b* version

dated 26 July 2013

*At Step 2 of the ICH Process, a consensus draft text or Guideline, agreed by the appropriate ICH Expert Working Group, is transmitted by the ICH Steering Committee to the regulatory authorities of the three ICH regions (the European Union, Japan and the USA) for internal and external consultation, according to national or regional procedures.*

P. 1

UT Ex. 2043  
SteadyMed v. United Therapeutics  
IPR2016-00006

**IPR2020-00769**  
**United Therapeutics EX2006**  
**Page 5211 of 7113**

**Q3D  
Document History**

**Current Step 2a version**

Code	History	Date
Q3D	Approval by the Steering Committee under <i>Step 2a</i> .	6 June 2013

**Current Step 2b version**

Code	History	Date
Q3D	Approval by the Steering Committee under <i>Step 2b</i> and release for public consultation.	6 June 2013
Q3D	Post sign-off corrigendum in: <ul style="list-style-type: none"> <li>• Table 4.1 W and Al were removed from the list of included elemental impurities in Class 2B and 3 respectively.</li> <li>• Table A.2.1 the Class for Ni was changed to read 3 instead of 2.</li> </ul>	14 June 2013
Q3D	Post sign-off minor editorial corrections including: removal of references to Appendix 5 (pgs i & 13); deletion of redundant text (pg 4); change of Option 2 to Option 2a (pg 10); insertion of omitted text under Safety Limiting Toxicity (pg 35); removal of duplicated redundant text (pg 41); replacing references to “metals” in text and “metal” in Table A.4.7 title with “elementals” and “elements” (pg 73); and deletion of header Table A.4.10 (pg 75).	26 July 2013
Q3D	Addition of line numbers to facilitate the provision of comments by stakeholders.	30 September 2013

**Legal notice:** This document is protected by copyright and may be used, reproduced, incorporated into other works, adapted, modified, translated or distributed under a public license provided that ICH's copyright in the document is acknowledged at all times. In case of any adaption, modification or translation of the document, reasonable steps must be taken to clearly label, demarcate or otherwise identify that changes were made to or based on the original document. Any impression that the adaption, modification or translation of the original document is endorsed or sponsored by the ICH must be avoided.

The document is provided "as is" without warranty of any kind. In no event shall the ICH or the authors of the original document be liable for any claim, damages or other liability arising from the use of the document.

The above-mentioned permissions do not apply to content supplied by third parties. Therefore, for documents where the copyright vests in a third party, permission for reproduction must be obtained from this copyright holder.



# GUIDELINE FOR ELEMENTAL IMPURITIES

## Draft ICH Consensus Guideline

Released for Consultation on 26 July 2013, at *Step 2b* of the ICH Process

### TABLE OF CONTENTS

1.	INTRODUCTION .....	1
2.	SCOPE.....	1
3.	SAFETY ASSESSMENT OF POTENTIAL ELEMENTAL IMPURITIES .....	2
3.1	Principles of the Safety Assessment of Elemental Impurities for Oral, Parenteral and Inhalation Routes of Administration.....	2
3.2	Other Routes of Administration .....	3
3.3	Justification for Element Impurity Levels Higher than the PDE .....	3
3.4	Parenteral Products.....	4
4.	ELEMENT CLASSIFICATION.....	4
5.	ASSESSMENT AND CONTROL OF ELEMENTAL IMPURITIES .....	5
5.1	General Principles .....	5
5.2	Potential Sources of Elemental Impurities .....	6
5.3	Assessment – Identification of Potential Elemental Impurities .....	7
5.4	Assessment – Analysis and Evaluation .....	9
5.5	Converting Between PDEs and Concentration Limits.....	9
5.6	Assessment Summary.....	11
5.7	Control of Elemental Impurities.....	12
5.8	Periodic Verification Testing.....	13
5.9	Special Considerations for Biotechnologically-Derived Products .....	13
6.	SPECIATION.....	14
7.	ANALYTICAL PROCEDURES .....	14
8.	LIFE-CYCLE MANAGEMENT OF THE CONTROL STRATEGY FOR ELEMENTAL IMPURITIES .....	14
9.	RECOMMENDATIONS FOR SUBMISSION OF ELEMENTAL IMPURITIES CONTROL STRATEGY.....	14
	REFERENCES .....	15
	GLOSSARY .....	16
	Appendix 1: Method for Establishing Exposure Limits.....	20
	Appendix 2: Established PDEs for Elemental Impurities .....	23
	Appendix 3: Individual Safety Assessments.....	25
	Appendix 4: Illustrative Example – Calculation Options for Converting PDEs to Concentrations.....	69



# GUIDELINE FOR ELEMENTAL IMPURITIES

## Q3D

1  
2  
3

### 4 1. INTRODUCTION

5 Elemental impurities in drug products may arise from several sources; they may be  
6 added intentionally in synthesis, or may be present as contaminants (e.g., through  
7 interactions with processing equipment or by being present in components of the drug  
8 product) and are consequently detectable in the drug product. Since elemental impurities  
9 do not provide any therapeutic benefit to the patient, element impurity levels should be  
10 controlled within acceptable limits in the drug product. There are three components of  
11 this guideline: the evaluation of the toxicity data for potential elemental impurities, the  
12 establishment of a Permitted Daily Exposure (PDE) for each element of toxicological  
13 concern, and development of controls designed to limit the inclusion of elemental  
14 impurities in drug products to levels at or below the PDE. It is not expected that an  
15 applicant tightens the limits based on process capability provided that the elemental  
16 impurities in drug products are held at or below the PDE. The PDEs established in this  
17 guideline are considered to be protective of public health for all patient populations,  
18 including pediatric patients. In some cases, lower levels of elemental impurities may be  
19 needed when levels below toxicity thresholds have been shown to have an impact on  
20 other quality attributes of the drug product (e.g., element catalyzed degradation of drug  
21 substances). In addition, in the case of high PDEs, other limits may have to be  
22 considered from a pharmaceutical quality perspective; other guidelines should be  
23 consulted.

24 Developing a strategy to limit elemental impurities in the drug product is consistent  
25 with risk management processes identified in ICH Q9. The process is described in this  
26 guideline as a four step process to assess and control elemental impurities in the drug  
27 product: identify, analyse, evaluate, and control.

28 The PDE of the elements may change if new safety data become available. The guideline  
29 may be updated to include other elemental impurities or other routes of administration  
30 as new data become available. Any interested party can make a request and submit the  
31 relevant safety data to be considered.

### 32 2. SCOPE

33 The PDEs in this guideline have been established based on acceptable safety limits of  
34 potentially toxic elemental impurities. The guideline applies to new finished drug  
35 products (as defined in ICH Q6A and Q6B) and new drug products employing existing  
36 drug substances. The drug products containing: proteins and polypeptides (produced  
37 from recombinant or non-recombinant cell-culture expression systems), their derivatives,  
38 and products of which they are components (e.g., conjugates) are in the scope of this  
39 guideline. In addition, drug products containing synthetically produced polypeptides,  
40 polynucleotides, and oligosaccharides are within scope of this guideline.

41 This guideline does not apply to herbal products, radiopharmaceuticals, vaccines, cell  
42 metabolites, DNA products, allergenic extracts, cells, whole blood, cellular blood  
43 components, crude products of animal or plant origin, dialysate solutions not intended  
44 for systemic circulation or drug products containing elements that are intentionally  
45 included for therapeutic benefit.

46 This guideline does not apply to drug products used during clinical research stages of  
47 development. In the later stages of development, the principles contained in this  
48 guideline can be useful in evaluating elemental impurities that may be present in new  
49 drug product prepared by the proposed commercial process.

50 The application of this guideline to existing marketed drug products will be addressed by  
51 regional regulatory processes.

### 52 **3. SAFETY ASSESSMENT OF POTENTIAL ELEMENTAL IMPURITIES**

#### 53 **3.1 Principles of the Safety Assessment of Elemental Impurities for Oral,** 54 **Parenteral and Inhalation Routes of Administration**

55 The method used for establishing the PDE for each element impurity is discussed in  
56 detail in Appendix 1. Elements evaluated in this guideline were assessed by reviewing  
57 the publicly available data contained in scientific journals, government research reports  
58 and studies, international regulatory standards (applicable to drug products) and  
59 guidance, and regulatory authority research and assessment reports. This process  
60 follows the principles employed in ICH Q3C: Residual Solvents. The available  
61 information was reviewed to establish the oral, parenteral and inhalation PDEs provided  
62 in the guideline.

63 A summary safety assessment identifying the critical study for setting a PDE for each  
64 element is included in Appendix 3. There are insufficient data to set PDEs by any route  
65 of administration for osmium, rhodium, ruthenium and iridium. The PDEs for these  
66 elements were established on the basis of their similarity to platinum. The PDEs for  
67 each element included in the guideline are summarized in Appendix 2, Table A.2.1.

68 The factors considered in the safety assessment for establishing the PDE were:

- 69 • The oxidation state of the element likely to be present in the drug product;
- 70 • Human exposure and safety data when it provided applicable information;
- 71 • The most relevant animal study;
- 72 • Route of administration;
- 73 • Selection of the relevant endpoints or designations (e.g., International Agency for  
74 Research on Cancer [IARC] classification, animal carcinogenicity, reproductive  
75 toxicology, target organ toxicity, etc);
- 76 • The longest duration animal study was generally used to establish the PDE. In  
77 some instances, a shorter duration animal study was considered the most  
78 relevant study. The rationale for using the shorter duration study is provided in  
79 the individual PDE assessment;
- 80 • In the absence of data and/or where data were available but were not considered  
81 sufficient for a safety assessment for the parenteral and or inhalation route of  
82 administration, default factors (see below) were used to derive the PDE from the  
83 oral PDE;
- 84 • In inhalation drug products, soluble salts are more relevant than particulates to  
85 assess elemental impurity toxicity. Therefore, inhalation studies using soluble  
86 salts (when available) were preferred over studies using particulates for  
87 inhalation assessment and derivation of inhalation PDEs.

88 In some cases, standards for daily intake for some of the elemental impurities discussed  
89 in this guideline exist for food, water, air, and occupational exposure. These standards  
90 have developed over time with different regional processes and may use different  
91 modifying factors or other estimates (e.g., body weight for an individual). In some cases,  
92 these standards are not only safety based, rather, based on practical considerations or

93 analytical capability. Where appropriate, these standards were considered in the  
94 assessment and establishment of the PDEs using the approach as outlined in Appendix 1.  
95 For PDEs established for inhalation (oral or parenteral routes as applicable), doses were  
96 normalized to a 24 hour, 7 day exposure. If data were available for local toxicity to the  
97 lung, those data were considered in establishing the inhalation PDE.  
98 Where data were available but were not considered sufficient for a safety assessment for  
99 the parenteral route of administration, modifying factors were employed as follows:

100           Oral bioavailability <1% divide by a modifying factor of 100  
101           Oral bioavailability < 50% divide by a modifying factor of 10  
102           Oral bioavailability between 50% and 90% divide by a modifying factor of 2  
103           Oral bioavailability > 90% divide by a modifying factor of 1

104 Where inhalation and/or parenteral data were available but were not considered  
105 sufficient for a safety assessment or Threshold Limit Value (TLV)/Time Weighted  
106 Average (TWA) values were not available for the inhalation route of administration, a  
107 calculated PDE was used based on the oral PDE divided by a modifying factor of 100  
108 (Ball *et al.* 2007). In cases where the TLV/TWA or a nonclinical inhalation study was  
109 used, the dose levels were normalized to a 24 hour, 7 day week.

110 PDEs for elements of low risk to human health as impurities in drug products were not  
111 established. The elements in this category include: Fe, B, Al, W, Zn, K, Ca, Na, Mn, and  
112 Mg.

113 For elements not included in this guideline for which there is limited or insufficient data,  
114 the concepts used in this guideline can be used to determine appropriate PDEs.

### 115 **3.2 Other Routes of Administration**

116 PDEs were only established for oral, parenteral and inhalation routes of administration.  
117 Sufficient data to permit the establishment of a PDE for other routes of administration  
118 were generally unavailable. However, the concepts applied and described in this  
119 guideline can be used to determine appropriate PDEs for other routes of administration.  
120 Application of the parenteral PDE can provide the basis of a route-specific safety  
121 assessment.

### 122 **3.3 Justification for Element Impurity Levels Higher than the PDE**

123 Levels of elemental impurities higher than the PDE may be acceptable in certain cases.  
124 These cases could include, but are not limited to the following situations:

- 125           • less than daily dosing
- 126           • short term exposures (i.e., 30 days or less)
- 127           • specific indications (e.g., life-threatening, unmet medical needs, rare diseases)

128 Justification for increased levels in these situations should be made on a case by case  
129 basis justifying the proposed level using a risk based approach. ICH Q3C and this  
130 guideline use modifying factors for interspecies (Factor F1) and individual (Factor F2)  
131 variability. These modifying factors serve as starting points in extrapolating available  
132 data to obtain a PDE. The sub-factor approach (WHO, 2009), may be used to justify a  
133 higher PDE, where data are available, using knowledge of the mode of action and  
134 pharmacokinetic considerations. A justification may also include but is not limited to a  
135 consideration of the duration of the study used to set the PDE relative to the intended  
136 clinical use (Factor F3), the nature and severity of the toxicity observed, and whether the  
137 toxicity was reversible (Factor F4).

138 An example of the sub-factor approach can be found elsewhere in a risk assessment for  
139 boron (US Environmental Protection Agency [EPA], 2004).

### 140 **3.4 Parenteral Products**

141 The parenteral PDEs are applied irrespective of dose volume.

## 142 **4. ELEMENT CLASSIFICATION**

143 The elemental impurities included in this guideline have been placed into categories that  
144 are intended to facilitate decisions during the risk assessment.

- 145 • Class 1 elemental impurities, As, Cd, Hg, and Pb, are significantly toxic across all  
146 routes of administration. Typically they have limited or no use in the  
147 manufacture of pharmaceuticals but can be present as impurities in commonly  
148 used materials (e.g., mined excipients) and can not be readily removed from the  
149 material. Because of their unique nature, these four elemental impurities require  
150 consideration during the risk assessment across all potential sources of elemental  
151 impurities.
- 152 • Class 2 elemental impurities are toxic to a greater or lesser extent based on route  
153 of administration. In addition, some of the elements present in this category are  
154 infrequently observed as impurities in materials used to produce drug products  
155 and as such, unless intentionally added have a low probability of inclusion in the  
156 drug product and do not present a significant risk. Class 2 elemental impurities  
157 are further categorized to establish when they should be considered in the risk  
158 assessment and when their contribution can be judged to be negligible.
  - 159 ○ Class 2A: The following elemental impurities require assessment across all  
160 potential sources and routes of administration: V, Mo, Se, and Co due to  
161 their higher relative natural abundance (US Geological Survey, 2005).
  - 162 ○ Class 2B: The following elemental impurities require assessment across  
163 potential elemental impurity sources only if they are intentionally added  
164 to the processes used to generate the material under evaluation: Au, Tl,  
165 Pd, Pt, Ir, Os, Rh, Ag and Ru.
- 166 • Class 3 elemental impurities are impurities with relatively low toxicity (high  
167 PDEs) by the oral route administration but require consideration in the risk  
168 assessment for other routes of administration (e.g., inhalation and parenteral  
169 routes). For oral routes of administration, unless these elements are intentionally  
170 added as part of the process generating the material, they do not need to be  
171 considered during the risk assessment. For parenteral and inhalation products,  
172 the potential for inclusion of these elemental impurities should be evaluated  
173 during the risk assessment. The elemental impurities in this class include: Sb,  
174 Ba, Li, Cr, Cu, Sn, and Ni.
- 175 • Class 4 elemental impurities are elemental impurities that have been evaluated  
176 but for which a PDE has not been established due to their low inherent toxicity  
177 and/or regional regulations. If these elemental impurities are present or included  
178 in the drug product they are addressed following the practices defined by other  
179 guidelines and regional regulation. The elements in this class include: Al, B, Fe,  
180 Zn, K, Ca, Na, Mn, Mg, and W.

181 The classification system is summarized in Table 4.1.

182

183 **Table 4.1: Elemental Impurity Classification**  
 184

	<b>Included Elemental Impurities</b>	<b>Include in Risk Assessment?</b>
<b>Class 1</b>	As, Pb, Cd, Hg	Yes
<b>Class 2A</b>	V, Mo, Se, and Co	Yes
<b>Class 2B</b>	Ag, Au, Tl, Pd, Pt, Ir, Os, Rh, and Ru	Yes only if intentionally added
<b>Class 3</b>	Sb, Ba, Li, Cr, Cu, Sn, Ni	Dependent upon route of administration – see Class 3 description
<b>Class 4</b>	B, Fe, Zn, K, Ca, Na, Mn, Mg, W, Al	No

185 **5. ASSESSMENT AND CONTROL OF ELEMENTAL IMPURITIES**

186 In developing the control strategy for elemental impurities in drug products, the  
 187 principles of quality risk management, described in ICH Q9, should be considered. The  
 188 risk assessment should be based on scientific knowledge and principles. It should link  
 189 patient safety considerations with an understanding of the product and its  
 190 manufacturing process (ICH Q8 and Q11). In the case of elemental impurities, the  
 191 product risk assessment would therefore be focused on assessing the levels of elemental  
 192 impurities in a drug product in relation to the PDEs presented in this guidance.  
 193 Information for this assessment includes but is not limited to: data generated by the  
 194 applicant, information supplied by drug substance, reagent and/or excipient  
 195 manufacturers or data available in published literature.

196 The applicant should document the assessment and control approaches in an appropriate  
 197 manner. The level of effort and formality of the assessment should be proportional to the  
 198 level of risk. It is neither always appropriate nor always necessary to use a formal risk  
 199 management process (using recognized tools and/or formal procedures, e.g., standard  
 200 operating procedures.) The use of informal risk management processes (using empirical  
 201 tools and/or internal procedures) can also be considered acceptable. Tools to assist in the  
 202 risk assessment are described in ICH Q9 and will not be presented in this guideline.

203 **5.1 General Principles**

204 For the purposes of this guideline, the assessment process can be described in four steps:  
 205 identify, analyse, evaluate and control. In many cases, the steps are considered  
 206 simultaneously. For example, the analyse and evaluate steps may be iterative steps that  
 207 initiate adjustments to control elements. The outcome of the assessment may be the  
 208 result of iterations to develop a final approach to ensure the potential elemental  
 209 impurities do not exceed the PDE.

210 Identify: Identify known and potential sources of elemental impurities that may  
 211 find their way into the drug product.

212 Analyze: Determine the probability of observance of a particular elemental impurity  
 213 in the drug product.

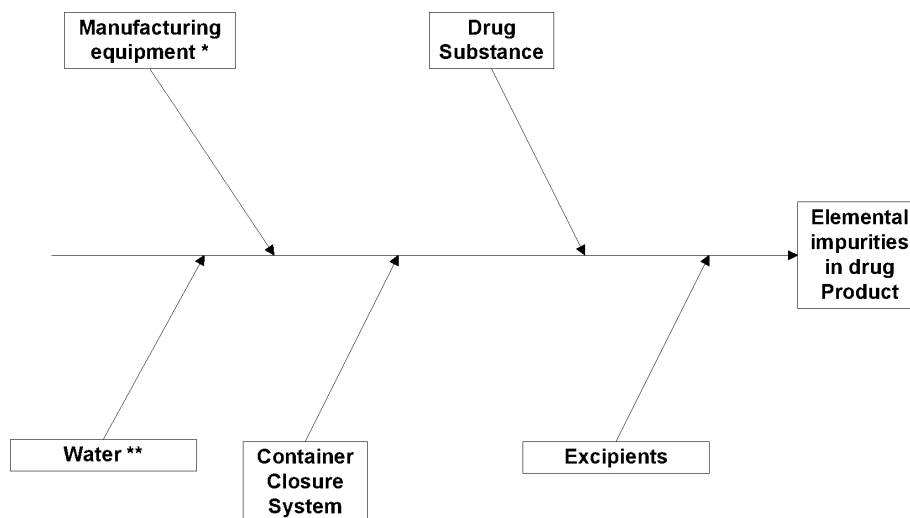
- 214 Evaluate: Compare the observed or predicted levels of elemental impurities with the  
215 established PDE.  
216 Control: Document and implement a control strategy to limit elemental impurities  
217 in the drug product.

218 **5.2 Potential Sources of Elemental Impurities**

219 In considering the production of a drug product, there are several broad categories of  
220 potential sources of elemental impurities.

- 221 • Residual elemental impurities resulting from elements intentionally added to  
222 reactions or processes leading up to the preparation of the drug substance,  
223 reagents, starting materials or excipients (e.g., metal catalysts).
- 224 • Elemental impurities known or suspected of being present in the drug substance,  
225 reagents, water, starting materials or excipients used in the preparation of the  
226 drug product.
- 227 • Elemental impurities known or suspected of being introduced into the drug  
228 substance and/or drug product from manufacturing equipment.
- 229 • Elemental impurities that are known or suspected of being leached into the drug  
230 substance and drug product from container closure systems.

231 The following diagram shows an example of typical materials or components used in the  
232 production of a drug product. Each of these materials or components may contribute  
233 elemental impurities to the drug product, through any individual or any combination of  
234 the potential sources listed above. During the assessment, the potential contributions  
235 from each of these materials or components should be considered to determine the  
236 overall contribution of elemental impurities to the drug product.



237  
238

239 \* The risk of inclusion of elemental impurities can be reduced through process  
240 understanding, equipment selection, equipment qualification and Good Manufacturing  
241 Practice (GMP) processes.

242 \*\* The risk of inclusion of elemental impurities from water can be reduced by complying  
243 with compendial (e.g., European Pharmacopoeia, Japanese Pharmacopoeia, US



244 Pharmacopeial Convention) water quality requirements, if purified water or water for  
245 injection is used in the process(es).

### 246 **5.3 Assessment – Identification of Potential Elemental Impurities**

247 **Class 1 elemental impurities:** Due to their inherent toxicity, the risk assessment  
248 should include an assessment of the Class 1 elemental impurities. All potential sources  
249 of elemental impurities should be evaluated for the potential to transfer the Class 1  
250 elemental impurities to the drug product.

251 **Potential elemental impurities derived from intentionally added catalysts or**  
252 **reagents:** For this category, the identity of the potential impurities is known and  
253 techniques for controlling the elemental impurities are easily characterized and defined.  
254 The predominant elemental impurities that comprise this group are the Class 2 and 3  
255 elemental impurities. Table 5.1 shows the suggested consideration in the risk  
256 assessment for each of the elemental impurities covered in this guideline. As identified,  
257 if any (Class 1, 2, or 3) elemental impurity is added, it should be considered in the risk  
258 assessment.

259 **Potential elemental impurities with a relatively high abundance and/or are**  
260 **impurities in excipients or reagents:** Elemental impurities known or suspected of  
261 being present in the drug substance, reagents, starting materials or excipients used in  
262 the preparation of the drug product should be considered. These elemental impurities  
263 are often associated with mined materials and excipients. The presence of these  
264 impurities can be variable, especially with respect to mined excipients, which can  
265 complicate the risk assessment. The variation should be considered when establishing  
266 the probability for inclusion in the drug product. The elemental impurities that are of  
267 most significant to this potential source include the Class 1 and Class 2A elemental  
268 impurities (see Table 4.1). For parenteral and inhalation routes of administration, the  
269 risk assessment should evaluate the probability for inclusion of the Class 1 and most 3  
270 elemental impurities as shown in Table 5.1.

271 **Potential elemental impurities derived from manufacturing equipment:** The  
272 contribution of elemental impurities may be limited and the subset of elemental  
273 impurities that should be considered in the risk assessment is relatively small and is  
274 dependent on the equipment involved. Application of process knowledge, selection of  
275 equipment, equipment qualification and GMP controls ensure a low contribution from  
276 manufacturing equipment. The specific elemental impurities of concern should be  
277 assessed based on knowledge of the composition of the components of the manufacturing  
278 equipment. The assessment of this source of elemental impurities is one that can be  
279 utilized potentially for many drug products using similar process trains and processes.

280 **Elemental impurities leached from container closure systems:** Identifying the  
281 potential elemental impurities extracted from container closure systems should be based  
282 on a scientific understanding of likely interactions between a particular drug product  
283 type and its packaging. When a review of the materials of construction demonstrates  
284 that the container closure system does not contain elemental impurities, no additional  
285 assessment needs to be performed. It is recognized that the probability of elemental  
286 leaching into solid dosage forms is minimal and does not require further consideration in  
287 the assessment. For liquid and semi-solid dosage forms there is a higher probability that  
288 elemental impurities could leach from the container closure system into the drug product  
289 during the shelf-life of the product. Studies to understand potential extractables and  
290 leachables from the final/actual container closure system (after washing sterilization,  
291 irradiation) should be performed.

- 292 Factors that should be considered (for liquid and semi-solid dosage forms) include but are  
 293 not limited to:
- 294 • Hydrophilicity/hydrophobicity
  - 295 • Ionic content
  - 296 • pH
  - 297 • Temperature (cold chain *vs* room temperature and processing conditions)
  - 298 • Contact surface area
  - 299 • Container/component composition
  - 300 • Terminal sterilization
  - 301 • Packaging process
  - 302 • Component sterilization
  - 303 • Migration potential
  - 304 • Duration of storage
  - 305 • Inclusion of metal chelating agents in the formulation (e.g., Ethylenediamine  
 306 Tetraacetic Acid [EDTA]).

307 **Table 5.1: Recommendation for Consideration During Risk Assessment**

Element	Class	If intentionally added (across all routes of administration)	If not intentionally added		
			Oral	Parenteral	Inhalation
As	1	yes	yes	yes	yes
Cd	1	yes	yes	yes	yes
Hg	1	yes	yes	yes	yes
Pb	1	yes	yes	yes	yes
Co	2A	yes	yes	yes	yes
Mo	2A	yes	yes	yes	yes
Se	2A	yes	yes	yes	yes
V	2A	yes	yes	yes	yes
Ag	2B	yes	no	no	no
Au	2B	yes	no	no	no
Ir	2B	yes	no	no	no
Os	2B	yes	no	no	no
Pd	2B	yes	no	no	no
Pt	2B	yes	no	no	no
Rh	2B	yes	no	no	no
Ru	2B	yes	no	no	no
Tl	2B	yes	no	no	no
Ba	3	yes	no	no	yes
Cr	3	yes	no	no	yes
Cu	3	yes	no	yes	yes
Li	3	yes	no	yes	yes
Ni	3	yes	no	yes	yes
Sb	3	yes	no	yes	yes
Sn	3	yes	no	yes	yes

308

**309 5.4 Assessment – Analysis and Evaluation**

310 As the potential elemental impurity identification process is concluded, there are several  
311 possible outcomes: the process and product review does not identify any potential  
312 elemental impurities or the process identifies a list of one or more potential elements.  
313 When present, the elemental impurities may have a single source or multiple sources. In  
314 addition, a number of elemental impurities will be excluded from consideration based on  
315 the assessment of their probability of occurrence and their potential to exceed the PDE.  
316 In order to accurately complete the assessment, data regarding potential elemental  
317 impurity levels may be needed. The data for this assessment can come from a number of  
318 sources that include, but are not limited to:

- 319 • Prior knowledge
- 320 • Published literature
- 321 • Data generated from similar processes
- 322 • Supplier information or data
- 323 • Analysis of the components of the drug product
- 324 • Analysis of the drug product

325 The applicant's risk assessment can be facilitated with information about the potential  
326 elemental impurities provided by suppliers of drug substances, excipients, starting  
327 materials, reagents, container closure systems, and manufacturing equipment.

328 Since the PDE is established on the drug product, it is necessary to compare the  
329 predicted or known levels of the elemental impurities identified with the established  
330 PDE in order to define the appropriate steps to take in developing an approach to control  
331 potential elemental impurities in the drug product. This may be done in several different  
332 ways and the applicant should consider which option is most appropriate for their use  
333 given the elemental impurities identified in combination with the source of the elemental  
334 impurity.

**335 5.5 Converting Between PDEs and Concentration Limits**

336 The PDEs, reported in micrograms per day ( $\mu\text{g}/\text{day}$ ) provided in this document give the  
337 maximum permitted quantity of each element that may be contained in the maximum  
338 daily intake of a drug product. Because the PDE reflects only total exposure to the  
339 drug product, it is useful to convert the PDE, into concentrations as a tool in evaluating  
340 elemental impurities in drug products or their components. The following options  
341 describe some acceptable approaches to establishing concentrations of elemental  
342 impurities in drug products or components that would assure that the drug product  
343 meets the PDEs. The applicant may select any of these options as long as the resulting  
344 permitted concentrations assure that the drug product meets the PDEs for elemental  
345 impurities. In the choice of a specific option the applicant must have knowledge of, or  
346 make assumptions about, the daily intake of the drug product. In all cases, the PDE  
347 should be met. The permitted concentration limits may be used:

- 348 • As a tool in the risk assessment to compare the observed or predicted levels to the  
349 PDE;
- 350 • In discussions with suppliers to help establish upstream controls that would  
351 assure that the product meets the PDE;
- 352 • To establish concentration targets when developing in-process controls on  
353 elemental impurities;
- 354 • To convey information regarding the controls on elemental impurities in  
355 regulatory submissions.

356 As discussed in Section 5.2, there are multiple sources for elemental impurities in drug  
 357 products. When applying any of the options described below, elemental impurities from  
 358 container closure systems and manufacturing equipment should be taken into account  
 359 prior to calculating the maximum permitted concentration in the remaining components  
 360 (excipients and drug substance). If it is determined during the risk assessment that the  
 361 container closure systems and manufacturing equipment do not contribute to the  
 362 elemental impurity level in the drug product, they do not need to be considered. Where  
 363 contributions from container closure systems and manufacturing equipment exist, these  
 364 contributions may be accounted for by subtracting the estimated daily intake from these  
 365 sources from the PDE prior to calculation of the allowed concentration in the excipients  
 366 and drug substance.

367 **Option 1: Common permitted concentration limits of elements across drug**  
 368 **product components for drug products with daily intakes of not more than 10**  
 369 **grams:**

370 This option is not intended to imply that all elements are present at the same  
 371 concentration, but rather provides a simplified approach to the calculations.

372 The option assumes the daily intake (amount) of the drug product is 10 grams or less,  
 373 and that elemental impurities identified in the risk assessment (the target elements) are  
 374 present in all components of the drug product. Using equation (1) below, and a daily  
 375 intake of 10 grams of drug product, this option calculates a common permissible target  
 376 elemental concentration for each component in the drug. This approach, for each target  
 377 element, allows determination of a fixed common maximum concentration in micrograms  
 378 per gram in each component. The calculated values are provided in Appendix 2 Table  
 379 A.2.2.

380

381 
$$\text{Concentration}(\mu\text{g}/\text{g}) = \frac{\text{PDE}(\mu\text{g}/\text{day})}{\text{daily amount of drug product}(\text{g}/\text{day})} \quad (1)$$

382

383 If all the components in a drug product meet the Option 1 concentrations for all target  
 384 elements identified in the risk assessment, then all these components may be used in  
 385 any proportion in the drug product. An example of this calculation is shown in Appendix  
 386 4 Table A.4.1. If the permitted concentrations in Appendix 2 Table A.2.2 are not applied,  
 387 Options 2a, 2b, or 3 must be followed.

388 **Option 2a: Common permitted concentration limits across drug product**  
 389 **components for a drug product with a specified daily intake:**

390 This option is similar to Option 1, except that the drug daily intake is not assumed to be  
 391 10 grams. The common permitted concentration of each element is determined using  
 392 Equation 1 and the actual maximum daily intake.

393 This approach, for each target element, allows determination of a fixed common  
 394 maximum concentration in micrograms per gram in each component based on the actual  
 395 daily intake provided. An example of this calculation is provided in Appendix 4 Table  
 396 A.4.2.

397 If all components in a drug product meet the Option 2a concentrations for all target  
 398 elements identified in the risk assessment, then all these components may be used in  
 399 any proportion in the drug product.

400 **Option 2b: Permitted concentration limits of elements across drug product**  
 401 **component materials for a product with a specified daily intake:**

402

403 This option requires additional information that the applicant may assemble regarding  
 404 the potential for specific elemental impurities to be present in specific drug product  
 405 components. The applicant may set permitted concentrations based on the distribution  
 406 of elements in the components (e.g., higher concentrations in components with the  
 407 presence of an element in question). For each element identified as potentially present  
 408 in the components of the drug product, the total mass of the elemental impurity in the  
 409 final drug product can be calculated as the sum of the product of the component material  
 410 masses at the maximum permitted concentrations established by the applicant. The  
 411 total mass of the elemental impurity in the drug product cannot exceed the PDEs given  
 412 in Appendix 2 Table A.2.1., as shown in equation 2. If the risk assessment has identified  
 413 that a specific element is not a potential impurity in a specific component, there is no  
 414 need to establish a quantitative result for that element in that component. This approach  
 415 allows that the maximum permitted concentration of an element in certain components  
 416 of the drug product may be higher than the Option 1 or Option 2a limit, but this should  
 417 then be compensated by lower allowable concentrations in the other components of the  
 418 drug product. Equation 2 may be used to set component-specific limits for each element  
 419 in each component of a drug product.

$$420 \quad \text{PDE } (\mu\text{g/day}) \geq \sum_{k=1}^N C_k \cdot M_k \quad (2)$$

421  $k =$  an index for each of  $N$  components in the drug product  
 422  $C_k =$  concentration of the elemental impurity in component  $k$  ( $\mu\text{g/g}$ )  
 423  $M_k =$  mass of component  $k$  in the maximum daily intake of the drug product (g)  
 424

425 An example of this calculation is provided in Appendix 4 Tables A.4.3 – A.4.5.

### 426 **Option 3: Finished Product Analysis:**

427 The concentration of each element may be measured in the final drug product. Equation  
 428 1 may be used with the maximum total daily dose of the drug product to calculate a  
 429 maximum permitted concentration of the elemental impurity. An example of this option  
 430 is provided in Appendix 4 Table A.4.6.

### 431 **5.6 Assessment Summary**

432 The process described above is intended to enable the applicant to focus on those  
 433 elements that require additional control elements. The process permits the applicant to  
 434 utilize information and knowledge gained across products to establish the particular  
 435 elemental impurities of concern in the specific drug product.

436 A number of factors can influence the level of the potential impurity in the drug product  
 437 and should also be considered in the assessment. These include but are not limited to:

- 438 • Efficiency of removal of elemental impurities during further processing;
- 439 • Natural abundance of elements (especially important for the categories of  
 440 elements which are not intentionally added);
- 441 • Prior knowledge of elemental impurity concentration factors from specific  
 442 sources.

443 For elements that are added or are known to be potentially present in excipients or raw  
 444 materials, the analysis should consider the percentage of the excipient or raw material in  
 445 the drug product. Assessment of probable concentrations based on this percent of the  
 446 total composition of the drug product is an additional tool to determine if the  
 447 contribution is relevant. The analysis may include an assessment of the levels or  
 448 concentrations that are identified either in each component (including contributions from  
 449 the container closure system) or in the drug product.

450 The initial design of the facility and qualification of utilities and equipment, as part of  
451 process qualification, would be expected to identify potential elemental impurities and  
452 anticipated potential contributions to the drug product. In general, the contribution of  
453 elemental impurities from manufacturing equipment and utilities is likely to be  
454 negligible and would normally be addressed by implementing appropriate GMP  
455 procedures. However, if the assessment demonstrated that the contribution was  
456 significant, the anticipated levels of the identified elements should be reviewed as part of  
457 the risk evaluation process.

458 Finally the applicant should consider the significance of the observed level relative to the  
459 PDE of the element. As a measure of the significance of the observed elemental impurity  
460 level, a control threshold is defined as a level that is 30% of the established PDE in the  
461 drug product. This threshold is used to determine if additional controls may be required.  
462 If the total elemental impurity level from all sources in the drug product is consistently  
463 less than 30% of the PDE, applying appropriate assessment of the data and  
464 demonstrating an adequate control strategy, then additional controls are not required.

465 If the assessment fails to demonstrate that an elemental impurity level is below the  
466 control threshold, controls should be established to ensure that the elemental impurity  
467 level does not exceed the PDE in the drug product.

468 In order to apply the control threshold, sources of variability should be understood.  
469 Important factors include:

- 470 • Variability of the analytical method
- 471 • Variability of the elemental impurity level in the specific sources
- 472 • Variability of the elemental impurity level in the drug product

473 There are many acceptable approaches to document the assessment and may include:  
474 tables, written summaries of considerations and conclusions of the assessment. The  
475 summary should identify the elemental impurities, their sources, and the controls and  
476 acceptance criteria as needed.

## 477 **5.7 Control of Elemental Impurities**

478 Control of elemental impurities includes decision making steps designed to reduce or  
479 accept the presence of elemental impurities and their respective concentrations that  
480 were identified and evaluated through the assessment process. When the assessment  
481 determines that the levels of elemental impurities are below the control threshold, no  
482 further control is required but periodic verification testing may be used to confirm that  
483 the expected levels are consistent and predictive of future (see Section 5.8). The applicant  
484 should provide a justification for the application of periodic verification testing.

485 When the control threshold is exceeded, the controls established should ensure that the  
486 PDE is not exceeded. There are a number of control elements or approaches that an  
487 applicant can pursue to control the elemental impurities in drug products. These include  
488 but are not limited to:

- 489 • Identification of the steps in the manufacturing process that result in the  
490 reduction of elemental impurities through specific or non-specific purification  
491 steps;
- 492 • Implementation of in-process or upstream controls, designed to limit the  
493 concentration of the elemental impurity in the drug product;
- 494 • Establishment of material (e.g., synthetic intermediates and raw materials) or  
495 excipient specifications to limit the level of elemental impurity contributions  
496 from those sources;

- 497 • Establishment of specification limits for the drug substance;
- 498 • Establishment of specification limits for the drug product;
- 499 • Reliance on the compliance with compendial standards for materials used in
- 500 drug product processes;
- 501 • Selection of appropriate container closure systems.

502 Where testing and acceptance criteria are established, periodic verification testing may  
503 be appropriate in some cases (see Section 5.8).

504 An illustration of the risk assessment process described above can be found in Appendix  
505 4.

### 506 **5.8 Periodic Verification Testing**

507 In situations where a test is recommended to be included in the specification to provide  
508 suitable control of elemental impurities, but where routine measurement for release of  
509 every batch may not be necessary, it may be possible to apply periodic verification testing  
510 (periodic or skip lot testing as described in ICH Q6A). It should be noted that allowance  
511 of periodic verification testing is considered to be helpful to provide periodic confirmation  
512 that the controls contained within a process perform consistently over the lifecycle of the  
513 product. Periodic testing is a means to ensure that the risk assessment assumptions are  
514 valid and ensure that unintended or unknown process or material attributes have not  
515 changed over time. Application of periodic verification testing should be applied to  
516 processes or materials that are under a state of control (i.e., consistently meets  
517 specifications and conforms to an appropriately established facility, equipment,  
518 processing, and operational control regimen). If upon testing, the elemental impurity  
519 level exceeds the PDE, the applicant should investigate the cause of the failure, reassess  
520 the controls that are in place and determine if additional controls may be required.  
521 Failures observed in periodic verification testing should be reported to the appropriate  
522 regulatory authorities following the established procedures.

### 523 **5.9 Special Considerations for Biotechnologically-Derived Products**

524 For biotechnology-derived products, the risks associated with elemental impurities being  
525 present at levels of safety concerns at the drug substance stage are considered low. This  
526 is largely due to the following factors: a) elements are not typically used as catalysts or  
527 reagents in the manufacturing of biotech products; b) elements are added at trace levels  
528 in media feeds during cell culture processes, without accumulation and with significant  
529 dilution/removal during further processing; c) typical purification schemes used in  
530 biotech manufacturing such as chromatography steps and dialysis or Ultrafiltration-  
531 Diafiltration (UF/DF) have the capacity to clear elements introduced in cell  
532 culture/fermentation steps or from contact with manufacturing equipment to negligible  
533 levels. As such, a specific control strategy that relates to the control of elements up to the  
534 biotech drug substance is not generally needed. In cases where the biotechnology derived  
535 drug substance contains synthetic elements (such as antibody-drug conjugates),  
536 appropriate controls on the small molecule element for elemental impurities should be  
537 performed.

538 However, potential elemental impurity sources included in drug product manufacturing  
539 (e.g., excipients) and other environmental sources should be considered for  
540 biotechnologically derived drug products. The contribution of these sources to the  
541 finished product should be assessed as typically they are introduced in the drug product  
542 manufacture at a step in the process where subsequent elemental impurity removal is  
543 not generally performed. Risk factors that should be considered in this assessment  
544 should include the type of excipients used, the processing conditions and their

545 susceptibility to contamination by environmental factors (e.g., controlled areas for sterile  
546 manufacturing and use of purified water), as well as the overall dosing frequency.

547 **6. SPECIATION**

548 Speciation is defined as the separation of elemental impurities based on oxidation state,  
549 organic combination or complexation state. The PDE has been established using the  
550 toxicity information on the species expected to be in the drug product.

551 The applicant is not expected to provide speciation information; however, such  
552 information could be used to justify higher levels for the more relevant or less toxic  
553 species.

554 **7. ANALYTICAL PROCEDURES**

555 The determination of elemental impurities should be conducted using appropriate  
556 procedures suitable for their intended purposes. Unless otherwise justified, the test  
557 should be specific for each elemental impurity identified for control during the risk  
558 assessment. Pharmacopoeial procedures or suitable validated alternative procedures for  
559 determining levels of elemental impurities should be used.

560 **8. LIFE-CYCLE MANAGEMENT OF THE CONTROL STRATEGY FOR ELEMENTAL**  
561 **IMPURITIES**

562 The quality system elements and management responsibilities described in ICH Q10 are  
563 intended to encourage the use of science-based and risk-based approaches at each  
564 lifecycle stage, thereby promoting continual improvement across the entire product  
565 lifecycle. Product and process knowledge should be managed from development through  
566 the commercial life of the product up to and including product discontinuation.

567 The effectiveness of the control strategy should be periodically evaluated throughout the  
568 product lifecycle. Knowledge gained from development combined with commercial  
569 manufacturing experience and data can be used to further improve process  
570 understanding and process performance which can be used to make improvements to the  
571 control strategy. It is recognized that the elemental impurity data available for some  
572 components is somewhat limited at this time which may direct the applicant to a specific  
573 series of control elements. Additional data, if developed, may lead to modifications of the  
574 control strategy.

575 If changes to the drug product process(es) have the potential to change the elemental  
576 impurity content of the drug product, the established control elements for elemental  
577 impurities should be re-evaluated. Such changes could include but are not limited to:  
578 changes in synthetic route, excipient supplier, raw materials, processes, equipment, or  
579 facilities. All changes are subject to internal change management process (ICH Q10) and  
580 if needed appropriate regional regulatory requirements.

581 **9. RECOMMENDATIONS FOR SUBMISSION OF ELEMENTAL IMPURITIES CONTROL**  
582 **STRATEGY**

583 The information on the control strategy that is provided in a regulatory submission  
584 should include the outcome of the risk assessment and a description of the controls  
585 established to limit elemental impurities. A good location for the description of the  
586 control strategy is Section 3.2.P.5.6. This summary should include appropriate references  
587 to the locations of controls on elemental impurities defined in the control strategy (e.g.,  
588 3.2.S and 3.2.P). A summary of the approach used to develop the control strategy may be  
589 included in the Quality Overall Summary.  
590



591 **REFERENCES**

592 Ball D, Blanchard J, Jacobson-Kram D, McClellan R, McGovern T, Norwood DL et al.  
593 Development of safety qualification thresholds and their use in orally inhaled and nasal  
594 drug product evaluation. *Toxicol Sci* 2007;97(2):226-36.

595 Haxel GB, Hedrick JB, Orris GJ. Rare earth elements-critical resources for high  
596 technology. US Geological Survey 2005;Fact Sheet 087-02.

597 IPCS. Principles and methods for the risk assessment of chemicals in food, chapter 5:  
598 dose-response assessment and derivation of health based guidance values.  
599 Environmental Health Criteria 240. International Programme on Chemical Safety.  
600 World Health Organization, Geneva. 2004; Table 5.5.

601 US EPA. 0410 Boron and Compounds. Integrated Risk Management System (IRIS).  
602 2004.

603

604 **GLOSSARY**

605 **ATSDR:**

606 Agency for Toxic Substances and Disease Registry.

607 **CEC:**

608 Commission of the European Community.

609 **CFR:**

610 Code of Federal Regulations (USA).

611 **Change Management:**

612 A systematic approach to proposing, evaluating, approving, implementing and reviewing  
613 changes. (ICH Q10)

614 **Container Closure System:**

615 The sum of packaging components that together contain and protect the dosage form.  
616 This includes primary packaging components and secondary packaging components, if  
617 the latter are intended to provide additional protection to the drug product. A packaging  
618 system is equivalent to a container closure system. (ICH Q1A)

619 **Control Strategy:**

620 A planned set of controls, derived from current product and process understanding,  
621 which assures process performance and product quality. The controls can include  
622 parameters and attributes related to drug substance and drug product materials and  
623 components, facility and equipment operating conditions, in-process controls, finished  
624 product specifications, and the associated methods and frequency of monitoring and  
625 control. (ICH Q10)

626 **Control Threshold:**

627 A limit that is applied during the assessment of elemental impurities to determine if  
628 additional control elements may be required to ensure that the PDE is not exceeded in  
629 the drug product. The limit is defined as 30% of the PDE of the specific elemental  
630 impurity under consideration.

631 **Daily Dose:**

632 The total mass of drug product that is consumed by a patient on a daily basis.

633 **EFSA:**

634 European Food Safety Agency.

635 **EHC:**

636 Environmental Health Criteria. (WHO)

637 **EU SCOEL:**

638 European Scientific Committee on Occupational Exposure Limits.

639 **IARC:**

640 International Agency for Research on Cancer.

641 **Inhalation Unit Risk:**

642 The upper-bound excess lifetime cancer risk estimated to result from continuous  
643 exposure to an agent at a concentration of 1 µg/L in water, or 1 µg/m<sup>3</sup> in air. The  
644 interpretation of inhalation unit risk would be as follows: if unit risk = 2 x 10<sup>-6</sup> per µg/L,  
645 2 excess cancer cases (upper bound estimate) are expected to develop per 1,000,000

646 people if exposed daily for a lifetime to 1 µg of the chemical in 1 liter of drinking water.  
647 (US EPA)

648 **IPCS:**  
649 International Programme for Chemical Safety.

650 **IUPAC:**  
651 International Union of Pure and Applied Chemistry.

652 **IRIS:**  
653 Integrated Risk Identification System, United States Environmental Protection Agency.

654 **Lowest-Observed-Adverse-Effect Level (LOAEL):**  
655 Lowest concentration or amount of a substance (dose), found by experiment or  
656 observation, which causes an adverse effect on morphology, functional capacity, growth,  
657 development, or life span of a target organism distinguishable from normal (control)  
658 organisms of the same species and strain under defined conditions of exposure. (IUPAC)

659 **Limit of Detection (LOD):**  
660 The limit of detection of an individual analytical procedure is the lowest amount of  
661 analyte in a sample which can be detected but not necessarily quantitated as an exact  
662 value. (ICH Q2)

663 **Lowest-Observed-Effect Level (LOEL):**  
664 The lowest dose of substance in a study or group of studies that produces biologically  
665 significant increases in frequency or severity of any effects in the exposed humans or  
666 animals.

667 **Modifying Factor:**  
668 A factor determined by professional judgment of a toxicologist and applied to bioassay  
669 data to relate that data to human safety. (Q3C) (See related term Safety Factor)

670 **MRL:**  
671 Minimal Risk Level.

672 **No-Observed-Adverse-Effect Level (NOAEL):**  
673 Greatest concentration or amount of a substance, found by experiment or observation,  
674 which causes no detectable adverse alteration of morphology, functional capacity, growth,  
675 development, or life span of the target organism under defined conditions of exposure.

676 **No-Observed-Effect Level (NOEL):**  
677 The highest dose of substance at which there are no biologically significant increases in  
678 frequency or severity of any effects in the exposed humans or animals.

679 **NTP:**  
680 National Toxicology Program.

681 **OELV:**  
682 Occupational Exposure Limit Value.

683 **OSHA:**  
684 Occupational Safety and Health Administration (USA).

685 **PEL:**  
686 Permitted Exposure Limit.

- 687 **Permitted Daily Exposure:**  
688 The maximum acceptable intake of elemental impurity in pharmaceutical products per  
689 day.
- 690 **Product Lifecycle:**  
691 All phases in the life of the product from the initial development through marketing  
692 until the product's discontinuation. (ICH Q9)
- 693 **Quality:**  
694 The degree to which a set of inherent properties of a product, system, or process fulfills  
695 requirements (see ICH Q6A definition specifically for *quality* of drug substance and drug  
696 products). (ICH Q9)
- 697 **Quality Risk Management:**  
698 A systematic process for the assessment, control, communication, and review of risks to  
699 the quality of the drug product across the product lifecycle. (ICH Q9)
- 700 **Quality System:**  
701 The sum of all aspects of a system that implements quality policy and ensures that  
702 quality objectives are met. (ICH Q10)
- 703 **Raw Material:**  
704 A general term used to denote starting materials, reagents, and solvents intended for use  
705 in the production of intermediates or Active Pharmaceutical Ingredients (APIs). (ICH  
706 Q7)
- 707 **Risk:**  
708 The combination of the probability of occurrence of harm and the severity of that harm.  
709 (ISO/IEC Guide 51, ICH Q9)
- 710 **Risk Acceptance:**  
711 The decision to accept risk. (ISO Guide 73)
- 712 **Risk Analysis:**  
713 The estimation of the risk associated with the identified hazards. (ICH Q9)
- 714 **Risk Assessment:**  
715 A systematic process of organizing information to support a risk decision to be made  
716 within a risk management process. It consists of the identification of hazards and the  
717 analysis and evaluation of risks associated with exposure to those hazards. (ICH Q9)
- 718 **Risk Control:**  
719 Actions implementing risk management decisions. (ISO Guide 73)
- 720 **Risk Identification:**  
721 The systematic use of information to identify potential sources of harm (hazards)  
722 referring to the risk question or problem description. (ICH Q9)
- 723 **Risk Management:**  
724 The systematic application of quality management policies, procedures, and practices to  
725 the tasks of assessing, controlling, communicating, and reviewing risk. (ICH Q9)
- 726  
727

- 728 **Safety:**  
729 Practical certainty that adverse effects will not result from exposure to an agent under  
730 defined circumstances. (EHC 240)
- 731 **Safety Assessment:**  
732 An approach that focuses on the scientific understanding and measurement of chemical  
733 hazards as well as chemical exposures, and ultimately the risks associated with them.  
734 Often (and in this guideline) used synonymously with risk assessment. *Related term:*  
735 Risk assessment. (EHC 340)
- 736 **Safety Factor:**  
737 A composite (reductive) factor applied by the risk assessment experts to the No-  
738 Observed-Adverse-Effect Level (NOAEL) or other reference point, such as the  
739 benchmark dose or benchmark dose lower confidence limit, to derive a reference dose  
740 that is considered safe or without appreciable risk, such as an acceptable daily intake or  
741 tolerable daily intake (the NOAEL or other reference point is divided by the safety factor  
742 to calculate the reference dose). The value of the safety factor depends on the nature of  
743 the toxic effect, the size and type of population to be protected, and the quality of the  
744 toxicological information available. Related terms: Assessment factor, Uncertainty factor.  
745 (EHC 240)
- 746 **Severity:**  
747 A measure of the possible consequences of a hazard. (ICH Q9)
- 748 **Starting Material:**  
749 A material used in the synthesis of a new drug substance that is incorporated as an  
750 element into the structure of an intermediate and/or of the new drug substance. Starting  
751 materials are normally commercially available and of defined chemical and physical  
752 properties and structure. (ICH Q3A)
- 753 **Threshold Limit Value (TLV):**  
754 The concentration in air to which it is believed that most workers can be exposed daily  
755 without an adverse effect (i.e., effectively, the threshold between safe and dangerous  
756 concentrations). The values were established (and are revised annually) by the ACGIH  
757 and are time-weighted concentrations (TWA) for a 7- or 8-hour workday and 40-hour  
758 workweek, and thus are related to chronic effects. (IUPAC)
- 759 **Time Weighted Average (TWA):**  
760 As defined by ACGIH, time-weighted average concentration for a conventional 8-hour  
761 workday and a 40-hour workweek. (IUPAC)
- 762 **URF:**  
763 Unit Risk Factor.
- 764 **US DoL:**  
765 United States Department of Labor.
- 766 **US EPA:**  
767 United States Environmental Protection Agency.
- 768 **WHO:**  
769 World Health Organization.  
770

771 **Appendix 1: Method for Establishing Exposure Limits**

772 The Gaylor-Kodell method of risk assessment (Gaylor DW, Kodell RL. Linear  
773 Interpolation algorithm for low dose assessment of toxic substance. *J Environ Pathol*  
774 *Toxicol* 1980;4:305) is appropriate for carcinogenic elemental impurities. Only in cases  
775 where reliable carcinogenicity data are available should extrapolation by the use of  
776 mathematical models be applied to setting exposure limits. Exposure limits for  
777 carcinogenic elemental impurities could be determined with the use of a large safety  
778 factor (i.e., 10,000 to 100,000) with respect to the No-Observed-Effect Level (NOEL).

779 Acceptable exposure levels for elemental impurities in this guideline were established by  
780 calculation of PDE values according to the procedures for setting exposure limits in  
781 pharmaceuticals (Pharmacoepial Forum, Nov-Dec 1989), and the method adopted by  
782 IPCS for Assessing Human Health Risk of Chemicals (Environmental Health Criteria  
783 [EHC] 170, WHO, 1994). These methods are similar to those used by the US EPA (IRIS)  
784 and the US FDA (Red Book) and others. The method is outlined here to give a better  
785 understanding of the origin of the PDE values. It is not necessary to perform these  
786 calculations in order to use the PDE values tabulated in Appendix 2 of this document.

787 PDE is derived from the NOEL, or the Lowest-Observed-Effect Level (LOEL) in the most  
788 relevant animal study as follows:

789 
$$PDE = NOEL \times \text{Mass Adjustment} / [F1 \times F2 \times F3 \times F4 \times F5] \quad (1)$$

790 The PDE is derived preferably from a NOEL. If no NOEL is obtained, the LOEL may be  
791 used. Modifying factors proposed here, for relating the data to humans, are the same  
792 kind of "uncertainty factors" used in Environmental Health Criteria (EHC 170, World  
793 Health Organization [WHO], Geneva, 1994), and "modifying factors" or "safety factors" in  
794 Pharmacoepial Forum. The assumption of 100% systemic exposure is used in all  
795 calculations regardless of route of administration.

796 The modifying factors are as follows:

797 F1 = A factor to account for extrapolation between species

798 F1 = 5 for extrapolation from rats to humans

799 F1 = 12 for extrapolation from mice to humans

800 F1 = 2 for extrapolation from dogs to humans

801 F1 = 2.5 for extrapolation from rabbits to humans

802 F1 = 3 for extrapolation from monkeys to humans

803 F1 = 10 for extrapolation from other animals to humans

804 F1 takes into account the comparative surface area: body mass ratios for the species  
805 concerned and for man. Surface area (S) is calculated as:

806 
$$S = kM^{0.67} \quad (2)$$

807 in which M = body mass, and the constant k has been taken to be 10. The body masses  
808 used in the equation are those shown below in Table A.1.1

809 F2 = A factor of 10 to account for variability between individuals

810 A factor of 10 is generally given for all elemental impurities, and 10 is used consistently  
811 in this guideline

812 F3 = A variable factor to account for toxicity studies of short-term exposure

813 F3 = 1 for studies that last at least one half lifetime (1 year for rodents or rabbits; 7  
814 years for cats, dogs and monkeys)

815 F3 = 1 for reproductive studies in which the whole period of organogenesis is covered  
816 F3 = 2 for a 6-month study in rodents, or a 3.5-year study in non-rodents  
817 F3 = 5 for a 3-month study in rodents, or a 2-year study in non-rodents  
818 F3 = 10 for studies of a shorter duration  
819 In all cases, the higher factor has been used for study durations between the time points,  
820 e.g., a factor of 2 for a 9-month rodent study.  
821 F4 = A factor that may be applied in cases of severe toxicity, e.g., non-genotoxic  
822 carcinogenicity, neurotoxicity or teratogenicity. In studies of reproductive toxicity, the  
823 following factors are used:  
824 F4 = 1 for fetal toxicity associated with maternal toxicity  
825 F4 = 5 for fetal toxicity without maternal toxicity  
826 F4 = 5 for a teratogenic effect with maternal toxicity  
827 F4 = 10 for a teratogenic effect without maternal toxicity  
828 F5 = A variable factor that may be applied if the no-effect level was not established  
829 When only an LOEL is available, a factor of up to 10 could be used depending on the  
830 severity of the toxicity.  
831 The mass adjustment assumes an arbitrary adult human body mass for either sex of 50  
832 kg. This relatively low mass provides an additional safety factor against the standard  
833 masses of 60 kg or 70 kg that are often used in this type of calculation. It is recognized  
834 that some adult patients weigh less than 50 kg; these patients are considered to be  
835 accommodated by the built-in safety factors used to determine a PDE.  
836 As an example of the application of this equation, consider a toxicity study of cobalt in  
837 human volunteers is summarized in Agency for Toxic Substances and Disease Registry  
838 (ATSDR, 2004, op/ cit., Davis JE and Fields JP. Proc Soc Exp Biol Med 1958;99:493-5).  
839 The Lowest-Observed-Adverse-Effect Level (LOAEL) for polycythemia is 1 mg/kg/day.  
840 The PDE for cobalt in this study is calculated as follows:  
841 
$$\text{PDE} = 1 \text{ mg/kg/day} \times 50 \text{ kg} / [1 \times 10 \times 10 \times 1 \times 10] = 0.05 \text{ mg/day} = 50 \text{ } \mu\text{g/day}$$
  
842 In this example,  
843 F1 = 1 study in humans  
844 F2 = 10 to account for differences between individual humans  
845 F3 = 10 because the duration of the study was only 3 weeks  
846 F4 = 1 because no severe toxicity was encountered  
847 F5 = 10 because a LOAEL was used  
848

849 **Table A.1.1: Values Used in the Calculations in this Document**

Rat body weight	425 g	Mouse respiratory volume	43 L/day
Pregnant rat body weight	330 g	Rabbit respiratory volume	1440 L/day
Mouse body weight	28 g	Guinea pig respiratory volume	430 L/day
Pregnant mouse body weight	30 g	Human respiratory volume	28,800 L/day
Guinea pig body weight	500 g	Dog respiratory volume	9,000 L/day
Rhesus monkey body weight	2.5 kg	Monkey respiratory volume	1,150 L/day
Rabbit body weight (pregnant or not)	4 kg	Mouse water consumption	5 mL/day
Beagle dog body weight	11.5 kg	Rat water consumption	30 mL/day
Rat respiratory volume	290 L/day	Rat food consumption	30 g/day

850



851 **Appendix 2: Established PDEs for Elemental Impurities**852 **Table A.2.1: Permitted Daily Exposures for Elemental Impurities<sup>1</sup>**

Element	Class <sup>2</sup>	Oral PDE µg/day	Parenteral PDE, µg/day	Inhalation PDE, µg/day
As	1	15	15	1.9
Cd	1	5.0	6.0	3.4
Hg	1	40	4.0	1.2
Pb	1	5.0	5.0	5.0
Co	2A	50	5.0	2.9
Mo	2A	180	180	7.6
Se	2A	170	85	140
V	2A	120	12	1.2
Ag	2B	170	35	6.9
Au	2B	130	130	1.3
Ir <sup>3</sup>	2B	1000	10	1.4
Os <sup>3</sup>	2B	1000	10	1.4
Pd	2B	100	10	1.0
Pt	2B	1000	10	1.4
Rh <sup>3</sup>	2B	1000	10	1.4
Ru <sup>3</sup>	2B	1000	10	1.4
Tl	2B	8.0	8.0	69
Ba	3	13000	1300	340
Cr	3	11000	1100	2.9
Cu	3	1300	130	13
Li	3	780	390	25
Ni	3	600	60	6.0
Sb	3	1200	600	22
Sn	3	6400	640	64

853 <sup>1</sup> PDEs reported in this table are rounded to 2 significant figures (µg/day).854 <sup>2</sup> Classification as defined in Section 4.855 <sup>3</sup> Insufficient data to establish an appropriate PDE; the PDE was established based on  
856 platinum PDE.  
857858 **Table A.2.2: Permitted Concentrations of Elemental Impurities for Option 1**

859 The values presented in this table represent permitted concentrations in micrograms per  
860 gram for elemental impurities in drug products, drug substances and excipients. These  
861 concentration limits are intended to be used when Option 1 is selected to assess the  
862 elemental impurity content in drug products with daily doses of not more than 10 grams  
863 per day. The numbers in this table are based on Table A.2.1.

Element	Class	Oral Concentration µg/g	Parenteral Concentration µg/g	Inhalation Concentration µg/g
As	1	1.5	1.5	0.29
Cd	1	0.50	0.60	0.34
Hg	1	4.0	0.40	0.12
Pb	1	0.50	0.50	0.50
Co	2A	5.0	0.50	0.29

*Guideline for Elemental Impurities*

---

Mo	2A	18	18	0.76
Se	2A	17	8.5	14
V	2A	12	1.2	0.12
Ag	2B	17	3.5	0.69
Au	2B	13	13	0.13
Ir**	2B	100	1.0	0.14
Os**	2B	100	1.0	0.14
Pd	2B	10	1.0	0.10
Pt	2B	100	1.0	0.14
Rh**	2B	100	1.0	0.14
Ru**	2B	100	1.0	0.14
Tl	2B	0.80	0.80	6.9
Ba	3	1300	130	34
Cr	3	1100	110	0.29
Cu	3	130	13	1.3
Li	3	78	39	2.5
Ni	3	60	6.0	0.60
Sb	3	120	60	2.2
Sn	3	640	64	6.4

864  
865  
866  
867

\*\* Insufficient data to establish an appropriate PDE; the PDE was established based on platinum PDE

868 **Appendix 3: Individual Safety Assessments**869 **ANTIMONY**870 **Summary of PDE for Antimony**

<b>Antimony (Sb)</b>			
	Oral	Parenteral	Inhalation
PDE (µg/day)	1200	600	22

871 **Introduction**

872 Antimony (Sb) is a silvery white naturally occurring metalloid element that is used in  
873 various manufacturing processes. Small amounts of Sb are found in the earth's crust. It  
874 exists in valence states of 3 and 5. Metallic Sb and a few trivalent Sb compounds are the  
875 most significant regarding exposure potential and toxicity. Some antimonials, such as Sb  
876 potassium tartrate, have been used medicinally as parasiticides. Antimony trioxide is  
877 being used as a catalyst (e.g., in the manufacturing of PolyEthylene Terephthalate [PET]  
878 used for container closure system components). Antimony is nutritionally not essential  
879 and no metabolic function is known (ATSDR, 1992).

880 **Safety Limiting Toxicity**

881 Because of the limited *in vitro* genotoxicity data and the lack of *in vivo* tests, the  
882 genotoxicity of Sb cannot be determined (ATSDR, 1992). In humans and animals, the  
883 gastrointestinal tract (irritation, diarrhea, vomiting) appears to be the primary target  
884 organ after oral exposure. In subchronic studies in rats lower mean body weights and  
885 adverse liver findings were the most sensitive endpoints. Inhalation of high levels of Sb  
886 over a long period can cause adverse respiratory effects in both humans and animals.

887 **PDE – Oral Exposure**

888 Limited oral data on Sb exposure is available in mice and rats (Schroeder *et al.* 1968;  
889 Schroeder *et al.* 1970; Poon *et al.* 1998). The WHO evaluated Sb in drinking water (WHO,  
890 2003). Lynch *et al.* concluded that a NOAEL from a 90 day drinking water rat study  
891 using antimony potassium tartrate was 6 mg/kg/day based on lower mean body weight  
892 and reduced food consumption (Lynch, 1999). This finding is consistent with the earlier  
893 reports from Schroeder *et al.* Thus, the Permitted Daily Exposure (PDE) for oral  
894 exposure was determined on the basis of the lowest NOAEL, i.e., 50 mg/L (equivalent to  
895 6.0 mg Sb/kg/day).

896 Taking into account the modifying factors (F1-F5 as discussed in Appendix 1), the oral  
897 PDE is calculated as below:

$$898 \text{ PDE} = 6000 \mu\text{g/kg/day} \times 50 \text{ kg} / 5 \times 10 \times 5 \times 1 \times 1 = 1200 \mu\text{g/day.}$$

899 **PDE – Parenteral Exposure**

900 Adverse liver findings were the most sensitive endpoint in rats after repeated  
901 intraperitoneal administration. Thus, the PDE for intraperitoneal exposure was  
902 determined on the basis of the lowest NOAEL, i.e., 3.0 mg Sb/kg/day. This value was  
903 obtained from a 90-day study in rats (based on adverse liver findings at 6 mg/kg in male  
904 rats exposed to Sb potassium tartrate *via* intraperitoneal injection) (NTP, 1992).

905 Taking into account the modifying factors (F1-F5 as discussed in Appendix 1), the  
906 human intraperitoneal PDE is calculated as below:

907 PDE = 3000 µg/kg/day x 50 kg / 5 x 10 x 5 x 1 x 1 = 600 µg/day.

908 **PDE – Inhalation Exposure**

909 Sub chronic and chronic inhalation rat studies have been conducted. The lung effects  
910 observed across these studies were consistent. Using the data from a 13 week inhalation  
911 rat study using antimony trioxide dust, (Newton *et al.* 1994), a NOAEL of 1.08 mg/m<sup>3</sup>  
912 was used to determine the inhalation PDE (~83% Sb). At higher dose levels an increase  
913 in mean absolute and relative lung weights were observed, a finding not seen in the one  
914 year oncogenicity study.

915 Taking into account the modifying factors (F1-F5 as discussed in Appendix 1), the  
916 inhalation PDE is calculated as:

917 For continuous dosing =  $0.9 \frac{\text{mg/m}^3 \times 6 \text{ h} \times 5 \text{ d}}{24 \text{ h} \times 7 \text{ d}} = \frac{0.16 \text{ mg/m}^3}{1000 \text{ L/m}^3} = 0.00016 \text{ mg/L}$

918  
919  
920 Daily dose =  $\frac{0.00016 \text{ mg/L} \times 290 \text{ L/d}}{.425 \text{ kg bw}} = 0.11 \text{ mg/kg/d}$

921  
922  
923 PDE = 0.11 mg/kg/d x 50 kg / 5 x 10 x 5 x 1 x 1 = 22 µg/d.  
924

925 **REFERENCES**

926 ATSDR. Toxicological profile for antimony and compounds. Agency for Toxic Substances  
927 and Disease Registry, Public Health Service, U.S. Department of Health and Human  
928 Services, Atlanta, GA. 1992.

929 Lynch BS, Capen CC, Nestmann ER, Veenstra G, Deyo JA. Review of subchronic/chronic  
930 toxicity of antimony potassium tartrate. *Reg Toxicol Pharmacol* 1999;30(1):9-17.

931 Newton PE, Bolte HF, Daly IW, Pillsbury BD, Terrill JB, Drew RT, et al. Subchronic  
932 and chronic inhalation toxicity of antimony trioxide in the rat. *Fundam Appl Toxicol*  
933 1994;22:561-76.

934 NTP. Technical report on toxicity studies of antimony potassium tartrate in F344/N rats  
935 and B6C3F1 mice (drinking water and intraperitoneal injection studies). National  
936 Toxicology Program, Public Health Service, U.S. Department of Health and Human  
937 Services, Research Triangle Park, NC. 1992; NTP Toxicity Report Series No. 11.

938 Poon R, Chu I, Lecavalier P, Valli VE, Foster W, Gupta S, et al. Effects of antimony on  
939 rats following 90-day exposure via drinking water. *Food Chem Toxicol* 1998;36:20–35.

940 Schroeder HA, Mitchner M, Nador AP, Balassa JJ, Kanisawa M. Zirconium, niobium,  
941 antimony and fluorine in mice: effects on growth, survival and tissue levels. *J Nutr*  
942 1968;95:95-101.

943 Schroeder HA, Mitchner M, Nador AP. Zirconium, niobium, antimony, vanadium and  
944 lead in rats: life term studies. *J. Nutr* 1970;100(1):59-68.

945 WHO. Antimony in drinking-water. Background document for development of WHO  
946 guidelines for drinking-water quality. World Health Organization, Geneva. 2003.

947

948 **ARSENIC**949 **Summary of PDE for Arsenic**

<b>Arsenic (As)</b>			
	Oral	Parenteral	Inhalation
PDE (µg/day)	15	15	1.9

950

951 **Introduction**

952 Arsenic (As) is ubiquitous in the environment and present in food, soil, drinking water  
 953 and in air. Inorganic As occurs in trivalent (e.g., arsenic trioxide, sodium arsenite) or  
 954 pentavalent forms (e.g., sodium arsenate, arsenic pentoxide, arsenic acid). Arsenic has no  
 955 known useful biological function in human or mammalian organisms. This assessment  
 956 focuses on inorganic As, since this is most relevant for drug products.

957 **Safety Limiting Toxicity**

958 Inorganic arsenic has shown to be genotoxic, but not mutagenic and has been  
 959 acknowledged as a human carcinogen (Group 1; IARC, 2012).

960 Due to its ubiquitous nature and toxicity profile, there have been many risk assessments  
 961 conducted of arsenic and arsenic compounds, which utilize non-threshold, linear dose  
 962 response approaches (Meharg and Raab, 2010).

963 The effects of arsenic in humans for the most part have not been reproduced in animals,  
 964 so the risk assessments have to rely heavily upon epidemiology data in populations with  
 965 high exposure concentrations (Schuhmacher-Wolz *et al.* 2009). In humans, both cancer  
 966 and non-cancer effects have been linked to arsenic exposure. Oral exposure has been  
 967 linked to cancers of the skin, liver, lung, kidney and bladder. Following inhalation  
 968 exposure there is evidence for an increased risk of lung cancer (ATSDR, 2007; IARC,  
 969 2012; EU EFSA, 2009; WHO, 2011; US EPA, 2010).

970 The skin (dyspigmentation, palmoplantar keratosis) and gastrointestinal tract (e.g.,  
 971 nausea) appear to be the most sensitive targets for non-cancer adverse effects after oral  
 972 ingestion while vascular disease, reproductive effects and neurological effects are also  
 973 reported as non-cancer endpoints (IARC, 2012; Schuhmacher-Wolz *et al.* 2009; US EPA,  
 974 2007). Oral exposure studies suggest that skin lesions may appear at levels above 0.02  
 975 mg As/kg/day; no effects were generally seen at levels from 0.0004 to 0.01 mg As/kg/day  
 976 (ATSDR, 2007). There are insufficient epidemiological data to set a LOEL or NOEL for  
 977 other endpoints. The regions of hyperkeratosis may evolve into skin cancers (ATSDR,  
 978 2007) and can possibly be considered predictive of skin and internal cancers and the non-  
 979 cancer long-term adverse health effects (Chen *et al.* 2005; Hsu *et al.* 2013; Ahsan and  
 980 Steinmaus, 2013).

981 Studies of large populations (~40,000) exposed to arsenic concentrations in well water at  
 982 1000 µg/L and higher in southwestern Chinese Taipei have been the basis of risk  
 983 assessments of skin cancer, and more recently of bladder and lung cancer (US EPA,  
 984 2010). Recent meta-analyses of cancer risk have indicated no additional bladder cancer  
 985 risk at low dose exposure (<100–200 µg/L) (Chu and Crawford-Brown, 2006, 2007; Mink  
 986 *et al.* 2008). This is consistent with the work of Schuhmacher-Wolz *et al.* (2009).

987 The inhalation unit risk for cancer is 0.0043 per µg/m<sup>3</sup> has been established by the US  
 988 EPA based on data from two US smelters (US EPA, 2007). The Texas Commission on  
 989 Environmental Quality provided an update to the US EPA Unit Risk Factor (URF),  
 990 incorporating additional years of follow-up to the US EPA data and additional data on

991 workers from the United Kingdom and Sweden, and calculated a URF of 0.0015 per  
992  $\mu\text{g}/\text{m}^3$ . This URF translates to an air concentration of 0.067  $\mu\text{g}/\text{m}^3$  at a risk of 1 in  
993 100,000 excess lung cancer mortality (Erraguntla *et al.* 2012).

994 **PDE – Oral Exposure**

995 The oral PDE is based on the chronic effects of As to skin and sets the limit at 15  $\mu\text{g}/\text{day}$   
996 based on ATSDR Minimal Risk Level (MRL) and US EPA limit of 0.0003 mg/kg/day  
997 (ATSDR, 2007; US EPA 2007; EU EFSA, 2009). The PDE calculated based on the  
998 ATSDR MRL is consistent with drinking water standards (WHO, 2011).

999  $0.0003 \text{ mg}/\text{kg}/\text{day} \times 50 \text{ kg human} = 0.015 \text{ mg}/\text{day} = 15 \mu\text{g}/\text{day}$ .

1000 No modifying factors were applied because they are incorporated into the derivation of  
1001 the MRL.

1002 **PDE – Parenteral Exposure**

1003 The oral bioavailability of As is ~95%. The most direct evidence is from a study that  
1004 evaluated the 6-day elimination of arsenic in healthy humans who were given water  
1005 from a high-arsenic sampling site (arsenic species not specified) and that reported  
1006 approximately 95% absorption (Zheng *et al.* 2002). Therefore the PDE is identical to the  
1007 oral PDE.

1008  $\text{PDE} = 15 \mu\text{g}/\text{day}$ .

1009 **PDE – Inhalation Exposure**

1010 Increased risk of lung cancer and other respiratory disorders have been reported  
1011 following inhalation exposure to workers in the occupational setting. The rationale for  
1012 using a cancer endpoint for inhalation to set the PDE is the relative lack of information  
1013 on linear-dose extrapolation, as compared to the oral route. No modifying factors are  
1014 needed as the URF were determined for the protection of the general public. Based on  
1015 the assessment conducted by Erraguntla *et al.* (2012), based on the risk of 1:100,000, the  
1016 inhalation PDE is:

1017  $0.067 \mu\text{g}/\text{m}^3 \div 1000 \text{ L}/\text{m}^3 \times 28800 \text{ L}/\text{d} = 1.9 \mu\text{g}/\text{d}$ .

1018 No modifying factors were applied because the PDE is based on the multiplicate relative  
1019 risk model described by Erraguntla *et al.* (2012).

1020 **REFERENCES**

1021 Ahsan H, Steinmaus C. Invited commentary: use of arsenical skin lesions to predict risk  
1022 of internal cancer-implications for prevention and future research. *Am J Epidemiol*  
1023 2013;177:213-16.

1024 ATSDR. Toxicological profile for arsenic. Agency for Toxic Substances and Disease  
1025 Registry, Public Health Service, U.S. Department of Health and Human Services,  
1026 Atlanta, GA. 2007.

1027 Chen CJ, Hsu LJ, Wang CH, Shih WL, Hsu YH, Tseng MP, et al. Biomarkers of exposure,  
1028 effect, and susceptibility of arsenic-induced health hazards in Taiwan. *Toxicol Appl*  
1029 *Pharmacol* 2005; 206:198-206.

1030 Chu HA, Crawford-Brown DJ. Inorganic arsenic in drinking water and bladder cancer: a  
1031 metaanalysis for dose-response assessment. *Int J Environ Res Public Health* 2006;3:316-  
1032 22.

- 1033 Chu HA, Crawford-Brown DJ. Inorganic arsenic in drinking water and bladder cancer: a  
1034 metaanalysis for dose-response assessment. *Int J Environ Res Public Health* 2007;4:340-  
1035 41.
- 1036 Erraguntla NK, Sielken RL Jr, Valdez-Flores C, Grant RL. An updated inhalation unit  
1037 risk factor for arsenic and inorganic arsenic compounds based on a combined analysis of  
1038 epidemiology studies. *Regul Toxicol Pharmacol* 2012;64: 329-41.
- 1039 EU EFSA. Scientific opinion on arsenic in food. European Food Safety Authority. *EFSA*  
1040 *Journal* 2009;7(10):1351.
- 1041 Hsu LI, Chen GS, Lee CH, Yang TY, Chen YH, Wang YH, et al. Use of arsenic-induced  
1042 palmo-plantar hyperkeratosis and skin cancers to predict risk of subsequent internal  
1043 malignancy. *Am J Epidemiol* 2013;173:202-12.
- 1044 IARC. Arsenic, metals, fibres, and dusts: a review of human carcinogens. Monographs on  
1045 the Evaluation of Carcinogenic Risks to Humans. International Agency for Research on  
1046 Cancer, World Health Organization, Lyon. 2012;100C.
- 1047 Meharg AA, Raab A. Getting to the bottom of arsenic standards and guidelines. *Environ*  
1048 *Sci Technol* 2010;44:4395-99.
- 1049 Mink PJ, Alexander DD, Barraj LM, Kelsh MA, Tsuji JS. Low-level arsenic exposure in  
1050 drinking water and bladder cancer: a review and meta-analysis. *Regul Toxicol*  
1051 *Pharmacol* 2008;58:299-310.
- 1052 Schuhmacher-Wolz U, Dieter HH, Klein D, Schneider K. Oral exposure to inorganic  
1053 arsenic: and evaluation of its carcinogenic and non-carcinogenic effects. *Crit Rev Toxicol*  
1054 2009;39:271-98.
- 1055 US EPA. Arsenic, inorganic. Integrated Risk Information System (IRIS). 1998.
- 1056 US EPA. Inorganic arsenic. TEACH Chemical Summary. 2007.
- 1057 US EPA. Toxicological review of inorganic arsenic (CAS No. 7440-38-2). In support of  
1058 summary information on the Integrated Risk Information System (IRIS). 2010.
- 1059 WHO. Arsenic in drinking-water. Background document of development of WHO  
1060 Guidelines for Drinking-water quality. World Health Organization. 2011.
- 1061 Zheng Y, Wu J, Ng JC, Wang G, Lian W. The absorption and excretion of fluoride and  
1062 arsenic in humans. *Toxicol Lett* 2002;133:77-82.
- 1063

1064 **BARIUM**

1065 **Summary of PDE for Barium**

<b>Barium (Ba)</b>			
	Oral	Parenteral	Inhalation
PDE (µg/day)	13000	1300	340

1066 **Introduction**

1067 Barium (Ba) is a dense, silver-white, soft alkaline earth metal that oxidizes readily in  
 1068 moist air and reacts with water. The Ba<sup>2+</sup> ion and the water soluble compounds of Ba  
 1069 (chloride, nitrate, hydroxide) are toxic. The insoluble compounds of barium, such as  
 1070 barium sulfate, do not generate free Ba<sup>2+</sup> ions in the gastrointestinal tract and therefore  
 1071 are generally nontoxic to humans. Ba is nutritionally not essential and no metabolic  
 1072 function is known. Barium sulfate is used as a support for catalyst (e.g., Pd).

1073 **Safety Limiting Toxicity**

1074 In animals and humans, the kidney appears to be the most sensitive target of toxicity  
 1075 resulting from repeated ingestion of soluble Ba salts. Chronic rodent studies support the  
 1076 evidence for an association between Ba exposure and renal toxicity. In humans, repeated  
 1077 exposure to Ba oxide *via* inhalation may cause bronchitis, including cough, phlegm,  
 1078 and/or shortness of breath.

1079 **PDE – Oral Exposure**

1080 Mice and rat Ba drinking water studies have been conducted (NTP, 1994). Based on the  
 1081 review of these data, the mouse was determined to be the more sensitive species. The 2-  
 1082 year drinking water study in mice with barium chloride dihydrate was selected as the  
 1083 principal study and compound-related nephropathy was identified as the critical effect  
 1084 for deriving a PDE for Ba and its soluble salts. The lesions were characterized by tubule  
 1085 dilatation, renal tubule atrophy, tubule cell regeneration, hyaline cast formation,  
 1086 multifocal interstitial fibrosis, and the presence of crystals, primarily in the lumen of the  
 1087 renal tubules. These changes were characterized as morphologically distinct from the  
 1088 spontaneous degenerative renal lesions commonly observed in aging mice.

1089 The oral PDE was determined on the basis of the NOAEL of 500 mg/L (equivalent to 30  
 1090 mg Ba/kg/day), using the modifying factors (F1-F5 as discussed in Appendix 1).

1091  $PDE = 30 \text{ mg/kg/day} \times 50 \text{ kg} / 12 \times 10 \times 1 \times 1 \times 1 = 12.5 \text{ mg/day} \sim 13,000 \text{ µg/day}$ .

1092 **PDE – Parenteral Exposure**

1093 No relevant data on parenteral exposure to barium compounds were found. The  
 1094 bioavailability of Ba is estimated to be 20 – 60% in adults and infants, respectively  
 1095 (ATSDR, 2007). Thus, a modifying factor of 10 of the oral PDE was used.

1096  $PDE = 13,000 \text{ µg/day} / 10 = 1300 \text{ µg/day}$ .

1097 **PDE – Inhalation Exposure**

1098 No relevant data on inhalation exposure to barium compounds were found. US DoL  
 1099 (2013) has a reported TWA of 0.5 mg/m<sup>3</sup> based on soluble Ba salts.

1100

1101 Taking into account the modifying factors (F1-F5 as discussed in Appendix 1), the  
 1102 inhalation PDE is calculated as:

1103



1104 For continuous dosing =  $\frac{500 \mu\text{g}/\text{m}^3 \times 8 \text{ hr}/\text{day} \times 5 \text{ days}/\text{week}}{24 \text{ hr}/\text{day} \times 7 \text{ days}/\text{week} \times 1000 \text{ L}/\text{m}^3}$   
1105  
1106 = 0.119  $\mu\text{g}/\text{L}$

1107 Daily dose =  $\frac{0.119 \mu\text{g}/\text{L} \times 28800 \text{ L}}{50 \text{ kg}}$  = 68.6  $\mu\text{g}/\text{kg}$   
1108

1109 PDE =  $\frac{68.6 \mu\text{g}/\text{kg} \times 50 \text{ kg}}{1 \times 10 \times 1 \times 1 \times 1}$  = 343  $\mu\text{g}/\text{day}$  ~340  $\mu\text{g}/\text{day}$ .  
1110

1111 **REFERENCES**

1112 ATSDR. Toxicological profile for barium and barium compounds. Agency for Toxic  
1113 Substances and Disease Registry, Public Health Service, U.S. Department of Health and  
1114 Human Services, Atlanta, GA. 2007.

1115 NTP. Technical report on the toxicology and carcinogenesis studies of barium chloride  
1116 dihydrate (CAS No. 10326-27-9) in F344/N rats and B6C3F1 mice (drinking water  
1117 studies). National Toxicology Program, Public Health Service, U.S. Department of  
1118 Health and Human Services, Research Triangle Park, NC. 1994;NTP TR 432.

1119 US DoL (OHSA). 29 CFR 1910.1000 Table Z-1. Limits for air contaminants. U.S.  
1120 Department of Labor. 2013.

1121

1122 **CADMIUM**

1123 **Summary of PDE for Cadmium**

Cadmium (Cd)			
	Oral	Parenteral	Inhalation
PDE (µg/day)	5.0	6.0	3.4

1124 **Introduction**

1125 Cadmium (Cd) is a transition metal whose most abundant naturally-occurring isotope is  
 1126 non-radioactive. It is found in nature in mineral forms and is obtained for commercial  
 1127 uses principally from cadmium ore (ATSDR, 2012). Cadmium exists as a salt form in the  
 1128 +2 oxidation state only. Some cadmium salts are water soluble such as cadmium chloride,  
 1129 cadmium sulfate and cadmium nitrate; other insoluble salts can become more soluble by  
 1130 interaction with acids, light or oxygen. Cadmium, cadmium oxide, cadmium salts on  
 1131 borosilicate carrier are used as catalysts in organic synthesis. Silver cadmium alloy is  
 1132 used in the selective hydrogenation of carbonyl compounds.

1133 **Safety Limiting Toxicity**

1134 Cadmium has shown to be genotoxic, but not mutagenic and has been acknowledged as a  
 1135 human carcinogen (Group 1; IARC, 2012). Cadmium and cadmium compounds cause  
 1136 cancer of the lung. Also, positive associations have been observed between exposure to  
 1137 cadmium and cadmium compounds and cancer of the kidney and of the prostate.

1138 A sensitive endpoint for oral exposure to cadmium and cadmium salts is renal toxicity  
 1139 (Buchet *et al.* 1990). Skeletal and renal effects are observed at similar exposure levels  
 1140 and are a sensitive marker of cadmium exposure (ATSDR, 2012).

1141 Evidence from numerous epidemiologic studies assessing inhalation exposures to  
 1142 cadmium *via* both occupational and environmental routes has demonstrated an  
 1143 increased risk of developing cancer (primarily lung) that correlates with inhalation  
 1144 exposure to cadmium (IARC, 2012; NTP, 2004).

1145 **PDE – Oral Exposure**

1146 A sensitive endpoint for oral exposure to cadmium and cadmium salts is renal toxicity  
 1147 (Buchet *et al.* 1990). Skeletal and renal effects are observed at similar exposure levels  
 1148 and are a sensitive marker of cadmium exposure (ATSDR, 2012). A number of oral  
 1149 exposure studies of cadmium in rats and mice showed no evidence of carcinogenicity.  
 1150 Therefore the renal toxicity endpoint was used to establish the oral PDE for cadmium,  
 1151 following the recommendations of ATSDR, a level of 0.1 µg/kg for chronic exposure is  
 1152 used to set the oral PDE. This is in line with the WHO drinking water limit of 0.003  
 1153 mg/L/day (WHO 2011).

1154 Taking into account the modifying factors (F1-F5 as discussed in Appendix 1), the oral  
 1155 PDE is calculated as:

1156  $PDE = 0.1 \mu\text{g/kg/day} \times 50 \text{ kg} = 5.0 \mu\text{g/day}$ .

1157

1158 **PDE – Parenteral Exposure**

1159 12 week study in rats given daily subcutaneous injections of 0.6 mg/kg Cd, 5 days per  
 1160 week showed renal damage at week 7 and later (Prozialeck, 2009). The LOEL of this  
 1161 study is 0.6 mg/kg.

1162 Taking into account the modifying factors (F1-F5 as discussed in Appendix 1), the  
 1163 parenteral PDE is calculated as:

1164  $PDE = 0.6 \text{ mg/kg/day} \times 50 \text{ kg} / 5 \times 10 \times 5 \times 10 \times 2 = 6.0 \text{ } \mu\text{g/day}$ .

1165 F4 was chosen as 10 because cadmium is carcinogenic by the inhalation route. F5 was  
 1166 set at 2, since no NOAEL was identified in this study.

1167 **PDE – Inhalation Exposure**

1168 The use of 5  $\mu\text{g}/\text{m}^3$  as the PEL (US DoL, 2013) was considered acceptable as cadmium is  
 1169 non-mutagenic. This PDE is similar to the quantitative estimate of carcinogenic risk  
 1170 from inhalation exposure to cadmium (1:10,000 risk, US EPA, 1992; EU SCOEL, 2010).

1171 Taking into account the modifying factors (F1-F5 as discussed in Appendix 1), the  
 1172 inhalation PDE is calculated as:

1173 For continuous dosing =  $5 \text{ } \mu\text{g}/\text{m}^3 \div 1000 \text{ L}/\text{m}^3 = 0.005 \text{ } \mu\text{g}/\text{L}$

1174  $0.005 \text{ } \mu\text{g}/\text{L} \times 8 \text{ hours} \times 5 \text{ days} \div 24 \text{ hours} \times 7 \text{ days} = 0.0012 \text{ } \mu\text{g}/\text{L}$

1175 Daily Dose =  $0.0012 \text{ } \mu\text{g}/\text{L} \times 28800 \text{ L}/\text{day} \div 50 \text{ kg} = 0.69 \text{ } \mu\text{g}/\text{kg}$

1176  $PDE = 0.69 \text{ } \mu\text{g}/\text{kg} \times 50 \text{ kg} / 1 \times 10 \times 1 \times 1 \times 1 = 3.4 \text{ } \mu\text{g}/\text{day}$ .

1177 A modifying factor F2 of 10 was applied to cover the full population with the data coming  
 1178 from the worker population.

1179 **REFERENCES**

1180 ATSDR. Toxicological profile of cadmium. Agency for Toxic Substances and Disease  
 1181 Registry, Public Health Service, U.S. Department of Health and Human Services,  
 1182 Atlanta, GA. 2012.

1183 Buchet JP, Lauwerys R, Roels H, Bernard A, Bruaux P, Claeys F, et al. Renal effects of  
 1184 cadmium body burden of the general population. *Lancet* 1990;336:699-702.

1185 EU SCOEL. Recommendation from the scientific committee on occupational exposure  
 1186 limits for cadmium and its inorganic compounds. European Union Scientific Committee  
 1187 on Occupational Exposure Limits. 2010;SCOEL/SUM/136.

1188 IARC. Arsenic, metals, fibres, and dusts: a review of human carcinogens. Monographs on  
 1189 the Evaluation of Carcinogenic Risks to Humans. International Agency for Research on  
 1190 Cancer, World Health Organization, Lyon. 2012;100C.

1191 NTP. Technical report on toxicity studies of cadmium oxide (CAS No. 1306-19-0)  
 1192 administered by inhalation to F344/N Rats and B6C3F1 mice. National Toxicology  
 1193 Program, Public Health Service, U.S. Department of Health and Human Services. 2004.

1194 Prozialeck WC, Edwards JR, Vaidya VS, Bonventre JV. Preclinical evaluation of novel  
 1195 urinary biomarkers of cadmium nephrotoxicity. *Toxicol Appl Pharmacol* 2009;238:301-  
 1196 305.

1197 US EPA. Cadmium. Integrated Risk Information System (IRIS). 1992.

1198 US DoL (OHS). 29 CFR 1910.1000 Table Z-1. Limits for air contaminants. U.S.  
 1199 Department of Labor. 2013.

1200 WHO. Cadmium in drinking water. Background document for development of WHO  
1201 Guidelines for drinking-water quality. World Health Organization.  
1202 2011;WHO/SDE/WSH/03.04/80/Rev/1.  
1203

1204 **CHROMIUM**1205 **Summary of PDE for Chromium**

<b>Chromium (Cr III)</b>			
	Oral	Parenteral	Inhalation
PDE (µg/day)	11000	1100	2.9

1206 **Introduction**

1207 Chromium (Cr) is found in a variety of oxidation states, the most important being Cr 0  
 1208 (in stainless steel) Cr II, III and VI. Cr II is readily oxidized and is used as a reducing  
 1209 agent in chemical synthesis. Cr VI is a powerful oxidant, chromate,  $\text{CrO}_4^{2-}$ , and  
 1210 dichromate,  $\text{Cr}_2\text{O}_7^{2-}$ , being the best known oxyanions. Cr III, the most abundant  
 1211 environmental form, is an essential element that plays a role in glucose metabolism.  
 1212 Chromium deficiency causes changes in the metabolism of glucose and lipids and may be  
 1213 associated with maturity-onset diabetes, cardiovascular diseases, and nervous system  
 1214 disorders (Anderson, 1993, 1995). Sources of chromium in pharmaceuticals may include  
 1215 colorants, leaching from equipment or container closure systems, and catalysts. With  
 1216 the exception of use as a catalyst, intake of chromium from pharmaceuticals will be in  
 1217 the form of metallic chromium (Cr 0) or Cr III rather than the more toxic Cr VI; therefore,  
 1218 for drug products, this safety assessment is based on the known toxicity of Cr III and Cr  
 1219 VI is excluded from this assessment. Chromium present as a colorant (e.g., chromium  
 1220 oxide green, chromium hydroxide green; see 21 CFR 72) is intentionally added and thus  
 1221 beyond the scope of this guidance.

1222 **Safety Limiting Toxicity**

1223 The data was reviewed to identify the safety limiting toxicities based on routes of  
 1224 administration.

1225 **PDE – Oral Exposure**

1226 No specific target organ toxicities have been identified for the oral intake of  
 1227 chromium. Generally oral intake of 5 mg/kg/day Cr III (US EPA, 1998) is not expected to  
 1228 be associated with adverse health.

1229 The 2 year NTP studies (2010) on the carcinogenicity of Cr (III) picolinate administered  
 1230 in feed to rats and mice provided the most relevant safety information for Cr as present  
 1231 in drug products. The NOAEL was 90 mg/kg Cr (III) picolinate (11.9 weight %; 10.7  
 1232 mg/kg/day Cr(III) in rats based on increase in the incidence of preputial gland adenoma  
 1233 in male rats at 460 mg/kg. This finding was not dose-dependent and was considered an  
 1234 equivocal finding by the study authors. This finding was not observed male mice or in  
 1235 the female counterpart in either species (clitoral gland). In the absence of a treatment-  
 1236 related carcinogenic finding, F4 was set at 1.

1237 Taking into account the modifying factors (F1-F5 as discussed in Appendix 1), the oral  
 1238 PDE is calculated as:

$$1239 \text{ PDE} = 10.7 \text{ mg/kg/day} \times 50 \text{ kg} / 5 \times 10 \times 1 \times 1 \times 1 = 10.7 \text{ mg/day} \sim 11000 \text{ } \mu\text{g/day}.$$

1240 **PDE – Parenteral Exposure**

1241 Recommendation for the nutritional intravenous administration of Chromium (III) vary  
 1242 per age group between 0.05 µg/kg/day in preterm infants and 15 µg/kg in adults  
 1243 (Moukazel, 2009). There is insufficient information to assess if exceeding these

1244 recommended daily doses may lead to adverse responses e.g., for the kidney especially in  
1245 newborns and preterm infants.

1246 The safety review for Cr was unable to identify any significant assessments upon which  
1247 to calculate a PDE for parenteral routes of exposure. On the basis of an oral  
1248 bioavailability of about 10% for chromium and inorganic chromium compounds (ATSDR,  
1249 2012), the recommended PDE for chromium for a parenteral exposure is:

1250  $PDE = 11000 \mu\text{g}/\text{day}/10 = 1100 \mu\text{g}/\text{day}$ .

#### 1251 **PDE – Inhalation Exposure**

1252 The study by Deralenko (1999) used inhalation of Cr (III) sulfate particles during 13  
1253 weeks (6h/day and 5 days per week) causing predominantly chronic inflammation of the  
1254 airways (mononuclear infiltrate, particular material) and locally thickening of alveolar  
1255 walls. The effect was observed at all doses. The LOAEL is  $17 \text{ mg}/\text{m}^3$  ( $3 \text{ mg CrIII}/\text{m}^3$ ). A  
1256 lack of systemic toxicity was noted in a 13 week inhalation study in rats administered  
1257 soluble or insoluble Cr (III). Based on these data the on these data, the inhalation MRL  
1258 of  $0.1 \mu\text{g}/\text{m}^3$  was used to set the PDE (ATSDR, 2012).

1259  $PDE = 0.0001 \text{ mg}/\text{m}^3 / 1000 \text{ m}^3/\text{L} \times 28800 \text{ L}/\text{day} = 2.9 \mu\text{g}/\text{day}$ .

#### 1260 **REFERENCES**

1261 Anderson RA. Recent advances in the clinical and biochemical effects of chromium  
1262 deficiency. *Prog Clin Biol Res* 1993;380:221-34.

1263 Anderson RA. Chromium and parenteral nutrition. *Nutr* 1995;11(1 suppl.):83-6.

1264 ATSDR. Toxicological profile of chromium. Agency for Toxic Substances and Disease  
1265 Registry, Public Health Service, U.S. Department of Health and Human Services,  
1266 Atlanta, GA. 2012.

1267 Derelanko MJ, Rinehart WE, Hilaski RJ, Thompson RB, Löser E. Thirteen week  
1268 subchronic rat inhalation toxicity study with a recovery phase of trivalent chromium  
1269 compounds, chromic oxide, and basic chromium sulfate. *Toxicol Sci* 1999;52:278-88.

1270 Glaser U, Hochrainer D, Klöppel H, Oldiges H. Carcinogenicity of sodium dichromate  
1271 and chromium (VI/III) oxide aerosols inhaled by male Wistar rats. *Toxicology*. 1986;42(2-  
1272 3):219-32.

1273 Moukarzel A. Chromium in parenteral nutrition: too little or too much. *Gastroenterology*  
1274 2009;137:S18-S28.

1275 NTP. Technical report on the toxicology and carcinogenesis studies of chromium  
1276 picolinate monohydrate in F344/N rats and B6C3F1 mice. National Toxicology Program,  
1277 Public Health Service, U.S. Department of Health and Human Services. 2010;NTP TR  
1278 556.

1279 US DoL (OHSA). 29 CFR 1910.1000 Table Z-1. Limits for air contaminants. U.S.  
1280 Department of Labor. 2013.

1281 US EPA. Chromium (III), insoluble salts. Integrated Risk Information System (IRIS).  
1282 1998.

1283

1284 **COBALT**1285 **Summary of PDE for Cobalt**

<b>Cobalt (Co)</b>			
	Oral	Parenteral	Inhalation
PDE (µg/day)	50	5.0	2.9

1286 **Introduction**

1287 Cobalt (Co) is a naturally-occurring element, often combined with other elements such as  
 1288 oxygen, sulfur, and arsenic. Co is essential in the human body because it is an integral  
 1289 component of Vitamin B-12 and functions as a co-enzyme for several enzymes critical in  
 1290 the synthesis of hemoglobin and the prevention of pernicious anemia. The Recommended  
 1291 Dietary Allowance of vitamin B12 is 2.4 µg/day, which corresponds to 0.1 µg of Co. No  
 1292 essential biological function of inorganic Co in the human body has been identified.  
 1293 Cobalt compounds (e.g., cobalt octoate) are being used as catalysts in selective  
 1294 hydrogenation.

1295 **Safety Limiting Toxicity**

1296 The IARC (2006) concluded that Co sulphate and other soluble Co (II) salts are possible  
 1297 human carcinogens (Group 2B). The data indicate the location of tumors is limited to the  
 1298 lung in rats and humans.

1299 Polycythemia is considered to be the most sensitive finding after repeated oral exposure  
 1300 to humans. Inhalation exposure of humans to Co has been associated with a severe and  
 1301 progressive respiratory disease known as hard-metal pneumoconiosis, as well as asthma  
 1302 and contact dermatitis.

1303 **PDE – Oral Exposure**

1304 The oral PDE is based on the available human data. Polycythemia was the most  
 1305 sensitive finding in humans after repeated oral exposure to 150 mg of cobalt chloride  
 1306 (~1 mg Co /kg/day). The oral PDE was determined on the basis of the LOAEL of 1  
 1307 mg/kg/day in male human volunteers after oral exposure over a period of 22 days (WHO,  
 1308 2006).

1309 Taking into account the modifying factors (F1-F5 as discussed in Appendix 1), the oral  
 1310 PDE is calculated as below:

$$1311 \text{ PDE} = 1 \text{ mg/kg/day} \times 50 \text{ kg} / 1 \times 10 \times 10 \times 1 \times 10 = 0.05 \text{ mg/day} = 50 \text{ µg/day.}$$

1312 **PDE – Parenteral Exposure**

1313 No relevant data on parenteral exposure to cobalt compounds were found. On the basis of  
 1314 the oral bioavailability ranging largely from 18-97% for cobalt and inorganic cobalt  
 1315 compounds (ATSDR, 2004). Using a safety factor of 10 to account for low bioavailability,  
 1316 the PDE for cobalt for parenteral exposure is:

$$1317 \text{ PDE} = 50 \text{ µg/day} / 10 = 5.0 \text{ µg/day.}$$

1318 **PDE – Inhalation Exposure**

1319 Co sulphate and other soluble Co (II) salts are possible human carcinogens (Group 2B)  
 1320 which can induce lung tumors.

1321 Pneumoconiosis, asthma and contact dermatitis were the principal non-carcinogenic  
1322 effects in humans after chronic inhalation. For the calculation of the inhalation PDE, the  
1323 chronic inhalation MRL of 0.1 microgram / m<sup>3</sup> was used (ATSDR, 2010).  
1324  $0.0001 \text{ mg/ m}^3 / 1000 \text{ m}^3/\text{L} \times 28800 \text{ L/day} = 2.9 \text{ } \mu\text{g/day}$ .

1325 **REFERENCES**

1326 ATSDR. Toxicological profile for cobalt. Agency for Toxic Substances and Disease  
1327 Registry, Public Health Service, U.S. Department of Health and Human Services,  
1328 Atlanta, GA. 2010.

1329 IARC. Cobalt in hard metals and cobalt sulfate, gallium arsenide, indium phosphide and  
1330 vanadium pentoxide. International Agency for Research on Cancer, World Health  
1331 Organization, Lyon. 2003;86, updated in 2006.

1332 WHO. Cobalt and inorganic cobalt compounds. Concise International Chemical  
1333 Assessment Document. Inter-Organization Programme for the Sound Management of  
1334 Chemicals (IOMC). World Health Organization. 2006;69.

1335  
1336



1337 **COPPER**1338 **Summary of PDE for Copper**

<b>Copper (Cu)</b>			
	Oral	Parenteral	Inhalation
PDE (µg/day)	1300	130	13

1339 **Introduction**

1340 Copper (Cu) is a Group 11 element of the first transition series and has two main  
 1341 oxidation states, Cu I and Cu II. It is an essential trace element in both animals and  
 1342 humans. Copper plays a vital role in a number of critical enzyme systems and is closely  
 1343 linked with normal hematopoiesis and cellular metabolism. Copper compounds (e.g.,  
 1344 copper chromite) are being used as catalysts in hydrogenolysis and decarboxylation  
 1345 reactions

1346 **Safety Limiting Toxicity**

1347 A general review of relevant safety data for animals and humans indicates that copper  
 1348 can produce adverse effects to the gastrointestinal tract, liver, and kidney upon ingestion  
 1349 of toxic doses (Araya *et al.* 2003).

1350 **PDE – Oral Exposure**

1351 Studies on cupric sulfate and copper 8-quinolinolate have been conducted in mice and  
 1352 rats and dogs (EHC, 1998). Rats were determined to be the more sensitive species to  
 1353 effects on liver and kidney. In a 13 week study in rats the NOAEL was 17 mg/kg/day for  
 1354 copper sulfate, equivalent to 6.7 mg Cu/kg/day (Hebert, 1993).

1355 Taking into account the modifying factors (F1-F5 as discussed in Appendix 1), the oral  
 1356 PDE is calculated as:

1357  $PDE = 6.7 \text{ mg/kg/day} \times 50 \text{ kg} / 5 \times 10 \times 5 \times 1 \times 1 = 1.34 \text{ mg/day} = 1340 \text{ µg/day} \sim 1300$   
 1358  $\text{µg/day}$ .

1359 **PDE – Parenteral Exposure**

1360 The safety review for copper was unable to identify any significant assessments upon  
 1361 which to calculate a PDE for parenteral routes of exposure. The human gastrointestinal  
 1362 system can absorb 30-40% of ingested copper from the typical diets consumed in  
 1363 industrialised countries (Wapnir, 1998). On the basis of limited oral bioavailability of  
 1364 30%-40% for copper and inorganic copper salts, the recommended PDE for copper for  
 1365 parenteral exposure is:  
 1366  $PDE = 1340 \text{ µg/day} / 10 = 134 \text{ µg/day} \sim 130 \text{ µg/day}$ .

1367 **PDE – Inhalation Exposure**

1368 The available data on the toxicity of inhaled copper were considered inadequate for  
 1369 derivation of acute-, intermediate-, or chronic-duration inhalation MRLs (ATSDR, 2004).

1370 The inhalation PDE was calculated by dividing the oral PDE by 100 (as described in  
 1371 Section 3.1).

1372  $1340/100 = 13.4 \text{ µg/day} \sim 13 \text{ µg/day}$ .

1373

1374 **REFERENCES**

- 1375 Araya M, Olivares M, Pizarro F, González M, Speisky H, Uauy R. Gastrointestinal  
1376 symptoms and blood indicators of copper load in apparently healthy adults undergoing  
1377 controlled copper exposure. *Am J Clin Nutr* 2003;77(3):646-50.
- 1378 ATSDR. Profile for copper. Agency for Toxic Substances and Disease Registry, Public  
1379 Health Service, U.S. Department of Health and Human Services, Atlanta, GA. 2004
- 1380 Hébert CD, Elwell MR, Travlos GS, Fitz CJ, Bucher JR. Subchronic toxicity of cupric  
1381 sulfate administered in drinking water and feed to rats and mice. *Fundam Appl Toxicol*  
1382 1993;21:461-75.
- 1383 IPCS. Copper. Environmental Health Criteria 200. International Programme on  
1384 Chemical Safety. World Health Organization, Geneva. 1998.
- 1385 Wapnir RA. Copper absorption and bioavailability. *Am J Clin Nutr*  
1386 1998;67(suppl):1054S-60S.
- 1387 WHO. Copper – toxicological evaluation of certain food additives. WHO Food Additive  
1388 Series 17 1982. World Health Organization.
- 1389

1390 **GOLD**1391 **Summary of PDE for Gold**

Gold (Au)			
	Oral	Parenteral	Inhalation
PDE (µg/day)	130	130	1.3

1392 **Introduction**

1393 Gold (Au) exists in metallic form and in oxidation states of +1 to +5, the monovalent and  
 1394 trivalent forms being the most common. Elemental gold is poorly absorbed and  
 1395 consequently is not considered biologically active. Gold is being used on a carrier or in  
 1396 complexes like gold chloride and L-Au<sup>+</sup> (where L is a phosphane, phosphite, or an arsine;  
 1397 Telles, 1998), as catalysts in organic synthesis. The only source for gold in drug products  
 1398 comes from the use as catalyst. Gold (I) salts are used therapeutically.

1399 **Safety Limiting Toxicity**

1400 Most knowledge of gold toxicity is based on therapeutic uses of gold. Currently available  
 1401 therapies are gold salts of monovalent gold (I) with a sulfur ligand (Au-S), but metallic  
 1402 gold has also been studied. No toxicity was seen in 10 patients administered colloidal  
 1403 metallic gold (monoatomic gold) at 30 mg/day for one week followed by 60 mg/day the  
 1404 second week or the reverse schedule. The patients were continued on trial for an  
 1405 additional 2 years at 30 mg/day. There was no evidence of hematologic, renal or hepatic  
 1406 cytotoxicity but some improvement in clinical symptoms of rheumatoid arthritis and in  
 1407 cytokine parameters were noted (Abraham and Himmel, 1997).

1408 Long term animal data are available with Au compounds. However, these studies have  
 1409 been performed with monovalent gold Au I and are not considered sufficiently relevant to  
 1410 assess the potential toxicity of Au in pharmaceutical products.

1411 Au (III) is thought to be the more toxic form and is used in catalysis, e.g., as gold  
 1412 trichloride. There is only limited data on gold (III) complexes. In one study, the gold (III)  
 1413 compound [Au(en)Cl<sub>2</sub>]Cl (dichloro(ethylenediamine-aurate(III) ion) caused minimal  
 1414 histological changes in the kidney and liver of rats, and no renal tubular necrosis, at a  
 1415 dose of 32.2 mg/kg in mice administered the compound intraperitoneally for 14 days  
 1416 (Ahmed *et al.* 2012).

1417 **PDE – Oral Exposure**

1418 The toxicologically significant endpoint for gold exposures is renal toxicity.

1419 Taking into account the modifying factors (F1-F5 as discussed in Appendix 1), the oral  
 1420 PDE is calculated as:

1421  $PDE = 32.2 \text{ mg/kg} \times 50 \text{ kg} / 12 \times 10 \times 10 \times 1 \times 10 = 134 \text{ µg/day} \sim 130 \text{ µg/day}$ .

1422 F5 was put at 10 because the NOAEL was not established and the toxicological  
 1423 assessment was not complete.

1424 **PDE – Parenteral Exposure**

1425 In humans, 50 mg intramuscular (IM) injections of gold sodium thiomalate resulted in  
 1426 >95% bioavailability (Blocka, 1986). In rabbits, ~70 % of the gold sodium thiomalate was  
 1427 absorbed after an IM injection of 2/mg/kg (Melethil, 1987).

1428 Based on high bioavailability, the parenteral PDE is equivalent to the oral PDE.

1429 PDE = 130 µg/day.

1430 **PDE – Inhalation Exposure**

1431 In the absence of relevant inhalation and parenteral data, a modifying factor of 100 was  
1432 applied to the oral PDE as described in Section 3.1.

1433  $PDE = 134 / 100 = 1.34 \mu\text{g}/\text{day} \sim 1.3 \mu\text{g}/\text{day}$ .

1434 **REFERENCES**

1435 Abraham GE, Himmel PB. Management of rheumatoid arthritis: rationale for the use of  
1436 colloidal metallic gold. *J Nutr Environ Med* 1997;7:295-305.

1437 Ahmed A, Al Tamimi DM, Isab AA, Alkhawajah AMM, Shawarby MA. Histological  
1438 changes in kidney and liver of rats due to gold (III) compound [Au(en)Cl<sub>2</sub>]Cl. *PLoS ONE*  
1439 2012;7(12):1-11.

1440 Blocka KL, Paulus HE, Furst DE. Clinical pharmacokinetics of oral and injectable gold  
1441 compounds. *Clin Pharmacokinet* 1986;11:133-43.

1442 Melethil S, Schoepp D. Pharmacokinetics of gold sodium thiomalate in rabbits. *Pharm*  
1443 *Res* 1987;4(4):332-6.

1444 Telles JH, Brode S, Chabanas M. Cationic gold (I) complexes: highly efficient catalysts  
1445 for the addition of alcohols to alkynes. *Angew Chem Int Ed* 1998;37:1415-18.

1446

1447 **LEAD**1448 **Summary of PDE for Lead**

<b>Lead (Pb)</b>			
	Oral	Parenteral	Inhalation
PDE (µg/day)	5.0	5.0	5.0

1449 **Introduction**

1450 Lead (Pb) is the most common heavy element. It occurs in organic and inorganic forms.  
 1451 The generally bivalent Pb compounds include water-soluble salts such as Pb acetate as  
 1452 well as insoluble salts such as Pb oxides. Organic Pb compounds include the gasoline  
 1453 additives tetramethyl- and tetraethyl-lead. Organic Pb compounds undergo fairly rapid  
 1454 degradation in the atmosphere and form persistent inorganic Pb compounds in water  
 1455 and soil. Pb has no known useful biological function in human or mammalian organisms  
 1456 (ATSDR, 2007).

1457 **Safety Limiting Toxicity**

1458 In humans and animals, exposure to Pb may cause neurological, reproductive,  
 1459 developmental, immune, cardiovascular and renal health effects. In general, sensitivity  
 1460 to Pb toxicity is greater when there is exposure *in utero* and in children compared to  
 1461 adults. A target blood level of 1-2 µg/dL was set, and using modelling programs (US EPA,  
 1462 2009) that assumed 100% bioavailability and no other exposure, a PDE was obtained.  
 1463 For this reason, the PDEs are the same regardless of the route of administration.

1464 **PDE – Oral Exposure**

1465 Adverse neurobehavioral effects are considered to be the most sensitive and most  
 1466 relevant endpoint in humans after oral exposure. Data from epidemiological studies  
 1467 show that blood Pb levels <5 µg/dL may be associated with neurobehavioral deficits in  
 1468 children (NTP, 2011).

1469 According to the US EPA model (Integrated Exposure Uptake Biokinetic (IEUBK) Model,  
 1470 1994) (100% absorption, no other sources of lead), oral intake of 5 µg/day translates into  
 1471 a blood level of 1-2 µg/dL for children age 0-7 years (0-82 months).

1472 PDE = 5.0 µg/day.

1473 **PDE – Parenteral Exposure**

1474 The oral effects of Pb are based on blood levels. Therefore, the parenteral PDE is equal  
 1475 to the oral PDE of 5.0 µg/day.

1476 **PDE – Inhalation Exposure**

1477 The oral effects of Pb are based on blood levels. Therefore, the inhalation PDE is equal  
 1478 to the oral PDE of 5.0 µg/day.

1479 **REFERENCES**

1480 ATSDR. Toxicological profile for lead. Agency for Toxic Substances and Disease Registry,  
 1481 Public Health Service, U.S. Department of Health and Human Services, Atlanta, GA.  
 1482 2007.

1483 NTP. Monograph on health effects of low-level lead. National Toxicology Program, U.S.  
 1484 Department of Health and Human Services. 2011.

1485 US EPA. Integrated Exposure Uptake Biokinetic (IEUBK) Model for Lead. 1994,  
1486 updated 2009.  
1487

1488 **LITHIUM**1489 **Summary of PDE for Lithium**

<b>Lithium (Li)</b>			
	<b>Oral</b>	<b>Parenteral</b>	<b>Inhalation</b>
<b>PDE (µg/day)</b>	780	390	25

1490 **Introduction**

1491 Lithium (Li) is a common metal that is present in plant and animal tissues. Lithium is  
 1492 used as a therapeutic agent to treat bipolar disease. Lithium is being used alone or in  
 1493 combination with other metals as catalyst. Lithium compounds (e.g., lithium aluminum  
 1494 hydride) are being used as reagents in organic synthesis.

1495 Lithium exists commonly as a salt in the +1 form oxidation state only.

1496 **Safety Limiting Toxicity**

1497 The data was reviewed to identify the safety limiting toxicities based on routes of  
 1498 administration.

1499 **PDE – Oral Exposure**

1500 There is a minimal amount of data on the effects of lithium carbonate on the immune  
 1501 system. A 14 day mouse study was conducted to assess the effects of lithium carbonate  
 1502 on the immune system (NTP, 1986). Doses were modified to 100, 300 and 400 mg/kg in  
 1503 repeat and later studies because of a lack of effect at 50 and 200 mg/kg. Findings  
 1504 included dose-dependent effects on decreased in liver and thymus weight, and changes in  
 1505 leukocytes and red blood cells and associated parameters.

1506 Using 200 mg/kg/day (18.7 mg Li/kg/day) as the NOAEL and modifying factors (F1-F5 as  
 1507 discussed in Appendix 1), the PDE is:

1508  $PDE = 18.7 \text{ mg/kg/day} \times 50 \text{ kg} / 12 \times 10 \times 10 \times 1 \times 1 = 0.78 \text{ mg/day} = 780 \text{ µg/day}$ .

1509 **PDE – Parenteral Exposure**

1510 There are no adequate data to develop a parenteral PDE. However, based on oral  
 1511 bioavailability of 85% (Grandjean, 2009) and using a modifying factor of 2, the parenteral  
 1512 PDE is calculated as:

1513  $PDE = 0.77 \text{ mg/day} / 2 = 0.39 \text{ mg/day} = 390 \text{ µg/day}$ .

1514 **PDE – Inhalation Exposure**

1515 Rabbits were exposed to lithium chloride at 0.6 and 1.9 mg/m<sup>3</sup> for 4-8 weeks, 5 days/week  
 1516 for 6 hours/d (Johansson *et al.* 1988). Lungs were studied by light and electron  
 1517 microscopy with focus on inflammatory changes. No significant effects were reported, so  
 1518 the highest dose was used to set the PDE.

1519 Taking into account the modifying factors (F1-F5 as discussed in Appendix 1), the oral  
 1520 PDE is calculated as:

1521 For continuous dosing:  $PDE = 1.9 \text{ mg/m}^3 / 1000 \text{ L/m}^3 = .0019 \text{ mg/L}$

1522  $0.0019 \text{ mg/L} \times 6 \text{ h/day} \times 5 \text{ days} / 24\text{h/day} \times 7\text{days} = 0.000339 \text{ mg/L}$

1523 Daily dose:  $0.339 \text{ µg/L} \times 1440 \text{ L/day} / 4 \text{ kg} = 122.04 \text{ µg/kg/day}$

1524  $PDE = 122.04 \text{ µg/kg/day} \times 50\text{kg} / 2.5 \times 10 \times 10 \times 1 \times 1 = 25 \text{ µg/day}$ .

1525 **REFERENCES**

1526 Grandjean EM, Aubry JM. Lithium: updated human knowledge using an evidence-based  
1527 approach. Part II: Clinical pharmacology and therapeutic monitoring. *CNS Drugs*  
1528 2009;23(4):331-49.

1529 Johansson A, Camner P, Curstedt T, Jarstrand C, Robertson B, Urban T. Rabbit lung  
1530 after inhalation of lithium chloride. *J Appl Toxicol* 1988;8:373-5.

1531 NTP. Immunotoxicity of lithium carbonate in female B6C3F1 mice (CAS No. 554-13-2).  
1532 National Toxicology Program, U.S. Department of Health and Human Services.  
1533 1986;NTP Report Number IMM85001.

1534



1535 **MERCURY**1536 **Summary of PDE for Mercury**

<b>Mercury (Hg)</b>			
	Oral	Parenteral	Inhalation
PDE (µg/day)	40	4.0	1.2

1537 **Introduction**

1538 Mercury (Hg) is an element widely existing in the global environment. Hg exists in three  
 1539 forms: elemental mercury, inorganic mercury and organic mercury. The most likely form  
 1540 of residual mercury in drug products is the inorganic form. Therefore, this safety  
 1541 assessment is based on the relevant toxicological data of elemental or inorganic Hg. This  
 1542 safety assessment and derived PDEs do not apply to organic mercury.

1543 **Safety Limiting Toxicity**

1544 There is no data to indicate that inorganic mercury is carcinogenic in human. There is  
 1545 limited evidence in experimental animals for the carcinogenicity of mercuric chloride.  
 1546 IARC concluded that inorganic mercury compounds are not classifiable as to their  
 1547 carcinogenicity to humans (Group 3; IARC, 1997).

1548 Inorganic mercury compounds show significantly lower oral bioavailability compared to  
 1549 organic mercury and induce different toxicological effects including neurological,  
 1550 corrosive, hematopoietic, renal effects and cutaneous disease (acrodynia). The safety  
 1551 limiting toxicity for inorganic mercury and salts is renal toxicity.

1552 **PDE – Oral Exposure**

1553 There were well organized NTP studies of HgCl<sub>2</sub> up to 2 years. The 6 month gavage  
 1554 study in rats was selected because it had more detailed clinical pathology assessment  
 1555 and wider range of doses than the 2 year study. Based on adverse renal effects from the  
 1556 6-months rat study (NTP, 1993), the LOAEL was 0.23 mg/kg/day for mercury (0.16  
 1557 mg/kg day for mercury when corrected for 7 days of exposure/week).

1558 Using the modifying factors (F1-F5 as discussed in Appendix 1) the oral PDE is  
 1559 calculated as:

$$1560 \text{ PDE} = 0.16 \text{ mg/kg /day} \times 50 \text{ kg} / 5 \times 10 \times 2 \times 1 \times 2 = 0.04 \text{ mg/day} = 40 \text{ µg/day.}$$

1561 F5 was set to 2, because no NOAEL was identified in the study and the effect at the  
 1562 LOAEL was a slight increase in incidence of an effect also present in the control animals.

1563 **PDE – Parenteral Exposure**

1564 Animal studies indicate that the oral bioavailability of inorganic mercury is in the 10-  
 1565 30% range (ATSDR, 1999). Therefore, the oral PDE is divided by a factor of 10 (as  
 1566 described in Section 3.1).

$$1567 \text{ PDE} = 40/10 = 4.0 \text{ µg/day.}$$

1568 **PDE – Inhalation Exposure**

1569 Neurobehavioral effects are considered to be the most sensitive endpoint following  
 1570 inhalation exposure in humans as shown in occupational studies at the range of air TWA  
 1571 levels between 14 and 20 µg/m<sup>3</sup> (US EPA, 1995; EU SCOEL, 2007).

1572 The presence of neurobehavioral effects at low-level mercury exposures (14  $\mu\text{g}/\text{m}^3$ ) in  
1573 dentists (Ngim *et al.* 1992) indicates that the TWA needs to be considered as a LOAEL.

1574 Taking into account the modifying factors (F1-F5 as discussed in Appendix 1), the  
1575 inhalation PDE is calculated based on the long-term inhalation exposure to elemental  
1576 mercury vapor:

$$\begin{aligned} 1577 \text{ For continuous dosing} &= \frac{14 \mu\text{g}/\text{m}^3 \times 8 \text{ hr}/\text{day} \times 6 \text{ days}/\text{week}}{24 \text{ hr}/\text{day} \times 7 \text{ days}/\text{week} \times 1000 \text{ L}/\text{m}^3} \\ 1578 & \\ 1579 &= 0.004 \mu\text{g}/\text{L} \end{aligned}$$

1580

$$\begin{aligned} 1581 \text{ Daily dose} &= \frac{0.004 \mu\text{g}/\text{L} \times 28800 \text{ L}}{50 \text{ kg}} = 2.30 \mu\text{g}/\text{kg} \\ 1582 & \end{aligned}$$

$$\begin{aligned} 1583 \text{ PDE} &= \frac{2.30 \mu\text{g}/\text{kg} \times 50 \text{ kg}}{1 \times 10 \times 1 \times 1 \times 10} = 1.2 \mu\text{g}/\text{day}. \\ 1584 & \end{aligned}$$

#### 1585 REFERENCES

1586 ATSDR. Toxicological profile for mercury. Agency for Toxic Substances and Disease  
1587 Registry, Public Health Service, U.S. Department of Health and Human Services,  
1588 Atlanta, GA. 1999.

1589 EU SCOEL. Recommendation from the scientific committee on occupational exposure  
1590 limits for elemental mercury and inorganic divalent mercury compounds. European  
1591 Union Scientific Committee on Occupational Exposure Limits. 2007;SCOEL/SUM/84.

1592 IARC. Beryllium, cadmium, mercury, and exposures in the glass manufacturing industry.  
1593 Monographs on the Evaluation of Carcinogenic Risks to Humans. International Agency  
1594 for Research on Cancer, World Health Organization, Lyon. 1993;58, updated in 1997.

1595 Ngim CH, Foo SC, Boey KW, and Jeyaratnam J. Chronic neurobehavioural effects of  
1596 elemental mercury in dentists. *Br J Ind Med* 1992;49(11):782-90.

1597 NTP. Technical report on the toxicology and carcinogenesis studies of mercuric chloride  
1598 (CAS No. 7487-94-7) in F344 rats and B6C3F1 mice (gavage studies). National  
1599 Toxicology Program, Public Health Service, U.S. Department of Health and Human  
1600 Services, Research Triangle Park, NC. 1993;NTP TR 408.

1601 US EPA. Mercuric chloride ( $\text{HgCl}_2$ ). Integrated Risk Information System (IRIS). 1995.

1602 WHO. Elemental mercury and inorganic mercury compounds: human health aspects.  
1603 Concise International Chemical Assessment Document 50. International Programme on  
1604 Chemical Safety (IPCS). World Health Organization. 2003.

1605

1606 **MOLYBDENUM**1607 **Summary of PDE for Molybdenum**

Molybdenum (Mo)			
	Oral	Parenteral	Inhalation
PDE (µg/day)	180	180	7.6

1608 **Introduction**

1609 The main oxidation states for Mo are IV and VI, the most common forms of which are  
 1610 oxyanions. The predominant form of Mo occurring in soils and natural waters is the  
 1611 molybdate ion,  $\text{MoO}_4^{2-}$  which forms soluble compounds with a variety of cations including  
 1612  $\text{K}^+$ ,  $\text{NH}_4^+$  and  $\text{Ca}^{2+}$ . Mo exists in soil in various forms at concentration of 0.1-10 mg/kg.  
 1613  $\text{MoO}_2$  and  $\text{MoS}_2$  are insoluble in water. It is widely present in vegetables, dairy products  
 1614 and meats. Mo combinations (e.g., Bi-Mo, Fe-Mo, molybdenum oxide and Mo-complexes)  
 1615 are being used as catalysts in organic synthesis.

1616 Mo deficiency is characterized by night blindness, nausea, disorientation, coma,  
 1617 tachycardia, tachypnea and associated with various biochemical abnormalities including  
 1618 high plasma methionine. In addition an almost undetectable serum uric acid  
 1619 concentration has been reported in a patient receiving total parenteral nutrition  
 1620 (Abumrad *et al.* 1981).

1621 **Safety Limiting Toxicity**

1622 Molybdenum as the trioxide was not mutagenic (NTP, 1997). Carcinogenicity has not  
 1623 been evaluated by IARC or US EPA.

1624 Alteration of estrus cycle is the most sensitive effect observed in the various rat studies.  
 1625 Absorption and retention of Mo is markedly influenced by interactions with dietary Cu  
 1626 and sulfate and the typical symptoms from excessive Mo intake were similar to those of  
 1627 copper deficiency including weight loss, growth retardation, anorexia, anemia, diarrhea,  
 1628 achromotrichia, testicular degeneration, poor conception, deficient lactation, dyspnea,  
 1629 incoordination and irritation of mucous membranes (Engel *et al.* 1956).

1630 **PDE – Oral Exposure**

1631 Fungwe *et al.* (1990) examined the effects on fertility and reproductive performance of  
 1632 sodium molybdenate in female rats given drinking water containing 0, 5, 10, 50 or 100  
 1633 mg Mo/L. After 6 weeks the effect of Mo on the estrous cycle (3 cycles) and vaginal  
 1634 cytology was determined, and some animals then mated to untreated males. Pregnant  
 1635 dams continued to be dosed to day 21 of gestation with Mo and fetal effects determined.  
 1636 Effects on the estrous cycle, gestational weight gain, and the fetus were observed at 10  
 1637 mg/L and higher; thus, a dose level of 5 mg/L can be considered a NOAEL. Vyskocil and  
 1638 Viau (1999) calculated this NOAEL to be 0.9 mg Mo/kg/day.

1639 Using modifying factors (F1-F5 as discussed in Appendix 1) the oral PDE is:

1640  $\text{PDE} = 0.9 \text{ mg/kg/day} \times 50 \text{ kg} / 5 \times 10 \times 1 \times 5 \times 1 = 0.180 \text{ mg/day} = 180 \text{ µg/day}$ .

1641 F4 was selected to be 5 based on the presence of fetal effects.

1642

1643 **PDE – Parenteral Exposure**

1644 In Vyskocil and Viau (1999), it was reported that oral bioavailability in humans ranged  
1645 from 28-77%. Turnland *et al.* (2005) report that molybdenum absorption was about 90%  
1646 in healthy men. Therefore, the parenteral PDE is the same as the oral PDE.

1647 PDE= 180 µg/day.

1648 **PDE – Inhalation Exposure**

1649 Chronic inflammation in the alveoli was seen in rat and mouse. In addition, a slight  
1650 trend for bronchiolar alveolar adenoma and carcinoma was observed in male rats  
1651 exposed to molybdenum trioxide in a 2-year inhalation study (NTP, 1997). Lung  
1652 neoplasms were not seen in female rats. In mice, bronchiolar alveolar adenoma and  
1653 carcinoma were observed at the lowest dose of 10 mg/m<sup>3</sup> (6.7 mg/m<sup>3</sup> of Mo).

1654 The inhalation PDE was calculated based on the low dose in the mouse carcinogenicity  
1655 study, where findings of alveolar and bronchiolar carcinoma were observed, using the  
1656 modifying factors (F1-F5 as discussed in Appendix 1).

1657  $6.7 \text{ mg/m}^3 \div 1000 \text{ m}^3/\text{L} = 0.0067 \text{ mg/L}$

1658 For continuous dosing =  $\frac{0.0067 \text{ mg/L} \times 6 \text{ hr} \times 5 \text{ d}}{24 \text{ hr} \times 7 \text{ d}} = 0.0012 \text{ mg/L}$

1660  
1661 Daily dose =  $\frac{0.0012 \text{ mg/L} \times 43 \text{ L/d}}{0.028 \text{ kg}} = 1.83 \text{ mg/kg}$

1662  
1663  
1664 PDE =  $\frac{1.83 \text{ mg/kg} \times 50 \text{ kg}}{12 \times 10 \times 1 \times 10 \times 10} = 7.6 \text{ µg/day.}$   
1665

1666 **REFERENCES**

1667 Abumrad NN, Schneider AJ, Steel D, Rogers LS. Amino acid intolerance during  
1668 prolonged total parenteral nutrition reversed by molybdate therapy. *Am J Clin Nutr*  
1669 1981;34(11):2551-9.

1670 Engel RW, Miller RF, Price NO. Added dietary inorganic sulfate and its effect upon rats  
1671 fed molybdenum. *J Nutr* 1956;60(4):539-47.

1672 Fundwe TV, Buddingh F, Demick DS, Lox CD, Yang MT, Yang SP. The role of dietary  
1673 molybdenum on estrous activity, fertility, reproduction and molybdenum and copper  
1674 enzyme activities of female rats. *Nutr Res* 1990;10:515-24.

1675 NTP. Toxicology and carcinogenesis studies of molybdenum trioxide (CAS No. 1313-27-5)  
1676 in F344 rats and B6C3F1 mice (inhalation studies). National Toxicology Program, Public  
1677 Health Service, U.S. Department of Health and Human Services. 1997.

1678 Turnland JR, Keyes WR, Peiffer GL. Molybdenum absorption, excretion, and retention  
1679 studied with stable isotopes in young men at five intakes of dietary molybdenum. *Am J*  
1680 *of Clin Nutr* 1995;62:790-6.

1681 Vyskocil A, Viau C. Assessment of molybdenum toxicity in humans. *J Appl Toxicol.*  
1682 1999;19:185-92.

1683

1684 **NICKEL**1685 **Summary of PDE for Nickel**

Nickel (Ni)			
	Oral	Parenteral	Inhalation
PDE (µg/day)	600	60	6.0

1686 **Introduction**

1687 Nickel (Ni) is a Group 10 element of the first transition series. Although Ni may have  
 1688 valences of 0, I, II and III, its main oxidation state is +2. Ni is a naturally occurring  
 1689 metal existing in various mineral forms. In general, the more soluble Ni compounds,  
 1690 including Ni chloride, Ni sulfate, and Ni nitrate, tend to be more toxic than less soluble  
 1691 forms, such as Ni oxide and Ni subsulfide. Ni is nutritionally not essential for humans,  
 1692 but Ni deficiency may cause adverse effects in animals. Nickel as Ni-Al alloys is being  
 1693 used as catalyst in hydrogenation reactions.

1694 **Safety Limiting Toxicity**

1695 Nickel is genotoxic, but not mutagenic (IARC 2012). There is no indication of  
 1696 carcinogenicity of Ni salts after oral administration. Depending on the type of salt there  
 1697 was an increase in tumors in some rodent inhalation studies (ATSDR, 2005; EU EFSA,  
 1698 2005). Combining all forms of Ni, IARC (2012) classified Ni as a human carcinogen  
 1699 (Group 1).

1700 In humans and animals, ingestion of large amounts of Ni may cause stomach pain,  
 1701 depression of body weight and adverse effects on blood and kidneys. Humans generally  
 1702 become sensitised to Ni after prolonged contact with the skin. Chronic inhalation may  
 1703 produce adverse changes in lung and nasal cavity in both humans and animals.

1704 **PDE – Oral Exposure**

1705 Human sensitisation to Ni was used to establish the oral PDE, because it is the most  
 1706 sensitive endpoint. Human data show that an oral challenge dose of 0.012 mg Ni/kg can  
 1707 induce dermatitis in nickel-sensitized individuals. Exposure to these nickel  
 1708 concentrations did not result in dermatitis in non-sensitized individuals (Nielsen 1999).  
 1709 Similar data were presented for 0.02 mg/kg by ATSDR (2005).

1710  $PDE = 0.012 \text{ mg/kg/day} \times 50 \text{ kg} = 0.60 \text{ mg/day} = 600 \text{ µg/day}$ .

1711 **PDE – Parenteral Exposure**

1712 A human study using a stable nickel isotope estimated that 29–40% of the ingested label  
 1713 was absorbed (based on fecal excretion data) (Patriarca *et al.* 1997). On the basis of  
 1714 limited oral bioavailability of Ni and water-soluble Ni compound. Therefore, the oral  
 1715 PDE is divided by a factor of 10 (as described in Section 3.1).

1716  $PDE = 600 \text{ µg/day} / 10 = 60 \text{ µg/day}$ .

1717 **PDE – Inhalation Exposure**

1718 For calculation of the inhalation PDE, a relevant form of Ni was selected from the  
 1719 available data. In 2 year studies with nickel oxide (the form commonly used in stainless  
 1720 steel coatings), no tumors were observed in hamsters (Wehner *et al.* 1984) or mice (NTP,  
 1721 1996), but there was some evidence of carcinogenicity in rats (NTP, 2006) and no  
 1722 evidence of carcinogenicity with inhalation of metallic nickel (Oller, 2008).

1723 Taking into account the modifying factors (F1-F5 as discussed in Appendix 1), the  
1724 inhalation PDE is calculated based on the NOAEL in the rat study of 0.5 mg Ni/m<sup>3</sup>/day.  
1725 For continuous dosing  $0.5 \text{ mg/m}^3 / 1000 \text{ L/m}^3 = 0.0005 \text{ mg/L}$   
1726  $0.0005 \text{ mg/L} \times 6 \text{ hr} \times 5 \text{ d} / 24 \text{ hr} \times 7 \text{ d} = 0.000089 \text{ mg/L}$   
1727 Daily dose  $0.000089 \text{ mg/L} \times 290 \text{ L/d} / 0.425 \text{ kg} = 0.060 \text{ mg/kg}$   
1728  $\text{PDE} = 0.060 \text{ mg/kg} \times 50 \text{ kg} / 5 \times 10 \times 1 \times 10 \times 1 = 6.0 \text{ } \mu\text{g/day}$ .

1729 **REFERENCES**

1730 ATSDR. Toxicological profile for nickel. Agency for Toxic Substances and Disease  
1731 Registry, Public Health Service, U.S. Department of Health and Human Services,  
1732 Atlanta, GA. 2005.

1733 Dunnick JK, Elwell MR, Benson JM, Hobbs CH, Hahn FF, Haly PJ, et al. Lung toxicity  
1734 after 13-week inhalation exposure to nickel oxide, nickel subsulfide, or nickel sulfate  
1735 hexahydrate in F344/N rats and B6C3F1 mice. *Fundam Appl Toxicol* 1989;12(3):584-94.

1736 Dunnick JK, Elwell MR, Radovsky AE, Benson JM, Hahn FF, Nikula KJ, et al.  
1737 Comparative carcinogenic effects of nickel subsulfide, nickel oxide, or nickel sulfate  
1738 hexahydrate chronic exposures in the lung. *Cancer Res* 1995;55(22):5251-6.

1739 EU EFSA. Opinion of the scientific panel on dietetic products, nutrition and allergies on  
1740 a request from the Commission related to the tolerable upper intake level of nickel.  
1741 European Food Safety Authority. *EFSA Journal* 2005;146:1-21.

1742 Goodman JE, Prueitt RL, Thakali S, Oller AR. The nickel ion bioavailability of the  
1743 carcinogenic potential of nickel-containing substances in the lung. *Crit Rev Toxicol*  
1744 2011;41:142-74.

1745 Haney JY, McCant DD, Sielken RL, Valdez-Flores C, Grant RL. Development of a unit  
1746 risk factor for nickel and inorganic nickel compounds based on an updated  
1747 carcinogenicity toxicity assessment. *Reg Toxicol Pharmacol* 2012;62: 191-201.

1748 Heim KE, Bates HK, Rush RE, Oller AR. Oral carcinogenicity study with nickel sulphate  
1749 hexahydrate in Fischer 344 rats. *Toxicol Sci* 2007;224:126-37.

1750 IARC. Arsenic, metals, fibres, and dusts: a review of human carcinogens. Monographs on  
1751 the Evaluation of Carcinogenic Risks to Humans. International Agency for Research on  
1752 Cancer, World Health Organization, Lyon. 2012;100C.

1753 Nielsen GD, Søderberg U, Jørgensen PJ, Templeton DM, Rasmussen SN, Andersen KE,  
1754 et al. Absorption and retention of nickel from drinking water in relation to food intake  
1755 and nickel sensitivity. *Toxicol Appl Pharmacol* 1999;154:67-75.

1756 NTP. Report on carcinogens. National Toxicology Program, Public Health Service, U.S.  
1757 Department of Health and Human Services, Bethesda, MD. 2002.

1758 NTP. Toxicology and carcinogenesis studies of nickel oxide. National Toxicology  
1759 Program, U.S. Department of Health and Human Services. 2006;Technical Report Series  
1760 No. 451.

1761 Oller AR, Kirkpatrick DT, Radovsky A, Bates HK. Inhalation carcinogenicity study with  
1762 nickel metal powder in Wistar rats. *Toxicol Appl Pharmacol* 2008;233:262-75.

1763 Ottolenghi AD, Haseman JK, Payne WW, Falk HL, MacFarland HN, et al. Inhalation  
1764 studies of nickel sulfide in pulmonary carcinogenesis of rats. *J Natl Cancer Inst*  
1765 1974;54:1165-72.

- 1766 Patriarca M, Lyon TD, Fell GS. Nickel metabolism in humans investigated with an oral  
1767 stable isotope. *Am J Clin Nutr* 1997;66:616-21.
- 1768 Wehner AP, Dagle GE, Busch RH. Pathogenicity of inhaled nickel compounds in  
1769 hamsters. *IARC Sci Publ* 1984;(53):143-51.
- 1770

1771 **PALLADIUM**1772 **Summary of PDE for Palladium**

<b>Palladium (Pd)</b>			
	Oral	Parenteral	Inhalation
PDE (µg/day)	100	10	1.0

1773 **Introduction**

1774 Palladium (Pd) is a steel-white, ductile metallic element resembling and occurring with  
1775 the other platinum group metals and nickel. It exists in three states: Pd<sup>0</sup> (metallic), Pd<sup>2+</sup>  
1776 and Pd<sup>4+</sup>. It can form organometallic compounds, only few of which have found industrial  
1777 uses. Palladium (on various supports) is being used as catalyst in hydrogenation  
1778 reactions. Palladium metal is stable in air and resistant to attack by most reagents  
1779 except aqua regia and nitric acid.

1780 Several mutagenicity tests of different palladium compounds with bacterial or  
1781 mammalian cells (Ames test with *Salmonella typhimurium*; SOS chromotest with  
1782 *Escherichia coli*; micronucleus test with human lymphocytes) *in vitro* gave negative  
1783 results.

1784 **Safety Limiting Toxicity**

1785 The data was reviewed to identify the safety limiting toxicities based on routes of  
1786 administration.

1787 **PDE – Oral Exposure**

1788 A number of long-term animal studies have been conducted exploring the toxicity and  
1789 carcinogenicity of palladium salts. However, none to date have been executed in  
1790 accordance with current guidelines for toxicological studies. The available data suggest  
1791 potential NOAELs for palladium in the range of 0.8 – 1.5 mg/kg. A lifetime study with  
1792 mice given palladium(II) chloride in drinking-water at a dose of about 1.2 mg Pd/kg/day  
1793 found a significantly higher incidence of amyloidosis in several inner organs of males and  
1794 females and suppressed growth in males, but not in females (Schroeder and Mitchner,  
1795 1971; IPCS, 2002). This study also contained a signal that suggested a possible  
1796 carcinogenic endpoint; however, the design of the study (single dose level, pooling of the  
1797 tumor rates from male and female animals, and a significant increase in the age of the  
1798 treated *vs* control animals) limited the utility of the data to assess the carcinogenic  
1799 potential.

1800 Taking into account the modifying factors (F1-F5 as discussed in Appendix 1), the oral  
1801 PDE is calculated based on the LOEL of 1.2 mg/kg/day.

1802  $PDE = 1.2 \text{ mg/kg/day} \times 50 \text{ kg} / 12 \times 10 \times 1 \times 5 \times 1 = 0.1 \text{ mg/day} = 100 \text{ µg/day}$ .

1803 **PDE – Parenteral Exposure**

1804 The safety review for Pd was unable to identify any significant assessments upon which  
1805 to calculate a PDE for parenteral routes of exposure. Palladium(II) chloride (PdCl<sub>2</sub>) was  
1806 poorly absorbed from the digestive tract (<0.5% of the initial oral dose in adult rats or  
1807 about 5% in suckling rats after 3-4 days). Absorption/retention in adult rats was higher  
1808 following intratracheal or intravenous exposure, resulting in total body burdens of 5% or  
1809 20%, respectively, of the dose administered, 40 days after dosing (IPCS, 2002). On the  
1810 basis of an oral bioavailability the PDE for palladium for parenteral exposure is:



1811 PDE = 100 µg/day / 10 = 10 µg/day.

1812 **PDE – Inhalation Exposure**

1813 There are no adequate inhalation data on Pd. Therefore, the inhalation PDE for  
1814 palladium was derived from the oral PDE by division by a factor of 100 (as described in  
1815 Section 3.1).

1816 PDE = 100 µg/day / 100 = 1.0 µg/day.

1817 **REFERENCES**

1818 IPCS. Palladium. Environmental Health Criteria 226. International Programme on  
1819 Chemical Safety. World Health Organization, Geneva. 2002.

1820 Schroeder HA, Mitchener M. Scandium, chromium (VI), gallium, yttrium, rhodium,  
1821 palladium, indium in mice: Effects on growth and life span. J Nutr 1971;101:1431-8.

1822

1823 **PLATINUM**1824 **Summary of PDE for Platinum**

Platinum (Pt)			
	Oral	Parenteral	Inhalation
PDE (µg/day)	1000	10	1.4

1825 **Introduction**

1826 Platinum (Pt) is a Group VIII element of the third transition series. It is the most  
1827 important of the six heaviest of the group VIII elements, collectively called the “platinum  
1828 group metals” or “platinoids”, including palladium, osmium, rhodium, ruthenium and  
1829 iridium. Platinum and Pd are more chemically reactive than the other platinoids.  
1830 Metallic Pt has been shown to catalyze many oxidation-reduction and decomposition  
1831 reactions and the major industrial use of Pt is as a catalyst. Pt complexes exhibiting a  
1832 range of oxidation states are known, although the principal valences are Pt II and IV. Pt  
1833 II forms a tetra-coordinate aqua ion  $[Pt(H_2O)_4]^{2+}$ . The most common Pt IV catalysts are  
1834 chloroplatinate salts such as tetra and hexachloroplatinate ions.

1835 **Safety Limiting Toxicity**

1836 The data was reviewed to identify the safety limiting toxicities based on routes of  
1837 administration.

1838 Chlorinated salts of platinum are responsible for platinum related hypersensitivity and  
1839 are a major occupational health concern (US EPA, 2009). The hypersensitivity appears to  
1840 be the most sensitive endpoint of chloroplatinate exposure, at least by the inhalation  
1841 route. Signs include urticaria, contact dermatitis of the skin, and respiratory disorders  
1842 ranging from sneezing, shortness of breath, and cyanosis to severe asthma (IPCS, 1991).  
1843 Exposure reduction was effective in resolving symptoms (Merget *et al.* 2001). Neutral  
1844 complexes and complexes without halogenated ligands do not appear allergenic (US EPA,  
1845 2009; EU SCOEL, 2011). The risk of hypersensitivity appears to be related to sensitizing  
1846 dose and dose and length of exposure (IPCS, 1991; US EPA, 2009; Arts *et al.* 2006) and  
1847 cigarette smoking (US EPA, 2009; Merget *et al.* 2000; Caverley, 1995).

1848 **PDE – Oral Exposure**

1849 No experimental data are available on the carcinogenicity of platinum and platinum  
1850 compounds, and toxicology data are limited (US EPA, 2009). In one study in male rats  
1851 administered  $PtCl_2$  (relatively insoluble) and  $PtCl_4$  (soluble) for 4 weeks, the toxicity of  
1852 the two platinum salts was investigated. No significant effects on body weight gain or  
1853 food consumption for either compound, and no effects were observed on hematological  
1854 parameters for  $PtCl_2$ . Some hematological parameters were influenced by  $PtCl_4$ ; a  
1855 reduction of about 13% in hematocrit and erythrocyte parameters was reported at the  
1856 dose of 50 mg Pt/kg in the diet. Platinum concentration increased in tissues in animals  
1857 dosed with either compound, particularly the kidney. For this reason plasma creatinine  
1858 was examined, and found to be increased in animals dosed with  $PtCl_4$  when added in the  
1859 diet at 50 mg Pt/kg diet for 4 weeks, but not  $PtCl_2$ . This dose corresponded to 21 mg  
1860 Pt/animal (Reichlmayr-Lais *et al.* 1992). This study was used in the determination of the  
1861 PDE as one endpoint in the study was renal toxicity (plasma creatinine), a target organ  
1862 of platinum and a site of accumulation. Renal toxicity is an also an adverse effect of  
1863 treatment with chemotherapeutic agents such as cisplatin.  
1864 Taking into account the modifying factors (F1-F5 as discussed in Appendix 1), the oral  
1865 PDE is calculated based on the NOAEL of 10 mg/kg/day.

1866  $PDE = 10 \text{ mg/kg/day} \times 50 \text{ kg} / 5 \times 10 \times 10 \times 1 \times 1 = 1 \text{ mg/day} = 1000 \text{ } \mu\text{g/day}$ .

1867 **PDE – Parenteral Exposure**

1868 The safety review for platinum identified limited assessments of platinum salt toxicity  
1869 for parenteral routes of administration. The oral absorption of platinum salts is very low  
1870 (<1%) (US EPA, 2009). Therefore, the oral PDE is divided by a factor of 100 (as described  
1871 in section 3.1).

1872  $PDE = 1000 \text{ } \mu\text{g/day} / 100 = 10 \text{ } \mu\text{g/day}$ .

1873 **PDE – Inhalation Exposure**

1874 Due to the use of the chloroplatinates in catalytic converters, numerous animal (Biagini  
1875 *et al.* 1983) and human (Pepys *et al.* 1972; Pickering 1972; Merget *et al.* 2000; Cristaudo  
1876 *et al.* 2007) studies have been conducted. The US EPA (1977; 2009) and the EU SCOEL  
1877 (2011) have also examined the safety of chloroplatinates based on sensitization. The EU  
1878 SCOEL concluded that the database does not allow for setting an occupational limit for  
1879 soluble platinum salts. The US DoL (2013) has established an occupational limit for  
1880 soluble Pt salts at  $2 \text{ } \mu\text{g/m}^3$ ; however, whether this exposure level is completely protective  
1881 of workers has been questioned (Merget and Rosner, 2001).

1882 Taking into account the modifying factors (F1-F5 as discussed in Appendix 1), the  
1883 inhalation PDE is calculated as:

1884  $2 \text{ } \mu\text{g/m}^3 \div 1000 \text{ m}^3/\text{L} = 0.002 \text{ } \mu\text{g/L}$

1885 For continuous dosing =  $0.002 \text{ } \mu\text{g/L} \times 8 \text{ hr} \times 5 \text{ d} = 0.00048 \text{ } \mu\text{g/L}$

1886  $24 \text{ hr} \times 7 \text{ d}$

1887 Daily dose =  $\frac{0.00048 \text{ } \mu\text{g/L} \times 28800 \text{ L/d}}{50 \text{ kg}} = 0.27 \text{ } \mu\text{g/kg/d}$

1888  $50 \text{ kg}$

1889  $PDE = \frac{0.27 \text{ } \mu\text{g/kg/d} \times 50 \text{ kg}}{1 \times 10 \times 1 \times 1 \times 1} = 1.37 \text{ } \mu\text{g/day} \sim 1.4 \text{ } \mu\text{g/day}$ .

1890  $1 \times 10 \times 1 \times 1 \times 1$

1891 **REFERENCES**

1892 Arts JHE, Mommers C, de Heer C. Dose-response relationships and threshold levels in  
1893 skin and respiratory allergy. *Crit Rev Toxicol* 2006; 36:219-51.

1894 Biagini RE, Moonman WJ, Smith RJ, Lewis TR, Bernstein IL. Pulmonary  
1895 hyperreactivity in cynomolgus monkeys (*Macaca fascicularis*) from nose-only inhalation  
1896 exposure to disodium hexachloroplatinate,  $\text{Na}_2\text{PtCl}_6$ . *Toxicol Appl Pharmacol*  
1897 1983;69:377-84.

1898 Caverley AE, Rees D, Dowdeswell RJ, Linnett PJ, Kielkowski D. Platinum salt  
1899 sensitivity in refinery workers: incidence and effects of smoking and exposure. *Int J*  
1900 *Occup Environ Med* 1995;52:661-66.

1901 Cristaudo A, Picardo M, Petrucci F, Forte G, Violante N, Senofonte O, Alimonti A.  
1902 Clinical and allergological biomonitoring of occupational hypersensitivity to platinum  
1903 group elements. *Anal Lett* 2007;40:3343-59.

1904 EU SCOEL. Recommendation from the scientific committee on occupational exposure  
1905 limits for platinum and platinum compounds. European Union Scientific Committee on  
1906 Occupational Exposure Limits. 2011;SCOEL/SUM/150.

1907 IPCS. Platinum. Environmental Health Criteria 125. International Programme on  
1908 Chemical Safety. World Health Organization, Geneva. 1991.

1909 Merget R; Kulzer R; Dierkes-Globisch A, Breitstadt R, Gebler A, Kniffka A, Artelt S,  
1910 Koenig HP, Alt F, Vormberg R, Baur X, Schultze-Werninghaus G. Exposure-effect  
1911 relationship of platinum salt allergy in a catalyst production plant: conclusions from a 5-  
1912 year prospective cohort study. *J Allergy Clin Immunol* 2000;105:364-370.

1913 Merget R, Caspari C, Kulzer SA, Dierkes-Globisch R, Kniffka A, Degens P, et al.  
1914 Effectiveness of a medical surveillance program for the prevention of occupational  
1915 asthma caused by platinum salts: a nested case control study. *J Allergy Clin Immunol*  
1916 2001;107:707-12.

1917 Merget R, Rosner G. Evaluation of the health risk of platinum group metals emitted  
1918 from automotive catalytic converters. *Sci Total Environ* 2001;270:165-73.

1919 Pepys J, Pickering CAC, Hughes EG. Asthma due to inhaled chemical agents--complex  
1920 salts of platinum. *Clin Exp Allergy* 1972;2:391-96.

1921 Pickering CAC. Inhalation tests with chemical allergens: complex salts of platinum. *Proc*  
1922 *R Soc Med* 1972;65:2-4.

1923 Reichlmayr-Lais AM, Kirchgessner M, Bader R. Dose-response relationships of  
1924 alimentary PtCl<sub>2</sub> and PtCl<sub>4</sub> in growing rats. *J Trace Elem Electrolytes Health Dis*  
1925 1992;6(3):183-7.

1926 US DoL (OHSA). 29 CFR 1910.1000 Table Z-1. Limits for air contaminants. U.S.  
1927 Department of Labor. 2013.

1928 US EPA. Platinum-group metals. *Environmental Health Effects Research Series*  
1929 1977;EPA-600/1-77-040.

1930 US EPA. Toxicological review of halogenated platinum salts and platinum compounds.  
1931 *Integrated Risk Information System (IRIS)*. 2009.

1932 US EPA. Toxicological review of halogenated platinum salts and platinum compounds.  
1933 *In support of summary information on the Integrated Risk Information System (IRIS)*.  
1934 2009.

1935

1936

1937 **SELENIUM**1938 **Summary of PDE for Selenium**

<b>Selenium (Se)</b>			
	Oral	Parenteral	Inhalation
PDE (µg/day)	170	85	140

1939 **Introduction**

1940 Selenium is present in the earth's crust, often in association with sulfur-containing  
 1941 minerals. It can assume four oxidation states (-2, 0, +4, +6) and occurs in many forms,  
 1942 including elemental selenium, selenites and selenates. Selenium is an essential trace  
 1943 element for many species, including humans. Selenium is incorporated into proteins *via*  
 1944 a specific selenocysteine tRNA. Selenium is being used as a catalyst in the manufacture  
 1945 of rubber. Ru-Se catalysts are used in oxygen reduction. Aryl- and alkyl-Selenium  
 1946 reagents have various applications in organic synthesis.

1947 **Safety Limiting Toxicity**

1948 Selenium was listed as a Group 3 compound by IARC (1987), not classifiable for  
 1949 carcinogenesis. The only selenium compound that has been shown to be carcinogenic in  
 1950 animals is selenium sulfide (NTP, 1980). According to the US EPA, selenium sulfide is  
 1951 in Group B2 (probable human carcinogen) (US EPA, 2002). Other selenium compounds  
 1952 are classified as D; not classifiable as to carcinogenicity in humans.

1953 The most significant toxicity observed in these assessments was hepatotoxicity.

1954 **PDE – Oral Exposure**

1955 In a rat carcinogenicity study of selenium sulfide, the NOAEL for hepatocellular carcinoma  
 1956 was 3 mg/kg/day (1.7 mg Se/kg/day) (NTP, 1980). There is insufficient data to assess  
 1957 carcinogenicity of other forms of selenium, and the human relevance of the rodent liver  
 1958 tumors has been questioned (IARC, 1999). Some human data are available but only in a  
 1959 limited number of subjects (ATSDR, 2003). The PDE is in line with the MRL of 5  
 1960 µg/kg/day for Se (ATSDR 2003).

1961 Taking into account the modifying factors (F1-F5 as discussed in Appendix 1), the oral  
 1962 PDE is calculated as below.

1963  $PDE = 1.7 \text{ mg/kg/day} \times 50 \text{ kg} / 5 \times 10 \times 1 \times 10 \times 1 = 170 \text{ µg/day}$ .

1964 **PDE – Parenteral Exposure**

1965 The safety review for selenium was unable to identify any significant assessments upon  
 1966 which to calculate a PDE for parenteral routes of exposure. Studies in humans and  
 1967 experimental animals indicate that, when ingested, several selenium compounds  
 1968 including selenite, selenate, and selenomethionine are readily absorbed, often to greater  
 1969 than 80% of the administered dose (ATSDR, 2003). On the basis of oral bioavailability of  
 1970 ~80%, the PDE for selenium for parenteral exposure is (as described in section 3.1).

1971  $PDE = 170 \text{ µg/day} / 2 = 85 \text{ µg/day}$ .

1972

1973 **PDE – Inhalation Exposure**

1974 The safety review for selenium was unable to identify any significant animal models or  
1975 clinical studies of inhalation toxicity. However, occupational limits have established  
1976 time weighted averages for selenium exposures of 0.2 mg/m<sup>3</sup> (US DoL, 2013).

1977 Taking into account the modifying factors (F1-F5 as discussed in Appendix 1), the  
1978 inhalation PDE is calculated as below.

1979  $0.2 \text{ mg/m}^3 / 1000 \text{ L/m}^3 = 0.0002 \text{ mg/L}$

1980 For continuous dosing =  $0.0002 \text{ mg/L} \times 8 \text{ h} \times 5 \text{ d}/24 \times 7 = 0.0000476 \text{ mg/L}$

1981 Daily dose =  $0.0000476 \text{ mg/L} \times 28800 \text{ L}/50 \text{ kg} = 0.027 \text{ mg/kg}$

1982 PDE =  $\frac{0.027 \text{ mg/kg} \times 50 \text{ kg}}{1 \times 10 \times 1 \times 1 \times 1} = 0.135 \text{ mg/day} = 140 \text{ } \mu\text{g/day}$ .

1983

1984 **REFERENCES**

1985 ATSDR. Toxicological profile for selenium. Agency for Toxic Substances and Disease  
1986 Registry, Public Health Service, U.S. Department of Health and Human Services,  
1987 Atlanta, GA. 2003.

1988 IARC. Overall evaluations of carcinogenicity: An update of IARC monographs volumes 1  
1989 to 42. Monographs on the Evaluation of the Carcinogenic Risks to Humans. International  
1990 Agency for Research on Cancer, World Health Organization, Lyon.1987;Suppl 7.

1991 IARC. Some aziridines, N-, S- and O-mustards and selenium. Summary of data reported  
1992 and evaluation. Monographs on the Evaluation of Carcinogenic Risks to Humans.  
1993 International Agency for Research on Cancer, World Health Organization, Lyon. 1999.

1994 NTP. Bioassay of selenium sulfide (gavage) for possible carcinogenicity. National  
1995 Toxicology Program, US Department of Health and Human Services. 1980;Technical  
1996 Report Series No 194.

1997 US DoL (OHSA). 29 CFR 1910.1000 Table Z-1. Limits for air contaminants. U.S.  
1998 Department of Labor. 2013.

1999 US EPA. Selenium and compounds (CAS No. 7782-49-2). Integrated Risk Information  
2000 System (IRIS). 2002.

2001

2002 **SILVER**2003 **Summary of PDE for Silver**

<b>Silver (Ag)</b>			
	Oral	Parenteral	Inhalation
PDE (µg/day)	170	35	6.9

2004 **Introduction**

2005 Silver (Ag) is present in silver compounds primarily in the oxidation state +1 and less  
 2006 frequently in the oxidation state +2. Ag occurs naturally mainly in the form of very  
 2007 insoluble and immobile oxides, sulfides and some salts. The most important silver  
 2008 compounds in drinking-water are silver nitrate and silver chloride. Most foods contain  
 2009 traces of silver in the 10–100 µg/kg range. Ag is nutritionally not essential and no  
 2010 metabolic function is known. Silver is being used as a catalyst in the oxidation of  
 2011 ethylene to ethyleneoxide. Silver-Cadmium alloy is used in selective hydrogenation of  
 2012 unsaturated carbonyl compounds. Silver oxide is used as a mild oxidizing agent in  
 2013 organic synthesis.

2014 **Safety Limiting Toxicity**

2015 Silver is not mutagenic. Animal toxicity studies and human occupational studies have  
 2016 not provided sufficient evidence of carcinogenicity. Based on these data Ag is not  
 2017 expected to be carcinogenic in humans (ATSDR, 1990).

2018 Argyria appears to be the most sensitive clinical effect in response to human Ag intake.  
 2019 Silver acetate lozenges are used in smoking cessation (Hymowitz and Eckholdt, 1996).  
 2020 Argyria, a permanent bluish-gray discoloration of the skin, results from the deposition of  
 2021 Ag in the dermis combined with an Ag-induced production of melanin. Inhalation of high  
 2022 levels of silver can result in lung and throat irritation and stomach pains (ATSDR, 1990).

2023 **PDE – Oral Exposure**

2024 Silver nitrate was added at 0.015% to the drinking water of female mice (0.9 g/mouse;  
 2025 32.14 mg/kg silver nitrate; 64% silver) for 125 days to examine neurobehavioral activity  
 2026 of the animals based on potential neurotoxicity of silver (Rungby and Danscher, 1984).  
 2027 Treated animals were hypoactive relative to controls; other clinical signs were not noted.  
 2028 In a separate study, silver was shown to be present in the brain after mice were injected  
 2029 with 1 mg/kg ip silver lactate (Rungby and Danscher, 1983). The oral PDE is in line with  
 2030 the reference dose of 5 µg/kg/day (US EPA, 2003).

2031 Taking into account the modifying factors (F1-F5 as discussed in Appendix 1), the oral  
 2032 PDE is calculated as below.

2033  $20 \text{ mg/kg} \times 50 \text{ kg} / 12 \times 10 \times 5 \times 1 \times 10 = 167 \text{ µg/d} \sim 170 \text{ µg/day}$ .

2034 A factor 10 was chosen for F5 as a NOAEL was not seen in this study and few  
 2035 toxicological endpoints were examined.

2036 **PDE – Parenteral Exposure**

2037 US EPA (2003) identified a LOAEL of 0.014 mg/kg Ag/d using long-term (2 to 9 years)  
 2038 human iv data based on argyria following colloidal and organic silver medication.

2039 Taking into account the modifying factors (F1-F5 as discussed in Appendix 1), the  
 2040 parenteral PDE is calculated as below.

- 2041  $0.014 \text{ mg/kg/d} \times 50 \text{ kg} = 700 \text{ ug/d/1} \times 10 \times 1 \times 1 \times 2 = 35 \text{ } \mu\text{g/day}$ .
- 2042 A factor of 2 was chosen for F5 as the finding of argyria was not considered a serious  
2043 toxicity and a factor of 10 is used for F2, for a combined modifying factor of 20.
- 2044 **PDE – Inhalation Exposure**
- 2045 Lung and throat irritation and stomach pains were the principal effects in humans after  
2046 inhalation of high Ag levels.
- 2047 Using the TLV of  $0.01 \text{ mg/m}^3$  for silver metal and soluble compounds (US DoL, 2013),  
2048 taking into account the modifying factors (F1-F5 as discussed in Appendix 1), the  
2049 inhalation PDE is calculated as:
- 2050  $0.01 \text{ mg/m}^3 / 1000 \text{ L/m}^3 = 0.00001 \text{ mg/L}$
- 2051 For continuous dosing =  $0.00001 \text{ mg/L} \times 8 \text{ h} \times 5 \text{ d}/24 \times 7 = 0.00000238 \text{ mg/L}$
- 2052 Daily dose =  $\frac{0.00000238 \text{ mg/L} \times 28800 \text{ L/day}}{50 \text{ kg}} = 0.00137 \text{ mg/kg/day}$
- 2053
- 2054  $\text{PDE} = \frac{0.00137 \text{ mg/kg} \times 50 \text{ kg}}{1 \times 10 \times 1 \times 1 \times 1} = 0.0069 \text{ mg/day} = 6.9 \text{ } \mu\text{g/day}$ .
- 2055
- 2056 The factor F2 was set to 10 to extrapolate to the general population.
- 2057 **REFERENCES**
- 2058 ATSDR. Toxicological Profile for Silver. Agency for Toxic Substances and Disease  
2059 Registry, Public Health Service, U.S. Department of Health and Human Services,  
2060 Atlanta, GA. 1990.
- 2061 Hymowitz N, Eckholt H. Effects of a 2.5-mg silver acetate lozenge on initial and long-  
2062 term smoking cessation. *Prev Med* 1996;25:537-46.
- 2063 Rungby J, Danscher G. Hypoactivity in silver exposed mice. *Acta Pharmacol Toxicol*  
2064 1984;55:398-401.
- 2065 Rungby J, Danscher G. Localization of exogenous silver in brain and spinal cord of silver  
2066 exposed rats. *Acta Neuropathol* 1983;(60)1-2:92-98.
- 2067 US DoL (OHSA). 29 CFR 1910.1000 Table Z-1. Limits for air contaminants. U.S.  
2068 Department of Labor. 2013.
- 2069 US EPA. Silver (CASRN 7440-22-4). Integrated Risk Information System (IRIS). 2003.
- 2070



2071 **THALLIUM**2072 **Summary of PDE for Thallium**

<b>Thallium (Tl)</b>			
	Oral	Parenteral	Inhalation
PDE (µg/day)	8.0	8.0	69

2073 **Introduction**

2074 Pure thallium (Tl) is a bluish-white metal. It exists primarily in two valence states:  
 2075 monovalent (thallous) and trivalent (thallic). Monovalent thallium is similar to  
 2076 potassium (K<sup>+</sup>) in ionic radius and electrical charge, which contribute to its toxic nature.  
 2077 Many of the thallium salts are soluble in water with the exception of the insoluble  
 2078 thallium (III) oxide. Tl sulfate has been used in medicine, primarily as a depilatory agent,  
 2079 but also to treat infections, such as venereal diseases, ringworm of the scalp, typhus,  
 2080 tuberculosis, and malaria. Thallium(III) salts are being used in organic synthesis. Tl is  
 2081 nutritionally not essential and no metabolic function is known (ATSDR, 1992).

2082 **Safety Limiting Toxicity**

2083 In humans and animals, the skin, especially the hair follicles, appears to be the most  
 2084 sensitive target of toxicity from repeated oral exposure to Tl (US EPA, 2009).

2085 **PDE – Oral Exposure**

2086 The primary target organ for oral exposure to Tl in humans and animals appears to be  
 2087 the skin, especially the hair follicles, as shown in a 90-day toxicity rat study with Tl  
 2088 sulfate. The NOAEL was defined at 0.04 mg Tl/kg on the basis of an increased incidence  
 2089 of alopecia at the higher doses (Stoltz *et al.* 1986; US EPA, 2009). Thus, the oral PDE  
 2090 was determined on the basis of the NOAEL of 0.04 mg Tl/kg in rat.

2091 Taking into account the modifying factors (F1-F5 as discussed in Appendix 1), the oral  
 2092 PDE is calculated as below.

$$2093 \text{ PDE} = 0.04 \text{ mg/kg/day} \times 50 \text{ kg} / 5 \times 10 \times 5 \times 1 \times 1 = 0.008 \text{ mg/day} = 8.0 \text{ } \mu\text{g/day.}$$

2094 **PDE – Parenteral Exposure**

2095 No relevant data on parenteral exposure to thallium compounds were found. The  
 2096 bioavailability of soluble thallium salts is high (> 80%) (US EPA, 2009). Therefore, the  
 2097 parenteral PDE is the same as the oral PDE.

$$2098 \text{ PDE} = 8.0 \text{ } \mu\text{g/day.}$$

2099 **PDE – Inhalation Exposure**

2100 No relevant data on inhalation exposure to thallium compounds were found. Using the  
 2101 TLV of 0.1 mg/m<sup>3</sup> for thallium, soluble compounds (US DoL, 2013; CEC, 2000).

2102 Taking into account the modifying factors (F1-F5 as discussed in Appendix 1), the  
 2103 inhalation PDE is calculated as:

$$2104 0.1 \text{ mg/m}^3 / 1000 \text{ L/m}^3 = 0.0001 \text{ mg/L}$$

$$2105 \text{ For continuous dosing} = 0.0001 \text{ mg/L} \times 8 \text{ h} \times 5 \text{ d/24} \times 7 = 0.0000238 \text{ mg/L}$$

2106

$$2107 \text{ Daily dose} = \underline{0.0000238 \text{ mg/L} \times 28800 \text{ L/day}} = 0.0137 \text{ mg/kg/day}$$



2130 **TIN**2131 **Summary of PDE for Tin**

<b>Tin (Sn)</b>			
	<b>Oral</b>	<b>Parenteral</b>	<b>Inhalation</b>
<b>PDE (µg/day)</b>	6400	640	64

2132 **Introduction**

2133 Tin (Sn) is a silvery-white metal that exists in valence states of 2 and 4. The most  
 2134 important inorganic compounds of tin are its oxides, chlorides, fluorides and halogenated  
 2135 sodium stannates and stannites. Tin is present in some multi-vitamin and mineral food  
 2136 supplements (levels up to 10 µg Sn/tablet). Tin is possibly nutritionally essential for  
 2137 some animals, it has not been shown to be essential for humans. Tin(II) chloride is being  
 2138 used as a reducing agent, and as a stabilizer of polyvinylchloride (PVC). This safety  
 2139 assessment focuses on inorganic tin considering that the more frequent occurrence of  
 2140 inorganic tin is more relevant with respect to metal impurities in drug products than  
 2141 organic tin compounds.

2142 **Safety Limiting Toxicity**

2143 There is no indication of *in vivo* genotoxicity or carcinogenicity for tin and tin salts. In  
 2144 several studies in rats, a decrease in hemoglobin as an early sign for anemia, was the  
 2145 most sensitive endpoint.

2146 **PDE – Oral Exposure**

2147 Anemia was the most sensitive endpoint in rats after repeated oral administration. Thus,  
 2148 the PDE for oral exposure was determined on the basis of the lowest NOAEL, i.e., 150  
 2149 ppm (equivalent to 32 mg Sn/kg/day). This value was obtained from a 90-day study in  
 2150 rats based on signs of anemia starting at 500 ppm in rats exposed to stannous chloride  
 2151 *via* diet (De Groot *et al.* 1973).

2152 Taking into account the modifying factors (F1-F5 as discussed in Appendix 1), the oral  
 2153 PDE is calculated as below.

$$2154 \text{ PDE} = 32 \text{ mg/kg/day} \times 50 \text{ kg} / 5 \times 10 \times 5 \times 1 \times 1 = 6.4 \text{ mg/day} = 6400 \text{ µg/day.}$$

2155 **PDE – Parenteral Exposure**

2156 The safety review for tin was unable to identify any significant assessments upon which  
 2157 to calculate a PDE for parenteral routes of exposure. On the basis of an oral  
 2158 bioavailability of about 5% for tin and inorganic tin compounds (ATSDR, 2005), and  
 2159 using the default factor of 10, the PDE for tin for a parenteral exposure is (as described  
 2160 in Section 3.1).

$$2161 \text{ PDE} = 6400 \text{ µg/day} / 10 = 640 \text{ µg/day.}$$

2162 **PDE – Inhalation Exposure**

2163 The safety review for tin was unable to identify any significant assessments on inorganic  
 2164 tin upon which to calculate a PDE for inhalation routes of exposure. Although a TLV is  
 2165 available for tin (2 mg/m<sup>3</sup>; US DoL, 2013), there is insufficient data to set a MRL (ATSDR  
 2166 2005; EU SCOEL 2003).

2167 Therefore, the PDE for tin is calculated by using a factor of 100 to convert the oral PDE  
 2168 to the inhalation PDE (as described in Section 3.1).

2169 PDE = 6400 µg/day / 100 = 64 µg/day.

2170 **REFERENCES**

2171 ATSDR. Toxicological profile for tin and tin compounds. Agency for Toxic Substances and  
2172 Disease Registry, Public Health Service, U.S. Department of Health and Human  
2173 Services, Atlanta, GA. 2005.

2174 De Groot AP, Feron V, Til H. Short-term toxicity studies on some salts and oxides of tin  
2175 in rats. *Food Cos and Toxicol* 1972;11:19-30.

2176 EU SCOEL. Recommendation from the scientific committee on occupational exposure  
2177 limits for tin and inorganic tin compounds. European Union Scientific Committee on  
2178 Occupational Exposure Limits. 2003;SCOEL/SUM/97.

2179 US DoL (OHSA). 29 CFR 1910.1000 Table Z-1. Limits for air contaminants. U.S.  
2180 Department of Labor. 2013.

2181

2182 **VANADIUM**2183 **Summary of PDE for Vanadium**

<b>Vanadium (V)</b>			
	Oral	Parenteral	Inhalation
PDE (µg/day)	120	12	1.2

2184 **Introduction**

2185 Vanadium (V) is present as a trace element in the earth's crust and can exist in a variety  
 2186 of oxidation states (-1, 0, +2, +3, +4 and +5). V is also present in trace quantities in most  
 2187 biological organisms with the principal ions being vanadate,  $\text{VO}_3^-$  and vanadyl,  $\text{VO}_2^+$ .  
 2188 Absorption of vanadium from the gastrointestinal tract is poor. Estimates of total  
 2189 dietary intake of vanadium in humans range from 10 to 60 µg/day. Intake from drinking  
 2190 water depends on the water source and estimates are up to 140 µg/day. Human  
 2191 populations have variable serum concentrations of vanadium, with 2 µg/L being the high  
 2192 end of the normal range. Despite its ubiquitous presence in the body, an essential  
 2193 biological role for vanadium in humans has not been established. Vanadium has been  
 2194 reported to have potentially beneficial effects in treatment of osteoporosis, osteopenia,  
 2195 cancer, and diabetes. Oral vanadyl sulfate in amounts up to 20 mg/day is included in  
 2196 some dietary supplements intended to promote muscle growth. Vanadium oxide is used  
 2197 as a catalyst in the manufacturing of sulfuric acid.

2198 **Safety Limiting Toxicity**

2199 Vanadium is genotoxic, but not mutagenic (ATSDR, 2009). Vanadium pentoxide is  
 2200 classified as a possible human carcinogen (Group 2B; IARC, 2012).

2201 **PDE – Oral Exposure**

2202 Following oral administration to animals and humans the gastrointestinal tract,  
 2203 cardiovascular, and hematological system are the primary targets of toxicity. The most  
 2204 appropriate study to assess vanadium toxicity through oral administration was  
 2205 conducted in humans exposed to vanadium for 12 weeks. In these studies, no significant  
 2206 alterations in hematological parameters, liver function (as measured by serum enzymes),  
 2207 cholesterol and triglyceride levels, kidney function (as measured by blood urea nitrogen),  
 2208 body weight, or blood pressure were observed in subjects administered *via* capsule 0.12  
 2209 or 0.19 mg vanadium as ammonium vanadyl tartrate or vanadyl sulfate for 6–12 weeks  
 2210 (ATSDR, 2012). The oral NOAEL of 0.12 mg vanadium/kg/day for hematological and  
 2211 blood pressure effects was used to calculate the oral PDE.

2212 Taking into account the modifying factors (F1-F5 as discussed in Appendix 1), the oral  
 2213 PDE is calculated as below.

$$2214 \text{ PDE} = 0.12 \text{ mg/kg/day} \times 50 \text{ kg} / 1 \times 10 \times 5 \times 1 \times 1 = 0.12 \text{ mg/day} = 120 \text{ µg/day.}$$

2215 **PDE – Parenteral Exposure**

2216 The safety review for vanadium was unable to identify any significant assessments upon  
 2217 which to calculate a PDE for parenteral routes of exposure. On the basis of an  
 2218 approximate oral bioavailability of <1–10% for vanadium and inorganic vanadium  
 2219 compounds (ATSDR, 2012), the oral PDE was divided by 10 (as described in Section 3.1).

$$2220 \text{ PDE} = 120 \text{ µg/day} / 10 = 12 \text{ µg/day.}$$

2221

2222 **PDE – Inhalation Exposure**

2223 A two year chronic inhalation exposure study in rats was considered for use for the  
2224 inhalation PDE for vanadium. In this study, carcinogenic effects were observed to the  
2225 lowest dose tested, 0.5 mg/m<sup>3</sup> vanadium pentoxide (Ress *et al.* 2003). Vanadium  
2226 pentoxide is a caustic agent and is not considered to be present in drug products.  
2227 Therefore, the inhalation PDE for vanadium was derived from the oral PDE by division  
2228 by a factor of 100 (as described in Section 3.1).

2229 PDE = 120/100 = 1.2 µg/day.

2230 **REFERENCES**

2231 ATSDR. Toxicological profile for vanadium. Agency for Toxic Substances and Disease  
2232 Registry, Public Health Service, U.S. Department of Health and Human Services,  
2233 Atlanta, GA. 2012.

2234 IARC. Arsenic, metals, fibres, and dusts: a review of human carcinogens. Monographs on  
2235 the Evaluation of Carcinogenic Risks to Humans. International Agency for Research on  
2236 Cancer, World Health Organization, Lyon. 2012;100C.

2237 Ress NB, Chou BJ, Renne RA, Dill JA, Miller RA, Roycroft JH, et al. Carcinogenicity of  
2238 inhaled vanadium pentoxide in F344/N rats and B6C3F1 mice. *Toxicol Sci*  
2239 2003;74(2):287-96.

2240

2241 **Appendix 4: Illustrative Example – Calculation Options for Converting PDEs**  
 2242 **to Concentrations**

2243 **Examples for Converting PDEs into Permitted Elemental Impurity**  
 2244 **Concentrations**

2245 **Option 1:** Permitted common concentration limits of elemental impurities across drug  
 2246 product component materials for products with daily intakes of not more than 10 grams.

2247 For this example, consider a solid oral drug product with a maximum daily intake of 2.5  
 2248 grams, containing 9 components (1 drug substance and 8 excipients, see Table A.4.1).  
 2249 Because this drug product does not exceed a maximum daily intake of 10 grams, the  
 2250 concentrations in Table A.2.2 may be used. As Option 1 has a common permitted  
 2251 concentration, each of the 9 components can be used at any level in the formulation. The  
 2252 drug substance synthesis uses Pd and Ni catalysts, and the applicant is also concerned  
 2253 about Pb, As, Cd, Hg, and V on the basis of the risk assessment. The maximum daily  
 2254 intake of each elemental impurity in the drug product is given in Table A.4.2 assuming  
 2255 that each elemental impurity is present at the concentration given in Table A.2.2. The  
 2256 maximum potential daily intake of an elemental impurity is determined using the actual  
 2257 drug product daily intake and the concentration limit for the elemental impurity in Table  
 2258 A.2.2 (concentration multiplied by the actual daily intake of the drug product of 2.5  
 2259 grams). The maximum daily intake given for each elemental impurity is not a  
 2260 summation of values found in the individual columns.

2261 This calculation demonstrates that no elemental impurities exceed their PDEs. Thus if  
 2262 these concentrations in each component are not exceeded, the drug product is assured to  
 2263 meet the PDEs for each identified elemental impurity.

2264 **Table A.4.1: Maximum Daily Intake of Components of the Drug Product**

<b>Component</b>	<b>Daily Intake, g</b>
Drug Substance	0.200
MCC	1.100
Lactose	0.450
Ca Phosphate	0.350
Crospovidone	0.265
Mg Stearate	0.035
HPMC	0.060
Titanium Dioxide	0.025
Iron Oxide	0.015
<b>Drug Product</b>	<b>2.500</b>

2265  
 2266

2267 **Table A.4.2: Permitted Concentrations from Table A.2.2 (assuming uniform**  
 2268 **concentrations and 10 grams daily intake)**

Component	Maximum Permitted Concentration (µg/g)						
	Pb	As	Cd	Hg	Pd	V	Ni
Drug Substance	0.5	1.5	0.5	4	10	12	60
MCC	0.5	1.5	0.5	4	10	12	60
Lactose	0.5	1.5	0.5	4	10	12	60
Ca Phosphate	0.5	1.5	0.5	4	10	12	60
Crospovidone	0.5	1.5	0.5	4	10	12	60
Mg Stearate	0.5	1.5	0.5	4	10	12	60
HPMC	0.5	1.5	0.5	4	10	12	60
Titanium Dioxide	0.5	1.5	0.5	4	10	12	60
Iron Oxide	0.5	1.5	0.5	4	10	12	60
<b>Maximum Daily intake, µg</b>	<b>1.25</b>	<b>3.75</b>	<b>1.25</b>	<b>10</b>	<b>25</b>	<b>30</b>	<b>150</b>
<b>PDE, µg/day</b>	<b>5.0</b>	<b>15</b>	<b>5.0</b>	<b>40</b>	<b>100</b>	<b>120</b>	<b>600</b>

2269  
 2270 **Option 2a:** Permitted common concentration limits across drug product component  
 2271 materials for a product with a specified daily intake:

2272 For this example, consider the same solid oral drug product with a maximum daily  
 2273 intake of 2.5 grams, containing 9 components (1 drug substance and 8 excipients, see  
 2274 Table A.4.1) used in Option 1. As Option 2a has a common permitted concentration,  
 2275 each of the 9 components can be used at any level in the formulation. The drug  
 2276 substance synthesis uses Pd and Ni catalysts, and the applicant is also concerned about  
 2277 Pb, As, Cd, Hg, and V on the basis of the risk assessment. The concentration of each  
 2278 elemental impurity identified in the risk assessment can be calculated using the PDEs in  
 2279 Table A.2.1 and equation 1.

2280 The maximum potential daily intake of an elemental impurity is determined using the  
 2281 actual drug product daily intake and the concentration limit for the elemental impurity  
 2282 in Table A.4.3 (concentration multiplied by the actual daily intake of the drug product of  
 2283 2.5 grams). The maximum daily intake given for each elemental impurity is not a  
 2284 summation of values found in the individual columns.

2285 This calculation also demonstrates that no elemental impurities exceed their PDEs. Thus  
 2286 if these concentrations in each component are not exceeded, the drug product is assured  
 2287 to meet the PDEs for each identified elemental impurity.

2288 The factor of 4 increase in Option 2a for permitted concentration seen when comparing  
 2289 Option 1 and Option 2a concentration limits is due to the use of 10 grams and 2.5 grams  
 2290 respectively as daily intake of the drug product.

2291



2292 **Table A.4.3: Calculation of Maximum Permitted Concentrations Assuming**  
 2293 **Uniform Concentrations in a Product with a Specified Daily Intake:**

Component	Maximum Permitted Concentration (µg/g)						
	Pb	As	Cd	Hg	Pd	V	Ni
Drug Substance	2	6	2	16	40	48	240
MCC	2	6	2	16	40	48	240
Lactose	2	6	2	16	40	48	240
Ca Phosphate	2	6	2	16	40	48	240
Crospovidone	2	6	2	16	40	48	240
Mg Stearate	2	6	2	16	40	48	240
HPMC	2	6	2	16	40	48	240
Titanium Dioxide	2	6	2	16	40	48	240
Iron Oxide	2	6	2	16	40	48	240
<b>Maximum Daily intake, µg</b>	<b>5.0</b>	<b>15</b>	<b>5.0</b>	<b>40</b>	<b>100</b>	<b>120</b>	<b>600</b>
<b>PDE, µg/day</b>	<b>5.0</b>	<b>15</b>	<b>5.0</b>	<b>40</b>	<b>100</b>	<b>120</b>	<b>600</b>

2294 **Option 2b:** Permitted concentration limits of elemental impurities across drug product  
 2295 component materials for a product with a specified daily intake:

2296 For this example, consider the same solid oral drug product with a maximum daily  
 2297 intake of 2.5 grams, containing 9 components (1 drug substance and 8 excipients, see  
 2298 Table A.4.1) used in Option 1 and 2a. The drug substance synthesis uses Pd and Ni  
 2299 catalysts, and the applicant is also concerned about Pb, As, Cd, Hg, and V on the basis of  
 2300 the risk assessment. To use Option 2b, the applicant must use the composition of the  
 2301 drug product and have additional knowledge regarding the content of each elemental  
 2302 impurity in the components. The applicant has generated the following data on  
 2303 elemental impurities in the components of the drug product:

2304 **Table A.4.4: Measured Concentrations of Elemental Impurities (µg/g) in the**  
 2305 **Components**

Component	Measured Concentration (µg/g)						
	Pb	As	Cd	Hg	Pd	V	Ni
Drug Substance	ND	0.5	ND	ND	20	ND	50
MCC	0.1	0.1	0.1	0.1	*	ND	ND
Lactose	0.1	0.1	0.1	0.1	*	ND	ND
Ca Phosphate	1	1	1	1	*	10	5
Crospovidone	0.1	0.1	0.1	0.1	*	ND	ND
Mg Stearate	0.5	0.5	0.5	0.5	*	ND	0.5
HPMC	0.1	0.1	0.1	0.1	*	ND	ND
Titanium Dioxide	20	1	1	1	*	1	ND
Iron Oxide	10	10	10	10	*	2000	50

2306 ND = Below the detection limit

2307 \* = The risk assessment identified that Pd was not a potential elemental impurity; a quantitative  
 2308 result was not obtained.

2309 The applicant also knows the maximum daily intake of the drug product is 2.5 grams  
 2310 and determines the maximum daily intake for each component as shown in Table A.4.5.  
 2311 Based on the observed levels (see Table A.4.4), the applicant evaluated the potential  
 2312 maximum permitted concentrations of each elemental impurity in the components. The  
 2313 concentrations selected (see Table A.4.5) were set at levels that would ensure the PDE is  
 2314 met if the maximum permitted concentration was reached for each component. The  
 2315 maximum daily intake in Table A.4.5 is the summation of the values obtained by  
 2316 multiplying the actual weight of the component by the maximum permitted  
 2317 concentration for each elemental impurity across all components.

2318 **Table A.4.5: Maximum Permitted Concentrations of Elemental Impurities in the**  
 2319 **Components**

Component	Maximum Permitted Concentration (µg/g)						
	Pb	As	Cd	Hg	Pd	V	Ni
Drug Substance	**	5	**	**	500	**	2000
MCC	0.5	5	1	10	*	**	**
Lactose	0.5	5	1	10	*	**	**
Ca Phosphate	5	5	5	40	*	125	475
Crospovidone	0.5	5	1	10	*	**	**
Mg Stearate	5	10	5	100	*	**	50
HPMC	2.5	5	1	10	*	**	**
Titanium Dioxide	40	20	10	25	*	50	**
Iron Oxide	20	100	50	200	*	5000	2000
<b>Maximum Daily intake, µg</b>	<b>4.3</b>	<b>14.5</b>	<b>4.8</b>	<b>39.9</b>	<b>100</b>	<b>120</b>	<b>598</b>
<b>PDE, µg/day</b>	<b>5.0</b>	<b>15</b>	<b>5.0</b>	<b>40</b>	<b>100</b>	<b>120</b>	<b>600</b>

2320 \* The risk assessment identified that Pd was not a potential elemental impurity; a quantitative  
 2321 result was not obtained.  
 2322 \*\* Quantitative results demonstrated less than the limit of detection.

2323 **Option 3: Finished Product Analysis**

2324 For this example, consider the same solid oral drug product with a maximum daily  
 2325 intake of 2.5 grams, containing 9 components (1 drug substance and 8 excipients) used in  
 2326 Option 1, 2a and 2b. The drug substance synthesis uses Pd and Ni catalysts, and the  
 2327 applicant is also concerned about Pb, As, Cd, Hg, and V on the basis of the risk  
 2328 assessment. The maximum concentration of each elemental impurity in the drug  
 2329 product may be calculated using the daily intake of drug product and the PDE of the  
 2330 elemental impurity using equation 1. The total mass of each elemental impurity should  
 2331 be not more than the PDE.

2332 
$$\text{Concentration}(\mu\text{g} / \text{g}) = \frac{\text{PDE}(\mu\text{g} / \text{day})}{2.5(\text{g} / \text{day})}$$

2333 **Table A.4.6: Calculation of Concentrations for the Finished Product**

	Daily Intake (g)	Maximum Permitted Concentration (µg/g)						
		Pb	As	Cd	Hg	Pd	V	Ni
Drug Product	2.5	2	6	2	16	40	40	800
Maximum Daily Intake (µg)		5	15	5	40	100	120	600

2334 **Illustrative Example – Elemental Impurities Assessment**  
 2335 The following example is intended as illustration of an elemental impurities risk  
 2336 assessment. This example is intended for illustrative purposes and not as the only way  
 2337 to document the assessment. There are many different ways to approach the risk  
 2338 assessment process and its documentation.

2339 This example relies on the oral drug product described in Appendix 4. Consider a solid  
 2340 oral drug product with a maximum daily intake of 2.5 grams, containing 9 components (1  
 2341 drug substance and 8 excipients). The drug substance synthesis uses Pd and Ni catalysts.

2342 The applicant conducts the risk assessment starting with the identification of potential  
 2343 elemental impurities following the process described in Section 5. Since the applicant  
 2344 had limited historical data for the excipients used in the drug product, the applicant  
 2345 determined that the Class 1 elementals (As, Cd, Hg, Pb) would be taken through the  
 2346 evaluation phase. The table below shows a summary of the findings of the identification  
 2347 stage of the assessment.

2348 **Table A.4.7: Identification of Potential Elemental Impurities**

Component	Potential Elemental Impurities			
	Intentionally added	Potential elemental impurities with a relatively high abundance and/or are impurities in excipients or reagents	Potential elemental impurities from manufacturing equipment	Potential elemental impurities from container closure systems
Drug Substance	Pd, Ni	As	Ni	None
MCC	None	As, Cd, Hg, Pb		None
Lactose	None	As, Cd, Hg, Pb		None
Ca Phosphate	None	As, Cd, Hg, Pb	V, Ni	None
Crospovidone	None	As, Cd, Hg, Pb		None
Mg stearate	None	As, Cd, Hg, Pb	Ni	None
HPMC	None	As, Cd, Hg, Pb		None
Titanium Dioxide	None	As, Cd, Hg, Pb	V	None
Iron Oxide	None	As, Cd, Hg, Pb	V, Ni	None

2349 The identification phase of the assessment identified seven potential elemental  
 2350 impurities requiring additional evaluation. Three of the identified elemental impurities  
 2351 were found in multiple components. The applicant continued the risk assessment  
 2352 collecting information from the vendor and available development data. The summary of  
 2353 the results can be found in Table A.4.3. The application of the individual component data  
 2354 to the evaluation in the assessment process is shown below in Table A.4.8.  
 2355  
 2356

2357 **Table A.4.8: Elemental Impurity Assessment – Evaluation of Daily Contribution to the Total Mass of Elemental Impurities in the Drug Product**

Component	Daily intake, g	Measured Concentration (µg/g)										Total Daily Mass of Elemental Impurity, µg									
		Pb	As	Cd	Hg	Pd	V	Ni	Pb	As	Cd	Hg	Pd	V	Ni						
Drug Substance	0.2	ND	0.5	ND	ND	20	ND	ND	50	0	0.1	0	4	0	10						
MCC	1.1	0.1	0.1	0.1	0.1	*	ND	ND	ND	0.11	0.11	0.11	0	0	0						
Lactose	0.45	0.1	0.1	0.1	0.1	*	ND	ND	ND	0.045	0.045	0.045	0	0	0						
Ca Phosphate	0.35	1	1	1	1	*	10	5	5	0.35	0.35	0.35	0	3.5	1.75						
Crospovidone	0.265	0.1	0.1	0.1	0.1	*	ND	ND	ND	0.0265	0.0265	0.0265	0	0	0						
Mg stearate	0.035	0.5	0.5	0.5	0.5	*	ND	0.5	0.5	0.0175	0.0175	0.0175	0	0	0.0175						
HPMC	0.06	0.1	0.1	0.1	0.1	*	ND	ND	ND	0.006	0.006	0.006	0	0	0						
Titanium Dioxide	0.025	20	1	1	1	*	1	ND	ND	0.5	0.025	0.025	0	0.025	0						
Iron Oxide	0.015	10	10	10	10	*	400	50	50	0.15	0.15	0.15	0	6	0.75						

total daily mass, µg/day	1.2	0.8	0.7	0.7	4.0	9.5	12.5
--------------------------	-----	-----	-----	-----	-----	-----	------

2358

2359 **Table A.4.9: Assessment Example – Data Entry Descriptions**

- 2360 Column 1: Review the components of drug product for any elements intentionally added in the production (the primary source is the drug substance). For those used, record the elements for further consideration in the assessment.
- 2361 Column 2: Identify any potential elements or impurities that are associated with excipients or reagents used in the preparation of the drug product. Record the source(s) for further consideration in the assessment.
- 2362 Column 3: Identify any elemental impurities known or expected to be leached from the manufacturing equipment. Record the specific elemental impurities for further consideration in the assessment.
- 2363 Column 4: Identify any elemental impurities known or expected to be leached from the container closure system. Record the specific elemental impurities for further consideration in the assessment.
- 2364 Column 5: Calculate the total contribution of the potential elemental impurity by summing the contributions across the components of the drug product.

- 2370 Column 6: Assess the variability of the elemental impurity level(s) in the components  
 2371 Column 7: Enter the control threshold of each potential elemental impurity identified. If the variability is known and it is within  
 2372 acceptable limits, the control threshold (30% of the PDE) for each elemental impurity can be applied.  
 2373 Column 8: Describe action taken – none if the value in column 6 is less than or equal to the control threshold (column 7). Define  
 2374 control element if material variability is high or control threshold is exceeded.  
 2375

Element	1 Intentionally added (if used in the process)	2 Elemental impurities with a relatively high abundance and/or are impurities in excipients or reagents	3 Manufacturing equipment	4 Leached from container closure systems	5 Total elemental impurity contribution µg/day	6 Acceptable variability of elemental impurity contribution	7 Control threshold	8 Action
As	No	Observed contaminant in all excipients and drug substance	No	No	0.8	yes	4.5	no further controls required
Cd	No	Observed contaminant in all excipients	No	No	0.7	yes	1.5	no further controls required
Hg	No	Observed contaminant in all excipients	No	No	0.7	yes	12	no further controls required
Pb	No	Observed contaminant in all excipients	No	No	1.2	yes	1.5	no further controls required
Pd	API catalyst	No	No	No	4.0	yes	30	no further controls required
Ni	API catalyst	Observed in 3 excipients	No	No	12.5	yes	180	no further controls required
V	No	Observed in 3 excipients	No	No	9.5	yes	36	no further controls required

2376

---

# **Guidance for Industry**

## **Q7A Good Manufacturing Practice Guidance for Active Pharmaceutical Ingredients**

**U.S. Department of Health and Human Services  
Food and Drug Administration  
Center for Drug Evaluation and Research (CDER)  
Center for Biologics Evaluation and Research (CBER)  
August 2001  
ICH**

# Guidance for Industry

## Q7A Good Manufacturing Practice Guidance for Active Pharmaceutical Ingredients

*Additional copies are available from:*

*Office of Training and Communications  
Division of Communications Management  
Drug Information Branch, HFD-210  
5600 Fishers Lane  
Rockville, MD 20857  
(Tel) 301-827-4573  
(Internet) <http://www.fda.gov/cder/guidance/index.htm>*

*or*

*Office of Communication, Training and  
Manufacturers Assistance, HFM-40  
Center for Biologics Evaluation and Research  
Food and Drug Administration  
1401 Rockville Pike, Rockville, MD 20852-1448  
Internet: <http://www.fda.gov/cber/guidelines.htm>.  
Fax: 1-888-CBERFAX or 301-827-3844  
Mail: the Voice Information System at 800-835-4709 or 301-827-1800*

**U.S. Department of Health and Human Services  
Food and Drug Administration  
Center for Drug Evaluation and Research (CDER)  
Center for Biologics Evaluation and Research (CBER)  
August 2001  
ICH**

P. 2

UT Ex. 2044  
SteadyMed v. United Therapeutics  
IPR2016-00006

IPR2020-00769  
United Therapeutics EX2006  
Page 5291 of 7113

**Table Of Contents**

**I. INTRODUCTION (1) ..... 1**

- A. Objective (1.1).....1
- B. Regulatory Applicability (1.2).....2
- C. Scope (1.3).....2

**II. QUALITY MANAGEMENT (2) ..... 5**

- A. Principles (2.1).....5
- B. Responsibilities of the Quality Unit(s) (2.2).....5
- C. Responsibility for Production Activities (2.3) .....6
- D. Internal Audits (Self Inspection) (2.4).....7
- E. Product Quality Review (2.5).....7

**III. PERSONNEL (3)..... 8**

- A. Personnel Qualifications (3.1).....8
- B. Personnel Hygiene (3.2).....8
- C. Consultants (3.3).....9

**IV. BUILDINGS AND FACILITIES (4) ..... 9**

- A. Design and Construction (4.1).....9
- B. Utilities (4.2).....10
- C. Water (4.3) .....10
- D. Containment (4.4).....11
- E. Lighting (4.5) .....11
- F. Sewage and Refuse (4.6) .....11
- G. Sanitation and Maintenance (4.7).....11

**V. PROCESS EQUIPMENT (5) ..... 12**

- A. Design and Construction (5.1).....12
- B. Equipment Maintenance and Cleaning (5.2).....12
- C. Calibration (5.3) .....13
- D. Computerized Systems (5.4).....14

**VI. DOCUMENTATION AND RECORDS (6) ..... 15**

- A. Documentation System and Specifications (6.1) .....15
- B. Equipment Cleaning and Use Record (6.2) .....15
- C. Records of Raw Materials, Intermediates, API Labeling and Packaging Materials (6.3)....16



D.	Master Production Instructions (Master Production and Control Records) (6.4)	16
E.	Batch Production Records (Batch Production and Control Records) (6.5)	17
F.	Laboratory Control Records (6.6)	18
G.	Batch Production Record Review (6.7)	19
<b>VII.</b>	<b>MATERIALS MANAGEMENT (7)</b>	<b>19</b>
A.	General Controls (7.1)	19
B.	Receipt and Quarantine (7.2)	19
C.	Sampling and Testing of Incoming Production Materials (7.3)	20
D.	Storage (7.4)	21
E.	Re-evaluation (7.5)	21
<b>VIII.</b>	<b>PRODUCTION AND IN-PROCESS CONTROLS (8)</b>	<b>21</b>
A.	Production Operations (8.1)	21
B.	Time Limits (8.2)	22
C.	In-process Sampling and Controls (8.3)	22
D.	Blending Batches of Intermediates or APIs (8.4)	23
E.	Contamination Control (8.5)	24
<b>IX.</b>	<b>PACKAGING AND IDENTIFICATION LABELING OF APIs AND INTERMEDIATES (9)</b>	<b>24</b>
A.	General (9.1)	24
B.	Packaging Materials (9.2)	25
C.	Label Issuance and Control (9.3)	25
D.	Packaging and Labeling Operations (9.4)	26
<b>X.</b>	<b>STORAGE AND DISTRIBUTION (10)</b>	<b>26</b>
A.	Warehousing Procedures (10.1)	26
B.	Distribution Procedures (10.2)	27
<b>XI.</b>	<b>LABORATORY CONTROLS (11)</b>	<b>27</b>
A.	General Controls (11.1)	27
B.	Testing of Intermediates and APIs (11.2)	28
C.	Validation of Analytical Procedures - See Section 12. (11.3)	29
D.	Certificates of Analysis (11.4)	29
E.	Stability Monitoring of APIs (11.5)	29
F.	Expiry and Retest Dating (11.6)	30
G.	Reserve/Retention Samples (11.7)	30

<b>XII. VALIDATION (12)</b> .....	<b>31</b>
A. Validation Policy (12.1) .....	31
B. Validation Documentation (12.2).....	31
C. Qualification (12.3) .....	32
D. Approaches to Process Validation (12.4) .....	32
E. Process Validation Program (12.5).....	33
F. Periodic Review of Validated Systems (12.6) .....	33
G. Cleaning Validation (12.7).....	34
H. Validation of Analytical Methods (12.8) .....	35
<b>XIII. CHANGE CONTROL (13)</b> .....	<b>35</b>
<b>XIV. REJECTION AND RE-USE OF MATERIALS (14)</b> .....	<b>36</b>
A. Rejection (14.1).....	36
B. Reprocessing (14.2) .....	36
C. Reworking (14.3) .....	36
D. Recovery of Materials and Solvents (14.4) .....	37
E. Returns (14.5) .....	37
<b>XV. COMPLAINTS AND RECALLS (15)</b> .....	<b>37</b>
<b>XVI. CONTRACT MANUFACTURERS (INCLUDING LABORATORIES) (16)</b> .....	<b>38</b>
<b>XVII. AGENTS, BROKERS, TRADERS, DISTRIBUTORS, REPACKERS, AND RELABELLERS (17)</b> .....	<b>39</b>
A. Applicability (17.1).....	39
B. Traceability of Distributed APIs and Intermediates (17.2) .....	39
C. Quality Management (17.3).....	39
D. Repackaging, Relabeling, and Holding of APIs and Intermediates (17.4) .....	39
E. Stability (17.5).....	40
F. Transfer of Information (17.6) .....	40
G. Handling of Complaints and Recalls (17.7) .....	40
H. Handling of Returns (17.8).....	41
<b>XVIII. SPECIFIC GUIDANCE FOR APIs MANUFACTURED BY CELL CULTURE/FERMENTATION (18)</b> .....	<b>41</b>
A. General (18.1) .....	41
B. Cell Bank Maintenance and Record Keeping (18.2).....	42
C. Cell Culture/Fermentation (18.3) .....	42

D. Harvesting, Isolation and Purification (18.4) .....	43
E. Viral Removal/Inactivation steps (18.5).....	44
<b>XIX. APIs FOR USE IN CLINICAL TRIALS (19) .....</b>	<b>44</b>
A. General (19.1) .....	44
B. Quality (19.2) .....	45
C. Equipment and Facilities (19.3) .....	45
D. Control of Raw Materials (19.4).....	45
E. Production (19.5).....	45
F. Validation (19.6).....	46
G. Changes (19.7) .....	46
H. Laboratory Controls (19.8) .....	46
I. Documentation (19.9).....	46
<b>GLOSSARY (20) .....</b>	<b>47</b>

# Guidance for Industry<sup>1</sup>

## Q7A Good Manufacturing Practice Guidance for Active Pharmaceutical Ingredients

This guidance represents the Food and Drug Administration's (FDA's) current thinking on this topic. It does not create or confer any rights for or on any person and does not operate to bind FDA or the public. An alternative approach may be used if such approach satisfies the requirements of the applicable statutes and regulations.

### I. INTRODUCTION (1)

#### A. Objective (1.1)

This document is intended to provide guidance regarding good manufacturing practice (GMP) for the manufacturing of active pharmaceutical ingredients (APIs) under an appropriate system for managing quality. It is also intended to help ensure that APIs meet the quality and purity characteristics that they purport, or are represented, to possess.

In this guidance, the term *manufacturing* is defined to include all operations of receipt of materials, production, packaging, repackaging, labeling, relabeling, quality control, release, storage and distribution of APIs and the related controls. In this guidance, the term *should* identifies recommendations that, when followed, will ensure compliance with CGMPs. An alternative approach may be used if such approach satisfies the requirements of the applicable statutes. For the purposes of this guidance, the terms *current good manufacturing practices* and *good manufacturing practices* are equivalent.

---

<sup>1</sup> This guidance was developed within the Expert Working Group (Q7A) of the International Conference on Harmonisation of Technical Requirements for Registration of Pharmaceuticals for Human Use (ICH) and has been subject to consultation by the regulatory parties, in accordance with the ICH process. This document has been endorsed by the ICH Steering Committee at *Step 4* of the ICH process, November 2000. At *Step 4* of the process, the final draft is recommended for adoption to the regulatory bodies of the European Union, Japan, and the United States.

Arabic numbers in subheadings reflect the organizational breakdown in the document endorsed by the ICH Steering Committee at *Step 4* of the ICH process, November 2000.

The guidance as a whole does not cover safety aspects for the personnel engaged in manufacturing, nor aspects related to protecting the environment. These controls are inherent responsibilities of the manufacturer and are governed by national laws.

This guidance is not intended to define registration and/or filing requirements or modify pharmacopoeial requirements. This guidance does not affect the ability of the responsible regulatory agency to establish specific registration/filing requirements regarding APIs within the context of marketing/manufacturing authorizations or drug applications. All commitments in registration/filing documents should be met.

## **B. Regulatory Applicability (1.2)**

Within the world community, materials may vary as to their legal classification as an API. When a material is classified as an API in the region or country in which it is manufactured or used in a drug product, it should be manufactured according to this guidance.

## **C. Scope (1.3)**

This guidance applies to the manufacture of APIs for use in human drug (medicinal) products. It applies to the manufacture of sterile APIs only up to the point immediately prior to the APIs being rendered sterile. The sterilization and aseptic processing of sterile APIs are not covered by this guidance, but should be performed in accordance with GMP guidances for drug (medicinal) products as defined by local authorities.

This guidance covers APIs that are manufactured by chemical synthesis, extraction, cell culture/fermentation, recovery from natural sources, or any combination of these processes. Specific guidance for APIs manufactured by cell culture/fermentation is described in Section XVIII (18).

This guidance excludes all vaccines, whole cells, whole blood and plasma, blood and plasma derivatives (plasma fractionation), and gene therapy APIs. However, it does include APIs that are produced using blood or plasma as raw materials. Note that cell substrates (mammalian, plant, insect or microbial cells, tissue or animal sources including transgenic animals) and early process steps may be subject to GMP but are not covered by this guidance. In addition, the guidance does not apply to medical gases, bulk-packaged drug (medicinal) products (e.g., tablets or capsules in bulk containers), or radiopharmaceuticals.

Section XIX (19) contains guidance that only applies to the manufacture of APIs used in the production of drug (medicinal) products specifically for clinical trials (investigational medicinal products).

An *API starting material* is a raw material, an intermediate, or an API that is used in the production of an API and that is incorporated as a significant structural fragment into the structure of the API. An API starting material can be an article of commerce, a material

purchased from one or more suppliers under contract or commercial agreement, or produced in-house. API starting materials normally have defined chemical properties and structure.

The company should designate and document the rationale for the point at which production of the API begins. For synthetic processes, this is known as the point at which API starting materials are entered into the process. For other processes (e.g., fermentation, extraction, purification), this rationale should be established on a case-by-case basis. Table 1 gives guidance on the point at which the API starting material is normally introduced into the process.

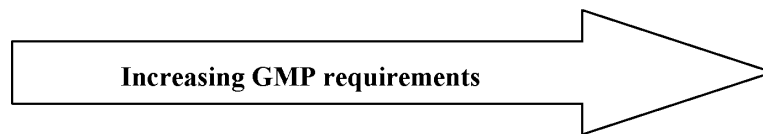
From this point on, appropriate GMP as defined in this guidance should be applied to these intermediate and/or API manufacturing steps. This would include the validation of critical process steps determined to impact the quality of the API. However, it should be noted that the fact that a company chooses to validate a process step does not necessarily define that step as critical.

The guidance in this document would normally be applied to the steps shown in gray in Table 1. However, all steps shown may not need to be completed. The stringency of GMP in API manufacturing should increase as the process proceeds from early API steps to final steps, purification, and packaging. Physical processing of APIs, such as granulation, coating or physical manipulation of particle size (e.g., milling, micronizing) should be conducted according to this guidance.

This GMP guidance does not apply to steps prior to the introduction of the defined API starting material.

**Table 1: Application of this Guidance to API Manufacturing**

<b>Type of Manufacturing</b>	<b>Application of this guidance to steps (shown in gray) used in this type of manufacturing</b>				
Chemical Manufacturing	Production of the API starting material	Introduction of the API starting material into process	Production of Intermediate(s)	Isolation and purification	Physical processing, and packaging
API derived from animal sources	Collection of organ, fluid, or tissue	Cutting, mixing, and/or initial processing	Introduction of the API starting material into process	Isolation and purification	Physical processing, and packaging
API extracted from plant sources	Collection of plant	Cutting and initial extraction(s)	Introduction of the API starting material into process	Isolation and purification	Physical processing, and packaging
Herbal extracts used as API	Collection of plants	Cutting and initial extraction		Further extraction	Physical processing, and packaging
API consisting of comminuted or powdered herbs	Collection of plants and/or cultivation and harvesting	Cutting/ comminuting			Physical processing, and packaging
Biotechnology: fermentation/ cell culture	Establishment of master cell bank and working cell bank	Maintenance of working cell bank	Cell culture and/or fermentation	Isolation and purification	Physical processing, and packaging
“Classical” Fermentation to produce an API	Establishment of cell bank	Maintenance of the cell bank	Introduction of the cells into fermentation	Isolation and purification	Physical processing, and packaging



## **II. QUALITY MANAGEMENT (2)**

### **A. Principles (2.1)**

Quality should be the responsibility of all persons involved in manufacturing.

Each manufacturer should establish, document, and implement an effective system for managing quality that involves the active participation of management and appropriate manufacturing personnel.

The system for managing quality should encompass the organizational structure, procedures, processes and resources, as well as activities to ensure confidence that the API will meet its intended specifications for quality and purity. All quality-related activities should be defined and documented.

There should be a quality unit(s) that is independent of production and that fulfills both quality assurance (*QA*) and quality control (*QC*) responsibilities. The quality unit can be in the form of separate QA and QC units or a single individual or group, depending upon the size and structure of the organization.

The persons authorized to release intermediates and APIs should be specified.

All quality-related activities should be recorded at the time they are performed.

Any deviation from established procedures should be documented and explained. Critical deviations should be investigated, and the investigation and its conclusions should be documented.

No materials should be released or used before the satisfactory completion of evaluation by the quality unit(s) unless there are appropriate systems in place to allow for such use (e.g., release under quarantine as described in Section X (10) or the use of raw materials or intermediates pending completion of evaluation).

Procedures should exist for notifying responsible management in a timely manner of regulatory inspections, serious GMP deficiencies, product defects and related actions (e.g., quality-related complaints, recalls, and regulatory actions).

### **B. Responsibilities of the Quality Unit(s) (2.2)**

The quality unit(s) should be involved in all quality-related matters.

The quality unit(s) should review and approve all appropriate quality-related documents.



The main responsibilities of the independent quality unit(s) should not be delegated. These responsibilities should be described in writing and should include, but not necessarily be limited to:

1. Releasing or rejecting all APIs. Releasing or rejecting intermediates for use outside the control of the manufacturing company
2. Establishing a system to release or reject raw materials, intermediates, packaging, and labeling materials
3. Reviewing completed batch production and laboratory control records of critical process steps before release of the API for distribution
4. Making sure that critical deviations are investigated and resolved
5. Approving all specifications and master production instructions
6. Approving all procedures affecting the quality of intermediates or APIs
7. Making sure that internal audits (self-inspections) are performed
8. Approving intermediate and API contract manufacturers
9. Approving changes that potentially affect intermediate or API quality
10. Reviewing and approving validation protocols and reports
11. Making sure that quality-related complaints are investigated and resolved
12. Making sure that effective systems are used for maintaining and calibrating critical equipment
13. Making sure that materials are appropriately tested and the results are reported
14. Making sure that there is stability data to support retest or expiry dates and storage conditions on APIs and/or intermediates, where appropriate
15. Performing product quality reviews (as defined in Section 2.5)

**C. Responsibility for Production Activities (2.3)**

The responsibility for production activities should be described in writing and should include, but not necessarily be limited to:

1. Preparing, reviewing, approving, and distributing the instructions for the production of intermediates or APIs according to written procedures
2. Producing APIs and, when appropriate, intermediates according to pre-approved instructions
3. Reviewing all production batch records and ensuring that these are completed and signed
4. Making sure that all production deviations are reported and evaluated and that critical deviations are investigated and the conclusions are recorded
5. Making sure that production facilities are clean and, when appropriate, disinfected
6. Making sure that the necessary calibrations are performed and records kept
7. Making sure that the premises and equipment are maintained and records kept
8. Making sure that validation protocols and reports are reviewed and approved
9. Evaluating proposed changes in product, process or equipment
10. Making sure that new and, when appropriate, modified facilities and equipment are qualified

**D. Internal Audits (Self Inspection) (2.4)**

To verify compliance with the principles of GMP for APIs, regular internal audits should be performed in accordance with an approved schedule.

Audit findings and corrective actions should be documented and brought to the attention of responsible management of the firm. Agreed corrective actions should be completed in a timely and effective manner.

**E. Product Quality Review (2.5)**

Regular quality-reviews of APIs should be conducted with the objective of verifying the consistency of the process. Such reviews should normally be conducted and documented annually and should include at least:

- A review of critical in-process control and critical API test results
- A review of all batches that failed to meet established specification(s)
- A review of all critical deviations or nonconformances and related investigations
- A review of any changes carried out to the processes or analytical methods;
- A review of results of the stability monitoring program

- A review of all quality-related returns, complaints and recalls
- A review of adequacy of corrective actions

The results of this review should be evaluated and an assessment made of whether corrective action or any revalidation should be undertaken. Reasons for such corrective action should be documented. Agreed corrective actions should be completed in a timely and effective manner.

### **III. PERSONNEL (3)**

#### **A. Personnel Qualifications (3.1)**

There should be an adequate number of personnel qualified by appropriate education, training, and/or experience to perform and supervise the manufacture of intermediates and APIs.

The responsibilities of all personnel engaged in the manufacture of intermediates and APIs should be specified in writing.

Training should be regularly conducted by qualified individuals and should cover, at a minimum, the particular operations that the employee performs and GMP as it relates to the employee's functions. Records of training should be maintained. Training should be periodically assessed.

#### **B. Personnel Hygiene (3.2)**

Personnel should practice good sanitation and health habits.

Personnel should wear clean clothing suitable for the manufacturing activity with which they are involved and this clothing should be changed, when appropriate. Additional protective apparel, such as head, face, hand, and arm coverings, should be worn, when necessary, to protect intermediates and APIs from contamination.

Personnel should avoid direct contact with intermediates or APIs.

Smoking, eating, drinking, chewing and the storage of food should be restricted to certain designated areas separate from the manufacturing areas.

Personnel suffering from an infectious disease or having open lesions on the exposed surface of the body should not engage in activities that could result in compromising the quality of APIs. Any person shown at any time (either by medical examination or supervisory observation) to have an apparent illness or open lesions should be excluded from activities where the health condition could adversely affect the quality of the APIs until the condition is corrected or qualified medical personnel determine that the person's inclusion would not jeopardize the safety or quality of the APIs.

**C. Consultants (3.3)**

Consultants advising on the manufacture and control of intermediates or APIs should have sufficient education, training, and experience, or any combination thereof, to advise on the subject for which they are retained.

Records should be maintained stating the name, address, qualifications, and type of service provided by these consultants.

**IV. BUILDINGS AND FACILITIES (4)**

**A. Design and Construction (4.1)**

Buildings and facilities used in the manufacture of intermediates and APIs should be located, designed, and constructed to facilitate cleaning, maintenance, and operations as appropriate to the type and stage of manufacture. Facilities should also be designed to minimize potential contamination. Where microbiological specifications have been established for the intermediate or API, facilities should also be designed to limit exposure to objectionable microbiological contaminants, as appropriate.

Buildings and facilities should have adequate space for the orderly placement of equipment and materials to prevent mix-ups and contamination.

Where the equipment itself (e.g., closed or contained systems) provides adequate protection of the material, such equipment can be located outdoors.

The flow of materials and personnel through the building or facilities should be designed to prevent mix-ups or contamination.

There should be defined areas or other control systems for the following activities:

- Receipt, identification, sampling, and quarantine of incoming materials, pending release or rejection
- Quarantine before release or rejection of intermediates and APIs
- Sampling of intermediates and APIs
- Holding rejected materials before further disposition (e.g., return, reprocessing or destruction)
- Storage of released materials
- Production operations
- Packaging and labeling operations
- Laboratory operations

Adequate and clean washing and toilet facilities should be provided for personnel. These facilities should be equipped with hot and cold water, as appropriate, soap or detergent, air

dryers, or single service towels. The washing and toilet facilities should be separate from, but easily accessible to, manufacturing areas. Adequate facilities for showering and/or changing clothes should be provided, when appropriate.

Laboratory areas/operations should normally be separated from production areas. Some laboratory areas, in particular those used for in-process controls, can be located in production areas, provided the operations of the production process do not adversely affect the accuracy of the laboratory measurements, and the laboratory and its operations do not adversely affect the production process, intermediate, or API.

#### **B. Utilities (4.2)**

All utilities that could affect product quality (e.g., steam, gas, compressed air, heating, ventilation, and air conditioning) should be qualified and appropriately monitored and action should be taken when limits are exceeded. Drawings for these utility systems should be available.

Adequate ventilation, air filtration and exhaust systems should be provided, where appropriate. These systems should be designed and constructed to minimize risks of contamination and cross-contamination and should include equipment for control of air pressure, microorganisms (if appropriate), dust, humidity, and temperature, as appropriate to the stage of manufacture. Particular attention should be given to areas where APIs are exposed to the environment.

If air is recirculated to production areas, appropriate measures should be taken to control risks of contamination and cross-contamination.

Permanently installed pipework should be appropriately identified. This can be accomplished by identifying individual lines, documentation, computer control systems, or alternative means. Pipework should be located to avoid risks of contamination of the intermediate or API.

Drains should be of adequate size and should be provided with an air break or a suitable device to prevent back-siphonage, when appropriate.

#### **C. Water (4.3)**

Water used in the manufacture of APIs should be demonstrated to be suitable for its intended use.

Unless otherwise justified, process water should, at a minimum, meet World Health Organization (WHO) guidelines for drinking (potable) water quality.

If drinking (potable) water is insufficient to ensure API quality and tighter chemical and/or microbiological water quality specifications are called for, appropriate specifications for physical/chemical attributes, total microbial counts, objectionable organisms, and/or endotoxins should be established.

Where water used in the process is treated by the manufacturer to achieve a defined quality, the treatment process should be validated and monitored with appropriate action limits.

Where the manufacturer of a nonsterile API either intends or claims that it is suitable for use in further processing to produce a sterile drug (medicinal) product, water used in the final isolation and purification steps should be monitored and controlled for total microbial counts, objectionable organisms, and endotoxins.

**D. Containment (4.4)**

Dedicated production areas, which can include facilities, air handling equipment and/or process equipment, should be employed in the production of highly sensitizing materials, such as penicillins or cephalosporins.

The use of dedicated production areas should also be considered when material of an infectious nature or high pharmacological activity or toxicity is involved (e.g., certain steroids or cytotoxic anti-cancer agents) unless validated inactivation and/or cleaning procedures are established and maintained.

Appropriate measures should be established and implemented to prevent cross-contamination from personnel and materials moving from one dedicated area to another.

Any production activities (including weighing, milling, or packaging) of highly toxic nonpharmaceutical materials, such as herbicides and pesticides, should not be conducted using the buildings and/or equipment being used for the production of APIs. Handling and storage of these highly toxic nonpharmaceutical materials should be separate from APIs.

**E. Lighting (4.5)**

Adequate lighting should be provided in all areas to facilitate cleaning, maintenance, and proper operations.

**F. Sewage and Refuse (4.6)**

Sewage, refuse, and other waste (e.g., solids, liquids, or gaseous by-products from manufacturing) in and from buildings and the immediate surrounding area should be disposed of in a safe, timely, and sanitary manner. Containers and/or pipes for waste material should be clearly identified.

**G. Sanitation and Maintenance (4.7)**

Buildings used in the manufacture of intermediates and APIs should be properly maintained and repaired and kept in a clean condition.

Written procedures should be established assigning responsibility for sanitation and describing the cleaning schedules, methods, equipment, and materials to be used in cleaning buildings and facilities.

When necessary, written procedures should also be established for the use of suitable rodenticides, insecticides, fungicides, fumigating agents, and cleaning and sanitizing agents to prevent the contamination of equipment, raw materials, packaging/labeling materials, intermediates, and APIs.

## **V. PROCESS EQUIPMENT (5)**

### **A. Design and Construction (5.1)**

Equipment used in the manufacture of intermediates and APIs should be of appropriate design and adequate size, and suitably located for its intended use, cleaning, sanitation (where appropriate), and maintenance.

Equipment should be constructed so that surfaces that contact raw materials, intermediates, or APIs do not alter the quality of the intermediates and APIs beyond the official or other established specifications.

Production equipment should only be used within its qualified operating range.

Major equipment (e.g., reactors, storage containers) and permanently installed processing lines used during the production of an intermediate or API should be appropriately identified.

Any substances associated with the operation of equipment, such as lubricants, heating fluids or coolants, should not contact intermediates or APIs so as to alter the quality of APIs or intermediates beyond the official or other established specifications. Any deviations from this practice should be evaluated to ensure that there are no detrimental effects on the material's fitness for use. Wherever possible, food grade lubricants and oils should be used.

Closed or contained equipment should be used whenever appropriate. Where open equipment is used, or equipment is opened, appropriate precautions should be taken to minimize the risk of contamination.

A set of current drawings should be maintained for equipment and critical installations (e.g., instrumentation and utility systems).

### **B. Equipment Maintenance and Cleaning (5.2)**

Schedules and procedures (including assignment of responsibility) should be established for the preventative maintenance of equipment.

Written procedures should be established for cleaning equipment and its subsequent release for use in the manufacture of intermediates and APIs. Cleaning procedures should contain sufficient details to enable operators to clean each type of equipment in a reproducible and effective manner. These procedures should include:

- Assignment of responsibility for cleaning of equipment
- Cleaning schedules, including, where appropriate, sanitizing schedules
- A complete description of the methods and materials, including dilution of cleaning agents used to clean equipment
- When appropriate, instructions for disassembling and reassembling each article of equipment to ensure proper cleaning
- Instructions for the removal or obliteration of previous batch identification
- Instructions for the protection of clean equipment from contamination prior to use
- Inspection of equipment for cleanliness immediately before use, if practical
- Establishing the maximum time that may elapse between the completion of processing and equipment cleaning, when appropriate

Equipment and utensils should be cleaned, stored, and, where appropriate, sanitized or sterilized to prevent contamination or carry-over of a material that would alter the quality of the intermediate or API beyond the official or other established specifications.

Where equipment is assigned to continuous production or campaign production of successive batches of the same intermediate or API, equipment should be cleaned at appropriate intervals to prevent build-up and carry-over of contaminants (e.g., degradants or objectionable levels of microorganisms).

Nondedicated equipment should be cleaned between production of different materials to prevent cross-contamination.

Acceptance criteria for residues and the choice of cleaning procedures and cleaning agents should be defined and justified.

Equipment should be identified as to its contents and its cleanliness status by appropriate means.

### **C. Calibration (5.3)**

Control, weighing, measuring, monitoring, and testing equipment critical for ensuring the quality of intermediates or APIs should be calibrated according to written procedures and an established schedule.

Equipment calibrations should be performed using standards traceable to certified standards, if they exist.

Records of these calibrations should be maintained.



The current calibration status of critical equipment should be known and verifiable.

Instruments that do not meet calibration criteria should not be used.

Deviations from approved standards of calibration on critical instruments should be investigated to determine if these could have had an effect on the quality of the intermediate(s) or API(s) manufactured using this equipment since the last successful calibration.

#### **D. Computerized Systems (5.4)**

GMP-related computerized systems should be validated. The depth and scope of validation depends on the diversity, complexity, and criticality of the computerized application.

Appropriate installation and operational qualifications should demonstrate the suitability of computer hardware and software to perform assigned tasks.

Commercially available software that has been qualified does not require the same level of testing. If an existing system was not validated at time of installation, a retrospective validation could be conducted if appropriate documentation is available.

Computerized systems should have sufficient controls to prevent unauthorized access or changes to data. There should be controls to prevent omissions in data (e.g., system turned off and data not captured). There should be a record of any data change made, the previous entry, who made the change, and when the change was made.

Written procedures should be available for the operation and maintenance of computerized systems.

Where critical data are being entered manually, there should be an additional check on the accuracy of the entry. This can be done by a second operator or by the system itself.

Incidents related to computerized systems that could affect the quality of intermediates or APIs or the reliability of records or test results should be recorded and investigated.

Changes to computerized systems should be made according to a change procedure and should be formally authorized, documented, and tested. Records should be kept of all changes, including modifications and enhancements made to the hardware, software, and any other critical component of the system. These records should demonstrate that the system is maintained in a validated state.

If system breakdowns or failures would result in the permanent loss of records, a back-up system should be provided. A means of ensuring data protection should be established for all computerized systems.

Data can be recorded by a second means in addition to the computer system.

## **VI. DOCUMENTATION AND RECORDS (6)**

### **A. Documentation System and Specifications (6.1)**

All documents related to the manufacture of intermediates or APIs should be prepared, reviewed, approved, and distributed according to written procedures. Such documents can be in paper or electronic form.

The issuance, revision, superseding, and withdrawal of all documents should be controlled by maintaining revision histories.

A procedure should be established for retaining all appropriate documents (e.g., development history reports, scale-up reports, technical transfer reports, process validation reports, training records, production records, control records, and distribution records). The retention periods for these documents should be specified.

All production, control, and distribution records should be retained for at least 1 year after the expiry date of the batch. For APIs with retest dates, records should be retained for at least 3 years after the batch is completely distributed.

When entries are made in records, these should be made indelibly in spaces provided for such entries, directly after performing the activities, and should identify the person making the entry. Corrections to entries should be dated and signed and leave the original entry still legible.

During the retention period, originals or copies of records should be readily available at the establishment where the activities described in such records occurred. Records that can be promptly retrieved from another location by electronic or other means are acceptable.

Specifications, instructions, procedures, and records can be retained either as originals or as true copies such as photocopies, microfilm, microfiche, or other accurate reproductions of the original records. Where reduction techniques such as microfilming or electronic records are used, suitable retrieval equipment and a means to produce a hard copy should be readily available.

Specifications should be established and documented for raw materials, intermediates where necessary, APIs, and labeling and packaging materials. In addition, specifications may be appropriate for certain other materials, such as process aids, gaskets, or other materials used during the production of intermediates or APIs that could critically affect quality. Acceptance criteria should be established and documented for in-process controls.

If electronic signatures are used on documents, they should be authenticated and secure.

### **B. Equipment Cleaning and Use Record (6.2)**

Records of major equipment use, cleaning, sanitation, and/or sterilization and maintenance should show the date, time (if appropriate), product, and batch number of each batch processed in the equipment and the person who performed the cleaning and maintenance.

If equipment is dedicated to manufacturing one intermediate or API, individual equipment records are not necessary if batches of the intermediate or API follow in traceable sequence. In cases where dedicated equipment is employed, the records of cleaning, maintenance, and use can be part of the batch record or maintained separately.

**C. Records of Raw Materials, Intermediates, API Labeling and Packaging Materials (6.3)**

Records should be maintained including:

- The name of the manufacturer, identity, and quantity of each shipment of each batch of raw materials, intermediates, or labeling and packaging materials for APIs; the name of the supplier; the supplier's control number(s), if known, or other identification number; the number allocated on receipt; and the date of receipt
- The results of any test or examination performed and the conclusions derived from this
- Records tracing the use of materials
- Documentation of the examination and review of API labeling and packaging materials for conformity with established specifications
- The final decision regarding rejected raw materials, intermediates, or API labeling and packaging materials

Master (approved) labels should be maintained for comparison to issued labels.

**D. Master Production Instructions (Master Production and Control Records) (6.4)**

To ensure uniformity from batch to batch, master production instructions for each intermediate and API should be prepared, dated, and signed by one person and independently checked, dated, and signed by a person in the quality unit(s).

Master production instructions should include:

- The name of the intermediate or API being manufactured and an identifying document reference code, if applicable
- A complete list of raw materials and intermediates designated by names or codes sufficiently specific to identify any special quality characteristics
- An accurate statement of the quantity or ratio of each raw material or intermediate to be used, including the unit of measure. Where the quantity is not fixed, the calculation for

each batch size or rate of production should be included. Variations to quantities should be included where they are justified

- The production location and major production equipment to be used
- Detailed production instructions, including the:
  - sequences to be followed
  - ranges of process parameters to be used
  - sampling instructions and in-process controls with their acceptance criteria, where appropriate
  - time limits for completion of individual processing steps and/or the total process, where appropriate
  - expected yield ranges at appropriate phases of processing or time
- Where appropriate, special notations and precautions to be followed, or cross-references to these
- The instructions for storage of the intermediate or API to ensure its suitability for use, including the labelling and packaging materials and special storage conditions with time limits, where appropriate.

#### **E. Batch Production Records (Batch Production and Control Records) (6.5)**

Batch production records should be prepared for each intermediate and API and should include complete information relating to the production and control of each batch. The batch production record should be checked before issuance to ensure that it is the correct version and a legible accurate reproduction of the appropriate master production instruction. If the batch production record is produced from a separate part of the master document, that document should include a reference to the current master production instruction being used.

These records should be numbered with a unique batch or identification number, dated and signed when issued. In continuous production, the product code together with the date and time can serve as the unique identifier until the final number is allocated.

Documentation of completion of each significant step in the batch production records (batch production and control records) should include:

- Dates and, when appropriate, times
- Identity of major equipment (e.g., reactors, driers, mills, etc.) used
- Specific identification of each batch, including weights, measures, and batch numbers of raw materials, intermediates, or any reprocessed materials used during manufacturing
- Actual results recorded for critical process parameters
- Any sampling performed

- Signatures of the persons performing and directly supervising or checking each critical step in the operation
- In-process and laboratory test results
- Actual yield at appropriate phases or times
- Description of packaging and label for intermediate or API
- Representative label of API or intermediate if made commercially available
- Any deviation noted, its evaluation, investigation conducted (if appropriate) or reference to that investigation if stored separately
- Results of release testing

Written procedures should be established and followed for investigating critical deviations or the failure of a batch of intermediate or API to meet specifications. The investigation should extend to other batches that may have been associated with the specific failure or deviation.

#### **F. Laboratory Control Records (6.6)**

Laboratory control records should include complete data derived from all tests conducted to ensure compliance with established specifications and standards, including examinations and assays, as follows:

- A description of samples received for testing, including the material name or source, batch number or other distinctive code, date sample was taken, and, where appropriate, the quantity and date the sample was received for testing
- A statement of or reference to each test method used
- A statement of the weight or measure of sample used for each test as described by the method; data on or cross-reference to the preparation and testing of reference standards, reagents and standard solutions
- A complete record of all raw data generated during each test, in addition to graphs, charts and spectra from laboratory instrumentation, properly identified to show the specific material and batch tested
- A record of all calculations performed in connection with the test, including, for example, units of measure, conversion factors, and equivalency factors
- A statement of the test results and how they compare with established acceptance criteria
- The signature of the person who performed each test and the date(s) the tests were performed
- The date and signature of a second person showing that the original records have been reviewed for accuracy, completeness, and compliance with established standards

Complete records should also be maintained for:

- Any modifications to an established analytical method
- Periodic calibration of laboratory instruments, apparatus, gauges, and recording devices

- All stability testing performed on APIs
- Out-of-specification (OOS) investigations

#### **G. Batch Production Record Review (6.7)**

Written procedures should be established and followed for the review and approval of batch production and laboratory control records, including packaging and labeling, to determine compliance of the intermediate or API with established specifications before a batch is released or distributed.

Batch production and laboratory control records of critical process steps should be reviewed and approved by the quality unit(s) before an API batch is released or distributed. Production and laboratory control records of noncritical process steps can be reviewed by qualified production personnel or other units following procedures approved by the quality unit(s).

All deviation, investigation, and OOS reports should be reviewed as part of the batch record review before the batch is released.

The quality unit(s) can delegate to the production unit the responsibility and authority for release of intermediates, except for those shipped outside the control of the manufacturing company.

### **VII. MATERIALS MANAGEMENT (7)**

#### **A. General Controls (7.1)**

There should be written procedures describing the receipt, identification, quarantine, storage, handling, sampling, testing, and approval or rejection of materials.

Manufacturers of intermediates and/or APIs should have a system for evaluating the suppliers of critical materials.

Materials should be purchased against an agreed specification, from a supplier, or suppliers, approved by the quality unit(s).

If the supplier of a critical material is not the manufacturer of that material, the name and address of that manufacturer should be known by the intermediate and/or API manufacturer.

Changing the source of supply of critical raw materials should be treated according to Section 13, Change Control.

#### **B. Receipt and Quarantine (7.2)**

Upon receipt and before acceptance, each container or grouping of containers of materials should be examined visually for correct labeling (including correlation between the name used by the

supplier and the in-house name, if these are different), container damage, broken seals and evidence of tampering or contamination. Materials should be held under quarantine until they have been sampled, examined, or tested, as appropriate, and released for use.

Before incoming materials are mixed with existing stocks (e.g., solvents or stocks in silos), they should be identified as correct, tested, if appropriate, and released. Procedures should be available to prevent discharging incoming materials wrongly into the existing stock.

If bulk deliveries are made in nondedicated tankers, there should be assurance of no cross-contamination from the tanker. Means of providing this assurance could include one or more of the following:

- certificate of cleaning
- testing for trace impurities
- audit of the supplier

Large storage containers and their attendant manifolds, filling, and discharge lines should be appropriately identified.

Each container or grouping of containers (batches) of materials should be assigned and identified with a distinctive code, batch, or receipt number. This number should be used in recording the disposition of each batch. A system should be in place to identify the status of each batch.

### **C. Sampling and Testing of Incoming Production Materials (7.3)**

At least one test to verify the identity of each batch of material should be conducted, with the exception of the materials described below. A *supplier's certificate of analysis* can be used in place of performing other tests, provided that the manufacturer has a system in place to evaluate suppliers.

Supplier approval should include an evaluation that provides adequate evidence (e.g., past quality history) that the manufacturer can consistently provide material meeting specifications. Complete analyses should be conducted on at least three batches before reducing in-house testing. However, as a minimum, a complete analysis should be performed at appropriate intervals and compared with the certificates of analysis. Reliability of certificates of analysis should be checked at regular intervals.

Processing aids, hazardous or highly toxic raw materials, other special materials, or materials transferred to another unit within the company's control do not need to be tested if the manufacturer's certificate of analysis is obtained, showing that these raw materials conform to established specifications. Visual examination of containers, labels, and recording of batch numbers should help in establishing the identity of these materials. The lack of on-site testing for these materials should be justified and documented.

Samples should be representative of the batch of material from which they are taken. Sampling methods should specify the number of containers to be sampled, which part of the container to sample, and the amount of material to be taken from each container. The number of containers to sample and the sample size should be based on a sampling plan that takes into consideration the criticality of the material, material variability, past quality history of the supplier, and the quantity needed for analysis.

Sampling should be conducted at defined locations and by procedures designed to prevent contamination of the material sampled and contamination of other materials.

Containers from which samples are withdrawn should be opened carefully and subsequently reclosed. They should be marked to indicate that a sample has been taken.

#### **D. Storage (7.4)**

Materials should be handled and stored in a manner to prevent degradation, contamination, and cross-contamination.

Materials stored in fiber drums, bags, or boxes should be stored off the floor and, when appropriate, suitably spaced to permit cleaning and inspection.

Materials should be stored under conditions and for a period that have no adverse effect on their quality, and should normally be controlled so that the oldest stock is used first.

Certain materials in suitable containers can be stored outdoors, provided identifying labels remain legible and containers are appropriately cleaned before opening and use.

Rejected materials should be identified and controlled under a quarantine system designed to prevent their unauthorized use in manufacturing.

#### **E. Re-evaluation (7.5)**

Materials should be re-evaluated, as appropriate, to determine their suitability for use (e.g., after prolonged storage or exposure to heat or humidity).

### **VIII. PRODUCTION AND IN-PROCESS CONTROLS (8)**

#### **A. Production Operations (8.1)**

Raw materials for intermediate and API manufacturing should be weighed or measured under appropriate conditions that do not affect their suitability for use. Weighing and measuring devices should be of suitable accuracy for the intended use.



If a material is subdivided for later use in production operations, the container receiving the material should be suitable and should be so identified that the following information is available:

- Material name and/or item code
- Receiving or control number
- Weight or measure of material in the new container
- Re-evaluation or retest date if appropriate

Critical weighing, measuring, or subdividing operations should be witnessed or subjected to an equivalent control. Prior to use, production personnel should verify that the materials are those specified in the batch record for the intended intermediate or API.

Other critical activities should be witnessed or subjected to an equivalent control.

Actual yields should be compared with expected yields at designated steps in the production process. Expected yields with appropriate ranges should be established based on previous laboratory, pilot scale, or manufacturing data. Deviations in yield associated with critical process steps should be investigated to determine their impact or potential impact on the resulting quality of affected batches.

Any deviation should be documented and explained. Any critical deviation should be investigated.

The processing status of major units of equipment should be indicated either on the individual units of equipment or by appropriate documentation, computer control systems, or alternative means.

Materials to be reprocessed or reworked should be appropriately controlled to prevent unauthorized use.

#### **B. Time Limits (8.2)**

If time limits are specified in the master production instruction (see 6.40), these time limits should be met to ensure the quality of intermediates and APIs. Deviations should be documented and evaluated. Time limits may be inappropriate when processing to a target value (e.g., pH adjustment, hydrogenation, drying to predetermined specification) because completion of reactions or processing steps are determined by in-process sampling and testing.

Intermediates held for further processing should be stored under appropriate conditions to ensure their suitability for use.

#### **C. In-process Sampling and Controls (8.3)**

Written procedures should be established to monitor the progress and control the performance of processing steps that cause variability in the quality characteristics of intermediates and APIs. In-process controls and their acceptance criteria should be defined based on the information gained during the developmental stage or from historical data.

The acceptance criteria and type and extent of testing can depend on the nature of the intermediate or API being manufactured, the reaction or process step being conducted, and the degree to which the process introduces variability in the product's quality. Less stringent in-process controls may be appropriate in early processing steps, whereas tighter controls may be appropriate for later processing steps (e.g., isolation and purification steps).

Critical in-process controls (and critical process monitoring), including control points and methods, should be stated in writing and approved by the quality unit(s).

In-process controls can be performed by qualified production department personnel and the process adjusted without prior quality unit(s) approval if the adjustments are made within pre-established limits approved by the quality unit(s). All tests and results should be fully documented as part of the batch record.

Written procedures should describe the sampling methods for in-process materials, intermediates, and APIs. Sampling plans and procedures should be based on scientifically sound sampling practices.

In-process sampling should be conducted using procedures designed to prevent contamination of the sampled material and other intermediates or APIs. Procedures should be established to ensure the integrity of samples after collection.

Out-of-specification (OOS) investigations are not normally needed for in-process tests that are performed for the purpose of monitoring and/or adjusting the process.

#### **D. Blending Batches of Intermediates or APIs (8.4)**

For the purpose of this document, blending is defined as the process of combining materials within the same specification to produce a homogeneous intermediate or API. In-process mixing of fractions from single batches (e.g., collecting several centrifuge loads from a single crystallization batch) or combining fractions from several batches for further processing is considered to be part of the production process and is not considered to be blending.

Out-of-specification batches should not be blended with other batches for the purpose of meeting specifications. Each batch incorporated into the blend should have been manufactured using an established process and should have been individually tested and found to meet appropriate specifications prior to blending.

Acceptable blending operations include, but are not limited to:

- Blending of small batches to increase batch size
- Blending of tailings (i.e., relatively small quantities of isolated material) from batches of the same intermediate or API to form a single batch

Blending processes should be adequately controlled and documented, and the blended batch should be tested for conformance to established specifications, where appropriate.

The batch record of the blending process should allow traceability back to the individual batches that make up the blend.

Where physical attributes of the API are critical (e.g., APIs intended for use in solid oral dosage forms or suspensions), blending operations should be validated to show homogeneity of the combined batch. Validation should include testing of critical attributes (e.g., particle size distribution, bulk density, and tap density) that may be affected by the blending process.

If the blending could adversely affect stability, stability testing of the final blended batches should be performed.

The expiry or retest date of the blended batch should be based on the manufacturing date of the oldest tailings or batch in the blend.

#### **E. Contamination Control (8.5)**

Residual materials can be carried over into successive batches of the same intermediate or API if there is adequate control. Examples include residue adhering to the wall of a micronizer, residual layer of damp crystals remaining in a centrifuge bowl after discharge, and incomplete discharge of fluids or crystals from a processing vessel upon transfer of the material to the next step in the process. Such carryover should not result in the carryover of degradants or microbial contamination that may adversely alter the established API impurity profile.

Production operations should be conducted in a manner that prevents contamination of intermediates or APIs by other materials.

Precautions to avoid contamination should be taken when APIs are handled after purification.

### **IX. PACKAGING AND IDENTIFICATION LABELING OF APIs AND INTERMEDIATES (9)**

#### **A. General (9.1)**

There should be written procedures describing the receipt, identification, quarantine, sampling, examination, and/or testing, release, and handling of packaging and labeling materials.

Packaging and labeling materials should conform to established specifications. Those that do not comply with such specifications should be rejected to prevent their use in operations for which they are unsuitable.

Records should be maintained for each shipment of labels and packaging materials showing receipt, examination, or testing, and whether accepted or rejected.

**B. Packaging Materials (9.2)**

Containers should provide adequate protection against deterioration or contamination of the intermediate or API that may occur during transportation and recommended storage.

Containers should be clean and, where indicated by the nature of the intermediate or API, sanitized to ensure that they are suitable for their intended use. These containers should not be reactive, additive, or absorptive so as to alter the quality of the intermediate or API beyond the specified limits.

If containers are reused, they should be cleaned in accordance with documented procedures, and all previous labels should be removed or defaced.

**C. Label Issuance and Control (9.3)**

Access to the label storage areas should be limited to authorized personnel.

Procedures should be established to reconcile the quantities of labels issued, used, and returned and to evaluate discrepancies found between the number of containers labeled and the number of labels issued. Such discrepancies should be investigated, and the investigation should be approved by the quality unit(s).

All excess labels bearing batch numbers or other batch-related printing should be destroyed. Returned labels should be maintained and stored in a manner that prevents mix-ups and provides proper identification.

Obsolete and out-dated labels should be destroyed.

Printing devices used to print labels for packaging operations should be controlled to ensure that all imprinting conforms to the print specified in the batch production record.

Printed labels issued for a batch should be carefully examined for proper identity and conformity to specifications in the master production record. The results of this examination should be documented.

A printed label representative of those used should be included in the batch production record.

**D. Packaging and Labeling Operations (9.4)**

There should be documented procedures designed to ensure that correct packaging materials and labels are used.

Labeling operations should be designed to prevent mix-ups. There should be physical or spatial separation from operations involving other intermediates or APIs.

Labels used on containers of intermediates or APIs should indicate the name or identifying code, batch number, and storage conditions when such information is critical to ensure the quality of intermediate or API.

If the intermediate or API is intended to be transferred outside the control of the manufacturer's material management system, the name and address of the manufacturer, quantity of contents, special transport conditions, and any special legal requirements should also be included on the label. For intermediates or APIs with an expiry date, the expiry date should be indicated on the label and certificate of analysis. For intermediates or APIs with a retest date, the retest date should be indicated on the label and/or certificate of analysis.

Packaging and labeling facilities should be inspected immediately before use to ensure that all materials not needed for the next packaging operation have been removed. This examination should be documented in the batch production records, the facility log, or other documentation system.

Packaged and labeled intermediates or APIs should be examined to ensure that containers and packages in the batch have the correct label. This examination should be part of the packaging operation. Results of these examinations should be recorded in the batch production or control records.

Intermediate or API containers that are transported outside of the manufacturer's control should be sealed in a manner such that, if the seal is breached or missing, the recipient will be alerted to the possibility that the contents may have been altered.

**X. STORAGE AND DISTRIBUTION (10)**

**A. Warehousing Procedures (10.1)**

Facilities should be available for the storage of all materials under appropriate conditions (e.g., controlled temperature and humidity when necessary). Records should be maintained of these conditions if they are critical for the maintenance of material characteristics.

Unless there is an alternative system to prevent the unintentional or unauthorized use of quarantined, rejected, returned, or recalled materials, separate storage areas should be assigned for their temporary storage until the decision as to their future use has been made.

**B. Distribution Procedures (10.2)**

APIs and intermediates should only be released for distribution to third parties after they have been released by the quality unit(s). APIs and intermediates can be transferred under quarantine to another unit under the company's control when authorized by the quality unit(s) and if appropriate controls and documentation are in place.

APIs and intermediates should be transported in a manner that does not adversely affect their quality.

Special transport or storage conditions for an API or intermediate should be stated on the label.

The manufacturer should ensure that the contract acceptor (contractor) for transportation of the API or intermediate knows and follows the appropriate transport and storage conditions.

A system should be in place by which the distribution of each batch of intermediate and/or API can be readily determined to permit its recall.

**XI. LABORATORY CONTROLS (11)**

**A. General Controls (11.1)**

The independent quality unit(s) should have at its disposal adequate laboratory facilities.

There should be documented procedures describing sampling, testing, approval, or rejection of materials and recording and storage of laboratory data. Laboratory records should be maintained in accordance with Section 6.6.

All specifications, sampling plans, and test procedures should be scientifically sound and appropriate to ensure that raw materials, intermediates, APIs, and labels and packaging materials conform to established standards of quality and/or purity. Specifications and test procedures should be consistent with those included in the registration/filing. There can be specifications in addition to those in the registration/filing. Specifications, sampling plans, and test procedures, including changes to them, should be drafted by the appropriate organizational unit and reviewed and approved by the quality unit(s).

Appropriate specifications should be established for APIs in accordance with accepted standards and consistent with the manufacturing process. The specifications should include control of impurities (e.g., organic impurities, inorganic impurities, and residual solvents). If the API has a specification for microbiological purity, appropriate action limits for total microbial counts and objectionable organisms should be established and met. If the API has a specification for endotoxins, appropriate action limits should be established and met.

Laboratory controls should be followed and documented at the time of performance. Any departures from the above-described procedures should be documented and explained.

Any out-of-specification result obtained should be investigated and documented according to a procedure. This procedure should include analysis of the data, assessment of whether a significant problem exists, allocation of the tasks for corrective actions, and conclusions. Any resampling and/or retesting after OOS results should be performed according to a documented procedure.

Reagents and standard solutions should be prepared and labeled following written procedures. *Use by* dates should be applied, as appropriate, for analytical reagents or standard solutions.

Primary reference standards should be obtained, as appropriate, for the manufacture of APIs. The source of each primary reference standard should be documented. Records should be maintained of each primary reference standard's storage and use in accordance with the supplier's recommendations. Primary reference standards obtained from an officially recognized source are normally used without testing if stored under conditions consistent with the supplier's recommendations.

Where a primary reference standard is not available from an officially recognized source, an *in-house primary standard* should be established. Appropriate testing should be performed to establish fully the identity and purity of the primary reference standard. Appropriate documentation of this testing should be maintained.

Secondary reference standards should be appropriately prepared, identified, tested, approved, and stored. The suitability of each batch of secondary reference standard should be determined prior to first use by comparing against a primary reference standard. Each batch of secondary reference standard should be periodically requalified in accordance with a written protocol.

#### **B. Testing of Intermediates and APIs (11.2)**

For each batch of intermediate and API, appropriate laboratory tests should be conducted to determine conformance to specifications.

An impurity profile describing the identified and unidentified impurities present in a typical batch produced by a specific controlled production process should normally be established for each API. The impurity profile should include the identity or some qualitative analytical designation (e.g., retention time), the range of each impurity observed, and classification of each identified impurity (e.g., inorganic, organic, solvent). The impurity profile is normally dependent upon the production process and origin of the API. Impurity profiles are normally not necessary for APIs from herbal or animal tissue origin. Biotechnology considerations are covered in ICH guidance Q6B.

The impurity profile should be compared at appropriate intervals against the impurity profile in the regulatory submission or compared against historical data to detect changes to the API

resulting from modifications in raw materials, equipment operating parameters, or the production process.

Appropriate microbiological tests should be conducted on each batch of intermediate and API where microbial quality is specified.

**C. Validation of Analytical Procedures - See Section 12. (11.3)**

**D. Certificates of Analysis (11.4)**

Authentic certificates of analysis should be issued for each batch of intermediate or API on request.

Information on the name of the intermediate or API including, where appropriate, its grade, the batch number, and the date of release should be provided on the certificate of analysis. For intermediates or APIs with an expiry date, the expiry date should be provided on the label and certificate of analysis. For intermediates or APIs with a retest date, the retest date should be indicated on the label and/or certificate of analysis.

The certificate should list each test performed in accordance with compendial or customer requirements, including the acceptance limits, and the numerical results obtained (if test results are numerical).

Certificates should be dated and signed by authorized personnel of the quality unit(s) and should show the name, address, and telephone number of the original manufacturer. Where the analysis has been carried out by a repacker or reprocessor, the certificate of analysis should show the name, address, and telephone number of the repacker/reprocessor and reference the name of the original manufacturer.

If new certificates are issued by or on behalf of repackers/reprocessors, agents or brokers, these certificates should show the name, address and telephone number of the laboratory that performed the analysis. They should also contain a reference to the name and address of the original manufacturer and to the original batch certificate, a copy of which should be attached.

**E. Stability Monitoring of APIs (11.5)**

A documented, on-going testing program should be established to monitor the stability characteristics of APIs, and the results should be used to confirm appropriate storage conditions and retest or expiry dates.

The test procedures used in stability testing should be validated and be stability indicating.

Stability samples should be stored in containers that simulate the market container. For example, if the API is marketed in bags within fiber drums, stability samples can be packaged in bags of



the same material and in small-scale drums of similar or identical material composition to the market drums.

Normally, the first three commercial production batches should be placed on the stability monitoring program to confirm the retest or expiry date. However, where data from previous studies show that the API is expected to remain stable for at least 2 years, fewer than three batches can be used.

Thereafter, at least one batch per year of API manufactured (unless none is produced that year) should be added to the stability monitoring program and tested at least annually to confirm the stability.

For APIs with short shelf-lives, testing should be done more frequently. For example, for those biotechnological/biologic and other APIs with shelf-lives of one year or less, stability samples should be obtained and should be tested monthly for the first 3 months, and at 3-month intervals after that. When data exist that confirm that the stability of the API is not compromised, elimination of specific test intervals (e.g., 9-month testing) can be considered.

Where appropriate, the stability storage conditions should be consistent with the ICH guidances on stability.

#### **F. Expiry and Retest Dating (11.6)**

When an intermediate is intended to be transferred outside the control of the manufacturer's material management system and an expiry or retest date is assigned, supporting stability information should be available (e.g., published data, test results).

An API expiry or retest date should be based on an evaluation of data derived from stability studies. Common practice is to use a retest date, not an expiration date.

Preliminary API expiry or retest dates can be based on pilot scale batches if (1) the pilot batches employ a method of manufacture and procedure that simulates the final process to be used on a commercial manufacturing scale and (2) the quality of the API represents the material to be made on a commercial scale.

A representative sample should be taken for the purpose of performing a retest.

#### **G. Reserve/Retention Samples (11.7)**

The packaging and holding of reserve samples is for the purpose of potential future evaluation of the quality of batches of API and not for future stability testing purposes.

Appropriately identified reserve samples of each API batch should be retained for 1 year after the expiry date of the batch assigned by the manufacturer, or for 3 years after distribution of the

batch, whichever is longer. For APIs with retest dates, similar reserve samples should be retained for 3 years after the batch is completely distributed by the manufacturer.

The reserve sample should be stored in the same packaging system in which the API is stored or in one that is equivalent to or more protective than the marketed packaging system. Sufficient quantities should be retained to conduct at least two full compendial analyses or, when there is no pharmacopoeial monograph, two full specification analyses.

## **XII. VALIDATION (12)**

### **A. Validation Policy (12.1)**

The company's overall policy, intentions, and approach to validation, including the validation of production processes, cleaning procedures, analytical methods, in-process control test procedures, computerized systems, and persons responsible for design, review, approval, and documentation of each validation phase, should be documented.

The critical parameters/attributes should normally be identified during the development stage or from historical data, and the necessary ranges for the reproducible operation should be defined. This should include:

- Defining the API in terms of its critical product attributes
- Identifying process parameters that could affect the critical quality attributes of the API
- Determining the range for each critical process parameter expected to be used during routine manufacturing and process control

Validation should extend to those operations determined to be critical to the quality and purity of the API.

### **B. Validation Documentation (12.2)**

A written validation protocol should be established that specifies how validation of a particular process will be conducted. The protocol should be reviewed and approved by the quality unit(s) and other designated units.

The validation protocol should specify critical process steps and acceptance criteria as well as the type of validation to be conducted (e.g., retrospective, prospective, concurrent) and the number of process runs.

A validation report that cross-references the validation protocol should be prepared, summarizing the results obtained, commenting on any deviations observed, and drawing the appropriate conclusions, including recommending changes to correct deficiencies.

Any variations from the validation protocol should be documented with appropriate justification.

### **C. Qualification (12.3)**

Before initiating process validation activities, appropriate qualification of critical equipment and ancillary systems should be completed. Qualification is usually carried out by conducting the following activities, individually or combined:

- Design Qualification (DQ): documented verification that the proposed design of the facilities, equipment, or systems is suitable for the intended purpose
- Installation Qualification (IQ): documented verification that the equipment or systems, as installed or modified, comply with the approved design, the manufacturer's recommendations and/or user requirements
- Operational Qualification (OQ): documented verification that the equipment or systems, as installed or modified, perform as intended throughout the anticipated operating ranges
- Performance Qualification (PQ): documented verification that the equipment and ancillary systems, as connected together, can perform effectively and reproducibly based on the approved process method and specifications

### **D. Approaches to Process Validation (12.4)**

Process Validation (PV) is the documented evidence that the process, operated within established parameters, can perform effectively and reproducibly to produce an intermediate or API meeting its predetermined specifications and quality attributes.

There are three approaches to validation. Prospective validation is the preferred approach, but there are situations where the other approaches can be used. These approaches and their applicability are discussed here.

Prospective validation should normally be performed for all API processes as defined in 12.1. Prospective validation of an API process should be completed before the commercial distribution of the final drug product manufactured from that API.

Concurrent validation can be conducted when data from replicate production runs are unavailable because only a limited number of API batches have been produced, API batches are produced infrequently, or API batches are produced by a validated process that has been modified. Prior to the completion of concurrent validation, batches can be released and used in final drug product for commercial distribution based on thorough monitoring and testing of the API batches.

An exception can be made for retrospective validation of well-established processes that have been used without significant changes to API quality due to changes in raw materials, equipment, systems, facilities, or the production process. This validation approach may be used where:

1. Critical quality attributes and critical process parameters have been identified
2. Appropriate in-process acceptance criteria and controls have been established
3. There have not been significant process/product failures attributable to causes other than operator error or equipment failures unrelated to equipment suitability
4. Impurity profiles have been established for the existing API

Batches selected for retrospective validation should be representative of all batches produced during the review period, including any batches that failed to meet specifications, and should be sufficient in number to demonstrate process consistency. Retained samples can be tested to obtain data to retrospectively validate the process.

#### **E. Process Validation Program (12.5)**

The number of process runs for validation should depend on the complexity of the process or the magnitude of the process change being considered. For prospective and concurrent validation, three consecutive successful production batches should be used as a guide, but there may be situations where additional process runs are warranted to prove consistency of the process (e.g., complex API processes or API processes with prolonged completion times). For retrospective validation, generally data from 10 to 30 consecutive batches should be examined to assess process consistency, but fewer batches can be examined if justified.

Critical process parameters should be controlled and monitored during process validation studies. Process parameters unrelated to quality, such as variables controlled to minimize energy consumption or equipment use, need not be included in the process validation.

Process validation should confirm that the impurity profile for each API is within the limits specified. The impurity profile should be comparable to, or better than, historical data and, where applicable, the profile determined during process development or for batches used for pivotal clinical and toxicological studies.

#### **F. Periodic Review of Validated Systems (12.6)**

Systems and processes should be periodically evaluated to verify that they are still operating in a valid manner. Where no significant changes have been made to the system or process, and a quality review confirms that the system or process is consistently producing material meeting its specifications, there is normally no need for revalidation.

## G. Cleaning Validation (12.7)

Cleaning procedures should normally be validated. In general, cleaning validation should be directed to situations or process steps where contamination or carryover of materials poses the greatest risk to API quality. For example, in early production it may be unnecessary to validate equipment cleaning procedures where residues are removed by subsequent purification steps.

Validation of cleaning procedures should reflect actual equipment usage patterns. If various APIs or intermediates are manufactured in the same equipment and the equipment is cleaned by the same process, a representative intermediate or API can be selected for cleaning validation. This selection should be based on the solubility and difficulty of cleaning and the calculation of residue limits based on potency, toxicity, and stability.

The cleaning validation protocol should describe the equipment to be cleaned, procedures, materials, acceptable cleaning levels, parameters to be monitored and controlled, and analytical methods. The protocol should also indicate the type of samples to be obtained and how they are collected and labeled.

Sampling should include swabbing, rinsing, or alternative methods (e.g., direct extraction), as appropriate, to detect both insoluble and soluble residues. The sampling methods used should be capable of quantitatively measuring levels of residues remaining on the equipment surfaces after cleaning. Swab sampling may be impractical when product contact surfaces are not easily accessible due to equipment design and/or process limitations (e.g., inner surfaces of hoses, transfer pipes, reactor tanks with small ports or handling toxic materials, and small intricate equipment such as micronizers and microfluidizers).

Validated analytical methods having sensitivity to detect residues or contaminants should be used. The detection limit for each analytical method should be sufficiently sensitive to detect the established acceptable level of the residue or contaminant. The method's attainable recovery level should be established. Residue limits should be practical, achievable, verifiable, and based on the most deleterious residue. Limits can be established based on the minimum known pharmacological, toxicological, or physiological activity of the API or its most deleterious component.

Equipment cleaning/sanitation studies should address microbiological and endotoxin contamination for those processes where there is a need to reduce total microbiological count or endotoxins in the API, or other processes where such contamination could be of concern (e.g., non-sterile APIs used to manufacture sterile products).

Cleaning procedures should be monitored at appropriate intervals after validation to ensure that these procedures are effective when used during routine production. Equipment cleanliness can be monitored by analytical testing and visual examination, where feasible. Visual inspection can allow detection of gross contamination concentrated in small areas that could otherwise go undetected by sampling and/or analysis.

## H. Validation of Analytical Methods (12.8)

Analytical methods should be validated unless the method employed is included in the relevant pharmacopoeia or other recognized standard reference. The suitability of all testing methods used should nonetheless be verified under actual conditions of use and documented.

Methods should be validated to include consideration of characteristics included within the ICH guidances on validation of analytical methods. The degree of analytical validation performed should reflect the purpose of the analysis and the stage of the API production process.

Appropriate qualification of analytical equipment should be considered before initiating validation of analytical methods.

Complete records should be maintained of any modification of a validated analytical method. Such records should include the reason for the modification and appropriate data to verify that the modification produces results that are as accurate and reliable as the established method.

## XIII. CHANGE CONTROL (13)

A formal change control system should be established to evaluate all changes that could affect the production and control of the intermediate or API.

Written procedures should provide for the identification, documentation, appropriate review, and approval of changes in raw materials, specifications, analytical methods, facilities, support systems, equipment (including computer hardware), processing steps, labeling and packaging materials, and computer software.

Any proposals for GMP relevant changes should be drafted, reviewed, and approved by the appropriate organizational units and reviewed and approved by the quality unit(s).

The potential impact of the proposed change on the quality of the intermediate or API should be evaluated. A classification procedure may help in determining the level of testing, validation, and documentation needed to justify changes to a validated process. Changes can be classified (e.g., as minor or major) depending on the nature and extent of the changes, and the effects these changes may impart on the process. Scientific judgment should determine what additional testing and validation studies are appropriate to justify a change in a validated process.

When implementing approved changes, measures should be taken to ensure that all documents affected by the changes are revised.

After the change has been implemented, there should be an evaluation of the first batches produced or tested under the change.

The potential for critical changes to affect established retest or expiry dates should be evaluated. If necessary, samples of the intermediate or API produced by the modified process can be placed on an accelerated stability program and/or can be added to the stability monitoring program.

Current dosage form manufacturers should be notified of changes from established production and process control procedures that can affect the quality of the API.

#### **XIV. REJECTION AND RE-USE OF MATERIALS (14)**

##### **A. Rejection (14.1)**

Intermediates and APIs failing to meet established specifications should be identified as such and quarantined. These intermediates or APIs can be reprocessed or reworked as described below. The final disposition of rejected materials should be recorded.

##### **B. Reprocessing (14.2)**

Introducing an intermediate or API, including one that does not conform to standards or specifications, back into the process and reprocessing by repeating a crystallization step or other appropriate chemical or physical manipulation steps (e.g., distillation, filtration, chromatography, milling) that are part of the established manufacturing process is generally considered acceptable. However, if such reprocessing is used for a majority of batches, such reprocessing should be included as part of the standard manufacturing process.

Continuation of a process step after an in-process control test has shown that the step is incomplete is considered to be part of the normal process. This is not considered to be reprocessing.

Introducing unreacted material back into a process and repeating a chemical reaction is considered to be reprocessing unless it is part of the established process. Such reprocessing should be preceded by careful evaluation to ensure that the quality of the intermediate or API is not adversely affected due to the potential formation of by-products and over-reacted materials.

##### **C. Reworking (14.3)**

Before a decision is taken to rework batches that do not conform to established standards or specifications, an investigation into the reason for nonconformance should be performed.

Batches that have been reworked should be subjected to appropriate evaluation, testing, stability testing if warranted, and documentation to show that the reworked product is of equivalent quality to that produced by the original process. Concurrent validation is often the appropriate validation approach for rework procedures. This allows a protocol to define the rework procedure, how it will be carried out, and the expected results. If there is only one batch to be reworked, a report can be written and the batch released once it is found to be acceptable.

Procedures should provide for comparing the impurity profile of each reworked batch against batches manufactured by the established process. Where routine analytical methods are inadequate to characterize the reworked batch, additional methods should be used.

#### **D. Recovery of Materials and Solvents (14.4)**

Recovery (e.g., from mother liquor or filtrates) of reactants, intermediates, or the API is considered acceptable, provided that approved procedures exist for the recovery and the recovered materials meet specifications suitable for their intended use.

Solvents can be recovered and reused in the same processes or in different processes, provided that the recovery procedures are controlled and monitored to ensure that solvents meet appropriate standards before reuse or commingling with other approved materials.

Fresh and recovered solvents and reagents can be combined if adequate testing has shown their suitability for all manufacturing processes in which they may be used.

The use of recovered solvents, mother liquors, and other recovered materials should be adequately documented.

#### **E. Returns (14.5)**

Returned intermediates or APIs should be identified as such and quarantined.

If the conditions under which returned intermediates or APIs have been stored or shipped before or during their return or the condition of their containers casts doubt on their quality, the returned intermediates or APIs should be reprocessed, reworked, or destroyed, as appropriate.

Records of returned intermediates or APIs should be maintained. For each return, documentation should include:

- Name and address of the consignee
- Intermediate or API, batch number, and quantity returned
- Reason for return
- Use or disposal of the returned intermediate or API

### **XV. COMPLAINTS AND RECALLS (15)**

All quality-related complaints, whether received orally or in writing, should be recorded and investigated according to a written procedure.

Complaint records should include:



- Name and address of complainant
- Name (and, where appropriate, title) and phone number of person submitting the complaint
- Complaint nature (including name and batch number of the API)
- Date complaint is received
- Action initially taken (including dates and identity of person taking the action);
- Any follow-up action taken
- Response provided to the originator of complaint (including date response sent)
- Final decision on intermediate or API batch or lot

Records of complaints should be retained to evaluate trends, product-related frequencies, and severity with a view to taking additional, and if appropriate, immediate corrective action.

There should be a written procedure that defines the circumstances under which a recall of an intermediate or API should be considered.

The recall procedure should designate who should be involved in evaluating the information, how a recall should be initiated, who should be informed about the recall, and how the recalled material should be treated.

In the event of a serious or potentially life-threatening situation, local, national, and/or international authorities should be informed and their advice sought.

## **XVI. CONTRACT MANUFACTURERS (INCLUDING LABORATORIES) (16)**

All contract manufacturers (including laboratories) should comply with the GMP defined in this guidance. Special consideration should be given to the prevention of cross-contamination and to maintaining traceability.

Companies should evaluate any contractors (including laboratories) to ensure GMP compliance of the specific operations occurring at the contractor sites.

There should be a written and approved contract or formal agreement between a company and its contractors that defines in detail the GMP responsibilities, including the quality measures, of each party.

A contract should permit a company to audit its contractor's facilities for compliance with GMP.

Where subcontracting is allowed, a contractor should not pass to a third party any of the work entrusted to it under the contract without the company's prior evaluation and approval of the arrangements.

Manufacturing and laboratory records should be kept at the site where the activity occurs and be readily available.

Changes in the process, equipment, test methods, specifications, or other contractual requirements should not be made unless the contract giver is informed and approves the changes.

## **XVII. AGENTS, BROKERS, TRADERS, DISTRIBUTORS, REPACKERS, AND RELABELLERS (17)**

### **A. Applicability (17.1)**

This section applies to any party other than the original manufacturer who may trade and/or take possession, repack, relabel, manipulate, distribute, or store an API or intermediate.

All agents, brokers, traders, distributors, repackers, and relabelers should comply with GMP as defined in this guidance.

### **B. Traceability of Distributed APIs and Intermediates (17.2)**

Agents, brokers, traders, distributors, repackers, or relabelers should maintain complete traceability of APIs and intermediates that they distribute. Documents that should be retained and available include:

- Identity of original manufacturer
- Address of original manufacturer
- Purchase orders
- Bills of lading (transportation documentation)
- Receipt documents
- Name or designation of API or intermediate
- Manufacturer's batch number
- Transportation and distribution records
- All authentic Certificates of Analysis, including those of the original manufacturer
- Retest or expiry date

### **C. Quality Management (17.3)**

Agents, brokers, traders, distributors, repackers, or relabelers should establish, document and implement an effective system of managing quality, as specified in Section 2.

### **D. Repackaging, Relabeling, and Holding of APIs and Intermediates (17.4)**

Repackaging, relabeling, and holding APIs and intermediates should be performed under appropriate GMP controls, as stipulated in this guidance, to avoid mix-ups and loss of API or intermediate identity or purity.

Repackaging should be conducted under appropriate environmental conditions to avoid contamination and cross-contamination.

**E. Stability (17.5)**

Stability studies to justify assigned expiration or retest dates should be conducted if the API or intermediate is repackaged in a different type of container than that used by the API or intermediate manufacturer.

**F. Transfer of Information (17.6)**

Agents, brokers, distributors, repackers, or relabelers should transfer all quality or regulatory information received from an API or intermediate manufacturer to the customer, and from the customer to the API or intermediate manufacturer.

The agent, broker, trader, distributor, repacker, or relabeler who supplies the API or intermediate to the customer should provide the name of the original API or intermediate manufacturer and the batch number(s) supplied.

The agent should also provide the identity of the original API or intermediate manufacturer to regulatory authorities upon request. The original manufacturer can respond to the regulatory authority directly or through its authorized agents, depending on the legal relationship between the authorized agents and the original API or intermediate manufacturer. (In this context *authorized* refers to authorized by the manufacturer.)

The specific guidance for certificate of analysis included in Section 11.4 should be met.

**G. Handling of Complaints and Recalls (17.7)**

Agents, brokers, traders, distributors, repackers, or relabelers should maintain records of complaints and recalls, as specified in Section 15, for all complaints and recalls that come to their attention.

If the situation warrants, the agents, brokers, traders, distributors, repackers, or relabelers should review the complaint with the original API or intermediate manufacturer to determine whether any further action, either with other customers who may have received this API or intermediate or with the regulatory authority, or both, should be initiated. The investigation into the cause for the complaint or recall should be conducted and documented by the appropriate party.

Where a complaint is referred to the original API or intermediate manufacturer, the record maintained by the agents, brokers, traders, distributors, repackers, or relabelers should include any response received from the original API or intermediate manufacturer (including date and information provided).

## H. Handling of Returns (17.8)

Returns should be handled as specified in Section 14.5. The agents, brokers, traders, distributors, repackers, or relabelers should maintain documentation of returned APIs and intermediates.

## XVIII. SPECIFIC GUIDANCE FOR APIs MANUFACTURED BY CELL CULTURE/FERMENTATION (18)

### A. General (18.1)

Section 18 is intended to address specific controls for APIs or intermediates manufactured by cell culture or fermentation using natural or recombinant organisms and that have not been covered adequately in the previous sections. It is not intended to be a stand-alone section. In general, the GMP principles in the other sections of this document apply. Note that the principles of fermentation for *classical* processes for production of small molecules and for processes using recombinant and nonrecombinant organisms for production of proteins and/or polypeptides are the same, although the degree of control will differ. Where practical, this section will address these differences. In general, the degree of control for biotechnological processes used to produce proteins and polypeptides is greater than that for classical fermentation processes.

The term *biotechnological process* (biotech) refers to the use of cells or organisms that have been generated or modified by recombinant DNA, hybridoma, or other technology to produce APIs. The APIs produced by biotechnological processes normally consist of high molecular weight substances, such as proteins and polypeptides, for which specific guidance is given in this Section. Certain APIs of low molecular weight, such as antibiotics, amino acids, vitamins, and carbohydrates, can also be produced by recombinant DNA technology. The level of control for these types of APIs is similar to that employed for classical fermentation.

The term *classical fermentation* refers to processes that use microorganisms existing in nature and/or modified by conventional methods (e.g., irradiation or chemical mutagenesis) to produce APIs. APIs produced by *classical fermentation* are normally low molecular weight products such as antibiotics, amino acids, vitamins, and carbohydrates.

Production of APIs or intermediates from cell culture or fermentation involves biological processes such as cultivation of cells or extraction and purification of material from living organisms. Note that there may be additional process steps, such as physicochemical modification, that are part of the manufacturing process. The raw materials used (media, buffer components) may provide the potential for growth of microbiological contaminants. Depending on the source, method of preparation, and the intended use of the API or intermediate, control of bioburden, viral contamination, and/or endotoxins during manufacturing and monitoring of the process at appropriate stages may be necessary.

Appropriate controls should be established at all stages of manufacturing to ensure intermediate and/or API quality. While this guidance starts at the cell culture/fermentation step, prior steps

(e.g., cell banking) should be performed under appropriate process controls. This guidance covers cell culture/fermentation from the point at which a vial of the cell bank is retrieved for use in manufacturing.

Appropriate equipment and environmental controls should be used to minimize the risk of contamination. The acceptance criteria for determining environmental quality and the frequency of monitoring should depend on the step in production and the production conditions (open, closed, or contained systems).

In general, process controls should take into account:

- Maintenance of the working cell bank (where appropriate)
- Proper inoculation and expansion of the culture
- Control of the critical operating parameters during fermentation/cell culture
- Monitoring of the process for cell growth, viability (for most cell culture processes) and productivity, where appropriate
- Harvest and purification procedures that remove cells, cellular debris and media components while protecting the intermediate or API from contamination (particularly of a microbiological nature) and from loss of quality
- Monitoring of bioburden and, where needed, endotoxin levels at appropriate stages of production
- Viral safety concerns as described in ICH guidance Q5A *Quality of Biotechnological Products: Viral Safety Evaluation of Biotechnology Products Derived from Cell Lines of Human or Animal Origin*

Where appropriate, the removal of media components, host cell proteins, other process-related impurities, product-related impurities and contaminants should be demonstrated.

#### **B. Cell Bank Maintenance and Record Keeping (18.2)**

Access to cell banks should be limited to authorized personnel.

Cell banks should be maintained under storage conditions designed to maintain viability and prevent contamination.

Records of the use of the vials from the cell banks and storage conditions should be maintained.

Where appropriate, cell banks should be periodically monitored to determine suitability for use.

See ICH guidance Q5D *Quality of Biotechnological Products: Derivation and Characterization of Cell Substrates Used for Production of Biotechnological/Biological Products* for a more complete discussion of cell banking.

#### **C. Cell Culture/Fermentation (18.3)**

Where cell substrates, media, buffers, and gases are to be added under aseptic conditions, closed or contained systems should be used where possible. If the inoculation of the initial vessel or subsequent transfers or additions (media, buffers) are performed in open vessels, there should be controls and procedures in place to minimize the risk of contamination.

Where the quality of the API can be affected by microbial contamination, manipulations using open vessels should be performed in a biosafety cabinet or similarly controlled environment.

Personnel should be appropriately gowned and take special precautions handling the cultures.

Critical operating parameters (for example temperature, pH, agitation rates, addition of gases, pressure) should be monitored to ensure consistency with the established process. Cell growth, viability (for most cell culture processes), and, where appropriate, productivity should also be monitored. Critical parameters will vary from one process to another, and for classical fermentation, certain parameters (cell viability, for example) may not need to be monitored.

Cell culture equipment should be cleaned and sterilized after use. As appropriate, fermentation equipment should be cleaned, sanitized, or sterilized.

Culture media should be sterilized before use, when necessary, to protect the quality of the API.

Appropriate procedures should be in place to detect contamination and determine the course of action to be taken. Procedures should be available to determine the impact of the contamination on the product and to decontaminate the equipment and return it to a condition to be used in subsequent batches. Foreign organisms observed during fermentation processes should be identified, as appropriate, and the effect of their presence on product quality should be assessed, if necessary. The results of such assessments should be taken into consideration in the disposition of the material produced.

Records of contamination events should be maintained.

Shared (multi-product) equipment may warrant additional testing after cleaning between product campaigns, as appropriate, to minimize the risk of cross-contamination.

#### **D. Harvesting, Isolation and Purification (18.4)**

Harvesting steps, either to remove cells or cellular components or to collect cellular components after disruption should be performed in equipment and areas designed to minimize the risk of contamination.

Harvest and purification procedures that remove or inactivate the producing organism, cellular debris and media components (while minimizing degradation, contamination, and loss of quality) should be adequate to ensure that the intermediate or API is recovered with consistent quality.

All equipment should be properly cleaned and, as appropriate, sanitized after use. Multiple successive batching without cleaning can be used if intermediate or API quality is not compromised.

If open systems are used, purification should be performed under environmental conditions appropriate for the preservation of product quality.

Additional controls, such as the use of dedicated chromatography resins or additional testing, may be appropriate if equipment is to be used for multiple products.

#### **E. Viral Removal/Inactivation steps (18.5)**

See ICH guidance Q5A *Quality of Biotechnological Products: Viral Safety Evaluation of Biotechnology Products Derived from Cell Lines of Human or Animal Origin* for more specific information.

Viral removal and viral inactivation steps are critical processing steps for some processes and should be performed within their validated parameters.

Appropriate precautions should be taken to prevent potential viral contamination from previral to postviral removal/inactivation steps. Therefore, open processing should be performed in areas that are separate from other processing activities and have separate air handling units.

The same equipment is not normally used for different purification steps. However, if the same equipment is to be used, the equipment should be appropriately cleaned and sanitized before reuse. Appropriate precautions should be taken to prevent potential virus carry-over (e.g., through equipment or environment) from previous steps.

### **XIX. APIs FOR USE IN CLINICAL TRIALS (19)**

#### **A. General (19.1)**

Not all the controls in the previous sections of this guidance are appropriate for the manufacture of a new API for investigational use during its development. Section XIX (19) provides specific guidance unique to these circumstances.

The controls used in the manufacture of APIs for use in clinical trials should be consistent with the stage of development of the drug product incorporating the API. Process and test procedures should be flexible to provide for changes as knowledge of the process increases and clinical testing of a drug product progresses from pre-clinical stages through clinical stages. Once drug development reaches the stage where the API is produced for use in drug products intended for clinical trials, manufacturers should ensure that APIs are manufactured in suitable facilities using appropriate production and control procedures to ensure the quality of the API.

**B. Quality (19.2)**

Appropriate GMP concepts should be applied in the production of APIs for use in clinical trials with a suitable mechanism for approval of each batch.

A quality unit(s) independent from production should be established for the approval or rejection of each batch of API for use in clinical trials.

Some of the testing functions commonly performed by the quality unit(s) can be performed within other organizational units.

Quality measures should include a system for testing of raw materials, packaging materials, intermediates, and APIs.

Process and quality problems should be evaluated.

Labeling for APIs intended for use in clinical trials should be appropriately controlled and should identify the material as being for investigational use.

**C. Equipment and Facilities (19.3)**

During all phases of clinical development, including the use of small-scale facilities or laboratories to manufacture batches of APIs for use in clinical trials, procedures should be in place to ensure that equipment is calibrated, clean, and suitable for its intended use.

Procedures for the use of facilities should ensure that materials are handled in a manner that minimizes the risk of contamination and cross-contamination.

**D. Control of Raw Materials (19.4)**

Raw materials used in production of APIs for use in clinical trials should be evaluated by testing, or received with a supplier's analysis and subjected to identity testing. When a material is considered hazardous, a supplier's analysis should suffice.

In some instances, the suitability of a raw material can be determined before use based on acceptability in small-scale reactions (i.e., use testing) rather than on analytical testing alone.

**E. Production (19.5)**

The production of APIs for use in clinical trials should be documented in laboratory notebooks, batch records, or by other appropriate means. These documents should include information on the use of production materials, equipment, processing, and scientific observations.

Expected yields can be more variable and less defined than the expected yields used in commercial processes. Investigations into yield variations are not expected.



#### **F. Validation (19.6)**

Process validation for the production of APIs for use in clinical trials is normally inappropriate, where a single API batch is produced or where process changes during API development make batch replication difficult or inexact. The combination of controls, calibration, and, where appropriate, equipment qualification ensures API quality during this development phase.

Process validation should be conducted in accordance with Section 12 when batches are produced for commercial use, even when such batches are produced on a pilot or small scale.

#### **G. Changes (19.7)**

Changes are expected during development, as knowledge is gained and the production is scaled up. Every change in the production, specifications, or test procedures should be adequately recorded.

#### **H. Laboratory Controls (19.8)**

While analytical methods performed to evaluate a batch of API for clinical trials may not yet be validated, they should be scientifically sound.

A system for retaining reserve samples of all batches should be in place. This system should ensure that a sufficient quantity of each reserve sample is retained for an appropriate length of time after approval, termination, or discontinuation of an application.

Expiry and retest dating as defined in Section 11.6 applies to existing APIs used in clinical trials. For new APIs, Section 11.6 does not normally apply in early stages of clinical trials.

#### **I. Documentation (19.9)**

A system should be in place to ensure that information gained during the development and the manufacture of APIs for use in clinical trials is documented and available.

The development and implementation of the analytical methods used to support the release of a batch of API for use in clinical trials should be appropriately documented.

A system for retaining production and control records and documents should be used. This system should ensure that records and documents are retained for an appropriate length of time after the approval, termination, or discontinuation of an application.

## GLOSSARY (20)

**Acceptance Criteria:** Numerical limits, ranges, or other suitable measures for acceptance of test results.

**Active Pharmaceutical Ingredient (API) (or Drug Substance):** Any substance or mixture of substances intended to be used in the manufacture of a drug (medicinal) product and that, when used in the production of a drug, becomes an active ingredient of the drug product. Such substances are intended to furnish pharmacological activity or other direct effect in the diagnosis, cure, mitigation, treatment, or prevention of disease or to affect the structure and function of the body.

**API Starting Material:** A raw material, intermediate, or an API that is used in the production of an API and that is incorporated as a significant structural fragment into the structure of the API. An API starting material can be an article of commerce, a material purchased from one or more suppliers under contract or commercial agreement, or produced in-house. API starting materials are normally of defined chemical properties and structure.

**Batch (or Lot):** A specific quantity of material produced in a process or series of processes so that it is expected to be homogeneous within specified limits. In the case of continuous production, a batch may correspond to a defined fraction of the production. The batch size can be defined either by a fixed quantity or by the amount produced in a fixed time interval.

**Batch Number (or Lot Number):** A unique combination of numbers, letters, and/or symbols that identifies a batch (or lot) and from which the production and distribution history can be determined.

**Bioburden:** The level and type (e.g., objectionable or not) of microorganisms that can be present in raw materials, API starting materials, intermediates or APIs. Bioburden should not be considered contamination unless the levels have been exceeded or defined objectionable organisms have been detected.

**Calibration:** The demonstration that a particular instrument or device produces results within specified limits by comparison with results produced by a reference or traceable standard over an appropriate range of measurements.

**Computer System:** A group of hardware components and associated software designed and assembled to perform a specific function or group of functions.

**Computerized System:** A process or operation integrated with a computer system.

**Contamination:** The undesired introduction of impurities of a chemical or microbiological nature, or of foreign matter, into or onto a raw material, intermediate, or API during production, sampling, packaging, or repackaging, storage or transport.

**Contract Manufacturer:** A manufacturer who performs some aspect of manufacturing on behalf of the original manufacturer.

**Critical:** Describes a process step, process condition, test requirement, or other relevant parameter or item that must be controlled within predetermined criteria to ensure that the API meets its specification.

**Cross-Contamination:** Contamination of a material or product with another material or product.

**Deviation:** Departure from an approved instruction or established standard.

**Drug (Medicinal) Product:** The dosage form in the final immediate packaging intended for marketing. (Reference Q1A)

**Drug Substance:** See Active Pharmaceutical Ingredient.

**Expiry Date (or Expiration Date):** The date placed on the container/labels of an API designating the time during which the API is expected to remain within established shelf life specifications if stored under defined conditions and after which it should not be used.

**Impurity:** Any component present in the intermediate or API that is not the desired entity.

**Impurity Profile:** A description of the identified and unidentified impurities present in an API.

**In-Process Control (or Process Control):** Checks performed during production to monitor and, if appropriate, to adjust the process and/or to ensure that the intermediate or API conforms to its specifications.

**Intermediate:** A material produced during steps of the processing of an API that undergoes further molecular change or purification before it becomes an API. Intermediates may or may not be isolated. (Note: this guidance only addresses those intermediates produced after the point that a company has defined as the point at which the production of the API begins.)

**Lot:** See Batch

**Lot Number:** See *Batch Number*

**Manufacture:** All operations of receipt of materials, production, packaging, repackaging, labeling, relabeling, quality control, release, storage, and distribution of APIs and related controls.

**Material:** A general term used to denote raw materials (starting materials, reagents, solvents), process aids, intermediates, APIs, and packaging and labeling materials.

**Mother Liquor:** The residual liquid that remains after the crystallization or isolation processes. A mother liquor may contain unreacted materials, intermediates, levels of the API, and/or impurities. It can be used for further processing.

**Packaging Material:** Any material intended to protect an intermediate or API during storage and transport.

**Procedure:** A documented description of the operations to be performed, the precautions to be taken, and measures to be applied directly or indirectly related to the manufacture of an intermediate or API.

**Process Aids:** Materials, excluding solvents, used as an aid in the manufacture of an intermediate or API that do not themselves participate in a chemical or biological reaction (e.g., filter aid, activated carbon).

**Process Control:** See *In-Process Control*.

**Production:** All operations involved in the preparation of an API from receipt of materials through processing and packaging of the API.

**Qualification:** Action of proving and documenting that equipment or ancillary systems are properly installed, work correctly, and actually lead to the expected results. Qualification is part of validation, but the individual qualification steps alone do not constitute process validation.

**Quality Assurance (QA):** The sum total of the organized arrangements made with the object of ensuring that all APIs are of the quality required for their intended use and that quality systems are maintained.

**Quality Control (QC):** Checking or testing that specifications are met.

**Quality Unit(s):** An organizational unit independent of production that fulfills both quality assurance and quality control responsibilities. This can be in the form of separate QA and QC units or a single individual or group, depending upon the size and structure of the organization.

**Quarantine:** The status of materials isolated physically or by other effective means pending a decision on their subsequent approval or rejection.

**Raw Material:** A general term used to denote starting materials, reagents, and solvents intended for use in the production of intermediates or APIs.

**Reference Standard, Primary:** A substance that has been shown by an extensive set of analytical tests to be authentic material that should be of high purity. This standard can be: (1) obtained from an officially recognized source, (2) prepared by independent synthesis, (3) obtained from existing production material of high purity, or (4) prepared by further purification of existing production material.

**Reference Standard, Secondary:** A substance of established quality and purity, as shown by comparison to a primary reference standard, used as a reference standard for routine laboratory analysis.

**Reprocessing:** Introducing an intermediate or API, including one that does not conform to standards or specifications, back into the process and repeating a crystallization step or other appropriate chemical or physical manipulation steps (e.g., distillation, filtration, chromatography, milling) that are part of the established manufacturing process. Continuation of a process step after an in-process control test has shown that the step is incomplete, is considered to be part of the normal process, and is not reprocessing.

**Retest Date:** The date when a material should be re-examined to ensure that it is still suitable for use.

**Reworking:** Subjecting an intermediate or API that does not conform to standards or specifications to one or more processing steps that are different from the established manufacturing process to obtain acceptable quality intermediate or API (e.g., recrystallizing with a different solvent).

**Signature (signed):** See definition for signed.

**Signed (signature):** The record of the individual who performed a particular action or review. This record can be initials, full handwritten signature, personal seal, or authenticated and secure electronic signature.

**Solvent:** An inorganic or organic liquid used as a vehicle for the preparation of solutions or suspensions in the manufacture of an intermediate or API.

**Specification:** A list of tests, references to analytical procedures, and appropriate acceptance criteria that are numerical limits, ranges, or other criteria for the test described. It establishes the set of criteria to which a material should conform to be considered acceptable for its intended use. *Conformance to specification* means that the material, when tested according to the listed analytical procedures, will meet the listed acceptance criteria.

**Validation:** A documented program that provides a high degree of assurance that a specific process, method, or system will consistently produce a result meeting predetermined acceptance criteria.

**Validation Protocol:** A written plan stating how validation will be conducted and defining acceptance criteria. For example, the protocol for a manufacturing process identifies processing equipment, critical process parameters and/or operating ranges, product characteristics, sampling, test data to be collected, number of validation runs, and acceptable test results.


**Yield, Expected:** The quantity of material or the percentage of theoretical yield anticipated at any appropriate phase of production based on previous laboratory, pilot scale, or manufacturing data.

**Yield, Theoretical:** The quantity that would be produced at any appropriate phase of production based upon the quantity of material to be used, in the absence of any loss or error in actual production.

# Diethylstilbestrol Exposure

SARINA SCHRAGER, M.D., and BETH E. POTTER, M.D.,  
University of Wisconsin Medical School, Madison, Wisconsin

Diethylstilbestrol is a synthetic nonsteroidal estrogen that was used to prevent miscarriage and other pregnancy complications between 1938 and 1971 in the United States. In 1971, the U.S. Food and Drug Administration issued a warning about the use of diethylstilbestrol during pregnancy after a relationship between exposure to this synthetic estrogen and the development of clear cell adenocarcinoma of the vagina and cervix was found in young women whose mothers had taken diethylstilbestrol while they were pregnant. Although diethylstilbestrol has not been given to pregnant women in the United States for more than 30 years, its effects continue to be seen. Women who took diethylstilbestrol during pregnancy have a slightly higher risk of breast cancer than the general population and therefore should be encouraged to have regular mammography. Women who were exposed to diethylstilbestrol in utero may have structural reproductive tract anomalies, an increased infertility rate, and poor pregnancy outcomes. However, the majority of these women have been able to deliver successfully. Recommendations for gynecologic examinations include vaginal and cervical digital palpation, which may provide the only evidence of clear cell adenocarcinoma. Initial colposcopic examination should be considered; if the findings are abnormal, colposcopy should be repeated annually. If the initial colposcopic examination is normal, annual cervical and vaginal cytology is recommended. Because of the higher risk of spontaneous abortion, ectopic pregnancy, and preterm delivery, obstetric consultation may be required for pregnant women who had in utero diethylstilbestrol exposure. The male offspring of women who took diethylstilbestrol during pregnancy have an increased incidence of genital abnormalities and a possibly increased risk of prostate and testicular cancer. Routine prostate cancer screening and testicular self-examination should be encouraged. (Am Fam Physician 2004;69:2395-400,2401-2. Copyright© 2004 American Academy of Family Physicians.)

 A patient information handout on diethylstilbestrol, written by the authors of this article, is provided on page 2401.

See page 2291 for definitions of strength-of-recommendation labels.

**B**etween 1938 and 1971, as many as 4 million women in the United States took diethylstilbestrol (DES), an oral synthetic nonsteroidal estrogen, for the purpose of improving pregnancy outcomes.<sup>1,2</sup> In 1953, it was demonstrated that DES did not prevent miscarriage and other pregnancy complications. However, physicians continued to prescribe DES to pregnant women until at least 1971, when a connection was established between in utero DES exposure and the development of clear cell adenocarcinoma of the vagina and cervix in the daugh-

ters of women who had taken DES during pregnancy.<sup>3</sup> In 1971, the U.S. Food and Drug Administration issued a warning against the use of DES in pregnant women.<sup>4</sup> DES continued to be used in various European countries until the early 1980s.

The association between in utero DES exposure and vaginal clear cell adenocarcinoma has been well documented. Other adverse associations have been identified in DES-exposed women and their offspring, and animal studies have shown effects in the next generation (grandchildren).<sup>5,6</sup> The Centers for Disease Control and Prevention has instituted a campaign to educate health care professionals and patients about the risks associated with exposure to this synthetic estrogen.

It is difficult to determine the number of persons with DES exposure. However, physicians should be alert for patients who may have been exposed to this agent and should be aware of the possible consequences of such exposure.

*In 1971, the U.S. Food and Drug Administration warned against the use of diethylstilbestrol in pregnant women because of an increased risk of clear cell adenocarcinoma in female offspring.*

Downloaded from the American Family Physician Web site at [www.aafp.org/afp](http://www.aafp.org/afp). Copyright© 2004 American Academy of Family Physicians. For the private, noncommercial use of one individual user of the Web site. All other rights reserved. Contact [copyrights@afp.org](mailto:copyrights@afp.org) for copyright questions and/or permission requests.

P. 1

UT Ex. 2045

SteadyMed v. United Therapeutics  
IPR2016-00006

IPR2020-00769

United Therapeutics EX2006

Page 5347 of 7113

Dosages of DES varied greatly, as did the time during pregnancy that DES was taken. These factors may contribute to the wide range of adverse effects in the offspring of women who took DES while they were pregnant.

### Illustrative Case

A 37-year-old woman who had been trying to conceive for two years came to her physician's office to discuss fertility issues. Her basal body temperature charts illustrated presumed ovulatory cycles, and her husband had a normal semen analysis. She had an abnormal Papanicolaou (Pap) smear 15 years previously, but all subsequent Pap smears had been normal. However, her previous physician had noted that her cervix "looked funny." The

patient was the oldest of four siblings; her mother had two miscarriages before the patient was born.

The patient's general physical examination was normal. On pelvic examination, her vagina was normal, but her cervix had a pseudopolyp. Because of the patient's history of infertility and the consideration that she might have been exposed to DES in utero, hysterosalpingography was ordered, and the patient was asked to discuss the possibility of DES exposure with her mother.

The patient's mother accompanied her to the follow-up visit. The hysterosalpingogram showed that the patient had a T-shaped uterus. Her mother vaguely remembered taking medication to prevent another miscarriage when she was pregnant with her daughter.

Subsequent to a follow-up visit, the patient's mother contacted her physician for a copy of her obstetric records. The patient was referred to a reproductive endocrinologist for evaluation of infertility.

### Identifying DES Exposure

It is important to include questions about DES in the routine medical history of women who gave birth between 1938 and 1971, and of patients who were born during those years<sup>3,7</sup> (Table 1).<sup>2</sup> In persons born outside the United States, there is a chance of DES exposure if they gave birth or were born as late as the 1980s. Many women may not be aware that they received DES during pregnancy, in part because the synthetic estrogen was marketed under many different names.<sup>2,8</sup>

One recent study<sup>9</sup> found that an office system intervention was successful in increasing awareness of DES exposure among clinical staff. The intervention entailed the addition of questions about DES exposure to the routine health history form.

### Women Who Took DES During Pregnancy

Women who took DES while they were pregnant have a slightly higher incidence of

TABLE 1  
Identifying DES-Exposed Patients

Patient	Approach to identifying DES exposure, and subsequent actions
Woman who may have taken DES during pregnancy*	<p>Questions: Have you ever had a miscarriage? More than one miscarriage? Did you take any prescription medicines while you were pregnant? If so, what medicine and for what reason?</p> <p>Actions: If the patient is not sure about the medications that she took, try to obtain her obstetric records. If DES exposure is documented or surmised from the history, counsel all of the patient's offspring.</p>
Daughter or son who may have been exposed to DES in utero†	<p>Questions: Did your mother have one or more miscarriages? Did your mother take any prescription medicines while she was pregnant with you?</p> <p>Actions: If the patient has reproductive tract anomalies consistent with those seen in DES-exposed offspring, attempt to obtain the mother's obstetric records. If the records cannot be obtained, consider the patient to have been exposed to DES.</p>

DES = diethylstilbestrol.

\*—Although DES was not used in pregnant women in the United States after 1971, it continued to be used in other countries until the early 1980s.

†—Born in the United States from 1938 through 1971, or born outside the United States from 1938 through the early 1980s.

Information from Centers for Disease Control and Prevention. DES update. Accessed online February 19, 2004, at: <http://www.cdc.gov/DES>.



TABLE 2  
**Structural Abnormalities in Women  
 with in Utero DES Exposure**

Cervix	Vagina
Hypoplastic cervix	Clear cell adenocarcinoma
Cockscomb cervix	Adenosis
Cervical collar	<b>Uterus</b>
Pseudopolyp	T-shaped uterus

DES = diethylstilbestrol

breast cancer compared with the general population. The relative risk ranges from 1.27 to 1.35 in several studies.<sup>10</sup> In comparison, the relative risk of breast cancer is 1.3 in women who have taken hormone therapy for more than five years,<sup>11</sup> and 2.1 in women with a family history of breast cancer.<sup>12</sup> Women who were prescribed DES during pregnancy should have annual mammography and clinical breast examinations after the age of 50.<sup>12</sup> [Strength of recommendation (SOR) A, evidence-based guideline]

No increased risk of other hormone-dependent cancers has been found in women with DES exposure during pregnancy. Therefore, other preventive and screening measures should be based on standard guidelines.

#### Daughters with in Utero DES Exposure

In the daughters of women who took DES during pregnancy, the incidence of clear cell adenocarcinoma of the vagina and cervix ranges from 1.4 cases per 1,000 exposed persons to one case per 10,000 exposed persons.<sup>13</sup> Clear cell adenocarcinoma is most likely to develop when women with in utero DES exposure are between 17 and 22 years of age. However, cases have been diagnosed in women in their 30s and 40s, and there is concern about a possible second age-incidence peak of clear cell adenocarcinoma as women with in utero DES exposure grow older.<sup>14</sup>

*Women who took diethylstilbestrol during pregnancy have a slightly increased risk of breast cancer*

Clear cell adenocarcinoma of the vagina and cervix is rare in women without in utero DES exposure; in such cases, the cancer usually develops in the postmenopausal period.<sup>15</sup>

Many women who were exposed to DES in utero are just beginning to reach menopause. Because of the concern about a second peak in the incidence of clear cell adenocarcinoma, continued surveillance for this cancer is warranted in these women.<sup>16</sup>

Women with in utero DES exposure do not have a higher documented incidence of any other cancer. Data from several studies<sup>17,18</sup> suggest that these women may have a higher incidence of high-grade cervical intraepithelial neoplasia, but not invasive cervical carcinoma. However, the findings of these studies have been questioned, in that women with in utero DES exposure may receive increased cytologic screening. A link with breast cancer is under investigation.<sup>2</sup>

Many women who were exposed to DES in utero have a range of structural reproductive tract abnormalities<sup>19,20</sup> (Table 2). The National Collaborative Diethylstilbestrol Adenosis project<sup>19</sup> followed approximately 4,500 DES-exposed women for almost 20 years and found an 18 percent incidence of structural uterine, cervical, or vaginal abnormalities. The incidence of these abnormalities may be as high as 33 percent in women with in utero DES exposure.<sup>2</sup>

DES can cause changes in the vaginal epithelium, including adenosis (columnar epithelium located in the upper one third of the vagina). Although vaginal adenosis is benign, it sometimes causes abnormal bleeding. The degree of adenosis depends on the DES dosage and the stage during the pregnancy that the agent was taken. The most severe changes occur in the daughters of

**TABLE 3**  
**Clinical Recommendation for Women with in Utero DES Exposure**

Perform colposcopy as part of the first pelvic examination. If the colposcopic examination is normal, no further screening is needed. If the examination is abnormal, repeat colposcopy annually along with cervical and vaginal (four-quadrant) cytology.

Perform annual cervical cytology, four-quadrant vaginal cytology, and careful digital palpation for adenosis and vaginal clear cell adenocarcinoma.

Provide counseling about increased risk of infertility and poor pregnancy outcome.

Refer pregnant patients for high-risk obstetric management.

women who took DES during the first trimester.<sup>20</sup> Although vaginal clear cell adenocarcinoma generally develops in areas of adenosis, whether individual areas of adenosis progress to this cancer remains unknown.

Performance of colposcopy (to assess for abnormal epithelium) frequently is recommended during the first pelvic examination in all women with in utero DES exposure (Table 3).<sup>21</sup> If the initial colposcopic examination is normal, annual pelvic examinations and annual cervical Pap smears and four-quadrant vaginal Pap smears are adequate, and colposcopy does not need to be

repeated.<sup>21,22</sup> [Reference 22: SOR C, consensus practice guideline based on expert opinion] If the initial colposcopic examination demonstrates any abnormalities, annual colposcopy with cytology is indicated.

For the four-quadrant Pap smear, cells are obtained from all four walls of the upper vagina. Cells first are obtained from the two lateral walls; then the speculum is rotated 90 degrees, and specimens are obtained from the anterior and posterior walls. The four-quadrant Pap smear should be performed annually to screen for adenosis and clear cell adenocarcinoma in women with in utero DES exposure.

Routine cervical cytology also should be performed annually in women who were exposed to DES in utero. In addition, the cervix and upper vaginal walls should be palpated carefully during the bimanual examination to feel for thickening that might indicate adenosis or clear cell adenocarcinoma.<sup>22</sup>

Women with in utero DES exposure should be counseled about their slightly increased risk of infertility and a possibly increased risk of adverse pregnancy outcome. Infertility is most common in women with underlying structural abnormalities and usually is caused by uterine or tubal factors.<sup>23</sup> Women who were exposed to DES in utero should be monitored closely during pregnancy.<sup>24-26</sup>

Although most women with in utero DES exposure have normal pregnancies, there is evidence for an increased risk of first- and second-trimester spontaneous abortion, ectopic pregnancy, and preterm delivery.<sup>26</sup> The most comprehensive study<sup>26</sup> to date found that 64.5 percent of women with in utero DES exposure had full-term infants, compared with 84.5 percent of matched women who had not been exposed to DES. In addition, the DES-exposed women had higher rates of preterm delivery (19.4 percent versus 7.5 percent), ectopic pregnancy (4.2 percent versus 0.77 percent), and second-trimester spontaneous abortion (6.3 percent versus 1.6 percent). Consequently, high-risk obstetric care

### The Authors

SARINA SCHRAGER, M.D., is assistant professor in the Department of Family Medicine at the University of Wisconsin Medical School, Madison. Dr. Schrager received her medical degree from the University of Illinois at Chicago College of Medicine. She completed a family practice residency and a primary care women's health fellowship at MacNeal Hospital, Berwyn, Ill.

BETH E. POTTER, M.D., is a faculty member in the family practice residency program at the University of Wisconsin Medical School, Madison. Dr. Potter received her medical degree from Rush Medical College of Rush University, Chicago, and completed a family practice residency at the University of Wisconsin.

Address correspondence to Sarina Schrager, M.D., University of Wisconsin Medical School, Department of Family Medicine, 777 S. Mills St., Madison, WI 53715 (e-mail: sbschrag@wisc.edu). Reprints are not available from the authors.

may be indicated for pregnant women who were exposed to DES in utero.

Contraceptive management may be complicated in women with in utero DES exposure. Use of intrauterine devices is controversial because of the high incidence of structural uterine abnormalities, as well as possible changes in the elasticity of endometrial tissue. Because of cervical abnormalities, diaphragms and cervical caps may be difficult to fit.<sup>27</sup> No evidence indicates that oral contraceptive pills are not safe for use in women with in utero DES exposure, although some experts are reluctant to prescribe hormonal contraception of any type to these women.<sup>3</sup>

#### Sons with in Utero DES Exposure

The sons of women who took DES during pregnancy are three times more likely to have genital structural abnormalities than men without such exposure.<sup>28</sup> The most common abnormalities are epididymal cysts, undescended testes, and small testes. Epididymal cysts have no clinical implications, but undescended testes and small testes are associated with an increased risk of testicular cancer.<sup>29</sup> Men with in utero DES exposure also have sperm and semen abnormalities but do not have an increased risk of infertility or sexual dysfunction.<sup>30</sup>

There is some concern about the effects of DES on the prostate.<sup>31</sup> One study<sup>32</sup> that examined the prostatic utricle of male stillborns who were exposed to DES in utero showed a significantly higher incidence of squamous metaplasia in this müllerian-derived tissue.

A recent study<sup>33</sup> showed a possibly increased incidence of testicular cancer in men with in utero DES exposure. Although this finding was not statistically significant, the investigators concluded that the connection between DES and testicular cancer "remains uncertain," and suggested that ongoing clinical surveillance would be prudent. Therefore, the sons of women who took DES during pregnancy should be encouraged to practice routine testicular self-examination.

*The sons of women who took diethylstilbestrol during pregnancy have an increased incidence of genital structural abnormalities, testicular cancer, and sperm and semen abnormalities.*

#### Future Considerations

An increased susceptibility to reproductive tract tumors has been demonstrated in mice that are descended from parents with prenatal DES exposure (i.e., multigenerational effect),<sup>6</sup> but this relationship has yet to be observed in humans. To date, no studies have shown an increased risk of cancer in the offspring of men and women who were exposed to DES in utero. Two studies<sup>34,35</sup> of "DES granddaughters" (third-generation females) have found no health effects related to DES exposure. However, one small study<sup>36</sup> of "DES grandsons" showed an increased risk of hypospadias.

DES currently is being studied as an experimental hormonal treatment (i.e., a type of estrogen therapy) in men with refractory prostate cancer.<sup>37</sup>

*The authors indicate that they do not have any conflicts of interest. Sources of funding: work on this article was supported by grants from the Centers for Disease Control and Prevention's Educational Campaign on DES and the University of Wisconsin National Center of Excellence in Women's Health.*

#### REFERENCES

1. Stillman RJ. In utero exposure to diethylstilbestrol: adverse effects on the reproductive tract and reproductive performance of male and female offspring. *Am J Obstet Gynecol* 1982;142:905-21.
2. Centers for Disease Control and Prevention. DES update. Accessed online February 19, 2004, at: <http://www.cdc.gov/DES>.
3. Giusti RM, Iwamoto K, Hatch EE. Diethylstilbestrol revisited: a review of the long-term health effects. *Ann Intern Med* 1995;122:778-88.
4. Exposure in utero to diethylstilbestrol and related synthetic hormones. Association with vaginal and cervical cancers and other abnormalities. *JAMA* 1976;236:1107-9.
5. Herbst AL, Ulfelder H, Poskanzer DC. Adenocarcinoma of the vagina. Association of maternal stilbestrol therapy with tumor appearance in young women. *N Engl J Med* 1971;284:878-81.

6. Walker BE, Haven M. Intensity of multigenerational carcinogenesis from diethylstilbestrol in mice. *Carcinogenesis* 1997;18:791-3.
7. Kaufman RH, ed. Physician information. How to identify and manage DES exposed individuals. Bethesda, Md.: National Cancer Institute, 1995; NIH publication no. 81-2049.
8. Kruse K, Lauver D, Hanson K. Clinical implications of DES. *Nurse Pract* 2003;28(7 pt 1):26-32,35.
9. Jackson R, O'Donnell L, Johnson C, Dietrich AJ, Lauridsen J, O'Donnell C. Office systems intervention to improve diethylstilbestrol screening in managed care. *Obstet Gynecol* 2000;96:380-4.
10. Colton T, Greenberg ER, Noller K, Resseguie L, Van Bennekom C, Heeren T, et al. Breast cancer in mothers prescribed diethylstilbestrol in pregnancy. Further follow-up. *JAMA* 1993;269:2096-100.
11. Rossouw JE, Anderson GL, Prentice RL, LaCroix AZ, Kooperberg C, Stefanick ML, et al. Risks and benefits of estrogen plus progestin in healthy postmenopausal women: principal results from the Women's Health Initiative randomized controlled trial. *JAMA* 2002;288:321-33.
12. Pharoah PD, Day NE, Duffy S, Easton DF, Ponder BA. Family history and risk of breast cancer: a systematic review and meta-analysis. *Int J Cancer* 1997;71:900-9.
13. Melnick S, Coie P, Anderson D, Herbst A. Rates and risks of diethylstilbestrol-related clear-cell adenocarcinoma of the vagina and cervix. An update. *N Engl J Med* 1987;316:514-6.
14. Hanselaar A, van Loosbroek M, Schuurbijs O, Helmerhorst T, Bulten J, Bernheim J. Clear cell adenocarcinoma of the vagina and cervix. An update of the central Netherlands registry showing twin age incidence peaks. *Cancer* 1997;79:2229-36.
15. Kaminski PF, Maier RC. Clear cell adenocarcinoma of the cervix unrelated to diethylstilbestrol exposure. *Obstet Gynecol* 1983;62:720-7.
16. Hatch EE, Palmer JR, Titus-Ernstoff L, Noller KL, Kaufman RH, Mittendorf R, et al. Cancer risk in women exposed to diethylstilbestrol in utero. *JAMA* 1998;280:630-4.
17. Robboy SJ, Szyfelbein WM, Goellner JR, Kaufman RH, Taft PD, Richard RM, et al. Dysplasia and cytologic findings in 4,589 young women enrolled in Diethylstilbestrol-Adenosis (DESAD) Project. *Am J Obstet Gynecol* 1981;140:579-86.
18. Robboy SJ, Noller KL, O'Brien P, Kaufman RH, Townsend D, Barnes AB, et al. Increased incidence of cervical and vaginal dysplasia in 3,980 diethylstilbestrol-exposed young women. Experience of the National Collaborative Diethylstilbestrol Adenosis Project. *JAMA* 1984;252:2979-83.
19. Jefferies JA, Robboy SJ, O'Brien PC, Bergstrahl EJ, Labarthe DR, Barnes AB, et al. Structural anomalies of the cervix and vagina in women enrolled in the Diethylstilbestrol Adenosis (DESAD) Project. *Am J Obstet Gynecol* 1984;148:59-66.
20. Kaufman RH. Lower genital tract changes associated with in utero exposure to diethylstilbestrol. In: Apgar BS, Brotzman GL, Spitzer M, eds. *Colposcopy, principles and practice: an integrated text and atlas*. Philadelphia: Saunders, 2002:383-90.
21. Noller KL. Role of colposcopy in the examination of diethylstilbestrol-exposed women. *Obstet Gynecol Clin North Am* 1993;20:165-76.
22. Diethylstilbestrol. ACOG committee opinion: Committee on Gynecologic Practice. Number 131—December 1993. *Int J Gynaecol Obstet* 1994;44:184.
23. Palmer JR, Hatch EE, Rao RS, Kaufman RH, Herbst AL, Noller KL, et al. Infertility among women exposed prenatally to diethylstilbestrol. *Am J Epidemiol* 2001;154:316-21.
24. Goldberg JM, Falcone T. Effect of diethylstilbestrol on reproductive function. *Fertil Steril* 1999;72:1-7.
25. Swan SH. Pregnancy outcome in DES daughters. In: Giusti RM, ed. *Report of the NIH workshop on long-term effects of exposure to diethylstilbestrol (DES)*. Washington, D.C.: U.S. Department of Health and Human Services, Public Health Service, National Institutes of Health, 1992:42-9.
26. Kaufman RH, Adam E, Hatch EE, Noller K, Herbst AL, Palmer JR, et al. Continued follow-up of pregnancy outcomes in diethylstilbestrol-exposed offspring. *Obstet Gynecol* 2000;96:483-9.
27. Edelman DA, Badrawi HH. Contraception for women exposed in utero to diethylstilbestrol. *Adv Contracept* 1988;4:241-6.
28. Cosgrove MD, Bernton B, Henderson BE. Male genitourinary abnormalities and maternal diethylstilbestrol. *J Urol* 1977;177:220-2.
29. Docimo SG, Silver RI, Cromie W. The undescended testicle: diagnosis and management. *Am Fam Physician* 2000;62:2037-44,2047-8.
30. Wilcox AJ, Baird DD, Weinberg CR, Hornsby PP, Herbst AL. Fertility in men exposed prenatally to diethylstilbestrol. *N Engl J Med* 1995;332:1411-6.
31. Laitman CJ, Jonler M, Messing EM. The effects on men of prenatal exposure to diethylstilbestrol. In: Lipshultz LI, Howards SS, eds. *Infertility in the male*. 3d ed. St. Louis: Mosby, 1997:268-79.
32. Driscoll SG, Taylor SH. Effects of prenatal maternal estrogen on the male urogenital system. *Obstet Gynecol* 1980;56:537-42.
33. Strohsnitter WC, Noller KL, Hoover RN, Robboy SJ, Palmer JR, Titus-Ernstoff L, et al. Cancer risk in men exposed in utero to diethylstilbestrol. *J Natl Cancer Inst* 2001;93:545-51.
34. Kaufman RH, Adam E. Findings in female offspring of women exposed in utero to diethylstilbestrol. *Obstet Gynecol* 2002;99:197-200.
35. Wilcox AJ, Umbach DM, Hornsby PP, Herbst AL. Age at menarche among diethylstilbestrol granddaughters. *Am J Obstet Gynecol* 1995;173(3 pt 1):835-6.
36. Klip H, Verloop J, van Gool JD, Koster ME, Burger CW, van Leeuwen FE, et al. Hypospadias in sons of women exposed to diethylstilbestrol in utero: a cohort study. *Lancet* 2002;359:1102-7.
37. Whitesel JA. The case for diethylstilbestrol. *J Urol* 2003;169:290-1.

**NTP REPORT ON CARCINOGENS BACKGROUND  
DOCUMENT for SACCHARIN**

**FINAL  
MARCH 1999**

Prepared for

the October 30-31, 1997,  
Meeting of the Report on Carcinogens Subcommittee  
of the NTP Board of Scientific Counselors

Prepared by

Integrated Laboratory Systems  
Post Office Box 13501  
Research Triangle Park, North Carolina 27709  
NIEHS Contract No. N01-ES-25346

P. 1

UT Ex. 2046  
SteadyMed v. United Therapeutics  
IPR2016-00006

IPR2020-00769  
United Therapeutics EX2006  
Page 5353 of 7113

## TABLE OF CONTENTS

<b>Proposed Report on Carcinogens Delisting for Saccharin.....</b>	<b>1</b>
<b>Listing Criteria from the Report on Carcinogens, Eighth Edition.....</b>	<b>7</b>
<b>1.0 CHEMICAL PROPERTIES.....</b>	<b>8</b>
<b>1.1 Chemical Identification .....</b>	<b>8</b>
<b>1.2 Physical-Chemical Properties.....</b>	<b>9</b>
<b>2.0 HUMAN EXPOSURE .....</b>	<b>10</b>
<b>2.1 Production .....</b>	<b>10</b>
<b>Table 2-1 Forms of Saccharin Produced by PMC Specialties Group....</b>	<b>11</b>
<b>2.2 Use .....</b>	<b>12</b>
<b>2.3 Environmental Exposure.....</b>	<b>13</b>
<b>2.3.1 Environmental Releases.....</b>	<b>13</b>
<b>Table 2-2 Releases of Saccharin to the Environment.....</b>	<b>13</b>
<b>2.3.2 Environmental Occurrence .....</b>	<b>13</b>
<b>2.3.3 Drinking Water and Food .....</b>	<b>14</b>
<b>2.3.4 Consumer Products.....</b>	<b>14</b>
<b>Table 2-3 USDA Nationwide Food Consumption Survey</b>	
<b>(1977-1978): Total Calculated Saccharin Intake Levels...14</b>	
<b>2.3.5 Biomarkers of Exposure.....</b>	<b>14</b>
<b>2.3.6 Occupational Exposure.....</b>	<b>15</b>
<b>Table 2-4 NIOSH National Occupational Exposure Survey</b>	
<b>(NOES, 1981-83): By Industry .....</b>	<b>15</b>
<b>2.4 Regulations .....</b>	<b>16</b>
<b>2.4.1 Occupational Exposure Limits.....</b>	<b>16</b>
<b>2.4.2 Other Standards and Criteria.....</b>	<b>16</b>
<b>3.0 HUMAN STUDIES.....</b>	<b>19</b>
<b>3.1 IARC (1980) Review of Saccharin Epidemiology.....</b>	<b>20</b>
<b>3.2 Human Studies Published Post IARC (1980) .....</b>	<b>21</b>
<b>3.2.1 U.S. Case-Control Studies.....</b>	<b>21</b>
<b>3.2.2 Canadian Case-Control Studies.....</b>	<b>23</b>
<b>3.2.3 Case-Control Studies From Other Countries .....</b>	<b>23</b>
<b>3.2.4 Descriptive Studies .....</b>	<b>24</b>
<b>3.2.5 Meta-Analysis.....</b>	<b>24</b>

<b>Table 3-1 Summary of Epidemiology Studies Published Post IARC (1980)</b>	<b>25</b>
<b>4.0 MAMMALIAN CARCINOGENICITY</b>	<b>35</b>
<b>4.1 Mammalian Carcinogenicity of Saccharin</b>	<b>35</b>
4.1.1 Hamsters	36
4.1.2 Mice	36
4.1.3 Rats	37
4.1.4 Nonhuman Primates	40
Table 4-1 Mammalian Carcinogenicity	41
<b>4.2 Initiation/Promotion and Co-Carcinogenicity Studies</b>	<b>48</b>
4.2.1 Benzo[ <i>a</i> ]pyrene (BP)	48
4.2.2 <i>N</i> -Butyl- <i>N</i> -(4-hydroxybutyl)nitrosamine (BBN)	48
4.2.3 2-Acetylaminofluorene (AAF)	49
4.2.4 <i>N</i> -[4-(5-Nitro-2-furyl)-2-thiazolyl]formamide (FANFT)	49
4.2.5 <i>N</i> -Methyl- <i>N</i> -nitrosourea (MNU)	51
4.2.6 Freeze Ulceration	52
Table 4-2 Initiation-Promotion and Co-Carcinogenicity Studies	53
<b>5.0 GENOTOXICITY</b>	<b>60</b>
<b>5.1 Noneukaryotic Systems</b>	<b>60</b>
5.1.1 Gene Mutations	60
5.1.2 DNA Damage	60
5.1.3 DNA Synthesis	60
<b>5.2 Lower Eukaryotic Systems</b>	<b>60</b>
5.2.1 <i>Saccharomyces cerevisiae</i>	60
5.2.2 <i>Drosophila melanogaster</i>	60
5.2.3 Higher Plants	61
<b>5.3 Mammalian Systems <i>In Vitro</i></b>	<b>61</b>
5.3.1 Gene Mutations	61
5.3.2 DNA Damage	61
5.3.3 Inhibition of DNA Repair	61
5.3.4 DNA Synthesis	61
5.3.5 Chromosomal Damage	62
5.3.6 Cell Transformation	62
<b>5.4 Mammalian Systems <i>In Vivo</i></b>	<b>62</b>
5.4.1 Gene Mutations and Dominant Lethal Mutations	62
5.4.2 DNA Damage	63
5.4.3 Chromosomal Aberrations	63

5.4.4 Induction of Micronuclei.....	63
Table 5-1 Summary of Saccharin Genotoxicity Studies.....	64
Figure 5-1 Genetic Activity Profile (GAP) for Saccharin .....	67
Figure 5-2 Genetic Activity Profile (GAP) for Sodium Saccharin.....	68
Figure 5-3 Schematic View of a Genetic Activity Profile .....	69
<b>6.0 OTHER RELEVANT DATA .....</b>	<b>70</b>
6.1 Absorption, Distribution, and Excretion .....	70
6.2 Metabolism.....	74
6.3 Pharmacokinetics .....	76
6.4 Structure-Activity Relationships.....	76
6.5 Cell Proliferation.....	76
6.5.1 Hamsters .....	76
6.5.2 Mice.....	76
6.5.3 Rats.....	76
6.5.4 Guinea Pigs.....	79
6.5.5 Nonhuman Primates .....	79
6.6 Cell Proliferation with Co-Administration of Known Carcinogens.....	80
6.6.1 <i>N</i> -Butyl- <i>N</i> -(4-hydroxybutyl)nitrosamine (BBN).....	80
6.6.2 2-Acetylaminofluorine (AAF).....	80
6.6.3 <i>N</i> -Methyl- <i>N</i> -nitrosourea (MNU).....	80
Table 6-1 Cell Proliferation .....	81
<b>7.0 MECHANISMS .....</b>	<b>90</b>
7.1 Mechanisms of Urinary Bladder Tumorigenesis Found Predominantly in Male Rats.....	91
7.1.1 The Role of pH in the Promotion of Bladder Carcinogenesis in Male Rats .....	91
7.1.2 The Role of Sodium Concentration in the Promotion of Bladder Carcinogenesis in Male Rats.....	92
7.1.3 The Combined Effect of pH Level and Sodium Concentration .....	94
7.1.4 The Association Between Increased Urinary Output and Sodium Saccharin-Induced Bladder Tumors .....	94
7.2 Dose Response in Cell Proliferation and Tumorigenesis.....	95
7.3 Relevance of Animal Cancers to Humans .....	97
7.3.1 Comparative Bladder Anatomy and Urine Chemistry .....	97
7.3.2 Dose-Response Extrapolation.....	99
7.4 Additional Mechanistic Information.....	100



7.4.1 Inhibition of Apoptosis.....	100
7.4.2 Intercellular Communication.....	100
Table 7-1 Effect of Various Forms of Saccharin on the Rat Urinary Bladder.....	101
Table 7-2 Urine Analysis in Rats Given Various Forms of Saccharin .....	101
Table 7-3 Sodium Salts that Produce Urothelial Hyperplasia and Increase the Incidence of Bladder Tumors in Rats Fed High Doses (>1%).....	102
Table 7-4 Summary of Positive Mammalian Carcinogenicity Studies.....	103
Table 7-5 Interspecies Comparison of the Effects of Sodium Saccharin on the Urinary Bladder.....	104
Table 7-6 Interstrain Comparison of the Effects of Sodium Saccharin on the Rat Urinary Bladder .....	105
Table 7-7 Interspecies Comparison of Fresh Void Urine Chemistry .....	106
<b>8.0 REFERENCES.....</b>	<b>107</b>
<b>APPENDIX A – Excerpts from the IARC Monograph on the Evaluation of the Carcinogenic Risk of Chemicals to Humans Volume 22 (Some Non-Nutritive Sweetening Agents), Saccharin, pp. 111-185, 1980.....</b>	<b>A-1</b>
<b>APPENDIX B – Excerpts from the IARC Monograph on the Evaluation of the Carcinogenic Risk of Chemicals to Humans Supplement 4 (Chemicals, Industrial Processes and Industries Associated with Cancer in Humans, IARC Monographs Volumes 1 to 29), Saccharin, pp. 224-226, 1982 .....</b>	<b>B-1</b>
<b>APPENDIX C – Excerpts from the IARC Monograph on the Evaluation of the Carcinogenic Risk of Chemicals to Humans Supplement 7 (Overall Evaluations of Carcinogenicity: An Updating of IARC Monographs Volumes 1 to 42), Saccharin, pp. 334-339, 1987.....</b>	<b>C-1</b>
<b>APPENDIX D – Description of Online Searches for Saccharin and Saccharin Salts.....</b>	<b>D-1</b>
<b>APPENDIX E – Listing of GAP Test Codes in Phylogenetic Order for Saccharin and Sodium Saccharin.....</b>	<b>E-1</b>
<b>APPENDIX F – Listing from the Eighth Report on Carcinogens.....</b>	<b>F-1</b>

### Proposed Report on Carcinogens Delisting for Saccharin<sup>1</sup>

Saccharin is currently listed in the Report on Carcinogens, 8th Edition as *reasonably anticipated to be a human carcinogen*. The basis for this listing was sufficient evidence of carcinogenicity in experimental animals. The Calorie Control Council has petitioned the NTP to consider delisting saccharin from its Report on Carcinogens based upon mechanistic data related to development of urinary bladder cancers in rats.

#### Carcinogenicity

In four studies of up to 30 months duration, sodium saccharin was carcinogenic in Charles River CD and Sprague-Dawley male rats as evidenced by a dose-related increased incidence of benign or malignant urinary bladder neoplasms at dietary concentrations of 1% or greater (Tisdell et al., 1974; Arnold et al., 1980; Taylor et al., 1980; Schoenig et al., 1985). Non-statistically significant increases in urinary bladder cancer have also been seen in saccharin-treated female rats from studies showing a positive effect in males (Arnold et al., 1980; Taylor et al., 1980). Furthermore, several initiation/promotion studies in different rat strains have shown a reduced latency and/or increased incidence of similar urinary bladder cancers in male and female rats fed sodium saccharin subsequent to treatment with different urinary bladder initiators (e.g., Hicks and Chowaniec, 1977; Cohen et al., 1979; Nakanishi et al., 1980b; West et al., 1986; Fukushima et al., 1990). Several additional rat studies in which sodium saccharin was administered either in the diet or in drinking water were negative for tumorigenicity (Fitzhugh et al., 1951; Lessel, 1971; Schmähl, 1973; cited by IARC, 1980; Chowaniec and Hicks, 1979; Hooson et al., 1980; Schmähl and Habs, 1984).

Three mouse studies have reported positive carcinogenicity following exposure to saccharin. Two of these studies involved surgical implantation of saccharin-containing cholesterol pellets into the urinary bladders and resulted in development of malignant urothelial neoplasms (Allen et al., 1957; Bryan et al., 1970). In the third study, dietary sodium saccharin resulted in increased incidences of malignant thyroid neoplasms (Prasad and Rai, 1986). While the mouse data cannot be discounted, some of these studies had methodological flaws, provided limited information, did not show a dose-response, or had unexpected outcomes that may be species or strain-specific and should be verified by additional studies. Four studies in mice were judged negative for tumorigenesis (Roe et al., 1970; Kroes et al., 1977; Homberger, 1978; Frederick et al., 1989) as were studies in nonhuman primates (McChesney et al., 1977 abstr.; Sieber and Adamson, 1978; both cited by IARC, 1980; Thorgierson et al., 1994; Cohen et al., 1996 abstr.) and a single hamster study (Althoff et al., 1975).

Much of the epidemiology has examined associations between urinary bladder cancer and artificial sweeteners, rather than saccharin per se. The time trend data for bladder cancer are essentially noninformative with no clear indication that the increased use of saccharin or artificial sweeteners commencing in the 1940s is associated with a general increase in bladder cancer when controlled for confounding factors, chiefly smoking. Risk of bladder cancer in diabetics, who presumably consume greater amounts of artificial sweeteners compared to the general population,

---

<sup>1</sup>Saccharin is produced commercially as calcium and sodium salts as well as the free acid, and the name saccharin has been applied to all three.

is not greater than risks in the general population (Armstrong and Doll, 1975). Based upon several case-control studies there is no overall association between use of artificial sweeteners and bladder cancer (reviewed by IARC, 1980; IARC, 1987b; JECFA, 1993). It is harder to reject an association between use of artificial sweeteners and bladder cancer in some case-control subgroups, even though the numbers are small<sup>2</sup> (Howe et al., 1980; Hoover and Strasser, 1980; Morrison and Buring, 1980; Cartwright et al., 1981; Morrison et al., 1982; Mommsen et al., 1983). Taken together, while the available epidemiology data show no consistent evidence that saccharin is associated with increased bladder cancer in general, a small increased risk in some subgroups, such as heavy users of artificial sweeteners, cannot be unequivocally excluded. With regard to the general population, if sodium saccharin is a risk factor, it is weak and cannot be proven or disproved due to lack of actual exposure data and intrinsic limitations of existing epidemiology studies.

### **Other Information Relating to Carcinogenesis or Possible Mechanisms of Carcinogenesis**

Extensive studies of the mutagenicity and genotoxicity of saccharin have shown generally negative but occasionally conflicting results. Sodium saccharin is essentially nonmutagenic in conventional bacterial systems but is weakly clastogenic or genotoxic in short-term *in vitro* and *in vivo* test systems (reviewed by Ashby, 1985; IARC, 1987a,b; Whysner and Williams, 1996) with evidence that equimolar ionic solutions of sodium chloride *in vitro* produce a comparable cytotoxic response (Garland et al., 1989a). Urine from mice treated with sodium saccharin was mutagenic in the Ames test (Batzinger et al., 1977). Saccharin does not covalently bind to DNA and does not induce unscheduled DNA synthesis in bladder urothelium.

Saccharin-induced carcinogenesis in rats shows a sex predilection for males (Tisdell et al., 1974; Arnold et al., 1980; Taylor et al., 1980), an organ specificity for urinary bladder (Tisdell et al., 1974; Arnold et al., 1980; Taylor et al., 1980; Fukushima et al., 1983; Schoenig et al., 1985), and a dose-response when exposure to dietary concentrations of 1 to 7.5% of the sodium salt of saccharin has begun early in life (beginning at birth or immediately at weaning) and is continued for approximately two years (Schoenig et al., 1985). The results of mechanistic studies have shown that certain physiological conditions must be simultaneously or sequentially present for induction of urinary bladder tumorigenesis. These conditions include a urinary pH greater than 6.5, increased urinary sodium concentration, increased urine volume, decreased urine osmolality, presence of urinary crystals or precipitate, and damage to the urothelium resulting in a proliferative (hyperplastic) response. All of these conditions have been studied extensively in male rats but less so in females. The high levels of urinary protein characteristic of many male rats may partially explain the sex predilection. The high intrinsic rate of urothelial proliferation at about the time of weaning is also believed to contribute to the observed tumorigenic effects. The urinary milieu in rats, especially male rats, is sufficiently different from that in humans or other species to support the contention that these observations are rat-specific. Pharmacokinetic

---

<sup>2</sup> Morrison and Buring (1980) indicate an increased risk for women. Hoover and Strasser (1980) suggest increased risk among low risk (non-smoking, non-occupationally exposed women) and high risk (male heavy smokers) subgroups.

## **NTP Report on Carcinogens 1997 Background Document for Saccharin**

and metabolism data on sodium saccharin do not explain the male rat sensitivity for induction of urinary bladder neoplasms (Sweatman and Renwick, 1979, 1980).

### **Conclusion**

There is evidence of the carcinogenicity of saccharin in rats but less convincing evidence in mice. Mechanistic studies indicate that the observed urinary bladder cancers in rat studies are related to urinary pH, osmolality, volume, presence of precipitate, and urothelial damage with attendant hyperplasia following dietary concentrations of 3% or higher with inconsistent findings at lower dietary concentrations. The factors thought to contribute to tumor induction by sodium saccharin in rats would not be expected to occur in humans. The mouse data are inconsistent and require verification by additional studies. Results of several epidemiology studies indicate no clear association between saccharin consumption and urinary bladder cancer. Although it is impossible to absolutely conclude that it poses no threat to human health, sodium saccharin is not reasonably anticipated to be a human carcinogen under conditions of general usage as an artificial sweetener.

### **Summary References**

- Allen, M. J., E. Boyland, C. E. Dukes, E. S. Horning, and J. G. Watson. 1957. Cancer of the Urinary Bladder Induced in Mice with Metabolites of Aromatic Amines and Tryptophan. *Br. J. Cancer* 11:212-231.
- Althoff, J., A. Cardesa, P. Pour, and P. Shubik. 1975. A Chronic Study of Artificial Sweeteners in Syrian Golden Hamsters. *Cancer Lett.* 1:21-24.
- Armstrong, B., and R. Doll. 1975. Bladder Cancer Mortality in Diabetics in Relation to Saccharin Consumption and Smoking Habits. *Br. J. Prev. Soc. Med.* 29:73-81.
- Arnold, D. L., C. A. Moodie, H. C. Grice, S. M. Charbonneau, B. Stavric, B. T. Collins, P. F. McGuire, Z. Z. Zawadzka, and I. C. Munro. 1980. Long-Term Toxicity of *ortho*-Toluenesulfonamide and Sodium Saccharin in the Rat. *Toxicol. Appl. Pharmacol.* 52:113-152.
- Ashby, J. 1985. The Genotoxicity of Sodium Saccharin and Sodium Chloride in Relation to Their Cancer-Promoting Properties. *Food Chem. Toxicol.* 23:507-519.
- Batzinger, R. P., S.-Y. L. Ou, and E. Bueding. 1977. Saccharin and Other Sweeteners: Mutagenic Properties. *Science* 198:944-946.
- Bryan, G. T., E. Erturk, and O. Yoshida. 1970. Production of Urinary Bladder Carcinomas in Mice by Sodium Saccharin. *Science* 168:1238-1240.
- Cartwright, R. A., R. Adib, R. Glashan, and B. K. Gray. 1981. The Epidemiology of Bladder Cancer in West Yorkshire. A Preliminary Report on Non-Occupational Aetiologies. *Carcinogenesis* 2:343-346.
- Chowaniec, J., and R. M. Hicks. 1979. Response of the Rat to Saccharin with Particular Reference to the Urinary Bladder. *Br. J. Cancer* 39:355-375.

**NTP Report on Carcinogens 1997 Background Document for Saccharin**

- Cohen, S. M., M. Arai, J. B. Jacobs, and G. H. Friedell. 1979. Promoting Effect of Saccharin and DL-Tryptophan in Urinary Bladder Carcinogenesis. *Cancer Res.* 39:1207-1217.
- Cohen, S. M., L. L. Arnold, M. Cano, U. Thorgeirsson, and S. Takayama. 1996. Lack of Effect of Sodium Saccharin Feeding on Monkey Urine and Urinary Bladder Epithelium. *Proc. Am. Assoc. Cancer Res.* 37:108. Abstract.
- Fitzhugh, O. G, A. A. Nelson, and J. P. Frawley. 1951. A Comparison of the Chronic Toxicities of Synthetic Sweetening Agents. *J. Am. Pharm. Assoc.* 40:583-586.
- Frederick, C. B., K. L. Dooley, R. L. Kodell, W. G. Sheldon, and F. F. Kadlubar. 1989. The Effect of Lifetime Sodium Saccharin Dosing on Mice Initiated with the Carcinogen 2-Acetylaminofluorene. *Fund. Appl. Toxicol.* 12:346-357.
- Fukushima, S., M. Arai, J. Nakanowatari, T. Hibino, M. Okuda, and N. Ito. 1983. Differences in Susceptibility to Sodium Saccharin Among Various Strains of Rats and Other Animal Species. *Gann* 74:8-20.
- Fukushima, S., S. Uwagawa, T. Shirai, R. Hasegawa, and K. Ogawa. 1990. Synergism by Sodium L-Ascorbate But Inhibition by L-Ascorbic Acid for Sodium Saccharin Promotion of Rat Two-Stage Bladder Carcinogenesis. *Cancer Res.* 50:4195-4198.
- Garland, E. M., J. M. Parr, D. S. Williamson, and S. M. Cohen. 1989a. *In Vitro* Cytotoxicity of the Sodium, Potassium, and Calcium Salts of Saccharin, Sodium Ascorbate, Sodium Citrate, and Sodium Chloride. *Toxicol. In Vitro* 3:201-205.
- Hicks, R. M., and J. Chowaniec. 1977. The Importance of Synergy Between Weak Carcinogens in the Induction of Bladder Cancer in Experimental Animals and Humans. *Cancer Res.* 37:2943-2949.
- Homburger, F. 1978. Negative Lifetime Carcinogen Studies in Rats and Mice Fed 50,000 ppm Saccharin. *Chemical Toxicology of Food*. Galli, C. L., R. Paoletti, and G. Vettorazzi, Eds. Elsevier/North-Holland Biomedical Press, Amsterdam, pp. 359-373.
- Hooson, J., R. M. Hicks, P. Grasso, and J. Chowaniec. 1980. *ortho*-Toluene Sulphonamide and Saccharin in the Promotion of Bladder Cancer in the Rat. *Br. J. Cancer* 42:129-147.
- Hoover, R. N., and P. H. Strasser. 1980. Artificial Sweeteners and Human Bladder Cancer: Preliminary Results. *Lancet* i:837-840.
- Howe, G. R., J. D. Burch, A. B. Miller, G. M. Cook, J. Esteve, B. Morrison, P. Gordon, L. W. Chambers, G. Fodor, and G. M. Winsor. 1980. Tobacco Use, Occupation, Coffee, Various Nutrients, and Bladder Cancer. *J. Natl. Cancer Inst.* 64:701-713.
- IARC (International Agency for Research on Cancer). 1980. Saccharin. *IARC Monogr. Eval. Carcinog. Risk Chem. Hum.* 22(Some Non-Nutritive Sweetening Agents):111-170.
- IARC (International Agency for Research on Cancer). 1987a. Saccharin. *IARC Monogr. Eval. Carcinog. Risks Hum. Suppl.* 6(Genetic and Related Effects: An Updating of Selected IARC Monographs From Volumes 1-42):488-496.
- IARC (International Agency for Research on Cancer). 1987b. Saccharin. *IARC Monogr. Eval. Carcinog. Risks Hum. Suppl.* 7(Overall Evaluations of Carcinogenicity: An Updating of IARC Monographs Volumes 1-42):334-339.

## NTP Report on Carcinogens 1997 Background Document for Saccharin

- JECFA. 1993. The Forty-First Meeting of the Joint FAO/WHO Expert Committee on Food Additives. Series 32. Toxicological Evaluation of Certain Food Additives and Contaminants: Saccharin and Its Salts. International Programme on Chemical Safety (IPCS). World Health Organization, pp. 106-133.
- Kroes, R., P. W. J. Peters, J. M. Berkvens, H. G. Verschuuren, T. De Vries, and G. J. van Esch. 1977. Long Term Toxicity and Reproduction Study (Including a Teratogenicity Study) with Cyclamate, Saccharin and Cyclohexylamine. *Toxicology* 8:285-300.
- Lessel, B. 1971. Carcinogenic and Teratogenic Aspects of Saccharin. In: *SOS/70 Proceedings of the Third International Congress of Food Science and Technology*, Washington, DC, pp. 764-770.
- McChesney, E. W., F. Coulston, and K.-F. Benitz. 1977. Six-Year Study of Saccharin in Rhesus Monkeys (Abstract No. 79). *Toxicol. Appl. Pharmacol.* 41:164. Abstract. (Cited by IARC, 1980)
- Mommsen, S., J. Aagaard and A. Sell. 1983. A Case-control Study of Female Bladder Cancer. *J. Cancer Clin. Oncol.* 19:725-729.
- Morrison, A., and J. Buring. 1980. Artificial sweeteners and cancer of the lower urinary tract. *N. Engl. J. Med.* 302(10):537-541.
- Morrison, A. S., W. G. Verhoek, I. Leck, K. Aoki, Y. Ohno, and K. Obata. 1982. Artificial Sweeteners and Bladder Cancer in Manchester, U.K. and Nagoya, Japan. *Br. J. Cancer* 45:332-336.
- Nakanishi, K., M. Hirose, T. Ogiso, R. Hasegawa, M. Arai, and N. Ito. 1980b. Effects of Sodium Saccharin and Caffeine on the Urinary Bladder of Rats Treated with *N*-Butyl-*N*-(4-hydroxybutyl)nitrosamine. *Gann* 71:490-500.
- Prasad, O., and G. Rai. 1986. Induction of Papillary Adenocarcinoma of Thyroid in Albino Mice by Saccharin Feeding. *Indian J. Exp. Biol.* 24:197-199.
- Roe, F. J. C., L. S. Levy, and R. L. Carter. 1970. Feeding Studies on Sodium Cyclamate, Saccharin and Sucrose For Carcinogenic and Tumor-Promoting Activity. *Food Cosmet. Toxicol.* 8:135-145.
- Schmähl, D. 1973. Lack of Carcinogenic Effect of Cyclamate, Cyclohexylamine and Saccharin in Rats (German). *Arzneim. Forsch.* 23:1466-1470. (Cited by IARC, 1980)
- Schmähl, D., and M. Habs. 1984. Investigations on the Carcinogenicity of the Artificial Sweeteners Sodium Cyclamate and Sodium Saccharin in Rats in a Two-Generation Experiment. *Arzneim. Forsch.* 34:604-608.
- Schoenig, G. P., E. I. Goldenthal, R. G. Geil, C. H. Frith, W. R. Richter, and F. W. Carlborg. 1985. Evaluation of the Dose Response and *In Utero* Exposure to Saccharin in the Rat. *Food Chem. Toxicol.* 23:475-490.
- Sieber, S. M., and R. H. Adamson. 1978. Long-Term Studies on the Potential Carcinogenicity of Artificial Sweeteners in Non-Human Primates. In: *Health and Sugar Substitutes*. Guggenheim, B., Ed. Basel, Karger, pp. 266-271. (Cited by IARC, 1980)

**NTP Report on Carcinogens 1997 Background Document for Saccharin**

- Sweatman, T. W., and A. G. Renwick. 1979. Saccharin Metabolism and Tumorigenicity. *Science* 205:1019-1020.
- Sweatman, T. W., and A. G. Renwick. 1980. The Tissue Distribution and Pharmacokinetics of Saccharin in the Rat. *Toxicol. Appl. Pharmacol.* 5:18-31.
- Taylor, J. M., M. A. Weinberger, and L. Friedman. 1980. Chronic Toxicity and Carcinogenicity to the Urinary Bladder of Sodium Saccharin in the in Utero-Exposed Rat. *Toxicol. Appl. Pharmacol.* 54:57-75.
- Thorgeirsson, U., D. Dalgard, J. Reeves, and R. Adamson. 1994. Tumor Incidence in a Chemical Carcinogenesis Study of Nonhuman Primates. *Regul. Toxicol. Pharmacol.* 19:130-151.
- Tisdell, M. O., P. O. Nees, D. L. Harris, and P. H. Derse. 1974. Long-Term Feeding of Saccharin in Rats. In: *Symposium: Sweeteners*. Inglett, G. E., Ed. Avi Publishing Co., Westport, CN, pp. 145-158.
- West, R. W., W. G. Sheldom, D. W. Gaylor, M. G. Haskin, R. R. Delongchamp, and F. F. Kadlubar. 1986. The Effects of Saccharin on the Development of Neoplastic Lesions Initiated with *N*-Methyl-*N*-nitrosourea in the Rat Urothelium. *Fundam. Appl. Toxicol.* 7:585-600.
- Whysner, J., and G. M. Williams. 1996. Saccharin Mechanistic Data and Risk Assessment: Urine Composition, Enhanced Cell Proliferation, and Tumor Promotion. *Pharmacol. Ther.* 71:225-252.

**Listing Criteria from the Report on Carcinogens, Eighth Edition**

*Known To Be A Human Carcinogen:*

There is sufficient evidence of carcinogenicity from studies in humans which indicates a causal relationship between exposure to the agent, substance or mixture and human cancer.

*Reasonably Anticipated To Be A Human Carcinogen:*

There is limited evidence of carcinogenicity from studies in humans, which indicates that causal interpretation is credible, but that alternative explanations, such as chance, bias or confounding factors, could not adequately be excluded; or

There is sufficient evidence of carcinogenicity from studies in experimental animals which indicates there is an increased incidence of malignant and/or a combination of malignant and benign tumors: (1) in multiple species or at multiple tissue sites, or (2) by multiple routes of exposure, or (3) to an unusual degree with regard to incidence, site or type of tumor, or age at onset; or

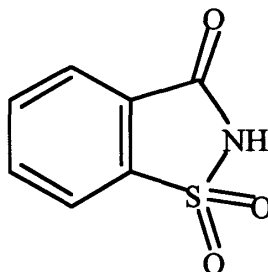
There is less than sufficient evidence of carcinogenicity in humans or laboratory animals; however, the agent, substance or mixture belongs to a well-defined, structurally related class of substances whose members are listed in previous Reports on Carcinogens as either known to be a human carcinogen or reasonably anticipated to be a human carcinogen, or there is convincing relevant information that the agent acts through mechanisms indicating it would likely cause cancer in humans.

Conclusions regarding carcinogenicity in humans or experimental animals are based on scientific judgment, with consideration given to all relevant information. Relevant information includes, but is not limited to dose response, route of exposure, chemical structure, metabolism, pharmacokinetics, sensitive sub populations, genetic effects, or other data relating to mechanism of action or factors that may be unique to a given substance. For example, there may be substances for which there is evidence of carcinogenicity in laboratory animals but there are compelling data indicating that the agent acts through mechanisms which do not operate in humans and would therefore not be reasonably anticipated to cause cancer in humans.



## 1.0 CHEMICAL PROPERTIES

Saccharin  
[81-07-2]



### 1.1 Chemical Identification

Saccharin (C<sub>7</sub>H<sub>5</sub>NO<sub>3</sub>S, mol. wt. = 183.19) is also called:

Anhydro-*o*-sulfaminebenzoic acid  
3-Benzisothiazolinone 1,1-dioxide  
1,2-Benzisothiazol-3(2*H*)-one 1,1-dioxide  
*o*-Benzoic sulfimide  
Benzoic sulphimide  
*o*-Benzoic sulphimide  
*o*-Benzosulfimide  
Benzosulphimide  
*o*-Benzosulphimide  
Benzo-2-sulphimide  
*o*-Benzoyl sulfimide  
*o*-Benzoyl sulphimide  
1,2-Dihydro-2-ketobenzisosulfonazole  
1,2-Dihydro-2-ketobenzisosulphonazole  
2,3-Dihydro-3-oxobenzisosulfonazole  
2,3-Dihydro-3-oxobenzisosulphonazole  
Garantose  
Glucid  
Gluside  
Hermesetas  
3-Hydroxybenzisothiazole-*S,S*-dioxide  
Insoluble saccharin  
Kandiset  
Sacarina

## NTP Report on Carcinogens 1997 Background Document for Saccharin

Saccharimide  
Saccharina  
Saccharin acid  
Saccharine  
Saccharin insoluble  
Saccharinol  
Saccharinose  
Saccharol  
Sacharin (Czech)  
Sucre edulcor  
Sucrette  
*o*-Sulfobenzimide  
*o*-Sulfobenzoic acid imide  
2-Sulphobenzoic imide  
Zaharina

Saccharin has the RCRA waste number U202.

### 1.2 Physical-Chemical Properties

Property	Information	Reference
Color	White	HSDB (1996)
Physical State	Monoclinic crystals	Budavari (1996)
Melting Point, °C	228.9-229.7	Budavari (1996)
Density, g/mL	0.828	Budavari (1996)
Odor	Odorless or has a faint aromatic odor	HSDB (1996)
Solubility:		
Water	Soluble in water	Weast and Astle (1980)
Organic Solvents	Soluble in acetone Slightly soluble in chloroform, ethyl ether, and benzene	Weast and Astle (1980); HSDB (1996)
Partition Coefficient:		
Log octanol/water	0.91	HSDB (1996)
Vapor pressure at 25 °C, mm Hg	9.11x10 <sup>-7</sup>	HSDB (1996)

## 2.0 HUMAN EXPOSURE

**Summary:** The original uses of saccharin were numerous. Today, it is primarily used as a nonnutritive sweetening agent. From the 1950's to the 1970's, the U.S. consumption of saccharin increased dramatically. Following the ban on saccharin in Canada, stricter legislation on the marketing of saccharin, and the introduction of other artificial sweeteners into the U.S. market, consumption steadily declined. Recently, however, it appears that U.S. saccharin consumption is steady, if not slightly increasing.

Saccharin and sodium saccharin have been produced commercially in the United States for over 80 years. The compounds are produced commercially only by the Maumee process. Calcium saccharin was first produced in the United States in 1953. U.S. imports and production of saccharin has steadily declined. Currently, PMC Specialties Group, Inc. is the only commercial producer of saccharin.

Potential exposure to saccharin occurs through the consumption of dietetic foods and drinks and by use of some personal hygiene products. The concentration of saccharin allowed in these products is regulated by the FDA. Potential exposure to saccharin also occurs in the workplace, specifically in occupations, industries, or facilities that produce and deal with saccharin and its salts.

Regulation of saccharin and its salts is accomplished through many agencies and legislation. The EPA regulates saccharin and its salts under the Comprehensive Environmental Response, Compensation, and Liability Act (CERCLA), Resource Conservation and Recovery Act (RCRA), and Superfund Amendments and Reauthorization Act (SARA). The FDA regulates saccharin under the Food, Drug, and Cosmetic Act (FD&CA). Saccharin is regulated by OSHA under the Hazard Communication Standard.

### 2.1 Production

The 1979 Toxic Substances Control Act (TSCA) Inventory identified three U.S. companies producing 1.1 million lb (499 metric tons [Mg]) of saccharin in 1977, while 6.3 million lb (2,860 Mg) were imported. Two U.S. companies produced 1.6 million lb (726 Mg) of sodium saccharin, and 281,000 lb (128 Mg) were imported in 1977. Imports of calcium saccharin, which was first produced commercially in the United States in 1953, amounted to 5,500 lb (2.5 Mg) in 1977. One U.S. company produced 550,000 lb (250 Mg) of the ammonium salt in 1977 (NTP, 1994).

Production of all forms of saccharin increased gradually from 180 Mg in 1957 to an estimated 2,040 Mg in 1970 to an estimated total of 2,177 Mg in 1977 (IARC, 1980). The USITC (1981-1991, 1993-1995) identified one U.S. producer of saccharin and its sodium salt from 1980 to 1994, but no production data were provided for these years. The USITC (1983-1985) also reported that one U.S. company produced saccharin, calcium salt, from 1982 to 1984, but no production data were provided. SRI International (1996) identified one U.S. producer of sodium saccharin, most likely PMC Specialties Group, Inc. which produces saccharin under the trade name SYNCAL<sup>®</sup> in the United States and worldwide (PMC Specialties Group, 1996).

PMC Specialties Group produces sodium saccharin in crystalline and powder forms, and calcium saccharin and insoluble (acid) saccharin in powder form (PMC Specialties Group, 1996). Production volumes were not available.

The forms of saccharin produced by PMC Specialties Group are listed below, in Table 2-1.

Table 2-1. Forms of Saccharin Produced by PMC Specialties Group

Trade Name	Synonym	Chemical Formula	CAS No.	Reference
SYNCAL <sup>®</sup> GS & GSD	soluble saccharin	(C <sub>6</sub> H <sub>4</sub> SO <sub>2</sub> NCO) Na•2H <sub>2</sub> O	128-44-9	PMC Specialties Group (1997a)
SYNCAL <sup>®</sup> S & SD	soluble saccharin	(C <sub>6</sub> H <sub>4</sub> SO <sub>2</sub> NCO)Na	128-44-9	PMC Specialties Group (1997b)
SYNCAL <sup>®</sup> CAS	calcium saccharin	(C <sub>6</sub> H <sub>4</sub> SO <sub>2</sub> NCO) <sub>2</sub> Ca	6485-34-3	PMC Specialties Group (1997c)
SYNCAL <sup>®</sup> SDI	insoluble (acid) saccharin	C <sub>7</sub> H <sub>5</sub> NO <sub>3</sub> S	81-07-2	PMC Specialties Group (1997d)

PMC Specialties Group also produces and markets the SYNCAL<sup>®</sup> saccharin products SWEET-CHEW<sup>®</sup> (for animal feed) and SHERBRITE<sup>®</sup> (for the plating industry) (PMC Specialties Group, 1996).

U.S. imports of saccharin have steadily declined from 5.9 million lb (2,700 Mg) in 1983 to 3.7 million lb (1,700 Mg) in 1984, about 1.8 million lb (817 Mg) in 1985, and 1.6 million lb (726 Mg) in 1987 (NTP, 1994). Calcium saccharin was first produced commercially in the United States in 1953.

Saccharin is manufactured commercially by both the Maumee process and the Remsen-Fahlberg method. In the United States, saccharin and sodium saccharin are produced commercially only by the Maumee process (HSDB, 1996), and have been produced for over 80 years (Crammer and Ikan, 1977; cited by IARC, 1980). In the Maumee process, diazotization of methyl anthranilate by treatment with sodium nitrate and hydrochloric acid gives 2-carbomethoxy-benzenediazonium chloride. Sulfonation of this intermediate gives 2-carbomethoxy-benzenesulfonic acid, which is treated with chlorine to give 2-carbomethoxy-benzenesulfonyl chloride with chlorine. Treatment of this sulfonyl chloride with ammonia, followed by acidification, gives saccharin (IARC, 1980). Saccharin is converted to the sodium salt by treating with sodium hydroxide or sodium bicarbonate. Twenty-three impurities have been reported in this process (Arnold et al., 1983).

In the Remsen-Fahlberg method of producing saccharin, toluene is reacted with chlorosulfonic acid to produce *o*- and *p*-toluenesulfonyl chlorides. The *o*-isomer is isolated and treated with ammonia to form *o*-toluenesulfonamide. Oxidation gives *o*-sulfamoylbenzoic acid, and when this intermediate is heated, saccharin forms (IARC, 1980). Thirty-one impurities have been reported when saccharin is synthesized by this method (Arnold et al., 1983).

## 2.2 Use

The primary use of saccharin is as a nonnutritive sweetening agent. Its use increased substantially after cyclamates (synthetic chemicals having a sweet taste) were banned in food in 1969 (FESA database). In 1976, the estimated U.S. consumption for all forms of saccharin was 77% in food uses (45% in soft drinks; 18% in tabletop sweeteners; 14% in fruit juices, sweets, chewing gum, and jellies), and 23% in non-food uses (10% in cosmetics and oral hygiene products, such as toothpastes, mouthwash, and lipstick; 7% in drugs, such as coatings on pills; 2% in smokeless tobacco products, such as chewing tobacco and snuff; 2% in electroplating, e.g., a brightener in nickel-plating baths used in the coating of automobile bumpers; 1% for cattle feed; and 1% in miscellaneous uses (IARC, 1980; HSDB, 1996).

The original uses of saccharin were numerous. A few of the original uses were as an antiseptic and preservative to retard fermentation in food, in estimating the circulation time of blood from an antecubital vein to the lingual capillaries, as an antistatic agent in plastics and textiles, as a polymer modifier and accelerator in photosensitive dispersions, as a light-fastness aid in nylon dyes, and as a chemical intermediate for the fungicide probenazole used in controlling rice blast in Japan (Arnold et al., 1983).

Based upon government legislation and market competition, the consumption of saccharin in the United States has varied. Saccharin and saccharin salts were approved under the 1958 Food Additives Amendment to the Food, Drug, and Cosmetics Act. Under the provisions of this act, saccharin was included in those substances that had been in use prior to 1958 and had been accorded GRAS (Generally Recognized As Safe) status. Saccharin was removed from the GRAS list in 1972, however, when questions by the Food and Drug Administration (FDA) about its safety arose (IARC, 1980). During the period when saccharin was recognized as having GRAS status, its consumption increased dramatically. For example, the consumption of saccharin in the United States in 1953 was 21,000 lb (9.5 Mg); in 1962, 2.5 million lb (1,100 Mg); and following the ban on cyclamates in 1969, consumption rose to 4.0 million lb (1,800 Mg) (Arnold et al., 1983). The approval and introduction of other artificial sweeteners such as aspartame and acesulfame-K into the U. S. market lowered the annual per capita consumer consumption of saccharin from 3.5 kg (9.6 mg/day) in 1980 to 2.7 kg (7.4 mg/day) in both 1985 and 1988 (Irving-Monshaw, 1989). The total U.S. consumption of saccharin in 1992 was 700,000 sugar sweetness equivalent tons (2,333 Mg) whereas aspartame's consumption was 1,500 sugar sweetness equivalent tons (8,333 Mg) (Research Studies-USDA ERS, 1992). According to SRI International, saccharin accounted for 39% of the world's consumption of high-intensity sweeteners in 1992, while aspartame accounted for 41% (Dawson, 1994b). The 1994 consumer consumption of saccharin was estimated to be 2,200 Mg in the United States and 1,100 Mg in Europe (Dawson, 1994a).

In 1983, the Calorie Control Council estimated that in the United States, 44 million adults consumed saccharin-sweetened products (NTP, 1994). It has been estimated that the average consumption of saccharin by humans in the United States is about 5 mg/kg body weight/day (Vesely and Levey, 1978). Saccharin consumption is greatest among diabetics and others whose medical conditions require the restriction of calories or carbohydrates (NTP, 1994).

**2.3 Environmental Exposure**

**2.3.1 Environmental Releases**

The Toxic Chemical Release Inventory (EPA) listed four industrial facilities that produced, processed, or otherwise used saccharin in 1988. In compliance with Community Right-to-Know Program, the facilities reported releases of saccharin to the environment which were estimated to total 750 lb (340.5 kg) (NTP, 1994). Facilities are required to notify the National Response Center (NRC) when release of saccharin equals or exceeds its reportable quantity of 100 lb (45.4 kg). When saccharin becomes a waste, as a commercial chemical product, a manufacturing chemical intermediate, an off-specification commercial chemical product, or a manufacturing chemical intermediate, it must be managed according to Federal and/or State hazardous waste regulations (HSDB, 1996).

Releases of saccharin to the environment as reported by PMC Specialties Group, the only U.S. commercial saccharin producer listed by the USITC and Cumberland-Swan, Inc., the manufacturer of Sweet 'n Low®, are listed below, in Table 2-2.

**Table 2-2. Releases of Saccharin to the Environment**

Company	Release	1989	1990	1991
PMC Specialties Group	Air	75 lb/yr (34.1 kg/yr)	65 lb/yr (29.5 kg/yr)	64 lb/yr (29.1 kg/yr)
	Land	0 lb/yr	0 lb/yr	0 lb/yr
	Water	0 lb/yr	0 lb/yr	0 lb/yr
	Sewer	0 lb/yr	10 lb/yr (4.5 kg/yr)	10 lb/yr (4.5 kg/yr)
	Other	1,700 lb/yr (771.8 kg/yr)	1,100 lb/yr (499 kg/yr)	1,400 lb/yr (635.6 kg/yr)
Cumberland-Swan, Inc.	Air		250 lb/yr (113.5 kg/yr)	250 lb/yr (113.5 kg/yr)
	Land		0 kg/yr	0 kg/yr
	Water		0 kg/yr	0 kg/yr
	Sewer		250 lb/yr (113.5 kg/yr)	250 lb/yr (113.5 kg/yr)
	Other		2,700 lb/yr (1,226 kg/yr)	350 lb/yr (158.9 kg/yr)

Source: Toxic Release Inventory Systems (TRIS, 1996)

**2.3.2 Environmental Occurrence**

Saccharin and its salts, as well as the impurity *o*-toluenesulfonamide, do not occur as natural products (IARC, 1980).

2.3.3 Drinking Water and Food

Refer to section 2.3.4 for any information regarding exposure to saccharin from food.

2.3.4 Consumer Products

Potential exposure to saccharin also occurs through the consumption of dietetic foods and drinks and some personal hygiene products, such as certain toothpastes and mouthwashes that use saccharin as a sweetening agent (NTP, 1994). The FDA has authorized the use of saccharin and its salts in beverages in concentrations not to exceed 12 mg/oz (413 mg/L), as a sugar substitute not to exceed 20 mg for each expressed teaspoonful of sugar sweetening equivalency, and in processed food not to exceed 30 mg per serving. Data from the Nationwide Food Consumption Survey, conducted by the USDA from 1977-1978, on calculated daily saccharin intake levels is presented in **Table 2-3**. The survey included responses from 30,770 U.S. residents from the 48 contiguous states. Respondents reported foods eaten and quantities consumed.

**Table 2-3. USDA Nationwide Food Consumption Survey (1977-1978): Total Calculated Saccharin Intake Levels, mg/kg bw/day**

<b>Age Group (years); Sex</b>	<b>1-2; M &amp; F</b>	<b>3-5; M &amp; F</b>	<b>6-8; M &amp; F</b>	<b>9-14; M &amp; F</b>	<b>15-18; M</b>	<b>19-34; M</b>	<b>19-34; F</b>	<b>35-64; M</b>
<b>Total Average Daily Intake</b>	11.46	9.62	6.76	5.6	5.23	4.98	5.26	4.96
<b>90th Percentile</b>	15.76	19.67	14.12	11.98	7.4	10.19	10.48	10.48

Source: Calorie Control Council (1996)

The amount of saccharin consumed by diabetics in Great Britain was estimated in a study conducted by researchers at the University of Southampton (MAFF, 1994). The highest level consumed (as measured by the 97.5th percentile) was 3.1 mg saccharin per kilogram body weight per day. The study included 761 participants, age 2 years and over. The average consumption of saccharin by diabetics was not provided.

Consumer exposure to saccharin has possibly decreased in recent years due to the introduction of Nutra-Sweet® (aspartame). According to SRI International, saccharin, packaged as an artificial sweetener under the product name Sweet 'n Low®, commands 31.8% of the U.S. market share in artificial tabletop sweeteners. Saccharin is second to aspartame, which commands 67.8% of the market share (Tomasula, 1994).

2.3.5 Biomarkers of Exposure

Saccharin has not been found to be mutagenic, and evidence shows it does not undergo covalent binding to the DNA of a rat's liver or bladder (Lutz and Schlatter, 1977).

2.3.6 Occupational Exposure

Occupational exposure occurs through dermal contact or inhalation of dust at places where saccharin is produced or used. The risk of potential occupational exposure exists for workers involved in the production of saccharin or its salts, in the manufacture and formulation of saccharin-containing products, and during the packaging of the consumer products. A National Occupational Exposure Survey (1981-1983) estimated that 225,095 total workers, including 97,729 women, representing 73 occupations in 107 industries at 7,347 facilities, potentially were exposed to saccharin (NIOSH, 1990). This survey also found 1,150 employees, including 591 women, representing 5 occupations in 1 industry at 11 facilities were potentially exposed to its sodium salt. This same survey found 10,053 employees, including 4,418 females, representing 16 occupations in 19 industries at 454 facilities that either were involved with the production of, dealt with, or were potentially exposed to sodium saccharin dihydrate (RTECS, 1996).

Table 2-4. NIOSH National Occupational Exposure Survey (NOES, 1981-83)\*: By Industry

Industry	No. of Plants	No. of Employees	No. of Female Employees
Agricultural Services	230	1838	1608
Heavy Construction Contractors	19	3129	75
Special Trade Contractors	20	1683	
Food and Kindred Products	149	497	
Textile Mill Products	66	252	
Lumber and Wood Products	166	2331	
Furniture and Fixtures	94	2630	376
Paper and Allied Products	132	6134	2295
Printing and Publishing	64	477	
Chemicals and Allied Products	23	1329	175
Rubber and Misc. Plastics Products	52	633	
Stone, Clay, and Glass Products	230	762	
Primary Metal Industries	9	264	
Fabricated Metal Products	307	11616	6172
Machinery, Except Electrical	2107	57361	16608
Electric and Electronic Equipment	881	26850	13490
Transportation Equipment	143	8947	1029
Instruments and Related Products	315	8910	3966
Miscellaneous Manufacturing Industries	86	839	116
Railroad Transportation	22	22	
Trucking and Warehousing	37	75	
Water transportation	39	774	
Transportation by Air	75	10086	57
Communication	152	3748	
Electric, Gas, and Sanitary Services	203	9025	
Business Services	24	1106	24
Auto Repair, Services, and Garages	299	1796	
Miscellaneous Repair Services	704	1110	
Health Services	699	60871	51738
Total	7347	225095	97729

\*National Institute of Occupational Safety and Health (unpublished provisional data as of July 1, 1990).



## 2.4 Regulations

### 2.4.1 Occupational Exposure Limits

No occupational standards or criteria have been promulgated (OSHA) or recommended (NIOSH, ACGIH) in the United States for exposure to saccharin in workroom air.

### 2.4.2 Other Standards and Criteria

The EPA regulates saccharin and its salts under the Comprehensive Environmental Response, Compensation, and Liability Act (CERCLA), Resource Conservation and Recovery Act (RCRA), and Superfund Amendments and Reauthorization Act (SARA). Saccharin is subject to reporting and record keeping rules under CERCLA, RCRA, and SARA. The EPA proposed raising the statutory reportable quantity (RQ) of 1 lb, established under CERCLA, to 100 lb for saccharin and its salts. The final rule adjusts the RQ from 1 lb to 100 lb. Saccharin is regulated as a hazardous constituent of waste under RCRA, and threshold amounts for facilities which may release saccharin have been established under SARA. OSHA regulates saccharin under the Hazard Communication Standard and as a chemical hazard in laboratories. The FDA regulates saccharin under the Food, Drug, and Cosmetic Act (FD&CA) as a food ingredient not to exceed specific concentrations (NTP, 1994). In compliance with the Delaney Clause, the FDA proposed to ban saccharin as a food additive in 1977 because of the available evidence of its carcinogenicity in animals. Due to conflicting scientific study results as well as the potential benefits of saccharin, a compromise solution was enacted instead of an outright ban. In November, 1977, Congress passed the Saccharin Study and Labeling Act which placed an 18-month moratorium on any action by the FDA against saccharin, and mandated that all products containing saccharin bear the following warning label: "Use of this product may be hazardous to your health. This product contains saccharin, which has been determined to cause cancer in laboratory animals" (Viscusi, 1994). In 1991, the FDA withdrew its call for an outright ban on saccharin in the United States, but warning labels are still required on all packaging (Tomasula, 1994). The moratorium against any further FDA action has been extended to May 1, 1997. FDA regulates, under the Food, Drug, and Cosmetic Act (FD&CA) and the Fair Packaging and Labeling Act, the labeling of various food products containing saccharin and/or saccharin salts. The FDA also regulates how saccharin and certain saccharin salts are used as sweetening agents in food and as a weight control drug under the FD&CA and the Public Health Service Act.

REGULATIONS

	Regulatory Action	Effect of Regulation/Other Comment
E P A	<p>40 CFR 261—PART 261— IDENTIFICATION AND LISTING OF HAZARDOUS WASTES. Appendix VII—Basis for Listing Hazardous Waste. Promulgated: 46 FR 4619, 1981 with numerous amendments. The hazardous waste number for saccharin and its salts is U202.</p> <p>40 CFR 261.30 ff.—Subpart D—Lists of Hazardous Wastes.</p> <p>40 CFR 302—PART 302— DESIGNATION, REPORTABLE QUANTITIES, AND NOTIFICATION. Promulgated: 50 FR 13474, 04/04/85. U.S. Code: 42 U.S.C. 9602, 9603, and 9604; 33 U.S.C. 1321 and 1361.</p> <p>40 CFR 302.4—Sec. 302.4 Designation of hazardous substances. Limits: Superfund (CERCLA, SARA) final reportable quantity (RQ) is 100 lb (45.4 kg).</p> <p>40 CFR 302.6—Sec. 302.6 Notification requirements.</p> <p>40 CFR 372-- PART 372--TOXIC CHEMICAL RELEASE REPORTING: COMMUNITY RIGHT-TO-KNOW. Promulgated: 53 FR 4525, 02/16/88. U.S. Code: 42 U.S.C. 11013, 11028. This part sets forth requirements for the submission of information relating to the release of toxic chemicals under section 313 of Title III of SARA (1986).</p>	<p>App. VIII lists the hazardous constituents of industrial waste streams listed in 40 CFR 261.31.</p> <p>This part designates under section 102(a) of CERCLA 1980 those substances in the statutes referred to in section 101(14) of CERCLA, identifies reportable quantities for these substances, and sets forth the notification requirements for releases of the substances. This part also sets forth reportable quantities for hazardous substances designated under section 311(b)(2)(A) of the CWA.</p> <p>EPA designated as hazardous those substances that when released into the environment may present substantial danger to the public health or welfare or the environment.</p> <p>Notification of EPA is required if the RQ is released to the environment.</p> <p>Information collected under this part is intended to inform the general public and the communities surrounding covered facilities about releases of toxic chemicals, to assist research, and aid in the development of regulations, guidelines, and standards.</p>

REGULATIONS

	Regulatory Action	Effect of Regulation/Other Comment
E P A	<p>40 CFR 372—Subpart D—Specific Toxic Chemical Listings.</p> <p>40 CFR 372.65—Sec. 372.65 Chemicals and chemical categories to which this part applies.</p>	
F D A	<p>21 CFR 100—PART 100—GENERAL. Promulgated: 42 FR 14306, 03/15/77. U.S. Code: 21 U.S.C. 321, 331, 337, 342, 343, 348, and 371.</p> <p>21 CFR 100.11—Sec. 100.130 Combinations of Nutritive and Nonnutritive Sweeteners in “Diet Beverages”.</p> <p>21 CFR 101—PART 101—FOOD LABELING. Promulgated: 42 FR 14308, 03/15/77. U.S. Code: 15 U.S.C. 1453, 1454, 1455; 21 U.S.C. 321, 331, 342, 343, 348, and 371.</p> <p>21 CFR 101.11—Sec. 101.11 Saccharin and Its Salts; Retail Establishment Notice.</p> <p>21 CFR 150—PART 150—FRUIT BUTTERS, JELLIES, PRESERVES, AND RELATED PRODUCTS. Promulgated: 42 FR 14445, 03/15/77. U.S. Code: 21 U.S.C. 321, 341, 343, 348, 381, and 379e.</p> <p>21 CFR 180—PART 180—FOOD ADDITIVES PERMITTED IN FOOD OR IN CONTACT WITH FOOD ON AN INTERIM BASIS PENDING ADDITIONAL STUDY. Promulgated: 61 FR 14482, 04/02/96. U.S. Code: 21 U.S.C. 321, 342, 343, 348, 371; 42 U.S.C. 241.</p>	<p>General state and local requirements along with specific administrative rulings and decisions for various food products.</p> <p>The label of any “diet beverage” or diet beverage base that contains saccharin must contain the statement “Contains _____ mg saccharin (or saccharin salt, as the case may be) per ounce, a nonnutritive artificial sweetener.</p> <p>Requirements are given for the principal display panel (the panel most likely to be examined under customary conditions of display for retail sale) of form food.</p> <p>Retail establishments (except restaurants) that sell food containing saccharin shall display a notice informing the consumer that saccharin products are sold at that location.</p> <p>Artificially sweetened fruit containing a packing medium sweetened with saccharin and/or sodium saccharin shall have the specified name “artificially sweetened _____”, the blank being filled by name of the fruit or fruit product.</p> <p>Regulations govern specific requirements for food additives in food or additives in contact with food. This regulation is pending additional study.</p>

REGULATIONS

	Regulatory Action	Effect of Regulation/Other Comment
F D A	21 CFR 180.37—Sec. 180.37 Saccharin, Ammonium Saccharin, Calcium Saccharin, and Sodium Saccharin.	Regulates how these saccharin food additives may be safely used as sweetening agents in food.
	21 CFR 310—PART 310—NEW DRUGS. U.S. Code: 21 U.S.C. 321, 331, 351, 352, 353, 355, 356, 357, 360b-360f, 360j, 361(a), 371, 374, 375, 379e; 42 U.S.C. 216, 241, 242(a), 262, 263b-263n.	Regulations govern the administrative rulings and decisions on new drug status, new drugs exempted from prescription-dispensing requirements, records, reports, and requests for specific new drugs or devices.
	21 CFR 310.545—Sec. 310.545 Drug products containing certain active ingredients offered over-the-counter (OTC) for certain uses.	There is inadequate data to establish general recognition of the safety and effectiveness of saccharin as a weight control drug product.

The regulations in this table have been updated through the Federal Register 100 Vol.62, May 23, 1997.

**3.0 HUMAN STUDIES**

A number of epidemiological studies have been conducted to determine whether the use of artificial sweeteners (AS), including saccharin, has been associated with human cancer. U.S. epidemiological studies of AS may not be as informative as those from Canada, the United Kingdom, Europe, and Japan, where widespread saccharin use first began (1945 [imported primarily from Japan and the United States], 1916, 1894, and 1945, respectively). Artificial sweetener use in the United States was not widespread until the middle of the 1960s, when cyclamate and saccharin were used together. The IARC Working Group reviewed saccharin epidemiology in the original monograph (IARC, 1980) and updated the review in Supplement 7 to the IARC Monographs (IARC, 1987b). In both reviews by the IARC Working Group, it was concluded that the results from epidemiological studies of saccharin are equivocal. In a review of saccharin by the Joint FAO/WHO Expert Committee on Food Additives (JECFA, 1993), however, it was concluded that “the epidemiological studies on saccharin did not show any evidence that saccharin ingestion increases the incidence of bladder cancer in human populations”.

Epidemiologic studies have in general examined associations between urinary bladder cancer and artificial sweeteners in general, rather than saccharin, per se; this could either inflate or disguise a risk due to saccharin alone. Time trend data are essentially uninformative, since information concerning use of artificial sweeteners and confounding factors is presented only for populations and not for individuals. Cohort studies of diabetics are confounded by reduced smoking in this group. Overall, case-control studies demonstrate at best a small risk for the general population (reviewed in IARC, 1980; IARC, 1987a,b; JECFA, 1993). However, some studies have demonstrated increased risk for groups otherwise at low risk, such as female nonsmokers (Howe et al., 1980; Hoover and Strasser, 1980; Cartwright et al., 1981; Morrison et al., 1982; Mommsen et al., 1983). Heavy users of artificial sweeteners may also be at increased

risk regardless of gender or smoking habits (Hoover and Strasser, 1980). While the available epidemiology data show no consistent evidence that saccharin is associated with increased bladder cancer in general, a small increased risk in some subgroups cannot be excluded.

### 3.1 IARC (1980) Review of Saccharin Epidemiology

IARC (1980, pp. 171-183; see Appendix A) examined time trends in the United States, England, and Wales and found that there was no marked increase in the incidence of bladder cancer following rapid increase in the use of artificial sweeteners (e.g., see Armstrong and Doll, 1974). In addition, the IARC Working Group found that in the United Kingdom diabetics as a group consume higher quantities of artificial sweeteners and experience lower mortality from bladder cancer than the general population (e.g., see Armstrong and Doll, 1975). The IARC Working Group stated that due to metabolic or dietary differences, use of drugs, exposure to tobacco, or occupational factors associated with diabetics, a carcinogenic effect of sweeteners cannot be excluded (IARC, 1980).

The IARC Working Group evaluated 7 case-control studies (Morgan and Jain, 1974; Simon et al., 1975; Howe et al., 1977; Wynder and Goldsmith, 1977; Miller et al., 1978; Connolly et al, 1978; Kessler and Clark, 1978). Five of the seven studies were negative for bladder cancer and were found to be limited by some inadequacies in experimental design. Of the two studies that examined possible confounding factors in detail, one (Howe et al., 1980 [a reanalysis of data from Howe et al., 1977]) suggested that artificial sweetener use was positively associated with bladder cancer in men but not in women. The association was limited to men who consumed an average of more than eight tablets of saccharin per day or men who used nine or more tablets of AS per day. In both instances, the relative risk (RR) was approximately 3. The IARC Working Group noted that in these small groups, the result could have been due to confounding factors that were not included in the analysis, residual confounding effects of those factors that were considered in the analysis, or chance.

The second study reviewed by the IARC Working Group that considered confounding factors (Kessler and Clark, 1978; cited by IARC, 1980) found no association between bladder cancer and use of AS and suggested that a relative risk of about 1.5 or higher was unlikely.

In 6 out of 7 of the case-control studies reviewed by the IARC Working Group, women with bladder cancer consumed less AS than the controls. The IARC Working Group stated that this observation suggests that there is no association between use of artificial sweeteners and bladder cancer in women.

In a case-control study that was in press when reviewed by IARC (1980), Wynder and Stellman (1980) reported that there was no association between use of artificial sweeteners or diet beverages and bladder cancer. The study included 302 male and 65 female bladder cancer patients who were matched by age, sex, hospital, and hospital-room status to an equal number of patients without bladder cancer. More details on this study after publication are given in subsection 3.2.1.

The 1980 IARC Working Group concluded their review of epidemiological data for AS with the following statement: The epidemiological data taken as a whole cannot with confidence exclude a small increase in risk but provide no clear evidence that artificial sweeteners cause bladder cancer in humans (IARC, 1980). In 1987, the IARC Working Group reiterated the

findings from their 1980 review by concluding that the evidence that the risk of cancer is increased among users of artificial sweeteners is inconsistent (IARC, 1987).

### 3.2 Human Studies Published Post IARC (1980)

Experimental details for the studies described in this section are presented in **Table 3-1**.

#### 3.2.1 U.S. Case-Control Studies

Hoover and Strasser (1980) conducted a large multicenter bladder cancer case-control study that included 3010 newly diagnosed, histologically confirmed bladder cancer cases and 5783 population-based controls chosen at random. Information collected by personal interview included information regarding quantity of AS consumed, either by table-top or diet-drink use. No increase in overall RR for bladder tumors was found when comparing the use of AS with never having used AS (males: RR = 0.99; CI [Confidence Interval] = 0.89-1.10; females: RR = 1.07; CI = 0.89-1.29). There was no trend found for men for either table-top or diet-drink AS use. A statistically significant trend for table-top, but not diet-drink, consumption was observed for females after adjustment for age, race, and cigarette smoking. For men and women who consumed at least 2 diet drinks and 3 table-top servings/day or at least some diet drinks and at least 6 table-top servings/day, there was a borderline statistically significant RR of 1.45 (CI = 1.00-2.10) after adjustment for sex, age, race, smoking, occupational exposures, region, and education (for males the RR was 1.47; for females the RR was 1.41). Two subgroups—females who had never smoked or been occupationally exposed to known bladder carcinogens and men who smoked heavily—showed a statistically significant relative risk estimate with daily AS use (men: table-top  $\geq 6$  uses, RR = 1.86; diet drinks  $\geq 3$  servings, RR = 2.62; women: table-top  $\geq 2$  uses for  $\geq 5$ -9 years, RR = 1.8;  $\geq 2$  uses  $> 10$  years RR = 2.7). Additional control for coffee drinking, history of geographic area, education, obesity, use of hair dyes, and history of urinary infections did not affect the relative risk. [IARC (1982) reviewed this study in Supplement 4 to the monographs.]

Using a different analytic approach, Walker et al. (1982) reevaluated the study conducted by Hoover and Strasser (1980) and found essentially the same overall result for AS use (RR = 1.2; CI = 1.0-1.5). These investigators used a composite variable that included education, bladder infection, job exposure, and coffee consumption to define baseline risk strata. Odds ratio estimates were adjusted for region, race, sex, and age. The authors found no trends in odds ratios associated with increasing AS use for the different risk categories. However, this reanalysis was criticized by Hoover and Hartge (1982; cited by IARC, 1987b), who argued that the use of stratification did not include sex and age, and suggested that the low- or high-risk groups based on the composite risk variable used in the reanalysis were actually of intermediate risk. [IARC (1982) mentioned these two studies in Supplement 4.]

Morrison and Buring (1980) reported an association of artificial sweetener use and increased risk of lower urinary tract cancer in females. The relative risk of lower urinary tract cancer was 1.6 (95% CI = 0.9-2.7; 69 cases/46 controls) among women who never used dietetic beverages, and 1.5 (95% CI = 0.9-2.6; 54 cases/39 controls) among women who reported use of sugar substitutes. There was also an increased lower urinary tract cancer risk among women after five or more years of dietetic beverage use (RR = 3.7; 22 cases/6 controls), but statistical

estimates were not provided. [This study was described by IARC (1980) as a footnote since it was published after the Working Group Meeting.]

A case-control study was conducted by Wynder and Stellman (1980) between 1977 and 1979 using 302 male and 65 female cases with bladder cancer. Controls were hospital admissions matched for sex, age, hospital, and hospital-room status (an indicator of socioeconomic status). The authors found no association between use of saccharin or diet beverages and bladder cancer. The RR for saccharin use was 0.93 (CI = 0.68-1.28) for men and 0.62 (CI = 0.26-1.40) for women. For diet beverage consumption, the RR was 0.85 (CI = 0.55-1.17) for men and 0.60 (CI = 0.27-1.29) for women. [This study was published after the Working Group meeting and was described in IARC (1980) as a footnote.]

Najem et al. (1982) compared 75 male and female bladder cancer cases with 142 hospital-based controls in a study conducted in 1978 in New Jersey. Controls were matched to cases by age, place of birth, sex, race, source of obtaining cases, and place of current residence. The authors found no statistically significant increased risk of bladder cancer from consumption of saccharin (RR = 1.3 [CI = 0.6-2.8]). However, only 12/75 cases (16%) and 19/142 controls (13%), reported having consumed saccharin. The relative risk was not adjusted for any potentially confounding factors.

Silverman et al. (1983) examined the use of population- versus hospital-based controls to estimate the risk of lower urinary tract cancer from AS consumption. The study was conducted in Detroit, MI as an add-on to the multicenter study conducted by Hoover and Strasser (1980). The study included 391 cases diagnosed from December 1977 to December 1978 in Detroit with transitional or squamous cell carcinoma of lower urinary tract, 305 population-based controls matched to cases by age and sex, and 440 hospital-based controls discharged from the same hospital as a case and matched by age, race, sex, discharge date. Population-based controls had a lower reported AS use compared with hospital-based controls. Using population-based controls, the RRs for men and women were 1.1 and 1.8, respectively. Using hospital-based controls, the RRs for men and women were 0.9 and 1.1, respectively. Using hospital controls without obesity-related diseases, RR was 1.1 for both men and women. Adjustment of RR values for age, smoking, education, and body mass index were found to have no effect on risk.

A New York state study reported no increased risk of bladder cancer for young (20 to 49 yr-old) women who reported using AS more than 100 times (Odds Ratio [OR] = 1.1 [CI = 0.7-1.7]). Cases (173) with bladder cancer diagnosed between 1975 and 1980 were matched by sex, age, and residence within an area code to 173 population-based controls (Piper et al., 1986).

In a study conducted by Nomura et al. (1991), men and women of Japanese or Caucasian ancestry, diagnosed with lower urinary tract cancer between 1977 and 1986 in Oahu were matched to population-based controls by sex, ethnic group, age, and residence. Participants were classified into non-users and users of saccharin based on consumption history 1 year prior to interview or diagnosis. There was no increased risk of lower urinary tract cancer in users (OR for men, 1.1 [CI = 0.7-1.8]; OR for women, 0.7 [CI = 0.3-1.5]).

In an analysis of data from the Hoover and Strasser (1980) study conducted by Sturgeon et al. (1994), it was found that heavy use of AS ( $\geq 1680$  mg/day) was associated with higher-grade, poorly differentiated bladder tumors (RR = 2.2; CI = 1.3-3.6). The analysis included 1860 cases from 10 geographic regions with bladder cancer identified between December 1977 and

March 1978, and 3934 population-based controls. The RR was adjusted for age, sex, cigarette use, history of urinary infection or bladder stones, coffee consumption, family history of urinary tract cancer, high-risk occupation, race, and education.

### 3.2.2 Canadian Case-Control Studies

Risch et al. (1988) conducted a large multicenter Canadian bladder cancer study that matched 826 cases with population-based controls during 1979-1982. No association with any table-top AS consumption, including a subgroup of nonsmoking females (OR = 1.04; CI = 0.4-2.71) was reported. An OR of approximately 2 was associated with females that drank diet soda; the dose-related trend reached borderline statistical significance. The authors noted that none of the diet soda consumption had exceeded 10 years (Risch et al., 1988). Thus, these authors failed to confirm the increased risk for bladder cancer that they previously reported (Howe et al., 1980) for consumers of artificial sweeteners.

### 3.2.3 Case-Control Studies From Other Countries

Morrison et al. (1982) conducted a case control study including cases of lower urinary tract cancer cases from Nagoya, Japan (293 cases) and Manchester, United Kingdom (555 cases). Controls (589 Japanese, 735 British) were population-based and were matched to cases by age and sex. The study found no increased risk of lower urinary tract cancer related to AS use (British men, RR = 0.9 [CI = 0.7-1.2]; British women, RR = 0.9 [CI = 0.6-1.4]; Japanese men, RR = 0.7 [CI = 0.5-0.9]; Japanese women, RR = 0.5 [CI = 0.3-0.8]). The study populations from Japan and the United Kingdom used saccharin predominantly (97% of British, 94% of Japanese) for 30-40 years prior to the study. The authors found an increased RR of 1.6 among nonsmoking men from the United Kingdom; the RR for nonsmoking British women was 1.2. There was no increased risk in nonsmoking Japanese or in any group of current or former smokers. The United Kingdom analysis for AS in tablets showed an increased RR among the over-10-tablets-a-day female group (RR = 2.3) and a decrease in males (RR = 0.6).

Another study from the United Kingdom, conducted by Cartwright et al. (1981), included 622 prevalent and 219 incident cases of bladder cancer in West Yorkshire, each of which was matched to hospital-based controls (622 for existing cases, 448 for new cases) for age and sex. Saccharin use was described as regular for > 1 year, at least 5 years prior to diagnosis. Risk was significantly elevated for nonsmoking males (RR = 2.2 [CI = 1.3-3.8]), but not for nonsmoking females (RR = 1.6 [CI = 0.8-3.2]), or for smokers of either sex (male RR = 0.9 [CI = 0.6-1.3]; female RR = 1.2 [CI = 0.5-2.6]). The RR values were adjusted for age and type of case (incident or prevalent).

Mommsen et al. (1983) conducted a small case-control study from Denmark comprised of 47 female cases newly diagnosed with bladder cancer and 94 population-based controls matched by sex, age, and geographic area, including degree of urbanization. Cases were interviewed in person at the hospital, whereas controls received a mailed questionnaire which was followed up by a phone interview. Only 6/47 cases and 2/94 controls reported consumption of saccharin. An elevated risk of bladder cancer was found for all women who had consumed saccharin (RR = 6.7 [CI = 1.5-30.2]). When only nonsmokers who used saccharin were included, the risk decreased (RR = 3.3 [CI = 1.4-7.8]).



In another study from Denmark, however, Møller-Jensen et al. (1983) found no increased risk of bladder cancer from consumption of saccharin (RR for men = 0.68 [CI = 0.45-1.02]; RR for women = 1.04 [CI = 0.51-2.09]). The study included 290 male and 98 female bladder cancer patients who were matched by age and sex to 592 male and 195 female controls selected at random from the general population. Participants were classified as users of saccharin only (72.9%), cyclamate only (10.7%), or both substances.

A case-control study using 117 cases with 117 population-based controls and 117 hospital-based controls was prompted following a report of high bladder cancer incidence in La Plata, Argentina. However, no association between saccharin use and bladder cancer was reported. Controls were matched to cases by sex, age, and residence (population-based controls) or hospital (hospital-based controls). Relative risk values were not provided (Iscovich et al., 1987).

No increased risk of bladder cancer from consumption of saccharin (as a food additive only) was found in a case-control study conducted by Momas et al. (1994) (OR = 1.5 [CI = 0.8-3.0]). The study included 219 men living in a region of France for > 5 years and diagnosed with primary bladder carcinoma between January 1987 and May 1989. The 794 controls were men from the same region who were over 50 years old and had lived in the region > 5 years. Saccharin use was defined as consumption of 365 (units were not given).

#### 3.2.4 Descriptive Studies

Jensen and Kamby (1982) found that *in utero* exposure to saccharin did not appear to increase the bladder cancer incidence in the first 3 decades of life, which was the limitation of their follow-up. This Danish study also found no increased incidence in bladder cancer mortality up to an age of 30 years for persons born from 1941 to 1945, which corresponds to a time period when saccharin use was high in Denmark due to war-time shortages of sugar.

#### 3.2.5 Meta-Analysis

In a meta-analysis that included 12 case-control studies on the relationship between AS and bladder cancer incidence, Elcock and Morgan (1993) estimated a summary RR of near unity (males, 0.958; females; 0.961).

**Table 3-1. Summary of Epidemiology Studies Published Post IARC (1980)**

Study Design	Study Participants				Nature of Exposure					Reference	
	Source	Number	Response Rate (%)	Substance	Duration	Level	Risk Ratio (95% Confidence Interval)	Covariates Used to Adjust OR	Evidence of Dose-Response		Data Collection Method
U.S. Case-control	cases: men and women from diagnosed with carcinoma of urinary bladder in 10 geographic regions between Dec. 1977 and Dec. 1978; aged 21-84 yr cases with history of urinary tract cancer were excluded) controls: age and sex stratified random sample of the general population from the same 10 geographic regions	cases: 3010 controls: 5783 75% of cases and controls were males	cases: 87 controls: 85 (aged 21-64 yr); 87 (aged 65-84)	artificial sweetener	lifetime	never used artificial sweetener ever used diet drink  ever used tabletop artificial sweetener ever used diet food  ever used any form	Relative Risks: M: 1.00 F: 1.00  M: 0.95 (0.84-1.07) F: 1.02 (0.83-1.25)  M: 1.04 (0.92-1.18) F: 1.04 (0.84-1.28)  M: 1.02 (0.85-1.22) F: 1.13 (0.87-1.47)  M: 0.99 (0.89-1.10) F: 1.07 (0.89-1.29)	race, cigarette use, coffee consumption, occupational exposure (additional control for age, sex, history of diabetes, geographic area, and education did not affect RR)	yes, for two subgroups (non-smoking females; heavy smoking males)	personal interview in home of participants	Hoover and Strasser (1980)

Table 3-1. Summary of Epidemiology Studies Published Post IARC (1980) (Continued)

Study Design	Study Participants				Nature of Exposure					Reference	
	Source	Number	Response Rate (%)	Substance	Duration	Level	Risk Ratio (95% Confidence Interval)	Covariates Used to Adjust OR	Evidence of Dose-Response		Data Collection Method
U.S. Case-control (cont.)	Low-Risk White Females (never smoked, no occupational exposures)	cases: 130 controls: 402		table-top sweeteners table-top sweeteners table-top sweeteners	5 years 5-9 years > 10 years	≥ 2 uses per day	Relative Risks for Use of Artificial Sweeteners in cases/controls: 1.3; 14/34 1.8; 13/22 2.7; 16/18 all RR had p < 0.01; 95% CI not provided	age			Hoover and Strasser (1980)
						≥ 2 uses per day					
U.S. Case-control (cont.)	High-Risk White Males (smoked more than 40 cigarettes per day)	cases: 104 controls: 167		table-top sweeteners table-top sweeteners table-top sweeteners table-top sweeteners table-top sweeteners diet drinks diet drinks		< 1 uses per day	1.28; 12/15 2.07; 19/14 1.96; 16/13 1.33; 8/10 1.86; 7/7 1.20; 14/19 3.33; 10/5 2.62; 6/4 all RR had p = 0.01; 95% CI not provided	age			Hoover and Strasser (1980)
						1-1.9 uses per day					
						2-3.9 uses per day					
						4-5.9 uses per day					
						≥ 6 uses per day					
						1-1.9 servings per day					
						2-2.9 servings per day					
						≥ 3 servings per day					

**Table 3-1. Summary of Epidemiology Studies Published Post IARC (1980) (Continued)**

Study Design	Study Participants		Nature of Exposure							Reference	
	Source	Number	Response Rate (%)	Substance	Duration	Level	Risk Ratio (95% Confidence Interval)	Covariates Used to Adjust OR	Evidence of Dose-Response		Data Collection Method
U.S. Case-control (cont.)	cases admitted to Boston hospitals for first primary neoplasm of the lower urinary tract from March 1976 through May 1977; controls from general population of study area	592 cases, 94% with bladder tumors and 74% male; 536 controls	cases: 81% controls: 80%	artificial sweetener	years of use: <5, 5-9, more than 10	no. drinks per day; no. sugar substitutes per day; no. dietetic food servings per week	Relative Risks for Lower Urinary Tract Cancer and Ever-Use of Artificial Sweeteners: no. cases/controls M and F: 0.9 (0.7-1.2) for dietetic beverages or sugar substitutes  <b>Dietetic Beverage Use History</b> M: 0.8 (0.6-1.1); 144/155 F: 1.6 (0.9-2.7); 69/46  <b>Sugar Substitute Use History</b> M: 0.8 (0.5-1.1); 101/113 F: 1.5 (0.9-2.6); 54/39  M: 1.1; 62/59 M: 0.7; 17/21 F: 1.0; 27/27 F: 3.7; 22/6  CI and p value not provided	age, sex, smoking history	weak because of low numbers of cases and controls and no statistical estimates of confidence for duration of use	interviews with subjects or proxies if subjects too ill, could not be contacted, or deceased	Morrison and Buring (1980)

Table 3-1. Summary of Epidemiology Studies Published Post IARC (1980) (Continued)

Study Design	Study Participants				Nature of Exposure				Reference		
	Source	Number	Response Rate (%)	Substance	Duration	Level	Risk Ratio (95% Confidence Interval)	Covariates Used to Adjust OR		Evidence of Dose-Response	Data Collection Method
U.S. Case-control (cont.)	cases: men and women with a first diagnosis of bladder cancer and admitted to hospital; interviewed between Aug. 1977 and June 1979 controls: patients admitted to hospital for other neoplastic and nonneoplastic conditions; matched to cases by age, sex, hospital, and hospital-room status	cases: 367 controls: 367	not specified	saccharin	≥ 10 yr	≥ 40 mg saccharin/day (as artificial sweetener) ≥ 2 cans diet beverage/day (≥ 192-264 mg saccharin/day)	Relative Risk: M: 0.93 (0.68-1.28) F: 0.62 (0.26-1.40)  M: 0.85 (0.55-1.17) F: 0.60 (0.27-1.29)	RR did not vary when adjusted for history of diabetes, obesity, occupation, education, religion, coffee or tea consumption, and cigarette use (data not provided)	no	personal interview in hospital	Wynder and Stellman (1980)
	cases: men and women with bladder cancer, but with no tobacco-related heart disease, admitted to hospitals/clinics in New Jersey during 1978, mean age, 66.8 yr controls: admitted to hospitals/clinics for other conditions, excluding tobacco-related heart disease and any neoplasm; matched to cases by age, place of birth, sex, race, source of obtaining cases, current residence; mean age, 70.9 yr	cases: 75 controls: 142	not specified	saccharin	not specified	regularly consumed vs. never or occasionally consumed	Risk Ratio: 1.3 (0.6-2.8) not significant; p > 0.05 (cases consumed an average of 3.6 tablets/day for a mean period of 6.4 yr; controls consumed an average of 2.5 tablets for 6.3 yr)	none	no	all cases and controls interviewed by 1 nurse; responses recorded on pre-coded form	Najem et al. (1982)
	see Hoover & Strasser (1980)	see Hoover & Strasser (1980)	see Hoover & Strasser (1980)	see Hoover & Strasser (1980)	see Hoover & Strasser (1980)	see Hoover & Strasser (1980)	Relative Risk: 1.2 (1.0-1.5)	age, sex, race, religion	no	re-evaluation of Hoover & Strasser (1980) data	Walker et al. (1982)

Table 3-1. Summary of Epidemiology Studies Published Post IARC (1980) (Continued)

Study Design	Study Participants				Nature of Exposure				Reference		
	Source	Number	Response Rate (%)	Substance	Duration	Level	Risk Ratio (95% Confidence Interval)	Covariates Used to Adjust OR		Evidence of Dose-Response	Data Collection Method
U.S. Case-control (cont.)	cases: diagnosed from December 1977 in Detroit with transitional or squamous cell carcinoma of lower urinary tract; aged 21-84 yr hospital-based controls: residents of Detroit, discharged from same hospital as case; matched by age, race, sex, discharge date population-based controls: matched by age and sex	cases: 391 hospital-based controls: 305 population-based controls: 440	cases: 91 hospital-based controls: 89 population-based controls: 91	artificial sweetener	lifetime	ever or never used	<u>Relative Risk:</u> using population controls: 1.1 (men); 1.8 (women) using hospital controls: 0.9 (men); 1.1 (women) using hospital controls without obesity-related diseases: 1.1 (men); 1.1 (women)	none (adjustment for age, smoking, education, and body mass index had no effect on relative risk)	not applicable	questionnaire given in person, by phone (only if necessary), or by proxy (only if necessary); add-on to Hoover and Strasser (1980) study	Silverman et al. (1983)
	cases: men and women of Japanese or Caucasian ancestry, diagnosed with lower urinary tract cancer between 1977 and 1986 in Oahu; aged 30-93 yr controls: population-based; matched to cases by sex, ethnic group, age, and residence	cases: 261 controls: 522	cases: 86 controls: 89	saccharin	1 yr	non-user  user  1-5 serving-yr  6+ serving-yr	<u>Odds Ratio:</u> M: 1.0; F: 1.0  M: 1.1(0.7-1.8) F: 0.7(0.3-1.5)  M: 1.2(0.6-2.4) F: 0.5(0.2-1.6)  M: 1.1(0.6-1.9) F: 0.9(0.3-2.9)	cigarette use	no	personal interview in home of participant	Nomura et al. (1991)

Table 3-1. Summary of Epidemiology Studies Published Post IARC (1980) (Continued)

Study Design	Study Participants				Nature of Exposure						
	Source	Number	Response Rate (%)	Substance	Duration	Level	Risk Ratio (95% Confidence Interval)	Covariates Used to Adjust OR	Evidence of Dose-Response	Data Collection Method	Reference
U.S. Case-control (cont.)	cases: women diagnosed with bladder cancer in New York state between January 1975 and September 1980; aged 20-49 controls: population-based; matched to cases by sex, age, and residence within an area code	cases: 173 controls: 173	cases: 80.8 controls: 71	artificial sweetener	ever used artificial sweetener ≥ 100 times	not specified	Odds Ratio: 1.1 (0.7-1.7)	none	not specified	telephone interview during 1982	Piper et al. (1986)
	cases: men and women diagnosed with transitional cell bladder cancer between 1977 and 1978 in 10 geographic regions; aged 21-84 years controls: randomly selected from general population	cases: 1860 controls: 3934	cases: 73 controls: 83	artificial sweetener	lifetime	< 1680 mg/day  ≥ 1680 mg/day	Relative Risk: noninvasive: 1.0 invasive: 1.0 Grade I: 1.0 Grade II: 1.0 Grade III/IV: 1.0  noninvasive: 1.3 (0.9-2.1) invasive: 1.3 (0.8-2.3) Grade I: 1.1 (0.5-2.3) Grade II: 1.1 (0.6-2.0) Grade III/IV: 2.2 (1.3-3.6)	age, sex, cigarette use, history of urinary infection or bladder stones, coffee consumption, family history of urinary tract cancer, high-risk occupation, race, education	not specified	personal interview in home of participant	Sturgeon et al. (1994)

Table 3-1. Summary of Epidemiology Studies Published Post IARC (1980) (Continued)

Study Design	Study Participants					Nature of Exposure					Reference
	Source	Number	Response Rate (%)	Substance	Duration	Level	Risk Ratio (95% Confidence Interval)	Covariates Used to Adjust OR	Evidence of Dose-Response	Data Collection Method	
Canada Case-control	cases: men and women newly diagnosed with urinary bladder cancer between 1979 and 1982 in Alberta or southcentral Ontario; aged 35-79 yr controls: randomly selected, population-based; matched to cases by age, sex, and area of residence	cases: 826 controls: 792	cases: 67 controls: 53	saccharin	lifetime	30 usage-yr (Usage-yr represent cumulative exposure, e.g., 3 uses/day for 10 yr=30 usage yr)	Odds Ratio: M: 1.01 (0.86-1.18) F: 0.96 (0.79-1.16)	lifetime cigarette consumption and history of diabetes	no	interview in home of participant	Risch et al. (1988)
Other Case-control	cases: residents of Manchester, United Kingdom or Nagoya, Japan diagnosed in 1976-1978 with lower urinary tract cancer; aged 21-89 controls: population-based, matched to cases by age and sex	cases: 555 British, 293 Japanese controls: 735 British, 589 Japanese	cases: 96 (British), 84 (Japanese) controls: 90 (British), 80 (Japanese)	artificial sweetener (97% of British and 94% of Japanese used saccharin)	~ 30-40 yr (most reported first use during or shortly after start of World War II)	ever or never used	<u>Relative Risk:</u> British men: 0.9 (0.7-1.2) British women: 0.9 (0.6-1.4) Japanese men: 0.7 (0.5-0.9) Japanese women: 0.5 (0.3-0.8) There was an increased RR of 1.6 among nonsmoking men from the United Kingdom. RR was not increased for any other nonsmoking group or for any current or former smokers group.	stratified by age (< 65 yr, 65-74 yr, or 75+ yr) Preliminary analysis of British men revealed no effect of occupational history on risk	British cases had an increased RR among the over-10-tablets/day female group (RR = 2.3), but not for 10-tablets/day male group (RR = 0.6). Japanese not evaluated for dose-response There was no association between duration of use and increase in risk for British or Japanese.	interview in home (British cases/controls) or interview in hospital (Japanese cases)	Morrison et al. (1982)



Table 3-1. Summary of Epidemiology Studies Published Post IARC (1980) (Continued)

Study Design	Study Participants					Nature of Exposure					
	Source	Number	Response Rate (%)	Substance	Duration	Level	Risk Ratio (95% Confidence Interval)	Covariates Used to Adjust OR	Evidence of Dose-Response	Data Collection Method	Reference
Other Case-control (cont.)	cases: men and women newly and previously diagnosed with bladder cancer in West Yorkshire, United Kingdom controls: hospital-based; matched to cases by age and sex	cases: 622 existing cases, 219 new cases controls: 622 for existing cases, 448 for new cases	not specified	saccharin (as food additive only)	> 1 yr; beginning at least 5 yr before cancer diagnosis	user or non-user	Relative Risk: male nonsmokers: 2.2 (1.3-3.8) female nonsmokers: 1.6 (0.8-3.2) male smokers: 0.9 (0.6-1.3) female smokers: 1.2 (0.5-2.6)	age and type of case (new or existing)	not specified	personal interview (site not specified); cases and controls interviewed by same person	Cartwright et al. (1981)
	cases: women from Denmark newly diagnosed with bladder cancer, average age, 66.4 yr controls: population-based; matched to cases by sex, age, and geographic area, including degree of urbanization	cases: 47 (of the 47 cases, only 6 had consumed saccharin) controls: 94 (of the 94 controls, only 2 had consumed saccharin)	cases: 81 controls: 100	saccharin	not specified	not specified	Relative Risk: all women: 6.7 (1.5-30.2) never-smokers only: 3.3 (1.4-7.8)	none	not specified	cases: personal interview in hospital controls: mailed questionnaire followed by phone interview	Monnsmen et al. (1983)
	cases: men and women diagnosed with bladder cancer in Copenhagen, Denmark between May 1979 and April 1981 controls: residents of Copenhagen, randomly selected; matched to cases by age and sex	cases: 388 controls: 787	cases: 94.4 controls: 75.1	artificial sweetener (72.9% used saccharin alone; 10.7% used cyclamate alone; 16.4% used both)	≥ 3 mo	never used or ever used	Relative Risk for Users of Saccharin Alone: M: 0.68 (0.45-1.02) F: 1.04 (0.51-2.09)	not specified	no	interview in home of participant	Møller-Jensen et al. (1983)

Table 3-1. Summary of Epidemiology Studies Published Post IARC (1980) (Continued)

Study Design	Study Participants				Nature of Exposure						Reference
	Source	Number	Response Rate (%)	Substance	Duration	Level	Risk Ratio (95% Confidence Interval)	Covariates Used to Adjust OR	Evidence of Dose-Response	Data Collection Method	
Other Case-control (cont.)	cases: men and women living in La Plata, Argentina for ≥ 5 yr and diagnosed with bladder cancer population-based controls: 117 hospital-based controls: 117 matched to cases by sex, age, residence (street block) hospital-based controls: matched to cases by sex, age, hospital	cases: 117 population-based controls: 117 hospital-based controls: 117	not specified	saccharin	not specified	not specified	RR not specified, but labeled as not significant	not specified	no	personal interview in home (population controls) or hospital (cases and hospital controls)	Iscovich et al. (1987)
Descriptive	cases: men living in the Hérault region of France for ≥ 5 yr and diagnosed with primary bladder carcinoma between Jan. 1987 and May 1989 controls: randomly selected men from Hérault region; only men over 50 yr old who had lived in Hérault region > 5 yr were included	cases: 219 controls: 794	cases: 80.5 controls: 77.8	saccharin (as a food additive only)	lifetime	< 365 or ≥ 365 (units not specified)	<u>Odds Ratio:</u> 1.5 (0.8-3.0)	not specified	not specified	telephone interview or mailed questionnaire (for those not listed in phone book)	Momas et al. (1994)
	cohorts: residents of Denmark born between 1941 and 1945 (when saccharin use was high); evaluated from 1961-1976 (aged ≤ 34 yr) controls: residents of Denmark born 1931-1940	not specified	not specified	saccharin	≤ 30 yr (exposure beginning in utero)	not specified	There was no increase in bladder cancer mortality during the first 3 decades of life in cohorts.	not specified	no	observed cases in cohorts compared to expected cases (i.e., cases among those born 1931-1940)	Jensen and Kamy (1982)

Table 3-1. Summary of Epidemiology Studies Published Post IARC (1980) (Continued)

Study Design	Study Participants				Nature of Exposure						
	Source	Number	Response Rate (%)	Substance	Duration	Level	Risk Ratio (95% Confidence Interval)	Covariates Used to Adjust OR	Evidence of Dose-Response	Data Collection Method	Reference
Meta-analysis	multiple sources	cases: 5499 M, 2082 F controls: not specified	not specified	artificial sweetener	not specified	not specified	Relative Risk: M <sup>a</sup> : 0.958 (0.69-1.33) F <sup>b</sup> : 0.961(0.85-1.08) all studies <sup>c</sup> : 0.979 (0.92-1.04)	RR inversely weighted by the variance from each study	not specified	meta-analysis of 13 case-control studies	Elcock and Morgan (1993)

Abbreviations: F = female; M = male; OR = odds ratio; RR = relative risk

<sup>a</sup> Unless otherwise noted, the type of artificial sweetener consumed was not specified

<sup>b</sup> This category included 12 studies

<sup>c</sup> This category included 13 studies

#### 4.0 MAMMALIAN CARCINOGENICITY

Several conventional carcinogenicity studies of dietary sodium saccharin have been conducted in rats. Four of these studies that meet contemporary standards for hazard identification, including absence of urinary bladder parasites, have shown induction of neoplasia in urinary bladder urothelium of male rats. A condition that appears to be necessary for positive results is exposure to high doses of sodium saccharin close to the time of weaning with continued exposure for two years. In four studies of up to 30 months duration, sodium saccharin was carcinogenic in Charles River CD and Sprague-Dawley male rats as evidenced by a dose-related increased incidence of benign or malignant urinary bladder neoplasms at dietary concentrations of 1% or greater (Tisdell et al., 1974; Arnold et al., 1980; Taylor et al., 1980; Schoenig et al., 1985) and statistically significant increased bladder neoplasia at 4% or greater (Schoenig et al., 1985; Squire, 1985). Non-statistically significant increases in urinary bladder cancer have also been seen in saccharin-treated female rats from studies showing a positive effect in males (Arnold et al., 1980; Taylor et al., 1980). Furthermore, several initiation/promotion studies in different rat strains have shown a reduced latency and/or increased incidence of similar urinary bladder cancers in male and female rats fed sodium saccharin subsequent to treatment with different urinary bladder initiators (e.g., Hicks and Chowanec, 1977; Cohen et al., 1979; Nakanishi et al., 1980b; West et al., 1986; Fukushima et al., 1990). Several additional rat studies in which sodium saccharin was administered either in the diet or in drinking water were negative for tumorigenicity (Fitzhugh et al., 1951; Lessel, 1971; Schmähl, 1973; Chowanec and Hicks, 1979; Hooson et al., 1980; Schmähl and Habs, 1984).

Conventional carcinogenicity studies of dietary sodium saccharin in mice have been less rigorously carried out, and have been negative for urinary bladder carcinogenesis. On the other hand, two studies in which saccharin-containing cholesterol pellets were surgically implanted into the urinary bladders of mice have yielded urinary bladder cancers. Three mouse studies have reported positive carcinogenicity following exposure to saccharin. Two of these studies involved surgical implantation of saccharin-containing cholesterol pellets into the urinary bladders and resulted in development of malignant urothelial neoplasms (Allen et al., 1957; Bryan et al., 1970). In the third study, dietary sodium saccharin resulted in increased incidences of malignant thyroid neoplasms (Prasad and Rai, 1986). While the mouse data cannot be discounted, some of these studies had methodological flaws, provided limited information, did not show a dose-response, or had unexpected outcomes that may be species or strain-specific and should be verified by additional studies. Four studies in mice were judged negative for tumorigenesis (Roe et al., 1970; Kroes et al., 1977; Homberger, 1978; Frederick et al., 1989) as were studies in nonhuman primates (McChesney et al., 1977 abstr.; Sieber and Adamson, 1978; both cited by IARC, 1980; Thorgiersson et al., 1994; Cohen et al., 1996 abstr.) and a single hamster study (Althoff et al., 1975).

#### 4.1 Mammalian Carcinogenicity of Saccharin

Full experimental details for the studies described in this section are presented in **Table 4-1**.

#### 4.1.1 Hamsters

No urinary tract tumors were observed in Syrian golden hamsters exposed to 0.156-1.25% sodium saccharin in drinking water for life (50-60 weeks). The incidence of tumors in other tissues was within the range of spontaneously occurring tumors (Althoff et al., 1975).

#### 4.1.2 Mice

Twenty-five days after application of saccharin to the skin (8% solution in acetone), "S" strain mice were given 18 weekly applications of 0.17% croton oil in acetone. Following treatment with croton oil, 14 skin tumors were observed in 7/20 mice exposed to saccharin, while 4 skin tumors were observed in 4/19 control mice treated with croton oil only. The difference was not significant (p value not given) (Salaman and Roe, 1956; cited by IARC, 1980).

An increased incidence of bladder cancer ( $p = 0.01$ ;  $\chi^2$  test) was observed in "stock" mice that had saccharin/cholesterol pellets (2 mg saccharin/8 mg cholesterol) implanted in their urinary bladder lumina for 40 or 52 weeks (Allen et al., 1957). The authors noted that the presence of the cholesterol pellet in the bladder may have had a promoting action, and that the method of bladder implantation detects incomplete carcinogens. It was not specified whether other tissues were examined. The saccharin used was of unknown purity and the study involved small numbers of animals whose sex was not specified.

As part of a combined carcinogenesis and tumor promotion study (Roe et al., 1970), female Swiss mice were given a 5% saccharin diet for 18 months. Based upon macroscopic examination of all major organs except brain, pituitary, and spinal cord, there were no alterations in gross lesions or tumor incidences in saccharin-treated mice. The necropsy included careful macroscopic examination of urinary bladder.

Stoner et al. (1973; cited by IARC, 1980) found that intraperitoneal (i.p.) saccharin exposure (8 weeks, 0.6 or 3.3 g/kg/day) of A/He mice was not associated with induction of pulmonary tumors. No other organs were examined. In a 6 generation study, Kroes et al. (1977) found that the incidence of urinary bladder carcinoma was not significantly increased in Swiss SPF mice exposed to 0.2 or 0.5% saccharin diet for 21 months. It was not specified whether other tissues were examined.

A second cholesterol:saccharin (4:1) pellet implantation study in female Swiss mice significantly increased the incidence of urinary bladder carcinomas but not in the degree of malignancy in mice living more than 175 days after bladder implantation versus controls (cholesterol pellet implants only) (Bryan et al., 1970). Since all of the saccharin was removed from the implanted pellets within 1.5 days and the cholesterol plus saccharin pellet was porous, having lost 20% of its weight, it has been argued that the cholesterol:saccharin pellet was different and perhaps more irritating than the pellet comprised of only cholesterol and, furthermore, there is some concern regarding how closely pellet implantation resembles chronic oral exposure to saccharin (Cranmer, 1980).

The incidence of transitional-cell bladder cancers, lung tumors, hepatomas, or lymphomas was not significantly increased in Charles River CD mice exposed to a 1 or 5% sodium saccharin diet for up to 2 years (Homburger, 1978). Any tissue with an abnormal appearance and all vital organs from at least half of the animals were examined histologically.

Prasad and Rai (1986) orally administered albino mice 0.5, 1.0, or 1.5 g/kg saccharin (purity not specified) dissolved in 1 mL of distilled water for 1 yr, beginning at 6 weeks of age. Papillary adenocarcinoma of the thyroid was found in male (5/10) and female (3/10) mice exposed to the highest dose. The tumors were detected during months 9-12 of the experiment and were malignant in nature; metastases were found in the lungs. No information was provided on gross or microscopic examinations of the bladder. Although a control group was used (10 males, 10 females), the tumor incidence in these mice was not reported. The saccharin used in this study was purchased from Boots Co., Bombay, India.

In female weanling BALB/c mice administered a 0, 0.1, 0.5, 1.0, or 5.0% sodium saccharin diet for 117 weeks, there was a marginally significant dose-response ( $p = 0.04$ ) in the incidence of Harderian neoplasms (27/163, 32/172, 29/160, 22/132, and 22/84, respectively). There was no significant increase, however, for bladder, liver, breast, adrenal, or lung tumors, or for reticulum cell sarcoma or lymphoma in any dose group (Frederick et al., 1989). Neither the authors nor the NTP staff consider the Harderian gland response to be biologically significant.

#### 4.1.3 Rats

Seven of 18, 21-day-old Osborne-Mendel rats exposed to a 5% saccharin diet for up to 2 years developed abdominal lymphosarcomas (Fitzhugh et al., 1951). The authors stated that this was not "out of line with the incidence (of abdominal lymphosarcomas) in a comparable group of rats", but noted an uncommon co-occurrence of thoracic lymphosarcomas with abdominal lymphosarcomas in 4 of the 7 rats treated for 102 or more weeks. Urinary bladders were not evaluated. Although controls were used in this study, the control tumor incidence was not provided. IARC (1980) reviewed Fitzhugh et al. (1951) and noted the small number of animals exposed.

Saccharin was negative for tumorigenesis in male and female Boots-Wistar rats exposed to a 0.005, 0.05, 0.5, or 5% saccharin diet for 2 years. Of 4 rats exposed to the highest dose and examined histologically, 1 female had a bladder papilloma (Lessel, 1971). IARC (1980) noted the small number of bladders examined histologically. It was not specified whether other tissues were examined.

There was no increase in the incidence of benign and malignant mesenchymal tumors or of bladder tumors in 70- to 90-day-old BD rats exposed to 0.2 or 0.5% sodium saccharin in the diet for up to 30 months (Schmähl, 1973; cited by IARC, 1980). It was not specified whether other tissues were examined.

In a two-generation study, the incidence of bladder cancer was not increased in F<sub>1</sub> male or female Charles River CD rats exposed to 0.01, 0.1, 1.0, or 5% sodium saccharin for up to 28 months. However, the incidence of urinary bladder transitional-cell neoplasms in F<sub>1</sub> male rats exposed to a 7.5% sodium saccharin diet for up to 28 months was significantly increased when compared to controls (7/23 vs. 1/29 in controls). In addition, there were 2/31 urinary bladder neoplasms in F<sub>1</sub> females exposed to 7.5% saccharin versus 0/24 in controls. The F<sub>0</sub> parents were fed test diets from weaning, through mating, and through gestation to the weaning of their litters. The occurrence of the bladder neoplasms was not correlated with the presence of bladder stones, and bladders were free of parasites (Taylor et al., 1980).

## NTP Report on Carcinogens 1997 Background Document for Saccharin

In a 2-generation study, there was an increased incidence of transitional-cell carcinoma of the bladder in F<sub>1</sub> male Sprague-Dawley rats fed 5% sodium saccharin in the diet for 100 weeks (7 tumors in 20 exposed rats vs. 0 tumors in 20 controls). Carcinomas were not observed in the bladder of female rats exposed similarly. Male and female rats fed a 0.05 or 0.5% sodium saccharin diet for 100 weeks did not show an increased incidence of neoplasms at any site (Tisdell et al., 1974).

Urinary bladder tumors were not observed in Wistar rats exposed to 2.5 g sodium saccharin/kg/day for up to 28 months (Furuya et al., 1975 abstr.). IARC (1980) noted the incomplete reporting of this study.

Sodium saccharin was negative for urinary bladder tumorigenesis in male and female weanling Charles River CD rats exposed in the diet to 90, 270, 810, or 2430 mg sodium saccharin/kg/day for 26 months. Non-invasive bladder tumors were detected in 1/60 males and 1/60 females exposed to 90 mg/kg and in 2/60 males exposed to 810 mg/kg, but none were detected in the rats exposed to 2430 mg/kg. The authors found that the presence of bladder calculi was not associated with exposure or the presence of bladder tumors. The combined incidence of lymphomas and leukemias in males given the highest dose was 7/54 (vs. 2/57 in controls), but the statistical significance of this was not specified. All major tissues were examined (Munro et al., 1975).

The incidences of tumors of the urinary bladder, pituitary, breast, and subcutaneous tissue were not increased in Charles River CD-1 rats exposed to 1 or 5% sodium saccharin for up to 2 years. The authors noted that in 33% of all examined urines, *Trichosomoides crassicauda* ova were found (Homburger, 1978). Any tissue with an abnormal appearance and all vital organs from at least half of the animals were examined histologically.

Sodium saccharin had no significant effect on tumor incidence in Wistar SPF rats exposed to 4 g saccharin/kg body weight in the diet for 2 years. Although there was an increase in the total number of exposed males with tumors at any site (10/70 males vs. 1/52 male controls), site-specific tumor incidences were not statistically significant. Sodium saccharin also had no significant effect on tumor incidence in Wistar SPF rats exposed to 2 g saccharin/kg in drinking water for 2 years. There was an increase in the total number of exposed males with tumors at any site (11/71 males vs. 1/52 male controls) in rats exposed to saccharin in drinking water, but site-specific tumor incidences were not statistically significant. All major organs were examined macroscopically. The bladder, kidneys, lungs, liver, spleen, pancreas, ovaries, uterus, and any other organ with an abnormal appearance were examined histopathologically (Chowaniec and Hicks, 1979).

In a two-generation study, the incidence of benign plus malignant bladder tumors was significantly increased ( $p < 0.03$ ) in male Sprague-Dawley rats from both the F<sub>0</sub> and F<sub>1</sub> generations (F<sub>0</sub>: 7/38 vs. 1/36 in controls; F<sub>1</sub>: 12/45 vs. 0/42 in controls). The F<sub>0</sub> generation was exposed to a 5% sodium saccharin diet for 90 days prior to mating with continued lifetime exposure (up to 142 weeks), while the F<sub>1</sub> pups were exposed for up to 127 weeks. The incidence of benign plus malignant bladder tumors was not statistically increased in F<sub>0</sub> and F<sub>1</sub> females and there was no increase in the incidence of tumors of other tissues in males or females. Two F<sub>1</sub> saccharin-dosed females, however, did have malignant urinary bladder tumors. All organs

and all grossly abnormal areas of dermal, supportive, or skeletal tissues were examined histologically (Arnold et al., 1980).

As part of an initiation/promotion study (Hoosan et al., 1980), female Wistar rats were exposed to 2 g/kg/day of sodium saccharin in drinking water or in diet. There was no increase in urinary bladder neoplasms or other tumors in rats exposed to saccharin for two years.

There was no statistically significant increase in tumor incidence in offspring of pregnant Sprague-Dawley rats administered 0.2, 1, or 5 g saccharin/kg in aqueous solution by gavage on gestation days 14, 17, and 20. Offspring were fed normal diet and observed for life (approximately 2 years) or were killed when moribund. Complete necropsies were performed. All urinary bladders and any organs with macroscopically visible abnormalities were examined histologically (Schmähl and Habs, 1980).

The incidence of urinary bladder transitional cell papilloma was significantly increased in male ACI rats administered 5% sodium saccharin in the diet for 52 weeks beginning at 6 weeks of age (9/32 vs. 0/28 in controls,  $p < 0.01$ ). Calculi were observed in 1 rat with bladder cancer and there was a higher level of urinary  $MgNH_4PO_4$  crystals in treated rats than in controls. At least half of the rats were infected with the bladder parasite *Trichosomoides crassicauda*, which could have enhanced cell proliferation in the bladder. The bladder, liver, and kidneys were the only tissues examined histologically. Females were not included in the study (Fukushima et al., 1983).

No tumors were detected in the bladder, liver, or kidneys of male F344, Sprague-Dawley, or Wistar rats administered 5% sodium saccharin in the diet for 52 weeks beginning at 6 weeks of age. Females were not evaluated (Fukushima et al., 1983).

In a two-generation study, administration of a mixture of 2 or 5% sodium saccharin and sodium cyclamate (1:10 ratio) in the diet of Sprague-Dawley rats was not carcinogenic. Full necropsies were performed, including evaluation of the urinary tract (Schmähl and Habs, 1984).

In a large 2-generation study,  $F_0$  rats were started on a test diet at 6 weeks of age;  $F_1$  rats were started on the same test diet between 28 and 38 days of age. There was a clear dose response for urinary bladder tumors in  $F_1$  male Charles River CD rats exposed to 1.0 to 7.5% sodium saccharin in the diet for up to 30 months (1.0%, 5/658; 3.0%, 8/472; 4.0%, 12/189; 5.0%, 15/120; 6.25%, 20/120; 7.5%, 37/118; controls, 0/324) (Schoenig et al., 1985). Females were not evaluated in this study. The authors concluded a no-effect level for bladder tumors at the 1% dietary level based upon lack of statistical significance and historic control incidences at their laboratory. Following independent review of the urinary bladder lesions, Squire also concluded a no-effect level for bladder tumors at 1% (Squire, 1985). The bladder tumor incidence in rats exposed to 5% sodium saccharin only during gestation was 0/122, while that in rats exposed to 5% sodium saccharin from birth for a single generation was 12/120 (Schoenig et al., 1985). The urinary bladder, urethra, ureter, kidneys, and all gross lesions and tissue masses were examined histologically (Schoenig et al., 1985).

Bladder carcinomas and precancerous lesions were not observed in 6-week-old male analbuminemic (low level of albumin in the serum) Sprague-Dawley rats exposed to 5% sodium saccharin in the diet for 80 weeks (Homma et al., 1991). Only the bladder was examined.



4.1.4 Nonhuman Primates

Histopathological examination of urinary bladders, kidneys, and testes of surviving and deceased male and female rhesus monkeys (exposed to 20, 100, or 500 mg saccharin/kg/day in the diet for 79 months) showed no abnormal pathology (McChesney et al., 1977 abstr.; cited by IARC, 1980).

Sieber and Adamson (1978; cited by IARC, 1980) found that sodium saccharin was negative for gross neoplasia in monkeys (4 strains, not specified by IARC) exposed to 25 mg/kg/day in the diet for 9 yr. This study was ongoing in 1980.

Twenty 0 to 1-yr-old monkeys (Cynomolgus, Rhesus, and African Green were used but additional details were not provided) were exposed to 25 mg sodium saccharin/kg/day by mouth in water for at least 20 yr. Five monkeys died from either varicella, pneumonia, or unknown reasons. No tumors were found in the dead monkeys nor were there any indications of tumors in the 15 surviving monkeys. Complete necropsies were performed on all animals that died. Various unspecified hematological and biochemical tests were routinely performed on survivors (Thorgeirsson et al., 1994).

Results from the surviving monkeys from the Thorgeirsson et al. (1994) study were subsequently reported (Cohen et al., 1996 abstr.). There were no calculi, unusual crystals, increased crystalluria, or calcium phosphate precipitate in urine of cynomolgus and rhesus monkeys administered 25 mg sodium saccharin/kg/day for 17 to 23 years. Urine was analyzed during the last year of life. There was no association between ingestion of sodium saccharin and urinary protein content. Urinary bladders were free of hyperplasia and tumors and scanning electron microscopy revealed no difference in the appearance of the urothelium in exposed and age-matched control monkeys (Cohen et al., 1996 abstr.). It was not specified in the abstract whether other tissues were examined.

NTP Report on Carcinogens 1997 Background Document for Saccharin

Table 4-1. Mammalian Carcinogenicity

Age, Strain, Species	No./Sex Exposed	Controls	Chemical Form and Purity	Dose	Duration	Results/Comments	Reference
<b>4.1.1 Hamsters</b>							
8-wk-old Syrian golden hamsters	30M, 30F	none	sodium saccharin made by Maunee process, purity not specified	0.156-1.25% in drinking water	50-60 wk	Negative No urinary tract neoplasms were observed. The incidence of other neoplasms was within the range of spontaneously occurring tumors.	Althoff et al. (1975)
<b>4.1.2 Mice</b>							
'S' strain mice (age not specified)	20 (sex not specified)	19 (sex not specified)	saccharin <sup>a</sup> made by Remsen-Fahlberg method, purity not specified	8% solution in acetone, applied to skin	22 wk	Negative Twenty-five days after application of saccharin, animals were given 18 weekly applications of 0.17% croton oil in acetone. Following treatment with croton oil, 14 skin tumors were observed in 7/20 animals exposed to saccharin, while 4 skin tumors were observed in 4/19 control animals treated with croton oil only. This difference was not significant (p value not given).	Salaman and Roe (1956; cited by IARC, 1980)
"stock" mice (age not specified)	20 (sex not specified)	28 (sex not specified)	saccharin <sup>a</sup> , method of production and purity not specified	2 mg saccharin/8 mg cholesterol pellets	40 or 52 wk	Positive Saccharin/cholesterol pellets were implanted in urinary bladder lumina. Controls received cholesterol pellets. Of mice which survived for at least 30 weeks, 4/13 saccharin-treated mice and 1/24 control mice had bladder cancer (p=0.01; $\chi^2$ test). The authors noted that the presence of the cholesterol pellet in the bladder may have had a promoting action and that the method of bladder implantation detects incomplete carcinogens. It was not specified whether other tissues were examined.	Allen et al. (1957)
60- to 90-day-old Swiss mice	100F	100F	sodium saccharin; method of production and purity not specified	20-24 mg pellets with 20% sodium saccharin suspended in cholesterol	13 mo	Positive Saccharin/cholesterol pellets were implanted into the urinary bladder lumina. Controls received cholesterol pellets. Incidences of mouse bladder carcinomas in exposed animals were 47 and 52% as compared with incidences of 13 and 12% in controls. The time required for 50% of the compound to be eluted was about 5.5 hours, so the exposure of the mouse bladder to saccharin was very brief.	Bryan et al. (1970)
Swiss mice (age not specified)	50F	50F	saccharin <sup>a</sup> , method of production and purity not specified	5% in diet	18 mo	Negative Saccharin did not alter incidence of tumors (type not specified) and did not affect urinary bladder pathology when bladder was observed macroscopically. It was not specified which other tissues were examined.	Roe et al. (1970)

Table 4-1. Mammalian Carcinogenicity (Continued)

Age, Strain, Species	No./Sex Exposed	Controls	Chemical Form and Purity	Dose	Duration	Results/Comments	Reference
A/He mice (age not specified)	20F per dose	30F	saccharin <sup>a</sup> method of production and purity not specified	0.6 or 3.3 g/kg/day i.p.	8 wk	Negative Exposed animals were killed after 21 weeks, controls were killed after 24 weeks. Exposure to saccharin was not associated with induction of pulmonary tumors. The lungs were the only tissue examined.	Stoner et al. (1973; cited by IARC, 1980)
Swiss SPF mice (age not specified)	50M, 50F per dose	50M, 50F	saccharin <sup>a</sup> , made by Remsen-Fahlberg method, 0.5% <i>o</i> -toluenesulfonamide, impurity	0.2 or 0.5% in diet (6-generation study)	21 mo	Negative Exposure to saccharin did not significantly alter the incidence of urinary bladder carcinoma. It was not specified whether other tissues were examined.	Kross et al. (1977)
Charles River CD mice (age not specified)	25M, 25F per dose	25M, 25F	sodium saccharin, method of production not specified, 345 mg/kg <i>o</i> -toluenesulfonamide	1 or 5%	≤ 2 yr	Negative Animals were sacrificed when obvious tumors were seen or when they were moribund. Survivors were killed at 2 years. Any tissue with an abnormal appearance and all vital organs from at least half of the animals were examined histologically. The incidence of transitional-cell bladder cancers in treated animals was not significantly different from that in controls. Lung tumors, hepatomas, and lymphomas occurred with similar frequency in exposed and control animals. This study was complicated by the presence of the worm <i>Trichostrongylus crassicauda</i> in treated and control animals. The author stated that this parasite is known to cause extensive papillomatosis of the bladder.	Homburger (1978)
6-wk-old albino mice	10M, 10F per dose	10M, 10F	saccharin <sup>a</sup> , method of production and purity not specified (purchased from Boos Co., Bombay, India)	0.5, 1.0, or 1.5 g/kg/day in 1 mL distilled water, by gavage (times/wk not specified)	1 yr	Positive Papillary adenocarcinoma of the thyroid was found in male (5/10) and female (3/10) mice exposed to the highest dose. The tumors were detected during months 9-12 of the experiment and were malignant in nature; metastatic deposits were found in the lungs. No information was provided on gross or microscopic examinations of the bladder. The tumor incidence in controls was not reported.	Prasad and Rai (1986)
18- to 19-wk-old BALB/c mice	192F (0.1%), 192F (0.5%), 144F (1.0%), 96F (5.0%)	192F (basal diet alone)	sodium saccharin, >98% pure, method of production not specified	0, 0.1, 0.5, 1.0, or 5.0% diet	117 wk	Negative There was a marginally significant trend ( $p=0.04$ ) in the incidence of Harderian neoplasms (2/1163, 32/1172, 29/1160, 22/132, 22/84). There was no significant dose-response for bladder, liver, breast, adrenal, or lung tumors, or for reticulum cell sarcoma or lymphoma in any dose group. The Harderian gland response was not considered to be biologically significant.	Frederick et al. (1989)

Table 4-1. Mammalian Carcinogenicity (Continued)

Age, Strain, Species	No./Sex Exposed	Controls	Chemical Form and Purity	Dose	Duration	Results/Comments	Reference
<b>4.1.3 Rats</b>							
21-day-old Osborne-Mendel rats	10M, 10F per dose	10M, 10F	saccharin <sup>b</sup> , method of production and purity not specified	0.01, 0.1, 0.5, 1, or 5% in diet	≤ 2 yr	Negative Seven of 18 animals (sex not specified) receiving 5% dose developed abdominal lymphosarcomas. The authors stated that this was not "out of line with the incidence (of abdominal lymphosarcomas) in a comparable group of rats", but noted the uncommon co-occurrence of thoracic lymphosarcomas with abdominal lymphosarcomas in 4 of the 7 rats treated for 102 or more weeks. Tumor incidence in controls was not provided. Urinary bladders were not evaluated. IARC (1980) noted the small number of animals used in this study.	Fitzhugh et al. (1951)
Boots-Wistar rats	20M, 20F per dose	20M, 20F	saccharin <sup>b</sup> , made by Remsen-Fahlberg method, purity not specified	0.005, 0.05, or 5% in diet	2 yr	Negative Tumor incidence was similar in control and exposed animals. Of 5 bladders from animals exposed to the highest dose, 1 female had a bladder papilloma. IARC (1980) noted the small number of bladders examined histologically. It was not specified whether other tissues were examined.	Lesel (1971)
70- to 90-day-old BD rats	52M, 52F per dose	52M, 52F	sodium saccharin, made by Remsen-Fahlberg method, purity not specified	0.2 or 0.5% in diet	≤ 30 mo	Negative The incidence of benign and malignant tumors was similar in control and exposed animals. No bladder tumors were observed. <i>Strongyloides capillaria</i> was found in the urinary tract of 16% of all animals. [original paper in German]	Schmähli (1973)
weanling SD rats	20M, 20F per dose	20M, 20F	sodium saccharin, made by Remsen-Fahlberg method, purity not specified	0.05, 0.5, or 5% in diet	100 wk	Positive (males only, at highest dose) F <sub>1</sub> generation was fed same dose as offspring. There were seven transitional-cell carcinomas of the urinary bladder, but only in males fed the highest dose. A review by IARC (1980) noted that this incidence was significant (p=0.001).	Tisdell et al. (1974)
Wistar rats (age not specified)	54-56M	54-56M	sodium saccharin, method of production and purity not specified	2.5 g/kg body weight/day	≤ 28 mo	Negative No urinary bladder tumors were observed. It was not specified whether other tissues were examined. IARC noted the incomplete reporting of this study.	Furuya et al. (1975 abstr.)

Table 4-1. Mammalian Carcinogenicity (Continued)

Age, Strain, Species	No./Sex Exposed	Controls	Chemical Form and Purity	Dose	Duration	Results/Comments	Reference
Weanling Charles River CD rats	240M, 240F	60M, 60F	sodium saccharin, method of production and purity not specified	90, 270, 810 or 2430 mg/kg/day in diet	26 mo	Negative Non-invasive bladder tumors were detected in 1/60 males and 1/60 females exposed to 90 mg/kg and in 2/60 males exposed to 810 mg/kg, but not in any rats exposed to 2430 mg/kg. The presence of bladder calculus was not associated with exposure or with the presence of bladder tumors. Saccharin administration was not accompanied by an increase in tumor incidence. The combined incidence of lymphomas and leukemias in males given the highest dose was 7/54 (vs. 2/57 controls), but the statistical significance of this was not specified. All major tissues were examined.	Munro et al. (1975)
Charles River CD-1 rats (age not specified)	25M, 25F per dose	25M, 25F	sodium saccharin, method of production not specified, 345 mg/kg o-toluenesulfonamide	1 or 5% in diet	≤ 2 yr	Negative Animals were sacrificed when obvious tumors were seen or when they were moribund. Survivors were killed at 2 yr. Any tissue with an abnormal appearance and all vital organs from at least half of the animals were examined histologically. The incidences of tumors of the urinary bladder, pituitary, breast, and subcutaneous tissue were similar in control and exposed animals. The author stated that one third of all examined urines were thought to contain <i>Trichosomoides crassicauda</i> ova.	Homburger (1978)
Wistar SPF rats (age not specified)	75M, 75F	55M, 50F (these controls also used for drinking water study; see below)	sodium saccharin, made by Kemsens-Fähberg method, 698 mg/kg o-toluenesulfonamide	4 g/kg body weight; in diet	2 yr	Negative Although there was an increase in the total number of exposed males with tumors at any site (10/70 males vs. 1/52 male controls), site-specific tumor incidences were not statistically significant. All major organs were examined macroscopically. The bladder, kidneys, lungs, liver, spleen, pancreas, ovaries, uterus, and any other organ with an abnormal appearance were examined histopathologically.	Chowaniec and Hicks (1979)
Wistar SPF rats (age not specified)	75M, 50F	55M, 50F	sodium saccharin, made by Kemsens-Fähberg method, 698 mg/kg o-toluenesulfonamide	2 g/kg body weight; in drinking water	2 yr	Negative Although there was an increase in the total number of exposed males with tumors at any site (11/71 males vs. 1/52 male controls), site-specific tumor incidences were not statistically significant. All major organs were examined macroscopically. The bladder, kidneys, lungs, liver, spleen, pancreas, ovaries, uterus, and any other organ with an abnormal appearance were examined histopathologically.	Chowaniec and Hicks (1979)

Table 4-1. Mammalian Carcinogenicity (Continued)

Age, Strain, Species	No./Sex Exposed	Controls	Chemical Form and Purity	Dose	Duration	Results/Comments	Reference
32-day-old SD rats	50M, 50F	50M, 50F	sodium saccharin, made by Maunee process, < 0.05 ppm <i>o</i> -toluenesulfonamide	5% in diet	90 days (adults), ~700 days (pups)	Positive (only males) Incidence of benign plus malignant bladder tumors was significantly increased ( $p < 0.03$ ) in exposed male rats from both the $F_0$ and $F_1$ generations ( $F_0$ : 7/38 vs. 1/36 controls; $F_1$ : 12/45 vs. 0/42 controls). The incidence of benign plus malignant bladder tumors was not statistically increased in $F_0$ or $F_1$ females and there was no increase in the incidence of tumors of other tissues in males or females. All organs and all grossly abnormal areas of dermal, supportive, or skeletal tissues were examined histologically. There were no effects on reproduction, longevity, or hematological parameters.	Arnold et al. (1980)
Wistar rats (age not specified)	50F	63F	sodium saccharin, made by Maunee process, purity not specified	2 g/kg body weight/day	2 yr	Negative No bladder neoplasms occurred in control or exposed rats. Overall tumor incidence did not differ between control and exposed rats. It was not specified in the review which tissues besides bladders were examined. IARC noted that animals were started on the test diet not at weaning, but after several weeks on a normal diet.	Hooson et al. (1980; cited by IARC, 1980)
pregnant SD rat	5F (low dose) 6F (mid dose) 7F (high dose)	5F	saccharin <sup>a</sup> [ $< 10$ ppm <i>o</i> -toluene sulfonamide], method of production not specified	0.2, 1, or 5 g/kg by gavage in aqueous solution, administered on gestation days 14, 17, and 20	3 days	Negative There was no statistically significant increase in tumor incidence in offspring that were fed normal diet and observed for life (~ 2 yr) or were killed when moribund, as compared to offspring of controls. Complete necropsies were performed. All urinary bladders and any organs with macroscopically visible abnormalities were examined histologically.	Schmähl and Habs (1980)
<i>in vitro</i> Charles River CD rats	240M, 240F	48M, 48F	sodium saccharin, made by Rensen-Fähberg method, 350 ppm <i>o</i> -toluenesulfonamide	0.01, 0.1, 1, 5, or 7.5% in diet	$\leq 2$ yr	Positive in males at highest dose. There was an increased incidence of urinary bladder tumors in $F_1$ males fed 7.5% sodium saccharin (7/23 vs. 1/29 controls). $F_0$ rats were fed test diet continuously from weaning through mating, and through gestation to weaning of their litters. Complete necropsies were performed. The urinary bladder, all tumors, and any grossly abnormal tissues were examined histologically.	Taylor et al. (1980)
6-wk-old ACI rats	48M	45M	sodium saccharin, >99.5% pure [7 ppm <i>o</i> -toluene sulfonamide] method of production not specified	5% in diet	52 wk	Positive The incidence of urinary bladder transitional cell papilloma was significantly increased at 52 wk (9/32 vs. 0/28 controls, $p < 0.01$ ). Calculi were observed in 1 rat with bladder cancer and there was a higher level of urinary "crystals" in treated rats than in controls. The bladder, liver, and kidneys were the only tissues examined histologically. At least half of the rats were infected with the bladder parasite <i>Trichosomoides crassicauda</i> .	Fukushima et al. (1983)

**Table 4-1. Mammalian Carcinogenicity (Continued)**

Age, Strain, Species	No./Sex Exposed	Controls	Chemical Form and Purity	Dose	Duration	Results/Comments	Reference
6-wk-old F344 rats	40M	40M	sodium saccharin, >99.5% pure [7 ppm <i>o</i> -toluene sulfonamide] method of production not specified	5% in diet	52 wk	Negative No tumors were detected in bladder, liver, or kidneys.	Fukushima et al. (1983)
6-wk-old SD rats	40M	40M	sodium saccharin, >99.5% pure [7 ppm <i>o</i> -toluene sulfonamide] method of production not specified	5% in diet	52 wk	Negative No tumors were detected in bladder, liver, or kidneys.	Fukushima et al. (1983)
6-wk-old Wistar rats	40M	40M	sodium saccharin, >99.5% pure [7 ppm <i>o</i> -toluene sulfonamide] method of production not specified	5% in diet	52 wk	Negative No tumors were detected in bladder, liver, or kidneys.	Fukushima et al. (1983)
newborn SD rats	33M, 39F (low dose) 34M, 37F (high dose)	36M, 34F	sodium saccharin [0.0005% <i>o</i> -toluene sulfonamide] and sodium cyclamate, method of production not specified	2 or 5% sodium saccharin and sodium cyclamate in the diet (1:10 ratio)	lifetime (parents were also fed same dose)	Negative The mixture of sodium saccharin and sodium cyclamate was not carcinogenic at either dose. Detailed necropsies were performed, including evaluation of the urinary tract.	Schmähl and Habs (1984)
28- to 38-day-old Charles River CD rats	1%, 700M; 3%, 500M; 4%, 200M; 5%, 125M; 6.25%, 125M; 7.5%, 125M; 5% (through gestation), 125M, 5% (following gestation), 125M	350M	sodium saccharin, made by Maumee process, >99% pure	1.0, 3.0, 4.0, 5.0, 6.25, or 7.5% in diet (same dose used for parent and offspring)	30 mo	Positive Parents were exposed to same dose from 6 weeks of age. A clear dose response for urinary bladder tumors was observed in F <sub>1</sub> male rats (1.0%, 5/658; 3.0%, 8/472; 4.0%, 12/189; 5.0%, 15/120; 6.25%, 20/120; 7.5%, 37/118; all vs. 0/324 in controls). Female F <sub>1</sub> rats were not evaluated. Tumor incidence in rats exposed only to 5% sodium saccharin during gestation was similar to controls. 12/120 rats exposed to 5% sodium saccharin from birth for a single generation had bladder tumors. The urinary bladder, urethra, ureter, kidneys, and all gross lesions and tissue masses were examined histologically.	Schoenig et al. (1985)
6-wk-old analbuminemic and SD rats	35M analbuminemi 36M SD	12M analbuminemic, 14M SD	sodium saccharin, method of production and purity not specified	5% in diet	80 wk	Negative No bladder carcinomas or precancerous lesions were observed in any of the rats. Only the bladder was examined.	Homma et al. (1991)

NTP Report on Carcinogens 1997 Background Document for Saccharin

Table 4-1. Mammalian Carcinogenicity (Continued)

Age, Strain, Species	No./Sex Exposed	Controls	Chemical Form and Purity	Dose	Duration	Results/Comments	Reference
<b>4.1.4 Nonhuman Primates</b>							
rhesus monkeys (age not specified)	7M, 7F	3M, 3F	sodium saccharin, method of production not specified, 'purified'	20, 100, or 500 mg/kg/day in diet	79 mo	Negative Histopathological examination of urinary bladders, kidneys, and testis of surviving and deceased animals showed no abnormal pathology.	McChesney et al. (1977 abstr.; cited by IARC, 1980)
monkeys (4 unspecified strains)	10 total	0	sodium saccharin, method of production not specified, 'purified'	25 mg/kg/day in diet	9 yr	Negative Clinical observation revealed no gross neoplasia. This study was ongoing in 1980.	Sieber and Adamson (1978; cited by IARC, 1980)
0 to 1-yr-old monkeys (Cynomolgus, Rhesus, and African Green)	20 total	0	sodium saccharin, method of production and purity not specified	25 mg/kg/day in diet	>20 yr	Negative Dose corresponds to 5 cans diet soda per day by 70 kg human. Five monkeys died from either varicella, pneumonia, or unknown reasons. No tumors were found in the dead or in any of the 15 surviving monkeys. Complete necropsies were performed on all animals that died. Various unspecified hematological and biochemical tests were routinely performed on survivors.	Thorgeirsson et al. (1994)
Cynomolgus and Rhesus monkeys (age not specified)	not specified	not specified	sodium saccharin, method of production and purity not specified	25 mg/kg/day in diet	17-23 yr	Negative Urine was analyzed during last year of life. There were no calculi, unusual crystals, increased crystalluria, or calcium phosphate precipitate in urine. There was no association between ingestion of sodium saccharin and urinary protein content. Urinary bladders were free of hyperplasia and tumors. There was no difference in appearance of urothelium in exposed and age-matched control monkeys. It was not specified whether other tissues were examined.	Cohen et al. (1996 abstr.)

Abbreviations: F = females; i.p. = intraperitoneally; M = males;

\*No distinction was made between saccharin and its sodium salt in the IARC discussion

<sup>a</sup>No distinction was made between saccharin and its sodium salt



#### 4.2 Initiation/Promotion and Co-Carcinogenicity Studies

Experimental details for the studies described in this section are presented in **Table 4-2**.

##### 4.2.1 Benzo[*a*]pyrene (BP)

Saccharin did not enhance the incidence of tumors in the forestomach of mice exposed to a test diet containing 5% saccharin (for 72 wk) starting 7 days after an initial single gastric instillation of 0.2 mL polyethylene glycol containing 50 µg BP. No pathological changes were observed macroscopically in urinary bladders of saccharin-exposed mice (Roe et al., 1970). It was noted that BP is not organotropic for the bladder and that histological examination of the urinary bladders was not conducted (IARC, 1980).

##### 4.2.2 *N*-Butyl-*N*-(4-hydroxybutyl)nitrosamine (BBN)

Sodium saccharin, administered in the diet at 0.04, 0.2, 1, or 5% for 32 wk, did not produce any effects in 6-wk-old Charles River F344 rats that were not pretreated with BBN (0.01% in water for 4 wk). A sodium saccharin dose-dependent increase in papillary or nodular hyperplasia of the urinary bladder was statistically significant in females (1% and 5% sodium saccharin groups) and males (5% sodium saccharin group) in the BBN-exposed groups (Nakanishi et al., 1980a).

The effects of sequential administration (initiation/promotion protocol) of 0.01% BBN in drinking water and 5.0% sodium saccharin in feed and co-administration of 0.001% BBN in drinking water and 5.0% sodium saccharin in feed, were studied in 8-wk-old male Wistar rats by Nakanishi et al. (1980b). In the first experiment (sequential administration), rats received BBN for 4 wk and then sodium saccharin for an additional 32 wk. In the second experiment (co-administration), rats were fed BBN and sodium saccharin for 40 wk. When rats were administered BBN and sodium saccharin concurrently, there was an increased incidence of urinary bladder papilloma (10/24 vs. 0/12 in controls). Sequential administration produced a non-statistically significant increase (9/31 vs. 0/12 in controls) in the incidence of bladder papilloma. In addition, there was one transitional cell carcinoma among the 31 rats that received saccharin sequentially and two transitional cell carcinomas among the 24 rats receiving saccharin concurrently with BBN. Transitional cell hyperplasia was noted in rats receiving sodium saccharin alone as well as in groups receiving BBN before and during saccharin administration.

Nakanishi et al. (1982) reported that there was no statistically significant increase in the incidence of hepatocellular carcinoma or urinary bladder papilloma in male F344 rats (age not specified) initiated with 0.01% BBN in drinking water for 4 wk and then fed 5% sodium saccharin in the diet for an additional 32 wk, as compared to rats administered BBN alone. Sodium saccharin significantly enhanced urothelial hyperplasia after BBN pretreatment and produced a non-statistically significant increase in urinary bladder papillomas (6/29 vs. 0/29 in controls).

The comparative tumor-promoting effects of 5% sodium saccharin, 5% sodium L-ascorbate, 5% L-ascorbic acid, 5% sodium saccharin plus sodium L-ascorbate, or 5% sodium saccharin plus L-ascorbic acid were studied in 6-wk-old male F344 rats. Rats were initiated with 0.05% BBN in drinking water for 4 wk and were then fed the test diets for an additional 32 wk. The authors found that bladder-cancer promotion by sodium saccharin was inhibited by L-

ascorbic acid and enhanced by sodium L-ascorbate, apparently as a function of urinary pH. Sodium saccharin alone, sodium L-ascorbate alone, and these two compounds in combination caused increased incidences of urothelial hyperplasia, papilloma, and carcinoma in the urinary bladder (Fukushima et al., 1990).

Yu et al. (1992) studied the tumor-promoting effects of sodium saccharin alone and in combination with nordihydroguaiaretic acid (an antioxidant and inhibitor of arachidonic acid metabolism) in BBN-initiated male F344 rats. BBN (0.05%) was administered to 6-wk-old rats in the drinking water for 4 wk. The rats were then fed 5% sodium saccharin with or without the antioxidant for an additional 36 wk. Nordihydroguaiaretic acid was coadministered at a concentration of 0.1% in the diet. The authors found that sodium saccharin promoted BBN tumorigenicity, while nordihydroguaiaretic acid plus sodium saccharin decreased the incidences of papilloma. Both groups receiving sodium saccharin had urothelial hyperplasia.

#### 4.2.3 2-Acetylaminofluorene (AAF)

Nakanishi et al. (1982) reported that there was no significant increase in the incidence of hepatocellular carcinoma or urinary bladder carcinoma in male F344 rats (age not specified) initiated with 0.02% AAF in the diet for 4 wk and then fed 5% sodium saccharin in the diet for an additional 32 wk, as compared to rats administered AAF alone. There was a statistically significant increase in urothelial hyperplasia in the sodium saccharin-promoted rats.

The effect of lifetime sodium saccharin dosing (0.1, 0.5, 1.0, or 5.0% diet for 117 wk), administered 2 wk after initiation with AAF (200 ppm diet for 13 weeks), on female weanling BALB/c mice was studied by Frederick et al. (1989). No dose-related increase in tumor incidence was found in initiated mice exposed to 0.1-5% sodium saccharin diet.

In female Horton SD rats (age not specified) co-administered 300 mg AAF/kg diet and 5% sodium saccharin in the diet for 40 wk, no animals developed malignant lesions of the urinary bladder. Eleven of the 12 AAF-treated rats (no sodium saccharin in diet) developed palpable mammary and ear-duct tumors, while 6/12 animals exposed to AAF and sodium saccharin developed these tumors. Liver tumors occurred in control and exposed animals (Ershoff and Bajwa, 1974; cited by IARC, 1980). IARC (1980) noted that the small number of animals used and the fact that food consumption was not measured prevented the evaluation of AAF and sodium saccharin exposure.

#### 4.2.4 N-[4-(5-Nitro-2-furyl)-2-thiazolyl]formamide (FANFT)

The effects of sodium saccharin in FANFT-initiated (0.2% diet for 6 wk) 4-wk-old male F344 rats were studied by Cohen et al. (1979). Subsequent to initiation with FANFT, rats were exposed to a 5% sodium saccharin diet (*o*-toluenesulfonamide free) for up to 83 wk. Two other groups received *o*-toluenesulfonamide-free sodium saccharin either with or without FANFT initiation following a 6-wk no-exposure period. The incidence of bladder cancer was not increased in the sodium saccharin-only group (0/20) when compared to the no-exposure control group (0/42). In the FANFT-initiated control group, 4/20 rats developed bladder cancer and 1/20 rats developed bladder papilloma. In the FANFT plus sodium saccharin groups with or without a 6-wk no-exposure period, the incidences of bladder cancer were 13/18 and 18/19, respectively.

Fukushima et al. (1981) fed 5-wk-old male F344 rats 0.2% FANFT diet for only a 4-wk initiation period in order to decrease the production of bladder cancer in the FANFT-only group. Rats were subsequently fed a 5% sodium saccharin or control diet for 100 wk. There was a significant increase ( $p < 0.03$ ) in the incidence of carcinoma of the bladder as compared to FANFT-only controls (5/26 vs. 0/25).

Murasaki and Cohen (1983a) evaluated the co-carcinogenicity of FANFT (0.005% diet) and sodium saccharin (5% diet) administered to 5-wk-old male Fischer rats for 2 yr. The authors reported that the incidence of bladder lesions was marginally significant ( $p < 0.06$ ), when compared to the incidence in FANFT-only controls (5/16 vs. 0/11). There were no statistically significant increases in tumor incidences for other tissues.

Imaida and Wang (1986) studied sodium saccharin as a promoter in a two-stage carcinogenesis model. Groups of 42 or 43 male weanling F344 rats were exposed to 5% sodium saccharin in AIN-76A diet for 100 wk subsequent to a 4-wk regimen of exposure to either 0.2% FANFT in Wayne diet or 0.005% *N,N*-dibutyl nitrosamine (DBN) in drinking water and control Wayne diet. None of the control rats fed sodium saccharin alone developed bladder, liver, esophageal, or forestomach tumors. There was no statistically significant increase in the incidence of tumors of the bladder, liver, or esophagus in rats initiated with FANFT or DBN, with a subsequent dietary administration of sodium saccharin, as compared to FANFT-only and DBN-only controls, respectively. However, the group receiving FANFT initiation followed by sodium saccharin promotion did have an increased incidence of urinary bladder carcinomas ( $p = 0.059$ ).

The comparative effects of different chemical forms of saccharin and ascorbate in conjunction with other chemicals that would affect the urinary ionic composition and pH were studied by Cohen et al. (1991b). Rats (5-wk-old male F344) were exposed to 0.02% FANFT or control diet for 6 wk. Subsequent to administration of FANFT, rats were exposed to 3 or 5% sodium saccharin, 3.12 or 5.2% calcium saccharin, 2.53 or 4.21% acid saccharin, 4.44% ascorbic acid, or 5% sodium ascorbate diet for 72 wk. Carcinomas and papillomas developed in 12/39 (31%) and 5/39 (13%) rats, respectively, in the FANFT-only group. A statistically significant increased incidence of tumorigenesis occurred in all of the other groups, with the exception of acid saccharin, ascorbic acid, and low-dose calcium saccharin. Sodium saccharin > sodium ascorbate > calcium saccharin for enhancement of bladder tumorigenesis; none of the forms of saccharin were tumorigenic without FANFT initiation. The authors found that an elevated urinary pH increased tumorigenicity. However, elevated urinary sodium concentrations are sufficient, as shown by the enhancement of bladder tumor promotion by sodium saccharin and sodium ascorbate, and by the enhanced bladder tumorigenicity of calcium saccharin when sodium chloride was added to the calcium saccharin exposure. Masui et al. (1991) analyzed the tumors in this study for *H-ras* mutations by Western blotting using a monoclonal antibody against p21. *H-ras* mutations were found in 2/3 and 3/6 bladder tumors from rats exposed to FANFT alone, and 4/20 and 1/10 *H-ras* mutations were found in tumors from rats exposed to FANFT initiation with 3 or 5% sodium saccharin promotion, respectively.

Okamura et al. (1991) compared the Prolab 3200 with the AIN-76A diet for the promoting effects of sodium saccharin and found that male F344 rats on Prolab 3200 diet exhibited sodium saccharin (5% diet for 100 wk) enhancement of bladder tumors when initiated

for 4 wk with 0.2% FANFT. This effect was not found in the AIN-76A-fed rats initiated with FANFT and fed 5% sodium saccharin for 100 wk.

#### 4.2.5 *N*-Methyl-*N*-nitrosourea (MNU)

A series of reports on studies conducted by Hicks et al. (1973, 1975) and Hicks and Chowanec (1977) evaluated sodium saccharin (2-yr exposure) following intravesicular instillation of MNU (single dose of 1.5 or 2 mg) in 6- to 8-wk-old Wistar rats. In 138 rats in the male and female 4 g/kg/day dietary sodium saccharin-only group, 3 bladder tumors were found. Administration of 2 g/kg/day of sodium saccharin in drinking water for two yr did not produce any bladder tumors in male and female Wistar rats. Bladder tumors were found in 23/49 (47%) female rats in an MNU plus 2 g/kg/day dietary sodium saccharin group. Bladder tumor incidence was increased in the MNU plus 4 g/kg/day sodium saccharin female group (27/47; 57%).

In an effort to reproduce the experiments of Hicks et al. (1973, 1975) and Hicks and Chowanec (1977), Mohr et al. (1978) instilled 2 mg MNU in the bladders of female Wistar/AF-Han rats which were subsequently fed 2% sodium saccharin for the first 10 wk and 4% afterwards [up to 2 yr] (specific dosing regimen not specified). In the MNU-only group, bladder tumors were found in 19/49 (39%) rats; and ureter tumors were found in 8/49 (17%) rats, while 14/49 (28%) rats developed renal pelvis tumors. In the MNU plus sodium saccharin group, incidences of renal pelvis, ureter, and bladder tumors were 43, 11, and 39%, respectively. The high incidence of tumors in the MNU-only group was explained by the original authors as a result of the use of MNU within 15 min of dissolution and the assumption that in their experiment the dose of MNU was not subcarcinogenic.

Hooson et al. (1980) studied the contribution of the sodium saccharin contaminant *o*-toluenesulfonamide in the promotion of MNU-initiated bladder carcinogenesis in female Wistar rats (age not specified). No statistically significant differences were found in bladder tumor incidence with administration of a single 0.15 mL-dose of MNU, followed 2 wk later by daily administration in drinking water or diet of either 2 g/kg *o*-toluenesulfonamide-free sodium saccharin or 2 g/kg sodium saccharin containing 40 mg/kg *o*-toluenesulfonamide for 2 yr, as compared to a control group given MNU alone. There was, however, a decrease in the latency period in the MNU+sodium saccharin treated groups (55 and 52 wk vs. 87 wk for MNU-only controls).

West et al. (1986) exposed 8-wk-old female Sprague-Dawley rats, which had previously been dosed with a single dose of MNU or by saline transurethral instillation into the bladder, to 0.1, 0.5, 1.0, 2.5, or 5% sodium saccharin in the diet. Other groups received MNU followed by 2% sodium saccharin in water or 5% acid saccharin diet. Sodium saccharin dosing was initiated 2 days after rats were dosed with MNU and continued until the termination at 102 wk. In MNU-exposed rats, histopathological examination revealed papillomas and carcinomas of the urinary bladder. A mortality-adjusted increase in tumor incidence and a decrease in time-to-tumor with increasing sodium saccharin dose for the 0-2.5% doses in dead and moribund rats was reported. A statistically significant increase in bladder tumor prevalence ( $p < 0.0012$ ) was found for the group of rats exposed to 2.5% sodium saccharin plus MNU vs. the MNU-only control group. The greatest number of tumors developed in rats that received four doses of MNU alone throughout the experiment. Rats not exposed to MNU that were dosed with a 0.1-5% sodium

saccharin or 5% acid saccharin diet or 2% sodium saccharin in the drinking water developed a small number of tumors that were not significantly different from controls.

In the bladders of female Sprague-Dawley rats exposed to 1.0, 2.5, or 5.0% dietary sodium saccharin (given 4 wk immediately preceding, following, or centered on the day of bladder instillation of 0.5mg MNU), MNU-induced tumorigenesis was not enhanced (West et al., 1994). After the 4-wk administration of dietary sodium saccharin, rats were maintained on control diet. Additional groups of rats were dosed neonatally in the milk by administration of the same three levels of dietary saccharin to the dams during three wk of lactation. These latter groups then received MNU by bladder instillation at 8 wk of age and remained on the control diet for up to 106 wk of age. This neonatal exposure to saccharin did not enhance MNU-induced bladder tumors.

#### 4.2.6 Freeze Ulceration

Five-wk-old male F344 rats had their bladder cells initiated with application of a steel rod frozen in dry ice and acetone (freeze ulceration). Rats were subsequently fed a control diet for two wk and then a sodium saccharin diet for 102 wk. This treatment resulted in 5/20 (25%) carcinomas and 1/20 (5%) papillomas compared with none when rats were exposed to either dosage regimen (freeze ulceration or sodium saccharin diet) alone. When 0.2% FANFT was administered in the diet for 2 wk after freeze ulceration followed by 5% sodium saccharin diet for 102 wk, 4/23 (17%) of the bladders had tumors. Reversing the order of FANFT and freeze ulceration exposure resulted in an 8/22 (36%) incidence of bladder tumors. Tumors were not found in rats that had received FANFT or sodium saccharin alone (Cohen et al., 1982).

Hasegawa et al. (1985) fed 5-wk-old male F344 rats 5% sodium saccharin diet either immediately or 2, 4, 6, or 18 wk following freeze ulceration of the bladder. There was a significant increase in the incidence of transitional cell carcinoma of the bladder in all of these groups as compared to a freeze ulceration-only control group, except in the group fed sodium saccharin 2 wk after freeze ulceration (11/36, 6/36, 12/40, 7/36, 9/39 vs. 1/39 in controls). No bladder carcinoma was detected in control rats administered saccharin alone.

Table 4-2. Initiation-Promotion and Co-Carcinogenicity Studies

Age, Strain, Species	No./Sex Exposed	Controls	Chemical Form and Purity	Dose	Duration	Results/Comments	Reference
<b>4.2.1 Benzo(a)pyrene (BP)</b>							
Swiss mice (age not specified)	50F	50F	saccharin <sup>a</sup> , method of production and purity not specified	5% diet	18 mo	Negative Animals were gavaged with a single 0.2 mL dose of polyethylene glycol, either alone or containing 50 µg BP. Seven days after BP treatment, exposure to saccharin was begun. BP induced an increased incidence of tumors of the forestomach but saccharin did not enhance this increase. No pathological changes were observed macroscopically in urinary bladders of saccharin-exposed mice. IARC (1980) noted that BP is not organotropic for the bladder and that a histological examination of the urinary bladders was not done.	Roe et al. (1970)
<b>4.2.2 N-Butyl-N-(4-hydroxybutyl)nitrosamine (BBN)</b>							
6-wk-old Charles River F344 rats	30M, 31F	30M, 31F	sodium saccharin	0.04, 0.2, 1, or 5% diet	32 wk	Positive Rats were preexposed to 0.01% BBN in water for 4 wk. Sodium saccharin did not produce any effects in rats that were not preexposed to BBN. In the BBN exposed groups, a sodium saccharin dose-dependent increase in papillary or nodular hyperplasia of the urinary bladder achieved statistical significance in females (1% and 5% sodium saccharin) and males (5% sodium saccharin).	Nakanishi et al. (1980a)
8-wk-old Wistar rats	40M (BBN/ sodium saccharin)	24M (BBN alone) 24M (sodium saccharin alone) 18M (no chemicals)	sodium saccharin, >99.5% pure, 7 ppm o-toluenesulfonamide	sodium saccharin: 5% diet 0.01% in drinking water	Rats pretreated with BBN for 4 wk and then given sodium saccharin for 32 wk	Negative for urinary bladder cancer There was no statistically significant increase in the incidence of urinary bladder cancer. There was an increased incidence of urinary bladder papillomas (10/24 vs. 0/12 in controls).	Nakanishi et al. (1980b)
F344 rats (age not specified)	31M	30M (BBN alone)	sodium saccharin, 7 ppm o-toluenesulfonamide; method of production and purity not specified	0.01% BBN in drinking water for 4 wk followed by 5% sodium saccharin in diet for 32 wk	see dose	Negative There was no significant increase in the incidence of hepatocellular carcinoma or urinary bladder papilloma.	Nakanishi et al. (1982)

Table 4-2. Initiation-Promotion and Co-Carcinogenicity Studies (Continued)

Age, Strain, Species	No./Sex Exposed	Controls	Chemical Form and Purity	Dose	Duration	Results/Comments	Reference
6-wk-old F344 rat	15-16M/ dose group	15-16M (BBN alone)	sodium saccharin sodium L-ascorbate L-ascorbic acid sodium saccharin plus sodium L-ascorbate sodium saccharin plus L- ascorbic acid Methods of production and purities not specified	5% diet 5% diet 5% diet 5% diet 5% diet	32 wk (All rats were administered drinking water containing 0.05% BBN for 4 wk and were then given test diet or control diet for an additional 32 wk)	Positive with BBN pretreatment. When administered individually following BBN initiation, sodium saccharin and sodium L-ascorbate significantly increased the incidence of urinary bladder hyperplasia (14/15 and 15/16), papilloma (9/15 and 13/16), and carcinoma (5/15 and 11/16) versus BBN controls (4/15, 4/15, and 0/15). Co-administration of sodium saccharin and sodium L-ascorbate also significantly increased the incidences of bladder hyperplasia, bladder papilloma, and bladder carcinoma. These increased incidences were accompanied by increases in urinary sodium ion concentration and pH. Co-administration of sodium saccharin and L-ascorbic acid caused a decrease in urinary pH and no change in urinary sodium ion levels, and did not increase the incidence of hyperplasia, papilloma, or carcinoma.	Fukushima et al. (1990)
6-wk-old F344 rats	23M (BBN + sodium saccharin) 23M (BBN + sodium saccharin + nordihydroguaiaretic acid) 11M (nordihydroguaiaretic acid alone) 20M (BBN alone) 20M (BBN + nordihydroguaiaretic acid)	11M (sodium saccharin alone) 11M (sodium saccharin + nordihydroguaiaretic acid ) 11M (nordihydroguaiaretic acid alone) 20M (BBN alone) 20M (BBN + nordihydroguaiaretic acid)	sodium saccharin nordihydroguaiaretic acid BBN Methods of production and purity not specified	5% diet 0.1% diet 0.05% in drinking water	36 wk	Positive for tumor promotion with 4-wk BBN pretreatment. Incidences of urinary bladder urothelial hyperplasia and papilloma were increased in sodium saccharin-treated rats versus controls. Incidences of papillary or nodular hyperplasia and papilloma were decreased by nordihydroguaiaretic acid (antioxidant; inhibitor of arachidonic acid metabolism) alone or in combination with sodium saccharin compared with sodium saccharin alone.	Yu et al. (1992)

Table 4-2. Initiation-Promotion and Co-Carcinogenicity Studies (Continued)

Age, Strain, Species	No./Sex Exposed	Controls	Chemical Form and Purity	Dose	Duration	Results/Comments	Reference
<b>4.2.3 2-Acetylaminofluorene (AAF)</b>							
21- to 26-day-old BALB/c mice	saccharin dose in parentheses 192F (0.1%) 192F (0.5%) 144F (1.0%) 96F (5.0%)	192F (AAF alone)	sodium saccharin, >98% pure, method of production not specified.	sodium saccharin: 0, 0.1, 0.5, 1.0 or 5.0% diet AAF: 200 ppm diet	13 wk initiation with AAF 2 wk control diet; 117 wk sodium saccharin diet (132 wk total)	Negative Sodium saccharin had no effect on the urinary bladder tumorigenic response of initiated mice. An increased trend (p=0.04) of Harderian gland neoplasms was not considered to represent a positive tumorigenic response.	Frederick et al. (1989)
Horton SD rats (age not specified)	62F	62F	sodium saccharin, method of production and purity not specified	5% diet	40 wk	Negative for tumorigenesis with co-administration of AAF All animals were fed 300 mg AAF/kg diet for the duration of the study. Eleven of the 12 controls (no sodium saccharin in diet) developed palpable mammary and ear-duct tumors, while 6/12 animals exposed to AAF and sodium saccharin developed these tumors. Liver tumors occurred in control and exposed animals. No animals had malignant lesions of the urinary bladder. IARC noted the small number of animals used and the fact that food consumption was not measured, preventing the evaluation of AAF and sodium saccharin exposure.	Ershoff and Bajwa (1974; cited by IARC, 1980)
F344 rats (age not specified)	31M	30M (AAF alone)	sodium saccharin, 7 ppm o-toluenesulfonamide; method of production and purity not specified	0.02% AAF in diet for 4 wk followed by 5% sodium saccharin in diet for 32 wk	see dose	Negative There was no significant increase in the incidence of hepatocellular carcinoma or urinary bladder papilloma. There was a statistically significant increase in urothelial hyperplasia in the sodium saccharin-promoted rats.	Nakanishi et al. (1982)



Table 4-2. Initiation-Promotion and Co-Carcinogenicity Studies (Continued)

Age, Strain, Species	No./Sex Exposed	Controls	Chemical Form and Purity	Dose	Duration	Results/Comments	Reference
<b>4.2.4 N-(4-(5-Nitro-2-furyl)-2-thiazolyl)formamide (FANFT)</b>							
4-wk-old Fischer rats	1) 20M 2) 20M	3) 20M (sodium saccharin alone) 4) 20M (FANFT alone) 5) 42M (no exposure)	sodium saccharin ( <i>o</i> -toluenesulfonamide free) Method of production and purity not specified	1) 0.2% FANFT for 6 wk followed by 5% sodium saccharin diet 2) 0.2% FANFT for 6 wk followed by 6-wk no-exposure period, followed by 5% sodium saccharin diet 3) 5% sodium saccharin diet alone 4) FANFT initiation alone 5) no exposure	83 wk	Positive with FANFT initiation Sodium saccharin was negative for bladder tumorigenesis when administered alone. Incidence of bladder cancer in groups 1, 2, 3, 4, and 5 were as follows: 18/19, 13/18, 0/20, 4/20, and 0/42, respectively.	Cohen et al. (1979)
5-wk-old F344 rats	26M	25M	sodium saccharin, method of production and purity not specified.	FANFT: 0.2% diet sodium saccharin: 5% diet	FANFT for 4 wk; sodium saccharin for 100 wk	Positive with FANFT pretreatment There was a significant increase ( $p < 0.03$ ) in the incidence of carcinoma of the bladder as compared to FANFT-only controls (5/26 vs. 0/25).	Fukushima et al. (1981)
5-wk-old Fischer rats	20M	20M	sodium saccharin FANFT Method of production and purity not specified	5% diet 0.005% diet	2 yr	Equivalent The incidence of bladder lesions was marginally significant ( $p < 0.06$ ), when compared to the incidence in FANFT-only controls (5/16 vs. 0/11). There were no statistically significant increases in tumor incidences for other tissues.	Murasaki and Cohen (1983a)
weaning F344 rats (age not specified)	42M (sodium saccharin and FANFT) 42M (sodium saccharin and DBN)	42M (FANFT alone) 43M (DBN alone) 42M (sodium saccharin alone)	sodium saccharin Method of production and purity not specified	4-wk exposure to either 0.2% FANFT in Wayne diet or 0.005% N,N-dibutyl/nitrosamine (DBN) in drinking water and control Wayne diet, followed by 5% sodium saccharin in AIN-76A diet for 100 wk	see dose	Negative None of the control rats fed sodium saccharin alone developed bladder, liver, or esophageal tumors. There was no statistically significant increase in the incidence of tumors of the bladder, liver, or esophagus in rats initiated with FANFT or DBN and subsequently promoted with sodium saccharin, as compared to FANFT-only and DBN-only controls, respectively. There was a non-statistically significant increase ( $p=0.059$ ) in urinary bladder carcinomas in FANFT-initiated, sodium saccharin-promoted rats.	Imaida and Wang (1986)

Table 4-2. Initiation-Promotion and Co-Carcinogenicity Studies (Continued)

Age, Strain, Species	No./Sex Exposed	Controls	Chemical Form and Purity	Dose	Duration	Results/Comments	Reference
5-wk-old F344 rats	240M	40M <sup>b</sup>	sodium saccharin	3 or 5% diet	72 wk	Positive with FANFT pretreatment. Without FANFT initiation, sodium saccharin, calcium saccharin, and acid saccharin were non-tumorigenic. With a 6 wk period of FANFT initiation, sodium saccharin was tumorigenic at the 5 and 5% dose levels. Calcium saccharin was slightly tumorigenic but not in a dose response manner. Acid saccharin was not tumorigenic. One of 2 diets was fed: Prolab 3200 or NIH-07. Urinary pH of rats fed Prolab was higher and sodium saccharin promoted more bladder tumors in these rats.	Cohen et al. (1991b)
	160M	40M <sup>b</sup>	calcium saccharin	3.12 or 5.2% diet			
	120M	40M <sup>b</sup>	acid saccharin	2.53% diet			
5-wk-old F344 rats	240M 160M 120M	40M <sup>b</sup> 40M <sup>b</sup> 40M <sup>b</sup> <sup>b</sup> shared controls	sodium saccharin calcium saccharin acid saccharin ascorbic acid sodium ascorbate	3 or 5% diet	72 wk	Tumors were analyzed for H-ras mutations by Western blotting using a monoclonal antibody against p21. H-ras mutations were found in 2/3 and 3/6 bladder tumors from rats exposed to FANFT alone, and 4/20 and 1/10 H-ras mutations were found in tumors from rats exposed to FANFT initiation with 3 or 5% sodium saccharin promotion, respectively.	Masui et al. (1991)
				3.12 or 5.2% diet			
				2.53% diet			
				4.44 % diet			
5-wk-old F344 rats	30M (FANFT + sodium saccharin)	30M (FANFT alone) 25M (sodium saccharin alone)	sodium saccharin, method of production and purity not specified	5% diet	100 wk	Negative Sodium saccharin did not promote bladder cancer in rats initiated for 4 wk with 0.2% FANFT and fed AIN-76A diet. This was probably due to the low urinary pH of rats fed AIN-76A diet.	Okamura et al. (1991)
				5% AIN-76A diet			
				5% Prolab diet			
5-wk-old F344 rats	30M (FANFT + sodium saccharin)	30M (FANFT alone)	sodium saccharin, method of production and purity not specified	5% Prolab diet	100 wk	Positive with FANFT pretreatment. Rats initiated with 0.2% FANFT for 4 wk and fed Prolab diet containing sodium saccharin had an increased incidence of bladder tumors, as compared to FANFT-controls (40% vs. 17% incidence of bladder tumors, respectively). Sodium saccharin was not administered alone in Prolab diet.	Okamura et al. (1991)
<b>4.2.5 N-Methyl-N-nitrosourea (MNU)</b>							
6- to 8-wk old Wistar rats	M and F (number used varied between reports)	M and F (number used varied between reports)	sodium saccharin, method of production and purity not specified	2 or 4 g/kg bw/day in diet or 2 g/kg bw/day in drinking water	2 yr	Positive with MNU pretreatment and dietary administration of sodium saccharin. Bladder tumor incidences were as follows: 3/138 in male and female 4 g/kg bw/day sodium saccharin-only group, 23/49 (47%) rats in the MNU plus 2 g/kg bw/day sodium saccharin female group, and 27/47 (57%) in the MNU plus 4 g/kg bw/day sodium saccharin female group. Administration of 2 g/kg bw/day of sodium saccharin in drinking water did not produce bladder tumors in either sex.	Hicks et al. (1973) preliminary report; Hicks et al. (1975); Hicks and Chowniec (1977); cited by Whyhner and Williams, 1996)

Table 4-2. Initiation-Promotion and Co-Carcinogenicity Studies (Continued)

Age, Strain, Species	No./Sex Exposed	Controls	Chemical Form and Purity	Dose	Duration	Results/Comments	Reference
Wistar/AF-Han rats (age not specified)	F (number not specified), instilled with 2 g MNU in the bladder	F (number not specified)	sodium saccharin, method of production and purity not specified	2% sodium saccharin in the diet for the first 10 wk and 4% afterwards	≤ 2 yr	Negative for increase following MNU pretreatment In the MNU-only group, bladder tumors were found in 19/49 (39%) rats; and ureter tumors were found in 8/49 (17%) rats, while 14/49 (28%) rats developed renal pelvis tumors. In the MNU plus sodium saccharin group, incidences of renal pelvis ureteran and bladder tumors were 43, 11 and 39% respectively. The high incidence of tumors in the MNU-only group was explained by the original authors as a result of the use of MNU within 15 min of dissolution.	Mohr et al. (1978)
Wistar rats (age not specified)	63F (MNU + sodium saccharin containing 40 mg/kg <i>o</i> -toluene-sulfonamide)	63F (MNU alone)	MNU sodium saccharin prepared by the Remsen-Fahlberg method, containing 40 mg/kg <i>o</i> -toluene-sulfonamide sodium saccharin prepared by the Maumee process, no <i>o</i> -toluenesulfonamide	0.15 mL instilled into bladder 2 g/kg/day in drinking water 2 g/kg/day in drinking water 2 g/kg/day in diet	single dose 2 yr (started 2 wk after MNU) 2 yr (started 2 wk after MNU) 2 yr (started 8 days after MNU)	Negative There was no increase in tumor incidence in rats administered <i>o</i> -toluene-sulfonamide-free sodium saccharin or in rats administered <i>o</i> -toluene-sulfonamide-free sodium saccharin, as compared to the MNU-only control group, but the latency period was shorter (55 and 52 wk vs. 87 wk for controls).	Hooson et al. (1980)
8-wk-old SD rats	960F 120F 120F	240F <sup>a</sup> 240F <sup>b</sup> 240F <sup>b</sup>	sodium saccharin sodium saccharin acid saccharin Methods of production and purities not specified	0.1, 0.5, 1, 2.5, or 5% diet 2% drinking water 5% diet	102 wk	Positive with MNU pretreatment with dietary administration of sodium saccharin. Rats were given either a single dose (300 µL) of saline or an initiating dose (0.5 mg/300 µL saline) of MNU, a potent direct acting carcinogen, via trans-urethral instillation. A significant increase in the incidence of benign papillomas was seen in MNU-pretreated rats when fed 0.1-2.5% sodium saccharin. Rats which received 5% sodium saccharin had a benign papilloma incidence similar to controls. Acid saccharin also required MNU initiation for production of tumors. Sodium saccharin administered in drinking water was not as effective in producing tumors as was sodium saccharin administered in the diet.	West et al. (1986)
8-wk-old Sprague-Dawley rats	30F (saccharin alone) 60F (saccharin plus MNU)	78F	sodium saccharin, method of production and purity not specified	up to 5% given 4 wk before, during or after MNU initiation; rats then fed control diet	112 wk	Negative MNU-induced tumorigenesis was not enhanced by the 4-wk sodium saccharin exposure	West et al. (1994)

**Table 4-2. Initiation-Promotion and Co-Carcinogenicity Studies (Continued)**

Age, Strain, Species	No./Sex Exposed	Controls	Chemical Form and Purity	Dose	Duration	Results/Comments	Reference
<b>4.2.6 Freeze Ulceration</b>							
5-wk-old F344 rats	M (number not specified)	not specified	sodium saccharin, method of production and purity not specified	5%	102 wk	Positive with freeze ulceration pretreatment. In rats with freeze ulceration initiation followed by saccharin diet, 5/20 (25%) had carcinomas or papillomas. FANFT pretreatment for 2 wk after freeze ulceration and subsequent sodium saccharin exposure resulted in 4/23 (17%) incidences of bladder tumors. Reversing order of FANFT and freeze ulceration exposure resulted in an 8/22 (36%) incidence of bladder tumors. Tumors were not found in rats that received FANFT, sodium saccharin, or freeze ulceration alone.	Cohen et al. (1982)
5-wk-old F344 rats	40M per group (freeze ulceration followed 0, 2, 4, 6, or 18 wk later with sodium saccharin)	40M (sodium saccharin alone) 40M (freeze ulceration alone) 40M (no treatment)	sodium saccharin, method of production and purity not specified	5% diet	104 wk total (saccharin was administered either immediately after freeze ulceration or after 2, 4, 6, or 18 wk)	Positive with freeze ulceration pretreatment. There was a significant increase in the incidence of transitional cell carcinoma of the bladder in rats subjected to freeze ulceration and then fed sodium saccharin either immediately or 4, 6, or 18 wk later, as compared to freeze ulceration-only control (11/36, 6/36, 12/40, 7/36, 9/39 vs. 1/39 in controls). The increase was not significant in rats fed sodium saccharin 2 wks after freeze ulceration. None of the saccharin-only or no-treatment control rats developed bladder carcinoma.	Hasegawa et al. (1985)

Abbreviations: F = females; M = males

<sup>a</sup>No distinction was made between saccharin and its sodium salt in the IARC discussion

<sup>b</sup>No distinction was made between saccharin and its sodium salt

## 5.0 GENOTOXICITY

Extensive reviews of the genotoxicity of saccharin have been conducted by Ashby (1985), IARC (1980, pp. 148-150, see Appendix A; 1982, see Appendix B; 1987b, see Appendix C), and, most recently, by Whysner and Williams (1996). The studies summarized below are largely based on these reviews; additional, relevant studies are presented in **Table 5-1**, while the Genetic Activity Profiles published by IARC (1987a) for saccharin are provided in **Figures 5-1** and **5-2**.

Most of the numerous *in vitro* and *in vivo* genotoxicity studies on sodium saccharin have been negative with occasional inconsistent or conflicting results and false positive results attributed to factors such as mutagenic impurities, inhibition of DNA synthesis, and osmotic effects.

### 5.1 Noneukaryotic Systems

#### 5.1.1 Gene Mutations

Both sodium saccharin and saccharin (form unspecified) have been reported as negative in 15 studies for the induction of reverse mutations in *Salmonella typhimurium* strains TA92, TA94, TA98, TA100, TA1535, TA1537, and TA1538 (not all strains were tested in all studies), with and without S9 activation, and using either the plate incorporation or pre-incubation forms of the assay.

In a study that evaluated the induction of reverse mutations in *S. typhimurium* by 4 commercially available saccharin samples and by 1 highly purified saccharin sample in the presence and absence of S9, the commercially produced samples were positive for mutation induction, whereas the highly purified sample was negative (Batzinger et al., 1977). The author concluded that commercial saccharin samples contain mutagenic impurities.

#### 5.1.2 DNA Damage

Saccharin (form unspecified) was reported as negative for the induction of prophage (Rossman et al., 1991) and DNA damage/SOS repair in *Escherichia coli* (DeFlora et al., 1984).

#### 5.1.3 DNA Synthesis

Saccharin did not alter DNA synthesis, as measured by the incorporation of [<sup>3</sup>H]thymidine, in *S. typhimurium* (Beljanski et al., 1982).

### 5.2 Lower Eukaryotic Systems

#### 5.2.1 *Saccharomyces cerevisiae*

Sodium saccharin without metabolic activation was reported to be positive in the yeast, *Saccharomyces cerevisiae*, for the induction of aneuploidy, gene conversion, and reverse mutations. However, in two other yeast studies (including one conducted using a 9-fold higher dose), saccharin (form unspecified) was negative for gene conversion and mutation induction but positive again for the induction of aneuploidy.

#### 5.2.2 *Drosophila melanogaster*

Sodium saccharin was initially found in a 1971 study to be positive for the induction of sex-linked recessive mutants and negative for heritable translocations in *Drosophila*

*melanogaster*. However, two subsequent studies conducted using equal or higher doses reported weak positive or negative results for the induction of sex-linked recessive mutations.

### 5.2.3 Higher Plants

Ma et al. (1995) concluded that saccharin induced micronuclei in the root-tips of *Allium cepa* (onions) and *Vicia fava* (beans) following a 6-hour exposure at 120 mM.

## 5.3 Mammalian Systems *In Vitro*

### 5.3.1 Gene Mutations

In two studies, sodium saccharin was reported to be weakly mutagenic in mouse lymphoma L5178Y cells at very high doses (>10 mg/mL) and only in the presence of metabolic activation. A third study using doses as high as 20 mg/mL up was negative. Sodium saccharin, at doses above 10 mg/mL, was also reported to induce a highly significant increase in the number of ouabain-resistant mutants in human R5a embryo cells (Suzuki and Suzuki, 1988), and to increase the number of mutations at the *k-ras* gene, codon 12 in SW480 human colon adenocarcinoma cells (Suzuki and Suzuki, 1993). However, based on either the weakness of the response and/or the magnitude of the doses required to elicit a positive response, these data would be considered to be of questionable value using current testing practices.

### 5.3.2 DNA Damage

Sodium saccharin (without metabolic activation) was weakly positive or positive for the induction of sister chromatid exchanges (SCE) in three studies using Chinese hamster cells and in two studies using human lymphocytes. Sodium saccharin and saccharin, in the absence of metabolic activation, were reported to be negative for SCE induction in one study using mouse embryo fibroblasts and in two studies using human lymphocytes. Studies with metabolic activation were either not conducted or were negative for SCE induction. In the positive studies, the doses capable of inducing a significant increase in SCE ranged from 1 to 12 mg/mL and the maximum increase in SCE was generally less than two-fold. As discussed by Ashby (1985) and based on our current appreciation of the various processes involved in SCE induction, this increase in SCE more likely reflects the ability of saccharin at high doses to inhibit DNA synthesis rather than an ability to cause DNA damage.

### 5.3.3 Inhibition of DNA Repair

Skare and Wong (1985) reported that sodium saccharin did not inhibit the repair of UV-induced DNA damage in WI-38 human fetal lung fibroblasts.

### 5.3.4 DNA Synthesis

Yanagisawa et al. (1987) and Heil and Reifferscheid (1992) both concluded that sodium saccharin at relatively high doses inhibited the rate of DNA synthesis, as measured by incorporation of [<sup>3</sup>H]thymidine after treatment, in human B-32 fibroblasts or HeLa S3 cells.

#### 5.3.5 Chromosomal Damage

Sodium saccharin was found to be positive without S9 activation in ten studies and negative in two studies for the induction of chromosome aberrations using Chinese hamster cells and human lymphocytes. Ashby (1985) and Whysner and Williams (1996) concluded that the high dose levels used (up to 48 mg/mL) may have caused osmotic changes leading to false positive results.

#### 5.3.6 Cell Transformation

Saccharin (form unspecified) was found to give negative results for cell transformation in BALB/c3T3 and C3H 10T1/2 mouse and RLV Fischer rat embryo cells. Sakai and Sato (1989) also reported that sodium saccharin did not increase the number of transformed foci in BALB/3T3 cells with or without a 2-week promotion period with TPA.

### 5.4 Mammalian Systems *In Vivo*

#### 5.4.1 Gene Mutations and Dominant Lethal Mutations

In a study that compared the mutagenic activities of 3 commercially available saccharin samples with a highly purified saccharin sample, Batzinger et al. (1977) administered 2.5 g saccharin/kg to mice (strain not specified) and collected 24-hour urine samples. The urine samples were then assayed for mutagenicity in *S. typhimurium* strains TA98 and TA100 in the presence and absence of S9 and the enzyme  $\beta$ -glucuronidase. In strain TA98, all commercial samples were positive for the induction of reverse mutations, but the purified sample was negative. In strain TA100, all samples were positive. Mutagenic activities of the urine was enhanced in TA98 by  $\beta$ -glucuronidase. In TA100, mutagens were inactivated by S9; in TA98, mutagens were activated by S9. The authors proposed that 2 mutagenic substances were present. A similar study using TA 98, TA 100 and TA 1537 performed on urine obtained from rats treated with 5% dietary sodium saccharin, Hasegawa et al. (1984) failed to show mutagenic activity after 0, 1, 5, or 14 days of treatment.

Batzinger et al. (1977) also conducted a host-mediated assay for the induction of reverse mutations by the 4 saccharin samples (3 commercially available, 1 highly purified). *S. typhimurium* strain TA98 or TA100 was incubated for 6 hours in the peritoneal cavity of mice administered 2.5 g saccharin/kg. The highly purified sample was negative for mutation induction in both bacterial strains. All of the commercially available samples were positive, except for one sample that was negative when incubated with strain TA98.

Both negative and positive results were obtained for sodium saccharin in the mouse spot test, examining somatic cell mutations induced in pup coat color. In his review of the literature, Ashby (1985) reported that the difference may have been due to the different routes of exposure (i.p. vs. orally, respectively) and the 7.5-fold higher oral dose levels in the positive study.

As compiled by Ashby (1985), IARC (1987a,b) and Whysner and Williams (1996) and discussed by Adler and Ashby (1989), saccharin has given conflicting results in the mouse dominant lethal mutation assay, with three positive and three negative studies for sodium saccharin. The strain of mice and the route of exposure were often the same and the doses often

## NTP Report on Carcinogens 1997 Background Document for Saccharin

overlapped for both negative and positive studies. The authors of the review articles concluded that the *in vivo* mutagenic ability of saccharin has not been adequately demonstrated.

### 5.4.2 DNA Damage

Sodium saccharin, when administered orally at doses between 5 and 10 g/kg, was reported to induce up to a two-fold increase in SCE in Chinese hamster bone marrow cells (Renner, 1979). Dropkin et al. (1985) reported that sodium saccharin at doses up to 25 mg/kg/day did not cause sister chromatid exchanges in the fetal pups of female ICR albino mice dosed on the 10th day of gestation and sacrificed on the 17th day.

### 5.4.3 Chromosomal Aberrations

In the reviews conducted by Ashby (1985), IARC (1987a,b), and Whysner and Williams (1996), both sodium saccharin and saccharin (form unspecified) were reported as negative for the induction of chromosomal damage in somatic and germ cells of rodents in seven studies and positive in somatic and germ cells in one study each. Dropkin et al. (1985) also reported that sodium saccharin at doses up to 2000 mg/kg did not cause chromosome aberrations in the fetal pups of female ICR albino mice dosed on the 10th day of gestation and sacrificed on the 17th day.

### 5.4.4 Induction of Micronuclei

Sodium saccharin was reported in two studies as negative for micronucleus induction in mouse bone marrow cells.



Table 5-1. Summary of Saccharin Genotoxicity Studies

System	Bot. Endpoint	S9 Metab. Activation	Chemical Form and Purity	Dose-Response; Doses Used	Endpoint Response	Comments	Reference
<b>5.1 Noneukaryotic Systems</b>							
<b>5.1.1 Gene Mutations</b>							
<i>Salmonella typhimurium</i> strains TA98 and TA100	Induction of reverse mutations	+/-	saccharin (4 commercially available samples and 1 highly purified sample), n.p.	No; up to 40 mg/plate (commercially available samples) or up to 80 mg/plate (highly purified sample); incubation time not specified	positive (commercially available samples) negative (highly purified sample)	There was considerable variation in mutagenic activity among the 4 commercially available samples.	Batzinger et al. (1977)
<i>S. typhimurium</i> strains TA98, TA100, and TA1537	Induction of reverse mutations	+/-	5% dietary sodium saccharin, method of production and purity not specified.	Yes; 0.02 and 0.3 mL urine used on days 0, 1, 5, and 14 of treatment.	negative (commercially available samples)	No dose-response relationship was observed. Results were interpreted as no mutagens being present in the urine following freeze-ulceration and/or sodium saccharin feeding.	Hasegawa et al. (1984)
<b>5.1.2 DNA Damage</b>							
<i>Escherichia coli</i> strain WP2	Lambda prophage induction (microscreen assay)	+/-	saccharin, n.p.	No; 100 µg/well for 20 h	negative/negative	No enhancement of plaque forming units per plate	Rossmann et al. (1991)
<b>5.1.3 DNA Synthesis</b>							
<i>S. typhimurium</i>	Stimulation of DNA synthesis	-	saccharin, n.p.	Yes; 1, 10, 20, 30, and 40 µg/ assay for 10 min	negative	Measured [3H]thymidine DNA synthesis	Beljanski et al. (1982)
<b>5.2 Lower Eukaryotic Systems</b>							
<b>5.2.3 Higher Plants</b>							
<i>Allium cepa</i> (onion) and <i>Vicia faba</i> (broad bean)	Micronucleus assay	-	saccharin, n.p.	Yes; 40, 80, and 120 mM for 6 h followed by 44 h recovery	positive	Significant increase in micronuclei 80 and 120 mM	Ma et al. (1995)

**Table 5-1. Summary of Saccharin Genotoxicity Studies (Continued)**

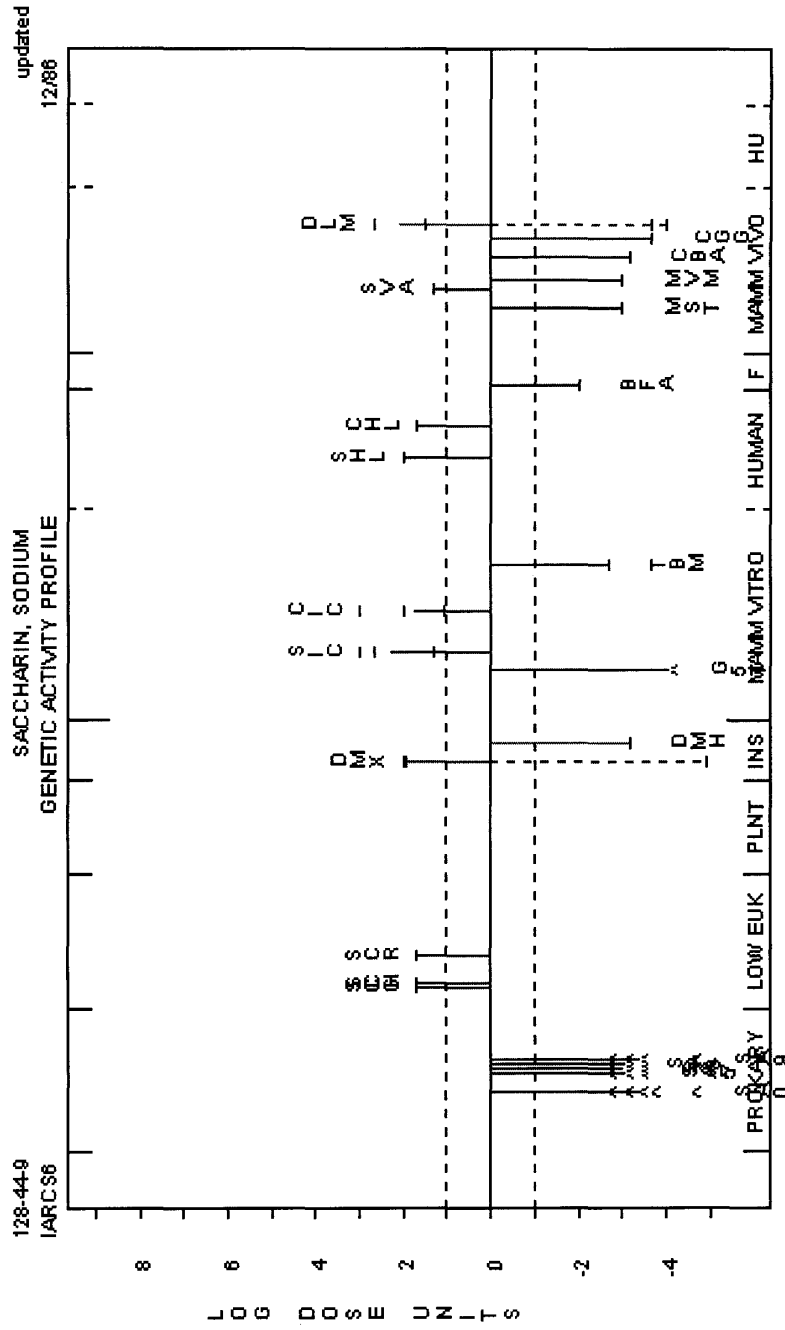
System	Biol. Endpoint	S9 Metab. Activation	Chemical Form and Purity	Dose-Response; Doses Used	Endpoint Response	Comments	Reference
<b>5.3 Mammalian Systems <i>In Vitro</i></b>							
<b>5.3.1 Gene Mutations</b>							
Human R5a embryo cells; SW480 human colon adenocarcinoma cells	Mutations at k-ras codon 12	-	sodium saccharin, n.p.	Yes; 10 to 30 mg/mL for 24 h	positive	DNA was extracted, amplified by PCR, dot-blotted, and hybridized to labeled probes, positive at 1.5 mg/mL	Suzuki and Suzuki (1993)
Human R5a embryo cells	Mutations to ouabain resistance	-	sodium saccharin, n.p.	Yes; 10 to 22.5 mg/mL for 24 h	positive	Dose dependent increase in mutant frequency with top dose being 45-fold higher than controls	Suzuki and Suzuki (1988)
<b>5.3.3 Inhibition of DNA Repair</b>							
WI-38 human fetal lung fibroblasts	Inhibition of DNA repair synthesis	-	sodium saccharin, n.p.	Yes; 10, 57, 319, 1785, and 10,000 µg/mL for 4 h	negative	Measured incorporation of [3H]thymidine after UV irradiation	Skare and Wong (1985)
<b>5.3.4 DNA Synthesis</b>							
Human B-32 fibroblasts	DNA synthesis inhibition	+	saccharin sodium, n.p.	No; 0.1 M for 0, 30, or 90 min	positive	Measured [3H]thymidine incorporation following treatment	Yanagisawa et al. (1987)
HeLa S3 cells	DNA synthesis inhibition	-	saccharin, n.p.	No; D150 (concn. which inhibited DNA synthesis by 50%) - 140 mM for 90 min	positive	Measured incorporation of BrdU using anti-BrdU antibody	Heil and Reifferscheid (1992)
<b>5.3.6 Cell Transformation</b>							
BALB/3T3 cells	Morphological cell transformation	-	sodium saccharin, n.p.	No; dose not provided, 72 h treatment followed by 2 wk with or without TPA promotion	negative	No increase in transformed foci with or without TPA	Sakai and Sato (1989)

Table 5-1. Summary of Saccharin Genotoxicity Studies (Continued)

System	Biol. Endpoint	S9 Metab. Activation	Chemical Form and Purity	Dose-Response; Doses Used	Endpoint Response	Comments	Reference
<b>5.4 Mammalian Systems <i>In Vivo</i></b>							
<b>5.4.1 Gene Mutations and Dominant Lethal Mutations</b>							
mice (strain not specified)	Induction of reverse mutations	+/-	saccharin (3 commercially available samples and 1 highly purified sample); n.p.	No; 2.5 g/kg by gavage	TA98: positive (all commercial samples)/negative (purified sample) TA100: positive (all samples)	The mutagenic activities of 24-hour urine samples were assayed in <i>S. typhimurium</i> strains TA98 and TA100. The strains were incubated both in the presence and absence of $\beta$ -glucuronidase. Mutagenic activities of the urines were enhanced in TA98 by $\beta$ -glucuronidase. In TA100, mutagens were inactivated by S9; in TA98, mutagens were activated by S9. The authors proposed that 2 mutagenic substances were present.	Batzinger et al. (1977)
mice (strain not specified)	Induction of reverse mutations	-	saccharin (3 commercially available samples and 1 highly purified sample); n.p.	No; 2.5 g/kg by gavage	TA98: positive (all commercial samples)/negative (purified sample) TA100: positive (2/3 commercial samples)/negative (1/3 commercial samples; purified sample)	<i>S. typhimurium</i> strain TA98 or TA100 was incubated for 6 hours in the peritoneal cavity of mice administered saccharin.	Batzinger et al. (1977)
<b>5.4.2 DNA Damage</b>							
ICR albino mice (pregnant)	SCE	-	saccharin sodium, >99%	Yes; i.p., 5, 10, and 25 mg/kg/day	negative	Dams dosed on 10th day of gestation and sacrificed on day 17	Dropkin et al. (1985)
<b>5.4.3 Chromosomal Aberrations</b>							
ICR albino mice (pregnant)	Chromosomal aberrations	-	saccharin sodium, >99%	Yes; i.p., 1000 and 2000 mg/kg	negative	Dams dosed on 10th day of gestation and sacrificed on day 17	Dropkin et al. (1985)

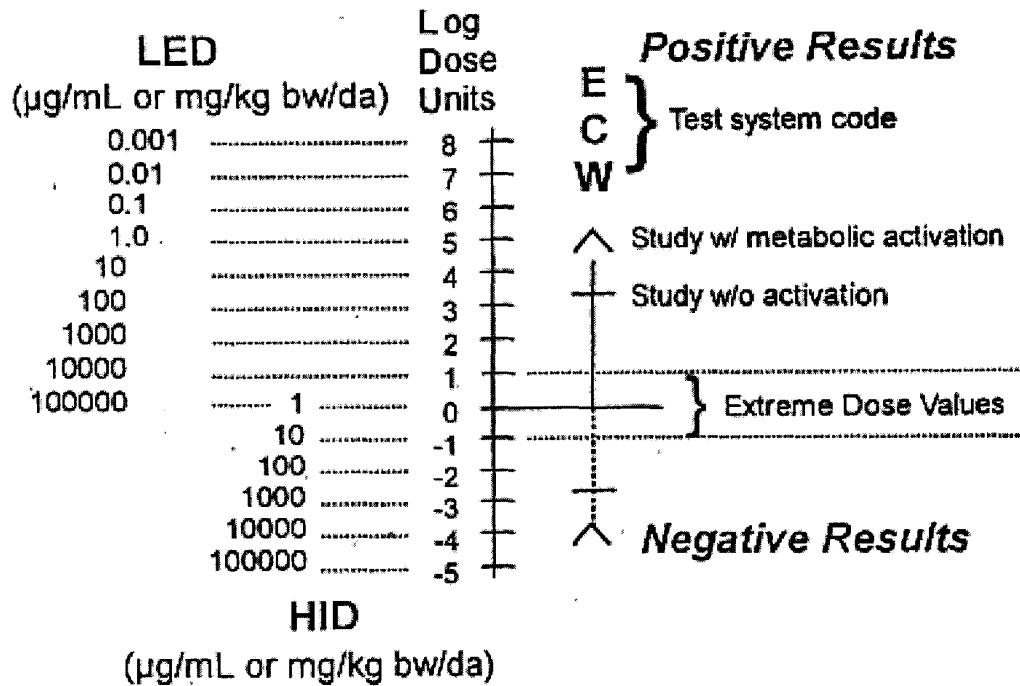


Figure 5-2. Genetic Activity Profile (GAP) for Sodium Saccharin



Left mouse button -- drag to zoom or click on a line for test results  
 Right mouse button -- click to view the full profile

Figure 5-3. Schematic View of a Genetic Activity Profile



A schematic view of a Genetic Activity Profile (GAP) representing four studies (two positive and two negative) for an example short-term test, ECW. Either the lowest effective dose (LED) or highest ineffective dose (HID) is recorded from each study, and a simple mathematical transformation (as illustrated above) is used to convert LED or HID values into the logarithmic dose unit (LDU) values plotted in a GAP. For each test the average of the LDUs of the majority call is plotted using a solid vertical bar drawn from the origin. A dashed vertical bar indicates studies that conflict with the majority call for the test. Note in cases where there are an equal number of positive and negative studies, as shown here, the overall call is determined positive. The GAP methodology and database have been reported previously (Garrett et al., 1984; Waters et al., 1988, 1991).

Garrett, N. E., H. F. Stack, M. R. Gross, and M. D. Waters. 1984. An Analysis of the Spectra of Genetic Activity Produced by Known or Suspected Human Carcinogens. *Mutat. Res.* 134:89-111.

Waters, M. D., H. F. Stack, A. L. Brady, P. H. M. Lohman, L. Haroun, and H. Vainio. 1988. Use of Computerized Data Listings and Activity Profiles of Genetic and Related Effects in the Review of 195 Compounds. *Mutat. Res.* 205:295-312.

Waters, M. D., H. F. Stack, N. E. Garrett, and M. A. Jackson. 1991. The Genetic Activity Profile Database. *Environ. Health Perspect.* 96:41-45.

## 6.0 OTHER RELEVANT DATA

**Summary:** Saccharin is a polar synthetic compound that is not a substrate for normal intermediary metabolism and is not used as an energy source. Earlier metabolic investigations using radiolabeled techniques indicated that saccharin underwent limited metabolism by ring opening to 2-sulfamoylbenzoic and 2-sulfabenzoic acids. However, these findings were not confirmed in later more extensive studies conducted on humans and rats using similar radiolabeled techniques. In humans, saccharin is almost completely (90%) absorbed from the intestinal tract and excreted unchanged in the urine largely (90%) by renal tubular secretion within 24 hours after oral administration. Human data fitted a two compartment model (plasma and renal clearance, half-life [ $t_{1/2}$ ] about 70 minutes) for intravenous (i.v.) administration of a bolus dose of sodium saccharin dihydrate ( $\text{NaSac}\cdot 2\text{H}_2\text{O}$ ).

After rats were i.v. dosed with [5-3H]saccharin, the plasma concentration-time curve clearly showed a biphasic decline during the first 2 hours, and about 90% of the dose was recovered in urine which was found to be consistent with the elimination  $t_{1/2}$  (30 minutes). At low doses (100 mg/kg or less) the plasma clearance (about  $10 \text{ mL min}^{-1} \text{ kg}^{-1}$ ) decreased at high doses (1000 mg/kg) to  $5.5 \text{ mL min}^{-1} \text{ kg}^{-1}$ , with the recovery in urine in 2 hours decreasing to 65% of the dose. The elimination  $t_{1/2}$  (30 minutes) was found to be similar for all doses less than 1000 mg/kg.

With occasional exceptions, studies in male and female rats dosed with 5% or greater levels of sodium saccharin in the diet typically show alterations in the ultrastructural morphology of urinary bladder urothelium, enhanced proliferation as evidenced by elevated labeling indexes (LIs), and morphological evidence of urothelial hyperplasia. These effects can be seen as soon as 90 days after commencement of in utero treatment and generally within 10 wk when treatment starts shortly after weaning, especially when treatment is preceded or accompanied by treatment with a urinary bladder initiator. It has been shown that the severity of urothelial changes is influenced by diet. Urinary bladder changes have been demonstrated in male and female rats but not in other species tested.

### 6.1 Absorption, Distribution, and Excretion

Sweatman et al. (1981) dosed three adult human males ages 25 to 37 years with saccharin either orally (2 g in gelatin capsules after an overnight fast or 1 to 2 hours after breaking fast) or i.v. (sodium saccharin dihydrate, 10 mg/kg) and recorded the excretion of saccharin over 96 hours. The results indicated that saccharin was almost completely (90%) absorbed from the intestinal tract after oral administration and excreted unchanged in the urine largely by renal tubular excretion, mostly within the first 24 hours of dosing. This study also found that saccharin administered either orally or intravenously resulted in 90% recovery of the dose in the urine and up to 8% in the feces.

In studies it was found that saccharin does not accumulate in any tissues, including the bladder (Renwick, 1986). Sweatman and Renwick (1980) studied eighteen adult male and six adult female rats fed ad libitum a diet containing 1 to 10%, and 5%, respectively, sodium saccharin dihydrate for 22 days. High-pressure liquid chromatography was used to detect the concentration of saccharin in tissues (well perfused; poorly perfused) and plasma. Saccharin

underwent significant plasma protein binding (69 to 86%) at all dietary levels. The well perfused tissues (adrenal, liver, lung, and spleen) contained 20 to 50% lower concentrations of saccharin than the corresponding plasma concentrations at each dietary level. The lowest levels of saccharin detected (10 to 20% plasma level) were found in poorly perfused tissues (muscle and fat). The highest concentrations were found in the gut wall. A tissue-to-plasma ratio greater than unity was observed in the kidneys (101.6 µg/mL : 29.6 µg/mL [3.43]) and urinary bladder (120.7 µg/mL : 29.6 µg/mL [4.1]). Although the tissue distribution was similar between male and female rats fed a diet containing 5% saccharin, the tissue concentrations of saccharin were higher in females than those found in males (liver, 2.4-fold; lung, 3-fold; muscle, 2.6-fold; kidney, 1.5-fold; bladder, 6.7-fold).

Sweatman and Renwick (1982) studied whether or not a two-generation feeding protocol was associated with uniquely elevated concentrations of saccharin in the bladder or other tissues of rats. Following a single oral dose of [3H]saccharin (sodium saccharin dihydrate; 50 mg/kg; 1.0 to 3.0 mCi; >99.8% pure) to female Sprague-Dawley rats in late pregnancy, concentrations of 3H in tissues of dams at 6 to 12 hr after administration of the dose were higher than those of the fetuses. At 6 hr, maternal liver, kidney, and bladder wall concentrations were ~5-fold, ~33.3-fold and ~16.7-fold, respectively, higher than those of the fetuses. At 12 hr, maternal liver, kidney, and bladder wall concentrations were ~1.4-fold, ~8.3-fold, and ~5.8-fold, respectively, higher than those of fetuses. The concentrations of 3H in fetal tissues decreased more slowly at 48 hr, exceeding the corresponding values obtained for maternal tissues: liver, 3.2-fold; kidney, 0.8-fold, and bladder wall, 5.4-fold. The authors suggested that these findings point to the possible accumulation of saccharin during chronic intake (Sweatman and Renwick, 1982).

In another experiment conducted by Sweatman and Renwick (1982), dams were fed a 5% saccharin diet ad libitum from 4 wk prior to mating until killed during late gestation. The observed liver and kidney concentrations were lower in the fetuses than the corresponding maternal values: liver, 80 µg/g maternal vs. 36.5 µg/g fetal; kidney, 382 µg/g maternal vs. 198 µg/g fetal. However, the average concentration of saccharin in fetal bladder tissue was approximately 3.8-fold higher than the corresponding maternal value. The saccharin levels in the bladder, but no other tissue, of females (189 ± 149 µg/g) were significantly lower than in males (292 ± 261 µg/g) ( $p < 0.05$  by unpaired Student's t-test). Between days 17 and 20, the concentration of saccharin in the amniotic fluid increased (males [n = 5], 15 µg/g; females [n = 7], 20 µg/g to males [n = 12] 361 µg/g; females [n = 18] 276 µg/g), which is a similar finding to Ball et al. (1977) who stated that the increase was possibly due to elimination of saccharin in fetal urine.

Liver concentrations of saccharin in F<sub>1</sub> animals exposed to a 5% saccharin diet reached a maximum of approximately 50 µg/g soon after weaning (between days 28 and 45). Due to the variability in the levels of saccharin in the bladder, no distinct maximum concentration was observed in F<sub>1</sub> animals. In previous studies conducted by Matthews et al. (1973), Lethco and Wallace (1975), Ball et al. (1977), and Sweatman and Renwick (1980), variability in the concentration of saccharin in the bladder wall was reported, either after a single dose or after chronic administration. Statistical analysis of the total bladder wall data showed that female levels were significantly (50%;  $p < 0.05$ ) lower than males when each individual result was expressed as a percentage of the mean for the animals killed at that time point (to eliminate temporal variation). Between days 18 and 23, which corresponds to the time of separation from



the mother and consumption of a 5% saccharin diet, the average concentration of saccharin in urine of F<sub>1</sub> animals showed a marked increase (males, [n = 5] 4.6 µg/mL vs. [n = 2] 17.9 µg/mL; females, [n = 2] 8.6 µg/mL vs. [n = 5] 11.1 µg/mL) (Sweatman and Renwick, 1982).

Sweatman and Renwick (1982) studied the distribution and turnover of [3H]saccharin in pregnant rats maintained on a 5% saccharin diet prior to mating and transferred to a 5% saccharin diet radiolabeled with [3H] (6.1 µCi/g) on the 10th day of gestation. On days 10 to 20 of gestation, the concentrations of [3H]saccharin in maternal and fetal livers were similar to the unlabeled concentrations found by HPLC on day 20 (see above), indicating that steady-state concentrations had been reached. In the fetal tissues, the levels of [3H]saccharin showed a relatively uniform distribution. However, markedly lower concentrations were found in the brain. Similar findings were reported by Ball et al. (1977). The concentrations of [3H]saccharin were below the limit of detection in the fetal bladder. Sweatman and Renwick (1982) suggested that this was due to the size of the fetal bladder and the relatively low specific activity of the [3H]saccharin diet given. There was a marked reduction in the 3H concentrations in most maternal and fetal tissues upon transferring back to an unlabeled 5% saccharin diet for 24 hr or 48 hr prior to killing. Tritium concentrations in fetal liver, kidney, and muscle decreased to an average of 29, 45, and 22%, respectively, of the steady-state level after 24 hr on the unlabeled saccharin diet, while the corresponding maternal tissues decreased to 19, 51, and 23%, respectively. Tritium concentrations were not detectable (< 200 µg/g) in the fetal bladder wall throughout the duration of [3H]saccharin diet (10-20 days).

Ball et al. (1977) studied three groups of rats, one on a normal diet without pretreatment with [<sup>14</sup>C]sodium saccharin for up to 12 months, and the others pre-treated with 1% or 5% saccharin diet for up to 12 months. Individual rats in each group were subsequently administered an oral dose of 16 to 22 mg/kg (5 to 9 µCi) sodium saccharin. In both groups about 95% of the dose was eliminated within 24 hours, with 72 to 92% detected in the urine and 0 to 22% detected in the feces. Within 3 days of dosing, excretion of <sup>14</sup>C was essentially complete. The final recovery in 6 days averaged 100%, with the urine containing 77 to 97% and feces containing 6 to 22% of the labeled dose. Pre-treatment of rats with a diet containing 1% and 5% saccharin for up to 12 months did not alter the pattern of absorption and excretion. The only alteration of this pattern was increased concentrations of [<sup>14</sup>C]saccharin in the feces after continued intake, especially at the 1% dietary level. The authors also investigated the excretion of [<sup>14</sup>C]saccharin in urine after i.p. injection and very little was associated with the gastrointestinal tract. The authors concluded that the increased concentration of [<sup>14</sup>C]saccharin in feces after oral administration arose from incomplete absorption in the gut.

Lethco and Wallace (1975) administered [3-<sup>14</sup>C]saccharin (5, 50, and 500 mg/kg) to male and female rats. The distribution of radioactivity in organs and tissues at various time intervals was monitored. One hour after administration of a 50 mg/kg dose, traces of <sup>14</sup>C were found in almost all of the organs. Saccharin reached a peak blood concentration within 8 hours. The kidney, urinary bladder, and liver tissues contained the highest <sup>14</sup>C concentration. All of the tissues except brain and spleen contained traces of <sup>14</sup>C 72 hours after dosing. The rats excreted 66 to 84 % of the labeled dose of [3-<sup>14</sup>C]saccharin in the urine and 10 to 40% in the feces. This study also compared the metabolic profiles of a dog, rabbit, guinea pig, and hamster. When

compared, the metabolic profiles indicated that there was very little difference in the pattern due to dose level or animal species.

The absorption, distribution, and excretion of radiolabeled saccharin was studied by Matthews et al. (1973). Male rats (seven groups of three or more) were studied after receiving a single oral dose of [<sup>14</sup>C]saccharin (1 mg/kg in 0.5 cm<sup>3</sup> distilled water). The dose was administered orally to animals that had been fed ad libitum or fasted overnight. Saccharin entered the bloodstream rapidly, most likely due to absorption through the stomach, with peak concentrations in the blood between 7.5 and 15 minutes after administration. Saccharin was absorbed by the fasted animals more rapidly than those that were fed. The saccharin concentration of fasted animals was approximately twice that found in animals fed ad libitum. The time to peak saccharin concentration and the general shape of the curve were similar in the kidney and blood. The authors found that glomerular filtration of saccharin from the blood and its excretion in the urine resulted in temporary accumulation of 5 times more saccharin in the kidneys than in other organs or tissues. Saccharin was detected in the urine taken from the bladders of every rat as soon as 3 minutes post saccharin administration.

The accumulation and clearance of multiple doses of saccharin was also investigated by Matthews et al. (1973). Saccharin (1 mg/kg/day) was administered to two groups of four rats each for 7 days. Saccharin concentrations in the major organs were measured 24 and 72 hours after administering the final dose. At 24 hours, the saccharin concentration was slightly higher in the gastrointestinal tract and considerably higher in the bladder than in any other tissues. The authors suggested that although elevated concentrations of saccharin were not present in these tissues, the tissues may have absorbed saccharin from their contents rather than by distribution of the blood. Most of the saccharin had been cleared from all of the tissues by 72 hours after the last dose, with none of the tissues having a significantly higher concentration than the others at that time. The authors also stated that the ratio of saccharin excreted in the urine and feces was approximately 9:1 when analyzed during the feeding period and after the last dose of saccharin had been administered.

The authors continued this study by treating rats 5 times with a dose of 1 mg/kg at 90-minute intervals for a total dose of 5 mg/kg within a 6-hour period. This dosing regimen was used to simulate the daily dose of saccharin humans would be expected to consume by using saccharin in food or beverages several times throughout the day. The rats receiving multiple doses of saccharin were reported to have a higher saccharin concentration in tissues than in the corresponding tissues of rats which had received single doses of saccharin (1 mg/kg). Rats that were sacrificed 90 minutes after the fifth (last) 1 mg/kg dose were found to have a saccharin concentration in the kidneys equal to or greater than 5 times the concentration of kidneys from rats which received only a single dose of 1 mg/kg. Thereafter, the saccharin concentration in the kidneys of all of these rats approached 9 to 10 times that of the animals which received only a single dose. Twenty-four hours later, the difference had decreased to approximately 2-fold. A 10-fold difference was observed after 24 hours between concentrations in the bladders of rats receiving multiple doses and those of rats receiving single doses. Still, at 24 hours, the concentration in the bladders of rats which received 5 doses was less than 10% of that observed 90 minutes after the last of the 5 doses (Matthews et al., 1973). These data showed that

significant concentrations of saccharin can occur in certain tissues such as the kidney and bladder that appear to be almost completely cleared by the following day.

## 6.2 Metabolism

Saccharin is a polar synthetic compound that is not a substrate for normal intermediary metabolism and is not used as an energy source (Renwick, 1986). Metabolic investigations using radiolabeling techniques have indicated that saccharin undergoes limited metabolism by ring opening to 2-sulfamoylbenzoic and 2-sulfobenzoic acids (Pitkin et al., 1971; Kennedy et al., 1972; Arnold, 1983; Renwick, 1986). Kennedy et al. (1972) fed [ $^{14}\text{C}$ ]saccharin to two rats (1 male and 1 female). Components of solvent extracts from their acidified urine were separated by thin layer chromatography (TLC) and compared to the authentic 2-sulfamoylbenzoic and sulfobenzoic acids. This experiment showed that in the urine samples collected between 0 to 24 hours after dosing, 0.4% to 0.6% of the dose was excreted as 2-sulfamoylbenzoic acid and less than 0.1% to 0.6% of the dose as 2-sulfobenzoic acid.

Pitkin et al. (1971) studied the metabolism of [ $^{14}\text{C}$ ]saccharin in eight female Rhesus monkeys using the same method as Kennedy et al. (1972), which was unpublished at the time. The authors reported that [ $^{14}\text{C}$ ]saccharin was excreted essentially unchanged in the urine of monkeys. The authors also found that urine samples collected and analyzed between 24 to 48 hours and 48 to 72 hours after dosing contained 1.2% of the dose as 2-sulfamoylbenzoic acid and 0.1% as 2-sulfobenzoic acid.

The Food and Drug Administration also detected 2-sulfamoylbenzoic in a more extensive study that focused on the metabolic profiles of a dog, guinea pig, hamster, rabbit, and six rats exposed to [ $3\text{-}^{14}\text{C}$ ]saccharin via gavage (Lethco and Wallace, 1975). In this study six rats (three males and three females) were given oral doses of 5, 50, and 500 mg/kg [ $3\text{-}^{14}\text{C}$ ]saccharin (10 to 15  $\mu\text{Ci/kg}$ ). Twenty-four hours after the dose was administered, the rate of  $^{14}\text{CO}_2$  expiration, and [ $^{14}\text{C}$ ]carbonate and 2-sulfamoylbenzoic acid excreted via the urine were identified using paper chromatography, TLC, UV spectrophotometry, and reverse isotope dilution techniques. These data showed that both male and female rats expired  $^{14}\text{CO}_2$  between 0.5 and 8 hours after dosing, while only female rats expired 0.01% of the dose at 24 hours. Male rats expired a total of 0.29, 0.03, and 0.10% of 5, 50, and 500 mg/kg doses, respectively, and female rats expired a total of 0.23, 0.55, and 0.27% of the 5, 50, and 500 mg/kg, doses, respectively, 24 hours post-dose. When 24 rats (12 males and 12 females; 4 rats/dose) were dosed with 5, 50, and 500 mg/kg [ $3\text{-}^{14}\text{C}$ ]saccharin, about 0.4% of the dose was excreted as 2-sulfamoylbenzoic acid in the urine with approximately equal amounts identified as  $^{14}\text{C}$  carbonate as detected by DEAE cellulose chromatography (Lethco and Wallace, 1975; Renwick, 1986). Generally, more than 99% of the urinary radioactivity was unmetabolized saccharin and all of the species' urine samples contained small amounts of 2-sulfamoylbenzoic acid. Comparative metabolic profiles of a dog, rabbit, guinea pig, and hamster indicated that there was little difference in the pattern due to animal species or dose level (Lethco and Wallace, 1975). The authors suggested that the breakdown of saccharin was due to a chemical reaction as opposed to enzymatic reactions.

Ball et al. (1977) used chromatographic, reverse isotope dilution techniques, and UV spectrophotometric techniques for the detection of radiolabeled metabolites of saccharin (2-sulfamoylbenzoic acid and  $^{14}\text{CO}_3^{2-}$  in the urine,  $^{14}\text{CO}_2$  in expired air). The limits of detection

## NTP Report on Carcinogens 1997 Background Document for Saccharin

were as low as 0.03% for  $^{14}\text{CO}_2$  and  $^{14}\text{CO}_3^{2-}$ . Rats were fed a diet containing 1% or 5% of saccharin for up to 12 months prior to receiving a [ $^{14}\text{C}$ ]saccharin dose (20 mg/kg) administered orally. The authors were unable to detect any metabolism in either the urine or in the expired air of the rats dosed with radiolabeled saccharin. Ball et al. (1977) were also unable to detect any metabolites of saccharin in the urine of three adult humans (one female, two males; 55 to 94 kg body weight) who ingested 1 g saccharin/day for 22 days as a treatment prior to receiving a final dose of [3- $^{14}\text{C}$ ]-saccharin (20  $\mu\text{Ci}$ ; 13 mg) on the 22nd day. The authors were also unable to detect metabolite production from the three adult humans when they were not subjected to the saccharin pretreatment before a dose of [3- $^{14}\text{C}$ ]saccharin (20  $\mu\text{Ci}$ /13 mg).

Sweatman and Renwick (1979) exposed male rats to saccharin both in utero and during lactation. The authors were unable to detect any metabolites of saccharin in the excreta of rats under these conditions. The authors also reported that after 3-methylcholanthrene treatment (inducer of metabolism), saccharin metabolites were undetectable using reverse isotope dilution with limits of detection as low as 0.01% for 2-sulfamoylbenzoic acid. These results found that significant metabolism is not induced by long term administration of saccharin during the neonatal and weaning-stages of two generations.

Clearly, a discrepancy between some of the earlier reports and later investigations exist. Earlier studies may have used saccharin with slight impurities resulting in metabolism of the impure substance. Pitkin et al. (1971) used benzene ring-labeled [ $^{14}\text{C}$ ]saccharin from Mallinckrodt Chemical Corp. Byard and Golberg (1973) reported that the benzene ring-labeled [ $^{14}\text{C}$ ]saccharin supplied by Mallinckrodt Chemical Works (St. Louis, MO, USA) contained an impurity which produced a 2 to 3% metabolic reaction if given to animals. In brief, the authors found that the metabolite produced *in vivo* from the impurity chromatographed as 2-sulfamoylbenzoic acid but did not recrystallize with added 2-sulfamoylbenzoic acid. Both Matthews et al. (1973) and Byard and Golberg (1973) found that solvent extraction and t.l.c. in neutral solutions would give rise to artifactual metabolites. In neither the Kennedy et al. (1972) study which used [3- $^{14}\text{C}$ ]saccharin from Monsanto Co. (St. Louis, MO, USA), nor the Pitkin et al. (1971) study, which used [ $^{14}\text{C}$ ]saccharin from Mallinckrodt Chemical Corp, was the purity of the saccharin specified. It seems likely that the results obtained from experiments conducted by Kennedy et al. (1972) and Pitkin et al. (1971) might be due to some unidentified impurity similar to that found by Byard and Golberg (1973). Experiments aimed at the induction of metabolism of [ $^{14}\text{C}$ ]saccharin by pretreatment with phenobarbital (Byard and Golberg, 1973) also failed to induce metabolic reactions producing 2-sulfamoylbenzoic acid, 2-sulfobenzoic acid,  $\text{CO}_2$ , or the carbonate.

Lethco and Wallace (1975) explained the presence of [ $^{14}\text{C}$ ]saccharin metabolites as a slight breakdown of saccharin due to simple decomposition rather than enzymatic mechanisms. Although the authors' data were substantiated by the large number of animals studied and the consistency of the extent of metabolism over a wide range of doses in various species, the saccharin molecule is resistant to chemical decarboxylation and thus slight breakdown to  $\text{CO}_2$  and  $\text{CO}_3^{2-}$  seems unlikely (Renwick, 1986).

### 6.3 Pharmacokinetics

The human data generated by Sweatman et al. (1981) fitted a two-compartment model (plasma and renal clearance) for i.v. administration of a bolus dose of saccharin (sodium saccharin dihydrate; 10 mg/kg) in the presence or absence of probenecid (competes for and inhibits renal tubular secretion of organic ions). Probenecid was administered (500 mg) 2 and 12 hours before and 2 hours after the i.v. dose of saccharin. Saccharin was rapidly eliminated via the urine after i.v. administration ( $t_{1/2}$  about 70 min). A significant decrease in the elimination rate constant (40%) and in the plasma clearance (36%) rate occurred when the i.v. dose was given during probenecid treatment. Thus, tubular secretion is responsible for the elimination of a minimum of 40% of circulating saccharin in humans, which is consistent with the high renal clearance noted in this study. The fact that plasma clearance values were slightly less than the corresponding renal clearance suggests the absence of significant metabolism. This supports earlier studies using [ $^{14}\text{C}$ ] saccharin in humans (Byard et al., 1974; Ball et al., 1977) that failed to detect significant metabolism after oral administration.

Sweatman and Renwick (1980) dosed ten male rats with low i.v. bolus doses (1, 20, 50 mg/kg). The plasma concentration-time curve clearly showed a biphasic decline during the first 2 hours. The plasma levels fit the equation

$$C_p = 3.12De + 1.35De^{-0.0213t},$$

where  $C_p$  is the plasma concentration in  $\mu\text{g mL}^{-1}$  at time (t) and D is the dose in mg/kg. About 90% of the dose was recovered in the urine within 2 hours. This finding is consistent with the elimination  $t_{1/2}$  (30 minutes).

### 6.4 Structure-Activity Relationships

No data were found.

### 6.5 Cell Proliferation

Experimental details for the studies described in this section are presented in **Table 6-1**.

#### 6.5.1 Hamsters

Neither hyperplasia of the urinary bladder nor significantly increased DNA synthesis was observed in 6-wk-old male Syrian hamsters administered a 5% sodium saccharin diet for 20 wk (Fukushima et al., 1983).

#### 6.5.2 Mice

Neither hyperplasia of the urinary bladder nor significantly increased DNA synthesis was observed in 6-wk-old male B6C3F1 mice administered a 5% sodium saccharin diet for 20 wk (Fukushima et al., 1983).

#### 6.5.3 Rats

Lessel (1971) reported that saccharin was positive for hyperplasia in rats exposed to a 5% saccharin diet for 2 yr. Of 5 bladders from animals exposed to 5% saccharin, 1 male and 1 female had urothelial hyperplasia. IARC (1980) noted the small number of bladders examined histologically.

## NTP Report on Carcinogens 1997 Background Document for Saccharin

A 5% sodium saccharin diet fed to 6-wk-old F344 male rats for up to 18 wk induced vacuolar degeneration of the bladder urothelium after 3 wk and simple hyperplasia at 5 wk. The degree of hyperplasia increased with a display of mitotic figures, hyperplastic foci and pleomorphic microvilli starting at 9 wk. Increased thymidine uptake (5- to 8-fold the rate seen in controls) was present in the bladders of exposed rats at all time periods measured through 18 wk (Fukushima and Cohen, 1980).

Hooson et al. (1980) reported mild focal urothelial hyperplasia in 1/50 female Wistar rats exposed to 2 g sodium saccharin/kg/day for 2 yr. IARC (1980) noted that the rats were not started on the test diet at weaning, but after several wk on a normal diet.

Six-week-old male and female F344 rats fed up to 5% sodium saccharin in a stock diet alone for 32 wk did not develop simple, papillary, or nodular hyperplasia (Nakanishi et al., 1980a). However, rats initiated with BBN for 4 wk and then fed 5% sodium saccharin stock diet for 32 wk developed papillary and nodular hyperplasia (Nakanishi et al., 1980a).

In a 2-generation study, male and female F<sub>1</sub> Charles River CD rats exposed to up to 7.5% sodium saccharin in the diet for up to 2 yr had an increased incidence of urinary bladder hyperplasia at the 7.5% dose, but it was not morphologically precancerous. Exposure to 0.01, 0.1, 1.0, or 5.0% sodium saccharin had no effect on the incidence of hyperplasia (Taylor et al., 1980).

Lawson and Hertzog (1981) reported that sodium saccharin did not induce DNA synthesis in male Sprague Dawley rat bladder epithelium, as measured by an LI or by specific activity of DNA. Animals were fed 7.5% sodium saccharin diet for 50 wk with interim sacrifices throughout. [Methyl-<sup>3</sup>H]thymidine was injected intraperitoneally 1 hour before death.

Murasaki and Cohen (1981) studied the dose response relationship between sodium saccharin exposure and cell proliferation in the urinary bladders of five-week-old male F344 rats fed sodium saccharin in the diet for 10 wk. The results of this experiment showed a dose-related increase in tritiated thymidine LI, the presence of pleomorphic microvilli, and hyperplasia. The no-observable-effect-level (NOEL) for statistically significant changes in LI was 0.1%.

The incidences of simple hyperplasia (25/32 vs. 1/28 controls) and papillary or nodular hyperplasia (20/32 vs. 0/28 controls) were significantly increased in male ACI rats administered 5% sodium saccharin in the diet for 52 wk beginning at 6 wk of age. At least half of the ACI rats were infected with the bladder parasite *Trichosomoides crassicauda* (Fukushima et al., 1983). Females were not evaluated.

Male F344 rats fed a 5% sodium saccharin diet for up to 20 wk beginning at 6 wk of age developed hyperplasia of the urinary bladder and significantly increased DNA synthesis at 20 wk (Fukushima et al., 1983).

Sodium saccharin induced hyperplasia of the urinary bladder in male ACI rats but not in F344, Sprague Dawley, or Wistar rats administered 5% sodium saccharin in the diet for 52 wk beginning at 6 wk of age. However, the concentration of urinary MgNH<sub>4</sub>PO<sub>4</sub> crystals was greater in all strains of treated rats than in their respective controls (Fukushima et al., 1983). The ACI rats also developed urinary bladder papillomas and carcinomas. Females were not evaluated.

The effects of sodium saccharin on freeze ulceration-induced cell proliferation in male F344 rats were studied by Murasaki and Cohen (1983b). The authors found that the degree of microvilli formation and hyperplasia was similar for the 2-wk period following freeze ulceration

whether or not 5% sodium saccharin was administered immediately following the procedure. In another experiment, Murasaki and Cohen (1983b) found that sodium saccharin administered 2 or 8 wk following freeze ulceration produced a similar increase in hyperplasia, LI, and microvilli.

Hasegawa and Cohen (1986) studied the impact of the cation associated with different dosage forms of saccharin. In male F344 rats fed a 5% sodium saccharin, acid saccharin, potassium saccharin, or calcium saccharin diet for 10 wk, the LI was increased approximately 2-fold for calcium saccharin, 3-fold for potassium saccharin, and 9-fold for sodium saccharin. No increased LI was found for acid saccharin, and only the increased LI associated with sodium and potassium salt exposures reached statistical significance. A statistically significant increase in rats with hyperplasia was found in the sodium saccharin-treated group. Evidence of simple hyperplasia following potassium saccharin and calcium saccharin exposure, and increases in microvilli with potassium saccharin exposure were found. However, these changes were not statistically significant.

Tatematsu et al. (1986) found that a 5% sodium saccharin diet for 21 wk did not increase DNA synthesis in the bladder epithelium of male Fischer rats.

A 2-generation study conducted by Masui et al. (1988 abstr.), evaluated the urinary bladder proliferative effects upon fetal and neonatal Sprague-Dawley rats of both sexes, when their dams were fed a 5% sodium saccharin diet prior to mating and up to weaning. In control and sodium saccharin-treated fetuses at days 17 and 21 of gestation, the LIs were similar in both groups. Similar LIs were also found for both exposed and control rats at day 7 after birth. However, the LI was greater in sodium saccharin-treated rats (higher in females than in males), at day 21 after birth, compared to controls.

Garland et al. (1989b) found that the proliferative effects of sodium saccharin were dependent upon diet. In Experiment 1, five-week-old male F344 rats were given 5 or 7.5% sodium saccharin in Prolab 3200, NIH-07 or AIN-76 diet for 4 or 10 wk. In Experiment 2, male F344 rats and 4-wk-old male Sprague-Dawley rats were dosed with 5 and 7.5% sodium saccharin in Prolab 3200 or Purina 5002 diet for 10 wk. The results of Experiment 1 showed that sodium saccharin had a greater effect on bladder urothelium in the rats fed the Prolab diet compared with those on the NIH diet. In addition, there was little effect in the rats on the AIN diet. Effects included urothelial hyperplasia at 4 and 10 wk and an increased thymidine LI for the Prolab and NIH diet at 10 wk. In Experiment 2, the response was greater in F344 rats than in Sprague-Dawley rats and greater for the Prolab rather than the Purina diet for hyperplasia, increased LI, and evidence of urothelial damage.

Male F344 rats were exposed to 3, 5, or 7.5% sodium saccharin diet (Prolab feed) for 4, 7, or 10 wk in a dose-response experiment conducted by Cohen et al. (1990). Cell exfoliation and necrosis were evident at 10 wk in the group fed 3% sodium saccharin. An apparent progression from mild to more severe necrotic changes during the 4- to 10-wk period was found in the 5 and 7.5% sodium saccharin group. In the 5% sodium saccharin-exposed group, a doubling of the LI with extensive cell damage was noted. In the 7.5% sodium saccharin-exposed group, the LI was increased several fold, with evidence of hyperplasia.

The effects of diet on cell proliferation induced by sodium saccharin were also studied by Debiec-Rychter and Wang (1990). Male F344 rats were exposed to 5% sodium saccharin in either Wayne or AIN-76A diet for 2, 4, 6, 10, or 16 wk. Both diets increased the LI

approximately 5-fold when measured at 2, 4, 6, 10, or 16 wk. The authors also found that 2% sodium bicarbonate increased the LI for the AIN-76A diet 6- to 9-fold. In addition, a sodium saccharin and sodium bicarbonate combination proved to have an additive effect on cell proliferation, except at the 2-wk interval. A similar study was not conducted for the Wayne diet.

Garland et al. (1991) reported that sodium saccharin at 7.5% dietary concentration was positive for hyperplasia in male SD rats exposed *in utero* from conception up to 90 days of age. Urothelial hyperplasia was not present at 30 days of age.

Two separate studies conducted by Garland et al. (1994) and Uwagawa et al. (1994) demonstrated that NCI-Black-Reiter (NBR) rats, which do not produce 2-globulin (the male rat-specific, low molecular weight urinary protein), do not exhibit sodium saccharin-induced urinary bladder cell proliferation. Male NBR, F344, and castrated F344 rats were fed 7.5% sodium saccharin in Prolab 3200 diet for 10 wk. The most severe changes were found in both normal and castrated sodium saccharin-exposed F344 rats. Hyperplastic changes were found in the bladders of 7/10 intact F344 rats compared with 1/10 NBR rats. Hyperplasia was not found in the bladders of control rats. Although the 2 $\mu$ -globulin urinary content in castrated F344 rats has been reported to be only 10% of that in intact normal F344 rats (Roy and Neuhaus, 1967; cited by Garland et al., 1994), examination of the saccharin-treated castrated F344 rats urinary bladders revealed that 4/10 showed signs of hyperplasia (Garland et al., 1994).

Uwagawa et al. (1994) exposed 6-wk-old F344 and NBR rats to 5% sodium saccharin, 5% sodium ascorbate, or 3% uracil for 8 wk. In both strains, the most severe urothelial changes were induced by uracil as shown by scanning electron microscopy (SEM). Sodium ascorbate-induced simple hyperplasia was found in the bladders of F344 rats but not in NBR rats. Sodium saccharin did not induce hyperplasia in the bladders of NBR; uracil-induced hyperplasia, however, was found in both strains. Increases in the BrdU LIs were found in F344 rats administered uracil (> 50-fold), ascorbate (36-fold), or sodium saccharin (20-fold).

Fischer 344 rats exposed to a 7.5% sodium saccharin diet for 10 wk developed hyperplasia. Amorphous precipitate was present in exposed rats along with an increased incidence of urothelial simple hyperplasia (Cohen et al., 1995a).

Sodium saccharin was positive for cell proliferation in male and female F344 rats exposed to a 5% sodium saccharin diet for 21 or 91 days; the effects were reversible over time (Cohen et al., 1995b).

#### 6.5.4 Guinea Pigs

Neither hyperplasia of the urinary bladder nor significantly increased DNA synthesis was observed in 6-wk-old male Hartley guinea pigs administered a 5% sodium saccharin diet for 20 wk (Fukushima et al., 1983).

#### 6.5.5 Nonhuman Primates

Sodium saccharin was negative for cell proliferation in *Macaca mulatta* monkeys fed 20, 100, or 500 mg/kg/day in diet for 79 months. Histopathological examination of urinary bladders, kidneys, and testis of surviving and deceased animals showed no abnormal pathology (McChesney et al., 1977 abstr.; cited by IARC, 1980).



## 6.6 Cell Proliferation with Co-Administration of Known Carcinogens

### 6.6.1 *N*-Butyl-*N*-(4-hydroxybutyl)nitrosamine (BBN)

Urinary bladder hyperplasia was enhanced in 6-wk-old male and female F344 rats exposed to 2000, 10,000, or 50,000, but not 400 ppm, sodium saccharin in the diet following BBN pretreatment. Exposure to sodium saccharin without BBN pretreatment did not induce any changes in urinary bladders of rats of either sex (Nakanishi et al., 1980a).

The effects of sequential administration (initiation/promotion protocol) of 0.01% BBN in drinking water and 5.0% sodium saccharin in feed and concurrent administration of 0.001% BBN in drinking water and 5.0% sodium saccharin in feed, were studied in 8-wk-old male Wistar rats by Nakanishi et al. (1980b). In the first experiment (sequential administration), rats received BBN for 4 wk and then sodium saccharin for an additional 32 wk. In the second experiment (concurrent administration), rats were fed both BBN and sodium saccharin for 40 wk. There was an enhancement of urinary bladder hyperplasia and bladder tumors when rats were exposed to BBN and sodium saccharin either sequentially or concurrently, while sodium saccharin alone caused urinary bladder urothelial hyperplasia.

Nakanishi et al. (1982) reported that there was a significant increase ( $p < 0.05$ ) in the incidences of simple, papillary, or nodular urinary bladder hyperplasia in male F344 rats (age not specified) initiated with 0.01% BBN in drinking water for 4 wk and then fed 5% sodium saccharin in the diet for an additional 32 wk, as compared to rats administered BBN alone (simple hyperplasia: 27/29 vs. 19/28; papillary or nodular hyperplasia: 24/29 vs. 11/28).

### 6.6.2 2-Acetylaminofluorene (AAF)

Sodium saccharin was positive for hyperplasia in female Horton SD rats fed a 5% sodium saccharin diet for 40 wk with co-administration of AAF. Hyperplasia of the urinary bladder mucosal lining occurred in all control and treated females fed AAF. The hyperplasia was most pronounced in the AAF/sodium saccharin-exposed animals, with one of these rats displaying squamous metaplasia and precancerous changes in the mucosal epithelium. IARC noted that the small number of animals used, and the fact that food consumption was not measured, prevented the evaluation of AAF and sodium saccharin exposure (Ershoff and Baja, 1974; cited by IARC, 1980).

Nakanishi et al. (1982) reported that there was a significant increase ( $p < 0.05$ ) in the incidences of simple, papillary, or nodular urinary bladder hyperplasia in male F344 rats (age not specified) initiated with 0.02% AAF in the diet for 4 wk and then fed 5% sodium saccharin in the diet for an additional 32 wk, as compared to rats administered BBN alone (simple hyperplasia: 6/29 vs. 0/28; papillary or nodular hyperplasia: 4/29 vs. 0/28).

### 6.6.3 *N*-Methyl-*N*-nitrosourea (MNU)

There was an increase in the number of proliferative bladder lesions in female Wistar rats (age not specified) administered a single 0.15 mL intravesicular dose of MNU, followed 2 wk later by daily administration of either 2 g/kg *o*-toluenesulfonamide-free sodium saccharin or 2 g/kg sodium saccharin containing 40 mg/kg *o*-toluenesulfonamide for 2 yr, as compared to a control group given MNU alone (incidence not given) (Hooson et al., 1980).

NTP Report on Carcinogens 1997 Background Document for Saccharin

Table 6-1. Cell Proliferation

Age, Strain, Species	No./Sex Exposed	Controls	Chemical Form and Purity	Dose	Duration	Results/Comments	Reference
<b>6.5.1 Hamsters</b>							
6-wk-old Syrian golden hamsters	50M	35M	sodium saccharin, >99.5% pure [7 ppm o-toluenesulfonamide]; method of production not specified	5% diet	up to 20 wk	Negative Sodium saccharin did not induce hyperplasia of the urinary bladder or significantly increase DNA synthesis.	Fukushima et al. (1983)
<b>6.5.2 Mice</b>							
6-wk-old B6C3F1 mice	50M	35M	sodium saccharin, >99.5% pure [7 ppm o-toluenesulfonamide]; method of production not specified	5% diet	up to 20 wk	Negative Sodium saccharin did not induce hyperplasia of the urinary bladder or significantly increase DNA synthesis.	Fukushima et al. (1983)
<b>6.5.3 Rats</b>							
Boots-Wistar rats (age not specified)	40M, 40F	20M, 20F	saccharin <sup>a</sup> , made by Remsen-Fahlberg method, purity not specified	0.005, 0.05, or 5% diet	2 yr	Positive with highest dose Of 5 bladders from animals exposed to the highest dose, 1 male and 1 female had urothelial hyperplasia. IARC (1980) noted the small number of bladders examined histologically.	Lesel (1971)
6-wk-old Charles River F344 rats	24M	6M	sodium saccharin, methods of production and purity not specified	5% diet	<18 wk	Positive Three treated rats were killed at 1, 3, 5, 7, 9, 12, 15, and 18 wk. Three controls killed at 0 and 18 wks. Vacuolar degeneration of the epithelial cells at 3 wk and simple hyperplasia at 5 wk were observed. At 9 wk, the degree of hyperplasia increased with occurrences of mitotic figures, hyperplastic foci and pleomorphic microvilli. Thymidine LIs were increased in bladders of exposed rats at all time periods measured.	Fukushima and Cohen (1980)
Wistar rats (age not specified)	50F	63F	sodium saccharin, made by Maunee process, purity not specified	2 g/kg body weight/day	2 yr	Negative Mild focal urothelial hyperplasia was seen in one rat fed sodium saccharin. IARC (1980) noted that animals were started on the test diet not at weaning, but after several wk on a normal diet.	Hooson et al. (1980)

NTP Report on Carcinogens 1997 Background Document for Saccharin

Table 6-1. Cell Proliferation (Continued)

Age, Strain, Species	No./Sex Exposed	Controls	Chemical Form and Purity	Dose	Duration	Results/Comments	Reference
6-wk-old inbred Charles River F344 rats	302M, 311F	29M, 30F	sodium saccharin, methods of production and purity not specified	0.04, 0.2, 1, or 5% diet with or without 4 wk of BEN pretreatment	32 wk	Negative Sodium saccharin alone did not induce simple, papillary or nodular hyperplasia except after pretreatment with BEN in the 5% groups of males and females.	Nakanishi et al. (1980a)
<i>in utero</i> Charles River CD rats	240M, 240F	8M, 48F	sodium saccharin, made by Remsen-Fahlberg method, 350 ppm <i>o</i> -toluenesulfonamide	0.01, 0.1, 1, 5, or 7.5% diet	2 yr	Positive with highest dose This was a 2-generation study. Males and females exposed to 7.5% sodium saccharin had an increased incidence of urinary bladder hyperplasia, but it was not morphologically precancerous. Exposure to 0.01, 0.1, 1, or 5% sodium saccharin had no effect on the incidence of hyperplasia.	Taylor et al. (1980)
3-wk-old Sprague-Dawley CD weanling rats	labeling index (LI) measurement group: 8M sacrificed at 3 defined durations of treatment DNA measurement group: varying numbers (19-24M) sacrificed at 9 defined durations of treatment	LI measurement group: 8M sacrificed at 3 defined durations of treatment specific activity of DNA measurement group: varying numbers (19-23M) sacrificed at 9 defined durations of treatment	sodium saccharin incorporated in the diet and then pelleted, purity not specified	7.5% sodium saccharin diet plus [Methyl- <sup>3</sup> H]thymidine injected intraperitoneally 1 h before death	LI measurement group: 1, 15, and 50 wk specific activity of DNA measurement group: 1, 2, 3, 6, 10, 15, 20, 30, and 50 wk	Negative Sodium saccharin did not increase bladder epithelial DNA synthesis (measured by the LI and by specific activity of DNA).	Lawson and Hertzog (1981)

Table 6-1. Cell Proliferation (Continued)

Age, Strain, Species	No./Sex Exposed	Controls	Chemical Form and Purity	Dose	Duration	Results/Comments	Reference
5-wk-old Fischer F344 rats	10M (for each dose level)	10M	sodium saccharin, made by Maumee process, purity not specified	0.1, 0.5, 1, 2.5, 5% diet	10 wk	Positive above 0.1% Sodium saccharin did not induce formation of papillary or nodular hyperplasia, papilloma, or cancer. The LI increased significantly in a dose response manner at dose above 0.1%. Administration of 1, 2.5, or 5% sodium saccharin increased the number of foci containing rosy microtortiges or uniform microvilli in intestines.	Murasaki and Cohen (1981)
rats (strain and age not specified)	M (number not specified)	M (number not specified)	sodium saccharin, methods of production and purity not specified.	5% diet	10 wk	Positive Dose-related increase in tritiated thymidine LI and the presence of uniform and pleomorphic microvilli and hyperplasia were observed. The no-observable-effect-level (NOEL) for statistically significant changes in LI was 0.1%.	Murasaki and Cohen (1981)
6-wk-old ACI rats	48M	45M	sodium saccharin, >99.5% pure [7 ppm o-toluene-sulfonamide]; method of production not specified	5% diet	52 wk	Positive The incidences of urinary bladder simple hyperplasia (25/32 vs. 1/28 controls) and papillary or nodular hyperplasia (20/32 vs. 0/28 controls) were significantly increased. At least half of the rats were infected with the bladder parasite <i>Trichosomoides crassicauda</i> .	Fukushima et al. (1983)
6-wk-old F344 rats	50M	35M	sodium saccharin, >99.5% pure [7 ppm o-toluene-sulfonamide]; method of production not specified	5% diet	up to 20 wk	Positive Sodium saccharin induced hyperplasia of the urinary bladder and significantly increased DNA synthesis at 20 wk.	Fukushima et al. (1983)
6-wk-old F344 rats	40M	40M	sodium saccharin, >99.5% pure [7 ppm o-toluene-sulfonamide]; method of production not specified	5% diet	52 wk	Negative Sodium saccharin did not induce hyperplasia of the urinary bladder, but the concentration of MgNH <sub>4</sub> PO <sub>4</sub> crystals in the urine of treated rats was greater than that in controls.	Fukushima et al. (1983)

Table 6-1. Cell Proliferation (Continued)

Age, Strain, Species	No./Sex Exposed	Controls	Chemical Form and Purity	Dose	Duration	Results/Comments	Reference
6-wk-old SD rats and Wistar rats	40M	40M	sodium saccharin, >99.5% pure [7 ppm o-toluene-sulfonamide]; method of production not specified	5% diet	52 wk	Negative Sodium saccharin did not induce hyperplasia of the urinary bladder, but the concentration of MgNH <sub>4</sub> PO <sub>4</sub> crystals in the urine of treated rats was greater than that in controls.	Fukushima et al. (1983)
5-wk-old inbred Fischer 344 rats	5-13M sacrificed at 9 defined durations up to 8 wk	5-13M sacrificed at defined durations up to 8 wk: 4 receiving freeze ulceration + control diet and 7 receiving freeze ulceration + control diet alone	sodium saccharin mixed in the diet and pelleted, purity not specified	5% diet either immediately after or 2 wk after freeze ulceration	8 wk	Positive Nodular and papillary hyperplasia and luminal surface abnormalities were detected when rats were fed sodium saccharin either immediately after freeze ulceration or 2 wk after freeze ulceration. Incidences high for entire 8 wk of the experiment.	Murasaki and Cohen (1983b)
5-wk-old inbred Fischer 344 rats	M (number not specified)	M (number not specified)	sodium saccharin mixed in the diet and pelleted, purity not specified	5% diet administered 8 wk after freeze ulceration 5% diet administered 2 wk after freeze ulceration	16 wk	Positive Development of nodular and papillary lesions, surface abnormalities, and increased LI were similar to results reported in the two groups above.	Murasaki and Cohen (1983b)

Table 6-1. Cell Proliferation (Continued)

Age, Strain, Species	No./Sex Exposed	Controls	Chemical Form and Purity	Dose	Duration	Results/Comments	Reference
5-wk-old F344 rats	M (number not specified)	M (number not specified)	sodium saccharin acid saccharin potassium saccharin calcium saccharin Methods of production and purity not specified	5% diet 5% diet 5% diet 5% diet	10 wk	Positive Sodium saccharin induced significant urinary bladder epithelial proliferation. Potassium saccharin also did, but not as much. Calcium saccharin and acid saccharin did not induce a significant increase in proliferation.	Hasegawa and Cohen (1986)
Fischer rats (age not specified)	not specified	not specified	sodium saccharin, methods of production and purity not specified	5% diet	21 wk	Negative Exposure did not increase DNA synthesis in the bladder epithelium.	Tatematsu et al. (1986)
fetal and neonatal Sprague-Dawley rats	not specified	not specified	sodium saccharin, methods of production and purity not specified	5% diet fed to dams before mating until weaning	fed to dams before mating until weaning	Positive At day 21 after birth, the LI in bladder was greater for exposed rats than control rats. The LI was higher in exposed females than in exposed males.	Masui et al. (1988 abstr.)
5-wk-old F344 rats and 4-wk-old Sprague-Dawley rats	105M	60M	sodium saccharin, 99.9% pure; method of production not specified	5 or 7.5% diet	4 or 10 wk	Positive when diet made urine alkaline One of 3 diets was fed: Prolab 3200, NIH-07, or AIN-76A. There was a higher incidence of simple or nodular hyperplasia of urothelium in rats fed Prolab than those fed NIH diet. There was little response with AIN diet. Urinary pH in rats fed AIN diet was $6.0 \pm 0.0$ . Rats fed NIH diet had a urinary pH of $6.3 \pm 0.2$ and rats fed Prolab had a urinary pH of $6.4 \pm 0.2$ . The response to sodium saccharin was greater in F344 rats than SD rats.	Garland et al. (1989b)
28-day-old F344 rats	30M (for each dose level)	30M	sodium saccharin, methods of production and purity not specified	3, 5, or 7.5% diet	4, 7, or 10 wk	Positive with highest dose Light microscopic changes in bladder and an increase in LI in bladder were seen at all time points but only in rats fed 7.5% dose level. Scanning electron microscopic changes were seen beginning at 4 wk, with increasing severity at higher doses.	Cohen et al. (1990)

Table 6-1. Cell Proliferation (Continued)

Age, Strain, Species	No./Sex Exposed	Controls	Chemical Form and Purity	Dose	Durations	Results/Comments	Reference
Weanling F344 rats (age not specified)	18-20M per group	20M (AIN-76A), M (number not specified; Wayne diet)	sodium saccharin, methods of production and purity not specified	5% diet AIN-76A or Wayne diet	2,4,6,10, or 16 wk	Positive Sodium saccharin in both diets caused a significant increase in the thymidine LI. Sodium bicarbonate alone increased the LI and in combination with sodium saccharin had an additive effect on bladder urothelial LI. A sodium bicarbonate study was not done with the Wayne diets.	Debled-Rychter and Wang (1990)
<i>in utero</i> and 30-day-old Sprague-Dawley rats	7M, 7F for each dose level ( <i>in utero</i> ); 7M, 7F for each dose level (30-day-old)	7M, 7F ( <i>in utero</i> ); 7M, 7F (30-day-old)	sodium saccharin, 99.2% pure; method of production not specified	1, 3, or 7.5% diet	30, 60, or 90 days	Positive with highest dose <i>In utero</i> rats were exposed to sodium saccharin from conception to 30 days. Thirty-day-old rats were exposed for 60 days. Mild simple hyperplasia of the urinary bladder occurred in 90-day-old male rats (4 cases) fed 7.5% sodium saccharin, one 30-day-old female rat fed 7.5% sodium saccharin, and eight 90-day-old female rats fed 7.5% sodium saccharin. There were 2 cases of moderate or severe hyperplasia in 90-day-old female rats fed 7.5% sodium saccharin and 1 case in a 30-day-old female control rat. One 30-day-old female control rat exhibited moderate or severe hyperplasia. Significance values were not included.	Garland et al. (1991)
4- to 5-wk-old intact F344, castrated F344, and NBR rats	10M (intact), 10M (castrated), 10M (NBR)	10M (intact), 10M (castrated), 10M (NBR)	sodium saccharin, 98.1% pure with no impurities > 1 ppm; method of production not specified	7.5% diet	10 wk	Positive only in rats that synthesized $\alpha$ 2u-globulin NBR rats don't synthesize $\alpha$ 2u-globulin. Castrated rats have lower levels than intact rats. Sodium saccharin produced less bladder proliferation in NBR rats than in intact F344 rats. Intermediate proliferation was seen in castrated rats.	Garland et al. (1994)
6-wk-old NBR and F344 rats	6M (NBR), 6M (F344)	10M (NBR), 5M (F344)	sodium saccharin, methods of production and purity not specified	5% diet	8 wk	Positive only in rats that synthesized $\alpha$ 2u-globulin NBR rats do not synthesize $\alpha$ 2u-globulin. Only F344 rats had an increase in cell proliferation in urinary bladder after exposure to sodium saccharin.	Uwagawa et al. (1994)

Table 6-1. Cell Proliferation (Continued)

Age, Strain, Species	No./Sex Exposed	Controls	Chemical Form and Purity	Dose	Duration	Results/Comments	Reference
5-wk-old F344 rats	10M	10M	sodium saccharin, pure, method of production not specified	7.5% diet	10 wk	Positive Amorphous precipitate was present in exposed rats along with an increased incidence of urothelial simple hyperplasia.	Cohen et al. (1995a)
8-wk-old and 6-wk-old F344 and Sprague-Dawley rats	M, F (numbers not specified)	not specified	sodium saccharin acid saccharin Methods of production and purity not specified	5% diet 5% diet	21 or 91 days	Positive (sodium saccharin) Sodium saccharin and acid saccharin were evaluated. Neither increased bladder proliferation when fed at birth through 7 days of age. Sodium saccharin increased proliferation at later times but acid saccharin did not. The effects of sodium saccharin were reversible over time.	Cohen et al. (1995b)
<b>6.5.4 Guinea Pigs</b>							
6-wk old Hartley guinea pigs	30M	20M	sodium saccharin, >99.5% pure [7 ppm <i>o</i> -toluene-sulfonamide]; method of production not specified	5% diet	up to 20 wk	Negative Sodium saccharin did not induce hyperplasia of the urinary bladder or significantly increase DNA synthesis.	Fukushima et al. (1983)
<b>6.5.5 Nonhuman Primates</b>							
<i>Macaca mulatta</i> monkeys (age not specified)	7M, 7F	3M, 3F	sodium saccharin, made by Remsen-Fahlberg method, containing 2.4 or 3.2 mg/kg <i>o</i> -toluene-sulfonamide	20, 100, or 500 mg/kg bw/day in diet	79 mo	Negative Histopathological examination of urinary bladders, kidneys, and testis of surviving and deceased animals showed no abnormal pathology.	McChesney et al. (1977 abstr., cited by IARC, 1980)
<b>6.6 Cell Proliferation with Co-Administration of Known Carcinogens</b>							
<b>6.6.1 <i>N</i>-butyl-<i>N</i>-(4-hydroxybutyl)nitrosamine (BBN)</b>							
6-wk-old F344 rats	242M, 249F	60M, 62F	sodium saccharin, >99.5% pure [7 ppm <i>o</i> -toluene-sulfonamide]; method of production not specified	400, 2000, 10,000, or 50,000 ppm diet with or without BBN pretreatment	32 wk	Positive with higher doses and BBN pretreatment Urinary bladder hyperplasia was enhanced in both sexes by exposure to 2000-50,000 ppm sodium saccharin following BBN pretreatment. Exposure to sodium saccharin without BBN pretreatment did not produce any changes in urinary bladders of rats of either sex.	Nakanishi et al. (1980a)



Table 6-1. Cell Proliferation (Continued)

Age, Strain, Species	No./Sex Exposed	Controls	Chemical Form and Purity	Dose	Duration	Results/Comments	Reference
8-wk-old Wistar rats	40M (BBN)/sodium saccharin	36M (BBN alone), 32M (sodium saccharin alone), 18M (no chemicals)	sodium saccharin, >99.5% pure [7 ppm o-toluenesulfonamide]	sodium saccharin: 5% diet; 0.01% in drinking water	Rats pretreated with BBN for 4 wk and then given sodium saccharin for 32 wk	Positive with BBN treatment There was an enhancement of urinary bladder papillary or nodular hyperplasia (21/31 vs. 6/23 BBN controls).	Nakanishi et al. (1980b)
8-wk-old Wistar rats	40M (BBN)/sodium saccharin	24M (BBN alone), 24M (sodium saccharin alone), 18M (no chemicals)	sodium saccharin, >99.5% pure [7 ppm o-toluenesulfonamide]	sodium saccharin: 5% diet BBN; 0.001% in drinking water	Rats were co-administered BBN and sodium saccharin for 40 wk	Positive with BBN treatment There was an enhancement of urinary bladder hyperplasia (simple hyperplasia, 24/24 vs. 2/22 BBN controls; papillary or nodular hyperplasia, 20/24 vs. 2/22).	Nakanishi et al. (1980b)
F344 rats (age not specified)	31M	30M (BBN alone)	Sodium saccharin [7 ppm o-toluenesulfonamide]; methods of production and purity not specified	0.01% BBN in drinking water for 4 wk followed by 5% sodium saccharin in diet for 32 wk	see dose	Positive with BBN pretreatment There was a significant increase in the incidences of simple and papillary or nodular hyperplasia in the urinary bladder (simple hyperplasia: 27/29 vs. 19/28; papillary or nodular hyperplasia: 24/29 vs. 11/28).	Nakanishi et al. (1982)
<b>6.6.2 2-Acetylaminofluorene (AAF)</b>							
Horton Sprague-Dawley rats (age not specified)	62F	62F	sodium saccharin, methods of production and purity not specified	5% diet	40 wk	Positive with co-administration of AAF Hyperplasia of the urinary bladder mucosal lining occurred in all animals but was more severe in AAF/sodium saccharin-exposed animals, with one of these animals displaying squamous metaplasia and precancerous changes in the mucosal epithelium. No animals had malignant lesions of the urinary bladder. IARC noted the small number of animals used and the fact that food consumption was not measured, preventing the evaluation of AAF and sodium saccharin exposure.	Ershoff and Baja (1974; cited by IARC, 1980)
F344 rats (age not specified)	31M	30M (BBN alone)	sodium saccharin [7 ppm o-toluenesulfonamide]; methods of production and purity not specified	0.02% AAF in diet for 4 wk followed by 5% sodium saccharin in diet for 32 wk	see dose	Positive with AAF pretreatment There was a significant increase in the incidences of simple and papillary nodular hyperplasia of the urinary bladder (simple hyperplasia: 6/29 vs. 0/28; papillary or nodular hyperplasia: 4/29 vs. 0/28).	Nakanishi et al. (1982)

NTP Report on Carcinogens 1997 Background Document for Saccharin

Table 6-1. Cell Proliferation (Continued)

Age, Strain, Species	No./Sex Exposed	Controls	Chemical Form and Purity	Dose	Duration	Results/Comments	Reference
<b>6.6.3 N-Methyl-N-nitrosourea (MNU)</b>							
Wistar rats (age not specified)	63F (MNU + sodium saccharin containing 40 mg/kg <i>o</i> -toluene-sulfonamide)	63F (MNU alone)	MNU	0.15 mL instilled into bladder	single dose	Positive with MNU pretreatment There was an increase in the number of proliferative bladder lesions in rats treated with MNU and sodium saccharin (incidence not given).	Hooson et al. (1980)
	63F (MNU + sodium saccharin free of <i>o</i> -toluene-sulfonamide)		sodium saccharin prepared by the Remsen-Fahlberg method, containing 40 mg/kg <i>o</i> -toluene-sulfonamide	2 g/kg/day in drinking water	2 yr (started 2 wk after MNU)		
			sodium saccharin prepared by the Maumee process (no <i>o</i> -toluenesulfonamide)	2 g/kg/day in drinking water	2 yr (started 2 wk after MNU)		

Abbreviations: F = females; LI = labeling index; M = males

## 7.0 MECHANISMS

**Summary:** Bladder tumors found predominantly in male rats exposed to high dietary concentrations of sodium saccharin (equal to or greater than 1% of the diet) prior to birth, at birth, or starting at up to 35 days of age are thought to occur and proceed in association with elevated urinary sodium ion concentration and pH above 6.5. Implications that the sodium ion, itself, may be at least partially responsible for the carcinogenic effects observed in the male rat bladder stem from studies involving many other sodium salts (e.g., of succinic acid and ascorbic acid) eliciting similar effects in the male rat. In addition, when rat bladder epithelial cells were incubated with sodium saccharin, calcium saccharin, potassium saccharin, sodium ascorbate, sodium chloride, sodium citrate, potassium chloride, or calcium chloride *in vitro* for 24 hours, all of the sodium salts proved to be cytotoxic, while the other salts did not display similar effects. Studies using diets varying in pH have shown that sodium saccharin does not significantly promote proliferation in the male rat urinary bladder when fed in the acidic AIN-76A diet, but sodium saccharin did increase urothelial proliferation when fed in the Prolab 3200 (alkaline) diet.

A number of studies have shown that pH above 6.5 and increased urinary sodium ion concentration in the male rat urinary bladder enhance the formation of urinary silicate crystals. These crystals have been shown to form by the binding of urinary proteins to saccharin, and may act as microabrasives in the rat urinary bladder, causing regenerative hyperplasia (increase in cell number) and increased cell proliferation, which, when sustained over a lifetime, provide the basis for urinary bladder tumorigenesis. The anatomy of the rat bladder is thought to play a role in rendering the rat susceptible to bladder tumorigenesis. It is known that the horizontal position of the rat during urination leaves the rat prone to the retention of calculi in the bladder, and the formation and retention of precipitate in the rat bladder has been linked to the induction of tumors predominantly in the male rat.

Other factors associated with induction of urinary bladder tumors in the rat include high urine volume, low urine osmolality, and intrinsically high urinary protein, especially in male rats. It is noteworthy that saccharin binds to urinary proteins, including  $\alpha_2\mu$ -globulin which is common in male rats, and that the most extensive mechanistic studies have been conducted only in male rats. Whether the female rat positive urinary bladder response seen in initiation/promotion studies is associated with increased urinary protein and urinary crystal formation has not been adequately studied. Furthermore, extensive mechanistic studies in mice exposed to high doses of sodium saccharin, with or without previous exposure to a urinary bladder initiator, have not been done to definitively rule out the possibility that mice could also develop urinary bladder neoplasia under specific experimental conditions.

The constellation of physiological characteristics of urine in rats fed high doses of sodium saccharin, particularly commencing at times when intrinsic bladder urothelial proliferation is high, would not be expected in humans exposed to normal usage levels of sodium saccharin.

### 7.1 Mechanism of Urinary Bladder Tumorigenesis Found Predominantly in Male Rats

Long-term studies of sodium saccharin have shown that bladder tumors are the most common malignancies and that they occur predominantly in the male rat. Tumors found in the bladder are detected only when sodium saccharin is fed at high dietary levels (equal to or greater than 1% in rats) beginning at birth or when fetal rats are exposed *in utero* by feeding the dams 5% sodium saccharin diet (Schoenig et al., 1985; for review, see Velazquez et al., 1996). Schoenig et al. (1985) also found that *in utero* exposure was not necessary and that the incidence of bladder tumors in rats given 5% sodium saccharin from birth was essentially identical to that in rats fed 5% sodium saccharin prior to conception and throughout life (for review, see Renwick, 1993; Williams and Whysner, 1996).

Cohen et al. (1991b) offered the following hypothesis to describe the events leading to urinary bladder tumorigenesis in male rats: When sodium saccharin is fed to male rats at high dietary levels (about 2.5%), the concentration of urinary sodium is increased and the pH level is elevated (above 6.5). Under these conditions, binding of saccharin and male-rat-specific  $\alpha_2\mu$ -globulin results in the formation of silicon-containing crystallized precipitate in the bladder (for review, see Ellwein and Cohen, 1990; Burin et al., 1995a; Cohen et al., 1995d; Velazquez et al., 1996). After binding, the precipitate enters the bladder urothelial cells and is cytotoxic. Acting as microabrasives, the silicate and precipitate particles irritate the mucosa and cause focal necrosis. The loss of urothelial cells results in regenerative hyperplasia and increased cell proliferation, which, when sustained over the rats' lifetime, provides the basis for urinary bladder tumorigenesis. Cohen et al. (1991a) further hypothesized that diet-, dose-, species-, and sex-specific effects of saccharin may be related to the formation of the particles (for review, see Burin et al., 1995a; Velazquez, 1996).

#### 7.1.1 The Role of pH in the Promotion of Bladder Carcinogenesis in Male Rats

Studies indicate that a urinary pH higher than 6.5 promotes the tumorigenicity of sodium saccharin in male rats (for reviews, see Murai et al., 1997; Cohen et al., 1995d). For instance, Okamura et al. (1991) compared the effects of sodium saccharin on 5-wk-old male F344 rats initiated with 0.2% FANFT for 4 weeks followed by administration for 100 weeks of either 0 or 5% sodium saccharin in either Prolab 3200 or AIN-76A diet. In rats, administration of AIN-76A diet results in a strongly acidic urine, with a pH lower than 6.0 (for review, see Cohen, 1995c; Velazquez et al., 1996) while Prolab 3200 produces a neutral or slightly alkaline urinary pH (Fisher et al., 1989). [Humans tend to have acidic urine, with a pH between 5.0 and 6.0, although diet can alter this (Cohen, 1995c)]. The data from the study by Okamura et al. (1991) demonstrated that sodium saccharin did not significantly promote urinary bladder tumors in the male rat if fed an AIN-76A diet. However, there was a significant increase the incidence of bladder tumors if male rats were fed the Prolab 3200 diet.

A study by Garland et al. (1989b) also evaluated the responses of 5-wk-old male F344 rats to sodium saccharin administered in different diets. However, while Okamura et al. (1991) used tumor formation as an endpoint, Garland et al. (1989b) looked only at cellular proliferation in the urinary bladder, presumably because of the short duration of the study (10 weeks). Rats were either administered 0 or 7.5% sodium saccharin in Prolab 3200, AIN-76A, or NIH-07 diet and killed after 4 weeks, or they were administered 0, 5, or 7.5% sodium saccharin in these same

diets and killed after 10 weeks. In rats killed after 4 weeks of treatment, there was a significantly higher incidence of hyperplasia with administration of sodium saccharin and this incidence was higher in rats fed the Prolab diet than in rats fed the NIH diet. There was little response when sodium saccharin was administered in the AIN-76A diet. In the group of rats killed after treatment for 10 weeks, there was a similar trend (these rats also demonstrated a dose-dependent increase in hyperplasia). Since the urinary pH of rats fed sodium saccharin in the NIH-07 diet is known to be slightly lower than the urinary pH in rats fed Prolab 3200, and the urinary pH of rats fed AIN-76A is known to be even lower than that of rats fed NIH-07 (*ibid.*), these results are consistent with the hypothesis that urinary pH participates in the mediation of the proliferative response in urinary bladders of male rats exposed to sodium saccharin.

The findings of Okamura et al. (1991) and Garland et al. (1989b) imply that alkaline urinary pH alone was responsible for mediating urothelial proliferation, but other factors might also explain this phenomenon. For instance, while different diets have been shown to produce different urinary pH levels, they also can produce different levels of ions such as calcium, potassium and sodium, and silicates (Cohen, 1995c). Other studies, however, have supported a role for urinary pH in saccharin-induced carcinogenesis, showing that a pH above 6.5 greatly enhances the formation of the bladder epithelium-irritating urinary silicate crystals in male rats fed sodium saccharin (for review, see Cohen et al., 1991a). For a review of the role of pH in oncogenesis, see Harguindey et al. (1995).

#### 7.1.2 The Role of Sodium Concentration in the Promotion of Bladder Carcinogenesis in Male Rats

There is evidence indicating that induction of bladder carcinogenesis in male rats exposed to saccharin is increased under conditions of high urinary sodium ion concentration. For instance, Hasegawa and Cohen (1986) fed weanling male F344 rats the sodium, potassium, or calcium salt of saccharin, or acid saccharin as 5% of the diet for ten weeks. They found that sodium saccharin induced a significantly higher level of urinary bladder epithelial proliferation than potassium saccharin. Calcium saccharin and acid saccharin, on the other hand, did not significantly change the bladder epithelium. Anderson et al. (1988) found similar results in weanling male CD rats. Like Hasegawa and Cohen (1986), they fed sodium saccharin, potassium saccharin, calcium saccharin, or acid saccharin to rats for 10 weeks and noticed that only sodium saccharin and potassium saccharin produced hyperplasia in the bladder. In a later study by Cohen et al. (1991b), after a 6-wk initiation period with 0.2% FANFT, sodium saccharin, administered as 3% or 5% of the diet for 72 weeks, was shown to be tumorigenic in male F344 rat bladders while calcium saccharin was only slightly so and acid saccharin was not at all.

In a review written by Cohen et al. (1997), it was noted that in rats, oral administration of sodium saccharin causes an increase in cell proliferation in the urothelium that is more pronounced than that induced by potassium saccharin, whereas calcium saccharin produces only slight changes and acid saccharin has no effect on the urinary bladder. It was also noted that these differences in potency occur even though urinary saccharin concentrations do not vary greatly among rats administered the different forms of saccharin. Refer to **Table 7-1** for a summary of the effects of various forms of saccharin on the rat urinary bladder. Refer to **Table 7-2** for results of urine analyses in rats given various forms of saccharin.

While sodium saccharin has been shown to induce carcinogenesis in the male rat bladder, so have many other sodium salts including those of vitamin C (Fukushima et al., 1986), glutamate and bicarbonate (for review see Cohen, 1995b), and succinic acid (Otoshi et al., 1993) (most of these studies did not evaluate the responses of female rats). This implies that the sodium ion, itself, may be at least partially responsible for these effects. Studies supporting this idea include those by Shioya et al. (1994) and Shibata et al. (1989), both of which only evaluated the responses of male rats. A list of sodium salts that produce changes in the rat bladder is provided in **Table 7-3**.

The results of an *in vitro* study performed by Garland et al. (1989a) suggest that the carcinogenic effect on the bladder of a high urinary sodium ion concentration could be mediated by the cytotoxicity of these ions. Transformed rat bladder epithelial cells (sex of donor animals not specified) were incubated in sodium saccharin, calcium saccharin, potassium saccharin, sodium ascorbate, sodium chloride, sodium citrate, potassium chloride, or calcium chloride for 24 hours and then attachment and viability of the cells were assessed. All of the sodium salts (and potassium saccharin) decreased cell attachment and viability, while potassium chloride and calcium chloride did neither. Calcium saccharin decreased only cell viability.

Another possible mechanism for sodium-induced carcinogenesis is direct induction of cellular proliferation and/or DNA synthesis by sodium ions (for review, see Cohen, 1995c). Several *in vitro* studies support this hypothesis. For example, Burns and Rozengurt (1984) used confluent quiescent Swiss mouse 3T3 cells to demonstrate that initiation of DNA synthesis in these cells by various stimulants was inhibited by limiting extracellular sodium ion concentration. Normally, 3T3 cells will initiate DNA synthesis when growth factors are included in their incubation media. However, when Burns and Rozengurt (1984) included one growth factor (i.e., epidermal growth factor, vasopressin, or insulin) in the media (serum-free), and removed extracellular sodium ions, there was no initiation of DNA synthesis.

Another study by Cameron et al. (1980) evaluated intracellular sodium ion concentrations in slowly and rapidly dividing cells, and in tumor cells. They found that sodium ion concentrations were highest in tumor cells and lowest in slowly dividing cells. They concluded that high sodium ion concentrations were, associated with mitogenesis while very high levels were associated with oncogenesis. However, the studies do not necessarily provide any support for the hypothesis that extraneous high sodium ion concentrations were responsible for induction of cellular proliferation or oncogenesis.

The most likely mechanism for a carcinogenic response to sodium saccharin mediated by sodium ions is the interaction of sodium ions with proteins in the urine (Cohen, 1995c). It has been shown that urinary proteins in rats bind to saccharin to produce a crystallized precipitate (Cohen, 1995b; Cohen et al., 1995a), which may act as an abrasive in the rat bladder, causing regenerative hyperplasia (Cohen et al., 1990; Hicks, 1984). The formation of this precipitate is greatly enhanced by high sodium ion concentrations (Cohen et al., 1991a), thus raising the possibility that high sodium ion concentration is a necessary condition for precipitate formation.

Renwick (1993) stated that the urinary concentration of the anion of sodium saccharin does not play a role in the overall mechanism for tumorigenesis in the rat bladder. In addition, Renwick (1993) suggests that dietary sodium saccharin provides a vehicle for the delivery of "massive" but non-toxic amounts of sodium ions to the urinary bladder. However, the sodium

ion concentrations in the feed containing carcinogenic doses of sodium saccharin are not much higher than in the rat feed alone. For example, Purina Rodent Chow consists of 0.3% sodium ions or 3000 ppm. When comparing this concentration to the highest sodium saccharin concentration known to promote tumorigenesis (7.5% or 75,000 ppm), we calculated that the sodium ion concentration in the feed at this dose was approximately 3-fold that found in a typical rat chow (75,000 ppm x 12.5% sodium ions in sodium saccharin = 9400 ppm). Although a 7.5% sodium saccharin diet increased the concentration of sodium ions approximately 3-fold, this concentration scarcely represents a large increase from the usual daily dietary intake of sodium ions.

#### 7.1.3 The Combined Effect of pH Level and Sodium Concentration

While both pH and sodium ions have been shown to affect cell proliferation in the bladder, most likely these two parameters do not act in isolation but are part of a set of parameters that regulate tumorigenesis. This hypothesis is supported by a study conducted by Fukushima et al. (1988) in which male F344 rats were initiated with 0.05% *N*-butyl-*N*-(4-hydroxybutyl)nitrosamine (BBN) and then fed a diet containing either 3% sodium bicarbonate, 1% sodium chloride, or a control diet. Sodium bicarbonate was found to increase urinary pH and sodium ion concentration and promote urinary bladder carcinogenesis. Administration of sodium chloride produced an increase in urinary sodium ions but not pH, and did not promote urinary bladder carcinogenesis.

Ito and Fukushima (1989) also found that both elevated pH and elevated sodium ion concentration were necessary conditions for induction of bladder tumorigenesis. They initiated male rats with 0.05% BBN and then administered either ascorbic acid, sodium ascorbate, sodium bicarbonate, or ammonium chloride alone or in several different combinations. Promotion of urinary bladder carcinogenesis occurred only under conditions of both elevated urinary pH and elevated urinary sodium ion concentration, induced by the administration of sodium bicarbonate and sodium ascorbate.

#### 7.1.4 The Association Between Increased Urinary Output and Sodium Saccharin-Induced Bladder Tumors

Schoenig et al. (1985) found that rats that ingested 7.5% sodium saccharin in a two-generation bioassay and developed bladder tumors had a higher urine volume throughout their lives than did those that did not develop bladder tumors. Schoenig et al. (1985) also found that the difference in urine volume between the non-tumor bearing group and the untreated controls was almost as great as the difference between the sodium saccharin-treated tumor bearing and non-tumor bearing rats.

Anderson et al. (1987b) studied the effect of inherent urine output (high urine volume or low urine volume) on the response of male rats fed 7.5% dietary sodium saccharin for 10 weeks. Rats exposed to 7.5% dietary sodium saccharin for 10 weeks showed an increased incidence of bladder epithelial hyperplasia (12/20 rats exposed to sodium saccharin vs. 2/20 controls). The incidence of hyperplasia was similar (6/10) in the sodium saccharin high and low urine output groups. One of the two control rats that had hyperplastic lesions in the bladder showed evidence

of inflammation and had a higher than average urine output, while the other had the highest urine output in the control group (73 g/kg).

Anderson et al. (1987a) found that high urine output rats in the control group consumed more feed than those in the low urine output control group. Therefore, the authors compared the mean daily sodium saccharin consumption between the exposed high and low urine output groups (g/kg bw) for the 10-week period. The authors found that the high urine output group consumed  $8.0 \pm 0.2$  g/kg bw and the low urine output group consumed  $7.8 \pm 0.2$  g/kg bw feed containing 7.5% sodium saccharin on an average daily basis. However, urinary concentrations of saccharin were similar in the high and low urine mass groups ( $41 \pm 3$  and  $46 \pm 2$  mg/mL, respectively). Thus, Anderson et al. (1987a) concluded that it is unlikely that a difference in urinary saccharin concentration or total saccharin exposure can account for the role of high urinary volume in saccharin-associated bladder tumorigenicity.

## 7.2 Dose Response in Cell Proliferation and Tumorigenesis

Numerous studies have been conducted that suggest high doses of sodium saccharin produce urinary bladder tumors in male rats. For example, Cohen et al. (1991b) and Fukushima et al. (1986) have demonstrated that the effects of high dietary concentrations of sodium saccharin on male rat bladder epithelium are associated with increased urinary bladder tumor promotion. Cohen et al. (1989 abstr.) found that feeding male rats high doses of sodium saccharin (7.5%) beginning 5 weeks after birth increased cell proliferation in the bladder urothelium. Cohen and Ellwein (1991) suggested that approximately one-third of the total mitoses of the urothelium occurs within the first 3 weeks of a rat's life. Therefore, when sodium saccharin dosing begins at birth, rather than after weaning, rats are somehow more susceptible to sodium saccharin-induced tumors in later life due to the increased cell proliferation occurring at this time. The increases of cell proliferation observed after short periods of high sodium saccharin administration are dose-responsive. Details of carcinogenesis experiments mentioned herein are in **Table 4-1**.

Schoenig et al. (1985) conducted a 2-generation rat bioassay on sodium saccharin. This study involved 2500 second-generation male Charles River CD rats ( $F_1$ , between 21 and 38 days of age; 6 treatment groups, 125 to 700 rats per group) receiving 1, 3, 4, 5, 6.25, and 7.5% sodium saccharin in their diet for up to 30 months. The parents ( $F_0$ ) of the  $F_1$  generation had been maintained on diets containing between 1 and 7.5% sodium saccharin. Except during mating, gestation, and lactation, all animals were housed individually in a single environmentally controlled room. The data resulting from this experiment, designed to determine the dose-response for urinary bladder tumors, indicated that a 1% dietary level of sodium saccharin represented a no-effect level. Higher dietary concentrations showed a very steep dose-response, indicating that tumor incidence increased rapidly with an increase in the dose. For example, significant increases in the incidence of primary neoplasia (benign and malignant tumors) in the urinary bladder of  $F_1$  male rats sacrificed during month 15 of this study were not found in the 1.0 or 3.0% sodium saccharin group. However, pairwise comparisons between the control group (0.0% total primary neoplasia) and all groups treated with 4, 5, 6.25, and 7.5% sodium saccharin showed significant increases in the incidence of benign (2.1, 3.3, 10.0, and 15.3%, respectively) and malignant tumors (4.2, 9.2, 6.7, and 16.1%, respectively) alone as well as of total primary



bladder neoplasia (6.3% to 31.4%). Total primary bladder neoplasia was also significantly higher in the 3.0% sodium saccharin group (1.7%). Therefore, the 1.0% sodium saccharin dietary level was considered to be a no-effect level for bladder neoplasia. However, 5 bladder tumors were found in the 1% sodium saccharin group and none were found in the concurrent controls. This finding prompted the authors to review the historical control data for the incidence of primary urinary bladder tumors in male Charles River CD rats at IRDC (Squire, 1985). The review included 10 studies that examined the urinary bladders from 982 male controls either *in utero* or over a lifetime. Of these animals, 863 survived for 67 weeks, which corresponds to the appearance of the first urinary bladder tumor observed in the bioassay conducted by Schoenig et al. (1985). No primary urinary bladder tumors appeared prior to week 67 in the controls of the ten studies reviewed. The percentage incidence of tumors was calculated from historical controls by using the number of rats that survived until the first bladder tumor was observed as the denominator. These data showed that total primary bladder neoplasia ranged from 0.0 to 3.3% with a mean of 0.8%. The corresponding incidence of total primary bladder neoplasia at the 1% dietary sodium saccharin observed by Schoenig et al. (1985) was also 0.8%. These findings suggest that the NOEL (1% sodium saccharin dietary level) proposed by Schoenig et al. (1985) is not significantly different from the results obtained from the controls (0.8%) studied by Squire (1985), and that the background tumor incidence for this strain of rat at IRDC was identical to that observed in the 1% sodium saccharin group (0.8%) studied by Schoenig et al. (1985).

Murusaki et al. (1981), who studied the light microscopic and electron microscopic changes in the bladder of rats fed sodium saccharin (dietary concentrations between 0.1 and 5%), also reported a steep dose-response curve over a narrow range of dose levels above 1%. Furthermore, Nakanishi et al. (1980a) and West et al. (1986), using light microscopy, autoradiography, and scanning electron microscopy, detected cellular responses in male rat bladders only with sodium saccharin dietary concentrations of 2.5% to 5% beginning at 6 to 8 weeks of age. Chappel (1992) reviewed and assessed the biological risk of sodium saccharin. The author stated that the steep dose-response curves representing both physiological changes in the urine and morphological changes in the urothelium provide strong evidence of a common threshold at a sodium saccharin dietary concentration between 1 and 3%. To Chappel (1992), these results provided strong evidence that these phenomena are interrelated.

Ellwein and Cohen (1988), using model-based simulations, demonstrated that the proliferative effects (hyperplasia; increase in LI) following high doses of sodium saccharin are sufficient to explain tumorigenic effects in the rat urinary bladder without having to postulate a genotoxic influence. Their database was generated from a large series of experiments dealing with the increase in LI and hyperplasia after the administration of high doses of sodium saccharin. The authors postulated a tumorigenic effect secondary to sodium saccharin administration only if it is administered during the neonatal period at a dose which will generate a cell proliferative response in the urothelium; and after weaning when ulcerations of the bladder occur. The authors suggested that a dietary level of at least 1% sodium saccharin is necessary for a cellular response to occur in the rat bladder, even though most experiments aimed at cellular responses detected by light microscopy, autoradiography, or scanning electron microscopy (West et al., 1986; Murusaki et al., 1981; Nakanishi et al., 1980a) have found these effects only at doses of 2.5% or higher.

Like Chappel (1992), Ellwein and Cohen (1990) suggested that saccharin exhibits a biological threshold.

### 7.3 Relevance of Animal Cancers To Humans

Numerous studies have investigated the carcinogenicity of sodium saccharin in rats (Cohen et al., 1995b; Cohen et al., 1990; Anderson, 1988; for review, see Oser, 1985; Williams and Whysner, 1996), mice (for review, see Oser, 1985), non-human primates (Thorgeirsson et al., 1994) and humans (Risch et al., 1988; for reviews, see Elcock and Morgan, 1993; Chappel, 1992; Ellwein and Cohen, 1990; Morgan and Wong, 1985). These studies have revealed that it is mainly the male rat which is susceptible to the formation of bladder tumors following chronic exposure to high doses of sodium saccharin (Cohen, 1995b; Chappel, 1992), i.e., greater than or equal to 1% of the diet (Ellwein and Cohen, 1990). A summary of positive mammalian carcinogenicity studies is presented in **Table 7-4**. An interspecies comparison of the effects of sodium saccharin on the urinary bladder is presented in **Table 7-5**, and a comparison of the effects of sodium saccharin in various rat strains is presented in **Table 7-6**.

Results from animal studies suggest that there is an intrinsic difference between male rats and other animals in how they react to sodium saccharin exposures and, in particular, they imply that there may be a peculiarity of the male rat bladder which makes the male rat uniquely susceptible to cancer of this organ following sodium saccharin exposures. Most likely, this peculiarity is not of a genetic origin but is, rather, physiologically based (Weisburger, 1990), since sodium saccharin has been shown to be non-genotoxic *in vivo* (Ellwein and Cohen, 1990; Ashby, 1985; Lutz and Schlatter, 1977).

If the male rat bladder is indeed a unique organ with respect to its response to sodium saccharin, it would have to be concluded that male rats do not accurately represent humans when considering such a response and that it would therefore not be appropriate to extrapolate data from male rat exposure studies to humans. This section will investigate the validity of these statements by comparing the anatomy and physiology of the male rat bladder with the human bladder.

#### 7.3.1 Comparative Bladder Anatomy and Urine Chemistry

The anatomy of the rat bladder is significantly different than that of the human bladder. For instance, the rat bladder is an abdominal organ, while the human bladder progresses from an abdominal organ in infancy and childhood to a pelvic organ in adulthood when the pelvis is fully developed and upright posture of the body is achieved (DeSesso, 1995).

The upright/vertical posture of mature humans versus the horizontal posture of rats is highly relevant to the nature of bladder response to sodium saccharin when the process of urination is considered. Specifically, it is known that the vertical position of humans allows for a more efficient elimination of calculi from the bladder while the horizontal position of the rat during urination leaves the rat more prone to retention of such material (Burin et al., 1995b; Cohen, 1995b).

Although other animals (e.g., mice) that maintain a horizontal position may also be susceptible to calculus retention, this phenomenon is uniquely relevant to rats when exposure to sodium saccharin is considered. This is due to the fact that sodium saccharin has been shown to

induce precipitate formation solely in male rat urine (see **Table 7-5**) (Cohen, 1995b; Cohen et al., 1995a; Cohen et al., 1991a), and the formation and retention of this precipitate has been linked to the formation of tumors of the male rat bladder (Cohen 1995b). Tumor formation may be the result of chronic irritation, and the damage it causes to bladder urothelium (Burin et al., 1995b; Clayson et al., 1995; Ellwein and Cohen, 1988). The precipitate is composed of mainly calcium phosphate, but also contains silicate, protein, saccharin, sulfur-containing substances, potassium, and chloride (Cohen, 1995b), and is jagged in nature (Cohen et al., 1989 abstr.).

When the urothelium is damaged by abrasion, regenerative hyperplasia is likely to occur (Cohen et al., 1990; Hicks, 1983). This results in an increase in the number of urothelial cell divisions (Cohen and Lawson, 1995) which may lead to tumor formation (Cohen and Ellwein, 1991).

After sodium saccharin exposure, the formation of precipitate in the male rat urine is thought to be the result of an interaction in the urine between saccharin and the male rat-specific protein,  $\alpha 2\mu$ -globulin (Murai et al., 1997; Garland et al., 1994; Swenberg et al., 1992). Alpha  $2\mu$ -globulin is a low-molecular-weight protein, weighing less than 40 kDa (Hard, 1995). It is synthesized in the liver and is quantitatively the major protein found in male rat urine (Roy and Neuhaus, 1966). It is not present in significant quantities in female rat urine and is not synthesized by humans (Hard, 1995).

It has been shown that rats lacking  $\alpha 2\mu$ -globulin are not as subject to bladder cell proliferation following sodium saccharin exposure as are rats producing this protein. Uwagawa et al. (1994) used the male NBR rat, which does not synthesize  $\alpha 2\mu$ -globulin, and the male F344 rat, which does, to demonstrate this. After chronic administration (starting at 6 weeks of age) of a diet containing 5% sodium saccharin, the F344 rat showed signs of cellular proliferation in the bladder urothelium, but the NBR rat did not.

A study by Garland et al. (1994) supports the findings of Uwagawa et al. (1994). Four- to 5-week-old intact F344, castrated F344, and NBR rats were administered 7.5% sodium saccharin in the diet for 10 weeks. Less cellular proliferation occurred in the bladders of the castrated rats, which had reduced levels of  $\alpha 2\mu$ -globulin, than in the bladders of intact F344 rats. Even less proliferation was seen in the bladders of NBR rats, which had lower levels of  $\alpha 2\mu$ -globulin than the castrated rats.

Since  $\alpha 2\mu$ -globulin is normally specific to the male rat and since this protein is thought to be at least partially responsible for the carcinogenicity of sodium saccharin in the bladder,  $\alpha 2\mu$ -globulin in the urinary bladder is probably the physiologic peculiarity that renders the male rat bladder susceptible to a carcinogenic response to sodium saccharin (for review, see Swenberg et al., 1992). However, it is important to note that while Uwagawa et al. (1994) and Garland et al. (1994) demonstrated an association between the presence of  $\alpha 2\mu$ -globulin in the male rat bladder and the occurrence of cellular proliferation of the bladder, no studies were found which evaluated the role of  $\alpha 2\mu$ -globulin in the formation of tumors in these animals.

It is also noteworthy that saccharin binds to other proteins besides  $\alpha 2\mu$ -globulin and that most extensive mechanistic studies have been conducted only in male rats. Whether the female

rat positive bladder response seen in I/P studies is associated with an increase in protein has not been studied.

Another problem with the accuracy of this hypothesis arises from integrating studies investigating the critical age of sodium saccharin administration to male rats for induction of bladder tumors with those investigating the age-dependent expression of  $\alpha_2\mu$ -globulin. It is thought that sodium saccharin produces urinary bladder tumors in male rats only if it is administered before the rats reach 35 days of age (Cohen et al., 1995b) unless exposure occurs after administration of an initiating agent (for review, see Cohen et al., 1995a). In several studies in which rats were exposed to sodium saccharin beginning after this time period, there was no increase in the incidence of bladder tumors in male rats (e.g., Homma et al., 1991; Murasaki and Cohen, 1981; Hooson et al., 1980; Schmähl, 1973; cited by IARC, 1980; for reviews, see Cohen and Ellwein, 1991a; National Academy of Sciences-National Research Council, 1974; cited by Arnold et al., 1980). It has also been shown that hepatic synthesis of  $\alpha_2\mu$ -globulin in the male rat does not begin until 35 to 40 days of age (Roy et al., 1983) and is thus undetectable in male rats below this age (Neuhaus and Flory, 1978). Therefore, the time of susceptibility to induction by sodium saccharin of cellular proliferation in the bladders of male rats does not correlate with the presence of  $\alpha_2\mu$ -globulin in these rats. While this does not necessarily preclude a role for  $\alpha_2\mu$ -globulin in sodium saccharin carcinogenesis, it does raise some doubts.

While the possibility of a role for  $\alpha_2\mu$ -globulin in sodium saccharin carcinogenesis is attractive because it can account for differences in species (e.g., rat and human) and sex (e.g., male and female rats) responses to sodium saccharin, other mechanisms of sodium saccharin carcinogenesis could exist that would also successfully explain these differences. For instance, proteins other than  $\alpha_2\mu$ -globulin may be responsible for the unique vulnerability of male rats to sodium saccharin-induced bladder tumorigenesis. Since male rats have up to 10 times more total protein in their urine than female rats (Lehman-McKeeman and Caudill, 1991) and about 90 times more total urinary protein than humans (Olson et al., 1990), the idea that a protein other than  $\alpha_2\mu$ -globulin can account for species and sex differences in sodium saccharin response is not implausible (for an interspecies comparison of urine chemistries see Table 7-7). Few studies have investigated this hypothesis, although the role of albumin was examined by Homma et al. (1991). This group compared the response of analbuminemic rats to sodium saccharin exposure to the response of Sprague-Dawley rats. Neither strain developed abnormal bladder growths and the study was inconclusive. Since albumin levels in humans are known to be higher than levels in male rats (Hard, 1995), future studies should probably focus on investigating low-molecular-weight proteins other than  $\alpha_2\mu$ -globulin that are more abundant in male rats than in female rats or humans (Olson et al., 1990).

### 7.3.2 Dose-Response Extrapolation

Two major issues to consider when deciding if dose-extrapolation from rats to humans is appropriate are the nature of the carcinogenic mechanism (i.e., does it operate in both rats and humans?) and the presence or absence of a threshold in dose-response. In fact, the majority of data summarized in previous sections of this document indicate that the carcinogenic mechanism of sodium saccharin may be unique to male rats, and that there is a threshold dose.

There is significant data indicating that the mechanism of sodium saccharin-induced bladder carcinogenesis in male rats is related to the formation and retention of urinary precipitate formed under conditions of high urinary pH and high sodium concentration and that this precipitate does not form in other species.

Studies using diets varying in pH have shown that sodium saccharin does not significantly promote proliferation in the male rat urinary bladder when fed in the acidic AIN-76A diet, but sodium saccharin does increase urothelial proliferation when fed in the alkaline Prolab 3200 diet. It has also been shown that in rats, oral administration of sodium saccharin causes an increase in cell proliferation in the urothelium that is more pronounced than that induced by potassium saccharin, whereas calcium saccharin produces only slight changes, and acid saccharin has no effect on the urinary bladder, even though urinary saccharin concentrations do not vary greatly between the different groups of rats. In addition, while sodium saccharin has been shown to induce carcinogenesis in the male rat bladder, so have other sodium salts.

There is also evidence from a number of studies that a threshold dose exists in male rats for sodium saccharin-induced bladder carcinogenesis, suggesting that use of a linear dose-response model is not appropriate to estimate risk in humans.

#### **7.4 Additional Mechanistic Information**

##### **7.4.1 Inhibition of Apoptosis (Programmed Cell Death)**

Wright et al. (1994) reported that pretreatment with saccharin inhibited apoptosis (specifically the DNA fragmentation induced by UV light or tumor necrosis factor) in human histiocytic (U937) lymphoma cells.

##### **7.4.2 Intercellular Communication**

A review by IARC (1987a,b) reported that saccharin (form unspecified) inhibited intercellular communication in mammalian cells *in vitro* in two studies but not a third. These studies administered doses that were 1/2 those used in the tumor-positive rat studies. In a later review by Klaunig and Ruch (1990), the authors reported that saccharin inhibited intercellular communication in Chinese hamster lung V79 cells but not in primary mouse hepatocytes.

**Table 7-1. Effect of Various Forms of Saccharin on the Rat Urinary Bladder**

Treatment <sup>a</sup>	Simple Hyperplasia	Microvilli on SEM		Labeling Index (%)
		Uniform	Pleomorphic	
sodium saccharin	5/12 <sup>b</sup>	2/6	2/6	0.55 ± 0.20 (5) <sup>c</sup>
potassium saccharin	2/12	2/6	0/6	0.18 ± 0.09 (6) <sup>d</sup>
calcium saccharin	2/12	1/6	0/6	0.12 ± 0.11 (6)
acid saccharin	0/12	0/6	0/6	0.07 ± 0.04 (6)
control	0/12	0/6	0/6	0.06 ± 0.04 (6)

<sup>a</sup> 5% in diet for 10 wk

<sup>b</sup> significantly different from acid saccharin and control group, p < 0.02

<sup>c</sup> significantly different from all other groups, p < 0.01

<sup>d</sup> significantly different from control group, p < 0.05

Source: Cohen (1994a)

**Table 7-2. Urine Analysis in Rats Given Various Forms of Saccharin**

Treatment <sup>a</sup>	Urine Volume (mL/day)	Saccharin (mmol/mL)	pH	Na <sup>+</sup> (mEq/L)	K <sup>+</sup> (mEq/L)	Ca <sup>++</sup> (mEq/L)	Osmolality (mOsm/L)
sodium saccharin	10.4	0.17	7.2	291	151	24.8	1520
potassium saccharin	13.5	0.14	6.8	153	298	23.9	1463
calcium saccharin	6.3	0.14	5.7	158	236	41.2	2145
acid saccharin	8.8	0.19	5.5	139	164	51.6	2029
control	6.7	0	7.1	158	201	34.5	1678

<sup>a</sup> 5% in diet for 4 wk

Source: Cohen (1994b)

**Table 7-3. Sodium Salts That Produce Urothelial Hyperplasia and Increase the Incidence of Bladder Tumors in Rats Fed High Doses (> 1%)**

---

Sodium ascorbate  
Sodium aspartate  
Sodium bicarbonate  
Sodium chloride  
Sodium citrate  
Sodium erythorbate  
Sodium glutamate  
Sodium phosphate  
Sodium phytate  
Sodium saccharin  
Sodium succinate

---

Source: Cohen et al. (1997)

Table 7-4. Summary of Positive Mammalian Carcinogenicity Studies

Age, Strain, Species	Chemical Form	Effective Dose and Duration	Primary Tumor Location	Comments on Mechanism of Action	Reference
<b>Mice</b>					
'stock' mice (age not specified)	saccharin <sup>a</sup>	2 mg saccharin/8 mg cholesterol pellets implanted in urinary bladder lumina for 52 wk (1-generation study)	urinary bladder	The presence of the cholesterol pellet in the bladder had a promoting action; saccharin was an incomplete carcinogen.	Allen et al. (1957)
6-wk-old albino mice	saccharin <sup>a</sup>	1.5 g/kg in 1 mL distilled water, force fed for 1 yr (1-generation study)	thyroid	Mechanism unknown, but results are questionable because control incidence was not reported, statistical analysis was not performed, sample size was small, purity of saccharin was not reported, and results have not been replicated.	Prasad and Rai (1986)
18- to 19-wk-old BALB/c mice	sodium saccharin	5.0% diet for 117 wk (1-generation study)	Harderian gland	No dose-response demonstrated. Marginally significant for trend. Probably not applicable to humans, since they only have rudimentary Harderian gland.	Frederick et al. (1989)
<b>Rats</b>					
Charles River CD rats (age not specified)	sodium saccharin	7.5% in diet for 28 mo (2-generation study)	urinary bladder	Mechanism specific to males fed high dose.	Taylor and Friedman (1974 abstr.)
Weanling SD rats (age not specified)	sodium saccharin	5% in diet for 100 wk (2-generation study)	urinary bladder	Mechanism specific to males fed high dose.	Tisdell et al. (1974)
32-day-old SD rats	sodium saccharin	5% in diet for 90 days (adults) or ~700 days (pups) (2-generation study)	urinary bladder	Mechanism specific to males fed high dose.	Arnold et al. (1980)
<i>in utero</i> Charles River CD rats	sodium saccharin	7.5% in diet for ≤ 2 yr (2-generation study)	urinary bladder	Mechanism specific to males fed high dose.	Taylor et al. (1980)
6-wk-old ACI rats <sup>b</sup>	sodium saccharin	5% in diet for 12 mo (1-generation study)	urinary bladder	Mechanism specific to males fed high dose. <i>Trichosomoides crassicauda</i> infection enhanced sodium saccharin-induced cell proliferation in urinary bladder.	Fukushima et al. (1983)
6-wk-old F <sub>0</sub> and 28- to 38-day-old F <sub>1</sub> Charles River CD rats	sodium saccharin	3.0, 4.0, 5.0, 6.25, or 7.5% in diet for 30 mo (2-generation study)	urinary bladder	Mechanism specific to males fed high dose.	Schoenig et al. (1985)

<sup>a</sup> No distinction was made between saccharin and its sodium salt.  
<sup>b</sup> At least half of these rats were infected with the bladder parasite *Trichosomoides crassicauda*.



**Table 7-5. Interspecies Comparison of the Effects of Sodium Saccharin on the Urinary Bladder**

Species	Bladder Hyperplasia <sup>a</sup>		Bladder Carcinogenesis <sup>a</sup>		Bladder Promotion <sup>a</sup>	Urinary Proliferate <sup>a</sup>
	1 Generation	2 Generation	1 Generation	2 Generation		
Hamster	+ (0) - (1)	NE	+ (0) - (1)	NE	NE	NE
Mouse	+ (0) - (1)	NE	+ (2) <sup>c</sup> - (6)	NE	-	-
Rat	+ (17) - (7)	+ (1) - (0)	+ (1) <sup>d</sup> - (14)	+ (5) - (0)	+	+
Guinea Pig	+ (0) - (1)	NE	NE	NE	NE	NE
Monkey	+ (0) - (1)	NE	+ (0) - (4)	NE	NE	-

NE = not evaluated

<sup>a</sup> Number of positive (+) and negative (-) studies in parentheses; data summarized from Tables 4-1 and 6-1

<sup>b</sup> Adapted from Cohen (1994c)

<sup>c</sup> These two studies were equivocal.

<sup>d</sup> This study was equivocal.

Table 7-6. Interstrain Comparison of the Effects of Sodium Saccharin on the Rat Urinary Bladder<sup>a</sup>

Rat Strain	Bladder Hypertrophy		Bladder Cancer Incidence	
	1 Generation	2 Generation	1 Generation	2 Generation
ACI	+ (1) <sup>b</sup> - (0)	NE	+ (1) <sup>b</sup> - (0)	NE
Charles River CD	NE	+ (1) - (0)	+ (0) - (2)	+ (3) - (0)
F344	+ (10) - (4)	NE	+ (0) - (1)	NE
NBR <sup>c</sup>	+ (0) - (1)	NE	NE	NE
Osborne-Mendel	NE	NE	+ (0) - (1)	NE
Sprague-Dawley	+ (4) - (1)	NE	+ (0) - (4)	+ (2) - (0)
Wistar	+ (1) - (2)	NE	+ (0) - (6)	NE

NE = not evaluated

<sup>a</sup> Number of positive (+) and negative (-) studies in parentheses; data summarized from Tables 4-1 and 6-1

<sup>b</sup> This study was equivocal; at least half of the rats were infected with the bladder parasite *Trichosomoides crassicauda*.

<sup>c</sup> NBR rats do not synthesize  $\alpha 2\mu$ -globulin.

Table 7-7. Interspecies Comparison of Fresh Void Urine Chemistry

Species Treatment	pH	Protein (mg/mL)	Sodium (mEq/L)	Potassium (mEq/L)	Calcium (mg/dL)	Creatinine (mg/dL)	Phosphorus (mg/dL)	Urea (mg/dL)	Chloride (mEq/L)	Magnesium (mg/dL)
Human Male	6.4 ± 0.23	0.02 ± 0.00	160 ± 18.8	63 ± 10.7	16.6 ± 3	119 ± 15.8	42 ± 7.7	780 ± 87	160 ± 17.2	9.2 ± 1.9
Human Female	5.8 ± 0.16	0.03 ± 0.01	140 ± 16.9	62 ± 10.1	11.9 ± 2	103 ± 17.3	42 ± 7.7	721 ± 114	162 ± 20.7	6.6 ± 1.3
Monkey-Cyano Control Male	7.2 ± 0.67	0.02 ± 0.02	15 ± 5.0	13 ± 11.0	4 ± 1.0	15 ± 6	1.5 ± 0.5	119 ± 98	15 ± 0	1.5 ± 0.5
Monkey-Cyano NaSac Male	7.0 ± 0.56	0.09 ± 0.02	10 ± 0	47.5 ± 43.5	58 ± 52	71.5 ± 58.5	1 ± 0	468 ± 406	16 ± 1.0	14 ± 1.2
Monkey-Cyano Control Female	6.7 ± 0.19	0.14 ± 0.13	46.5 ± 36.5	58.5 ± 29.5	55 ± 54	131 ± 102	1 ± --	792 ± 588	39 ± 24	11.5 ± 10.5
Monkey-Cyano NaSac Female	6.8 ± 0.32	0.17 ± 0.07	16.5 ± 6.5	19 ± 7	13 ± 4	30 ± 7	2 ± 0	376 ± 114	14 ± 1	7.5 ± 3.5
Monkey-Rhesus Control Male	7.0 ± 0.11	0.13 ± 0.05	13.5 ± 3.5	21 ± 13	12 ± 2	25.5 ± 11.5	1 ± 0	219 ± 115	15 ± 0	5 ± 0
Monkey-Rhesus NaSac Male	7.0 ± 0.24	0.10 ± 0.03	15 ± 5	31 ± 25	10 ± 6	40.5 ± 24.5	1 ± 0	326 ± 249	25 ± 10	5.5 ± 3.5
Monkey-Rhesus Control Female	6.8 ± 0.75	0.07 ± 0.01	10 ± 0	11 ± 5	5.5 ± 0.5	18.0 ± 1.0	1 ± 0	138 ± 8.5	15 ± 0	2.5 ± 0.5
Monkey-Rhesus NaSac Female	6.5 ± 1.4	0.08 ± 0.08	10 ± 0	9.5 ± 7.5	3 ± 1	16 ± 6	1.5 ± 0.5	94 ± 61	15 ± 0	1.5 ± 0.5
Mouse Control Male	7.2 ± 0.07	1.10 ± 0.03	214 ± 22	216 ± 11.2	3 ± 0.38	20.2 ± 0.65	130 ± 6.5	2845 ± 131	218 ± 19	27.8 ± 3.5
Rat Control Male	6.8 ± 0.13	1.7 ± 0.08	199 ± 9.7	406 ± 19.4	6.8 ± 0.4	117 ± 4.0	223 ± 6.4	4069 ± 163.0	242 ± 11.6	29 ± 2.1
Rat NaSac Male	6.5 ± 0.05	0.30 ± 0.05	251 ± 17.3	130 ± 7.5	12.5 ± 0.6	37 ± 2.6	136 ± 9.4	1328 ± 88.0	80.9 ± 6.0	43.6 ± 3.9
Rat Control Female	7.2 ± 0.09	0.20 ± 0.06	222 ± 20.3	437 ± 38.7	14.8 ± 0.9	113 ± 7.0	250 ± 14.8	4281 ± 270.0	264 ± 22.5	36 ± 4.6
Rat NaSac Female	6.6 ± 0.07	0.10 ± 0.02	274 ± 15.1	141 ± 3.7	14.9 ± 1.3	40 ± 1.7	142 ± 7.2	1591 ± 62.0	88 ± 3.4	56.3 ± 3.2

NaSac = sodium saccharin

Source: Cohen (1994d)

## 8.0 REFERENCES

- Adler, I., and J. Ashby. 1989. The Present Lack of Evidence for Unique Rodent Germ-Cell Mutagens. *Mutat. Res.* 212:55-66.
- Allen, M. J., E. Boyland, C. E. Dukes, E. S. Horning, and J. G. Watson. 1957. Cancer of the Urinary Bladder Induced in Mice with Metabolites of Aromatic Amines and Tryptophan. *Br. J. Cancer* 11:212-231.
- Althoff, J., A. Cardesa, P. Pour, and P. Shubik. 1975. A Chronic Study of Artificial Sweeteners in Syrian Golden Hamsters. *Cancer Lett.* 1:21-24.
- Anderson, R. L. 1988. An Hypothesis of the Mechanism of Urinary Bladder Tumorigenesis in Rats Ingesting Sodium Saccharin. *Food Chem. Toxicol.* 26:637-644.
- Anderson, R. L., W. R. Francis and F. R. Lefever. 1987a. Effect of Dietary Carbohydrate Type and Content on the Response of Male Rats to Dietary Sodium Saccharin. *Food Chem. Toxicol.* 25:271-275.
- Anderson, R. L., F. R. Lefever, and J. K. Maurer. 1987b. Effect of Inherent Urine Output of the Response of Male Rats to 7.5% Dietary Sodium Saccharin. *Food Chem. Toxicol.* 25:641-645.
- Anderson, R. L., F. R. Lefever, and J. K. Maurer. 1988. The Effect of Various Saccharin Forms on Gastro-Intestinal Tract, Urine and Bladder of Male Rats. *Food Chem. Toxicol.* 26:665-669.
- Armstrong, B., and R. Doll. 1974. Bladder Cancer Mortality in England and Wales in Relation to Cigarette Smoking and Saccharin Consumption. *Br. J. Prev. Soc. Med.* 28:233-240.
- Armstrong, B., and R. Doll. 1975. Bladder Cancer Mortality in Diabetics in Relation to Saccharin Consumption and Smoking Habits. *Br. J. Prev. Soc. Med.* 29:73-81.
- Arnold, D. L. 1983. Two-Generation Saccharin Bioassays. *Environ. Health Perspect.* 50:27-36.
- Arnold, D. L., C. A. Moodie, H. C. Grice, S. M. Charbonneau, B. Stavric, B. T. Collins, P. F. McGuire, Z. Z. Zawadzka, and I. C. Munro. 1980. Long-Term Toxicity of *ortho*-Toluenesulfonamide and Sodium Saccharin in the Rat. *Toxicol. Appl. Pharmacol.* 52:113-152.
- Arnold, D. L., D. Krewski, and I. C. Munro. 1983. Saccharin: A Toxicological and Historical Perspective. *Toxicology* 27:179-256.
- Ashby, J. 1985. The Genotoxicity of Sodium Saccharin and Sodium Chloride in Relation to Their Cancer-Promoting Properties. *Food Chem. Toxicol.* 23:507-519.

**NTP Report on Carcinogens 1997 Background Document for Saccharin**

- Ball, L. M., A. G. Renwick, and R. T. Williams. 1977. The Fate of [<sup>14</sup>C]Saccharin in Man, Rat, and Rabbit and of 2-Sulphamoyl [<sup>14</sup>C]Benzoic Acid in the Rat. *Xenobiotica* 7:189-203.
- Batzinger, R. P., S.-Y. L. Ou, and E. Bueding. 1977. Saccharin and Other Sweeteners: Mutagenic Properties. *Science* 198:944-946.
- Beljanski, M., L. Le Goff, and M. Beljanski. 1982. *In Vitro* Screening of Carcinogens Using DNA of the His<sup>r</sup> Mutant of *Salmonella typhimurium*. *Exp. Cell Biol.* 50:271-280.
- Bryan, G. T., E. Erturk, and O. Yoshida. 1970. Production of Urinary Bladder Carcinomas in Mice by Sodium Saccharin. *Science* 168:1238-1240.
- Budavari, S., Ed. 1996. *The Merck Index*, 12th ed. Merck & Co., Inc., Whitehall, NJ.
- Burin, G., H. Gibb, and R. Hill. 1995a. Human Bladder Cancer: Evidence for a Potential Irritation-Induced Mechanism. *Food Chem. Toxicol.* 33:785-795.
- Burin, G. J., D. B. Clayson, S. M. Cohen, J. M. DeSesso, L. B. Ellwein, L. Fishbein, C. Frederick, H. Gibb, N. J. Gorelick, G. C. Hard, C. King, R. J. Lorentzen, R. Oyasu, J. M. Rice, C. Y. Wang, and J. M. Ward. 1995b. Urinary Bladder Carcinogenesis: Implications for Risk Assessment. *Food Chem. Toxicol.* 33:797-802.
- Burns, P. C., and E. Rozengurt. 1984. Extracellular Na<sup>+</sup> and Initiation of DNA Synthesis: Role on Intracellular pH and K<sup>+</sup>. *J. Cell Biol.* 98:1082-1089.
- Byard, J. L., and L. Golberg. 1973. The Metabolism of Saccharin in Laboratory Animals. *Food Cosmet. Toxicol.* 11:391-402.
- Byard, J. L., E. W. McChesney, L. Goldberg, and F. Coulston. 1974. Excretion and Metabolism of Saccharin in Man. II. Studies with <sup>14</sup>C-Labelled and Unlabelled Saccharin. *Food Cosmet. Toxicol.* 12:175-184.
- Calorie Control Council. 1996. Saccharin: A Scientific Review. Petition to Delist Saccharin From National Toxicology Program's Report on Carcinogens. 143 pp.
- Cameron, I. L., N. K. R. Smith, T. B. Pool, and R. L. Sparks. 1980. Intracellular Concentrations of Sodium and Other Elements as Related to Mitogenesis and Oncogenesis *In Vivo*. *Cancer Res.* 40:1493-1500.
- Cartwright, R. A., R. Adib, R. Glashan, and B. K. Gray. 1981. The Epidemiology of Bladder Cancer in West Yorkshire. A Preliminary Report on Non-Occupational Aetiologies. *Carcinogenesis* 2:343-346.

**NTP Report on Carcinogens 1997 Background Document for Saccharin**

Chappel, C. I. 1992. A Review and Biological Risk Assessment of Sodium Saccharin. *Regul. Toxicol. Pharmacol.* 15:253-270.

Chowaniec, J., and R. M. Hicks. 1979. Response of the Rat to Saccharin with Particular Reference to the Urinary Bladder. *Br. J. Cancer* 39:355-375.

Clayson, D. B., L. Fishbein, and S. M. Cohen. 1995. Effects of Stones and Other Physical Factors on the Induction of Rodent Bladder Cancer. *Food Chem. Toxicol.* 33:771-784.

Cohen, S. 1994a. Slide 11: Effect of Various Forms of Saccharin on the Rat Urinary Bladder. In: *Transcripts from the Workshop, Assessing the Cancer Risk of Saccharin and Sodium Saccharin.* San Francisco, CA, April 14-16. Sponsored by California EPA.

Cohen, S. 1994b. Slide 12: Urine Analysis in Rats Given Various Forms of Saccharin for 4 Weeks. In: *Transcripts from the Workshop, Assessing the Cancer Risk of Saccharin and Sodium Saccharin.* San Francisco, CA, April 14-16. Sponsored by California EPA.

Cohen, S. 1994c. Slide 27: Interspecies Comparison of Sodium Saccharin. In: *Transcripts from the Workshop, Assessing the Cancer Risk of Saccharin and Sodium Saccharin.* San Francisco, CA, April 14-16. Sponsored by California EPA.

Cohen, S. 1994d. Slide 28: Fresh Void Urine Chemistries. In: *Transcripts from the Workshop, Assessing the Cancer Risk of Saccharin and Sodium Saccharin.* San Francisco, CA, April 14-16. Sponsored by California EPA.

Cohen, S. 1995a. Human Relevance of Animal Carcinogenicity Studies. *Regul. Toxicol. Pharmacol.* 21:75-80.

Cohen, S. 1995b. Cell Proliferation in the Bladder and Implications for Cancer Risk Assessment. *Toxicology* 102:149-159.

Cohen, S. 1995c. Role of Urinary Physiology and Chemistry in Bladder Carcinogenesis. *Food Chem. Toxicol.* 33:715-730.

Cohen, S. M., and L. B. Ellwein. 1991. Cell Proliferation and Bladder Tumor Promotion. *Progress in Clinical and Biological Research*, Vol. 369. *Chemically Induced Cell Proliferation: Implications for Risk Assessment; Chemically Induced Cell Proliferation Conference*, Austin, TX, USA; November 29-December 2, 1989. Butterworth, B. E., et al., Eds. Wiley-Liss, Inc., New York, NY, pp. 347-356.

Cohen, S., and T. Lawson. 1995. Rodent Bladder Tumors Do Not Always Predict for Humans. *Cancer Lett.* 93:9-16.

**NTP Report on Carcinogens 1997 Background Document for Saccharin**

Cohen, S. M., M. Arai, J. B. Jacobs, and G. H. Friedell. 1979. Promoting Effect of Saccharin and DL-Tryptophan in Urinary Bladder Carcinogenesis. *Cancer Res.* 39:1207-1217.

Cohen, S. M., G. Murasaki, S. Fukushima, and R.E. Greenfield. 1982. Effect of Regenerative Hyperplasia on the Urinary Bladder: Carcinogenicity of Sodium Saccharin and *N*-[4-(5-Nitro-2-furyl)-2-thiazolyl]formamide. *Cancer Res.* 42:65-71.

Cohen, S. M., M. Cano, E. M. Garland, and R. A. Earl. 1989. Silicate Crystals in the Urine and Bladder Epithelium of Male Rats Fed Sodium Saccharin. *Carcinogenesis* 30:A205. Abstract.

Cohen, S., M. Fisher, T. Sakata, M. Cano, G. Schoenig, C. Chappel, and E. Garland. 1990. Comparative Analysis of the Proliferative Response of the Rat Urinary Bladder to Sodium Saccharin by Light and Scanning Electron Microscopy and Autoradiography. *Scanning Microsc.* 4:135-142.

Cohen, S., M. Cano, R. Earl, S. Carson, and E. Garland. 1991a. A Proposed Role for Silicates and Protein in the Proliferative Effects of Saccharin on the Male Rat Urothelium. *Carcinogenesis* 12:1551-1555.

Cohen, S., L. Ellwein, T. Okamura, T. Masui, S. Johansson, R. Smith, J. Wehner, M. Khachab, C. Chappel, G. Schoenig, J. Emerson, and E. Garland. 1991b. Comparative Bladder Tumor Promoting Activity of Sodium Saccharin, Sodium Ascorbate, Related Acids, and Calcium Salts in Rats. *Cancer Res.* 51:1766-1777.

Cohen, S. M., M. Cano, E. M. Garland, M. St. John, and L. L. Arnold. 1995a. Urinary and Urothelial Effects of Sodium Salts in Male Rats. *Carcinogenesis* 16:343-348.

Cohen, S. M., M. Cano, M. K. St. John, E. M., Garland, M. Khachab, and L. B. Ellwein. 1995b. Effect of Sodium Saccharin on the Neonatal Rat Bladder. *Scanning Microsc.* 9:137-148.

Cohen, S. M., E. M. Garland, M. Cano, M. St. John, M. Khachab, J. M. Wehner, and L. L. Arnold. 1995c. Effects of Sodium Ascorbate, Sodium Saccharin and Ammonium Chloride on the Male Rat Urinary Bladder. *Carcinogenesis* 16:2743-2750.

Cohen, S. M., L. L. Arnold, M. Cano, U. Thorgeirsson, and S. Takayama. 1996. Lack of Effect of Sodium Saccharin Feeding on Monkey Urine and Urinary Bladder Epithelium. *Proc. Am. Assoc. Cancer Res.* 37:108. Abstract.

Cohen, S. M., T. Masui, E. M. Garland, and L. L. Arnold. 1997. Effects of Diet on Urinary Bladder Carcinogenesis and Cancer Prevention. *J. Nutr.* 127(Suppl. 5):826S-829S.

Connolly, J. G., W. D. Rider, L. Rosenbaum, and J.-A. Chapman. 1978. Relation Between the Use of Artificial Sweeteners and Bladder Cancer. *Can. Med. Assoc. J.* 119:408.

**NTP Report on Carcinogens 1997 Background Document for Saccharin**

Crammer, B., and R. Ikan. 1977. Properties and Syntheses of Sweetening Agents. Chem. Soc. Rev. 6:431-453. (Cited by IARC, 1980)

Cranmer, M. F. 1980. Saccharin: A Report. [Scherr, G. H., Ed.] Pathotox Publishers, Park Forest South, IL. 586 pp.

Dawson, H. 1994a. Economic Substitution. Beverage World 55-58, April.

Dawson, H. 1994b. Holding Aces. Beverage World 58-60, April.

Debiec-Rychter, M., and C. Y. Wang. 1990. Induction of DNA Synthesis by Sodium Phenobarbital, Uracil, and Sodium Saccharin in Urinary Bladder of the F344 Rat. Toxicol. Appl. Pharmacol. 105:345-349.

DeFlora, S., P. Zanicchi, A. Camoirano, C. Bennicelli, and G. S. Badolati. 1984. Genotoxic Activity and Potency of 135 Compounds in the Ames Reversion Test and in a Bacterial DNA-Repair Test. Mutat. Res. 133:161-198.

DeSesso, J. 1995. Anatomical Relationships of Urinary Bladders Compared: Their Potential Role in the Development of Bladder Tumours in Humans and Rats. Food Chem. Toxicol. 33:705-714.

Dropkin, R. H., D. F. Salo, S. M. Tucci, and G. I. Kaye. 1985. Effects on Mouse Embryos of *In Utero* Exposure to Saccharin: Teratogenic and Chromosome Effects. Arch. Toxicol. 56:283-287.

Elcock, M., and R. Morgan. 1993. Update on Artificial Sweeteners and Bladder Cancer. Regul. Toxicol. Pharmacol. 17:35-43.

Ellwein, L. B., and S. M. Cohen. 1988. A Cellular Dynamics Model of Experimental Bladder Cancer: Analysis of the Effect of Sodium Saccharin in the Rat. Risk Anal. 8:215.

Ellwein, L., and S. Cohen. 1990. The Health Risks of Saccharin Revisited. Crit. Rev. Toxicol. 20:311-326.

Ershoff, B. H., and G.S. Bajwa. 1974. Inhibitory Effect of Sodium Cyclamate and Sodium Saccharin on Tumor Induction by 2-Acetylaminofluorene in Rats. Proc. Soc. Exp. Biol. (NY) 145:1293-1297. (Cited by IARC, 1980)

Fisher, M. J., T. Sakata, T. S. Tibbels, R. A. Smith, K. Patil, M. Khachab, S. L. Johansson, and S. M. Cohen. 1989. Effect of Sodium Saccharin and Calcium Saccharin on Urinary Parameters in Rats Fed Prolab 3200 or AIN-76 Diet. Food Chem. Toxicol. 27:1-9.



**NTP Report on Carcinogens 1997 Background Document for Saccharin**

Fitzhugh, O. G., A. A. Nelson, and J. P. Frawley. 1951. A Comparison of the Chronic Toxicities of Synthetic Sweetening Agents. *J. Am. Pharm. Assoc.* 40:583-586.

Frederick, C. B., K. L. Dooley, R. L. Kodell, W. G. Sheldon, and F. F. Kadlubar. 1989. The Effect of Lifetime Sodium Saccharin Dosing on Mice Initiated with the Carcinogen 2-Acetylaminofluorene. *Fund. Appl. Toxicol.* 12:346-357.

Fukushima, S., and S. M. Cohen. 1980. Saccharin-Induced Hyperplasia of the Rat Urinary Bladder. *Cancer Res.* 40:734-736.

Fukushima, S., G. H. Friedell, J. B. Jacobs, and S. M. Cohen. 1981. Effect of L-Tryptophan and Sodium Saccharin on Urinary Tract Carcinogenesis Initiated by *N*-[4-(5-Nitro-2-furyl)-2-thiazolyl]formamide. *Cancer Res.* 41:3100-3103.

Fukushima, S., M. Arai, J. Nakanowatari, T. Hibino, M. Okuda, and N. Ito. 1983. Differences in Susceptibility to Sodium Saccharin Among Various Strains of Rats and Other Animal Species. *Gann* 74:8-20.

Fukushima, S., M. Shibata, T. Shirai, S. Tamano, and N. Ito. 1986. Roles of Urinary Sodium Ion Concentration and pH in Promotion by Ascorbic Acid of Urinary Bladder Carcinogenesis in Rats. *Cancer Res.* 46:1623-1626.

Fukushima, S., S. Tamano, M. A. Shibata, Y. Kurata, M. Hirose, and N. Ito. 1988. The Role of Urinary pH and Sodium Ion Concentration in the Promotion Stage of Two-stage Carcinogenesis of the Rat Urinary Bladder. *Carcinogenesis* 9:1203-1206.

Fukushima, S., S. Uwagawa, T. Shirai, R. Hasegawa, and K. Ogawa. 1990. Synergism by Sodium L-Ascorbate But Inhibition by L-Ascorbic Acid for Sodium Saccharin Promotion of Rat Two-Stage Bladder Carcinogenesis. *Cancer Res.* 50:4195-4198.

Furuya, T., K. Kawamata, T. Kaneko, O. Uchida, S. Horiuchi, and Y. Ikeda. 1975. Long-term Toxicity Study of Sodium Cyclamate and Saccharin Sodium in Rats. *Jpn. J. Pharmacol.* 25:55P-56P. Abstract.

Garland, E. M., J. M. Parr, D. S. Williamson, and S. M. Cohen. 1989a. *In Vitro* Cytotoxicity of the Sodium, Potassium, and Calcium Salts of Saccharin, Sodium Ascorbate, Sodium Citrate, and Sodium Chloride. *Toxicol. In Vitro* 3:201-205.

Garland, E. M., T. Sakata, M. J. Fisher, M. Tsuneo, and S. M. Cohen. 1989b. Influences of Diet and Strain on the Proliferation Effect on the Rat Urinary Bladder Induced by Sodium Saccharin. *Cancer Res.* 49:3789-3794.

**NTP Report on Carcinogens 1997 Background Document for Saccharin**

Garland, E. M., P. L. Kraft, R. Shapiro, M. Khachab, K. Patil, L. B. Ellwein, and S. M. Cohen. 1991. Effects of *In Utero* and Postnatal Sodium Saccharin Exposure on the Nutritional Status of the Young Rat. I. Effects at 30 Days Post-Birth. *Food Chem. Toxicol.* 29:657-67.

Garland, E., M. St. John, M. Asamoto, S. Eklund, B. Mattson, L. Johnson, M. Cano, and S. Cohen. 1994. Comparison of the Effects of Sodium Saccharin in NBR Rats and in Intact and Castrated Male F344 Rats. *Cancer Lett.* 78:99-107.

Hard, G. 1995. Species Comparison of the Content and Composition of Urinary Proteins. *Food Chem. Toxicol.* 33:731-746.

Harguindey, S., J. L. Pedraz, R. G. Cañero, J. Pérez de Diego, and E. J. Cragoe, Jr. 1995. Hydrogen Ion-Dependent Oncogenesis and Parallel New Avenues to Cancer Prevention and Treatment Using a H<sup>+</sup>-Mediated Unifying Approach: pH-Related and pH-Unrelated Mechanisms. *Crit. Rev. Oncogen.* 6:1-33.

Hasegawa, R., and S. M. Cohen. 1986. The Effect of Different Salts of Saccharin on the Rat Urinary Bladder. *Cancer Lett.* 30:261-268.

Hasegawa, R., M. K. St. John, M. Cano, P. Issenberg, D.A. Klein, B. A. Walker, J. W. Jones, R. C. Schnell, B. A. Merrick, M. H. Davies, D. T. McMillan, and S. M. Cohen. 1984. Bladder Freeze Ulceration and Sodium Saccharin Feeding in the Rat: Examination for Urinary Nitrosamines, Mutagens and Bacteria, and Effects on Hepatic Microsomal Enzymes. *Food Chem. Toxicol.* 22(12):935-942.

Hasegawa, R., R. E. Greenfield, G. Murasaki, T. Suzuki, and S. M. Cohen. 1985. Initiation of Urinary Bladder Carcinogenesis in Rats by Freeze Ulceration with Sodium Saccharin Promotion. *Cancer Res.* 45:1469-1473.

Heil, J., and G. Reifferscheid. 1992. Detection of Mammalian Carcinogens with an Immunological DNA Synthesis-Inhibition Test. *Carcinogenesis* 12:2389-94.

Hicks, R. M. 1983. Effect of Promoters on Incidence of Bladder Cancer in Experimental Animal Models. *Environ. Health Perspect.* 50:37-49.

Hicks, R. M. 1984. Promotion: Is Saccharin a Promoter in the Urinary Bladder? *Food Chem. Toxicol.* 22:755-760.

Hicks, R. M., and J. Chowaniec. 1977. The Importance of Synergy Between Weak Carcinogens in the Induction of Bladder Cancer in Experimental Animals and Humans. *Cancer Res.* 37:2943-2949.

**NTP Report on Carcinogens 1997 Background Document for Saccharin**

Hicks, R. M., J. Wakefield, and J. Chowaniec. 1973. Co-carcinogenic Action of Saccharin in the Chemical Induction of Bladder Cancer. *Nature* 243:347-349.

Hicks, R. M., J. S. J. Wakefield, and J. Chowaniec. 1975. Evaluation of a New Model to Detect Bladder Carcinogens or Co-Carcinogens; Results Obtained with Saccharin, Cyclamate and Cyclophosphamide. *Chem. Biol. Interact.* 11:225-233.

Hicks, R. M., J. Chowaniec, and J. St. J. Wakefield. 1978. Experimental Induction of Bladder Tumors By a Two-Stage System. In: *Carcinogenesis, Vol. 2, Mechanisms of Tumor Promotion and Cocarcinogenesis*. Slaga, T. J., A. Sivak, and R. K. Boutwell, Eds. Raven Press, NY, pp. 475-489.

Homburger, F. 1978. Negative Lifetime Carcinogen Studies in Rats and Mice Fed 50,000 ppm Saccharin. *Chemical Toxicology of Food*. Galli, C. L., R. Paoletti, and G. Vettorazzi, Eds. Elsevier/North-Holland Biomedical Press, Amsterdam, pp. 359-373.

Homma, Y., Y. Kondo, T. Kakizoe, Y. Aso, and S. Nagase. 1991. Lack of Bladder Carcinogenicity of Dietary Sodium Saccharin in Analbuminaemic Rats, Which Are Highly Susceptible to *N*-Nitroso-*n*-butyl-(4-hydroxybutyl)amine. *Food Chem. Toxicol.* 29:373-376.

Hooson, J., R. M. Hicks, P. Grasso, and J. Chowaniec. 1980. *ortho*-Toluene Sulphonamide and Saccharin in the Promotion of Bladder Cancer in the Rat. *Br. J. Cancer* 42:129-147.

Hoover, R. N., and P. H. Strasser. 1980. Artificial Sweeteners and Human Bladder Cancer: Preliminary Results. *Lancet* i:837-840.

Hoover, R., and P. Hartge. 1982. Non-Nutritive Sweeteners and Bladder Cancer. *Am. J. Public Health* 72:382-383. (Cited by IARC, 1987b)

Howe, G. R., J. D. Burch, A. B. Miller, B. Morrison, P. Gordon, L. Weldon, L. W. Chambers, G. Fodor, and G. M. Winsor. 1977. Artificial Sweeteners and Human Bladder Cancer. *Lancet* ii:578-581.

Howe, G. R., J. D. Burch, A. B. Miller, G. M. Cook, J. Esteve, B. Morrison, P. Gordon, L. W. Chambers, G. Fodor, and G. M. Winsor. 1980. Tobacco Use, Occupation, Coffee, Various Nutrients, and Bladder Cancer. *J. Natl. Cancer Inst.* 64:701-713.

HSDB (Hazardous Substances Data Bank). 1996. Saccharin. Online available from the National Library of Medicine's TOXNET system. Profile last updated 1/19/96.

IARC (International Agency for Research on Cancer). 1980. Saccharin. *IARC Monogr. Eval. Carcinog. Risk Chem. Hum.* 22(Some Non-Nutritive Sweetening Agents):111-170.

**NTP Report on Carcinogens 1997 Background Document for Saccharin**

IARC (International Agency for Research on Cancer). 1982. Saccharin. IARC Monogr. Eval. Carcinog. Risk Chem. Hum. Suppl. 4(Chemicals, Industrial Processes and Industries Associated with Cancer in Humans):224-226.

IARC (International Agency for Research on Cancer). 1987a. Saccharin. IARC Monogr. Eval. Carcinog. Risks Hum. Suppl. 6(Genetic and Related Effects: An Updating of Selected IARC Monographs From Volumes 1-42):488-496.

IARC (International Agency for Research on Cancer). 1987b. Saccharin. IARC Monogr. Eval. Carcinog. Risks Hum. Suppl. 7(Overall Evaluations of Carcinogenicity: An Updating of IARC Monographs Volumes 1-42):334-339.

Imaida, K., and C.Y. Wang. 1986. Effect of Sodium Phenobarbital and Sodium Saccharin in AIN-76A Diet on Carcinogenesis Initiated with *N*-[4-(5-Nitro-2-furyl)-2-thiazolyl]formamide and *N,N*-Dibutylnitrosamine in Male F344 Rats. *Cancer Res.* 46:6160-6164.

Irving-Monshaw, S. 1989. New Sugar Substitutes Are Poised to Hit the Table. *Chem. Eng. News*, pp. 47-50, July.

Iscovich, J., R. Castelletto, J. Estève, N. Muñoz, R. Colanzi, A. Coronel, I. Deamezola, V. Tassi, and A. Arslan. 1987. Tobacco Smoking, Occupational Exposure and Bladder Cancer in Argentina. *Int. J. Cancer* 40:734-740.

Ito, N., and S. Fukushima. 1989. Promotion of Urinary Bladder Carcinogenesis in Experimental Animals. *Exp. Pathol.* 36:1-15.

JECFA. 1993. The Forty-First Meeting of the Joint FAO/WHO Expert Committee on Food Additives. Series 32. Toxicological Evaluation of Certain Food Additives and Contaminants: Saccharin and Its Salts. International Programme on Chemical Safety (IPCS). World Health Organization, pp. 106-133.

Jensen, O. M., and C. Kamby. 1982. Intra-uterine Exposure to Saccharin and Risk of Bladder Cancer in Man. *Int. J. Cancer* 29:507-509.

Kennedy, G., O. E. Fancher, J. C. Calandra, and R. E. Keller. 1972. Metabolic Fate of Saccharin in the Albino Rat. *Food Cosmet. Toxicol.* 10:143-149.

Kessler, I. I., and J. P. Clark. 1978. Saccharin, Cyclamate, and Human Bladder Cancer. No Evidence of an Association. *J. Am. Med. Assoc.* 240:349-355. (Cited by IARC, 1980)

Klaunig, J. E., and R. J. Ruch. 1990. Role of Inhibition of Intercellular Communication in Carcinogenesis. *Lab. Invest.* 62:135-146.

**NTP Report on Carcinogens 1997 Background Document for Saccharin**

Kroes, R., P. W. J. Peters, J. M. Berkvens, H. G. Verschuuren, T. De Vries, and G. J. van Esch. 1977. Long Term Toxicity and Reproduction Study (Including a Teratogenicity Study) with Cyclamate, Saccharin and Cyclohexylamine. *Toxicology* 8:285-300.

Lawson, T. A., and P. J. Hertzog. 1981. The Failure of Chronically Administered Saccharin to Stimulate Bladder Epithelial DNA Synthesis in FO Rats. *Cancer Lett.* 11:221-224.

Lehman-McKeeman, L. D., and D. Caudill. 1991. Quantitation of Urinary  $\alpha$ 2 $\mu$ -Globulin and Albumin in by Reverse-Phase High Performance Liquid Chromatography. *J. Pharmacol. Methods* 26:239-247.

Lehman-McKeeman, L. D., M. I. Rivera-Torres, and D. Caudill. 1990. Lysosomal Degradation of  $\alpha$ 2 $\mu$ -Globulin and  $\alpha$ 2 $\mu$ -Globulin-Xenobiotic Conjugates. *Toxicol. Appl. Pharmacol.* 103:539-548.

Lessel, B. 1970. Carcinogenic and Teratogenic Aspects of Saccharin. In: *Proceedings SOS/70 Third International Congress of Food Science and Technology*, Washington, DC, pp. 764-770.

Lethco, E. J., and W. C. Wallace. 1975. The Metabolism of Saccharin in Animals. *Toxicology* 3:287-300.

Lutz, W. K., and C. H. Schlatter. 1977. Saccharin Does Not Bind to DNA of Liver or Bladder in the Rat. *Chem. Biol. Interact.* 19:253-257.

Ma, T. H., Z. Xu, C. Xu, H. McConnell, E. V. Rabago, G. A. Arreola, and H. Zhang. 1995. The Improved Allium/Vicia Root Tip Micronucleus Assay for Clastogenicity of Environmental Pollutants. *Mutat. Res.* 334:185-195.

MAFF. 1994. Food Safety Directorate Food Surveillance Information Sheet. Number 46. MAFF U.K. Survey of the Intake of Sweeteners by Diabetics.  
<http://www.maff.gov.uk/food/infosheet/1994/no46/46sweet.htm>.

Masui, T., T. Sakata, E.M. Garland, L. B. Ellwein, S. L. Johansson, and S. M. Cohen. 1988. Effects of Sodium Saccharin (NaS) on Rat Fetal and Neonatal Urinary Bladder. *Proc. AACR*, 29:161. Abstract.

Masui, T., A. M. Mann, T. L. Macatee, T. Okamura, E. M. Garland, H. Fujii, J. C. Pelling, and S. M. Cohen. 1991. *H-ras* Mutations in Rat Urinary Bladder Carcinomas Induced by *N*-[4-(5-Nitro-2-furyl)-2-thiazolyl]formamide and Sodium Saccharin, Sodium Ascorbate or Related Salts. *Cancer Res.* 51:3471-3475

**NTP Report on Carcinogens 1997 Background Document for Saccharin**

Matthews, H. B., M. Fields, and L. Fishbein. 1973. Saccharin: Distribution and Excretion of a Limited Dose in the Rat. *J. Agric. Food Chem.* 21:916-919.

McChesney, E. W., F. Coulston, and K.-F. Benitz. 1977. Six-Year Study of Saccharin in Rhesus Monkeys (Abstract No. 79). *Toxicol. Appl. Pharmacol.* 41:164. Abstract. (Cited by IARC, 1980)

Miller, C. T., C. I. Neutel, R. C. Nair, L. D. Marrett, J. M. Last, and W. E. Collins. 1978. Relative Importance of Risk Factors in Bladder Carcinogenesis. *J. Chronic Dis.* 31:51-56. (Cited by IARC, 1980)

Mohr, U., U. Green, J. Althoff, and P. Schneider. 1978. Syncarcinogenic Action of Saccharin and Sodium-Cyclamate in the Induction of Bladder Tumours in MNU-Pretreated Rats. In: *Health and Sugar Substitutes*. Guggenheim, B., Ed. Karger, Basel, pp. 64-69.

Møller-Jensen, O., J. B. Knudsen, B. L. Sørensen, and J. Clemmesen. 1983. Artificial Sweeteners and Absence of Bladder Cancer Risk in Copenhagen. *Int. J. Cancer* 32:577-582.

Momas, I., J.-P. Daurès, B. Festy, J. Bontoux, and F. Grémy. 1994. Relative Importance of Risk Factors in Bladder Carcinogenesis: Some New Results about Mediterranean Habits. *Cancer Causes Controls* 5:326-332.

Mommsen, S., J. Aagaard, and A. Sell. 1983. A Case-control Study of Female Bladder Cancer. *J. Cancer Clin. Oncol.* 19:725-729.

Morgan, R. W., and M. G. Jain. 1974. Bladder Cancer: Smoking, Beverages, and Artificial Sweeteners. *Can. Med. Assoc. J.* 111:1067-1070.

Morgan, R., and O. Wong. 1985. Review of Epidemiological Studies on Artificial Sweeteners and Bladder Cancer. *Food Chem. Toxicol.* 23:529-533.

Morrison, A., and J. Buring. 1980. Artificial Sweeteners and Cancer of the Lower Urinary Tract. *N. Engl. J. Med.* 302(10):537-541.

Morrison, A. S., W. G. Verhoek, I. Leck, K. Aoki, Y. Ohno, and K. Obata. 1982. Artificial Sweeteners and Bladder Cancer in Manchester, U.K. and Nagoya, Japan. *Br. J. Cancer* 45:332-336.

Munro, I. C., C. A. Noodie, D. Krewski, and H. C. Grice. 1975. A Carcinogenicity Study of Commercial Saccharin in the Rat. *Toxicol. Appl. Pharmacol.* 32:513-526.

Murai, T., S. Mori, M. Hosomo, A. Takashima, S. Machino, T. Oohara, H. Yamashita, S. Makino, T. Matsuda, H. Wanibuchi, and S. Fukushima. 1997. Strain Differences in Sensitivity to

**NTP Report on Carcinogens 1997 Background Document for Saccharin**

the Promoting Effect of Sodium L-Ascorbate in a Two-Stage Rat Urinary Bladder Carcinogenesis Model. *Jpn. J. Cancer Res.* 88:245-253.

Murasaki, G., and S. M. Cohen. 1981. Effect of Dose of Sodium Saccharin on the Induction of Rat Urinary Bladder Proliferation. *Cancer Res.* 41:942-944.

Murasaki, G., and S. M. Cohen. 1983a. Co-carcinogenicity of Sodium Saccharin and *N*-[4-(5-Nitro-2-furyl)-2-thiazolyl]formamide for the Urinary Bladder. *Carcinogenesis* 4:97-99.

Murasaki, G., and S. M. Cohen. 1983b. Effect of Sodium Saccharin on Urinary Bladder Epithelial Regenerative Hyperplasia Following Freeze Ulceration. *Cancer Res.* 43(1):182-187.

Najem, G. R., D. B. Louria, J. J. Seebode, I. S. Thind, J. M. Prusakowski, R. B. Ambrose, and A. R. Femicola. 1982. Life Time Occupation, Smoking, Caffeine, Saccharine, Hair Dyes and Bladder Carcinogenesis. *Int. J. Epidemiol.* 11:212-217.

Nakanishi, K., A. Hagiwara, M. Shibata, K. Imaida, W. Tatematsu, and N. Ito. 1980a. Dose Response of Saccharin in Induction of Urinary Bladder Hyperplasias in Fischer 344 Rats Pretreated with *N*-Butyl-*N*-(4-hydroxybutyl)nitrosamine. *J. Natl. Cancer Inst.* 65:1005-1010.

Nakanishi, K., M. Hirose, T. Ogiso, R. Hasegawa, M. Arai, and N. Ito. 1980b. Effects of Sodium Saccharin and Caffeine on the Urinary Bladder of Rats Treated with *N*-Butyl-*N*-(4-hydroxybutyl)nitrosamine. *Gann* 71:490-500.

Nakanishi, K., S. Fukushima, A. Hagiwara, S. Tamano, and N. Ito. 1982. Organ-Specific Promoting Effects of Phenobarbital Sodium and Sodium Saccharin in the Induction of Liver and Urinary Bladder Tumors in Male F344 Rats. *J. Natl. Cancer Inst.* 68:497-500.

National Academy of Sciences-National Research Council. 1974. Report to FDA on the Safety of Saccharin and Sodium Saccharin in the Human Diet. Publication No. 238 137. (Cited by Arnold et al., 1980)

Neuhaus, O., and W. Flory. 1978. Age-Dependent Changes in the Excretion of Urinary Proteins by the Rat. *Nephron* 22:570-576.

NIOSH (National Institute of Occupational Safety and Health). 1990. National Occupational Hazard Survey, 1981-1983. Unpublished provisional data as of July 1, 1990. Department of Health, Education and Welfare, Cincinnati, OH.

Nomura, A. M. Y., L. N. Kolonel, J. H. Hankin, and C. N. Yoshizawa. 1991. Dietary Factors in Cancer of the Lower Urinary Tract. *Int. J. Cancer* 48: 199-205.

**NTP Report on Carcinogens 1997 Background Document for Saccharin**

NTP (National Toxicology Program). 1994. Saccharin. In: Seventh Annual Report on Carcinogens, Summary 1994. U.S. Department of Health and Human Services, Public Health Service, National Toxicology Program, Research Triangle Park, NC, pp. 352-355.

Okamura, T., E. Garland, T. Masui, T. Sakata, M. St. John, and S. Cohen. 1991. Lack of Bladder Tumor Promoting Activity in Rats Fed Sodium Saccharin in AIN-76A Diet. *Cancer Res.* 51:1778-1782.

Olson, M., J. Johnson, and C. Reidy. 1990. Comparison of Male Rat and Human Urinary Proteins: Implications for Human Resistance to Hyaline Droplet Nephropathy. *Toxicol. Appl. Pharmacol.* 102:524-536.

Oser, B. 1985. Highlights in the History of Saccharin Toxicology. *Food Chem. Toxicol.* 23:535-542.

Otoshi, T., H. Iwata, S. Yamamoto, T. Murai, S. Yamaguchi, I. Matsui-Yuasa, S. Otani, and S. Fukushima. 1993. Severity of Promotion by Sodium Salts of Succinic Acid in Rat Urinary Bladder Carcinogenesis Correlates with Sodium Ion Concentration Under Conditions of Equal Urinary pH. *Carcinogenesis* 14:2277-2281.

Piper, J. M., G. M. Mantonoski, and J. Tonascia. 1986. Bladder Cancer in Young Women. *Am. J. Epidemiol.* 123:1033-1042.

Pitkin, R. M., D. W. Andersen, W. A. Reynolds, and L. J. Filer, Jr. 1971. Saccharin Metabolism in *Macaca mulatta*. *Proc. Soc. Exp. Biol. (NY)* 137:803-806.

PMC Specialties Group, Inc. 1996. High Potency Sweeteners. Information Bulletin No. FFIGEN01.

PMC Specialties Group, Inc. 1997a. Food/Feed Ingredients: SYNCAL<sup>®</sup> GS & SYNCAL<sup>®</sup> GSD (FCC, USP). Technical Bulletin No. FFI4210-11.

PMC Specialties Group, Inc. 1997b. Food/Feed Ingredients: SYNCAL<sup>®</sup> SDS (FCC, USP). Technical Bulletin No. FFI4213-14.

PMC Specialties Group, Inc. 1997c. Food/Feed Ingredients: SYNCAL<sup>®</sup> CAS (FCC, USP). Technical Bulletin No. FFI4216.

PMC Specialties Group, Inc. 1997d. Food/Feed Ingredients: SYNCAL<sup>®</sup> SDI (FCC, USP). Technical Bulletin No. FFI4215.

Prasad, O., and G. Rai. 1986. Induction of Papillary Adenocarcinoma of Thyroid in Albino Mice by Saccharin Feeding. *Indian J. Exp. Biol.* 24:197-199.



**NTP Report on Carcinogens 1997 Background Document for Saccharin**

Renner, H. W. 1979. Possible Mutagenic Activity of Saccharin. *Experientia* 35:1364-1365.

Renwick, A. G. 1986. The Metabolism of Intense Sweeteners. *Xenobiotica* 16:1057-1071.

Renwick A. G. 1993. A Data-derived Safety (Uncertainty) Factor For the Intense Sweetener, Saccharin. *Food Addit. Contam.* 10:337-350.

Research Studies-USDA ERS. 1992. Sugar and Sweetener. U.S. Consumption, 1992: Synthetic Sweeteners, p. 16.

Risch, H., J. Burch, A. Miller, G. Hill, R. Steele, and G. Howe. 1988. Dietary Factors and the Incidence of Cancer of the Urinary Bladder. *Am. J. Epidemiol.* 127:1179-1191.

Roe, F. J. C., L. S. Levy, and R. L. Carter. 1970. Feeding Studies on Sodium Cyclamate, Saccharin and Sucrose for Carcinogenic and Tumor-Promoting Activity. *Food Cosmet. Toxicol.* 8:135-145.

Rossman, T. G., M. Molina, L. Meyer, P. Boone, C. B. Klein, Z. Wang, F. Li, W. C. Lin, and P. L. Kinney. 1991. Performance of 133 Compounds in the Lambda Prophage Induction Endpoint of the Microscreen Assay and a Comparison with *S. typhimurium* Mutagenicity and Rodent Carcinogenicity Assays. *Mutat. Res.* 260:349-367.

Roy, A. K., and O. W. Neuhaus. 1966. Identification of Rat Urinary Proteins by Zone and Immunoelectrophoresis. *Proc. Soc. Exp. Biol. Med.* 894-899.

Roy, A. K., and O. W. Neuhaus. 1967. Androgenic Control of a Sex-Dependent Protein in the Rat. *Nature* 214:618-620. (Cited by Garland et al., 1994)

Roy, A. K., T. S. Nath, N. M. Motwani, and B. Chatterjee. 1983. Age-Dependent Regulation of the Polymorphic Forms of  $\alpha_{2\mu}$ -Globulin. *J. Biol. Chem.* 258:10123-10127.

RTECS (Registry of Toxic Effects of Chemical Substances). 1996. Saccharin. Online database available from the National Library of Medicine's TOXNET system. Profile last updated on 2/7/96.

Sakai, A., and M. Sato. 1989. Improvement of Carcinogen Identification in Balb/3T3 Cell Transformation by Application of a 2-Stage Method. *Mutat. Res.* 214:285-296.

Salaman, M. H., and F. J. C. Roe. 1956. Further Tests For Tumour-Initiating Activity: *N,N*-Di-(2-chloroethyl)-*p*-aminophenylbutyric acid (CB1348) as an Initiator of Skin Tumour Formation in the Mouse. *Br. J. Cancer.* 10:363-378. (Cited by IARC, 1980)

**NTP Report on Carcinogens 1997 Background Document for Saccharin**

Schmähl, D. 1973. Lack of Carcinogenic Effect of Cyclamate, Cyclohexylamine and Saccharin in Rats (German). *Arzneim. Forsch.* 23:1466-1470. (Cited by IARC, 1980)

Schmähl, D., and M. Habs. 1980. Absence of Carcinogenic Response to Cyclamate and Saccharin in Sprague-Dawley Rats after Transplacental Application. *Arzneim. Forsch.* 30:1905-1906.

Schmähl, D., and M. Habs. 1984. Investigations on the Carcinogenicity of the Artificial Sweeteners Sodium Cyclamate and Sodium Saccharin in Rats in a Two-Generation Experiment. *Arzneim. Forsch.* 34:604-608.

Schoenig, G. P., E. I. Goldenthal, R. G. Geil, C. H. Frith, W. R. Richter, and F. W. Carlborg. 1985. Evaluation of the Dose Response and *In Utero* Exposure to Saccharin in the Rat. *Food Chem. Toxicol.* 23:475-490.

Shibata, M. A., S. Tamano, Y. Kurata, A. Hagiwara, and S. Fukushima. 1989. Participation of Urinary Na<sup>+</sup>, K<sup>+</sup>, Ph, and l-Ascorbic Acid in the Proliferation Response of the Bladder Epithelium after the Oral Administration of Various Salts and/or Ascorbic Acid to Rats. *Food Chem. Toxicol.* 27:403-413.

Shioya, S., R. Nagami-Ogihara, S. Ogihara, T. Kimura, and K. Imaida. 1994. Roles of Bladder Distension, Urinary pH and Urinary Sodium Ion Concentration in Cell Proliferation of Urinary Bladder Epithelium in Rats Ingesting Sodium Salts. *Food Chem. Toxicol.* 32:165-171.

Sieber, S. M., and R. H. Adamson. 1978. Long-Term Studies on the Potential Carcinogenicity of Artificial Sweeteners in Non-Human Primates. In: *Health and Sugar Substitutes*. Guggenheim, B., Ed. Basel, Karger, pp. 266-271. (Cited by IARC, 1980)

Silverman, D. T., R. N. Hoover, and G. M. Swanson. 1983. Artificial Sweeteners and Lower Urinary Tract Cancer: Hospital vs. Population Controls. *Am. J. Epidemiol.* 117:326-334.

Simon, D., S. Yen, and P. Cole. 1975. Coffee Drinking and Cancer of the Lower Urinary Tract. *J. Natl. Cancer Inst.* 54:587-591.

Skare, J. A., and T. K. Wong. 1985. Lack of Specific Inhibition of DNA Repair in WI-38 Human Diploid Fibroblasts by Sodium Saccharin. *Cancer Lett.* 26:191-200.

Squire, R. A. 1985. Histopathological Evaluation of Rat Urinary Bladders from the IRDC Two-Generation Bioassay of Sodium Saccharin. *Food Chem. Toxicol.* 23:491.

SRI International. 1996. *SRI Directory of Chemical Producers, United States*. SRI International, Menlo Park, CA, pp. 311, 638.

**NTP Report on Carcinogens 1997 Background Document for Saccharin**

Stoner, G. D., M. B. Shimkin, A. J. Kniazeff, J. H. Weisburger, E. K. Weisburger, and G. B. Gori. 1973. Test for Carcinogenicity of Food Additives and Chemotherapeutic Agents by the Pulmonary Tumor Response in Strain A Mice. *Cancer Res.* 33:3069-3085. (Cited by IARC, 1980)

Sturgeon, S. R., P. Hartge, D. T. Silverman, A. F. Kantor, W. M. Linehan, C. Lynch, and R. N. Hoover. 1994. Associations Between Bladder Cancer Risk Factors and Tumor Stage and Grade at Diagnosis. *Epidemiology* 5:218-225.

Suzuki, H., and N. Suzuki. 1988. Mutagenicity of Saccharin in a Human Cell Strain. *Mutat. Res.* 209:13-16.

Suzuki, H., and N. Suzuki. 1993. Detection of K-ras Codon 12 Mutation by Polymerase Chain Reaction and Differential Dot-Blot Hybridization in Sodium Saccharin-Treated Human RSA Cell. *Biochem. Biophys. Res. Commun.* 196:956-61.

Sweatman, T. W., and A. G. Renwick. 1979. Saccharin Metabolism and Tumorigenicity. *Science* 205:1019-1020.

Sweatman, T. W., and A. G. Renwick. 1980. The Tissue Distribution and Pharmacokinetics of Saccharin in the Rat. *Toxicol. Appl. Pharmacol.* 5:18-31.

Sweatman, T. W., and A. G. Renwick. 1982. Tissue Levels of Saccharin in the Rat During Two-Generation Feeding Studies. *Toxicol. Appl. Pharmacol.* 62:465-473.

Sweatman, T. W., A. G. Renwick, and C. D. Burgess. 1981. The Pharmacokinetics of Saccharin in Man. *Xenobiotica* 11:531-540.

Swenberg, J. A., D. R. Dietrich, R. M. McClain, and S. M. Cohen. 1992. Species-Specific Mechanisms of Carcinogenesis. *Mechanisms of Carcinogenesis in Risk Identification*. Vainio, H. et al., Eds. International Agency for Research On Cancer, Lyon, France. 477-500.

Tatematsu, M., Y. Mera, K. Kohda, Y. Kawazoe, and N. Ito. 1986. Ornithine Decarboxylase Activity and DNA Synthesis in Rats after Long Term Treatment with Butylated Hydroxyanisole, Sodium Saccharin or Phenobarbital. *Cancer Lett.* 33:119-124.

Taylor, J. M., and L. Friedman. 1974. Combined Chronic Feeding and Three-Generation Reproduction Study of Sodium Saccharin in the Rat (Abstract No. 200). *Toxicol. Appl. Pharmacol.* 29:154. Abstract.

Taylor, J. M., M. A. Weinberger, and L. Friedman. 1980. Chronic Toxicity and Carcinogenicity to the Urinary Bladder of Sodium Saccharin in the in Utero-Exposed Rat. *Toxicol. Appl. Pharmacol.* 54:57-75.

**NTP Report on Carcinogens 1997 Background Document for Saccharin**

Thorgeirsson, U., D. Dalgard, J. Reeves, and R. Adamson. 1994. Tumor Incidence in a Chemical Carcinogenesis Study of Nonhuman Primates. *Regul. Toxicol. Pharmacol.* 19:130-151.

Tisdell, M. O., P. O. Nees, D. L. Harris, and P. H. Derse. 1974. Long-Term Feeding of Saccharin in Rats. In: *Symposium: Sweeteners*. Inglett, G. E., Ed. Avi Publishing Co., Westport, CN, pp. 145-158.

Tomasula, D. 1994. Sweet As Sugar. *Chem. Mark. Rep.*, pp. SR22-SR23, June 27.

TRIS (Toxic Release Inventory Systems). 1996. Federal Environmental Site Liability Records. TRIS Database. 1989, 1990, 1991. "Copr. (c) West 1996, No claim to original U.S. government works."

USITC (U.S. International Trade Commission). 1991. Synthetic Organic Chemicals, United States Production and Sales, 1990. USITC Publication No. 2470. U.S. Government Printing Office, Washington, DC.

USITC (U.S. International Trade Commission). 1993. Synthetic Organic Chemicals, United States Production and Sales, 1991. USITC Publication No. 2607. U.S. Government Printing Office, Washington, DC.

USITC (U.S. International Trade Commission). 1994. Synthetic Organic Chemicals, United States Production and Sales, 1992. USITC Publication No. 2720. U.S. Government Printing Office, Washington, DC.

USITC (U.S. International Trade Commission). 1995. Synthetic Organic Chemicals, United States Production and Sales, 1994. USITC Publication No. 2933. U.S. Government Printing Office, Washington, DC.

Uwagawa, S., K. Saito, Y. Okundo, H. Kawasaki, A. Yoshitake, H. Yamada, and S. Fukushima. 1994. Lack of Induction of Epithelial Cell Proliferation by Sodium Saccharin and Sodium l-Ascorbate in the Urinary Bladder of NCI-Black-Reiter (NBR) Male Rats. *Toxicol. Appl. Pharmacol.* 127:182-186.

Velazquez, S. F., R. Schoeny, G. E. Rice, and J. J. Cogliano. 1996. Cancer Risk Assessment: Historical Perspectives, Current Issues, and Future Directions. *Drug Chem. Toxicol.* 19:161-185.

Vesely, D. L., and G. S. Levey. 1978. Saccharin Inhibits Guanylate Cyclase Activity: Possible Relationship to Carcinogenesis. *Biochem. Biophys. Res. Commun.* 81:1384-1389.

Viscusi, W. K. 1994. Efficacy of Labeling of Foods and Pharmaceuticals. *Annu. Rev. Public Health* 15:325-343.

**NTP Report on Carcinogens 1997 Background Document for Saccharin**

Walker, A. M., N. A. Dreyer, E. Friedlander, J. Loughlin, K. J. Rothman, and H. I. Kohn. 1982. An Independent Analysis of the National Cancer Institute Study on Non-Nutritive Sweeteners and Bladder Cancer. *Am. J. Public Health* 72:376-383.

Weast, R. C., and M. J. Astle, Eds. 1980. *The Merck Index*, 12th ed. Merck & Co., Inc., Whitehall, NJ.

Weisburger, E. 1990. Mechanistic Considerations in Chemical Carcinogenesis. *Regul. Toxicol. Pharmacol.* 12:41-52.

West, R. W., W. G. Sheldom, D. W. Gaylor, M. G. Haskin, R. R. Delongchamp, and F. F. Kadlubar. 1986. The Effects of Saccharin on the Development of Neoplastic Lesions Initiated with *N*-Methyl-*N*-nitrosourea in the Rat Urothelium. *Fundam. Appl. Toxicol.* 7:585-600.

West, R. W., W. G. Sheldon, D. W. Gaylor, R. R. Allen, and F. F. Kadulbar. 1994. Study of Sodium Saccharin Co-Carcinogenicity in the Rat. *Food Chem. Toxicol.* 32:207-213.

Whysner, J., and G. M. Williams. 1996. Saccharin Mechanistic Data and Risk Assessment: Urine Composition, Enhanced Cell Proliferation, and Tumor Promotion. *Pharmacol. Ther.* 71:225-252.

Williams, G. M., and J. Whysner. 1996. Epigenetic Carcinogens: Evaluation and Risk Assessment. *Exp. Toxicol. Pathol.* 48:189-195.

Wright, S. C., J. Zhong, and J. W. Larrick. 1994. Inhibition of Apoptosis as a Mechanism of Tumor Promotion. *FASEB J.* 8:654-60.

Wynder, E. L., and R. Goldsmith. 1977. The Epidemiology of Bladder Cancer. A Second Look. *Cancer* 40:1246-1268.

Wynder, E. L., and S. D. Stellman. 1980. Artificial Sweetener Use and Bladder Cancer: A Case-Control Study. *Science* 207:1214-1216.

Yanagisawa, K., K. Nishio, and S. Gotoh. 1987. Screening for Carcinogens by the DNA Synthesis Inhibition Test Using Human Fibroblasts. *Mutat Res.* 183:89-94.

Yu, A., T. Hashimura, Y. Nishio, H. Kanamaru, S. Fukuzawa, and O. Yoshida. 1992. Anti-Promoting Effect of Nordihydroguaiaretic acid on *N*-Butyl-*N*-(4-hydroxybutyl)nitrosamine and Sodium Saccharin-Induced Rat Urinary Bladder Carcinogenesis. *Jpn. J. Cancer Res.* 83:944-948.

**APPENDIX A**

**Excerpts from the IARC Monograph on the  
Evaluation of the Carcinogenic Risk of Chemicals to Humans  
Volume 22 (Some Non-Nutritive Sweetening Agents)  
Saccharin, pp. 111-185, 1980**

**APPENDIX B**

**Excerpts from the IARC Monograph on the  
Evaluation of the Carcinogenic Risk of Chemicals to Humans  
Supplement 4 (Chemicals, Industrial Processes and Industries  
Associated with Cancer in Humans, IARC Monographs Volumes 1 to 29)  
Saccharin  
pp. 224-226, 1982**

**APPENDIX C**

**Excerpts from the IARC Monograph on the  
Evaluation of the Carcinogenic Risk of Chemicals to Humans  
Supplement 7 (Overall Evaluations of Carcinogenicity:  
An Updating of IARC Monographs Volumes 1 to 42)  
Saccharin  
pp. 334-339, 1987**



**APPENDIX D**

**Description of Online Searches for  
Saccharin and Saccharin Salts**

## DESCRIPTION OF ONLINE SEARCHES FOR SACCHARIN AND SACCHARIN SALTS

Initial online searches for saccharin [CASRN 128-44-9] and its sodium [81-07-2, anhydrous; 6155-57-3, dihydrate] and ammonium [6381-61-9] salts were performed in February and March 1996 in databases on the systems of STN International, DIALOG, NLM's TOXNET, and the Chemical Information System. Toxicology information was sought in the databases CCRIS (Chemical Carcinogenesis Research Information System), CHEMHAZIS (from the NTP Chemical Repository), EMIC, EMICBACK, GENETOX, RTECS (one record for each), and TOXLINE (name and CASRNs combined with terms for metabolism and the MESH heading for all neoplasms). Since that time, we have monitored 1200 life sciences journals for saccharin information using Current Contents on Diskette<sup>®</sup> (and cumulative issues on CD-ROM). We monitored not only for saccharin but also for information on rat bladder carcinogenesis induced by other chemicals and for articles by S. Cohen. We had requested and received many reprints on these topics by the time work resumed on this compound in 1997.

Market information, including production, shipments, sales and consumption, labor use, and workers by type was sought in IAC PROMT and the FOODLINE files Food Science and Technology and International Food Market Data in March 1996.

Regulatory information was sought in March 1996 from CHEMTOX and the FOODLINE file CURRENT FOOD LEGISLATION and more recently from the in-house FESA CD-ROM containing the latest *Code of Federal Regulations* and the *Federal Register* pertaining to the title 21 (FDA) and title 40 (EPA) regulations.

**APPENDIX E**

**Listing of GAP Test Codes in Phylogenetic Order  
For Saccharin and Sodium Saccharin**

**LISTING OF GAP TEST CODES IN PHYLOGENETIC ORDER  
FOR SACCHARIN AND SODIUM SACCHARIN**

**Prokaryotic Systems:**

PRB = Prophage, induction, SOS repair, DNA strand breaks or cross-links  
SA5 = Salmonella typhimurium TA1535, reverse mutation  
SA7 = Salmonella typhimurium TA1537, reverse mutation  
SA8 = Salmonella typhimurium TA1538, reverse mutation  
SA9 = Salmonella typhimurium TA98, reverse mutation  
SA0 = Salmonella typhimurium TA100, reverse mutation

**Lower Eukaryotic Systems:**

SCG = Saccharomyces cerevisiae, gene conversion  
SCH = S. cerevisiae, homozygosis by recombination or gene conversion  
SCR = Saccharomyces cerevisiae, reverse mutation  
SCN = Saccharomyces cerevisiae, aneuploidy  
DMX = Drosophila melanogaster, sex-linked recessive lethal mutation  
DMH = Drosophila melanogaster, heritable translocation test

**Mammalian Systems in vitro:**

DIA = DNA strand breaks, cross-links or rel. damage, animal cells in vitro  
G5T = Gene mutation, mouse L5178Y cells in vitro, TK locus  
SIC = Sister chromatid exchange, Chinese hamster cells in vitro  
CIC = Chromosomal aberrations, Chinese hamster cells in vitro  
TBM = Cell transformation, BALB/C3T3 mouse cells  
TCM = Cell transformation, C3H10T1/2 mouse cells  
TRR = Cell transformation, RLV/Fischer rat embryo cells  
SHL = Sister chromatid exchange, human lymphocytes in vitro  
CHL = Chromosomal aberrations, human lymphocytes in vitro

**Mammalian Systems in vivo:**

BFA = Body fluids from animals, microbial mutagenicity  
DVA = DNA strand breaks, cross-links or rel. damage, animals in vivo  
MST = Mouse spot test  
SVA = Sister chromatid exchange, animal cells in vivo  
MVM = Micronucleus test, mice in vivo  
CBA = Chromosomal aberrations, animal bone-marrow cells in vivo  
CGC = Chromosomal aberrations, spermatogonia treated in vivo and cytes obs.  
CGG = Chromosomal aberrations, spermatogonia treated in vivo and gonia obs.  
DLM = Dominant lethal test, mice

**\* Alternative test codes (not shown in profiles)**

BVD = Binding (covalent) to DNA, animal cells in vivo

ICR = Inhibition of intercellular communication, rodent in vitro

ICR = Inhibition of intercellular communication, rodent in vitro

ICR = Inhibition of intercellular communication, rodent in vitro

SPM = Sperm morphology, mouse

**APPENDIX F**

**Listing from the Eighth Report on Carcinogens**

**SACCHARIN**  
**CAS No. 128-44-9**

First Listed in the *Second Annual Report on Carcinogens*

**CARCINOGENICITY**

There is sufficient evidence for the carcinogenicity of saccharin in experimental animals (IARC V.22, 1980; IARC S.4, 1982; IARC S.7, 1987). Saccharin is produced commercially as calcium and sodium salts (6485-34-3 and 128-44-9, respectively) as well as the free acid, and the name saccharin has been applied to all these chemicals. When saccharin was administered in the diet or drinking water, increased incidences of lymphomas/leukemias and transitional cell carcinomas of the urinary bladder were seen in rats. In multigeneration studies using rats, administration of saccharin in the diet induced transitional cell carcinomas and papillomas of the urinary bladder in the first generation male offspring. In one study when administered in the diet, saccharin induced papillary adenocarcinomas of the thyroid in mice. Several studies in which saccharin was administered orally to mice, rats, hamsters, and monkeys were considered inadequate for evaluation by IARC Working Groups. Surgical insertion of pellets containing saccharin resulted in urinary bladder cancer in mice and urinary bladder carcinomas in female mice. Other studies involving topical administration of saccharin to mice and intraperitoneal injection of female mice were considered to be inadequate for complete evaluation by IARC Working Groups. Transplacental exposure of rats to sodium saccharin and to saccharin did not produce any treatment-related neoplasms. Pretreatment with a single instillation in the urinary bladder of a low dose of *N*-methyl-*N*-nitrosourea or feeding of *N*-[4-(5-nitro-2-furyl)-2-thiazolyl]formamide and subsequent oral administration of sodium saccharin for long periods increased the incidence of urinary bladder neoplasms in rats over that induced by the nitrosourea or the amide alone. Simultaneous administration of *N*-nitroso-*N*-(4-hydroxybutyl)butylamine and sodium saccharin significantly enhanced the induction of urinary bladder papillomas over that seen after treatment with the nitrosamine alone.

An IARC Working Group reported that there is no adequate evidence for the carcinogenicity of saccharin in humans (IARC S.7, 1987). Since the positive report of Howe et al. (1980), the results of seven case-control studies and one population study of urinary bladder cancer have been inconsistent. The largest was a population-based study in 10 areas of the United States. Significant trends of increasing risk with increasing average daily consumption were found in female nonsmokers and male heavy smokers. Subsequent, independent reanalysis of the same data by a different statistical technique (multiple logistic regression) confirmed the original findings overall but cast doubt on the significance of the findings in the two subgroups because of inconsistent dose-response trends, especially among the male heavy smokers. Three other case-control studies have also shown increased risks among subgroups, but other studies have given negative results. In another study of patients hospitalized for cancer and control patients, a greater proportion of artificial sweetener users was found only among women with cancer of the stomach. Little information was available on urinary tract cancer. No overall association was found between artificial sweetener use and cancer.

**PROPERTIES**

Saccharin is a white crystalline powder with an intensely sweet taste. It is soluble in water, acetone, ethanol, and glycerol and slightly soluble in chloroform and diethyl ether. Saccharin is also available as the calcium and sodium salts. Calcium saccharin is a free-flowing white powder that is odorless or has a faint aromatic odor. Sodium saccharin occurs as white, nondusting granules with no odor. Both salts are soluble in water. When heated to decomposition, saccharin and its calcium and sodium salts emit toxic fumes of nitrogen oxides (NO<sub>x</sub>) and sulfur oxides (SO<sub>x</sub>). Saccharin is

## Saccharin (Continued)

available as a grade containing up to 98-101% active ingredients. Calcium saccharin is available as a grade 95% pure. Sodium saccharin is available as a grade 98-101% pure.

### USE

Saccharin is used primarily as a nonnutritive sweetening agent, with usage increasing substantially after cyclamates were banned in food in 1970. In 1976, the estimated U.S. consumption for all forms of saccharin was 45% in soft drinks; 18% in tabletop sweeteners; 14% in fruit juices, sweets, chewing gum, and jellies; 10% in cosmetics and oral hygiene products; 7% in drugs, such as coatings on pills; 2% in smokeless tobacco products; 2% in electroplating; and 2% for other uses (IARC V.22, 1980).

### PRODUCTION

The USITC identified one U.S. producer for saccharin and its sodium salt from 1980 to 1988, but no production data were provided (USITC, 1981, 1982, 1983, 1984, 1985, 1986, 1987, 1988, 1989). The USITC also reported that one U.S. company produced saccharin, calcium salt, from 1982 to 1984, but no production data were provided. U.S. imports of saccharin have steadily declined from 5.9 million lb in 1983 to 3.7 million lb in 1984, about 1.8 million lb in 1985, and to 1.6 million lb in 1987 (USITCa, 1984; USDOC Imports, 1985 1986, 1988). The 1979 TSCA Inventory identified three U.S. companies producing 1.1 million lb of saccharin in 1977, and 6.3 million lb were imported. Two U.S. companies produced 1.6 million lb of saccharin, sodium salt, and 281,000 lb were imported in 1977. Imports of saccharin, calcium salt, amounted to 5,500 lb, and one U.S. company produced 550,000 lb of saccharin, ammonium salt, in 1977 (TSCA, 1979).

### EXPOSURE

The primary routes of potential human exposure to saccharin are ingestion and dermal contact. Potential exposure occurs through the consumption of dietetic foods and drinks and some personal hygiene products, such as certain toothpastes and mouthwashes. The FDA has authorized the use of saccharin and its salts in beverages in concentrations not to exceed 12 mg/oz, as a sugar substitute not to exceed 20 mg for each expressed teaspoonful of sugar sweetening equivalency, and in processed food not to exceed 30 mg per serving. In 1983, the Calorie Control Council estimated that in the United States, 44 million adults consumed saccharin-sweetened products. Saccharin consumption is greatest among diabetics and others whose medical conditions require the restriction of calories or carbohydrates. Exposure to saccharin has possibly decreased in recent years due to the introduction of Nutra-Sweet® and Equal® (aspartame). The risk of potential occupational exposure exists for workers involved in the production of saccharin or its salts, in the manufacture and formulation of saccharin-containing products, and during the packaging of the consumer products. The National Occupational Hazard Survey, conducted by NIOSH from 1972 to 1974, estimated that about 28,000 workers were potentially exposed to saccharin in the workplace (NIOSH, 1976). The National Occupational Exposure Survey (1981-1983) estimated that 12,994 total workers, including 11,182 women, potentially were exposed to saccharin and 18,952 total workers, including 11,801 women, potentially were exposed to its sodium salt (NIOSH, 1984). The Toxic Chemical Release Inventory (EPA) listed four industrial facilities that produced, processed or otherwise used saccharin in 1988 (TRI, 1990). In compliance with Community Right-to-Know Program, the facilities reported releases of saccharin to the environment which were estimated to total 750 lb.



**REGULATIONS**

The EPA regulates saccharin and its salts under the Comprehensive Environmental Response, Compensation, and Liability Act (CERCLA), Resource Conservation and Recovery Act (RCRA), and Superfund Amendments and Reauthorization Act (SARA). Saccharin is subject to reporting and recordkeeping rules under CERCLA, RCRA, and SARA. The EPA proposed raising the statutory reportable quantity (RQ) of 1 lb, established under CERCLA, to 100 lb for saccharin and its salts. The final rule adjusts the RQ from 1 lb to 100 lb. Saccharin is regulated as a hazardous constituent of waste under RCRA, and threshold amounts for facilities which may release saccharin have been established under SARA. The FDA regulates saccharin under the Food, Drug, and Cosmetic Act (FD&CA) as a food ingredient not to exceed specific concentrations. In compliance with the Delaney Clause, the FDA proposed to ban saccharin as a food additive in 1977 because of the available evidence of its carcinogenicity in animals. However, final regulations are pending because of congressional action in 1977 requiring further study and labeling of saccharin. OSHA regulates saccharin under the Hazard Communication Standard and as a chemical hazard in laboratories.