



US 20040184398A1

(19) **United States**

(12) **Patent Application Publication** (10) **Pub. No.: US 2004/0184398 A1**
Walton et al. (43) **Pub. Date: Sep. 23, 2004**

(54) **TRANSMISSION MODE SELECTION FOR DATA TRANSMISSION IN A MULTI-CHANNEL COMMUNICATION SYSTEM**

(52) U.S. Cl. 370/203; 370/332

(57) **ABSTRACT**

(76) Inventors: **Jay Rod Walton**, Carlisle, MA (US);
Irina Medvedev, Somerville, MA (US)

Techniques to select a suitable transmission mode for a data transmission in a multi-channel communication system with multiple transmission channels having varying SNRs. In one method, an SNR estimate is initially obtained for each of multiple transmission channels used to transmit a data stream. An average SNR and an unbiased variance are then computed for the SNR estimates for the multiple transmission channels. A back-off factor is determined, for example, based on the SNR variance and a scaling factor. An operating SNR for the transmission channels is next computed based on the average SNR and the back-off factor. The transmission mode is then selected for the data stream based on the operating SNR. The selected transmission mode is associated with a highest required SNR that is less than or equal to the operating SNR. The method may be used for any system with multiple transmission channels having varying SNRs.

Correspondence Address:
Qualcomm Incorporated
Patents Department
5775 Morehouse Drive
San Diego, CA 92121-1714 (US)

(21) Appl. No.: **10/394,529**

(22) Filed: **Mar. 20, 2003**

Publication Classification

(51) Int. Cl.⁷ **H04Q 7/00**

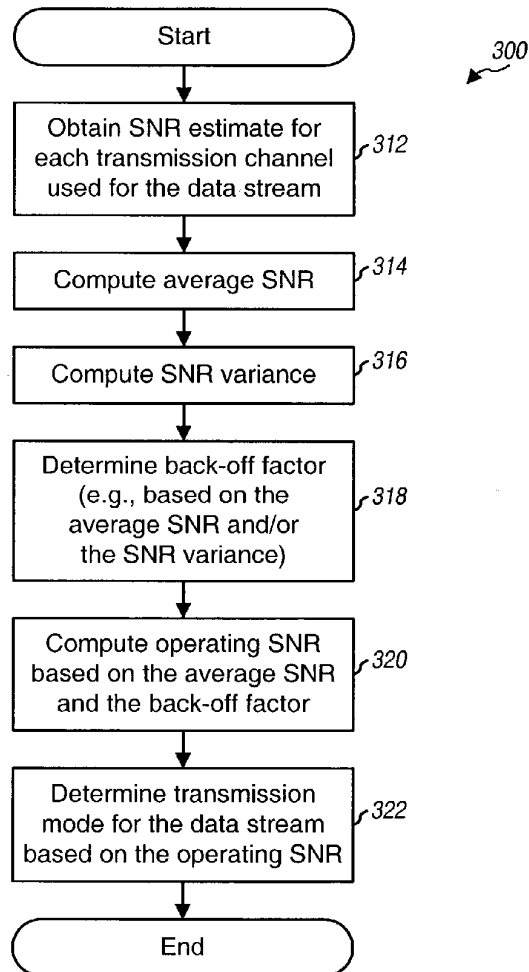

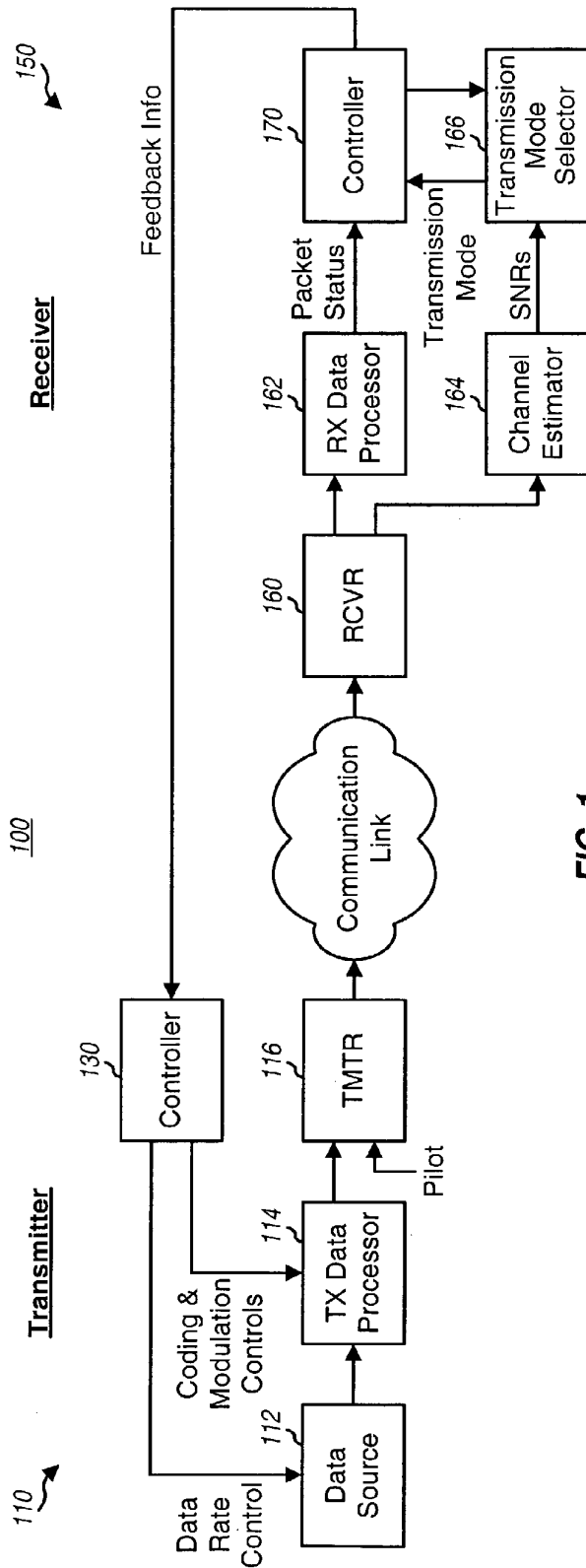

FIG. 1

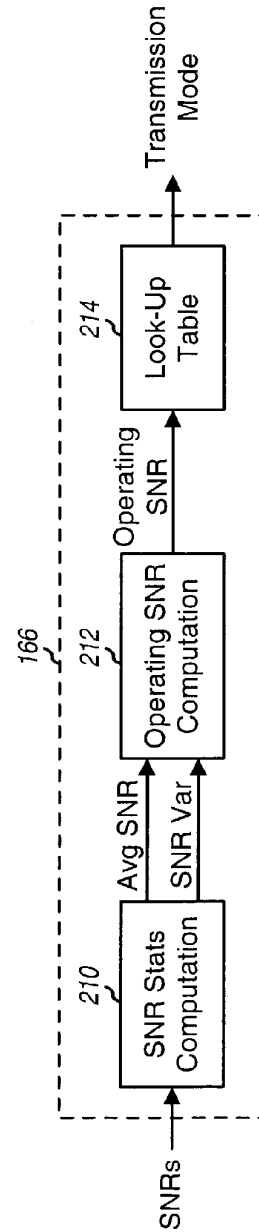

FIG. 2

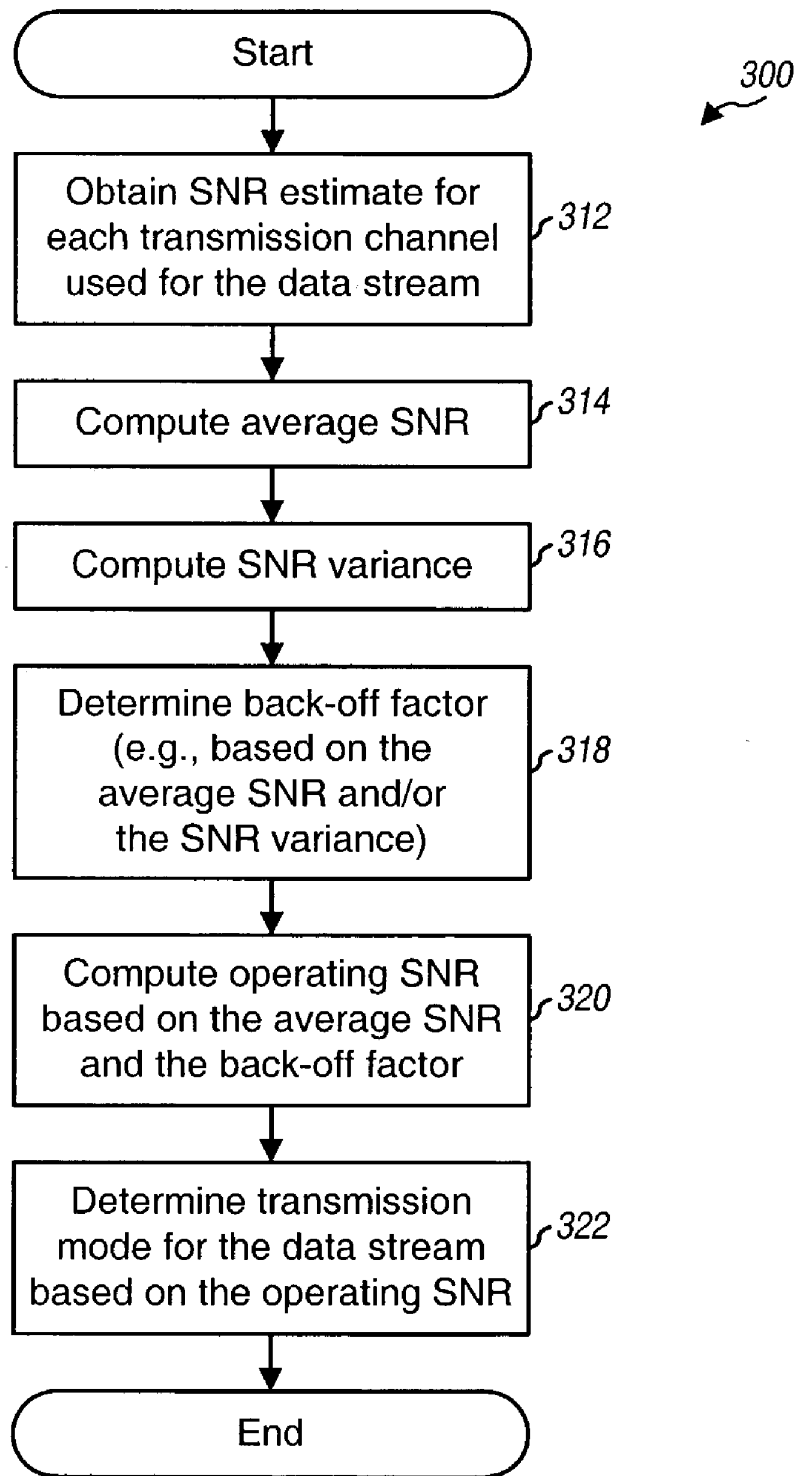

FIG. 3

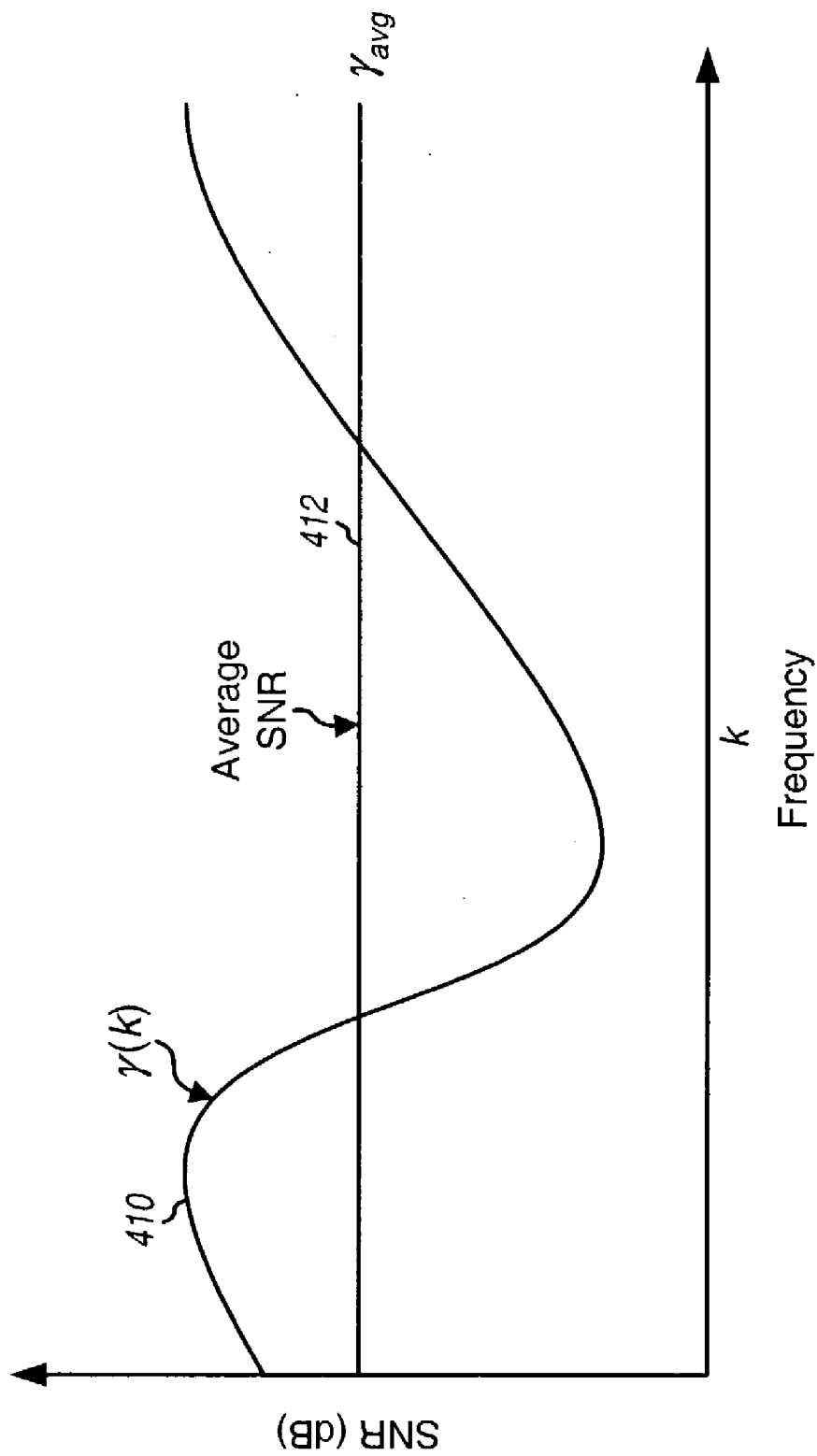

FIG. 4

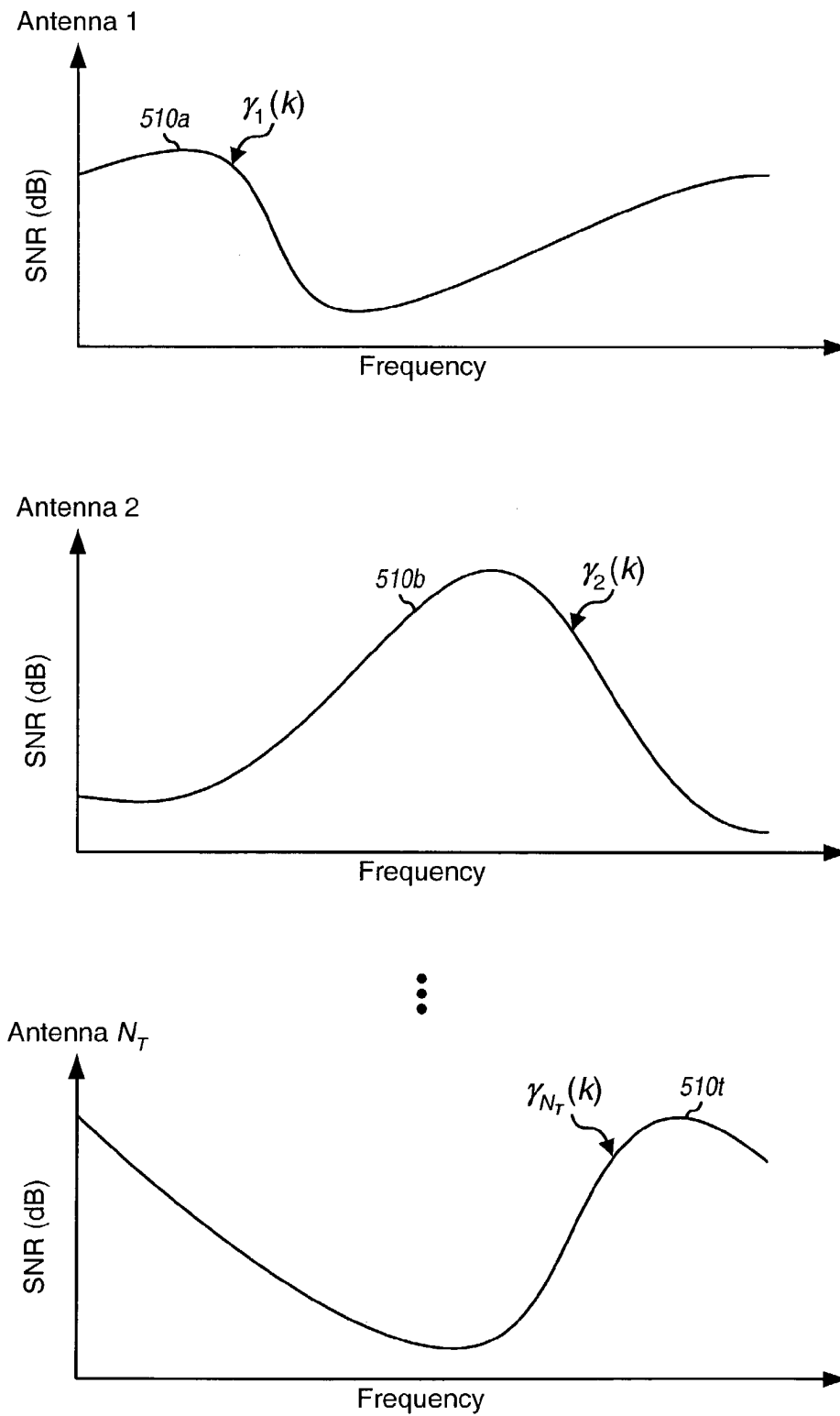

FIG. 5A

Explore Litigation Insights

Docket Alarm provides insights to develop a more informed litigation strategy and the peace of mind of knowing you're on top of things.

Real-Time Litigation Alerts



Keep your litigation team up-to-date with **real-time alerts** and advanced team management tools built for the enterprise, all while greatly reducing PACER spend.

Our comprehensive service means we can handle Federal, State, and Administrative courts across the country.

Advanced Docket Research



With over 230 million records, Docket Alarm's cloud-native docket research platform finds what other services can't. Coverage includes Federal, State, plus PTAB, TTAB, ITC and NLRB decisions, all in one place.

Identify arguments that have been successful in the past with full text, pinpoint searching. Link to case law cited within any court document via Fastcase.

Analytics At Your Fingertips



Learn what happened the last time a particular judge, opposing counsel or company faced cases similar to yours.

Advanced out-of-the-box PTAB and TTAB analytics are always at your fingertips.

API

Docket Alarm offers a powerful API (application programming interface) to developers that want to integrate case filings into their apps.

LAW FIRMS

Build custom dashboards for your attorneys and clients with live data direct from the court.

Automate many repetitive legal tasks like conflict checks, document management, and marketing.

FINANCIAL INSTITUTIONS

Litigation and bankruptcy checks for companies and debtors.

E-DISCOVERY AND LEGAL VENDORS

Sync your system to PACER to automate legal marketing.