



US005197140A

United States Patent [19]

[11] Patent Number: **5,197,140**

Balmer

[45] Date of Patent: **Mar. 23, 1993**

[54] **SLICED ADDRESSING MULTI-PROCESSOR AND METHOD OF OPERATION**

[75] Inventor: **Keith Balmer**, Bedford, England

[73] Assignee: **Texas Instruments Incorporated**, Dallas, Tex.

[21] Appl. No.: **437,946**

[22] Filed: **Nov. 17, 1989**

[51] Int. Cl.⁵ **G06F 12/00; G06F 15/00; G06F 7/33; G06F 7/50**

[52] U.S. Cl. **395/400; 395/300; 364/749; 364/786; 364/787**

[58] Field of Search **395/400, 800, 163, 166; 364/749, 786, 787**

[56] **References Cited**

U.S. PATENT DOCUMENTS

3,260,840	7/1966	King	364/787
3,683,163	8/1972	Hanslip	364/749
3,728,532	4/1973	Pryor	364/787
4,562,535	12/1985	Vincent et al.	395/325
4,644,496	2/1987	Andrews	395/800
4,747,043	5/1988	Rodman	395/425
4,860,248	8/1989	Lumelsky	395/163
4,888,679	12/1989	Fossum et al.	395/800
4,953,101	8/1980	Kelleher et al.	395/166
5,101,338	3/1992	Fujiwara et al.	395/400

OTHER PUBLICATIONS

"The Connection Machine", W. D. Hillis, published in The MIT Press (1985).

"Handling Real Time Images Comes Naturally to Systolic Array Chip", by Hannaway, Shea, Bishop in Electronic Design, pp. 289-300, Nov. 1984.

"Systolic Array Chip Recognizes Visual Patterns Quicker Than a Wink", by W. W. Smith, P. Sullivan, in Electronic Design, pp. 257-266, No. 29, 1984.

"Real Time 3D Object Tracking in a Rapid Prototyping Environment", Robert J. Gove, Electronic Imaging '88, Oct. 4, 1989, pp. 54-59.

"Integration of Symbolic and Multiple Digital Signal Processors with the Explorer/Odyssey for Image Processing and Understanding-Applications", Robert J. Gove, Proceedings to the IEEE International Symposium of Circuits and Systems, pp. 968-971 (May, 1987).

"The Use of Parallel-Processing Computers in Digital

Image Processing", Lew Brown, Electronic Imaging '87, International Electronic Imaging Exposition and Conference, Nov. 2, 1987, pp. 1057-1060.

"VITec Parallel C Compiler", by Butler, Electronic Imaging '89, International Electronic Imaging Exposition and Conference, Nov. 1989, pp. 741-747.

"A Single Board Image Computer with 64 Parallel Processors" by Stephen Wilson, Electronic Imaging '87, International Electronic Imaging Exposition & Conference, Nov. 2, 1987, pp. 470-475.

"The Androx Parallel Image Array Processor", Wayne Threath, Electronic Imaging '87, International Electronic Imaging Exposition & Conference, Nov. 2, 1987, pp. 1061-1064.

"Design of a Massively Parallel Processor", Kenneth Batcher, IEEE Transactions on Computers, v. C-29, No. 9, Sep. 1980, pp. 836-840.

"High Resolution Frame Grabbing and Processing Through Parallel Architecture", Daniel Crevier, Electronic Imaging '87, International Electronic Imaging Exposition & Conference, Nov. 2, 1987, pp. 681-682.

(List continued on next page.)

Primary Examiner—Joseph L. Dixon
Assistant Examiner—Michael A. Whitfield
Attorney, Agent, or Firm—Robert D. Marshall, Jr.; James C. Kesterson; Richard L. Donaldson

[57] **ABSTRACT**

A multi-processor system arranged, in one embodiment, as an image and graphics processor. The processor is structured with several individual processors all having communication links to several memories. An addressing scheme, called sliced addressing, is used to spread contiguous related data over several memories so that the data can be concurrently accessed by several processors. A crossbar switch serves to establish the processor memory links. The entire image processor, including the individual processors, the crossbar switch and the memories, is contained on a single silicon chip.

13 Claims, 35 Drawing Sheets

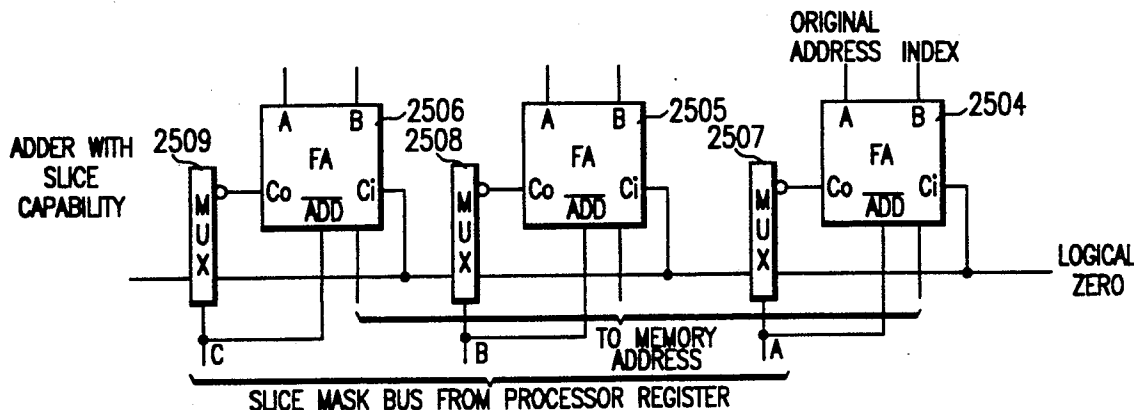

OTHER PUBLICATIONS

"Multiple Digital Signal Processor Environment for Intelligent Signal Processors by Gass et al.", Proceedings of the IEEE, v. 75, No. 9 (Sep. 1987) pp. 1246-1259.

"Architecture and Design of the Mars Hardware Accelerator", AGRA Wall, in 24th ACM/IEEE Design Automation Conference (1987), pp. 101-107.

"A 200 MIPS Single-Chip IKFFY Processor", by O'Brien, Mather & Holland, IEEE International Solid-State Circuits Conference, Feb. 16, 1989, pp. 166-167.

"An Architectural Study, Design and Implementation of Digital Image Acquisition Processing and Display Systems with Micro-Processor-Based Personal Computers and Charge-Coupled Device Imaging Technology", a Dissertation by Robert J. Gove, SMU, May 17, 1986.

"A Medium Grained Parallel Computer for Image Processing" by R. S. Cok, published by Digital Technology Center, Eastman Kodak Co., Rochester, N.Y., pp. 927-936.

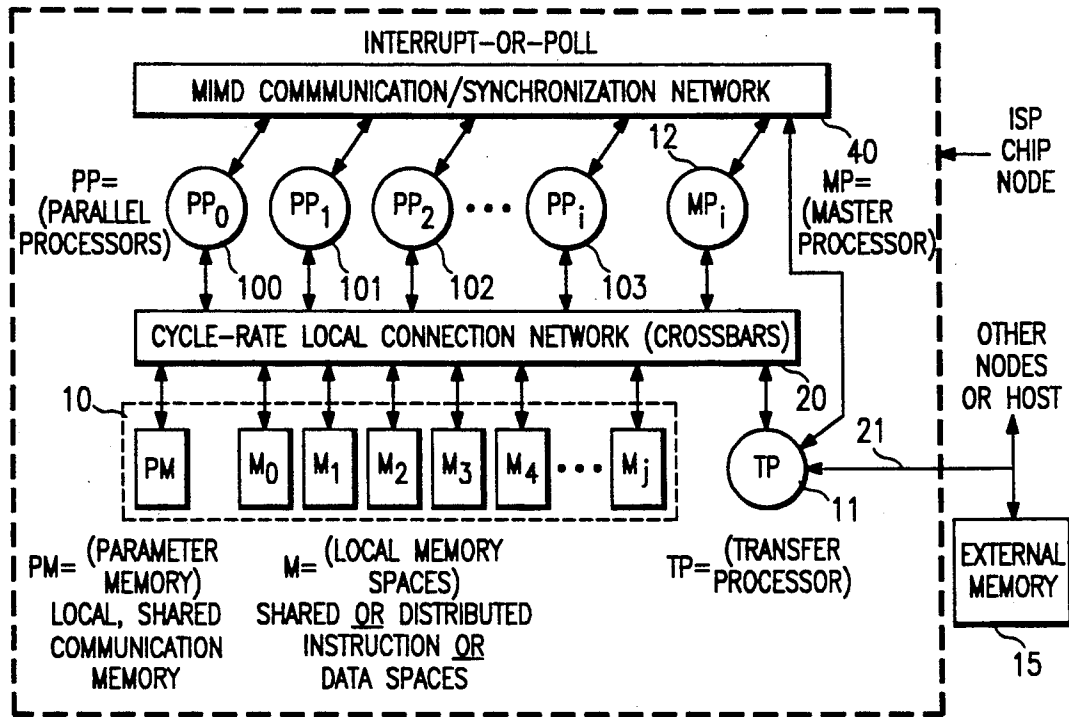

FIG. 1

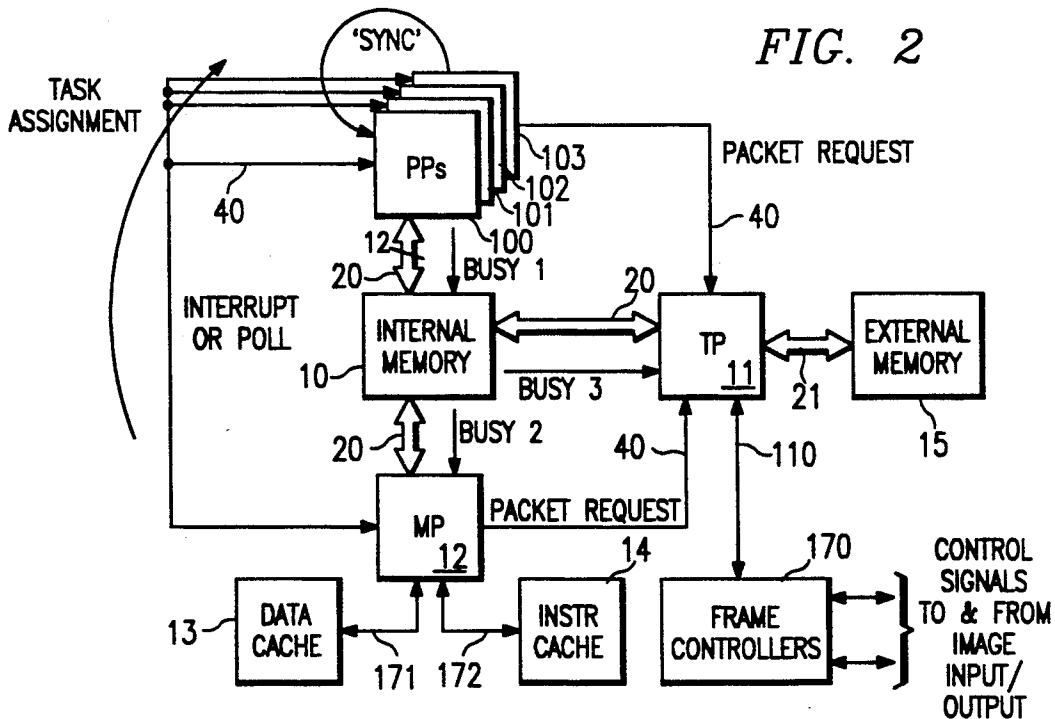
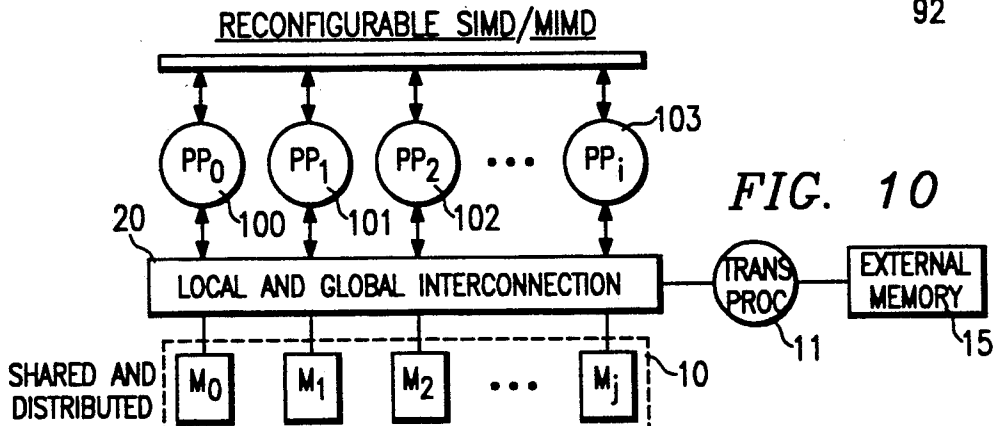
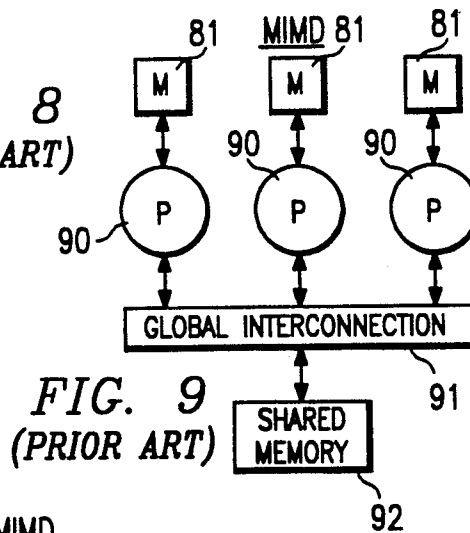
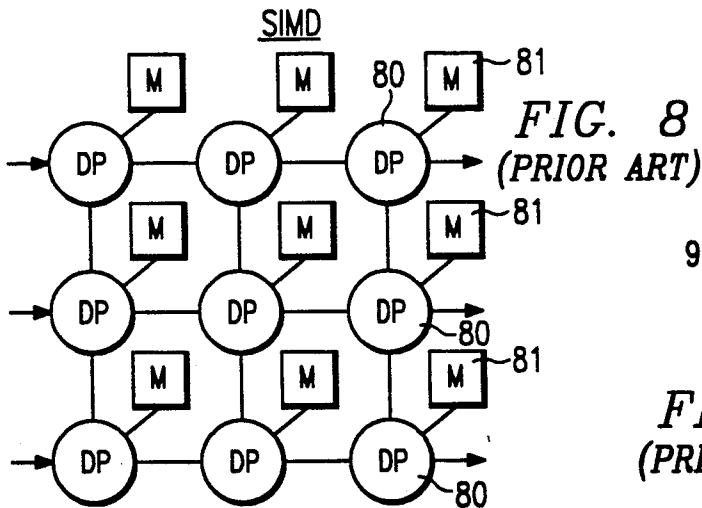
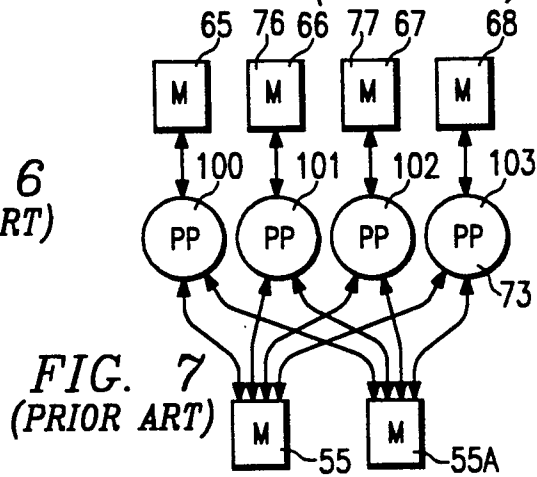
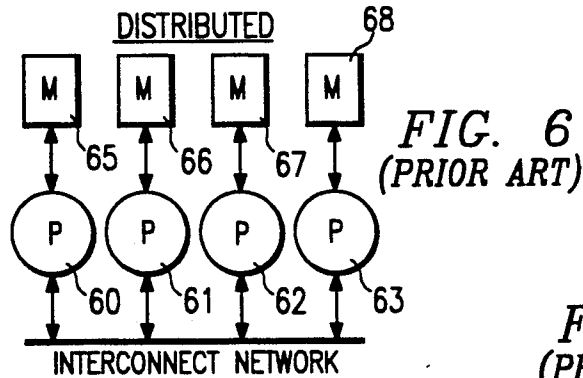
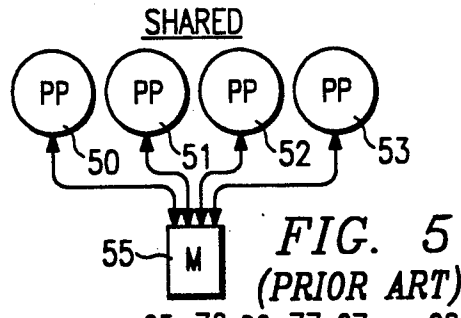
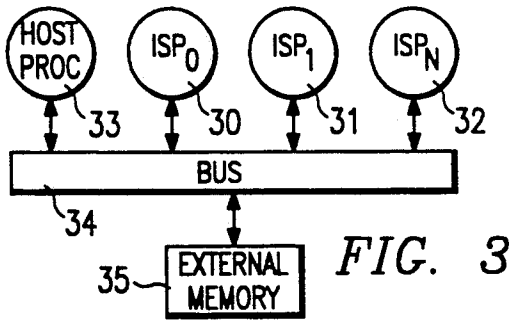
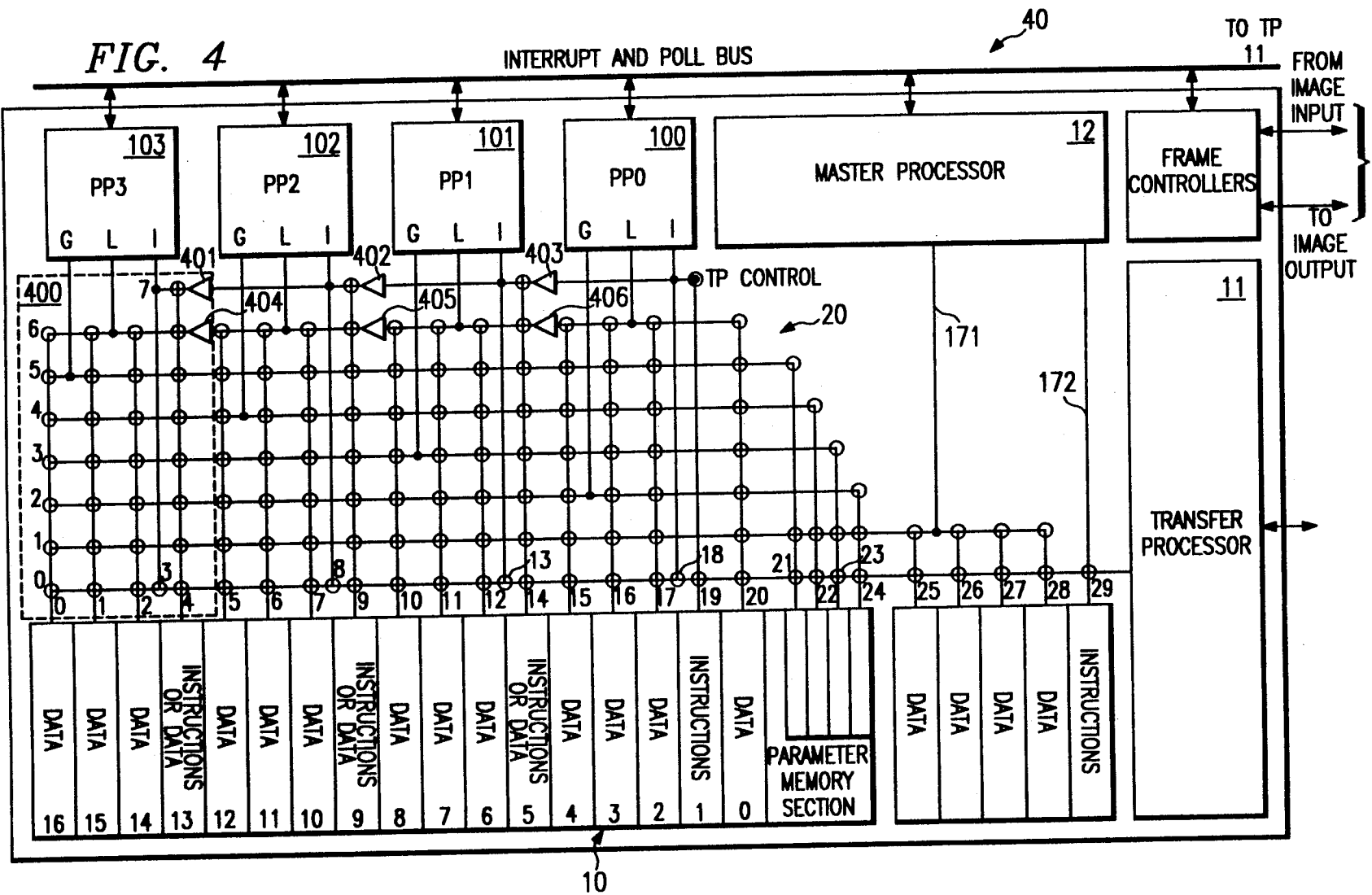

FIG. 2





Explore Litigation Insights

Docket Alarm provides insights to develop a more informed litigation strategy and the peace of mind of knowing you're on top of things.

Real-Time Litigation Alerts



Keep your litigation team up-to-date with **real-time alerts** and advanced team management tools built for the enterprise, all while greatly reducing PACER spend.

Our comprehensive service means we can handle Federal, State, and Administrative courts across the country.

Advanced Docket Research



With over 230 million records, Docket Alarm's cloud-native docket research platform finds what other services can't. Coverage includes Federal, State, plus PTAB, TTAB, ITC and NLRB decisions, all in one place.

Identify arguments that have been successful in the past with full text, pinpoint searching. Link to case law cited within any court document via Fastcase.

Analytics At Your Fingertips



Learn what happened the last time a particular judge, opposing counsel or company faced cases similar to yours.

Advanced out-of-the-box PTAB and TTAB analytics are always at your fingertips.

API

Docket Alarm offers a powerful API (application programming interface) to developers that want to integrate case filings into their apps.

LAW FIRMS

Build custom dashboards for your attorneys and clients with live data direct from the court.

Automate many repetitive legal tasks like conflict checks, document management, and marketing.

FINANCIAL INSTITUTIONS

Litigation and bankruptcy checks for companies and debtors.

E-DISCOVERY AND LEGAL VENDORS

Sync your system to PACER to automate legal marketing.