

Under the Paperwork Reduction Act of 1995, no persons are required to respond to a collection of information unless it displays a valid OMB control number.

<b>UTILITY                  PATENT APPLICATION                  TRANSMITTAL</b>  <i>(Only for new nonprovisional applications under 37 CFR 1.53(b))</i>	Attorney Docket No. REMB-0109
	First Inventor Gordon Bremer
	Title System and Method of Communication
	Express Mail Label No.

<b>APPLICATION ELEMENTS</b> <i>See MPEP chapter 600 concerning utility patent application contents.</i>	<b>ADDRESS TO:</b> Commissioner for Patents P.O. Box 1450 Alexandria VA 22313-1450
--	---

1. <input type="checkbox"/> <b>Fee Transmittal Form</b> (e.g., PTO/SB/17) 2. <input type="checkbox"/> <b>Applicant claims small entity status.</b> See 37 CFR 1.27. 3. <input checked="" type="checkbox"/> <b>Specification</b> [Total Pages <u>15</u> ] Both the claims and abstract must start on a new page (For information on the preferred arrangement, see MPEP 608.01(a)) 4. <input checked="" type="checkbox"/> <b>Drawing(s)</b> (35 U.S.C. 113) [Total Sheets <u>8</u> ] 5. <b>Oath or Declaration</b> [Total Sheets _____ ] a. <input type="checkbox"/> Newly executed (original or copy) b. <input type="checkbox"/> A copy from a prior application (37 CFR 1.63(d)) (for continuation/divisional with Box 18 completed) i. <input type="checkbox"/> <b>DELETION OF INVENTOR(S)</b> Signed statement attached deleting inventor(s) name in the prior application, see 37 CFR 1.63(d)(2) and 1.33(b). 6. <input checked="" type="checkbox"/> <b>Application Data Sheet.</b> See 37 CFR 1.76 7. <input type="checkbox"/> <b>CD-ROM or CD-R</b> in duplicate, large table or Computer Program (Appendix) <input type="checkbox"/> Landscape Table on CD 8. <b>Nucleotide and/or Amino Acid Sequence Submission</b> (if applicable, items a. – c. are required) a. <input type="checkbox"/> Computer Readable Form (CRF) b. <input type="checkbox"/> Specification Sequence Listing on: i. <input type="checkbox"/> CD-ROM or CD-R (2 copies); or ii. <input type="checkbox"/> Paper c. <input type="checkbox"/> Statements verifying identity of above copies	<b>ACCOMPANYING APPLICATION PARTS</b> 9. <input type="checkbox"/> <b>Assignment Papers</b> (cover sheet & document(s)) Name of Assignee _____ 10. <input type="checkbox"/> <b>37 CFR 3.73(b) Statement</b> <input type="checkbox"/> <b>Power of Attorney</b> (when there is an assignee) 11. <input type="checkbox"/> <b>English Translation Document</b> (if applicable) 12. <input type="checkbox"/> <b>Information Disclosure Statement</b> (PTO/SB/08 or PTO-1449) <input type="checkbox"/> Copies of citations attached 13. <input type="checkbox"/> <b>Preliminary Amendment</b> 14. <input type="checkbox"/> <b>Return Receipt Postcard</b> (MPEP 503) (Should be specifically itemized) 15. <input type="checkbox"/> <b>Certified Copy of Priority Document(s)</b> (if foreign priority is claimed) 16. <input type="checkbox"/> <b>Nonpublication Request</b> under 35 U.S.C. 122(b)(2)(B)(i). Applicant must attach form PTO/SB/35 or equivalent. 17. <input type="checkbox"/> Other: _____
---	--

18. If a CONTINUING APPLICATION, check appropriate box, and supply the requisite information below and in the first sentence of the specification following the title, or in an Application Data Sheet under 37 CFR 1.76:

Continuation     
  Divisional     
  Continuation-in-part (CIP)     
 of prior application No.: 1.1774803.....

Prior application information:     
 Examiner Dac V. Ha     
 Art Unit: 2611

**19. CORRESPONDENCE ADDRESS**

The address associated with Customer Number: 23377     
 OR     
 Correspondence address below

Name			
Address			
City	State	Zip Code	
Country	Telephone	Email	

Signature	/Michael A. Koptiw/	Date	August 19, 2009
Name (Print/Type)	Michael A. Koptiw	Registration No. (Attorney/Agent)	57900

This collection of information is required by 37 CFR 1.53(b). The information is required to obtain or retain a benefit by the public which is to file (and by the USPTO to process) an application. Confidentiality is governed by 35 U.S.C. 122 and 37 CFR 1.11 and 1.14. This collection is estimated to take 12 minutes to complete, including gathering, preparing, and submitting the completed application form to the USPTO. Time will vary depending upon the individual case. Any comments on the amount of time you require to complete this form and/or suggestions for reducing this burden, should be sent to the Chief Information Officer, U.S. Patent and Trademark Office, U.S. Department of Commerce, P.O. Box 1450, Alexandria, VA 22313-1450. DO NOT SEND FEES OR COMPLETED FORMS TO THIS ADDRESS. **SEND TO: Commissioner for Patents, P.O. Box 1450, Alexandria, VA 22313-1450.**

*If you need assistance in completing the form, call 1-800-PTO-9199 and select option 2.*

## Privacy Act Statement

The **Privacy Act of 1974 (P.L. 93-579)** requires that you be given certain information in connection with your submission of the attached form related to a patent application or patent. Accordingly, pursuant to the requirements of the Act, please be advised that: (1) the general authority for the collection of this information is 35 U.S.C. 2(b)(2); (2) furnishing of the information solicited is voluntary; and (3) the principal purpose for which the information is used by the U.S. Patent and Trademark Office is to process and/or examine your submission related to a patent application or patent. If you do not furnish the requested information, the U.S. Patent and Trademark Office may not be able to process and/or examine your submission, which may result in termination of proceedings or abandonment of the application or expiration of the patent.

The information provided by you in this form will be subject to the following routine uses:

1. The information on this form will be treated confidentially to the extent allowed under the Freedom of Information Act (5 U.S.C. 552) and the Privacy Act (5 U.S.C. 552a). Records from this system of records may be disclosed to the Department of Justice to determine whether disclosure of these records is required by the Freedom of Information Act.
2. A record from this system of records may be disclosed, as a routine use, in the course of presenting evidence to a court, magistrate, or administrative tribunal, including disclosures to opposing counsel in the course of settlement negotiations.
3. A record in this system of records may be disclosed, as a routine use, to a Member of Congress submitting a request involving an individual, to whom the record pertains, when the individual has requested assistance from the Member with respect to the subject matter of the record.
4. A record in this system of records may be disclosed, as a routine use, to a contractor of the Agency having need for the information in order to perform a contract. Recipients of information shall be required to comply with the requirements of the Privacy Act of 1974, as amended, pursuant to 5 U.S.C. 552a(m).
5. A record related to an International Application filed under the Patent Cooperation Treaty in this system of records may be disclosed, as a routine use, to the International Bureau of the World Intellectual Property Organization, pursuant to the Patent Cooperation Treaty.
6. A record in this system of records may be disclosed, as a routine use, to another federal agency for purposes of National Security review (35 U.S.C. 181) and for review pursuant to the Atomic Energy Act (42 U.S.C. 218(c)).
7. A record from this system of records may be disclosed, as a routine use, to the Administrator, General Services, or his/her designee, during an inspection of records conducted by GSA as part of that agency's responsibility to recommend improvements in records management practices and programs, under authority of 44 U.S.C. 2904 and 2906. Such disclosure shall be made in accordance with the GSA regulations governing inspection of records for this purpose, and any other relevant (*i.e.*, GSA or Commerce) directive. Such disclosure shall not be used to make determinations about individuals.
8. A record from this system of records may be disclosed, as a routine use, to the public after either publication of the application pursuant to 35 U.S.C. 122(b) or issuance of a patent pursuant to 35 U.S.C. 151. Further, a record may be disclosed, subject to the limitations of 37 CFR 1.14, as a routine use, to the public if the record was filed in an application which became abandoned or in which the proceedings were terminated and which application is referenced by either a published application, an application open to public inspection or an issued patent.
9. A record from this system of records may be disclosed, as a routine use, to a Federal, State, or local law enforcement agency, if the USPTO becomes aware of a violation or potential violation of law or regulation.

## Electronic Patent Application Fee Transmittal

<b>Application Number:</b>	
<b>Filing Date:</b>	
<b>Title of Invention:</b>	System and Method of Communication Via Embedded Modulation
<b>First Named Inventor/Applicant Name:</b>	Gordon Bremer
<b>Filer:</b>	Michael Koptiw Jr./Kathy Franchi
<b>Attorney Docket Number:</b>	REMB-0109

Filed as Large Entity

### Utility under 35 USC 111(a) Filing Fees

Description	Fee Code	Quantity	Amount	Sub-Total in USD(\$)
<b>Basic Filing:</b>				
Utility application filing	1011	1	330	330
Utility Search Fee	1111	1	540	540
Utility Examination Fee	1311	1	220	220

### Pages:

### Claims:

Claims in excess of 20	1202	80	52	4160
Independent claims in excess of 3	1201	3	220	660

### Miscellaneous-Filing:

Description	Fee Code	Quantity	Amount	Sub-Total in USD(\$)
<b>Petition:</b>				
<b>Patent-Appeals-and-Interference:</b>				
<b>Post-Allowance-and-Post-Issuance:</b>				
<b>Extension-of-Time:</b>				
<b>Miscellaneous:</b>				
			<b>Total in USD (\$)</b>	<b>5910</b>



## Electronic Acknowledgement Receipt

<b>EFS ID:</b>	5918253
<b>Application Number:</b>	12543910
<b>International Application Number:</b>	
<b>Confirmation Number:</b>	8306
<b>Title of Invention:</b>	System and Method of Communication Via Embedded Modulation
<b>First Named Inventor/Applicant Name:</b>	Gordon Bremer
<b>Customer Number:</b>	23377
<b>Filer:</b>	Michael Koptiw Jr./Kathy Franchi
<b>Filer Authorized By:</b>	Michael Koptiw Jr.
<b>Attorney Docket Number:</b>	REMB-0109
<b>Receipt Date:</b>	19-AUG-2009
<b>Filing Date:</b>	
<b>Time Stamp:</b>	16:16:29
<b>Application Type:</b>	Utility under 35 USC 111(a)

### Payment information:

Submitted with Payment	yes
Payment Type	Deposit Account
Payment was successfully received in RAM	\$5910
RAM confirmation Number	2440
Deposit Account	233050
Authorized User	

The Director of the USPTO is hereby authorized to charge indicated fees and credit any overpayment as follows:

Charge any Additional Fees required under 37 C.F.R. Section 1.17 (Patent application and reexamination processing fees)

<b>File Listing:</b>					
<b>Document Number</b>	<b>Document Description</b>	<b>File Name</b>	<b>File Size(Bytes)/ Message Digest</b>	<b>Multi Part /.zip</b>	<b>Pages (if appl.)</b>
1	Application Data Sheet	REMB-0109-app-data-sheet. PDF	4312568  1651825b5a0ac2223f7a7ac63e9aa4edbcd4b203	no	4
<b>Warnings:</b>					
<b>Information:</b>					
2	Drawings-only black and white line drawings	REMB-0029-as-filed-drawings. PDF	333657  65ce7ea026824a3a50a4d6f5987b4c4db2899c6c	no	8
<b>Warnings:</b>					
<b>Information:</b>					
3	Extension of Time	REMB-0109-ext.PDF	74873  d5fc6fd4cf1cfd7b6f9c3d2ec069dfd79f2069a	no	1
<b>Warnings:</b>					
<b>Information:</b>					
4		REMB-0109-As-Filed-Specification.PDF	137458  e833547c25b26fcb65def0ffbbe86c1b2aac38	yes	22
	<b>Multipart Description/PDF files in .zip description</b>				
	<b>Document Description</b>		<b>Start</b>	<b>End</b>	
	Specification		1	11	
	Claims		12	21	
Abstract		22	22		
<b>Warnings:</b>					
<b>Information:</b>					
5	Transmittal of New Application	REMB-0109-transmittal.PDF	1095280  bbbc942020379f5f8544f96d383fa8aa53d7f3d9	no	2
<b>Warnings:</b>					
<b>Information:</b>					
6	Fee Worksheet (PTO-875)	fee-info.pdf	37865  66ebb9d5018b42911c21ea2a279b24586c7546c3	no	2
<b>Warnings:</b>					
<b>Information:</b>					
<b>Total Files Size (in bytes):</b>			5991701		

**This Acknowledgement Receipt evidences receipt on the noted date by the USPTO of the indicated documents, characterized by the applicant, and including page counts, where applicable. It serves as evidence of receipt similar to a Post Card, as described in MPEP 503.**

**New Applications Under 35 U.S.C. 111**

**If a new application is being filed and the application includes the necessary components for a filing date (see 37 CFR 1.53(b)-(d) and MPEP 506), a Filing Receipt (37 CFR 1.54) will be issued in due course and the date shown on this Acknowledgement Receipt will establish the filing date of the application.**

**National Stage of an International Application under 35 U.S.C. 371**

**If a timely submission to enter the national stage of an international application is compliant with the conditions of 35 U.S.C. 371 and other applicable requirements a Form PCT/DO/EO/903 indicating acceptance of the application as a national stage submission under 35 U.S.C. 371 will be issued in addition to the Filing Receipt, in due course.**

**New International Application Filed with the USPTO as a Receiving Office**

**If a new international application is being filed and the international application includes the necessary components for an international filing date (see PCT Article 11 and MPEP 1810), a Notification of the International Application Number and of the International Filing Date (Form PCT/RO/105) will be issued in due course, subject to prescriptions concerning national security, and the date shown on this Acknowledgement Receipt will establish the international filing date of the application.**

Under the Paperwork Reduction Act of 1995, no persons are required to respond to a collection of information unless it contains a valid OMB control number.

<b>Application Data Sheet 37 CFR 1.76</b>		Attorney Docket Number	REMB-0109
		Application Number	
Title of Invention	System and Method of Communication Via Embedded Modulation		
The application data sheet is part of the provisional or nonprovisional application for which it is being submitted. The following form contains the bibliographic data arranged in a format specified by the United States Patent and Trademark Office as outlined in 37 CFR 1.76. This document may be completed electronically and submitted to the Office in electronic format using the Electronic Filing System (EFS) or the document may be printed and included in a paper filed application.			

**Secrecy Order 37 CFR 5.2**

Portions or all of the application associated with this Application Data Sheet may fall under a Secrecy Order pursuant to 37 CFR 5.2 (Paper filers only. Applications that fall under Secrecy Order may not be filed electronically.)

**Applicant Information:**

<b>Applicant 1</b>					<input type="button" value="Remove"/>
<b>Applicant Authority</b> <input checked="" type="radio"/> Inventor		<input type="radio"/> Legal Representative under 35 U.S.C. 117		<input type="radio"/> Party of Interest under 35 U.S.C. 118	
<b>Prefix</b>	<b>Given Name</b>	<b>Middle Name</b>	<b>Family Name</b>	<b>Suffix</b>	
	Gordon		Bremer		
<b>Residence Information (Select One)</b> <input checked="" type="radio"/> US Residency <input type="radio"/> Non US Residency <input type="radio"/> Active US Military Service					
<b>City</b>	Clearwater	<b>State/Province</b>	FL	<b>Country of Residence i</b>	US
<b>Citizenship under 37 CFR 1.41(b) i</b>		US			
<b>Mailing Address of Applicant:</b>					
<b>Address 1</b>	1930 Cove Lane				
<b>Address 2</b>					
<b>City</b>	Clearwater	<b>State/Province</b>	FL		
<b>Postal Code</b>	33764	<b>Country<sup>i</sup></b>	US		
All Inventors Must Be Listed - Additional Inventor Information blocks may be generated within this form by selecting the <b>Add</b> button.					<input type="button" value="Add"/>

**Correspondence Information:**

Enter either Customer Number or complete the Correspondence Information section below. For further information see 37 CFR 1.33(a).			
<input type="checkbox"/> An Address is being provided for the correspondence information of this application.			
<b>Customer Number</b>	23377		
<b>Email Address</b>		<input type="button" value="Add Email"/>	<input type="button" value="Remove Email"/>

**Application Information:**

<b>Title of the Invention</b>	System and Method of Communication Via Embedded Modulation		
<b>Attorney Docket Number</b>	REMB-0109	<b>Small Entity Status Claimed</b>	<input type="checkbox"/>
<b>Application Type</b>	Nonprovisional		
<b>Subject Matter</b>	Utility		
<b>Suggested Class (if any)</b>		<b>Sub Class (if any)</b>	
<b>Suggested Technology Center (if any)</b>			
<b>Total Number of Drawing Sheets (if any)</b>	8	<b>Suggested Figure for Publication (if any)</b>	3

<b>Application Data Sheet 37 CFR 1.76</b>	Attorney Docket Number	REMB-0109
	Application Number	
Title of Invention	System and Method of Communication Via Embedded Modulation	

**Publication Information:**

<input type="checkbox"/>	Request Early Publication (Fee required at time of Request 37 CFR 1.219)
<input type="checkbox"/>	<b>Request Not to Publish.</b> I hereby request that the attached application not be published under 35 U.S. C. 122(b) and certify that the invention disclosed in the attached application <b>has not and will not</b> be the subject of an application filed in another country, or under a multilateral international agreement, that requires publication at eighteen months after filing.

**Representative Information:**

<p>Representative information should be provided for all practitioners having a power of attorney in the application. Providing this information in the Application Data Sheet does not constitute a power of attorney in the application (see 37 CFR 1.32). Enter either Customer Number or complete the Representative Name section below. If both sections are completed the Customer Number will be used for the Representative Information during processing.</p>			
Please Select One:	<input checked="" type="radio"/> Customer Number	<input type="radio"/> US Patent Practitioner	<input type="radio"/> Limited Recognition (37 CFR 11.9)
Customer Number	23377		

**Domestic Benefit/National Stage Information:**

This section allows for the applicant to either claim benefit under 35 U.S.C. 119(e), 120, 121, or 365(c) or indicate National Stage entry from a PCT application. Providing this information in the application data sheet constitutes the specific reference required by 35 U.S.C. 119(e) or 120, and 37 CFR 1.78(a)(2) or CFR 1.78(a)(4), and need not otherwise be made part of the specification.			
Prior Application Status	Pending	<a href="#">Remove</a>	
Application Number	Continuity Type	Prior Application Number	Filing Date (YYYY-MM-DD)
	Continuation of	11774803	2007-07-09
Prior Application Status		<a href="#">Remove</a>	
Application Number	Continuity Type	Prior Application Number	Filing Date (YYYY-MM-DD)
11774803	Continuation of	10412878	2003-04-14
Prior Application Status		<a href="#">Remove</a>	
Application Number	Continuity Type	Prior Application Number	Filing Date (YYYY-MM-DD)
10412878	Continuation in part of	09205205	1998-12-04
Prior Application Status		<a href="#">Remove</a>	
Application Number	Continuity Type	Prior Application Number	Filing Date (YYYY-MM-DD)
09205205	non provisional of	60067562	1997-12-05
Additional Domestic Benefit/National Stage Data may be generated within this form by selecting the <b>Add</b> button.			<a href="#">Add</a>

**Foreign Priority Information:**

This section allows for the applicant to claim benefit of foreign priority and to identify any prior foreign application for which priority is not claimed. Providing this information in the application data sheet constitutes the claim for priority as required by 35 U.S.C. 119(b) and 37 CFR 1.55(a).
---

Under the Paperwork Reduction Act of 1995, no persons are required to respond to a collection of information unless it contains a valid OMB control number.

<b>Application Data Sheet 37 CFR 1.76</b>	Attorney Docket Number	REMB-0109
	Application Number	
Title of Invention	System and Method of Communication Via Embedded Modulation	

			<input type="button" value="Remove"/>
Application Number	Country <sup>i</sup>	Parent Filing Date (YYYY-MM-DD)	Priority Claimed
			<input checked="" type="radio"/> Yes <input type="radio"/> No
Additional Foreign Priority Data may be generated within this form by selecting the Add button.			<input type="button" value="Add"/>

**Assignee Information:**

Providing this information in the application data sheet does not substitute for compliance with any requirement of part 3 of Title 37 of the CFR to have an assignment recorded in the Office.				
<b>Assignee 1</b>				<input type="button" value="Remove"/>
If the Assignee is an Organization check here. <input type="checkbox"/>				
Prefix	Given Name	Middle Name	Family Name	Suffix
<b>Mailing Address Information:</b>				
Address 1				
Address 2				
City		State/Province		
Country <sup>i</sup>		Postal Code		
Phone Number		Fax Number		
Email Address				
Additional Assignee Data may be generated within this form by selecting the Add button.				<input type="button" value="Add"/>

**Signature:**

A signature of the applicant or representative is required in accordance with 37 CFR 1.33 and 10.18. Please see 37 CFR 1.4(d) for the form of the signature.				
<b>Signature</b>	/Michael A. Koptiw/		Date (YYYY-MM-DD)	2009-08-19
First Name	Michael	Last Name	Koptiw	Registration Number
				57900

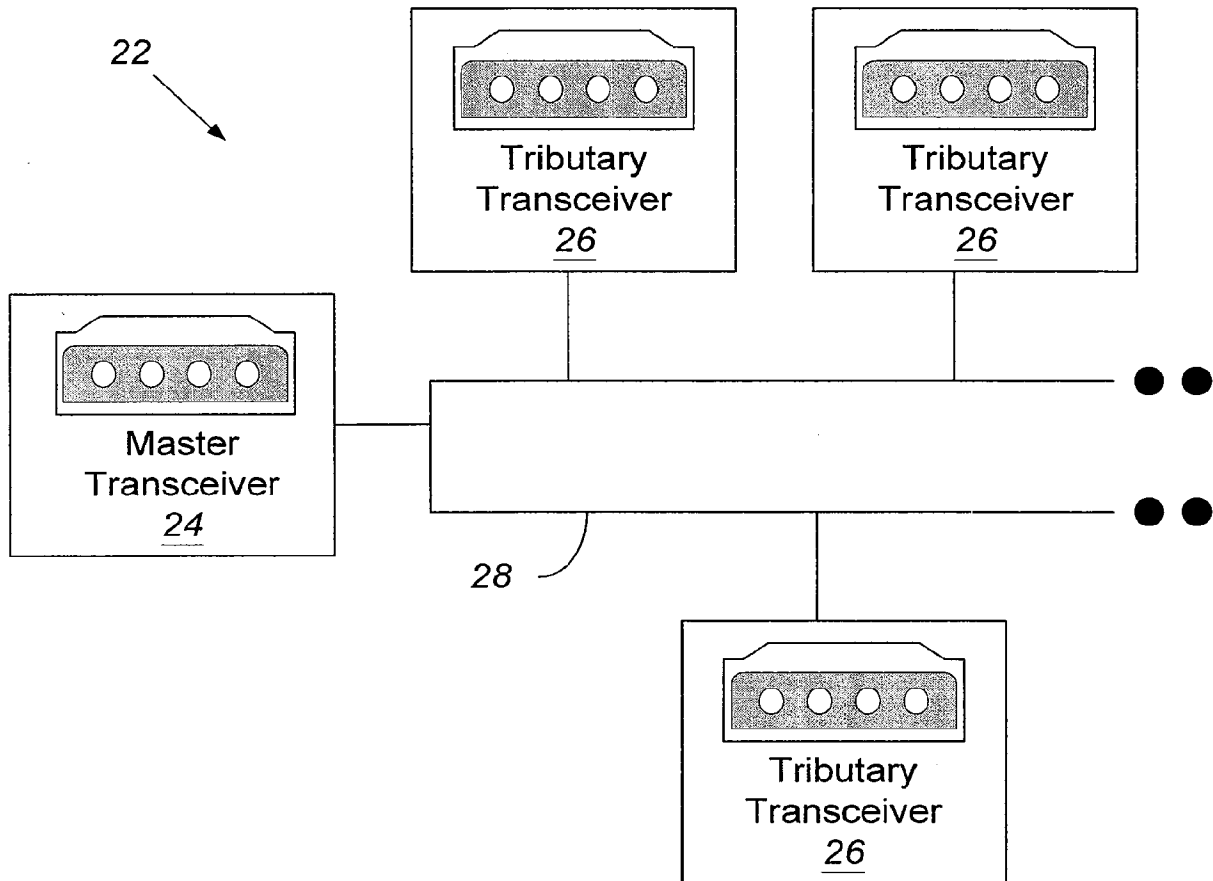
This collection of information is required by 37 CFR 1.76. The information is required to obtain or retain a benefit by the public which is to file (and by the USPTO to process) an application. Confidentiality is governed by 35 U.S.C. 122 and 37 CFR 1.14. This collection is estimated to take 23 minutes to complete, including gathering, preparing, and submitting the completed application data sheet form to the USPTO. Time will vary depending upon the individual case. Any comments on the amount of time you require to complete this form and/or suggestions for reducing this burden, should be sent to the Chief Information Officer, U.S. Patent and Trademark Office, U.S. Department of Commerce, P.O. Box 1450, Alexandria, VA 22313-1450. DO NOT SEND FEES OR COMPLETED FORMS TO THIS ADDRESS. **SEND TO: Commissioner for Patents, P.O. Box 1450, Alexandria, VA 22313-1450.**

## Privacy Act Statement

The Privacy Act of 1974 (P.L. 93-579) requires that you be given certain information in connection with your submission of the attached form related to a patent application or patent. Accordingly, pursuant to the requirements of the Act, please be advised that: (1) the general authority for the collection of this information is 35 U.S.C. 2(b)(2); (2) furnishing of the information solicited is voluntary; and (3) the principal purpose for which the information is used by the U.S. Patent and Trademark Office is to process and/or examine your submission related to a patent application or patent. If you do not furnish the requested information, the U.S. Patent and Trademark Office may not be able to process and/or examine your submission, which may result in termination of proceedings or abandonment of the application or expiration of the patent.

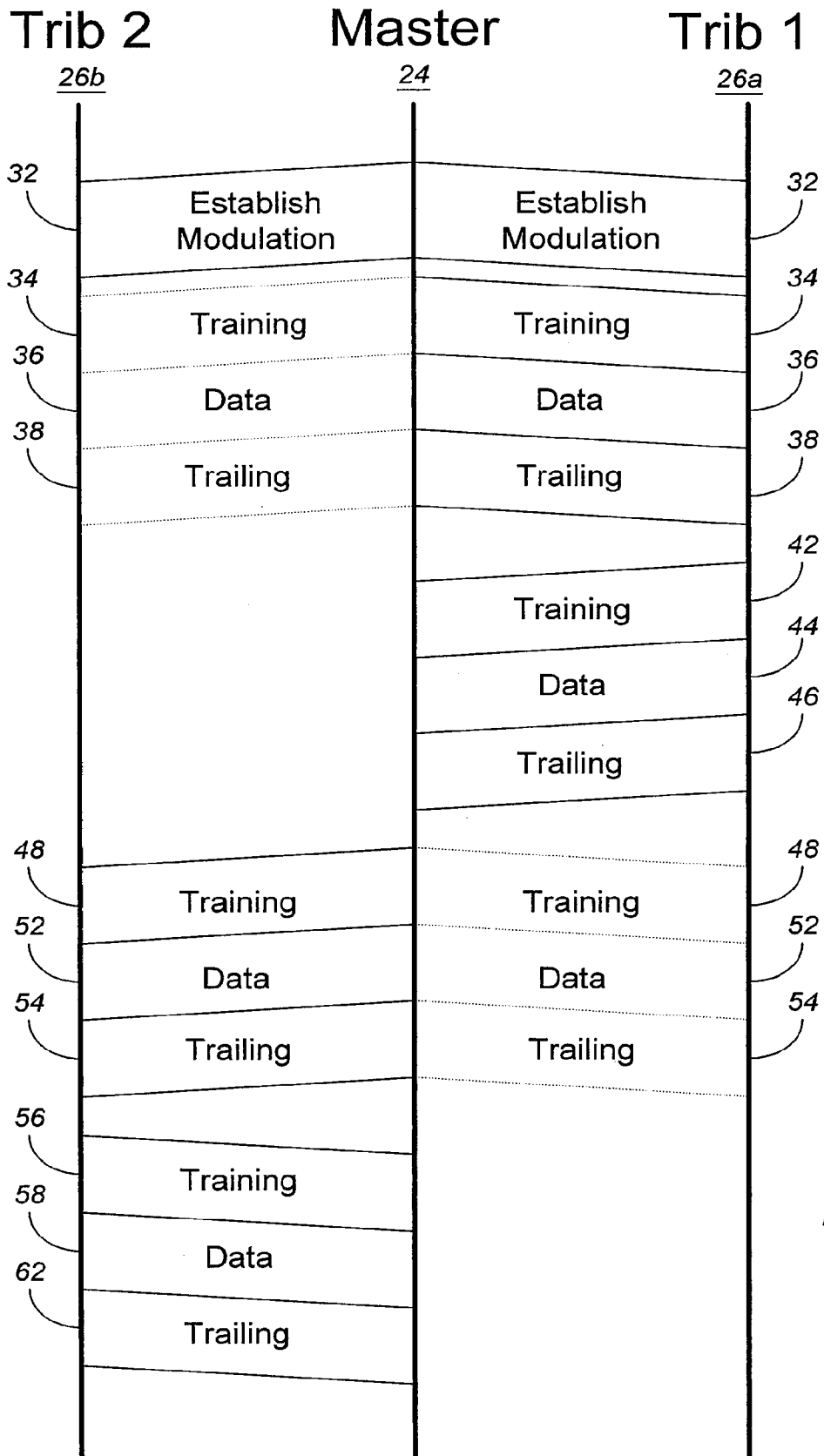
The information provided by you in this form will be subject to the following routine uses:

1. The information on this form will be treated confidentially to the extent allowed under the Freedom of Information Act (5 U.S.C. 552) and the Privacy Act (5 U.S.C. 552a). Records from this system of records may be disclosed to the Department of Justice to determine whether the Freedom of Information Act requires disclosure of these records.
2. A record from this system of records may be disclosed, as a routine use, in the course of presenting evidence to a court, magistrate, or administrative tribunal, including disclosures to opposing counsel in the course of settlement negotiations.
3. A record in this system of records may be disclosed, as a routine use, to a Member of Congress submitting a request involving an individual, to whom the record pertains, when the individual has requested assistance from the Member with respect to the subject matter of the record.
4. A record in this system of records may be disclosed, as a routine use, to a contractor of the Agency having need for the information in order to perform a contract. Recipients of information shall be required to comply with the requirements of the Privacy Act of 1974, as amended, pursuant to 5 U.S.C. 552a(m).
5. A record related to an International Application filed under the Patent Cooperation Treaty in this system of records may be disclosed, as a routine use, to the International Bureau of the World Intellectual Property Organization, pursuant to the Patent Cooperation Treaty.
6. A record in this system of records may be disclosed, as a routine use, to another federal agency for purposes of National Security review (35 U.S.C. 181) and for review pursuant to the Atomic Energy Act (42 U.S.C. 218(c)).
7. A record from this system of records may be disclosed, as a routine use, to the Administrator, General Services, or his/her designee, during an inspection of records conducted by GSA as part of that agency's responsibility to recommend improvements in records management practices and programs, under authority of 44 U.S.C. 2904 and 2906. Such disclosure shall be made in accordance with the GSA regulations governing inspection of records for this purpose, and any other relevant (i.e., GSA or Commerce) directive. Such disclosure shall not be used to make determinations about individuals.
8. A record from this system of records may be disclosed, as a routine use, to the public after either publication of the application pursuant to 35 U.S.C. 122(b) or issuance of a patent pursuant to 35 U.S.C. 151. Further, a record may be disclosed, subject to the limitations of 37 CFR 1.14, as a routine use, to the public if the record was filed in an application which became abandoned or in which the proceedings were terminated and which application is referenced by either a published application, an application open to public inspections or an issued patent.
9. A record from this system of records may be disclosed, as a routine use, to a Federal, State, or local law enforcement agency, if the USPTO becomes aware of a violation or potential violation of law or regulation.

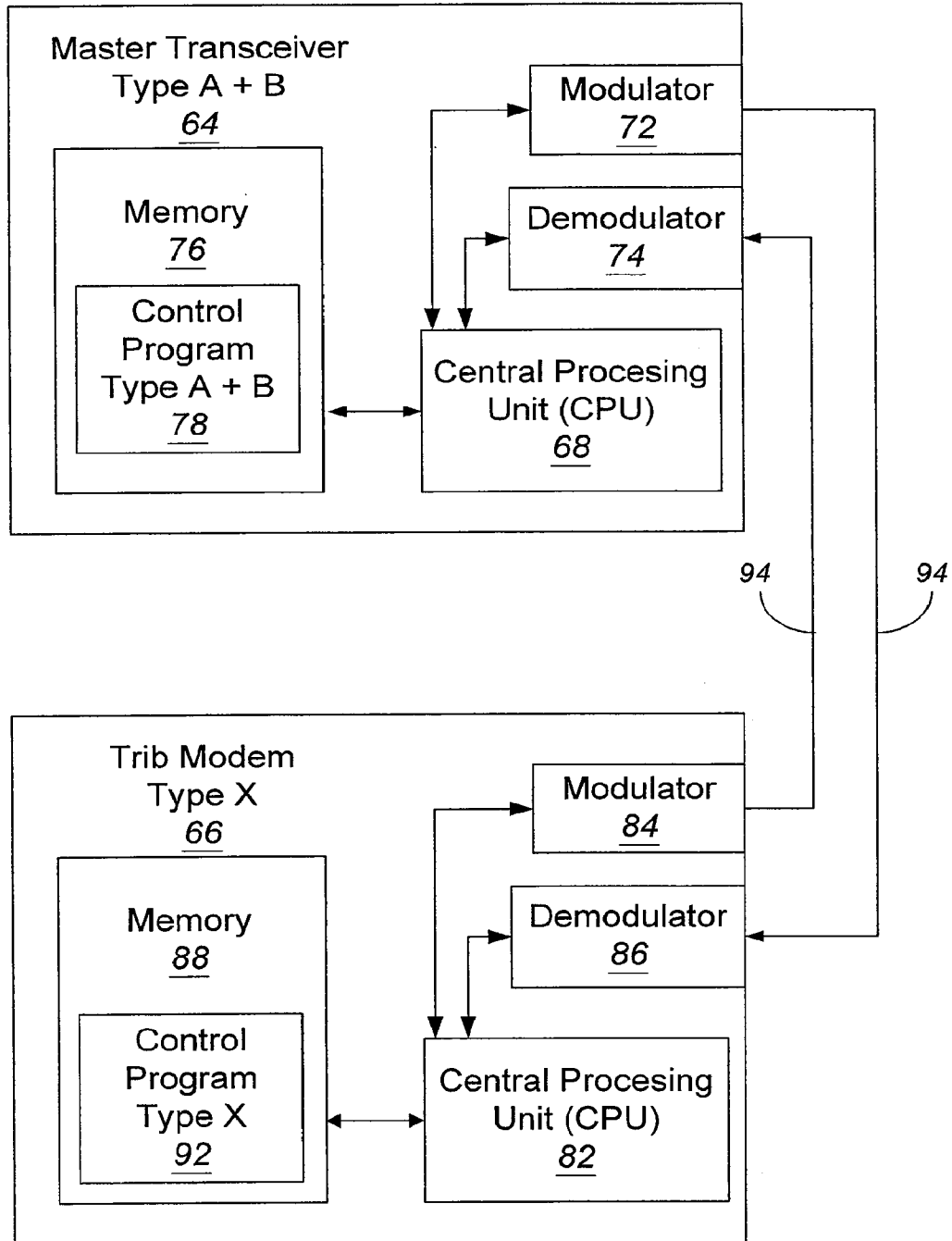


**FIG. 1**  
**Prior Art**

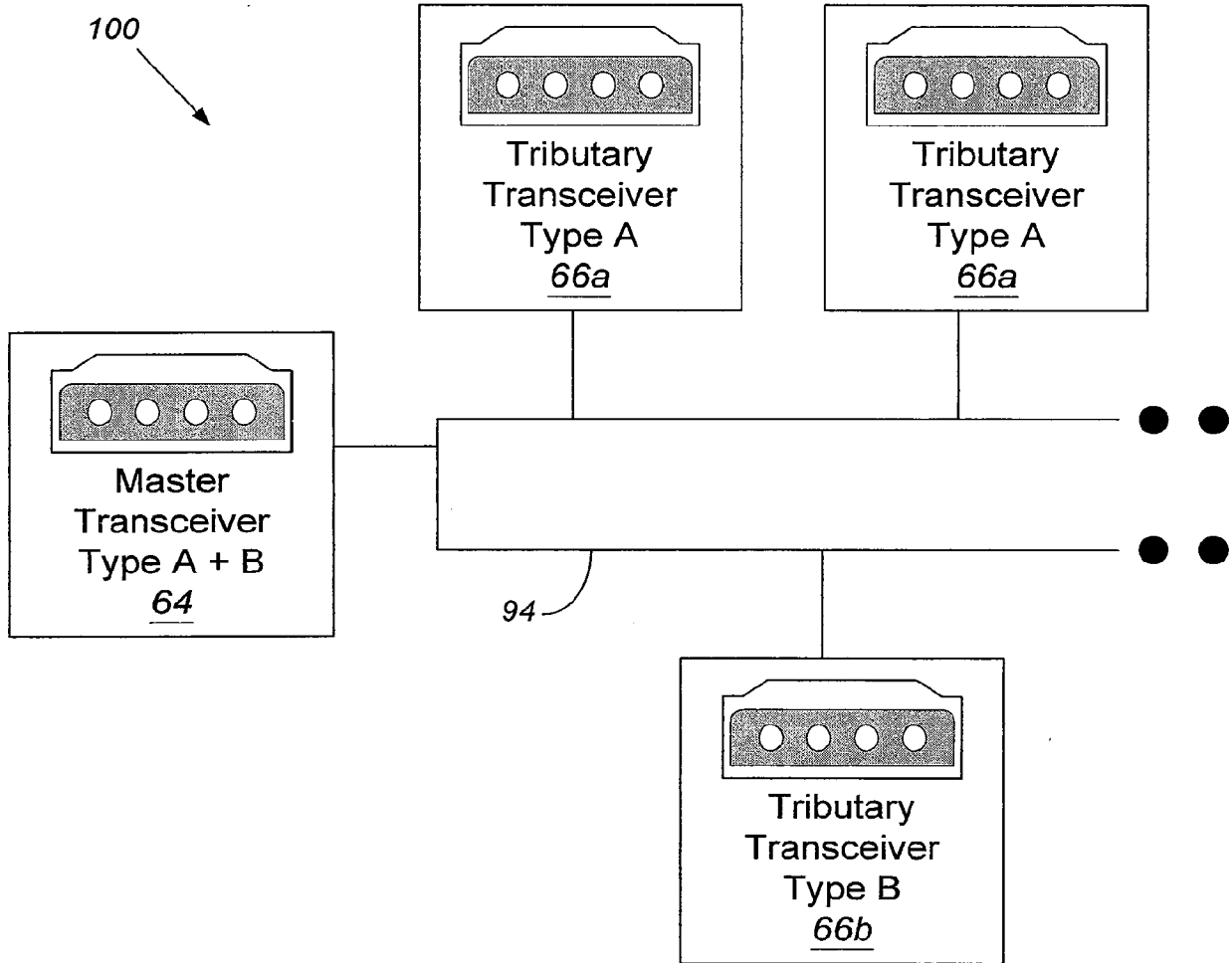




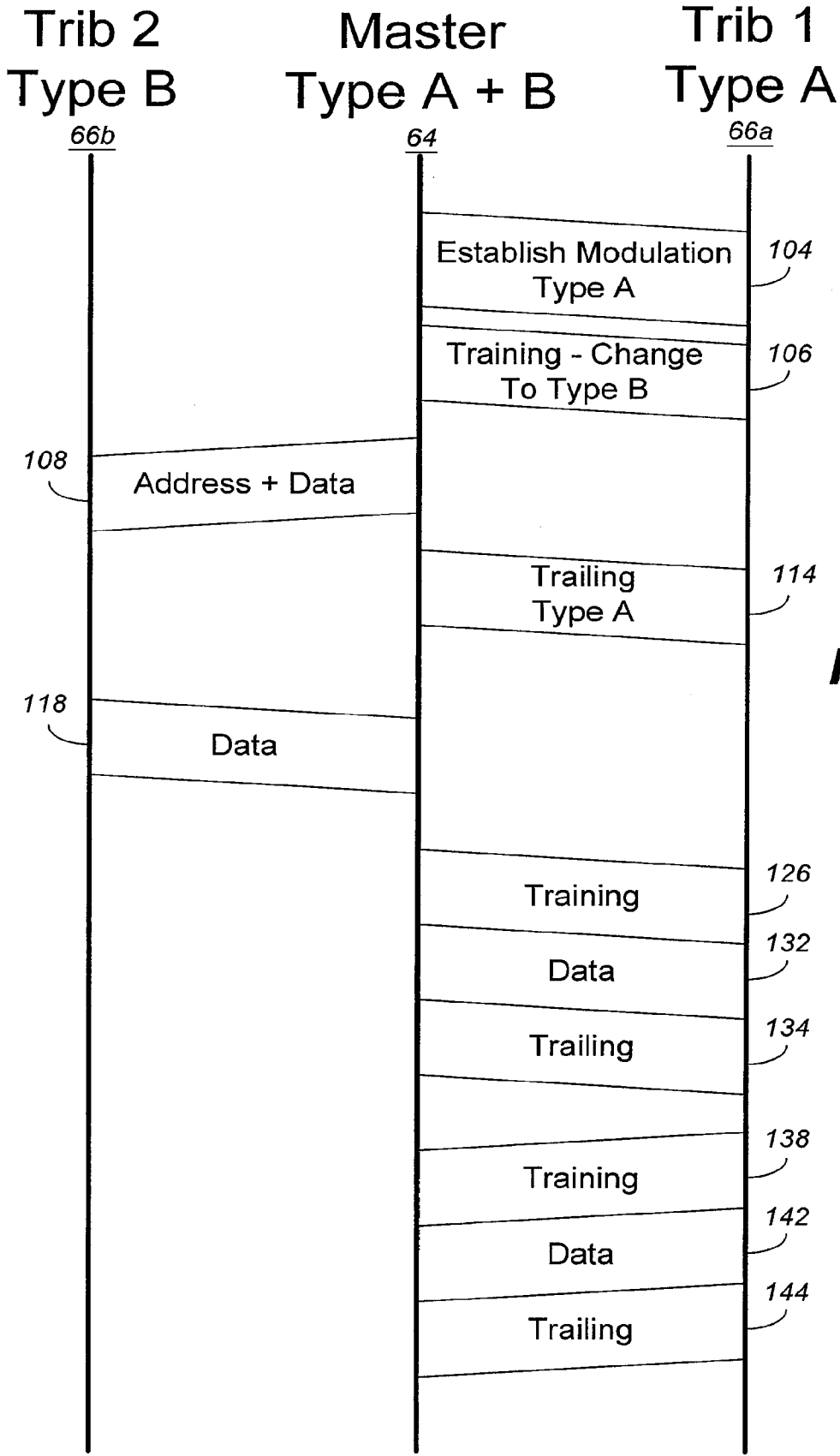
**FIG. 2**



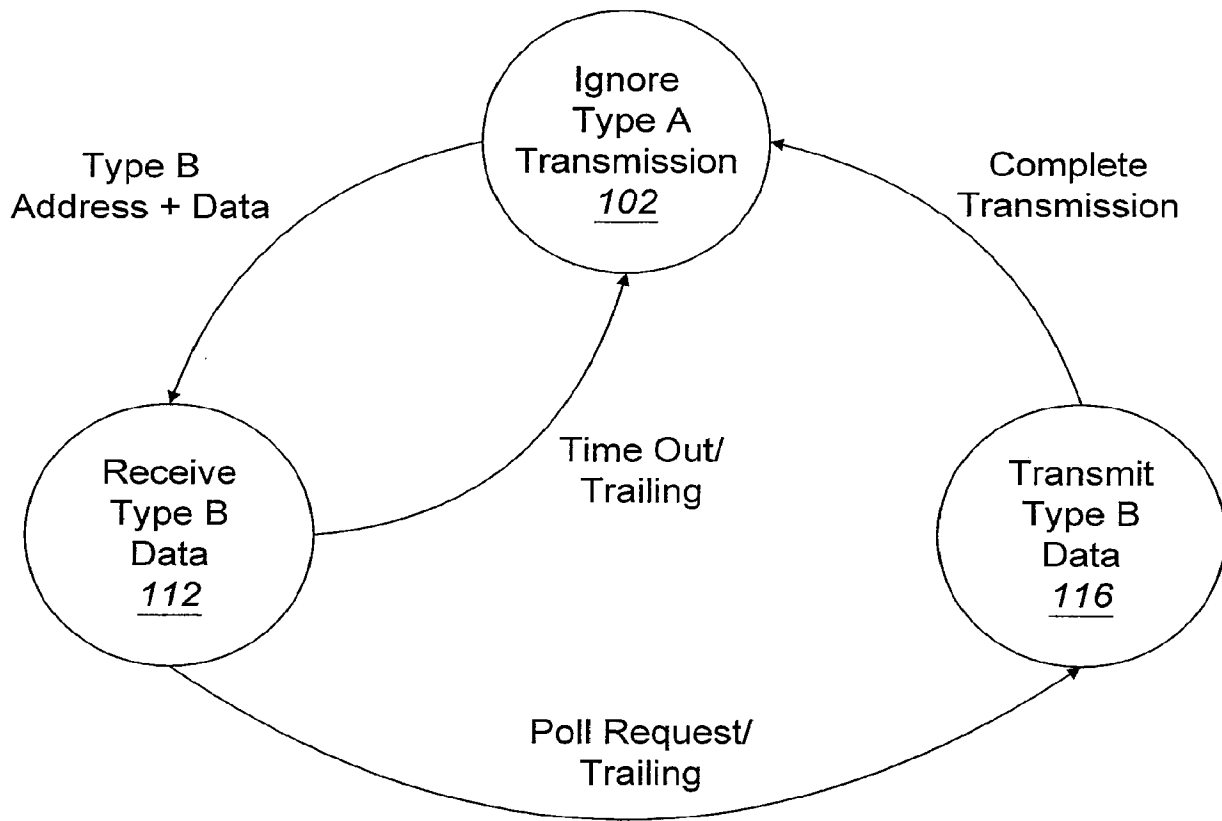
**FIG. 3**



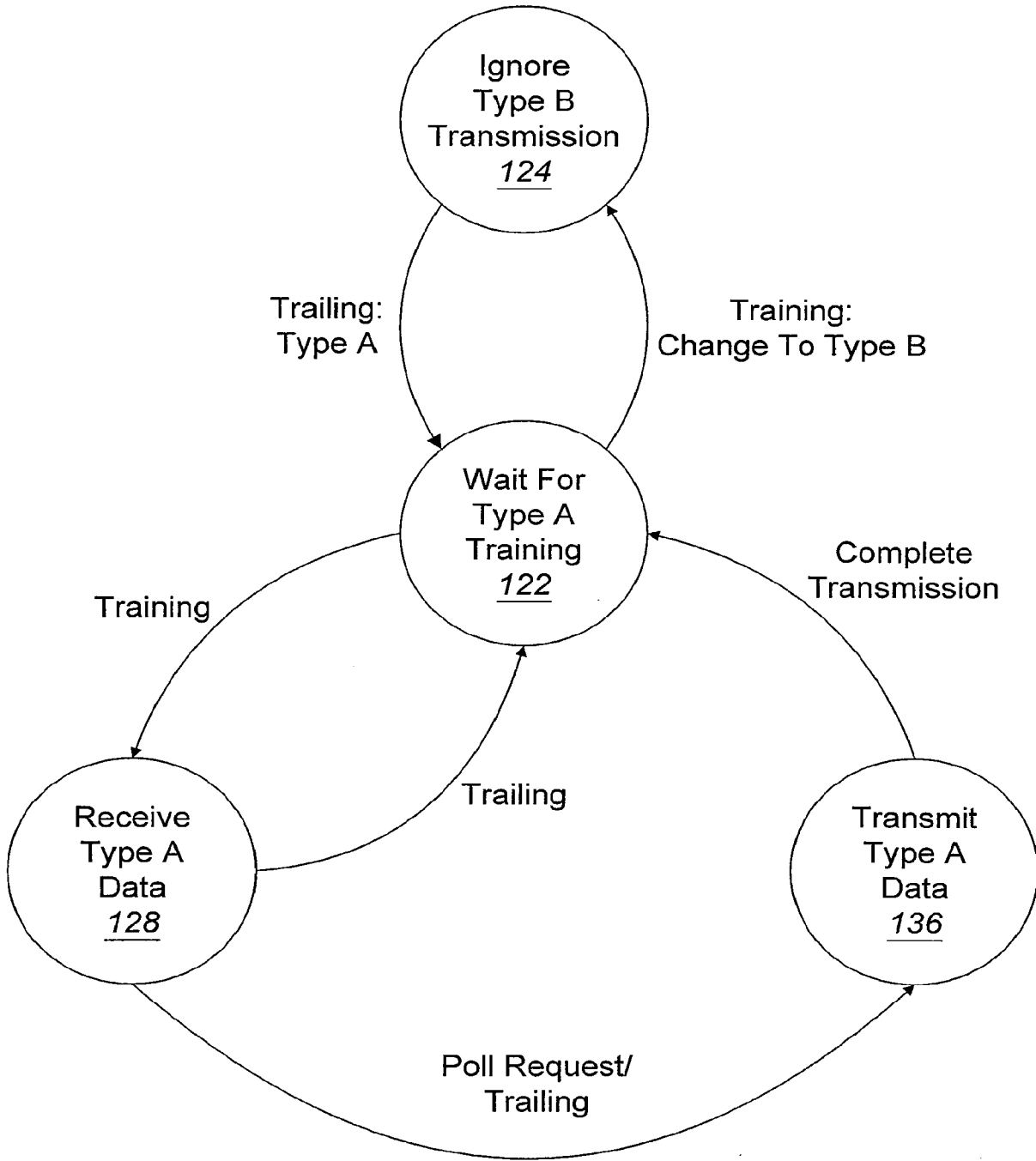
**FIG. 4**



**FIG. 5**

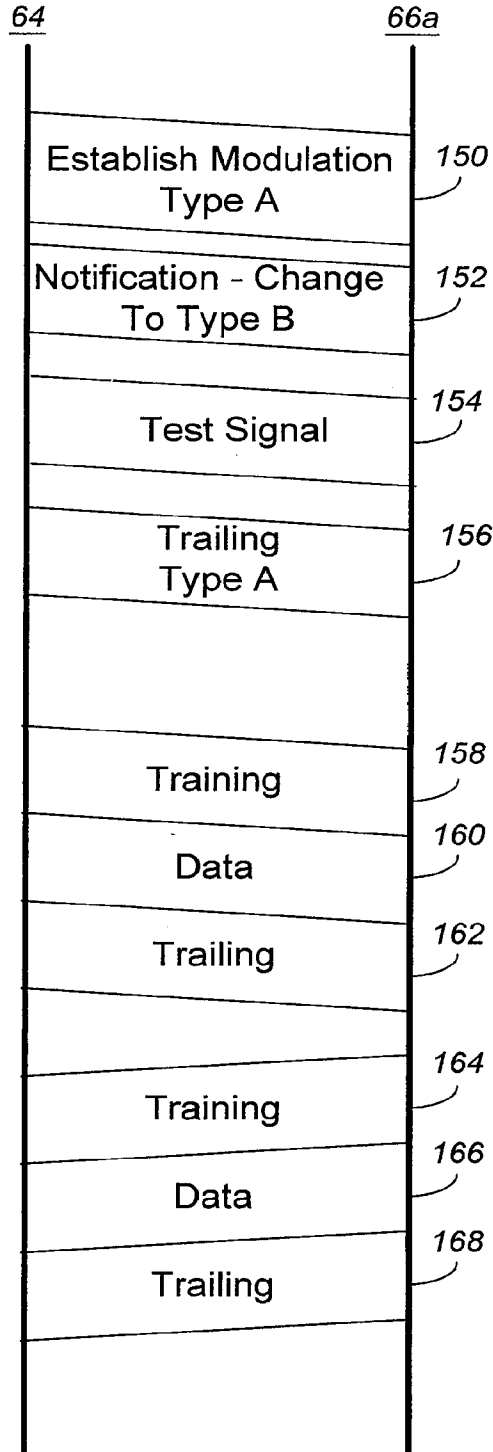


**FIG. 6**



**FIG. 7**

Master                      Trib  
Type A + B      Type A + B



**FIG. 8**

**IN THE UNITED STATES PATENT AND TRADEMARK OFFICE**

**In Re Application of:**

**Gordon Bremer**

**For: System And Method Of Communication Via Embedded Modulation**

Commissioner for Patents  
P.O. Box 1450  
Alexandria, VA 22313-1450

Sir:

**AUTHORIZATION TO TREAT A REPLY AS INCORPORATING AN EXTENSION OF  
TIME UNDER C.F.R. §1.136(a)(3)**

The Commissioner is hereby requested to grant an extension of time for the appropriate length of time, should one be necessary, in connection with this filing or any future filing submitted to the U.S. Patent and Trademark Office in the above-identified application during the pendency of this application. The Commissioner is further authorized to charge any fees related to any such extension of time to Deposit Account No. 23-3050.

Date: August 19, 2009

/Michael A. Koptiw/  
Michael A. Koptiw  
Registration No. 57,900



## **SYSTEM AND METHOD OF COMMUNICATION VIA EMBEDDED MODULATION**

### **CROSS REFERENCE TO RELATED APPLICATION**

[0001] This application is a continuation of U.S. Application No. 11/774,803, filed on July 9, 2007, which is a continuation of U.S. Application No. 10/412,878, filed April 14, 2003, which is a continuation-in-part of U.S. Application No. 09/205,205, filed December 4, 1998, and which claims priority to and the benefit of the filing date of U. S. Provisional Application No. 60/067,562, filed December 5, 1997, each of which is incorporated by reference herein.

### **TECHNICAL FIELD**

[0002] The present invention relates generally to the fields of data communications and modulator/demodulators (modems), and, more particularly, to a data communications system in which a plurality of modulation methods are used to facilitate communication among a plurality of modem types.

### **BACKGROUND**

[0003] In existing data communications systems, a transmitter and receiver modem pair can successfully communicate only when the modems are compatible at the physical layer. That is, the modems must use compatible modulation methods. This requirement is generally true regardless of the network topology. For example, point- to-point, dial-up modems operate in either the industry standard V.34 mode or the industry standard V.22 mode. Similarly, in a multipoint architecture, all modems operate, for example, in the industry standard V.27bis mode.

While the modems may be capable of using several different modulation methods, a single common modulation is negotiated at the beginning of a data session to be used throughout the duration of the session. Should it become necessary to change modulation methods, the existing data session is torn down, and a new session is negotiated using the new modulation method. Clearly, tearing down an existing data session causes a significant disruption in communication between the two modems.

**[0004]** As discussed in the foregoing, communication between modems is generally unsuccessful unless a common modulation method is used. In a point-to-point network architecture, if a modem attempts to establish a communication session with an incompatible modem, one or both of the modems will make several attempts to establish the communication link until giving up after a timeout period has expired or the maximum number of retry attempts has been reached. Essentially, communication on the link is impossible without replacing one of the modems such that the resulting modem pair uses a common modulation method.

**[0005]** In a multipoint architecture, a single central, or "master," modem communicates with two or more tributary or "trib" modems using a single modulation method. If one or more of the trib modems are not compatible with the modulation method used by the master, those tribs will be unable to receive communications from the master. Moreover, repeated attempts by the master to communicate with the incompatible trib(s) will disturb communications with compatible trib(s) due to time wasted in making the futile communication attempts.

**[0006]** Thus, communication systems comprised of both high performance and low or moderate performance applications can be very cost inefficient to construct. For example, some applications (e.g., internet access) require high performance modulation, such as quadrature amplitude modulation (QAM), carrier amplitude and phase (CAP) modulation, or discrete multitone (DMT) modulation, while other applications (e.g., power monitoring and control) require only modest data rates and therefore a low performance modulation method. All users in the system will generally have to be equipped with a high performance modem to ensure modulation compatibility. These state of the art modems are then run at their lowest data rates for those applications that require relatively low data throughput performance. The replacement of inexpensive modems with much more expensive state of the art devices due to modulation compatibility imposes a substantial cost that is unnecessary in terms of the service and performance to be delivered to the end user.

**[0007]** Accordingly, what is sought, and what is not believed to be provided by the prior art, is a system and method of communication in which multiple modulation methods are

used to facilitate communication among a plurality of modems in a network, which have heretofore been incompatible.

## **SUMMARY**

**[0008]** The present invention is generally directed to a system and method of communication between a master transceiver and a plurality of tributary transceivers in a multipoint communication system in which the tributary transceivers use different types of modulation methods. Broadly stated, the communication system includes a master transceiver in communication with a first tributary transceiver and a second tributary transceiver over a communication medium. The first tributary transceiver uses a primary modulation method for communication while the second tributary transceiver uses a secondary or embedded modulation method for communication. The master transceiver and tributary transceivers each include a processor, memory, and control logic for controlling their operation. While the primary modulation method is normally used for transmissions on the communication medium, the master transceiver can communicate with the second tributary transceiver by notifying the first tributary transceiver that the primary modulation method is being temporarily replaced by the secondary or embedded modulation method. The master transceiver can then exchange information with the second tributary transceiver while the first tributary transceiver ignores any secondary modulation transmissions. In the meantime, the first tributary transceiver conditions itself to look for a trailing sequence from the master transceiver indicating that communication with the second tributary transceiver is complete. When the master transceiver transmits the trailing sequence using the primary modulation method, the first tributary transceiver conditions itself to look for primary modulation transmissions while the second tributary transceiver conditions itself to ignore primary modulation transmissions.

**[0009]** The present invention has many advantages, a few of which are delineated hereafter as merely examples.

**[0010]** One advantage of the present invention is that it provides to the use of a plurality of modem modulation methods on the same communication medium.

**[0011]** Another advantage of the present invention is that a master transceiver can communicate seamlessly with tributary transceivers or modems using incompatible modulation methods.

**[0012]** Another advantage of the present invention is that a master and tributary transceiver can calculate a channel parameter using a test signal sent using embedded modulation.

[0013] Other features and advantages of the present invention will become apparent to one with skill in the art upon examination of the following drawings and detailed description. It is intended that all such additional features and advantages be included herein within the scope of the present invention.

#### **BRIEF DESCRIPTION OF THE DRAWINGS**

[0014] The present invention can be better understood with reference to the following drawings. The components and representations in the drawings are not necessarily to scale, emphasis instead being placed upon clearly illustrating the principles of the present invention. Moreover, in the drawings, like reference numerals designate corresponding parts throughout the several views.

[0015] FIG. 1 is a block diagram of a prior art multipoint communication system including a master transceiver and a plurality of tributary transceivers;

[0016] FIG. 2 is a ladder diagram illustrating the operation of the multipoint communication system of FIG. 1;

[0017] FIG. 3 is a block diagram of a master transceiver and tributary transceiver for use in the multipoint communication system of FIG. 1 in accordance with the principles of the present invention;

[0018] FIG. 4 is a block diagram of a multipoint communication system including the master transceiver and a plurality of tributary transceivers of the type illustrated in FIG. 3;

[0019] FIG. 5 is a ladder diagram illustrating the operation of the multipoint communication system of FIG. 4;

[0020] FIG. 6 is a state diagram for a tributary transceiver of FIGS. 3-5 using a secondary modulation method in accordance with the principles of the present invention;

[0021] FIG. 7 is a state diagram for a tributary transceiver of FIGS. 3-5 using a primary modulation method in accordance with the principles of the present invention; and

[0022] FIG. 8 is a ladder diagram illustrating the operation of an alternative embodiment of the multipoint communication system of FIG. 4.

#### **DETAILED DESCRIPTION OF ILLUSTRATIVE EMBODIMENTS**

[0023] While the invention is susceptible to various modifications and alternative forms, a specific embodiment thereof is shown by way of example in the drawings and will herein be described in detail. It should be understood, however, that there is no intent to limit the

invention to the particular form disclosed, but on the contrary, the invention is to cover all modifications, equivalents, and alternatives falling within the spirit and scope of the invention as defined by the claims.

**[0024]** With reference to FIG. 1, a prior art multipoint communication system 22 is shown to comprise a master modem or transceiver 24, which communicates with a plurality of tributary modems (tribs) or transceivers 26-26 over communication medium 28. Note that all tribs 26-26 are identical in that they share a common modulation method with the master transceiver 24. Thus, before any communication can begin in multipoint system 22, the master transceiver and the tribs 26-26 must agree on a common modulation method. If a common modulation method is found, the master transceiver 24 and a single trib 26 will then exchange sequences of signals that are particular subsets of all signals that can be communicated via the agreed upon common modulation method. These sequences are commonly referred to as training signals and can be used for the following purposes: 1) to confirm that the common modulation method is available, 2) to establish received signal level compensation, 3) to establish time recovery and/or carrier recovery, 4) to permit channel equalization and/or echo cancellation, 5) to exchange parameters for optimizing performance and/or to select optional features, and 6) to confirm agreement with regard to the foregoing purposes prior to entering into data communication mode between the users. In a multipoint system, the address of the trib with which the master is establishing communication is also transmitted during the training interval. At the end of a data session a communicating pair of modems will typically exchange a sequence of signals known as trailing signals for the purpose of reliably stopping the session and confirming that the session has been stopped. In a multipoint system, failure to detect the end of a session will delay or disrupt a subsequent session.

**[0025]** Referring now to FIG. 2, an exemplary multipoint communication session is illustrated through use of a ladder diagram. This system uses polled multipoint communication protocol. That is, a master controls the initiation of its own transmission to the tribs and permits transmission from a trib only when that trib has been selected. At the beginning of the session, the master transceiver 24 establishes a common modulation as indicated by sequence 32 that is used by both the master 24 and the tribs 26a, 26b for communication. Once the modulation scheme is established among the modems in the multipoint system, The master transceiver 24 transmits a training sequence 34 that includes the address of the trib that the master seeks to communicate with. In this case, the training sequence 34 includes the address of trib 26a. As a result, trib 26b ignores training sequence 34. After completion of the training sequence 34, master transceiver 24 transmits data 36 to trib 26a followed by trailing sequence 38, which

signifies the end of the communication session. Note that trib 26b ignores data 36 and trailing sequence 38 as it was not requested for communication during training sequence 34.

**[0026]** At the end of trailing sequence 38, trib 26a transmits training sequence 42 to initiate a communication session with master transceiver 24. Because master transceiver 24 selected trib 26a for communication as part of training sequence 34, trib 26a is the only modem that will return a transmission. Thus, trib 26a transmits data 44 destined for master transceiver 24 followed by trailing sequence 46 to terminate the communication session.

**[0027]** The foregoing procedure is repeated except master transceiver identifies trib 26b in training sequence 48. In this case, trib 26a ignores the training sequence 48 and the subsequent transmission of data 52 and trailing sequence 54 because it does not recognize its address in training sequence 48. Master transceiver 24 transmits data 52 to trib 26b followed by trailing sequence 54 to terminate the communication session. To send information back to master transceiver 24, trib 26b transmits training sequence 56 to establish a communication session. Master transceiver 24 is conditioned to expect data only from trib 26b because trib 26b was selected as part of training sequence 48. Trib 26b transmits data 58 to master transceiver 24 terminated by trailing sequence 62.

**[0028]** The foregoing discussion is based on a two-wire, half-duplex multipoint system. Nevertheless, it should be understood that the concept is equally applicable to four-wire systems.

**[0029]** Consider the circumstance in which master transceiver 24 and trib 26b share a common modulation type A while trib 26a uses a second modulation type B. When master transceiver attempts to establish A as a common modulation during sequence 32, trib 26a will not be able to understand that communication. Moreover, trib 26a will not recognize its own address during training interval 34 and will therefore ignore data 36 and trailing sequence 38. Master transceiver 24 may time out waiting for a response from trib 26a because trib 26a will never transmit training sequence 42, data 44, and trailing sequence 46 due to the failure of trib 26a to recognize the communication request (training sequence 34) from master transceiver 24. Thus, if the tribes in a multipoint communication system use a plurality of modulation methods, the overall communication efficiency will be disrupted as specific tribes will be unable to decipher certain transmissions from the master transceiver and any unilateral transmission by a trib that has not been addressed by the master transceiver will violate the multipoint protocol.

**[0030]** As discussed hereinbefore, however, it is desirable to design a multipoint communication system comprising tribes that use a plurality of modulation methods. For example, one moderately priced trib may be used to communicate at a relatively high data rate for some applications, such as Internet access, while another, lower priced, trib is used to communicate at

a lower data rate for other applications, such as power monitoring and control. The needs of these different applications cannot be efficiently met by a single modulation. While it is possible to use high performance tribes running state of the art modulation methods such as QAM, CAP, or DMT to implement both the high and low data rate applications, significant cost savings can be achieved if lower cost tribes using low performance modulation methods are used to implement the lower data rate applications.

**[0031]** A block diagram of a master transceiver 64 in communication with a tribe 66 in accordance with the principles of the present invention is shown in FIG. 3. Master transceiver 64 comprises a central processing unit (CPU) 68 in communication with modulator 72, demodulator 74, and memory 76. Memory 76 holds software control program 78 and any data necessary for the operation of master transceiver 64. Control program 78 includes logic for implementing a plurality of modulation methods. For purposes of illustration, control program 78 can implement both a type A and a type B modulation through modulator 72 and demodulator 74.

**[0032]** Tribe 66 comprises CPU 82 in communication with modulator 84, demodulator 86, and memory 88. Memory 88, likewise holds software control program 92 and any data necessary for the operation of tribe 66. Control programs 78 and 92, are executed by CPUs 68 and 82 and provide the control logic for the processes to be discussed herein. Control program 92 includes logic for implementing a particular modulation method, which, for purposes of illustration, is called type X. Inasmuch as master transceiver 64 is capable of running either a type A or a type B modulation method, type X refers to one of those two modulation methods. The master transceiver 64 communicates with tribe 66 over communication medium 94.

**[0033]** Referring now to FIG. 4, a multipoint communication system 100 is shown comprising a master transceiver 64 along with a plurality of tribes 66-66. In this example, two tribes 66a-66a run a type A modulation method while one tribe 66b runs a type B modulation method. The present invention permits a secondary or embedded modulation method (e.g., type B) to replace the standard modulation method (e.g., type A) after an initial training sequence. This allows the master transceiver 64 to communicate seamlessly with tribes of varying types.

**[0034]** The operation of multipoint communication system 100 will be described hereafter with reference to the ladder diagram of FIG. 5 and the state diagrams of FIGS. 6 and 7. A communication session between the master transceiver 64 and a type B tribe 66b will be discussed first. A state diagram for a type B tribe 66b is shown in FIG. 6. Type B tribe 66b is initialized in state 102 in which type A modulation transmissions are ignored. In the present example, the primary modulation method is type A, thus, as shown in FIG. 5, master transceiver 64 establishes type A as the primary modulation in sequence 104. Note that because tribe 66b

responds only to type B modulation transmissions, only the type A trib 66a are receptive to transmission sequence 104.

**[0035]** To switch from type A modulation to type B modulation, master transceiver 64 transmits a training sequence 106 to type A trib 66a in which these trib 66a are notified of an impending change to type B modulation. The switch to type B modulation could be limited according to a specific time interval or for the communication of a particular quantity of data. After notifying the type A trib 66a of the change to type B modulation, master transceiver 64, using type B modulation, transmits data along with an address in sequence 108, which is destined for a particular type B trib 66b. The type B trib 66b targeted by the master transceiver 64 will transition to state 112 as shown in FIG. 6 upon detecting its own address where it processes the data transmitted in sequence 108.

**[0036]** After completing transmission sequence 108, master transceiver 64 transmits a trailing sequence 114 using type A modulation thus notifying all type A trib 66a that type B modulation transmission is complete. If master transceiver 64 has not transmitted a poll request to the type B trib 66b in sequence 108, then the type B trib 66b that was in communication with the master transceiver 64 will return to state 102 after timing out based on the particular time interval defined for the type B modulation transmission or transfer of the particular quantity of data. Note that the trailing sequence 114 is ineffective in establishing the termination of a communication session between master transceiver 64 and a type B trib 66b because the trailing sequence is transmitted using type A modulation.

**[0037]** If, however, master transceiver 64 transmitted a poll request in sequence 108, then the type B trib 66b transitions to state 116 where it will transmit data, using type B modulation, to master transceiver 64 in sequence 118. After completion of this transmission, the type B trib 66b returns to state 102 where type A transmissions are ignored.

**[0038]** With reference to FIG. 5 and FIG. 7, a communication session between the master transceiver 64 and a type A trib 66a will now be discussed. A state diagram for a type A trib 66a is shown in FIG. 7. A type A trib 66a is initialized in state 122 in which it awaits a type A modulation training sequence. If, however, master transceiver transmits a training sequence in which the type A trib 66a-66a are notified of a change to type B modulation as indicated by sequence 106, then a transition is made to state 124 where all type B transmissions are ignored until a type A modulation trailing sequence (e.g., sequence 114) is detected. Upon detecting the type A trailing sequence, a type A trib 66a returns to state 122 where it awaits a training sequence.



**[0039]** To initiate a communication session with a type A trib 66a, master transceiver 64 transmits a training sequence 126 in which an address of a particular type A trib 66a is identified. The identified type A trib 66a recognizes its own address and transitions to state 128 to receive data from master transceiver 64 as part of sequence 132.

**[0040]** After completing transmission sequence 132, master transceiver 64 transmits a trailing sequence 134 using type A modulation signifying the end of the current communication session. If master transceiver 64 has not transmitted a poll request to the type A trib 66a in sequence 132, then the type A trib 66a that was in communication with the master transceiver 64 will return to state 122 after receiving trailing sequence 134.

**[0041]** If, however, master transceiver 64 transmitted a poll request in sequence 132, then the type A trib 66a transitions to state 136 after receiving trailing sequence 134 where it will transmit training sequence 138, followed by data sequence 142, and terminated by trailing sequence 144 all using type A modulation. After completion of these transmissions, the type A trib 66a returns to state 122 to await the next type A modulation training sequence by master transceiver 64.

**[0042]** In an alternative embodiment of the present invention, embedded modulations can be used as a way to measure transmission line characteristics between a master transceiver and tributary transceiver, as shown in FIG. 8. In this embodiment, both a master transceiver 64 and a tributary transceiver 66a would have the ability to transmit using at least two modulation methods, type A and type B. In the present example, the primary transmission type is type A. Thus, as shown in FIG. 8, the master transceiver 64 establishes type A as the primary modulation in sequence 150.

**[0043]** To switch from type A to type B modulation, master transceiver 64 transmits a notification sequence 152 to the tributary 66a. Thus, the tributary 66a is notified of an impending change to modulation type B. The switch to type B modulation could be limited according to a specific time interval or for the communication of a particular quantity of data, such as a test signal. After notifying the tributary 66a of the change to type B modulation, the master transceiver 64, transmits a test signal sequence 154 using type B modulation.

**[0044]** In this embodiment, the tributary transceiver can contain logic which enables the tributary 66a to calculate at least one channel parameter from the test signal sequence 154. Channel parameters typically include transmission line characteristics, such as, for example, loss versus frequency, non-linear distortion, listener echoes, talker echoes, bridge tap locations, impedance mismatches, noise profile, signal-to-noise ratio, group delay versus frequency, cross-

talk presence, cross-talk type, etc. Moreover, the tributary transceiver 66a could be configured to communicate a channel parameter back to the master transceiver 64.

**[0045]** After transmitting the test signal sequence 154 to the tributary transceiver 66a, the master transceiver 64 can transmit a trailing sequence 156 to the tributary transceiver 66a using type A modulation to indicate the end of the transmission using type B modulation. The master transceiver 64 can then send information to the tributary transceiver 66a using primary modulation type A, as shown by training, data and trailing sequences 158, 160 and 162.

Likewise, the tributary transceiver 66a can send information to the master transceiver 64 using primary modulation type A, as shown by training, data and trailing sequences 164, 166 and 168.

**[0046]** In a further alternative embodiment, the master transceiver 64 or tributary transceiver 66a may identify a time period within which test signal sequences may be transmitted. This would eliminate the training and trailing sequences which alert the tributary transceiver 66a to the beginning of a new modulation method. The identification of the time period could be initiated by the master transceiver 64 or tributary transceiver 66a and could include a time period noted in the header of a transmission between the tributary transceiver 66a and master transceiver 64.

**[0047]** The control programs 78 and 92 of the present invention can be implemented in hardware, software, firmware, or a combination thereof. In the preferred embodiment(s), the control programs 78 and 92 are implemented in software or firmware that is stored in a memory and that is executed by a suitable instruction execution system.

**[0048]** The control programs 78 and 92, which comprise an ordered listing of executable instructions for implementing logical functions, can be embodied in any computer-readable medium for use by or in connection with an instruction execution system, apparatus, or device, such as a computer-based system, processor-containing system, or other system that can fetch the instructions from the instruction execution system, apparatus, or device and execute the instructions. In the context of this document, a "computer-readable medium" can be any means that can contain, store, communicate, propagate, or transport the program for use by or in connection with the instruction execution system, apparatus, or device. The computer readable medium can be, for example but not limited to, an electronic, magnetic, optical, electromagnetic, infrared, or semiconductor system, apparatus, device, or propagation medium. More specific examples (a nonexhaustive list) of the computer-readable medium would include the following: an electrical connection (electronic) having one or more wires, a portable computer diskette (magnetic), a random access memory (RAM) (magnetic), a read-only memory (ROM) (magnetic), an erasable programmable read-only memory (EPROM or Flash memory)

(magnetic), an optical fiber (optical), and a portable compact disc read-only memory (CDROM) (optical). Note that the computer-readable medium could even be paper or another suitable medium upon which the program is printed, as the program can be electronically captured, via for instance optical scanning of the paper or other medium, then compiled, interpreted or otherwise processed in a suitable manner if necessary, and then stored in a computer memory.

**[0049]** In concluding the detailed description, it should be noted that it will be obvious to those skilled in the art that many variations and modifications can be made to the preferred embodiment without substantially departing from the principles of the present invention. All such variations and modifications are intended to be included herein within the scope of the present invention, as set forth in the following claims. Further, in the claims hereafter, the corresponding structures, materials, acts, and equivalents of all means or step plus function elements are intended to include any structure, material, or acts for performing the functions with other claimed elements as specifically claimed.

**What is Claimed:**

1. A communication system, comprising:
  - a transmitter capable of transmitting at least two modulation methods, wherein the at least two modulation methods comprise a first modulation method and a second modulation, wherein the second method is different than the first modulation method, and wherein the first transceiver is configured to transmit
    - a first sequence, in the first modulation method, that indicates an impending change from the first modulation method to the second modulation method, and
    - a second sequence, in the second modulation method, wherein the second sequence is transmitted after the first data sequence.
2. The system of claim 1, wherein the transceiver is configured to transmit a third sequence after the second sequence, wherein the third sequence is transmitted in the first modulation method and indicates that communication has reverted to the first modulation method.
3. The system of claim 1, wherein first modulation method is a frequency shift keying modulation.
4. The system of claim 3, wherein the second modulation method is a shift keying modulation.
5. The system of claim 1, wherein the second modulation method is different than the first modulation method in performance.
6. The system of claim 5, wherein the first modulation method has a lower performance than the second modulation method.
7. The system of claim 1, wherein the second modulation method is different than the first modulation method in data rate.
8. The system of claim 7, wherein the first modulation method has a lower data rate than the second modulation method.

9. The system of claim 1, wherein the first transceiver is configured to transmit the second sequence according to a specific time interval.
10. The system of claim 1, wherein the first transceiver is configured to transmit the second sequence according to a particular quantity of data.
11. The system of claim 1, further comprising a processor and a memory, wherein the memory has stored therein instructions that when executed by the processor cause the transmitter to transmit the first sequence and the second sequence.
12. The system of claim 11, wherein the memory has stored therein program code for the first modulation method and the second modulation method.
13. The system of claim 11, wherein the memory comprises random access memory.
14. The system of claim 11, wherein the memory comprises read-only memory.
15. The device of claim 11, wherein the memory has stored therein program code for a multipoint communications protocol.
16. The system of claim 1, wherein the first sequence comprises an address.
17. The system of claim 1, wherein the first sequence and the second sequence are contained in a burst transmission.
18. The system of claim 17, wherein the burst transmission is a poll in accordance with a multipoint communications protocol.
19. A communications device, comprising:
  - a processor; and
  - a memory having stored therein executable instructions for execution by the processor, wherein the executable instructions direct transmission of first data with a first modulation method followed by second data with a second modulation method, wherein the first modulation method is different than the second modulation method, and wherein the first data comprises an

indication of an impending change from the first modulation method to the second modulation method.

20. The device of claim 19, wherein the executable instructions direct transmission of third data with the first modulation method after the second data, wherein the third data indicates that communication has reverted to the first modulation method.

21. The device of claim 19, wherein first modulation method is a frequency shift keying modulation.

22. The device of claim 21, wherein second modulation method is a shift keying modulation.

23. The device of claim 19, wherein the second modulation method is different than the first modulation method in performance.

24. The device of claim 23, wherein the first modulation method has a lower performance than the second modulation method.

25. The device of claim 19, wherein the second modulation method is different than the first modulation method in data rate.

26. The device of claim 25, wherein the first modulation method has a lower data rate than the second modulation method.

27. The device of claim 19, wherein transmission of the second data is according to a specific time interval.

28. The device of claim 19, wherein transmission of the second data is according to a particular quantity of data.

29. The device of claim 19, further comprising transmitter configured to transmit the first data and the second data.

30. The device of claim 19, wherein the memory has stored therein program code for the first modulation method and the second modulation method.

31. The device of claim 19, wherein the memory comprises random access memory.
32. The device of claim 19, wherein the memory comprises read-only memory.
33. The device of claim 19, wherein the memory has stored therein program code for a multipoint communications protocol.
34. The device of claim 19, wherein the first data comprises an address.
35. The device of claim 19, wherein the transmission of the first data and the second data is a burst transmission.
36. The device of claim 35, wherein the burst transmission is a poll in accordance with a multipoint communications protocol.
37. A device, comprising:
  - a first modulation logic;
  - a second modulation logic that is different than the first modulation logic; and
  - a transceiver adapted to use the first modulation logic and the second modulation logic,wherein the transceiver is configured to transmit:
  - a first sequence, in accordance with the first modulation logic, that indicates a change from the first modulation logic to the second modulation logic, and
  - a second sequence, in accordance with the second modulation logic, that follows the first data sequence.
38. The device of claim 37, wherein the transceiver is configured to transmit a third sequence after the second sequence, wherein the third sequence is transmitted in accordance with the first modulation logic and indicates that communication has reverted to the first modulation logic.
39. The device of claim 37, wherein first modulation logic uses a frequency shift keying modulation.
40. The device of claim 39, wherein the second modulation logic uses a shift keying modulation.

41. The device of claim 37, wherein the second modulation logic is different than the first modulation logic in performance.
42. The device of claim 41, wherein the first modulation logic has a lower performance than the second modulation logic.
43. The device of claim 37, wherein the second modulation logic is different than the first modulation logic in data rate.
44. The device of claim 43, wherein the first modulation logic result in a lower data rate than the second modulation logic.
45. The device of claim 37, wherein the first transceiver is configured to transmit the second sequence according to a specific time interval.
46. The device of claim 37, wherein the first transceiver is configured to transmit the second sequence according to a particular quantity of data.
47. The device of claim 37, further comprising a processor and a memory, wherein the memory has stored therein instructions that when executed by the processor cause the transmitter to transmit the first sequence and the second sequence.
48. The device of claim 47, wherein the memory comprises random access memory.
49. The device of claim 47, wherein the memory comprises read-only memory.
50. The device of claim 47, wherein the memory has stored therein program code for a multipoint communications protocol.
51. The device of claim 37, wherein the first sequence comprises an address.
52. The device of claim 37, wherein the first sequence and the second sequence are contained in a burst transmission.



53. The device of claim 52, wherein the burst transmission is a poll in accordance with a multipoint communications protocol.
54. The device of claim 37, wherein the first modulation logic is hardware.
55. The device of claim 37, wherein the first modulation logic is firmware.
56. The device of claim 37, wherein the second modulation logic is hardware.
57. The device of claim 37, wherein the second modulation logic is firmware.
58. A method, comprising:  
transmitting, from a transmitter, a first sequence of a burst transmission segment, wherein the first sequence is modulated according to a first modulation method;  
indicating in the first sequence that a second sequence of the burst transmission segment will use a second modulation method, wherein the second modulation method is different from the first modulation method; and  
transmitting the second sequence of the burst transmission segment, wherein the second sequence follows the first sequence and wherein the second sequence is modulated according to the second modulation method.
59. The method of claim 58, further comprising transmitting a third sequence after the second sequence, wherein the third sequence is transmitted in the first modulation method and indicates that communication has reverted to the first modulation method.
60. The method of claim 58, wherein the first modulation method is a frequency shift keying modulation.
61. The method of claim 60, wherein the second modulation method is a shift keying modulation.
62. The method of claim 58, wherein the second modulation method is different than the first modulation logic in performance.

63. The method of claim 62, wherein the first modulation method has a lower performance than the second modulation method.
64. The method of claim 58, wherein the second modulation method is different than the first modulation method in data rate.
65. The method of claim 64, wherein the first modulation method has a lower data rate than the second modulation method.
66. The method of claim 58, wherein transmitting the second sequence comprises transmitting the second sequence according to a specific time interval.
67. The method of claim 58, wherein transmitting the second sequence comprises transmitting the second sequence according to a particular quantity of data.
68. The method of claim 58, further comprising storing, in a memory, program code for a multipoint communications protocol.
69. The method of claim 58, wherein the first sequence comprises an address.
70. The method of claim 58, wherein the first sequence and the second sequence are contained in poll transmission.
71. The method of claim 70, wherein the poll transmission is in accordance with a multipoint communications protocol.
72. A computer-readable storage medium having computer instructions stored thereon that when executed by a processor cause the processor to direct actions, comprising:
  - transmitting, from a transmitter, a first sequence of a burst transmission segment, wherein the first sequence is modulated according to a first modulation method;
  - indicating in the first sequence that a second sequence of the burst transmission segment will use a second modulation method, wherein the second modulation method is different from the first modulation method; and

transmitting the second sequence of the burst transmission segment, wherein the second sequence follows the first sequence and wherein the second sequence is modulated according to the second modulation method.

73. The computer-readable storage medium of claim 72, wherein the actions further comprise transmitting a third sequence after the second sequence, wherein the third sequence is transmitted in the first modulation method and indicates that communication has reverted to the first modulation method.

74. The computer-readable storage medium of claim 72, wherein the first modulation method is a frequency shift keying modulation.

75. The computer-readable storage medium of claim 74, wherein the second modulation method is a shift keying modulation.

76. The computer-readable storage medium of claim 72, wherein the second modulation method is different than the first modulation logic in performance.

77. The computer-readable storage medium of claim 76, wherein the first modulation method has a lower performance than the second modulation method.

78. The computer-readable storage medium of claim 72, wherein the second modulation method is different than the first modulation method in data rate.

79. The computer-readable storage medium of claim 78, wherein the first modulation method has a lower data rate than the second modulation method.

80. The computer-readable storage medium of claim 72, wherein transmitting the second sequence comprises transmitting the second sequence according to a specific time interval.

81. The computer-readable storage medium of claim 72, wherein transmitting the second sequence comprises transmitting the second sequence according to a particular quantity of data.

82. The computer-readable storage medium of claim 72, further comprising fetching, from a memory, program code for a multipoint communications protocol.

83. The computer-readable storage medium of claim 72, wherein the first sequence comprises an address.
84. The computer-readable storage medium of claim 72, wherein the first sequence and the second sequence are contained in poll transmission.
85. The computer-readable storage medium of claim 72, wherein the poll transmission is in accordance with a multipoint communications protocol.
86. A computer-readable storage medium having a computer executable instructions stored therein that when executed by a processor control a master transceiver, said computer executable instructions, comprising:
- first logic configured to establish a first modulation method for communication;
  - second logic configured to transmit a first sequence to notify of a change from said first modulation method to a second modulation method; and
  - third logic configured to transmit information in said second modulation method.
87. The computer-readable storage medium of claim 86, further comprising fourth logic configured to transmit a second sequence after the information is transmitted, wherein the second sequence is transmitted in the first modulation method and indicates that communication has reverted to the first modulation method.
88. The computer-readable storage medium of claim 86, wherein first modulation method is a frequency shift keying modulation.
89. The computer-readable storage medium of claim 88, wherein the second modulation method is a shift keying modulation.
90. The computer-readable storage medium of claim 86, wherein the second modulation method is different than the first modulation method in performance.
91. The computer-readable storage medium of claim 90, wherein the first modulation method has a lower performance than the second modulation method.

92. The computer-readable storage medium of claim 86, wherein the second modulation method is different than the first modulation method in data rate.
93. The computer-readable storage medium of claim 92, wherein the first modulation method has a lower data rate than the second modulation method.
94. The computer-readable storage medium of claim 86, wherein the first transceiver is configured to transmit the second sequence according to a specific time interval.
95. The computer-readable storage medium of claim 86, wherein the first transceiver is configured to transmit the second sequence according to a particular quantity of data.
96. The computer-readable storage medium of claim 11, further comprising program code for the first modulation method and the second modulation method.
97. The computer-readable storage medium of claim 11, further comprising program code for a multipoint communications protocol.
98. The computer-readable storage medium of claim 1, wherein the first sequence comprises an address.
99. The computer-readable storage medium of claim 1, wherein the first sequence and the information are contained in a burst transmission.
100. The computer-readable storage medium of claim 17, wherein the burst transmission is a poll in accordance with a multipoint communications protocol.

**ABSTRACT**

A single subscriber line multi-point communication system is disclosed. In general, the multi-point communication system can include a first transceiver coupled to a subscriber line capable of transmitting and receiving at least two modulation methods, either of said modulation methods being operable to transmit a test signal, and a second transceiver coupled to said subscriber line capable of transmitting and receiving said at least two modulation methods, the second transceiver being operable to receive the test signal and determine at least one channel parameter from the test signal. A master transceiver that can be used in various embodiments of a single subscriber line multi-point communication system, and a tributary transceiver are further disclosed.

Filing Date: 08/19/09

Approved for use through 7/31/2006. OMB 0651-0032

U.S. Patent and Trademark Office; U.S. DEPARTMENT OF COMMERCE

Under the Paperwork Reduction Act of 1995, no persons are required to respond to a collection of information unless it displays a valid OMB control number.

PATENT APPLICATION FEE DETERMINATION RECORD					Application or Docket Number		
Substitute for Form PTO-875					12/543,910		
<b>APPLICATION AS FILED – PART I</b>							
(Column 1)			(Column 2)		SMALL ENTITY		
OR			OTHER THAN SMALL ENTITY				
FOR	NUMBER FILED	NUMBER EXTRA	RATE (\$)	FEE (\$)	RATE (\$)	FEE (\$)	
BASIC FEE (37 CFR 1.16(a), (b), or (c))	N/A	N/A	N/A		N/A	330	
SEARCH FEE (37 CFR 1.16(k), (l), or (m))	N/A	N/A	N/A		N/A	540	
EXAMINATION FEE (37 CFR 1.16(o), (p), or (q))	N/A	N/A	N/A		N/A	220	
TOTAL CLAIMS (37 CFR 1.16(i))	100	minus 20 = 80	x\$26		x\$52	4160	
INDEPENDENT CLAIMS (37 CFR 1.16(h))	6	minus 3 = 3	x\$110		x\$220	660	
APPLICATION SIZE FEE (37 CFR 1.16(s))	If the specification and drawings exceed 100 sheets of paper, the application size fee due is \$270 (\$135 for small entity) for each additional 50 sheets or fraction thereof. See 35 U.S.C. 41(a)(1)(G) and 37 CFR						
MULTIPLE DEPENDENT CLAIM PRESENT (37 CFR 1.16(j))							
			195		390		
			TOTAL		TOTAL	5910	
* If the difference in column 1 is less than zero, enter "0" in column 2.							
<b>APPLICATION AS AMENDED – PART II</b>							
(Column 1)		(Column 2)		(Column 3)		SMALL ENTITY	
OR		OTHER THAN SMALL ENTITY					
AMENDMENT A	CLAIMS REMAINING AFTER AMENDMENT	HIGHEST NUMBER PREVIOUSLY PAID FOR	PRESENT EXTRA	RATE (\$)	ADDITIONAL FEE (\$)	RATE (\$)	ADDITIONAL FEE (\$)
	Total (37 CFR 1.16(i))	Minus **	=	X =		X =	
	Independent (37 CFR 1.16(h))	Minus ***	=	X =		X =	
	Application Size Fee (37 CFR 1.16(s))						
	FIRST PRESENTATION OF MULTIPLE DEPENDENT CLAIM (37 CFR 1.16(j))			N/A		N/A	
			TOTAL ADD'T FEE		TOTAL ADD'T FEE		
(Column 1)		(Column 2)		(Column 3)		SMALL ENTITY	
OR		OTHER THAN SMALL ENTITY					
AMENDMENT B	CLAIMS REMAINING AFTER AMENDMENT	HIGHEST NUMBER PREVIOUSLY PAID FOR	PRESENT EXTRA	RATE (\$)	ADDITIONAL FEE (\$)	RATE (\$)	ADDITIONAL FEE (\$)
	Total (37 CFR 1.16(i))	Minus **	=	X =		X =	
	Independent (37 CFR 1.16(h))	Minus ***	=	X =		X =	
	Application Size Fee (37 CFR 1.16(s))						
	FIRST PRESENTATION OF MULTIPLE DEPENDENT CLAIM (37 CFR 1.16(j))			N/A		N/A	
			TOTAL ADD'T FEE		TOTAL ADD'T FEE		
* If the entry in column 1 is less than the entry in column 2, write "0" in column 3. ** If the "Highest Number Previously Paid For" IN THIS SPACE is less than 20, enter "20". *** If the "Highest Number Previously Paid For" IN THIS SPACE is less than 3, enter "3". The "Highest Number Previously Paid For" (Total or Independent) is the highest number found in the appropriate box in column 1.							

This collection of information is required by 37 CFR 1.16. The information is required to obtain or retain a benefit by the public which is to file (and by the USPTO to process) an application. Confidentiality is governed by 35 U.S.C. 122 and 37 CFR 1.14. This collection is estimated to take 12 minutes to complete, including gathering, preparing, and submitting the completed application form to the USPTO. Time will vary depending upon the individual case. Any comments on the amount of time you require to complete this form and/or suggestions for reducing this burden, should be sent to the Chief Information Officer, U.S. Patent and Trademark Office, U.S. Department of Commerce, P.O. Box 1450, Alexandria, VA 22313-1450. DO NOT SEND FEES OR COMPLETED FORMS TO THIS ADDRESS. SEND TO: Commissioner for Patents, P.O. Box 1450, Alexandria, VA 22313-1450.

If you need assistance in completing the form, call 1-800-PTO-9199 and select option 2.



UNITED STATES PATENT AND TRADEMARK OFFICE

UNITED STATES DEPARTMENT OF COMMERCE
United States Patent and Trademark Office
Address: COMMISSIONER FOR PATENTS
P.O. Box 1450
Alexandria, Virginia 22313-1450
www.uspto.gov

Table with 7 columns: APPLICATION NUMBER, FILING or 371(c) DATE, GRP ART UNIT, FIL FEE REC'D, ATTY.DOCKET.NO, TOT CLAIMS, IND CLAIMS. Row 1: 12/543,910, 08/19/2009, 2611, 5910, REMB-0109, 100, 6

CONFIRMATION NO. 8306

23377
WOODCOCK WASHBURN LLP
CIRA CENTRE, 12TH FLOOR
2929 ARCH STREET
PHILADELPHIA, PA 19104-2891

FILING RECEIPT



Date Mailed: 09/08/2009

Receipt is acknowledged of this non-provisional patent application. The application will be taken up for examination in due course. Applicant will be notified as to the results of the examination. Any correspondence concerning the application must include the following identification information: the U.S. APPLICATION NUMBER, FILING DATE, NAME OF APPLICANT, and TITLE OF INVENTION. Fees transmitted by check or draft are subject to collection. Please verify the accuracy of the data presented on this receipt. If an error is noted on this Filing Receipt, please submit a written request for a Filing Receipt Correction. Please provide a copy of this Filing Receipt with the changes noted thereon. If you received a "Notice to File Missing Parts" for this application, please submit any corrections to this Filing Receipt with your reply to the Notice. When the USPTO processes the reply to the Notice, the USPTO will generate another Filing Receipt incorporating the requested corrections

Applicant(s)

Gordon Bremer, Clearwater, FL;

Power of Attorney: None

Domestic Priority data as claimed by applicant

This application is a CON of 11/774,803 07/09/2007
which is a CON of 10/412,878 04/14/2003 PAT 7,248,626
which is a CIP of 09/205,205 12/04/1998 PAT 6,614,838
which claims benefit of 60/067,562 12/05/1997

Foreign Applications

If Required, Foreign Filing License Granted: 08/31/2009

The country code and number of your priority application, to be used for filing abroad under the Paris Convention, is US 12/543,910

Projected Publication Date: To Be Determined - pending completion of Missing Parts

Non-Publication Request: No

Early Publication Request: No



**Title**

System and Method of Communication Via Embedded Modulation

**Preliminary Class**

375

**PROTECTING YOUR INVENTION OUTSIDE THE UNITED STATES**

Since the rights granted by a U.S. patent extend only throughout the territory of the United States and have no effect in a foreign country, an inventor who wishes patent protection in another country must apply for a patent in a specific country or in regional patent offices. Applicants may wish to consider the filing of an international application under the Patent Cooperation Treaty (PCT). An international (PCT) application generally has the same effect as a regular national patent application in each PCT-member country. The PCT process **simplifies** the filing of patent applications on the same invention in member countries, but **does not result** in a grant of "an international patent" and does not eliminate the need of applicants to file additional documents and fees in countries where patent protection is desired.

Almost every country has its own patent law, and a person desiring a patent in a particular country must make an application for patent in that country in accordance with its particular laws. Since the laws of many countries differ in various respects from the patent law of the United States, applicants are advised to seek guidance from specific foreign countries to ensure that patent rights are not lost prematurely.

Applicants also are advised that in the case of inventions made in the United States, the Director of the USPTO must issue a license before applicants can apply for a patent in a foreign country. The filing of a U.S. patent application serves as a request for a foreign filing license. The application's filing receipt contains further information and guidance as to the status of applicant's license for foreign filing.

Applicants may wish to consult the USPTO booklet, "General Information Concerning Patents" (specifically, the section entitled "Treaties and Foreign Patents") for more information on timeframes and deadlines for filing foreign patent applications. The guide is available either by contacting the USPTO Contact Center at 800-786-9199, or it can be viewed on the USPTO website at <http://www.uspto.gov/web/offices/pac/doc/general/index.html>.

For information on preventing theft of your intellectual property (patents, trademarks and copyrights), you may wish to consult the U.S. Government website, <http://www.stopfakes.gov>. Part of a Department of Commerce initiative, this website includes self-help "toolkits" giving innovators guidance on how to protect intellectual property in specific countries such as China, Korea and Mexico. For questions regarding patent enforcement issues, applicants may call the U.S. Government hotline at 1-866-999-HALT (1-866-999-4158).

**LICENSE FOR FOREIGN FILING UNDER****Title 35, United States Code, Section 184****Title 37, Code of Federal Regulations, 5.11 & 5.15****GRANTED**

The applicant has been granted a license under 35 U.S.C. 184, if the phrase "IF REQUIRED, FOREIGN FILING LICENSE GRANTED" followed by a date appears on this form. Such licenses are issued in all applications where the conditions for issuance of a license have been met, regardless of whether or not a license may be required as

set forth in 37 CFR 5.15. The scope and limitations of this license are set forth in 37 CFR 5.15(a) unless an earlier license has been issued under 37 CFR 5.15(b). The license is subject to revocation upon written notification. The date indicated is the effective date of the license, unless an earlier license of similar scope has been granted under 37 CFR 5.13 or 5.14.

This license is to be retained by the licensee and may be used at any time on or after the effective date thereof unless it is revoked. This license is automatically transferred to any related applications(s) filed under 37 CFR 1.53(d). This license is not retroactive.

The grant of a license does not in any way lessen the responsibility of a licensee for the security of the subject matter as imposed by any Government contract or the provisions of existing laws relating to espionage and the national security or the export of technical data. Licensees should apprise themselves of current regulations especially with respect to certain countries, of other agencies, particularly the Office of Defense Trade Controls, Department of State (with respect to Arms, Munitions and Implements of War (22 CFR 121-128)); the Bureau of Industry and Security, Department of Commerce (15 CFR parts 730-774); the Office of Foreign Assets Control, Department of Treasury (31 CFR Parts 500+) and the Department of Energy.

**NOT GRANTED**

No license under 35 U.S.C. 184 has been granted at this time, if the phrase "IF REQUIRED, FOREIGN FILING LICENSE GRANTED" DOES NOT appear on this form. Applicant may still petition for a license under 37 CFR 5.12, if a license is desired before the expiration of 6 months from the filing date of the application. If 6 months has lapsed from the filing date of this application and the licensee has not received any indication of a secrecy order under 35 U.S.C. 181, the licensee may foreign file the application pursuant to 37 CFR 5.15(b).



UNITED STATES PATENT AND TRADEMARK OFFICE

UNITED STATES DEPARTMENT OF COMMERCE
United States Patent and Trademark Office
Address: COMMISSIONER FOR PATENTS
P.O. Box 1450
Alexandria, Virginia 22313-1450
www.uspto.gov

Table with 4 columns: APPLICATION NUMBER (12/543,910), FILING OR 371(C) DATE (08/19/2009), FIRST NAMED APPLICANT (Gordon Bremer), ATTY. DOCKET NO./TITLE (REMB-0109)

CONFIRMATION NO. 8306

FORMALITIES LETTER



23377
WOODCOCK WASHBURN LLP
CIRA CENTRE, 12TH FLOOR
2929 ARCH STREET
PHILADELPHIA, PA 19104-2891

Date Mailed: 09/08/2009

NOTICE TO FILE MISSING PARTS OF NONPROVISIONAL APPLICATION

FILED UNDER 37 CFR 1.53(b)

Filing Date Granted

Items Required To Avoid Abandonment:

An application number and filing date have been accorded to this application. The item(s) indicated below, however, are missing. Applicant is given TWO MONTHS from the date of this Notice within which to file all required items and pay any fees required below to avoid abandonment.

- The oath or declaration is missing. A properly signed oath or declaration in compliance with 37 CFR 1.63, identifying the application by the above Application Number and Filing Date, is required. Note: If a petition under 37 CFR 1.47 is being filed, an oath or declaration in compliance with 37 CFR 1.63 signed by all available joint inventors, or if no inventor is available by a party with sufficient proprietary interest, is required.

The applicant needs to satisfy supplemental fees problems indicated below.

The required item(s) identified below must be timely submitted to avoid abandonment:

- To avoid abandonment, a surcharge (for late submission of filing fee, search fee, examination fee or oath or declaration) as set forth in 37 CFR 1.16(f) of \$130 for a non-small entity, must be submitted with the missing items identified in this notice.

SUMMARY OF FEES DUE:

Total additional fee(s) required for this application is \$130 for a non-small entity

- \$130 Surcharge.

Replies should be mailed to:

Mail Stop Missing Parts  
Commissioner for Patents  
P.O. Box 1450  
Alexandria VA 22313-1450

Registered users of EFS-Web may alternatively submit their reply to this notice via EFS-Web.  
<https://sportal.uspto.gov/authenticate/AuthenticateUserLocalEPF.html>

For more information about EFS-Web please call the USPTO Electronic Business Center at **1-866-217-9197** or visit our website at <http://www.uspto.gov/ebc>.

If you are not using EFS-Web to submit your reply, you must include a copy of this notice.

/ltaba/

---

Office of Data Management, Application Assistance Unit (571) 272-4000, or (571) 272-4200, or 1-888-786-0101

IN THE UNITED STATES PATENT AND TRADEMARK OFFICE

In Re Application of:

12/543,910

Confirmation No.: 8306

Application No.: 12/543,910

Group Art Unit: 2611

Filing Date: August 19, 2009

Examiner: To be assigned

For: System and Method of Communication Via Embedded Modulation

Commissioner for Patents  
P.O. Box 1450  
Alexandria, VA 22313-1450

Dear Sir:

INFORMATION DISCLOSURE STATEMENT

Pursuant to 37 CFR § 1.56 and in accordance with 37 CFR §§ 1.97-1.98, information relating to the above-identified application is hereby disclosed. Inclusion of information in this statement is not to be construed as an admission that this information is material as that term is defined in 37 CFR § 1.56(b).

- In accordance with § 1.97(b), since this Information Disclosure Statement is being filed either within three months of the filing date of the above-identified application, within three months of the date of entry into the national stage of the above identified application as set forth in § 1.491, before the mailing date of a first Office Action on the merits of the above-identified application, or before the mailing date of a first Office Action after

the filing of request for continued examination under § 1.114, no additional fee is required.

In accordance with § 1.97(c), this Information Disclosure Statement is being filed after the period set forth in § 1.97(b) above but before the mailing date of either a Final Action under § 1.116 or a Notice of Allowance under § 1.311, or before an action that otherwise closes prosecution in the application, therefore:

Certification in Accordance with § 1.97(e) is attached; or

The fee of \$180.00 as set forth in § 1.17(p) is attached.

In accordance with § 1.97(d), this Information Disclosure Statement is being filed after the mailing date of either a Final Action under § 1.113 or a Notice of Allowance under § 1.311 but before, or simultaneously with, the payment of the Issue Fee, therefore included are: Certification in Accordance with § 1.97(e); and the submission fee of \$180.00 as set forth in § 1.17(p).

Copies of reference numbers listed on the attached Form PTO-1449 are enclosed herewith.

Copies of reference numbers 1 - 22 on the attached Form PTO 1449 are not required to be submitted pursuant to 37 CFR § 1.98(a)(2)(ii).

Copies of references are not being submitted because they were previously cited by or submitted to the U.S. Patent and Trademark Office in patent application number , filed , for which a claim for priority under 35 U.S.C. § 120 has been made in the instant application;

There are no listed references which are not in the English language.

Please charge any deficiency or credit any overpayment to Deposit Account No. 23-3050.

Date: 10/23/2009

/Michael A. Koptiw/  
Michael A. Koptiw  
Registration No. 57,900

WOODCOCK WASHBURN LLP  
Cira Centre  
2929 Arch Street, 12th Floor  
Philadelphia, PA 19104-2891  
Telephone: (215) 568-3100  
Facsimile: (215) 568-3439

Substitute for 1449/PTO  <b>INFORMATION DISCLOSURE STATEMENT BY APPLICANT</b>  <i>(use as many sheets as necessary)</i>				<b>Complete if Known</b>	
				<b>Application Number</b>	12/543910
				<b>Filing Date</b>	August 19, 2009
				<b>First Named Inventor</b>	Gordon Bremer
				<b>Art Unit</b>	2611
<b>Examiner Name</b>	To be assigned				
Sheet	1	of	2	<b>Attorney Docket Number</b>	REMB-0109

<b>U. S. PATENT DOCUMENTS</b>						
Examiner Initials	Cite No.	Document Number		Publication Date MM-DD-YYYY	Name of Patentee or Applicant of Cited Document	Page, Columns, Lines, Where Relevant Passages or Relevant Figures Appear
		Number – Kind Code (if known)				
	1	3970926		7/20/1996	Rigby et al.	
	2	4091422		5/23/1978	Amster	
	3	4630286		12/16/1986	Betts	
	4	5050536		9/24/1991	Baker	
	5	5537398		7/16/1996	Siwiak	
	6	5540456		7/30/1996	Meier-Burkamp et al.	
	7	5548222		8/20/1996	Jensen et al.	
	8	5563883		10/8/1996	Cheng	
	9	5577087		11/19/1996	Furuya	
	10	5793800		8/11/1998	Jylha et al.	
	11	5936949		8/10/1999	Pasternak et al.	
	12	5999563		12/7/1999	Polley et al.	
	13	6021158		2/1/2000	Schurr et al.	
	14	6067297		5/23/2000	Beach	
	15	6072779		6/6/2000	Tzannes et all.	
	16	6212227		4/3/2001	Ko et al.	
	17	6348986		2/19/2002	Doucet et al.	
	18	6445733		9/3/2002	Zuranski et al.	
	19	6614838		9/2/2003	Bremer	
	20	6671328		12/30/2003	Poon et al.	
	21	7006445		2/28/2006	Cole et al.	
	22	7170867		1/30/2007	O'Toole et al.	

<b>Examiner Signature</b>		<b>Date Considered</b>	
---------------------------	--	------------------------	--



Substitute for 1449/PTO  <b>INFORMATION DISCLOSURE STATEMENT BY APPLICANT</b>  <i>(use as many sheets as necessary)</i>				<b>Complete if Known</b>		
				<b>Application Number</b>	12/543910	
				<b>Filing Date</b>	August 19, 2009	
				<b>First Named Inventor</b>	Gordon Bremer	
				<b>Art Unit</b>	2611	
				<b>Examiner Name</b>	To be assigned	
Sheet	2	of	2	<b>Attorney Docket Number</b>	REMB-0109	

FOREIGN PATENT DOCUMENTS						
Examiner Initials	Cite No	Foreign Patent Document Country Code- Number -Kind Code (if known)	Publication Date MM-DD-YYYY	Name of Patentee or Applicant of Cited Document	Pages, Columns, Lines, Where Relevant Passages or Relevant Figures Appear	T

NON PATENT LITERATURE DOCUMENTS			
Examiner Initials	Cite No.	Include name of the author (in CAPITAL LETTERS), title of the article (when appropriate), title of the item (book, magazine, journal, serial, symposium, catalog, etc.), date, page(s), Volume-issue Number(s), publisher, city and/or country where published.	T

<b>Examiner Signature</b>		<b>Date Considered</b>	
---------------------------	--	------------------------	--

## Electronic Acknowledgement Receipt

<b>EFS ID:</b>	6318625
<b>Application Number:</b>	12543910
<b>International Application Number:</b>	
<b>Confirmation Number:</b>	8306
<b>Title of Invention:</b>	System and Method of Communication Via Embedded Modulation
<b>First Named Inventor/Applicant Name:</b>	Gordon Bremer
<b>Customer Number:</b>	23377
<b>Filer:</b>	Michael Koptiw Jr./Janis Calvo
<b>Filer Authorized By:</b>	Michael Koptiw Jr.
<b>Attorney Docket Number:</b>	REMB-0109
<b>Receipt Date:</b>	23-OCT-2009
<b>Filing Date:</b>	19-AUG-2009
<b>Time Stamp:</b>	12:33:42
<b>Application Type:</b>	Utility under 35 USC 111(a)

### Payment information:

Submitted with Payment	no
------------------------	----

### File Listing:

Document Number	Document Description	File Name	File Size(Bytes)/ Message Digest	Multi Part /.zip	Pages (if appl.)
1	Information Disclosure Statement (IDS) Filed (SB/08)	INFORMATION_DISCLOSURE_S TATEMENT.pdf	328808 <small>ebb7cc2a06e8ff085b6d14bbbbde1f2abeb 284ab</small>	no	5

### Warnings:

### Information:

Total Files Size (in bytes):

328808

**This Acknowledgement Receipt evidences receipt on the noted date by the USPTO of the indicated documents, characterized by the applicant, and including page counts, where applicable. It serves as evidence of receipt similar to a Post Card, as described in MPEP 503.**

**New Applications Under 35 U.S.C. 111**

**If a new application is being filed and the application includes the necessary components for a filing date (see 37 CFR 1.53(b)-(d) and MPEP 506), a Filing Receipt (37 CFR 1.54) will be issued in due course and the date shown on this Acknowledgement Receipt will establish the filing date of the application.**

**National Stage of an International Application under 35 U.S.C. 371**

**If a timely submission to enter the national stage of an international application is compliant with the conditions of 35 U.S.C. 371 and other applicable requirements a Form PCT/DO/EO/903 indicating acceptance of the application as a national stage submission under 35 U.S.C. 371 will be issued in addition to the Filing Receipt, in due course.**

**New International Application Filed with the USPTO as a Receiving Office**

**If a new international application is being filed and the international application includes the necessary components for an international filing date (see PCT Article 11 and MPEP 1810), a Notification of the International Application Number and of the International Filing Date (Form PCT/RO/105) will be issued in due course, subject to prescriptions concerning national security, and the date shown on this Acknowledgement Receipt will establish the international filing date of the application.**

Under the Paperwork Reduction Act of 1995, no persons are required to respond to a collection of information unless it displays a valid OMB control number.

<b>TRANSMITTAL FORM</b>  <i>(to be used for all correspondence after initial filing)</i>	Application Number	12/543,910
	Filing Date	08-19-2009
	First Named Inventor	Gordon Bremer
	Art Unit	2611
	Examiner Name	Not Yet Assigned
Total Number of Pages in This Submission	Attorney Docket Number	REMB-0109

<b>ENCLOSURES (Check all that apply)</b>		
<input type="checkbox"/> Fee Transmittal Form <input type="checkbox"/> Fee Attached <input type="checkbox"/> Amendment/Reply <input type="checkbox"/> After Final <input type="checkbox"/> Affidavits/declaration(s) <input checked="" type="checkbox"/> Extension of Time Request <input type="checkbox"/> Express Abandonment Request <input type="checkbox"/> Information Disclosure Statement  <input type="checkbox"/> Certified Copy of Priority Document(s) <input checked="" type="checkbox"/> Reply to Missing Parts/ Incomplete Application <input checked="" type="checkbox"/> Reply to Missing Parts under 37 CFR 1.52 or 1.53	<input type="checkbox"/> Drawing(s) <input type="checkbox"/> Licensing-related Papers <input type="checkbox"/> Petition <input type="checkbox"/> Petition to Convert to a Provisional Application <input checked="" type="checkbox"/> Power of Attorney, Revocation Change of Correspondence Address <input type="checkbox"/> Terminal Disclaimer <input type="checkbox"/> Request for Refund <input type="checkbox"/> CD, Number of CD(s) _____ <input type="checkbox"/> Landscape Table on CD	<input type="checkbox"/> After Allowance Communication to TC <input type="checkbox"/> Appeal Communication to Board of Appeals and Interferences <input type="checkbox"/> Appeal Communication to TC (Appeal Notice, Brief, Reply Brief) <input type="checkbox"/> Proprietary Information <input type="checkbox"/> Status Letter <input checked="" type="checkbox"/> Other Enclosure(s) (please identify below): Executed Declaration of Gordon Bremer
Remarks		

<b>SIGNATURE OF APPLICANT, ATTORNEY, OR AGENT</b>			
Firm Name	Woodcock Washburn LLP		
Signature	/Michael A. Koptiw/		
Printed name	Michael A. Koptiw		
Date	March 31, 2010	Reg. No.	57,900

<b>CERTIFICATE OF TRANSMISSION/MAILING</b>			
I hereby certify that this correspondence is being facsimile transmitted to the USPTO or deposited with the United States Postal Service with sufficient postage as first class mail in an envelope addressed to: Commissioner for Patents, P.O. Box 1450, Alexandria, VA 22313-1450 on the date shown below:			
Signature			
Typed or printed name		Date	

This collection of information is required by 37 CFR 1.5. The information is required to obtain or retain a benefit by the public which is to file (and by the USPTO to process) an application. Confidentiality is governed by 35 U.S.C. 122 and 37 CFR 1.11 and 1.14. This collection is estimated to 2 hours to complete, including gathering, preparing, and submitting the completed application form to the USPTO. Time will vary depending upon the individual case. Any comments on the amount of time you require to complete this form and/or suggestions for reducing this burden, should be sent to the Chief Information Officer, U.S. Patent and Trademark Office, U.S. Department of Commerce, P.O. Box 1450, Alexandria, VA 22313-1450. DO NOT SEND FEES OR COMPLETED FORMS TO THIS ADDRESS. SEND TO: Commissioner for Patents, P.O. Box 1450, Alexandria, VA 22313-1450.

*If you need assistance in completing the form, call 1-800-PTO-9199 and select option 2.*

## Privacy Act Statement

The **Privacy Act of 1974 (P.L. 93-579)** requires that you be given certain information in connection with your submission of the attached form related to a patent application or patent. Accordingly, pursuant to the requirements of the Act, please be advised that: (1) the general authority for the collection of this information is 35 U.S.C. 2(b)(2); (2) furnishing of the information solicited is voluntary; and (3) the principal purpose for which the information is used by the U.S. Patent and Trademark Office is to process and/or examine your submission related to a patent application or patent. If you do not furnish the requested information, the U.S. Patent and Trademark Office may not be able to process and/or examine your submission, which may result in termination of proceedings or abandonment of the application or expiration of the patent.

The information provided by you in this form will be subject to the following routine uses:

1. The information on this form will be treated confidentially to the extent allowed under the Freedom of Information Act (5 U.S.C. 552) and the Privacy Act (5 U.S.C. 552a). Records from this system of records may be disclosed to the Department of Justice to determine whether disclosure of these records is required by the Freedom of Information Act.
2. A record from this system of records may be disclosed, as a routine use, in the course of presenting evidence to a court, magistrate, or administrative tribunal, including disclosures to opposing counsel in the course of settlement negotiations.
3. A record in this system of records may be disclosed, as a routine use, to a Member of Congress submitting a request involving an individual, to whom the record pertains, when the individual has requested assistance from the Member with respect to the subject matter of the record.
4. A record in this system of records may be disclosed, as a routine use, to a contractor of the Agency having need for the information in order to perform a contract. Recipients of information shall be required to comply with the requirements of the Privacy Act of 1974, as amended, pursuant to 5 U.S.C. 552a(m).
5. A record related to an International Application filed under the Patent Cooperation Treaty in this system of records may be disclosed, as a routine use, to the International Bureau of the World Intellectual Property Organization, pursuant to the Patent Cooperation Treaty.
6. A record in this system of records may be disclosed, as a routine use, to another federal agency for purposes of National Security review (35 U.S.C. 181) and for review pursuant to the Atomic Energy Act (42 U.S.C. 218(c)).
7. A record from this system of records may be disclosed, as a routine use, to the Administrator, General Services, or his/her designee, during an inspection of records conducted by GSA as part of that agency's responsibility to recommend improvements in records management practices and programs, under authority of 44 U.S.C. 2904 and 2906. Such disclosure shall be made in accordance with the GSA regulations governing inspection of records for this purpose, and any other relevant (*i.e.*, GSA or Commerce) directive. Such disclosure shall not be used to make determinations about individuals.
8. A record from this system of records may be disclosed, as a routine use, to the public after either publication of the application pursuant to 35 U.S.C. 122(b) or issuance of a patent pursuant to 35 U.S.C. 151. Further, a record may be disclosed, subject to the limitations of 37 CFR 1.14, as a routine use, to the public if the record was filed in an application which became abandoned or in which the proceedings were terminated and which application is referenced by either a published application, an application open to public inspection or an issued patent.
9. A record from this system of records may be disclosed, as a routine use, to a Federal, State, or local law enforcement agency, if the USPTO becomes aware of a violation or potential violation of law or regulation.

Under the Paperwork Reduction Act of 1995, no persons are required to respond to a collection of information unless it displays a valid OMB control number.

**DECLARATION (37 CFR 1.63) FOR UTILITY OR DESIGN APPLICATION USING AN APPLICATION DATA SHEET (37 CFR 1.76)**

<b>Title of Invention</b>	<b>Splitterless Communication</b>
---------------------------	-----------------------------------

As the below named inventor(s), I/we declare that:

This declaration is directed to:

- The attached application, or  
 Application No. 12/543,910 filed on August 19, 2009  
 As amended on \_\_\_\_\_ (if applicable);

I/we believe that I/we am/are the original and first inventor(s) of the subject matter which is claimed and for which a patent is sought;

I/we have reviewed and understand the contents of the above-identified application, including the claims, as amended by any amendment specifically referred to above;

I/we acknowledge the duty to disclose to the United States Patent and Trademark Office all information known to me/us to be material to patentability as defined in 37 CFR 1.56, including for continuation-in-part applications, material information which became available between the filing date of the prior application and the national or PCT International filing date of the continuation-in-part application.

**WARNING:**

Petitioner/applicant is cautioned to avoid submitting personal information in documents filed in a patent application that may contribute to identity theft. Personal information such as social security numbers, bank account numbers, or credit card numbers (other than a check or credit card authorization form PTO-2038 submitted for payment purposes) is never required by the USPTO to support a petition or an application. If this type of personal information is included in documents submitted to the USPTO, petitioners/applicants should consider redacting such personal information from the documents before submitting them to the USPTO. Petitioner/applicant is advised that the record of a patent application is available to the public after publication of the application (unless a non-publication request in compliance with 37 CFR 1.213(a) is made in the application) or issuance of a patent. Furthermore, the record from an abandoned application may also be available to the public if the application is referenced in a published application or an issued patent (see 37 CFR 1.14). Checks and credit card authorization forms PTO-2038 submitted for payment purposes are not retained in the application file and therefore are not publicly available.

All statements made herein of my/our own knowledge are true, all statements made herein on information and belief are believed to be true, and further that these statements were made with the knowledge that willful false statements and the like are punishable by fine or imprisonment, or both, under 18 U.S.C. 1001, and may jeopardize the validity of the application or any patent issuing thereon.

**FULL NAME OF INVENTOR(S)**

Inventor one: Gordon F. Bremer Date: 3-30-10  
 Signature: *Gordon F. Bremer* Citizen of: United States

Inventor two: \_\_\_\_\_ Date: \_\_\_\_\_  
 Signature: \_\_\_\_\_ Citizen of: \_\_\_\_\_

Additional inventors or a legal representative are being named on \_\_\_\_\_ additional form(s) attached hereto.

This collection of information is required by 35 U.S.C. 115 and 37 CFR 1.63. The information is required to obtain or retain a benefit by the public which is to file (and by the USPTO to process) an application. Confidentiality is governed by 35 U.S.C. 122 and 37 CFR 1.11 and 1.14. This collection is estimated to take 1 minute to complete, including gathering, preparing, and submitting the completed application form to the USPTO. Time will vary depending upon the individual case. Any comments on the amount of time you require to complete this form and/or suggestions for reducing this burden, should be sent to the Chief Information Officer, U.S. Patent and Trademark Office, U.S. Department of Commerce, P.O. Box 1450, Alexandria, VA 22313-1450. DO NOT SEND FEES OR COMPLETED FORMS TO THIS ADDRESS. SEND TO: Commissioner for Patents, P.O. Box 1450, Alexandria, VA 22313-1450.  
 If you need assistance in completing the form, call 1-800-PTO-9199 and select option 2.

Under the Paperwork Reduction Act of 1995, no persons are required to respond to a collection of information unless it displays a valid OMB control number.

<b>POWER OF ATTORNEY                  OR                  REVOCATION OF POWER OF ATTORNEY                  WITH A NEW POWER OF ATTORNEY                  AND                  CHANGE OF CORRESPONDENCE ADDRESS</b>	Application Number	12/543,910
	Filing Date	08-19-2009
	First Named Inventor	Gordon Bremer
	Title	System and Method of Communic
	Art Unit	2611
	Examiner Name	Not Yet Assigned
Attorney Docket Number	REMB-0109	

I hereby revoke all previous powers of attorney given in the above-identified application.

A Power of Attorney is submitted herewith.

OR

I hereby appoint Practitioner(s) associated with the following Customer Number as my/our attorney(s) or agent(s) to prosecute the application identified above, and to transact all business in the United States Patent and Trademark Office connected therewith:

23377

OR

I hereby appoint Practitioner(s) named below as my/our attorney(s) or agent(s) to prosecute the application identified above, and to transact all business in the United States Patent and Trademark Office connected therewith:

Practitioner(s) Name	Registration Number

Please recognize or change the correspondence address for the above-identified application to:

The address associated with the above-mentioned Customer Number.

OR

The address associated with Customer Number:

Firm or Individual Name

Address

City	State	Zip
Country		
Telephone	Email	

I am the:

Applicant/Inventor.

OR

Assignee of record of the entire interest. See 37 CFR 3.71.  
 Statement under 37 CFR 3.73(b) (Form PTO/SB/96) submitted herewith or filed on \_\_\_\_\_

**SIGNATURE of Applicant or Assignee of Record**

Signature	<i>Gordon Bremer</i>	Date	3-30-10
Name	Gordon Bremer	Telephone	727-656-6702
Title and Company			

**NOTE:** Signatures of all the inventors or assignees of record of the entire interest or their representative(s) are required. Submit multiple forms if more than one signature is required, see below\*.

\*Total of 1 forms are submitted.

This collection of information is required by 37 CFR 1.31, 1.32 and 1.33. The information is required to obtain or retain a benefit by the public which is to file (and by the USPTO to process) an application. Confidentiality is governed by 35 U.S.C. 122 and 37 CFR 1.11 and 1.14. This collection is estimated to take 3 minutes to complete, including gathering, preparing, and submitting the completed application form to the USPTO. Time will vary depending upon the individual case. Any comments on the amount of time you require to complete this form and/or suggestions for reducing this burden, should be sent to the Chief Information Officer, U.S. Patent and Trademark Office, U.S. Department of Commerce, P.O. Box 1450, Alexandria, VA 22313-1450. DO NOT SEND FEES OR COMPLETED FORMS TO THIS ADDRESS. SEND TO: Commissioner for Patents, P.O. Box 1450, Alexandria, VA 22313-1450.

If you need assistance in completing the form, call 1-800-PTO-9199 and select option 2.

## Electronic Patent Application Fee Transmittal

<b>Application Number:</b>	12543910
<b>Filing Date:</b>	19-Aug-2009
<b>Title of Invention:</b>	System and Method of Communication Via Embedded Modulation
<b>First Named Inventor/Applicant Name:</b>	Gordon Bremer
<b>Filer:</b>	Michael Koptiw Jr./Darleen Yacovone
<b>Attorney Docket Number:</b>	REMB-0109

Filed as Large Entity

### Utility under 35 USC 111(a) Filing Fees

Description	Fee Code	Quantity	Amount	Sub-Total in USD(\$)
<b>Basic Filing:</b>				
<b>Pages:</b>				
<b>Claims:</b>				
<b>Miscellaneous-Filing:</b>				
Late filing fee for oath or declaration	1051	1	130	130

**Petition:**

**Patent-Appeals-and-Interference:**

**Post-Allowance-and-Post-Issuance:**

**Extension-of-Time:**



Description	Fee Code	Quantity	Amount	Sub-Total in USD(\$)
Extension - 5 months with \$0 paid	1255	1	2350	2350
<b>Miscellaneous:</b>				
<b>Total in USD (\$)</b>				<b>2480</b>

## Electronic Acknowledgement Receipt

<b>EFS ID:</b>	7330929
<b>Application Number:</b>	12543910
<b>International Application Number:</b>	
<b>Confirmation Number:</b>	8306
<b>Title of Invention:</b>	System and Method of Communication Via Embedded Modulation
<b>First Named Inventor/Applicant Name:</b>	Gordon Bremer
<b>Customer Number:</b>	23377
<b>Filer:</b>	Michael Koptiw Jr./Darleen Yacovone
<b>Filer Authorized By:</b>	Michael Koptiw Jr.
<b>Attorney Docket Number:</b>	REMB-0109
<b>Receipt Date:</b>	31-MAR-2010
<b>Filing Date:</b>	19-AUG-2009
<b>Time Stamp:</b>	21:44:31
<b>Application Type:</b>	Utility under 35 USC 111(a)

### Payment information:

Submitted with Payment	yes
Payment Type	Deposit Account
Payment was successfully received in RAM	\$2480
RAM confirmation Number	7959
Deposit Account	233050
Authorized User	

The Director of the USPTO is hereby authorized to charge indicated fees and credit any overpayment as follows:

Charge any Additional Fees required under 37 C.F.R. Section 1.16 (National application filing, search, and examination fees)

Charge any Additional Fees required under 37 C.F.R. Section 1.17 (Patent application and reexamination processing fees)

Charge any Additional Fees required under 37 C.F.R. Section 1.19 (Document supply fees)

Charge any Additional Fees required under 37 C.F.R. Section 1.20 (Post Issuance fees)

Charge any Additional Fees required under 37 C.F.R. Section 1.21 (Miscellaneous fees and charges)

### File Listing:

Document Number	Document Description	File Name	File Size(Bytes)/ Message Digest	Multi Part /.zip	Pages (if appl.)
1	Applicant Response to Pre-Exam Formalities Notice	Missing_Parts_Transmittal_as_filed_3_31_10.pdf	274101 384b8af33e2ee4081cfe84659198738770841a19	no	2

### Warnings:

### Information:

2	Oath or Declaration filed	Executed_Declaration_as_filed_3_31_10.pdf	123684 af072e9d8f5c99a97c67c1a0a4c1b566346dd058	no	1
---	---------------------------	---	--	----	---

### Warnings:

The page size in the PDF is too large. The pages should be 8.5 x 11 or A4. If this PDF is submitted, the pages will be resized upon entry into the Image File Wrapper and may affect subsequent processing

### Information:

3	Power of Attorney	Executed_Power_of_Attorney_as_filed_3_31_10.pdf	105193 c030f77f4d8cc8b50a4a4f7578b7c09695cd3609	no	1
---	-------------------	---	--	----	---

### Warnings:

The page size in the PDF is too large. The pages should be 8.5 x 11 or A4. If this PDF is submitted, the pages will be resized upon entry into the Image File Wrapper and may affect subsequent processing

### Information:

4	Fee Worksheet (PTO-875)	fee-info.pdf	32191 e9b39706b1bef35e3a7fef5ffc47b3f597266013	no	2
---	-------------------------	--------------	---	----	---

### Warnings:

### Information:

<b>Total Files Size (in bytes):</b>			535169		
-------------------------------------	--	--	--------	--	--

**This Acknowledgement Receipt evidences receipt on the noted date by the USPTO of the indicated documents, characterized by the applicant, and including page counts, where applicable. It serves as evidence of receipt similar to a Post Card, as described in MPEP 503.**

**New Applications Under 35 U.S.C. 111**

**If a new application is being filed and the application includes the necessary components for a filing date (see 37 CFR 1.53(b)-(d) and MPEP 506), a Filing Receipt (37 CFR 1.54) will be issued in due course and the date shown on this Acknowledgement Receipt will establish the filing date of the application.**

**National Stage of an International Application under 35 U.S.C. 371**

**If a timely submission to enter the national stage of an international application is compliant with the conditions of 35 U.S.C. 371 and other applicable requirements a Form PCT/DO/EO/903 indicating acceptance of the application as a national stage submission under 35 U.S.C. 371 will be issued in addition to the Filing Receipt, in due course.**

**New International Application Filed with the USPTO as a Receiving Office**

**If a new international application is being filed and the international application includes the necessary components for an international filing date (see PCT Article 11 and MPEP 1810), a Notification of the International Application Number and of the International Filing Date (Form PCT/RO/105) will be issued in due course, subject to prescriptions concerning national security, and the date shown on this Acknowledgement Receipt will establish the international filing date of the application.**



UNITED STATES PATENT AND TRADEMARK OFFICE

UNITED STATES DEPARTMENT OF COMMERCE
United States Patent and Trademark Office
Address: COMMISSIONER FOR PATENTS
P.O. Box 1450
Alexandria, Virginia 22313-1450
www.uspto.gov

Table with 7 columns: APPLICATION NUMBER, FILING or 371(c) DATE, GRP ART UNIT, FIL FEE REC'D, ATTY. DOCKET NO, TOT CLAIMS, IND CLAIMS. Row 1: 12/543,910, 08/19/2009, 2611, 6040, REMB-0109, 100, 6

CONFIRMATION NO. 8306

UPDATED FILING RECEIPT



23377
WOODCOCK WASHBURN LLP
CIRA CENTRE, 12TH FLOOR
2929 ARCH STREET
PHILADELPHIA, PA 19104-2891

Date Mailed: 04/13/2010

Receipt is acknowledged of this non-provisional patent application. The application will be taken up for examination in due course. Applicant will be notified as to the results of the examination. Any correspondence concerning the application must include the following identification information: the U.S. APPLICATION NUMBER, FILING DATE, NAME OF APPLICANT, and TITLE OF INVENTION. Fees transmitted by check or draft are subject to collection. Please verify the accuracy of the data presented on this receipt. If an error is noted on this Filing Receipt, please submit a written request for a Filing Receipt Correction. Please provide a copy of this Filing Receipt with the changes noted thereon. If you received a "Notice to File Missing Parts" for this application, please submit any corrections to this Filing Receipt with your reply to the Notice. When the USPTO processes the reply to the Notice, the USPTO will generate another Filing Receipt incorporating the requested corrections

Applicant(s)

Gordon F. Bremer, Clearwater, FL;

Power of Attorney: The patent practitioners associated with Customer Number 23377

Domestic Priority data as claimed by applicant

This application is a CON of 11/774,803 07/09/2007 PAT 7,675,965
which is a CON of 10/412,878 04/14/2003 PAT 7,248,626
which is a CIP of 09/205,205 12/04/1998 PAT 6,614,838
which claims benefit of 60/067,562 12/05/1997

Foreign Applications

If Required, Foreign Filing License Granted: 08/31/2009

The country code and number of your priority application, to be used for filing abroad under the Paris Convention, is US 12/543,910

Projected Publication Date: 07/22/2010

Non-Publication Request: No

Early Publication Request: No

**Title**

System and Method of Communication Via Embedded Modulation

**Preliminary Class**

375

**PROTECTING YOUR INVENTION OUTSIDE THE UNITED STATES**

Since the rights granted by a U.S. patent extend only throughout the territory of the United States and have no effect in a foreign country, an inventor who wishes patent protection in another country must apply for a patent in a specific country or in regional patent offices. Applicants may wish to consider the filing of an international application under the Patent Cooperation Treaty (PCT). An international (PCT) application generally has the same effect as a regular national patent application in each PCT-member country. The PCT process **simplifies** the filing of patent applications on the same invention in member countries, but **does not result** in a grant of "an international patent" and does not eliminate the need of applicants to file additional documents and fees in countries where patent protection is desired.

Almost every country has its own patent law, and a person desiring a patent in a particular country must make an application for patent in that country in accordance with its particular laws. Since the laws of many countries differ in various respects from the patent law of the United States, applicants are advised to seek guidance from specific foreign countries to ensure that patent rights are not lost prematurely.

Applicants also are advised that in the case of inventions made in the United States, the Director of the USPTO must issue a license before applicants can apply for a patent in a foreign country. The filing of a U.S. patent application serves as a request for a foreign filing license. The application's filing receipt contains further information and guidance as to the status of applicant's license for foreign filing.

Applicants may wish to consult the USPTO booklet, "General Information Concerning Patents" (specifically, the section entitled "Treaties and Foreign Patents") for more information on timeframes and deadlines for filing foreign patent applications. The guide is available either by contacting the USPTO Contact Center at 800-786-9199, or it can be viewed on the USPTO website at <http://www.uspto.gov/web/offices/pac/doc/general/index.html>.

For information on preventing theft of your intellectual property (patents, trademarks and copyrights), you may wish to consult the U.S. Government website, <http://www.stopfakes.gov>. Part of a Department of Commerce initiative, this website includes self-help "toolkits" giving innovators guidance on how to protect intellectual property in specific countries such as China, Korea and Mexico. For questions regarding patent enforcement issues, applicants may call the U.S. Government hotline at 1-866-999-HALT (1-866-999-4158).

**LICENSE FOR FOREIGN FILING UNDER****Title 35, United States Code, Section 184****Title 37, Code of Federal Regulations, 5.11 & 5.15****GRANTED**

The applicant has been granted a license under 35 U.S.C. 184, if the phrase "IF REQUIRED, FOREIGN FILING LICENSE GRANTED" followed by a date appears on this form. Such licenses are issued in all applications where the conditions for issuance of a license have been met, regardless of whether or not a license may be required as

set forth in 37 CFR 5.15. The scope and limitations of this license are set forth in 37 CFR 5.15(a) unless an earlier license has been issued under 37 CFR 5.15(b). The license is subject to revocation upon written notification. The date indicated is the effective date of the license, unless an earlier license of similar scope has been granted under 37 CFR 5.13 or 5.14.

This license is to be retained by the licensee and may be used at any time on or after the effective date thereof unless it is revoked. This license is automatically transferred to any related applications(s) filed under 37 CFR 1.53(d). This license is not retroactive.

The grant of a license does not in any way lessen the responsibility of a licensee for the security of the subject matter as imposed by any Government contract or the provisions of existing laws relating to espionage and the national security or the export of technical data. Licensees should apprise themselves of current regulations especially with respect to certain countries, of other agencies, particularly the Office of Defense Trade Controls, Department of State (with respect to Arms, Munitions and Implements of War (22 CFR 121-128)); the Bureau of Industry and Security, Department of Commerce (15 CFR parts 730-774); the Office of Foreign Assets Control, Department of Treasury (31 CFR Parts 500+) and the Department of Energy.

**NOT GRANTED**

No license under 35 U.S.C. 184 has been granted at this time, if the phrase "IF REQUIRED, FOREIGN FILING LICENSE GRANTED" DOES NOT appear on this form. Applicant may still petition for a license under 37 CFR 5.12, if a license is desired before the expiration of 6 months from the filing date of the application. If 6 months has lapsed from the filing date of this application and the licensee has not received any indication of a secrecy order under 35 U.S.C. 181, the licensee may foreign file the application pursuant to 37 CFR 5.15(b).



UNITED STATES PATENT AND TRADEMARK OFFICE

UNITED STATES DEPARTMENT OF COMMERCE  
United States Patent and Trademark Office  
Address: COMMISSIONER FOR PATENTS  
P.O. Box 1450  
Alexandria, Virginia 22313-1450  
www.uspto.gov

APPLICATION NUMBER	FILING OR 371(C) DATE	FIRST NAMED APPLICANT	ATTY. DOCKET NO./TITLE
12/543,910	08/19/2009	Gordon F. Bremer	REMB-0109

**CONFIRMATION NO. 8306**

**POA ACCEPTANCE LETTER**



23377  
WOODCOCK WASHBURN LLP  
CIRA CENTRE, 12TH FLOOR  
2929 ARCH STREET  
PHILADELPHIA, PA 19104-2891

Date Mailed: 04/13/2010

**NOTICE OF ACCEPTANCE OF POWER OF ATTORNEY**

This is in response to the Power of Attorney filed 03/31/2010.

The Power of Attorney in this application is accepted. Correspondence in this application will be mailed to the above address as provided by 37 CFR 1.33.

/mbayou/

Office of Data Management, Application Assistance Unit (571) 272-4000, or (571) 272-4200, or 1-888-786-0101





UNITED STATES PATENT AND TRADEMARK OFFICE

UNITED STATES DEPARTMENT OF COMMERCE
United States Patent and Trademark Office
Address: COMMISSIONER FOR PATENTS
P.O. Box 1450
Alexandria, Virginia 22313-1450
www.uspto.gov

Table with 4 columns: APPLICATION NUMBER (12/543,910), FILING OR 371(C) DATE (08/19/2009), FIRST NAMED APPLICANT (Gordon F. Bremer), ATTY. DOCKET NO./TITLE (REMB-0109)

CONFIRMATION NO. 8306

PUBLICATION NOTICE

23377
WOODCOCK WASHBURN LLP
CIRA CENTRE, 12TH FLOOR
2929 ARCH STREET
PHILADELPHIA, PA 19104-2891



Title: System and Method of Communication Via Embedded Modulation

Publication No. US-2010-0183055-A1
Publication Date: 07/22/2010

NOTICE OF PUBLICATION OF APPLICATION

The above-identified application will be electronically published as a patent application publication pursuant to 37 CFR 1.211, et seq. The patent application publication number and publication date are set forth above.

The publication may be accessed through the USPTO's publically available Searchable Databases via the Internet at www.uspto.gov. The direct link to access the publication is currently http://www.uspto.gov/patft/.

The publication process established by the Office does not provide for mailing a copy of the publication to applicant. A copy of the publication may be obtained from the Office upon payment of the appropriate fee set forth in 37 CFR 1.19(a)(1). Orders for copies of patent application publications are handled by the USPTO's Office of Public Records. The Office of Public Records can be reached by telephone at (703) 308-9726 or (800) 972-6382, by facsimile at (703) 305-8759, by mail addressed to the United States Patent and Trademark Office, Office of Public Records, Alexandria, VA 22313-1450 or via the Internet.

In addition, information on the status of the application, including the mailing date of Office actions and the dates of receipt of correspondence filed in the Office, may also be accessed via the Internet through the Patent Electronic Business Center at www.uspto.gov using the public side of the Patent Application Information and Retrieval (PAIR) system. The direct link to access this status information is currently http://pair.uspto.gov/. Prior to publication, such status information is confidential and may only be obtained by applicant using the private side of PAIR.

Further assistance in electronically accessing the publication, or about PAIR, is available by calling the Patent Electronic Business Center at 1-866-217-9197.

Office of Data Management, Application Assistance Unit (571) 272-4000, or (571) 272-4200, or 1-888-786-0101



# UNITED STATES PATENT AND TRADEMARK OFFICE

UNITED STATES DEPARTMENT OF COMMERCE  
United States Patent and Trademark Office  
Address: COMMISSIONER FOR PATENTS  
P.O. Box 1450  
Alexandria, Virginia 22313-1450  
www.uspto.gov

APPLICATION NO.	FILING DATE	FIRST NAMED INVENTOR	ATTORNEY DOCKET NO.	CONFIRMATION NO.
12/543,910	08/19/2009	Gordon F. Bremer	REMB-0109	8306
23377	7590	09/01/2010	EXAMINER	
WOODCOCK WASHBURN LLP CIRA CENTRE, 12TH FLOOR 2929 ARCH STREET PHILADELPHIA, PA 19104-2891			HA, DAC V	
			ART UNIT	PAPER NUMBER
			2611	
			MAIL DATE	DELIVERY MODE
			09/01/2010	PAPER

**Please find below and/or attached an Office communication concerning this application or proceeding.**

The time period for reply, if any, is set in the attached communication.



## DETAILED ACTION

### *Claim Objections*

1. **Claims 1-18, 37-57, 96-100** are objected to because of the following informalities:

Claim 1, line 9, "the first data sequence" should be changed to i.e. "a first data sequence" to avoid potential antecedent basis problem.

Similar problem exists in claim 37.

Claims 96-100 seem to have incorrect dependency (i.e. should be depending from claims 86 on).

Appropriate correction is required.

### *Claim Rejections - 35 USC § 102*

2. The following is a quotation of the appropriate paragraphs of 35 U.S.C. 102 that form the basis for the rejections under this section made in this Office action:

A person shall be entitled to a patent unless –

(b) the invention was patented or described in a printed publication in this or a foreign country or in public use or on sale in this country, more than one year prior to the date of application for patent in the United States.

3. **Claims 19, 21, 23-27, 29, 34, 86, 88-94, 96** are rejected under 35 U.S.C. 102(b) as being anticipated by Siwiak (US 5,537,398).

**Re claim 19**, Siwiak discloses:

"a processor" (Fig. 6, elements 606, 610);

"transmission of first data with a first modulation method followed by second data with a second modulation method, wherein the first modulation method is different than

Art Unit: 2611

the second modulation method, and wherein the first data comprises an indication of an impending change from the first modulation method to the second modulation method” in Fig. 2; col. 3, line 61 to col. 4, line 2; col. 4, lines 31-39; abstract.

Further, even though Siwiak does not explicitly disclose "a memory having stored therein executable instructions for execution by the processor", it should be inherent that the "processor" of Siwiak must have some associate memory with instruction information stored therein for execution by such processor.

**Re claim 86**, see similar subject matter in claim 19 above, wherein elements 606, 610 teach all first, second and third logic.

**Re claim 21**, Siwiak further discloses “wherein the first modulation method is a frequency shift keying modulation” in col. 6, lines 25-29.

**Re claim 23**, Siwiak further discloses “wherein the second modulation method is different than the first modulation method in performance” in col. 6, lines 23-29.

**Re claim 24**, Siwiak further discloses “wherein the first modulation method has a lower performance than the second modulation method” in col. 6, lines 23-29.

**Re claim 25**, Siwiak further discloses “wherein the second modulation method is different than the first modulation in data rate” in col. 6, lines 23-29.

**Re claim 26**, Siwiak further discloses “wherein the first modulation method has a lower data rate than the second modulation method” in col. 6, lines 23-29.

**Re claim 27**, Siwiak further discloses “wherein transmission of the second data is according to a specific time interval” in Fig. 2; col. 3, line 61 to col. 4, line 2.

Art Unit: 2611

**Re claim 29**, Siwiak further discloses "transmitter configured to transmit the first data and the second data" in Fig. 5, 2; col. 3, lines 45-48; col. 4, lines 31-39.

**Re claim 34**, Siwiak further discloses "the first data comprises an address" in col. 4, lines 31-39; Fig. 2.

**Re claims 88-94, 98**, see similar claimed subject matter in claims 21-27, 34, respectively.

### ***Claim Rejections - 35 USC § 103***

4. The following is a quotation of 35 U.S.C. 103(a) which forms the basis for all obviousness rejections set forth in this Office action:

(a) A patent may not be obtained though the invention is not identically disclosed or described as set forth in section 102 of this title, if the differences between the subject matter sought to be patented and the prior art are such that the subject matter as a whole would have been obvious at the time the invention was made to a person having ordinary skill in the art to which said subject matter pertains. Patentability shall not be negated by the manner in which the invention was made.

5. **Claims 30-33, 96, 97** are rejected under 35 U.S.C. 103(a) as being unpatentable over Siwiak.

**Re claim 30**, Siwiak discloses all claimed subject matter of claim 30, as stated above, except for "the memory has stored therein program code for the first modulation method and the second modulation method". However, it would have been easily understood by one skilled the art that, for software implementation standpoint, the (associate) memory would have stored therein information in the form of program code for execution by the processor.

Art Unit: 2611

**Re claims 31-32**, the claimed subject matter "random access memory" and "read-only memory" would have been easily realized by one skill in the art as application specific for the type of memory used.

**Re claim 33**, the claimed subject matter "the memory has stored therein program code for a multipoint communication protocol" would have been easily realized by one skilled in the art since Siwiak also directs to "multipoint communication" (Fig. 5).

**Re claims 96, 97**, see similar claimed subject matter in claims 30, 33 above, respectively.

6. **Claims 22, 35, 58, 60-66, 68, 69, 72, 74-80, 82, 83** are rejected under 35 U.S.C. 103(a) as being unpatentable over Siwiak in view of Frodigh et al. (US 6,125,148) (hereafter Frodigh).

**Re claim 58**, Siwiak discloses "transmitting, from a transmitter, a first sequence" "transmission segment, wherein the first sequence is modulated according to a first modulation method; indicating in the first sequence that a second sequence of" "transmission segment will use a second modulation method, wherein the second modulation method is different from the first modulation method; and transmitting the second sequence of" "transmission segment, wherein the second sequence follows the first sequence and wherein the second sequence is modulated according to the second modulation method" in Fig. 1, 5, 6; Abstract; col. 3, line 19 to col. 4, line 2; col. 4, lines 31-39; col. 7, lines 33-37; col. 9, lines 25-44.

Siwiak differs from the claimed invention in that Siwiak does not disclose "burst".

Art Unit: 2611

Frodigh, in the same field of endeavor, discloses communication between base station and mobile station wherein the system utilizes "burst" format (Fig. 3, 4; col. 7, line 48 to col. 8, line 5).

Therefore, it would have been obvious to a person of ordinary skill in the art at the time of the invention to incorporate the transmission of "burst" format, taught in Frodigh, into Siwiak and predictable result would have still been expected.

**Re claim 35**, see claim 58 above for "burst transmission" claimed subject matter.

**Re claim 72**, see corresponding method claim 58.

**Re claims 22, 61**, Siwiak discloses all claimed subject matter of claim 22, as stated above, except for "wherein second modulation method is a shift keying modulation". Frodigh, in the same field of endeavor, discloses communication system that supports multiple modulation methods (Abstract; col. 3, lines 56-67). Therefore, it would have been obvious to a person of ordinary skill in the at the time of the invention to incorporate the teaching of multiple modulation methods supported by the system, taught by Frodigh, into Siwiak, and predictable result can still be expected.

**Re claim 60**, Siwiak further discloses "wherein the first modulation method is a frequency shift keying modulation" in col. 6, lines 25-29.

**Re claim 62**, Siwiak further discloses "wherein the second modulation method is different than the first modulation method in performance" in col. 6, lines 23-29.

**Re claim 63**, Siwiak further discloses "wherein the first modulation method has a lower performance than the second modulation method" in col. 6, lines 23-29.



**Re claim 64**, Siwiak further discloses "wherein the second modulation method is different than the first modulation in data rate" in col. 6, lines 23-29.

**Re claim 65**, Siwiak further discloses "wherein the first modulation method has a lower data rate than the second modulation method" in col. 6, lines 23-29.

**Re claim 66**, Siwiak further discloses "wherein transmission of the second data is according to a specific time interval" in Fig. 2; col. 3, line 61 to col. 4, line 2.

**Re claim 68**, the claimed subject matter "the memory has stored therein program code for a multipoint communication protocol" would have been easily realized by one skilled in the art since Siwiak also directs to "multipoint communication" (Fig. 5).

**Re claim 69**, Siwiak further discloses "the first data comprises an address" in col. 4, lines 31-39; Fig. 2.

**Re claims 74-80, 82, 83, 99**, see similar claimed subject matter of claims 60-66, 68, 69, 58, respectively.

### ***Allowable Subject Matter***

7. Claim 20, 28, 36, 59, 67, 70, 71, 73, 81, 84, 85, 87, 95, 100 are objected to as being dependent upon a rejected base claim, but would be allowable if rewritten in independent form including all of the limitations of the base claim and any intervening claims.

8. Claims 1-18, 37-57 are allowed.

### ***Conclusion***

9. The prior art made of record and not relied upon is considered pertinent to applicant's disclosure.

Art Unit: 2611

Sridhar et al. (US 5,550,881)

Gilbert et al. (US 5,559,810)

Poon et al. (US 5,940,438)

Needham et al. (US 5,764,699)

Any inquiry concerning this communication or earlier communications from the examiner should be directed to Dac V. Ha whose telephone number is 571-272-3040. The examiner can normally be reached on 4/4.

If attempts to reach the examiner by telephone are unsuccessful, the examiner's supervisor, David Payne can be reached on 571-272-3024. The fax phone number for the organization where this application or proceeding is assigned is 571-273-8300.

Information regarding the status of an application may be obtained from the Patent Application Information Retrieval (PAIR) system. Status information for published applications may be obtained from either Private PAIR or Public PAIR. Status information for unpublished applications is available through Private PAIR only. For more information about the PAIR system, see <http://pair-direct.uspto.gov>. Should you have questions on access to the Private PAIR system, contact the Electronic Business Center (EBC) at 866-217-9197 (toll-free). If you would like assistance from a USPTO Customer Service Representative or access to the automated information system, call 800-786-9199 (IN USA OR CANADA) or 571-272-1000.

/Dac V. Ha/  
Primary Examiner, Art Unit 2611

Application/Control Number: 12/543,910  
Art Unit: 2611

Page 9

<b>Notice of References Cited</b>	Application/Control No. 12/543,910	Applicant(s)/Patent Under Reexamination BREMER, GORDON F.	
	Examiner Dac V. Ha	Art Unit 2611	Page 1 of 1

**U.S. PATENT DOCUMENTS**

*	Document Number Country Code-Number-Kind Code	Date MM-YYYY	Name	Classification
	A US-			
*	B US-5,764,699	06-1998	Needham et al.	375/261
*	C US-5,940,438	08-1999	Poon et al.	375/222
*	D US-5,559,810	09-1996	Gilbert et al.	714/704
*	E US-5,550,881	08-1996	Sridhar et al.	375/377
*	F US-6,125,148	09-2000	Frodigh et al.	375/261
	G US-			
	H US-			
	I US-			
	J US-			
	K US-			
	L US-			
	M US-			


**FOREIGN PATENT DOCUMENTS**

*	Document Number Country Code-Number-Kind Code	Date MM-YYYY	Country	Name	Classification
	N				
	O				
	P				
	Q				
	R				
	S				
	T				

**NON-PATENT DOCUMENTS**

*	Document Number Country Code-Number-Kind Code	Date MM-YYYY	Country	Name	Classification
	Include as applicable: Author, Title Date, Publisher, Edition or Volume, Pertinent Pages)				
	U				
	V				
	W				
	X				

\*A copy of this reference is not being furnished with this Office action. (See MPEP § 707.05(a).)  
Dates in MM-YYYY format are publication dates. Classifications may be US or foreign.

<b>Index of Claims</b>  	<b>Application/Control No.</b> 12543910	<b>Applicant(s)/Patent Under Reexamination</b> BREMER, GORDON F.
	<b>Examiner</b> Dac V Ha	<b>Art Unit</b> 2611

✓	<b>Rejected</b>
=	<b>Allowed</b>


-	<b>Cancelled</b>
÷	<b>Restricted</b>

N	<b>Non-Elected</b>
I	<b>Interference</b>

A	<b>Appeal</b>
O	<b>Objected</b>

Claims renumbered in the same order as presented by applicant
  CPA
  T.D.
  R.1.47

CLAIM		DATE							
Final	Original	08/13/2010							
	1	○							
	2	○							
	3	○							
	4	○							
	5	○							
	6	○							
	7	○							
	8	○							
	9	○							
	10	○							
	11	○							
	12	○							
	13	○							
	14	○							
	15	○							
	16	○							
	17	○							
	18	○							
	19	✓							
	20	○							
	21	✓							
	22	✓							
	23	✓							
	24	✓							
	25	✓							
	26	✓							
	27	✓							
	28	○							
	29	✓							
	30	✓							
	31	✓							
	32	✓							
	33	✓							
	34	✓							
	35	✓							
	36	○							

<b>Index of Claims</b>  	<b>Application/Control No.</b> 12543910	<b>Applicant(s)/Patent Under Reexamination</b> BREMER, GORDON F.
	<b>Examiner</b> Dac V Ha	<b>Art Unit</b> 2611

✓	<b>Rejected</b>
=	<b>Allowed</b>


-	<b>Cancelled</b>
÷	<b>Restricted</b>

N	<b>Non-Elected</b>
I	<b>Interference</b>

A	<b>Appeal</b>
O	<b>Objected</b>

Claims renumbered in the same order as presented by applicant
  CPA
  T.D.
  R.1.47

CLAIM		DATE							
Final	Original	08/13/2010							
	37	○							
	38	○							
	39	○							
	40	○							
	41	○							
	42	○							
	43	○							
	44	○							
	45	○							
	46	○							
	47	○							
	48	○							
	49	○							
	50	○							
	51	○							
	52	○							
	53	○							
	54	○							
	55	○							
	56	○							
	57	○							
	58	✓							
	59	○							
	60	✓							
	61	✓							
	62	✓							
	63	✓							
	64	✓							
	65	✓							
	66	✓							
	67	○							
	68	✓							
	69	✓							
	70	○							
	71	○							
	72	✓							

<b>Index of Claims</b>  	<b>Application/Control No.</b> 12543910	<b>Applicant(s)/Patent Under Reexamination</b> BREMER, GORDON F.
	<b>Examiner</b> Dac V Ha	<b>Art Unit</b> 2611

✓	<b>Rejected</b>
=	<b>Allowed</b>


-	<b>Cancelled</b>
÷	<b>Restricted</b>

N	<b>Non-Elected</b>
I	<b>Interference</b>

A	<b>Appeal</b>
O	<b>Objected</b>

Claims renumbered in the same order as presented by applicant
  CPA
  T.D.
  R.1.47

CLAIM		DATE							
Final	Original	08/13/2010							
	73	○							
	74	✓							
	75	✓							
	76	✓							
	77	✓							
	78	✓							
	79	✓							
	80	✓							
	81	○							
	82	✓							
	83	✓							
	84	○							
	85	○							
	86	✓							
	87	○							
	88	✓							
	89	✓							
	90	✓							
	91	✓							
	92	✓							
	93	✓							
	94	✓							
	95	○							
	96	=							
	97	=							
	98	=							
	99	=							
	100	○							

<b>Search Notes</b>  	<b>Application/Control No.</b>  12543910	<b>Applicant(s)/Patent Under Reexamination</b>  BREMER, GORDON F.
	<b>Examiner</b>  Dac V Ha	<b>Art Unit</b>  2611

SEARCHED			
Class	Subclass	Date	Examiner
375	261, 269, 285, 222, 298, 302, 305, 308	8/13/2010	DH
455	102, 110	8/13/2010	DH
332	108, 119, 120, 151	8/13/2010	DH

SEARCH NOTES		
Search Notes	Date	Examiner
BRS and Inventor's search	8/13/2010	DH

INTERFERENCE SEARCH			
Class	Subclass	Date	Examiner
	PGPUB text search	8/13/2010	DH

--	--





UNITED STATES PATENT AND TRADEMARK OFFICE

UNITED STATES DEPARTMENT OF COMMERCE  
 United States Patent and Trademark Office  
 Address: COMMISSIONER FOR PATENTS  
 P.O. Box 1450  
 Alexandria, Virginia 22313-1450  
 www.uspto.gov

BIB DATA SHEET

CONFIRMATION NO. 8306

<b>SERIAL NUMBER</b> 12/543,910	<b>FILING or 371(c) DATE</b> 08/19/2009	<b>CLASS</b> 375	<b>GROUP ART UNIT</b> 2611	<b>ATTORNEY DOCKET NO.</b> REMB-0109		
<b>APPLICANTS</b> Gordon F. Bremer, Clearwater, FL;						
<b>** CONTINUING DATA *****</b> This application is a CON of 11/774,803 07/09/2007 PAT 7,675,965 which is a CON of 10/412,878 04/14/2003 PAT 7,248,626 which is a CIP of 09/205,205 12/04/1998 PAT 6,614,838 which claims benefit of 60/067,562 12/05/1997						
<b>** FOREIGN APPLICATIONS *****</b>						
<b>** IF REQUIRED, FOREIGN FILING LICENSE GRANTED **</b> 08/31/2009						
Foreign Priority claimed <input type="checkbox"/> Yes <input checked="" type="checkbox"/> No	35 USC 119(a-d) conditions met <input type="checkbox"/> Yes <input checked="" type="checkbox"/> No	<input type="checkbox"/> Met after Allowance Initials	<b>STATE OR COUNTRY</b> FL	<b>SHEETS DRAWINGS</b> 8	<b>TOTAL CLAIMS</b> 100	<b>INDEPENDENT CLAIMS</b> 6
<b>ADDRESS</b> WOODCOCK WASHBURN LLP CIRA CENTRE, 12TH FLOOR 2929 ARCH STREET PHILADELPHIA, PA 19104-2891 UNITED STATES						
<b>TITLE</b> System and Method of Communication Via Embedded Modulation						
<b>FILING FEE RECEIVED</b> 6040	FEES: Authority has been given in Paper No. _____ to charge/credit DEPOSIT ACCOUNT No. _____ for following:			<input type="checkbox"/> All Fees <input type="checkbox"/> 1.16 Fees (Filing) <input type="checkbox"/> 1.17 Fees (Processing Ext. of time) <input type="checkbox"/> 1.18 Fees (Issue) <input type="checkbox"/> Other _____ <input type="checkbox"/> Credit		

## EAST Search History

## EAST Search History (Prior Art)

Ref #	Hits	Search Query	DBs	Default Operator	Plurals	Time Stamp
S11	1	"6445733".pn. and ((test\$3 adj signal) with (noise interference antennuat\$4 character\$5 condition fad\$3 distortion))	USPAT	OR	ON	2009/02/03 14:35
S12	5111	((test\$3 adj signal) with (noise interference antennuat \$4 character\$5 condition fad \$3 distortion))	US-PGPUB; USPAT	OR	ON	2009/02/03 14:37
S13	19	S12 with ((error near1 ratio) ber)	US-PGPUB; USPAT	OR	ON	2009/02/03 14:38
S14	4	S13 not @ad>="19971205"	US-PGPUB; USPAT	OR	ON	2009/02/03 14:38
S15	4	S14 and (test\$3 near1 signal)	US-PGPUB; USPAT	OR	ON	2009/02/03 14:41
S16	0	S11 and ((error near1 ratio) ber)	US-PGPUB; USPAT	OR	ON	2009/02/03 14:45
S17	33	S12 same ((error near1 ratio) ber)	US-PGPUB; USPAT	OR	ON	2009/02/03 14:45
S18	8	S17 not @ad>="19971205"	US-PGPUB; USPAT	OR	ON	2009/02/03 14:45
S20	113	(test\$3 adj signal) with ((error near1 ratio) ber)	US-PGPUB; USPAT	OR	ON	2009/02/03 14:48
S21	15	S20 not @ad>="19971205"	US-PGPUB; USPAT	OR	ON	2009/02/03 14:49
S22	11	S21 not (S14 S18)	US-PGPUB; USPAT	OR	ON	2009/02/03 14:49
S23	97	(test\$3 adj signal) with (data adj rate)	US-PGPUB; USPAT	OR	ON	2009/02/03 14:59
S24	130	(test\$3 adj signal) with ((transmi\$6 data) adj rate)	US-PGPUB; USPAT	OR	ON	2009/02/03 14:59
S25	201	(test\$3 adj signal) with ((transmi\$6 data frame symbol bit) adj rate)	US-PGPUB; USPAT	OR	ON	2009/02/03 15:00
S26	47	S25 not @ad>="19971205"	US-PGPUB; USPAT	OR	ON	2009/02/03 15:00
S27	1	S22 and S25	US-PGPUB; USPAT	OR	ON	2009/02/03 15:01
S28	26	S23 and S26	US-PGPUB; USPAT	OR	ON	2009/02/03 15:02

S29	6176	(channel adj (parameter character\$6 condition)) with ((rate ratio impedance power))	US-PGPUB; USPAT	OR	ON	2009/02/03 15:05
S30	0	S29 with S25	US-PGPUB; USPAT	OR	ON	2009/02/03 15:05
S31	0	S29 same S25	US-PGPUB; USPAT	OR	ON	2009/02/03 15:06
S32	1392	S29 with (data adj rate)	US-PGPUB; USPAT	OR	ON	2009/02/03 15:06
S33	50	S32 not @ad>="19971205"	US-PGPUB; USPAT	OR	ON	2009/02/03 15:06
S36	85	S29 with (impedance)	US-PGPUB; USPAT	OR	ON	2009/02/03 15:08
S38	6	S29 with (impedance adj (match\$3 mismatch\$3))	US-PGPUB; USPAT	OR	ON	2009/02/03 15:09
S40	10	S29 same (impedance adj (match\$3 mismatch\$3))	US-PGPUB; USPAT	OR	ON	2009/02/03 15:10
S41	2	S40 not @ad>="19971205"	US-PGPUB; USPAT	OR	ON	2009/02/03 15:10
S42	102	S29 with (power adj (dissipat \$4 consum\$5))	US-PGPUB; USPAT	OR	ON	2009/02/03 15:13
S47	3	S36 same (test\$3 adj signal)	US-PGPUB; USPAT	OR	ON	2009/02/03 15:35
S49	716	(channel adj (parameter character\$6 condition)) with ((noise near1 ratio))	US-PGPUB; USPAT	OR	ON	2009/02/03 15:43
S51	5	S49 same (test\$3 adj signal)	US-PGPUB; USPAT	OR	ON	2009/02/03 15:43
S54	7803	(cross adj talk) with (noise interference)	US-PGPUB; USPAT	OR	ON	2009/02/03 15:52
S55	262	S54 same ((subscriber adj line) \$2dsl)	US-PGPUB; USPAT	OR	ON	2009/02/03 15:53
S57	1785	(channel adj (parameter character\$6 condition estimat \$4)) with ((feed\$3 adj back) feedback)	US-PGPUB; USPAT	OR	ON	2009/02/03 15:59
S58	95	S57 not @ad>="19971205"	US-PGPUB; USPAT	OR	ON	2009/02/03 15:59
S60	131	S57 same (\$2dsl modem transceiv\$3)	US-PGPUB; USPAT	OR	ON	2009/02/03 16:02
S62	6251	((feed\$3 adj back) feedback) with ((central adj office) (base adj station) master)	US-PGPUB; USPAT	OR	ON	2009/02/03 16:12
S63	255	S57 same S62	US-PGPUB; USPAT	OR	ON	2009/02/03 16:13
S64	3	S63 not @ad>="19971205"	US-PGPUB; USPAT	OR	ON	2009/02/03 16:13

S68	1	"20080013608"	US-PGPUB; USPAT; USOCR	OR	OFF	2009/02/03 17:32
S70	56	(test\$3 adj signal) with (group\$3 near1 delay\$3)	US-PGPUB; USPAT; USOCR	OR	ON	2009/02/03 17:46
S72	19	S70 not @ad>="19971205"	US-PGPUB; USPAT	OR	ON	2009/02/03 17:46
S75	105	(gordon near1 bremer).in.	US-PGPUB; USPAT	OR	ON	2009/02/03 18:10
S84	106	(gordon near1 bremer).in.	US-PGPUB; USPAT	OR	ON	2009/10/08 15:50
S86	1	poon.in. and (dac near1 ha)	USPAT	OR	OFF	2010/08/03 15:22
S87	21	("4425665"   "4931250"   "5349635"   "5367563"   "5491832"   "5533004"   "5537398"   "5550881"   "5557634"   "5559810"   "5577087"   "5602868"   "5655003"   "5671253"   "5717471"   "5764699"   "5872810"   "5940438"   "5982819"   "6037835"   "6208663").PN.	US-PGPUB; USPAT; USOCR	OR	OFF	2010/08/03 15:22
S88	113	(gordon near1 bremer).in.	US-PGPUB; USPAT; USOCR	OR	ON	2010/08/03 15:42
S89	41	S88 and modulat\$5.clm.	US-PGPUB; USPAT; USOCR	OR	ON	2010/08/03 15:43
S90	125714	(plural\$5 multi\$5 among differen\$4) near1 (modulat\$4 cod\$4)	US-PGPUB; USPAT	OR	ON	2010/08/03 15:59
S91	81473	S90 and (modulat\$4 cod\$4). clm.	US-PGPUB; USPAT	OR	ON	2010/08/03 15:59
S92	24337	(identif\$5 indicat\$5 notif\$6 inform\$4 ask\$3 let\$4) with ((modulat\$4 cod\$4) near1 (method scheme technique level type))	US-PGPUB; USPAT	OR	ON	2010/08/03 16:02
S93	6900	S91 and S92	US-PGPUB; USPAT	OR	ON	2010/08/03 16:02
S94	651	(plural\$5 multi\$5 among differen\$4) near1 (modulat\$4 cod\$4).ab. and S93	US-PGPUB; USPAT	OR	ON	2010/08/03 16:02
S95	278	S94 and "375"/\$.ccls.	US-PGPUB; USPAT	OR	ON	2010/08/03 16:03
S96	25	S95 and 375/295.ccls.	US-PGPUB; USPAT	OR	ON	2010/08/03 16:03

S97	1	S96 not @ad> = "19971205"	US-PGPUB; USPAT	OR	ON	2010/08/03 16:04
S98	2	("7675965" "248626" "6614838").pn.	USPAT	OR	OFF	2010/08/06 13:56
S99	3	("7675965" "7248626" "6614838").pn.	USPAT	OR	OFF	2010/08/06 13:56
S100	22	("5537398").URPN.	USPAT	OR	OFF	2010/08/06 14:22
S101	8	("6671328").URPN.	USPAT	OR	OFF	2010/08/06 14:22
S102	7	("4866395"   "5982819"   "6181734"   "6192070"   "6359934"   "6452964"   "6671328").PN.	US-PGPUB; USPAT; USOCR	OR	OFF	2010/08/06 14:26
S103	8	("6804309").URPN.	USPAT	OR	OFF	2010/08/06 14:26
S104	125899	(plural\$5 multi\$5 among differen\$4) near1 (modulat\$4 cod\$4)	US-PGPUB; USPAT	OR	ON	2010/08/06 14:27
S105	11	S100 and S104	US-PGPUB; USPAT	OR	ON	2010/08/06 14:27
S106	125899	(plural\$5 multi\$5 among differen\$4) near1 (modulat\$4 cod\$4)	US-PGPUB; USPAT	OR	ON	2010/08/06 14:31
S107	81583	S106 and (modulat\$4 cod\$4). clm.	US-PGPUB; USPAT	OR	ON	2010/08/06 14:31
S108	24381	(identif\$5 indicat\$5 notif\$6 inform\$4 ask\$3 let\$4) with ((modulat\$4 cod\$4) near1 (method scheme technique level type))	US-PGPUB; USPAT	OR	ON	2010/08/06 14:31
S109	6916	S107 and S108	US-PGPUB; USPAT	OR	ON	2010/08/06 14:31
S110	653	(plural\$5 multi\$5 among differen\$4) near1 (modulat\$4 cod\$4).ab. and S109	US-PGPUB; USPAT	OR	ON	2010/08/06 14:31
S111	278	S110 and "375"/\$.ccls.	US-PGPUB; USPAT	OR	ON	2010/08/06 14:31
S112	41	S111 not @ad> = "19971205"	US-PGPUB; USPAT	OR	ON	2010/08/06 14:31
S113	2500	(plural\$5 multi\$5 among\$3 differen\$4) near1 (modulat \$4 ).ab.	US-PGPUB; USPAT	OR	ON	2010/08/06 16:16
S114	2500	((plural\$5 multi\$5 among\$3 differen\$4) near1 modulat \$4 ).ab.	US-PGPUB; USPAT	OR	ON	2010/08/06 16:16

S115	9963	(identif\$5 indicat\$5 notif\$6 inform\$4 ask\$3 let\$4) with ((modulat\$4 ) near1 (method scheme technique level type))	US-PGPUB; USPAT	OR	ON	2010/08/06 16:17
S116	232	S114 and S115	US-PGPUB; USPAT	OR	ON	2010/08/06 16:17
S117	28	S116 not @ad>="19971205"	US-PGPUB; USPAT	OR	ON	2010/08/06 16:17
S118	113	(gordon near1 bremer).in.	US-PGPUB; USPAT; USOCR	OR	ON	2010/08/06 16:30
S119	41	S118 and modulat\$5.clm.	US-PGPUB; USPAT; USOCR	OR	ON	2010/08/06 16:30
S120	0	S116 and S119	US-PGPUB; USPAT; USOCR	OR	ON	2010/08/06 16:30
S121	39538	(identif\$5 indicat\$5 notif\$6 inform\$4 ask\$3 let\$4) with ((modulat\$4 ) with (method scheme technique level type))	US-PGPUB; USPAT	OR	ON	2010/08/06 16:31
S122	14	S119 and S121	US-PGPUB; USPAT	OR	ON	2010/08/06 16:31
S123	421	S114 and S121	US-PGPUB; USPAT	OR	ON	2010/08/06 16:39
S124	72	S123 not @ad>="19971205"	US-PGPUB; USPAT	OR	ON	2010/08/06 16:39
S125	2500	((plural\$5 multi\$5 among\$3 differen\$4) near1 modulat \$4 ).ab.	US-PGPUB; USPAT	OR	ON	2010/08/07 08:04
S126	9963	(identif\$5 indicat\$5 notif\$6 inform\$4 ask\$3 let\$4) with ((modulat\$4 ) near1 (method scheme technique level type))	US-PGPUB; USPAT	OR	ON	2010/08/07 08:04
S127	232	S125 and S126	US-PGPUB; USPAT	OR	ON	2010/08/07 08:04
S128	28	S127 not @ad>="19971205"	US-PGPUB; USPAT	OR	ON	2010/08/07 08:04
S129	39538	(identif\$5 indicat\$5 notif\$6 inform\$4 ask\$3 let\$4) with ((modulat\$4 ) with (method scheme technique level type))	US-PGPUB; USPAT	OR	ON	2010/08/07 08:04
S130	421	S125 and S129	US-PGPUB; USPAT	OR	ON	2010/08/07 08:04
S131	72	S130 not @ad>="19971205"	US-PGPUB; USPAT	OR	ON	2010/08/07 08:04

S132	44	S131 not S128	US-PGPUB; USPAT	OR	ON	2010/08/07 08:04
S133	15	S132 and ("375"/\$.ccls. "455"/\$.ccls.)	US-PGPUB; USPAT	OR	ON	2010/08/07 08:13
S134	0	S133 not S133	US-PGPUB; USPAT	OR	ON	2010/08/07 08:20
S135	29	S132 not S133	US-PGPUB; USPAT	OR	ON	2010/08/07 08:21
S136	1	"5537398".pn. and memory	USPAT	OR	ON	2010/08/12 17:06
S137	1	"5537398".pn. and burst	USPAT	OR	ON	2010/08/12 17:39
S138	1	"6125148".pn. and burst	USPAT	OR	ON	2010/08/12 17:40

**8/ 13/ 2010 1:34:05 PM**

**C:\ Documents and Settings\dha\ My Documents\ EAST\ Workspace2\ 12543910.wsp**

Substitute for 1449/PTO  <b>INFORMATION DISCLOSURE STATEMENT BY APPLICANT</b>  <i>(use as many sheets as necessary)</i>				<b>Complete if Known</b>	
				<b>Application Number</b>	12/543910
				<b>Filing Date</b>	August 19, 2009
				<b>First Named Inventor</b>	Gordon Bremer
				<b>Art Unit</b>	2611
<b>Examiner Name</b>	To be assigned				
Sheet	1	of	2	<b>Attorney Docket Number</b>	REMB-0109

U. S. PATENT DOCUMENTS						
Examiner Initials	Cite No.	Document Number		Publication Date MM-DD-YYYY	Name of Patentee or Applicant of Cited Document	Page, Columns, Lines, Where Relevant Passages or Relevant Figures Appear
		Number - Kind Code (if known)				
/D.H./	1	3970926		7/20/1996	Rigby et al.	
	2	4091422		5/23/1978	Amster	
	3	4630286		12/16/1986	Betts	
	4	5050536		9/24/1991	Baker	
	5	5537398		7/16/1996	Siwiak	
	6	5540456		7/30/1996	Meier-Burkamp et al.	
	7	5548222		8/20/1996	Jensen et al.	
	8	5563883		10/8/1996	Cheng	
	9	5577087		11/19/1996	Furuya	
	10	5793800		8/11/1998	Jylha et al.	
	11	5936949		8/10/1999	Pasternak et al.	
	12	5999563		12/7/1999	Polley et al.	
	13	6021158		2/1/2000	Schurr et al.	
	14	6067297		5/23/2000	Beach	
	15	6072779		6/6/2000	Tzannes et all.	
	16	6212227		4/3/2001	Ko et al.	
	17	6348986		2/19/2002	Doucet et al.	
	18	6445733		9/3/2002	Zuranski et al.	
	19	6614838		9/2/2003	Bremer	
	20	6671328		12/30/2003	Poon et al.	
	21	7006445		2/28/2006	Cole et al.	
/D.H./	22	7170867		1/30/2007	O'Toole et al.	

<b>Examiner Signature</b>	/Dac Ha/	<b>Date Considered</b>	08/03/2010
---------------------------	----------	------------------------	------------



Substitute for 1449/PTO  <b>INFORMATION DISCLOSURE STATEMENT BY APPLICANT</b>  <i>(use as many sheets as necessary)</i>				<b>Complete if Known</b>	
				<b>Application Number</b>	12/543910
				<b>Filing Date</b>	August 19, 2009
				<b>First Named Inventor</b>	Gordon Bremer
				<b>Art Unit</b>	2611
				<b>Examiner Name</b>	To be assigned
Sheet	2	of	2	<b>Attorney Docket Number</b>	REMB-0109

FOREIGN PATENT DOCUMENTS						
Examiner Initials	Cite No	Foreign Patent Document Country Code- Number -Kind Code (if known)	Publication Date MM-DD-YYYY	Name of Patentee or Applicant of Cited Document	Pages, Columns, Lines, Where Relevant Passages or Relevant Figures Appear	T

NON PATENT LITERATURE DOCUMENTS			
Examiner Initials	Cite No.	Include name of the author (in CAPITAL LETTERS), title of the article (when appropriate), title of the item (book, magazine, journal, serial, symposium, catalog, etc.), date, page(s), Volume-issue Number(s), publisher, city and/or country where published.	T

<b>Examiner Signature</b>	/Dac Ha/	<b>Date Considered</b>	08/03/2010
-------------------------------	----------	----------------------------	------------

IN THE UNITED STATES PATENT AND TRADEMARK OFFICE

In Re Application of:

Gordon F. Bremer

Confirmation No.: 8306

Application No.: 12/543,910

Group Art Unit: 2611

Filing Date: August 19, 2009

Examiner: Dac V. Ha

For: SYSTEM AND METHOD OF COMMUNICATION VIA EMBEDDED MODULATION

Filed Via EFS

INFORMATION DISCLOSURE STATEMENT

Pursuant to 37 CFR § 1.56 and in accordance with 37 CFR §§ 1.97-1.98, information relating to the above-identified application is hereby disclosed. Inclusion of information in this statement is not to be construed as an admission that this information is material as that term is defined in 37 CFR § 1.56(b).

**IDS Filed Under 37 CFR 1.97(b)**

In accordance with § 1.97(b), since this Information Disclosure Statement is being filed either within three months of the filing date of the above-identified application, within three months of the date of entry into the national stage of the above identified application as set forth in § 1.491, before the mailing date of a first Office Action on the merits of the above-identified application, or before the mailing date of a first Office Action after the filing of request for continued examination under § 1.114, no additional fee is required.

**IDS filed Under 37 CFR 1.97(c)**

In accordance with § 1.97(c), this Information Disclosure Statement is being filed after the period set forth in § 1.97(b) above but before the mailing date of either a Final Action under § 1.116 or a Notice of Allowance under § 1.311, or before an action that otherwise closes prosecution in the application, therefore:

- Certification in Accordance with § 1.97(e) is attached; or
- The fee of **\$180.00** as set forth in § 1.17(p) is attached.

**IDS filed Under 37 CFR 1.97(d)**

In accordance with § 1.97(d), this Information Disclosure Statement is being filed after the mailing date of either a Final Action under § 1.113 or a Notice of Allowance under § 1.311 but before, or simultaneously with, the payment of the Issue Fee, therefore included are: Certification in Accordance with § 1.97(e); and the submission fee of **\$180.00** as set forth in § 1.17(p).

**CONTENT OF IDS PURSUANT TO 37 CFR 1.98**

Copies of reference numbers 1-220 listed on the attached Form PTO-1449 are not required to be submitted pursuant to 37 CFR § 1.98(a)(2)(iii).

Copies of reference numbers 221-252 listed on the attached Form PTO-1449 are enclosed herewith.

Copies of reference numbers \_\_\_\_\_ are not being submitted because they were previously cited by or submitted to the U.S. Patent and Trademark Office in patent application number \_\_\_\_\_, filed \_\_\_\_\_ for which a claim for priority under 35 U.S.C. § 120 has been made in the instant application.

The month of publication for reference numbers 223-226, 230, 232-241, 245-247, 249-252 is not available. However, the year of publication for these references is sufficiently earlier than the effective US filing date and any foreign priority date so that the particular month of publication is not in issue pursuant to 37 CFR § 1.98(b).

**REFERENCES IN A LANGUAGE OTHER THAN ENGLISH**

The following documents are not in the English language. Accordingly, a concise explanation of the relevance of the document was incorporated in the specification passages identified below, the document was identified in a foreign communication as identified below or an English language counterpart application has been provided as indicated below.

Foreign Language Document	Cite No.	Pages of Reference in Specification or Relevance of Document

Foreign Language Document	Cite No.	English Language Counterpart	Cite No.

**CERTIFICATION IN ACCORDANCE WITH § 1.97(e)**

I hereby certify that:

- Each item of information contained in this information disclosure statement was first cited in any communication from a foreign patent office in a counterpart foreign application not more than three months prior to the filing of this information disclosure statement.
- No item of information contained in this information disclosure statement was cited in a communication from a foreign patent office in a counterpart foreign application, and, to the knowledge of the person signing the certification after making reasonable inquiry, no item of information contained in this information disclosure statement was known to any individual designated in § 1.56(c) more than three months prior to the filing of this information disclosure statement.

Please charge any deficiency or credit any overpayment to Deposit Account No. 23-3050.

Date: 3/1/2011

/Michael A. Koptiw/  
 Michael A. Koptiw  
 Registration No. 57,900

WOODCOCK WASHBURN LLP  
 Cira Centre  
 2929 Arch Street, 12th Floor  
 Philadelphia, PA 19104-2891  
 Telephone: (215) 568-3100  
 Facsimile: (215) 568-3439

## Electronic Patent Application Fee Transmittal

<b>Application Number:</b>	12543910
<b>Filing Date:</b>	19-Aug-2009
<b>Title of Invention:</b>	System and Method of Communication Via Embedded Modulation
<b>First Named Inventor/Applicant Name:</b>	Gordon F. Bremer
<b>Filer:</b>	Michael Koptiw Jr./Summer Uchin
<b>Attorney Docket Number:</b>	REMB-0109

Filed as Large Entity

### Utility under 35 USC 111(a) Filing Fees

Description	Fee Code	Quantity	Amount	Sub-Total in USD(\$)
<b>Basic Filing:</b>				
<b>Pages:</b>				
<b>Claims:</b>				
<b>Miscellaneous-Filing:</b>				
<b>Petition:</b>				
<b>Patent-Appeals-and-Interference:</b>				
<b>Post-Allowance-and-Post-Issuance:</b>				
<b>Extension-of-Time:</b>				

Description	Fee Code	Quantity	Amount	Sub-Total in USD(\$)
<b>Miscellaneous:</b>				
Submission- Information Disclosure Stmt	1806	1	180	180
<b>Total in USD (\$)</b>				<b>180</b>

## Electronic Acknowledgement Receipt

<b>EFS ID:</b>	9562863
<b>Application Number:</b>	12543910
<b>International Application Number:</b>	
<b>Confirmation Number:</b>	8306
<b>Title of Invention:</b>	System and Method of Communication Via Embedded Modulation
<b>First Named Inventor/Applicant Name:</b>	Gordon F. Bremer
<b>Customer Number:</b>	23377
<b>Filer:</b>	Michael Koptiw Jr./Summer Uchin
<b>Filer Authorized By:</b>	Michael Koptiw Jr.
<b>Attorney Docket Number:</b>	REMB-0109
<b>Receipt Date:</b>	01-MAR-2011
<b>Filing Date:</b>	19-AUG-2009
<b>Time Stamp:</b>	16:53:40
<b>Application Type:</b>	Utility under 35 USC 111(a)

### Payment information:

Submitted with Payment	yes
Payment Type	Deposit Account
Payment was successfully received in RAM	\$180
RAM confirmation Number	3746
Deposit Account	233050
Authorized User	

### File Listing:

Document Number	Document Description	File Name	File Size(Bytes)/ Message Digest	Multi Part / Zip	Pages (if appl.)
-----------------	----------------------	-----------	-------------------------------------	---------------------	---------------------

1	Transmittal Letter	REMB-0109_IDS_Trans_3-1-11. PDF	14660	no	3
			74a1f1026c27923045c13077d62042adb98 2e4bf		

**Warnings:**

**Information:**

2	Fee Worksheet (PTO-875)	fee-info.pdf	30403	no	2
			07a4124ca2fdb54da805e15aeceec047f96 35514		

**Warnings:**

**Information:**

<b>Total Files Size (in bytes):</b>			45063		
-------------------------------------	--	--	-------	--	--

**This Acknowledgement Receipt evidences receipt on the noted date by the USPTO of the indicated documents, characterized by the applicant, and including page counts, where applicable. It serves as evidence of receipt similar to a Post Card, as described in MPEP 503.**

**New Applications Under 35 U.S.C. 111**

**If a new application is being filed and the application includes the necessary components for a filing date (see 37 CFR 1.53(b)-(d) and MPEP 506), a Filing Receipt (37 CFR 1.54) will be issued in due course and the date shown on this Acknowledgement Receipt will establish the filing date of the application.**

**National Stage of an International Application under 35 U.S.C. 371**

**If a timely submission to enter the national stage of an international application is compliant with the conditions of 35 U.S.C. 371 and other applicable requirements a Form PCT/DO/EO/903 indicating acceptance of the application as a national stage submission under 35 U.S.C. 371 will be issued in addition to the Filing Receipt, in due course.**

**New International Application Filed with the USPTO as a Receiving Office**

**If a new international application is being filed and the international application includes the necessary components for an international filing date (see PCT Article 11 and MPEP 1810), a Notification of the International Application Number and of the International Filing Date (Form PCT/RO/105) will be issued in due course, subject to prescriptions concerning national security, and the date shown on this Acknowledgement Receipt will establish the international filing date of the application.**



Substitute for 1449/PTO  <b>INFORMATION DISCLOSURE STATEMENT BY APPLICANT</b>  <i>(use as many sheets as necessary)</i>				<b>Complete if Known</b>	
				<b>Application Number</b>	12/543,910
				<b>Filing Date</b>	August 19, 2009
				<b>First Named Inventor</b>	Gordon F. Bremer
				<b>Art Unit</b>	2611
<b>Examiner Name</b>	Dac V. Ha				
<b>Attorney Docket Number</b>	REMB-0109				
Sheet	1	of	11		

<b>U. S. PUBLICATION AND PATENT DOCUMENTS</b>				
Examiner Initials	Cite No.	Document Number	Publication or Grant Date MM-DD-YYYY	Name of Patentee or Applicant of Cited Document
		Number – Kind Code (if known)		
	23	2001/0022836 A1	09-20-2001	Bremer et al.
	24	2002/0041662 A1	04-11-2002	Bremer et al.
	25	2002/0167949	11-14-2002	Bremer et al.
	26	2003/0039348A1	02-27-2003	Bremer et al.
	27	2003/0210773 A1	11-13-2003	Bremer et al.
	28	2003/0210779 A1	11-13-2003	Bremer et al.
	29	2004/0013183 A1	01-22-2004	Bremer
	30	2004/0042510 A1	03-04-2004	Bremer et al.
	31	2004/0052361 A1	03-18-2004	Betts et al.
	32	2004/0066929 A1	04-08-2004	Bremer et al.
	33	2004/0081233 A1	04-29-2004	Bremer et al.
	34	2004/0179662 A1	09-10-2004	Bremer et al.
	35	2004/0213170 A1	10-28-2004	Bremer et al.
	36	2004/0258236 A1	12-23-2004	Bremer et al.
	37	2005/0025153 A1	02-03-2005	Bremer et al.
	38	2005/0074057 A1	04-07-2005	Bremer et al.
	39	2005/0147158	07-07-2005	Bremer et al.
	40	2005/0152404	07-15-2005	Holmquist et al.
	41	2005/0163303 A1	07-28-2005	Bremer
	42	2005/0180545 A1	08-18-2005	Bremer et al.
	43	2006/0188088 A1	08-24-2006	Bingel et al.
	44	2006/0193465 A1	08-31-2006	Betts
	45	2006/0195712 A1	08-31-2006	Bremer et al.
	46	2007/0047730 A1	03-01-2007	Bremer

<b>Examiner Signature</b>		<b>Date Considered</b>	
---------------------------	--	------------------------	--

Substitute for 1449/PTO  <b>INFORMATION DISCLOSURE STATEMENT BY APPLICANT</b>  <i>(use as many sheets as necessary)</i>				<b>Complete if Known</b>	
				Application Number	12/543,910
				Filing Date	August 19, 2009
				First Named Inventor	Gordon F. Bremer
				Art Unit	2611
Examiner Name	Dac V. Ha				
Sheet	2	of	11	Attorney Docket Number	REMB-0109

U. S. PUBLICATION AND PATENT DOCUMENTS				
Examiner Initials	Cite No.	Document Number	Publication or Grant Date MM-DD-YYYY	Name of Patentee or Applicant of Cited Document
		Number – Kind Code (if known)		
	47	2007/0047733 A1	03-01-2007	Bremer
	48	2007/0286187 A1	12-13-2007	Bremer
	49	2008/0013608 A1	01-17-2008	Bremer
	50	2008/0019432 A1	01-24-2008	Bremer et al.
	51	2009/0111422 A1	04-30-2009	Bremer
	52	2009/0262911 A1	10-22-2009	Bremer
	53	2009/0262912 A1	10-22-2009	Bremer
	54	2010/0183055 A1	07-22-2010	Bremer
	55	2010/0246598 A1	09-30-2010	Bremer
	56	3,736,528A	05-29-1973	Acker et al.
	57	3,761,840A	09-25-1973	Bremer
	58	4,335,464	06-15-1982	Armstrong et al.
	59	4,381,546	04-26-1983	Armstrong
	60	4,464,767	08-07-1984	Bremer
	61	4,503,545	03-05-1985	Bremer et al.
	62	4,509,171	04-02-1985	Bremer et al.
	63	4,516,216	05-07-1985	Armstrong
	64	4,525,846	06-25-1985	Bremer et al.
	65	4,525,847	06-25-1985	Bremer
	66	4,532,640	07-30-1985	Bremer et al.
	67	4,645,871	02-24-1987	Bremer et al.
	68	4,654,807	03-31-1987	Bremer
	69	4,663,766	05-05-1987	Bremer
	70	4,677,625	06-30-1987	Betts et al.

Examiner Signature		Date Considered	
--------------------	--	-----------------	--

Substitute for 1449/PTO  <b>INFORMATION DISCLOSURE STATEMENT BY APPLICANT</b>  <i>(use as many sheets as necessary)</i>				<b>Complete if Known</b>	
				<b>Application Number</b>	12/543,910
				<b>Filing Date</b>	August 19, 2009
				<b>First Named Inventor</b>	Gordon F. Bremer
				<b>Art Unit</b>	2611
<b>Examiner Name</b>	Dac V. Ha				
<b>Attorney Docket Number</b>	REMB-0109				
Sheet	3	of	11		

<b>U. S. PUBLICATION AND PATENT DOCUMENTS</b>				
Examiner Initials	Cite No.	Document Number	Publication or Grant Date MM-DD-YYYY	Name of Patentee or Applicant of Cited Document
		Number – Kind Code (if known)		
	71	4,782,498	11-01-1988	Copeland, III
	72	4,811,357	03-07-1989	Betts et al.
	73	4,862,464	08-29-1989	Betts et al.
	74	4,924,516 A	05-08-1990	Bremer et al.
	75	4,926,448	05-15-1990	Kraul et al.
	76	4,939,748	07-03-1990	Betts et al.
	77	5,008,903	04-16-1991	Betts et al.
	78	5,081,647 A	01-14-1992	Bremer
	79	5,099,478 A	03-24-1992	Bremer et al.
	80	5,168,535	12-01-1992	Laor
	81	5,206,854	04-27-1993	Betts et al.
	82	5,230,010 A	07-20-1993	Betts et al.
	83	5,239,306	08-24-1993	Siwiak et al.
	84	5,239,607	08-24-1993	Da Silva et al.
	85	5,251,236	10-05-1993	Brehmer et al.
	86	5,251,328	10-05-1993	Shaw
	87	5,257,396	10-26-1993	Auld, Jr. et al.
	88	5,280,503 A	01-18-1994	Betts et al.
	89	5,311,557	05-10-1994	Betts et al.
	90	5,311,578 A	05-10-1994	Bremer et al.
	91	5,345,332	09-06-1994	Da Silva et al.
	92	5,355,362	10-11-1994	Gorshe et al.
	93	5,373,149	10-13-1994	Rasmussen
	94	5,392,154	02-21-1995	Chang et al.

<b>Examiner Signature</b>		<b>Date Considered</b>	
---------------------------	--	------------------------	--

Substitute for 1449/PTO  <b>INFORMATION DISCLOSURE STATEMENT BY APPLICANT</b>  <i>(use as many sheets as necessary)</i>				<b>Complete if Known</b>	
				<b>Application Number</b>	12/543,910
				<b>Filing Date</b>	August 19, 2009
				<b>First Named Inventor</b>	Gordon F. Bremer
				<b>Art Unit</b>	2611
<b>Examiner Name</b>	Dac V. Ha				
<b>Attorney Docket Number</b>	REMB-0109				
Sheet	4	of	11		

**U. S. PUBLICATION AND PATENT DOCUMENTS**

Examiner Initials	Cite No.	Document Number	Publication or Grant Date MM-DD-YYYY	Name of Patentee or Applicant of Cited Document
		Number – Kind Code (if known)		
	<b>95</b>	5,412,651	05-02-1995	Gorshe
	<b>96</b>	5,414,540	05-09-1995	Patel et al.
	<b>97</b>	5,436,930 A	07-25-1995	Bremer et al.
	<b>98</b>	5,444,704	08-22-1995	Henderson et al.
	<b>99</b>	5,448,555 A	09-05-1995	Bremer et al.
	<b>100</b>	5,473,675	10-05-1995	Chapman et al.
	<b>101</b>	5,475,713 A	12-12-1995	Bremer et al.
	<b>102</b>	5,506,866 A	04-09-1996	Bermer et al.
	<b>103</b>	5,513,212 A	04-30-1996	Bremer
	<b>104</b>	5,513,213	04-30-1996	Patel et al.
	<b>105</b>	5,521,942 A	05-28-1996	Betts et al.
	<b>106</b>	5,530,718	06-25-1996	Gradeler et al.
	<b>107</b>	5,537,398	07-16-1996	Siwiak
	<b>108</b>	5,537,411 A	07-16-1996	Plas
	<b>109</b>	5,537,436 A	07-16-1996	Bottoms et al.
	<b>110</b>	5,559,791 A	09-24-1996	Bremer et al.
	<b>111</b>	5,559,792 A	09-24-1996	Bottoms et al.
	<b>112</b>	5,570,295	10-29-1996	Isenberg et al.
	<b>113</b>	5,602,869	02-11-1997	Scott
	<b>114</b>	5,629,992	05-13-1997	Amersfoort
	<b>115</b>	5,642,379 A	06-24-1997	Bremer et al.
	<b>116</b>	5,651,114	07-22-1997	Davidson, Jr.
	<b>117</b>	5,661,718 A	08-26-1997	Bremer et al.
	<b>118</b>	5,671,250 A	09-23-1997	Bremer et al.

<b>Examiner Signature</b>		<b>Date Considered</b>	
---------------------------	--	------------------------	--

Substitute for 1449/PTO  <b>INFORMATION DISCLOSURE STATEMENT BY APPLICANT</b>  <i>(use as many sheets as necessary)</i>				<b>Complete if Known</b>	
				<b>Application Number</b>	12/543,910
				<b>Filing Date</b>	August 19, 2009
				<b>First Named Inventor</b>	Gordon F. Bremer
				<b>Art Unit</b>	2611
<b>Examiner Name</b>	Dac V. Ha	<b>Attorney Docket Number</b>	REMB-0109		
Sheet	5	of	11		

<b>U. S. PUBLICATION AND PATENT DOCUMENTS</b>				
Examiner Initials	Cite No.	Document Number	Publication or Grant Date MM-DD-YYYY	Name of Patentee or Applicant of Cited Document
		Number – Kind Code (if known)		
	<b>119</b>	5,684,825	11-04-1997	Ko
	<b>120</b>	5,684,834 A	11-04-1997	Betts et al.
	<b>121</b>	5,711,012 A	01-20-1998	Bottoms et al.
	<b>122</b>	5,719,922 A	02-17-1998	Bremer et al.
	<b>123</b>	5,719,923 A	02-17-1998	Bremer et al.
	<b>124</b>	5,748,811	05-05-1998	Amersfoort et al.
	<b>125</b>	5,805,669	09-08-1998	Bingel et al.
	<b>126</b>	5,805,755	09-08-1998	Amersfoort et al.
	<b>127</b>	5,812,537	09-22-1998	Betts et al.
	<b>128</b>	5,825,517	10-20-1998	Antoniades et al.
	<b>129</b>	5,828,657	10-27-1998	Betts et al.
	<b>130</b>	5,841,500	10-24-1998	Patel
	<b>131</b>	5,844,944 A	12-01-1998	Betts et al.
	<b>132</b>	5,859,877 A	01-12-1999	Betts et al.
	<b>133</b>	5,881,047 A	03-09-1999	Bremer et al.
	<b>134</b>	5,881,142	03-09-1999	Frankel et al.
	<b>135</b>	5,901,205	05-04-1999	Smith et al.
	<b>136</b>	5,915,003 A	06-22-1999	Bremer et al.
	<b>137</b>	5,960,400 A	09-28-1999	Bremer
	<b>138</b>	5,963,620	10-05-1999	Frankel et al.
	<b>139</b>	6,011,814	01-04-2000	Martinez et al.
	<b>140</b>	6,031,897 A	02-29-2000	Bremer et al.
	<b>141</b>	6,061,392 A	05-09-2000	Bremer et al.
	<b>142</b>	6,075,512	06-13-2000	Patel et al.

<b>Examiner Signature</b>		<b>Date Considered</b>	
---------------------------	--	------------------------	--

Substitute for 1449/PTO  <b>INFORMATION DISCLOSURE STATEMENT BY APPLICANT</b>  <i>(use as many sheets as necessary)</i>				<b>Complete if Known</b>	
				<b>Application Number</b>	12/543,910
				<b>Filing Date</b>	August 19, 2009
				<b>First Named Inventor</b>	Gordon F. Bremer
				<b>Art Unit</b>	2611
<b>Examiner Name</b>	Dac V. Ha	<b>Attorney Docket Number</b>	REMB-0109		
Sheet	6	of	11		

<b>U. S. PUBLICATION AND PATENT DOCUMENTS</b>				
Examiner Initials	Cite No.	Document Number	Publication or Grant Date MM-DD-YYYY	Name of Patentee or Applicant of Cited Document
		Number – Kind Code (if known)		
	<b>143</b>	6,097,858	08-01-2000	Laor
	<b>144</b>	6,097,860	08-01-2000	Laor
	<b>145</b>	6,101,299	08-08-2000	Laor
	<b>146</b>	6,108,347	08-22-2000	Holmquist
	<b>147</b>	6,111,936 A	08-29-2000	Bremer
	<b>148</b>	6,134,245	10-17-2000	Scarmalis
	<b>149</b>	6,154,524 A	11-28-2000	Bremer
	<b>150</b>	6,157,680 A	12-05-2000	Betts et al.
	<b>151</b>	6,160,790 A	12-12-2000	Bremer
	<b>152</b>	6,175,436	01-16-2001	Jackel
	<b>153</b>	6,185,083	02-06-2001	Mathieu et al.
	<b>154</b>	6,236,481	05-22-2001	Laor
	<b>155</b>	6,236,717 B1	05-22-2001	Bremer et al.
	<b>156</b>	6,243,391	06-05-2001	Holmquist
	<b>157</b>	6,252,644	06-26-2001	Patel
	<b>158</b>	6,272,108	08-07-2001	Chapman
	<b>159</b>	6,272,154	08-07-2001	Bala et al.
	<b>160</b>	6,292,281	09-18-2001	Bala et al.
	<b>161</b>	6,307,653	10-23-2001	Bala et al.
	<b>162</b>	6,307,893 B1	10-23-2001	Bremer et al.
	<b>163</b>	6,307,923 B1	10-23-2001	Bremer et al.
	<b>164</b>	6,320,879 B1	11-20-2001	Bremer
	<b>165</b>	6,320,993	11-20-2001	Laor
	<b>166</b>	6,330,275 B1	12-11-2001	Bremer

<b>Examiner Signature</b>		<b>Date Considered</b>	
---------------------------	--	------------------------	--

Substitute for 1449/PTO  <b>INFORMATION DISCLOSURE STATEMENT BY APPLICANT</b>  <i>(use as many sheets as necessary)</i>				<b>Complete if Known</b>	
				<b>Application Number</b>	12/543,910
				<b>Filing Date</b>	August 19, 2009
				<b>First Named Inventor</b>	Gordon F. Bremer
				<b>Art Unit</b>	2611
<b>Examiner Name</b>	Dac V. Ha	<b>Attorney Docket Number</b>	REMB-0109		
Sheet	7	of	11		

U. S. PUBLICATION AND PATENT DOCUMENTS				
Examiner Initials	Cite No.	Document Number	Publication or Grant Date	Name of Patentee or Applicant of Cited Document
		Number – Kind Code (if known)	MM-DD-YYYY	
	<b>167</b>	6,335,992	01-01-2002	Bala et al.
	<b>168</b>	6,347,008	02-12-2002	Vodhanel
	<b>169</b>	6,408,056 B1	06-18-2002	Bremer et al.
	<b>170</b>	6,470,110	10-22-2002	Lin
	<b>171</b>	6,480,645	11-12-2002	Peale et al.
	<b>172</b>	6,493,475	12-10-2002	Lin
	<b>173</b>	6,529,652	03-04-2003	Bremer
	<b>174</b>	6,535,589	03-18-2003	Nauman et al.
	<b>175</b>	6,546,090 B1	04-08-2003	Bremer et al.
	<b>176</b>	6,549,692	04-15-2003	Harel et al.
	<b>177</b>	6,556,540	04-29-2003	Mawhinney et al.
	<b>178</b>	6,580,709	06-17-2003	Gorshe et al.
	<b>179</b>	6,580,785 B2	06-17-2003	Bremer et al.
	<b>180</b>	6,591,029	07-08-2003	Lin et al.
	<b>181</b>	6,597,827	07-22-2003	Bremer et al.
	<b>182</b>	6,603,894	08-05-2003	Pu
	<b>183</b>	6,614,838 B1	09-02-2003	Bremer
	<b>184</b>	6,628,857	09-30-2003	Bonadeo et al.
	<b>185</b>	6,631,119	10-07-2003	Mawhinney et al.
	<b>186</b>	6,633,693	10-14-2003	Peale et al.
	<b>187</b>	6,647,058 B1	11-11-2003	Bremer et al.
	<b>188</b>	6,658,096 B2	12-02-2003	Bremer et al.
	<b>189</b>	6,690,644	02-10-2004	Gorshe
	<b>190</b>	6,690,849	02-10-2004	Dadap, Jr., et al.

<b>Examiner Signature</b>		<b>Date Considered</b>	
---------------------------	--	------------------------	--

Substitute for 1449/PTO  <b>INFORMATION DISCLOSURE STATEMENT BY APPLICANT</b>  <i>(use as many sheets as necessary)</i>				<b>Complete if Known</b>	
				<b>Application Number</b>	12/543,910
				<b>Filing Date</b>	August 19, 2009
				<b>First Named Inventor</b>	Gordon F. Bremer
				<b>Art Unit</b>	2611
<b>Examiner Name</b>	Dac V. Ha	<b>Attorney Docket Number</b>	REMB-0109		
Sheet	8	of	11		

U. S. PUBLICATION AND PATENT DOCUMENTS				
Examiner Initials	Cite No.	Document Number	Publication or Grant Date	Name of Patentee or Applicant of Cited Document
		Number – Kind Code (if known)	MM-DD-YYYY	
	<b>191</b>	6,715,124	03-30-2004	Betts
	<b>192</b>	6,744,883 B1	06-01-2004	Bingel et al.
	<b>193</b>	6,771,740	08-03-2004	Bingel
	<b>194</b>	6,775,355 B1	08-10-2004	Bingel et al.
	<b>195</b>	6,782,094	08-24-2004	Venz et al.
	<b>196</b>	6,782,096 B1	08-24-2004	Bremer et al.
	<b>197</b>	6,885,730 B1	04-26-2005	Bremer
	<b>198</b>	6,922,415 B1	07-26-2005	Bremer et al.
	<b>199</b>	6,950,444	09-27-2005	Holmquist et al.
	<b>200</b>	6,970,501 B1	11-29-2005	Bremer et al.
	<b>201</b>	7,013,421	03-14-2006	Betts
	<b>202</b>	7,020,266 B2	03-28-2006	Bremer et al.
	<b>203</b>	7,023,829	04-04-2006	Holmquist et al.
	<b>204</b>	7,035,380 B1	04-25-2006	Bingel et al.
	<b>205</b>	7,046,798 B2	05-16-2006	Betts et al.
	<b>206</b>	7,058,833 B1	06-06-2006	Bremer et al.
	<b>207</b>	7,065,205 B1	06-20-2006	Bingel et al.
	<b>208</b>	7,127,048 B2	10-24-2006	Bremer et al.
	<b>209</b>	7,130,338 B2	10-31-2006	Bremer et al.
	<b>210</b>	7,155,016 B1	12-26-2006	Betts et al.
	<b>211</b>	7,248,626 B2	07-24-2007	Bremer
	<b>212</b>	7,272,215 B2	09-18-2007	Bremer et al.
	<b>213</b>	7,289,604 B2	10-30-2007	Bremer
	<b>214</b>	7,289,610 B2	10-30-2007	Bremer et al.

<b>Examiner Signature</b>		<b>Date Considered</b>	
---------------------------	--	------------------------	--



Substitute for 1449/PTO  <b>INFORMATION DISCLOSURE STATEMENT BY APPLICANT</b>  <i>(use as many sheets as necessary)</i>				<b>Complete if Known</b>	
				<b>Application Number</b>	12/543,910
				<b>Filing Date</b>	August 19, 2009
				<b>First Named Inventor</b>	Gordon F. Bremer
				<b>Art Unit</b>	2611
<b>Examiner Name</b>	Dac V. Ha				
<b>Attorney Docket Number</b>	REMB-0109				
Sheet	9	of	11		

U. S. PUBLICATION AND PATENT DOCUMENTS				
Examiner Initials	Cite No.	Document Number	Publication or Grant Date	Name of Patentee or Applicant of Cited Document
		Number – Kind Code (if known)	MM-DD-YYYY	
	<b>215</b>	7,352,803 B2	04-01-2008	Bremer et al.
	<b>216</b>	7,471,777 B2	12-30-2008	Bremer et al.
	<b>217</b>	7,675,965 B2	03-09-2010	Bremer
	<b>218</b>	7,707,446 B2	04-27-2010	Bremer et al.
	<b>219</b>	7,711,109 B2	05-04-2010	Betts et al.
	<b>220</b>	7,747,000 B2	06-29-2010	Bremer et al.

NON PATENT LITERATURE DOCUMENTS			
Examiner Initials	Cite No.	Include name of the author, title of the article (when appropriate), title of the item (book, magazine, journal, serial, symposium, catalog, etc.), date, page(s), Volume-issue Number(s), publisher, city and/or country where published.	T
	<b>221</b>	"Conelrad Emergency Radio Notification System Born in 1951", <a href="http://www.modestoradiomuseum.org">www.modestoradiomuseum.org</a> , Accessed on December 5, 2010, 2 pages	
	<b>222</b>	"Emergency Alert System", Public Safety and Homeland Security Bureau, <a href="http://www.fcc.gov/pshs/services/eas">www.fcc.gov/pshs/services/eas</a> , Accessed on December 5, 2010, 2 pages	
	<b>223</b>	"Specialized Communications Techniques for the Radio Amateur", The American Radio Relay League, Inc., 1975, 1 <sup>st</sup> Edition, Chapter 4, 78- 83	
	<b>224</b>	"Specialized Communications Techniques for the Radio Amateur", The American Radio Relay League, Inc., 1975, 1 <sup>st</sup> Edition, Chapter 5, 99-113	
	<b>225</b>	Bates (Ed.), "Broadband Telecommunications Handbook", McGraw-Hill Publishing, NY, 2000, Chapter 9, 128, 129, 131, 132, 133 and 134	
	<b>226</b>	Benson (Ed.), "Television Engineering Handbook", McGraw-Hill Publishers, NY, 1992, 5 pages, 4.14, 4.15, 4.24, 4.34 and 4.35	
	<b>227</b>	Bluetooth®, "Specification of the Bluetooth System, Master Table of Contents & Compliance Requirements", Specification Volume 0, November 4, 2004, V2.0, 1-1230	
	<b>228</b>	Bluetooth™, "Specification of the Bluetooth System, Core", December 1, 1999, V1.0B, 1-1082	

<b>Examiner Signature</b>		<b>Date Considered</b>	
---------------------------	--	------------------------	--

Substitute for 1449/PTO  <b>INFORMATION DISCLOSURE STATEMENT BY APPLICANT</b>  <i>(use as many sheets as necessary)</i>				<b>Complete if Known</b>	
				<b>Application Number</b>	12/543,910
				<b>Filing Date</b>	August 19, 2009
				<b>First Named Inventor</b>	Gordon F. Bremer
				<b>Art Unit</b>	2611
<b>Examiner Name</b>	Dac V. Ha				
<b>Attorney Docket Number</b>	REMB-0109				
Sheet	10	of	11		

<b>NON PATENT LITERATURE DOCUMENTS</b>			
<b>229</b>	Bluetooth™, "Specification of the Bluetooth System, Profiles", Specification Volume 2, December 1, 1999, V1.0B, 1-440		
<b>230</b>	Chorafas (Ed.), "Telephony: Today and Tomorrow", Prentice-Hall, Inc., NJ, Chapter 15, 1984, 191-197		
<b>231</b>	Erickson (Ed.), "Options for Presentation of Multilingual Text: Use of the Unicode Standard", March 14, 1997, 20 pages		
<b>232</b>	Freeman (Ed.), "Telecommunications Systems Engineering: Analog and Digital Network Design", John Wiley and Sons, Inc., NY, 1980, 1 page, 180		
<b>233</b>	Goodman (Ed.), "Radio Amateur's Handbook", The American Radio Relay League, Inc., CN, 1965, Chapter 10, 291-295		
<b>234</b>	Green (Ed.), "RTTY Handbook", Tab Books, Chapter 4, 1972, 266-273		
<b>235</b>	IEEE Information Technology, "Wireless LAN Medium Access Control (MAC) and Physical Layer (PHY) Specifications", 1997, 1-466		
<b>236</b>	Jurgen (Ed.), "Digital Consumer Electronics Handbook", McGraw-Hill Publications, NY, 1997, 27.7-27.10		
<b>237</b>	Kuecken (Ed.), "Talking Computers and Telecommunications", Van Nostrand Reinhold Company, Inc., NY, 1983, 32-36		
<b>238</b>	Margulies (Ed.), "SCSA Book", Telecom Library, Inc., NJ, Chapter 8, 1993, 250		
<b>239</b>	Martin (Ed.), "Telecommunications and The Computer", Prentice-Hall, Inc., NJ, 2 <sup>nd</sup> Edition, Chapter 21, 1976, 410-423		
<b>240</b>	Mazda, (Ed.), "Electronics Engineer's Reference Book", 5 <sup>th</sup> Edition, Butterworth and Company Publishers, London, 1983, 54.5-54.8		
<b>241</b>	Newton (Ed.), "Newton's Telecom Dictionary", Flatiron Publications, Inc., NY, April 1994, 7 <sup>th</sup> Edition, 9, 363, 364, 426, 427, 428, 429 and 430		
<b>242</b>	Pallott and Miller, "Implementing Message Priority Polices Over an 802.11 Based Mobile Ad Hoc Network", IEEE, Military Communications Conference, 2001, MILCOM 2001, Communications for Network-Centric Operations: Creating the Information Force, October 28-31, 2001, 2, 860-864		

<b>Examiner Signature</b>		<b>Date Considered</b>	
---------------------------	--	------------------------	--

Substitute for 1449/PTO  <b>INFORMATION DISCLOSURE STATEMENT BY APPLICANT</b>  <i>(use as many sheets as necessary)</i>				<b>Complete if Known</b>	
				<b>Application Number</b>	12/543,910
				<b>Filing Date</b>	August 19, 2009
				<b>First Named Inventor</b>	Gordon F. Bremer
				<b>Art Unit</b>	2611
				<b>Examiner Name</b>	Dac V. Ha
Sheet	11	of	11	<b>Attorney Docket Number</b>	REMB-0109

<b>NON PATENT LITERATURE DOCUMENTS</b>			
<b>243</b>		The National Association for Amateur Radio (ARRL), Radioteletype (RTTY), "Basic Principles and Machines", Chapter 2.1, Book or Journal Title Unknown, Date Unknown, pages 13 and 14	
<b>244</b>		The National Association for Amateur Radio (ARRL), Radioteletype (RTTY), "Autostart", Chapter 3.4, "references", Chapter 8, Book or Journal Title Unknown, Date Unknown, pages 107-111, 183, 185, 186 and 187	
<b>245</b>		Rzeszewski (Ed.), "Color Television", IEEE Press, John Wiley and Sons, Inc, NY, 1983, 3, 8 and 9	
<b>246</b>		Shrader (Ed.), "Electronic Communication", 1959, McGraw-Hill Publishers, NY, 551-555	
<b>247</b>		Shrader (Ed.), "Electronic Communication", 1959, McGraw-Hill Publishers, NY, 519	
<b>248</b>		Third Generation Partnership Project (3GPP) – Technologies Web Page, <a href="http://www.3gpp.org/-technologies-">http://www.3gpp.org/-technologies-</a> , Accessed on February 8, 2011, 2 pages	
<b>249</b>		Vilips (Ed.), "Data Modem: Selection and Evaluation Guide", Artech House, Inc, MA, Section 1, 1972, 3 pages	
<b>250</b>		Wilson et al (Ed.), "The ARRL Handbook for Radio Communications", 64 <sup>th</sup> Edition, The American Radio Relay League, Inc., Chapter 19, 1986, 19-9 - 19-13	
<b>251</b>		Wilson et al. (Ed.), "The ARRL Handbook for Radio Communications", 85 <sup>th</sup> Edition, The American Radio Relay League, Chapter 9, 2008, 9.32, 9.33 and 9.34	
<b>252</b>		Wilson et al. (Ed.), "The ARRL Handbook for Radio Communications", 64 <sup>th</sup> Edition, The American Radio Relay League Inc., Chapter 14, 1986, 14-13 and 14-14	

<b>Examiner Signature</b>		<b>Date Considered</b>	
---------------------------	--	------------------------	--

IN THE UNITED STATES PATENT AND TRADEMARK OFFICE

In Re Application of:

Gordon F. Bremer

Confirmation No.: 8306

Application No.: 12/543,910

Group Art Unit: 2611

Filing Date: August 19, 2009

Examiner: Dac V. Ha

For: SYSTEM AND METHOD OF COMMUNICATION VIA EMBEDDED MODULATION

Filed Via EFS

INFORMATION DISCLOSURE STATEMENT

Pursuant to 37 CFR § 1.56 and in accordance with 37 CFR §§ 1.97-1.98, information relating to the above-identified application is hereby disclosed. Inclusion of information in this statement is not to be construed as an admission that this information is material as that term is defined in 37 CFR § 1.56(b).

**IDS Filed Under 37 CFR 1.97(b)**

In accordance with § 1.97(b), since this Information Disclosure Statement is being filed either within three months of the filing date of the above-identified application, within three months of the date of entry into the national stage of the above identified application as set forth in § 1.491, before the mailing date of a first Office Action on the merits of the above-identified application, or before the mailing date of a first Office Action after the filing of request for continued examination under § 1.114, no additional fee is required.

**IDS filed Under 37 CFR 1.97(c)**

In accordance with § 1.97(c), this Information Disclosure Statement is being filed after the period set forth in § 1.97(b) above but before the mailing date of either a Final Action under § 1.116 or a Notice of Allowance under § 1.311, or before an action that otherwise closes prosecution in the application, therefore:

- Certification in Accordance with § 1.97(e) is attached; or
- The fee of **\$180.00** as set forth in § 1.17(p) is attached.

**IDS filed Under 37 CFR 1.97(d)**

In accordance with § 1.97(d), this Information Disclosure Statement is being filed after the mailing date of either a Final Action under § 1.113 or a Notice of Allowance under § 1.311 but before, or simultaneously with, the payment of the Issue Fee, therefore included are: Certification in Accordance with § 1.97(e); and the submission fee of **\$180.00** as set forth in § 1.17(p).

**CONTENT OF IDS PURSUANT TO 37 CFR 1.98**

Copies of reference numbers 1-220 listed on the attached Form PTO-1449 are not required to be submitted pursuant to 37 CFR § 1.98(a)(2)(iii).

Copies of reference numbers 221-252 listed on the attached Form PTO-1449 are enclosed herewith.

Copies of reference numbers \_\_\_\_\_ are not being submitted because they were previously cited by or submitted to the U.S. Patent and Trademark Office in patent application number \_\_\_\_\_, filed \_\_\_\_\_ for which a claim for priority under 35 U.S.C. § 120 has been made in the instant application.

The month of publication for reference numbers 223-226, 230, 232-241, 245-247, 249-252 is not available. However, the year of publication for these references is sufficiently earlier than the effective US filing date and any foreign priority date so that the particular month of publication is not in issue pursuant to 37 CFR § 1.98(b).

**REFERENCES IN A LANGUAGE OTHER THAN ENGLISH**

The following documents are not in the English language. Accordingly, a concise explanation of the relevance of the document was incorporated in the specification passages identified below, the document was identified in a foreign communication as identified below or an English language counterpart application has been provided as indicated below.

Foreign Language Document	Cite No.	Pages of Reference in Specification or Relevance of Document

Foreign Language Document	Cite No.	English Language Counterpart	Cite No.

**CERTIFICATION IN ACCORDANCE WITH § 1.97(e)**

I hereby certify that:

- Each item of information contained in this information disclosure statement was first cited in any communication from a foreign patent office in a counterpart foreign application not more than three months prior to the filing of this information disclosure statement.
- No item of information contained in this information disclosure statement was cited in a communication from a foreign patent office in a counterpart foreign application, and, to the knowledge of the person signing the certification after making reasonable inquiry, no item of information contained in this information disclosure statement was known to any individual designated in § 1.56(c) more than three months prior to the filing of this information disclosure statement.

Please charge any deficiency or credit any overpayment to Deposit Account No. 23-3050.

Date: 3/1/2011

/Michael A. Koptiw/  
 Michael A. Koptiw  
 Registration No. 57,900

WOODCOCK WASHBURN LLP  
 Cira Centre  
 2929 Arch Street, 12th Floor  
 Philadelphia, PA 19104-2891  
 Telephone: (215) 568-3100  
 Facsimile: (215) 568-3439

## Electronic Acknowledgement Receipt

<b>EFS ID:</b>	9560134
<b>Application Number:</b>	12543910
<b>International Application Number:</b>	
<b>Confirmation Number:</b>	8306
<b>Title of Invention:</b>	System and Method of Communication Via Embedded Modulation
<b>First Named Inventor/Applicant Name:</b>	Gordon F. Bremer
<b>Customer Number:</b>	23377
<b>Filer:</b>	Michael Koptiw Jr./Summer Uchin
<b>Filer Authorized By:</b>	Michael Koptiw Jr.
<b>Attorney Docket Number:</b>	REMB-0109
<b>Receipt Date:</b>	01-MAR-2011
<b>Filing Date:</b>	19-AUG-2009
<b>Time Stamp:</b>	16:43:27
<b>Application Type:</b>	Utility under 35 USC 111(a)

### Payment information:

Submitted with Payment	no
------------------------	----

### File Listing:

Document Number	Document Description	File Name	File Size(Bytes)/ Message Digest	Multi Part /.zip	Pages (if appl.)
1	NPL Documents	Conelrad_ControlElectromagnt icRadiation_1951_2pgs.PDF	345122 <small>e0b3bf39ec24cd0ffdfb6b3218b75f278a622b70</small>	no	2

### Warnings:

### Information:

2	NPL Documents	EmergencyAlertSystem_2010_2pgs.PDF	233186 ec534e168294165680a6f745439cf6506385f13c	no	2
<b>Warnings:</b>					
<b>Information:</b>					
3	NPL Documents	SpecializedCommsTech_AmericanRadioRelayLeague_1975_7pgs.PDF	1152047 fdf3fcaf0d9f827e3d594c8c3f2aa87cf5e16db1	no	7
<b>Warnings:</b>					
<b>Information:</b>					
4	NPL Documents	SpecializedCommsTech_AmericanRadioRelayLeague_1975_15pgs.PDF	2508065 ebbc9695b019ddde22a3f7c618f6cdc6028db5b	no	15
<b>Warnings:</b>					
<b>Information:</b>					
5	NPL Documents	Bates_BroadbandTelecommHandbook_2000_7pgs.PDF	1151070 27911ea15db5bd60829660d75a4171ded1c629e7	no	7
<b>Warnings:</b>					
<b>Information:</b>					
6	NPL Documents	Benson_TVandEngineeringHandbook_1992_6pgs.PDF	1457895 3a7d64745033640e07ab76ed519ed1d0f802bdba	no	6
<b>Warnings:</b>					
<b>Information:</b>					
7	NPL Documents	SpecofBluetoothSystem_MasterTOC_ComplRequir_2004_1-1230.PDF	6269444 d4ba0cfd223453211c1fe54a2d74a3fe9fd7a699	no	1230
<b>Warnings:</b>					
<b>Information:</b>					
8	NPL Documents	SpecofBluetoothSystem_Core_1999_1-1082.PDF	5700526 56e8d81768c0c14d25b4cf9c40da0abc51e04526	no	1082
<b>Warnings:</b>					
<b>Information:</b>					
9	NPL Documents	SpecofBluetoothSystem_Profiles_1999_1-440.PDF	2485132 aefc6a7161ea9867096c58aeb1c4a156ea06f	no	440
<b>Warnings:</b>					
<b>Information:</b>					
10	NPL Documents	Chorafas_Telephony_1984_8pgs.PDF	1978205 836b1fb1a18d2637292d97047d93ad3b0e767320	no	8
<b>Warnings:</b>					
<b>Information:</b>					



11	NPL Documents	Erickson_OptionsPresentMultilingulaText_1997_20pgs.PDF	145700 7c2053227b91e3c755ccd0160276f9e629014453	no	20
<b>Warnings:</b>					
<b>Information:</b>					
12	NPL Documents	Freeman_TelecommSysEngin_1980_2pgs.PDF	445458 d4da42b2532d2f474674e50b5778a5f9e9770ca7	no	2
<b>Warnings:</b>					
<b>Information:</b>					
13	NPL Documents	Goodman_RadioAmateursHandbook_1965_6pgs.PDF	906642 60742dbbad3b5dc274b8a1d9721c157c7549e87d	no	6
<b>Warnings:</b>					
<b>Information:</b>					
14	NPL Documents	Green_RTTY_Handbook_1972_6pgs.PDF	816870 380aef70a3c0d6ae0bc613b32a3c78b6b130c98b	no	6
<b>Warnings:</b>					
<b>Information:</b>					
15	NPL Documents	IEEE_InformationTechnology_1997_466pgs.PDF	4378895 df95057117696a4132b81fbae1fb8c63ee12cbd9	no	466
<b>Warnings:</b>					
<b>Information:</b>					
16	NPL Documents	Jurgen_DigitalConsumerElectronicsHandbook_1997_5pgs.PDF	855184 d1dd9416977c31c114908b18503c15c6c72ddd0f	no	5
<b>Warnings:</b>					
<b>Information:</b>					
17	NPL Documents	Kuecken_TalkingComputersandTelecomms_1983_6pgs.PDF	1341889 c29b9c8251b9442a1c1db0f613ae3aa7f0df84371	no	6
<b>Warnings:</b>					
<b>Information:</b>					
18	NPL Documents	Margulies_SCSABook_1993_4pgs.PDF	521298 7123ee4011ef14969ea491b08fbc52c14c1021a1	no	4
<b>Warnings:</b>					
<b>Information:</b>					
19	NPL Documents	Martin_TelecommsandComputer_1976_15pgs.PDF	1615390 5c6f0d724657b017c7275ef4e778c8a8672b40bd	no	15
<b>Warnings:</b>					
<b>Information:</b>					

20	NPL Documents	Mazda_ElectrEngineerRefBook_1983_5pgs.PDF	1422534 88a019dd568508a59603991651a35f3789358ed9	no	5
<b>Warnings:</b>					
<b>Information:</b>					
21	NPL Documents	NewtonsTelecomDictionary_1994_9pgs.PDF	2225645 326d966ee1bc8ed48cf08d28b75ba6c8f6cf6080	no	9
<b>Warnings:</b>					
<b>Information:</b>					
22	NPL Documents	Pallott_WirelessCommsTechGroup_5pgs.PDF	241345 3c92c905b9324701fe4b0553ea255c1885d6d8a1	no	5
<b>Warnings:</b>					
<b>Information:</b>					
23	NPL Documents	RTTY-ARRL_1955_7pgs.PDF	666980 1ba9bc009dc9e5138fa9f1d673c0a81876a6256e	no	7
<b>Warnings:</b>					
<b>Information:</b>					
24	NPL Documents	RTTY-ARRL_1955_2pgs.PDF	256494 1d20157b04da2bc93b9e301441cca3bb06dd4382	no	2
<b>Warnings:</b>					
<b>Information:</b>					
25	NPL Documents	Rzeszewski_IEEEPRESS_1983_5pgs.PDF	526955 23fe580e50b366660064ddeb3921d0f53e21e0dc	no	5
<b>Warnings:</b>					
<b>Information:</b>					
26	NPL Documents	Shrader_ElectronicComm_1959_2pgs.PDF	469781 decbec7e8674667c5c8c9737516db1f4395d0f16	no	2
<b>Warnings:</b>					
<b>Information:</b>					
27	NPL Documents	Shrader_ElectronicComm_1959_6pgs.PDF	1146527 064520b4b7ce7185614aa37aa945fa0e8d03acd1	no	6
<b>Warnings:</b>					
<b>Information:</b>					
28	NPL Documents	3GPPTechnologies_WebPage_2011_2pgs.PDF	64927 7bb054e1acefb7d8e071dd8a603a00f17f2df219	no	2
<b>Warnings:</b>					
<b>Information:</b>					

29	NPL Documents	Vilips_DataModemSelectionEvaluationGuide_1972_3pgs.PDF	345107 8de5a73561d9867d7182f507b316fe10e65de282	no	3
<b>Warnings:</b>					
<b>Information:</b>					
30	NPL Documents	Wilson_ARRLHandbook_1986_6pgs.PDF	1754650 2038dc869831db4af662f12aa26759d18cf9f4b7	no	6
<b>Warnings:</b>					
<b>Information:</b>					
31	NPL Documents	Wilson_ARRLHandbook_2008_4pgs.PDF	1163381 0598692bb9641deb61da85518b8ef786ad1de10b	no	4
<b>Warnings:</b>					
<b>Information:</b>					
32	NPL Documents	Wilson_ARRLHandbook_1986_2pgs.PDF	896933 48383f1a7582e6a6c6bf129c261658eebd540a77	no	3
<b>Warnings:</b>					
<b>Information:</b>					
33	Information Disclosure Statement (IDS) Filed (SB/08)	REMB-0109_IDS_1449_3-1-11.PDF	80642 4882cc3d48f1849d0d0977969304d2a0a29f2e02	no	11
<b>Warnings:</b>					
<b>Information:</b>					
This is not an USPTO supplied IDS fillable form					
34	Transmittal Letter	REMB-0109_IDS_Trans_3-1-11_2.PDF	14719 853ea6005a7f26560b420bd4401809b4d74c29f1	no	3
<b>Warnings:</b>					
<b>Information:</b>					
<b>Total Files Size (in bytes):</b>			45584638		

**This Acknowledgement Receipt evidences receipt on the noted date by the USPTO of the indicated documents, characterized by the applicant, and including page counts, where applicable. It serves as evidence of receipt similar to a Post Card, as described in MPEP 503.**

**New Applications Under 35 U.S.C. 111**

**If a new application is being filed and the application includes the necessary components for a filing date (see 37 CFR 1.53(b)-(d) and MPEP 506), a Filing Receipt (37 CFR 1.54) will be issued in due course and the date shown on this Acknowledgement Receipt will establish the filing date of the application.**

**National Stage of an International Application under 35 U.S.C. 371**

**If a timely submission to enter the national stage of an international application is compliant with the conditions of 35 U.S.C. 371 and other applicable requirements a Form PCT/DO/EO/903 indicating acceptance of the application as a national stage submission under 35 U.S.C. 371 will be issued in addition to the Filing Receipt, in due course.**

**New International Application Filed with the USPTO as a Receiving Office**

**If a new international application is being filed and the international application includes the necessary components for an international filing date (see PCT Article 11 and MPEP 1810), a Notification of the International Application Number and of the International Filing Date (Form PCT/RO/105) will be issued in due course, subject to prescriptions concerning national security, and the date shown on this Acknowledgement Receipt will establish the international filing date of the application.**

**DOCKET NO.:** REMB-0109  
**Application No.:** 12/543,910  
**Office Action Dated:** September 1, 2010

**PATENT**

**IN THE UNITED STATES PATENT AND TRADEMARK OFFICE**

**In re Application of:  
Gordon Bremer**

**Confirmation No.: 8306**

**Application No.: 12/543,910**

**Group Art Unit: 2611**

**Filing Date: August 19, 2009**

**Examiner: Dac V Ha**

**For: System and Method of Communication Via Embedded Modulation**

Mail Stop Amendment  
Commissioner for Patents  
P.O. Box 1450  
Alexandria, VA 22313-1450

Sir:

**REPLY PURSUANT TO 37 CFR § 1.111**

In response to the Official Action dated **September 1, 2010**, reconsideration is respectfully requested in view of the amendments and/or remarks as indicated below:

- Amendments to the Specification** begin on page 2 of this paper.
- Amendments to the Claims** are reflected in the listing of the claims which begins on page 7 of this paper.
- Amendments to the Drawings** begin on page 19 of this paper and include an attached replacement sheet.
- Remarks** begin on page 20 of this paper.
- Request For Refund** submitted herewith.

**Amendments to the Specification:**

Please replace the Summary section, which corresponds to paragraphs [0008] – [0013] of the specification, with the following:

[0008] The present invention disclosed herein includes communication systems, devices, and methods. For example, a device may be capable of communicating according to a master/slave relationship in which a communication from a slave to a master occurs in response to a communication from the master to the slave. The device may include a transceiver in the role of the master for sending transmissions modulated using at least two types of modulation methods, for example a first modulation method and a second modulation method. The first modulation method may be of a different type than the second modulation method. The transmissions may be groups of transmission sequences. A group may be structured with a first portion and a payload portion. First information in the first portion may indicate which of the first modulation method or the second modulation method is used for modulating second information in the payload portion. The transmissions may be addressed for an intended destination of the payload portion. First information in a transmission that includes an address for an intended destination may include a first sequence in the first portion that is modulated according to the first modulation method and that indicates an impending change from the first modulation method to the second modulation method. Second information in a transmission that includes an address for an intended destination may include a second sequence in the payload portion that is modulated according to the second modulation method. The second sequence may be transmitted after the first sequence.

~~[0008] The present invention is generally directed to a system and method of communication between a master transceiver and a plurality of tributary transceivers in a multipoint communication system in which the tributary transceivers use different types of modulation methods. Broadly stated, the communication system includes a master transceiver in communication with a first tributary transceiver and a second tributary transceiver over a communication medium. The first tributary transceiver uses a primary modulation method for communication while the second tributary transceiver uses a secondary or embedded modulation method for communication. The master transceiver and~~

~~tributary transceivers each include a processor, memory, and control logic for controlling their operation. While the primary modulation method is normally used for transmissions on the communication medium, the master transceiver can communicate with the second tributary transceiver by notifying the first tributary transceiver that the primary modulation method is being temporarily replaced by the secondary or embedded modulation method. The master transceiver can then exchange information with the second tributary transceiver while the first tributary transceiver ignores any secondary modulation transmissions. In the meantime, the first tributary transceiver conditions itself to look for a trailing sequence from the master transceiver indicating that communication with the second tributary transceiver is complete. When the master transceiver transmits the trailing sequence using the primary modulation method, the first tributary transceiver conditions itself to look for primary modulation transmissions while the second tributary transceiver conditions itself to ignore primary modulation transmissions.~~

[0009] The present invention has many advantages, a few of which are delineated hereafter as merely examples.

[0010] One advantage of the present invention is that it provides to the use of a plurality of modem modulation methods on the same communication medium.

[0011] Another advantage of the present invention is that a master transceiver can communicate seamlessly with tributary transceivers or modems using incompatible modulation methods.

~~[0012] Another advantage of the present invention is that a master and tributary transceiver can calculate a channel parameter using a test signal sent using embedded modulation.~~

[0013] Other features and advantages of the present invention will become apparent to one with skill in the art upon examination of the following drawings and detailed description. It is intended that all such additional features and advantages be included herein within the scope of the present invention.

Please amend paragraph [0022] of the specification as follows:

~~[0022] FIG. 8 is a ladder diagram illustrating the operation of an alternative embodiment of the multipoint communication system of FIG. 4~~ is a signal diagram for an exemplary transmission according to an embodiment.

Please amend paragraph [0025] of the specification as follows:

[0025] Referring now to FIG. 2, an exemplary multipoint communication session is illustrated through use of a ladder diagram. This system uses polled multipoint communication protocol. That is, a master controls the initiation of its own transmission to the tribs and permits transmission from a trib only when that trib has been selected. At the beginning of the session, the master transceiver 24 establishes a common modulation as indicated by sequence 32 that is used by both the master 24 and the tribs 26a, 26b for communication. Once the modulation scheme is established among the modems in the multipoint system, The master transceiver 24 transmits a training sequence 34 that includes the address of the trib that the master seeks to communicate with. In this case, the training sequence 34 includes the address of trib 26a. As a result, trib 26b ignores training sequence 34. After completion of the training sequence 34, master transceiver 24 transmits data 36 to trib 26a followed by trailing sequence 38, which signifies the end of the communication session. Similarly, with reference to FIG. 8, the sequence 170 illustrates a Type A modulation training signal, followed by a Type A modulation data signal. Note that trib 26b ignores data 36 and trailing sequence 38 as it was not requested for communication during training sequence 34.

Please amend paragraph [0027] of the specification as follows:

[0027] The foregoing procedure is repeated except master transceiver identifies trib 26b in training sequence 48. In this case, trib 26a ignores the training sequence 48 and the subsequent transmission of data 52 and trailing sequence 54 because it does not recognize its address in training sequence 48. Master transceiver 24 transmits data 52 to trib 26b followed by trailing sequence 54 to terminate the communication session. Similarly, with reference to FIG. 8, sequence 172 illustrates a Type A modulation signal, with notification of a changes to Type B, followed by a Type B modulation data signal. To send information back to master transceiver 24, trib 26b transmits training sequence 56 to establish a communication session.



Master transceiver 24 is conditioned to expect data only from trib 26b because trib 26b was selected as part of training sequence 48. Trib 26b transmits data 58 to master transceiver 24 terminated by trailing sequence 62.

Please delete paragraphs [0042] – [0046]

~~[0042]—In an alternative embodiment of the present invention, embedded modulations can be used as a way to measure transmission line characteristics between a master transceiver and tributary transceiver, as shown in FIG. 8. In this embodiment, both a master transceiver 64 and a tributary transceiver 66a would have the ability to transmit using at least two modulation methods, type A and type B. In the present example, the primary transmission type is type A. Thus, as shown in FIG. 8, the master transceiver 64 establishes type A as the primary modulation in sequence 150.~~

~~[0043]—To switch from type A to type B modulation, master transceiver 64 transmits a notification sequence 152 to the tributary 66a. Thus, the tributary 66a is notified of an impending change to modulation type B. The switch to type B modulation could be limited according to a specific time interval or for the communication of a particular quantity of data, such as a test signal. After notifying the tributary 66a of the change to type B modulation, the master transceiver 64, transmits a test signal sequence 154 using type B modulation.~~

~~[0044]—In this embodiment, the tributary transceiver can contain logic which enables the tributary 66a to calculate at least one channel parameter from the test signal sequence 154. Channel parameters typically include transmission line characteristics, such as, for example, loss versus frequency, non-linear distortion, listener echoes, talker echoes, bridge tap locations, impedance mismatches, noise profile, signal to noise ratio, group delay versus frequency, cross talk presence, cross talk type, etc. Moreover, the tributary transceiver 66a could be configured to communicate a channel parameter back to the master transceiver 64.~~

~~[0045]—After transmitting the test signal sequence 154 to the tributary transceiver 66a, the master transceiver 64 can transmit a trailing sequence 156 to the tributary transceiver 66a using type A modulation to indicate the end of the transmission using type B modulation. The master transceiver 64 can then send information to the tributary transceiver 66a using primary modulation type A, as shown by training, data and trailing sequences 158, 160 and 162. Likewise, the tributary transceiver 66a can send information to the master transceiver 64~~

using primary modulation type A, as shown by training, data and trailing sequences 164, 166 and 168.

~~{0046}~~—In a further alternative embodiment, the master transceiver 64 or tributary transceiver 66a may identify a time period within which test signal sequences may be transmitted. This would eliminate the training and trailing sequences which alert the tributary transceiver 66a to the beginning of a new modulation method. The identification of the time period could be initiated by the master transceiver 64 or tributary transceiver 66a and could include a time period noted in the header of a transmission between the tributary transceiver 66a and master transceiver 64.

Please amend the Abstract as shown below. A clean version of the Abstract submitted on a separate sheet is also submitted herewith.

A device may be capable of communicating using at least two type types of modulation methods. ~~single subscriber line multi-point communication system is disclosed. In general, the multi-point communication system can~~ The device may include a first transceiver coupled to a subscriber line capable of acting as a master according to a master/slave relationship in which communication from a slave to a master occurs in response to communication from the master to the slave. ~~transmitting and receiving at least two modulation methods, either of said modulation methods being operable to transmit a test signal, and a second transceiver coupled to said subscriber line capable of transmitting and receiving said at least two modulation methods, the second transceiver being operable to receive the test signal and determine at least one channel parameter from the test signal. A~~ The master transceiver may send transmissions structured with a first portion and a payload portion. ~~that can be used in various embodiments of a single subscriber line multi-point communication system, and a tributary transceiver are further disclosed~~ Information in the first portion may be modulated according to a first modulation method and indicate an impending change to a second modulation method, which is used for transmitting the payload portion. The transmissions may be addressed for an intended destination of the payload portion.

This listing of claims will replace all prior versions, and listings, of claims in the application.

**Listing of Claims:**

1. (Currently Amended) A communication ~~system~~ device capable of communicating according to a master/slave relationship in which a slave communication from a slave to a master occurs in response to a master communication from the master to the slave, the device comprising:

a transceiver, in the role of the master according to the master/slave relationship, for sending at least ~~transmitter capable of transmitting~~ transmissions modulated using at least two types of modulation methods, wherein the at least two types of modulation methods comprise a first modulation method and a second modulation method, wherein the second modulation method is of a different type than the first modulation method, and wherein the first transceiver is configured to transmit transmissions comprise groups of transmission sequences, each group of said groups of transmission sequences structured with a first portion and a payload portion wherein first information in the first portion indicates at least which of the first modulation method and the second modulation method is used for modulating second information in the payload portion, wherein at least one group of transmission sequences is addressed for an intended destination of the payload portion, and wherein for the at least one group of transmission sequences:

the first information for said at least one group of transmission sequences comprises a first sequence, in the first portion and modulated according to the first modulation method, wherein the first sequence ~~that~~ indicates an impending change from the first modulation method to the second modulation method, and

the second information for said at least one group of transmission sequences comprises a second sequence, ~~in~~ modulated according to the second modulation method, wherein the second sequence is transmitted after the first ~~data~~ sequence.

2. (Currently Amended) The ~~system~~ device of claim 1, wherein the transceiver is configured to transmit a third sequence after the second sequence, wherein the third sequence is transmitted in the first modulation method and indicates that communication from the master to the slave has reverted to the first modulation method.

3. – 8. (Canceled)

9. (Currently Amended) The ~~system~~ device of claim 1, wherein the ~~first~~ transceiver is configured to transmit the second sequence according to a specific time interval.

10. (Currently Amended) The ~~system~~ device of claim 1, wherein the ~~first~~ transceiver is configured to transmit the second sequence according to a particular quantity of data.

11. (Currently Amended) The ~~system~~ device of claim 1, further comprising a processor and a memory, wherein the memory has stored therein instructions that when executed by the processor cause the transceiver transmitter to transmit the first sequence and the second sequence.

12. (Currently Amended) The ~~system~~ device of claim 11, wherein the memory has stored therein program code for the first modulation method and the second modulation method.

13. (Currently Amended) The ~~system~~ device of claim 11, wherein the memory comprises random access memory.

14. (Currently Amended) The ~~system~~ device of claim 11, wherein the memory comprises read-only memory.

15. (Currently Amended) The device of claim 11, wherein the memory has stored therein program code for operating the transceiver in a multipoint master/slave relationship communications protocol.

16. – 17. (Canceled)

18. (Currently Amended) The ~~system~~ device of claim ~~1~~ 17, wherein the first communication from the master to the slave burst transmission is a poll in accordance with a multipoint communications ~~protocol~~ relationship, wherein the poll indicates that the master has selected the slave for transmission.

19. (Canceled)
20. (Currently Amended) ~~The device of claim 19~~ A communications device, comprising:  
a processor; and  
a memory having stored therein executable instructions for execution by the  
processor, wherein the executable instructions direct transmission of a first data with a first  
modulation method followed by a second data with a second modulation method, wherein the  
first modulation method is different than the second modulation method, wherein the first  
data comprises an indication of an impending change from the first modulation method to the  
second modulation method, wherein the executable instructions direct transmission of a third  
data with the first modulation method after the second data, and wherein the third data  
indicates that communication has reverted to the first modulation method.
21. – 26. (Canceled)
27. (Currently Amended) The device of claim 20 ~~19~~, wherein transmission of the second  
data is according to a specific time interval.
28. (Currently Amended) ~~The device of claim 19~~, A communications device, comprising:  
a processor; and  
a memory having stored therein executable instructions for execution by the  
processor, wherein the executable instructions direct transmission of a first data with a first  
modulation method followed by a second data with a second modulation method, wherein the  
first modulation method is different than the second modulation method, wherein the first  
data comprises an indication of an impending change from the first modulation method to the  
second modulation method wherein the executable instructions direct transmission of a third  
data with the first modulation method after the second data, and wherein transmission of the  
second data is according to a particular quantity of data.
29. (Currently Amended) The device of claim 20 ~~19~~, further comprising a transmitter  
configured to transmit the first data and the second data.

30. (Currently Amended) The device of claim 20 ~~49~~, wherein the memory has stored therein program code for the first modulation method and the second modulation method.

31. (Currently Amended) The device of claim 20 ~~49~~, wherein the memory comprises random access memory.

32. (Currently Amended) The device of claim 20 ~~49~~, wherein the memory comprises read-only memory.

33. (Currently Amended) The device of claim 20 ~~49~~, wherein the memory has stored therein program code for a multipoint communications protocol.

34. – 36. (Canceled)

37. (Currently Amended) A device ~~comprising: that transmits in accordance with~~ a first modulation ~~logic; method and~~ a second modulation ~~logic-method~~ that is different than the first modulation ~~logic; and method~~, said device comprising:

at least one modulator;

a transceiver that includes the at least one modulator ~~adapted to use the first modulation logic and the second modulation logic~~, wherein the transceiver is configured to transmit:

a first sequence, modulated in accordance with the first modulation method ~~logic~~, that indicates a an impending change from the first modulation method ~~logic~~ to the second modulation method ~~logic~~, and

a second sequence, in accordance with the second modulation method ~~logic~~, that is transmitted at a time after ~~follows~~ the first data sequence.

38. (Currently Amended) The device of claim 37, wherein the transceiver is configured to transmit a third sequence after the second sequence, wherein the third sequence is transmitted in accordance with the first modulation method ~~logic~~ and indicates that a subsequent communication has reverted to the first modulation method ~~logic~~.

39. – 44. (Canceled)

45. (Currently Amended) The device of claim 37, wherein the ~~first~~ transceiver is configured to transmit the second sequence according to a specific time interval.

46. (Currently Amended) The device of claim 37, wherein the ~~first~~ transceiver is configured to transmit the second sequence according to a particular quantity of data.

47. (Original) The device of claim 37, further comprising a processor and a memory, wherein the memory has stored therein instructions that when executed by the processor cause the transmitter to transmit the first sequence and the second sequence.

48. (Original) The device of claim 47, wherein the memory comprises random access memory.

49. (Original) The device of claim 47, wherein the memory comprises read-only memory.

50. (Original) The device of claim 47, wherein the memory has stored therein program code for a multipoint communications protocol.

51. – 86. (Canceled)

87. (Currently Amended) ~~The computer-readable storage medium of claim 86, further comprising~~ A computer-readable storage medium having a computer executable instructions stored therein that when executed by a processor control a master transceiver, said computer executable instructions, comprising:

first logic configured to transmit first information in a first modulation method for communication;

second logic configured to transmit a first sequence to notify of a change from said first modulation method to a second modulation method;

third logic configured to transmit second information in said second modulation method; and

fourth logic configured to transmit a second sequence after the second information is transmitted, wherein the second sequence is transmitted in the first modulation method and indicates that communication has reverted to the first modulation method.

88. – 93. (Canceled)

94. (Currently Amended) The computer-readable storage medium of claim 87 ~~86~~, wherein the first transceiver is configured to transmit the second sequence according to a specific time interval.

95. (Currently Amended) ~~The computer-readable storage medium of claim 86,~~ A computer-readable storage medium having a computer executable instructions stored therein that when executed by a processor control a master transceiver, said computer executable instructions, comprising:

first logic configured to transmit first information in a first modulation method for communication;

second logic configured to transmit a first sequence to notify of a change from said first modulation method to a second modulation method;

third logic configured to transmit second information in said second modulation method; and

fourth logic configured to transmit a second sequence after the second information is transmitted, wherein the first transceiver is configured to transmit the second sequence according to a particular quantity of data.

96. (Currently Amended) The computer-readable storage medium of claim 87 ~~44~~, further comprising program code for the first modulation method and the second modulation method.

97. (Currently Amended) The computer-readable storage medium of claim 87 ~~44~~, further comprising program code for a multipoint communications protocol.

98. – 100. (Canceled)



101. (New) The device of claim 1, wherein the transceiver is configured to be the master.

102. (New) The device of claim 1, wherein the first information in the first portion indicates the first modulation method when the intended destination is a first type of receiver and indicates the second modulation when the intended destination is a second type of receiver.

103. (New) The device of claim 102, wherein the second type of receiver differs from the first type of receiver at least by the second type of receiver being designated for transmitting in the second modulation method.

104. (New) The device of claim 102, wherein the second type of receiver differs from the first type of receiver at least by the second type of receiver being operable to ignore transmissions intended for the first type of receiver.

105. (New) The device of claim 104, wherein the intended destination ignores transmissions in the second modulation when the intended destination is the first type of receiver.

106. (New) The device of claim 104, wherein the intended destination ignores transmissions in the first modulation when the intended destination is the second type of receiver.

107. (New) The device of claim 104, wherein the intended destination is the first type of receiver and unable to demodulate the second modulation method.

108. (New) The device of claim 102, wherein the transceiver is configured to receive data from the intended destination in the first modulation method when the intended destination is the first type of receiver.

109. (New) The device of claim 102, wherein the transceiver is configured to receive data from the intended destination in the second modulation method when the intended destination is the second type of receiver.

110. (New) The device of claim 1, the transceiver is configured to transmit a third sequence, according to the first modulation method, at a time after the second sequence is transmitted.

111. (New) The device of claim 1, wherein the transceiver transmits data modulated according to either the first modulation method or the second modulation method at any given point in time when the transceiver is transmitting.

112. (New) The device of claim 20, wherein transmission of the second data is according to a particular quantity of data.

113. (New) The device of claim 28, wherein transmission of the second data is according to a specific time interval.

114. (New) The device of claim 28, further comprising a transmitter configured to transmit the first data and the second data.

115. (New) The device of claim 28, wherein the memory has stored therein program code for the first modulation method and the second modulation method.

116. (New) The device of claim 28, wherein the memory comprises random access memory.

117. (New) The device of claim 28, wherein the memory comprises read-only memory.

118. (New) The device of claim 28, wherein the memory has stored therein program code for a multipoint communications protocol.

119. (New) The computer-readable storage medium of claim 87, wherein the first transceiver is configured to transmit the second sequence according to a particular quantity of data.

120. (New) The computer-readable storage medium of claim 95, wherein the first transceiver is configured to transmit the second sequence according to a specific time interval.

121. (New) The computer-readable storage medium of claim 95, further comprising program code for the first modulation method and the second modulation method.

122. (New) The computer-readable storage medium of claim 95, further comprising program code for a multipoint communications protocol.

123. (New) A communication device capable of communicating according to a master/slave relationship in which a slave message from a slave to a master occurs in response to a master message from the master to the slave, the device comprising:

a transceiver, in the role of the master according to the master/slave relationship, capable of transmitting using at least two types of modulation methods, wherein the at least two types of modulation methods comprise a first modulation method and a second modulation method, wherein the second modulation method is of a different type than the first modulation method, and wherein the ~~first~~ transceiver is configured to transmit messages with:

a first sequence, in the first modulation method, that indicates at least which of the first modulation method and the second modulation method is used for modulating a second sequence, wherein, in at least one message, the first sequence indicates an impending change from the first modulation method to the second modulation method, and wherein the at least one message is addressed for an intended destination of the second sequence, and

the second sequence, modulated in accordance with the modulation method indicated by the first sequence and, in the at least one message, modulated using ~~in~~ the second modulation method, wherein the second sequence is transmitted after the first ~~data~~ sequence.

124. (New) The device of claim 123, wherein the transceiver is configured to transmit a third sequence after the second sequence, wherein the third sequence is transmitted in the first modulation method and indicates that communication from the master to the slave has reverted to the first modulation method.

125. (New) The device of claim 123, wherein the transceiver is configured to transmit the second sequence according to a specific time interval.

126. (New) The device of claim 123, wherein the transceiver is configured to transmit the second sequence according to a particular quantity of data.

127. (New) The device of claim 123, further comprising a processor and a memory, wherein the memory has stored therein instructions that when executed by the processor cause the transceiver to transmit the first sequence and the second sequence.

128. (New) The device of claim 127, wherein the memory has stored therein program code for the first modulation method and the second modulation method.

129. (New) The device of claim 127, wherein the memory comprises random access memory.

130. (New) The device of claim 127, wherein the memory comprises read-only memory.

131. (New) The device of claim 127, wherein the memory has stored therein program code for operating the transceiver in a multipoint master/slave relationship.

132. (New) The device of claim 123, wherein the first communication from the master to the slave is a poll in accordance with a multipoint communications relationship, wherein the poll indicates that the master has selected the slave for transmission.

133. (New) The device of claim 123, wherein the transceiver is configured to be the master.

134. (New) The device of claim 123, wherein the first information in the first portion indicates the first modulation method when the intended destination is a first type of receiver and indicates the second modulation when the intended destination is a second type of receiver.

135. (New) The device of claim 134, wherein the second type of receiver differs from the first type of receiver at least by the second type of receiver being designated for transmitting in the second modulation method.

136. (New) The device of claim 134, wherein the second type of receiver differs from the first type of receiver at least by the second type of receiver being operable to ignore transmissions intended for the first type of receiver.

137. (New) The device of claim 136, wherein the intended destination ignores transmissions in the second modulation when the intended destination is the first type of receiver.

138. (New) The device of claim 136, wherein the intended destination ignores transmissions in the first modulation when the intended destination is the second type of receiver.

139. (New) The device of claim 136, wherein the intended destination is the first type of receiver and unable to demodulate the second modulation method.

140. (New) The device of claim 134, wherein the transceiver is configured to receive data from the intended destination in the first modulation method when the intended destination is the first type of receiver.

141. (New) The device of claim 134, wherein the transceiver is configured to receive data from the intended destination in the second modulation method when the intended destination is the second type of receiver.

142. (New) The device of claim 123, the transceiver is configured to transmit a third sequence, according to the first modulation method, at a time after the second sequence is transmitted.

143. (New) The device of claim 123, wherein the transceiver transmits data modulated according to either the first modulation method or the second modulation method at any given point in time when the transceiver is transmitting.

144. (New) The device of claim 127, wherein the memory comprises an erasable programmable read-only memory.

145. (New) The device of claim 11, wherein the memory comprises an erasable programmable read-only memory.

146. The device of claim 20, wherein the memory comprises an erasable programmable read-only memory.

147. (New) The device of claim 28, wherein the memory comprises an erasable programmable read-only memory.

148. (New) The device of claim 47, wherein the memory comprises an erasable programmable read-only memory.

**DOCKET NO.:** REMB-0109  
**Application No.:** 12/543,910  
**Office Action Dated:** September 1, 2010

**PATENT**

**Amendments to the Drawings**

The attached sheets of drawings include replacement FIG. 8. The sheets, which include new FIG. 8, replace the original sheets.

Attachment: Replacement Sheets 1-8

**REMARKS**

Claims 1-2, 9-15, 18, 20, 27-33, 37-38, 45-50, 87, 94-97, and 101-148 are pending in the present application.

Claims 3-8, 16-17, 19, 21-26, 34-36, 39-44, 51-86, 88-93, and 98-100 have been canceled.

Claims 1-2, 9-15, 18, 20, 27-33, 37-38, 45-46, 87, and 94-97 have been amended for clarification.

Claims 101-148 have been added. Support for the claim amendments and new claims can be found throughout the specification, for example paragraphs [0031] – [0035] and [0048]. No new matter has been added.

**Allowable Subject Matter**

Applicant thanks Examiner Ha for the indication that claims 1-18, and 37-57 are allowed (office action, p. 7). Applicant has further amended claims 1-2, 9-15, 18, 37-38, and 45-46 with additional recitations to more precisely claim the subject-matter. For example, the language of independent claim 1 has been clarified to refer to two *types* of modulation methods, *i.e.*, different families of modulation techniques, such as the FSK family of modulation methods and the QAM family of modulation methods. Support for the clarifying amendments can be found throughout the specification, for example [0024], [0025] and [0031] – [0036].

Applicant thanks Examiner Ha for the indication that claims 20, 28, 36, 59, 67, 70-71, 73, 81, 84, 85, 87, 95, and 100 would be allowable if rewritten in independent form including all of the limitation of the base claim and any intervening claims (office action, p. 7). Accordingly, claims 20, 28, 87, and 95 have been rewritten in independent form.

Claims 3-8, 16-17, 19, 21-26, 34-36, 39-44, 51-86, 88-93, and 98-100 have been canceled.

Accordingly, Applicant respectfully submits that pending claims 1-2, 9-15, 18, 20, 27-33, 37-38, 45-50, 87, and 94-97, are allowable.



### **New Claims**

New claims 101-148 have been added. New dependent claims 101-111 depend from allowed claim 1. Therefore, Applicant respectfully submits claims 101-111 define over the asserted prior art for at least the same reasons as allowed claim 1.

Applicant has added new dependent claims 112-122 that correspond to subject matter that was previously presented in dependent claim form. The new claims 112-122 have been added to depend from allowable dependent claims that have been rewritten into independent form (*i.e.* claims 20, 28, 87, and 95). Accordingly, Applicant respectfully submits that claims 112-122 are allowable.

Furthermore, Applicant has added new independent claim 123 and corresponding dependent claims 124-144. Applicant respectfully submits that new claim 123 recites patentable subject matter not disclosed by the asserted references, and is therefore in condition for allowance. In addition, Applicant also respectfully submits that dependent claims 124-144, which depend from new claim 123, are also patentable for at least the same reason.

Applicant has added new dependent claims 145-148 which recite “wherein the memory comprises an erasable programmable read-only memory.” Support for new claims 145-148 can be found throughout the specification, for example paragraph [0048]. Applicant submits that new claims 145-148 are allowable for at least the reason that they depend either directly or indirectly from claims 1, 20, 28, and 37, which are now presented in allowable form.

Therefore, Applicant respectfully submits that new claims 101-148 are in condition for allowance.

### **Replacement Drawings**

Applicant has included replacement sheets 1-8 including replacement FIG. 8. New FIG. 8 corresponds to FIG. 4A & 4B of U.S. Provisional Application 60/067,562 (the “Provisional Application”), which is incorporated into the present application by reference. Original FIG. 8 has been removed. Applicant respectfully requests acceptance of Replacement Sheets 1-8.

### **Amendments to the specification**

Applicant has made certain amendments to the specification. Applicant submits that the amendments contain no new matter.

Applicant has included a replacement summary section and a replacement abstract. The MPEP suggests that the applicant modify the brief summary of the invention and restrict the descriptive subject matter “so as to be in harmony with the claims.” *MPEP 1302.01*, General Review of Disclosure. Accordingly, Applicant has deleted paragraphs [0042] – [0046]. Applicant has amended [0022], [0025] and [0027] to describe a new FIG. 8, which was included in the replacement sheets discussed above. Support for the amended paragraphs can be found throughout the specification and the Provisional Application. For example, support for the amendments may be found in the Summary Description section on page 4 of the Provisional Application and paragraphs [0025] – [0027] of the present application.

### **Claim Objections**

Claims 1-18, 37-57, and 96-100 stand objected to for antecedent basis and dependency. Applicant has amended or canceled the claims to address the objections. Claims 20, 28, 36, 59, 67, 70-71, 73, 81, 84, 85, 87, 95, and 100 stand objected to as being dependent upon a rejected base claim. As discussed above, claims 20, 28, 87, and 95 have been rewritten in independent form. Claims 36, 59, 67, 70-71, 73, 81, 84, 85, and 100 have been cancelled.

Accordingly, Applicant respectfully requests the objections to the claims be withdrawn.

### **Claim Rejections under 35 U.S.C. §§ 102 & 103**

Claims 19, 21, 23-27, 29, 34, 86, 88-94, and 96 stand rejected under 35 U.S.C. § 102(b) as allegedly being anticipated by U.S. Patent No. 5,537,398 to Siwiak. Claims 30-33, 96, and 97 stand rejected under 35 U.S.C. § 103(a) as allegedly being unpatentable over Siwiak. Claims 22, 35, 58, 60-66, 69, 72, 74-80, 82, and 83 stand rejected under 35 U.S.C. § 103(a) as allegedly being unpatentable over Siwiak in view of U.S. Patent No. 6,125,148 to Frodigh *et al.*

**DOCKET NO.:** REMB-0109  
**Application No.:** 12/543,910  
**Office Action Dated:** September 1, 2010

**PATENT**

Claims 19, 21-26, 34, 58, 60-65, 72, 74-79, 83, 86, 88-93, and 98-99 have been cancelled. As discussed above, claims 27, 29, 94, and 96-97 have been amended to depend from a claim indicated as allowable.

Accordingly, Applicants respectfully request the rejections under 35 U.S.C. §§ 102 and 103 be withdrawn.

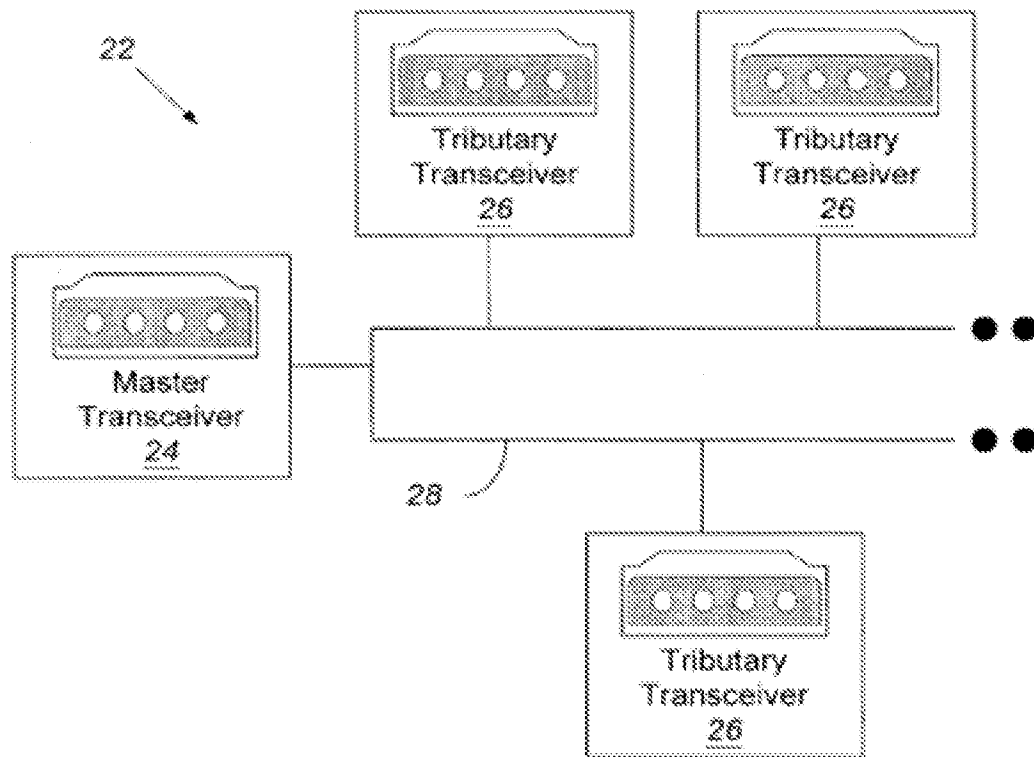
### **Conclusion**

In light of the above amendments and remarks, Applicant respectfully submits that the present application is in condition for allowance, and Applicant respectfully requests a Notice of Allowance for the pending claims 1-2, 9-15, 18, 20, 27-33, 37-38, 45-50, 87, 94-97, and 101-148.

Date: March 1, 2011

/Michael A. Koptiw/  
Michael A. Koptiw  
Registration No. 57,900

Woodcock Washburn LLP  
Cira Centre  
2929 Arch Street, 12th Floor  
Philadelphia, PA 19104-2891  
Telephone: (215) 568-3100  
Facsimile: (215) 568-3439



**FIG. 1**  
**Prior Art**

REPLACEMENT SHEET

2/8

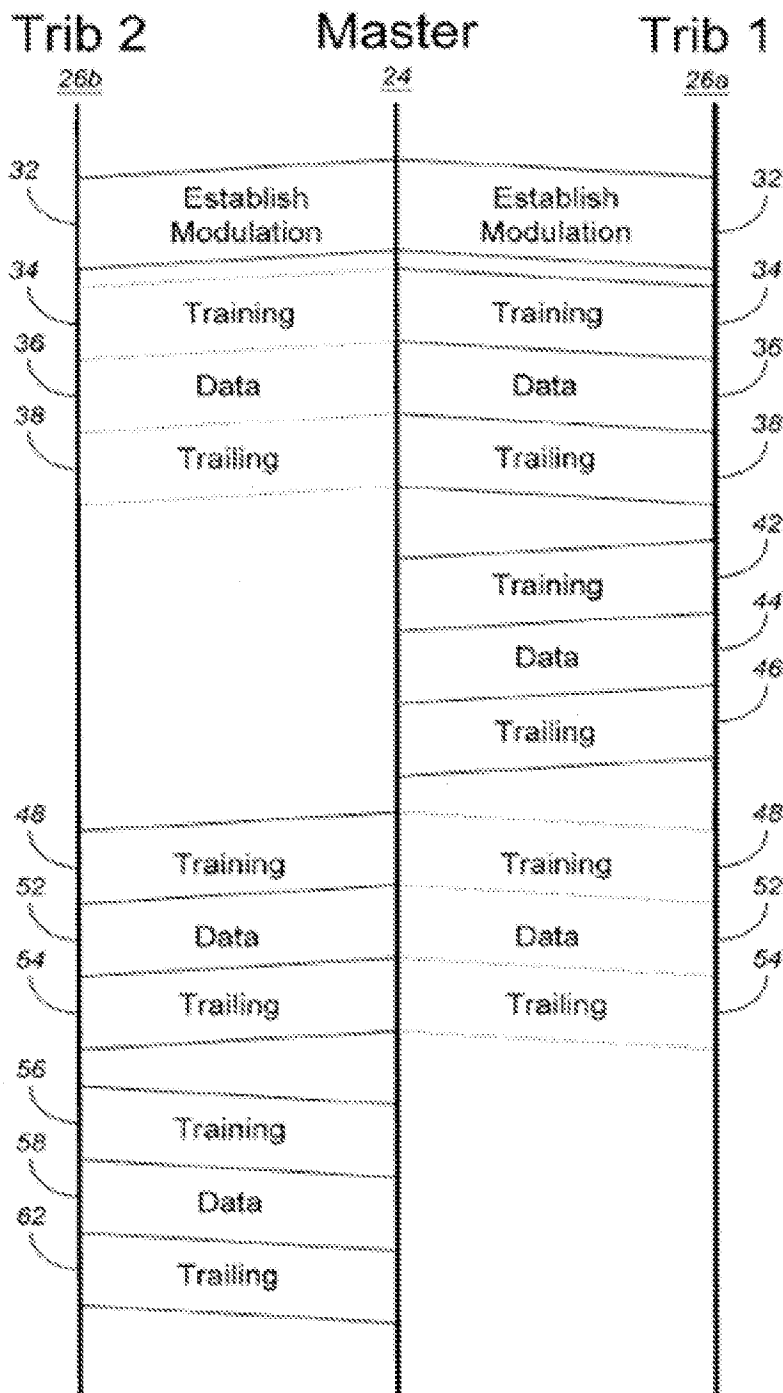
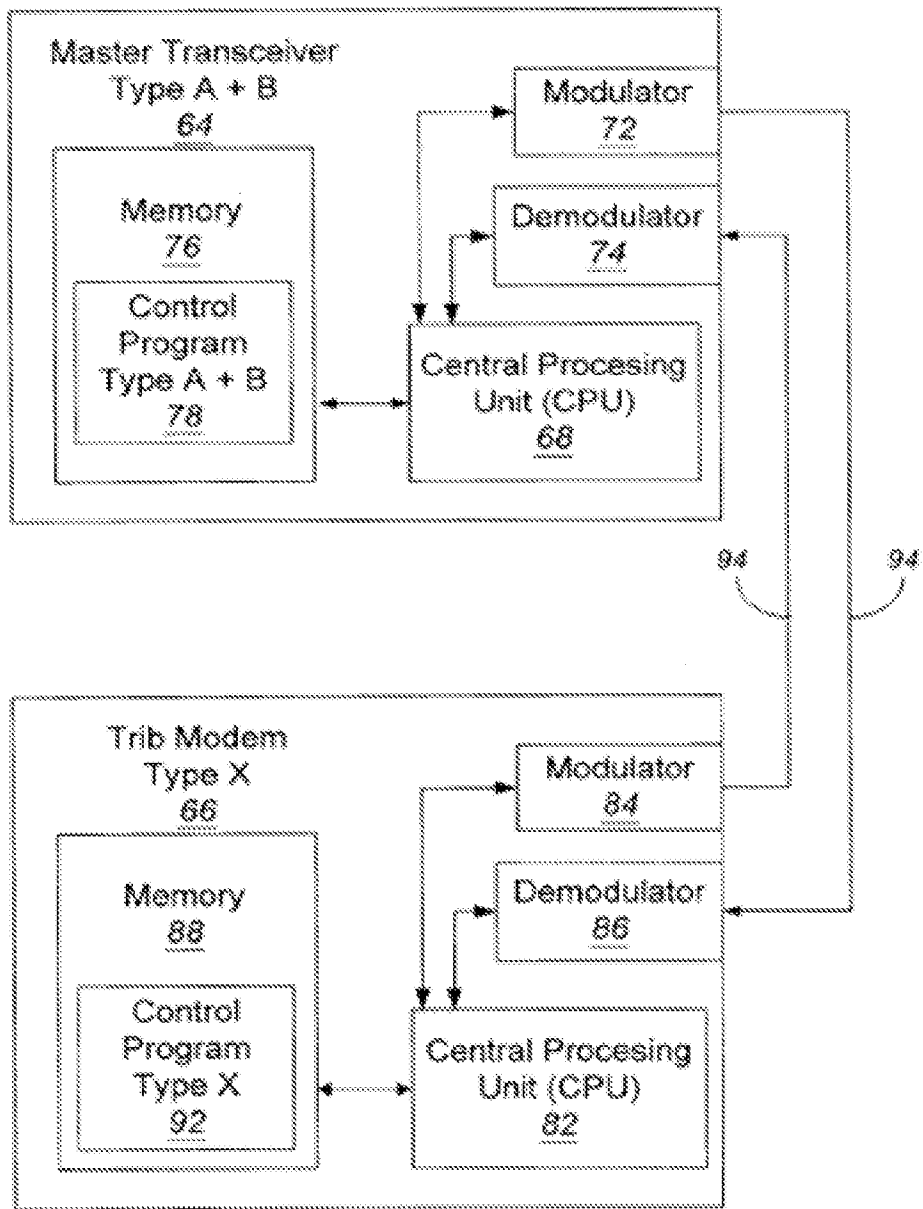
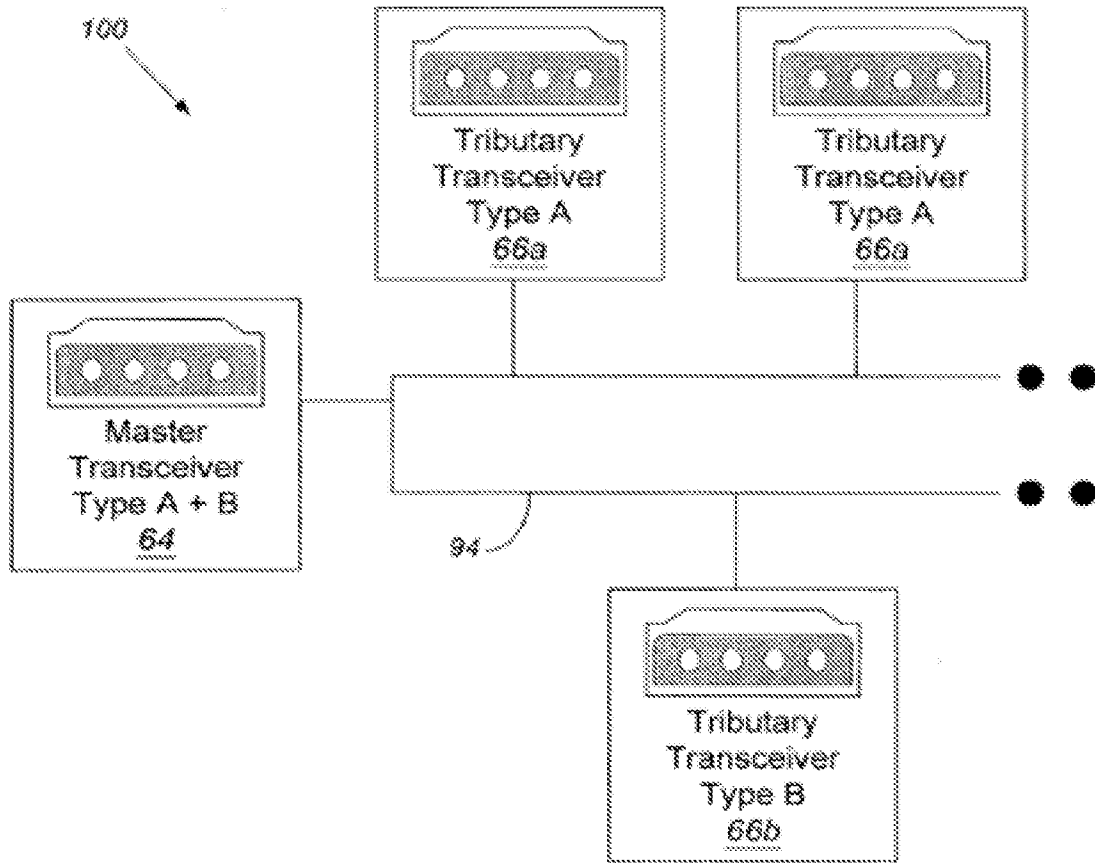


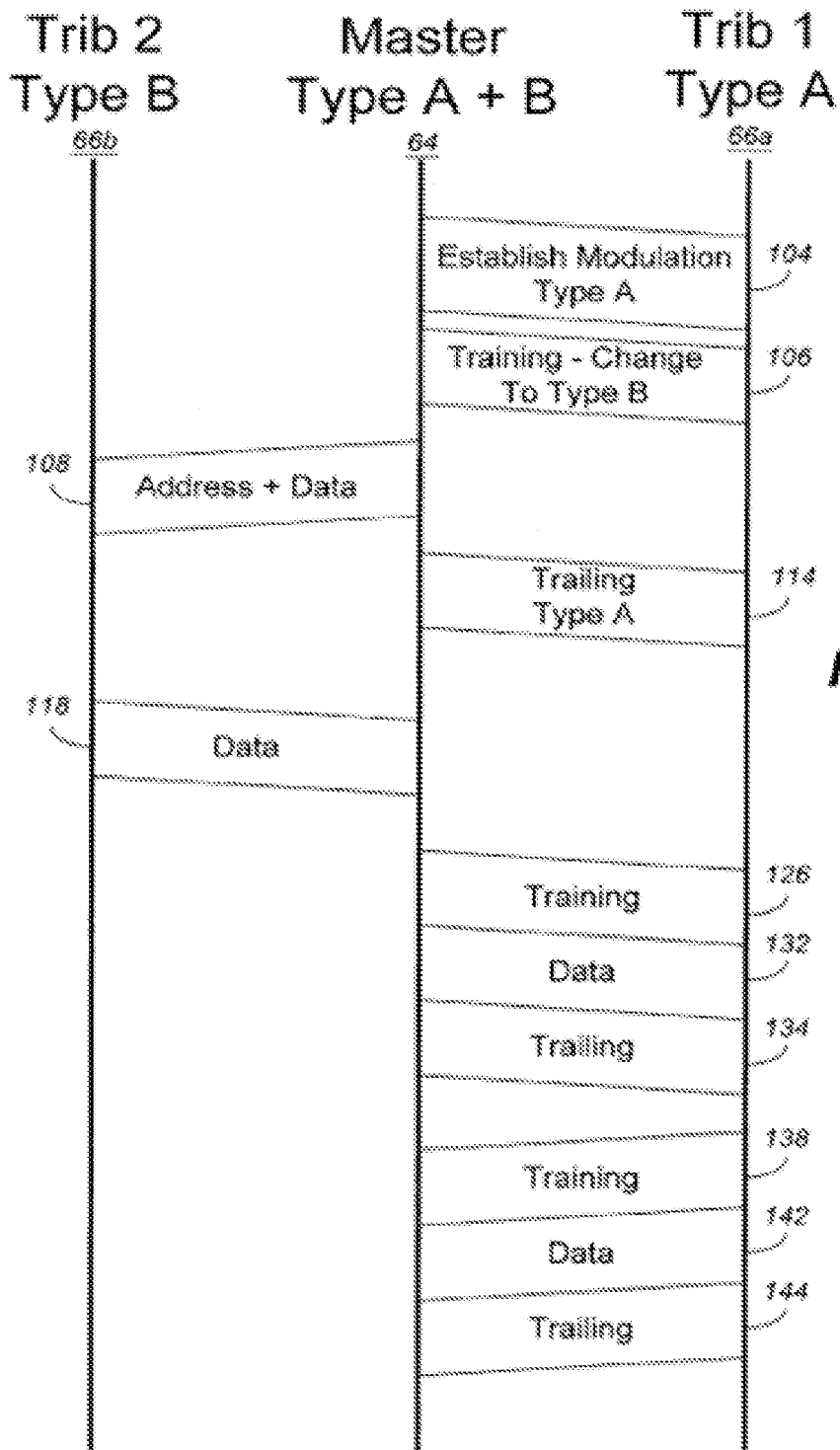
FIG. 2



**FIG. 3**

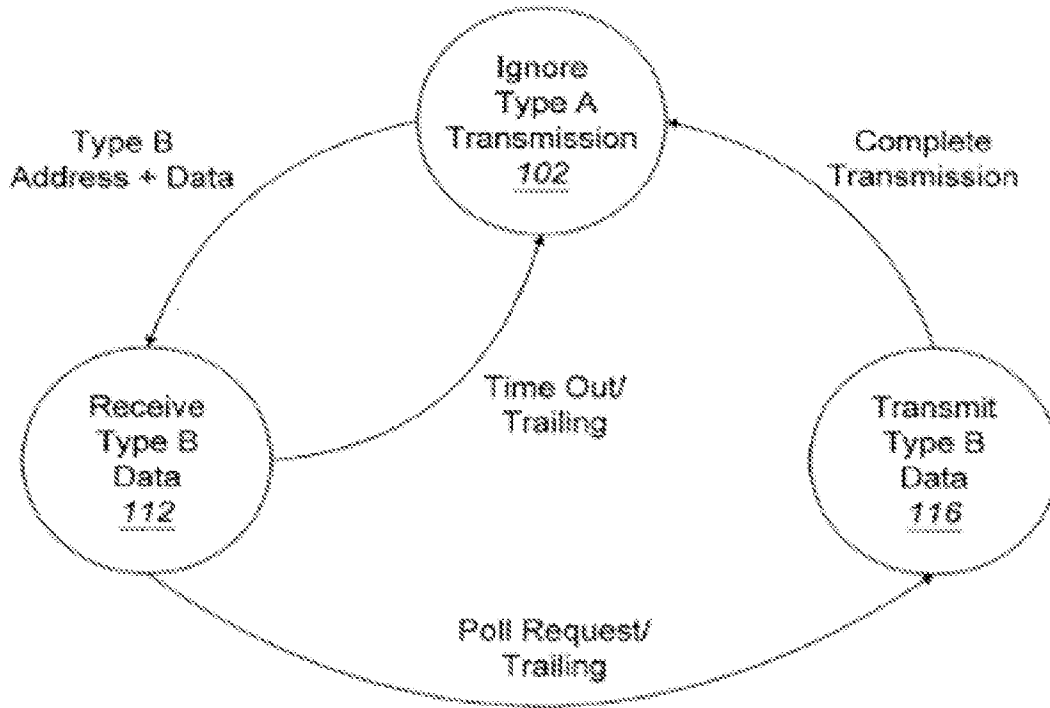


**FIG. 4**

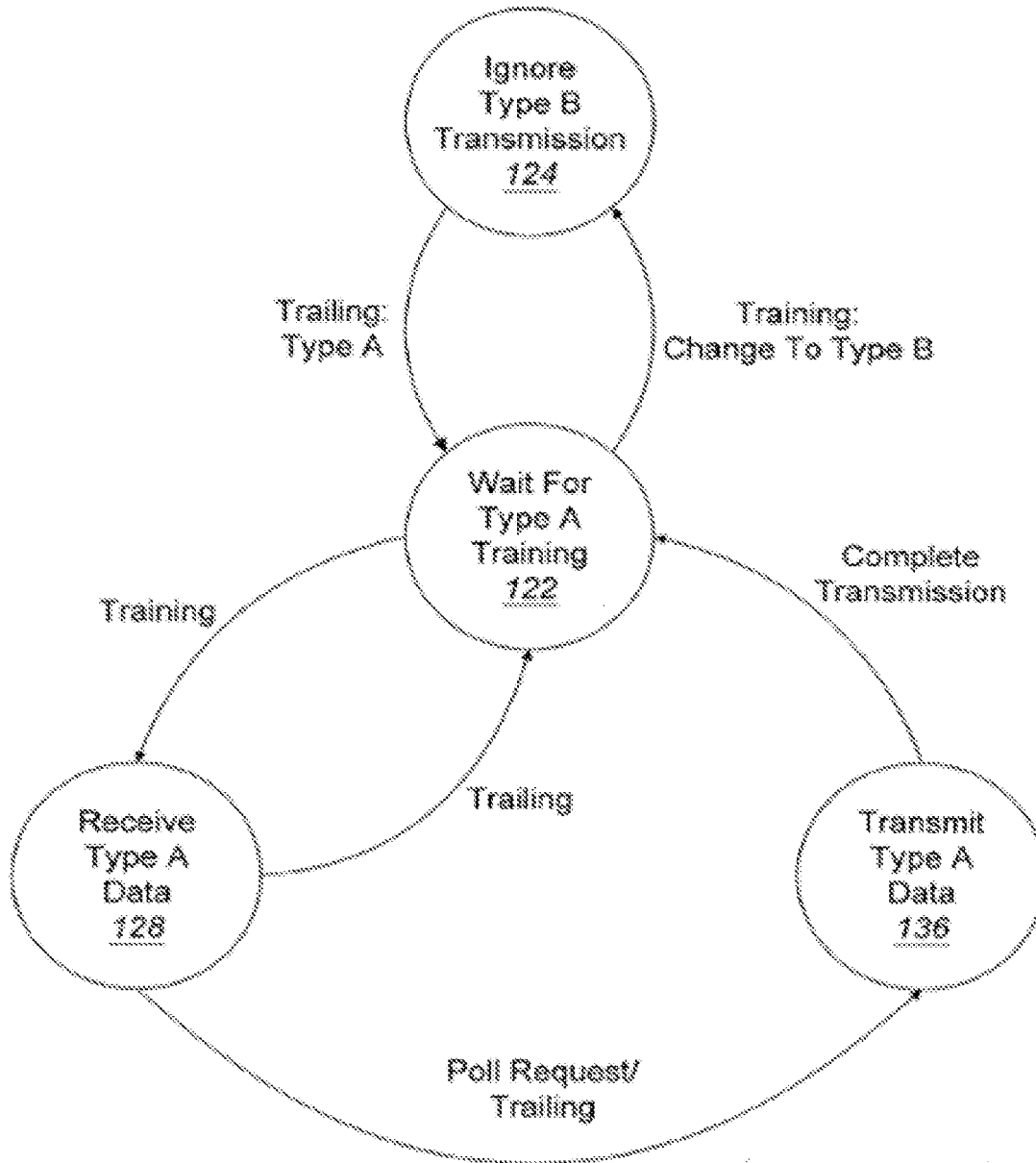


**FIG. 5**

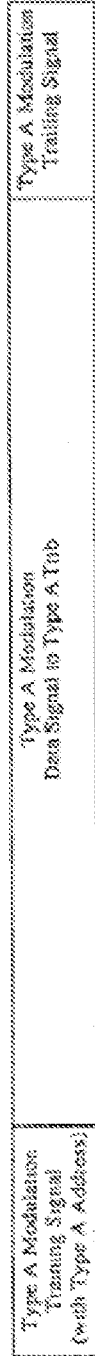




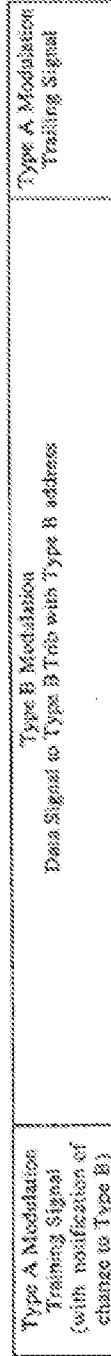
**FIG. 6**



**FIG. 7**



**170**



**172**

**FIG. 8**

**ABSTRACT**

A device may be capable of communicating using at least two type types of modulation methods. The device may include a transceiver capable of acting as a master according to a master/slave relationship in which communication from a slave to a master occurs in response to communication from the master to the slave. The master transceiver may send transmissions discrete transmissions structured with a first portion and a payload portion. Information in the first portion may be modulated according to a first modulation method and indicate an impending change to a second modulation method, which is used for transmitting the payload portion. The discrete transmissions may be addressed for an intended destination of the payload portion.

## Electronic Patent Application Fee Transmittal

<b>Application Number:</b>	12543910
<b>Filing Date:</b>	19-Aug-2009
<b>Title of Invention:</b>	System and Method of Communication Via Embedded Modulation
<b>First Named Inventor/Applicant Name:</b>	Gordon F. Bremer
<b>Filer:</b>	Michael Koptiw Jr./Joanne Gallagher
<b>Attorney Docket Number:</b>	REMB-0109

Filed as Large Entity

### Utility under 35 USC 111(a) Filing Fees

Description	Fee Code	Quantity	Amount	Sub-Total in USD(\$)
<b>Basic Filing:</b>				
<b>Pages:</b>				
<b>Claims:</b>				
<b>Miscellaneous-Filing:</b>				
<b>Petition:</b>				
<b>Patent-Appeals-and-Interference:</b>				
<b>Post-Allowance-and-Post-Issuance:</b>				
<b>Extension-of-Time:</b>				
Extension - 3 months with \$0 paid	1253	1	1110	1110

Description	Fee Code	Quantity	Amount	Sub-Total in USD(\$)
<b>Miscellaneous:</b>				
<b>Total in USD (\$)</b>				<b>1110</b>

## Electronic Acknowledgement Receipt

<b>EFS ID:</b>	9564128
<b>Application Number:</b>	12543910
<b>International Application Number:</b>	
<b>Confirmation Number:</b>	8306
<b>Title of Invention:</b>	System and Method of Communication Via Embedded Modulation
<b>First Named Inventor/Applicant Name:</b>	Gordon F. Bremer
<b>Customer Number:</b>	23377
<b>Filer:</b>	Michael Koptiw Jr./Joanne Gallagher
<b>Filer Authorized By:</b>	Michael Koptiw Jr.
<b>Attorney Docket Number:</b>	REMB-0109
<b>Receipt Date:</b>	01-MAR-2011
<b>Filing Date:</b>	19-AUG-2009
<b>Time Stamp:</b>	18:22:36
<b>Application Type:</b>	Utility under 35 USC 111(a)

### Payment information:

Submitted with Payment	yes
Payment Type	Deposit Account
Payment was successfully received in RAM	\$1110
RAM confirmation Number	6306
Deposit Account	233050
Authorized User	

The Director of the USPTO is hereby authorized to charge indicated fees and credit any overpayment as follows:

Charge any Additional Fees required under 37 C.F.R. Section 1.16 (National application filing, search, and examination fees)

Charge any Additional Fees required under 37 C.F.R. Section 1.17 (Patent application and reexamination processing fees)

Charge any Additional Fees required under 37 C.F.R. Section 1.19 (Document supply fees)

Charge any Additional Fees required under 37 C.F.R. Section 1.20 (Post Issuance fees)

**File Listing:**

Document Number	Document Description	File Name	File Size(Bytes)/ Message Digest	Multi Part /.zip	Pages (if appl.)
1	Miscellaneous Incoming Letter	1900775_1.PDF	284118 <small>4153cb6c7ea9eeebad6d6d3b13b05ad7eb7bb2fb</small>	no	2

**Warnings:**

**Information:**

2	Extension of Time	1900741_1.PDF	315144 <small>e78c827afaf831bbd00de729c316c1fd2bef29c3</small>	no	2
---	-------------------	---------------	---	----	---

**Warnings:**

**Information:**

3		1902010_1.PDF	140470 <small>2dccb210fad5f042b034c4f8cc88db30ba0960d32</small>	yes	23
---	--	---------------	--	-----	----

**Multipart Description/PDF files in .zip description**

Document Description	Start	End
Amendment/Req. Reconsideration-After Non-Final Reject	1	1
Specification	2	6
Amendment Copy Claims/Response to Suggested Claims	7	18
Drawings-only black and white line drawings	19	19
Applicant Arguments/Remarks Made in an Amendment	20	23

**Warnings:**

**Information:**

4	Drawings-only black and white line drawings	1901871_1.PDF	297090 <small>b5152c6e1a14f49bd4d5a2888262ced9c55c74d</small>	no	8
---	---	---------------	--	----	---

**Warnings:**

**Information:**

5	Abstract	1901767_1.PDF	52905 <small>b7ace6cfa602566d4c3507894d3870843a17c3ff</small>	no	1
---	----------	---------------	--	----	---

**Warnings:**

**Information:**



6	Fee Worksheet (PTO-875)	fee-info.pdf	30054 cfce7d8159733f80d794a24e96bbb6768ab0cfd	no	2
---	-------------------------	--------------	--	----	---

**Warnings:**

**Information:**

<b>Total Files Size (in bytes):</b>	1119781
-------------------------------------	---------

**This Acknowledgement Receipt evidences receipt on the noted date by the USPTO of the indicated documents, characterized by the applicant, and including page counts, where applicable. It serves as evidence of receipt similar to a Post Card, as described in MPEP 503.**

**New Applications Under 35 U.S.C. 111**

**If a new application is being filed and the application includes the necessary components for a filing date (see 37 CFR 1.53(b)-(d) and MPEP 506), a Filing Receipt (37 CFR 1.54) will be issued in due course and the date shown on this Acknowledgement Receipt will establish the filing date of the application.**

**National Stage of an International Application under 35 U.S.C. 371**

**If a timely submission to enter the national stage of an international application is compliant with the conditions of 35 U.S.C. 371 and other applicable requirements a Form PCT/DO/EO/903 indicating acceptance of the application as a national stage submission under 35 U.S.C. 371 will be issued in addition to the Filing Receipt, in due course.**

**New International Application Filed with the USPTO as a Receiving Office**

**If a new international application is being filed and the international application includes the necessary components for an international filing date (see PCT Article 11 and MPEP 1810), a Notification of the International Application Number and of the International Filing Date (Form PCT/RO/105) will be issued in due course, subject to prescriptions concerning national security, and the date shown on this Acknowledgement Receipt will establish the international filing date of the application.**

Under the Paperwork Reduction Act of 1995, no persons are required to respond to a collection of information unless it displays a valid OMB control number.

<b>TRANSMITTAL FORM</b>  <small>(to be used for all correspondence after initial filing)</small>	Application Number	12/543,910
	Filing Date	August 19, 2009
	First Named Inventor	Gordon Bremer
	Art Unit	2611
	Examiner Name	Dac V Ha
Total Number of Pages in This Submission	Attorney Docket Number	REMB-0109

<b>ENCLOSURES (Check all that apply)</b>		
<input type="checkbox"/> Fee Transmittal Form <input type="checkbox"/> Fee Attached <input checked="" type="checkbox"/> Amendment/Reply <input type="checkbox"/> After Final <input type="checkbox"/> Affidavits/declaration(s) <input checked="" type="checkbox"/> Extension of Time Request <input type="checkbox"/> Express Abandonment Request <input type="checkbox"/> Information Disclosure Statement  <input type="checkbox"/> Certified Copy of Priority Document(s) <input type="checkbox"/> Reply to Missing Parts/ Incomplete Application <input type="checkbox"/> Reply to Missing Parts under 37 CFR 1.52 or 1.53	<input type="checkbox"/> Drawing(s) <input type="checkbox"/> Licensing-related Papers <input type="checkbox"/> Petition <input type="checkbox"/> Petition to Convert to a Provisional Application <input type="checkbox"/> Power of Attorney, Revocation <input type="checkbox"/> Change of Correspondence Address <input type="checkbox"/> Terminal Disclaimer <input type="checkbox"/> Request for Refund <input type="checkbox"/> CD, Number of CD(s) _____ <input type="checkbox"/> Landscape Table on CD	<input type="checkbox"/> After Allowance Communication to TC <input type="checkbox"/> Appeal Communication to Board of Appeals and Interferences <input type="checkbox"/> Appeal Communication to TC (Appeal Notice, Brief, Reply Brief) <input type="checkbox"/> Proprietary Information <input type="checkbox"/> Status Letter <input checked="" type="checkbox"/> Other Enclosure(s) (please identify below): Replacement Abstract Replacement Figures
Remarks <input style="width: 100%;" type="text"/>		

<b>SIGNATURE OF APPLICANT, ATTORNEY, OR AGENT</b>			
Firm Name	Woodcock Washburn, LLP		
Signature	/Michael A. Koptiw/		
Printed name	Michael A. Koptiw		
Date	March 1, 2011	Reg. No.	57900

<b>CERTIFICATE OF TRANSMISSION/MAILING</b>			
I hereby certify that this correspondence is being facsimile transmitted to the USPTO or deposited with the United States Postal Service with sufficient postage as first class mail in an envelope addressed to: Commissioner for Patents, P.O. Box 1450, Alexandria, VA 22313-1450 on the date shown below:			
Signature			
Typed or printed name		Date	

This collection of information is required by 37 CFR 1.5. The information is required to obtain or retain a benefit by the public which is to file (and by the USPTO to process) an application. Confidentiality is governed by 35 U.S.C. 122 and 37 CFR 1.11 and 1.14. This collection is estimated to 2 hours to complete, including gathering, preparing, and submitting the completed application form to the USPTO. Time will vary depending upon the individual case. Any comments on the amount of time you require to complete this form and/or suggestions for reducing this burden, should be sent to the Chief Information Officer, U.S. Patent and Trademark Office, U.S. Department of Commerce, P.O. Box 1450, Alexandria, VA 22313-1450. DO NOT SEND FEES OR COMPLETED FORMS TO THIS ADDRESS. SEND TO: Commissioner for Patents, P.O. Box 1450, Alexandria, VA 22313-1450.

*If you need assistance in completing the form, call 1-800-PTO-9199 and select option 2.*

## Privacy Act Statement

The **Privacy Act of 1974 (P.L. 93-579)** requires that you be given certain information in connection with your submission of the attached form related to a patent application or patent. Accordingly, pursuant to the requirements of the Act, please be advised that: (1) the general authority for the collection of this information is 35 U.S.C. 2(b)(2); (2) furnishing of the information solicited is voluntary; and (3) the principal purpose for which the information is used by the U.S. Patent and Trademark Office is to process and/or examine your submission related to a patent application or patent. If you do not furnish the requested information, the U.S. Patent and Trademark Office may not be able to process and/or examine your submission, which may result in termination of proceedings or abandonment of the application or expiration of the patent.

The information provided by you in this form will be subject to the following routine uses:

1. The information on this form will be treated confidentially to the extent allowed under the Freedom of Information Act (5 U.S.C. 552) and the Privacy Act (5 U.S.C. 552a). Records from this system of records may be disclosed to the Department of Justice to determine whether disclosure of these records is required by the Freedom of Information Act.
2. A record from this system of records may be disclosed, as a routine use, in the course of presenting evidence to a court, magistrate, or administrative tribunal, including disclosures to opposing counsel in the course of settlement negotiations.
3. A record in this system of records may be disclosed, as a routine use, to a Member of Congress submitting a request involving an individual, to whom the record pertains, when the individual has requested assistance from the Member with respect to the subject matter of the record.
4. A record in this system of records may be disclosed, as a routine use, to a contractor of the Agency having need for the information in order to perform a contract. Recipients of information shall be required to comply with the requirements of the Privacy Act of 1974, as amended, pursuant to 5 U.S.C. 552a(m).
5. A record related to an International Application filed under the Patent Cooperation Treaty in this system of records may be disclosed, as a routine use, to the International Bureau of the World Intellectual Property Organization, pursuant to the Patent Cooperation Treaty.
6. A record in this system of records may be disclosed, as a routine use, to another federal agency for purposes of National Security review (35 U.S.C. 181) and for review pursuant to the Atomic Energy Act (42 U.S.C. 218(c)).
7. A record from this system of records may be disclosed, as a routine use, to the Administrator, General Services, or his/her designee, during an inspection of records conducted by GSA as part of that agency's responsibility to recommend improvements in records management practices and programs, under authority of 44 U.S.C. 2904 and 2906. Such disclosure shall be made in accordance with the GSA regulations governing inspection of records for this purpose, and any other relevant (*i.e.*, GSA or Commerce) directive. Such disclosure shall not be used to make determinations about individuals.
8. A record from this system of records may be disclosed, as a routine use, to the public after either publication of the application pursuant to 35 U.S.C. 122(b) or issuance of a patent pursuant to 35 U.S.C. 151. Further, a record may be disclosed, subject to the limitations of 37 CFR 1.14, as a routine use, to the public if the record was filed in an application which became abandoned or in which the proceedings were terminated and which application is referenced by either a published application, an application open to public inspection or an issued patent.
9. A record from this system of records may be disclosed, as a routine use, to a Federal, State, or local law enforcement agency, if the USPTO becomes aware of a violation or potential violation of law or regulation.

Under the paperwork Reduction Act of 1995, no persons are required to respond to a collection of information unless it displays a valid OMB control number.

<b>PETITION FOR EXTENSION OF TIME UNDER 37 CFR 1.136(a)</b> <b>FY 2009</b> <i>(Fees pursuant to the Consolidated Appropriations Act, 2005 (H.R. 4818).)</i>		Docket Number (Optional) REMB-0109
Application Number 12/543,910		Filed August 19, 2009
For System and Method of Communication Via Embedded Modulation		
Art Unit 2611		Examiner Dac V Ha
This is a request under the provisions of 37 CFR 1.136(a) to extend the period for filing a reply in the above identified application.		
The requested extension and fee are as follows (check time period desired and enter the appropriate fee below):		
	<u>Fee</u>	<u>Small Entity Fee</u>
<input type="checkbox"/> One month (37 CFR 1.17(a)(1))	\$130	\$65 \$ _____
<input type="checkbox"/> Two months (37 CFR 1.17(a)(2))	\$490	\$245 \$ _____
<input checked="" type="checkbox"/> Three months (37 CFR 1.17(a)(3))	\$1110	\$555 \$ <u>1110</u>
<input type="checkbox"/> Four months (37 CFR 1.17(a)(4))	\$1730	\$865 \$ _____
<input type="checkbox"/> Five months (37 CFR 1.17(a)(5))	\$2350	\$1175 \$ _____
<input type="checkbox"/> Applicant claims small entity status. See 37 CFR 1.27.		
<input type="checkbox"/> A check in the amount of the fee is enclosed.		
<input type="checkbox"/> Payment by credit card. Form PTO-2038 is attached.		
<input type="checkbox"/> The Director has already been authorized to charge fees in this application to a Deposit Account.		
<input checked="" type="checkbox"/> The Director is hereby authorized to charge any fees which may be required, or credit any overpayment, to Deposit Account Number <u>233050</u> .		
<b>WARNING: Information on this form may become public. Credit card information should not be included on this form. Provide credit card information and authorization on PTO-2038.</b>		
I am the <input type="checkbox"/> applicant/inventor.		
<input type="checkbox"/> assignee of record of the entire interest. See 37 CFR 3.71. Statement under 37 CFR 3.73(b) is enclosed (Form PTO/SB/96).		
<input checked="" type="checkbox"/> attorney or agent of record. Registration Number <u>57900</u>		
<input type="checkbox"/> attorney or agent under 37 CFR 1.34. Registration number if acting under 37 CFR 1.34 _____		
<u>/Michael A. Koptiw/</u>		<u>March 1, 2011</u>
Signature		Date
<u>Michael A. Koptiw</u>		<u>215-564-8379</u>
Typed or printed name		Telephone Number
NOTE: Signatures of all the inventors or assignees of record of the entire interest or their representative(s) are required. Submit multiple forms if more than one signature is required, see below.		
<input type="checkbox"/> Total of _____ forms are submitted.		

This collection of information is required by 37 CFR 1.136(a). The information is required to obtain or retain a benefit by the public which is to file (and by the USPTO to process) an application. Confidentiality is governed by 35 U.S.C. 122 and 37 CFR 1.11 and 1.14. This collection is estimated to take 6 minutes to complete, including gathering, preparing, and submitting the completed application form to the USPTO. Time will vary depending upon the individual case. Any comments on the amount of time you require to complete this form and/or suggestions for reducing this burden, should be sent to the Chief Information Officer, U.S. Patent and Trademark Office, U.S. Department of Commerce, P.O. Box 1450, Alexandria, VA 22313-1450. DO NOT SEND FEES OR COMPLETED FORMS TO THIS ADDRESS. **SEND TO: Commissioner for Patents, P.O. Box 1450, Alexandria, VA 22313-1450.**

If you need assistance in completing the form, call 1-800-PTO-9199 and select option 2.

## Privacy Act Statement

**The Privacy Act of 1974 (P.L. 93-579)** requires that you be given certain information in connection with your submission of the attached form related to a patent application or patent. Accordingly, pursuant to the requirements of the Act, please be advised that: (1) the general authority for the collection of this information is 35 U.S.C. 2(b)(2); (2) furnishing of the information solicited is voluntary; and (3) the principal purpose for which the information is used by the U.S. Patent and Trademark Office is to process and/or examine your submission related to a patent application or patent. If you do not furnish the requested information, the U.S. Patent and Trademark Office may not be able to process and/or examine your submission, which may result in termination of proceedings or abandonment of the application or expiration of the patent.

The information provided by you in this form will be subject to the following routine uses:

1. The information on this form will be treated confidentially to the extent allowed under the Freedom of Information Act (5 U.S.C. 552) and the Privacy Act (5 U.S.C. 552a). Records from this system of records may be disclosed to the Department of Justice to determine whether disclosure of these records is required by the Freedom of Information Act.
2. A record from this system of records may be disclosed, as a routine use, in the course of presenting evidence to a court, magistrate, or administrative tribunal, including disclosures to opposing counsel in the course of settlement negotiations.
3. A record in this system of records may be disclosed, as a routine use, to a Member of Congress submitting a request involving an individual, to whom the record pertains, when the individual has requested assistance from the Member with respect to the subject matter of the record.
4. A record in this system of records may be disclosed, as a routine use, to a contractor of the Agency having need for the information in order to perform a contract. Recipients of information shall be required to comply with the requirements of the Privacy Act of 1974, as amended, pursuant to 5 U.S.C. 552a(m).
5. A record related to an International Application filed under the Patent Cooperation Treaty in this system of records may be disclosed, as a routine use, to the International Bureau of the World Intellectual Property Organization, pursuant to the Patent Cooperation Treaty.
6. A record in this system of records may be disclosed, as a routine use, to another federal agency for purposes of National Security review (35 U.S.C. 181) and for review pursuant to the Atomic Energy Act (42 U.S.C. 218(c)).
7. A record from this system of records may be disclosed, as a routine use, to the Administrator, General Services, or his/her designee, during an inspection of records conducted by GSA as part of that agency's responsibility to recommend improvements in records management practices and programs, under authority of 44 U.S.C. 2904 and 2906. Such disclosure shall be made in accordance with the GSA regulations governing inspection of records for this purpose, and any other relevant (i.e., GSA or Commerce) directive. Such disclosure shall not be used to make determinations about individuals.
8. A record from this system of records may be disclosed, as a routine use, to the public after either publication of the application pursuant to 35 U.S.C. 122(b) or issuance of a patent pursuant to 35 U.S.C. 151. Further, a record may be disclosed, subject to the limitations of 37 CFR 1.14, as a routine use, to the public if the record was filed in an application which became abandoned or in which the proceedings were terminated and which application is referenced by either a published application, an application open to public inspection or an issued patent.
9. A record from this system of records may be disclosed, as a routine use, to a Federal, State, or local law enforcement agency, if the USPTO becomes aware of a violation or potential violation of law or regulation.

Document code: WFEE

United States Patent and Trademark Office  
Sales Receipt for Accounting Date: 03/09/2011

MBYARS	SALE #00000001	Mailroom Dt: 03/01/2011	233050	12543910
	01 FC : 1201		220.00 DA	

## SCORE Placeholder Sheet for IFW Content

Application Number: 12543910

Document Date: 3/1/2011

The presence of this form in the IFW record indicates that the following document type was received in electronic format on the date identified above. This content is stored in the SCORE database.

- Drawings – Other than Black and White Line Drawings

Since this was an electronic submission, there is no physical artifact folder, no artifact folder is recorded in PALM, and no paper documents or physical media exist. The TIFF images in the IFW record were created from the original documents that are stored in SCORE.

To access the documents in the SCORE database, refer to instructions developed by SIRA.

At the time of document entry (noted above):

- Examiners may access SCORE content via the eDAN interface.
- Other USPTO employees can bookmark the current SCORE URL (<http://es/ScoreAccessWeb/>).
- External customers may access SCORE content via the Public and Private PAIR interfaces.

Under the Paperwork Reduction Act of 1995, no persons are required to respond to a collection of information unless it displays a valid OMB control number.

<b>PATENT APPLICATION FEE DETERMINATION RECORD</b> Substitute for Form PTO-875	Application or Docket Number <b>12/543,910</b>	Filing Date <b>08/19/2009</b>	<input type="checkbox"/> To be Mailed
---	---	----------------------------------	---------------------------------------

APPLICATION AS FILED – PART I			OTHER THAN SMALL ENTITY				
	(Column 1)	(Column 2)	SMALL ENTITY <input type="checkbox"/>	OR			
FOR	NUMBER FILED	NUMBER EXTRA	RATE (\$)	FEE (\$)	OR	RATE (\$)	FEE (\$)
<input type="checkbox"/> BASIC FEE <small>(37 CFR 1.16(a), (b), or (c))</small>	N/A	N/A	N/A			N/A	
<input type="checkbox"/> SEARCH FEE <small>(37 CFR 1.16(k), (j), or (m))</small>	N/A	N/A	N/A			N/A	
<input type="checkbox"/> EXAMINATION FEE <small>(37 CFR 1.16(o), (p), or (q))</small>	N/A	N/A	N/A			N/A	
TOTAL CLAIMS <small>(37 CFR 1.16(j))</small>	minus 20 =	*	X \$ =		OR	X \$ =	
INDEPENDENT CLAIMS <small>(37 CFR 1.16(h))</small>	minus 3 =	*	X \$ =			X \$ =	
<input type="checkbox"/> APPLICATION SIZE FEE <small>(37 CFR 1.16(s))</small>	If the specification and drawings exceed 100 sheets of paper, the application size fee due is \$250 (\$125 for small entity) for each additional 50 sheets or fraction thereof. See 35 U.S.C. 41(a)(1)(G) and 37 CFR 1.16(s).						
<input type="checkbox"/> MULTIPLE DEPENDENT CLAIM PRESENT <small>(37 CFR 1.16(j))</small>							
* If the difference in column 1 is less than zero, enter "0" in column 2.			TOTAL			TOTAL	

APPLICATION AS AMENDED – PART II					OTHER THAN SMALL ENTITY				
	(Column 1)	(Column 2)	(Column 3)						
AMENDMENT	03/01/2011	CLAIMS REMAINING AFTER AMENDMENT	HIGHEST NUMBER PREVIOUSLY PAID FOR	PRESENT EXTRA	RATE (\$)	ADDITIONAL FEE (\$)	OR	RATE (\$)	ADDITIONAL FEE (\$)
	Total <small>(37 CFR 1.16(i))</small>	* 79	Minus ** 100	= 0	X \$ =		OR	X \$52=	0
	Independent <small>(37 CFR 1.16(h))</small>	* 7	Minus ***6	= 1	X \$ =		OR	X \$220=	220
	<input type="checkbox"/> Application Size Fee <small>(37 CFR 1.16(s))</small>								
	<input type="checkbox"/> FIRST PRESENTATION OF MULTIPLE DEPENDENT CLAIM <small>(37 CFR 1.16(j))</small>						OR		
					TOTAL ADD'L FEE		OR	TOTAL ADD'L FEE	<b>220</b>

	(Column 1)	(Column 2)	(Column 3)						
AMENDMENT		CLAIMS REMAINING AFTER AMENDMENT	HIGHEST NUMBER PREVIOUSLY PAID FOR	PRESENT EXTRA	RATE (\$)	ADDITIONAL FEE (\$)	OR	RATE (\$)	ADDITIONAL FEE (\$)
	Total <small>(37 CFR 1.16(i))</small>	*	Minus **	=	X \$ =		OR	X \$ =	
	Independent <small>(37 CFR 1.16(h))</small>	*	Minus ***	=	X \$ =		OR	X \$ =	
	<input type="checkbox"/> Application Size Fee <small>(37 CFR 1.16(s))</small>								
	<input type="checkbox"/> FIRST PRESENTATION OF MULTIPLE DEPENDENT CLAIM <small>(37 CFR 1.16(j))</small>						OR		
					TOTAL ADD'L FEE		OR	TOTAL ADD'L FEE	

\* If the entry in column 1 is less than the entry in column 2, write "0" in column 3.  
 \*\* If the "Highest Number Previously Paid For" IN THIS SPACE is less than 20, enter "20".  
 \*\*\* If the "Highest Number Previously Paid For" IN THIS SPACE is less than 3, enter "3".  
 The "Highest Number Previously Paid For" (Total or Independent) is the highest number found in the appropriate box in column 1.

Legal Instrument Examiner:  
/MARGARET BYARS/

This collection of information is required by 37 CFR 1.16. The information is required to obtain or retain a benefit by the public which is to file (and by the USPTO to process) an application. Confidentiality is governed by 35 U.S.C. 122 and 37 CFR 1.14. This collection is estimated to take 12 minutes to complete, including gathering, preparing, and submitting the completed application form to the USPTO. Time will vary depending upon the individual case. Any comments on the amount of time you require to complete this form and/or suggestions for reducing this burden, should be sent to the Chief Information Officer, U.S. Patent and Trademark Office, U.S. Department of Commerce, P.O. Box 1450, Alexandria, VA 22313-1450. DO NOT SEND FEES OR COMPLETED FORMS TO THIS ADDRESS. **SEND TO: Commissioner for Patents, P.O. Box 1450, Alexandria, VA 22313-1450.**

If you need assistance in completing the form, call 1-800-PTO-9199 and select option 2.





UNITED STATES PATENT AND TRADEMARK OFFICE

UNITED STATES DEPARTMENT OF COMMERCE  
U.S. Patent and Trademark Office

Address: COMMISSIONER FOR PATENTS  
P.O. Box 1450  
Alexandria, Virginia 22313-1450  
www.uspto.gov

23377 e 03/10/2011

WOODCOCK WASHBURN LLP  
CIRA CENTRE, 12TH FLOOR  
2929 ARCH STREET  
PHILADELPHIA, PA 19104-2891

**Paper No.**

Application No.:	12/543,910	Date Mailed:	03/10/2011
	<b>*12543910*</b>		
First Named Inventor:	Bremer, Gordon, F.	Examiner:	HA, DAC V
Attorney Docket No.:	REMB-0109	Art Unit:	2611
Confirmation No.:	8306	Filing Date:	08/19/2009

**Please find attached an Office communication concerning this application or proceeding.**

**Commissioner for Patents**

<b>Notice of Non-Compliant Amendment (37 CFR 1.121)</b>	<b>Application No.</b> 12/543,910	<b>Applicant(s)</b> BREMER, GORDON F.	
		<b>Art Unit</b> 3998	

*-- The MAILING DATE of this communication appears on the cover sheet with the correspondence address --*

The amendment document filed on 01 March, 2011 is considered non-compliant because it has failed to meet the requirements of 37 CFR 1.121 or 1.4. In order for the amendment document to be compliant, correction of the following item(s) is required.

THE FOLLOWING MARKED (X) ITEM(S) CAUSE THE AMENDMENT DOCUMENT TO BE NON-COMPLIANT:

- 1. Amendments to the specification:
  - A. Amended paragraph(s) do not include markings.
  - B. New paragraph(s) should not be underlined.
  - C. Other \_\_\_\_\_.
- 2. Abstract:
  - A. Not presented on a separate sheet. 37 CFR 1.72.
  - B. Other \_\_\_\_\_.
- 3. Amendments to the drawings:
  - A. The drawings are not properly identified in the top margin as "Replacement Sheet," "New Sheet," or "Annotated Sheet" as required by 37 CFR 1.121(d).
  - B. The practice of submitting proposed drawing correction has been eliminated. Replacement drawings showing amended figures, without markings, in compliance with 37 CFR 1.84 are required.
  - C. Other \_\_\_\_\_.
- 4. Amendments to the claims:
  - A. A complete listing of all of the claims is not present.
  - B. The listing of claims does not include the text of all pending claims (including withdrawn claims)
  - C. Each claim has not been provided with the proper status identifier, and as such, the individual status of each claim cannot be identified. Note: the status of every claim must be indicated after its claim number by using one of the following status identifiers: (Original), (Currently amended), (Canceled), (Previously presented), (New), (Not entered), (Withdrawn) and (Withdrawn-currently amended).
  - D. The claims of this amendment paper have not been presented in ascending numerical order.
  - E. Other: *New claim 123 should not have markings.*
- 5. Other (e.g., the amendment is unsigned or not signed in accordance with 37 CFR 1.4): For further explanation of the amendment format required by 37 CFR 1.121, see MPEP § 714.

TIME PERIODS FOR FILING A REPLY TO THIS NOTICE:

1. Applicant is given **no new time period** if the non-compliant amendment is an after-final amendment or an amendment filed after allowance, or a drawing submission (only) If applicant wishes to resubmit the non-compliant after-final amendment with corrections, the **entire corrected amendment** must be resubmitted.
2. Applicant is given **one month**, or thirty (30) days, whichever is longer, from the mail date of this notice to supply the correction, if the non-compliant amendment is one of the following: a preliminary amendment, a non-final amendment (including a submission for a request for continued examination (RCE) under 37 CFR 1.114), a supplemental amendment filed within a suspension period under 37 CFR 1.103(a) or (c), and an amendment filed in response to a Quayle action. If any of above boxes 1 to 4 are checked, the correction required is only the corrected section of the non-compliant amendment in compliance with 37 CFR 1.121.

**Extensions of time** are available under 37 CFR 1.136(a) only if the non-compliant amendment is a non-final amendment or an amendment filed in response to a *Quayle* action.

**Failure to timely respond** to this notice will result in:

- Abandonment** of the application if the non-compliant amendment is a non-final amendment or an amendment filed in response to a *Quayle* action; or
- Non-entry** of the amendment if the non-compliant amendment is a preliminary amendment or supplemental amendment.

Legal Instruments Examiner (LIE), if applicable /MARGARET BYARS/

Telephone No: (571)272-6581

**DOCKET NO.:** REMB-0109  
**Application No.:** 12/543,910  
**Notice of Non-Compliant Amendment Dated:** March 10, 2011  
**Office Action Dated:** September 1, 2010

**PATENT**

**IN THE UNITED STATES PATENT AND TRADEMARK OFFICE**

<b>In re Application of:</b> <b>Gordon Bremer</b>	<b>Confirmation No.:</b> 8306
<b>Application No.:</b> 12/543,910	<b>Group Art Unit:</b> 2611
<b>Filing Date:</b> August 19, 2009	<b>Examiner:</b> Dac V Ha
<b>For:</b> System and Method of Communication Via Embedded Modulation	

Mail Stop Amendment  
Commissioner for Patents  
P.O. Box 1450  
Alexandria, VA 22313-1450

Sir:

**REPLY PURSUANT TO 37 CFR § 1.121**

In response to the Notice of Non-Compliant Amendment dated **March 10, 2011**, reconsideration is respectfully requested in view of the amendments and/or remarks as indicated below:

- Amendments to the Specification** begin on page of this paper.
- Corrected Amendments to the Claims** are reflected in the listing of the claims which begins on page 2 of this paper.
- Amendments to the Drawings** begin on page of this paper and include an attached replacement sheet.
- Remarks** begin on page 14 of this paper.
- Request For Refund** submitted herewith.

This listing of claims will replace all prior versions, and listings, of claims in the application.

**Listing of Claims:**

1. (Currently Amended) A communication ~~system~~ device capable of communicating according to a master/slave relationship in which a slave communication from a slave to a master occurs in response to a master communication from the master to the slave, the device comprising:

a transceiver, in the role of the master according to the master/slave relationship, for sending at least transmitter capable of transmitting transmissions modulated using at least two types of modulation methods, wherein the at least two types of modulation methods comprise a first modulation method and a second modulation method, wherein the second modulation method is of a different type than the first modulation method, and wherein the first transceiver is configured to transmit transmissions comprise groups of transmission sequences, each group of said groups of transmission sequences structured with a first portion and a payload portion wherein first information in the first portion indicates at least which of the first modulation method and the second modulation method is used for modulating second information in the payload portion, wherein at least one group of transmission sequences is addressed for an intended destination of the payload portion, and wherein for the at least one group of transmission sequences:

the first information for said at least one group of transmission sequences comprises a first sequence, in the first portion and modulated according to the first modulation method, wherein the first sequence ~~that~~ indicates an impending change from the first modulation method to the second modulation method, and

the second information for said at least one group of transmission sequences comprises a second sequence, ~~in~~ modulated according to the second modulation method, wherein the second sequence is transmitted after the first ~~data~~ sequence.

2. (Currently Amended) The ~~system~~ device of claim 1, wherein the transceiver is configured to transmit a third sequence after the second sequence, wherein the third sequence

is transmitted in the first modulation method and indicates that communication from the master to the slave has reverted to the first modulation method.

3. – 8. (Canceled)

9. (Currently Amended) The ~~system~~ device of claim 1, wherein the ~~first~~ transceiver is configured to transmit the second sequence according to a specific time interval.

10. (Currently Amended) The ~~system~~ device of claim 1, wherein the ~~first~~ transceiver is configured to transmit the second sequence according to a particular quantity of data.

11. (Currently Amended) The ~~system~~ device of claim 1, further comprising a processor and a memory, wherein the memory has stored therein instructions that when executed by the processor cause the ~~transceiver transmitter~~ to transmit the first sequence and the second sequence.

12. (Currently Amended) The ~~system~~ device of claim 11, wherein the memory has stored therein program code for the first modulation method and the second modulation method.

13. (Currently Amended) The ~~system~~ device of claim 11, wherein the memory comprises random access memory.

14. (Currently Amended) The ~~system~~ device of claim 11, wherein the memory comprises read-only memory.

15. (Currently Amended) The device of claim 11, wherein the memory has stored therein program code for operating the transceiver in a multipoint master/slave relationship communications protocol.

16. – 17. (Canceled)

18. (Currently Amended) The ~~system device~~ of claim ~~1~~ 17, wherein the first communication from the master to the slave burst transmission is a poll in accordance with a multipoint communications ~~protocol~~ relationship, wherein the poll indicates that the master has selected the slave for transmission.

19. (Canceled)

20. (Currently Amended) ~~The device of claim 19~~ A communications device, comprising:  
a processor; and  
a memory having stored therein executable instructions for execution by the processor, wherein the executable instructions direct transmission of a first data with a first modulation method followed by a second data with a second modulation method, wherein the first modulation method is different than the second modulation method, wherein the first data comprises an indication of an impending change from the first modulation method to the second modulation method, wherein the executable instructions direct transmission of a third data with the first modulation method after the second data, and wherein the third data indicates that communication has reverted to the first modulation method.

21. – 26. (Canceled)

27. (Currently Amended) The device of claim ~~20~~ 19, wherein transmission of the second data is according to a specific time interval.

28. (Currently Amended) ~~The device of claim 19,~~ A communications device, comprising:  
a processor; and  
a memory having stored therein executable instructions for execution by the processor, wherein the executable instructions direct transmission of a first data with a first modulation method followed by a second data with a second modulation method, wherein the first modulation method is different than the second modulation method, wherein the first data comprises an indication of an impending change from the first modulation method to the second modulation method wherein the executable instructions direct transmission of a third

data with the first modulation method after the second data, and wherein transmission of the second data is according to a particular quantity of data.

29. (Currently Amended) The device of claim 20 ~~19~~, further comprising a transmitter configured to transmit the first data and the second data.

30. (Currently Amended) The device of claim 20 ~~19~~, wherein the memory has stored therein program code for the first modulation method and the second modulation method.

31. (Currently Amended) The device of claim 20 ~~19~~, wherein the memory comprises random access memory.

32. (Currently Amended) The device of claim 20 ~~19~~, wherein the memory comprises read-only memory.

33. (Currently Amended) The device of claim 20 ~~19~~, wherein the memory has stored therein program code for a multipoint communications protocol.

34. – 36. (Canceled)

37. (Currently Amended) A device ~~comprising:~~ that transmits in accordance with a first modulation logic; method and a second modulation ~~logic-method~~ that is different than the first modulation logic; and method, said device comprising:

at least one modulator;

a transceiver that includes the at least one modulator ~~adapted to use the first modulation logic and the second modulation logic~~, wherein the transceiver is configured to transmit:

a first sequence, modulated in accordance with the first modulation method ~~logic~~, that indicates a an impending change from the first modulation method ~~logic~~ to the second modulation method ~~logic~~, and

a second sequence, in accordance with the second modulation method logic, that is transmitted at a time after ~~follows~~ the first data sequence.

38. (Currently Amended) The device of claim 37, wherein the transceiver is configured to transmit a third sequence after the second sequence, wherein the third sequence is transmitted in accordance with the first modulation method logic and indicates that a subsequent communication has reverted to the first modulation method logic.

39. – 44. (Canceled)

45. (Currently Amended) The device of claim 37, wherein the ~~first~~ transceiver is configured to transmit the second sequence according to a specific time interval.

46. (Currently Amended) The device of claim 37, wherein the ~~first~~ transceiver is configured to transmit the second sequence according to a particular quantity of data.

47. (Original) The device of claim 37, further comprising a processor and a memory, wherein the memory has stored therein instructions that when executed by the processor cause the transmitter to transmit the first sequence and the second sequence.

48. (Original) The device of claim 47, wherein the memory comprises random access memory.

49. (Original) The device of claim 47, wherein the memory comprises read-only memory.

50. (Original) The device of claim 47, wherein the memory has stored therein program code for a multipoint communications protocol.

51. – 86. (Canceled)



87. (Currently Amended) ~~The computer-readable storage medium of claim 86, further comprising~~ A computer-readable storage medium having a computer executable instructions stored therein that when executed by a processor control a master transceiver, said computer executable instructions, comprising:

first logic configured to transmit first information in a first modulation method for communication;

second logic configured to transmit a first sequence to notify of a change from said first modulation method to a second modulation method;

third logic configured to transmit second information in said second modulation method; and

fourth logic configured to transmit a second sequence after the second information is transmitted, wherein the second sequence is transmitted in the first modulation method and indicates that communication has reverted to the first modulation method.

88. – 93. (Canceled)

94. (Currently Amended) The computer-readable storage medium of claim ~~87~~ ~~86~~, wherein the first transceiver is configured to transmit the second sequence according to a specific time interval.

95. (Currently Amended) ~~The computer-readable storage medium of claim 86, A~~ computer-readable storage medium having a computer executable instructions stored therein that when executed by a processor control a master transceiver, said computer executable instructions, comprising:

first logic configured to transmit first information in a first modulation method for communication;

second logic configured to transmit a first sequence to notify of a change from said first modulation method to a second modulation method;

third logic configured to transmit second information in said second modulation method; and

fourth logic configured to transmit a second sequence after the second information is transmitted, wherein the first transceiver is configured to transmit the second sequence according to a particular quantity of data.

96. (Currently Amended) The computer-readable storage medium of claim 87 ~~44~~, further comprising program code for the first modulation method and the second modulation method.

97. (Currently Amended) The computer-readable storage medium of claim 87 ~~44~~, further comprising program code for a multipoint communications protocol.

98. – 100. (Canceled)

101. (New) The device of claim 1, wherein the transceiver is configured to be the master.

102. (New) The device of claim 1, wherein the first information in the first portion indicates the first modulation method when the intended destination is a first type of receiver and indicates the second modulation when the intended destination is a second type of receiver.

103. (New) The device of claim 102, wherein the second type of receiver differs from the first type of receiver at least by the second type of receiver being designated for transmitting in the second modulation method.

104. (New) The device of claim 102, wherein the second type of receiver differs from the first type of receiver at least by the second type of receiver being operable to ignore transmissions intended for the first type of receiver.

105. (New) The device of claim 104, wherein the intended destination ignores transmissions in the second modulation when the intended destination is the first type of receiver.

106. (New) The device of claim 104, wherein the intended destination ignores transmissions in the first modulation when the intended destination is the second type of receiver.
107. (New) The device of claim 104, wherein the intended destination is the first type of receiver and unable to demodulate the second modulation method.
108. (New) The device of claim 102, wherein the transceiver is configured to receive data from the intended destination in the first modulation method when the intended destination is the first type of receiver.
109. (New) The device of claim 102, wherein the transceiver is configured to receive data from the intended destination in the second modulation method when the intended destination is the second type of receiver.
110. (New) The device of claim 1, the transceiver is configured to transmit a third sequence, according to the first modulation method, at a time after the second sequence is transmitted.
111. (New) The device of claim 1, wherein the transceiver transmits data modulated according to either the first modulation method or the second modulation method at any given point in time when the transceiver is transmitting.
112. (New) The device of claim 20, wherein transmission of the second data is according to a particular quantity of data.
113. (New) The device of claim 28, wherein transmission of the second data is according to a specific time interval.
114. (New) The device of claim 28, further comprising a transmitter configured to transmit the first data and the second data.

115. (New) The device of claim 28, wherein the memory has stored therein program code for the first modulation method and the second modulation method.
116. (New) The device of claim 28, wherein the memory comprises random access memory.
117. (New) The device of claim 28, wherein the memory comprises read-only memory.
118. (New) The device of claim 28, wherein the memory has stored therein program code for a multipoint communications protocol.
119. (New) The computer-readable storage medium of claim 87, wherein the first transceiver is configured to transmit the second sequence according to a particular quantity of data.
120. (New) The computer-readable storage medium of claim 95, wherein the first transceiver is configured to transmit the second sequence according to a specific time interval.
121. (New) The computer-readable storage medium of claim 95, further comprising program code for the first modulation method and the second modulation method.
122. (New) The computer-readable storage medium of claim 95, further comprising program code for a multipoint communications protocol.
123. (New) A communication device capable of communicating according to a master/slave relationship in which a slave message from a slave to a master occurs in response to a master message from the master to the slave, the device comprising:  
a transceiver, in the role of the master according to the master/slave relationship, capable of transmitting using at least two types of modulation methods, wherein the at least two types of modulation methods comprise a first modulation method and a second

modulation method, wherein the second modulation method is of a different type than the first modulation method, and wherein the transceiver is configured to transmit messages with:

a first sequence, in the first modulation method, that indicates at least which of the first modulation method and the second modulation method is used for modulating a second sequence, wherein, in at least one message, the first sequence indicates an impending change from the first modulation method to the second modulation method, and wherein the at least one message is addressed for an intended destination of the second sequence, and

the second sequence, modulated in accordance with the modulation method indicated by the first sequence and, in the at least one message, modulated using the second modulation method, wherein the second sequence is transmitted after the first sequence.

124. (New) The device of claim 123, wherein the transceiver is configured to transmit a third sequence after the second sequence, wherein the third sequence is transmitted in the first modulation method and indicates that communication from the master to the slave has reverted to the first modulation method.

125. (New) The device of claim 123, wherein the transceiver is configured to transmit the second sequence according to a specific time interval.

126. (New) The device of claim 123, wherein the transceiver is configured to transmit the second sequence according to a particular quantity of data.

127. (New) The device of claim 123, further comprising a processor and a memory, wherein the memory has stored therein instructions that when executed by the processor cause the transceiver to transmit the first sequence and the second sequence.

128. (New) The device of claim 127, wherein the memory has stored therein program code for the first modulation method and the second modulation method.

129. (New) The device of claim 127, wherein the memory comprises random access memory.

130. (New) The device of claim 127, wherein the memory comprises read-only memory.

131. (New) The device of claim 127, wherein the memory has stored therein program code for operating the transceiver in a multipoint master/slave relationship.

132. (New) The device of claim 123, wherein the first communication from the master to the slave is a poll in accordance with a multipoint communications relationship, wherein the poll indicates that the master has selected the slave for transmission.

133. (New) The device of claim 123, wherein the transceiver is configured to be the master.

134. (New) The device of claim 123, wherein the first information in the first portion indicates the first modulation method when the intended destination is a first type of receiver and indicates the second modulation when the intended destination is a second type of receiver.

135. (New) The device of claim 134, wherein the second type of receiver differs from the first type of receiver at least by the second type of receiver being designated for transmitting in the second modulation method.

136. (New) The device of claim 134, wherein the second type of receiver differs from the first type of receiver at least by the second type of receiver being operable to ignore transmissions intended for the first type of receiver.

137. (New) The device of claim 136, wherein the intended destination ignores transmissions in the second modulation when the intended destination is the first type of receiver.

138. (New) The device of claim 136, wherein the intended destination ignores transmissions in the first modulation when the intended destination is the second type of receiver.
139. (New) The device of claim 136, wherein the intended destination is the first type of receiver and unable to demodulate the second modulation method.
140. (New) The device of claim 134, wherein the transceiver is configured to receive data from the intended destination in the first modulation method when the intended destination is the first type of receiver.
141. (New) The device of claim 134, wherein the transceiver is configured to receive data from the intended destination in the second modulation method when the intended destination is the second type of receiver.
142. (New) The device of claim 123, the transceiver is configured to transmit a third sequence, according to the first modulation method, at a time after the second sequence is transmitted.
143. (New) The device of claim 123, wherein the transceiver transmits data modulated according to either the first modulation method or the second modulation method at any given point in time when the transceiver is transmitting.
144. (New) The device of claim 127, wherein the memory comprises an erasable programmable read-only memory.
145. (New) The device of claim 11, wherein the memory comprises an erasable programmable read-only memory.
146. (New) The device of claim 20, wherein the memory comprises an erasable programmable read-only memory.

**DOCKET NO.:** REMB-0109

**PATENT**

**Application No.:** 12/543,910

**Notice of Non-Compliant Amendment Dated:** March 10, 2011

**Office Action Dated:** September 1, 2010

147. (New) The device of claim 28, wherein the memory comprises an erasable programmable read-only memory.

148. (New) The device of claim 47, wherein the memory comprises an erasable programmable read-only memory.



**DOCKET NO.:** REMB-0109

**PATENT**

**Application No.:** 12/543,910

**Notice of Non-Compliant Amendment Dated:** March 10, 2011

**Office Action Dated:** September 1, 2010

### **REMARKS**

The Notice of Non-Compliant Amendment dated March 10, 2011 indicates that new claim 123, as submitted in Applicant's amendment/response dated March 1, 2011, contained improper markings. In the claim listing submitted herewith, this informality in claim 123 has been corrected. Applicant respectfully requests that the corrected claim listing above replace the claim listing contained in the response dated March 1, 2011.

Date: March 10, 2011

/Michael A. Koptiw/  
Michael A. Koptiw  
Registration No. 57,900

Woodcock Washburn LLP  
Cira Centre  
2929 Arch Street, 12th Floor  
Philadelphia, PA 19104-2891  
Telephone: (215) 568-3100  
Facsimile: (215) 568-3439

## Electronic Acknowledgement Receipt

<b>EFS ID:</b>	9633247
<b>Application Number:</b>	12543910
<b>International Application Number:</b>	
<b>Confirmation Number:</b>	8306
<b>Title of Invention:</b>	System and Method of Communication Via Embedded Modulation
<b>First Named Inventor/Applicant Name:</b>	Gordon F. Bremer
<b>Customer Number:</b>	23377
<b>Filer:</b>	Michael Koptiw Jr./Kathy Franchi
<b>Filer Authorized By:</b>	Michael Koptiw Jr.
<b>Attorney Docket Number:</b>	REMB-0109
<b>Receipt Date:</b>	10-MAR-2011
<b>Filing Date:</b>	19-AUG-2009
<b>Time Stamp:</b>	16:21:58
<b>Application Type:</b>	Utility under 35 USC 111(a)

### Payment information:

Submitted with Payment	no
------------------------	----

### File Listing:

Document Number	Document Description	File Name	File Size(Bytes)/ Message Digest	Multi Part /.zip	Pages (if appl.)
1	Miscellaneous Incoming Letter	REMB-0109-transmittal.PDF	277493 <small>bc6c00887f407a2891deeae56666bc286592ef03</small>	no	2

### Warnings:

### Information:

2	REMB-0109-reply.PDF	101051	yes	15
		45f340da5306f4944db8df010b230ec178af2343		

Multipart Description/PDF files in .zip description			
Document Description	Start	End	
Amendment/Req. Reconsideration-After Non-Final Reject	1	1	
Claims	2	14	
Applicant Arguments/Remarks Made in an Amendment	15	15	

**Warnings:**

**Information:**

<b>Total Files Size (in bytes):</b>	378544
-------------------------------------	--------

This Acknowledgement Receipt evidences receipt on the noted date by the USPTO of the indicated documents, characterized by the applicant, and including page counts, where applicable. It serves as evidence of receipt similar to a Post Card, as described in MPEP 503.

**New Applications Under 35 U.S.C. 111**

If a new application is being filed and the application includes the necessary components for a filing date (see 37 CFR 1.53(b)-(d) and MPEP 506), a Filing Receipt (37 CFR 1.54) will be issued in due course and the date shown on this Acknowledgement Receipt will establish the filing date of the application.

**National Stage of an International Application under 35 U.S.C. 371**

If a timely submission to enter the national stage of an international application is compliant with the conditions of 35 U.S.C. 371 and other applicable requirements a Form PCT/DO/EO/903 indicating acceptance of the application as a national stage submission under 35 U.S.C. 371 will be issued in addition to the Filing Receipt, in due course.

**New International Application Filed with the USPTO as a Receiving Office**

If a new international application is being filed and the international application includes the necessary components for an international filing date (see PCT Article 11 and MPEP 1810), a Notification of the International Application Number and of the International Filing Date (Form PCT/RO/105) will be issued in due course, subject to prescriptions concerning national security, and the date shown on this Acknowledgement Receipt will establish the international filing date of the application.

Under the Paperwork Reduction Act of 1995, no persons are required to respond to a collection of information unless it displays a valid OMB control number.

<b>TRANSMITTAL FORM</b>  <i>(to be used for all correspondence after initial filing)</i>	Application Number	12/543,910
	Filing Date	August 19, 2009
	First Named Inventor	Gordon Bremer
	Art Unit	2611
	Examiner Name	Dac V. Ha
Total Number of Pages in This Submission	Attorney Docket Number	REMB-0109

<b>ENCLOSURES (Check all that apply)</b>				
<input type="checkbox"/> Fee Transmittal Form <input type="checkbox"/> Fee Attached <input type="checkbox"/> Amendment/Reply <input type="checkbox"/> After Final <input type="checkbox"/> Affidavits/declaration(s) <input type="checkbox"/> Extension of Time Request <input type="checkbox"/> Express Abandonment Request <input type="checkbox"/> Information Disclosure Statement  <input type="checkbox"/> Certified Copy of Priority Document(s) <input type="checkbox"/> Reply to Missing Parts/ Incomplete Application <input type="checkbox"/> Reply to Missing Parts under 37 CFR 1.52 or 1.53	<input type="checkbox"/> Drawing(s) <input type="checkbox"/> Licensing-related Papers <input type="checkbox"/> Petition <input type="checkbox"/> Petition to Convert to a Provisional Application <input type="checkbox"/> Power of Attorney, Revocation <input type="checkbox"/> Change of Correspondence Address <input type="checkbox"/> Terminal Disclaimer <input type="checkbox"/> Request for Refund <input type="checkbox"/> CD, Number of CD(s) _____ <input type="checkbox"/> Landscape Table on CD	<input type="checkbox"/> After Allowance Communication to TC <input type="checkbox"/> Appeal Communication to Board of Appeals and Interferences <input type="checkbox"/> Appeal Communication to TC (Appeal Notice, Brief, Reply Brief) <input type="checkbox"/> Proprietary Information <input type="checkbox"/> Status Letter <input checked="" type="checkbox"/> Other Enclosure(s) (please identify below): Amendment in response to Notice of Non-Compliant Amendment		
<table border="1" style="width: 100%; border-collapse: collapse;"> <tr> <td style="width: 100px;">Remarks</td> <td></td> </tr> </table>			Remarks	
Remarks				

<b>SIGNATURE OF APPLICANT, ATTORNEY, OR AGENT</b>			
Firm Name	Woodcock Washburn, LLP		
Signature	/Michael A. Koptiw/		
Printed name	Michael A. Koptiw		
Date	March 10, 2011	Reg. No.	57900

<b>CERTIFICATE OF TRANSMISSION/MAILING</b>			
I hereby certify that this correspondence is being facsimile transmitted to the USPTO or deposited with the United States Postal Service with sufficient postage as first class mail in an envelope addressed to: Commissioner for Patents, P.O. Box 1450, Alexandria, VA 22313-1450 on the date shown below:			
Signature			
Typed or printed name		Date	

This collection of information is required by 37 CFR 1.5. The information is required to obtain or retain a benefit by the public which is to file (and by the USPTO to process) an application. Confidentiality is governed by 35 U.S.C. 122 and 37 CFR 1.11 and 1.14. This collection is estimated to 2 hours to complete, including gathering, preparing, and submitting the completed application form to the USPTO. Time will vary depending upon the individual case. Any comments on the amount of time you require to complete this form and/or suggestions for reducing this burden, should be sent to the Chief Information Officer, U.S. Patent and Trademark Office, U.S. Department of Commerce, P.O. Box 1450, Alexandria, VA 22313-1450. DO NOT SEND FEES OR COMPLETED FORMS TO THIS ADDRESS. **SEND TO: Commissioner for Patents, P.O. Box 1450, Alexandria, VA 22313-1450.**

If you need assistance in completing the form, call 1-800-PTO-9199 and select option 2.

## Privacy Act Statement

The **Privacy Act of 1974 (P.L. 93-579)** requires that you be given certain information in connection with your submission of the attached form related to a patent application or patent. Accordingly, pursuant to the requirements of the Act, please be advised that: (1) the general authority for the collection of this information is 35 U.S.C. 2(b)(2); (2) furnishing of the information solicited is voluntary; and (3) the principal purpose for which the information is used by the U.S. Patent and Trademark Office is to process and/or examine your submission related to a patent application or patent. If you do not furnish the requested information, the U.S. Patent and Trademark Office may not be able to process and/or examine your submission, which may result in termination of proceedings or abandonment of the application or expiration of the patent.

The information provided by you in this form will be subject to the following routine uses:

1. The information on this form will be treated confidentially to the extent allowed under the Freedom of Information Act (5 U.S.C. 552) and the Privacy Act (5 U.S.C. 552a). Records from this system of records may be disclosed to the Department of Justice to determine whether disclosure of these records is required by the Freedom of Information Act.
2. A record from this system of records may be disclosed, as a routine use, in the course of presenting evidence to a court, magistrate, or administrative tribunal, including disclosures to opposing counsel in the course of settlement negotiations.
3. A record in this system of records may be disclosed, as a routine use, to a Member of Congress submitting a request involving an individual, to whom the record pertains, when the individual has requested assistance from the Member with respect to the subject matter of the record.
4. A record in this system of records may be disclosed, as a routine use, to a contractor of the Agency having need for the information in order to perform a contract. Recipients of information shall be required to comply with the requirements of the Privacy Act of 1974, as amended, pursuant to 5 U.S.C. 552a(m).
5. A record related to an International Application filed under the Patent Cooperation Treaty in this system of records may be disclosed, as a routine use, to the International Bureau of the World Intellectual Property Organization, pursuant to the Patent Cooperation Treaty.
6. A record in this system of records may be disclosed, as a routine use, to another federal agency for purposes of National Security review (35 U.S.C. 181) and for review pursuant to the Atomic Energy Act (42 U.S.C. 218(c)).
7. A record from this system of records may be disclosed, as a routine use, to the Administrator, General Services, or his/her designee, during an inspection of records conducted by GSA as part of that agency's responsibility to recommend improvements in records management practices and programs, under authority of 44 U.S.C. 2904 and 2906. Such disclosure shall be made in accordance with the GSA regulations governing inspection of records for this purpose, and any other relevant (*i.e.*, GSA or Commerce) directive. Such disclosure shall not be used to make determinations about individuals.
8. A record from this system of records may be disclosed, as a routine use, to the public after either publication of the application pursuant to 35 U.S.C. 122(b) or issuance of a patent pursuant to 35 U.S.C. 151. Further, a record may be disclosed, subject to the limitations of 37 CFR 1.14, as a routine use, to the public if the record was filed in an application which became abandoned or in which the proceedings were terminated and which application is referenced by either a published application, an application open to public inspection or an issued patent.
9. A record from this system of records may be disclosed, as a routine use, to a Federal, State, or local law enforcement agency, if the USPTO becomes aware of a violation or potential violation of law or regulation.

Under the Paperwork Reduction Act of 1995, no persons are required to respond to a collection of information unless it displays a valid OMB control number.

<b>PATENT APPLICATION FEE DETERMINATION RECORD</b> Substitute for Form PTO-875	Application or Docket Number <b>12/543,910</b>	Filing Date <b>08/19/2009</b>	<input type="checkbox"/> To be Mailed
---	---	----------------------------------	---------------------------------------

APPLICATION AS FILED – PART I			OTHER THAN SMALL ENTITY				
	(Column 1)	(Column 2)	SMALL ENTITY <input type="checkbox"/>	OR			
FOR	NUMBER FILED	NUMBER EXTRA	RATE (\$)	FEE (\$)	OR	RATE (\$)	FEE (\$)
<input type="checkbox"/> BASIC FEE <small>(37 CFR 1.16(a), (b), or (c))</small>	N/A	N/A	N/A			N/A	
<input type="checkbox"/> SEARCH FEE <small>(37 CFR 1.16(k), (j), or (m))</small>	N/A	N/A	N/A			N/A	
<input type="checkbox"/> EXAMINATION FEE <small>(37 CFR 1.16(o), (p), or (q))</small>	N/A	N/A	N/A			N/A	
TOTAL CLAIMS <small>(37 CFR 1.16(j))</small>	minus 20 =	*	X \$ =		OR	X \$ =	
INDEPENDENT CLAIMS <small>(37 CFR 1.16(h))</small>	minus 3 =	*	X \$ =			X \$ =	
<input type="checkbox"/> APPLICATION SIZE FEE <small>(37 CFR 1.16(s))</small>	If the specification and drawings exceed 100 sheets of paper, the application size fee due is \$250 (\$125 for small entity) for each additional 50 sheets or fraction thereof. See 35 U.S.C. 41(a)(1)(G) and 37 CFR 1.16(s).						
<input type="checkbox"/> MULTIPLE DEPENDENT CLAIM PRESENT <small>(37 CFR 1.16(j))</small>							
			TOTAL		OR	TOTAL	

\* If the difference in column 1 is less than zero, enter "0" in column 2.

APPLICATION AS AMENDED – PART II					OTHER THAN SMALL ENTITY				
	(Column 1)	(Column 2)	(Column 3)		SMALL ENTITY	OR			
AMENDMENT	<b>03/10/2011</b>	CLAIMS REMAINING AFTER AMENDMENT	HIGHEST NUMBER PREVIOUSLY PAID FOR	PRESENT EXTRA	RATE (\$)	ADDITIONAL FEE (\$)	OR	RATE (\$)	ADDITIONAL FEE (\$)
	Total <small>(37 CFR 1.16(i))</small>	* 79	Minus	** 100	=		OR	X \$ =	
	Independent <small>(37 CFR 1.16(h))</small>	* 7	Minus	*** 7	=		OR	X \$ =	
	<input type="checkbox"/> Application Size Fee <small>(37 CFR 1.16(s))</small>						OR		
	<input type="checkbox"/> FIRST PRESENTATION OF MULTIPLE DEPENDENT CLAIM <small>(37 CFR 1.16(j))</small>						OR		
					TOTAL ADD'L FEE		OR	TOTAL ADD'L FEE	

	(Column 1)	(Column 2)	(Column 3)		SMALL ENTITY	OR			
AMENDMENT		CLAIMS REMAINING AFTER AMENDMENT	HIGHEST NUMBER PREVIOUSLY PAID FOR	PRESENT EXTRA	RATE (\$)	ADDITIONAL FEE (\$)	OR	RATE (\$)	ADDITIONAL FEE (\$)
	Total <small>(37 CFR 1.16(i))</small>	*	Minus	**	=		OR	X \$ =	
	Independent <small>(37 CFR 1.16(h))</small>	*	Minus	***	=		OR	X \$ =	
	<input type="checkbox"/> Application Size Fee <small>(37 CFR 1.16(s))</small>						OR		
	<input type="checkbox"/> FIRST PRESENTATION OF MULTIPLE DEPENDENT CLAIM <small>(37 CFR 1.16(j))</small>						OR		
					TOTAL ADD'L FEE		OR	TOTAL ADD'L FEE	

\* If the entry in column 1 is less than the entry in column 2, write "0" in column 3.  
 \*\* If the "Highest Number Previously Paid For" IN THIS SPACE is less than 20, enter "20".  
 \*\*\* If the "Highest Number Previously Paid For" IN THIS SPACE is less than 3, enter "3".

The "Highest Number Previously Paid For" (Total or Independent) is the highest number found in the appropriate box in column 1.

Legal Instrument Examiner:  
 /PEGGY YARBOROUGH/

This collection of information is required by 37 CFR 1.16. The information is required to obtain or retain a benefit by the public which is to file (and by the USPTO to process) an application. Confidentiality is governed by 35 U.S.C. 122 and 37 CFR 1.14. This collection is estimated to take 12 minutes to complete, including gathering, preparing, and submitting the completed application form to the USPTO. Time will vary depending upon the individual case. Any comments on the amount of time you require to complete this form and/or suggestions for reducing this burden, should be sent to the Chief Information Officer, U.S. Patent and Trademark Office, U.S. Department of Commerce, P.O. Box 1450, Alexandria, VA 22313-1450. DO NOT SEND FEES OR COMPLETED FORMS TO THIS ADDRESS. **SEND TO: Commissioner for Patents, P.O. Box 1450, Alexandria, VA 22313-1450.**

If you need assistance in completing the form, call 1-800-PTO-9199 and select option 2.

**DOCKET NO.:** REMB-0109  
**Application No.:** 12/543,910

**PATENT**

**Notice of Non-Compliant Amendment Dated:** March 10, 2011  
**Office Action Dated:** September 1, 2010

**IN THE UNITED STATES PATENT AND TRADEMARK OFFICE**

**In re Application of:**  
**Gordon Bremer**

**Confirmation No.:** 8306

**Application No.:** 12/543,910

**Group Art Unit:** 2611

**Filing Date:** August 19, 2009

**Examiner:** Dac V Ha

**For:** System and Method of Communication Via Embedded Modulation

Mail Stop Amendment  
Commissioner for Patents  
P.O. Box 1450  
Alexandria, VA 22313-1450

Sir:

**REPLY PURSUANT TO 37 CFR § 1.111(a)(2)**

Further to the response to the Office Action dated September 1, 2010 and the Notice of Non-Compliant Amendment dated March 10, 2011.

- Amendments to the Specification** begin on page of this paper.
- Amendments to the Claims** are reflected in the listing of the claims which begins on page 2 of this paper.
- Amendments to the Drawings** begin on page of this paper and include an attached replacement sheet.
- Remarks** begin on page 14 of this paper.
- Request For Refund** submitted herewith.

**Notice of Non-Compliant Amendment Dated:** March 10, 2011  
**Office Action Dated:** September 1, 2010

This listing of claims will replace all prior versions, and listings, of claims in the application.

**Listing of Claims:**

1. (Currently Amended) A communication device capable of communicating according to a master/slave relationship in which a slave communication from a slave to a master occurs in response to a master communication from the master to the slave, the device comprising:

a transceiver, in the role of the master according to the master/slave relationship, for sending at least transmissions modulated using at least two types of modulation methods, wherein the at least two types of modulation methods comprise a first modulation method and a second modulation method, wherein the second modulation method is of a different type than the first modulation method, wherein ~~the~~ each transmission[[s]] comprises a group[[s]] of transmission sequences, wherein each group ~~of said groups~~ of transmission sequences is structured with at least a first portion and a payload portion wherein first information in the first portion indicates at least which of the first modulation method and the second modulation method is used for modulating second information in the payload portion, wherein at least one group of transmission sequences is addressed for an intended destination of the payload portion, and wherein for the at least one group of transmission sequences:

the first information for said at least one group of transmission sequences comprises a first sequence, in the first portion and modulated according to the first modulation method, wherein the first sequence indicates an impending change from the first modulation method to the second modulation method, and

the second information for said at least one group of transmission sequences comprises a second sequence[[,]] that is modulated according to the second modulation method, wherein the second sequence is transmitted after the first sequence.

2. (Previously Presented) The device of claim 1, wherein the transceiver is configured to transmit a third sequence after the second sequence, wherein the third sequence is transmitted in the first modulation method and indicates that communication from the master to the slave has reverted to the first modulation method.



**Notice of Non-Compliant Amendment Dated:** March 10, 2011  
**Office Action Dated:** September 1, 2010

3. – 8. (Canceled)

9. (Previously Presented) The device of claim 1, wherein the transceiver is configured to transmit the second sequence according to a specific time interval.

10. (Previously Presented) The device of claim 1, wherein the transceiver is configured to transmit the second sequence according to a particular quantity of data.

11. (Previously Presented) The device of claim 1, further comprising a processor and a memory, wherein the memory has stored therein instructions that when executed by the processor cause the transceiver to transmit the first sequence and the second sequence.

12. (Previously Presented) The device of claim 11, wherein the memory has stored therein program code for the first modulation method and the second modulation method.

13. (Previously Presented) The device of claim 11, wherein the memory comprises random access memory.

14. (Previously Presented) The device of claim 11, wherein the memory comprises read-only memory.

15. (Previously Presented) The device of claim 11, wherein the memory has stored therein program code for operating the transceiver in a multipoint master/slave relationship.

16. – 17. (Canceled)

18. (Previously Presented) The device of claim 1, wherein the first communication from the master to the slave is a poll in accordance with a multipoint communications relationship, wherein the poll indicates that the master has selected the slave for transmission.

19. (Canceled)

**Notice of Non-Compliant Amendment Dated:** March 10, 2011  
**Office Action Dated:** September 1, 2010

20. (Previously Presented) A communications device, comprising:
- a processor; and
  - a memory having stored therein executable instructions for execution by the processor, wherein the executable instructions direct transmission of a first data with a first modulation method followed by a second data with a second modulation method, wherein the first modulation method is different than the second modulation method, wherein the first data comprises an indication of an impending change from the first modulation method to the second modulation method, wherein the executable instructions direct transmission of a third data with the first modulation method after the second data, and wherein the third data indicates that communication has reverted to the first modulation method.
21. – 26. (Canceled)
27. (Previously Presented) The device of claim 20, wherein transmission of the second data is according to a specific time interval.
28. (Previously Presented) A communications device, comprising:
- a processor; and
  - a memory having stored therein executable instructions for execution by the processor, wherein the executable instructions direct transmission of a first data with a first modulation method followed by a second data with a second modulation method, wherein the first modulation method is different than the second modulation method, wherein the first data comprises an indication of an impending change from the first modulation method to the second modulation method wherein the executable instructions direct transmission of a third data with the first modulation method after the second data, and wherein transmission of the second data is according to a particular quantity of data.
29. (Previously Presented) The device of claim 20, further comprising a transmitter configured to transmit the first data and the second data.

**Notice of Non-Compliant Amendment Dated:** March 10, 2011  
**Office Action Dated:** September 1, 2010

30. (Previously Presented) The device of claim 20, wherein the memory has stored therein program code for the first modulation method and the second modulation method.

31. (Previously Presented) The device of claim 20, wherein the memory comprises random access memory.

32. (Previously Presented) The device of claim 20, wherein the memory comprises read-only memory.

33. (Previously Presented) The device of claim 20, wherein the memory has stored therein program code for a multipoint communications protocol.

34. – 36. (Canceled)

37. (Previously Presented) A device that transmits in accordance with a first modulation method and a second modulation method that is different than the first modulation method, said device comprising:

at least one modulator;

a transceiver that includes the at least one modulator, wherein the transceiver is configured to transmit:

a first sequence, modulated in accordance with the first modulation method, that indicates an impending change from the first modulation method to the second modulation method, and

a second sequence, in accordance with the second modulation method, that is transmitted at a time after the first data sequence.

38. (Previously Presented) The device of claim 37, wherein the transceiver is configured to transmit a third sequence after the second sequence, wherein the third sequence is transmitted in accordance with the first modulation method and indicates that a subsequent communication has reverted to the first modulation method.

**Notice of Non-Compliant Amendment Dated:** March 10, 2011  
**Office Action Dated:** September 1, 2010

39. – 44. (Canceled)

45. (Previously Presented) The device of claim 37, wherein the transceiver is configured to transmit the second sequence according to a specific time interval.

46. (Previously Presented) The device of claim 37, wherein the transceiver is configured to transmit the second sequence according to a particular quantity of data.

47. (Original) The device of claim 37, further comprising a processor and a memory, wherein the memory has stored therein instructions that when executed by the processor cause the transmitter to transmit the first sequence and the second sequence.

48. (Original) The device of claim 47, wherein the memory comprises random access memory.

49. (Original) The device of claim 47, wherein the memory comprises read-only memory.

50. (Original) The device of claim 47, wherein the memory has stored therein program code for a multipoint communications protocol.

51. – 86. (Canceled)

87. (Previously Presented) A computer-readable storage medium having a computer executable instructions stored therein that when executed by a processor control a master transceiver, said computer executable instructions, comprising:

    first logic configured to transmit first information in a first modulation method for communication;

    second logic configured to transmit a first sequence to notify of a change from said first modulation method to a second modulation method;

    third logic configured to transmit second information in said second modulation method; and

**Notice of Non-Compliant Amendment Dated:** March 10, 2011  
**Office Action Dated:** September 1, 2010

fourth logic configured to transmit a second sequence after the second information is transmitted, wherein the second sequence is transmitted in the first modulation method and indicates that communication has reverted to the first modulation method.

88. – 93. (Canceled)

94. (Previously Presented) The computer-readable storage medium of claim 87, wherein the first transceiver is configured to transmit the second sequence according to a specific time interval.

95. (Currently Amended) A computer-readable storage medium having a computer executable instructions stored therein that when executed by a processor control a master transceiver, said computer executable instructions, comprising:

first logic configured to transmit first information in a first modulation method for communication;

second logic configured to transmit a first sequence to notify of a change from said first modulation method to a second modulation method;

third logic configured to transmit second information in said second modulation method; and

fourth logic configured to transmit a second sequence after the second information is transmitted, wherein the fourth logic ~~first transceiver~~ is configured to transmit the second sequence according to a particular quantity of data.

96. (Previously Presented) The computer-readable storage medium of claim 87, further comprising program code for the first modulation method and the second modulation method.

97. (Previously Presented) The computer-readable storage medium of claim 87, further comprising program code for a multipoint communications protocol.

98. – 100. (Canceled)

**Notice of Non-Compliant Amendment Dated:** March 10, 2011  
**Office Action Dated:** September 1, 2010

101. (Previously Presented) The device of claim 1, wherein the transceiver is configured to be the master.

102. (Previously Presented) The device of claim 1, wherein the first information in the first portion indicates the first modulation method when the intended destination is a first type of receiver and indicates the second modulation when the intended destination is a second type of receiver.

103. (Previously Presented) The device of claim 102, wherein the second type of receiver differs from the first type of receiver at least by the second type of receiver being designated for transmitting in the second modulation method.

104. (Previously Presented) The device of claim 102, wherein the second type of receiver differs from the first type of receiver at least by the second type of receiver being operable to ignore transmissions intended for the first type of receiver.

105. (Previously Presented) The device of claim 104, wherein the intended destination ignores transmissions in the second modulation when the intended destination is the first type of receiver.

106. (Previously Presented) The device of claim 104, wherein the intended destination ignores transmissions in the first modulation when the intended destination is the second type of receiver.

107. (Previously Presented) The device of claim 104, wherein the intended destination is the first type of receiver and unable to demodulate the second modulation method.

108. (Previously Presented) The device of claim 102, wherein the transceiver is configured to receive data from the intended destination in the first modulation method when the intended destination is the first type of receiver.

**Notice of Non-Compliant Amendment Dated:** March 10, 2011  
**Office Action Dated:** September 1, 2010

109. (Previously Presented) The device of claim 102, wherein the transceiver is configured to receive data from the intended destination in the second modulation method when the intended destination is the second type of receiver.

110. (Previously Presented) The device of claim 1, the transceiver is configured to transmit a third sequence, according to the first modulation method, at a time after the second sequence is transmitted.

111. (Previously Presented) The device of claim 1, wherein the transceiver transmits data modulated according to either the first modulation method or the second modulation method at any given point in time when the transceiver is transmitting.

112. (Previously Presented) The device of claim 20, wherein transmission of the second data is according to a particular quantity of data.

113. (Previously Presented) The device of claim 28, wherein transmission of the second data is according to a specific time interval.

114. (Previously Presented) The device of claim 28, further comprising a transmitter configured to transmit the first data and the second data.

115. (Previously Presented) The device of claim 28, wherein the memory has stored therein program code for the first modulation method and the second modulation method.

116. (Previously Presented) The device of claim 28, wherein the memory comprises random access memory.

117. (Previously Presented) The device of claim 28, wherein the memory comprises read-only memory.

**Notice of Non-Compliant Amendment Dated:** March 10, 2011  
**Office Action Dated:** September 1, 2010

118. (Previously Presented) The device of claim 28, wherein the memory has stored therein program code for a multipoint communications protocol.

119. (Previously Presented) The computer-readable storage medium of claim 87, wherein the first transceiver is configured to transmit the second sequence according to a particular quantity of data.

120. (Previously Presented) The computer-readable storage medium of claim 95, wherein the first transceiver is configured to transmit the second sequence according to a specific time interval.

121. (Previously Presented) The computer-readable storage medium of claim 95, further comprising program code for the first modulation method and the second modulation method.

122. (Previously Presented) The computer-readable storage medium of claim 95, further comprising program code for a multipoint communications protocol.

123. (Previously Presented) A communication device capable of communicating according to a master/slave relationship in which a slave message from a slave to a master occurs in response to a master message from the master to the slave, the device comprising:

- a transceiver, in the role of the master according to the master/slave relationship, capable of transmitting using at least two types of modulation methods, wherein the at least two types of modulation methods comprise a first modulation method and a second modulation method, wherein the second modulation method is of a different type than the first modulation method, and wherein the transceiver is configured to transmit messages with:
  - a first sequence, in the first modulation method, that indicates at least which of the first modulation method and the second modulation method is used for modulating a second sequence, wherein, in at least one message, the first sequence indicates an impending change from the first modulation method to the second modulation method, and wherein the at least one message is addressed for an intended destination of the second sequence, and



**Notice of Non-Compliant Amendment Dated:** March 10, 2011  
**Office Action Dated:** September 1, 2010

the second sequence, modulated in accordance with the modulation method indicated by the first sequence and, in the at least one message, modulated using the second modulation method, wherein the second sequence is transmitted after the first sequence.

124. (Previously Presented) The device of claim 123, wherein the transceiver is configured to transmit a third sequence after the second sequence, wherein the third sequence is transmitted in the first modulation method and indicates that communication from the master to the slave has reverted to the first modulation method.

125. (Previously Presented) The device of claim 123, wherein the transceiver is configured to transmit the second sequence according to a specific time interval.

126. (Previously Presented) The device of claim 123, wherein the transceiver is configured to transmit the second sequence according to a particular quantity of data.

127. (Previously Presented) The device of claim 123, further comprising a processor and a memory, wherein the memory has stored therein instructions that when executed by the processor cause the transceiver to transmit the first sequence and the second sequence.

128. (Previously Presented) The device of claim 127, wherein the memory has stored therein program code for the first modulation method and the second modulation method.

129. (Previously Presented) The device of claim 127, wherein the memory comprises random access memory.

130. (Previously Presented) The device of claim 127, wherein the memory comprises read-only memory.

131. (Previously Presented) The device of claim 127, wherein the memory has stored therein program code for operating the transceiver in a multipoint master/slave relationship.

**Notice of Non-Compliant Amendment Dated:** March 10, 2011  
**Office Action Dated:** September 1, 2010

132. (Previously Presented) The device of claim 123, wherein the first communication from the master to the slave is a poll in accordance with a multipoint communications relationship, wherein the poll indicates that the master has selected the slave for transmission.

133. (Previously Presented) The device of claim 123, wherein the transceiver is configured to be the master.

134. (Previously Presented) The device of claim 123, wherein the first information in the first portion indicates the first modulation method when the intended destination is a first type of receiver and indicates the second modulation when the intended destination is a second type of receiver.

135. (Previously Presented) The device of claim 134, wherein the second type of receiver differs from the first type of receiver at least by the second type of receiver being designated for transmitting in the second modulation method.

136. (Previously Presented) The device of claim 134, wherein the second type of receiver differs from the first type of receiver at least by the second type of receiver being operable to ignore transmissions intended for the first type of receiver.

137. (Previously Presented) The device of claim 136, wherein the intended destination ignores transmissions in the second modulation when the intended destination is the first type of receiver.

138. (Previously Presented) The device of claim 136, wherein the intended destination ignores transmissions in the first modulation when the intended destination is the second type of receiver.

139. (Previously Presented) The device of claim 136, wherein the intended destination is the first type of receiver and unable to demodulate the second modulation method.

**Notice of Non-Compliant Amendment Dated:** March 10, 2011  
**Office Action Dated:** September 1, 2010

140. (Previously Presented) The device of claim 134, wherein the transceiver is configured to receive data from the intended destination in the first modulation method when the intended destination is the first type of receiver.

141. (Previously Presented) The device of claim 134, wherein the transceiver is configured to receive data from the intended destination in the second modulation method when the intended destination is the second type of receiver.

142. (Previously Presented) The device of claim 123, the transceiver is configured to transmit a third sequence, according to the first modulation method, at a time after the second sequence is transmitted.

143. (Previously Presented) The device of claim 123, wherein the transceiver transmits data modulated according to either the first modulation method or the second modulation method at any given point in time when the transceiver is transmitting.

144. (Previously Presented) The device of claim 127, wherein the memory comprises an erasable programmable read-only memory.

145. (Previously Presented) The device of claim 11, wherein the memory comprises an erasable programmable read-only memory.

146. (Previously Presented) The device of claim 20, wherein the memory comprises an erasable programmable read-only memory.

147. (Previously Presented) The device of claim 28, wherein the memory comprises an erasable programmable read-only memory.

148. (Previously Presented) The device of claim 47, wherein the memory comprises an erasable programmable read-only memory.

**DOCKET NO.:** REMB-0109  
**Application No.:** 12/543,910

**PATENT**

**Notice of Non-Compliant Amendment Dated:** March 10, 2011  
**Office Action Dated:** September 1, 2010

**REMARKS**

The present supplemental reply is submitted to amend claims 1 and 95. Applicant requests that this amendment be entered.

Date: May 11, 2011

/Steven B. Samuels/  
Steven B. Samuels  
Registration No. 37,711

Woodcock Washburn LLP  
Cira Centre  
2929 Arch Street, 12th Floor  
Philadelphia, PA 19104-2891  
Telephone: (215) 568-3100  
Facsimile: (215) 568-3439

## Electronic Acknowledgement Receipt

<b>EFS ID:</b>	10070607
<b>Application Number:</b>	12543910
<b>International Application Number:</b>	
<b>Confirmation Number:</b>	8306
<b>Title of Invention:</b>	System and Method of Communication Via Embedded Modulation
<b>First Named Inventor/Applicant Name:</b>	Gordon F. Bremer
<b>Customer Number:</b>	23377
<b>Filer:</b>	Steven Samuels/Kathy Franchi
<b>Filer Authorized By:</b>	Steven Samuels
<b>Attorney Docket Number:</b>	REMB-0109
<b>Receipt Date:</b>	11-MAY-2011
<b>Filing Date:</b>	19-AUG-2009
<b>Time Stamp:</b>	17:10:04
<b>Application Type:</b>	Utility under 35 USC 111(a)

### Payment information:

Submitted with Payment	no
------------------------	----

### File Listing:

Document Number	Document Description	File Name	File Size(Bytes)/ Message Digest	Multi Part /.zip	Pages (if appl.)
1	Miscellaneous Incoming Letter	REMB-0109-Transmittal.PDF	283415 <small>88908dcbf9c9d856909217b32cb7abc00e2 bedea</small>	no	2

### Warnings:

### Information:

2	REMB-0109-Reply.PDF	91422	yes	14
		77966549c5a1bd4db4212e3b7fdab9d847561fb8		

<b>Multipart Description/PDF files in .zip description</b>			
<b>Document Description</b>		<b>Start</b>	<b>End</b>
Supplemental Response or Supplemental Amendment		1	1
Claims		2	13
Applicant Arguments/Remarks Made in an Amendment		14	14

**Warnings:**

**Information:**

<b>Total Files Size (in bytes):</b>	374837
-------------------------------------	--------

**This Acknowledgement Receipt evidences receipt on the noted date by the USPTO of the indicated documents, characterized by the applicant, and including page counts, where applicable. It serves as evidence of receipt similar to a Post Card, as described in MPEP 503.**

**New Applications Under 35 U.S.C. 111**

**If a new application is being filed and the application includes the necessary components for a filing date (see 37 CFR 1.53(b)-(d) and MPEP 506), a Filing Receipt (37 CFR 1.54) will be issued in due course and the date shown on this Acknowledgement Receipt will establish the filing date of the application.**

**National Stage of an International Application under 35 U.S.C. 371**

**If a timely submission to enter the national stage of an international application is compliant with the conditions of 35 U.S.C. 371 and other applicable requirements a Form PCT/DO/EO/903 indicating acceptance of the application as a national stage submission under 35 U.S.C. 371 will be issued in addition to the Filing Receipt, in due course.**

**New International Application Filed with the USPTO as a Receiving Office**

**If a new international application is being filed and the international application includes the necessary components for an international filing date (see PCT Article 11 and MPEP 1810), a Notification of the International Application Number and of the International Filing Date (Form PCT/RO/105) will be issued in due course, subject to prescriptions concerning national security, and the date shown on this Acknowledgement Receipt will establish the international filing date of the application.**

Under the Paperwork Reduction Act of 1995, no persons are required to respond to a collection of information unless it displays a valid OMB control number.

<b>TRANSMITTAL FORM</b>  <i>(to be used for all correspondence after initial filing)</i>	Application Number	12/543,910
	Filing Date	August 19, 2009
	First Named Inventor	Gordon Bremer
	Art Unit	2611
	Examiner Name	Dac V. Ha
Total Number of Pages in This Submission	Attorney Docket Number	REMB-0109

<b>ENCLOSURES (Check all that apply)</b>		
<input type="checkbox"/> Fee Transmittal Form <input type="checkbox"/> Fee Attached <input checked="" type="checkbox"/> Amendment/Reply <input type="checkbox"/> After Final <input type="checkbox"/> Affidavits/declaration(s) <input type="checkbox"/> Extension of Time Request <input type="checkbox"/> Express Abandonment Request <input type="checkbox"/> Information Disclosure Statement  <input type="checkbox"/> Certified Copy of Priority Document(s) <input type="checkbox"/> Reply to Missing Parts/ Incomplete Application <input type="checkbox"/> Reply to Missing Parts under 37 CFR 1.52 or 1.53	<input type="checkbox"/> Drawing(s) <input type="checkbox"/> Licensing-related Papers <input type="checkbox"/> Petition <input type="checkbox"/> Petition to Convert to a Provisional Application <input type="checkbox"/> Power of Attorney, Revocation <input type="checkbox"/> Change of Correspondence Address <input type="checkbox"/> Terminal Disclaimer <input type="checkbox"/> Request for Refund <input type="checkbox"/> CD, Number of CD(s) _____ <input type="checkbox"/> Landscape Table on CD	<input type="checkbox"/> After Allowance Communication to TC <input type="checkbox"/> Appeal Communication to Board of Appeals and Interferences <input type="checkbox"/> Appeal Communication to TC (Appeal Notice, Brief, Reply Brief) <input type="checkbox"/> Proprietary Information <input type="checkbox"/> Status Letter <input type="checkbox"/> Other Enclosure(s) (please identify below):
<input type="text"/> Remarks		

<b>SIGNATURE OF APPLICANT, ATTORNEY, OR AGENT</b>			
Firm Name	Woodcock Washburn, LLP		
Signature	/Steven B. Samuels/		
Printed name	Steven B. Samuels		
Date	May 11, 2011	Reg. No.	37,711

<b>CERTIFICATE OF TRANSMISSION/MAILING</b>			
I hereby certify that this correspondence is being facsimile transmitted to the USPTO or deposited with the United States Postal Service with sufficient postage as first class mail in an envelope addressed to: Commissioner for Patents, P.O. Box 1450, Alexandria, VA 22313-1450 on the date shown below:			
Signature			
Typed or printed name		Date	

This collection of information is required by 37 CFR 1.5. The information is required to obtain or retain a benefit by the public which is to file (and by the USPTO to process) an application. Confidentiality is governed by 35 U.S.C. 122 and 37 CFR 1.11 and 1.14. This collection is estimated to 2 hours to complete, including gathering, preparing, and submitting the completed application form to the USPTO. Time will vary depending upon the individual case. Any comments on the amount of time you require to complete this form and/or suggestions for reducing this burden, should be sent to the Chief Information Officer, U.S. Patent and Trademark Office, U.S. Department of Commerce, P.O. Box 1450, Alexandria, VA 22313-1450. DO NOT SEND FEES OR COMPLETED FORMS TO THIS ADDRESS. **SEND TO: Commissioner for Patents, P.O. Box 1450, Alexandria, VA 22313-1450.**

If you need assistance in completing the form, call 1-800-PTO-9199 and select option 2.

## Privacy Act Statement

The **Privacy Act of 1974 (P.L. 93-579)** requires that you be given certain information in connection with your submission of the attached form related to a patent application or patent. Accordingly, pursuant to the requirements of the Act, please be advised that: (1) the general authority for the collection of this information is 35 U.S.C. 2(b)(2); (2) furnishing of the information solicited is voluntary; and (3) the principal purpose for which the information is used by the U.S. Patent and Trademark Office is to process and/or examine your submission related to a patent application or patent. If you do not furnish the requested information, the U.S. Patent and Trademark Office may not be able to process and/or examine your submission, which may result in termination of proceedings or abandonment of the application or expiration of the patent.

The information provided by you in this form will be subject to the following routine uses:

1. The information on this form will be treated confidentially to the extent allowed under the Freedom of Information Act (5 U.S.C. 552) and the Privacy Act (5 U.S.C. 552a). Records from this system of records may be disclosed to the Department of Justice to determine whether disclosure of these records is required by the Freedom of Information Act.
2. A record from this system of records may be disclosed, as a routine use, in the course of presenting evidence to a court, magistrate, or administrative tribunal, including disclosures to opposing counsel in the course of settlement negotiations.
3. A record in this system of records may be disclosed, as a routine use, to a Member of Congress submitting a request involving an individual, to whom the record pertains, when the individual has requested assistance from the Member with respect to the subject matter of the record.
4. A record in this system of records may be disclosed, as a routine use, to a contractor of the Agency having need for the information in order to perform a contract. Recipients of information shall be required to comply with the requirements of the Privacy Act of 1974, as amended, pursuant to 5 U.S.C. 552a(m).
5. A record related to an International Application filed under the Patent Cooperation Treaty in this system of records may be disclosed, as a routine use, to the International Bureau of the World Intellectual Property Organization, pursuant to the Patent Cooperation Treaty.
6. A record in this system of records may be disclosed, as a routine use, to another federal agency for purposes of National Security review (35 U.S.C. 181) and for review pursuant to the Atomic Energy Act (42 U.S.C. 218(c)).
7. A record from this system of records may be disclosed, as a routine use, to the Administrator, General Services, or his/her designee, during an inspection of records conducted by GSA as part of that agency's responsibility to recommend improvements in records management practices and programs, under authority of 44 U.S.C. 2904 and 2906. Such disclosure shall be made in accordance with the GSA regulations governing inspection of records for this purpose, and any other relevant (*i.e.*, GSA or Commerce) directive. Such disclosure shall not be used to make determinations about individuals.
8. A record from this system of records may be disclosed, as a routine use, to the public after either publication of the application pursuant to 35 U.S.C. 122(b) or issuance of a patent pursuant to 35 U.S.C. 151. Further, a record may be disclosed, subject to the limitations of 37 CFR 1.14, as a routine use, to the public if the record was filed in an application which became abandoned or in which the proceedings were terminated and which application is referenced by either a published application, an application open to public inspection or an issued patent.
9. A record from this system of records may be disclosed, as a routine use, to a Federal, State, or local law enforcement agency, if the USPTO becomes aware of a violation or potential violation of law or regulation.



Under the Paperwork Reduction Act of 1995, no persons are required to respond to a collection of information unless it displays a valid OMB control number.

<b>PATENT APPLICATION FEE DETERMINATION RECORD</b> Substitute for Form PTO-875	Application or Docket Number <b>12/543,910</b>	Filing Date <b>08/19/2009</b>	<input type="checkbox"/> To be Mailed
---	---	----------------------------------	---------------------------------------

APPLICATION AS FILED – PART I			OTHER THAN SMALL ENTITY			
	(Column 1)	(Column 2)	SMALL ENTITY <input type="checkbox"/>	OR		
FOR	NUMBER FILED	NUMBER EXTRA	RATE (\$)	FEE (\$)	RATE (\$)	FEE (\$)
<input type="checkbox"/> BASIC FEE <small>(37 CFR 1.16(a), (b), or (c))</small>	N/A	N/A	N/A		N/A	
<input type="checkbox"/> SEARCH FEE <small>(37 CFR 1.16(k), (j), or (m))</small>	N/A	N/A	N/A		N/A	
<input type="checkbox"/> EXAMINATION FEE <small>(37 CFR 1.16(o), (p), or (q))</small>	N/A	N/A	N/A		N/A	
TOTAL CLAIMS <small>(37 CFR 1.16(j))</small>	minus 20 =	*	X \$ =	OR	X \$ =	
INDEPENDENT CLAIMS <small>(37 CFR 1.16(h))</small>	minus 3 =	*	X \$ =		X \$ =	
<input type="checkbox"/> APPLICATION SIZE FEE <small>(37 CFR 1.16(s))</small>	If the specification and drawings exceed 100 sheets of paper, the application size fee due is \$250 (\$125 for small entity) for each additional 50 sheets or fraction thereof. See 35 U.S.C. 41(a)(1)(G) and 37 CFR 1.16(s).					
<input type="checkbox"/> MULTIPLE DEPENDENT CLAIM PRESENT <small>(37 CFR 1.16(j))</small>						
* If the difference in column 1 is less than zero, enter "0" in column 2.			TOTAL		TOTAL	

APPLICATION AS AMENDED – PART II					OTHER THAN SMALL ENTITY				
	(Column 1)	(Column 2)	(Column 3)						
AMENDMENT	<b>05/11/2011</b>	CLAIMS REMAINING AFTER AMENDMENT	HIGHEST NUMBER PREVIOUSLY PAID FOR	PRESENT EXTRA	RATE (\$)	ADDITIONAL FEE (\$)	RATE (\$)	ADDITIONAL FEE (\$)	
	Total <small>(37 CFR 1.16(i))</small>	* 79	Minus ** 100	= 0	X \$ =		OR	X \$52=	0
	Independent <small>(37 CFR 1.16(h))</small>	* 7	Minus ***7	= 0	X \$ =		OR	X \$220=	0
	<input type="checkbox"/> Application Size Fee <small>(37 CFR 1.16(s))</small>						OR		
	<input type="checkbox"/> FIRST PRESENTATION OF MULTIPLE DEPENDENT CLAIM <small>(37 CFR 1.16(j))</small>						OR		
					TOTAL ADD'L FEE		OR	TOTAL ADD'L FEE	<b>0</b>

	(Column 1)	(Column 2)	(Column 3)						
AMENDMENT		CLAIMS REMAINING AFTER AMENDMENT	HIGHEST NUMBER PREVIOUSLY PAID FOR	PRESENT EXTRA	RATE (\$)	ADDITIONAL FEE (\$)	RATE (\$)	ADDITIONAL FEE (\$)	
	Total <small>(37 CFR 1.16(i))</small>	*	Minus **	=	X \$ =		OR	X \$ =	
	Independent <small>(37 CFR 1.16(h))</small>	*	Minus ***	=	X \$ =		OR	X \$ =	
	<input type="checkbox"/> Application Size Fee <small>(37 CFR 1.16(s))</small>						OR		
	<input type="checkbox"/> FIRST PRESENTATION OF MULTIPLE DEPENDENT CLAIM <small>(37 CFR 1.16(j))</small>						OR		
					TOTAL ADD'L FEE		OR	TOTAL ADD'L FEE	

\* If the entry in column 1 is less than the entry in column 2, write "0" in column 3.  
 \*\* If the "Highest Number Previously Paid For" IN THIS SPACE is less than 20, enter "20".  
 \*\*\* If the "Highest Number Previously Paid For" IN THIS SPACE is less than 3, enter "3".  
 The "Highest Number Previously Paid For" (Total or Independent) is the highest number found in the appropriate box in column 1.

Legal Instrument Examiner:  
 /BRENDA MURPHY/

This collection of information is required by 37 CFR 1.16. The information is required to obtain or retain a benefit by the public which is to file (and by the USPTO to process) an application. Confidentiality is governed by 35 U.S.C. 122 and 37 CFR 1.14. This collection is estimated to take 12 minutes to complete, including gathering, preparing, and submitting the completed application form to the USPTO. Time will vary depending upon the individual case. Any comments on the amount of time you require to complete this form and/or suggestions for reducing this burden, should be sent to the Chief Information Officer, U.S. Patent and Trademark Office, U.S. Department of Commerce, P.O. Box 1450, Alexandria, VA 22313-1450. DO NOT SEND FEES OR COMPLETED FORMS TO THIS ADDRESS. **SEND TO: Commissioner for Patents, P.O. Box 1450, Alexandria, VA 22313-1450.**

If you need assistance in completing the form, call 1-800-PTO-9199 and select option 2.

MAY 11 2011

COPY OF RESPONSE FILED MAY 11, 2011

PATENT

DOCKET NO.: REMB-0109  
Application No.: 12/543,910

Notice of Non-Compliant Amendment Dated: March 10, 2011  
Office Action Dated: September 1, 2010

IN THE UNITED STATES PATENT AND TRADEMARK OFFICE

In re Application of:  
Gordon Bremer

Confirmation No.: 8306

Application No.: 12/543,910

Group Art Unit: 2611

Filing Date: August 19, 2009

Examiner: Dac V Ha

For: System and Method of Communication Via Embedded Modulation

Mail Stop Amendment  
Commissioner for Patents  
P.O. Box 1450  
Alexandria, VA 22313-1450

Sir:

REPLY PURSUANT TO 37 CFR § 1.111(a)(2)

Further to the response to the Office Action dated September 1, 2010 and the Notice of Non-Compliant Amendment dated March 10, 2011.

- Amendments to the Specification begin on page of this paper.
- Amendments to the Claims are reflected in the listing of the claims which begins on page 2 of this paper.
- Amendments to the Drawings begin on page of this paper and include an attached replacement sheet.
- Remarks begin on page 14 of this paper.
- Request For Refund submitted herewith.

**COPY OF RESPONSE FILED MAY 11, 2011**

**PATENT**

**DOCKET NO.: REMB-0109**

**Application No.: 12/543,910**

**Notice of Non-Compliant Amendment Dated: March 10, 2011**

**Office Action Dated: September 1, 2010**

This listing of claims will replace all prior versions, and listings, of claims in the application.

**Listing of Claims:**

1. (Currently Amended) A communication device capable of communicating according to a master/slave relationship in which a slave communication from a slave to a master occurs in response to a master communication from the master to the slave, the device comprising:

a transceiver, in the role of the master according to the master/slave relationship, for sending at least transmissions modulated using at least two types of modulation methods, wherein the at least two types of modulation methods comprise a first modulation method and a second modulation method, wherein the second modulation method is of a different type than the first modulation method, wherein the each transmission comprises a group of transmission sequences, wherein each group of transmission sequences is structured with at least a first portion and a payload portion wherein first information in the first portion indicates at least which of the first modulation method and the second modulation method is used for modulating second information in the payload portion, wherein at least one group of transmission sequences is addressed for an intended destination of the payload portion, and wherein for the at least one group of transmission sequences:

the first information for said at least one group of transmission sequences comprises a first sequence, in the first portion and modulated according to the first modulation method, wherein the first sequence indicates an impending change from the first modulation method to the second modulation method, and

the second information for said at least one group of transmission sequences comprises a second sequence that is modulated according to the second modulation method, wherein the second sequence is transmitted after the first sequence.

2. (Previously Presented) The device of claim 1, wherein the transceiver is configured to transmit a third sequence after the second sequence, wherein the third sequence is transmitted in the first modulation method and indicates that communication from the master to the slave has reverted to the first modulation method.

**COPY OF RESPONSE FILED MAY 11, 2011**

**PATENT**

**DOCKET NO.: REMB-0109**  
**Application No.: 12/543,910**

**Notice of Non-Compliant Amendment Dated: March 10, 2011**  
**Office Action Dated: September 1, 2010**

3. – 8. (Canceled)

9. (Previously Presented) The device of claim 1, wherein the transceiver is configured to transmit the second sequence according to a specific time interval.

10. (Previously Presented) The device of claim 1, wherein the transceiver is configured to transmit the second sequence according to a particular quantity of data.

11. (Previously Presented) The device of claim 1, further comprising a processor and a memory, wherein the memory has stored therein instructions that when executed by the processor cause the transceiver to transmit the first sequence and the second sequence.

12. (Previously Presented) The device of claim 11, wherein the memory has stored therein program code for the first modulation method and the second modulation method.

13. (Previously Presented) The device of claim 11, wherein the memory comprises random access memory.

14. (Previously Presented) The device of claim 11, wherein the memory comprises read-only memory.

15. (Previously Presented) The device of claim 11, wherein the memory has stored therein program code for operating the transceiver in a multipoint master/slave relationship.

16. – 17. (Canceled)

18. (Previously Presented) The device of claim 1, wherein the first communication from the master to the slave is a poll in accordance with a multipoint communications relationship, wherein the poll indicates that the master has selected the slave for transmission.

**COPY OF RESPONSE FILED MAY 11, 2011**

**PATENT**

**DOCKET NO.:** REMB-0109  
**Application No.:** 12/543,910

**Notice of Non-Compliant Amendment Dated:** March 10, 2011  
**Office Action Dated:** September 1, 2010

19. (Canceled)

20. (Previously Presented) A communications device, comprising:

a processor; and

a memory having stored therein executable instructions for execution by the processor, wherein the executable instructions direct transmission of a first data with a first modulation method followed by a second data with a second modulation method, wherein the first modulation method is different than the second modulation method, wherein the first data comprises an indication of an impending change from the first modulation method to the second modulation method, wherein the executable instructions direct transmission of a third data with the first modulation method after the second data, and wherein the third data indicates that communication has reverted to the first modulation method.

21. - 26. (Canceled)

27. (Previously Presented) The device of claim 20, wherein transmission of the second data is according to a specific time interval.

28. (Previously Presented) A communications device, comprising:

a processor; and

a memory having stored therein executable instructions for execution by the processor, wherein the executable instructions direct transmission of a first data with a first modulation method followed by a second data with a second modulation method, wherein the first modulation method is different than the second modulation method, wherein the first data comprises an indication of an impending change from the first modulation method to the second modulation method wherein the executable instructions direct transmission of a third data with the first modulation method after the second data, and wherein transmission of the second data is according to a particular quantity of data.

**COPY OF RESPONSE FILED MAY 11, 2011**

**PATENT**

**DOCKET NO.: REMB-0109**  
**Application No.: 12/543,910**

**Notice of Non-Compliant Amendment Dated: March 10, 2011**  
**Office Action Dated: September 1, 2010**

29. (Previously Presented) The device of claim 20, further comprising a transmitter configured to transmit the first data and the second data.
30. (Previously Presented) The device of claim 20, wherein the memory has stored therein program code for the first modulation method and the second modulation method.
31. (Previously Presented) The device of claim 20, wherein the memory comprises random access memory.
32. (Previously Presented) The device of claim 20, wherein the memory comprises read-only memory.
33. (Previously Presented) The device of claim 20, wherein the memory has stored therein program code for a multipoint communications protocol.
34. - 36. (Canceled)
37. (Previously Presented) A device that transmits in accordance with a first modulation method and a second modulation method that is different than the first modulation method, said device comprising:
- at least one modulator;
  - a transceiver that includes the at least one modulator, wherein the transceiver is configured to transmit:
    - a first sequence, modulated in accordance with the first modulation method, that indicates an impending change from the first modulation method to the second modulation method, and
    - a second sequence, in accordance with the second modulation method, that is transmitted at a time after the first data sequence.

**COPY OF RESPONSE FILED MAY 11, 2011**

**PATENT**

**DOCKET NO.:** REMB-0109  
**Application No.:** 12/543,910

**Notice of Non-Compliant Amendment Dated:** March 10, 2011  
**Office Action Dated:** September 1, 2010

38. (Previously Presented) The device of claim 37, wherein the transceiver is configured to transmit a third sequence after the second sequence, wherein the third sequence is transmitted in accordance with the first modulation method and indicates that a subsequent communication has reverted to the first modulation method.

39. – 44. (Canceled)

45. (Previously Presented) The device of claim 37, wherein the transceiver is configured to transmit the second sequence according to a specific time interval.

46. (Previously Presented) The device of claim 37, wherein the transceiver is configured to transmit the second sequence according to a particular quantity of data.

47. (Original) The device of claim 37, further comprising a processor and a memory, wherein the memory has stored therein instructions that when executed by the processor cause the transmitter to transmit the first sequence and the second sequence.

48. (Original) The device of claim 47, wherein the memory comprises random access memory.

49. (Original) The device of claim 47, wherein the memory comprises read-only memory.

50. (Original) The device of claim 47, wherein the memory has stored therein program code for a multipoint communications protocol.

51. – 86. (Canceled)

87. (Previously Presented) A computer-readable storage medium having a computer executable instructions stored therein that when executed by a processor control a master transceiver, said computer executable instructions, comprising:

**COPY OF RESPONSE FILED MAY 11, 2011**

**DOCKET NO.: REMB-0109**  
**Application No.: 12/543,910**

**PATENT**

**Notice of Non-Compliant Amendment Dated: March 10, 2011**  
**Office Action Dated: September 1, 2010**

first logic configured to transmit first information in a first modulation method for communication;

second logic configured to transmit a first sequence to notify of a change from said first modulation method to a second modulation method;

third logic configured to transmit second information in said second modulation method; and

fourth logic configured to transmit a second sequence after the second information is transmitted, wherein the second sequence is transmitted in the first modulation method and indicates that communication has reverted to the first modulation method.

88. - 93. (Canceled)

94. (Previously Presented) The computer-readable storage medium of claim 87, wherein the first transceiver is configured to transmit the second sequence according to a specific time interval.

95. (Currently Amended) A computer-readable storage medium having a computer executable instructions stored therein that when executed by a processor control a master transceiver, said computer executable instructions, comprising:

first logic configured to transmit first information in a first modulation method for communication;

second logic configured to transmit a first sequence to notify of a change from said first modulation method to a second modulation method;

third logic configured to transmit second information in said second modulation method; and

fourth logic configured to transmit a second sequence after the second information is transmitted, wherein the fourth logic ~~first transceiver~~ is configured to transmit the second sequence according to a particular quantity of data.



**COPY OF RESPONSE FILED MAY 11, 2011**

**PATENT**

**DOCKET NO.: REMB-0109**

**Application No.: 12/543,910**

**Notice of Non-Compliant Amendment Dated: March 10, 2011**

**Office Action Dated: September 1, 2010**

96. (Previously Presented) The computer-readable storage medium of claim 87, further comprising program code for the first modulation method and the second modulation method.

97. (Previously Presented) The computer-readable storage medium of claim 87, further comprising program code for a multipoint communications protocol.

98. - 100. (Canceled)

101. (Previously Presented) The device of claim 1, wherein the transceiver is configured to be the master.

102. (Previously Presented) The device of claim 1, wherein the first information in the first portion indicates the first modulation method when the intended destination is a first type of receiver and indicates the second modulation when the intended destination is a second type of receiver.

103. (Previously Presented) The device of claim 102, wherein the second type of receiver differs from the first type of receiver at least by the second type of receiver being designated for transmitting in the second modulation method.

104. (Previously Presented) The device of claim 102, wherein the second type of receiver differs from the first type of receiver at least by the second type of receiver being operable to ignore transmissions intended for the first type of receiver.

105. (Previously Presented) The device of claim 104, wherein the intended destination ignores transmissions in the second modulation when the intended destination is the first type of receiver.

**COPY OF RESPONSE FILED MAY 11, 2011**

**PATENT**

**DOCKET NO.: REMB-0109**  
**Application No.: 12/543,910**

**Notice of Non-Compliant Amendment Dated: March 10, 2011**  
**Office Action Dated: September 1, 2010**

106. (Previously Presented) The device of claim 104, wherein the intended destination ignores transmissions in the first modulation when the intended destination is the second type of receiver.

107. (Previously Presented) The device of claim 104, wherein the intended destination is the first type of receiver and unable to demodulate the second modulation method.

108. (Previously Presented) The device of claim 102, wherein the transceiver is configured to receive data from the intended destination in the first modulation method when the intended destination is the first type of receiver.

109. (Previously Presented) The device of claim 102, wherein the transceiver is configured to receive data from the intended destination in the second modulation method when the intended destination is the second type of receiver.

110. (Previously Presented) The device of claim 1, the transceiver is configured to transmit a third sequence, according to the first modulation method, at a time after the second sequence is transmitted.

111. (Previously Presented) The device of claim 1, wherein the transceiver transmits data modulated according to either the first modulation method or the second modulation method at any given point in time when the transceiver is transmitting.

112. (Previously Presented) The device of claim 20, wherein transmission of the second data is according to a particular quantity of data.

113. (Previously Presented) The device of claim 28, wherein transmission of the second data is according to a specific time interval.

**COPY OF RESPONSE FILED MAY 11, 2011**

**PATENT**

**DOCKET NO.: REMB-0109**  
**Application No.: 12/543,910**

**Notice of Non-Compliant Amendment Dated: March 10, 2011**  
**Office Action Dated: September 1, 2010**

114. (Previously Presented) The device of claim 28, further comprising a transmitter configured to transmit the first data and the second data.
115. (Previously Presented) The device of claim 28, wherein the memory has stored therein program code for the first modulation method and the second modulation method.
116. (Previously Presented) The device of claim 28, wherein the memory comprises random access memory.
117. (Previously Presented) The device of claim 28, wherein the memory comprises read-only memory.
118. (Previously Presented) The device of claim 28, wherein the memory has stored therein program code for a multipoint communications protocol.
119. (Previously Presented) The computer-readable storage medium of claim 87, wherein the first transceiver is configured to transmit the second sequence according to a particular quantity of data.
120. (Previously Presented) The computer-readable storage medium of claim 95, wherein the first transceiver is configured to transmit the second sequence according to a specific time interval.
121. (Previously Presented) The computer-readable storage medium of claim 95, further comprising program code for the first modulation method and the second modulation method.
122. (Previously Presented) The computer-readable storage medium of claim 95, further comprising program code for a multipoint communications protocol.

**COPY OF RESPONSE FILED MAY 11, 2011**

**PATENT**

**DOCKET NO.:** REMB-0109  
**Application No.:** 12/543,910

**Notice of Non-Compliant Amendment Dated:** March 10, 2011  
**Office Action Dated:** September 1, 2010

123. (Previously Presented) A communication device capable of communicating according to a master/slave relationship in which a slave message from a slave to a master occurs in response to a master message from the master to the slave, the device comprising:
- a transceiver, in the role of the master according to the master/slave relationship, capable of transmitting using at least two types of modulation methods, wherein the at least two types of modulation methods comprise a first modulation method and a second modulation method, wherein the second modulation method is of a different type than the first modulation method, and wherein the transceiver is configured to transmit messages with:
    - a first sequence, in the first modulation method, that indicates at least which of the first modulation method and the second modulation method is used for modulating a second sequence, wherein, in at least one message, the first sequence indicates an impending change from the first modulation method to the second modulation method, and wherein the at least one message is addressed for an intended destination of the second sequence, and
    - the second sequence, modulated in accordance with the modulation method indicated by the first sequence and, in the at least one message, modulated using the second modulation method, wherein the second sequence is transmitted after the first sequence.
124. (Previously Presented) The device of claim 123, wherein the transceiver is configured to transmit a third sequence after the second sequence, wherein the third sequence is transmitted in the first modulation method and indicates that communication from the master to the slave has reverted to the first modulation method.
125. (Previously Presented) The device of claim 123, wherein the transceiver is configured to transmit the second sequence according to a specific time interval.
126. (Previously Presented) The device of claim 123, wherein the transceiver is configured to transmit the second sequence according to a particular quantity of data.

**COPY OF RESPONSE FILED MAY 11, 2011**

**DOCKET NO.: REMB-0109**  
**Application No.: 12/543,910**

**PATENT**

**Notice of Non-Compliant Amendment Dated: March 10, 2011**  
**Office Action Dated: September 1, 2010**

127. (Previously Presented) The device of claim 123, further comprising a processor and a memory, wherein the memory has stored therein instructions that when executed by the processor cause the transceiver to transmit the first sequence and the second sequence.

128. (Previously Presented) The device of claim 127, wherein the memory has stored therein program code for the first modulation method and the second modulation method.

129. (Previously Presented) The device of claim 127, wherein the memory comprises random access memory.

130. (Previously Presented) The device of claim 127, wherein the memory comprises read-only memory.

131. (Previously Presented) The device of claim 127, wherein the memory has stored therein program code for operating the transceiver in a multipoint master/slave relationship.

132. (Previously Presented) The device of claim 123, wherein the first communication from the master to the slave is a poll in accordance with a multipoint communications relationship, wherein the poll indicates that the master has selected the slave for transmission.

133. (Previously Presented) The device of claim 123, wherein the transceiver is configured to be the master.

134. (Previously Presented) The device of claim 123, wherein the first information in the first portion indicates the first modulation method when the intended destination is a first type of receiver and indicates the second modulation when the intended destination is a second type of receiver.

**COPY OF RESPONSE FILED MAY 11, 2011**

**PATENT**

**DOCKET NO.: REMB-0109**  
**Application No.: 12/543,910**

**Notice of Non-Compliant Amendment Dated: March 10, 2011**  
**Office Action Dated: September 1, 2010**

135. (Previously Presented) The device of claim 134, wherein the second type of receiver differs from the first type of receiver at least by the second type of receiver being designated for transmitting in the second modulation method.

136. (Previously Presented) The device of claim 134, wherein the second type of receiver differs from the first type of receiver at least by the second type of receiver being operable to ignore transmissions intended for the first type of receiver.

137. (Previously Presented) The device of claim 136, wherein the intended destination ignores transmissions in the second modulation when the intended destination is the first type of receiver.

138. (Previously Presented) The device of claim 136, wherein the intended destination ignores transmissions in the first modulation when the intended destination is the second type of receiver.

139. (Previously Presented) The device of claim 136, wherein the intended destination is the first type of receiver and unable to demodulate the second modulation method.

140. (Previously Presented) The device of claim 134, wherein the transceiver is configured to receive data from the intended destination in the first modulation method when the intended destination is the first type of receiver.

141. (Previously Presented) The device of claim 134, wherein the transceiver is configured to receive data from the intended destination in the second modulation method when the intended destination is the second type of receiver.

142. (Previously Presented) The device of claim 123, the transceiver is configured to transmit a third sequence, according to the first modulation method, at a time after the second sequence is transmitted.

**COPY OF RESPONSE FILED MAY 11, 2011**

**PATENT**

**DOCKET NO.:** REMB-0109  
**Application No.:** 12/543,910

**Notice of Non-Compliant Amendment Dated:** March 10, 2011  
**Office Action Dated:** September 1, 2010

143. (Previously Presented) The device of claim 123, wherein the transceiver transmits data modulated according to either the first modulation method or the second modulation method at any given point in time when the transceiver is transmitting.
144. (Previously Presented) The device of claim 127, wherein the memory comprises an erasable programmable read-only memory.
145. (Previously Presented) The device of claim 11, wherein the memory comprises an erasable programmable read-only memory.
146. (Previously Presented) The device of claim 20, wherein the memory comprises an erasable programmable read-only memory.
147. (Previously Presented) The device of claim 28, wherein the memory comprises an erasable programmable read-only memory.
148. (Previously Presented) The device of claim 47, wherein the memory comprises an erasable programmable read-only memory.

**COPY OF RESPONSE FILED MAY 11, 2011**

**PATENT**

**DOCKET NO.:** REMB-0109  
**Application No.:** 12/543,910

**Notice of Non-Compliant Amendment Dated:** March 10, 2011  
**Office Action Dated:** September 1, 2010

**REMARKS**

The present supplemental reply is submitted to amend claims 1 and 95. Applicant requests that this amendment be entered.

**Date:** May 11, 2011

/Steven B. Samuels/  
Steven B. Samuels  
Registration No. 37,711

Woodcock Washburn LLP  
Cira Centre  
2929 Arch Street, 12th Floor  
Philadelphia, PA 19104-2891  
Telephone: (215) 568-3100  
Facsimile: (215) 568-3439



MAY 11 2011



INTELLECTUAL PROPERTY LAW  
ATLANTA • PHILADELPHIA • SEATTLE

# FACSIMILE

DATE: May 11, 2011  
**OFFICIAL PAPER**

JOB CODE:

*Please deliver this and the following pages to:*

Examiner: **Dac V. Ha**  
U.S.P.T.O. Group Art Unit: **2611**  
Telecopier No.: **571-273-8300**  
U.S. Serial No.: **12/543,910**  
Client/Matter No.: **REMB-0109**  
Sender's Name: **Steven B. Samuels**  
Pages to Follow: **15**

If transmission is not complete, please call our Philadelphia Office at (215) 568-3100.

COVER MESSAGE:

**OFFICIAL FACSIMILE. PLEASE DELIVER TO EXAMINER IMMEDIATELY.**

Attached hereto is the following document:

- 1) Supplemental Reply to Office Action

THIS MESSAGE IS INTENDED ONLY FOR THE USE OF THE INDIVIDUAL OR ENTITY TO WHICH IT IS ADDRESSED AND MAY CONTAIN INFORMATION THAT IS PRIVILEGED, CONFIDENTIAL AND EXEMPT FROM DISCLOSURE UNDER APPLICABLE LAW. IF THE READER OF THIS MESSAGE IS NOT THE INTENDED RECIPIENT, OR THE EMPLOYEE OR AGENT RESPONSIBLE FOR DELIVERY OF THE MESSAGE TO THE INTENDED RECIPIENT, YOU ARE HEREBY NOTIFIED THAT ANY DISSEMINATION, DISTRIBUTION OR COPYING OF THIS COMMUNICATION IS STRICTLY PROHIBITED. IF YOU HAVE RECEIVED THIS COMMUNICATION IN ERROR, PLEASE NOTIFY US IMMEDIATELY BY TELEPHONE AND RETURN THE ORIGINAL TO US AT THE ABOVE ADDRESS VIA THE U.S. POSTAL SERVICE. THANK YOU.

WOODCOCK WASHBURN LLP  
A Partnership Including Professional Corporations  
[www.woodcock.com](http://www.woodcock.com)

Substitute for 1449/PTO  <b>INFORMATION DISCLOSURE STATEMENT BY APPLICANT</b>  <i>(use as many sheets as necessary)</i>				<b>Complete if Known</b>	
				<b>Application Number</b>	12/543,910
				<b>Filing Date</b>	August 19, 2009
				<b>First Named Inventor</b>	Gordon F. Bremer
				<b>Art Unit</b>	2611
				<b>Examiner Name</b>	Dac V. Ha
<b>Sheet</b>	1	of	1	<b>Attorney Docket Number</b>	REMB-0109

NON PATENT LITERATURE DOCUMENTS			
Examiner Initials	Cite No.	Include name of the author, title of the article (when appropriate), title of the item (book, magazine, journal, serial, symposium, catalog, etc.), date, page(s), Volume-issue Number(s), publisher, city and/or country where published.	T
	253	International Telecommunications Union, Telecommunication Standardization Sector of ITU (ITU-T), Series T: Terminal Equipments and Protocols For Telematic Services, "Procedures for Document Facsimile Transmission in the General Switched Telephone Network", ITU-T Recommendation T.30, July 1996, 176 pages	
	254	International Telecommunications Union, The International Telegraph and Telephone Consultative Committee (CCITT), Data Communication Over The Telephone Network, "A 2-Wire Modem For Facsimile Applications With Rates Up to 14 400 bit/s", Recommendation V.17, February 1991, 13 pages	
	255	International Telecommunications Union, Telecommunication Standardization Sector of ITU (ITU-T), Series T: Terminal Equipments and Protocols For Telematic Services, "Standardization of Group 3 Facsimile Terminals for Document Transmission", ITU-T Recommendation T.4, July 1996, 60 pages	
	256	International Telecommunications Union, Telecommunication Standardization Sector of ITU (ITU-T), Series T: Terminals For Telematic Services, "Standardization of Group 3 Facsimile Terminals for Document Transmission", ITU-T Recommendation T.4 – Amendment 1, July 1997, 10 pages	
	257	International Telecommunications Union, Telecommunication Standardization Sector of ITU (ITU-T), Series T: Terminals For Telematic Services, "Standardization of Group 3 Facsimile Terminals for Document Transmission", ITU-T Recommendation T.4 – Amendment 2, October 1997, 14 pages	
	258	International Telecommunications Union, Telecommunication Standardization Sector of ITU (ITU-T), Series T: Terminals For Telematic Services, "Procedures for Document Facsimile Transmission in the General Switched Telephone Network", ITU-T Recommendation T.30 – Amendment 1, July 1997, 110 pages	
	259	International Telecommunications Union, Telecommunication Standardization Sector of ITU (ITU-T), Series T: Terminals For Telematic Services, "Procedures for Document Facsimile Transmission in the General Switched Telephone Network", ITU-T Recommendation T.30 – Amendment 2, October 1997, 18 pages	

<b>Examiner Signature</b>		<b>Date Considered</b>	
---------------------------	--	------------------------	--

IN THE UNITED STATES PATENT AND TRADEMARK OFFICE

In Re Application of:

Gordon F. Bremer

Confirmation No.: 8306

Application No.: 12/543,910

Group Art Unit: 2611

Filing Date: August 19, 2009

Examiner: Dac V. Ha

For: SYSTEM AND METHOD OF COMMUNICATION VIA EMBEDDED MODULATION

Filed Via EFS

INFORMATION DISCLOSURE STATEMENT

Pursuant to 37 CFR § 1.56 and in accordance with 37 CFR §§ 1.97-1.98, information relating to the above-identified application is hereby disclosed. Inclusion of information in this statement is not to be construed as an admission that this information is material as that term is defined in 37 CFR § 1.56(b).

**IDS Filed Under 37 CFR 1.97(b)**

In accordance with § 1.97(b), since this Information Disclosure Statement is being filed either within three months of the filing date of the above-identified application, within three months of the date of entry into the national stage of the above identified application as set forth in § 1.491, before the mailing date of a first Office Action on the merits of the above-identified application, or before the mailing date of a first Office Action after the filing of request for continued examination under § 1.114, no additional fee is required.

**IDS filed Under 37 CFR 1.97(c)**

In accordance with § 1.97(c), this Information Disclosure Statement is being filed after the period set forth in § 1.97(b) above but before the mailing date of either a Final Action under § 1.116 or a Notice of Allowance under § 1.311, or before an action that otherwise closes prosecution in the application, therefore:

- Certification in Accordance with § 1.97(e) is attached; or
- The fee of **\$180.00** as set forth in § 1.17(p) is attached.

**IDS filed Under 37 CFR 1.97(d)**

In accordance with § 1.97(d), this Information Disclosure Statement is being filed after the mailing date of either a Final Action under § 1.113 or a Notice of Allowance under § 1.311 but before, or simultaneously with, the payment of the Issue Fee, therefore included are: Certification in Accordance with § 1.97(e); and the submission fee of **\$180.00** as set forth in § 1.17(p).

**CONTENT OF IDS PURSUANT TO 37 CFR 1.98**

Copies of reference numbers listed on the attached Form PTO-1449 are not required to be submitted pursuant to 37 CFR § 1.98(a)(2)(iii).

Copies of reference numbers 253-259 listed on the attached Form PTO-1449 are enclosed herewith.

Copies of reference numbers are not being submitted because they were previously cited by or submitted to the U.S. Patent and Trademark Office in patent application number , filed for which a claim for priority under 35 U.S.C. § 120 has been made in the instant application.

The month of publication for reference numbers is not available. However, the year of publication for these references is sufficiently earlier than the effective US filing date and any foreign priority date so that the particular month of publication is not in issue pursuant to 37 CFR § 1.98(b).

**REFERENCES IN A LANGUAGE OTHER THAN ENGLISH**

The following documents are not in the English language. Accordingly, a concise explanation of the relevance of the document was incorporated in the specification passages identified below, the document was identified in a foreign communication as identified below or an English language counterpart application has been provided as indicated below.

Foreign Language Document	Cite No.	Pages of Reference in Specification or Relevance of Document

Foreign Language Document	Cite No.	English Language Counterpart	Cite No.

**CERTIFICATION IN ACCORDANCE WITH § 1.97(e)**

I hereby certify that:

- Each item of information contained in this information disclosure statement was first cited in any communication from a foreign patent office in a counterpart foreign application not more than three months prior to the filing of this information disclosure statement.
- No item of information contained in this information disclosure statement was cited in a communication from a foreign patent office in a counterpart foreign application, and, to the knowledge of the person signing the certification after making reasonable inquiry, no item of information contained in this information disclosure statement was known to any individual designated in § 1.56(c) more than three months prior to the filing of this information disclosure statement.

Please charge any deficiency or credit any overpayment to Deposit Account No. 23-3050.

Date: May 12, 2011

/Steven B. Samuels/  
 Steven B. Samuels  
 Registration No. 37,711

WOODCOCK WASHBURN LLP  
 Cira Centre  
 2929 Arch Street, 12th Floor  
 Philadelphia, PA 19104-2891  
 Telephone: (215) 568-3100  
 Facsimile: (215) 568-3439

## Electronic Patent Application Fee Transmittal

<b>Application Number:</b>	12543910
<b>Filing Date:</b>	19-Aug-2009
<b>Title of Invention:</b>	System and Method of Communication Via Embedded Modulation
<b>First Named Inventor/Applicant Name:</b>	Gordon F. Bremer
<b>Filer:</b>	Steven Samuels/Nicole Spencer
<b>Attorney Docket Number:</b>	REMB-0109

Filed as Large Entity

### Utility under 35 USC 111(a) Filing Fees

Description	Fee Code	Quantity	Amount	Sub-Total in USD(\$)
<b>Basic Filing:</b>				
<b>Pages:</b>				
<b>Claims:</b>				
<b>Miscellaneous-Filing:</b>				
<b>Petition:</b>				
<b>Patent-Appeals-and-Interference:</b>				
<b>Post-Allowance-and-Post-Issuance:</b>				
<b>Extension-of-Time:</b>				

Description	Fee Code	Quantity	Amount	Sub-Total in USD(\$)
<b>Miscellaneous:</b>				
Submission- Information Disclosure Stmt	1806	1	180	180
<b>Total in USD (\$)</b>				<b>180</b>

## Electronic Acknowledgement Receipt

<b>EFS ID:</b>	10074371
<b>Application Number:</b>	12543910
<b>International Application Number:</b>	
<b>Confirmation Number:</b>	8306
<b>Title of Invention:</b>	System and Method of Communication Via Embedded Modulation
<b>First Named Inventor/Applicant Name:</b>	Gordon F. Bremer
<b>Customer Number:</b>	23377
<b>Filer:</b>	Steven Samuels/Nicole Spencer
<b>Filer Authorized By:</b>	Steven Samuels
<b>Attorney Docket Number:</b>	REMB-0109
<b>Receipt Date:</b>	12-MAY-2011
<b>Filing Date:</b>	19-AUG-2009
<b>Time Stamp:</b>	16:31:29
<b>Application Type:</b>	Utility under 35 USC 111(a)

### Payment information:

Submitted with Payment	yes
Payment Type	Deposit Account
Payment was successfully received in RAM	\$180
RAM confirmation Number	3111
Deposit Account	233050
Authorized User	

### File Listing:

Document Number	Document Description	File Name	File Size(Bytes)/ Message Digest	Multi Part /Zip	Pages (if appl.)
-----------------	----------------------	-----------	-------------------------------------	--------------------	---------------------



1	NPL Documents	IntrnlTelecomUnion_DataCom mOverTeleNetwork_1991_13p gs.PDF	162067 ce922ed348e487602f45e6176e09f1058515 c044	no	13
<b>Warnings:</b>					
<b>Information:</b>					
2	NPL Documents	IntrnlTelecomUnion_TerminEq uipProtoTelematServ_1997_16 7pgs.PDF	1196727 92d1fc2e37e416c992267a237a79ac0bf714 9b30	no	176
<b>Warnings:</b>					
<b>Information:</b>					
3	NPL Documents	IntrnlTelecomUnion_TerminEq uipProtoTelematServ_1997_60. PDF	309416 308e1d7644fe634384cb124e54baa3c704ff6 7b4e	no	60
<b>Warnings:</b>					
<b>Information:</b>					
4	NPL Documents	IntrnlTelecomUnion_Terminals TelematicServices_1998_110. PDF	668492 1720750f17acb154f6d916c73b29ab5d4d3 21495	no	110
<b>Warnings:</b>					
<b>Information:</b>					
5	NPL Documents	IntrnlTelecomUnion_Terminals TelematicServices_1998_18pgs .PDF	138144 2c14ed4663c6544e2169bb1933573d5d55 466400	no	18
<b>Warnings:</b>					
<b>Information:</b>					
6	NPL Documents	IntrnlTelecomUnion_Terminals TelematicServices_1997_14pgs .PDF	109169 3f0f907feba441e32179211dd84f02cfe3fff 6c	no	14
<b>Warnings:</b>					
<b>Information:</b>					
7	NPL Documents	IntrnlTelecomUnion_Terminals TelematicServices_1998_10pgs .PDF	94635 02e632b3266452c563a9827926594f1f2fc3 453f	no	10
<b>Warnings:</b>					
<b>Information:</b>					
8	Information Disclosure Statement (IDS) Filed (SB/08)	REMB-0109_SIDS_1449_5-12-1 1.PDF	11996 e5ee0e7632ce12f0f629f67122045848788b a843	no	1
<b>Warnings:</b>					
<b>Information:</b>					
This is not an USPTO supplied IDS fillable form					
9	Transmittal Letter	REMB-0109_SIDS_Trans_5-12-1 1.PDF	14528 071d2fddebbs167e968c56f61ee57f577fc 00be	no	3

<b>Warnings:</b>					
<b>Information:</b>					
10	Fee Worksheet (PTO-875)	fee-info.pdf	30279	no	2
			4ad0bdf2310c1bc87f95625c28cb5aa3819ff418		
<b>Warnings:</b>					
<b>Information:</b>					
<b>Total Files Size (in bytes):</b>				2735453	
<p><b>This Acknowledgement Receipt evidences receipt on the noted date by the USPTO of the indicated documents, characterized by the applicant, and including page counts, where applicable. It serves as evidence of receipt similar to a Post Card, as described in MPEP 503.</b></p> <p><b><u>New Applications Under 35 U.S.C. 111</u></b>  <b>If a new application is being filed and the application includes the necessary components for a filing date (see 37 CFR 1.53(b)-(d) and MPEP 506), a Filing Receipt (37 CFR 1.54) will be issued in due course and the date shown on this Acknowledgement Receipt will establish the filing date of the application.</b></p> <p><b><u>National Stage of an International Application under 35 U.S.C. 371</u></b>  <b>If a timely submission to enter the national stage of an international application is compliant with the conditions of 35 U.S.C. 371 and other applicable requirements a Form PCT/DO/EO/903 indicating acceptance of the application as a national stage submission under 35 U.S.C. 371 will be issued in addition to the Filing Receipt, in due course.</b></p> <p><b><u>New International Application Filed with the USPTO as a Receiving Office</u></b>  <b>If a new international application is being filed and the international application includes the necessary components for an international filing date (see PCT Article 11 and MPEP 1810), a Notification of the International Application Number and of the International Filing Date (Form PCT/RO/105) will be issued in due course, subject to prescriptions concerning national security, and the date shown on this Acknowledgement Receipt will establish the international filing date of the application.</b></p>					

**RECEIVED  
CENTRAL FAX CENTER**

**MAY 12 2011**

Substitute for 1449/PTO  <b>INFORMATION DISCLOSURE STATEMENT BY APPLICANT</b>  <i>(use as many sheets as necessary)</i>			<i>Complete if Known</i>	
			Application Number	12/543,910
			Filing Date	August 19, 2009
			First Named Inventor	Gordon F. Bremer
			Art Unit	2611
Examiner Name	Dac V. Ha			
Attorney Docket Number	REMB-0109			
Sheet	1	of	1	

NON PATENT LITERATURE DOCUMENTS			
Examiner Initials	Cite No.	Include name of the author, title of the article (when appropriate), title of the item (book, magazine, journal, serial, symposium, catalog, etc.), date, page(s), Volume-Issue Number(s), publisher, city and/or country where published.	T
	253	International Telecommunications Union, Telecommunication Standardization Sector of ITU (ITU-T), Series T: Terminal Equipments and Protocols For Telematic Services, "Procedures for Document Facsimile Transmission in the General Switched Telephone Network", ITU-T Recommendation T.30, July 1996, 176 pages	
	254	International Telecommunications Union, The International Telegraph and Telephone Consultative Committee (CCITT), Data Communication Over The Telephone Network, "A 2-Wire Modem For Facsimile Applications With Rates Up to 14 400 bit/s", Recommendation V.17, February 1991, 13 pages	
	255	International Telecommunications Union, Telecommunication Standardization Sector of ITU (ITU-T), Series T: Terminal Equipments and Protocols For Telematic Services, "Standardization of Group 3 Facsimile Terminals for Document Transmission", ITU-T Recommendation T.4, July 1996, 60 pages	
	256	International Telecommunications Union, Telecommunication Standardization Sector of ITU (ITU-T), Series T: Terminals For Telematic Services, "Standardization of Group 3 Facsimile Terminals for Document Transmission", ITU-T Recommendation T.4 - Amendment 1, July 1997, 10 pages	
	257	International Telecommunications Union, Telecommunication Standardization Sector of ITU (ITU-T), Series T: Terminals For Telematic Services, "Standardization of Group 3 Facsimile Terminals for Document Transmission", ITU-T Recommendation T.4 - Amendment 2, October 1997, 14 pages	
	258	International Telecommunications Union, Telecommunication Standardization Sector of ITU (ITU-T), Series T: Terminals For Telematic Services, "Procedures for Document Facsimile Transmission in the General Switched Telephone Network", ITU-T Recommendation T.30 - Amendment 1, July 1997, 110 pages	
	259	International Telecommunications Union, Telecommunication Standardization Sector of ITU (ITU-T), Series T: Terminals For Telematic Services, "Procedures for Document Facsimile Transmission in the General Switched Telephone Network", ITU-T Recommendation T.30 - Amendment 2, October 1997, 18 pages	

Examiner Signature		Date Considered	
--------------------	--	-----------------	--



INTELLECTUAL PROPERTY LAW  
ATLANTA • PHILADELPHIA • SEATTLE

RECEIVED  
CENTRAL FAX CENTER

MAY 12 2011

# FACSIMILE

DATE: May 12, 2011  
**OFFICIAL PAPER**

JOB CODE:

*Please deliver this and the following pages to:*

Examiner: **Dac V. Ha**

U.S.P.T.O. Group Art Unit: **2611**

Telecopier No.: **571-273-8300**

U.S. Serial No.: **12/543,910**

Client/Matter No.: **REMB-0109**

Sender's Name: **Steven B. Samuels/Joseph R. Klinicki**

Pages to Follow: **4**

If transmission is not complete, please call our Philadelphia Office at (215) 568-3100.

**COVER MESSAGE:**

**OFFICIAL FACSIMILE. PLEASE DELIVER TO EXAMINER IMMEDIATELY.**

Attached hereto is the following document:

- 1) Supplemental Information Disclosure Statement transmittal (3 pages)
- 2) Information Disclosure Statement by Applicant (1 page)

Please find attached the SIDS which was electronically filed today (5/12/11). Please contact the above identified Sender if you desire copies of the documents cited in the SIDS provided directly via fax, email or other means. Please confirm receipt of this facsimile.

THIS MESSAGE IS INTENDED ONLY FOR THE USE OF THE INDIVIDUAL OR ENTITY TO WHICH IT IS ADDRESSED AND MAY CONTAIN INFORMATION THAT IS PRIVILEGED, CONFIDENTIAL AND EXEMPT FROM DISCLOSURE UNDER APPLICABLE LAW. IF THE READER OF THIS MESSAGE IS NOT THE INTENDED RECIPIENT, OR THE EMPLOYEE OR AGENT RESPONSIBLE FOR DELIVERY OF THE MESSAGE TO THE INTENDED RECIPIENT, YOU ARE HEREBY NOTIFIED THAT ANY DISSEMINATION, DISTRIBUTION OR COPYING OF THIS COMMUNICATION IS STRICTLY PROHIBITED. IF YOU HAVE RECEIVED THIS COMMUNICATION IN ERROR, PLEASE NOTIFY US IMMEDIATELY BY TELEPHONE AND RETURN THE ORIGINAL TO US AT THE ABOVE ADDRESS VIA THE U.S. POSTAL SERVICE. THANK YOU.

WOODCOCK WASHBURN LLP  
A Partnership Including Professional Corporations  
[www.woodcock.com](http://www.woodcock.com)

RECEIVED  
CENTRAL FAX CENTER

MAY 12 2011

DOCKET NO.: REMB-0109

PATENT

IN THE UNITED STATES PATENT AND TRADEMARK OFFICE

In Re Application of:

Gordon F. Bremer

Confirmation No.: 8306

Application No.: 12/543,910

Group Art Unit: 2611

Filing Date: August 19, 2009

Examiner: Dac V. Ha

For: SYSTEM AND METHOD OF COMMUNICATION VIA EMBEDDED  
MODULATION

Filed Via EFS

INFORMATION DISCLOSURE STATEMENT

Pursuant to 37 CFR § 1.56 and in accordance with 37 CFR §§ 1.97-1.98, information relating to the above-identified application is hereby disclosed. Inclusion of information in this statement is not to be construed as an admission that this information is material as that term is defined in 37 CFR § 1.56(b).

IDS Filed Under 37 CFR 1.97(b)

In accordance with § 1.97(b), since this Information Disclosure Statement is being filed either within three months of the filing date of the above-identified application, within three months of the date of entry into the national stage of the above identified application as set forth in § 1.491, before the mailing date of a first Office Action on the merits of the above-identified application, or before the mailing date of a first Office Action after the filing of request for continued examination under § 1.114, no additional fee is required.

IDS filed Under 37 CFR 1.97(c)

In accordance with § 1.97(c), this Information Disclosure Statement is being filed after the period set forth in § 1.97(b) above but before the mailing date of either a Final Action under § 1.116 or a Notice of Allowance under § 1.311, or before an action that otherwise closes prosecution in the application, therefore:

- Certification in Accordance with § 1.97(e) is attached; or  
 The fee of \$180.00 as set forth in § 1.17(p) is attached.

**IDS filed Under 37 CFR 1.97(d)**

In accordance with § 1.97(d), this Information Disclosure Statement is being filed after the mailing date of either a Final Action under § 1.113 or a Notice of Allowance under § 1.311 but before, or simultaneously with, the payment of the Issue Fee, therefore included are: Certification in Accordance with § 1.97(e); and the submission fee of \$180.00 as set forth in § 1.17(p).

**CONTENT OF IDS PURSUANT TO 37 CFR 1.98**

Copies of reference numbers listed on the attached Form PTO-1449 are not required to be submitted pursuant to 37 CFR § 1.98(a)(2)(iii).

Copies of reference numbers 253-259 listed on the attached Form PTO-1449 are enclosed herewith.

Copies of reference numbers are not being submitted because they were previously cited by or submitted to the U.S. Patent and Trademark Office in patent application number , filed for which a claim for priority under 35 U.S.C. § 120 has been made in the instant application.

The month of publication for reference numbers is not available. However, the year of publication for these references is sufficiently earlier than the effective US filing date and any foreign priority date so that the particular month of publication is not in issue pursuant to 37 CFR § 1.98(b).

**REFERENCES IN A LANGUAGE OTHER THAN ENGLISH**

The following documents are not in the English language. Accordingly, a concise explanation of the relevance of the document was incorporated in the specification passages identified below, the document was identified in a foreign communication as identified below or an English language counterpart application has been provided as indicated below.

Foreign Language Document	Cite No.	Pages of Reference in Specification or Relevance of Document

DOCKET NO.: REMB-0109

PATENT

Foreign Language Document	Cite No.	English Language Counterpart	Cite No.

CERTIFICATION IN ACCORDANCE WITH § 1.97(e)

I hereby certify that:

- Each item of information contained in this information disclosure statement was first cited in any communication from a foreign patent office in a counterpart foreign application not more than three months prior to the filing of this information disclosure statement.
- No item of information contained in this information disclosure statement was cited in a communication from a foreign patent office in a counterpart foreign application, and, to the knowledge of the person signing the certification after making reasonable inquiry, no item of information contained in this information disclosure statement was known to any individual designated in § 1.56(c) more than three months prior to the filing of this information disclosure statement.

Please charge any deficiency or credit any overpayment to Deposit Account No. 23-3050.

Date: May 12, 2011

/Steven B. Samuels/

Steven B. Samuels

Registration No. 37,711

WOODCOCK WASHBURN LLP  
Cira Centre  
2929 Arch Street, 12th Floor  
Philadelphia, PA 19104-2891  
Telephone: (215) 568-3100  
Facsimile: (215) 568-3439

MAY 12 2011

Substitute for 1449/PTO			<i>Complete if Known</i>	
<b>INFORMATION DISCLOSURE STATEMENT BY APPLICANT</b>			Application Number	12/543,910
			Filing Date	August 19, 2009
			First Named Inventor	Gordon F. Bremer
			Art Unit	2611
			Examiner Name	Dac V. Ha
<i>(use as many sheets as necessary)</i>			Attorney Docket Number	REMB-0109
Sheet	1	of	1	

NON PATENT LITERATURE DOCUMENTS				
Examiner Initials	Cite No.	Include name of the author, title of the article (when appropriate), title of the item (book, magazine, journal, serial, symposium, catalog, etc.), date, page(s), Volume-Issue Number(s), publisher, city and/or country where published.		T
	253	International Telecommunications Union, Telecommunication Standardization Sector of ITU (ITU-T), Series T: Terminal Equipments and Protocols For Telematic Services, "Procedures for Document Facsimile Transmission in the General Switched Telephone Network", ITU-T Recommendation T.30, July 1996, 176 pages		
	254	International Telecommunications Union, The International Telegraph and Telephone Consultative Committee (CCITT), Data Communication Over The Telephone Network, "A 2-Wire Modem For Facsimile Applications With Rates Up to 14 400 bit/s", Recommendation V.17, February 1991, 13 pages		
	255	International Telecommunications Union, Telecommunication Standardization Sector of ITU (ITU-T), Series T: Terminal Equipments and Protocols For Telematic Services, "Standardization of Group 3 Facsimile Terminals for Document Transmission", ITU-T Recommendation T.4, July 1996, 60 pages		
	256	International Telecommunications Union, Telecommunication Standardization Sector of ITU (ITU-T), Series T: Terminal: For Telematic Services, "Standardization of Group 3 Facsimile Terminals for Document Transmission", ITU-T Recommendation T.4 - Amendment 1, July 1997, 10 pages		
	257	International Telecommunications Union, Telecommunication Standardization Sector of ITU (ITU-T), Series T: Terminal: For Telematic Services, "Standardization of Group 3 Facsimile Terminals for Document Transmission", ITU-T Recommendation T.4 - Amendment 2, October 1997, 14 pages		
	258	International Telecommunications Union, Telecommunication Standardization Sector of ITU (ITU-T), Series T: Terminal: For Telematic Services, "Procedures for Document Facsimile Transmission in the General Switched Telephone Network", ITU-T Recommendation T.30 - Amendment 1, July 1997, 110 pages		
	259	International Telecommunications Union, Telecommunication Standardization Sector of ITU (ITU-T), Series T: Terminal: For Telematic Services, "Procedures for Document Facsimile Transmission in the General Switched Telephone Network", ITU-T Recommendation T.30 - Amendment 2, October 1997, 18 pages		

Examiner Signature		Date Considered	
--------------------	--	-----------------	--





INTELLECTUAL PROPERTY LAW  
ATLANTA • PHILADELPHIA • SEATTLE

RECEIVED  
CENTRAL FAX CENTER  
MAY 12 2011

# FACSIMILE

DATE: May 12, 2011  
**OFFICIAL PAPER**

JOB CODE:

*Please deliver this and the following pages to:*

Examiner: **Dac V. Ha**

U.S.P.T.O. Group Art Unit: **2611**

Telecopier No.: **571-273-8300**

U.S. Serial No.: **12/543,910**

Client/Matter No.: **REMB-0109**

Sender's Name: **Steven B. Samuels/Joseph R. Klinicki**

Pages to Follow: **4**

If transmission is not complete, please call our Philadelphia Office at (215) 568-3100.

**COVER MESSAGE:**

**OFFICIAL FACSIMILE. PLEASE DELIVER TO EXAMINER IMMEDIATELY.**

Attached hereto is the following document:

- 1) Supplemental Information Disclosure Statement transmittal (3 pages)
- 2) Information Disclosure Statement by Applicant (1 page)

Please find attached the SIDS which was electronically filed today (5/12/11). Please contact the above identified Sender if you desire copies of the documents cited in the SIDS provided directly via fax, email or other means.

THIS MESSAGE IS INTENDED ONLY FOR THE USE OF THE INDIVIDUAL OR ENTITY TO WHICH IT IS ADDRESSED AND MAY CONTAIN INFORMATION THAT IS PRIVILEGED, CONFIDENTIAL AND EXEMPT FROM DISCLOSURE UNDER APPLICABLE LAW. IF THE READER OF THIS MESSAGE IS NOT THE INTENDED RECIPIENT, OR THE EMPLOYEE OR AGENT RESPONSIBLE FOR DELIVERY OF THE MESSAGE TO THE INTENDED RECIPIENT, YOU ARE HEREBY NOTIFIED THAT ANY DISSEMINATION, DISTRIBUTION OR COPYING OF THIS COMMUNICATION IS STRICTLY PROHIBITED. IF YOU HAVE RECEIVED THIS COMMUNICATION IN ERROR, PLEASE NOTIFY US IMMEDIATELY BY TELEPHONE AND RETURN THE ORIGINAL TO US AT THE ABOVE ADDRESS VIA THE U.S. POSTAL SERVICE. THANK YOU.

WOODCOCK WASHBURN LLP  
A Partnership Including Professional Corporations  
[www.woodcock.com](http://www.woodcock.com)

RECEIVED  
CENTRAL FAX CENTER  
MAY 12 2011

DOCKET NO.: REMB-0109

PATENT

IN THE UNITED STATES PATENT AND TRADEMARK OFFICE

In Re Application of:

Gordon F. Bremer

Confirmation No.: 8306

Application No.: 12/543,910

Group Art Unit: 2611

Filing Date: August 19, 2009

Examiner: DRC V. Ha

For: **SYSTEM AND METHOD OF COMMUNICATION VIA EMBEDDED  
MODULATION**

Filed Via EFS

**INFORMATION DISCLOSURE STATEMENT**

Pursuant to 37 CFR § 1.56 and in accordance with 37 CFR §§ 1.97-1.98, information relating to the above-identified application is hereby disclosed. Inclusion of information in this statement is not to be construed as an admission that this information is material as that term is defined in 37 CFR § 1.56(b).

**IDS Filed Under 37 CFR 1.97(b)**

In accordance with § 1.97(b), since this Information Disclosure Statement is being filed either within three months of the filing date of the above-identified application, within three months of the date of entry into the national stage of the above identified application as set forth in § 1.491, before the mailing date of a first Office Action on the merits of the above-identified application, or before the mailing date of a first Office Action after the filing of request for continued examination under § 1.114, no additional fee is required.

**IDS filed Under 37 CFR 1.97(c)**

In accordance with § 1.97(c), this Information Disclosure Statement is being filed after the period set forth in § 1.97(b) above but before the mailing date of either a Final Action under § 1.116 or a Notice of Allowance under § 1.311, or before an action that otherwise closes prosecution in the application, therefore:

- Certification in Accordance with § 1.97(e) is attached; or  
 The fee of \$180.00 as set forth in § 1.17(p) is attached.

**IDS filed Under 37 CFR 1.97(d)**

In accordance with § 1.97(d), this Information Disclosure Statement is being filed after the mailing date of either a Final Action under § 1.113 or a Notice of Allowance under § 1.311 but before, or simultaneously with, the payment of the Issue Fee, therefore included are: Certification in Accordance with § 1.97(e); and the submission fee of \$180.00 as set forth in § 1.17(p).

**CONTENT OF IDS PURSUANT TO 37 CFR 1.98**

Copies of reference numbers listed on the attached Form PTO-1449 are not required to be submitted pursuant to 37 CFR § 1.98(a)(2)(iii).

Copies of reference numbers 253-259 listed on the attached Form PTO-1449 are enclosed herewith.

Copies of reference numbers are not being submitted because they were previously cited by or submitted to the U.S. Patent and Trademark Office in patent application number , filed for which a claim for priority under 35 U.S.C. § 120 has been made in the instant application.

The month of publication for reference numbers is not available. However, the year of publication for these references is sufficiently earlier than the effective US filing date and any foreign priority date so that the particular month of publication is not in issue pursuant to 37 CFR § 1.98(b).

**REFERENCES IN A LANGUAGE OTHER THAN ENGLISH**

The following documents are not in the English language. Accordingly, a concise explanation of the relevance of the document was incorporated in the specification passages identified below, the document was identified in a foreign communication as identified below or an English language counterpart application has been provided as indicated below.

Foreign Language Document	Cite No.	Pages of Reference in Specification or Relevance of Document

DOCKET NO.: REMB-0109

PATENT

Foreign Language Document	Cite No.	English Language Counterpart	Cite No.

**CERTIFICATION IN ACCORDANCE WITH § 1.97(e)**

I hereby certify that:

- Each item of information contained in this information disclosure statement was first cited in any communication from a foreign patent office in a counterpart foreign application not more than three months prior to the filing of this information disclosure statement.
- No item of information contained in this information disclosure statement was cited in a communication from a foreign patent office in a counterpart foreign application, and, to the knowledge of the person signing the certification after making reasonable inquiry, no item of information contained in this information disclosure statement was known to any individual designated in § 1.56(c) more than three months prior to the filing of this information disclosure statement.

Please charge any deficiency or credit any overpayment to Deposit Account No. 23-3050.

Date: May 12, 2011

/Steven B. Samuels/  
Steven B. Samuels  
Registration No. 37,711

WOODCOCK WASHBURN LLP  
Cira Centre  
2929 Arch Street, 12th Floor  
Philadelphia, PA 19104-2891  
Telephone: (215) 568-3100  
Facsimile: (215) 568-3439

**POWER OF ATTORNEY TO PROSECUTE APPLICATIONS BEFORE THE USPTO**

I hereby revoke all previous powers of attorney given in the application identified in the attached statement under 37 CFR 3.73(b).

I hereby appoint:

Practitioners associated with the Customer Number: 15027

OR

Practitioner(s) named below (if more than ten patent practitioners are to be named, then a customer number must be used):

Name	Registration Number	Name	Registration Number

as attorney(s) or agent(s) to represent the undersigned before the United States Patent and Trademark Office (USPTO) in connection with any and all patent applications assigned only to the undersigned according to the USPTO assignment records or assignment documents attached to this form in accordance with 37 CFR 3.73(b).

Please change the correspondence address for the application identified in the attached statement under 37 CFR 3.73(b) to:

The address associated with Customer Number: 15027

OR

<input type="checkbox"/> Firm or Individual Name			
Address			
City	State	Zip	
Country			
Telephone	Email		

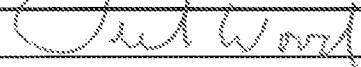
Assignee Name and Address:

Summit Technology Systems, LP  
401 City Avenue  
Bala Cynwyd, PA 19004

**A copy of this form, together with a statement under 37 CFR 3.73(b) (Form PTO/SB/98 or equivalent) is required to be filed in each application in which this form is used. The statement under 37 CFR 3.73(b) may be completed by one of the practitioners appointed in this form if the appointed practitioner is authorized to act on behalf of the assignee, and must identify the application in which this Power of Attorney is to be filed.**

**SIGNATURE of Assignee of Record**

The individual whose signature and title is supplied below is authorized to act on behalf of the assignee

Signature		Date	6/9/2011
Name	Derek Wood	Telephone	410-722-0100
Title	Secretary of Rembrandt Technologies Management II, LLC, general partner of Assignee		

This collection of information is required by 37 CFR 1.31, 1.32 and 1.33. The information is required to obtain or retain a benefit by the public which is to file (and by the USPTO to process) an application. Confidentiality is governed by 35 U.S.C. 122 and 37 CFR 1.11 and 1.14. This collection is estimated to take 3 minutes to complete, including gathering, preparing, and submitting the completed application form to the USPTO. Time will vary depending upon the individual case. Any comments on the amount of time you require to complete this form and/or suggestions for reducing this burden, should be sent to the Chief Information Officer, U.S. Patent and Trademark Office, U.S. Department of Commerce, P.O. Box 1450, Alexandria, VA 22313-1450. DO NOT SEND FEES OR COMPLETED FORMS TO THIS ADDRESS. SEND TO: Commissioner for Patents, P.O. Box 1450, Alexandria, VA 22313-1450.

If you need assistance in completing the form, call 1-800-PTO-9199 and select option 2.

## Privacy Act Statement

The **Privacy Act of 1974 (P.L. 93-579)** requires that you be given certain information in connection with your submission of the attached form related to a patent application or patent. Accordingly, pursuant to the requirements of the Act, please be advised that: (1) the general authority for the collection of this information is 35 U.S.C. 2(b)(2); (2) furnishing of the information solicited is voluntary; and (3) the principal purpose for which the information is used by the U.S. Patent and Trademark Office is to process and/or examine your submission related to a patent application or patent. If you do not furnish the requested information, the U.S. Patent and Trademark Office may not be able to process and/or examine your submission, which may result in termination of proceedings or abandonment of the application or expiration of the patent.

The information provided by you in this form will be subject to the following routine uses:

1. The information on this form will be treated confidentially to the extent allowed under the Freedom of Information Act (5 U.S.C. 552) and the Privacy Act (5 U.S.C. 552a). Records from this system of records may be disclosed to the Department of Justice to determine whether disclosure of these records is required by the Freedom of Information Act.
2. A record from this system of records may be disclosed, as a routine use, in the course of presenting evidence to a court, magistrate, or administrative tribunal, including disclosures to opposing counsel in the course of settlement negotiations.
3. A record in this system of records may be disclosed, as a routine use, to a Member of Congress submitting a request involving an individual, to whom the record pertains, when the individual has requested assistance from the Member with respect to the subject matter of the record.
4. A record in this system of records may be disclosed, as a routine use, to a contractor of the Agency having need for the information in order to perform a contract. Recipients of information shall be required to comply with the requirements of the Privacy Act of 1974, as amended, pursuant to 5 U.S.C. 552a(m).
5. A record related to an International Application filed under the Patent Cooperation Treaty in this system of records may be disclosed, as a routine use, to the International Bureau of the World Intellectual Property Organization, pursuant to the Patent Cooperation Treaty.
6. A record in this system of records may be disclosed, as a routine use, to another federal agency for purposes of National Security review (35 U.S.C. 181) and for review pursuant to the Atomic Energy Act (42 U.S.C. 218(c)).
7. A record from this system of records may be disclosed, as a routine use, to the Administrator, General Services, or his/her designee, during an inspection of records conducted by GSA as part of that agency's responsibility to recommend improvements in records management practices and programs, under authority of 44 U.S.C. 2904 and 2906. Such disclosure shall be made in accordance with the GSA regulations governing inspection of records for this purpose, and any other relevant (*i.e.*, GSA or Commerce) directive. Such disclosure shall not be used to make determinations about individuals.
8. A record from this system of records may be disclosed, as a routine use, to the public after either publication of the application pursuant to 35 U.S.C. 122(b) or issuance of a patent pursuant to 35 U.S.C. 151. Further, a record may be disclosed, subject to the limitations of 37 CFR 1.14, as a routine use, to the public if the record was filed in an application which became abandoned or in which the proceedings were terminated and which application is referenced by either a published application, an application open to public inspection or an issued patent.
9. A record from this system of records may be disclosed, as a routine use, to a Federal, State, or local law enforcement agency, if the USPTO becomes aware of a violation or potential violation of law or regulation.

Under the Paperwork Reduction Act of 1995, no persons are required to respond to a collection of information unless it displays a valid OMB control number.

**STATEMENT UNDER 37 CFR 3.73(b)**

Applicant/Patent Owner: SUMMIT TECHNOLOGY SYSTEMS, LP

Application No./Patent No.: 12/543,910 Filed/Issue Date: 08-19-2009

Titled: SYSTEM AND METHOD OF COMMUNICATION VIA EMBEDDED MODULATION

SUMMIT TECHNOLOGY SYSTEMS, LP, a CORPORATION  
(Name of Assignee) (Type of Assignee, e.g., corporation, partnership, university, government agency, etc.)

states that it is:

- 1.  the assignee of the entire right, title, and interest in;
- 2.  an assignee of less than the entire right, title, and interest in  
(The extent (by percentage) of its ownership interest is \_\_\_\_\_ %); or
- 3.  the assignee of an undivided interest in the entirety of (a complete assignment from one of the joint inventors was made)

the patent application/patent identified above, by virtue of either:

A.  An assignment from the inventor(s) of the patent application/patent identified above. The assignment was recorded in the United States Patent and Trademark Office at Reel \_\_\_\_\_, Frame \_\_\_\_\_, or for which a copy therefore is attached.

**OR**

B.  A chain of title from the inventor(s), of the patent application/patent identified above, to the current assignee as follows:

1. From: INVENTORS To: PARADYNE CORPORATION

The document was recorded in the United States Patent and Trademark Office at  
Reel 018986, Frame 0586, or for which a copy thereof is attached.

2. From: ZHONE TECHNOLOGIES, INC.; PARADYNE To: SUMMIT TECHNOLOGY SYSTEMS, LP

The document was recorded in the United States Patent and Trademark Office at  
Reel 019649, Frame 0818, or for which a copy thereof is attached.

3. From: \_\_\_\_\_ To: \_\_\_\_\_

The document was recorded in the United States Patent and Trademark Office at  
Reel \_\_\_\_\_, Frame \_\_\_\_\_, or for which a copy thereof is attached.

Additional documents in the chain of title are listed on a supplemental sheet(s).

As required by 37 CFR 3.73(b)(1)(i), the documentary evidence of the chain of title from the original owner to the assignee was, or concurrently is being, submitted for recordation pursuant to 37 CFR 3.11.

[NOTE: A separate copy (i.e., a true copy of the original assignment document(s)) must be submitted to Assignment Division in accordance with 37 CFR Part 3, to record the assignment in the records of the USPTO. See MPEP 302.08]

The undersigned (whose title is supplied below) is authorized to act on behalf of the assignee.

/Michael A. Koptiw/  
Signature

June 13, 2011  
Date

Michael A. Koptiw/Reg. No. 57,900  
Printed or Typed Name

Attorney of Record  
Title

## Privacy Act Statement

The **Privacy Act of 1974 (P.L. 93-579)** requires that you be given certain information in connection with your submission of the attached form related to a patent application or patent. Accordingly, pursuant to the requirements of the Act, please be advised that: (1) the general authority for the collection of this information is 35 U.S.C. 2(b)(2); (2) furnishing of the information solicited is voluntary; and (3) the principal purpose for which the information is used by the U.S. Patent and Trademark Office is to process and/or examine your submission related to a patent application or patent. If you do not furnish the requested information, the U.S. Patent and Trademark Office may not be able to process and/or examine your submission, which may result in termination of proceedings or abandonment of the application or expiration of the patent.

The information provided by you in this form will be subject to the following routine uses:

1. The information on this form will be treated confidentially to the extent allowed under the Freedom of Information Act (5 U.S.C. 552) and the Privacy Act (5 U.S.C. 552a). Records from this system of records may be disclosed to the Department of Justice to determine whether disclosure of these records is required by the Freedom of Information Act.
2. A record from this system of records may be disclosed, as a routine use, in the course of presenting evidence to a court, magistrate, or administrative tribunal, including disclosures to opposing counsel in the course of settlement negotiations.
3. A record in this system of records may be disclosed, as a routine use, to a Member of Congress submitting a request involving an individual, to whom the record pertains, when the individual has requested assistance from the Member with respect to the subject matter of the record.
4. A record in this system of records may be disclosed, as a routine use, to a contractor of the Agency having need for the information in order to perform a contract. Recipients of information shall be required to comply with the requirements of the Privacy Act of 1974, as amended, pursuant to 5 U.S.C. 552a(m).
5. A record related to an International Application filed under the Patent Cooperation Treaty in this system of records may be disclosed, as a routine use, to the International Bureau of the World Intellectual Property Organization, pursuant to the Patent Cooperation Treaty.
6. A record in this system of records may be disclosed, as a routine use, to another federal agency for purposes of National Security review (35 U.S.C. 181) and for review pursuant to the Atomic Energy Act (42 U.S.C. 218(c)).
7. A record from this system of records may be disclosed, as a routine use, to the Administrator, General Services, or his/her designee, during an inspection of records conducted by GSA as part of that agency's responsibility to recommend improvements in records management practices and programs, under authority of 44 U.S.C. 2904 and 2906. Such disclosure shall be made in accordance with the GSA regulations governing inspection of records for this purpose, and any other relevant (*i.e.*, GSA or Commerce) directive. Such disclosure shall not be used to make determinations about individuals.
8. A record from this system of records may be disclosed, as a routine use, to the public after either publication of the application pursuant to 35 U.S.C. 122(b) or issuance of a patent pursuant to 35 U.S.C. 151. Further, a record may be disclosed, subject to the limitations of 37 CFR 1.14, as a routine use, to the public if the record was filed in an application which became abandoned or in which the proceedings were terminated and which application is referenced by either a published application, an application open to public inspection or an issued patent.
9. A record from this system of records may be disclosed, as a routine use, to a Federal, State, or local law enforcement agency, if the USPTO becomes aware of a violation or potential violation of law or regulation.



## Electronic Acknowledgement Receipt

<b>EFS ID:</b>	10289992
<b>Application Number:</b>	12543910
<b>International Application Number:</b>	
<b>Confirmation Number:</b>	8306
<b>Title of Invention:</b>	System and Method of Communication Via Embedded Modulation
<b>First Named Inventor/Applicant Name:</b>	Gordon F. Bremer
<b>Customer Number:</b>	23377
<b>Filer:</b>	Michael Jordan/Darleen Yacovone
<b>Filer Authorized By:</b>	Michael Jordan
<b>Attorney Docket Number:</b>	REMB-0109
<b>Receipt Date:</b>	13-JUN-2011
<b>Filing Date:</b>	19-AUG-2009
<b>Time Stamp:</b>	15:32:24
<b>Application Type:</b>	Utility under 35 USC 111(a)

### Payment information:

Submitted with Payment	no
------------------------	----

### File Listing:

Document Number	Document Description	File Name	File Size(Bytes)/ Message Digest	Multi Part /.zip	Pages (if appl.)
1	Power of Attorney	REMB_0109_USCON_Executed _POA_as_filed.pdf	753834 <small>4bce63dcbfb8997b275a802e2768d27267f cc736</small>	no	2

### Warnings:

The page size in the PDF is too large. The pages should be 8.5 x 11 or A4. If this PDF is submitted, the pages will be resized upon entry into the Image File Wrapper and may affect subsequent processing

**Information:**

2	Assignee showing of ownership per 37 CFR 3.73(b).	REMB_0109_USCON_373b_as_ filed.pdf	427862  39597a5cd0376bb9b78419bb63a4d5d3f5 b2c6e	no	2
---	---	---------------------------------------	---	----	---

**Warnings:**

**Information:**

<b>Total Files Size (in bytes):</b>	1181696
-------------------------------------	---------

**This Acknowledgement Receipt evidences receipt on the noted date by the USPTO of the indicated documents, characterized by the applicant, and including page counts, where applicable. It serves as evidence of receipt similar to a Post Card, as described in MPEP 503.**

**New Applications Under 35 U.S.C. 111**

**If a new application is being filed and the application includes the necessary components for a filing date (see 37 CFR 1.53(b)-(d) and MPEP 506), a Filing Receipt (37 CFR 1.54) will be issued in due course and the date shown on this Acknowledgement Receipt will establish the filing date of the application.**

**National Stage of an International Application under 35 U.S.C. 371**

**If a timely submission to enter the national stage of an international application is compliant with the conditions of 35 U.S.C. 371 and other applicable requirements a Form PCT/DO/EO/903 indicating acceptance of the application as a national stage submission under 35 U.S.C. 371 will be issued in addition to the Filing Receipt, in due course.**

**New International Application Filed with the USPTO as a Receiving Office**

**If a new international application is being filed and the international application includes the necessary components for an international filing date (see PCT Article 11 and MPEP 1810), a Notification of the International Application Number and of the International Filing Date (Form PCT/RO/105) will be issued in due course, subject to prescriptions concerning national security, and the date shown on this Acknowledgement Receipt will establish the international filing date of the application.**



UNITED STATES PATENT AND TRADEMARK OFFICE

UNITED STATES DEPARTMENT OF COMMERCE  
United States Patent and Trademark Office  
Address: COMMISSIONER FOR PATENTS  
P.O. Box 1450  
Alexandria, Virginia 22313-1450  
www.uspto.gov

APPLICATION NUMBER	FILING OR 371(C) DATE	FIRST NAMED APPLICANT	ATTY. DOCKET NO./TITLE
12/543,910	08/19/2009	Gordon F. Bremer	REMB-0109

**CONFIRMATION NO. 8306**

**POWER OF ATTORNEY NOTICE**

23377  
WOODCOCK WASHBURN LLP  
CIRA CENTRE, 12TH FLOOR  
2929 ARCH STREET  
PHILADELPHIA, PA 19104-2891



Date Mailed: 06/20/2011

**NOTICE REGARDING CHANGE OF POWER OF ATTORNEY**

This is in response to the Power of Attorney filed 06/13/2011.

- The Power of Attorney to you in this application has been revoked by the assignee who has intervened as provided by 37 CFR 3.71. Future correspondence will be mailed to the new address of record(37 CFR 1.33).

/gbien-aime/

Office of Data Management, Application Assistance Unit (571) 272-4000, or (571) 272-4200, or 1-888-786-0101



UNITED STATES PATENT AND TRADEMARK OFFICE

UNITED STATES DEPARTMENT OF COMMERCE  
United States Patent and Trademark Office  
Address: COMMISSIONER FOR PATENTS  
P.O. Box 1450  
Alexandria, Virginia 22313-1450  
www.uspto.gov

APPLICATION NUMBER	FILING OR 371(C) DATE	FIRST NAMED APPLICANT	ATTY. DOCKET NO./TITLE
12/543,910	08/19/2009	Gordon F. Bremer	REMB-0109

**CONFIRMATION NO. 8306**

**POA ACCEPTANCE LETTER**

15027  
Condo Roccia LLP  
3 Greenvale Road  
Moorestown, NJ 08057



Date Mailed: 06/20/2011

**NOTICE OF ACCEPTANCE OF POWER OF ATTORNEY**

This is in response to the Power of Attorney filed 06/13/2011.

The Power of Attorney in this application is accepted. Correspondence in this application will be mailed to the above address as provided by 37 CFR 1.33.

/gbien-aime/

Office of Data Management, Application Assistance Unit (571) 272-4000, or (571) 272-4200, or 1-888-786-0101



NOTICE OF ALLOWANCE AND FEE(S) DUE

15027 7590 07/22/2011
Condo Roccia LLP
1650 Market Street
Suite 2200
Philadelphia, PA 19103

EXAMINER
HA, DAC V
ART UNIT PAPER NUMBER
2611

DATE MAILED: 07/22/2011

Table with 5 columns: APPLICATION NO., FILING DATE, FIRST NAMED INVENTOR, ATTORNEY DOCKET NO., CONFIRMATION NO.

12/543,910 08/19/2009 Gordon F. Bremer REMB-0109 8306

TITLE OF INVENTION: SYSTEM AND METHOD OF COMMUNICATION VIA EMBEDDED MODULATION

Table with 7 columns: APPLN. TYPE, SMALL ENTITY, ISSUE FEE DUE, PUBLICATION FEE DUE, PREV. PAID ISSUE FEE, TOTAL FEE(S) DUE, DATE DUE

nonprovisional NO \$1510 \$300 \$0 \$1810 10/24/2011

THE APPLICATION IDENTIFIED ABOVE HAS BEEN EXAMINED AND IS ALLOWED FOR ISSUANCE AS A PATENT. PROSECUTION ON THE MERITS IS CLOSED. THIS NOTICE OF ALLOWANCE IS NOT A GRANT OF PATENT RIGHTS. THIS APPLICATION IS SUBJECT TO WITHDRAWAL FROM ISSUE AT THE INITIATIVE OF THE OFFICE OR UPON PETITION BY THE APPLICANT. SEE 37 CFR 1.313 AND MPEP 1308.

THE ISSUE FEE AND PUBLICATION FEE (IF REQUIRED) MUST BE PAID WITHIN THREE MONTHS FROM THE MAILING DATE OF THIS NOTICE OR THIS APPLICATION SHALL BE REGARDED AS ABANDONED. THIS STATUTORY PERIOD CANNOT BE EXTENDED. SEE 35 U.S.C. 151. THE ISSUE FEE DUE INDICATED ABOVE DOES NOT REFLECT A CREDIT FOR ANY PREVIOUSLY PAID ISSUE FEE IN THIS APPLICATION. IF AN ISSUE FEE HAS PREVIOUSLY BEEN PAID IN THIS APPLICATION (AS SHOWN ABOVE), THE RETURN OF PART B OF THIS FORM WILL BE CONSIDERED A REQUEST TO REAPPLY THE PREVIOUSLY PAID ISSUE FEE TOWARD THE ISSUE FEE NOW DUE.

HOW TO REPLY TO THIS NOTICE:

I. Review the SMALL ENTITY status shown above.

If the SMALL ENTITY is shown as YES, verify your current SMALL ENTITY status:

A. If the status is the same, pay the TOTAL FEE(S) DUE shown above.

B. If the status above is to be removed, check box 5b on Part B - Fee(s) Transmittal and pay the PUBLICATION FEE (if required) and twice the amount of the ISSUE FEE shown above, or

If the SMALL ENTITY is shown as NO:

A. Pay TOTAL FEE(S) DUE shown above, or

B. If applicant claimed SMALL ENTITY status before, or is now claiming SMALL ENTITY status, check box 5a on Part B - Fee(s) Transmittal and pay the PUBLICATION FEE (if required) and 1/2 the ISSUE FEE shown above.

II. PART B - FEE(S) TRANSMITTAL, or its equivalent, must be completed and returned to the United States Patent and Trademark Office (USPTO) with your ISSUE FEE and PUBLICATION FEE (if required). If you are charging the fee(s) to your deposit account, section "4b" of Part B - Fee(s) Transmittal should be completed and an extra copy of the form should be submitted. If an equivalent of Part B is filed, a request to reapply a previously paid issue fee must be clearly made, and delays in processing may occur due to the difficulty in recognizing the paper as an equivalent of Part B.

III. All communications regarding this application must give the application number. Please direct all communications prior to issuance to Mail Stop ISSUE FEE unless advised to the contrary.

IMPORTANT REMINDER: Utility patents issuing on applications filed on or after Dec. 12, 1980 may require payment of maintenance fees. It is patentee's responsibility to ensure timely payment of maintenance fees when due.

**PART B - FEE(S) TRANSMITTAL**

**Complete and send this form, together with applicable fee(s), to: Mail Mail Stop ISSUE FEE  
 Commissioner for Patents  
 P.O. Box 1450  
 Alexandria, Virginia 22313-1450  
 or Fax (571)-273-2885**

**INSTRUCTIONS:** This form should be used for transmitting the ISSUE FEE and PUBLICATION FEE (if required). Blocks 1 through 5 should be completed where appropriate. All further correspondence including the Patent, advance orders and notification of maintenance fees will be mailed to the current correspondence address as indicated unless corrected below or directed otherwise in Block 1, by (a) specifying a new correspondence address; and/or (b) indicating a separate "FEE ADDRESS" for maintenance fee notifications.

CURRENT CORRESPONDENCE ADDRESS (Note: Use Block 1 for any change of address)

Note: A certificate of mailing can only be used for domestic mailings of the Fee(s) Transmittal. This certificate cannot be used for any other accompanying papers. Each additional paper, such as an assignment or formal drawing, must have its own certificate of mailing or transmission.

15027 7590 07/22/2011  
**Condo Roccia LLP**  
 1650 Market Street  
 Suite 2200  
 Philadelphia, PA 19103

**Certificate of Mailing or Transmission**

I hereby certify that this Fee(s) Transmittal is being deposited with the United States Postal Service with sufficient postage for first class mail in an envelope addressed to the Mail Stop ISSUE FEE address above, or being facsimile transmitted to the USPTO (571) 273-2885, on the date indicated below.

_____ (Depositor's name)
_____ (Signature)
_____ (Date)

APPLICATION NO.	FILING DATE	FIRST NAMED INVENTOR	ATTORNEY DOCKET NO.	CONFIRMATION NO.
12/543,910	08/19/2009	Gordon F. Bremer	REMB-0109	8306

TITLE OF INVENTION: SYSTEM AND METHOD OF COMMUNICATION VIA EMBEDDED MODULATION

APPLN. TYPE	SMALL ENTITY	ISSUE FEE DUE	PUBLICATION FEE DUE	PREV. PAID ISSUE FEE	TOTAL FEE(S) DUE	DATE DUE
nonprovisional	NO	\$1510	\$300	\$0	\$1810	10/24/2011

EXAMINER	ART UNIT	CLASS-SUBCLASS
HA, DAC V	2611	375-302000

<p>1. Change of correspondence address or indication of "Fee Address" (37 CFR 1.363).</p> <p><input type="checkbox"/> Change of correspondence address (or Change of Correspondence Address form PTO/SB/122) attached.</p> <p><input type="checkbox"/> "Fee Address" indication (or "Fee Address" Indication form PTO/SB/47; Rev 03-02 or more recent) attached. <b>Use of a Customer Number is required.</b></p>	<p>2. For printing on the patent front page, list</p> <p>(1) the names of up to 3 registered patent attorneys or agents OR, alternatively, 1 _____</p> <p>(2) the name of a single firm (having as a member a registered attorney or agent) and the names of up to 2 registered patent attorneys or agents. If no name is listed, no name will be printed. 2 _____</p> <p>3 _____</p>
---	---

3. ASSIGNEE NAME AND RESIDENCE DATA TO BE PRINTED ON THE PATENT (print or type)

PLEASE NOTE: Unless an assignee is identified below, no assignee data will appear on the patent. If an assignee is identified below, the document has been filed for recordation as set forth in 37 CFR 3.11. Completion of this form is NOT a substitute for filing an assignment.

(A) NAME OF ASSIGNEE \_\_\_\_\_ (B) RESIDENCE: (CITY and STATE OR COUNTRY) \_\_\_\_\_

Please check the appropriate assignee category or categories (will not be printed on the patent) :  Individual  Corporation or other private group entity  Government

<p>4a. The following fee(s) are submitted:</p> <p><input type="checkbox"/> Issue Fee</p> <p><input type="checkbox"/> Publication Fee (No small entity discount permitted)</p> <p><input type="checkbox"/> Advance Order - # of Copies _____</p>	<p>4b. Payment of Fee(s); (Please first reapply any previously paid issue fee shown above)</p> <p><input type="checkbox"/> A check is enclosed.</p> <p><input type="checkbox"/> Payment by credit card. Form PTO-2038 is attached.</p> <p><input type="checkbox"/> The Director is hereby authorized to charge the required fee(s), any deficiency, or credit any overpayment, to Deposit Account Number _____ (enclose an extra copy of this form).</p>
---	--

5. Change in Entity Status (from status indicated above)

a. Applicant claims SMALL ENTITY status. See 37 CFR 1.27.  b. Applicant is no longer claiming SMALL ENTITY status. See 37 CFR 1.27(g)(2).

NOTE: The Issue Fee and Publication Fee (if required) will not be accepted from anyone other than the applicant; a registered attorney or agent; or the assignee or other party in interest as shown by the records of the United States Patent and Trademark Office.

Authorized Signature \_\_\_\_\_ Date \_\_\_\_\_

Typed or printed name \_\_\_\_\_ Registration No. \_\_\_\_\_

This collection of information is required by 37 CFR 1.311. The information is required to obtain or retain a benefit by the public which is to file (and by the USPTO to process) an application. Confidentiality is governed by 35 U.S.C. 122 and 37 CFR 1.14. This collection is estimated to take 12 minutes to complete, including gathering, preparing, and submitting the completed application form to the USPTO. Time will vary depending upon the individual case. Any comments on the amount of time you require to complete this form and/or suggestions for reducing this burden, should be sent to the Chief Information Officer, U.S. Patent and Trademark Office, U.S. Department of Commerce, P.O. Box 1450, Alexandria, Virginia 22313-1450. DO NOT SEND FEES OR COMPLETED FORMS TO THIS ADDRESS. SEND TO: Commissioner for Patents, P.O. Box 1450, Alexandria, Virginia 22313-1450.

Under the Paperwork Reduction Act of 1995, no persons are required to respond to a collection of information unless it displays a valid OMB control number.



UNITED STATES PATENT AND TRADEMARK OFFICE

UNITED STATES DEPARTMENT OF COMMERCE
United States Patent and Trademark Office
Address: COMMISSIONER FOR PATENTS
P.O. Box 1450
Alexandria, Virginia 22313-1450
www.uspto.gov

Table with 5 columns: APPLICATION NO., FILING DATE, FIRST NAMED INVENTOR, ATTORNEY DOCKET NO., CONFIRMATION NO.
12/543,910 08/19/2009 Gordon F. Bremer REMB-0109 8306

15027 7590 07/22/2011
Condo Roccia LLP
1650 Market Street
Suite 2200
Philadelphia, PA 19103

EXAMINER

HA, DAC V

ART UNIT PAPER NUMBER

2611

DATE MAILED: 07/22/2011

Determination of Patent Term Adjustment under 35 U.S.C. 154 (b)
(application filed on or after May 29, 2000)

The Patent Term Adjustment to date is 0 day(s). If the issue fee is paid on the date that is three months after the mailing date of this notice and the patent issues on the Tuesday before the date that is 28 weeks (six and a half months) after the mailing date of this notice, the Patent Term Adjustment will be 0 day(s).

If a Continued Prosecution Application (CPA) was filed in the above-identified application, the filing date that determines Patent Term Adjustment is the filing date of the most recent CPA.

Applicant will be able to obtain more detailed information by accessing the Patent Application Information Retrieval (PAIR) WEB site (http://pair.uspto.gov).

Any questions regarding the Patent Term Extension or Adjustment determination should be directed to the Office of Patent Legal Administration at (571)-272-7702. Questions relating to issue and publication fee payments should be directed to the Customer Service Center of the Office of Patent Publication at 1-(888)-786-0101 or (571)-272-4200.

## Privacy Act Statement

**The Privacy Act of 1974 (P.L. 93-579)** requires that you be given certain information in connection with your submission of the attached form related to a patent application or patent. Accordingly, pursuant to the requirements of the Act, please be advised that: (1) the general authority for the collection of this information is 35 U.S.C. 2(b)(2); (2) furnishing of the information solicited is voluntary; and (3) the principal purpose for which the information is used by the U.S. Patent and Trademark Office is to process and/or examine your submission related to a patent application or patent. If you do not furnish the requested information, the U.S. Patent and Trademark Office may not be able to process and/or examine your submission, which may result in termination of proceedings or abandonment of the application or expiration of the patent.

The information provided by you in this form will be subject to the following routine uses:

1. The information on this form will be treated confidentially to the extent allowed under the Freedom of Information Act (5 U.S.C. 552) and the Privacy Act (5 U.S.C. 552a). Records from this system of records may be disclosed to the Department of Justice to determine whether disclosure of these records is required by the Freedom of Information Act.
2. A record from this system of records may be disclosed, as a routine use, in the course of presenting evidence to a court, magistrate, or administrative tribunal, including disclosures to opposing counsel in the course of settlement negotiations.
3. A record in this system of records may be disclosed, as a routine use, to a Member of Congress submitting a request involving an individual, to whom the record pertains, when the individual has requested assistance from the Member with respect to the subject matter of the record.
4. A record in this system of records may be disclosed, as a routine use, to a contractor of the Agency having need for the information in order to perform a contract. Recipients of information shall be required to comply with the requirements of the Privacy Act of 1974, as amended, pursuant to 5 U.S.C. 552a(m).
5. A record related to an International Application filed under the Patent Cooperation Treaty in this system of records may be disclosed, as a routine use, to the International Bureau of the World Intellectual Property Organization, pursuant to the Patent Cooperation Treaty.
6. A record in this system of records may be disclosed, as a routine use, to another federal agency for purposes of National Security review (35 U.S.C. 181) and for review pursuant to the Atomic Energy Act (42 U.S.C. 218(c)).
7. A record from this system of records may be disclosed, as a routine use, to the Administrator, General Services, or his/her designee, during an inspection of records conducted by GSA as part of that agency's responsibility to recommend improvements in records management practices and programs, under authority of 44 U.S.C. 2904 and 2906. Such disclosure shall be made in accordance with the GSA regulations governing inspection of records for this purpose, and any other relevant (i.e., GSA or Commerce) directive. Such disclosure shall not be used to make determinations about individuals.
8. A record from this system of records may be disclosed, as a routine use, to the public after either publication of the application pursuant to 35 U.S.C. 122(b) or issuance of a patent pursuant to 35 U.S.C. 151. Further, a record may be disclosed, subject to the limitations of 37 CFR 1.14, as a routine use, to the public if the record was filed in an application which became abandoned or in which the proceedings were terminated and which application is referenced by either a published application, an application open to public inspection or an issued patent.
9. A record from this system of records may be disclosed, as a routine use, to a Federal, State, or local law enforcement agency, if the USPTO becomes aware of a violation or potential violation of law or regulation.



<b>Notice of Allowability</b>	<b>Application No.</b>	<b>Applicant(s)</b>
	12/543,910	BREMER, GORDON F.
	<b>Examiner</b>	<b>Art Unit</b>
	DAC HA	2611

**-- The MAILING DATE of this communication appears on the cover sheet with the correspondence address--**

All claims being allowable, PROSECUTION ON THE MERITS IS (OR REMAINS) CLOSED in this application. If not included herewith (or previously mailed), a Notice of Allowance (PTOL-85) or other appropriate communication will be mailed in due course. **THIS NOTICE OF ALLOWABILITY IS NOT A GRANT OF PATENT RIGHTS.** This application is subject to withdrawal from issue at the initiative of the Office or upon petition by the applicant. See 37 CFR 1.313 and MPEP 1308.

1.  This communication is responsive to 05/11/11.
2.  The allowed claim(s) is/are 1, 2, 9-11, 145, 12-18, 18, 101-111, 20, 27, 29-33, 112, 146, 28, 113-118, 147, 37, 38, 45-50, 148, 87, 94, 96, 97, 119, 95, 120-131, 144, 132-143, renumbered as 1-79, respectively.

3.  Acknowledgment is made of a claim for foreign priority under 35 U.S.C. § 119(a)-(d) or (f).  
a)  All b)  Some\* c)  None of the:  
1.  Certified copies of the priority documents have been received.  
2.  Certified copies of the priority documents have been received in Application No. \_\_\_\_\_.  
3.  Copies of the certified copies of the priority documents have been received in this national stage application from the International Bureau (PCT Rule 17.2(a)).

\* Certified copies not received: \_\_\_\_\_.

Applicant has THREE MONTHS FROM THE "MAILING DATE" of this communication to file a reply complying with the requirements noted below. Failure to timely comply will result in ABANDONMENT of this application.

**THIS THREE-MONTH PERIOD IS NOT EXTENDABLE.**

4.  A SUBSTITUTE OATH OR DECLARATION must be submitted. Note the attached EXAMINER'S AMENDMENT or NOTICE OF INFORMAL PATENT APPLICATION (PTO-152) which gives reason(s) why the oath or declaration is deficient.
5.  CORRECTED DRAWINGS ( as "replacement sheets") must be submitted.  
(a)  including changes required by the Notice of Draftsperson's Patent Drawing Review ( PTO-948) attached  
1)  hereto or 2)  to Paper No./Mail Date \_\_\_\_\_.  
(b)  including changes required by the attached Examiner's Amendment / Comment or in the Office action of Paper No./Mail Date \_\_\_\_\_.


**Identifying indicia such as the application number (see 37 CFR 1.84(c)) should be written on the drawings in the front (not the back) of each sheet. Replacement sheet(s) should be labeled as such in the header according to 37 CFR 1.121(d).**

6.  DEPOSIT OF and/or INFORMATION about the deposit of BIOLOGICAL MATERIAL must be submitted. Note the attached Examiner's comment regarding REQUIREMENT FOR THE DEPOSIT OF BIOLOGICAL MATERIAL.

**Attachment(s)**

1. <input type="checkbox"/> Notice of References Cited (PTO-892)	5. <input type="checkbox"/> Notice of Informal Patent Application
2. <input type="checkbox"/> Notice of Draftsperson's Patent Drawing Review (PTO-948)	6. <input type="checkbox"/> Interview Summary (PTO-413), Paper No./Mail Date _____.
3. <input checked="" type="checkbox"/> Information Disclosure Statements (PTO/SB/08), Paper No./Mail Date _____	7. <input type="checkbox"/> Examiner's Amendment/Comment
4. <input type="checkbox"/> Examiner's Comment Regarding Requirement for Deposit of Biological Material	8. <input type="checkbox"/> Examiner's Statement of Reasons for Allowance
	9. <input type="checkbox"/> Other _____.

/Dac V. Ha/  
Primary Examiner, Art Unit 2611

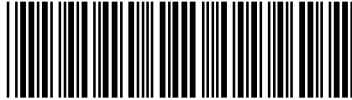
<b>Search Notes</b>  	<b>Application/Control No.</b>  12543910	<b>Applicant(s)/Patent Under Reexamination</b>  BREMER, GORDON F.
	<b>Examiner</b>  Dac V Ha	<b>Art Unit</b>  2611

SEARCHED			
Class	Subclass	Date	Examiner
375	261, 269, 285, 222, 298, 302, 305, 308	8/13/2010	DH
455	102, 110	8/13/2010	DH
332	108, 119, 120, 151	8/13/2010	DH

SEARCH NOTES		
Search Notes	Date	Examiner
BRS and Inventor's search	8/13/2010	DH

INTERFERENCE SEARCH			
Class	Subclass	Date	Examiner
	PGPUB text search	8/13/2010	DH

--	--

<b>Index of Claims</b> 	<b>Application/Control No.</b> 12543910	<b>Applicant(s)/Patent Under Reexamination</b> BREMER, GORDON F.
	<b>Examiner</b> Dac V Ha	<b>Art Unit</b> 2611

✓	<b>Rejected</b>
=	<b>Allowed</b>

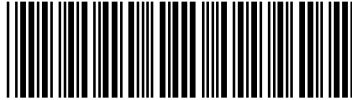
-	<b>Cancelled</b>
÷	<b>Restricted</b>

N	<b>Non-Elected</b>
I	<b>Interference</b>

A	<b>Appeal</b>
O	<b>Objected</b>

Claims renumbered in the same order as presented by applicant
  CPA
  T.D.
  R.1.47

CLAIM		DATE							
Final	Original	08/13/2010	07/07/2011						
1	1	○	=						
2	2	○	=						
	3	○	-						
	4	○	-						
	5	○	-						
	6	○	-						
	7	○	-						
	8	○	-						
3	9	○	=						
4	10	○	=						
5	11	○	=						
7	12	○	=						
8	13	○	=						
9	14	○	=						
10	15	○	=						
	16	○	-						
	17	○	-						
11	18	○	=						
	19	✓	-						
23	20	○	=						
	21	✓	-						
	22	✓	-						
	23	✓	-						
	24	✓	-						
	25	✓	-						
	26	✓	-						
24	27	✓	=						
32	28	○	=						
25	29	✓	=						
26	30	✓	=						
27	31	✓	=						
28	32	✓	=						
29	33	✓	=						
	34	✓	-						
	35	✓	-						
	36	○	-						

<b>Index of Claims</b> 	<b>Application/Control No.</b> 12543910	<b>Applicant(s)/Patent Under Reexamination</b> BREMER, GORDON F.
	<b>Examiner</b> Dac V Ha	<b>Art Unit</b> 2611

✓	<b>Rejected</b>
=	<b>Allowed</b>

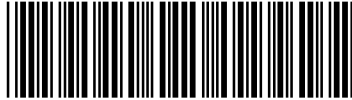
-	<b>Cancelled</b>
÷	<b>Restricted</b>

N	<b>Non-Elected</b>
I	<b>Interference</b>

A	<b>Appeal</b>
O	<b>Objected</b>

Claims renumbered in the same order as presented by applicant
  CPA
  T.D.
  R.1.47

CLAIM		DATE							
Final	Original	08/13/2010	07/07/2011						
40	37	○	=						
41	38	○	=						
	39	○	-						
	40	○	-						
	41	○	-						
	42	○	-						
	43	○	-						
	44	○	-						
42	45	○	=						
43	46	○	=						
44	47	○	=						
45	48	○	=						
46	49	○	=						
47	50	○	=						
	51	○	-						
	52	○	-						
	53	○	-						
	54	○	-						
	55	○	-						
	56	○	-						
	57	○	-						
	58	✓	-						
	59	○	-						
	60	✓	-						
	61	✓	-						
	62	✓	-						
	63	✓	-						
	64	✓	-						
	65	✓	-						
	66	✓	-						
	67	○	-						
	68	✓	-						
	69	✓	-						
	70	○	-						
	71	○	-						
	72	✓	-						

<b>Index of Claims</b> 	<b>Application/Control No.</b> 12543910	<b>Applicant(s)/Patent Under Reexamination</b> BREMER, GORDON F.
	<b>Examiner</b> Dac V Ha	<b>Art Unit</b> 2611

✓	<b>Rejected</b>
=	<b>Allowed</b>

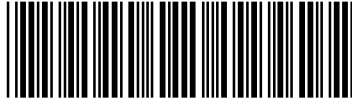
-	<b>Cancelled</b>
÷	<b>Restricted</b>

N	<b>Non-Elected</b>
I	<b>Interference</b>

A	<b>Appeal</b>
O	<b>Objected</b>

Claims renumbered in the same order as presented by applicant
  CPA
  T.D.
  R.1.47

CLAIM		DATE							
Final	Original	08/13/2010	07/07/2011						
	73	○	-						
	74	✓	-						
	75	✓	-						
	76	✓	-						
	77	✓	-						
	78	✓	-						
	79	✓	-						
	80	✓	-						
	81	○	-						
	82	✓	-						
	83	✓	-						
	84	○	-						
	85	○	-						
	86	✓	-						
49	87	○	=						
	88	✓	-						
	89	✓	-						
	90	✓	-						
	91	✓	-						
	92	✓	-						
	93	✓	-						
50	94	✓	=						
54	95	○	=						
51	96	=	=						
52	97	=	=						
	98	=	-						
	99	=	-						
	100	○	-						
12	101		=						
13	102		=						
14	103		=						
15	104		=						
16	105		=						
17	106		=						
18	107		=						
19	108		=						

<b>Index of Claims</b> 	<b>Application/Control No.</b> 12543910	<b>Applicant(s)/Patent Under Reexamination</b> BREMER, GORDON F.
	<b>Examiner</b> Dac V Ha	<b>Art Unit</b> 2611

✓	<b>Rejected</b>
=	<b>Allowed</b>

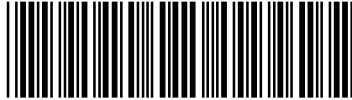
-	<b>Cancelled</b>
÷	<b>Restricted</b>

N	<b>Non-Elected</b>
I	<b>Interference</b>

A	<b>Appeal</b>
O	<b>Objected</b>

Claims renumbered in the same order as presented by applicant
  CPA
  T.D.
  R.1.47

CLAIM		DATE							
Final	Original	08/13/2010	07/07/2011						
20	109		=						
21	110		=						
22	111		=						
30	112		=						
33	113		=						
34	114		=						
35	115		=						
36	116		=						
37	117		=						
38	118		=						
53	119		=						
55	120		=						
56	121		=						
57	122		=						
58	123		=						
59	124		=						
60	125		=						
61	126		=						
62	127		=						
63	128		=						
64	129		=						
65	130		=						
66	131		=						
68	132		=						
69	133		=						
70	134		=						
71	135		=						
72	136		=						
73	137		=						
74	138		=						
75	139		=						
76	140		=						
77	141		=						
78	142		=						
79	143		=						
67	144		=						

<b>Index of Claims</b>  	<b>Application/Control No.</b>  12543910	<b>Applicant(s)/Patent Under Reexamination</b>  BREMER, GORDON F.
	<b>Examiner</b>  Dac V Ha	<b>Art Unit</b>  2611

✓	<b>Rejected</b>
=	<b>Allowed</b>

-	<b>Cancelled</b>
÷	<b>Restricted</b>

N	<b>Non-Elected</b>
I	<b>Interference</b>

A	<b>Appeal</b>
O	<b>Objected</b>

Claims renumbered in the same order as presented by applicant
  CPA
  T.D.
  R.1.47

CLAIM		DATE							
Final	Original	08/13/2010	07/07/2011						
6	145		=						
31	146		=						
39	147		=						
48	148		=						





RECEIVED  
CENTRAL FAX CENTER

MAY 12 2011

Substitute for 1449/PTO  <b>INFORMATION DISCLOSURE STATEMENT BY APPLICANT</b>  <i>(use as many sheets as necessary)</i>		<i>Complete if Known</i>	
		Application Number	12/543,910
		Filing Date	August 19, 2009
		First Named Inventor	Gordon F. Bremer
		Art Unit	2611
Examiner Name	Dac V. Ha	Attorney Docket Number	REMB-0109
Sheet	1	of	1

NON PATENT LITERATURE DOCUMENTS			
Examiner Initials	Cite No.	Include name of the author, title of the article (when appropriate), title of the item (book, magazine, journal, serial, symposium, catalog, etc.), date, page(s), Volume-Issue Number(s), publisher, city and/or country where published.	T
	253	International Telecommunications Union, Telecommunication Standardization Sector of ITU (ITU-T), Series T: Terminal Equipments and Protocols For Telematic Services, "Procedures for Document Facsimile Transmission in the General Switched Telephone Network", ITU-T Recommendation T.30, July 1996, 176 pages	
	254	International Telecommunications Union, The International Telegraph and Telephone Consultative Committee (CCITT), Data Communication Over The Telephone Network, "A 2-Wire Modem For Facsimile Applications With Rates Up to 14 400 bit/s", Recommendation V.17, February 1991, 13 pages	
	255	International Telecommunications Union, Telecommunication Standardization Sector of ITU (ITU-T), Series T: Terminal Equipments and Protocols For Telematic Services, "Standardization of Group 3 Facsimile Terminals for Document Transmission", ITU-T Recommendation T.4, July 1996, 60 pages	
	256	International Telecommunications Union, Telecommunication Standardization Sector of ITU (ITU-T), Series T: Terminals For Telematic Services, "Standardization of Group 3 Facsimile Terminals for Document Transmission", ITU-T Recommendation T.4 - Amendment 1, July 1997, 10 pages	
	257	International Telecommunications Union, Telecommunication Standardization Sector of ITU (ITU-T), Series T: Terminals For Telematic Services, "Standardization of Group 3 Facsimile Terminals for Document Transmission", ITU-T Recommendation T.4 - Amendment 2, October 1997, 14 pages	
	258	International Telecommunications Union, Telecommunication Standardization Sector of ITU (ITU-T), Series T: Terminals For Telematic Services, "Procedures for Document Facsimile Transmission in the General Switched Telephone Network", ITU-T Recommendation T.30 - Amendment 1, July 1997, 110 pages	
	259	International Telecommunications Union, Telecommunication Standardization Sector of ITU (ITU-T), Series T: Terminals For Telematic Services, "Procedures for Document Facsimile Transmission in the General Switched Telephone Network", ITU-T Recommendation T.30 - Amendment 2, October 1997, 18 pages	

Examiner Signature	/Dac Ha/	Date Considered	07/07/2011
--------------------	----------	-----------------	------------

Substitute for 1449/PTO  <b>INFORMATION DISCLOSURE STATEMENT BY APPLICANT</b>  <i>(use as many sheets as necessary)</i>				<b>Complete if Known</b>			
				<b>Application Number</b>		12/543,910	
				<b>Filing Date</b>		August 19, 2009	
				<b>First Named Inventor</b>		Gordon F. Bremer	
				<b>Art Unit</b>		2611	
				<b>Examiner Name</b>		Dac V. Ha	
<b>Sheet</b>		1 of 11		<b>Attorney Docket Number</b>		REMB-0109	

**U. S. PUBLICATION AND PATENT DOCUMENTS**

Examiner Initials	Cite No.	Document Number	Publication or Grant Date	Name of Patentee or Applicant of Cited Document
		Number – Kind Code (if known)	MM-DD-YYYY	
	23	2001/0022836 A1	09-20-2001	Bremer et al.
	24	2002/0041662 A1	04-11-2002	Bremer et al.
	25	2002/0167949	11-14-2002	Bremer et al.
	26	2003/0039348A1	02-27-2003	Bremer et al.
	27	2003/0210773 A1	11-13-2003	Bremer et al.
	28	2003/0210779 A1	11-13-2003	Bremer et al.
	29	2004/0013183 A1	01-22-2004	Bremer
	30	2004/0042510 A1	03-04-2004	Bremer et al.
	31	2004/0052361 A1	03-18-2004	Betts et al.
	32	2004/0066929 A1	04-08-2004	Bremer et al.
	33	2004/0081233 A1	04-29-2004	Bremer et al.
	34	2004/0179662 A1	09-10-2004	Bremer et al.
	35	2004/0213170 A1	10-28-2004	Bremer et al.
	36	2004/0258236 A1	12-23-2004	Bremer et al.
	37	2005/0025153 A1	02-03-2005	Bremer et al.
	38	2005/0074057 A1	04-07-2005	Bremer et al.
	39	2005/0147158	07-07-2005	Bremer et al.
	40	2005/0152404	07-15-2005	Holmquist et al.
	41	2005/0163303 A1	07-28-2005	Bremer
	42	2005/0180545 A1	08-18-2005	Bremer et al.
	43	2006/0188088 A1	08-24-2006	Bingel et al.
	44	2006/0193465 A1	08-31-2006	Betts
	45	2006/0195712 A1	08-31-2006	Bremer et al.
	46	2007/0047730 A1	03-01-2007	Bremer

<b>Examiner Signature</b>	/Dac Ha/	<b>Date Considered</b>	07/07/2011
---------------------------	----------	------------------------	------------

Substitute for 1449/PTO  <b>INFORMATION DISCLOSURE STATEMENT BY APPLICANT</b>  <i>(use as many sheets as necessary)</i>				<b>Complete if Known</b>		
				<b>Application Number</b>		12/543,910
				<b>Filing Date</b>		August 19, 2009
				<b>First Named Inventor</b>		Gordon F. Bremer
				<b>Art Unit</b>		2611
<b>Examiner Name</b>		Dac V. Ha	<b>Attorney Docket Number</b>		REMB-0109	
Sheet	2	of	11			

**U. S. PUBLICATION AND PATENT DOCUMENTS**

Examiner Initials	Cite No.	Document Number	Publication or Grant Date	Name of Patentee or Applicant of Cited Document
		Number – Kind Code (if known)	MM-DD-YYYY	
	47	2007/0047733 A1	03-01-2007	Bremer
	48	2007/0286187 A1	12-13-2007	Bremer
	49	2008/0013608 A1	01-17-2008	Bremer
	50	2008/0019432 A1	01-24-2008	Bremer et al.
	51	2009/0111422 A1	04-30-2009	Bremer
	52	2009/0262911 A1	10-22-2009	Bremer
	53	2009/0262912 A1	10-22-2009	Bremer
	54	2010/0183055 A1	07-22-2010	Bremer
	55	2010/0246598 A1	09-30-2010	Bremer
	56	3,736,528A	05-29-1973	Acker et al.
	57	3,761,840A	09-25-1973	Bremer
	58	4,335,464	06-15-1982	Armstrong et al.
	59	4,381,546	04-26-1983	Armstrong
	60	4,464,767	08-07-1984	Bremer
	61	4,503,545	03-05-1985	Bremer et al.
	62	4,509,171	04-02-1985	Bremer et al.
	63	4,516,216	05-07-1985	Armstrong
	64	4,525,846	06-25-1985	Bremer et al.
	65	4,525,847	06-25-1985	Bremer
	66	4,532,640	07-30-1985	Bremer et al.
	67	4,645,871	02-24-1987	Bremer et al.
	68	4,654,807	03-31-1987	Bremer
	69	4,663,766	05-05-1987	Bremer
	70	4,677,625	06-30-1987	Betts et al.

<b>Examiner Signature</b>	/Dac Ha/	<b>Date Considered</b>	07/07/2011
---------------------------	----------	------------------------	------------

Substitute for 1449/PTO  <b>INFORMATION DISCLOSURE STATEMENT BY APPLICANT</b>  <i>(use as many sheets as necessary)</i>				<b>Complete if Known</b>	
				<b>Application Number</b>	12/543,910
				<b>Filing Date</b>	August 19, 2009
				<b>First Named Inventor</b>	Gordon F. Bremer
				<b>Art Unit</b>	2611
<b>Examiner Name</b>	Dac V. Ha				
<b>Attorney Docket Number</b>	REMB-0109				
Sheet	3	of	11		

**U. S. PUBLICATION AND PATENT DOCUMENTS**

Examiner Initials	Cite No.	Document Number	Publication or Grant Date MM-DD-YYYY	Name of Patentee or Applicant of Cited Document
		Number - Kind Code (if known)		
	71	4,782,498	11-01-1988	Copeland, III
	72	4,811,357	03-07-1989	Betts et al.
	73	4,862,464	08-29-1989	Betts et al.
	74	4,924,516 A	05-08-1990	Bremer et al.
	75	4,926,448	05-15-1990	Kraul et al.
	76	4,939,748	07-03-1990	Betts et al.
	77	5,008,903	04-16-1991	Betts et al.
	78	5,081,647 A	01-14-1992	Bremer
	79	5,099,478 A	03-24-1992	Bremer et al.
	80	5,168,535	12-01-1992	Laor
	81	5,206,854	04-27-1993	Betts et al.
	82	5,230,010 A	07-20-1993	Betts et al.
	83	5,239,306	08-24-1993	Siwiak et al.
	84	5,239,607	08-24-1993	Da Silva et al.
	85	5,251,236	10-05-1993	Brehmer et al.
	86	5,251,328	10-05-1993	Shaw
	87	5,257,396	10-26-1993	Auld, Jr. et al.
	88	5,280,503 A	01-18-1994	Betts et al.
	89	5,311,557	05-10-1994	Betts et al.
	90	5,311,578 A	05-10-1994	Bremer et al.
	91	5,345,332	09-06-1994	Da Silva et al.
	92	5,355,362	10-11-1994	Gorshe et al.
	93	5,373,149	10-13-1994	Rasmussen
	94	5,392,154	02-21-1995	Chang et al.

<b>Examiner Signature</b>	/Dac Ha/	<b>Date Considered</b>	07/07/2011
---------------------------	----------	------------------------	------------

Substitute for 1449/PTO  <b>INFORMATION DISCLOSURE STATEMENT BY APPLICANT</b>  <i>(use as many sheets as necessary)</i>				<b>Complete if Known</b>	
				<b>Application Number</b>	12/543,910
				<b>Filing Date</b>	August 19, 2009
				<b>First Named Inventor</b>	Gordon F. Bremer
				<b>Art Unit</b>	2611
<b>Examiner Name</b>	Dac V. Ha	<b>Attorney Docket Number</b>	REMB-0109		
Sheet	4	of	11		

**U. S. PUBLICATION AND PATENT DOCUMENTS**

Examiner Initials	Cite No.	Document Number	Publication or Grant Date MM-DD-YYYY	Name of Patentee or Applicant of Cited Document
		Number - Kind Code (if known)		
	95	5,412,651	05-02-1995	Gorshe
	96	5,414,540	05-09-1995	Patel et al.
	97	5,436,930 A	07-25-1995	Bremer et al.
	98	5,444,704	08-22-1995	Henderson et al.
	99	5,448,555 A	09-05-1995	Bremer et al.
	100	5,473,675	10-05-1995	Chapman et al.
	101	5,475,713 A	12-12-1995	Bremer et al.
	102	5,506,866 A	04-09-1996	Bermer et al.
	103	5,513,212 A	04-30-1996	Bremer
	104	5,513,213	04-30-1996	Patel et al.
	105	5,521,942 A	05-28-1996	Betts et al.
	106	5,530,718	06-25-1996	Gradeler et al.
	107	5,537,398	07-16-1996	Siwiak
	108	5,537,411 A	07-16-1996	Plas
	109	5,537,436 A	07-16-1996	Bottoms et al.
	110	5,559,791 A	09-24-1996	Bremer et al.
	111	5,559,792 A	09-24-1996	Bottoms et al.
	112	5,570,295	10-29-1996	Isenberg et al.
	113	5,602,869	02-11-1997	Scott
	114	5,629,992	05-13-1997	Amersfoort
	115	5,642,379 A	06-24-1997	Bremer et al.
	116	5,651,114	07-22-1997	Davidson, Jr.
	117	5,661,718 A	08-26-1997	Bremer et al.
	118	5,671,250 A	09-23-1997	Bremer et al.

<b>Examiner Signature</b>	/Dac Ha/	<b>Date Considered</b>	07/07/2011
---------------------------	----------	------------------------	------------

Substitute for 1449/PTO  <b>INFORMATION DISCLOSURE STATEMENT BY APPLICANT</b>  <i>(use as many sheets as necessary)</i>				<b>Complete if Known</b>	
				<b>Application Number</b>	12/543,910
				<b>Filing Date</b>	August 19, 2009
				<b>First Named Inventor</b>	Gordon F. Bremer
				<b>Art Unit</b>	2611
<b>Examiner Name</b>	Dac V. Ha				
<b>Attorney Docket Number</b>	REMB-0109				
Sheet	5	of	11		

**U. S. PUBLICATION AND PATENT DOCUMENTS**

Examiner Initials	Cite No.	Document Number	Publication or Grant Date MM-DD-YYYY	Name of Patentee or Applicant of Cited Document
		Number – Kind Code (if known)		
	119	5,684,825	11-04-1997	Ko
	120	5,684,834 A	11-04-1997	Betts et al.
	121	5,711,012 A	01-20-1998	Bottoms et al.
	122	5,719,922 A	02-17-1998	Bremer et al.
	123	5,719,923 A	02-17-1998	Bremer et al.
	124	5,748,811	05-05-1998	Amersfoort et al.
	125	5,805,669	09-08-1998	Bingel et al.
	126	5,805,755	09-08-1998	Amersfoort et al.
	127	5,812,537	09-22-1998	Betts et al.
	128	5,825,517	10-20-1998	Antoniades et al.
	129	5,828,657	10-27-1998	Betts et al.
	130	5,841,500	10-24-1998	Patel
	131	5,844,944 A	12-01-1998	Betts et al.
	132	5,859,877 A	01-12-1999	Betts et al.
	133	5,881,047 A	03-09-1999	Bremer et al.
	134	5,881,142	03-09-1999	Frankel et al.
	135	5,901,205	05-04-1999	Smith et al.
	136	5,915,003 A	06-22-1999	Bremer et al.
	137	5,960,400 A	09-28-1999	Bremer
	138	5,963,620	10-05-1999	Frankel et al.
	139	6,011,814	01-04-2000	Martinez et al.
	140	6,031,897 A	02-29-2000	Bremer et al.
	141	6,061,392 A	05-09-2000	Bremer et al.
	142	6,075,512	06-13-2000	Patel et al.

<b>Examiner Signature</b>	/Dac Ha/	<b>Date Considered</b>	07/07/2011
---------------------------	----------	------------------------	------------

Substitute for 1449/PTO  <b>INFORMATION DISCLOSURE STATEMENT BY APPLICANT</b>  <i>(use as many sheets as necessary)</i>				<b>Complete if Known</b>	
				<b>Application Number</b>	12/543,910
				<b>Filing Date</b>	August 19, 2009
				<b>First Named Inventor</b>	Gordon F. Bremer
				<b>Art Unit</b>	2611
<b>Examiner Name</b>	Dac V. Ha				
<b>Attorney Docket Number</b>	REMB-0109				
Sheet	6	of	11		

**U. S. PUBLICATION AND PATENT DOCUMENTS**

Examiner Initials	Cite No.	Document Number	Publication or Grant Date MM-DD-YYYY	Name of Patentee or Applicant of Cited Document
		Number - Kind Code (if known)		
	143	6,097,858	08-01-2000	Laor
	144	6,097,860	08-01-2000	Laor
	145	6,101,299	08-08-2000	Laor
	146	6,108,347	08-22-2000	Holmquist
	147	6,111,936 A	08-29-2000	Bremer
	148	6,134,245	10-17-2000	Scarmalis
	149	6,154,524 A	11-28-2000	Bremer
	150	6,157,680 A	12-05-2000	Betts et al.
	151	6,160,790 A	12-12-2000	Bremer
	152	6,175,436	01-16-2001	Jackel
	153	6,185,083	02-06-2001	Mathieu et al.
	154	6,236,481	05-22-2001	Laor
	155	6,236,717 B1	05-22-2001	Bremer et al.
	156	6,243,391	06-05-2001	Holmquist
	157	6,252,644	06-26-2001	Patel
	158	6,272,108	08-07-2001	Chapman
	159	6,272,154	08-07-2001	Bala et al.
	160	6,292,281	09-18-2001	Bala et al.
	161	6,307,653	10-23-2001	Bala et al.
	162	6,307,893 B1	10-23-2001	Bremer et al.
	163	6,307,923 B1	10-23-2001	Bremer et al.
	164	6,320,879 B1	11-20-2001	Bremer
	165	6,320,993	11-20-2001	Laor
	166	6,330,275 B1	12-11-2001	Bremer

<b>Examiner Signature</b>	/Dac Ha/	<b>Date Considered</b>	07/07/2011
---------------------------	----------	------------------------	------------

Substitute for 1449/PTO  <b>INFORMATION DISCLOSURE STATEMENT BY APPLICANT</b>  <i>(use as many sheets as necessary)</i>				<b>Complete if Known</b>	
				<b>Application Number</b>	12/543,910
				<b>Filing Date</b>	August 19, 2009
				<b>First Named Inventor</b>	Gordon F. Bremer
				<b>Art Unit</b>	2611
<b>Examiner Name</b>	Dac V. Ha				
<b>Attorney Docket Number</b>	REMB-0109				
Sheet	7	of	11		

**U. S. PUBLICATION AND PATENT DOCUMENTS**

Examiner Initials	Cite No.	Document Number	Publication or Grant Date MM-DD-YYYY	Name of Patentee or Applicant of Cited Document
		Number – Kind Code (if known)		
	<b>167</b>	6,335,992	01-01-2002	Bala et al.
	<b>168</b>	6,347,008	02-12-2002	Vodhanel
	<b>169</b>	6,408,056 B1	06-18-2002	Bremer et al.
	<b>170</b>	6,470,110	10-22-2002	Lin
	<b>171</b>	6,480,645	11-12-2002	Peale et al.
	<b>172</b>	6,493,475	12-10-2002	Lin
	<b>173</b>	6,529,652	03-04-2003	Bremer
	<b>174</b>	6,535,589	03-18-2003	Nauman et al.
	<b>175</b>	6,546,090 B1	04-08-2003	Bremer et al.
	<b>176</b>	6,549,692	04-15-2003	Harel et al.
	<b>177</b>	6,556,540	04-29-2003	Mawhinney et al.
	<b>178</b>	6,580,709	06-17-2003	Gorshe et al.
	<b>179</b>	6,580,785 B2	06-17-2003	Bremer et al.
	<b>180</b>	6,591,029	07-08-2003	Lin et al.
	<b>181</b>	6,597,827	07-22-2003	Bremer et al.
	<b>182</b>	6,603,894	08-05-2003	Pu
	<b>183</b>	6,614,838 B1	09-02-2003	Bremer
	<b>184</b>	6,628,857	09-30-2003	Bonadeo et al.
	<b>185</b>	6,631,119	10-07-2003	Mawhinney et al.
	<b>186</b>	6,633,693	10-14-2003	Peale et al.
	<b>187</b>	6,647,058 B1	11-11-2003	Bremer et al.
	<b>188</b>	6,658,096 B2	12-02-2003	Bremer et al.
	<b>189</b>	6,690,644	02-10-2004	Gorshe
	<b>190</b>	6,690,849	02-10-2004	Dadap, Jr., et al.

<b>Examiner Signature</b>	/Dac Ha/	<b>Date Considered</b>	07/07/2011
---------------------------	----------	------------------------	------------



Substitute for 1449/PTO  <b>INFORMATION DISCLOSURE STATEMENT BY APPLICANT</b>  <i>(use as many sheets as necessary)</i>				<b>Complete if Known</b>			
				<b>Application Number</b>		12/543,910	
				<b>Filing Date</b>		August 19, 2009	
				<b>First Named Inventor</b>		Gordon F. Bremer	
				<b>Art Unit</b>		2611	
<b>Examiner Name</b>		Dac V. Ha					
<b>Sheet</b>	8	of	11	<b>Attorney Docket Number</b>	REMB-0109		

**U. S. PUBLICATION AND PATENT DOCUMENTS**

Examiner Initials	Cite No.	Document Number	Publication or Grant Date MM-DD-YYYY	Name of Patentee or Applicant of Cited Document
		Number – Kind Code (if known)		
	191	6,715,124	03-30-2004	Betts
	192	6,744,883 B1	06-01-2004	Bingel et al.
	193	6,771,740	08-03-2004	Bingel
	194	6,775,355 B1	08-10-2004	Bingel et al.
	195	6,782,094	08-24-2004	Venz et al.
	196	6,782,096 B1	08-24-2004	Bremer et al.
	197	6,885,730 B1	04-26-2005	Bremer
	198	6,922,415 B1	07-26-2005	Bremer et al.
	199	6,950,444	09-27-2005	Holmquist et al.
	200	6,970,501 B1	11-29-2005	Bremer et al.
	201	7,013,421	03-14-2006	Betts
	202	7,020,266 B2	03-28-2006	Bremer et al.
	203	7,023,829	04-04-2006	Holmquist et al.
	204	7,035,380 B1	04-25-2006	Bingel et al.
	205	7,046,798 B2	05-16-2006	Betts et al.
	206	7,058,833 B1	06-06-2006	Bremer et al.
	207	7,065,205 B1	06-20-2006	Bingel et al.
	208	7,127,048 B2	10-24-2006	Bremer et al.
	209	7,130,338 B2	10-31-2006	Bremer et al.
	210	7,155,016 B1	12-26-2006	Betts et al.
	211	7,248,626 B2	07-24-2007	Bremer
	212	7,272,215 B2	09-18-2007	Bremer et al.
	213	7,289,604 B2	10-30-2007	Bremer
	214	7,289,610 B2	10-30-2007	Bremer et al.

<b>Examiner Signature</b>	/Dac Ha/	<b>Date Considered</b>	07/07/2011
---------------------------	----------	------------------------	------------

Substitute for 1449/PTO  <b>INFORMATION DISCLOSURE STATEMENT BY APPLICANT</b>  <i>(use as many sheets as necessary)</i>				<b>Complete if Known</b>	
				<b>Application Number</b>	12/543,910
				<b>Filing Date</b>	August 19, 2009
				<b>First Named Inventor</b>	Gordon F. Bremer
				<b>Art Unit</b>	2611
<b>Examiner Name</b>	Dac V. Ha				
<b>Attorney Docket Number</b>	REMB-0109				
Sheet	9	of	11		

**U. S. PUBLICATION AND PATENT DOCUMENTS**

Examiner Initials	Cite No.	Document Number	Publication or Grant Date	Name of Patentee or Applicant of Cited Document
		Number – Kind Code (if known)	MM-DD-YYYY	
	<b>215</b>	7,352,803 B2	04-01-2008	Bremer et al.
	<b>216</b>	7,471,777 B2	12-30-2008	Bremer et al.
	<b>217</b>	7,675,965 B2	03-09-2010	Bremer
	<b>218</b>	7,707,446 B2	04-27-2010	Bremer et al.
	<b>219</b>	7,711,109 B2	05-04-2010	Betts et al.
	<b>220</b>	7,747,000 B2	06-29-2010	Bremer et al.

**NON PATENT LITERATURE DOCUMENTS**

Examiner Initials	Cite No.	Include name of the author, title of the article (when appropriate), title of the item (book, magazine, journal, serial, symposium, catalog, etc.), date, page(s), Volume-issue Number(s), publisher, city and/or country where published.	T
	<b>221</b>	"Conelrad Emergency Radio Notification System Born in 1951", <a href="http://www.modestoradiomuseum.org">www.modestoradiomuseum.org</a> , Accessed on December 5, 2010, 2 pages	
	<b>222</b>	"Emergency Alert System", Public Safety and Homeland Security Bureau, <a href="http://www.fcc.gov/pshs/services/eas">www.fcc.gov/pshs/services/eas</a> , Accessed on December 5, 2010, 2 pages	
	<b>223</b>	"Specialized Communications Techniques for the Radio Amateur", The American Radio Relay League, Inc., 1975, 1 <sup>st</sup> Edition, Chapter 4, 78- 83	
	<b>224</b>	"Specialized Communications Techniques for the Radio Amateur", The American Radio Relay League, Inc., 1975, 1 <sup>st</sup> Edition, Chapter 5, 99-113	
	<b>225</b>	Bates (Ed.), "Broadband Telecommunications Handbook", McGraw-Hill Publishing, NY, 2000, Chapter 9, 128, 129, 131, 132, 133 and 134	
	<b>226</b>	Benson (Ed.), "Television Engineering Handbook", McGraw-Hill Publishers, NY, 1992, 5 pages, 4.14, 4.15, 4.24, 4.34 and 4.35	
	<b>227</b>	Bluetooth®, "Specification of the Bluetooth System, Master Table of Contents & Compliance Requirements", Specification Volume 0, November 4, 2004, V2.0, 1-1230	
	<b>228</b>	Bluetooth™, "Specification of the Bluetooth System, Core", December 1, 1999, V1.0B, 1-1082	

<b>Examiner Signature</b>	/Dac Ha/	<b>Date Considered</b>	07/07/2011
---------------------------	----------	------------------------	------------

Substitute for 1449/PTO  <b>INFORMATION DISCLOSURE STATEMENT BY APPLICANT</b>  <i>(use as many sheets as necessary)</i>				<b>Complete if Known</b>	
				<b>Application Number</b>	12/543,910
				<b>Filing Date</b>	August 19, 2009
				<b>First Named Inventor</b>	Gordon F. Bremer
				<b>Art Unit</b>	2611
<b>Examiner Name</b>	Dac V. Ha				
<b>Attorney Docket Number</b>	REMB-0109				
Sheet	10	of	11		

NON PATENT LITERATURE DOCUMENTS			
229		Bluetooth™, "Specification of the Bluetooth System, Profiles", Specification Volume 2, December 1, 1999, V1.0B, 1-440	
230		Chorafas (Ed.), "Telephony: Today and Tomorrow", Prentice-Hall, Inc., NJ, Chapter 15, 1984, 191-197	
231		Erickson (Ed.), "Options for Presentation of Multilingual Text: Use of the Unicode Standard", March 14, 1997, 20 pages	
232		Freeman (Ed.), "Telecommunications Systems Engineering: Analog and Digital Network Design", John Wiley and Sons, Inc., NY, 1980, 1 page, 180	
233		Goodman (Ed.), "Radio Amateur's Handbook", The American Radio Relay League, Inc., CN, 1965, Chapter 10, 291-295	
234		Green (Ed.), "RTTY Handbook", Tab Books, Chapter 4, 1972, 266-273	
235		IEEE Information Technology, "Wireless LAN Medium Access Control (MAC) and Physical Layer (PHY) Specifications", 1997, 1-466	
236		Jurgen (Ed.), "Digital Consumer Electronics Handbook", McGraw-Hill Publications, NY, 1997, 27.7-27.10	
237		Kuecken (Ed.), "Talking Computers and Telecommunications", Van Nostrand Reinhold Company, Inc., NY, 1983, 32-36	
238		Margulies (Ed.), "SCSA Book", Telecom Library, Inc., NJ, Chapter 8, 1993, 250	
239		Martin (Ed.), "Telecommunications and The Computer", Prentice-Hall, Inc., NJ, 2 <sup>nd</sup> Edition, Chapter 21, 1976, 410-423	
240		Mazda, (Ed.), "Electronics Engineer's Reference Book", 5 <sup>th</sup> Edition, Butterworth and Company Publishers, London, 1983, 54.5-54.8	
241		Newton (Ed.), "Newton's Telecom Dictionary", Flatiron Publications, Inc., NY, April 1994, 7 <sup>th</sup> Edition, 9, 363, 364, 426, 427, 428, 429 and 430	
242		Pallott and Miller, "Implementing Message Priority Polices Over an 802.11 Based Mobile Ad Hoc Network", IEEE, Military Communications Conference, 2001, MILCOM 2001, Communications for Network-Centric Operations: Creating the Information Force, October 28-31, 2001, 2, 860-864	

<b>Examiner Signature</b>	/Dac Ha/	<b>Date Considered</b>	07/07/2011
---------------------------	----------	------------------------	------------

Substitute for 1449/PTO  <b>INFORMATION DISCLOSURE STATEMENT BY APPLICANT</b>  <i>(use as many sheets as necessary)</i>				<b>Complete if Known</b>	
				<b>Application Number</b>	12/543,910
				<b>Filing Date</b>	August 19, 2009
				<b>First Named Inventor</b>	Gordon F. Bremer
				<b>Art Unit</b>	2611
				<b>Examiner Name</b>	Dac V. Ha
Sheet	11	of	11	<b>Attorney Docket Number</b>	REMB-0109

NON PATENT LITERATURE DOCUMENTS			
243		The National Association for Amateur Radio (ARRL), Radioteletype (RTTY), "Basic Principles and Machines", Chapter 2.1, Book or Journal Title Unknown, Date Unknown, pages 13 and 14	
244		The National Association for Amateur Radio (ARRL), Radioteletype (RTTY), "Autostart", Chapter 3.4, "references", Chapter 8, Book or Journal Title Unknown, Date Unknown, pages 107-111, 183, 185, 186 and 187	
245		Rzeszewski (Ed.), "Color Television", IEEE Press, John Wiley and Sons, Inc, NY, 1983, 3, 8 and 9	
246		Shrader (Ed.), "Electronic Communication", 1959, McGraw-Hill Publishers, NY, 551-555	
247		Shrader (Ed.), "Electronic Communication", 1959, McGraw-Hill Publishers, NY, 519	
248		Third Generation Partnership Project (3GPP) – Technologies Web Page, <a href="http://www.3gpp.org/-technologies-">http://www.3gpp.org/-technologies-</a> , Accessed on February 8, 2011, 2 pages	
249		Vilips (Ed.), "Data Modem: Selection and Evaluation Guide", Artech House, Inc, MA, Section 1, 1972, 3 pages	
250		Wilson et al (Ed.), "The ARRL Handbook for Radio Communications", 64 <sup>th</sup> Edition, The American Radio Relay League, Inc., Chapter 19, 1986, 19-9 - 19-13	
251		Wilson et al. (Ed.), "The ARRL Handbook for Radio Communications", 85 <sup>th</sup> Edition, The American Radio Relay League, Chapter 9, 2008, 9.32, 9.33 and 9.34	
252		Wilson et al. (Ed.), "The ARRL Handbook for Radio Communications", 64 <sup>th</sup> Edition, The American Radio Relay League Inc., Chapter 14, 1986, 14-13 and 14-14	

<b>Examiner Signature</b>	/Dac Ha/	<b>Date Considered</b>	07/07/2011
---------------------------	----------	------------------------	------------

Substitute for 1449/PTO  <b>INFORMATION DISCLOSURE STATEMENT BY APPLICANT</b>  <i>(use as many sheets as necessary)</i>				<b>Complete if Known</b>	
				<b>Application Number</b>	12/543,910
				<b>Filing Date</b>	August 19, 2009
				<b>First Named Inventor</b>	Gordon F. Bremer
				<b>Art Unit</b>	2611
<b>Examiner Name</b>	Dac V. Ha				
<b>Attorney Docket Number</b>	REMB-0109				
Sheet	1	of	1		

NON PATENT LITERATURE DOCUMENTS			
Examiner Initials	Cite No.	Include name of the author, title of the article (when appropriate), title of the item (book, magazine, journal, serial, symposium, catalog, etc.), date, page(s), Volume-issue Number(s), publisher, city and/or country where published.	T
	253	International Telecommunications Union, Telecommunication Standardization Sector of ITU (ITU-T), Series T: Terminal Equipments and Protocols For Telematic Services, "Procedures for Document Facsimile Transmission in the General Switched Telephone Network", ITU-T Recommendation T.30, July 1996, 176 pages	
	254	International Telecommunications Union, The International Telegraph and Telephone Consultative Committee (CCITT), Data Communication Over The Telephone Network, "A 2-Wire Modem For Facsimile Applications With Rates Up to 14 400 bit/s", Recommendation V.17, February 1991, 13 pages	
	255	International Telecommunications Union, Telecommunication Standardization Sector of ITU (ITU-T), Series T: Terminal Equipments and Protocols For Telematic Services, "Standardization of Group 3 Facsimile Terminals for Document Transmission", ITU-T Recommendation T.4, July 1996, 60 pages	
	256	International Telecommunications Union, Telecommunication Standardization Sector of ITU (ITU-T), Series T: Terminals For Telematic Services, "Standardization of Group 3 Facsimile Terminals for Document Transmission", ITU-T Recommendation T.4 – Amendment 1, July 1997, 10 pages	
	257	International Telecommunications Union, Telecommunication Standardization Sector of ITU (ITU-T), Series T: Terminals For Telematic Services, "Standardization of Group 3 Facsimile Terminals for Document Transmission", ITU-T Recommendation T.4 – Amendment 2, October 1997, 14 pages	
	258	International Telecommunications Union, Telecommunication Standardization Sector of ITU (ITU-T), Series T: Terminals For Telematic Services, "Procedures for Document Facsimile Transmission in the General Switched Telephone Network", ITU-T Recommendation T.30 – Amendment 1, July 1997, 110 pages	
	259	International Telecommunications Union, Telecommunication Standardization Sector of ITU (ITU-T), Series T: Terminals For Telematic Services, "Procedures for Document Facsimile Transmission in the General Switched Telephone Network", ITU-T Recommendation T.30 – Amendment 2, October 1997, 18 pages	

<b>Examiner Signature</b>	/Dac Ha/	<b>Date Considered</b>	07/07/2011
---------------------------	----------	------------------------	------------

MAY 12 2011

Substitute for 1449/PTO  <b>INFORMATION DISCLOSURE STATEMENT BY APPLICANT</b>  <i>(use as many sheets as necessary)</i>			<i>Complete if Known</i>		
			Application Number	12/543,910	
			Filing Date	August 19, 2009	
			First Named Inventor	Gordon F. Bremer	
			Art Unit	2611	
			Examiner Name	Dac V. Ha	
Sheet	1	of	1	Attorney Docket Number	REMB-0109

NON PATENT LITERATURE DOCUMENTS			
Examiner Initials	Cite No.	Include name of the author, title of the article (when appropriate), title of the item (book, magazine, journal, serial, symposium, catalog, etc.), date, page(s), Volume-Issue Number(s), publisher, city and/or country where published.	T
	253	International Telecommunications Union, Telecommunication Standardization Sector of ITU (ITU-T), Series T: Terminal Equipments and Protocols For Telematic Services, "Procedures for Document Facsimile Transmission in the General Switched Telephone Network", ITU-T Recommendation T.30, July 1996, 176 pages	
	254	International Telecommunications Union, The International Telegraph and Telephone Consultative Committee (CCITT), Data Communication Over The Telephone Network, "A 2-Wire Modem For Facsimile Applications With Rates Up to 14 400 bit/s", Recommendation V.17, February 1991, 13 pages	
	255	International Telecommunications Union, Telecommunication Standardization Sector of ITU (ITU-T), Series T: Terminal Equipments and Protocols For Telematic Services, "Standardization of Group 3 Facsimile Terminals for Document Transmission", ITU-T Recommendation T.4, July 1996, 60 pages	
	256	International Telecommunications Union, Telecommunication Standardization Sector of ITU (ITU-T), Series T: Terminal: For Telematic Services, "Standardization of Group 3 Facsimile Terminals for Document Transmission", ITU-T Recommendation T.4 - Amendment 1, July 1997, 10 pages	
	257	International Telecommunications Union, Telecommunication Standardization Sector of ITU (ITU-T), Series T: Terminal: For Telematic Services, "Standardization of Group 3 Facsimile Terminals for Document Transmission", ITU-T Recommendation T.4 - Amendment 2, October 1997, 14 pages	
	258	International Telecommunications Union, Telecommunication Standardization Sector of ITU (ITU-T), Series T: Terminal: For Telematic Services, "Procedures for Document Facsimile Transmission in the General Switched Telephone Network", ITU-T Recommendation T.30 - Amendment 1, July 1997, 110 pages	
	259	International Telecommunications Union, Telecommunication Standardization Sector of ITU (ITU-T), Series T: Terminal: For Telematic Services, "Procedures for Document Facsimile Transmission in the General Switched Telephone Network", ITU-T Recommendation T.30 - Amendment 2, October 1997, 18 pages	

Examiner Signature	/Dac Ha/	Date Considered	07/07/2011
--------------------	----------	-----------------	------------

**DOCKET NO.:** REMB\_0109  
**Application No.:** 12/543,910  
**Notice of Allowance Dated:** July 22, 2011

**PATENT**

**IN THE UNITED STATES PATENT AND TRADEMARK OFFICE**

<b>In re Application of:</b> <b>Gordon Bremer</b>	<b>Confirmation No.: 8306</b>
<b>Application No.: 12/543,910</b>	<b>Group Art Unit: 2611</b>
<b>Filing Date: August 19, 2009</b>	<b>Examiner: Dac V Ha</b>
<b>For: SYSTEM AND METHOD OF COMMUNICATION VIA EMBEDDED MODULATION</b>	

Mail Stop Issue Fee  
Commissioner for Patents  
P.O. Box 1450  
Alexandria, VA 22313-1450

Sir:

**AMENDMENT AFTER ALLOWANCE PURSUANT TO 37 CFR § 1.312**

In response to the Notice of Allowance dated **July 22, 2011**, reconsideration is respectfully requested in view of the amendments and/or remarks as indicated below:

- Amendments to the Specification** begin on page 2 of this paper.
- Amendments to the Claims** are reflected in the listing of the claims which begins on page 3 of this paper.
- Amendments to the Drawings** begin on page \_\_\_\_\_ of this paper and include an attached replacement sheet.
- Remarks** begin on page 16 of this paper.
- The Commissioner is hereby authorized to charge any fee deficiency, charge any additional fees, or credit any overpayment of fees, associated with this application in connection with this filing, or any future filing, submitted to the U.S. Patent and Trademark Office during the pendency of this application, to Deposit Account No. 50-5519.

**DOCKET NO.:** REMB\_0109  
**Application No.:** 12/543,910  
**Notice of Allowance Dated:** July 22, 2011

**PATENT**

Please amend the Title of the Application, which is presented above paragraph [0001] of the specification, as follows:

**SYSTEM AND METHOD OF COMMUNICATION ~~VIA EMBEDDED~~ USING AT LEAST TWO MODULATION METHODS**



This listing of claims will replace all prior versions, and listings, of claims in the application.

**Listing of Claims:**

1. (Previously Presented) A communication device capable of communicating according to a master/slave relationship in which a slave communication from a slave to a master occurs in response to a master communication from the master to the slave, the device comprising:

a transceiver, in the role of the master according to the master/slave relationship, for sending at least transmissions modulated using at least two types of modulation methods, wherein the at least two types of modulation methods comprise a first modulation method and a second modulation method, wherein the second modulation method is of a different type than the first modulation method, wherein each transmission comprises a group of transmission sequences, wherein each group of transmission sequences is structured with at least a first portion and a payload portion wherein first information in the first portion indicates at least which of the first modulation method and the second modulation method is used for modulating second information in the payload portion, wherein at least one group of transmission sequences is addressed for an intended destination of the payload portion, and wherein for the at least one group of transmission sequences:

the first information for said at least one group of transmission sequences comprises a first sequence, in the first portion and modulated according to the first modulation method, wherein the first sequence indicates an impending change from the first modulation method to the second modulation method, and

the second information for said at least one group of transmission sequences comprises a second sequence that is modulated according to the second modulation method, wherein the second sequence is transmitted after the first sequence.

2. (Previously Presented) The device of claim 1, wherein the transceiver is configured to transmit a third sequence after the second sequence, wherein the third sequence is transmitted in the first modulation method and indicates that communication from the master to the slave has reverted to the first modulation method.

3. – 8. (Canceled)

9. (Previously Presented) The device of claim 1, wherein the transceiver is configured to transmit the second sequence according to a specific time interval.

10. (Previously Presented) The device of claim 1, wherein the transceiver is configured to transmit the second sequence according to a particular quantity of data.

11. (Previously Presented) The device of claim 1, further comprising a processor and a memory, wherein the memory has stored therein instructions that when executed by the processor cause the transceiver to transmit the first sequence and the second sequence.

12. (Previously Presented) The device of claim 11, wherein the memory has stored therein program code for the first modulation method and the second modulation method.

13. (Previously Presented) The device of claim 11, wherein the memory comprises random access memory.

14. (Previously Presented) The device of claim 11, wherein the memory comprises read-only memory.

15. (Previously Presented) The device of claim 11, wherein the memory has stored therein program code for operating the transceiver in a multipoint master/slave relationship.

16. – 17. (Canceled)

18. (Previously Presented) The device of claim 1, wherein the first communication from the master to the slave is a poll in accordance with a multipoint communications relationship, wherein the poll indicates that the master has selected the slave for transmission.

19. (Canceled)

20. (Previously Presented) A communications device, comprising:

a processor; and

a memory having stored therein executable instructions for execution by the processor, wherein the executable instructions direct transmission of a first data with a first modulation method followed by a second data with a second modulation method, wherein the first modulation method is different than the second modulation method, wherein the first data comprises an indication of an impending change from the first modulation method to the second modulation method, wherein the executable instructions direct transmission of a third data with the first modulation method after the second data, and wherein the third data indicates that communication has reverted to the first modulation method.

21. – 26. (Canceled)

27. (Previously Presented) The device of claim 20, wherein transmission of the second data is according to a specific time interval.

28. (Previously Presented) A communications device, comprising:

a processor; and

a memory having stored therein executable instructions for execution by the processor, wherein the executable instructions direct transmission of a first data with a first modulation method followed by a second data with a second modulation method, wherein the first modulation method is different than the second modulation method, wherein the first data comprises an indication of an impending change from the first modulation method to the second modulation method wherein the executable instructions direct transmission of a third data with the first modulation method after the second data, and wherein transmission of the second data is according to a particular quantity of data.

29. (Previously Presented) The device of claim 20, further comprising a transmitter configured to transmit the first data and the second data.

30. (Previously Presented) The device of claim 20, wherein the memory has stored therein program code for the first modulation method and the second modulation method.

31. (Previously Presented) The device of claim 20, wherein the memory comprises random access memory.

32. (Previously Presented) The device of claim 20, wherein the memory comprises read-only memory.

33. (Previously Presented) The device of claim 20, wherein the memory has stored therein program code for a multipoint communications protocol.

34. – 36. (Canceled)

37. (Currently Amended) A device that transmits in accordance with a first modulation method and a second modulation method that is different than the first modulation method, said device comprising:

at least one modulator;

a transceiver that includes the at least one modulator, wherein the transceiver is configured to transmit:

a first sequence, modulated in accordance with the first modulation method, that indicates an impending change from the first modulation method to the second modulation method, and

a second sequence, in accordance with the second modulation method, that is transmitted at a time after the first ~~data~~ sequence.

38. (Previously Presented) The device of claim 37, wherein the transceiver is configured to transmit a third sequence after the second sequence, wherein the third sequence is transmitted in accordance with the first modulation method and indicates that a subsequent communication has reverted to the first modulation method.

39. – 44. (Canceled)

45. (Previously Presented) The device of claim 37, wherein the transceiver is configured to transmit the second sequence according to a specific time interval.

46. (Previously Presented) The device of claim 37, wherein the transceiver is configured to transmit the second sequence according to a particular quantity of data.

47. (Original) The device of claim 37, further comprising a processor and a memory, wherein the memory has stored therein instructions that when executed by the processor cause the transmitter to transmit the first sequence and the second sequence.

48. (Original) The device of claim 47, wherein the memory comprises random access memory.

49. (Original) The device of claim 47, wherein the memory comprises read-only memory.

50. (Original) The device of claim 47, wherein the memory has stored therein program code for a multipoint communications protocol.

51. – 86. (Canceled)

87. (Currently Amended) A computer-readable storage medium having [[a]] computer executable instructions stored therein that when executed by a processor control a master transceiver, said computer executable instructions, comprising:

first logic configured to transmit first information in a first modulation method for communication;

second logic configured to transmit a first sequence to notify of a change from said first modulation method to a second modulation method;

third logic configured to transmit second information in said second modulation method;  
and

fourth logic configured to transmit a second sequence after the second information is transmitted, wherein the second sequence is transmitted in the first modulation method and indicates that communication has reverted to the first modulation method.

88. – 93. (Canceled)

94. (Previously Presented) The computer-readable storage medium of claim 87, wherein the first transceiver is configured to transmit the second sequence according to a specific time interval.

95. (Currently Amended) A computer-readable storage medium having [[a]] computer executable instructions stored therein that when executed by a processor control a master transceiver, said computer executable instructions, comprising:

first logic configured to transmit first information in a first modulation method for communication;

second logic configured to transmit a first sequence to notify of a change from said first modulation method to a second modulation method;

third logic configured to transmit second information in said second modulation method;  
and

fourth logic configured to transmit a second sequence after the second information is transmitted, wherein the fourth logic is configured to transmit the second sequence according to a particular quantity of data.

96. (Previously Presented) The computer-readable storage medium of claim 87, further comprising program code for the first modulation method and the second modulation method.

97. (Previously Presented) The computer-readable storage medium of claim 87, further comprising program code for a multipoint communications protocol.

98. – 100. (Canceled)

101. (Previously Presented) The device of claim 1, wherein the transceiver is configured to be the master.

102. (Previously Presented) The device of claim 1, wherein the first information in the first portion indicates the first modulation method when the intended destination is a first type of receiver and indicates the second modulation when the intended destination is a second type of receiver.

103. (Previously Presented) The device of claim 102, wherein the second type of receiver differs from the first type of receiver at least by the second type of receiver being designated for transmitting in the second modulation method.

104. (Previously Presented) The device of claim 102, wherein the second type of receiver differs from the first type of receiver at least by the second type of receiver being operable to ignore transmissions intended for the first type of receiver.

105. (Previously Presented) The device of claim 104, wherein the intended destination ignores transmissions in the second modulation when the intended destination is the first type of receiver.

106. (Previously Presented) The device of claim 104, wherein the intended destination ignores transmissions in the first modulation when the intended destination is the second type of receiver.

107. (Previously Presented) The device of claim 104, wherein the intended destination is the first type of receiver and unable to demodulate the second modulation method.

108. (Previously Presented) The device of claim 102, wherein the transceiver is configured to receive data from the intended destination in the first modulation method when the intended destination is the first type of receiver.

109. (Previously Presented) The device of claim 102, wherein the transceiver is configured to receive data from the intended destination in the second modulation method when the intended destination is the second type of receiver.

110. (Previously Presented) The device of claim 1, the transceiver is configured to transmit a third sequence, according to the first modulation method, at a time after the second sequence is transmitted.

111. (Previously Presented) The device of claim 1, wherein the transceiver transmits data modulated according to either the first modulation method or the second modulation method at any given point in time when the transceiver is transmitting.

112. (Previously Presented) The device of claim 20, wherein transmission of the second data is according to a particular quantity of data.

113. (Previously Presented) The device of claim 28, wherein transmission of the second data is according to a specific time interval.



114. (Previously Presented) The device of claim 28, further comprising a transmitter configured to transmit the first data and the second data.
115. (Previously Presented) The device of claim 28, wherein the memory has stored therein program code for the first modulation method and the second modulation method.
116. (Previously Presented) The device of claim 28, wherein the memory comprises random access memory.
117. (Previously Presented) The device of claim 28, wherein the memory comprises read-only memory.
118. (Previously Presented) The device of claim 28, wherein the memory has stored therein program code for a multipoint communications protocol.
119. (Previously Presented) The computer-readable storage medium of claim 87, wherein the first transceiver is configured to transmit the second sequence according to a particular quantity of data.
120. (Previously Presented) The computer-readable storage medium of claim 95, wherein the first transceiver is configured to transmit the second sequence according to a specific time interval.
121. (Previously Presented) The computer-readable storage medium of claim 95, further comprising program code for the first modulation method and the second modulation method.
122. (Previously Presented) The computer-readable storage medium of claim 95, further comprising program code for a multipoint communications protocol.

123. (Previously Presented) A communication device capable of communicating according to a master/slave relationship in which a slave message from a slave to a master occurs in response to a master message from the master to the slave, the device comprising:

a transceiver, in the role of the master according to the master/slave relationship, capable of transmitting using at least two types of modulation methods, wherein the at least two types of modulation methods comprise a first modulation method and a second modulation method, wherein the second modulation method is of a different type than the first modulation method, and wherein the transceiver is configured to transmit messages with:

a first sequence, in the first modulation method, that indicates at least which of the first modulation method and the second modulation method is used for modulating a second sequence, wherein, in at least one message, the first sequence indicates an impending change from the first modulation method to the second modulation method, and wherein the at least one message is addressed for an intended destination of the second sequence, and

the second sequence, modulated in accordance with the modulation method indicated by the first sequence and, in the at least one message, modulated using the second modulation method, wherein the second sequence is transmitted after the first sequence.

124. (Previously Presented) The device of claim 123, wherein the transceiver is configured to transmit a third sequence after the second sequence, wherein the third sequence is transmitted in the first modulation method and indicates that communication from the master to the slave has reverted to the first modulation method.

125. (Previously Presented) The device of claim 123, wherein the transceiver is configured to transmit the second sequence according to a specific time interval.

126. (Previously Presented) The device of claim 123, wherein the transceiver is configured to transmit the second sequence according to a particular quantity of data.

127. (Previously Presented) The device of claim 123, further comprising a processor and a memory, wherein the memory has stored therein instructions that when executed by the processor cause the transceiver to transmit the first sequence and the second sequence.

128. (Previously Presented) The device of claim 127, wherein the memory has stored therein program code for the first modulation method and the second modulation method.

129. (Previously Presented) The device of claim 127, wherein the memory comprises random access memory.

130. (Previously Presented) The device of claim 127, wherein the memory comprises read-only memory.

131. (Previously Presented) The device of claim 127, wherein the memory has stored therein program code for operating the transceiver in a multipoint master/slave relationship.

132. (Previously Presented) The device of claim 123, wherein the first communication from the master to the slave is a poll in accordance with a multipoint communications relationship, wherein the poll indicates that the master has selected the slave for transmission.

133. (Previously Presented) The device of claim 123, wherein the transceiver is configured to be the master.

134. (Previously Presented) The device of claim 123, wherein the first information in the first portion indicates the first modulation method when the intended destination is a first type of receiver and indicates the second modulation when the intended destination is a second type of receiver.

135. (Previously Presented) The device of claim 134, wherein the second type of receiver differs from the first type of receiver at least by the second type of receiver being designated for transmitting in the second modulation method.

136. (Previously Presented) The device of claim 134, wherein the second type of receiver differs from the first type of receiver at least by the second type of receiver being operable to ignore transmissions intended for the first type of receiver.

137. (Previously Presented) The device of claim 136, wherein the intended destination ignores transmissions in the second modulation when the intended destination is the first type of receiver.

138. (Previously Presented) The device of claim 136, wherein the intended destination ignores transmissions in the first modulation when the intended destination is the second type of receiver.

139. (Previously Presented) The device of claim 136, wherein the intended destination is the first type of receiver and unable to demodulate the second modulation method.

140. (Previously Presented) The device of claim 134, wherein the transceiver is configured to receive data from the intended destination in the first modulation method when the intended destination is the first type of receiver.

141. (Previously Presented) The device of claim 134, wherein the transceiver is configured to receive data from the intended destination in the second modulation method when the intended destination is the second type of receiver.

142. (Previously Presented) The device of claim 123, the transceiver is configured to transmit a third sequence, according to the first modulation method, at a time after the second sequence is transmitted.

143. (Previously Presented) The device of claim 123, wherein the transceiver transmits data modulated according to either the first modulation method or the second modulation method at any given point in time when the transceiver is transmitting.

144. (Previously Presented) The device of claim 127, wherein the memory comprises an erasable programmable read-only memory.

145. (Previously Presented) The device of claim 11, wherein the memory comprises an erasable programmable read-only memory.

146. (Previously Presented) The device of claim 20, wherein the memory comprises an erasable programmable read-only memory.

147. (Previously Presented) The device of claim 28, wherein the memory comprises an erasable programmable read-only memory.

148. (Previously Presented) The device of claim 47, wherein the memory comprises an erasable programmable read-only memory.

**DOCKET NO.:** REMB\_0109  
**Application No.:** 12/543,910  
**Notice of Allowance Dated:** July 22, 2011

**PATENT**

**REMARKS**

Claims 1, 2, 9-15, 18, 20, 27-33, 37, 38, 45-50, 87, 94-97, and 101-148 are pending and have been allowed. Applicant has amended claims 37, 87, and 95 to address informalities. No claims have been added or canceled. Applicant has amended the Title to more closely reflect the present subject matter (*See* MPEP §§ 1302.04(a) and 606.01). No new matter has been added and the issue fee has not yet been paid.

Applicant respectfully request the foregoing amendments be entered and be made of record.

Date: July 26, 2011

/Michael A. Koptiw/  
Micheal A. Koptiw  
Registration No. 57,900

Condo Roccia LLP  
One Liberty Place  
1650 Market Street, Suite 2200  
Philadelphia, PA 19103  
Telephone: (215) 558-5714  
Facsimile: (215) 558-5676

Under the Paperwork Reduction Act of 1995, no persons are required to respond to a collection of information unless it displays a valid OMB control number.

<b>TRANSMITTAL FORM</b>  <i>(to be used for all correspondence after initial filing)</i>	Application Number	12/543,910	
	Filing Date	August 19, 2009	
	First Named Inventor	Gordon Bremer	
	Art Unit	2611	
	Examiner Name	Dac V Ha	
Total Number of Pages in This Submission	18	Attorney Docket Number	REMB_0109

<b>ENCLOSURES (Check all that apply)</b>				
<input type="checkbox"/> Fee Transmittal Form <input type="checkbox"/> Fee Attached <input type="checkbox"/> Amendment/Reply <input type="checkbox"/> After Final <input type="checkbox"/> Affidavits/declaration(s) <input type="checkbox"/> Extension of Time Request <input type="checkbox"/> Express Abandonment Request <input type="checkbox"/> Information Disclosure Statement  <input type="checkbox"/> Certified Copy of Priority Document(s) <input type="checkbox"/> Reply to Missing Parts/ Incomplete Application <input type="checkbox"/> Reply to Missing Parts under 37 CFR 1.52 or 1.53	<input type="checkbox"/> Drawing(s) <input type="checkbox"/> Licensing-related Papers <input type="checkbox"/> Petition <input type="checkbox"/> Petition to Convert to a Provisional Application <input type="checkbox"/> Power of Attorney, Revocation <input type="checkbox"/> Change of Correspondence Address <input type="checkbox"/> Terminal Disclaimer <input type="checkbox"/> Request for Refund <input type="checkbox"/> CD, Number of CD(s) _____ <input type="checkbox"/> Landscape Table on CD	<input checked="" type="checkbox"/> After Allowance Communication to TC <input type="checkbox"/> Appeal Communication to Board of Appeals and Interferences <input type="checkbox"/> Appeal Communication to TC (Appeal Notice, Brief, Reply Brief) <input type="checkbox"/> Proprietary Information <input type="checkbox"/> Status Letter <input type="checkbox"/> Other Enclosure(s) (please identify below):		
<table border="1" style="width: 100%; border-collapse: collapse;"> <tr> <td style="width: 100px;">Remarks</td> <td></td> </tr> </table>			Remarks	
Remarks				

<b>SIGNATURE OF APPLICANT, ATTORNEY, OR AGENT</b>			
Firm Name	Condo Roccia LLP		
Signature	/Michael A. Koptiw/		
Printed name	Michael A. Koptiw		
Date	July 26, 2011	Reg. No.	57900

<b>CERTIFICATE OF TRANSMISSION/MAILING</b>			
I hereby certify that this correspondence is being facsimile transmitted to the USPTO or deposited with the United States Postal Service with sufficient postage as first class mail in an envelope addressed to: Commissioner for Patents, P.O. Box 1450, Alexandria, VA 22313-1450 on the date shown below:			
Signature			
Typed or printed name		Date	

This collection of information is required by 37 CFR 1.5. The information is required to obtain or retain a benefit by the public which is to file (and by the USPTO to process) an application. Confidentiality is governed by 35 U.S.C. 122 and 37 CFR 1.11 and 1.14. This collection is estimated to 2 hours to complete, including gathering, preparing, and submitting the completed application form to the USPTO. Time will vary depending upon the individual case. Any comments on the amount of time you require to complete this form and/or suggestions for reducing this burden, should be sent to the Chief Information Officer, U.S. Patent and Trademark Office, U.S. Department of Commerce, P.O. Box 1450, Alexandria, VA 22313-1450. DO NOT SEND FEES OR COMPLETED FORMS TO THIS ADDRESS. **SEND TO: Commissioner for Patents, P.O. Box 1450, Alexandria, VA 22313-1450.**

If you need assistance in completing the form, call 1-800-PTO-9199 and select option 2.

## Privacy Act Statement

The **Privacy Act of 1974 (P.L. 93-579)** requires that you be given certain information in connection with your submission of the attached form related to a patent application or patent. Accordingly, pursuant to the requirements of the Act, please be advised that: (1) the general authority for the collection of this information is 35 U.S.C. 2(b)(2); (2) furnishing of the information solicited is voluntary; and (3) the principal purpose for which the information is used by the U.S. Patent and Trademark Office is to process and/or examine your submission related to a patent application or patent. If you do not furnish the requested information, the U.S. Patent and Trademark Office may not be able to process and/or examine your submission, which may result in termination of proceedings or abandonment of the application or expiration of the patent.

The information provided by you in this form will be subject to the following routine uses:

1. The information on this form will be treated confidentially to the extent allowed under the Freedom of Information Act (5 U.S.C. 552) and the Privacy Act (5 U.S.C. 552a). Records from this system of records may be disclosed to the Department of Justice to determine whether disclosure of these records is required by the Freedom of Information Act.
2. A record from this system of records may be disclosed, as a routine use, in the course of presenting evidence to a court, magistrate, or administrative tribunal, including disclosures to opposing counsel in the course of settlement negotiations.
3. A record in this system of records may be disclosed, as a routine use, to a Member of Congress submitting a request involving an individual, to whom the record pertains, when the individual has requested assistance from the Member with respect to the subject matter of the record.
4. A record in this system of records may be disclosed, as a routine use, to a contractor of the Agency having need for the information in order to perform a contract. Recipients of information shall be required to comply with the requirements of the Privacy Act of 1974, as amended, pursuant to 5 U.S.C. 552a(m).
5. A record related to an International Application filed under the Patent Cooperation Treaty in this system of records may be disclosed, as a routine use, to the International Bureau of the World Intellectual Property Organization, pursuant to the Patent Cooperation Treaty.
6. A record in this system of records may be disclosed, as a routine use, to another federal agency for purposes of National Security review (35 U.S.C. 181) and for review pursuant to the Atomic Energy Act (42 U.S.C. 218(c)).
7. A record from this system of records may be disclosed, as a routine use, to the Administrator, General Services, or his/her designee, during an inspection of records conducted by GSA as part of that agency's responsibility to recommend improvements in records management practices and programs, under authority of 44 U.S.C. 2904 and 2906. Such disclosure shall be made in accordance with the GSA regulations governing inspection of records for this purpose, and any other relevant (*i.e.*, GSA or Commerce) directive. Such disclosure shall not be used to make determinations about individuals.
8. A record from this system of records may be disclosed, as a routine use, to the public after either publication of the application pursuant to 35 U.S.C. 122(b) or issuance of a patent pursuant to 35 U.S.C. 151. Further, a record may be disclosed, subject to the limitations of 37 CFR 1.14, as a routine use, to the public if the record was filed in an application which became abandoned or in which the proceedings were terminated and which application is referenced by either a published application, an application open to public inspection or an issued patent.
9. A record from this system of records may be disclosed, as a routine use, to a Federal, State, or local law enforcement agency, if the USPTO becomes aware of a violation or potential violation of law or regulation.



## Electronic Acknowledgement Receipt

<b>EFS ID:</b>	10601306
<b>Application Number:</b>	12543910
<b>International Application Number:</b>	
<b>Confirmation Number:</b>	8306
<b>Title of Invention:</b>	SYSTEM AND METHOD OF COMMUNICATION VIA EMBEDDED MODULATION
<b>First Named Inventor/Applicant Name:</b>	Gordon F. Bremer
<b>Customer Number:</b>	15027
<b>Filer:</b>	Michael Koptiw Jr./diana kang
<b>Filer Authorized By:</b>	Michael Koptiw Jr.
<b>Attorney Docket Number:</b>	REMB-0109
<b>Receipt Date:</b>	26-JUL-2011
<b>Filing Date:</b>	19-AUG-2009
<b>Time Stamp:</b>	16:40:08
<b>Application Type:</b>	Utility under 35 USC 111(a)

### Payment information:

Submitted with Payment	no
------------------------	----

### File Listing:

Document Number	Document Description	File Name	File Size(Bytes)/ Message Digest	Multi Part /.zip	Pages (if appl.)
1		REMB0109amend312filed0726 11.pdf	137370  d49e664f1022202f6a138ca76fc83dc79627 b009	yes	16

Multipart Description/PDF files in .zip description			
Document Description	Start	End	
Amendment after Notice of Allowance (Rule 312)	1	1	
Specification	2	2	
Claims	3	15	
Applicant Arguments/Remarks Made in an Amendment	16	16	

**Warnings:**

**Information:**

2	Transmittal Letter	REMB0109amend312filed0726 11transmittal.pdf	262085	no	2
			83bce1ffb22f447885ac890b9f6745aa1f4573ab		

**Warnings:**

**Information:**

<b>Total Files Size (in bytes):</b>	399455
-------------------------------------	--------

**This Acknowledgement Receipt evidences receipt on the noted date by the USPTO of the indicated documents, characterized by the applicant, and including page counts, where applicable. It serves as evidence of receipt similar to a Post Card, as described in MPEP 503.**

**New Applications Under 35 U.S.C. 111**

**If a new application is being filed and the application includes the necessary components for a filing date (see 37 CFR 1.53(b)-(d) and MPEP 506), a Filing Receipt (37 CFR 1.54) will be issued in due course and the date shown on this Acknowledgement Receipt will establish the filing date of the application.**

**National Stage of an International Application under 35 U.S.C. 371**

**If a timely submission to enter the national stage of an international application is compliant with the conditions of 35 U.S.C. 371 and other applicable requirements a Form PCT/DO/EO/903 indicating acceptance of the application as a national stage submission under 35 U.S.C. 371 will be issued in addition to the Filing Receipt, in due course.**

**New International Application Filed with the USPTO as a Receiving Office**

**If a new international application is being filed and the international application includes the necessary components for an international filing date (see PCT Article 11 and MPEP 1810), a Notification of the International Application Number and of the International Filing Date (Form PCT/RO/105) will be issued in due course, subject to prescriptions concerning national security, and the date shown on this Acknowledgement Receipt will establish the international filing date of the application.**



UNITED STATES PATENT AND TRADEMARK OFFICE

UNITED STATES DEPARTMENT OF COMMERCE  
United States Patent and Trademark Office  
Address: COMMISSIONER FOR PATENTS  
P.O. Box 1450  
Alexandria, Virginia 22313-1450  
www.uspto.gov

APPLICATION NO.	FILING DATE	FIRST NAMED INVENTOR	ATTORNEY DOCKET NO.	CONFIRMATION NO.
12/543,910	08/19/2009	Gordon F. Bremer	REMB-0109	8306
15027	7590	08/02/2011	EXAMINER	
Condo Roccia LLP 1650 Market Street Suite 2200 Philadelphia, PA 19103			HA, DAC V	
			ART UNIT	PAPER NUMBER
			2611	
			MAIL DATE	DELIVERY MODE
			08/02/2011	PAPER

**Please find below and/or attached an Office communication concerning this application or proceeding.**

The time period for reply, if any, is set in the attached communication.

<b>Response to Rule 312 Communication</b>	<b>Application No.</b>	<b>Applicant(s)</b>
	12/543,910	BREMER, GORDON F.
	<b>Examiner</b>	<b>Art Unit</b>
	DAC HA	2611

*-- The MAILING DATE of this communication appears on the cover sheet with the correspondence address --*

1.  The amendment filed on 26 July 2011 under 37 CFR 1.312 has been considered, and has been:
- a)  entered.
  - b)  entered as directed to matters of form not affecting the scope of the invention.
  - c)  disapproved because the amendment was filed after the payment of the issue fee.  
Any amendment filed after the date the issue fee is paid must be accompanied by a petition under 37 CFR 1.313(c)(1) and the required fee to withdraw the application from issue.
  - d)  disapproved. See explanation below.
  - e)  entered in part. See explanation below.

	/Dac V. Ha/ Primary Examiner, Art Unit 2611
--	--



UNITED STATES PATENT AND TRADEMARK OFFICE

UNITED STATES DEPARTMENT OF COMMERCE
United States Patent and Trademark Office
Address: COMMISSIONER FOR PATENTS
P.O. Box 1450
Alexandria, Virginia 22313-1450
www.uspto.gov

Table with 6 columns: APPLICATION NUMBER, FILING or 371(c) DATE, GRP ART UNIT, FIL FEE REC'D, ATTY. DOCKET NO, TOT CLAIMS, IND CLAIMS. Row 1: 12/543,910, 08/19/2009, 2611, 6260, REMB-0109, 100, 6

CONFIRMATION NO. 8306

CORRECTED FILING RECEIPT



15027
Condo Roccia LLP
1650 Market Street
Suite 2200
Philadelphia, PA 19103

Date Mailed: 08/04/2011

Receipt is acknowledged of this non-provisional patent application. The application will be taken up for examination in due course. Applicant will be notified as to the results of the examination. Any correspondence concerning the application must include the following identification information: the U.S. APPLICATION NUMBER, FILING DATE, NAME OF APPLICANT, and TITLE OF INVENTION. Fees transmitted by check or draft are subject to collection. Please verify the accuracy of the data presented on this receipt. If an error is noted on this Filing Receipt, please submit a written request for a Filing Receipt Correction. Please provide a copy of this Filing Receipt with the changes noted thereon. If you received a "Notice to File Missing Parts" for this application, please submit any corrections to this Filing Receipt with your reply to the Notice. When the USPTO processes the reply to the Notice, the USPTO will generate another Filing Receipt incorporating the requested corrections

Applicant(s)

Gordon F. Bremer, Clearwater, FL;

Power of Attorney: The patent practitioners associated with Customer Number 15027

Domestic Priority data as claimed by applicant

This application is a CON of 11/774,803 07/09/2007 PAT 7,675,965
which is a CON of 10/412,878 04/14/2003 PAT 7,248,626
which is a CIP of 09/205,205 12/04/1998 PAT 6,614,838
which claims benefit of 60/067,562 12/05/1997

Foreign Applications (You may be eligible to benefit from the Patent Prosecution Highway program at the USPTO. Please see http://www.uspto.gov for more information.)

If Required, Foreign Filing License Granted: 08/31/2009

The country code and number of your priority application, to be used for filing abroad under the Paris Convention, is US 12/543,910

Projected Publication Date: Not Applicable

Non-Publication Request: No

Early Publication Request: No

**Title**

SYSTEM AND METHOD OF COMMUNICATION USING AT LEAST TWO MODULATION METHODS

**Preliminary Class**

375

**PROTECTING YOUR INVENTION OUTSIDE THE UNITED STATES**

Since the rights granted by a U.S. patent extend only throughout the territory of the United States and have no effect in a foreign country, an inventor who wishes patent protection in another country must apply for a patent in a specific country or in regional patent offices. Applicants may wish to consider the filing of an international application under the Patent Cooperation Treaty (PCT). An international (PCT) application generally has the same effect as a regular national patent application in each PCT-member country. The PCT process **simplifies** the filing of patent applications on the same invention in member countries, but **does not result** in a grant of "an international patent" and does not eliminate the need of applicants to file additional documents and fees in countries where patent protection is desired.

Almost every country has its own patent law, and a person desiring a patent in a particular country must make an application for patent in that country in accordance with its particular laws. Since the laws of many countries differ in various respects from the patent law of the United States, applicants are advised to seek guidance from specific foreign countries to ensure that patent rights are not lost prematurely.

Applicants also are advised that in the case of inventions made in the United States, the Director of the USPTO must issue a license before applicants can apply for a patent in a foreign country. The filing of a U.S. patent application serves as a request for a foreign filing license. The application's filing receipt contains further information and guidance as to the status of applicant's license for foreign filing.

Applicants may wish to consult the USPTO booklet, "General Information Concerning Patents" (specifically, the section entitled "Treaties and Foreign Patents") for more information on timeframes and deadlines for filing foreign patent applications. The guide is available either by contacting the USPTO Contact Center at 800-786-9199, or it can be viewed on the USPTO website at <http://www.uspto.gov/web/offices/pac/doc/general/index.html>.

For information on preventing theft of your intellectual property (patents, trademarks and copyrights), you may wish to consult the U.S. Government website, <http://www.stopfakes.gov>. Part of a Department of Commerce initiative, this website includes self-help "toolkits" giving innovators guidance on how to protect intellectual property in specific countries such as China, Korea and Mexico. For questions regarding patent enforcement issues, applicants may call the U.S. Government hotline at 1-866-999-HALT (1-866-999-4158).

**LICENSE FOR FOREIGN FILING UNDER****Title 35, United States Code, Section 184****Title 37, Code of Federal Regulations, 5.11 & 5.15****GRANTED**

The applicant has been granted a license under 35 U.S.C. 184, if the phrase "IF REQUIRED, FOREIGN FILING LICENSE GRANTED" followed by a date appears on this form. Such licenses are issued in all applications where

the conditions for issuance of a license have been met, regardless of whether or not a license may be required as set forth in 37 CFR 5.15. The scope and limitations of this license are set forth in 37 CFR 5.15(a) unless an earlier license has been issued under 37 CFR 5.15(b). The license is subject to revocation upon written notification. The date indicated is the effective date of the license, unless an earlier license of similar scope has been granted under 37 CFR 5.13 or 5.14.

This license is to be retained by the licensee and may be used at any time on or after the effective date thereof unless it is revoked. This license is automatically transferred to any related applications(s) filed under 37 CFR 1.53(d). This license is not retroactive.

The grant of a license does not in any way lessen the responsibility of a licensee for the security of the subject matter as imposed by any Government contract or the provisions of existing laws relating to espionage and the national security or the export of technical data. Licensees should apprise themselves of current regulations especially with respect to certain countries, of other agencies, particularly the Office of Defense Trade Controls, Department of State (with respect to Arms, Munitions and Implements of War (22 CFR 121-128)); the Bureau of Industry and Security, Department of Commerce (15 CFR parts 730-774); the Office of Foreign Assets Control, Department of Treasury (31 CFR Parts 500+) and the Department of Energy.

**NOT GRANTED**

No license under 35 U.S.C. 184 has been granted at this time, if the phrase "IF REQUIRED, FOREIGN FILING LICENSE GRANTED" DOES NOT appear on this form. Applicant may still petition for a license under 37 CFR 5.12, if a license is desired before the expiration of 6 months from the filing date of the application. If 6 months has lapsed from the filing date of this application and the licensee has not received any indication of a secrecy order under 35 U.S.C. 181, the licensee may foreign file the application pursuant to 37 CFR 5.15(b).

**PART B - FEE(S) TRANSMITTAL**

**Complete and send this form, together with applicable fee(s), to: Mail Mail Stop ISSUE FEE  
 Commissioner for Patents  
 P.O. Box 1450  
 Alexandria, Virginia 22313-1450  
 or Fax (571)-273-2885**

**INSTRUCTIONS:** This form should be used for transmitting the ISSUE FEE and PUBLICATION FEE (if required). Blocks 1 through 5 should be completed where appropriate. All further correspondence including the Patent, advance orders and notification of maintenance fees will be mailed to the current correspondence address as indicated unless corrected below or directed otherwise in Block 1, by (a) specifying a new correspondence address; and/or (b) indicating a separate "FEE ADDRESS" for maintenance fee notifications.

CURRENT CORRESPONDENCE ADDRESS (Note: Use Block 1 for any change of address)

Note: A certificate of mailing can only be used for domestic mailings of the Fee(s) Transmittal. This certificate cannot be used for any other accompanying papers. Each additional paper, such as an assignment or formal drawing, must have its own certificate of mailing or transmission.

15027 7590 07/22/2011  
**Condo Roccia LLP**  
 1650 Market Street  
 Suite 2200  
 Philadelphia, PA 19103

**Certificate of Mailing or Transmission**

I hereby certify that this Fee(s) Transmittal is being deposited with the United States Postal Service with sufficient postage for first class mail in an envelope addressed to the Mail Stop ISSUE FEE address above, or being facsimile transmitted to the USPTO (571) 273-2885, on the date indicated below.

(Depositor's name)
(Signature)
(Date)

APPLICATION NO.	FILING DATE	FIRST NAMED INVENTOR	ATTORNEY DOCKET NO.	CONFIRMATION NO.
12/543,910	08/19/2009	Gordon F. Bremer	REMB-0109	8306

TITLE OF INVENTION: SYSTEM AND METHOD OF COMMUNICATION VIA EMBEDDED MODULATION

APPLN. TYPE	SMALL ENTITY	ISSUE FEE DUE	PUBLICATION FEE DUE	PREV. PAID ISSUE FEE	TOTAL FEE(S) DUE	DATE DUE
nonprovisional	NO	\$1510	\$300	\$0	\$1810	10/24/2011

EXAMINER	ART UNIT	CLASS-SUBCLASS
HA, DAC V	2611	375-302000

<p>1. Change of correspondence address or indication of "Fee Address" (37 CFR 1.363).</p> <p><input type="checkbox"/> Change of correspondence address (or Change of Correspondence Address form PTO/SB/122) attached.</p> <p><input type="checkbox"/> "Fee Address" indication (or "Fee Address" Indication form PTO/SB/47; Rev 03-02 or more recent) attached. <b>Use of a Customer Number is required.</b></p>	<p>2. For printing on the patent front page, list</p> <p>(1) the names of up to 3 registered patent attorneys or agents OR, alternatively, 1 <u>Condo Roccia LLP</u></p> <p>(2) the name of a single firm (having as a member a registered attorney or agent) and the names of up to 2 registered patent attorneys or agents. If no name is listed, no name will be printed. 2 _____</p> <p>3 _____</p>
---	---

3. ASSIGNEE NAME AND RESIDENCE DATA TO BE PRINTED ON THE PATENT (print or type)

PLEASE NOTE: Unless an assignee is identified below, no assignee data will appear on the patent. If an assignee is identified below, the document has been filed for recordation as set forth in 37 CFR 3.11. Completion of this form is NOT a substitute for filing an assignment.

(A) NAME OF ASSIGNEE \_\_\_\_\_ (B) RESIDENCE: (CITY and STATE OR COUNTRY) \_\_\_\_\_

Please check the appropriate assignee category or categories (will not be printed on the patent) :  Individual  Corporation or other private group entity  Government

<p>4a. The following fee(s) are submitted:</p> <p><input checked="" type="checkbox"/> Issue Fee</p> <p><input checked="" type="checkbox"/> Publication Fee (No small entity discount permitted)</p> <p><input type="checkbox"/> Advance Order - # of Copies _____</p>	<p>4b. Payment of Fee(s); (Please first reapply any previously paid issue fee shown above)</p> <p><input type="checkbox"/> A check is enclosed.</p> <p><input type="checkbox"/> Payment by credit card. Form PTO-2038 is attached.</p> <p><input checked="" type="checkbox"/> The Director is hereby authorized to charge the required fee(s), any deficiency, or credit any overpayment, to Deposit Account Number <u>5045519</u> (enclose an extra copy of this form).</p>
---	--

5. Change in Entity Status (from status indicated above)

a. Applicant claims SMALL ENTITY status. See 37 CFR 1.27.  b. Applicant is no longer claiming SMALL ENTITY status. See 37 CFR 1.27(g)(2).

NOTE: The Issue Fee and Publication Fee (if required) will not be accepted from anyone other than the applicant; a registered attorney or agent; or the assignee or other party in interest as shown by the records of the United States Patent and Trademark Office.

Authorized Signature /Michael A. Koptiw/ Date August 4, 2011  
 Typed or printed name Michael A. Koptiw Registration No. 57,900

This collection of information is required by 37 CFR 1.311. The information is required to obtain or retain a benefit by the public which is to file (and by the USPTO to process) an application. Confidentiality is governed by 35 U.S.C. 122 and 37 CFR 1.14. This collection is estimated to take 12 minutes to complete, including gathering, preparing, and submitting the completed application form to the USPTO. Time will vary depending upon the individual case. Any comments on the amount of time you require to complete this form and/or suggestions for reducing this burden, should be sent to the Chief Information Officer, U.S. Patent and Trademark Office, U.S. Department of Commerce, P.O. Box 1450, Alexandria, Virginia 22313-1450. DO NOT SEND FEES OR COMPLETED FORMS TO THIS ADDRESS. SEND TO: Commissioner for Patents, P.O. Box 1450, Alexandria, Virginia 22313-1450.

Under the Paperwork Reduction Act of 1995, no persons are required to respond to a collection of information unless it displays a valid OMB control number.



## Electronic Patent Application Fee Transmittal

<b>Application Number:</b>	12543910
<b>Filing Date:</b>	19-Aug-2009
<b>Title of Invention:</b>	SYSTEM AND METHOD OF COMMUNICATION USING AT LEAST TWO MODULATION METHODS
<b>First Named Inventor/Applicant Name:</b>	Gordon F. Bremer
<b>Filer:</b>	Michael Koptiw Jr./Darleen Yacovone
<b>Attorney Docket Number:</b>	REMB-0109

Filed as Large Entity

### Utility under 35 USC 111(a) Filing Fees

Description	Fee Code	Quantity	Amount	Sub-Total in USD(\$)
<b>Basic Filing:</b>				
<b>Pages:</b>				
<b>Claims:</b>				
<b>Miscellaneous-Filing:</b>				
<b>Petition:</b>				
<b>Patent-Appeals-and-Interference:</b>				
<b>Post-Allowance-and-Post-Issuance:</b>				
Utility Appl issue fee	1501	1	1510	1510
Publ. Fee- early, voluntary, or normal	1504	1	300	300

Description	Fee Code	Quantity	Amount	Sub-Total in USD(\$)
<b>Extension-of-Time:</b>				
<b>Miscellaneous:</b>				
<b>Total in USD (\$)</b>				<b>1810</b>

## Electronic Acknowledgement Receipt

<b>EFS ID:</b>	10669831
<b>Application Number:</b>	12543910
<b>International Application Number:</b>	
<b>Confirmation Number:</b>	8306
<b>Title of Invention:</b>	SYSTEM AND METHOD OF COMMUNICATION USING AT LEAST TWO MODULATION METHODS
<b>First Named Inventor/Applicant Name:</b>	Gordon F. Bremer
<b>Customer Number:</b>	15027
<b>Filer:</b>	Michael Koptiw Jr./Darleen Yacovone
<b>Filer Authorized By:</b>	Michael Koptiw Jr.
<b>Attorney Docket Number:</b>	REMB-0109
<b>Receipt Date:</b>	04-AUG-2011
<b>Filing Date:</b>	19-AUG-2009
<b>Time Stamp:</b>	16:27:32
<b>Application Type:</b>	Utility under 35 USC 111(a)

### Payment information:

Submitted with Payment	yes
Payment Type	Deposit Account
Payment was successfully received in RAM	\$1810
RAM confirmation Number	3007
Deposit Account	505519
Authorized User	

The Director of the USPTO is hereby authorized to charge indicated fees and credit any overpayment as follows:

Charge any Additional Fees required under 37 C.F.R. Section 1.16 (National application filing, search, and examination fees)

Charge any Additional Fees required under 37 C.F.R. Section 1.17 (Patent application and reexamination processing fees)

Charge any Additional Fees required under 37 C.F.R. Section 1.19 (Document supply fees)

Charge any Additional Fees required under 37 C.F.R. Section 1.20 (Post Issuance fees)

Charge any Additional Fees required under 37 C.F.R. Section 1.21 (Miscellaneous fees and charges)

### File Listing:

Document Number	Document Description	File Name	File Size(Bytes)/ Message Digest	Multi Part /.zip	Pages (if appl.)
1	Issue Fee Payment (PTO-85B)	REMB_0109_USCON_Issue_Fee _Transmittal_as_filed.pdf	95125 7f62f3d3f2c72decb25d1cc8afe5c74e8d39 192	no	1

### Warnings:

### Information:

2	Fee Worksheet (SB06)	fee-info.pdf	32146 8276b518976ea7ebdff3a97cb0334c0996 35e15	no	2
---	----------------------	--------------	--	----	---

### Warnings:

### Information:

**Total Files Size (in bytes):** 127271

**This Acknowledgement Receipt evidences receipt on the noted date by the USPTO of the indicated documents, characterized by the applicant, and including page counts, where applicable. It serves as evidence of receipt similar to a Post Card, as described in MPEP 503.**

#### **New Applications Under 35 U.S.C. 111**

**If a new application is being filed and the application includes the necessary components for a filing date (see 37 CFR 1.53(b)-(d) and MPEP 506), a Filing Receipt (37 CFR 1.54) will be issued in due course and the date shown on this Acknowledgement Receipt will establish the filing date of the application.**

#### **National Stage of an International Application under 35 U.S.C. 371**

**If a timely submission to enter the national stage of an international application is compliant with the conditions of 35 U.S.C. 371 and other applicable requirements a Form PCT/DO/EO/903 indicating acceptance of the application as a national stage submission under 35 U.S.C. 371 will be issued in addition to the Filing Receipt, in due course.**

#### **New International Application Filed with the USPTO as a Receiving Office**

**If a new international application is being filed and the international application includes the necessary components for an international filing date (see PCT Article 11 and MPEP 1810), a Notification of the International Application Number and of the International Filing Date (Form PCT/RO/105) will be issued in due course, subject to prescriptions concerning national security, and the date shown on this Acknowledgement Receipt will establish the international filing date of the application.**



UNITED STATES PATENT AND TRADEMARK OFFICE

UNITED STATES DEPARTMENT OF COMMERCE  
 United States Patent and Trademark Office  
 Address: COMMISSIONER FOR PATENTS  
 P.O. Box 1450  
 Alexandria, Virginia 22313-1450  
 www.uspto.gov



Bib Data Sheet

CONFIRMATION NO. 8306

<b>SERIAL NUMBER</b> 12/543,910	<b>FILING OR 371(c) DATE</b> 08/19/2009 <b>RULE</b>	<b>CLASS</b> 375	<b>GROUP ART UNIT</b> 2611	<b>ATTORNEY DOCKET NO.</b> REMB-0109
------------------------------------	---	---------------------	-------------------------------	---

**APPLICANTS**

Gordon F. Bremer, Clearwater, FL;

**\*\* CONTINUING DATA \*\*\*\*\***

This application is a CON of 11/774,803 07/09/2007 PAT 7,675,965  
 which is a CON of 10/412,878 04/14/2003 PAT 7,248,626  
 which is a CIP of 09/205,205 12/04/1998 PAT 6,614,838  
 which claims benefit of 60/067,562 12/05/1997

**\*\* FOREIGN APPLICATIONS \*\*\*\*\***

**IF REQUIRED, FOREIGN FILING LICENSE GRANTED**

\*\* 08/31/2009

Foreign Priority claimed <input type="checkbox"/> yes <input type="checkbox"/> no	<b>STATE OR COUNTRY</b> FL	<b>SHEETS DRAWING</b> 8	<b>TOTAL CLAIMS</b> 100	<b>INDEPENDENT CLAIMS</b> 6	
35 USC 119 (a-d) conditions met <input type="checkbox"/> yes <input type="checkbox"/> no <input type="checkbox"/> Met after Allowance					
Verified and Acknowledged	Examiner's Signature _____	Initials _____			

**ADDRESS**

15027

**TITLE**

SYSTEM AND METHOD OF COMMUNICATION USING AT LEAST TWO MODULATION METHODS

<b>FILING FEE RECEIVED</b> 6260	FEES: Authority has been given in Paper No. _____ to charge/credit DEPOSIT ACCOUNT No. _____ for following:	<input type="checkbox"/> All Fees
		<input type="checkbox"/> 1.16 Fees ( Filing )
		<input type="checkbox"/> 1.17 Fees ( Processing Ext. of time )
		<input type="checkbox"/> 1.18 Fees ( Issue )
		<input type="checkbox"/> Other _____
		<input type="checkbox"/> Credit



APPLICATION NO.	ISSUE DATE	PATENT NO.	ATTORNEY DOCKET NO.	CONFIRMATION NO.
12/543,910	09/20/2011	8023580	REMB-0109	8306

15027 7590 08/31/2011  
Condo Roccia LLP  
1650 Market Street  
Suite 2200  
Philadelphia, PA 19103

### ISSUE NOTIFICATION

The projected patent number and issue date are specified above.

#### **Determination of Patent Term Adjustment under 35 U.S.C. 154 (b)** (application filed on or after May 29, 2000)

The Patent Term Adjustment is 0 day(s). Any patent to issue from the above-identified application will include an indication of the adjustment on the front page.

If a Continued Prosecution Application (CPA) was filed in the above-identified application, the filing date that determines Patent Term Adjustment is the filing date of the most recent CPA.

Applicant will be able to obtain more detailed information by accessing the Patent Application Information Retrieval (PAIR) WEB site (<http://pair.uspto.gov>).

Any questions regarding the Patent Term Extension or Adjustment determination should be directed to the Office of Patent Legal Administration at (571)-272-7702. Questions relating to issue and publication fee payments should be directed to the Application Assistance Unit (AAU) of the Office of Data Management (ODM) at (571)-272-4200.

APPLICANT(s) (Please see PAIR WEB site <http://pair.uspto.gov> for additional applicants):

Gordon F. Bremer, Clearwater, FL;

UNITED STATES PATENT AND TRADEMARK OFFICE

---

BEFORE THE PATENT TRIAL AND APPEAL BOARD

---

SAMSUNG ELECTRONICS CO. LTD., SAMSUNG ELECTRONICS  
AMERICA, INC., SAMSUNG TELECOMMUNICATIONS AMERICA,  
LLC, and SAMSUNG AUSTIN SEMICONDUCTOR, LLC,  
Petitioner,

v.

REMBRANDT WIRELESS TECHNOLOGIES, LP,  
Patent Owner.

---

Case IPR2014-00514  
Patent 8,023,580 B2

---

Before JAMESON LEE, HOWARD B. BLANKENSHIP, and  
JUSTIN BUSCH, *Administrative Patent Judges*.

BLANKENSHIP, *Administrative Patent Judge*.

DECISION  
Denying Institution of *Inter Partes* Review  
*37 C.F.R. § 42.108*

I. BACKGROUND

Samsung Electronics Co. Ltd., Samsung Electronics America, Inc.,  
Samsung Telecommunications America, LLC, and Samsung Austin

IPR2014-00514  
Patent 8,023,580 B2

Semiconductor, LLC (collectively, "Petitioner") request *inter partes* review of claims 1, 2, 4, 5, 10, 13, 19–22, 49, 52–54, 57–59, 61, 62, 66, 70, and 76–79 of U.S. Patent No. 8,023,580 B2 ("the '580 patent") (Ex. 1001) under 35 U.S.C. §§ 311–319. Paper 4 (Corrected Petition, or "Pet."). Rembrandt Wireless Technologies, LP (Patent Owner) filed a preliminary response (Paper 14, "Prelim. Resp.") provided by 37 C.F.R. § 42.107. We have jurisdiction under 35 U.S.C. § 314.

For the reasons that follow, we do not institute an *inter partes* review as to any of the challenged claims of the '580 patent.

#### *Related Proceeding*

According to Petitioner, the '580 patent is involved in the following lawsuit: *Rembrandt Wireless Tech., LP v. Samsung Elect. Co. LTD.*, No. 2:13-cv-00213 (E.D. Tex. 2013). Pet. 2. The '580 patent has also been challenged in the following cases: IPR2014–00515; IPR2014–00518; and IPR2014–00519.

#### *The '580 Patent*

The '580 Patent issued from an application filed August 19, 2009, which claimed priority, through a chain of intervening applications, under 35 U.S.C. § 120 to an application filed December 4, 1998, and which claimed priority under 35 U.S.C. § 119 to a provisional application filed December 5, 1997.

The technical field of the patent relates to data communications and modulators/demodulators (modems), and in particular to a data communications system in which a plurality of modems use different types



of modulation in a network. Ex. 1201, col. 1, ll. 19-23; col. 1, l. 56 – col. 2, l. 20.

*Illustrative Claim*

Claim 58 is illustrative.

58. A communication device capable of communicating according to a master/slave relationship in which a slave message from a slave to a master occurs in response to a master message from the master to the slave, the device comprising:

a transceiver, in the role of the master according to the master/slave relationship, capable of transmitting using at least two types of modulation methods, wherein the at least two types of modulation methods comprise a first modulation method and a second modulation method, wherein the second modulation method is of a different type than the first modulation method, and wherein the transceiver is configured to transmit messages with:

a first sequence, in the first modulation method, that indicates at least which of the first modulation method and the second modulation method is used for modulating a second sequence, wherein, in at least one message, the first sequence indicates an impending change from the first modulation method to the second modulation method, and wherein the at least one message is addressed for an intended destination of the second sequence, and

the second sequence, modulated in accordance with the modulation method indicated by the first sequence and, in the at least one message, modulated using the second modulation method, wherein the second sequence is transmitted after the first sequence.

*Prior Art and Other Evidence Included with Petition*

Boer et al. US 5,706,428 Jan. 6, 1998 (Ex. 1016)  
("Boer")

IEEE P802.11, *Draft Standard for Wireless LAN, Medium Access Control (MAC) and Physical Layer (PHY) Specification*, P802.11D4.0, May 20, 1996 (Ex. 1005) ("Draft Standard")

Declaration of Robert O'Hara, Mar. 11, 2014 (Ex. 1004).

*Asserted Grounds of Unpatentability*

Petitioner asserts the following grounds of unpatentability (Pet. 3):

Evidence	Basis (35 U.S.C.)	Claims
Draft Standard	§ 102(b)/103(a)	1, 2, 4,5, 10, 13, 19-22, 49, 52-54, 57-59, 61, 62, 66, 70, and 76-79
Draft Standard and Boer	§ 103(a)	1, 2, 4,5, 10, 13, 19-22, 49, 52-54, 57-59, 61, 62, 66, 70, and 76-79

II. ANALYSIS

*A. Asserted Anticipation and Obviousness Grounds Based on Draft Standard*

The dispositive issue in this proceeding is whether Draft Standard, on which both of Petitioner's asserted grounds of unpatentability rely, is a printed publication.

*B. Overview of Draft Standard (Ex. 1005)*

Draft Standard is an unapproved draft of a proposed IEEE [Institute of Electrical and Electronics Engineers] Standard. Ex. 1005, i.<sup>1</sup> The purpose of the proposed standard was “[t]o provide wireless connectivity to automatic machinery, equipment [, or] stations that require rapid deployment, which may be portable, or hand-held or which may be mounted on moving vehicles within a local area” and “[t]o offer a standard for use by regulatory bodies to standardize access to one or more frequency bands for the purpose of local area communication.” *Id.* at 1.

*C. Declaration of Robert O’Hara (Ex. 1004)*

Mr. Robert O’Hara was an editor of the IEEE 802.11-1997 standard. Ex. 1004 ¶ 1; Ex. 1005, iii. Mr. O’Hara states that drafts of the 802.11-1997 standard, including Draft Standard, were available to members of the 802.11 Working Group for download from the 802.11 Working Group’s server. Ex. 1004 ¶ 9. According to Mr. O’Hara, announcements were sent to the Working Group’s e-mail list when drafts became available, and a person could be added to the Working Group’s e-mail list by providing an e-mail address to the chair of the Working Group. *Id.* ¶¶ 9-10. Mr. O’Hara states that there “were no restrictions on who could attend the 802.11 Working Group’s meetings [or] on who could provide an e-mail address” and that, according to his “recollection,” anyone who made a request to be added to the e-mail list would be added. *Id.* ¶ 10.

---

<sup>1</sup> In this decision, we refer to the original pagination of Draft Standard rather than the Exhibit page number.

Mr. O'Hara states that the copies of the drafts of the Standard available on the Working Group's servers were password-protected files, and that the members of the e-mail list were provided with passwords to access the documents, either as part of an announcement of a new draft or via "another way." *Id.* ¶ 11. According to Mr. O'Hara, the passwords were intended to limit distribution to "interested individuals, as opposed to the entire [I]nternet." *Id.* Mr. O'Hara also states that attending an 802.11 Working Group meeting or asking for access prior to a meeting demonstrated sufficient interest such that that person would receive the password necessary to access the drafts on the Working Group's server. *Id.*

Further, according to Mr. O'Hara, each of the 802.11 standard drafts, including Draft Standard, would have been discussed at the Working Group meetings and made available to all attendees. *Id.* ¶ 12. Mr. O'Hara also states that the meetings were not limited to IEEE members but were open to the general public. *Id.*

*D. Analysis of Whether Draft Standard Is a Printed Publication*

We look to the underlying facts to make a legal determination as to whether a document is a printed publication. *Suffolk Techs., LLC v. AOL Inc.*, 752 F.3d 1358, 1364 (Fed. Cir. 2014). The determination of whether a document is a "printed publication" under 35 U.S.C. § 102(b) involves a case-by-case inquiry into the facts and circumstances surrounding its disclosure to members of the public. *In re Klopfenstein*, 380 F.3d 1345, 1350 (Fed. Cir. 2004). Public accessibility is a key question in determining whether a document is a printed publication and is determined on a case-by-case basis. *Suffolk Techs.*, 752 F.3d at 1364. To qualify as a printed

publication, a document “must have been sufficiently accessible to the public interested in the art.” *In re Lister*, 583 F.3d 1307, 1311 (Fed. Cir. 2009).

The O’Hara Declaration is the only extrinsic evidence that Petitioner submits in support of its position that Draft Standard is a printed publication. *See* Pet. 12-13. Petitioner asserts that Draft Standard “was completed on May 20, 1996, and was available to *anyone who wanted to view it* on May 23, 1996.” Pet. 12 (citing Ex. 1004 ¶¶ 4, 5, 10, and 12) (emphasis added). Petitioner indicates, initially, that this availability resulted in a publication date of May 23, 1996. *Id.* Petitioner also argues that Draft Standard “was available to any interested parties” no later than July 8, 1996, because it “was available to all members of the 802.11 Working Group’s email list” and discussed and distributed at an 802.11 Working Group meeting held July 8–12, 1996. *Id.* at 13. Thus, Petitioner concludes that this alleged distribution and availability to any interested parties by July 8, 1996 renders Draft Standard a “printed publication” under 35 U.S.C. § 102(b). *Id.*

Notably absent, however, from the Petition and Mr. O’Hara’s declaration are any assertions or evidence in support of the availability of Draft Standard to individuals other than members of the 802.11 Working Group and those who already knew about Draft Standard or the July 8–12 meeting of the 802.11 Working Group. We do not find sufficient argument or evidence to indicate that the July 8–12 meeting of the 802.11 Working Group (or any other 802.11 Working Group meeting) was advertised or otherwise announced to the public. Nor do we find sufficient argument or evidence that any individual who was not already a member of, or otherwise aware of, the 802.11 Working Group would have known about Draft

Standard such that he or she would have known to request a copy or ask to be added to an email list for access to the document.

“A given reference is ‘publicly accessible’ upon a satisfactory showing that such document has been disseminated or otherwise made available to the extent that persons interested and ordinarily skilled in the subject matter or art exercising reasonable diligence, can locate it.” *SRI Int’l, Inc. v. Internet Sec. Sys., Inc.* 511 F.3d 1186, 1194 (Fed. Cir. 2008) (quoting *Bruckelmyer v. Ground Heaters, Inc.*, 445 F.3d 1374, 1378 (Fed. Cir. 2006)). Although Mr. O’Hara declares that “[t]here were no restrictions on who could attend the 802.11 Working Group’s meetings” (Ex. 1004 ¶ 10) and that the meetings “were open to the general public” (*id.* ¶ 12), Petitioner has not presented persuasive argument or evidence regarding how members of the potentially interested public would have been made aware of these meetings. Similarly, although Mr. O’Hara declares that an individual could provide the chair with an e-mail address to be added to the Working Group’s e-mail list (*id.* ¶ 10), the petition has not established how an individual would have known to attend a meeting or contact the chair in order to be added to the e-mail list.

Based on the evidence before us, we find that the purpose of the 802.11 Working Group’s storage of drafts of the standard on a server is similar to the placement of a file on an “FTP server solely to facilitate peer review in preparation for later publication,” which the U.S. Court of Appeals for the Federal Circuit found weighed against public accessibility of the file. *SRI Int’l*, 511 F.3d at 1197. In *SRI*, even though the “paper was ‘posted’ on an open FTP server and might have been available to anyone with FTP know-how and knowledge of the” subdirectory in which it resided, the

Federal Circuit found the fact that the paper was not publicized suggested an absence of public availability. *Id.* In this case, the submitted evidence does not show that the 802.11 Working Group's server was an open server and, to the extent that it was, the evidence shows that the documents were password protected. Ex. 1004 ¶ 11.

Moreover, notwithstanding Mr. O'Hara's statement that passwords were distributed to the 802.11 Working Group e-mail list (*id.*), the fact that an interested individual needed to contact IEEE in order to obtain a password or other means of accessing Draft Standard (and needed to know who to contact in the first place) weighs against public accessibility. *Cf. Kyocera Wireless Corp. v. Int'l Trade Comm'n*, 545 F.3d 1340, 1351 (finding facts weighed towards public accessibility because "[t]he specifications themselves were visible to any member of the interested public without requesting them from an ETSI member"). Mr. O'Hara states that the drafts of the 802.11 standards, including Draft Standard, were (and still are) protected by passwords in order to limit distribution to "interested individuals, as opposed to the entire [I]nternet." Ex. 1004 ¶ 11. However, as previously discussed, the record does not contain persuasive evidence showing how an individual not already in, or already familiar with, the 802.11 Working Group would have known of the existence of the Draft Standard, the 802.11 Working Group meetings, or the 802.11 Working Group itself. Therefore, we are not persuaded that such an individual, exercising reasonable diligence, would be able to change his status from an anonymous member of "the entire [I]nternet" to an "interested individual."

Therefore, based on the evidence Petitioner provided, we conclude Petitioner has not made a sufficient showing that Draft Standard was a

printed publication as of July 1996 or earlier, as alleged, i.e., that Draft Standard was available as of July 1996 or earlier to an ordinarily skilled individual, exercising reasonable diligence, who might have been interested in the subject matter of Draft Standard.

*E. Asserted Grounds of Unpatentability*

Because Petitioner has not met its burden in establishing that Draft Standard is a “printed publication” and, thus, prior art, Petitioner has not shown a reasonable likelihood of prevailing on the grounds asserted.

III. CONCLUSION

The Petition fails to demonstrate a reasonable likelihood of prevailing on the grounds that the challenged claims are anticipated by, or obvious over, Draft Standard or obvious over Draft Standard and Boer.

IV. ORDER

In consideration of the foregoing, it is  
ORDERED that the petition is denied as to all challenged claims and no trial is instituted.



IPR2014-00514  
Patent 8,023,580 B2

For Petitioner:

Jeffrey A. Miller  
Daniel G. Cardy  
DICKSTEIN SHAPIRO LLP  
[millerj@dicksteinshapiro.com](mailto:millerj@dicksteinshapiro.com)  
[cardyd@dicksteinshapiro.com](mailto:cardyd@dicksteinshapiro.com)

For Patent Owner:

Thomas Engellenner  
Reza Mollaaghababa  
Lana Gladstein  
PEPPER HAMILTON LLP  
[engellennert@pepperlaw.com](mailto:engellennert@pepperlaw.com)  
[mollaaghababar@pepperlaw.com](mailto:mollaaghababar@pepperlaw.com)  
[gladsteinl@pepperlaw.com](mailto:gladsteinl@pepperlaw.com)

UNITED STATES PATENT AND TRADEMARK OFFICE

---

BEFORE THE PATENT TRIAL AND APPEAL BOARD

---

SAMSUNG ELECTRONICS CO. LTD., SAMSUNG ELECTRONICS  
AMERICA, INC., SAMSUNG TELECOMMUNICATIONS AMERICA,  
LLC, and SAMSUNG AUSTIN SEMICONDUCTOR, LLC,  
Petitioner,

v.

REMBRANDT WIRELESS TECHNOLOGIES, LP,  
Patent Owner.

---

Case IPR2014-00518  
Patent 8,023,580 B2

---

Before JAMESON LEE, HOWARD B. BLANKENSHIP, and  
JUSTIN BUSCH, *Administrative Patent Judges*.

BLANKENSHIP, *Administrative Patent Judge*.

DECISION  
Institution of *Inter Partes* Review  
37 C.F.R. § 42.108

I. BACKGROUND

Samsung Electronics Co. Ltd., Samsung Electronics America, Inc.,  
Samsung Telecommunications America, LLC, and Samsung Austin

IPR2014-00518  
Patent 8,023,580 B2

Semiconductor, LLC (collectively, “Petitioner”) request *inter partes* review of claims 1, 2, 4, 5, 10, 13, 19–22, 49, 52–54, 57–59, 61, 62, 66, 70, and 76–79 of U.S. Patent No. 8,023,580 B2 (“the ’580 patent,” Ex. 1201) under 35 U.S.C. §§ 311–319. Paper 4 (Corrected Petition or “Pet.”). Rembrandt Wireless Technologies, LP (Patent Owner) filed a preliminary response (Paper 14, “Prelim. Resp.”) under 37 C.F.R. § 42.107. We have jurisdiction under 35 U.S.C. § 314.

For the reasons that follow, we institute an *inter partes* review of claims 1, 4, 5, 10, 13, 20–22, 54, 57, 58, 61, 62, 66, 70, and 76–79 of the ’580 patent. We do not institute review of challenged claims 2, 19, 49, 52, 53, and 59.

#### *Related Proceedings*

According to Petitioner, the ’580 patent is involved in the following lawsuit: *Rembrandt Wireless Technologies, LP v. Samsung Electronics Co. Ltd.*, No. 2:13-cv-00213 (E.D. Tex. 2013). Pet. 2. The ’580 patent also has been challenged in the following cases: *Samsung Electronics Company, Ltd v. Rembrandt Wireless Technologies, LP*, IPR2014-00514; *Samsung Electronics Company, Ltd v. Rembrandt Wireless Technologies, LP*, IPR2014-00515; and *Samsung Electronics Company, Ltd v. Rembrandt Wireless Technologies, LP*, IPR2014-00519.

#### *The ’580 Patent*

The ’580 Patent issued from an application filed August 19, 2009, which claimed priority under 35 U.S.C. § 120 through a chain of intervening applications to an application filed December 4, 1998, and which further

claimed priority under 35 U.S.C. § 119 to a provisional application filed December 5, 1997.

The technical field of the patent relates to data communications and modulators/demodulators (modems), and in particular to a data communications system in which a plurality of modems use different types of modulation in a network. Ex. 1201, col. 1, ll. 19–23; col. 1, l. 56 – col. 2, l. 20.

*Illustrative Claim*

1. A communication device capable of communicating according to a master/slave relationship in which a slave communication from a slave to a master occurs in response to a master communication from the master to the slave, the device comprising:

a transceiver, in the role of the master according to the master/slave relationship, for sending at least transmissions modulated using at least two types of modulation methods, wherein the at least two types of modulation methods comprise a first modulation method and a second modulation method, wherein the second modulation method is of a different type than the first modulation method, wherein each transmission comprises a group of transmission sequences, wherein each group of transmission sequences is structured with at least a first portion and a payload portion wherein first information in the first portion indicates at least which of the first modulation method and the second modulation method is used for modulating second information in the payload portion, wherein at least one group of transmission sequences is addressed for an intended destination of the payload portion, and wherein for the at least one group of transmission sequences:

the first information for said at least one group of transmission sequences comprises a first sequence, in the first

portion and modulated according to the first modulation method, wherein the first sequence indicates an impending change from the first modulation method to the second modulation method, and

the second information for said at least one group of transmission sequences comprises a second sequence that is modulated according to the second modulation method, wherein the second sequence is transmitted after the first sequence.

*Prior Art*

Boer            US 5,706,428            Jan. 6, 1998            (Ex. 1204)

*Asserted Ground of Unpatentability*

Petitioner asserts the following ground of unpatentability as to claims 1, 2, 4, 5, 10, 13, 19–22, 49, 52–54, 57–59, 61, 62, 66, 70, and 76–79 (Pet. 2–3): obviousness under 35 U.S.C. § 103(a) over Admitted Prior Art (“APA”) and Boer.

## II. ANALYSIS

### *Claim Interpretation*

In an *inter partes* review, the Board construes claim terms in an unexpired patent using their broadest reasonable construction in light of the specification of the patent in which they appear. 37 C.F.R. § 42.100(b); Office Patent Trial Practice Guide, 77 Fed. Reg. 48,756, 48,766 (Aug. 14, 2012). The claim language should be read in light of the specification as it would be interpreted by one of ordinary skill in the art. *In re Am. Acad. of Sci. Tech. Ctr.*, 367 F.3d 1359, 1364 (Fed. Cir. 2004). The Office must apply the broadest reasonable meaning to the claim language, taking into

account any definitions presented in the specification. *Id.* (citing *In re Bass*, 314 F.3d 575, 577 (Fed. Cir. 2002)). There is a “heavy presumption” that a claim term carries its ordinary and customary meaning. *CCS Fitness, Inc. v. Brunswick Corp.*, 288 F.3d 1359, 1366 (Fed. Cir. 2002). The “ordinary and customary meaning” is that which the term would have to a person of ordinary skill in the art in question. *In re Translogic Tech., Inc.*, 504 F.3d 1249, 1257 (Fed. Cir. 2007).

#### *Types of Modulation Methods*

Each of claims 1 and 58 recites a transceiver capable of transmitting using at least two types of modulation methods, “wherein the at least two types of modulation methods comprise a first modulation method and a second modulation method, wherein the second modulation method is of a different type than the first modulation method . . . .”

Petitioner submits that the ordinary meaning of “modulation” is “[t]he process by which some characteristic of a carrier is varied in accordance with a modulating wave.” Pet. 11 (quoting Ex. 1206, 3 (technical dictionary)). Petitioner contends that a “first modulation method” should be interpreted as “*a process of varying characteristic(s) of a carrier wave that is different from a second modulation method,*” and a “second modulation method” should be interpreted as “*a process of varying characteristic(s) of a carrier wave that is different from a first modulation method.*” Pet. 13. Petitioner submits that, in essence, such an interpretation extends to modulation methods that are known to be incompatible with each other. *Id.* at 12.

Patent Owner, on the other hand, submits that the terms should be construed as a “first modulation method” being “a first method for varying one or more characteristics of a carrier in accordance with information to be communicated” and a “second modulation method” being “a second method for varying one or more characteristics of a carrier in accordance with information to be communicated.” Prelim. Resp. 7. Patent Owner submits that the broadest reasonable interpretation of “types” of modulation methods does not extend to modulation methods that are known merely to be incompatible with each other, but is limited to different “families” of modulation techniques, e.g., the FSK (frequency shift keying) “family” of modulation methods and the QAM (quadrature amplitude modulation) “family” of modulation methods. As such, two modulation methods that are incompatible with each other (e.g., differential binary phase shift keying (DBPSK) modulation and differential quadrature phase shift keying (DQPSK) modulation) may still be part of the same “type” of modulation method. *Id.* at 9–12. Patent Owner’s position is thus contrary to Petitioner’s position, in that Petitioner contends that “different PSK [phase shift keying] modulation methods” may be considered as different “types” of modulation, with the “different modulation methods” within the same (PSK) “family” being incompatible with each other. Pet. 12.

For purposes of this decision, we need not, and do not, determine the scope of the above-noted terms in controversy. We are persuaded that elements in the prior art are within the scope of the relevant terms under any reasonable construction. *See* § II.D, *infra*.

*Proposed Grounds of Unpatentability*

*A. "Prior Art"*

Section 103 of Title 35 U.S.C., which makes nonobviousness of the invention a prerequisite to patentability, requires a determination of the differences between the subject matter sought to be patented and "[t]he prior art." *In re Bergy*, 596 F.2d 952, 965 n.7 (CCPA 1979), *aff'd sub nom.*

*Diamond v. Chakrabarty*, 447 U.S. 303 (1980) (citations omitted).

However, Title 35 nowhere defines the term "prior art." *Id.*

Its exact meaning is a somewhat complex question of law which has been the subject of legal papers and whole chapters of books. . . . Basically, the concept of prior art is that which is publicly known, or at least known to someone who has taken steps which do make it known to the public, . . . or known to the inventor against whose application it is being applied.

*Id.* (citations omitted).

"The term 'prior art' as used in section 103 refers at least to the statutory material named in 35 U.S.C. § 102. . . . However, section 102 is not the only source of section 103 prior art. Valid prior art may be created by the admissions of the parties."

*Riverwood Int'l Corp. v. R.A. Jones & Co., Inc.*, 324 F.3d 1346, 1354 (Fed. Cir. 2003) (citations omitted). However, while a reference can become prior art by admission, that doctrine is inapplicable when the subject matter at issue is the inventor's own work. *Id.*

*B. Admitted Prior Art*

Petitioner contends that the '580 patent contains material that may be used as prior art against the patent under 35 U.S.C. § 103(a). Figure 1 of the patent is labeled as "Prior Art." Pet. 6; Ex. 1201, Fig. 1. Further, the '580



patent's specification refers to "prior art" multipoint communication system 22 comprising master modem or transceiver 24, which communicates with a plurality of tributary modems ("tribs") or transceivers 26. Pet. 6; Ex. 1201, col. 3, ll. 40–44. Further, the '580 patent describes Figure 2 as illustrating the operation of the multipoint communication system of (prior art) Figure 1. Pet. 7; Ex. 1201, col. 3, ll. 9–10.

Patent Owner argues that Petitioner has not shown that the "alleged admitted prior art" is the work of another – i.e., not the inventor's own work. Prelim. Resp. 15; *see also id.* at 16–18. Petitioner has met its initial burden, however, in demonstrating that the subject matter of the '580 patent's Figure 1, and accompanying description, constitutes "prior art" by pointing out that the patent expressly describes the subject matter as such. *See in re Nomiya*, 509 F.2d 566, 570–71 (CCPA 1975) ("We see no reason why appellants' representations in their application should not be accepted at face value as admissions that Figs. 1 and 2 may be considered 'prior art' for any purpose, including use as evidence of obviousness under [§] 103.").

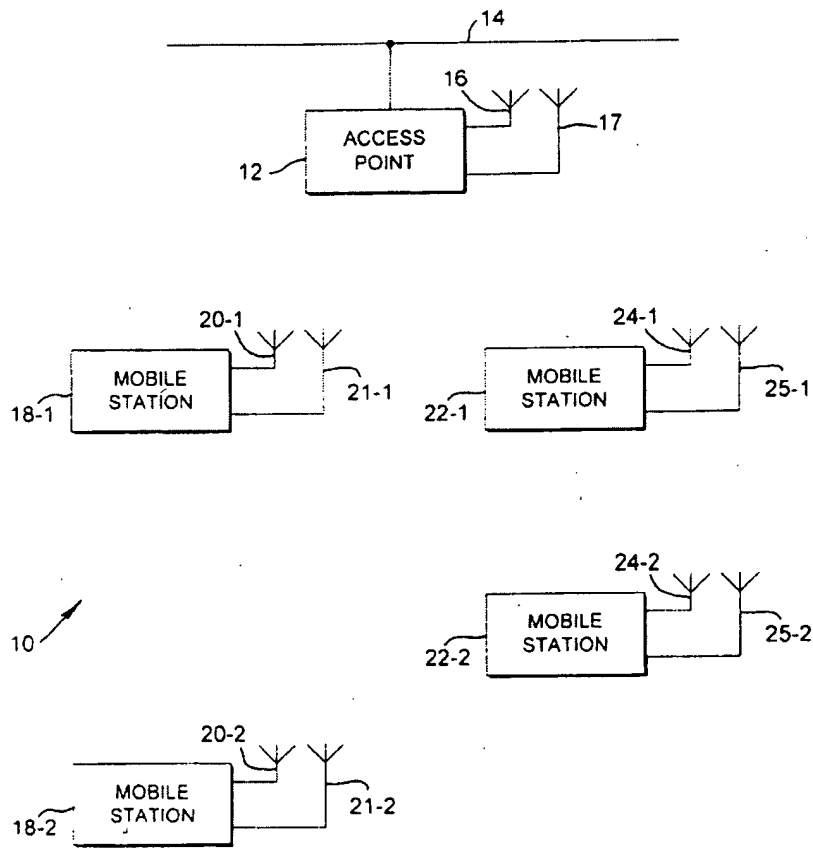
Patent Owner's argument that Figures 1 and 2 of the '580 patent represent the inventor's identification of a "source of a problem" (Prelim. Resp. 19–21) is, similarly, inapposite. Petitioner does not rely on the face-value admissions in the patent as a problem to be solved or as identifying a problem in the prior art. *See, e.g.*, Pet. 19.

For the foregoing reasons, we are persuaded that, on this record, the subject matter of Figures 1 and 2 of the '580 patent, and the text of the patent that further describes those Figures, may be applied as prior art in this proceeding.

*C. Boer*

Boer describes a wireless LAN that includes first stations that operate at 1 or 2 Mbps (Megabits per second) data rate and second stations that operate at 1, 2, 5, or 8 Mbps data rate. Ex. 1204, Abstract.

Figure 1 of Boer is reproduced below.



**FIG.1**

Figure 1 is said to be a block diagram of a wireless LAN embodying Boer's invention. Ex. 1204, col. 1, ll. 53-54. LAN 10 includes access point 12, serving as a base station. The network includes mobile stations 18-1 and 18-2 that are capable of transmitting and receiving messages at a data rate of

1 or 2 Mbps using DSSS (direct sequence spread spectrum) coding. When operating at 1 Mbps, a station uses DBPSK modulation. When operating at 2 Mbps, a station uses DQPSK modulation. *Id.* at col. 2, ll. 6–27. Mobile stations 22-1 and 22-2 are capable of operating at the 1 and 2 Mbps data rates using the same modulation and coding as stations 181 and 182. In addition, stations 22-1 and 22-2 can operate at 5 and 8 Mbps data rates using PPM/DQPSK (pulse position modulation–differential quadrature phase shift keying) in combination with the DSSS coding. *Id.* at ll. 34-44.

*D. Claims 1, 4, 5, 10, 13, 20–22, 54, 57, 58, 61, 62, 66, 70,  
and 76–79 – APA and Boer*

Petitioner applies the teachings of APA and Boer to demonstrate obviousness of the subject matter of claim 1, relying on APA for teaching of master/slave communication systems. Pet. 19–24, 28–33 (claim chart). Petitioner submits that a person having ordinary skill in the art would have been motivated to combine Boer with APA because the combination would increase the flexibility and efficiency of prior art master/slave communication systems, thus allowing the APA master/slave network to adapt to the needs of applications. *Id.* at 18 (referring to the Declaration of David Goodman, Ex. 1220 ¶¶ 100–101).

Patent Owner responds that Petitioner fails to explain how Boer’s statement that “it may be advantageous to provide systems operating at higher data rates, which are not in accordance with the [draft 802.11] standard” would motivate one of ordinary skill to implement the teachings of Boer with APA. Ex. 1204, col. 1, ll. 16–25; Prelim. Resp. 28. We agree with Patent Owner. Petitioner, however, submits an alternative reason for

the combination that is founded on simplicity and determinacy. Pet. 18; Ex. 1220 ¶¶ 102–103. In particular, Mr. Goodman testifies that polled multiport master/slave communications systems were well known to those of ordinary skill in the art for simplicity and determinacy, referring to Exhibit 1218. Ex. 1220 ¶ 103. Petitioner submits Exhibit 1218 is a November 1994 publication that compares various strengths and weaknesses for communication protocols for embedded systems. Ex. 1218, 7. The document states that polling is one of the more popular protocols for embedded systems “because of its simplicity and determinacy.” *Id.* In that protocol, a centrally assigned master periodically sends a polling message to the slave nodes, giving them explicit permission to transmit on the network. *Id.* The protocol “is ideal for a centralized data-acquisition system where peer-to-peer communication and global prioritization are not required.” *Id.* We are persuaded that Petitioner has identified sufficient motivation from the prior art for the combination proposed.

Turning to the requirements of claim 1, the claim recites two types of modulation methods, in particular “wherein the at least two types of modulation methods comprise a first modulation method and a second modulation method,” and the second modulation method is of “a different type” than the first modulation method. Petitioner contends that Boer’s DBPSK modulation corresponds to the claimed “first” modulation method. Pet. 30 (claim chart). Petitioner submits that either of Boer’s DQPSK modulation and PPM/DQPSK modulation corresponds to the claimed “second” modulation method. *Id.*

Patent Owner argues that neither of DQPSK and PPM/DQPSK can be considered a modulation method of a type different from DBPSK. Prelim.

Resp. 32–35. For purposes of this decision, we need not determine the breadth of a different “type” of modulation method as claimed, and need not determine whether one of ordinary skill in the art would regard DQPSK to be a “type” of modulation method different from DBPSK. Boer’s description of PPM/DQPSK modulation falls within the meaning of a “different type” of modulation method under any reasonable construction of the terms. *Cf.* Ex. 1220 ¶ 123 (“It is my opinion that PPM/DQPSK is a different ‘type’ of modulation than DBPSK under any possible claim construction.”). According to Mr. Goodman, phase is not used in PPM, unlike in DBPSK and DQPSK modulation. *Id.* ¶ 124. In PPM, the start and stop time of a transmission is varied in response to the information to be transmitted, with the time shift being indicative of data bits. *Id.*

Patent Owner submits that “varying the start and stop time of a transmission of a carrier wave does not result in varying any characteristic of the carrier wave.” Prelim. Resp. 33. Patent Owner does not explain, however, how the “start and stop time” of a transmission of a carrier wave cannot be considered one or more “characteristic[s]” of the carrier wave. We acknowledge there is *some* support in Boer for Patent Owner’s position, in Boer’s reference to PPM as “PPM type coding.” *Id.*; Ex. 1204, col. 4, ll. 45–48. The fact remains, however, that the term “modulation” is part of the descriptive name for PPM – pulse position *modulation*. Patent Owner has not explained sufficiently why pulse position *modulation* cannot be considered a type of modulation method, even if the method might be applied for “coding” in Boer. *Id.*

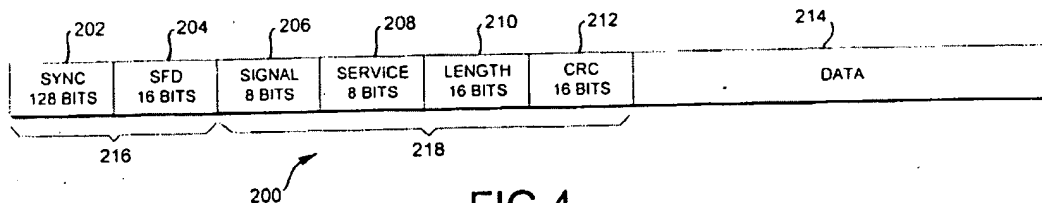
Each of independent claims 54 and 58 recites limitations similar to those of claim 1. We have reviewed the information presented in the

Petition and Patent Owner's Preliminary Response. We are persuaded there is a reasonable likelihood that Petitioner would prevail in its challenge of independent claims 1, 54, and 58 and dependent claims 4, 5, 10, 13, 20–22, 57, 61, 62, 66, 70, and 76–79.

*E. Claims 2, 49, 52, 53, and 59 – APA and Boer*

Claim 2, which depends from claim 1, recites that the transceiver is configured to transmit a third sequence after the second sequence, wherein the third sequence is transmitted in the first modulation method “and indicates that communication from the master to the slave has reverted to the first modulation method.” Petitioner submits that the recitation is met by material in Boer.

Figure 4 of Boer is reproduced below.



**FIG.4**

Figure 4 is said to be a diagram illustrating the format of a data message circulating in Boer's LAN. Ex. 1204, col. 1, ll. 59–60. Message 200 includes preamble 216 and header 218, always transmitted at the 1 Mbps rate using DBPSK modulation. Subsequent DATA field 214, however, may be transmitted at any one of the four rates 1, 2, 5, or 8 Mbps, using the modulation and coding appropriate for the selected rate. *Id.* at col. 3, ll. 56–62. SIGNAL field 206 has a first value if DATA field 214 is transmitted at the 1 Mbps rate and a second value if the DATA field is transmitted at the 2, 5, or 8 Mbps rate. SERVICE field 208 has a first value

for the 1 and 2 Mbps rates, a second value for the 5 Mbps rate, and a third value for the 8 Mbps rate. *Id.* at col. 4, ll. 4–11.

Petitioner submits that the “first sequence” of base claim 1 corresponds to Boer’s description of SIGNAL field 206 and SERVICE FIELD 208. *E.g.*, Pet. 32 (claim chart). According to Petitioner, the “third sequence” of claim 2 corresponds to a subsequent transmission of SIGNAL field 206 and SERVICE field 208. Pet. 25. Petitioner concludes that the subject matter of claim 2 would have been obvious because header 218 is always transmitted using DBPSK (the “first” modulation method). *Id.* Petitioner refers to paragraph 143 of the Goodman Declaration for support. *Id.*

Mr. Goodman submits:

Claim 2 further requires that the third sequence be “transmitted in the first modulation method and indicates that communication from the master to the slave has reverted to the first modulation method.” As discussed above, Header 208, which includes SIGNAL 206 and SERVICE 208 fields, [is] always transmitted using DBPSK (the “first modulation method”). Ex. 1204, 3:56–58.

Therefore, it is my opinion that claim 2 is obvious in view of the prior art.

Ex. 1220 ¶¶ 143–144.

Petitioner has not provided sufficient evidence or explanation in support of why the fact that Boer’s SIGNAL and SERVICE fields are always transmitted using DBPSK (the “first” modulation method) might demonstrate obviousness of the subject matter of claim 2. Petitioner has failed to show, in particular, how the SIGNAL and SERVICE fields might

be deemed, as alleged, to “indicate” that communication from the master to the slave has reverted to the first modulation method, as recited in claim 2.

Independent claim 49, from which challenged claims 52 and 53 depend, recites a similar limitation with respect to how a sequence “indicates” that communication has reverted to the first modulation method. Petitioner relies, again, on Boer’s description of header 218 being always transmitted using the “first” modulation method. Pet. 39; Ex. 1220 ¶¶ 192–195. Petitioner’s asserted ground of obviousness with respect to claim 49, thus, fails for the same reasons as that of claim 2.

Claim 59, which depends from independent claim 58, also recites a third sequence that is transmitted in the first modulation method that “indicates” communication from the master to the slave has reverted to the first modulation method. Petitioner submits, correctly, that Boer teaches that the SIGNAL and SERVICE fields in the header “indicate which modulation method is used to transmit DATA field 218.” Pet. 49. “When Boer is combined with the APA, it could therefore indicate that communication from the master to the slave has reverted to the first modulation method.” *Id.* (citing Ex. 1220 ¶¶ 232–237). Mr. Goodman repeats that “it could therefore indicate” that communication has reverted to the first modulation method (Ex. 1220 ¶ 237) and concludes, “[t]herefore, it is my opinion that claim 59 is obvious in view of the prior art” (*id.* ¶ 238). Although it appears that Petitioner attempts to provide more explanation in its challenge of dependent claim 59, as compared with that of claim 2 or 49, we are not persuaded there is a reasonable likelihood that Petitioner would prevail in its challenge of any of claims 2, 49, and 59.



*F. Claim 19 – APA and Boer*

Claim 19 depends from claim 13, which depends from claim 1. Claim 19 recites “wherein the transceiver is configured to receive data from the intended destination in the first modulation method when the intended destination is the first type of receiver.” The “transceiver” is defined by base claim 1 as being “in the role of the master” according to the master/slave relationship, for sending transmissions modulated “using at least two types of modulation methods” as further specified in the claim.

Petitioner submits, with respect to claim 19, that Boer “discloses that a station 18 (first type) can receive DBPSK (‘first modulation method[’]) transmissions. *See* claim 13.” Pet. 36 (claim chart). Petitioner makes plain, in its assessment of intervening claim 13, that Boer’s LAN 10 (Fig. 1) contains mobile stations 18 of a “first type,” operating at 1 or 2 Mbps data rate, and mobile stations 22 of a “second” type, operating at 1, 2, 5, or 8 Mbps data rate. *Id.* at 35–36 (claim chart).

We agree with Patent Owner (Prelim. Resp. 38–39) that, as we noted previously, Boer describes stations 18 as not capable of using modulation for a “second” type of modulation associated with the higher rates of 5 and 8 Mbps. *See* Ex. 1204, col. 2, ll. 19–27 (mobile stations 18-1 and 18-2 (Fig. 1) transmit and receive messages at 1 or 2 Mbps, using DBPSK or DQPSK modulation, respectively). Thus, alleging that a station 18 can receive a “first” (DBPSK) modulation method transmission (Pet. 36) fails to demonstrate the obviousness of the *transceiver* which, according to claim 1, sends transmissions using at least two types of modulation methods, further being configured to receive data in the first modulation method in accordance with the requirements of claim 19. Petitioner provides no further

explanation for the discrepancy between claim 19 and the alleged corresponding disclosure of Boer. *See* Pet. 27; Ex. 1220 ¶¶ 159–160.

For the foregoing reasons, we are not persuaded there is a reasonable likelihood that Petitioner would prevail in its challenge of claim 19.

### III. CONCLUSION

The Petition demonstrates a reasonable likelihood of prevailing on the obviousness grounds of unpatentability as to claims 1, 4, 5, 10, 13, 20–22, 54, 57, 58, 61, 62, 66, 70, and 76–79 based on APA and Boer. The Petition does not demonstrate a reasonable likelihood of prevailing on the obviousness grounds of unpatentability as to claims 2, 19, 49, 52, 53, and 59 based on APA and Boer.

The Board has not made a final determination on the patentability of any challenged claim.

### IV. ORDER

In consideration of the foregoing, it is

ORDERED that an *inter partes* review is instituted as to claims 1, 4, 5, 10, 13, 20–22, 54, 57, 58, 61, 62, 66, 70, and 76–79 of the '580 patent on the obviousness ground based on APA and Boer;

FURTHER ORDERED that the Petition is denied as to all other grounds set forth in the Petition;

FURTHER ORDERED that pursuant to 35 U.S.C. § 314(a), *inter partes* review of the '580 patent is instituted with trial commencing on the entry date of this Order, and pursuant to 35 U.S.C. § 314(c) and 37 C.F.R. § 42.4, notice is given of the institution of the trial; and

IPR2014-00518  
Patent 8,023,580 B2

FURTHER ORDERED that the trial is limited to the grounds identified immediately above and no other ground is authorized for the '580 patent claims.

IPR2014-00518  
Patent 8,023,580 B2

For Petitioner:

Jeffrey A. Miller  
Daniel G. Cardy  
DICKSTEIN SHAPIRO LLP  
[millerj@dicksteinshapiro.com](mailto:millerj@dicksteinshapiro.com)  
[cardyd@dicksteinshapiro.com](mailto:cardyd@dicksteinshapiro.com)  
[Samsung.Rembrandt@dicksteinshapiro.com](mailto:Samsung.Rembrandt@dicksteinshapiro.com)

For Patent Owner:

Thomas Engellenner  
Reza Mollaaghababa  
Lana Gladstein  
PEPPER HAMILTON LLP  
[engellennert@pepperlaw.com](mailto:engellennert@pepperlaw.com)  
[mollaaghababar@pepperlaw.com](mailto:mollaaghababar@pepperlaw.com)  
[gladsteinl@pepperlaw.com](mailto:gladsteinl@pepperlaw.com)

UNITED STATES PATENT AND TRADEMARK OFFICE

---

BEFORE THE PATENT TRIAL AND APPEAL BOARD

---

SAMSUNG ELECTRONICS CO., LTD.,  
SAMSUNG ELECTRONICS AMERICA, INC.,  
SAMSUNG TELECOMMUNICATIONS AMERICA, LLC, and  
SAMSUNG AUSTIN SEMICONDUCTOR, LLC,  
Petitioner,

v.

REMBRANDT WIRELESS TECHNOLOGIES, LP,  
Patent Owner.

---

Case IPR2014-00519  
Patent 8,023,580 B2

---

Before JAMESON LEE, HOWARD B. BLANKENSHIP, and  
JUSTIN BUSCH, *Administrative Patent Judges*.

BUSCH, *Administrative Patent Judge*.

DECISION  
Institution of *Inter Partes* Review  
37 C.F.R. § 42.108

I. INTRODUCTION

*A. Background*

Samsung Electronics Co., Ltd., Samsung Electronics America, Inc., Samsung Telecommunications America, LLC, and Samsung Austin Semiconductor, LLC (collectively, “Petitioner”) filed an Amended Petition requesting an *inter partes* review of claims 23, 25, 29, 30, 32, 34, 38, 40, 41, 43, 44, and 47 (“the challenged claims”) of U.S. Patent No. 8,023,580 B2 (“the ’580 patent,” Ex. 1301) on April 3, 2014. Paper 4 (“Pet.”). Rembrandt Wireless Technologies, LP (“Patent Owner”) filed a Patent Owner Preliminary Response on July 3, 2014. Paper 14 (“Prelim. Resp.”). We have jurisdiction under 35 U.S.C. § 314.

*Inter partes* review may be instituted only if “there is a reasonable likelihood that the petitioner would prevail with respect to at least 1 of the claims challenged in the petition.” 35 U.S.C. § 314. Upon consideration of the Petition and the Patent Owner Preliminary Response, we conclude Petitioner has established a reasonable likelihood that it would prevail with respect to claims 32, 34, 38, 40, 43, 44, and 47 of the ’580 patent. Accordingly, we institute an *inter partes* review of claims 32, 34, 38, 40, 43, 44, and 47.

*B. Related Proceedings*

Petitioner indicates that the ’580 patent was asserted against Petitioner in *Rembrandt Wireless Technologies, LP v. Samsung Electronics Co.*, No. 2:13-cv-00213 (E.D. Tex.). Pet. 1–2. The same parties and patent

IPR2014-00519  
Patent 8,023,580 B2

are involved in *Samsung Electronics Co. v. Rembrandt Wireless Technologies, LP*, Case IPR2014-00514 (PTAB); *Samsung Electronics Co. v. Rembrandt Wireless Technologies, LP*, Case IPR2014-00515 (PTAB); and *Samsung Electronics Co. v. Rembrandt Wireless Technologies, LP*, Case IPR2014-00518 (PTAB).

*C. The '580 Patent (Ex. 1301)*<sup>1</sup>

The specification of the '580 patent describes “a data communications system in which a plurality of modulation methods are used to facilitate communication among a plurality of modem types.” Ex. 1301, 1:21–23. The '580 patent explains that the invention addresses a problem that conventional modem pairs can communicate successfully only when the modems use compatible modulation methods. *Id.* at 1:27–30, 1:45–47.

Of the challenged claims, claims 23, 32, and 40 are independent claims. Illustrative claim 23 is reproduced as follows:

23. A communications device, comprising:  
a processor; and  
a memory having stored therein executable instructions for execution by the processor, wherein the executable instructions direct transmission of a first data with a first modulation method followed by a second data with a second modulation method, wherein the first modulation method is different than the second modulation method, wherein the first data comprises an indication of an impending change from the first modulation method to the second modulation method, wherein the executable instructions direct transmission of a

---

<sup>1</sup> In our decision, we refer to the '580 patent by its original column and line numbers, not the page numbers inserted by the Petitioner.

third data with the first modulation method after the second data, and wherein the third data indicates that communication has reverted to the first modulation method.

*D. Asserted Grounds of Unpatentability*

Petitioner asserts the following grounds of unpatentability under 35 U.S.C. §§ 102 and 103:

Evidence	Basis	Challenged Claims
Boer <sup>2</sup>	§ 102(e)	23, 25, 30, 32, 34, 40, 41, 43, and 44
Boer	§ 103(a)	23, 25, 30, 32, and 34
Boer and APA <sup>3</sup>	§ 103(a)	29, 38, and 47

II. ANALYSIS

*A. Claim Construction*

Petitioner and Patent Owner each propose a construction of “first modulation method” and “second modulation method.” However, we do not construe any term at this time because no term needs to be construed for purposes of this decision.

*B. Asserted Grounds Based on Boer*

*1. Overview of Boer (Ex. 1304)*

Boer discloses “a method of operating a wireless local area network station adapted to transmit and receive messages at a plurality of data rates.”

---

<sup>2</sup> U.S. Patent No. 5,706,428 (filed Mar. 14, 1996, issued Jan. 6, 1998) (Ex. 1304) (“Boer”).

<sup>3</sup> Petitioner alleges that Figures 1 and 2 of the ’580 patent and the accompanying descriptions are admitted prior art. Pet. 37–38 (citing Ex. 1301, Figs. 1, 2, 2:16–20, 3:40–46) (“APA”).



Ex. 1304, 1:34–36. Boer’s local area network stations “may be data processing devices (such as PCs) having a wireless communication ability.” *Id.* at 1:13–15. Boer’s mobile stations may modulate the carrier signals using differential binary phase shift keying (“DBPSK”) modulation when communicating at 1 Megabit per second (“Mbps”) and differential quadrature phase shift keying (“DQPSK”) modulation when communicating at 2 Mbps. *Id.* at 2:16–27. Boer further discloses that other mobile stations in the system also may be capable of operating at 5 or 8 Mbps by modulating the carrier signals using pulse position modulation—DQPSK (“PPM/DQPSK”). *Id.* at 2:34–43. Boer discloses that a typical message includes various fields, including “signal,” “service,” “length,” and “CRC” fields (collectively referred to as a header) and a “data” field. *Id.* at 3:42–54. Boer further explains that the “header [is] always transmitted at the 1 Mbps rate using DBPSK modulation [and t]he subsequent DATA field . . . may be transmitted at a selected one of the four possible rates 1, 2, 5 or 8 Mbps, using the modulation and coding discussed hereinabove.” *Id.* at 3:57–62.

*2. Analysis of Asserted Anticipation Grounds of Claims 23, 25, and 30 Based on Boer*

Petitioner argues Boer discloses each limitation of independent claim 23 and provides claim charts, specifying where each of the limitations is described in Boer. Pet. 12–24. Petitioner argues Boer’s communication system is comprised of stations communicating with each other using different modulation methods, and that each of the stations may be a PC,

including a processor and a memory to execute instructions in order for the stations to communicate with each other. *Id.* at 12–13.

Petitioner argues that Boer’s transmission of its “service” and “length” fields of a first message, “data” field of the first message, and “service” and “length” fields of a subsequent message meet the recited “first data,” “second data,” and “third data,” respectively. *Id.* at 14–18. Petitioner argues Boer teaches sending headers of each message, which include the “service” and “length” fields, using DBPSK and that the “service” and “length” fields indicate which modulation method (DBPSK, DQPSK, or PPM/DQPSK) is used to transmit the “data” field of the same message. *Id.* at 16–18.

Next, Petitioner argues Boer’s disclosure of sending and receiving multiple messages at more than one data rate indicates a succession of transmissions will be made where each message follows the same format. *Id.* at 17. Petitioner argues Boer describes transmitting a first message’s “data” field using either DQPSK or PPM/DQPSK followed by a second message with a header indicating that the “data” field of the second message is transmitted using DBPSK. Petitioner asserts that sequence of messages described by Boer discloses “direct[ing] transmission of a third data with the first modulation method after the second data . . . indicat[ing] that communication has reverted to the first modulation method” (the “third data transmission limitation”). *Id.* at 17–18.

With respect to independent claim 23, Patent Owner argues Petitioner “ignores the limitation of claim 23 that requires that the third data *indicate* that ‘communication from the master to the slave has reverted to the first modulation method.’” Prelim. Resp. 26. Patent Owner also argues “there is no indication in Boer that a message . . . that is transmitted at a [second rate] is followed by a message having . . . fields that would *indicate* that its respective DATA 214 field shall be transmitted at” the first rate. *Id.* Therefore, Patent Owner asserts the Petition fails to establish a reasonable likelihood that Boer anticipates claim 23. *Id.* at 27.

Petitioner has presented sufficient evidence supporting its position that Boer discloses each of the limitations of claim 23, except for the third data transmission limitation. With respect to the third data transmission limitation, we note first that a portion of Patent Owner’s assertions is not commensurate with the scope of the claim language. Claim 23 of the ’580 patent does not recite communication from a master to a slave, but rather it merely recites that “communication has reverted to the first modulation method.” Nevertheless, although the Petition sufficiently establishes that Boer discloses sending messages at multiple data rates and using multiple associated modulation methods, the Petition has not established sufficiently that Boer either expressly or inherently discloses the third data transmission limitation. We agree with Patent Owner that the Petition has not established sufficiently

that a message that includes a DATA field 214 that is transmitted at a rate other than 1 Mbps (i.e., transmitted at a rate

different than the rate at which the SIGNAL 206 and SERVICE 208 fields of the message are transmitted) is followed by a message having SIGNAL 206 and SERVICE 208 fields that would indicate that its respective DATA 214 field shall be transmitted at a rate of 1 Mbps.

Prelim. Resp. 26 (emphasis omitted).

Boer's system may be capable of transmitting a first message's data field using either DQPSK or PPM/DQPSK followed, a subsequent message's header field using DBPSK, where the subsequent message's header field indicates that the subsequent message's data field will be transmitted using DBPSK. However, the Petition has not established that the specific series of transmissions as recited in independent claim 23 is explicitly disclosed by or necessarily present in Boer.

Thus, based on the evidence and arguments submitted, Petitioner has not demonstrated sufficiently that Boer discloses transmitting a third data—subsequent to a second data transmitted using a second modulation method—that indicates “communication has reverted to the first modulation method,” as recited in claim 23. Therefore, for the reasons discussed, Petitioner has not established a reasonable likelihood that claim 23 is anticipated by Boer. Dependent claims 25 and 30 depend from claim 23 and include all of the limitations recited in claim 23. Therefore, for the same reasons as discussed with respect to independent claim 23, Petitioner has not established a reasonable likelihood that claims 25 and 30 are anticipated by Boer.

3. *Analysis of Asserted Obviousness Grounds of Claims 23, 25, and 30 Based on Boer*

Petitioner asserts that, to the extent Boer does not anticipate claims 23, 25, and 30, Boer renders those claims obvious. Pet. 12–25. With respect to claim 23, Petitioner merely makes a conclusory statement that “it would have been obvious to a person of ordinary skill in the art to implement Boer’s teachings with a processor and memory that stores executable instructions that implements Boer’s functionality.” *Id.* at 13. Claims 25 and 30 depend from claim 23, and Petitioner argues Boer renders obvious claims 25 and 30 for the same reasons as discussed with respect to claim 23. *Id.* at 18, 19, 25. Petitioner presents no other argument regarding what aspects of Boer would need to be modified in order to meet the recited limitations and why. The underlying factual inquiries necessary for a proper obviousness analysis, as set forth in *Graham v. John Deere Co.*, 383 U.S. 1, 17–18 (1966), have not been discussed sufficiently. In particular, Petitioner has not submitted persuasive argument or evidence curing the deficiency identified with respect to its anticipation challenge. Therefore, on the record, Petitioner has not established a reasonable likelihood that claims 23, 25, and 30 would have been obvious in view of Boer.

4. *Analysis of Asserted Anticipation Grounds of Claims 32, 34, 40, 43, and 44 Based on Boer*

Independent claim 32 is similar to claim 23, except claim 32 does not recite that “the third data indicates that communication has reverted to the first modulation method” and includes an additional recitation that

“transmission of the second data is according to a particular quantity of data.” Petitioner argues Boer discloses that additional limitation because Boer uses its “length” field to identify the number of bytes transmitted in its “data” field, which Petitioner maps to the recited second data. *Id.* at 19, 25–26. Dependent claim 34, which depends from claim 32, further recites a transmitter. Petitioner argues Boer discloses RF transmitters 50 and 150, shown in Figures 2 and 3. Pet. 18–19, 25–27. Therefore, Petitioner asserts Boer discloses each limitation of independent claims 32 and 34 for the same reasons asserted with respect to claims 23 and because Boer discloses the transmission according to a quantity of data and using a transmitter, as recited in claims 32 and 34, respectively. Pet. 25–27.

Independent claim 40 recites limitations similar to those recited in claim 32, except claim 40 recites a transceiver, which further comprises a modulator, instead of reciting a processor and a memory. Petitioner points to Boer’s transceivers and argues the transceivers include a modulator. Pet. 27–28. Petitioner presents arguments for the remaining limitations of claim 40 similar to those presented with respect to the commensurate limitations recited in claims 23 and 32. *Id.* at 27–29.

Dependent claim 43, which depends from independent claim 40, recites “the transceiver is configured to transmit the second sequence according to a particular quantity of data.” Petitioner argues Boer discloses that additional limitation because Boer uses its “length” field to identify the number of bytes transmitted in its “data” field, which Petitioner maps to the

recited second data. *Id.* at 19, 30, 36–37. Dependent claim 44, which also depends from independent claim 40, recites a processor and a memory and instructions stored in the memory to cause the transmitter to transmit the recited data. Petitioner argues Boer discloses that limitation because it describes embodiments of devices including PCs or other data processing devices, which have processors and memories and use instructions to cause transceivers to transmit messages. Pet. 30, 37.

Claims 32, 34, 40, 43, and 44 do not recite a limitation similar to the limitation recited in claim 23 that Petitioner has failed to demonstrate is disclosed by Boer. Therefore, Petitioner has presented sufficient evidence supporting its position that Boer discloses each of the limitations of claims 32, 34, 40, 43, and 44. Thus, Petitioner has demonstrated a reasonable likelihood that claims 32, 34, 40, 43, and 44 are anticipated by Boer.

*5. Analysis of Asserted Obviousness Grounds of Claims 32 and 34  
Based on Boer*

As discussed above, Petitioner does not identify specifically any differences between Boer's disclosure and the subject matter recited in claims 32 and 34. Petitioner presents no other argument regarding what aspects of Boer would need to be modified in order to meet the recited limitations and why, thus failing to address the underlying factual inquiries necessary for a proper obviousness analysis. Therefore, we do not institute review on the ground that claims 32 and 34 would have been obvious in view of Boer. *See* 37 C.F.R. § 42.108(a).

*6. Analysis of Asserted Anticipation Grounds of Claim 41 Based on Boer*

Dependent claim 41 recites that the “transceiver is configured to transmit a third sequence after the second sequence, wherein the third sequence is transmitted in accordance with the first modulation method and indicates that a subsequent communication has reverted to the first modulation method,” which is similar in scope to the third data transmission limitation recited in independent claim 23. Petitioner presents similar arguments regarding this limitation as presented with respect to the third data transmission limitation. Pet. 29–30, 35–36.

Patent Owner presents arguments that Petitioner has not shown Boer anticipates claim 41, which are similar to the arguments it presented with respect to claim 23. We note that at least part of Patent Owner’s arguments regarding Petitioner’s failure to demonstrate that claim 41 is anticipated are not relevant or commensurate with the scope of the claims. *See* Prelim. Resp. 29–30. For example, Patent Owner argues Petitioner ignores elements recited in claim 23 and elements related to a master and a slave, which are not recited in claim 41. *Id.* at 29. Patent Owner also argues “Boer does not necessarily lead to the limitation of Claim 41 that ‘the third sequence indicates that communication from the master to the slave has reverted to the first modulation method.’” *Id.* at 30.

For the same reasons discussed above with respect to the third data transmission limitation of claim 23, Petitioner has not demonstrated sufficiently that Boer discloses “the transceiver is configured to transmit a



third sequence after the second sequence, wherein the third sequence is transmitted in accordance with the first modulation method and indicates that a subsequent communication has reverted to the first modulation method,” as recited in dependent claim 41. Therefore, Petitioner has not established a reasonable likelihood that claim 41 is anticipated by Boer.

*C. Asserted Obviousness Grounds Based on Boer and APA*

*1. Overview of APA*

Petitioner argues that Figures 1 and 2, as well as the accompanying descriptions, are admitted prior art because the '580 patent labeled Figure 1 as prior art and provided a description of Figure 2 as “a ladder diagram illustrating the operation of the multipoint communication system of” Figure 1. Pet. 5–7 (citing Ex. 1304, 3:40–44). Therefore, Petitioner asserts that a multipoint communication system using a master and multiple slaves is admitted prior art. *Id.* at 5–8, 37–38.

*2. Analysis of Asserted Obviousness Grounds of Claims 29, 38, and 47 Based on Boer and APA*

Petitioner asserts that an ordinarily skilled artisan would have combined Boer’s teachings with APA (the multipoint communication system) because they would have understood that the access points disclosed by Boer “often operate as a master” and integrating multi-modulation methods would have increased the flexibility and efficiency of a multipoint communication system. Pet. 40 (citing Ex. 1318 ¶¶ 162–167).

Dependent claims 29, 38, and 47 ultimately depend from independent claims 23, 32, and 40, respectively. Dependent claims 29, 38, and 47 merely

add the additional limitation that “the memory has stored therein program code for a multipoint communications protocol,” which Petitioner asserts is taught by APA. Pet. 41–43. Therefore, Petitioner asserts that it would have been obvious to combine Boer and the multipoint communications protocol of APA, resulting in the matter recited in claims 29, 38, and 47.

Patent Owner argues Petitioner’s allegations of admitted prior art cannot serve as a basis for instituting trial because admitted prior art is not applicable to an inventor’s own work and the inventor’s identification of a problem that needs to be solved cannot be separated from the invention as a whole (and, thus, cannot be admitted prior art). Prelim. Resp. 9–15. In sum, Patent Owner appears to argue that the identification of a problem leading to the ’580 patent cannot be prior art. Although the inventor of the ’580 patent identified a problem for which a system with stations communicating using multiple modulation methods provided a solution, Petitioner does not rely on identification of the problem as admitted prior art. Rather, based on the record, Petitioner merely relies on the ’580 patent’s disclosure of a multipoint communication system using a master and multiple slaves being well-known at the time of the invention. On the record currently before us, we are not persuaded that anything in the specification of the ’580 patent indicates that invention of a multipoint communications system using a master and multiple slaves is the work of the inventor of the ’580 patent.

On the evidence submitted, we are persuaded both that a multipoint communications system is APA in the ’580 patent and that a person of

IPR2014-00519  
Patent 8,023,580 B2

ordinary skill in the art would have combined Boer and such a multipoint communications system. Therefore, on this record, Petitioner has demonstrated a reasonable likelihood that claims 38 and 47 are obvious in view of the combination of Boer and APA. However, because claim 29 depends from and incorporates the limitations of claim 23 and Petitioner has not shown that APA cures the deficiencies of Boer with respect to claim 23, Petitioner has not demonstrated a reasonable likelihood that the subject matter of claim 29 would have been obvious in view of the combination of Boer and APA.

### III. CONCLUSION

For the foregoing reasons, we determine that Petitioner has shown a reasonable likelihood that it would prevail in demonstrating that claims 32, 34, 38, 40, 43, 44, and 47 of the '580 patent are unpatentable on at least one challenged ground, but Petitioner has not shown a reasonable likelihood that it would prevail in demonstrating that claims 23, 25, 29, 30, and 41 of the '580 patent are unpatentable on any ground. The Board has not made a final determination on the patentability of any challenged claim.

IPR2014-00519  
Patent 8,023,580 B2

IV. ORDER

For the reasons given, it is:

ORDERED that pursuant to 35 U.S.C. § 314(a), an *inter partes* review is hereby instituted for the following alleged grounds of unpatentability:

(a) claims 32, 34, 40, 43, and 44 of the '580 patent are unpatentable, under 35 U.S.C. § 102(e), as anticipated by Boer; and

(b) claims 38 and 47 of the '580 patent are unpatentable, under 35 U.S.C. § 103(a), over the combination of Boer and APA;

FURTHER ORDERED that no other ground of unpatentability alleged in the Petition for any claim is authorized; and

FURTHER ORDERED that pursuant to 35 U.S.C. § 314(c) and 37 C.F.R. § 42.4, the trial commences on the entry date of this decision, and notice is hereby given of the institution of a trial.

IPR2014-00519  
Patent 8,023,580 B2

PETITIONER:

Jeffrey Miller  
[millerj@dicksteinshapiro.com](mailto:millerj@dicksteinshapiro.com)

Daniel G. Cardy  
[cardyd@dicksteinshapiro.com](mailto:cardyd@dicksteinshapiro.com)

PATENT OWNER:

Thomas Engellenner  
[engellennert@pepperlaw.com](mailto:engellennert@pepperlaw.com)

Reza Mollaaghababa  
[mollaaghababar@pepperlaw.com](mailto:mollaaghababar@pepperlaw.com)

Lana Gladstein  
[gladsteinl@pepperlaw.com](mailto:gladsteinl@pepperlaw.com)

Under the Paperwork Reduction Act of 1995, no persons are required to respond to a collection of information unless it displays a valid OMB control number.

<b>POWER OF ATTORNEY OR REVOCATION OF POWER OF ATTORNEY WITH A NEW POWER OF ATTORNEY AND CHANGE OF CORRESPONDENCE ADDRESS</b>	Application Number	12/543,910
	Filing Date	August 19, 2009
	First Named Inventor	Gordon Bremer
	Title	System And Method Of Communication...
	Art Unit	2611
	Examiner Name	Dac V Ha
	Attorney Docket Number	

I hereby revoke all previous powers of attorney given in the above-identified application.

 A Power of Attorney is submitted herewith.

OR

 I hereby appoint Practitioner(s) associated with the following Customer Number as my/our attorney(s) or agent(s) to prosecute the application identified above, and to transact all business in the United States Patent and Trademark Office connected therewith:

15027

OR

 I hereby appoint Practitioner(s) named below as my/our attorney(s) or agent(s) to prosecute the application identified above, and to transact all business in the United States Patent and Trademark Office connected therewith:

Practitioner(s) Name	Registration Number

Please recognize or change the correspondence address for the above-identified application to:

 The address associated with the above-mentioned Customer Number.

OR

 The address associated with Customer Number:

15027

OR

 Firm or Individual Name

Address

City

State

Zip

Country

Telephone

Email

I am the:

 Applicant/Inventor.

OR

 Assignee of record of the entire interest. See 37 CFR 3.71.

Statement under 37 CFR 3.73(b) (Form PTO/SB/96) submitted herewith or filed on \_\_\_\_\_

SIGNATURE of Applicant or Assignee of Record

Signature

Date

12/3/2014

Name

Derek Wood

Telephone

610-822-0100

Title and Company

Secretary of the general partner (Rembrandt Virginia Management, LLC) of Rembrandt Wireless Technologies, LP

NOTE: Signatures of all the inventors or assignees of record of the entire interest or their representative(s) are required. Submit multiple forms if more than one signature is required, see below\*.

 \*Total of 1 forms are submitted.

This collection of information is required by 37 CFR 1.31, 1.32 and 1.33. The information is required to obtain or retain a benefit by the public which is to file (and by the USPTO to process) an application. Confidentiality is governed by 35 U.S.C. 122 and 37 CFR 1.11 and 1.14. This collection is estimated to take 3 minutes to complete, including gathering, preparing, and submitting the completed application form to the USPTO. Time will vary depending upon the individual case. Any comments on the amount of time you require to complete this form and/or suggestions for reducing this burden, should be sent to the Chief Information Officer, U.S. Patent and Trademark Office, U.S. Department of Commerce, P.O. Box 1450, Alexandria, VA 22313-1450. DO NOT SEND FEES OR COMPLETED FORMS TO THIS ADDRESS. SEND TO: Commissioner for Patents, P.O. Box 1450, Alexandria, VA 22313-1450.

If you need assistance in completing the form, call 1-800-PTO-9199 and select option 2.

Under the Paperwork Reduction Act of 1995, no persons are required to respond to a collection of information unless it displays a valid OMB control number.

**STATEMENT UNDER 37 CFR 3.73(b)**

Applicant/Patent Owner: Gordon Bremer

Application No./Patent No.: 8,023,580 Filed/Issue Date: September 20, 2011

Titled: SYSTEM AND METHOD OF COMMUNICATION USING AT LEAST TWO MODULATION METHODS

Rembrandt Wireless Technologies, LP, a partnership  
(Name of Assignee) (Type of Assignee, e.g., corporation, partnership, university, government agency, etc.)

states that it is:

- 1.  the assignee of the entire right, title, and interest in;
  - 2.  an assignee of less than the entire right, title, and interest in  
(The extent (by percentage) of its ownership interest is \_\_\_\_\_ %); or
  - 3.  the assignee of an undivided interest in the entirety of (a complete assignment from one of the joint inventors was made)
- the patent application/patent identified above, by virtue of either:

A.  An assignment from the inventor(s) of the patent application/patent identified above. The assignment was recorded in the United States Patent and Trademark Office at Reel \_\_\_\_\_, Frame \_\_\_\_\_, or for which a copy therefore is attached.

**OR**

B.  A chain of title from the inventor(s), of the patent application/patent identified above, to the current assignee as follows:

1. From: Gordon Bremer To: Paradyne Corporation

The document was recorded in the United States Patent and Trademark Office at  
Reel 009844, Frame 0480, or for which a copy thereof is attached.

2. From: Zhone Technologies, Inc; Paradyne Corp. To: Summit Technology Systems, LP

The document was recorded in the United States Patent and Trademark Office at  
Reel 019649, Frame 0818, or for which a copy thereof is attached.

3. From: Summit Technology Systems, LP To: Rembrandt Wireless Technologies, LP

The document was recorded in the United States Patent and Trademark Office at  
Reel 027085, Frame 0636, or for which a copy thereof is attached.

Additional documents in the chain of title are listed on a supplemental sheet(s).

As required by 37 CFR 3.73(b)(1)(i), the documentary evidence of the chain of title from the original owner to the assignee was, or concurrently is being, submitted for recordation pursuant to 37 CFR 3.11.

[NOTE: A separate copy (i.e., a true copy of the original assignment document(s)) must be submitted to Assignment Division in accordance with 37 CFR Part 3, to record the assignment in the records of the USPTO. See MPEP 302.08]

The undersigned (whose title is supplied below) is authorized to act on behalf of the assignee.

/Michael A. Koptiw/  
Signature

December 4, 2014  
Date

Michael A. Koptiw  
Printed or Typed Name

Patent Attorney  
Title

## Privacy Act Statement

The **Privacy Act of 1974 (P.L. 93-579)** requires that you be given certain information in connection with your submission of the attached form related to a patent application or patent. Accordingly, pursuant to the requirements of the Act, please be advised that: (1) the general authority for the collection of this information is 35 U.S.C. 2(b)(2); (2) furnishing of the information solicited is voluntary; and (3) the principal purpose for which the information is used by the U.S. Patent and Trademark Office is to process and/or examine your submission related to a patent application or patent. If you do not furnish the requested information, the U.S. Patent and Trademark Office may not be able to process and/or examine your submission, which may result in termination of proceedings or abandonment of the application or expiration of the patent.

The information provided by you in this form will be subject to the following routine uses:

1. The information on this form will be treated confidentially to the extent allowed under the Freedom of Information Act (5 U.S.C. 552) and the Privacy Act (5 U.S.C. 552a). Records from this system of records may be disclosed to the Department of Justice to determine whether disclosure of these records is required by the Freedom of Information Act.
2. A record from this system of records may be disclosed, as a routine use, in the course of presenting evidence to a court, magistrate, or administrative tribunal, including disclosures to opposing counsel in the course of settlement negotiations.
3. A record in this system of records may be disclosed, as a routine use, to a Member of Congress submitting a request involving an individual, to whom the record pertains, when the individual has requested assistance from the Member with respect to the subject matter of the record.
4. A record in this system of records may be disclosed, as a routine use, to a contractor of the Agency having need for the information in order to perform a contract. Recipients of information shall be required to comply with the requirements of the Privacy Act of 1974, as amended, pursuant to 5 U.S.C. 552a(m).
5. A record related to an International Application filed under the Patent Cooperation Treaty in this system of records may be disclosed, as a routine use, to the International Bureau of the World Intellectual Property Organization, pursuant to the Patent Cooperation Treaty.
6. A record in this system of records may be disclosed, as a routine use, to another federal agency for purposes of National Security review (35 U.S.C. 181) and for review pursuant to the Atomic Energy Act (42 U.S.C. 218(c)).
7. A record from this system of records may be disclosed, as a routine use, to the Administrator, General Services, or his/her designee, during an inspection of records conducted by GSA as part of that agency's responsibility to recommend improvements in records management practices and programs, under authority of 44 U.S.C. 2904 and 2906. Such disclosure shall be made in accordance with the GSA regulations governing inspection of records for this purpose, and any other relevant (*i.e.*, GSA or Commerce) directive. Such disclosure shall not be used to make determinations about individuals.
8. A record from this system of records may be disclosed, as a routine use, to the public after either publication of the application pursuant to 35 U.S.C. 122(b) or issuance of a patent pursuant to 35 U.S.C. 151. Further, a record may be disclosed, subject to the limitations of 37 CFR 1.14, as a routine use, to the public if the record was filed in an application which became abandoned or in which the proceedings were terminated and which application is referenced by either a published application, an application open to public inspection or an issued patent.
9. A record from this system of records may be disclosed, as a routine use, to a Federal, State, or local law enforcement agency, if the USPTO becomes aware of a violation or potential violation of law or regulation.



**IN THE UNITED STATES PATENT AND TRADEMARK OFFICE**

In re Patent Application of: Gordon Bremer

Patent No.: 8,023,580

Issued: September 20, 2011

For: SYSTEM AND METHOD OF COMMUNICATION  
USING AT LEAST TWO MODULATION METHODS

Confirmation No.: 8306

Art Unit: 2611

Examiner: Dac V. Ha

**SUBMISSION OF DISCLAIMER PURSUANT TO 37 C.F.R. § 1.321(a)**

Commissioner for Patents  
P.O. Box 1450  
Alexandria, VA 22313-1450

Dear Madam:

Appended hereto is a completed form PTO/SB/43 (Disclaimer in Patent Under 37 C.F.R. § 1.321(a)). Also appended hereto is a Statement Under 37 C.F.R. § 3.73(b), showing that Rembrandt Wireless Technologies, LP is the assignee of record for U.S. Patent No. 8,023,580 (issued September 20, 2011). As reflected in the appended Disclaimer, the assignee of record disclaims Claims 32, 34, 40, 43, and 44, and authorizes payment of all necessary fees.

The Director is hereby authorized to charge any appropriate fees that may be required by the Disclaimer and this paper, and to credit any overpayment, to Deposit Account 50-5519.

Date: December 4, 2014

Respectfully submitted,

/ Michael A. Koptiw /  
Name: Michael A. Koptiw  
Registration No.: 57,900

## Electronic Patent Application Fee Transmittal

<b>Application Number:</b>	12543910
<b>Filing Date:</b>	19-Aug-2009
<b>Title of Invention:</b>	SYSTEM AND METHOD OF COMMUNICATION USING AT LEAST TWO MODULATION METHODS
<b>First Named Inventor/Applicant Name:</b>	Gordon F. Bremer
<b>Filer:</b>	Arshid A. Sheikh/Marissa Antonelli
<b>Attorney Docket Number:</b>	REMB-0109

Filed as Large Entity

### Utility under 35 USC 111(a) Filing Fees

Description	Fee Code	Quantity	Amount	Sub-Total in USD(\$)
<b>Basic Filing:</b>				
<b>Pages:</b>				
<b>Claims:</b>				
<b>Miscellaneous-Filing:</b>				
<b>Petition:</b>				
<b>Patent-Appeals-and-Interference:</b>				
<b>Post-Allowance-and-Post-Issuance:</b>				
<b>Extension-of-Time:</b>				

Description	Fee Code	Quantity	Amount	Sub-Total in USD(\$)
<b>Miscellaneous:</b>				
Statutory or Terminal Disclaimer	1814	1	160	160
<b>Total in USD (\$)</b>				<b>160</b>

## Electronic Acknowledgement Receipt

<b>EFS ID:</b>	20863865
<b>Application Number:</b>	12543910
<b>International Application Number:</b>	
<b>Confirmation Number:</b>	8306
<b>Title of Invention:</b>	SYSTEM AND METHOD OF COMMUNICATION USING AT LEAST TWO MODULATION METHODS
<b>First Named Inventor/Applicant Name:</b>	Gordon F. Bremer
<b>Customer Number:</b>	15027
<b>Filer:</b>	Arshid A. Sheikh/Marissa Antonelli
<b>Filer Authorized By:</b>	Arshid A. Sheikh
<b>Attorney Docket Number:</b>	REMB-0109
<b>Receipt Date:</b>	04-DEC-2014
<b>Filing Date:</b>	19-AUG-2009
<b>Time Stamp:</b>	12:30:16
<b>Application Type:</b>	Utility under 35 USC 111(a)

### Payment information:

Submitted with Payment	yes
Payment Type	Deposit Account
Payment was successfully received in RAM	\$160
RAM confirmation Number	11549
Deposit Account	505519
Authorized User	

The Director of the USPTO is hereby authorized to charge indicated fees and credit any overpayment as follows:

Charge any Additional Fees required under 37 C.F.R. Section 1.16 (National application filing, search, and examination fees)

Charge any Additional Fees required under 37 C.F.R. Section 1.17 (Patent application and reexamination processing fees)

Charge any Additional Fees required under 37 C.F.R. Section 1.19 (Document supply fees)

Charge any Additional Fees required under 37 C.F.R. Section 1.20 (Post Issuance fees)

Charge any Additional Fees required under 37 C.F.R. Section 1.21 (Miscellaneous fees and charges)

**File Listing:**

Document Number	Document Description	File Name	File Size(Bytes)/ Message Digest	Multi Part /.zip	Pages (if appl.)
1	Statutory disclaimers per MPEP 1490.	Disclaimer_in_patent_under_37_1321.pdf	145902 9faee619adce3e092640e328ca1bc7b3e20d59ef	no	2
<b>Warnings:</b>					
<b>Information:</b>					
2	Power of Attorney	POA.pdf	2717489 f578da2df89d0deb102c3e67ed5b2b72b3bf16789	no	1
<b>Warnings:</b>					
<b>Information:</b>					
3	Assignee showing of ownership per 37 CFR 3.73.	Final_Statement_under_373.pdf	75567 de98e7ebd6efb67dbc5302b5295634cf14c0471e	no	2
<b>Warnings:</b>					
<b>Information:</b>					
4	Miscellaneous Incoming Letter	Transmittal_Ltr.pdf	77069 019a9547139888bcdc4856391f4101c4875e8b4d	no	1
<b>Warnings:</b>					
<b>Information:</b>					
5	Fee Worksheet (SB06)	fee-info.pdf	30321 6c97c973901ad0aae0f4e61d0f4f9b625d960c4e	no	2
<b>Warnings:</b>					
<b>Information:</b>					
<b>Total Files Size (in bytes):</b>			3046348		

**This Acknowledgement Receipt evidences receipt on the noted date by the USPTO of the indicated documents, characterized by the applicant, and including page counts, where applicable. It serves as evidence of receipt similar to a Post Card, as described in MPEP 503.**

**New Applications Under 35 U.S.C. 111**

**If a new application is being filed and the application includes the necessary components for a filing date (see 37 CFR 1.53(b)-(d) and MPEP 506), a Filing Receipt (37 CFR 1.54) will be issued in due course and the date shown on this Acknowledgement Receipt will establish the filing date of the application.**

**National Stage of an International Application under 35 U.S.C. 371**

**If a timely submission to enter the national stage of an international application is compliant with the conditions of 35 U.S.C. 371 and other applicable requirements a Form PCT/DO/EO/903 indicating acceptance of the application as a national stage submission under 35 U.S.C. 371 will be issued in addition to the Filing Receipt, in due course.**

**New International Application Filed with the USPTO as a Receiving Office**

**If a new international application is being filed and the international application includes the necessary components for an international filing date (see PCT Article 11 and MPEP 1810), a Notification of the International Application Number and of the International Filing Date (Form PCT/RO/105) will be issued in due course, subject to prescriptions concerning national security, and the date shown on this Acknowledgement Receipt will establish the international filing date of the application.**

Under the Paperwork Reduction Act of 1995, no persons are required to respond to a collection of information unless it displays a valid OMB control number.

<b>DISCLAIMER IN PATENT UNDER 37 CFR 1.321(a)</b>	
Name of Patentee Gordon Bremer	Docket Number (Optional) REMB__0109__USCON
Patent Number 8,023,580	Date Patent Issued September 20, 2011
Title of Invention System And Method Of Communication Using At Least Two Modulation Methods	
I hereby disclaim the following complete claims in the above identified patent: _____ Claims 32, 34, 40, 43, and 44	
The extent of my interest in said patent is (if assignee of record, state liber and page, or reel and frame, where assignment is recorded): <u>Assignee of record as shown on 3.73(b) submitted</u> <u>herewith and having a chain of title recorded at (009844/0480),</u> <u>(019649/0818), and (027085/0636).</u> The fee for this disclaimer is set forth in 37 CFR 1.20(d).	
<input type="checkbox"/> Patentee claims small entity status. See 37 CFR 1.27. <input type="checkbox"/> Small entity status has already been established in this case, and is still proper. <input type="checkbox"/> A check in the amount of the fee is enclosed. <input type="checkbox"/> Payment by credit card. Form PTO-2038 is attached. <input checked="" type="checkbox"/> The Director is hereby authorized to charge any fees which may be required or credit any overpayment to Deposit Account No. <u>50-5519</u> .	
<b>WARNING: Information on this form may become public. Credit card information should not be included on this form. Provide credit card information and authorization on PTO-2038.</b>	
Signed at <u>Philadelphia</u> , State of <u>Pennsylvania</u> , this <u>4</u> day of <u>December</u> 20 <u>14</u> .	
<u>/Michael A. Koptiw/</u>	<u>57,900</u>
Signature	Registration Number, if applicable
<u>Michael A. Koptiw</u>	<u>215-558-5740</u>
Typed or printed name of patentee/ attorney or agent of record	Telephone Number
<u>1800 JFK Boulevard, Suite 1700</u>	
Address	
<u>Philadelphia, Pennsylvania 19103, United States of America</u>	
City, State, Zip Code or Foreign Country as applicable	

This collection of information is required by 37 CFR 1.321. The information is required to obtain or retain a benefit by the public which is to file (and by the USPTO to process) an application. Confidentiality is governed by 35 U.S.C. 122 and 37 CFR 1.11 and 1.14. This collection is estimated to take 12 minutes to complete, including gathering, preparing, and submitting the completed application form to the USPTO. Time will vary depending upon the individual case. Any comments on the amount of time you require to complete this form and/or suggestions for reducing this burden, should be sent to the Chief Information Officer, U.S. Patent and Trademark Office, U.S. Department of Commerce, P.O. Box 1450, Alexandria, VA 22313-1450. DO NOT SEND FEES OR COMPLETED FORMS TO THIS ADDRESS. **SEND TO: Commissioner for Patents, P.O. Box 1450, Alexandria, VA 22313-1450.**

If you need assistance in completing the form, call 1-800-PTO-9199 and select option 2.

## Privacy Act Statement

The **Privacy Act of 1974 (P.L. 93-579)** requires that you be given certain information in connection with your submission of the attached form related to a patent application or patent. Accordingly, pursuant to the requirements of the Act, please be advised that: (1) the general authority for the collection of this information is 35 U.S.C. 2(b)(2); (2) furnishing of the information solicited is voluntary; and (3) the principal purpose for which the information is used by the U.S. Patent and Trademark Office is to process and/or examine your submission related to a patent application or patent. If you do not furnish the requested information, the U.S. Patent and Trademark Office may not be able to process and/or examine your submission, which may result in termination of proceedings or abandonment of the application or expiration of the patent.

The information provided by you in this form will be subject to the following routine uses:

1. The information on this form will be treated confidentially to the extent allowed under the Freedom of Information Act (5 U.S.C. 552) and the Privacy Act (5 U.S.C. 552a). Records from this system of records may be disclosed to the Department of Justice to determine whether disclosure of these records is required by the Freedom of Information Act.
2. A record from this system of records may be disclosed, as a routine use, in the course of presenting evidence to a court, magistrate, or administrative tribunal, including disclosures to opposing counsel in the course of settlement negotiations.
3. A record in this system of records may be disclosed, as a routine use, to a Member of Congress submitting a request involving an individual, to whom the record pertains, when the individual has requested assistance from the Member with respect to the subject matter of the record.
4. A record in this system of records may be disclosed, as a routine use, to a contractor of the Agency having need for the information in order to perform a contract. Recipients of information shall be required to comply with the requirements of the Privacy Act of 1974, as amended, pursuant to 5 U.S.C. 552a(m).
5. A record related to an International Application filed under the Patent Cooperation Treaty in this system of records may be disclosed, as a routine use, to the International Bureau of the World Intellectual Property Organization, pursuant to the Patent Cooperation Treaty.
6. A record in this system of records may be disclosed, as a routine use, to another federal agency for purposes of National Security review (35 U.S.C. 181) and for review pursuant to the Atomic Energy Act (42 U.S.C. 218(c)).
7. A record from this system of records may be disclosed, as a routine use, to the Administrator, General Services, or his/her designee, during an inspection of records conducted by GSA as part of that agency's responsibility to recommend improvements in records management practices and programs, under authority of 44 U.S.C. 2904 and 2906. Such disclosure shall be made in accordance with the GSA regulations governing inspection of records for this purpose, and any other relevant (*i.e.*, GSA or Commerce) directive. Such disclosure shall not be used to make determinations about individuals.
8. A record from this system of records may be disclosed, as a routine use, to the public after either publication of the application pursuant to 35 U.S.C. 122(b) or issuance of a patent pursuant to 35 U.S.C. 151. Further, a record may be disclosed, subject to the limitations of 37 CFR 1.14, as a routine use, to the public if the record was filed in an application which became abandoned or in which the proceedings were terminated and which application is referenced by either a published application, an application open to public inspection or an issued patent.
9. A record from this system of records may be disclosed, as a routine use, to a Federal, State, or local law enforcement agency, if the USPTO becomes aware of a violation or potential violation of law or regulation.





UNITED STATES PATENT AND TRADEMARK OFFICE

UNITED STATES DEPARTMENT OF COMMERCE  
United States Patent and Trademark Office  
Address: COMMISSIONER FOR PATENTS  
P.O. Box 1450  
Alexandria, Virginia 22313-1450  
www.uspto.gov

APPLICATION NUMBER	FILING OR 371(C) DATE	FIRST NAMED APPLICANT	ATTY. DOCKET NO./TITLE
12/543,910	08/19/2009	Gordon F. Bremer	REMB-0109

**CONFIRMATION NO. 8306**

**POA ACCEPTANCE LETTER**



15027  
Condo Roccia Koptiw LLP  
1800 JFK Boulevard  
Suite 1700  
Philadelphia, PA 19103

Date Mailed: 12/10/2014

**NOTICE OF ACCEPTANCE OF POWER OF ATTORNEY**

This is in response to the Power of Attorney filed 12/04/2014.

The Power of Attorney in this application is accepted. Correspondence in this application will be mailed to the above address as provided by 37 CFR 1.33.

/zabraha/

Office of Data Management, Application Assistance Unit (571) 272-4000, or (571) 272-4200, or 1-888-786-0101

Under the Paperwork Reduction Act of 1995, no persons are required to respond to a collection of information unless it displays a valid OMB control number.

<b>DISCLAIMER IN PATENT UNDER 37 CFR 1.321(a)</b>	
Name of Patentee Gordon Bremer	Docket Number (Optional) REMB_0109_USCON
Patent Number 8,023,580	Date Patent Issued September 20, 2011
Title of Invention System And Method Of Communication Using At Least Two Modulation Methods	
I hereby disclaim the following complete claims in the above identified patent: _____ Claims 24, 26-28, 31, 33, 35-37, 39, 42, 45, 46, and 48.	
The extent of my interest in said patent is (if assignee of record, state liber and page, or reel and frame, where assignment is recorded): <u>Assignee of record as shown at chain of title</u> recorded at (009844/0480), (019649/0818), and (027085/0636).	
The fee for this disclaimer is set forth in 37 CFR 1.20(d).	
<input type="checkbox"/> Patentee claims small entity status. See 37 CFR 1.27. <input type="checkbox"/> Small entity status has already been established in this case, and is still proper. <input type="checkbox"/> A check in the amount of the fee is enclosed. <input type="checkbox"/> Payment by credit card. Form PTO-2038 is attached. <input checked="" type="checkbox"/> The Director is hereby authorized to charge any fees which may be required or credit any overpayment to Deposit Account No. <u>50-5519</u> .	
<b>WARNING: Information on this form may become public. Credit card information should not be included on this form. Provide credit card information and authorization on PTO-2038.</b>	
Signed at <u>Philadelphia</u> , State of <u>Pennsylvania</u> , this <u>15</u> day of <u>December</u> 20 <u>14</u> .	
<u>/Michael A. Koptiw/</u> Signature	<u>57,900</u> Registration Number, if applicable
<u>Michael A. Koptiw</u> Typed or printed name of patentee/ attorney or agent of record	<u>215-558-5740</u> Telephone Number
<u>1800 JFK Boulevard, Suite 1700</u> Address	
<u>Philadelphia, Pennsylvania, 19103, United States of America</u> City, State, Zip Code or Foreign Country as applicable	

This collection of information is required by 37 CFR 1.321. The information is required to obtain or retain a benefit by the public which is to file (and by the USPTO to process) an application. Confidentiality is governed by 35 U.S.C. 122 and 37 CFR 1.11 and 1.14. This collection is estimated to take 12 minutes to complete, including gathering, preparing, and submitting the completed application form to the USPTO. Time will vary depending upon the individual case. Any comments on the amount of time you require to complete this form and/or suggestions for reducing this burden, should be sent to the Chief Information Officer, U.S. Patent and Trademark Office, U.S. Department of Commerce, P.O. Box 1450, Alexandria, VA 22313-1450. DO NOT SEND FEES OR COMPLETED FORMS TO THIS ADDRESS. **SEND TO: Commissioner for Patents, P.O. Box 1450, Alexandria, VA 22313-1450.**

If you need assistance in completing the form, call 1-800-PTO-9199 and select option 2.

## Privacy Act Statement

The **Privacy Act of 1974 (P.L. 93-579)** requires that you be given certain information in connection with your submission of the attached form related to a patent application or patent. Accordingly, pursuant to the requirements of the Act, please be advised that: (1) the general authority for the collection of this information is 35 U.S.C. 2(b)(2); (2) furnishing of the information solicited is voluntary; and (3) the principal purpose for which the information is used by the U.S. Patent and Trademark Office is to process and/or examine your submission related to a patent application or patent. If you do not furnish the requested information, the U.S. Patent and Trademark Office may not be able to process and/or examine your submission, which may result in termination of proceedings or abandonment of the application or expiration of the patent.

The information provided by you in this form will be subject to the following routine uses:

1. The information on this form will be treated confidentially to the extent allowed under the Freedom of Information Act (5 U.S.C. 552) and the Privacy Act (5 U.S.C. 552a). Records from this system of records may be disclosed to the Department of Justice to determine whether disclosure of these records is required by the Freedom of Information Act.
2. A record from this system of records may be disclosed, as a routine use, in the course of presenting evidence to a court, magistrate, or administrative tribunal, including disclosures to opposing counsel in the course of settlement negotiations.
3. A record in this system of records may be disclosed, as a routine use, to a Member of Congress submitting a request involving an individual, to whom the record pertains, when the individual has requested assistance from the Member with respect to the subject matter of the record.
4. A record in this system of records may be disclosed, as a routine use, to a contractor of the Agency having need for the information in order to perform a contract. Recipients of information shall be required to comply with the requirements of the Privacy Act of 1974, as amended, pursuant to 5 U.S.C. 552a(m).
5. A record related to an International Application filed under the Patent Cooperation Treaty in this system of records may be disclosed, as a routine use, to the International Bureau of the World Intellectual Property Organization, pursuant to the Patent Cooperation Treaty.
6. A record in this system of records may be disclosed, as a routine use, to another federal agency for purposes of National Security review (35 U.S.C. 181) and for review pursuant to the Atomic Energy Act (42 U.S.C. 218(c)).
7. A record from this system of records may be disclosed, as a routine use, to the Administrator, General Services, or his/her designee, during an inspection of records conducted by GSA as part of that agency's responsibility to recommend improvements in records management practices and programs, under authority of 44 U.S.C. 2904 and 2906. Such disclosure shall be made in accordance with the GSA regulations governing inspection of records for this purpose, and any other relevant (*i.e.*, GSA or Commerce) directive. Such disclosure shall not be used to make determinations about individuals.
8. A record from this system of records may be disclosed, as a routine use, to the public after either publication of the application pursuant to 35 U.S.C. 122(b) or issuance of a patent pursuant to 35 U.S.C. 151. Further, a record may be disclosed, subject to the limitations of 37 CFR 1.14, as a routine use, to the public if the record was filed in an application which became abandoned or in which the proceedings were terminated and which application is referenced by either a published application, an application open to public inspection or an issued patent.
9. A record from this system of records may be disclosed, as a routine use, to a Federal, State, or local law enforcement agency, if the USPTO becomes aware of a violation or potential violation of law or regulation.

**IN THE UNITED STATES PATENT AND TRADEMARK OFFICE**

In re Patent Application of: Gordon Bremer

Patent No.: 8,023,580

Issued: September 20, 2011

For: SYSTEM AND METHOD OF COMMUNICATION  
USING AT LEAST TWO MODULATION METHODS

Confirmation No.: 8306

Art Unit: 2611

Examiner: Dac V. Ha

**SUBMISSION OF DISCLAIMER PURSUANT TO 37 C.F.R. § 1.321(a)**

Commissioner for Patents  
P.O. Box 1450  
Alexandria, VA 22313-1450

Dear Madam:

Appended hereto is a completed form PTO/SB/43 (Disclaimer in Patent Under 37 C.F.R. § 1.321(a)). Rembrandt Wireless Technologies, LP is the assignee of record for U.S. Patent No. 8,023,580 (issued September 20, 2011) as shown on the chain of title recorded at reel/frame (009844/0480),(019649/0818), and (027085/0636).

As reflected in the appended Disclaimer, the assignee of record disclaims Claims 24, 26-28, 31, 33, 35-37, 39, 42, 45, 46, and 48, and authorizes payment of all necessary fees.

The Director is hereby authorized to charge any appropriate fees that may be required by the Disclaimer and this paper, and to credit any overpayment, to Deposit Account 50-5519.

Dated: December 15, 2014

/Michael A. Koptiw/  
Name: Michael A. Koptiw  
Registration No.: 57,900

## Electronic Patent Application Fee Transmittal

<b>Application Number:</b>	12543910
<b>Filing Date:</b>	19-Aug-2009
<b>Title of Invention:</b>	SYSTEM AND METHOD OF COMMUNICATION USING AT LEAST TWO MODULATION METHODS
<b>First Named Inventor/Applicant Name:</b>	Gordon F. Bremer
<b>Filer:</b>	Arshid A. Sheikh/Cassandra Katz
<b>Attorney Docket Number:</b>	REMB-0109

Filed as Large Entity

**Filing Fees for Utility under 35 USC 111(a)**

Description	Fee Code	Quantity	Amount	Sub-Total in USD(\$)
<b>Basic Filing:</b>				
<b>Pages:</b>				
<b>Claims:</b>				
<b>Miscellaneous-Filing:</b>				
<b>Petition:</b>				
<b>Patent-Appeals-and-Interference:</b>				
<b>Post-Allowance-and-Post-Issuance:</b>				
<b>Extension-of-Time:</b>				

Description	Fee Code	Quantity	Amount	Sub-Total in USD(\$)
<b>Miscellaneous:</b>				
Statutory or Terminal Disclaimer	1814	1	160	160
<b>Total in USD (\$)</b>				<b>160</b>

## Electronic Acknowledgement Receipt

<b>EFS ID:</b>	20957925
<b>Application Number:</b>	12543910
<b>International Application Number:</b>	
<b>Confirmation Number:</b>	8306
<b>Title of Invention:</b>	SYSTEM AND METHOD OF COMMUNICATION USING AT LEAST TWO MODULATION METHODS
<b>First Named Inventor/Applicant Name:</b>	Gordon F. Bremer
<b>Customer Number:</b>	15027
<b>Filer:</b>	Arshid A. Sheikh/Cassandra Katzcx
<b>Filer Authorized By:</b>	Arshid A. Sheikh
<b>Attorney Docket Number:</b>	REMB-0109
<b>Receipt Date:</b>	15-DEC-2014
<b>Filing Date:</b>	19-AUG-2009
<b>Time Stamp:</b>	12:24:09
<b>Application Type:</b>	Utility under 35 USC 111(a)

### Payment information:

Submitted with Payment	yes
Payment Type	Deposit Account
Payment was successfully received in RAM	\$160
RAM confirmation Number	9857
Deposit Account	505519
Authorized User	

The Director of the USPTO is hereby authorized to charge indicated fees and credit any overpayment as follows:

Charge any Additional Fees required under 37 C.F.R. Section 1.16 (National application filing, search, and examination fees)

Charge any Additional Fees required under 37 C.F.R. Section 1.17 (Patent application and reexamination processing fees)

Charge any Additional Fees required under 37 C.F.R. Section 1.19 (Document supply fees)  
 Charge any Additional Fees required under 37 C.F.R. Section 1.20 (Post Issuance fees)  
 Charge any Additional Fees required under 37 C.F.R. Section 1.21 (Miscellaneous fees and charges)

**File Listing:**

Document Number	Document Description	File Name	File Size(Bytes)/ Message Digest	Multi Part /.zip	Pages (if appl.)
1	Statutory disclaimers per MPEP 1490.	REMB_0109_USCON_SB0043A_dated_15Dec2014.pdf	176130 d83495fe06369fc2f70c5ad15b0d1f54183e10b0	no	2
<b>Warnings:</b>					
<b>Information:</b>					
2	Miscellaneous Incoming Letter	REMB_0109_USCON_Transmittal_Ltr_dated_15Dec2014.pdf	77036 7a7f418b7129118efcb5eb4285f0dbec779c8d74	no	1
<b>Warnings:</b>					
<b>Information:</b>					
3	Fee Worksheet (SB06)	fee-info.pdf	30675 746b46ce6531fb6a93f8e136869b36f7cd467218	no	2
<b>Warnings:</b>					
<b>Information:</b>					
<b>Total Files Size (in bytes):</b>			283841		

**This Acknowledgement Receipt evidences receipt on the noted date by the USPTO of the indicated documents, characterized by the applicant, and including page counts, where applicable. It serves as evidence of receipt similar to a Post Card, as described in MPEP 503.**

**New Applications Under 35 U.S.C. 111**

**If a new application is being filed and the application includes the necessary components for a filing date (see 37 CFR 1.53(b)-(d) and MPEP 506), a Filing Receipt (37 CFR 1.54) will be issued in due course and the date shown on this Acknowledgement Receipt will establish the filing date of the application.**

**National Stage of an International Application under 35 U.S.C. 371**

**If a timely submission to enter the national stage of an international application is compliant with the conditions of 35 U.S.C. 371 and other applicable requirements a Form PCT/DO/EO/903 indicating acceptance of the application as a national stage submission under 35 U.S.C. 371 will be issued in addition to the Filing Receipt, in due course.**

**New International Application Filed with the USPTO as a Receiving Office**

**If a new international application is being filed and the international application includes the necessary components for an international filing date (see PCT Article 11 and MPEP 1810), a Notification of the International Application Number and of the International Filing Date (Form PCT/RO/105) will be issued in due course, subject to prescriptions concerning national security, and the date shown on this Acknowledgement Receipt will establish the international filing date of the application.**



UNITED STATES PATENT AND TRADEMARK OFFICE

---

BEFORE THE PATENT TRIAL AND APPEAL BOARD

---

SAMSUNG ELECTRONICS CO. LTD., SAMSUNG ELECTRONICS  
AMERICA, INC., SAMSUNG TELECOMMUNICATIONS AMERICA,  
LLC, and SAMSUNG AUSTIN SEMICONDUCTOR, LLC,

Petitioner,

v.

REMBRANDT WIRELESS TECHNOLOGIES, LP,  
Patent Owner.

---

Case IPR2015-00114  
Patent 8,023,580 B2

---

Before JAMESON LEE, HOWARD B. BLANKENSHIP, and  
JUSTIN BUSCH, *Administrative Patent Judges*.

BLANKENSHIP, *Administrative Patent Judge*.

DECISION

Denial of Institution of *Inter Partes* Review  
*37 C.F.R. § 42.108*

Denial of Motion for Joinder  
*37 C.F.R. § 42.122*

## I. BACKGROUND

Samsung Electronics Co. Ltd., Samsung Electronics America, Inc., Samsung Telecommunications America, LLC, and Samsung Austin Semiconductor, LLC (collectively, “Petitioner”) filed a petition requesting *inter partes* review of claims 2, 19, 49, 52, 53, and 59 of U.S. Patent No. 8,023,580 B2 (“the ’580 patent”) (Ex. 1201) under 35 U.S.C. §§ 311–319. *See* Paper 1 (Petition, or “Pet.”). With the Petition, Petitioner filed a motion for joinder (Paper 3, “Mot. Join.”), seeking to join with *Samsung Electronics Co. v. Rembrandt Wireless Technologies, LP*, Case IPR2014-00518 (“IPR ’518”). Patent Owner Rembrandt Wireless Technologies, LP filed an opposition to the motion for joinder (Paper 8, “Opp.”) and a preliminary response (*see* Paper 10, “Prelim. Resp.”). Petitioner filed a reply to the motion for joinder. Paper 9 (“Reply”). We have jurisdiction under 35 U.S.C. § 314.

For the reasons that follow, we deny the motion for joinder and do not institute an *inter partes* review as to any of the challenged claims of the ’580 patent.

### *A. Related Proceedings*

According to Petitioner, the ’580 patent is involved in the following lawsuit: *Rembrandt Wireless Technologies, LP v. Samsung Electronics Co.*, No. 2:13-cv-00213 (E.D. Tex.). Pet. 1. The same parties and patent also are involved in *Samsung Electronics Co. v. Rembrandt Wireless Technologies, LP*, Case IPR2014-00514 (PTAB) (institution denied on Sept. 9, 2014); *Samsung Electronics Co. v. Rembrandt Wireless Technologies, LP*, Case IPR2014-00515 (PTAB) (institution denied on Sept. 9, 2014); *Samsung*

IPR2015-00114  
Patent 8,023,580 B2

*Electronics Co. v. Rembrandt Wireless Technologies, LP*, Case IPR2014-00518 (PTAB) (trial instituted on Sept. 23, 2014); and *Samsung Electronics Co. v. Rembrandt Wireless Technologies, LP*, Case IPR2015-00118 (PTAB).

*B. The '580 Patent*

The '580 Patent issued from an application filed August 19, 2009, which claimed priority under 35 U.S.C. § 120 through a chain of intervening applications to an application filed December 4, 1998, and which further claimed priority under 35 U.S.C. § 119 to a provisional application filed December 5, 1997.

The technical field of the patent relates to data communications and modulators/demodulators (modems), and in particular, to a data communications system in which modems use different types of modulation in a network. Ex. 1201, col. 1, ll. 19–23; col. 1, l. 56 – col. 2, l. 20.

*C. Illustrative Claim*

Claim 49, the sole independent claim that is challenged, is reproduced below.

49. A computer-readable storage medium having computer executable instructions stored therein that when executed by a processor control a master transceiver, said computer executable instructions, comprising:

- first logic configured to transmit first information in a first modulation method for communication;
- second logic configured to transmit a first sequence to notify of a change from said first modulation method to a second modulation method;
- third logic configured to transmit second information in said second modulation method; and

fourth logic configured to transmit a second sequence after the second information is transmitted, wherein the second sequence is transmitted in the first modulation method and indicates that communication has reverted to the first modulation method.

*D. Prior Art*

Boer            US 5,706,428            Jan. 6, 1998            (Ex. 1204)

*E. Asserted Ground of Unpatentability*

Petitioner asserts the following ground of unpatentability as to claims 2, 19, 49, 52, 53, and 59 (Pet. 3): obviousness under 35 U.S.C. § 103(a) over Admitted Prior Art (“APA”)<sup>1</sup> and Boer.

II. ANALYSIS

*A. Background*

In IPR ’518, Petitioner asserted that claims 2, 19, 49, 52, 53, and 59 of the ’580 patent were unpatentable over APA and Boer. IPR ’518, Paper 4 at 24–25, 27, 33–34, 36–44, 48–49, and 56–57. We did not institute an *inter partes* review of claims 2, 49, 52, 53, and 59 based on that ground in IPR ’518, and explained as follows:

Petitioner has not provided sufficient evidence or explanation in support of why the fact that Boer’s SIGNAL and SERVICE fields are always transmitted using DBPSK (the “first” modulation method) might demonstrate obviousness of the subject matter of claim 2. Petitioner has failed to show, in particular, how the SIGNAL and SERVICE fields might be

---

<sup>1</sup> In this proceeding and in IPR ’518, Petitioner asserts that Patent Owner made admissions in the ’580 patent disclosure and in the prosecution history of a parent application regarding prior art. Pet. 6–8; IPR ’518, Paper 4 at 5–7.

deemed, as alleged, to “indicate” that communication from the master to the slave has reverted to the first modulation method, as recited in claim 2.

Independent claim 49, from which challenged claims 52 and 53 depend, recites a similar limitation with respect to how a sequence “indicates” that communication has reverted to the first modulation method. Petitioner relies, again, on Boer’s description of header 218 being always transmitted using the “first” modulation method. Petitioner’s asserted ground of obviousness with respect to claim 49, thus, fails for the same reasons as that of claim 2.

Claim 59, which depends from independent claim 58, also recites a third sequence that is transmitted in the first modulation method that “indicates” communication from the master to the slave has reverted to the first modulation method. Petitioner submits, correctly, that Boer teaches that the SIGNAL and SERVICE fields in the header “indicate which modulation method is used to transmit DATA field 218.” “When Boer is combined with the APA, it could therefore indicate that communication from the master to the slave has reverted to the first modulation method.” Mr. Goodman repeats that “it could therefore indicate” that communication has reverted to the first modulation method and concludes, “[t]herefore, it is my opinion that claim 59 is obvious in view of the prior art.” Although it appears that Petitioner attempts to provide more explanation in its challenge of dependent claim 59, as compared with that of claim 2 or 49, we are not persuaded there is a reasonable likelihood that Petitioner would prevail in its challenge of any of claims 2, 49, and 59.

IPR ’518, slip op. at 14–15 (PTAB Sept. 23, 2014) (Paper16) (citations to record omitted). Nor did we institute an *inter partes* review of claim 19 on the obviousness ground over APA and Boer because Petitioner’s allegation that station 18 (Ex. 1204, col. 2, ll. 19–27; Fig. 1) can receive a “first” (DBPSK) modulation method transmission failed to demonstrate the obviousness of the *transceiver* which, according to claim 1, sends

transmissions using at least two types of modulation methods, further being configured to receive data in the first modulation method in accordance with the requirements of claim 19. IPR '518, slip op. at 16–17 (PTAB Sept. 23, 2014) (Paper 16).

We do not reach the merits of Petitioner's additional reasoning in the instant Petition as to why Petitioner asserts that the subject matter of claims 2, 19, 49, 52, 53, and 59 would have been obvious over the combination of APA and Boer. Instead, for the reasons discussed below, we exercise our discretion under 35 U.S.C. § 325(d) to deny institution of *inter partes* review in this proceeding.

#### *B. Principles of Law*

A petitioner is not entitled to multiple challenges against a patent:

In determining whether to institute or order a proceeding under . . . chapter 31, the Director may take into account whether, and reject the petition or request because, the same or substantially the same prior art or arguments previously were presented to the Office.

35 U.S.C. § 325(d) (titled: "MULTIPLE PROCEEDINGS"). Further, in construing our authority to institute *inter partes* review under 37 C.F.R. § 42.108, we are mindful of the guidance provided in § 42.1(b): "[37 C.F.R. § 42] shall be construed to secure the just, speedy, and inexpensive resolution of every proceeding."

#### *C. Discussion*

On its face, it is more efficient for the parties and the Board to address a matter once rather than twice. The sole difference between what Petitioner

presents in this proceeding and what Petitioner presented in IPR '518 with respect to the challenge of claims 2, 19, 49, 52, 53, and 59 of the '580 patent is that Petitioner now provides further reasoning in support of the same combination of prior art. Pet. 3; Mot. Join. 2–3; Opp. 1. Therefore, the “same prior art” was “previously presented” to the Board, with respect to the same claims. *See* 35 U.S.C. § 325(d).

Petitioner is requesting, essentially, a second chance to challenge the claims. We, however, are not persuaded that a second chance would help “secure the just, speedy, and inexpensive resolution of every proceeding.” 37 C.F.R. § 42.1(b). Permitting second chances in cases like this one ties up the Board’s limited resources; we must be mindful not only of this proceeding, but of “every proceeding.” *Id.*; *see also* *ZTE Corp. v. ContentGuard Holdings, Inc.*, Case IPR2013-00454, slip op. at 5–6 (PTAB Sept. 25, 2013) (Paper 12) (“The Board is concerned about encouraging, unnecessarily, the filing of petitions which are partially inadequate.”); *cf.* *Ariosa Diagnostics v. Isis Innovation, Ltd.*, Case IPR2013-00250, slip op. at 2, 4 (PTAB Sept. 8, 2013) (Paper 25) (granting joinder when a new product was launched, leading to a threat of new assertions of infringement); *Microsoft Corp. v. Proxyconn, Inc.*, Case IPR2013-00109, slip op. at 3 (PTAB Feb. 25, 2014) (Paper 15) (granting joinder when additional claims had been asserted against petitioner in concurrent district court litigation).

In this proceeding, however, we are not apprised of a reason that merits a second chance. Petitioner simply presents arguments now that it could have made in IPR '518, had it merely chosen to do so. In view of the foregoing, and especially in light of the fact that, barring joinder, this petition is time-barred under 35 U.S.C. § 315(b), we exercise our discretion

IPR2015-00114  
Patent 8,023,580 B2

under 35 U.S.C. § 325(d) to deny the Petition, because it presents merely “the same or substantially the same prior art or arguments” presented to us in IPR ’518. As a consequence, Petitioner’s motion for joinder is dismissed as moot.

### III. ORDER

In view of the foregoing, it is

ORDERED that Petitioner’s motion for joinder is *dismissed*; and

FURTHER ORDERED that no trial is instituted.



IPR2015-00114  
Patent 8,023,580 B2

PETITIONER:

Jeffrey A. Miller  
Daniel G. Cardy  
DICKSTEIN SHAPIRO LLP  
millerj@dicksteinshapiro.com  
cardyd@dicksteinshapiro.com

PATENT OWNER:

Thomas Engellenner  
Reza Mollaaghababa  
Lana Gladstein  
PEPPER HAMILTON LLP  
engellenert@pepperlaw.com  
mollaaghababar@pepperlaw.com  
gladsteinl@pepperlaw.com

UNITED STATES PATENT AND TRADEMARK OFFICE

---

BEFORE THE PATENT TRIAL AND APPEAL BOARD

---

SAMSUNG ELECTRONICS CO., LTD.,  
SAMSUNG ELECTRONICS AMERICA, INC.,  
SAMSUNG TELECOMMUNICATIONS AMERICA, LLC, and  
SAMSUNG AUSTIN SEMICONDUCTOR, LLC,  
Petitioner,

v.

REMBRANDT WIRELESS TECHNOLOGIES, LP,  
Patent Owner.

---

Case IPR2015-00118  
Patent 8,023,580 B2

Before JAMESON LEE, HOWARD B. BLANKENSHIP, and  
JUSTIN BUSCH, *Administrative Patent Judges*.

BUSCH, *Administrative Patent Judge*.

DECISION

Denial of Institution of *Inter Partes* Review  
*37 C.F.R. § 42.108*

Denial of Motion for Joinder  
*37 C.F.R. § 42.122*

## I. INTRODUCTION

Petitioner filed a Petition (Paper 1, “Pet.”) requesting an *inter partes* review of claims 23, 25, 29, 30, and 41 of U.S. Patent No. 8,023,580 B2 (Ex. 1301, “the ’580 patent”). Petitioner also timely filed a motion requesting joinder (Paper 3, “Mot. Join.”) of this proceeding to IPR2014-00519, in which we instituted an *inter partes* review of claims 32, 34, 38, 40, 43, 44, and 47 of the ’580 patent, but denied review of claims 23, 25, 29, 30, and 41. Mot. Join. 2. Patent Owner filed a Preliminary Response (Paper 10, “Prelim. Resp.”) and an Opposition to the Motion for Joinder (Paper 8, “Opp.”). Petitioner filed a Reply (Paper 9, “Reply”) to Patent Owner’s Opposition. We have jurisdiction under 35 U.S.C. § 314.

We have reviewed the aforementioned papers. For the reasons given below, we do not institute an *inter partes* review and we deny Petitioner’s Motion for Joinder.

### A. Related Matters

Petitioner indicates that the ’580 patent was asserted against Petitioner in *Rembrandt Wireless Technologies, LP v. Samsung Electronics Co.*, No. 2:13-cv-00213 (E.D. Tex.). Pet. 1.

Petitioner seeks to join this proceeding to *Samsung Electronics Co. v. Rembrandt Wireless Technologies, LP*, Case IPR2014-00519 (PTAB) (trial instituted September 23, 2014) (hereinafter “IPR-519”), in which Petitioner challenged claims 23, 25, 29, 30, 32, 34, 38, 40, 41, 43, 44, and 47 of the ’580 patent, but no trial was instituted with respect to claims 23, 25, 29, 30, and 41. Pet. 1. The same parties and patent also are involved in *Samsung Electronics Co. v. Rembrandt Wireless Technologies, LP*, Case IPR2014-00514 (PTAB) (institution denied on Sept. 9, 2014); *Samsung Electronics Co. v. Rembrandt Wireless*

IPR2015-00118  
US 8,023,580 B2

*Technologies, LP*, Case IPR2014-00515 (PTAB) (institution denied on Sept. 9, 2014); *Samsung Electronics Co. v. Rembrandt Wireless Technologies, LP*, Case IPR2014-00518 (PTAB) (trial instituted on Sept. 23, 2014); and *Samsung Electronics Co. v. Rembrandt Wireless Technologies, LP*, Case IPR2015-00114 (PTAB). *Id.*

*B. The '580 Patent (Ex. 1301)*

The specification of the '580 patent describes “a data communications system in which a plurality of modulation methods are used to facilitate communication among a plurality of modem types.” Ex. 1301, 1:21–23. The '580 patent explains that the invention addresses the problem that conventional modem pairs can communicate successfully only when the modems use compatible modulation methods. *Id.* at 1:27–30, 1:45–47.

Of the challenged claims, only claim 23 is independent and is reproduced as follows:

23. A communications device, comprising:  
a processor; and  
a memory having stored therein executable instructions for execution by the processor, wherein the executable instructions direct transmission of a first data with a first modulation method followed by a second data with a second modulation method, wherein the first modulation method is different than the second modulation method, wherein the first data comprises an indication of an impending change from the first modulation method to the second modulation method, wherein the executable instructions direct transmission of a third data with the first modulation method after the second data, and wherein the third data indicates that communication has reverted to the first modulation method.

*C. The Asserted Grounds & Prior Art*

Petitioner asserts the following grounds of unpatentability under 35 U.S.C. § 103:

Evidence	Basis	Challenged Claim(s)
Boer <sup>1</sup>	§ 103(a)	23, 25, 30, and 41
Boer and APA <sup>2</sup>	§ 103(a)	29

II. DISCUSSION

*A. Background*

In IPR-519, Petitioner asserted that claims 23, 25, 30, and 41 of the '580 patent are unpatentable as anticipated by Boer, that claims 23, 25, and 30 are unpatentable as obvious over Boer, and that claim 29 is unpatentable as obvious over Boer and APA. Pet. 1. We did not institute an *inter partes* review of claims 23, 25, 29, 30, and 41 as anticipated by Boer, and explained as follows<sup>3</sup>:

Boer's system may be capable of transmitting a first message's data field using either DQPSK or PPM/DQPSK followed, a subsequent message's header field using DBPSK, where the subsequent message's

---

<sup>1</sup> U.S. Patent No. 5,706,428 (filed Mar. 14, 1996, issued Jan. 6, 1998) (Ex. 1304) ("Boer").

<sup>2</sup> Petitioner alleges that Figures 1 and 2 of the '580 patent and the accompanying descriptions are admitted prior art. Pet. 37–38 (citing Ex. 1301, Figs. 1, 2, 2:16–20, 3:40–46) ("APA").

<sup>3</sup> Institution of *inter partes* review with respect to the obviousness of claims 25 and 30 in view of Boer and claim 29 in view of Boer and APA was denied because claims 25, 29, and 30 depend from, and incorporate the limitations of, claim 23. Further, with respect to claim 29, Petitioner did not show that APA cures the deficiencies identified with respect to claim 23.

header field indicates that the subsequent message's data field will be transmitted using DBPSK. However, the Petition has not established that the specific series of transmissions as recited in independent claim 23 is explicitly disclosed by or necessarily present in Boer.

IPR-519, Dec. Inst. 8 (Paper 16); *id.* at 12–13.

We did not institute an *inter partes* review of claims 23, 25, and 30 as obvious in view of Boer, and explained as follows:

Petitioner presents no other argument regarding what aspects of Boer would need to be modified in order to meet the recited limitations and why. The underlying factual inquiries necessary for a proper obviousness analysis, as set forth in *Graham v. John Deere Co.*, 383 U.S. 1, 17–18 (1966), have not been discussed sufficiently. In particular, Petitioner has not submitted persuasive argument or evidence curing the deficiency identified with respect to its anticipation challenge.

*Id.* at 9.

Petitioner argues in the Petition in the instant proceeding that Boer explicitly teaches the limitations we found to be missing from Petitioner's challenges to claims 23, 25, 29, 30, and 41, as explained in our institution decision in IPR-519. Pet. 11–12. In this proceeding, notwithstanding Petitioner's arguments that Boer explicitly teaches the limitations, Petitioner presents challenges arguing why the limitations identified as not having been shown sufficiently as anticipated by Boer would have been obvious in view of Boer. Pet. 12–37. We do not reach the merits of Petitioner's new argument that the previously insufficiently shown limitations would have been obvious. Instead, for the reasons discussed below, we exercise our discretion under 35 U.S.C. § 325(d) to deny institution of *inter partes* review in this proceeding.

*B. Relevant Law*

A petitioner is not entitled to multiple challenges against a patent:

In determining whether to institute or order a proceeding under . . . chapter 31, the Director may take into account whether, and reject the petition or request because, the same or substantially the same prior art or arguments previously were presented to the Office.

35 U.S.C. § 325(d) (titled: “MULTIPLE PROCEEDINGS”). Further, in construing our authority to institute *inter partes* review under 37 C.F.R. § 42.108, we are mindful of the guidance provided in § 42.1(b): “[37 C.F.R. § 42] shall be construed to secure the just, speedy, and inexpensive resolution of every proceeding.”

*C. Analysis*

On its face, it is more efficient for the parties and the Board to address a matter once rather than twice. The sole difference between what Petitioner presents in this proceeding and what Petitioner presented in IPR-519, with respect to the challenge of claims 23, 25, 29, 30, and 41 of the '580 patent, is the presence of additional reasoning to support the assertion of unpatentability over the same prior art. Mot. Join. 1, 4; Opp. 1, 3, 9–10.

Petitioner is requesting, essentially, a second chance to address claims 23, 25, 29, 30, and 41. We, however, are not persuaded that a second chance would help “secure the just, speedy, and inexpensive resolution of every proceeding.” 37 C.F.R. § 42.1(b). Permitting second chances without constraint ties up the Board’s limited resources; we must be mindful not only of this proceeding, but of “every proceeding.” *Id.*; see also *ZTE Corp. v. ContentGuard Holdings, Inc.*, Case IPR2013-00454, slip op. at 5–6 (PTAB Sept. 25, 2013) (Paper 12) (“The Board is concerned about encouraging, unnecessarily, the filing of petitions which are partially inadequate.”). Accordingly, we look to see if this case presents a

IPR2015-00118  
US 8,023,580 B2

circumstance that merits a second chance. *Cf. Ariosa Diagnostics v. Isis Innovation, Ltd.*, Case IPR2013-00250, slip op. at 2, 4 (PTAB Sept. 8, 2013) (Paper 25) (granting joinder when a new product was launched, leading to a threat of new assertions of infringement); *Microsoft Corp. v. Proxycorr, Inc.*, Case IPR2013-00109, slip op. at 3 (PTAB Feb. 25, 2014) (Paper 15) (additional claims had been asserted against Petitioner in concurrent district court litigation).

In this proceeding, however, we are not apprised of a reason that merits a second chance. Petitioner simply presents an argument now that it could have made in IPR-519, had it merely chosen to do so. In view of the above, and especially in light of the fact that, barring joinder, this Petition is time-barred under 35 U.S.C. § 315(b), we exercise our discretion under 35 U.S.C. § 325(d) to deny the Petition, because it presents merely “the same or substantially the same prior art or arguments” presented to us in IPR-519. As a consequence, Petitioner’s motion for joinder is dismissed as moot.

### III. ORDER

In view of the foregoing, it is hereby:

ORDERED that no trial is instituted; and

FURTHER ORDERED that Petitioner’s motion for joinder is *dismissed*.



IPR2015-00118  
US 8,023,580 B2

PETITIONER:

Jeffrey Miller  
[millerj@dicksteinshapiro.com](mailto:millerj@dicksteinshapiro.com)

Daniel Cardy  
[cardyd@dicksteinshapiro.com](mailto:cardyd@dicksteinshapiro.com)

PATENT OWNER:

Thomas Engellenner  
[engellennert@pepperlaw.com](mailto:engellennert@pepperlaw.com)

Reza Mollaaghababa  
[mollaaghababar@pepperlaw.com](mailto:mollaaghababar@pepperlaw.com)

Lana Gladstein  
[gladsteinl@pepperlaw.com](mailto:gladsteinl@pepperlaw.com)

UNITED STATES PATENT AND TRADEMARK OFFICE

---

BEFORE THE PATENT TRIAL AND APPEAL BOARD

---

SAMSUNG ELECTRONICS CO. LTD., SAMSUNG ELECTRONICS  
AMERICA, INC., SAMSUNG TELECOMMUNICATIONS AMERICA,  
LLC, and SAMSUNG AUSTIN SEMICONDUCTOR, LLC,  
Petitioner,

v.

REMBRANDT WIRELESS TECHNOLOGIES, LP,  
Patent Owner.

---

Case IPR2014-00518  
Patent 8,023,580 B2

---

Before JAMESON LEE, HOWARD B. BLANKENSHIP, and  
JUSTIN BUSCH, *Administrative Patent Judges*.

BLANKENSHIP, *Administrative Patent Judge*.

FINAL WRITTEN DECISION  
*35 U.S.C. § 318(a) and 37 C.F.R. § 42.73*

## I. BACKGROUND

Samsung Electronics Co. Ltd., Samsung Electronics America, Inc., Samsung Telecommunications America, LLC, and Samsung Austin Semiconductor, LLC (collectively, “Petitioner”) filed a request for *inter partes* review of claims 1, 2, 4, 5, 10, 13, 19–22, 49, 52–54, 57–59, 61, 62, 66, 70, and 76–79 of U.S. Patent No. 8,023,580 B2 (“the ’580 patent,” Ex. 1201) under 35 U.S.C. §§ 311–319. Paper 4 (“Petition” or “Pet.”) The Board instituted an *inter partes* review of claims 1, 4, 5, 10, 13, 20–22, 54, 57, 58, 61, 62, 66, 70, and 76–79 on an asserted ground of unpatentability for obviousness. Paper 16 (“Dec. on Inst.”).

Subsequent to institution, Patent Owner Rembrandt Wireless Technologies, LP, filed a patent owner response (Paper 25, “PO Resp.”). Petitioner filed a reply to the Patent Owner Response (Paper 32, “Pet. Reply”).

Oral hearing was held on April 24, 2015.<sup>1</sup>

The Board has jurisdiction under 35 U.S.C. § 6(c). This final written decision is issued pursuant to 35 U.S.C. § 318(a) and 37 C.F.R. § 42.73.

For the reasons that follow, we determine that Petitioner has shown by a preponderance of the evidence that claims 1, 4, 5, 10, 13, 20–22, 54, 57, 58, 61, 62, 66, 70, and 76–79 of the ’580 patent are unpatentable.

### *A. Related Proceedings*

According to Petitioner, the ’580 patent is involved in the following lawsuit: *Rembrandt Wireless Technologies, LP v. Samsung Electronics Co.*, No. 2:13-cv-00213 (E.D. Tex. 2013). Pet. 2. The ’580 patent also has been

---

<sup>1</sup> The record includes a transcript of the oral hearing. Paper 46 (“Tr.”).

IPR2014-00518  
Patent 8,023,580 B2

challenged in the following cases: *Samsung Electronics Co. v. Rembrandt Wireless Technologies, LP*, IPR2014-00514 (not instituted); *Samsung Electronics Co. v. Rembrandt Wireless Technologies, LP*, IPR2014-00515 (not instituted); and *Samsung Electronics Co. v. Rembrandt Wireless Technologies, LP*, IPR2014-00519 (final decision issuing concurrently).

### *B. The '580 Patent*

The '580 patent issued from an application filed August 19, 2009, which claimed priority under 35 U.S.C. § 120 through a chain of intervening applications to an application filed December 4, 1998, and which further claimed priority under 35 U.S.C. § 119 to a provisional application filed December 5, 1997.

The technical field of the patent relates to data communications and modulators/demodulators (modems) and in particular to a data communications system in which a plurality of modems uses different types of modulation in a network. Ex. 1201, col. 1, ll. 19–23; col. 1, l. 56 – col. 2, l. 20.

### *C. Illustrative Claim*

1. A communication device capable of communicating according to a master/slave relationship in which a slave communication from a slave to a master occurs in response to a master communication from the master to the slave, the device comprising:

a transceiver, in the role of the master according to the master/slave relationship, for sending at least transmissions modulated using at least two types of modulation methods, wherein the at least two types of modulation methods comprise

a first modulation method and a second modulation method, wherein the second modulation method is of a different type than the first modulation method, wherein each transmission comprises a group of transmission sequences, wherein each group of transmission sequences is structured with at least a first portion and a payload portion wherein first information in the first portion indicates at least which of the first modulation method and the second modulation method is used for modulating second information in the payload portion, wherein at least one group of transmission sequences is addressed for an intended destination of the payload portion, and wherein for the at least one group of transmission sequences:

the first information for said at least one group of transmission sequences comprises a first sequence, in the first portion and modulated according to the first modulation method, wherein the first sequence indicates an impending change from the first modulation method to the second modulation method, and

the second information for said at least one group of transmission sequences comprises a second sequence that is modulated according to the second modulation method, wherein the second sequence is transmitted after the first sequence.

*D. Prior Art*

Boer            US 5,706,428            Jan. 6, 1998            (Ex. 1204)

*E. Asserted Ground of Unpatentability*

The Board instituted *inter partes* review on the following asserted ground of unpatentability under 35 U.S.C. § 103(a) (Dec. on Inst. 17): claims 1, 4, 5, 10, 13, 20–22, 54, 57, 58, 61, 62, 66, 70, and 76–79 of the '580 patent on the ground of obviousness over Admitted Prior Art (“APA”) and Boer.

## II. ANALYSIS

### A. Claim Interpretation

In an *inter partes* review, the Board construes claim terms in an unexpired patent using their broadest reasonable construction in light of the specification of the patent in which they appear. 37 C.F.R. § 42.100(b); *In re Cuozzo Speed Techs., LLC*, 793 F.3d 1268, 1275–79 (Fed. Cir. 2015). The claim language should be read in light of the specification as it would be interpreted by one of ordinary skill in the art. *In re Am. Acad. of Sci. Tech. Ctr.*, 367 F.3d 1359, 1364 (Fed. Cir. 2004). The Office must apply the broadest reasonable meaning to the claim language, taking into account any definitions presented in the specification. *Id.* (citing *In re Bass*, 314 F.3d 575, 577 (Fed. Cir. 2002)). The “ordinary and customary meaning” is that which the term would have to a person of ordinary skill in the art in question. *In re Translogic Tech., Inc.*, 504 F.3d 1249, 1257 (Fed. Cir. 2007).

#### 1. Modulation Methods

Illustrative claim 1 recites a transceiver capable of transmitting using at least two types of modulation methods, “wherein the at least two types of modulation methods comprise a first modulation method and a second modulation method, wherein the second modulation method is of a different type than the first modulation method . . . .”

Petitioner submits that the ordinary meaning of “modulation” is “[t]he process by which some characteristic of a carrier is varied in accordance with a modulating wave.” Pet. 11 (quoting Ex. 1206, 3 (technical dictionary)). Patent Owner submits that “modulation method” is

generally recognized in the pertinent art to mean “a technique for varying one or more characteristics of a carrier wave in a predetermined manner to convey information.” PO Resp. 9. Patent Owner submits further, and we agree, that there appears to be no significant difference between these two proffered constructions of “modulation.” *Id.* at 11.

Later in its Patent Owner Response, however, Patent Owner advocates a narrower definition for “modulation method” for the purpose of addressing the prior art. In particular, Patent Owner submits that the only three characteristics of a carrier wave are frequency, phase, and amplitude and, thus, “modulation” is limited to varying one or more of the frequency, phase, and amplitude of the carrier wave. *Id.* at 12–13. Patent Owner relies on the Declaration of Dr. Christopher R. Jones (Ex. 2214 ¶ 40). Dr. Jones, in turn, relies on a definition in one of several technical dictionaries that have been provided by Patent Owner. Ex. 2214 ¶ 39. In the particular technical dictionary upon which Dr. Jones relies,<sup>2</sup> two of the six definitions of “modulation” use the terms amplitude, frequency, and phase. Ex. 2215, 3. The entry contains broader definitions for “modulation,” as, for example, the first definition, which states that modulation is the process of varying some characteristic of a carrier wave, whereby the carrier wave can be a direct current, an alternating current, or “a series of regularly repeating, uniform pulses called a pulse chain.” *Id.*

Patent Owner does not point to anything in the ’580 patent’s disclosure that would limit the definition of “modulation” to varying the amplitude, frequency, or phase of the carrier wave. Our reviewing court has “cautioned against relying on dictionary definitions at the expense of a fair

---

<sup>2</sup> Rudolf F. Graf, MODERN DICTIONARY OF ELECTRONICS, 6th ed. (1997).

reading of the claims, which must be understood in light of the specification.” *Interval Licensing LLC v. AOL, Inc.*, 766 F.3d 1364, 1377 (Fed. Cir. 2014). We, therefore, interpret “modulation” in accordance with its customary and ordinary meaning as the process by which some characteristic of a carrier is varied in accordance with a modulating wave.

## 2. *Types of Modulation Methods*

As we have noted, the claims recite “types” of modulation methods. Petitioner and Patent Owner disagree with respect to the meaning of a “type” of modulation method. Patent Owner submits that the broadest reasonable interpretation of “types” of modulation methods does not extend to modulation methods that are known merely to be incompatible with each other, but is limited to different “families” of modulation techniques, e.g., the FSK (frequency shift keying) “family” of modulation methods and the QAM (quadrature amplitude modulation) “family” of modulation methods. PO Resp. 11–12. Petitioner, on the other hand, contends that “different PSK [phase shift keying] modulation methods” may be considered as different “types” of modulation, with the “different PSK modulation methods” within the same (PSK) “family” being incompatible with each other. Pet. 12.

Patent Owner contends that a “special definition” was provided during prosecution of the ’580 patent, which defined the term different “types” of modulation to mean different “families” of modulation. PO Resp. 11–12. At the outset, we agree with Petitioner (Pet. Reply 10) to the extent that prosecution history is entitled to little weight under the broadest reasonable interpretation standard. *See Tempo Lighting, Inc. v. Tivoli, LLC*, 742 F.3d 973, 978 (Fed. Cir. 2014) (“This court also observes that the PTO is under



no obligation to accept a claim construction proffered as a prosecution history disclaimer, which generally only binds the patent owner.”). In any event, Patent Owner relies on the following statements during prosecution for the asserted “special definition”:

Applicant thanks [the Examiner] for the indication that claims 1-18, and 37-57 are allowed (office action, p. 7). Applicant has further amended claims 1-2, 9-15, 18, 37-38, and 45-46 with additional recitations to more precisely claim the subject-matter. For example, the language of independent claim 1 has been clarified to refer to two *types* of modulation methods, *i.e.*, different families of modulation techniques, such as the FSK family of modulation methods and the QAM family of modulation methods.

Ex. 1209, 20 (Reply Pursuant to 37 CFR § 1.111).

As made plain in the above remarks, the claim amendments with respect to two “types” of modulation methods were not made in response to a rejection, as the relevant claims had been allowed. *Cf. Tempo Lighting*, 742 F.3d at 978 (“[I]n this instance, the PTO itself requested Tivoli rewrite the ‘non-photoluminescent’ limitation in positive terms. Tivoli complied, and then supplied clarification about the meaning of the ‘inert to light.’”). Nor do the above remarks explain what a “family” might be, or why FSK is considered to be a member of one “family” and QAM a member of another “family.” “Although an inventor is indeed free to define the specific terms used to describe his or her invention, this must be done with reasonable clarity, deliberateness, and precision.” *In re Paulsen*, 30 F.3d 1475, 1480 (Fed. Cir. 1994). Patent Owner’s purported “definition” is anything but clear or precise. Further, the only modulation methods named in the text of the ’580 patent are QAM, carrierless amplitude and phase (CAP)

modulation,<sup>3</sup> and discrete multitone (DMT) modulation, each of which the patent calls “high performance modulation.” *See, e.g.*, Ex. 1201, col. 2, ll. 1–5.

Patent Owner provides, as an exhibit, Provisional Application No. 60/067,562 (Ex. 2201), which the ’580 patent purports to incorporate by reference (Ex. 1201, col. 1, ll. 8–15). That provisional distinguishes between “high performance modulation, such as QAM, CAP, or DMT,” which are optimized for high performance, and “low performance modulation, such as FSK, PAM or DSB,” which may be implemented in much less expensive devices. Ex. 2201, 3. An objective reading of the above-noted remarks during prosecution suggests that, contrary to Patent Owner’s arguments, the “different families of modulation techniques” refer to high performance modulation (such as QAM) and low performance modulation (such as FSK). The prosecution history is, at best, ambiguous. “It is inappropriate to limit a broad definition of a claim term based on prosecution history that is itself ambiguous.” *Inverness Med. Switz. GmbH v. Warner Lambert Co.*, 309 F.3d 1373, 1382 (Fed. Cir. 2002).

Moreover, Patent Owner’s proffered construction (*e.g.*, PO Resp. 13) of “types” of modulation methods being based on “one or more” of the carrier wave’s frequency, phase, and amplitude “families” is, itself, ambiguous. We reproduce the following exchange during oral argument:

JUDGE LEE: How do you summarize your position?  
What is the definition of different family?

---

<sup>3</sup> According to Patent Owner, the patent contains a typographical error in that “[c]arrier” should be “[c]arrierless.” PO Resp. 10 n.3.

MR. MOLLAAGHABABA: Okay. I believe these three characteristics, phase, amplitude and frequency of the carrier wave, define these three families.

Now, if two methods are using the same characteristic to modulate the wave, then they are not different types. I mean, DBPSK and DQPSK, they both use the phase, that characteristic of the carrier wave to modulate and convey information.

JUDGE LEE: Okay. So phase is one family, amplitude is one, and frequency is another. So those are broad categories.

MR. MOLLAAGHABABA: Yes.

JUDGE LEE: So you can only have three types then.

MR. MOLLAAGHABABA: But you can have situations where the modulation can belong to two categories.

I mean, there are some intersections. QAM modulates both amplitude and phase.

JUDGE LEE: So to which family would they belong?

MR. MOLLAAGHABABA: Well, they are part of both families. I mean, they belong to two -- both families. There is some intersections where some modulation techniques use more than one characteristic. They use two characteristics.

JUDGE LEE: Then are they of different types? If there is just only partial overlap, are they still different types, or is it the same type because they also share something in common?

MR. MOLLAAGHABABA: Yes, our contention is that they are not of different types. They are different in the sense that they are different methods, like QAM and PSK, but they share a family so, therefore, they are not different types. They share the family for both.

Tr. 88:8–89:17. Thus, according to counsel for Patent Owner, two modulation methods that are different in one characteristic but the same in another, e.g., one varying phase and amplitude and the other varying frequency and amplitude, would be regarded as belonging in the same family. Such an understanding of the classification or categorization of “family” in case of partial overlap was not a part of any representation during prosecution history, but presented for the first time by counsel for Patent Owner during oral argument. It reflects ambiguity in the construction proposed by Patent Owner.

The ’580 patent describes Type A and Type B modulation methods (and tributary modems, or “tribs”), but does not associate directly any particular modulation method with a Type A or a Type B method (or “trib”). *See, e.g.*, Ex. 1201, col. 5, l. 23 – col. 7, l. 3. The provisional application, however, associates lower-cost FSK modems with Type B “tribs.” Ex. 2201, 5; *see also* ’580 patent —

While it is possible to use high performance tribs running state of the art modulation methods such as QAM, CAP, or DMT to implement both the high and low data rate applications, significant cost savings can be achieved if lower cost tribs using low performance modulation methods are used to implement the lower data rate applications.

Ex. 1201, col. 5, ll. 17–22.

Further, the ’580 patent does not draw distinctions between “families” of modulation techniques directed to differences in modulation with respect to amplitude, phase, or frequency. Rather, the ’580 patent draws distinctions between relatively expensive high performance techniques and relatively inexpensive low performance techniques. The ’580 patent attempts to

remedy the asserted deficiency in the prior art that all modems in a system must use a single modulation method, and thus must all be high-performance modems, with the high-performance, relatively expensive modems merely lowering the data rate for lower data-rate applications. As the '580 patent explains:

All users in the system will generally have to be equipped with a high performance modem to ensure modulation compatibility. These state of the art modems are then run at their lowest data rates for those applications that require relatively low data throughput performance. The replacement of inexpensive modems with much more expensive state of the art devices due to modulation compatibility imposes a substantial cost that is unnecessary in terms of the service and performance to be delivered to the end user.

Ex. 1201, col. 2, ll. 8–15.

Further, the '580 patent refers to an objective of using multiple modulation methods to facilitate communication among a plurality of modems in a network, which have heretofore been “incompatible.” *Id.* at col. 2, ll. 16–20.

In view of the foregoing, we do not interpret a “type” of modulation method as referring to some vague or undefined “family” of modulation methods. We interpret different “types” of modulation methods as modulation methods that are incompatible with one another. Thus, contrary to Patent Owner’s construction, two modulation methods that are based on varying the same one of the frequency, amplitude, or phase of the carrier wave may be different “types” of modulation methods.

*B. Prior Art*

*1. Admitted Prior Art*

Petitioner contends that the '580 patent's disclosed multipoint communication systems (or master/slave systems), depicted in Figures 1 and 2 and described in column 3, line 40 through column 4, line 50, contains material that may be used as prior art against the patent under 35 U.S.C. § 103(a). We agree. Figure 1 of the patent is labeled as "Prior Art." Pet. 6; Ex. 1201, Fig. 1. Further, the '580 patent's specification refers to "prior art" multipoint communication system 22 comprising master modem or transceiver 24, which communicates with a plurality of tributary modems ("tribs") or transceivers 26. Pet. 6; Ex. 1201, col. 3, ll. 40–44. Further, the '580 patent describes Figure 2 as illustrating the operation of the multipoint communication system of (prior art) Figure 1. Pet. 7; Ex. 1201, col. 3, ll. 9–10.

*2. Boer*

Boer describes a wireless LAN that includes first stations that operate at 1 or 2 Mbps (Megabits per second) data rate and second stations that operate at 1, 2, 5, or 8 Mbps data rate. Ex. 1204, Abstract.

Figure 1 of Boer is reproduced below.

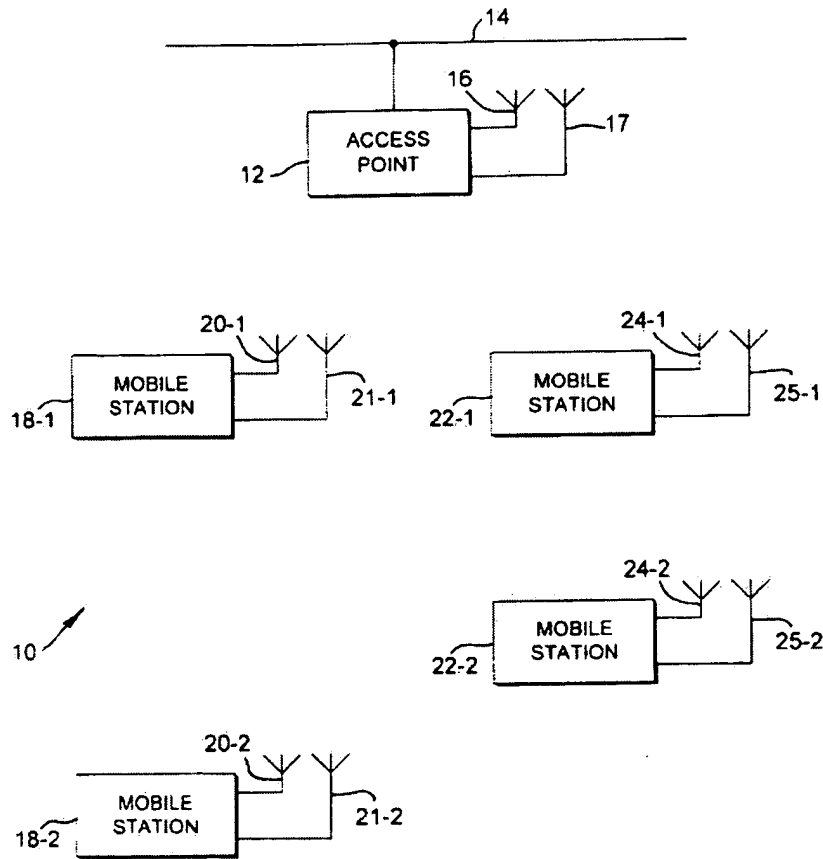


FIG. 1

Figure 1 is said to be a block diagram of a wireless LAN embodying Boer's invention. Ex. 1204, col. 1, ll. 53-54. LAN 10 includes access point 12, serving as a base station. The network includes mobile stations 18-1 and 18-2 that are capable of transmitting and receiving messages at a data rate of 1 or 2 Mbps using DSSS (direct sequence spread spectrum) coding. When operating at 1 Mbps, a station uses DBPSK (differential binary phase shift keying) modulation. When operating at 2 Mbps, a station uses DQPSK (differential quadrature phase shift keying) modulation. *Id.* at col. 2, ll. 6-

27. Mobile stations 22-1 and 22-2 are capable of operating at the 1 and 2 Mbps data rates using the same modulation and coding as stations 181 and 182. In addition, stations 22-1 and 22-2 can operate at 5 and 8 Mbps data rates using PPM/DQPSK (pulse position modulation–differential quadrature phase shift keying) in combination with the DSSS coding. *Id.* at col. 2, ll. 34–44.

*C. Claims 1, 4, 5, 10, 13, 20–22, 54, 57, 58, 61, 62, 66, 70,  
and 76–79 – APA and Boer*

*1. Asserted Ground*

Petitioner applies the teachings of the APA and Boer to demonstrate obviousness of the subject matter of illustrative claim 1, relying on APA for teaching of master/slave communication systems. Pet. 19–24, 28–33 (claim chart). Petitioner submits that a person having ordinary skill in the art would have been motivated to combine Boer with APA, referring to the Declaration of Dr. David Goodman (Ex. 1220 ¶¶ 102–104). *Id.* at 18.

Dr. Goodman testifies that polled multiport master/slave communications systems were well known to those of ordinary skill in the art for simplicity and determinacy, referring to Exhibit 1218. Ex. 1220 ¶ 103. Petitioner submits Exhibit 1218 (“Upender”) as a November 1994 publication that compares various strengths and weaknesses for communication protocols for embedded systems. Ex. 1218, 7. The document states that polling is one of the more popular protocols for embedded systems “because of its simplicity and determinacy.” *Id.* In that protocol, a centrally assigned master periodically sends a polling message to the slave nodes, giving them explicit permission to transmit on the network.



*Id.* The protocol “is ideal for a centralized data-acquisition system where peer-to-peer communication and global prioritization are not required.” *Id.*

## 2. Motivation to Combine

Patent Owner in its Response argues that Upender does not reflect a proper motivation from the prior art for the proffered combination of Boer and APA. Patent Owner submits a Declaration from a co-author of Upender to show that the article did not suggest the use of a master/slave communication system. Ex. 2208 (Declaration of Dr. Philip Koopman).

We have considered Patent Owner’s arguments and evidence but find that the clear teachings in Upender are not diminished or rebutted. Upender investigates tradeoffs in different communication protocols. The article concludes that CSMA/CA (carrier sense multiple access with collision avoidance), or RCSMA (reservation CSMA), is a good choice for some embedded systems. Ex. 1218, 10–11. The article also indicates that polling may not provide sufficient flexibility for “advanced systems,” classifying polling as “simple,” but noting that the discussion of the different protocol strengths and weaknesses “should allow you to select the best protocol to match your needs.” *Id.* In fact, Dr. Koopman admits that there are some systems for which master/slave is a better match for the design requirements. Pet. Reply 8; Ex. 1238, 39:2–20.

That Upender may identify some advantages of CSMA/CA over a master/slave protocol is not a “teaching away” from the master/slave protocol. Upender teaches that master/slave protocols were widely used and a good choice for simple systems. *See In re Gurley*, 27 F.3d 551, 553 (Fed. Cir. 1994) (“[A] person seeking to improve the art of flexible circuit boards,

on learning from [a reference] that epoxy was inferior to polyester-imide resins, might well be led to search beyond epoxy for improved products. However, [the reference] also teaches that epoxy is usable and has been used for Gurley's purpose.”).

Patent Owner's position appears to be that the prior art teaches that one and only one communication protocol should ever be used, which is directly contrary to the clear teachings of Upender. In view of Upender, one of ordinary skill in the art would have found it obvious to use a different prior art communication protocol (e.g., a simpler protocol) when using multiple data rates as described by Boer.

Further, we agree with Petitioner that Boer does not describe CSMA as central to an alleged goal of seeking a “reduction of overhead-in-time per transmission,” but relates that reduction to the use of short acknowledgment (ACK) messages. PO Resp. 40–41; Pet. Reply 8; Ex. 1204, col. 8, ll. 16–29.

Patent Owner submits that Dr. Goodman's Declaration (Ex. 1220) is unreliable because it is unclear what level of skill it attributes to the ordinary artisan. PO Resp. 32. The alleged lack of clarity, however, does not affect the outcome. We note that specifying the level of ordinary skill in terms of an academic degree in a field of study and the number of years of practical working experience is generally unhelpful, as a practical matter, because it does not convey whether one with ordinary skill in the art would have been aware of anything specific or particular. Patent Owner has not directed us to evidence establishing what someone who has earned a certain degree or who has a certain number of years of experience necessarily knows. It is not always necessary, however, to have an express proposition on the level of ordinary skill in the art. The level of ordinary skill in the art may be

reflected by the prior art of record. *See Okajima v. Bourdeau*, 261 F.3d 1350, 1355 (Fed. Cir. 2001); *In re GPAC Inc.*, 57 F.3d 1573, 1579 (Fed. Cir. 1995); *In re Oelrich*, 579 F.2d 86, 91 (CCPA 1978).

We agree with Patent Owner to the extent that one of skill in the art would not consider using a CSMA/CA protocol in a master/slave configuration. PO Resp. 43–44. That combination, however, is not contemplated by the asserted ground of unpatentability. As Patent Owner and Dr. Koopman recognize, the transmitted data used in Boer to effect the CSMCA/CA protocol would be “totally unnecessary” in a master/slave configuration. *Id.* at 44; Ex. 2208 ¶ 96.

### *3. Different Types of Modulation Methods*

Illustrative claim 1 recites two types of modulation methods, in particular “wherein the at least two types of modulation methods comprise a first modulation method and a second modulation method,” and the second modulation method is of “a different type” than the first modulation method. Petitioner contends that Boer’s DBPSK modulation corresponds to the claimed “first” modulation method. Pet. 30 (claim chart). Petitioner submits that either of Boer’s DQPSK modulation and PPM/DQPSK modulation corresponds to the claimed “second” modulation method, because each of DQPSK modulation and PPM/DQPSK modulation is of a different type — i.e., not compatible with — DBPSK modulation. Pet. 20–21, 30; Ex. 1220 ¶¶ 105–111. On the record before us, we agree that DQPSK and PPM/DQPSK modulation methods are incompatible with DBPSK modulation. *See, e.g.*, Ex. 1220 ¶¶ 122–124.

Patent Owner responds, however, that neither of DQPSK and PPM/DQPSK can be considered a modulation method of a type different from DBPSK. PO Resp. 47–53. Patent Owner argues that DBPSK and DQPSK are not different “types” of modulation methods because the methods are within the same “family,” because both vary the same fundamental characteristic of a carrier wave — its phase. *Id.* at 47–48. We do not find Patent Owner’s argument to be persuasive because we are not convinced that the broadest reasonable interpretation of “types” of modulation is so limited. *See Claim Interpretation, § II.A.2, supra.*

Patent Owner alleges also that Boer does not describe DBPSK and DQPSK as “incompatible” modulation methods because mobile stations are disclosed as capable of transmitting and receiving using DBPSK and also using DQPSK. PO Resp. 46–47. However, whether one “type” of modulation is incompatible with another “type” concerns the method of modulation, not necessarily the modem for carrying out that method. That is, a modem might be designed (as in Boer) to transmit and receive using, separately, two incompatible modulation methods, but that does not mean the two modulation methods are compatible with each other.

Moreover, Boer describes PPM/DQPSK modulation, which falls within the meaning of a “different type” of modulation method, with respect to DBPSK, under our construction of the term. *Cf.* Ex. 1220 ¶ 123 (“It is my opinion that PPM/DQPSK is a different ‘type’ of modulation than DBPSK under any possible claim construction.”). According to Dr. Goodman, phase is not used in PPM, unlike in DBPSK and DQPSK modulation. *Id.* ¶ 124. In PPM, the start and stop time of a transmission is varied in response to the

information to be transmitted, with the time shift being indicative of data bits. *Id.*

Patent Owner argues that PPM as used in Boer is not a modulation method. PO Resp. 48–52. Patent Owner’s position, however, is based on the argument that a “modulation method” is limited to varying one or more of the “fundamental characteristics” of amplitude, frequency, and phase. We do not find the argument persuasive, in view of the requirement of construing the term in accordance with its broadest reasonable interpretation. *See* § II.A.1, *supra*. We acknowledge that Boer refers to PPM as “PPM type coding.” PO Resp. 52; Ex. 1204, col. 4, ll. 45–48. However, as pointed out by Petitioner, Boer appears to use the terms “coding” and “modulation” interchangeably. Pet. Reply 15.

Moreover, Dr. Jones’ Declaration is unclear in what is meant by PPM being not a carrier wave modulation technique “as utilized in Boer” or “within the context of Boer.” Ex. 2214 ¶ 58. Dr. Jones submits that he holds numerous patents in types of modulation that include pulse-amplitude modulation (PAM). *Id.* ¶ 7. Patent Owner provides, as an exhibit, a technical treatise on communication systems engineering<sup>4</sup> that addresses PAM and PPM as two types of “Pulse Modulation Signals.” Ex. 2202, 438–444 (original page numbering). In PAM, “the information is conveyed by the amplitude of the pulse.” *Id.* at 438. In PPM (consistent with Dr. Goodman’s testimony (Ex. 1220 ¶ 124)), “the information is conveyed by the time interval in which the pulse is transmitted.” Ex. 2202, 439.

---

<sup>4</sup> John G. Proakis and Masoud Salehi, *Communication Systems Engineering*, Prentice Hall, Digital Transmission Through and AWGN Channel, Chap. 7, 438–444 (1994).

With respect to whether PPM can be considered a modulation method, we credit the testimony of Petitioner's witness, Dr. Goodman, over that of Patent Owner's, Dr. Jones, for the additional reason that the term "modulation" is part of the descriptive name for PPM – pulse position *modulation*. Patent Owner has not explained sufficiently why pulse position *modulation* cannot be considered a *modulation* method. Although DBPSK and PPM/DQPSK may both vary the "phase" characteristic of the carrier wave, we are persuaded that with PPM the timing (start and stop time) of the transmission is another characteristic of the carrier wave that is varied. Pet. 21; PO Resp. 50–51 (both parties referencing testimony of Dr. Goodman); § II.A.1 *supra*.

#### 4. APA and Boer — Conclusion

Upon review of the Petition and supporting evidence, as well as the Patent Owner Response and supporting evidence, we conclude that Petitioner has demonstrated, by a preponderance of the evidence, that claims 1, 4, 5, 10, 13, 20–22, 54, 57, 58, 61, 62, 66, 70, and 76–79 are unpatentable for obviousness over APA and Boer.

### III. CONCLUSION

Petitioner has demonstrated by a preponderance of the evidence that claims 1, 4, 5, 10, 13, 20–22, 54, 57, 58, 61, 62, 66, 70, and 76–79 are unpatentable for obviousness over APA and Boer.

IV. ORDER

In consideration of the foregoing, it is

ORDERED that claims 1, 4, 5, 10, 13, 20–22, 54, 57, 58, 61, 62, 66, 70, and 76–79 of the '580 patent are *unpatentable*; and

FURTHER ORDERED that, because this is a final written decision, parties to the proceeding seeking judicial review of the decision must comply with the notice and service requirements of 37 C.F.R. § 90.2.

IPR2014-00518  
Patent 8,023,580 B2

Petitioner:

Jeffrey A. Miller  
Daniel G. Cardy  
DICKSTEIN SHAPIRO LLP  
[millerj@dicksteinshapiro.com](mailto:millerj@dicksteinshapiro.com)  
[cardyd@dicksteinshapiro.com](mailto:cardyd@dicksteinshapiro.com)  
[Samsung.Rembrandt@dicksteinshapiro.com](mailto:Samsung.Rembrandt@dicksteinshapiro.com)  
*(via e-mail only)*  
*(via e-mail only)*

Patent Owner:

Thomas Engellenner  
Reza Mollaaghababa  
Lana Gladstein  
PEPPER HAMILTON LLP  
[engellennert@pepperlaw.com](mailto:engellennert@pepperlaw.com)  
[mollaaghababar@pepperlaw.com](mailto:mollaaghababar@pepperlaw.com)  
[gladsteinl@pepperlaw.com](mailto:gladsteinl@pepperlaw.com)



UNITED STATES PATENT AND TRADEMARK OFFICE

---

BEFORE THE PATENT TRIAL AND APPEAL BOARD

---

SAMSUNG ELECTRONICS CO. LTD.,  
SAMSUNG ELECTRONICS AMERICA, INC.,  
SAMSUNG TELECOMMUNICATIONS AMERICA, LLC, and  
SAMSUNG AUSTIN SEMICONDUCTOR, LLC,  
Petitioner,

v.

REMBRANDT WIRELESS TECHNOLOGIES, LP,  
Patent Owner.

---

Case IPR2014-00519  
Patent 8,023,580 B2

---

Before JAMESON LEE, HOWARD B. BLANKENSHIP, and  
JUSTIN BUSCH, *Administrative Patent Judges*.

BUSCH, *Administrative Patent Judge*.

FINAL WRITTEN DECISION  
35 U.S.C. § 318(a) and 37 C.F.R. § 42.73

## I. BACKGROUND

Samsung Electronics Co. Ltd., Samsung Electronics America, Inc., Samsung Telecommunications America, LLC, and Samsung Austin Semiconductor, LLC (collectively, “Petitioner”) filed a request for *inter partes* review of claims 23, 25, 29, 30, 32, 34, 38, 40, 41, 43, 44, and 47 of U.S. Patent No. 8,023,580 B2 (“the ’580 patent,” Ex. 1301) under 35 U.S.C. §§ 311–319. The Board instituted an *inter partes* review of claims 32, 34, 38, 40, 43, 44, and 47. Paper 16 (“Dec. on Inst.”).

Subsequent to institution, Patent Owner Rembrandt Wireless Technologies, LP, filed a Notice of Filing a Disclaimer (Paper 26), indicating that Patent Owner filed a disclaimer under 35 U.S.C. § 1.321(a) disclaiming claims 32, 34, 40, 43, and 44. Therefore, the trial is terminated with respect to claims 32, 34, 40, 43, and 44. *See* 37 C.F.R. §§ 42.72, 42.73. Patent Owner also filed a patent owner response (Paper 25, “PO Resp.”). Petitioner filed a reply to the Patent Owner Response (Paper 34, “Pet. Reply”).

Oral hearing was held on April 24, 2015.<sup>1</sup>

The Board has jurisdiction under 35 U.S.C. § 6(c). This final written decision is issued pursuant to 35 U.S.C. § 318(a) and 37 C.F.R. § 42.73.

For the reasons that follow, we determine that Petitioner has shown by a preponderance of the evidence that claims 38 and 47 of the ’580 patent are unpatentable.

---

<sup>1</sup> The record includes a transcript of the oral hearing. Paper 48.

IPR2014-00519  
Patent 8,023,580 B2

*A. Related Proceedings*

According to Petitioner, the '580 patent is involved in the following district court proceeding: *Rembrandt Wireless Technologies, LP v. Samsung Electronics Co.*, No. 2:13-cv-00213 (E.D. Tex. 2013). Pet. 2. The '580 patent also has been challenged in the following cases: *Samsung Electronics Co. v. Rembrandt Wireless Technologies, LP*, IPR2014-00514 (not instituted); *Samsung Electronics Co. v. Rembrandt Wireless Technologies, LP*, IPR2014-00515 (not instituted); and *Samsung Electronics Co. v. Rembrandt Wireless Technologies, LP*, IPR2014-00518 (final decision issuing concurrently).

*B. The '580 Patent*

The '580 patent issued from an application filed August 19, 2009, which claimed priority under 35 U.S.C. § 120 through a chain of intervening applications to an application filed December 4, 1998, and which further claimed priority under 35 U.S.C. § 119 to a provisional application filed December 5, 1997.

The technical field of the patent relates to data communications and modulators/demodulators (modems) and in particular to a data communications system in which a plurality of modems uses different types of modulation in a network. Ex. 1301, 1:19–23, 1:56–2:20.

*C. Illustrative Claim*

Illustrative claim 38 and claim 32, from which claim 38 depends, are reproduced below:

32. A communications device, comprising:

a processor; and

a memory having stored therein executable instructions for execution by the processor, wherein the executable instructions direct transmission of a first data with a first modulation method followed by a second data with a second modulation method, wherein the first modulation method is different than the second modulation method, wherein the first data comprises an indication of an impending change from the first modulation method to the second modulation method wherein the executable instructions direct transmission of a third data with the first modulation method after the second data, and wherein transmission of the second data is according to a particular quantity of data.

38. The device of claim 32, wherein the memory has stored therein program code for a multipoint communications protocol.

*D. Prior Art*

Boer            US 5,706,428            Jan. 6, 1998            (Ex. 1304)

*E. Asserted Ground of Unpatentability*

The Board instituted *inter partes* review on the asserted grounds that claims 32, 34, 40, 43, and 44 of the '580 patent are unpatentable as anticipated by Boer and claims 38 and 47 are unpatentable as obvious over Admitted Prior Art ("APA") and Boer. Dec. on Inst. 16. Patent Owner's

disclaimer, discussed above, leaves the anticipation ground as the only ground at issue in this proceeding.

## II. ANALYSIS

### *A. Prior Art*

#### *1. Admitted Prior Art*

Petitioner contends that the '580 patent's disclosed multipoint communication systems (or master/slave systems), depicted in Figures 1 and 2 and described in column 3, line 40 through column 4, line 50, constitutes material that may be used as prior art against the patent under 35 U.S.C. § 103(a). We agree. Figure 1 of the patent is labeled as "Prior Art." Pet. 6; Ex. 1301, Fig. 1. Further, the '580 patent's specification refers to "prior art" multipoint communication system 22 comprising master modem or transceiver 24, which communicates with a plurality of tributary modems ("tribs") or transceivers 26. Pet. 6; Ex. 1301, 3:40–44. Further, the '580 patent describes Figure 2 as illustrating the operation of the multipoint communication system of (prior art) Figure 1. Pet. 7; Ex. 1301, 3:9–10.

#### *2. Boer*

Boer describes a wireless LAN that includes first stations that operate at 1 or 2 Mbps (Megabits per second) data rate and second stations that operate at 1, 2, 5, or 8 Mbps data rate. Ex. 1304, Abstract.

Figure 1 of Boer is reproduced below.

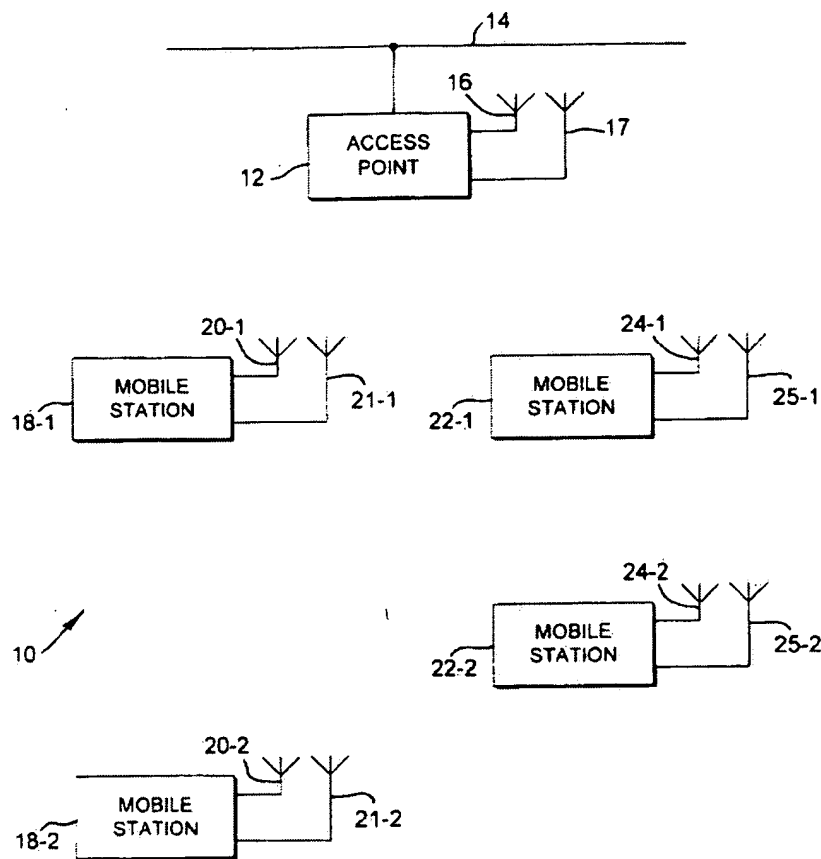


FIG. 1

Figure 1 is said to be a block diagram of a wireless LAN embodying Boer's invention. Ex. 1304, 1:53-54. LAN 10 includes access point 12, serving as a base station. The network includes mobile stations 18-1 and 18-2 that are capable of transmitting and receiving messages at a data rate of 1 or 2 Mbps using DSSS (direct sequence spread spectrum) coding. When operating at 1 Mbps, a station uses DBPSK (differential binary phase shift keying) modulation. When operating at 2 Mbps, a station uses DQPSK (differential quadrature phase shift keying) modulation. *Id.* at 2:6-27.

Mobile stations 22-1 and 22-2 are capable of operating at the 1 and 2 Mbps data rates using the same modulation and coding as stations 181 and 182. In addition, stations 22-1 and 22-2 can operate at 5 and 8 Mbps data rates using PPM/DQPSK (pulse position modulation–differential quadrature phase shift keying) in combination with the DSSS coding. *Id.* at 2:34–44.

*B. Claims 38 and 47 – APA and Boer*

*1. Asserted Ground*

Petitioner applies the teachings of the APA and Boer to demonstrate obviousness of the subject matter of illustrative claim 29 (which recites the similar limitation present in claims 38 and 47 of a multipoint communications protocol), relying on APA for teaching of master/slave communication systems. Pet. 37–43. Petitioner submits that a person having ordinary skill in the art would have been motivated to combine Boer with APA, referring to the Declaration of Dr. David Goodman (Ex. 1318 ¶¶ 162–170). *Id.* at 38–41. Petitioner maps the disclosures of Boer to claim 32 (*id.* at 25–26) from which claim 38 depends and claims 40 (*id.* at 31–35) and 44 (*id.* at 37), from which claim 47 depends.

Dr. Goodman testifies that polled multiport master/slave communications systems were well known to those of ordinary skill in the art for simplicity and determinacy, referring to Exhibit 1317. Ex. 1318 ¶ 169. Petitioner submits Exhibit 1317 (“Upender”) as a November 1994 publication that compares various strengths and weaknesses for communication protocols for embedded systems. Ex. 1317, 7. The document states that polling is one of the more popular protocols for embedded systems “because of its simplicity and determinacy.” *Id.* In that

protocol, a centrally assigned master periodically sends a polling message to the slave nodes, giving them explicit permission to transmit on the network. *Id.* The protocol “is ideal for a centralized data-acquisition system where peer-to-peer communication and global prioritization are not required.” *Id.*

## 2. *Motivation to Combine*

Patent Owner argues, in its Response, that Upender does not reflect a proper motivation from the prior art for the proffered combination of Boer and APA. Patent Owner submits a Declaration from a co-author of Upender to show that the article did not suggest the use of a master/slave communication system. Ex. 2302 (Declaration of Dr. Philip Koopman).

We have considered Patent Owner’s arguments and evidence but find that the clear teachings in Upender are not diminished or rebutted. Upender investigates tradeoffs in different communication protocols. The article concludes that CSMA/CA (carrier sense multiple access with collision avoidance), or RCSMA (reservation CSMA), is a good choice for some embedded systems. Ex. 1317, 10–11. The article also indicates that polling may not provide sufficient flexibility for “advanced systems,” classifying polling as “simple,” but noting that the discussion of the different protocol strengths and weaknesses “should allow you to select the best protocol to match your needs.” *Id.* at 10–11. In fact, Dr. Koopman admits that there are some systems for which master/slave is a better match for the design requirements. Pet. Reply 9; Ex. 1319, 39:2–20.

That Upender may identify some advantages of CSMA/CA over a master/slave protocol is not a “teaching away” from the master/slave protocol. Upender teaches that master/slave protocols were widely used and



a good choice for simple systems. *See In re Gurley*, 27 F.3d 551, 553 (Fed. Cir. 1994) (“[A] person seeking to improve the art of flexible circuit boards, on learning from [a reference] that epoxy was inferior to polyester-imide resins, might well be led to search beyond epoxy for improved products. However, [the reference] also teaches that epoxy is usable and has been used for Gurley’s purpose.”).

Patent Owner’s position appears to be that the prior art teaches that one and only one communication protocol should ever be used, which is directly contrary to the clear teachings of Upender. In view of Upender, one of ordinary skill in the art would have found it obvious to use a different prior art communication protocol (e.g., a simpler protocol) when using multiple data rates as described by Boer.

Further, we agree with Petitioner that Boer does not describe CSMA as central to an alleged goal of seeking a “reduction of overhead-in-time per transmission,” but relates that reduction to the use of short acknowledgment (ACK) messages. PO Resp. 40; Pet. Reply 8; Ex. 1304, 8:16–29.

Patent Owner submits that Dr. Goodman’s Declaration (Ex. 1318) is unreliable because it is unclear what level of skill it attributes to the ordinary artisan. PO Resp. 29–30. The alleged lack of clarity, however, does not affect the outcome. We note that specifying the level of ordinary skill in terms of an academic degree in a field of study and the number of years of practical working experience is generally unhelpful, as a practical matter, because it does not convey whether one with ordinary skill in the art would have been aware of anything specific or particular. Patent Owner has not directed us to evidence establishing what someone who has earned a certain degree or who has a certain number of years of experience necessarily

knows. It is not always necessary, however, to have an express proposition on the level of ordinary skill in the art. The level of ordinary skill in the art may be reflected by the prior art of record. *See Okajima v. Bourdeau*, 261 F.3d 1350, 1355 (Fed. Cir. 2001); *In re GPAC Inc.*, 57 F.3d 1573, 1579 (Fed. Cir. 1995); *In re Oelrich*, 579 F.2d 86, 91 (CCPA 1978).

We agree with Patent Owner to the extent that one of skill in the art would not consider using a CSMA/CA protocol in a master/slave configuration. PO Resp. 21. That combination, however, is not contemplated by the asserted ground of unpatentability. As Patent Owner and Dr. Koopman recognize, the transmitted data used in Boer to effect the CSMCA/CA protocol would be “totally unnecessary” in a master/slave configuration. *Id.*; Ex. 2302 ¶ 96.

### 3. APA and Boer — Conclusion

Upon review of the Petition and supporting evidence, as well as the Patent Owner Response and supporting evidence, we conclude that Petitioner has demonstrated, by a preponderance of the evidence, that claims 38 and 47 are unpatentable for obviousness over APA and Boer.

## III. CONCLUSION

Petitioner has demonstrated by a preponderance of the evidence that claims 38 and 47 are unpatentable for obviousness over APA and Boer.

IV. ORDER

In consideration of the foregoing, it is

ORDERED that the trial is terminated with respect to claims 32, 34, 40, 43, and 44;

FURTHER ORDERED that claims 38 and 47 of the '580 patent are *unpatentable*; and

FURTHER ORDERED that, because this is a final written decision, parties to the proceeding seeking judicial review of the decision must comply with the notice and service requirements of 37 C.F.R. § 90.2.

IPR2014-00519  
Patent 8,023,580 B2

Petitioner

Jeffrey A. Miller  
Daniel G. Cardy  
DICKSTEIN SHAPIRO LLP  
millerj@dicksteinshapiro.com  
cardyd@dicksteinshapiro.com  
Samsung.Rembrandt@dicksteinshapiro.com

Patent Owner

Thomas Engellenner  
Reza Mollaaghababa  
Lana Gladstein  
PEPPER HAMILTON LLP  
engellennert@pepperlaw.com  
mollaaghababar@pepperlaw.com  
gladsteinl@pepperlaw.com

<b>POWER OF ATTORNEY and CORRESPONDENCE ADDRESS INDICATION FORM</b>	<b>Application/Patent Number</b>	12/543,910 / 8,023,580
	<b>Filing Date</b>	August 19, 2009
	<b>First Named Inventor</b>	Gordon F. Bremer
	<b>Art Unit</b>	2611
	<b>Examiner Name</b>	Dac V. Ha
	<b>Attorney Docket Number</b>	3277-114
	<b>Title</b>	System and Method of Communication Using at Least Two Modulation Methods

The below-named Assignee of record of the entire interest in the subject application, through its authorized representative identified below, hereby revokes all previous powers of attorney given in the above-identified application and hereby appoints the practitioners associated with the Customer Number 06449 as my/our attorney(s) or agent(s) to prosecute the application identified above, and to transact all business in the United States Patent and Trademark Office connected therewith.

*Statement under 37 CFR 3.73(b)*

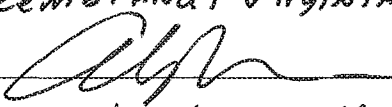
A chain of title from the inventors, of the patent application/patent identified above to the current assignee as follows:

1. Assignment From: Summit Technology Systems, LP  
To: Rembrandt Wireless Technologies, LP

The document was recorded in the U.S. Patent and Trademark Office at Reel 027085, Frame 0636.

**ACKNOWLEDGEMENT AND CONSENT BY ASSIGNEE TO OBTAIN INSTRUCTIONS FROM ANOTHER PARTY**

Assignee, through its undersigned authorized representative, hereby acknowledges that the practitioners appointed herein may obtain instructions as to any action to be taken in the U.S. Patent and Trademark Office on any application to which this power of attorney may be directed, or on any patent which may issue on any such application, from assignee's third-party agents or attorneys, or other designee, who have been authorized by assignee to convey such instructions, and assignee expressly consents to this arrangement. In the event of a change in the persons from whom instructions are to be taken, the practitioners appointed herein shall be so notified by the assignee.

<b>Assignee Name</b>	Rembrandt Wireless Technologies, LP, by its general partner,
<b>Signature of Authorized Representative</b>	Rembrandt Virginia Management, LLC 
<b>Typed or Printed Name</b>	Alex Lempinen
<b>Typed or Printed Title</b>	Secretary
<b>Date</b>	9/27/2016

## Electronic Acknowledgement Receipt

<b>EFS ID:</b>	27050173
<b>Application Number:</b>	12543910
<b>International Application Number:</b>	
<b>Confirmation Number:</b>	8306
<b>Title of Invention:</b>	SYSTEM AND METHOD OF COMMUNICATION USING AT LEAST TWO MODULATION METHODS
<b>First Named Inventor/Applicant Name:</b>	Gordon F. Bremer
<b>Customer Number:</b>	15027
<b>Filer:</b>	Martin M. Zoltick/Tamika Miles
<b>Filer Authorized By:</b>	Martin M. Zoltick
<b>Attorney Docket Number:</b>	REMB-0109
<b>Receipt Date:</b>	27-SEP-2016
<b>Filing Date:</b>	19-AUG-2009
<b>Time Stamp:</b>	17:27:23
<b>Application Type:</b>	Utility under 35 USC 111(a)

### Payment information:

Submitted with Payment	no
------------------------	----

### File Listing:

Document Number	Document Description	File Name	File Size(Bytes)/ Message Digest	Multi Part /.zip	Pages (if appl.)
1	Power of Attorney	Power_of_Attorney.pdf	163808  <small>3e1a5f9569830f74b911f20740490b970634 bdfc</small>	no	1

**Warnings:**

<b>Information:</b>	
<b>Total Files Size (in bytes):</b>	163808
<p><b>This Acknowledgement Receipt evidences receipt on the noted date by the USPTO of the indicated documents, characterized by the applicant, and including page counts, where applicable. It serves as evidence of receipt similar to a Post Card, as described in MPEP 503.</b></p> <p><b><u>New Applications Under 35 U.S.C. 111</u></b>  <b>If a new application is being filed and the application includes the necessary components for a filing date (see 37 CFR 1.53(b)-(d) and MPEP 506), a Filing Receipt (37 CFR 1.54) will be issued in due course and the date shown on this Acknowledgement Receipt will establish the filing date of the application.</b></p> <p><b><u>National Stage of an International Application under 35 U.S.C. 371</u></b>  <b>If a timely submission to enter the national stage of an international application is compliant with the conditions of 35 U.S.C. 371 and other applicable requirements a Form PCT/DO/EO/903 indicating acceptance of the application as a national stage submission under 35 U.S.C. 371 will be issued in addition to the Filing Receipt, in due course.</b></p> <p><b><u>New International Application Filed with the USPTO as a Receiving Office</u></b>  <b>If a new international application is being filed and the international application includes the necessary components for an international filing date (see PCT Article 11 and MPEP 1810), a Notification of the International Application Number and of the International Filing Date (Form PCT/RO/105) will be issued in due course, subject to prescriptions concerning national security, and the date shown on this Acknowledgement Receipt will establish the international filing date of the application.</b></p>	







UNITED STATES PATENT AND TRADEMARK OFFICE

UNITED STATES DEPARTMENT OF COMMERCE  
United States Patent and Trademark Office  
Address: COMMISSIONER FOR PATENTS  
P.O. Box 1450  
Alexandria, Virginia 22313-1450  
www.uspto.gov

APPLICATION NUMBER	FILING OR 371(C) DATE	FIRST NAMED APPLICANT	ATTY. DOCKET NO./TITLE
12/543,910	08/19/2009	Gordon F. Bremer	REMB-0109

**CONFIRMATION NO. 8306**

**POWER OF ATTORNEY NOTICE**

15027  
Condo Roccia Koptiw LLP  
1800 JFK Boulevard  
Suite 1700  
Philadelphia, PA 19103



Date Mailed: 09/30/2016

**NOTICE REGARDING CHANGE OF POWER OF ATTORNEY**

This is in response to the Power of Attorney filed 09/27/2016.

- The Power of Attorney to you in this application has been revoked by the assignee who has intervened as provided by 37 CFR 3.71. Future correspondence will be mailed to the new address of record(37 CFR 1.33).

Questions about the contents of this notice and the requirements it sets forth should be directed to the Office of Data Management, Application Assistance Unit, at (571) 272-4000 or (571) 272-4200 or 1-888-786-0101.

/rbell/



UNITED STATES PATENT AND TRADEMARK OFFICE

UNITED STATES DEPARTMENT OF COMMERCE  
United States Patent and Trademark Office  
Address: COMMISSIONER FOR PATENTS  
P.O. Box 1450  
Alexandria, Virginia 22313-1450  
www.uspto.gov

APPLICATION NUMBER	FILING OR 371(C) DATE	FIRST NAMED APPLICANT	ATTY. DOCKET NO./TITLE
12/543,910	08/19/2009	Gordon F. Bremer	REMB-0109

**CONFIRMATION NO. 8306**

**POA ACCEPTANCE LETTER**

6449  
ROTHWELL, FIGG, ERNST & MANBECK, P.C.  
607 14th Street, N.W.  
SUITE 800  
WASHINGTON, DC 20005



Date Mailed: 09/30/2016

**NOTICE OF ACCEPTANCE OF POWER OF ATTORNEY**

This is in response to the Power of Attorney filed 09/27/2016.

The Power of Attorney in this application is accepted. Correspondence in this application will be mailed to the above address as provided by 37 CFR 1.33.

Questions about the contents of this notice and the requirements it sets forth should be directed to the Office of Data Management, Application Assistance Unit, at (571) 272-4000 or (571) 272-4200 or 1-888-786-0101.

/rbell/

(12) **INTER PARTES REVIEW CERTIFICATE** (152nd)

**United States Patent  
Bremer**

(10) **Number:** US **8,023,580 K1**  
(45) **Certificate Issued:** Dec. 13, 2016

---

(54) **SYSTEM AND METHOD OF  
COMMUNICATION USING AT LEAST TWO  
MODULATION METHODS**

(75) **Inventor:** **Gordon F. Bremer**

(73) **Assignee:** **REMBRANDT WIRELESS  
TECHNOLOGIES, LP**

**Trial Numbers:**

IPR2014-00518 filed Mar. 20, 2014

IPR2014-00519 filed Mar. 20, 2014

**Petitioners:** Samsung Electronics Co. Ltd.;  
Samsung Electronics America, Inc.;  
Samsung Telecommunications  
America, LLC; Samsung Austin  
Semiconductor, LLC

**Patent Owner:** Rembrandt Wireless Technologies, LP

**Inter Partes Review Certificate for:**

Patent No.: **8,023,580**

Issued: **Sep. 20, 2011**

Appl. No.: **12/543,910**

Filed: **Aug. 19, 2009**

The results of IPR2014-00518 and IPR2014-00519 are reflected in this inter partes review certificate under 35 U.S.C. 318(b).

**INTER PARTES REVIEW CERTIFICATE**  
**U.S. Patent 8,023,580 K1**  
**Trial No. IPR2014-00518**  
**Certificate Issued Dec. 13, 2016**

**1**

**2**

AS A RESULT OF THE INTER PARTES  
REVIEW PROCEEDING, IT HAS BEEN  
DETERMINED THAT:

Claims 1, 4, 5, 10, 13, 20-22, 38, 47, 54, 57, 58, 61, 62, <sup>5</sup>  
66, 70 and 76-79 are cancelled.

Claims 32, 34, 40, 43 and 44 are disclaimed.

\* \* \* \* \*