

**IN THE UNITED STATES DISTRICT COURT
FOR THE EASTERN DISTRICT OF TEXAS
MARSHALL DIVISION**

**OPTIS WIRELESS TECHNOLOGY, LLC,
OPTIS CELLULAR TECHNOLOGY, LLC,
AND PANOPTIS PATENT MANAGEMENT,
LLC,**

Plaintiffs,

v.

**HUAWEI TECHNOLOGIES CO. LTD,
HUAWEI DEVICE USA, INC., AND HUAWEI
DEVICE CO. LTD**

Defendants.

Civil Action No. 2:17-cv-123

JURY TRIAL REQUESTED

PLAINTIFFS' THIRD AMENDED COMPLAINT FOR PATENT INFRINGEMENT

Plaintiffs Optis Wireless Technology, LLC, Optis Cellular Technology, LLC, and PanOptis Patent Management, LLC (collectively, "PanOptis") file this Third Amended Complaint for patent infringement under 35 U.S.C. § 271 against Huawei Technologies Co. Ltd., Huawei Device USA, Inc., and Huawei Device Co. Ltd. (collectively, "Huawei"), and allege as follows:

NATURE OF THE ACTION

1. This is an action for patent infringement. Huawei has infringed and continues to infringe, contribute to the infringement of, and/or actively induce others to infringe U.S. Patent Nos. 7,769,238 ("the '238 patent"), 6,604,216 ("the '216 patent"), 7,940,851 ("the '851 patent"), 8,385,284 ("the '284 patent"), 8,208,569 ("the '569 patent"), 8,102,833 ("the '833 patent"), and 8,437,293 ("the '293 patent") (collectively, "the Asserted Patents" or "the Patents-in-Suit").

PARTIES

2. Plaintiff Optis Wireless Technology, LLC (“Optis Wireless”) is a limited liability company organized and existing under the laws of the State of Delaware, and maintains its principal place of business at 7160 Dallas Parkway, Suite 250, Plano, TX 75024.

3. Plaintiff Optis Cellular Technology, LLC (“Optis Cellular”) is a limited liability company organized and existing under the laws of the State of Delaware, and maintains its principal place of business at 7160 Dallas Parkway, Suite 250, Plano, TX 75024.

4. Plaintiff PanOptis Patent Management, LLC (“PPM”) is a limited liability company organized and existing under the laws of the State of Delaware, and maintains its principal place of business at 7160 Dallas Parkway, Suite 250, Plano, TX 75024.

5. Upon information and belief, Huawei Technologies Co. Ltd. (“Huawei Technologies”) is a Chinese corporation with its principal place of business at Bantian, Longgang District, Shenzhen, People’s Republic of China.

6. Upon information and belief, Huawei Device USA, Inc. (“Huawei Device”) is a corporation organized under the laws of Texas, having its principal place of business at 5700 Tennyson Parkway, Suite 500, Plano, Texas 75024.

7. Upon information and belief, Huawei Device Co. Ltd. (“Huawei Device China”) is a Chinese corporation with its principal place of business at Bantian, Longgang District, Shenzhen, People’s Republic of China.

JURISDICTION AND VENUE

8. This Court has exclusive subject matter jurisdiction over this case under 28 U.S.C. §§ 1331 and 1338.

9. Venue is proper in this Court pursuant to 28 U.S.C. §§ 1391 and 1400(b) because Huawei has committed acts of infringement in this judicial district and is subject to personal

jurisdiction in this judicial district.

10. This Court has personal jurisdiction over Huawei. Huawei Device is organized under the laws of Texas, and maintains its principal place of business in this District. Huawei has continuous and systematic business contacts with the State of Texas. Huawei, directly or through subsidiaries or intermediaries (including distributors, retailers, and others), conducts its business extensively throughout Texas, by shipping, distributing, offering for sale, selling, and advertising (including the provision of interactive web pages) its products and services (including its infringing products and services) in the State of Texas and the Eastern District of Texas. Huawei, directly and through subsidiaries or intermediaries (including distributors, retailers, and others), has purposefully and voluntarily placed its infringing products and services into this District and into the stream of commerce with the intention and expectation that they will be purchased and used by consumers in this District. These infringing products and services have been and continue to be purchased and used by consumers in this District. Huawei has committed acts of patent infringement within the State of Texas and, more particularly, within this District. Jurisdiction over Huawei in the matter is also proper inasmuch as Huawei has voluntarily submitted itself to the jurisdiction of the courts by commencing litigations within the State of Texas (including in this District), by registering with the Texas Secretary of State's Office to do business in the State of Texas, and by appointing a registered agent.

THE PANOPTIS PATENTS

11. On August 3, 2010, the '238 patent was duly and legally issued for an invention titled, "Picture Coding Method and Picture Decoding Method." PanOptis owns all rights to the '238 patent necessary to bring this action. A true and correct copy of the '238 patent is attached hereto as Exhibit 1.

12. On August 5, 2003, the '216 patent was duly and legally issued for an invention

titled, “Telecommunications System and Method for Supporting an Incremental Redundancy Error Handling Scheme Using Available Gross Rate Channels.” PanOptis owns all rights to the ’216 patent necessary to bring this action. A true and correct copy of the ’216 patent is attached hereto as Exhibit 2.

13. On May 10, 2011, the ’851 patent was duly and legally issued for an invention titled, “Radio Communication Apparatus and Radio Communication Method.” PanOptis owns all rights to the ’851 patent necessary to bring this action. A true and correct copy of the ’851 patent is attached hereto as Exhibit 3.

14. On February 26, 2013, the ’284 patent was duly and legally issued for an invention titled, “Control Channel Signaling Using a Common Signaling Field for Transport Format and Redundancy Version.” PanOptis owns all rights to the ’284 patent necessary to bring this action. A true and correct copy of the ’284 patent is attached hereto as Exhibit 4.

15. On June 26, 2012, the ’569 patent was duly and legally issued for an invention titled, “Method and Apparatus for Multicarrier Communication.” PanOptis owns all rights to the ’569 patent necessary to bring this action. A true and correct copy of the ’569 patent is attached hereto as Exhibit 5.

16. On January 24, 2012, the ’833 patent was duly and legally issued for an invention titled, “Method for Transmitting Uplink Signals.” PanOptis owns all rights to the ’833 patent necessary to bring this action. A true and correct copy of the ’833 patent is attached hereto as Exhibit 6.

17. On May 7, 2013, the ’293 patent was duly and legally issued for an invention titled, “Methods and Systems for Scheduling Resources in a Telecommunication System.” PanOptis owns all rights to the ’293 patent necessary to bring this action. A true and correct copy

of the '293 patent is attached hereto as Exhibit 7.

PLAINTIFFS' LTE STANDARDS ESSENTIAL PATENTS

18. PanOptis incorporates by reference the preceding paragraphs as though fully set forth herein.

19. The European Telecommunications Standards Institute ("ETSI") is a standard setting organization ("SSO") that produces globally-accepted standards for the telecommunication industry. ETSI is an organizational partner of the Third Generation Partnership Project ("3GPP"), which maintains and develops globally applicable technical specifications for mobile systems, including the specifications for implementation and use of wireless communications for high-speed data referred to as the Long Term Evolution ("LTE") Standard.

20. Implementation and use of the LTE standard, including, but not limited to, use of wireless communications for high-speed data compliant with the LTE specifications as detailed in the 3GPP specification series TS 36.101-36.978, has increased in recent years and continues to increase at a rapid pace.

21. ETSI has developed and promulgated an IPR Policy (found at Annex 6 to the ESTI Rules of Procedure, published November 19, 2014). This policy is intended to strike a balance between the needs of standardization for public use in the field of telecommunications on the one hand, and the rights of IPR owners on the other hand. ETSI requires its members to disclose patents that "are or become, and remain ESSENTIAL to practice" its standards or technical specifications. Clause 15.6 of the ETSI IPR Policy defines the term "ESSENTIAL" to mean that "it is not possible on technical (but not commercial) grounds, taking into account normal technical practice and the state of the art generally available at the time of standardization, to make, sell, lease, otherwise dispose of, repair, use or operate EQUIPMENT or

METHODS which comply with a STANDARD without infringing that IPR.”

22. Optis Wireless is the assignee of numerous patents, originally assigned to either Telefonaktiebolaget LM Ericsson (“Ericsson”) or Panasonic Corporation (“Panasonic”), that are, and remain, essential (as that term is defined by ETSI) to practicing the LTE Standard.

23. Optis Cellular is the assignee of numerous patents, originally assigned to either Ericsson or LG Electronics Inc. (“LG”), that are, and remain, essential (as that term is defined by ETSI) to practicing the LTE Standard.

24. Ericsson, the original assignee of the ’216 patent, declared that patent as essential to practicing the LTE Standard in 2009.

25. Panasonic, the original assignee of the ’851, ’284, and ’569 patents, declared those patents as essential to practicing the LTE Standard. Optis Wireless, upon acquisition of those patents from Panasonic, re-declared those patents to ETSI as essential to practicing the LTE Standard.

26. LG, the original assignee of the ’833 patent, declared that patent as essential to practicing the LTE Standard in 2009. Optis Cellular, upon acquisition of that patent, re-declared it to ETSI as essential to practicing the LTE Standard.

27. Ericsson, the original assignee of the ’293 patent, declared that patent as essential to practicing the LTE Standard in 2009. Optis Cellular, upon acquisition of that patent, re-declared it to ETSI as essential to practicing the LTE Standard.

28. PanOptis, in conformance with ETSI’s IPR Policy, has informed Huawei that PanOptis is prepared to grant Huawei an irrevocable license to its LTE essential patents, including the ’216, ’851, ’284, ’569, ’833, and ’293 patents, on terms that are Fair, Reasonable, and Non-Discriminatory (“FRAND”).

29. Huawei requires a license to PanOptis's LTE essential patents because Huawei makes, has made, sells, leases, disposes of, repairs, uses, and operates products (including Huawei's mobile communication devices) that are configured to, and do, operate in compliance with the LTE Standard, and thus infringe PanOptis's LTE essential patents.

30. In April 2014, PanOptis sent Huawei correspondence that initiated PanOptis's good faith efforts to license its LTE essential patents to Huawei on FRAND terms.

31. On July 18, 2014, PanOptis sent correspondence to Huawei that contained lists of PanOptis's patents, including the Patents-in-Suit.

32. PanOptis representatives, at their own expense, traveled and met face-to-face with Huawei representatives at least ten times in Hong Kong and Shenzhen, China, on June 5, 2014; August 28, 2014; November 4, 2014; January 27, 2015; April 8, 2015; June 18, 2015; August 20, 2015; November 13, 2015; February 1, 2016; and May 25, 2016. During those meetings, PanOptis presented, in good faith, material concerning its LTE essential patents, along with FRAND terms for its LTE essential patents, including a proposed term sheet for a global license.

33. In addition to meeting with Huawei numerous times, PanOptis has initiated and exchanged written correspondence with Huawei and has contacted Huawei by phone on numerous occasions. PanOptis also provided Huawei with a number of exemplary claim charts showing infringement by Huawei's products that are configured to operate in compliance with the LTE Standard, including, but not limited to, claim charts for the '569 and '833 patents.¹

34. On January 27, 2017, PanOptis sent another letter to Huawei, reiterating that it was prepared to offer, and has offered, to license its standard essential patents on terms that are FRAND.

¹ PanOptis also provided Huawei with a claim chart showing infringement by Huawei's products of the '238 implementation patent.

35. To date, Huawei has not reciprocated PanOptis's good faith efforts. Huawei instead has resisted taking a license to PanOptis's valuable intellectual property.

36. Huawei has been operating and continues to operate without a license to PanOptis's LTE essential patents. Given Huawei's unwillingness to engage in meaningful licensing discussions, to license PanOptis's LTE essential patents, or to cease infringing PanOptis's patents, PanOptis has filed this lawsuit for the purpose of protecting its patent rights in the United States.

GENERAL ALLEGATIONS

37. The infringing Huawei devices include, but are not limited to, those devices that are compatible with the 3GPP Long Term Evolution ("LTE") Standard and/or that can decode picture and audio data. This list includes, but is not limited to, the Huawei Nexus 6P, Huawei Mate 9, Huawei Mate 8, Huawei P8 Lite, Huawei SnapTo, Huawei Ascend Mate 2, Ascend Mate 7, Huawei Ascend P7, Huawei Mate S, Huawei P8, Huawei P9, Huawei Ascend G7, Huawei GX8, Huawei G7 Plus, Honor 5X, Honor 6, Honor 7, Honor 8, Huawei Union, Huawei Vitria, Huawei Vision 3 LTE, Huawei MediaPad T1 8.0, Huawei MediaPad T1 8.0 Pro, and Huawei MediaPad M3 (collectively, "the Huawei Accused Products").

38. Huawei has and continues to directly and indirectly infringe each of the Patents-in-Suit by engaging in acts constituting infringement under 35 U.S.C. § 271(a), (b), and/or (c), including, but not necessarily limited to, one or more of making, using, selling, and offering to sell, in this District and elsewhere in the United States, and importing into the United States, the Huawei Accused Products.

39. Huawei and/or its authorized retailers operate stores throughout the United States, including stores in this District, such as the Best Buy stores in Longview and Tyler, Texas. Upon information and belief, Huawei and/or its authorized retailers sell and offer to sell the Huawei

Accused Products, including those that are configured to connect and operate on an LTE network and those that can decode picture and audio data. Furthermore, upon information and belief, Huawei uses the Huawei Accused Products within the United States, including in support of its promotions and advertisements that highlight the LTE network and picture and audio decoding capabilities of the Huawei Accused Products. *See, e.g.,* <http://www.youtube.com/user/huaweideviceusa/videos>; *see also* http://www.youtube.com/watch?v=eoKRN-2Tb_U (showing the Huawei MediaPad T1 playing a streaming video).

40. Huawei takes specific steps to actively induce others, including its customers, to infringe the Patents-in-Suit with the Huawei Accused Products. Huawei actively induces the direct infringement of one or more claims of the Patents-in-Suit by others by promoting, instructing, offering, and encouraging others to use the Huawei Accused Products in an infringing manner. As an example and without limitation, Huawei actively promotes the use of its products' LTE functionality, including for example and without limitation, by way of authorized resellers, customer service and sales representatives, and/or its internet sales websites. Such active promotion includes advertising that the Huawei Accused Products possess full 4G LTE network capabilities and can decode picture and audio data. *See, e.g.,* <http://www.gethuawei.com/huawei-snapto>; http://www.youtube.com/watch?v=eoKRN-2Tb_U (showing the Huawei MediaPad T1 playing a streaming video). Given that Huawei was given notice of the Patents-in-Suit on July 18, 2014, Huawei knows or should know that such sales and promotions actively induce others to directly infringe one or more claims of the Patents-in-Suit, including, for example, by prompting them to use the Huawei Accused Products in an infringing manner. Huawei has performed and continues to perform these affirmative acts with knowledge

of the Patents-in-Suit and with the intent, or willful blindness, that the induced acts directly infringe the patents.

41. As another example, on information and belief, Huawei provides and/or authorizes the providing of instruction manuals, product manuals, specifications, and other materials for customers and other users of the Huawei Accused Products that demonstrate how to make use of the Huawei Accused Products in an infringing manner. For instance, Huawei's instruction materials demonstrate to its customers how to connect to and operate the Huawei Accused Products on LTE networks. And, on information and belief, Huawei knows or should know that such instruction actively induces others to directly infringe one or more claims of the Patents-in-Suit.

42. Additionally, Huawei and/or its authorized retailers operate stores throughout the United States, including stores in this District that, upon information and belief, sell, promote, and instruct the use of the Huawei Accused Products by, for example, selling and/or offering for sale the Huawei Accused Products configured to connect to and operate on LTE networks. For example, Huawei and/or its authorized resellers offer the Huawei Accused Products for sale in the United States. *See, e.g.,* <http://www.bestbuy.com/site/huawei-honor-8-4g-lte-with-32gb-memory-cell-phone-unlocked-sapphire-blue/5514802.p?id=bb4796300&skuid=5514802> (showing Huawei Honor 8 4G LTE phones available at Best Buy's Longview, Texas location as of February 9, 2017 at 11:00 a.m.).

43. Furthermore, Huawei makes, uses, sells, offers for sale, and/or imports into the United States products that contribute to the infringement of one or more claims of the Patents-in-Suit when used by customers and others for their benefit. For example, Huawei and/or its authorized retailers sell Huawei Accused Products specifically to make use of the devices' LTE

and/or picture and audio decoding capabilities. Additionally, the Huawei Accused Products are specifically configured by Huawei and/or its authorized retailers to facilitate the use of the devices' LTE and/or picture and audio decoding capabilities. Further, on information and belief, the Huawei Accused Products and components, once configured, have no substantial uses other than to operate in an infringing manner (*e.g.*, to practice the LTE standard). On information and belief, Huawei knows that the Huawei Accused Products and/or components included therein are specially made or specially adapted for infringement of the Patents-in-Suit, and are not staple articles or commodities of commerce suitable for substantial non-infringing use.

44. Huawei's acts of infringement have caused damage to PanOptis. PanOptis is entitled to recover from Huawei the past damages sustained by PanOptis as a result of Huawei's wrongful acts in an amount subject to proof at trial. PanOptis is also entitled to recover from Huawei a compulsory future royalty payable on each infringing product sold by Huawei following trial or that is not captured in the damages awarded to PanOptis.

HUAWEI'S INFRINGEMENT

45. In the interest of providing detailed averments of infringement, PanOptis has identified below at least one exemplary claim per patent to demonstrate infringement by one exemplary product. However, the selection of claims and products should not be considered limiting, and additional infringing Huawei products and infringed claims of the PanOptis Patents-in-Suit will be disclosed in compliance with the Court's rules related to infringement contentions.

A. Huawei Makes, Imports, Uses, Sells, and/or Offers for Sale Products and Services that Infringe the '238 Patent.

46. Huawei's products at issue include at least the Huawei Nexus 6P, Huawei Mate 9, Huawei Mate 8, Huawei P8 Lite, Huawei SnapTo, Huawei Ascend Mate 2, Ascend Mate 7,

Huawei Ascend P7, Huawei Mate S, Huawei P8, Huawei P9, Huawei Ascend G7, Huawei GX8, Huawei G7 Plus, Honor 5X, Honor 6, Honor 7, Honor 8, Huawei Union, Huawei Vitria, Huawei Vision 3 LTE, Huawei MediaPad T1 8.0, Huawei MediaPad T1 8.0 Pro, and Huawei MediaPad M3 (collectively, “the ’238 Accused Products”).

47. The ’238 Accused Products infringe the ’238 patent. For example, the Nexus 6P infringes claim 1 of the ’238 patent.

48. The ’238 Accused Products comprise a receiving apparatus which receives multiplexed data which is obtained by multiplexing coded audio data and coded picture data. For example, the ’238 Accused Products are capable of receiving media streams or files, *e.g.*, ISO/IEC 14496-15 AVC file format, IS/IEC 14496-12 ISO Base Media File Format, MPEG-4 file format, and/or MPEG-4 streams containing audio and video.

49. The ’238 Accused Products comprise a demultiplexing unit configured to separate the multiplexed data into the coded audio data and the coded picture data. The ’238 Accused Products, by virtue of their ability to decode video and audio from an MPEG-4 stream satisfy this limitation.

50. The ’238 Accused Products comprise an audio processing unit configured to decode the separated coded audio data. For example, the Nexus 6P is capable of decoding coded audio, such as MP3 and AAC. *See, e.g.,* <http://consumer.huawei.com/en/mobile-phones/nexus6p/specifications.htm>.

51. The ’238 Accused Products comprise a picture decoding unit configured to decode the separated coded picture data, wherein said picture decoding unit includes a block decoding unit configured to decode coded block data included in the coded picture data, the coded block data being obtained by dividing a picture signal into plural blocks, generating a

residual block image from a block image of the respective blocks and a predictive block image obtained by intra-picture prediction or inter-picture prediction, and coding, on a block basis, coefficients obtained by performing orthogonal transformation and quantization on the residual block image. *See, e.g.*, ITU-T Rec. H.264. Further evidence that the '238 Accused Products satisfy this claim element is outlined below.

52. The '238 Accused Products comprise a coefficient number decoding unit configured to decode the coded block data to obtain the number of non-zero coefficients which are coefficients included in a current block to be decoded and having a value other than "0." For example, the '238 Accused Products comprise an H.264/AVC decoder capable of decoding Baseline, Main or High Profile bitstreams according to ITU-T Rec. H.264 section A.2. This functionality is described in the H.264 Standard, including, but not limited to, § 9.2.1.

53. The '238 Accused Products comprise a unit configured to obtain coefficients corresponding to a residual block image of the current block by decoding the coded block data. For example, the '238 Accused Products comprise an H.264/AVC decoder capable of decoding Baseline, Main or High Profile bitstreams. This functionality is described in the H.264 Standard, including, but not limited to, § 9.2, describing a process that decodes a block of data and produces the transform coefficient levels of a residual block.

54. The '238 Accused Products comprise a unit configured to obtain the residual block image of the current block by performing inverse quantization and inverse orthogonal transformation on the coefficients corresponding to the residual block image of the current block. For example, as explained above, the '238 Accused Products comprise an H.264/AVC decoder. This functionality is described in the H.264 Standard, including, but not limited to, § 8.5.11, which describes taking an input block of coefficients corresponding to a block of coefficients

(array c) performing an inverse quantization and inverse orthogonal transformation, and producing a residual block array (array r). *See, e.g.*, H.264 Standard at § 8.5.11.

55. The '238 Accused Products comprise a reproducing unit configured to reproduce a block image of the current block, from the obtained residual block image and a predictive block image obtained by intra-picture prediction or inter-picture prediction. For example, as explained above, the '238 Accused Products comprise an H.264/AVC decoder. This functionality is described in the H.264 Standard, including, but not limited to, § 8.5.1, which describes the reconstruction of decoded block u from predicted block predL and residual block r. *See, e.g.*, H.264 Standard at § 8.5.1.

56. The '238 Accused Products comprise a coefficient number decoding unit, as described above, which includes a determining unit configured to determine a predictive value for the number of non-zero coefficients included in the current block based on the number of non-zero coefficients included in a decoded block located on a periphery of the current block. This functionality is described in the H.264 Standard, including, but not limited to, § 9.2.1, which describes the determining of predictive value nC, which is derived based on nA (number of non-zero coefficients in a left-hand adjacent block) and nB (number of non-zero coefficients in an upper adjacent block). *See, e.g.*, H.264 Standard at § 9.2.1.

57. The '238 Accused Products comprise a coefficient number decoding unit, as described above, which includes a selecting unit configured to select a variable length code table based on the determined predictive value. The '238 Accused Products comprise an H.264/AVC decoder which practices this functionality. The functionality is described in the H.264 Standard, including, but not limited to, Table 9-5, in which the selection of a particular column (*i.e.*, a particular variable length code table) depends on the predictive value nC. *See, e.g.*, H.264

Standard at § 9.2.1.

58. The '238 Accused Products comprise a coefficient number decoding unit, as described above, which includes a variable length decoding unit configured to perform variable length decoding on a coded stream which is generated by coding the number of the non-zero coefficients included in the current block, by using the selected variable length code table. The '238 Accused Products comprise an H.264/AVC decoder which practices this functionality. This functionality is described in the H.264 Standard, including, but not limited to, § 9.2.1, which describes the variable length decoding of TotalCoeff, the number of non-zero coefficient in a block.

59. Thus, as described above, the '238 Accused Products, including the Nexus 6P, infringe one or more claims of the '238 patent, including claim 1.

60. The '238 Accused Products are pre-configured and sold by Huawei to infringe the '238 patent. Huawei provides instruction manuals that instruct the users of the '238 Accused Products to use the '238 Accused Products in a manner that infringes the '238 patent.

B. Huawei Makes, Imports, Uses, Sells, and/or Offers for Sale Products and Services that Infringe the '216 Patent.

61. On information and belief, Huawei makes, uses, sells, and offers to sell, in the United States, and imports into the United States, LTE compliant devices, such as mobiles and tablets, including, but not limited to, the Huawei Nexus 6P, Huawei Mate 9, Huawei Mate 8, Huawei P8 Lite, Huawei SnapTo, Huawei Ascend Mate 2, Huawei Ascend Mate 7, Huawei Ascend P7, Huawei Mate S, Huawei P8, Huawei P9, Huawei Ascend G7, Huawei GX8, Huawei G7 Plus, Honor 5X, Honor 6, Honor 7, Honor 8, Huawei Union, Huawei Vitria, Huawei Vision 3 LTE, Huawei MediaPad T1 8.0 Pro, and Huawei MediaPad M3 (hereinafter, "LTE Accused Products").

62. The LTE Accused Products infringe one or more claims of the '216 patent.

63. The '216 patent is essential to the LTE Standard. Thus, for example and as shown below, the LTE Accused Products infringe claim 1 of the '216 patent by virtue of their compatibility with and practice of the LTE Standard, as demonstrated by the 3GPP LTE Standard Specifications.

64. The 3GPP LTE Specifications cover transmitters for transmitting a digital data block to a receiver. For example, the LTE Specifications cover the use of mobile stations in LTE connectivity and communication. *See, e.g.*, 3GPP TS 36.201.

65. The 3GPP LTE Specifications require that LTE compliant devices include a coding circuit for coding the digital data block and generating a mother code word. *See, e.g.*, 3GPP TS 36.212, 3GPP TS 36.213.

66. The 3GPP LTE Specifications require that LTE compliant devices include a reordering circuit for reordering the mother code word and generating a reordered mother code word, wherein the reordered mother code word is generated based on an ordering vector, the ordering vector defining an order in which bits forming the reordered mother code word are to be modulated and forwarded to a receiver. *See, e.g.*, 3GPP TS 36.212.

67. The 3GPP LTE Specifications require that LTE compliant devices include a modulating circuit for modulating at least one subsequence and for forwarding, to the receiver, the at least one modulated subsequence, each of the at least one modulated subsequence having a desired number of bits taken from the reordered mother code word to fill the available bandwidth of at least one available gross rate channel. *See, e.g.*, 3GPP TS 36.211, 3GPP TS 36.212, 3GPP TS 36.213.

68. Thus, as described above, the LTE Accused Products infringe one or more claims

of the '216 patent, including claim 1.

69. The LTE Accused Products are pre-configured and sold by Huawei to infringe the '216 patent. Huawei advertises the ability of the LTE Accused Products to infringe the '216 patent, at least by advertising that the LTE Accused Products are compatible with the LTE Standard. Huawei provides instruction manuals that instruct the users of the LTE Accused Products to use the LTE Accused Products in a manner that infringes the '216 patent.

C. Huawei Makes, Imports, Uses, Sells, and/or Offers for Sale Products and Services that Infringe the '851 Patent.

70. The LTE Accused Products infringe one or more claims of the '851 patent.

71. The '851 patent is essential to the LTE Standard. Thus, for example and as shown below, the LTE Accused Products infringe claim 1 of the '851 patent by virtue of their compatibility with and practice of the LTE Standard, as demonstrated by the 3GPP LTE Standard Specifications.

72. The 3GPP LTE Specifications cover radio communication apparatuses. For example, the LTE Specifications cover the use of mobile stations in LTE connectivity and communication. *See, e.g.*, 3GPP TS 36.201.

73. The 3GPP LTE Specifications require that LTE compliant devices include a receiving unit configured to receive first data and second data, which are transmitted from a plurality of antennas for spatial-multiplexing using a plurality of blocks, into which a plurality of consecutive subcarriers in a frequency domain are divided. *See, e.g.*, 3GPP TS 36.211, 3GPP TS 36.213.

74. The 3GPP LTE Specifications require that LTE compliant devices include a calculating unit configured to calculate a first absolute channel quality indicator (CQI) value per each of the blocks for the first data and a second absolute CQI value per each of the blocks for

the second data, and calculate a relative CQI value of the second absolute CQI value with respect to the first absolute CQI value, per each of the blocks, from the first absolute CQI value and the second absolute CQI value in the same block. *See, e.g.*, 3GPP TS 36.211, 3GPP TS 36.213.

75. The 3GPP LTE Specifications require that LTE compliant devices include a transmitting unit configured to transmit the first absolute CQI value and the relative CQI value of the second absolute CQI value in the same block. *See, e.g.*, 3GPP TS 36.211, 3GPP TS 36.213.

76. The 3GPP LTE Specifications require that LTE compliant devices include a transmitting unit configured to transmit the first absolute CQI value and the relative CQI value of the second absolute CQI value in the same block; wherein the relative CQI value of the second absolute CQI value in the first block of the plurality of blocks for the second data is calculated with respect to the first absolute CQI value in the first block of the plurality of blocks for the first data, and the relative CQI value of the second absolute CQI value in the second block of the plurality of blocks for the second data is calculated with respect to the first absolute CQI value in the second block of the plurality of blocks for the first data. *See, e.g.*, 3GPP TS 36.211, 3GPP TS 36.213.

77. Thus, as described above, the LTE Accused Products infringe one or more claims of the '851 patent, including claim 1.

78. The LTE Accused Products are pre-configured and sold by Huawei to infringe the '851 patent. Huawei advertises the ability of the LTE Accused Products to infringe the '851 patent, at least by advertising that the LTE Accused Products are compatible with the LTE Standard. Huawei provides instruction manuals that instruct the users of the LTE Accused Products to use the LTE Accused Products in a manner that infringes the '851 patent.

D. Huawei Makes, Imports, Uses, Sells, and/or Offers for Sale Products and Services that Infringe the '284 Patent.

79. The LTE Accused Products infringe one or more claims of the '284 patent.

80. The '284 patent is essential to the LTE Standard. Thus, for example and as shown below, the LTE Accused Products infringe claim 1 of the '284 patent by virtue of their compatibility with and practice of the LTE Standard, as demonstrated by the 3GPP LTE Standard Specifications.

81. The 3GPP LTE Specifications cover radio communication apparatuses. For example, the LTE Specifications cover the use of mobile stations in LTE connectivity and communication. *See, e.g.*, 3GPP TS 36.201.

82. The 3GPP LTE Specifications require that LTE compliant devices include a receiver unit for receiving a sub-frame of physical radio resources comprising a control channel signal destined to the mobile terminal. *See, e.g.*, 3GPP TS 36.213.

83. The 3GPP LTE Specifications require that LTE compliant devices include a processing unit for determining based on the received control channel signal a transport format of and a redundancy version for an initial transmission or a retransmission of a protocol data unit conveying user data. *See, e.g.*, 3GPP TS 36.213; 3GPP TS 36.212.

84. The 3GPP LTE Specifications require that LTE compliant devices include a transmitter unit for transmitting the protocol data unit on at least one physical radio resource using the transport format and the redundancy version of the protocol data unit indicated in the received control channel signal. *See, e.g.*, 3GPP TS 36.213; 3GPP TS 36.212.

85. The 3GPP LTE Specifications require that LTE compliant devices include a transmitter unit for transmitting the protocol data unit on at least one physical radio resource using the transport format and the redundancy version of the protocol data unit indicated in the

received control channel signal; wherein the control channel signal received within said sub-frame comprises a control information field, in which the transport format and the redundancy version of the protocol data unit are jointly encoded. *See, e.g.*, 3GPP TS 36.213; 3GPP TS 36.212.

86. The 3GPP LTE Specifications require that LTE compliant devices include a processing unit further configured for the determination of the control information field, which consists of a number of bits representing a range of values that can be represented in the control information field. *See, e.g.*, 3GPP TS 36.213.

87. The 3GPP LTE Specifications require that LTE compliant devices include a processing unit further configured for the determination of the control information field, which consists of a number of bits representing a range of values that can be represented in the control information field, wherein a first subset of the values is reserved for indicating the transport format of the protocol data unit and a second subset of the values, different from the first subset of the values, is reserved for indicating the redundancy version for transmitting the user data. *See, e.g.*, 3GPP TS 36.213.

88. The 3GPP LTE Specifications require that LTE compliant devices include a processing unit further configured for the determination of the control information field, which consists of a number of bits representing a range of values that can be represented in the control information field, wherein a first subset of the values is reserved for indicating the transport format of the protocol data unit and a second subset of the values, different from the first subset of the values, is reserved for indicating the redundancy version for transmitting the user data, wherein the first subset of the values contains more values than the second subset of the values. *See, e.g.*, 3GPP TS 36.213.

89. Thus, as described above, the LTE Accused Products infringe one or more claims of the '284 patent, including claim 1.

90. The LTE Accused Products are pre-configured and sold by Huawei to infringe the '284 patent. Huawei advertises the ability of the LTE Accused Products to infringe the '284 patent, at least by advertising that the LTE Accused Products are compatible with the LTE Standard. Huawei provides instruction manuals that instruct the users of the LTE Accused Products to use the LTE Accused Products in a manner that infringes the '284 patent.

E. Huawei Makes, Imports, Uses, Sells, and/or Offers for Sale Products and Services that Infringe the '569 Patent.

91. The LTE Accused Products infringe one or more claims of the '569 patent.

92. The '569 patent is essential to the LTE Standard. Thus, for example and as shown below, the LTE Accused Products infringe claim 11 of the '569 patent by virtue of their compatibility with and practice of the LTE Standard, as demonstrated by the 3GPP LTE Standard Specifications.

93. The 3GPP LTE Specifications require that LTE compliant devices include a reception apparatus. *See, e.g.*, 3GPP TS 36.104.

94. The 3GPP LTE Specifications require that LTE compliant devices include a receiving section configured to receive encoded first data which is mapped to symbols in a first part of a domain comprising a time index and a frequency index, and encoded second data which is mapped to groups of symbols in a second part of the domain. *See, e.g.*, 3GPP TS 36.211.

95. The 3GPP LTE Specifications require that LTE compliant devices include a decoding section configured to decode the encoded first data and the encoded second data. *See, e.g.*, 3GPP TS 36.213, 3GPP TS 36.211.

96. The 3GPP LTE Specifications require that LTE compliant devices include a

decoding section configured to decode the encoded first data and the encoded second data, wherein at least a part of the encoded first data is mapped to at least a part of the symbols in the first part of the domain in an increasing order according to the frequency index. *See, e.g.*, 3GPP TS 36.213, 3GPP TS 36.211.

97. The 3GPP LTE Specifications require that LTE compliant devices include a decoding section configured to decode the encoded first data and the encoded second data, wherein at least a part of the encoded second data is mapped to at least a part of the groups of symbols in the second part of the domain and each group of the at least a part of the groups of symbols is aligned in an increasing order according to the time index. *See, e.g.*, 3GPP TS 36.213, 3GPP TS 36.211.

98. The 3GPP LTE Specifications require that LTE compliant devices include a decoding section configured to decode the encoded first data and the encoded second data, wherein at least a part of the encoded first data is mapped to at least a part of the symbols in the first part of the domain in an increasing order according to the frequency index; at least a part of the encoded second data is mapped to at least a part of the groups of symbols in the second part of the domain and each group of the at least a part of the groups of symbols is aligned in an increasing order according to the time index; and each symbol within each of the groups of symbols is aligned along the frequency index. *See, e.g.*, 3GPP TS 36.213, 3GPP TS 36.211.

99. Thus, as described above, the LTE Accused Products infringe one or more claims of the '569 patent, including claim 11.

100. The LTE Accused Products are pre-configured and sold by Huawei to infringe the '569 patent. Huawei advertises the ability of the LTE Accused Products to infringe the '569 patent, at least by advertising that the LTE Accused Products are compatible with the LTE

Standard. Huawei provides instruction manuals that instruct the users of the LTE Accused Products to use the LTE Accused Products in a manner that infringes the '569 patent.

F. Huawei Makes, Imports, Uses, Sells, and/or Offers for Sale Products and Services that Infringe the '833 Patent.

101. The LTE Accused Products infringe one or more claims of the '833 patent.

102. The '833 patent is essential to the LTE Standard. Thus, for example and as shown below, the LTE Accused Products infringe claim 1 of the '833 patent by virtue of their compatibility with and practice of the LTE Standard, as demonstrated by the 3GPP LTE Standard Specifications.

103. The 3GPP LTE Specifications require that LTE compliant devices be configured to perform a method for transmitting uplink signals comprising control signals and data signals in a wireless communication system. *See, e.g.*, 3GPP TS 36.212.

104. The 3GPP LTE Specifications require that LTE compliant devices be configured to perform the step of serially multiplexing first control signals and data signals in a mobile station, wherein the first control signals are placed at a front part of the multiplexed signals and the data signals are placed at a rear part of the multiplexed signals. *See, e.g.*, 3GPP TS 36.212.

105. The 3GPP LTE Specifications require that LTE compliant devices be configured to perform the step of mapping the multiplexed signals to a 2-dimensional resource matrix comprising a plurality of columns and a plurality of rows, wherein the columns and the rows of the 2-dimensional resource matrix correspond to single carrier frequency divisional multiple access (SC-FDMA) symbols and subcarriers for each SC-FDMA symbol, respectively, wherein a number of columns of the 2-dimensional resource matrix corresponds to a number of SC-FDMA symbols within one subframe except specific SC-FDMA symbols used for a reference signal, and wherein the multiplexed signals are mapped from the first column of the first row to the last

column of the first row, the first column of the second row to the last column of the second row, and so on, until all the multiplexed signals are mapped to the 2-dimensional resource matrix. *See, e.g.*, 3GPP TS 36.212, 3GPP TS 36.211.

106. The 3GPP LTE Specifications require that LTE compliant devices be configured to perform the step of mapping ACK/NACK control signals to specific columns of the 2-dimensional resource matrix, wherein the specific columns correspond to SC-FDMA symbols right adjacent to the specific SC-FDMA symbols, wherein the ACK/NACK control signals overwrite some of the multiplexed signals mapped to the 2-dimensional resource matrix from the last row of the specific columns. *See, e.g.*, 3GPP TS 36.212, 3GPP TS 36.211.

107. The 3GPP LTE Specifications require that LTE compliant devices be configured to perform the step of transmitting the signals mapped to the 2-dimensional resource matrix by column by column to a base station. *See, e.g.*, 3GPP TS 36.211.

108. Thus, as described above, the LTE Accused Products infringe one or more claims of the '833 patent, including claim 1.

109. The LTE Accused Products are pre-configured and sold by Huawei to infringe the '833 patent. Huawei advertises the ability of the LTE Accused Products to infringe the '833 patent, at least by advertising that the LTE Accused Products are compatible with the LTE Standard. Huawei provides instruction manuals that instruct the users of the LTE Accused Products to use the LTE Accused Products in a manner that infringes the '833 patent.

G. Huawei Makes, Imports, Uses, Sells, and/or Offers for Sale Products and Services that Infringe the '293 Patent.

110. The LTE Accused Products infringe one or more claims of the '293 patent.

111. The '293 patent is essential to the LTE Standard. Thus, for example and as shown below, the LTE Accused Products infringe claim 1 of the '293 patent by virtue of their

compatibility with and practice of the LTE Standard, as demonstrated by the 3GPP LTE Standard Specifications.

112. The 3GPP LTE Specifications require that LTE compliant devices be configured to perform a method for transmitting scheduling requests from a mobile terminal to a base station. *See, e.g.*, 3GPP TS 36.321.

113. The 3GPP LTE Specifications require that LTE compliant devices be configured to perform the step of transmitting a first scheduling request from the mobile terminal to the base station in response to first data becoming available for transmission from the mobile terminal to the base station. *See, e.g.*, 3GPP TS 36.321.

114. The 3GPP LTE Specifications require that LTE compliant devices be configured to perform the step of, after transmitting the first scheduling request, receiving at the mobile terminal a scheduling grant transmitted from the base station. *See, e.g.*, 3GPP TS 36.321.

115. The 3GPP LTE Specifications require that LTE compliant devices be configured to perform the step of, in response to receiving the scheduling grant, transmitting from the mobile terminal to the base station transmit buffer status information. *See, e.g.*, 3GPP TS 36.321.

116. The 3GPP LTE Specifications require that LTE compliant devices be configured to, while at least some of the first data is waiting to be transmitted to the base station and after transmitting the buffer status information, but prior to transmitting any subsequent scheduling requests to the base station, perform the steps of (1) determining whether a scheduling request triggering event has occurred, and (2) if a triggering event has occurred, then, in response to determining that the triggering event has occurred, at a next opportunity, transmitting a second scheduling requests to the base station. *See, e.g.*, 3GPP TS 36.321.

117. Thus, as described above, the LTE Accused Products infringe one or more claims

of the '293 patent, including claim 1.

118. The LTE Accused Products are pre-configured and sold by Huawei to infringe the '293 patent. Huawei advertises the ability of the LTE Accused Products to infringe the '293 patent, at least by advertising that the LTE Accused Products are compatible with the LTE Standard. Huawei provides instruction manuals that instruct the users of the LTE Accused Products to use the LTE Accused Products in a manner that infringes the '293 patent.

COUNT I: PATENT INFRINGEMENT OF THE '238 PATENT

119. PanOptis incorporates by reference the preceding paragraphs as though fully set forth herein.

120. The '238 patent, originally assigned to Panasonic and subsequently assigned to PanOptis, is not, and has not been declared, a standards-essential patent.

121. Huawei infringes the '238 patent by making, using, selling, offering for sale, and/or importing into the United States products and/or methods covered by one or more claims of the '238 patent. For example, the Nexus 6P, one of the '238 Accused Products, infringes at least claim 1 of the '238 patent. The accused devices that infringe one or more claims of the '238 patent include, but are not limited to, at least the '238 Accused Products.

122. The '238 Accused Products directly infringe one or more claims of the '238 Patent. Huawei makes, uses, sells, offers for sale, and/or imports, in this District and elsewhere in the United States these devices and thus directly infringes the '238 patent.

123. Huawei has knowledge of the '238 patent. Huawei has received actual notice of the '238 Patent at least as early as July 18, 2014, and again as of the date this lawsuit was filed and/or the date(s) the Original Complaint was served upon Huawei and/or a courtesy copy was provided.

124. Huawei indirectly infringes the '238 Patent, as provided in 35 U.S.C. § 271(b), by

inducing infringement by others, such as Huawei's customers and end-users, in this District and elsewhere in the United States. For example, Huawei's customers and end-users directly infringe through their use of the inventions claimed in the '238 patent. Huawei induces this direct infringement through its affirmative acts of manufacturing, selling, distributing, and/or otherwise making available the '238 Accused Products, and providing instructions, documentation, and other information to customers and end-users suggesting that they use the '238 Accused Products in an infringing manner, including in-store technical support, online technical support, marketing, product manuals, advertisements, online documentation, developer information, and API documentation. As a result of Huawei's inducement, Huawei's customers and end-users use the '238 Accused Products in the way Huawei intends and directly infringe the '238 patent. Huawei has performed and continues to perform these affirmative acts with knowledge of the '238 patent and with the intent, or willful blindness, that the induced acts directly infringe the '238 patent.

125. Huawei also indirectly infringes the '238 patent, as provided by 35 U.S.C. § 271(c), by contributing to direct infringement committed by others, such as customers and end-users, in this District and elsewhere in the United States. Huawei's affirmative acts of selling and offering to sell, in this District and elsewhere in the United States, the '238 Accused Products and causing the '238 Accused Products to be manufactured, used, sold, and offered for sale contribute to Huawei's customers' and end-users' use of the '238 Accused Products, such that the '238 patent is directly infringed. The accused components within the '238 Accused Products are material to the invention of the '238 patent, are not staple articles or commodities of commerce, have no substantial non-infringing uses, and are known by Huawei to be especially made or especially adapted for use in infringement of the '238 patent.

Huawei has performed and continues to perform these affirmative acts with knowledge of the '238 patent and with intent, or willful blindness, that they cause the direct infringement of the '238 patent.

126. Huawei's infringement of the '238 patent has been and continues to be willful.

127. Huawei's infringement of the '238 patent has damaged and will continue to damage PanOptis.

COUNT II: PATENT INFRINGEMENT OF THE '216 PATENT

128. PanOptis incorporates by reference the preceding paragraphs as though fully set forth herein.

129. Huawei infringes the '216 patent by making, using, selling, offering for sale, and/or importing into the United States products and/or methods covered by one or more claims of the '216 patent. For example, the LTE Accused Products infringe at least claim 1 of the '216 patent. The accused devices that infringe one or more claims of the '216 patent include, but are not limited to, at least the LTE Accused Products.

130. The LTE Accused Products directly infringe one or more claims of the '216 patent. Huawei makes, uses, sells, offers for sale, and/or imports, in this District and elsewhere in the United States these devices and thus directly infringes the '216 patent.

131. Huawei has knowledge of the '216 patent. Huawei has received actual notice of the '216 patent at least as early as July 18, 2014, and again as of the date this lawsuit was filed and/or the date(s) the Original Complaint was served upon Huawei and/or a courtesy copy was provided.

132. Huawei indirectly infringes the '216 patent, as provided in 35 U.S.C. § 271(b), by inducing infringement by others, such as Huawei's customers and end-users, in this District and elsewhere in the United States. For example, Huawei's customers and end-users directly infringe

through their use of the inventions claimed in the '216 patent. Huawei induces this direct infringement through its affirmative acts of manufacturing, selling, distributing, and/or otherwise making available the LTE Accused Products, and providing instructions, documentation, and other information to customers and end-users suggesting they use the LTE Accused Products in an infringing manner, including in-store technical support, online technical support, marketing, product manuals, advertisements, online documentation, developer information, and API documentation. As a result of Huawei's inducement, Huawei's customers and end-users use the LTE Accused Products in the way Huawei intends and directly infringe the '216 patent. Huawei has performed and continues to perform these affirmative acts with knowledge of the '216 patent and with the intent, or willful blindness, that the induced acts directly infringe the '216 patent.

133. Huawei also indirectly infringes the '216 patent, as provided by 35 U.S.C. § 271(c), by contributing to direct infringement committed by others, such as customers and end-users, in this District and elsewhere in the United States. Huawei's affirmative acts of selling and offering to sell, in this District and elsewhere in the United States, the LTE Accused Products and causing the LTE Accused Products to be manufactured, used, sold, and offered for sale contribute to Huawei's customers' and end-users' use of the LTE Accused Products, such that the '216 patent is directly infringed. The accused components within the LTE Accused Products are material to the invention of the '216 patent, are not staple articles or commodities of commerce, have no substantial non-infringing uses, and are known by Huawei to be especially made or especially adapted for use in infringement of the '216 patent. Huawei has performed and continues to perform these affirmative acts with knowledge of the '216 patent and with intent, or willful blindness, that they cause the direct infringement of the '216 patent.

134. Huawei's infringement of the '216 patent has been and continues to be willful.

135. Huawei's infringement of the '216 patent has damaged and will continue to damage PanOptis.

COUNT III: PATENT INFRINGEMENT OF THE '851 PATENT

136. PanOptis incorporates by reference the preceding paragraphs as though fully set forth herein.

137. Huawei infringes the '851 patent by making, using, selling, offering for sale, and/or importing into the United States products and/or methods covered by one or more claims of the '851 patent. For example, the LTE Accused Products infringe at least claim 1 of the '851 patent. The accused devices that infringe one or more claims of the '851 patent include, but are not limited to, at least the LTE Accused Products.

138. The LTE Accused Products directly infringe one or more claims of the '851 patent. Huawei makes, uses, sells, offers for sale, and/or imports, in this District and elsewhere in the United States these devices and thus directly infringes the '851 patent.

139. Huawei has knowledge of the '851 patent. Huawei has received actual notice of the '851 patent at least as early as July 18, 2014, and again as of the date this lawsuit was filed and/or the date(s) the Original Complaint was served upon Huawei and/or a courtesy copy was provided.

140. Huawei indirectly infringes the '851 patent, as provided in 35 U.S.C. § 271(b), by inducing infringement by others, such as Huawei's customers and end-users, in this District and elsewhere in the United States. For example, Huawei's customers and end-users directly infringe through their use of the inventions claimed in the '851 patent. Huawei induces this direct infringement through its affirmative acts of manufacturing, selling, distributing, and/or otherwise making available the LTE Accused Products, and providing instructions, documentation, and

other information to customers and end-users suggesting they use the LTE Accused Products in an infringing manner, including in-store technical support, online technical support, marketing, product manuals, advertisements, online documentation, developer information, and API documentation. As a result of Huawei's inducement, Huawei's customers and end-users use the LTE Accused Products in the way Huawei intends and directly infringe the '851 patent. Huawei has performed and continues to perform these affirmative acts with knowledge of the '851 patent and with the intent, or willful blindness, that the induced acts directly infringe the '851 patent.

141. Huawei also indirectly infringes the '851 patent, as provided by 35 U.S.C. § 271(c), by contributing to direct infringement committed by others, such as customers and end-users, in this District and elsewhere in the United States. Huawei's affirmative acts of selling and offering to sell, in this District and elsewhere in the United States, the LTE Accused Products and causing the LTE Accused Products to be manufactured, used, sold, and offered for sale contribute to Huawei's customers' and end-users' use of the LTE Accused Products, such that the '851 patent is directly infringed. The accused components within the LTE Accused Products are material to the invention of the '851 patent, are not staple articles or commodities of commerce, have no substantial non-infringing uses, and are known by Huawei to be especially made or especially adapted for use in infringement of the '851 patent. Huawei has performed and continues to perform these affirmative acts with knowledge of the '851 patent and with intent, or willful blindness, that they cause the direct infringement of the '851 patent.

142. Huawei's infringement of the '851 patent has been and continues to be willful.

143. Huawei's infringement of the '851 patent has damaged and will continue to damage PanOptis.

COUNT IV: PATENT INFRINGEMENT OF THE '284 PATENT

144. PanOptis incorporates by reference the preceding paragraphs as though fully set forth herein.

145. Huawei infringes the '284 patent by making, using, selling, offering for sale, and/or importing into the United States products and/or methods covered by one or more claims of the '284 patent. For example, the LTE Accused Products infringe at least claim 1 of the '284 patent. The accused devices that infringe one or more claims of the '284 patent include, but are not limited to, at least the LTE Accused Products.

146. The LTE Accused Products directly infringe one or more claims of the '284 patent. Huawei makes, uses, sells, offers for sale, and/or imports, in this District and elsewhere in the United States these devices and thus directly infringes the '284 patent.

147. Huawei has knowledge of the '284 patent. Huawei has received actual notice of the '284 patent at least as early as July 18, 2014, and again as of the date this lawsuit was filed and/or the date(s) the Original Complaint was served upon Huawei and/or a courtesy copy was provided.

148. Huawei indirectly infringes the '284 patent, as provided in 35 U.S.C. § 271(b), by inducing infringement by others, such as Huawei's customers and end-users, in this District and elsewhere in the United States. For example, Huawei's customers and end-users directly infringe through their use of the inventions claimed in the '284 patent. Huawei induces this direct infringement through its affirmative acts of manufacturing, selling, distributing, and/or otherwise making available the LTE Accused Products, and providing instructions, documentation, and other information to customers and end-users suggesting they use the LTE Accused Products in an infringing manner, including in-store technical support, online technical support, marketing, product manuals, advertisements, online documentation, developer information, and API

documentation. As a result of Huawei's inducement, Huawei's customers and end-users use the LTE Accused Products in the way Huawei intends and directly infringe the '284 patent. Huawei has performed and continues to perform these affirmative acts with knowledge of the '284 patent and with the intent, or willful blindness, that the induced acts directly infringe the '284 patent.

149. Huawei also indirectly infringes the '284 patent, as provided by 35 U.S.C. § 271(c), by contributing to direct infringement committed by others, such as customers and end-users, in this District and elsewhere in the United States. Huawei's affirmative acts of selling and offering to sell, in this District and elsewhere in the United States, the LTE Accused Products and causing the LTE Accused Products to be manufactured, used, sold, and offered for sale contribute to Huawei's customers' and end-users' use of the LTE Accused Products, such that the '284 patent is directly infringed. The accused components within the LTE Accused Products are material to the invention of the '284 patent, are not staple articles or commodities of commerce, have no substantial non-infringing uses, and are known by Huawei to be especially made or especially adapted for use in infringement of the '284 patent. Huawei has performed and continues to perform these affirmative acts with knowledge of the '284 patent and with intent, or willful blindness, that they cause the direct infringement of the '284 patent.

150. Huawei's infringement of the '284 patent has been and continues to be willful.

151. Huawei's infringement of the '284 patent has damaged and will continue to damage PanOptis.

COUNT V: PATENT INFRINGEMENT OF THE '569 PATENT

152. PanOptis incorporates by reference the preceding paragraphs as though fully set forth herein.

153. Huawei infringes the '569 patent by making, using, selling, offering for sale,

and/or importing into the United States products and/or methods covered by one or more claims of the '569 patent. For example, the LTE Accused Products infringe at least claim 11 of the '569 patent. The accused devices that infringe one or more claims of the '569 patent include, but are not limited to, at least the LTE Accused Products.

154. The LTE Accused Products directly infringe one or more claims of the '569 patent. Huawei makes, uses, sells, offers for sale, and/or imports, in this District and elsewhere in the United States these devices and thus directly infringes the '569 patent.

155. Huawei has knowledge of the '569 patent. Huawei has received actual notice of the '569 patent at least as early as July 18, 2014, and again as of the date this lawsuit was filed and/or the date(s) the Original Complaint was served upon Huawei and/or a courtesy copy was provided.

156. Huawei indirectly infringes the '569 patent, as provided in 35 U.S.C. § 271(b), by inducing infringement by others, such as Huawei's customers and end-users, in this District and elsewhere in the United States. For example, Huawei's customers and end-users directly infringe through their use of the inventions claimed in the '569 patent. Huawei induces this direct infringement through its affirmative acts of manufacturing, selling, distributing, and/or otherwise making available the LTE Accused Products, and providing instructions, documentation, and other information to customers and end-users suggesting they use the LTE Accused Products in an infringing manner, including in-store technical support, online technical support, marketing, product manuals, advertisements, online documentation, developer information, and API documentation. As a result of Huawei's inducement, Huawei's customers and end-users use the LTE Accused Products in the way Huawei intends and directly infringe the '569 patent. Huawei has performed and continues to perform these affirmative acts with knowledge of the '569 patent

and with the intent, or willful blindness, that the induced acts directly infringe the '569 patent.

157. Huawei also indirectly infringes the '569 patent, as provided by 35 U.S.C. § 271(c), by contributing to direct infringement committed by others, such as customers and end-users, in this District and elsewhere in the United States. Huawei's affirmative acts of selling and offering to sell, in this District and elsewhere in the United States, the LTE Accused Products and causing the LTE Accused Products to be manufactured, used, sold, and offered for sale contribute to Huawei's customers' and end-users' use of the LTE Accused Products, such that the '569 patent is directly infringed. The accused components within the LTE Accused Products are material to the invention of the '569 patent, are not staple articles or commodities of commerce, have no substantial non-infringing uses, and are known by Huawei to be especially made or especially adapted for use in infringement of the '569 patent. Huawei has performed and continues to perform these affirmative acts with knowledge of the '569 patent and with intent, or willful blindness, that they cause the direct infringement of the '569 patent.

158. Huawei's infringement of the '569 patent has been and continues to be willful.

159. Huawei's infringement of the '569 patent has damaged and will continue to damage PanOptis.

COUNT VI: PATENT INFRINGEMENT OF THE '833 PATENT

160. PanOptis incorporates by reference the preceding paragraphs as though fully set forth herein.

161. Huawei infringes the '833 patent by making, using, selling, offering for sale, and/or importing into the United States products and/or methods covered by one or more claims of the '833 patent. For example, the LTE Accused Products infringe at least claim 1 of the '833 patent. The accused devices that infringe one or more claims of the '833 patent include, but are

not limited to, at least the LTE Accused Products.

162. The LTE Accused Products directly infringe one or more claims of the '833 patent. Huawei makes, uses, sells, offers for sale, and/or imports, in this District and elsewhere in the United States these devices and thus directly infringes the '833 patent.

163. Huawei has knowledge of the '833 patent. Huawei has received actual notice of the '833 patent at least as early as July 18, 2014, and again as of the date this lawsuit was filed and/or the date(s) the Second Amended Complaint was served upon Huawei and/or a courtesy copy was provided.

164. Huawei indirectly infringes the '833 patent, as provided in 35 U.S.C. § 271(b), by inducing infringement by others, such as Huawei's customers and end-users, in this District and elsewhere in the United States. For example, Huawei's customers and end-users directly infringe through their use of the inventions claimed in the '833 patent. Huawei induces this direct infringement through its affirmative acts of manufacturing, selling, distributing, and/or otherwise making available the LTE Accused Products, and providing instructions, documentation, and other information to customers and end-users suggesting they use the LTE Accused Products in an infringing manner, including in-store technical support, online technical support, marketing, product manuals, advertisements, online documentation, developer information, and API documentation. As a result of Huawei's inducement, Huawei's customers and end-users use the LTE Accused Products in the way Huawei intends and directly infringe the '833 patent. Huawei has performed and continues to perform these affirmative acts with knowledge of the '833 patent and with the intent, or willful blindness, that the induced acts directly infringe the '833 patent.

165. Huawei also indirectly infringes the '833 patent, as provided by 35 U.S.C. § 271(c), by contributing to direct infringement committed by others, such as

customers and end-users, in this District and elsewhere in the United States. Huawei's affirmative acts of selling and offering to sell, in this District and elsewhere in the United States, the LTE Accused Products and causing the LTE Accused Products to be manufactured, used, sold, and offered for sale contribute to Huawei's customers' and end-users' use of the LTE Accused Products, such that the '833 patent is directly infringed. The accused components within the LTE Accused Products are material to the invention of the '833 patent, are not staple articles or commodities of commerce, have no substantial non-infringing uses, and are known by Huawei to be especially made or especially adapted for use in infringement of the '833 patent. Huawei has performed and continues to perform these affirmative acts with knowledge of the '833 patent and with intent, or willful blindness, that they cause the direct infringement of the '833 patent.

166. Huawei's infringement of the '833 patent has been and continues to be willful.

167. Huawei's infringement of the '833 patent has damaged and will continue to damage PanOptis.

COUNT VII: PATENT INFRINGEMENT OF THE '293 PATENT

168. PanOptis incorporates by reference the preceding paragraphs as though fully set forth herein.

169. Huawei infringes the '293 patent by making, using, selling, offering for sale, and/or importing into the United States products and/or methods covered by one or more claims of the '293 patent. For example, the LTE Accused Products infringe at least claim 1 of the '293 patent. The accused devices that infringe one or more claims of the '293 patent include, but are not limited to, at least the LTE Accused Products.

170. The LTE Accused Products directly infringe one or more claims of the '293 patent. Huawei makes, uses, sells, offers for sale, and/or imports, in this District and elsewhere in

the United States these devices and thus directly infringes the '293 patent.

171. Huawei has knowledge of the '293 patent. Huawei has received actual notice of the '293 patent at least as early as July 18, 2014, and again as of the date this lawsuit was filed and/or the date(s) the Second Amended Complaint was served upon Huawei and/or a courtesy copy was provided.

172. Huawei indirectly infringes the '293 patent, as provided in 35 U.S.C. § 271(b), by inducing infringement by others, such as Huawei's customers and end-users, in this District and elsewhere in the United States. For example, Huawei's customers and end-users directly infringe through their use of the inventions claimed in the '293 patent. Huawei induces this direct infringement through its affirmative acts of manufacturing, selling, distributing, and/or otherwise making available the LTE Accused Products, and providing instructions, documentation, and other information to customers and end-users suggesting they use the LTE Accused Products in an infringing manner, including in-store technical support, online technical support, marketing, product manuals, advertisements, online documentation, developer information, and API documentation. As a result of Huawei's inducement, Huawei's customers and end-users use the LTE Accused Products in the way Huawei intends and directly infringe the '293 patent. Huawei has performed and continues to perform these affirmative acts with knowledge of the '293 patent and with the intent, or willful blindness, that the induced acts directly infringe the '293 patent.

173. Huawei also indirectly infringes the '293 patent, as provided by 35 U.S.C. § 271(c), by contributing to direct infringement committed by others, such as customers and end-users, in this District and elsewhere in the United States. Huawei's affirmative acts of selling and offering to sell, in this District and elsewhere in the United States, the LTE Accused Products and causing the LTE Accused Products to be manufactured, used,

sold, and offered for sale contribute to Huawei's customers' and end-users' use of the LTE Accused Products, such that the '293 patent is directly infringed. The accused components within the LTE Accused Products are material to the invention of the '293 patent, are not staple articles or commodities of commerce, have no substantial non-infringing uses, and are known by Huawei to be especially made or especially adapted for use in infringement of the '293 patent. Huawei has performed and continues to perform these affirmative acts with knowledge of the '293 patent and with intent, or willful blindness, that they cause the direct infringement of the '293 patent.

174. Huawei's infringement of the '293 patent has been and continues to be willful.

175. Huawei's infringement of the '293 patent has damaged and will continue to damage PanOptis.

COUNT VIII: WILLFUL INFRINGEMENT

176. PanOptis incorporates by reference the preceding paragraphs as though fully set forth herein.

177. Huawei has willfully infringed and/or does willfully infringe each of the Patents-in-Suit.

178. Huawei received actual notice of each of the Patents-in-Suit at least as early as July 18, 2014, by way of correspondence that PanOptis sent to Huawei.

179. After receiving such actual notice of each of the Patents-in-Suit, Huawei proceeded to make, use, test, sell, and offer to sell in this District and elsewhere in the United States, and import into this District and elsewhere in the United States, the Huawei Accused Products.

180. On information and belief, Huawei engaged in such activities despite an objectively high likelihood that its actions constituted infringement of valid patents.

Furthermore, Huawei knew or should have known that its actions constituted and/or would cause the direct infringement of each of the Patents-in-Suit.

COUNT IX: DECLARATORY JUDGMENT

181. PanOptis incorporates by reference the preceding paragraphs as though fully set forth herein.

182. PanOptis owns patents essential to various standards—including, for example, LTE—and PPM possesses the full rights to license these patents to Huawei. PanOptis, as possessing the full rights in patents that are standards essential and remain standards essential, is obligated to offer Huawei a license to its standards essential patents on FRAND terms.

183. Huawei makes, has made, sells, leases, disposes of, repairs, uses, and operates products and uses methods that practice various standards—including, for example, LTE—and is, therefore, required to obtain a license under the PanOptis standards essential patents.

184. There is a case or controversy, of sufficient immediacy and reality to warrant declaratory judgment as to whether PanOptis has complied with its commitments to offer a license to its essential patents on FRAND terms. PanOptis has in good faith presented Huawei with FRAND terms for a worldwide license under PanOptis's entire portfolio of standards essential patents. Huawei, however, has rebuffed and continues to rebuff PanOptis's good faith efforts to negotiate a license with Huawei.

185. PanOptis is entitled to a declaratory judgment that it has complied with its obligations arising from declaring its patents essential to various standards, and any applicable laws, during their negotiations with Huawei concerning a worldwide license under the PanOptis standards essential patents.

DAMAGES

186. Under the law, PanOptis is entitled to compensation for Huawei's infringement as

set forth herein. However, the full compensation due cannot be ascertained except through discovery and special accounting. To the fullest extent permitted by law, PanOptis seeks recovery of at least reasonable royalties. PanOptis further seeks any other damages to which PanOptis is entitled under law or in equity.

187. Pursuant to 35 U.S.C. § 287(a), PanOptis is entitled to pre-suit damages from at least the date that Huawei was given notice of infringement of the Patents-in-Suit starting on July 18, 2014.

ATTORNEYS' FEES

188. PanOptis is entitled to recover reasonable attorneys' fees under applicable law, including 35 U.S.C. § 285 given the exceptional nature of this case.

DEMAND FOR JURY TRIAL

189. PanOptis hereby demands a trial by jury for all claims so triable.

PRAYER FOR RELIEF

WHEREFORE, PanOptis respectfully requests that this Court enter judgment in its favor as follows:

- A. that Huawei infringes the Patents-in-Suit;
- B. that Huawei's infringement of the Patents-in-Suit was willful, and that Huawei's continued infringement of these patents is willful;
- C. awarding PanOptis damages in an amount adequate to compensate PanOptis for Huawei's infringement of the Patents-in-Suit, but in no event less than a reasonable royalty under 35 U.S.C. § 284, including supplemental damages for any continuing post-verdict infringement up until entry of the final judgment;
- D. awarding enhanced damages pursuant to 35 U.S.C. § 284;
- E. awarding PanOptis pre-judgment and post-judgment interest to the full extent

allowed under the law, as well as its costs;

- F. awarding a compulsory future royalty payable on each infringing product sold by Huawei following trial or that is not captured in the damages awarded to PanOptis;
- G. entering an order finding that this is an exceptional case and awarding PanOptis its reasonable attorneys' fees pursuant to 35 U.S.C. § 285;
- H. entering a declaratory judgment that PanOptis has complied with its obligations arising from its licensing declarations to ETSI, ETSI's IPR Policy, and any applicable laws during its negotiations with Huawei concerning a worldwide license under the PanOptis standards essential patents;
- I. ordering an accounting of damages;
- J. awarding PanOptis its costs of suit; and
- K. awarding such other relief as the Court may deem appropriate and just under the circumstances.

Dated: April 14, 2017.

McKool Smith, P.C.

/s/ Kevin L. Burgess

Kevin L. Burgess – Lead Counsel

Texas State Bar No. 24006927

kburgess@McKoolSmith.com

Steve J. Pollinger

Texas State Bar No. 24011919

spollinger@McKoolSmith.com

Scott L. Cole

Texas State Bar No. 00790481

scole@McKoolSmith.com

Yusuf A. Rangwala

Texas State Bar No. 24086557

yrangwala@McKoolSmith.com

Kevin P. Hess

Texas State Bar No. 24087717

khess@McKoolSmith.com

Christine M. Woodin

Texas State Bar No. 24100051

cwoodin@McKoolSmith.com

McKool Smith, P.C.

300 W. 6th Street Suite 1700

Austin, TX 78701

Telephone: (512) 692-8700

Telecopier: (512) 692-8744

Samuel F. Baxter

Texas State Bar No. 1938000

sbaxter@McKoolSmith.com

Jennifer Truelove

Texas State Bar No. 24012906

jtruelove@McKoolSmith.com

McKool Smith, P.C.

104 E. Houston Street, Suite 300

Marshall, TX 75670

Telephone: (903) 923-9000

Telecopier: (903) 923-9099

Marcus L. Rabinowitz

Texas State Bar No. 24098293

mrabinowitz@McKoolSmith.com

McKool Smith, P.C.

300 Crescent Court, Suite 1500

Dallas, TX 75201

Telephone: (214) 978-4000

Telecopier: (214) 978-4044

Eric S. Tautfest
Texas Bar No. 24028534
etautfest@grayreed.com
Jared Hoggan
Texas Bar No. 24065435
jhoggan@grayreed.com
David T. DeZern
Texas Bar No. 24059677
ddezern@grayreed.com
M. Jill Bindler
Texas Bar No. 02319600
jbindler@grayreed.com
David Lisch
Texas Bar No. 24077179
dlish@grayreed.com
GRAY REED & MCGRAW, LLP
1601 Elm Street, Suite 4600
Dallas, Texas 75201
Telephone: (214) 954-4135
Facsimile: (469) 320-6901

**ATTORNEYS FOR PLAINTIFFS
OPTIS WIRELESS TECHNOLOGY,
LLC, OPTIS CELLULAR
TECHNOLOGY, LLC, AND PANOPTIS
PATENT MANAGEMENT, LLC**

EXHIBIT 1

(12) **United States Patent**
Abe et al.

(10) **Patent No.:** **US 7,769,238 B2**
 (45) **Date of Patent:** **Aug. 3, 2010**

(54) **PICTURE CODING METHOD AND PICTURE DECODING METHOD**

(56) **References Cited**

(75) Inventors: **Kiyofumi Abe**, Kadoma (JP); **Shinya Kadono**, Nishinomiya (JP); **Satoshi Kondo**, Yawata (JP); **Makoto Hagai**, Moriguchi (JP)

(73) Assignee: **Panasonic Corporation**, Osaka (JP)

(*) Notice: Subject to any disclaimer, the term of this patent is extended or adjusted under 35 U.S.C. 154(b) by 508 days.

U.S. PATENT DOCUMENTS

5,500,678 A	3/1996	Puri	
5,510,841 A	4/1996	Iwamura	
5,512,952 A	4/1996	Iwamura	
5,563,593 A	10/1996	Puri	
5,576,765 A	11/1996	Cheney et al.	
5,603,012 A *	2/1997	Sotheran	712/208
5,668,599 A	9/1997	Cheney et al.	
5,740,283 A	4/1998	Meeker	
5,777,679 A	7/1998	Cheney et al.	
5,784,631 A *	7/1998	Wise	382/246
5,821,887 A	10/1998	Zhu	
5,974,184 A	10/1999	Eifrig et al.	
6,020,923 A	2/2000	Hosaka et al.	

(21) Appl. No.: **11/976,758**

(Continued)

(22) Filed: **Oct. 26, 2007**

FOREIGN PATENT DOCUMENTS

(65) **Prior Publication Data**
 US 2008/0175315 A1 Jul. 24, 2008

JP 4-100390 4/1992

(Continued)

Related U.S. Application Data

OTHER PUBLICATIONS

(60) Continuation of application No. 11/453,078, filed on Jun. 15, 2006, now Pat. No. 7,308,143, which is a division of application No. 10/479,831, filed as application No. PCT/JP03/03794 on Mar. 27, 2003, now Pat. No. 7,095,896.

Office Action issued Sep. 3, 2009 in U.S. Appl. No. 11/976,552.

(Continued)

Primary Examiner—Kanji Patel
 (74) *Attorney, Agent, or Firm*—Wenderoth, Lind & Ponack, L.L.P.

(30) **Foreign Application Priority Data**
 Apr. 15, 2002 (JP) 2002-112665

(57) **ABSTRACT**

(51) **Int. Cl.**
G06K 9/36 (2006.01)
H04N 7/12 (2006.01)
H03M 7/40 (2006.01)

(52) **U.S. Cl.** 382/233; 375/240.13; 341/67

(58) **Field of Classification Search** 382/232–251, 382/276, 305; 375/240.03, 240.12, 240.16, 375/240.2, 240.23, 240.24; 348/14.13, 408.1; 341/106

The method includes the following units: a coefficient number detecting unit (109) for detecting the number of coefficients which has a value other than 0 for each block according to the generated coefficient, a coefficient number storing unit (110) for storing the number of coefficients detected, a coefficient number coding unit (111) for selecting a table for variable length coding based on the numbers of coefficients in the coded blocks located on the periphery of a current block to be coded with reference to the selected table for variable length coding so as to perform variable length coding for the number of coefficients.

See application file for complete search history.

1 Claim, 30 Drawing Sheets

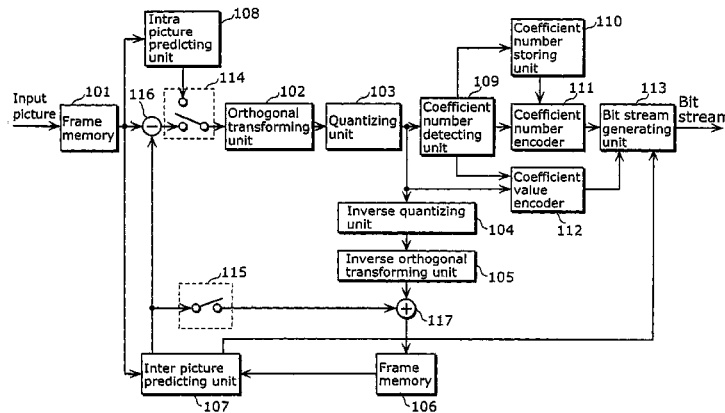

US 7,769,238 B2

Page 2

U.S. PATENT DOCUMENTS

6,035,126	A *	3/2000	Wise et al.	712/29
6,292,588	B1	9/2001	Shen et al.	
6,341,144	B1	1/2002	Haskell et al.	
6,449,395	B1	9/2002	Kobayashi	
6,473,459	B1	10/2002	Sugano et al.	
6,625,211	B1	9/2003	Etoh et al.	
6,658,157	B1	12/2003	Satoh et al.	
6,748,020	B1 *	6/2004	Eifrig et al.	375/240.26
6,907,142	B2	6/2005	Kalevo et al.	
2002/0037108	A1	3/2002	Matsumoto	

FOREIGN PATENT DOCUMENTS

JP	4-223773	8/1992
JP	5-347710	12/1993
JP	6-232765	8/1994
JP	7-107492	4/1995
JP	10-191324	7/1998
JP	0 876 058	11/1998
KR	2002-0006149	1/2002

KR	2002-0006150	1/2002
KR	2002-0006250	1/2002
TW	373408	11/1999
TW	393856	6/2000

OTHER PUBLICATIONS

Office Action issued Sep. 9, 2009 in U.S. Appl. No. 11/976,550.
 Richardson, I. E.G., entitled "*H.264/MPEG-4 Part 10 White Paper, Variable-Length Coding*", MPEG-4 Part 10 White Paper, Oct. 17, 2002 (XP002258064).
 Bjontegaard, G., entitled "*Improved Low Complexity Entropy Coding For Transform Coefficients*", Joint Video Team (JVT) of ISO/IEC MPEG & ITU-T VCEG (ISO/IEC JTC1/SC29/WG11 and ITU-T SG16 Q6), XX, XX, Jan. 29, 2002 (XP002257294).
 Hartung, F., et al., entitled "*Improved Encoding of DCT Coefficients For Low Bit-Rate Video Coding Using Multiple VLC Tables*", Image Processing, 1999. ICIP 99. Proceedings. 1999 International Conference of Kobe, Japan Oct. 24-28, 1999, Piscataway, NJ, USA, IEEE, US, Oct. 24, 1999, pp. 51-55, (XP010368953).

* cited by examiner

Fig. 1

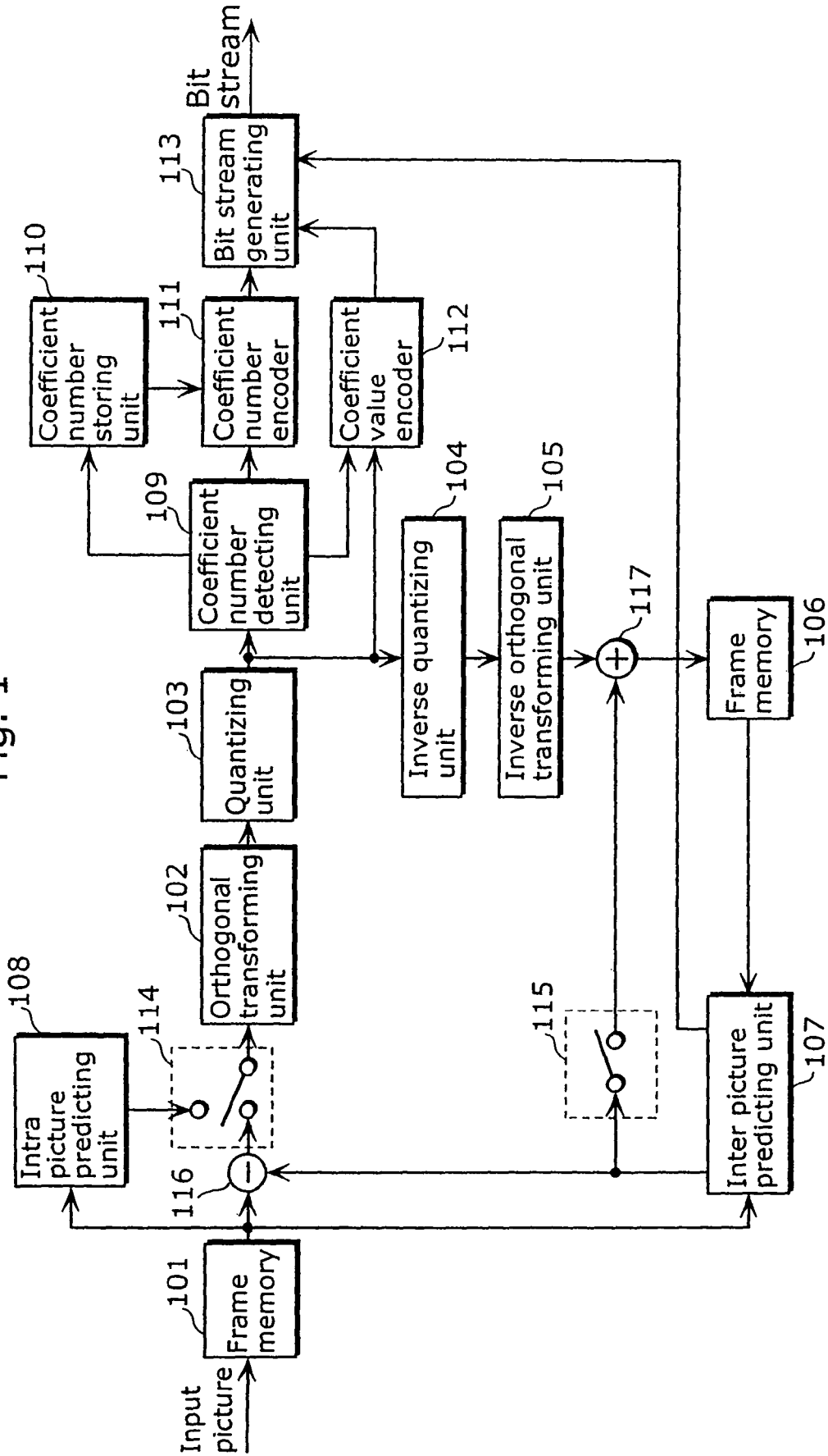

Fig. 2A

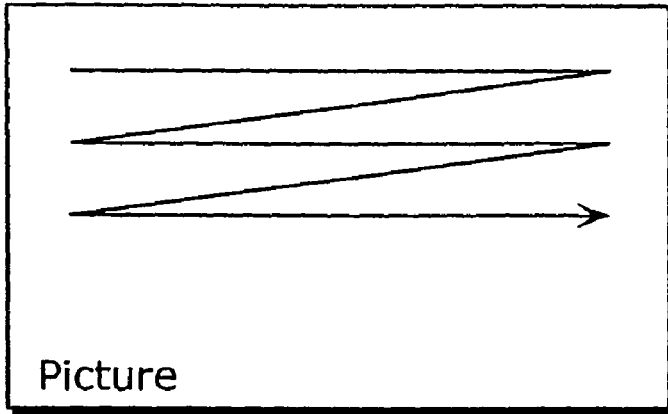

Fig. 2B

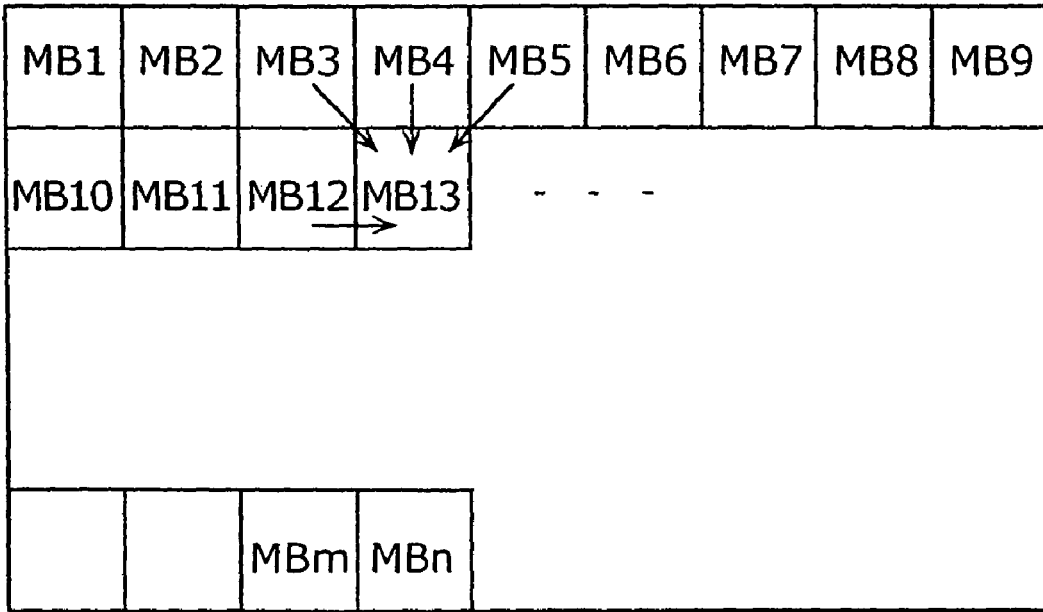

Fig. 3A

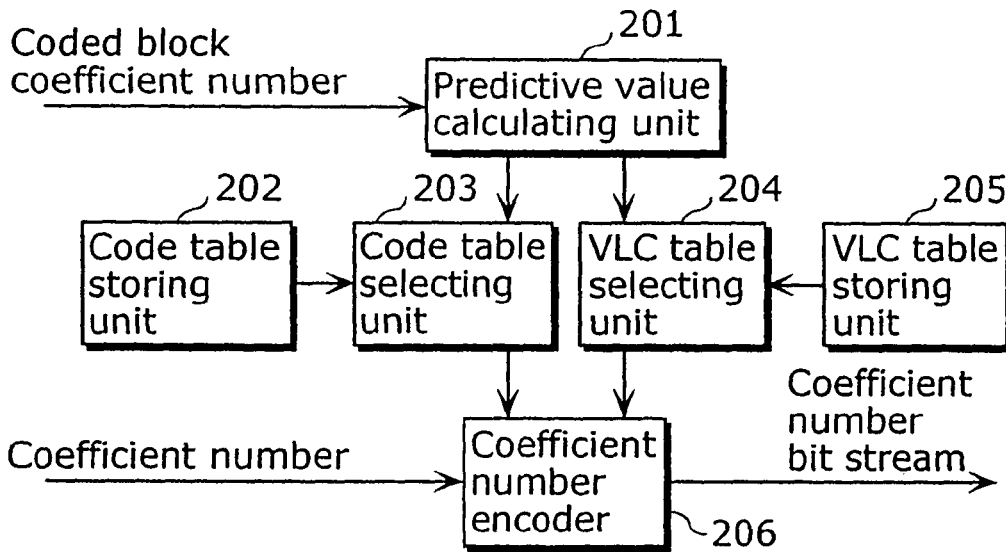

Fig. 3B

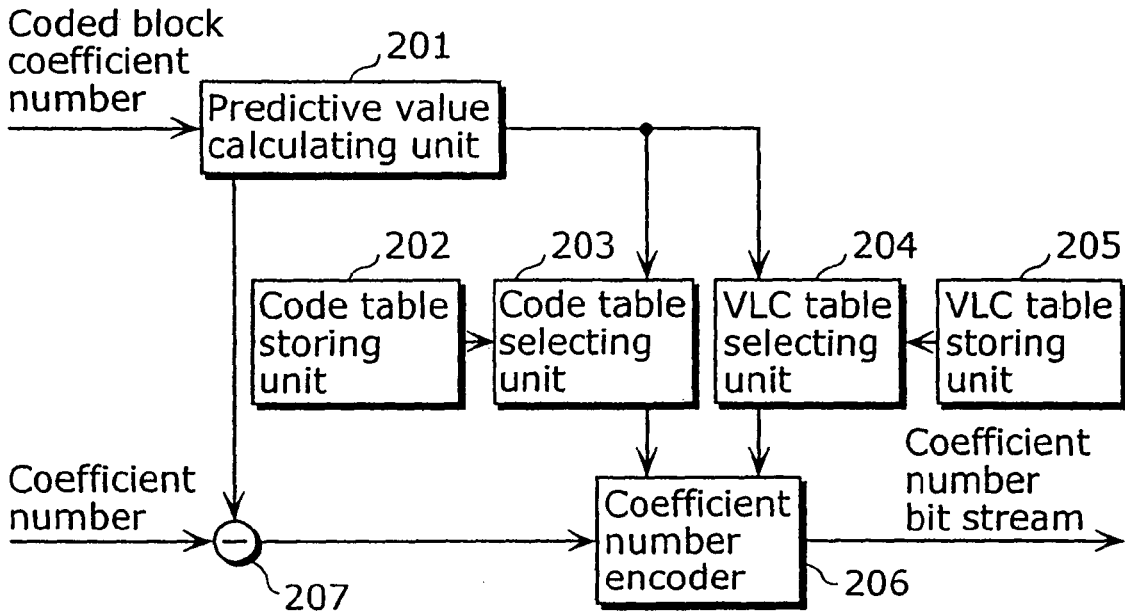

Fig. 4A

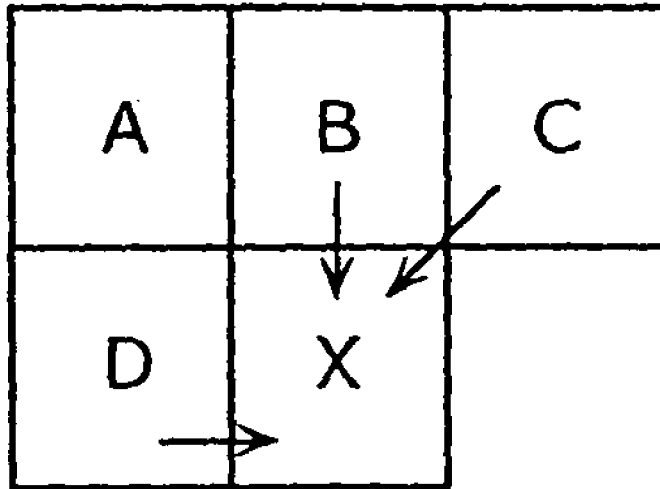

Fig. 4B

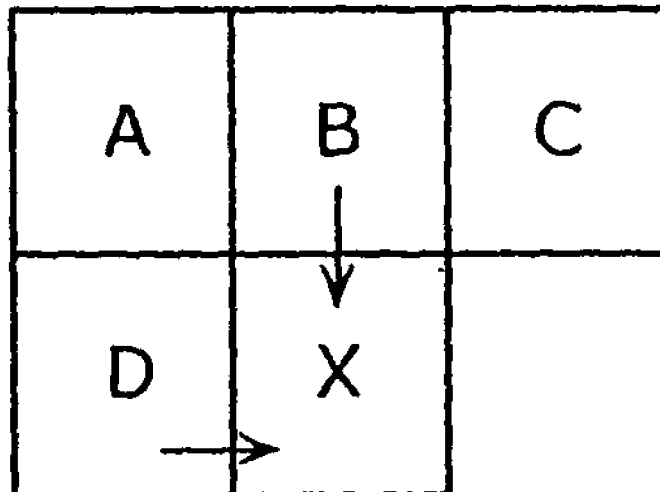

Fig. 5

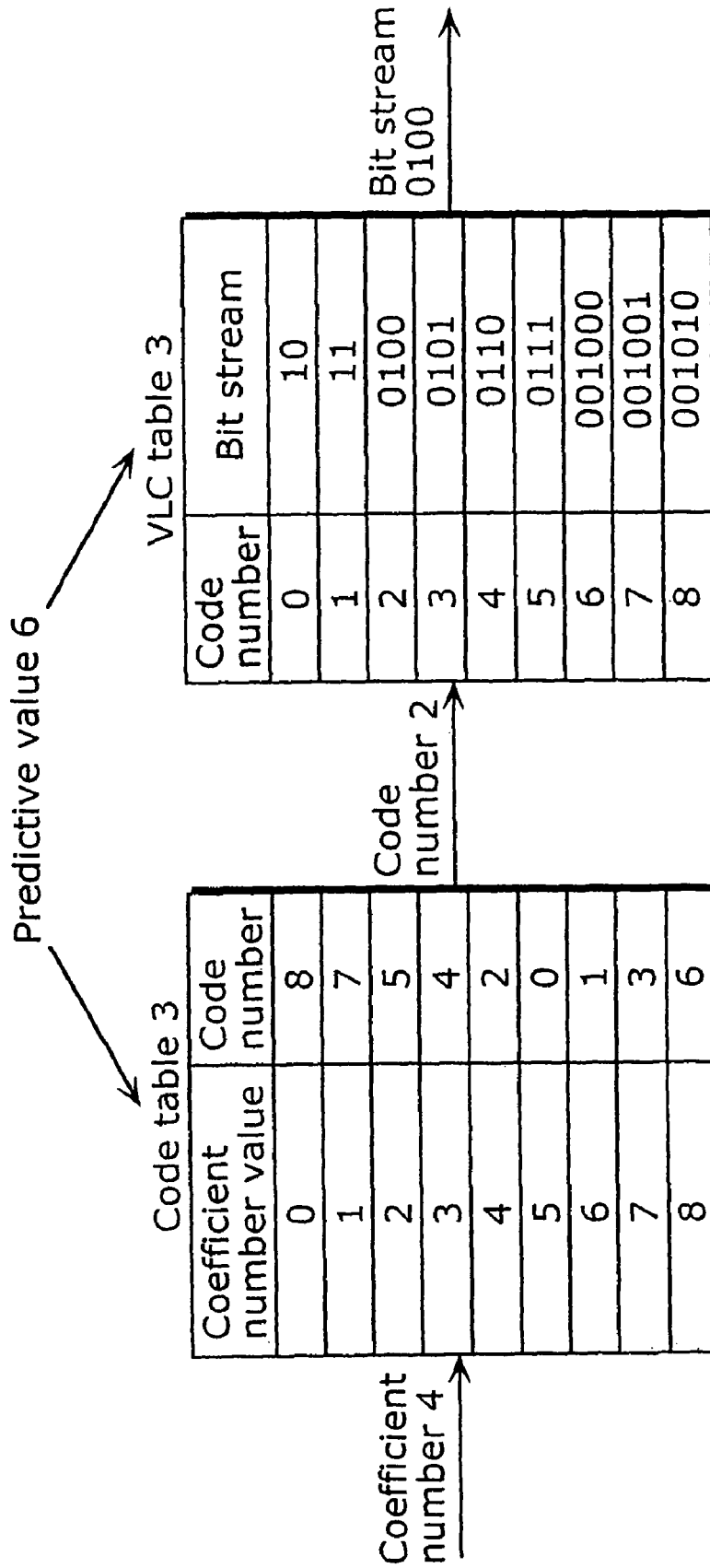

Fig. 6B

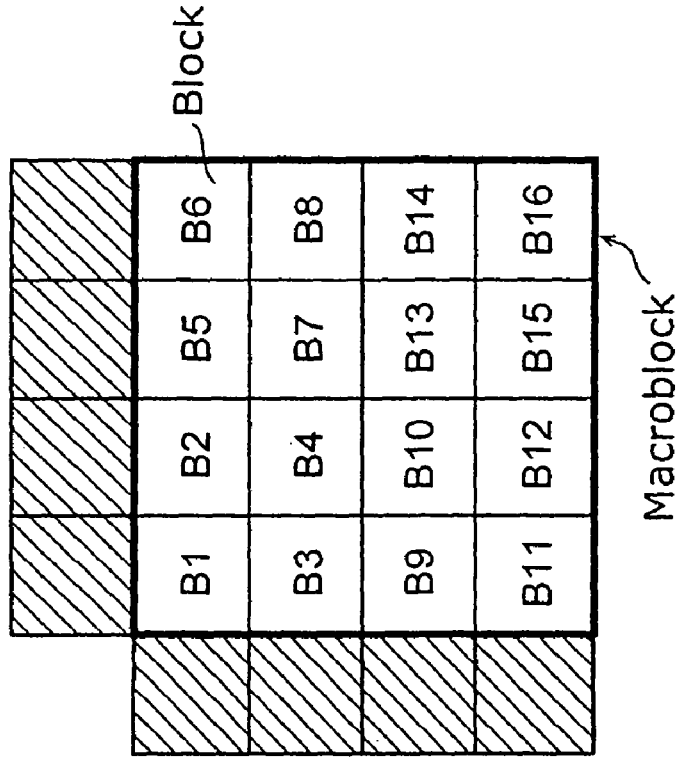

Fig. 6A

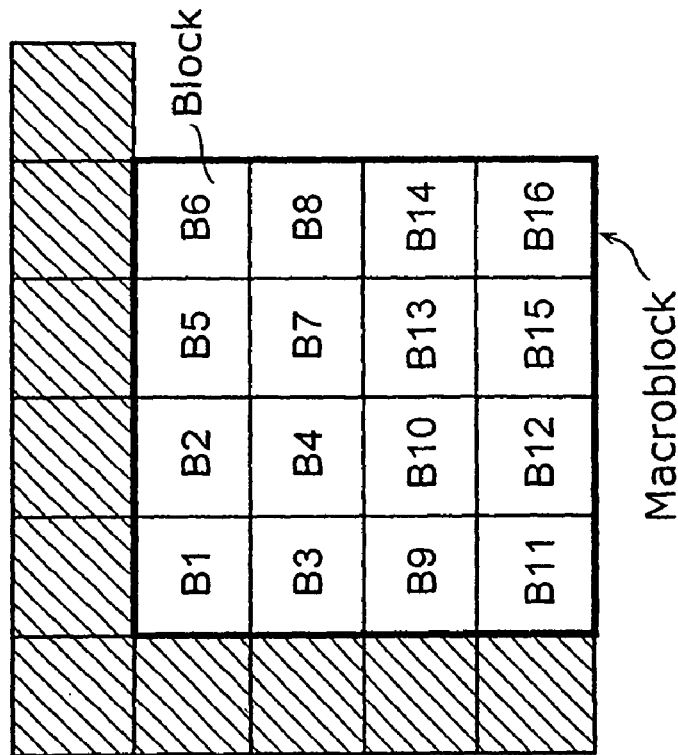

Fig. 7A

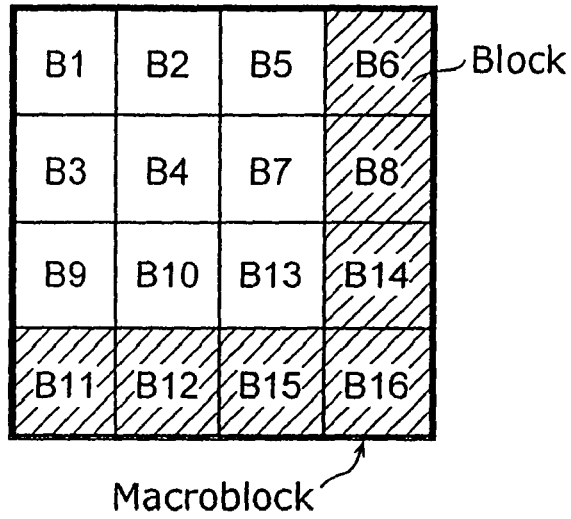

Fig. 7B

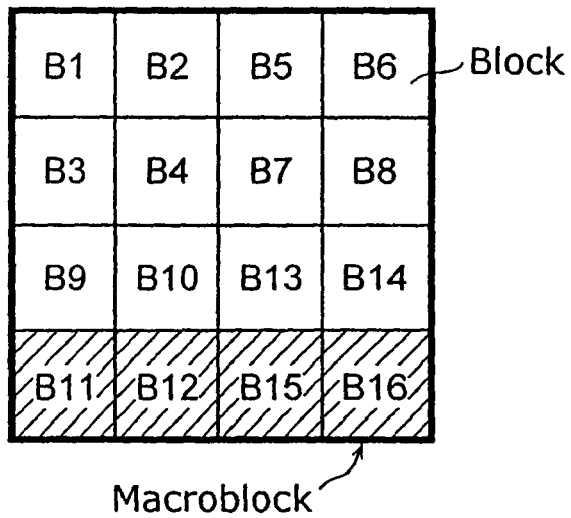
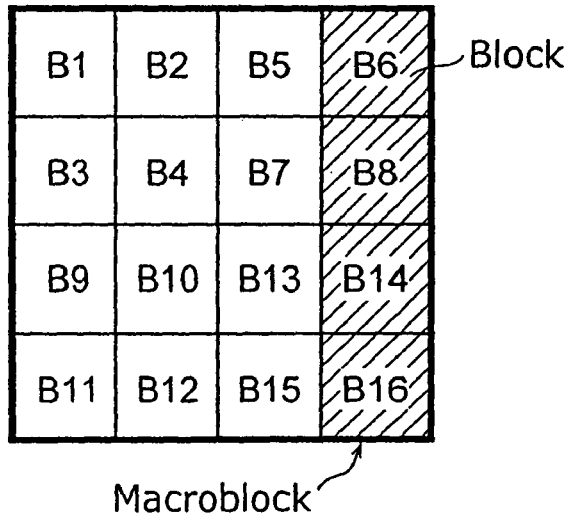

Fig. 7C



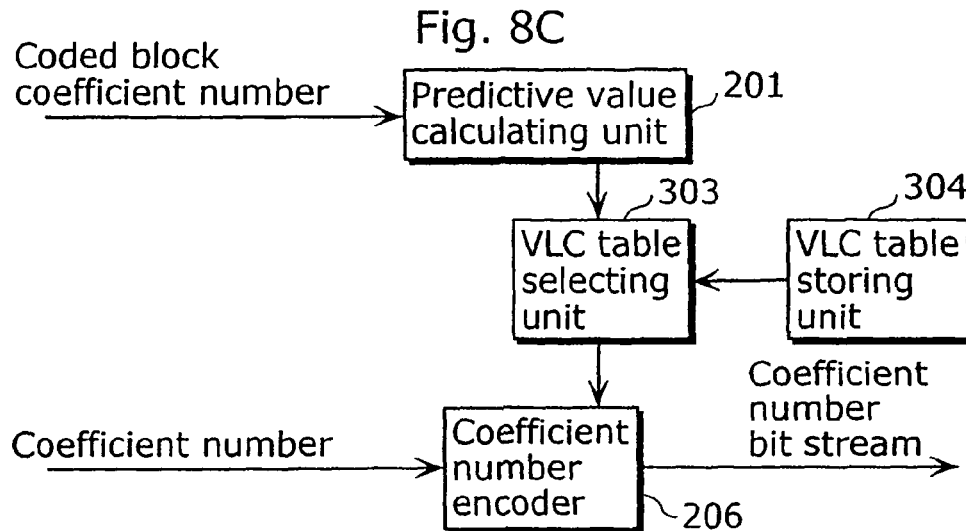
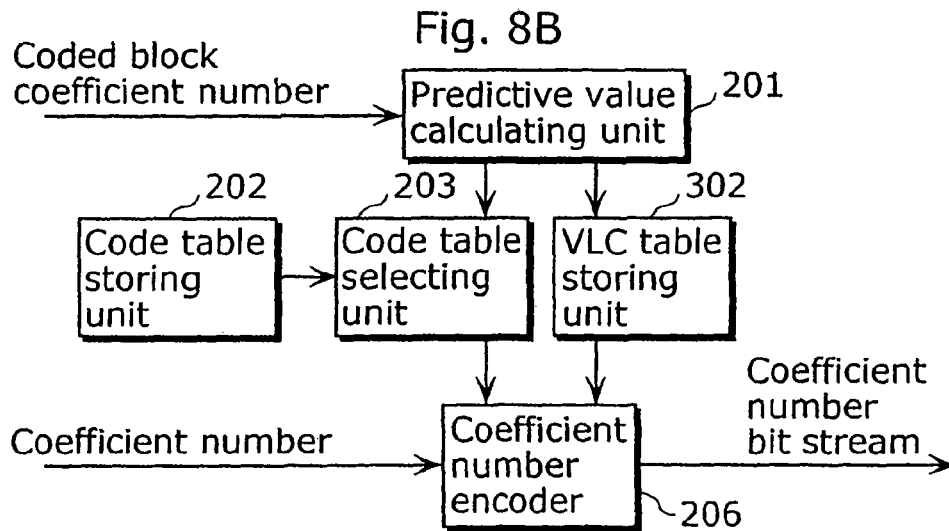
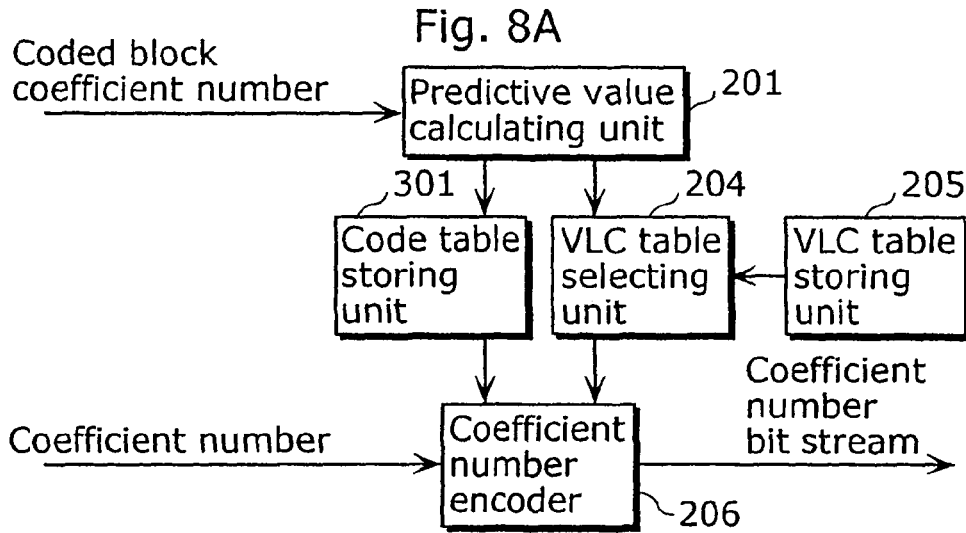

Fig. 9

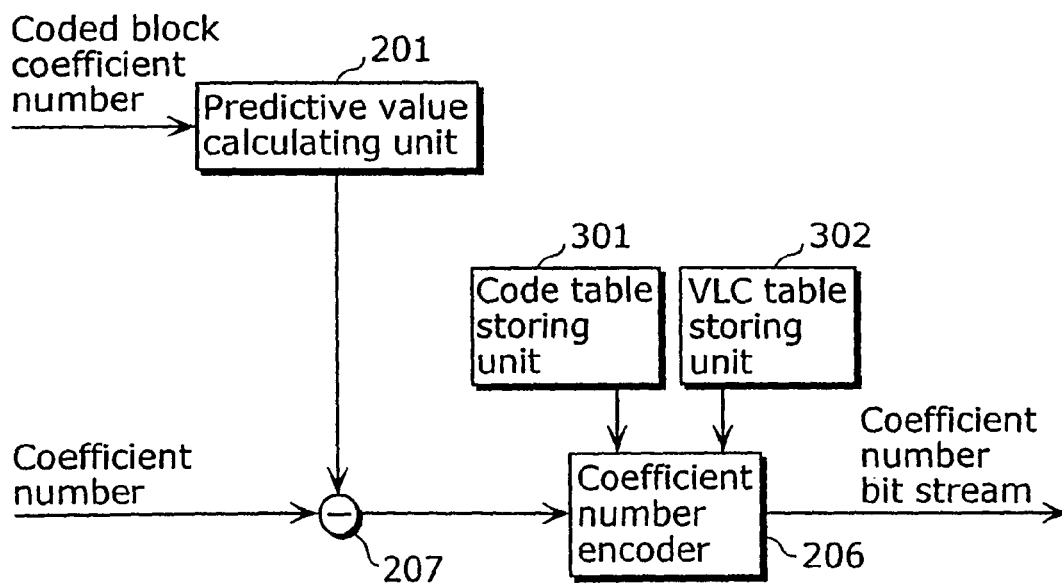

Fig. 10A

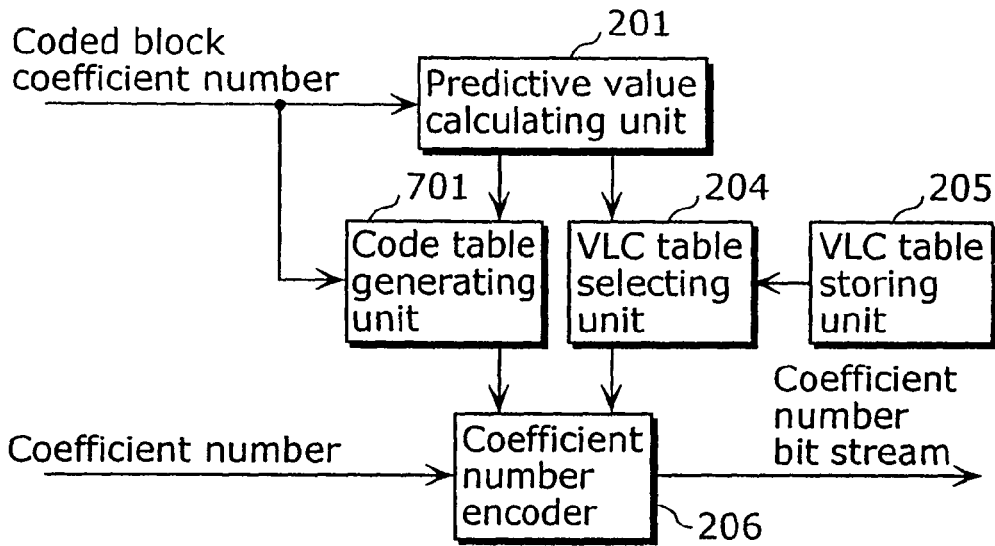

Fig. 10B

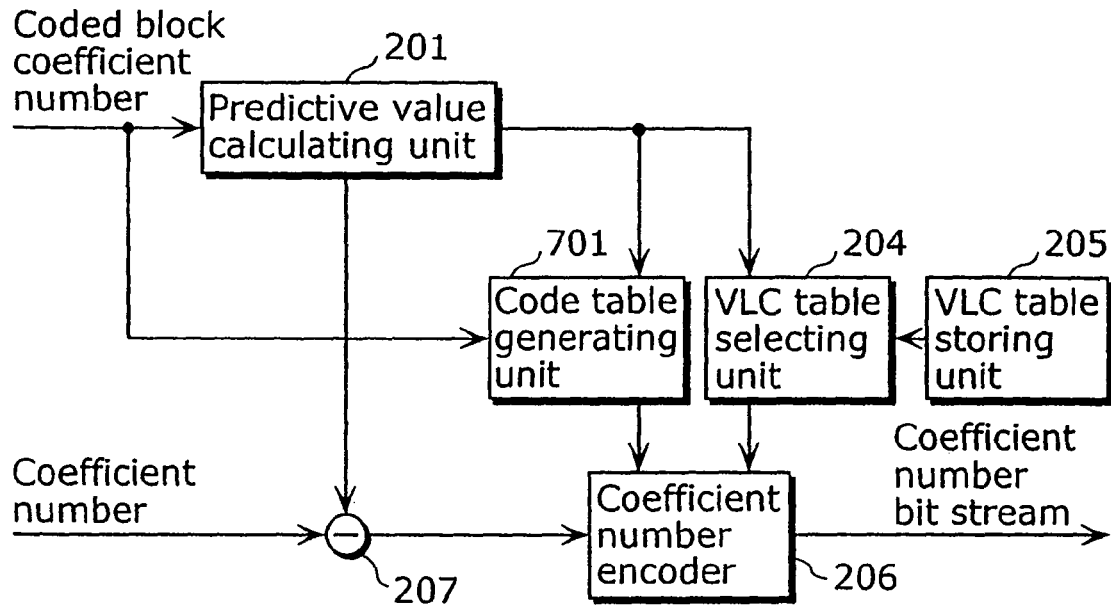
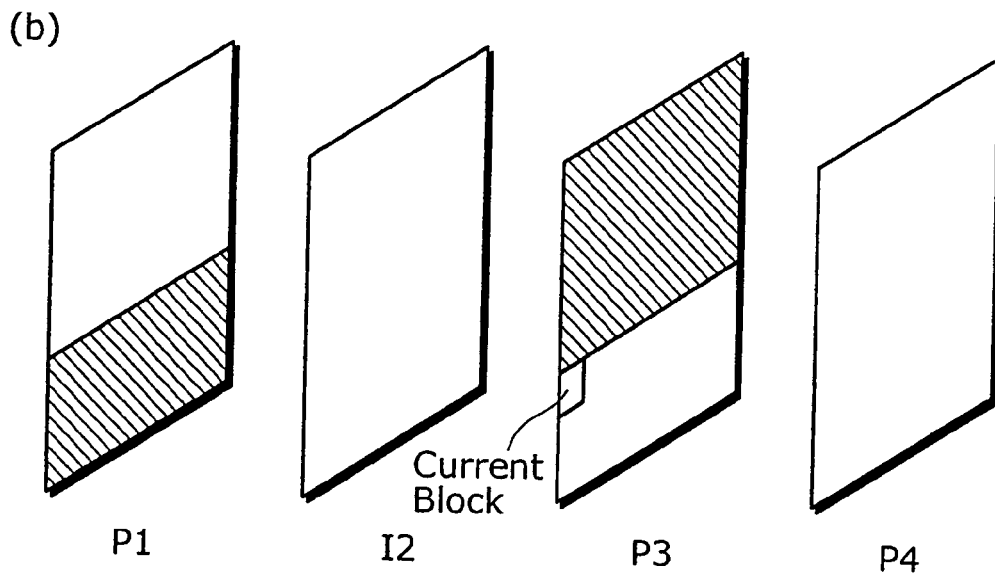
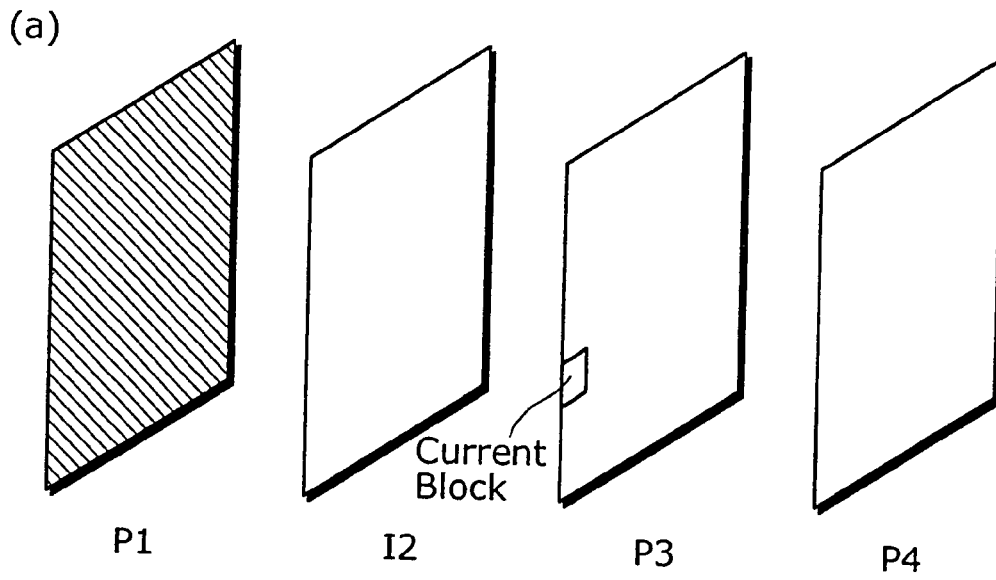

Fig. 11



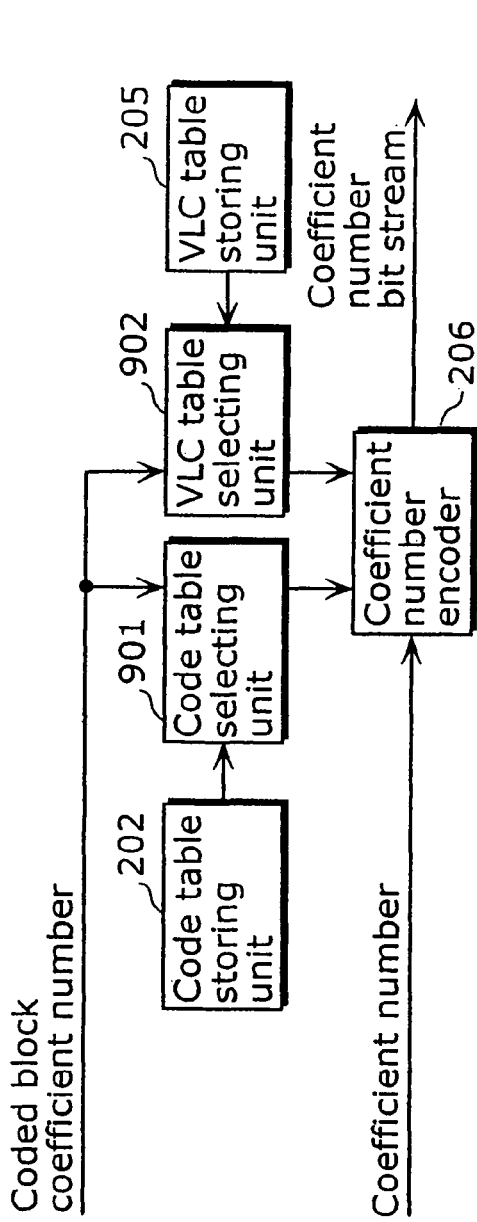

Fig. 12A

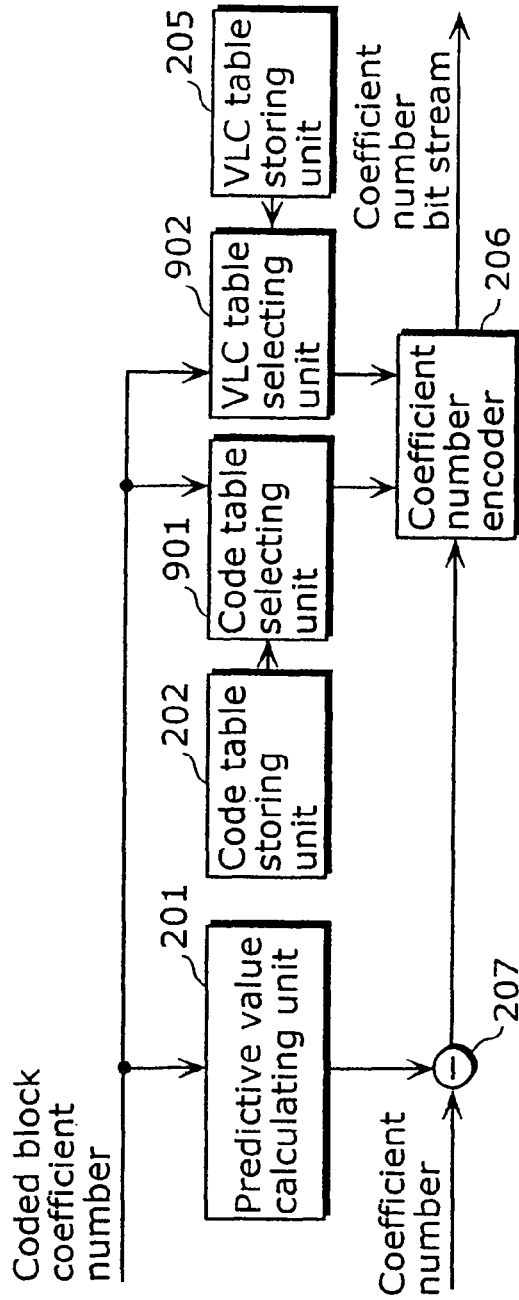

Fig. 12B

Fig. 13A

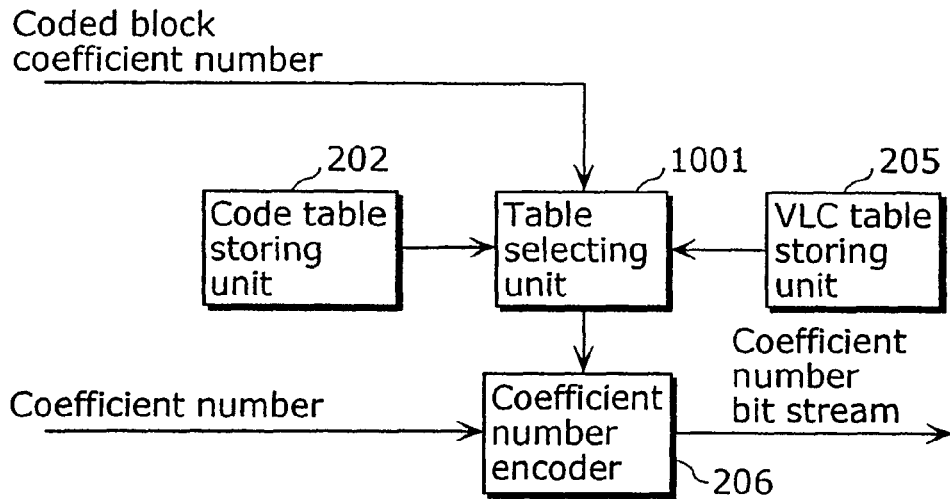

Fig. 13B

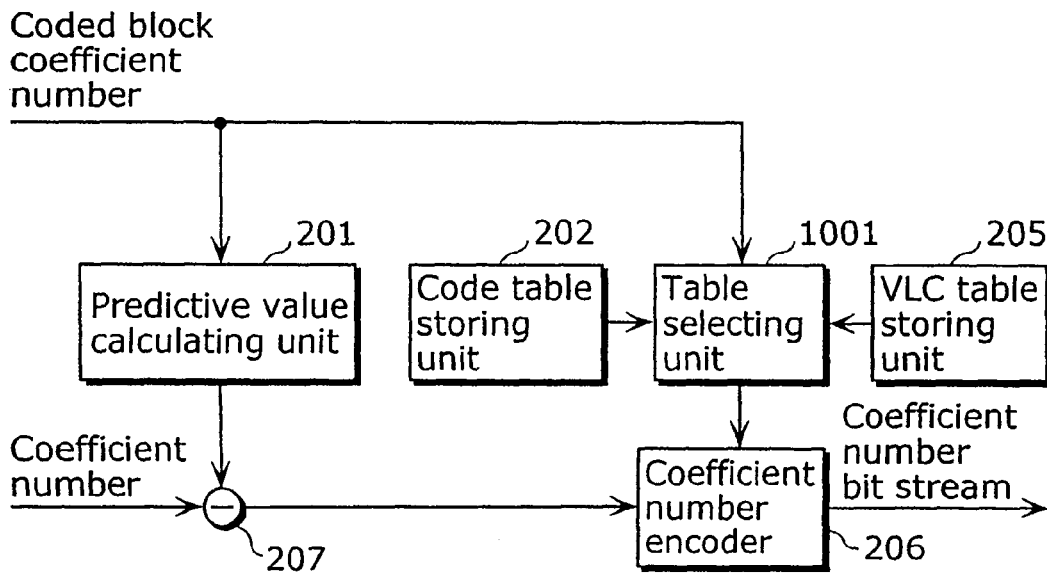

Fig. 14

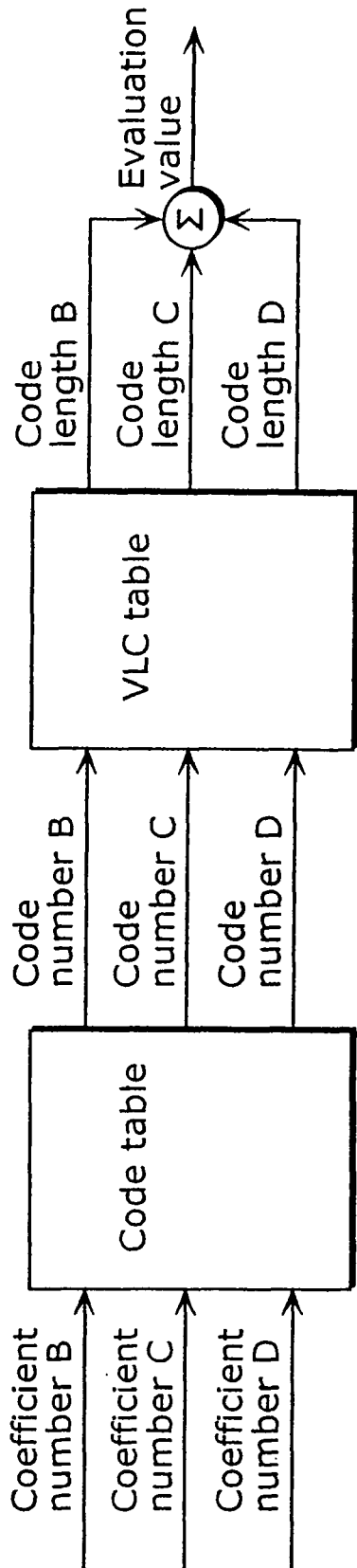

Fig. 15

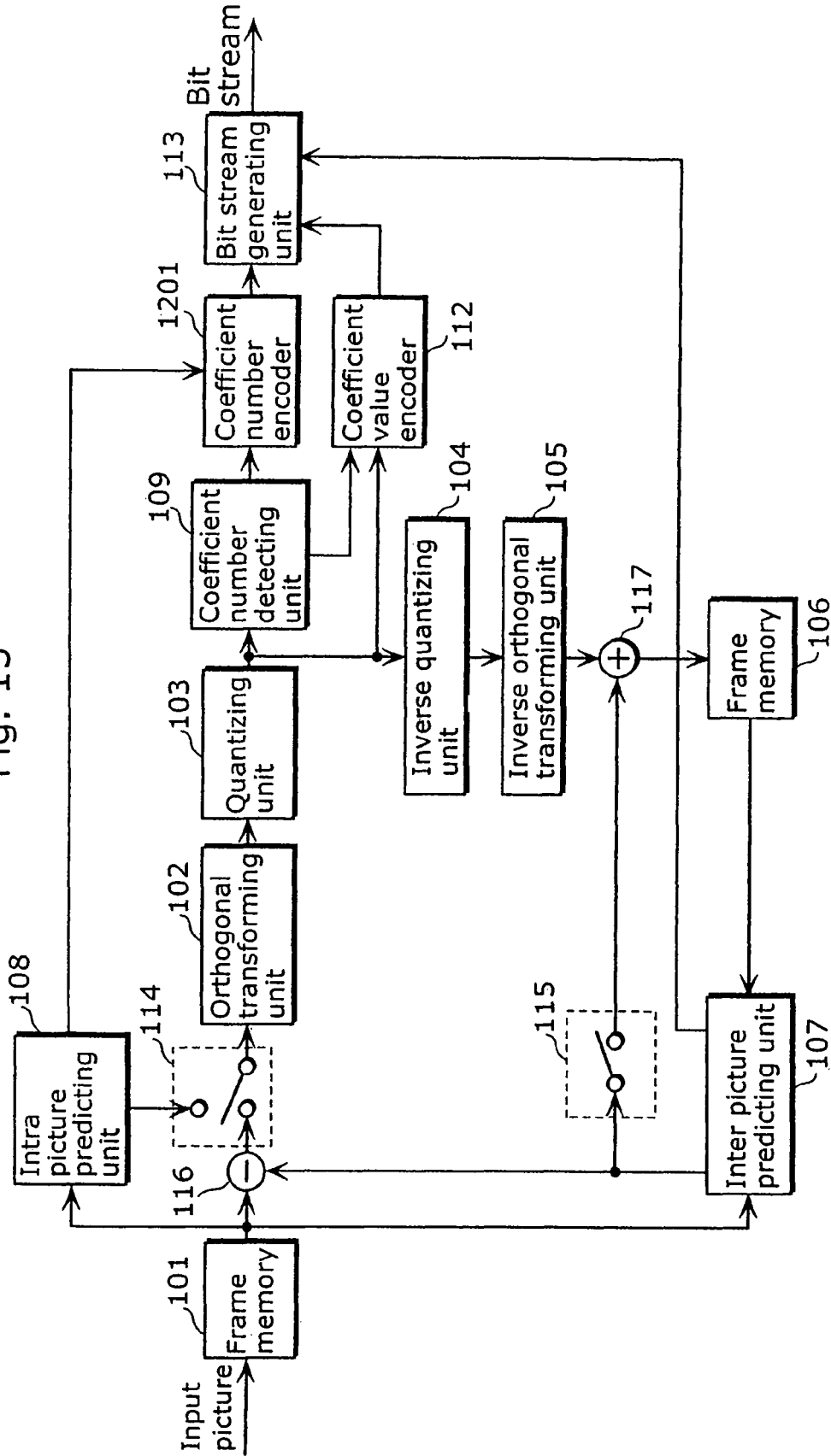

Fig. 16

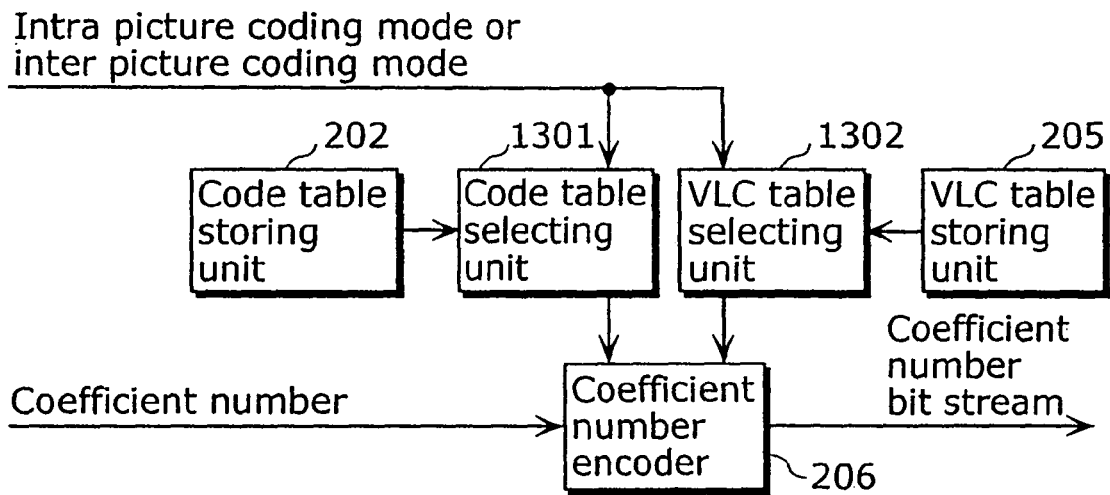

Fig. 17

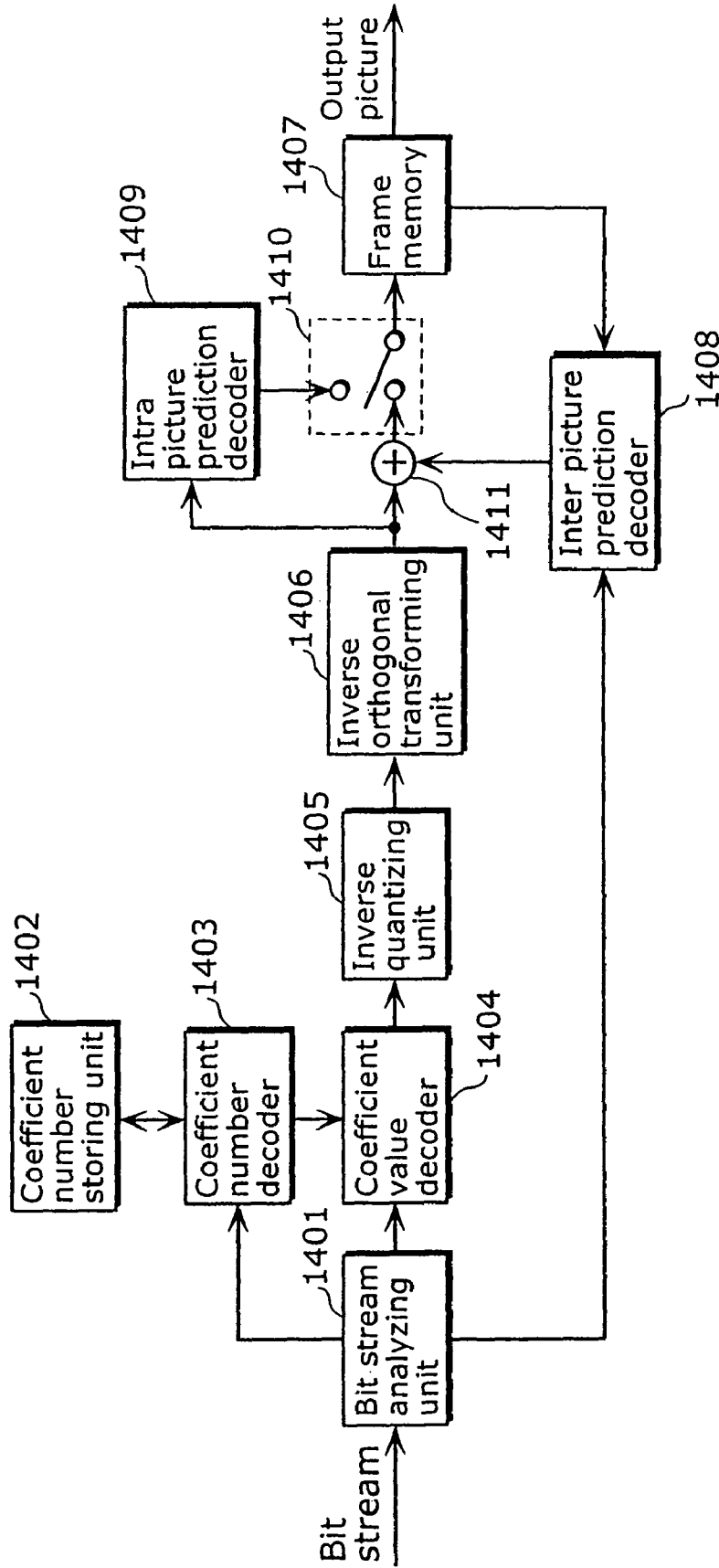

Fig. 18A

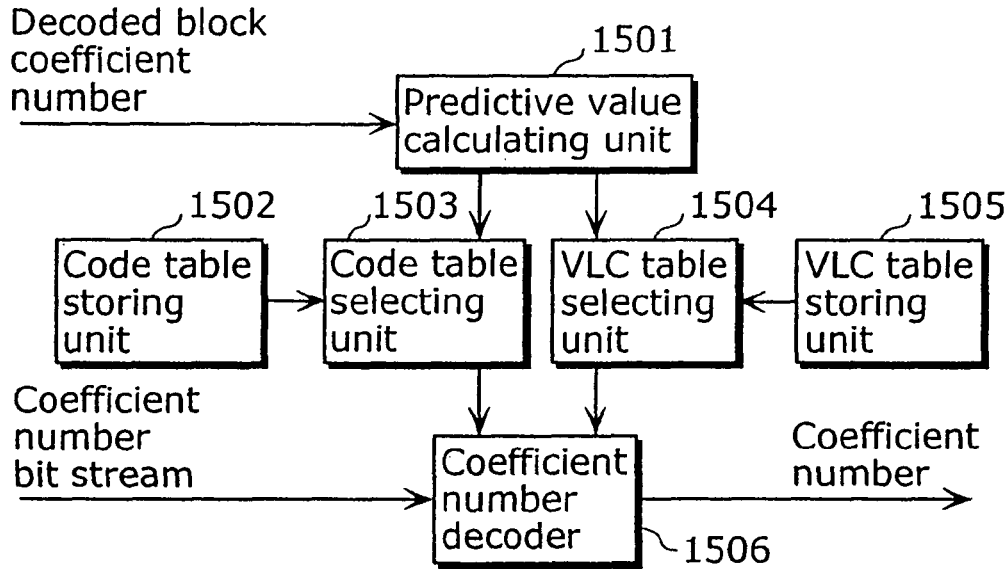

Fig. 18B

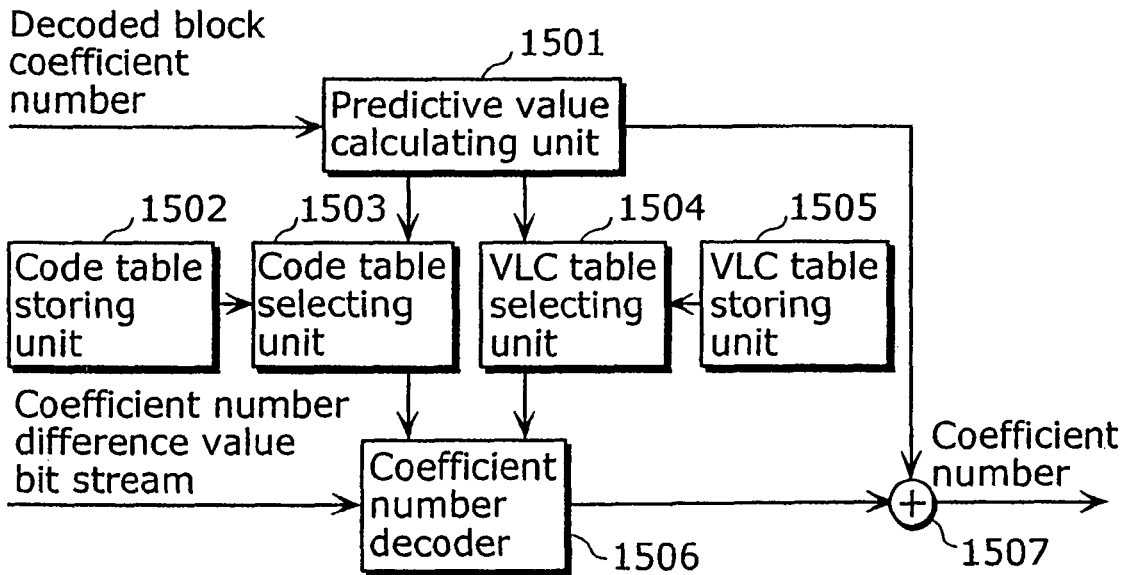
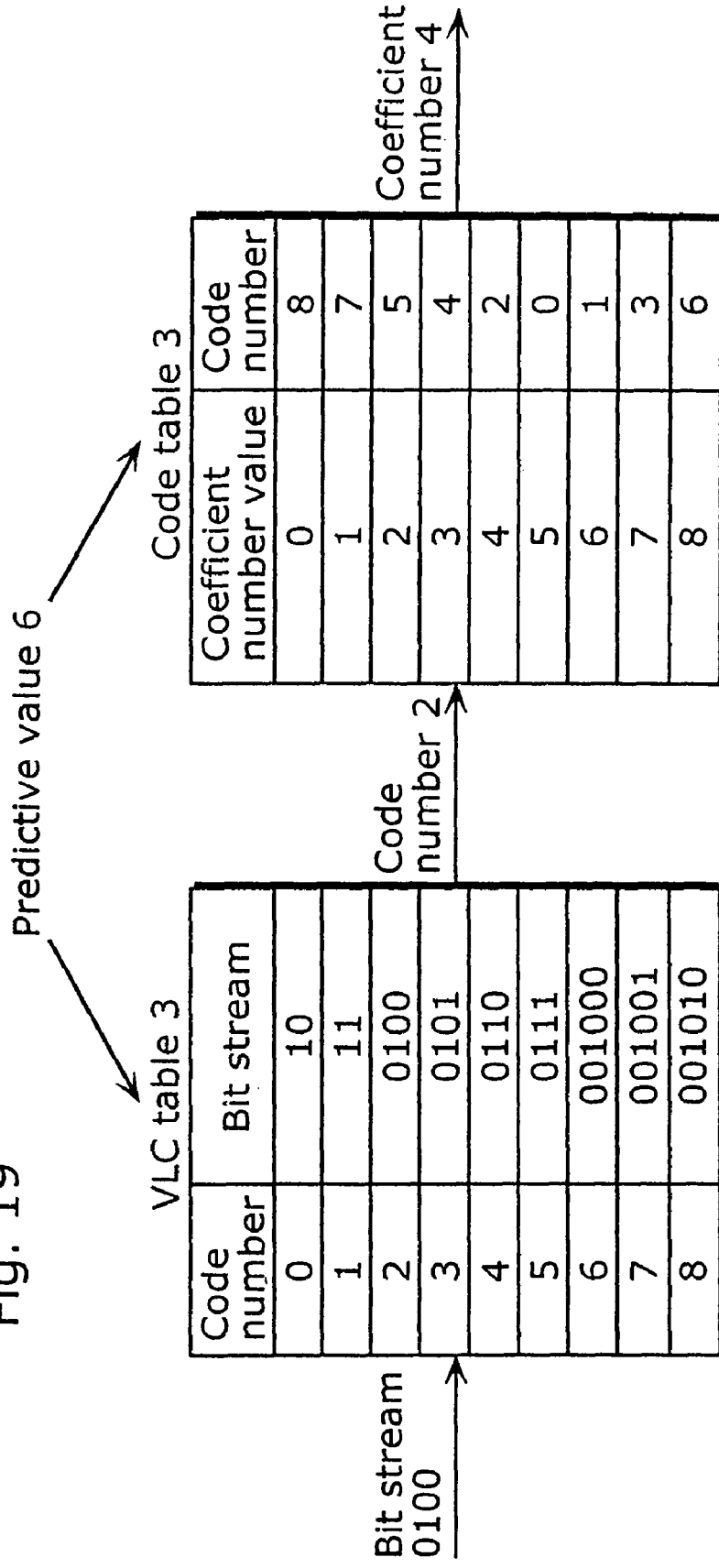

Fig. 19



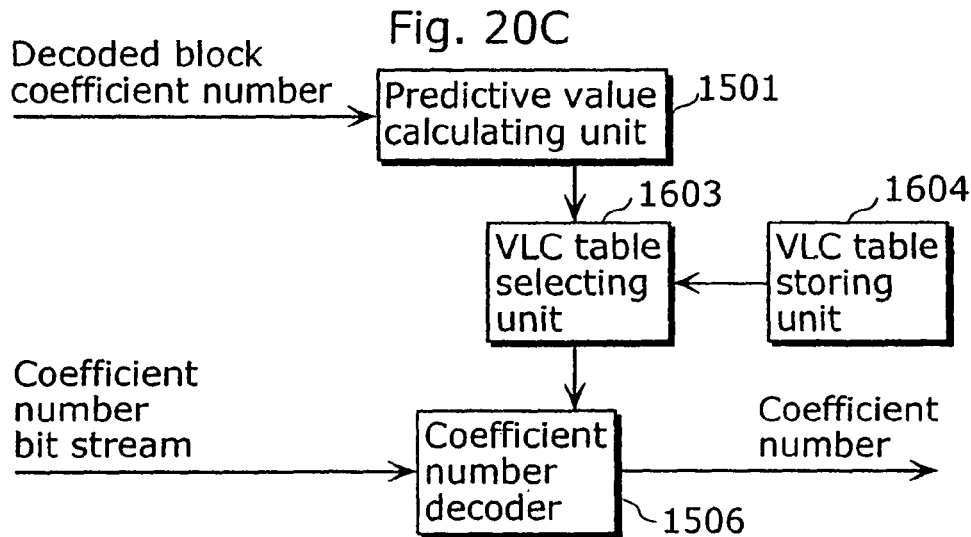
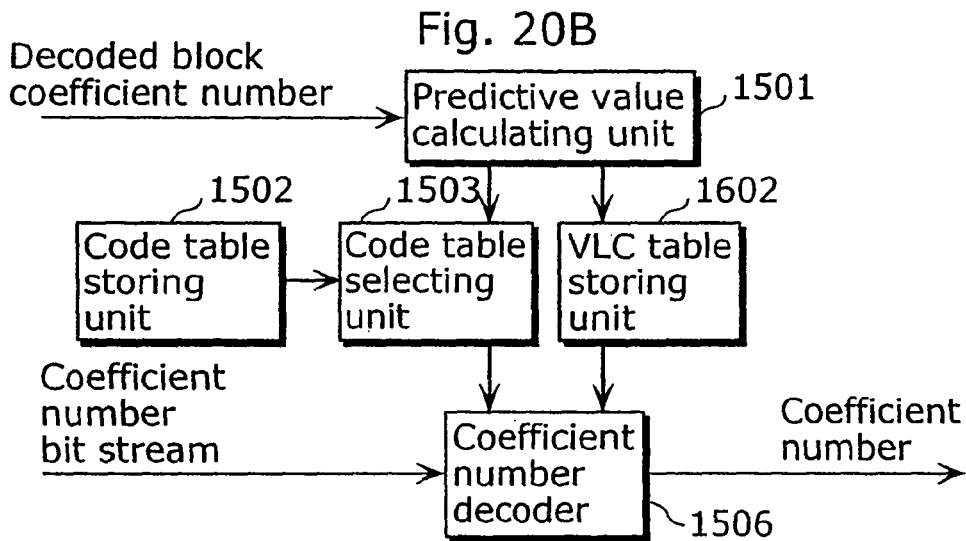
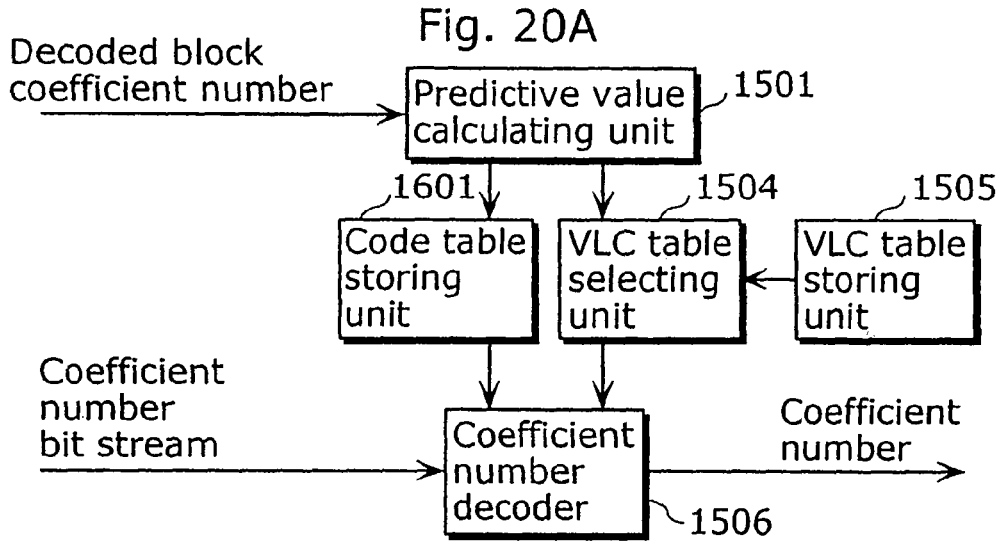

Fig. 21

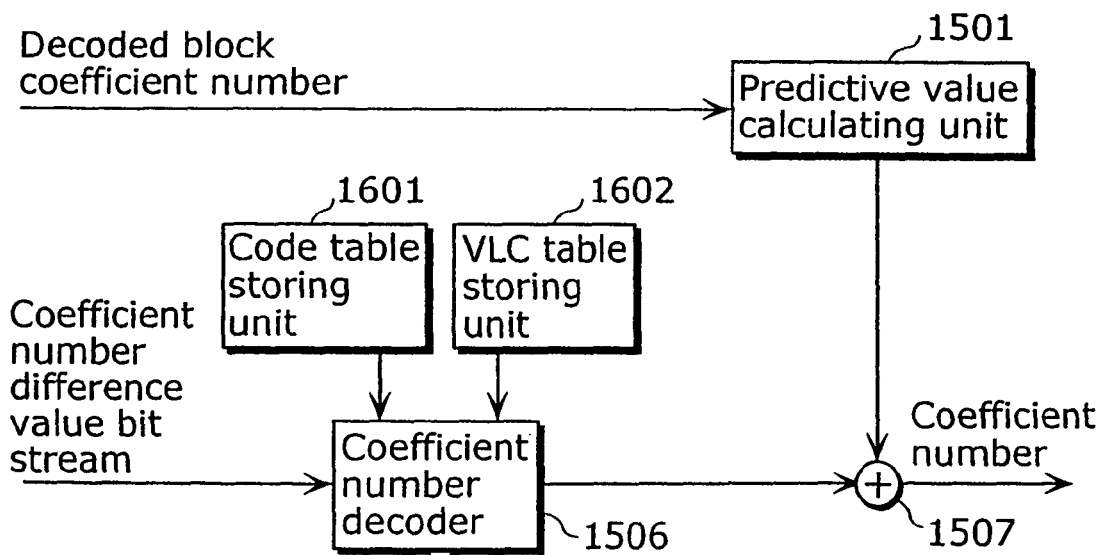

Fig. 22A

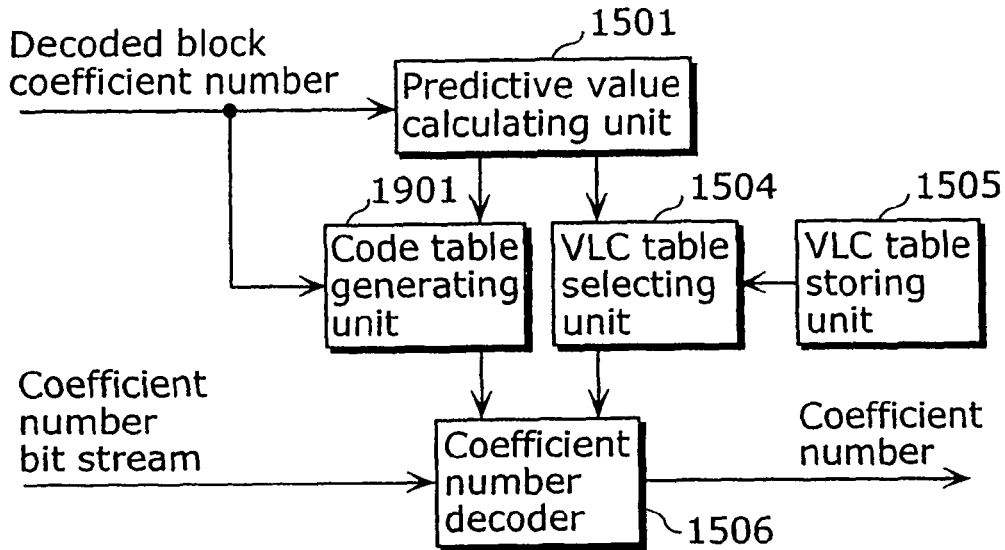
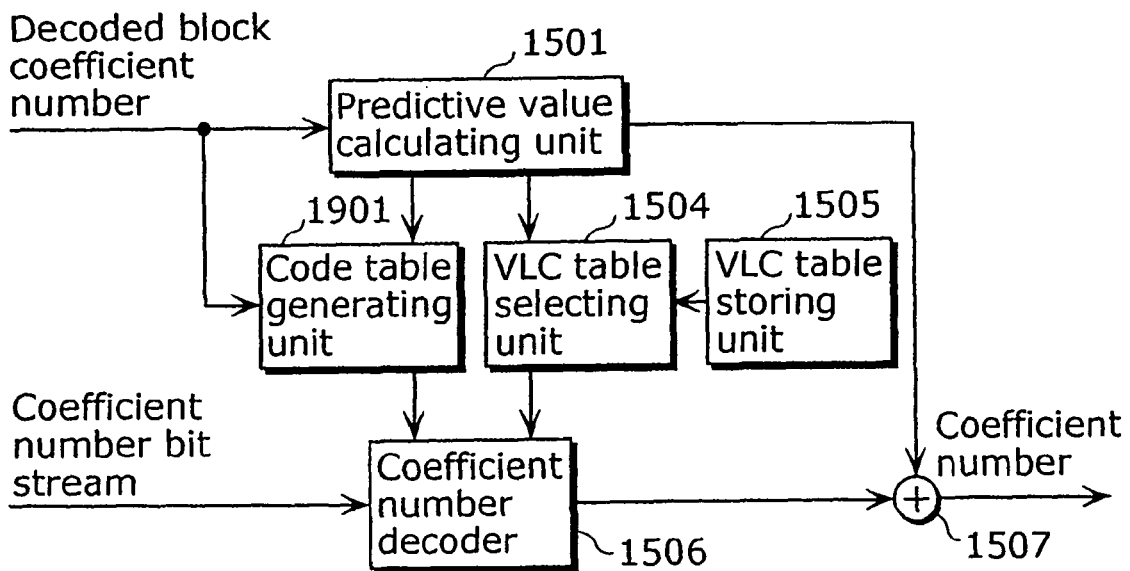

Fig. 22B



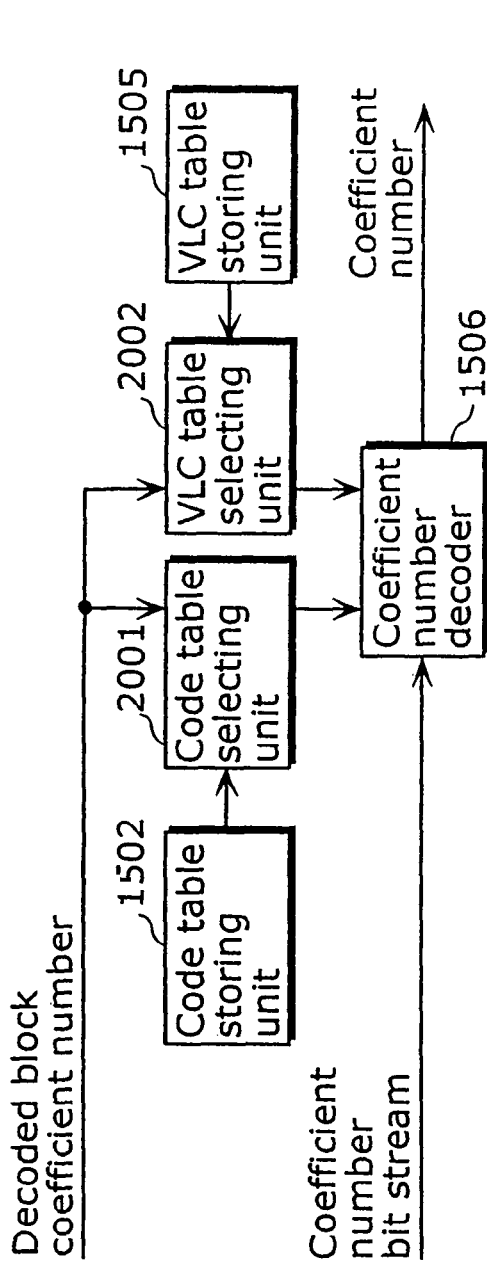

Fig. 23A

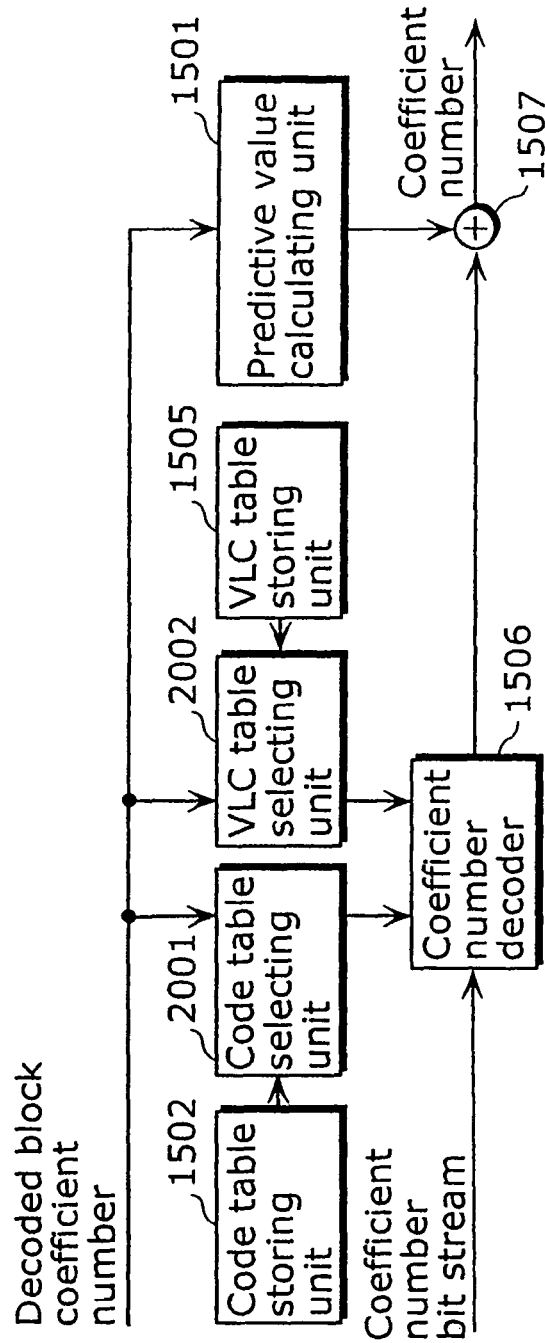

Fig. 23B

Fig. 24A

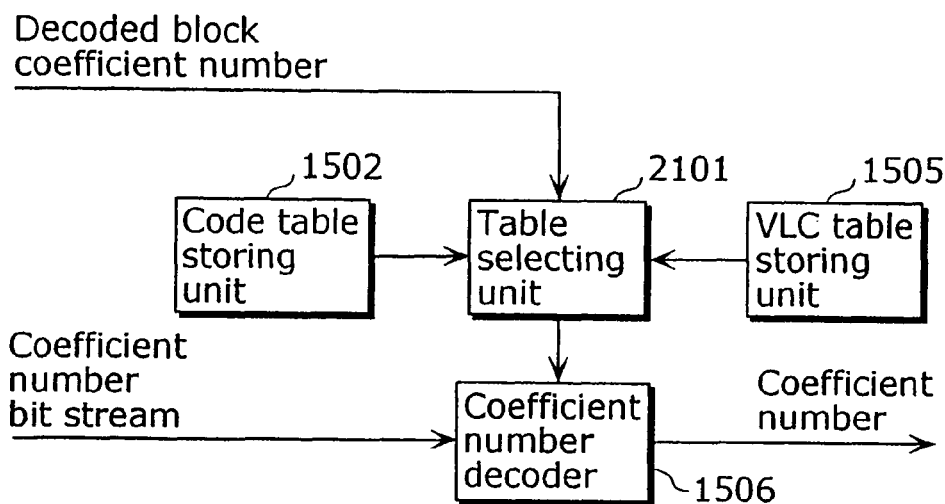

Fig. 24B

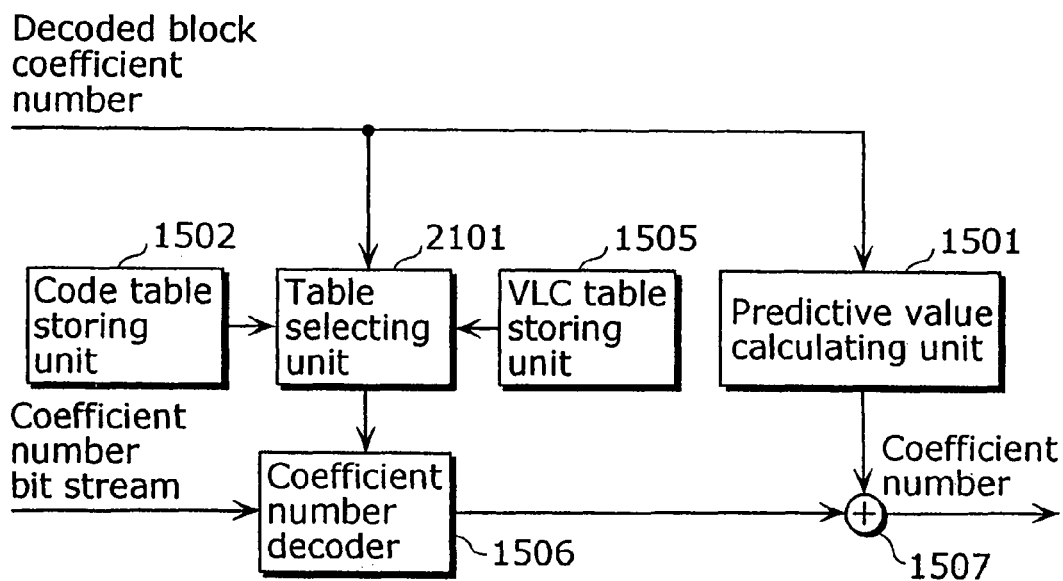

Fig. 25

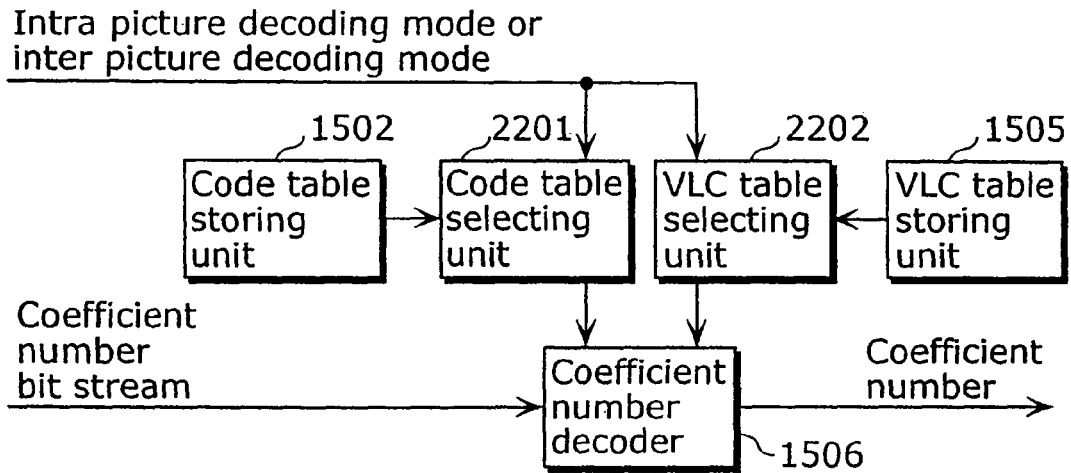

Fig. 26A

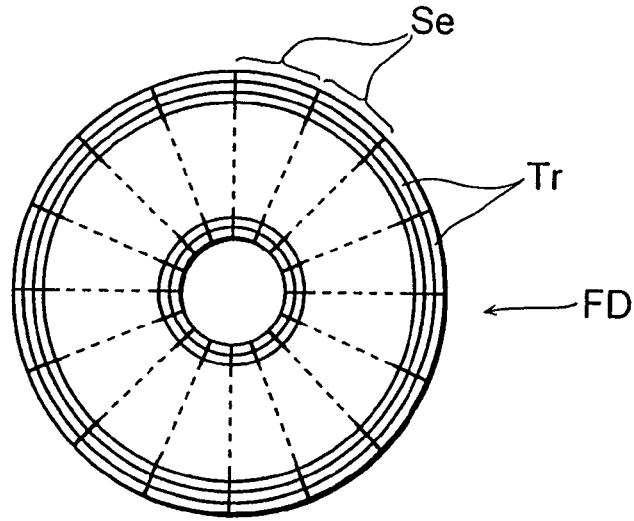

Fig. 26B

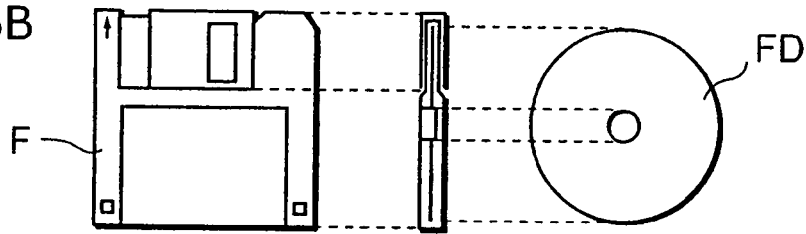
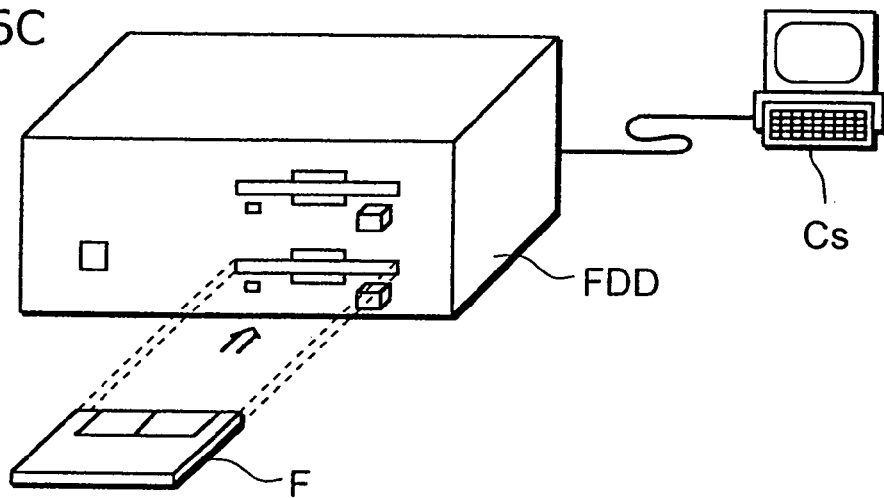

Fig. 26C



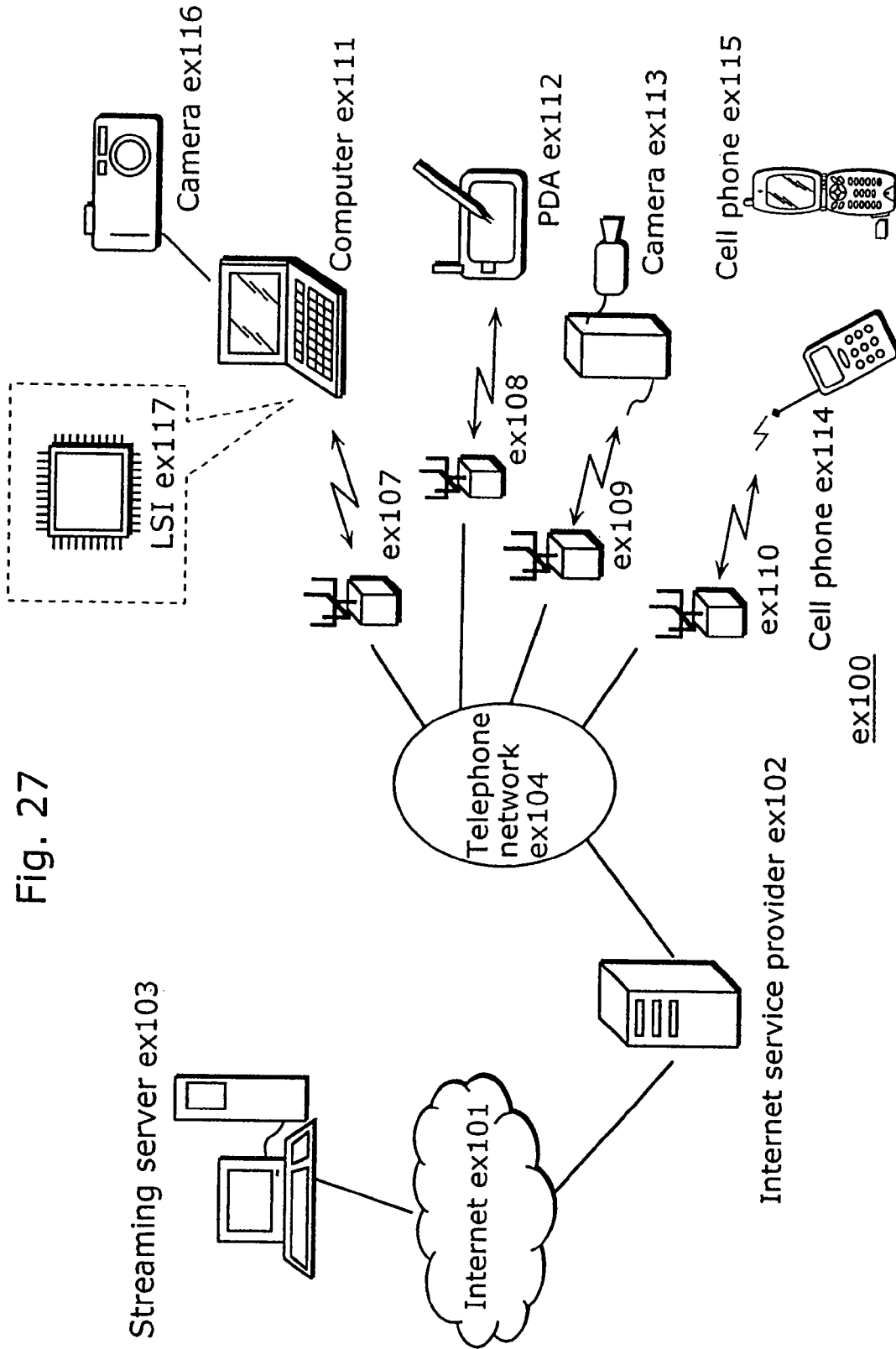
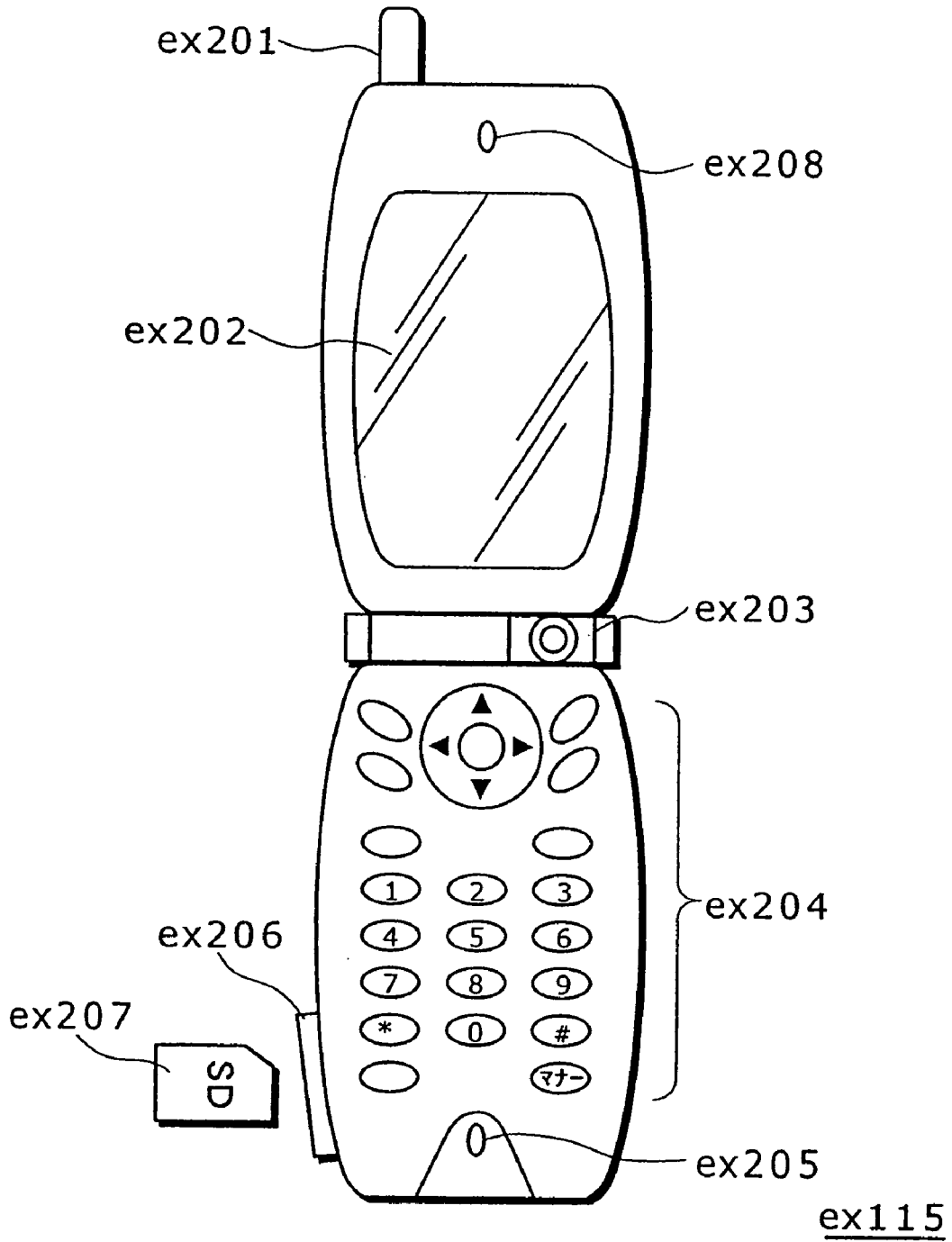

Fig. 27

Fig. 28



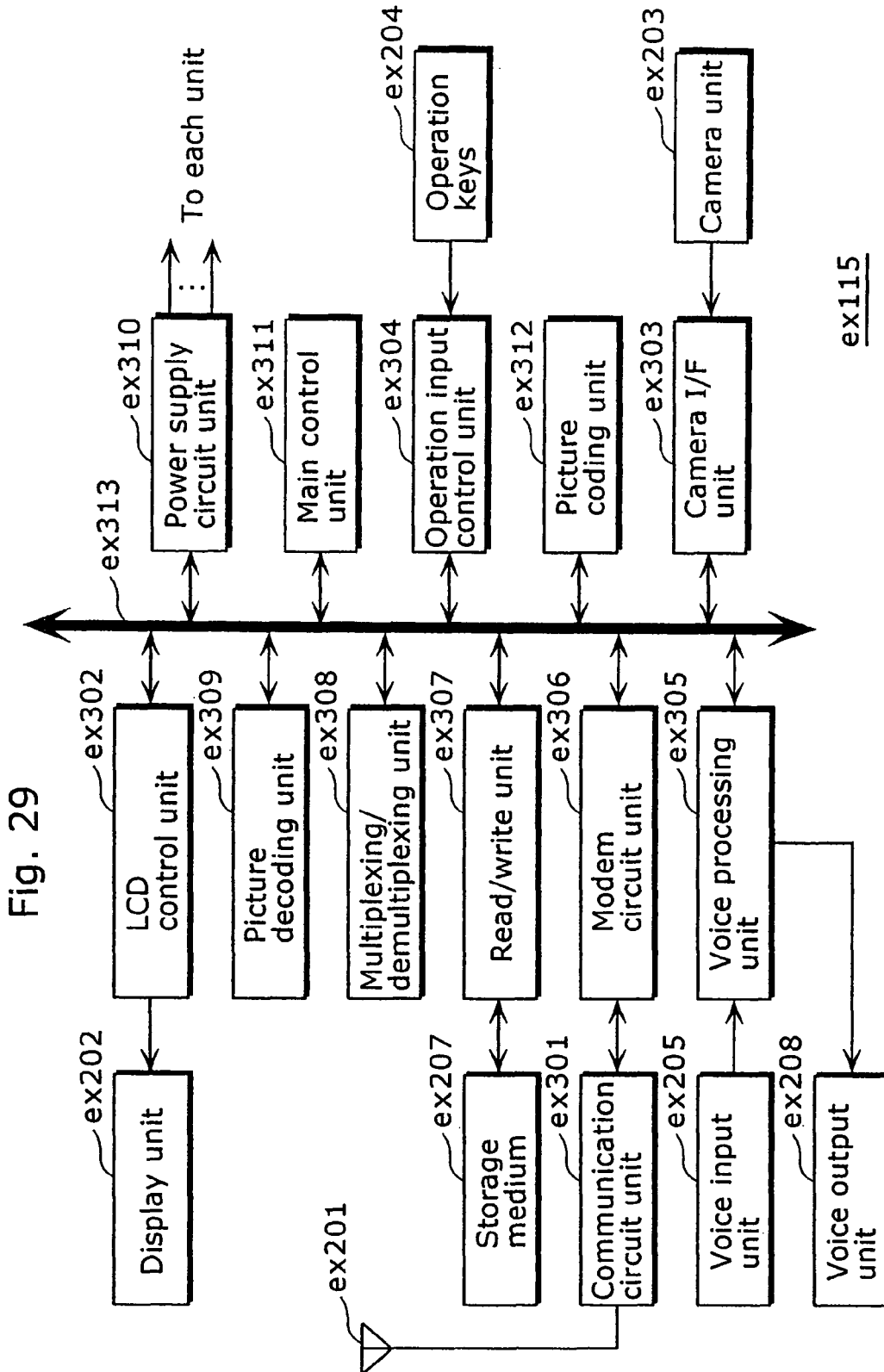
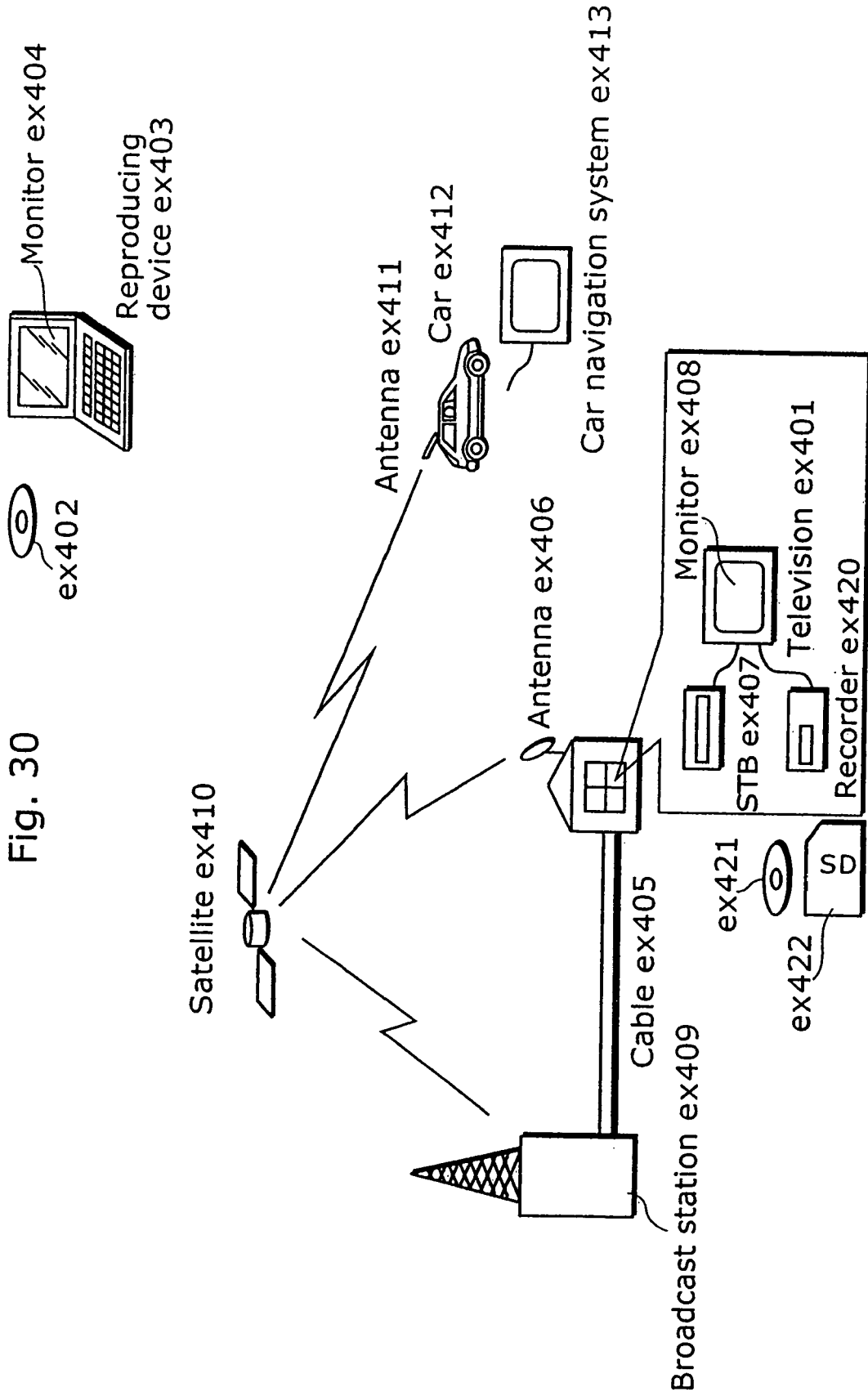

Fig. 29



1

**PICTURE CODING METHOD AND PICTURE
DECODING METHOD**

This application is a continuation of U.S. patent applica-
tion Ser. No. 11/453,078, filed Jun. 15, 2006 now U.S. Pat. 5
No. 7,308,143, which is a divisional of U.S. patent applica-
tion Ser. No. 10/479,831 filed on Dec. 08, 2003, now U.S. Pat.
No. 7,095,896, which is the National Stage of International
Application No. PCT/JP03/03794, filed Mar. 27, 2003.

TECHNICAL FIELD

The present invention relates to a picture coding method
and a picture decoding method for coding an image digitally
so as to transfer or store it.

BACKGROUND ART

A coding of moving pictures, in general, divides a picture
into a certain size of blocks and performs intra picture pre-
diction and inter picture prediction for each block. It then
applies orthogonal transformation, for example, discrete
cosine transform or the like for each block of the smallest unit
of a division (i.e. 4×4 pixels) so as to perform coding using
variable length coding based on run level coding for coeffi-
cients showing spatial frequency components gained by
orthogonal transformation.

The variable length coding assigns variable length code to
values of the coefficients contained in the block to which
orthogonal transformation is applied (level) as well as to
numbers consisting of a series of a coefficient 0 (run). In this
case, a table which corresponds the values with variable
length code is called a VLC table. Under the conventional
method, only one table is prepared as a VLC table respec-
tively for intra prediction coding and inter prediction coding
(reference to ISO/IEC 14496-2:1999(E) Information tech-
nology—coding of audio-visual objects Part 2: Visual (1999-
12-01) P.119 7.4.1 Variable length decoding).

Under the variable length coding method explained in the
existing technique, only one table is prepared as a VLC table
respectively for intra prediction coding and inter prediction
coding. Therefore, it contains a problem that coding effi-
ciency differs greatly depending on a quality of a current
picture to be coded.

In order to solve this problem, a method of preparing a
plurality of tables so as to refer to them by switching between
them according to the number of coefficients other than 0
contained in a current block to which orthogonal transforma-
tion is applied is conceivable. For realizing this, it is necessary
to perform coding by applying variable length coding for the
numbers of the coefficients other than 0, however, the coding
method and the decoding method are not yet established.

DISCLOSURE OF INVENTION

The present invention has been devised in view of these
circumstances and it is an object of the present invention to
suggest a picture coding method as well as a picture decoding
method that realize coding of the number of coefficients other
than 0 contained in the block to which orthogonal transforma-
tion is applied with high efficiency regardless of the qual-
ity of the current picture.

In order to solve the problem as mentioned above, a picture
coding method according to the present invention codes, on a
block-to-block basis, an image by transforming the image
into coefficients showing spatial frequency components and
comprises: a predicting step for calculating a predictive value

2

of the number of coefficients other than 0 contained in a
current block to be coded based on the numbers of coeffi-
cients other than 0 contained in coded blocks located on a
periphery of the current block; a table selecting step for
selecting tables for variable length coding based on the pre-
dictive value calculated in the predicting step; and a variable
length coding step for performing variable length coding for
the number of the coefficients other than 0 contained in the
current block with reference to the tables for variable length
coding selected in the table selecting step.

Thus, it realizes an improvement in coding efficiency since
it is possible to refer to optimal tables for variable length
coding when coding the number of the coefficients other than
0 contained in the current block.

Also, in the predicting step, the predictive value is calcu-
lated using an average value of the numbers of the coefficients
other than 0 contained in the coded blocks.

Also, the tables for variable length coding include at least
one VLC table. In the table selecting step, the VLC table is
selected based on the predictive value calculated in the pre-
dicting step and in the variable length coding step, the number
of the coefficients other than 0 contained in the current block
is transformed into a variable length code with reference to
the VLC table selected in the table selecting step.

The tables for variable length coding include at least one
code table and one VLC table. In the table selecting step, a
code table and a VLC table are selected based on the predic-
tive value calculated in the predicting step and in the variable
length coding step, the number of the coefficients other than
0 contained in the current block is transformed into a code
number with reference to the code table selected in the table
selecting step and then the code number is transformed into a
variable length code with reference to the VLC table selected
in the table selecting step.

The picture coding method comprises a keeping step for
keeping the numbers of the coefficients other than 0 contained
in the coded blocks neighboring an uncoded block at least
until the uncoded block is coded.

In the predicting step, the predictive value of the number of
coefficients other than 0 contained in the current block is
calculated based on the numbers of the coefficients other than
0 contained in the coded blocks located above and on the left
of the current block.

In the predicting step, a value 0 is set as the predictive value
when no coded blocks are found above and on the left of the
current block.

In the predicting step, an average value of the numbers of
the coefficients other than 0 contained in the coded blocks
located above and on the left of the current block is calculated
as the predictive value when the coded blocks are found above
and on the left of the current block.

In the predicting step, the number of the coefficients other
than 0 contained in the coded block on the left of the current
block is set as the predictive value when the coded block is
found on the left but not above the current block.

In the predicting step, the number of the coefficients other
than 0 contained in the coded block above the current block is
set as the predictive value when the coded block is found
above but not on the left of the current block.

In the predicting step, a value 0 is set as the predictive value
when upper and left boundaries of the current block are either
a boundary of pictures, each of which is a unit of the picture
or a boundary of slices, each of which is what the picture is
divided into a plurality of sections.

In the predicting step, an average value of the numbers of
the coefficients other than 0 contained in the coded blocks
located above and on the left of the current block is set as the

US 7,769,238 B2

3

predictive value when upper and left boundaries of the current block are neither a boundary of pictures, each of which is a unit of the picture nor a boundary of slices, each of which is what the picture is divided into a plurality of sections.

In the predicting step, the number of the coefficients other than 0 contained in the coded block on the left of the current block is set as the predictive value when an upper boundary of the current block is either a boundary of pictures, each of which is a unit of the picture or a boundary of slices, each of which is what the picture is divided into a plurality of sections, and the left boundary is neither the boundary of pictures nor the boundary of slices.

In the predicting step, the number of the coefficients other than 0 contained in the coded block above the current block is set as the predictive value when a left boundary of the current block is either a boundary of pictures, each of which is a unit of the picture or a boundary of slices, each of which is what the picture is divided into a plurality of sections, and an upper boundary is neither the boundary of pictures nor the boundary of slices.

A picture decoding method according to the present invention decodes, on a block-to-block basis, an image that is coded by transforming the image into coefficients showing spatial frequency components and comprises:

a predicting step for calculating a predictive value of the number of the coefficients other than 0 contained in a current block to be decoded based on numbers of coefficients other than 0 contained in decoded blocks located on a periphery of the current block;

a table selecting step for selecting tables for variable length decoding based on the predictive value calculated in the predicting step; and

a variable length decoding step for performing variable length decoding for the number of the coefficients other than 0 contained in the current block with reference to the tables for variable length decoding selected in the table selecting step.

Thus, it realizes a correct decoding of a bit stream, in which the number of the coefficients other than 0 contained in the block is coded, referring to optimal tables for variable length decoding.

Also, in the predicting step, the predictive value is calculated using an average value of the numbers of the coefficients other than 0 contained in the decoded blocks.

Also, the tables for variable length decoding include at least one VLC table. In the table selecting step, the VLC table is selected based on the predictive value calculated in the predicting step, and in the variable length decoding step, a variable length code showing the number of coefficients other than 0 contained in the current block is transformed into said number of the coefficients other than 0 contained in the current block, with reference to the VLC table selected in the table selecting step.

The tables for variable length decoding include at least one code table and one VLC table. In the table selecting step, the code table and the VLC table are selected based on the predictive value calculated in the predicting step, and in the variable length decoding step, a variable length code showing the number of coefficients other than 0 contained in the current block is transformed into a code number with reference to the VLC table selected in the table selecting step, and then the code number is transformed into said number of the coefficients other than 0 contained in the current block, with reference to the code table selected by the table selecting step.

The picture decoding method comprises a keeping step for keeping the numbers of the coefficients other than 0 contained

4

in the decoded blocks neighboring an undecoded block at least until the undecoded block is decoded.

In the predicting step, the predictive value of the number of the coefficients other than 0 contained in the current block is calculated based on the numbers of the coefficients other than 0 contained in the decoded blocks located above and on the left of the current block.

In the predicting step, a value 0 is set as the predictive value when no decoded blocks are found above and on the left of the current block.

In the predicting step, an average value of the numbers of the coefficients other than 0 contained in the decoded blocks located above and on the left of the current block is set as the predictive value when the decoded blocks are found above and on the left of the current block.

In the predicting step, the number of the coefficients other than 0 contained in the decoded block on the left of the current block is set as the predictive value when the decoded block is found on the left but not above.

In the predicting step, the number of the coefficients other than 0 contained in the decoded block above the current block is set as the predictive value when the decoded block is found above but not on the left of the current block.

In the predicting step, a value 0 is set as the predictive value when upper and left boundaries of the current block are either a boundary of pictures, each of which is a unit of the picture or a boundary of slices, each of which is what the picture is divided into a plurality of sections.

In the predicting step, an average value of the numbers of the coefficients other than 0 contained in the decoded blocks located above and on the left of the current block is set as the predictive value when upper and left boundaries of the current block are neither a boundary of pictures, each of which is a unit of the picture nor a boundary of slices, each of which is what the picture is divided into a plurality of sections.

In the predicting step, the number of the coefficients other than 0 contained in the decoded block on the left of the current block is set as the predictive value when an upper boundary of the current block is either a boundary of pictures, each of which is a unit of the picture or a boundary of slices, each of which is what the picture is divided into a plurality of sections, and a left boundary of the block is neither the boundary of pictures nor the boundary of slices.

In the predicting step, the number of coefficients other than 0 contained in the decoded block above the current block is set as the predictive value when a left boundary of the current block is either the boundary of pictures, each of which is a unit of the picture or a boundary of slices, each of which is what the picture is divided into a plurality of sections, and an upper boundary of the block is neither the boundary of pictures nor the boundary of slices.

The present invention is realized not only as a picture coding method and a picture decoding method, but also as a picture coding device and a picture decoding device including the characteristic steps contained in these methods as means. It is realized also as a program which causes a computer to execute these steps or as a bit stream created by the picture coding method. Such a program can surely be distributed through a storage medium like CD-ROM and a transmission medium like Internet.

BRIEF DESCRIPTION OF DRAWINGS

FIG. 1 is a block diagram showing a structure of an embodiment of a picture coding device using a picture coding method according to the present invention.

US 7,769,238 B2

5

FIG. 2A is a pattern diagram showing a sketch of a processing order of macroblocks in each picture. FIG. 2B is a pattern diagram showing macroblocks which belong to coded blocks used for reference in order to encode a number of coefficients of a current block to be coded.

FIG. 3A is a block diagram showing a structure of a coefficient number encoder according to the first embodiment of the present invention. FIG. 3B is a block diagram showing a structure of a transformational example of the coefficient number encoder.

FIG. 4A and FIG. 4B are pattern diagrams showing a physical position of a current block to be coded and the coded blocks used for the reference. FIG. 4A presents a case of using three adjacent blocks whereas FIG. 4B presents a case of using two adjacent blocks.

FIG. 5 is a pattern diagram showing an example of a flow when the number of coefficients is transformed into a bit stream with reference to tables.

FIG. 6A and FIG. 6B are pattern diagrams showing reference blocks for a current macroblock to be coded. FIG. 6A presents a case of using three adjacent blocks whereas FIG. 6B presents a case of using two adjacent blocks.

FIG. 7A, FIG. 7B and FIG. 7C are pattern diagrams showing an operation in which a coefficient number storing unit stores the numbers of coefficients. FIG. 7A presents a case where a processing proceeds to the next macroblock whereas FIG. 7B presents a case where the processing further proceeds to the next macroblock. FIG. 7C presents a case where the current macroblock is located at the right edge of the picture and the processing shifts to the next macroblock.

FIG. 8A, FIG. 8B and FIG. 8C are block diagrams showing a structure of a transformational example of a coefficient number encoder according to the first embodiment of the present invention.

FIG. 8A presents a case of fixing a code table. FIG. 8B presents a case of fixing a VLC table. The FIG. 8C presents a case of using only a VLC table without using code tables.

FIG. 9 is a block diagram showing a structure of a transformational example of the coefficient number encoder according to the first embodiment of the present invention.

FIG. 10A is a block diagram showing a structure of a coefficient number encoder according to the second embodiment of the present invention. FIG. 10B is a block diagram showing a structure of a transformational example of the coefficient number encoder.

FIG. 11A and FIG. 11B are pattern diagrams for showing a position of blocks targeted for statistics of the numbers of coefficients according to the second and the seventh embodiments of the present invention.

FIG. 12A is a block diagram showing a structure of a coefficient number encoder according to the third embodiment of the present invention. FIG. 12B is a block diagram showing a structure of a transformational example of the coefficient number encoder.

FIG. 13A is a block diagram showing a structure of a coefficient number encoder according to the fourth embodiment of the present invention. FIG. 13B is a block diagram showing a structure of a transformational example of the coefficient number encoder.

FIG. 14 is a block diagram for showing a method of calculating an evaluation value obtained by the table switching according to the fourth and the ninth embodiments of the present invention.

FIG. 15 is a block diagram showing a structure of a picture coding device according to the fifth embodiment of the present invention.

6

FIG. 16 is a block diagram showing a structure of a coefficient number encoder according to the fifth embodiment of the present invention.

FIG. 17 is a block diagram showing a structure of an embodiment of a picture decoding device using a picture decoding method according to the present invention.

FIG. 18A is a block diagram showing a structure of a coefficient number decoder according to the sixth embodiment of the present invention. FIG. 18B is a block diagram showing a structure of a transformational example of the coefficient number decoder.

FIG. 19 is a pattern diagram showing an example of a flow when a bit stream of a number of coefficients is transformed into the number of coefficients with reference to tables.

FIG. 20A and FIG. 20B are block diagrams showing a structure of a transformational example of a coefficient number decoder according to the sixth embodiment of the present invention. FIG. 20A presents a case of fixing a code table. FIG. 20B presents a case of fixing a VLC table. FIG. 20C presents a case of using a VLC table without using code tables.

FIG. 21 is a block diagram showing a structure of a transformational example of a coefficient number decoder according to the sixth embodiment of the present invention.

FIG. 22A is a block diagram for explaining an operation of processing showing a structure of a coefficient number decoder according to the seventh embodiment of the present invention.

FIG. 22B is a block diagram showing a structure of a transformational example of the coefficient number decoder.

FIG. 23A is a block diagram for explaining an operation of processing showing a structure of a coefficient number decoder according to the eighth embodiment of the present invention. FIG. 23B is a block diagram showing a structure of a transformational example of the coefficient number decoder.

FIG. 24A is a block diagram for explaining an operation of processing which shows a structure of the coefficient number decoder according to the ninth embodiment of the present invention. FIG. 24B is a block diagram showing a structure of a transformational example of the coefficient number decoder.

FIG. 25 is a block diagram for explaining an operation of processing which shows a structure of a coefficient number decoder according to the tenth embodiment of the present invention.

FIG. 26A and FIG. 26B are illustrations regarding a recording medium for storing a program in order to realize a picture coding method as well as a picture decoding method of each embodiment in a computing system. FIG. 26A is an explanatory diagram showing an example of a physical format of a flexible disk which is a main body of a recording medium. FIG. 26B is an explanatory diagram showing a full appearance of the flexible disk, a structure at cross section and the flexible disk itself. FIG. 26C is an illustration showing a structure for recording and reproducing the program on the flexible disk FD.

FIG. 27 is a block diagram showing a whole structure of a content providing system which realizes a content delivery service.

FIG. 28 is a sketch showing an example of a cell phone.

FIG. 29 is a block diagram showing an internal structure of the cell phone.

FIG. 30 is a block diagram showing a whole system of a digital broadcasting system.

BEST MODE FOR CARRYING OUT THE INVENTION

The following describes the embodiments of the present invention with reference to the diagrams and equations.

First Embodiment

FIG. 1 is a block diagram showing a structure of an embodiment of a picture coding device using a picture coding method according to the present invention.

The picture coding device includes, as shown in FIG. 1, frame memories 101 and 106, an orthogonal transforming unit 102, a quantizing unit 103, an inverse quantizing unit 104, an inverse orthogonal transforming unit 105, an inter picture predicting unit 107, an intra picture predicting unit 108, a coefficient number detecting unit 109, a coefficient number storing unit 110, a coefficient number encoder 111, a coefficient value encoder 112, a bit stream generating unit 113, switches 114 and 115, a difference calculating unit 116 and an addition calculating unit 117.

The frame memory 101 stores moving pictures inputted on a picture-to-picture basis in display order. The inter picture predicting unit 107 detects motion vectors which show a position predicted as optimal in the searching area in the picture, using picture data reconstructed in a coding device as reference pictures so as to create predictive picture data based on the motion vectors. The difference calculating unit 116 calculates a difference between the input picture data read out from the frame memory 101 and the predictive picture data inputted from the inter picture predicting unit 107 so as to create predictive residual picture data.

The intra picture predicting unit 108 creates predictive picture data using the picture data of the coded area in the current picture and creates predictive residual picture data by calculating the difference between the created predictive picture data and the input picture data.

The orthogonal transforming unit 102 performs orthogonal transformation to the inputted predictive residual picture data. The quantizing unit 103 performs a quantization to the orthogonal transformed data and creates coefficients showing spatial frequency components which is an object for variable length coding. The inverse quantizing unit 104 performs inverse quantization to the coefficients created in the aforementioned processing. The inverse orthogonal transforming unit 105 performs inverse orthogonal transformation to the inverse quantized data and creates reconstructed predictive residual picture data. The addition calculating unit 117 adds the reconstructed residual picture data inputted from the inverse orthogonal transforming unit 105 and the predictive picture data inputted from the inter predicting unit 107 and creates reconstructed picture data. The frame memory 106 stores the created reconstructed picture data.

The coefficient number detecting unit 109 detects the number of coefficients having a value other than 0 (hereafter simply refers to number of coefficients) from each block by examining the value of the created coefficient. The coefficient number storing unit 110 stores the numbers of coefficients detected by the coefficient number detecting unit 109. The coefficient number encoder 111 refers to the values of the coefficients in the block, that are already coded and stored in the coefficient number storing unit 110 and performs coding for the numbers of the coefficients using a method to be mentioned later. The coefficient value encoder 112 performs variable length coding for the values of the coefficients themselves with reference to VLC tables necessary for variable length coding by switching between them using the numbers

of the coefficients detected by the coefficient number detecting unit 109. The bit stream generating unit 113 generates a bit stream by adding other information on the motion vectors or the like inputted from the inter picture prediction unit 107 to the numbers of the coefficients and the values of the coefficients, which are coded.

Next, an explanation regarding an operation of a picture coding device constructed as above follows.

The moving pictures targeted for coding are inputted to the frame memory 101 on a picture-to-picture basis in display order and then reordered in the order of coding. Each picture is divided into a block of, for instance, 16 (horizontal)×16 (vertical) pixels called macroblock, and subsequent processing take place using the unit of macroblock. FIG. 2A is a pattern diagram showing a sketch of a processing order of macroblocks in each picture whereas FIG. 2B is a pattern diagram showing macroblocks to which the coded blocks used for reference in order to encode the numbers of the coefficients in the current block belong. The FIG. 2B shows a case where a macroblock MB13 is the current macroblock.

Coding of the macroblocks in each picture starts from upper left, one by one, to the right, as shown in the FIG. 2A, goes one step down when it comes to the right edge and starts again from the left to the right. The macroblock, which is read out from the frame memory 101, is firstly inputted to the inter picture predicting unit 107 when a current macroblock to be coded is coded using inter picture prediction. The inter picture predicting unit 107 uses reconstructed picture data of the coded pictures stored in the frame memory 106 as reference pictures for detecting motion vectors in each block [i.e. 4 (horizontal)×4(vertical) pixels] which is a further divided macroblock. The inter picture predicting unit 107 outputs predictive picture data created by the detected motion vectors to the difference calculating unit 116. The difference calculating unit 116 creates predictive residual picture data by measuring the difference between the predictive picture data and the input picture data of the current macroblock.

On the contrary, for coding the target macroblock by means of intra picture prediction, the macroblock which is read out from the frame memory 101 is firstly inputted to the intra picture predicting unit 108. The intra picture predicting unit 108 performs intra picture prediction using the information on the surrounding blocks and creates predictive residual picture data.

The thus created predictive residual picture data goes through processing of orthogonal transformation at the orthogonal transforming unit 102, processing of a quantization at the quantizing unit 103 for each block and then is transformed into the coefficients for which variable length coding is to be performed. These coefficients are inputted to the coefficient number detecting unit 109, to the coefficient value encoder 112 and to the inverse quantizing unit 104.

The coefficient number detecting unit 109 detects the number of coefficients having a value other than 0 in each block. The numbers of coefficients detected here are stored in the coefficient number storing unit 110. The coefficient number encoder 111 refers to the values by reading out from the coefficient number storing unit 110 the numbers of the coefficients in the coded blocks and performs coding for the number of the coefficients of the current block. Also, the coefficient value encoder 112 performs coding of the values of the coefficients themselves using the numbers of the coefficients detected by the coefficient number detecting unit 109. Lastly, the bit stream generating unit 113 generates a definitive bit stream by adding, to the bit stream, the numbers of the

US 7,769,238 B2

9

coefficients and the values of the coefficients, which are coded, together with other information on the motion vectors or the like.

The coefficients inputted to the inverse quantizing unit 104 go through the processing of inverse quantization at the inverse quantizing unit 104 as well as the processing of inverse orthogonal transformation at the inverse orthogonal transforming unit 105, and then, are transformed into reconstructed predictive residual picture data. Next, the addition calculating unit 117 adds the reconstructed predictive residual picture data and the predictive picture data inputted from the inter picture predicting unit 107 so as to create reconstructed picture data and stores it in the frame memory 106.

Thus, a sequence of coding is explained above. As for variable length coding processing of the numbers of coefficients performed by the coefficient number encoder 111, the detail is explained with reference to FIG. 3~FIG. 9 as well as Chart 1~Chart 7.

FIG. 3A is a block diagram showing in detail an internal structure of the coefficient number encoder 111.

Here, an example of using two tables of a code table and a VLC table in order to perform variable length coding for the number of coefficients is shown. The code table is a table for transforming the number of coefficients into a code number whereas the VLC table is a table for transforming the code number gained by the code table into variable length code.

The coefficient number encoder 111 includes, as shown in FIG. 3A, a predictive value calculating unit 201, a code table storing unit 202, a code table selecting unit 203, a VLC table selecting unit 204, a VLC table storing unit 205 and a coefficient number encoder 206.

Firstly, the numbers of coefficients of coded blocks on the periphery are inputted from the coefficient number storing unit 110 shown in the FIG. 1 to the predictive value calculating unit 201. The predictive value calculating unit 201 determines the predictive value by calculating an average value of these values. A maximum value, a minimum value or a medium value may be used instead of the average value as a method to determine the predictive value.

FIG. 4A is a pattern diagram showing a location relationship between a current block to be coded and the coded blocks to be used for the reference. Here, a block X is a current block whereas three blocks in a position of blocks B, C and D are reference blocks. As for the three blocks in the position of the blocks B, C and D, when blocks which are neither coded nor located outside the picture or outside the slice which is a picture divided into a plurality of sections, occurs, a change is made to the reference blocks as in Chart 1.

CHART 1

B	C	D	Reference block
○	○	○	B, C, D
○	X	○	A, B, D
X	X	○	D
○	○	X	B, C
X	X	X	None

As for signs in Chart 1, a sign O signifies a coded block and a sign X signifies a block which can not be referred to since it is neither coded nor located outside the picture or outside the slice. For example, when only a block C can not be referred to, it shows that the references are blocks A, B and D. Chart 1 shows a relation between a condition of the reference blocks and the block(s) which can be referred to, however, the pat-

10

terns are not limited to this. Also, if no reference blocks are found, either a value 0 or other arbitrary value is given directly as a predictive value.

The code table selecting unit 203 selects a code table for an actual use from a plurality of code tables stored in the code table storing unit 202 in accordance with a predictive value calculated by the predictive value calculating unit 201.

Chart 2 is an example of a code table in which numbers of coefficients correspond to code numbers prepared beforehand by the code table storing unit 202.

CHART 2

Coefficient number value	Code table 1	Code table 2	Code table 3	Code table 4
0	0	4	8	8
1	1	2	7	7
2	2	0	5	6
3	3	1	4	5
4	4	3	2	4
5	5	5	0	3
6	6	6	1	2
7	7	7	3	1
8	8	8	6	0

According to this example, a code table 1, for example, assigns code numbers which are identical to numbers of coefficients whereas a code table 2 assigns the code numbers so that a value 2 of the coefficient number plays a central role. Four types of code tables are prepared here; however, the numbers of types of tables and values of tables are not limited to those used in Chart 2. Also, Chart 3 presents selection criteria for code tables based on a predictive value.

CHART 3

Predictive value	Reference table
0~2	Code table 1
3~5	Code table 2
6~8	Code table 3
9~16	Code table 4

According to this example, the code table selecting unit 203 selects a code table as follows: it refers to a code table 1 when the predictive value calculated by the predictive calculating unit 201 is no more than 2 whereas it refers to a code table 2 when the predictive value is more than or equal to 3 and less than or equal to 5. The way of assigning predictive values and the items of reference tables are not limited to those used in Chart 3.

The VLC table selecting unit 204 selects a VLC table for actual use from a plurality of VLC tables stored in the VLC table storing unit 205 in accordance with the predictive value calculated by the predictive calculating unit 201.

Chart 4 is an example of a VLC table in which code numbers prepared in advance by the VLC table storing unit 205 correspond with variable length codes.

CHART 4

Code number	VLC table 1	VLC table 2	VLC table 3	VLC table 4
0	0	1	10	100
1	01	010	11	101
2	001	011	0100	110
3	0001	00100	01012	111
4	00001	00101	0110	01000
5	000001	00110	0111	01001

CHART 4-continued

Code number	VLC table 1	VLC table 2	VLC table 3	VLC table 4
6	0000001	00111	001000	01010
7	00000001	0001000	001001	01011
8	000000001	0001001	001010	01100

According to this example, a VLC table 1, in comparison with a VLC table 4, is designed with a tendency that an amount of bit increases if the code number is large and decreases if the code number is small. It shows that the VLC table 1 can perform variable length coding more efficiently when an apparition probability of the code number concentrates in the area where the values are small while the VLC table 4 can perform more efficiently when the apparition probability scatters to the area where the values are big. Four types of tables are prepared here; however, the numbers of types of tables and the values of tables are not limited to those used in Chart 4. Also, Chart 5 presents selection criteria for VLC tables based on a predictive value.

CHART 5

Predictive value	Reference table
0~1	VLC table 1
2~3	VLC table 2
4~6	VLC table 3
7~16	VLC table 4

According to this example, the VLC table selecting unit 204 selects a VLC table as follows: it refers to a VLC table 1 when the predictive value calculated by the predictive value calculating unit 201 is no more than 1 whereas it refers to a VLC table 2 when the predictive value is more than or equal to 2 and less than or equal to 3. The way of assigning predictive values and the items of reference tables are not limited to those used in Chart 5.

The coefficient number encoder 206 refers to the code table and the VLC table which are selected by the above processing and performs variable length coding of the number of the coefficients in the inputted current block. The coefficient number encoder 206 firstly transforms the number of coefficients into a code number using the code table and then transforms it into a variable length code corresponded to the code number, using the VLC table. FIG. 5 is a pattern diagram showing an example of coding when the predictive value calculated by the predictive calculating unit 201 is "6" and the number of the coefficients in the current block is "4". A code table 3 shown in FIG. 5 is selected at the code table selecting unit 203 using Chart 3 and Chart 2 according to the predictive value "6" and also a VLC table 3 shown in FIG. 5 is selected at the VLC table selecting unit 204 using Chart 5 and Chart 4. The coefficient number encoder 206 transforms the inputted number of the coefficients "4" into a code number "2" according to the code table 3 and furthermore creates a definitive bit stream "0100" according to the VLC table 3.

Next, as for a storing processing of number of coefficients performed by the coefficient number storing unit 110, the detail is explained. FIG. 6A is a pattern diagram showing reference blocks with respect to a current macroblock to be coded in the predictive value calculating unit 201. Here, a black border containing the blocks coded as B1~B16 shows the current macroblock whereas a hatched section shows the

reference blocks with respect to the current macroblock. Also, the numbers assigned to the blocks indicate the order of coding in the macroblock.

The coefficient number storing unit 110, for example, at the time of starting the processing of the current macroblock shown in FIG. 6A stores the numbers of coefficients detected by the coefficient number detecting unit 109, at least for the reference blocks shown in FIG. 6A which are necessary for the current macroblock. Namely, the coefficient number storing unit 110 stores the numbers of coefficients detected according to the blocks of the current macroblock (B1, B2, B3, . . . and B16) which are to be processed sequentially. For example, when the current block is a block B6, the coefficient number storing unit 110 stores the numbers of each coefficient of B1, B2, B3, B4 and B5 which are already processed in addition to the reference blocks shown as hatched in FIG. 6A. Then, the coefficient number storing unit 110 stores the number of coefficients of this block B6 when it is detected by the coefficient number detecting unit 109. Thus, the coefficient number storing unit 110 stores the numbers of the coefficients detected from the blocks in the current macroblocks (B1, B2, B3, . . . and B16) which are to be processed sequentially.

Then, for example, when the current macroblock is a macroblock MB11 shown in FIG. 2, the coefficient number storing unit 110 at least stores the numbers of the coefficients of the blocks in a bottom row and a right column (hatched blocks) of the macroblock MB11 as shown in FIG. 7A when the processing of the macroblock MB11 terminates and proceeds to the next macroblock MB12. Next, when the processing of the macroblock MB12 terminates and the processing proceeds to the next macroblock MB13, the coefficient number storing unit 110 stores at least the numbers of the coefficients for the blocks located in the bottom row and in the right column of the macroblock MB12 in the same way as well as the numbers of coefficients of the blocks in the bottom row of the macroblock MB11 (hatched blocks) as shown in FIG. 7B.

For example, when the current macroblock is located in the right edge of the picture as the macroblock MB9 shown in FIG. 2B, the coefficient number storing unit 110 stores at least the numbers of coefficients of the blocks in the bottom row of the macroblock MB9 (hatched blocks) as shown in FIG. 7B when the processing of the macroblock MB9 terminates and the processing proceeds to the next macroblock MB10.

When the current macroblock is located in the bottom edge of the picture as MBm shown in FIG. 2B, the coefficient number storing unit 110 stores at least the numbers of the coefficients of the blocks in the right column of the macroblock MBm as shown in FIG. 7C when the processing of the macroblock MBm terminates and the processing proceeds to the next macroblock MBn.

The coefficient number storing unit 110 thus stores the numbers of coefficients for the blocks to be referred to. It is possible to delete, in an arbitrary timing, the information on the number of coefficients of the blocks other than those to be stored in the above explanation if they are no longer used for reference. For example, it is possible to delete when processing proceeds to the next macroblock as well as while processing the macroblock. Also, the numbers of coefficients in the blocks which are no longer used for reference do not always need processing of deleting. For instance, the coefficient number storing unit 110 may identify the numbers of coefficients in the blocks which are not referred to any longer as unnecessary and may overwrite to them if necessary.

It is explained above that it is possible to refer to the numbers of the coefficients of the coded blocks by storing them in the coefficient number storing unit 110. A system for

calculating the number of coefficients, however, may be used, if necessary, by storing not the values of the number of the coefficients themselves but, for instance, the values of the coefficients in the blocks, which are transformed into spatial frequency components.

In the present embodiment, it is possible, as mentioned above, to calculate a predictive value using the numbers of the coefficients in the coded adjacent blocks so as to perform coding of the number of coefficients efficiently even to the pictures whose apparition probability of the coefficients is not even by referring to the code table and the VLC table adaptively according to the predictive value.

Also, it can, as described above, correspond to a fluctuation of a position where the apparition probability of the number of coefficients is the highest with reference to the code table by switching them according to the predictive value. It can also correspond to the size of the dispersion of the apparition probability of the number of coefficients by switching the VLC tables for reference according to the predictive value. Consequently, it is possible to perform effectively coding of the number of coefficients.

It is also possible to use only two blocks located in the position of blocks B and D for a current block X to be coded as shown in FIG. 4B in stead of using three neighboring blocks as reference blocks as shown in FIG. 4A at the predictive value calculating unit 201. A change is made concerning reference blocks as in Chart 6 when it happens that either of two blocks in the position of the blocks B and D is neither coded nor located outside the picture nor outside the slice.

CHART 6

B	D	Reference block
○	○	B, D
X	○	D
○	X	B
X	X	None

As for signs in Chart 6, a sign O signifies a coded block and a sign X signifies a block which can not be referred to since it is neither coded nor located outside the picture nor outside the slice as in Chart 1. Chart 6 shows a relation between conditions of the reference blocks and the block(s) which can be referred to, however, the patterns are not limited to this. If no reference blocks are found, either a value 0 or other arbitrary value can be given directly as a predictive value. In this case, the coefficient number storing unit 110 may only store the numbers of coefficients detected at the coefficient number detecting unit 109, at least for the reference blocks shown in FIG. 6B, which are necessary for the current macroblock.

It is also possible, as a method to calculate a predictive value in the predictive value calculating unit 201, for example, to select an optimal method according to each sequence, each GOP, each picture or each slice rather than to fix the method to use either of an average value, a maximum value, a minimum value or a medium value. The code for identifying the calculating method then selected is added at a header section of the sequence, the GOP, the picture or the slice. The slice is a picture divided into a plurality of sections. A section of one column in a transverse direction sectioned on a macroblock-to-macroblock basis is an example of this.

Also, it is possible to select, for example, either of an average value, a maximum value, a minimum value or a medium value according to the average value of the number of the coefficients in the coded reference blocks. Chart 7 shows its selection criteria.

CHART 7

Average value	Predictive value calculation method
0~4	Minimum value
5~8	Average value
9~16	Maximum value

According to this example, a minimum value of the numbers of the coefficients of more than one reference blocks is applied as a predictive value when, for example, an average value is less than or equal to 4 and an average value is applied as a predictive value when the average value is more than or equal to 5 and less than or equal to 8. The positive effects of improvement in coding efficiency can be obtained in both cases: by selecting a maximum value since a probability that greater number of coefficients appears becomes higher in the blocks in which the quantization step is small and the movements are complicated; and by selecting a minimum value since a probability that smaller number of coefficients appears becomes higher in the blocks in which the quantization step is inversely big and the movement is simple. The way of assigning the average value or the items indicated as predictive value calculating methods is not limited to those indicated in Chart 7.

The coefficient number encoder 111 in the present embodiment performs variable length coding for the value of the number of coefficients itself. The difference calculating unit 207 may, however, calculate a difference value between the predictive value calculated at the predictive value calculating unit 201 and the value of number of coefficients which is inputted so as to perform coding for the gained value with the same processing as described in the above embodiment. The positive effects can be obtained for the improvement in coding efficiency for a picture in which a change in the number of coefficients among the surrounding blocks becomes smaller when changes in luminance and in chrominance are monotonous across the screen.

Also, the coefficient number encoder 111 performs coding by switching both the code table and the VLC table according to the predictive value based on the number of coefficients in the neighboring blocks; however, these tables may not be switched but fixed. This can be realized by using only a storing unit which has either one certain type of code tables or one certain type of VLC tables in stead of using table selecting units. FIG. 8A is a block diagram showing a structure of the coefficient number encoder 111 for performing variable length coding of the number of coefficients by fixing only a code table. Also, FIG. 8B is a block diagram showing a structure of the coefficient number encoder 111 for performing variable length coding of the number of coefficients by fixing only a VLC table. In case of fixing only a code table, the coefficient number encoder 111 as shown in FIG. 8A includes a code table storing unit 301 in stead of the code table storing unit 202 and the code table selecting unit 203 shown in FIG. 3A. The code table storing unit 301 has one type of code table. Then, the coefficient number encoder 206 first transforms the number of coefficients into a code number using a code table stored in the code table storing unit 301 then transforms the code number to variable length code using a VLC table selected by the VLC table selecting unit 204.

On the other hand, the coefficient number encoder 111 as shown in FIG. 8B includes a VLC table storing unit 302 in stead of the VLC table storing unit 205 and the VLC table selecting unit 204 shown in FIG. 3A. The VLC table storing unit 302 has one type of VLC table. Then, the coefficient

number encoder **206** firstly transforms the number of coefficients into a code number using the code table selected by the code table selecting unit **203** then transforms the code number into a variable length code using the VLC table stored in the VLC table storing unit **302**.

Thus by fixing either the code table or the VLC table in stead of switching between them, the throughput for switching tables can be reduced or an amount of memory for storing a plurality of tables can be reduced although the effects of coding efficiency decreases more or less.

Also, the coefficient number encoder **111** may perform variable length coding by switching only the VLC tables according to the predictive value based on the numbers of coefficients in the neighboring blocks without using code tables. FIG. **8C** is a block diagram showing a structure of the coefficient number encoder **111** for performing variable length coding of the number of coefficients using only the VLC tables without code tables. In this case, as shown in FIG. **8C**, the coefficient number encoder **111** includes neither the code table storing unit **202** nor the code table selecting unit **203**. The coefficient number encoder **111** selects a VLC table for actual use from a plurality of VLC tables stored in the VLC table storing unit **304**. Then, the coefficient number encoder **206** directly transforms the number of coefficients into variable length code without transforming it into the code number as shown above. In this case, in the examples of VLC tables shown in Chart 4, the part shown as code numbers is replaced by values of number of coefficients.

Also, the case in which the coefficient number encoder **111** performs variable length coding using a difference value between a predictive value and a value of number of coefficients instead of a value of number of coefficients can be handled in the same way. FIG. **9** is a block diagram showing, as an example of it, a structure of the coefficient number encoder **111** for performing variable length coding for a difference value between the predictive value and the number of coefficients by fixing both a code table and a VLC table. In this case, the coefficient number encoder **111** as in FIG. **9** includes a code table storing unit **301** in stead of the code table storing unit **202** and the code table selecting unit **203** shown in FIG. **3A** as well as a VLC table storing unit **302** in stead of the VLC table storing unit **205** and the VLC table selecting unit **204**. The code table storing unit **301** has one type of code tables whereas the code VLC table storing unit **302** has one type of VLC tables. Then, the coefficient number encoder **206** firstly transforms the difference value between the number of coefficients and the predictive value into a code number using the code table stored in the code table storing unit **301** then transforms the code number into a variable length code using the VLC table stored in the VLC table storing unit **302**.

Second Embodiment

The structure of the picture coding device and the outline of the coding processing according to the present embodiment are totally the same as those described in the first embodiment excepting the coefficient number encoder **111** shown in FIG. **1**. Here, regarding variable length coding processing of the number of coefficients performed by the coefficient number encoder **111** in the second embodiment, the detail is explained using FIGS. **10** and **11**.

FIG. **10A** is a block diagram showing in detail an internal structure of the coefficient number encoder **111**.

As shown in FIG. **10A**, the coefficient number encoder **111** includes a code table generating unit **701** in stead of the code table storing unit **202** and the code table selecting unit **203** shown in FIG. **3A**. The numbers of coefficients in the coded

blocks are inputted to the code table generating unit **701** from the coefficient number storing unit **110**. The code table generating unit **701** counts the number of the coded blocks having the same number of coefficients as the value of the number of coefficients at each of the values and creates code tables by assigning code numbers in descending order starting from a coefficient number which recorded the highest frequency based on the statistic. FIG. **11A** is a pattern diagram presenting a position of the coded blocks targeted for statistic. Here, a **P1**, a **P3** and a **P4** are pictures in which inter picture prediction coding is performed whereas an **I2** is a picture in which intra picture prediction coding is performed. Supposing that a current block belongs to the **P3**, all the blocks, which are coded using the same method as used for the current block, contained in the **P1**, which is a picture immediately preceding the current picture, are targeted for statistics. The case in which the blocks equivalents of one picture including the coded blocks in the current picture are targeted for statistics as in FIG. **11B** can be handled in the same way. Also, a table for the initial condition in ascending order starting from the number **0** shall be used as a code table when the coded blocks equivalent to one picture which can be targeted for statistic do not exist. Here, the blocks equivalent to one picture are targeted for statistics, however, the case in which the number of blocks other than this is used as a parameter can be handled in the same way. In case of applying a referring method as shown in FIG. **11A** so as to generate a code table, the table may be generated only once when encoding of the current picture is started.

Meanwhile, the numbers of coefficients in the coded blocks situated on the periphery are inputted to the predictive value calculating unit **201**. The predictive value calculating unit **201** determines the predictive value by calculating an average value based on these values as described in the first embodiment. A maximum value, a minimum value or a medium value may be used in stead of the average value as a method to determine the predictive value. The coded blocks then used as the reference, are determined according to Chart 1 using three blocks in the position of the blocks B, C and D for the current block X shown in FIG. **4A** in the first embodiment. Chart 1 shows a relation between conditions of the reference blocks and the block(s) which can be referred to, however, the patterns are not limited to this. Either a value **0** or other arbitrary value is given directly as a predictive value when no reference blocks are found.

The predictive value calculated by the predictive value calculating unit **201** is used only at the VLC table selecting unit **204**. The VLC table selecting unit **204** selects, as in the first embodiment, according to this predictive value, a VLC table for coding the number of coefficients from a plurality of VLC tables prepared in the VLC table storing unit **205** in advance as shown in Chart 4 in accordance with the selection criteria shown in Chart 5.

The coefficient number encoder **206** refers to the code table created by the code table generating unit **701** and the VLC table selected by the VLC table selecting unit **204** and then performs variable length coding of the number of the coefficients in the current block targeted for coding which is inputted in the same way as described in the first embodiment.

Thus, in the present embodiment, a code table is created by taking statistics of the numbers of the coefficients in the coded blocks, furthermore, a VLC table is determined according to the predictive value calculated from the number of the coefficients in the coded blocks, and by referring to both of the tables, it is possible to perform coding of the number of coefficients efficiently even for a picture whose apparition frequency of coefficients is uneven.

As in the first embodiment, it is also possible to determine the coded blocks used for reference at the predictive value calculating unit **201** as in the first embodiment according to Chart 6 using only two blocks located in the position of the blocks B and D for the current block X shown in FIG. 4B in

stead of using three neighboring blocks as shown in FIG. 4A. Chart 6 shows a relation between conditions of the reference blocks and the block(s) which can be referred to, however, the patterns are not limited to this. Either a value 0 or other arbitrary value is given directly as a predictive value when no reference blocks are found.

As in the first embodiment, it is also possible to select, for example, either of an average value, a maximum value, a minimum value or a medium value according to an average value of the numbers of the coefficients in the coded reference blocks as a method to calculate a predictive value in the predictive value calculating unit **201** as in the first embodiment. Chart 7 shows the selection criteria, however a way of assigning the average value and items indicated as predictive value calculating methods are not limited to this.

In the present embodiment, the coefficient number encoder **111** performs variable length coding for the value of the number of coefficients itself. However, as in the first embodiment, it is possible, as shown in FIG. 10, that a difference value between the predictive value calculated by the predictive value calculating unit **201** and the inputted value of the number of coefficients is calculated by the subtractor **207** and variable length coding is performed for the gained value by the same processing as described above.

Also, in the present embodiment, the coefficient number encoder **111** performs variable length coding by switching the VLC tables according to the predictive value based on the numbers of coefficients in the neighboring blocks. It is, however, possible to fix the table rather than to switch the VLC tables as in the first embodiment. In this case, this is realized by using only a VLC table storing unit which has one certain type of VLC tables in stead of using the VLC table selecting unit.

Third Embodiment

The structure of the picture coding device and the outline of the coding processing according to the present embodiment are totally the same as those described in the first embodiment, excepting the coefficient number encoder **111** shown in FIG. 1. Here, regarding variable length coding processing of the number of coefficients performed at the coefficient number encoder **111** in the third embodiment, the detail is explained using FIGS. 12A and 12B as well as Charts 8 and 9.

FIG. 12A is a block diagram showing in detail an internal structure of the coefficient number encoder **111**.

As shown in FIG. 12A, the coefficient number encoder **111** does not include the predictive value calculating unit **201** shown in FIG. 3A. A code table selecting unit **901** and a VLC table selecting unit **902** therefore select a table for actual use differently from the first embodiment by using directly the numbers of the coefficients in the coded blocks, without using a predictive value. As for the coded blocks then used for the reference as shown in FIG. 4B, only two blocks in the position of the block B (above) and the block D (left) for the current block X are used. However, when the blocks located above and on the left are neither coded nor situated outside the picture nor outside the slice, either a value 0 or other arbitrary value can be substituted.

Chart 8 shows a method of selecting a code table in the code table selecting unit **901**.

CHART 8

				Coefficient number (above)	
				0~5	6~16
Coefficient number (left)	0~5	Code table 1	Code table 2		
	6~16	Code table 3	Code table 4		

The code table selecting unit **901** classifies into two groups the respective number of coefficients in the blocks situated above and on the left of the current block as shown in Chart 8 according to the value and selects a table using a combination of the four thus formed. For example, a code table 2 is selected when the number of the coefficients in the left block is 3 and the number of the coefficients in the above block is 8. The method to classify the number of the coefficients in the upper and the left blocks and the way to assign code tables are not limited to those used in Chart 8.

Chart 9 shows a method of selecting a VLC table at the VLC table selecting unit **902**.

CHART 9

				Coefficient number (above)	
				0~5	6~16
Coefficient number (left)	0~5	VLC table 1	VLC table 2		
	6~16	VLC table 3	VLC table 4		

The VLC table selecting unit **902** selects a VLC table for actual reference using the selection method as shown in Chart 9 as in the case of code table selecting unit **901**.

The coefficient number encoder **206** refers to the code table selected by the code table selecting unit **901** and the VLC table selected by the VLC table selecting unit **902** so as to perform variable length coding for the number of coefficients in the current block which is inputted in the same way as in the first embodiment.

Thus, in the present embodiment, by classifying the numbers of coefficients in the coded blocks located above and on the left of the current block into "n" group(s) according to the value with reference to the code table and the VLC table according to the combination of N×N ways then formed and by switching between them adaptively, it is possible to perform efficiently the coding of the number of coefficients for the picture whose apparition frequency of coefficients is uneven.

In the present embodiment, the coefficient number encoder **111** performs variable length coding for the value of the number of coefficients itself. The difference calculating unit **207** may, however, calculate a difference value between the predictive value calculated at the predictive value calculating unit **201** as shown in FIG. 12B as in the first embodiment and a value of the number of coefficients inputted so as to perform variable length coding.

Also, in the present embodiment, the coefficient number encoder **111** performs variable length coding by switching both the VLC table and the code table according to the numbers of the coefficients in the neighboring blocks. It is, however, possible to fix either of these tables rather than to switch them as in the first embodiment. In this case, variable length coding is realized by using a storing unit which has either one certain type of code tables or one certain type of VLC tables in stead of using table selecting units. Furthermore, it is also

19

possible to perform variable length coding by switching only the VLC tables according to the numbers of the coefficients in the neighboring blocks without using code tables, as in the first embodiment.

Fourth Embodiment

The structure of the picture coding device and the outline of the coding processing according to the present embodiment are totally the same as those described in the first embodiment, excepting the coefficient number encoder 111 shown in FIG. 1. Here, regarding variable length coding processing of the number of coefficients performed by the coefficient number encoder 111 in the fourth embodiment, the detail is explained using FIGS. 13 and 14.

FIG. 13A is a block diagram showing in detail an internal structure of the coefficient number encoder 111.

The coefficient number encoder 111 as shown in FIG. 13A includes a table selecting unit 1001 in stead of the predictive value calculating unit 201, the code table selecting unit 203 and the VLC table selecting unit 204 shown in FIG. 3A. The table selecting unit 1001 uses directly the number of coefficients in the coded blocks without using a predictive value so as to select tables for actual use by evaluating both a code table and a VLC table at the same time, which is different from the first embodiment. As for the coded blocks then used for the reference, the three blocks in the position of the blocks B, C and D for the current block X are used as in FIG. 4A. However, when the blocks located as such are neither coded nor situated outside the picture nor outside the slice, either a value 0 or other arbitrary value can be substituted.

The table selecting unit 1001 calculates a sum of a length of a bit stream which is created as a result of coding the numbers of the coefficients in the reference blocks using both the code table and the VLC table at the same time and determines it as an evaluation value. FIG. 14 is a pattern diagram showing a method to perform coding for the numbers of coefficients in the three reference blocks using the code tables and the VLC tables and calculate the sum of the length of the gained bit stream so as to determine it as the estimation value. Then, the table selecting unit 1001 performs this processing to all the combinations of the code tables and the VLC tables stored in the code table storing unit 202 as well as the VLC table storing unit 205 and selects a combination of a code table and a VLC table in which the gained evaluation value is the smallest.

The coefficient number encoder 206 refers to the code table and the VLC table selected by the table selecting unit 1001 and performs variable length coding of the number of the coefficients in the current block which is inputted in the same way as described in the first embodiment.

In the present embodiment as shown above, it is possible to perform coding for the numbers of the coefficients in the neighboring blocks which are coded using the code table and the VLC table and determine the sum of the length of the bit stream at that time as an estimation value so as to perform efficiently the coding of the number of coefficients even for the picture whose apparition frequency of coefficients is uneven.

As for the coded blocks then used for the reference, the case in which only two blocks in the position of blocks B and D in stead of using three blocks in the position of blocks B, C and D for the current block X as shown in FIG. 4A are used can be treated in the same way. In this regard, when the blocks located above and on the left are neither coded nor situated outside the picture nor outside the slice, either a value 0 or other arbitrary value can be substituted.

20

In the present embodiment, the coefficient number encoder 111 performs variable length coding for the value of the number of coefficients itself. However, as in the first embodiment, it is possible, as shown in FIG. 13, that a difference value between the predictive value calculated by the predictive value calculating unit 201 and the inputted value of the number of coefficients is calculated by the difference value calculating unit 207 and variable length coding is performed for the gained value by the same processing as described in the above-mentioned embodiments.

Also, in the present embodiment, the code table and the VLC table are to be switched in the coefficient number encoder 111, however, it is possible to fix either of them rather than to switch between them.

Fifth Embodiment

FIG. 15 is a block diagram showing a structure of a picture coding device in the fifth embodiment using a picture coding method according to the present invention. A sequence of coding processing is totally the same as the first embodiment. The difference, however, is that the present embodiment does not use the coefficient number storing unit 110 but employs inter picture prediction mode in case of inter picture prediction coding and intra picture prediction mode in case of intra picture prediction coding as referring information at a coefficient number encoder 1201 instead of using the number of the coefficients in the coded blocks as in the first embodiment.

Here, regarding an explanation of variable length coding processing at the coefficient number encoder 1201 shown in FIG. 15, the detail is explained using FIG. 16, Chart 10 and Chart 11.

FIG. 16 is a block diagram showing in detail an internal structure of the coefficient number encoder 1201.

As shown in FIG. 16, the coefficient number encoder 1201 does not include the predictive value calculating unit 201 shown in Chart 3A. An inter picture prediction mode is inputted from an inter picture predicting unit 107 and an intra picture prediction mode is inputted from an intra picture predicting unit 108 to a code table selecting unit 1301 and a VLC table selecting unit 1302. Consequently, the code table selecting 1301 selects a table based on the mode: the inter picture prediction mode for inter picture prediction and the intra picture prediction mode for intra picture prediction. Chart 10 shows a selection method for code tables at the code table selecting unit 1301.

CHART 10

Reference table	Inter picture prediction mode	Intra picture prediction mode
Code table 1	16 × 16, 16 × 8, 8 × 16	Plane prediction
Code table 2	8 × 8	Oblique prediction
Code table 3	8 × 4, 4 × 8	Oblique prediction
Code table 4	4 × 4	Vertical and horizontal prediction

For example, in case where the current picture is coded using inter picture prediction, a code table 2 is selected accordingly for variable length coding of the number of coefficients when a prediction of the current block sized 8×8 is selected. The items are not limited to those used in Chart 10. Chart 11 shows a selecting method at the VLC table selecting unit 1302.

CHART 11

Reference table	Inter picture prediction mode	Intra picture prediction mode
VLC table 1	16 × 16, 16 × 8, 8 × 16	Plane prediction
VLC table 2	8 × 8	Oblique prediction
VLC table 3	8 × 4, 4 × 8	Oblique prediction
VLC table 4	4 × 4	Vertical and horizontal prediction

The VLC table selecting unit 1302 selects a VLC table for actual reference using a selection method shown in Chart 11 as in the case of the code table selecting unit 1301.

The coefficient number encoder 206 refers to the code table selected by the code table selecting unit 1301 and a VLC table selected by the VLC table selecting unit 1302 and performs variable length coding for the numbers of the coefficients in the current block which is inputted in the same way as in the first embodiment.

The present embodiment as shown above has shown a coding method which realizes efficient coding of the number of coefficients even for the picture whose apparition frequency of coefficients is uneven, with reference to the code table and the VLC table by switching between them adaptively according to the mode: inter picture prediction mode for inter picture prediction coding and intra picture prediction mode for intra picture prediction coding.

In the present embodiment, the coefficient number encoder 1201 performs variable length coding for the value of the number of coefficients itself as in the first embodiment. However, it is possible, as in the first embodiment, to determine a predictive value using the numbers of the coefficients in the neighboring blocks which are coded as in the first embodiment and obtain a difference value between this predictive value and the inputted value of the number of coefficients so as to perform variable length coding for the gained value in the same processing as in the above-mentioned embodiments.

Also, in the present embodiment the coefficient number encoder 1201 performs variable length coding by switching both the code table and the VLC table. It is, however, possible to fix either of them rather than switching either or both of them. In this case, this is realized by preparing only a storing unit which has one certain type of code tables or one certain type of VLC tables in stead of using table selecting units.

Sixth Embodiment

FIG. 17 is a block diagram showing a structure of an embodiment of a picture decoding device using a picture decoding method according to the present invention. The bit stream created by the picture coding device according to the first embodiment shall be inputted here.

The picture decoding device includes a bit stream analyzing unit 1401, a coefficient number storing unit 1402, a coefficient number decoder 1403, a coefficient value decoder 1404, an inverse quantizing unit 1405, an inverse orthogonal transforming unit 1406, a frame memory 1407, an inter picture prediction decoder 1408, an intra picture prediction decoder 1409 and a switch 1410.

The bit stream analyzing unit 1401 extracts from the inputted bit stream various types of information such as a coding mode, motion vectors used for coding, a bit stream of the number of coefficients (the number of coefficients showing a spatial frequency component which has a value other than 0 for each block) and various types of information on the bit stream of the value of the coefficients. The coefficient number

storing unit 1402 stores the numbers of the coefficients of the decoded blocks. The coefficient number decoder 1403 decodes the bit stream of the numbers of coefficients by referring to the numbers of the coefficients in the decoded blocks.

The coefficient value decoder 1404 decodes the bit stream of the value of the coefficients using the numbers of coefficients decoded by the coefficient number decoder 1403. The inverse quantizing unit 1405 performs inverse quantization to the decoded coefficients. The inverse orthogonal transforming unit 1406 performs inverse orthogonal transformation to the data inversely quantized and transforms it to predictive residual picture data.

The inter picture prediction decoder 1408 creates motion compensation picture data based on the motion vectors extracted by the bit stream analyzing unit 1401 as well as decoded pictures or the like when a current macroblock to be decoded is coded with inter picture prediction. An addition calculating unit 1411 adds the predictive residual picture data inputted from the inverse orthogonal transforming unit 1406 and the motion compensation picture data inputted from the inter picture prediction decoder 1408 so as to create decoded picture data. The frame memory 1407 stores the created decoded picture data.

The intra picture prediction decoder 1409 performs intra picture prediction using information on the adjacent decoded blocks so as to create decoded picture data when the current macroblock is coded with intra picture prediction.

Next, an explanation of an operation of a picture decoding device as constructed above follows.

As a start, a bit stream is inputted to the bit stream analyzing unit 1401. The bit stream analyzing unit 1401 extracts from the inputted bit stream various types of information on motion vectors, a bit stream of the number of coefficients and a bit stream of the value of the coefficients and so on. Then, the bit stream analyzing unit 1401 outputs respectively as follows: the motion vectors to the inter picture prediction decoding unit 1408, the bit stream of the number of coefficients to the coefficient number decoder 1403 and the bit stream of the value of the coefficients to the coefficient value decoder 1404.

The coefficient number decoder 1403 to which the bit stream of the number of coefficients is inputted decodes this bit stream as the number of coefficients which has a value other than 0 for each block. In this case, the coefficient number decoder 1403 performs decoding by referring to the numbers of coefficients in the decoded blocks stored in the coefficient number storing unit 1402 with a method which is to be explained later on. Then, the coefficient value decoder 1404 performs decoding of the value of the coefficients itself with reference to the code tables and the VLC tables necessary for variable length decoding by switching between them using number information of the coefficient gained by the coefficient number decoder 1403. The gained coefficient is transformed into predictive residual picture data by the inverse quantizing unit 1405 as well as the inverse orthogonal transforming unit 1406.

The motion vectors extracted by the bit stream analyzing unit 1401 are inputted to the inter picture prediction decoder 1408, when a current macroblock to be decoded is coded with inter picture prediction. The inter picture prediction decoder 1408 creates motion compensation picture data by having decoded picture data of the decoded pictures stored in the frame memory 1407 as reference pictures, based on the information on the motion vectors. The motion compensation picture data thus gained is created as decoded picture data by

being added to the predictive residual picture data at the addition calculating unit **1411** and then stored in the frame memory **1407**.

On the other hand, when the current macroblock is coded using intra picture prediction, intra picture prediction is performed using information on the adjacent decoded blocks by the intra picture prediction decoder **1409**, and decoded picture data is created and stored in the frame memory **1407**. Then, the frame memory **1407** outputs it as definitive output picture in display order.

The outline of a flow of decoding has been explained above. Next, a decoding processing of the number of coefficients performed by the coefficient number decoder **1403** is explained in detail using FIG. **18**-FIG. **21**.

FIG. **18A** is a block diagram showing in detail an internal structure of the coefficient number decoder **1403**.

Here, an example of using two tables of a VLC table and a code table for performing variable length decoding of the numbers of coefficients. The VLC table is a table used for transforming variable length code in a bit stream into a code number whereas the code table is table used for transforming the code number gained by the VLC table into the number of coefficients.

As shown in FIG. **18A**, the coefficient number decoder **1403** includes a predictive value calculating unit **1501**, a code table storing unit **1502**, a code table selecting unit **1503**, a VLC table selecting unit **1504**, a VLC table storing unit **1505** and a coefficient number decoder **1506**.

Firstly, the numbers of the coefficients in the decoded blocks located on the periphery are inputted from the coefficient number storing unit **1402** as shown in FIG. **17** to the predictive value calculating unit **1501**. The predictive value calculating unit **1501** determines a predictive value by calculating an average value of these values. A maximum value, a minimum value or a medium value may be used according to the predictive value calculating method for coding. The decoded blocks to be then referred to are determined following Chart 1 using three blocks in the position of blocks B, C and D for the current block X shown in FIG. **4A**, as in the first embodiment. As for signs in Chart 1, a sign O signifies a coded block and a sign X signifies a block which can not be referred to since it is either not decoded or situated outside the picture or outside the slice. Chart 1 shows a relation between conditions of the reference blocks and the block(s) which can be referred to, however, the patterns are not limited to this. If no reference blocks are found, either a value 0 or other arbitrary value can be given directly as a predictive value.

The code table selecting unit **1503** selects a code table for actual use from a plurality of code tables stored in the code table storing unit **1502**, according to the predictive value calculated by the predictive value calculating unit **1501**.

Chart 2 is an example of a code table which relates numbers of coefficients and code numbers, prepared in advance by the code table storing unit **1502**. Here, four types of code tables are prepared; however, the numbers of types of tables and the values indicated in the tables are not limited to those used in Chart 2. In this case, however, the same table as the one used for coding shall be used. Also, Chart 3 shows selection criteria for code tables based on a predictive value. The way of assigning the predictive value or the items of table is not limited to those used in Chart 3. However, the same table as the one used for coding shall be used.

The VLC table selecting unit **1504** selects a VLC table for actual use from a plurality of VLC tables stored in the VLC table selecting unit **1505** according to the predictive value calculated by the predictive value calculating unit **1501**.

Chart 4 shows an example of a VLC table which relates number of coefficients and code numbers, prepared in advance by the VLC table storing unit **1505**. Here, four types of VLC tables are prepared, however, the numbers of types of tables and the values indicated in the tables are not limited to those used in Chart 4. However, in this case, the same table as the one used for coding shall be used. Also, Chart 5 shows selecting criteria for VLC tables based on a predictive value. The way of assigning the predictive value and the items indicated in the reference tables are not limited to those used in Chart 5. However, in this case, it is conditioned to use the same table as the one used for coding.

The coefficient number decoder **1506** refers to the code table as well as the VLC table selected in the above processing and performs variable length decoding for a bit stream of the number of the coefficients in the inputted current block. The coefficient number decoder **1506** first transforms the number of coefficients into a code number using the VLC table and then transforms it into a value of the number of coefficients corresponding to the code number using the code table. FIG. **19** is a pattern diagram showing an example of decoding when a predictive value calculated at the predictive value calculating unit **1501** is "6" and a bit stream of the number of coefficients in the current block is "0100". The predictive value being "6", the code table selecting unit **1503** selects a code table 3 shown in FIG. **19** using Chart 3 and Chart 2, and the VLC table selecting unit **1504** selects a VLC table 3 shown in FIG. **19** using Chart 5 and Chart 4. The coefficient number decoder **1506** transforms the inputted bit stream "0100" into a code number "2" according to the VLC table 3 and then determines the definitive number of coefficients "4" according to the code table.

The following describes in detail storing processing of the number of coefficients performed by the coefficient number storing unit **1402**, the detail is explained. FIG. **6A** used for the description of the first embodiment is used here, however, a black boarder containing blocks coded B1~B16 shows a current macroblock to be decoded whereas hatched blocks show reference blocks for the current macroblock. The numbers put for the blocks indicates an order of decoding performed within the macroblock.

The coefficient number storing unit **1402** stores the numbers of coefficients decoded by the coefficient number decoder **1403**, at least for the reference blocks which are hatched as shown in FIG. **6A** necessary for the current macroblock at the time of starting the processing of the current macroblock shown in FIG. **6A**. Namely, the coefficient number storing unit **1402** stores the number of the coefficients detected from the blocks of the current macroblock (B1, B2, B3, . . . and B16) which are to be processed sequentially. For example, when a block B6 is a current block, the coefficient number storing unit **1402** stores the numbers of each coefficient of the block B1, B2, B3, B4 and B5 which are already processed, in addition to those of the reference blocks as shown in FIG. **6A**. When the coefficient number decoder **1403** decodes the number of coefficients of the block B6, the coefficient number storing unit **1402** stores it. The coefficient number storing unit **1402** thus stores the numbers of the coefficients of the blocks in the current macroblock, which are to be processed sequentially.

When a current macroblock is a macroblock MB11 shown in FIG. **2B**, the coefficient number storing unit **1402** at least stores the numbers of the coefficients of the blocks in the bottom row and in the right column of the macroblock MB11 (hatched blocks) in FIG. **7A** when the processing of this macroblock MB11 terminates and shifts to the next macroblock MB12. Next, the coefficient number storing unit **1402** at

US 7,769,238 B2

25

least stores the numbers of the coefficients of the blocks in the bottom row and in the right column of the macroblock MB12 in the same way as well as the numbers of the coefficients of the blocks in the bottom row of the macroblock MB11 (shaded blocks) as shown in FIG. 7B when the processing of the macroblock MB12 terminates and the processing proceeds to the next macroblock MB13.

When a current macroblock is located at the right edge of the picture as in a macroblock MB9 shown in FIG. 2B, the coefficient number storing unit 1402 at least stores the numbers of the coefficients of the blocks in the bottom row of the macroblock MB9 when the processing of this macroblock MB9 terminates and proceeds to the next macroblock MB10.

When a current block is located at the bottom edge of the picture as a macroblock MBm shown in FIG. 2B, the coefficient number storing unit 1402 at least stores the numbers of the coefficients of the blocks in the right column of this macroblock MBm (hatched blocks) as shown in FIG. 7C.

Thus the coefficient number storing unit 1402 at least stores the numbers of coefficients for the blocks to be referred to. It is possible to delete, in an arbitrary timing, the information on the numbers of coefficients of the blocks other than those to be stored as described in the above explanation when the blocks are no longer used for reference. For example, it is possible to delete the information when processing proceeds to the next macroblock as well as while processing the macroblock. Also, the numbers of the coefficients of the blocks which are not used for reference do not always need processing of deleting. For instance, the coefficient number storing unit 1402 may identify the numbers of coefficients of the blocks which are not referred to any longer as unnecessary and may overwrite to them if necessary.

It is explained above that it is possible to refer to the numbers of the coefficients of the decoded blocks by storing them in the coefficient number storing unit 1402. However, a system for calculating the number of coefficients, may be used, if necessary, by storing not the values of the number of coefficients themselves but, for instance, the values of the coefficients of the blocks, indicating spatial frequency components.

Thus, in the present embodiment, it is possible to calculate the predictive value using the numbers of coefficients in the decoded adjacent blocks and decode the number of coefficients with reference to the code table and the VLC table by switching between them adaptively according to the predictive value.

Also, it handles the changes in a position where the apparition probability of the number of coefficients is the highest, with reference to the code tables by switching them adaptively according to the predictive value. At the same time, it can correspond to a size of the dispersion of the apparition probability of the number of coefficients with reference to the VLC tables by switching them according to the predictive value. It is possible to use only two blocks in the position of the blocks B and D as the blocks to be referred to by the predictive value calculating unit 1501 for the current block X as shown in FIG. 4B instead of using three neighboring blocks as shown in FIG. 4A. In this case, changes in the reference blocks can be made as in Chart 6 when the blocks are either not decoded or located outside the picture or outside the slice. As for the signs in Chart 6, a sign O signifies a decoded block and a sign X signifies a block which can not be referred to since it is either not decoded or situated outside the picture or outside the slice, as in Chart 1. Chart 6 shows a relation between conditions of the reference blocks and the block(s) which can be referred to, however, the patterns are not limited to this. Either a value 0 or other arbitrary value is given

26

directly as a predictive value when no reference blocks are found. However, the same value as the one used for coding shall be used. In this case, the coefficient number storing unit 1402 may only store the numbers of coefficients decoded by the coefficient number decoder 1403, at least those of the reference blocks necessary for the current macroblock, shown in FIG. 6B.

It is also possible, as a method to calculate a predictive value at the predictive value calculating unit 1501, for example, to select an optimal method according to each sequence, each GOP, each picture or each slice rather than to fix the method of using either of an average value, a maximum value, a minimum value or a medium value. In this case, a calculating method is determined by decoding the signals for identifying a calculation method described in the header section of the sequence or the picture or the slice, of the bit stream. The slice is a picture further divided into a plurality of sections. A section equivalent to one column in transverse direction in each macroblock is an example of this.

Also, it is possible to select, for example, either of an average value, a maximum value, a minimum value or a medium value according to the average value of the numbers of coefficients in the decoded reference blocks as a method to calculate a predictive value at the predictive value calculating unit 1501. Chart 7 shows the selection criteria. The way of assigning the average value and the items indicated as predictive value calculation methods are not limited to those used in Chart 7. In this regard, the same method as the one used for coding shall be used.

The present embodiment shows a decoding processing method of a bit stream in which variable length coding is performed for the values of the number of coefficients themselves by the coefficient number decoder 1403. It is, however, possible to perform decoding of a bit stream in which variable length coding is performed for a difference value between the predictive value and the number of coefficients. In this case, the number of coefficients is determined by the fact that the addition calculating unit 1507 adds the predictive value calculated by the predictive value calculating unit 1501 to the difference value of the number of coefficients decoded by the coefficient number decoder 1506.

Also, the coefficient number decoder 1403 performs variable length decoding by switching both the code table and the VLC table according to the predictive value based on the numbers of the coefficients of the neighboring blocks. It is, however, possible to fix either of them rather than to switch between them. In this case, this is realized by preparing a storing unit which has either one certain type of code tables or one certain type of VLC tables. FIG. 20A is a block diagram showing a structure of the coefficient number decoder 1403 for performing variable length decoding of the number of coefficients by fixing only the code table. FIG. 20B is a block diagram showing a structure of the coefficient number decoder 1403 for performing variable length decoding of the number of coefficients by fixing only the VLC table. In case of fixing only the code table, the coefficient number decoder 1403 as shown in FIG. 20A includes a code table storing unit 1601 in stead of the code table storing unit 1502 and the code table selecting unit 1503 shown in FIG. 18A. The code table storing unit 1601 has one certain type of code tables. The coefficient number decoder 1506 first transforms variable length code into a code number using the VLC table selected by the VLC table selecting unit 1504 and then transforms the code number into the number of coefficients using the code table stored in the code table storing unit 1601.

On the other hand, in case of fixing only the VLC table, the coefficient number decoder 1403 as shown in FIG. 20B

includes a VLC table storing unit **1602** in stead of the VLC table storing unit **1505** and the VLC table selecting unit **1504** shown in FIG. **18A**. The VLC table storing unit **1602** has one certain type of VLC table. The coefficient number decoder **1506** firstly transforms a variable length code into a code number using the VLC table stored in the VLC table storing unit **1602** and then transforms the code number into the number of coefficients using the code table selected by the code table selecting unit **1503**.

Thus it is possible to reduce memory capacity for storing a plurality of tables by fixing either of a code table and a VLC table.

It is also possible to perform variable length decoding in the coefficient number decoder **1403** by switching only the VLC tables without using code tables, according to the predictive value based on the numbers of the coefficients of the neighboring blocks. FIG. **20C** is a block diagram showing a structure of the coefficient number decoder **1403** when performing variable length decoding of the coefficient number using only a VLC table without using code tables. In this case, as shown in FIG. **20C**, the coefficient number decoder **1403** includes neither the code table storing unit **1502** nor the code table selecting unit **1503** shown in FIG. **18A**. In the coefficient number decoder **1403**, the VLC table selecting unit **1603** selects the VLC table for actual use from a plurality of VLC tables stored in the VLC table storing unit **1604**, based on the predictive value calculated by the predictive value calculating unit **1501**. Then, the coefficient number decoder **1506** transforms directly a variable length code into the number of coefficients without transforming the number of coefficients into a code number using the code table as described above.

Thus by fixing either of the code table or the VLC table in stead of switching between them, the throughput for switching tables can be reduced or an amount of memory for storing a plurality of tables can be reduced although the effects of coding efficiency decreases more or less.

Also, a case in which the coefficient number decoder **1403** decodes a bit stream in which variable length coding is performed to the difference value between the predictive value and the number of coefficients, in stead of the value of the number of coefficients, can be handled in the same way. FIG. **21** is a block diagram of its example showing a structure of the coefficient number decoder **1403** for performing decoding of the bit stream in which variable length decoding is performed to the difference value between the predictive value and the number of coefficients by fixing both the code table and the VLC table. In this case, as shown in FIG. **21**, the coefficient number decoder **1403** includes a code table storing unit **1601** in stead of the code table storing unit **1502** and the code table selecting unit **1503** shown in FIG. **18A** as well as a VLC table storing unit **1602** in stead of the VLC table storing unit **1505** and the VLC table selecting unit **1504** shown in FIG. **18A**. This code table storing unit **1601** has one certain type of code tables whereas the VLC table storing unit **1602** has one certain type of VLC table. The coefficient number decoder **1506** first transforms a variable length code into a code number using the VLC table stored in the VLC table storing unit **1602** and then transforms the code number into a difference value between the predictive value and the number of coefficients using the code table stored in the code table storing unit **1601**. The addition calculating unit **1507** calculates the number of coefficients by adding the difference value to the predictive value.

The structure of the picture decoding device and the outline of the decoding processing are totally the same as in the sixth embodiment, apart from the coefficient number decoder **1403** shown in FIG. **17**. As for a variable length decoding processing of the number of coefficients performed at the coefficient number decoder **1403** according to the seventh embodiment, the detail is explained here using FIGS. **11** and **22**. The bit stream created at the picture coding device according to the second embodiment shall be inputted.

FIG. **22A** is a block diagram showing in detail an internal structure of the coefficient number decoder **1403**.

As shown in FIG. **22A**, the coefficient number decoder **1403** includes a code table generating unit **1901** in stead of the code table storing unit **1502** and the code table selecting unit **1503** shown in FIG. **18A**. The numbers of coefficients in the decoded blocks are inputted from the coefficient number storing unit **1402** shown in FIG. **17** to the code table generating unit **1901**. The code table generating unit **1901** counts the number of the decoded blocks having the same number of coefficients as the value of the number of coefficients at each value of the number of coefficients and creates code tables by assigning code numbers in descending order starting from a number of coefficients which recorded the highest frequency based on the statistic. FIG. **11A** is a pattern diagram presenting a position of decoded blocks targeted for statistics. Here, a **P1**, a **P3** and a **P4** are pictures in which inter picture prediction is performed whereas an **I2** is a picture in which intra picture prediction is performed. Supposing that a current block to be decoded belongs to the **P3**, all the blocks in the **P1**, a picture immediately preceding the current picture decoded with the same method, are targeted for statistics. The case in which the blocks equivalent to one picture including the decoded blocks in the current picture are targeted for statistics can be handled in the same way. Also, a table for the initial condition in ascending order starting from the value 0 is used when the decoded blocks equivalent to one picture which can be targeted for statistics do not exist. Here, the blocks equivalent to one picture are targeted for statistics, however, the case in which the number of blocks other than this is used as a parameter can be handled in the same way. In this regard, the same number as the one used for coding shall be used. In the case of generating the code table as described above by making reference as shown in FIG. **11A**, the table may be generated only once when encoding of the current picture is started.

Meanwhile, the numbers of coefficients in the decoded blocks located on the periphery are inputted to the predictive value calculating unit **1501**. The predictive value calculating unit **1501** determines the predictive value by calculating an average value based on these values as in the sixth embodiment. A maximum value, a minimum value or a medium value may be used in stead of the average value as a method to determine the predictive value. As in the sixth embodiment, the decoded blocks then used as reference, are determined using the three blocks located in the position of the blocks **B**, **C** and **D** for the current block **X** shown in FIG. **4A** according to Chart 1. Chart 1 shows a relation between conditions of the reference blocks and the block(s) which can be referred to, however, the patterns are not limited to this. Either a value 0 or other arbitrary value is given directly as a predictive value when no reference blocks are found. In this regard, the same value as the one used for coding shall be used.

The predictive value calculated by the predictive value calculating unit **1501** is used only in the VLC table selecting unit **1504**. The VLC table selecting unit **1504** selects, as in the sixth embodiment, a VLC table for decoding the number of

US 7,769,238 B2

29

coefficients from a plurality of VLC tables prepared beforehand in the VLC table storing unit **1505** as shown in Chart 4, according to the selection criteria shown in Chart 5.

The coefficient number decoder **1506** refers to the code table created by the code table generating unit **1901** and the VLC table selected by the VLC table selecting unit **1504** and performs variable length decoding for the bit stream of the number of coefficients inputted in the same way as in the sixth embodiment.

Thus, in the present embodiment, it is possible to create a code table by taking statistics of the numbers of coefficients in the decoded blocks and determine a VLC table according to the predictive value calculated using the numbers of the coefficients in the decoded blocks and perform the decoding of the number of coefficients by referring to both of the tables.

It is also possible to determine the decoded blocks to be used for reference at the predictive value calculating unit **1501** as in the sixth embodiment according to Chart 6, using only two blocks located in the position of the blocks B and D with respect to the current block X shown in FIG. 4B, in stead of using three adjacent blocks as shown in FIG. 4A. Chart 6 shows a relation between conditions of the reference blocks and the block(s) which can be referred to, however, the patterns are not limited to this. Either a value 0 or other arbitrary value is given directly as a predictive value when no reference blocks are found. In this regard, the same value as the one used for coding shall be used.

It is also possible, as a method to calculate a predictive value at the predictive value calculating unit **1501**, for example, to select an optimal method according to each sequence, each GOP, each picture or each slice rather than to fix the method to use either of an average value, a maximum value, a minimum value or a medium value. In this case, the calculation method is determined by decoding the signals for identifying the calculating method described in the header of the sequence, the GOP or the picture or the slice, of the bit stream.

Also, it is possible to select, for example, either of an average value, a maximum value, a minimum value or a medium value according to the average value of the numbers of coefficients in the decoded reference blocks as a method to calculate a predictive value at the predictive value calculating unit **1501**. Chart 7 shows its selection criteria. The way of assigning the average value and the items indicated as predictive value calculation methods are not limited to those used in Chart 7. In this regard, the same method as the one used for coding shall be used.

Also, the present embodiment shows a decoding processing method of a bit stream in which variable length coding is performed to the values of the number of coefficients themselves. It is, however, possible to perform decoding of a bit stream in which variable length coding is performed to a difference value between a predictive value and the number of coefficients. In this case, the number of coefficients is determined by the fact that the addition calculating unit **1507** adds the difference value between the predictive value calculated at the predictive value calculating unit **1501** as shown in FIG. 22 to the number of coefficients decoded by the coefficient number decoder **1506**.

Also, in the above-mentioned embodiment, the coefficient number decoder **1403** performs variable length decoding by switching the VLC tables according to the predictive value based on the numbers of the coefficients in the adjacent blocks. It is, however, possible to fix the table rather than to switch between the tables as in the sixth embodiment. In this

30

case, this is realized by using only a VLC table storing unit which has one certain type of VLC tables, in stead of using the VLC table selecting unit.

Eighth Embodiment

The structure of the picture decoding device and the outline of the decoding processing are totally the same as in the sixth embodiment, apart from the coefficient number decoder **1403** shown in FIG. 17. As for variable length decoding processing of the number of coefficients performed by the coefficient number decoder **1403** according to the eighth embodiment, the detail is explained here using FIG. 23, Chart 8 and Chart 9. The bit stream created by the picture coding device according to the third embodiment shall be inputted.

FIG. 23A is a block diagram showing in detail an internal structure of the coefficient number decoder **1403**.

As shown in FIG. 23A, the coefficient number decoder **1403** does not include the predictive value calculating unit **1501** shown in FIG. 18A. A code table selecting unit **2001** and a VLC table selecting unit **2002** select a table for actual use by using directly the numbers of coefficients in the decoded blocks without using a predictive value, which is different from the sixth embodiment. As for the decoded blocks then used for the reference shown in FIG. 4B, only two blocks in the position of the block B (above) and the block D (left) with respect to the current block X are used. However, when the blocks located above and on the left are neither decoded nor situated outside the picture nor outside the slice, either a value 0 or other arbitrary value can be substituted. In this regard, the same value as the one used for coding shall be used.

Chart 8 shows a selection method for code tables at the code table selecting unit **2001**. The code table selecting unit **2001** classifies into two groups the respective numbers of coefficients in the blocks situated above and on the left of the current block, as shown in Chart 8, according to the value, and selects a table using a combination of the four thus formed. The method to classify the number of coefficients in the upper and the left blocks and the way to assign the code tables are not limited to those used in Chart 8. In this regard, the same method as the one used for coding is used in this case. Also, the VLC table selecting unit **2002** selects a VLC table for actual reference using the selection method shown in Chart 9, as in the case of the code table selecting unit **2001**.

The coefficient number decoder **1506** refers to the code table selected by the code table selecting unit **2001** and the VLC table selected by the VLC table selecting unit **2002** and performs variable length decoding for the number of coefficients in the current block which is inputted in the same way as in the sixth embodiment.

The present embodiment as shown above, by classifying the number of coefficients in the decoded blocks located above and on the left of the current block into "N" group(s) according to the value with reference to the code table and the VLC table, according to the combination of N×N ways then formed, and by switching between them adaptively, it is possible to perform efficiently the decoding of the number of coefficients.

The present embodiment shows a decoding processing method of a bit stream in which variable length coding is performed to the values of the number of coefficients themselves. It is, however, possible to perform decoding of a bit stream in which variable length coding is performed to a difference value between the predictive value and the number of coefficients. In this case, the number of coefficients is determined by the fact that the addition calculating unit **1507** adds the difference value between the predictive value calcu-

31

lated at the predictive value calculating unit **1501** to the number of coefficients decoded by the coefficient number decoder **1506**.

Also, the coefficient number decoder **1403** performs variable length decoding by switching both the code table and the VLC table according to the numbers of coefficients in the neighboring blocks. It is, however, possible to fix either of these tables rather than to switch between them as in the sixth embodiment. In this case, this is realized by using a storing unit which has either one certain type of code tables or one certain type of VLC tables, in stead of using the table selecting units. Furthermore, it is possible to perform variable length decoding by switching only the VLC tables without using code tables according to the numbers of coefficients in the adjacent blocks, as in the sixth embodiment.

Ninth Embodiment

The structure of the picture decoding device and the outline of the decoding processing according to the present embodiment are totally the same as the sixth embodiment apart from the coefficient number decoder **1403** shown in FIG. 17. Regarding variable length decoding processing of the number of coefficients performed by the coefficient number decoder **1403** according to the ninth embodiment, the detail is explained here using FIGS. 24 and 14. The bit stream created by the picture coding device according to the fourth embodiment shall be inputted.

FIG. 24A is a block diagram showing in detail an internal structure of the coefficient number decoder **1403**.

As shown in FIG. 24A, the coefficient number decoder **1403** includes a table selecting unit **2101** instead of the predictive value calculating unit **1501**, the code table selecting unit **1503** and the VLC table selecting unit **1504** shown in FIG. 18A. The table selecting unit **2101** uses directly the number of the coefficients in the decoded blocks without using a predictive value and selects a table for actual use by evaluating both the code table and the VLC table at the same time, which is different from the sixth embodiment. As for the decoded blocks then used for the reference, the three blocks in the position of the blocks B, C and D with respect to the current block X are used as in FIG. 4A. In this regard, when the blocks thus located are neither decoded nor situated outside the picture nor outside the slice, either a value 0 or other arbitrary value is substituted as the number of coefficients. However, the same value as the one used for coding shall be used.

As shown in FIG. 14, the table selecting unit **2101** calculates a sum of a length of a bit stream which is created as a result of coding the numbers of the coefficients in the reference blocks using both the code table and the VLC table at the same time and determines it as an evaluation value as in the fourth embodiment. Then, the table selecting unit **2101** performs this processing for all the combinations of the code table and the VLC table stored in the code table storing unit **1502** as well as the VLC table storing unit **1505** and selects a combination of a code table and a VLC table in which the gained evaluation value is the smallest.

The coefficient number decoder **1506** refers to the code table and the VLC table selected by the table selecting unit **2101** and performs variable length coding for the number of the coefficients in the current block which is inputted in the same way as in the sixth embodiment.

Thus, in the present embodiment, the coding is performed for the numbers of coefficients in the neighboring blocks which are decoded using the code table and the VLC table, an estimation value is determined using the sum of the length of

32

the bit stream at that time and decoding is performed for the number of coefficients by referring to the code table and the VLC table whose combination generates the smallest evaluation value.

As for the decoded blocks used for reference by the table selecting unit **2101**, a case of using only two blocks located in the position of the blocks B and D with respect to the current block X as shown in FIG. 4B in stead of using three neighboring blocks shown in FIG. 4A, can be handled in the same way as in the sixth embodiment. In this regard, when the blocks thus located are neither decoded nor situated outside the picture nor outside the slice, either a value 0 or other arbitrary value can be substituted as a number of coefficients.

Also, the present embodiment shows a decoding processing method of a bit stream in which variable length coding is performed for the values of the number of coefficients themselves. It is, however, possible to perform decoding of a bit stream in which variable length coding is performed for a difference value between the predictive value and the number of coefficients. In this case, the number of coefficients is determined by the fact that the addition calculating unit **1507** adds the difference value between the predictive value calculated by the predictive value calculating unit **1501** to the number of coefficients decoded by the coefficient number decoder **1506**, as shown in FIG. 24B.

Also, in the present embodiment, the code table and the VLC table are targeted for switching in the coefficient number decoder **1403**, however, it is possible to fix either of them rather than to switch between them.

Tenth Embodiment

The structure of the picture decoding device and the outline of the decoding processing according to the present embodiment are totally the same as in the sixth embodiment, apart from the coefficient number decoder **1403** shown in FIG. 17. The present embodiment uses an inter picture prediction mode for inter picture prediction decoding and an intra picture prediction mode for intra picture prediction decoding as referring information at the coefficient number decoder **1403** in stead of the numbers of coefficients in the decoded blocks as in the sixth embodiment. The bit stream which is created at the picture coding device according to the fifth embodiment shall be inputted.

Here, regarding variable length decoding processing of the number of coefficients performed by the coefficient number decoder **1403** shown in FIG. 17, the detail is explained with reference to FIG. 25.

FIG. 25 is a block diagram showing in detail an internal structure of the coefficient number decoder **1403**.

As shown in FIG. 25, the coefficient number decoder **1403** does not include the predictive value calculating unit **1501** shown in FIG. 18A. The inter picture prediction mode for inter picture prediction decoding and the intra picture prediction mode for intra picture prediction decoding are inputted from the bit stream analyzing unit **1401** to a code table selecting unit **2201** as well as a VLC table selecting unit **2202**. The code table selecting unit **2201** selects a table to be used based on the mode: the inter picture prediction mode for inter picture prediction decoding and the intra picture prediction mode for intra picture prediction decoding. Chart 10 shows a selection method for the code tables stored in the code table selecting unit **2201**.

For example, in case where the current picture is decoded using inter picture prediction, a code table 2 is selected accordingly for variable length decoding of the number of coefficients when the size of the current block 8x8 is selected

for prediction. The items are not limited to those used in Chart 10. In this regard, the same items as the ones used for coding shall be used.

Also, the VLC table selecting unit **2202** selects a VLC table for actual reference using the selection method as shown in Chart 11 as in the case of the code table selecting unit **2201**.

The coefficient number decoder **1506** refers to the code table selected by the code table selecting unit **2201** as well as to the VLC table selected by the VLC table selecting unit **2202** so as to perform variable length decoding of the number of the coefficients in the current block which is inputted in the same way as in the sixth embodiment.

Thus in the present embodiment can perform decoding of the number of coefficients by referring to the code table and the VLC table in switching between them adaptively according to the mode: the inter picture prediction mode for inter picture prediction decoding and the intra picture prediction mode for intra picture prediction decoding.

The present embodiment shows a decoding processing method of a bit stream in which variable length coding is performed to the values of the number of coefficients themselves. It is, however, possible to perform decoding of a bit stream in which variable length coding is performed to a difference value between a predictive value and a number of coefficients. In this case, the predictive value is determined by using the numbers of the coefficients in the adjacent decoded blocks and the number of coefficients is determined by adding this value to the difference value of the number of coefficients, which is decoded by the coefficient number decoder **1506**, as in the sixth embodiment.

Also, in the present embodiment, the coefficient number decoder **1403** performs variable length decoding by switching both of the code table and the VLC table. It is, however, possible to fix them rather than switching either or both of them. In this case, this is realized by preparing only a storing unit which has either one certain type of code tables or one certain type of VLC tables.

Eleventh Embodiment

If a program for realizing the structure of the coding method or the decoding method as shown in the above-mentioned embodiments is recorded on a memory medium such as a flexible disk, it becomes possible to perform the processing as shown in these embodiments easily in an independent computer system.

FIGS. **26A**, **26B** and **26C** are illustrations showing the case where the processing shown in the 1-10 above-mentioned embodiments is performed in a computer system using a flexible disk which stores the coding method or the decoding method of the above-mentioned embodiments.

FIG. **26B** shows a full appearance of a flexible disk, its structure at cross section and the flexible disk itself whereas FIG. **26A** shows an example of a physical format of the flexible disk as a main body of a recording medium. A flexible disk **FD** is contained in a case **F**, a plurality of tracks **Tr** are formed concentrically from the periphery to the inside on the surface of the disk, and each track is divided into 16 sectors **Se** in the angular direction. Therefore, the flexible disk storing the above-mentioned program stores the data as the aforementioned program in an area assigned for it on the flexible disk **FD**.

FIG. **26C** shows a structure for recording and reading out the program on the flexible disk **FD**. When the program is recorded on the flexible disk **FD** The computer system **Cs** writes in the data as the program via a flexible disk drive. When the coding device and the decoding device are con-

structed in the computer system by the program on the flexible disk, the program is read out from the flexible disk by the flexible disk drive and then transferred to the computer system.

The above explanation is made on an assumption that a flexible disk is used as a data recording medium, but the same processing can also be performed using an optical disk. In addition, the recording medium is not limited to a flexible disk and an optical disk, but any other medium such as an IC card and a ROM cassette capable of recording a program can be used.

Following is an explanation of the applications of the picture coding method as well as the picture decoding method as shown in the above-mentioned embodiments, and a system using them.

FIG. **27** is a block diagram showing an overall configuration of a content supply system **ex100** for realizing content distribution service. The area for providing communication service is divided into cells of desired size, and cell sites **ex107~ex110** which are fixed wireless stations placed in respective cells.

This content supply system **ex100** is connected to devices such as a computer **ex111**, a PDA (Personal Digital Assistant) **ex112**, a camera **ex113**, a cell phone **ex114** and a cell phone with a camera **ex115** via the Internet **ex101**, an Internet service provider **ex102**, a telephone network **ex104** and cell sites **ex107~ex110**.

However, the content supply system **ex100** is not limited to the configuration as shown in FIG. **27** and may be connected to a combination of any of them. Also, each device may be connected directly to the telephone network **ex104** not through the cell sites **ex107~ex110**.

The camera **ex113** is a device capable of shooting video such as a digital video camera. The cell phone **ex114** may be a cell phone of a PDC (Personal Digital Communications) system, a CDMA (Code Division Multiple Access) system, a W-CDMA (Wideband-Code Division Multiple Access) system or a GSM (Global System for Mobile Communications) system, a PHS (Personal Handyphone System) or the like.

A streaming server **ex103** is connected to the camera **ex113** via the telephone network **ex104** and the cell site **ex109**, which realizes a live distribution or the like using the camera **ex113** based on the coded data transmitted from the user. Either the camera **ex113** or the server which transmits the data may code the data. Also, the picture data shot by a camera **ex116** may be transmitted to the streaming server **ex103** via the computer **ex111**. In this case, either the camera **ex116** or the computer **ex111** may code the picture data. An LSI **ex117** included in the computer **ex111** or the camera **ex116** actually performs coding processing. Software for coding and decoding pictures may be integrated into any type of storage medium (such as a CD-ROM, a flexible disk and a hard disk) that is a recording medium which is readable by the computer **ex111** or the like. Furthermore, a cell phone with a camera **ex115** may transmit the picture data. This picture data is the data coded by the LSI included in the cell phone **ex115**.

The content supply system **ex100** codes contents (such as a music live video) shot by users using the camera **ex113**, the camera **ex116** or the like in the same way as shown in the above-mentioned embodiments and transmits them to the streaming server **ex103**, while the streaming server **ex103** makes stream distribution of the content data to the clients at their requests. The clients include the computer **ex111**, the PDA **ex112**, the camera **ex113**, the cell phone **ex114** and so on capable of decoding the above-mentioned coded data. In the content supply system **ex100**, the clients can thus receive and

US 7,769,238 B2

35

reproduce the coded data, and can further receive, decode and reproduce the data in real time so as to realize personal broadcasting.

When each device in this system performs coding or decoding, the picture coding device or the picture decoding device, as shown in the above-mentioned embodiments, can be used.

A cell phone will be explained as an example of the device.

FIG. 28 is a diagram showing the cell phone ex115 using the picture coding method and the picture decoding method explained in the above-mentioned embodiments. The cell phone ex115 has an antenna ex201 for communicating with the cell site ex110 via radio waves, a camera unit ex203 such as a CCD camera capable of shooting moving and still pictures, a display unit ex202 such as a liquid crystal display for displaying the data such as decoded pictures and the like shot by the camera unit ex203 and received by the antenna ex201, a body unit including a set of operation keys ex204, a voice output unit ex208 such as a speaker for outputting voices, a voice input unit 205 such as a microphone for inputting voices, a storage medium ex207 for storing coded or decoded data such as data of moving or still pictures shot by the camera, data of received e-mails and data of moving or still pictures, and a slot unit ex206 for attaching the storage medium ex207 to the cell phone ex115. The storage medium ex207 stores in itself a flash memory element, a kind of EEPROM (Electrically Erasable and Programmable Read Only Memory) that is a nonvolatile memory electrically erasable from and rewritable to a plastic case such as a SD card.

Next, the cell phone ex115 will be explained with reference to FIG. 29. In the cell phone ex115, a main control unit ex311, designed in order to control overall each unit of the main body which contains the display unit ex202 as well as the operation keys ex204, is connected mutually to a power supply circuit unit ex310, an operation input control unit ex304, a picture coding unit ex312, a camera interface unit ex303, an LCD (Liquid Crystal Display) control unit ex302, a picture decoding unit ex309, a multiplexing/demultiplexing unit ex308, a read/write unit ex307, a modem circuit unit ex306 and a voice processing unit ex305 via a synchronous bus ex313.

When a call-end key or a power key is turned ON by a user's operation, the power supply circuit unit ex310 supplies respective units with power from a battery pack so as to activate the camera attached digital cell phone ex115 as a ready state.

In the cell phone ex115, the voice processing unit ex305 converts the voice signals received by the voice input unit ex205 in conversation mode into digital voice data under the control of the main control unit ex311 including a CPU, ROM and RAM, the modem circuit unit ex306 performs spread spectrum processing of the digital voice data, and the communication circuit unit ex301 performs digital-to-analog conversion and frequency transformation of the data, so as to transmit it via the antenna ex201. Also, in the cell phone ex115, the communication circuit unit ex301 amplifies the data received by the antenna ex201 in conversation mode and performs frequency transformation and analog-to-digital conversion to the data, the modem circuit unit ex306 performs inverse spread spectrum processing of the data, and the voice processing unit ex305 converts it into analog voice data, so as to output it via the voice output unit 208.

Furthermore, when transmitting an e-mail in data communication mode, the text data of the e-mail inputted by operating the operation keys ex204 of the main body is sent out to the main control unit ex311 via the operation input control unit ex304. In the main control unit ex311, after the modem circuit unit ex306 performs spread spectrum processing of the

36

text data and the communication circuit unit ex301 performs digital-to-analog conversion and frequency transformation to it, the data is transmitted to the cell site ex110 via the antenna ex201.

When picture data is transmitted in data communication mode, the picture data shot by the camera unit ex203 is supplied to the picture coding unit ex312 via the camera interface unit ex303. When it is not transmitted, it is also possible to display the picture data shot by the camera unit ex203 directly on the display unit 202 via the camera interface unit ex303 and the LCD control unit ex302.

The picture coding unit ex312, which includes the picture coding device as explained in the present invention, compresses and codes the picture data supplied from the camera unit ex203 by the coding method used for the picture coding device as shown in the above-mentioned first embodiment so as to transform it into coded picture data, and sends it out to the multiplexing/demultiplexing unit ex308. At this time, the cell phone ex115 sends out the voices received by the voice input unit ex205 during the shooting with the camera unit ex203 to the multiplexing/demultiplexing unit ex308 as digital voice data via the voice processing unit ex305.

The multiplexing/demultiplexing unit ex308 multiplexes the coded picture data supplied from the picture coding unit ex312 and the voice data supplied from the voice processing unit ex305 using a predetermined method, the modem circuit unit ex306 performs spread spectrum processing of the multiplexed data obtained as a result of the multiplexing, and the communication circuit unit ex301 performs digital-to-analog conversion and frequency transformation of the data for the transmission via the antenna ex201.

As for receiving data of a moving picture file which is linked to a Web page or the like in data communication mode, the modem circuit unit ex306 performs inverse spread spectrum processing of the data received from the cell site ex110 via the antenna ex201, and sends out the multiplexed data obtained as a result of the processing to the multiplexing/demultiplexing unit ex308.

In order to decode the multiplexed data received via the antenna ex201, the multiplexing/demultiplexing unit ex308 separates the multiplexed data into a bit stream of picture data and a bit stream of voice data, and supplies the coded picture data to the picture decoding unit ex309 and the voice data to the voice processing unit ex305 respectively via the synchronous bus ex313.

Next, the picture decoding unit ex309, which includes the picture decoding device as explained in the above-mentioned invention, decodes the bit stream of picture data by the decoding method corresponding to the coding method as shown in the above-mentioned embodiments to generate reproduced moving picture data, and supplies this data to the display unit ex202 via the LCD control unit ex302, and thus picture data included in a moving picture file linked to a Web page, for instance, is displayed. At the same time, the voice processing unit ex305 converts the voice data into analog voice data, and supplies this data to the voice output unit ex208, and thus voice data included in the moving picture file linked to a Web page, for instance, is reproduced.

The present invention is not limited to the above-mentioned system, and either the picture coding device or the picture decoding device in the above-mentioned embodiments can be incorporated into a digital broadcasting system as shown in FIG. 30. Such ground-based or satellite digital broadcasting has been in the news lately. More specifically, a bit stream of video information is transmitted from a broadcast station ex409 to or communicated with a broadcast satellite ex410 via radio waves. Upon receipt of it, the broadcast

satellite ex410 transmits radio waves for broadcasting. Then, a home-use antenna ex406 with a satellite broadcast reception function receives the radio waves, and a television (receiver) ex401 or a set top box (STB) ex407 decodes the bit stream for reproduction. The picture decoding device as shown in the reproducing device ex403 for reading out and decoding the bit stream recorded on a storage medium ex402 that is a recording medium such as a CD and a DVD. In this case, the reproduced video signals are displayed on a monitor ex404. It is also conceivable to implement the picture decoding device in the set top box ex407 connected to a cable ex405 for a cable television or the antenna ex406 for satellite and/or ground-based broadcasting so as to reproduce them on a monitor ex408 of the television ex401. The picture decoding device may be incorporated into the television, not in the set top box. Also, a car ex412 having an antenna ex411 can receive signals from the satellite ex410 or the cell site ex107 for reproducing moving pictures on a display device such as a car navigation system ex413.

Furthermore, the picture coding device as shown in the above-mentioned embodiments can code picture signals for recording on a recording medium. As a concrete example, there is a recorder ex420 such as a DVD recorder for recording picture signals on a DVD disk ex421 and a disk recorder for recording them on a hard disk. They can be recorded on an SD card ex422. If the recorder ex420 includes the picture decoding device as shown in the above-mentioned embodiments, the picture signals recorded on the DVD disk ex421 or the SD card ex422 can be reproduced for display on the monitor ex408.

As for the structure of the car navigation system ex413, the structure without the camera unit ex203, the camera interface unit ex303 and the picture coding unit ex312, out of the components shown in FIG. 29, is conceivable. The same goes for the computer ex111, the television (receiver) ex401 and others.

In addition, three types of implementations can be conceived for a terminal such as the above-mentioned cell phone ex114; a sending/receiving terminal implemented with both an encoder and a decoder, a sending terminal implemented with an encoder only, and a receiving terminal implemented with a decoder only.

As described above, it is possible to use the picture coding method or the picture decoding method in the above-mentioned embodiments for any of the above-mentioned devices and systems, and by using this method, the effects described in the above-mentioned embodiments can be obtained.

Also, the present invention is not limited to the above-mentioned embodiments and a wide range of variations or modifications within the scope of the following claims are possible.

A picture coding method according to the present invention improves coding efficiency since optimal tables for variable length coding can be referred to when the number of coefficients other than 0 contained in a current block to be coded is encoded.

Also, a picture decoding method according to the present invention decodes correctly a bit stream in which a number of coefficients other than 0 contained in a block after orthogonal transformation is coded with reference to optimal tables for variable length coding.

INDUSTRIAL APPLICABILITY

Thus, the picture coding method and the picture decoding method according to the present invention are useful as a method to encode an image so as to create a bit stream as well as to decode the created bit stream using devices such as a cell phone, a DVD device, a personal computer or the like.

The invention claimed is:

1. A receiving apparatus which receives multiplexed data which is obtained by multiplexing coded audio data and coded picture data, said receiving apparatus comprising:

- a demultiplexing unit configured to separate the multiplexed data into the coded audio data and the coded picture data;
- an audio processing unit configured to decode the separated coded audio data; and
- a picture decoding unit configured to decode the separated coded picture data,

wherein said picture decoding unit includes a block decoding unit configured to decode coded block data included in the coded picture data, the coded block data being obtained by dividing a picture signal into plural blocks, generating a residual block image from a block image of the respective blocks and a predictive block image obtained by intra-picture prediction or inter-picture prediction, and coding, on a block basis, coefficients obtained by performing orthogonal transformation and quantization on the residual block image,

said block decoding unit includes:

- a coefficient number decoding unit configured to decode the coded block data to obtain the number of non-zero coefficients which are coefficients included in a current block to be decoded and having a value other than "0";
- a unit configured to obtain coefficients corresponding to a residual block image of the current block by decoding the coded block data;
- a unit configured to obtain the residual block image of the current block by performing inverse quantization and inverse orthogonal transformation on the coefficients corresponding to the residual block image of the current block; and

a reproducing unit configured to reproduce a block image of the current block, from the obtained residual block image and a predictive block image obtained by intra-picture prediction or inter-picture prediction,

said coefficient number decoding unit includes:

- a determining unit configured to determine a predictive value for the number of non-zero coefficients included in the current block based on the number of non-zero coefficients included in a decoded block located on a periphery of the current block;
- a selecting unit configured to select a variable length code table based on the determined predictive value; and
- a variable length decoding unit configured to perform variable length decoding on a coded stream which is generated by coding the number of the non-zero coefficients included in the current block, by using the selected variable length code table.

* * * * *

EXHIBIT 2

(12) **United States Patent**
Jäverbring et al.

(10) **Patent No.: US 6,604,216 B1**
 (45) **Date of Patent: Aug. 5, 2003**

(54) **TELECOMMUNICATIONS SYSTEM AND METHOD FOR SUPPORTING AN INCREMENTAL REDUNDANCY ERROR HANDLING SCHEME USING AVAILABLE GROSS RATE CHANNELS**

(75) Inventors: **Stefan Jäverbring**, Haninge (SE);
Anders Furuskär, Stockholm (SE);
Stefan Eriksson, Stockholm (SE);
Magnus Frodigh, Sollentuna (SE)

(73) Assignee: **Telefonaktiebolaget LM Ericsson**, Stockholm (SE)

(*) Notice: Subject to any disclaimer, the term of this patent is extended or adjusted under 35 U.S.C. 154(b) by 0 days.

(21) Appl. No.: **09/505,792**

(22) Filed: **Feb. 17, 2000**

Related U.S. Application Data

(60) Provisional application No. 60/170,209, filed on Dec. 10, 1999.

(51) **Int. Cl.**⁷ **H03M 13/00**

(52) **U.S. Cl.** **714/751**

(58) **Field of Search** 714/751, 752,
 714/786, 748-749, 18; 375/225

(56) **References Cited**

U.S. PATENT DOCUMENTS

5,657,325 A 8/1997 Lou et al. 370/334
 5,940,439 A * 8/1999 Kleider et al. 375/225

FOREIGN PATENT DOCUMENTS

DE 196 30 343 A1 2/1998
 EP 104703 10/2000

OTHER PUBLICATIONS

Li et al., Variable Rate rellis Coded Modulation Using Punctured Codes, IEEE, p. 624-627, 1997.*
 Eroz et al., A Multiple Trellis-Coded Hybrid-ARQ Scheme for Land Mobile Communication Channels, IEEE, p. 496-500, 1995.*

Comparison of Link Quality Control Strategies for Packet Data Services in EDGE by Stefan Eriksson, Anders Furuskär, Mikael Höök, Stefan Jäverbring, Håkan Olofsson and Johan Sköld; Ericsson Radio Systems AB, S-164 80, Stockholm Sweden; 1999 IEEE; XP-002127832; pp. 938-942.

S. Lin, et al.; "Automatic-Repeat-Request Error-Control Schemes", *IEEE Communications*, vol. 12, Dec. 1984; pp. 5-17.

J. Hagenauer; "Rate-Compatible Punctured Convolutional Codes (RCPC Codes) and their Applications", *IEEE Transactions on Communications*, vol. 36, No. 4, Apr. 1988, pp. 389-400.

S. Kallel; "Complementary Punctured Convolutional (CPC) Codes and Their Applications", *IEEE Transactions on Communications*, vol. 43, No. 6, Jun. 1995, pp. 2005-2009.

* cited by examiner

Primary Examiner—Albert DeCady
Assistant Examiner—Shelly A Chase
 (74) *Attorney, Agent, or Firm*—Jenkins & Gilchrist, PC

(57) **ABSTRACT**

A wireless communications system, transmitter, receiver and method are provided that are capable of supporting incremental redundancy error handling schemes using available gross rate channels. More specifically, the transmitter includes a coding circuit for coding a digital data block and generating a mother code word, and a reordering circuit for reordering the mother code word and generating a reordered mother code word. The transmitter also includes a modulating circuit for modulating at least one subsequence each of which has a desired number of bits taken from the reordered mother code word to fill the available bandwidth of at least one available gross rate channel. The transmitter continues to forward the modulated subsequences to the receiver until the receiver successfully decodes the digital data block.

34 Claims, 6 Drawing Sheets

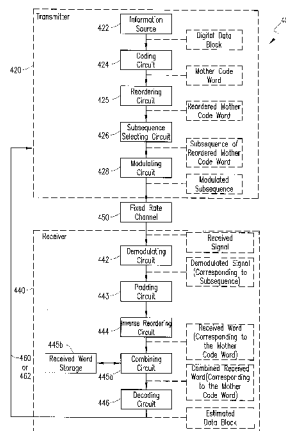

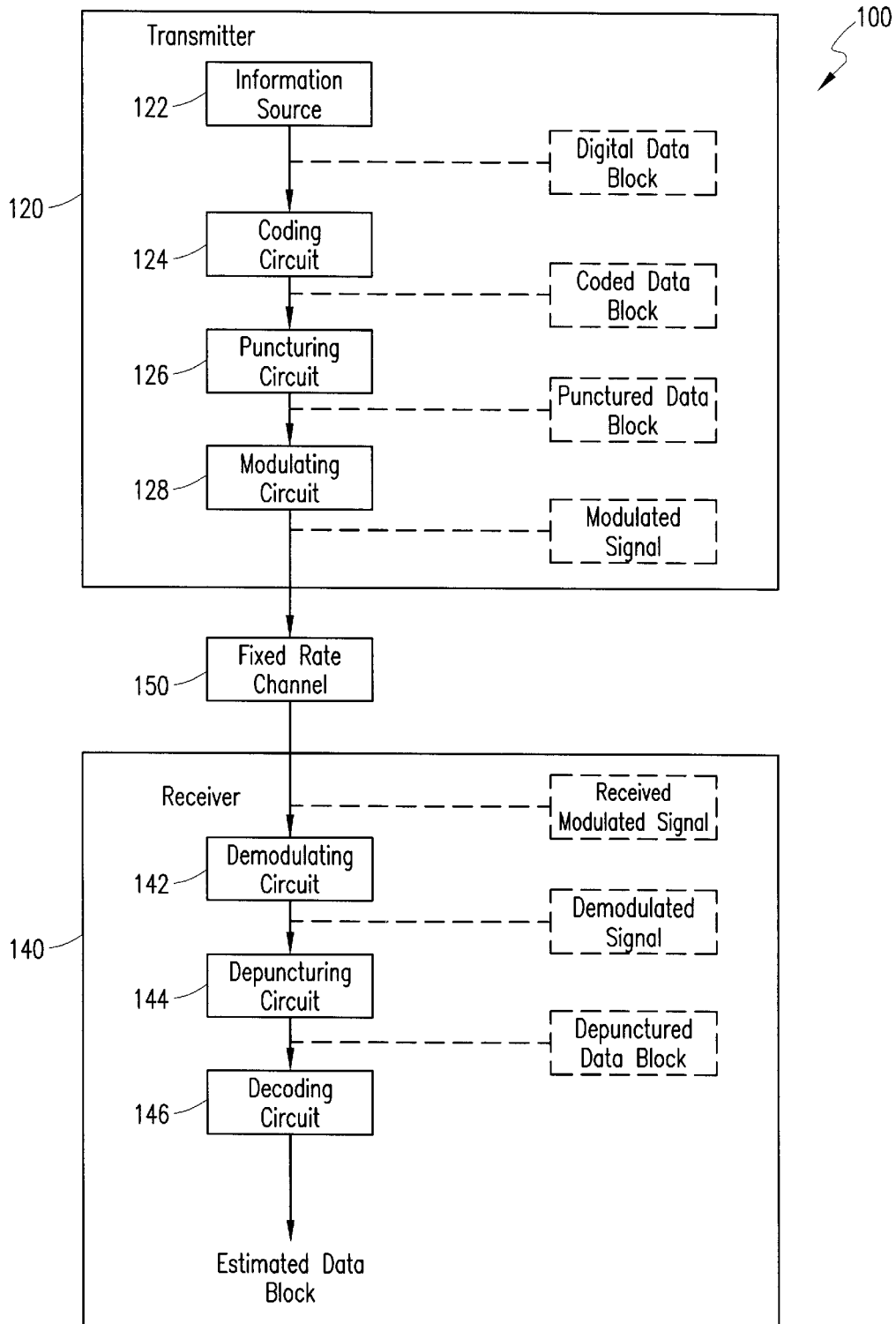

FIG. 1
(PRIOR ART)

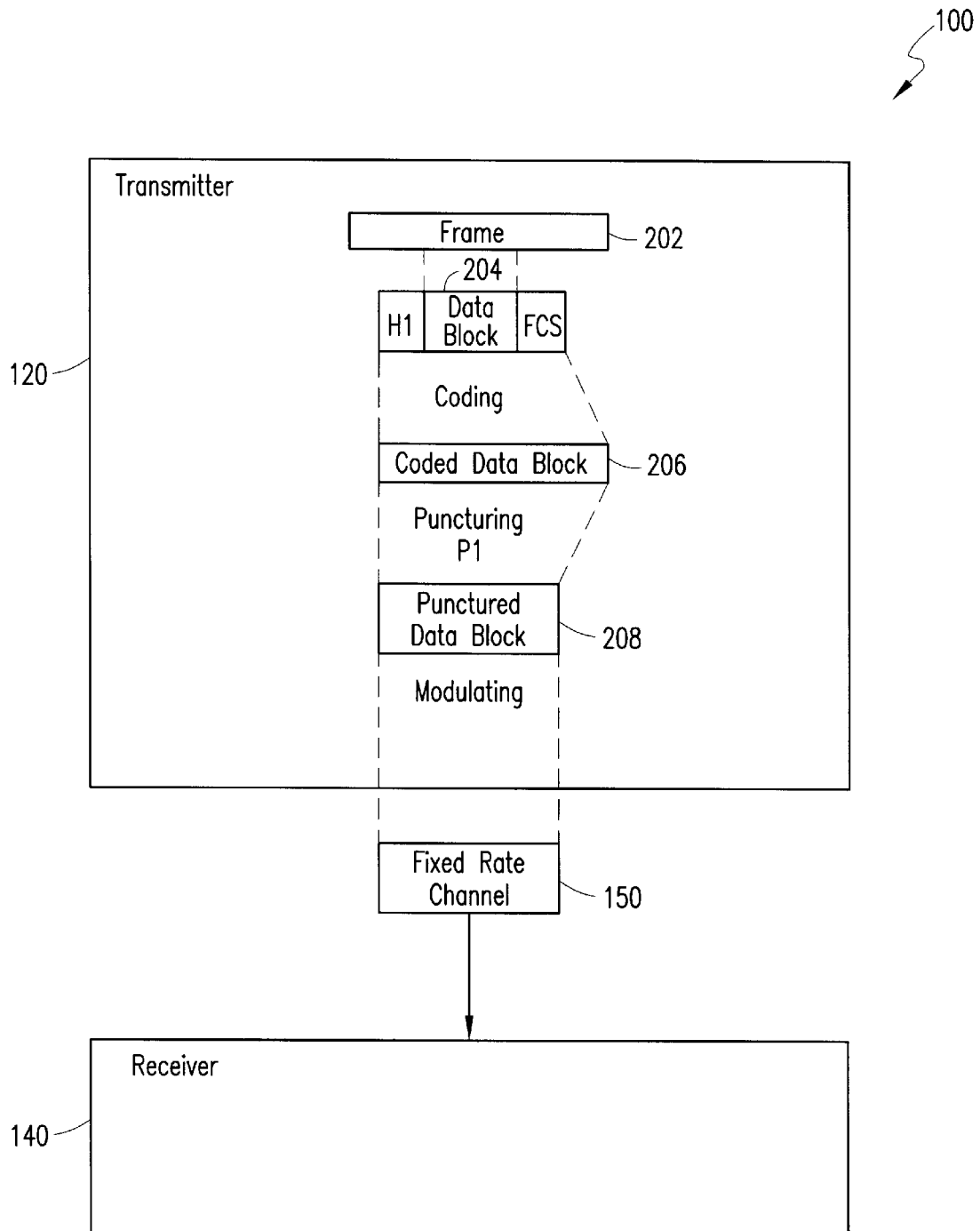

FIG. 2
(PRIOR ART)

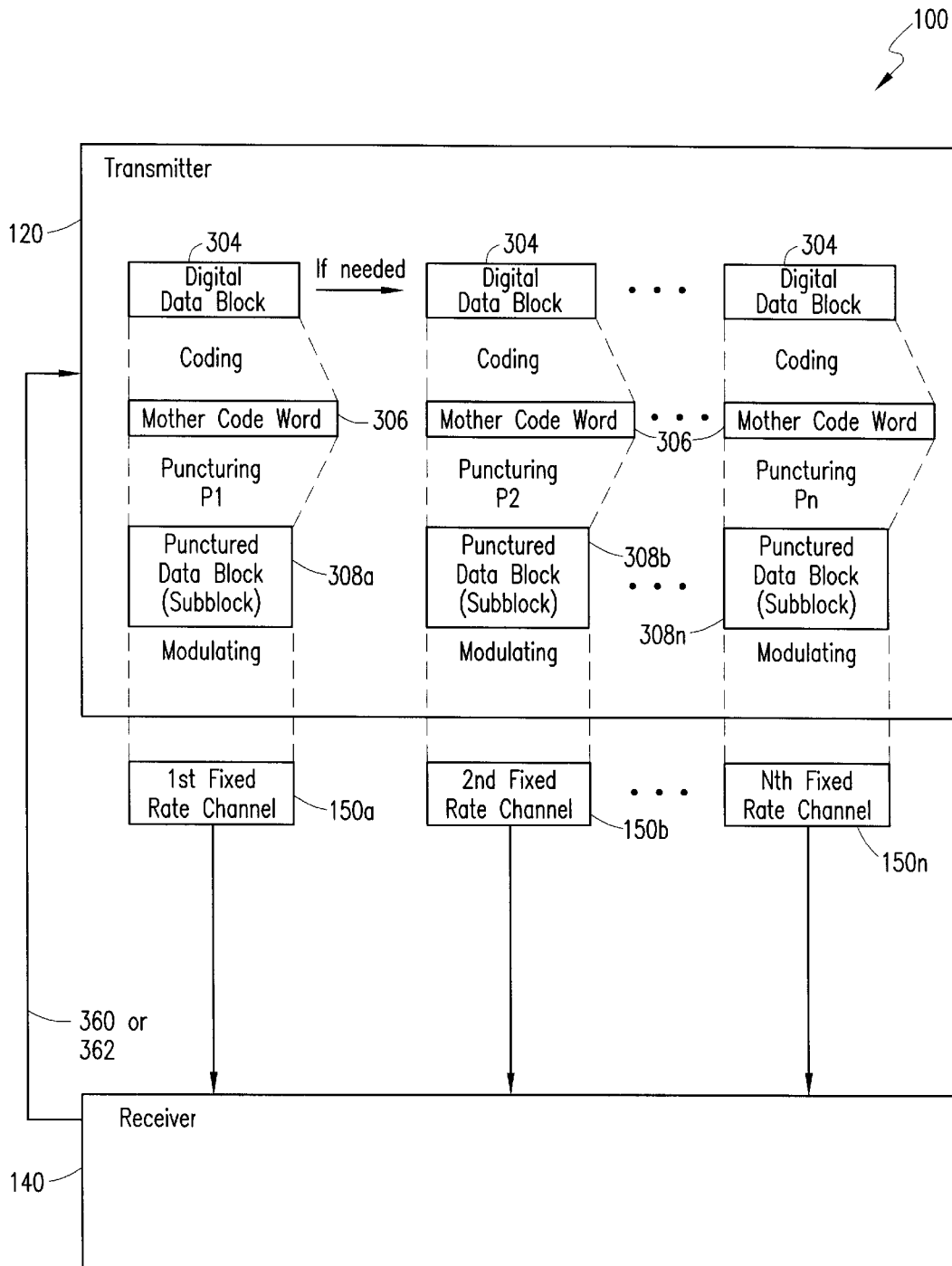

FIG. 3
(PRIOR ART)

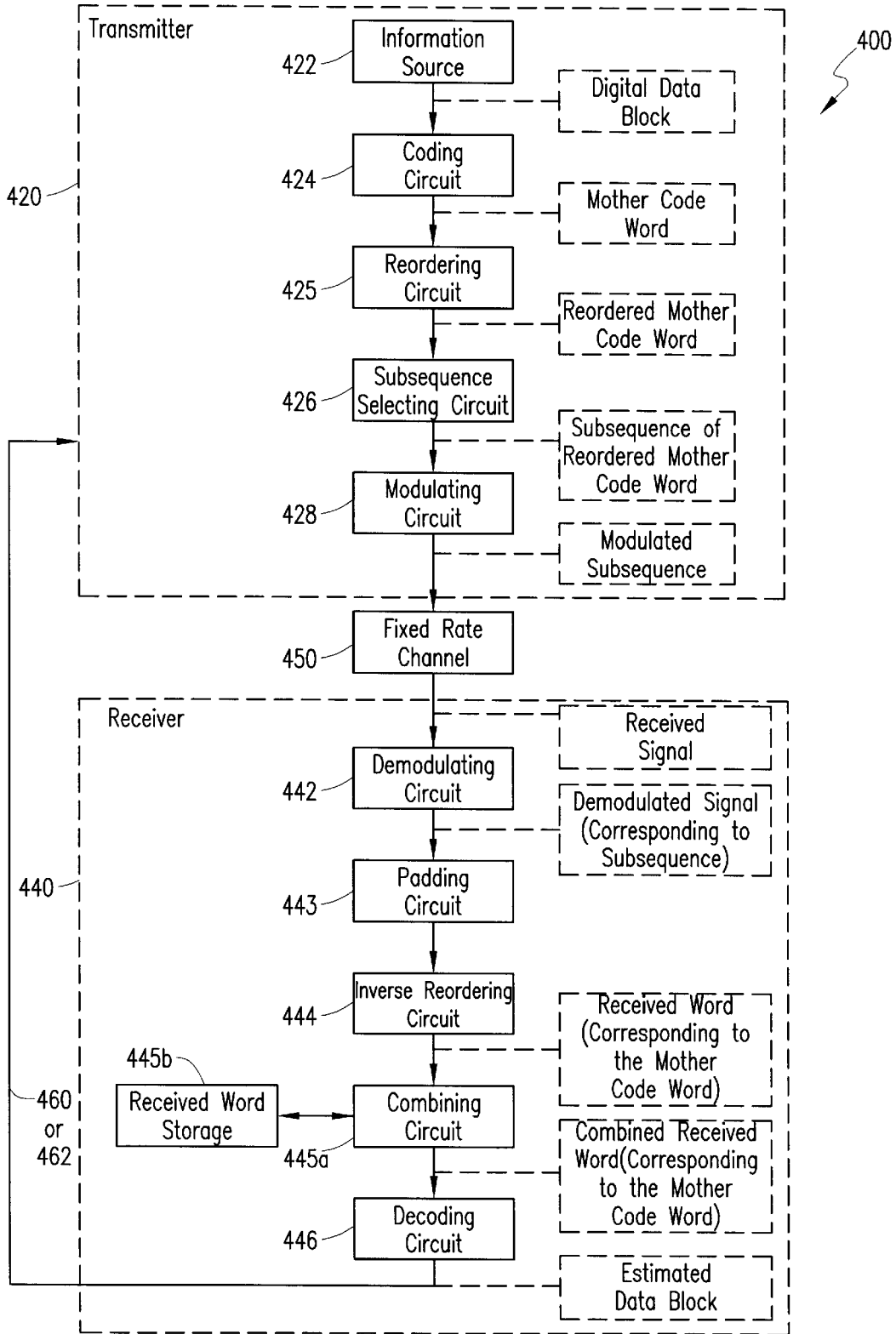

FIG. 4

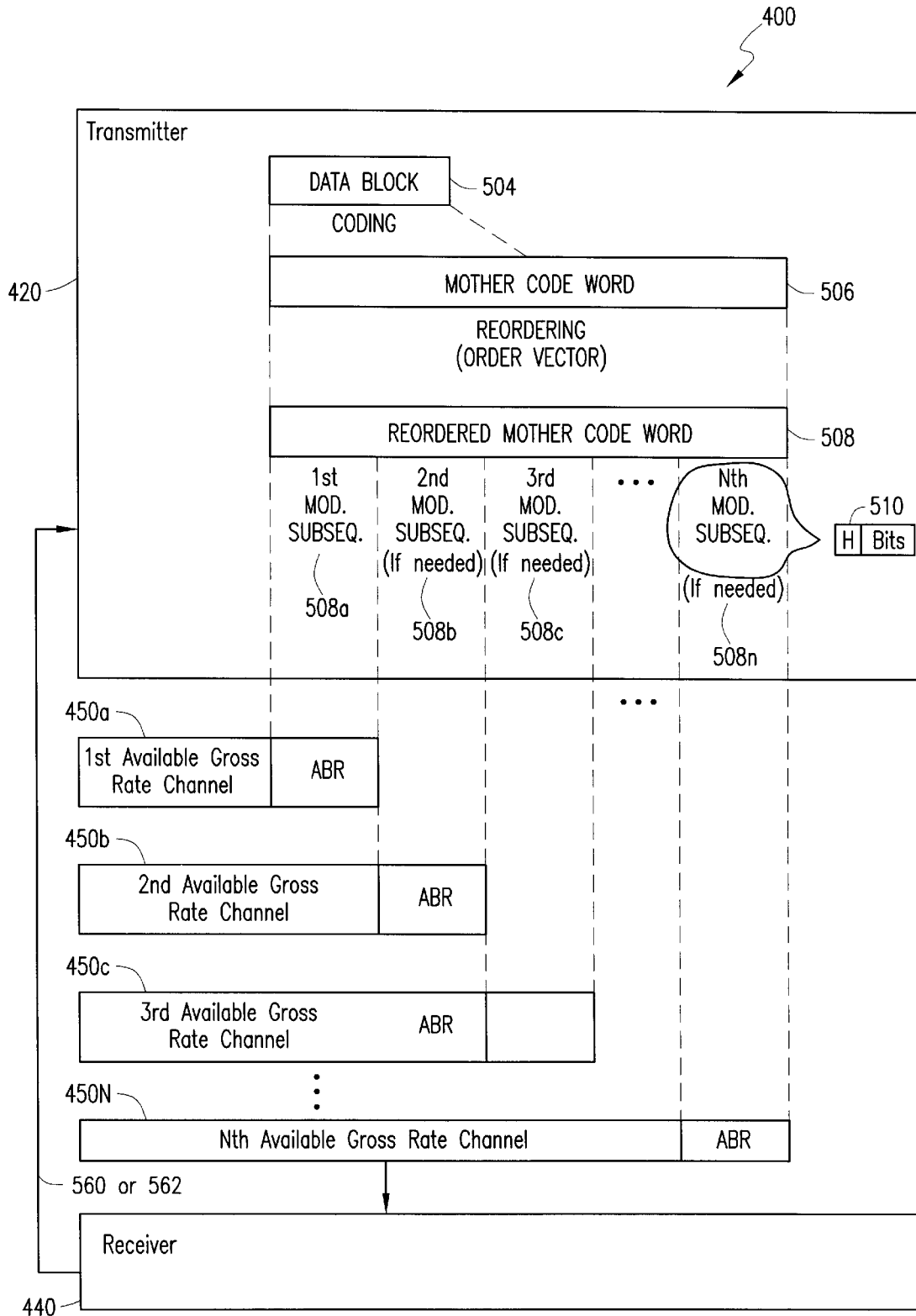

FIG. 5

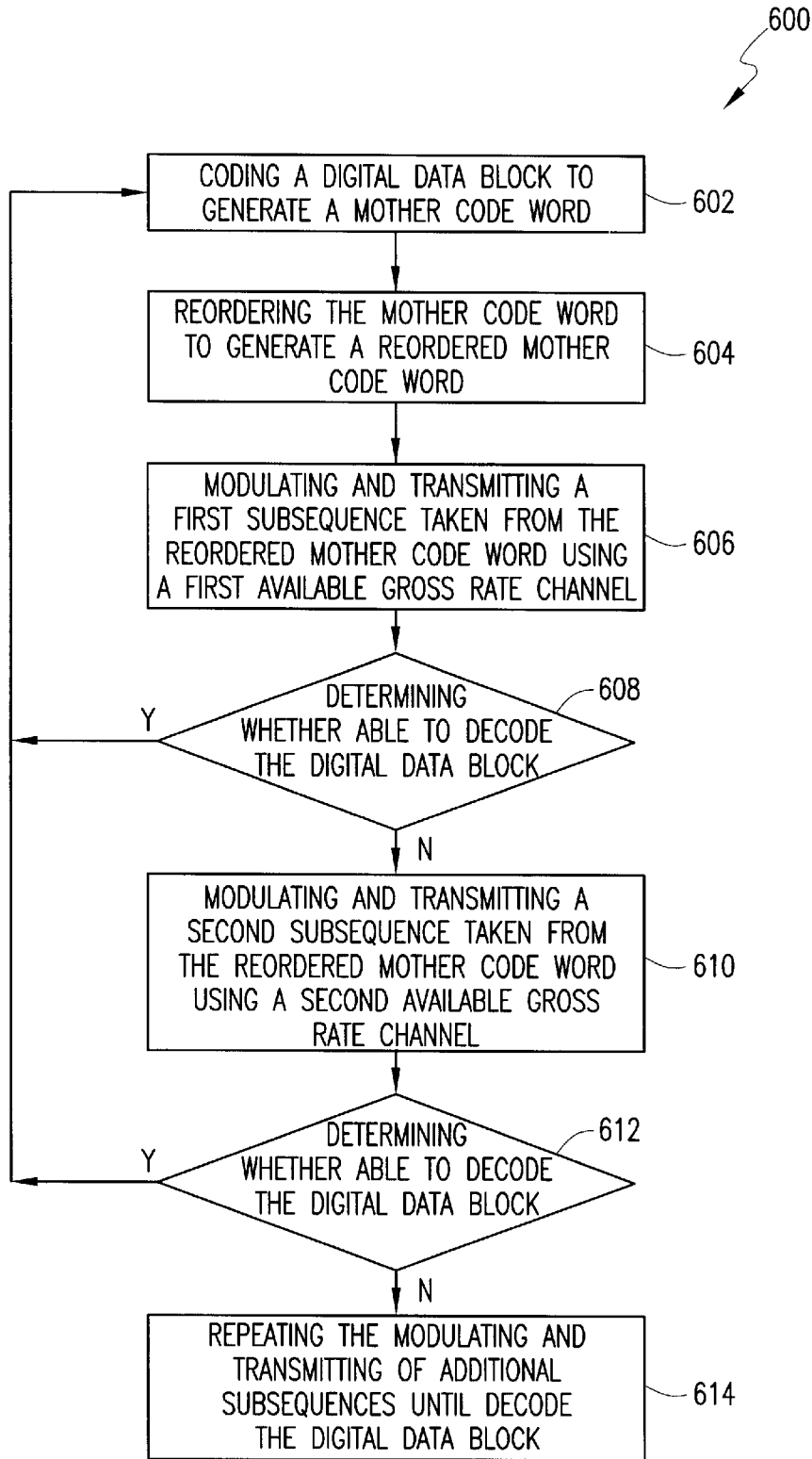

FIG. 6

**TELECOMMUNICATIONS SYSTEM AND
METHOD FOR SUPPORTING AN
INCREMENTAL REDUNDANCY ERROR
HANDLING SCHEME USING AVAILABLE
GROSS RATE CHANNELS**

**CROSS REFERENCE TO RELATED
PROVISIONAL APPLICATION**

This patent application claims the benefit of priority from, and incorporates by reference the entire disclosure of co-pending U.S. Provisional Patent Application Serial No. 60/170,209 filed on Dec. 10, 1999.

BACKGROUND OF THE INVENTION

1. Technical Field of the Invention

The present invention generally relates to the telecommunications field and, in particular, to a wireless communications system and method capable of supporting an incremental redundancy error handling scheme using available gross rate channels.

2. Description of Related Art

Wireless communication systems convey a digital data block by transmitting a modulated signal from a transmitter to a receiver over a transmission channel. Transmission channels often contain noise that tends to corrupt the transmitted signal, resulting in transmission errors and the loss of part of the transmitted data block. For instance, this noise could be interference from other transmitters. Furthermore, fading (e.g. log-normal fading, Rayleigh fading) can corrupt the transmitted channel. Corruption of the transmitted digital data block is problematic for wireless communication systems.

To minimize the impact of noise on the transmitted digital data block, various coding techniques often referred to as Link Adaptation (LA) and Type I/II/III hybrid ARQ (Automatic Repeat-Request) schemes that make use of Forward Error Correction (FEC) and Incremental Redundancy (IR) have been proposed. Brief descriptions of a known wireless communications system **100** and how these known coding techniques are incorporated therein are discussed below with respect to FIGS. 1-3.

Referring to FIG. 1, there is illustrated a block diagram of a traditional wireless communications system **100**. The traditional wireless communications system **100** includes a transmitter **120** for coding and transmitting a modulated signal, and a receiver **140** for receiving and decoding the received modulated signal. The transmitter **120** and receiver **140** include components, described below, which are selected, arranged and configured to communicate with one another over a fixed rate channel **150**.

The transmitter **120** includes an information source **122**, a coding circuit **124**, a puncturing circuit **126** and a modulating circuit **128**. The information source **122** generates a digital data block formed by a stream of bits. The coding circuit **124** codes the digital data block to form a coded data block, and a puncturing circuit **126** punctures the coded data block to produce a punctured data block. More specifically, the digital data block is coded according to a selected code rate to provide error protection for symbols of the digital data block. And, the coded data block is punctured according to a selected deleting pattern to produce a corresponding punctured data block having erasures. The modulating circuit **128** uses the punctured data block to produce a modulated signal which is transmitted over the fixed rate channel **150**.

The receiver **140** includes a demodulating circuit **142**, a depuncturing circuit **144** and a decoding circuit **146**. The demodulating circuit **142** demodulates the received modulated signal and outputs a demodulated signal. The demodulated signal corresponds to the punctured data block after it has been corrupted by the communication channel. The depuncturing circuit **144** uses the deleting pattern of the puncturing circuit **126** to depuncture the demodulated signal and output a depunctured data block. The decoding circuit **146** uses the code of the coding circuit **124** to decode the depunctured data block and output an estimated data block.

Referring to FIG. 2, there is a block diagram illustrating in greater detail the coding, puncturing and modulating of a digital data block in the traditional wireless communications system **100** according to the FEC coding technique. In the LA coding technique, Modulation and Coding Schemes (MCS) are selected based on link quality measurements. For example, the GPRS (General Packet Radio Service) standard uses GMSK (Gaussian Minimum Shift Keying) modulation and allows the use of four different Coding Schemes (CS) i.e. CS-1 through CS-4 with coding rates $\frac{1}{2}$, $\frac{2}{3}$, $\frac{3}{4}$, and 1 respectively. An example of Logical Link Control (LLC) frame segmentation in GPRS is depicted in FIG. 2. A frame **202** is segmented into digital data blocks **204** (one shown) having a header **H1** and a Frame Check Sequence (FCS). The digital data block **204** is coded with a convolutional code rate $\frac{1}{2}$ (for example) to form a coded data block **206** and then punctured (if needed) to form a punctured data block **208**. It should be noted that a single puncturing pattern (e.g., puncturing pattern **P1**) is used for a given coding scheme because there is one-to-one relation between the data block **204** and the resulting punctured data block **208**. Thereafter, the punctured data block **208** is modulated and transmitted to the receiver **140** over the fixed rate channel **150**.

Referring to FIG. 3, there is a block diagram illustrating in greater detail the coding, puncturing and modulating of a digital data block in the traditional wireless communications system **100** according to the Type II hybrid ARQ coding techniques. Basically, the ARQ coding techniques are link level techniques that can provide low bit error rates by effectively retransmitting modulated signals to the receiver **140**. In other words, the ARQ coding technique uses at least one fixed rate channel **150a**, **150b**, . . . **150n** to support the retransmission of a modulated signal. The ARQ coding techniques can be divided into fixed redundancy and variable redundancy error control schemes. The Type I hybrid ARQ coding technique is essentially a fixed redundancy error control scheme. And, the Type II hybrid ARQ coding technique is based on a variable redundancy control scheme. The LA coding technique of FIG. 1 can be viewed as using a set of Type I hybrid ARQ coding techniques.

In the Type II hybrid ARQ coding technique shown in FIG. 3, data redundancy or retransmission of modulated signals which are not necessarily the same signals is continued until the receiver **140** successfully decodes a digital data block **304**. As shown, the digital data block **304** (shown on left) is coded using a predetermined code (e.g., systematic convolutional code) to form a mother code word **306** (shown on left). The mother code word **306** (shown on left) is punctured using a predetermined puncturing pattern **P1** to form a subblock **308a**. The subblock **308a** is then modulated and transmitted to the receiver **140** over a first fixed rate channel **150a**. If the receiver **140** is able to successfully decode the digital data block **304** then an acknowledgment signal **360** is sent to the transmitter **120** and the next digital data block (not shown) is transmitted to the receiver **140**. In

the event the receiver 140 is not able to successfully decode the digital data block 304, then a retransmission request, signal 362 is sent to the transmitter 120.

Upon receiving the retransmission request signal 362, the transmitter 120 operates again to code the digital data block 304 (shown in middle) using the predetermined code to form the mother code word 306 (shown in middle). The mother code word 306 (shown in middle) is punctured using another predetermined puncturing pattern P2 to form a subblock 308b. The subblock 308b which may not have the same bits as subblock 308a is modulated and transmitted to the receiver 140 over a second fixed rate channel 150b. If the receiver 140 is now able to successfully decode the digital data block 304 also using information from previously received subblocks in joint decoding then an acknowledgment signal 360 is sent to the transmitter 120 and the next digital data block (not shown) is transmitted to the receiver 140. In the event the receiver 140 is still not able, to successfully decode the digital data block 304, then another retransmission request signal 362 is sent to the transmitter 120.

Upon receiving the retransmission request signal 362, the transmitter 120 yet again operates to code the digital data block 304 (shown on right) using the predetermined code to form the mother code word 306 (shown on right). The mother code word 306 (shown on right) is punctured using another predetermined puncturing pattern Pn to form a subblock 308n. It should be understood that the number “n” of subblocks is arbitrary, i.e., that the subblock 308n does not necessarily come after subblock 308b. The subblock 308n is modulated and transmitted to the receiver 140 over another fixed rate channel 150n. If the receiver 140 is still not able to successfully decode the digital data block 304 then this process of coding, puncturing, modulating and transmitting the digital data block 304 is repeated until the receiver 140 successfully decodes the digital data block 304 and forwards the acknowledgment signal 360 to the transmitter 120.

A description about the Type II hybrid ARQ coding technique can be found in: (1) S. Lin, D. J. Costello, “Automatic Repeat-Request Error Control Schemes”; IEEE Commun. Mag., vol. 12, pp. 5-17, December 1984; and (2) J. Hagenauer, “Rate-Compatible Punctured Convolutional Codes (RCPC Codes) and their Applications”, IEEE Trans. Comm., vol. 36, no. 4, April 1988. Both of these articles are hereby incorporated into the present application.

The Type III Hybrid ARQ coding technique is a special form of the Type II Hybrid PRQ coding technique, where all the subblocks have certain properties. A description about the Type III hybrid ARQ coding technique can be found in S. Kallel, “Complementary Punctured Convolutional (CPC) Codes and Their Application”, IEEE transactions on-communications, vol. 43, no. 6, June 1995. However, it should be understood that both Type II and Type III Hybrid ARQ coding techniques can be designed so that decoding of single sub-blocks themselves is possible. Both the Type II Hybrid ARQ and Type III Hybrid ARQ coding techniques are referred to as Incremental Redundancy (IR) hereinafter. Unfortunately, the traditional wireless communications system 100 that use fixed rate channels 150a, 150b . . . 150n have several disadvantages. For instance, some of the disadvantages are as follows:

1. No good solution using incremental redundancy over available gross rate channels exists. Since the subblocks 308a, 308b . . . 308n are of equal or fixed sizes, they are not suitable for transmission over available gross rate channels. One problematic solution is to have very small

subblocks, and hence one would be able to fit different numbers of these subblocks on the available gross rate channel. However, this causes much overhead, since each subblock normally contains a header.

2. No flexible way of designing and utilizing incremental redundancy code words exists. Current methods require one puncturing pattern for each subblock. If many different subblocks (e.g., of different lengths) are needed to cope with available gross rate channels, then as many puncturing patterns are needed. This causes high complexity. Additionally, the signaling of which puncturing pattern that has been used gives a large overhead.
3. No flexible way of signaling which puncturing pattern P1, P2 . . . Pn is used exists. Normally a number of predetermined puncturing schemes, i.e. bitmaps containing one's and zero's are applied, and which puncturing scheme is used is signaled to the receiver 120 in the subblock header.

Accordingly, there is a need for a wireless communications system and method that addresses the aforementioned problems of the traditional wireless communications system by supporting incremental redundancy error handling schemes using available gross rate channels. This need and other needs are satisfied by the wireless communications system, transmitter, receiver and method of the present invention.

DESCRIPTION OF THE INVENTION

The present invention is a wireless communications system, transmitter, receiver and method that addresses the deficiencies of the prior art by supporting incremental redundancy error handling schemes using available gross rate channels. More specifically, the transmitter includes a coding circuit for coding a digital data block and generating a mother code word, and a reordering circuit for reordering the mother code word and generating a reordered mother code word. The transmitter also includes a subsequence selection circuit for selecting at least one subsequence from the reordered mother code word, and a modulating circuit for modulating and forwarding at least one subsequence to the receiver. Each subsequence has desired number of bits, taken from the reordered mother code word, to fill the available bandwidth of at least one available gross bitrate channel. The transmitter continues to forward and modulate subsequences of the reordered mother code word until the receiver successfully decodes the digital data block.

BRIEF DESCRIPTION OF THE DRAWINGS

A more complete understanding of the method and apparatus of the present invention may be had by reference to the following detailed description when taken in conjunction with the accompanying drawings wherein:

FIG. 1, prior art, is a block diagram illustrating a traditional wireless communications system;

FIG. 2, prior art, is a block diagram illustrating in greater detail the traditional wireless communications system of FIG. 1 using a forward error correction (FEC) coding technique;

FIG. 3, prior art, is a block diagram illustrating in greater detail the traditional wireless communications system of FIG. 1 using an Incremental Redundancy (IR) coding technique;

FIG. 4 is a block diagram illustrating the basic components of the wireless communications system in accordance with the present invention;

FIG. 5 is a block diagram illustrating in greater detail the wireless communications system of FIG. 4 using an incremental redundancy coding technique; and

FIG. 6 is a flowchart illustrating the basic steps of the preferred method in accordance with the present invention.

DETAILED DESCRIPTION OF THE DRAWINGS

Referring to the Drawings, wherein like numerals represent like parts throughout FIGS. 4–6, there are disclosed an exemplary wireless communications system 400 and preferred method 600 in accordance with the present invention.

Although the wireless communications system 400 is described with reference to the Global System for Mobile Communications/(Enhanced) General Packet Radio Services-Global System for Mobile Communications/Enhanced Data Global System for Mobile Communications/Evolution Radio Access Network (GSM/(E) GPRS-GRAN) standards, those skilled in the art will appreciate that other standards and specifications including, for example, other third generation standards may also utilize the principles of the present invention. Accordingly, the wireless communications system 400 and preferred method 600 described should not be construed in a limited manner.

Referring to FIG. 4, there is a block diagram illustrating the basic components of the wireless communications system 400 in accordance with the present invention. The wireless communications system 400 is similar to the traditional wireless communications system 100 of FIG. 1, except that the wireless communications system 400 is capable of effectively supporting incremental redundancy error handling schemes (e.g., Type II/III hybrid ARQ coding techniques) using the available bandwidth of available gross rate channel(s).

The wireless communications system 400 includes a transmitter 420 for coding and transmitting a modulated signal (shown as modulated subsequence), and a receiver 440 for receiving and decoding a received signal. The transmitter 420 and receiver 440 may be any communication device that communicates over at least one available gross rate channel 450 including a cordless or cellular mobile phone, two way radio, MODEM (modulator-demodulator), radio, base station, or the like.

The transmitter 420 includes an information source 422, a coding circuit 424, a reordering circuit 425, a subsequence selecting circuit 426 and a modulating circuit 428. The information source 422 generates a digital data block formed by a stream of bits. The coding circuit 424 codes the digital data block to form a mother code word. More specifically, the digital data block is coded according to a selected code rate to provide error protection for symbols of the digital data block. The mother code word is reordered by the reordering circuit 425 using an ordering vector (described below) to produce a reordered mother code word. The subsequence selecting circuit 426 then selects enough bits (known as a subsequence) from the reordered mother code word to fill all or most of the available bandwidth of an available gross rate channel 450. Thereafter, the modulating circuit 428 uses the subsequence to produce and transmit a modulated subsequence using the available bandwidth of the available gross rate channel 450 (see FIG. 5 for a detailed description about multiple transmissions of modulated subsequences).

The receiver 440 includes a demodulating circuit 442, a padding circuit 443, an inverse reordering circuit 444, a combining circuit 445a (attached to a storage unit 445b) and a decoding circuit 446. The demodulating circuit 442 demodulates one received modulated signal and outputs a demodulated signal. The demodulated signal corresponds to the subsequence of the reordered mother code word after it

has been corrupted by the noise in the available gross rate channel 450. The padding circuit 443 and inverse reordering circuit 444 use the demodulated signal to generate a received word corresponding to the mother code word. More specifically, the padding circuit 443 and inverse reordering circuit 444 use the ordering vector (described below) to pad and reorder the demodulated signal and output the received word. The combining circuit 445a combines the received word (corresponding to the mother code word) with previously received information stored in the storage unit 445b and outputs a combined received word (corresponding to the mother code word). Thereafter, if the receiver 440 is able to successfully decode the combined received word using the decoding circuit 446, then an acknowledgment signal 460 is sent to the transmitter 440 which transmits the next digital data block. Otherwise, if the receiver 440 is not able to successfully decode the combined received word using the decoding circuit 446, then a retransmission request signal 462 is sent to the transmitter 420 which forwards another modulated subsequence to the receiver 440. A more detailed discussion about the reordering of the mother code word and the selecting and modulating of multiple subsequences of the reordered mother code word's provided below with respect to FIG. 5.

Referring to FIG. 5, there is a block diagram illustrating in greater detail the wireless communications system 400 of the present invention. Basically, the wireless communications system 400 enables the transmission of a modulated subsequence and, if needed, subsequent transmissions of additional modulated subsequences each of which is sized to effectively use the available bandwidth in available gross rate channels 450a, 450b, 450c . . . 450n. Compare this with the traditional wireless communications system 100 which supports the transmission and retransmission of modulated subblocks 308a, 308b . . . 308n each of which have the same size so as to fit in fixed rate channels 150a, 150b . . . 150n (see FIG. 3).

As shown, a data block 504 is coded using a predetermined code (e.g., a systematic convolutional code) to form a mother code word 506. The mother code word is reordered to form a reordered mother code word 508. The reordered mother code word 508 is based on an ordering vector that defines the order in which bits forming each subsequence 508a, 508b, 508c . . . 508n are modulated and forwarded to the receiver 440.

For example, different puncturing patterns P1, P2, P3 . . . Pn may be used in sequence to reorder and form the reordered mother code word 508. Whereas, in the prior art different puncturing patterns P1, P2 . . . Pn (all different) would be used separately to puncture each mother code word 306 (all the same) and form different subblocks 308a, 308b . . . 308n (see FIG. 3). Exemplary puncturing patterns P1, P2 and P3 are given below:

$$P1=[100100100100100100 \dots 100]$$

$$P2=[010010010010010010 \dots 010]$$

$$P3=[001001001001001001 \dots 001]$$

In the prior art, the subblock 308a would contain the bits in positions 1,4,7,10, . . . of the mother code word 306, since the puncturing pattern P1 has ones in these positions. Similarly, the subblock 308b would contain the bits in positions 2,5,8,11, . . . of the mother code word 306, and the subblock 308c (not shown) would contain the bits in positions 3,6,9,12 . . . of the mother code word 306. These subblocks 308a, 308b and 308c are sequentially sent to the receiver 120 until the receiver successfully decodes the digital data block 304.

In the preferred embodiment of the present invention, the mother code word **506** is sequentially punctured using one or more puncturing patterns **P1, P2, P3 . . . Pn** that together form the ordering vector. An exemplary ordering vector is given below:

$$O=[1,4,7,10, \dots, 2,5,8,11, \dots, 3,6,9,12, \dots]$$

The ordering vector defines the order in which the bits forming the reordered mother code word **508** are to be modulated and transmitted to the receiver **440**, which also knows the ordering vector. Basically, the transmitter **420** can start and stop as needed within the reordered mother code word **508** to create subsequences **508a, 508b, 508c . . . 508n** each of which has a desired number of bits so that they can fit within the available bandwidth ABR of the available gross rate channels **450a, 450b, 450c . . . 450n**. This enables IR transmission on available gross rate channels.

Referring back to the reordered mother code word **508** shown in FIG. 5, a first subsequence **508a** taken from a first sequence of bits in the reordered mother code word **508** is modulated and transmitted to the receiver **440** using the available bandwidth ABR of the first available gross rate channel **550a**. Again, the first subsequence **508a** has a desired number of bits so that it can fit within the available bandwidth ABR of the first available gross rate channel **550a**. If the receiver **440** is able to successfully decode the first subsequence **508a** and estimate the digital data block **504**, then an acknowledgment signal **560** is sent to the transmitter **420** and the next data block (not shown) is transmitted to the receiver **440** using the principles of the present invention. If the receiver **440** is not able to successfully decode the first subsequence **508a** and estimate the digital data block **504** then, a retransmission request signal **562** is sent to the transmitter **420**.

Upon receiving the retransmission request signal **562**, the transmitter **420** operates to modulate a second subsequence **508b** using a second sequence of bits taken from the reordered mother code word **508**. The second sequence of bits can be adjacent to the first sequence of bits associated with the first subsequence **508a**. Again, the second subsequence **508b** has a desired number of bits so that it can fit within the available bandwidth ABR of the second available gross rate channel **550b**. The transmitter **420** then transmits the modulated second subsequence **508b** to the receiver **440** using the available bandwidth ABR of the second available gross rate channel **550b**. If the receiver **440** after decoding the first and second subsequences **508a** and **508b** is able to estimate the digital data block **504**, then an acknowledgment signal **560** is sent to the transmitter **420** and the next digital data block (not shown) is transmitted to the receiver **440** using the principles of the present invention. If the receiver **440** is not able to successfully decode the second subsequence **508b** and estimate the digital data block **504**, then the receiver **440** sends another retransmission request signal **562** to the transmitter **420**.

Upon receiving the second retransmission request signal **562**, The transmitter **420** operates to modulate a third subsequence **508c** using a third sequence of bits taken from the reordered mother code word **508**. The third sequence of bits can be adjacent to the second sequence of bits associated with the second subsequence **508b**. Again, the third subsequence **508c** has a desired number of bits so that it can fit within the available bandwidth ABR of the third available gross rate channel **550c**. The transmitter **420** then transmits the modulated third subsequence **508c** to the receiver **440** using the available bandwidth ABR of the third available gross rate channel **550c**. If the receiver **440** after decoding the first, second and third subsequences **508a, 508b** and

508c is able to estimate the digital data block **504**, then an acknowledgment signal **560** is sent to the transmitter **420** and the next digital data block (not shown) is transmitted to the receiver **440** using the principles of the present invention. If the receiver **440** is still not able to successfully estimate the digital data block **504**, then the transmitter **440** operates to repeat the process of modulating and forwarding of additional subsequences **508n** taken from additional sequences of bits in the reordered mother code word **508** until the receiver successfully estimates the digital data block **504**.

Each subsequence **508a, 508b, 508c . . . 508n** may include a header **510** indicating a starting point or starting bit in the reordered mother code word **508** and a length of the particular modulated subsequencing. However, the header **510** may not need to include the length of the modulated subsequence **508a, 508b, 508c** or **508n**, if the receiver **440** can automatically assume that the available bandwidth ABR of the available gross rate channels **550a, 550b, 550c . . . 550n** are "filled out" with the respective subsequence **508a, 508b, 508c . . . 508n**. In addition, the starting point need not be included either if it can be derived some other way, e.g., if the receiver can keep track of exactly how many bits that have been sent so far (if transmitted blocks can disappear on the channel, this may not be the case though).

It should also be understood that the available bandwidths ABRs of the different available gross rate channels **550a, 550b, 550c . . . 550n** can be and are often different lengths. As such, the transmitter **440** may initially send one or more subsequences **508a** and **508b** (for example) resulting in a combined code rate higher than some threshold rate **R**, e.g., **R=1**. This means that even very small available bandwidths ABRs of the available gross rate channel(s) **550a, 550b, 550c . . . 550n** can be utilized. Of course, decoding of only the subsequences **508a** and **508b** (for example) with a combined code rate higher than 1 will likely fail, but it can still be used in combination with other subsequences **508a, 508b** and **508c** (for example) if the combined code rate together provide an equivalent code rate ≤ 1 .

Moreover; the transmitter **420** may be designed such that it transmits new subsequences **508b, 508c . . . 508n** (for example) until the equivalent code rate reaches a predetermined threshold such as an equivalent code rate of 1, without awaiting acknowledgments from the receiver **440**. In other words, the transmitter **420** can forward a series of modulated subsequences **508a, 508b, 508c . . . 508n** to the receiver **440** even when the transmitter fails to receive an acknowledgment signal **560** from the receiver. This scheme may reduce delays and memory requirements. Alternatively, the transmitter **420** can be designed to transmit a new subsequence **508b, 508c . . . 508n** only after it has received an acknowledgment signal **560** from the receiver **440**.

Referring to FIG. 6, there is a flowchart illustrating the basic steps of the preferred method **600** that supports an incremental redundancy error handling scheme by mapping the available bandwidth ABR of available gross rate channels **550a, 550b, 550c . . . 550n**. Beginning at step **602**, a digital data block **504** is coded by a predetermined coding rate to generate a mother code word **506**. At step **604**, the mother code word **504** is reordered using, for example, at least one puncture pattern **P1, P2, P3 . . . Pn** to generate a reordered mother code word **508**. As described above, the reordered code mother word **508** is based on an ordering vector that defines the order in which bits forming each subsequence **508a, 508b, 508c . . . 508n** are modulated and forwarded to the receiver **440**. And, the ordering vector is based on the one or more puncturing patterns **P1, P2, P3 . . . Pn**.

At step 606, a first subsequence 508a taken from a first sequence of bits (e.g., starting from the leftmost value) in the reordered mother code word 508 is modulated and transmitted to the receiver 440 using the available bandwidth ABR of the first available gross rate channel 550a. Again, the first subsequence 508a is sized to fit within the available bandwidth ABR of the first available gross rate channel 550a.

At step 612, a determination is made as to whether the receiver 440 is able to successfully decode the first subsequence 508a and estimate the digital data block 504. If yes, the receiver 440 sends an acknowledgment signal 560 to the transmitter 420 which then transmits a new digital data block to the receiver 440 (go back to step 602).

Otherwise, at step 610, the receiver 440 sends a retransmission request signal 562 to the transmitter 420, which then transmits a second subsequence 508b that is sized to use the available bandwidth ABR of a second available gross rate channel 550b. The second subsequence 508b uses a second sequence of bits preferably starting from where the first subsequence 508 stopped in the reordered mother code word 508.

At step 612, a determination is made as to whether the receiver 440 is able to successfully decode the second subsequence 508b and estimate the digital data block 504. In fact, the receiver 440 may use the second subsequence 508b alone or both the first and second subsequences 508a and 508b to estimate the digital data block 504. If the receiver is able to estimate the digital data block 504, then the receiver 440 sends an acknowledgment signal 560 to the transmitter 420, which then transmits a new digital data block to the receiver 440 (go back to step 602).

Otherwise, at step 614, the receiver 440 sends another retransmission request signal 562 to the transmitter 520, which then operates to repeat the process of modulating and forwarding of additional subsequences 508c . . . 508n taken from additional sequences of bits in the reordered mother code word 508 until the receiver successfully estimates the digital data block 504. After estimating the digital data block 502, the receiver 440 sends an acknowledgment signal 560 to the transmitter 520, which then transmits a new digital data block to the receiver 440.

It should be understood that different methods of the IR coding technique exist and can be used with the present invention. For instance, the stop and wait scheme wherein one digital data block at a time must be correctly received before the transmitter goes on with the next digital data block. The go back n scheme wherein the transmitter keeps on sending new digital data blocks and when some block is NACKed (not acknowledged), then the transmitter retransmits that block and all subsequent blocks. Due to delay in the NACK, this can mean retransmitting several blocks apart from the NACKed block, even if they are not erroneous. The selective repeat scheme wherein the transmitter keeps on sending new digital data blocks and when some block(s) is NACKed, thereafter the transmitter retransmits that block(s) and then resumes transmitting new digital data blocks. This application describes the stop and wait method. However, the present invention works equally well for the other methods too. It should also be understood that the “bit ordering scheme” of the present invention may also be used to flexibly obtain arbitrary code rates for LA schemes on variable rate, i.e., the transmitter controls the occupied bit rate channels. More specifically, the digital data block is encoded and reordered according to the present invention. In a well known manner a suitable code rate is chosen (e.g., based on estimates of channel quality and/or quality of

service requirements). Then, as many bits as is needed to obtain the subsequence are transmitted from the reordered mother code word. For retransmission if employed, the same number of bits if the same code rate is desired, more or fewer bits if not, are taken from the same ordering vector (e.g., from the beginning of the vector) and transmitted to the receiver. Hence, the number of transmitted bits can vary, but the number of bits are decided based on the wanted code rate. This could be a first stream on a physical bearer, a best effort service based on “IR on variable bitrate channels” can fill out the remaining part of the bearer.

From the foregoing, it can be readily appreciated by those skilled in the art that the present invention addresses the deficiencies of the prior art by providing a wireless communications system capable of supporting various incremental redundancy error handling schemes using available gross rate channels. Basically, the wireless communications system of the present invention enables the transmission of a modulated subsequence and, if need, subsequent transmissions of additional modulated subsequences each of which can be sized to effectively use the available bandwidth in available gross rate channels.

Although one embodiment of the present invention has been illustrated in the accompanying Drawings and described in the foregoing Detailed Description, it will be understood that the invention is not limited to the embodiment disclosed, but is capable of numerous rearrangements, modifications and substitutions without departing from the spirit of the invention as set forth and defined by the following claims.

What is claimed is:

1. A transmitter for transmitting a digital data block to a receiver, said transmitter comprising:
 - a coding circuit for coding the digital data block and generating a mother code word;
 - a reordering circuit for reordering the mother code word and generating a reordered mother code word, wherein the reordered mother code word is generated based on an ordering vector, the ordering vector defining an order in which bits forming the reordered mother code word are to be modulated and forwarded to a receiver; and
 - a modulating circuit for modulating at least one subsequence and for forwarding, to the receiver, the at least one modulated subsequence, each of the at least one modulated subsequence having a desired number of bits taken from the reordered mother code word to fill the available bandwidth of at least one available gross rate channel.
2. The transmitter of claim 1, wherein said ordering vector is based on at least one puncturing pattern, each of the at least one puncturing pattern being used to reorder the mother code word.
3. The transmitter of claim 1, wherein said receiver knows the ordering vector.
4. The transmitter of claim 1, wherein each modulated subsequence includes a header indicating a starting point in the reordered mother code word.
5. The transmitter of claim 1, wherein each modulated subsequence includes a header indicating a starting point in the reordered mother code word and a length of the modulated subsequence.
6. The transmitter of claim 1, wherein said modulating circuit is capable of forwarding a plurality of the modulated subsequences to the receiver until an equivalent code rate is less than a predetermined threshold rate R.
7. The transmitter of claim 6, wherein said predetermined threshold rate R is one.

11

8. The transmitter of claim 1, wherein said modulating circuit is capable of forwarding a plurality of the modulated subsequences to the receiver even when said transmitter fails to receive an acknowledgment signal from the receiver.

9. The transmitter of claim 1, wherein said modulating circuit is capable of forwarding one of the modulated subsequences only after said transmitter receives an acknowledgment signal from the receiver.

10. The transmitter of claim 1, wherein said transmitter is a mobile terminal or is incorporated within a wireless communications system.

11. A transmitter for supporting an error handling scheme using at least one available gross rate channel, said transmitter comprising:

- a coding circuit for coding a digital data block and generating a mother code word,
- a reordering circuit for reordering the mother code word and generating a reordered mother code word, wherein the reordered mother code word is generated based on an ordering vector, the ordering vector defining an order in which bits forming the reordered mother code word are to be modulated and forwarded to a receiver; and
- a modulating circuit for modulating a subsequence taken from a first sequence of bits in the reordered mother code word and for forwarding the modulated first subsequence to the receiver using the available bandwidth of a first available gross rate channel, said modulating circuit being further capable of repeating the process of modulating and forwarding other subsequences taken from the reordered mother code word until the receiver successfully decodes the digital data block.

12. The transmitter of claim 11, wherein said error handling scheme is an incremental redundancy error handling scheme.

13. The transmitter of claim 12, wherein said incremental redundancy error handling scheme is further classified as a Type II hybrid ARQ (Automatic Repeat Request) scheme or a Type III hybrid ARQ scheme.

14. The transmitter of claim 11, wherein said ordering vector is based on at least one puncturing pattern, each of the at least one puncturing pattern being used to reorder the mother code word.

15. The transmitter of claim 11, wherein each modulated subsequence includes a header indicating a starting point in the reordered mother code word.

16. The transmitter of claim 11, wherein each modulated subsequence includes a header indicating a starting point in the reordered mother code word and a length of the modulated subsequence.

17. The transmitter of claim 11, wherein said modulating circuit is capable of forwarding a plurality of the modulated subsequences to the receiver until an equivalent code rate is less than a predetermined threshold rate R.

18. The transmitter of claim 17, wherein said predetermined threshold rate R is one.

19. A method for supporting an incremental redundancy error handling scheme using at least one available gross rate channel, said method comprising the steps of:

- coding a digital data block to generate a mother code word;
- reordering the mother code word to generate a reordered mother code word, wherein the reordered mother code word is generated based on an ordering vector, the ordering vector defining an order in which bits forming

12

- the reordered mother code word are to be modulated and forwarded to a receiver; and
- modulating at least one subsequence from the reordered mother code word and forwarding the at least one modulated subsequence to the receiver using the available bandwidth of the at least one available gross rate channel.

20. The method of claim 19, wherein said steps of modulating and forwarding further include the steps of:

- modulating a first subsequence taken from a first sequence of bits in the reordered mother code word and forwarding the modulated first subsequence to the receiver in a first available gross rate channel;
- modulating a second subsequence taken from a second sequence of bits in the reordered mother code word and forwarding the modulated second subsequence word to the receiver in a second available gross rate channel; and
- modulating and forwarding additional subsequences taken from additional sequences of bits in the reordered mother code word until the receiver successfully decodes the digital data block.

21. The method of claim 19, wherein said ordering vector is based on a plurality of puncturing patterns.

22. The method of claim 19, wherein said steps of modulating and forwarding further include the step of forwarding a plurality of the modulated subsequences to the receiver until an equivalent code rate is less than a predetermined threshold rate R.

23. The method of claim 22, wherein said predetermined threshold rate R is one.

24. The method of claim 19, wherein said steps of modulating and forwarding further include the step of forwarding a plurality of the modulated subsequence to the receiver even when said transmitter fails to receive an acknowledgment signal from the receiver.

25. The method of claim 19, wherein said steps of modulating and forwarding further include the step of forwarding one of the modulated subsequences only after said transmitter receives an acknowledgment signal from the receiver.

26. The method of claim 19, wherein each modulated subsequence includes a header indicating a starting point in the reordered mother code word.

27. The method of claim 19, wherein each modulated subsequence includes a header indicating a starting point in the reordered mother code word and a length of the modulated subsequence.

28. The method of claim 19, wherein said transmitter is a mobile terminal or is incorporated within a wireless communications system.

29. The method of claim 19, wherein said receiver is a mobile terminal or is incorporated within a wireless communications system.

30. A wireless communications system comprising:

- a receiver;
- a transmitter operatively coupled to said receiver, said transmitter including:
 - a coding circuit for coding a digital data block and generating a mother code word;
 - a reordering circuit for reordering the mother code word and generating a reordered mother code word, wherein the mother code word is reordered based on an ordering vector, the ordering vector defining an order in which bits forming the reordered mother code word are to be modulated and forwarded to the receiver; and

a modulating circuit for modulating a first subsequence taken from a first sequence of bits in the reordered mother code word and forwarding the modulated first subsequence to the receiver in the available bandwidth of a first available gross rate channel, said modulating circuit being further capable of modulating a second subsequence taken from a second sequence of bits in the reordered mother code word and forwarding the modulated second subsequence to the receiver in the available bandwidth of a second available gross rate channel, said modulating circuit also being capable of repeating the process of modulating and forwarding additional subsequences taken from additional sequences of bits in the reordered mother code word until the receiver successfully decodes the digital data block.

31. The wireless communications system of claim 30, wherein said transmitter is capable of forwarding a plurality of the modulated subsequences to the receiver until an equivalent code rate is less than one.

32. The wireless communications system of claim 30, wherein said transmitter is capable of forwarding a plurality of the modulated subsequences to the receiver even when said transmitter fails to receive an acknowledgment signal from the receiver.

33. The wireless communications system of claim 30, wherein said transmitter is capable of forwarding one of the modulated subsequences only after said transmitter receives an acknowledgment signal from the receiver.

34. A transmitter comprising:

a coding circuit for coding a digital data block and generating a mother code word;

a reordering circuit for reordering the mother code word according to an ordering vector based on at least one puncturing pattern and generating a reordered mother code word, wherein the ordering vector defines an order in which bits forming the reordered mother code word are to be modulated and forwarded to a receiver; and

a modulating circuit for modulating at least one subsequence from the reordered mother code word and forwarding the at least one modulated subsequence to the receiver using at least one fixed net rate channel, wherein said at least one subsequence has as many bits as needed to obtain a desired code rate in view of at least one quality of service requirement.

* * * * *

EXHIBIT 3

(12) **United States Patent**
Duan et al.

(10) **Patent No.:** **US 7,940,851 B2**
 (45) **Date of Patent:** **May 10, 2011**

(54) **RADIO COMMUNICATION APPARATUS AND RADIO COMMUNICATION METHOD**

(75) Inventors: **Jinsong Duan**, Kanagawa (JP); **Keisuke Ebiko**, Kanagawa (JP); **Ryohei Kimura**, Kanagawa (JP)

(73) Assignee: **Panasonic Corporation**, Osaka (JP)

(*) Notice: Subject to any disclaimer, the term of this patent is extended or adjusted under 35 U.S.C. 154(b) by 320 days.

(21) Appl. No.: **12/297,617**

(22) PCT Filed: **Apr. 21, 2006**

(86) PCT No.: **PCT/JP2006/308461**

§ 371 (c)(1),
 (2), (4) Date: **Oct. 17, 2008**

(87) PCT Pub. No.: **WO2007/122727**

PCT Pub. Date: **Nov. 1, 2007**

(65) **Prior Publication Data**

US 2009/0232233 A1 Sep. 17, 2009

(51) **Int. Cl.**
H04K 1/10 (2006.01)

(52) **U.S. Cl.** **375/260; 375/299; 375/347; 375/349; 375/324; 375/340; 375/358**

(58) **Field of Classification Search** **375/260, 375/299, 347, 349, 324, 340, 358**
 See application file for complete search history.

(56) **References Cited**

U.S. PATENT DOCUMENTS

7,272,190 B2* 9/2007 Blankenship et al. 375/260
 7,542,514 B2* 6/2009 Song et al. 375/260

2003/0054847 A1 3/2003 Kim
 2005/0128993 A1* 6/2005 Yu et al. 370/342
 2006/0023745 A1* 2/2006 Koo et al. 370/468
 2006/0072508 A1 4/2006 Zou
 2007/0026813 A1* 2/2007 Khan 455/69

FOREIGN PATENT DOCUMENTS

JP 2003-169036 6/2003
 JP 2004-522387 7/2004

(Continued)

OTHER PUBLICATIONS

3GPP TSG RAN WG1 Ad Hoc on LTE (Physical Channels and Multiplexing in Evolved UTRA Downlink, Jun. 21, 2005, 3GPP TSG RAN WG1 Ad Hoc on LTE, France, R1-050590, pp. 124)).*

(Continued)

Primary Examiner — Kabir A Timory

(74) *Attorney, Agent, or Firm* — Seed IP Law Group PLLC

(57) **ABSTRACT**

A radio communication apparatus and an associated method are provided. The apparatus includes a receiving unit configured to receive first data and second data, which are transmitted from a plurality of antennas for spatial-multiplexing using a plurality of blocks, into which a plurality of consecutive subcarriers in a frequency domain are divided. The apparatus further includes a calculating unit configured to calculate a first absolute CQI value per each of the blocks for the first data and a second absolute CQI value per each of the blocks for the second data, and calculate a relative value of the second absolute CQI value with respect to the first absolute CQI value, per each of the blocks. The apparatus still further includes a transmitting unit configured to transmit the first absolute CQI value and the relative value of the second absolute CQI value in the same block.

5 Claims, 19 Drawing Sheets

400

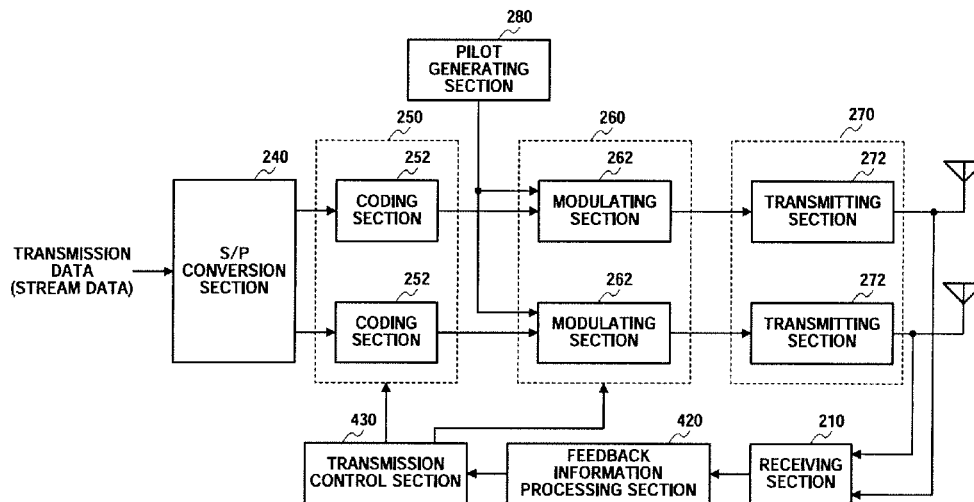

US 7,940,851 B2

FOREIGN PATENT DOCUMENTS

JP 2006-109458 4/2006

OTHER PUBLICATIONS

Notice of the Reasons for Rejection mailed Jan. 5, 2010, issued in corresponding Japanese Patent Application No. 2008-511925, filed Apr. 17, 2008, 4 pages.

Ntt DoCoMo, et al., "AMC and HARQ Using Frequency Domain Channel-Dependent Scheduling in MIMO Channel Transmission," Report R1-050942, 3rd Generation Partnership Project (3GPP™) TSG RAN WG1 Meeting #42 on LTE, London, Aug. 29-Sep. 2, 2005, pp. 1-8.

Ntt DoCoMo, et al., "Physical Channels and Multiplexing in Evolved UTRA Downlink," Report R1-050707, 3rd Generation Partnership Project (3GPP™) TSG RAN WG1 Meeting #42 on LTE, London, Aug. 29-Sep. 2, 2005, pp. 1-15.

QUALCOMM Europe, "Description and Link Simulations of MIMO Schemes for OFDMA Based E-UTRA Downlink Evaluation,"

Report R1-050903, 3rd Generation Partnership Project (3GPP™) TSG RAN WG1 Meeting #42 on LTE, London, Aug. 29-Sep. 2, 2005, pp. 1-12.

Ericsson, et al., "Adaptive Modulation and Channel Coding Rate Control for Frequency Domain Scheduling in Evolved UTRA Downlink," Report R1-051149, 3rd Generation Partnership Project (3GPP™) TSG RAN WG1 Meeting #42bis, San Diego, Oct. 10-14, 2005, pp. 1-10.

Notice of the Reasons for Rejection mailed Mar. 16, 2010, issued in corresponding Japanese Patent Application No. 2008-511925, 2 pages.

International Search Report dated Jul. 25, 2009 with English Translation.

3GPP TSG RAN WGI, TSG R1-010879, "Increasing MIMO throughput with per-antenna rate control," Aug. 2001, pp. 1-14, p. 2, line 14.

* cited by examiner

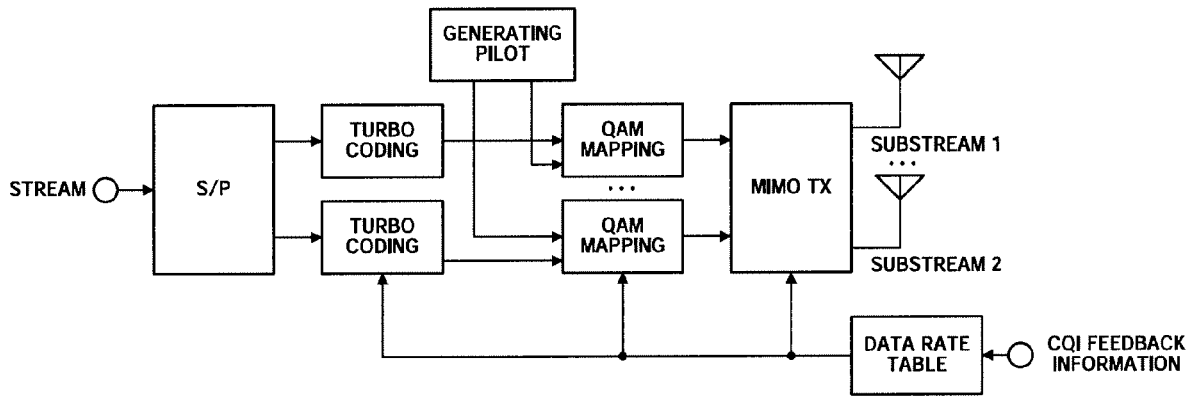

PRIOR ART
FIG.1

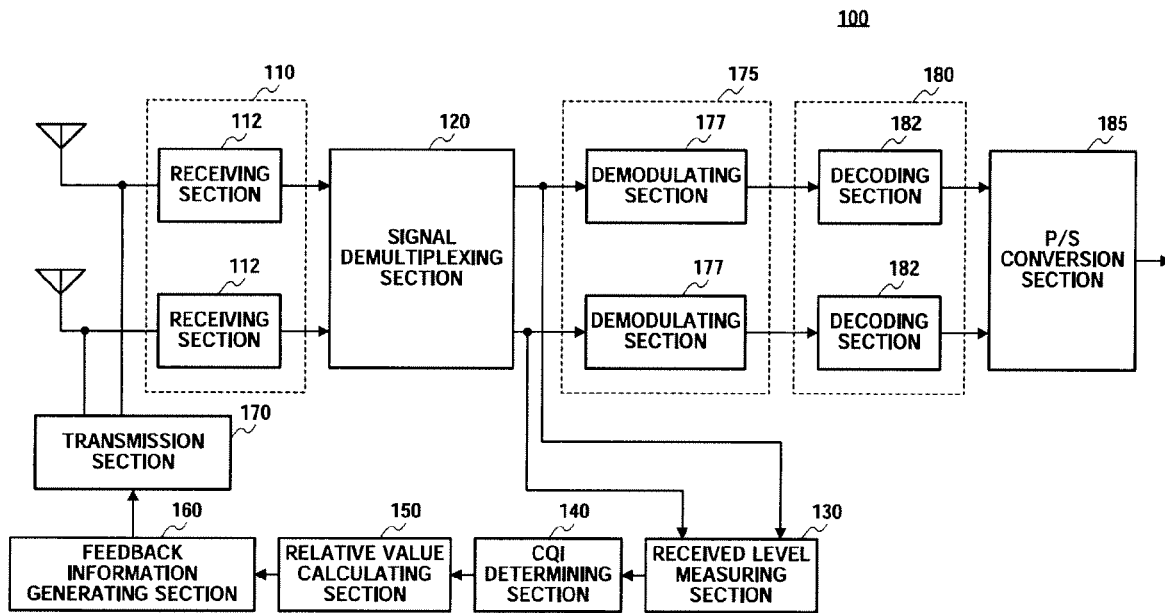

FIG.2

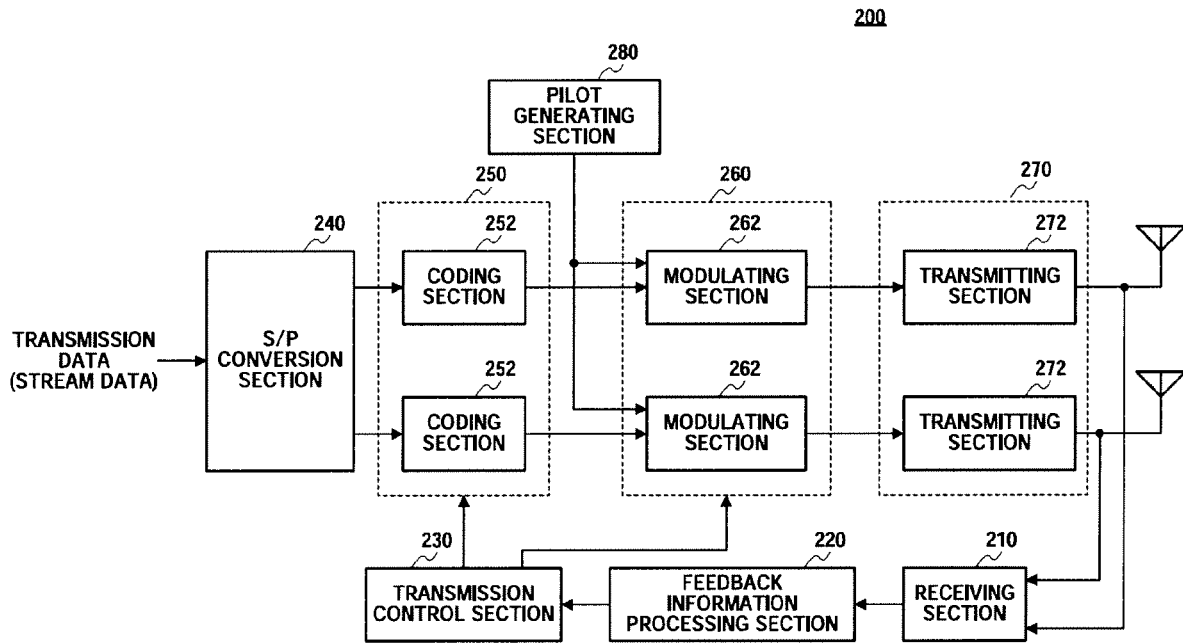

FIG.3

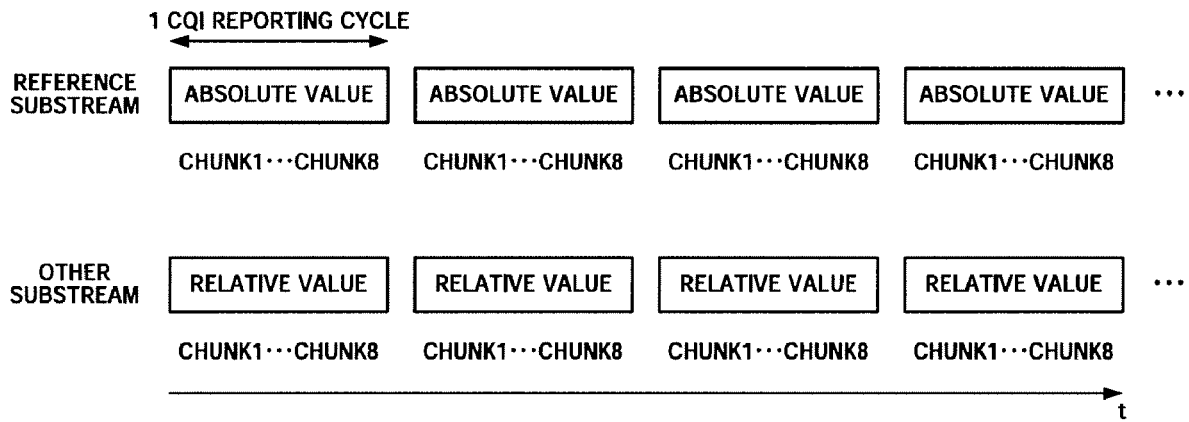

FIG.4

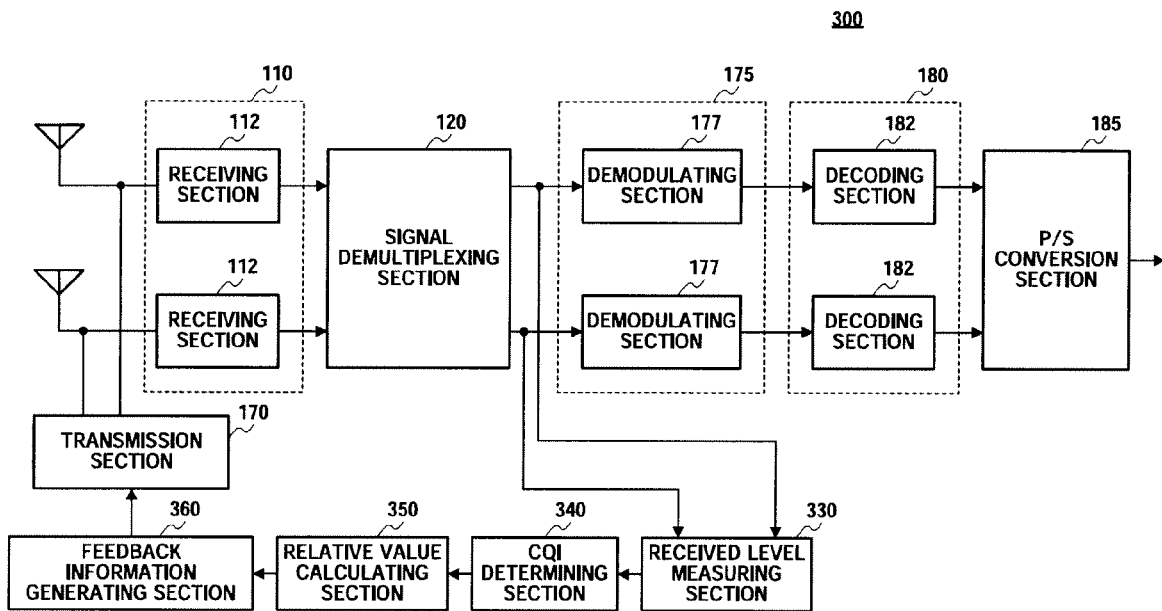

FIG.5

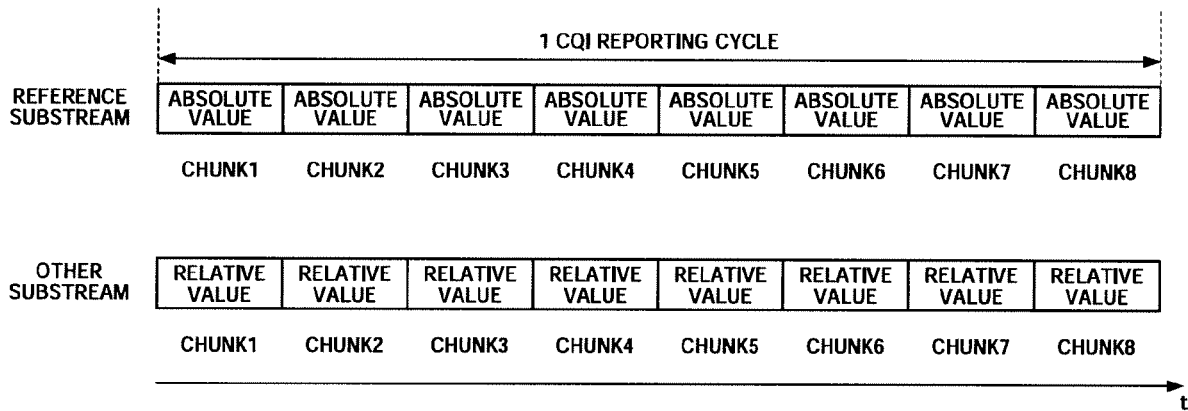

FIG.6

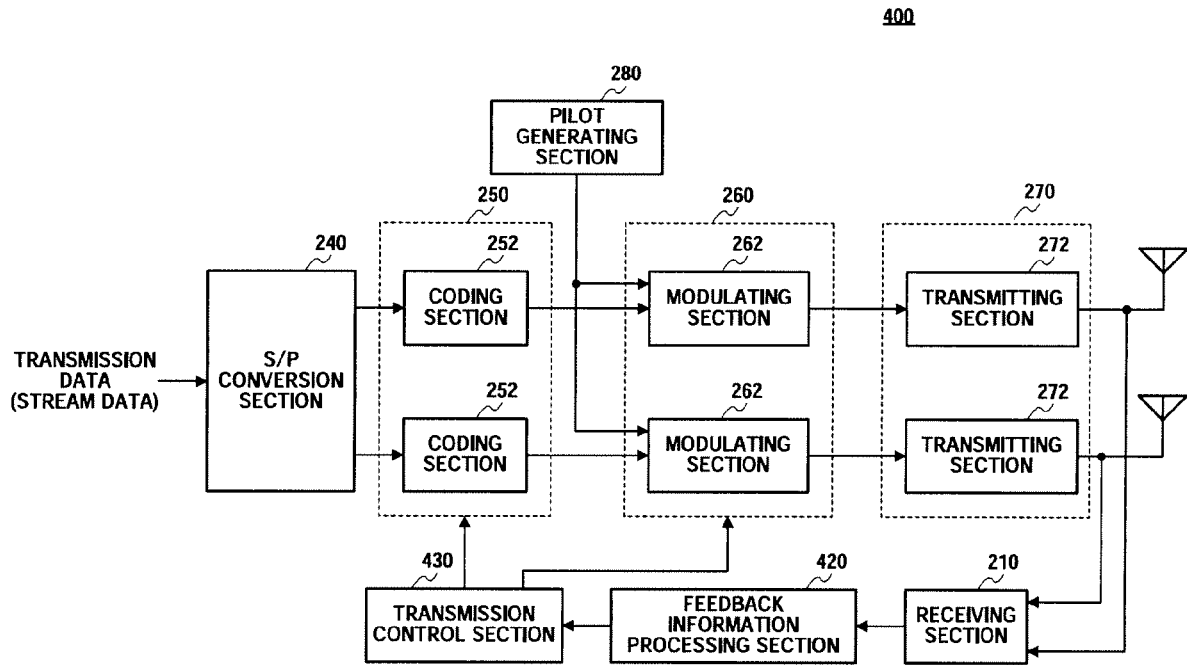

FIG.7

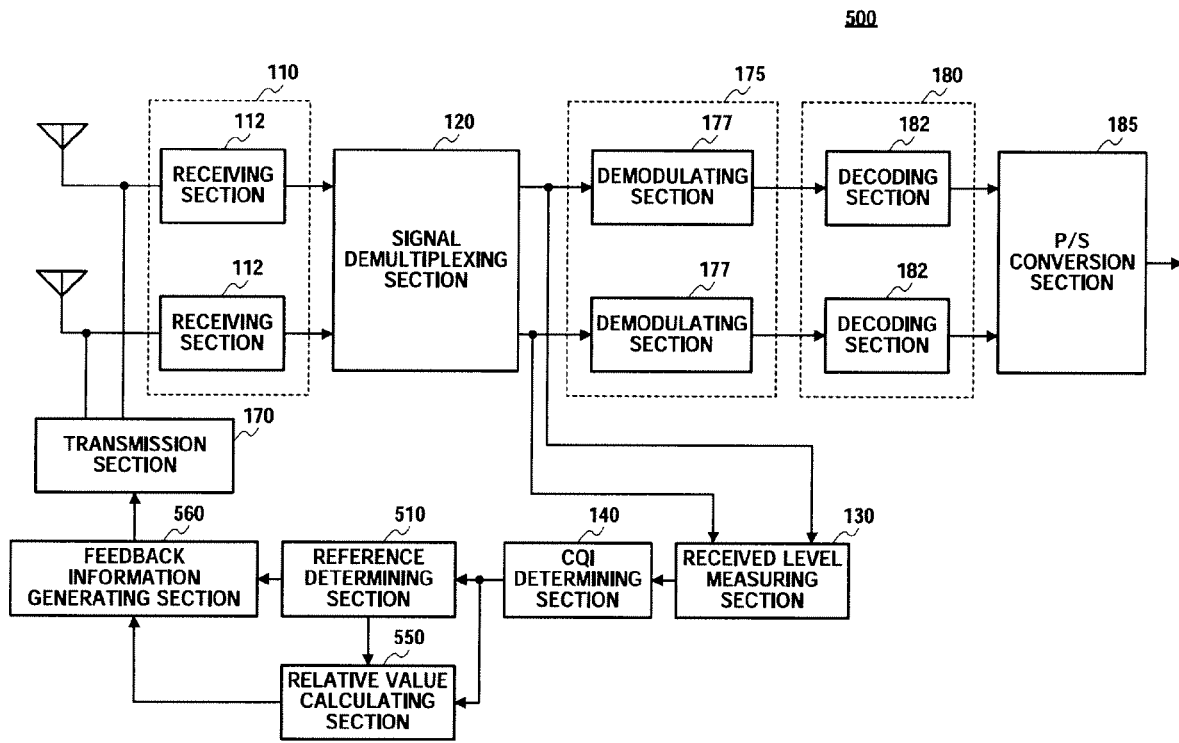

FIG.8

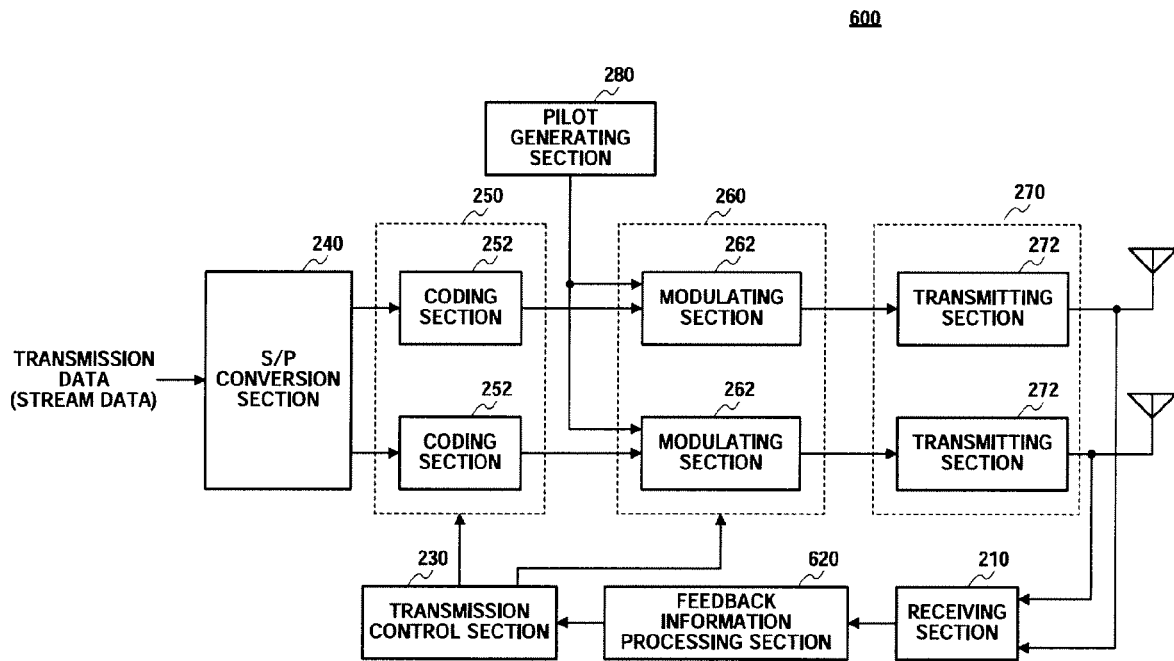

FIG.9

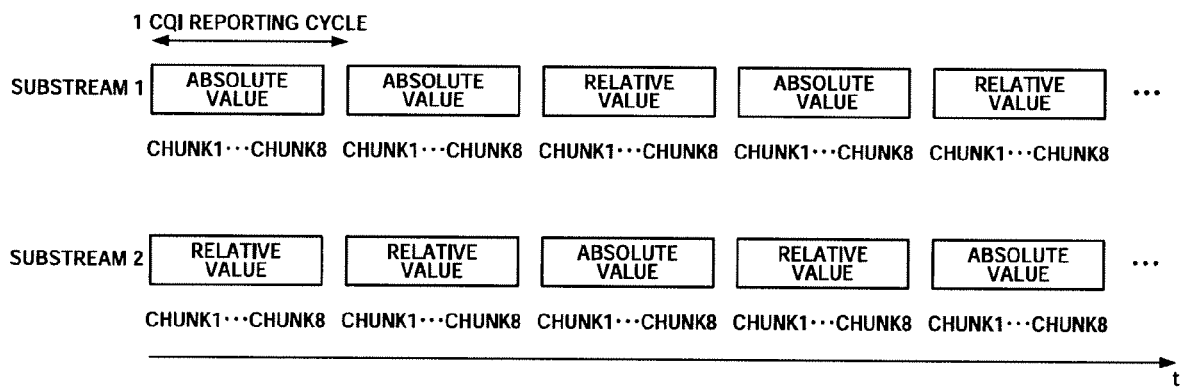

FIG.10

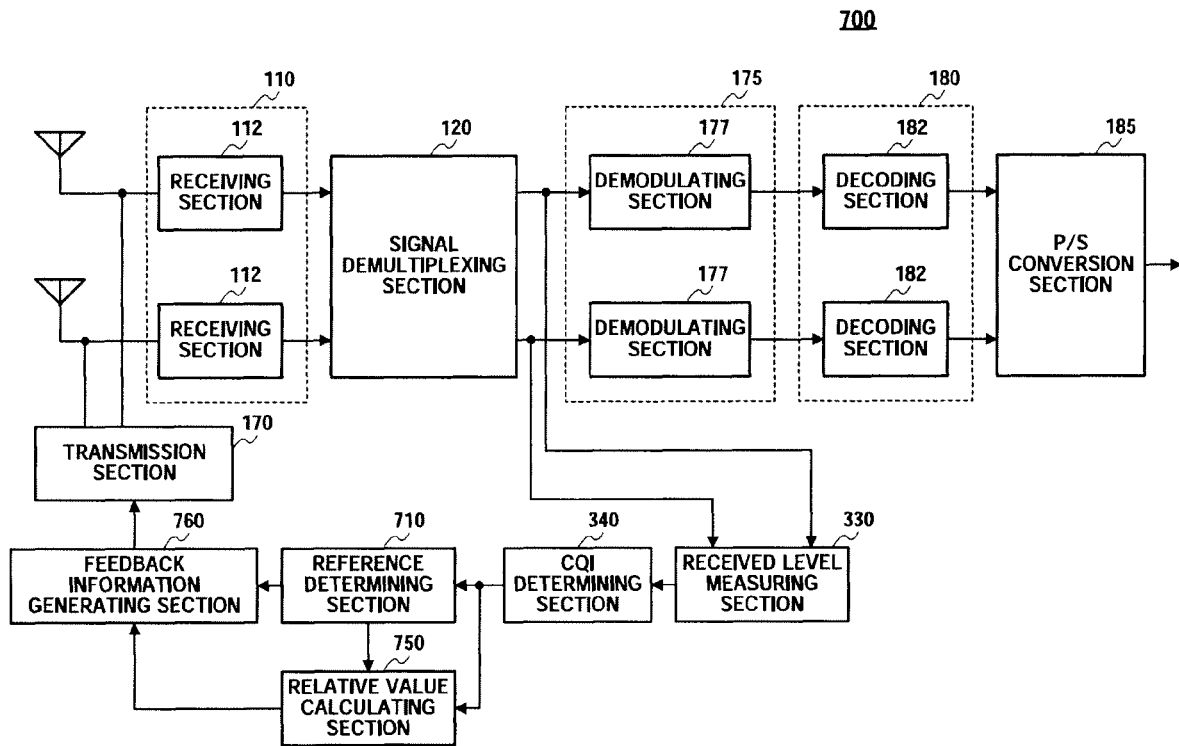

FIG.11

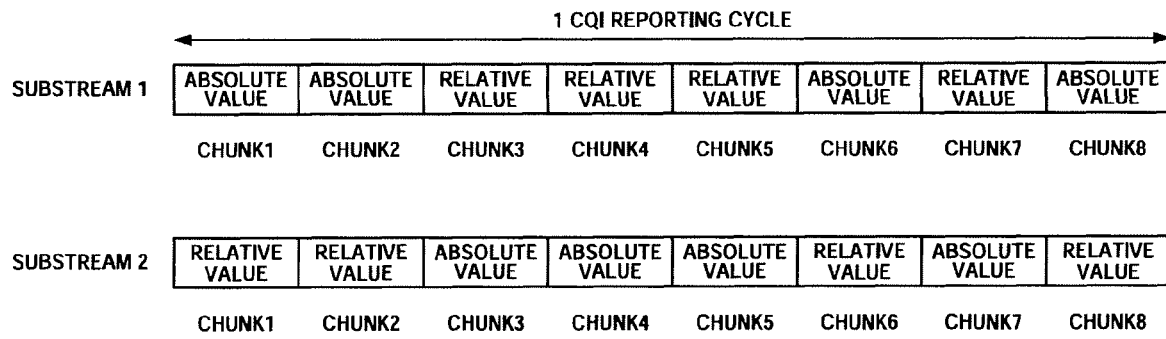

FIG.12

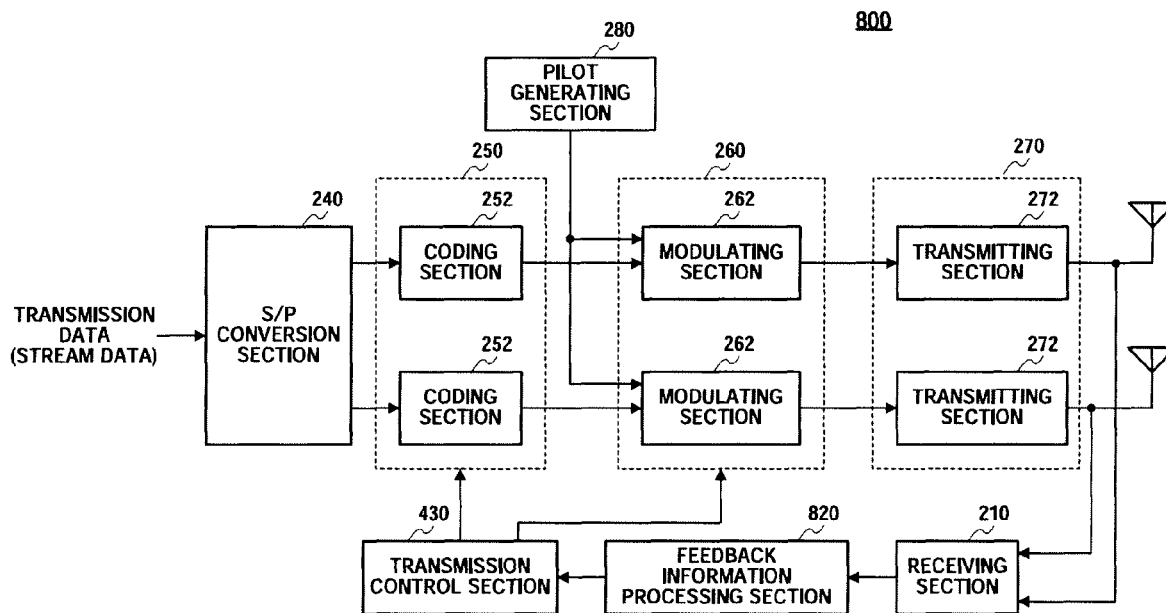

FIG.13

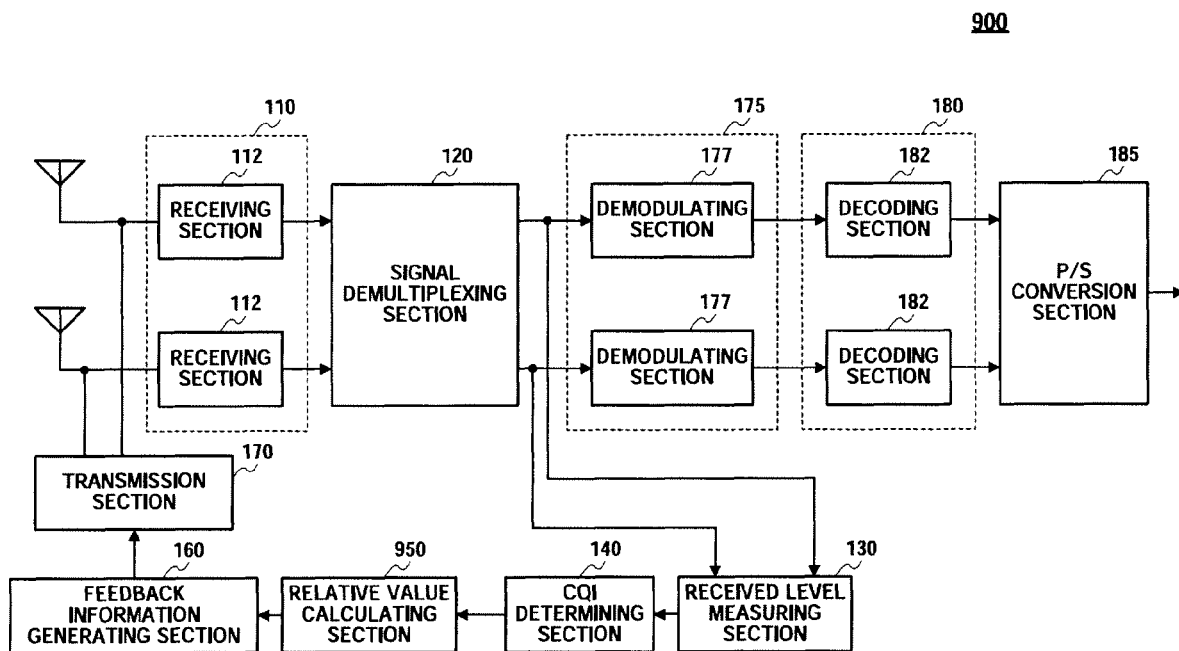

FIG.14

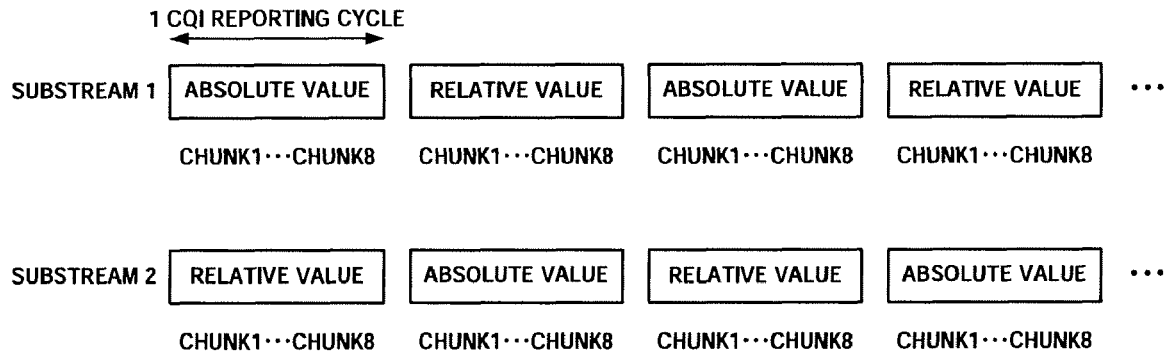

FIG.15

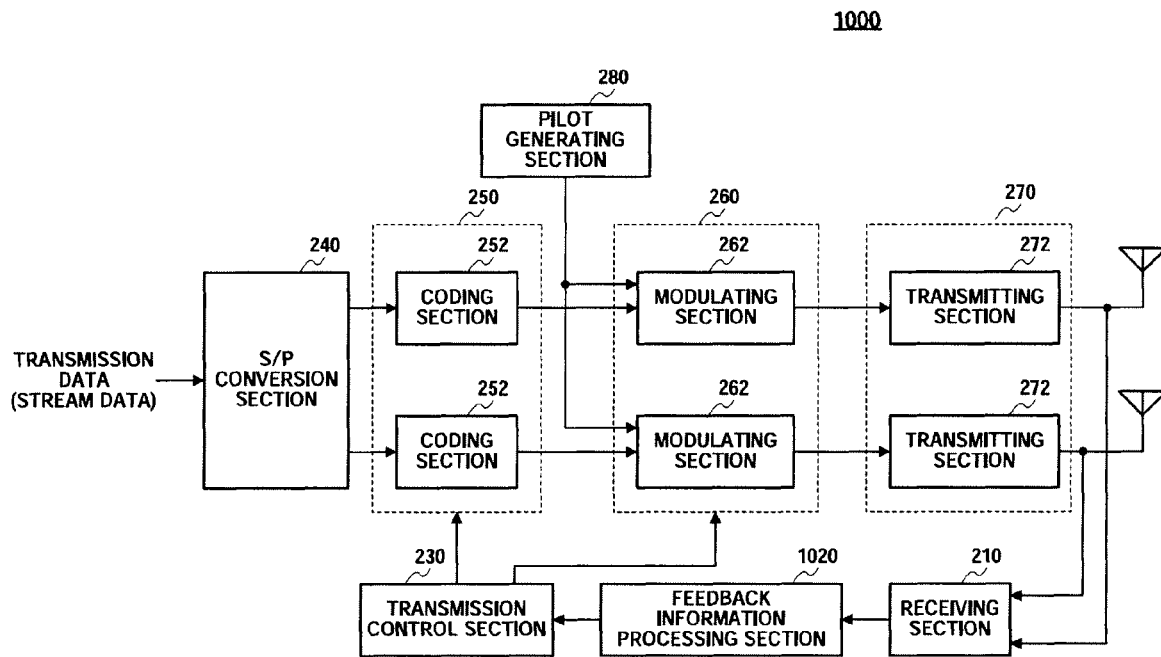

FIG.16

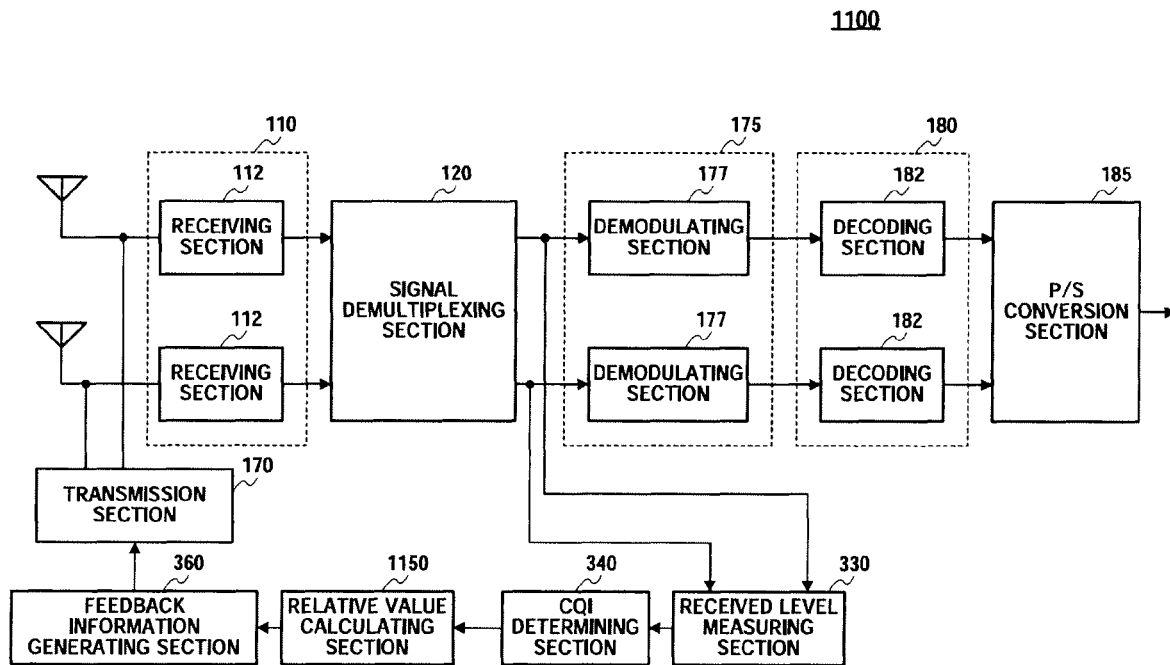

FIG.17

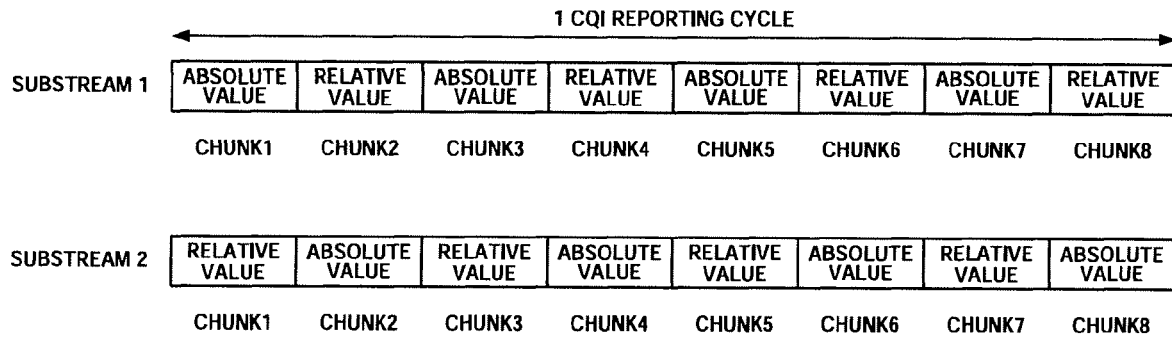

FIG.18

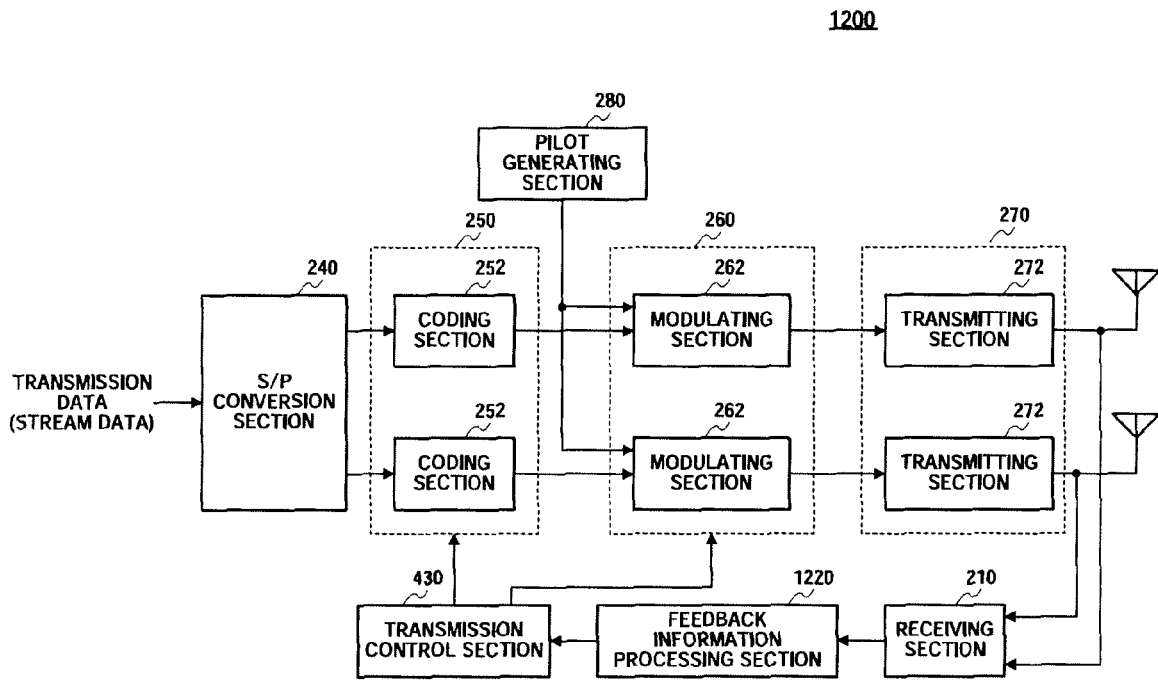

FIG.19

RADIO COMMUNICATION APPARATUS AND RADIO COMMUNICATION METHOD

TECHNICAL FIELD

The present invention relates to a MIMO receiving apparatus and a MIMO transmitting apparatus. More particularly, the present invention relates to a MIMO receiving apparatus and MIMO transmitting apparatus in which the transmitting system performs transmission control on a per antenna basis by feedback information from the receiving system.

BACKGROUND ART

In standardization of 3GPP Long Term Evolution (LTE), PARC (Per Antenna Rate Control) scheme, which is one of MIMO (Multi Input Multi Output) transmission schemes, is discussed. In PARC, modulation and coding schemes are selected according to channel quality (CQI) report values on a per transmission antenna (stream) basis. Patent Document 1 discloses a conventional MIMO PARC scheme.

FIG. 1 shows a configuration of the MIMO transmitting apparatus in the MIMO communication system adopting the conventional MIMO PARC scheme. As shown in the figure, the MIMO transmitting apparatus transmits pilot signals on a per antenna basis by using several subcarriers. On the other hand, the receiving apparatus (not shown) measures the received intensity of each pilot signal transmitted from the antennas in the MIMO transmitting apparatus, generates a CQI (channel quality indicator) per antenna based on the channel quality condition for each antenna, and feeds back the CQIs to the MIMO transmitting apparatus. The MIMO transmitting apparatus determines the optimal modulation scheme (QPSK, 16QAM, 64QAM and so on) and coding rate on a per antenna basis based on the CQI information per antenna and transmits substreams from the antennas. In this way, by selecting optimal modulation and coding scheme based on the channel quality condition of each antenna, the maximum peak rate and communication capacity are achieved.

Non-patent Document 1: Lucent 3GPP R1-010879

DISCLOSURE OF INVENTION

Problems to be Solved by the Invention

However, the conventional MIMO communication system has a problem of increasing the CQI feedback overhead in proportion to the number of antennas (i.e. streams). Moreover, when the transmitting side performs frequency scheduling, CQI is required per chunk, which is a subcarrier block, and therefore the above problem is further prominent.

It is therefore an object of the present invention to provide a MIMO receiving apparatus and MIMO transmitting apparatus that can reduce the amount of feedback information and system traffic.

Means for Solving the Problem

The MIMO receiving apparatus of the present invention adopts a configuration including: a communication quality measuring section that measures communication quality of individual antennas using pilot signals transmitted from antennas of a transmitting side; a transmitting section that feeds back feedback information based on the communication quality to the transmitting side; a relative value calculating section that calculates relative values of the communi-

tion quality for the antennas between the communication quality of a reference antenna and the communication quality of the antennas other than the reference antenna in the antennas in the transmitting side; and a feedback information generating section that generates the feedback information from an absolute value of the communication quality of the reference antenna and the relative values of the communication quality.

The MIMO transmitting apparatus of the present invention adopts a configuration including: a receiving section that receives feedback information containing absolute values of communication quality of a reference antenna and relative values of communication quality of antennas other than the reference antenna; a feedback information processing section that calculates communication quality of each antenna from the feedback information; and a transmission control section that controls transmission of substreams via the antennas based on the calculated communication quality.

Advantageous Effect Of The Invention

According to the present invention, a MIMO receiving apparatus and MIMO transmitting apparatus that can reduce the amount of feedback information and system traffic is provided.

BRIEF DESCRIPTION OF DRAWINGS

FIG. 1 is a block diagram showing a configuration of the conventional MIMO transmitting apparatus;

FIG. 2 is a block diagram showing a configuration of the radio communication apparatus of the receiving system according to Embodiment 1;

FIG. 3 is a block diagram showing a configuration of the radio communication apparatus of the transmitting system according to Embodiment 1;

FIG. 4 explains the feedback information in Embodiment 1;

FIG. 5 is a block diagram showing a configuration of the radio communication apparatus of the receiving system according to Embodiment 2;

FIG. 6 explains the feedback information in Embodiment 2;

FIG. 7 is a block diagram showing a configuration of the radio communication apparatus of the transmitting system according to Embodiment 2;

FIG. 8 is a block diagram showing a configuration of the radio communication apparatus of the receiving system according to Embodiment 3;

FIG. 9 is a block diagram showing a configuration of the radio communication apparatus of the transmitting system according to Embodiment 3;

FIG. 10 explains the feedback information in Embodiment 3;

FIG. 11 is a block diagram showing a configuration of the radio communication apparatus of the receiving system according to Embodiment 4;

FIG. 12 explains the feedback information in Embodiment 4;

FIG. 13 is a block diagram showing a configuration of the radio communication apparatus of the transmitting system according to Embodiment 4;

FIG. 14 is a block diagram showing a configuration of the radio communication apparatus of the receiving system according to Embodiment 5;

FIG. 15 explains the feedback information in Embodiment 5;

3

FIG. 16 is a block diagram showing a configuration of the radio communication apparatus of the transmitting system according to Embodiment 5;

FIG. 17 is a block diagram showing a configuration of the radio communication apparatus of the receiving system according to Embodiment 6;

FIG. 18 explains the feedback information in Embodiment 6; and

FIG. 19 is a block diagram showing a configuration of the radio communication apparatus of the transmitting system according to Embodiment 6.

BEST MODE FOR CARRYING OUT THE INVENTION

Now, embodiments of the present invention will be described in detail with reference to the accompanying drawings. In embodiments, the components having the same functions will be assigned the same reference numerals and overlapping descriptions will be omitted.

Embodiment 1

As shown in FIG. 2, radio communication apparatus 100 in the MIMO (Multi Input Multi Output) communication system according to Embodiment 1 has a plurality of antennas, receiving section 110, signal demultiplexing section 120, received level measuring section 130, CQI determining section 140, relative value calculating section 150, feedback information generating section 160, transmitting section 170, demodulating section 175, decoding section 180 and P/S conversion section 185.

Receiving section 110, which has the same number of receiving sections 112 as the antennas, receives a space-multiplexed signal, in which signals transmitted from the transmission system in the MIMO communication system are space-multiplexed, and performs radio receiving processing on the received signal. When transmission signals transmitted from the individual antennas of the transmission system form an OFDM signal, which is one kind of multicarrier signal, receiving section 110 performs OFDM receiving processing including FFT processing and P/S conversion processing in addition to normal radio receiving processing (e.g. down-conversion and A/D conversion processing). Moreover, receiving section 110 receives a pilot signal transmitted from each antenna in the transmission system and performs receiving processing.

Signal demultiplexing section 120 demultiplexes the signal after radio receiving processing in receiving section 110 into the signals transmitted from the individual antennas of the transmission system (i.e. corresponding to the substreams in the transmission system and therefore hereinafter may be referred to as "substreams") using methods including MMSE (Minimum Mean Square Error) and so on. Moreover, signal demultiplexing section 120 receives as input the pilot signal after receiving processing in receiving section 110, and outputs the pilot signals of the individual antennas utilized for transmission in the transmission system (corresponding to the substreams in the transmission system).

Received level measuring section 130 measures the received levels of the pilot signals, which are demultiplexed in signal demultiplexing section 120, of the individual antennas (e.g. SINR: Signal-to-Interference and Noise Power Ratio) and outputs the received levels of the pilot signals to CQI determining section 140.

4

CQI determining section 140 stores a CQI table and determines the CQI value of each substream based on the received levels of the pilot signals measured in received level measuring section 130.

Relative value calculating section 150 calculates relative CQI values between the CQI value of the reference substream and the CQI values of substreams other than the reference substream. In the present embodiment, the reference substream is determined in advance and fixed. The substreams correspond to the individual antennas of the transmission system respectively, so that the reference substream may be regarded as "the reference antenna," and relative value calculating section 150 may be construed to calculate relative CQI values between the CQI value of the reference antenna and the CQI values of the antennas other than the reference antenna.

Feedback information generating section 160 generates feedback information for the transmission system from the CQI value of the reference substream and the relative CQI values found for the streams other than the reference substream.

Transmitting section 170 transmits the feedback information generated in feedback information generating section 160 to the transmission system using at least one of a plurality of antennas provided in radio communication apparatus 100. That is, transmitting section 170 may transmit the feedback information to the transmission system by a transmission scheme using one antenna or by a multi-antenna communication scheme such as MIMO communication scheme and space-time coding communication scheme.

Demodulating section 175, which has demodulating sections 177 matching the number of the substreams, demodulates each substream demultiplexed in signal demultiplexing section 120.

Decoding section 180, which has decoding sections 182 matching the number of the substreams, decodes each substream after demodulating processing.

P/S conversion section 185 performs parallel-to-serial conversion on the substreams after decoding processing, and outputs the result as a serial data sequence.

As shown in FIG. 3, radio communication apparatus 200 of the transmission system, has a plurality of antennas, receiving section 210, feedback information processing section 220, transmission control section 230, S/P conversion section 240, coding section 250, modulating section 260, transmitting section 270 and pilot generating section 280.

Receiving section 210 performs radio receiving processing on feedback information, which is from radio communication apparatus 100, and which is received through at least one of the antennas in radio communication apparatus 200. To be more specific, receiving section 210 performs receiving processing on feedback information in a reception scheme corresponding to the transmission scheme applied in transmitting section 170 of radio communication apparatus 100, and outputs the feedback information after receiving processing to feedback information processing section 220.

Feedback information processing section 220 calculates the CQI value of each substream from the feedback information from receiving apparatus 210. To be more specific, as described above, the feedback information from radio communication apparatus 100 contains the CQI value of the reference substream and the relative CQI values found for the substreams other than the reference substream, so that feedback information processing section 220 calculates the CQI value of each substream from the relative CQI values found between the CQI value of the reference substream and the substreams other than the reference substream.

Transmission control section **230**, which stores a CQI table that is the same as in radio communication apparatus **100**, outputs the coding rates, modulation schemes and so on, associated with the CQI values of the individual substreams calculated in feedback information processing section **220** to coding section **250** and modulating section **260**.

S/P conversion section **240** converts inputted transmission data (stream data) from serial to parallel, and divides the transmission data into a plurality of substreams.

Coding section **250**, which has coding sections **252** matching the number of the substreams, encodes the individual substreams based on the coding rate of each substream received from transmission control section **230**.

Modulating section **260**, which has modulating sections **262** matching the number of the substreams, modulates the substreams based on the modulation scheme of each substream (e.g. QPSK, 16QAM, 64QAM and so on) received from transmission control section **230**. Moreover, modulating section **260** modulates the pilot signals generated in pilot generating section **280**. Further, modulating section **260** performs OFDM modulation processing including S/P conversion processing and IFFT processing when radio communication apparatus **200** transmits OFDM signals from the antennas.

Transmitting section **270**, which has transmitting sections **272** matching the number of the substreams, performs radio processing including D/A conversion and up-conversion for the substreams and transmits them from the corresponding antennas. Moreover, transmitting section **270** performs radio processing on the pilot signals modulated in modulating section **260** and transmits them from the corresponding antennas.

Next, the operations of radio communication apparatus **100** and radio communication apparatus **200** having the above-described configurations will be explained.

In radio communication apparatus **100**, a signal after receiving processing in receiving section **110** is demultiplexed into substreams using methods including MMSE (Minimum Mean Square Error) in signal demultiplexing section **120**.

In received level measuring section **130**, the received levels of the pilot signals demultiplexed in signal demultiplexing section **120** are measured per antenna of the transmission system. To be more specific, when the pilot signals are transmitted in the form of OFDM signals from the antennas in radio communication apparatus **200**, received level measuring section **130** measures the received level of each pilot signal on a per chunk basis, and outputs an “average received level,” which is an average of all chunks in one CQI reporting cycle, to CQI determining section **140**. Here, a “chunk” refers to a bundle of consecutive subcarriers in the frequency domain.

In CQI determining section **140**, the CQI value of each substream is determined based on the “average received levels” of the pilot signals from received level measuring section **130**. In relative value calculating section **150**, relative CQI values are calculated between the CQI value of the reference substream and the CQI values of substreams other than the reference substream.

In feedback information generating section **160**, feedback information for the transmission system is generated from the relative CQI values found between the CQI value of the reference substream and the substreams other than the reference substream.

The feedback information generated in this feedback information generating section **160** will be explained with reference to FIG. 4.

As shown in the figure, as for the reference substream, a CQI value determined based on an “average received level,” which is an average of all chunks (i.e. chunks **1** to **8** in the figure), is fed back to radio communication apparatus **200** every CQI reporting cycle. Moreover, as for substreams other than the reference substream (“other substreams” in the figure), relative CQI values, which are relative to the CQI value determined for the reference substream, are fed back to radio communication apparatus **200** every CQI reporting cycle.

In this way, feedback information is generated such that the CQI of the reference substream alone is given in an absolute value and the CQIs of the other substreams are given in relative CQI values with respect to the reference substream, so that it is possible to reduce the amount of feedback information, compared to conventional cases of feeding back the absolute values of the CQI values of all substreams. As a result, it is possible to reduce the traffic in the MIMO communication system. This working effect becomes prominent when the number of antennas mounted in a radio communication apparatus in the MIMO communication system increases.

In radio communication apparatus **200**, receiving processing is performed on feedback information in receiving section **210**, and, in feedback information processing section **220**, CQI values of the individual substreams are calculated from the feedback information in receiving section **210**.

In transmission control section **230**, coding rates, modulation schemes and so on, associated with the CQI values of the individual substreams calculated in feedback information processing section **220**, are outputted to coding section **250** and modulating section **260**.

In coding section **250**, coding processing is performed on the individual substreams based on the coding rate of each substream received from transmission control section **230**.

In modulating section **260**, modulating processing is performed on the substreams based on the modulation scheme of each substream (e.g. QPSK, 16QAM, 64QAM and so on) received from transmission control section **230**.

In this way, according to Embodiment 1, radio communication apparatus **100** has: received level measuring section **130** as a communication quality measuring means for measuring communication quality (e.g. SINR) of individual antennas (corresponding to the substreams) using the pilot signals transmitted from the antennas of the transmitting side (radio communication apparatus **200**); transmitting section **170** that feeds back feedback information based on the communication quality, to the transmitting side; relative value calculating section **150** as a relative value calculating means for calculating relative values of communication quality between a reference antenna and individual antennas other than the reference antenna, from communication quality of the reference antenna (corresponding to the reference substream) and communication quality of the antennas other than the reference antenna in the transmitting antennas; and feedback information generating section **160** as a feedback generating means for generating the feedback information from the absolute value of communication quality of the reference antenna and the relative values of communication quality.

By this means, the feedback information is generated such that the communication quality of the reference antenna alone is given in an absolute value and the communication quality of other antennas is given in the relative values of the communication quality with respect to the reference antenna, so that it is possible to reduce the amount of feedback information, compared to conventional cases of feeding back the absolute values of the CQI values of all antennas. As a result, it is possible to reduce the amount of overhead of control

information channels and interference power by the amount in the MIMO communication system. This working effect becomes prominent when the number of antennas mounted in a radio communication apparatus in the MIMO communication system increases.

Moreover, radio communication apparatus **100** has: received level measuring section **130** that measures the received levels of the individual pilot signals transmitted from the antennas of the transmitting side (radio communication apparatus **200**); CQI determining section **140** that determines the CQI value of each transmitting antenna based on the received levels; relative value calculating section **150** that calculates relative CQI values showing the relative values of the CQI values between the reference antenna and the antennas other than the reference antenna, from the CQI value determined for the reference antenna and the CQI values determined for the antennas other than the reference antenna, in the transmitting antennas by CQI determining section **140**; and feedback information generating section **160** that generates feedback information for the transmitting side including the CQI value of the reference antenna and the relative CQI values.

By this means, feedback information is generated such that the CQI of the reference antenna alone is given in an absolute value and the CQIs of the other antennas are given in the relative values of the CQI with respect to the reference antenna, so that it is possible to reduce the amount of feedback information, compared to conventional cases of feeding back the absolute values of the CQI values of all antennas. As a result, it is possible to reduce the amount of overhead of control information channels and interference power in the MIMO communication system. This working effect becomes prominent when the number of antennas mounted in a radio communication apparatus in the MIMO communication system increases. Moreover, by using the CQI values used in conventional systems to generate feedback information, the present invention can be applicable for conventional systems.

Moreover, according to Embodiment 1, radio communication apparatus **200** has: receiving section **210** as a receiving means for receiving feedback information containing the absolute value of communication quality (e.g. CQI values) of the reference antenna (corresponding to the reference substream) and the relative values of communication quality of the antennas other than the reference antenna; feedback information processing section **220** as a calculating means for calculating communication quality of each antenna from the feedback information; and transmission control section **230** as a transmission control means for controlling the transmission of the substreams via the antennas based on the calculated communication quality.

By this means, it is possible to control to transmit substreams transmitted from the antennas and reduce the amount of overhead of control information channels and interference power in the MIMO communication system.

Embodiment 2

In Embodiment 1, the CQI value of each substream is fed back. By contrast with this, in Embodiment 2, a MIMO communication scheme of transmitting multicarrier signals (e.g. OFDM signals) from the individual antennas of the transmission system is presumed, and the CQI values of individual chunks related to substreams are fed back. The embodiments are the same in that feedback is carried out using the absolute value of the CQI value with respect to the reference substream and relative CQI values with respect to substreams other than the reference substream. In this way, by feeding back CQI

values of individual chunks related to the substreams, what is commonly referred to as “frequency scheduling” for controlling subcarriers used in the transmission system can be carried out efficiently.

As shown in FIG. 5, radio communication apparatus **300** according to Embodiment 2 has received level measuring section **330**, CQI determining section **340**, relative value calculating section **350** and feedback information generating section **360**.

Received level measuring section **330** measures the received levels (e.g. SINRs) of the individual chunks, for the pilot signals demultiplexed in signal demultiplexing section **120** of the individual antennas of the transmission system.

CQI determining section **340** determines the CQI values of the individual chunks related to the substreams based on the received levels per chunk related to the pilot signals from received level measuring section **330**.

Relative value calculating section **350** calculates relative CQI values of the individual chunks (hereinafter may be referred to as “relative chunk CQI values”) between the CQI value of the reference substream and the CQI values of substreams other than the reference substream. In the present embodiment, the reference substream is determined in advance and fixed.

Feedback information generating section **360** generates feedback information (see FIG. 6) for the transmission system from the CQI value of each chunk related to the reference substream and the relative chunk CQI values found for the streams other than the reference substream.

As shown in FIG. 7, radio communication apparatus **400** of the transmission system has feedback information processing section **420** and transmission control section **430**.

Feedback information processing section **420** calculates the CQI values of the individual chunks related to the substreams from the feedback information from receiving apparatus **210**. To be more specific, the feedback information from radio communication apparatus **300** contains the CQI value of each chunk related to the reference substream and the relative chunk CQI values found for the substreams other than the reference substream, so that feedback information processing section **420** calculates the CQI values of the individual chunks related to the substreams from the CQI value of each chunk related to the reference substream and the relative chunk CQI values found for the substreams other than the reference substream.

Transmission control section **430** performs frequency scheduling for the individual substreams based on the CQI values of the individual chunks related to the substreams from feedback information processing section **420**, and outputs frequency scheduling information for each substream to modulating section **260**.

Modulating section **260** sequentially changes the subcarriers per substream based on the frequency scheduling information from transmission control section **430**.

In this way, according to Embodiment 2, radio communication apparatus **300** has: received level measuring section **330** that measures the received levels of the individual pilot signals transmitted from the antennas of the transmitting side (radio communication apparatus **400**); CQI determining section **340** that determines the CQI value of each transmitting antenna based on the received levels; relative value calculating section **350** that calculates relative CQI values showing the relative values of the CQI values between the reference antenna and the antennas other than the reference antenna, from the CQI value determined for the reference antenna and the CQI values determined for the antennas other than the reference antenna, in the transmitting antennas by CQI deter-

mining section **340**; and feedback information generating section **360** that generates feedback information for the transmitting side including the CQI values of the reference antenna and the relative CQI values, and received level measuring section **330** measures the received levels per chunk formed with a plurality of subcarriers; CQI determining section **340** determines the CQI value of each chunk related to the transmitting antennas based on the received levels; relative value calculating section **350** calculates relative chunk CQI values showing relative CQI values of the individual chunks between the CQI value of the chunk determined for the reference antenna and the CQI values of the individual chunks determined for the antennas other than the reference antenna; and feedback information generating section **360** generates feedback information including the CQI value of the chunk of the reference substream and the relative chunk CQI values.

By this means, CQI values of individual chunks related to the antennas are fed back, so that what is commonly referred to as “frequency scheduling” for controlling subcarriers used in the transmission system can be carried out efficiently.

Embodiment 3

In Embodiment 1, the reference substream is fixed. By contrast with this, in Embodiment 3, the substream of the best communication quality every reporting cycle, is selected as the reference substream. The embodiments are the same in that feedback is carried out using the absolute value of the CQI value with respect to the reference substream and relative CQI values with respect to substreams other than the reference substream. In this way, the substream of the best communication quality is selected as the reference substream, and, by feeding back the absolute value of communication quality of the reference substream and the relative values of the substreams other than the reference substream, the reliability of CQI feedback information of the substream of the best channel communication quality especially improves. As a result, the transmission system receiving the feedback information can perform transmission control based on reliable feedback information, thereby improving system throughput.

As shown in FIG. 8, radio communication apparatus **500** according to Embodiment 3 has reference determining section **510**, relative value calculating section **550** and feedback information generating section **560**.

Reference determining section **510** receives as input the CQI values for the substreams from CQI determining section **140** and determines the reference substream. To be more specific, reference determining section **510** selects the substream associated with the CQI value of the highest received level as the reference substream every CQI reporting cycle. That is, reference determining section **510** selects the reference substream based on the received level. Then, reference determining section **510** outputs information specifying the reference substream (hereinafter may be referred to as “the reference substream information”) to relative value calculating section **550** and feedback information generating section **560**.

Relative value calculating section **550** calculates relative CQI values between the CQI value of the reference substream selected in reference determining section **510** and the CQI values of substreams other than the reference substream.

Feedback information generating section **560** generates feedback information for the transmission system from the CQI value of the reference substream, the relative CQI values found for the streams other than the reference substream and the reference substream information (e.g. stream index information identifying the reference substream).

As shown in FIG. 9, radio communicating apparatus **600** has feedback information processing section **620**.

Feedback information processing section **620** calculates the CQI value of each substream from the feedback information from receiving apparatus **210**. To be more specific, the feedback information from radio communication apparatus **500** contains the CQI value of the reference substream, the relative CQI values found for the substreams other than the reference substream and the reference substream information (e.g. stream index information identifying the reference substream), so that feedback information processing section **620** calculates the CQI value of each substream from the CQI value of the reference substream and the relative CQI values found for the substreams other than the reference substream specified from the reference substream information.

Next, the operations of radio communication apparatus **500** and radio communication apparatus **600** having the above-described configurations will be explained.

In reference determining section **510**, the CQI values for the substreams from CQI determining section **140** are received as input, and the reference substream is determined. To be more specific, in reference determining section **510**, the substream associated with the CQI value of the highest received level is selected as the reference substream every CQI reporting cycle. That is, in reference determining section **510**, the reference substream is selected based on the received level.

In relative value calculating section **550**, relative CQI values are calculated between the CQI value of the reference substream selected in reference determining section **510** and the CQI values of substreams other than the reference substream.

In feedback information generating section **560**, feedback information for the transmission system is generated from the CQI value of the reference substream, the relative CQI values found for the streams other than the reference substream and the reference substream information.

The feedback information generated in this feedback information generating section **560** will be explained with reference to FIG. 10. In the figure, for ease of the explanation, the case is shown where the number of substreams is two.

As shown in the figure, the substream associated with the CQI value of the highest received level is selected as the reference substream every reporting cycle. Then, as for the reference substream of each CQI reporting cycle, a CQI value determined based on an “average received level,” which is an average of all chunks (i.e. chunks **1** to **8** in the figure) on a per CQI reporting cycle basis, is fed back to radio communication apparatus **600**. Moreover, as for the substreams other than the reference substream, relative CQI values, which are relative to the CQI value determined for the reference substream on a per CQI reporting cycle basis, are fed back to radio communication apparatus **600**. In the figure, substream **1** is selected as the reference substream in the first and second CQI reporting cycles, and substream **2** is selected as the reference substream in the third CQI reporting cycle. Then, as described above, the reference substream information (not shown in the figure) in the CQI reporting cycles is also fed back.

Incidentally, in what is referred to as a “2×2 MIMO communication system” in which the transmission system and the reception system each have two antennas, one bit is necessary for the reference substream information (e.g. stream index information identifying the reference substream), and, in a 4×4 MIMO communication system, only two bits are necessary.

In radio communication apparatus **600**, in feedback information processing section **620**, CQI values of the individual

11

substreams are calculated from the feedback information from receiving section 210. To be more specific, the feedback information from radio communication apparatus 500 contains the CQI value of the reference substream, the relative CQI values found for the substreams other than the reference substream and the reference substream information, so that feedback information processing section 620 calculates the CQI value of each substream from the relative CQI values found between the CQI value of the reference substream specified from the reference substream information and the substreams other than the reference substream.

In this way, according to Embodiment 3, radio communication apparatus 500 has reference determining section 510 that selects the reference antenna (corresponding to the reference substream) from the antennas of the transmitting side (radio communication apparatus 600) based on the CQI values determined by CQI determining section 140, and relative value calculating section 550 calculates relative CQI values between the CQI value determined for the reference antenna selected in reference determining section 510 and the CQI values determined for the antennas other than the reference antenna. Especially, reference determining section 510 selects the antenna of the highest CQI value as the reference antenna.

By this means, the antenna of the best communication quality (e.g. SINR) is selected as the reference antenna, and, by feeding back the absolute value of communication quality of the reference antenna (the absolute value of the CQI value) and the relative values of the antennas other than the reference antenna (relative CQI values), the reliability of CQI feedback information of the substream of the best channel communication quality especially improves. As a result, the transmission system receiving the feedback information can perform transmission control based on reliable feedback information, thereby improving system throughput.

Embodiment 4

In Embodiment 2, the reference substream is fixed between all chunks. By contrast with this, in Embodiment 4, the substream of the best communication quality is selected as the reference substream on a per chunk basis. The embodiments are the same in that feedback is carried out using the absolute value of the CQI value with respect to the reference substream and relative CQI values with respect to substreams other than the reference substream. In this way, the substream of the best communication quality is selected as the reference substream per chunk, and by feeding back the absolute value of communication quality of the reference substream and the relative values of the substreams other than the reference substream, so that the reliability of feedback information improves. Moreover, by feeding back communication quality of individual chunks related to the substreams, frequency scheduling can be carried out efficiently in the transmission system. As a result, the transmission system receiving the feedback information can perform transmission control based on the feedback information, which is reliable and which contains communication quality per chunk, thereby improving system throughput.

As shown in FIG. 11, radio communication apparatus 700 according to Embodiment 4 has reference determining section 710, relative value calculating section 750 and feedback information generating section 760.

Reference determining section 710 receives as input the CQI values of the individual chunks related to the substreams from CQI determining section 340 and determines the reference substream of each chunk. To be more specific, reference

12

determining section 710 selects the substream associated with the CQI value of the highest received level as the reference substream on a per chunk basis. That is, reference determining section 710 selects the reference substream per chunk based on the received level of each chunk. Then, reference determining section 710 outputs information specifying the reference substream of each chunk (hereinafter may be referred to as "the reference chunk substream information") to relative value calculating section 750 and feedback information generating section 760.

Relative value calculating section 750 calculates relative chunk CQI values, which are the CQI values of the individual chunks, between the CQI value of the reference substream selected in reference determining section 710 and the CQI values of substreams other than the reference substream.

Feedback information generating section 760 generates feedback information (see FIG. 12) for the transmission system from the CQI value of the reference substream of each chunk, the relative chunk CQI values found for streams other than the reference substream per chunk and the reference chunk substream information.

As shown in FIG. 13, radio communicating apparatus 800 has feedback information processing section 820.

Feedback information processing section 820 calculates the CQI value of each chunk related to the substream from the feedback information from receiving apparatus 210. To be more specific, the feedback information from radio communication apparatus 700 contains the CQI value of the reference substream of each chunk, the relative chunk CQI values found for the substreams other than the reference substream per chunk and the reference chunk substream information, so that feedback information processing section 820 calculates the CQI values of the individual chunks related to the substreams from the CQI value of the reference substream per chunk and the relative chunk CQI values found for the substreams other than the reference substream specified from the reference chunk substream information.

In this way, according to Embodiment 4, radio communication apparatus 700 has reference determining section 710 that selects the reference antenna from the antennas of the transmitting side (radio communication apparatus 800) on a per chunk basis based on the CQI values of the individual chunks related to the transmitting antennas determined by CQI determining section 340, relative value calculating section 750 calculates relative chunk CQI values of the individual chunks between the reference antenna and the antennas other than the reference antenna, from the CQI value of the reference antenna per chunk and the CQI values of the antennas other than the reference antenna, and feedback information generating section 760 generates feedback information containing the CQI value of the reference antenna of each chunk, the relative chunk CQI values and the identification information of the reference antenna per chunk. Especially, reference determining section 710 selects the antenna of the highest CQI value on a per chunk basis as the reference antenna.

By this means, the antenna of the best communication quality (e.g. SINR) for each chunk is selected as the reference antenna, and by feeding back the absolute value of communication quality of the reference antenna (the absolute value of the CQI value) and the relative values of the antennas other than the reference antenna (relative chunk CQI values), the reliability of CQI feedback information of the substream of the best channel communication quality per chunk especially improves. Moreover, by feeding back communication quality per chunk related to the antennas, frequency scheduling can be carried out efficiently in the transmission system. As a

result, the transmission system receiving the feedback information can perform transmission control based on the feedback information, which is reliable and which contains communication quality per chunk, thereby improving system throughput.

Embodiment 5

In Embodiment 1, the reference substream is fixed. By contrast with this, in Embodiment 5, the reference substream changes every reporting cycle according to a predetermined pattern. The embodiments are the same in that feedback is carried out using the absolute value of the CQI value with respect to the reference substream and relative CQI values with respect to substreams other than the reference substream. In this way, by changing the reference substream every predetermined cycle according to a predetermined cycle and by feeding back the absolute value of communication quality of the reference substream and the relative values of the substreams other than the reference substream, the reliability of the feedback information can be kept in good balance. As a result, the transmission system receiving the feedback information can perform transmission control based on reliable feedback information, thereby improving system throughput.

As shown in FIG. 14, radio communication apparatus 900 according to Embodiment 5 has relative value calculating section 950.

Relative value calculating section 950 changes the reference substream every CQI reporting cycle according to the predetermined pattern and calculates relative CQI values between the CQI value of the reference substream and the CQI values of substreams other than the reference substream.

In feedback information generating section 160, feedback information for the transmission system is generated from the relative CQI values between the CQI value of the reference substream per CQI reporting cycle and substreams other than the reference substream per CQI reporting cycle.

FIG. 15 shows the feedback information when the reference substream alternately changes between substream 1 and substream 2 every CQI reporting cycle.

As shown in FIG. 16, radio communication apparatus 1000 in Embodiment 5 has feedback information processing section 1020.

Feedback information processing section 1020 calculates the CQI value of each substream from the feedback information from receiving apparatus 210. To be more specific, as described above, the feedback information from radio communication apparatus 900 contains the CQI value of the reference substream per CQI reporting cycle and the relative CQI values found for the substreams other than the reference substream per CQI reporting cycle, so that feedback information processing section 1020 calculates the CQI value every CQI reporting cycle related to the substreams from the CQI value of the reference substream per CQI reporting cycle and the relative CQI values found for the substreams other than the reference substream per CQI reporting cycle.

Feedback information processing section 1020 needs to specify the reference substream in order to calculate the CQI values, and the CQI values of the substreams can be calculated if feedback information processing section 1020 acquires the change pattern of the reference substream in advance in relative value calculating section 950 of radio communication apparatus 900. If the change pattern of the reference substream is determined in advance between transmitting side and receiving side, signaling for reporting the reference substream is not necessary.

In this way, according to Embodiment 5, relative value calculating section 950 of radio communication apparatus 900 sequentially changes the reference antenna according to the predetermined change pattern of the reference antenna and calculates relative CQI values.

By this means, by changing the reference antenna according to the predetermined pattern and by feeding back the absolute value of communication quality of the reference antenna (the absolute value of the CQI value) and the relative values (relative CQI values) of the antennas other than the reference antenna, the reliability of the feedback information can be kept in good balance. As a result, the transmission system receiving the feedback information can perform transmission control based on reliable feedback information, thereby improving system throughput.

Embodiment 6

In Embodiment 2, the reference substream is fixed between all chunks. By contrast with this, in Embodiment 6, the reference substream changes on a per chunk basis according to a predetermined pattern. The embodiments are the same in that feedback is carried out using the absolute value of the CQI value with respect to the reference substream and relative CQI values with respect to substreams other than the reference substream. In this way, by changing the reference substream on a per chunk basis according to the predetermined pattern and by feeding back the absolute value of communication quality of the reference substream and the relative values of the substreams other than the reference substream, the reliability of the feedback information can be kept in good balance. Moreover, by feeding back communication quality per chunk related to the substreams, frequency scheduling can be carried out efficiently in the transmission system. As a result, the transmission system receiving the feedback information can perform transmission control based on the feedback information, which is kept reliability and which contains communication quality per chunk, thereby improving System throughput.

As shown in FIG. 17, radio communication apparatus 1100 according to Embodiment 6 has relative value calculating section 1150.

Relative value calculating section 1150 changes the reference substream according to the predetermined pattern on a per chunk basis and calculates relative chunk CQI values, which are the CQI values per chunk, between the CQI value of the reference substream and the CQI values of substreams other than the reference substream.

In feedback information generating section 360, feedback information for the transmission system is generated from the relative CQI values between the CQI value of each chunk for reference substream and substreams other than the reference substream of each chunk.

FIG. 18 shows the feedback information when the reference substream alternately changes between substream 1 and substream 2 on a per chunk basis.

As shown in FIG. 19, radio communication apparatus 1200 in Embodiment 6 has feedback information processing section 1220.

Feedback information processing section 1220 calculates the CQI value of each chunk for the substreams from the feedback information from receiving apparatus 210. To be more specific, as described above, the feedback information from radio communication apparatus 1100 contains the CQI value of each chunk for the reference substream and the relative chunk CQI values found for the substreams other than the reference substream of each chunk, so that feedback infor-

mation processing section 1220 calculates the CQI values of the individual chunks related to the substreams from the CQI value of each chunk for the reference substream and the relative chunk CQI values found for the substreams other than the reference substream of each chunk.

Feedback information processing section 1220 needs to specify the reference substream of each chunk in order to calculate the CQI values, and CQI values of individual chunks related to the substreams can be calculated if feedback information processing section 1220 acquires the change pattern of the reference substream in advance in relative value calculating section 1150 of radio communication apparatus 1100. If the change pattern of the reference substream is determined in advance between transmitting side and receiving side, signaling for reporting the reference substream is not necessary.

In this way, according to Embodiment 6, radio communication apparatus 1100 has: received level measuring section 330 that measures the received levels of the individual pilot signals transmitted from the antennas of the transmitting side (radio communication apparatus 1200); CQI determining section 340 that determines the CQI value of each transmitting antenna based on the received levels; relative value calculating section 1150 that calculates relative CQI values showing the relative values of the CQI values between the reference antenna and the antennas other than the reference antenna, from the CQI value determined for the reference antenna and the CQI values determined for the antennas other than the reference antenna, in the transmitting antennas by CQI determining section 340; and feedback information generating section 360 that generates feedback information for the transmitting side including the CQI values of the reference antenna and the relative CQI values. Received level measuring section 330 measures the received levels of the individual chunks formed with a plurality of subcarriers, CQI determining section 340 determines the CQI value of each chunk related to the transmitting antennas based on the received levels, and relative value calculating section 1150 changes the reference antenna according to the predetermined pattern per chunk and calculates relative chunk CQI values showing the relative values of the CQI values of the individual chunks between the reference antenna and the antennas other than the reference antenna.

By this means, by changing the reference antenna on a per chunk basis according to the predetermined pattern and by feeding back the absolute value of communication quality of the reference antenna (the absolute value of the CQI value) and the relative values of the antennas other than the reference antenna (the relative chunk CQI values), the reliability of the feedback information can be kept in good balance. Moreover, by feeding back communication quality per chunk related to the antennas, frequency scheduling can be carried out efficiently in the transmission system. As a result, the transmission system receiving the feedback information can perform transmission control based on the feedback information, which is kept reliability and which contains communication quality per chunk, thereby improving system throughput.

INDUSTRIAL APPLICABILITY

The MIMO receiving apparatus and the MIMO transmitting apparatus of the present invention are suitable for use in reducing an amount of feedback information and system traffic.

The invention claimed is:

1. A radio communication apparatus comprising:
 - a receiving unit configured to receive first data and second data, which are transmitted from a plurality of antennas for spatial-multiplexing using a plurality of blocks, into which a plurality of consecutive subcarriers in a frequency domain are divided;
 - a calculating unit configured to calculate a first absolute channel quality indicator (CQI) value per each of the blocks for the first data and a second absolute CQI value per each of the blocks for the second data, and calculate a relative CQI value of the second absolute CQI value with respect to the first absolute CQI value, per each of the blocks, from the first absolute CQI value and the second absolute CQI value in the same block; and
 - a transmitting unit configured to transmit the first absolute CQI value and the relative CQI value of the second absolute CQI value in the same block,
 wherein the relative CQI value of the second absolute CQI value in the first block of the plurality of blocks for the second data is calculated with respect to the first absolute CQI value in the first block of the plurality of blocks for the first data, and the relative CQI value of the second absolute CQI value in the second block of the plurality of blocks for the second data is calculated with respect to the first absolute CQI value in the second block of the plurality of blocks for the first data.
2. The radio communication apparatus according to claim 1, wherein said transmitting unit transmits feedback information comprising the first absolute CQI value and the relative CQI value of the second absolute CQI value.
3. The radio communication apparatus according to claim 1, wherein said receiving unit receives the first data and the second data, which are modulated per each one of the data.
4. The radio communication apparatus according to claim 1, wherein the absolute CQI value indicates a code rate and a modulation scheme.
5. A radio communication method comprising:
 - receiving first data and second data, which are transmitted from a plurality of antennas for spatial-multiplexing using a plurality of blocks, into which a plurality of consecutive subcarriers in a frequency domain are divided;
 - calculating a first absolute channel quality indicator (CQI) value per each of the blocks for the first data and a second absolute CQI value per each of the blocks for the second data;
 - calculating a relative CQI value of the second absolute CQI value with respect to the first absolute CQI value, per each of the blocks, from the first absolute CQI value and the second absolute CQI value in the same block; and
 - transmitting the first absolute CQI value and the relative CQI value of the second absolute CQI value in the same block,
 wherein the relative CQI value of the second absolute CQI value in the first block of the plurality of blocks for the second data is calculated with respect to the first absolute CQI value in the first block of the plurality of blocks for the first data, and the relative CQI value of the second absolute CQI value in the second block of the plurality of blocks for the second data is calculated with respect to the first absolute CQI value in the second block of the plurality of blocks for the first data.

* * * * *

EXHIBIT 4

(12) **United States Patent**
Wengert et al.

(10) **Patent No.:** **US 8,385,284 B2**
 (45) **Date of Patent:** **Feb. 26, 2013**

(54) **CONTROL CHANNEL SIGNALING USING A COMMON SIGNALING FIELD FOR TRANSPORT FORMAT AND REDUNDANCY VERSION**

(56) **References Cited**

U.S. PATENT DOCUMENTS
 (Continued)

(75) Inventors: **Christian Wengert**, Langen (DE);
Akihiko Nishio, Kanagawa (JP);
Hidetoshi Suzuki, Kanagawa (JP);
Joachim Loehr, Langen (DE);
Katsuhiko Hiramatsu, Kanagawa (JP)

FOREIGN PATENT DOCUMENTS

EP 1 293 059 B1 3/2004
 EP 1 313 248 B1 8/2005

(Continued)

(73) Assignee: **Panasonic Corporation**, Osaka (JP)

OTHER PUBLICATIONS

(*) Notice: Subject to any disclaimer, the term of this patent is extended or adjusted under 35 U.S.C. 154(b) by 95 days.

“3rd Generation Partnership Project; Technical Specification Group Radio Access Network; Physical layer aspects for evolved Universal Terrestrial Radio Access (UTRA) (Release 7),” 3GPP TR 25.814 V7.1.0, Sep. 2006, 132 pages.

(Continued)

(21) Appl. No.: **12/809,423**

(22) PCT Filed: **Dec. 18, 2008**

Primary Examiner — Ronald Abelson

(86) PCT No.: **PCT/EP2008/010845**

(74) *Attorney, Agent, or Firm* — Seed IP Law Group PLLC

§ 371 (c)(1),
 (2), (4) Date: **Aug. 16, 2010**

(57) **ABSTRACT**

(87) PCT Pub. No.: **WO2009/080290**

PCT Pub. Date: **Jul. 2, 2009**

The invention relates to a method for providing control signalling associated to a protocol data unit conveying user data in a mobile communication system and to the control channel signal itself. Furthermore, the invention also provides a mobile station and a base station and their respective operation in view of the newly defined control channel signals defined herein. In order to reduce the control channel overhead, the invention suggests defining a common field for the transport format and redundancy version in the control channel information format. According to one approach, the common field is used to jointly encode transport format and redundancy version therein. According to another aspect, one shared field is provided on the control channel signal that indicates either a transport format or a redundancy version depending of whether the control channel signal relates to an initial transmission or a retransmission. In another embodiment, further enhancements to a HARQ protocol are suggested for addressing certain error cases.

(65) **Prior Publication Data**

US 2010/0309870 A1 Dec. 9, 2010

(30) **Foreign Application Priority Data**

Dec. 20, 2007 (EP) 07024829

(51) **Int. Cl.**

H04W 4/00 (2009.01)
H04L 1/14 (2006.01)

(52) **U.S. Cl.** **370/329; 714/750**

(58) **Field of Classification Search** **370/328, 370/329; 714/748, 750**

See application file for complete search history.

35 Claims, 7 Drawing Sheets

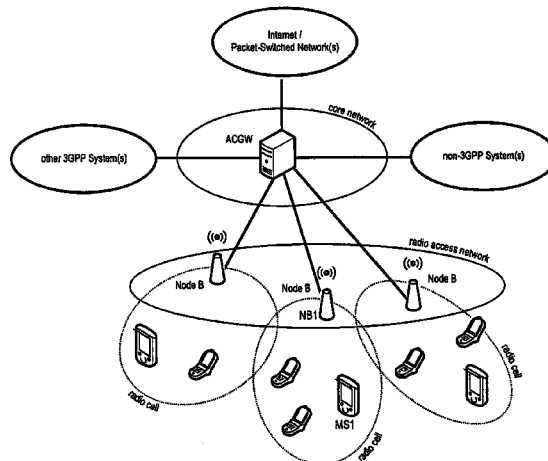

US 8,385,284 B2

Page 2

U.S. PATENT DOCUMENTS

- 2003/0123470 A1 7/2003 Kim et al.
- 2005/0047393 A1 3/2005 Liu
- 2007/0195809 A1 8/2007 Blanz et al.
- 2008/0313521 A1* 12/2008 Frederiksen et al. 714/748

FOREIGN PATENT DOCUMENTS

- WO 2008/083804 A2 7/2008

OTHER PUBLICATIONS

“3rd Generation Partnership Project; Technical Specification Group Radio Access Network; Multiplexing and channel coding (FDD) (Release 7),” 3GPP TS 25.212 V7.6.0, Sep. 2007, Sections 4.5 and 4.6, 29 pages.

Ericsson, “MIMO HS-SCCH structure,” R1-063548, Agenda Item: 7.1, 3GPP TSG WG1 #47, Riga, Latvia, Nov. 6-10, 2006, 6 pages.

Ericsson, “Notes from offline discussions on PDCCCH contents,” R1-073870, Agenda Item: 7.2.3, TSG-RAN WG1 #50, Athens, Greece, Aug. 20-24, 2007, 3 pages.

NTT DoCoMo, Ericsson, Fujitsu, Mitsubishi Electric, NEC, Panasonic, Sharp, Toshiba Corporation, “Comparison between RB-level and Sub-carrier-level Distributed Transmission for Shared Data

Channel in E-UTRA Downlink,” R1-062089 (Original R1-061182), Agenda Item: 8.2, 3GPP TSG RAN WG1 Meeting #46, Tallinn, Estonia, Aug. 28-Sep. 1, 2006, 14 pages.

“3rd Generation Partnership Project; Technical Specification Group Radio Access Network; High Speed Downlink Packet Access (HSDPA); Overall description; Stage 2 (Release 7),” 3GPP TS 25.308 V7.4.0, Sep. 2007, 50 pages.

Toskala et al., “High-speed Downlink Packet Access,” in Harri Holma and Antti Toskala (eds.), WCDMA for UMTS—Radio Access for Third Generation Mobile Communications, Third Edition, John Wiley & Sons, Ltd., 2004, chapters 11.1 to 11.5, pp. 307-319. (25 pages).

“Coding Scheme of L1/L2 Control Channel for E-UTRA Downlink,” NTT DoCoMo, Fujitsu, Mitsubishi Electric, NEC, Sharp, Toshiba Corporation, R1-061672, 3GPP TSG RAN WG1 LTE Ad Hoc, Cannes, France, Jun. 27-30, 2006, 19 pages.

European Search Report relating to European Patent Application No. 07 02 4829, mailed Jul. 24, 2008, 4 pages.

International Search Report relating to International Patent Application No. PCT/EP20081010845, mailed May 29, 2009, 5 pages.

* cited by examiner

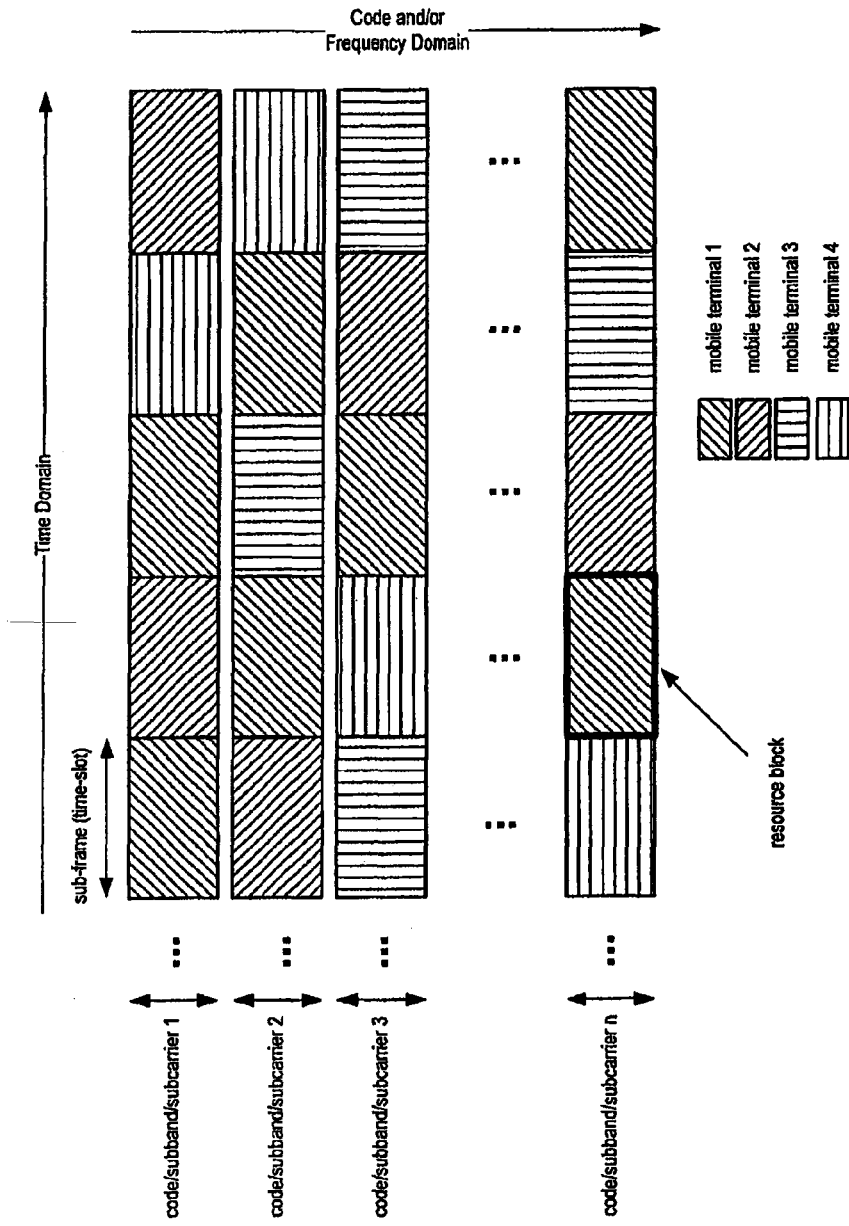

Fig. 1

PRIOR ART

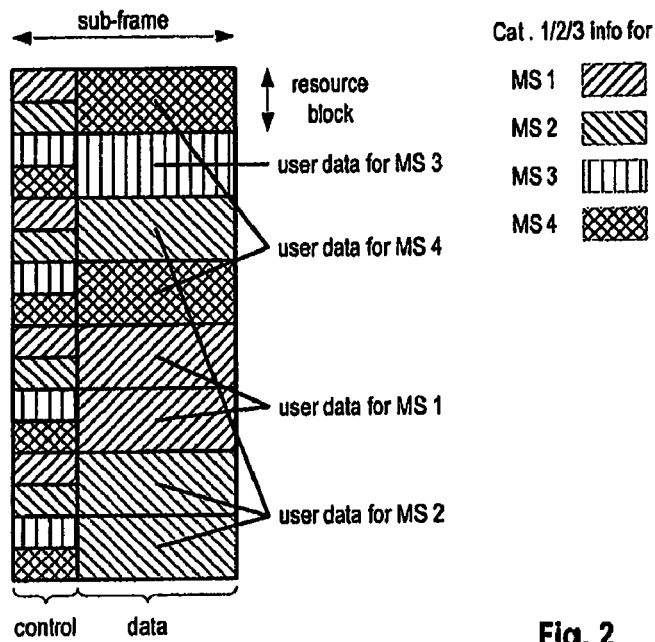

Fig. 2

PRIOR ART

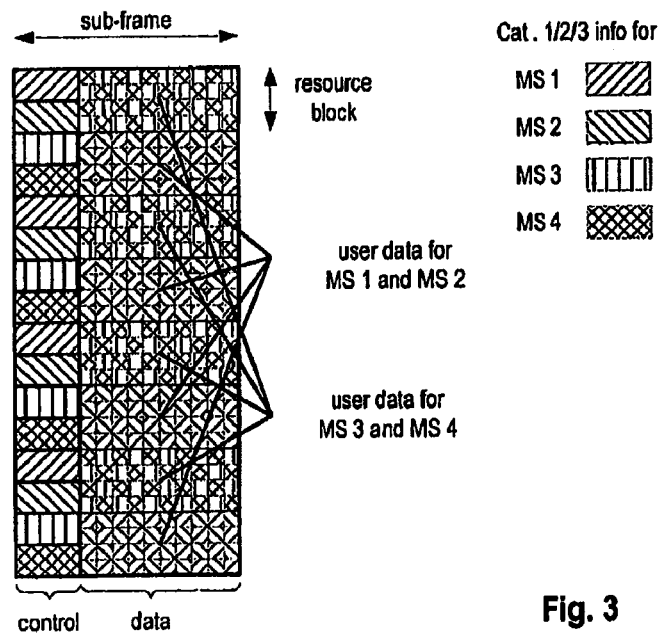

Fig. 3

PRIOR ART

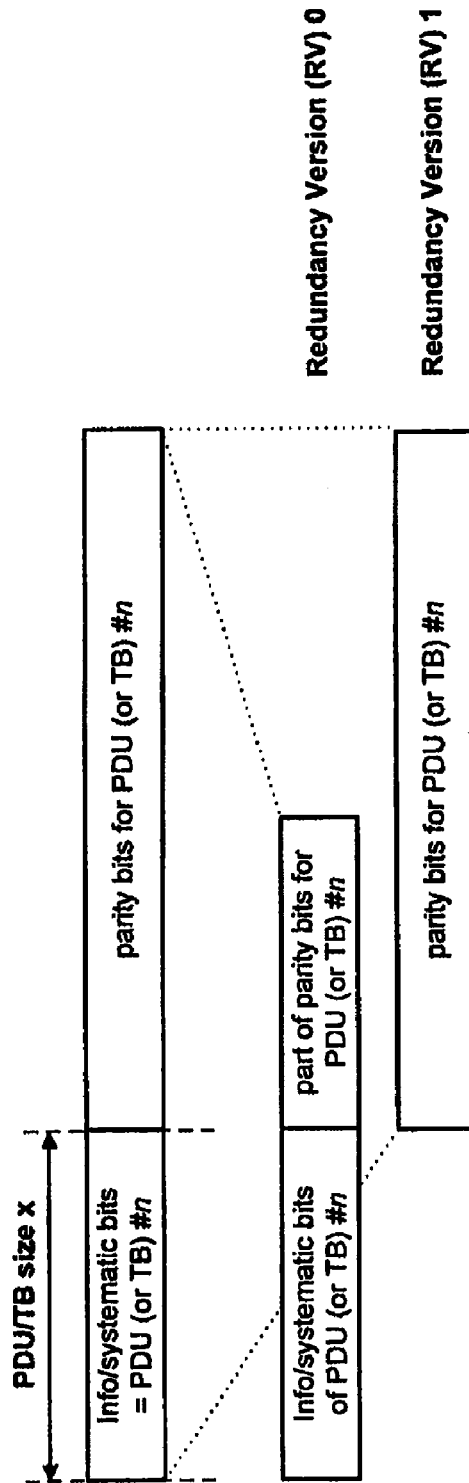

Fig. 4

PRIOR ART

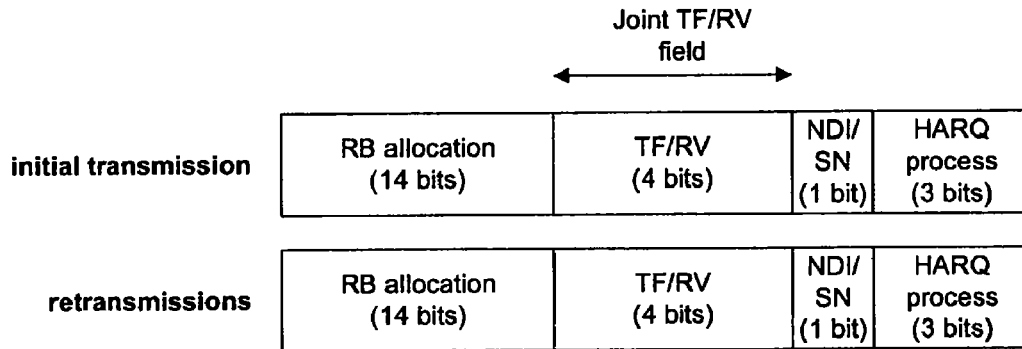

Fig. 5

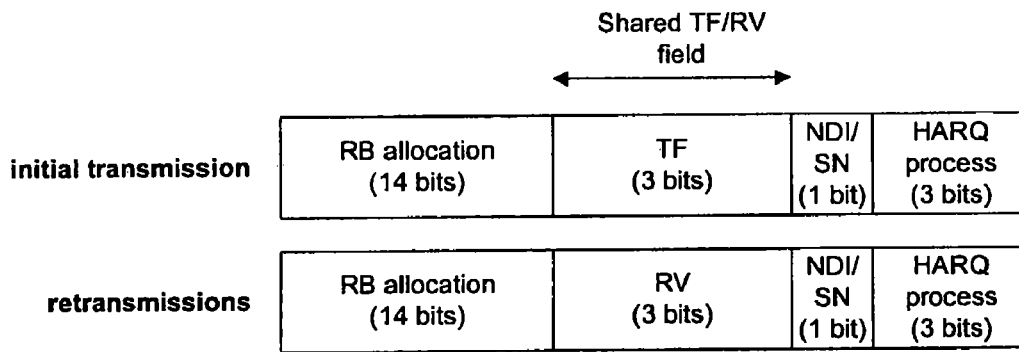

Fig. 6

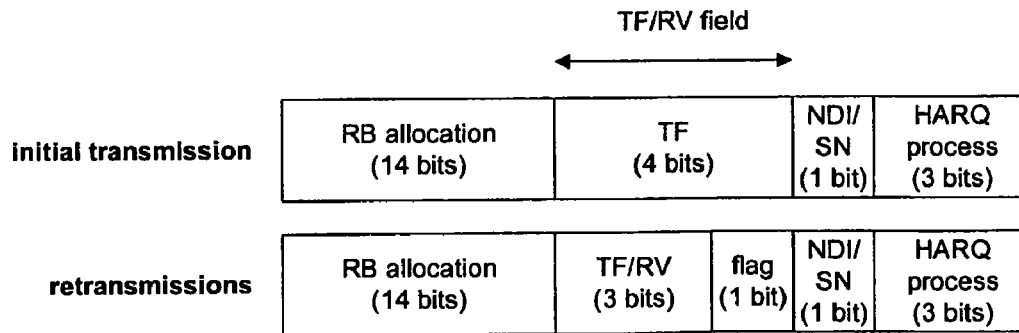

Fig. 7

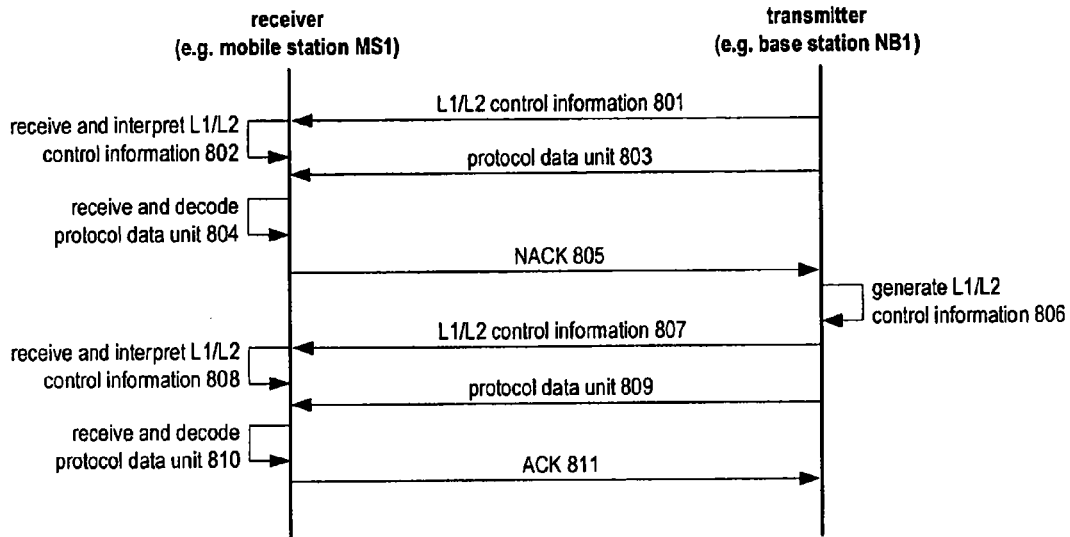

Fig. 8

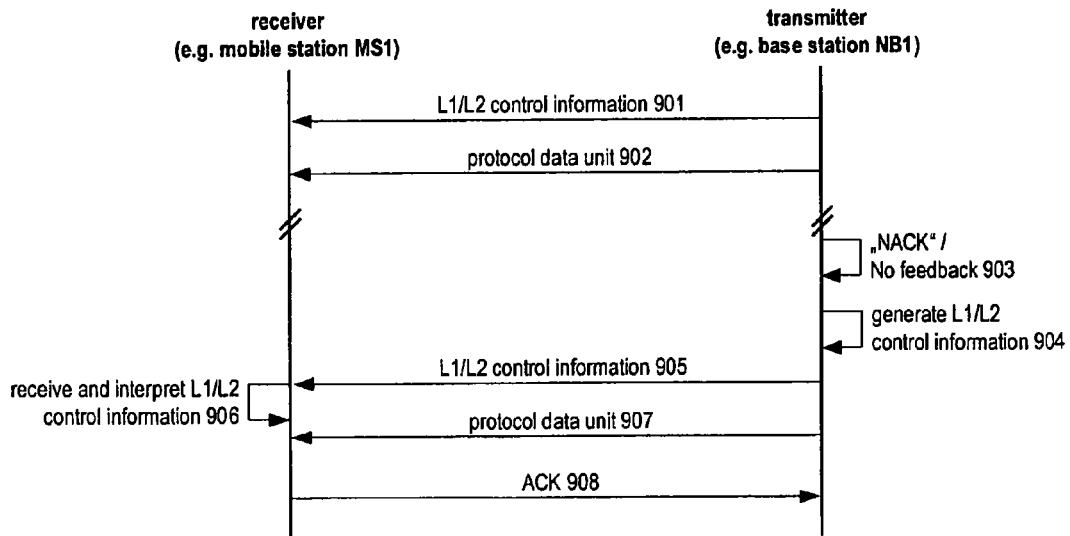

Fig. 9

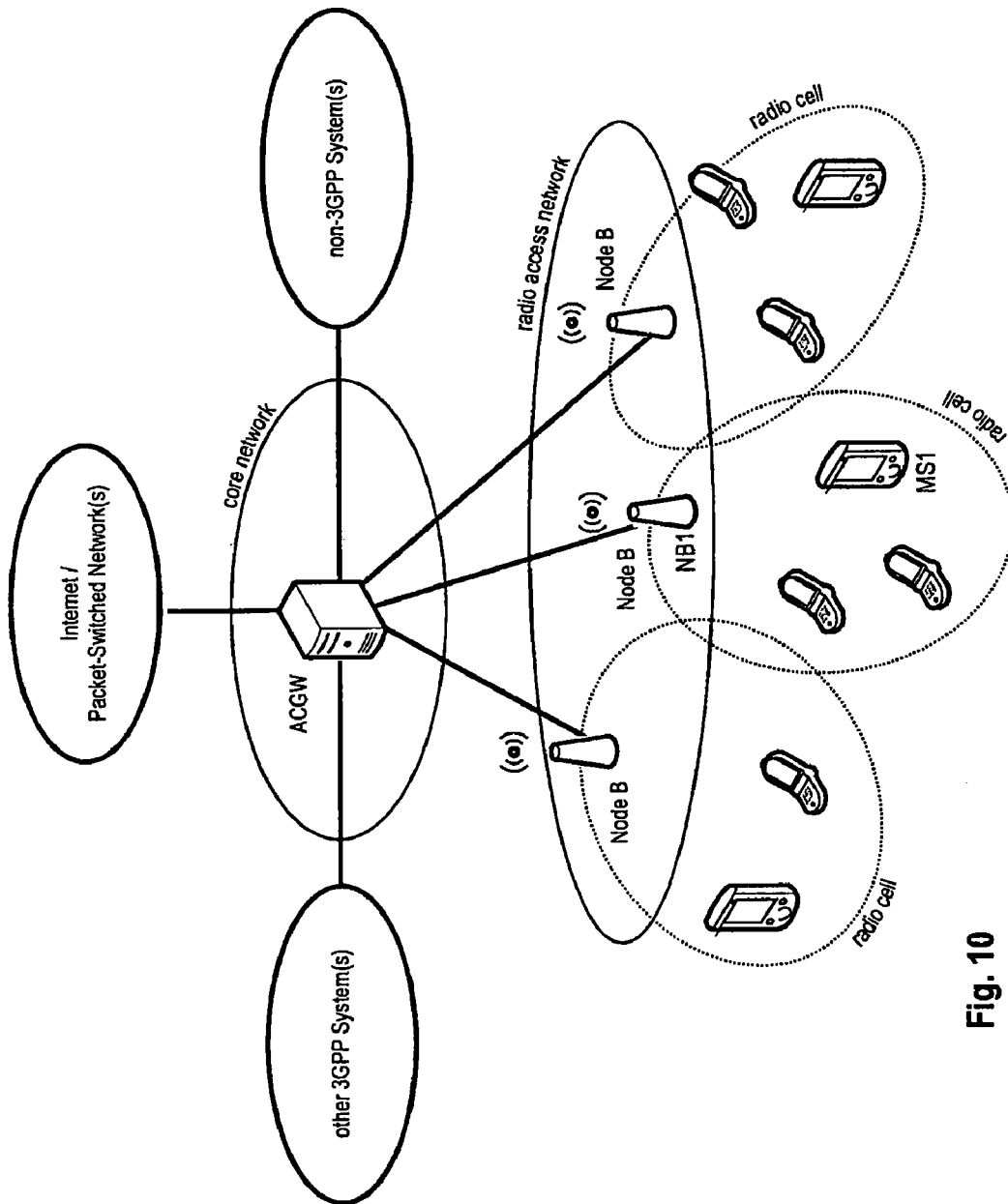

Fig. 10

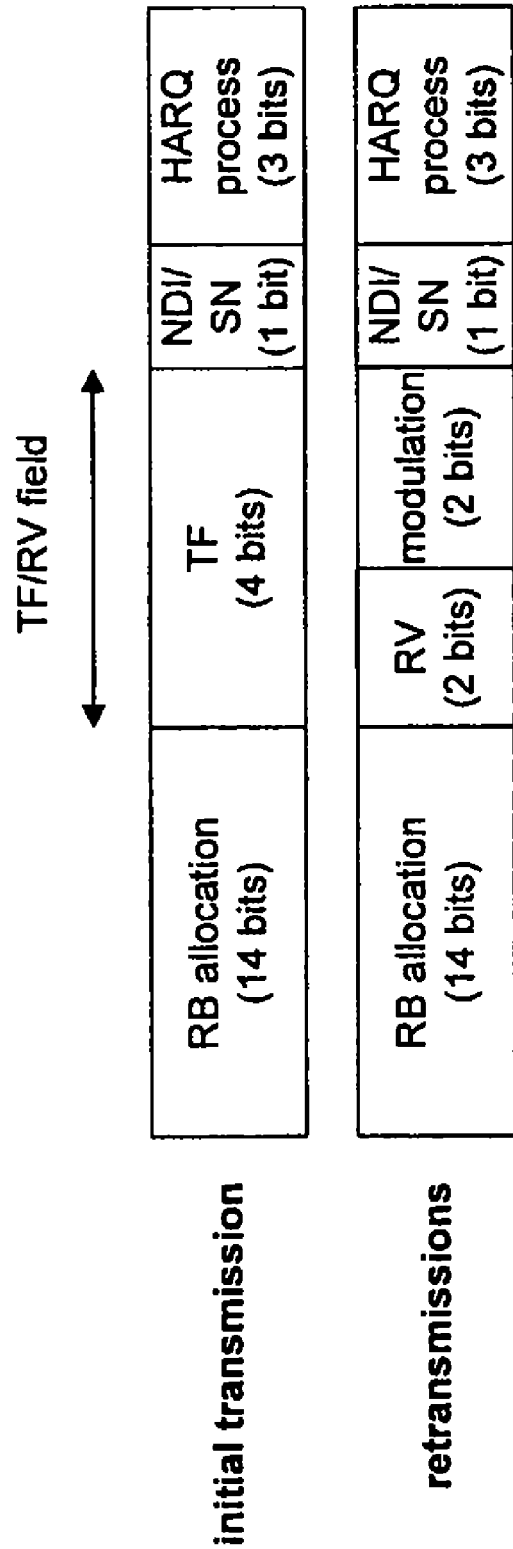

Fig. 11

US 8,385,284 B2

1

**CONTROL CHANNEL SIGNALING USING A
COMMON SIGNALING FIELD FOR
TRANSPORT FORMAT AND REDUNDANCY
VERSION**

FIELD OF THE INVENTION

The invention relates to a method for providing control signalling associated to a protocol data unit conveying user data in a mobile communication system and to the control channel signal itself. Furthermore, the invention also provides a mobile station and a base station and their respective operation in view of the newly defined control channel signals defined herein.

TECHNICAL BACKGROUND

Packet-Scheduling and Shared Channel Transmission

In wireless communication systems employing packet-scheduling, at least part of the air-interface resources are assigned dynamically to different users (mobile stations—MS or user equipments—UE). Those dynamically allocated resources are typically mapped to at least one Physical Uplink or Downlink Shared CHannel (PUSCH or PDSCH). A PUSCH or PDSCH may for example have one of the following configurations:

- One or multiple codes in a CDMA (Code Division Multiple Access) system are dynamically shared between multiple MS.

- One or multiple subcarriers (subbands) in an OFDMA (Orthogonal Frequency Division Multiple Access) system are dynamically shared between multiple MS.

- Combinations of the above in an OFCDMA (Orthogonal Frequency Code Division Multiplex Access) or a MC-CDMA (Multi Carrier-Code Division Multiple Access) system are dynamically shared between multiple MS.

FIG. 1 shows a packet-scheduling system on a shared channel for systems with a single shared data channel. A sub-frame (also referred to as a time slot) reflects the smallest interval at which the scheduler (e.g. the Physical Layer or MAC Layer Scheduler) performs the dynamic resource allocation (DRA). In FIG. 1, a TTI (transmission time interval) equal to one sub-frame is assumed. It should be born noted that generally a TTI may also span over multiple sub-frames.

Further, the smallest unit of radio resources (also referred to as a resource block or resource unit), which can be allocated in OFDM systems, is typically defined by one sub-frame in time domain and by one subcarrier/subband in the frequency domain. Similarly, in a CDMA system this smallest unit of radio resources is defined by a sub-frame in the time domain and a code in the code domain.

In OFCDMA or MC-CDMA systems, this smallest unit is defined by one sub-frame in time domain, by one subcarrier/subband in the frequency domain and one code in the code domain. Note that dynamic resource allocation may be performed in time domain and in code/frequency domain.

The main benefits of packet-scheduling are the multi-user diversity gain by time domain scheduling (TDS) and dynamic user rate adaptation.

Assuming that the channel conditions of the users change over time due to fast (and slow) fading, at a given time instant the scheduler can assign available resources (codes in case of CDMA, subcarriers/subbands in case of OFDMA) to users having good channel conditions in time domain scheduling.

2

Specifics of DRA and Shared Channel Transmission in OFDMA

Additionally to exploiting multi-user diversity in time domain by Time Domain Scheduling (TDS), in OFDMA multi-user diversity can also be exploited in frequency domain by Frequency Domain Scheduling (FDS). This is because the OFDM signal is in frequency domain constructed out of multiple narrowband subcarriers (typically grouped into subbands), which can be assigned dynamically to different users. By this, the frequency selective channel properties due to multi-path propagation can be exploited to schedule users on frequencies (subcarriers/subbands) on which they have a good channel quality (multi-user diversity in frequency domain).

For practical reasons in an OFDMA system the bandwidth is divided into multiple subbands, which consist out of multiple subcarriers. I.e. the smallest unit on which a user may be allocated would have a bandwidth of one subband and a duration of one slot or one sub-frame (which may correspond to one or multiple OFDM symbols), which is denoted as a resource block (RB). Typically, a subband consists of consecutive subcarriers. However, in some case it is desired to form a subband out of distributed non-consecutive subcarriers. A scheduler may also allocate a user over multiple consecutive or non-consecutive subbands and/or sub-frames.

For the 3GPP Long Term Evolution (3GPP TR 25.814: “Physical Layer Aspects for Evolved UTRA”, Release 7, v. 7.1.0, October 2006—available at <http://www.3gpp.org> and incorporated herein by reference), a 10 MHz system (normal cyclic prefix) may consist out of 600 subcarriers with a sub-carrier spacing of 15 kHz. The 600 subcarriers may then be grouped into 50 subbands (a 12 adjacent subcarriers), each subband occupying a bandwidth of 180 kHz. Assuming, that a slot has a duration of 0.5 ms, a resource block (RB) spans over 180 kHz and 0.5 ms according to this example.

In order to exploit multi-user diversity and to achieve scheduling gain in frequency domain, the data for a given user should be allocated on resource blocks on which the users have a good channel condition. Typically, those resource blocks are close to each other and therefore, this transmission mode is in also denoted as localized mode (LM).

An example for a localized mode channel structure is shown in FIG. 2. In this example neighboring resource blocks are assigned to four mobile stations (MS1 to MS4) in the time domain and frequency domain. Each resource block consists of a portion for carrying Layer 1 and/or Layer 2 control signaling (L1/L2 control signaling) and a portion carrying the user data for the mobile stations.

Alternatively, the users may be allocated in a distributed mode (DM) as shown in FIG. 3. In this configuration, a user (mobile station) is allocated on multiple resource blocks, which are distributed over a range of resource blocks. In distributed mode a number of different implementation options are possible. In the example shown in FIG. 3, a pair of users (MSs 1/2 and MSs 3/4) shares the same resource blocks. Several further possible exemplary implementation options may be found in 3GPP RAN WG#1 Tdoc R1-062089, “Comparison between RB-level and Sub-carrier-level Distributed Transmission for Shared Data Channel in E-UTRA Downlink”, August 2006 (available at <http://www.3gpp.org> and incorporated herein by reference).

It should be noted, that multiplexing of localized mode and distributed mode within a sub-frame is possible, where the amount of resources (RBs) allocated to localized mode and distributed mode may be fixed, semi-static (constant for tens/hundreds of sub-frames) or even dynamic (different from sub-frame to sub-frame).

3

In localized mode as well as in distributed mode in— a given sub-frame—one or multiple data blocks (which are inter alia referred to as transport-blocks) may be allocated separately to the same user (mobile station) on different resource blocks, which may or may not belong to the same service or Automatic Repeat reQuest (ARQ) process. Logically, this can be understood as allocating different users.

L1/L2 Control signaling

In order to provide sufficient side information to correctly receive or transmit data in systems employing packet scheduling, so-called L1/L2 control signaling (Physical Downlink Control CHannel—PDCCH) needs to be transmitted. Typical operation mechanisms for downlink and uplink data transmission are discussed below.

Downlink Data Transmission

Along with the downlink packet data transmission, in existing implementations using a shared downlink channel, such as 3GPP-based High Speed Data Packet Access (HSDPA), L1/L2 control signaling is typically transmitted on a separate physical (control) channel.

This L1/L2 control signaling typically contains information on the physical resource(s) on which the downlink data is transmitted (e.g. subcarriers or subcarrier blocks in case of OFDM, codes in case of CDMA). This information allows the mobile station (receiver) to identify the resources on which the data is transmitted. Another parameter in the control signaling is the transport format used for the transmission of the downlink data.

Typically, there are several possibilities to indicate the transport format. For example, the transport block size of the data (payload size, information bits size), the Modulation and

4

Coding Scheme (MCS) level, the Spectral Efficiency, the code rate, etc. may be signaled to indicate the transport format (TF). This information (usually together with the resource allocation) allows the mobile station (receiver) to identify the information bit size, the modulation scheme and the code rate in order to start the demodulation, the de-rate-matching and the decoding process. In some cases the modulation scheme maybe signaled explicitly.

In addition, in systems employing Hybrid ARQ (HARQ), HARQ information may also form part of the L1/L2 signaling. This HARQ information typically indicates the HARQ process number, which allows the mobile station to identify the Hybrid ARQ process on which the data is mapped, the sequence number or new data indicator, allowing the mobile station to identify if the transmission is a new packet or a retransmitted packet and a redundancy and/or constellation version. The redundancy version and/or constellation version tells the mobile station, which Hybrid ARQ redundancy version is used (required for de-rate-matching) and/or which modulation constellation version is used (required for demodulation)

A further parameter in the HARQ information is typically the UE Identity (UE ID) for identifying the mobile station to receive the L1/L2 control signaling. In typical implementations this information is used to mask the CRC of the L1/L2 control signaling in order to prevent other mobile stations to read this information.

The table below (Table 1) illustrates an example of a L1/L2 control channel signal structure for downlink scheduling as known from 3GPP TR 25.814 (see section 7.1.1.2.3—FFS=for further study):

TABLE 1

	Field	Size	Comment	
Cat. 1 (Resource indication)	ID (UE or group specific)	[8-9]	Indicates the UE (or group of UEs) for which the data transmission is intended	
	Resource assignment	FFS	Indicates which (virtual) resource units (and layers in case of multi-layer transmission) the UE(s) shall demodulate.	
	Duration of assignment	2-3	The duration for which the assignment is valid, could also be used to control the TTI or persistent scheduling.	
Cat. 2 (transport format)	Multi-antenna related information	FFS	Content depends on the MIMO/beamforming schemes selected.	
	Modulation scheme	2	QPSK, 16 QAM, 64 QAM . . . In case of multi-layer transmission, multiple instances may be required.	
	Payload size	6	Interpretation could depend on e.g. modulation scheme and the number of assigned resource units (c.f. HSDPA). In case of multi-layer transmission, multiple instances may be required.	
Cat. 3 (HARQ)	If asynchronous hybrid ARQ is adopted	Hybrid ARQ process number	3	Indicates the hybrid ARQ process the current transmission is addressing.
		Redundancy version	2	To support incremental redundancy.
		New data indicator	1	To handle soft buffer clearing.
	If synchronous hybrid ARQ is adopted	Retransmission sequence number	2	Used to derive redundancy version (to support incremental redundancy) and 'new data indicator' (to handle soft buffer clearing).

5

Uplink Data Transmission

Similarly, also for uplink transmissions, L1/L2 signaling is provided on the downlink to the transmitters in order to inform them on the parameters for the uplink transmission. Essentially, the L1/L2 control channel signal is partly similar

6

The table below (Table 2) illustrates an example of a L1/L2 control channel signal structure for uplink scheduling as known from 3GPP TR 25.814 (see section 7.1.1.2.3—FFS—for further study):

TABLE 2

	Field	Size	Comment
Resource assignment	ID (UE or group specific)	[8-9]	Indicates the UE (or group of UEs) for which the grant is intended
	Resource assignment	FFS	Indicates which uplink resources, localized or distributed, the UE is allowed to use for uplink data transmission.
	Duration of assignment	2-3	The duration for which the assignment is valid. The use for other purposes, e.g., to control persistent scheduling, 'per process' operation, or TTI length, is FFS.
TF	Transmission parameters	FFS	The uplink transmission parameters (modulation scheme, payload size, MIMO-related information, etc) the UE shall use. If the UE is allowed to select (part of) the transport format, this field sets determines an upper limit of the transport format the UE may select.

to the one for downlink transmissions. It typically indicates the physical resource(s) on which the UE should transmit the data (e.g. subcarriers or subcarrier blocks in case of OFDM, codes in case of CDMA) and a transport format the mobile station should use for uplink transmission. Further, the L1/L2 control information may also comprise Hybrid ARQ information, indicating the HARQ process number, the sequence number or new data indicator, and further the redundancy and/or constellation version. In addition, there may be a UE Identity (UE ID) comprised in the control signaling.

Variants

There are several different flavors how to exactly transmit the information pieces mentioned above. Moreover, the L1/L2 control information may also contain additional information or may omit some of the information. For example, the HARQ process number may not be needed in case of using no or a synchronous HARQ protocol. Similarly, the redundancy and/or constellation version may not be needed, if for example Chase Combining is used (i.e. always the same redundancy and/or constellation version is transmitted) or if the sequence of redundancy and/or constellation versions is pre-defined.

Another variant may be to additionally include power control information in the control signaling or MIMO related control information, such as e.g. pre-coding information. In case of multi-codeword MIMO transmission transport format and/or HARQ information for multiple code words may be included.

In case of uplink data transmission, part or all of the information listed above may be signaled on uplink, instead of on the downlink. For example, the base station may only define the physical resource(s) on which a given mobile station shall transmit. Accordingly, the mobile station may select and signal the transport format, modulation scheme and/or HARQ parameters on the uplink. Which parts of the L1/L2 control information is signaled on the uplink and which proportion is signaled on the downlink is typically a design issue and depends on the view how much control should be carried out by the network and how much autonomy should be left to the mobile station.

Another, more recent suggestion of a L1/L2 control signaling structure for uplink and downlink transmission may be found in 3GPP TSG-RAN WG1 #50 Tdoc. R1-073870, "Notes from offline discussions on PDCCCH contents", August 2007, available at <http://www.3gpp.org> and incorporated herein by reference.

As indicated above, L1/L2 control signaling has been defined for systems that are already deployed to in different countries, such as for example, 3GPP HSDPA. For details on 3GPP HSDPA it is therefore referred to 3GPP TS 25.308, "High Speed Downlink Packet Access (HSDPA); Overall description; Stage 2", version 7.4.0, September 2007 (available at <http://www.3gpp.org>) and Harri Holma and Antti Toskala, "WCDMA for UMTS, Radio Access For Third Generation Mobile Communications", Third Edition, John Wiley & Sons, Ltd., 2004, chapters 11.1 to 11.5, for further reading.

As described in section 4.6 of 3GPP TS 25.212, "Multiplexing and Channel Coding (FDD)", version 7.6.0, September 2007 (available at <http://www.3gpp.org>) in HSDPA the "Transport Format" (TF) (Transport-block size information (6 bits)), the "Redundancy and constellation Version" (RV/CV) (2 bits) and the "New Data Indicator" (NDI) (1 bit) are signaled separately by in total 9 bits. It should be noted that the NDI is actually serving as a 1-bit HARQ Sequence Number (SN), i.e. the value is toggled with each new transport-block to be transmitted.

SUMMARY OF THE INVENTION

One object of the invention is to reduce the amount of bits required for control channel signaling, such as for example L1/L2 control signaling, in uplink or downlink. Further, it is desirable that such solution does further not introduce additional problematic HARQ protocol error cases.

The object is solved by the subject matter of the independent claims. Advantageous embodiments of the invention are subject matters of the dependent claims.

One main aspect of the invention is to suggest a new format for the control channel information. According to this aspect, the transport format/transport block size/payload size/modu-

lation and coding scheme and the redundancy version/constellation version for the associated transmission of the user data (typically in form of a protocol data unit or transport block) is provided in a single field of the control channel information. This single field is referred to as the control information field herein, but may for example also be denoted a transport format/redundancy version field or, in abbreviated form, a TF/RV field. In addition, some embodiment of the invention foresee to combine the transport format transport block size/payload size/modulation and coding scheme, the redundancy version/constellation version and additionally HARQ related information (sequence number or new data indicator) within a single field of the control channel information.

According to one embodiment, the invention provides a control channel signal (such as for example a L1/L2 control channel signal) for use in a mobile communication system. The control channel signal is associated to protocol data unit transporting user data and comprises a control information field consisting of a number of bits jointly encoding a transport format and a redundancy version used for transmitting the protocol data unit.

In one exemplary embodiment of the invention, the bits of the control information field jointly encode the transport format, a redundancy version used for transmitting the protocol data unit and a sequence number of the protocol data unit.

Further, in another exemplary embodiment, the bits of the control information field not only jointly encode the transport format and a redundancy version used for transmitting the protocol data unit, but further include a new data indicator for indicating whether the transmission of the protocol data unit is an initial transmission of the user data. Hence, in this example, a single field of the control channel signal is utilized to encode the three before mentioned control information related to the associated transmission of the user data.

According to another exemplary embodiment of the invention, the control information field consists of a number of bits yielding a range of values that can be represented in the control information field (e.g. if there are N bits provided in the field, 2^N different values may be represented in the field) and wherein a first subset of the values is reserved for indicating a transport format of the protocol data unit and a second subset of values are reserved for indicating a redundancy version for transmitting the user data. In one exemplary implementation, the first subset of values contains more values than the second subset of values.

Moreover, in another exemplary embodiment of the invention, the redundancy version of the protocol data unit is implicit to its transport format that indicated by the corresponding value of the first subset. In other words, each individual transport format that is represented by a specific bit combination of the first subset is univocally linked to a respective redundancy version so that no explicit signaling of the redundancy version of the protocol data unit is necessary. Another possibility would be that the redundancy version to be used for the initial transmission of the user data in the protocol data unit is fixed or preconfigured.

In another embodiment, it may be assumed that the transmission of the before-mentioned protocol data unit is an initial transmission of the user data. In this case, the value of the encoded information bits in the control channel field is representing a value of the first subset of values. Hence, in general, in case of an initial transmission, the transport format and optionally the redundancy version of the protocol data unit is indicated in the control channel signal. As indicated previously, the redundancy version may also be implicit to the transport format.

In a similar fashion, in case the transmission of the protocol data unit is a retransmission of the user data, the value of the encoded information bits in the control channel field is representing a value of the second subset of values. This may be for example advantageous in a system design, where the transport format (e.g. transport block size) of a protocol data unit does not change between initial transmission and retransmission or if the transport format can be determined from the transport format and the resource allocation information for the initial transmission and the resource allocation information for the retransmission. Accordingly, if a retransmission needs to be sent for the user data, the control channel signal for this retransmission does not need to explicitly signal the transport format for the retransmitted protocol data unit, but rather the bits of the control information field indicate the redundancy version of the protocol data unit, while assuming the transport format of the retransmission to be the same as for the initial transmission or to be determined from the transport format and (optionally) the resource allocation information of the initial transmission and, optionally further, the resource allocation information in the retransmission.

However, in other exemplary designs, the transport format of the initial transmission of the user data may not be known, e.g. in case the receiving terminal has missed the transmission of the control channel signal, or the same transport format can no longer be used for the retransmission, e.g. due to a reconfiguration of resources allocated to the transmission of the protocol data unit. Accordingly, in another embodiment of the invention, in case the transmission of the protocol data unit is a retransmission of the user data, the value of the encoded information bits in the control channel field is representing a value of the first subset or the second subset of values.

Hence, in this example, the control information field may either indicate the redundancy version of the protocol data unit, while assuming the transport format of the retransmission to be known from the initial transmission, or a transport format (and implicitly or explicitly the redundancy version) for the retransmission may be indicated in the retransmission, as appropriate.

Another exemplary embodiment, the transport format, a redundancy version used for transmitting the protocol data unit and a new data indicator for indicating whether the transmission of the protocol data unit is an initial transmission of the user data are assumed to be jointly encoded in the control information field, while the values that can be represented by the control information field bits are again split into a first and second subset in a similar fashion as described above. In this example, use of one of the values of a first subset set also indicates the transmission of the protocol data unit to be an initial transmission. I.e. in this case the values of the first subset may be considered a new data indicator being set, i.e. indicating an initial transmission, while the values of the second subset may be considered a new data indicator not being set, i.e. indicating a retransmission.

In case the sequence number/new data indicator is not jointly encoded together with the transport format and the redundancy version, in an alternative embodiment of the invention, a respective field may be realized in the control channel signal.

According to a further embodiment of the invention, the control channel signal comprises a resource allocation field for indicating the physical radio resource or resources allocated to a receiver for receiving the protocol data unit or the physical radio resource or resources on which a transmitter is to transmit the protocol data unit.

In another embodiment, the control channel signal further comprises a mobile terminal identifier field for indicating the

mobile terminal or a group of mobile terminals that are to receive the control channel signal.

In a further embodiment of the invention, the control channel signal or rather the bits of the control information field include a flag indicating the type of information indicated by the remaining bits of the control information field, in case the protocol data packet is a retransmission for the user data.

In an alternative solution according to another embodiment of the invention, another control channel signal is provided. Also this alternative control channel signal is associated to protocol data unit transporting user data and comprises a control information field consisting of a number of bits representing a transport format and implicitly a redundancy version of the protocol data unit, if the transmission of the protocol data unit is an initial transmission of the user data, or representing a redundancy version of the protocol data unit, if the transmission of the protocol data unit is a retransmission of the user data.

Further, in a variation of this embodiment, the bits of the control information field represent a redundancy version and optionally a transport format of the protocol data unit, if the transmission of the protocol data unit is a retransmission.

Another embodiment of the invention relates to a method for encoding control signaling associated to a protocol data unit conveying user data in a mobile communication system. In this method, the base station generates a control channel signal comprising a control information field in which a transport format and a redundancy version of the protocol data unit is jointly encoded, and subsequently transmits the control channel signal to at least one mobile terminal.

In a further embodiment, the base station receives feedback from the at least one mobile terminal. The feedback indicates whether the protocol data unit has been successfully decoded at the mobile terminal. If no successful decoding has been possible, the base station may retransmit the protocol data unit and may further transmit a second control channel signal comprising a control information field in which a transport format and a redundancy version of the protocol data unit is jointly encoded. Thereby, the second control channel signal is associated to a retransmission of the protocol data unit to the mobile terminal.

In one exemplary embodiment, the protocol data unit and the second protocol data unit are transmitted or received using the same HARQ process.

Another embodiment of the invention relates to a method for providing control signaling associated to a protocol data unit conveying user data in a mobile communication system. According to this method, a base station of the mobile communication system generates a control channel signal that comprises a control information field consisting of a number of bits representing:

- a transport format and implicitly a redundancy version of the protocol data unit, if the transmission of the protocol data unit is an initial transmission of the user data, or
- a redundancy version of the protocol data unit, if the transmission of the protocol data unit is a retransmission of the user data.

Subsequently the base station transmits the control channel signal to at least one mobile terminal.

In a further embodiment of the invention, in both methods mentioned above, the base station may also transmit the protocol data unit to a mobile terminal or receiving the protocol data unit from the mobile terminal utilizing a HARQ retransmission protocol. In one example, the protocol data unit is transmitted or received using a HARQ process indicated in the control channel signal. In another example, the protocol data unit is transmitted or received using a HARQ process

determined based on to the sub-frame number of the sub-frame conveying the protocol data unit. The protocol data unit may be transmitted or received using the physical radio resource or resources indicated in the control channel signal.

In one exemplary embodiment of the invention the mobile communication system is a multi-carrier system, such as for example an OFDM-based system, and the control channel signal is transmitted within the physical radio resources of a sub-frame allocated to the L1/L2 control channels of the multi-carrier system.

Furthermore, in another exemplary embodiment of the invention the protocol data unit is transmitted in the same sub-frame as the associated control channel signal.

Though the exemplary embodiments described herein are mainly focusing on outlining the relation between one base station and one mobile terminal, it is apparent that the base station may be serving a plurality of mobile terminals, and a control channel signal is generated and transmitted by the base station for each mobile terminal or group of mobile terminals.

A further embodiment of the invention is related to the operation of the mobile terminal. Accordingly, a method is provided in which a mobile terminal receive a sub-frame of physical radio resources comprising a control channel signal destined to the mobile terminal. The control channel signal comprises a control information field in which a transport format and a redundancy version of a protocol data unit are jointly encoded. The mobile terminal next determines the transport format and the redundancy version for the protocol data packet conveying user data based on the received control channel signal, and receives or transmits the protocol data packet on at least one physical radio resource using the transport format and the redundancy version of the protocol data packet indicated in the received control information field.

In one example, the transport format is transport block size information of the protocol data unit, and the received control channel signal comprises a resource allocation field indicating the physical radio resource or resources allocated to the mobile terminal. Accordingly, the mobile terminal may determine the transport block size of the protocol data unit depending on the information comprised in the resource allocation field and the control information field.

In another example, the control channel signal indicates the protocol data packet to be a retransmission (e.g. new data indicator not set) of user data and wherein the method further comprises the step of transmitting a positive acknowledgment for the received protocol data packet to the base station, if the control channel signaling associated to the initial transmission for the user data has been missed. Hence, even though the mobile terminal has not received the control channel signal and could not receive the associated transmission of the user data, the mobile terminal may acknowledge "successful reception" of the user data and may for example rely on upper layer protocols, such as for example the Radio Link Control (RLC) protocol, to take care of handling retransmission.

In case the protocol data unit is a retransmission, according to another example, the mobile terminal may reuse the transport format information of the protocol data unit indicated in a control channel signal for the initial transmission for the transmission or reception of the retransmission of the protocol data unit. Accordingly, the control channel signal may be "only" indicating the redundancy version of the retransmission (though one may still consider the control channel signal to implicitly indicate the transport format).

In another exemplary embodiment of the invention, the information bits in the control information field of the control channel signal are associated to a single reference informa-

tion indicating a transport format and a redundancy version used for transmitting the protocol data unit associated to the respective value represented by the information bits of the control information field for initial transmissions and retransmissions of the protocol data packet.

In a further embodiment of the invention relates to the operation of the mobile terminal. In this embodiment, the mobile terminal receives a sub-frame of physical radio resources comprising a control channel signal. The control channel signal thereby comprises a control information field consisting of a number of bits representing:

- a transport format and implicitly a redundancy version of the protocol data unit, if the transmission of the protocol data unit is an initial transmission of the user data, or
- a redundancy version of the protocol data unit, if the transmission of the protocol data unit is a retransmission of the user data.

Next, the mobile terminal determines (based on the received control channel signal) the transport format of and the redundancy version for the protocol data packet conveying user data, and further receive or transmits the protocol data packet on at least one physical radio resource using the transport format and the redundancy version of the protocol data packet indicated in the received control information field.

In this exemplary embodiment, the information bits of the control information are associated to two different reference information (based on which the control information field content is interpreted). If the transmission of the protocol data packets is an initial transmission, the first reference information is utilized when determining the transport format and the redundancy version of the protocol data packet. If the transmission of the protocol data packets is a retransmission, the second reference is used when determining the transport format and the redundancy version of the protocol data packet.

In one example, the first reference information indicates a transport format associated to the respective value represented by the information bits of the control information field, and the second reference information indicates a redundancy version associated to the respective value represented by the information bits of the control information field.

Another embodiment of the invention provides a base station for providing control signaling associated to a protocol data unit conveying user data in a mobile communication system. The base station comprises a processing unit for generating a control channel signal comprising a control information field in which a transport format and a redundancy version of the protocol data unit is jointly encoded, and a transmitter unit transmitting control signaling comprising the control channel signal to at least one mobile terminal.

Further, another embodiment of the invention relates to a mobile terminal for use in a mobile communication system, whereby the mobile terminal comprises a receiver unit for receiving a sub-frame of physical radio resources comprising a control channel signal destined to the mobile terminal. The control channel signal comprises a control information field in which a transport format and a redundancy version of a protocol data unit is jointly encoded, as mentioned previously herein. The mobile terminal also comprises a processing unit for determining based on the received control channel signal the transport format of and the redundancy version for the protocol data packet conveying user data, and a transmitter unit for transmitting the protocol data packet on at least one physical radio resource using the transport format and the redundancy version of the protocol data packet indicated in the received control information field.

In an alternative embodiment, the mobile terminal comprises a receiver unit for receiving a sub-frame of physical radio resources comprising a control channel signal destined to the mobile terminal, and a processing unit for determining based on the received control channel signal the transport format of and the redundancy version for the protocol data packet conveying user data. Furthermore, the receiver unit is capable of receiving the protocol data packet on at least one physical radio resource using the transport format and the redundancy version of the protocol data packet indicated in the received control information field.

Moreover, the invention according to other exemplary embodiments relates to the implementation of the methods described herein in software and hardware. Accordingly, another embodiment of the invention provides a computer readable medium storing instructions that, when executed by a processor unit of a base station, cause the base station to generate a control channel signal comprising a control information field in which a transport format and a redundancy version of the protocol data unit is jointly encoded, and to transmit the control channel signal to at least one mobile terminal.

A further embodiment relates to a computer readable medium storing instructions that, when executed by a processor unit of a mobile terminal, cause the mobile terminal to receive a sub-frame of physical radio resources comprising a control channel signal destined to the mobile terminal, determine based on the received control channel signal the transport format of and the redundancy version for the protocol data packet conveying user data, and receive or transmit the protocol data packet on at least one physical radio resource using the transport format and the redundancy version of the protocol data packet indicated in the received control information field.

BRIEF DESCRIPTION OF THE FIGURES

In the following, the invention is described in more detail in reference to the attached figures and drawings. Similar or corresponding details in the figures are marked with the same reference numerals.

FIG. 1 shows an exemplary data transmission to users in an OFDMA system in localized mode (LM) having a distributed mapping of L1/L2 control signaling.

FIG. 2 shows an exemplary data transmission to users in an OFDMA system in localized mode (LM) having a distributed mapping of L1/L2 control signaling.

FIG. 3 shows an exemplary data transmission to users in an OFDMA system in distributed mode (DM) having a distributed mapping of L1/L2 control signaling.

FIG. 4 exemplarily highlights the interrelation between transport block/protocol data unit and its different redundancy versions as well as the transport block size/protocol data unit size.

FIG. 5 shows an example of a control channel signal with a common field for jointly encoding transmission format and redundancy version of a protocol data unit according to one embodiment of the invention.

FIG. 6 shows an example of a control channel signal with a common, shared field for signaling the transmission format or the redundancy version of a protocol data unit according to one embodiment of the invention.

FIG. 7 shows another example of a control channel signal with a common, shared field for signaling the transmission format, the redundancy version or other information for a protocol data unit according to one embodiment of the invention.

13

FIG. 8 shows an exemplary, typical message flow between a transceiver and receiver of a control channel signal according to an exemplary embodiment of the invention,

FIG. 9 shows an exemplary message flow between a transceiver and receiver of a control channel signal in which the retransmission protocol operation of the receiver is optimized according to an exemplary embodiment of the invention,

FIG. 10 shows a mobile communication system according to one embodiment of the invention, in which the ideas of the invention may be implemented, and

FIG. 11 shows another example of a control channel signal with a common, shared field for signaling the transmission format or the redundancy version of a protocol data unit according to one embodiment of the invention,

DETAILED DESCRIPTION OF THE INVENTION

The following paragraphs will describe various embodiments of the invention. For exemplary purposes only, most of the embodiments are outlined in relation to an (evolved) UMTS communication system according to the SAE/LTE discussed in the Technical Background section above. It should be noted that the invention may be advantageously used for example in connection with a mobile communication system such as the SAE/LTE communication system previously described or in connection with multi-carrier systems such as OFDM-based systems, but the invention is not limited to its use in this particular exemplary communication network.

Before discussing the various embodiments of the invention in further detail below, the following paragraphs will give a brief overview on the meaning of several terms frequently used herein and their interrelation and dependencies. Generally, a protocol data unit may be considered a data packet of a specific protocol layer that is used to convey one or more transport blocks. In one example, the protocol data unit is a MAC Protocol Data Unit (MAC PDU), i.e. a protocol data unit of the MAC (Medium Access Control) protocol layer. The MAC PDU conveys data provided by the MAC layer to the PHY (Physical) layer. Typically, for a single user allocation (one L1/L2 control channel—PDCCH—per user), one MAC PDU is mapped onto one transport block (TB) on Layer 1. A transport block defines the basic data unit exchanged between Layer 1 and MAC (Layer 2). Typically, the when mapping a MAC PDU onto a transport block one or multiple CRCs are added. The transport block size is defined as the size (number of bits) of a transport block. Depending on the definition, the transport size may include or exclude the CRC bits. In general, the transport format defines the modulation and coding scheme (MCS) and/or the transport block size, which is applied for the transmission of a transport block and is, therefore, required for appropriate (de)modulation and (de) coding. In a 3GPP-based system as for example discussed in 3GPP TR 25.814, the following relationship between the modulation and coding scheme, the transport block size and the resource allocation size is valid:

$$TBS=CR \cdot M \cdot N_{RE}$$

where N_{RE} is the number of allocated resource elements (RE)—one RE being identical to one modulation symbol—, CR is the code rate for encoding the transport block, and M is the number of bits mapped onto one modulation symbol, e.g. M=4 for 16-QAM.

Due to this relationship described above, the L1/L2 control signaling may only need to indicate either the transport block size or the modulation and coding scheme. In case the modulation and coding scheme should be signaled, there are several

14

options how to implement this signaling. For example, separate fields for modulation and coding or a joint field for signaling both, the modulation and coding parameters may be foreseen. In case the transport block size should be signaled, the transport block size is typically not explicitly signaled, but is rather signaled as a TBS index. The interpretation of the TBS index to determine the actual transport block size may for example depend on the resource allocation size.

In the following, the transport format field on the L1/L2 control signaling is assumed to be indicating either the modulation and coding scheme or the transport block size. It should be noted, that the transport block size for a given transport block typically does not change during transmissions. However, even if the transport block size is not changed, the modulation and coding scheme may change between transmissions, e.g. if the resource allocation size is changed (as apparent for the described relationship above).

It should be also noted that in some embodiments of the invention, for retransmissions the transport block size is typically known from the initial transmission. Therefore, the transport format (MCS and/or TBS) information (even if the modulation and coding scheme changes between transmissions) does not have to be signaled in retransmissions, since the modulation and coding scheme can be determined from the transport block size and the resource allocation size, which can be determined from the resource allocation field.

A redundancy version denotes a set of encoded bits generated from a given transport block, as shown in FIG. 4. In systems, where the code rate for the data transmission is generated by a fixed rate encoder and a rate matching unit (e.g. in HSDPA of UMTS or LTE systems), different redundancy versions are generated for a single transport block (or protocol data unit) by selecting different sets of available encoded bits, where the set size (number of selected bits) depends on the actual code rate (CR) for the data transmission. In case the actual code rate for a transmission (or retransmission) is higher than the encoder rate, a redundancy version is constructed out of a subset of encoded bits. In case the actual code rate for a transmission (or retransmission) is lower than the encoder rate, a redundancy version is typically constructed out of all encoded bits with selected bits being repeated.

A constellation version denotes the constellation diagram being applied for the modulation of the data transmission. In some cases, this may simply refer to a specific bit-to-symbol mapping for a given modulation scheme. In other cases, this may refer to a specific bit operations by interleaving and/or inversion of bit values in order to achieve a similar effect as by applying a specific bit-to-symbol mapping (see for example EP 1 293 059 B1 or EP 1 313 248 B1 or 3GPP TS 25.212, “Multiplexing and Channel Coding (FDD)”, version 7.6.0, September 2007 available at <http://www.3gpp.org>)

A New Data Indicator (NDI) denotes a flag (or field) indicating whether a transmission of a transport block (or protocol data unit) is an initial transmission or a retransmission. If the NDI is set, the transmission of a transport block (or protocol data unit) is an initial transmission. In some implementations, the new data indicator is a 1-bit sequence number (SN), which is incremented every other transport block (or protocol data unit). In case of using a single bit for the NDI/SN the increment is identical to toggling the bit. Generally, however, a sequence number may comprise more than one bit.

One main aspect of the invention is to suggest a new format for the control channel information. According to this aspect, the transport format/transport block size/payload size/modulation and coding scheme and the redundancy version/con-

stellation version for the associated transmission of the user data (typically in form of a protocol data unit) is provided in a single field of the control channel information. The control channel information may for example be L1/L2 control information/a L1/L2 control channel signal that is transmitted on the PDCCH (Physical Downlink Control CHannel) of a 3GPP LTE system.

It should be noted that for simplicity it is referred to transport format and redundancy version in most of the examples herein. However, in all embodiments of this invention the term “transport format” means either one of “transport format”, “transport block size”, “payload size” or “modulation and coding scheme”. Similarly, in all embodiments of this invention the term “redundancy version” can be replaced by “redundancy version and/or constellation version”.

In addition, some embodiment of the invention foresee to combine the transport format, the redundancy version and additionally HARQ related information ((Retransmission/HARQ) sequence number or new data indicator—NDI) within a single field of the control channel information.

There are two basic approaches suggested herein. According to different embodiments of the invention, a joint encoding of transport format and redundancy version is provided or alternatively a shared signaling of transport format and redundancy version is used. In both cases, only a single control channel information field is provided for the transport format and the redundancy version, however the use of the field is different.

When using joint encoding, there is one common field for the transport format and the redundancy version defined in the control channel information/signal. The transport format and redundancy version are jointly coded, e.g. a field of N bits is used yielding 2^N values, which can be signaled. Out of the 2^N values M ($<2^N$) values are used to indicate a transport format which is for example associated to a given fixed or pre-configured redundancy version (In this case one could speak of an explicit signaling of the transport format and a simultaneous implicit signaling of the redundancy version). All or part of the remaining values is used to indicate additional redundancy versions that may be for example used for retransmissions of the protocol data unit.

The latter may for example be especially applicable in a system design, where the transport format of a transport block/protocol data unit does not change between initial and retransmission or can be derived from other information in the control channel signal for the retransmission and/or the initial transmission (for example, in some systems it may be possible to derive the transport format of a retransmission from the transport format and optionally resource allocation information related to the initial transmission—further also the information on the resource allocation for the retransmission may be taken into account). In this example, the control signaling for the retransmission may explicitly indicate the redundancy version of the protocol data unit used for its retransmission and implicitly yielding the transport format (i.e. the same transport format as used for the initial transmission of the protocol data unit that has been indicated in a previous control channel signal for the initial transmission or the transport format can be derived from other control channel signaling information as mentioned above).

As mentioned previously, as an additional enhancement, the new data indicator or sequence number may be additionally jointly coded with the transport format and redundancy version.

Utilizing the second approach of having a shared field for the transport format and the redundancy version defined in the control channel information structure, at one signaling instant

the shared field is used to signal the transport format and at another signaling instant the shared field is used to signal the redundancy version.

Accordingly, when jointly encoding the transport format and the redundancy version only on single set of reference information to map the bit value indicated by the bit combination in the common control information field in the control channel signal to a respective combination of transport format and redundancy version of the protocol data unit providing the user data may be needed, irrespective of whether the transmission is an initial transmission of the protocol data unit or a retransmission thereof.

In case of having a shared control information field in the control channel signal, there may be two sets of reference information to map the bit value indicated by the bit combination in the common control information field to a respective combination of transport format and redundancy version, depending on whether the transmission is an initial transmission of the protocol data unit or a retransmission thereof. For example, in case there is a pre-configured or fixed redundancy version for the initial transmission, the control channel signal for the initial transmission may explicitly indicate the transport format of the initial transmission within the shared field. For some retransmissions, the transport format of the initial transmission may be reused, so that the control channel signal for the retransmission may “only” explicitly indicate the redundancy version of the retransmission (while the transport format may be considered implicitly identified or known from the control channel signal for the initial or any previous transmission).

One significant difference between the general concept of the invention and existing systems, such as 3GPP HSDPA, from the viewpoint of an efficient system operation is related to HARQ protocol errors. In HSDPA a lost transport block (MAC PDU), e.g. due to an ACK/NACK misdetection or a lost L1/L2 downlink control signaling carrying the scheduling information (TF, HARQ, etc.), comes at a high resource cost and high delay, since the RLC protocol taking care of these errors is slow and heavy. In LTE systems (which is one of the target systems for employing the this invention), the higher-layer RLC protocol is lightweight and fast, which allows designing the L1/L2 downlink control signaling to be less robust, which in turn allows for optimizations disclosed herein. As indicated above, one approach suggested herein is the use of a single/common field in the control channel information format to indicate the transport format and (at least implicitly) the redundancy version of the transmission of a protocol data unit and to jointly encode (at least) these two parameters using the bits of the common field. According to one exemplary embodiment of the invention, the common field in the control channel information may be assumed to consist of N bits so that 2^N values can be represented and signaled. Out of the 2^N values M ($<2^N$) values may be for example used to indicate a transport format associated with a given fixed or pre-configured redundancy version. All or part of the remaining values is/are used to indicate additional redundancy versions.

Table 3 below illustrates an example, where the common field (Signaled Value) consists of 4 bits. The first part (denoted TF range) of the total range of values representable by the 4 bits is used to indicate different transport formats that are associated to a given redundancy version (RV 0). The remaining values representable by the 4 bits form a second part (denoted RV range) and indicate a redundancy version of the respective transmission.

TABLE 3

Signaled Value (binary)	Signaled Value (decimal)	TF (TBS)	RV	Ranges
0000	0	—	0	TF range
0001	1	—	0	
0010	2	—	0	
0011	3	—	0	
0100	4	—	0	
0101	5	100	0	
0110	6	120	0	
0111	7	150	0	
1000	8	200	0	
1001	9	—	0	
1010	10	—	0	
1011	11	—	0	
1100	12	—	0	
1101	13	N/A	1	RV range
1110	14	—	2	
1111	15	—	3	

In Table 3 above, all values of the TF range are assigned to a single redundancy version (RV 0) only. Of course, it may be also possible that the respective values/transport formats are associated to different redundancy versions. This is exemplified in FIG. 4 below.

TABLE 4

Signaled Value (binary)	Signaled Value (decimal)	TF (TBS)	RV	Ranges
0000	0	—	0	TF range
0001	1	—	0	
0010	2	—	0	
0011	3	—	0	
0100	4	—	1	
0101	5	100	1	
0110	6	120	1	
0111	7	150	1	
1000	8	200	2	
1001	9	—	2	
1010	10	—	2	
1011	11	—	2	
1100	12	—	2	
1101	13	N/A	0	RV range
1110	14	—	1	
1111	15	—	2	

According to the example in Table 4, redundancy versions may be defined depending on the actual signaling value. In one embodiment, for small transport block sizes or low MCS levels, one specific redundancy version (RV 0) could be used and for larger transport block sizes/high MCS levels, another redundancy version (RV 1 or RV 2) are used. Furthermore, in another example, the same transport format may be associated to different redundancy versions.

In operation, when initially transmitting a protocol data unit (or transport block), the base station may send a control channel signal comprising a common TF/RV field having a value selected from the “TF range”. Accordingly, the signaled value does not only identify a transport format of the protocol data unit but also indicates the respective redundancy version. If a protocol data unit is retransmitted, a value from the “RV range” indicating a specific redundancy version is signaled, as it may be assumed that the transport format is constant or known for all transmissions of a respective protocol data unit (transport block) to facilitate soft-combining by the HARQ protocol.

Alternatively, e.g. depending on the feedback of the receiver (e.g. the mobile station) of the protocol data unit provided to the transmitter (e.g. the base station) of the pro-

col data unit, the transmitter may decide to send the retransmission with the same transport format and redundancy version as the initial transmission. Using a reference table as shown in Table 3, the control channel signal for the retransmission may thus indicate the same value in the TF/RV field of the control channel signal as the control channel signal for the initial transmission (as the “RV range” does not allow to signal RV 0). If using a reference table as shown in Table 4, it should be noted that the “RV range” yields three the same three redundancy versions that are identified in the “TF range”, so that the TF/RV field in the control channel signal may always a value of the “RV range” for the retransmissions.

In case there should be the possibility to send retransmissions with the same redundancy version as the initial transmission, e.g. due to using HARQ with Chase combining as a retransmission protocol for the protocol data units the following exemplary implementations may be foreseen.

In one exemplary implementation, any “TF range” value can be signaled in the control channel signal for retransmissions, even if the signaled value does not matching the TF (TBS) value of the transport block (or in other words the TF of the initial transmission of the protocol data unit). In this case, the receiver (e.g. mobile station) simply ignores the transport format that would be yielded by the signaled “TF range” value, and simply applies the signaled redundancy version. Accordingly, in order to distinguish when to ignore the signaled transport format, the receiver may evaluate the sequence number (field) or new data indicator first, so as to recognize whether the associated transmission of the protocol data unit is an initial transmission or a retransmission.

In another, second exemplary implementation, also for a retransmission the “TF range” value can be signaled that is matching the transport format (TBS) of the first, initial transmission. In this case, the receiver (e.g. mobile station) shall typically not ignore the signaled transport format (TBS) value, as this might help to discover error cases. If for example the receiver has missed the control signaling of the initial transmission (and hence missed also the first transmission of the protocol data unit/transport block), the receiver may try to decode the data based on the signaling for the retransmission, since the control signaling contains the transport format.

In a third exemplary implementation, the interpretation of the transport format (TBS) value in the common TF/RV field depends on the resource allocation field also comprised in the control channel information. This means that for a given resource allocation size, only a specific range of transport block sizes may be signaled (typically, the transport block size TBS is related to the amount of allocated resources—measured in resource blocks RBs—as follows: $TBS=N \cdot RB$, where $N=1, 2, 3, \dots$). In case the resource allocation size changes between initial transmission and retransmissions, it may happen that it is not possible to signal the correct transport block size. In this case, it may be advantageous to include an “Out of Range” TF value in the reference table used at the receiver of the control channel signal to interpret the content of the TF/RV field. This latter case is exemplified in Table 5 below.

TABLE 5

Signaled Value (binary)	Signaled Value (decimal)	TF (TBS)	RV	Ranges
0000	0	—	0	TF range
0001	1	—	0	
0010	2	—	0	
0011	3	—	0	
0100	4	—	0	
0101	5	100	0	

19

TABLE 5-continued

Signaled Value (binary)	Signaled Value (decimal)	TF (TBS)	RV	Ranges
0110	6	120	0	
0111	7	150	0	
1000	8	200	0	
1001	9	—	0	
1010	10	—	0	
1011	11	—	0	
1100	12	“Out of Range”	0	
1101	13	NA	1	RV range
1110	14		2	
1111	15		3	

In another, fourth exemplary implementation, it may be ensured that the same redundancy version as used for an initial transmission may be used for a retransmission by having including in the “RV range” a value that yields the same redundancy version as yielded by the values of the “TF range”. This implementation is exemplified in Table 6 below, where the “RV range” also comprises a value (“1101”) that is indicating use of redundancy RV 0.

TABLE 6

Signaled Value (binary)	Signaled Value (decimal)	TF (TBS)	RV	Ranges
0000	0	—	0	TF range
0001	1	—	0	
0010	2	—	0	
0011	3	—	0	
0100	4	—	0	
0101	5	100	0	
0110	6	120	0	
0111	7	150	0	
1000	8	200	0	
1001	9	—	0	
1010	10	—	0	
1011	11	—	0	
1100	12	—	0	
1101	13	NA	0	RV range
1110	14		1	
1111	15		2	

In another embodiment of the invention, the control channel signal also includes a new data indicator (indicating whether the data is new data/a new protocol data unit) or a sequence number of the protocol data unit, which allows the receiver to detect the transmission of new data/a new protocol data unit.

According to one example, the new data indicator or the sequence number may be transmitted in a separate field or flag in the control channel signal. In one exemplary implementation the sequence number field is one bit, i.e. incrementing is identical to toggling the flag. Similarly, the new data indicator may be implemented as a 1-bit field. In case, a new transport block is transmitted (initial transmission) the new data indicator value is set (e.g. to value 1) and, if a transport block is retransmitted, the new data indicator is not set (e.g. is set to value 0).

According to another exemplary implantation, the sequence number or new data indicator is jointly encoded together with the transport format and the redundancy version in a single, common field of the control channel signal. Hence, the NDI/SN field may be no longer required, which allows to reduce signaling overhead.

20

The joint encoding of the new data indicator (NDI) with the transport format and the redundancy version according to two exemplary embodiments of the invention is shown in Table 7 and Table 8. In Table 8, the use of redundancy version RV 0 may be considered to implicitly also indicate new data, i.e. could therefore also be interpreted as a NDI flag being set (e.g. NDI=1), and all other redundancy versions RVs (RV 1-3) indicate retransmissions, i.e. could be also interpreted as the NDI flag not being set (e.g. NDI=0)

TABLE 7

Signaled Value (binary)	Signaled Value (decimal)	TF (TBS)	RV	NDI	Ranges
0000	0	—	0	1	TF range
0001	1	—	0	1	(new data range)
0010	2	—	0	1	
0011	3	—	0	1	
0100	4	—	0	1	
0101	5	100	0	1	
0110	6	120	0	1	
0111	7	150	0	1	
1000	8	200	0	1	
1001	9	—	0	1	
1010	10	—	0	1	
1011	11	—	0	1	
1100	12	—	0	1	
1101	13	N/A	0	0	RV range
1110	14		1	0	(retransmission range)
1111	15		2	0	

TABLE 8

Signaled Value (binary)	Signaled Value (decimal)	TF (TBS)	RV	NDI	Ranges
0000	0	—	0	1	TF range
0001	1	—	0	1	(new data range)
0010	2	—	0	1	
0011	3	—	0	1	
0100	4	—	0	1	
0101	5	100	0	1	
0110	6	120	0	1	
0111	7	150	0	1	
1000	8	200	0	1	
1001	9	—	0	1	
1010	10	—	0	1	
1011	11	—	0	1	
1100	12	—	0	1	
1101	13	N/A	1	0	RV range
1110	14		2	0	(retransmission range)
1111	15		3	0	

Essentially, Table 7 is similar to Table 6 (so is Table 8 to Table 3), except for adding another column to the reference table indicating the identified NDI setting for a respective signaled value. In general, independent from the specific example given in Table 7, it should be recognized that the definition of two ranges of values (“TF range” and “RV range”) also defines two ranges of values indicating, whether new data is sent or whether a retransmission is provided. Essentially, selecting a value from the “TF range” indicates a new transmission, and is thus equivalent to a new data indicator being set (or a sequence number being incremented). Similarly, selecting a value from the “RV range” indicates no new data being transmitted and is thus equivalent to new data indicator not being set (or a sequence number not being incremented). As the setting of a new data indicator (incrementing the sequence number) typically coincides with the transmission of an initial transmission of a protocol data unit

21

or transport block respectively, for initial transmissions a value from the “TF range” should be signaled and for retransmissions, a value from the “RV range” should be signaled.

Another alternative approach to the joint encoding of transport format and redundancy version is the use of a shared field (which could be also referred to as a shared TF/RV field) in the control channel information format to be used for the signaling of transport format and redundancy version. In this alternative approach, according to another embodiment of the invention, it is assumed that the transport format is generally associated to a specific redundancy version for the initial transmission (or the redundancy version for the initial transmission is either fixed or pre-defined). Accordingly, in case of an initial transmission, the shared field is interpreted as signaling a transport format, as shown in Table 9, and so to say implicitly indicating a redundancy version of the respective transmission in a similar fashion as discussed in some examples above relating to the joint encoding approach.

Furthermore, it is also assumed, that the transport block size is not changing between initial transmission and retransmission of a protocol data unit or transport block. Hence, in case of a retransmission the shared field in the control channel signal is interpreted as a redundancy version, as shown in Table 10.

TABLE 9

Signaled Value (binary)	Signaled Value (decimal)	TF (TBS)
0000	0	—
0001	1	—
0010	2	—
0011	3	—
0100	4	—
0101	5	100
0110	6	120
0111	7	150
1000	8	200
1001	9	—
1010	10	—
1011	11	—
1100	12	—
1101	13	—
1110	14	—
1111	15	—

TABLE 10

Signaled Value (binary)	Signaled Value (decimal)	RV
0000	0	RV 0
0001	1	RV 1
0010	2	RV 2
0011	3	RV 3
0100	4	RV 4
0101	5	—
0110	6	—
0111	7	—
1000	8	—
1001	9	—
1010	10	—
1011	11	—
1100	12	—
1101	13	—
1110	14	reserved
1111	15	reserved

Comparing the joint encoding approach and the use of a shared field, the main difference between the approaches is

22

the interpretation of the bits of the respective fields. In the joint encoding case, the same reference table is used for interpreting the bits of the common field in the control channel signal to determine transport format and redundancy version of a transmission, irrespective of whether the transmission is an initial transmission or a retransmission. Furthermore, in case of additionally jointly encoding the sequence number or a new data indicator, the value range that can be represented by the bits in the common field should be separated into two ranges so as to be able to differentiate between initial transmission and retransmission and to thereby recognize a new data indicator being set or a sequence number being incremented. In contrast, the shared field approach is using two different reference tables for the interpretation of the bits contained in the common field for transport format and redundancy version (see Tables 9 and 10 above), depending on whether an initial transmission or a retransmission is sent. This allows more freedom and flexibility to indicate a larger variety of transport formats and redundancy versions or may allow reducing the size of the signaling field.

However, the receiver of the control channel signal must be aware of whether an initial transmission or a retransmission is associated to the respective control channel signal. In theory, the receiver of the control channel signal may derive the information from its own feedback, which is however not necessarily very reliable as the feedback may be lost or misinterpreted.

Therefore, in one further embodiment of the invention, it is suggested that the control channel signal further comprises an additional sequence number field or new data indicator. In case of using a new data indicator, the interpretation of the shared TF/RV field depends on the value of the new data indicator field, i.e. returning to the example above, the receiver (e.g. mobile station) of the control channel signal either chooses Table 9 or table 10 for interpreting the shared TF/RV field depending on the setting of the new data indicator. Similarly, in case of having a sequence number field, the receiver selects the reference table for interpreting the content of the shared TF/RV field based on the sequence number being incremented or not.

The differences between a joint encoding of transport format and redundancy version in a common field and the use of a shared field will be exemplified with respect to FIG. 5 and FIG. 6. In FIG. 5 a control channel signal according to one exemplary embodiment is shown. The control channel signal comprises a resource allocation field (RB allocation), a TF/RV field for jointly encoding transport format and redundancy version (“Joint TF/RV field”), a NDI/SN field and HARQ process field. The same configuration of the control channel signal is provided on FIG. 6.

In FIG. 5, the transport format and redundancy version are jointly encoded in a common field (“Joint TF/RV field”) irrespective of whether the control channel information relate to an initial transmission or a retransmission. The four bits of the common field for transport format and redundancy version may for example represent the transport format and redundancy versions as outlined above with respect to Tables 3 to 6.

In FIG. 6, the shared field approach according to one exemplary embodiment of the invention is illustrated in further detail. The NDI/SN field may either comprise a new data indicator or a sequence number and is used to determine, whether the control channel information relates to an initial transmission and which reference information are to be used for interpreting the content of the shared TF/RV field. If the control channel information is related to an initial transmis-

sion of a protocol data unit or transport block, the shared TF/RV field indicates the transport format thereof, as for example shown in Table 9 above. If the control channel information is related to a retransmission, the shared TF/RV field indicates the redundancy version of the protocol data unit, as for example shown in Table 10 above.

Next, operation of the transmitter of the control channel signal according to one of the various embodiments described herein and the receiver thereof will be described in further detail, thereby exemplarily relating to the case of downlink data transmission. For exemplary purposes a network as exemplified in FIG. 10 may be assumed. The mobile communication system of FIG. 10 is considered to have a “two node architecture” consisting of at least one Access and Core Gateway (ACGW) and Node Bs. The ACGW may handle core network functions, such as routing calls and data connections to external networks, and it may also implement some RAN functions. Thus, the ACGW may be considered as to combine functions performed by GGSN and SGSN in today’s 3G networks and RAN functions as for example radio resource control (RRC), header compression, ciphering/integrity protection.

The base stations (also referred to as Node Bs or enhanced Node Bs=eNode Bs) may handle functions as for example segmentation/concatenation, scheduling and allocation of resources, multiplexing and physical layer functions, but also RRC functions, such as outer ARQ. For exemplary purposes only, the eNodeBs are illustrated to control only one radio cell. Obviously, using beam-forming antennas and/or other techniques the eNodeBs may also control several radio cells or logical radio cells.

In this exemplary network architecture, a shared data channel may be used for communication of user data (in form or protocol data units) on uplink and/or downlink on the air interface between mobile stations (UEs) and base stations (eNodeBs). This shared channel may be for example a Physical Uplink or Downlink Shared CHannel (PUSCH or PDSCH) as known in LTE systems. However, it is also possible that the shared data channel and the associated control channels are mapped to the physical layer resources as shown in FIG. 2 or FIG. 3.

The control channel signals/information may be transmitted on separate (physical) control channels that are mapped into the same subframe to which the associated user data (protocol data units) are mapped or may be alternatively sent in a subframe preceding the one containing the associated information. In one example, the mobile communication system is a 3GPP LTE system, and the control channel signal is L1/L2 control channel information (e.g. information on the Physical Downlink Control CHannel—PDCCH). Respective L1/L2 control channel information for the different users (or groups of users) may be mapped into a specific part of the shared uplink or downlink channel, as exemplarily shown in FIGS. 2 and 3, where the control channel information of the different users is mapped to the first part of a downlink subframe (“control”).

FIG. 8 shows a message exchange and tasks performed by a transmitter and a receiver of a control channel signal according to an exemplary embodiment of the invention. The message exchange may be performed in the mobile communication network shown in FIG. 10. Accordingly, as the example in FIG. 8 is relating to the downlink data transmission, the transmitter shown in FIG. 8 may be assumed to correspond to base station/Node B NB1 in FIG. 10 and the receiver shown in FIG. 8 may be assumed to correspond to mobile station/UE MS1 in FIG. 10. Generally, it may be assumed in FIG. 8 that a retransmission protocol, such as

Hybrid ARQ, is used between the transmitter (here: base station NB1) and receiver (here: mobile station MS1) of the data (protocol data unit) so as to ensure successful decoding of the data at the receiver.

Mobile station MS1 is first receiving 801 the PDCCH and obtains a L1/L2 control channel signal. Subsequently, the mobile station MS1 interprets (or decodes) 802 the content of L1/L2 control channel signal. The control channel signal may be assumed to have a format as exemplified in FIG. 6. Next, the mobile station MS1 receives and tries to decode 804 the protocol data unit transmitted 803 on the associated downlink data channel with the parameters indicated by the L1/L2 control channel signal.

In case the mobile station MS1 can decode the protocol data unit successfully (known due to correct CRC), it transmits an ACK on the uplink. Alternatively, the mobile station MS1 transmits 805 a NACK on the uplink, if it has not decoded the data correctly (known due to false CRC). In case mobile station MS1 did not receive (decode correctly) the control channel signal from the PDCCH, it does not transmit an ACK or NACK on the uplink (DTX).

In case of receiving a NACK at the base station NB1, same will provide a retransmission of the protocol data unit to the mobile station. As the retransmission of the protocol data unit is exemplarily assumed to be another redundancy version of the same protocol data unit, the base station NB1 generates 806 a control channel signal for the retransmission and transmits 807, this control channel signal and the retransmission of the protocol data unit 809 to mobile station MS1. Similar to steps 802 and 804, mobile station MS1 receives 808 the control channel signal for the retransmission and uses the parameters indicated therein to receive and decode 810 the retransmission of the protocol data unit. As it is assumed that the protocol data unit may be correctly decoded after having received the retransmission, mobile station MS1 informs 811 the base station NB1 on the successful (unsuccessful) decoding by means of an ACK (NACK).

In a further embodiment, some further improvement to the retransmission protocol is suggested. This improvement will be outlined with the exemplary signaling flow and data exchange as illustrated in FIG. 9. It may be assumed that the retransmission protocol is provided on the Medium Access Layer (MAC) of the mobile communication system and that another higher layer protocol in the protocol stack provides another retransmission function to ensure successful data delivery. For example, this higher layer protocol may be the Radio Link Control (RLC) protocol.

Generally, if a mobile station misses 901 the control signaling (e.g. on the PDCCH) for the initial transmission of a protocol data unit (e.g. MAC PDU), it may also not receive 903 the initial transmission of the protocol data unit as well. Furthermore, the mobile station is also not aware of the transport format that will be used for the transmission and retransmissions of the protocol data unit and provides no feedback to the transmitting base station.

In case the base station does not receive any feedback for the initial transmission, a typical implementation of the scheduler unit of the base station considers 903 this absence of feedback as a NACK (two-state ACK/NACK receiver) and the base station generates 904 and transmits 905, another L1/L2 control signaling for the retransmission of the protocol data unit.

If the mobile station subsequently receives 906 this L1/L2 control signaling for the retransmission. Assuming now that there is a common field for the transport format and the redundancy version within the control signaling, the bits in the common TF/RV field do not yield the transport format

25

(e.g. transport block sizes, MCS, etc.) of the protocol data unit, but may only indicate the redundancy version (see for example Tables 3 to 8 and assuming that a value of the “RV range” is signaled for retransmission or see Table 9 for the shared TF/RV field approach). Even though the mobile station is not capable of receiving the retransmission of the protocol data unit, according to this embodiment of the invention, the mobile station sends a positive acknowledgement (ACK) in order to abort the transmission of the current protocol data unit (MAC PDU), since otherwise (transmitting NACK) the base station would continue with retransmissions without the mobile terminal having a chance to correctly decode the transport block. The transmission of an ACK causes the transport block being lost, however retransmission of this transport block (protocol data unit) can be taken care of by higher layer (ARQ) protocols, if available (e.g. RLC).

A similar behavior can for example also be implemented in case the base station (or rather the scheduling unit) has the capability to not only detect ACK/NACKs from but also a transmitted DTX (i.e. no transmission of ACK/NACK)—i.e. a three-state ACK/NACK/DTX receiver—for situations where the mobile station missed the control signaling on the PDCCH, but due to an error in receiving/decoding the feedback—the base station wrongly detects a NACK instead of DTX. In this case the base station will send a retransmission for the protocol data packet together with an associated control channel signal indicating the transmission to be a retransmission, similar as for the 2-state ACK/NACK receiver case described above. In this case, the mobile station may detect a protocol error and sends a positive acknowledgement to abort the retransmissions. In case the base station correctly detects the DTX signal, the base station may transmit another initial transmission (indicating the transport format) of the same transport block or of a newly constructed transport block.

The exemplary embodiments discussed above have been mainly focused on L1/L2 control signaling for downlink data transmission. Also in case of uplink data transmissions, the L1/L2 control signaling may be transmitted in the downlink. As the transmission of the (user) data is on another link (uplink), the transmissions of the data may take place on different sub-frames numbers than the associated control signaling (because uplink and downlink may not really be synchronized, i.e. the timing of the uplink and downlink sub-frames are different). In any case there needs to be a well-defined mapping of the sub-frame the control signaling takes place and the sub-frame the actual data transmission takes place. Accordingly in TDD systems, the subframes may be different for uplink and for downlink.

In the following further options and improvements to the L1/L2 control signaling discussed previously herein will be discussed.

Another embodiment of the invention relates to a further improvement of the use of a shared TF/RV field in the control channel signal. The number of signaling bits for the transport format (e.g. 4-7 bits) is typically larger than the bits needed for the redundancy (e.g. 1-3 bits). Therefore, in case of signaling the redundancy version for retransmissions some bits (or values) of the shared TF/RV field may for example be used to transmit other useful control information. For example, some or all bits not used for signaling the redundancy version may be used to signal:

the modulation scheme as shown in FIG. 11, e.g. in case the modulation scheme should be controlled for each retransmission independently. In this case the code rate for decoding can be determined from the transport block size known from a previous transmission (typically initial transmission), the signaled resource allocation (from

26

which the resource allocation size can be determined) and the signaled modulation scheme.

additional restricted transport format related information, e.g. on modulation only, on the MCS level, on the TBS, etc.

MIMO HARQ sub-process information, as for example suggested in 3GPP TSG RAN WG1 #47 Tdoc. R1-063548, “MIMO HS-SCCH structure”, November 2006 (available at <http://www.3gpp.org> and incorporated herein by reference). Assuming a MIMO mode supporting a 2 code word transmission and 2 HARQ processes, typically, the sub process number needs to be signaled in the L1/L2 control channel, which requires an additional bit for the HARQ process. Assuming that this bit is not required in initial transmissions, in retransmissions this bit can be signaled on the available space.

additional power control information for uplink/downlink control and data channels.

information on the resources used (by the base station) or to be used (by the UE) for the ACK/NACK signaling. This information maybe e.g. an explicit indication of the resources or maybe restricting the resources.

a flag bit indicating that the remaining bits in the shared field are used for RV information or e.g. for (restricted) TF information (see FIG. 7). This maybe especially beneficial in case of self-decodable retransmissions, where the base station has the flexibility to choose what to signal in the retransmissions.

It should be noted, that in a further embodiment of the invention, control channel signaling is transmitted for initial transmissions and optionally in addition for selected retransmissions of a protocol data unit. Thus, some or all retransmissions may be transmitted without a control channel. In this case the control information for being able to receive the transmission of the associated protocol data unit may be derived from the control signaling for the initial transmission of the protocol data unit, from an earlier (re)transmission of the protocol data unit or the transport format and redundancy version for the retransmissions may be predefined. E.g. the resource allocation may be derived from the resource allocation of an earlier transmission (e.g. identical resource allocation or predefined hopping and resizing of the resource allocation). This implementation may be for example used for uplink data transmission with a synchronous HARQ protocol.

In comparison to conventional schemes the use of a common field for transport format and redundancy version (and optionally the NDI/SN) has the following advantages. The reduction of the L1/L2 control signaling overhead compared to having separate field in the control channel format for transport format, redundancy version and NDI/SN fields by the disclosed concept is up to 3 bits depending on the actual embodiment. Assuming L1/L2 control signaling formats as described in the co-pending PCT application no. PCT/EP2007/010755, “Configuration of Control Channels in a Mobile Communication System” (by the same applicant, filed Dec. 10, 2007) yielding sizes between ~25 and ~80 bits for the L1/L2 control channel signal, this results into an overhead reduction of 4-12%. Especially, for the small L1/L2 control signaling formats the reduction is beneficial (up to 12% reduction), since these are used for cell-edge mobile stations, where the (power and time-frequency) resources per L1/L2 control channel (PDCCH) are large due to power and MCS control of the L1/L2 control channel (PDCCH). Therefore, the concept of having a common field for encoding transport format and redundancy version (and optionally the NDI/SN) allows for an increased coverage and cell size.

Furthermore, the use of a common field for encoding transport format and redundancy version (and optionally the NDI/SN) in the control signaling also allows signaling more transport format sizes. Assuming that e.g. in total 8 bits for transport format, redundancy version and NDI/SN (5 bits TF, 2 bits RV, 1 bit NDI/SN) are used in a conventional system to code the respective fields individually, the joint encoding of transport format and redundancy version and still having a separate NDI/SN field allows using 7 bits for a common field. The prior art yields up to $2^5-1=31$ transport format values (one value reserved for “Out of Range”), whereas the joint encoding of transport format and redundancy version in a TF/RC field yields $2^7-3=125$ transport format values (assuming 3 values are to be reserved for signaling 3 RVs defined for retransmissions). This provides a significantly finer granularity of transport block sizes allowing e.g. for a lower MAC PDU padding overhead or a finer link adaptation by MCS selection. In case of additionally jointly encoding the NDI, the number of transport formats values further increases to $2^8-3=253$.

Furthermore, as discussed in several examples above, in implementations where the transport format (Transport Block Size) does not change for retransmissions, which should be the case, since otherwise soft-combining is not feasible, no transport format needs to be signaled for retransmissions. In a conventional design, the transport format is also signaled in retransmissions. In certain cases, the signaling of the transport format for retransmissions can help from recovering error cases (e.g. if the receiver missed the transmission of the control signaling for the initial transmission). However, these error cases are very unlikely for certain systems, and therefore, it is more efficient to avoid signaling of the transport format for retransmissions, which saves control signaling overhead.

The signaling of the transport format for retransmission typically causes additional overhead in the control signaling so as to account for error cases in case the resource allocation size is changing for retransmissions. In certain cases, it can happen that the transport format (transport blocks size), which needs to be signaled for retransmissions in conventional designs, is not within the range of the values that can be signaled after the update of the resource allocation. In this case, conventional systems typically define an “Out of Range” value to account for these situations. In some of the embodiments of the invention discussed herein, this “Out of Range” value is not required since the transport format (transport block size) is not signaled in retransmissions.

Another feature of the invention according to some embodiments of the invention is that it does not allow for a dynamic selection of the redundancy version for the initial transmission. This is not necessarily a drawback in comparison with conventional solutions (which may allow for a free choice of the redundancy version for initial transmissions), since dynamic redundancy version selection is typically not beneficial and may only be applied in rare cases.

Examples of mobile communication systems in which the principles of the invention outlined herein may be utilized are communication systems utilizing an OFDM scheme, a MC-CDMA scheme or an OFDM scheme with pulse shaping (OFDM/OQAM).

Another embodiment of the invention relates to the implementation of the above described various embodiments using hardware and software. It is recognized that the various embodiments of the invention may be implemented or performed using computing devices (processors). A computing device or processor may for example be general purpose processors, digital signal processors (DSP), application spe-

cific integrated circuits (ASIC), field programmable gate arrays (FPGA) or other programmable logic devices, etc. The various embodiments of the invention may also be performed or embodied by a combination of these devices.

Further, the various embodiments of the invention may also be implemented by means of software modules, which are executed by a processor or directly in hardware. Also a combination of software modules and a hardware implementation may be possible. The software modules may be stored on any kind of computer readable storage media, for example RAM, EPROM, EEPROM, flash memory, registers, hard disks, CD-ROM, DVD, etc.

Furthermore, it should be noted that the terms mobile terminal and mobile station are used as synonyms herein. A user equipment may be considered one example for a mobile station and refers to a mobile terminal for use in 3GPP-based networks, such as LTE.

In the previous paragraphs various embodiments of the invention and variations thereof have been described. It would be appreciated by a person skilled in the art that numerous variations and/or modifications may be made to the present invention as shown in the specific embodiments without departing from the spirit or scope of the invention as broadly described.

It should be further noted that most of the embodiments have been outlined in relation to a 3GPP-based communication system and the terminology used in the previous sections mainly relates to the 3GPP terminology. However, the terminology and the description of the various embodiments with respect to 3GPP-based architectures is not intended to limit the principles and ideas of the inventions to such systems.

Also the detailed explanations given in the Technical Background section above are intended to better understand the mostly 3GPP specific exemplary embodiments described herein and should not be understood as limiting the invention to the described specific implementations of processes and functions in the mobile communication network. Nevertheless, the improvements proposed herein may be readily applied in the architectures described in the Technical Background section. Furthermore, the concept of the invention may be also readily used in the LTE RAN currently discussed by the 3GPP.

The invention claimed is:

1. A mobile terminal for use in a mobile communication system, the mobile terminal comprising:

a receiver unit for receiving a sub-frame of physical radio resources comprising a control channel signal destined to the mobile terminal,

a processing unit for determining based on the received control channel signal a transport format of and a redundancy version for an initial transmission or a retransmission of a protocol data unit conveying user data, and

a transmitter unit for transmitting the protocol data unit on at least one physical radio resource using the transport format and the redundancy version of the protocol data unit indicated in the received control channel signal,

wherein the control channel signal received within said sub-frame comprises a control information field, in which the transport format and the redundancy version of the protocol data unit are jointly encoded,

wherein the processing unit is further configured for the determination of the control information field, which consists of a number of bits representing a range of values that can be represented in the control information field, wherein a first subset of the values is reserved for indicating the transport format of the protocol data unit and a second subset of the values, different from the first

29

subset of the values, is reserved for indicating the redundancy version for transmitting the user data, and wherein the first subset of the values contains more values than the second subset of the values.

2. The mobile terminal according to claim 1, wherein every value of the first subset of the values indicates a transport format and every value of the second subset of the values indicates a redundancy version.

3. The mobile terminal according to claim 1, wherein the redundancy version of the protocol data unit is implicit in the transport format indicated by a corresponding value of the first subset.

4. The mobile terminal according to claim 1, wherein the value of the encoded information bits in the control information field is representing a value of the first subset of the values, in case the transmission of the protocol data unit is an initial transmission of the user data.

5. The mobile terminal according to claim 1, wherein the value of the encoded information bits in the control information field is representing a value of the first subset or the second subset of the values, in case the transmission of the protocol data unit is a retransmission of the user data.

6. The mobile terminal according to claim 1, wherein the value of the encoded information bits in the control information field is representing a value of the second subset of the values, in case the transmission of the protocol data unit is a retransmission of the user data.

7. The mobile terminal according to claim 1, wherein the bits of the control information field jointly encode the transport format, the redundancy version used for transmitting the protocol data unit, and a new data indicator for indicating whether the transmission of the protocol data unit is an initial transmission of the user data, and

wherein use of one of the values of the first subset also indicates the transmission of the protocol data unit to be an initial transmission.

8. The mobile terminal according to claim 1, wherein the redundancy version to be used for the initial transmission of the user data in the protocol data unit is fixed or preconfigured.

9. The mobile terminal according to claim 1, wherein the control channel signal is further comprising a sequence number field indicating a sequence number of the protocol data unit.

10. The mobile terminal according to claim 1, wherein the control channel signal is further comprising a new data indicator field indicating whether the transmission of the protocol data unit is an initial transmission or a retransmission of the user data.

11. The mobile terminal according to claim 1, wherein the control channel signal further comprises a mobile terminal identifier field for indicating the mobile terminal or a group of mobile terminals that are to receive the control channel signal.

12. The mobile terminal according to claim 1, wherein the control channel signal is a L1/L2 control channel signal.

13. The mobile terminal according to claim 1, wherein in case the transmission of the protocol data unit is a retransmission of the user data, the bits of the control information field include a flag indicating a type of information indicated by the remaining bits of the control information field.

14. A method for use in a mobile communication system, the method comprising the following steps performed by a mobile terminal:

receiving a sub-frame of physical radio resources comprising a control channel signal destined to the mobile terminal,

30

determining based on the received control channel signal a transport format of and a redundancy version for an initial transmission or a retransmission a protocol data unit conveying user data, and

transmitting the protocol data unit on at least one physical radio resource using the transport format and the redundancy version of the protocol data unit indicated in the received control channel signal,

wherein the control channel signal received within said sub-frame comprises a control information field, in which the transport format and the redundancy version of the protocol data unit are jointly encoded,

wherein the control information field consists of a number of bits representing a range of values that can be represented in the control information field, wherein a first subset of the values is reserved for indicating the transport format of the protocol data unit and a second subset of the values, different from the first subset of the values, is reserved for indicating the redundancy version for transmitting the user data, and

wherein the first subset of the values contains more values than the second subset of the values.

15. The method according to claim 14, wherein every value of the first subset of the values indicates a transport format and every value of the second subset of the values indicates a redundancy version.

16. The method according to claim 14, wherein the redundancy version of the protocol data unit is implicit in the transport format indicated by a corresponding value of the first subset.

17. The method according to claim 14, wherein the value of the encoded information bits in the control information field is representing a value of the first subset of the values, in case the transmission of the protocol data unit is an initial transmission of the user data.

18. The method according to claim 14, wherein the value of the encoded information bits in the control information field is representing a value of the first subset or the second subset of the values, in case the transmission of the protocol data unit is a retransmission of the user data.

19. The method according to claim 14, wherein the value of the encoded information bits in the control information field is representing a value of the second subset of the values, in case the transmission of the protocol data unit is a retransmission of the user data.

20. The method according to claim 14, wherein the bits of the control information field jointly encode the transport format, the redundancy version used for transmitting the protocol data unit, and a new data indicator for indicating whether the transmission of the protocol data unit is an initial transmission of the user data, and

wherein use of one of the values of the first subset also indicates the transmission of the protocol data unit to be an initial transmission.

21. The method according to claim 14, wherein the redundancy version to be used for the initial transmission of the user data in the protocol data unit is fixed or preconfigured.

22. The method according to claim 14, wherein the control channel signal is further comprising a sequence number field indicating a sequence number of the protocol data unit.

23. The method according to claim 14, wherein the control channel signal is further comprising a new data indicator field indicating whether the transmission of the protocol data unit is an initial transmission or a retransmission of the user data.

24. The method according to claim 14, wherein the control channel signal further comprises a mobile terminal identifier

31

field for indicating the mobile terminal or a group of mobile terminals that are to receive the control channel signal.

25. The method according to claim 14, wherein the control channel signal is a L1/L2 control channel signal.

26. The method according to claim 14, wherein in case the transmission of the protocol data unit is a retransmission of the user data, the bits of the control information field include a flag indicating a type of information indicated by the remaining bits of the control information field.

27. The method according to claim 14, wherein the transport format is transport block size information of the protocol data unit, and wherein the received control channel signal further comprises a resource allocation field indicating the physical radio resource or resources allocated to the mobile terminal,

and said determining depends on the information comprised in the resource allocation field and the control information field.

28. The method according to claim 14, further comprising reusing the transport format of the protocol data unit indicated in the control channel signal for the initial transmission, for the retransmission of the protocol data unit.

29. The method according to claim 14, wherein the bits of the control information field are associated with single reference information indicating a transport format and a redundancy version used for transmitting the protocol data unit, the single reference information being associated with respective values represented by the bits of the control information field for an initial transmission and a retransmission of the protocol data unit.

30. A base station for use in a mobile communication system, the base station comprising:

a transmitter unit for transmitting a sub-frame of physical radio resources comprising a control channel signal to a mobile terminal, the control channel signal indicating a transport format of and a redundancy version for an initial transmission or a retransmission of a protocol data unit conveying user data for use in an uplink transmission from the mobile terminal, and

a receiver unit for receiving the uplink transmission of the protocol data unit from the mobile terminal on at least

32

one physical radio resource using the transport format and the redundancy version indicated in the control channel signal,

wherein the control channel signal transmitted within said sub-frame comprises a control information field, in which the transport format and the redundancy version of the protocol data unit are jointly encoded,

wherein the control information field consists of a number of bits representing a range of values that can be represented in the control information field, wherein a first subset of the values is reserved for indicating the transport format used for the uplink transmission of the protocol data unit and a second subset of the values, different from the first subset of the values, is reserved for indicating the redundancy version used for the uplink transmission of the protocol data unit, and

wherein the first subset of the values contains more values than the second subset of the values.

31. The base station according to claim 30, wherein every value of the first subset of the values indicates a transport format and every value of the second subset of the values indicates a redundancy version.

32. The base station according to claim 30, wherein the redundancy version for the uplink transmission of the protocol data unit is implicit in the transport format indicated by a corresponding value of the first subset.

33. The base station according to claim 30, wherein the value of the encoded information bits in the control information field is representing a value of the first subset of the values, in case the transmission of the protocol data unit is an initial transmission of the user data.

34. The base station according to claim 30, wherein the value of the encoded information bits in the control information field is representing a value of the first subset or the second subset of the values, in case the transmission of the protocol data unit is a retransmission of the user data.

35. The base station according to claim 30, wherein the value of the encoded information bits in the control information field is representing a value of the second subset of the values, in case the transmission of the protocol data unit is a retransmission of the user data.

* * * * *

EXHIBIT 5

(12) **United States Patent**
Miyoshi et al.

(10) **Patent No.:** **US 8,208,569 B2**
 (45) **Date of Patent:** **Jun. 26, 2012**

(54) **METHOD AND APPARATUS FOR MULTICARRIER COMMUNICATION**

(75) Inventors: **Kenichi Miyoshi**, Kanagawa (JP); **Jun Cheng**, Kyoto (JP)

(73) Assignee: **Panasonic Corporation**, Osaka (JP)

(*) Notice: Subject to any disclaimer, the term of this patent is extended or adjusted under 35 U.S.C. 154(b) by 0 days.

(21) Appl. No.: **12/901,220**

(22) Filed: **Oct. 8, 2010**

(65) **Prior Publication Data**

US 2011/0026615 A1 Feb. 3, 2011

Related U.S. Application Data

(63) Continuation of application No. 10/559,472, filed on Jan. 31, 2006, now Pat. No. 7,817,729.

(30) **Foreign Application Priority Data**

Jun. 12, 2003 (JP) 2003-168287

(51) **Int. Cl.**
H04K 1/10 (2006.01)

(52) **U.S. Cl.** **375/260**

(58) **Field of Classification Search** 375/260
 See application file for complete search history.

(56) **References Cited**

U.S. PATENT DOCUMENTS

6,865,232 B1 3/2005 Isaksson
 6,870,826 B1 3/2005 Ishizu
 7,277,498 B2 10/2007 Hanaoka

7,418,240 B2 8/2008 Hsu
 2001/0055287 A1 12/2001 Sawada
 2002/0159422 A1* 10/2002 Li et al. 370/342
 2002/0159425 A1 10/2002 Uesugi
 2003/0097623 A1 5/2003 Razavilar
 2004/0081248 A1 4/2004 Parolari

FOREIGN PATENT DOCUMENTS

JP 07-183862 7/1995
 JP 11-074804 3/1999
 JP 3061768 7/2000
 JP 2000-332724 11/2000
 JP 2001-103032 4/2001
 JP 2002-9734 1/2002
 JP 3538098 6/2004
 WO 01/86826 11/2001
 WO 02/073831 9/2002

OTHER PUBLICATIONS

Zhang, "Turbo coding in ADSL DMT", ICC 2001, IEEE International Conference on Communications, 2001, Issue Date: Jun. 11-14, 2001, on pp. 151-155 vol. 1.*
 Zhang, "Turbo coding for transmission over ADSL" WCC-ICCT 2000. International Conference on Communication Technology Proceedings, 2000, Issue Date: 2000, on pp. 124-131 vol. 1, Meeting Date: Aug. 21, 2000-Aug. 25, 2000.*

(Continued)

Primary Examiner — Juan A Torres
 (74) *Attorney, Agent, or Firm* — Dickinson Wright PLLC

(57) **ABSTRACT**

A multicarrier communication method and a multicarrier communication apparatus used for the method for adjusting the arrangement in code block units according to the actual reception state of the multicarrier signal, when arranging code blocks generated through error correcting coding processing not only in the time axis direction but also in the frequency axis direction in order to improve an error correction rate of a multicarrier signal.

44 Claims, 10 Drawing Sheets

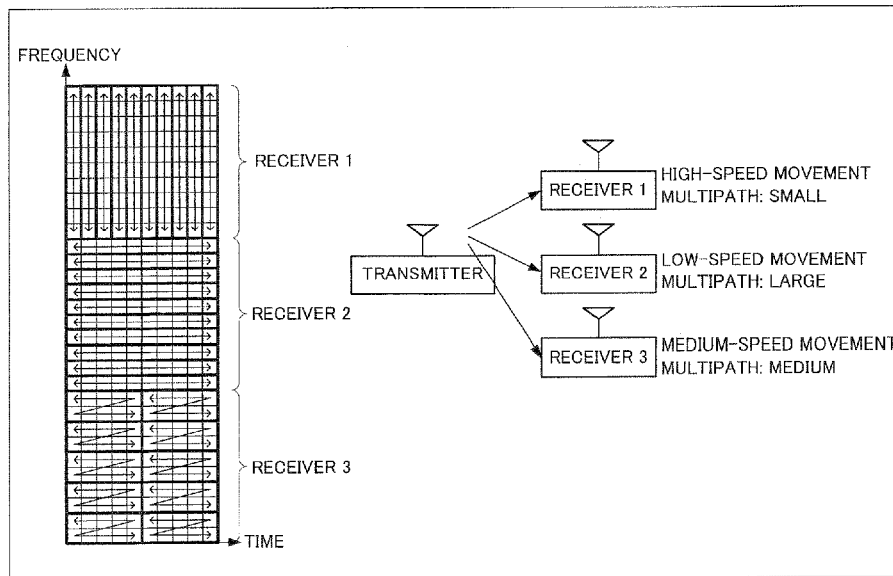

US 8,208,569 B2

Page 2

OTHER PUBLICATIONS

- IEEE80216a, "OFDM proposal for the IEEE80216a PHY draft standard", IEEE, 2001.*
- IEEE802.11a, "Wireless LAN Medium Access Control (MAC) and Physical Layer (PHY) specification High-speed Physical Layer in the 5 GHz Band" IEEE 1999 pp. 16-24.*
- Rauschmayer, "ADSL/VDSL Principles", Macmillan Technical Publishing 1999, pp. 171 and 208.*
- PCT International Search Report dated Aug. 3, 2004.
- N. Maeda, et al., "Nijigen Kakusan o Mochiuru VSF-OFCDM to Sono Tokusei—VSF/OFCDM Using Two-Dimensional Spreading and Its Performance," Technical Report of IEICE, vol. 102, No. 86, RCS2002-61, May 2002, pp. 59-64.
- K. Sudo, et al., "Shuhasu Sentakusei Phasing Tsushinro ni Okeru Kukan Jikan Shuhasu Block Fugo no Tokusei Hyoka—Performance Evaluation of Space-Time-Frequency Block Codes over Frequency Selective Fading Channels," Technical Report of IEICE, vol. 102, No. 282, RCS2002-156, Aug. 2002, pp. 59-64.
- Japanese Office Action dated May 23, 2006, with English translation.
- Korean Office Action dated Aug. 28, 2006 with English translation.
- V. Lau, "Performance of Variable Rate Bit Interleaved Coding for High Bandwidth Efficiency," IEEE, VTC 2000, Aug. 1999, pp. 2054-2058.
- S. Lei, et al., "Performance Analysis of Adaptive Interleaving for OFDM Systems," IEEE Transactions on Vehicular Technology, vol. 51, No. 3, May 2002, pp. 435-444.
- Lei, "Adaptive interleaving for bandwidth-efficient OFDM systems," MILCOM 2000, 21st Century Military Communications Conference Proceedings, vol. 2, Oct. 2000, pp. 927-931.
- Lei, "Adaptive interleaving for OFDM in TDD systems," IEE Proceedings-Communications, vol. 148, Issue 2, Apr. 2001, pp. 77-80.
- Wang, "Time-frequency code for multi-carrier DS-CDMA systems," Vehicular Technology Conference 2002, IEEE 55th Publication Date: 2002, vol. 3, Spring 2002, pp. 1224-1227.
- Harada, "OFDM systems with multiple trellis coded modulation," PIMRC 2000, 11th IEEE International Symposium on Personal, Indoor and Mobile Radio Communications, 2000, vol. 2, Sep. 2000, pp. 814-818.
- Qiao, "Goodput Enhancement of IEEE 802.11a Wireless LAN via Link Adaptation," 2001 IEEE International Conference on Communications, vol. 1, Jun. 2001, pp. 1995-2000.
- "Wireless LAN Medium Access Control (MAC) and Physical Layer (PHY) specifications High-speed Physical Layer in the 5 GHz Band," IEEE 802.11a, 1999.
- "Asymmetric digital subscriber line (ADSL) transceivers," ITU, G.992.1, Jul. 1999.

* cited by examiner

FIG. 1 A
RELATED
ART

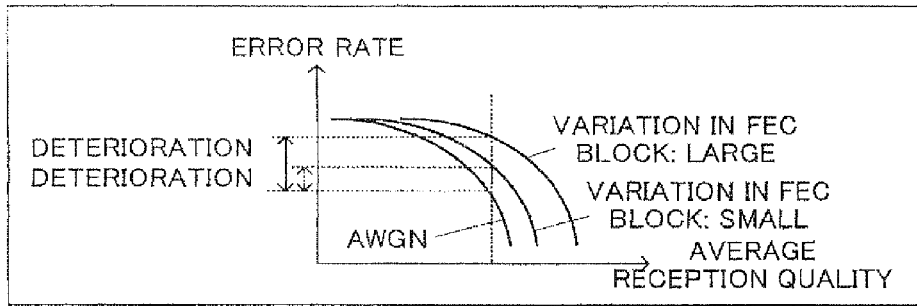

FIG. 1 B
RELATED
ART

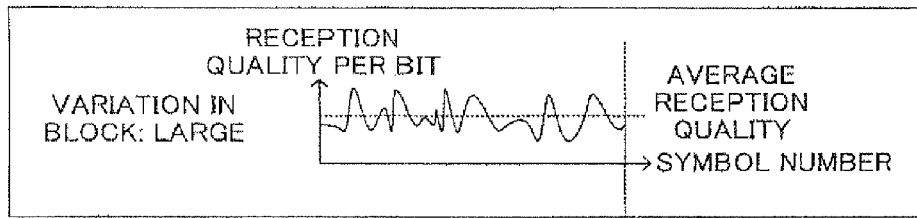

FIG. 1 C
RELATED
ART

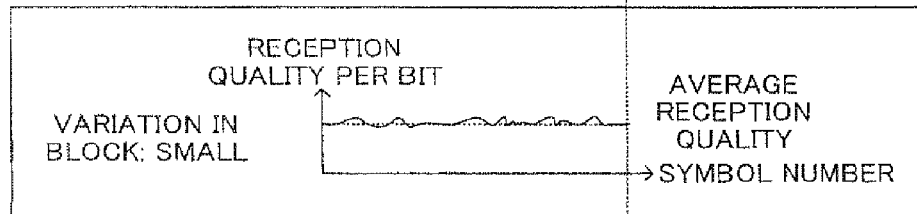
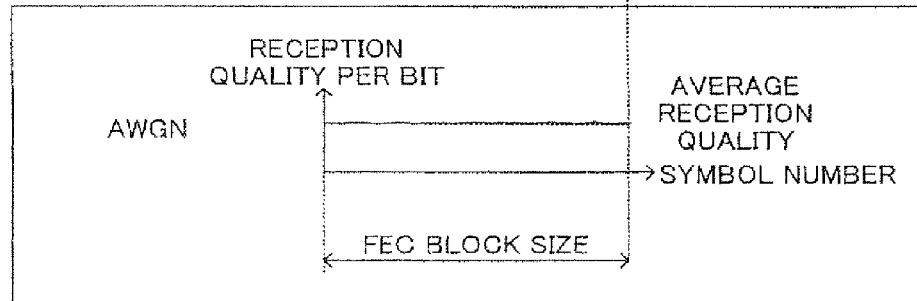

FIG. 1 D
RELATED
ART



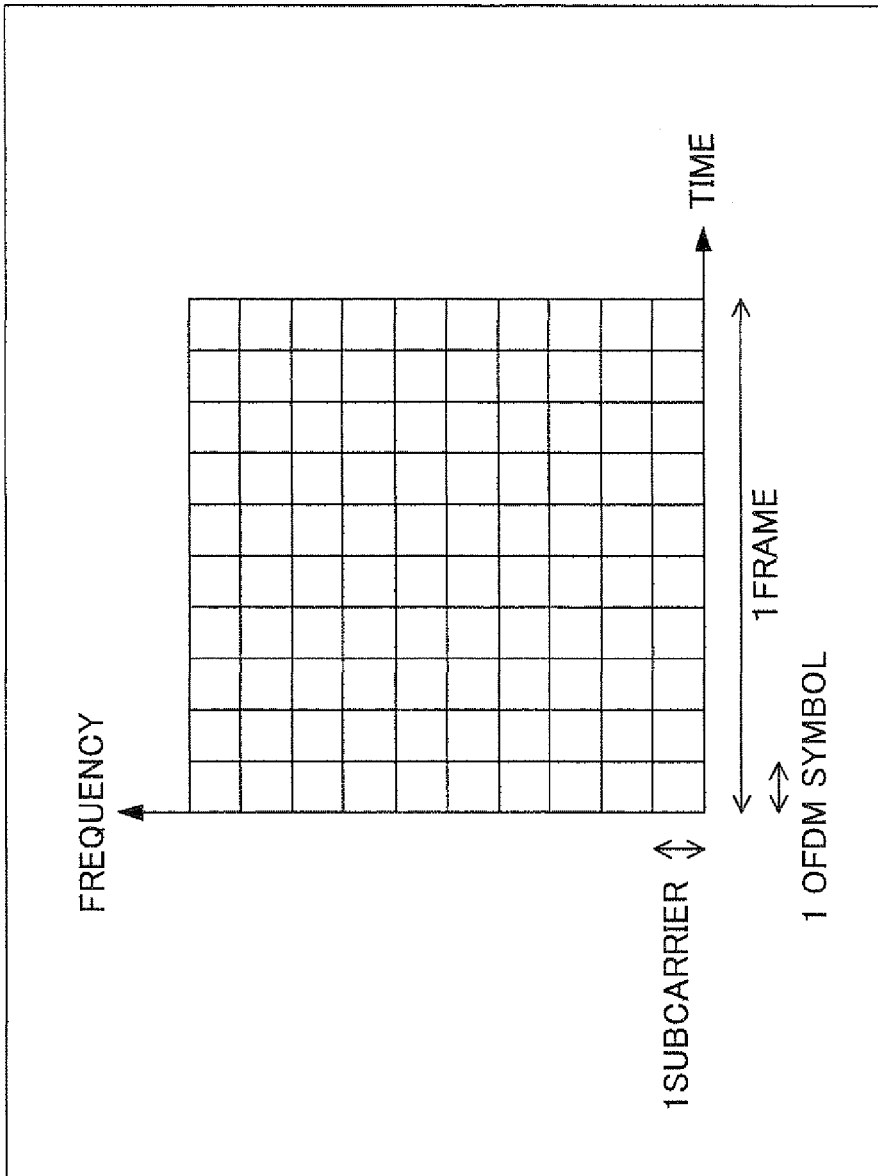

FIG.2

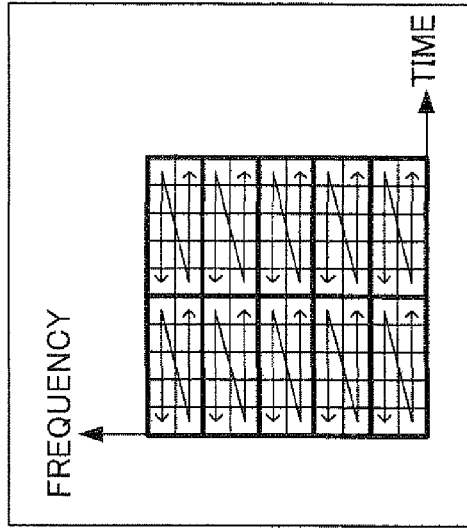

FIG. 3C

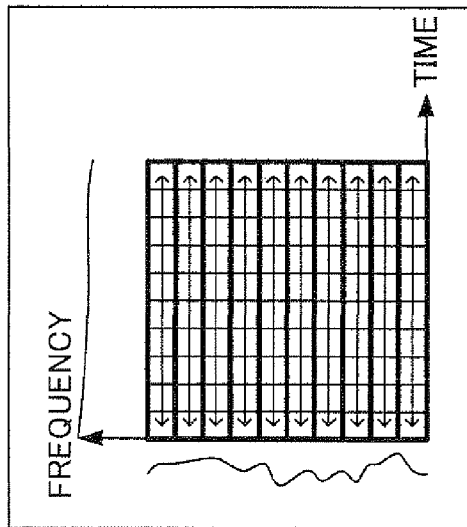

FIG. 3B

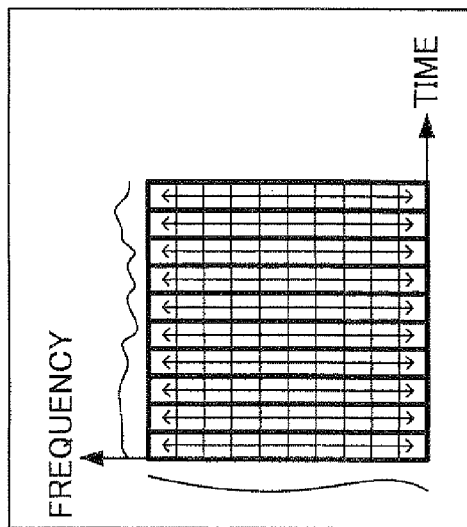

FIG. 3A

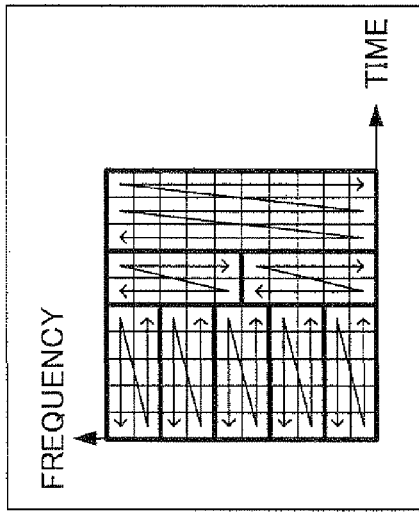

FIG. 4A

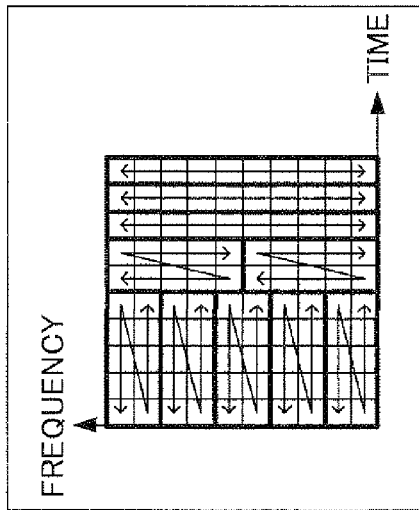

FIG. 4B

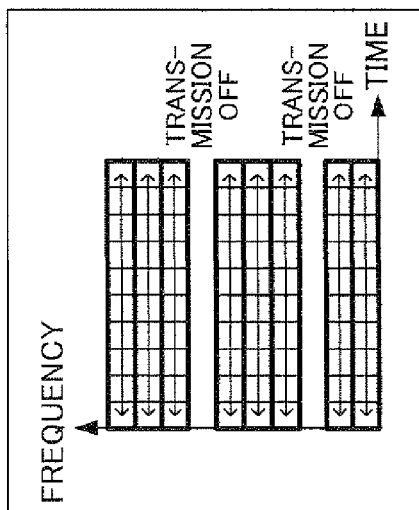

FIG. 4C

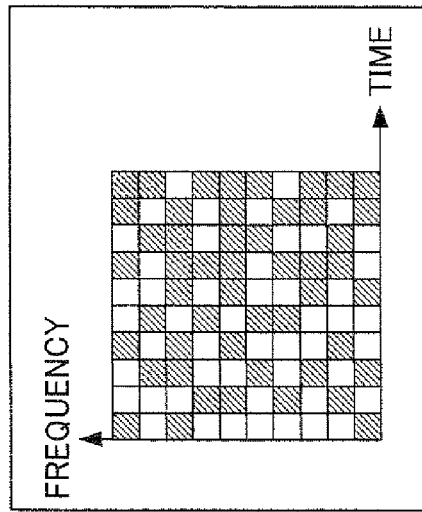

FIG. 4D

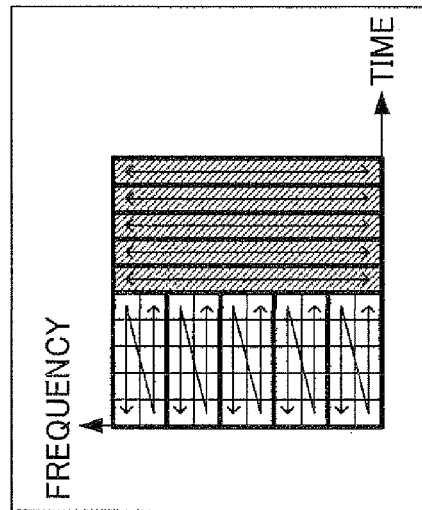

FIG. 4E

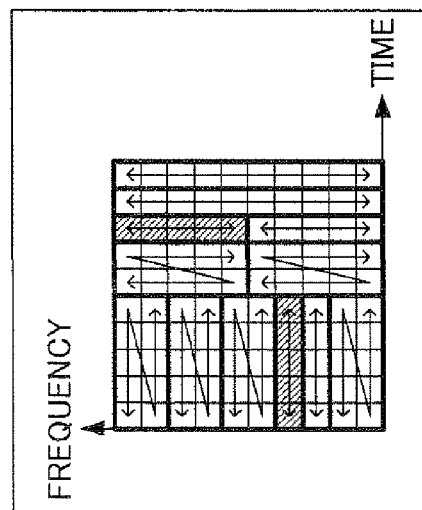

FIG. 4F

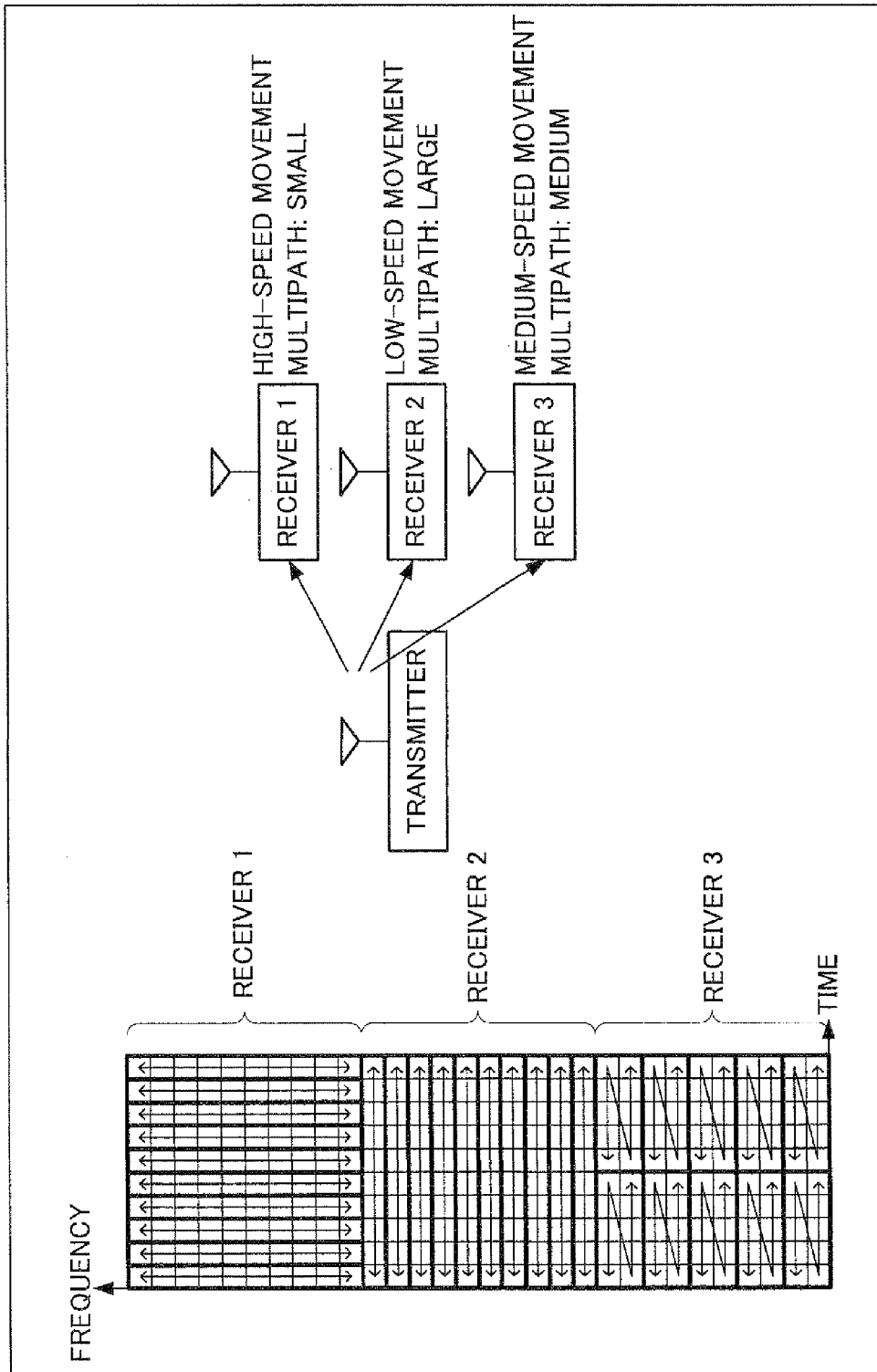

FIG.5

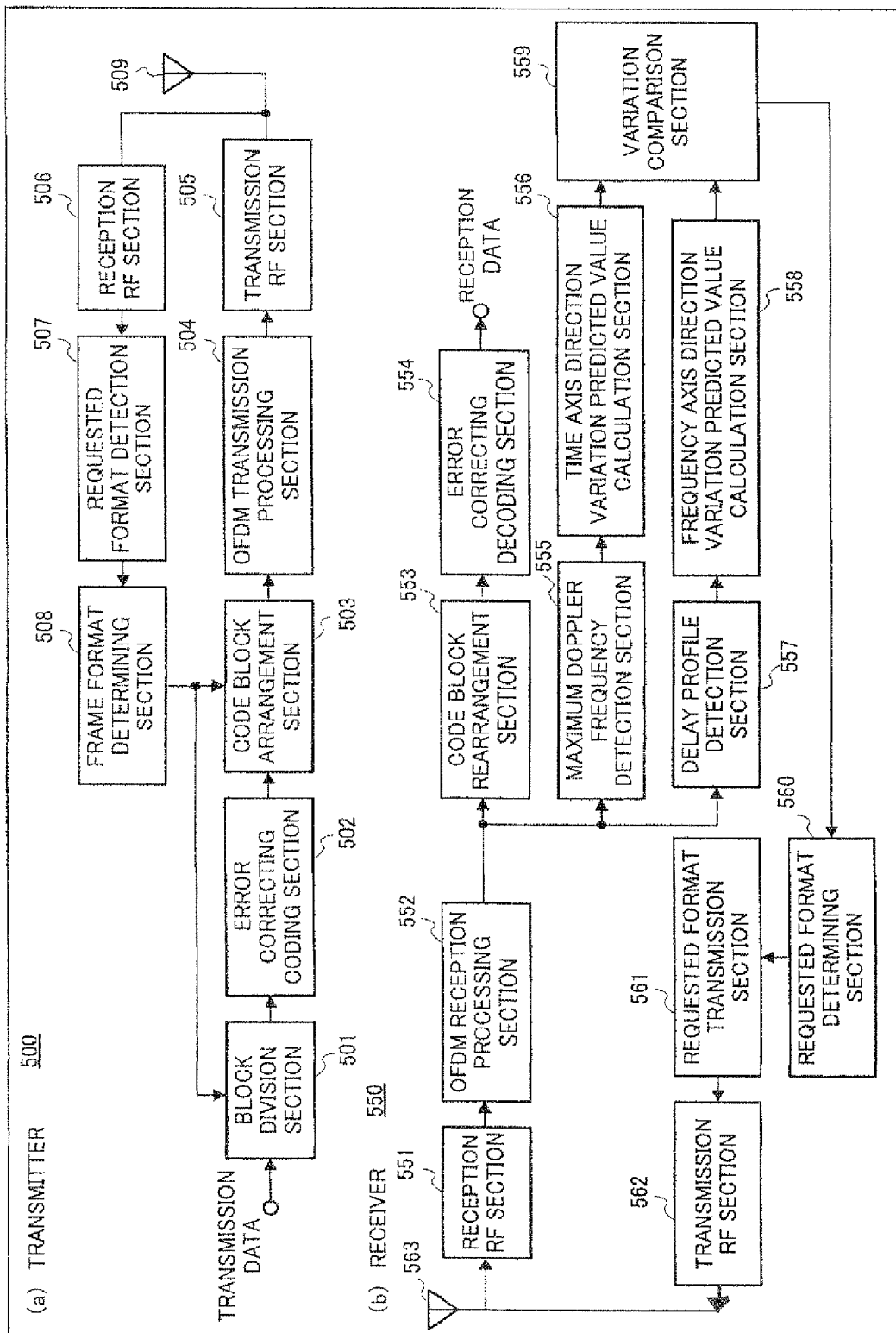

FIG. 6

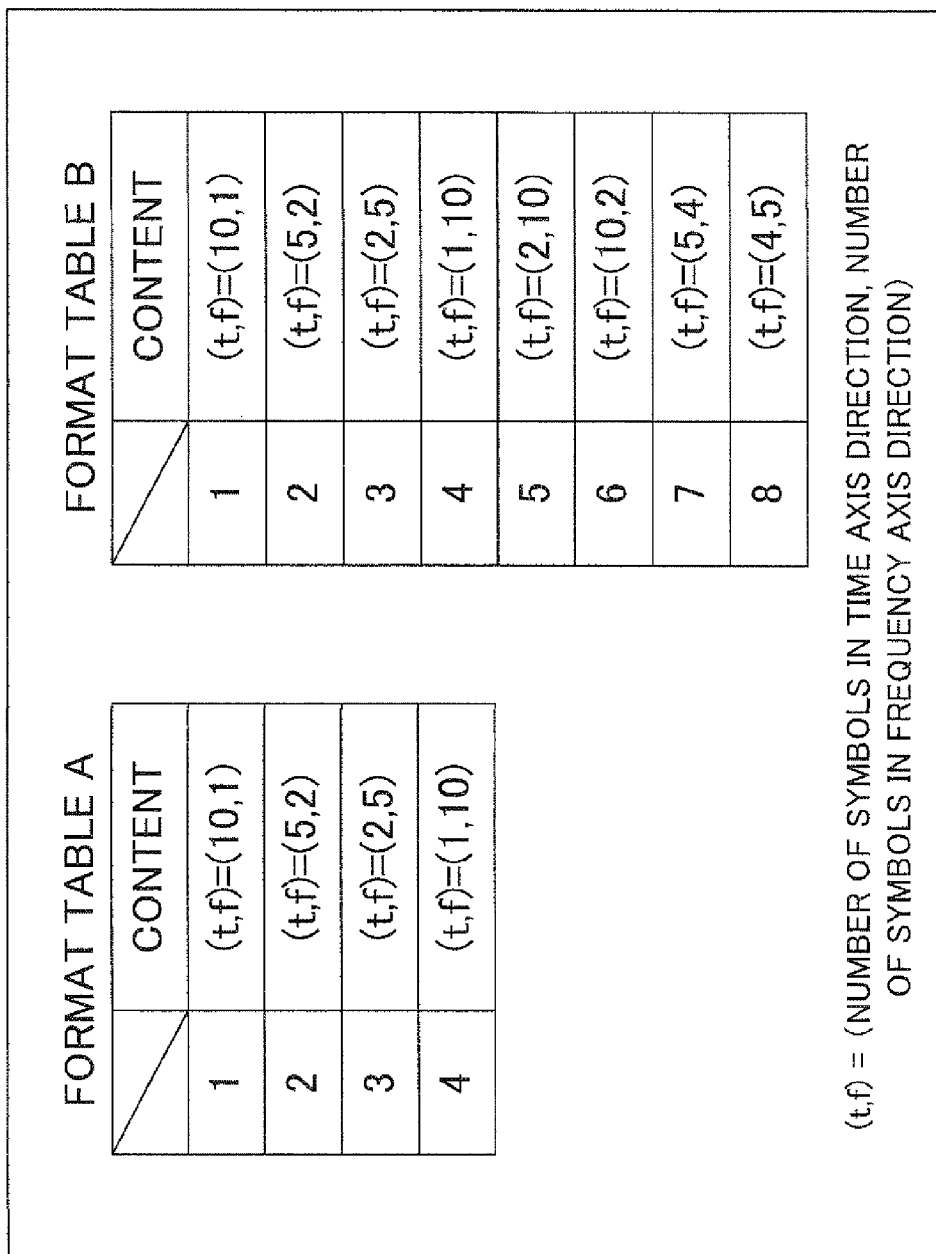

FIG. 7

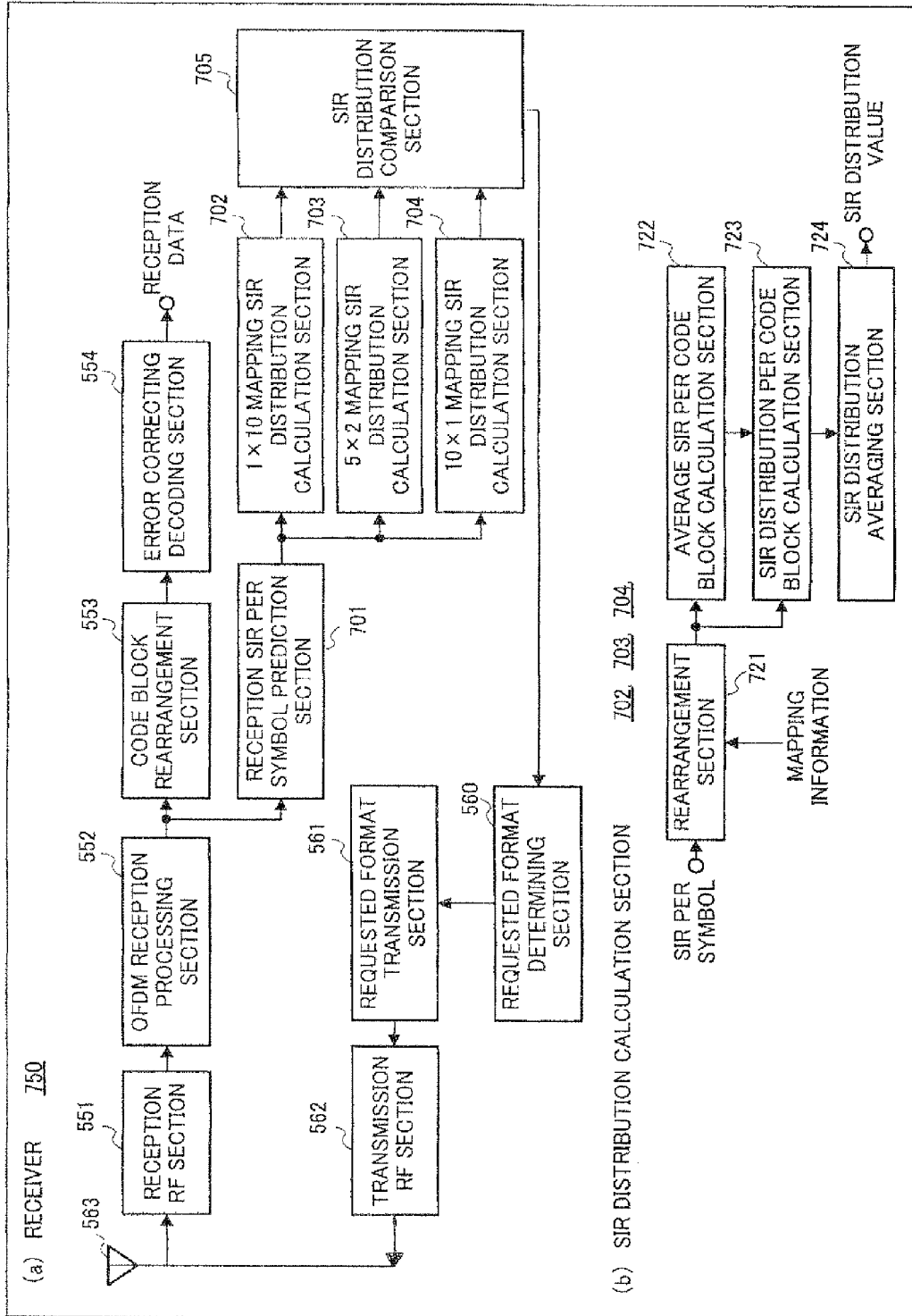

FIG.8

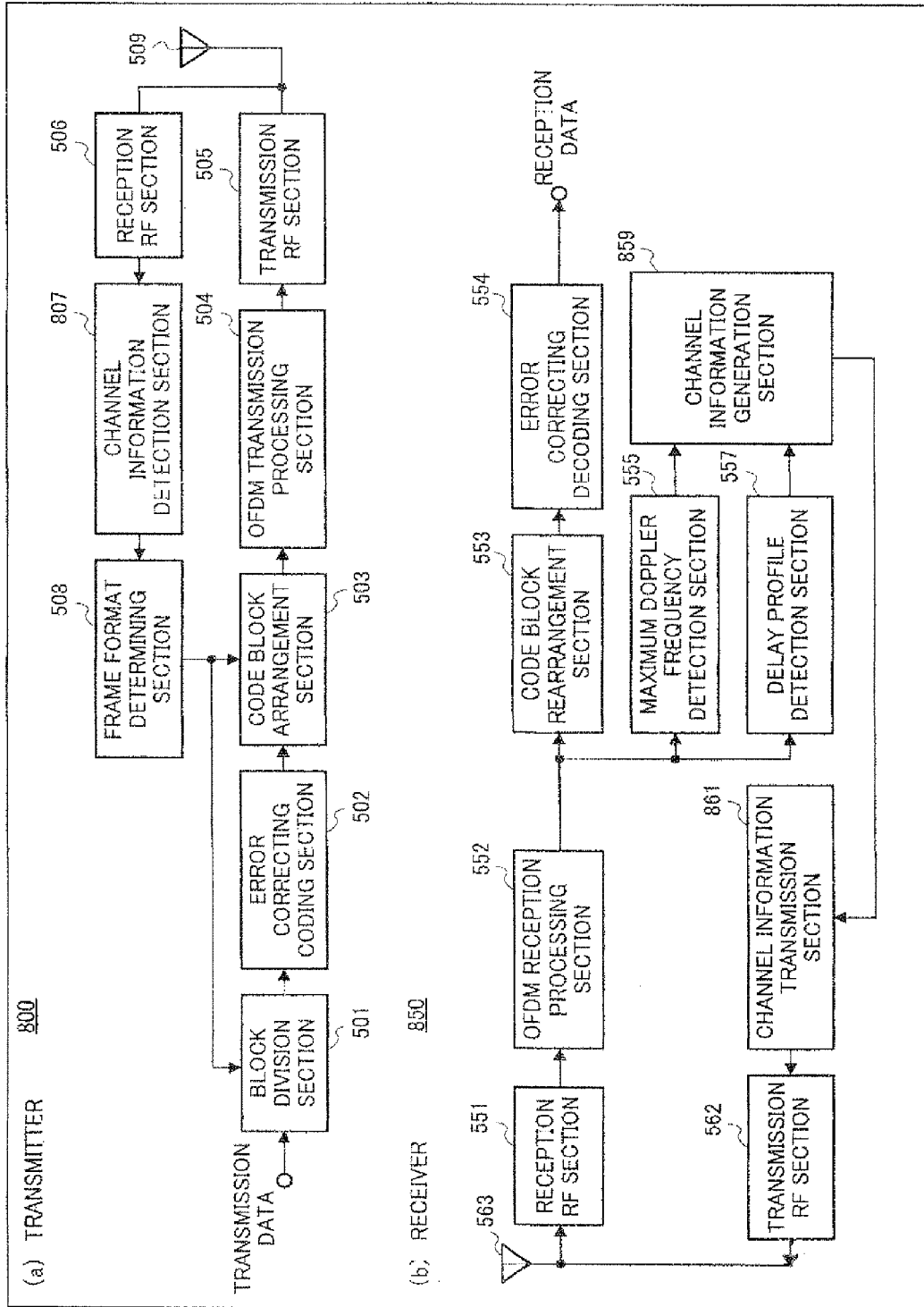

FIG. 9

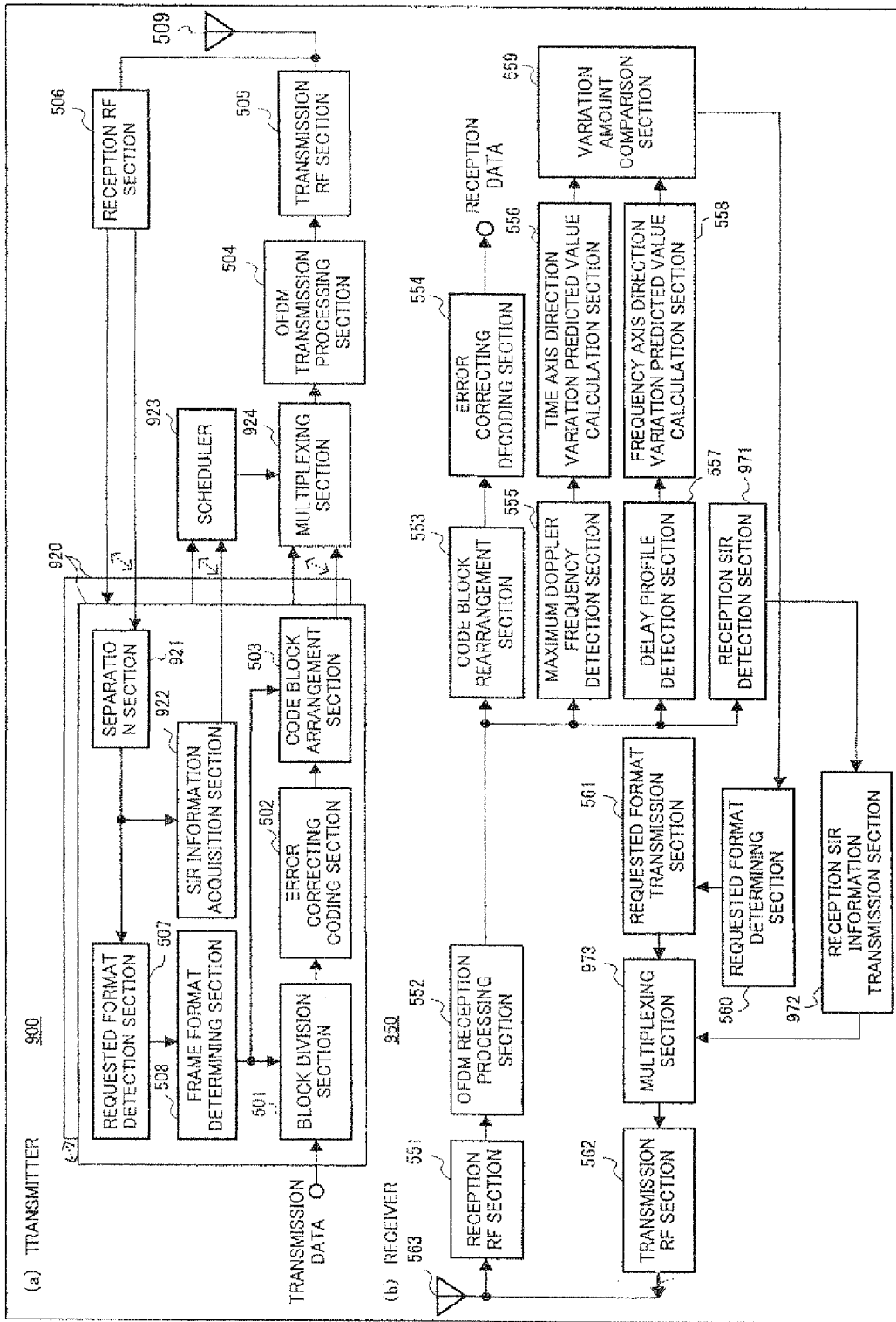

FIG. 10

1

**METHOD AND APPARATUS FOR
MULTICARRIER COMMUNICATION**

This is a continuation application of application Ser. No. 10/559,472 filed Dec. 5, 2005, which is a national stage of PCT/JP2004/008366 filed Jun. 9, 2004, which is based on Japanese Application No. 2003-168287 filed Jun. 12, 2003, the entire contents of each which are incorporated by reference herein.

TECHNICAL FIELD

The present invention relates to a multicarrier communication method and a multicarrier communication apparatus.

BACKGROUND ART

Conventionally, a technology for enhancing reception performance by carrying out two-dimensional spreading in an OFDM (Orthogonal Frequency Division Multiplexing)/CDMA (Code Division Multiple Access) communication system is described, for example, in Unexamined Japanese Patent Publication No. 2000-332724. The technology described in this Unexamined Japanese Patent Publication No. 2000-332724 arranges spreading chips not only in the time axis direction but also in the frequency axis direction in an OFDM/CDMA communication system so as to reduce inter-code interference caused by loss of orthogonality between the spreading codes.

However, the technology described in Unexamined Japanese Patent Publication No. 2000-332724 is intended to prevent loss of orthogonality between spreading codes in the OFDM/CDMA communication system, and therefore there is a problem that this technology is not capable to use for multicarrier communications other than CDMA scheme communications that do not use spreading chips. Furthermore, since an influence of frequency selective fading per spreading chip becomes a problem, it is not clear whether or not the technology described in Unexamined Japanese Patent Publication No. 2000-332724 is capable to obtain the same effect as a spreading chip even when symbols much longer than spreading chips are arranged two-dimensionally. Moreover, normally in a multicarrier communication, multicarrier signal is subjected to error correcting coding processing such as turbo coding and convolutional coding, and therefore when symbols are arranged two-dimensionally, it is necessary to consider their arrangement in units of code blocks generated through the error correcting coding processing. For this reason, when code blocks are arranged two-dimensionally, it is necessary to consider not only the influence of frequency selective fading but also the influence of multipaths and fading.

Generally, the error rate characteristic of an error correcting code such as turbo code and convolutional code is such that the error rate decreases as the variation of reception quality (e.g., likelihood per bit) of code blocks generated through the error correcting coding processing decreases, while the error rate increases as the variation of quality increases (see FIG. 1A to FIG. 1D).

Furthermore, the likelihood per bit depends on the quality per symbol after modulation, that is to say, SNR (Signal to Noise Ratio) and suchlike. For example, when data having 100 bits is subjected to error correcting (FEC) coding at a coding rate $R=1/2$ and transmitted in QPSK symbols, a signal having 200 bits are generated through FEC coding processing and QPSK symbols are transmitted in 2 bits per one symbol, and therefore 100 QPSK symbols are transmitted. The trans-

2

mitted QPSK symbols are received by a receiver through a propagation path, but at this time, when an SNR changes for every QPSK symbol, the likelihood changes for every 2 bits after decoding. Deterioration of FEC performance due to the above-described variation in data quality causes a problem that the error rate characteristic of a signal after error correcting deteriorates when a variation in SNR per symbol in a code block is large, even if average reception quality of a received signal, for example, SNR, is the same,

The deterioration of the error rate characteristic due to such SNR variation per symbol in a code block results in a serious problem in a mobile communication system using OFDM signals. A mobile communication system using OFDM signals is affected by the SNR variation in the time axis direction due to fading and affected by the SNR variation in the frequency axis direction due to frequency selective fading caused by multipaths. At this time, there is a feature that the variation in the time axis direction increases as the moving speed of the receiver increases, while the variation in the frequency axis direction increases as a maximum delay time of multipath signals between the transmitter and receiver increases. Furthermore, interference from other cells also increases a great deal for each subcarrier or for each symbol of an OFDM signal. For this reason, especially in cell edge, an SNR per symbol in 1 frame of the OFDM signal fluctuates a great deal, causing reception performance of the OFDM signal to deteriorate.

DISCLOSURE OF INVENTION

It is an object of the present invention, when arranging code blocks generated through error correcting coding processing not only in the time axis direction but also in the frequency axis direction in order to improve an error correction rate of a multicarrier signal, to provide a multicarrier communication method and a multicarrier communication apparatus used for the method for adjusting the arrangement of the multicarrier signal in code block units according to an actual reception state of the multicarrier signal.

The multicarrier communication method according to an embodiment of the present invention comprises a coding processing step of carrying out error correcting coding processing on a multicarrier signal, a transmission step of transmitting the multicarrier signal subjected to the error correcting coding processing, a reception step of receiving the multicarrier signal transmitted, an analysis step of analyzing a reception state based on the multicarrier signal received, and an arrangement adjusting step of adjusting an arrangement of code blocks generated through the error correcting coding processing according to the analysis result in the analysis step.

In the above described multicarrier communication method, preferably in the analysis step, the reception state is analyzed based on Doppler frequency and delay profile of the received multicarrier signal.

In the above described multicarrier communication method, preferably in the analysis step the reception state is preferably analyzed based on a ratio of signal power to interference power for each symbol of the received multicarrier signal.

A multicarrier communication apparatus according to another embodiment of the present invention comprises a coding processing section that carries out error correcting coding processing on a multicarrier signal, an arrangement adjusting section that adjusts an arrangement of code blocks generated through the error correcting coding processing according to an analysis result of a reception state of the

3

multicarrier signal and a transmission section that transmits the multicarrier signal, the arrangement of which has been adjusted.

The above described multicarrier communication apparatus is preferably provided with a plurality of the arrangement adjusting sections and a scheduler that schedules the plurality of multicarrier signals, the arrangements of which have been adjusted.

BRIEF DESCRIPTION OF DRAWINGS

FIG. 1A illustrates the relationship between variation in reception quality of each symbol of a code block and error rate characteristic thereof;

FIG. 1B illustrates a mode of reception quality when a variation in reception quality of each bit in a code block is large;

FIG. 1C illustrates a mode of reception quality when a variation in reception quality of each bit in a code block is small;

FIG. 1D illustrates a mode of reception quality of additive white Gaussian noise (AWGN);

FIG. 2 illustrates a mode of 1 frame of an OFDM signal used according to Embodiment 1 of the present invention;

FIG. 3A illustrates a mode according to Embodiment 1 of the present invention in which data in 1 frame of an OFDM signal is arranged in the frequency axis direction when a variation of reception quality in the frequency axis direction is small;

FIG. 3B illustrates a mode according to Embodiment 1 of the present invention in which data in 1 frame of an OFDM signal is arranged in the time axis direction when variation of reception quality in the time axis direction is small;

FIG. 3C illustrates a mode according to Embodiment 1 of the present invention in which data in 1 frame of an OFDM signal is arranged as circumstances de d according to variation of reception quality in the frequency axis direction and time axis direction;

FIG. 4A illustrates an example according to Embodiment 1 of the present invention in which code blocks are not arranged on specific subcarriers in 1 frame;

FIG. 4B illustrates an example of arrangement according to Embodiment 1 of the present invention in which the mode of a code block consisting of 10 symbols in 1 frame is modified;

FIG. 4C illustrates an example of arrangement according to Embodiment 1 of the present invention in which the size of a code block (the number of symbols) is changed as appropriate according to a characteristic of error correcting codes;

FIG. 4D illustrates an example of arrangement according to Embodiment 1 of the present invention in which one code block is divided and arranged at locations apart from each other, in other words, two code blocks each consisting of 5 symbols are arranged at locations apart from each other;

FIG. 4E illustrates an example of arrangement according to Embodiment 1 of the present invention in which when identical OFDM signals are transmitted to a plurality of receivers, code blocks are arranged according to reception states of the respective receivers;

FIG. 4F illustrates an example of arrangement according to Embodiment 1 of the present invention in which when identical OFDM signals are transmitted to two receivers, 50 symbols in 1 frame are distributed and assigned to the respective receivers;

FIG. 5 illustrates an example of arrangement of code blocks in 1 frame of an OFDM signal when there are a plurality of receivers used in Embodiment 1 of the present invention;

4

FIG. 6 illustrates a block diagram showing the configuration of a transmitter and receiver used in Embodiment 1 of the present invention;

FIG. 7 illustrates an example of a format table referenced when determining an arrangement of code blocks in Embodiment 1 of the present invention;

FIG. 8 illustrates a block diagram showing the configuration of a receiver used in Embodiment 2 of the present invention;

FIG. 9 illustrates a block diagram showing the configuration of a transmitter and receiver used in Embodiment 3 of the present invention; and

FIG. 10 illustrates a block diagram showing the configuration of a transmitter and receiver used in Embodiment 4 of the present invention.

BEST MODE FOR CARRYING OUT THE INVENTION

An essence of the present invention is to give feedback of an analysis result of a reception state of a multicarrier signal to a transmitter and arrange code blocks generated through error correcting coding processing of a multicarrier signal not only in the time axis direction but also in the frequency axis direction in 1 frame of multicarrier signal in order to equalize the reception state in the same coding block.

Embodiments of the present invention will be explained in detail below with reference now to the accompanied drawings as appropriate. (Embodiment 1)

FIG. 2 shows an OFDM signal consisting of a total of 100 symbols as 1 frame; 10 symbols in the time axis direction and 10 symbols in the frequency axis direction. Embodiment 1 will be explained more specifically by taking a case where this OFDM signal having 100 symbols as 1 frame is transmitted and received as an example.

If a code block generated by carrying out error correcting coding processing on the OFDM signal is assumed to consist of 10 symbols, it is possible to arrange 10 code blocks in 1 frame. This embodiment analyzes SNR variation (reception state) of each symbol in 1 frame of an OFDM signal which has been actually received by a receiver through a propagation path by observing Doppler frequency and delay profile and adjusts the arrangement of code blocks in 1 frame of OFDM signals to be transmitted subsequently based on the analysis result and thereby reduces SNR variations per symbol of code blocks.

The SNR of each symbol fluctuates drastically in the time axis direction when a maximum Doppler frequency observed here is high, while the SNR fluctuates drastically in the frequency axis direction when a maximum delay time is large. Therefore, when the result of an observation of SNR of each symbol shows that the variation is larger in the time axis direction than in the frequency axis direction, for example, when the receiver is moving at a high speed, it is possible to reduce the SNR variation per symbol by arranging code blocks continuously in the frequency axis direction (see FIG. 3A). Likewise, when the variation is larger in the frequency axis direction than in the time axis direction, it is possible to reduce the SNR variation per symbol by arranging code blocks continuously in the time axis direction (see FIG. 3B). Moreover, when the result of an observation of SNR of each symbol shows that although the variation in the frequency axis direction is larger than the variation in the time axis direction, the variation in the time axis direction cannot be ignored, it is also possible, as shown in FIG. 3C, to arrange code blocks each consisting of 5 symbols in the time axis

5

direction having smaller SNR variation and 2 symbols in the frequency axis direction having larger SNR variation.

Thus, code blocks in 1 frame of the OFDM signal can be arranged by analyzing the actual reception state of the OFDM signal and adjusting the arrangement according to the analysis result as appropriate so that the SNR variation per symbol in code blocks becomes smaller. The following modes can be taken as examples of arrangement of code blocks in 1 frame.

FIG. 4A shows an example in which no code blocks are arranged for specific subcarriers in 1 frame. According to this arrangement example, when there is considerable influence of frequency selective fading on a specific subcarrier, subcarriers whose reception states severely deteriorated are not used, and it is thereby possible to avoid useless signal transmission, reduce the amount of interference against other cells, suppress transmit power and reduce power consumption.

Furthermore, FIG. 4B shows an arrangement example in which modes of code blocks each consisting of 10 symbols in 1 frame are modified. For example, when shown in terms of frequency axis direction×time axis direction, there can be a mixture of code blocks consisting of 10 symbols×1 symbol, 5 symbols×2 symbols and 2 symbols×5 symbols. This arrangement example is adaptable even when the amount of SNR variation per symbol in 1 frame partly changes.

Furthermore, FIG. 4C shows an arrangement example in which the size (the number of symbols) of a code block is changed according to the characteristic of the error correcting code as appropriate. The error correction rate of a turbo code or the like improves as the number of symbols of the code block increases, and therefore it is possible to increase the size of the code block that can be arranged within in 1 frame. In FIG. 4C, there are 7 code blocks of 10 symbols and 1 code block of 30 symbols.

Furthermore, FIG. 4D shows an example in which 1 code block is divided and the divided portions are arranged away from each other, that is, 2 code blocks each consisting of 5 symbols are arranged away from each other (see hatching of FIG. 4D). According to this arrangement example, it is also possible to adaptively handle a case where parts having approximate reception states appear separately in 1 frame.

Furthermore, FIG. 4F shows an example in which when identical OFDM signals are transmitted to a plurality of receivers, code blocks are arranged according to the reception states of the receivers. According to this arrangement example, it is possible to arrange code blocks according to the reception states of the respective receivers and improve the error rate characteristics of all the receivers.

Furthermore, FIG. 4F shows an arrangement example in which, when identical OFDM signals are transmitted to two receivers, 50 symbols are distributed and assigned to the respective receivers in 1 frame. According to this arrangement example, it is only necessary to select 50 symbols having approximate SNR values in 1 frame as appropriate and construct code blocks with the selected 50 symbols, and therefore it is possible to provide a meticulous arrangement according to the reception state of each receiver and improve the error rate characteristics of all the receivers.

Furthermore, FIG. 5 shows an example of arrangement of code blocks when identical OFDM signals are transmitted to three receivers having different OFDM signal reception states. In FIG. 5, receiver 1 is a mobile communication terminal apparatus which is moving at a high speed and is in a reception state in which the influences of multipaths is small. On the other hand, receiver 2 is a mobile communication terminal apparatus which is moving at a low speed and is in a reception state in which the influences of multipaths is large.

6

Furthermore, receiver 3 is a mobile communication terminal apparatus which is moving at a medium speed and is in a reception state in which the influences of multipaths is also at a medium level. When code blocks are arranged in 1 frame according to the reception states of the receivers, it is preferable to arrange code blocks in the frequency axis direction continuously for receiver 1, while it is preferable to arrange code blocks in the time axis direction continuously for receiver 2 and it is preferable to arrange code blocks with 5 symbols in the time axis direction continuously and 2 symbols in the frequency axis direction continuously for receiver 3. By subjecting the code blocks arranged for these three receivers to frequency division multiplexing (FDMA), it is possible to generate a 1-frame OFDM signal. 1 frame of the OFDM signal generated in this way consists of 10 symbols in the time axis direction and 30 symbols in the frequency axis direction, 300 symbols in total.

FIG. 6 is a block diagram showing the configuration of a transmitter (a) and a receiver (b) used for a one-to-one OFDM communication. Transmitter 500 is provided with block division section 501, error correcting coding section 502, code block arrangement section 503, OFDM transmission processing section 504, transmission radio frequency (RF) section 505, reception RF section 506, requested format detection section 507, frame format determining section 508 and antenna element 509. Receiver 550 is provided with reception RF section 551, OFDM reception processing section 552, code block rearrangement section 553, error correcting decoding section 554, maximum Doppler frequency detection section 555, time axis direction variation predicted value calculation section 556, delay profile detection section 557, frequency axis direction variation predicted value calculation section 558, variation amount comparison section 559, requested format determining section 560, requested format transmission section 561, transmission RF section 562 and antenna element 563.

Block division section 501 in transmitter 500 divides transmission data into portions of predetermined size corresponding to code blocks according to an instruction from frame format determining section 508. Individual portions of the transmission data divided by block division section 501 are input to error correcting coding section 502, where the transmission data are subjected to error correcting coding processing such as convolutional coding or the like and processed into code blocks. These code blocks are input to code block arrangement section 503 and rearranged in an arrangement instructed by frame format determining section 508, in other words, in an arrangement instructed in 1 frame converted into an OFDM signal. The code blocks input from code block arrangement section 503 to OFDM transmission processing section 504 are subjected to publicly known processing for generating OFDM signals such as serial/parallel conversion, IFFT (Inverse Fast Fourier Transform), parallel/serial conversion and guard interval insertion at OFDM transmission processing section 504. The OFDM signal input from OFDM transmission processing section 504 to transmission RF section 505 is subjected to signal processing such as digital/analog (D/A) conversion, carrier multiplication and amplification here and then transmitted by radio from antenna element 509.

Next, the OFDM signal transmitted from transmitter 500 is received by antenna element 563 of receiver 550 through a propagation path. The OFDM signal received at antenna element 563 is input to reception RF section 551, where it is subjected to signal processing such as amplification, frequency conversion and analog/digital (A/D) conversion. The OFDM signal input from reception RF section 551 to OFDM

reception processing section 552 is subjected to signal processing such as serial/parallel conversion, FFT processing and parallel/serial conversion here and then input to code block rearrangement section 553, maximum Doppler frequency detection section 555 and delay profile detection section 557. The code blocks contained in each frame of the OFDM signal input to code block rearrangement section 553 are returned to the original arrangement before the rearrangement in code block arrangement section 503. The code blocks extracted by the rearrangement to the original arrangement are decoded by error correcting decoding section 554 using a publicly known decoding algorithm such as a Viterbi algorithm and sequentially output upon decoding.

Furthermore, a Doppler frequency per symbol of the OFDM signal is measured by maximum Doppler frequency detection section 555 in 1-frame units. Then, the maximum Doppler frequency measured for each symbol is input to time axis direction variation predicted value calculation section 556, where the amount of variation in the time axis direction in 1 frame is calculated. Furthermore, time axis direction variation predicted value calculation section 556 predicts an amount of variation of OFDM signals to be received subsequently in the time axis direction based on the calculated amount of variation in the time axis direction. The amount of variation predicted value in the time axis direction is input to variation amount comparison section 559.

Furthermore, delay profile detection section 557 averages the delay time and signal intensity per symbol of the input OFDM signal in 1-frame units, calculates the distribution of each symbol with respect to the average value and thereby generates a delay profile for each symbol. This delay profile is input to frequency axis direction variation predicted value calculation section 558, where amounts of variation in the frequency axis direction of OFDM signals to be received subsequently are predicted based on the amount of variation in the frequency axis direction in 1 frame of the OFDM signal. These predicted values of amounts of variation in the frequency axis direction are input to variation amount comparison section 559.

Variation amount comparison section 559 compares the predicted values of amounts of variation in the time axis direction about the maximum Doppler frequency input from time axis direction variation predicted value calculation section 556 with the predicted values of amounts of variation in the frequency axis direction about the delay profile input from frequency axis direction variation predicted value calculation section 558 and calculates the ratio of the degree of SNR variation per symbol in the time axis direction in 1 frame of OFDM signals to be received subsequently to the degree of SNR variation in the frequency axis direction. The calculated ratio of SNR variations for each symbol in 1 frame of the OFDM signal is input to requested format determining section 560. Requested format determining section 560 determines an arrangement of code blocks that minimizes the SNR variations per symbol of the code blocks according to the variation ratio in total view of 1 frame of the OFDM signal. It is possible to determine such a code block arrangement, for example, by combining modes of one code block described in the format tables A, B described in FIG. 7 by trial and error and the total evaluation of 1 frame every time. FIG. 7 will be described later.

The format of code block arrangement in 1 frame of the OFDM signal determined by requested format determining section 560 is subjected to publicly known signal processing when the signal is passing through requested format transmission section 561 and transmission RF section 562 and transmitted by radio from antenna element 563.

Next, the signal transmitted by radio from receiver 550 is received by antenna element 509 of transmitter 500 and subjected to signal processing such as amplification, frequency conversion and A/D conversion by reception RF section 506. Then, this transmission signal is input to requested format detection section 507, where the content of the aforementioned format is extracted. Furthermore, this extracted format is input to frame format determining section 508, where sizes of code blocks and arrangement of the code blocks in 1 frame are determined specifically. Then, based on this determination, an instruction on the size (number of symbols) of one code block is input to block division section 501 and an instruction on the arrangement of code blocks in 1 frame of the OFDM signal is input to code block arrangement section 503 respectively from frame format determining section 508. Thereafter, the above described respective sections repeat their respective signal processing.

FIG. 7 shows examples of modes of one code block available to generate a format of an arrangement of code blocks in 1 frame of the OFDM signal determined by requested format determining section 560. Format table A shows examples of modes of a code block consisting of 10 symbols. "(t, f)" in the table represents "(the number of symbols in the time axis direction, the number of symbols in the frequency axis direction)." Furthermore, format table B shows examples of code block modes in a mixture of a code block consisting of 10 symbols and a code block consisting of 20 symbols. Using the format table A or format table B, requested format determining section 560 can determine the arrangement of code blocks in 1 frame by combining these code blocks as appropriate according to the reception state of an OFDM signal.

As explained above, according to the multicarrier communication method and the communication apparatus thereof according to this embodiment, receiver 550 analyzes the reception state of an OFDM signal based on its maximum Doppler frequency and its delay profile, and therefore it is possible to individually analyze adverse influences of a multicarrier signal on the frequency axis direction and adverse influences on the time axis direction caused by the signal passing through a propagation path and meticulously adjust the arrangement of code blocks in 1 frame of the multicarrier signal based on these analysis results. (Embodiment 2)

FIG. 8 is a block diagram showing the configuration of a receiver used for a multicarrier communication method according to Embodiment 2, in this embodiment, during one-to-one OFDM communication, the receiver predicts the amount of SNR variation per symbol in code blocks of an OFDM signal based on its SIR (Signal-to-Interference power Ratio) and determine the arrangement of the code blocks.

Hereinafter, the multicarrier communication method and a receiver used for the method according to this embodiment will be explained with reference to the attached drawings as appropriate, but components having functions similar to those of the components shown in Embodiment 1 are assigned the same reference numerals and explanations thereof will be omitted.

Receiver 750 corresponds to receiver 550 provided with reception SIR per symbol prediction section 701, 1×10 mapping SIR distribution calculation section 702, 5×2 mapping SIR distribution calculation section 703, 10×1 mapping SIR distribution calculation section 704 and SIR distribution value comparison section 705 instead of maximum Doppler frequency detection section 555, time axis direction variation predicted value calculation section 556, delay profile detec-

tion section 557, frequency axis direction variation predicted value calculation section 558 and variation amount comparison section 559.

Furthermore, these three SIR distribution calculation sections 702, 703, 704 are provided with rearrangement section 721, average SIR per code block calculation section 722, SIR distribution per code block calculation section 723 and SIR distribution averaging section 724.

Reception SIR per symbol prediction section 701 stores a 1-frame OFDM signal output from OFDM reception processing section 552 and measures SIRs for all symbols contained therein. The SIRs for all symbols obtained through the measurements are input to 1×10 mapping SIR distribution calculation section 702, 5×2 mapping SIR distribution calculation section 703 and 10×1 mapping SIR distribution calculation section 704.

In 1×10 mapping SIR distribution calculation section 702, the SIR of each input symbol is input to rearrangement section 721. Rearrangement section 721 assumes that code blocks are arranged as shown in FIG. 3A, sorts SIRs of the respective symbols by code block based on this assumption and then sequentially inputs these SIRs for each code block to average SIR per code block calculation section 722 and SIR distribution per code block calculation section 723 in parallel. Average SIR per code block calculation section 722 calculates an average SIR for each code block. This average SIR is input to SIR distribution per code block calculation section 723. SIR distribution per code block calculation section 723 calculates the distribution for each code block based on the input average SIR and SIR of each symbol in the code block corresponding to the average SIR. This SIR distribution per code block is input to SIR distribution averaging section 724, where the SIR distribution per code block corresponding to 1 frame is collected and averaged. Then, this averaged SIR distribution per code block corresponding to 1 frame is sequentially input to SIR distribution value comparison section 705 as an SIR distribution. Signal processing similar to signal processing by this 1×10 mapping SIR distribution calculation section 702 is also performed by 5×2 mapping SIR distribution calculation section 703 and 10×1 mapping SIR distribution calculation section 704 and respective SIR distribution are input to SIR distribution value comparison section 705. SIR distribution comparison section 705 compares the SIR distribution input from 1×10 mapping SIR distribution calculation section 702, 5×2 mapping SIR distribution calculation section 703 and 10×1 mapping SIR distribution calculation section 704 and selects an arrangement of code blocks in 1 frame so that this SIR distribution becomes a minimum. This selected arrangement of code blocks is reported to requested format determining section 560 and then the format of the arrangement of code blocks is transmitted by radio to transmitter 500 as in the case of Embodiment 1.

As explained above, according to the multicarrier communication method according to this embodiment, the reception state of a multicarrier signal is analyzed based on an SIR per symbol, and therefore it is possible to meticulously analyze the reception state and reliably improve the error correction rate of the multicarrier signal.

This embodiment has explained the case where three SIR distribution calculation sections 702, 703, 704 are used on an assumption that code blocks each consisting of 10 symbols are arranged in 1 frame of an OFDM signal, but the present invention is not limited to such a case alone. For example, as long as a plurality of code blocks can be accommodated in 1 frame of the OFDM signal, it is possible to change the size

and mode of code blocks or also increase the number of SIR distribution calculation sections.

(Embodiment 3)

FIG. 9 is a block diagram showing the configuration of a multicarrier communication apparatus according to Embodiment 3. In this embodiment, during one-to-one OFDM communication, a receiver does not analyze a reception state of an OFDM signal and sends information on the reception state to a transmitter, and then the transmitter analyzes the reception state based on the information and thereby determines an arrangement of code blocks in 1 frame of the OFDM signal.

Hereinafter, the multicarrier communication method and the communication apparatus thereof will be explained with reference to the accompanying drawings as appropriate, but components having the same functions as those of the components shown in Embodiment 1 are assigned the same reference numerals and explanations thereof will be omitted.

Transmitter 800 corresponds to transmitter 500 provided with channel information detection section 807 instead of requested format detection section 507. Channel information detection section 807 analyzes the reception state of an OFDM signal transmitted from receiver 850 based on the following information on the reception state and thereby determines the arrangement of code blocks in 1 frame of the OFDM signal. This information on the reception state of the OFDM signal refers to a maximum Doppler frequency, delay profile, maximum delay time, number of delay waves and delay times of paths, power of the respective paths and channel estimated values of the respective subcarriers or the like.

Furthermore, receiver 850 corresponds to receiver 550 provided with channel information generation section 859 and channel information transmission section 861 instead of time axis direction variation predicted value calculation section 556, frequency axis direction variation predicted value calculation section 558, variation amount comparison section 559, requested format determining section 560 and requested format transmission section 561. Channel information generation section 859 and channel information transmission section 861 generate information on the reception state of the OFDM signal and transmit the information to transmitter 800 by radio.

The multicarrier communication method and the communication apparatus can analyze adverse influences of a multicarrier signal caused by passing through a propagation path on the frequency axis direction and adverse influences on the time axis direction individually and meticulously adjust the arrangement of code blocks in 1 frame of the multicarrier signal based on these analysis results and reduce the load of signal processing on the receiver. In this way, it is possible to simplify the configuration of the receiver and reduce the weight and size of the receiver.

(Embodiment 4)

FIG. 10 is a block diagram showing the configuration of a multicarrier communication apparatus according to Embodiment 4. In this embodiment, a plurality of receivers simultaneously carry out OFDM communications with one transmitter. The multicarrier communication method and the communication apparatus thereof according to this embodiment will be explained below with reference to the accompanying drawings as appropriate, but components having the same functions as those of the components shown in Embodiment 1 will be assigned the same reference numerals and explanations thereof will be omitted.

Transmitter 900 is provided with OFDM transmission processing section 504, transmission RE section 505, reception RF section 506, antenna element 509, scheduler 923, multiplexing section 924 and a plurality of code blocking units

11

920. Furthermore, code blocking unit 920 is provided in the same number as receivers communicating simultaneously and includes block division section 501, error correcting coding section 502, code block arrangement section 503, requested format detection section 507, frame format determining section 508, separation section 921 and SIR information acquisition section 922. On the other hand, in addition to the components provided for receiver 550, receiver 950 is further provided with reception SIR detection section 971, reception SIR information transmission section 972 and multiplexing section 973.

In receiver 950, an OFDM signal is input from OFDM reception processing section 552 to reception SIR detection section 971. Reception SIR detection section 971 stores SIRs of all symbols in 1 frame of the OFDM signal. These stored SIRs of symbols corresponding to 1 frame are input to reception SIR information transmission section 972, where the SIRs are averaged in 1-frame units. This average SIR is input to multiplexing section 973, multiplexed with a format of an arrangement of code blocks input from requested format transmission section 561 here and then transmitted by radio to transmitter 900.

This signal transmitted by radio from receiver 950 is received by transmitter 900 and then input to separation section 921 in code blocking unit 920. Separation section 921 decides whether or not code blocking unit 920 in which it is included should process the input signal and separates and extracts the average SIR and the format of arrangement of code blocks included in the signal only when separation section 921 obtains a decision result indicating that the input signal should be processed. This average SIR is input to SIR information acquisition section 922, while the format of the arrangement of code blocks is input to requested format detection section 507. SIR information acquisition section 922 acquires information on a reception state of the OFDM signal at receiver 950 based on the input average SIR. All the information on the reception state of the OFDM signal at receiver 950, of which each code blocking unit 920 communicate with, is input to scheduler 923. Scheduler 923 determines the number of symbols and arrangement of code blocks assigned to each receiver 950 about the OFDM signal to be transmitted next time based on the information about reception state of each receiver 950. This determination at scheduler 923 is input to multiplexing section 924, where desired signal processing is performed and the determination is thereby realized.

Therefore, the multicarrier communication method and the communication apparatus thereof according to this embodiment provides a plurality of code blocking units 920 corresponding to the arrangement adjusting sections and a scheduler that selects and combines the outputs from the code blocking units as appropriate, and therefore when multicarrier signals are transmitted to a plurality of receivers, it is possible to adjust the arrangement of code blocks on the multicarrier signal considering the reception states of all receivers so as to increase overall error correction rate.

In this embodiment, M-ary modulation scheme may be adopted, and in that case code blocks can be arranged by separately grouping bits into higher bits and lower bits.

As described above, the present invention analyzes the actual reception states of multicarrier signals, adjusts the arrangement of code blocks according to the analysis result as appropriate, and therefore it is possible to adaptively correspond to adverse influences from constantly changing propagation path and reliably improve the error correction rate of the multicarrier signal.

12

Furthermore, the present invention observes a Doppler frequency and delay profile simultaneously, thereby making it possible to analyze adverse influences caused by passing through a propagation path on the frequency axis direction and adverse influences on the time axis direction individually and meticulously adjust the arrangement of code blocks based on these analysis results.

Furthermore, the present invention analyzes the reception state of a multicarrier signal based on SIRs of respective symbols, and can thereby obtain a much more accurate analysis result and reliably improve the error correction rate of the multicarrier signal.

Furthermore, the present invention is provided with a scheduler that selects and combines outputs from a plurality of arrangement adjusting sections as appropriate, and therefore when multicarrier signals are transmitted to a plurality of receivers, it is possible to adjust the arrangement of code blocks of a multicarrier signal considering all the receivers so as to increase overall error correction rate.

The present invention analyzes the actual reception states of a multicarrier signal and adjusts the arrangement of code blocks according to the analysis result as appropriate, and it is possible to reliably improve the error correction rate of the multicarrier signal by adaptively responding to adverse influences from a momentarily changing propagation path.

This application is based on Japanese Patent Application No. 2003-168287 filed on Jun. 12, 2003, entire content of which is expressly incorporated by reference herein.

Industrial Applicability

The present invention is applicable to a multicarrier transmission apparatus and multicarrier reception apparatus mounted in a mobile station apparatus or base station apparatus in a mobile communication system.

The invention claimed is:

1. A transmission apparatus comprising:
 - a coding section configured to encode first data and second data; and
 - a mapping section configured to map the encoded first data to symbols in a first part of a domain comprising a time index and a frequency index, and the encoded second data to groups of symbols in a second part of the domain, wherein:
 - at least a part of the encoded first data is mapped to at least a part of the symbols in the first part of the domain in an increasing order according to the frequency index;
 - at least a part of the encoded second data is mapped to at least a part of the groups of symbols in the second part of the domain and each group of the at least a part of the groups of symbols is aligned in an increasing order according to the time index; and
 - each symbol within each of the groups of symbols is aligned along the frequency index.
2. The transmission apparatus according to claim 1, wherein a number of symbols along the frequency index for the first part of the domain and for the groups of symbols in the second part of the domain is different.
3. The transmission apparatus according to claim 1, wherein a number of symbols in the first part of the domain is greater than a number of symbols within each of the groups of symbols.
4. The transmission apparatus according to claim 1, wherein a number of symbols for the encoded second data is configured to be changed at a predetermined interval.
5. The transmission apparatus according to claim 1, wherein the first part of the domain to which the encoded first

13

data is mapped and the second part of the domain to which the encoded second data is mapped are allocated continuously according to the time index.

6. The transmission apparatus according to claim 1, wherein at least a part of the encoded first data is not continuously mapped to the symbols in the first part of the domain.

7. The transmission apparatus according to claim 1, wherein at least a part of the encoded second data is not continuously mapped to each symbol within each of the groups of symbols aligned along the frequency index.

8. The transmission apparatus according to claim 1, wherein said coding section carries out turbo coding or convolutional coding for each of the first data and the second data.

9. The transmission apparatus according to claim 1, wherein said coding section carries out error correcting coding for the first data and the second data, and said mapping section maps each of the encoded first data and the encoded second data depending on characteristics of the error correcting coding.

10. The transmission apparatus according to claim 1, wherein the mapping of the at least a part of the second data to at least a part of the groups of symbols in the second part of the domain is performed in increasing order according to the time index.

11. A reception apparatus comprising:

a receiving section configured to receive encoded first data which is mapped to symbols in a first part of a domain comprising a time index and a frequency index, and encoded second data which is mapped to groups of symbols in a second part of the domain; and

a decoding section configured to decode the encoded first data and the encoded second data, wherein:

at least a part of the encoded first data is mapped to at least a part of the symbols in the first part of the domain in an increasing order according to the frequency index;

at least a part of the encoded second data is mapped to at least a part of the groups of symbols in the second part of the domain and each group of the at least a part of the groups of symbols is aligned in an increasing order according to the time index; and

each symbol within each of the groups of symbols is aligned along the frequency index.

12. The reception apparatus according to claim 11, wherein a number of symbols along the frequency index for the first part of the domain and for the groups of symbols in the second part of the domain is different.

13. The reception apparatus according to claim 11, wherein a number of symbols in the first part of the domain is greater than a number of symbols within each of the groups of symbols.

14. The reception apparatus according to claim 11, wherein a number of symbols for the encoded second data is configured to be changed at a predetermined interval.

15. The reception apparatus according to claim 11, wherein the first part of the domain to which the encoded first data is mapped and the second part of the domain to which the encoded second data is mapped are allocated continuously according to the time index.

16. The reception apparatus according to claim 11, wherein at least a part of the encoded first data is not continuously mapped to the symbols in the first part of the domain.

17. The reception apparatus according to claim 11, wherein at least a part of the encoded second data is not continuously mapped to each symbol within each of the groups of symbols aligned along the frequency index.

14

18. The reception apparatus according to claim 11, wherein said receiving section receives the encoded first data and the encoded second data, which are encoded with turbo coding or convolutional coding.

19. The reception apparatus according to claim 11, wherein said receiving section receives the encoded first data and the encoded second data, which are encoded with error correcting coding, and the encoded first data and the encoded second data are mapped depending on characteristics of the error correcting coding.

20. The reception apparatus according to claim 11, wherein the mapping of the at least a part of the second data to at least a part of the groups of symbols in the second part of the domain is performed in increasing order according to the time index.

21. A transmission method comprising:

encoding first data and second data; and

mapping the encoded first data to symbols in a first part of a domain comprising a time index and a frequency index, and the encoded second data to groups of symbols in a second part of the domain, wherein:

at least a part of the encoded first data is mapped to at least a part of the symbols in the first part of the domain in an increasing order according to the frequency index;

at least a part of the encoded second data is mapped to at least a part of the groups of symbols in the second part of the domain and each group of the at least a part of the groups of symbols is aligned in an increasing order according to the time index; and

each symbol within each of the groups of symbols is aligned along the frequency index.

22. The transmission method according to claim 21, wherein a number of symbols along the frequency index for the first part of the domain and for the groups of symbols in the second part of the domain is different.

23. The transmission method according to claim 21, wherein a number of symbols in the first part of the domain is greater than a number of symbols within each of the groups of symbols.

24. The transmission method according to claim 21, wherein a number of symbols for the encoded second data is configured to be changed at a predetermined interval.

25. The transmission method according to claim 21, wherein the first part of the domain to which the encoded first data is mapped and the second part of the domain to which the encoded second data is mapped are allocated continuously according to the time index.

26. The transmission method according to claim 21, wherein at least a part of the encoded first data is not continuously mapped to the symbols in the first part of the domain.

27. The transmission method according to claim 21, wherein at least a part of the encoded second data is not continuously mapped to each symbol within each of the groups of symbols aligned along the frequency index.

28. The transmission method according to claim 21, wherein said encoding is turbo coding or convolutional coding for each of the first data and the second data.

29. The transmission method according to claim 21, wherein said encoding is error correcting coding for the first data and the second data, and said mapping is mapping each of the first encoded data and the second encoded data depending on characteristics of the error correcting coding.

30. The transmission method according to claim 21, wherein the mapping of the at least a part of the second data to at least a part of the groups of symbols in the second part of the domain is performed in increasing order according to the time index.

15

31. A reception method comprising:
 receiving encoded first data which is mapped to symbols in
 a first part of a domain comprising a time index and a
 frequency index, and encoded second data which is
 mapped to groups of symbols in a second part of the domain; and
 decoding the encoded first data and the encoded second
 data, wherein:
 at least a part of the encoded first data is mapped to at least
 a part of the symbols in the first part of the domain in an
 increasing order according to the frequency index;
 at least a part of the encoded second data is mapped to at
 least a part of the groups of symbols in the second part of
 the domain and each group of the at least a part of the
 groups of symbols are aligned in an increasing order
 according to the time index; and
 each symbol within each of the groups of symbols is
 aligned along the frequency index.

32. The reception method according to claim 31, wherein a
 number of symbols along the frequency index for the first part
 of the domain and for the groups of symbols in the second part
 of the domain is different.

33. The reception method according to claim 31, wherein a
 number of symbols in the first part of the domain is greater
 than a number of symbols within each of the groups of sym-
 bols.

34. The reception method according to claim 31, wherein a
 number of symbols for the encoded second data is configured
 to be changed at a predetermined interval.

35. The reception method according to claim 31, wherein
 the first part of the domain to which the encoded first data is
 mapped and the second part of the domain to which the
 encoded second data is mapped are allocated continuously
 according to the time index.

36. The reception method according to claim 31 wherein at
 least a part of the encoded first data is not continuously
 mapped to the symbols in the first part of the domain.

37. The reception method according to claim 31, wherein at
 least a part of the encoded second data is not continuously
 mapped to each symbol within each of the groups of symbols
 aligned along the frequency index.

38. The reception method according to claim 31, wherein
 said receiving comprises receiving the encoded first data and
 the encoded second data, which are encoded with turbo cod-
 ing or convolutional coding.

39. The reception method according to claim 31, wherein
 said receiving comprises receiving the encoded first data and
 the encoded second data, which are encoded with error cor-
 recting coding, and the encoded first data and the encoded
 second data are mapped depending on characteristics of the
 error correcting coding.

40. The reception method according to claim 31, wherein
 the mapping of the at least a part of the second data to at least
 a part of the groups of symbols in the second part of the
 domain is performed in increasing order according to the time
 index.

16

41. A transmission apparatus comprising:
 a coding section configured to encode first data and second
 data; and
 a mapping section configured to map the encoded first data
 to symbols in a first part of a domain and the encoded
 second data to symbols in a second part of the domain,
 wherein:
 the first part of the domain and the second part of the
 domain each comprise a time index and a frequency
 index;
 at least a part of the encoded first data and at least a part of
 the encoded second data are mapped to symbols along
 the frequency indices of the first part of the domain and
 the second part of the domain, respectively, in an
 increasing order, and when the mapping exceeds a pre-
 determined number of symbols along the frequency
 indices, a next part of the encoded first data and a next
 part of the encoded second data are then mapped along
 the frequency indices of the first part of the domain and
 the second part of the domain, respectively, in an
 increasing order, to symbols where the time indices are
 increased by one compared to the previous mapping; and
 the predetermined number of symbols for the encoded first
 data and the encoded second data is different.

42. The transmission apparatus according to claim 41,
 wherein the predetermined number of symbols is predeter-
 mined according to third data.

43. A reception apparatus comprising:
 a receiving section configured to receive encoded first data
 which is mapped to symbols in a first part of a domain
 and encoded second data which is mapped to symbols in
 a second part of the domain; and
 a decoding section configured to decode the encoded first
 data and the encoded second data, wherein:
 the first part of the domain and the second part of the
 domain each comprise a time index and a frequency
 index;

at least a part of the encoded first data and at least a part of
 the encoded second data are mapped to symbols along
 the frequency indices of the first part of the domain and
 the second part of the domain, respectively, in an
 increasing order, and when the mapping exceeds a pre-
 determined number of symbols along the frequency
 indices, a next part of the encoded first data and a next
 part of the encoded second data are then mapped along
 the frequency indices of the first part of the domain and
 the second part of the domain, respectively, in an
 increasing order, to symbols where the time indices are
 increased by one compared to the previous mapping; and
 the predetermined number of symbols for the encoded first
 data and the encoded second data is different.

44. The reception apparatus according to claim 43, wherein
 the predetermined number of symbols is predetermined
 according to third data.

* * * * *

EXHIBIT 6

(12) **United States Patent**
Lee et al.

(10) **Patent No.:** **US 8,102,833 B2**
 (45) **Date of Patent:** **Jan. 24, 2012**

- (54) **METHOD FOR TRANSMITTING UPLINK SIGNALS**
- (75) Inventors: **Dae Won Lee**, Gyeonggi-do (KR); **Bong Hoe Kim**, Gyeonggi-do (KR); **Young Woo Yun**, Gyeonggi-do (KR); **Ki Jun Kim**, Gyeonggi-do (KR); **Dong Wook Roh**, Gyeonggi-do (KR); **Hak Seong Kim**, Gyeonggi-do (KR); **Hyun Wook Park**, Gyeonggi-do (KR)
- (73) Assignee: **LG Electronics Inc.**, Seoul (KR)
- (*) Notice: Subject to any disclaimer, the term of this patent is extended or adjusted under 35 U.S.C. 154(b) by 725 days.
- (21) Appl. No.: **12/209,136**
- (22) Filed: **Sep. 11, 2008**
- (65) **Prior Publication Data**
 US 2009/0097466 A1 Apr. 16, 2009

Related U.S. Application Data

- (60) Provisional application No. 60/972,244, filed on Sep. 13, 2007, provisional application No. 60/987,427, filed on Nov. 13, 2007, provisional application No. 60/988,433, filed on Nov. 16, 2007.

Foreign Application Priority Data

Jul. 15, 2008 (KR) 10-2008-0068634

- (51) **Int. Cl.**
H04B 7/208 (2006.01)
- (52) **U.S. Cl.** **370/344**; 370/319
- (58) **Field of Classification Search** 370/206, 370/278, 344, 208, 252, 294, 295, 315, 319, 370/328, 329, 330, 335, 336, 338; 455/450, 455/509

See application file for complete search history.

(56) **References Cited**

U.S. PATENT DOCUMENTS

2003/0185159	A1 *	10/2003	Seo et al.	370/278
2005/0232138	A1	10/2005	Byun et al.	
2005/0286402	A1	12/2005	Byun et al.	
2006/0098568	A1 *	5/2006	Oh et al.	370/206
2008/0304467	A1 *	12/2008	Papasakellariou et al. ...	370/344

FOREIGN PATENT DOCUMENTS

EP	1569403	8/2005
EP	1806867	7/2007
EP	1811701	7/2007
KR	10-2004-0056976	7/2004
KR	10-2005-0114569	12/2005

* cited by examiner

Primary Examiner — Derrick Ferris

Assistant Examiner — Mang Yeung

(74) *Attorney, Agent, or Firm* — Lee, Hong, Degerman, Kang & Waimey

(57) **ABSTRACT**

A method for transmitting uplink signals, which include ACK/NACK signals, control signals other than the ACK/NACK signals, and data signals, is disclosed. The method comprises serially multiplexing the control signals and the data signals; sequentially mapping the multiplexed signals within a specific resource region in accordance with a time-first mapping method, the specific resource region including a plurality of symbols and a plurality of virtual subcarriers; and arranging the ACK/NACK signals at both symbols near symbols to which a reference signal of the plurality of symbols is transmitted. Thus, the uplink signals can be transmitted to improve receiving reliability of signals having high priority.

14 Claims, 9 Drawing Sheets

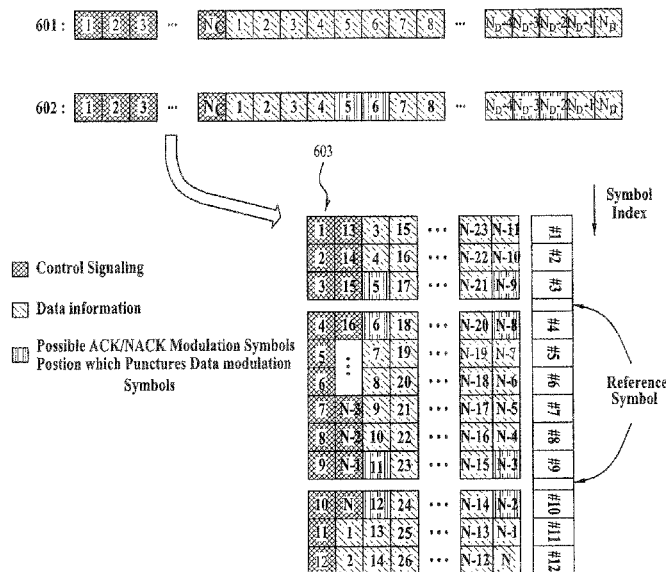

FIG. 1

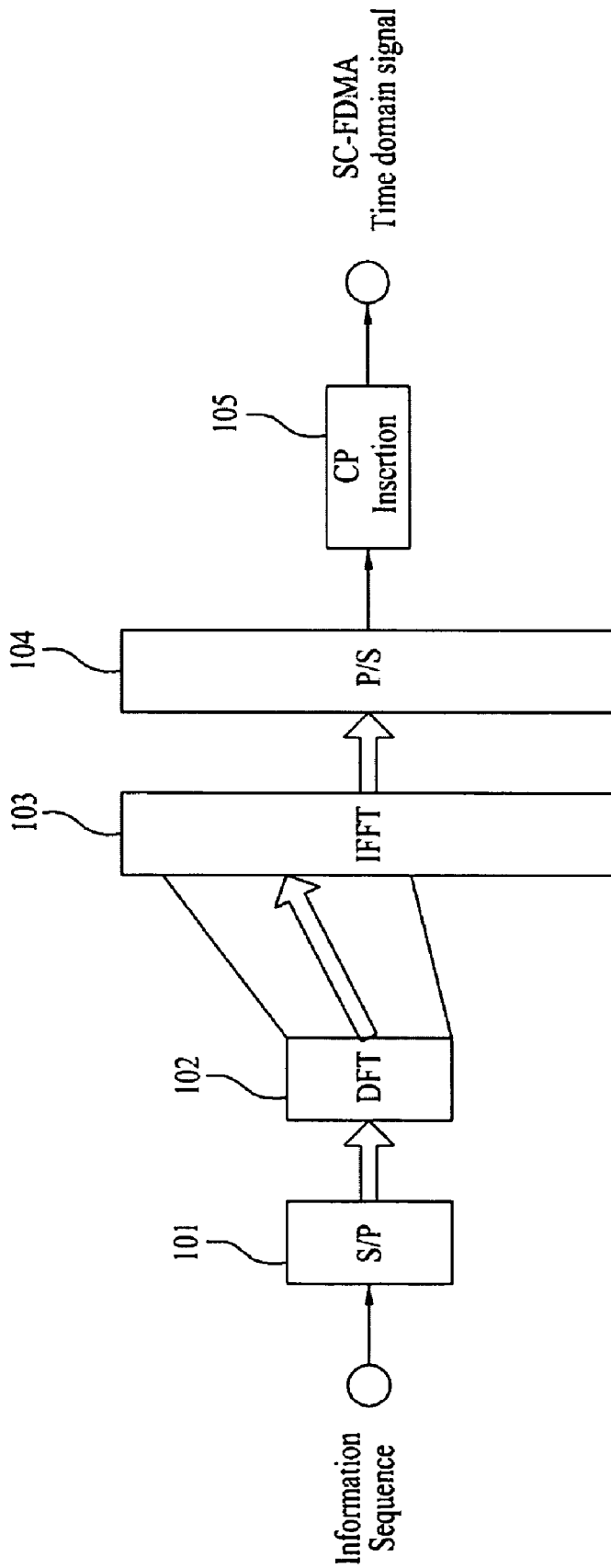

FIG. 2

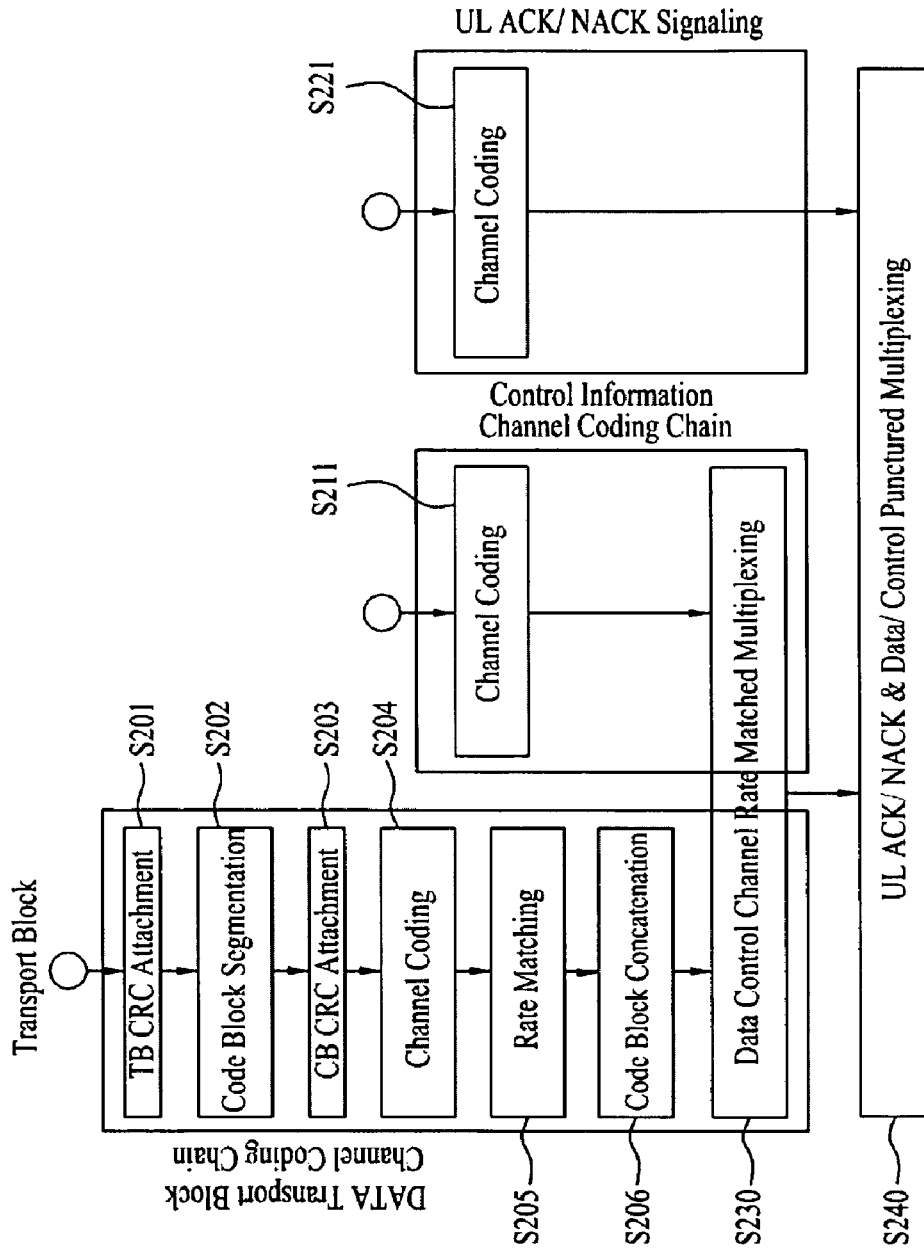

FIG. 3

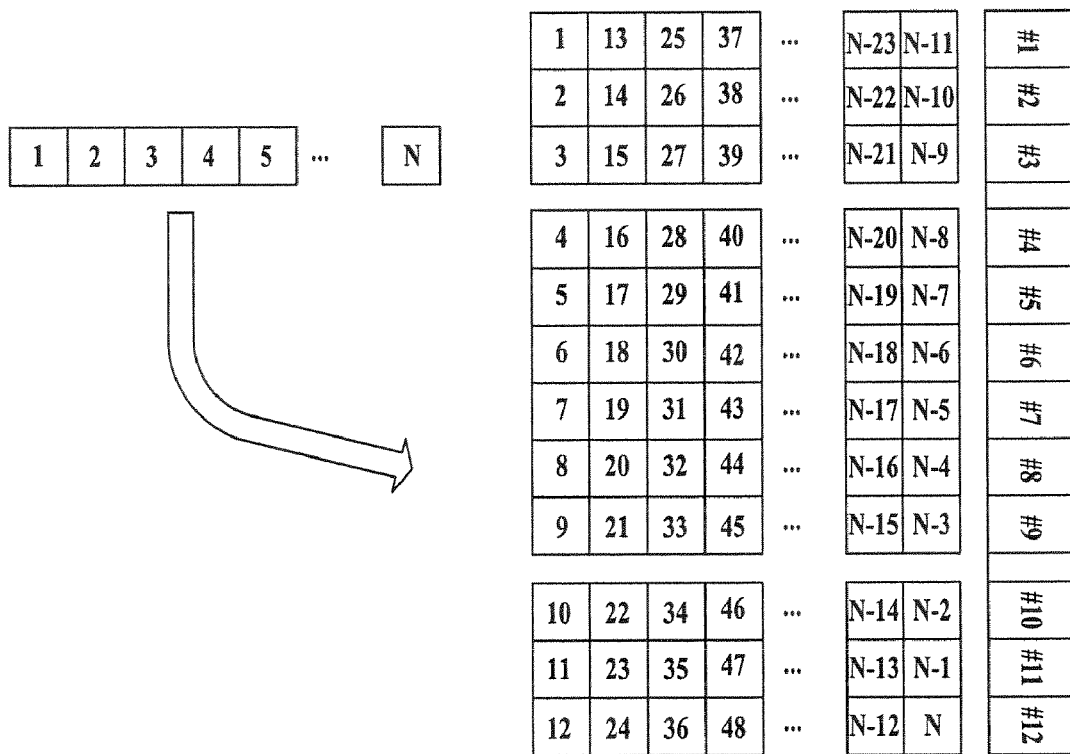

FIG. 4

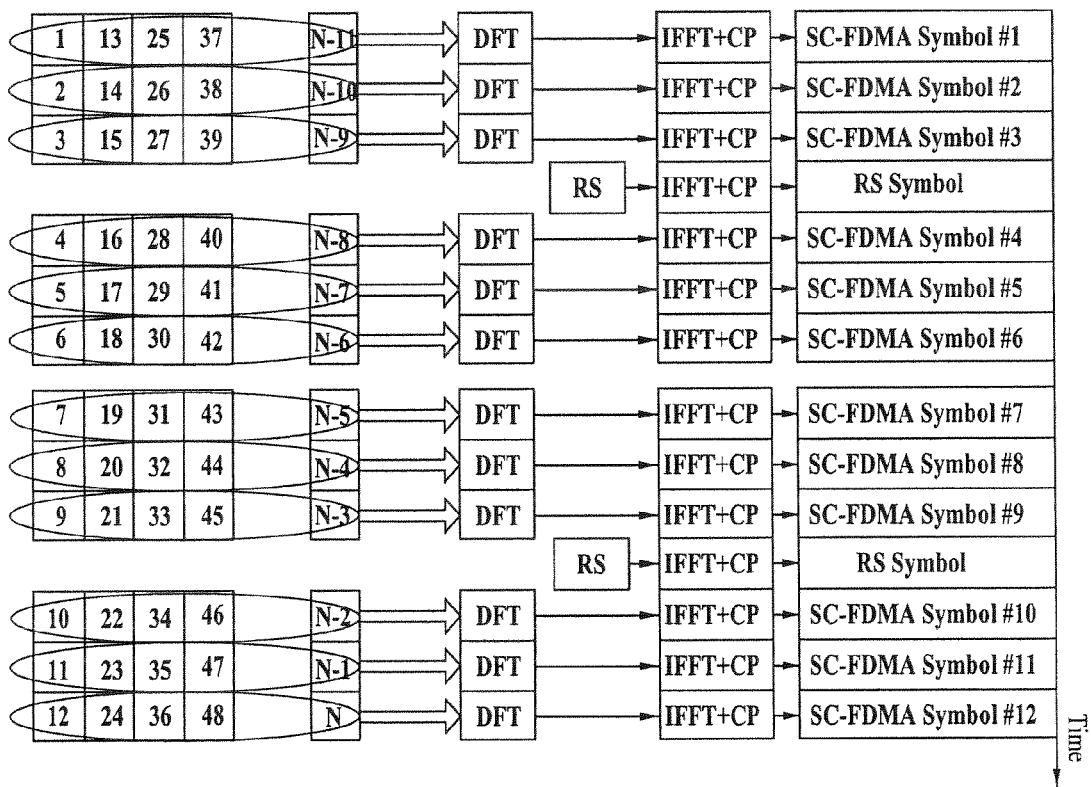

FIG. 5

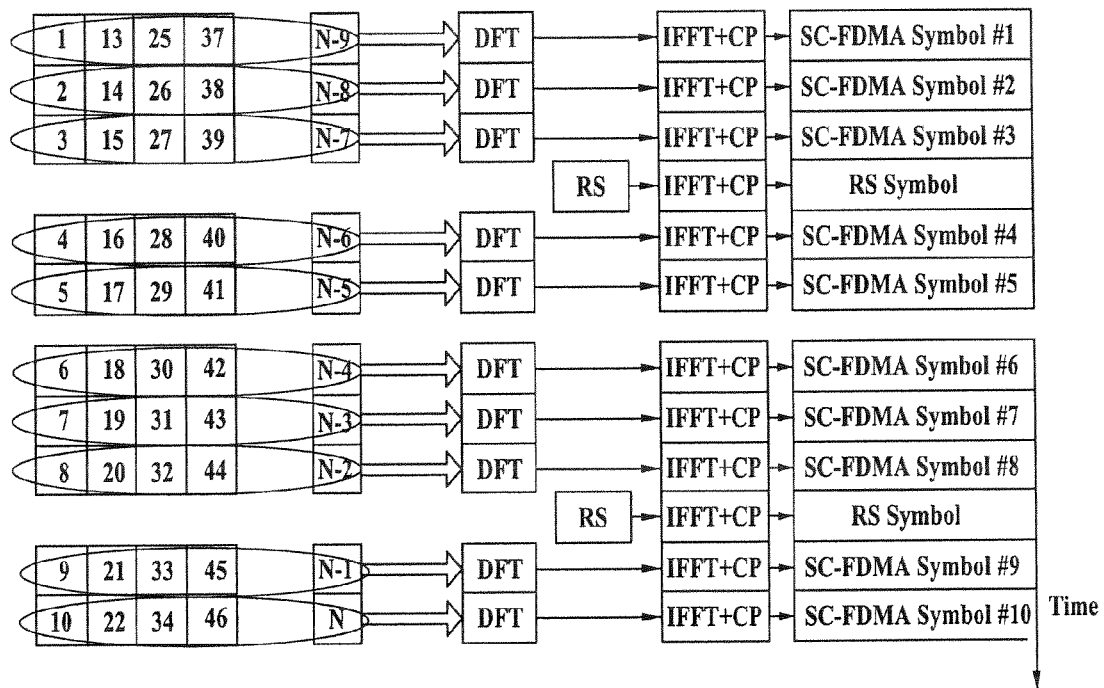

FIG. 6

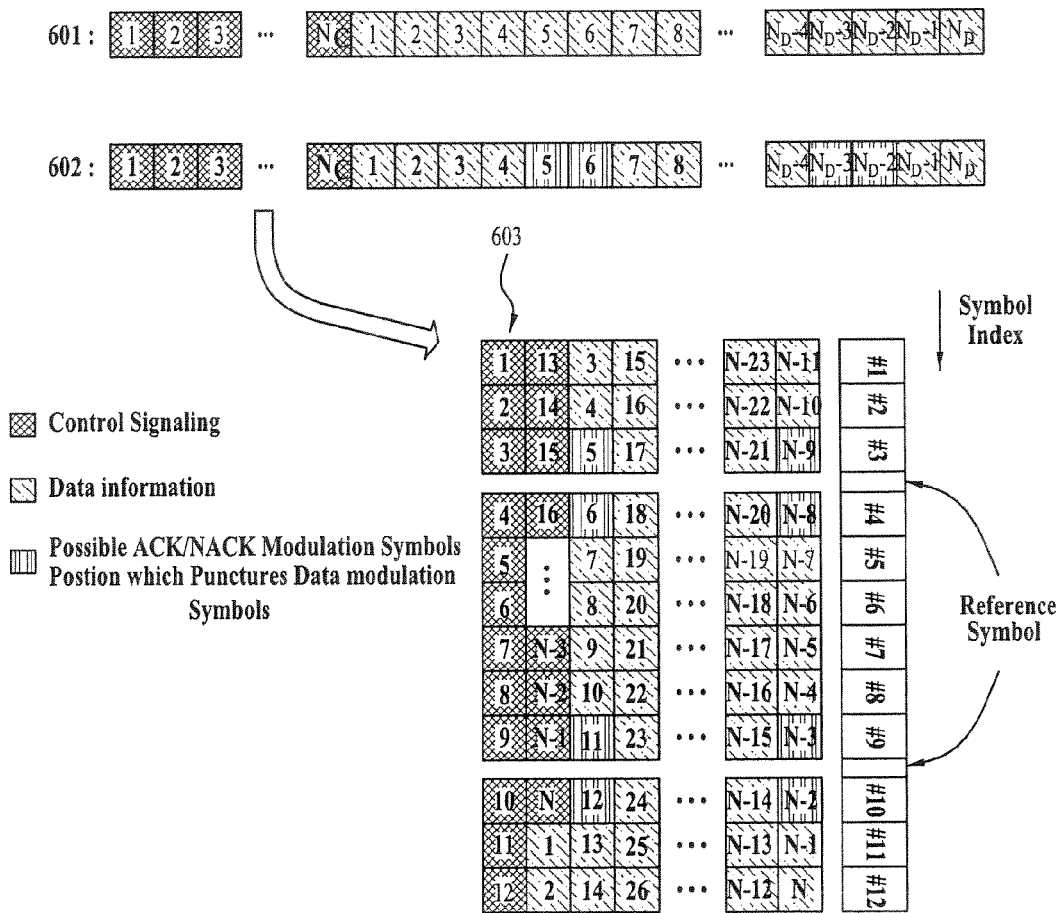

FIG. 7

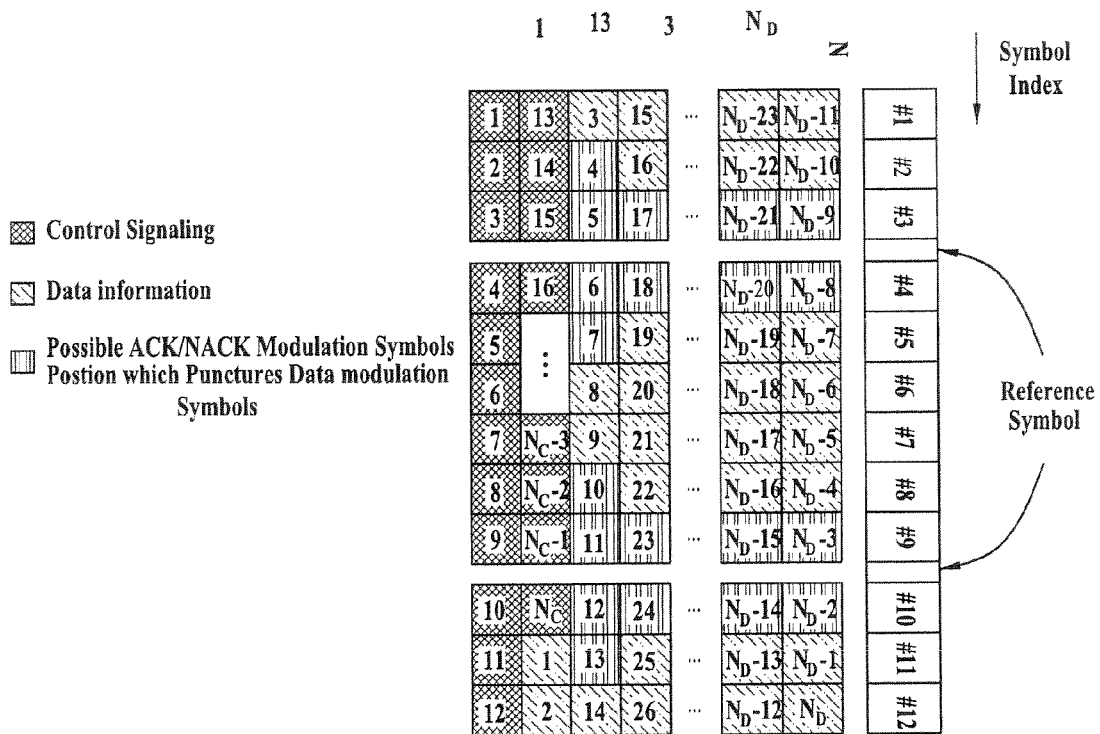

FIG. 8

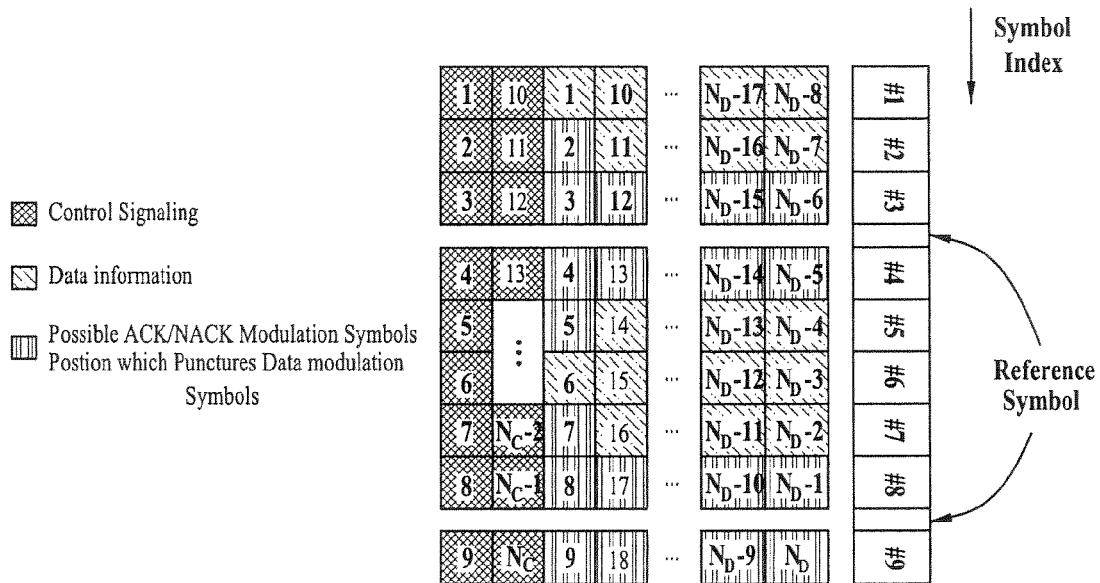
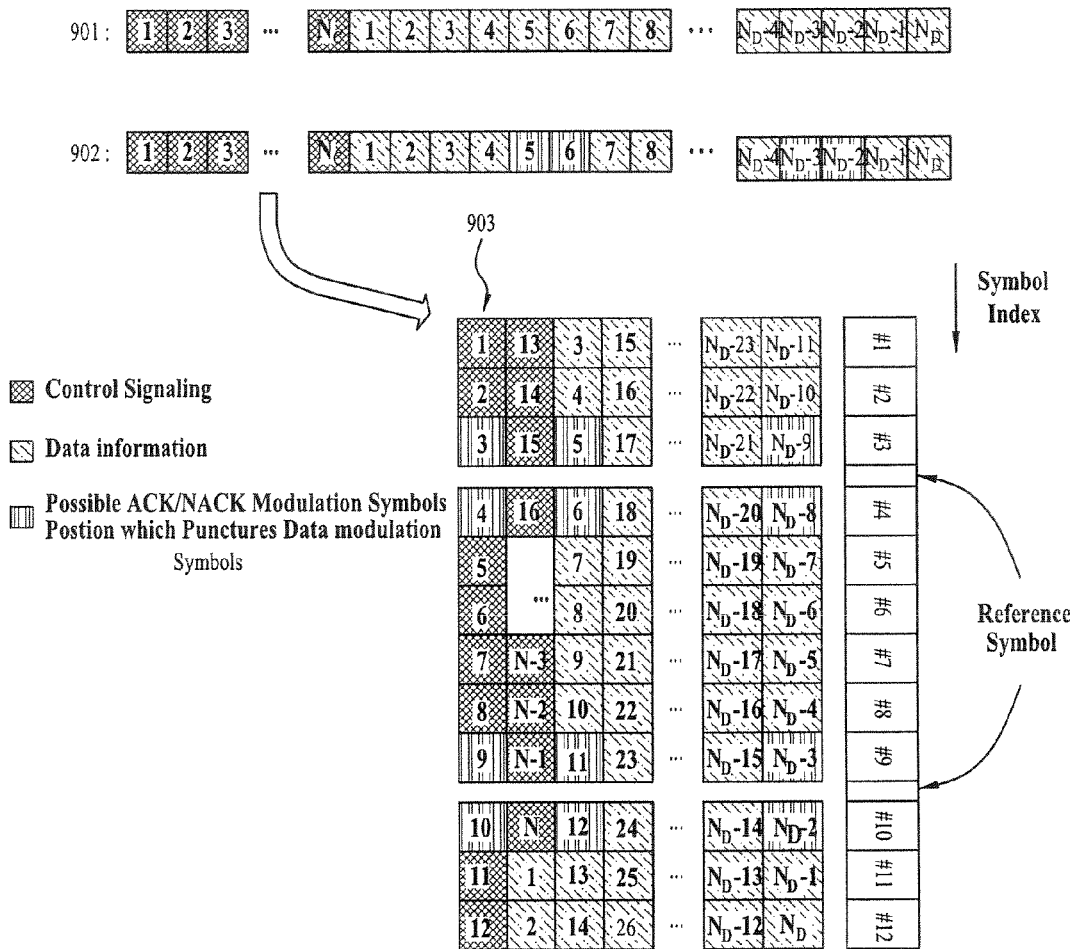

FIG. 9



METHOD FOR TRANSMITTING UPLINK SIGNALS

CROSS-REFERENCE TO RELATED APPLICATIONS

This application claims the benefit of the Korean Patent Application No. 10-2008-0068634, filed on Jul. 15, 2008, which is hereby incorporated by reference as if fully set forth herein.

This application also claims the benefit of U.S. Provisional Application Ser. Nos. 60/972,244, filed on Sep. 13, 2007, 60/987,427, filed on Nov. 13, 2007 and 60/988,433, filed on Nov. 16, 2007, the contents of which are hereby incorporated by reference herein in their entirety.

BACKGROUND OF THE INVENTION

1. Field of the Invention

The present invention relates to mobile communication technology, and more particularly, to technology of transmitting uplink signals including ACK/NACK signals, control signals other than the ACK/NACK signals, and data signals.

2. Discussion of the Related Art

A user equipment (UE) of a mobile communication system transmits various signals through an uplink. Uplink signals transmitted by the user equipment can be segmented into data signals and control signals. Also, examples of the control signals transmitted to the uplink include uplink ACK/NACK signals for HARQ communication, channel quality indicator (CQI) information, and preceding matrix index (PMI).

3GPP LTE system uses a single carrier frequency division multiplexing access (SC-FDMA) scheme for uplink signal transmission. Also, the 3GPP LTE system prescribes that data signals and control signals among the uplink signals are first multiplexed and ACK/NACK signals are transmitted to the multiplexed signals by puncturing the data or control signals when uplink ACK/NACK signal transmission is required for downlink data. Hereinafter, in order that the ACK/NACK signals are divided from control signals other than the ACK/NACK signals, the control signals will mean those except for the ACK/NACK signals.

Meanwhile, Athens conference (#50) for 3GPP LTE has decided that data information is rate matched together with control information when the control information is multiplexed with the data information, wherein the control information is transmitted near a reference signal. This is to improve channel estimation performance by approximating all the control signals to the reference signal as the control signals generally require higher reliability than the data signals.

However, the control signals transmitted to the uplink include various signals as described above, and the ACK/NACK signals require higher reliability than the other control signals. In this case, when uplink ACK/NACK signal transmission is required while all the control signals are transmitted by approximating to the reference signal, problems occur in that the ACK/NACK signals can neither be transmitted by puncturing the control signals arranged near the reference signal nor be transmitted near the reference signal.

In this respect, a technology of transmitting uplink signals by efficiently arranging ACK/NACK signals and other control signals in a resource region considering priority among them is required.

SUMMARY OF THE INVENTION

Accordingly, the present invention is directed to a method for transmitting uplink signals, which substantially obviates one or more problems due to limitations and disadvantages of the related art.

An object of the present invention is to provide a method for transmitting uplink signals by efficiently arranging ACK/NACK signals and other control signals in a resource region considering priority among them.

Another object of the present invention is to provide transmitting uplink signals using the aforementioned signal arrangement.

To achieve these objects and other advantages and in accordance with the purpose of the invention, as embodied and broadly described herein, the present invention provides a method for transmitting uplink signals, which include ACK/NACK signals, control signals other than the ACK/NACK signals, and data signals. The method comprises serially multiplexing the control signals and the data signals; sequentially mapping the multiplexed signals within a specific resource region in accordance with a time-first mapping method, the specific resource region including a plurality of symbols and a plurality of virtual subcarriers; and arranging the ACK/NACK signals at both symbols near to symbols through which a reference signal is transmitted.

At this time, the ACK/NACK signals are overwritten on a part of the multiplexed signals. And, the part of the multiplexed signals, on which the ACK/NACK signals are overwritten, includes one or more of the control signals and the data signals.

Also, the method further comprises performing a discrete fourier transform (DFT) for the signals mapped on the specific resource region in a unit of each symbols of the plurality of symbols in accordance with each index of the plurality of virtual subcarriers; performing an inverse fast fourier transform (IFFT) for the DFT symbol unit signals and attaching a cyclic prefix (CP) the signals; and transmitting the symbol unit signals attached with the CP as single carrier frequency division multiplexing access (SC-FDMA) symbols.

Also, the method further comprises transmitting the signals mapped on the specific resource region through a physical uplink sharing channel (PUSCH).

In another aspect of the present invention, the present invention provides a method for transmitting uplink signals, which include ACK/NACK signals, control signals other than the ACK/NACK signals, and data signals. The method comprises performing channel coding for each of the data signals, the control signals, and the ACK/NACK signals; serially multiplexing the channel coded data and control signals; sequentially mapping the multiplexed signals in accordance with a time-first mapping method within a specific resource region in accordance with a time-first mapping method, the specific resource region including a plurality of symbols and a plurality of virtual subcarriers; and arranging the ACK/NACK signals at both symbols near to the symbols through which a reference signal is transmitted.

At this time, the step of performing channel coding for the data signals includes attaching a CRC for a transport block (TB) to a transport block for transmission of the data signals; segmenting the transport block attached with the CRC for the transport block in a code block unit and attaching a CRC for a code block to the segmented code block; performing channel coding for the data attached with the CRC for a code block; and performing rate matching and code block concatenation for the channel coded data.

3

According to the aforementioned embodiments of the present invention, it is possible to transmit uplink signals by efficiently arranging ACK/NACK signals and other control signals in a resource region in accordance with priority among them.

In addition, the ACK/NACK signals having high priority can be set in such a manner that they acquire more channel estimation effect.

BRIEF DESCRIPTION OF THE DRAWINGS

The accompanying drawings, which are included to provide a further understanding of the invention and are incorporated in and constitute a part of this specification, illustrate embodiments of the invention and together with the description serve to explain the principles of the invention.

In the drawings:

FIG. 1 is a block diagram illustrating a transmitter to describe a method for transmitting signals in accordance with a single carrier frequency division multiplexing access (SC-FDMA) scheme;

FIG. 2 is a diagram illustrating a procedure of multiplexing data information, control information and ACK/NACK signals for uplink signal transmission;

FIG. 3 is a diagram illustrating an example of mapping information sequences according to one embodiment of the present invention in accordance with a time-first mapping method

FIG. 4 and FIG. 5 are diagrams illustrating a method for transmitting information, which is mapped in accordance with the time-first mapping method as illustrated in FIG. 3, in accordance with the SC-FDMA scheme;

FIG. 6 is a diagram illustrating a method for transmitting uplink signals in accordance with one embodiment of the present invention;

FIG. 7 and FIG. 8 are diagrams illustrating a method for processing a number of ACK/NACK information data to be transmitted in accordance with one embodiment of the present invention; and

FIG. 9 is a diagram illustrating that ACK/NACK signals are inserted by puncturing the control signals as well as the data signals in accordance with another embodiment of the present invention.

DETAILED DESCRIPTION OF THE INVENTION

Hereinafter, the preferred embodiments of the present invention will be described with reference to the accompanying drawings. It is to be understood that the detailed description, which will be disclosed along with the accompanying drawings, is intended to describe the exemplary embodiments of the present invention, and is not intended to describe a unique embodiment with which the present invention can be carried out. Hereinafter, the following detailed description includes detailed matters to provide full understanding of the present invention. However, it will be apparent to those skilled in the art that the present invention can be carried out without the detailed matters.

Meanwhile, in some cases, to prevent the concept of the present invention from being ambiguous, structures and apparatuses of the known art will be omitted, or will be shown in the form of a block diagram based on main functions of each structure and apparatus. Also, wherever possible, the same reference numbers will be used throughout the drawings and the specification to refer to the same or like parts.

As described above, the embodiment of the present invention is intended to provide a method for transmitting uplink

4

signals by efficiently arranging ACK/NACK signals and other control signals in a resource region considering priority among them. To this end, a detailed method for transmitting uplink signals in a 3GPP LTE system will be described.

FIG. 1 is a block diagram illustrating a transmitter to describe a method for transmitting signals in accordance with a single carrier frequency division multiplexing access (SC-FDMA) scheme.

As described above, a 3GPP LTE system transmits uplink signals in accordance with a single carrier frequency division multiplexing access (SC-FDMA) scheme. In detail, direct-to-parallel conversion is performed for information sequences to be transmitted, to perform a discrete fourier transform (DFT) (101). The DFT is performed for the signals converted to the parallel sequences (102), and then inverse fast fourier transform (IFFT) can be performed to obtain a single carrier feature (103). At this time, a length of information inserted to an IFFT module 103 may not be equal to a size of the IFFT module 103. However, it is required that the DFT result performed by the DFT module 102 should be mapped with continuous IFFT input indexes.

Values undergone IFFT are again converted to serial signals by a parallel-to-serial conversion module 104. Afterwards, the signals are changed to a format of OFDM symbols by a cyclic prefix (CP) (105) and then transmitted to a real time space.

The aforementioned SC-FDMA scheme has advantages in that it has low peak power-to-average power ratio (PAPR) and/or cubic metric (CM) while maintaining a single carrier feature. However, in order to satisfy low PAPR/CM condition while maintaining a single carrier feature, it is required that information undergone DFT preceding should be input to the IFFT module 103 in an OFDM format by mapping with continuous indexes. In other words, it is required that DFT precoded information should be inserted to continuous sub-carriers of OFDM. Accordingly, it is preferable that information data (for example, control information and data information) having different features are multiplexed together when they are transmitted to an uplink so that they undergo DFT precoding together and then are transmitted in an OFDM format.

Hereinafter, a procedure of multiplexing data information and control information will be described.

FIG. 2 is a diagram illustrating a procedure of multiplexing data information, control information and ACK/NACK signals for uplink signal transmission.

Data information multiplexed with control information is segmented into several code blocks (CB) in accordance with a size of a transport block (TB) to be transmitted to the uplink after CRC for TB is attached to the TB (S201 and S202). Afterwards, the CRC for CB is attached to several CBs (S203), and channel coding is performed for the result value obtained by attaching the CRC for CB to several CBs (S204). Also, after the channel coded data undergo rate matching (S205), concatenation among CBs is performed (S206). The CBs are then multiplexed with control information (S230). Meanwhile, the aforementioned steps may be subject to channel coding chain for a data transport block.

Channel coding can be performed for the control information separately from the data information (S211). The channel coded control information can later be multiplexed with the data information by a data and control channel rate mapping multiplexer (S230).

Channel coding can be performed for the ACK/NACK signals separately from the data and control signals (S221). Some of the uplink signals in which the data and control

5

signals are multiplexed (S230) may be transmitted to the uplink through puncturing (S240).

As described above, the control information that can be transmitted together with the data information is segmented into two types, i.e., uplink (UL) ACK/NACK signals for downlink data and other control information. The uplink ACK/NACK signals for downlink data are transmitted only when downlink data exist. A user equipment may not know whether to receive downlink data even though it should transmit the UL ACK/NACK signals. Accordingly, the user equipment segments the two types of control information from each other and transmits them to the uplink together with the data information. Hereinafter, in order to segment the ACK/NACK signals from the control signals transmitted separately from the ACK/NACK signals, "control signals" will mean those other than the ACK/NACK signals. In more detailed embodiment, the control signals may mean those other than a rank indicator as well as the ACK/NACK signals. In other words, in a specific embodiment, the control signals may include CQI and PMI. However, since the following description relates to efficient arrangement among the control signals, the data signals and the ACK/NACK signals, if the control signals are those other than the ACK/NACK signals, their detailed type will not be suggested.

When the data information is transmitted to the uplink, the data information can be transmitted together with the control information. Also, ACK/NACK information can be transmitted together with the data information and the control information. Moreover, only the data information and the ACK/NACK information can be transmitted to the uplink.

Transmission information sequences obtained to transmit the data information multiplexed with the control information or the ACK/NACK information can be transmitted in accordance with the SC-FDMA scheme. At this time, the transmission information sequences can be mapped in a resource region in accordance with a time-first mapping method.

For example, it is supposed that the information sequences are transmitted using one resource block, i.e., twelve (12) OFDM subcarriers and information is transmitted through one sub-frame. Also, it is supposed that one sub-frame includes fourteen (14) SC-FDMA symbols and two of the fourteen SC-FDMS symbols are used as reference signals that are pilot signals. At this time, the number of modulation symbols of the information that can be transmitted to the uplink becomes $12 \times 12 = 144$.

144 information sequence symbols can be transmitted through 12 virtual subcarriers and 12 SC-FDMA symbols. This can be represented by a matrix structure of 12×12 called a time-frequency mapper. The information sequences to be transmitted to the uplink are mapped one by one based on the SC-FDMA symbols. This is called time-first mapping because the SC-FDMA symbols are segmented temporally.

FIG. 3 is a diagram illustrating an example of mapping information sequences according to one embodiment of the present invention in accordance with a time-first mapping method, and FIG. 4 and FIG. 5 are diagrams illustrating a method for transmitting information, which is mapped in accordance with the time-first mapping method as illustrated in FIG. 3, in accordance with the SC-FDMA scheme.

The information sequences to be transmitted to the uplink can be arranged temporally in the time-frequency mapper as illustrated in FIG. 3. In other words, 12 information data are mapped temporally in a first virtual subcarrier region, and then subsequent 12 information data are mapped temporally in a second virtual subcarrier region.

After time-frequency mapping is performed as above, the sequences arranged on a frequency axis as illustrated in FIG.

6

4 and FIG. 5 undergo DFT and then are inserted to a desired frequency band. Afterwards, IFFT and CP insertion are performed for each frequency region information, which can be transmitted as SC-FDMA symbols. FIG. 4 and FIG. 5 illustrate a procedure of generating and transmitting the SC-FDMA symbols. FIG. 4 illustrates a case where a normal CP is used, and FIG. 5 illustrates a case where an extended CP is used.

When data are transmitted to the uplink, the control information can also be transmitted thereto. At this time, the control information and the data information are multiplexed through rate matching. However, the ACK/NACK information can be transmitted in such a manner that it is overwritten in bit streams of the data information or symbols where data information and control information are multiplexed. In this case, "overwritten" means that specific information mapped in the resource region is skipped and the corresponding region is mapped. Also, "overwritten" means that the length of the entire information is maintained equally even after specific information is inserted. This overwriting procedure may be represented by puncturing.

Generally, the control information requires higher reliability than the data information. To this end, the control information should be multiplexed or inserted near the reference signal. In this case, it is possible to obtain the effect of channel estimation performance, thereby expecting improvement of performance.

However, since the ACK/NACK information also requires high reliability in a receiver, if the general control information is arranged near the reference signal, priority between the control information and the ACK/NACK signals should be considered.

Accordingly, methods for multiplexing data information bit streams, control information bit streams, and ACK/NACK information sequences at different priorities will be described as various embodiments of the present invention.

According to one embodiment of the present invention, the control information is multiplexed serially with the data information, and is mapped with a multiplexing region in accordance with the aforementioned time-first mapping method. In this case, "multiplexed serially" means that the data information is mapped with a sequence corresponding to the multiplexed result directly after the control information is mapped with the sequence, or vice versa. Also, according to one embodiment of the present invention, the ACK/NACK signals are arranged to be transmitted through both symbols near a symbol through which the reference signal is transmitted.

FIG. 6 is a diagram illustrating a method for transmitting uplink signals in accordance with one embodiment of the present invention.

According to this embodiment, when the control information and the data information are multiplexed, they are serially connected with each other so that they are mapped with SC-FDMS symbols in accordance with the time-first mapping method and then are transmitted to the uplink. If the ACK/NACK information should also be transmitted, among the serially multiplexed data, modulation symbols located near the reference signal are punctured so that the ACK/NACK signals are inserted thereto. In FIG. 6, a reference numeral 601 illustrates that the data and control signals are multiplexed serially if the ACK/NACK signals are not transmitted. A reference numeral 602 illustrates that the ACK/NACK signals are arranged by puncturing the multiplexed data if the ACK/NACK signals should be transmitted to the uplink. Also, a reference numeral 603 illustrates that information sequences such as the reference numeral 602 are

mapped in the time-frequency region in accordance with the time-first mapping method. In the reference numeral 603 of FIG. 6, it is supposed that the reference signal is transmitted through a part between symbol indexes #3 and #4 and a part between symbol indexes #9 and #10.

As can be aware of it from the mapping type illustrated in the reference numeral 603 of FIG. 6, after the control signals are serially connected with data and then multiplexed, they are mapped in the time-frequency region in accordance with the time-first mapping method. Also, the ACK/NACK signals can be set in such a manner that they are overwritten in the data signals multiplexed with two symbols (symbols #3, 4, 9 and 10 in FIG. 6) at both sides of the SC-FDMA symbols to which the reference signal is transmitted;

FIG. 7 and FIG. 8 are diagrams illustrating a method for processing a number of ACK/NACK information data to be transmitted in accordance with one embodiment of the present invention.

In detail, when the number of ACK/NACK information data to be transmitted is more than the number of subcarriers (of a virtual frequency region) to which data are transmitted before and after the reference signal, the ACK/NACK information can be transmitted through additional SC-FDMA symbols in addition to both symbols nearest to the reference signal. In FIG. 7 and FIG. 8, the ACK/NACK information is transmitted through additional symbols in the order of the symbols near reference symbols in addition to both symbols near the reference symbols.

At this time, the SC-FDMA symbols existing based on the reference signal may not be arranged symmetrically depending on a structure of the SC-FDMA sub-frame of the uplink as illustrated in FIG. 8. Accordingly, considering this, the ACK/NACK information should be inserted by puncturing.

When the control information is arranged on the time-axis in accordance with the aforementioned embodiment of the present invention, the control information and the data information are arranged in due order so that they are mapped in the resource region. Also, if the ACK/NACK information is arranged near the reference signal, the ACK/NACK information can be overwritten in the control information as well as the data information.

FIG. 9 is a diagram illustrating that the ACK/NACK signals are inserted by puncturing the control signals as well as the data signals in accordance with another embodiment of the present invention.

According to this embodiment, since the ACK/NACK information is substantially control information, priority is given to control information channels, so that the control information channel having the highest priority is arranged near the reference signal for protection of channel estimation while the control information channels having relatively low priority are sequentially mapped on the time axis and then transmitted. Particularly, in this embodiment, it is supposed that the ACK/NACK information has higher priority than the control information. At this time, the control information and the data information are sequentially arranged on the time axis in accordance with the time-first mapping method and then multiplexed. The ACK/NACK information punctures the data/control information located near the reference signal.

In detail, a reference numeral 901 of FIG. 9 illustrates that the data and control signals are multiplexed if the ACK/NACK signals need not to be transmitted. A reference numeral 902 of FIG. 9 illustrates that data, control signals and ACK/NACK signals are multiplexed if the ACK/NACK signals should be transmitted. Also, a reference numeral 903 of FIG. 9 illustrates that the multiplexed uplink signals are mapped in the time-frequency region as illustrated in the reference numeral 902.

As illustrated in the reference numeral 903 of FIG. 9, it is noted from this embodiment that the ACK/NACK signals can

puncture the control signals as well as the data matched near the reference signal. In this way, if resource mapping is performed by giving priority to the control signals, good channel estimation effect can be obtained as the ACK/NACK information is located near the reference signal. On the other hand, since a small number of control signals are punctured by the ACK/NACK signals, it may not affect performance. In one embodiment shown in FIG. 9, the ACK/NACK signals may puncture the control signals/data equally distributed in the virtual frequency axis. That is, if the number of virtual subcarriers available for the above puncturing by the ACK/NACK signals is "N" and the number of ACK/NACK to be transmitted per SC-FDMA symbol is "m", the ACK/NACK signals may puncture the control signals/data equally distributed having the interval of "N/m" or equivalent.

Also, since the control information and the data information are multiplexed simply, a multiplexing block can be formed simply.

Hereinafter, a whole procedure of transmitting uplink signals in accordance with the aforementioned embodiments of the present invention will be described. For convenience of description, this procedure will be described with reference to FIG. 2.

In order to transmit the uplink signals in accordance with each of the embodiments of the present invention, the transmitter performs channel coding for each of data signals, control signals, and ACK/NACK signals. Channel coding for each of the uplink signals can be performed independently as illustrated in FIG. 2.

At this time, as illustrated in FIG. 2, the procedure of performing channel coding for the data signals can include steps of segmenting a TB attached with CRC for TB in a unit of CB (S202), attaching a CRC for CB to the segmented CBs (S203), performing channel coding for the data attached with the CRC for CB (S204), performing rate matching for the channel coded data (S206), and performing CB concatenation (S207).

The one embodiment of the present invention suggests that the channel coded data and control signals are multiplexed serially. Serial multiplexing means that the control signals are mapped with sequential indexes directly after the data signals are mapped with them, or vice versa. Meanwhile, the multiplexed signals can sequentially be mapped within a specific resource region in accordance with the time-first mapping method, wherein the specific resource region includes a plurality of symbols (for example, 12 SC-FDMA symbols) and a plurality of virtual subcarriers.

In addition, in this embodiment of the present invention, the ACK/NACK signals are preferably arranged near the symbols to which the reference signal is transmitted, among the plurality of symbols.

It will be apparent to those skilled in the art that the present invention can be embodied in other specific forms without departing from the spirit and essential characteristics of the invention. Thus, the above embodiments are to be considered in all respects as illustrative and not restrictive. The scope of the invention should be determined by reasonable interpretation of the appended claims and all change which comes within the equivalent scope of the invention are included in the scope of the invention.

The embodiments of the present invention can be applied to various systems, which require data signal transmission, control signal transmission, and ACK/NACK signal transmission through the uplink, in addition to the 3GPP LTE system.

What is claimed is:

1. A method for transmitting uplink signals comprising control signals and data signals in a wireless communication system, the method comprising:

- (a) serially multiplexing first control signals and data signals in a mobile station, wherein the first control signals are placed at a front part of the multiplexed signals and the data signals are placed at a rear part of the multiplexed signals;
 - (b) mapping the multiplexed signals to a 2-dimensional resource matrix comprising a plurality of columns and a plurality of rows, wherein the columns and the rows of the 2-dimensional resource matrix correspond to single carrier frequency divisional multiple access (SC-FDMA) symbols and subcarriers for each SC-FDMA symbol, respectively, wherein a number of columns of the 2-dimensional resource matrix corresponds to a number of SC-FDMA symbols within one subframe except specific SC-FDMA symbols used for a reference signal, and wherein the multiplexed signals are mapped from the first column of the first row to the last column of the first row, the first column of the second row to the last column of the second row, and so on, until all the multiplexed signals are mapped to the 2-dimensional resource matrix
 - (c) mapping ACK/NACK control signals to specific columns of the 2-dimensional resource matrix, wherein the specific columns correspond to SC-FDMA symbols right adjacent to the specific SC-FDMA symbols, wherein the ACK/NACK control signals overwrite some of the multiplexed signals mapped to the 2-dimensional resource matrix at step (b) from the last row of the specific columns; and
 - (d) transmitting the signals mapped to the 2-dimensional resource matrix at steps (b) and (c) by column by column to a base station.
2. The method of claim 1, wherein the first control signals comprise at least one of:
 - precoding matrix index (PMI) signals; or
 - channel quality indicator (CQI) signals.
 3. The method of claim 1, wherein one subframe comprises two slots, wherein the specific SC-FDMA symbols correspond to fourth SC-FDMA symbols out of seven SC-FDMA symbols in each slot.
 4. The method of claim 1, wherein the ACK/NACK control signals are transmitted via subcarriers corresponding to third SC-FDMA symbols and fifth SC-FDMA symbols out of seven SC-FDMA symbols in each slot.
 5. The method of claim 1, wherein the ACK/NACK control signals are channel coded independently of the data signals or first control signals.
 6. The method of claim 1, wherein the step (d) comprises:
 - respectively performing a discrete Fourier transform (DFT) for the signals mapped to each column of the 2-dimensional resource matrix signals;
 - respectively performing an inverse fast Fourier transform (IFFT) on the DFT-transformed signals corresponding to the signals mapped to each column of the 2-dimensional resource matrix signals;
 - respectively attaching a cyclic prefix to the IFFT-transformed signals corresponding to the signals mapped to each column of the 2-dimensional resource matrix signals; and
 - transmitting the cyclic prefix attached signals to the base station.
 7. The method of claim 1, wherein the signals mapped to the 2-dimensional resource matrix are transmitted through a physical uplink shared channel (PUSCH).
 8. A mobile station for transmitting uplink signals comprising control signals and data signals in a wireless communication system, the mobile station comprising:

- a processor serially multiplexing first control signals and data signals, wherein the first control signals are placed at a front part of the multiplexed signals and the data signals are placed at a rear part of the multiplexed signals;
 - the processor mapping the multiplexed signals to a 2-dimensional resource matrix comprising a plurality of columns and a plurality of rows, wherein the columns and the rows of the 2-dimensional resource matrix correspond to single carrier frequency divisional multiple access (SC-FDMA) and subcarriers for each SC-FDMA symbol, respectively, wherein a number of columns of the 2-dimensional resource matrix corresponds to a number of SC-FDMA symbols within one subframe except specific SC-FDMA symbols used for a reference signal, and wherein the multiplexed signals are mapped from the first column of the first row to the last column of the first row, the first column of the second row to the last column of the second row, and so on, until all the multiplexed signals are mapped to the 2-dimensional resource matrix; and
 - the processor mapping ACK/NACK control signals to specific columns of the 2-dimensional resource matrix, wherein the specific columns correspond to SC-FDMA symbols right adjacent to the specific SC-FDMA symbols, wherein the ACK/NACK control signals overwrite some of the multiplexed signals mapped to the 2-dimensional resource matrix from the last row of the specific columns.
9. The mobile station of claim 8, wherein the first control signals comprise at least one of:
 - precoding matrix index (PMI) signals; or
 - channel quality indicator (CQI) signals.
 10. The mobile station of claim 8, wherein one subframe comprises two slots, wherein the specific SC-FDMA symbols correspond to fourth SC-FDMA symbols out of seven SC-FDMA symbols in each slot.
 11. The mobile station of claim 8, wherein the ACK/NACK control signals are transmitted via subcarriers corresponding to third SC-FDMA symbols and fifth SC-FDMA symbols out of seven SC-FDMA symbols in each slot.
 12. The mobile station of claim 8, wherein the ACK/NACK control signals are channel coded independently of the data signals or first control signals.
 13. The mobile station of claim 8, wherein the processor further adapted for:
 - respectively performing, a discrete Fourier transform (DFT) the signals mapped to each column of the 2-dimensional resource matrix signals;
 - respectively performing an inverse fast Fourier transform (IFFT) on the DFT-transformed signals corresponding to the signals mapped to each column of the 2-dimensional resource matrix signals;
 - respectively attaching a cyclic prefix to the IFFT-transformed signals corresponding to the signals mapped to each column of the 2-dimensional resource matrix signals; and
 - transmitting the cyclic prefix attached signals to a base station.
 14. The mobile station of claim 8, wherein the signals mapped to the 2-dimensional resource matrix are transmitted through a physical uplink shared channel (PUSCH).

EXHIBIT 7

(12) **United States Patent**
Jersenius et al.

(10) **Patent No.:** **US 8,437,293 B2**
(45) **Date of Patent:** **May 7, 2013**

(54) **METHODS AND SYSTEMS FOR SCHEDULING RESOURCES IN A TELECOMMUNICATION SYSTEM**

(58) **Field of Classification Search** None
See application file for complete search history.

(75) Inventors: **Kristina Jersenius**, Linkoping (SE);
Henning Wiemann, Aachen (DE); **Anna Larmo**, Espoo (FI); **Peter Moberg**, Stockholm (SE); **Eva Englund**, Linkoping (SE)

(56) **References Cited**

U.S. PATENT DOCUMENTS

7,145,889 B1	12/2006	Zhang et al.	
2005/0135416 A1 *	6/2005	Ketchum et al.	370/469
2007/0047451 A1 *	3/2007	Lohr et al.	370/242
2007/0047452 A1 *	3/2007	Lohr et al.	370/242
2007/0189205 A1	8/2007	Terry et al.	
2007/0201397 A1 *	8/2007	Zhang	370/329
2008/0080381 A1 *	4/2008	Maheshwari et al.	370/235
2008/0081628 A1 *	4/2008	Ye et al.	455/445

(Continued)

FOREIGN PATENT DOCUMENTS

EP	1507352 A1	2/2005
EP	1708523 A1	10/2006

(Continued)

OTHER PUBLICATIONS

Office Action issued on Nov. 25, 2010 in Mexican Patent Application No. MX/a/2009/013430, 2 pages.

(Continued)

Primary Examiner — Eunsook Choi

(74) *Attorney, Agent, or Firm* — Rothwell, Figg, Ernst & Manbeck, P.C.

(73) Assignee: **Telefonaktiebolaget L M Ericsson (publ)**, Stockholm (SE)

(*) Notice: Subject to any disclaimer, the term of this patent is extended or adjusted under 35 U.S.C. 154(b) by 495 days.

(21) Appl. No.: **12/664,962**

(22) PCT Filed: **Dec. 19, 2007**

(86) PCT No.: **PCT/SE2007/051044**
§ 371 (c)(1),
(2), (4) Date: **Dec. 16, 2009**

(87) PCT Pub. No.: **WO2008/156402**
PCT Pub. Date: **Dec. 24, 2008**

(65) **Prior Publication Data**
US 2010/0202420 A1 Aug. 12, 2010

(30) **Foreign Application Priority Data**
Jun. 19, 2007 (SE) 0701516

(51) **Int. Cl.**
H04W 4/00 (2009.01)
H04L 12/28 (2006.01)

(52) **U.S. Cl.**
USPC **370/329; 370/431**

(57) **ABSTRACT**

Aspects of the present invention relate to the scheduling of resources in a telecommunication system that includes a mobile terminal and base station. In one embodiment, the mobile terminal sends an initial scheduling request to a base station. Subsequently, the mobile terminal does not transmit a scheduling request to the base station unless and until a scheduling request triggering event is detected.

24 Claims, 10 Drawing Sheets

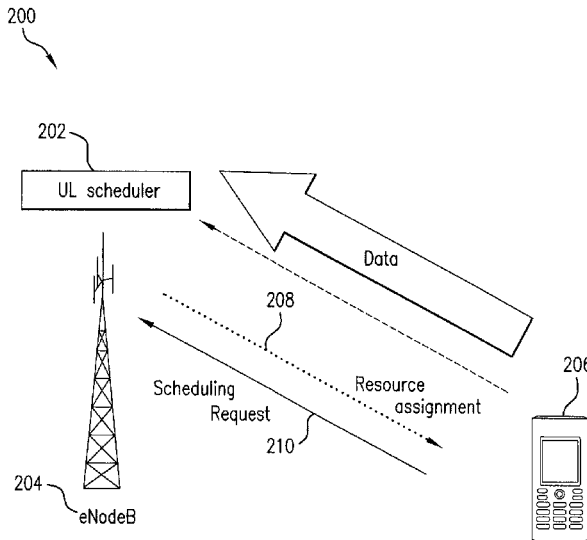

US 8,437,293 B2

U.S. PATENT DOCUMENTS

2008/0225693	A1*	9/2008	Zhang et al.	370/210
2009/0034487	A1*	2/2009	Lohr et al.	370/335
2011/0255492	A1*	10/2011	Dai et al.	370/329

FOREIGN PATENT DOCUMENTS

EP	1608194	B1	1/2008
WO	2005099161	A1	10/2005
WO	2006037492	A1	4/2006
WO	2006077141	A1	7/2006
WO	2007089797	A2	8/2007
WO	2008004914	A1	1/2008

OTHER PUBLICATIONS

International Preliminary Report on Patentability and Written Opinion issued in PCT/SE2007/051044 on Dec. 22, 2009, 8 pages.
 International Search Report issued in PCT/SE2007/051044 on Sep. 23, 2008, 4 pages.
 Qualcomm, "SI Transmission Triggering Schemes", R2-050956, 3GPP, Mar. 30, 2005, 7 pages.
 Qualcomm, "SI Transmission Triggering Schemes", R2-051445, 3GPP, May 5, 2005, 4 pages.

Nortel Networks, "Triggering of Scheduling Info when UE has grant available", R2-051972, 3GPP, Aug. 24, 2005, 3 pages.
 Japanese Office Action issued in Application No. 2010-513154 on Mar. 12, 2012 (associate's letter summarizing the Office Action submitted in lieu thereof), 3 pages.
 Response to Written Opinion in corresponding Singapore Patent Application No. 200908014-4, dated Sep. 7, 2011, 11 pages.
 Oct. 7, 2011 email from client regarding Indonesian Patent Application No. W-00 2009 03599 (1 page).
 Decision on Grant of a Patent for Invention, Russian Patent Application No. 2010101419/08(0001950), 8 pages.
 First Office Action, Japanese Patent Application No. 2010-513154, dated Nov. 7, 2011, 3 pages.
 Ericsson, Scheduling Request in E-UTRAN, R2-063215, 3GPP TSG-RAN WG #56, dated Nov. 10, 2006, 11 pages.
 Nokia, Buffer Reporting for E-UTRAN, R2-060829, 3GPP TSG-RAN WG2 Meeting #52, dated Mar. 31, 2006, 5 pages.
 Nortel Networks, Indication of Scheduling Request in Advance, R2-051034, 3GPP TSG-RAN2#46bis, dated Apr. 8, 2005, 2 pages.
 Office Action issued in corresponding Australian Patent Application No. 2007355223 on Jul. 4, 2012, 3 pages.

* cited by examiner

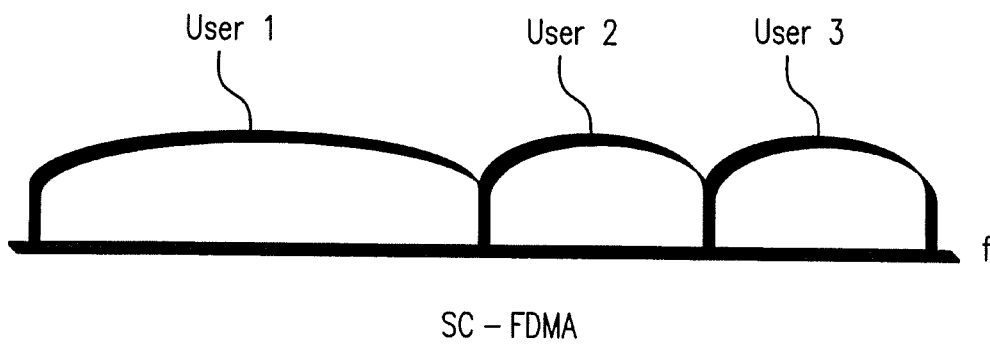

FIG. 1

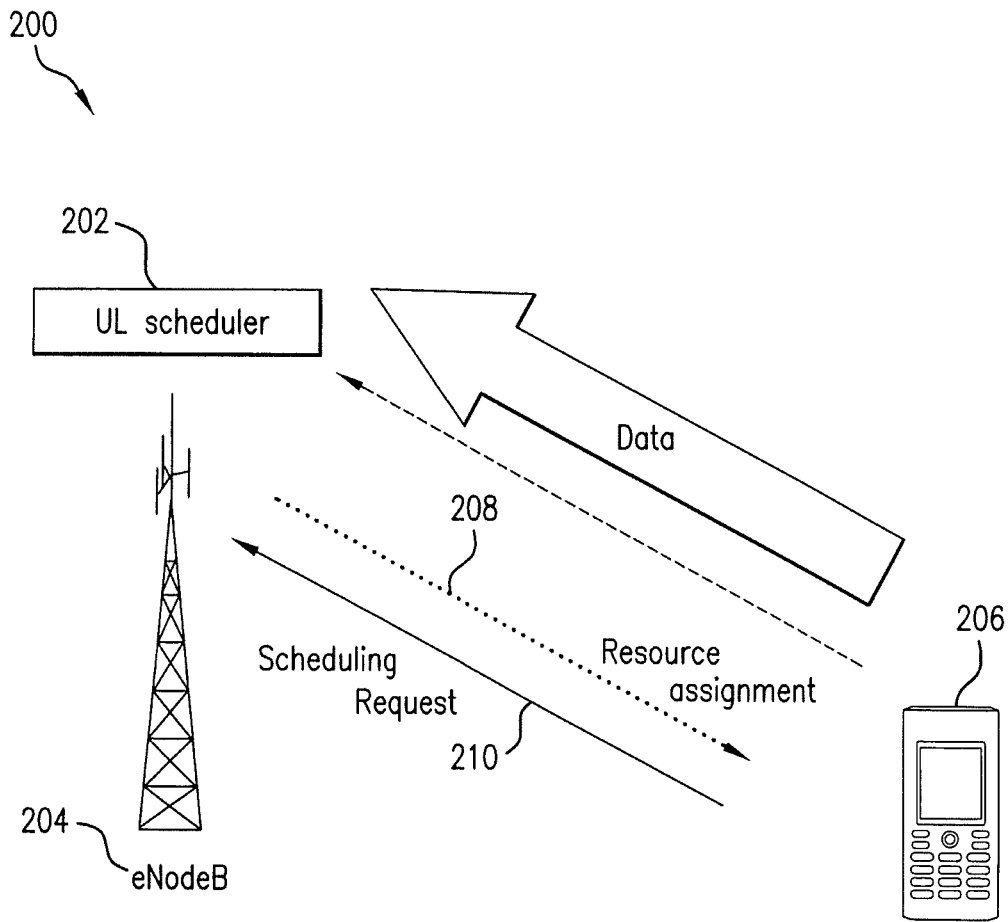

FIG. 2

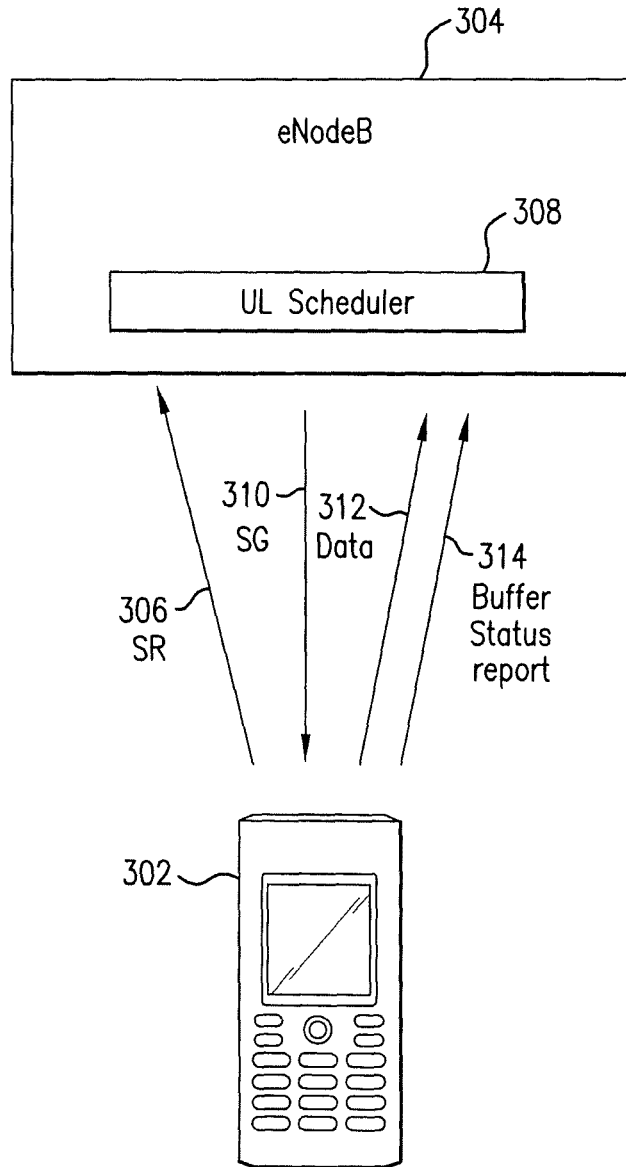

FIG. 3

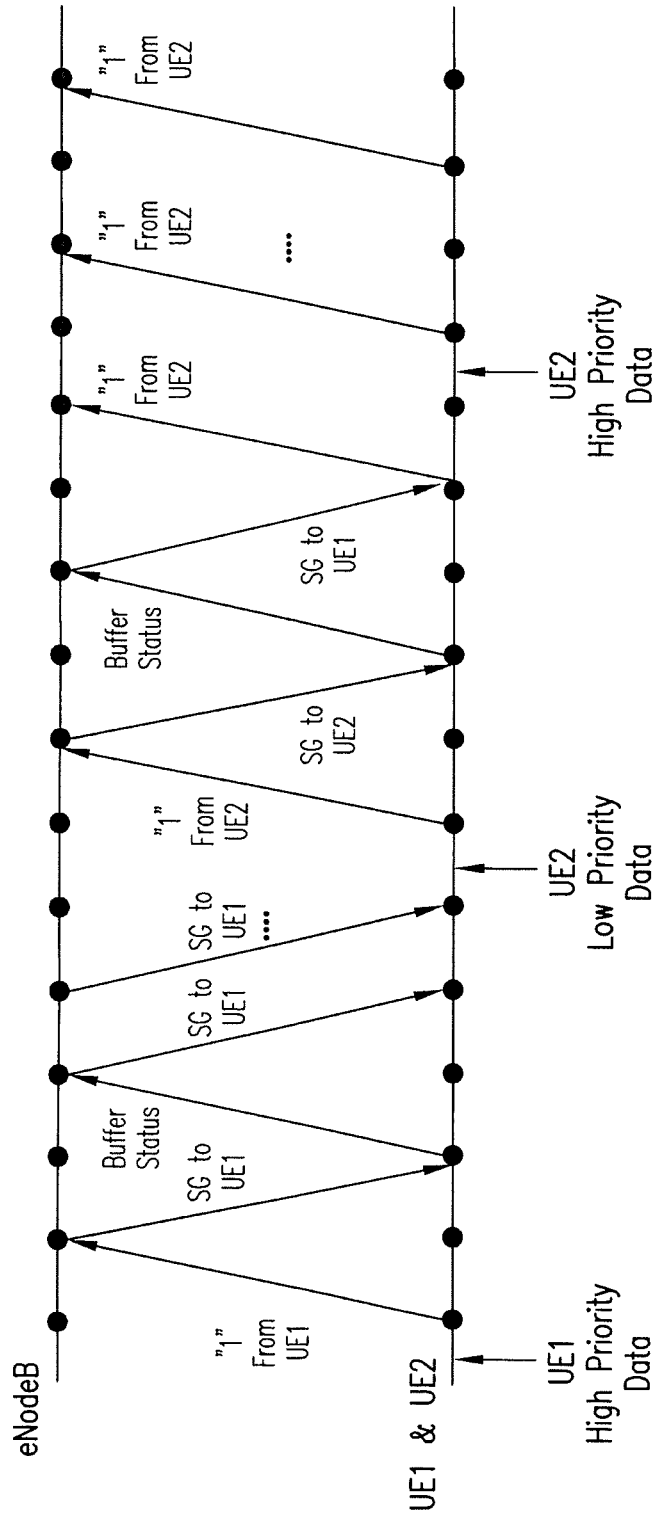

FIG.4

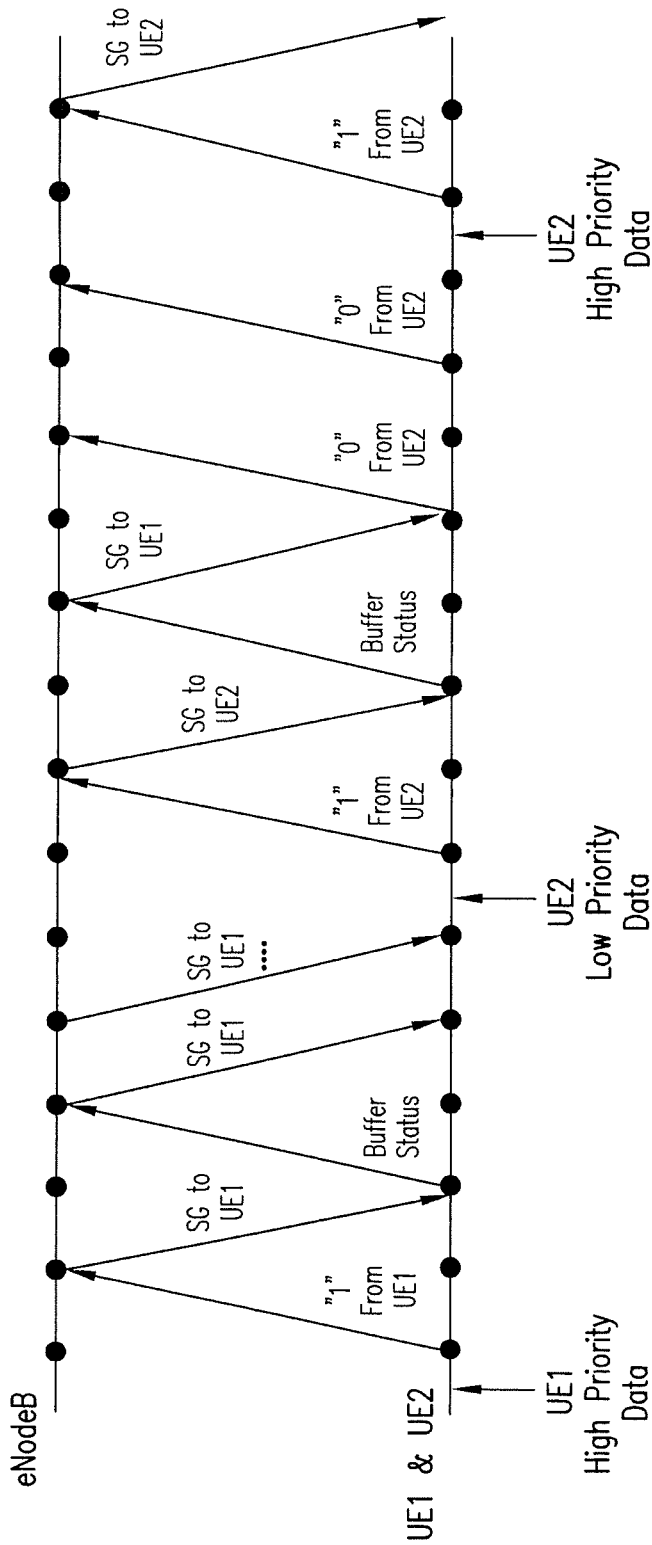

FIG. 5

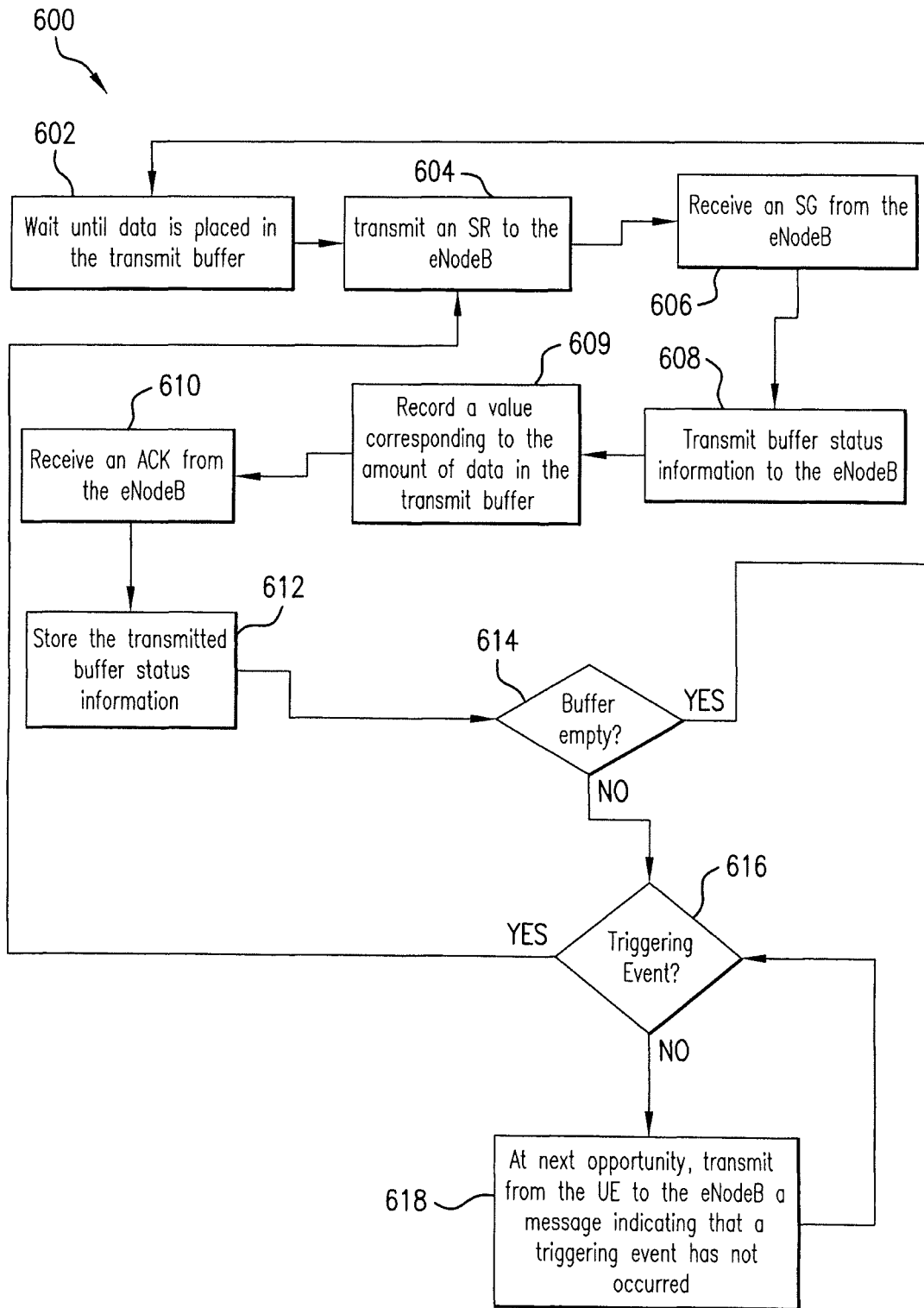

FIG. 6a

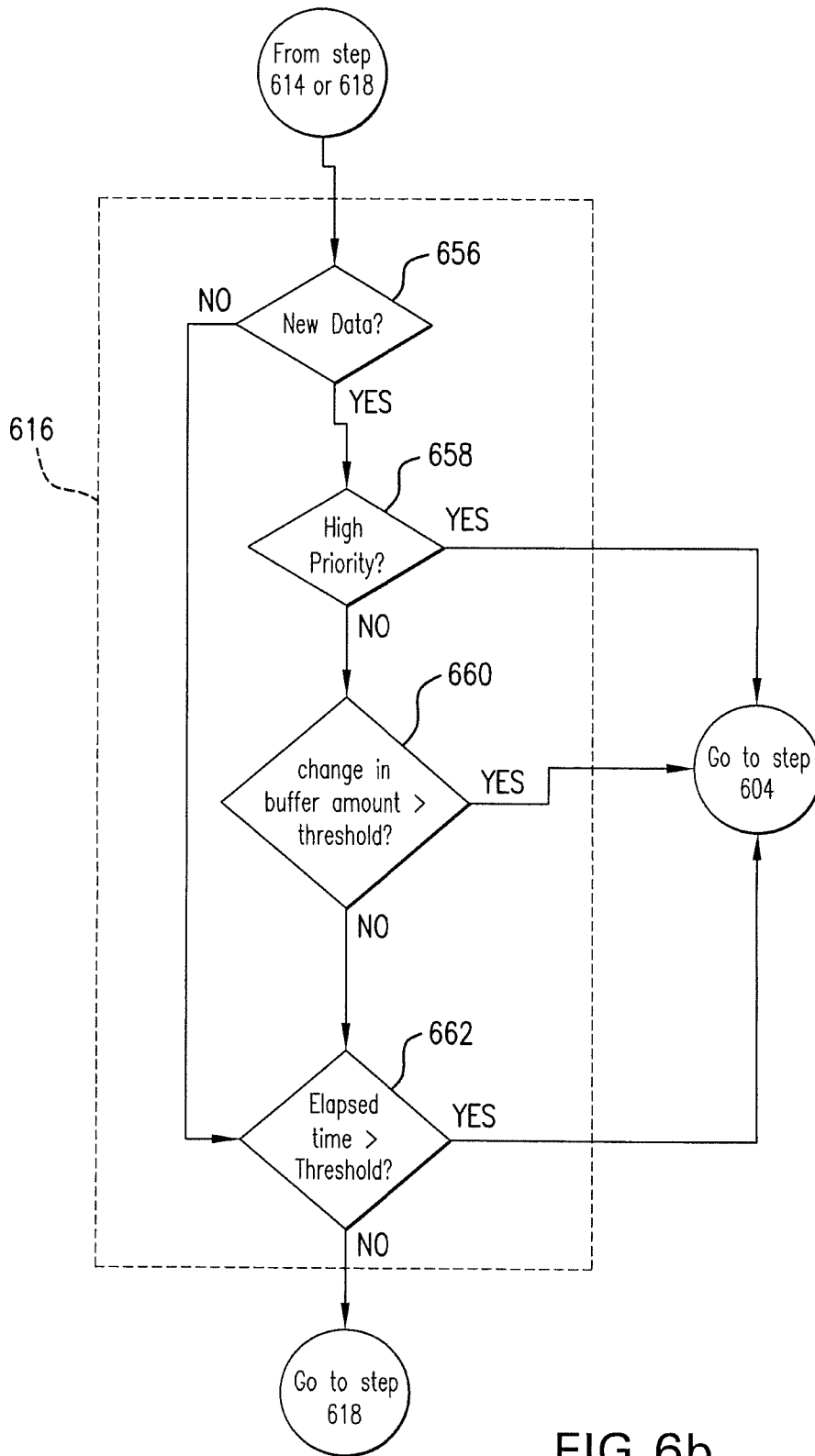

FIG.6b

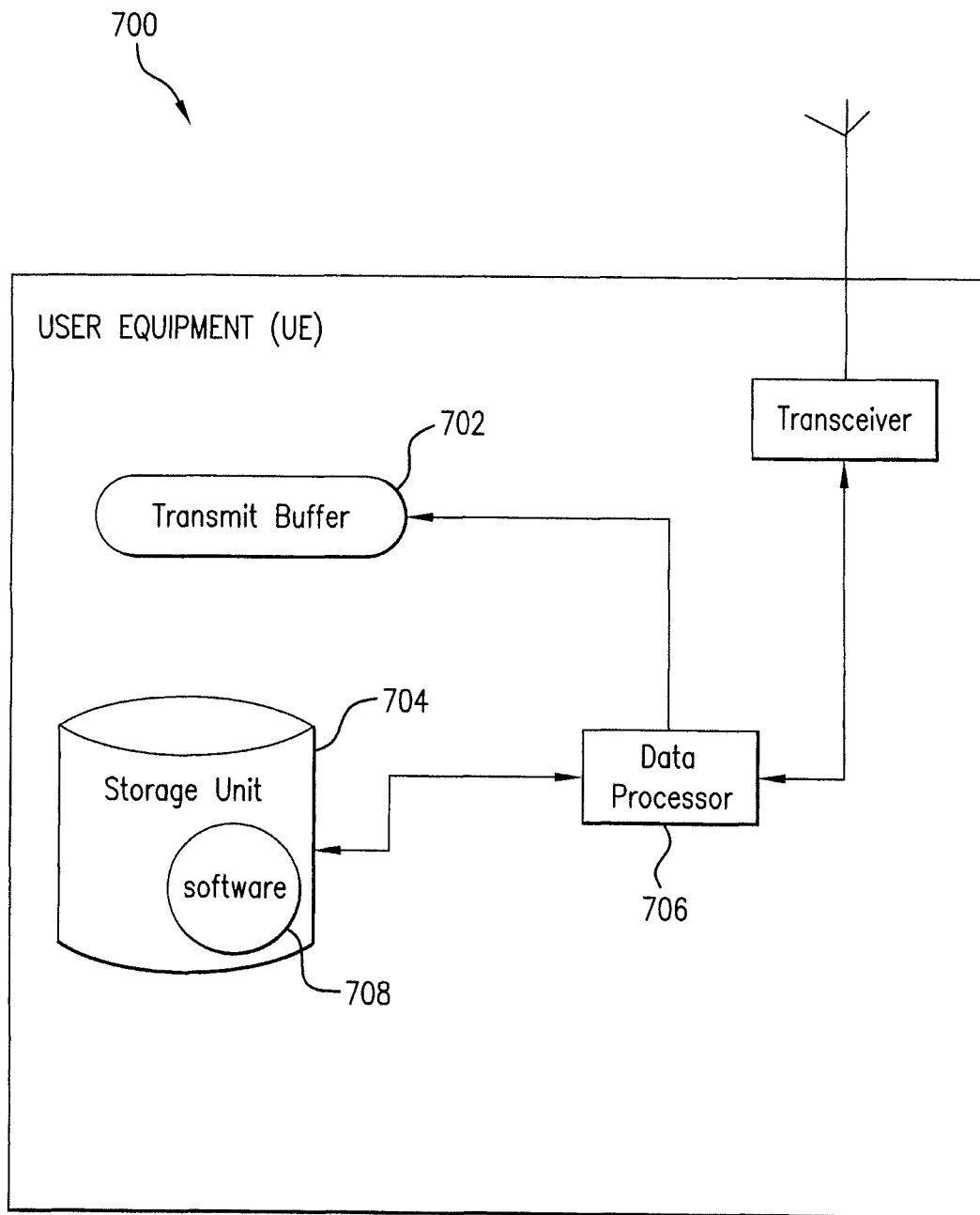

FIG. 7

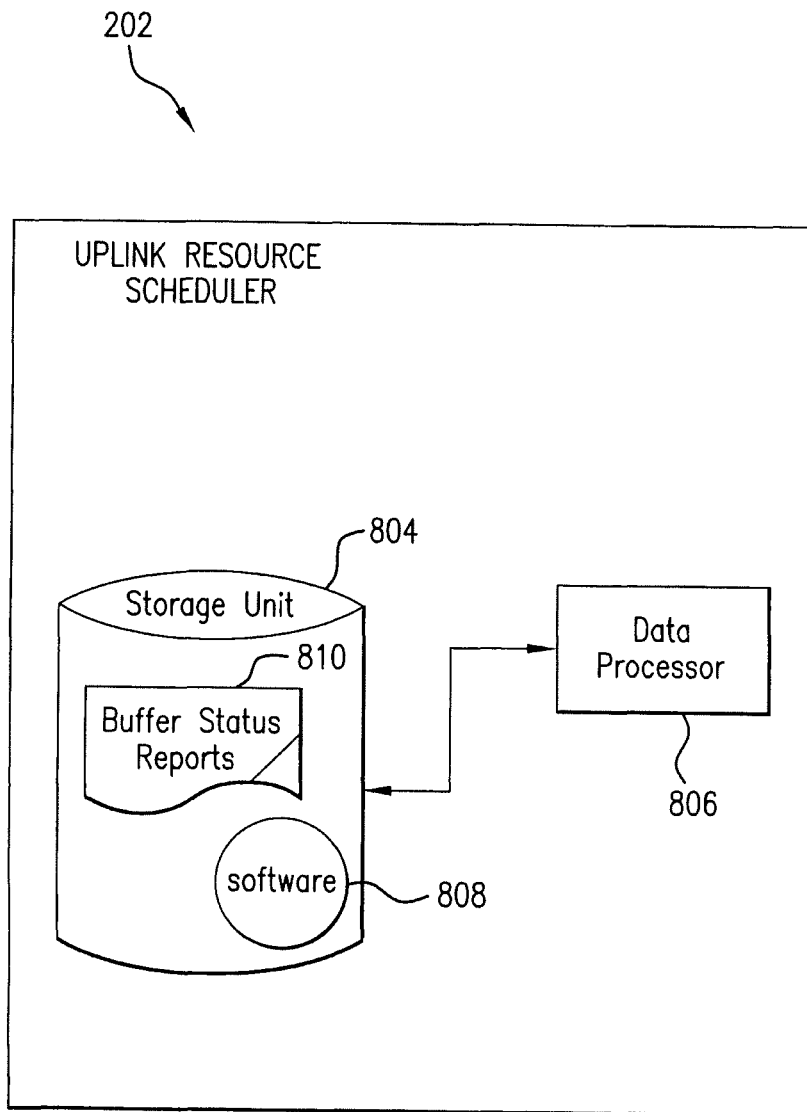

FIG. 8

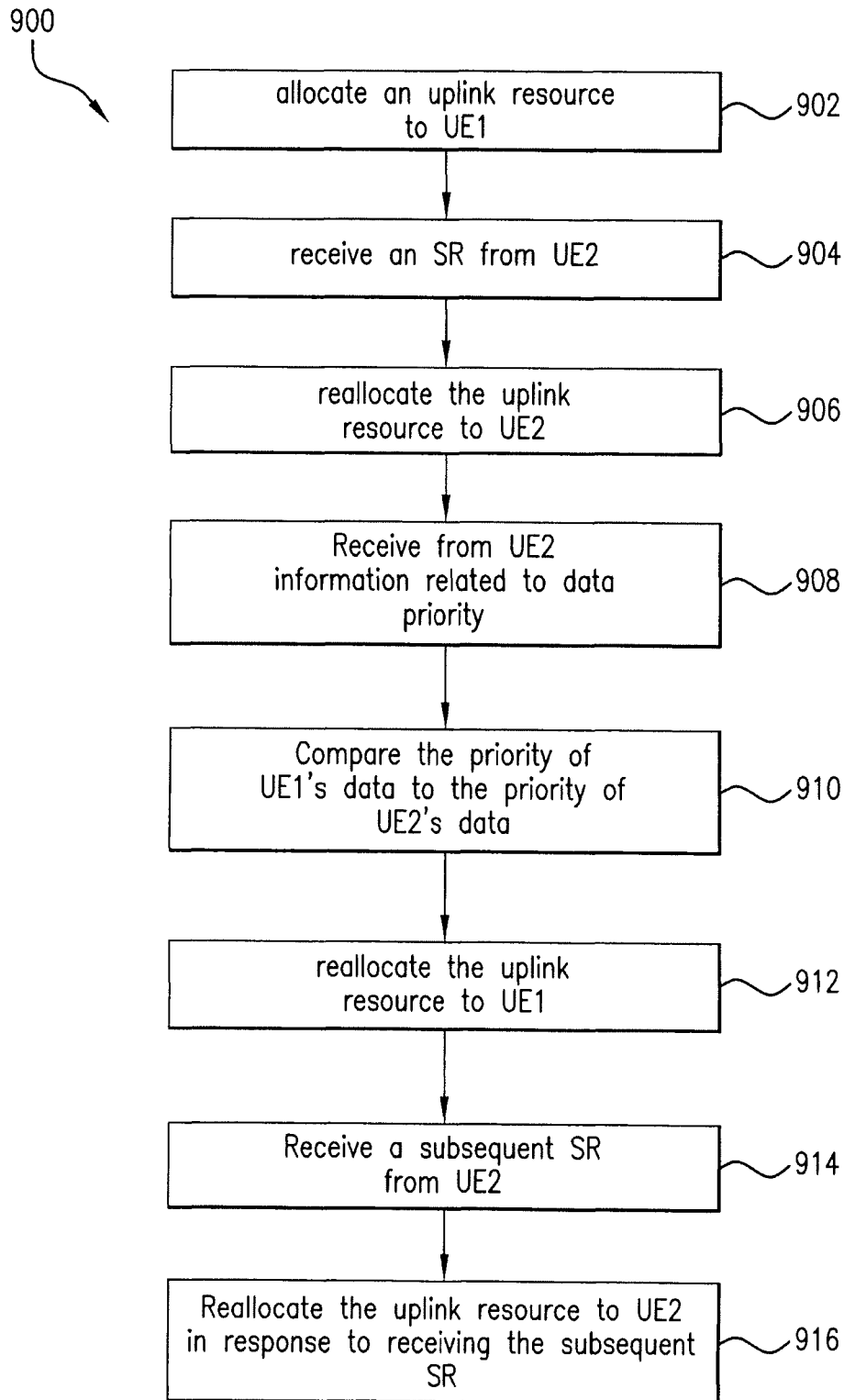

FIG. 9

US 8,437,293 B2

1

METHODS AND SYSTEMS FOR SCHEDULING RESOURCES IN A TELECOMMUNICATION SYSTEM

CROSS-REFERENCE TO RELATED APPLICATIONS

This application is a 35 U.S.C. §371 National Phase Application from PCT/SE2007/051044, filed Dec. 19, 2007, and designating the United States, which claims the benefit of Sweden Patent Application No. 0701516-7, filed Jun. 19, 2007.

TECHNICAL FIELD

The present invention relates generally to telecommunication systems. Embodiments of the present invention relate to the scheduling of resources in a telecommunication system.

BACKGROUND

Radio access technologies for cellular mobile networks are continuously being evolved to meet future demands for high data rates, improved coverage and improved capacity. Examples of recent evolutions of the wideband code-division multiple access (WCDMA) technology are the High-Speed Packet Access (HSPA) protocols. Currently, further evolutions of the third generation (3G) systems, 3G Long Term Evolution (LTE), including new access technologies and new architectures, are being developed within the 3rd Generation Partnership Project (3GPP) standardisation body.

A main objective of LTE systems is to provide a flexible access technology that can be used in existing frequency allocations and in new frequency allocations. Also, LTE systems should enable the use of different duplex solutions. For example, both frequency division duplex (FDD) and time division duplex (TDD), where the uplink and downlink are separated in frequency and in time, respectively, should be supported to provide usage in both paired and unpaired spectrum.

An access technology based on Orthogonal Frequency Division Multiplexing (OFDM) for the downlink and Single Carrier Frequency Division Multiple Access (SC-FDMA) for the uplink, for example, allows such flexible spectrum solutions.

Since the LTE concept is being designed to support fast scheduling in frequency and time both for the uplink and the downlink, the resource assignment in time and frequency should be preferably adjustable to the users' momentary traffic demand and channel variations. In the LTE uplink it is possible to schedule several users in one Time Transmission Interval (TTI) by assigning different frequency segments to different users. To maintain the single carrier structure, each user should only receive contiguous assignments in frequency as illustrated in FIG. 1.

Referring now to FIG. 2, a scheduler **202** in an evolved Node B (base station) **204** may perform resource assignment. Scheduling resources among two or more users in the uplink is complicated by the fact that the scheduler **202** is not automatically aware of each user's uplink data and resource demand. That is, for example, the scheduler **202** may not be aware of how much data there is in the transmit buffers of each user's mobile terminal **206** (e.g., mobile phone, portable digital assistant, or any other mobile terminal). Mobile terminal **206** may also be referred to as user equipment (UE). In order

2

to support fast scheduling, the scheduler **202** would have to be made aware of the UE's momentary traffic demands (e.g., the transmit buffer status).

The basic uplink scheduling concept is illustrated in FIG. 2. Typically, to inform the uplink (UL) scheduler **202** of the UE's momentary traffic demands, the system **200** supports (i) a dedicated scheduling request (SR) channel and (ii) buffer status reports. Alternatively, a synchronized random access channel (RACH) can be used for the same purpose.

The scheduler **202** monitors each UE's traffic demands and assigns resources accordingly. The scheduler **202** informs a UE (e.g., UE **206**) of a scheduling decision by transmitting resource assignments **208** to the UE. In addition, there is a possibility to configure a UE to transmit channel sounding reference signals to enable the evolved Node B (eNodeB) to do broad band channel estimation for fast link adaptation and channel dependent scheduling.

A synchronized UE also has the opportunity to use, as a fallback solution, the Random Access Channel (RACH) to request a UL resource. In general, however, the RACH is intended mostly for non-synchronized UEs. In the dedicated SR channel approach, each active UE is assigned a dedicated channel for transmitting messages that indicate to the eNodeB that the UE requires a UL resource. Such a message is referred to as a scheduling request (SR) **210**. The benefit with this method is that no UE identifier (ID) has to be transmitted, since the UE is identified by virtue of the "channel" it uses. Furthermore, in contrast to the contention based approach, no intra-cell collisions will occur.

In response to receiving an SR **210**, the scheduler **202** may issue to the UE a scheduling grant (SG) **208**. That is, the scheduler may select the resource(s) (e.g., time slot and/or frequency) the UE shall use and communicate this information to the UE. The scheduler **202** may also select, with support from the link adaptation function, a transport block size, a modulation scheme, coding scheme and an antenna scheme (i.e., the link adaptation is performed in the eNodeB and the selected transport format is signalled together with information on the user ID to the UE). The scheduling grant addresses a UE and not a specific radio bearer. In its simplest form, the scheduling grant is valid only for the next UL TTI. However, to reduce the amount of control signalling required, several proposals with alternative durations are possible.

After transmitting an initial SR, the UE may transmit a more detailed buffer status report to the scheduler **202**. The buffer status report may be transmitted in-band (e.g., the buffer status report may be included as part of a medium access control (MAC) header). It is a common view in, for example, 3GPP that the buffer status report should contain more information than is contained in the initial SR.

The above described procedure is further illustrated in FIG. 3. As shown in FIG. 3, a UE **302** having data to transmit to an eNodeB **304** first transmits an SR **306** to the eNodeB **304**, which SR **306** is then processed by an uplink scheduler **308** of eNodeB **304**. In response to SR **306**, uplink scheduler **308** transmits an SG (e.g., resource assignments) **310** to UE **302**. Thereafter, UE **302** transmits data **312** to eNodeB **304** together with a buffer status report **314**, which report is processed by the uplink scheduler **308**. As discussed above, buffer status report **314** may be transmitted in-band with data **312**.

SUMMARY

It is an object to provide improved systems and methods for triggering uplink scheduling requests in a telecommunication system.

In one aspect, the invention provides a method for transmitting scheduling requests from a mobile terminal (or "UE") to a base station. In some embodiments, the method starts with the UE transmitting a first scheduling request (SR) to the base station in response to data becoming available for transmission to the base station. After transmitting the first SR, the UE receives a scheduling grant (SG) transmitted from the base station. In response to receiving the SG, the UE transmits to the base station transmit buffer status information. After transmitting the buffer status information to the base station, but prior to transmitting any subsequent SRs to the base station and while at least some of the data is waiting to be transmitted to the base station, the UE: (1) determines whether a scheduling request triggering event has occurred, and, if a triggering event has occurred, then the UE transmits a second SR to the base station at a next opportunity in response to determining that the triggering event has occurred; otherwise, if a triggering event has not occurred, then, the UE transmits to the base station at the next opportunity a message indicating that a triggering event has not occurred in response to determining that the triggering event has not occurred.

In some embodiments, the step of determining whether a scheduling request triggering event has occurred includes: (a) determining whether additional data that became available for transmission to the base station after the first SR was transmitted has a higher priority than the initial data; (b) determining whether the amount of time that has elapsed since the first SR was transmitted exceeds a threshold; and/or (c) determining whether the difference between the current amount of data in the transmit buffer and a previous, non-zero amount of data that was in the transmit buffer exceeds a threshold. In this or other embodiments, the step of determining whether a scheduling request triggering event has occurred includes: comparing the transmit buffer status information transmitted to the base station with new information concerning the status of the transmit buffer.

In some embodiments, the message indicating that a triggering event has not occurred is a one bit message and the SR is also a one bit message. Additionally, in some embodiments, the thresholds may be configured in the UE by the base station through radio resource control (RRC) signaling. Further, in some embodiments the UE is configured so that it transmits an SR at the next available opportunity every time that data arrives to an empty transmit buffer in the UE.

In another aspect, the invention relates to an improved mobile terminal. In some embodiments the improved mobile terminal includes a transmit buffer and a data processor. The data processor may be configured to cause the mobile terminal to transmit a first scheduling request (SR) to a base station in response to data arriving at an empty transmit buffer in the mobile terminal and cause the mobile terminal to transmit to the base station status information concerning the transmit buffer in response to receiving a scheduling grant (SG) from the base station. In some embodiments, the data processor may further be configured to determine whether a scheduling request triggering event has occurred; cause the mobile terminal to transmit a second SR to the base station at a next opportunity in response to determining that a triggering event has occurred; and cause the mobile terminal to transmit to the base station, at a next opportunity, a message indicating that a triggering event has not occurred in response to determining that no triggering event has occurred. Preferably, these three steps are performed while at least some of the first data is waiting to be transmitted to the base station and after the UE transmits the buffer status information, but prior to the UE transmitting any subsequent SRs to the base station.

In some embodiments the improved mobile terminal includes: means for transmitting a first SR to a base station in response to an empty transmit buffer in the mobile terminal receiving data; means for receiving an SG transmitted from the base station; means for transmitting to the base station status information concerning the transmit buffer status in response to receiving the SG; triggering event detections means for determining whether a scheduling request triggering event has occurred; and means for transmitting to the base station, at a next opportunity, a second SR in response to determining that a scheduling request triggering event has occurred. In some embodiments, the triggering event detection means is configured to perform the determination while at least some of the data is waiting to be transmitted to the base station.

In another aspect, the invention relates to a method performed by a base station for granting uplink resources to mobile terminals. In some embodiments, the base station: allocates an uplink resource to a first mobile terminal, thereby enabling the first mobile terminal to transmit data to the base station; receives an SR from a second mobile terminal while the first mobile terminal is utilizing the uplink resource; re-allocates the uplink resource to the second mobile terminal in response to receiving the SR; receives from the second mobile terminal information related to the priority of the data in the second mobile station that is waiting to be transmitted to the base station; compares the priority of the first mobile terminal's data to the priority of the second mobile terminal's data using respective priority information; reallocates the uplink resource to the first mobile terminal in response to determining that the first mobile terminal has higher priority data than the second mobile terminal; receives a subsequent SR from the second mobile terminal, where the subsequent SR is received after receiving the priority information from the second mobile terminal but before receiving any other priority information from the second mobile terminal; and re-allocates the uplink resource to the second mobile terminal in response to receiving the subsequent SR.

In another aspect, the invention relates to an improved base station. In some embodiments, the improved base station includes means for communicating with a plurality of mobile terminals; means for allocating an uplink resource to one of the mobile terminals based on respective buffer status data transmissions from the terminals; means for reallocating the uplink resources to another one of the plurality of terminals based on receipt of a single bit message indicating a change of buffer status data of the other terminal.

In yet another aspect, the invention relates to a telecommunication system comprising an improved mobile terminal and improved base station.

The above and other aspects and embodiments of the present invention are described below with reference to the accompanying drawings.

BRIEF DESCRIPTION OF DRAWINGS

The accompanying drawings, which are incorporated herein and form part of the specification, illustrate various embodiments of the present invention.

FIG. 1 schematically illustrates resource allocation to different users in an SC-FDMA system.

FIG. 2 illustrates uplink scheduling in an LTE system.

FIG. 3 illustrates a scheme for providing to a UE a resource for data transmission.

FIG. 4 illustrates an improved scheduling message flow between an eNodeB and two UEs.

5

FIG. 5 illustrates a further improved scheduling message flow between an eNodeB and two UEs.

FIGS. 6a and 6b illustrate a process according to an embodiment of the invention.

FIG. 7 is a functional block diagram illustrating some of the components of a mobile terminal.

FIG. 8 is a functional block diagram illustrating some of the components of an uplink scheduler.

FIG. 9 is a flow chart illustrating a process according to an embodiment of the invention.

DETAILED DESCRIPTION

One possible scheduling request scheme is to define an SR as being a single bit message where the single bit (i.e., the “signal request bit”) has been set to a particular predefined value (e.g., set to “1”) and to configure the UEs such that the UEs transmit an SR to the scheduler whenever: (1) the UE has data to transmit (e.g., the UE has data in a transmit buffer) and (2) the UE does not have an uplink resource allocation for transmitting the data to the eNodeB. However, a potential drawback of this approach is illustrated by the example scheduling message flow shown in FIG. 4.

The example shown in FIG. 4 assumes there are two synchronized UEs (i.e., UE1 and UE2), neither of which initially has an uplink resource allocation for data transmission. It is further assumed that the UEs have a dedicated SR channel.

As shown in FIG. 4, when data arrives in the transmit buffer of UE1, UE1 provides to the scheduler notification of this event by transmitting an SR (e.g., a “1”) to the scheduler using its next SR opportunity. In response, the scheduler grants UE1 some resources for data transmission and transmits an SG to the UE1. In response, the UE1 transmits a buffer status report to the eNodeB. The UE1 may also transmit data to the eNodeB, depending on the UL resources allocated to it.

As further shown in FIG. 4, when UE2 has data for transmission, UE2 transmits an SR (e.g., a “1”) at its next SR opportunity. For the sake of this example, we shall assume that UE2’s data has a lower priority than UE1’s data. In response to receiving the SR transmitted by UE2, the scheduler, which at this point in time does not know that UE2’s data has a lower priority than UE1’s data, grants UE2 some resources blindly. UE2 uses the allocated resource to transmit a buffer status report containing QoS information and some data depending on the size of the allocation. Using the buffer status reports transmitted by UE1 and UE2, respectively, the scheduler compares UE1’s buffer status to UE2’s buffer status and, based on the comparison, prioritizes the data from UE1 because the comparison indicates the low priority nature of UE2’s data. Because the data from UE1 is prioritized, the scheduler does not schedule the UE2 further, thus preventing UE2 from transmitting its data. Consequently, because UE2 has data to send, UE2 will continue to transmit an SR in each of the TTP’s in which it has an SR opportunity.

Relying on the data buffer report last transmitted from UE2, which reports indicated that the UE2 had only low priority data waiting for transmission, the scheduler ignores the SRs transmitted from UE2. The scheduler ignores these SRs even after the UE2 subsequently has high priority data to send because, other than through transmitting a buffer status report, there is no way for UE2 to notify the scheduler that it has higher priority data. Accordingly, in some cases, the scheduler may not be immediately aware of new high priority data arriving at UE2’s transmit buffer.

This problem could be avoided if the scheduler were configured to grant some uplink resources to UE2 every once in a while, thereby providing the UE2 with opportunities to

6

transmit to the scheduler a buffer status report indicating the new high priority data. However, if there are many users, this solution is quite costly in terms of resources. Another solution is to extend the SR from one bit to more than one bit so that the SR can contain information regarding data priority. However, this solution creates significant overhead for the SR channel, particularly if there are many priority levels. Embodiments of the present invention overcome the above described problem without the disadvantages suffered by these two solutions.

Embodiments of the present invention define an alternative SR triggering mechanism that is based on changes in transmit buffer status. With such an alternative triggering mechanism, the problems described above can be solved without increasing the SR from one bit to several bits and without periodically scheduling UEs to transmit buffer status reports.

According to embodiments of the present invention, the UEs are configured to transmit an SR only when certain predefined conditions are met, such as, for example, changes in the UE’s transmit buffer content compared to what has been reported previously or what has been transmitted previously. For example, a predefined condition may be met whenever data arrives in the UE’s transmit buffer and the data has a higher priority than the priority of the previously reported data (or transmitted data). The changes in buffer status that trigger an SR are typically configured through radio resource control (RRC) signaling.

In some embodiments, the UEs are configured to transmit an SR only when all of the following are true: (1) the UE has no uplink grant; (2) the UE has data to transmit to the eNodeB; and (3) the buffer status has “changed” since the last acknowledged buffer report was transmitted by the UE or the last acknowledged transmission was transmitted by the UE. In these embodiments, the scheduler is configured so that it will not ignore an SR from a UE configured as described above.

In some embodiments, the buffer status is considered to have “changed” only if one or more of the following conditions are met: (1) higher prioritized data has arrived in buffer; (2) the buffer size increase exceeds a predetermined threshold (Threshold A); or (3) the elapsed time since the transmission of the last SR exceeds a predetermined threshold (Threshold B). The thresholds A and B can typically be configured through RRC signaling. One exception to the above rule is that when data arrives to an empty buffer in the UE, the UE should always transmit an SR at the next SR opportunity.

In the above examples, when a UE receives a UL scheduling grant from the scheduler, the scheduler is subsequently made aware of the UE’s buffer content through regular buffer status reports transmitted by the UE. This could be a continuous buffer report for each scheduled transmission. However, in some embodiments criteria are used for causing the UE to transmit buffer status reports. This means that if a UE is not granted further UL resources the latest acknowledged buffer report will be up-to date. It is also possible to use a variation of the above described SR triggering rules in case the UE does not send regular buffer reports.

For example, assuming the UE employs strict priority between radio bearers (i.e., data from higher prioritised radio bearers is always transmitted before data from lower prioritised radio bearers), then the scheduler will know that there is no higher priority data in the transmit buffer than what is being transmitted. In such a situation, the buffer status is considered to have “changed” only if one or more of the following conditions are met: (1) higher prioritized data has arrived in the buffer; or (2) the elapsed time since the last SR was transmitted exceeds a threshold (Threshold B). As before, one exception to the rule is that when data arrives to an

empty buffer in the UE, the UE should always transmit an SR at its next SR opportunity. The threshold B is typically configured through RRC signaling.

Several alternatives and combinations of the examples above can be constructed. The present invention provides an improvement in that, instead of configuring the UE to transmit an SR whenever the UE has data to transmit, the UE is configured to transmit an SR only when it has data to transmit AND some other event has occurred (e.g., a certain amount of time has elapsed since the last SR was transmitted, the amount of data in the buffer grew by at least a certain amount since the most recent transmission of data or a status report, or the transmit buffer was empty just prior to it receiving the data).

In some embodiments, a triggered but not yet transmitted SR should be cancelled whenever the UE obtains a scheduling grant from the eNodeB before the SR transmission opportunity. In these cases, the UE will send high priority data first and optionally include a detailed buffer status report. In any case, the eNodeB is aware of the change even without obtaining a scheduling request.

Referring now to FIG. 5, FIG. 5 illustrates a message flow in a system according to an embodiment of the invention, which system includes two UEs (UE1 and UE2). The illustrated message flow begins when UE1 receives high priority data in its transmit buffer. As shown in FIG. 5, in response to this event, UE1 transmits an SR to the eNodeB at its next SR opportunity.

In response, the eNodeB transmits an SG to UE1. In response to the SG, UE1 may transmit a buffer report that indicates the high priority of the data in UE1's transmit buffer. Some time after UE1 transmits the buffer report, UE2 may receive data in its transmit buffer, which event causes UE2 to transmit an SR at its next SR opportunity.

For the sake of this example, we shall assume that UE2's data has a lower priority than UE1's data. In response to receiving the SR transmitted by UE2, the eNodeB, which at this point in time does not know that UE2's data has a lower priority than UE1's data, grants UE2 some resources blindly. UE2 uses the allocated resource to transmit a buffer status report containing QoS information and some data depending on the size of the allocation. Based on the buffer status report, which indicates the low priority nature of UE2's data, the eNodeB prioritizes the data from UE1 and, thus, does not schedule the UE2 further, thereby preventing UE2 from transmitting its data (e.g., the eNodeB transmits to UE2 a Hybrid Automatic Repeat Request (HARQ) ACK for the transmission containing the buffer report and the UE2 stores the latest ACK'ed report).

However, rather than continue to transmit an SR at each subsequent SR opportunity, as is shown in FIG. 4, UE2 is configured so as to not transmit an SR until after one or more certain predefined events occur (e.g., the UE2 may transmit to the eNodeB the signal request bit with the bit set to the value of "0" instead of "1" until one of the events happen, as is shown in FIG. 5). Accordingly, UE2 is configured to check whether one or more certain events have occurred (such as the receipt of high priority data) prior to each subsequent SR opportunity so that, if one such event has occurred, the UE2 can transmit an SR at that next SR opportunity.

In this example, some time after UE2 transmitted the buffer status report, high priority data arrives in UE2's transmit buffer. The UE2 detects this event and, in response, transmits an SR (e.g., a "1") to the eNodeB. The UE2 may be configured to detect this event by comparing the last acknowledged buffer status report, which indicates the status of the transmit buffer at some previous point in time, to a newly generated

buffer status information that indicates the current status of the transmit buffer. The eNodeB is configured to respond to the SR by granting an uplink resource to UE2, as opposed to ignoring the SR, even though the eNodeB has not received from UE2 a new buffer status report indicating that UE2 now has higher priority data. Accordingly, in this manner, embodiments of the present invention solve the problem discussed in connection with FIG. 4.

Referring now to FIG. 6a, FIG. 6a is a flow chart illustrating a process 600, according to some embodiments of the invention, performed by a UE. Process 600 may begin in step 602. Process 600 assumes that the UE initially has no data to transmit to the eNodeB (e.g., the UE's transmit buffer is initially empty), accordingly, in step 602 the UE waits until data is placed in the transmit buffer. In response to the UE having data to send to the eNodeB, the UE transmits an SR to the eNodeB (step 604). In step 606, the UE receives an SG from the eNodeB. In step 608, the UE uses the resource allocated by the eNodeB to transmit to the eNodeB a buffer status report and/or some data depending on the allocated resource. In step 609, the UE may record a value representing the amount of data currently in its transmit buffer.

In step 610, the UE receives from the eNodeB a HARQ ACK for the transmission containing the buffer status report. In step 612, the UE stores the latest ACK'ed buffer status report (i.e., the report transmitted in step 608). In step 614, the UE determines whether it has data to send to the eNodeB (e.g., the UE determines whether its transmit buffer is empty). If it does not have data to send (e.g., the buffer is empty), process 600 may proceed back to step 602, otherwise it may proceed to step 616.

In step 616, the UE determines whether an SR triggering event has occurred. If so, process 600 proceeds back to step 604, otherwise process 600 may proceed to step 618. In step 618, at the very next SR transmission opportunity, the UE transmits to the eNodeB a message indicating that a triggering event has not occurred (e.g., the UE transmits a one bit message to the eNodeB where the value of the bit is set to "0"). After step 618, process 600 may proceed back to step 616.

Referring now to FIG. 6b, FIG. 6b illustrates a process, according to some embodiments of the invention, for determining whether a triggering event has occurred. That is, FIG. 6b illustrates steps that may be performed in performing step 616 of process 600.

As shown in FIG. 6b, the process may begin in step 656, where the UE determines whether new data has arrived in the transmit buffer since a particular point in time. For example, the UE may determine whether new data has arrived in the transmit buffer since the last buffer status report was generated or since the last time the UE performed step 616. If the UE determines that new data has arrived, then the process may proceed to step 658, otherwise it may proceed to step 662.

In step 658, the UE determines whether the new data has a higher priority than the data that was in the transmit buffer when the new data arrived. The UE may determine this by comparing information in the buffer status report stored in step 612 to newly generated information reflecting the status of the current state of the transmit buffer. If the new data has a higher priority, then process may proceed to step 604 (i.e., the UE transmits an SR to the eNodeB), otherwise the process may proceed to step 660.

In step 660, the UE determines whether the difference between the amount of data currently in the transmit buffer and the amount of data that was in the transmit buffer at a previous point in time exceeds a threshold. For example, in

step 660, the UE may find the difference between a value representing the amount of data currently in the transmit buffer and the value that was recorded in step 609 and compare the difference to the threshold value. If the difference equals or exceeds the threshold, then the process may proceed to step 604, otherwise the process may proceed to step 662.

In step 662, the UE determines whether the amount of time that has elapsed since the last SR was transmitted exceeds a threshold. If so, the process may proceed to step 604, otherwise the process may proceed to step 618.

We will now discuss error cases that may occur.

Error Case 1: In this first error case, either (a) the eNodeB misinterprets an SR (e.g., the eNodeB detects that the signal request bit is set to a "0" instead of a "1") and will not grant a resource or (b) the resource assignment message cannot be decoded by the UE. To handle this situation, the UE is configured to transmit an SR in all SR occasions until a UL grant is obtained (i.e., until the UE is given the opportunity to transmit data and/or a buffer status report).

Error Case 2: In the second error case, the eNodeB fails to decode the message containing the buffer status report or the initial data transmission. Waiting for the HARQ retransmission could cause excessive delay. The scheduler repeats the UL grant: (1) until a reliable report is obtained if buffer reports are transmitted with each UL transmission; (2) if buffer reports are triggering with similar criteria as for the SR (the UE will have a buffer change compared with the latest acknowledged report and continue to transmit reports until a reliable report is obtained); or (3) if no buffer reports are triggered new data is transmitted until the eNodeB is able to decode.

Error Case 3: In the third error case, the eNodeB detects the message containing the buffer report or the initial data transmission but the HARQ ACK is misinterpreted as a NACK by the UE. In this situation, the UE performs a regular HARQ retransmission, which fails as the eNodeB does not expect any further transmission attempts. The UE stops after the maximum number of transmission attempts. The UE does not need to perform another scheduling request if some subsequent transmission has succeeded. With the error handling in case 2, the eNodeB would have issued another grant if the transmission had failed.

Referring now to FIG. 7, FIG. 7 is functional block diagram of some components of a UE 700 according to an embodiment of the invention. As shown in FIG. 7, the UE may include: a transmit buffer 702 for buffering data to be transmitted to an eNodeB; a storage unit 704 for storing the last transmitted buffer status report; a data processor 706 for executing software 708 for determining whether an SR should or should not be transmitted (i.e., software 708 may be configured to perform, among other steps, steps 616-622 of process 600) and for causing an SR to be transmitted if it determines that an SR should be transmitted; a transmitter for wirelessly transmitting data to an eNodeB; and other elements.

Referring now to FIG. 8, FIG. 8 is functional block diagram of uplink resource scheduler 202 according to an embodiment of the invention. As shown in FIG. 8, scheduler 202 includes: a storage unit 804 for storing buffer status reports 810; a data processor 806 for executing software 808. Software 808 is configured such that, when executed by data processor 806, software 808 causes the scheduler 202 to function as described above. That is, for example, software 808 may cause the scheduler 202 to schedule uplink resources based on a comparison of the buffer status of the UE's attempting to communicate with the eNodeB 240 and to respond to each SR. Although not shown, data processor 806 is coupled to a

transmission means (e.g., transmit buffers and/or transmitters or the like) that enables the scheduler to communicate with UEs.

Referring now to FIG. 9, FIG. 9 is a flow chart illustrating a process 900 performed by a base station configured according to an embodiment of the invention. As illustrated in FIG. 9, in step 902 the base station allocates an uplink resource to a first UE (UE1), thereby enabling UE1 to transmit data to the base station. In step 904, the base station receives an SR from a second UE (UE2) while UE1 is utilizing the uplink resource. In step 906, the base station reallocates the uplink resource to UE2 in response to receiving the SR. In step 908, the base station receives from UE2 information related to the priority of the data in UE2 that is waiting to be transmitted to the base station. In step 910, the base station compares the priority of UE1's data to the priority of UE2's data using the respective priority information. In step 912, the base station reallocates the uplink resource to UE1 in response to determining that UE1 has higher priority data than UE2. In step 914, the base station receives a subsequent SR from UE2, wherein the subsequent SR is received after receiving the priority information from UE2 and before receiving any other data priority information from UE2. In step 916, the base station reallocates the uplink resource to UE2 in response to receiving the subsequent SR.

One advantage of embodiments of the invention is that the scheduler in the base station (eNodeB) is provided with selected updates of the terminal's buffer status and appropriate quality of service (QoS) knowledge even with a single bit SR, while decreasing the UE power consumption for the scheduling request channel (in case ON/OFF keying is used).

While various embodiments/variations of the present invention have been described above, it should be understood that they have been presented by way of example only, and not limitation. Thus, the breadth and scope of the present invention should not be limited by any of the above-described exemplary embodiments. Further, unless stated, none of the above embodiments are mutually exclusive. Thus, the present invention may include any combinations and/or integrations of the features of the various embodiments.

Additionally, while the processes described above and illustrated in the drawings are shown as a sequence of steps, this was done solely for the sake of illustration. Accordingly, it is contemplated that some steps may be added, some steps may be omitted, and the order of the steps may be re-arranged.

What is claimed is:

1. A method for transmitting scheduling requests from a mobile terminal to a base station, the method comprising:
 - (a) transmitting a first scheduling request (SR) from the mobile terminal to the base station in response to first data becoming available for transmission from the mobile terminal to the base station;
 - (b) after transmitting the first SR, receiving at the mobile terminal a scheduling grant (SG) transmitted from the base station;
 - (c) in response to receiving the SG, transmitting from the mobile terminal to the base station transmit buffer status information; and
 - (d) while at least some of the first data is waiting to be transmitted to the base station and after transmitting the buffer status information, but prior to transmitting any subsequent SRs to the base station, further performing the steps of:
 - (d1) determining whether a scheduling request triggering event has occurred; and

11

(d2) if a triggering event has occurred, then, in response to determining that the triggering event has occurred, at a next opportunity, transmitting a second SR to the base station.

2. The method according to claim 1, wherein the step of determining whether a scheduling request triggering event has occurred comprises comparing the transmit buffer status information transmitted to the base station with new information concerning the status of the transmit buffer.

3. The method according to claim 1, wherein the step of determining whether a scheduling request triggering event has occurred comprises determining whether second data that is available for transmission from the mobile terminal to the base station has a higher priority than the first data, wherein the second data became available for transmission to the base station after the first SR was transmitted.

4. The method according to claim 1, wherein the step of determining whether a scheduling request triggering event has occurred comprises determining whether the amount of time that has elapsed since the first SR was transmitted exceeds a threshold.

5. The method according to claim 1, wherein the step of determining whether a scheduling request triggering event has occurred comprises determining whether the difference between the current amount of data in a transmit buffer and a previous, non-zero amount of data that was in the transmit buffer exceeds a threshold.

6. The method of claim 1, wherein the step of determining whether a scheduling request triggering event has occurred consists of:

- (a) determining whether second data that became available for transmission to the base station after the first SR was transmitted has a higher priority than the first data;
- (b) determining whether the amount of time that has elapsed since the first SR was transmitted exceeds a threshold; and
- (c) determining whether the difference between the current amount of data in a transmit buffer and a previous, non-zero amount of data that was in the transmit buffer exceeds a threshold.

7. The method of claim 1, wherein the step of determining whether a scheduling request triggering event has occurred consists of:

- (a) determining whether second data that became available for transmission to the base station after the first SR was transmitted has a higher priority than the first data; and
- (b) determining whether the amount of time that has elapsed since the first SR was transmitted exceeds a threshold.

8. The method according to claim 1, wherein the SR is a one bit message.

9. The method according to claim 1, wherein the thresholds are configured in the mobile terminal by the base station through radio resource control (RRC) signaling.

10. The method according to claim 1, further comprising transmitting an SR at a next available opportunity every time that data arrives to an empty transmit buffer in the mobile terminal.

11. The method according to claim 1, further comprising receiving at the mobile terminal a HARQ ACK transmitted from the base station after transmitting from the mobile terminal to the base station the transmit buffer status information and storing the ACK in the mobile terminal.

12. A mobile terminal, comprising:
 a transmit buffer; and
 a data processor, wherein the data processor is configured to:

12

(a) cause the mobile terminal to transmit a first scheduling request (SR) to a base station in response to data arriving at an empty transmit buffer in the mobile terminal;

(b) cause the mobile terminal to transmit to the base station transmit buffer status information in response to receiving a scheduling grant (SG) from the base station; and

(c) perform steps (c1)-(c2) while at least some of the first data is waiting to be transmitted to the base station and after transmitting the buffer status information, but prior to transmitting any subsequent SRs to the base station: (c1) determine whether a scheduling request triggering event has occurred; and (c2) cause the mobile terminal to transmit a second SR to the base station at a next opportunity in response to determining that a triggering event has occurred.

13. The mobile terminal according to claim 12, wherein the data processor is configured to determine whether a scheduling request triggering event has occurred by comparing the transmit buffer status information transmitted to the base station with new information concerning the status of the transmit buffer.

14. The mobile terminal according to claim 12, wherein the data processor is configured to determine whether a scheduling request triggering event has occurred by determining whether second data that became available for transmission to the base station after the first SR was transmitted has a higher priority than the first data.

15. The mobile terminal according to claim 12, wherein the data processor is configured to determine whether a scheduling request triggering event has occurred by determining whether the amount of time that has elapsed since the first SR was transmitted exceeds a threshold.

16. The mobile terminal according to claim 12, wherein the data processor is configured to determine whether a scheduling request triggering event has occurred by determining whether the difference between the current amount of data in a transmit buffer and a previous, non-zero amount of data that was in the transmit buffer exceeds a threshold.

17. The mobile terminal according to claim 12, wherein the message indicating that a triggering event has not occurred is a one bit message.

18. The mobile terminal according to claim 12, wherein the SR is a one bit message.

19. A communication system comprising a mobile terminal according to claim 12.

20. A mobile terminal, comprising:
- (a) means for transmitting a first scheduling request (SR) to a base station in response to an empty transmit buffer in the mobile terminal receiving data;
 - (b) means for receiving a scheduling grant (SG) transmitted from the base station;
 - (c) means for transmitting to the base station transmit buffer status information in response to receiving the SG;
 - (d) triggering event detection means for determining whether a scheduling request triggering event has occurred, wherein the triggering event detection means is configured to perform the determination while at least some of the data is waiting to be transmitted to the base station; and
 - (e) means for transmitting to the base station, at a next opportunity, a second SR in response to determining that a scheduling request triggering event has occurred.

21. The mobile terminal according to claim 20, wherein triggering event detections means comprises means for com-

paring the transmit buffer status information transmitted to the base station with new information concerning the status of the transmit buffer.

22. The mobile terminal according to claim 20, wherein the triggering event detections means comprises means for determining whether second data that is available for transmission from the mobile terminal to the base station has a higher priority than the first data, wherein the second data became available for transmission to the base station after the first SR was transmitted.

23. The mobile terminal according to claim 20, wherein the triggering event detections means comprises means for determining whether the amount of time that has elapsed since the first SR was transmitted exceeds a threshold.

24. The mobile terminal according to claim 20, wherein the triggering event detections means comprises means for determining whether the difference between the current amount of data in a transmit buffer and a previous, non-zero amount of data that was in the transmit buffer exceeds a threshold.

* * * * *

UNITED STATES PATENT AND TRADEMARK OFFICE
CERTIFICATE OF CORRECTION

PATENT NO. : 8,437,293 B2
APPLICATION NO. : 12/664962
DATED : May 7, 2013
INVENTOR(S) : Jersenius et al.

Page 1 of 1

It is certified that error appears in the above-identified patent and that said Letters Patent is hereby corrected as shown below:

Title Page, Item (75), under "Inventors", in Column 1, Line 1, delete "Linkoping" and insert -- Linköping --, therefor.

Title Page, Item (75), under "Inventors", in Column 1, Line 5, delete "Linkoping" and insert -- Linköping --, therefor.

Signed and Sealed this
Fifth Day of November, 2013



Teresa Stanek Rea
Deputy Director of the United States Patent and Trademark Office