



(19) **United States**

(12) **Patent Application Publication**

**Lee et al.**

(10) **Pub. No.: US 2010/0067495 A1**

(43) **Pub. Date: Mar. 18, 2010**

(54) **METHOD OF PERFORMING RANDOM ACCESS IN A WIRELESS COMMUNICATION SYSTEM**

**Publication Classification**

(51) **Int. Cl.**  
*H04B 7/216* (2006.01)

(76) **Inventors:** **Young Dae Lee**, Anyang-si (KR);  
**Sung Duck Chun**, Anyang-si (KR);  
**Sung Jun Park**, Anyang-si (KR);  
**Seung June Yi**, Anyang-si (KR)

(52) **U.S. Cl.** ..... **370/335**

(57) **ABSTRACT**

Correspondence Address:  
**MCKENNA LONG & ALDRIDGE LLP**  
**1900 K STREET, NW**  
**WASHINGTON, DC 20006 (US)**

A method of performing random access in a wireless communication system is disclosed. The method of performing random access in a user equipment of a wireless communication system which uses multiple carriers includes transmitting a preamble for random access to a network, receiving a random access response message from the network in response to the preamble, transmitting a connection setup request message to the network, the connection setup request message requesting connection establishment with the network, and receiving a first message from the network, the first message including connection setup information and contention resolution information in a random access procedure. If a user equipment identifier of the user equipment is included in the message, the user equipment determines that it has successfully performed random access and performs a next procedure in accordance with the connection setup information. If the user equipment identifier of the user equipment is not included in the message, the user equipment determines that it has failed in random access and transmits a random access preamble to the network again after the lapse of a predetermined time period.

(21) **Appl. No.:** **12/312,172**

(22) **PCT Filed:** **Oct. 30, 2007**

(86) **PCT No.:** **PCT/KR2007/005384**

§ 371 (c)(1),  
(2), (4) **Date:** **Apr. 29, 2009**

**Related U.S. Application Data**

(60) **Provisional application No. 60/863,545, filed on Oct. 30, 2006.**

**Foreign Application Priority Data**

(30) **Feb. 7, 2007 (KR) ..... 1020070012749**

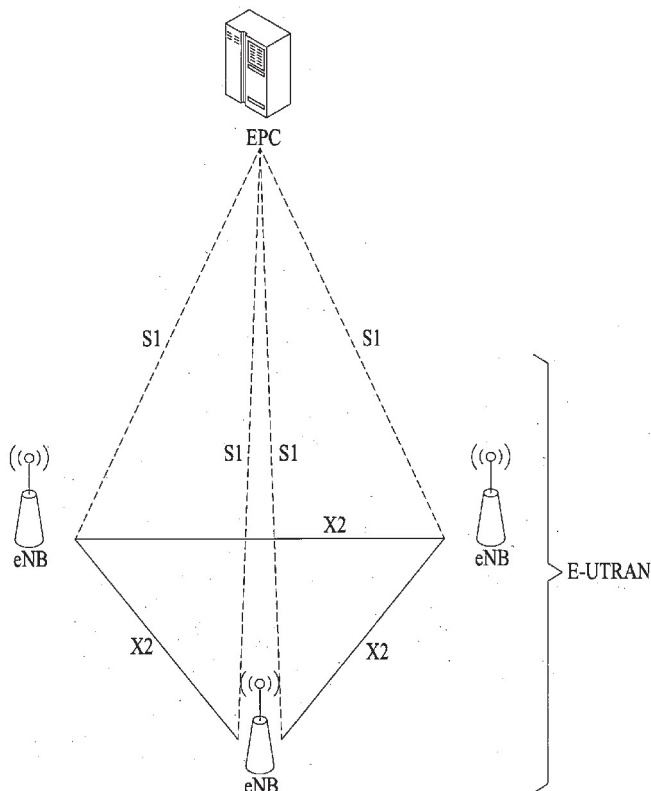

FIG. 1

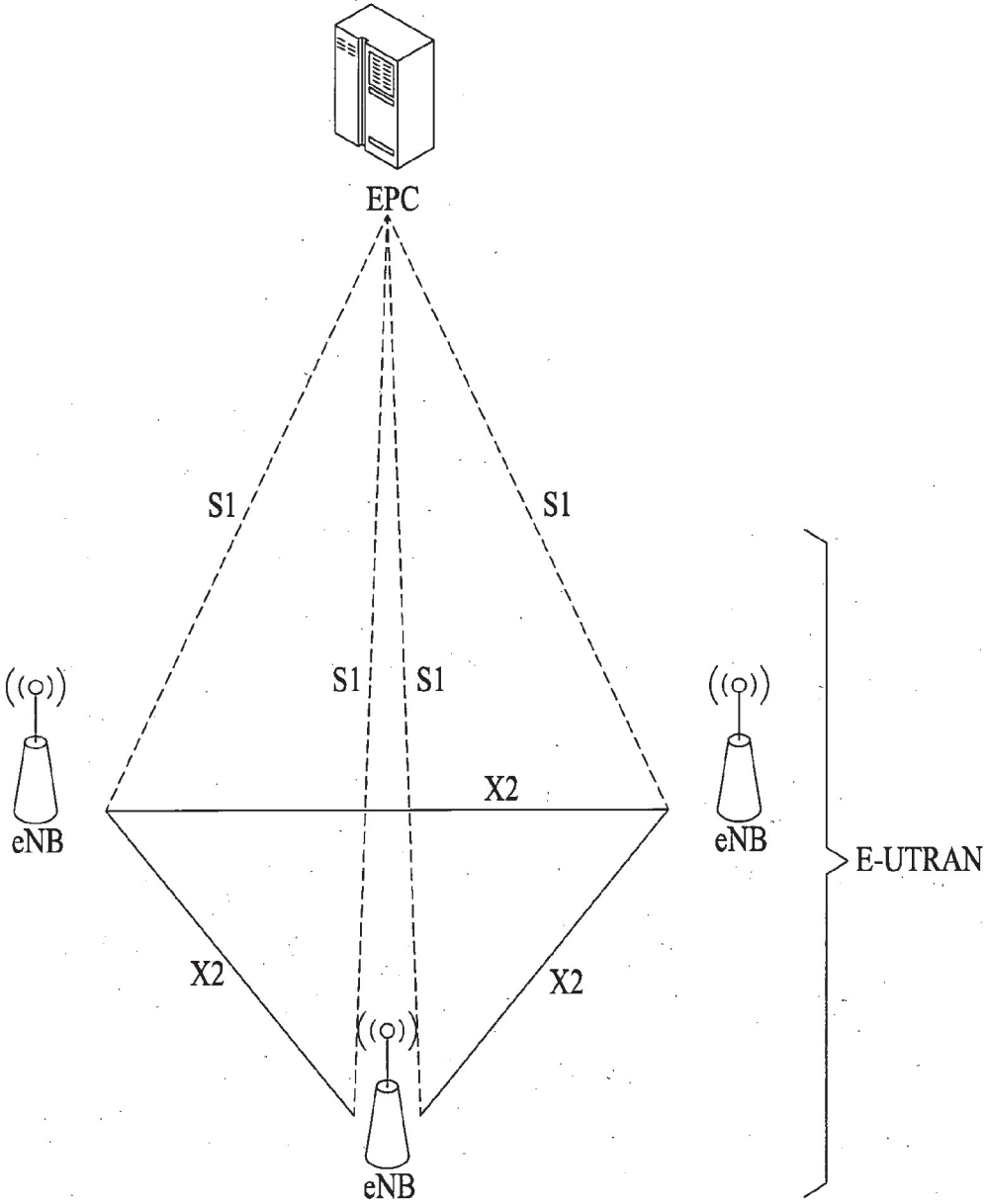

FIG. 2

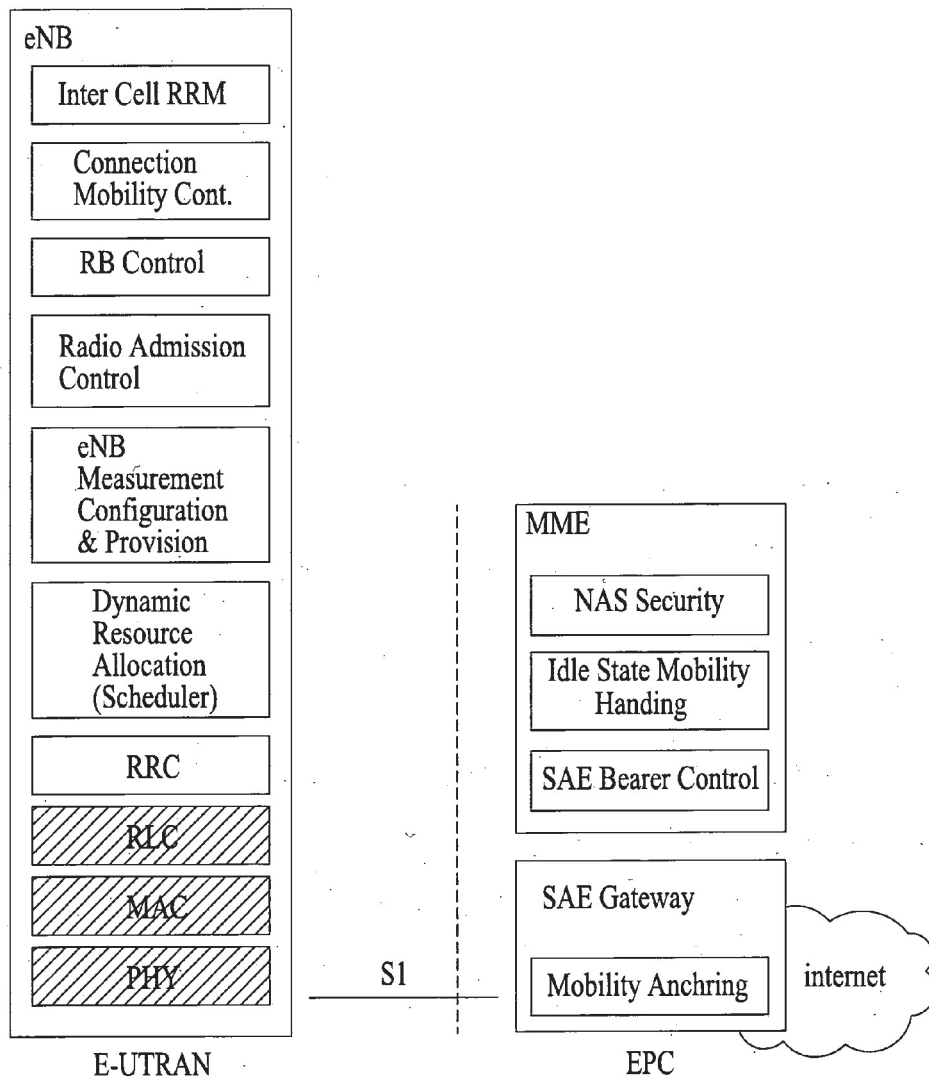

FIG. 3A

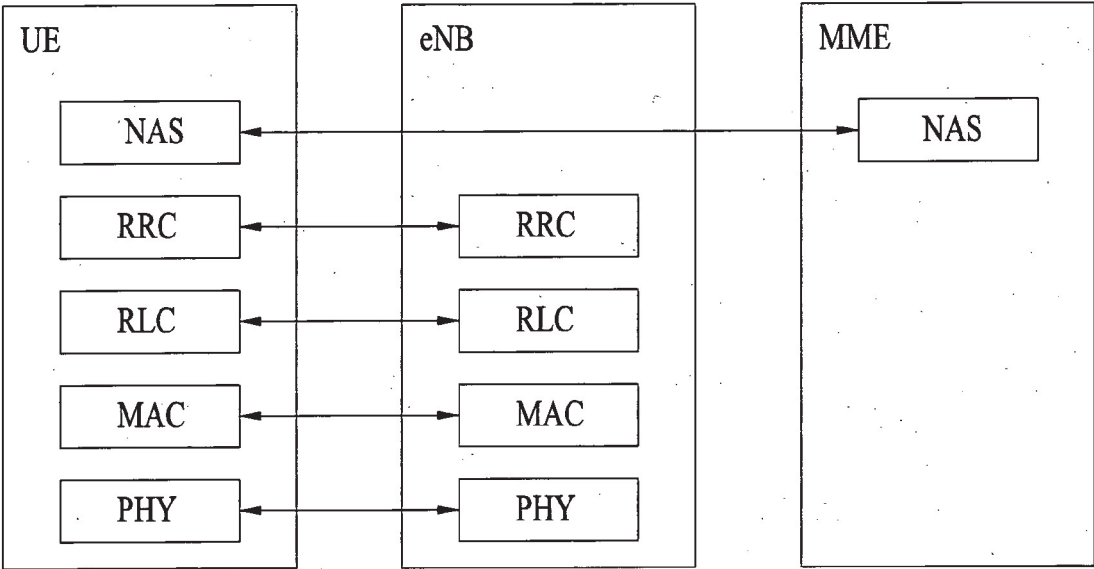

FIG. 3B

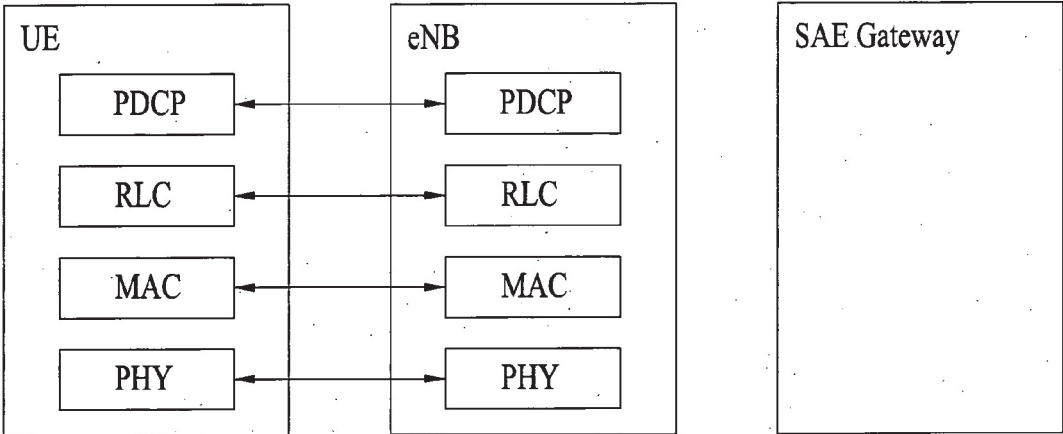

FIG. 4

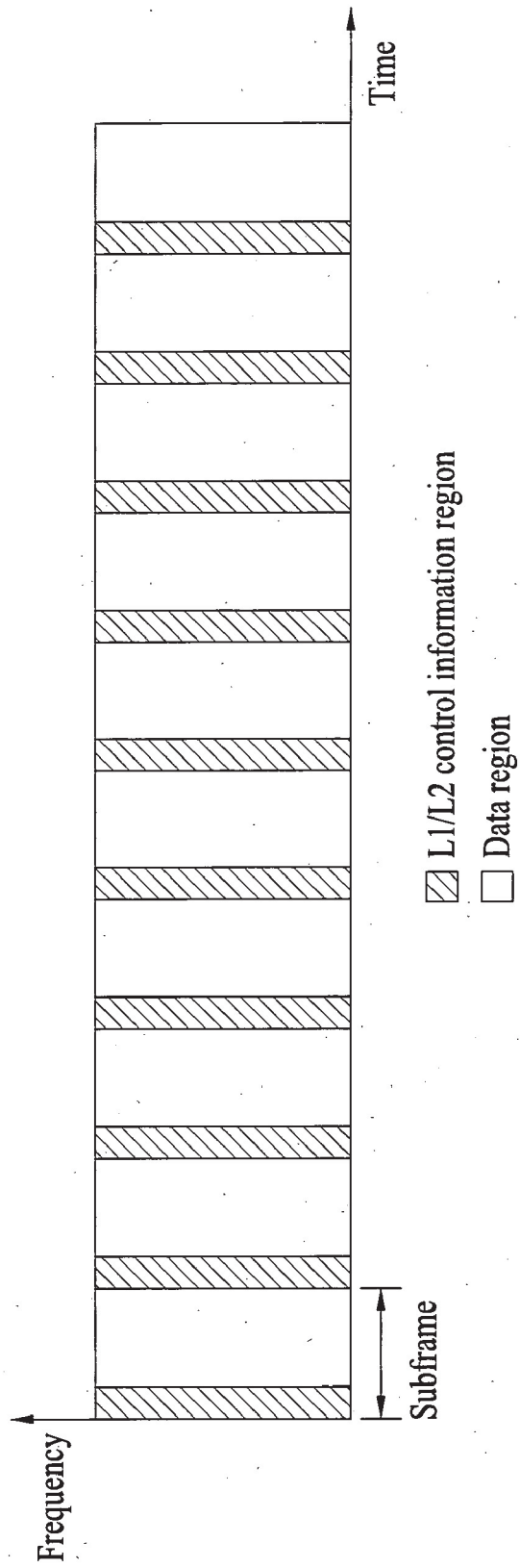

FIG. 5

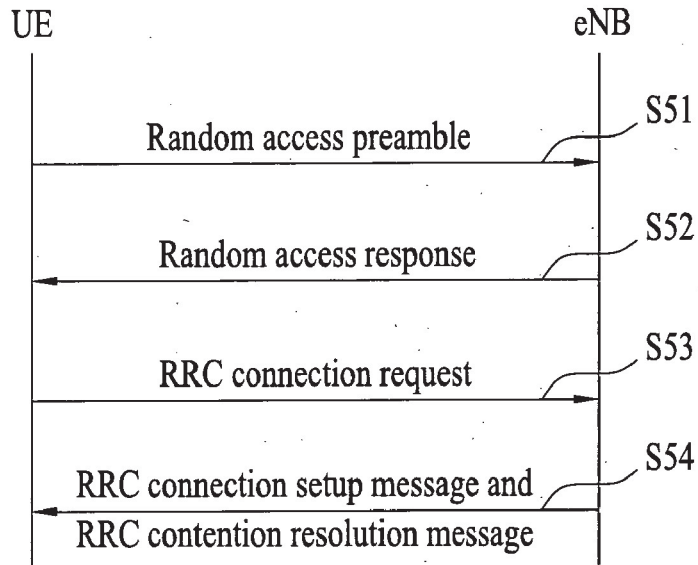
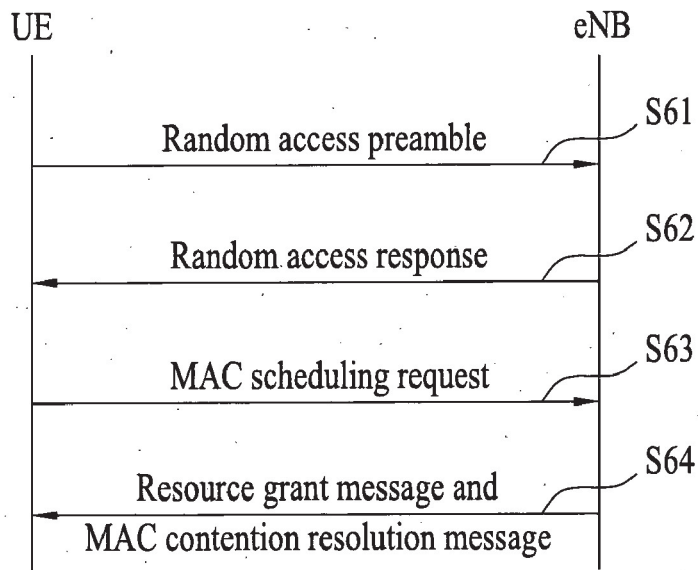

FIG. 6



**METHOD OF PERFORMING RANDOM  
ACCESS IN A WIRELESS COMMUNICATION  
SYSTEM**

TECHNICAL FIELD

**[0001]** The present invention relates to a wireless communication system, and more particularly, to a method of performing random access in a wireless communication system.

BACKGROUND ART

**[0002]** In a wideband code division multiple access (WCDMA) system according to asynchronous mobile communication system standard (3GPP: 3<sup>rd</sup> Generation Partnership Project), examples of a downlink transmission channel which transmits data from a network (UTRAN: UMTS Terrestrial Radio Access Network) to a user equipment include a broadcast channel (BCH) which transmits system information and a downlink shared channel (DL-SCH) which transmits user traffic or control messages. Traffic or control messages of downlink multicast or broadcast service (MBMS: Multimedia Broadcasting and Multicast Service) may be transmitted through the DL-SCH or a separate multicast channel (MCH). Meanwhile, examples of an uplink transmission channel which transmits data from a user equipment to a network include a random access channel (RACH) which transmits initial control message and an uplink shared channel (UL-SCH) which transmits user traffic or control messages.

**[0003]** Hereinafter, the RACH in the WCDMA system will be described. The RACH is used to transmit data of short length to an uplink, and some RRC messages such as RRC connection request message, cell update message, and URA update message can be transmitted through the RACH. Furthermore, a common control channel (CCCH), a dedicated control channel (DCCH), or a dedicated traffic channel (DTCH), which is one of logical channels, can be mapped with the RACH which is one of transmission channels. Furthermore, the RACH which is one of transmission channels is again mapped with a physical random access channel (PRACH) which is one of physical channels.

**[0004]** If a medium access control (MAC) layer of a user equipment commands a physical layer of the user equipment to perform PRACH transmission, the physical layer of the user equipment selects one access slot and one signature and transmits PRACH preamble to the uplink depending on the selected result. The preamble is transmitted for an access slot period of length of 1.33 ms, and one signature among 16 kinds of signatures is selected and transmitted for a first certain length of the access slot.

**[0005]** If the user equipment transmits the preamble, a base station transmits a response signal through an acquisition indicator channel (AICH) which is a downlink physical channel. The AICH transmitted in response to the preamble transmits the signature selected by the preamble for a first certain time period of an access slot corresponding to the access slot to which the preamble is transmitted. At this time, the base station transmits acknowledgement (ACK) or non-acknowledgement (NACK) through the signature transmitted from the AICH. If the user equipment receives ACK, the user equipment transmits a message part of 10 ms or 20 ms by using an orthogonal variable spreading factor (OVSF) code corresponding to the transmitted signature. If the user equipment receives NACK, the MAC of the UE again commands

the physical layer of the user equipment to perform the PRACH transmission after a proper time period. Meanwhile, if the user equipment does not receive the AICH corresponding to the transmitted preamble, the user equipment transmits a new preamble at a power higher than that of the previous preamble by one level after a given access slot.

**[0006]** Hereinafter, examples where the user equipment transmits messages by using the RACH in the WCDMA system will be described.

**[0007]** In case of the first example, the user equipment which is in an idle mode transmits an initial control message to a network through the RACH. Generally, the user equipment uses the RACH when the user equipment temporally synchronizes with the network and when the user equipment desires to acquire radio resources to transmit data to an uplink. For example, if the user equipment is powered on and first accesses a new cell, the user equipment generally synchronizes with a downlink and receives system information in a cell where the user equipment desires to access. After receiving system information, the user equipment transmits an access request message for RRC connection. However, since the user equipment is not synchronized with the network temporally and does not yet acquire radio resource of the uplink, the user equipment uses the RACH. In other words, the user equipment requests the network to provide radio resources for transmission of a connection request message, through the RACH. The base station which has been requested to provide corresponding radio resources allocates proper radio resources to the user equipment so that the user equipment can transmit RRC connection request message. Then, the user equipment can transmit the RRC connection request message to the network through the radio resources.

**[0008]** In case of the second example, in a state that the user equipment is connected with the network in a type of RRC, the user equipment which is in an RRC connected mode uses the RACH. In this case, the user equipment is allocated with radio resources in accordance with radio resource scheduling of the network, and transmits data to the network through the allocated radio resources. However, if data to be transmitted do not remain in a buffer of the user equipment any longer, the network will not allocate radio resources of the uplink any longer. This is because that allocating radio resources of the uplink to the user equipment having no data to be transmitted is inefficient.

**[0009]** The buffer status of the user equipment is reported to the network periodically or whenever a specific event occurs. If new data occur in the buffer of the user equipment having no radio resources, since there are no radio resources of the uplink allocated to the user equipment, the user equipment uses the RACH. In other words, the user equipment requests the network to provide radio resources required for data transmission, through the RACH.

**[0010]** The RACH is an uplink common channel and is a channel available for all user equipments which desires to try initial access to the network. Accordingly, if two or more user equipments use the RACH simultaneously, collision may occur. If collision occurs due to the two or more user equipments, the network should select one of the user equipments to perform a normal procedure, and should perform next procedures for the other user equipments after resolving a problem caused by the collision. In this case, it is necessary to define a procedure of avoiding delay in procedures after ran-



dom access for the selected user equipment and resolving the problem caused by collision for the other user equipments.

#### DISCLOSURE OF THE INVENTION

**[0011]** Accordingly, the present invention is directed to a method of performing random access in a wireless communication system, which substantially obviates one or more problems due to limitations and disadvantages of the related art.

**[0012]** An object of the present invention is to provide a method of performing random access in a wireless communication system, in which random access is provided to avoid unnecessary delay in the wireless communication system.

**[0013]** Another object of the present invention is to provide a method of performing random access in a wireless communication system, in which radio resources are efficiently used in the wireless communication system.

**[0014]** To achieve these objects and other advantages and in accordance with the purpose of the invention, as embodied and broadly described herein, a method of performing random access in a user equipment of a wireless communication system which uses multiple carriers comprises transmitting a preamble for random access to a network, receiving a random access response message from the network in response to the preamble, transmitting a connection setup request message to the network, the connection setup request message requesting connection establishment with the network, and receiving a first message from the network, the first message including connection setup information and contention resolution information in a random access procedure. If a user equipment identifier of the user equipment is included in the message, the user equipment realizes that it has succeeded in random access and performs a next procedure in accordance with the connection setup information. If the user equipment identifier of the user equipment is not included in the message, the user equipment realizes that it has failed in random access and transmits a random access preamble to the network again after the lapse of a predetermined time period.

**[0015]** In another aspect of the present invention, a method of performing random access in a user equipment of a wireless communication system which uses multiple carriers comprises transmitting a preamble for random access to a network in a state that the user equipment is connected with the network, receiving a random access response message from the network in response to the preamble, the random access response message including a temporary user equipment identifier of the user equipment, requesting the network to allocate uplink resources, and receiving at least one of a resource grant message and a contention resolution message from the network by using the temporary user equipment identifier and a private user equipment identifier of the user equipment.

#### BRIEF DESCRIPTION OF THE DRAWINGS

**[0016]** FIG. 1 illustrates a network structure of an E-UMTS (Evolved-Universal Mobile Telecommunications System);

**[0017]** FIG. 2 is a schematic view illustrating an E-UTRAN (Evolved Universal Terrestrial Radio Access Network);

**[0018]** FIG. 3A and FIG. 3B illustrate a structure of a radio interface protocol between a user equipment (UE) and E-UTRAN, in which FIG. 3A is a schematic view of a control plane protocol and FIG. 3B is a schematic view of a user plane protocol;

**[0019]** FIG. 4 illustrates an example of a structure of physical channels used in an E-UMTS system;

**[0020]** FIG. 5 is a flow chart illustrating a procedure according to one embodiment of the present invention; and

**[0021]** FIG. 6 is a flow chart illustrating a procedure according to another embodiment of the present invention.

#### BEST MODE FOR CARRYING OUT THE INVENTION

**[0022]** Hereinafter, structures, operations, and other features of the present invention will be understood readily by the preferred embodiments of the present invention, examples of which are illustrated in the accompanying drawings. Embodiments described later are examples in which technical features of the present invention are applied to E-UMTS (Evolved Universal Mobile Telecommunications System).

**[0023]** FIG. 1 illustrates a network structure of an E-UMTS. An E-UMTS is a system evolving from the conventional WCDMA UMTS and its basic standardization is currently handled by the 3GPP (3<sup>rd</sup> Generation Partnership Project). The E-UMTS can also be called an LTE (Long Term Evolution) system. Release 7 and Release 8 of 3GPP technical specifications (3<sup>rd</sup> Generation Partnership Project; Technical Specification Group Radio Access Network) can be referred to obtain detailed information about the UMTS and E-UMTS.

**[0024]** Referring to FIG. 1, an E-UTRAN includes base stations (hereinafter, referred to as 'eNode B' or 'eNB'), wherein respective eNBs are connected with each other through X2 interface. Also, each of eNBs is connected with a user equipment (UE) through a radio interface and connected with EPC (Evolved Packet Core) through Si interface. The EPC includes a mobility management entity/system architecture evolution (MME/SAE) gateway.

**[0025]** Layers of a radio interface protocol between a UE and a network can be classified into a first layer L1, a second layer L2 and a third layer L3 based on three lower layers of OSI (open system interconnection) standard model widely known in communication systems. A physical layer belonging to the first layer L1 provides an information transfer service using a physical channel. A radio resource control (hereinafter, abbreviated as 'RRC') located at the third layer plays a role in controlling radio resources between the UE and the network. For this, the RRC layer enables RRC messages to be exchanged between the UE and the network. The RRC layer can be distributively located at network nodes including Node B, an AG and the like or at either the Node B or the AG.

**[0026]** FIG. 2 is a schematic view illustrating an E-UTRAN (UMTS terrestrial radio access network). In FIG. 2, a hatching part represents functional entities of a user plane and a non-hatching part represents functional entities of a control plane.

**[0027]** FIG. 3A and FIG. 3B illustrate a structure of a radio interface protocol between the user equipment (UE) and the E-UTRAN, in which FIG. 3A is a schematic view of a control plane protocol and FIG. 3B is a schematic view of a user plane protocol. Referring to FIG. 3A and FIG. 3B, a radio interface protocol vertically includes a physical layer, a data link layer, and a network layer and horizontally includes a user plane for data information transfer and a control plane for signaling transfer. The protocol layers in FIG. 3A and FIG. 3B can be classified into L1 (first layer), L2 (second layer), and L3 (third

layer) based on three lower layers of the open system interconnection (OSI) standard model widely known in the communications systems.

**[0028]** The physical layer as the first layer provides information transfer service to an upper layer using physical channels. The physical layer (PHY) is connected to a medium access control (hereinafter, abbreviated as 'MAC') layer above the physical layer via transport channels. Data are transferred between the medium access control layer and the physical layer via the transport channels. Moreover, data are transferred between different physical layers, and more particularly, between one physical layer of a transmitting side and the other physical layer of a receiving side via the physical channels. The physical channel of the E-UMTS is modulated according to an orthogonal frequency division multiplexing (OFDM) scheme, and time and frequency are used as radio resources.

**[0029]** The medium access control (hereinafter, abbreviated as 'MAC') layer of the second layer provides a service to a radio link control (hereinafter, abbreviated as 'RLC') layer above the MAC layer via logical channels. The RLC layer of the second layer supports reliable data transfer. In order to effectively transmit IP packets (e.g., IPv4 or IPv6) within a radio-communication period having a narrow bandwidth, a PDCP layer of the second layer (L2) performs header compression to reduce the size of a relatively-large IP packet header containing unnecessary control information.

**[0030]** A radio resource control (hereinafter, abbreviated as 'RRC') layer located on a lowest part of the third layer is defined in the control plane only and is associated with configuration, reconfiguration and release of radio bearers (hereinafter, abbreviated as 'RBs') to be in charge of controlling the logical, transport and physical channels. In this case, the RB means a service provided by the second layer for the data transfer between the UE and the UTRAN.

**[0031]** As downlink transport channels carrying data from the network to UEs, there are provided a broadcast channel (BCH) carrying system information, a paging channel (PCH) carrying paging message, and a downlink shared channel (SCH) carrying user traffic or control messages. The traffic or control messages of a downlink multicast or broadcast service can be transmitted via the downlink SCH or an additional downlink multicast channel (MCH). Meanwhile, as uplink transport channels carrying data from UEs to the network, there are provided a random access channel (RACH) carrying an initial control message and an uplink shared channel (UL-SCH) carrying user traffic or control message. As logical channels located above the transport channels and mapped with the transport channels, there are provided a broadcast channel (BCCH), a paging control channel (PCCH), a common control channel (CCCH), a multicast control channel (MCCH), and a multicast traffic channel (MTCH).

**[0032]** In the E-UMTS system, an OFDM is used on the downlink and a single carrier frequency division multiple access (SC-FDMA) on the uplink. The OFDM scheme using multiple carriers allocates resources by unit of multiple sub-carriers including a group of carriers and utilizes an orthogonal frequency division multiple access (OFDMA) as an access scheme.

**[0033]** A physical layer of an OFDM or OFDMA scheme divides active carriers into a plurality of groups and transmits respective groups to different receiving sides. Radio resource allocated to each UE which is defined by a time-frequency region on a two-dimensional sphere comprises continuous

sub-carriers. A time-frequency region in the OFDM or OFDMA scheme is a rectangular form sectioned by time and sub-carrier coordinates. In other words, one time-frequency region could be a rectangular form sectioned by at least one symbol on a time axis and sub-carriers on a frequency axis. Such a time-frequency region can be allocated to an uplink for a specific UE, or an eNB can transmit the time-frequency region to a specific UE in a downlink. In order to define such a time-frequency region on the two-dimensional sphere, the number of OFDM symbols and the number of continuous sub-carriers starting from a point having an offset from a reference point should be given.

**[0034]** The E-UMTS which is currently being discussed uses 10 ms radio frame comprising 20 sub-frames. Namely, a sub-frame has a length of 0.5 ms. A resource block comprises one sub-frame and twelve sub-carriers, each of which is 15 kHz. One sub-frame comprises a plurality of OFDM symbols and a part (for example, first symbol) of the plurality of OFDM symbols can be used for transmission of L1/L2 control information.

**[0035]** FIG. 4 is a diagram illustrating a structure of physical channels used in the E-UMTS. In FIG. 4, a sub-frame comprises an L1/L2 control information transmission region (the hatching part) and a data transmission region (the non-hatching part).

**[0036]** FIG. 5 is a flow chart illustrating a procedure according to one embodiment of the present invention. In the embodiment of FIG. 5, technical features of the present invention are applied to a procedure of initial random access of a user equipment which is in an idle mode.

**[0037]** Referring to FIG. 5, the user equipment transmits a random access preamble to a base station eNB [S51]. In other words, the user equipment selects a specific signature among a plurality of signatures through one access slot and transmits the selected signature to the base station. At this time, the random access preamble may include uplink message information or channel measurement information so that the base station may perform resource allocation for uplink message transmission. In this case, if at least two user equipments simultaneously perform uplink transmission of random access preambles by using same radio resources such as same signatures, collision may occur.

**[0038]** The base station transmits a random access response message to the user equipment in response to the random access preamble [S52]. The random access response message includes the signature transmitted from the user equipment, grant or rejection information of the random access preamble transmission, a temporary cell radio network temporary identifier (Temporary C-RNTI) allocated to the user equipment, and control information related to transmission of the RRC connection request message, etc. The control information related to transmission of the RRC connection request message includes radio resource allocation information, a message size, and radio parameters (modulation and coding information and hybrid ARQ information) for transmission of the RRC connection request message.

**[0039]** The base station transmits signaling information for receiving the random access response message to the user equipment through L1/L2 control channel. The signaling information includes a random access radio network temporary identifier (RA-RNTI) indicating transmission of the random access response message and transmission parameters related to transmission of the random access response message. Since the RA-RNTI is previously forwarded from the

user equipment to the base station through system information, etc., the user equipment acquires the signaling information through the L1/L2 control channel by using the RA-RNTI and receives the random access response message by using the acquired signaling information.

**[0040]** If the signature transmitted from the user equipment and grant information for signature transmission are included in the random access response message, the user equipment transmits the RRC connection request message to the base station [S53]. At this time, the user equipment transmits the RRC connection request message to the base station by using the uplink radio resource allocation information, the message size, and the radio parameters, which are included in the random access response message. The RRC connection request message includes a user equipment identifier for identifying the user equipment. Examples of the user equipment identifier include wideband UE identifiers such as an international mobile subscriber identity (IMSI) or a temporary mobile subscriber identity (TMSI).

**[0041]** If the signature transmitted from the user equipment and the rejection information of the signature transmission are included in the random access response message, or if the signature transmitted from the user equipment is not included in the random access response message, the user equipment retransmits the random access preamble after a certain time without transmitting the RRC connection request message.

**[0042]** If the RRC connection request message is received from the user equipment, the RRC layer of the base station transmits the RRC connection setup message or the RRC contention resolution message to the user equipment. Preferably, the RRC layer transmits one RRC message which includes the RRC connection setup message and the RRC contention resolution message. For another example, after transmitting the RRC connection setup message to the user equipment, the base station can transmit the RRC contention resolution message.

**[0043]** If one RRC message which including the RRC connection setup message and the RRC contention resolution message is transmitted, padding included in the message can be reduced, whereby the radio resources can be used efficiently. The RRC message includes user equipment identifier of a user equipment which has succeeded in random access. Preferably, the user equipment identifier is a user equipment identifier included in the RRC connection request message, for example, IMSI and TMSI.

**[0044]** If a plurality of user equipments collide with one another during a transmission procedure of the random access preamble or the RRC connection setup message, only one user equipment which has successfully performed random access is operated in accordance with the RRC connection setup message. In this case, the success of the user equipment which has succeeded in the random access means that the random access preamble transmitted from the user equipment has been successfully received by the base station and then the RRC connection request has been successfully performed.

**[0045]** As described above, the RRC connection setup message included in the RRC message includes the wideband user equipment identifier such as IMSI and TMSI of the user equipment which has succeeded in the random access. The user equipment receives control information required to receive the RRC message through the L1/L2 control channel by using its temporary C-RNTI. For example, the user equipment can identify whether a specific channel of the L1/L2

control channel is transmitted to itself in accordance with the result of cyclic redundancy code (CRC) test of the specific channel by using the temporary C-RNTI. For another example, the user equipment receives a message indicated by the temporary C-RNTI if the temporary C-RNTI is received through the L1/L2 control channel. If the specific channel is transmitted to the user equipment, the user equipment receives the RRC message transmitted to a downlink channel of a data region, for example, a downlink shared channel (DL-SCH) by using control information transmitted through the specific channel.

**[0046]** If the wideband user equipment identifier transmitted through the RRC connection request message is included in the RRC connection setup message, the user equipment realizes that it has succeeded in the random access and recognizes the RRC connection setup message as its message. At this time, the user equipment uses the temporary user equipment identifier (temporary C-RNTI) as a private C-RNTI for performing communication with a network later.

**[0047]** If the wideband user equipment identifier transmitted through the RRC connection request message is not included in the RRC message, the user equipment realizes that it has failed in the random access. Also, if the RRC message which includes the wideband user equipment identifier is not received for a certain time period, the user equipment realizes that it has failed in the random access. At this time, the user equipment can start a random access procedure again by retransmitting the random access preamble to the base station after a certain time period.

**[0048]** The aforementioned embodiments of the present invention can be applied to a random access procedure for initial access performed after radio link failure or handover.

**[0049]** FIG. 6 is a flow chart illustrating a procedure according to another embodiment of the present invention. In the embodiment of FIG. 6, technical features of the present invention are applied to a random access procedure of a user equipment which is in an RRC connected mode. For example, if radio resources for data to be transmitted to the base station are not allocated to the user equipment, the user equipment can transmit data through the random access procedure through the RACH. The embodiments described hereinafter can be applied to the case where the base station is not uplink-synchronized with the user equipment even though it has downlink data to be transmitted to the user equipment which is in the RRC connected mode.

**[0050]** Referring to FIG. 6, the user equipment transmits a random access preamble to the base station eNB [S61], and receives a random access response message from the base station in response to the random access preamble [S62]. Since the steps S61 and S61 are the same as S51 and S52 of FIG. 5, their detailed description will be omitted.

**[0051]** If the signature transmitted from the user equipment and grant information for signature transmission are included in the random access response message, the user equipment transmits a MAC scheduling request message to the base station [S63]. At this time, the user equipment transmits the MAC scheduling request message to the base station by using the uplink radio resource allocation information, the message size, and the radio parameters, which are included in the random access response message. Preferably, the MAC scheduling request message includes a wideband user equipment identifier for identifying the user equipment. Examples of the user equipment identifier include wideband UE identifiers such as international mobile subscriber identity (IMSI)

or temporary mobile subscriber identity (TMSI). The embodiment of FIG. 6 is different from that of FIG. 5 in that scheduling request and contention resolution procedures are performed by the MAC layer.

**[0052]** If the signature transmitted from the user equipment and the rejection information of the signature transmission are included in the random access response message, or if the signature transmitted from the user equipment is not included in the random access response message, the user equipment retransmits the random access preamble after a certain time without transmitting the MAC scheduling request message.

**[0053]** If the MAC scheduling request message is received from the user equipment, the MAC layer of the base station transmits a resource grant message and MAC contention resolution message to the user equipment [S64]. The base station may simultaneously transmit the resource grant message and the MAC contention resolution message or may transmit the MAC contention resolution message after transmitting the resource grant message.

**[0054]** The resource grant message may be transmitted through the L1/L2 control channel, or may be transmitted through L1 signaling by using a physical channel for resource allocation, such as an absolute grant channel (AGCH) or a relative grant channel (RGCH). On the other hand, the MAC contention resolution message may be transmitted in a type of MAC control PDU. Alternatively, the base station may transmit the resource grant message and the MAC contention resolution message in a type of one MAC control PDU by combining them with each other. Moreover, a method of transmitting the resource grant message and the MAC contention resolution message to the user equipment through the L1/L2 control channel may be considered. The MAC control PDU includes a header and a payload, wherein the header may include information indicating the MAC control PDU, and an indicator indicating that the resource grant message or the MAC contention resolution message is included in the MAC control PDU. The payload may include contents of the resource grant message or the MAC contention resolution message.

**[0055]** If the MAC contention resolution message is transmitted in a type of one MAC control PDU, the MAC control PDU includes a private C-RNTI of the user equipment which has succeeded in the random access. If the private C-RNTI of the user equipment is included in one MAC control PDU, a problem may occur in that radio resources are wasted. Accordingly, private C-RNTIs of a plurality of user equipments which have successfully performed random access for a certain time period can be included in one MAC contention resolution message.

**[0056]** Since the user equipment which is in the RRC connected mode previously knows its private C-RNTI before trying random access, the base station transmits the resource grant message which includes the private C-RNTI of the user equipment which has passed contention. If the resource grant message is transmitted through L1 signaling, the user equipment recognizes the resource grant message as its message when receiving the resource grant message, which includes the private C-RNTI, through the resource allocation channel or the L1/L2 control channel. However, when receiving the resource grant message, which does not include the private C-RNTI of the user equipment, through the resource allocation channel or the L1/L2 control channel, the user equipment does not recognize the resource grant message as its message.

**[0057]** If the resource grant message is transmitted in a type of the MAC control PDU, the control information included in the L1/L2 control channel includes the private C-RNTI of the user equipment to instruct transmission of the MAC control PDU. Accordingly, the user equipment receives the resource grant message only if the private C-RNTI is included in the L1/L2 control channel.

**[0058]** The control information transmitted from the base station through the L1/L2 control channel to instruct transmission of the MAC contention resolution message includes the temporary C-RNTI. Accordingly, the user equipment can receive the MAC contention resolution message only if the temporary C-RNTI is included in the L1/L2 control channel. The temporary C-RNTI is a user equipment identifier allocated from the base station through the random access response message. If the temporary C-RNTI is received through the L1/L2 control channel, the user equipment receives the MAC contention resolution message by using the control information transmitted through the L1/L2 control channel. The MAC contention resolution message includes a wideband user equipment identifier which has passed contention.

**[0059]** If the resource grant message is transmitted to the user equipment through the L1/L2 control channel and the MAC contention resolution message is transmitted to the user equipment through the data region, the operation of the user equipment will be described hereinafter.

**[0060]** If the temporary C-RNTI of the user equipment is received through the L1/L2 control channel before receiving the resource grant message from the base station and the MAC contention resolution message indicated by the temporary C-RNTI is received, the user equipment identifies whether the MAC contention resolution message includes the private C-RNTI of the user equipment. If the private C-RNTI of the user equipment is included in the MAC contention resolution message, the user equipment recognizes that it has succeeded in the random access and monitors reception of the resource grant message, which includes the private C-RNTI of the user equipment, through the L1/L2 control channel. If the resource grant message is not received within a certain time period which is previously set, the user equipment starts the random access procedure again. If the resource grant message is received within the certain time period, the user equipment transmits uplink data to the base station through the radio resources allocated by the resource grant message.

**[0061]** If the user equipment receives the resource grant message, which includes the private C-RNTI, through the L1/L2 control channel before receiving the MAC contention resolution message, the user equipment realizes that it has successfully performed the random access regardless of reception of the MAC contention resolution message, and transmits uplink data to the base station through the radio resources allocated by the resource grant message. If the user equipment receives its temporary C-RNTI through the L1/L2 control channel after receiving the resource grant message, the user equipment disregards packet data indicated by the temporary C-RNTI.

**[0062]** In FIG. 5 and FIG. 6, the contention resolution message and the connection setup message or the resource grant message may include the signature transmitted from the user equipment and included in the random access preamble or information related to the radio resources used for the random access preamble. For another example, the contention resolution message and the connection setup message or the

resource grant message may include information related to the radio resources used to transmit the connection request message or the scheduling request message. The radio resources include information related to frequency and/or time. At this time, if the preamble signature transmitted from the user equipment or the information related to the radio resources is included in the contention resolution message and the connection setup message or the resource grant message, the user equipment recognizes the contention resolution message and the connection setup message or the resource grant message as its messages and is operated in accordance with contents of the contention resolution message and the connection setup message or the resource grant message.

**[0063]** The aforementioned embodiments are achieved by combination of structural elements and features of the present invention in a predetermined type. Each of the structural elements or features should be considered selectively unless specified separately. Each of the structural elements or features may be carried out without being combined with other structural elements or features. Also, some structural elements and/or features may be combined with one another to constitute the embodiments of the present invention. The order of operations described in the embodiments of the present invention may be changed. Some structural elements or features of one embodiment may be included in another embodiment, or may be replaced with corresponding structural elements or features of another embodiment. Moreover, it will be apparent that some claims referring to specific claims may be combined with another claims referring to the other claims other than the specific claims to constitute the embodiment or add new claims by means of amendment after the application is filed.

**[0064]** The embodiments of the present invention have been described based on data transmission and reception between the base station and the user equipment. In this case, the base station means a terminal node of a network, which performs direct communication with the user equipment. A specific operation which has been described as being performed by the base station may be performed by an upper node of the base station as the case may be. In other words, it will be apparent that various operations performed for communication with the user equipment in the network which includes a plurality of network nodes along with the base station may be performed by the base station or network nodes other than the base station. The base station may be replaced with terms such as a fixed station, Node B, eNode B (eNB), and access point. Also, the user equipment may be replaced with terms such as mobile station and mobile subscriber station.

**[0065]** The embodiments according to the present invention may be implemented by various means, for example, hardware, firmware, software, or their combination. If the embodiment according to the present invention is implemented by hardware, the random access method in the wireless communication system according to the embodiment of the present invention may be implemented by one or more application specific integrated circuits (ASICs), digital signal processors (DSPs), digital signal processing devices (DSPDs), programmable logic devices (PLDs), field programmable gate arrays (FPGAs), processors, controllers, microcontrollers, microprocessors, etc.

**[0066]** If the embodiment according to the present invention is implemented by firmware or software, the random access method in the wireless communication system accord-

ing to the embodiment of the present invention may be implemented by a type of a module, a procedure, or a function, which performs functions or operations described as above. A software code may be stored in a memory unit and then may be driven by a processor. The memory unit may be located inside or outside the processor to transmit and receive data to and from the processor through various means which are well known.

**[0067]** According to the present invention, unnecessary delay can be avoided in the random access procedure of the wireless communication system, and the radio resources can be used efficiently.

**[0068]** It will be apparent to those skilled in the art that the present invention can be embodied in other specific forms without departing from the spirit and essential characteristics of the invention. Thus, the above embodiments are to be considered in all respects as illustrative and not restrictive. The scope of the invention should be determined by reasonable interpretation of the appended claims and all change which comes within the equivalent scope of the invention are included in the scope of the invention.

#### INDUSTRIAL APPLICABILITY

**[0069]** The present invention can be used in a wireless communication system such as a mobile communication system or a wireless Internet system.

1. A method of performing random access in a user equipment of a wireless communication system using multiple carriers, the method comprising:
  - transmitting a preamble for random access to a network;
  - receiving a random access response message from the network in response to the preamble;
  - transmitting a connection setup request message to the network, the connection setup request message requesting connection establishment with the network; and
  - receiving a first message from the network, the first message including connection setup information and contention resolution information in a random access procedure.
2. The method of claim 1, wherein the random access response message includes a temporary user equipment identifier temporarily given to the user equipment.
3. The method of claim 2, wherein the connection setup request message includes a wideband user equipment identifier of the user equipment.
4. The method of claim 3, wherein the first message includes a wideband user equipment identifier of a user equipment succeeding in random access.
5. The method of claim 4, further comprising receiving control information for reception of the first message by using the temporary user equipment identifier through a control channel.
6. The method of claim 4, wherein the user equipment is operated in accordance with the connection setup information if the wideband user equipment identifier of the user equipment is included in the first message.
7. The method of claim 4, further comprising transmitting a random access preamble from a user equipment to the network if a wideband user equipment identifier of the user equipment is not included in the first message.
8. The method of claim 1, wherein the connection setup is radio resource control (RRC) connection setup.

**9.** The method of claim **3**, wherein the wideband user equipment identifier is an international mobile subscriber identity (IMSI) or temporary mobile subscriber identity (TMSI).

**10.** A method of performing random access in a user equipment of a wireless communication system which uses multiple carriers, the method comprising:

a first step of transmitting a preamble for random access to a network in a state that the user equipment is connected with the network;

a second step of receiving a random access response message from the network in response to the preamble, the random access response message including a temporary user equipment identifier of the user equipment;

a third step of requesting the network to allocate uplink resources; and

a fourth step of receiving at least one of a resource grant message and a contention resolution message from the network by using the temporary user equipment identifier and a private user equipment identifier of the user equipment.

**11.** The method of claim **10**, wherein the fourth step comprises:

receiving the temporary user equipment identifier through a specific control channel; and

receiving the contention resolution message indicated by the temporary user equipment identifier.

**12.** The method of claim **11**, further comprising receiving the resource grant message by using the private user equipment identifier if the private user equipment identifier of the user equipment is included in the contention resolution message.

**13.** The method of claim **10**, wherein the fourth step further comprises transmitting uplink data to the network in accordance with resource allocation information included in the resource grant message if the user equipment receives the resource grant message which includes the private user equipment identifier.

**14.** The method of claim **11**, further comprising transmitting a random access preamble to the network after the lapse of a certain time period if the private user equipment identifier of the user equipment is not included in the contention resolution message.

**15.** The method of claim **13**, wherein the user equipment does not receive a contention resolution message indicated by the temporary user equipment identifier.

**16.** The method of claim **12**, wherein the resource grant message is received through a control channel, and the contention resolution message is received through a data channel.

**17.** The method of claim **13**, wherein the resource grant message is received through a control channel.

**18.** The method of claim **16**, wherein the contention resolution message is received by being included in MAC control PDU.

\* \* \* \* \*