



US 20080304467A1

(19) **United States**

(12) **Patent Application Publication**

Papasakellariou et al.

(10) **Pub. No.: US 2008/0304467 A1**

(43) **Pub. Date: Dec. 11, 2008**

(54) **CONTROL AND DATA SIGNALING IN SC-FDMA COMMUNICATION SYSTEMS**

Publication Classification

(75) Inventors: **Aris Papasakellariou**, Dallas, TX (US); **Joon-Young Cho**, Suwon-si (KR)

(51) **Int. Cl.**
H04B 7/208 (2006.01)

(52) **U.S. Cl.** **370/344**

Correspondence Address:
THE FARRELL LAW FIRM, P.C.
333 EARLE OVINGTON BOULEVARD, SUITE 701
UNIONDALE, NY 11553 (US)

(57) **ABSTRACT**

Apparatus and method for multiplexing control information bits and data information bits into sub-frame symbols depending on the location of symbols carrying a reference signal (RS), to provide an estimate for the channel medium and enable coherent demodulation for signals carrying information bits. The control information bits include ACK or NAK and/or channel CQI bits. The ACK/NAK bits are placed with priority in symbols around the symbols carrying the RS, to allow for improved accuracy of the channel estimate, followed by the CQI bits when both ACK/NAK and CQI bits exist. Moreover, the sub-frame resources required to achieve the desired reception reliability for the control information depend on the operating conditions and can varied to minimize the associated control overhead.

(73) Assignee: **SAMSUNG ELECTRONICS CO., LTD.**, Suwon-si (KR)

(21) Appl. No.: **12/133,120**

(22) Filed: **Jun. 4, 2008**

Related U.S. Application Data

(60) Provisional application No. 60/942,843, filed on Jun. 8, 2007.

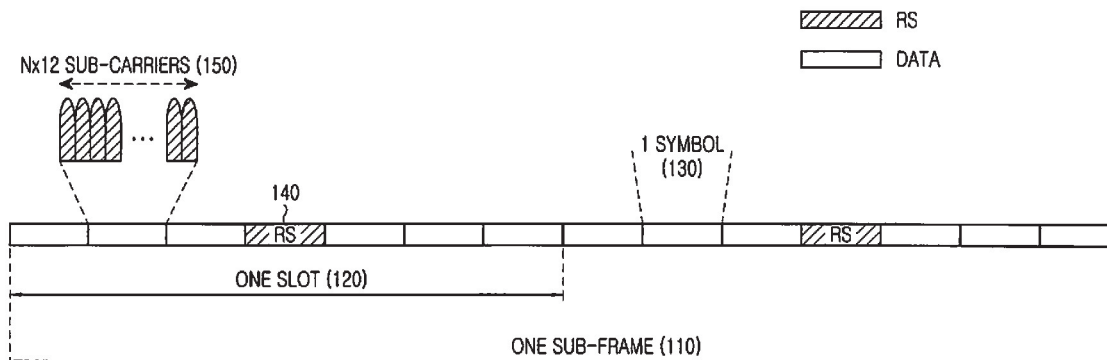

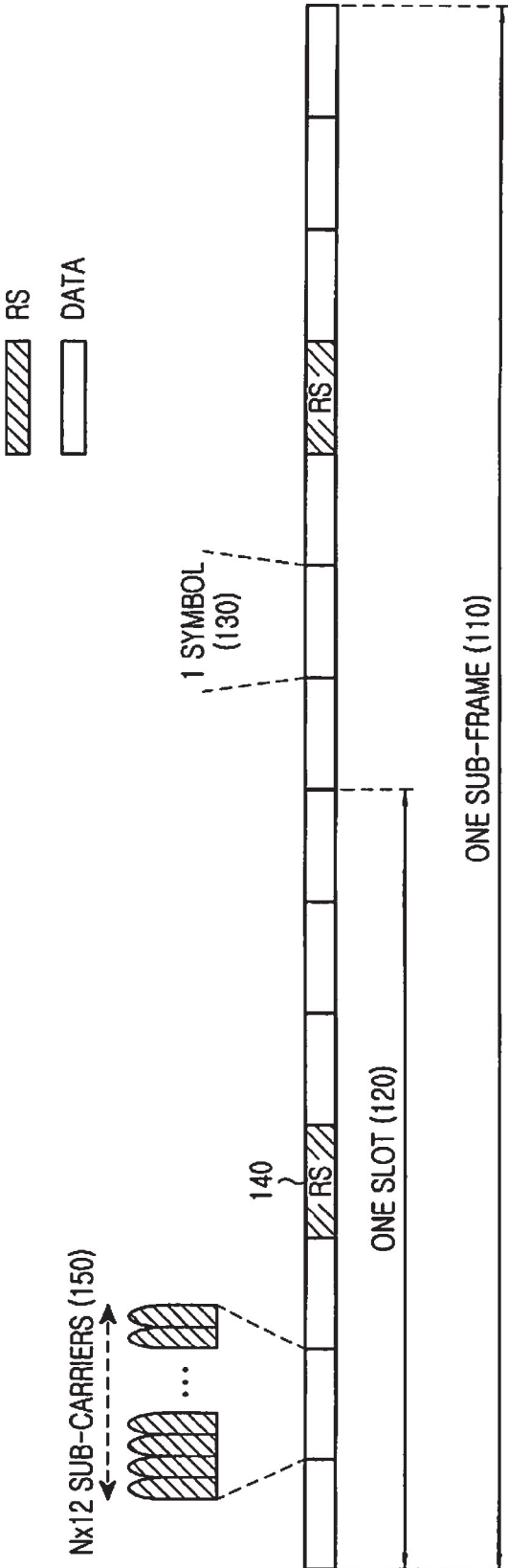

FIG.1

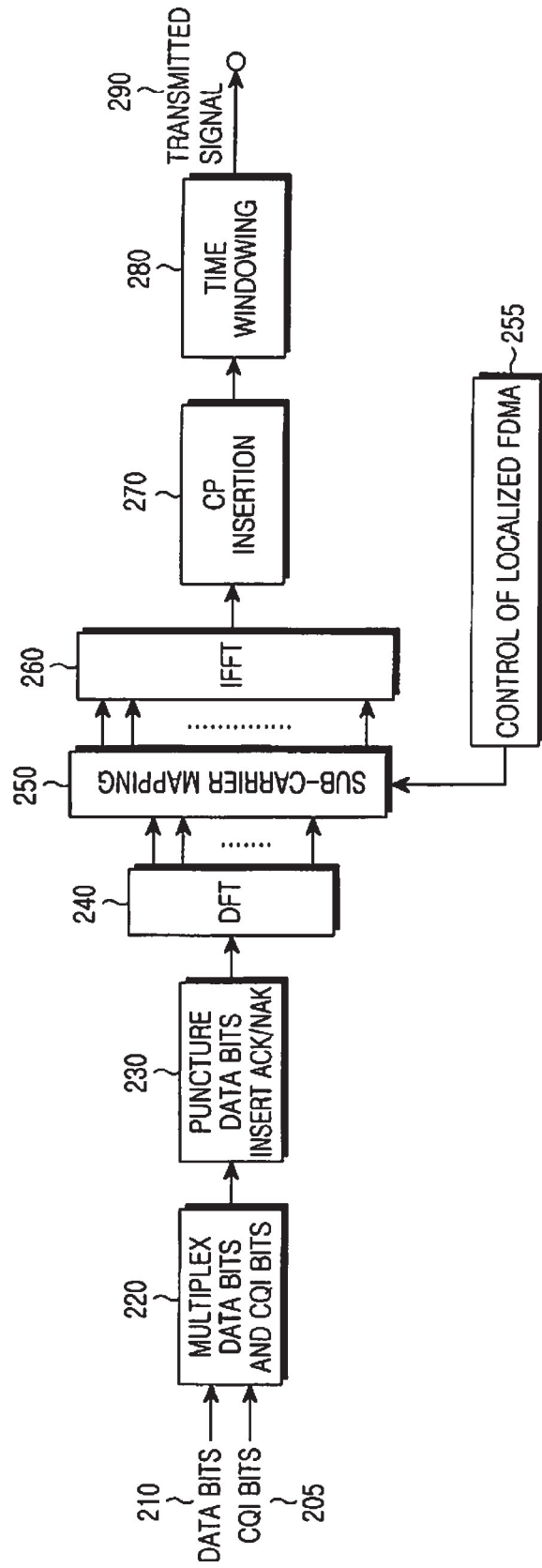

FIG. 2

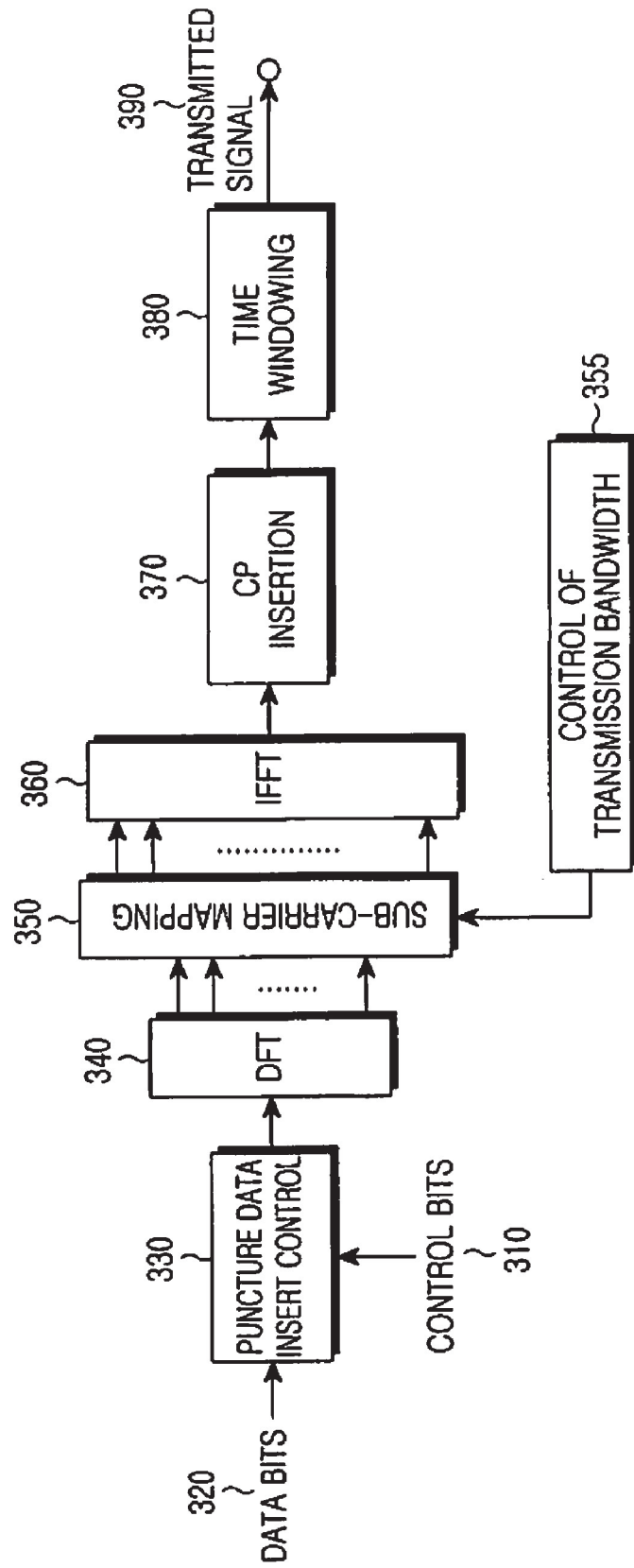

FIG.3

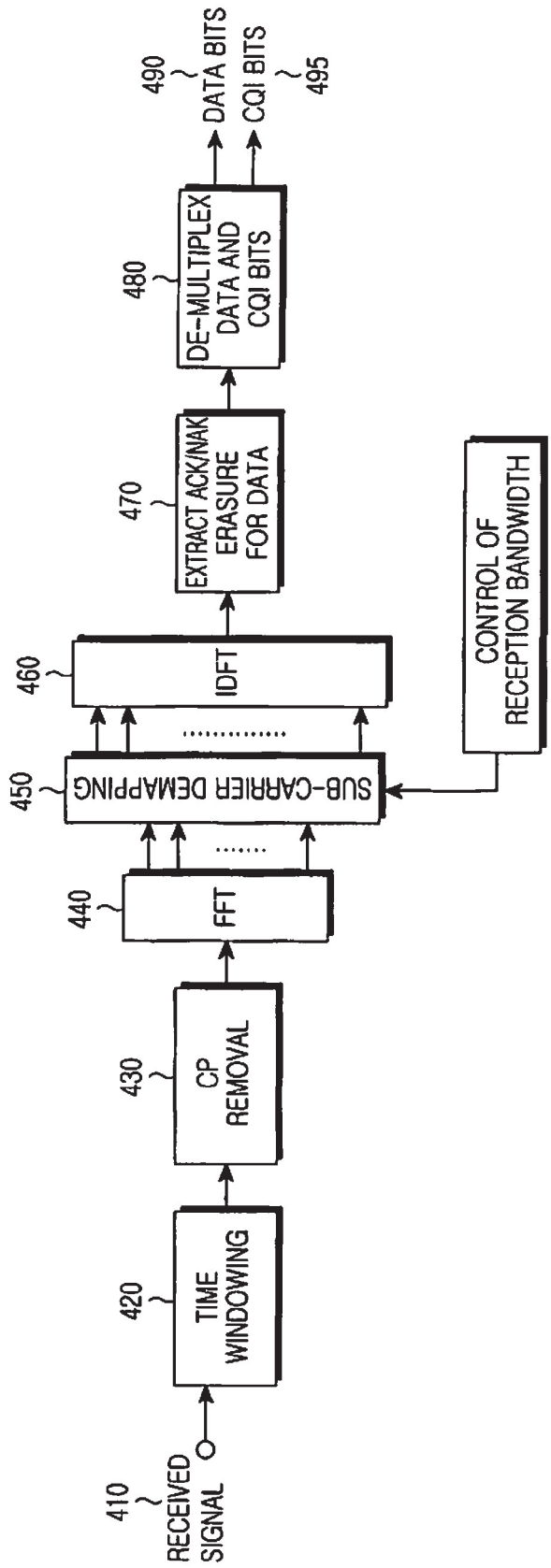

FIG. 4

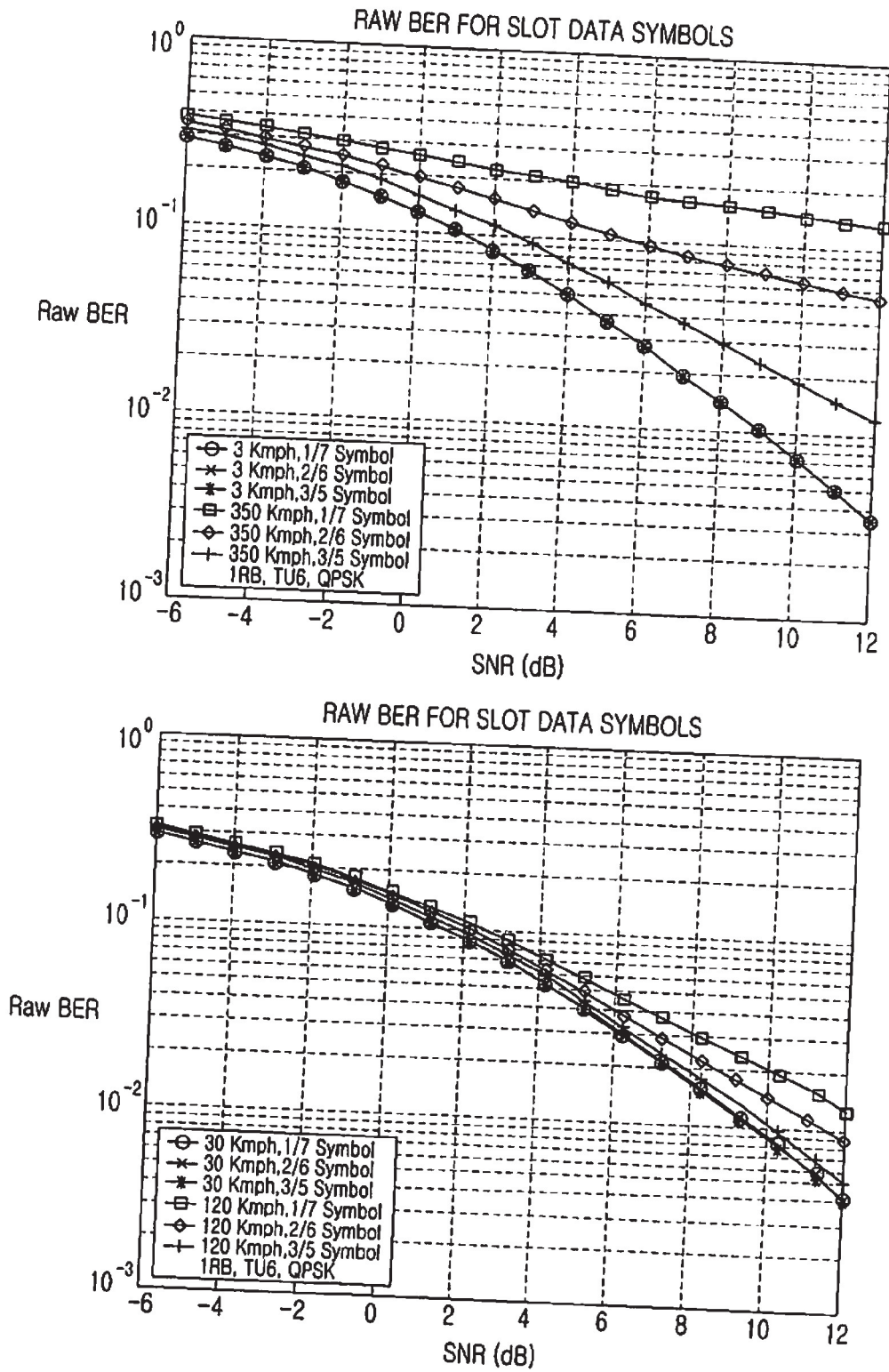

FIG.5

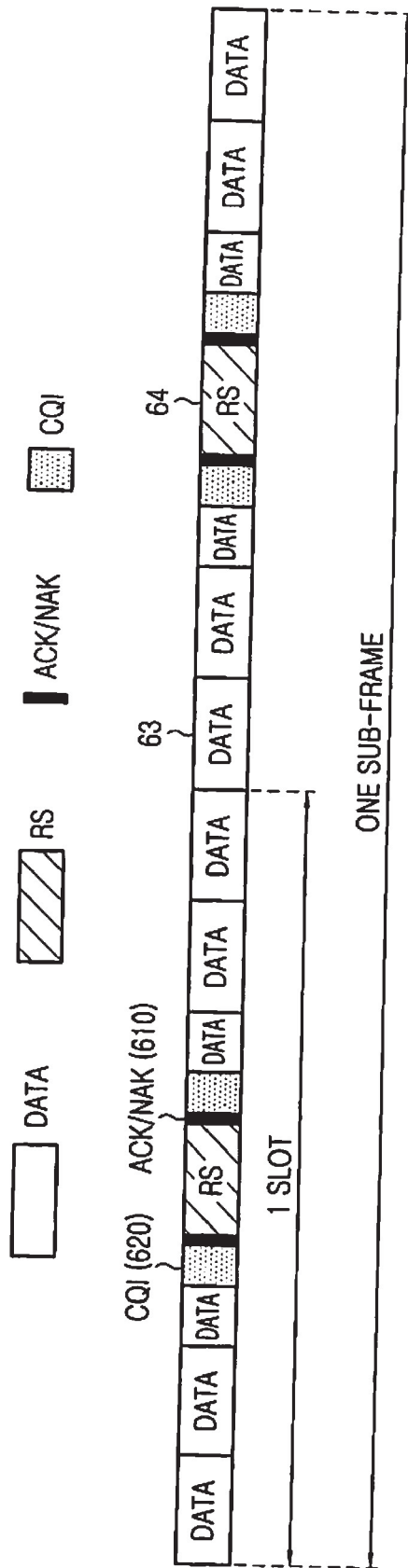

FIG.6

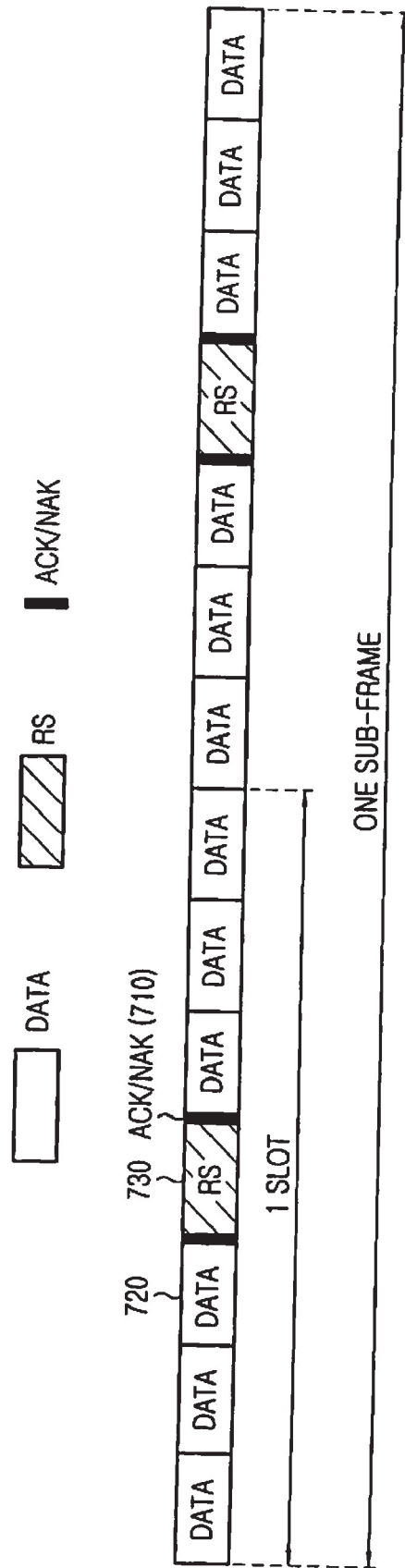

FIG.7

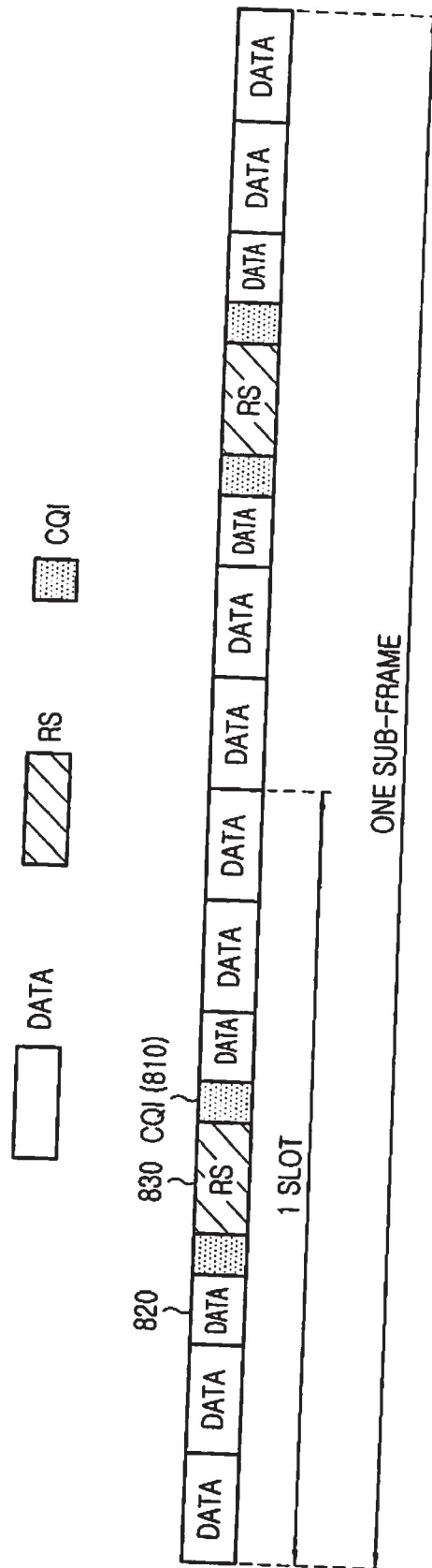

FIG.8

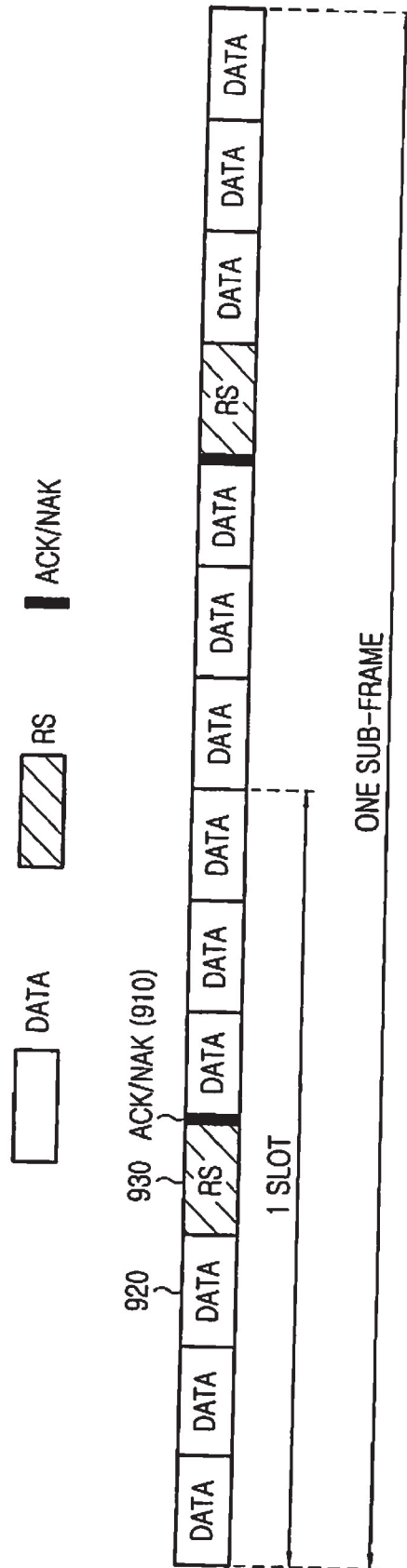

FIG.9

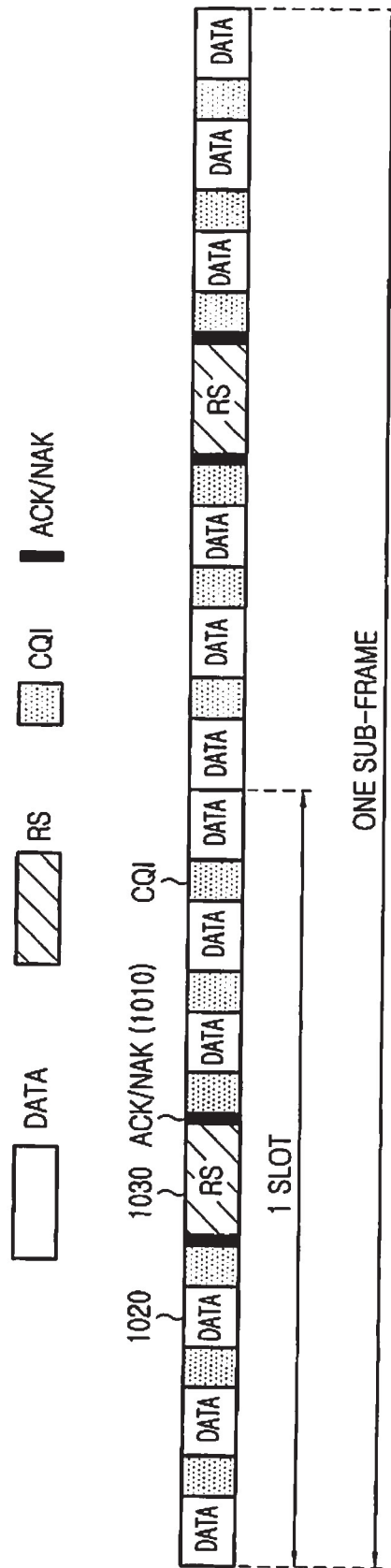

FIG.10

CONTROL AND DATA SIGNALING IN SC-FDMA COMMUNICATION SYSTEMS

PRIORITY

[0001] The present Application for Patent claims priority to U.S. Provisional Application No. 60/942,843 entitled "Control and Data Signaling in SC-FDMA Communication Systems" filed Jun. 8, 2007, the contents of which is incorporated by reference herein.

BACKGROUND OF THE INVENTION

[0002] 1. Field of the Invention

[0003] The present invention is directed, in general, to wireless communication systems and, more specifically, to multiplexing control and data information in single-carrier frequency division multiple access (SC-FDMA) communication systems.

[0004] 2. Description of the Related Art

[0005] In particular, the present invention considers the transmission of positive or negative acknowledgement bits (ACK or NAK, respectively) and channel quality indicator (CQI) bits together with data information bits in an SC-FDMA communications system and is further considered in the development of the 3rd Generation Partnership Project (3GPP) Evolved Universal Terrestrial Radio Access (E-UTRA) long term evolution (LTE). The invention assumes the uplink (UL) communication corresponding to the signal transmission from mobile user equipments (UEs) to a serving base station (Node B). A UE, also commonly referred to as a terminal or a mobile station, may be fixed or mobile and may be a wireless device, a cellular phone, a personal computer device, a wireless modem card, etc. A Node B is generally a fixed station and may also be called a base transceiver system (BTS), an access point, or some other terminology. The ACK/NAK bits and CQI bits may also be referred to simply as control information bits.

[0006] The ACK or NAK bits are in response to the correct or incorrect, respectively, data packet reception in the downlink (DL) of the communication system, which corresponds to signal transmission from the serving Node B to a UE. The CQI transmitted from a reference UE is intended to inform the serving Node B of the channel conditions the UE experiences for signal reception, enabling the Node B to perform channel-dependent scheduling of DL data packets. Either or both of the ACK/NAK and CQI may be transmitted by a UE in the same transmission time interval (TTI) with data or in a separate TTI with no data. The disclosed invention considers the former case, which may also be referred to as data-associated transmission of the ACK/NAK and/or CQI.

[0007] The UEs are assumed to transmit control and data bits over a TTI corresponding to a sub-frame. FIG. 1 illustrates a block diagram of the sub-frame structure 110 assumed in the exemplary embodiment of the disclosed invention. The sub-frame includes two slots. Each slot 120 further includes seven symbols and each symbol 130 further includes of a cyclic prefix (CP) for mitigating interference due to channel propagation effects, as it is known in the art. The signal transmission in the two slots may be in the same part or it may be at two different parts of the operating bandwidth. Furthermore, the middle symbol in each slot carries the transmission of reference signals (RS) 140, also known as

pilot signals, which are used for several purposes including for providing channel estimation for coherent demodulation of the received signal.

[0008] The transmission bandwidth (BW) is assumed to include frequency resource units, which will be referred to herein as resource blocks (RBs). An exemplary embodiment assumes that each RB includes 12 sub-carriers and UEs are allocated a multiple N of consecutive RBs 150. Nevertheless, the above values are only illustrative and not restrictive to the invention.

[0009] An exemplary block diagram of the transmitter functions for SC-FDMA signaling is illustrated in FIG. 2. Coded CQI bits 205 and coded data bits 210 are multiplexed 220. If ACK/NAK bits also need to be multiplexed, the exemplary embodiment assumes that data bits are punctured to accommodate ACK/NAK bits 230. Alternatively, CQI bits (if any) may be punctured or different rate matching, as it is known in the art, may apply to data bits or CQI bits to accommodate ACK/NAK bits. The discrete Fourier transform (DFT) of the combined data bits and control bits is then obtained 240, the sub-carriers 250 corresponding to the assigned transmission bandwidth are selected 255, the inverse fast Fourier transform (IFFT) is performed 260 and finally the cyclic prefix (CP) 270 and filtering 280 are applied to the transmitted signal 290.

[0010] Alternatively, as illustrated in FIG. 3, in order to transmit the control (ACK/NAK and/or CQI) bits 310, puncturing of coded data bits 320 may apply 330 (instead of also applying rate matching as in FIG. 2) and certain coded data bits (for example, the parity bits in case of turbo coding) may be replaced by control bits. The discrete Fourier transform (DFT) 340 of the combined bits is then obtained, the sub-carriers 350 corresponding to the assigned transmission bandwidth are selected 355 (localized mapping is assumed but distributed mapping may also be used), the inverse fast Fourier transform (IFFT) 360 is performed and finally the cyclic prefix (CP) 370 and filtering 380 are applied to the transmitted signal 390.

[0011] This time division multiplexing (TDM) illustrated in FIG. 2 and FIG. 3 between control (ACK/NAK and/or CQI) bits and data bits prior to the DFT is necessary to preserve the single carrier property of the transmission. Zero padding, as it is known in the art, is assumed to be inserted by a reference UE in sub-carriers used by another UE and in guard sub-carriers (not shown). Moreover, for brevity, additional transmitter circuitry such as digital-to-analog converter, analog filters, amplifiers, and transmitter antennas are not illustrated in FIG. 2 and FIG. 3. Similarly, the encoding process for the data bits and the CQI bits, as well as the modulation process for all transmitted bits, are well known in the art and are omitted for brevity.

[0012] At the receiver, the inverse (complementary) transmitter operations are performed. This is conceptually illustrated in FIG. 4 where the reverse operations of those illustrated in FIG. 2 are performed. As it is known in the art (not shown for brevity), an antenna receives the radio-frequency (RF) analog signal and after further processing units (such as filters, amplifiers, frequency down-converters, and analog-to-digital converters) the digital received signal 410 passes through a time windowing unit 420 and the CP is removed 430. Subsequently, the receiver unit applies an FFT 440, selects 445 the sub-carriers 450 used by the transmitter, applies an inverse DFT (IDFT) 460, extracts the ACK/NAK bits and places respective erasures for the data bits 470, and

de-multiplexes 480 the data bits 490 and CQI bits 495. As for the transmitter, well known in the art receiver functionalities such as channel estimation, demodulation, and decoding are not shown for brevity and they are not material to the present invention.

[0013] The control bits typically require better reception reliability than the data bits. This is primarily because hybrid-automatic-repeat-request (HARQ) usually applies to data transmission but not to control transmission. Additionally, ACK/NAK bits typically require better reception reliability than CQI bits as erroneous reception of ACK/NAK bits has more detrimental consequences to the overall quality and efficiency of communication than does erroneous reception for the CQI bits.

[0014] The size of resources in a transmission sub-frame required for control signaling for a given desired reception reliability depend on the channel conditions the signal transmission from a UE experiences and in particular, on the signal-to-interference and noise ratio (SINR) of the received signal at the serving Node B.

[0015] There is a need to determine the placement of control bits when transmitted in the same sub-frame with data bits so that better reception reliability is provided for the control bits than for the data bits.

[0016] There is another need to determine the placement of acknowledgement bits relative to channel quality indication bits, in case they are simultaneously multiplexed, in order to provide better reception reliability for the former.

[0017] There is another need to dimension the resources required for the transmission of acknowledgement bits, in a sub-frame also containing data bits, as a function of the channel conditions experienced by the signal transmission from a UE.

SUMMARY OF THE INVENTION

[0018] Accordingly, the present invention has been designed to solve the above-mentioned problems occurring in the prior art, and embodiments of the invention provide an apparatus and a method for allocating resources in a sub-frame for the transmission of control bits and data bits.

[0019] In accordance with an embodiment of the present invention, provided are an apparatus and method for the placement of signals carrying the control bits and data bits in transmission symbols relative to the symbols used for transmission of reference signals in order to enable better reception reliability of the control bits.

[0020] Another embodiment of the present invention provides an apparatus and method for the placement of acknowledgement bits with higher priority than channel quality indication bits to enable better reception reliability of the acknowledgement bits.

[0021] Another embodiment of the present invention provides an apparatus and method for dimensioning and placing acknowledgement bits in a sub-frame according to the corresponding resources needed to achieve desired reception reliability.

BRIEF DESCRIPTION OF THE DRAWINGS

[0022] The above and other aspects, features, and advantages of the present invention will be more apparent from the following detailed description taken in conjunction with the accompanying drawings, in which:

[0023] FIG. 1 is a block diagram illustrating an exemplary sub-frame structure for the SC-FDMA communication system;

[0024] FIG. 2 is a block diagram illustrative of a first exemplary SC-FDMA transmitter for multiplexing data bits, CQI bits, and ACK/NAK bits in a transmission sub-frame;

[0025] FIG. 3 is another block diagram illustrative of a second exemplary SC-FDMA transmitter or multiplexing data bits, CQI bits, and ACK/NAK bits in a transmission sub-frame;

[0026] FIG. 4 is a block diagram illustrative of an exemplary SC-FDMA receiver, corresponding to the first exemplary SC-FDMA transmitter, for de-multiplexing data bits, CQI bits, and ACK/NAK bits in a reception sub-frame;

[0027] FIG. 5 presents un-coded bit error rate (BER) results as a function of the symbol number (symbol position) in the sub-frame slot and the UE velocity;

[0028] FIG. 6 is a block diagram illustrating a first method for the selection of the sub-frame symbols carrying the transmission of CQI bits and ACK/NAK bits;

[0029] FIG. 7 is a block diagram illustrating a first method for the selection of the sub-frame symbols carrying the transmission of ACK/NAK bits;

[0030] FIG. 8 is a block diagram illustrating a first method for the selection of the sub-frame symbols carrying the transmission of CQI bits;

[0031] FIG. 9 is a block diagram illustrating a second method for the selection of the sub-frame symbols carrying the transmission of ACK/NAK bits with reduced overhead; and

[0032] FIG. 10 is a block diagram illustrating a second method for the selection of the sub-frame symbols carrying the transmission CQI bits and ACK/NAK bits.

DETAILED DESCRIPTION OF THE EXEMPLARY EMBODIMENTS

[0033] The present invention now will be described more fully hereinafter with reference to the accompanying drawings. This invention may, however, be embodied in many different forms and should not be construed as limited to the embodiments set forth herein. Rather, these embodiments are provided so that this disclosure will be thorough and complete, and will fully convey the scope of the invention to those skilled in the art.

[0034] Additionally, although the invention assumes a single-carrier frequency division multiple access (SC-FDMA) communication system, it also applies to all FDM systems in general and to OFDMA, OFDM, FDMA, DFT-spread OFDM, DFT-spread OFDMA, single-carrier OFDMA (SC-OFDMA), and single-carrier OFDM in particular.

[0035] Basically, the system and methods of the embodiments of the present invention solve problems related to the need for providing the desired reliability for the reception of control signaling under indicative transmission sub-frame structures and provide additional advantages such as the reduction of resource overhead for the transmission of control signals.

[0036] A first observation for the sub-frame structure illustrated in FIG. 1 is that the reference signal (RS) exists only in the middle symbol of each slot. In case of a mobile terminal, or user equipment (UE), with high speed, this can substantially degraded channel estimation for symbols located further away from the RS (that is, for symbols near the beginning

and end of each slot) due to the faster variation of the channel medium as the UE velocity increases. This may be acceptable for data transmission that is coded, which has typically a relatively large target block error rate (BLER), such as 10% or above, and can benefit from retransmissions through a conventional HARQ process. Conversely, the CQI and particularly the ACK/NAK have much stricter performance requirements, HARQ typically does not apply to the corresponding transmissions, and providing an accurate channel estimate is essential in achieving the desired reception reliability.

[0037] A brief set of simulation results for the un-coded (raw) bit error rate (BER) is provided to illustrate the impact of inaccurate channel estimation on the reception quality as a function of the symbol position in the slot and the UE speed. Table I provides the simulation setup under optimistic conditions for the performance loss due to imperfect channel estimation at symbols further away from the RS for the following reasons:

[0038] Transmission bandwidth is 1 RB. This maximizes power per sub-carrier.

[0039] Channel frequency selectivity is large and there are 2 uncorrelated Node B receiver antennas. This maximizes the slope of the un-coded (raw) BER curve and minimizes the relative performance loss due to imperfect channel estimation for a target BER value.

[0040] Operating signal-to-interference and noise ratio (SINR) is large. This minimizes the impact of inaccurate channel estimation.

TABLE I

Simulation Assumptions	
Parameters	Assumptions
Operating Bandwidth @ Carrier Frequency	5 MHz @ 2.6 GHz
Modulation Scheme	Quadrature Phase Shift Keying (QPSK)
Data Transmission Bandwidth (BW)	1 RB
UE Speed	3, 30, 120 and 350 Kilometers per hour (Kmph)
Transmission Type	Localized (at same RB) over the sub-frame at 3, 30 Kmph Frequency Hopping Between Slots at 120 and 350 Kmph
Channel Model	GSM-Terrestrial-Urban with 6 paths (TU6)
Number of Node B Receiver Antennas	2
Number of UE Transmitter Antennas	1

[0041] FIG. 5 presents the un-coded BER. At symbol locations symmetric to the RS, the BER is typically the same. At 120 Kmph and 350 Kmph, the transmission in the first slot is assumed to occur at a different BW than the one in the second slot (frequency hopped transmission per slot). As only 1 RS per slot is available for channel estimation, the BER is the same at symbols symmetric (equidistant) to the RS. At low speeds, such as 3 Kmph, this is also the case because the channel does not change over the sub-frame duration. Some small variability does exist for medium UE speeds, such as 30 Kmph, but, for simplicity, the average BER of symbols equidistant to the RS is only shown.

[0042] Even under the previous optimistic assumptions for the un-coded (raw) BER degradation due to degraded channel estimation at symbols further away from the RS, at 350 Kmph

the BER saturates at the 1st/7th and 2nd/6th symbols. However, the impact on the BER of the 3rd/5th symbols is rather contained and saturation is avoided (the difference relative to the BER at 3 Kmph is also partly due to the fact that the latter uses both RS in the sub-frame for channel estimation which therefore effectively operates with twice as much SINR). The BER at 120 Kmph is also degraded by about 3 dB for the 1st/7th symbols and by about 1.5 dB for the 2nd/6th symbols relative to the one of the 3rd/5th symbols at about the 1% point. Obviously, due to the flattening of the BER curves for the 1st/7th and 2nd/6th symbols, the degradation will be much larger for BER operating points below 1% as it is typically needed for the NAK reception.

[0043] Based on the results in FIG. 5 it becomes apparent that the control transmission should be placed with priority immediately next to the RS.

[0044] FIG. 6 illustrates such a placement when a UE transmits both ACK/NAK bits 610 and CQI bits 620 during a sub-frame. These control bits are placed on symbols next to the RS 630 while the data bits 640 are included in symbols transmitted over the entire sub-frame (with the obvious exception of the symbols carrying the RS transmission). Due to the requirement for better reception reliability, the ACK/NAK bits are placed closer to the RS than the CQI bits.

[0045] FIG. 7 illustrates the case in which the UE transmits only ACK/NAK bits 710 together with data bits 720 during a sub-frame. The ACK/NAK bits are placed at the two symbols next to the RS 730 in each of the two sub-frame slots while the data bits are included in symbols transmitted over the entire sub-frame.

[0046] FIG. 8 illustrates the case in which the UE transmits only CQI bits 810 together with data bits 820 during a sub-frame. The CQI bits are placed at the two symbols next to the RS 830 in each of the two sub-frame slots while the data bits are included in symbols transmitted over the entire sub-frame.

[0047] To minimize channel estimation losses, the ACK/NAK bits should be placed with priority in the symbol after the first symbol carrying the RS. This does not impact demodulation latency as a channel estimate is available only after this first RS symbol. To address low SINR or coverage issues, the ACK/NAK bits can also be placed in the symbol before the second RS. For medium UE speeds, this second placement of ACK/NAK bits benefits from improved channel estimation and time diversity while for high UE speeds, it benefits from frequency and time diversity. This is illustrated in FIG. 9 where the ACK/NAK bits 910 are placed in only one symbol next to the RS 920 in each slot, these two symbols (one in each slot) are located between the two RS, while the data bits 930 are transmitted throughout the sub-frame (with the obvious exception of the symbols carrying the RS).

[0048] Provisioning for the transmission of ACK/NAK bits in the sub-carriers over 2 symbols is typically adequate to achieve the desired BER for the ACK reception. Nevertheless, because the NAK reception has typically a lower BER target, it is appropriate to have the ACK/NAK transmission over the number of sub-carriers in 1 symbol in each slot. If further ACK/NAK transmissions are needed, because of low SINR or coverage issues, the other symbols next to the RS in the 2 slots may also be used as illustrated in FIG. 6 and FIG. 7.

[0049] Depending on the number of information bits carried in the CQI reporting, which are typically several times more than the ACK/NAK information bits, the symbols

immediately adjacent to the RS may not suffice for the CQI transmission, especially for coverage or SINR limited UEs that are also typically assigned small bandwidth allocations (a small number of RBs). In such cases, the CQI transmission may also extend to one or more symbols that are adjacent to the symbols also carrying CQI information that are adjacent to the symbols carrying the RS. An exemplary embodiment of this principle is illustrated in FIG. 10. As previously discussed, the location of the ACK/NAK bits 1010 remains in symbols next to the RS 1030 but the CQI bits 1020 are located in symbols throughout the transmission sub-frame, similarly to the data symbols 1040.

[0050] While the present invention has been shown and described with reference to certain exemplary embodiments thereof, it will be understood by those skilled in the art that various changes in form and details may be made therein without departing from the spirit and scope of the invention as defined by the appended claims.

What is claimed is:

1. An apparatus for forming a signal in a communication system, the signal being transmitted over a time period including a plurality of symbols with at least one symbol of the plurality of symbols carrying a reference signal and remaining symbols of the plurality of symbols carrying an information signal, the information signal including at least control information bits and data information bits, said apparatus comprising:

a mapping unit for placing at least one of the control bits in at least one of the remaining symbols located only next to the at least one symbol carrying the reference signal, for placing at least one of the data information bits in at least one of the remaining symbols not located next to the at least one symbol of the symbols carrying the reference signal; and

a transmitter unit for transmitting during the at least one of the plurality of symbols carrying the reference signal and transmitting during the remaining symbols of said the plurality of symbols carrying the information signal.

2. The apparatus as in claim 1, wherein the control information bits comprise acknowledgement bits.

3. The apparatus as in claim 1, wherein the control information bits comprise channel quality indication bits.

4. The apparatus as in claim 1, wherein the communication system comprises a single-carrier frequency division multiple access (SC-FDMA) communication system and the transmitter uses the SC-FDMA transmission method.

5. An apparatus for forming a signal in a communication system, the signal being transmitted over a time period including a plurality of symbols with at least one symbol of the plurality of symbols carrying a reference signal and remaining symbols of the plurality of symbols carrying an information signal, the information signal including acknowledgement bits, channel quality indication bits, and data information bits, the apparatus comprising:

a mapping unit for placing at least one of the acknowledgement bits in at least one of the remaining symbols located only next to the at least one symbol carrying the reference signal, for placing at least one of the channel quality indication bits in at least one of the remaining symbols not located next to the at least one symbol of the symbols carrying the reference signal, and for placing at least one of the data information bits in at least one of the remaining symbols not located next to the at least one symbol of the symbols carrying the reference signal; and

a transmitter unit for transmitting during the at least one of the plurality of symbols carrying the reference signal and transmitting during the remaining symbols of the plurality of symbols carrying the information signal.

6. The apparatus as in claim 5, wherein the communication system comprises a single-carrier frequency division multiple access (SC-FDMA) communication system and the transmitter uses the SC-FDMA transmission method.

7. An apparatus for forming a signal in a communication system, the signal being transmitted over a time period including a plurality of symbols with at least two symbols of the plurality of symbols carrying a reference signal and remaining symbols of the plurality of symbols carrying an information signal, the information signal including acknowledgement bits and data bits, the apparatus comprising:

a mapping unit for placing the acknowledgement bits only at a symbol after a first of the at least two symbols carrying the reference signal and only at a symbol before a last of the at least two symbols carrying the reference signal, and for placing the data bits in at least one of the remaining symbols not located next to the at least two symbols carrying the reference signal; and

a transmitter unit for transmitting during the at least two symbols carrying the reference signal and transmitting during the remaining symbols carrying the information signal.

8. The apparatus as in claim 7, wherein the communication system comprises a single-carrier frequency division multiple access (SC-FDMA) communication system and the transmitter uses the SC-FDMA transmission method.

9. An apparatus for forming a signal in a user equipment, the signal being transmitted over a time period in a channel medium, the time period including a plurality of symbols with at least one symbol of the plurality of symbols carrying an information signal, the information signal including acknowledgement bits and data bits, the apparatus comprising:

a mapping unit for placing the acknowledgement bits in a first set of resources when the user equipment operates in first channel medium conditions, and for placing the acknowledgement bits in a second set of resources when the user equipment operates in second channel medium conditions; and

a transmitter unit for transmitting during the at least one symbol carrying the information signal.

10. The apparatus as in claim 9, wherein the channel medium conditions correspond to a signal-to-interference and noise ratio (SINR).

11. The apparatus as in claim 9, wherein the communication system comprises a single-carrier frequency division multiple access (SC-FDMA) communication system and the transmitter uses the SC-FDMA transmission method.

12. An apparatus for forming a signal in a communication system, the apparatus comprising:

a transmitter for transmitting a reference signal over at least one symbol having a transmission period; and

a mapper for mapping acknowledgement bits for transmission only to symbols around adjacent to the at least one symbol for reference signal transmission, and for mapping data information bits for transmission over at least one symbol not adjacent to the at least one symbol for the reference signal transmission.

13. The apparatus as in claim **12**, wherein the transmitter comprises a single-carrier frequency division multiple access (SC-FDMA) transmitter.

14. The apparatus as in claim **12**, wherein the mapper further maps channel quality indication bits for transmission over at least one symbol not adjacent to the at least one symbol for the reference signal transmission.

15. An apparatus for forming a signal in a communication system, the apparatus comprising:

a receiver for receiving a reference signal over at least one symbol period having a reception period; and

a de-mapper for de-mapping acknowledgement bits located only in symbols around adjacent to the at least one symbol for reference signal reception and for de-mapping data information bits located over at least one symbol not adjacent to the at least one symbol for the reference signal reception.

16. The apparatus as in claim **15**, wherein the receiver comprises a single-carrier frequency division multiple access (SC-FDMA) receiver.

17. The apparatus as in claim **15**, wherein the de-mapper further de-maps channel quality indication bits located over at least one symbol not adjacent to the at least one symbol for the reference signal reception.

18. A method for forming a signal in a communication system, the signal being transmitted over a time period including a plurality of symbols with at least one symbol of the plurality of symbols carrying a reference signal and remaining symbols of the plurality of symbols carrying an information signal, the information signal including control information bits and data information bits, the method comprising:

mapping at least one of the control information bits in at least one of the remaining symbols located only next to the at least one symbol carrying the reference signal;

mapping at least one of the data information bits in at least one of the remaining symbols not located next to the at least one symbol of the symbols carrying the reference signal;

transmitting the at least one of the plurality of symbols carrying the reference signal; and

transmitting the remaining symbols of the plurality of symbols carrying the information signal.

19. The method as in claim **18**, the control information bits include acknowledgement bits.

20. The method as in claim **18**, wherein the control information bits include channel quality indication bits.

21. The method as in claim **18**, wherein the communication system transmits using a single-carrier frequency division multiple access (SC-FDMA) communication method.

22. A method for forming a signal in a communication system, the signal being transmitted over a time period including a plurality of symbols with at least one symbol of the plurality of symbols carrying a reference signal and remaining symbols of the plurality of symbols carrying an information signal, the information signal including acknowledgement bits, channel quality indication bits, and data information bits, the method comprising:

mapping at least one of the acknowledgement bits in at least one of the remaining symbols located only next to the at least one symbol carrying the reference signal;

mapping at least one of the channel quality indication bits in at least one of the remaining symbols not located next to the at least one symbol of the symbols carrying the reference signal;

mapping at least one of the data information bits in at least one of the remaining symbols not located next to the at least one symbol of the symbols carrying the reference signal;

transmitting the at least one of the plurality of symbols carrying the reference signal; and

transmitting the remaining symbols of the number of symbols carrying the information signal.

23. The method as in claim **22**, wherein the communication system transmits using a single-carrier frequency division multiple access (SC-FDMA) communication transmission method.

24. A method for forming a signal in a communication system, the signal being transmitted over a time period including a plurality of symbols with at least two symbols of the plurality of symbols carrying a reference signal and remaining symbols of the plurality of symbols carrying an information signal, the information signal including acknowledgement bits and data bits, the method comprising:

mapping the acknowledgement bits in only the symbol after a first of the at least two symbols carrying the reference signal and only at the symbol before a last of the at least two symbols carrying the reference signal;

mapping the data bits in at least one of the remaining symbols not located next to the at least two symbols carrying the reference signal;

transmitting the at least two symbols carrying the reference signal; and

transmitting the remaining symbols carrying the information signal.

25. The method as in claim **24**, wherein the communication system transmits using a single-carrier frequency division multiple access (SC-FDMA) communication transmission method.

26. A method for forming a signal in a user equipment, the signal being transmitted over a time period in a channel medium, the time period including a plurality of symbols with at least one symbol of the plurality of symbols carrying an information signal, the information signal including acknowledgement bits and data bits, the method comprising:

mapping the acknowledgement bits in a first set of resources when the user equipment operates in first channel medium conditions;

mapping the acknowledgement bits in a second set of resources when the user equipment operates in second channel medium conditions; and

transmitting the at least one symbol carrying the information signal.

27. The method as in claim **26**, wherein the channel medium conditions correspond to a signal-to-interference and noise ratio (SINR).

28. An apparatus for forming a signal in a communication system, the signal being transmitted over a time period including a plurality of symbols with two symbols of a sub-frame carrying a reference signal and remaining symbols of the sub-frame carrying an information signal, the information signal including at least control information bits and data information bits, said apparatus comprising:

a mapping unit for mapping the control bits in at least one of the remaining symbols within around next to the at least one symbol carrying the reference signal; and

a transmitter unit for transmitting the at least one of the plurality of symbols carrying the reference signal.